

BIRLA CENTRAL LIBRARY

PIHANI ( RAJASTHAN )

Call No. 624  
S79P V.2

Accession No. 55046





PRACTICAL DESIGN OF SIMPLE  
STEEL STRUCTURES

BY THE SAME AUTHOR  
PRACTICAL DESIGN OF SIMPLE  
STEEL STRUCTURES  
*VOLUME I*  
*SHOP PRACTICE, RIVETED CONNECTIONS*  
*AND BEAMS, TABLES, ETC*

INFLUENCE LINES  
*THEIR PRACTICAL USE IN BRIDGE*  
*CALCULATION*

# PRACTICAL DESIGN OF SIMPLE STEEL STRUCTURES

VOL. II

GIRDERS, COLUMNS, TRUSSES, BRIDGES, ETC.

*A TEXT-BOOK*

*SUITABLE FOR CIVIL ENGINEERS, STRUCTURAL  
ENGINEERS, ROAD AND RAILWAY ENGINEERS, AND  
STUDENTS AT UNIVERSITIES AND TECHNICAL COLLEGES*

BY

DAVID S. STEWART, B.Sc.(HONS.)(LOND.) PH.D.(EDIN.)

M.Inst.C.E., F.R.S.E., A.R.T.C.

SENIOR LECTURER IN STRUCTURAL ENGINEERING DRAWING AND DESIGN, UNIVERSITY OF EDINBURGH,  
FORMERLY A CIVIL ENGINEER WITH SIR WILLIAM ARROL & Co, LTD., BRIDGE BUILDERS, GLASGOW

CONSTABLE & COMPANY LTD

10 ORANGE STREET LONDON W.C.2

LONDON  
PUBLISHED BY  
*Constable and Company Ltd*

INDIA  
*Orient Longmans Private Ltd*  
BOMBAY      CALCUTTA      MADRAS

CANADA  
*Longmans, Green and Company*  
TORONTO

SOUTH AND EAST AFRICA  
*Longmans, Green and Company Ltd*  
CAPE TOWN      NAIROBI

*First Published* 1929  
*Second Edition* 1940  
*Reprinted* 1942  
*Reprinted* 1947  
*Reprinted* 1950  
*Third Edition* 1953  
*Reprinted* 1955  
*Reprinted* 1957

## PREFACE TO THIRD EDITION

WHERE necessary the text has been re-written to conform with the latest specifications and, at the same time, much fresh material has been added. As in the previous edition, the calculations and the explanatory text of each of the complete designs are not intermingled in the usual manner but are kept apart on opposite pages. The calculations are thus presented as they would be carried out in the design office, but with the additional advantage to the reader that they are explained, step by step, on the opposing pages. The calculations are more or less in register with the relevant explanatory text, but a definite connection between the two is maintained by means of item numbers tagged on to each important result.

The fabrication by welding has not been mentioned. In the space at the author's disposal only a few pages could have been allotted to this particular branch and, rather than treat it so unfairly, it was omitted altogether.

Naturally, in a text-book on this subject, quotations from various sources have been made and the author trusts that these have been suitably indicated or acknowledged in the text. Specifications issued by different authorities, in this and other countries, have often many rules in common, and when a quotation involving such a rule occurs the acknowledgment is always made to that specification which is most easily obtained.

D. S. S. <sup>61</sup> 4



## EXTRACT FROM THE PREFACE TO THE FIRST EDITION

THANKS to the many excellent books upon the Theory of Structures, the student has usually no great difficulty in calculating the primary stresses acting within a structure, but he often finds that these text-books afford very little guidance in the actual design and in the choice of sections. There are also several books of outstanding merit which give complete drawings of various structures, but these—although of great value to the more experienced designer—seldom explain why the particular sections used in the design were adopted in preference to others.

In the following pages the author has endeavoured to supply this want and also to provide a detailed guide for young engineers and architects who are entering the study of the Design of Structures. Special attention has been devoted to giving full details of each step in the process of making a complete design. Only a slight knowledge of the Theory of Structures is presumed, and none whatsoever of Sections or Shop Practice. As far as possible, an endeavour has been made to keep to the more elementary Mathematics, but it is well to warn the student that a good working knowledge of Mathematics and the principles of Mechanics is essential if he is to proceed to the study of more complicated structures.

Calculations are essential in designing, especially in structures, but it should be pointed out to beginners that figures must not be used too dogmatically in every case, since they often provide merely an indication of comparative values to the experienced designer. Practical knowledge is just as essential to a good design as ability to make calculations. The aim in designing is to make a structure which will be as far as is possible equally strong in all its parts, so that when purposely overloaded to cause failure each part will collapse simultaneously.

“ Have you heard of the wonderful one-hoss shay,  
That was built in such a logical way  
It ran for a hundred years to a day,  
And then, of a sudden, it . . .  
. . . went to pieces all at once,—  
All at once, and NOTHING FIRST,—  
Just as bubbles do when they burst.”

“ The Deacon’s Masterpiece,” by Dr. Oliver Wendell Holmes.

It is hoped this treatise will fill a niche amongst the other books on Structural Design and that it will be found useful to those for whom it is intended. The methods employed in the text are those used by the author while engaged in practice, modified by his experience in teaching students.



# CONTENTS

ABBREVIATIONS AND SYMBOLS . . . . .	PAGE xiii
-------------------------------------	--------------

## CHAPTER I PLATE GIRDERS

EFFECTIVE DEPTH . . . . .	1
MOMENT OF INERTIA : ALLOWANCE FOR HOLES . . . . .	3
FLANGES : STRESSES, RULES AND EXAMPLES . . . . .	5
WEB PLATE : STRESSES, RULES AND EXAMPLES . . . . .	9
SHEAR AND RIVET PITCH :	
SHALLOW GIRDERS AND PLATED JOISTS . . . . .	11
DEEP GIRDERS : EXAMPLES . . . . .	14
STIFFENERS : STRESSES, TYPES, RULES AND EXAMPLES . . . . .	17
CURTAILMENT OF FLANGE AND WEB PLATES . . . . .	28
CAMBER . . . . .	29
BEARINGS : WEIGHT OF PLATE GIRDERS . . . . .	31
PLATE GIRDERS WITH INCLINED FLANGES . . . . .	33

## CHAPTER II

### THE DESIGN OF A 40-FT. SPAN GANTRY GIRDER

DEAD LOAD, LIVE LOAD AND IMPACT : B.M. AND SHEAR . . . . .	41
FLANGE WIDTH, WORKING STRESSES, AREAS . . . . .	43
SHEARS AND RIVET PITCHES . . . . .	49
STIFFENERS AND VERTICAL RIVETING TO WEB PLATE . . . . .	51

## CHAPTER III

### AXIALLY LOADED COLUMNS AND THEIR FOUNDATIONS

STRUTS : COLUMNS : RATIO OF SLENDERNESS . . . . .	56
END CONDITIONS AND EQUIVALENT COLUMN LENGTHS :	
EULER'S FORMULA . . . . .	57
NOTES ON THE PRACTICAL COLUMN . . . . .	60
COLUMN FORMULÆ : END CONDITIONS IN PRACTICE . . . . .	61
NUMERICAL EXAMPLE ON END RESTRAINT . . . . .	72

	PAGE
WORKING STRESSES ON MILD STEEL FOR BUILDINGS . . . . .	74
THE DESIGN OF A BUILT-UP WAREHOUSE COLUMN . . . . .	76
STEELWORK : THE SHAFT, THE BASE AND THE RIVETING . . . . .	77
FOUNDATION : DEPTH AND PRESSURE ON THE SOIL . . . . .	84
ALTERNATIVE DESIGNS :	
(1) ORDINARY CONCRETE ON GOOD SOIL . . . . .	85
(2) STEEL BEAM GRILLAGE ON POOR SOIL . . . . .	88
(3) REINFORCED CONCRETE ON POOR SOIL . . . . .	90
(4) ORDINARY CONCRETE ON ROCK . . . . .	94
SAFE PRESSURES ON SOILS . . . . .	94
ALTERNATIVE BASES AND COLUMN SHAFTS . . . . .	95

## CHAPTER IV

COLUMNS—*Continued*TYPES : LACING, ETC., NON-AXIALLY LOADED  
COLUMNS AND THEIR FOUNDATIONS

TYPES OF COLUMNS . . . . .	98
LACING AND BATTEN PLATES . . . . .	103
STRUTS LOADED NON-AXIALLY :	
ECCENTRIC LOADING AND CROSS BENDING . . . . .	109
HORIZONTAL MOVEMENT AT END OF A BEAM . . . . .	110
ECCENTRICITY OF LOADS IN BEAM TO COLUMN CONNECTIONS . . . . .	112
BRACKET ON A PIN-ENDED COLUMN . . . . .	114
COLUMN CONTINUOUS THROUGH SEVERAL FLOORS . . . . .	118
COMBINED DIRECT AND LATERAL THRUST . . . . .	122
FOUNDATIONS LOADED NON-AXIALLY . . . . .	127

## CHAPTER V

## THE DESIGN OF A 55-FT. SPAN ROOF TRUSS

VELOCITY AND PRESSURE OF THE WIND . . . . .	130
WEIGHTS OF ROOF COVERINGS AND LIVE LOADS ON FLOORS . . . . .	132
DESIGN OF PURLINS . . . . .	135
STRESS DIAGRAMS . . . . .	140
DESIGN OF MEMBERS, ETC. . . . .	144
ROOF DRAINAGE . . . . .	154
WIND BRACING AT ENDS AND SIDES OF BUILDINGS, ETC. . . . .	156
THE DESIGN OF A ROOF TRUSS WITH MONITOR . . . . .	162

## CHAPTER VI

## ROOF TRUSSES, PORTAL TRUSSES AND WORKSHOPS

TRUSSES.—TYPES : SPACING : WEIGHT : LIFTING TRUSSES :	
TRUSS SHOES . . . . .	168

## CONTENTS

xi

	PAGE
"PORTAL" TRUSSES : DEAD LOAD FORCES . . . . .	174
COLUMNS HINGED AT CAP AND BASE :	
WIND LOAD FORCES IN TRUSS . . . . .	175
LOADS ON THE COLUMNS . . . . .	179
ALTERNATIVE W.L. STRESS DIAGRAM . . . . .	181
COLUMNS HINGED AT CAP AND FIXED AT BASE :	
WIND LOAD FORCES IN TRUSS . . . . .	184
ALTERNATIVE W.L. STRESS DIAGRAM . . . . .	186
LOADS ON THE COLUMNS . . . . .	187
DESIGN OF A SHOP :	
COLUMN SHAFT AND HORIZONTALS . . . . .	188
BRICK SIDE WALLS AND STEEL FRAMING . . . . .	190
COL. BASE SUBJECTED TO B.M., ETC. . . . .	191
H.D. BOLTS : PRESSURE ON CONCRETE AND SOIL . . . . .	192
SIDE COVERING OF CORRUGATED SHEETING . . . . .	194
CRANE SHAFT AND FOUNDATION . . . . .	196
POSITION OF POINT OF CONTRAFLEXURE. . . . .	197

### CHAPTER VII

THE DESIGN OF A LATTICE GIRDER, FOOT BRIDGE	
TIMBER FLOOR AND CROSS BEAMS . . . . .	202
MAIN GIRDER :	
FLANGE FORCES BY : (i.) SECTIONS AND MOMENTS, (ii.) STRESS DIAGRAM, (iii.) INFLUENCE LINES . . . . .	205
MAXIMAL SHEARS BY : (i.) NEUTRAL POINTS, (ii.) INFLUENCE LINES . . . . .	209
FORCES IN WEB MEMBERS : STRESS REVERSAL . . . . .	211
SECTIONS . . . . .	214
RIVETING . . . . .	217

### CHAPTER VIII

EQUIVALENT UNIFORMLY DISTRIBUTED LIVE LOAD	
CIRCUMSCRIBING AND EQUIVALENT PARABOLAS FOR B.M. . . . .	222
E.U.D.L.L. FOR B.M. AND SHEAR FOR A 70-FT. SPAN RAILWAY BRIDGE . . . . .	226
STANDARD LOADING FOR RAILWAY BRIDGES . . . . .	229

### CHAPTER IX

THE DESIGN OF A 70-FT. SPAN THROUGH RAILWAY BRIDGE	
CLEARANCES, ETC. . . . .	231
WORKING STRESSES ON MILD STEEL FOR GIRDER BRIDGES (1923) . . . . .	233

	PAGE
ALTERNATIVE DESIGNS FOR THE STRINGERS OR RAIL BEARERS	235
CROSS GIRDERS ; SPACING, STRESSES AND SECTIONS . . .	239
MAIN GIRDERS :	
FORCES BY ALTERNATIVE METHODS . . . . .	245
SECTIONS AND RIVETING . . . . .	251
STIFFENERS . . . . .	253
SPICES IN FLANGE PLATES AND ANGLES . . . . .	255
CAST-IRON BEARINGS . . . . .	255
TRACTIVE AND BRAKING FORCES . . . . .	256
WEB PLATE SPLICE . . . . .	259
WIND AND COMBINED STRESSES . . . . .	261

## CHAPTER X

THE DESIGN OF A 70-FT. SPAN PRATT TRUSS  
ROAD BRIDGE

LIVE LOAD ON ROAD BRIDGES . . . . .	263
STEEL TROUGHING . . . . .	265
WORKING STRESSES IN MILD STEEL FOR GIRDER BRIDGES (1937) . . . . .	268
CROSS GIRDER . . . . .	269
MAIN TRUSS :	
FORCES . . . . .	273
WEB VERTICALS AS BRACKETS . . . . .	279
TOP AND BOTTOM CHORDS . . . . .	281
WEB MEMBERS . . . . .	285
RIVETING . . . . .	289
FOOTWAYS . . . . .	291

# ABBREVIATIONS AND SYMBOLS

*The following symbols are also explained throughout the text.*

<p><math>A</math> . . . Area of one flange of a plate girder.</p> <p><math>A_c</math> . . . Ditto for compression flange.</p> <p><math>A_t</math> . . . Ditto for tension flange.</p> <p><math>B</math> . . . Bearing (of a rivet).</p> <p><math>B.M.</math> . . . Bending Moment.</p> <p><math>B.S.</math> . . . British Standard.</p> <p><math>C.G.</math> . . . Centre of gravity.</p> <p><math>C/C</math> or <math>C</math> to <math>C</math> . . . Centre to centre.</p> <p><math>C</math> of <math>P.</math> . . . Code of Practice, Bridges.</p> <p><math>D</math> . . . Effective depth of girder.</p> <p><math>D.L.</math> . . . Dead load.</p> <p><math>D.S.</math> . . . Double shear.</p> <p><math>E.</math> . . . Young's modulus.</p> <p><math>E.U.D.L.</math> . . . Equivalent uniformly distributed load.</p> <p><math>F</math> . . . Shearing force.</p> <p><math>G</math> . . . The first moment.</p> <p><math>H</math> . . . Horizontal force.</p> <p><math>I</math> . . . Impact coefficient or moment of inertia, as per text.</p> <p><math>I_x</math> . . . Moment of inertia about horizontal axis.</p> <p><math>I_y</math> . . . Ditto, vertical axis.</p> <p><math>L</math> . . . Span of girder.</p> <p><math>L.L.</math> . . . Live load.</p> <p><math>M</math> . . . Moment.</p> <p><math>M_A</math>; <math>M_B</math> . . . Moment at <math>A</math>; at <math>B</math>.</p> <p><math>Max.</math> . . . Maximum.</p> <p><math>M.R.</math> . . . Moment of resistance.</p> <p><math>N.A.</math> . . . Neutral axis.</p> <p><math>P</math> . . . Force, generally a pull.</p> <p><math>Pl.</math> . . . Plate.</p> <p><math>R</math> . . . Rivet value: least in <math>S.S.</math>, <math>D.S.</math>, or <math>B</math>.</p> <p><math>R_A</math> . . . Reaction at <math>A</math>.</p> <p><math>R.S.J.</math> . . . Rolled steel joist.</p> <p><math>S</math> . . . Shear or stress, as per text.</p> <p><math>S.S.</math> . . . Single shear.</p> <p><math>T</math> . . . Tee bars.</p> <p><math>\tau</math> . . . Superscript, small capital = tons (British or "long" ton of 2,240 lb.).</p> <p><math>U.D.D.L.</math> . . . Uniformly distributed dead load.</p>	<p><math>U.D.L.</math> . . . Uniformly distributed load.</p> <p><math>U.D.L.L.</math> . . . Uniformly distributed live load.</p> <p><math>V</math> . . . Vertical component.</p> <p><math>V_L</math>; <math>V_R</math> . . . Vertical reaction at left hand; ditto right hand.</p> <p><math>W</math> . . . Load or web area, as per text.</p> <p><math>Z</math> . . . Section modulus.</p> <p><math>b</math> . . . Breadth of a section.</p> <p><math>d</math> . . . Diameter of a rivet or hole.</p> <p><math>d</math> . . . Depth of a rectangle.</p> <p><math>e</math> . . . Eccentricity of load in inches.</p> <p><math>f</math> and <math>F</math> . . . Actual and permissible stress in tons/sq. in.</p> <p><math>f_c</math> and <math>F_c</math> . . . Ditto, compressive</p> <p><math>f_t</math> and <math>F_t</math> . . . Ditto, tension.</p> <p><math>f_u</math> and <math>F_u</math> . . . Ditto, shear on web pls.</p> <p><math>f_b</math> and <math>F_b</math> . . . Ditto, bearing on rivets.</p> <p><math>f_{d_s}</math> and <math>F_{d_s}</math> . . . Ditto, double shear on rivets.</p> <p><math>f_s</math> and <math>F_s</math> . . . Ditto, single shear on rivets.</p> <p>ft. or ' . . . Feet.</p> <p>ft.<sup>T</sup> or 'T . . . Foot tons.</p> <p><math>k</math> . . . Radius of gyration.</p> <p><math>l</math> . . . Span or length in inches.</p> <p><math>l/k</math> . . . Slenderness ratio.</p> <p><math>p</math> . . . Rivet pitch.</p> <p><math>q</math> . . . Intensity of shear stress.</p> <p><math>t</math> . . . Plate thickness in inches.</p> <p><math>y</math> . . . Distance to outer fibres from the N.A.</p> <p><math>\Delta</math> . . . Deflection (Delta).</p> <p><math>\triangle</math> . . . Triangle.</p> <p><math>\phi</math> . . . Diameter of a rivet or hole.</p> <p><math>\theta</math>, <math>\phi</math> . . . Angles (theta and phi).</p> <p><math>\angle ABC</math> . . . Angle ABC.</p> <p><math>&lt;</math> . . . Less than.</p> <p><math>&gt;</math> . . . Greater than.</p> <p><math>\nless</math> . . . Not less than.</p> <p><math>\Sigma</math> . . . The sum of (Sigma)</p> <p><math>=</math> . . . Equal to.</p> <p><math>\llcorner</math> . . . Angle section.</p>
---	--





# PRACTICAL DESIGN OF SIMPLE STEEL STRUCTURES

## VOLUME II

### CHAPTER I

#### *PLATE GIRDERS*

**Depth.** Owing to the decrease in the number of flange plates towards the abutments the depth of a girder is shown on a drawing as "depth over angles," or the distance between the heels of the main angles of the top and bottom flanges, and not as the variable dimension between the outer plates of the two flanges (Fig. 1).

It is easy to deduce a mathematical expression for this depth over angles so as to obtain the girder of minimum weight, but such an expression is practically valueless, since minimum weight and economy are by no means synonymous terms.

Where this depth is not predetermined by considerations of head-room the following approximately states the economic depth in terms of the span  $L$ . Depth over angles =  $0.15L - 0.0006L^2$ , which gives the depth =  $\frac{\text{Span}}{7.25}$  and  $\frac{\text{Span}}{11.11}$  for spans of 20 ft. and 100 ft. respectively. In America the practice is to use deeper girders than is done in this country. British practice is, generally speaking, depth over angles =  $\frac{1}{10}$  to  $\frac{1}{12}$  the span. This last and simple rule is perhaps the best of all, in view of the many factors which bear upon the question of economic depth, such as :—Shop equipment, shipment (8 ft. 6 in. is the usual maximum width for railway transportation ; the girder is usually carried in a vertical position, *i.e.*, web vertical), whether the girder has flange plates or not, and whether the web is assumed to contribute any help to the flanges, etc.

**Effective Depth** is the distance between the centres of gravity of the top and bottom flanges. Where flange plates are not continuous throughout the full length of the girder this dimension is also a

variable, but since the percentage variation is small the effective depth at the point of maximum bending moment is usually assumed to be constant throughout the girder.

When the girder has one or two flange plates it will be found that the centre of gravity of a flange lies very near to the heels of the

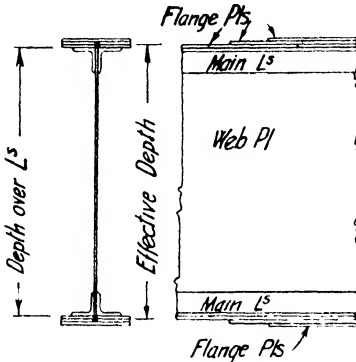

FIG. 1

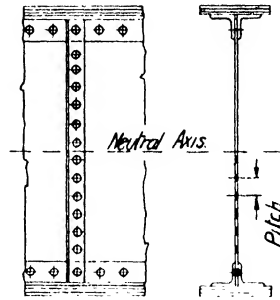

FIG. 2

angles, and so the effective depth is approximately the depth over angles. Where no flange plates are used the flange metal is taken as being concentrated at the centre of gravity of the angles, as given by the section lists, even when the web is assumed to help the flanges in counteracting bending moment.

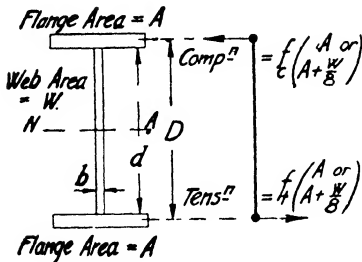

FIG. 3

FIG. 4

MOMENT OF INERTIA OF PLATE GIRDERS

**Shallow Girders.** Plate girders under 30 in., about, in depth closely resemble rolled steel joists, and the method of calculation should be to assume a trial cross-section and then find its moment of inertia *I*.

The extreme fibre stresses in the flanges can then be obtained from the formula  $\frac{M}{I} = \frac{f}{y}$ . The value, whether net or gross, to use for *I* will be discussed later in this chapter. Also see Chapter X (Vol. I).

**Deep Girders.** The following approximation to the gross moment



2 in. of unholed material for every 3 in. of depth, or, net area : gross area :: 2 : 3. In equation (1) the term  $W/6$  represented gross area, and the net area corresponding to this is  $\frac{2}{3}$  of  $W/6 = W/9$ . If the pitch be increased to  $4d$ , or 4 in. with 1 in. diameter holes, the ratio of net to gross area is  $\frac{3}{4}$  and the net value for the web area is  $\frac{3}{4}$  of  $W/6 = W/8$ , as employed in most specifications.

So allowing for holes in the web, equation (1) now becomes

$$M = f \left( A + \frac{W}{8} \right) D \dots \dots \dots (3)$$

Equation (3) can only be used if the web is continuous without a joint, or, if there is a joint, then the joint must be covered so as to withstand both the bending moment and the shear carried by the web at that position. The compression flange could have  $W/6$  added to it as the web's contribution, but for simplicity  $W/8$  is used for both the tension and the compression flanges.

**Allowance for Holes in Tension Flange.** Fig. 4 shows the flange area as being concentrated at the flange centre of gravity, and as each effective square inch of metal can carry  $f$  tons, the total flange force on either flange is  $f \cdot A$  or  $f(A + W/8)$ , equations (2) or (3). This is equivalent to stating that the external bending moment is resisted by an internal couple whose value is the total flange force of  $fA$  or  $f(A + W/8)$  multiplied by the lever arm  $D$ .

Conversely, the bending moment  $\div$  the lever arm  $D$  gives the total flange force  $S$  in either the top or bottom flange, *i.e.*,

$$S = M \div D \text{ tons} \dots \dots \dots (4)$$

Since holes must be deducted in the tensile flange the procedure is to find the net area of metal  $A_t$  required, and then by trial find a section whose gross area is slightly larger than this, but which will, on subtracting the area of the holes, give a net area equal to, or slightly greater than, the required  $A_t$ . No allowance is made for holes in the compression flange, because gross area  $A_c$  is required, and not net area.

$$\therefore A_t = S \div F_t \text{ and } A_c = S \div F_c \dots \dots (5) \text{ and } (6)$$

Where  $A_t$  and  $A_c$  may or may not include  $W/8$  by equations (2) and (3).

A numerical example will show the extreme simplicity of the method.

Design a simply supported plate girder of 40 ft. span, which has its upper or compression flange supported laterally at points 10 ft. apart. (These supports may be braced cross frames between adjoining girders or R. S. J.'s laid on top of, and bolted to, the upper flanges of adjoining girders.) In the formulæ (which are

explained later),  $l$  = unsupported length of top flange,  $b$  = breadth of top flange,  $d$  = clear depth between flange angles or stiffeners,  $t$  = web thickness.

$$F_c = 12.5 - 0.175l/b, \text{ but } \not> 9 = 12.5 - 0.175 \times 120/14.$$

$$= 12.5 - 1.5, \text{ adopt } 9, \text{ as under.}$$

$$F_w = 5.5 - 0.06(d/t - 120) = 5.5 - 0.06(38/\frac{5}{16} - 120)$$

$$= 5.5 - 0.096 = 5.4, \text{ see p. 11.}$$

Distributed load, including wt. of girder  $\tau/\text{ft.} = 2\frac{1}{4}$

The following are the permissible or working stresses which must not be exceeded (*C. of P.—Bridges*) :—

Tension, on net section, $F_t$	$\tau/\text{sq. in.} = 9$
Compression, on gross section, $F_c$	" = 9
Shear, on gross section of web, $F_w$	" = 5.4
Effective depth, say span $\div 10 = 40' \div 10$	= ft. 4
Maximum $B.M = WL \div 8 = (40 \times 2\frac{1}{4}) \div 8$	= ft. tons 450
Total flange force = $M \div D = 450 \div 4$	= tons 112.5
Area, gross, required for compression flange = $112.5 \div 9$	= gross sq. in. 12.5
Area, net, required for tension flange = $112.5 \div 9$	= net " 12.5
Web plate adopted (see p. 11) = $48'' \times \frac{5}{16}''$	= gross " 15

Neglecting the web, equation (2), the upper flange plate and angles should have a gross area of 12.5 and the lower flange plate and angles a net area of 12.5 sq. in. Taking the web into account, equation (3), these areas are  $(12.5 - \frac{1}{16})$ , viz., 10.62 sq. in. gross and net respectively. The actual sections adopted are given later.

#### PLATE GIRDER FLANGES

It will be recalled that the compression flange is a horizontal strut continuously upheld in the vertical plane by the web plate. In the horizontal plane no such support is afforded, unless extra-neously by cross beams or brackets, and the compression flange has to rely upon its own rigidity to withstand the tendency to buckle laterally.

If  $l$  is the unsupported lateral length of a compression flange and  $b$  its breadth, both in inches, then the larger the ratio of  $l/b$  the greater is the lateral flexibility and the weaker the girder. The working stress in compression,  $F_c$  in tons per gross square inch, is usually derived from some special type of strut formula, which takes this relationship between  $l$  and  $b$  into consideration. In the following,  $F_t$  is the working stress in tension in tons per net square inch.

Two British Standard Specifications, No. 153 (*Girder Bridges*) and

No. 466 (*Electric Overhead Travelling Cranes*) connect  $F_c$  and  $F_t$  in the following manner :—

Unstiffened edges, as in Figs. 5 and 6.— $F_c = F_t (1 - 0.01 l/b)$  . (a)

Stiffened edges, as in Figs. 8 to 10.—  $F_c = F_t (1 - 0.0075 l/b)$  (b)

The width of the compression flange is 14 in. so, substituting in (a)  $F_c = 9 [1 - 0.01 (10 \times 12) \div 14] = 8.32 \tau/\text{sq. in. gross}$ .

*The Code of Practice for Simply Supported Steel Bridges* specifies a formula of similar form :— $F_c = F_t = 9\tau/\text{sq. in.}$  when  $l$  does not exceed  $20b$ . Where  $l$  is greater than  $20b$  then  $F_c = 12.5 - 0.175 l/b$ , with a maximum value of  $9 \tau/\text{sq. in. gross}$ .

*British Standard 449, Use of Structural Steel in Building*, obtains the value for the working stress  $F_c$  in a rather more complicated manner, as shown in the next chapter.

The use of different values for  $F_c$  is apt to bewilder the beginner, but it will simplify his outlook if he is reminded that different types of structures have different loads and physical conditions to withstand ; also the specification appertaining to any one type of structure has been drawn up by a group of specialists in that particular branch of structural work. Hence, due to the different origins of the specifications, there are items which vary from each other to a greater or lesser degree. When given a job of work to do the student will have access to the specification which is to govern his design.

The obsolete forms of plate girders illustrated in Figs. 13 and 14 vividly portray the alertness of the pioneer designers towards the

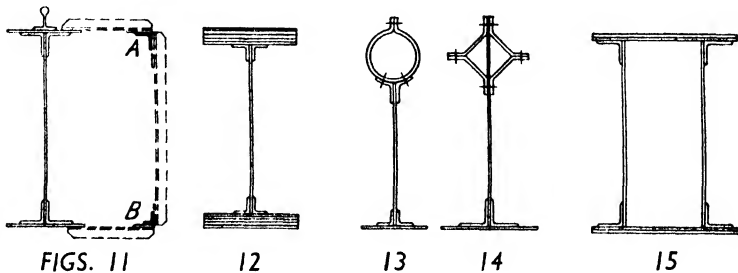
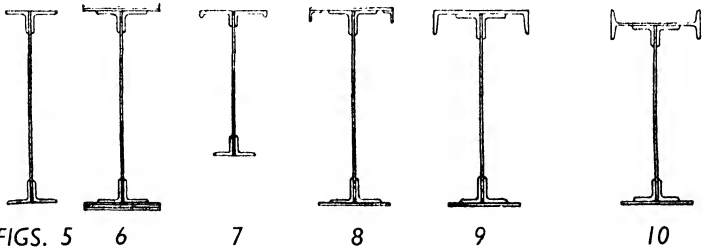

strut action of the top flange. Fig. 6, devoid of any expensive smithwork, is the modern form of compression flange and is highly efficient if designed in keeping with the rules given later. Figs. 7 to 10 are also representative of present-day practice, but illustrate the special case of the crane girder. Here the girder has to withstand not only a vertical load, but also a horizontal force, in the plane of the compression flange, caused by the crane cross-travelling or hauling loads across the shop floor. The top flange is now more prone than ever to buckle laterally, and hence the special flange, which, virtually, is a horizontal girder complete with web and flanges. With Fig. 11 the heavy angle *A* and the horizontal lattice web to the upper flange of the plate girder form the horizontal thrust girder. Angle *B* is light, and so also is the vertical web system connecting *A* to *B*, since these only carry the dead load of the outrigger steelwork. The horizontals from *B* to the main tension flange are simply light stay angles with no calculated stress. The outrigger type is, of course, only used in large spans with heavy cranes.

Flanges of the type shown in Fig. 12 are eliminated by rule 2, as under. This is an atrocious type of flange with a deep pile of flange plates stacked upon two puny angles, and is obviously poor design.

A flange need not necessarily have a flange plate (Fig. 5); in fact, a considerable saving in workmanship is effected by not having one, *viz.*, the holing of the outstanding angle legs plus the holing, edge-planing, riveting, etc., of the plate. On the other hand, the addition of a plate adds considerably to the flange breadth *b* in such formulæ as  $F_c = F_t (1 - 0.01 l/b)$  and so reduces the amount of compression steel required. It would appear to be advantageous, therefore, to adopt lighter angles plus a plate for the compression flange, and thicker angles with no plate for the tensile flange; the latter flange gains considerably by this arrangement.

#### Rules for Girder Flanges:—

(1) The breadth of the flange should not be less than one-fortieth (some specifications give one forty-fifth) of the span.

(2) At least one-third of the total flange area should be given by the flange angles, and in the event of this not being possible the main angles should be at least 6" × 6". The gross cross-sectional area of the compression flange should not be less than the gross cross-sectional area of the tension flange.

(3) Keep the thickest plate next the flange angles. Preferably have as many plates of the same thickness as possible, both in the upper and lower flanges. Plates and angles may be obtained in sizes varying by  $\frac{1}{8}$  in. in thickness.

(4) If the span is small and the girder is not near the eye, flats and



"universal plates" can be used instead of ordinary plates to save edge-planning.

(5) Plate widths are usually in even inches, viz., 10 in., 12 in., 14 in., etc., and seldom in odd inches as 11 in., 13 in., 15 in., etc., although there is no particular reason for this practice.

(6) The working stress in compression is varied according to the form of the flange and the number of lateral supports given.

(7) The distance from the edge of the flange plate to the adjoining rivet line in the flange angle should not exceed sixteen times the thickness of the thinnest flange plate, distance  $Z$  on Fig. 16.

(8) Occasionally the bottom or tension flange plates are made narrower than the top or compression flange plates Fig. 8; see rule (2) above.

**Flange Sections; Numerical Examples.** Areas required were, in square inches,  $A_c = 12.50$  gross;  $A_t = 12.50$  net.

*Compression Flange, Neglecting Web.*

		Alternative Section.
2  s 5" × 5" × ½" = 9.50 gross.		2  s 6" × 6" × ⅜" = 8.72 gross
1 Pl. 14" × ⅜" = 5.25 ,,		1 Pl. 14" × ⅞" = 6.12 ,,
(a) Sq. in. <u>14.75</u> ,,		(b) Sq. in. <u>14.84</u> ,,

*Tension Flange, Neglecting Web.* Rivet holes are ¾ in. diameter.

2  s 5" × 5" × ½" - 4 holes = 8.00 net.	
1 Pl. 14" × ⅜" - 2 holes = 4.69 ,,	
(a) Sq. in. <u>12.69</u> ,,	
Or	2  s 6" × 6" × ⅜" - 4 holes = 7.59 net.
	1 Pl. 14" × ⅞" - 2 holes = 5.46 ,,
	(b) Sq. in. <u>13.05</u> ,,

*Compression Flange, to Include Web.* No alternative will be given

2  s 5" × 5" × ⅜" = 7.22 gross	
1 Pl. 14" × ⅜" = 5.25 ,,	
½ web = 15 ÷ 8 = 1.88 ,,	(Web. Pl. is 48" × ⅝", see later)
Sq. in. <u>14.35</u> ,,	

*Tension Flange, to Include Web.\** No alternative will be given

2  s 5" × 5" × ⅜" - 4 holes @ ¾" × ⅜" = 6.10 net.	
1 Pl. 14" × ⅜" - 2 holes @ ¾" × ⅜" = 4.69 ,,	
½ web = 15 ÷ 8 = 1.88 ,,	
Sq. in. <u>12.67</u> ,,	

\* The centre of gravity of each flange lies 1.09 in. inwards from the outer face of the flange plate. The effective girder depth is thus 46.57 in. or 3.9 ft. (i.e., less than the 4 ft. assumed). Total flange stress =  $M \div D = 450 \div 3.9 = 115.4r$ . Net tensile area required =  $115.4 \div 9 = 12.82$  sq. in., or slightly greater than the net area given. See results by moment of inertia method, p. 26.



splits up the external loads equally between the systems, and then considers each system separately. In  $d$  there are many systems all superimposed one upon the other, thus giving that type of foot-bridge so common at railway stations. The web members are narrow thin flats riveted together wherever one laps across another. The compression members are, relatively, much weaker than the tension members, so that the latter need no longer be considered. It is but a step now in the reasoning to the plated web, where, although there are no openings, the same diagonal compressive and tensile stresses must exist.

In  $a$ , if  $S$  = vertical shear at any section, the force in the web diagonal is  $S \operatorname{cosec} \theta$ , *i.e.*, the diagonal compression is a function of the vertical shear; the greater the vertical shear the greater the diagonal compression. Therefore, if the working vertical shear stress at any section of a plate web girder be kept at a safe figure, there will also be no necessity to investigate the diagonal compression.

The working stress intensity for shear in the web plate  $F_w$  is often taken at  $\frac{5}{8} F_t$ . Further, although  $F_t$  is in tons per net square inch,  $F_w$  is in tons per gross square inch, since shear and compression are calculated on the gross area.

#### Rules for Web Plates :—

(1) The working stress  $F_w$  on the gross cross-sectional area of the web plate is usually in the near neighbourhood of  $\frac{5}{8} F_t$ .

(2) The area of the web plate resisting vertical shear is the gross area found by multiplying the web thickness by the total depth of (a) the web plate of plate girders, and (b) the section in the case of rolled steel joists and channels. See also the succeeding article on the distribution of the horizontal and vertical shear.

(3) The working stress,  $F_w$ , is often made a function of the clear distance between either the flange angles or the adjacent stiffeners. Calling the lesser of these two distances  $d$  and the web thickness  $t$ , then  $F_w = 5.5 \tau/\text{sq. in.}$  provided that  $t$  is not thinner than  $d \div 120$ . When  $t$  is thinner than  $d \div 120$ ,  $F_w = 5.5 - 0.06 (d/t - 120)$  with a limiting value for  $d/t = 180$ . (*C. of P.—Bridges.*)

B.S. 449 (*Buildings*) specifies that the working stress  $F_w$  is the lesser of the two values  $6.5 \tau/\text{sq. in.}$  and  $\left(\frac{225}{b/t}\right)^2 \left[1 + \frac{3}{4} (b/a)^2\right]$  in  $\tau/\text{sq. in.}$  where :— $a$  and  $b$  are the greater and lesser unsupported dimensions of the web in a panel, respectively, (*i.e.*,  $l$  and  $D$  of Fig. 25) and  $t$  is the web thickness. If the stiffeners of the girder, under consideration, be spaced so that  $a = b$ , ( $48'' - 2 @ 5'' = 38''$ ),

then  $F_w = \left[\frac{225}{38 \div 5/16}\right]^2 \left[1 + \frac{3}{4} (1)^2\right] = 5.99 \tau/\text{sq. in.}$

If the stiffeners be spaced at a clear distance apart of  $35\frac{1}{2}$ " then  $F_w$  rises to the maximum value of  $6.5 \tau/\text{sq. in.}$

From the foregoing it follows that stiffeners should be close pitched near the reaction and open pitched near mid span, the regions of maximum and minimum intensity of the shear stress in the web.

(4) If one-eighth of the gross area of the web has been included in the flange area, then the web plate must either be in one unbroken length, or, if in two or more lengths, it should have the splices sufficiently strong to develop both the vertical shear and the bending moment at the joints.

(5) Light internal girders may have the web plates of the minimum thickness of  $\frac{1}{4}$  in. With light external work (both faces frequently painted), such as a light road bridge, the minimum is  $\frac{5}{16}$  in., and for railway bridges the minimum thickness is usually  $\frac{3}{8}$  in.

To facilitate fabrication the web plate may be kept about  $\frac{1}{4}$  in. down from the heels of the upper angles and a similar amount up from the lower angles, as in Fig. 22 *b*, *i.e.*, the depth of the web plate is about  $\frac{1}{2}$  in. less than the girder depth over angles. When this is done the upper or compression edge may be left as a sheared edge, but the lower or tensile edge should be planed. If the girder is an external one without flange plates the upper edge should be planed and made flush with the heels of the angles.

When constructional depth is limited the web must be made very thick, or, alternatively, the box type of girder (Fig. 15), with double or treble web, may be used. In the calculations the vertical shear is divided equally between the web plates. Diaphragms are used between the webs as mentioned in the chapter on columns. Box girders are sometimes objected to on the score of painting and upkeep.

### Section of Web ; Numerical Example.

The total load was $2\frac{1}{4}\tau$ per ft. $\times 40'$	= tons	90
Maximum vertical shear = reaction of $90\tau \div 2$	= "	45
Try a plate $48" \times \frac{1}{4}"$	= sq. in. gross	12
Stress at reaction = $45 \div 12$	= $\tau/\text{sq. in.}$	3.75
Permissible stress by rule (3) above		
= $5.5 - 0.06 [(48" - 2 @ 5") \div \frac{1}{4} - 120]$ , reject	= " " "	3.58
Increase to $48" \times \frac{5}{16}"$	= sq. in. gross	15
Stress at reaction = $45 \div 15$	= $\tau/\text{sq. in.}$	3
Permissible stress by rule (3)		
= $5.5 - 0.06 [38" \div \frac{5}{16} - 120]$ , adopt	= " "	5.4

### HORIZONTAL SHEAR AND RIVET PITCH

#### Rivet Pitch in Shallow Girders and Plated R.S.J.'s.

Let *A* and *B* be two sections distant *x* in. apart on the span of a

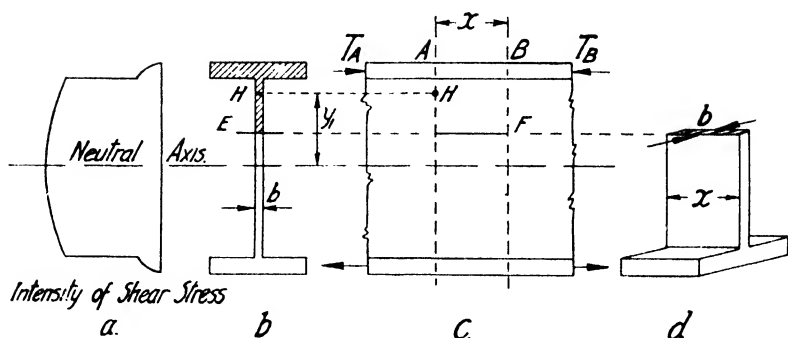

FIG. 18

beam (Fig. 18), and let the bending moments thereat be  $M_1$  and  $M_2$ , respectively, both in inch tons. From  $\frac{M}{I} = \frac{f}{y}$  the stress intensity  $f$  at a point  $H$  on section  $A$ , distant  $y_1$  from the neutral axis, is, in tons per square inch,  $= \frac{M_1 y_1}{I}$ .

Let the area at this point be  $a$  sq. in. (Fig. (b)), then the load thereon is  $\frac{M_1 y_1 a}{I}$  tons.

Similarly the load on another element of area  $a$  distant  $y_2$  from the N.A. is  $\frac{M_1 y_2 a}{I}$  tons.

The total thrust on the hatched area of Fig. (b) above the line  $EF$  is  $\Sigma \left[ \frac{M_1 y_1 a}{I} + \frac{M_1 y_2 a}{I} + \frac{M_1 y_3 a}{I} + \text{etc.} \right] =$   
 $\frac{M_1}{I} \Sigma (ay_1 + ay_2 + ay_3 + \text{etc.})$ .

But  $ay_1 + ay_2 + ay_3$ , etc., is the summation of area  $\times$  distance from the neutral axis, and is, therefore, the first moment  $G$ . Hence the total thrust above  $EF$  at section  $A$  is  $T_1 = \frac{M_1 G}{I}$ .

Similarly the thrust on section  $B$  above the  $EF$  line is  $T_2 = \frac{M_2 G}{I}$ .

The unbalanced thrust of  $T_1 - T_2 = (M_1 - M_2) \frac{G}{I}$  tends to slide the upper hatched portion of the beam horizontally along the line  $EF$  relatively to the lower portion in Fig. (c). If  $q$  is the resulting shear stress per square inch on this horizontal area of  $b \times x$

Fig. (d), then the total horizontal shear balances the thrust of  $T_1 - T_2$ , i.e.,  $qbx = (M_1 - M_2) \frac{G}{I}$ , or  $q = \left( \frac{M_1 - M_2}{x} \right) \frac{G}{Ib}$ .

But  $(M_1 - M_2) \div x$  is the rate at which the bending moment increases or decreases in the distance  $x$  and is, therefore, equal to the vertical shear  $S$ .

Hence 
$$q = \frac{SG}{Ib} \dots \dots \dots (7)$$

A verification that  $(M_1 - M_2) \div x = S$  may be had on referring to Figs. 208 and 209. The difference of the bending moments at the two rails, Fig. 208, is  $(400.4 - 233.6)$  ft. tons. And this divided by the distance  $x$  between them of 5 ft. gives the panel shear, Fig. 209, of  $33.37\tau$ . Conversely, if the areas of the shear curve be summed the bending moment curve can be obtained. Thus in Fig. 209: Height  $66.74\tau \times$  base of  $3.5$  ft.  $= M_2 = 233.6$  ft. tons. Similarly,  $66.74\tau \times 3.5$  ft. plus  $33.37\tau \times 5$  ft.  $= 400.4$  ft. tons  $= M_1$ .

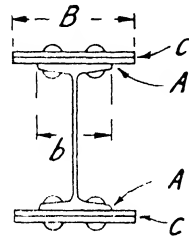

FIG. 19

When calculating the riveting for a section, such as Fig. 19, it is only necessary to consider the rivets at face  $A$ , because the horizontal shear  $q$  decreases in intensity as the outer flange plate is approached; see the intensity curve of Fig. 18 (a) and the succeeding article.

The total shearing force along face  $A$  per foot length of girder is  $F$  tons and is equal to  $q$  in tons per square inch  $\times$  area of  $b'' \times 12''$ ,

i.e., 
$$F = 12qb = \frac{12bSG}{Ib} = \frac{12SG}{I} \text{ tons} \dots \dots \dots (8)$$

Or if breadth  $B$  is used, then

$$F = \frac{12BSG}{IB} = \frac{12SG}{I} \text{ tons,}$$

so that it is immaterial which breadth is used when dealing with the total shearing force  $F$ . If the lesser rivet value in S.S. or bearing be  $R'$ , then the number of rivets required per foot length of the girder is total shearing force  $F$  tending to move the flange plates along face  $A$  of the joist  $\div$  the rivet value, i.e.  $(12SG \div I) \div R$ . Numerical examples are given in Chapter X (Vol. I), and elsewhere in the text. It will be noted that at every cut-off of a flange plate new values will occur for  $G$  and  $I$  in the formula.

**Distribution of the Horizontal and Vertical Shear.** For the ordinary rectangular beam of Fig. 20 the intensities of the horizontal shear  $q$  in pounds (or tons) per square inch at various positions

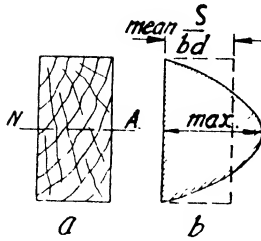

FIG. 20

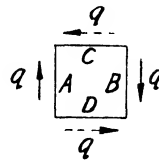

FIG. 21

in the depth of the beam are shown by the parabola of diagram (b). The maximum horizontal shear intensity occurs at the neutral axis and its value is

$$q = \frac{SG}{Ib} = \frac{S(\frac{1}{2}bd \times \frac{1}{4}d)}{\frac{1}{12}b d^3 \times b} = 1\frac{1}{2} \frac{S}{bd}$$

But  $S \div bd$  is the mean vertical shear in pounds (or tons) per square inch, and hence the maximum value for  $q$  horizontal is one and a half times the mean vertical shear intensity.

Fig. 18 (a) illustrates the curve for  $q$  for a simple type of beam section, where, since the section is built up of rectangles, the curved portions of diagram (a) are also parabolas.

A vertical shear at any point in the cross-section of a beam must be accompanied by a horizontal shear of the same intensity. Thus, in Fig. 21, if a force of  $q$  lb. (*i.e.*, intensity of  $q$  lb. per square inch if the cube be of unit side) acts along face  $A$  of the cube, another equal force  $q$  is required to act as shown on face  $B$  to balance the cube for translation. These two equal forces  $q$ , however, form a couple which would rotate the cube unless an equal and opposite couple is applied through the forces  $q$  at  $C$  and  $D$ ; which proves the statement that a vertical shear is accompanied by a horizontal shear of the same intensity.

From the foregoing and Fig. 18 (a) it is seen that the amount of vertical shear carried by the flanges is small, especially in deep girders, and the approximation may be made that the vertical shear  $S$  at any section is resisted entirely by the web plate. The mean vertical shear stress of  $S \div bd$  (rule (2) for web plates) gives a value very close on the average to that obtained from the formula of  $q = \frac{SG}{Ib}$ .

**Horizontal Shearing Force on the Flange Rivets of Deep Girders.**

*Case I.* Flanges where  $W/8$  is included, *i.e.*,

$$M = f \left( A + \frac{W}{8} \right) D \dots \dots \dots (3)$$

In connection with this and Fig. 3, the approximate moment of inertia was shown to be  $I = \frac{D^2}{2} \left( A + \frac{W}{6} \right)$ , and using  $W/8$  for the reasons stated this becomes  $I = \frac{D^2}{2} \left( A + \frac{W}{8} \right)$ . Substituting this value in (8), the total horizontal shearing force of  $F = \frac{12SG}{I}$  tons/ft.

run, now becomes  $F = \frac{12SG}{\frac{1}{2}D^2 \left( A + \frac{W}{8} \right)}$  tons/ft. run . . . . (9)

Considering the rivets connecting the web to the flange, whose gross area is  $A$  and whose first moment  $G$  is approximately  $A \times \frac{1}{2}D$ , it follows that

$$F = \frac{12SA \cdot \frac{1}{2}D}{\frac{1}{2}D^2 \left( A + \frac{W}{8} \right)} \text{ tons/ft.} = \frac{SA}{(D \div 12) \left( A + \frac{W}{8} \right)} \text{ tons/ft.}; \text{ where}$$

$D$  is in inches. If the effective depth,  $D$ , (*i.e.*, approximately the depth over angles) be stated in feet instead of in inches, then

$$F = \frac{SA}{D \left( A + \frac{W}{8} \right)} = \frac{S}{D} \times \frac{A}{\left( A + \frac{W}{8} \right)} \text{ tons/ft.} \quad \dots (10)$$

Where  $A$  is the gross area of one flange (plates and angles) and  $W$  is the gross area of the web plate.

The horizontal load on each rivet =  $F \div$  number of rivets in a foot length =  $h$ .

*Case II.* Flanges where  $W/8$  is neglected, *i.e.*,

$$M = f \cdot A \cdot D \quad \dots \dots \dots (2)$$

Neglecting the web in  $I = \frac{D^2}{2} \left( A + \frac{W}{6} \right)$ , the approximate  $I$  is  $\frac{D^2}{2} (A)$ . Therefore in (9) and (10) replace  $\left( A + \frac{W}{6} \right)$  by  $A$  and so

arrive at  $F = \frac{S}{D}$  tons/ft., if  $D$  is in feet . . . . (10a)

Briefly, then, when  $W/8$  is neglected the horizontal shear per foot of span equals the vertical shear per foot of depth, and when  $W/8$  is included this horizontal shear is reduced by multiplying by

$$\frac{A}{\left( A + \frac{W}{8} \right)}$$

**Local Vertical Shear on the Flange Rivets.** From Fig. 22 it is clear that the load which rests on the top flange of the girder must



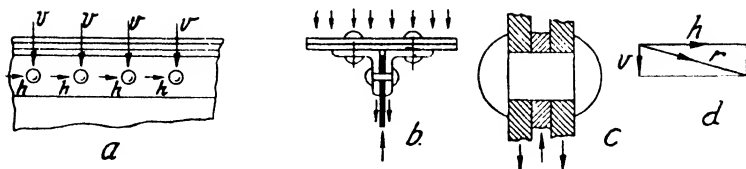

FIG. 22

place every rivet through the web in vertical double shear  $v$ , or bearing, in addition to the horizontal force  $h$  per rivet, found from (10) and (10a). The resultant load per rivet is given by the diagonal of the force parallelogram of (d) and is  $\sqrt{h^2 + v^2}$ .

**Numerical Example on Rivet Pitch in Deep Plate Girders.** The girder which has been under discussion is of 40 ft. effective span and carries an inclusive load of  $2\frac{1}{4}\tau$ /ft. Vertical shear at the end is  $45\tau$ , at 4 ft. from the end  $36\tau$ , and at 8 ft. from the end the vertical shear is  $27\tau$ . The  $\frac{3}{4}$ -in. diameter rivets through web and flange angles are in *D.S.* ( $5\cdot30\tau$ ) and  $\frac{5}{16}$  in. bearing ( $2\cdot81\tau$ ), see Table on p. 75.

*Case I.* Web neglected in the flange area.  $\therefore F = \frac{S}{D}$ , where

$D = 4$  ft. effective depth.

Mean vertical shear/ft. of depth of web  $= 45\tau \div 4' =$  tons 11.25

$\therefore$  Mean horizontal shear/ft. run also  $=$  „ 11.25

Local vertical load on rivets is  $2\frac{1}{4}\tau$ /ft. run of girder.

Resultant load per foot length  $= \sqrt{11\cdot25^2 + 2\cdot25^2} =$  „ 11.47

Number of rivets per foot run of girder  $= 11\cdot47 \div 2\cdot81 =$  4.08

Reeled pitch (double rivet line)  $= 12 \div 4\cdot08 = (2\cdot94'') =$  in. 3

Similarly at 4 ft. and 8 ft. from the end the calculated pitches are (3.63 in.)  $3\frac{1}{2}$  in. and (4.74 in.)  $4\frac{3}{4}$  in.

*Case II.* Web included in the flange area.

$$\therefore F = \frac{S}{D} \times \frac{A}{A + \frac{W}{8}}, \text{ where } \frac{A}{A + \frac{W}{8}} = \frac{12\cdot47}{14\cdot35} = 0\cdot87$$

(see numerical examples on the compression flange), i.e.,  $F = 0\cdot87 \frac{S}{D}$ .

Mean vertical shear/ft. of depth  $= (45\tau \div 4') \times 0\cdot87 =$  tons 9.79

Resultant load per foot length  $= \sqrt{9\cdot79^2 + 2\cdot25^2} =$  „ 10.04

Number of rivets per foot run of girder  $= 10\cdot04 \div 2\cdot81 =$  3.6

Reeled pitch (double rivet line)  $= 12 \div 3\cdot6 = (3\cdot33'') =$  in.  $3\frac{1}{3}$

Similarly at 4 ft. and 8 ft. the calculated pitches are (4.14 in.) 4 in.

and (5.5 in.)  $5\frac{1}{2}$  in. Maximum straight line pitch on an angle leg with two rivet lines is  $24t = 24 \times \frac{3}{8}'' = 9''$ , see item 64, p. 250.

The rivet pitch in the bottom flange angles could be wider than that in the top flange, because there is no local vertical load on these rivets. For simplicity of fabrication, however, both pitches are made the same.

The rivets connecting the horizontal legs of the angles to the flange plates must reel with those through the vertical legs, and so only the pitch of the latter need be calculated. This practice is not at variance with theory, because there is a rapid decrease in the intensity of the horizontal shear as the outer flange plate is approached, with a consequent reduction in the number of rivets required. Although the rivets through the horizontal legs of the equal angles are only in single shear, as against the double shear value of the rivets through the vertical legs, the shearing value for both sets is the same, since there are twice as many horizontal leg rivets as there are vertical leg rivets.

#### STIFFENERS

Stiffeners, as the name implies, strengthen and stiffen the web plate against any possible crumpling action due to the compressive stresses in the web. They may be classified into two groups—(a) those which are placed at points of concentrated loading, and (b) those which are placed in intermediate positions between such points.

That a plate girder is strengthened by stiffeners both during transit (a very important consideration) and after erection is well known, but what the extent of this beneficial action is in the latter case has never been definitely ascertained. Many theories have been evolved as to their disposition on the girder, but there is hardly one which cannot be disproved by some existing girder.

The following argument, although in itself highly debatable, may, nevertheless, help the beginner to grasp the essential points in stiffener design without forcing him into an exhaustive study of the involved stresses which exist in a plate girder. The theory of the plate girder is exceedingly intricate, yet, despite this fact, modern methods of designing make it the simplest type of girder to calculate.

*Group (a).* Every one is in agreement as to the necessity of a stiffener under a concentrated load. Its function of distributing the load from the top flange into the girder is self-evident, but is it not possible that this stiffener acts as a strut of the imaginary N truss, which may be supposed to act within the web plate? Here the diagonals, formed by the web plate, are in tension, while the

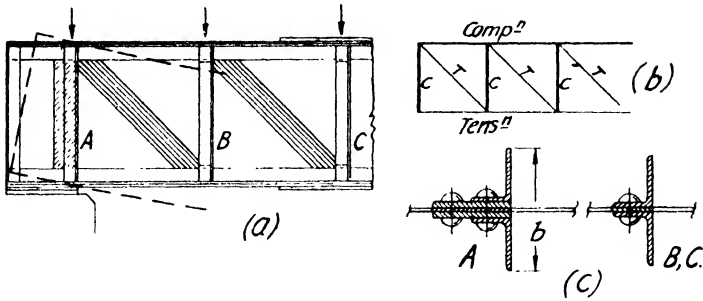

FIG. 23

stiffeners act as the compression members (Fig. 23). (Roughly this is the theory of the Wagner diagonal-tension field.) A very thin web—as used in aeroplane construction—may buckle because of elastic instability but still carry its load. The reason is that the shear is now being carried in diagonal-tension by the web, with the stiffeners in compression.

Consider stiffener *A*. This stiffener is designed to carry the total end reaction as a strut. Usually these double angles are not joggled, but are carried straight and unbent on packings on the web and are made to fit tightly against the horizontal legs of the top and bottom main angles.

Stiffeners *B* and *C*, placed at points of local concentrations, are also designed to carry the total vertical shear *S* at their point of attachment. These angles are usually joggled, but if the local load is a heavy one, or if the flanges are thicker than  $\frac{5}{8}$  in., packings are used on both sides of the web as for stiffener *A*.

The effective area of the stiffener is usually specified as being the gross cross-sectional area of the pair of angles forming the stiffener and not the hatched area of angles and packings of Fig. 23 (c). In the case of bearing stiffeners, only, *i.e.*, *A* of Fig. 23, B.S. 449 (*Buildings*) permits the inclusion of a length of web on each side of the stiffener centre line of twenty times the web thickness where available, hence gross area = area of 2 angles plus  $40t \times t$ , where *t* is the web thickness. (American practice permits an addition of  $25t^2$  at bearing stiffeners and at stiffeners placed at points of concentrated loading.)

Stiffeners should be designed as struts from the strut formula in the specification issued with the contract, but due to the help afforded by the web the effective length *l* is taken as three-fourths of the girder's depth in inches.

It is here suggested that  $F_c = F_t (1 - 0.01 l/b)$  could be successfully employed; it is simple, involving no calculation of radius of

gyration, and is quite in keeping with our knowledge of stiffeners. In this formula  $b$  is the breadth over the stiffener angles and  $l$  is the girder depth in inches.

In all double-angle stiffeners the rivets connecting the angles to the webs must develop, in *D.S.* or bearing on the web, the load allotted to the pair of angles forming each stiffener. If the stiffener is a single angle (on one web face only) then the connecting rivets to the web are in *S.S.* or bearing on the lesser thickness.

*Group (b).* Intermediate stiffeners  $E$  and  $F$  are shown in the two end panels of Fig. 24. In panel  $BC$  the intermediate stiffener  $F$  and the imaginary connecting web diagonals form a double web system, which share the vertical shear  $S$  between them. Similarly if an additional intermediate stiffener were placed in panel  $BC$  and its lower extremity joined to the cap of stiffener  $B$  and its upper extremity joined to the base of stiffener  $C$ , as is done with  $F$  in Fig. 24, there would be three web systems to share the vertical shear, *i.e.*, the load on an intermediate stiffener is a function of the spacing adopted.

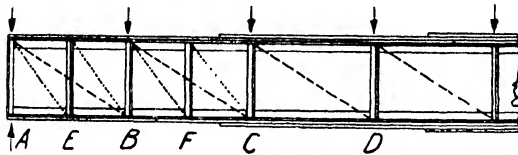

FIG. 24

*B.S. No. 153 (Bridges) and C. of P. (Bridges)* state that each pair of intermediate stiffener angles shall be designed to carry a vertical load  $s = Sp \div 4D$  where the symbol  $p$  represents the distance between the centre lines of the immediately adjoining stiffeners on each side of the stiffener considered; *e.g.*, with reference to stiffener  $F$  it is the distance  $BC$  of Fig. 24. Intermediate stiffeners should not be further apart than  $1\frac{1}{2}$  times the girder depth,  $D$ , by one specification, and  $2D$  by another. Hence the maximum design load, occurring with the maximum value of  $p$ , is  $\frac{3}{4}S$  and  $S$ , respectively.

Text-books on the Strength of Materials point out that the curved lines of principal stress in a web plate cut the neutral axis at  $45^\circ$ . At the neutral axis, therefore, the tension lines (such as those of Fig. 23) cut the compression ones (those of Fig. 25) at right angles. Assuming the compression lines to be constantly inclined at  $45^\circ$ , a more orthodox treatment of intermediate stiffeners can now be described.

The maximum length of any diagonal strip between the supporting elements of stiffeners or flange angles, Fig. 25, is either  $D\sqrt{2}$  or  $L\sqrt{2}$ , whichever is the lesser. This  $\sqrt{2}$  can be included in the strut constant  $C$  and only the lesser length  $D$  or  $L$  stated. These strips are, obviously, not simple compression members, since the tendency to buckle outwards from the plane of the paper is restrained to a

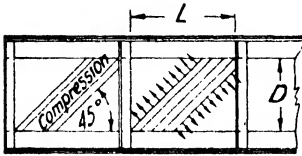

FIG. 25

large extent by the diagonal tension strips at right angles to the strip under consideration; a fact which is allowed for when fixing the value of the strut constant. Although a function of the working tensile stress  $F_t$ , the safe shear stress  $F_w$  depends upon the load carried by the diagonal strut. Finally, taking the remaining factor of web thickness  $t$  into account the Rankine type of web formula is

$$F_w = \frac{F_t}{1 + C \left(\frac{d}{t}\right)^2}, \text{ where } d \text{ is the spacing of the stiffeners or the}$$

unsupported depth of the web, whichever is the lesser.

An example of this type is furnished by the *B.S.S. No. 466—Electric Overhead Travelling Cranes*, which, using  $F_t = 6\tau$  per sq. in., gives

$$F_w = \frac{6}{1 + \frac{1}{5,000} \left(\frac{d}{t}\right)^2}$$

The girders of these cranes (not to be confused with the shop gantry girders over which the crane runs) are subjected to very heavy loads, suddenly applied, *i.e.*, large impact stresses are induced, and to allow for these the working stresses are purposely kept low. This formula cannot be satisfactorily applied to other structures because it will give abnormally low working stresses on the web or, conversely, very close spacing of the stiffeners. Fig. 26 gives this formula in the form of a chart.

Another formula of this type connecting web stress with stiffener spacing is given by Fig. 27. The basic working stresses for plate girders are :—

$$F_t = F_c = 20,000 \text{ lb./sq. in.} = 8.93\tau/\text{sq. in. (i.e., } 9\tau/\text{sq. in.)}$$

$F_w = 13,000 \text{ lb./sq. in.} = 5.8\tau/\text{sq. in.}$  This formula gives rather close spacing of stiffeners.

To illustrate the complex nature of the web stresses in a plate girder a model of such a structure should be made in stiff drawing

paper, but let the web project downwards past the bottom angles, thus providing a means for suspending light weights. It will be found that the girder can carry heavier loads when thus suspended than when the weights are placed on the top flange. Moreover, the capacity of the girder to carry loads on the top flange can be further increased if small additional weights are suspended at the bottom flange.

Stiffeners have even been placed on plate girders at an angle of  $45^\circ$  along the web in a direction shown by the compression lines of Fig. 25, but this is all that can be said in favour of such a procedure.

An experienced designer seldom uses any formula for the spacing ; appearance more than anything else governs the position of the intermediate stiffeners. Briefly, close space the stiffeners near the end of a simply supported girder, and open out the pitch near the centre of the span, as in Fig. 29.

**Types of Stiffeners** are illustrated in Fig. 28. Stiffeners (*a*) and (*f*) are usually reserved for the ends of the girder, although they are frequently used as intermediate stiffeners. Types (*c*) and (*d*) are practically always intermediate stiffeners.

**Rules for Stiffeners :—**

(1) Two angles are usually employed to form one stiffener, although a single angle may be used. Stiffeners over bearings should project outwards from the web as far as possible and should bear tightly against the flanges. Provided that the flange angles are not thicker than  $\frac{5}{8}$  in. the intermediate stiffener angles may be joggled ; so also may stiffeners at points of local concentrations, but end stiffeners must be carried straight and unbent on web packings.

(2) Stiffeners and their connecting rivets to the webs should be designed to carry loads not less than those specified under :—

(*a*) *Bearing Stiffeners.* The total reaction at the bearing.

(*b*) *Stiffeners at Points of Local Concentrations.* The maximum vertical shear at the point of attachment.

(*c*) *Intermediate Stiffeners.* That portion, *s*, of the vertical shear, *S*, at the point of attachment as given by  $s = Sp \div 4D$ , where *D* is the girder depth and *p* is the *C* to *C* distance between the neighbouring stiffener on the immediate right to that on the immediate left of the stiffener considered.

(3) The working stress  $F_c$  should be obtained from the strut formula in the specification covering the contract, with the effective strut length *l* taken as three-quarters the girder's depth in inches.

Alternatively use  $F_c = F_t (1 - 0.01 l/b)$ , where *l* is now the girder's depth in inches and *b* is the total breadth over the outstanding legs of the stiffener angles.

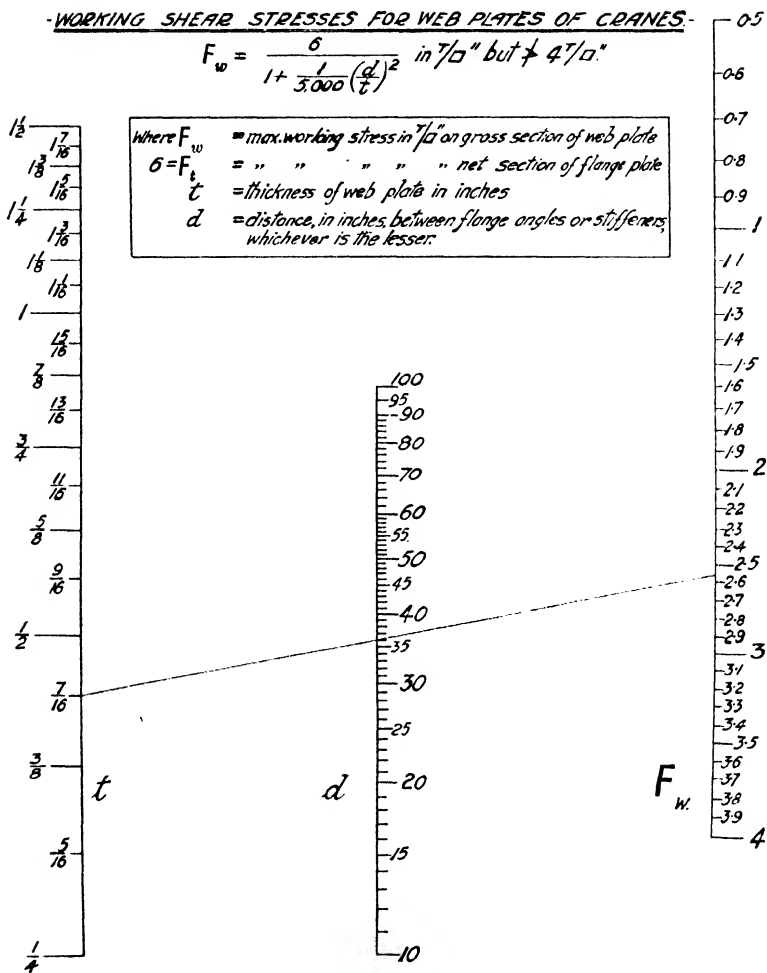

FIG. 26

ALIGNMENT CHART GIVING THE WORKING SHEAR STRESSES ON THE WEB PLATES OF CRANE GIRDERS

*Example.* If the web plate thickness  $t$  is  $7/16"$  and the distance  $d$  is 36", what is the working stress on the web plate? The answer is  $F_w$  should not exceed 2.55T per gross sq. in.

*Method.* Lay a straight edge so as to join points  $t = 7/16$  to  $d = 36$  and this gives the point of cutting on the  $F_w$  vertical as 2.55.

Similarly, if any one of the three quantities is unknown, it can be found from the straight line joining the other two.

If  $t$  and  $d$  are given then this chart may also be used for any value of  $F_t$  by multiplying the value given on the  $F_w$  line by  $F_t/6$ : e.g., if  $F$  is 8 or 9 then the multiplier is  $8/6$  or  $9/6$ , respectively.

SPACING OF STIFFENERS ON PLATE GIRDERS  
AMERICAN PRACTICE.

$$d = \frac{11,000t}{\sqrt{F_w}}$$

Where,  $d$  = clear distance in inches between stiffeners.  
 $t$  = web thickness in inches.  
 $F_w$  = stress in web plate in lb./sq. in.

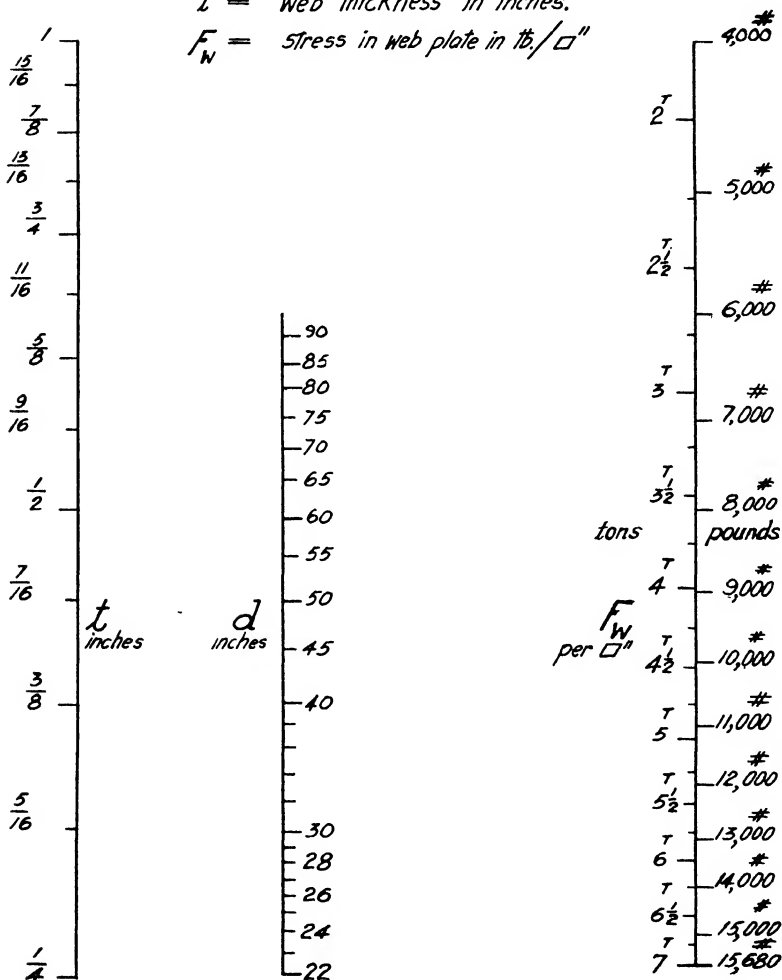
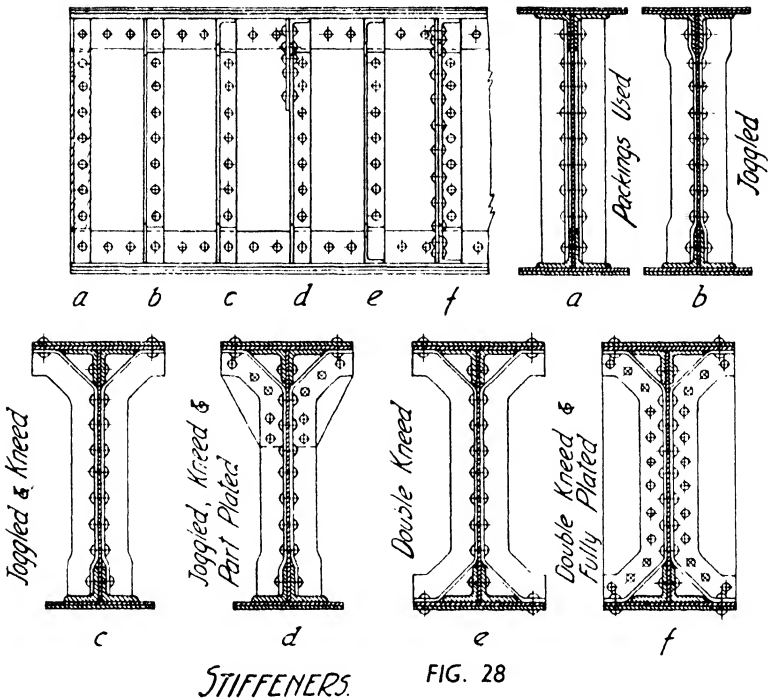

FIG. 27

ALIGNMENT CHART GIVING THE SPACING OF STIFFENERS ON PLATE GIRDERS  
(AMERICAN PRACTICE)





The effective area of the stiffener strut is the gross cross-sectional area of the two angles forming it and excludes any packings, but, as previously mentioned, a bearing stiffener within a building may have  $40t^2$  added to the gross area of the angles, where  $t$  is the web thickness in inches.

(4) Size of Angles. Preferably use angles with unequal legs; the longer leg should be the unriveted, or outstanding one. If the girder depth in inches be  $D$  then each outstanding leg should be

(a)  $(D \div 30) + 2$  in. for a two-angle stiffener, and

(b)  $(D \div 30) + 4$  in. for a single-angle stiffener.

(5) The minimum pitch of intermediate stiffeners may be settled by Rule (3) for web plates. The maximum pitch is usually about  $1\frac{1}{2}$  times the girder depth.

(6) Eschew the use of tee bars as they break into the main horizontal rivet pitch. Always use a double-angle stiffener over a web joint.

(7) Where the web is thicker than one-sixtieth of the unsupported depth between flange angles (which is seldom) stiffeners are not required.

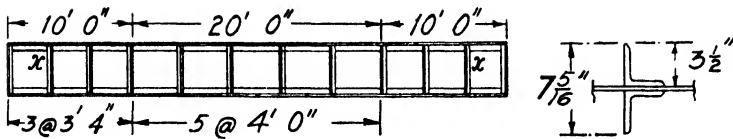

FIG. 29

**Numerical Example.** Since the loading on the 40 ft. span girder (depth 4') was  $2\frac{1}{4}\tau$  per ft. the vertical shear at  $x$ , Fig. 29, is equal to the reaction of  $45\tau$  less  $3\cdot33'$  ( $@ 2\frac{1}{4}\tau/\text{ft}$ ). =  $37\cdot5\tau$

Design load on stiffener,  $s = Sp \div 4D =$

$$37\cdot5\tau \times 6\cdot7' \div (4 \times 4') = 15\cdot7\tau$$

Free leg of a stiffener angle =  $(48 \div 30) + 2''$  say =  $3\cdot5''$

Adopt 2  $\lfloor s \ 3\frac{1}{2}'' \times 3'' \times \frac{1}{4}''$ ; gross area in sq. in. =  $3\cdot12$

Effective length  $l = 3/4$  of  $48''$  =  $36''$

Radius of gyration,  $k$ , of two angles about web centre line =  $1\cdot6''$

Slenderness ratio,  $l/k = 36'' \div 1\cdot6'' = 22\cdot5$

Permissible load by three alternative formulæ, depending upon specification employed.

(a)  $F_c = 9 (1 - 0\cdot0038 \times 22\cdot5)$ , p. 268,  $\tau/\text{sq. in.}$  =  $8\cdot23$

(b)  $F_c$  for  $l/k = 22\cdot5$ , p. 67,  $\tau/\text{sq. in.}$  =  $7\cdot11$

(c)  $F_c = F_t (1 - 0\cdot01 l/b) = 9 (1 - 0\cdot01 \times 48''/7\frac{5}{16}'')$ ,  $\tau/\text{sq. in.}$  =  $8\cdot4$

Permissible load =  $3\cdot12 \times 7\cdot11$ , item (b) is minimum =  $22\cdot18\tau$

No. of rivets =  $15\cdot7\tau \div 2\cdot81\tau (\frac{5}{16}'' B)$ , minimum =  $6$

All the intermediate stiffeners will be given the same section as that at  $x$ , which carries the heaviest design load. The stiffeners adopted are over-strong, but are used because they are composed of practically minimum sections.

**Fig. 29.** An alternative to the stiffener spacing for the mid 20 ft. of span is four panels at 5 ft. in place of five panels at 4 ft., thereby saving a stiffener per girder.

#### MOMENT OF INERTIA METHOD

Many specifications do not particularly specify what method should be employed for the design of plate girders, but a few now state that the moment of inertia method must be used. In this case, a trial section is always found by the  $M = f.A.D$  method and then its moment of inertia calculated. Only the sections making up both flanges are affected by this mode of calculation, the web, stiffeners rivets, etc., are all designed as previously explained.

To simplify this additional calculation the following procedure is adopted.

- The neutral axis is taken as being at the centre of gravity of the gross section.
- The moment of inertia of the entire gross section is used for calculating the stress in the extreme fibres of the compression flange.
- The moment of inertia of the entire net section is employed for computing the stress in the extreme fibres of the tension flange.

Consider the girder previously designed with the sections as shown on Fig. 16.

$$\text{Maximum bending moment was } 450 \text{ ft.}^\tau = 5,400 \text{ in.}^\tau$$

$$\text{Gross moment of inertia, Fig. 16} = 16,453 \text{ in.}^4$$

$$\text{Gross section modulus, } Z = 16,453 \text{ in.}^4 \div 24\frac{3}{8} \text{ in.} = \underline{675 \text{ in.}^3}$$

$M$  of  $I$  of  $\frac{3}{4}$  in. dia. holes in entire section, assuming 4" vertical pitch in web. ( $M$  of  $I$  of holes about own axis is negligible. The web pitch has little effect upon the result. Thus a 3" pitch increases the total of 2,300 by only  $2\frac{1}{2}$  per cent. to 2,358.)

$$\text{In web : } AD^2 = 2 \text{ off} \times \frac{3}{4}'' \times \frac{5}{16}'' (4^2 + 8^2 + 12^2 + 16^2) = 225 \text{ in.}^4$$

$$\text{Web and } \underline{s} = 2 \text{ off} \times \frac{3}{4}'' \times 1\frac{1}{16}'' (22^2) = 772 \text{ ,,}$$

$$\underline{s} \text{ and fl. pls.} = 4 \text{ off} \times \frac{3}{4}'' \times \frac{3}{4}'' (24^2) = 1,296 \text{ ,,}$$

$$\text{Total } M. \text{ of } I. \text{ of holes} = 2,293 \text{ ,,}$$

$$M. \text{ of } I. \text{ of entire net section} = 16,453 - 2,293 = 14,160 \text{ ,,}$$

$$\text{Net section modulus } Z = 14,160 \text{ in.}^4 \div 24\frac{3}{8} \text{ in.} = 581 \text{ in.}^3$$

Extreme fibre stress,

$$\text{compression} = M \div Z$$

$$= 5,400 \text{ in.}^\tau \div 675 \text{ in.}^3 = 8^\tau/\text{sq. in.}$$

$$\text{tension} = 5,400 \text{ in.}^\tau \div 581 \text{ in.}^3 = 9.29 \text{ ,,}$$

This last value is too high being above  $9^\tau/\text{sq. in.}$ , so thicken the flange plates by  $\frac{1}{16}$  in. up to  $\frac{7}{16}$  in. Only the tension flange requires this, but since the gross area of the compression flange must not be less than the gross area of the tension flange both flange plates now be 14 in. by  $\frac{7}{16}$  in. In consequence the  $M. \text{ of } I.$  of the flange plates now rise from 6,144, as given on Fig. 16, to 7,191 and so the total gross  $M. \text{ of } I.$  is 17,500 in.<sup>4</sup> and the gross  $Z$  is 716 in.<sup>3</sup> The  $M. \text{ of } I.$  of the holes is slightly higher at 2,408 in.<sup>4</sup>

$$\text{Net } M. \text{ of } I. \text{ is } 17,500 - 2,408 = 15,092 \text{ in.}^4$$

$$\text{Net } Z \text{ is } 15,092 \text{ in.}^4 \div 24\frac{7}{16} \text{ in.} = 617 \text{ in.}^3$$

$$\text{Extreme fibre stress, compression} = 5,400 \text{ in.}^\tau \div 716 \text{ in.}^3 = 7.54^\tau/\text{sq. in.}$$

$$\text{,, ,, ,, tension} = 5,400 \text{ in.}^\tau \div 617 \text{ in.}^3 = 8.75 \text{ ,,}$$

It is thus apparent that a  $\frac{3}{8}$ -in. thick flange plate is rather thin, while a  $\frac{1}{8}$ -in. thick plate is rather thick. The  $M = f.A.D$  method therefore gives very reasonable results.\* The permissible stress of 9 tons used in the  $M = f.A.D$  method is the average stress at the centre of gravity of the flange section, whereas the tensile stresses of 9.29 and 8.75 occur at the extreme fibres of the section, thus explaining the apparent overstress. Further, only the rivet holes in the lower or tensile portion of the simply supported girder should be deducted. If this were done the neutral axis would shift its position to about  $1\frac{1}{2}$  in. above mid-height although the resulting extreme fibre stress in tension would be only (very) slightly lessened.

**Combined Shear and Bending.** At the reactions of a simply supported girder, with a uniformly distributed load, the web plate is subjected to shear only, but elsewhere throughout its length it is also subjected to bending stresses, which may seriously affect the web plate, especially if it is thin and deep (see "Strength of Materials": principal stresses). The *Code of Practice for Simply Supported Steel Bridges* states that the actually occurring shear stress should not exceed the permissible shear stress reduced by the percentage,  $p = Kf_b^2$  where:— $K$  has the value given in the table;  $f_b$  is the bending stress in tons/sq. in. in the flange at the section considered;  $d$  is the lesser of the clear distances between either flange angles or web stiffeners;  $t$  is the web thickness.

$d/t$	70	80	90	100	110	120	130	140	150	160	170	180
$K$	0	.04	.06	.09	.12	.17	.25	.33	.46	.62	.86	1.23

At the quarter span point the shear =

$$45\tau - 10 @ 2\frac{1}{4}\tau = 22.5\tau$$

and the *B.M.* =  $45\tau \times 10' - (2\frac{1}{4}\tau \times 10) 5' = 337.5\tau = 4,050''\tau$

Actual shear stress =  $22.5\tau \div (48'' \times \frac{5}{16}'')$  = 1.5 $\tau$ /sq. in.

Fibre stress in compression =  $M \div Z = 4,050 \div 675 = 6$

    "    "    tension = " =  $4,050 \div 581 = 6.97$  "

Considering the web panel, Fig. 29, on right-hand

    side of quarter point, the smaller value for  $d$  = 38"

Hence  $d/t = 38'' \div \frac{5}{16}'' = 121.6$

Value of  $K$  from table = 0.18

Percentage reduction  $p = Kf_b^2 = 0.18 \times 6.97^2 = 8.7\%$

Working shear stress in web (combined shear and bending) is (100 - 8.7)% of 5.4 $\tau$ /sq. in.

(p. 11) = 4.93 $\tau$ /sq. in.

\* See footnote on p. 8.

At mid-span the bending stress is higher at  $9.29\tau/\text{sq. in.}$  but there is no shear stress under static loading.

At the reaction the fibre stress due to bending is zero but the actual shear stress has the max. value of  $45\tau \div (48'' \times \frac{5}{16}'')$

$$= 3 \tau/\text{sq. in.}$$

The web section used is thus satisfactory.

The *B.S.S. 449-Building* asks that the permissible shear stress, p. 74 "be multiplied by the reducing factor  $(1 - K_3 f_b^2/100)$  in which  $K_3 = [(b/t \div 170)^5]$  and  $f_b$  is the maximum co-existent compressive bending stress in tons/sq. in. in the web at the section in question." Where  $b$  is the lesser unsupported dimension of a web panel (*i.e.*,  $d$  used previously) and  $t$  is the web thickness.

#### CURTAILMENT OF FLANGE AND WEB PLATES, CAMBER, ETC.

##### Curtailment of Flange Plates.

Both equations (2) and (3), *viz.*  $M = f \cdot A \cdot D$  and  $M = f(A + W/8)D$ , can be written  $M = f \cdot D \cdot \text{flange area}$ . Economy demands that  $f$  should be at its maximum value whenever possible; while  $D$ , in a deep parallel flanged girder, is practically constant throughout the span. Hence  $M$  can be written = a constant  $\times$  the flange area; or  $M$  varies as the flange area. Briefly, then, if the bending moment is doubled the flange area should also be doubled, and so on.

Let Fig. 30 represent a bending moment diagram to some suitable

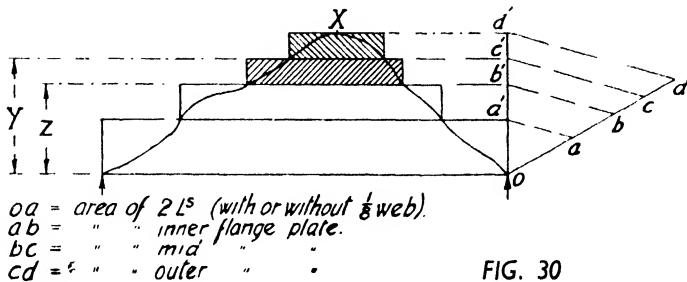

FIG. 30

scale, *e.g.*,  $1'' = 100 \text{ ft. tons or inch tons}$ . Draw any line  $od$  at any angle and measure along it the flange areas to some scale, such as  $1'' = 4 \text{ sq. in. or } 8 \text{ sq. in.}$ , etc. These areas will be gross areas for the compression flange and net areas when considering the tension flange. Erect the perpendicular  $od'$  and join  $d$  to  $d'$ . Through

$a$ ,  $b$  and  $c$  draw the parallels  $cc'$ , etc., then  $od'$  is divided in the same ratio as  $od$ . The total flange area of  $od = od'$  is required for the total bending moment of  $X$  units, but when the bending moment falls below  $Y$  units in value the outer flange plate can be cut off. All the plates can be so curtailed, but it is usual, although not always essential, to allow the inner top flange and bottom flange plates to remain unshortened. If the compression flange is without lateral support it is advisable to keep the inner flange plate on for the full length of the girder to increase the breadth and rigidity of this flange.

Numerical examples are given throughout the text, but the example headed "Curtailement of Beam Flange Plates" in Chapter X of Vol. I explains the reasons underlying the requirements of most specifications as to providing from 2 to 3 additional rivets in each longitudinal rivet line in the plate past each theoretical point of curtailement. The actual plate length is thus from 4 to 6 rivet pitches longer than the theoretical length.

**Curtailement of the Web Plate** may be effected by decreasing the thickness of the plate whenever the vertical shear is sufficiently low in value to warrant such a step. Let the vertical shear have two values, viz., a value  $V_1$  at the bearings and a value  $V_2$  at some intermediate point and if  $F_w =$  permissible shear stress per square

inch, then  $F_w = \frac{V_1}{\text{web area}} = \frac{V_1}{t_1 d}$ ; and, similarly, at the internal

section,  $t_2$  can be so arranged that  $F_w = \frac{V_2}{t_2 d}$ . Hence  $\frac{V_1}{t_1 d} = \frac{V_2}{t_2 d}$  i.e.,

$\frac{V_1}{V_2} = \frac{t_1}{t_2}$  which, if  $t_2$  and  $t_1$  are suitable thicknesses, fixes the position

of the splice (Fig. 31) from the shear curve.

In small spans there is no gain in so thinning down the web plate, and, further, the web plate must be in at least three sections before this change in thickness can be made.

The use of packings at these splices has been dealt with in Chapter VII, Vol. I.

**Flange and Web Plate Splices** are dealt with in Chapters V., VI. and VII., Vol. I.

**Camber** is the initial set, in an upward direction, given to a structure during fabrication. The reasons for camber are :—

(a) So that the centre of gravity lines of the elements of the

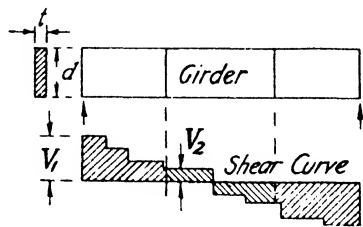

FIG. 31

structure have the same relative positions to each other when under load as were assumed in the calculations.

(b) *Æsthetic.*

(c) Sometimes to facilitate drainage.

(a) In the calculations of a horizontal and parallel flanged plate girder both flanges are assumed to be horizontal when the girder is loaded, a condition which can only be had if the girder be given an initial set upwards during fabrication. This initial set should be equal in amount to the deflection which the girder has when under full load.

(b) A high wall is often given a slight batter backwards from the face to eliminate the optical illusion of tilting forward. In bridge work a somewhat similar illusion takes place, and the girders, although perfectly horizontal, may appear to sag. Flange plates are numerous near the centre of the span, and this protuberance of metal, when viewed against the skyline, gives the sagging effect. By giving the girder a slightly arched outline during manufacture it appears to be perfectly horizontal when erected.

(c) An example of this is the common plate web girder bridge with a ballasted floor. A summit may be obtained at the bridge centre line, for surface water drainage, by giving a camber to the main girders. The surface water then flows to the abutments, where it is carried away by the down pipes.

Camber is hardly worth considering unless the girder is over 70 ft. span, a fact which is embodied in many specifications, which state that spans under 70 ft., some say 100 ft., shall not be cambered. The actual deflection can be used for the camber, but empirical rules are sometimes used, such as  $\frac{1}{16}$  in. to  $\frac{1}{10}$  in. for each 10 ft. of span.

Camber can only be economically obtained if the web plate be in at least two portions (Fig. 32). Here the riveting pulls the flange angles into an easy curve which disguises the straight lines of the web plate. In America camber is obtained by the simple

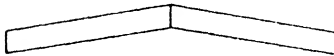

FIG. 32



FIG. 33

expedient of opening out the web plate at the upper edge (Fig. 33), but it is preferable that the end faces of the plates at the splice should bear evenly against each other, especially at the upper or compression edge.

**Bearings.** A plate girder may be bolted or riveted through the end stiffeners to a column or a main girder at right angles to itself ; or, again, it may simply rest upon the upper flange of another girder, in which case the fastenings through the two flanges in contact only serve to keep the two girders rigid in the horizontal plane.

When the girder rests upon masonry, brickwork or concrete walling, a bearing is used to distribute the pressure on the wall, and allowance is made for temperature expansion. Freedom for the changing in length is provided at one end of the girder by elongating or slotting the holes through which the holding down bolts pass (Fig. 34). This would be quite efficient if it could be definitely arranged, as in the 70 ft. span railway bridge drawings, that the nuts are not screwed tightly up against the girder or its shoe plate. The rivets connecting the shoe plate (*a*) to the girder are countersunk on the underside ; no rivets pass through the bed plate (*b*). One end of the girder is thus free to move over its bed plate, which cannot move, since the H.D. (holding down) bolts fit the circular holes. At the fixed end both plates (*a*) and (*b*) have circular holes.

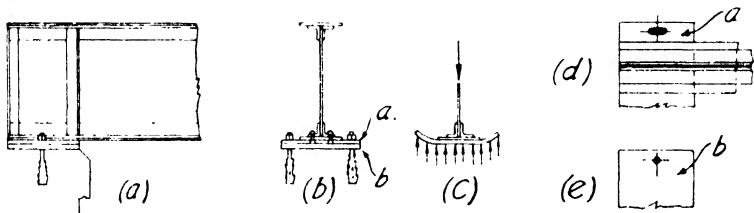

FIG. 34

The bed plate area = reaction  $\div$  permissible bearing pressure on the bed stone. The length of the shoe plate generally runs from one to one and a half times its breadth. The minimum breadth of this plate must be such as to give clearance to the nuts of the H.D. bolts, while the maximum breadth of the plate is fixed by the thickness of plate used. Fig. 63 gives the relationship between thickness, cantilever overhang and bearing pressure. Both shoe and bed plates are made in mild steel, both are of the same thickness ( $\frac{5}{8}$  in. to  $1\frac{1}{8}$  in.) and both have their common surfaces, which are in contact, planed.

Bed plate (*b*) rests upon a carefully levelled bed block of stone or concrete built into the wall. To take up any inequalities a piece of 8 lb. lead or felt is interposed between the plate and the stone, or, alternatively, it may be grouted with neat cement.



The diameters of the H.D. bolts are governed by the shear from the braking and tractive forces they have to withstand. A numerical example will be found in the calculations of the undermentioned bridge.

The drawing of the bearings for the 70-ft. span railway through bridge (Chapter IX) illustrates the cast-iron type with phosphor bronze strips. Phosphor bronze, an alloy of copper and tin, with up to about 1 per cent. of phosphorus, is an excellent metal for bearings. Its properties are :-- Ultimate tensile strength may run up to  $45\pi$ /sq. in. ; it is very fluid when molten and gives splendid castings free from blow-holes ; the coefficient of friction on mild steel (0.15) is less than that for steel on steel (0.25) ; and, finally, its principal property for bridge bearings is its resistance to rust action. Economy is obtained by using it in strips, the spaces between being tallow filled for lubrication. The allowable bearing pressure on these strips is  $2\pi$ /sq. in.

By raising the girder on a cast-iron or cast-steel pedestal bearing (Fig. 35), more latitude is given for inspection and maintenance,

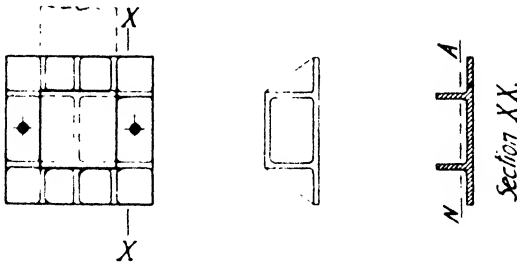

FIG. 35

accompanied by a slight saving in the height of the masonry wall. As with the simple plate bearing, the pedestal is calculated as a cantilever withstanding the uniformly distributed upthrust. The moment of resistance at the line *XX* is that furnished by the hatched section. There is an upper and lower section modulus and the stresses are compression at the top of the webs and tension at the bottom face.

*Roller bearings* are used when the span exceeds 80 ft. or thereby, but as an adequate description would require more space than can be allotted to it, readers are referred to *Details of Bridge Construction*, by Skinner.

**Weight of Plate Girders.** It will be found that the weight of the

web plate, the weight of the upper flange composed of angles and flange plates, and the weight of the lower flange are roughly equal to one another; while the total weight of the stiffeners, cover angles and plates at joints together with rivet heads is practically half of that for one flange. Hence an approximate estimate can be made of the girder's weight for calculation purposes by obtaining the weight of one flange and then multiplying by  $3\frac{1}{2}$ .

Since  $M = F \cdot D$ , flange area, *i.e.*, flange area =  $M \div FD$ , therefore take the external bending moment (*i.e.*, exclusive of that caused by the unknown weight of the girder) and divide by  $FD$ . This gross area multiplied by 3.4 (or by the approximation of  $\frac{10}{3}$ ) is the weight in pounds per foot for one flange. The total weight =  $((M \div FD) \times \frac{10}{3} \times \text{length in feet})$  multiplied by a constant, varying from  $3\frac{1}{2}$  to about 4.

*Unwin's Rule* can be so derived, and is :-

Where  $W$  = weight of girder in tons.

$W^1$  = load carried.

$L$  = span in feet.

$$W = \frac{W^1 L r}{c F - L r}$$

$r$  = ratio of span to depth.

$F$  = stress in the flanges.

$c$  = a constant varying from 1,400 for small spans to 1,800 for large spans.

*Anderson's Rule* of  $W = \frac{W^1 L}{600}$  is much simpler; but all three are only intended to give a rough estimate of the weight.

#### PLATE GIRDERS WITH INCLINED FLANGES

It is sometimes deemed necessary to curve or incline the upper or lower flange of a plate girder. In Fig. 36 the lower flange is inclined upwards towards the abutment with the result that the vertical shear at a section, such as  $XX$ , is resisted by both the web plate and the inclined flange. This results in a relief of stress for the web plate, but it is to be observed that the web area (depth  $\times$  thickness) rapidly decreases from  $B$  to  $A$  because of the curtailment in web depth. In some cases, especially with short span shallow girders carrying heavy shears, the portion  $BA$  of the web plate may require to be thickened up. The mid-portion  $BC$  of the girder, being of the standard parallel-flange type, is calculated throughout in accordance with the methods previously given, but the sloping portions  $BA$  and  $CD$  require special consideration.

A good example of the relief of stress given to a plated web by

inclining a flange or boom is given by the classic example of the 103' 0" span bowstring through plate girder bridge at New Brunswick, which carried a single railroad track for many years although it had an original web plate thickness of only  $\frac{1}{8}$ ". The depth of the girder at midspan was 10' 6" and then, following a parabolic outline, the curved upper flange ultimately met the horizontal lower flange at a point 2' 0" behind the face of the abutment. The end 8' 0" or thereby of the girder had, however, an auxiliary web piece projecting through the main upper flange for a height of 40" forming a small parallel-flange girder of that depth whose web plate thickness was still  $\frac{1}{8}$ ".

**Flange Sections between B and A, Fig. 37.**

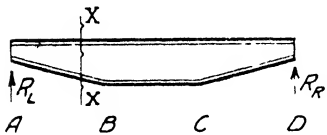

FIG. 36

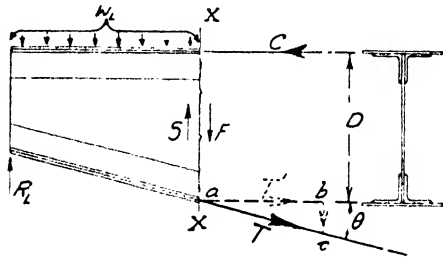

FIG. 37

Bending moment in inch tons at section  $XX = M$ .

Effective depth at  $XX$ , from C.G. to C.G. of flanges, in inches  $= D$ .

Total compressive force, in tons in top flange  $= C$ .

Total inclined or axial force in bottom flange in tons  $= T$ .

From the fact that the internal flange couple equals the external bending moment, or from (4) p. 4,  $C \times D = T^1 \times D = M$ , it follows that—

$$\text{Total flange force } C = M/D \quad . \quad . \quad (a)$$

$$\text{Horizontal component } T^1 \text{ (i.e., where } T^1 = T \cos \theta) = M/D \quad . \quad . \quad (b)$$

$$\therefore \text{ Total flange force } T = M/D \cos \theta \quad . \quad (c)$$

**Web Plate between B and A, Fig. 37.**

Actual internal shearing force in the web plate  
in tons  $\qquad\qquad\qquad = F$

The total shear at the section  $XX =$   
 $R_L -$  downward load  $W_L \qquad\qquad = S$

By the first law of statics the vertical forces at section  $XX$   
balance for equilibrium

$$\begin{aligned} \therefore S &= R_L - W_L = F + \text{vert. component } bc \\ &\text{of } T = F + T \sin \theta = F + (M/D \cos \theta) \sin \theta \\ &\text{by (c), above} \qquad\qquad\qquad = F + M \tan \theta / D \end{aligned}$$

$$\therefore F, \text{ the shearing force in the web,} \qquad = S - M \tan \theta / D \text{ (d)}$$

**Rivet Pitches in Flanges between B and A.**

Bottom rivet pitch in inches measured along  
the slope, Fig. 38  $\qquad\qquad\qquad = p_b$

Top rivet pitch in inches measured hori-  
zontally, Fig. 38  $\qquad\qquad\qquad = p_t$

Resistance of one rivet in double shear or web  
bearing in tons  $\qquad\qquad\qquad = R$

Depth from single rivet line to single rivet line  
in inches, Fig. 38  $\qquad\qquad\qquad = d$

If double rivet lines then  $d$  is the average distance as in Fig. 39  
and the distances  $p_t$  and  $p_b$  become the reeled or alternate pitches.

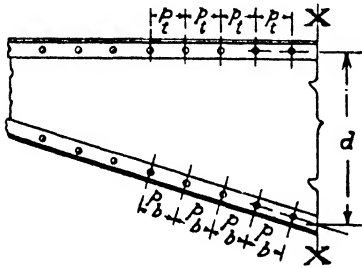

FIG. 38

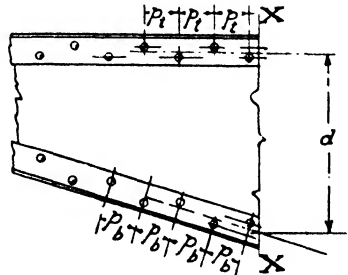

FIG. 39

*Bottom Rivet Pitch.* Consider the stability of a small strip of the web plate of sloping width equal to a pitch  $p_b$ , Fig. 40. The horizontal width of this segment is  $p_b \cos \theta$ , where  $\theta$  is the angle made by the lower flange to the horizontal. The vertical external load acting on this strip is very small and is  $\delta w$ . By the first law of statics, there being no vertical translation, the internal shearing force in the web plate upwards of  $F$  at the left-hand side is balanced by  $\delta w$  and  $(F - \delta F)$  on the right, i.e.,  $F = \delta w + F - \delta F$ . As these do not lie in the same line of action they form a turning moment whose value can be found by taking moments at some suitable point such as the upper rivet in black.

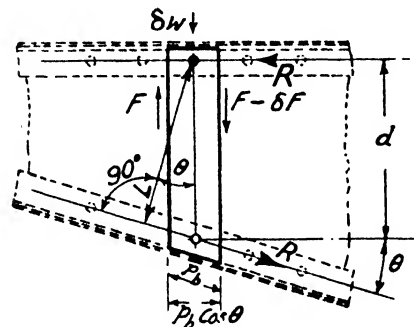

FIG. 40

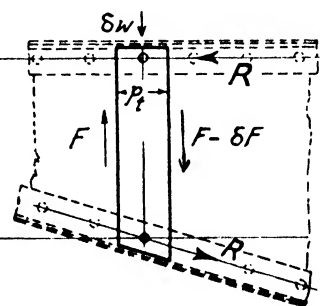

FIG. 41

$F \times \frac{1}{2} p_b \cos \theta + \delta w \times 0 + (F - \delta F) \times \frac{1}{2} p_b \cos \theta = F p_b \cos \theta - \frac{1}{2} p_b \cos \theta \cdot \delta F$ . The last term, with the negative sign, is negligible in comparison with the other quantities and this clockwise moment on the strip evaluates to  $F p_b \cos \theta$ .

The segment of the web shown in heavy line is prevented from rotating in the slots between the upper and lower flange angles by the upper and lower rivets and the value of this counter-clockwise moment is given by multiplying the force by the perpendicular lever arm to the line of action,  $R \times L$ .

$$\therefore \quad F p_b \cos \theta = R \times L = R \times d \cos \theta,$$

whence 
$$p_b = R d / F \quad \dots \dots \dots (e)$$

*Top Rivet Pitch.* Similarly in Fig. 41 the clockwise moment on the web strip of width  $p_t$  is  $F p_t$  and the counter-clockwise moment, moments about the lower rivet, is  $R \times$  perpendicular distance of  $d$ ,

i.e., 
$$p_t = R d / F \quad \dots \dots \dots (f)$$

which proves that the rivet pitches in the vertical legs of the upper and lower flange angles are the same when measured along the rivet lines ;  $p_t$  measured horizontally equals  $p_b$  measured along the incline. The rivets through the horizontal, or outstanding, legs for both flanges will reel with those in the vertical legs and so, as previously explained for the standard plate girder, will be ample in number.

*Rivet Pitches when no Help is given by the Web in Carrying Bending Moment.* The foregoing pitches have been derived by neglecting the assistance of the web in counteracting bending moment as given by (2), p. 3, in  $M = f . A . D$ . On this assumption and on substituting the value for  $F$  as found in (d) above, then—

$$p_t = p_b = Rd \div F = \frac{Rd}{S - \frac{M \tan \theta}{D}} \quad \dots \quad (g)$$

A rougher approximation, but one which is constantly used in designing, is to substitute  $d$  for  $D$  in equation (g) whereby

$$p_t = p_b = \frac{Rd}{S - \frac{M \tan \theta}{d}} \quad \dots \quad (h)$$

*Rivet Pitches when the Web assists in Carrying Bending Moment* by giving  $\frac{1}{8}$  of its area to the flanges. (Item (3), p. 4 :— $M = f(A + W/8)D$ .)

The flange rivets now carry a smaller load because the web shares in the bending moment instead of passing it all on to the flanges, and if a lesser load is carried fewer rivets are necessary and therefore the pitch can be opened out to

$$p_t = p_b = \frac{Rd}{S - \frac{M \tan \theta}{D}} \frac{\left(A + \frac{W}{8}\right)}{A} \text{ or } \frac{Rd}{S - \frac{M \tan \theta}{d}} \frac{\left(A + \frac{W}{8}\right)}{A} \quad (i)$$

*Local Vertical Shear on Upper Flange Rivets.* If local shear is to be taken into account, as in Fig. 22, the best procedure is to try a somewhat closer pitch for  $p_t$  than that given by (h) or (i) above, because the upper rivets have to carry still another load, namely, the vertical local load in addition to the horizontal shearing load newly calculated.

Thus if the rivet value,  $R$ , for a  $\frac{7}{8}$ " dia. rivet of  $5.25\tau$  ( $7.21\tau$  *D.S.*,  $5.25\tau$  *B*  $\frac{1}{2}$ " ) when substituted in (h) or (i) gives a pitch  $p_i$  of, say,  $4.91$ ", then, given that no local vertical load is present, the nearest practical pitch is either  $5$ " or  $4\frac{3}{4}$ ". If local shear has to be considered try the lesser pitch of  $4\frac{3}{4}$ ". Place this value for  $p_i$  in (h) or (i) and so find the actual load on the rivet, which will now be  $h$ , a value less than  $R$  since, due to closer pitching, there are more rivets than are apparently required. Now combine  $h$  and  $v$  as for Fig. 22 and if the resulting rivet load of  $\sqrt{h^2 + v^2}$  is somewhat higher than the permissible  $R$  try once more the smaller pitch of, say,  $4\frac{1}{2}$ " for  $p_i$  in equations (h) or (i).

The actual pitch  $p_i$  adopted will be less than the calculated pitch  $p_b$ , but the latter, for simplicity in fabrication, can be made the same as  $p_i$ , or the rivets in the sloping flange can be pitched vertically under the upper flange rivets, or, lastly, the different pitches  $p_i$  and  $p_b$  can be used, depending on stiffener placing and the whim of the designer.

#### Upper Flange Inclined, Figs. 42 and 43.

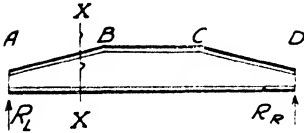

FIG. 42

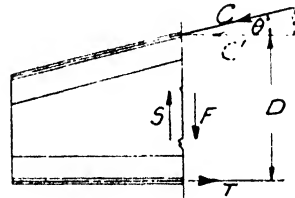

FIG. 43

$$\text{Total tensile flange force } T = C' = C \cos \theta = M/D \quad (a')$$

$$\text{Total axial or inclined compressive force } C = M/D \cos \theta \quad (c')$$

$$\begin{aligned} S &= R_L - W_L = F + C \sin \theta \\ &= F + (M/D \cos \theta) \sin \theta \end{aligned}$$

$$\therefore F = S - M \tan \theta / D \quad (d')$$

By turning Figs. 40 and 41 upside down these become appropriate to this case and it again follows that

$$p_t = p_b = \frac{Rd}{F} = \frac{Rd}{S - \frac{M \tan \theta}{D}} \dots \dots \dots (g')$$

or approximately 
$$= \frac{Rd}{S - \frac{M \tan \theta}{d}} \dots \dots \dots (h')$$

If  $\frac{1}{8}$  web is taken into account  $p_t = p_b =$  value given by equation (i).

REFERENCES

THEORY

ANDREWS, E. S. *Theory and Design of Structures*. (Chapman and Hall Ltd.)  
 CASSIE AND DOBBIE. *The Torsional Stiffness of Structural Sections*. (Structural Engineer, 1948.)  
 JOHNSON, BRYAN AND TURNEAURE. *Modern Framed Structures—Part III., Design*. (Wiley.)  
 MORLEY, A. *Strength of Materials*. (Longmans, Green & Co.)  
 SPARKES, S. R. *Behaviour of Webs of Plate Girders*. (Trans. Inst. Welding, 1947.)  
 TIMOSHENKO, S. *Elements of Strength of Materials also Theory of Elastic Stability*. (Macmillan & Co.)

DETAILS

KETCHUM, M. S. *Design of Highway Bridges*. (McGraw-Hill.)  
 KUNZ, F. C. *Design of Steel Bridges*. (McGraw-Hill.)  
 SKINNER, F. W. *Details of Bridge Construction—Plate Girders*. (McGraw-Hill.)  
 THOMSON, W. C. *Design of Typical Steel Railway Bridges*. (Engineering News.)

SPECIFICATIONS

HUNTER, A. *Arrol's Bridge Engineer's Handbook*. (Spon.)  
 SKINNER, F. W. *Details of Bridge Construction—Specifications and Standards*. (McGraw-Hill.)



## BRITISH STANDARD SPECIFICATIONS

*(Published by the British Standards Institution, 2 Park Street,  
London, W.1)*

- No. 153. *Parts 3, 4 and 5. Girder Bridges.*  
No. 449. *Use of Structural Steel in Building.*  
No. 466. *Electric Overhead Travelling Cranes.*

THE INSTITUTIONS OF CIVIL AND STRUCTURAL ENGINEERS. *Code of  
Practice for Simply Supported Steel Bridges. (3s. 6d. post free.)*

## CHAPTER II

### THE DESIGN OF A 40-FT. SPAN GANTRY GIRDER

#### PLATE I

THE gantry girder, now to be designed, is one which has to support a heavy duty electric overhead travelling crane in a foundry dealing with heavy castings. The vertical bending moments and shears, which are calculated on the assumption that the wheels are momentarily at rest, will be increased in value by 25 per cent. (the impact factor or coefficient  $I$ ) to allow for the dynamic effects of the impact of wheel loads, shock caused by slings slipping, acceleration and retardation, etc. For hand-operated cranes the impact factor is 10 per cent.

Lateral forces induced by the sudden stoppage of the crab and its load while cross travelling the shop, and by the indirect lifting and side hauling of the loads along the shop floor, act horizontally and transversely at rail level. Their total effect is assumed to be equivalent to 10 per cent. of the combined weights of crab and load lifted (5 per cent. for hand-operated cranes) and is to be considered as being shared equally by both rails.

Longitudinal travel and braking cause forces to act along the length of each rail. The resultant effect of these forces is assessed at 5 per cent. of the actual wheel loads for both electric and hand-operated cranes.

Specifications vary as to the values of these impact coefficients, but so also do the conditions under which cranes, even of the same capacity, have to work—a very important factor, which should be carefully considered when fixing the values to be used.

The foregoing values are those given in the *B.S. 449—Building*, as also are the working stresses employed in this design.

An indirect method of allowing for the increase in stress due to the load being live is employed by some specifications. The internal forces are calculated as if entirely due to static loads (*i.e.*, no impact increment), but lower working stresses (*e.g.*,  $F_t = 6\pi/\text{sq. in.}$ , etc.) are employed in the calculations for the amount of steel required.

## EXPLANATORY TEXT

The maximum load on the end carriage wheels depends upon the maximum weight lifted, the nearest position of the crane hook and its load to the gantry girder, and upon the span of the crane. The values of these loads and the length of the wheel base, which is never less than one-fifth of the span of the crane, together with the amount of headroom (crane rail to roof truss main tie) and the end clearance between carriage and shop columns are figures which are obtainable from the catalogues of the various crane makers.

The depth from heel to heel of main angles for this type of girder is usually about one-tenth of the span, or 4 ft. in the present case ; the effective depth will be about 3 in. less than this, *i.e.*, about 3.75 ft. between the centres of gravity.

*Crane Rail.* The rule given in Chapter XI, Vol. I, was "Every  $3\frac{1}{2}$  to 4 $\tau$  of wheel load requires 10 lb. per yard of flat bottomed rail." A similar F.B. rail would be  $(32\tau \div 4\tau) \times 10 = 80$  lb./yd. The rule is only approximate, and a 70-lb./yd. bridge rail will be substituted for an F.B. rail. Some crane catalogues suggest the size of rail to be used.

*Dead Load, Item 1.* Using the first method advocated in the article "Weight of Plate Girders" in the preceding chapter, the live bending moment, inclusive of impact, is 551 ft. tons (item 4). This divided by the first approximation of 3.75 ft. to the girder's effective depth gives a total flange force of  $\pm 147\tau$ . The upper flange of this girder has to withstand both horizontal and vertical forces and therefore it will be simpler, at this stage, to estimate the weight by considering the lower or tension flange.

With  $F_t = 9.5\tau$ /sq. in. net, the net area =  $147 \div 9.5 = 15.5$ . But this net area is roughly 80 per cent. of its own gross area, and therefore the gross area is approximately 20 sq. in. Hence the weight of the tension flange is :—

$$20 \text{ sq. in.} \times (10 \div 3) \times 40' = 2,670 \text{ lb.}$$

Now, to allow for the crane rail and the extra weight in the top flange, which also acts as a thrust girder, the constant 4 (instead of the usual  $3\frac{1}{2}$ ) will be used. Total weight =  $2,670 \times 4$  lb. = 4.8 tons.

Using Anderson's rule. The external load (Fig. 44) =  $64\tau$  from the wheels plus  $0.41\tau$  from the crane rail at 70 lb./yd.

$$\text{Total } W^1 = 64.41\tau.$$

$$\therefore \text{ weight of girder } W = \frac{W^1 L}{600} = \frac{64.41 \times 40}{600} = 4.3\tau.$$

*Item 2* is the maximum end shear found by taking moments about *B*.

CALCULATIONS

THE DESIGN OF A 40-FT. SPAN GANTRY GIRDER, PLATE I.

**Loading.** One E.O.T. Crane of 50 tons capacity with a 13 ft. wheel base. Maximum load on each end carriage wheel is 32 tons,

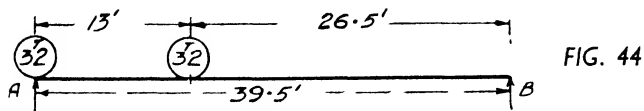

which occurs when the crab and the load are adjacent to the main gantry rails.

**Working Stresses** adopted are those given on p. 74. For loads acting vertically the impact allowance is 25 per cent.

**Effective Span.** Allowing that the girder has a 6-in. length of bearing on each column bracket support, the effective span is 39 ft. 6 in., i.e., centre to centre of bearings.

*Dead Load of Girder and rail estimated at* 4.8<sup>†</sup> 1

**Maximum Vertical Shear, Fig. 44.**

Live load reaction <i>A</i> =			
$32\tau (26.5' + 39.5') \div 39.5'$	— tons	53.5	
Impact add 25%	..	13.4	
		66.9	<b>2</b>
Total <i>L.L.</i> + <i>I.</i>	..	66.9	
Dead load reaction <i>A</i> = $4.8 \div 2$	..	2.4	
Total end shear, <i>L.L.</i> + <i>I.</i> + <i>D.L.</i>		69 <sup>†</sup>	<b>3</b>

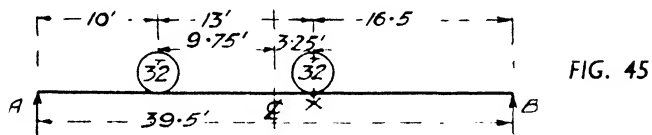

**Maximum Vertical B.M., Fig. 45.**

Live load reaction <i>B</i> =			
$32\tau (10' + 23') \div 39.5' = 26.73\tau$			
Live load maximum <i>B.M.</i> at <i>X</i>			
$R_B \times 16.5' = 26.73\tau \times 16.5'$	— ft. tons	441	
Impact add 25%	..	110	
		551	<b>4</b>
Total <i>B.M.</i> , <i>L.L.</i> + <i>I.</i>	..	551	
Dead load maximum <i>B.M.</i> at mid-span = $4.8 \times 39.5 \div 8$	..	24	
Total maximum <i>B.M.</i> at <i>X</i> approximately		575	<b>5</b>

*Maximum Vertical B.M.* under any wheel occurs when the centre line of the span is midway between the centre of gravity of the load system and the wheel considered.\*

*Maximum Dead Load B.M. of  $Wl \div 8$*  occurs at mid-span. The dead load bending moment at point X, Fig. 45, is practically that at mid-span.

*Item 6.* The weight of the crab is usually about one-fifth of the maximum load lifted plus  $\frac{1}{2}$  ton. This value may be used if the actual crab weight is unknown. As previously mentioned, the lateral thrust is 10 per cent. of the combined weights of crab and load lifted.

*Lateral Thrust, items 7 and 8.* Figs. 44 and 45 give not only the positions of the wheels for maximum vertical shear and bending moment, but also those for maximum lateral shear and bending moment. The planes of loading and the arithmetical values of the loads are, of course, different. The lateral values can be obtained from the vertical ones of items 2 and 4 on multiplying by the ratio of the lateral force to the vertical wheel load.

*Item 9.* The effective depth  $D$  is from the centre of gravity of the top flange (excluding the edge angles) to the centre of gravity of the bottom flange.

The centre of gravity of a  $6'' \times 6'' \times \frac{1}{2}''$  angle is 1.66 in. from the heel. On the addition of a flange plate the joint centre of gravity will approach the heel. The effective depth was taken at 3.8 ft. in the preliminary calculations, and when the sections were found the depth was checked and found to be 3.84 ft.

*Item 11.* The width of the compression flange of a crane girder is usually in the neighbourhood of one-twenty-fifth of the span, 19 in. in this example. A width of 20 in. is adopted, giving a  $\frac{5}{16}$ -in. clearance between the toes of the main and edge angles, thereby providing for any sectional growth.

The tension flange is not subjected to a strut action, and hence a narrower plate can be used.

*Item 12.* The formulæ quoted are those given in the list of working stresses. Their use entails a trial section and spacing of stiffeners from which the working stresses are determined. The clear distance between the flange angles =  $a = 36$  in. and between the end stiffeners is the lesser distance  $b = 30.8$  in. ; see Plate I.

*Items 13 and 15.* On comparing these items it would appear that a  $48'' \times \frac{5}{16}''$  web plate is sufficient. However, if a thickness of  $\frac{5}{16}$  in. be adopted the bearing value of the rivets is lowered and a closer pitching of rivets is required. At the end of the girder the rivets

\* For a proof of this statement see p. 22, *Influence Lines - Their Practical Use in Bridge Calculation.*

Weight of Crab =  $\frac{1}{5}$  of  $50\tau + \frac{1}{2}\tau = 10.5\tau$

**Lateral Force.**

$= \frac{1}{10} (10.5 + 50)$	$=$	$6\tau$	
per wheel $= 6\tau \div 4$ wheels	$=$	$1.5\tau$	<b>6</b>
Lateral Maximum Shear	$= 53.5 (1.5/32)$	$= 2.5\tau$	<b>7</b>
Lateral Maximum B.M.	$= 441 (1.5/32)$	$= 20.7\tau$	<b>8</b>
Longitudinal Force along Rail	$= 5\% (2 @ 32)\tau$	$= 3.2\tau$	
Effective Depth of Vertical Girder	$= D$	$= 3.8'$	<b>9</b>
Total Flange Force. Vertical load- ing $= B.M. \div D = 575 \div 3.8$	$=$	$151\tau$	<b>10</b>

**Flange Width (top flange)**

Not less than span  $\div 25 = 19''$ ; adopt  $20''$  **11**

Working Stresses (p. 74).--  $F_t = \tau_1 \text{sq. in.}$   $9.5$  **12**

$F_c$  is the lesser of  $9.5\tau/\text{sq. in.}$  or

$(1,000 \div l/k_y) K_1$ . From Fig. 47

$K_1$  is unity since  $k_x \div k_y$  is

$20.56 \div 4.04 = 5.1$

$\therefore F_c = 1,000 \div (39.5 \times 12/4.04) = 8.5$

$F_w$  is the lesser of:—  $F_w = 8.5$

or  $\left(\frac{225}{b/t}\right)^2 [1 + \frac{3}{4} (b/a)^2]$

$= \left(\frac{225}{30.8/0.375}\right)^2 [1 + \frac{3}{4} (30.8/36)^2]$

$= 11.6 \tau/\text{sq. in.}$

**Areas required for Vertical Girder.**

Web	$=$ end shear $\div F_w$	
	$= 69 \div 6.5 = \text{sq. in. gross}$	<b>10.6 13</b>
Tension flange	$= 151 \div 9.5 = \text{sq. in. net}$	<b>15.9</b>
Compression flange	$= 151 \div 8.5 = \text{sq. in. gross}$	<b>17.8 14</b>

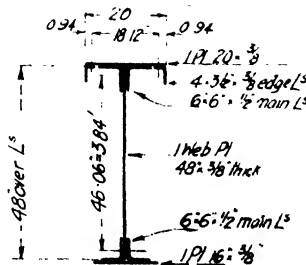

FIG. 46

are closest together,  $2\frac{3}{8}$  in. reeled pitch, and the more this figure is reduced the greater will be the difficulty of riveting; also the question of diagonal tearing may arise with the possibility that the flange areas may have to be increased accordingly.

Further, one-quarter of the extra web metal is added to the flange area (one-eighth web area to each flange). The extra  $\frac{1}{8}$  in. thickness of web metal is, therefore, not aimlessly thrown away.

**Edge Angles.** In this  $M = f . A . D$  method the crane girder is assumed to be composed of two girders. A vertical one carrying vertical loads, and a horizontal one, at top flange level, carrying the lateral thrusts. The edge angles are presumed to be wholly occupied in counteracting the horizontal bending moment. Innumerable girders have been so designed and these have faithfully carried both ordinary and test loads.

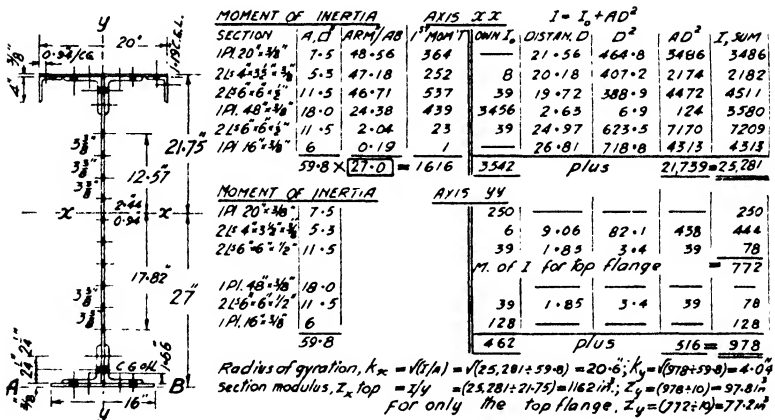

FIG. 47

**Moment of Inertia Method (Fig. 47).** The specification accepts the  $M = f . A . D$  method of designing plate girders when both top and bottom flanges have the same gross area, but when this condition is not fulfilled requires that the design be based upon the moment of inertia of the cross-section.

Fig. 47 sets the calculations out in the form of a table. With the under face of the lower flange plate as the reference line AB, moments are taken of the areas of the component parts of the section. The summation  $1,616 \text{ in}^3$  of the first moments, divided by the total

**Areas given for Vertical Girder.**

Web.	1 Plate $48'' \times \frac{3}{8}''$	= sq. in. gross	18	15
Tension flange.	$\frac{1}{8}$ web	= $18 \div 8$	= sq. in. net	2.25
	2 $\underline{\text{L}} 6'' \times 6'' \times \frac{1}{2}''$			
	4 holes $\frac{15}{16}'' \times \frac{1}{2}''$	= ,,	9.62	
	1 Plate $16'' \times \frac{3}{8}''$			
	2 holes $\frac{15}{16}'' \times \frac{3}{8}''$	= ,,	5.3	
Total net area of tension flange			= ,,	17.2 16
Compression flange.	$\frac{1}{8}$ web	=	2.25	
	2 $\underline{\text{L}} 6'' \times 6'' \times \frac{1}{2}''$	= sq. in. gross	11.5	
	1 Plate $20'' \times \frac{3}{8}''$	= ,,	7.5	
Total gross area of compression flange in sq. in. gross			=	21.2 17

**Areas required for Horizontal Girder.**

Total flange force	= 20.7 ft. tons $\div$ effective			
depth in ft.	= $20.7 \div (18 \cdot 12 \div 12)$	= $\pm 14^r$	18	
Web area	= $2.5 \div 6.5$	= sq. in. gross	0.4	
Tension flange	= $14 \div 9.5$	= sq. in. net	1.5	
Compression flange	= $14 \div 8.5$	= sq. in. gross	1.7	

**Areas given for Horizontal Girder.**

Compression Flange.	1 $\underline{\text{L}} 4'' \times 3\frac{1}{2}'' \times \frac{3}{8}''$			
	( $3\frac{1}{2}''$ leg for $\frac{15}{16}''$ diameter rivet).	Area in sq. in. gross	2.67	19
Tension Flange.	1 $\underline{\text{L}} 4'' \times 3\frac{1}{2}'' \times \frac{3}{8}''$			
	1 hole $\frac{15}{16}'' \times \frac{3}{8}''$	Area in sq. in. net	2.32	
Web.	No special provision made as the required area is very low.			
	The 20-in. flange plate at the end carries no stress from the vertical bending moment and therefore this area is free to carry the horizontal thrust shear.			

<b>M of I of rivet holes.</b>	Web ; ( $\frac{15}{16} \times \frac{3}{8}$ ) [ $2 \cdot 44^2 + 5 \cdot 82^2 + 9 \cdot 19^2 + 12 \cdot 57^2 + (0 \cdot 94^2 + 4 \cdot 32^2 + 7 \cdot 69^2 + 11 \cdot 07^2 + 14 \cdot 44^2 + 17 \cdot 82^2)$ ]	= in. <sup>4</sup>	354
Main $\underline{\text{L}}$ , vert. leg ; ( $\frac{15}{16} \times 1\frac{3}{8}$ )	( $19 \cdot 13^2 + 24 \cdot 38^2$ )	= ,,	1,248
„ horiz. leg ; 2 ( $\frac{15}{16} \times \frac{7}{8}$ )	( $21 \cdot 31^2 + 26 \cdot 56^2$ )	= ,,	1,900
Edge $\underline{\text{L}}$ ; 2 ( $\frac{15}{16} \times \frac{3}{4}$ )	( $21 \cdot 38^2$ )	= ,,	640

Total M of I for rivet holes = ,, 4,142 20

**M of I, entire section.** = ,, 25,281

Net M of I, entire section = ,, 21,139



area of 59.8 in., places the  $C$  of  $G$  ( $xx$ ) of the section at 27 in. above  $AB$ .

The moment of inertia of, say, the top main angles about  $xx$  is composed of two parts, viz., the moment of inertia about their own appropriate gravity axis ( $2 \times 19.5$ , as given in Table 1, Appendix, Vol. I), plus the area of the angles multiplied by the square of the distance between the angle gravity line and  $xx$ ; i.e.  $(21.75 - 1.66 - \frac{3}{8})^2 = 19.72^2$ . The moments of inertia of the upper and lower flange plates about their own axes are negligible for axis  $xx$ , but not so when considering the vertical axis  $yy$ .

*Item 20.* Similarly, the moments of inertia of the holes about their own axes are neglected, and thus the total  $M$  of  $I = \text{sum of } AD^2$ ; the area of each rivet hole multiplied by the square of its distance to axis  $xx$ . Any approximate vertical pitch for the rivets in the web may be used without greatly affecting the result.

*Item 22.* The section modulus of the net section is required for the bottom or tension flange because the stress therein is based upon net area. (Most specifications advise the use of the net area of the entire section.)

*Item 23.* The portion of the girder which resists the horizontal lateral forces at rail level is the top flange since neither the web nor bottom flange can afford much aid. Hence the  $Z$ , or section modulus, used is that for the upper flange as was done in the  $M = f \cdot A \cdot D$  method.

*Item 24.* Under vertical loading the top fibres of the upper flange have a compressive stress of  $5.94\tau/\text{sq. in.}$  If the maximal horizontal forces on the upper flange also act, say from left to right, then the extreme left-hand fibres of the flange have a stress of  $+ 3.22\tau/\text{sq. in.}$  and the right-hand fibres a tensile stress of  $- 3.22\tau/\text{sq. in.}$  The summation of these stresses shows the left-hand corner to have a maximum compressive fibre stress of  $5.94$  plus  $3.22$ , i.e.,  $9.16\tau/\text{sq. in.}$ , while the right-hand corner fibre will be stressed to  $+ 5.94 - 3.22$  or  $+ 2.72\tau/\text{sq. in.}$

It will be very seldom indeed when both these worst cases of vertical and horizontal loadings occur simultaneously, but should it happen a temporary over stress of 10 per cent. is permitted by the specification.

*Item 25* shows that a close approximation to the shearing force per foot of depth, due to vertical shear, is obtained by dividing  $S$  by the depth over angles, 4 ft. in this case;  $0.25 S$  as against  $0.235 S$ .

*Item 27.* The rail distributes the wheel load over a small length of girder, but just how long is a moot point. A length equal to the girder's depth, but not longer than 4 ft., represents a fair

Section Modulus ( <i>xx</i> axis), gross = 25,281 ÷ 21.75,		top = in. <sup>3</sup> 1,162	21
„	„ net = 21,139 ÷ 27,	bottom = „ 783	22
„	( <i>yy</i> axis), top flange only = 772 ÷ 10 = „ 77		23
Max. vertical <i>B.M.</i>	= 575 ft.τ or	in.τ = 6,900	
Max. stress in extreme fibre	= $M \div Z$		
„ „ compression	= 6,900 ÷ 1,162, τ/sq. in. = +5.94		
„ „ tension	= 6,900 ÷ 783, „ = -8.81		
Max. lateral <i>B.M.</i>	= 20.7 ft.τ or	in.τ = 248	
Max. fibre stress	= 248 ÷ 77 τ/sq. in. = ±3.22		
Combined fibre stress, top flange	+ 5.94 ± 3.22	„ = +9.16	
		and „ = +2.72	
Working stress in compression when vert. and lateral <i>B.M.</i> occur simultaneously	= 110% of 8.5, τ/sq. in. = +9.35		24

**Rivets in Main Angles.** Formula from Chapter I.

$$F = \frac{S}{D} \times \frac{A}{A + \frac{W}{8}}$$

Where *F* is the horizontal shearing force per foot if *D* is in feet ;  
*D* = the effective depth of the girder, viz., 3.8'.

Take the gross area of the vertical girder compression flange, but neglect the edge angles, which are the flanges of the horizontal girder.

$$F = S \times \frac{A}{D \left( A + \frac{W}{8} \right)} = S \times \frac{19}{3.8 (19 + 2.25)} =$$

Shear in tons per foot = 0.235S 25

In a foot length of girder :-

Horizontal shear *F* at end = 0.235S = .235 × 69τ = 16.2τ 26

Local vertical shear from wheel =

32 ÷ 4 ft. = 8τ 27

Resulting shear = √(16.2<sup>2</sup> + 8<sup>2</sup>) = 18.1τ 28

½ in. diameter rivets are in *D.S.* or bearing on ¾ in. thick web plate.

*D.S.* value per rivet @ 12τ/sq. in. = 8.28τ and the bearing value per rivet = 4.22τ

Number of rivets required in a foot length at end of girder = 18.1 ÷ 4.22 = 4.28

Distance apart of rivets in the end foot of girder = 12 ÷ 4.28 = 2.8"

Adopt a reeled pitch of 2½ in. 29

average of current practice. This load comes through the rail on to the top main angles and from them through the upper "flange to web rivets" into the girder. These rivets have, therefore, a horizontal and a vertical shearing force, viz., items 26 and 27.

*Item 28* gives the resultant of these two forces by the law of the parallelogram of forces.

*Item 29.* The nearest practical pitch to the calculated value of 2.8 in. is  $2\frac{7}{8}$  in. The shears and the resulting rivet pitches for other points on the girder are given in the table and are incorporated in Plate I.

*Fig. 48* shows the position of the live load for the maximum shear at a point distant 3 ft. from the end of the girder.  $R_1 =$  live shear  $= 32^T (23.5' + 36.5') \div 39.5' = 48.6$  tons.

The dead load shear at this point, by similar triangles from the dead load shear curve is  $(16.75' \div 19.75')$  of  $2.4^T = 2$  tons. The remainder of the table is then completed as for items 25 to 29.

*Bottom Flange Rivets.* The shear  $S$  has the same value as used in the top flange, but there is no local shear from the wheel loads. The rivets could therefore be given a wider pitch, but for simplicity are always kept at the same pitch as the corresponding top flange rivets.

*Item 30.* The end stiffener has to be designed to carry the full reaction of  $69.3^T$ .

*Item 31.* By the given rule a  $3\frac{1}{2}'' \times 3\frac{1}{2}''$  angle would just do, but one with a slightly larger outstanding leg was chosen to give greater lateral stability.

*Items 32 and 33.* It is emphasized that the 6 in. by  $\frac{1}{2}$  in. plates under the end or bearing stiffener angles, Plate I, are doubling plates and not packings since they are riveted independently to the web plate; only that area of these plates under the stiffener angles have been included in the strut area. In addition (by rule (3) for stiffeners, previous chapter)  $20t \times t$  for the web plate on one side of the stiffener may be included. The shaped vertical end plate (section at  $A$ , Plate I) also contributes to the area of the bearing stiffener but it has not been included.

*Item 34.* *B.S. Table 7* is given in the following chapter.

*Item 35.* The web rivets through the end stiffeners are in bearing on a total thickness of  $1\frac{3}{8}''$  because the two doubling plates have previously been firmly attached to the web. If the doubling plates had not this outer row of rivets they would really only be inert packings under the stiffener angles and the stiffener rivets would then be in bearing on the  $\frac{3}{8}''$  thick web plate.

*Item 36.* There is also the possibility that each stiffener angle

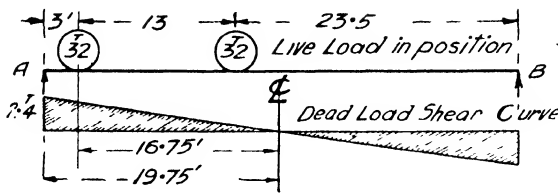

FIG. 48

Rivet Pitches and Shears. See Fig. 48 and text thereon.

Distance from end of girders.	Shear in tons.							Riveted rivet pitch in inches.	
	Live L.	Dead L.	Impact	Total S.	Per foot.	Local.	Result shear/ft.	Reqd.	Given.
End	53.5	2.4	13.4	69.3	16.2	8	18.1	2.8	2.87
3 ft.	48.6	2	12.1	62.7	14.7	8	16.7	3	3
10 ft.	37.3	1.2	9.3	47.8	11.2	8	13.7	3.7	3.5
15 ft.	29.2	0.6	7.3	37.1	8.7	8	11.8	4.3	4
19 ft. 9 in.	21.5	0	5.4	26.9	6.3	8	10.2	5	4

**End Stiffeners.** Load is total reaction = 69.3τ 30

Outstanding leg = (girder depth ÷ 30) + 2" = (48 ÷ 30) + 2" = 3.6" 31

Adopt a leg = 4"

Leg adjacent to web must take a 1 1/8" dia. rivet, so adopt the minimum leg = 3 1/2"

Hence try 2 [s 4" × 3 1/2" × 3/8", area = sq. in. gross 5.34 32

Effective area of doubling pls., 2 (3 1/2" × 1/2") = .. .. 3.5 33

Add 20t² = 20 × 3/8 × 3/8 = .. .. 2.81

Total effective strut area (see text) = .. .. 11.65

l/k = 3/4 of 48" ÷ 1.5" = 24

Working stress, B.S. Table 7, p. 68 = τ/sq. in. 7.84 34

Total permissible load = 7.84 × 11.65 = 91τ

Rivets. Angles to doubling plates and web.

Rivets in D.S. (8.28τ) or in bearing on a thickness of 1 1/8 in. (15.5τ), i.e., 10 @ 8.28τ = 82.8τ 35

Angles and doubling plates to the 3/8 in. thick web. Rivets in D.S. (8.28τ) or in bearing on a thickness of 3/8 in. (4.22τ). At the common surfaces there are 20 rivets @ 4.22τ = 84.4τ 36

plus its doubling plate, acting as one, may slide downwards or upwards relatively to the long  $\frac{3}{8}$  in. web plate.

Only one pair of end stiffeners per girder have an end plate riveted to them. When erected at site the girders are tightly butted (no allowance for expansion) and the end plate becomes common to both butting girders. This end plate also forms part of the end stiffeners, but has not been calculated to carry any vertical load. In one case, where this system was used, the crane girders "gathered" 3 in. in the total length of the track.

In view of the invariable tendency for built-up steelwork to grow, it would be good policy to dimension the overall length of the girder as being  $\frac{1}{16}$  in. less than the actual length. If the lineal growth is small then  $\frac{1}{4}$  in. thick vertical packing plates may be inserted between any convenient pair of butting ends.

In all stiffeners, except that over the web splice where there is practically no joggle, the end rivets are  $2\frac{1}{8}$  in. from the toes of the main angles. The riveting is therefore well clear both of the joggle and of the knee.

*Items 37 and 39* indicate that the  $4" \times 3\frac{1}{2}" \times \frac{3}{8}"$  angles used on the drawing could be replaced, quite satisfactorily, by  $4" \times 3\frac{1}{2}" \times \frac{5}{16}"$ . Adopting the former section means that all the stiffeners throughout the girder have the same thickness (a questionable economy); but a more important reason is the extra rigidity given against lateral thrust. It is also because of this lateral thrust that the small stiffening plates have been added to the kneed stiffeners at sections marked *C*, Plate I.

The intermediate stiffener which is at the point of greatest shear is that situated 3 ft. from the end. The distance *p* between adjoining stiffeners is 3 ft. plus 3 ft. 6 in. In the absence of more definite guidance as to the design load on an intermediate stiffener the formula used here is that given in other British specifications.

The intermediate stiffeners are positioned by dividing the girder into four equal lengths of 10 ft. and then subdividing the end 10 ft. into three parts and the adjoining 10 ft. into two parts: the actual site of the stiffener is governed (in this design) by the rivet pitch. But any other arrangement of stiffeners is acceptable: thus, stiffeners spaced 4 ft. (*i.e.*, depth of girder) apart would do, only remember that the permissible stress in the web depends upon the stiffener spacing. The adopted method close pitches the stiffeners where the shear is large and pitches them wide where the shear is small.

*Rivets in Edge Angles.* The shear which occurs in the horizontal girder is extremely small, as shown in item 7. Therefore, if every second rivet in the main angles be opposed by a corresponding rivet

<b>Intermediate Stiffeners.</b> Max. shear, item 29	=	62.7τ	
Design load $s = Sp \div 4D = 62.7\tau \times 6.5 \div (4 \times 4')$	=	25.5τ	<b>37</b>
Adopt 2 $\lfloor_s 4" \times 3\frac{1}{2}" \times \frac{3}{8}"$ (item 31), area	=	sq. in. gross 5.34	<b>38</b>
$l/k = \frac{3}{4}$ of 48" $\div 1.85"$ (Table 14, Vol. I, Appendix)	=	19.5	
Working stress, <i>B.S. Table 7</i>	=	τ/sq. in. 8.03	
Total permissible load = 5.34 × 8.03	=	42.9τ	<b>39</b>
Rivets. 10 in web in <i>D.S.</i> (8.28τ) or bearing on $\frac{3}{8}$ -in. web (4.22τ)	=	42.2τ	<b>40</b>

**Web Splice.**

*B.M. at Web Splice.*

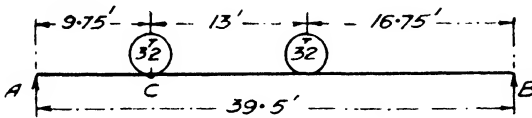

FIG. 49

<i>D.L.</i> = 4.8τ; $R_1 = 2.4\tau$ ; wt./ft. = 4.8 $\div$ 39.5	=	0.12τ	
<i>L.L.R.</i> , Fig. 49 = 32τ (16.75 + 29.75) $\div$ 39.5	=	38τ	<b>41</b>

<i>L.L.B.M.</i> , = 38τ × 9.75'	=	ft.τ 370	
Impact add 25%	=	" 92	
<i>D.L.B.M.</i> , = 2.4 × 9.75 -- (9.75 × 0.12τ)	=	" 17.7	

Total <i>B.M.</i> ,	=	" 479.7	<b>42</b>
---------------------	---	---------	-----------

*Shear at Web Splice.*

<i>L.L.</i> shear at C = $R_1$	=	38τ	
Impact add 25%	=	9.5τ	
<i>D.L.</i> shear at C = 2.4τ -- 9.75 × 0.12τ	=	1.2τ	

Total shear at C	=	48.7τ	<b>43</b>
------------------	---	-------	-----------

*Vertical Riveting in Web.*

In the formula where  $B.M = fD(A + W/6)$ , the term  $W/6$  is for gross area of web.

At the tensile end of covers the ratio of the net area of the web to the gross area is  $(2\frac{3}{4}" - \frac{1}{8}" ) \div 2\frac{3}{4}"$  (allowing for holes in the web at  $2\frac{3}{4}$  in. pitch) =  $\frac{2}{3}$  **44**

For all other stiffeners, including that at the centre line, the pitch is  $3\frac{3}{8}$  in.

∴ Ratio of net to gross area is  $(3\frac{3}{8}" - \frac{1}{8}" ) \div 3\frac{3}{8}" = 0.722$  **45**

Area of web helping the tensile flange is :-

At splice, $(\frac{2}{3})W/6$	=	$\frac{1}{9}W$	<b>46</b>
At centre line, $(0.722) W/6 = 0.12W$	=	$\frac{1}{8}W$	<b>47</b>

in the edge angles, sufficient rivet area will be given and template-making will be facilitated. The latter would not have been the case had another pitch been adopted. Despite this, however, in the two centre panels an unopposed pitch of 6 in. is used because the opposed pitch, described above, would result in the rivets being 8 in. apart. The specification states that the maximum straight line pitch for rivets under stress in a compression member must not exceed  $16t$  or 6 in., whichever is the lesser; but when an angle has a double line of staggered rivets (as in each leg of the 6 in.  $\times$  6 in.  $\times$   $\frac{1}{2}$  in. main angles) the maximum straight-line pitch, on each rivet line, is  $1\frac{1}{2}$  times that for the angle with a single line of rivets.

*Web Splice.* A 48"  $\times$   $\frac{3}{8}$ " web plate can be obtained up to 36 ft. long, thus necessitating one web splice at least in the 40-ft. length. In this particular design the web plate is calculated to carry part of the bending moment, and for this reason the splice should not be placed at or near the centre line where the moment is a maximum. Had the web been calculated for shear only, then the web splice is placed at mid-span, since it is the point of minimum shear.

If the splice be placed at 9.75 ft. from the reaction there will be two lengths of web plate. Should the unsymmetrical position of this splice offend the æsthetic eye of the designer he can then make two splices spaced at equal distances from the centre line.

*Items 46 and 47.* The latter is the allowance in item 16, viz.  $2\frac{1}{4}$  sq. in. The term  $\frac{1}{2}W$  is equivalent to 2 sq. in. This discrepancy of  $\frac{1}{4}$  sq. in. takes place not at mid-span (where every square inch of tension flange metal is required) but at the web splice, whose position is just previous to the flange plate cut off, where there is an excess of flange area. The calculations for the type of splice shown on Plate I are fully given in Chapter VII, Vol. I.

*Parabola.* A quick graphical construction is illustrated on the bottom left-hand corner of the plate. The maximum bending moment occurs at points 3 ft. 3 in. on either side of the centre line. The apices of the parabolas are vertically above these points at a distance of 551 ft. tons, *item 4*, pricked off to any suitable scale. Join  $O$  to  $M$ . Take any point  $P$  on this line and project it horizontally to  $Q$ . The intersection  $R$ , where the line joining  $Q$  to  $O$  cuts the vertical through  $P$ , is a point on the parabola. When the curve is near the apex the points similar to  $P$  can be grouped closer together in order to give a better estimate of the outline of the curve.

*Curtailment of Flange Plates.* The compression flange plate, an integral part of both horizontal and vertical girders, is carried the full length. Had there been two plates, the lower one would be carried the full length and the upper cut short where required, with packers of rail-base width for the remaining lengths.

Some specifications advocate that "where there is only one flange plate it shall be carried the full length of the girder." In the example the only tensile flange plate has been cut short, with little impairment to either the appearance or the utility of the girder.

The graphical construction for obtaining the point of cut-off illustrated on the plate is that described in Chapter I. It is shown applied to the live load bending moment curve: actually, of course, the dead load bending moment should also be included. The neglect of the dead load involves an error of about 4 per cent., item 4.

The cut-off may also be arrived at mathematically from the approximate bending moment parabolas. The equation of a parabola, origin at vertex, is  $x^2 = 4ay$  or  $x^2/y = 4a$ . Let the  $x$ 's be the abscissæ, or lengths measured horizontally from the apex, and let the  $y$ 's be the ordinates measured downwards from a horizontal line through the vertex. The amount of flange metal is directly proportional to the flange force, which in turn is directly proportional to the bending moment, and hence ordinates  $y$  may be expressed in terms of square inches of flange metal instead of foot tons,  $x_1^2/y_1 = 4a = x_2^2/y_2$ . At the end of the girder  $x_1$  is 16.5 ft. and  $y_1$ , the depth, is 17.2 sq. in. (Plate I).

At the point of cut-off the  $x_2$  is unknown, but  $y_2$ , the depth, is 5.3 sq. in.

Hence  $x_2 = \sqrt{(x_1^2 \times y_2/y_1)} = \sqrt{(16.5^2 \times 5.3/17.2)} = 9.159$  ft.

The distance of the theoretical point of cut-off from the girder centre line is  $9.159 + 3.25 = 12.4$  ft. Most specifications ask that the plate be extended a sufficient length past this point to permit the addition of three extra rivets per each longitudinal rivet line. This is roughly equivalent to developing half the strength of the curtailed plate by means of these extra rivets. The theoretical and actual distances of the end of the bottom flange plate to the girder centre line are thus 12.4 ft. and 13 ft. 10 in., respectively.

Had there been an inner flange plate of area, say, 7 sq. in., then  $x_1$  and  $y_1$  co-ordinates as before, but  $y_2$  would now be  $5.3 + 7 = 12.3$ , i.e., area of the outer plate or plates including the area of the plate under consideration.

## REFERENCES

### BRITISH STANDARD SPECIFICATIONS

(Published by the British Standards Institution, 2 Park Street,  
London, W.1)

- No. 449. *Use of Structural Steel in Building.*  
No. 466. *Electric Overhead Travelling Cranes.*



## CHAPTER III

### AXIALLY LOADED COLUMNS AND THEIR FOUNDATIONS

THE generic term *strut* is applied to any structural member under compression whose slenderness ratio is larger than 20. The ratio of slenderness is the abstract number obtained by dividing the unsupported length of the column in inches by the least radius of gyration, also in inches, *i.e.*, the  $l/k$ , or, as it is sometimes called, the  $l/r$ .

In building construction the particular term *column* is definitely assigned to the vertical post, prop or pillar supporting the floors. (Because of the fact that specimens are usually tested in a vertical position they are also termed columns.)

A *long strut* is one which fails by elastic instability. The lack of breadth permits of the strut bending sidewise, and when failure occurs it is due to this bending action and not to the intensity of the direct stress,  $P/A$ .

Consider this long and slender strut to be perfectly straight and to have the end load,  $P$ , applied without any eccentricity whatsoever (the Euler conditions). No matter how strong the steel is, if this perfect column is slender enough it can be made to deflect sidewise by the application of a very small lateral force: it is a case of stability and not one of strength. Thus, in Fig. 51 (1), if a load  $P$  is applied at the top and the column is purposely deflected sidewise by the application of a lateral force, the column will return to the vertical on the withdrawal of the lateral force. By judicious increments of the end load  $P$  it is possible to arrive at the critical stage when the column will remain deflected even when the side thrust, which was applied at the mid-point of the column's length, is withdrawn. The slightest addition to the critical end load now causes the column to deflect of its own accord until it finally buckles. This total end load is termed the ultimate or crippling load, and is that given by the graphs of the column formulæ. The stress per square inch at a point midway up the shaft is due to (1) the direct thrust of  $+ P/A$ , tons per square inch, where  $A$  is the gross cross-sectional area of the column in square inches, plus (2) the fibre stress due to bending of  $\pm BM/Z$ ; the  $+$  or compressive sign on the concave, and the  $-$  sign on the convex side. For a long strut as



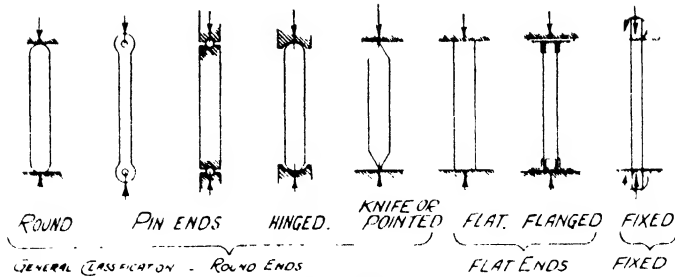

FIG. 50

ends are met with in their descriptions of the experiments. The particular list given above may be roughly said to represent the same end condition, *viz.*, that the ends of the specimen are fixed in position while, at the same time, permitting every freedom for the strut to deflect in one or all planes. Briefly, the ends are position fixed, but deflection free.

Pointed and knife ends closely approach the ideal condition under light loads, but under heavy loads there occurs indentation in the end bearing plates and this, because of the slight fixity now afforded, raises the ultimate strength of the specimen. The hinge and pin ended specimens are, theoretically, identical to the round-ended specimen except that they are deflection free in one plane only. In practice, however, the friction at the pin or hinge is sometimes so high that the specimen is almost a fixed ended one. In the text hereafter when the term pin-ended is used it is for the purpose of denoting a strut which is round-ended, *i.e.*, deflection free, in only one plane.

Flat ends exist when the end surfaces of the column are plane or flat and are at right angles to the column axis. The edges of this surface give a resistance against deflection, so that the column will be stronger because of this restraint than if it had the deflection freedom of a round-ended column. No tensile stresses, however, are developed at the ends. A flanged end is an exaggerated flat end with the edges still wider apart. The column should carry a larger load than the flat-ended one of the same length because of the additional resistance against deflection. The analogy of a chemical retort stand with its wide base will make this point clear.

Fixed ends are those which are fixed both in position and in direction, *i.e.*, position and deflection fixed. Because the ends are rigid and immovable tensile stresses can be, and are, developed there. Fixed ends do not occur so often in practice as they are assumed to do. Thus, if a 20-ft. long R.S.J. strut had the end 5 ft.

of each extremity buried in a rigid mass of concrete it could be termed fixed ended. Whereas, if only buried for 1 ft., the column, in all fairness, could only be said to have ends of which the equivalent values lie between round and flat. In one case the strut is unrestrained for 10 ft. and in the other for 18 ft. These figures are used for illustrative purposes only, and the ratios are not to be interpreted as defining a fixed or a round-ended strut.

**Equivalent Lengths of Columns.** Fig. 51 shows the elastic curves of the various types of columns or struts when loaded with the same load  $P$ .

1. **R.R.** is the standard case of reference, *i.e.*, a column with two round ends. The unsupported length  $L$  equals the distance  $l$  between the points of no bending moment.

2. **F.F.** is a column of unsupported length  $L$  which has both the ends fixed. At a distance of  $l/2$  from each end, points of inflection

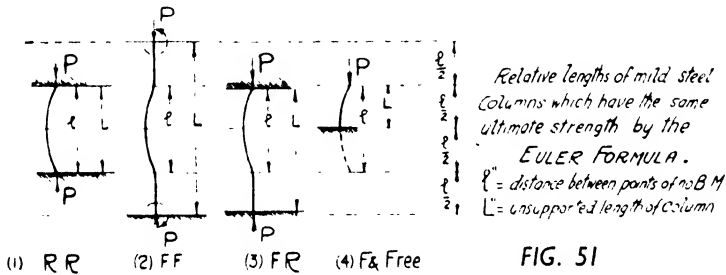

(contra-flexure or contrary flexure) occur. Now, because the curvature of the elastic line changes sign, and since this can only be produced by a change in sign of the bending moment, these points of turning must also be points of no bending moment: in other words, a round end virtually occurs at each point of inflection. The equivalent length  $l$  as a round-ended column is thus  $L/2$ .

3. **F.R.** represents one end fixed and the other end round. The equivalent round-ended length of the column =  $l = L/\sqrt{2} = 0.707L$ , sometimes given as  $\frac{2}{3}$  or 0.667 of  $L$ .

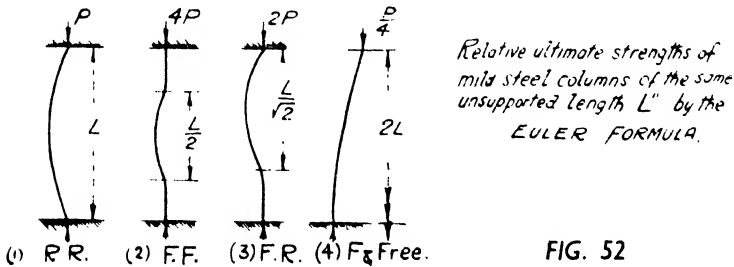

**4. F. and Free**, *i.e.*, fixed at one end, but entirely free—position and deflection—at the other. If the curve be continued under the base line the outline of (1) is obtained, and hence  $l = 2L$ .

**Euler Formula** for Long Struts. (Fig. 52.) All four types have the same unsupported length of  $L$ .

(1) *Ends, R.R.* (The fundamental case.)

$$\text{Ultimate load} = \frac{\pi^2 EI}{L^2}, \text{ i.e., the constant is 1.}$$

(2) *Ends, F.F.*

$$\begin{aligned} \text{Ultimate load} &= \pi^2 EI \div (\text{equivalent round-end length})^2 \\ &= \frac{\pi^2 EI}{(\frac{1}{2}L)^2} = \frac{4\pi^2 EI}{L^2}, \text{ i.e., the constant is 4.} \end{aligned}$$

(3) *Ends, F.R.*

$$\begin{aligned} \text{Ultimate load} &= \pi^2 EI \div (\text{equivalent round-end length})^2 \\ &= \frac{\pi^2 EI}{(L/\sqrt{2})^2} = \frac{2\pi^2 EI}{L^2}, \text{ i.e., the constant is 2.} \end{aligned}$$

(4) *Ends, F. and Free.*

$$\begin{aligned} \text{Ultimate load} &= \pi^2 EI \div (\text{equivalent round-end length})^2 \\ &= \frac{\pi^2 EI}{(2L)^2} = \frac{\pi^2 EI}{4L^2}, \text{ i.e., the constant is } \frac{1}{4}. \end{aligned}$$

Where  $E$  = Young's modulus of elasticity (*i.e.*, the stretch modulus) = 13,000 tons per square inch.

$I$  = least moment of inertia of the column's cross-section in inches.<sup>4</sup>

$L$  = unsupported length in inches and  $\pi = 3.14159$ .

The Euler formula (*i.e.*, for ends *R.R.* as (2), (3) and (4) are special cases of this) is entirely theoretical, and a mathematical proof of it can be found in some of the books of reference given in the list at the conclusion of the chapter. Its use is confined to exceptionally long columns carrying light axial loads.

**Remarks on Columns.** Previous to discussing formulæ for the practical column the following brief notes are given:—

(1) The ideal column is assumed to be absolutely straight; this never occurs in practice.

(2) Axial loading may be assumed and arranged for in the design; this, by item (1) and others, cannot occur, although the eccentricity of loading may be very slight.

(3) The modulus of elasticity is not constant in a built-up column. Even in one individual section the  $E$  of the web metal may be different from that of the flanges (Tetmajer). In an ordinary round bar of solid steel Christie found that the elastic axis was seldom coincident with the geometric axis of symmetry.

(4) There are stresses set up in fabrication and erection which

vary in amount even in a set of columns made from the same templates. Among the causes may be listed :—Cold straightening, slight differences in marking off, drifting of holes not in register, riveting, machined surfaces not butting in truth, columns not vertical, driving of base wedges when plumbing the column previous to grouting up, faulty connections of beams to the columns causing eccentricity of loading, etc.

(5) A shallow beam may, because of its deflection, severely affect the lateral support it should have given to the column, and in addition will create eccentricity of loading and, therefore, bending in the column.

(6) The type of section affects the column strength. Column *A* may have the same radius of gyration *k*, as column *B*, similarly *k<sub>y</sub>* for *A* may be identical with *k<sub>y</sub>* for *B*, yet one column is inherently the stronger. (The subscripts *x* and *y* denote the two axes about which the radii of gyration are taken.)

(7) It frequently happens that a column fails when tested about one axis, even though the slenderness ratio about that axis is the least. This is contrary to general expectation and theory.

(8) Eccentricity of loading is more serious with a compression member than with a tension member. Any increase of load on the strut will cause not a proportional but a larger increase in stress, and the strut will bend further from the axis of loading. An eccentrically loaded tension member will seek to place itself in the line of pull, so reducing the eccentricity and not increasing it like the strut.

Fortunately, however, the above items are not cumulative in their effect.

**Gordon-Rankine Formula.** The practical strut can be said to be of medium length, since the direct or “crushing” stress (short prism) is as important as the bending stress (long strut). Therefore, no matter which formula is employed, it should give results at either end of the scale which are not altogether absurd; *e.g.*, in the Rankine formula if an *l/k* of 10 be used the denominator is practically unity, and the value obtained for *P* is approximately the “crushing” value.

Probably the best-known formula is the Rankine—often termed the Gordon-Rankine formula. It exists in many guises, the users altering the constants to suit either their particular mode of expression or to conform with some particular set of experiments. As used in the United Kingdom its commonest form is

$$P = \frac{f_c}{1 + a \left(\frac{l}{k}\right)^2}$$

Where  $P$  = the ultimate load in tons per gross square inch.

$f_c$  = the "crushing" stress in tons per square inch = 21 for mild steel.

$a$  = the "constant" varies somewhat, but the usual value assigned to it for mild steel is  $\frac{1}{7,500}$  for the standard case of both ends round.

For cast iron,  $f_c = 36^T$ /sq. in. and  $a = \frac{1}{1,600}$  } ends R.R.  
 for wrought iron  $f_c = 16^T$ /sq. in. and  $a = \frac{1}{9,000}$  }

The formulæ can now be derived for the various end conditions as was done with the Euler formula (see Fig. 52) by reducing the columns to their equivalent round-ended lengths. Material: mild steel.  $L$  = actual unsupported column length in inches.

*Ends R.R. (i.e., both round).*

$$P = \frac{21}{1 + \frac{1}{7,500} \left(\frac{L}{k}\right)^2} = \frac{21}{1 + \frac{1}{30,000} \left(\frac{L}{k}\right)^2}$$

*Ends, F.F. (i.e., both fixed).*

$$P = \frac{21}{1 + \frac{1}{7,500} \left(\frac{L \div 2}{k}\right)^2} = \frac{21}{1 + \frac{1}{30,000} \left(\frac{L}{k}\right)^2}$$

*Ends, F.R. (i.e., one fixed, one round).*

$$P = \frac{21}{1 + \frac{1}{7,500} \left(\frac{L \div \sqrt{2}}{k}\right)^2} = \frac{21}{1 + \frac{2}{30,000} \left(\frac{L}{k}\right)^2}$$

*Ends, F. and Free (i.e., one fixed, one free).*

$$P = \frac{21}{1 + \frac{1}{7,500} \left(\frac{L \times 2}{k}\right)^2} = \frac{21}{1 + \frac{16}{30,000} \left(\frac{L}{k}\right)^2}$$

The first three have been graphed on Fig. 53.

*Ends, "Flat, Flat."* A column with both ends flat would appear to have the same ultimate strength as a fixed ended column of the same unsupported length for all slenderness ratios up to 100 - Christie's and other experiments. Thereafter the ultimate strength of the flat-ended column falls away from that of the fixed-ended column.

The column base colloquially termed flat in practice is, with the shorter columns, really flanged, a much better condition than flat.

It is often the practice to design the base of a mild steel column solely from the aspect of the bearing pressure on the concrete foundation. Thus, two columns both with base ends "flat" and both carrying the same load will have the same area of base, although the

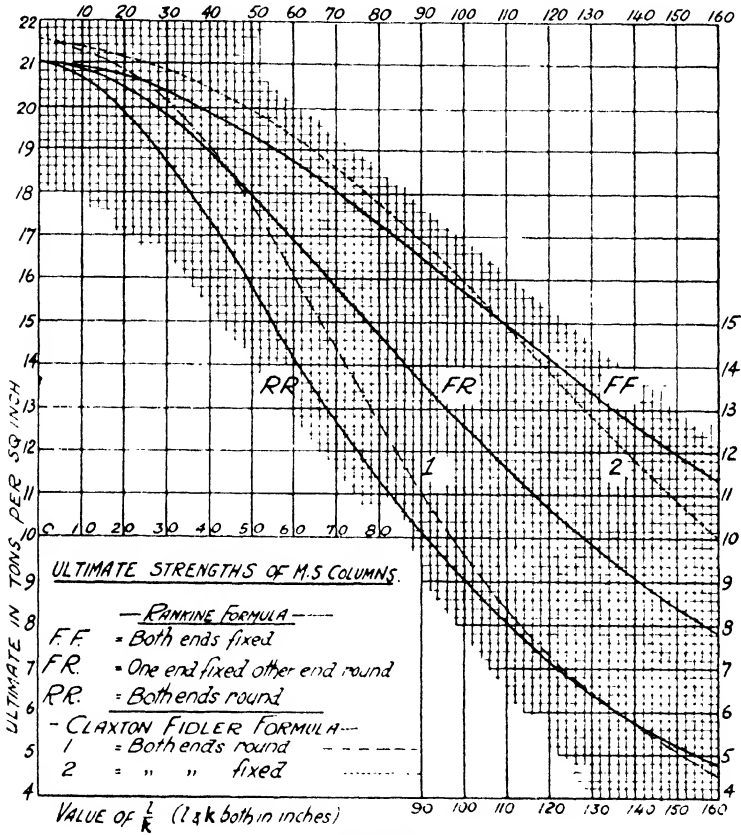

FIG. 53

slenderness ratio may be 80 in one case and 160 in the other. If in the shorter column the base is effectively a flat end, then it cannot be so with the longer column, the base of which must therefore be approaching, relatively, the round-ended condition. From the point of view of practice a more rational definition of a flat end would be one which connected the least width of the base with the unsupported length of the column.

It follows from the paragraph headed "Remarks on Columns" that theoretically derived formulæ must have their constants



—which, of course, vary with the material—adjusted to conform with the knowledge gained from experimental and other sources. Every authority has its own conception as to what these adjustments should be, with the result that there are innumerable formulæ for columns. As an example here is another form of Rankine's formula :—

*American formulæ—buildings.*

- (a) For main and subsidiary members with  $l/k$  not greater than 120 the parabolic type of formula (mentioned later) is used.
- (b) For subsidiary members with  $l/k$  greater than 120 the following Rankine formula is used (ends fixed).

$$\text{Working load} = \frac{18,000}{1 + \frac{1}{18,000} \left(\frac{l}{k}\right)^2}$$

in pounds per square inch.

- (c) For main members with  $l/k$  greater than 120 but less than 200, ends fixed.

$$\text{Working load} = \frac{18,000}{1 + \frac{1}{18,000} \left(\frac{l}{k}\right)^2} \times \left[ 1.6 - \frac{1}{200} \left(\frac{l}{k}\right) \right].$$

in pounds per square inch.

**Fidler Formula.** The standard case of round ends and also that of both ends fixed will be found graphed on Fig. 53, but the reader is referred to Professor Fidler's book for the actual formula.

The differences exhibited between the two sets of curves of Rankine and Fidler are sufficient to indicate that there is no necessity for great refinement of calculation.

Both these formulæ, Fidler and Rankine, are gradually being superseded by others of more recent development.

The method of using these graphs is as follows. If a strut has both ends round and the  $l/k$  is 100, the ultimate loads are : — Rankine, 9 ; and Fidler, 9.6 tons per square inch. These values are then divided by the "factor of safety," or load factor (4 was almost the universal value at one time) to give the working load intensity. Using 4 the respective working intensities are 2.25 and 2.4 tons per square inch. As against these the Perry-Robertson formula gives 4.13 tons per square inch. This last working stress represents a load factor of 2.18 on the Rankine ultimate and 2.32 on the Fidler ultimate, for  $l/k = 100$ . (As explained later, the Perry-Robertson formula has a load factor, or factor of safety, of 2.) Working stresses have been increased considerably during the last few years. Thus, in axial tension, the one time working stresses of 7 and  $7\frac{1}{2}$  have been raised to 9 and 10 tons per square inch. Increased

knowledge, better materials and steel shortage have decreased the factors of safety, or factors of ignorance as they have been facetiously termed.

**Straight Line Formulæ** of the form  $y = a - bx$  are, from their geometrical nature, limited in application between certain values of  $l/k$ . Thus, a straight line drawn in Fig. 53 from the point 160,  $11^{\tau}$ , to the point 20,  $22^{\tau}$  ( $x$  and  $y$  co-ordinates), is an approximation to Rankine  $FF$  for all values of  $l/k$  between 60 and 150 ; and on taking Fidler's  $FF$  curve also into consideration the straight line is usable for all values of  $l/k$  between 30 and 160. The equation; or formula, of this curve is

$$\text{Ultimate} = 23.57 - 0.0786 l/k \text{ in tons per square inch,}$$

which, in turn, can be modified to, say,  $\text{Ultimate} = 24 - 0.08 l/k$ , with the proviso that the ultimate is not to exceed 21 tons per square inch ; and so the formula becomes usable for all ratios of slenderness up to 160.

The formula just derived is an example of an empirical formula devised to express the average of a set of results or of other formulæ, but neither the formula nor the methods used in its derivation are recommended.

The B.S.S. uses straight line formulæ on several occasions, but these are usually only applicable to bridge design, because of the particular stresses and impact allowances specified ; see pages 233 and 268.

The two following American formulæ give the working stresses in pounds per square inch.

Both ends pinned. Working stress =  $16,000 - 70 l/k$ .

Both ends fixed. Working stress =  $18,000 - 70 l/k$ .

The latter is used for columns which are continuous through several floors of a building frame. In both formulæ the working stress must not exceed 14,000 and the  $l/k$  must not be larger than 160.

In the continental states of Europe the most common formula is the straight line one of Tetmajer.

**Parabolic Formulæ** are of the form  $y = a - bx^2$ . These are also empirical. One greatly used for the design of fixed-ended or continuous columns in buildings in America, to which reference was made on the previous page, is :—

Working stress in pounds per square inch =  $17,000 - 0.485 (l/k)^2$ .  
The maximum value for  $l/k$  is limited to 120.

**Perry-Robertson Formula.** A preceding paragraph headed "Remarks on Columns" gave a list of the defects to be expected in a practical column. Because of these defects an initial bending moment is created. One way to allow for this unintentional but

inherent moment is to assume that the theoretical column has an equivalent initial deflection curve. From the equation of such an assumed curve Perry derived formula (a) for the fundamental case of both ends round.

$$p = \frac{p_1 + (\eta + 1)p_c}{2} - \sqrt{\left(\frac{p_1 + (\eta + 1)p_c}{2}\right)^2 - p_1 p_c} \quad (a)$$

As a result of the investigations of Professor Andrew Robertson the Steel Structures Research Committee embodied his proposed modifications in their report. This amended form of the Perry formula has been adopted by the British Standards Institution as the standard column formula for Specification No. 449, Building, and by the Code of Practice for Simply Supported Steel Bridges. The standard formula is :—

$$CF_a = \frac{p_v + (\eta + 1)p_c}{2} - \sqrt{\left(\frac{p_v + (\eta + 1)p_c}{2}\right)^2 - p_v p_c} \quad (b)$$

Where  $C = 2.0 =$  load factor.

$p =$  end load applied,  $\tau/\text{sq. in. gross, i.e., } P/A.$

$F_a =$  permissible end load,  $\tau/\text{sq. in. gross.}$

$p_1 =$  compressive stress,  $\tau/\text{sq. in. gross, on concave side.}$

$p_c =$  Eulerian load,  $\tau/\text{sq. in. gross} = \pi^2 \times 13,000 \div (l/k)^2.$

$p_v =$  compressive yield stress,  $\tau/\text{sq. in. gross.} = 15.25.$

$\eta = 0.003 l/k.$

Two expressions commonly used with strut formulæ are ultimate compressive (or crushing) stress and yield stress. With ductile materials, such as mild steel, a specimen has a compressive yield point which can be definitely ascertained. Increasing the load on the test piece, after the yield point has been reached, will decrease the length and increase the cross-sectional area of the specimen without actually fracturing it; provided, of course, that the test piece is short, otherwise it will fail by buckling. There is no definite ultimate crushing strength in the same sense as there is an ultimate strength in tension. Robertson showed that when a practical strut is fabricated in mild steel, collapse occurred when the compressive stress on the concave side ( $p_1$  in (a)) reached the yield stress,  $p_v$  in (b). Therefore giving  $p_1$  of equation (a) the value of the yield stress  $p_v$  ( $15.25 \tau/\text{sq. in.}$  for mild steel) results in  $CF_a$  being the ultimate end load in tons per square inch. Dividing this ultimate end load intensity by the "factor of safety" or, more correctly, load factor of  $C = 2.0$  gives the working end load in tons for each square inch of gross cross-section. This "load factor" 2.0 is the ratio between the ultimate and permissible end loads and not between the collapse or yield stress and the maximum resulting fibre stress. The latter

ratio is the factor of safety in accordance with the definition, "ratio of the ultimate stress to the working stress."

It will be more apparent from equation (a) than from (b) that any increase of the end load  $p$  will cause not a proportional but a larger increase in the concave fibre stress  $p_1$ . Thus in (a) if  $l/k$  be kept constant at the value of 100 then only the load and the fibre stress will vary, whence the Eulerian value  $p_e = 12.83$  and  $(\eta + 1) = 1.3$ . Substituting these values in the first formula gives the following loads and stresses :—

End load $p^\tau$ /sq. in.	=	2.2	5.8	8.27 (ultimate load).
Fibre stress $p_1^\tau$ /sq. in.	=	3	9	15.25 (yield stress).

When the resulting fibre stress is 15.25 $\tau$ /sq. in. the yield stress has been reached and the corresponding ultimate end load is 8.27 $\tau$ /sq. in. : the permissible end load  $F_a$  is, by formula (b), 8.27  $\div$  2.0 = 4.13 $\tau$ /sq. in. as given in the following table for  $l/k = 100$ .

*Code of Practice for Simply Supported Steel Bridges.*

WORKING STRESSES IN COMPRESSION MEMBERS ( $F_a$ )

BOTH ENDS ROUND

*Perry-Robertson Formula for Mild Steel to B.S. 15*

$l/k$	$F_a$ $\tau$ -sq. in.	$l/k$	$F_a$ $\tau$ -sq. in.	$l/k$	$F_a$ $\tau$ -sq. in.	$l/k$	$F_a$ $\tau$ -sq. in.
20	7.17	50	6.36	80	5.12	110	3.67
30	6.93	60	5.98	90	4.62	120	3.26
40	6.65	70	5.57	100	4.13		

Main members  $\longrightarrow$

Subsidiary members  $\longrightarrow$

Intermediate values may be determined by interpolation.

*Table 7.* For all values of the slenderness ratio,  $l/k$ , of 80 and above the figures given in the table were derived from the Perry-Robertson formula, and are thus in agreement with the values given in the *C. of P.* table immediately above.

For values of the slenderness ratio,  $l/k$ , below 80 the Perry-Robertson formula was not used ; for this range the working stresses = 9 - 0.0485  $l/k$ .

**Effective Length of Struts.** As hitherto defined, the actual length  $L$  of a strut is the length measured along the member between the

British Standard 449. *The Use of Structural Steel in Building.*

TABLE 7 (B.S. 449)

Permissible working stresses in tons/sq. in. of gross section for axial loads.

$l/k$	$F_a$ T/sq. in.	$l/k$	$F_a$ T/sq. in.	$l/k$	$F_a$ T/sq. in.	$l/k$	$F_a$ T/sq. in.
0	9.00	50	6.57	90	4.62	130	2.89
4	8.81	52	6.48	92	4.53	132	2.82
8	8.61	54	6.38	94	4.43	134	2.76
12	8.42	56	6.28	96	4.33	136	2.70
16	8.22	58	6.19	98	4.23	138	2.63
20	8.03	60	6.09	100	4.13	140	2.57
22	7.93	62	6.00	102	4.04	150	2.30
24	7.84	64	5.90	104	3.95	160	2.06
26	7.74	66	5.80	106	3.85	170	1.86
28	7.64	68	5.70	108	3.76	180	1.68
30	7.54	70	5.60	110	3.67	190	1.52
32	7.45	72	5.51	112	3.59	200	1.39
34	7.35	74	5.41	114	3.50	210	1.27
36	7.25	76	5.31	116	3.42	220	1.17
38	7.16	78	5.22	118	3.34	230	1.08
40	7.06	80	5.12	120	3.26	240	0.99
42	6.96	82	5.02	122	3.18	250	0.92
44	6.87	84	4.92	124	3.11	300	0.65
46	6.77	86	4.82	126	3.03	350	0.49
48	6.67	88	4.72	128	2.96		

Intermediate values may be determined by interpolation.

points of lateral support. The effective length  $l$  for use in the foregoing tables is defined as follows:—

*C. of P.*—*Bridges*: *Web members* of trusses with a single triangulation.

When the members are end connected by:—

- (a) Pins; if  $L$  is the distance, measured along the member, between the pins, then  $l = L$ .
- (b) Rivets or welding; if  $L$  is the distance, measured along the member, between the centres of gravity of upper and lower chords, then  $l = 0.7L$ .

Special provision is made in the Code for webs composed of more than one system of triangulation.

*Compression Chords and End Posts of Trusses*,  $L$  is the length taken in the weakest plane of bending, either between the points of intersection of the vertical and lateral bracing with the main com-

- pression member (chords and posts) or between the points at which the cross girders are rigidly connected to the chords . . . . .  $l = L$ .
- For pin-connected members with the pins  $L$  apart then  $l = L$ .
- When the compression chord has no lateral bracing throughout its entire length  $L$  between the centres of the tops of the two end posts, then . . . . .  $l = 0.75L$ .
- However, should such a compression chord be adequately stiffened at the connections to the cross girders then the effective length  $l$  may be reduced in value but not less than the centre-to-centre distance between adjacent girder brackets.

*B.S. 449 Building.*

- Both ends fixed in position and restrained in direction  $l = 0.7L$ .
- Both ends fixed in position and one end restrained in direction . . . . .  $l = 0.85L$ .
- Both ends fixed in position but neither end restrained in direction . . . . .  $l = L$ .
- One end fixed in position and restrained in direction with the other end partially restrained in direction but not fixed in position . . . . .  $l = 1.5L$ .
- One end fixed in position and restrained in direction and the other end entirely free . . . . .  $l = 2.0L$ .

**Angle Struts.** Much laboratory testing has been done on single and double angle struts connected to gusset plates by one, two or more rivets or bolts. It is thus possible to derive tables giving the working loads with greater accuracy than could be obtained by using a general strut formula combined with one's own estimation as to the values of the end restraints.

*Table 7 and Fig. 54 (a)* refer to double angle struts with not less than two rivets or bolts as end connections at each end. To prevent either angle buckling away from its neighbour the two angles must have :—

- (a) not less than two riveted (or bolted) distance washers in the length  $L = l$ .
- (b) the slenderness ratio of either angle between the distance washers not greater than the lesser of the following values, viz., 0.6 times the slenderness ratio of the double angle strut as a single unit, or the slenderness ratio of 40.

*Table 8 and Fig. 54 (b)* refer to a single angle strut connected to a gusset plate or other member by not less than two end fastenings. The equivalent length  $l$  is to be taken as 0.8 times the distance  $L$

between the centre of connections, while the radius of gyration  $k$  is the minimum ( $zz$ ).

Table 8 and Fig. 54 (d) apply to a two-angle strut connected to the same face of a gusset plate by one or more fastenings in each angle. The two angles must be connected together throughout their length by rivets or bolts with or without distance washers, as specified for Fig. 54 (a).

Table 9 and 54 (c) refer to a single-angle strut with a single bolt or rivet at each end: the radius of gyration for  $l/k$  is the minimum about axis  $zz$ .

TABLE 8 (B.S. 449)

*Permissible Working Stresses in Tons per Square Inch of Gross Section for Discontinuous Angle Struts of Steel to B.S. 15*

$l/k$	$F_w$ , τ, sq. in.	$l/k$	$F_w$ , τ, sq. in.	$l/k$	$F_w$ , τ, sq. in.	$l/k$	$F_w$ , τ, sq. in.
0	6.00	70	3.97	140	2.15	210	1.16
10	5.71	80	3.68	150	1.95	220	1.08
20	5.42	90	3.40	160	1.77	230	1.00
30	5.13	100	3.12	170	1.61	240	0.93
40	4.84	110	2.85	180	1.47	250	0.86
50	4.55	120	2.60	190	1.35	300	0.62
60	4.26	130	2.37	200	1.25	350	0.47

Intermediate values may be determined by interpolation.

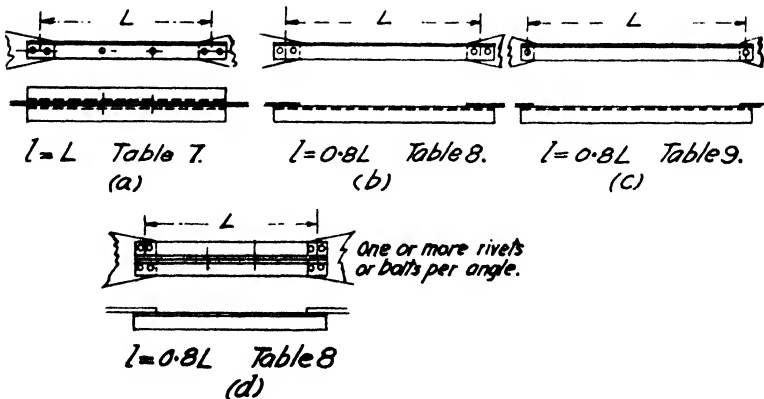

FIG. 54

TABLE 9 (B.S. 449)

*Permissible Working Stresses in Tons per Square Inch of Gross Section for Discontinuous Angle Struts of Steel to B.S. 15 (Single-bolted or single-rieveted at ends)*

$l/k$	$F_w$ 1/sq. in.	$l/k$	$F_w$ 1/sq. in.	$l/k$	$F_w$ 1/sq. in.	$l/k$	$F_w$ 1/sq. in.
0	3.00	70	2.19	140	1.41	210	0.90
10	2.88	80	2.08	150	1.32	220	0.84
20	2.77	90	1.96	160	1.24	230	0.79
30	2.65	100	1.85	170	1.16	240	0.75
40	2.54	110	1.73	180	1.09	250	0.71
50	2.42	120	1.62	190	1.02	300	0.53
60	2.31	130	1.51	200	0.96	350	0.43

Intermediate values may be determined by interpolation.

**Practical End Conditions.** The strength of a column largely depends upon the end conditions, and the design really rests upon the assessment made of the degree of fixity, especially deflection fixity. The end conditions of a practical column are not nearly so simple as those of the test-room, which, in turn, are vastly different from the ends they are supposed to represent in the theory of columns. To further complicate the subject, practice will obviously furnish cases which cannot be definitely assigned to any particular class : round ends may merge into pin, which, in turn, may gradually merge into fixed ends. When in doubt err on the safe side by taking the lower value for the ultimate.

There are fifteen pages of drawings given in the present edition of *B.S. 449 - Building*, illustrating nearly every type of stanchion and end connection encountered in the design of a modern steel-framed building. The designer has only to look for the type of stanchion he is designing and given alongside the drawing he will find the value of the effective column length  $l$  in terms of the actual length  $L$ .

Thus, as an example, consider Fig. 79, which shows an outer column to which horizontal angle rails will be attached to carry the vertical corrugated sheeting. Let the  $xx$  axis be that which lies in the plane of the paper, e.g., along the horizontal line marked  $A : A A$ . The axis perpendicular to this is the  $yy$  axis.

**Continuous Roof Shaft.** Axis  $xx$  (along web centre line) :— $l =$  greatest distance between the horizontal angle rails supporting the sheeting. Axis  $yy$  :— $l = 1.5L$ , where  $L$  is the length from underside of crane girder to underside of Warren roof girder.

**Crane Shaft.**  $L =$  length from underside of crane girder to underside of base plate. axis  $xx$  :— $l = 0.85L$ . Axis  $yy$  :— $l =$  greatest unsupported distance between diaphragms. See page 196 for



Beginners always have difficulty in estimating the end conditions of a strut, and a previous edition of *B.S. 449 Building*, now obsolete, gave the following empirical assessment of the end restraint of a strut. Students found this helpful and for this reason it is retained in the text.

*Restrained Ends.*

(i) When the effective slenderness ratio  $l/k$  does not exceed 120 a strut may be taken as having its ends restrained in direction (i.e., deflection fixed) if:—(a) The restraining members at the end of the strut and (b) the common connection (e.g., angle cleat, gusset plate, rivets or bolts) attaching the strut to the restraining members have each a moment of resistance ( $M$  or  $R$ ) equal to at least a quarter of that of the strut considered as a beam.

(ii) When  $l/k$  exceeds 120 then the moment of resistance of the restraining members (a) and the common connections (b) should at least be  $0.25 + 0.02(l/k - 120)$  of the moment of resistance of the strut considered as a beam.

(iii) If the strut is continuous through a point of lateral support the moment of resistance of the restraining members and their connections (a) and (b) need only be one-half of the values specified above in (i) and (ii).

*Partially Restrained Ends and Flat Ends.* When one or both ends of a strut do not satisfy the foregoing definitions for full restraint, but are not entirely unrestrained in direction, then the designer may use a suitable value for the effective length to take cognizance of this partial restraint.

A flat-ended strut (such as the base of a column resting on concrete and attached thereto by holding-down bolts) is assumed to be effectively restrained—thus satisfying the conditions mentioned in (i) above—for effective slenderness ratios  $l/k$  not exceeding 120. If the value for  $l/k$  exceeds 120 then the end of the strut is to be considered as being partially restrained.

**NUMERICAL EXAMPLE.** To evaluate the degree of restraint given by the end connections to a rafter panel of a 55' span roof truss. The rafter section is slightly heavier than that of Chapter V and Plate II, but otherwise the conditions are identical.

*Rafter in Vertical Plane, Fig. 55.* The section adopted is  $2 \lfloor_s 3" \times 2\frac{1}{2}" \times \frac{1}{4}"$ . The rivet values of a  $\frac{3}{4}"$  dia. shop rivet are:— $S.S. = 2.65'$ ;  $D.S. = 5.3'$ ;  $\frac{1}{8}" B = 2.25'$ ;  $\frac{1}{16}" B = 2.81'$ . Refer to page 75.

Consider any panel length,  $AB$  or  $BC$ , etc., as a simple beam carrying a normal load in the vertical plane (i.e., the plane of the paper), as indicated by the upper feathered arrow in Fig. 55 (a).

From tables, modulus $Z_x$ of $2 \lfloor_s 3" \times 2\frac{1}{2}" \times \frac{1}{4}"$	= in. <sup>3</sup>	1.08
$B.M.$ which rafter could carry, i.e., $M$ of $R = Z_x F_t$	$= 1.08 \times 10 =$	in. tons 10.8
$M$ of $R$ of rivet couples: $\frac{1}{16}" B \times 3"$ lever arm in rafter	= .. ..	8.43
and $\frac{1}{8}" B$ in member $Bb \times 2\frac{1}{2}"$ lever arm	= $2.25 \times 2\frac{1}{2} =$	.. .. 5.62
$M$ of $R$ of restraining member $Bb$ is $Z_x F_t = 0.38 \times 10 =$	= .. ..	3.80

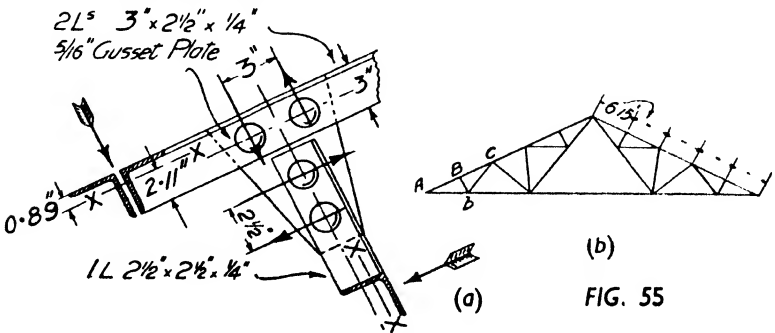

FIG. 55

The riveted connections and the restraining members have, individually, moments of resistance greater than the necessary one-eighth of that of the continuous rafter. As the end of panel detail just examined is obviously the weakest on the rafter, the rafter will be considered as being restrained at each panel point in the plane of the truss.

*Rafter in Plane of Roof Slope.* In Figs. 56 and 57 if the rafter acts as a beam in the plane of the roof covering, under a load applied as indicated by the feathered arrow, then the moment of resistance of the double angle rafter about axis *yy* is best obtained from a list of the radii of gyration of two unequal angles placed back to back on a  $\frac{5}{16}$ " gusset.

Radius of gyration $k_y$	=	1.10"
$I_y = Ak_y^2 = 2.62 \times 1.10^2$	= in. <sup>4</sup>	3.17
$Z_y = I_y \div \text{fibre distance} = 3.17 \div 2.65$	= in. <sup>3</sup>	1.20
$\therefore M \text{ of } R \text{ of rafter} = Z_y F_t = 1.2 \times 10$	= in. tons	12.00
$M \text{ of } R \text{ of } 4" \times 3" \times \frac{5}{16}" \text{ purlin angle} = Z_y F_t = 0.71 \times 10$	= " "	7.10
Now consider the resistance moment of the bolting.		
$\frac{3}{8}$ " dia. bolt in S.S. = 0.442 sq. in. @ 4 <sup>1</sup> / <sub>2</sub> sq. in.	=	1.77 <sup>r</sup>
" " " $\frac{1}{4}$ " B = $\frac{1}{4} \times \frac{3}{4} \times 8$	=	1.5 <sup>t</sup>
" " " area at bottom of the thread	= sq. in.	0.3
" " " permissible axial tension = 0.3 sq. in. @ 6 <sup>7</sup> / <sub>8</sub> sq. in.	=	1.8 <sup>r</sup>
$M \text{ of } R \text{ at } A, \text{ Fig. 56,} = \frac{1}{4}" B \times \text{arm} = 1.5 \times 3 \frac{1}{8}"$	= in. tons	4.59

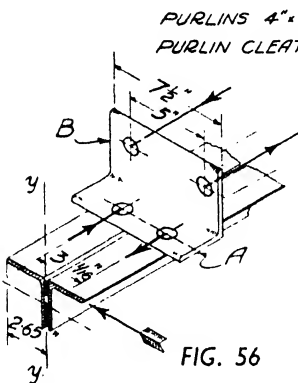

FIG. 56

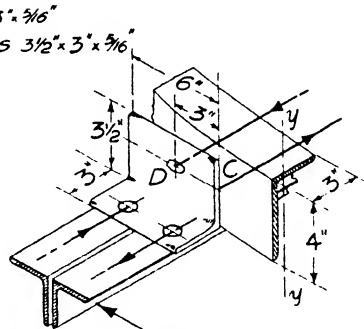

FIG. 57

In Fig. 57, with the rafter bending, the purlin is levered away from the cleat about the edge *C* as the fulcrum. The restoring couple is the pull on bolt *D* by the lever arm *DC*. *i.e.*,  $M \text{ of } R = 1.8^r \times 3^r =$  in. tons 5.4

Some designers prefer to use the double bolted cleat of Fig. 56 at joints and intermediate points of the purlins alike, and like to be safe by considering the couple at *B* as the bolt pull by the 5" lever arm between the bolt centres instead of to the cleat edge.

$\therefore M \text{ of } R = 1.8^r \times 5^r =$  " " 9.0

The resistance moment of the cleats, the bolts and the attached purlin are each greater than  $\frac{1}{4}$   $M$  of  $R$  of the continuous rafter. Hence the rafter may be considered as being restrained at each panel point in the plane of the roof slope, *i.e.*, the rafter angles are restrained in direction at each panel point about both the *xx* and the *yy* axis.

The design of the rafter strut then follows, as given in item 40, Chapter V.

PERMISSIBLE STRESSES ON MILD STEEL \* FOR BUILDINGS

		Stress Symbol.		Tons per sq. in.
		Actual.	Permissible.	
<b>TENSION.</b>	Axial stress on net section	$f_t$	$F_t$	9
<b>COMPRESSION.</b>	<b>Columns.</b> See tables	$f_c$	$F_c$	
<b>BENDING.</b>	<b>Beams.</b> Extreme fibre stress ; tension	$f_t$	$F_t$	10
	compression, either	$f_c$	$F_c$	10
	or (lesser of)	"	"	$\frac{1,000}{l/k} K_1$
	where			
	$l$ = unsupported lateral length.			
	$k$ = rad. of gyrat., axis $yy$ .			
	$K_1$ = unity, except for R.S.J. and plate girders symmetrical about both principal axes when it has the following values			
	$k_x/k_y$   5   $4\frac{1}{2}$   4   $3\frac{1}{2}$   3 or less			
	$K_1$   1   $1\frac{1}{8}$   $1\frac{1}{4}$   $1\frac{3}{8}$   $1\frac{1}{2}$			
	<b>Plate Girders.</b> The above permissible values $F_t$ and $F_c$ shall be reduced by 5 per cent., i.e., 9.5, 9.5, etc.			
<b>SHEAR.</b>	Stress on gross cross-section of webs, (the lesser of) either	$f_w$	$F_w$	6.5
	or $\left(\frac{225}{b/t}\right)^2 \left[1 + \frac{3}{4} \left(\frac{b}{a}\right)^2\right]$			
	where $a$ and $b$ = greater and lesser unsupported dimensions of a web panel, respectively.			
	$t$ = web thickness.			
<b>BEARING.</b>	Steel on steel	$f_b$	$F_b$	12
<b>RIVETS.</b>	See opposite page.			
<b>BOLTS.</b>	" " "			

\* Based upon the British Standard Specification, No. 449.

RIVET AND BOLT VALUES  
FOR WORKSHOPS AND STEEL FRAMED BUILDINGS

Dia. of hole in inches.	Area in sq. inches.	Shear value in tons per Rivet.	Bearing value in tons per rivet for a plate thickness (in inches) of †												Axial tension in tons. Value of one Rivet, Bolt.*	Tons per sq. inch.			
			1/4	1/2	3/4	1	1 1/4	1 1/2	1 3/4	2	2 1/4	2 1/2	2 3/4	3					
1/4	0.1963	1.18	2.36	1.50	1.88	2.25	2.63									0.98	0.61	6	Single shear =
1/2	0.3068	1.84	3.68	1.88	2.34	2.81	3.28	3.75								1.53	1.02	12	Double shear =
3/4	0.4418	2.65	5.30	2.25	2.81	3.38	3.94	4.50	5.06	5.63						2.21	1.82	12	Bearing =
1	0.5185	3.11	6.23	2.44	3.05	3.66	4.27	4.88	5.48	6.10	6.70					2.59	2.20	12	Axial stress on rivets less than 3/4" dia. and up =
1 1/4	0.6913	3.61	7.21	2.63	3.28	3.94	4.59	5.25	5.91	6.56	7.22					3.01	2.53	10	Axial stress on rivets less than 1" dia. and up =
1 1/2	0.8003	4.14	8.28	2.81	3.52	4.22	4.92	5.63	6.32	7.03	7.73	8.44				3.45	2.98	10	Axial stress on rivets less than 1 1/4" dia. and up =
1 3/4	0.7854	4.71	9.42	3.00	3.75	4.50	5.25	6.00	6.75	7.50	8.25	9.00				3.93	3.32	6	Axial stress on rivets less than 1 1/2" dia. and up =
2	0.1963	0.98	1.96	1.25	1.56	1.88	2.19									0.79	—	5	Single shear =
2 1/4	0.3068	1.53	3.07	1.56	1.95	2.34	2.73	3.13								1.23	—	10	Double shear =
2 1/2	0.4418	2.21	4.42	1.88	2.34	2.81	3.28	3.75	4.22	4.69						1.77	—	10	Bearing =
2 3/4	0.5185	2.60	5.19	2.03	2.54	3.05	3.55	4.06	4.57	5.08	5.58					2.07	—	10	Axial stress on rivets =
3	0.6913	3.01	6.01	2.19	2.73	3.28	3.83	4.38	4.92	5.47	6.02					2.41	—	4	
3 1/4	0.8003	3.45	6.90	2.34	2.93	3.52	4.10	4.69	5.27	5.86	6.45	7.03				2.76	—	4	
3 1/2	0.7854	3.93	7.85	2.50	3.13	3.75	4.38	5.00	5.63	6.25	6.88	7.50				3.14	—	4	
3 3/4	0.1963	0.79	1.57	1.00	1.25	1.50	1.75									—	0.61	4	Single shear =
4	0.3068	1.23	2.45	1.25	1.56	1.88	2.19	2.50								—	1.02	8	Double shear =
4 1/4	0.4418	1.77	3.53	1.50	1.88	2.25	2.63	3.00	3.38	3.75						—	1.82	8	Bearing =
4 1/2	0.5185	2.07	4.15	1.63	2.03	2.44	2.84	3.25	3.66	4.06	4.46					—	2.50	8	Axial stress on rivets less than 1 1/4" dia. =
4 3/4	0.6913	2.41	4.81	1.75	2.19	2.63	3.06	3.50	3.94	4.38	4.81					—	2.53	5	Axial stress on rivets less than 1 1/2" dia. =
5	0.8003	2.76	5.52	1.88	2.34	2.81	3.28	3.75	4.22	4.69	5.16	5.62				—	2.98	5	Axial stress on rivets less than 1 3/4" dia. and up =
5 1/4	0.7854	3.14	6.28	2.00	2.50	3.00	3.50	4.00	4.50	5.00	5.50	6.00				—	3.32	6	Axial stress on rivets less than 1 3/4" dia. and up =

\* Axial stress on the area at the bottom of the bolt thread.

† The bearing values to the right of the upper zigzag line are greater than the corresponding double shear value. The bearing values to the right of the lower zigzag line are lower than the corresponding double shear value.

## EXPLANATORY TEXT

**NUMERICAL EXAMPLE.** Design the lower length of an internal column, Fig. 62, to carry an axial load of 125 tons, inclusive of self. If there is a possibility of the superimposed floor load being applied to the first floor on only one side of the column, key elevation, then this part of the column load is non-axial—a case which will be dealt with in the succeeding chapter.

*Item 2.* The column is continuous through several floors, which are of massive and rigid construction, and, therefore, the top end of the basement shaft will have a fair degree of deflection fixity and a high degree of position fixity.

The base is wide in comparison with the shaft, and is held in position by the holding-down bolts and the friction due to the load. It is definitely position fixed, and has a better deflection fixity than a flat-ended column, in fact, it is so widely flanged that the base approaches as near a fixed column base as can be attained in ordinary practice. The column will therefore be assumed as having both ends fully restrained: the *B.S. 449 Building* also does so on its drawing of this type of column. This assumption will be verified later by the employment of the moment of resistance method of calculation.

The length of the column is taken as being from the underside of the base plate to the centre of the floor connections (say, 6" below floor level).

*Item 3.* A preliminary trial section, or, alternatively, one from the constructional trade handbooks, furnishes the cross-section of item 3 and Fig. 58. Alternative column shafts and bases are given at the end of the present chapter and are illustrated by Figs. 71 to 74.

*Item 4.* The moment of inertia of each flange plate about its own axis is very small and is neglected.

*Item 5.* This is the least radius of gyration.

*Item 6.* Refer to the definitions given regarding equivalent lengths for the Perry-Robertson formula.

*Item 10.* The diameter of the rivets in struts cannot be calculated as in plate girders, and, unfortunately, but little guidance is given to the beginner by specifications. A common clause is that the maximum rivet pitch shall not exceed  $12t$  or  $16t$ , so that a  $\frac{1}{2}$ " dia. or a 1" dia. rivet could be used to satisfy this requirement. There is usually a clause, however, which connects the rivet diameter with the pitch for the base and cap ends and this indirectly serves as a guide. The argument used in this item is that a rivet, where possible, should be as strong in shear as in bearing.

The transverse links or rodding binding the main longitudinal

CALCULATIONS

*Formula.* Perry-Robertson.

*Working Stresses.* See page 74.

*Axial load* = 125<sup>r</sup> **1**

*Ends.* Both effectively restrained. For verification, see item **20** . . . . **2**

Distance between upper surfaces of found and 1st floor = 15'

Length of column = 15' less 6" = 14' 6"

Section.—

Try 1 R.S.J. 10"  $\times$  6"  $\times$  40 lb. = 11.77 sq. in. **3**

Plus 2 Pls., 10"  $\times$   $\frac{1}{2}$ " = 10 „

Total area = „ 21.77

*Moments of Inertia, etc.,*

$I_x$ . R.S.J. (from list of joist properties) = 204.8 in.<sup>4</sup>

2 Pls. = area  $\times$  distance<sup>2</sup> = 2 off @ 10"  $\times$   $\frac{1}{2}$   $\times$  5.25<sup>2</sup> = 275.6 „

Total  $I_x$  = „ 180.4 **4**

$k_x = \sqrt{I/A} = \sqrt{(180.4 \div 21.77)} = 4.7''$

$I_y$ . R.S.J. (from list of joist properties) = 21.76 „

2 Pls. = 2 ( $a \frac{1}{12} bd^3$ ) = 2  $\times$   $\frac{1}{12} \times \frac{1}{2} \times 10^3 = 83.33$  „

Total  $I_y$  = „ 105.09

$k_y = \sqrt{I/A} = \sqrt{(105.09 \div 21.77)} = 2.2''$  **5**

*Equivalent length*, both ends restrained

= 0.7L = 0.7  $\times$  14.5'  $\times$  12 = 122" **6**

Max. equivalent  $l/k = 122 \div 2.2 = 56$  **7**

Permissible axial end load from B.S.

Table 7, p. 68,  $F_a$  =  $\tau$ /sq. in. 6.28 **8**

Actual axial end load = 125  $\div$  21.77 = „ 5.71 **9**

*Rivet Values.*

$\frac{3}{4}$ " dia. S.S. = 2.65<sup>r</sup> :  $\frac{5}{8}$ " B = 5.63 : Ratio = 1 : 2.12 **10**

$\frac{7}{8}$ " dia. S.S. = 3.61<sup>r</sup> :  $\frac{5}{8}$ " B = 6.56 : Ratio = 1 : 1.81

The latter is the more economical rivet.

Unwin's rule is  $1.2\sqrt{t} = 1.2\sqrt{\frac{1}{2}} = 0.84''$ .

Adopt a dia. of  $\frac{7}{8}$ "

*Connections at base.*—

Number of  $\frac{7}{8}$ " dia. rivets in S.S. required = 125<sup>r</sup>  $\div$  3.61<sup>r</sup> = 35 **11**

Number given in 2 side pls. to flange pls. = 32

bars of a reinforced concrete pile are closer pitched at the cap and the shoe than elsewhere throughout the pile length, because it is at these two points that the shock of driving enters and distributes itself into the pile. Similarly, in a reinforced concrete column for an end length of  $1\frac{1}{2}$  diameters the links are close-pitched; and with a mild steel built-up column the maximum rivet pitch is limited to  $4\frac{1}{2}$  rivet diameters for the end lengths of  $1\frac{1}{2}$  times the column width. The maximal pitches are therefore :—base and cap 4 in., elsewhere in shaft  $12t = 6$  in.

*Item 11.* The foot of the column need not be machined if sufficient rivets are provided to transfer all the column load from the shaft to the foundation. Cases will arise where there is insufficient room for the necessary number of rivets to be inserted. When this occurs only 60 per cent. of the requisite number of rivets need be given provided that the complete bearing end of the built-up base of the column (*i.e.*, bottom faces of shaft, side plates, angles and cleats, etc.) is machined over all the area in contact with the machined upper surface of the base plate. The small web cleats should transfer the web's portion of the load to the base plate.

*Item 12.* The side plates take the upthrust from the base plate as cantilevers and transfer their load into the column shaft and so balance the downward load of 125 tons. If these be designed to carry all the reaction between them, they will be on the safe side. The small upper diagram of Fig. 59 illustrates the similarity between the present example and the crane brackets of Volume I.

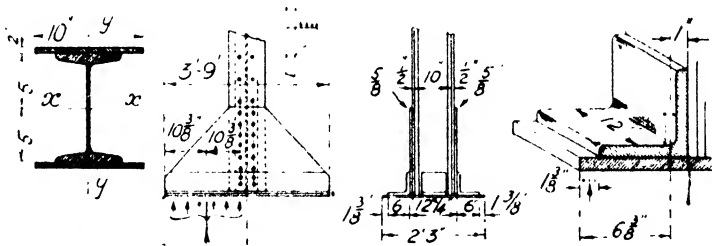

FIG. 58

FIG. 59

FIG. 60

FIG. 61

*Item 13.* The design of the base can only be approximate as it cannot be definitely ascertained how much of the load enters the concrete by direct bearing of the shaft upon the sole plate, or how much enters by way of the side plates. The most rigid parts of the base will carry the greatest portion of the load, hence, there must be a concentration of pressure under the side plates, side angles, and the

Plus 3 in web cleat in <i>D.S.</i> and 0.36" <i>B</i>	= 3	
Total rivets given	=	35 ✓
Number given, side pls. to base angles	=	32
<i>Side plates as cantilevers.</i> Upthrust on two (Fig. 59) = $125^T(20\frac{3}{4} \div 45)$	=	57.64 <sup>T</sup>
Max. <i>B.M.</i> at rivet line = $57.64^T \times 10\frac{3}{8}$	= in. tons	598
<i>Z</i> of two side plates, 24" deep $\times \frac{5}{8}$ " thick = 2 off @ $\frac{1}{8} \times 24^2$	= in. <sup>3</sup>	120
Extreme fibre stress = $M/Z = 598 \div 120$	= <sup>T</sup> /sq. in.	± 4.98
Vertical shear stress = $57.64^T \div$ gross area of 2 @ $24" \times \frac{5}{8}"$	= ,,	1.92
<i>Base plate.</i> Area required = $125^T \div$ safe pressure of 20 <sup>T</sup> for 1 : 2 : 4 concrete	= sq. ft.	6.25
Bearing area given = 2' 3" $\times$ 3' 9"	= ,,	8.44
Resulting pressure per sq. ft. = $125^T \div$ 8.44	= <sup>T</sup> /sq. ft.	14.81
Try a thickness of base plate of $\frac{3}{4}"$ . The upthrust on the $1\frac{3}{8}"$ cantilever of the base plate, Fig. 61, for a ft. length, at 14.81 <sup>T</sup> per sq. ft.	=	1.7 <sup>T</sup>
<i>B.M.</i> on this cantilever = $1.7^T \times \frac{1}{2}$ of $1\frac{3}{8}"$	= in. tons	1.17
<i>Z</i> of $\frac{3}{4}"$ thick plate = $\frac{1}{6} \times 12 \times (\frac{3}{4})^2$	= in. <sup>3</sup>	1.13
Extreme fibre stress = $1.17 \div 1.13$	= <sup>T</sup> /sq. in.	± 1
Vertical shear stress = $1.7^T \div$ area of $12" \times \frac{3}{4}"$	= ,,	0.19
Alternatively make use of the alignment chart, Fig. 63		14
The horizontal angle leg plus the sole plate may, or may not, act as one thick plate, depending upon the number of rivets connecting the two.		
Load on $6\frac{3}{8}"$ cantilever (Fig. 61), 12" broad at 14.81 <sup>T</sup> /sq. ft.	=	7.86 <sup>T</sup>
Max. <i>B.M.</i> (at half-way along root fillet of angle) = $7.86^T \times \frac{1}{2}$ of $6\frac{3}{8}"$	= in. tons	25.05
(a) <i>Z</i> of angle plus base pl. acting as one = $\frac{1}{6} \times 12 \times (1\frac{1}{2})^2$	= in. <sup>3</sup>	4.5
(b) <i>Z</i> of angle plus base pl. acting separately = 2 @ $\frac{1}{6} \times 12 \times (\frac{3}{4})^2$	= ,,	2.25
Extreme fibre stress = <i>B.M.</i> $\div Z$ = $25.05 \div (4.5 \text{ or } 2.25)$	= <sup>T</sup> /sq.in.	± 5.6 or 11.1



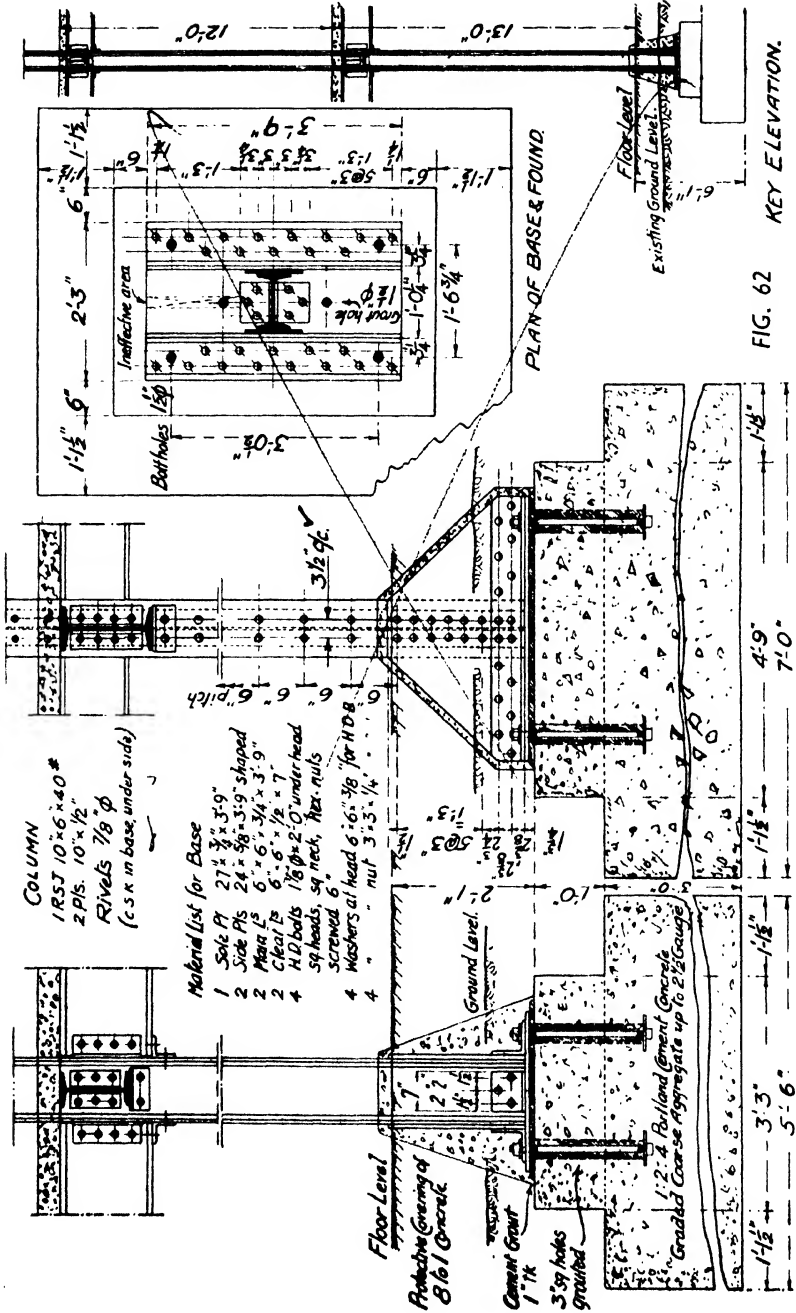

FIG. 62 KEY ELEVATION.

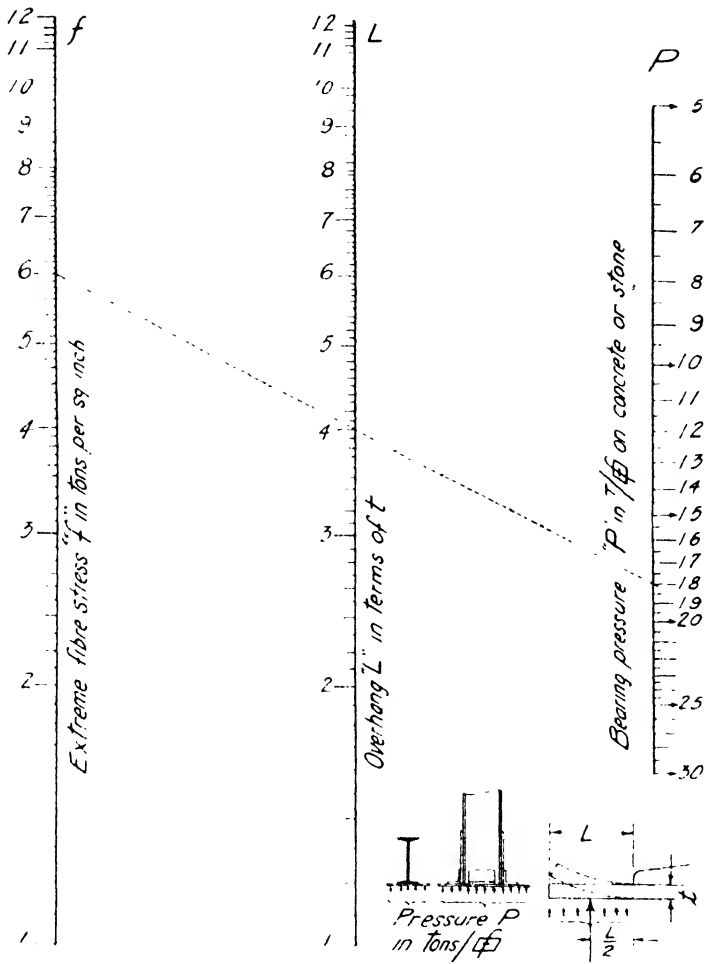

FIG. 63

ALIGNMENT CHART GIVING THE SAFE OVERHANG OF THE BASE PLATES OF COLUMNS BEAMS, GIRDERS AND ROOF TRUSS SHOES, ETC.

*Example.* If the permissible bearing pressure  $P$  on the stone base is to be 18 tons per square foot and the extreme fibre stress  $f$  on the mild steel base plate is not to exceed 6 tons per square inch find the allowable overhang  $L$ . The answer is  $L$  should not be longer than 4 $t$ .

*Method.* Lay a straight edge so as to join points  $P = 18$  to  $f = 6$  and this gives the point of cutting on the  $L$  vertical as 4.

Similarly if any one of the three quantities is unknown, it can be found from the straight line joining the other two.

mid-angle cleats to web, while the portion marked "ineffective" (Fig. 62) will have very little upthrust upon it.

The sole plate acts as a cantilever, outwards past the toe of the horizontal leg of the angle of Fig. 61, taking the upthrust from the coarse aggregate concrete (permissible pressure,  $20^{\tau}$  per sq. ft.) at the rate of 14.81 tons per square foot of base, item 13. As this cantilever increases in overhang, so also does its thickness by the addition of the horizontal leg of the base angle. Similarly, there are small cantilevers running out, one on each side, from the column web.

*Item 14.* From the alignment chart (Fig. 63), with  $P = 14.81^{\tau}/\text{sq. ft.}$  and  $F_t = 10^{\tau}/\text{sq. in.}$ , the overhang can be 5.69 times the thickness of the sole plate, which gives the cantilevered lengths as not exceeding 4.27 in. for a  $\frac{3}{4}$ -in. plate, and 8.54 in. for a  $1\frac{1}{2}$ -in. thick section of plate and angle acting as one, *provided that the riveting is sufficient*; see items 15 and 16. In the case discussed the riveting is insufficient, and in order to make use of the alignment chart, first find that plate which has a  $Z$  equal to the sum of the  $Z$ 's of the two  $\frac{3}{4}$ -in. plates, viz.,  $\frac{1}{6}bD^2 = 2(\frac{1}{6}bd^2)$  or  $D = 1.414d$ . With  $d$  at  $\frac{3}{4}$  in., the equivalent plate thickness  $D$  is 1.06 in. and the overhang is  $5.69 \times 1.06''$  or 6.03 in., which is less than the actual overhang of  $6\frac{3}{8}$  in.

*Items 15 and 16.* Because the riveting, as indicated by item 16, is insufficient the two thicknesses of steel cannot be considered to act as one but as two separate cantilevers, and therefore the higher stress of item 15 is the theoretical one to use. However, the actual stress will be much less than  $11.1^{\tau}/\text{sq. in.}$  since the angle and base plate cantilevers do not act freely but are heavily reinforced and stiffened by the deep bracket formed by the 8 to 1 protective concrete covering. Further, although the riveting is insufficient there is a large frictional resistance to the horizontal shearing action between the angle and base plate given by the heavy vertical load (equal to the load from the column multiplied by the coefficient of friction). That the foregoing contentions are valid is evinced by the fact that several firms have, for years and without any apparent ill effects, used only stitching rivets to connect the base angles to the sole plate. (See :—stresses in grillage beams buried in concrete.)

*Items 18 and 19.* The length of bolt should be such that the bolt when pulled to destruction should break at the same instant as it starts to withdraw from the concrete owing to the adhesion failing. The net area of the bolt is at the bottom of the threads, and the working stresses for steel and adhesion have been taken at  $6^{\tau}/\text{sq. in.}$  and  $100 \text{ lb./sq. in.}$  respectively. Since holding-down bolts are usually large in diameter the screwing-up stresses are not so serious as with smaller diameter bolts and, consequently, the higher working

Vertical shear stress $= 7.86\tau \div$ vertical area of $1\frac{1}{2}"$ thick $\times 12"$ long	$= \tau/\text{sq. in.}$	0.43	
Horizontal shear intensity $q = SG/Ib$ (see Chapter I) and is, for a rectangular cross-section, a max. at the neutral axis of $1\frac{1}{2}$ times the mean vertical shear	$= 1\frac{1}{2} \times 0.43$	$=$	0.64
Horizontal shear between sole pl. and angle $= q \times$ area $= 0.64 \times 12"$ length $\times$ breadth of $(6\frac{3}{8}" - 1\frac{3}{8}" )$	$=$		38 $\tau$
Number of $\frac{7}{8}"$ dia. rivets required in SS for a 12" length $= 38 \div 3.61$	$=$		10
Number given in a 12" length of angle	$=$		<u>4</u> <b>16</b>
The cantilever angle is also helped by the 8 to 1 concrete covering, etc., see text.			
<i>Foundation Bolts.</i> Give without calculation 4 bolts at $1\frac{1}{8}"$ dia. These bolts are usually made 24 dias. in length. For reasons given in text take axial $F_t$ at $6\tau$ .			<b>17</b>
Permissible axial load $=$ area at base of thread $0.697$ sq. in. $\times 6\tau/\text{sq. in.}$	$=$		$4.18\tau$ <b>18</b>
Adhesive strength of bolt $=$ area in contact with concrete at $100$ lb./sq. in. $=$ circumfer. $\times$ length $l \times 100 = 3.14 \times 1.125 \times 100l$	$=$ lb.	$353.3l$	<b>19</b>
If item <b>18</b> $=$ item <b>19</b> then $4.18 \times 2240 = 353.3l$ , whence $l$ i.e., approximately 24 diameters of $1\frac{1}{8}"$ .	$=$	$27"$	
<i>Verification of End Restraint.</i>			<b>20</b>
$\frac{7}{8}"$ dia. bolts ; area at base of threads	$=$ sq. in.	$0.42$	
Axial load for 2 bolts $= 2 \times 0.42 @ 6\tau$	$=$	$5.04\tau$	
Fig. 62. Elevation of column web at floor level. Distance between top pair of bolts in vertical cleats and bottom pair in shelf angle, about		$11"$	<b>21</b>
Resisting couple given by only these 4 extreme bolts $= 5.04\tau \times 11"$	$=$ in. tons	$55.4$	<b>22</b>
$M$ of $R$ of column as a beam, Fig. 58 and item <b>5</b> $= F_t Z_v = F_t I_v/x = 10 \times 105 \div 5 =$	$=$	$210$	
Column is continuous $\therefore \frac{1}{3}$ of this	$=$	$26$	
End restraint is effective since $55.4 > 26$ .			<b>23</b>
Fig. 62. Elevation of column flange at floor level. Distance between top pair			

stress of at least  $6\tau$ /sq. in. is allowed. If a foundation washer is used the bolt length may be considerably lessened.

*Item 20.* With the cross-section of the column shaft settled it is now possible to verify the earlier assumptions made regarding the degree of restraint in item 2.

The base has a flat end and, since the  $l/k$  of the shaft is less than 120 (see the previous suggestions given in small type on page 72), is therefore equivalent to being fully restrained.

The upper end of the shaft is continuous at the first floor level, so that if the resistance moment of the floor beams and their connections to the column are not less than one-eighth of that of the shaft considered as a beam, then this end also is effectively restrained.

*Item 21.* The size of the floor beam will settle how deep the beam web cleats can be.

*Item 22.* Actually each bolt in the cleats will contribute its quota to the resistance moment but if only four bolts of the group prove to be sufficient then there is no necessity to investigate the complete joint. As seen from item 23 even the partial value of 55.4 inch tons is more than is demanded by the specification.

*Items 24 and 25* are similar in reasoning to items 21 and 22.

*Item 26.* In the web there is one set of bolts common to both faces of the web, whereas in the flanges there are two separate sets of bolts—one to each flange face.

Each set of floor beams has, obviously, a higher section modulus than one-eighth of the corresponding modulus of the column considered as a beam, and, because of the concrete floor, there is little chance of the floor beams buckling laterally. The column is thus well supported by both the floor beams and their common connections to the column.

**Foundation.** The subsoil of coarse sandy gravel will be assumed to offer a good foundation at a safe bearing pressure of  $4\tau$ /sq. ft. ; weight of soil = 112 lb./ft. cube, and  $\phi$ , the angle of repose of the soil =  $33^\circ 42'$  (equivalent to a slope of  $1\frac{1}{2}$  to 1). The design is illustrated by Fig. 62.

A preliminary estimate is made of the weight of the concrete found and a tentative design is based upon this. From this follows the more accurate calculations given under.

*Item 27.* *Depth of foundation* is found by making use of the relationship between the conjugate stresses as given by Rankine.\*

\* This method (which applies to unstable soils lacking in cohesion) is falling into disuse as it is found to be more satisfactory to sink a test pit at site and to load therein a miniature found of not less than 4 square feet bearing area. Refer to text-books on "Soil Mechanics."

of bolts in vertical cleat and bottom pair in shelf angle, about	=	14"	<b>24</b>
Resisting couple given by only these 4 extreme bolts = $5.04^{\tau} \times 14''$	= in. tons	70.6	<b>25</b>
Same amount in other flange, <i>i.e.</i> , total	= ,,	141.2	<b>26</b>
<i>M</i> of <i>R</i> of column as a beam, Fig. 58, and item 4 = $F_t Z_x = F_t I_x / y = 10 \times 480 \div 5\frac{1}{2}$	∴ ,,	873	
Column is continuous ∴ $\frac{1}{8}$ of this	∴ ,,	109	
End restraint is effective since $141.2 > 109$ .			
<b>Foundation.</b> Total weight of (column load + self) + found concrete + (earth on ledges + concrete covering on top) = $(125^{\tau}) + 8^{\tau} + (5^{\tau})$	=	138 $^{\tau}$	<b>27</b>
Subsoil of coarse sandy gravel ; safe pres- sure	= $^{\tau}$ /sq. ft.	4	
Bearing area required = $138 \div 4$	= sq. ft.	34.5	
„ „ given = $7' \times 5' 6''$	= „	38.5	
Actual bearing pressure = $138 \div 38.5$	= $^{\tau}$ /sq. ft.	3.58	
Depth of found.			

$$p_1 = p \left( \frac{1 - \sin 33^{\circ} 42'}{1 + \sin 33^{\circ} 42'} \right)^2$$

$$\therefore H \times 112 = 3.58 \times 2240 \left( \frac{1 - 0.5548}{1 + 0.5548} \right)^2$$

Whence *H* in feet = 5.9

Depth below finished floor must be equal to or greater than this : amount given = 6' 1"

*Stresses in Concrete.* First and approx. method, neglecting the weight of the materials :—

Upthrust on  $1' 1\frac{1}{2}''$  cantilever (see plan of Fig. 62),  $1'$  wide @  $3.58^{\tau}$ /sq. ft. = lb. 9,020

Maximum *B.M.* at root of overhang =  $9,020 \times$  lever arm of  $\frac{1}{2}$  of  $13\frac{1}{2}''$  = in. lb. 60,890

*Z* given of a rectangle,  $12''$  wide  $\times$   $36''$  deep =  $\frac{1}{8} \times 12 \times 36^2$  = in.<sup>3</sup> 2,592

Resulting tension in the extreme fibres =  $M \div Z = 60,890 \div 2,592$  = lb./sq. in. 23.5

Second and more correct method :—

Net upthrust = difference between upthrust at  $3.58^{\tau}$ /sq. ft. and the downward weight of the cantilever and earth thereon @  $0.125^{\tau} + 0.154^{\tau}$  =  $^{\tau}$ /sq. ft. 3.3

If subsidence occurs under the found, then, on the cube thereat,  $p > q$  and the ratio :—

$$\frac{\text{lesser}}{\text{greater}} = \frac{1 - \sin \phi}{1 + \sin \phi} = \frac{q}{p}, \text{ or } q = p \left( \frac{1 - \sin \phi}{1 + \sin \phi} \right) \dots a$$

If upheaval takes place then  $q > p_1$  and the ratio is now :—

$$\frac{\text{lesser}}{\text{greater}} = \frac{1 - \sin \phi}{1 + \sin \phi} = \frac{p_1}{q}, \text{ or } q = p_1 \left( \frac{1 + \sin \phi}{1 - \sin \phi} \right) \dots b$$

$$\text{Since } q = q \therefore a = b, \text{ or } p_1 = p \left( \frac{1 - \sin \phi}{1 + \sin \phi} \right)^2 \dots c$$

$p$  = pressure/sq. ft. due to weight of column + load + concrete found, etc.

$p_1$  = pressure/sq. ft. due to weight of a column of earth of height  $H$ , which weighs  $w$  lb. per foot cube.

$$\therefore H \times w = p \left( \frac{1 - \sin \phi}{1 + \sin \phi} \right)^2, \text{ whence } H.$$

Note.  $p$  is stated in the same units as  $w$ , *e.g.*, pounds.

The minimum depth for  $H$  is from 2 ft. 6 in. to 3 ft., as a shallower depth than this may result in the disintegration of the soil under the found through frost action. Further, as the bottom of the

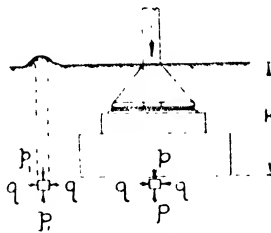

FIG. 64

found is less than 5 ft. from the existing ground surface (see the key elevation of Fig. 62), no timbering will probably be necessary ; while the excavated soil is single-throw. A greater depth than 5 ft. results in double handling of the excavated material, and therefore a larger price. Timbering, pumping and depth are economical factors in the design. By stepping the concrete instead of carrying down one huge massive block there results a saving in concrete and in the cartage of the spoil, together with a lowering of the pressure on the soil. It will not be forgotten that when estimating for the disposal of the spoil an allowance must be made for increase in bulk.

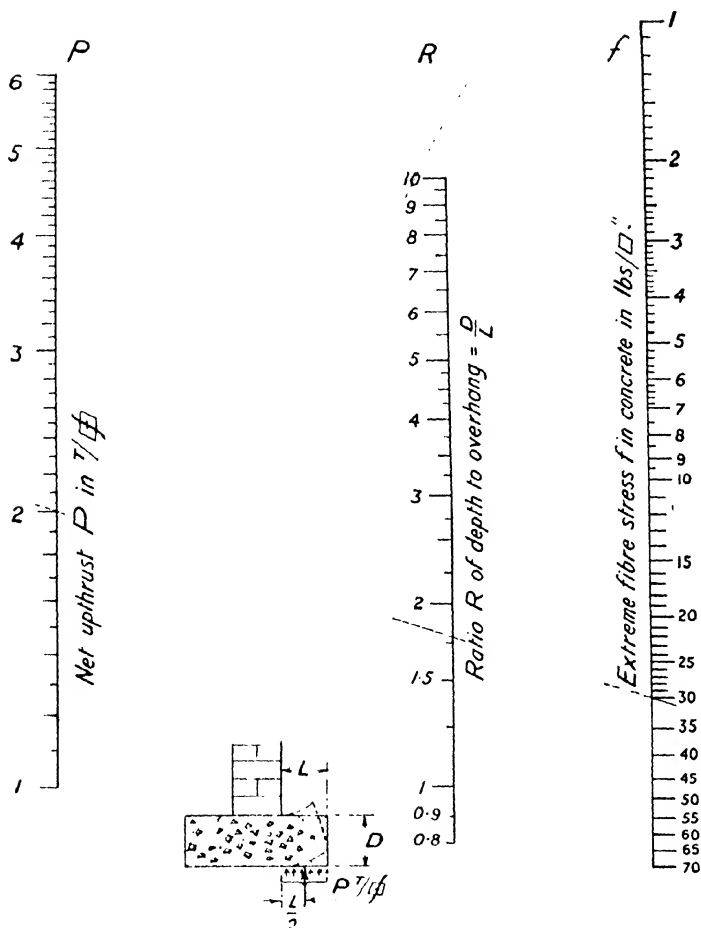

FIG. 65

ALIGNMENT CHART GIVING THE SAFE PROJECTION FOR WALL AND COLUMN FOUNDATIONS.

*Example.* If the net upthrust  $P$  on a cantilevered foundation is at the rate of 2 tons per square foot and  $f$  the extreme fibre stress, for ordinary concrete, is not to exceed 30 lb. per square inch, find the thickness of the concrete found. The answer is that  $D$  should not be less than 1.76 times  $L$ .

*Method.* Lay a straight edge so as to join points  $P = 2$  to  $f = 30$  and this gives the point of cutting on the  $R$  vertical as 1.76.

Similarly if any one of the three quantities is unknown it can be found from the straight line joining the other two.

$P$  is often taken as being the pressure per square foot on the soil.



The boxes, which form the holes surrounding the H.D. (holding down) bolts, are tapered to facilitate their withdrawal when the concrete is set. Ample freedom is given to the erectors, when finally lining up the column, by the presence of these holes and by the clearances given in the main angle and base plate holes and by similar clearances in the 6-in. square washers.

The column is plumbed by driving in small steel wedges round the base plate until it is in register with the plumb-bob suspended from the column cap by a piano wire. Thereafter a small embankment of sand is placed on the concrete found and surrounding the base plate edges, which prevents the grout from spreading when the foundation bolts are grouted in from the edge of the base and from the two holes made especially for this purpose in the sole plate. These, by the way, have been placed in the area previously termed ineffective. When the base is small the grouting holes may be eliminated.

*Items 28 to 30.* In the reinforced concrete foundation the permissible transverse compressive stress is taken at 600 lb./sq. in. The tensile stress and the vertical shear stress for plain concrete may be taken at one-tenth of this, viz., 60 lb./sq. in. Ordinary foundation concrete does not come up to the high standard of reinforced concrete, which has a finer aggregate and is more carefully poured, and therefore the working stresses in the coarse aggregate concrete should be kept well under the values mentioned.

**Alternative Foundation: Steel Beam Grillage for Poor Soil.** Assume that part of the site is of poorer ground and only affords a safe bearing pressure of  $1\frac{1}{2}$  tons/sq. ft. A grillage foundation and a reinforced concrete one will be designed, as both types spread the load over a large area and are, at the same time, relatively shallow and light.

*Item 31.* The beams are calculated as cantilevers acted upon by the unbalanced upthrust from the soil and by the downward load from the column. The latter acts at the side plates of the column on the upper tier, and at points distant  $a$  from the centre line of the lower tier (Fig. 66).

It is better to use several small joists than one large one of equivalent modulus, even though the latter presents a saving of steel, as the smaller joists make for shallower and lighter foundations. The permanent edge angles on the joists are mainly for the purpose of keeping them in position during concreting. Sometimes tie bolts through the joist webs are used. A ferrule of gas piping is threaded on the bolt between each web to ensure the proper spacing.

The grillage adopted requires a slight alteration in the position

∴ resulting tension in extreme fibres  
 $= 23.5(3.3 \div 3.58) = \text{lb./sq. in. } 21.7 \quad \mathbf{29}$   
 Alternatively by alignment chart (Fig. 65)  
 $R = D \div L = 3' \div 1' 1\frac{1}{2}'' = 2.66$   
 First method. The line joining  $P = 3.58$  to  $R = 2.66$  cuts  $f$  at 23.5  
 Second method.  $P = 3.3, R = 2.66$  and  $f = 21.7$   
 Vertical shear at heel of cantilever :—  
 First method  $= 9,020 \div (12'' \times 36'') = \text{lb./sq. in. } 20.9 \quad \mathbf{30}$   
 Second method  $= 20.9(3.3 \div 3.58) = \text{,, } 19.3$   
 The bending stresses within the main block of concrete need not be investigated if the base lies within the  $45^\circ$  dispersion angle on each side of the vertical centre line. Depth of main found  $= 4'$ , therefore permissible width is  $2 \times 4' = 8'$ .

**Alternative Foundation : Steel Beam Grillage, Fig. 66.**

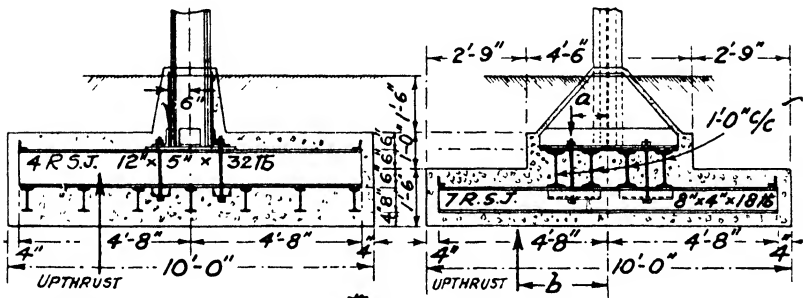

(4) H. D. Washers of  $6'' \times 3\frac{1}{2}'' \times 16\frac{1}{2}''$  Channels  $\times 1'-4''$  ✓  
 Edge L<sup>s</sup>  $2\frac{1}{2}'' \times 2\frac{1}{2}'' \times \frac{1}{4}''$ ; 2 @  $9'-4''$  & 2 @  $3'-6''$   
**GRILLAGE FOUNDATION.**

FIG. 66

Safe pressure on soil  $= \tau/\text{sq. ft. } 1.5$   
 Working stresses are those in table on page 74 increased by  $33\frac{1}{3}$  per cent.  
 Estimated weight of concrete found and protective covering + earth on ledges + steel beams  $= 23\tau$   
 Total load on ground  $= 125\tau$  from column +  $23\tau$  from foundation  $= 148\tau$   
 Area of foundation at  $1\frac{1}{3}\tau/\text{sq. ft.} = 148 \div 1.5 = \text{sq. ft. } 98.7$   
 Given a square foundation of 10 ft. side, area  $= \text{,, } 100$

of the H.D. bolts. The H.D. channel washers, anchoring the column to the upper tier of beams, are often placed with the hollow side down, a pernicious detail which prevents the proper placing of the concrete and produces large voids in the concrete mass. Some designers bolt the sole plate to each joist of the upper tier with 8 or 16 bolts; this detail necessitates more labour in the placing of the grillage beams than that of Fig. 66, which gives great latitude for column alignment.

*Item 32.* Grillage beams obtain a substantial help from the concrete in which they are embedded, in fact the foundation is really a particular form of reinforced concrete. Nevertheless the strength calculations cannot be made by employing standard reinforced concrete data, since neither the depth of the steel sections nor their positions in the concrete conform with the necessary theoretical requirements. Because the stress distribution in steel and concrete is very complex, a compromise is made for simplicity by assuming that the rolled steel sections carry all the load while the concrete remains inert. On this assumption it is apparent that the beams are well supported laterally against the buckling action of compression flange and web, so that high working stresses may be employed.

The indeterminacy of the problem is reflected in specifications. The B.S. 449—*Building* permits the ordinary mild steel working stresses to be increased by  $33\frac{1}{3}$  per cent. on all grillage beams. These working stresses may only be used provided that the concrete is a 1 : 2 : 4 or richer mix; the aggregate being usually limited to a maximum of  $\frac{3}{4}$  in. mesh. The concrete must be carefully poured and well tamped into position between the beams, which must be at least 3 in. apart between adjoining flange edges and nowhere may the protective covering of concrete be less than 4 in. in thickness. If 2-in. ring aggregate be used instead of  $\frac{3}{4}$  in., great care should be exercised in filling the voids by tamping and ramming the concrete, while the increase of working stress should be limited to about 15 per cent.

The alternative 10 in.  $\times$  5 in.  $\times$  30 lb. R.S.J. for the upper tier would suit admirably and, although less rigid, results in a saving of 2 in. of depth and 2 lb. per ft. of joist.

#### **Alternative Foundation : Reinforced Concrete.**

*Item 33.* The unbalanced upthrust on one-half of the found is equal to one-half of  $125\tau$  acting at the centre of gravity of the area, i.e., at a point on the *yy* centre line distant 2' 6" from the *xx* line, about which line moments are being taken. Assuming that the column load is uniformly distributed throughout the sole plate then half the column load acts downwards at the centre of gravity of the

*Bottom Tier.* Max. *B.M.* at centre line, 31  
 considering one-half of the base, = un-  
 balanced upthrust  $\times$  lever arm  $b = \frac{1}{2}$   
 column load  $\times$  lever arm  $a = \frac{1}{2}$  of  
 $125^T \times \frac{1}{4}$  of  $10' - \frac{1}{2}$  of  $125^T \times 1' = \frac{1}{2}$   
 $\times 125 \times 18'' =$  in. tons 1,125

Z required at  $13\frac{1}{3}^T$ /sq. in. (see text) = *B.M.* 32  
 $\div 13\frac{1}{3} = 1,125 \div 13\frac{1}{3} =$  in.<sup>3</sup> 85

Z given : 7 R.S.J.,  $8'' \times 4'' \times 18$  lb. (13-91) = ,, 97-37  
 (Z of 7 R.S.J.,  $7'' \times 4'' \times 16$  lb. (11-29)  
 = 79-03)

Shear area required at  $(6.5 + 33\frac{1}{3}\%)^T$ /sq.  
 in. =  $\frac{1}{2}$  of  $125^T \div 8.67 =$  sq. in. 7-21

Shear area given = 7 webs @  $8'' \times 0.28'' =$  ,, 15-68

✓ *Upper Tier.* Max. *B.M.* at centre line  
 =  $\frac{1}{2}$  of  $125^T \times \frac{1}{4}$  of  $10' - \frac{1}{2}$  of  $125^T \times 6''$   
 (say) = in. tons 1,500

Z required =  $M \div 13\frac{1}{3} = 1,500 \div 13\frac{1}{3} =$  in.<sup>3</sup> 113

Z given : 4 R.S.J.,  $12'' \times 5'' \times 32$  lb. (36-8) = ,, 147

(Z of 4 R.S.J.,  $10'' \times 5'' \times 30$  lb. (29-3)  
 = 117)

Shear area given = 4 webs @  $12'' \times 0.35 =$  sq. in. 16-8

✓ Minimum depth of foundation = item 27 of  
 previous found of  $5.9' \times$  ratio  $1.5^T/3.58^T =$  2-47'

**Alternative Foundation : Reinforced Concrete, Fig. 70.**

Safe pressure on soil =  $^T$ /sq. ft. 1-5 33

Total *B.M.* at line *xx* =  $62.5^T \times \frac{1}{4}$  of  $10'$   
 =  $62.5^T \times \frac{1}{4}$  of  $2' 3'' =$  in. tons 1,453

Total *B.M.* at line *yy* =  $62.5^T \times \frac{1}{4}$  of  $10'$   
 =  $62.5^T \times \frac{1}{4}$  of  $3' 9'' =$  ,, 1,172

$89 bd^2 =$  *B.M.* inch lb., where  $b = 120''$  ;  
*i.e.*,  $89 \times 120d^2 = 1453 \times 2240$ , whence  $d =$  17-5" 34

Area of steel required = 0-0056 of effec-  
 tive area of  $17.5'' \times 120'' =$  sq. in. 11-76 35

Alternatively, from the analogy to the  
 plate girder, "flange" force = *B.M.*  
 $\div$  depth between "flanges" =  $1453$   
 $\times 2240 \div 0.889$  of  $17.5 =$  lb. 209,200 36

Area of steel required =  $209,200 \div 18,000 =$  sq. in. 11-62 37

Area of steel given = 20 bars of  $\frac{7}{8}$  dia.  
 =  $20 \times 0.6 =$  ,, 12

half-base, *i.e.*, at a quarter of the sole plate width from the moment line  $xx$ . The 6-in. pad of concrete and grout, which is otherwise neglected, is very useful in dispersing the load to the concrete raft.

In fixing the working stresses, mild steel was taken at the Code of Practice figure of 18,000 lb. per sq. in. The compressive stress on the concrete, however, was taken at the low value of 600 lb. per sq. in., since possibly the only concrete work on the site would be that of the foundations. Because of this fact both workmanship and inspection might not be of a high order.

*Items 34 to 37.* Since no restrictions are placed upon the depth of concrete in foundation work, the quantities of steel and concrete can be so arranged that both materials are worked up to their full working stresses of 18,000 and 600 lb./sq. in. respectively. When this occurs the following relationships exist (units are pounds and inches) :—

\* (1) The *B.M.* in inch pounds is numerically equal to  $89bd^2$ .

(2) The *N.A.* lies  $0.333d$  down from the top edge (Fig. 69).

(3) The lever arm  $a$  of the concrete beam—equivalent to the depth  $D$  between the centres of gravity of the flanges of a plate girder—is, therefore,  $0.889d$ .

(4) The area of the steel is  $0.0056bd$ . Any alteration of this amount of steel will, of course, immediately alter the other ratios. The beam adopted should therefore have the depth  $d$  and the steel area equal to, or greater than, the calculated value. The derivation of these ratios will be found in any text-book upon Reinforced Concrete.



FIG. 67

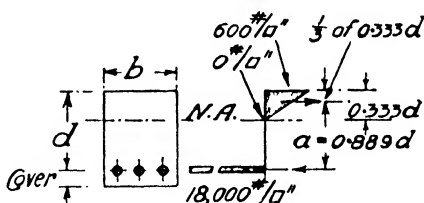

SECTION.

FIG. 68

STRESSES.

FIG. 69

*Items 38 and 39.* As in a plate girder the shear should be taken over the effective depth, *c/c* of flanges =  $a$ . Continuing this analogy, the vertical shear per inch depth = the horizontal shear per inch run. Now this shear can only enter the longitudinal steel

\* The values of (1), (2), (3) and (4) are, respectively, for

750 lb./sq. in. concrete :— $126bd^2$ ;  $0.385d$ ;  $0.87d$ ;  $0.008bd$ .

1,000 lb./sq. in. concrete :— $193bd^2$ ;  $0.455d$ ;  $0.848d$ ;  $0.0127bd$

It is not necessary to check the concrete ;  
 however, area req<sup>d</sup>. =  $209,200 \div 300 =$  sq. in. 697  
 (Where 300 = average of 600 and 0.)  
 Area given =  $120'' \times 0.333$  of 17.5 = ,, 700  
 Max. vertical shear at minimum depth of  
 concrete is at line at  $A = AB/10'$  of  $125\tau =$  39 $\tau$   
 Vertical shear per sq. in. =  $39 \times 2,240 \div$   
 effective depth of  $(0.889 \times 17.5) \times 120'' =$  lb./sq. in. 47  
 No shear reinforcement is necessary, since  
 the working stress on plain concrete  
 =  $\frac{1}{10}$  of  $F_c =$  ,, 60

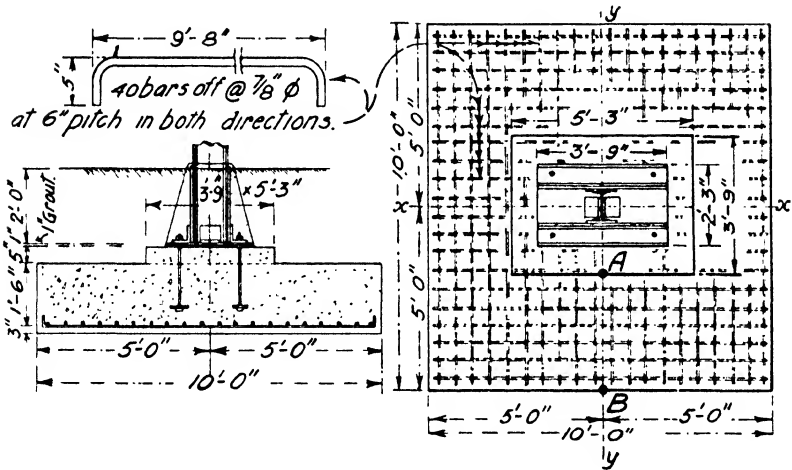

REINFORCED CONCRETE FOUNDATION. FIG. 70

Total vertical shear per inch of depth at  $A$   
 =  $39 \times 2,240 \div 0.889$  of 17.5 = lb./in. 5,614 38  
 This is also the horizontal shear per inch  
 run and equals the adhesion per inch run.  
 Circumferential area of bars required per  
 inch run =  $5,614 \div$  adhesion @ 100  
 lb./sq. in. = sq. in. 56.14  
 Area given = 20 bars of  $\frac{7}{8}$ " dia.  $\times 3.14 =$  ,, 55 39  
 Net pressure on foundation =  $125\tau \div 100$   
 sq. ft. =  $\tau$ /sq. ft. 1.25  
 Punching shear caused by unbalanced load  
 of (found area - base pl. area)  $\times$   
 $1.25\tau$ /sq. ft. =  $(100 - 8.44) \times 1.25 =$  114.45 $\tau$  40

through adhesion, so that the adhesion between the concrete and the steel plays the part of the plate girder rivets by transferring the shear into the steel reinforcement or flange.

*Items 40 and 41 also Fig. 67.* If the column could punch a hole through the raft the resulting shear is known as punching shear; the working stress for which is 180 lb./sq. in., or thrice that of ordinary shear on plain concrete. The required depth is less than that necessary for bending moment, but with a reinforced concrete shaft instead of one in mild steel the reverse might hold because of the smaller perimeter of the former.

The treatment is somewhat unsatisfactory, but the foregoing method is the most conservative and safe of several theories.

**Alternative Foundation : On Rock.** The minimum concrete block that could be carried down to the rock is the central portion of Fig. 62, which measures 4' 9"  $\times$  3' 3", as, usually, a 6-in. ledge of concrete is left surrounding the sole plate. The resulting pressure per square foot is :  $(125^T$  from column  $\div$  1.7<sup>T</sup> from earth and protective concrete  $\div$  weight of concrete found at 1<sup>T</sup> per foot of depth)  $\div$  (4.75  $\times$  3.25). Assuming the same depth of excavation as for the plain concrete found, the pressure runs out at 8.5 tons per square foot.

#### Safe Pressures on Soils, etc.\*

Material.	Pressure in tons.	Weight per foot cube in lbs.	Angle of repose.
Clay, soft . . . . .	1 to 2	120 to 130	15° to 35°
Clay, ordinary . . . . .	2 to 3	120	30° to 40°
Clay, hard . . . . .	3 to 6	110 to 130	—
Earth . . . . .	1 to 2	90 to 115	30° to 45°
Gravel, compact . . . . .	4 to 9	100 to 120	30° to 45°
Sand, dry . . . . .	3	90 to 112	35°
Sand, moist . . . . .	1½	110 to 120	30°
Rock, hard . . . . .	9 upwards; better, ½ of the crushing load.		

**Alternative Base Connections.** It is sometimes desirable to have the long way of the base plate at right angles to that of Fig. 62, as shown by Fig. 71. The angles extract the load from the shaft flanges and carry it into the side plates. The alternative to this is

\* These and similar tables of values, lacking index properties, should be accepted with reserve as it is impossible to classify soils correctly in this manner. It is preferable that the soil be tested at site as stated in the footnote to item 27 of the text.

The methods of carrying out various tests are described in text-books dealing with Soil Mechanics. The British Standard Specification, B.S. 1377 : *Methods of Test for Soil Classification and Compaction*, gives details of field and laboratory tests.

Resisting area = base pl. perimeter × depth = 144" × 17.5"	= sq. in.	2,520	
Punching shear stress = 114.45 × 2,240 ÷ 2,520	= lb./sq. in.	102	
Permissible punching shear stress, about	"	180	<b>41</b>
Weight of concrete found + pad + earth on ledges + protective concrete + column load of 125τ	=	23τ + 125τ	
Resulting pressure on soil = 148τ ÷ 100 sq. ft.	= τ/sq. ft.	1.48	
Permissible pressure	= "	1.5	

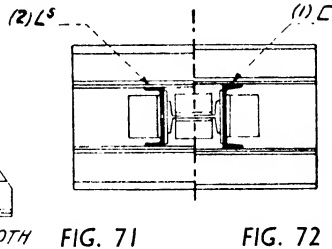
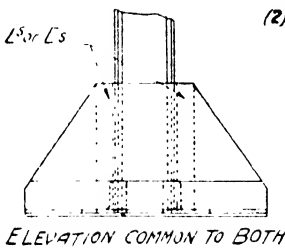

**Alternative Shafts.**

2 R.S.J.'s, 12" × 5" × 32 lb. (Fig. 73) area	= sq. in.	18.9	<b>42</b>
M of $I_y = 2(I_{own axis} + A \times distance^2) = 2(9.69 + 9.45 \times 5^2)$	= in. <sup>4</sup>	492	
$k_y = \sqrt{I \div A} = \sqrt{492 \div 18.9}$	---	5.1"	
$k_x$ as listed for one joist	---	4.84"	
$l$ , the equivalent length (item 6)	---	122"	
$l/k_x = 122 \div 4.84$	---	25	
Permissible axial end load (B.S. Table 7)	= τ <sub>v</sub> /sq. in.	7.79	
Total working load = 7.79 × 18.9	---	147τ	
Weight per foot of shaft excluding rivet heads = 64 lb. + lacing on both sides	= lb.	74	

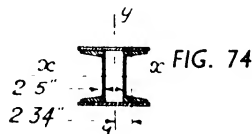
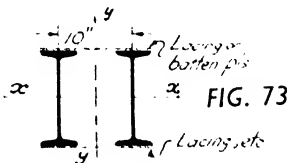

<b>A Further Alternative.</b> 2 channels 7" × 3½" × 18.28 lb. + 2 Pls. 10" × ½", gross area	= sq. in.	20.75	<b>43</b>
---	-----------	-------	-----------



the channel connection of Fig. 72. The length of these angles or channels is determined by the number of rivets necessary to carry the load in single shear or bearing.

**Alternative Column Shafts.** Since the web of each joist is also the mass centre line, it follows that the radius of gyration, axis  $yy$  of Fig. 73, must be very nearly 5 in. If the end fixity is of the same value about both axes, then the shaft is apparently of equal strength about both axes, since  $k_y = k_x$  approximately. Theory, however, shows that for equal strength the two joists, forming the laced section of Fig. 73, should be spaced far enough apart to ensure that the radius of gyration  $k_y$  is greater than the radius of gyration  $k_x$ . Clause 51 (a) of the *B.S. 449—Building* embodies this fact by asking that, where possible,  $k_y$  should not be less than  $k_x$ .

**Fig. 74** is theoretically the best of the three shafts, but has this disadvantage that, after erection, the internal surfaces cannot be inspected. Observe the overhang of the side plates past the toes of the channels hiding any sectional growth of the latter. By using  $11" \times \frac{7}{16}"$  plates instead of  $10" \times \frac{1}{2}"$  the channels can be spaced wider apart and so increasing the  $k_y$ , *i.e.*, a stronger column with less material.

The channel depth of 7 in. is less than 40 times the web thickness, *i.e.* less than 40 times 0.3 in., or 12 in. (see rule at top of p. 100). Similarly, if 11 in. by  $\frac{7}{16}$  in. flange plates be used with the space between the backs of the channels increased from  $2\frac{1}{2}$  in. to  $3\frac{1}{2}$  in., then the unsupported distance between the rivets attaching the  $\frac{7}{16}$  in. plates to the channel flanges is  $7\frac{1}{2}$  in., which dimension is less than 40 times  $\frac{7}{16}$  in., or  $17\frac{1}{2}$  in. Therefore, by the mentioned clause (50) of Specification 449, all the channel and flange plate areas effectively contribute to the cross-sectional area of the column.

$k_v = 2.72''$ and $k_s = 3.30''$		
$l/k_v = 122 \div 2.72$	=	45
Permissible axial end load (B.S. Table 7)	= $\tau$ /sq. in.	6.82
Total working load = $6.82 \times 20.75$	=	141 <sup>T</sup>
Weight per foot of shaft excluding rivet heads (Fig. 74)	= lb.	70.6

## REFERENCES

## STRUTS

- AMERICAN SOC. C.E. Transactions, October, 1934. *Tests of Riveted and Welded Steel Columns.* (Slater and Fuller.)
- AMERICAN SOC. C.E. Transactions, No. 101, 1936. *Rational Design of Steel Columns.* (D. H. Young.)
- British Standard Specification *The Use of Structural Steel in Building*, No. 449.
- HUNTER, A. *Arrol's Structural Engineer's Handbook.* (Shop columns and permissible loads on soils.) (Spon.)
- INSTITUTION OF CIVIL ENGINEERS. Selected Engineering Papers, No. 28. *The Strength of Struts.* (Andrew Robertson.)
- JOHNSON, BRYAN AND TURNEAURE. *Modern Framed Structures, Part III, Design.* (Chapman and Hall.)
- MORLEY, A. *Strength of Materials*, also *The Theory of Structures.* (Longmans, Green & Co.)
- PIPPARD AND BAKER. *The Analysis of Engineering Structures.* (Arnold & Co.)
- STEEL STRUCTURES RESEARCH COMMITTEE. *Recommendations for the Design of Steel Structures* (1936). (H.M. Stationery Office.)
- TIMOSHENKO, S. *Strength of Materials.* (Macmillan & Co. Ltd.)
- TIMOSHENKO AND YOUNG. *Theory of Structures.* (McGraw-Hill.)

## FOUNDATIONS

- BRITISH STANDARD SPECIFICATION. *Methods of Test for Soil Classification and Compaction*, No. 1377.
- CAPPER AND CASSIE. *The Mechanics of Engineering Soils.* (Spon.)
- HOOL AND KINNE. *Foundations, Abutments and Footings.* (McGraw-Hill.)
- HOOL. *Reinforced Concrete Construction*, Vol. I. (McGraw-Hill.)
- INSTITUTION OF CIVIL ENGINEERS. *Soil Mechanics.* See Index to Publications of the Institution.
- JACOBY AND DAVIS. *Foundations of Bridges and Buildings.* (McGraw-Hill.)
- NEWMAN, J. *Cylinder Bridge Piers.* (For permissible loads on soils.) (Spon.)
- PLUMMER AND DORE. *Soil Mechanics and Foundations.* (Pitman.)
- SIMPSON, W. *Preliminary Investigations for Foundations.* (Constable & Co. Ltd.)
- TERZACHI AND PECK. *Soil Mechanics in Engineering Practice.* (Wiley & Sons.)
- WOLLASTON, C. H. *Foundations and Earth Pressures.* (Hutchinson.)

## CHAPTER IV

### COLUMNS *continued*

#### TYPES : LACING, ETC. : NON-AXIALLY LOADED COLUMNS AND THEIR FOUNDATIONS

**Various Types.** The majority of the struts illustrated in cross-section in Figs. 75 to 78 are especially suitable for columns. No general rule can be laid down as to where any particular type should be used, because the manner of loading a column and the connections to it pre-determine the most suitable form; it is of course understood that simple cross-sections are cheaper than complicated compound ones. The illustrations given are arranged so that the commoner types are indicated on the left hand of the page, while the more unusual ones are shown towards the right.

**End Fixing and  $l/k$ .** When better end fixing can be obtained in one plane than another, then *ceteris paribus*, arrange the column so that the lesser radius of gyration goes with the better end fixing. As an example, an  $8'' \times 6'' \times 35$  lb. R.S.J.  $\times 12'$  can be so erected that the upper and lower ends are deflection and position fixed in one plane, but in the plane at right angles to this, both ends can only be regarded as position fixed and deflection free.

The actual column length is  $144''$  and this is also the effective length for the plane in which both ends are position fixed but unrestrained in direction (ends *R.R*). The plane at right angles to this has upper and lower ends fixed both as to position and direction (ends *F.F*), and therefore the effective length is  $0.7 \times 144'' = 101''$ . The radii of gyration of the joist are  $k_x = 3.31''$  and  $k_y = 1.38''$ . Then, placing the joist as suggested,  $l/k_x = 144'' \div 3.31'' = 43$  and  $l/k_y = 101'' \div 1.38'' = 73$ .

Similarly, a column with the same conditions of end fixing for both axes should have the radii of gyration as nearly the same as possible.

**Fig. 75.** A plated column (*i.e.*, rolled sections plus continuous plates) employing two or more joists cannot be effectively riveted because only one joist can have rivets pitched along all four of its rivet lines. Further, it is not good practice to pile plate upon plate at the joist flanges in an effort to obtain a large radius of gyration, for these heavy flanges are only tied together by a relatively very thin web, which may buckle and cause complete column failure.

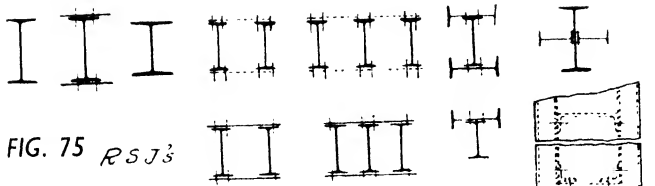

FIG. 75 R.S.J.s

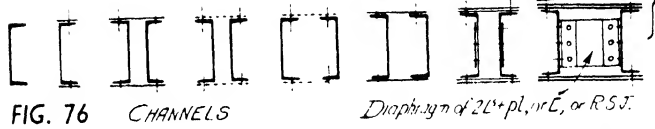

FIG. 76 CHANNELS

Diagram of 2L+pl, or E, or R.S.J.



FIG. 77 CHANNELS & JOISTS

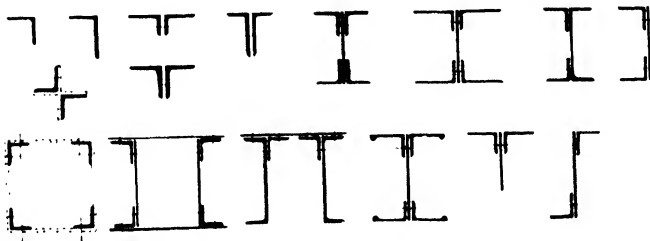

FIG. 78 ANGLES & PLATES, ETC

Lacing & batten plates indicated by broken lines rivets by single or lines

Christie had single tees, channels and angles cut to length such that the  $l/k$  value was the same for all. Under test the channel sections always failed first because of the relatively thin webs and thick flanges. For this reason the *B.S. 449—Building*, limits the depth of a web in the clear to not more than  $60t$  (where  $t$  is the web thickness) while not more than  $40t$  shall be included in the effective column area. Similarly, broad-flanged beams are not nearly so efficient as they are commonly supposed to be.

**Fig. 76.** The diaphragm indicated in the last section may be made up of a plate and two (or four) angles riveted to form a built-up channel (or joist) section. These are used when the distance between the main webs of the column does not permit the use of the simpler and cheaper diaphragm, the rolled joist, or the channel; occasionally, however, the latter can be used if a packing plate is interposed at one or both flanges of the diaphragm, previously to the latter being riveted into position. The diaphragms stiffen up the webs and their spacing in the example can be ascertained as for batten plates.

**Figs. 77 and 78.** The flange channels of the second section of Fig. 77 must have sufficient clearance between the toes of the opposing flanges to allow the satisfactory closing of the rivets in the joist flanges; the same point arises with regard to the riveting of the lacing of the fourth section, joist and channel, of this set and other such sections.

**Workshop Columns** are illustrated in Figs. 79 to 83. The first two are alternative designs for the columns of the workshop with the cantilevered roof trusses of Fig. 82, while for the more common type of shop of Fig. 83 either the design of Fig. 80 or Fig. 81 can be used, since that of Fig. 79 is rather wasteful due to the smaller roof load. The spacing of the diaphragms and lacing will be dealt with later.

The roof shaft of the column of Fig. 80 is, unlike the other two examples, not continuous from roof to base, but sheds the outstanding joist and plate at crane cap level. This roof shaft has a large radius of gyration about both the  $xx$  and  $yy$  axes and is fully capable of carrying the bending moment due to portal action in addition to its direct vertical load from the roof. The rivets at the crane cap level, section  $BB$ , should be sufficient in number to counteract the bending moment at this point and also to transfer the direct load into the side plates. Part of this vertical direct load will enter the crane shaft; the exact amount will be found by taking the moments of the vertical loads about the web of the continuous single roof shaft joist. Below crane cap level, section  $CC$ , any bending moment due to portal action or other causes is resisted by the

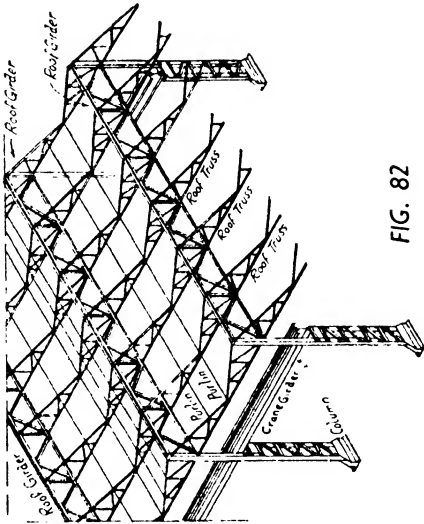
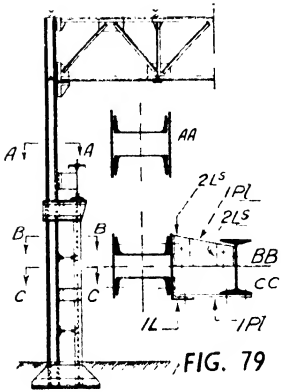

FIG. 82

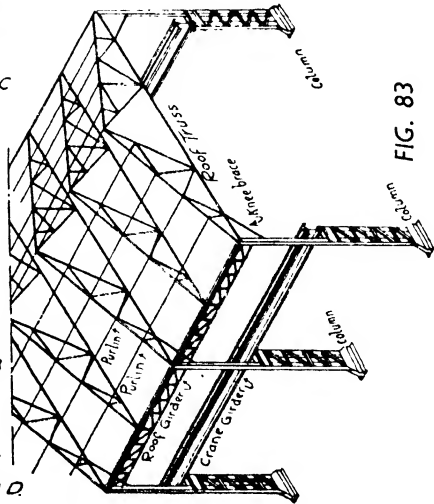
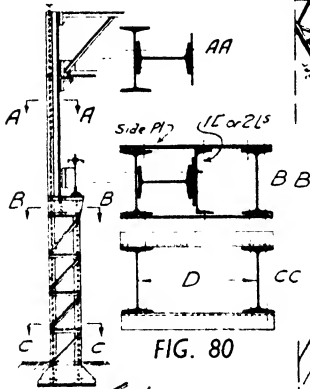

FIG. 83

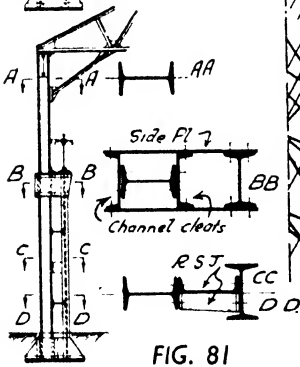

FIG. 81

widely spaced joists. The two joists,  $D$  in. apart, form, as it were, the flanges of a girder of which the web system is the N type of lacing. The load per joist is approximately  $\pm M \div D$  plus the direct load from the roof and cranes. When the two joists forming the lower shaft of the column are widely different in area the flexural stresses should be found from  $\pm My/I$ ; where  $I$  is the inertia of the combined section and  $y$  has two values as for an ordinary parallel flanged girder.

The roof shaft of the column of Fig. 79 is strong in the direction across the shop, but has less resistance against deflection in the direction parallel to the length of the shop. When the outer covering was corrugated steel sheeting it used to be the practice, with workshops over 30 ft. in height, to attach a light horizontal framing girder from roof shaft to roof shaft for the sole purpose of lowering the slenderness ratio,  $l/k$ , in this direction. The *B.S. 449.--Building*, however, takes full cognizance of the lateral rigidity of the sheeting and its horizontal framing angles by specifying that the effective column length to be used in deriving the slenderness ratio in this plane is the largest vertical distance between the horizontal framing angles, as described in the previous chapter under the heading of Practical End Conditions.

If the outer covering is of brickwork in horizontal joists, as in Fig. 177, then the effective column length is  $0.75 \times$  (the vertical spacing of the joists), *i.e.*, 7' 6" in the figure.

Occasionally the upper roof shaft is wrongly formed of a single R.S.J. with the web parallel to the side covering, but, very fortunately, these buildings are generally low and not exposed to heavy wind pressures, otherwise the portal action would cause their destruction; although on one occasion an apparently sheltered workshop with this type of roof shaft had to be guyed with ropes until it could be strengthened.

Unless the cranes are very light it is more economical to have a separate shaft to support the crane girders than to employ a crane bracket from the roof shaft.

Box sections have the disadvantage of not being open to inspection and, therefore, on no account carry a rainwater downpipe inside them. Open sections are always free for inspection and painting. Box column sections are sometimes concrete filled, but such a procedure is a gross misuse of material.

*Crane Clearance.* In cross-sections 79, 80 and 82 the crane has ample headroom, as only a small bracket projects into the shop. In Figs. 81 and 83 this is not the case, because of the knee brace, which, if it is to be retained, requires the shop to be heightened, or the cross travel of the crane to be restricted. For this reason

where overhead cranes run the length of the shop the knee brace is often discarded in favour of the simple bracket, and hence it follows that the cantilevered roof is much the stronger of the two types when subjected to portal stresses. Shops which are high and wide and which are equipped with heavy cranes are better if built after the manner of Fig. 82, and small shops with light or no cranes at all to the cross-section of Fig. 83.

## LACING AND BATTEN PLATES

Let a laced or batted column with both ends round (*i.e.*, both ends fixed in position but unrestrained in direction) have, as its

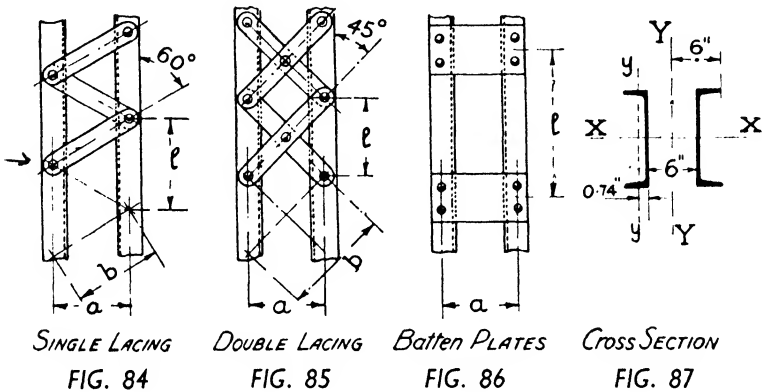

overall slenderness ratio, the value of  $L/K$  when considered as a complete unit. Here  $L$  is the length in inches and  $K$  is the radius of gyration of two channels about the main axis  $YY$  of Fig. 87.

This column is really made up of a continuous series of small columns, of length  $l$ , placed end to end, and each of these small columns has both ends pinned because of the single rivet connecting it to the lacing, or the two rivets connecting it to the batten plate. The slenderness ratio of the tiny columns is  $l/k$ , where  $k$  is the radius of gyration of one single channel about its own axis  $yy$ , and length  $l$  is as dimensioned on Figs. 84 and 85.

Should one of the small columns of length  $l$  buckle sideways the complete column, of which it is an element, would also buckle and collapse; *i.e.*, the strength of column  $l$  must not be less than that of column  $L$ ; or, since the end conditions are the same throughout, the slenderness ratio of column  $l$  may equal but must not be greater than that of column  $L$ . Whence  $l/k \leq L/K$ , or the pitch  $l \geq Lk/K$ .



**Numerical Example.** Column section of two channels  $10'' \times 3'' \times 19.3$  lb. at  $6''$  apart, Figs. 84 to 87. Area gross =  $11.34$  sq. in.  $K_y = 3.83''$  and  $K_x = 3.82''$ , also  $k_y = 0.838''$ . Length  $20'$  with one end fixed and the other end round. Axial load =  $60$  tons. First, to find the spacing of the lacing.

From the rules concerning column lengths, the equivalent column length is  $0.85 \times 240'' = 204''$  (i.e., equivalent to a column  $204''$  long with ends *R.R.*)

$$\therefore L/K_y = 204'' \div 3.83'' = 53$$

Now the elemental column  $l$  has both ends pinned (*R.R.*) and therefore the slenderness ratio should not exceed  $53$ , i.e.,  $l/k \leq 53$  and therefore the slenderness ratio should not exceed  $53$ , i.e.,  $l/k \leq 53$ , whence  $l \leq 53k \leq 53 \times 0.838'' \leq 44''$ . Actually the dimension  $l$ , Fig. 84, is much less than this. Since  $a = 6'' + 2 @ 1\frac{3}{4}'' = 9\frac{1}{2}''$ , then  $l = 2a \tan 30^\circ = 2 \times 9\frac{1}{2}'' \times 0.58 = 11''$ .

From Table 7 (*B.S. 449*) the working load for  $l/k = 53$  is  $6.43$  t/sq. in.

*Lacing*, as with the parental column, has been the subject of many experiments and theories from which it would appear that the spacing thus obtained is too great. The *B.S. 449—Building*, limits the slenderness ratio of the small elemental column to  $50$  or  $0.7 L/K$  of the main column, whichever is the lesser, and  $0.7 \times 53 = 37.1$ . Hence the maximum distance  $l$  between rivets, Fig. 84, is  $37.1 \times k_y = 37.1 \times 0.838'' = 31''$ . The *C. of P.—Bridges*, states that the subsidiary  $l/k$  shall be appreciably less than the  $L/K$  of the main column.

*Batten Plates* should be spaced such that the vertical distance between the lower rivet in one batten plate to the topmost rivet in the next lower batten plate is the same as that for lacing (*B.S. 449—Building*). Thus if the rivets in one batten plate are at  $3$ -in. vertical pitch then the maximum centre to centre spacing of the batten plates is  $31 + 3$  or  $34$  in. The corresponding limit for the subsidiary  $l/k$  by the *C. of P.—Bridges* is the lesser value of  $40$  and  $0.75 L/K$ .

Where the column sections are  $18$  in. or more apart single angle bar lacing is used, and it is in this case that calculations should be made to find the length  $l$ . With very heavy compound stanchions built up of several joists the lacing is, not infrequently, of light channels, the webs of which (at least  $6$  in. wide, thus giving two rivet lines) are riveted to the joist flanges. Although the maximum value of  $l$  is fixed by the slenderness ratio the actual value is often determined by such considerations as beam connections to the column and "pleasing the eye." When spaced too closely the angle lacing is not economical and, above all, lessens that suggestion of lightness appertaining to a latticed column. Lacing is to be preferred to batten plates where a shear has to be carried to the base as in the case of a workshop column of Figs. 79 to 83.

**Stresses in Lacing.** There are two methods in general use for estimating the end shear, which the lacing bars have to withstand. A "theoretical" method, which arrives at the required value by calculation, and the percentage method, which simply takes the lateral end shear as being from 1 to 3 per cent. of the end load on the column ( $2\frac{1}{2}$  per cent. is the generally accepted value).

*Straight line formula* of  $9 - 0.0485 l/k$  gives the end load on a pin-ended column in tons per sq. in. for the  $l/k$  values of 0 to 80 in Table 7, B.S. 449.

If it were possible to have no bending on a column carrying an axial load, but only compression as with a short prism, the working stress would be  $9\tau$  per sq. in. However, due to bending action this stress is reduced by the amount  $0.0485 l/k$ ; i.e.,  $0.0485 l/k$  represents the stress in tons per sq. in. due to bending, where  $l$  and  $k$  refer to the main column.

Therefore  $f$ , due to column bending, in  $\tau/\text{sq. in.}$   $= 0.0485 l/k$  (a)

Now this same transverse compressive stress  $f$  could be obtained by laterally loading the column as a beam with a uniformly distributed load  $W$  tons along one face, Fig. 88 (a).

The max. *B.M.* in inch tons  $= Wl/8$  (b)

Resulting stress  $f$ , in  $\tau/\text{sq. in.}$   $= M/Z$   
 $= Wl/8 \div Z$  and (since  $Z = I/y_1$ )  $= Wl/8$   
 $\div I/y_1 = Wl/8 \div Ak^2/y_1 = W/y_1 \cdot 8Ak^2$  (c)

Equating (a) to (c),  $\therefore 0.0485 l/k = W/y_1 \cdot 8Ak^2$ , whence  $W$  in tons  $= 0.388 Ak^2/y_1$  (d)

End shear on column  $= \frac{1}{2}W$ , tons,  $= 0.194 Ak^2/y_1$  (e)

Ditto per column face (there being two faces)  $= 0.097 Ak^2/y_1$  (f)

Load per end lacing bar of single system, Fig. 84, is the end shear  $\times b/a$ , i.e., end shear  $\times \text{cosec } \theta = 0.097 Ak^2 \text{ cosec } \theta/y_1$  (g)

For a double lacing system, as in Fig. 85, there are twice the number of bars, i.e., half the above load per bar, or, load per bar  $= 0.0485 Ak^2 \text{ cosec } \theta/y_1$  (h)

Substituting the arithmetical values of the example in (g) then load on end bar  $= 0.097 \times 11.34 \times 3.83 \times \text{cosec } 60^\circ \div 6 = 0.81\tau$  (i)

By the Percentage Method.

End shear =  $2\frac{1}{2}\%$  of  $60\tau$ , the vertical load on the column =  $1.50\tau$  (e')

Ditto per column face (there being two faces) =  $0.75\tau$  (f')

Load per end lacing bar of single system, Fig. 84, is  $0.75 \times \operatorname{cosec} 60^\circ = 0.87\tau$  (i')

The lattice bars form a Warren truss web system in which one bar is in tension and its neighbour on the same rivet is in compression. Therefore design the lacing bars, both as pin-ended struts and as tension members, to take the end load given by either of the two items lettered (i) above. The size of the lacing flat or angle thus determined is kept constant throughout the length of the column. The percentage method gives the larger load. Also see page 283 for the complete calculations of the bars forming the lacing of the top chord of a road bridge Pratt truss.

Experimental evidence goes to show that the actual stresses in lacing or latticing are extremely small.

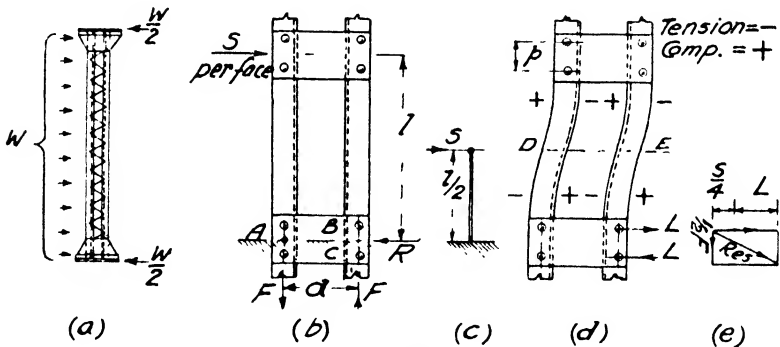

FIG. 88

**Rivets in Batten Plates.** Consider the forces acting on a length  $l$  of the column of Fig. 88 (b). There is a constant side shear of  $2\frac{1}{2}\%$  per cent. of the axial load on the main column and, since there are two faces, the horizontal shear on the near face is one half of this, viz.  $1\frac{1}{4}\%$  per cent. =  $S$ .

Since  $\Sigma H = 0$  then the value of the reaction  $R$ , at the line through  $A$ , is  $S$ . Also  $\Sigma M = 0$  and thus the overturning moment about  $A$  of  $Sl$  is resisted by the couple  $Fa$ , whence  $F = Sl/a$ . The near face reactions have thus been established at the section through  $A$ .

The column tends to distort as in Fig. 88 (d) with the fibre stresses

changing in sign from tension to compression, or *vice versa* at points *D* and *E*, which are thus points of contra-flexure (points of no bending moment) and therefore virtual pins. In effect each channel becomes a short cantilever of length  $l/2$  and the bending moment on it is due to the constant shear  $S$  above the pin. Hence the total maximum bending moment at level  $AR$  on the near face of the two channels is  $Sl/2$ , or per channel  $Sl/4$ . The two rivets  $B$  and  $C$ , at  $p$  in. apart, on the near face of the right-hand channel, provide a couple  $Lp$  resisting this cantilever moment of  $Sl/4$ , whence the rivet load  $L$  is  $Sl/4p$ . The distorted channel tends to push rivet  $B$  horizontally towards the right and rivet  $C$  horizontally to the left. Each of these rivets is also pushed towards the right by an active shear  $S/4$  to meet the reaction  $R$ . In addition there is a downward load on each of the rivets  $B$  and  $C$  equal to  $Sl/2a$ , which is one half the value of the upthrust  $F$ .

The resultant load on rivet  $B$  is, by the parallelogram of forces of Fig. 88 (e), equal to  $\sqrt{[(Sl/4p + S/4)^2 + (Sl/2a)^2]}$ .

*Numerical Example.* The double-channel column, previously considered, carried an axial load of  $60\tau$ , while the maximum pitch of the batten plates could be 34". The minimum thickness of the batten plates, by the rules which follow, is  $a \div 50 = 9.5" \div 50$ .

Adopt batten plates, 12" wide  $\times$  6" deep  $\times$   $\frac{5}{16}"$  tk. @ 30" c/c with  $\frac{3}{4}"$  dia. rivets at 3" apart vertically.

Shear $S$ on one face	= $\frac{1}{2}$ of $2\frac{1}{2}$ per cent. of $60\tau$	= $0.75\tau$
Horiz. shear on rivet $B$	= $\frac{1}{4}$ of $S$	= $0.19\tau$
Horiz. load ,, ,,	= $Sl \div 4p = 0.75 \times 30 \div (4 \times 3)$	= $1.88\tau$
Total horiz. load ,, ,,		= $2.07\tau$
Vert. load ,, ,,	= $Sl \div 2a = 0.75 \times 30 \div (2 \times 9.5)$	= $1.18\tau$
Result. load ,, ,,	= $\sqrt{(2.07^2 + 1.18^2)}$	= $2.38\tau$
Rivet values, $\frac{3}{4}"$ dia. shop rivet ; $\frac{5}{16}" B$	= $2.81\tau$ and S.S.	= $2.65\tau$
Stress at top and bottom of batten pl.	= $M \div Z = Sl/2 \div Z$	= $0.75\tau \times 30/2 \div \frac{1}{8} \times \frac{5}{16} \times 6^2 = 11.25\tau \div 1.87$ in. <sup>3</sup> or in $\tau$ /sq. in. = 6.

If  $\frac{1}{4}$ -in. thick batten plates had been used then the rivet at  $B$  would have been overstressed since the  $\frac{1}{4}$ -in. bearing value is only  $2.25\tau$ . This thickness of plate could have been retained by the simple expedient of increasing pitch  $p$  from 3 in. to  $3\frac{1}{2}$  in., which causes the resultant load on the rivet  $B$  to fall to  $2.15\tau$ ; the fibre stress due to bending on the  $\frac{1}{4}$ -in. tk. batten plate is  $\pm 7.5\tau$ /sq. in.

### Rules for Flat Bar Lacing and Batten Plates.

#### Single Lacing.

Maximum angle of inclination to the column axis =  $60^\circ$

Thickness. Not thinner than  $b \div 40$ , Fig. 84.

Breadth. Not less than  $3d$ , where  $d$  = rivet diameter, *i.e.*, 2", 2½" and 2¾" breadths for ⅝", ¾" and ⅞" dia. rivets, respectively.

*Double Lacing.*

Maximum angle of inclination to the column axis = 45°.

Thickness. Not less than  $b \div 60$ , when single riveted at mid-intersection, Fig. 85.

Breadth. As for single lacing.

*Batten Plates.*

Thickness. Not less than  $a \div 50$ , Fig. 86.

Depth. Sufficient for 2 rivets (*i.e.*, 6 rivet diameters in depth) at least, but not unusual to give a plate square in elevation or one whose length is from one and a half times to twice its breadth.

Spacing. The maximum vertical unsupported distance between any pair of adjoining rivets on a component part of the column shall be such that the slenderness ratio  $l/k$  of this element is not greater than (1) 50 or 0.7  $L/K$  (*B.S. 449.—Building*): 40 or 0.75  $L/K$  (*C. of P.—Bridges*).

*Shear on Lacing and Batten Plates.*

At any point in the column, transverse shear = 2½ per cent. of the axial load.

**Types of Lacing.** Figs. 89 to 95 illustrate different types of lacing or latticing and these, for simplicity, have been shown as

*Far side dotted.*

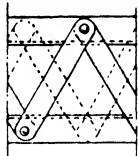

FIG. 89

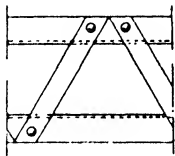

FIG. 90

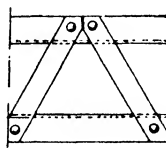

FIG. 91

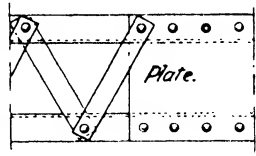

FIG. 92

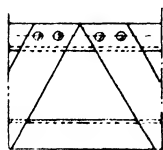

FIG. 93

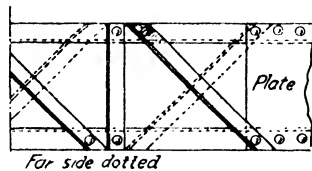

FIG. 94

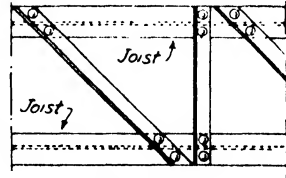

FIG. 95

single bar at 60°. The neatest and, withal, probably about as cheap as any single rivet lacing, is that of Figs. 84, 85 and 89. The rounded end and the hole for the rivet are punched at one

operation. Should the end of the lacing project past the edge of the main section, which it should not do, it is less unsightly than any of the others. An objection is sometimes offered against the use of this single rivet lacing in that if one rivet fails the unsupported length of the main section is  $2l$  in Fig. 84, whereas in Figs. 90 and 91 it is practically still  $l$ . When the primary stress in a member is so small that only one rivet is required as the end fastener some specifications demand that two rivets shall be given, because one rivet may be faulty, with serious results; it is hardly possible that both rivets could be so extremely poor as to endanger the structure. But this objection cannot be offered to such secondary members as flat-bar lacing, wherein the stresses are somewhat indeterminate and small, and moreover, one has only to examine the wide spacing of the lacing in some of the most famous and oldest of British bridges to derive further confidence. By reeling the lacing (*i.e.*, where single lacing is used) on the far side, as shown dotted in Figs. 89 and 94, this difficulty concerning a faulty rivet is somewhat minimized. The angles of  $60^\circ$  and  $45^\circ$  for lacing bars are not rigidly enforced, but they should be adhered to as closely as possible.

Such a heavy flat as exhibited in Fig. 93 might be necessary where the shear stress in the lacing is high through the addition of a bracket to the column; see Fig. 103.

The packing under the last angle of Fig. 94 permits it to be in the same plane as the batten or end plate.

**Tie Plates.** Not infrequently tie plates are placed at mid-height on a latticed column, and, if the length is long in comparison with the width, at the quarter points also; a custom which rather adds to, than detracts from, the column's strength and appearance. When the lacing gives way to plates, as at the cap and base side plates, or at intermediate "batten" plates, the last lacing bar is usually brought over on to the plate to catch the end rivet which is thus common to both lacing bar and plate. Tie plates are also placed at the junction of a beam to a latticed column for the dual purpose of better distribution of the load into the column and for appearance.

Since a tie plate may be regarded as an isolated batten plate incorporated into a lacing system, the dimensions and design of tie plates follow the rules for batten plates.

### STRUTS LOADED NON-AXIALLY

It has been emphasized that a practical column rarely has its load coincident with its geometrical axis, but so long as the load is as central as ordinary workmanship can achieve, no special heed need be paid to the induced flexural stresses; the column formulæ automatically make provision for these unintentional stresses. Obviously

however, when the load is intentionally applied out of line with the column axis the ordinary column formulæ no longer apply.

Intentional eccentricity of loading may be divided into two classes :—

(a) When the line of action of the load is parallel to, but not coincident with, the axis of the compression member. This case is generally spoken of as *eccentric loading*. Example.—The vertical load on a crane bracket is eccentric to the supporting column.

(b) When the line of action of the load is at right angles to the axis of the member. This loading is usually designated *lateral*, or as causing *lateral bending* or *cross bending*. Example.—A horizontal strut in addition to carrying axial stress must also act as a beam to carry its own weight, which force acts at right angles to the horizontal axis. In fact, every inclined strut is so affected, but where the span is short or the member light the cross bending effect is entirely neglected.

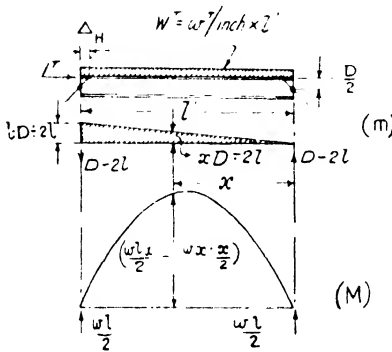

FIG. 96

A load inclined at any angle between 0° and 90° can be resolved into two components : (1) parallel, and (2) at right angles to the axis. The

stresses resulting from this separate treatment can then be summed.

The following discussion is a continuation of that entered into in Chapter VIII, Vol. I, but before taking examples it will be of interest to find how much movement there is at the ends of the flanges of a beam which is supported by cleats between a pair of columns.

**Beam End Movement.** The horizontal movement of the end of the flange of Fig. 96 can be found by placing unit load at that point and making it act in the desired direction of the movement. The vertical end supports are supposed to be at the points indicated on the neutral axis of the beam. The vertical reactions *V*, due to the unit load, are found by taking moments about either support :  $1 \times \frac{1}{2}D = Vl$ , or  $V = D/2l$ , where *D* = the depth of the beam. Then, as explained in text-books upon the Theory of Structures, the deflection

$$\Delta_H = \int_0^l \frac{Mm dx}{EI}$$

Substituting the values for  $M$  (due to  $W$ ) and  $m$  (due to  $1\tau$ ) it follows that

$$\Delta_u = \int_0^l \left( \frac{wlx}{2} - \frac{wx^2}{2} \right) \times \left( \frac{xD}{2l} \right) dx = \frac{wl^3 D}{48EI} = \frac{Wl^2}{48EI} \times D. \quad (1)$$

The vertical deflection at mid-span is

$$\Delta_v = \frac{5Wl^3}{384EI} = \frac{Wl^2}{48EI} \times 0.63l \quad \dots \dots \dots (2)$$

The depth  $D$  of a beam varies from  $\frac{1}{15}$  to  $\frac{1}{2.5}$  of the span, with a mean and commonly used value of  $\frac{1}{15}l$ . Replacing  $D$  in equation (1) by this value it follows that,

$$\Delta_u = \frac{Wl^2}{48EI} \times 0.066l. \quad \text{Hence, } \Delta_u = \frac{1}{10} \Delta_v \text{ approximately.}$$

Similarly, with a concentrated load  $W$  applied at mid-span :—

$$\Delta_u = \frac{Wl^2}{16EI} \times \frac{D}{2},$$

and on substituting  $\frac{1}{15}l$  for  $D$ ,

$$\Delta_u = \frac{Wl^2}{16EI} \times 0.033l \quad \dots \dots \dots (3)$$

$$\Delta_v = \frac{Wl^3}{48EI} = \frac{Wl^2}{16EI} \times 0.33l \quad \dots \dots \dots (4)$$

Again  $\Delta_u = \frac{1}{10} \Delta_v$ .

Any other distribution of load will lie between these two cases (*i.e.*, with freely supported ends) and it may be taken, therefore, that  $\Delta_u = \frac{1}{10} \Delta_v$ .

But vertical deflection is usually limited to span  $\div 360$  or span  $\div 480$ , with, say, a mean value of span  $\div 400$ , whence it follows that the end movement of the beam is  $\frac{1}{10} \Delta_v = \frac{1}{1000}$  of the span.

A properly designed beam 15 ft. span  $\times$  1 ft. deep will thus have an end movement of the lower and upper ends of the flanges of  $15 \times 12 \div 4,000 = 0.045$  in. The lower ends of the beam will not touch the column face, as there is at least  $\frac{1}{4}$  in. constructional clearance between the ends of the joist and the column face. Further, if the cleat, which will be about 9 in. deep, be riveted to the column and bolted to the joist, the outermost bolts in the cleat will be midway between the flange and the neutral axis, *i.e.*, on using the common 3-in. vertical pitch in the cleat. The longitudinal horizontal movement at this point will therefore be one half of 0.045 or 0.0225 in. If the nuts are not screwed up absolutely tight



the bolts will act as pins, permitting deflection, since the bolt hole clearance is  $\frac{1}{16}$  in., or 0.063 in. ; this clearance may be more or less, depending upon whether the holes are in register or not. If a general expression is desired the cleat depth may be taken at 0.8 the beam depth and the outermost bolts in the cleat  $1\frac{1}{2}$  in. from its ends.

This investigation into cleated connections is interesting, as it affords some idea of what happens, but a little thought will soon show how easily it is vitiated by holes not in register, cleats not exactly parallel with beam and column centre lines, the degree of tightness of bolts and rivets, etc. ; however, it will, perhaps, be an aid to a better understanding of the suggestions as to eccentric loading given under.

**The Value of the Eccentricity in Beam to Column Connections.**

*Figs. 97 and 98.* If the end shear from beam  $L$  is equal to that from beam  $R$  the column is axially loaded.

If end shear  $L$  is greater than end shear  $R$  by  $P$  tons, then the column is subjected to a direct load of  $L + R$  tons + a bending moment whose maximum possible value is  $P \cdot e$  inch tons as for *Figs. 99 and 100* ; the position of the beam in the column's length also affects the value of the bending moment, as will be shown shortly.

*Fig. 99.* When the double cleats are riveted to the beam and bolted to the column they may be considered as part of the beam, just as if the beam had been of cast-iron with the cleats cast on it.

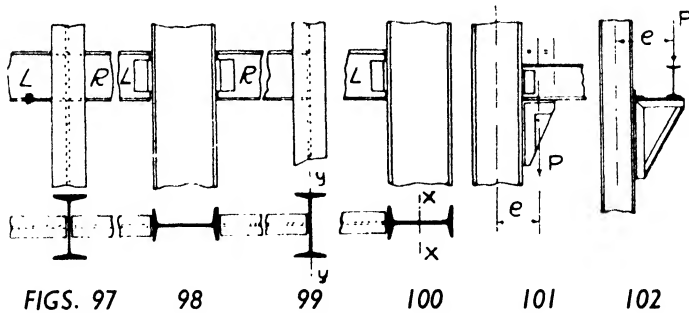

The eccentricity of the load on the column is the distance from the geometrical axis  $yy$  to the face of the cleats =  $\frac{1}{2}$  web thickness +, say,  $\frac{1}{4}$  in. clearance = an average of  $\frac{1}{2}$  in. Now, when one considers the lack of straightness which can, and does, exist in a slender column, and that column formulæ allow for slight eccentricities, it is understandable why some designers neglect this eccentricity of

$\frac{1}{2}$  in. and assume the load central if applied at the web of a column. In Fig. 97, by this assumption, the load is always central no matter whether  $L = R$  or not, provided that the bolts are placed through the column web.

If the single cleat be riveted to the column and bolted to the web of the beam of detail 99, the eccentricity  $e$  is from  $yy$  to the line of bolt holes in the joist, and if two lines of holes, then, to the centre of gravity of the bolt group in the beam. Similarly, in Fig. 97, when the two single cleats are riveted to the column web, and  $L$  is greater than  $R$  by  $P$  tons, there is a possible maximum bending moment of  $P \cdot e$  inch tons, where  $e$  is the eccentricity as just described.

*Fig. 100.* When the cleats are bolted to the column the eccentricity =  $\frac{1}{2}$  column width. If the cleat (there can be now only one vertical cleat) be riveted to the column and bolted to the beam the eccentricity is half column width + distance to the cleat bolt line.

In the foregoing cases it will be observed that the riveted face of the cleat is taken as being an immovable part of the member to which it is riveted. If the rivets give slightly, as they must, then the eccentric lever arm will be different from the values given.

From the above it is seen that the average distance from the face of the column (web or flange) to the line of the fastenings (bolts or rivets) in the leg of the cleat attached to the beam web is about 2 in. Also actual strain measurements taken on beam to column connections show the existence of large moments and eccentricities. Instead of differentiating between bolted and riveted connections it is now considered good practice to make use of the following:—

*Rule for Eccentricities.* The end load from a beam cleated to the web or flange of a joist column shall, in all cases, be considered to have an eccentricity of not less than 2 in. from the geometric axis of the column (*B.S. 449.—Building*).

*Fig. 101.* The eccentricity can be taken as half the column width +  $\frac{1}{2}$  the width of the bracket. Where the beam is free to deflect all the reaction will come on to the nose of the bracket and so increase the eccentric arm  $e$ . Generally, however, the beam is not so shallow as to have quite this effect and, besides, the cleats carry part of the load. There is, in addition, the bolting to the horizontal leg of the bracket, but little account need be taken of the fixing couples given by this or by the cleat fasteners; for the former generally only two bolts are given, and these without calculation.

*Fig. 102.* The eccentricity is  $e$  as dimensioned, but whether the bending moment should be taken as  $P \cdot e$  or not is discussed in the following paragraphs.

**Bracket on a Pin-Ended Column.\*** *Correct Treatment, Fig. 103.*

Taking moments about the heel or the toe of the bracket of Fig. (a),  $H = P \cdot e \div b$ , which is the force acting thereat, while the force on the column will be equal in value to this, but opposite in sense. Similarly, to prevent overturning of the column,  $R \cdot L = H \cdot b = P \cdot e$  or  $R = P \cdot e \div L$ .

Bending moment at point  $O = 0$ ; thence the curve follows a straight line law to  $A$ , where its value is

$$- R \cdot a = - P \cdot e (a/L) \dots \dots \dots (1)$$

Similarly at  $C$  the bending moment is 0, rising to a maximum value at  $B$  of

$$+ R \cdot c = + P \cdot e (c/L) \dots \dots \dots (2)$$

Between  $A$  and  $B$  the bending moment curve will be a straight line for an open bracket and approximately so for a plated bracket with edge angles. The bending moment at  $B$  can be verified by considering the upper forces instead of the lower ones, thus :---

$$- R(a + b) + Hb = - R(L - c) + RL = + Rc,$$

as above. The shear curve automatically follows and is given in (e).

The bending moment curve is always composed of parts of the straight lines  $CO'$  and  $OC'$ , since the bending moment =  $R$  multiplied by a variable distance and because  $R$  is constant in value and

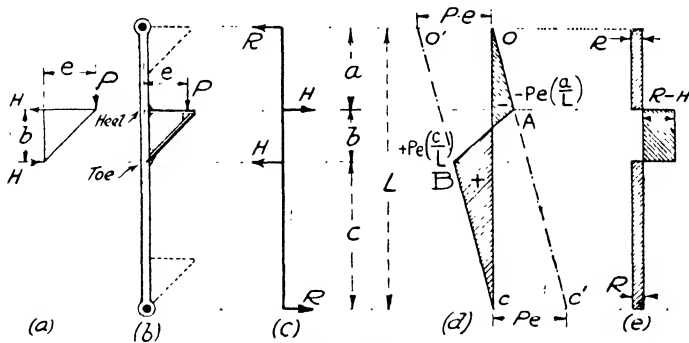

FIG. 103

is independent of the position of the bracket. The absolute maximum value for the bending moment therefore occurs with the bracket at the top or at the bottom of the column as dotted in (b), and its value is

$$\pm R(L - b) = \pm P \cdot e (1 - b/L) \dots \dots \dots (3)$$

\* A comprehensive set of columns with different types of end fixity and carrying bracket loads will be found in *Arrol's Handbook* (Hunter).

When the bracket is mid-way up the column, *i.e.*, when  $a = c$ , the maximum bending moment is

$$\pm R \cdot c = \pm P \cdot e \cdot \frac{1}{2} (1 - b/L) \dots (4)$$

In no case does the maximum bending moment reach the value of  $P \cdot e$ .

*Approximate Treatment.\* Fig. 104.*

When the bracket is very shallow in depth, *i.e.*, the heel and toe of Fig. 103 practically coincident, the bending moment diagram is approximately that given by Fig. 104c.  $R = P \cdot e \div L$ .

$$B.M. \text{ at } A = - R \cdot a = - P \cdot e (a/L) \dots (1')$$

$$B.M. \text{ at } B = + R \cdot c = + P \cdot e (c/L) \dots (2')$$

With the bracket at the top or bottom of the column the maximum *B.M.*

$$= \pm R \cdot L = \pm P \cdot e \dots (3')$$

When the bracket is at mid-height,

$$B.M. = \pm R \cdot \frac{1}{2} L = \pm P \cdot e \cdot \frac{1}{2} \dots (4')$$

Equations (1') to (4') can be obtained directly from the previous four equations ; in (3) and (4) the term  $b$  is zero.

The bending moment curve of (c) cannot occur under practical conditions because the bracket must have some appreciable depth,

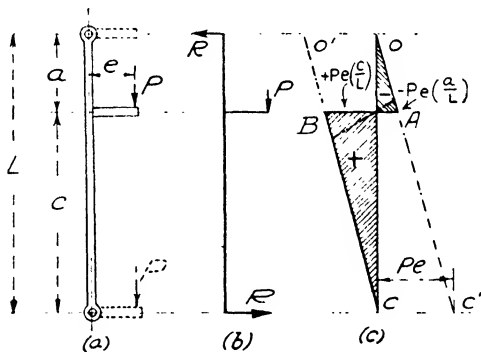

FIG. 104

and, thus, the line  $AB$  is not horizontal, but is inclined as indicated by the dotted line. The actual values of the bending moments are, therefore, smaller than those given by equations (1') to (4').

There is usually a certain amount of indefiniteness regarding the exact value of the end fixity of the practical column and so it would

\* For other cases see *Theory of Structures*, by A. Morley.

appear that the approximate treatment will give results just as trustworthy (and on the safe side) as those found by using the previous and correct treatment.

*Numerical Example.* A column supports an axial load of 20 tons, which includes its own weight, together with an eccentric load of

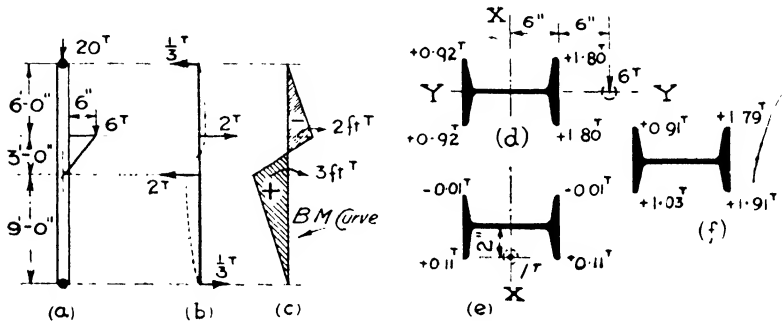

FIG. 105

6 tons at 6 in. clear from the column face. The column is position fixed at both ends, but the deflection fixity is considered to be so poor that both ends will be taken as pin-ended. All the load is carried by the base; the sketch (Fig. 105) gives the remaining information. (The example is practically an illustration of a workshop column carrying a crane girder.)

Try a $12'' \times 8'' \times 65$ lb. R.S.J. area	= sq. in.	19.12
Section modulus, $Z_x$ ,	= in. <sup>3</sup>	81.3
Total eccentricity = $6'' + 6''$ , Fig. (d)	=	1'
Direct stress, $f_a$ , = $(20T + 6T) \div 19.12$	= T/sq. in.	+ 1.36
Bending stress = $M \div Z_x$ , Fig. c, $(3 \times 12)$ in.	=	
tons $\div 81.3$ in. <sup>3</sup>	= ,,	$\pm 0.44$
Total stress, Fig. (d), bracket side	= ,,	+ 1.80
,, far side	= ,,	+ 0.92
$l/k_x = 18 \times 12 \div 5.05$ is less than		
$l/k_y = 18 \times 12 \div 1.85$	=	117
Working stress, $F_w$ , (Table 7, B.S. 449)	= ,,	3.38

*Numerical Example.* What is the effect on the above column if an additional load of 1 ton is applied on an angle cleat midway up the shaft and distant 2 in. on the  $xx$  axis from the  $yy$  axis? See Fig. (e).

*B.M.*, about the  $yy$  axis is  $P \cdot e \times c/L =$

$$1T \times 2'' \times 9' \div 18'$$

$$\text{in. tons} = 1$$

Additional direct stress =  $1^T \div 19.12$  sq. in. of

R.S.J. cross-sectional area  $\tau/\text{sq. in.} = + 0.05$

Stress due to bending =  $M \div Z_y = 1 \div 16.3$  „ =  $\pm 0.06$

The resulting additional fibre stresses as given in

(c) are  $+ 0.11$  and  $- 0.01$  „

Fig. (f) gives the summation of all these stresses for the point of maximum bending moment at 9 ft. up the column. The 65-lb. R.S.J. is obviously too strong, hence a lighter section can be employed as is shown under.

Had the 1-ton load been eccentric to both the  $xx$  and  $yy$  axes it would have been necessary to find the bending moments about each separate axis and then sum the resulting fibre stresses as above. Or, had the 1-ton load occurred elsewhere than at the mid-point, which is the point of maximum bending moment for the bracket load, then, before summing the stresses due to the 6 tons and the 1-ton eccentric loads, the appropriate value of the bending moment due to the 1<sup>T</sup> load would require to be scaled from its bending moment diagram at a point half-way up the column.

*Revised Section for Column.* A  $12'' \times 5'' \times 32$ -lb. R.S.J. is too slender since  $l/k_y = 216'' \div 1.01'' = 214$ , which exceeds the (B.S. 449) limit of 180 for this type of loading.

A  $12'' \times 6'' \times 44$ -lb. R.S.J. has  $A = 13$  sq. in. and  $k_y = 1.3''$ .

For  $l/k_y = 216'' \div 1.3'' = 166$  the  $F_a$  (Table 7, B.S.) =  $\tau/\text{sq. in.} = 1.94$

Direct stress  $f_a$  (too high) =  $26^T \div 13$  sq. in. „ = 2

Try a  $12'' \times 6'' \times 54$ -lb. R.S.J. area = sq. in. 15.89

$l/k_y = 216'' \div 1.33''$  „ 162

Working stress,  $F_a$ , (Table 7, B.S. 449) =  $\tau/\text{sq. in.} = 2.04$

Direct stress,  $f_a$ , =  $27^T \div 15.89$  sq. in. „ = 1.69

Bending stress,  $xx$ , =  $36''^T \div Z_{xx}$  of 62.63 „ = 0.57

„ „ „  $yy$ , =  $1''^T \div Z_{yy}$  of 9.43 „ = 0.11

Combined fibre stress at one corner = „ =  $+ 2.37$

In this case the axial stress  $f_a$  is well below the working stress  $F_a$ , but the combined stress due to axial load and the bending in two planes exceeds  $F_a$ . When this occurs employ the formula given on the next page but two, *viz.*

$$f_a/F_a + f_{bc}/F_{bc} \text{ should not exceed unity,}$$

*i.e.*,  $1.69/2.04 + (0.57 + 0.11)/10$ ,

or  $0.83 + 0.07 = 0.9$ , which is less than unity and therefore acceptable.

Hence, instead of  $12'' \times 8'' \times 65$  lb. R.S.J. employ a  $12'' \times 6'' \times 54$ -lb. R.S.J., which results in a saving in weight of 198 pounds of steel per column.

**Building Frames : Columns with Intentional Eccentric Loading.**

Fig. 106a. If it were possible to place the load  $P$  axially on a stable and perfect column then the stress at any cross-section in the stanchion length would be a direct compressive stress. There would be no bending stresses whatsoever.

Fig. 106b. Such ideal conditions do not exist and the practical pin-ended column bends. Hence at any point in the column's length there is a direct compressive stress together with a bending stress, the latter reaching its maximum value at mid-height.

Fig. 106c. Now let the load  $P$  be applied eccentrically to the shaft. Since the resulting bending moment is the product of the load  $P$  by the lever arm  $e$ , then, by increasing  $e$  to a high value, it is possible to have a large bending moment with practically no direct compressive stress at all.

The stanchion has thus passed through all the stages from pure compression to pure bending, and the problem arises as to which

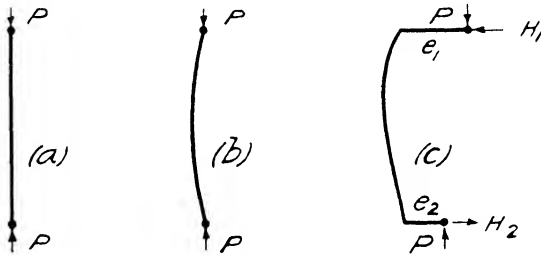

FIG. 106

method of procedure should be adopted when a member in a structure acts simultaneously as a strut and as a beam.

*Columns Continuous through Several Floors* Roughly there are two methods of calculation employed. By far the most common one is to assume that for vertical loading the floor beams are simply supported by the columns; in other words, they have simple pin connections at their ends. Since the beam reactions are usually assumed to be situated about 2 in. away from the column face there is a bending moment, at floor level, on the stanchion equal to the beam reaction multiplied by the total lever arm to the gravity axis of the column. When dealing with wind stresses, however, the horizontal members, which may now form part of the wind bracing system, are assumed to have fixed ends and the restraint values of the beam to column cleats and their fastenings are fully allowed for in the calculations; although the same cleats and fastenings have been considered as simple pins when carrying their vertical loads.

The end connections may vary in character from the theoretical pin (as represented by the simple shelf angle) to the fully restrained end, as illustrated by Figs. 107 and 108. Both the bracket and the split joist (R.S.J. with one flange cut off) are typical wind connections.

The bending moment which occurs on a freely supported beam

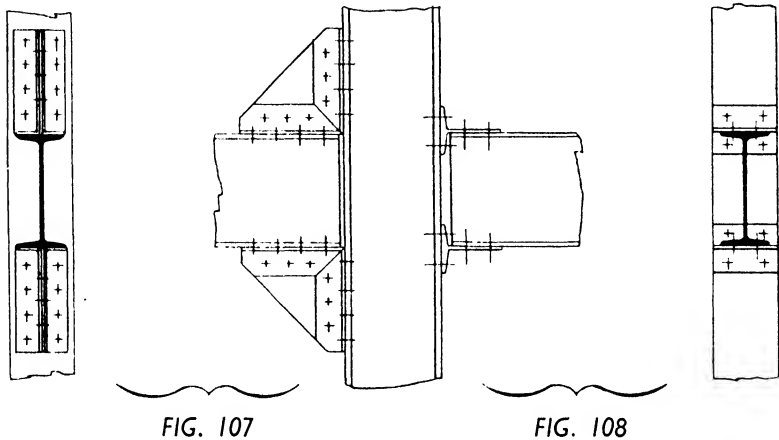

FIG. 107

FIG. 108

will be greatly reduced in value if the ends of the beam can be restrained or fixed. The negative or reducing moment given by the restraint of the cleats and their fastenings must ultimately be provided by the columns to which the beam is cleated, and therefore equal and opposite moments are induced on the stanchions. The other method of calculating the stresses caused by vertical loads in multi-storeyed building frames is to make due allowance for the restraints or fixities provided by the rigid or semi-rigid end connections between beams and columns. This method, although admittedly the correct one, has not found many adherents in practice because of the very heavy and laborious work involved in the calculations. Nevertheless, it is possible that a simple approximate method may yet be evolved which will be acceptable to practice. If welded connections supplant bolted and riveted ones the necessity for such a solution will become imperative.

The report of the Steel Structures Research Committee give results of some extremely interesting experiments carried out on actual steel-framed buildings.

*Direct and Bending Stresses.* The recordings of many of these experiments conclusively showed that the maximum bending stress



occurred at the end of the column, where it is cleated to the floor beams. Now this bending stress is due to the beam action of the stanchion and not to the column bending action, which takes place at mid-heights as in Fig. 106*b*. The working stress at the end of the column can therefore be raised from that given by the column formula to the higher value used in the design of beams.

The members of a rigid frame have the points of contraflexure, or no bending moment, usually at or near mid-length. In Fig. 167 maximum bending moment occurs at the base of the column and at the knee brace, *i.e.*, the positions of maximum beam moment are at the ends of the column while maximum bending moment through column action takes place midway along the length of the strut. So long as the member is in "double" or "reverse" curvature, *i.e.*, subjected to "reverse" moment (see the columns of Fig. 162), the effects of these two types of bending moments are not accumulative. (Where single curvature or simple bending moment occurs in the strut simultaneously with column bending moment the maximum bending, and therefore fibre stress, will be encountered at or near mid-length. This case is dealt with in the text to Fig. 109.)

When a pin-ended column is subjected to eccentric end loads, as in Fig. 106*c*, the maximum bending moment takes place at the end of the column where there is the greater eccentricity, provided that the load  $P$  does not exceed a definite critical value. If this value for  $P$  is exceeded then the point of maximum bending moment leaves that end for some other position along the column length, thereby increasing the deflection of the elastic line of the column with a consequent increase in column bending.

*Combined Stresses.* Several specifications state that members subject to both axial load and bending stresses should be so proportioned that :—

in compression,  $f_a/F_a + f_{bc}/F_{bc}$  does not exceed unity.  
 in tension,  $f_t/F_t + f_{bt}/F_{bt}$  " " "

In both cases the fractions, representing actual stress  $\div$  permissible stress, when summed should not exceed unity.

Where  $f_a$  &  $F_a$  = actual and permissible axial compressive stress, respectively.

$f_t$  &  $F_t$  = " " " " tensile " "  
 $f_{bc}$  &  $F_{bc}$  = " " " compressive stress in bending, respectively.  
 $f_{bt}$  &  $F_{bt}$  = " " " tensile " " " "

Furthermore, when a beam frames into a column, continuous through several floors, the principal specifications of this and other countries allow the two following assumptions to be made :—

(a) The bending moment due to the eccentricity of the beam's end reaction may be assumed to affect only the immediately adjoining portions of the column's length, and to have no effect on the column at the levels of the floors above or below the beam considered. (Experimental evidence refutes this assumption.)

(b) Also the bending moment may be assumed to be shared between the lengths of the continuous column shaft above or below the floor beam considered in the ratio of their stiffnesses, *i.e.*,  $I/l$  values.

*Numerical Example.* The column of Fig. 62 will be assumed to have part of its load applied eccentrically as follows. One of the floor beams framing into the flange has 6 tons more end shear than the opposing beam on the other flange. Similarly one of the floor beams cleated to the web of the column gives 2 tons more load to the stanchion than that on the other side of the web. The upper shaft will be supposed to differ slightly from the lower shaft by having  $10'' \times \frac{3}{8}''$  flange plates instead of  $10'' \times \frac{1}{2}''$  plates. Despite the fact that somewhat similar eccentricities may have occurred at the various floor levels above that now considered, the sum of these upper loads are assumed, by specifications, to be axial at the present floor level.

Axial load at 1st floor level	..	117τ
Eccentric loads ,, ,, - 6τ + 2τ	..	8τ
-----		
Total direct load on lower shaft	..	125τ
Effective $l$ , lower shaft was $0.7 \times 14.5 \times 12$	..	122"
Ditto upper shaft = $0.7 \times 12 \times 12$	..	101"
Max. $l/k$ , lower shaft, was	..	56
Permissible stress, $F_a$ , from Table 7 was	.. τ/sq. in.	6.28
Lower shaft : $I_x = 480.4$ ; $I_y$	.. in. <sup>4</sup>	105.1
,,    ,, $Z_x = 87.34$ ; $Z_y$	.. in. <sup>3</sup>	21.02
Upper    ,, $I_x = 406.6$ ; $I_y$	.. in. <sup>4</sup>	84.26
Stiffness of shaft, <i>i.e.</i> , $I/l$ :		
$I_x/l$ , upper = $406.6 \div 101$	.. in. <sup>3</sup>	4.03
$I_x/l$ , lower = $480.4 \div 122$	.. ..	3.94
-----		
Sum	.. ..	7.97
-----		
$I_y/l$ , upper = $84.26 \div 101$	= ..	0.83
$I_y/l$ , lower = $105.1 \div 122$	= ..	0.86
-----		
Sum	= ..	1.69

Eccentricity of $6^r$ load = $\frac{1}{2}$ col. width + $2''$		
= $\frac{1}{2}$ of $11'' + 2''$	=	$7.5''$
B.M. due to $6^r$ load = $6^r \times 7.5''$	= in. $^r$	45
Amount carried by lower shaft =		
45 ( $3.94 \div 7.97$ )	= ,,	22.3
Eccentricity of $2^r$ load = $\frac{1}{2}$ web tk. + $2''$	= say	$2''$
B.M. due to $2^r$ = $2^r \times 2''$	= in. $^r$	4
Amount carried by lower shaft =		
4 ( $0.86 \div 1.69$ )	= ,,	2.03

Maximum fibre stress will occur at one corner of a flange, similar to Fig. 105.

Direct stress = $125^r \div 21.77$ sq. in.	= $^r$ /sq. in. +	5.74
Bending ,, = $22.3 \div 87.34$	= ,, $\pm$	0.26
,, ,, = $2.03 \div 21.02$	= ,, $\pm$	0.09

Max. fibre stress = ,, + 6.09

which is less than the permissible  $F_a$  value of 6.26 and therefore satisfactory ; but employ the combined stress formula,

$$f_a/F_a + f_{bc}/F_{bc} = 5.74/6.28 + 0.35/10 = 0.91 + 0.04 = 0.95$$

which, being less than unity, is satisfactory.

**Combined Direct and Lateral Loading.** *Rough Approximation.* The structural element of Fig. 109 is hinged at the ends and is

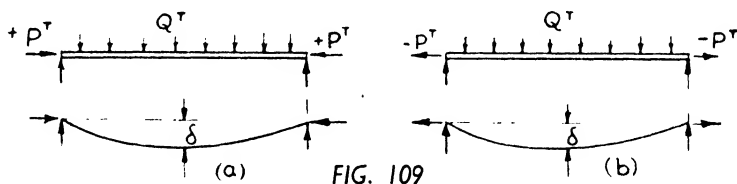

subjected to a direct axial load  $P$  ( $(a)$  compression,  $(b)$  tension) and to a loading  $Q$  which causes cross bending.

Let  $A$  = cross sectional area of the member ;  $l$  = its length between the pins ;  $I$  = its inertia of cross-section ;  $y$  = distance from the neutral axis to the extreme fibre ; all in inch units. And let  $m$  be the value of the maximum bending moment due to the transverse load  $Q$  in inch tons.

The axial load causes a uniform stress over the cross-section of  $+P/A$  for a thrust and  $-P/A$  tons per square inch for a pull ; while the extreme fibre stress due to  $Q$  is  $\pm my/I$  ; + on the upper and - on the lower side.

Total stress on the upper fibres

$$(a) = + \frac{P}{A} + \frac{my}{I} \text{ and } (b) = - \frac{P}{A} + \frac{my}{I} \quad . . . . . (1)$$

Total stress on the lower fibres

$$(a) = + \frac{P}{A} - \frac{my}{I} \text{ and } (b) = - \frac{P}{A} - \frac{my}{I} \text{ all in tons/sq. in.} \quad (2)$$

Where the member is relatively rigid these results are sufficiently accurate for practical design, as the deflection  $\delta$  may be disregarded.

In the event of  $P$  being non-axial it will cause a bending moment throughout the span of  $P \cdot e$ , where  $e$  is the eccentricity from the neutral axis. The value for  $m$  will now be obtained by adding algebraically the bending moment of  $P \cdot e$  to that caused by  $Q$ . The effect of this eccentricity of  $P$  is to decrease the total bending moment, when  $+ P$  is below (Fig. *a*) and  $- P$  above (Fig. *b*) the neutral axis ; while the bending moment is increased if  $+ P$  is above (Fig. *a*) and  $- P$  is below (Fig. *b*) the neutral axis.

*Closer Approximation (Johnston's)*. If the member is long and shallow it will deflect an amount  $\delta$  because of the transverse load  $Q$ , and the line of action of load  $P$  will be eccentric with the neutral axis of the member at mid-span by this amount. There is now an additional bending moment caused by this eccentricity, the value of which at mid-span is  $+ P \cdot \delta$  when  $P$  is a thrust, or (a lessening bending moment of)  $- P \cdot \delta$  when  $P$  is a pull.

$$\text{The total bending moment} = M = m \pm P\delta \quad . . . . . (3)$$

Now this total bending moment of  $M$  could also be obtained by applying to the simply supported span a uniformly distributed load of  $w$  tons per foot. The total transverse load of  $wl$  tons =  $W$  tons would, therefore, create a maximum deflection of

$$\frac{5}{384} \frac{Wl^3}{EI} = \frac{5l^2}{48EI} \left( \frac{Wl}{8} \right) = \frac{0.104l^2}{EI} (M).$$

As deflections are very small in comparison with the span lengths (the usual ratio being in the neighbourhood of 1 to 400 or 500) this deflection will be approximately equal to  $\delta$ , i.e.,  $\delta = \frac{0.104l^2}{EI} (M)$ , or since approximations are being dealt with,

$$\delta = \frac{l^2 M}{10 EI} \quad . . . . . (4)$$

Substituting in (3) the value of  $\delta$  obtained in (4) :—

Fig. (a), when  $P$  is +.

$$M = m + \frac{Pl^2 M}{10 EI}$$

$$\therefore M \left( 1 - \frac{Pl^2}{10 EI} \right) = m$$

$$\text{Hence } M = \frac{m}{1 - \frac{Pl^2}{10 EI}}$$

Fig. (b), when  $P$  is -.

$$M = m - \frac{Pl^2 M}{10 EI}$$

$$\therefore M \left( 1 + \frac{Pl^2}{10 EI} \right) = m$$

$$\text{Hence } M = \frac{m}{1 + \frac{Pl^2}{10 EI}} \quad (5)$$

The extreme fibre stress due to this bending moment is

$$\pm \frac{My}{I} = \pm \frac{my}{I \mp \frac{Pl^2}{10 E}} \quad (6)$$

The total fibre stress is now obtained by adding to (6) the stress caused by the direct load of  $\pm \frac{P}{A}$ .

The upper sign in the denominator of (6) is for  $P$  as a thrust.

Stress in the :	When $P$ is compressive, (a)	When $P$ is tensile, (b)
Uppermost fibres :	$+ \frac{P}{A} + \frac{my}{I - \frac{Pl^2}{10 E}}$	$- \frac{P}{A} + \frac{my}{I + \frac{Pl^2}{10 E}} \quad (7)$
Lowermost fibres :	$+ \frac{P}{A} - \frac{my}{I - \frac{Pl^2}{10 E}}$	$- \frac{P}{A} - \frac{my}{I + \frac{Pl^2}{10 E}} \quad (8)$

Compare equations (7) and (8) with the rougher approximations of equations (1) and (2).

The stresses of (7) and (8), (a) and (b), refer, of course, to the extreme fibres at mid-span. The figure 10 of the denominator is used for simply supported elements of length  $l$ . Where the element is continuous over the supports, or is fixed at both ends, the figure 10 is replaced by 32 for the centre moment and mid-span fibres and 64 for the end moment and fibres.\*

*Example.* Find the effects of transposing the 1-ton loads from the panel points of Fig. 110 to the mid-points of the spans, as in Fig. 111.

\* For a full theoretical treatment of this and other cases see *The Analysis of Engineering Structures*, by Pippard and Baker.

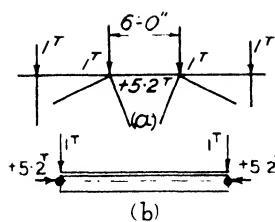

FIG. 110

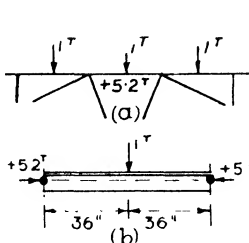

FIG. 111

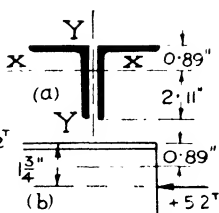

FIG. 112

The member considered has pin-ends and has the direct force applied along the longitudinal centre of gravity line of the section.

To calculate the direct force of Fig. 111a the panel point loads must be estimated first. Since the loads are at mid-span, half of each load will come on to the panel points on each side of it, and hence, because the panel point loads are still 1 ton each, the direct force of + 5.2 tons on the member under consideration will remain unaltered.

Section properties. Two angles,  $3'' \times 2\frac{1}{2}'' \times \frac{1}{4}''$ ; area gross = 2.6 sq. in.; weight 8.92 lb. per foot or 0.024 tons per 6 ft. length. Moment of inertia ( $xx$ ) = 2.28 in.<sup>4</sup>, while  $y$  has the two values as indicated in Fig. 112a.

Maximum <i>B.M.</i> due to own weight (negligible) = $0.024 \times 72 \div 8$ , concave upwards	in. tons	= + 0.22
Maximum <i>B.M.</i> due to 1T central load $1 \times 72 \div 4$ , concave upwards	,,	= + 18.00
Total <i>B.M.</i> , concave upwards	,,	= + <u>18.22</u>

Approximate solution : -

Flexural stress =  $\pm \frac{My}{I}$ , where  $y$  has  
two values.

Uppermost fibre $f = + \frac{18.22 \times 0.89}{2.28}$	τ/sq. in.	= + 7.11
Lowermost fibre $f = - \frac{18.22 \times 2.11}{2.28}$	,,	= - 16.86

Direct compressive stress =  $5.2T \div$  area  
of 2.6 sq. in. , , = + 2.00

Combined stresses :-

Top = + 2τ + 7.11τ	,,	= + 9.11
Bottom = + 2τ - 16.86τ	,,	= - 14.86

More correct solution :—

See equations (7) and (8) with a compressive (+)  $P$ .

Uppermost fibre

$$= + 2 + \frac{18.22 \times 0.89}{2.28 - \frac{5.2 \times 72 \times 72}{10 \times 13,000}} = + 2 + 7.82 \text{ or in tons/sq. in.} = + 9.82$$

Lowermost fibre

$$= + 2 - \frac{18.22 \times 2.11}{2.28 - \frac{5.2 \times 72 \times 72}{10 \times 13,000}} = + 2 - 18.54 \quad ,, \quad = - 16.54$$

*Example.* What are the resulting combined stresses if the direct load is applied along the rivet line, which is  $1\frac{3}{4}$  in. from the angle heel, instead of along the centre of gravity line? See Fig. 112*b*.

$B.M.$  due to eccentricity of end load =

5.2τ (1.75" - 0.89"), convex upwards,	in. tons = - 4.47
$B.M.$ due to own weight and central 1τ load, concave upwards, was	,, = + 18.22
Total $B.M.$ is, therefore, reduced to	,, = <u>+ 13.75</u>
∴ The flexural stresses will be reduced in the ratio of 13.75 : 18.22, viz.	$\frac{3}{4}$

Approximate method

Uppermost fibres = + 2τ + 7.11 × $\frac{3}{4}$	tons/sq. in. = + 7.33
Lowermost fibres = + 2τ - 16.86 × $\frac{3}{4}$	,, = - 10.64

More correct method

Uppermost fibres = + 2τ + 7.82 × $\frac{3}{4}$	,, = + 7.86
Lowermost fibres = + 2τ - 18.54 × $\frac{3}{4}$	,, = - 11.90

The above two examples show in a striking manner the dangers attending the practice of shifting purlins away from the panel points without increasing the scantlings of the rafters for the additional flexural stresses.

**Foundation Bolts to withstand Bending Moment, Fig. 113.** When a column is subjected to a bending moment at its base holding-down bolts must be provided to anchor the column securely down to the concrete block.

Suppose that this overturning moment,  $M$ , is clockwise tending to heel the column about edge  $A$ . Now, no matter whether the

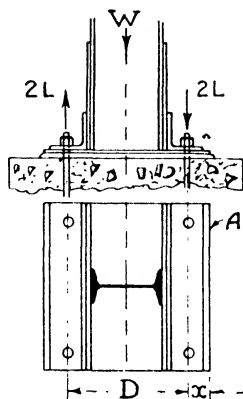

FIG. 113

overturning moment is clockwise or counter-clockwise, the axial load  $W$  always causes a counteracting or stabilizing moment about either bolt line equal to  $W \times \frac{1}{2}D$ , so that the net overturning moment acting at base plate level is  $M - W \times \frac{1}{2}D$ .

Let  $L$  be the tensile load on one bolt, then, taking moments about the line through the right-hand bolts,  $2L \times D = M - W \times \frac{1}{2}D$ , or the uplift per left-hand bolt is  $L = (M - \frac{1}{2}WD) \div 2D$ .

As was the case with brackets, some designers assume the column as tending to heel about the edge  $A$  and so placing all four bolts in tension. If  $L =$  uplift per left-hand bolt, then the uplift per right-hand bolt is proportional to its distance from  $A$ , *i.e.*, the uplift is  $L \times \frac{x}{D+x}$ .

The value of  $L$  can be found by taking moments about the line  $A$ , *viz.*,  $2L(D+x) + \frac{2Lx^2}{D+x} = M - W \left( \frac{D}{2} + x \right)$ .

The first assumption is the safer, since there is less chance of the grout crushing (recalling that edge  $A$  is practically the stoppage line of the grout) or the thin base plate bending owing to the high concentration of load at the supposed fulcrum.

**Eccentrically Loaded Foundations, Fig. 114.** Let  $W =$  total load on base  $D$  by  $L$ . Load per foot of length  $= W \div L = P$  and bending moment per foot  $= P \cdot e$ . The modulus of a 1-ft. length of the base area in contact with the soil about the centre line  $= \frac{1}{6} \times 1 \times D^2 = D^2/6$ . (It may be a help to consider the foundation as being cantilevered up from the earth and subjected to a bending moment of  $P \cdot e$ .)



Pressure on soil caused by direct load

$$= P \div (D \times 1) = + \frac{P}{D} \dots \dots \dots a$$

Due to "bending"

$$= \pm \frac{My}{I} = \pm \frac{M}{Z} = \pm Pe \div \frac{D^2}{6} = \pm \frac{6Pe}{D^2} \dots \dots \dots b$$

∴ Combined pressures

$$= a + b = + \frac{P}{D} \left( 1 \pm \frac{6e}{D} \right) \dots \dots c$$

When the total pressure on one edge just comes to zero it follows from Figs. (a) and (b) that

$$\frac{P}{D} = \frac{6Pe}{D^2}, \text{ i.e., } e = \frac{D}{6}.$$

Therefore,  $P$  may be eccentric by  $\frac{1}{6}D$  on either side of the centre line  $XX$ , i.e., within a central distance of  $\frac{1}{3}D$  or the "middle third," and still the base exerts a thrust upon the soil throughout all its bearing area.

If the load is eccentric to both the geometrical axes  $XX$  and  $YY$ , find the bending moment about each axis and so procure the two diagrams (b). Write the

resulting thrusts against each of the four edges and then add to these the thrust due to the direct stress, i.e., diagram (a).

To find the stresses acting on the concrete cantilever at  $A$  proceed as explained for axially loaded foundations, but note that in this case the total upthrust on the cantilever is represented by the shaded area of Fig. (c), and that it acts through the centre of gravity of this area as represented by the dot.

"Tension" on Base. Fig. 114d shows the base as exerting a positive pressure or thrust throughout

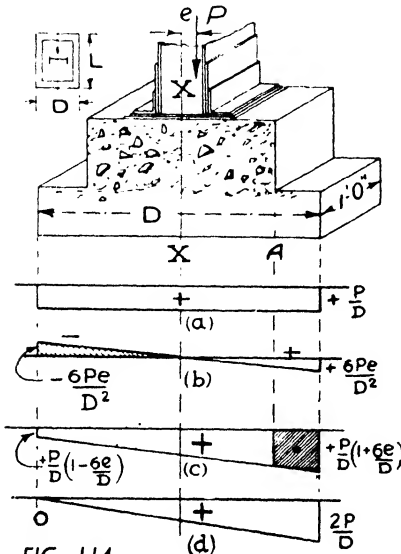

FIG. 114

its entire area, but occasions arise when this is not so, *i.e.*, when the sum curve will have a minus area on the left hand instead of zero pressure. Now, there cannot be tension, or negative pressure, on the left-hand side of the base if the concrete is laid on earth, and so this method of calculating fails. The procedure now to be adopted is indicated in an example towards the end of Chapter VI.

#### REFERENCES

As given at the end of Chapter III.

NATIONAL BUILDING STUDIES. *Research Paper No. 10, An Economical Design of Rigid Steel Frames for Multi-storey Buildings.* (H.M. Stationery Office.)

## CHAPTER V

### THE DESIGN OF A 55-FT. SPAN ROOF TRUSS

#### PLATE II

**Specifications for Wind Loads.** One of the most difficult loads to assess properly is the wind load. It was known at one time, about thirty years ago, that the positive or inward acting pressure occurring on the windward slope of a roof was accompanied by a suction, or negative pressure, acting outwards on the leeward slope. There was, however, great indefiniteness as to the values of these forces, and practice took cognizance of this by simply specifying a positive pressure on the windward slope only and made no mention of the suction. The design was thus simplified, while safety was assured by specifying that the normal positive wind pressure to be assumed in the design should be that derived from a horizontal wind pressure of 30 lb. per sq. ft. of vertical surface. This "30 lb. horizontal wind" is that due to a wind velocity of about 100 m.p.h. and is of rare occurrence, and even then at only one or two extremely isolated and very exposed positions around our coasts. Full provision was thereby made for the neglect of the suction effect.

Modern research has made it possible to be more accurate in the estimation of the probable velocity of the wind acting in various parts of Great Britain, and nine different values have now been specified to be used for design purposes in place of the one-time excessive and universal value of 100 miles per hour.

**Wind Velocity.** It is common knowledge that the west coast of the British Isles suffers more from storms than the east coast; while inland districts suffer least of all. Within each of these roughly defined areas there are building sites, which, depending upon altitude and the local configuration of the ground, suffer more from storms than others in the same county.

The British Standard Specification No. 449 : 1948 has adopted a classification on these lines and the following values for  $v$ , the wind velocity in miles per hour, are those recommended in the specification:

*Central England (including the Severn estuary).* Considering this, the most sheltered part of the British Isles, the following values for  $v$  are to be used in the design :—

Where the building will be

- |   |                 |
|---|-----------------|
| (a) Shielded from the full effects of the wind by the configuration of the ground           | $v = 50$ m.p.h. |
| (b) Situated in open and comparatively flat country not higher than 500 ft. above sea level | $v = 60$ m.p.h. |
| (c) Very exposed and on a site at least 900 ft. above sea level                             | $v = 70$ m.p.h. |

*East Scotland, E. and S.E. England and N.E. Ireland.* The above values are increased to 55, 65 and 75 m.p.h., respectively.

*West Scotland, Wales, N.W. and S.W. England, also N.W. Ireland.* The values for  $v$  are increased by 10 m.p.h. to 60, 70 and 80 m.p.h. respectively for positions (a), (b) and (c).

✓ **Wind Pressures** on flat vertical surfaces depend upon the height above ground level, the velocity of the wind and the presence or absence of some natural obstacle or building, thus :—

$$p = \frac{v^2}{600} \sqrt{1 + 0.06(h - s)}$$

where  $p$  = uniform pressure in lb. per sq. ft.

$v$  = velocity of wind in m.p.h. at 40 ft. above ground level on an open site.

$h$  = height in feet of the surface above ground level.

$s$  = height in feet above ground level of the area assumed to be sheltered by some obstacle :  $s$  shall not exceed  $\frac{1}{2}h$  in the formula, while  $(h - s)$  shall not be taken as less than 10 ft.

Thus for a building 80 ft. high on a very exposed site, in central England, surrounded by permanent buildings 30 ft. high,

$$p = (70^2 \div 600) \sqrt{1 + 0.06(80 - 30)} = 16\frac{1}{2} \text{ lb. per sq. ft.}$$

This is also the design pressure for an unsheltered building 50 ft. high to be erected in flat country, inland from the sea, in the West of Scotland ( $v = 70$  m.p.h.).

If, in the above formula, the specified unsheltered height of 40 ft. be taken then  $p = (v^2 \div 600) \sqrt{1 + 0.06 \times 40} = 0.00307v^2$ , which is in agreement with the old and well-known formula,  $p = 0.0031v^2$ .

For a building seen in elevation the height  $h$  should be measured to the eaves, and for gable ends to a point midway between eaves and roof ridge.

**External Wind Pressure on Roofs.** When the wind is blowing at right angles to the ridge of a roof it causes a suction effect on the leeward side of the roof. For the purposes of design the *B.S. 449* (Clause 12, c) specifies that the intensity of this suction, normal to the roof, shall be taken at the constant value of  $-\frac{1}{2}p$ , no matter what the angle of inclination of the roof may be. The minus sign indicates suction or outward acting pressure ; while  $p$  is the wind pressure due to the horizontal wind assumed to act in the locality, as derived in the previous paragraph.

If the windward roof slope is steep then there is a positive or inward-acting wind pressure perpendicular to the roof surface. When the angle of inclination of the roof surface to the horizontal decreases this positive wind pressure also decreases, reaches zero value when the inclination is  $30^\circ$ , and then becomes increasingly negative as the roof surface tends to become horizontal. If  $\theta$  be the

angle in degrees of the inclination of the roof to the horizontal then the wind pressure, acting normal to the roof surface, in terms of the horizontal wind pressure  $p$ , is as follows :—

$\theta$ varying from	Pressure intensity, normal to roof.
0° to 30° . . . . .	$p(\theta/30 - 1)$
30° to 45° . . . . .	$p(\theta/60 - 0.5)$
45° to 70° (and over) . . . . .	$p(\theta/100 - 0.2)$

Thus on the windward half of a flat roof the pressure is  $-p$  (suction) and on the leeward half the value is  $-\frac{1}{2}p$ . Several values for  $\theta$  will illustrate the variation in the intensity :—

Slope.	Windward intensity.	Leeward intensity.
0° . . . . .	$-p$	$-\frac{1}{2}p$
20° . . . . .	$-\frac{1}{3}p$	$-\frac{1}{2}p$
30° . . . . .	0	$-\frac{1}{2}p$
45° . . . . .	$+\frac{1}{4}p$	$-\frac{1}{2}p$
70° (and over) . . . . .	$+\frac{1}{2}p$	$-\frac{1}{2}p$

**Internal Pressure.** Simple illustrations of this are given by the wind blowing into an open-sided shed on a harbour wall or through a large open door into a workshop. In both cases the internal pressure tends to force the roof and side coverings outwards.

A suction within the building, tending to pull the roof and side coverings inwards, is created by the wind blowing in the opposite direction. An ordinary dwelling house is practically immune from these internal positive and negative air pressures. On the other hand, a workshop with sheeted sides and roof, with say a monitor fitted with louvres, is not impervious to the passage of the air into and out of the building.

The *B.S.* 449 specifies that the framework of structures shall be designed to withstand these internal pressures (acting normal to the surface considered) in addition to the external pressures previously mentioned. For buildings where the air flow through the sides and roof is negligible no attention need be paid to the internal pressures. Where the buildings have "normal permeability" to air flow the internal pressures are to be taken as having the values of  $+0.2p$  and  $-0.2p$ ; and  $+0.5p$  and  $-0.5p$  where the buildings have large openings.

**Weights of Roof Coverings, etc.** Many engineers design steel roof trusses with a rise of a quarter span, i.e.  $\theta = 26^\circ 34'$  (the rise is the height from shoe level to ridge). Others, though fewer in number, now use a rise of a fifth span; while most architects seem to prefer a roof slope of  $30^\circ$  for ordinary industrial buildings. The flatter the roof slope the greater is the possibility of wind blowing the rain into the shop under the laps of corrugated sheeting. In order that the weights of roof covering may be used for any angle of inclination

they are given in pounds per square foot of actual or **slope area**, and not the area as seen in plan.

<i>Slates</i> with 3-in. laps and nails. Cornish medium thickness	=	7.5
Welsh, medium thickness	=	6
<i>Slates</i> on $1\frac{1}{8}$ in. T. & G. boarding with timber common rafters (7.5 + 3.6), but excluding steel purlins	=	11.1
<i>Glazing</i> , $\frac{1}{4}$ -in. rough-cast or wire-woven glass 3.1 lb., steel tee bar astragals, plus putty, pins, etc., at 1.8 to 2.1 lb.	=	5.2
<i>Glazing, patent.</i> Lead-covered steel astragals with $\frac{1}{4}$ -in. glass from		6
<i>Purlins</i> can be easily calculated. For slates on boarding, wt.	=	2 to 3
For glazing, 1.6 to 2.75 lb.; corrugated steel sheeting	=	1.2 to 1.8
<i>Corrugated asbestos cement sheeting</i> , $\frac{1}{4}$ -in. thick as laid	=	3.3
<i>Galvanized corrugated sheeting</i> of 18 gauge, 10 corrugations of 3-in. double-side laps and 6-in. end laps plus fastenings such as hook bolts, nuts, washers, etc.	=	3.1
For 20, 22, 24 and 26 gauges the weights are, respectively, 2.4, 2, 1.7 and 1.3 lb.		

The following weights are in pounds per square foot of **plan area** :—

<i>Snow</i> , all slopes from 0° to 65°, minimum weight	=	10
<i>Flat roofs</i> and up to 10° slope (including 2 ft. of loose snow)	=	30
or a minimum uniformly distributed load on each ft. width of roof	=	240
<i>Plaster ceilings</i>	=	9
<i>Wind bracing</i> , in plane of main tie	=	• 0.25

*Workman* on repairs. If the slope is such that a man :—

- (a) can stand upright, allow for a concentrated load = 200
- (b) requires to rest on a ladder    ,,    ,,    ,,    = 100

*Weights of Roof Trusses.* Because of the increase in working stress and the decrease in wind pressure now specified, the weights of roof trusses are now less than formerly.

When the roof covering is of corrugated sheeting and the trusses are spaced at 12 ft. 6 in. apart and have a rise of a quarter or a fifth span then the weight of the truss, *w*, in lb. per sq. ft. of plan area of roof supported by one truss is :—

$$w = \frac{\text{span in feet}}{50} + 1$$

Thus for a 55' 0" span truss at 12' 6" c/c,  $w = (55 \div 50) + 1 = 2.1$  lb.

Total weight of truss = 2.1 × plan area carried by truss  
 = 2.1 × 55 × 12.5 = 1,444 lb. = 0.65r.

If the trusses are spaced at  $x'$  apart, multiply the above weight by  $x \div 12.5$ .

For glazed and slated roofs increase the above weight by about 10 and 15 per cent. respectively. Also see the article on "Weight of Trusses" in the succeeding chapter.

**Floor Live Loads** are here given as equivalent dead loads in pounds per square foot ; the values given include for any impact effects.

- (a) Column (a) gives the superimposed load per square foot of floor.
- (b) This column states the alternative minimum total load (independent of span), uniformly distributed along the span, which each foot width of floor boarding or slab must be capable of supporting.
- (c) The last column gives the minimum total uniformly distributed load which each joist or beam (independent of span) must carry. This loading will be used in the design only when it exceeds the load given by using value (a). If the joist or beam spacing is less than 3 ft. centres then only loadings (a) and (b) need be considered.

For the complete list of superimposed floor loads consult *B.S. 449*, from which the following have been abstracted : -

Type of building.	(a) lb./sq. ft.	(b) lb.	(c) lb.
Hospital wards, hotel and domestic bedrooms . . . . .	40	320	2,560
Offices . . . . .	50	400	3,200
Schools, colleges and light workshops . . . . .	60	480	3,840
Banks and thronged offices . . . . .	70	560	4,480
Retail shops, restaurants, churches and halls with fixed seating . . . . .	80	640	5,120
Dance halls, halls without fixed seats and light workshops . . . . .	100	800	6,400
Medium workshops and stores . . . . .	150	---	---
Warehouses and heavy workshops, etc. . . . .	200	---	---

*Example.* Consider a 1-foot width of a freely supported floor slab in an office building when the span is (i) 6 ft. and (ii) 10 ft. The total superimposed design load on a 1-ft. width of floor slab is : -

- (i) Not  $6 \times 50$  but 400 lb. (max. B.M. =  $400 \times 6 \div 8 = 300$  ft. lb.).
- (ii)  $10 \times 50$  and not 400 lb. (max. B.M. =  $500 \times 10 \div 8 = 625$  ft. lb.).

At 8-ft. span, loadings (a) and (b) give the same total load of 400 lb.

For floor joists at 6-ft. centres and 11-ft. span the total uniformly distributed load thereon is : (a)  $6 \times 11 \times 50 = 3,300$  lb., which should be used in the design since it is larger than 3,200 lb.

The reason for specifying alternative loadings is that part of a floor may be relatively free of load while another may have to carry a heavy concentration due to furnishings.

**Data.** The complete design of a roof truss will be given in accordance with the following requirements.

*Span, etc.* Theoretical span 55 ft., intersection to intersection of the rivet lines of rafters and main tie. Trusses at 12 ft. 6 in. centres ; this is a popular figure in shop design as it gives dimensions of 25 ft., 50 ft., etc., for shop lengths. Rise of roof to be quarter span.

*Roof Covering.* Of 18 gauge galvanized corrugated sheeting, 10/3 in., with double side laps and 6 in. end laps and carried on steel angle purlins ; see Plate II.

*Position.* It will be assumed that the proposed building is to be erected in Wales on a very exposed and unsheltered site, at least 900 ft. above sea level. The height of the eaves above ground level is to be 30 ft.

*Wind velocity* is 80 m.p.h. (from previous specified values).

**Purlins.** A skeleton layout of the truss reveals that it is possible to arrange the panel points on the rafters so that 6 ft. 6 in. long sheets can be used throughout with the exception of the bottom sheet, and, allowing for 6 in. end laps, the purlins will be spaced about 6 ft. apart measured on the slope. It is highly advantageous to make the truss suit the sheets and not, as is so often done, make the sheets of various lengths to fit the truss. The economic gain of this simple procedure is very often lost sight of, especially in glazed roofs, where its application results in every pane of glass, whether at erection or replacement, being of the same length.

Nevertheless, the positions of the purlins cannot be definitely ascertained until the scantlings and rivet details have been fixed ; but the preliminary layout reveals that for the initial stages of the design, *i.e.*, purlin and stress diagram calculations, the rafter could be assumed to be divided into five equal panel lengths.

The purlins are made continuous over three bays of 12 ft. 6 in., and the joints are reeled so that on one truss, reading up the rafter, there occurs one purlin joint, then two purlins without joints, next a purlin with a joint, and so on. The fish-plates and cleats will be assumed to give sufficient cover at the joints so as to develop continuity to some extent. On this assumption, and for the reasons given under, the maximum bending moment will be taken at  $Wl \div 10$ .

The wind load need not be considered when calculating the modulus of an angle purlin provided that the roof slope does not exceed  $30^\circ$ . If the roof slope is steeper than this then the normal thrust due to the wind will require to be added to the normal load,  $W \cos \theta$  of Fig. 115, mentioned under. When the roof has an inclination less than  $30^\circ$  then the wind tends to create a suction, *i.e.*, an outward and upward pull, and so lessen the effect of the dead and snow loads on the purlin.



## EXPLANATORY TEXT

The vertical dead load  $W$  on a purlin, due to snow and dead load, can be resolved into two components, one normal to the roof and the other parallel to the roof slope.

The effective load on the purlin is taken as that component which is parallel to its longer leg (Fig. 115). The component of  $W \sin \theta$ , parallel to the roof slope, is entirely neglected. The covering, of sheeting, glazing, or slates on boarding, forms a deep plate girder lying on the rafters whose upper and lower flanges are the apex and shoe purlins respectively. The depth of this inclined girder is from twice to thrice its span of 12 ft. 6 in., and, hence, the transverse stresses produced by the small tangential components of  $W \sin \theta$  must be extremely small and negligible.

The rigidity of the roof covering, and its effect in distributing the loads over the purlins, plays an important part in the load carrying capacity of the purlins.

Those conversant with erection of light steel cantilever roofs will recall that such trusses spring and vibrate in unison with the movement of any one on the roof, but when once the glazing or sheeting is laid the roof becomes stiff and rigid. No estimate can be made for this effect, but it is worth remembering that glass, the weakest of all coverings, has ultimate tensile and compressive strengths of 5 and 8 tons per square inch respectively.

*Item 3.* B.S. 449 says that the dead and snow loads shall be taken as if they were normal to the roof slope, i.e.,  $W$  instead of  $W \cos \theta$ , Fig. 115, or  $0.46\tau$  in place of  $0.46 \times 0.8944 = 0.41\tau$ .

*Item 5.*  $I_x$  for a  $3\frac{1}{2}'' \times 2\frac{1}{2}'' \times \frac{5}{16}''$  angle is  $2.14 \text{ in.}^4$  and the modulus is  $2.14 \div 1.12 = 1.91 \text{ in.}^3$ , top; and  $2.11 \div 2.38 = 0.9 \text{ in.}^3$ , bottom. The lesser modulus is that used in the calculations and on the alignment chart. The value of  $0.77$  is also given on the alignment chart of Fig. 116.

*Items 6 and 7.* The depth and breadth of the angle purlin must not be less than the minimum values stated. These rules ensure that the

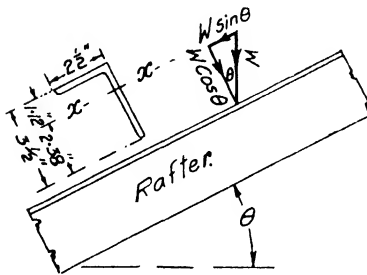

FIG. 115

deflection of the purlin is not excessive.

Not only is the load on the purlin inclined to the principal axes but additional objections could be raised against the mode of calculation, nevertheless, the fact remains that purlins so designed are amply strong.

CALCULATIONS

**Working Stresses.** See p. 74.

**Purlins.** Span 12' 6".

Length of rafter	= $\sqrt{[(55 \div 2)^2 + (55 \div 4)^2]}$	=	30.75'	
Slope area of one side	= 30.75' $\times$ 12.5'	=	sq. ft. 384.4	
Slope area supported by one purlin	= 384.4 $\div$ 5	=	sq. ft. 76.9	<b>1</b>
Plan area supported by one purlin	= 12.5' (55' $\div$ 10)	=	sq. ft. 68.75	<b>2</b>
Dead load per sq. ft. of slope area	= 3.1 lb. (sheeting) + 1.5 lb. (purlins and cleats)	=	lb. 4.6	
Dead load on one purlin	= 76.9 $\times$ 4.6 = 354 lb.	=	<u>0.15<math>\tau</math></u>	
Snow load on one purlin (10 lb./sq. ft. plan area)	= 68.75 $\times$ 10 = 688 lb.	=	0.31 $\tau$	
Total load on one purlin		=	<u>0.46<math>\tau</math></u>	<b>3</b>
Max. <i>B.M.</i> , assumed as $WL \div 10$	= 0.46 $\times$ 12.5 $\times$ 12 $\div$ 10	=	in. $\tau$ 6.9	<b>4</b>
Modulus, <i>Z</i> , reqd.	= $M \div F_t = 6.9 \div 9^*$	=	in. <sup>3</sup> 0.77	<b>5</b>
Minimum depth of purlin	= $L \div 45$	=	3.33"	<b>6</b>
Minimum breadth of purlin	= $L \div 60$	=	2.5"	<b>7</b>
Adopt 1 $\frac{1}{2}$ " $\times$ 3 $\frac{1}{2}$ " $\times$ 2 $\frac{1}{2}$ " $\times$ $\frac{5}{16}$ " ; <i>Z</i>		=	in. <sup>3</sup> 0.90	
Shoe and apex purlins carry one-half the standard load, therefore use thinner angle of same depth, viz., 3 $\frac{1}{2}$ " $\times$ 2 $\frac{1}{2}$ " $\times$ $\frac{3}{4}$ " ; <i>Z</i>		=	in. <sup>3</sup> 0.73	

**Alignment Chart.** (Fig. 116) gives the same section without all the foregoing calculation, viz., one angle 3  $\frac{1}{2}$ "  $\times$  2  $\frac{1}{2}$ "  $\times$   $\frac{5}{16}$ ".

**Panel Point Loads.**

**Dead Load.** (See previous list of weights.)

Roof truss self	= 2.1 lb./sq. ft., plan area.		<b>8</b>
Main-tie bracing	= 0.25 " " "		
Per panel point	= 2.35 $\times$ 68.75	=	162 lb.
Sheeting " " = item 3		=	354 lb.
Full panel load		=	<u>516 lb.</u> = 0.23 $\tau$

\* B.S. 449, Clause 55 :—The numerical value of the section modulus of the purlin in inch units should not be less than  $WL/90$ . This is equivalent to using  $WL/10$  for the bending moment with  $F_t = 9$ /sq. in. Hence, for bending in the purlins and axial tensile loading on the truss members  $F_t = 9$ /sq. in.

ANGLE PURLINS FOR CORR. SHEETING. RISE OF ROOF =  $\frac{1}{4}$ .

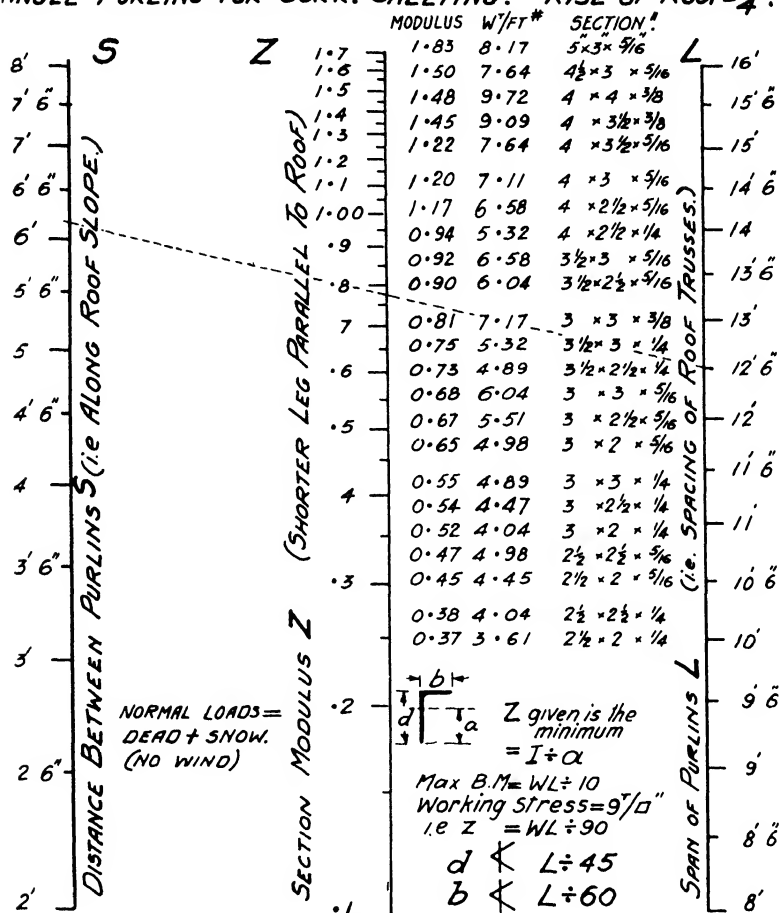

FIG. 116

*Example.* If the purlin spacing and span are 6-15' and 12' 6" respectively, what is a suitable size of angle purlin ?

*Method.* Lay a straight edge so as to join points  $S = 6-15'$  and  $L = 12' 6''$  and this gives the point of cutting on the  $Z$  vertical as 0.77. From the list given alongside it is seen that the lightest and most economical angle is  $3\frac{1}{2}'' \times 2\frac{1}{2}'' \times \frac{5}{16}''$ , which has  $Z = 0.9''^3$  and wt./ft. = 6.04 lb.

Similarly, if any one of the three quantities is unknown it can be found from the straight line joining the other two.

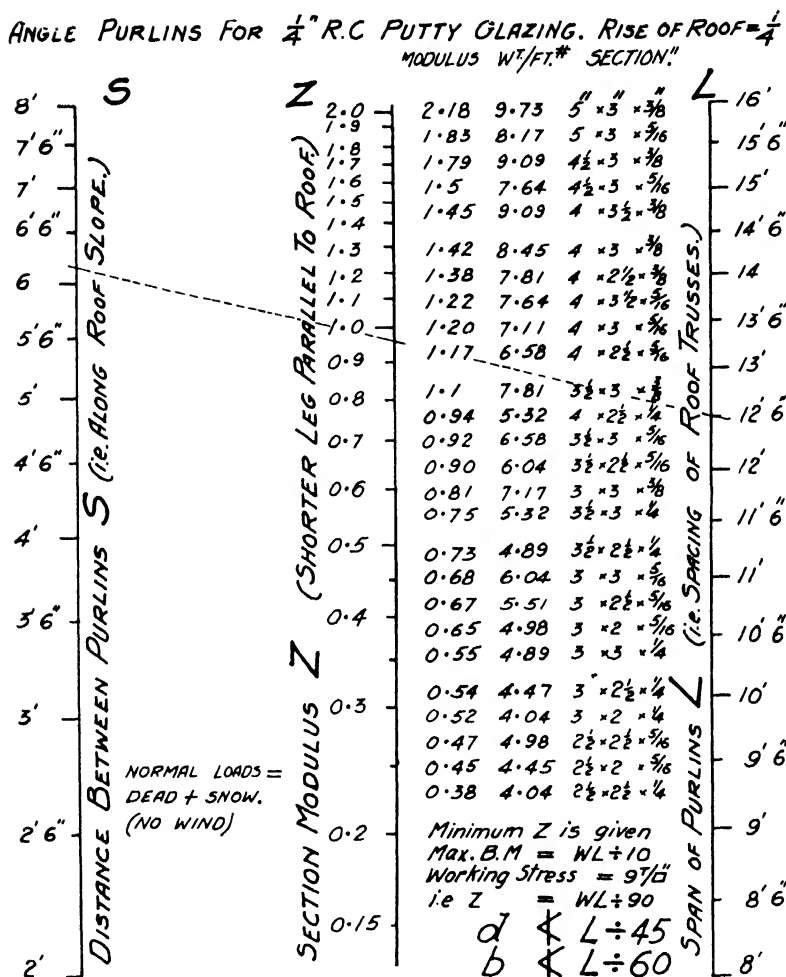

FIG. 117

Example. If the purlin spacing and span are 6-15' and 12' 6" respectively, what is a suitable size of angle purlin ?

Method. Lay a straight edge so as to join points S = 6-15' and L = 12' 6" and this gives the point of cutting on the Z vertical as 0.96. From the list given alongside it is seen that the lightest and most economical angle is 4" x 2 1/2" x 3/8", which has Z = 0.94 and wt./ft. = 5.32 lb. (Alternatively a 4" x 2 1/2" x 5/16".)

Similarly, if any one of the three quantities is unknown it can be found from the straight line joining the other two.

This chart may also be used for angle purlins carrying Slates on Boarding by multiplying the value obtained on the Z line by 1 1/2.

*Item 8.* This weight is derived from the approximate rule, previously mentioned.

*Item 9.* The vertical load at each of the shoe panel points is one half of this item, because they support only one half the standard panel area of roof. Similarly, each purlin at the apex supports one half panel but with dead load these jointly give the apex a full panel load.

*Item 11.* The snow, covering all the roof, acts like an additional dead load and, therefore, the resulting snow forces are proportional to the dead load forces and are of the same sign.

*Items 12 and 13.* These formulæ have been discussed previously.

*Items 14 to 17.* Combining the internal pressures with the external suction gives *Wind Loading, Case 1*, while the internal suction added to the external suction provides *Wind Loading, Case 2*. These additions are shown diagrammatically on Fig. 118 and the resulting panel loads are employed for the respective stress diagrams.

**Stress Diagrams.** As explained in Chapter VII., Vol. I., the skeleton centre line frame of the truss is composed of the rivet lines of the angle bars and not the centre of gravity lines.

When the span of a roof truss is less than 60 or 70 ft. the shoes are usually firmly bolted to the walls or columns without any allowance for temperature expansion. With both shoes fixed in position the truss in effect is an arch.

*Fig. 119.* The reactions are statically indeterminate, but a very close approximate solution is obtained by assuming that the vertical loads create only vertical reactions. Alternatively, this condition can be obtained by assuming one shoe of the truss free to move horizontally, thus ensuring no horizontal thrust.

The structure diagram should be drawn to a much larger scale, relative to the stress diagram, than that indicated; because it is imperative that a primary line of the structure diagram should be as long as, or longer than, the derived parallel line of the stress diagram. More often than not the reason for a stress diagram not closing is due to this lack of true parallelism.

If the stress diagram be commenced at *A* no progress can be made beyond joint *D:E* or 3:8, as there are more than two unknowns at each. For the completion of the diagram the force in 8:0, however, can be found by calculation. Compression is indicated by the + sign and heavy line and tension by the - sign and fine line.

*Item 18.* Even when not necessary it is advisable to place a check upon the stress diagram by calculating the force in one important bar by the method of section and moments.\* Assume

\* See *Influence Lines: Their Practical Use in Bridge Calculation*, by D. S. Stewart (Constable & Co.), for a full explanation of the Method of Section and Moments.

**Snow Load** per panel point, item 3 = 688 lb. = 0.31τ 10  
 Snow load forces can be obtained from the  
 dead load forces on multiplying by the load  
 ratio of 688 ÷ 516 = 1.33 11

**Wind Load.** Pressure on vertical surface is

$p = (v^2 \div 600)\sqrt{1 \pm 0.06(h - s)}$   
 =  $(80^2 \div 600)\sqrt{1 \pm 0.06(30 - 0)}$  = lb./sq. ft. 17.9 12  
 Roof inclination =  $\frac{1}{2}$ , i.e.,  $\theta$  = 26.57°  
 Normal pressure on roof, leeward = -0.5p  
 " " " windward =  $p(\theta/30 - 1)$   
 =  $p(26.57/30 - 1)$  = -0.114p 13  
 Normal permeability = ± 0.2p and -0.2p

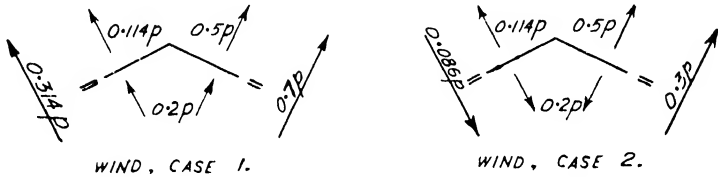

FIG. 118

Slope area on one panel point × full pressure p  
 (items 1 and 12) = 76.9 × 17.9 = lb. 1,376.5

Case 1.

Windward load = 0.314 × 1,376.5 = 432 lb. = - 0.19τ 14  
 Leeward load = 0.7 × 1,376.5 = 964 lb. = - 0.43τ 15

Case 2.

Windward load = 0.086 × 1,376.5 = 118 lb. = + 0.05τ 16  
 Leeward load = 0.3 × 1,376.5 = 413 lb. = - 0.18τ 17

**Stress Diagrams.**

**Dead Load.** Moments about apex to find force S in main tie,  
 Fig. 119.

$S \times \frac{55'}{4} = \text{Reaction} \times \frac{55'}{2} - \text{Resultant} \times \frac{55'}{4}$ ,  
 $\frac{1}{4}S = 1.15\tau \times \frac{1}{2} - 1.15\tau \times \frac{1}{4}$ , whence S = tension, 1.15τ 18

**Wind, Case 1, Fig. 120.**

Horiz. components ;  $0.95\tau \sin \theta = 0.95\tau \times 0.4472 = - 0.425\tau$  19  
 $2.15\tau \sin \theta = 2.15\tau \times 0.4472 = + 0.962\tau$   
 Horiz. reactions at shoes = 2 @ 0.27τ = 0.54τ 20

the truss cut into two parts by a vertical cutting plane through the apex and the main tie. On taking moments about the apex, and considering all the forces acting on the left-hand side of the section, it will be seen that the left-hand portion of the truss tends to revolve clockwise. The imaginary cut in the main tie tends to open, thus showing that the restraining force in the main tie is tensile.

A proportional part of the dead weight of the roof truss itself should be assigned, theoretically, to each panel point on the rafters and main tie, but practice takes all the dead load as being concentrated at the purlin panel points, which simplifies matters considerably.

*Figs. 120 and 121.* Here also the reactions are statically indeterminate and again a very close approximation is given by two alternative assumptions, *viz.*, either that :—

(1) The horizontal components of both shoe reactions are equal to each other. Or, that—

(2) The reactions are parallel in direction to the resultant wind pressure.

The first is the one which will be used, because it is consistent with the usual assumption that the side walls or supporting columns share the horizontal side thrust equally between them. The second solution will be dealt with later in connection with Fig. 153.

*Item 20.* From the geometry of the layout of the truss the line of action of the  $0.95^r$  resultant (of the forces on the left-hand roof slope) cuts the horizontal line joining the shoes at the point  $4:O$  and the  $2.15^r$  right-hand resultant cuts at the point  $12:O$ . The unbalanced horizontal force is  $0.54^r$  and the equal and opposite horizontal force to be applied at each shoe is thus  $0.27^r$ .

*Item 23.* Since the horizontal components act along the main tie they possess no lever arm to the shoes and, therefore, if moments be taken at either shoe only the vertical components need be considered. Items **22** and **24** are equal in magnitude but opposite in direction.

Had the resultants been resolved into their vertical and horizontal components at the points where they intersect the rafter lines, then the horizontal components would require to be taken into the moment equation, because each horizontal component has a lever arm to the shoes equal in length to span  $\div 8$ . Alternatively, the vertical components of the reactions can be found by taking moments about either shoe of the unresolved resultants.

$$\begin{aligned} V_L &= [0.95^r (18.45' + 15.375') + 2.15^r \times 15.375'] \div 55' = 1.18^r \\ V_R &= [2.15^r (18.45' + 15.375') + 0.95^r \times 15.375'] \div 55' = 1.59^r \end{aligned}$$

On the load line *mn* and *no* represent the horizontal and vertical





components, respectively, of the right-hand reaction *mo*. Similarly, *oa* is the left-hand reaction.

*Item 25.* It is necessary to calculate the force in the main tie before the stress diagram can be completed, as explained for item 18.

*Items 26 to 32* correspond to items 19 to 25 of *Wind Case, 1*. Taking moments about each shoe in turn and considering the unresolved resultants :—

$$V_L = [-0.25\tau(18.45' + 15.375') + 0.9\tau \times 15.375'] \div 55' = 0.098\tau$$

$$V_R = [+0.9\tau(18.45' + 15.375') - 0.25\tau \times 15.375'] \div 55' = 0.483\tau$$

**Design of Members.** The table under Fig. 121 gives the forces as scaled from the stress diagrams and from it can be obtained the "most adverse combination" of dead, snow and wind loads for each member of the truss. It has to be recalled that each member of the windward half of the truss has a mirror reflection of itself on the leeward half and thus a member will require to be designed for the greater force which occurs either in itself or in its reflection; because the wind can blow in the opposite direction and change the leeward side into the windward side and *vice versa*.

**Fig. 122.** To facilitate the design calculations the maximal forces from both sides of the truss have been written alongside each member of the half truss.

*Item 33.* The main tie is a tension member under constant dead load. When the wind acts in addition, a reversal of stress occurs, and the tie becomes a strut for part of its length. It will be designed primarily as a tension member and then the section will be examined to see if it can support its temporary strut load. In this case a high slenderness ratio is permitted so long as it does not exceed 350.

The term "reversal of stress" has hardly the same meaning here as it has in bridge design, for in the latter structure the web members near mid-span may suffer a sudden maximum reversal of stress during each passage of the load and also many times during the day. The roof truss, on the other hand, is subjected to stress reversal only occasionally when a storm arises. Had the roof covering been of heavier material, *e.g.*, slates on boarding, the stress reversals would have been fewer in number.

*Item 34.* As shown by Fig. 123, and as explained in Vol. I, the effective net area of a tension angle is taken as the area of the riveted leg minus its rivet hole and half the area of the outstanding (*i.e.*, non-riveted) leg. At first sight the old practice of using flats and rods for tension members would appear to be nearer the ideal than the modern one of using angle bars. Flats, however, especially long ones, have an awkward tendency to buckle sideways. In a long range of saw-tooth (north light) trusses, placed shoe to shoe,

THE DESIGN OF A 55-FT. SPAN ROOF TRUSS 145

Vert. components ; $0.95^T \cos \theta = 0.95^T \times 0.8944 =$	+ 0.85 <sup>T</sup>	21
$2.15^T \cos \theta = 2.15^T \times 0.8944 =$	+ 1.92 <sup>T</sup>	
Sum =	+ 2.77 <sup>T</sup>	22

To find vertical comp. of reactions take moments about either shoe.

$V_L = [1.92^T \times 17.19' + 0.85^T (17.19' + 20.62')] \div 55 =$	- 1.18 <sup>T</sup>	23
$V_R = [0.85^T \times 17.19' + 1.92^T (17.19' + 20.62')] \div 55 =$	- 1.59 <sup>T</sup>	
Sum =	- 2.77 <sup>T</sup>	24

Moments about apex to find force  $S$  in main tie,

$$S \times \frac{55'}{4} = -1.18^T \times \frac{55'}{2} + 0.27^T \times \frac{55'}{4} + 0.95^T \times 15.375',$$

whence  $S$ , compression, = 1.03<sup>T</sup> 25

**Wind, Case 2, Fig. 121.**

Horiz. components ; $0.25^T \sin \theta = 0.25^T \times 0.4472 =$	+ 0.112 <sup>T</sup>	26
$0.9^T \sin \theta = 0.9^T \times 0.4472 =$	+ 0.402 <sup>T</sup>	
Horiz. reactions at shoes = 2 @ 0.257 <sup>T</sup>	0.514 <sup>T</sup>	27
Vert. components ; $0.25^T \cos \theta = 0.25^T \times 0.8944 =$	- 0.224 <sup>T</sup>	28
$0.9^T \cos \theta = 0.9^T \times 0.8944 =$	+ 0.805 <sup>T</sup>	
Sum =	+ 0.581 <sup>T</sup>	29

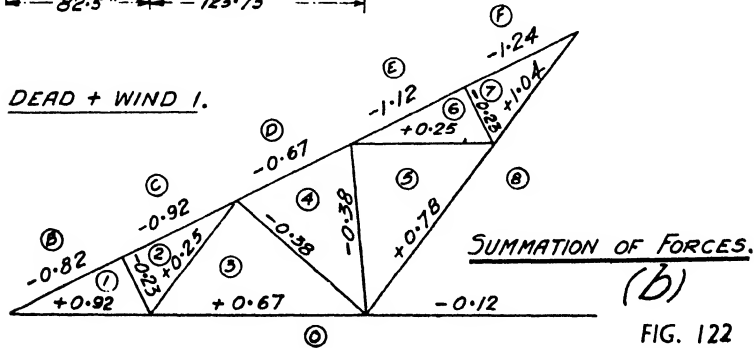
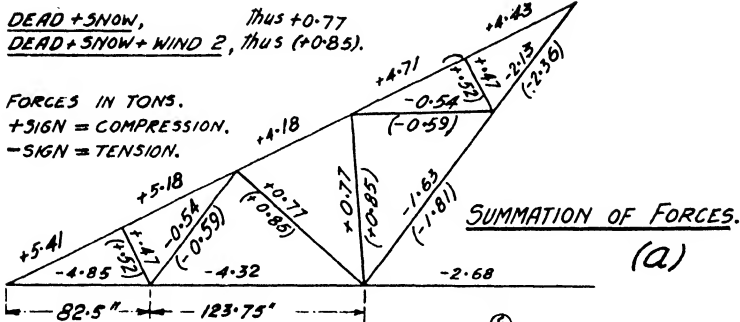

FIG. 122

it is quite common to find at least one truss per line with its flat-bar main tie buckled sideways out of the vertical plane of the truss, caused by the constructional "growth" or "gather." The old gib and cotter connection (also expensive) helped to eradicate this buckling. Similarly with rods, although their rejection is due, primarily, to the expensive smithing of the fork and eye end connections. Of course, neither the flat bar nor rod section could carry the strut load caused by the wind.

The truss will be shop riveted and dispatched in two parts (maximum rail "shipping width" is 8 ft. 6 in.), necessitating joints at  $O:4$  and  $O:12$ .

*Item 35.* An approximate rule to ensure that the member will not deflect unduly and look unsightly.

*Item 36.* Panel point  $O:2$  breaks the strut length of  $206\frac{1}{4}$  in., from  $A$  to  $O:4$  into two lengths of  $82\frac{1}{2}$  in. and  $123\frac{3}{4}$  in. when either the radius of gyration  $k_x$  or  $k_y$  is considered. The main tie, however, is free to bend horizontally outwards away from the vertical plane of the truss anywhere in the unsupported length of  $206\frac{1}{4}$  in., since the only horizontal support it receives is at the shoe and at the continuous horizontal bracing angle (running from truss to truss) at panel point  $O:4$ . It is, therefore, a discontinuous single angle strut with not less than two rivets at each end and the permissible stress is given by B.S. Table 8, p. 70.

*Item 37.* From the end of the angle to midway between the two end rivets is approximately  $2\frac{1}{2}$  in. Hence the strut length, centre to centre of end fastenings, is the overall length of the member on the skeleton drawing less 5 in. as an average value.

An angle,  $3" \times 2" \times \frac{1}{4}"$  was originally tried and proved itself satisfactory as a tie but not as a strut. The values were:— $l/k_y = 161" \div 0.56" = 288$ ;  $F_e/2 = 0.68\tau/\text{sq. in.}$  and  $f_e/2 = 0.92 \div 1.19 = 0.77\tau/\text{sq. in.}$ , i.e., the working stress would have been higher than the permissible.

*Item 38.* An angle  $2\frac{1}{2}" \times 2" \times \frac{1}{4}"$  is ample as a tie but not as a strut. The values are:— $l/k_y = 161" \div 0.58" = 280$ .  $F_e/2 = 0.72\tau/\text{sq. in.}$  and  $f_e = 1.04 \div 1.06 = 1\tau/\text{sq. in.}$

*Item 39.* The mid-portion of the tie bar, which has a very large span relative to its depth, would sag badly if no king tie bar were employed. The stress in this vertical bar is negligible, as it only supports its own weight plus half the weight of the centre portion of the main tie.

*Bending Stresses.* It is customary, when a free choice is offered, to place the heel of an inclined angle on top, because:—First, the angle must act as a beam to carry its own weight and thus the compression or top edge should be the wide one. Second, with the

$$V_L = [+0.805\tau \times 17.19' - 0.224\tau(17.19' + 20.62')] \div 55 = -0.098\tau \quad \mathbf{30}$$

$$V_R = [-0.224\tau \times 17.19' + 0.805\tau(17.19' + 20.62')] \div 55 = -0.483\tau$$

$$\text{Sum} = \underline{-0.581\tau} \quad \mathbf{31}$$

Moments about apex to find force  $S$  in main tie,

$$S \times \frac{55'}{4} = -0.098\tau \times \frac{55'}{2} + 0.257\tau \times \frac{55'}{4} - 0.25\tau \times 15.375',$$

$$\text{whence } S, \text{ compression,} \quad = 0.22\tau \quad \mathbf{32}$$

Tension is allotted the negative sign. The terms tie and strut refer to members of the truss which are normally (*i.e.*, due to dead load) in tension and compression, respectively.

*Main Tie.* (A to O:A.) Max. force = - 4.85 $\tau$  **33**

Adopt 1  $\angle 3" \times 2\frac{1}{2}" \times \frac{1}{4}"$  Gross area = sq. in. 1.31

Less hole,  $\frac{3}{4}" \times \frac{1}{4}"$ , and  $\frac{1}{2}(2\frac{1}{2}" - \frac{1}{4}") \frac{1}{4}"$  for

out-leg = " " 0.47

Net area given, Fig. 123 = " " 0.84 **34**

Actual stress,  $f_t = 4.85 \div 0.84 = \tau/\text{sq. in. } \underline{5.77}$

Permissible stress,  $F_t = \tau/\text{sq. in. } 9$

Depth of vert. leg  $\llcorner$  horiz. span  $\div 45$   
 $\llcorner 123\frac{3}{4}" \div 45 \llcorner 2.75" \quad \mathbf{35}$

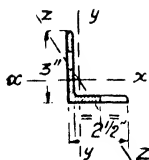

FIG. 123

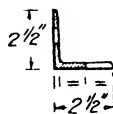

FIG. 124

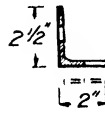

FIG. 125

Check as a strut. Max. force = + 0.92 $\tau$

$k_x = 0.93"$ ;  $k_y = 0.74"$ ;  $k_z = \underline{0.52}"$

(Table 2, Vol. I).

Max. length,  $L = 206" - 5"$ ,  $l = 0.8 \times 201" = 161" \quad \mathbf{36}$

$l/k_y = 161" \div 0.74"$  (B.S. Table 8), = 218 **37**

Max. value for  $l/k$  (tie as strut) = 350 **33**

Permissible stress,  $F_e = \tau/\text{sq. in. } + 1.1$

Actual "  $f_e = 0.92 \div 1.31 = \tau/\text{sq. in. } + 0.70$

*Main Tie.* (O:8) always tension. Max. = - 2.68 $\tau$

Adopt 1  $\angle 3" \times 2\frac{1}{2}" \times \frac{1}{4}"$  by item **35**.

*Secondary Ties.* (8:7 continuous with 8:5.)

Max. force = - 2.36 $\tau$  **38**

heel down, the angle, acting as a gutter, leads water (rain, or moisture from condensation) to the lower connection. Member 5:8 and 7:8 should have, on this reasoning, the heel facing the rafter, but the appearance of the truss is enhanced by carrying out the continuity of outline suggested by the rafter and main tie; a continuous border line enclosing the web members.

*Rafter, Item 40.* The rafter section adopted is lighter than that used in the arithmetical example on p. 72, where it is shown that the effective strut length is 0.7 times the actual length of the strut between the centres of support. The previous deduction of 5 in. from the length is not applicable in this case. Since the loading will be considered axial B.S. Table 7 (p. 68) will be used to find the permissible stress.

*Item 41.* The rafter angles are symmetrically placed on each side of the gusset plates and at points in their length, not further apart than 3 ft. 6 in., they are firmly connected together by means of rivets through distance washers. For this type of tension member the net area is taken as the gross area minus the rivet holes only. The reason is that the tensile load is more uniformly distributed across the sectional area than is the case with the non-symmetrical single angle tension member of item 34. The inner opposing surfaces of two such angle sections cannot be painted after erection, and consequently their use in an external structure, exposed to the weather, is sometimes forbidden. The alternative is to rivet the two angles firmly back to back without any distance washers in between.

*Item 42.* The alternative single angle section for the rafter is satisfactory, provided it can be transported and erected without incident. It has very little lateral rigidity for a component almost 31 ft. long.

The two-angle rafter is much to be preferred as the extra strength of this section is useful during erection, when the trusses have to stand without being properly braced together by the roof covering and main tie bracing.

*Item 43.* The slenderness ratio of members which normally act as struts must not exceed 180. These struts will be provided with two rivets at each end and their permissible stresses will thus be obtained from B.S. Table 8. If only one rivet was used at each end the permissible strut load would be lowered in value, and should the single rivet prove faulty then structural failure might follow.

*Flat-bar Struts.* The old-fashioned compound strut formed by two flats held apart by rivets or bolts threaded through short lengths of piping is now practically never used.

Adopt 1 $\lfloor 2\frac{1}{2}'' \times 2\frac{1}{2}'' \times \frac{1}{4}''$	Gross area = sq. in.	1.19
Less hole, $\frac{3}{4}'' \times \frac{1}{4}''$ , and $\frac{1}{2} (2\frac{1}{2}'' - \frac{1}{4}'') \frac{1}{4}''$	= ,, ,,	0.47
Net area given, Fig. 124	= ,, ,,	0.72
Actual stress, $f_t = -2.36 \div 0.72$	= $\tau$ /sq. in. -	3.28
Check as a strut	Max. force =	+ 1.04 $\tau$
$k_x = k_y = 0.76''$ ; $k_z = 0.49''$ (Table 1, Vol. I).		
Max. length, $L = 206'' - 5''$ , $l = 0.8 \times 201''$	=	161''
$l/k_y = 161'' \div 0.76''$ (B.S. Table 8)	=	212
Max. value for $l/k$ (tie as strut)	=	350
Permissible stress, $F_c 2$	= $\tau$ /sq. in. +	1.14
Actual ,, $f_c 2 = +1.04 \div 1.19$	= ,, ,, +	0.87
<i>Small Ties.</i> (2:3 and 5:6.)	Max. force =	- 0.6 $\tau$
Adopt 1 $\lfloor 2\frac{1}{2}'' \times 2'' \times \frac{1}{4}''$	Gross area = sq. in.	1.06
Less hole, $\frac{3}{4}'' \times \frac{1}{4}''$ , and $\frac{1}{2} (2'' - \frac{1}{4}'') \frac{1}{4}''$	= ,, ,,	0.41
Net area given, Fig. 125	=	0.65
Actual stress, $f_t = 0.6 \div 0.65$	= $\tau$ /sq. in. -	0.93
Check as a strut.	Max. force =	+ 0.25 $\tau$
Min. rad. gy. - $k_z$	=	0.42''
$L = 82.5'' - 5''$ , $l = 0.8 \times 78''$	=	62''
$l/k_z = 62'' \div 0.42''$	=	147
Permissible stress, $F_c 2$	= ,, ,, +	2.01
Actual ,, $f_c 2 = 0.25 \div 1.06$	= ,, ,, +	0.23
<i>King Tie.</i> Vertical bar from apex, adopt		
1 $\lfloor 2\frac{1}{2}'' \times 2'' \times \frac{1}{4}''$ , Fig. 125		

39

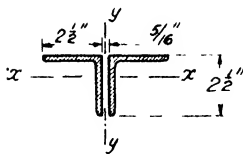

FIG. 126

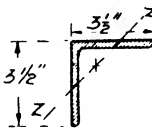

FIG. 127

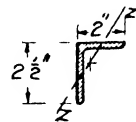

FIG. 128

*Rafters.* (B:1, C:2, etc., continuous.)

	Max. force =	+ 5.41 $\tau$
Adopt 2 $\lfloor_s 2\frac{1}{2}'' \times 2\frac{1}{2}'' \times \frac{1}{4}''$ , Fig. 126.		
	Gross area = sq. in.	2.38
$L = 73''$ , $l = 0.7 \times 73''$	=	51''
$l/k_x = 51'' \div 0.76''$	=	67
$l/k_y = 51'' \div 1.15''$ (Table 15, Vol. I)	=	45
Permissible stress, $F_a (l/k = 67)$	= $\tau$ /sq. in. +	5.75
Actual ,, $f_a = +5.41 \div 2.38$	= ,, ,, +	2.27
Check as a tie.	Max. force =	- 1.24 $\tau$
Area net = 2.38 - 2 @ $\frac{3}{4}'' \times \frac{1}{4}''$	= sq. in.	2.0

41

*Item 44.* The smallest angle leg for a  $\frac{3}{4}$ -in. dia. rivet is  $2\frac{1}{2}$  in., hence the 2-in. leg is the outstanding or non-riveted leg.

*Riveting. Item 45.* At the site joint  $O:8:5$ , Fig. 122 (a), since "action and reaction are alike and opposite," the force of  $2.68\tau$  in the mid-portion of the main tie must be countered by the site rivets at the end of the bar; whence number of rivets =  $2.68\tau \div$  minimum site rivet value in *S.S.* or  $\frac{1}{4}$  in. *B.*

Similarly shop joint  $O:3:4$  of the main tie has the load of  $4.32\tau$  developed by the shop-driven rivets.

At joint  $O:1:3$  there is no break in the main tie, yet there is an increase in the force from  $4.32\tau$  to  $4.85\tau$ . The increment can only have entered the main tie from the gusset plate through the attaching rivets, which must be, therefore, sufficient in number to develop or carry this force difference.

The alternative case shown by Fig. 122 (b) gives fewer rivets than the foregoing.

*Fig. 129.* Although there are three vertical thicknesses of metal at the connection of the main tie to the shoe gusset plate, the rivets through the vertical leg of the main tie angle are in *S.S.* and  $\frac{1}{4}$  in. *B* on the angle. Failure in *S.S.* at plane *yy* would free the main tie angle. In the case of a double angle main tie, the reverse angle cleat of the shoe has lengthened itself out into being the second main tie angle, and the rivets are now in *D.S.* or  $\frac{5}{16}$  in. *B* on the  $\frac{5}{16}$  in. web plate.

*Item 48.* To simplify the calculations the safe assumption will be made (as was done with the design of purlins) that the dead and snow panel point loads (of  $0.23\tau + 0.31\tau = 0.54\tau$ ) act normal to the rafter instead of the lesser amount of  $\cos \theta$  times these values; items **9** and **10**.

On examining the most adverse cases of loading, Fig. 122 (a) and (b), it is seen that the worse case from the riveting point of view is that given by the first diagram.

The rivets of Fig. 130 have to transfer into the gusset plate not only the force difference of  $0.23\tau$  (*i.e.*,  $5.41\tau - 5.18\tau$ ), but also the normal panel load of  $0.54\tau$ .

The final load on the rafter rivets is the resultant of these two forces, *viz.*,  $\sqrt{(0.54^2 + 0.23^2)}$ . The resultant load, having entered the gusset plate, is balanced in turn by the force provided by the web member. A similar case of rivet loading is to be found in the upper flange of a plate girder, where the rivets through the vertical legs of the main angles are subjected to both vertical and horizontal forces, see Fig. 22, p. 16.

Although the rafter stops at the apex and shoe the loads which it carries must continue, and thus the rivets at the ends must be

Actual stress =  $-1.24 \div 2 = \tau/\text{sq. in.} - 0.62$

*Alternative section*

1  $\lfloor 3\frac{1}{2}'' \times 3\frac{1}{2}'' \times \frac{5}{16}''$  Gross area = sq. in. 2.09 **42**

$k_x = k_y = 1.07''$   $k_z = 0.68''$ .

$l/k_z = 51'' \div 0.68''$ , Fig. 127 = 75

Permissible stress,  $F_a$  =  $\tau/\text{sq. in.} + 5.36$

Actual ,,  $f_a = 5.41 \div 2.09 = ,, ,, + 2.59$

Check as a tie.

Area net =  $2.09 - 0.73$  (Table 10, Vol. I) = sq. in. 1.36

Actual stress =  $-1.24 \div 1.36 = \tau/\text{sq. in.} - 0.91$

*Long Struts.* (3:4 and 4:5.) Max. force =  $+0.85\tau$

Adopt 1  $\lfloor 2\frac{1}{2}'' \times 2\frac{1}{2}'' \times \frac{1}{4}''$ . Gross area = sq. in. 1.19

$L = 99'' - 5''$ ,  $l = 0.8 \times 94'' = 75''$

$k_x = k_y = 0.76''$ ;  $k_z = 0.49''$

$l/k_z = 75'' \div 0.49''$  (B.S. Table 8) = 153

Max. value for  $l/k$ , loading other than wind = 180 **43**

Permissible stress,  $F_c2$  =  $\tau/\text{sq. in.} + 1.90$

Actual ,,  $f_c2 = +0.85 \div 1.19 = ,, ,, + 0.72$

Check as a tie. Max. force =  $-0.38\tau$

Area net =  $1.19 - 0.47$  (Table 10, Vol. I) = sq. in. 0.72

Actual stress =  $-0.38 \div 0.72 = \tau/\text{sq. in.} - 0.53$

*Short Struts.* (1:2 and 6:7.) Max. force =  $+0.52\tau$

Adopt 1  $\lfloor 2\frac{1}{2}'' \times 2'' \times \frac{1}{4}''$ . Gross area = sq. in. 1.06 **44**

Min. rad. gy. =  $k_z = 0.42''$

$L = 37'' - 5''$ ,  $l = 0.8 \times 32'' = 26''$

$l/k_z = 26'' \div 0.42''$ , Fig. 128 = 62

Permissible stress,  $F_c2$  =  $\tau/\text{sq. in.} + 4.2$

Actual ,,  $f_c2 = 0.52 \div 1.06 = ,, ,, + 0.5$

Check as a tie. Max. force =  $-0.23\tau$

Obviously safe.

**Riveting.** Values in tons per rivet ( $\frac{3}{4}''$  dia. holes).

Rivets	S.S.	D.S.	$\frac{1}{4}'' B$	$\frac{5}{16}'' B$	$\frac{3}{8}'' B$	Axial	<b>45</b>
--------	------	------	-------------------	--------------------	-------------------	-------	-----------

Shop	2.65	5.30	2.25	2.81	3.38	2.21	
------	------	------	------	------	------	------	--

Site	2.21	4.42	1.88	2.34	2.81	1.77	
------	------	------	------	------	------	------	--

*Main Tie Rivets.* The shop rivets attaching gusset pls. **46**

to main tie angle are in S.S. ( $2.65\tau$ ) and in bearing

on the  $\frac{1}{4}''$  thick angle ( $2.25\tau$ ).

*Joint on Centre Line.* To counteract sag. Rivets  $\nless 1$

*Site Joint, 0:8:5.* Site rivets must develop  $2.68\tau$

No. of rivets reqd. =  $2.68\tau \div 1.88\tau$  ( $\frac{1}{4}'' B$ , site). Rivets  $\nless 2$

*Shop Joint, 0:3:4.* Shop rivets reqd.

=  $4.32\tau \div 2.25\tau$ . Rivets  $\nless 2$



sufficient in number to transfer these loads from the rafter angles into the apex and shoe plates to meet their respective reactions.

*Item 49.* The numbers given are for shop-driven rivets. If it is necessary to replace these by field rivets increase the calculated number by 20 per cent.—a relationship established by the table of working stresses on p. 75. Alternatively, use the values for site rivets given at the commencement of the rivet calculations.

It will be seen from Plate II that more rivets than the calculated number have been given at several joints. This was necessary either on account of gusset plate shape or of the rules for riveting, *viz.*, the end distance of one and a half rivet diameters and maximum rivet pitch of sixteen times the thickness of the thinnest outside plate or angle.

**Distance Washers, Item 50.** As explained for lacing in Chapter IV, the strength of each component should not be less than that of the compound column of which it is part.

The two angles of the rafter, as separate pieces, tend to buckle away from each other, but are restrained by the rivets through the distance washers, *i.e.*, a series of small internal pin-ended columns are formed of length equal to the spacing of the distance washers, and of minimum radius of gyration  $zz$ .

The slenderness ratio of each of these small columns forming the rafter section should not be greater than 0.6 times that of the rafter considered as a whole, neither, in accordance with current specifications, should it exceed 40, nor should there be less than two tacking rivets in the length of a compression member. The least of these three values should be that used in the design.

In tension members formed of two angles the tacking rivets are spaced without calculation at any suitable pitch not exceeding 3 ft. 6 in. These rivets and their distance washers keep the angles in alignment, help to equalize the stress, and, finally, if the structure is subjected to vibration, prevent the angles from chattering against each other.

**Shoe eccentricity** is purposely introduced without calculating its result, but allowance is made indirectly in that the shoe members are given more rivets than the calculated number for direct load; see also Chapter VIII, Vol. I. Further, the actual distance between reactions is 53 ft. against the 55 ft. of the stress diagrams. The alternative type of shoe illustrated by Figs. 148 and 150 may be used if preferred. By employing this detail eccentricity is eliminated but the shoe is not so rigid.

*Item 51.* The total vertical shoe reaction of  $2.68^T$  (Fig. 119) only requires an area of sole plate of 0.1 sq. ft. at  $30^T$ /sq. ft. safe bearing pressure on concrete; actual area given is  $11\frac{1}{2}'' \times 12''$ . The sole

*Joint, O:1:3.* Force difference  
 $= 4.85\tau - 4.32\tau = 0.53\tau$   
 No. of rivets  $\nless 1$

*Joint at Shoe.* Rivets must develop  $4.85\tau$ .  
 No. of rivets reqd.  $= 4.85\tau \div 2.25\tau (\frac{1}{4}" B)$  i.e.  $\nless 3$

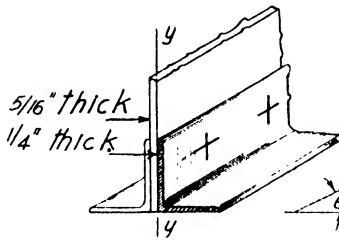

FIG. 129

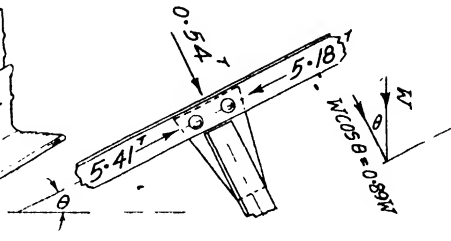

FIG. 130

*Rafter Rivets.* The rivets attaching gusset pls. to rafter angles are in *D.S.* ( $5.3\tau$ ) and in bearing on the  $\frac{5}{16}$  in.-gusset pls. ( $2.81\tau$ ). 47

Normal panel load  $= 0.23\tau + 0.31\tau$  (Fig. 130)  $= 0.54\tau$  48

*Joint B:C.* Force difference  $= 5.41\tau - 5.18\tau = 0.23\tau$

$\sqrt{(0.54^2 + 0.23^2)} = 0.59\tau$  Rivets  $\nless 1$

*Joint C:D.* Force difference  $= 5.18\tau - 4.18\tau = 1.0\tau$

$\sqrt{(0.54^2 + 1^2)} = 1.14\tau$  Rivets  $\nless 1$

*Joint D:E.* Force difference  $= 4.71\tau - 4.18\tau = 0.53\tau$

$\sqrt{(0.54^2 + 0.53^2)} = 0.76\tau$  Rivets  $\nless 1$

*Joint E:F.* Force difference  $= 4.71\tau - 4.43\tau$  Rivets  $\nless 1$

*Joint, Apex.* Rivets must develop  $4.43\tau$ ; panel

load  $\frac{1}{3}$  of  $0.54\tau$ .

$\sqrt{(0.27^2 + 4.43^2)} = 4.44\tau$ . No. of rivets  $= 4.44\tau \div 2.81\tau \nless 2$

*Joint, Shoe.* Rivets must develop  $5.41\tau$ ; panel load

$\frac{1}{3}$  of  $0.54\tau$ .

$\sqrt{(0.27^2 + 5.41^2)} = 5.42\tau$ . No. of rivets  $= 5.42\tau \div 2.81\tau \nless 2$

*End of Bar Rivets* should develop the total force in the bar. 49

*Bars 1:2 and 6:7.* Rivets are in *S.S.* and  $\frac{1}{4}" B$  on angle.

No. of rivets reqd.  $= 0.52\tau \div 2.25\tau$  i.e.  $\nless 1$

*Bars 2:3 and 5:6.* Rivets are in *S.S.* and  $\frac{1}{4}" B$  on angle.

No. of rivets reqd.  $= 0.59\tau \div 2.25\tau$  i.e.  $\nless 1$

plate acts as a cantilever outwards from the vertical gusset plate and tends to bend upwards under the vertical reaction; the calculations are similar to those of the column base previously designed. From the alignment chart of Fig. 63 the permissible overhang for an actual bearing pressure of 3 tons per square foot is about eleven times the thickness of the sole plate, or sole plate plus horizontal leg of angle.

*Item 52.* The two H.D. bolts,  $\frac{3}{4}$  in. diameter, roughly ragged by the smith, give an ample shank shear area to carry the horizontal component of the wind reaction without counting upon the frictional resistance of the sole plate upon the concrete pad-stone.

**Gusset Plates.** It is advisable to carry the angles as far up the gusset plates as possible and so stiffen these against lateral bending. The gusset plate is usually made of the same thickness as the angle to which it is attached, since the bearing value of the rivet depends upon the thinner of two thicknesses of metal.

*Fig. 131.* At this stage of the calculations it is usual to give a free-hand sketch summarizing the foregoing information, which diagram is of immense help when drawing the truss to scale. Not infrequently this is all the information supplied by the designer to the detailing draughtsman.

**Sheeting.** *Figs. 132 to 138* illustrate sheeting details for roof and side covering. The details are common to all gauges of sheeting. Double side laps and 6 in. end laps are used practically exclusively for roof coverings, since water has more chance to penetrate the joints of a sloping than of a vertical covering.

**Dimensioning Trusses.** In the U.S.A. every bar has its actual length and the length between intersections written against it. In this country the custom is to give the main dimensions such as span and rise, and then leave the template-maker to draw the truss out full size. The actual lengths are now obtained from this drawing by cheaper labour than that employed in the drawing office.

**Camber** may be given to the truss if desired. The usual custom is to specify the amount on the drawing without actually showing the main tie bent, and the loftsmen, when striking out the truss on the floor, lifts the central portion of the main tie the desired amount. The two end portions (about 17 ft. long each) then slope from the shoes up to the site joints in the main tie. The excessive camber indicated on so many architectural drawings is not conducive to simple wind bracing in the plane of the main tie. Camber, if given, should be at the rate of  $\frac{1}{4}$  in. per every 10 ft. of span;  $1\frac{1}{2}$  in. in this case.

**Roof Drainage.** Give 1 sq. in. of downpipe cross-section for every 75 to 100 sq. ft. of roof surface

- Bars 3:4 and 4:5. Rivets are in *S.S.* and  $\frac{1}{4}$ " *B* on angle.  
 No. of rivets reqd. =  $0.85^T \div 2.81^T$  i.e.  $\leq 1$   
 Bar 7:8, *Apex*. Rivets are in *S.S.* and  $\frac{1}{4}$ " *B* on angle.  
 No. of rivets reqd. =  $2.36^T \div 2.25^T$  i.e.  $\leq 2$   
 Joint 8:5:6:7. Continuous ; force dif. =  $2.36^T - 1.81^T = 0.55^T$   
 No. of rivets reqd. =  $0.55^T \div 2.25^T$  i.e.  $\leq 1$   
 Bar 5:8, at *Main Tie*. *S.S.* and  $\frac{1}{4}$ " *B* on angle.  
 No. of rivets reqd. =  $1.81^T \div 2.25^T$  i.e.  $\leq 1$

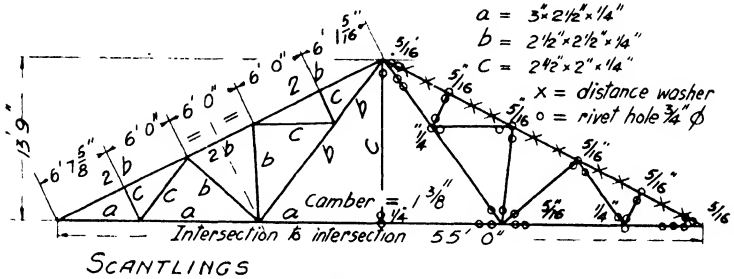

FIG. 131

*Distance Washers in Rafter.*

50

- Min. rad. of gy., *zz*, of 1  $\lfloor 2\frac{1}{2}'' \times 2\frac{1}{2}'' \times \frac{1}{4}''$  = 0.49"  
 The slenderness ratio of  $l/k$  (*zz*) =  $l/0.49$   
 should not exceed  $0.6 \times 67$  of item 40 = 40.2  
 " " " 40, by specification.  
 Further, the tacking rivets  $\leq 2$   
 $\therefore l/0.49 = 40$ , whence pitch  $l = 20''$   
 Give two washers per panel length.

*Shoe Reactions.*

51

- Max. down thrust, dead + snow load  
 =  $1.15^T + 1\frac{1}{3}$  ( $1.15^T$ ), see item 11, total =  $2.68^T$   
 Max. uplift at shoe, Fig. 120, Wind 1 =  $1.59^T$   
 Dead load at shoe, Fig. 119 =  $1.15^T$   
 Unbalanced uplift at shoe =  $0.44^T$   
 Counteracting are two H.D. bolts of  $\frac{3}{4}''$  dia.  
 Area at bottom of thread = 2 @ 0.304, sq. in. = 0.61  
 Axial tension on bolts =  $0.44 \div 0.61$ ,  $\tau$ /sq. in. = 0.7  
 Max. horiz. shear on bolts, Fig. 120, Wind 1 =  $0.27^T$  52  
 Shear area of two  $\frac{3}{4}''$  dia. bolts, sq. in. = 0.88  
 Shear stress on H.D. bolts =  $0.27 \div 0.88$ ,  $\tau$ /sq. in. = 0.31

drained. With downpipes at every column the area of downpipe necessary =  $31'$  (eaves to ridge)  $\times 25'$  between columns  $\div 75$  or  $100$ . In sq. in. =  $10.3$  to  $7.75$

Use a 4-in. diameter downpipe. Cross-sectional area in square inches =  $12.56$

Half-round gutter. Diameter must not be less than twice the diameter of downpipe.

Adopt an 8 in. "half-round" gutter.

Gutter fall about 1 in 75.

[The foregoing represents a fair average of current practice. Downpipe area varies from 1 sq. in. per 60 sq. ft. to 150 sq. ft. of roof area. Distance apart is limited to about 30 or 40 ft.]

**Roof Trusses on Columns.** The truss which has just been designed is really one carried on side walls, because portal action (see next chapter) was not considered; for the purpose of illustrating more details, however, the same truss is also shown mounted on columns. Once the forces have been ascertained the procedure is the same for both types of trusses.

**Wind Bracing.** The disposition of this bracing is shown on the key plan of Plate II.

With the wind blowing on the right-hand side of the building the framing vertical and the intermediate roof truss thereat will cause a horizontal load at point  $H$ , which is at main tie level. Since the vertical acts as a beam against side wind, the bottom end of the vertical will deliver the remainder of its load to the concrete foundation.

The upper flange of the vertical girder  $EG$  is not sufficiently rigid to carry the lateral load at  $H$ , which must therefore travel along the main tie to point  $F$  and so adding a compressive stress to the  $HF$  part of the main tie; the resulting stress in this portion may thus be tension or compression, as was remarked when the main tie was being designed. Now, since  $FE$  and  $FG$  will have less deformation under load than  $FK$ , the load, which has now been traced to point  $F$ , will split into two equal parts, one travelling from  $F$  to  $E$  and the other from  $F$  to  $G$ . The force in each of these diagonals is the numerical value of the load at  $H \times \frac{1}{2}$  of  $FE \div HF$  and is tensile under positive external pressure. The wind thrust at  $H$  has thus arrived at the column cap on either side of  $H$  and ultimately reaches the ground through the portals formed by the columns and the roof trusses attached to them.

The diagonal ties  $XYZ$  and  $CZ$ , etc., brace the structure against the racking stresses caused by the cross travel of the crane or by a wind blowing diagonally and horizontally upon one side and one end of the building. These bars are usually made of the same

WEIGHTS FOR ONE TRUSS

Member.	Section.	Length.	Wt. ft. (lbs.)	Total Wt. (lbs.)
Rafters . . .	4 [s 2½" × 2½" × ¼"	30' 4"	4.04	490
Long struts . .	4 [s 2½" × 2½" × ¼"	7' 11"	4.04	128
Short struts . .	4 [s 2½" × 2" × ¼"	2' 11"	3.61	42
Main tie . . .	1 [s 3" × 2½" × ¼"	54' 1"	4.46	241
Secondary ties .	2 [s 2½" × 2½" × ¼"	16' 3"	4.04	131
King tie . . .	1 [s 2½" × 2" × ¼"	13' 3"	3.61	48
Small ties . . .	4 [s " " " "	6' 1"	3.61	88
Purlin cleats . .	12 [s 3½" × 3" × ⅝"	6"	6.58	39
				1207(=87.7%)

Gusset Plates. (Given in equivalent rectangles.)

Shoe (vertical) .	2 @ 11½" × ⅝"	9" aver.	12.22	18
Main tie . . .	2 @ 9¼" × ¼"	8½"	7.86	11
" " . . .	2 @ 8½" × ⅝"	1' 3"	9.03	23
" " . . .	1 @ 8¼" × ¼"	4½" aver.	7.01	3
Secondary tie .	2 @ 9¼" × ¼"	8"	7.86	11
Rafters . . .	4 @ 8¼" × ⅝"	4½" aver.	8.77	13
" . . .	4 @ 15¼" × ⅝"	9" aver.	16.20	49
" apex . . .	1 @ 15" av. × ⅝"	8" aver.	15.94	11
Sole pls. . . .	2 @ 11½" × ⅝"	1' 0"	14.66	29
				168(=12.3%)
				1375(=100%)
Distance washers	2¼" dia. × ⅝" tk.	20 off	—	7
Rivet heads . .	368	@ per 100	14.1	52
				59(=4.3%)
				1434

Total weight per truss = 1,434 lb. or 2.08 lb. per square foot.

Rule was,  $\left[ \frac{\text{Span}}{50} + 1 \right] \times \text{plan area} = \left[ \frac{55}{50} + 1 \right] \times 55 \times 12.5 = 2.1 \times 687.5 = 1,444 \text{ lb.};$  an error of less than 1 per cent.

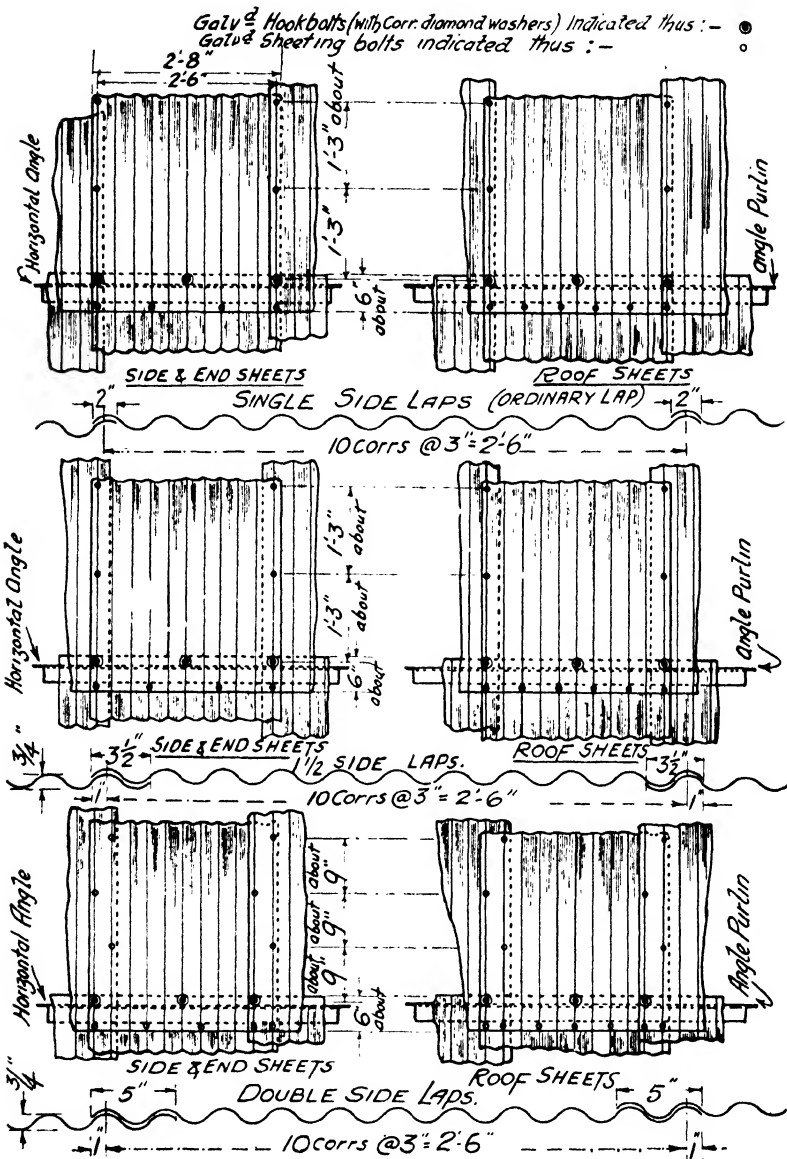

NOTE:- Roof sheet fastenings should have an additional washer of lead.

DETAILS OF CORRUG<sup>d</sup> STEEL SHEETING.

FIGS. 132 to 137

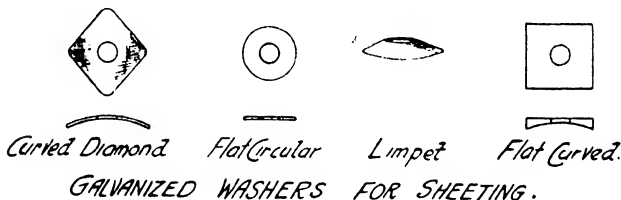
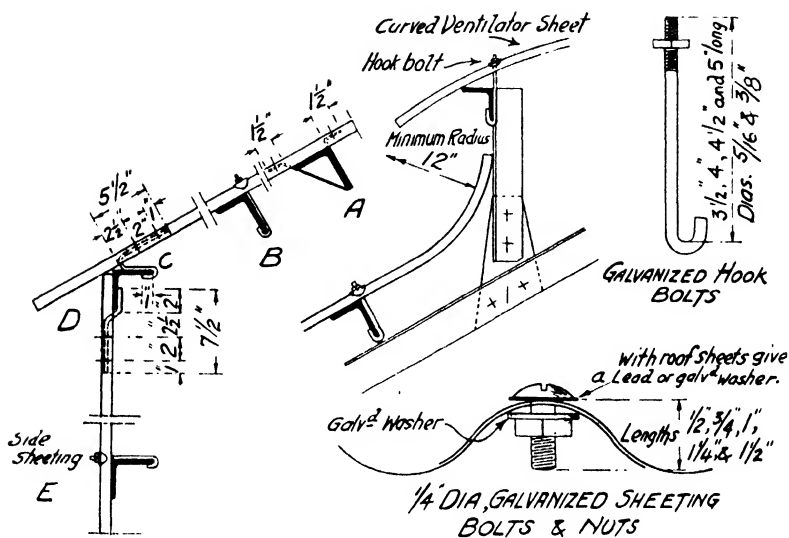

3" Corrugations in 24 & 26 gauge .12" girth, in lengths up to 6'-0"  
 Plain, in any gauge 16 to 26 .12", 14", 15" (stock), etc. up to 36" girth, in 6'-0" lengths

- A = Galv. Straps,  $3/4 \times 1/16$  2 per sheet: bolts  $1/4$ "  $\phi$  with lead washers
- B & E = Galv. hook bolts with diamond or other curved washers.
- C & D = Galv. Clips,  $7/8 \times 3/16$ , 2 per sheet: bolts  $1/4$ "  $\phi$  with lead washers.  
 (Alternative to flat straps, use cape bar section)

Commence by laying the bottom sheets and work up towards the ridge. In very good work a lead and an iron washer are often used together on the external face of the sheet

FIG. 138



section as the wind bracing previously calculated, since no definite value can be assigned to the racking stresses. With experience dictating the scantlings the common practice is to use unequal angles (bolted at underside of main tie) with the longer leg upwards, and to limit the maximum value of the deflection due to dead load of self to span  $\div$  400.

The actual distribution of wind and racking stresses is extremely complex, as every bar in the plane of the main tie will participate in carrying the loads; the more rigid bars will take a greater proportion than the flexible ones.

The wind girder, at the end 12 ft. 6 in. panel, supports the upper ends of the end framing verticals against end wind. No cross bending is caused in the main tie of the second end truss by the dead load of this 53-ft. span girder, because the latter is purposely built to the panel points of the main tie, which explains the non-symmetrical appearance of the girder. The main tie of the second truss now acts in the dual capacity of a main tie and as a flange of the wind girder, which is quite permissible since the building will not have the maximum wind blowing simultaneously on the side and the end of the building. Flat bar diagonal bracing in the vertical plane between the end and second end column of each side then transfers the 53-ft. span girder reactions into the ground (Fig. 139).

Wind bracing of shops is usually designed with the permissible stresses increased by 25 per cent., *i.e.*, for wind loading only the permissible tensile stress  $F_t$  is increased from 9 tons per net sq. in. to  $11\frac{1}{4}$  tons per net sq. in. The angle sections commonly used (often without any pretence at calculation) are  $2\frac{1}{2}'' \times 2'' \times \frac{1}{4}''$  and  $\frac{5}{16}''$ ,  $3'' \times 2'' \times \frac{1}{4}''$  and  $\frac{5}{16}''$ , up to  $3\frac{1}{2}'' \times 2\frac{1}{2}'' \times \frac{1}{4}''$ ,  $\frac{5}{16}''$  or  $\frac{3}{8}''$ . Struts may be permitted a slenderness ratio of 250. There is no standard method of bracing a shop, because span, column spacing and position of the main tie panel points (to which the bracing should be attached) influence the layout. With the shop under discussion some designers would prefer to complete the internal bracing by adding angles in the blank bays, *i.e.*, *A* to *C* and *D* to *X*. The site of the building governs the amount of bracing to be given, because a low building requires less wind bracing than a high one on the same site, and still less if well sheltered by other and higher buildings.

*Rafter Diagonal Bracing* of Figs. 139 and 140 is formed of flat bars, or angles with the outstanding legs turned down to clear the purlins, and is usually placed on the end pair of trusses at each end when the trusses are carried on side walls, and between the end three trusses for the type of shop under discussion. This bracing is

extremely effective during erection, and is a good insurance against demolition by storms until the roof is completely laid.

Fig. 141 is an alternative to the rafter bracing and shows diagonal flat bar, or better still, angle bar bracing between the aforesaid trusses, which bracing lies in the planes of the members indicated by heavy lines.

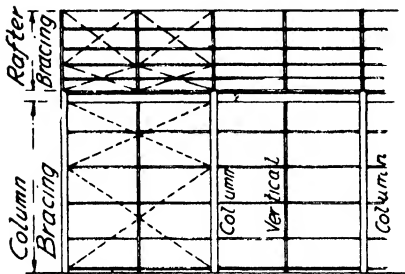
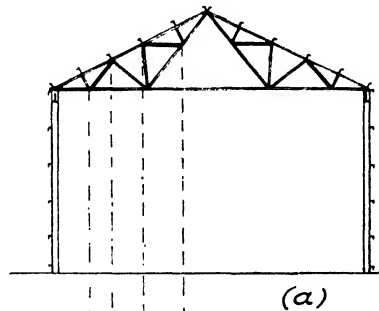

FIG. 139 SIDE ELEVATION.



(a)

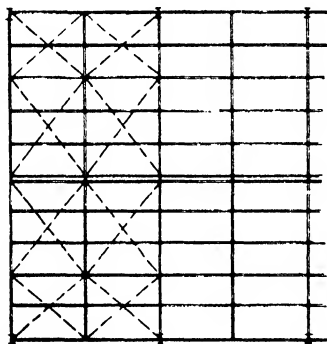
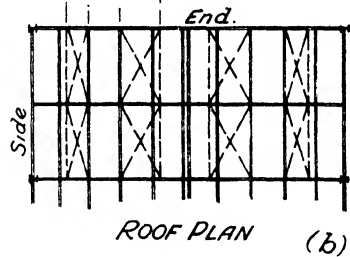

FIG. 140 ROOF PLAN



ROOF PLAN (b)

FIG. 141

*Roof Trusses on Walls.* The main tie has to act as a strut on occasions and its slenderness ratio was reduced, in the calculations, by the use of two continuous angles running the length of the shop. These two longitudinal horizontal angles are bolted through horizontal gusset plates to the underside of the main tie, one at each of the one-third span points. These gusset plates permit the longer legs of the longitudinal angles to be turned upwards towards the roof, and no encroachment is made upon the clear headroom of

the shop. The vertical and horizontal gusset plates at these panel points of the truss now serve as covers for both legs of the main tie angle, which is jointed at these points. The double horizontal longitudinals stiffen the whole roof system against longitudinal collapse more effectively than a single longitudinal bolted to the underside of the main tie at its centre line. Rafter diagonal bracing or its alternative (Figs. 139 to 141) is generally used, and occasionally both systems simultaneously.

ROOF TRUSS WITH MONITOR (PLATE III)

EXPLANATORY TEXT

This roof was designed to the following specification :—

*Span, etc.* 45 ft. c/c of walls and 47 ft. between shoe intersections of rivet lines. Trusses at 12 ft. 6 in. centres ; rise of truss =  $\frac{1}{4}$  span, i.e.,  $\sin \theta = 0.4472$  ; monitor covers the two centre panels.

*Roof Covering.* No. 18 gauge galvanized corrugated sheeting, 10/3 in., with double side laps and 6 in. end laps on main slopes.

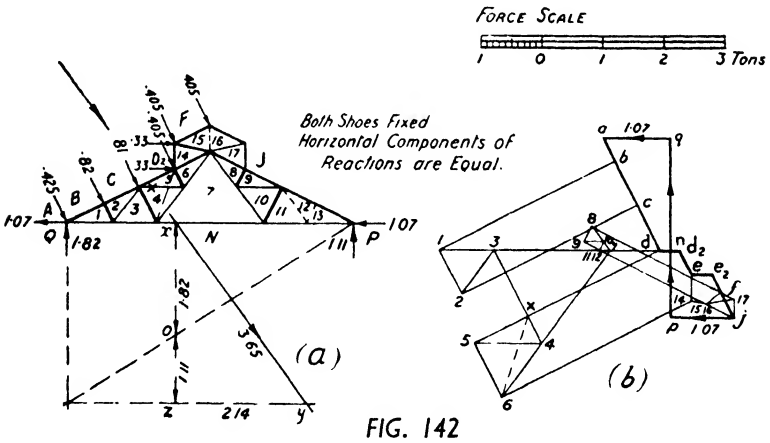

FIG. 142

The roof covering of the monitor is of  $\frac{1}{4}$ -in. thick rough-cast or wire-woven glass in steel astragals, while the side coverings are of 18-gauge galvanized louvres, 11-in. girth in 6 ft. 6 in. lengths. All purlins are of steel.

This truss was designed to a specification which employed positive wind pressure on the windward side (no suction allowance whatso-

ever) and a working stress lower than that used in the previous example. If designed to the specification employed for the 55-ft. truss a saving of at least 10 per cent. should be obtained in the truss weight.

The wind pressure taken was 30 lb. per vertical square foot, and is that due to a 100 m.p.h. wind. With this velocity no snow could possibly remain on the roof and two stress diagrams, dead and wind, suffice in the design of the truss.

As shown in Vol. I, the normal pressure on the roof is obtained from the Duchemin formula :—

$$\begin{aligned}
 P \text{ normal} &= P \times \frac{2 \sin \theta}{1 + \sin^2 \theta} \\
 &= 30 \text{ lb.} \times \frac{0.8944}{1 + 0.2} = 30 \text{ lb.} \times 0.745 = 22.35 \text{ lb.}
 \end{aligned}$$

Hence, panel load *BC*, Figs. 142 and 143 (*a*),

$$\begin{aligned}
 &= \text{slope length} \times \text{truss spacing} \times 22.35 \text{ lb.} \\
 &= \frac{1}{2}(6.5 + 6.78) \times 12.5 \times 22.35 \text{ lb.} = 0.82\tau.
 \end{aligned}$$

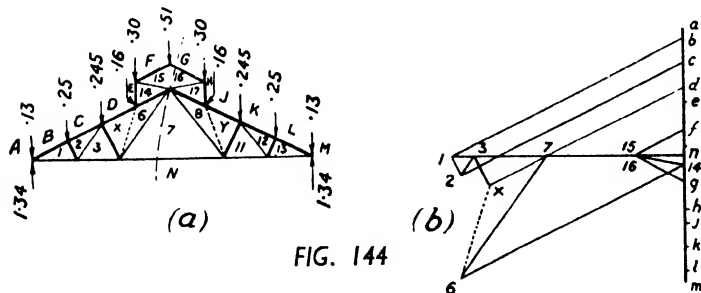
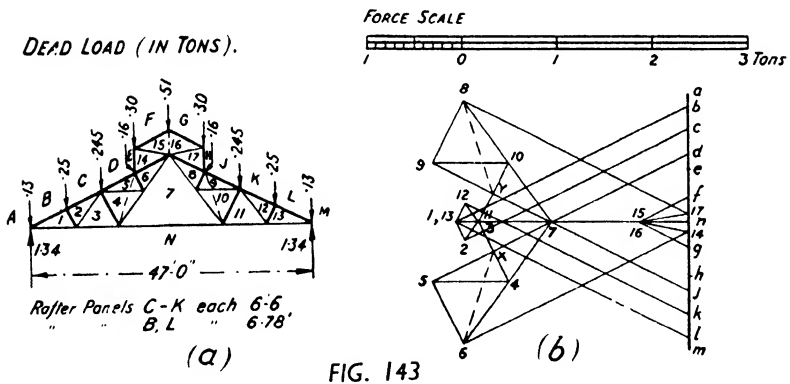

*Weights.* The monitor steelwork runs out at 5 lb. per square foot of its own plan area. The louvres, inclusive of fastenings, laps, blades, etc., but not steelwork, run out at 4 lb. per square foot of elevation area ; alternatively, at 3 lb. per foot run per blade ; or, as a third method, twice the elevation area ( $12' 6'' \times 4'$ ) multiplied by the weight of the material of 2 lb. per square foot.

*Fig. 145* illustrates various glazing details. Glass under 6 ft. 6 in. in length has no extra charged. Any fraction of an inch is charged as if it were a whole inch ; thus, the glass of the monitor must be  $24\frac{1}{2}$  in. wide to give 25 in. centres of astragals, whereas if the astragals had been at  $25\frac{1}{2}$  in. centres the glass would not have cost any more per sheet, with a consequent saving in the cost of the entire roof.

*Notes.* The outside verticals of the monitor are supported at panel points on the principal rafters and do not cause any cross bending in the rafter angles. The cross bending due to the main roof purlins at these panel points is negligible because of the small eccentricity.

#### CALCULATIONS FOR ROOF TRUSS WITH MONITOR

The detailed calculations are not given as they can be obtained from the previous set on substituting the forces scaled from the stress diagrams.

*Forces in Main Tie by Moments.* Bar 15:16 (Figs. 142 and 143) is not required for the stability of the roof and is therefore redundant, *i.e.*, an extra bar which could be eliminated if desired.

The difficulty of completing the stress diagrams, previously encountered with in Figs. 119 and 121, again occurs here.

To find the force in 7:N take moments about the main apex. The section shown in Fig. 144*a* now cuts an additional bar G:16, the force in which can be easily ascertained by drawing the triangle of forces for the monitor apex, 15:F, F:G, G:16. The force in G:16 is compression. Consider the right-hand side of the truss. Then the thrust in G:16 acts towards the eaves of the monitor at G:H, *i.e.*, it has a clockwise moment about the main apex.

$\therefore [G:16 \times \text{perpendicular distance to main roof apex} + (0.3 + 0.16) \times (\text{horizontal distance from main apex} = l_1) + 0.245 \times l_2 + 0.25 \times l_3 + 0.13(l_4 = \frac{1}{2} \text{ span})] - 1.34 \times \frac{1}{2} \text{ span} = 7:N \times \text{rise of } \frac{1}{4} \text{ span.}$  Hence the force in 7:N can now be pricked off on the stress diagram and the latter completed.

*Forces in Main Tie, Graphical Solution.* The stress diagram of Fig. 143 cannot be carried past joints C:D and 3:7 because there are more than two unknowns at each. If the truss of Fig. 144*a* be

substituted for that of Fig. 143a, the force in the main tie will remain unchanged, because the external loads and reactions are unaltered. Bar X:6 thus replaces 4:5 and 5:6. (The reason why this truss is not used in practice is that X:6 is a very long com-

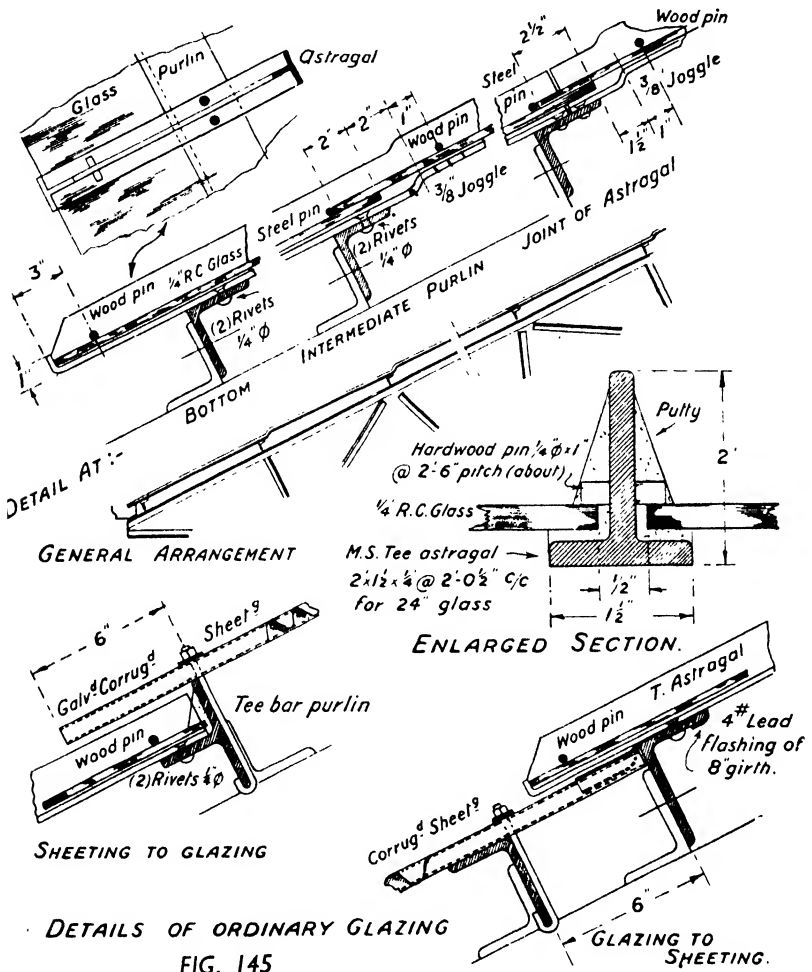

pression member, and it is more economical to use the short strut 5:6 and tension member 4:5.) Fig. 144b is the stress diagram for the left-hand half of the truss. Joints A:B, B:C, 2:N and C:D present no difficulty as there are never more than two unknowns.

At joint  $X:N$ , however, there are three unknowns,  $X:6$ ,  $6:7$  and  $7:N$ , so next try joint  $D:6$ , where again there are too many unknowns. (This will not happen, of course, in the case of the truss without the monitor.) So proceed to joint  $F:G$  and find  $F:15$  and  $G:16$ . Now joint  $E:15$  has  $F:15$  and  $E:F$  known, hence  $E:14$  and  $14:15$  are found from the stress diagram. Return to joint  $D:6$ , where there are now only two unknowns, *viz.*,  $14:6$  and  $X:6$ . Having found  $X:6$ , work round joint  $X:N$  and so find  $6:7$  and  $7:N$ .

With  $7:N$  known, revert to the original truss of Fig. 143, and then complete the stress diagram. Figs. 143 and 144, being drawn separately, should make the method clear.

### REFERENCES

For *Stress Diagrams*, etc., see :—

- ANDREWS, E. S. *Theory of Structures*. (Chapman and Hall.)  
 BECK, E. G. *Structural Steelwork*. (Longmans & Co.)  
 FIDLER, H. *Notes on Construction in Mild Steel*. (Longmans & Co.)  
 Gutter and roof details ; experiments on roof drainage.  
 HUSBAND AND HARBY. *Structural Engineering*. (Longmans & Co.)  
 JOHNSON, BRYAN AND TURNEAURE. *Modern Framed Structures*,  
*Part I*. (Wiley & Sons.)  
 MORLEY, A. *Theory of Structures*. (Longmans & Co.)  
 RICKER. *Design and Construction of Roofs*. (U.S.A. Practice.)  
 (Wiley & Sons.)

For *Specifications of Roofs and Shops*, see :—

- AMERICAN INSTITUTE OF STEEL CONSTRUCTION ; MANUAL. (U.S.A. Practice.)  
 HUNTER, A. *Arrol's Handbook*. (British Practice.) (Spon.)  
 KETCHUM, M. S. *Steel Mill Buildings*. (U.S.A. Practice.) (McGraw-Hill.)

For *Specifications of Working Stresses and Wind Pressures*, etc., see :—

- BRITISH STANDARD SPECIFICATION. *For the Use of Structural Steel in Building*. No. 449. (British Standards Institution.)  
 INSTITUTION OF STRUCTURAL ENGINEERS. *Report on Steelwork for Buildings*. *Part I, Loads and Stresses*. (Broadwater Press, 1s.)  
 DEPARTMENT OF SCIENTIFIC AND INDUSTRIAL RESEARCH. *Steel Structures Research—Recommendations for Design*. (6d. net. H.M. Stationery Office.)  
 HOUSE CONSTRUCTION. *Post-War Building Studies No. 1*. (2s. net. H.M. Stationery Office.)  
 STEEL STRUCTURES. *Post-War Building Studies No. 7*. (2s. net. H.M. Stationery Office.)

## THE DESIGN OF A ROOF TRUSS WITH MONITOR 167

*Corrugated Sheetin*g :—For stock sizes, details, etc., see the handbooks issued by the following firms :—F. Braby & Co. Ltd., Glasgow ; John Lysaght Ltd., Bristol ; Edward Wood & Co. Ltd., Manchester ; Dorman, Long & Co. Ltd., Middlesbrough, etc.

*Cast Iron Downpipes, Gutters, etc.* :—Walter Macfarlane & Co., Saracen Foundry, Glasgow, and others.



## CHAPTER VI

### ROOF TRUSSES, PORTAL TRUSSES AND WORKSHOPS

**The Outline of a Truss** is generally governed by the spacing adopted for the purlins, which are usually from 5 ft. to 7 ft. (about) apart, measured on the slope. This spacing gives an economical covering, as stock sizes can be used of corrugated sheets, steel tee astragals or timber boarding ; wider spacing necessitates heavier and longer elements for the covering, and, owing to the increased unsupported length, heavier angles for the rafters. The skeleton outline of the truss should be so arranged that all the long members are in tension.

In keeping with the foregoing the various types illustrated in Fig. 146 are graded in spans, and in no case does the slope distance between purlin points exceed 7 ft. when the rise of the truss is a quarter of the span, although the distance is not necessarily a maximum.

**Spacing of Trusses** may depend upon :—

- a.* A site which is very irregular in plan.
- b.* The position of doors and windows, which, in turn, settle the position of the columns and, therefore, of the roof trusses.
- c.* The span.

Obviously *a* and *b* cannot be discussed, while in regard to *c* it is advisable, if time permits, to price out approximate designs with the trusses spaced at the common intervals of 10 ft., 12 ft. 6 in. and 15 ft. It does not necessarily follow that the design yielding the least weight of steel is the cheapest. Excavation, concrete work, stock sizes of steel sections, suitable lengths for transportation and the erection scheme all influence the cost. A common rule is that the distance between trusses should lie between one-third and one-fifth of the span of the trusses ; but for most ordinary cases the 12 ft. 6 in. spacing will be found to give very satisfactory results. These figures are only rough guides, for instance, if the building be 104 ft. long it is better to have eight bays at 13 ft. than six bays at 12 ft. 6 in. plus two end bays at 14 ft. 6 in. ; the first layout keeps all the longitudinal elements to one set of templates.

**Weight of Trusses.** An approximate rule for estimating the

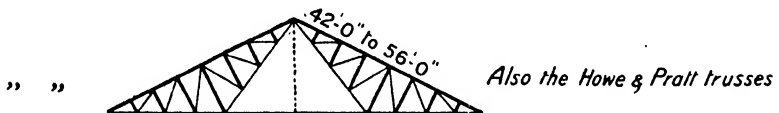
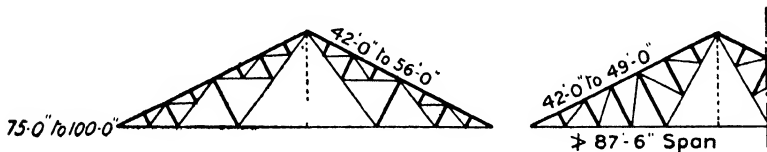
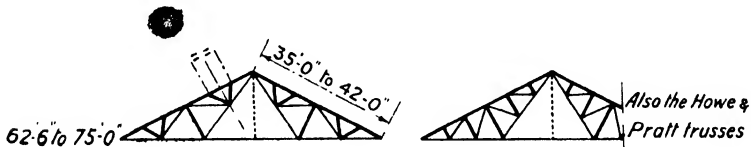
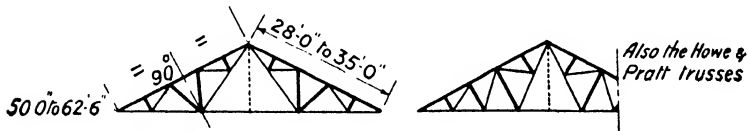
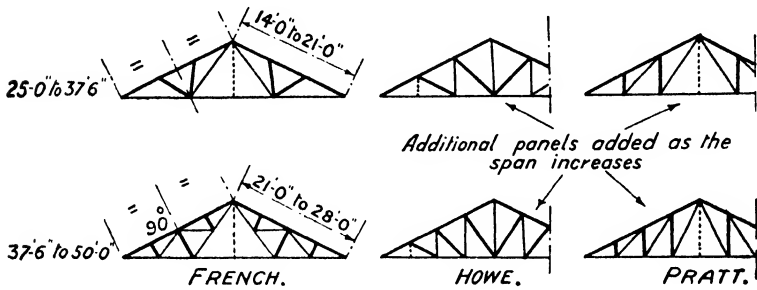
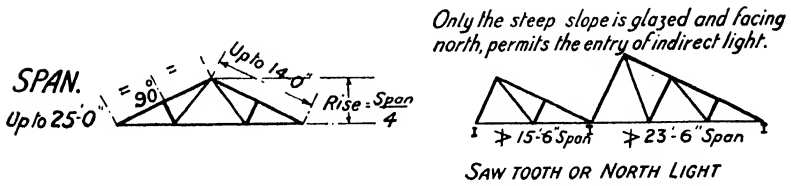

**NOTE:-** Light & heavy lines indicate tension & Compression members respectively

FIG. 146

weight of a roof truss was given in the previous chapter, but where access can be had to previous designs a very close estimate of the weight can be made. When two roof principals of different spans but similar in outline are spaced at the same distance apart and carry the same type of roof covering, then the ratio between the forces in the similar members of the trusses is that which exists between the spans. Thus, the force in any member of a proposed truss of span  $B$  can be obtained from an existing and similar truss of span  $A$  on multiplying the force in the corresponding member of truss  $A$  by the coefficient  $B/A$ . If the spacing of the trusses be  $b$  and  $a$  feet, respectively, the coefficient becomes  $Bb/Aa$ . Also the theoretical weight of  $B$  can be arrived at by multiplying that of  $A$  by the coefficient  $B/A$  or  $Bb/Aa$ .

A verification of this will be given for the main tie. Let  $w$  = load per square foot on both trusses ; it will be approximately the same. Then total load on truss  $A = wAa$ , and the bending moment at the centre line is  $wAa \cdot A/8$ . The depth of truss at centre line is span  $\div 4$ , i.e.,  $A \div 4$ , and hence the flange force (i.e., in main tie) = B.M.  $\div$  depth =  $\frac{wA^2a}{8} \div \frac{A}{4} = \frac{1}{2}wAa$ . Similarly for truss  $B$  the main tie force is  $\frac{1}{2}wBb$  and the ratio between the two is  $Bb/Aa$ . If the roof coverings are different bring  $w$  into the coefficient.

**Special Trusses.** In a shop equipped with overhead travelling cranes it is advisable to have either one or two adjacent trusses (to share the load) especially strengthened to allow the crab and crane cross girders to be erected, or dismantled, in the event of a breakdown. The cheapest method is to eliminate separate gusset plates and run an unbroken plate continuously from shoe to apex between

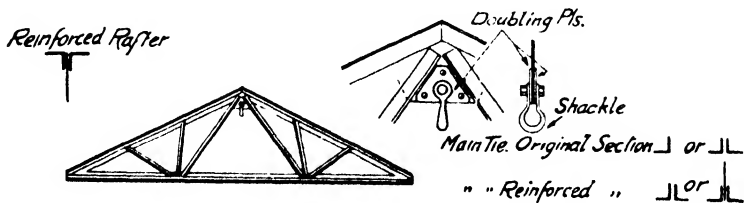

FIG. 147

the rafter angles, and from shoe to shoe for the main tie angles ; the other members require no reinforcement. The additional forces in the rafters and main tie are  $\frac{1}{2} W \operatorname{cosec} \theta$  and  $\frac{1}{2} W \cot \theta$ , respectively ; where  $W$  is the apex load and  $\theta$  the angle of inclination of the rafter. As, needless to say, chances are against this very

occasional load being lifted during a hurricane the same factor of safety may be employed in the calculations for the reinforcement as was used for the ordinary trusses. The shackle could be suspended at the bottom of the king post, at main tie level, but this would encroach on the crane clearance and would give very little room for block and tackle (Fig. 147).

**Erection.** A crane or a guyed pole with block and tackle at the top is used for erecting the truss. The lifting slings are fastened,

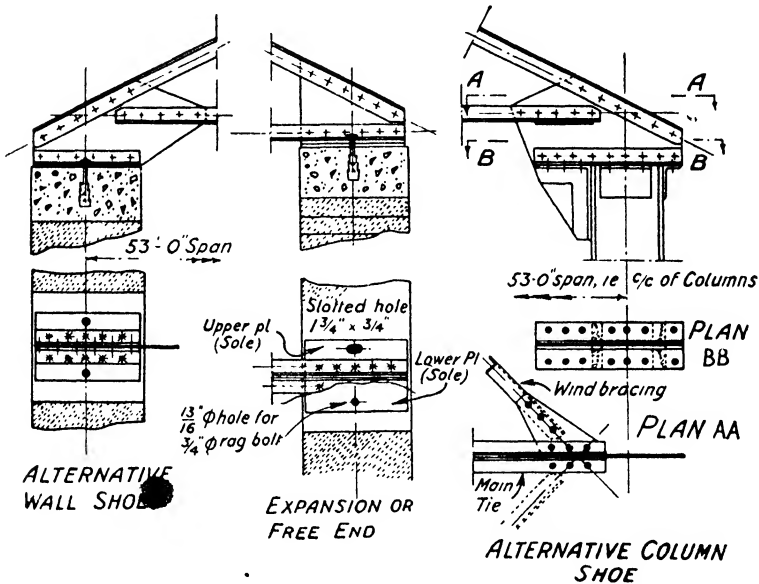

FIG. 148

FIG. 149

FIG. 150

necessarily, close to the ridge, and so the main tie is in compression when the truss is lifted—the two shoes tending to close in. The crumpling of the main tie is averted by temporarily roping a long pole to the main tie until the truss shoes are bolted into position, when the main tie becomes a tension member under its own dead load on removal of the slings.

**Truss Shoes. One End Free.** The assumed temperature range in Britain is from 30° F. to 90° F. Expansion is disregarded for wall-borne trusses under 70-ft. span. Larger trusses have one shoe left free for expansion as in the sliding shoe of Fig. 149. (Rollers are used for spans over 100 ft. : no expansion allowance is made for trusses carried on columns.) The bed or lower plate of Fig. 149 is held fast to the wall, while the shoe plate is assumed perfectly free to slide

outwards or inwards because of the slotted hole. This is an assumption which may be very far wrong, for if the nuts of the rag bolts are firmly tightened, the sole and bed plates become securely attached to each other, and the shoe is really fixed as in the design of the 55-ft. span truss of the previous chapter. Freedom for expansion could be obtained by placing a ferrule round the holding-down bolt in a similar manner to that adopted for the bearings of the railway bridge on Plate VIII.

ROOF TRUSS WITH ONE SHOE FIXED AND THE OTHER SHOE FREE.  
WIND LOAD, OF 15 LB./SQ. FT. OF ROOF SURFACE, ACTING INWARDS.

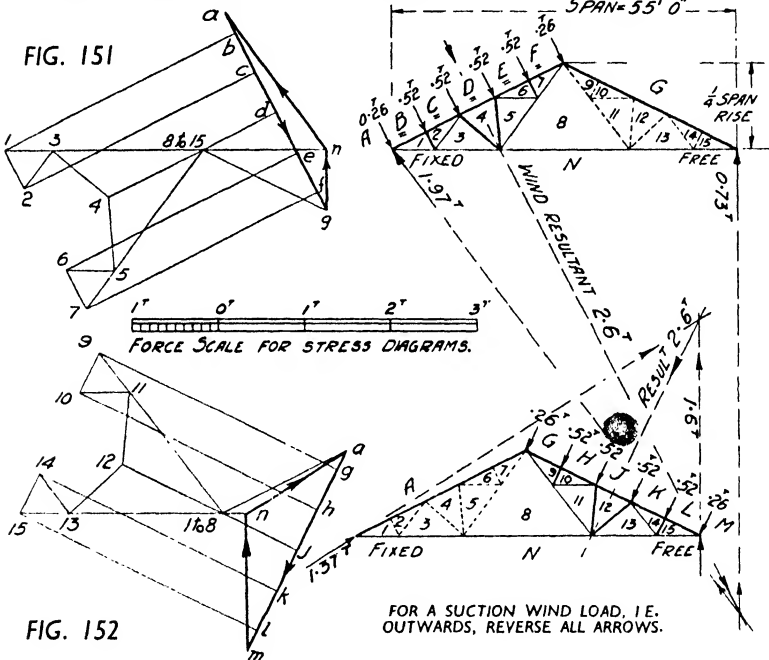

Theoretically, the reaction at the free end is vertical (Figs. 151 and 152). Two diagrams are required for the determination of the wind forces because the magnitude, sense and direction of the reactions depend upon whether the wind blows from the right or left hand. The dead load stress diagram is unaffected by the freeing of one shoe for expansion. The word theoretically was used because friction will occur, and the reaction at the free end will not be vertical, but will be inclined owing to the additional horizontal force of friction opposing motion ; the value of this force is  $\mu$  times the vertical

reaction, where  $\mu$  is the coefficient of friction for steel on steel. This allowance for friction is, however, seldom made.

The inclined reaction must pass through the point of intersection of the vertical reaction and the resultant of the wind loads—triangle of forces—since the forces on the truss have been reduced to three non-parallel forces. The reactions can be found, therefore, either graphically (heavy line triangle of stress diagram) or by moments, etc.

Both ends fixed make the truss statically indeterminate ; in fact, it is then an arch rib. The correct solution, involving the calculation of the elastic deformation of every bar, is rather laborious for simple truss work ; but even then the assumption is made that the

ROOF TRUSS WITH BOTH SHOES FIXED. REACTIONS PARALLEL TO WIND. WIND LOAD, OF  $1510/\phi$ , ACTING INWARDS.

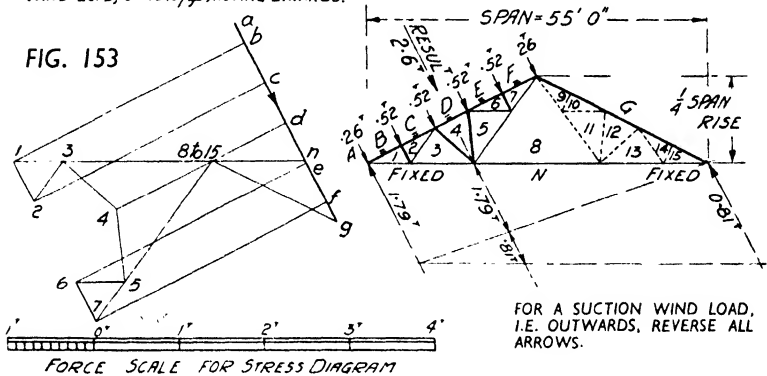

joints are each provided with one pin instead of several rivets. Approximate solutions, close enough for all practical purposes, can be had by making either of two assumptions :—(1) That the horizontal components of the reactions are equal ; this is the method used in Fig. 120 of the previous chapter, and in the following cases of "portal trusses." (2) That the reactions are parallel in direction to that of the resultant wind (Fig. 153). Both assumptions are in common use. Only one diagram is required for the wind forces, because if the wind changes from left to right the new stress diagram is a reflection of the old one.

The simplest way to compare the various stress diagrams is to draw them on tracing paper and superimpose them one upon the other, which will show that any real difference in force exists only in the main tie ; that of Fig. 151 carries the largest force.

**Alternative Shoe Details**, where eccentricity of force is eliminated, are illustrated by Figs. 148 and 150. Although the theoretical span

(i.e., between intersections of rivet lines at shoes) of the trusses in these figures is 53 ft., in contrast to 55 ft. of the truss with the eccentric shoes, there is but little difference in the net width of the shop. However, by employing the eccentric shoe a more rigid roof is obtained in which the wind bracing acts, and is attached, at the level of the column cap. This detail is given in the plate of the preceding chapter. In Fig. 150 the wind bracing has an eccentric lever arm of 6 in. to its reaction at the column cap. Briefly, if the shoes of the trusses are eccentric, the wind bracing lies in the plane of the column cap reaction, and if the truss shoes are of the type where there is no eccentricity then the wind bracing is eccentric; in fact, in the latter case the whole roof is perched 6 in. up on very thin plates which have no rigidity in the direction at right angles to the span.

**Knee Braces** are sometimes used indiscriminately without full appreciation of the huge changes involved in the forces of the roof truss. The wind forces in a knee-braced truss supported on columns with fixed bases are much smaller than those which occur when the columns have hinged bases; and both, in turn, are quite different from the forces occurring in the ordinary trusses previously mentioned. The dead load forces for all these cases are, however, taken to be the same, as it is usually assumed that the knee braces do not act when the truss is subjected to vertical loads.

### “ PORTAL ” TRUSSES

The two standard cases will now be dealt with, *viz.*, a shop with a knee-braced truss carried on columns, which are (1) hinged at the base and at the cap, and (2) fixed at the base and hinged at the cap.

**Dead Load Stress Diagram for Roof Truss.** The truss will be of the same outline and span as that which has been investigated, except for the addition of knee braces to the supporting columns. These knee braces are taken as being non-existent when the dead load (and snow load) forces are being calculated, and so the dead load stress diagram is identical with that in the preceding chapter, see Fig. 119. For this assumption to be correct the knee braces should not be riveted to the columns until all the roof covering is in position and the truss has its maximum deflection due to dead load. This, in turn, means that the marking off of the correct position of the holes on the column faces, and then the drilling and the riveting be done at site. A rather expensive operation to satisfy a theoretical point, which, after all, is of a minor nature when compared to the other assumptions made.

**Wind Load Stress Diagram. Columns Hinged at the Base and the Cap.** The portal frames will be spaced, as were the trusses, at 12 ft. 6 in. centres and the height of the eaves will again be taken as 30 ft. ; so that the wind pressure  $p$  per sq. ft. of vertical surface is 17.9 lb. (item 12, Chapter V).

*B.S. 449—Building*, states that when a wind blows at right angles to a building with an intensity of  $p$  lb. per sq. ft. then  $\frac{1}{2}p$  shall be assumed as a normal pressure on the windward vertical surface and the remaining  $\frac{1}{2}p$  as a normal suction on the leeward vertical surface.

Due to the assumed permeability, there was either an internal pressure of  $0.2p$ , or an internal suction of  $0.2p$ . Hence the wind loads on the roof of the portal frame are as given on Figs. 120 and 121.

Thus there were two cases of loading, viz. :

Case 1, the external wind plus an internal pressure, and

Case 2, the external wind with an internal suction, Fig. 154.

To illustrate the methods of calculation only Case 2 will be examined, but it will be understood that Case 1 must also be examined in a similar manner. Any one member will then be designed to withstand the more adverse condition.

*Case 2. External wind with internal suction.*

Area supported by one column =  $30 \times 12.5$  sq. ft. = 375  
 Pressure  $p$  ((item 12, Chapter V), lb./sq. ft. = 17.9

*Windward Column :—*

External pressure, left to right	=	0.5 $p$
Internal suction, left to right	=	0.2 $p$
Total load, left to right = $0.7p \times 375$		
= $0.7 \times 17.9 \text{ lb.} \times 375 = 4,699 \text{ lb.}$	=	2.1 $\tau$
Load/ft. of height = $2.1\tau \div 30$	=	0.07 $\tau$
Panel load at eaves = $\frac{1}{2}$ of $8' \times 0.07\tau/\text{ft.}$	=	0.28 $\tau$
,, ,, ,, knee brace = $\frac{1}{2}$ ( $8' + 22'$ ) $\times 0.07$	=	1.05 $\tau$
,, ,, ,, col. base = $\frac{1}{2}$ of $22' \times 0.07$	=	0.77 $\tau$

*Leeward Column :—*

External suction, left to right	=	0.5 $p$
Internal suction, right to left	=	0.2 $p$
Total load, left to right = $0.3p \times 375$		
= $0.3 \times 17.9 \text{ lb.} \times 375 = 2,014 \text{ lb.}$	=	0.9 $\tau$
Load/ft. of height = $0.9\tau \div 30$	=	0.03 $\tau$
Panel load at eaves = $\frac{1}{2}$ of $8' \times 0.03\tau$	=	0.12 $\tau$
,, ,, ,, knee brace = $\frac{1}{2}$ ( $8' + 22'$ ) $\times 0.03\tau$	=	0.45 $\tau$
,, ,, ,, col. base = $\frac{1}{2}$ of $22' \times 0.03\tau$	=	0.33 $\tau$

*Horiz. component of wind*, left to right (Fig. 154)

=  $2.1\tau + 0.9\tau + \sin 26^\circ 34' (0.25 + 0.9)\tau = 3.514\tau$



The wind load on each column has been distributed between the side panel points in proportion to the loaded side area supported by each, *viz.*, at the column cap, the foot of the knee brace and the column shoe. In reality these point loads should be applied to the column at the actual points of attachment of the horizontal framing members or "rails" to the column, but this would complicate the solution by introducing a large number of minor forces in place of a

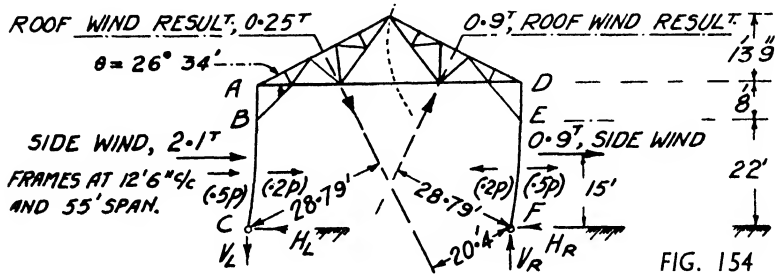

FIG. 154

few large forces. There is but slight difference in the values of the bending moments on the column as obtained by either method.

The vertical reaction at one base can be found by taking the moments of all the external forces about the other base. The remaining vertical reaction and the two horizontal reactions are automatically eliminated from this equation, since these all pass through the moment point and, therefore, have no lever arm or moment about that point. The values of the horizontal reactions cannot be so simply determined, and, for a rapid approximation, recourse is made to another assumption which takes the two horizontal reactions as being equal in value, *i.e.*, each is one half of the sum of all the horizontal components of the external forces acting on the structure, *viz.*,  $\frac{1}{2}$  of  $3.514T = 1.757T$  (see above).

Moments about the right-hand pin of Fig. 154 :—

$$V_L = [(2.1 + 0.9) \times 15' + 0.9 \times 28.79' - 0.25 \times 20.4'] \div 55' = \text{downwards} \quad 1.196T$$

Moments about left-hand pin :—

$$V_R = [(2.1 + 0.9) \times 15' - 0.9 \times 20.4' + 0.25 \times 28.79'] \div 55' = \text{upwards} \quad 0.615T$$

$$\text{Check.} - (0.25T - 0.9T) (\cos 26^\circ 34' = 0.8944) = 0.581T$$

Although the vertical components of the reactions at the basal pins have been found by moments, as above, the values of the horizontal components cannot be so ascertained, *i.e.*, they are statically indeterminate. Recourse has to be made to another method for their solution and this involves finding the deformation of every bar in the frame, due to external loading.

However, when a simple portal frame, with both columns identical, is subjected to a horizontal wind load the horizontal reactions at the basal pins are approximately equal. The assumption that  $H_L$  and  $H_R$  are equal is based upon this fact.

A graphical check may be placed, as in Fig. 155, upon the accuracy of the work (but not upon the assumptions made).

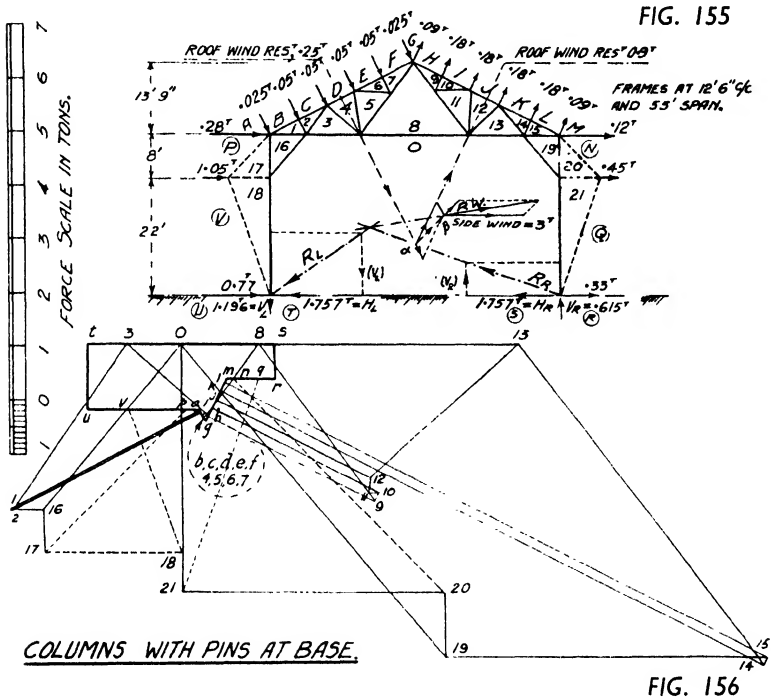

The two roof loads intersect at  $\alpha$ , on the centre line, and their resultant is  $\alpha\beta$ . Combining this with the 3<sup>rd</sup> total horizontal side wind gives  $RW$  as the final resultant wind load on the structure. If the vertical and horizontal reactions at each pin be now combined into single forces  $R_L$  and  $R_R$ , these should meet at a point on  $RW$ , for all the forces in the structure have been reduced to three in number, and, by the triangle of forces, these should pass through one point as the structure is at rest.

All the external forces are now known, at least in accordance with the assumptions made.

All the previous diagrams encountered had the reactions applied at the ends of a braced frame, and not at the ends of single members

as in Fig. 154. Obviously, single members like  $BC$  and  $EF$  must be subjected to bending moments and shear stresses in addition to direct or axial stresses, and for this reason a stress diagram cannot be drawn, as it only considers axial forces. Now, the roof forces remain unaltered no matter whether the reactions at  $C$  and  $F$  ultimately act upon the truss through single members such as  $AC$  or through a braced frame, such as that shown in Fig. 155, so long as they arrive at the truss.

Similarly, in Fig. 157, the force in the heavily lined web diagonal can be found by drawing a complete stress diagram for the girder of  $a$ , or, more expeditiously, by assuming that all the web diagonals between the left reaction and the bar considered are replaced by a single web diagonal shown in broken line in (b). The effect of the left reaction on the heavily lined member is still the same.

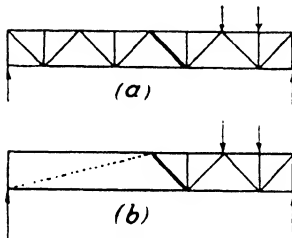

FIG. 157

Therefore, by tacking the wholly imaginary frames  $V, P, 17, 18$  and  $N, 21, 20$  on to the two columns a simple stress diagram can be drawn, starting from the left and finishing at the right-hand pin. The forces obtained for all the roof truss members, including the knee braces,

are correct, but the forces which this diagram gives as being those in the column shafts cannot be correct. From the foregoing reasoning it will be apparent that it is immaterial whether 17, 18 (the dotted horizontal additional member of Fig. 155) is long or short, the forces which act in the roof truss members will remain undisturbed and all that the alteration in length of the auxiliary members 17:18 or  $V:18$ , etc., does is to alter the forces in the imaginary frames below the shoes of the truss.

Starting from the left pin, no progress can be made in the stress diagram beyond joint 3:4:5:8:O, but the unknown main-tie force can be found by a section and moments calculation. A suitable section is that of the wavy broken line in Fig. 154. Consider the equilibrium of the right-hand side, and, taking moments at the apex :—

$$\begin{aligned} \text{Main-tie force} \times 13' 9'' &= -0.9\tau \text{ (roof)} \times \frac{1}{2} \text{ of } 30.75' - 0.9\tau \text{ (side)} \\ &\quad \times (13.75' + 15') - 0.615\tau \times \frac{1}{2} \text{ of } 55' + 1.757\tau \times (13.75' + 30'). \\ &= -56.625 + 76.869 = +20.244. \end{aligned}$$

$\therefore$  Force =  $1.47\tau$ , compression (break in main-tie tends to close).

The immense change in the forces acting in the truss will be apparent on comparing Fig. 156 with Figs. 120 and 121.

**Loads on Windward Column, Fig. 158.**

*Diagram (a).* Although the known external forces acting on the left-hand side of the column sum to  $2.1^T$  the only known counter-acting force is that of  $1.757^T$  at the basal pin. Additional horizontal forces, at present unknown, must therefore act at point *A*, the column cap, and at point *B* at the foot of the knee brace.

*Diagram (b).* Let these unknown forces be termed *x* and *y*, respectively. Taking moments at point *A* :— $.987^T \times 30' = y \times 8'$ , whence the total horizontal force, *y*, is  $3.701^T$ , acting from left to right. Similarly, moments about *B* gives  $.987^T \times 22' = x \times 8'$  or *x* is equal to  $2.714^T$  acting towards the left. Finally, as a check, these resultant forces should sum to zero, viz.,  $2.714^T + .987^T - 3.701^T = 0$ .

*Diagram (c).* Since the total horizontal force at *B* of  $3.701^T$  acts in the same direction as one of its components ( $1.05^T$ ) then the

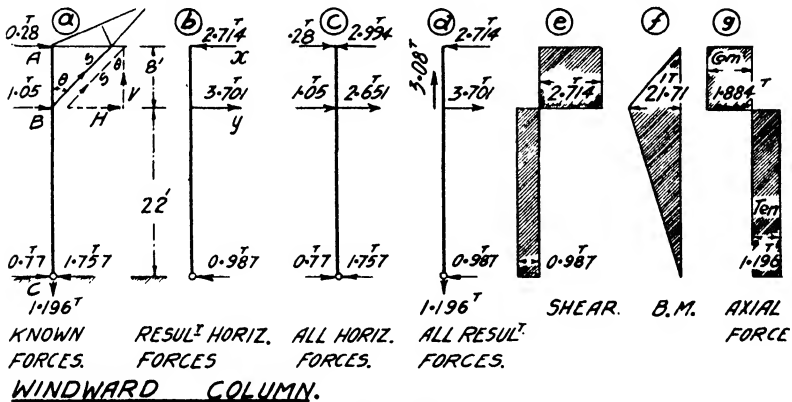

FIG. 158

remaining component, due to the action of the knee brace, must also act in the same direction ; while its numerical value must be the difference between  $3.701^T$  and  $1.05^T$ , i.e.,  $2.651^T$ .

At point *A*, however, the total horizontal force of  $2.714^T$  acts in the opposite direction to that of its known component,  $0.28^T$ , therefore the remaining component must be such that when  $0.28^T$  is subtracted from it the result is  $2.714^T$ . Hence the force brought into play at the inner face of the column by the truss is  $0.28^T + 2.714^T = 2.994^T$ .

*Diagram (d).* Refer for a moment to diagram (a). The force *S* in the knee brace has two components, *V* and *H*. The latter has been found to be the  $2.651^T$  of diagram (c), acting from left to right, which indicates that the load *S* on the knee brace is a pull away

from point *B*. The fact that there is a tensile load on the knee brace is verified by the distorted frame of Fig. 154. From the small force triangle of diagram (a) :— $V \div H = \cot \theta$ , or  $V = H \cot \theta = 2.651^T \times 1.1626 = 3.08^T$ , where  $\theta = 40.7^\circ$  from the geometry of the truss as dimensioned on Fig. 120. The tensile load on the knee brace tends to move *B* towards *A*, so that the compressive force in *AB*, applied at *A* by the knee brace, is  $3.08^T$ . In addition to this force there is a vertical pull downwards at the base of the column of  $1.196^T$  and hence the total axial compressive load on portion *AB* is  $3.08^T - 1.196^T$ , as given by diagram (g).

Diagram (e) is the horizontal shear curve derived from diagram (b).

Diagram (f). No moment can exist at a pin, consequently the bending moment curve rises from zero value at the basal pin to  $.987^T \times 22' = 21.7$  ft. tons at *B*, and then descends again to zero value at the theoretical pin connection at *A*.

Diagram (g) follows from what has been said concerning diagram (d).

**Knee Brace.** The tensile force in the knee brace *S*, diagram (a), is  $H \operatorname{cosec} \theta = 2.651 \operatorname{cosec} 40.7^\circ = 2.651 \times 1.5335 = 4.06^T$  as against  $-4.10^T$  as scaled from the stress diagram of Fig. 156.

**Loads on Leeward Column, Fig. 159.** Similarly the forces acting on the leeward column are found by taking moments about points *D* and *E* of Fig. 159. Thus, moments about *D*,  $y \times 8' = 1.427^T \times 30'$ ,

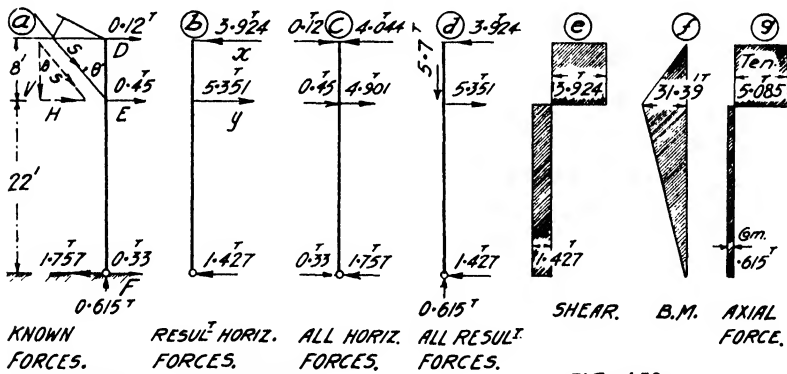

FIG. 159

hence  $y = 5.351^T$  and, by taking moments at *E*,  $x = (1.427^T \times 22') \div 8' = 3.924^T$ .

The leeward knee brace is in compression (Fig. 154 or 156), thus tending to make *DE* elongate. As for the windward column  $V \div H = \cot \theta$ , and therefore  $V = H \cot \theta = 4.901^T \cot 40.7^\circ = 4.901^T \times 1.1626 = 5.70^T$ , acting as shown in diagram (d). The

direct force in  $FE$  is  $\cdot 615\tau$ , compression, and in  $ED$  it is  $+ \cdot 615\tau - 5\cdot 7\tau = 5\cdot 085\tau$ , tension.

The compressive force in the knee brace follows from  $S \div H = \operatorname{cosec} \theta$ , or  $S = H \operatorname{cosec} \theta = 4\cdot 901\tau \times 1\cdot 5335 = + 7\cdot 52\tau$  as against  $+ 7\cdot 60\tau$  as scaled from the stress diagram of Fig. 156.

Comparing the last three diagrams of Figs. 158 and 159, it will be appreciated that the leeward forces are those used when designing the columns.

**Alternative Stress Diagram.** The finding of the forces which act on the columns immediately suggests a solution for the roof truss reactions. Consider the structure made in three portions, the two

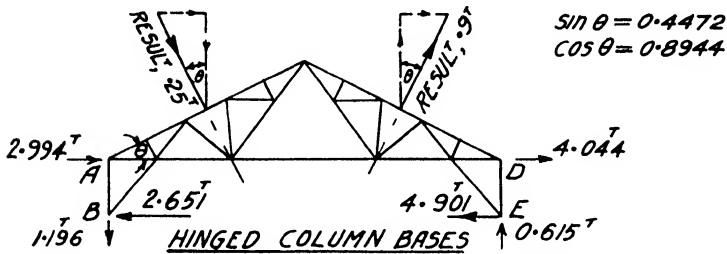

FIG. 160

columns, base to cap,  $CA$  and  $FD$  of the previous figures, and jammed in between them the truss of Fig. 160. The upper portions of the column shafts may, if it helps the conception of the idea, be considered as being thinner than the lower portions, and the truss  $ABDE$  lowered in and attached to the shafts at  $A, B, D$  and  $E$ .

Now it has just been shown that the roof truss acts upon the columns to cause the additional horizontal forces of  $2\cdot 994\tau$  and  $2\cdot 651\tau$  on the windward and  $4\cdot 044\tau$  and  $4\cdot 901\tau$  on the leeward columns (these are the forces shown on the right-hand side of the column in both figures marked (c)), therefore, the columns must act upon the truss with forces of exactly the same magnitude but opposite in direction, since action and reaction are alike in magnitude, but *opposite* in sense. A verification of this may be had by checking the external forces acting upon the amputated structure.

Left to right :	$-2\cdot 994\tau + (\cdot 25 + \cdot 9)\tau \sin \theta + 4\cdot 044\tau$	$= 7\cdot 552\tau$
Right to left :	$-2\cdot 651\tau + 4\cdot 901\tau$	$= 7\cdot 552\tau$
Upwards :	$-\cdot 9\tau \cos \theta + \cdot 615\tau = \cdot 805\tau + \cdot 615\tau$	$= 1\cdot 420\tau$
Downwards :	$-1\cdot 196 + \cdot 25\tau \cos \theta = 1\cdot 196\tau + \cdot 224\tau$	$= 1\cdot 420\tau$

*i.e.*, forces balance. Having checked the system from the point of view of translation, a similar check can be applied for rotation by taking moments about any point.

With the reactions settled the stress diagram for the truss will be found to offer no difficulties, and, moreover, that it gives the correct forces for the knee braces and the portions of the column shafts opposite the braces. Such a diagram has been drawn for the following case of the columns with fixed bases.

**Wind Load Stress Diagram. Columns Fixed at the Base and Hinged at the Cap.** Data as for the columns with hinged bases.

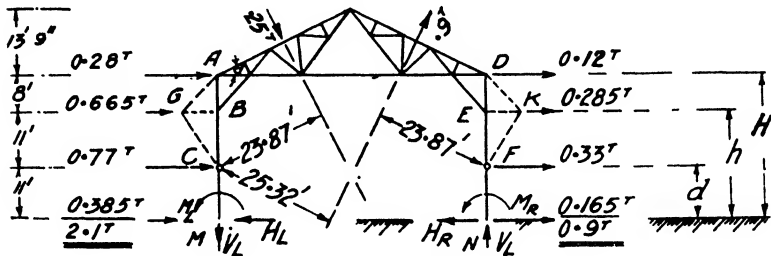

FIG. 161

At each base there occurs a vertical and a horizontal reaction and, in addition, now, an unknown fixing couple.

On the assumption that  $A$  and  $B$  deflect by similar amounts horizontally, when the portal is under load (see Figs. 161 and 162c), *i.e.*, an incompressible truss, the point of contraflexure or zero bending moment is shown in the last article of this chapter to lie at a distance up from the base of

$$d = \frac{h}{2} \left( \frac{2H + h}{H + 2h} \right).$$

It has been emphasized that the ideal condition of a fixed base is seldom realized in practice, and, further, the practical connection of the column cap to the shoe of the truss is by no means the simple pin connection of the hypothesis. For the usual depths  $AB$  of knee braces the theoretical values for  $d$  lie between  $\frac{1}{2}h$  and  $\frac{5}{8}h$ , but owing to the indefiniteness of the whole problem many designers take  $d$  at the constant value of  $\frac{1}{2}h$ , while others take cognizance of the partial fixity of the base by assuming that  $d$  has a constant value of  $\frac{1}{3}h$ , thus approaching nearer to the previous case of hinged bases.

The column as fabricated and erected will have a fixity of base lying, in varying degrees, between the theoretical cases of fixed and hinged. Similarly the cap will, in all probability, be more rigid than the assumed pinned connection. A timid designer will assume the worse case, *viz.*, pins at the top and the bottom of the shaft, and this will result in what experience has definitely proved to be an overstrong structure. With the ordinary types of column bases

used in this country the common assumption is that the point of contraflexure rests either  $\frac{1}{2}$  or  $\frac{1}{3} h$  up from the base, and thereafter the design proceeds without further trouble. In Figs. 163 to 166 the point of contraflexure is taken at  $\frac{1}{2} h$  up from the base.

A great refinement of calculation is hardly warranted for the portal truss, since the accepted solution depends upon so many

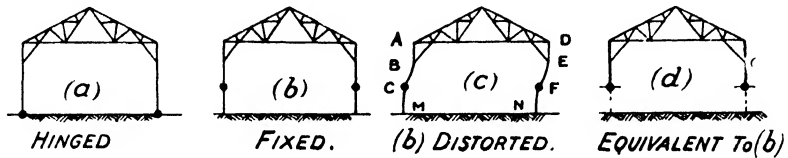

FIG. 162

assumptions, the accuracy of which, in turn, depends upon the designer's details and the erector ; in other words they vary, more or less, with every shop. In addition to the assumptions made, there emerges the fact that, although dead load can be estimated, the actually occurring wind loads cannot be accurately ascertained. Our knowledge of the value of the suction effect on the leeward side is still indefinite, and therefore the actually occurring forces may differ somewhat widely from those given by calculation. An investigation into the supposed stresses in some existing shops would apparently prove that these shops should have been blown down immediately after their erection.

It is by no means advocated that theoretical investigations and accuracy are discredited—very far from it—but the point is that the embryo designer should recall that the primary object of his calculations is the building of a structure which will safely carry the loads to which it will be subjected, and therefore the number of decimal places in his arithmetical working, together with his choice of scantlings, should be in keeping with the thought and care he expended on his original assumptions.

*Fig. 162.* To return from the digression to the problem on hand. There can be no bending moment at a hinge because the hinge adjusts itself to the force, and thus the points of contraflexure can be regarded as theoretical hinges. The solution can now be obtained by considering the structure above the points *C* and *F*—the points of no bending moment—as a hinged portal truss with hinges at *C* and *F* ; *i.e.*, the structure has been amputated and set on hinges, which, in turn, are carried at the top of short stilts or cantilevers from the ground.

*Case 2. External Wind with Internal Suction.* The roof loads



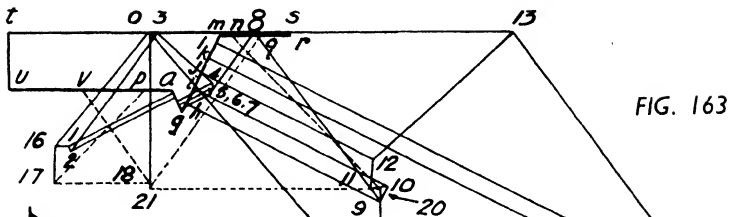

FIG. 163

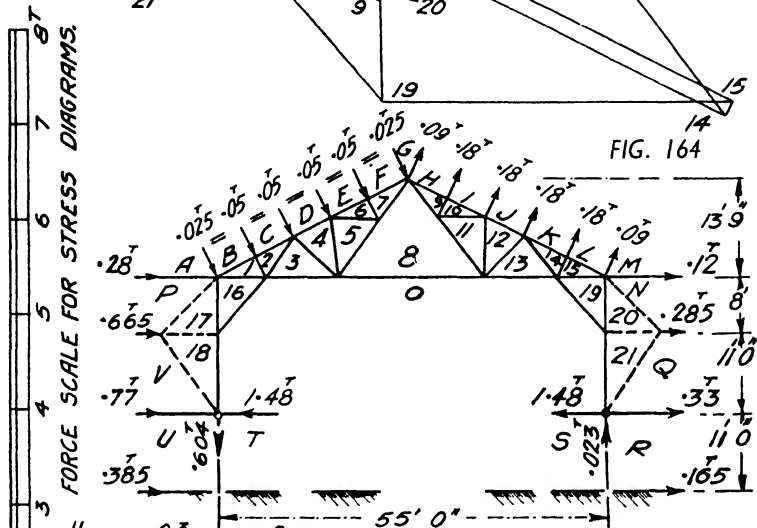

FIG. 164

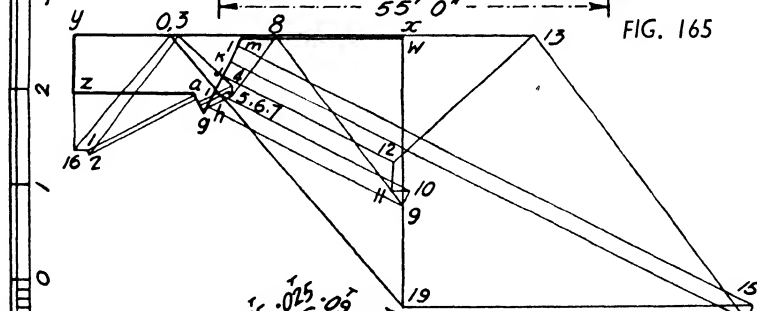
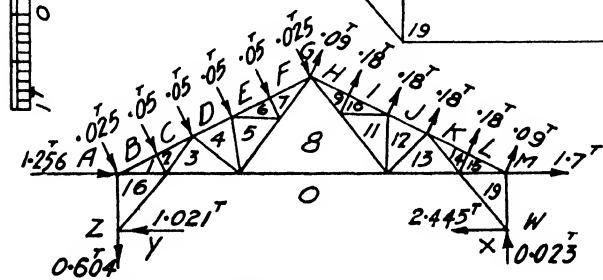

FIG. 165



COLUMN BASES FIXED.

FIG. 166

remain unaltered. So also do the respective loads acting on each vertical foot of both columns. This load, as with the pin-ended columns, is then distributed between the panel points *A, B, C, M* and *D, E, F, N*, Fig. 161, in proportion to the side area supported by each.

The horizontal reactions at the points of contra-flexure, *C* and *F* (which are now equivalent to pins), are equal to each other and to half the sum of the horizontal components of the roof and side wind, as explained for the previous case ; in fact, the lettering has been purposely kept the same so that the text for the hinged portal truss should apply to the fixed base portal truss also. On Fig. 161,

$$\begin{aligned}
 V_L &= [(0.665 + 0.285)\tau \times 11' + (0.28 + 0.12)\tau \times 19' + \\
 &\quad 0.9\tau \times 23.87' - 0.25\tau \times 25.32'] \div 55', \quad \text{down} = 0.604\tau \\
 V_R &= [(0.665 + 0.285)\tau \times 11' + (0.28 + 0.12)\tau \times 19' - \\
 &\quad 0.9\tau \times 25.32' + 0.25\tau \times 23.87'] \div 55', \quad \text{up} = 0.023\tau \\
 \text{(Check :--}(0.9 - 0.25)\tau (\cos \theta = 0.8944), &\quad \text{up} = 0.581\tau \\
 H_L = H_R = \frac{1}{2} [0.77 + 0.665 + 0.28 + 0.12 + 0.285 + \\
 &\quad 0.33 + (0.25 + 0.9) (\sin \theta = 0.4472)] = 1.48\tau
 \end{aligned}$$

The remarks relative to the imaginary frames *V, P, 17, 18* and *N, 21, 20* and the resulting stress diagram of Fig. 163 are similar to those given in the discussion of the two previous Figs. 155 and 156. Main-tie force =  $[(1.48 - 0.33)\tau \times 32.75' - 0.023\tau \times \frac{1}{2}(55') - 0.285\tau \times 21.75' - 0.12\tau \times 13.75' - 0.9\tau \times \frac{1}{2}(30.75')] \div 13.75' = 1.116\tau$  compression.

**Loads on the Columns, Figs. 167 and 168.** The 11 ft. portions of the columns below the pins can be regarded as being separate structures, and the unknown forces *x* and *y* found as in the case of the hinged bases ; see text relative to Figs. 158 and 159.

The .385 $\tau$  panel load at the base of the windward column comes from the wind acting only on the windward stilt, which, by our supposition, is a self-contained unit. This force is immediately counteracted by a local reaction of .385 $\tau$  from the foundation, and so does not affect the other base. With the hinged bases the similar panel load came from wind forces on the structure above the pin, and therefore affected the right-hand reaction ; similarly, in the present instance, the panel load of 0.77 $\tau$  at the theoretical pin *C* affects the horizontal reactions of both pins.

The reactions of 1.48 $\tau$  at these pins, both diagrams marked (c), are given by the base cantilevers and are the unbalanced shears from the base. Regarding *AC* and *DF* as individual units, the forces of 1.48 $\tau$  are external forces ; but looking upon the columns as being *AM* and *DN* (Figs. (d) ), these forces are the base horizontal reactions. Probably the easiest way to obtain the diagrams is to find

the values of the bending moment and shear, etc., for the separate portions of the columns above and below the contraflexure points and afterwards to sum them together so as to present continuous diagrams for each column as a whole. The bending moment at  $M$ , Fig. 167, is  $1.48^T \times 11'$  and not  $(1.48^T - 0.77^T) \times 11'$ , because  $0.77^T$  belongs to the superstructure while  $1.48^T$  belongs to the lower

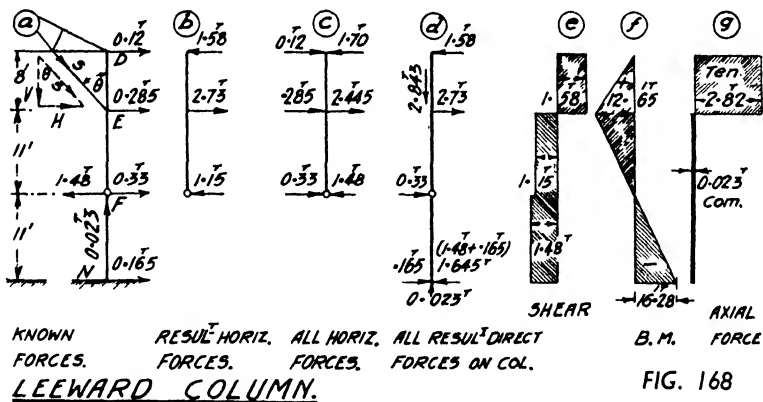
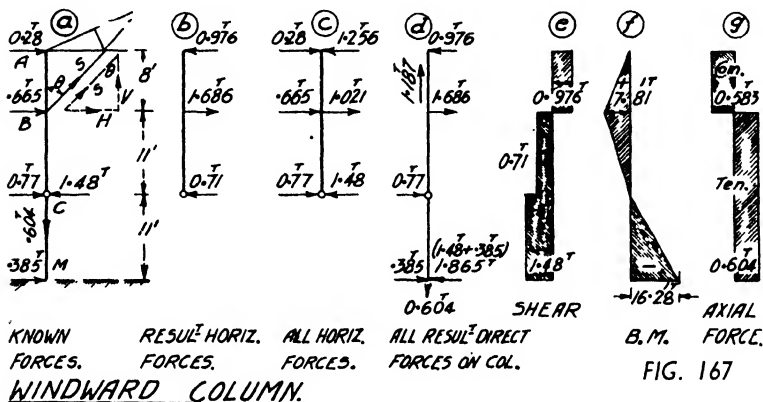

structure and is the only load at the nose of the cantilever  $MC$ . This may be verified from the fact that the area of the shear curve gives the bending moment value, or, arithmetically from diagrams  $e$  and  $f$ , shear of  $1.48^T \times 11' = 16.28$  ft. tons.

**Alternative Stress Diagrams, Figs. 165 and 166.** See remarks about the corresponding frame of the hinged column (Fig. 160).

Diagrams 163 and 165 are similar except for the load line and the auxiliary framework, and both register the same force for any

member of the truss ; the latter stress diagram, however, gives the correct forces in the portions of the columns above the junctions of the knee braces.

The load in the knee braces is again  $S = \operatorname{cosec} \theta \times H = 1.5335H$ . For the windward brace, Fig. 167, the load is tensile  $= 1.5335 \times 1.021\tau = -1.57\tau$  and for the leeward brace, Fig. 168, the load is compressive  $= 1.5335 \times 2.445\tau = +3.75\tau$ . These are also the values obtained by scaling either of the stress diagrams of Figs. 163 and 165.

**Sections.** The sections for the various members of the roof truss will, for the majority of the members, be the same as those used for the wall-supported truss, but those adjacent to the knee braces will require to be thickened up. The calculations for the roof truss members will not be repeated.

**Knee Brace.** If composed of a single angle the permissible strut value will be given on B.S. Table 8, and if of two angles by B.S. Table 7.

Wind load	$= +3.75\tau$ & $-1.57\tau$
Adopt 2 $\left[ \begin{smallmatrix} s \\ \text{---} \end{smallmatrix} 3'' \times 2\frac{1}{2}'' \times \frac{1}{4}'' \right]$ , gross area	$=$ sq. in. 2.63
$l/k_x = 11' \times 12 \div 0.93''$	$=$ 139
$l/k_y = 11' \times 12 \div 1.1''$	$=$ 120
Working stress, B.S. Table 7 (139)	$=$ $\tau$ /sq. in. 2.6
Area reqd. for compression $= 3.75 \div 2.6$	$=$ sq. in. 1.44

The brace is also obviously safe in tension.

Possibly 2  $\left[ \begin{smallmatrix} s \\ \text{---} \end{smallmatrix} 2\frac{1}{2}'' \times 2\frac{1}{2}'' \times \frac{1}{4}'' \right]$  would be ample, but the final decision depends upon the forces in the brace caused by the loading of Case I, viz. external wind plus internal pressure, which has not been investigated.

<b>Columns.</b> Maximum <i>B.M.</i> (Figs. 167 and 168)	$=$ ft. tons 16.28
<i>Axial Loads</i> :—Wind, Fig. 168 ( <i>g</i> )	$=$ tons $+0.02$
Roof, dead and snow (Fig. 120 and item 11, Chapter V)	$=$ „ $+2.68$
Column dead load, say	$=$ „ $+0.5$
· Total axial load, compression	$=$ „ $+3.2$
Try one R.S.J. $12'' \times 5'' \times 32$ lb. Figs. 170 and 171. Gross area	$=$ sq. in. 9.45
$k_x = 4.84$ ; $k_y = 1.01$ and <i>Z</i>	$=$ in. <sup>3</sup> 36.84
<i>Axis yy</i> :—Effective length, Fig. 177, is $.75 \times 10'$ (B.S.449—Building).	$=$ in. 90
$l/k_y = 90'' \div 1.01''$	$=$ 90
Working stress, B.S. Table 7	$=$ $\tau$ /sq. in. 4.62

*Axis xx*:—Column is fixed at base but is “only partially restrained in direction and is not held in position” at knee brace (B.S. 449—Building).

Effective length = $1.5 \times 22'$	= in.	396
$l/k_x = 396'' \div 4.84''$	=	82
Working stress, B.S. Table 7	= $\tau$ /sq. in.	5.02
Lesser working stress is the previous one	= „	4.62

For the loading of Case II, the extreme fibre stresses are:—

Due to $B.M = M/Z = 16.28 \times 12 \div 36.84$	= „	$\pm 5.30$
Due to direct force = $3.2 \div 9.45$	= „	$+ 0.33$
Maximum fibre stress	= „	$+ 5.63$

The column is subjected to combined stress due to bending and axial compression.

Bending, the fraction, $f_{bc}/F_{bc} = 5.3/10$	=	0.53
(where permissible $F_{bc} = 10\tau$ /sq. in.)		
Compression, the fraction, $f_a/F_a = 0.33/4.62$	=	0.07
These stresses are satisfactory since the sum does not exceed unity.		$\frac{0.6}{}$

**Alternative Section, Fig. 173.** One R.S.J.

$15'' \times 5'' \times 42$ lb.	Gross area = sq. in.	12.36
$k_x = 5.89''$ ; $k_y = 0.98''$ and $Z$	= in. <sup>3</sup>	57.13
$l/k_x = 396'' \div 5.89''$	=	67
Working stress, B.S. Table 7,	= $\tau$ /sq. in.	5.75

The extreme fibre stresses are:—

Due to $B.M = M/Z = 16.28 \times 12 \div 57.13$	= „	$\pm 3.42$
Due to direct force = $3.2 \div 12.36$	= „	$+ 0.26$
Maximum fibre stress	= „	$+ 3.68$

**Hinged Base.** The stresses for this case are derived in a similar manner by using the appropriate values for the bending moment and thrust, *i.e.*, 31.39 ft. tons in place of 16.28 ft. tons, etc.

**Partially Fixed Base.** An allowance for the partial nature of the base fixity may also be made by taking some intermediate value for the bending moment between the fixed base and hinged base values; it is true that this allowance can only be very rough, but then after all so are the assumptions as to the exact value of the end fixing moment.

**Horizontal Framing Joists** of Fig. 177 support a vertical area of  $10' \times 12.5' = 125$  sq. ft. The load per sq. ft. of windward wall was 17.9 lb. (p. 141), but because there is a possibility of a small localized area of high pressure within the larger area an individual

wall panel should be capable of resisting a 10 per cent. increase of pressure (+ or -), B.S. 449.—Building.

The load on one joist =  $125 (17.9 \times 11/10) \div 2,240 =$  tons 1.1  
 Max. *B.M.* =  $Wl \div 8 = 1.10 (12.5 \times 12) \div 8 =$  in. tons 20.63  
 Adopt a 10"  $\times$  4½"  $\times$  25 lb. R.S.J. to suit the  
 brickwork. *Z* given = in.<sup>3</sup> 24.47  
 Extreme fibre stress =  $M/Z = 20.63 \div 24.47 =$   $\tau$ /sq. in.  $\pm$  0.84

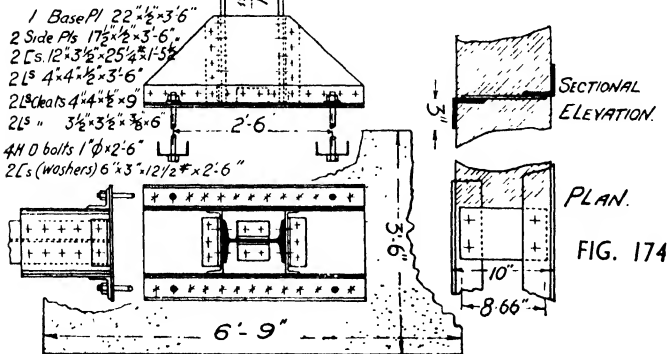
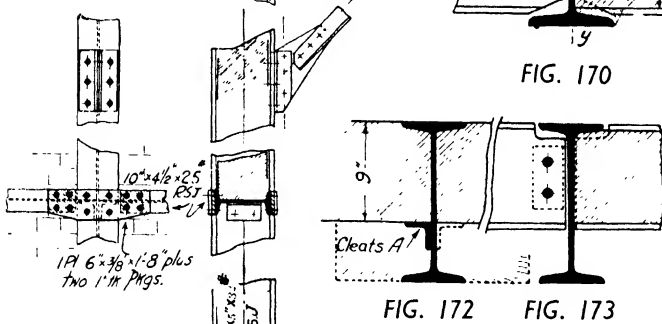
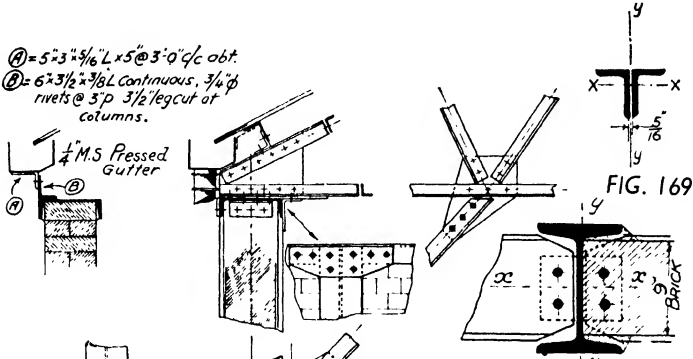

FIG. 171

This section is also safe in shear. In a vertical plane the steel does not require to act as a beam because the brickwork carries its own weight down into the foundations. Also see Figs. 170, 171 and 173.

*Alternative Section of Fig. 174.* Two angles with batten plates.

$$1 \left| \begin{array}{l} \text{— } 3'' \times 2\frac{1}{2}'' \times \frac{5}{16}'' - \text{one } \frac{3}{4}'' \text{ in. diameter hole} \\ M = f \cdot A \cdot d \end{array} \right. = \text{net sq. in. } 1.39$$

$$\therefore f = M \div (Ad) = 20.63 \div (1.39 \times 8.66) = \tau/\text{sq. in. } \pm 1.71$$

Where  $d = 8.66$  in. = 10 in. (over heels of angles) minus 2 @ 0.67 in. to the C.G. of angles. The thickness of  $\frac{5}{16}$  in. is used in view of corrosion.

**Brickwork.** To permit of grouting the brickwork to the steel 1 in. diameter holes are spaced about 2 ft. apart in the web of the horizontal joists. Any space between the brickwork and the steel is carefully filled in with mortar, which is generally a 3 (sand) to 1 (Portland cement) mix; see Fig. 170.

With the double angle and batten plated horizontal the shear may be assumed to be carried by the brickwork, while the steel reinforcement obtains its increment of flange stress by the adhesion of the mortar, in exactly the same manner as a concrete beam with compressive and tensile reinforcement. The batten plates, 5 in. wide  $\times \frac{1}{4}$  in. thick, are used to give rigidity and alignment when the work is green. A suitable spacing for these plates would be one batten plate at each end to catch the column cleat and two intermediate plates. Needless to say, this section is the one preferred by the bricklayer.

It is advisable that the vertical spacing between the framing horizontals should not exceed sixteen times the wall thickness. For 9 in. work this represents a height of 12 ft., a figure which appears to be considered the maximum with even thicker walls. The horizontal distance between the verticals is similarly kept at this figure, but if the vertical spacing is decreased the horizontal dimension may be increased proportionately; the enclosed area between the reinforcement remaining constant.

The bottom 8 ft. or so of the side wall is frequently increased in thickness by half a brick (into the shop) to give a  $13\frac{1}{2}$  in. wall, as material is often piled against the wall's inner face; the increase of thickness adds substantially to the strength of this miniature retaining wall.

*Fig. 170* shows the brickwork central with the steel reinforcement and practically no cutting of brick is necessary. Alternatively, the

brickwork can be brought forward to the line of the external face of the steel as in the following figure.

*Figs. 172 and 173* show the brickwork flush with the steel framing, but this has only been obtained at the sacrifice of the brickwork, which has to be cut to suit. Not only has the wall been weakened, but the extra handling of the bricks means a more expensive wall.

The cleats marked *A* are of  $2\frac{1}{2}''$  or  $3'' \times 2\frac{1}{2}'' \times \frac{1}{4}''$  angles riveted to the column before dispatch, and are in 12 in. lengths at 4 ft. reeled pitch. These cleats support the wall against the external wind pressure. Alternatively, these cleats could be eliminated, more expensively, by building an 18 in. brick butt up to the inner flange of the column as indicated by the dotted lines. Finally, the external face of the column can be wholly enclosed within a brick butt or pillar should the locality of the building demand such architectural embellishment.

**The Base of the Fixed Column, Fig. 171.**

The design calculations for the column gave the total axial load on the shaft from wind and dead load of roof and shaft as

	$=$	3.2 $\tau$
Bending moment, Figs. 167 and 168	$=$ ft. tons	16.28

This bending moment has to be transferred into the side plates of the base through the rivets connecting the joist flanges to the webs of the channels. These rivets are in single shear and bearing on the channel webs ; the two groups being separated by a lever arm of 1 ft. One set will be pulled up while the other set will be pushed down, as will be seen from the distorted outline of the shop of Fig. 162.  
 $\therefore 16.28$  ft. tons  $= 10$  rivets per side  $\times 1$  ft. arm  $\times$  load per rivet.

Hence the load per rivet due to <i>B.M.</i> $= 16.28$		
$\div 10$	$= \pm$	1.63 $\tau$
Add the direct load on each rivet $= 3.2\tau \div$	$= +$	<u>0.16<math>\tau</math></u>
20 rivets	$=$	1.79 $\tau$
The rivet load on the thrust side is the greater	$=$	1.79 $\tau$
$= 1.63\tau + 0.16\tau$	$=$	1.79 $\tau$

The rivets connecting the channels to the side plate, reeling with the web rivets, are the same in number and therefore are not over-loaded.



*Pressure of Base Plate on the Concrete.*

Direct load = $3 \cdot 2^{\tau}$ (just derived) and the <i>B.M.</i>	= ft. tons	16.28
Area of base plate given $1 \cdot 83' \times 3 \cdot 5'$	= sq. ft.	6.41
<i>Z</i> of this area = $\frac{1}{8} \times 1 \cdot 83 \times 3 \cdot 5^2$	= ft. <sup>3</sup>	<u>3.74</u>

Pressure due to overturning moment		
= $M/Z = 16 \cdot 28 \div 3 \cdot 74$	= $\tau$ /sq. ft.	$\pm 4 \cdot 35$
Pressure due to axial thrust = $3 \cdot 2^{\tau} \div 6 \cdot 41$	= „	<u>+ 0.50</u>
Resulting maximum pressure	= „	<u>+ 4.85</u>
The uplift is taken by the holding-down bolts		

*Foundation Bolts* In keeping with the above assume that the two pairs of bolts give a couple resisting the overturning or *B.M.* (Fig. 171). However, the axial thrust gives a stabilizing moment in the leeward column (the windward column is slightly less) of  $3 \cdot 2^{\tau} \times \frac{1}{2}$  of 2.5'

Unbalanced moment = $16 \cdot 28 - 4 \cdot 00$	= ft. tons	4.00
Load per pair of bolts = $12 \cdot 28 \div 2 \cdot 5$ , or per bolt = $\frac{1}{2} \times 12 \cdot 28 \div 2 \cdot 5$	= „	12.28
The shear per bolt = $1 \cdot 48^{\tau}$ horizontal reaction $\div 4$ bolts	=	2.45 $\tau$
		<u>0.37<math>\tau</math></u>

*Pressure on the Soil.*

Concrete found 6' 9" long $\times$ 3' 6" $\times$ 4' deep	=	5.90 $\tau$
Weight of brickwork on this found = 30' high $\times$ 3.5' $\times$ $\frac{3}{4}$ ' @ 112 lb.	=	3.94 $\tau$
Axial load, see base plate pressure,	=	3.2 $\tau$
Total direct load on soil	=	<u>13.04<math>\tau</math></u>

The *B.M.* at the bottom of the shaft was 16.28 ft. tons or the reaction of 1.48 $\tau$  at the point of contraflexure  $\times$  the lever arm of 11 ft. Similarly the *B.M.* at the underside of the concrete found is 1.48 $\tau$   $\times$  (11' + 4' additional depth)

Area of concrete in contact with the soil = $6 \cdot 75' \times 3 \cdot 5'$	= sq. ft.	23.63
<i>Z</i> of this area = $\frac{1}{8} \times 3 \cdot 5 \times 6 \cdot 75^2$	= ft. <sup>3</sup>	<u>26.58</u>
Pressure due to overturning = $22 \cdot 2 \div 26 \cdot 58$	= $\tau$ /sq. ft.	$\pm 0 \cdot 83$
Pressure due to direct load = $13 \cdot 04 \div 23 \cdot 63$	= „	+ 0.56
Resulting pressure on the soil = - 0.27 $\tau$ /sq. ft. and	= „	+ 1.39

As there cannot be "tension" on the soil (Fig. 175) this method of estimating the pressure fails whenever the base pressure becomes negative.

Now, acting on the soil is a direct axial thrust of  $13.04^T$  plus a bending or overturning moment of 22.2 ft. tons, which is equivalent to placing the  $13.04^T$  load eccentrically with the foundation by an amount  $= 22.2 \div 13.04 = 1.70'$  (Fig. 176). This in nowise alters

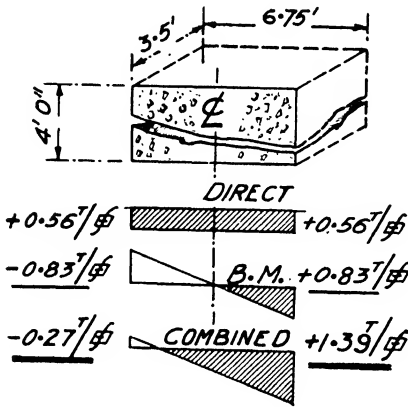

FIG. 175

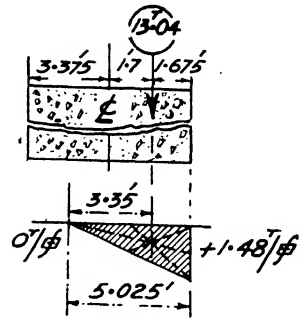

FIG. 176

the forces acting on the base, because the direct (not axial) load is still  $13.04^T$ , while the bending moment remains unchanged at  $1.70' \times 13.04^T$  or 22.2 ft. tons.

The intensity of the pressure will be a maximum at the outer edge of  $p^T/\text{sq. ft.}$ , and will be zero somewhere within the base. The resulting positive pressure triangle will be as shown in the figure. Now the total upthrust acting through the centre of pressure of this triangle must coincide with the line of action of the  $13.04^T$  load, and, at the same time, must be equal in magnitude to it but opposite in sense. From the geometry of the figure it then follows that the length of the base of the triangle must be three times the distance between the edge of the base and the point of application of the downward load. The active area of the base is thus

$$5.025' \times 3.5' \text{ wide} = 17.59 \text{ sq. ft.}$$

The average pressure on the soil is  $(p + 0) \div 2 = \frac{1}{2}p$ .

$$\therefore \text{The total upthrust} = \frac{1}{2}p \times 17.59 = 13.04^T;$$

$$\text{whence } p = 1.48^T/\text{sq. ft.}$$

i.e., within the permissible pressure of  $2^T/\text{sq. ft.}$  usually allowed on good soil.

Knowing the distribution of the upthrust, the stresses in the concrete are then determined as already explained in Chapter III.

**Side Covering of Corrugated Sheeting.** Cleats are bolted to the columns and the verticals, on to which are laid and bolted the longitudinal framing angles, in a manner identical with the purlins and their cleats. Usually the horizontal framing bars are of unequal angles, with the longer leg horizontal to withstand the wind pressure.  $Wl \div 10$  is frequently used for the maximum bending moment instead of  $Wl \div 8$ , because of the slight continuity of the rails and the distributing effect of the sheeting. The vertical load is more often than not entirely neglected. This may be explained if

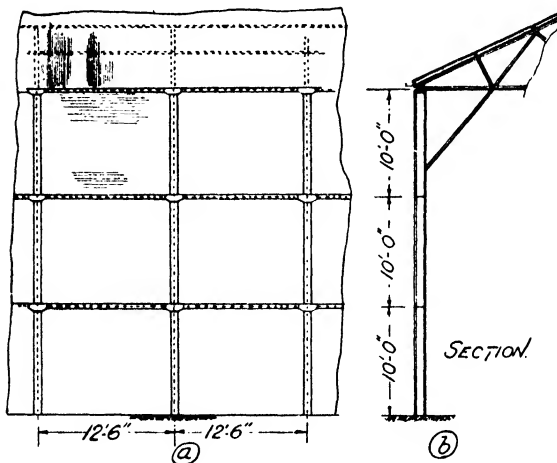

FIG. 177

the topmost, or eaves rail, and the bottom rail nearest the ground are assumed to form the flanges of a very deep vertical plate girder—30 ft. in this case—the web of which is formed by the sheeting. The resulting flange stresses must be very small, for in  $M = f \cdot A \cdot d$ , the dead load bending moment  $M$  is small, while  $d$  is very large at 360 in. Alternatively, the sheeting can be considered to carry its own weight. Experience shows this assumption to be justifiable.

Side framing horizontals formed the subject of special mention in Chapter X (Vol. I), and a series of design curves were given which incorporated the above data.

Usually a dado or dwarf brick wall is built to a height of 6 ft. or 8 ft. above ground level. The sheeting, stopping 6 in. below the top of this wall, is protected against corrosion and rough treatment to which it would be subjected if it were in closer proximity to the ground.

**The Columns of a Sheeted Building** and the amount of support received from the framing rails was discussed in Chapter V.

A joist is sometimes used at the top of the columns (Fig. 178 and Plate II) to stiffen the shop in a longitudinal direction. The deeper this joist, or girder, the more rigid will be the shop, and, hence, the use of the N girder of Fig. 178b. There now exist a continuous series of portals, formed by the columns and the eaves girders, giving the shop rigidity against end wind.

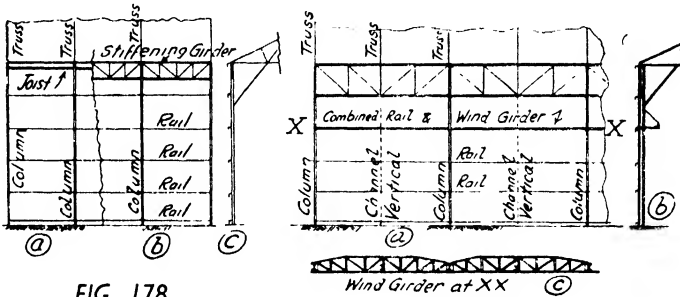

FIG. 178

FIG. 179

The type of construction illustrated by Fig. 179 is naturally evolved from the previous figure. The eaves girder, which previously was used wholly for stiffening the shop, is now made to bear an intermediate truss. When this girder has its maximum vertical load it will carry practically no end wind, and *vice versa*. This last type of eaves girder having double the span will also have double the depth, and so will still further stiffen the column about the *yy* axis.

Still referring to the same figure, the intermediate vertical is of a light joist or channel section, and it acts as a beam simply supported at the ground and cantilevered past the horizontal wind girder *XX*. The horizontal rails give up a portion of their load to this vertical, which transfers part of its load to the ground and the remainder back on to the main column through the wind girder. The upper end of the vertical is attached to the lower flange of the eaves girder, but to prevent any vertical load coming on to the former, which is not a column, but a beam, slotted holes are used ; the longer axis of the holes lying with the length of the channel.

When the wind loads are not too large each flange of the wind girder may be composed of a single angle. The external and compressive flange is the heavier because it acts in a dual capacity, being also the local horizontal rail for the sheeting. On designing this angle allow for the cross bending in addition to the direct compressive wind force ; by a suitable choice of web system

frequent points of support can be given to the front flange with a consequent reduction in the cross bending stresses. Half the dead weight of the girder *XX* is carried by the inclined tie of Fig. 179*b*, so that from the point of view of dead load the span is only 12 ft. 6 in. The final stresses in the flange angles will be the sum of the wind direct stress, dead load, and cross bending in the case of the outer flange angle.

The column is now much stiffer about the *yy* axis because of the support given by the girders at *XX* and the eaves.

**Crane Shaft.** The knee brace should be raised, or replaced by a bracket, to give the crane sufficient headroom. However, as it is the method of designing the extra shaft which is desired the assumption will be made that the crane column is 20 ft. long, base to cap. The shaft will be designed to carry the crane girder track of Chapter II. The maximum load on the shaft occurs when the crane is over the column shaft and is lifting its full load from a position on the floor close against the column.

As is usual with rolled steel joists, the *yy* axis is that along and parallel to the web of the joist, and the *xx* axis that at right angles to the web and marked *BB* on the cross section of Fig. 79. With regard to the *xx* axis the shaft is effectively held in position at both ends and is restrained in direction at the base; hence the effective strut length  $l_x = 0.85L$ . Considering axis *yy*, the effective strut length  $l_y$  is the greatest distance between the bottom rivet of one diaphragm to the topmost rivet of the lower adjoining diaphragm or batten plate. This agrees with the type drawing given in the B.S. 449—Building. (The moment of resistance method may be used as a check. The end fixing moment, axis *xx*, is that given by two pairs of 1 in. dia. bolts,  $16\frac{1}{8}$  in. apart, attaching the column cap plate to the underside of the crane girders, see Plate I. The value of this moment is more than the requisite  $\frac{1}{4} M$  of *R* of the crane shaft considered as a beam.)

Max. live load from crane (item 2, Chapter II)	=	53.5 $\tau$
Impact add 25 per cent.	--	13.4 $\tau$
Dead load from two adjacent crane girders	=	4.8 $\tau$
Weight of crane shaft, say,	--	0.4 $\tau$
Equivalent axial load	=	$\frac{72.1\tau}{4.17''}$
Try a 10" $\times$ 6" $\times$ 40 lb. R.S.J. ; $k_y$	=	$\frac{4.17''}{4.17''}$
$k_y = 1.36''$ ; $Z_x = 41 \text{ in.}^3$ ; gross area	= sq. ins.	11.77
Effective length (axis <i>xx</i> ) = $0.85 \times 20' \times 12$	=	204"
$l/k_x = 204'' \div 4.17''$	=	49
Working stress, B.S. Table 7	$\tau/\text{sq. in.}$	6.62
Actual stress = $72.1\tau \div 11.77 \text{ sq. in.}$	= ,,	6.13

Let the spacing of the diaphragms	=	$l''$
From p. 104, $l/k_y = 50$ or $0.7 \times 49$	=	34
$\therefore l = 34k_y = 34 \times 1.36$	=	46

A suitable spacing for the diaphragms would be from 4' 0" to 4' 6". Allowing for the length occupied by the side plates at the base and cap this spacing gives the three diaphragms shown by Fig. 79.

The lower roof shaft and crane shaft can be arranged as in Fig. 80. The roof shaft above crane cap level may be either the compound section of Plan *AA*, or the single joist section, such as a 12"  $\times$  8"  $\times$  65 lb. or 15"  $\times$  6"  $\times$  45 lb. with the web projecting into the shop, illustrated by Plan *AA* of Fig. 81. The upper roof shaft runs into and is riveted to the lower shaft, which may be of a lighter section. The connecting rivets at the joint should develop the bending moment thereat, in addition to transferring the direct load; the calculations for this follow the method given in the text concerning the column base of Fig. 171. The spacing of the horizontal angles of the bracing is found as for the diaphragms mentioned above.

The bending moment on the lower part of the column is now resisted by the compound column, and the stresses acting in the two elements can be found by dividing the bending moment by the section modulus of the vertical cantilever formed by the roof and crane shafts.

*Foundations.* Find the centre of gravity of all the loads acting :—

(a) On the *windward* column base for  
dead load plus full wind. (Chance of uplift.)

(b) On the *leeward* column base for  
dead plus snow plus full wind plus crane carrying maximum load and resting over the crane shaft. (Maximum down thrust.) This should be done for both Case I and Case II, *i.e.*, with internal pressure and internal suction, respectively.

Now arrange the concrete foundation so that its centre of gravity coincides with the centre of gravity of the loads causing the worst case, or, as a compromise, in an intermediate position between two extreme cases.

If there is a possibility of uplift or overturning then the fastenings and dead weight of anchorages should exceed the uplift or moment by at least 50 per cent.

**Position of Point of Contraflexure.** The column considered is one with a variable cross section as illustrated by Figs. 180 and 181. In this column the larger moment of inertia  $I_1$  is expressed as being  $\alpha$  times the smaller inertia  $I_2$ , and the heights from the base to the various levels as fractions of the total column length. Thus

$AB/AE = a$ , whence  $AB = a \cdot AE = aH$  ; similarly  $AD/AE = b$  and  $AD = b \cdot AE = bH$ .

It is desired to find the distance  $d$  to the point of contraflexure, or inflection, on the column shaft, on the assumption that the lateral distortions in the cross frame  $DEFG$  are negligible compared to the deflections of the columns. Because of this assumption the solution is approximate, but one whose use is justified by the fact that the actual degree of end fixity provided at the base is always somewhat indefinite in the case of ordinary shop columns.

The equation of the elastic line  $DE$  will now be derived. In order to find the constants of integration it is necessary to trace the slope equations from  $A$  outwards, making use of the fact that the slope at any point is the same whether it be obtained from one slope equation or another.

*Length AB.*  $x$  varies in value from nothing to  $aH$ .

The bending moment anywhere between  $A$  and  $B = M_x = P(H - x) - L(bH - x)$ .

Since  $M = \frac{EI}{R} = EI \frac{d^2y}{dx^2}$

$$\therefore EI_1 \frac{dy}{dx} = PHx - \frac{1}{2}Px^2 - LbHx + \frac{1}{2}Lx^2 + C_1 \dots \dots (1)$$

When  $x = 0$  then the slope  $\frac{dy}{dx} = 0$ , hence  $C_1 = 0$ .

Value of  $\phi$ , or slope, at point  $B$ , *i.e.*, when  $x = aH$ , may be obtained from

$$EI_1 \frac{dy}{dx} = PH \cdot aH - \frac{1}{2}Pa^2H^2 - LbH \cdot aH + \frac{1}{2}L \cdot a^2H^2.$$

or  $E\alpha I_2 \frac{dy}{dx} = aH^2(P - \frac{1}{2}Pa - Lb + \frac{1}{2}La)$ .

$$\therefore EI_2 \frac{dy}{dx} = \frac{aH^2}{\alpha} (P - \frac{1}{2}Pa - Lb + \frac{1}{2}La) \dots \dots \dots (2)$$

*Length BD.*  $x$  varying in value from  $aH$  to  $bH$ .

$$M_x = P(H - x) - L(bH - x) \text{ as above.}$$

$$\therefore EI_2 \frac{dy}{dx} = PHx - \frac{1}{2}Px^2 - LbHx + \frac{1}{2}Lx^2 + C_2 \dots \dots (3)$$

The value of  $\phi$  at point  $B$ , where  $x = aH$ , may be obtained from

$$EI_2 \frac{dy}{dx} = PH \cdot aH - \frac{1}{2}P \cdot a^2H^2 - LbH \cdot aH + \frac{1}{2}L \cdot a^2H^2 + C_2 \dots (3a)$$

Since (2) and (3a) both give the slope at *B* then (2) = (3a),

$$i.e., \quad \frac{aH^2}{\alpha} (P - \frac{1}{2}Pa - Lb + \frac{1}{2}La) = PaH^2 - \frac{1}{2}Pa^2H^2 - LabH^2 + \frac{1}{2}La^2H^2 + C_2$$

whence  $C_2 = aH^2 \left( \frac{1}{\alpha} - 1 \right) (P - \frac{1}{2}Pa - Lb + \frac{1}{2}La)$ . To simplify this

expression replace the constant  $\left( \frac{1}{\alpha} - 1 \right)$  by *k*.

$$= aH^2k(P - \frac{1}{2}Pa - Lb + \frac{1}{2}La).$$

The value of  $\phi$ , or slope, at point *D* can now be obtained from (3) by giving *x* its value of *bH*, and  $C_2$  the value just ascertained, *i.e.*,

$$EI_2 \frac{dy}{dx} = PH \cdot bH - \frac{1}{2}Pb^2H^2 - LbH \cdot bH + \frac{1}{2}Lb^2H^2 + aH^2k(P - \frac{1}{2}Pa - Lb + \frac{1}{2}La) = H^2b(P - \frac{1}{2}Pb - \frac{1}{2}Lb) + aH^2k(P - \frac{1}{2}Pa - Lb + \frac{1}{2}La) \quad (4)$$

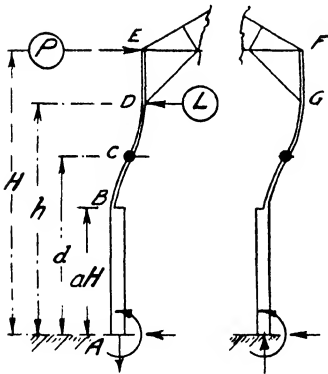

FIG. 180

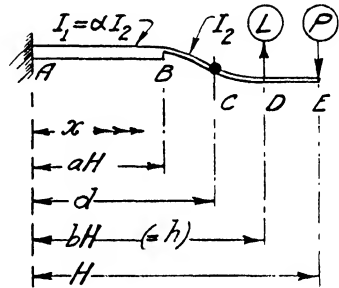

FIG. 181

Length *DE*. *x* varying in value from *bH* to *H*.

$$M_x = EI_2 \frac{d^2y}{dx^2} = P(H - x)$$

$$\therefore EI_2 \frac{dy}{dx} = PHx - \frac{1}{2}Px^2 + C_3 \quad (5)$$

To evaluate  $C_3$  place  $x = bH$  and equate against (4) since the slope of the elastic line of the column at point *D* is the same whether obtained from (4) or (5), *i.e.*,

$$PH \cdot bH - \frac{1}{2}Pb^2H^2 + C_3 = H^2b(P - \frac{1}{2}Pb - \frac{1}{2}Lb) + aH^2k(P - \frac{1}{2}Pa - Lb + \frac{1}{2}La).$$

whence  $C_3 = aH^2k(P - \frac{1}{2}Pa - Lb + \frac{1}{2}La) - \frac{1}{2}Lb^2H^2$ .



Thus the slope equation for section *DE* is

$$EI_2 \frac{dy}{dx} = PHx - \frac{1}{2}Px^2 + aH^2k(P - \frac{1}{2}Pa - Lb + \frac{1}{2}La) - \frac{1}{2}Lb^2H^2 \dots \dots \dots (5a)$$

Now integrating the slope equation of (5a) will give the deflection equation to the elastic line *DE* and, since the deflection of *D* relative to *E* is nothing, then

$$\int_{x=bH}^{x=H} [PHx - \frac{1}{2}Px^2 + aH^2k(P - \frac{1}{2}Pa - Lb + \frac{1}{2}La) - \frac{1}{2}Lb^2H^2] dx = 0$$

or  $[\frac{1}{2}PHx^2 - \frac{1}{6}Px^3 + aH^2kx(P - \frac{1}{2}Pa - Lb + \frac{1}{2}La) - \frac{1}{2}Lb^2H^2x]_{bH}^H = 0$

$$\therefore [\frac{1}{2}PH^3 - \frac{1}{6}PH^3 + aH^3k(P - \frac{1}{2}Pa - Lb + \frac{1}{2}La) - \frac{1}{2}Lb^2H^3] - [\frac{1}{2}Pb^2H^3 - \frac{1}{6}Pb^3H^3 + abH^3k(P - \frac{1}{2}Pa - Lb + \frac{1}{2}La) - \frac{1}{2}Lb^3H^3] = 0$$

$$\therefore \frac{1}{6}P[2H^3 + 6aH^3k - 3a^2H^3k - 3b^2H^3 + b^3H^3 - 6abH^3k + 3a^2bH^3k] = \frac{1}{2}L[-a^2H^3k + 2abH^3k + b^2H^3 - 2ab^2H^3k + a^2bH^3k - b^3H^3]$$

$$\therefore \frac{P}{L} = \frac{6(-a^2H^3k + 2abH^3k + b^2H^3 - 2ab^2H^3k + a^2bH^3k - b^3H^3)}{2(2H^3 + 6aH^3k - 3a^2H^3k - 3b^2H^3 + b^3H^3 - 6abH^3k + 3a^2bH^3k)}$$

$$= \frac{3(-a^2k + 2abk + b^2 - 2ab^2k + a^2bk - b^3)}{2 + 6ak - 3a^2k - 3b^2 + b^3 - 6abk + 3a^2bk} \dots \dots (6)$$

The bending moment at the point of contraflexure must be zero, i.e.,

$$P(H - d) - L(bH - d) = 0$$

Whence  $\frac{P}{L} = \frac{bH - d}{H - d} \dots \dots \dots (7)$

Now, since the left-hand sides of equations (6) and (7) are identical, therefore the right-hand sides are equal to each other.

$$\therefore \frac{3(-a^2k + 2abk + b^2 - 2ab^2k + a^2bk - b^3)}{2 + 6ak - 3a^2k - 3b^2 + b^3 - 6abk + 3a^2bk} = \frac{bH - d}{H - d} \dots \dots (8)$$

whence  $d = \frac{H(3a^2k - 6a^2bk + 3a^2b^2k - 3b^2 + 2b + b^4)}{6ak - 12abk + 6ab^2k - 6b^2 + 4b^3 + 2}$

$$= \frac{H[3a^2k(b - 1)^2 + b(b + 2)(b - 1)^2]}{6ak(b - 1)^2 + 2(2b + 1)(b - 1)^2}$$

$$= \frac{H[3a^2k + b(b + 2)]}{6ak + 2(2b + 1)} = \frac{H \left[ 3a^2 \left( \frac{1}{\alpha} - 1 \right) + b(b + 2) \right]}{6a \left( \frac{1}{\alpha} - 1 \right) + 2(2b + 1)} \dots \dots (9)$$

Since  $\left(\frac{1}{\alpha} - 1\right)$  was, for simplicity, replaced by  $k$  in evaluating  $C_2$ .

Expression (9) gives the height of the point of contraflexure above the base plate of the column.

If the column is of constant section, as in Figs. 161 to 171, then  $I_1 = I_2$  and  $\alpha = 1$ , therefore  $k = \left(\frac{1}{\alpha} - 1\right) = 0$ . In equation (9) the two terms containing  $k$  then disappear and

$$d = \frac{H(b^2 + 2b)}{2(2b + 1)} \dots \dots \dots (10)$$

But in Fig. 161 the heights to the foot of knee brace and column cap from the base are given as  $h$  and  $H$  respectively, *i.e.*,  $h = bH$  in the foregoing or  $b = h/H$ . Substituting this value for  $b$  in (10), then—

$$d = \frac{H(h^2/H^2 + 2h/H)}{2(2h/H + 1)} = \frac{h(2H + h)}{2(H + 2h)}$$

which is the formula used in connection with Fig. 161.

REFERENCES

PORTALS AND PORTAL TRUSSES

MORLEY, A. *The Theory of Structures.* (Longmans & Co.)  
 ANDREWS, E. S. *Further Problems in the Theory and Design of Structures.* (Chapman and Hall.)  
 JOHNSON, BRYAN AND TURNEAURE. *Modern Framed Structures.* (Wiley & Sons.)  
 KETCHUM, M. S. *Steel Mill Buildings.* (McGraw-Hill.)  
 BECK, E. G. *Structural Steelwork.* (Longmans & Co.)

## CHAPTER VII

### LATTICE GIRDER FOOT BRIDGE (PLATE IV)

#### EXPLANATORY TEXT

THE intensity of the loading due to pedestrian traffic is usually taken at 84 lb. per square foot of walking surface. Where the footwalk borders a carriage way this allowance is ample ; indeed, when the bridge is a long span one, this figure is frequently lowered in value in the same ratio as the Ministry of Transport *E.U.D.L.L.* (p. 265) is lessened in intensity with the increase in span. Where a heavy concentration of pedestrians is anticipated, or where, as in the present example, the span is small and the footway narrow (with no overflow space offered by an adjacent carriage way) the loading is often taken at 100 lb. per square foot. The values of 84 and 100 lb. per square foot, especially the latter, are also taken as an inclusive load for pedestrian and light vehicular traffic, flocks of sheep, herds of cattle and horses. There is no necessity to add an allowance for impact to these figures, because the denser the crowd is the more nearly static becomes the load. Of course, the sparser the pedestrians are the greater is the possibility for impact, but it will be appreciated that on balance the two values given are inclusive of all variations in concentrations and impact effects.

When troops cross a bridge the order is always given to break step. Professor Steiner, experimenting on a suspension bridge at Prague (1892), found that the violent longitudinal and transverse vibrations set up by troops marching in step was accompanied by a stress of  $2.86\tau$ /sq. in., as against a stress of  $1\tau$ /sq. in. when the troops were at rest.

*Item 1,* It was thought that eight panels of 6 ft. 3 in. appeared more pleasing than ten at 5 ft.

*Item 2,* Although the planks are continuous over at least two spans they are considered as having simply supported spans of 6 ft. 3 in. ; the current practice with timber work.

*Item 4,* In a rectangular beam the maximum intensity of the horizontal shear is along the neutral axis and is one and a half times the mean vertical shear. This was derived from the formula  $q = SG \div Ib$  in Chapter I.

*Item 5,* If the resulting stress is  $\pm 7.61\tau$ /sq. in. when only

## CALCULATIONS

**Data.** Span 50 ft. c/c of bearings ; clear walking width between main girders 8 ft. ; floor of longitudinal timbers carried on steel cross beams. Loading.—Pedestrian traffic of 1 cwt. per square foot with no allowance for impact.

*Working Stresses.* See page 268.

*Working Drawing.* Plate IV.

**Planking.** Span 6 ft. 3 in. Try the usual minimum thickness of 3 in. 1

Dead + live load per foot of width =

$$0.25' \times 6.25' \times 1' @ 42 \text{ lb.} + 6.25 \text{ cwt.} = \text{lb.} \quad 765$$

$$\text{Maximum } B.M. = Wl \div 8 = 765 \times 75 \div 8 = \text{in. lb.} \quad 7172$$

$$\text{Modulus per foot width} = \frac{1}{8} \times 12 \times 3^2 = \text{in.}^3 \quad 18$$

$$\text{Extreme fibre stress} = M \div Z = 7,172 \div 18 = \text{lb./sq. in.} \pm 399 \quad 2$$

Mean vertical end shear

$$= \frac{1}{2} \text{ of } 765 \div (3'' \times 12'') = \text{,,} \quad 10.6 \quad 3$$

$$\text{Maximum shear along grain} = 1\frac{1}{2} \times 10.6 = \text{,,} \quad 15.9 \quad 4$$

$$\text{Maximum } \Delta = \frac{5 \times W \cdot l^3}{384 \times E \cdot I} =$$

$$\frac{5 \times 765 \times 75^3}{384 \times 1,500,000 \times 27} = \quad 0.10''$$

Permissible deflection = span  $\div$  480 =

$$75 \div 480 = \quad 0.15''$$

Common working stresses for **2, 3** and **4** =

$$900, 900 \text{ and } 120 \text{ lb./sq. in.}$$

**Cross Beams.** Span, simply supported = 106''

Uniformly distributed load from item 1

$$= 765 \text{ lb.} \times 8' \text{ wide} = \quad 2.73^r$$

Maximum *B.M.* =  $Wl \div 8 = 2.73 \times 106$

$$\div 8, \text{ approx.} = \text{in. tons} \quad 36.17$$

Give 1 channel,  $5'' \times 2\frac{1}{2}'' \times 10\frac{1}{4}''$  lb. Modu-

$$\text{lus, } Z = \text{in.}^3 \quad 4.75$$

Resulting stresses =  $M \div Z = 36.17 \div$

$$4.75, \text{ approx.} = \tau/\text{sq. in.} \pm 7.61 \quad 5$$

Web area for shear =  $5'' \times \frac{1}{4}''$

$$= \text{gross sq. in.} \quad 1.25$$

Permissible web shear stress

$$= \tau/\text{sq. in.} \quad 5.5$$

Actual " " " =  $(\frac{1}{2} \text{ of } 2.73^r) \div 1.25$

$$= \text{,,} \quad 1.09$$

the channel  $Z$  is considered, it is obvious that the actual stress must be less than this because of the light angle which is riveted to the channel. (For the combined section the stresses are  $+4.76$  and  $-7.14\tau/\text{sq. in.}$ )

*Item 9.* The forces for the various members of the structure will be obtained by two methods; firstly by direct calculation, and secondly by influence lines.

*Item 10, Section and Moments.* The maximal forces in the flanges occur when the bridge is completely covered by the live load. This rule does not apply to the web members.

As previously stated, the rule for "Section and Moments" is "Take a section to cut three bars, including the desired bar, and take moments where the two unwanted bars meet." The section through  $C$ , Fig. 182, cuts  $F_2F_3$ ,  $F_2C$  and  $DC$ . The two last are the unwanted bars, and as these meet at  $C$  this point becomes the moment centre.

The portion of the bridge shown in thin line may now be disregarded and the stability of the portion in heavy line examined. Acting on the heavily lined portion are six forces, *viz.*, reaction  $EF$  of  $5.425\tau$ , panel load  $D$  of  $1.55\tau$ , panel load  $C$  of  $1.55\tau$  and the three internal unknown forces acting on the cut members  $F_2F_3$ ,  $F_2C$  and  $DC$ .

Since the structure is in equilibrium the moments of all these forces about any point must sum to zero, *i.e.*,  $\Sigma M = 0$ . Since  $C$  is to be the moment centre, then the panel load at  $C$  of  $1.55\tau$  has no moment about  $C$ , because, passing through  $C$ , it has no lever arm. Similarly the unknown forces in diagonal  $F_2C$  and flange member  $DC$  pass through  $C$  and have no moment. There is thus only one unknown force to consider, *viz.*, that in  $F_2F_3$  and, giving the clockwise moments about  $C$  the positive sign, the moment equation is  $5.425\tau \times 12.5' - 1.55\tau \times 6.25' = F_2F_3 \times 4.8'$ , whence the force in  $F_2F_3$ . The algebraic sum of the moments on the left-hand side of the equation is clockwise in sign, showing that the heavily lined portion of the truss if free to move would do so clockwise round  $C$  as centre. The cut ends of the member  $F_2F_3$  would then be forced together, an indication that the stress in this member is compression. Had the cut ends tended to leave each other, as they do in the lower flange, then the stress would have been tension.

For the forces in the bottom flange members take moments about the panel points on the top flange.

It will be noted that the forces in any pair of top and bottom flange panels contained between an adjacent pair of diagonals are the same in magnitude.

*Fig. 184. Influence Lines* for the moment centres mentioned in

**Main Girder.**

Estimated dead weight of steel and timber, per girder	=	2.4 <sup>T</sup>	<b>6</b>
Total live load (static) per girder = 50' × 4' @ 1 cwt./sq. ft.	=	10 <sup>T</sup>	<b>7</b>
Girder depth over angles, say, span ÷ 10	--	5'	
Girder effective depth, i.e., between flange C's. of G.	--	4.8'	
Panel load, D+L, bridge fully loaded = (2.4 <sup>T</sup> + 10 <sup>T</sup> ) ÷ 8	=	1.55 <sup>T</sup>	<b>8</b>

## FLANGE FORCES BY ALTERNATIVE METHODS

**Section and Moments.** See Fig. 182 for complete results.

$F_1F_2$ . Moments at D. $5.425 \times 6.25 \div 4.8$	--	7.06 <sup>T</sup>	<b>10</b>
$F_2F_3$ . Moments at C. $(5.425 \times 12.5 - 1.55 \times 6.25) \div 4.8$	--	+ 12.11 <sup>T</sup>	
ED. Moments at $F_1$ . No moments, ∴ no stress	=	0	
DC. Moments at $F_2$ . $5.425 \times 6.25 \div 4.8$	=	- 7.06 <sup>T</sup>	
CB. Moments at $F_3$ . $(5.425 \times 12.5 - 1.55 \times 6.25) \div 4.8$	=	- 12.11 <sup>T</sup>	

**Stress Diagram,** Fig. 183, gives the maximal forces in the flanges but not in the web members. **11**

**Influence Lines,** Fig. 184.

The dead load/ft. of span = 2.4 <sup>T</sup> ÷ 50. (item 6)	--	0.048 <sup>T</sup>	<b>12</b>
The live load/ft. of span = 10 <sup>T</sup> ÷ 50. (item 7)	=	0.2 <sup>T</sup>	<b>13</b>
B.M. @ 2 and 8 = 136.72 (0.048 + 0.2) for D. + L.	-- ft. tons	33.91	
B.M. @ 3 and 7 = 234.37 (0.048 + 0.2) for D. + L.	-- ..	58.12	<b>14</b>
B.M. @ 4 and 6 = 292.97 (0.248) for D. and L.	-- ..	72.66	
B.M. @ 5 = 312.5 (0.248) for D. and L.	-- ..	77.50	
Flange force in $F_1F_2$ and DC = 33.91 ÷ 4.8 =	=	7.06 <sup>T</sup>	
$F_2F_3$ and CB = 58.12 ÷ 4.8 =	=	12.11 <sup>T</sup>	<b>15</b>
and the remainder are 72.66 and 77.5, both ÷ 4.8	--	15.14 & 16.14 <sup>T</sup>	

item 10. The construction for, say, point 7 is : With  $B$  as centre and  $B7$  as radius, draw an arc to cut the perpendicular through  $B$  at  $b_7$ . Similarly with  $A$  as centre and  $A7$  as radius obtain point  $a_7$ . Join  $a_7$  to  $B$ , and  $b_7$  to  $A$ . The triangle enclosed by these two lines and the base line  $AB$  is the influence line for the bending moment at point 7. Since the span is symmetrical about a centre line, the three triangles on the immediate left are identical but "other hand," i.e., reflections, to the corresponding set on the right.

Alternatively, and more accurately, place unit load at point 7. Then—

$$R_A = 1^r \times B7 \div AB = 1^r \times 12.5' \div 50' = \frac{1}{4}^r.$$

$$B.M._7 = A7 \times R_A = 37.5' \times \frac{1}{4}^r = 9.375 \text{ ft. tons, the apex value for point 7.}$$

The area of the triangle is  $\frac{1}{2}$  height  $\times$  base =  $\frac{1}{2} \times 9.375 \times 50 = 234.375$ , i.e., the value given for point 3, which is similar to point 7.

*Item 14.* For a uniformly distributed load the area of the influence triangle multiplied by the distributed load per foot run gives the bending moment at the point considered.

*Item 15.* The *B.M.* of item 14  $\div$  effective depth = flange force.

*Neutral Points for Shear.* These can be found graphically as shown by Fig. 185. Thus, the neutral point for the second panel from the left is found by drawing a line from  $A$  through 2 until it intersects at  $C$  the line from  $B$  through 3. The horizontal distance from  $B$  to the vertical through  $C$ , viz., 42.86', should be covered by the live load to give the maximum positive shear in the panel. The remaining length of 50' - 42.86' should be loaded if maximum negative shear for the panel is desired ; but there is no necessity to do so, because the positive shear of the 7th panel is equal in magnitude to this. The neutral points are also given by the shear influence lines, viz., where the diagonal lines cut the base line, since a neutral point is such that if a load be placed on it there is no shear in the panel. (See p. 44, *Influence Lines, Their Practical Use in Bridge Calculation.*)

*Item 16* indicates the method of obtaining the neutral points by calculation. The neutral point of a panel divides the panel in the same ratio as it divides the span. This can be seen from the similar triangles in the construction of Fig. 185.

*Item 17.* The dead load shear forces in the web members can be found from those given on Figs. 182 and 183 on multiplying the latter by 0.3  $\div$  1.55, or as explained later.

*Item 18.* There is no cross beam at the end  $A$ , as the longitudinal floor planks rest directly upon the abutment. Hence, under full

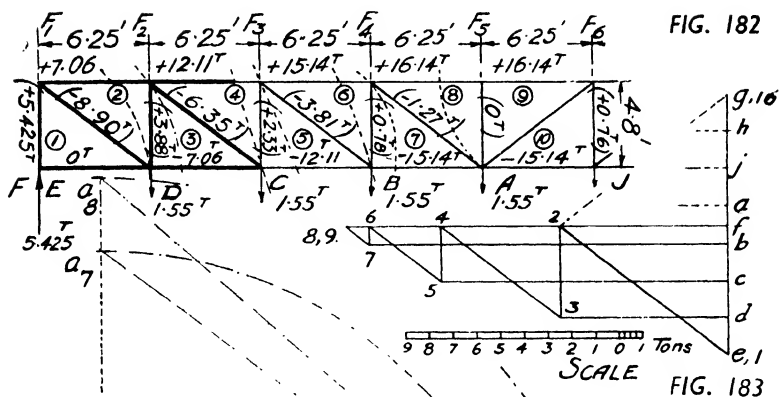

INFLUENCE LINES FOR BENDING MOMENT.

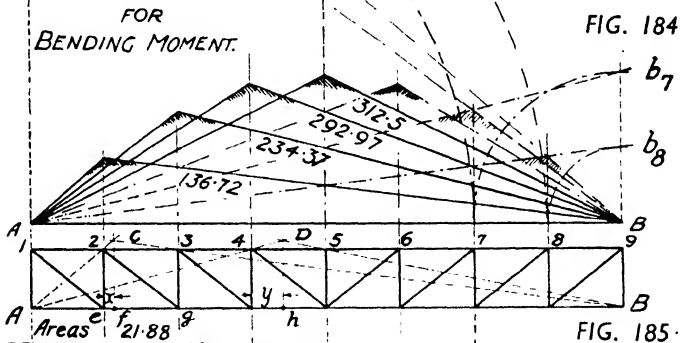

INFLUENCE LINES FOR SHEAR.

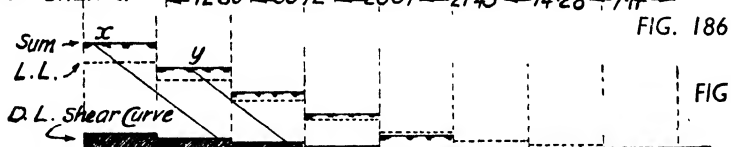

Sum	+5.43 <sup>T</sup>	+3.96 <sup>T</sup>	+2.68 <sup>T</sup>	+1.58 <sup>T</sup>	+0.65 <sup>T</sup>	-0.09 <sup>T</sup>	-0.66 <sup>T</sup>	-1.05 <sup>T</sup>
L.L.	+4.38	+3.21	+2.23	+1.43	+0.80	+0.36	+0.09	0
D.L.	+1.05	+0.75	+0.45	+0.15	-0.15	-0.45	-0.75	-1.05

Diagram for Live Load Shear & Dead Load Shear Curve.



load, the planks of the end panel deliver half their load to the abutment without passing through the main girder, and therefore the total end shear on the girder =  $\frac{1}{2}$  total load on span -  $\frac{1}{2}$  panel load = maximum shear in the end panel.

*Item 19.* For maximum shear in the second panel the live load should extend from the right-hand abutment up to the neutral point *f*. The reaction at the left abutment, due to this live load, is 3.67 tons, which is also the live load shear on the main girder between points *A* and *e*.

*Item 20.* Now the planks of the second panel are themselves tiny bridges within the main bridge, and they cause downward loads, or reactions, at *e* and *g*.

*Item 21.* Therefore the maximum live load shear in the second panel is the upthrust of 3.67 tons minus the local load downwards at *e* of 0.46 tons. The third and remaining panels are calculated in a similar manner.

*Shear Influence Lines* (Fig. 186). If there had been a cross beam at end *A* the influence line for reaction would be the triangle *AaB*, but since the end planks deliver part of their load directly on to the abutment the correct triangle is *A1B*. The area of this figure =  $\frac{1}{2}$  perpendicular height  $\times AB = \frac{1}{2} \times \frac{7}{8} \times 50 = 21.88$  units. The perpendicular height is  $\frac{7}{8}$ , as the end ordinate at *A* is unity.

*Item 22.* The total reaction at *A*, or maximum shear in the end panel, occurs when the girder is fully loaded and is therefore the area of triangle No. 1 multiplied by (dead + live) load per foot run of girder.

*Item 23.* Since the dead load covers all the span the *D.L.* shear in the 2nd panel = area of triangles  $(2 + 14) \times D.L./ft.$  run =  $(16.07 - 0.45) 0.048\tau$ . Triangle 14, under the base line, is negative and its area equals that of triangle 7.

*Item 24.* The live load should cover the length of 42.86 ft. to give maximum positive panel shear, *i.e.*, only the positive triangle 2; see also items 19 and 21. Should the live load pass the neutral point the shear would decrease in value, for with every foot of advance into the negative area of triangle 14 there would require to be deducted a corresponding amount of shear = negative area  $\times$  load/ft. run.

*Item 25. Forces in Diagonals.* As an example take the 2nd panel and consider any section such as *Cf* in Fig. 185. Under maximum positive shear in this panel the left-hand portion *Af* tends to rise relatively to *fB*, the longer portion on the right of the section, but is restrained from doing so by only one member, *viz.*, the diagonal *g2*. Therefore, the vertical component of the force in *g2* balances the vertical shear *S*; *i.e.*, force in *g2*  $\times$  sin of angle

## WEB FORCES BY ALTERNATIVE METHODS

**Neutral Points.** Second panel from *A*, Figs. 185 and 186. **16**

$$\frac{ef}{gf} = \frac{Af}{Bf}, \text{ i.e., } \frac{x}{6.25 - x} = \frac{6.25 + x}{43.75 - x}$$

$$\begin{aligned} \text{hence } x &= & 0.89' \\ \therefore fB &= 43.75' - 0.89' &= 42.86' \end{aligned}$$

Similarly for 4th panel,  $\frac{y}{6.25 - y} =$

$$\begin{aligned} \frac{18.75 + y}{31.25 - y}, \text{ hence } y &= & 2.68' \\ \therefore hB &= 31.25' - 2.68' &= 28.57' \end{aligned}$$

**Dead Load Shear.** See Fig. 187.

$$\text{Panel load} = 2.4^{\tau} \div 8 = 0.3^{\tau} \quad \mathbf{17}$$

**Live Load Shear by Neutral Points,** Figs. 186 and 187.

$$\begin{aligned} \text{1st panel, } R_1 &= \frac{1}{2} \text{ of } 50' \times 0.2^{\tau}/\text{ft. of} \\ &\text{item } \mathbf{13} - \frac{1}{2} \text{ of } 6.25' \times 0.2^{\tau}/\text{ft.} = & 4.38^{\tau} \quad \mathbf{18} \end{aligned}$$

$$\begin{aligned} \text{2nd panel, } R_1 &= [(42.86 \times 0.2) \times \\ &(\frac{1}{2} \text{ of } 42.86)] \div 50 = 3.67^{\tau} & \mathbf{19} \end{aligned}$$

$$\begin{aligned} \text{Reaction at } e &= [(5.36 \times 0.2) \times \\ &(\frac{1}{2} \text{ of } 5.36)] \div 6.25 = 0.46^{\tau} & \mathbf{20} \end{aligned}$$

$$\begin{aligned} \text{Difference} &= \text{maximum } L.L. \text{ shear} \\ &\text{in panel} = & 3.21^{\tau} \quad \mathbf{21} \end{aligned}$$

$$\begin{aligned} \text{3rd panel, } R_1 &= [(35.72 \times 0.2) \times \\ &(\frac{1}{2} \times 35.72)] \div 50 = 2.55^{\tau} \end{aligned}$$

$$\begin{aligned} \text{Reaction at } g &= [(4.47 \times 0.2) \times \\ &(\frac{1}{2} \times 4.47)] \div 6.25 = 0.32^{\tau} & 2.23^{\tau} \end{aligned}$$

$$\begin{aligned} \text{4th panel shear} &= (\frac{1}{2} \times 0.2 \times 28.57^2 \div 50) \\ &- (\frac{1}{2} \times 0.2 \times 3.57^2 \div 6.25) = & 1.43^{\tau} \end{aligned}$$

$$\begin{aligned} \text{5th, 6th and 7th panels respectively} \\ &= 0.8, 0.36 \text{ and } 0.09 \quad \text{tons.} \end{aligned}$$

**Dead and Live Load Shears by Influence Lines,** Figs. 186 and 187.

$$\begin{aligned} \text{1st panel } (0.048 + 0.2) \text{ of items } \mathbf{12} \text{ and } \mathbf{13}, \\ &\times 21.88 = 1.05 + 4.38 = & 5.43^{\tau} \quad \mathbf{22} \end{aligned}$$

$$\begin{aligned} \text{2nd panel, } D.L. &= \\ (16.07 - 0.45) \times 0.048 &= 0.75^{\tau} & \mathbf{23} \end{aligned}$$

$$\begin{aligned} \text{2nd panel, } L.L. &= \\ (16.07 \times 0.2) &= 3.21^{\tau} \quad \text{Total} = & 3.96^{\tau} \quad \mathbf{24} \end{aligned}$$

$$\begin{aligned} \text{3rd panel, } D.L. + L.L. &= (11.16 - 1.79) \\ 0.048 + 11.16 \times 0.2 &= 0.45 + 2.23 = & 2.68^{\tau} \end{aligned}$$

$eg_2 = S$ , or force in  $g_2 = S \operatorname{cosec} eg_2$ , which is equal to  $S$  (length of diagonal  $\div$  effective depth of girder) =  $1.64 S$ .

*Fig. 187* gives a summary of the shears in a diagrammatic form. It is to be noted that the sum and *L.L.* diagrams are not shear curves in the same sense as the curve designated the *D.L.* shear curve. These diagrams are not essential, but their purpose is to indicate that the 5th panel from the left, like the preceding four panels, has a positive shear, but, since the diagonal of this panel is inclined in an opposite direction to the four diagonals on its left, the force will be of opposite sign, *viz.*, compression. The diagonals of the 6th, 7th and 8th panels are inclined in the same direction as the 5th, but the shears in these three panels are negative, and so the forces in the diagonals are tensile ones. However, if the load advances along the span from the left hand, instead of from the right as in the calculations, the solution is "other hand," *i.e.*, the 4th panel from the left-hand end is equivalent to the 5th panel of the previous case, where the load was taken as advancing from the right hand.

*Item 26.* The foregoing explains the arrangement of this table. The 1st diagonal may become the 8th, the 2nd the 7th, and so on, but in all cases there is no change in the nature of the stress except in the 4th and 5th panels, where there is a reversal of stress.

*Item 27.* If  $xx$  and  $yy$  (*Fig. 187*) be drawn parallel to the web diagonals then the lengths  $xx$ ,  $yy$ , etc., give the forces in the diagonals of the 1st and 2nd panels, etc., to the same scale as the curves were drawn to originally.

*Item 28.* Since there is no external load at any panel point in the top flange the vertical component of the force in any web diagonal must balance, *i.e.*, be equal in magnitude, but opposite in nature to, the force in the vertical which meets it. Hence, by the reasoning of *item 25*, the force in the vertical must be equal in magnitude to the panel shear. Note the reversal of stress in the 4th and 6th verticals according to the direction of the live load.

*Item 29.* Although there is no direct force in the centre vertical it is required to keep the unsupported length of the top flange down to the 6 ft. 3 in. figure, but, apart from this, appearance demands its use.

*Item 30.* The maximum reversal is with the loading of *Fig. 188a*. The forces given by *Fig. 188b* agree with the calculated values for the vertical and diagonal bars under consideration.

*Item 31.* The compression flange is designed for the maximum load which occurs in its length. As both the span and the scantlings are small, the same section will be used throughout without splices. When rakers or brackets are used the overall width of the flange is

<b>4th panel, <math>D.L. + L.L. = (7.14 - 4.01)</math></b>	
0.048 + 7.14 × 0.2 = 0.15 + 1.43 =	1.58τ
<b>5th panel, <math>D.L. + L.L. = (4.01 - 7.14)</math></b>	
0.048 + 4.01 × 0.2 = - 0.15 + 0.8 =	0.65τ
<b>6th panel, <math>D.L. + L.L. = (1.79 - 11.16)</math></b>	
0.048 + 1.79 × 0.2 = - 0.45 + 0.36 =	- 0.09τ
<b>7th panel, <math>D.L. + L.L. = (0.45 - 16.07)</math></b>	
0.048 + 0.45 × 0.2 = - 0.75 + 0.09 =	- 0.66τ
<b>8th panel, <math>D.L. + L.L. = (0 - 21.88)</math></b>	
0.048 + 0.00 × 0.2 =	- 1.05τ

**Forces in Web Diagonals.**

Length of diagonal ÷ girder's effective depth = 7.88' ÷ 4.8' =	1.64
The foregoing shears × 1.64 = the forces in the diagonals in tons.	<b>25</b>
End = 8.91τ, tension and 8th = 1.72τ, tension	
2nd = 6.49τ, tension and 7th = 1.08τ, tension	
3rd = 4.40τ, tension and 6th = 0.15τ, tension	
4th = 2.59τ, tension and 5th = 1.07τ compression.	<b>26</b>
Alternatively by drawing the diagonals in Fig. 187	<b>27</b>

**Forces in Web Verticals** = the shear in the corresponding panel. **28**

End = 5.43τ, compression and 9th = 1.05τ compression	
2nd = 3.96τ, compression and 8th = 0.66τ compression	
3rd = 2.68τ, compression and 7th = 0.09τ compression	
4th = 1.58τ, compression and 6th = 0.65τ, tension	
5th and centre vertical is redundant and has no direct force.	<b>29</b>

*Figs. 188 and 189* are not necessary, but they illustrate the fact that reversal takes place only in members 9, 10 and 10, 11 **30**

usually about one-fifteenth of the distance between the rakers. Where there is no direct horizontal support given to the upper flange its width should be about one-fortieth to one-forty-fifth of its total length.

*Item 32.* The column formula used in the calculations is one which has been specially devised for the compression members of truss and lattice girders with riveted end connections. Provided that the clauses of the specification, accompanying the formula, are observed there is no necessity to estimate the degree of fixity given to a strut by its end connections.

When the upper flange has no lateral support given to it, either by lateral bracing or side brackets, the effective lateral strut length should be assumed to be three-quarters of the distance between the two end posts. When efficient brackets or rakers are employed the effective lateral strut length is taken as being the distance between alternate rakers, *i.e.*, 25 ft., see Plate IV. This question of the lateral stability of the upper flange of a truss girder is considered more fully in Chapter X.

The continuous top flange is supported in the vertical plane every 75 in. by the web members.

*Item 33.* The low resulting stress indicates that a lighter section might have been used, but, as it is necessary to have a minimum flange width of 10 in. and a minimum thickness of metal for a main member of  $\frac{5}{16}$  in., the suggested section will be retained.

*Distance Washers.* The minimum radius of gyration,  $k_z$ , for a single  $5'' \times 3'' \times \frac{5}{16}''$  angle is 0.65 in. Since the slenderness ratio,  $l/k$ , for the combined section of two angles is 123, then the slenderness ratio of each angle forming the section should not exceed this value. The rivets through the distance washers, which tie the two separate angles together, should therefore be spaced  $l$  in. apart, such that  $l/0.65$  is not greater than 123, *i.e.*,  $l$  not greater than 80 in. By using one rivet and distance washer at mid-panel the actual length  $l$  between points of attachment is only about 34 in.

*Item 34.* On referring to details 4 and 10 of Plate IV, it will be observed that diagonal tearing of the bottom flange angles might be possible. In addition to the  $\frac{3}{4}$  in. dia. rivet holes in the vertical legs of the angles (Fig. 192), there also occur the four  $\frac{1}{8}$  in. dia. bolt holes in the horizontal legs for the cross channel. Due to the close pitching of these holes the deduction will be two holes per angle and not one.

Since this tension member receives its maximum stress through a series of increments, and not all at once as with the web members, half the areas of the outstanding legs will not be deducted. Distance washers are used, without calculation, to reduce vibrating lengths

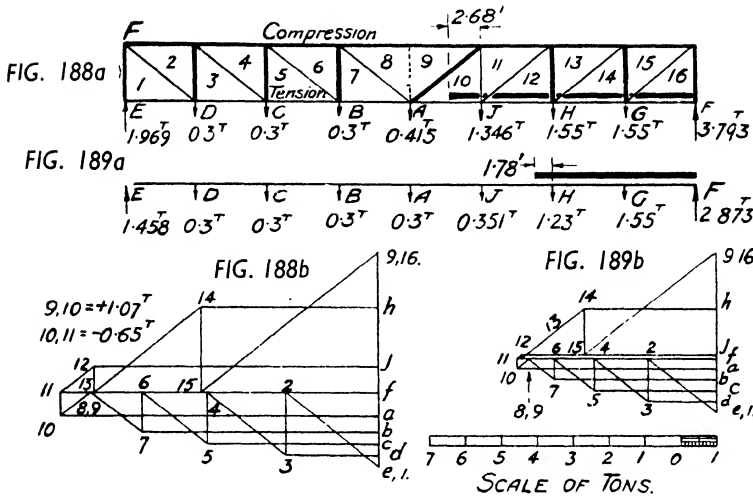

SECTIONS

<b>Top or Compression Flange.</b>	Max. load =	+ 16.14T	<b>31</b>
Flange width reqd. =	$l \div 15 = 150'' \div 15 =$	10"	
" "	given	10 $\frac{5}{16}$ "	
Viz., 2 $\lfloor$ 5" $\times$ 3" $\times$ $\frac{5}{16}$ " , area		sq. in. gross	4.81
From tables and Fig. 191	$k_x =$	0.83"	
	$k_y =$	2.43"	
Strut length, laterally (for $k_y$ )	=	300"	<b>32</b>
" " vertically (for $k_x$ )	=	75"	
Slenderness ratio, $l/k_y = 300'' \div 2.43''$	=	123	
" " $l/k_x = 75'' \div 0.83''$	=	90	
$F_c = F_t(1 - 0.0038l/k)$			
= $9(1 - 0.0038 \times 123)$	= $\tau$ /sq. in.	4.79	
Actual stress = $16.14 \div 4.81$	= "	3.36	<b>33</b>

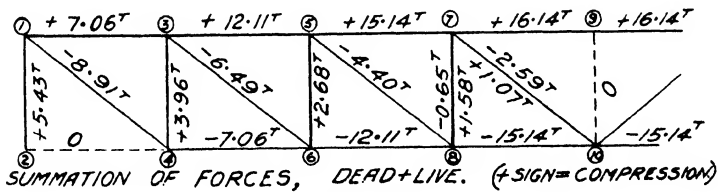

FIG. 190

As  $\frac{5}{16}$  in. is the minimum thickness of metal for the main members  $3" \times 3" \times \frac{1}{4}"$  angles cannot be employed.

*Item 35.* In addition to the rivet hole, deduct half the area of the outstanding leg as mentioned above (see Fig. 193).

*Sections of Web Members.* Arrange these sections with the broad elements near the abutment and the narrow ones near the centre ; the angle thickness and the length of the outstanding leg may be varied to obtain this effect in the front elevation.

*Items 36 and 37.* In keeping with the above the front elevational breadths of the 2nd and 3rd diagonals were increased from  $2\frac{1}{2}$  to 3 in. so as not to be less than that of the 4th diagonal.

*Item 38.* The dead load force in diagonal 9:10 (Fig. 188a) is a tensile one. When the uniformly distributed live load, longer in length than the span, enters the bridge at *F* it causes a compressive live load force in diagonal 9:10. This live load compressive force gradually increases in value as the loaded length becomes longer and ultimately neutralizes the dead load tensile force. Thereafter the total force in 9:10, due to the combined dead and live loads, is a compressive one, which attains its maximum value of  $+1.07T$  when the loaded length is the 21.43 ft. shown in heavy line. When the head of the live load passes the neutral point of the panel the compressive force in 9:10 decreases, reaches zero value, and becomes maximum tensile when the left-hand length of 28.57 ft. only is covered by the live load, *i.e.*, triangle 11 of Fig. 186. Member 9:10 during the passage of the load has therefore to function both as a strut and as a tie. As a strut the section is settled by the permissible slenderness ratio (maximum about 160), and this section is ample to carry the design tensile load. For a member subject to stress reversal most specifications give the design load as being the greater load added to one-half of the lesser load. The sign of the design load is that of the greater load. Also see the text to item 40, reversal of stress, in Chapter X.

The sizes of the angles forming the top and bottom flanges having been settled, it is now possible to ascertain the correct lengths of the web members.

*Item 39.* Appearance demands that the end vertical should be of the same width as the top flange.

*Items 40 and 41.* Here again appearance was the governing factor in the choice of sections used because the actual stresses are very low.

*Item 42.* This member was designed as a compression member and checked for its tensile load.

*Item 43.* See item 29 of the explanatory text.

*Item 44.* For list of working stresses see page 268.

**Bottom or Tension Flange.** Max. load = - 15.14<sup>T</sup> **34**  
 2 L<sub>s</sub> 3" × 3" ×  $\frac{5}{16}$ ", area = 3.55 sq. in. gross.  
 Less 2 holes per angle = 0.98  
 Total net area = sq. in. net 2.57  
 Actual stress = 15.14 ÷ 2.57 = T/sq. in. - 5.90

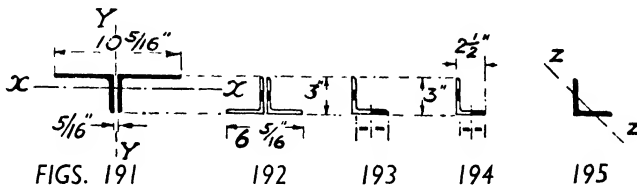

**Web Diagonals.**

**End Diagonal.** Max. load = - 8.91<sup>T</sup> **35**  
 1 L<sub>s</sub> 3" × 3" ×  $\frac{3}{8}$ " area = sq. in. gross  $\frac{2.11}{-}$   
 Less 1 hole =  $\frac{3}{8}$ " ×  $\frac{3}{4}$ " = 0.28  
 „  $\frac{1}{2}$  out. leg =  $\frac{1}{2}(3 - \frac{3}{8})\frac{3}{8}$  = 0.49  $\frac{0.77}{-}$   
 Total net area = sq. in. net 1.34  
 Actual stress = 8.91 ÷ 1.34 = T/sq. in. - 6.65

**2nd Diagonal.** Max. load = - 6.49<sup>T</sup> **36**  
 1 L<sub>s</sub> 2 $\frac{1}{2}$ " × 2 $\frac{1}{2}$ " ×  $\frac{5}{16}$ " area = sq. in. gross  $\frac{1.47}{-}$   
 Less 1 hole =  $\frac{5}{16}$ " ×  $\frac{3}{4}$ " = 0.23  
 „  $\frac{1}{2}$  out. leg =  $\frac{1}{2}(2\frac{1}{2} - \frac{5}{16})\frac{5}{16}$  = 0.34  $\frac{0.57}{-}$   
 Total net area = sq. in. net 0.90  
 Actual stress = 6.49 ÷ 0.9 = T/sq. in. - 7.21

But a 3" × 2 $\frac{1}{2}$ " ×  $\frac{5}{16}$ " angle will be used  
 for appearance, see text and Fig. 194.

**3rd Diagonal.** Max. load = - 4.40<sup>T</sup> **37**  
 Same section as for previous item.

**4th Diagonal.** Max. loads = + 1.07<sup>T</sup> & - 2.59<sup>T</sup> **38**  
 For + 1.07<sup>T</sup> try 1 L<sub>s</sub> 2 $\frac{1}{2}$ " × 2 $\frac{1}{2}$ " ×  $\frac{5}{16}$ "  
 $l/k_z = 93.9 \div 0.48$  = (too large) 196  
 Now try 3" × 3" ×  $\frac{5}{16}$ ", Fig. 195. Area = sq. in. gross 1.78  
 $l/k_z = 93.9 \div 0.58$  = 162  
 $F_c = 9(1 - 0.0038 \times 162)$  = T/sq. in. 3.46  
 Actual stress = 1.07 ÷ 1.78 = „ + 0.60

Stress reversal, ∴ design load = greater  
 load +  $\frac{1}{2}$  lesser = 2.59<sup>T</sup> +  $\frac{1}{2}$  of 1.07<sup>T</sup> = - 3.13<sup>T</sup>  
 Area of 1 L<sub>s</sub> 3" × 3" ×  $\frac{5}{16}$ " less 1 hole and  
 $\frac{1}{2}$  out. leg = sq. in. net 1.13  
 Actual stress = 3.13 ÷ 1.13 = T/sq. in. - 2.77



*Item 45.* Because the upper flange angles finish at the gusset plate the load carried by them must be transferred into the plate by the connecting rivets, which are in double shear and  $\frac{3}{8}$  in. bearing.

Similarly the diagonal angle gives up its load to the gusset plate through the end rivets (S.S. and  $\frac{5}{16}$ " B). The horizontal component of this load balances that brought into the gusset plate by the flange angles, while the vertical component finds its way to the end vertical.

*Item 46.* Since the flange angles are continuous the only place where the increment of flange force can come from is the gusset plate, and, neglecting secondary stresses, the sole function of the connecting rivets is to transfer this increment of force from the gusset plate into the flange.

The increment of force comes from the horizontal component of the load in the web diagonal when the bridge is totally covered by the live load. The maximum load in the diagonal, however, occurs when the bridge is partially loaded up to the neutral point, and it is this maximum load which is developed into the gusset plate by the end rivets, which are in single shear and  $\frac{5}{16}$  in. bearing.

The calculated number of rivets may be increased, but never diminished, on detailing, while never less than two rivets should be given to any member.

*Item 48.* Most specifications ask that the connecting rivets at the ends of a member subjected to reversal of stress should be sufficient in number to develop the *sum* of the maximum loads into the gusset plate, and not the greater load plus half the lesser as was used in the design of the member itself.

*Item 49.* The load of  $5.43\tau$  leaves the lower end of the vertical for the gusset plate through the attaching rivets. Then it enters the vertical legs of the redundant lower flange angles and so into the horizontal legs and base plate. The gusset plates were increased to  $\frac{3}{8}$  in. on detailing, so as to conform with the sole plate which is made  $\frac{3}{8}$  in. thick. The calculation for the latter is similar to that for the shoe of the roof truss. Alternatively, use may be made of the chart given on Fig. 63; the pressure on the abutment being only  $5.43\tau/\text{sq. ft.}$  The complete details are shown on Plate IV.

*Item 50.* The external panel load of  $1.55\tau$  enters the flange angles through their horizontal legs and thence into the gusset plate by way of the rivets through the vertical legs. These vertical leg rivets are thus loaded in two directions, *viz.*, a vertical load of  $1.55\tau$  and a direct horizontal one of  $7.06\tau$ ; these rivets have therefore to carry the resultant,  $7.3\tau$ , of the two loads (parallelogram of forces).

The ends of the vertical and diagonal web members at this joint must each have the same number of rivets as are given at their upper extremities (action and reaction are alike and opposite).

**Web Verticals.**

<i>End Vertical.</i> Max. load	=	+ 5.43 <sup>τ</sup>	<b>39</b>
Same section as top flange, <i>i.e.</i> ,			
2 $\lfloor$ 5" × 3" × $\frac{5}{16}$ "	area = sq. in. gross	4.81	
$l/k_z = 56.5" \div 0.83"$	=	68	
$F_c = 9(1 - 0.0038 \times 68)$	= $\tau$ /sq. in.	6.67	
Actual stress = 5.43 $\div$ 4.81	= ,,	+ 1.13	
 <i>2nd Vertical.</i> Max. load	=	+ 3.96 <sup>τ</sup>	<b>40</b>
1 $\lfloor$ 3" × 3" × $\frac{5}{16}$ "	area = sq. in. gross	1.78	
$l/k_z = 56.5" \div 0.58"$	=	97	
$F_c = 9(1 - 0.0038 \times 97)$	= $\tau$ /sq. in.	5.68	
Actual stress = 3.96 $\div$ 1.78	= ,,	+ 2.22	
 <i>3rd Vertical.</i> Max. load	=	+ 2.68 <sup>τ</sup>	<b>41</b>
1 $\lfloor$ 3" × 2½" × $\frac{5}{16}$ "	area = sq. in. gross	1.62	
$l/k_z = 56.5" \div 0.52"$	=	109	
$F_c = 9(1 - 0.0038 \times 109)$	= $\tau$ /sq. in.	5.27	
Actual stress = 2.68 $\div$ 1.62	= ,,	+ 1.65	
 <i>4th Vertical.</i> Max. loads	=	+ 1.58 <sup>τ</sup> & - 0.65 <sup>τ</sup>	<b>42</b>
Because of stress reversal the design load			
is the greater plus half the lesser,			
= 1.58 + $\frac{1}{2}$ of 0.65	=	+ 1.91 <sup>τ</sup>	
1 $\lfloor$ 3" × 2½" × $\frac{5}{16}$ "	area = sq. in. gross	1.62	
Less 1 hole + $\frac{1}{2}$ out. leg	=	0.57	
Total area for tension	= sq. in. net	1.05	
$F_c$ , from item <b>41</b>	= $\tau$ /sq. in.	5.27	
Actual stress, + 1.91 $\div$ 1.62	= $\tau$ /sq. in.	+ 1.18	
"    "    tension = - 0.65 $\div$ 1.05	= ,,	- 0.62	
 <i>5th or Centre Vertical.</i> Redundant ; load	=	0	<b>43</b>
Use 1 $\lfloor$ 2½" × 2½" × $\frac{5}{16}$ "			

**Riveting.** Rivet diameter =  $\frac{3}{4}$ ".

$F_s = 6.5$ , $F_{ds} = 13$ and $F_b = 15$	$\tau$ /sq. in.	<b>44</b>
Value of one rivet in single shear ( <i>S.S.</i> )	= $\tau$ /rivet	2.87
"    "    in double shear ( <i>D.S.</i> )	= ,,	5.74
"    "    in bearing on $\frac{5}{16}$ " ( $\frac{5}{16}$ " <i>B</i> )	= ,,	3.51
"    "    in bearing on $\frac{3}{8}$ " ( $\frac{3}{8}$ " <i>B</i> )	= ,,	4.22

Refer to Plate IV and Fig. 190.

**Joint 1.**  $\frac{3}{8}$ " Gusset. Rivets required for :

Vertical = 5.43 <sup>τ</sup> $\div$ 4.22 <sup>τ</sup>	=	2	<b>45</b>
Diagonal = 8.91 <sup>τ</sup> $\div$ 2.87 <sup>τ</sup>	=	3 or 4	
Flange = 7.06 <sup>τ</sup> $\div$ 4.22 <sup>τ</sup>	=	2	

*Item 51.* In this case the horizontal load is the increment of flange force, because the flange angles are unbroken, while the vertical load is  $1.55T$  as mentioned above.

*Item 53.* The web diagonal obtains its maximum force when the bridge is partially loaded and with this loading there will be a difference in the flange forces on either side of this joint. The maximum flange force of  $-15.14T$  only takes place when the bridge is completely covered by the live load. In any case the increment or difference in force in the flange angles at this joint will be small and the number of rivets given in the detail, flange angles to gusset plate, are ample in number. This will be apparent on examination of the previously designed bottom flange panel points.

*Raker.* In order to fix a reasonable size for the raker, the horizontal side thrust at the upper or compression flange, which thrust the raker counteracts, is usually taken at 2 or 3 per cent. of the maximum compressive stress in the upper flange, *i.e.*, a figure similar to that used in the lacing of columns and compression members. The thrust in the raker is small and is  $0.02 \times 16.14T \times \text{cosec } \theta$ , where  $\theta$  is the inclination of the raker to the vertical. Alternatively, a crowd of people could be supposed to lean against the sides or handrailing at the rate of  $\frac{1}{2}$  cwt. per foot run, *i.e.*, a side thrust per raker of  $12.5 \times \frac{1}{2}$  cwt. =  $0.3T$ , giving the axial load on raker of  $0.3T \text{ cosec } \theta$ . This load is so small that the effects of the eccentricity caused by the bottom segmental bend were not investigated.

An increase in the stability of the upper flange could be obtained if rakers were added at each end vertical. This may be done by attaching the special end raker to the lower end of the end vertical, now joggled over the flange angles, as indicated on Fig. 196. The

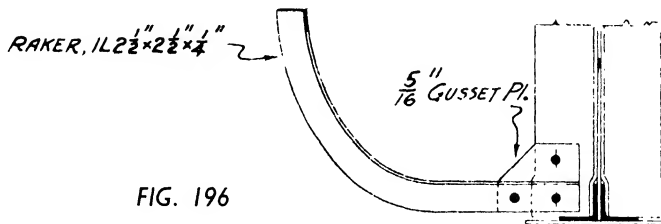

FIG. 196

end detail given on the plate, however, is quite common. The end vertical and gusset plates are heavier than are necessary and so also is the end diagonal tie, all of which contribute towards stability. Furthermore, the stress in the compression flange has its minimum value at this point.

*Wind.* But little area is exposed to wind pressure, so that the

<i>Joint 3.</i>	$\frac{5}{16}$ " Gusset. Rivets required for	<b>46</b>
	Vertical = $3.96^{\tau} \div 2.87^{\tau}$ =	2
	Diagonal = $6.49^{\tau} \div 2.87^{\tau}$ =	3
	Flange = $(12.11^{\tau} - 7.06^{\tau}) \div 3.51^{\tau}$ =	2
<i>Joint 5.</i>	$\frac{5}{16}$ " Gusset. Rivets required for :	<b>47</b>
	Vertical = $2.68^{\tau} \div 2.87^{\tau}$ =	1
	Diagonal = $4.40^{\tau} \div 2.87^{\tau}$ =	2
	Flange = $(15.14^{\tau} - 12.11^{\tau}) \div 3.51^{\tau}$ =	1
<i>Joint 7.</i>	$\frac{5}{16}$ " Gusset. Rivets required for :	
	Vertical = $(1.58^{\tau} + 0.65^{\tau}) \div 2.87^{\tau}$ =	1
	Diagonal = $(1.07^{\tau} + 2.59^{\tau}) \div 2.87^{\tau}$ =	2
	Flange = $(16.14^{\tau} - 15.14^{\tau}) \div 3.51^{\tau}$ =	1
<i>Joint 2.</i>	$\frac{3}{8}$ " Gusset.	<b>49</b>
	Flange has no direct stress, see text.	
<i>Joint 4.</i>	$\frac{5}{16}$ " Gusset. Rivets in flange $\left  \underline{s} \right.$ .	<b>50</b>
	Horizontal load = $7.06^{\tau}$	
	Vertical .. = $1.55^{\tau}$	
	Resultant .. = $\sqrt{(7.06^2 + 1.55^2)}$	
	= $7.3^{\tau}$	
	Number of rivets = $7.3^{\tau} \div 3.51^{\tau}$ =	2 or 3
<i>Joint 6.</i>	$\frac{5}{16}$ " Gusset. Rivets in flange $\left  \underline{s} \right.$ .	<b>51</b>
	Horizontal load = $(12.11^{\tau} - 7.06^{\tau})$	
	= $5.05^{\tau}$	
	Vertical .. = $1.55^{\tau}$	
	Resultant .. = $\sqrt{(5.05^2 + 1.55^2)}$	
	= $5.3^{\tau}$	
	Number of rivets = $5.3^{\tau} \div 3.51^{\tau}$ =	2
<i>Joint 8.</i>	$\frac{5}{16}$ " Gusset. Rivets in flange $\left  \underline{s} \right.$ .	<b>52</b>
	Horizontal load = $(15.14^{\tau} - 12.11^{\tau})$	
	= $3.03^{\tau}$	
	Resultant .. = $\sqrt{(3.03^2 + 1.55^2)}$	
	= $3.4^{\tau}$	
	Number of rivets = $3.4^{\tau} \div 3.51^{\tau}$ =	1
<i>Joint 10.</i>	$\frac{5}{16}$ " Gusset. Rivets in flange $\left  \underline{s} \right.$ .	<b>53</b>
	Settled by detail, see text.	

floor system is sufficiently rigid to carry the wind loads to both abutments. However, should the site be greatly exposed, light angle bracing,  $2\frac{1}{2}'' \times 2\frac{1}{2}''$  or  $3'' \times 3'' \times \frac{1}{4}''$  or  $\frac{5}{16}''$ , would be ample, and should be placed as indicated in broken line in the part plan of Plate IV. These diagonals would take tensile stress only; the cross beams acting as the struts of the web system.

To obtain the maximum force in the diagonal or strut of any panel of the horizontal wind girder assume only the longer segment of the girder exposed to the wind load, as was done with the main vertical girders when carrying the live load.

## REFERENCES

### BRITISH STANDARD SPECIFICATIONS

*(Published by the British Standards Institution, 2 Park Street,  
London, W.1.)*

B.S. 940. *Part 1 and Part 2. "Grading rules for structural timber."*

Included in these are the working stresses for the commoner types of timber under varying conditions of exposure, together with the maximum permissible defects, etc.

B.S. 913, "*Pressure creosoting of timber,*" which gives method of preserving timber, quantity of creosote, absorption, etc.

B.S. 144. "*Coal tar creosote for the preservation of timber.*"

*Code of Practice, C.P. 112: 1952. "The structural use of timber in buildings."* Deals with the design, fabrication and erection of timber used in buildings. Design data for nails, screws, bolts and connectors used in timber joints are included.

## CHAPTER VIII

### *EQUIVALENT UNIFORMLY DISTRIBUTED LIVE LOAD*

THE curve of maximum bending moments produced by a series of concentrated wheel loads crossing a span is made up of a large number of portions of parabolas, to which curve each load contributes one parabola. When the number of wheels dealt with is small, and the loads are of constant maximum intensity—as in the crane girder—the proper and simplest way of obtaining the bending moment for any point of the span is to draw the curve of maximum bending moments. Where the number of wheels is large—as in Plate V—the labour involved in such a process is prodigious, since an innumerable series of curves would require to be drawn, entailing one involved curve for each particular set of loads occupying the span. Let but one wheel pass off the span and there is presented an entirely new series of wheel loads.

The difficulty of estimating the correct maxima is further complicated in that the bending moments and shears actually occurring are much larger than those obtained on the assumption that the loads are static, *i.e.*, the train momentarily at rest. Unbalanced reciprocating and revolving masses in the locomotive, the lurching caused by bad springs, the wear of the tyres, inequalities of track, centrifugal force, etc., etc.—effects now loosely gathered under the one term, impact—all help in increasing the bending moments and shears. The final values for these quantities cannot be accurately ascertained, and the most common method employed is to find the static value and then increase them by using an empirical multiplier, known as an impact factor.

The fact then emerges that individual curves for bending moment and shear are not worth the trouble they involve, and recourse is made to the funicular polygon; from this are obtained two uniformly distributed loads, which have approximately the same effect as the concentrated loads; one *U.D.L.* for bending moment and another for shear.

Unfortunately, the closeness of the approximation hinges on the “circumscribing” parabola, upon which there are various ideas current. It is hoped that the following arithmetical examples will illustrate and clarify this particular point.

*Example.* Loading. Two 5-ton wheels, 12 ft. apart, on a 30-ft. span girder. Maximum bending moment occurs under either wheel when the span centre line is midway between the centre of gravity of the loads and the chosen wheel. Thus, from Fig. 198, the maximum  $B.M. = R_1 \times 12'$ , or 48 foot tons. In the four sets of examples,  $ABCDE$  is the actual curve of maximum bending moments, where  $B$  and  $D$  are 48 foot tons above the base line  $AE$ .

*Case I. The Circumscribing Parabola, Fig. 197.* It is a property of the parabola that when a tangent such as  $AH$  is drawn to it at  $A$ , the subtangent  $FH$  is bisected by the vertex at  $B$ . The enveloping parabola, if it is to circumscribe in the mathematical sense, must also have  $AH$  as a common tangent. Hence produce  $AH$  to cut the centre line  $CL$  at  $J$ , and the vertex  $M$  of the circumscribing parabola is midway between  $L$  and  $J$ .

Since  $FH =$  twice  $FB = 96$ , therefore, by similar triangles,  $LJ = 120$  and  $LM = 60$ . The parabola  $AME$  is the smallest parabola which truly circumscribes the original curve  $ABCDE$  without cutting it.

A curve identical to  $AME$  can also be obtained by wholly covering the span with a uniformly distributed total load  $W$ . Therefore, the maximum bending moment, due to  $W = Wl \div 8 = LM$ ; hence, the "equivalent"  $W = LM \times 8 \div l = 60 \times 8 \div 30 = 16$  tons.

If  $w$  per foot run is desired, divide  $W$  by the span, *i.e.*,  $w = LM \times 8 \div l^2$ .

When the wheel loads are unequal draw the tangent to the larger of the two original parabolas.

If the flange area be allotted according to the circumscribing parabola the girder will be overstrong throughout its entire length. Near the centre the difference, or overstrength, is 25 per cent.

*Case II. Fig. 199.* In this example the "equivalent" (and not circumscribing) parabola is that drawn from  $A$  to  $E$  with the vertex on the span's centre-line and having a vertical height  $LN = FB = 48$ . Equivalent total  $W = LN \times 8 \div l = 48 \times 8 \div 30 = 12.8$  tons.

If the equivalent parabola is used to design the flanges they will be weak except for a small portion near the centre.

*Case III. Fig. 200.* The equivalent parabola is the dotted curve  $ABODE$  which passes through the actual points,  $B$  and  $D$ , of maximum bending moment. If the wheel loads are unequal, then through the higher of the two points,  $B$  or  $D$ , and above the remaining point.

The equation of the parabola  $AOE$  with origin at  $A$  can be found thus :-

$s(l - s) = Q \cdot FB$ , where  $Q$  is a constant.

$$\therefore Q = s(l - s) \div FB = 12 \times 18 \div 48 = 4.5.$$

Ordinate  $LO$  then follows from  $AL \cdot LE = Q \cdot LO$ , or  $15^2 = 4.5 LO$ , and therefore  $LO = 50$ .  $LO$  is now the maximum ordinate of  $Wl \div 8$  of the bending moment curve in dotted line.

$\therefore$  Equivalent total  $W = LO \times 8 \div l = 50 \times 8 \div 30 = 13\frac{1}{3}$  tons.

The equivalent parabola gives flanges 4 per cent. overstrong for the centre 6 ft., but too weak elsewhere.

Case IV. Fig. 201. The equivalent parabola is drawn through

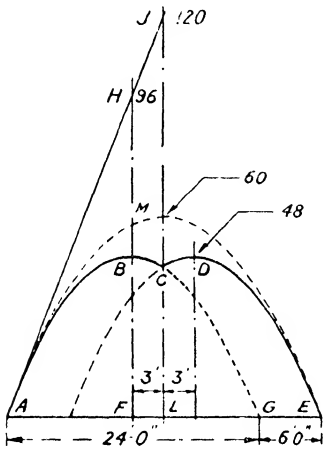

FIG. 197

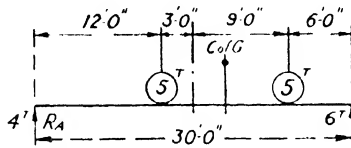

FIG. 198

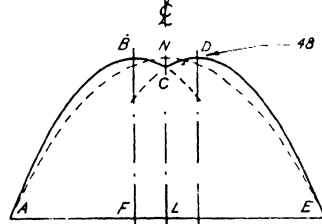

FIG. 199

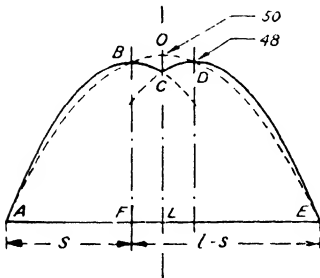

FIG. 200

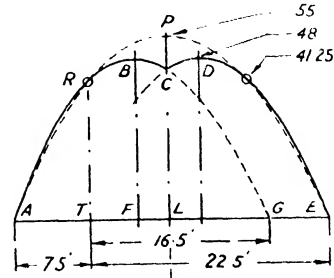

FIG. 201

the point  $R$  the actual bending moment at quarter span. (The greater of the two quarter span  $B.M.$ 's, if these be unequal.)

To find the value of  $Q$ , the constant, for parabola  $ARBCG$  :--

$$AF \cdot FG = Q \cdot BF \therefore Q = 12^2 \div 48 = 3 \quad \dots (a)$$



The value  $TR$  then follows, since

$$AT \cdot TG = Q \cdot TR, \therefore TR = 7.5 \times 16.5 \div 3 = 41.25. \quad (b)$$

To find the value of  $Q_1$ , the constant, for parabola  $ARPE$  :—

$$AT \cdot TE = Q_1 \cdot TR \therefore Q_1 = 7.5 \times 22.5 \div 41.25 = 4.091 \quad (c)$$

The height  $LP$  is now found from

$$AL \cdot LE = Q_1 \cdot LP, \therefore LP = 15^2 \div 4.091 = 55 \quad (d)$$

The equivalent total  $W = LP \times 8 \div l = 55 \times 8 \div 30 = 14\frac{2}{3}$  tons.

The percentage overstrength near the centre is about 14.5. The equivalent parabola is very nearly coincident with the curve of maximum bending moments between the quarter points and the ends. The difference can be neglected, as there is generally an excess of flange area, because both the main angles and the  $\frac{1}{8}$  web must be carried right to the ends and not curtailed like flange plates.

*Conclusions.* The *E.U.D.L.* obtained from the circumscribing parabola of Fig. 197 is rather expensive to use in competitive design, and practice now makes use of the quarter point method, either directly or indirectly. However, perfect safety united with economy could be obtained by providing flange area near mid-span for the actual maximum bending moment of 48 foot tons, and then cut off the flange plates to either the circumscribing parabola of Case I or the equivalent parabola of Case IV.

PLATE V, 70-FT. SPAN RAILWAY BRIDGE. The method of arriving at the equivalent uniformly distributed live load (*E.U.D.L.L.*) for bending moment will be described first.

To avoid the tedious plotting and replotting of the wheels in their correct position the span is moved relatively to the loads ; the reverse of what actually occurs. Next, the load line is plotted on the extreme left, the top load being that of the leading wheel, while succeeding loads correspond to succeeding wheels. Point, or pole,  $O$  is chosen so that the polar distance  $H$  is an integral number of tons, measured to the load scale. If  $H$  be made about half the length of the total load line, and  $O$  be placed approximately midway up the load line, the resulting funicular polygon (also known as link or equilibrium polygon) will come well within the sheet. No other reason governs the position of  $O$  and the length of  $H$ .

From the pole  $O$  draw the rays  $a, b, c, d$ , etc., to the load line, and with a clinograph or a plain or rolling parallel ruler draw links parallel to these between the verticals dropped from the wheels. Thus, link  $a$  is outside the vertical from the leading wheel, while ray  $a$  is to the outside of the load line. Link  $b$ , parallel to ray  $b$  of the force polygon, is drawn between the verticals from the first and second wheels, while ray  $b$  was drawn between the first and

second loads of the force polygon. Ray  $g$ , which lies between the  $7\cdot5^x$  load and the  $7\cdot7^x$  load, therefore ordains the position of the  $g$  link as being between the verticals from the  $7\cdot5^x$  wheel and the  $7\cdot7^x$  wheel, and so on.

If the ends of the funicular polygon were joined it would be a bending moment diagram for a bridge whose span would be from the leading buffer to the last of the 5-ton loads, and the loads causing the moments would be the entire train, at rest, in the position shown. Similarly, if the span is only 70 ft. the *B.M.* curve is 70 ft. long, horizontally, as for position  $A$  of the span. The curve for this position is shown hatched, and is lettered  $hj$ . The *B.M.* diagram for position  $D$  is obtained by dropping verticals from the ends of  $D$  and joining the two points so obtained on the link polygon. The funicular polygon can therefore be used for various spans, 20 ft., 30 ft., 40 ft., etc., by simply drawing in the appropriate length of span at  $A$ ,  $B$ ,  $C$ , etc.

The bending moment curve for position  $A$  only holds good for that one position of the wheels and span; move the train 1 ft. to the right (or its equivalent, the span to the left) and a new curve is created. Therefore, the *B.M.* curve  $B$  is for a position of the wheels when these have moved a distance of about 10 ft.; if they move a further 10 ft., then position  $C$ .

Position  $A$  will give the maximum bending moment near the centre of the span, while position  $D$  may give a maximum at some other point on the span. A summary of these is made as follows. Draw a base line 70 ft. to scale and erect perpendiculars at intervals of, say, 10 ft., as in the curve marked "7 panels at 10 ft." Span  $A$  is divided into the same number of parts,  $\alpha$ ,  $\beta$ ,  $\gamma$ ,  $\delta$ , etc. The vertical intercept  $mn$ , the *B.M.* at 10 ft. from the right-hand end of  $A$ , is now measured or pricked through on to tracing paper. Shift the tracing paper, or actually measure the corresponding intercepts for spans  $B$ ,  $C$ , and  $D$ , etc. If the bottom prick-mark is common, the largest intercept is automatically registered by the highest prick-mark, and this distance is now marked upon the *B.M.* diagram at  $m'n'$ . The distance  $m'n'$  is, therefore, the largest bending moment which occurs 10 ft. from the right-hand end of all the spans  $A$ ,  $B$ ,  $C$ , etc., and, thus, the largest bending moment which happens thereat when the train runs across the bridge. Repeat this operation for  $op$ , the intercept at 20 ft. from the right-hand end of each of the spans  $A$ ,  $B$ ,  $C$ ,  $D$ , etc.; the greater the number of span positions taken, the greater the accuracy. (The cross girders in the actual bridge are 10 ft. apart and this suggested the taking of the *B.M.* intercepts at the points of attachment of the cross girders to the span.) Thus the straight line maximum bending moment curve on a horizontal base

line is finally completed ; the maxima, be it noted, do not occur simultaneously, since the loading is composed of different point loads at various spacings.

Maximum *B.M.* near mid-span is easily found by placing the heaviest and closest together wheels in this position and then making use of the rule that maximum *B.M.* occurs when the span centre line is midway between the centre of gravity of the load system and the heaviest wheel. The centre of gravity for position *A* is located by producing the outer links *h* and *j* until they intersect at *k* ; after which span *A* is definitely placed so that its centre line lies midway between the *C.G.* line through *k* and the 10<sup>r</sup> wheel. Maximum bending moment, which occurs under this wheel, is the intercept on the vertical dropped from the 10<sup>r</sup> wheel to the shaded curve *hj*.

The arithmetical value of the *B.M.* = intercept measured to the linear scale  $\times$  the polar distance *H* as measured on the load scale. An actual *B.M.* scale can be arrived at thus. On the original drawing *H* = 3.75", linear scale was 1" = 10', load scale was 1" = 16<sup>r</sup>, while the largest intercept was 1.07 in.

$$\therefore \text{B.M.} = \text{intercept} \times \text{linear scale} \times H \times \text{load scale in foot tons,} \\ = 1.07 (10 \times 3.75 \times 16) = 1.07 (600) = 642 \text{ ft. tons.}$$

The *B.M.* scale is, therefore, 1" = 600 ft. tons.

By calculation the absolute maximum bending moment was found to be 640 ft. tons, an error in drawing of less than one-third of 1 per cent.

Different draughtsmen should obtain the same results, more or less, for the previous work, but slight differences will be apparent in the *E.U.D.L.L.*, as the final step requires the estimating of the equivalent, or so-called circumscribing, parabola. A trial vertex is assumed, slightly above the 640 ft. tons point, on the centre line and a parabola swung in. After one or two attempts the final equivalent parabola is drawn, which may be permitted to cut the straight line curve anywhere between the abutments and the quarter points.

*E.U.D.L.L. for B.M.*  $Wl \div 8 = 664$ ,  $\therefore$  the total equivalent uniformly distributed live load =  $W = 664 \times 8 \div 70 = 75.885^r$ , or per foot run per rail =  $75.885 \div 70 = 1.084^r$ , and per single line of way of two rails is  $2.17^r$ . The main girders at mid-span will be designed to the *E.U.D.L.L.*, *i.e.*, the 664 figure and not the actual one of 640. This will give an extra factor of safety to the bridge and may also prove useful for some future contingencies.

*Shear.* Group the heavy loads near the left hand of the span, when the maximum end shear or reaction is desired, *i.e.*, move the

span until the requisite position is obtained. If maximum shear is desired at point  $\beta$ , 10 ft. from the left-hand end of the span, place the span so that the heavy wheels are to the right of  $\beta$  and only the light wheels, if any, between  $\beta$  and  $\alpha$ . For maximum shear at  $\gamma$ , 20 ft. from the left end, place the heavy loads to the right of  $\gamma$ , as explained for  $\beta$ . As a second trial for the points place the leading light wheel at, or slightly to the left of, the neutral point of the panel considered, and the remaining loads between the neutral point and  $\theta$  the right-hand end. See Fig. 213, Chapter IX, for the position of the neutral points. After the trial position of the span has been fixed comes the problem of finding the reactions. As a detailed arithmetical example, position A, although not an appropriate case for shear, will be considered.

The loads on A are shown on the force polygon by the heavy line  $xyz$ . Points  $h$  and  $j$  are joined as for the *B.M.* diagram, and through pole  $O$  a parallel  $Oy$  is drawn to  $hj$ . Then  $zy$ , =  $36.15^T$ , is the right-hand reaction at  $\theta$ , and  $yx$ , =  $32.55^T$ , is the left-hand reaction at A. Similarly, the  $yx$  is measured for other positions of the span and the greatest,  $41^T$ , is plotted on the shear curve at  $qr$ . Still considering position A, the shears at  $\beta$ , etc., are probably best found by arithmetic.

Thus shear at $\alpha$ = $32.55^T$ upwards or	= + $32.55^T$
Shear at $\beta$ = $32.55^T$ upwards - $7.6^T$ load downwards,	
	see link polygon = + $24.95^T$
Shear at $\gamma$ = $32.55^T - (7.6 + 4.4) = \beta - 4.4$	= + $20.55^T$
Shear at $\delta$ = $32.55^T - (7.6 + 4.4 + 4.4 + 10)$ or	
	concisely = $\gamma - 14.4 = + 6.15^T$
Shear at $\epsilon$ = $32.55^T - (7.6 + 4.4 + 4.4 + 10 + 10)$	
	or concisely = $\delta - 10 = - 3.85^T$
Shear at $\zeta$ = $\epsilon - 9.5 = - 3.85 - 9.5$	= - $13.35^T$
Shear at $\eta$ = $\zeta - 7.5 = - 13.35 - 7.5$	= - $20.85^T$
Shear at $\theta$ = $\eta - (7.7 + 7.6) = - 20.85 - 15.3$	= - $36.15^T$
	= right-hand reaction $zy$ of load line as a
check	= - $36.15^T$

*E.U.D.L.L. for Shear.* The shear curve,  $q, r, s, t$ , etc., gives the maximal values plotted to scale, and a circumscribing inverted parabola, vertex at right end, is drawn through the positive shears. The same procedure is repeated for the negative shears plotted on the underside of the horizontal base line. As the train may run in either direction across the same span the larger value of  $41^T$  is taken for the end shear. If the span was covered by a uniformly distributed load, half the total load would be the value of each reaction. Therefore, total *E.U.D.L.L.* =  $2 \times$  end reaction =  $2 \times 41^T = 82^T$ .



Hence the *E.U.D.L.L.* per foot per rail =  $w = 82 \div 70 = 1.171^r$ , and per single line of way of two rails is  $2.34^r$ .

Comparing the two *E.U.D.L.L.* it will be observed that the shear is the greater by  $0.087^r$  per foot per rail, or 8 per cent. larger than the *B.M.* equivalent load. The corresponding figure obtained from the curves of the British Standard Unit Loadings is about 17 per cent. as an average for the spans between 30 ft. and 100 ft.

**Standard Loading.** In the foregoing example the actual axle loads were adjusted slightly to give wheel loads correct to the first decimal place. The two locomotives may, for the purpose of the design which follows in the next chapter, be supposed to be the heaviest which the particular line will have to carry. There are heavier locomotives, but the  $20^r$  axle seems to be about the present-day limit. Succeeding the two locomotives is a train supposed to weigh 2 tons per foot run of single way, which is taken as a series of  $5^r$  concentrations every 5 ft. of one rail. Five-foot intervals give a more flowing curve than the 10 ft. intervals of the *B.S.U.L.* Naturally, when only the loading of  $1^r$  per foot run per rail is on the bridge the *E.U.D.L.L.* for both shear and bending moment is also  $1^r$  per foot run.

*Fig. 202* gives the maximum bending moments and shears for the new unit loading for railway bridges, up to 100 ft. of span, for a single line of way. For heavy main line bridges the Minister of Transport recommends 20 units. Comparing the maximum *B.M.* for a 70-ft. span:—The *B.S.U.L.* gives 84.918 ft. tons for unit loading and the graphical example described gives 640 ft. tons per rail or 1,280 ft. tons for a single line of way of two rails. On this basis the number of units, or multiplier for the unit loading, is  $1,280 \div 84.918 = 15$ , as the shear is less, *viz.*,  $41^r \times 2 \div 5.586 = 14.7$  units. It will be appreciated that these two ratios will hardly ever agree, since the wheel loads and their spacings vary with different types of locomotives.

The plate only shows plotted values for spans up to 100 ft., but if values for all spans up to 300 ft. be graphed it will be found that the following equations give very close approximations to the published calculated values. *S* is the span in feet.

Span	B.M. at	Equation	Maximum per-centage error about
10 to 55 ft.	Centre	<i>B.M.</i> = $0.06730S^{1.675}$	3
25 to 55 ft.	Quarter point	<i>B.M.</i> = $0.05309S^{1.675}$	$3\frac{3}{4}$
55 to 300 ft.	Centre	<i>B.M.</i> = $0.03451S^{1.838}$	$2\frac{3}{4}$
55 to 300 ft.	Quarter point	<i>B.M.</i> = $0.02655S^{1.838}$	2, if spans 55 to 59 ft. be excluded.

Considering that the rolling mills claim a margin of  $\pm 2\frac{1}{2}$  per cent. the above errors are small.

For a uniformly distributed load the bending moment at the quarter point is three-quarters of that at the centre of the span ; for the first pair of equations the ratio of the coefficients is 0.788 and for the second pair it is 0.769 ; *i.e.*, approaching nearer the 0.75 figure as the span increases.

#### REFERENCES

- ANDERSON, C. W. *On Impact Coefficients for Railway Girders.* Min. Proc. Inst. C. E., Vol. CC.
- FABER, W. B. *Moving Loads on Railway Underbridges.* Min. Proc. Inst. C. E., Vol. CXLI and CCH.
- GRAHAM, J. *Arle Loads on Railway Bridges.* Min. Proc. Inst. C. E., Vol. CLVIII.
- BAMFORD, H. *Moving Loads on Railway Underbridges.* (Whittaker, 1907).
- ALEXANDER AND THOMSON. *Elementary Applied Mechanics.* (Macmillan & Co.)
- Tables of British Standard Unit Loadings for Railway Girder Bridges.* Specification No. 153—Parts 3, 4 and 5, Appendix No. 1, British Standards Institution, 2 Park Street, London, W.1.
- DEPT. OF SCIENTIFIC AND INDUSTRIAL RESEARCH. *The Report of the Bridge Stress Committee.* (1929.)
- GRIBBLE, C. *Impact in Railway Bridges with Particular Reference to the Report of the Bridge Stress Committee.* Min. Proc. Inst. C. E. Session 1928-29.

## CHAPTER IX

### *THE DESIGN OF A 70-FT. SPAN THROUGH RAILWAY BRIDGE (FOLDING PLATES VI, VII AND VIII)*

THE advantages and disadvantages of this particular type of bridge, from a railway engineer's point of view, will not be entered upon ; its appearance in these pages is governed by the fact that it presents important and interesting points in design.

The structure is an underbridge, in that the railway passes over it ; had the bridge passed over and above the track, then it would have had the term of overbridge assigned to it.

Another railway definition refers to the floor system. When ballast is used the sleepers can be placed in any position and the track carried on without interruption. The bridge has then a free floor. This is in contradistinction to a non-ballasted floor, which is usually so arranged that the sleepers (usually longitudinal timbers or way-beams) must occupy definite and predetermined positions, *i.e.*, a tied floor.

Again, the bridge is of the through type, a general engineering term denoting that the traffic (road or railroad) passes between the main girders. When the headroom is not limited the traffic may be carried on top of the main girders, upon a decking, from which the bridge derives the name of a deck bridge.

In bridge design future maintenance must be carefully considered. Thus, in the floor of the bridge the steel is preserved by a 1-in. thick covering of asphalt. This, in turn, is armoured against a carelessly driven platelayer's pick by a layer of fine aggregate concrete, which has a slight fall from the centre towards each main girder. The rain, after percolating through the ballast, ultimately finds its way into the side channels there provided.

Where the bridge is not over a road, the floor plating may be tapped at 5 ft. or 10 ft. intervals and short lengths of gas-piping inserted, through which the water is discharged clear of all steel-work ; if over a road, these gas-pipes discharge into half-round gutters—suspended from the underside of the bridge—which are carried to the downpipes at the abutments.

No camber will be given to the bridge, as it is not required either for drainage, æsthetic or theoretical reasons.



**Impact Allowance.** Much has been, and remains to be, written upon impact. In the current edition of B.S. 153—Bridges the committee advises that the provisional formula set out in the 1923 edition be discontinued, but it could not reach agreement "upon any one method which should be recommended in its place." Alternative methods are indicated in Appendix 3, but the decision as to the necessary allowance has been left to the Engineer (who thus may use the 1923 formula if he so desires).

Similarly, the committee which formulated the Code of Practice for Simply Supported Steel Bridges (1949) decided against adopting any empirical formula because of the lack of precise experimental data, which would justify it doing so. Since even the type of bridge affects the amount of impact allowance it felt that the Engineer "was in as good a position as the committee" to assess the necessary factor for a proposed bridge. The student, for whom this text-book is written, has no experience to draw upon and the formula with the accompanying working stresses of the B.S. 153 of 1923 have been retained in the text. This simple (or over simplified) formula permits the student an easy entry to the design calculations.

An extract from the current edition of B.S. 153 is given on page 268. In this the permissible axial tensile stress has been increased from 8 to 9 tons per net sq. in., and the other working stresses proportionately increased. The Code of Practice also uses 9 tons per sq. in.

When the young Engineer has his first bridge to design in practice he will be given a specification setting forth the values of the working stresses and the impact factors used by the particular office to which he is attached.

#### EXPLANATORY TEXT

*Item 1.* The Board of Trade's dictum on clearance is that "No structure, other than a platform, is to be nearer the side of a carriage than 2 ft. 4 in." To meet this regulation the bridge will be designed to the following clearance dimensions.

(1) The main girder may project above the running surface of the rail a distance not greater than 2 ft. 6 in., provided that the inner edge of the main girder is at least 2 ft. 3 in. away from the nearer edge of the adjoining rail.

(2) The height of 2 ft. 6 in. can only be exceeded if the horizontal distance, edge of rail to edge of flange, is 4 ft. 4½ in. or over. This is equivalent to stating that the clear width between handrailing is 25 ft.

*Item 3.* See main cross section. The rail bearers are placed slightly out of centre with the rails to facilitate the design and the construction. There is no eccentricity of loading on the rail bearers, as the sleepers cause the load to come centrally upon the stringers. The inner stringer carries a width of 5 ft. 6 in. made up thus:—½ (of 6 ft. way + 5 ft. distance between stringers) = 5 ft. 6 in.

The most economical spacing of the cross girders appears to be about one and half times the distance between the heaviest axles ;

WORKING STRESSES ON MILD STEEL FOR  
 GIRDER BRIDGES\* (1923)

		Symbol.	Tons per sq. in.
<b>TENSION.</b>	Axial stress on net section and extreme fibre stress on beams and girders	$F_t$	8
<b>COMPRESSION.</b>	Extreme fibre stress on gross cross-section of compression flanges of girders and beams, where these are :— Stiffened by edge angles, etc., or connected to flooring Unstiffened edges $l$ = max. unsupported length ; $b$ = flange breadth.	$F_c$	8 (1-0-0075 $l/b$ ) 8 (1-0-01 $l/b$ )
<b>STRUTS.</b>	Axial stress on the gross cross-section :— Riveted connections Pin connections But not to exceed $l$ = actual length in inches between intersections of gravity lines. $k$ = least radius of gyration in inches.		8 (1-0-0033 $l/k$ ) 8 (1-0-005 $l/k$ ) 6·8
<b>SHEAR.</b>	Stress on gross cross-section of web	$F_{sv}$	5
<b>DIRECT BEARING.</b>	Steel on steel	$F_b$	12
<b>SHOP RIVETS AND TURNED BOLTS (TIGHT FITTING)</b>	Single shear	$F_s$	6
	Double shear	$F_{ds}$	12
	Bearing	$F_b$	12

**RIVETS THROUGH PACKINGS** (thicker than  $\frac{3}{8}$ "). Increase number by 20 per cent.

**SITE RIVETS.** Calculate the number of shop rivets required and increase this number by 15 per cent.

**BLACK BOLTS.** Calculate the number of shop rivets required and increase this number by 20 per cent.

\* Based, by permission, upon British Standard Specification No. 153—Parts 3, 4 and 5 ; 1923—for Girder Bridges. This specification has been superseded by the current edition.

in this case =  $1\frac{1}{2} \times 7' 3'' = 10' 10\frac{1}{2}''$ , but 10 ft. will be adopted for obvious reasons. This spacing ensures that no cross girder occurs at the centre line—the point of maximum bending moment—of the 70-ft. span main girders.

*Item 6.* The live load moment of item 7 is that calculated on the assumption that the live loads are momentarily at rest. The wheel loads, however, are dynamic (and not static) loads, so that the actually occurring stresses are much higher than those caused by the same loads at rest.

Many types of formulæ have been used to assess this increment of stress due to impact, and that given in item 6 is the provisional one from the B.S.S. No. 153 of 1923.

Other contributory causes to this increment of stress, or impact effect, are:—flats on the treads of the wheels, rail joints, hammer blows on the rails induced by unbalanced reciprocating masses, lurching and nosing of the locomotive, friction locked springs, etc. In addition it has been found that the following also influence the value of the impact, *viz.*—the type of the girder, size of span, nature of the bridge floor, type of end bearing, piers and abutments, etc. Despite all these various and important items, which affect the amount of the impact stresses, the great majority of the impact formulæ are based directly upon the intensity of the wheel loads only.

*Item 7.* Other two probable cases of maximum bending moment were tried but were found to be less than that detailed. (1) The two  $10^T$  wheels at 7 ft. 3 in. centres on the span. (2) The  $4\cdot4^T$  and the  $10^T$  wheels at 5 ft.  $9\frac{1}{2}$  in. centres. This pair can be arranged so that the span centre line lies midway between the centre of gravity of the load system and the heavier wheel. This case gives a maximum bending moment under the  $10^T$  wheel of 292·6 in. tons.

It will be observed that the wheel loads are considered as point or concentrated loads on the stringers, whereas, in reality, they are distributed over a considerable length of each rail bearer, because of the distributing action of the rail coupled with the cushioning effect of the sleepers, ballast and concrete. This distribution is not uniform, as there must be points of intensive loading, depending upon the position of the

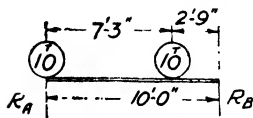

FIG. 203

wheels. Thus, with a wheel at the centre of the stringer span, the maximum moment will not be quite so large as  $Wl \div 4$  (single concentrated load) nor so small as  $Wl \div 8$  (the same load uniformly distributed). There is a further reduction in the maximum bending moment at midspan, because of the end fixity caused by the end

CALCULATIONS

**Width of Bridge.** Minimum width of main girder top flange = span  $\div$  40 ; *i.e.*, 70'  $\div$  40 or  $1\frac{3}{4}$  ft.

Top flanges as above, 2 half-widths @  $10\frac{1}{2}$  in. each = 1' 9"

Side clearances, edge of rail to edge of girder, 2 @ 2 ft. 3 in. each = 4' 6"

Rails, 4 @  $2\frac{1}{2}$  in. each = 10"

2 gauges @ 4 ft.  $8\frac{1}{2}$  in. + 6-ft. way = 15' 5"

For constructional purposes allow 3 in. extra at each side of bridge = 6"

Total width of bridge centre to centre of main girders. = 23' 1

**Loading** as indicated on Plate V.

*Floor Depth.* Rail + chair, minimum =  $7\frac{11}{16}$ "

Sleeper 5 in. deep, plus 4 in. minimum of ballast under it = 9"

Asphalt 1 in. deep, plus 2 in. minimum covering of fine concrete = 3"

Floor plating ; usual thicknesses, without calculation,  $\frac{3}{8}$  in.,  $\frac{7}{16}$  in. and  $\frac{1}{2}$  in. =  $\frac{7}{16}$ " 1' 8 $\frac{1}{8}$ " 2

STRINGERS OR RAIL BEARERS, PLATES VI, VII AND VIII

*Length, i.e.*, distance centre to centre of cross girders, adopt 10' 3

**Dead Load.** Consider the inner stringers.

Load on one :-

Floor plating,  $\frac{7}{16}$ " plate  $\times$  5' 6"  $\times$  10' @ 98.2 lb. per ft. of 66" wide plate = 982 lb.

Ballast, 9" average depth  $\times$  5' 6"  $\times$  10' @ 90 lb. per cubic foot = 3,712 ,,

Concrete, 2" deep  $\times$  5' 6"  $\times$  10' @ 140 lb. per cubic foot = 1,283 ,,

Asphalt, 1" deep  $\times$  5' 6"  $\times$  10' @ 136 lb. per cubic foot = 623 ,,

6,600 ,, = 2.95<sup>T</sup>

Track self (of two rails, chairs, sleepers, keys, etc.,  $1\frac{1}{2}$  c/ft.) per stringer =  $\frac{3}{4}$  c  $\times$  10' = 0.38<sup>T</sup>

Stringer self (approximate modulus and hence weight obtained from live *B.M.*) = 0.3<sup>T</sup>

Total distributed dead load = 3.63<sup>T</sup> 4

cleats and rivets attaching the stringer to the cross girder ; *i.e.*, the stringer is not really freely supported at the ends. Counteracting these is the heavy impact to which the short span stringers are subjected, since the wheel reaches the mid-point of the span practically instantaneously. Erring on the safe side the maximum bending moment is taken as  $Wl \div 4$ , with no allowance for either distribution of loading or for end fixing.

*Items 9 to 17.* The joist will be used in preference to the alternative type of Figs. 204 and 205, even if the built-up section is the lighter, because the drilling, riveting, kneeling and joggling, especially the two last items, make the built-up stringer a very costly one.

A key elevation of the built-up stringer, together with enlarged details, are given in Fig. 204*a, b, c, d* and *e*. View (*a*), detail on left,

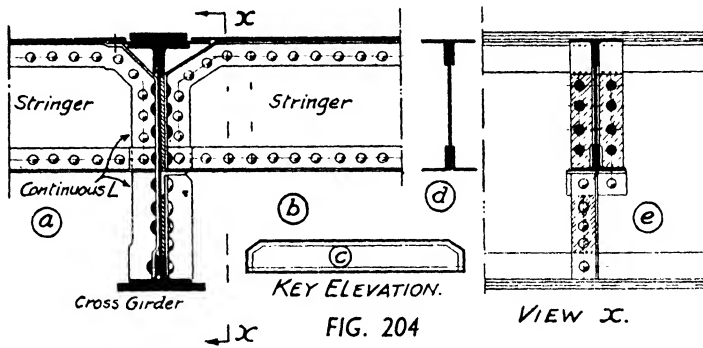

FIG. 204

shows a very expensive detail, as the stringer angles are joggled under the wide flange plate of the deep cross girder in order to catch two rivets thereto. These angles then continue, and project past the bottom flange of the stringer until they meet and are joggled over the lower flange angles of the cross girder, so as to act simultaneously as flange angles, end cleats and stiffeners. The bottom flange angles of the stringer are joggled over these stiffener angles, as is also done with the better detail on the right. The cost of the smithwork brings the tonnage price up to a prohibitive figure.

Compare this involved connection with that on the right hand of the cross girder web. The uppermost joggle is eliminated by kneeling the flange angles before the 14-in. flange plate is encountered, and erection is simplified by stopping these angles at the lower flange of the stringer. The stringer is swung into position and rests on the shelf angles, when it can be riveted up to the cross girder.

*Dead Load B.M.* =  $3.63\tau \times (10 \times 12)'' \div 8$ ,  
*i.e.,  $Wl \div 8$ , maximum* = in. tons 54.5 5

**\*Impact Factor =**

$$I = \frac{120}{90 + \frac{n+1}{2} L} = \frac{120}{90 + \frac{1+1}{2} 10} = 1.2$$

but not to exceed 1.15 6

*Live Load B.M.* Case 1. The 10<sup>τ</sup> wheel at mid span.

Maximum *B.M.* =  $Wl \div 4 = 10\tau \times (10 \times 12)'' \div 4$  = in. tons 300 7

**Total B.M.**

<i>D.L.</i> (item 5)	in. tons =	54.5	
<i>L.L.</i> (item 7)	" =	300.0	
Impact = $300 \times$ factor of 1.15	" =	345.0	
Total	" = say	700	8

**Shear.** The maximum shear is the end reaction *A*, Fig. 203

*D.L.* = item 4  $\div 2$  tons = 1.82

*L.L.* =  $R_1 = \frac{1}{6} (10 + 2.75)$  " = 12.75

*I.* =  $12.75 \times 1.15$  " = 14.66

Total maximum end shear " = 29.23 9

*Modulus Required* =  $700 \div F_t$  of 8 in.<sup>3</sup> = 87.5 10

*Web Area Required* =  $29.23 \div F_w$  of 5 = gross sq. in. 5.9 11

**Given.** 1 R.S.J. 18"  $\times$  6"  $\times$  55 lb. *Z* = 93.5 12

Web area =  $18 \times 0.42$  gross sq. in. = 7.6 13

**Alternative Section.** Built-up stringer.

Overall depth 18 in., effective depth 16 in.

Total flange force =  $B.M. \div D = 700 \div 16 = 43.7\tau$

Net tension flange area required =  $43.7 \div 8 =$  net sq. in. 5.47 14

Try 1 web plate 18" deep  $\times \frac{3}{8}$ " (item 11) = gross sq. in. 6.75 15

Tension flange 2  $\left[ \frac{3}{8} \times 3\frac{1}{2}'' \times 3\frac{1}{2}'' \times \frac{7}{16}'' \right]$   
 = 1 rivet each, net sq. in. = 5.04

$\frac{1}{8}$  web =  $6.75 \div 8$  " = 0.84

Total net area of tension flange " = 5.88 16

Compression flange (gross area); same section as tension flange =  $5.74 + 0.84 = 6.58$  17

\* Where *n* = the number of tracks which the girder supports or assists in supporting;  
 and *L* = the loaded length in feet of the track or tracks, producing the maximum stress in such girder.

Fig. 205 illustrates other details which aim at further reducing the smithwork. Where it is possible packings are used to prevent joggling.

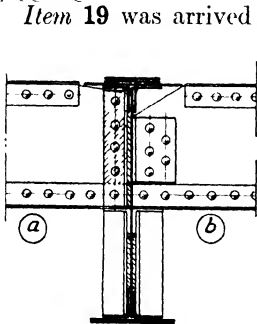

FIG. 205

Item 19 was arrived at by the method explained in the article headed "weight of plate girders," Chapter I. The net tensile flange area was found by slide rule, taking all the loading into account except that due to the unknown dead load of self. Roughly this area is that of item 26, viz., 18.2 sq. in. net. Therefore, the weight per foot of net area is  $18.2 \times 10 \div 3 = 61$  lb. (rule, p. 33). The gross weight per foot for the completed girder is  $3\frac{1}{2}$  times 61 lb. = 213 lb. Hence the total weight is 213 lb. per foot  $\times$  23 ft. = the weight as given in 19. It will be noted that the constant of  $3\frac{1}{2}$  is taken with the net area ; had the gross area been used the constant would require to be less than  $3\frac{1}{2}$  because there are no splices on the web or flange angles and practically no weight of stiffeners.

The dead weight of self, although in reality uniformly distributed, is assumed, with little error, as being concentrated at the panel points to facilitate the calculations.

Items 20 and 21. From the inspection of the wheel loads of Plate V it is evident that the maximum load on the cross girder occurs either when the wheels are in the position shown in Fig. 206

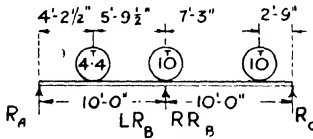

FIG. 206

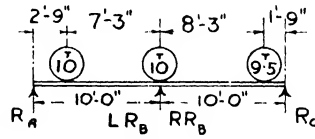

FIG. 207

or as indicated by Fig. 207. The total load on the centre cross girder of these diagrams is obtained by taking moments about A and C.

Fig. 210. There is no shear in the centre 6-ft. panel of the cross girder when both tracks are loaded (the case for maximum bending moment) or when both tracks are unoccupied by traffic. By loading only one track the maximum shear taking place in the mid-panel is found to be 15.23 tons. This figure is required for the rivet spacing in that panel.

*Rivets.* Try  $\frac{13}{16}$  in. diameter in *D.S.*  
(6·23 $\tau$ /rivet) or in  $\frac{3}{8}$  in. bearing (3·66 $\tau$ /  
rivet).

Horizontal shear per inch run = vertical  
shear per inch depth = approximately  $29\cdot23 \div 16 = 1\cdot83\tau$

More accurately by the formula on p. 15,

$$\frac{29\cdot23}{16} \times \frac{5\cdot74}{5\cdot74 + 0\cdot84} = 1\cdot6\tau$$

The horizontal shear per foot at ends of  
stringer =  $1\cdot6 \times 12 = 19\cdot2\tau$

Number of rivets per foot horizontally =  
 $19\cdot2 \div 3\cdot66 = 5\cdot25$

$\therefore$  pitch =  $12'' \div 5\cdot25 = 2\cdot28''$

The minimum pitch is  $3d$  or  $2\frac{7}{16}''$ , so that the web will require to be thickened up to  $\frac{1}{2}$  in. and the rivet diameter increased to  $\frac{13}{16}$  in. This gives 5·63 $\tau$ /rivet and the rivet pitch as 3 or  $3\frac{1}{2}$  in.

A suitable section now would be that composed of 4  $\frac{1}{2}$   $\times$   $3\frac{1}{2}$   $\times$   $3\frac{1}{2}$   $\times$   $3\frac{3}{8}$   $\times$  18  $\times$   $\frac{1}{2}$  web; the angles being decreased from  $\frac{7}{16}$  in. thickness because of the increase of the  $\frac{1}{2}$  web which is included in the flange section.

CROSS GIRDERS, PLATE VI

*Span* is 23 ft. c/c of main girders and  
spacing apart 10'.

*Effective Depth.*  $\frac{1}{8}$  to  $\frac{1}{2}$  of span (2·9' to 2')  
adopt 2' 9" = 2·75'

**Dead Load.** Concentrated loads from  
stringers (item 4) each = 3·63 $\tau$  18

Self. Uniformly distributed load, say = 2·18 $\tau$  19

**Live Load.**  $LR_n = (4\cdot4\tau \times 4' 2\frac{1}{2}'') \div 10' =$  tons 1·85

Case I, Fig. 206  $RR_n = 10\tau(2' 9'' + 10') \div 10' =$  ,, 12·75 14·6 $\tau$  20

Case II, Fig. 207  $LR_n = 10\tau(2' 9'' + 10') \div 10' =$  ,, 12·75

$RR_n = (9\cdot5\tau \times 1' 9'') \div 10' =$  ,, 1·66 14·41 $\tau$  21

**Impact factor,  $I$**  =  $\frac{120}{90 + \frac{2+1}{2} - 20} =$  1·00 22

**Load Summation** per panel point, *i.e.*, at a  
stringer (Fig. 208) = item 18 +  $\frac{1}{4}$  of  
item 19 + item 20 which is the maximum  
+ item 22 = 3·63 $\tau$  + 0·54 $\tau$  + 14·6 $\tau$  + 14·6 $\tau$  = 33·37 $\tau$  23



*Item 27.* Since the floor plating (aided by the stringers) supports the compression flange laterally throughout its full length,  $l$ , in  $F_c = 8(1 - 0.01 l/b)$ , is zero, but recall that the gross area of the compression flange should be not less than the gross area of the tension flange ; see also items **30** and **31** of the calculations.

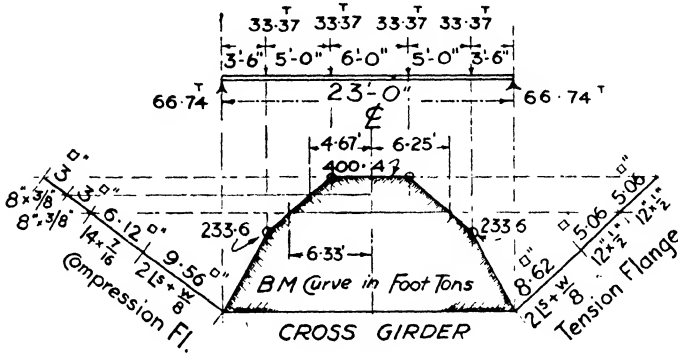
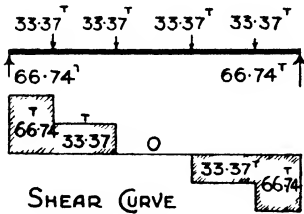

FIG. 208

*Items 30 and 31.* Constructional details fix the type of compression or upper flange to be used. The innermost plate is made 14 in. wide in order to project past the flange angles and the two 8-in. upper flange plates. Upon this ledge the floor plating is laid and then riveted, but, as this plating is not continuous throughout the



Both tracks loaded

FIG. 209

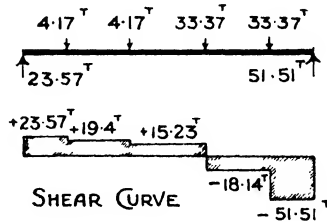

One track not loaded

FIG. 210

length of the cross girder, no addition in flange area is given thereby to the cross girder. A clearance, useful in erection, of at least  $\frac{1}{4}$  in. is allowed between the edges of the 8-in. flange plates and the skin plating of the floor. The asphalt fills up these interstices and also the voids caused by the cut-off of the two 8-in. outer flange plates. These, by the way, are entirely independent of the flooring and may

Total Flange Force =  $B.M. \div D = 400.4 \div 2.75$  (Fig. 208) =145.6 $\tau$  24

**Areas Required.** Web. =  $S \div F_w = 66.74 \div 5$  (Fig. 209) sq. in. gross=13.35 25  
 Tension flange  $145.6 \div 8$  sq. in. net=18.2 26

Compression flange gross area to be not less than the gross area of the tension flange. This is equivalent to 27

making  $F_c = F_t \frac{\text{net area}}{\text{gross area}} = 8 \times \frac{18.74}{21.56} = 7\tau/\text{sq. in. gross.}$   
 by items 30 and 31. 28

**Areas Given.** Web. 1 Pl. 33" deep  $\times \frac{1}{2}$ " thick = sq. in. gross 16.5 29

Tension Flange. Assume  $\frac{15}{16}$  in. diameter rivets.

	Gross area, sq. in.	Net area, sq. in.
2 $\left[ \begin{array}{l} s \\ \text{Pl. } 4" \times 4" \times \frac{1}{2}" \end{array} \right] = 7.5 - 2$ rivets	= 6.56	= 6.56 ✓
1 Pl. $12" \times \frac{1}{2}" = 6.0 - 2$ ,,	= 6.0	= 5.06
1 Pl. $12" \times \frac{1}{2}" = 6.0 - 2$ ,,	= 6.0	= 5.06 ✓
$\frac{1}{8}$ of web pl. =		
$\frac{1}{8}$ of item 29 = 2.06	= 2.06	
21.56 gross	= total net	18.74 30

Compression Flange

2 $\left[ \begin{array}{l} s \\ \text{Pl. } 4" \times 4" \times \frac{1}{2}" \end{array} \right]$	sq. in. gross = 7.50	
1 Pl. $14" \times \frac{7}{16}"$	,, = 6.12	
1 Pl. $8" \times \frac{3}{8}"$	,, = 3.00	
1 Pl. $8" \times \frac{3}{8}"$	,, = 3.00	sq. in. gross
$\frac{1}{8}$ web pl.	,, = 2.06	21.68 31

✓ Rivets.  $\frac{15}{16}$  in. diameter are in D.S. (8.28 $\tau$ ) and in bearing on  $\frac{1}{2}$  in. web (5.63 $\tau$ ).

Mid-panel, maximum shear, Fig. 210 = 15.23 $\tau$ . The horizontal shear per foot

$$= F = \frac{15.23}{D} \times \frac{A}{A + (W \div 8)}$$

where  $D$  is in feet.

$$\therefore F = \frac{15.23 \times 19.62}{2.75 \times 21.68} = 5.01\tau.$$

$$\therefore \text{Rivets per foot} = 5.01 \div 5.63 = 0.89 \quad 32$$

5 ft. panel, maximum shear, Fig. 209 = 33.37 $\tau$ .

$$\therefore \text{Number of rivets per foot} = \text{item 32} \times 33.37 \div 15.23 = 0.89 \times 33.37 \div 15.23 = 2$$

be stopped anywhere in their length, whereas the 14-in. plates must be continuous between the main girders.

There is a natural inclination to make the tension flange plates 14 in. wide to correspond with the compression flange, but there is a distinct advantage in narrowing them down to 12 in. and using thicker plates. If 14-in. wide plates are used then four rows of rivets are required, *viz.*, one row in each horizontal angle leg and another row between the toe of this leg and the outside edge of the plate. The requirements of the specification *re* diagonal tearing might call for four holes—even though these holes be reeled—to be deducted from the gross area when calculating the net area of the tension flange. Narrower plates therefore not only save drilling holes and riveting for an extra couple of lines of rivets, but also economize in metal.

**Item 34.** Because there is a cleat on both sides of the joist web, the rivets are in double shear ( $8 \cdot 28^r$ ) and in bearing on the 0.42-in. thick joist web ( $4 \cdot 73^r$ ). Part of the reaction is carried by the web cleat and the remainder by resting on the shelf angle.

**Item 35** considers the strength of the rivets connecting the two angle cleats to the same face of the cross girder. From this standpoint the rivets are in *S.S.*, or  $\frac{1}{2}$ -in. bearing on the cross girder web plate or  $\frac{3}{8}$ -in. bearing on the  $4'' \times 4'' \times \frac{3}{8}''$  cleat itself ( $4 \cdot 22^r$ ).

**Item 36.** On referring to Fig. 206 it will be seen that the cross girder carries a stringer on each face of the web. The total load on the cross girder web is therefore  $LR_n$  in addition to  $RR_n$ , and the lesser value of the rivets is the bearing value on the  $\frac{1}{2}$ -in. web plate.

**Item 37.** The cleats used are two  $4'' \times 3\frac{1}{2}'' \times \frac{1}{2}''$  angles. With the  $3\frac{1}{2}$ -in. legs against the main girder web, the distance apart of the rivet lines in the main web can be arranged at  $5\frac{1}{2}$  in. to suit the rivet lines of the stiffeners on the outside face of the main girder. See also the text in connection with item 71 and the enlarged detail on the cross-section drawing of Plate VI.

**Item 38.** By using  $\frac{1}{2}$ -in. doubling plates the rivets through the 4-in. legs of the cleats are in *D.S.* and in bearing on a total thickness of  $1\frac{1}{2}$  in., the former value being the lesser. The demand of the specification for 20 per cent. increase in the number of rivets through packings is satisfied by giving eleven rivets. The outer row of five rivets, through the packings and web only, more than develop the extra rivet value made use of in the vertical row through the cleat; *i.e.*, the row through the cleat would only be in  $\frac{1}{2}$ -in. bearing on the web (instead of  $1\frac{1}{2}$ -in. bearing) if the packings had not been extended out and separately riveted.

**Item 39.** The effective depth assumed in this item is practically correct; see the remarks concerning item 57.

*End panel*, maximum shear, Fig. 209 = 66.74<sup>r</sup>. Here "A" and "A + (W ÷ 8)" fall to 13.62 and 15.68 respectively, because of the curtailment of the 8" ×  $\frac{3}{8}$ " plates; see plan, Plate VI.

$$\therefore F = \frac{66.74}{2.75} \times \frac{13.62}{15.68} = 21.1. \quad \therefore \text{Rivets per foot} \\ = 21.1 \div 5.63 = 3.8$$

*Rivets Given.* Mid panel, 5 in. pitch; 5 ft. panel, 4 in. pitch or 3 rivets per foot; End panel, 2 $\frac{3}{4}$  in. pitch or 4.36 rivets per foot (3" pitch is also satisfactory).

**Cut-off of Flange Plates.** Net lengths scaled from the *B.M.* diagram of Fig. 208. Strength of 8" ×  $\frac{3}{8}$ " (comp. fl.) = area ×  $F_c$  = 3.00 × 7 = 21<sup>r</sup> 33

*S.S.* rivets to develop half of this =  $\frac{1}{2}(21.00 \div S.S. \text{ of } 4.14^r)$  = 3

Overall length of 8" ×  $\frac{3}{8}$ " pl. = net of 2 × 4.67' + two ends long enough to contain at least 3 rivets each. Length of inner 8" ×  $\frac{3}{8}$ " pl. is 2 × 6.33' + two end lengths to contain 3 rivets each. These lengths are respectively 11 ft. and 14 ft. 3 in. on the completed drawing. The 14" ×  $\frac{7}{16}$ " compression flange plate is carried the full length of the girder.

*Tension Flange.* The inner, 12" ×  $\frac{1}{2}$ ", plate is carried the full length.

Outer, 12" ×  $\frac{1}{2}$ ", plate. Half strength =  $\frac{1}{2}$  net area ×  $F_t$  =  $\frac{1}{2}$  × 5.06 × 8 = 20.24<sup>r</sup>

Number of *S.S.* rivets to develop this = 20.24 ÷ 4.14 = 5

Overall length of plate (see Fig. 208) = 2 × 6.25' + two ends each to contain 6 rivets = 14' 3"

**Cleats.** 4" × 4" ×  $\frac{3}{8}$ "  $\perp$  cleats to joist web. Maximum end shear, item 9 = 29.23<sup>r</sup>

Number of shops rivets required,  $\frac{15}{16}$  in. diameter (bearing) = 29.23 ÷ 4.73 in joist web = 6.2

Number given:—5 in joist web + 2 in vertical leg of shelf angle = 7 34

4" × 4" ×  $\frac{3}{8}$ "  $\perp$  cleats to cross girder web. Consider first the end connection of one stringer.

Number of shop rivets required,  $\frac{15}{16}$  in. diameter = 29.23 ÷ 4.14 (*S.S.*) = 7.06. Site rivets, add 15% = 8.12

Number of site rivets given through cleats alone = 10 35

The case of the cross girder web carrying two stringers. Rivets in *D.S.* or  $\frac{1}{2}$  in. bearing on web.

*Item 40.* The dead load of the girder itself is uniformly distributed, but, for simplicity of calculation, it is assumed as being concentrated equally at the panel points. The resulting error is very small. The method of estimating the dead load of the main girder is that explained in the text to item 19.

*Item 41.* When both tracks are occupied by the moving load each main girder, in effect, carries the live load of one track of two rails, so explaining why some designers take the value of  $n$  in the formula as 1 ( $n$  is the number of tracks which the girder supports or assists in supporting). It would appear to be more correct that  $n$  should be taken as 2, because each main girder assists in carrying two tracks. The respective impact coefficients are 0.75 and 0.62.

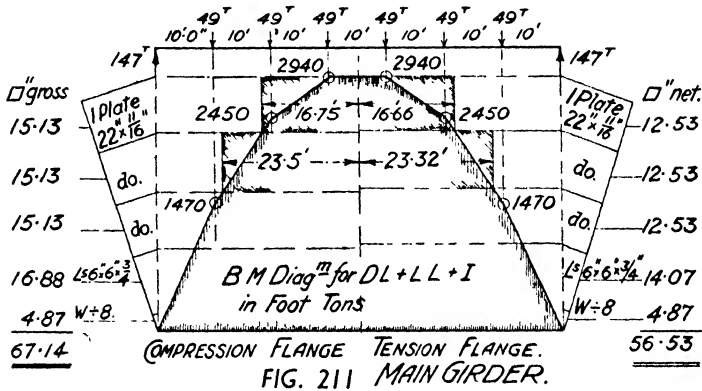

It has to be recalled that, for simplicity of design, both tracks are assumed to be loaded with an identical set of wheel loads keeping abreast of each other and crossing the bridge in perfect unison in the same direction. In usage the trains will run in opposite directions and the tendency will be for one train to damp or neutralize the vibration effects of the other, an additional reason for the use of the smaller coefficient. However, a preference, possibly due to experience, seems to exist in some offices for the higher coefficient of 0.75 and this is the value which will be used in the calculations.

*Items 44 and 45.* The maximum B.M. occurs when the bridge is completely loaded. Note that the end stringers rest directly upon the abutments.

*Item 47, Neutral Points.* It will be recalled from p. 206 that no shear existed in a panel if a concentrated load be placed at the neutral point of that panel. Hence, for maximum shear in, say, panel 2, let the uniformly distributed live load cover the longer

Maximum load on the cross girder web. Item <b>23</b> and Fig. 206	=	33·37 <sup>r</sup>	
Number of shop rivets required, $\frac{1}{8}$ in. diameter	---		
33·37 ÷ 5·63 ( $\frac{1}{2}$ in. bearing)	=	5·9	
Number of site rivets given, cleats to web of cross girder	=	10	<b>36</b>
<i>Cross Girder to Main Girder.</i> End shear, item <b>25</b> and Fig. 209	=	66·7 <sup>r</sup>	
$\frac{1}{8}$ in. diameter rivets. <i>D.S.</i> = 8·28 <sup>r</sup> and $\frac{1}{2}$ in. bearing = 5·63 <sup>r</sup> per rivet.			
Cleats to cross girder web. Number of rivets required = 66·7 ÷ 5·63	=	12	
Cannot be given in the depth. Use $\frac{1}{2}$ in. thick doubling plates. Rivets in <i>D.S.</i> or $1\frac{1}{2}$ in. bearing (16·89 <sup>r</sup> ).			
Number of shop rivets required = 66·7 ÷ 8·28 = 8·06, and number given	=	11	<b>37</b>
Cleats to main girder web :— Rivets in <i>S.S.</i> (4·14 <sup>r</sup> ) and in $\frac{1}{2}$ in. bearing (5·63 <sup>r</sup> ).			
Number of site rivets required = 66·7 ÷ 4·14 + 20% (through packings)	=	19	
Number of site rivets given in addition to resting on the lower main angles	=	18	<b>38</b>

MAIN GIRDERS, PLATE VII

<i>Span.</i> Centre to centre of bearings	=	70'	
<i>Effective Depth.</i> $\frac{1}{10}$ to $\frac{1}{12}$ span (7 ft. to 6 ft.)			
Adopt over angles	=	6' 6"	<b>39</b>
<b>Dead Load.</b> From cross girders. Half weight of cross girder, item <b>19</b>	tons	---	1·09
Track, flooring, stringers, etc., items <b>18</b> and <b>4</b> = 2 @ 3·63	tons	=	7·26
Main girder self, estimated at 18·9 <sup>r</sup> , or per panel = 18·9 ÷ 7	=	$\frac{2·7}{}$	
Total dead load at every cross girder panel point	=		11 <sup>r</sup> <b>40</b>

**Impact Factor** (see text).

$$I = \frac{120}{90 + \frac{n+1}{2} L}$$

$$= \frac{120}{90 + \frac{1+1}{2} 70} = \frac{120}{160} = \frac{3}{4} \quad \mathbf{41}$$

length from the neutral point to the further abutment ; in this case, until it extends from the right-hand abutment up to the neutral point, a distance of  $58\frac{1}{3}$  ft., a loading which gives maximum positive shear. If the load be considered as advancing from the left hand the maximum positive shears in the panels are found by considering panel 7 as becoming panel 1 ; the 6th panel becoming the 2nd, the 5th panel becoming the 3rd, and so on. Items 49 to

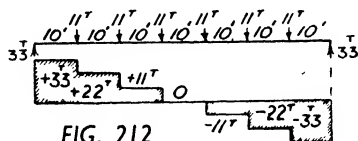

52 are the calculations for the maximum positive shear in each 10-ft. panel, obtained by using the neutral points.

The worst possible cases of the live loading of the bridge are obtained when the rolling loads on both tracks cross the bridge together, and both in the same direction.

Fig. 213 shows the influence lines for shear for each of the four left-hand panels. The construction of these curves is simple.

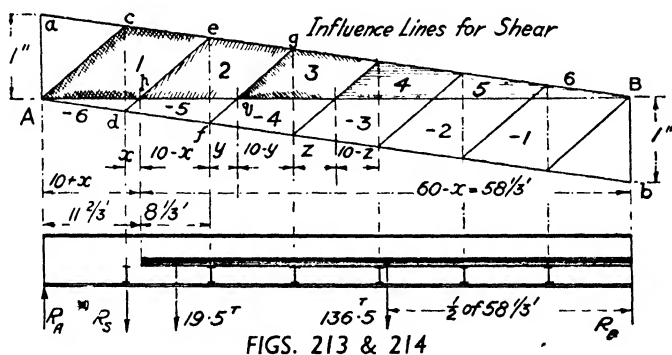

Erect a perpendicular of unit length at each end of the horizontal base line  $AB$ . Join  $a$  to  $B$  and  $A$  to  $b$ . Draw a series of parallel vertical lines 10 ft. apart to represent the 10-ft. panels and then join  $c$  to  $A$ ,  $e$  to  $d$ ,  $g$  to  $f$ , and so on.  $AcB$  is the influence line for shear for the end panel 1,  $peB$  is the influence line for positive shear for panel 2,  $qgB$  for the positive shear for panel 3, etc. In all cases the diagonal line cuts the base line  $AB$  at the neutral point of its own panel.

*E.U.D.L.L. for B.M.* From Plate V of Chapter VIII the equivalent uniformly distributed live load is  $1.084^{\text{r}}$ /ft. per rail, or per single track of 2 rails =  $2.17^{\text{r}}$  **42**

The panel live load with both tracks completely loaded is =  $2.17 \times 10'$  =  $21.7^{\text{r}}$  **43**

**Maximum B.M.** The total panel load = *D.L.* **40** + *L.L.* **43** + *I*, item **41**

=  $11.0^{\text{r}}$  +  $21.7^{\text{r}}$  +  $\frac{3}{4}$  of  $21.7^{\text{r}}$  =  $49^{\text{r}}$  **44**

Maximum *B.M.* at mid-span, from Fig. 211 = ft. tons 2,940 **45**

**Maximum Shears.** The dead load shear curve is given in Fig. 212 **46**

*Neutral Points*, Fig. 213, end panel. Load all the span.

2nd panel. By similar triangles

$$x : 10 - x :: 10 + x : 60 - x, \\ \therefore x = 1\frac{2}{3}' \text{ and } 60 - x = 58\frac{1}{3}'$$

3rd panel. By similar triangles,

$$y : 10 - y :: 20 + y : 50 - y, \\ \therefore y = 3\frac{1}{3}' \text{ and } 50 - y = 46\frac{2}{3}'$$

4th panel. By similar triangles,

$$z : 10 - z :: 30 + z : 40 - z, \\ \therefore z = 5' \text{ and } 40 - z = 35' \quad \mathbf{47}$$

*E.U.D.L.L. for Shear* is  $1.17^{\text{r}}$ /ft. per rail, or per single track of 2 rails =  $2.34^{\text{r}}$  **48**

*Live Load.* Maximum live shear at end occurs when every panel point carries a full live load of  $2.34^{\text{r}} \times 10 = 23.4^{\text{r}}$ . The end live reaction = 3 panels  $\times 23.4^{\text{r}}$  =  $70.2^{\text{r}}$  **49**

2nd panel, Fig. 214,

$$R_A = \left[ 136.5^{\text{r}} \times \frac{58\frac{1}{3}}{2} \right] \div 70, \text{ where}$$

$$136.5^{\text{r}} = 58\frac{1}{3} @ 2.34^{\text{r}}/\text{ft.} \therefore R_A = 56.88^{\text{r}}$$

$$R_S = \left[ 19.5^{\text{r}} \times \frac{8\frac{1}{3}}{2} \right] \div 10, \text{ where}$$

$$19.5^{\text{r}} = 8\frac{1}{3}' @ 2.34^{\text{r}}/\text{ft.} \therefore R_S = 8.13^{\text{r}}$$

$\therefore$  Maximum live shear in 2nd panel is the difference =  $R_A - R_S$  =  $48.75^{\text{r}}$  **50**

3rd panel, similarly,



\* Alternatively, the results of items 53 to 56 can be obtained directly from the influence lines if the dead load of 11 $\frac{1}{2}$  per 10-ft. panel be converted into a uniformly distributed *D.L.* of 1.17/ft. run. Since the dead load covers all the span, both the negative and positive triangles must be considered.

$$\begin{aligned} \therefore \text{End shear} &= \text{Area of } \Delta_1 (D.L. + L.L. + \text{Imp.})/\text{ft.} - 0 \\ &= 30 (1.1 + 2.34 \times 1\frac{1}{2}) = 30 (5.195) = 155.9 \\ \text{2nd Panel} &= \text{Area of } \Delta_2 (D.L. + L.L. + \text{Imp.})/\text{ft.} - \text{Area of } \Delta_{-3} (D.L.)/\text{ft.} \\ &= 20.832 (5.195) - 0.834 (1.1) = 107.3 \\ \text{3rd Panel} &= \text{Area of } \Delta_3 (D.L. + L.L. + I.)/\text{ft.} - \text{Area of } \Delta_{-5} (D.L.)/\text{ft.} \\ &= 13.334 (5.195) - 3.335 (1.1) = 65.6 \\ \text{4th Panel} &= \text{Area of } \Delta_4 (D.L. + L.L. + I.)/\text{ft.} - \text{Area of } \Delta_{-4} (D.L.)/\text{ft.} \\ &= 7.5 (5.195) - 7.5 (1.1) = 30.7 \end{aligned}$$

*Item 57.* The effective depth, *i.e.*, distance between the centres of gravity of the flanges, is taken as being from heel to heel of the main angles. In reality, the centre of gravity of the three plates and two main angles lies within the inner  $\frac{11}{16}$  in. flange plate, at about a  $\frac{1}{4}$  in. outside the heels of the main angles. The effective depth is therefore 78 $\frac{1}{2}$  in. instead of 78 in., but, by adopting the latter figure, the resulting flange stresses and areas of metal required will be slightly larger and therefore on the safe side. So long as three plates are used on each flange the error is small, about  $\frac{1}{8}$  of 1 per cent. After the cut-off of the outermost flange plate the centre of gravity of the remaining two plates and two main angles lies approximately on the heels; and within the main angles when only one flange plate remains. The figure of 78 in. is thus the average effective depth of the girder.

*Item 60.* The top flange is supported laterally, every 10 ft., at the cross girders, and the *l* of the formula is 10 ft. or 120 in. The support is given by the plated knee brackets from the ends of the cross girder compression flange to the main girder. This, in conjunction with the plated stiffeners thereat, form, with the cross girder, a powerful U frame.

*Items 62 and 63.* Usually about one-third of the total flange area should be allotted to the main angles, which in this case have been limited to 6"  $\times$  6"  $\times$   $\frac{3}{4}$ ". As these angles have to be spliced for length, a thicker angle would require a correspondingly thicker bent cover plate, and the greater is the encroachment upon the fairway of the rivets. See explanation in Chapter I, Vol. I. Angles 8"  $\times$  8" and 9"  $\times$  9" although listed are not so easily obtained.

*Item 64.* The factor 0.143 should also be applied to the shear *S* at points in the girder where there is no curtailment of flange plates. Its use for the end panel gives a closer pitch than that demanded by the correct factor which, for this position, is 0.134, necessitating

\* For further information see *Influence Lines: Their Practical Use in Bridge Calculation*. Chapter VII of this book gives the complete stress calculations for a similar bridge of 63' span by employing influence lines and the actual wheel loads, without recourse to the *E.U.D.L.L.*

$$R_i = \left[ (46\frac{2}{3} \times 2.34^T) \times \frac{46\frac{2}{3}}{2} \right] \div 70 = 36.4^T$$

$$R_s = \left[ (6\frac{2}{3} \times 2.34^T) \times \frac{6\frac{2}{3}}{2} \right] \div 10 = 5.2^T$$

∴ Maximum live shear in 3rd panel is  
the difference =  $R_i - R_s = 31.2^T$  **51**

4th panel,

$$R_i = \left[ (35 \times 2.34^T) \times \frac{35}{2} \right] \div 70 = 20.475^T$$

$$R_s = \left[ (5 \times 2.34^T) \times \frac{5}{2} \right] \div 10 = 2.925^T$$

∴ Maximum live shear in the 4th panel  
is  $R_i - R_s = 17.55^T$  **52**

*Alternatively by Influence Lines.* See Fig. 213.

Maximum live shear in panel No.  $x =$  area of triangle No.  $x \times E.U.D.L.L. =$  ordinate  $\times \frac{1}{2}$  base  $\times 2.34$ .

End panel, maximum live shear =  $\frac{9}{7}$  of  $1 \times \frac{1}{2}$  of 70  $\times 2.34 = 30 \times 2.34 = 70.2^T$  **49a**

Maximum live shear, 2nd panel =  $\frac{5}{7}$  of  $1 \times \frac{1}{2}$  of 58.33  $\times 2.34 = 20.832 \times 2.34 = 48.75^T$  **50a**

Maximum live shear, 3rd panel =  $\frac{4}{7}$  of  $1 \times \frac{1}{2}$  of 46.67  $\times 2.34 = 13.334 \times 2.34 = 31.2^T$  **51a**

Maximum live shear, 4th panel =  $\frac{3}{7}$  of  $1 \times \frac{1}{2}$  of 35  $\times 2.34 = 7.5 \times 2.34 = 17.55^T$  **52a**

**Total Maximum Shear** =  $D.L. + L.L. +$

Impact factor of  $\frac{3}{4} \times L.L.$

*End Shear.*

= item **46** +  $1\frac{3}{4}$  item **49** =  $33 + 1\frac{3}{4} \times 70.2 = 155.9^T$  **53**

*2nd panel*

= item **46** +  $1\frac{3}{4}$  item **50** =  $22 + 1\frac{3}{4} \times 48.75 = 107.3^T$  **54**

*3rd panel*

= item **46** +  $1\frac{3}{4}$  item **51** =  $11 + 1\frac{3}{4} \times 31.2 = 65.6^T$  **55**

*4th panel*

= item **46** +  $1\frac{3}{4}$  item **52** =  $0 + 1\frac{3}{4} \times 17.55 = 30.7^T$  **56**

**Total Flange Force.**

=  $B.M. \div D = 2,940 \div 6.5$  (item **45**) =  $452^T$  **57**

a pitch of 3.23 in. However, there is no necessity to go to this degree of accuracy. The  $S$ 's of this item are those of items **53** to **56**.

The maximum pitch for the rivets in a compression angle with a single rivet line is variously specified as  $12t$  or  $16t$ , where  $t$  is the thickness of the outermost plate or rolled section ( $\frac{1}{8}$ " ). When the angle has a double rivet line the maximum straight line pitch between rivets on the same rivet line is usually given as one and a half times the foregoing, or from  $18t$  to  $24t$  ( $12\frac{3}{8}$ " to  $16\frac{1}{2}$ " ). The reeled pitch of 6", i.e., 12" straight line pitch, is therefore satisfactory.

*Item 65.* The anomaly whereby the plate is stronger in compression than in tension is caused by the usual specification clause which states that "the gross area of the compression flange shall not be less than the gross area of the tension flange." The permissible working  $F_c$  is 7.56<sup>r</sup>/sq. in., but the actual working stress is less, since more than the requisite area of metal is given.

Actual  $f_c = 7.56 \times \text{items } 60 \div 63 = 7.56 \times 59.8 \div 67.14$ , and, substituting in **65**, 12 rivets are obtained instead of 14. In any case the corresponding flange plates are made the same length in both flanges. This simplifies the order sheets and improves the appearance of the completed girder.

*Item 66.* The outstanding plate is thin in comparison with the height and, therefore, only the blackened portion is assumed to be effective. This is a compromise to a feeling of security rather than to theory. The full width of  $10\frac{3}{4}$  in. is used to give lateral stability to the upper flange. See remarks anent the formula for stiffeners in Chapter I. This item shows the large difference between the two specifications, B.S.S., 1937, and B.S.S., 1923, as to what constitutes the load on an intermediate stiffener. For reasons given at the commencement of this chapter the working stresses of the 1923 specification govern the design.

*Item 68.* The rivets connecting the  $10\frac{3}{4}$ "  $\times$   $\frac{1}{2}$ " plate to the  $4$ "  $\times$   $4$ "  $\times$   $\frac{1}{2}$ "  $\perp$  must reel with those connecting the angle to the main web. The number of rivets given is therefore in excess of the number necessary to develop the  $10\frac{3}{4}$ -in. plate into the angle.

*Item 69.* When the girder carries its maximum load it will deflect, and practically all the reaction will pass through the edge of the bearing into the massive stiffener above.

*Item 70.* For the reason given above in item **69** the end stiffeners of item **70** are adopted without calculation.

*Item 71.* See remarks against item **37**. The size of these stiffeners is settled by the detail. The angle legs, on the outside face of the main web, must be of such a width as will permit the closing of the site rivets through the cross girder end cleats and the stiffeners

**Areas Required.**

$Web = S \div F_w = 155.9 \div 5$  (item 53) = sq. in. gross 31.2 **58**  
 $Tension\ flange = 452 \div 8$  (item 57) = sq. in. net 56.5 **59**  
 $Compression\ flange = 452 \div F_c =$   
 $452 \div 7.56$  (see under) = sq. in. gross 59.8 **60**  
 $F_c = 8(1 - 0.01l/b) = 8(1 - 0.01 \times 120 \div 22) = 7.56$  r/sq. in. 7.56  
 where  $b$  in the formula is taken at 22 in.  
 The preliminary estimate was about 21 in. ;  
 see item 1.

**Areas Given.** *Web.* 1 Pl. 78" deep  $\times \frac{1}{2}$ " thick = sq. in. gross 39 **61**

*Tension flange* gross area in sq. in. sq. in. net

$2 \left| \frac{1}{8} 6" \times 6" \times \frac{3}{4}" = 16.88 - 4r @ \frac{15}{16}$  in. dia. = 14.07  
 1 Pl. 22"  $\times \frac{11}{16}" = 15.13 - 4r @ \frac{15}{16}$  in. dia. = 12.55  
 1 Pl. 22"  $\times \frac{11}{16}" = 15.13 - 4r @ \frac{15}{16}$  in. dia. = 12.55  
 1 Pl. 22"  $\times \frac{11}{16}" = 15.13 - 4r @ \frac{15}{16}$  in. dia. = 12.55  
 $\frac{1}{8}$  web pl. =  $39 \div 8 = 4.87$  = 4.87  
 Total area 67.14 56.59 **62**

*Compression flange* as for tension flange.

$2 \left| \frac{1}{8} 6" \times 6" \times \frac{3}{4}"$ , area in sq. in. gross = 16.88  
 1 Pl. 22"  $\times \frac{11}{16}"$  " " " = 15.13  
 1 Pl. 22"  $\times \frac{11}{16}"$  " " " = 15.13  
 1 Pl. 22"  $\times \frac{11}{16}"$  " " " = 15.13  
 $\frac{1}{8}$  web pl. " " " = 4.87 67.14 **63**

**Rivets.**  $\frac{15}{16}$  in. diameter, *S.S.* value =  $4.14r$ /  
 rivet and  $8.28r$  for *D.S.* Bearing on  $\frac{1}{2}$  in.  
 web pl. =  $5.63r$ /rivet.

The rivets fastening the main angles to the  
 web plate are in *D.S.* and  $\frac{1}{2}$  in. *B.*

The horizontal shear per foot,

$$F = \frac{S}{D} \times \frac{A}{A + \frac{W}{8}} = S \times \frac{62.27}{6.5 \times 67.14} = 0.143S$$

Number of rivets required =  $F \div 5.63$  ;  
 and the reeled pitch =  $12" \div$  number of  
 rivets.

Panel.	<i>S</i> in tons.	$F = 0.143S$ .	Rivets/ft.	Reeled pitch required	Reeled pitch given.	
End	155.9	22.29	3.96	3.03"	3"	
2nd	107.3	15.34	2.73	4.40"	4"	
3rd	65.6	9.38	1.67	7.18"	6"	
4th	30.7	4.39	0.78	15.38"	6"	<b>64</b>

themselves. The "standard" position of the rivet lines in both cleats and stiffeners may be altered to suit, provided, of course, that no encroachment is made upon the  $1\frac{1}{2}d$  marginal distance from the rivet lines to the toes of either the cleat or the stiffener angles. The cross girder end cleats are  $1\frac{1}{2}$  in. apart ( $\frac{1}{2}$  in. web plus two  $\frac{1}{2}$  in. packings) and the stiffeners to which they are riveted are only  $\frac{1}{2}$  in. apart (the thickness of the  $10\frac{3}{4}$  in. gusset plate). The same point arises with the small kneed bracket stiffener which is placed on top of the cross girder.

In view of the strength of the previous stiffeners, coupled with the fact that the shear decreases towards the centre of the bridge, the sections adopted for the cross girder stiffeners will be satisfactory.

*Item 72.* The position of the splices have been so arranged that all the plates can be edge planed in a machine of 25 ft. travel without

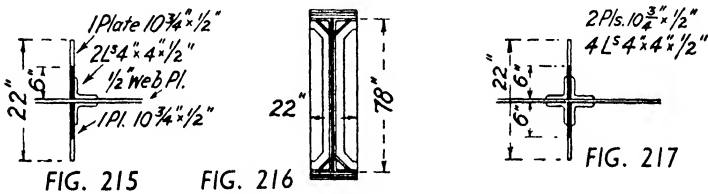

resetting. The outer flange plates are carried past their points of cut-off and made to act as covers for the mid-plates underneath.

*Item 73.* The vertical leg of the broken angle is covered on both faces, but the horizontal leg is covered on the root face only. If the joint be placed just previous to a flange plate cut-off the excess of flange metal will serve as the remaining cover, and, if not actually required for area, will tend to make a symmetrical joint.

*Item 75.* The upward pressure is assumed to be uniformly distributed throughout the casting. Therefore, one-half the reaction of  $156^T$  acts on one-half the casting. The centre of pressure is, by the assumption, at the mid-point of the area considered. The downward force of  $156^T$  is also assumed to be evenly distributed throughout the flange plates, and the centre of pressure of one-half the flange is  $5\frac{1}{2}$  in. away from the centre line. See Figs. 218 and 219.

*Item 78.* The inner flange plate and a main angle are cantilevered out on each side of the main girder web plate, and resist the upthrust or reaction from the casting. This double cantilever is reinforced at the bearing by a  $22" \times 1" \times 33\frac{1}{2}"$  M.S. plate being riveted (c's'k on underside) to the main girder. Because of the rivets and the large frictional resistance between each plate the resisting section modulus  $Z$  is that due to a local thickness of metal of

At the end of the plates, where curtailed, the rivet pitch must not exceed  $4\frac{1}{2}$  diameters = 4.22".

**Curtailement of Flange Pls., Fig. 211.**

22" ×  $\frac{1}{16}$ " pl. Tensile strength =  
 net area ×  $F_t$  = 12.55 × 8 = 100.40<sup>r</sup>  
 22" ×  $\frac{1}{16}$ " pl. Compressive strength =  
 gross area ×  $F_c$  = 15.13 × 7.56 = 114.38<sup>r</sup>  
 Number of S.S. rivets to develop half these strengths  
 =  $\frac{1}{2} \times 100.4 \div 4.14 = 12$   
 and =  $\frac{1}{2} \times 114.38 \div 4.14 = 14$  **65**

**Stiffeners. Intermediate.** That at 5 ft. from the end carries the heaviest shear, which is approximately 155.9<sup>r</sup> item **53**.

Load on stiffener, formula, p. 19, is  
 $s = Sp \div 4D = 155.9^r(2 \times 4' 5\frac{3}{4}'' ) \div (4 \times 6' 6'')$   
 = 155.9<sup>r</sup> × 8.96' ÷ 26' = 53.72<sup>r</sup> **66**

Load on stiffener, by the B.S.S. 153 of 1923,  $\frac{2}{3}$  of 155.9<sup>r</sup> = 104<sup>r</sup>

Figs. 215 and 216. The gross area of 2 Pls. 6" ×  $\frac{1}{2}$ " + 2  $\underline{L}_s$  @ 3.75 sq. in. = sq. in. gross 13.5 **67**

Permissible  $F_c = 8(1 - 0.01l/b)$  where  $l$  for this formula =  $D$  = 78"

$F_c = 8(1 - 0.01 \times 78'' \div 12.5'')$  =  $\tau$ /sq. in. gross 7.5

Alternatively by column formula :—

\*Rad. of gyr.,  $k$ , of 6" ×  $\frac{1}{2}$ " pls. +  $\underline{L}_s$  = 2.82"

Effective length =  $\frac{3}{4}D = \frac{3}{4} \times 78''$  = 58.5"

$F_c = 8(1 - 0.0033l/k)$   
 =  $8(1 - 0.0033 \times 58.5 \div 2.82)$  =  $\tau$ /sq. in. gross 7.45

Permissible load = area ×  $F_c$   
 = 13.5 (7.5 or 7.45) = 101.25<sup>r</sup>

Rivets given, stiffener to web = 18 **68**

Permissible load = 18 × 5.625<sup>r</sup> ( $\frac{1}{2}$ " B) = 101.25<sup>r</sup>

*Stiffeners at Edge of Bearing.*

Load = total shear or reaction = 155.9<sup>r</sup> **69**

\*  $k$  is obtained thus :—

$M.$  of  $I.$  2  $\underline{L}_s$ , own axis = 2 × 5.46 (from tables) = 10.92

+ Area × dist.<sup>2</sup> = 2 × 3.75(25 × 1.17)<sup>2</sup> = 15.12

Pl. own axis = 2 ×  $\frac{1}{2} \times \frac{1}{2} \times 6^3$  = 18

+ Area × dist.<sup>2</sup> = 2 × 3 × 3.25<sup>2</sup> = 63.36

Total  $I = 107.40$  ins.<sup>4</sup>

$\therefore k = \sqrt{\frac{I}{A}} = \sqrt{\frac{107.4}{13.5}} = 2.82''.$

$\frac{3}{4}'' + \frac{11}{16}'' + 1'' = 2\frac{7}{16}''$ . Had there been no rivets connecting the various elements together the *Z* would have been the sum of the individual *Z*'s of each thickness—a much lower value. In the cantilevered length *CE*, which is of constant thickness, the maximum *B.M.* occurs at *C*, and the worst position in the *DE* cantilever is at *D*, just outside the vertical angle leg.

The resulting stress is apparently high on using a base plate of

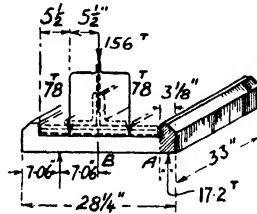

FIG. 218

only 1 in. in thickness, until it is recalled that the kneed four-angle plated and two-angle plated end stiffeners must afford a very substantial reinforcement to these cantilevers.

*Stringer Base Plates* are calculated in a similar manner. These, however, simply rest on flat steel plates on the abutments; see alignment chart, Fig. 63.

**Expansion Due to Temporary Rise.** An allowance of  $\frac{3}{4}$  in. made in the slotted holes of the main bearings permits the free

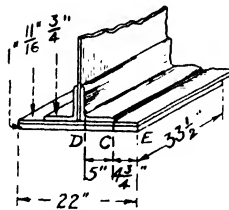

FIG. 219

expansion of the main steel girders. British specifications ask for 1 in. per 100 ft. The ferrules in the slotted holes keep the upper nuts and washers from bearing on the main angles, which are, therefore, really free to expand. These ferrules are not required at the fixed ends.

No special arrangement is required in the bearing castings to allow free deflection of the bridge, as the span is less than 100 ft.

Section as in Fig. 217. Area = 4 @ 3.75  
 sq. in. for  $\underline{L}_s + 2$  Pls. @  $6'' \times \frac{1}{2}''$  = sq. in. gross 21  
 Permissible load =  $21 \times 7.5$  = 157.5<sup>r</sup>  
 Min. number of rivets reqd. to attach  
 stiffener to web =  $155.9 \div 5.625$  = 27  
*Stiffener at Extreme End.* Give 2  $\underline{L}_s$   
 $4'' \times 4'' \times \frac{1}{2}''$  + an end or fascia plate  
 $22''$  wide  $\times \frac{3}{8}''$  thick. 70  
*Stiffeners at Cross Girders.* Sections  
 shown on drawings adopted without  
 calculation. 71

**Flange Plate Splice.** Net area of  
 $22'' \times \frac{11}{16}''$  Pl. = sq. in. net 12.55 72  
 Number of *S.S.* rivets (or  $\frac{11}{16}$  in. bearing)  
 to develop this plate =  $12.55 \times 8 \div 4.14$  = 24  
 Cover area =  $\frac{11}{16}'' + 10\%$ .  $\therefore$  thickness =  $\frac{3}{4}''$   
**Angle Splice.** Net area of a  $6'' \times 6'' \times \frac{3}{4}''$   
 angle (item 62) = sq. in. net 7.03 73  
 Number of *S.S.* rivets (or  $\frac{3}{4}$  in. bearing)  
 to develop the angle =  $7.03 \times 8 \div 4.14$  = 14  
 Only one angle will be spliced at any  
 part of the flange.  
 Cover area required =  $7.03 + 10\%$  = sq. in. net 7.74  
 Cover area given = 2 bent Pls. or  
 machined  $\underline{L}_s$ ,  $5\frac{1}{4}'' \times 5\frac{1}{4}'' \times \frac{1}{2}''$  = ,, 8.12  
 Plus any excess of flange plate area.  
 Number of *S.S.* rivets to develop the  
 covers =  $8.12 \times 8 \div 4.14$  = 16  
 Number of rivets given :- 4 in. vertical  
 leg in *D.S.*, equivalent in *S.S.* = 8  
 Plus 2 horizontal legs each with 4 rivets  
 in *S.S.* = 8 16  
 These splices are illustrated in Plate VII.

C. I. BEARINGS, PLATE VIII

Maximum end shear,  $D.L. + L.L. + I.$   
 (item 53) =  $155.9^r$ , say 156<sup>r</sup> 74  
 Bearing area of granite required under  
 casting at  $25^r/\text{sq. ft.}$  =  $156 \div 25$  = sq. ft. 6.24 ✓  
 Width = 2 rims @  $3''$  + 2 side clearances  
 of  $\frac{1}{8}''$  +  $22''$  flange ✓ = 28.25" ✓  
 Length of bearing =  $(6.24 \times 144)$  sq. in.  
 $\div 28.25'' = 32''$ . Length adopted = 33" ✓



**The Tractive and Braking Forces** which have their origin at the running surface of the rails find their way into the sleepers and ballast. Frictional resistance then permits the forces to travel through the skin plating into the stringers, thence into the cross girders, and ultimately into the bottom flanges of the main girder. The stringers and cross girders are thus subjected to horizontal forces in addition to the vertical forces for which these members were designed. However, due to the continuous riveting of the floor plating, this type of floor is practically one huge plate reinforced on the under side by massive ribs, and the actual distribution of the tractive or braking forces among the various elements composing the floor is more or less conjectural. The continuous plating gives an exceptionally strong floor, and usually no additional calculations are made regarding the strength of stringers or cross girders.

When there is no floor plating, lateral bracing is used to carry the tractive and braking forces into the main girder flanges ; here, since definite paths are provided for the passage of the forces, an estimate can and must be made of their numerical value.

The bottom flanges of the main girders are in tension when the train of loads enters the bridge from the fixed end, and in compression if the load enters from the free end. The stress intensity in the bottom flanges, in both cases of loading, increases from zero at the free end (if frictionless) by equal increments at each cross girder, until the maximum intensity is reached at the fixed end. The worse case for the main girder tension flanges is when the load travels from the fixed end towards the free end, as this results in an addition to the tensile stresses in these flanges.

**Ballast Plate.** The pitting and corroding action which ballast has on steel takes place at the ballast plate—a secondary member, easily renewed—and not at the main girder web plate, which is left clear and free for inspection and painting.

In the majority of bridge floors the plating is site riveted to the underside of the bottom ballast angle with the connecting rivets in tension. By using a wider legged angle the floor plating is laid on the horizontal leg of the angle and not under it. This leg, which is unbroken between the cross girders, is wide enough to give a clearance over and above that necessary for the root fillet. The top angle, which stiffens the ballast plate against lateral thrust from the ballast, is broken every 5 ft. to clear the intermediate stiffeners ; these in turn support the ballast plate and the vertical dead load of the floor which it carries.

**Wind Pressure.** *Item 80.* The total horizontal wind pressure on the bridge, unoccupied by a moving load, is twice the area seen

Resulting pressure per square inch on granite = $156 \div (28.25 \times 33)$	= tons/sq. in.	0.167
Since "action and reaction are alike and opposite" the upward pressure on the shaded cantilever, Fig. 218		
= $3\frac{1}{8}'' \times 33'' \times 0.167$	=	17.2 $\tau$
<i>B.M. @ A</i> = load $\times$ lever arm		
= $17.2\tau \times \frac{1}{2}$ of $3\frac{1}{8}''$	= in. tons	26.9 ✓
<i>Z</i> given of 3 in. thick C.I. (neglecting tooth) = $\frac{1}{6} bd^2 = \frac{1}{6} \times 33 \times 3^2$	= in. <sup>3</sup>	49.5 ✓
Extreme fibre stress in C.I. at <i>A</i> =		
<i>B.M. <math>\div</math> Z</i> = $26.9 \div 49.5$	= tons/sq. in. $\pm$	0.54 ✓
<i>B.M. @ B</i> = $78\tau$ upwards $\times 7.06'' - 78\tau$ downwards $\times 5\frac{1}{2}'' = 78\tau \times 1.56''$	= in. tons	121.7 <b>75</b>
Extreme fibre stress in C.I. at <i>B</i> =		
<i>B.M. <math>\div</math> Z</i> = $121.7 \div 49.5$	= tons/sq. in. $\pm$	2.46
Permissible stress in C.I. in tension	= ,,	- 2.5
Tractive factor, <i>B.S.S.</i> ,		
= $\frac{20}{L + 75} = \frac{20}{70 + 75}$	=	0.138 <b>76</b>
Braking factor, <i>B.S.S.</i> ,		
= $\frac{12}{L + 90} + 0.075$	=	0.15
$\therefore$ Longitudinal pull on bearings = 0.15		
$\times 1\frac{3}{4}$ maximum live shear ( <i>B.S.S.</i> )		
= $0.15 \times 1\frac{3}{4} \times$ item <b>49</b> of 70.2 $\tau$	=	18.4 $\tau$ <b>77</b>
Friction at bearings due to <i>L.L. + D.L.</i> (no impact) = 15% of items <b>49</b> and <b>46</b>		
= 0.15 of (70.2 + 33) tons	=	<u>15.5<math>\tau</math></u>
(See phosphor bronze, p. 32.)		
Unbalanced force	=	2.9 $\tau$
The bolts provided, girder to casting at fixed end, are bright bolts 1 in. diameter. Area in shear = $4 \times 0.7854$	= sq. in.	3.14
The working shear stress total, on these bolts = 3.14 sq. in. @ 6 $\tau$ /sq. in.	=	18.84 $\tau$
<i>i.e.</i> , more than sufficient to counteract the braking effort without relying upon the 15.5 tons of frictional resistance.		
Shear on cast-iron tooth embedded in granite.		

in elevation of one main girder multiplied by 50 lb. per square foot, with no allowance for suction or impact.

The two bottom flanges of the main girder in conjunction with the plated floor form a 23-ft. deep horizontal plate web girder against the action of the wind. The general idea is very similar to that of the built-up crane girder's top flange. The ballast plating and part of the main web also participate in the horizontal flange forces, but the calculations will err on the safe side by assuming that the forces are concentrated in the main girder tension flanges.

*Item 82 and Fig. 221a.* The area of the train will be taken as 10 sq. ft. vertically per horizontal foot run; and the centre of pressure of this area is usually taken as being 7 ft. to 7 ft. 6 in. above the running surface of the rail. With the latter dimension the height of the centre of pressure is 12 ft. above the bottom flange. This eccentricity of the C. of P. also exists in the main girders themselves, but it is neglected, partly because the error is small and partly to simplify the calculations.

The horizontal floor girder resists two horizontal forces, *viz.*, that due to the horizontal wind *C*, plus that due to *G*, which here acts only on the exposed windward girder, as the leeward girder is sheltered. The force of item 84 is thus obtained from Case I by multiplying by half and then by the ratio of the 30-lb. to the 50-lb. wind. The shear stresses in the web plate are very small, owing to the huge depth of web plate, and are entirely neglected.

Wind *C* on the windward carriages increases the load on the leeward wheels and lessens that on the windward wheels, as indicated by the arrow heads. The unbalanced couple, passing through the cross girders into the main girders, is resisted by the couple  $V \times D$ , *i.e.*,  $V \times D = C \times H$ , or  $V = CH \div D$ ; item 85. Since the outer arrow heads show the sense of the reactions, therefore, the actual active forces on the vertical girders are opposite in sense, *viz.*, downwards in the leeward and upwards in the windward girder. The summation of the various forces of Case II is given in Fig. 221b.

*Fig. 222.* In some light truss through bridges with open floors there may be a calculated uplift on the windward girder which would necessitate anchorage bolts at the bearings. The worst condition occurs with the leeward track loaded with an empty train when three-quarters of the vertical train load is taken by the leeward girder and only a quarter to the windward girder to weight it against uplift.

No actual uplift can occur, however, with the type of bridge under consideration, because when the carriage is just on the point of overturning under its maximum wind load all the reaction must

Area to be sheared before casting can move = $3\frac{1}{2}'' \times 28\frac{1}{4}''$	= sq. in.	98.9
If the frictional resistance between the sole of the casting and the granite be neglected, then the shear stress per square inch on the tooth = $18.4$ tons $\div$ $98.9$ sq. in.	= tons/sq. in.	0.18
<i>Base Plate, Fig. 219.</i> Upthrust on cantilever at $D = (9\frac{3}{4}'' \div 22'')$ of $156^{\tau}$	--	$69^{\tau}$ <b>78</b>
<i>B.M.</i> at $D = 69^{\tau} \times$ lever arm of $\frac{1}{2}$ of $9\frac{3}{4}$ in.	= in. tons	336
<i>Z</i> required = $336 \div 8$ , where $8 = F_b$	= in. <sup>3</sup>	42
<i>i.e.</i> , $\frac{1}{6}bd^2 = \frac{1}{6} \times 33.5 \times d^2 = 42$ .		
$\therefore d$ , the thickness	--	$2\frac{3}{4}''$
Thickness given = $\frac{3}{4}'' + \frac{11}{16}'' + 1''$	=	$2\frac{7}{16}''$
as the stiffeners relieve the cantilevered plates of load ; see notes.		

**Web Plate Splice, Plate VII.**

<i>B.M.</i> , from Fig. 211, at splice = $(2,940 + 2,450) \div 2$ , for <i>D.L.</i> + <i>L.L.</i> + <i>I.</i>	= ft. tons	2,695	<b>79</b>
<i>B.M.</i> carried by web = $(4.87 \div 56.59)$ of 2,695, see item <b>62</b> = $232.0$ ft. tons or	= in. tons	2,784	
Simultaneously occurring shear, from Fig. 211 = $147^{\tau} - 2 \times 49^{\tau}$	=	$49^{\tau}$	
Rivets at 3 in. vertical pitch ; for 1 row $\Sigma$ distance <sup>2</sup> = $2\Sigma 3^2 + 6^2 + 9^2 + 12^2 + \dots + 27^2 + 30^2$	=	6,930	
$\therefore Z$ of 3 rows of rivets on each side of joint = $\Sigma$ area $\times$ distance <sup>2</sup> $\div$ extreme distance = $3A \times 6,930 \div 30$	=	693A	
Where <i>A</i> is the area of 1 rivet, either the shear area or the bearing area.			
Horizontal stress on outermost rivet = $M \div Z = 2,784 \div 693A$	= tons/sq. in.	= $4.02 \div A$	
Horizontal load = area times the stress = $A(4.02 \div A)$	=	$4.02^{\tau}$	
Vertical load on any rivet = vertical shear of $49^{\tau} \div 63$ rivets in splice plate	=	$0.78^{\tau}$	
Resultant load on extreme rivet = $\sqrt{(4.02^2 + 0.78^2)}$	=	$4.1^{\tau}$	
Permissible load per rivet at flanges, <i>i.e.</i> , at 39 in. from the <i>N.A.</i> was in $\frac{1}{2}$ in. bearing	=	$5.63^{\tau}$	
$\therefore$ Value at extreme rivet of web splice at 30 in. from the <i>N.A.</i> = $5.63^{\tau} \times (30'' \div 39'')$	=	$4.33^{\tau}$	

come on to the rail next the leeward girder. The down thrust on this single rail must, perforce, cause downward loads on both the main girders. Had the windward wheels been clipped or attached to their rail then there would be a possibility of the uplift  $V$  becoming larger than the downward load on the windward girder. What happens in the present instance, therefore, is that the windward force  $V$  of Fig. 221 tends to lessen the downward load on the windward girder.

Item 87. This condition of loading implies that two of the

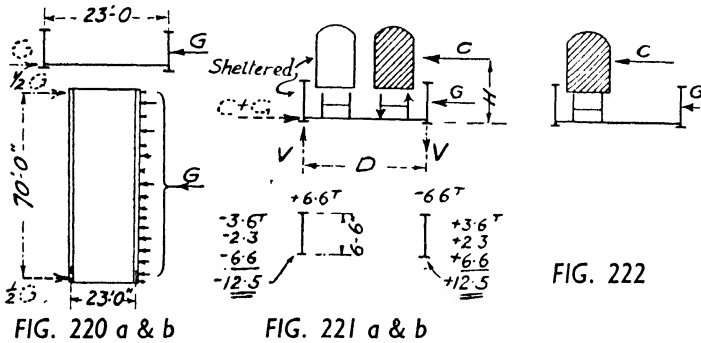

heaviest trains of the system should be running over the bridge at the same instant of time ; that both should do so from the same end ; that both should keep pace with each other so as to have the resulting vibrations in unison, *i.e.*, maximum impact effect ; that a violent hurricane should occur and that the wind should be blowing in the worst possible direction. The possibility of this combination of loads occurring frequently and simultaneously during the lifetime of the bridge is rather remote, so that the bridge will not be endangered if at rare intervals the actually occurring stress in the members be permitted to increase by 25 per cent. Even when  $F_t$  of 8 $\tau$ /sq. in. is increased temporarily to 10 $\tau$ /sq. in. there is still a large margin of safety before the elastic limit is reached.

REFERENCES

As given at the end of Chapter X.

Net $Z$ of 2 covers, $65\frac{3}{4}$ in. deep $\times$ $\frac{1}{2}$ in. thick, allowing for holes	in. <sup>3</sup>	= 523
Fibre stress at extreme edge distant 32.875 in. from $NA = 2,784 \div 523$	= tons/sq. in.	$\pm 5.32$
Permissible stress at extreme edge distant 32.875 in. from $NA = 8^T$ /sq. in. $\times (32.875" \div 39")$	"	= 6.74
Cover area given for vertical shear = 2 @ $65\frac{3}{4}" \times \frac{1}{2}"$	= sq. in. gross	65.75
Original gross area of web = $78" \times \frac{1}{2}"$	= "	39

**Wind Stresses, Case I.** Bridge unoccupied—50-lb. wind.

Exposed area of bridge, $c/c$ of bearings = 2 off $\times 70' \times 6.5'$	= sq. ft.	910	<b>80</b>
Total uniformly distributed load = 910 $\times 50 \div 2,240$	=	20.3 <sup>T</sup>	
Maximum $B.M.$ at centre of 70-ft. span, Fig. 220 <i>b</i> = $20.3 \times 70 \div 8$	= ft. tons	178	
Flange force = $B.M. \div$ effective depth = $178 \div 23$	=	$\pm 7.74^T$	<b>81</b>

**Case II.** Bridge occupied—30-lb. wind on bridge and carriages.

Wind pressure on carriages = $C = 10' \times 70' \times 30 \div 2,240$ ; see text	=	9.4 <sup>T</sup>	<b>82</b>
Maximum $B.M.$ at centre of span due to $C = 9.4 \times 70 \div 8$	= ft. tons	82.3	
Flange force = $B.M. \div D = 82.3 \div 23$	=	$\pm 3.6^T$	<b>83</b>
Flange force due to wind $G$ , see text = $\frac{1}{2}$ of $\frac{2}{3}$ of item <b>81</b>	=	$\pm 2.3^T$	<b>84</b>
Force $V$ in the vertical plane = $C \times H \div D = 9.4 \times 12 \div 23$	=	$\pm 4.9^T$	<b>85</b>
applied through the cross girders, but approximately uniformly distributed.			
$\therefore$ Approximate maximum $B.M.$ , vertical plane = $4.9 \times 70 \div 8$	= ft. tons	43	
Force in top and bottom flanges of main vertical girders = $B.M. \div D = 43 \div 6.5$	=	$\pm 6.6^T$	
Case II is the worse; the maximum additional force (obtained by adding items <b>83</b> and <b>84</b> to $6.6^T$ , as in Fig. 221 <i>b</i> ) occurs in the leeward girder's bottom flange, which, already in tension, receives an additional tensile force	=	12.5 <sup>T</sup>	<b>86</b>

**Combined Stresses.** Caused by *D.L.* + *L.L.* + *I* + tractive forces + wind ; all occurring at their maximum value at one instant. The element most affected is the leeward tension flange of Fig. 221.

By items **76** and **77** the tractive effort at the main bearing =  $0.138 \times 1\frac{3}{4} \times 70.2^T$  =  $17^T$   
 and at mid-span it is approximately half of this (load entering from fixed end) =  $8.5^T$   
*D.L.* + *L.L.* + *I*, flange force at mid-span, item **57** =  $452.0^T$   
 Wind forces, Case II, item **86** =  $12.5^T$   
 Total tensile flange force =  $473^T$  **87**  
 $473^T$ , being only a 5 per cent. increase on  $452^T$ , is quite permissible, as it is well within the limit mentioned of 25 per cent.

## CHAPTER X

### THE DESIGN OF A 70-FT. SPAN PRATT TRUSS ROAD BRIDGE (FOLDING PLATES IX, X AND XI)

#### EXPLANATORY TEXT

THE bridge will be designed to carry two lanes of traffic and, since the Ministry of Transport specifies a 10-ft. width per lane, the clear width of roadway will be 20 ft. No footpaths will be provided, thus simplifying the calculations a little. Once the design of the two-lane traffic bridge is understood the addition of a couple of footways adds but little extra labour to the design calculations.

#### STANDARD LOAD FOR HIGHWAY BRIDGES

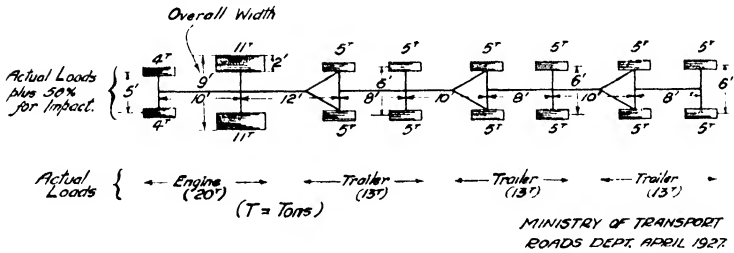

Note. The bridge shall be assumed to be loaded with such standard trains or parts of standard trains as will produce the maximum stress in any bridge member, provided that in any line of trains there shall not be more than one engine per 75' 0" of the span of the bridge, and each standard train shall occupy a width of 10' 0". Where the width of the carriageway exceeds a multiple of 10' 0", such excess shall be assumed to be loaded with a fraction of the axle loads of a standard train. The fraction to be used shall be the excess width in feet divided by ten.

FIG. 223

**The Live Load** is the Ministry of Transport wheel loads as given by Fig 223 or the alternative *Equivalent Uniformly Distributed Load* of 220 lb. per sq. ft. plus the *Knife-Edge Load* of 2,700 lb. per lineal ft. placed anywhere, see Fig. 224.

The wheel loads will be used for the design of the floor troughing and thereafter the *E.U.D.L.*, with its accompanying knife-edge load, for the remainder of the structure. The wheel loads lose much



of their concentrated effect after the load has travelled through the cushion of tar macadam and concrete (or ballast) fill on its way to the cross girder, and also because of the distributive effect of the troughing, as mentioned under.

These reasons favoured the adoption of the *E.U.D.L.*, which is

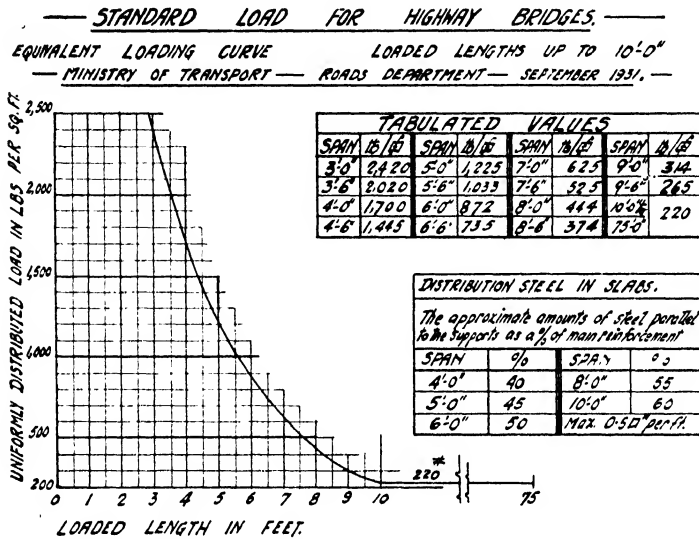

The uniformly distributed load applicable to the "loaded length" of the bridge or member in question is selected from the curve or table.

The "loaded length" is the length of member loaded in order to produce the most severe stresses. In a freely supported span the "loaded length" would thus be (a) for bending moment, the full span; (b) for shear at the support, the full span; (c) for shear at intermediate points, from this point to the farther support.

In arches and continuous spans the "loaded length" can be taken from the influence line curves.

The live load to be used consists of two items: (1) The uniformly distributed load which varies with the loaded length, and which represents the ordinary axle loads of the M.T. standard train, perfectly distributed; (2) an invariable knife-edge load, of 2,700 lb. per ft. of width applied at the section where it will, when combined with the uniformly distributed load, be most effective, i.e., in a freely supported span; (a) for bending moment at midspan, at midspan point; (b) for shear at the support, at the support; (c) for shear at any section, at the section.

FIG. 224 (a)

also much simpler to use than the wheel loading. Both these imaginary loadings have been obtained by increasing the actual loads by 50 per cent. to include for impact, and no separate additional allowance requires to be made to the stresses. Some specifications, on the other hand, prefer to work with the net wheel loads and to increase the resulting forces by some percentage, fixed or

# DESIGN OF A 70-FT. SPAN PRATT TRUSS ROAD BRIDGE 265

variable. A discussion on the various methods of allowing for impact is given in the author's book on influence lines.

**Steel Troughing** has a serious rival in the reinforced concrete bridge floor. All the concrete of the latter floor actively participates in carrying the load, whereas in the former, if used for fill, it is

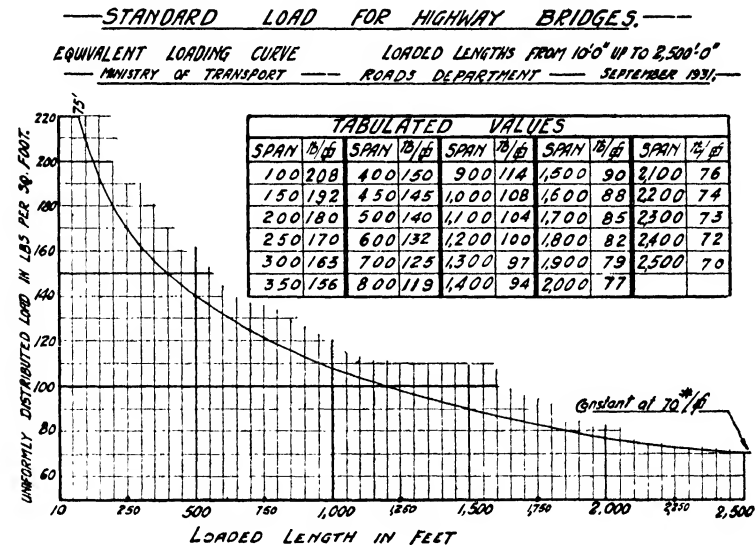

(Continued)

This knife-edge load represents the excess in the M.T. standard train of the heavy axle over the other axles, this excess being undistributed (except laterally as already assumed).

In spans of less than 10' (i.e., less than the axle spacing) the concentration serves to counteract the over-dispersion of the distributed load.

In slabs the knife-edge load of 2,700 lb. per ft. of width is taken as acting parallel to the supporting members, irrespective of the direction in which the slab spans.

In longitudinal girders, stringers, etc., this concentrated loading is taken as acting transversely to them (i.e., parallel with their supports).

In transverse beams the concentrated loading is taken as acting in line with them (i.e., 2,700 lb. per ft. run of beam).

If longitudinal or transverse members are spaced more closely than at 5' centres, the live load allocated to them shall be that calculated on a 5' wide strip. With wider spacing this strip will be equal to the girder spacing.

In all cases, irrespective of span length, one knife-edge load of 2,700 lb. per ft. of width is taken as acting in conjunction with the uniform distributed load appropriate to the span or "loaded length."

FIG. 224 (b)

practically inert. On the other hand, mild steel pressed (or rolled) troughing is quickly and easily laid, it eliminates timber form work, or shuttering, and may be filled with a lean mix concrete, tar concrete, or ballast.

Experiments carried out on the dispersion effects of concentrated loads on trough flooring (Report of the Bridge Stress Committee) show that if contiguous troughs  $D$ ,  $C$ ,  $B$ ,  $A$ ,  $B'$ ,  $C'$  and  $D'$  have a load  $W$  placed at the crest of trough  $A$ , then this mid-trough  $A$  carries  $\frac{4}{16}$  of  $W$ . Troughs  $B$  and  $B'$  immediately on each side of the loaded trough carry  $\frac{3}{16}$   $W$  each; troughs  $C$  and  $C'$  receive  $\frac{2}{16}$   $W$  each, while the troughs  $D$  and  $D'$  take  $\frac{1}{16}$   $W$  each.

When two of the specified engines pass each other there is an eleven-tons wheel load immediately on each side of the longitudinal centre line. Thus there is a possibility of approximately  $\frac{4}{16}$   $W$  (*i.e.*, one-quarter of eleven tons) from each driving wheel coming on to the mid-trough, or a total of 5.5 $\tau$ , item 2.

The outermost trough, adjacent to the main truss, lacks the help mentioned in the report, and to reinforce this trough it is riveted through a continuous shelf angle to the fascia channel.

Some designers assume, no matter what size the troughs may be, that two adjacent troughs always share a concentrated load equally between them: others assume that a concentrated load is carried by a 3-ft. plan width of troughing for a road bridge, and by a 5-ft. plan width in the case of a railroad carried on cross sleepers and ballast.

The flooring adopted is a single pressed trough section riveted along each crest. It may also be obtained pressed to a double width of two troughs; a form which saves a complete 70-ft. length of riveting along every second crest.

The alternative is to build the floor of rolled trough sections. One advantage is that the metal is made thicker at the top and bottom flanges (crests and hollows) where it is most usefully employed, while the disadvantage is the necessity for an extra row of rivets, because a longitudinal joint occurs along each sloping web. If stock sizes of troughing do not suit the design the cost of having a new pressing made to one's own requirements is very reasonable, but the cost of having the section rolled, especially for a small tonnage, is prohibitive.

**CROSS GIRDER.** Since the effective span is from centre to centre of main trusses it is now necessary to make an estimate of the width of the top chord of the main truss. Taking the width of this member at about  $\frac{1}{50}$  of the span (alternatively, about  $\frac{1}{40}$  of its own length), the chord width is thus about 16 in. The effective span is therefore two half chord widths of 8 in. plus 20 ft. roadway, a total of 21' 4", or, allowing for contingencies such as rivet projections, etc., say, 21' 6" meantime.

*Item 6.* The dead load was estimated as explained at the end of Chapter I.

CALCULATIONS

**Trough Flooring.** span 12' 0".

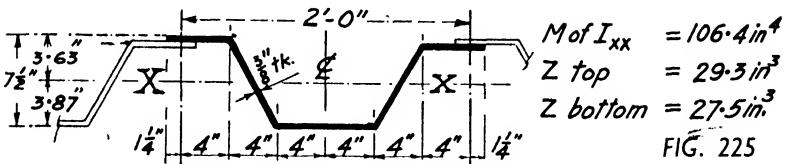

Tar macadam, 4" av. (@ 140 lb./cub. ft.	= lb./sq. ft.	47	
Concrete overlay, 3" (@ " " "	" " "	35	
" " in hollows 3.6" " " "	" " "	42	
$\frac{3}{8}$ " M.S. trough, wt./sq. ft. plan area	" " "	24	
Total per sq. ft. of			
plan area = 148 lb.	say — " "	150	1
Assume 0.5W on one trough	=	5.5 <sup>r</sup>	2
Dead Load per			
trough = 2' x 12' (@ 150 lb./sq. ft. =		1.6 <sup>r</sup>	
Dead Load max.			
B.M. = $Wl \div 8 = 1.6 \times 144 \div 8 =$ in. <sup>r</sup>		29	
Live Load max.			
B.M. = $Wl \div 4 = 5.5 \times 144 \div 4 =$ "		198	
		<u>227</u>	3
Resulting stress,			
upper fibres = $227 \div 29.3$	= <sup>r</sup> /sq. in.	+ 7.75	
Resulting stress,			
lower fibres = $227 \div 27.5$	= "	- 8.26	4
Max. end shear for			
D.L. + L.L. = $(1.6 \div 2) + 5.5$	—	6.3 <sup>r</sup>	
Shear area per trough of two webs	= sq. in.	5.7	
Resulting shear stress is safe.			
Deflection ∴ Due to D.L.			
$= \frac{5Wl^3}{384EI} = \frac{5 \times 1.6 \times 144^3}{384 \times 13,000 \times 106.4} =$		.045"	
Due to L.L.			
$= \frac{Wl^3}{48EI} = \frac{5.5 \times 144^3}{48 \times 13,000 \times 106.4} =$		.248"	
Total	=	<u>0.29"</u>	
Deflection $\div$ span = $0.29" \div 144" = 1 \div$			
500, satisfactory.			
Rivets ∴ $\frac{3}{4}$ " dia. at $4\frac{1}{2}$ " pitch ( $12t = 12 \times \frac{3}{8}$ ).			5

WORKING STRESSES IN MILD STEEL FOR  
GIRDER BRIDGES \* (1937)

		Symbol.	Tons per sq. in.
<b>TENSION.</b>	Axial stress on net section	$F_t$	9
<b>COMPRESSION.</b>	Extreme fibre stress on gross cross-section of compression flanges of girders and beams, where these are :— Stiffened by edge angles, etc., or connected to flooring Unstiffened edges $l$ = max. unsupported length ; $b$ = flange breadth.	$F_c$	9 (1-0-0075 $l/b$ ) 9 (1-0-01 $l/b$ )
<b>STRUTS.</b>	Axial stress on the gross cross-section :— Riveted connections Pin connections But not to exceed $l$ = actual length in inches between intersections of gravity lines. $k$ = least radius of gyration in inches.		9 (1-0-0038 $l/k$ ) 9 (1-0-0054 $l/k$ ) 7-65
<b>SHEAR.</b>	Stress on gross cross-section of web	$F_w$	5-5
<b>DIRECT BEARING.</b>	Steel on steel	$F_b$	15
<b>SHOP RIVETS AND TURNED BOLTS (TIGHT FITTING).</b>	Single shear Double shear Bearing	$F_s$ $F_{ds}$ $F_b$	6-5 13-0 15-0
<b>RIVETS THROUGH PACKINGS</b> (thicker than $\frac{3}{8}$ ").	Increase calculated number by		20 per cent.
<b>SITE RIVETS.</b>	Calculate the number of shop rivets required and increase this number by		15 per cent.
<b>BLACK BOLTS.</b>	Calculate the number of shop rivets required and increase this number by		20 per cent.

\* Based, by permission, upon British Standard Specification No. 153—Parts 3, 4 and 5 ; 1937—for Girder Bridges, official copies of which can be obtained from the British Standards Institution, 2, Park Street, London, W.1.

**CROSS GIRDERS** at 12' c/c and 21' 6"

span, c/c of main girders.

<i>D.L.</i> from trough floor (item 1), 20·7' × 12'			
@ 150 lb. ÷ 2,240	=	16·63 <sup>T</sup>	<b>6</b>
<i>D.L.</i> of Cross Girder self, estimate	=	1·37 <sup>T</sup>	
<i>D.L.</i> total,	=	<u>18·00<sup>T</sup></u>	<b>7</b>
<i>E.U.D.L.L.</i> 20' × 12' @ 220 lb. ÷ 2,240	=	23·57 <sup>T</sup>	<b>8</b>
<i>Knife L.</i> 20' @ 2,700 lb.	=	24·10 <sup>T</sup>	<b>9</b>
Total <i>U.D. Live Load</i>	=	<u>47·67<sup>T</sup></u>	<b>10</b>
Total distributed load on <i>C.G.</i> = items 7			
+ 10	—	65·67 <sup>T</sup>	<b>11</b>

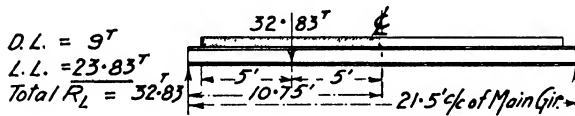

FIG. 226

Max. <i>B.M.</i> , <i>D.L.</i> + <i>L.L.</i> = 32·83(10·75' - 5')	= ft. <sup>T</sup>	189	<b>12</b>
Girder depth overall = 2' 8" : say effective depth	= ft.	2·5	<b>13</b>
Max. flange force = $M \div D = 189$			
÷ 2·5	=	75·6 <sup>T</sup>	
Web area reqd. = 32·83 ÷ 5·5	= sq. in.	6	
Ten. flange, area reqd. = 75·6 ÷ 9	= net sq. in.	8·4	
Areas given :— Web pl. $\frac{5}{16}$ " min. tk. =			
32" × $\frac{5}{16}$ "	= gross sq. in.	10	<b>14</b>

Flanges :—

Area in sq. in.	gross	net	
$\frac{1}{8}$ web.	1·25	1·25	
2   s 6" × 3½"	9·0	8·25 (2 holes @	
× ½"		¾" dia.)	
	<u>10·25</u>	<u>9·5</u>	

<i>i.e.</i> , Tension flange	= net sq. in.	9·5	
Compression flange, same section	= gross sq. in.	10·25	<b>15</b>

**Riveting.**

Rivet values in tons per rivet.

Bearing on	$\frac{5}{16}$ "	$\frac{3}{8}$ "	$\frac{7}{16}$ "	$\frac{1}{2}$ "	<i>S.S.</i>	<i>D.S.</i>	
$\frac{3}{4}$ " dia. value	3·52	4·22	4·92	5·63	2·87	5·75	<b>16</b>
$\frac{1}{2}$ " ,, ,,	4·10	4·92	5·74	6·56	3·91	7·81	
No. of rivets reqd. to connect cross girder to main truss :—							<b>17</b>

*Item 12.* Max. bending moment and end shear happen when the *E.U.D.L.* and the knife load of items 8 and 9 completely cover the 20-ft. width of roadway.

*Item 13.* When fixing the overall depth of the cross girder the following points were considered :—

(a) A plateless top flange, clear of rivet heads, gives a clean landing for the troughs. This means a saving in riveting and edge planing of flange plates.

(b) A reasonable rivet pitch at the ends of the flange angles—the deeper the girder the wider the rivet pitch.

(c) A deep cross girder aids the lateral rigidity of the top chord of the main truss, see explanatory text for Top Chord “Brackets.”

(d) The flange angles must not be too thick if the stiffener angles have to be joggled over them.

*Item 17.* Comparatively small loads are encountered in the floor system so  $\frac{3}{4}$  in. dia. rivets are used throughout the cross girders and troughing, but  $\frac{7}{8}$  in. dia. rivets are employed in the main truss. The end cleats, cross girder to main truss, will therefore have  $\frac{3}{4}$  in. dia. holes in the cross girder leg and  $\frac{7}{8}$  in. dia. in the main truss leg.

*Item 18.* The formula is derived in Chapter I.

*Item 19.* If the reason is not apparent refer to Fig. 22.

*Item 20.* Max. shear at any point on a span occurs when the *U.D.L.L.* covers the span between the point and the further abutment.

*Item 21.* If further explanation is necessary refer to Rules for Stiffeners, Chapter I.

**MAIN TRUSS.** In deep and large span trusses the dead weight of the truss is allocated between the upper and lower panel points, but in small span shallow trusses it is, for simplicity and practically without error, assumed to act at the loaded panel points only.

*Item 25.* As given by the Ministry of Transport diagram, Fig. 224 (a), the equivalent uniformly distributed live load for a 70-ft. span bridge is 220 lb. per sq. ft. of road surface. Half the 20-ft. roadway is carried by each truss. The knife-edge load of item 26 may thus be looked upon as a single concentration on the main truss, placed at that position on the span where it will have the greatest effect, *viz.*, at an apex point on the influence line. If wheel concentrations had been the loading specified then each main truss would carry a set of axle loads, *i.e.*, a complete train of engine and trailers.

*Influence Lines of Figs. 228 and 229* are the diagrams for the force calculations of the main truss. These are given in full, and where there is a possible dubiety as to which of two loadings pro-

DESIGN OF A 70-FT. SPAN PRATT TRUSS ROAD BRIDGE 271

Through cleat to web of C.G.,  $\frac{3}{4}$ " dia.  
rivets :—

No. reqd. = end shear of  $32.83^r \div 3.52^r$   
( $\frac{5}{16}$ " B & D.S.) = 10

Through cleat to Main Truss Vertical,  $\frac{7}{8}$ "  
dia. rivets :—

No. reqd. = end shear of  $32.83^r \div 3.91^r$   
(S.S &  $\frac{5}{16}$ " B) = 8.4  
site rivets add 15% = 1.3  
Total = 10

(No extras for  $\frac{3}{8}$ " packing.)

Flanges. Horiz. shear/ft.,

$$F = S \frac{A}{D \left( A + \frac{W}{8} \right)} = S \frac{9}{2.5(10.25)} = 0.351S. \quad 18$$

At end,  $F = 0.351S = 0.351 \times 32.83 = 11.52^r$

Local vertical shear  $V$ /ft. =  $65.67^r \div 21.5'$   
item 11 = 3<sup>r</sup>

Resulting shear/ft. =  $\sqrt{(11.52^2 + 3^2)}$  = 11.9<sup>r</sup>

Reqd. No. of rivets,  $\frac{3}{4}$ " dia. =  $11.9^r \div 3.52^r$   
( $\frac{5}{16}$ " B & D.S.) = 3.38

Reqd. pitch of rivets =  $12" \div 3.38 = 3.55"$

Adopt an end pitch of 3" 19

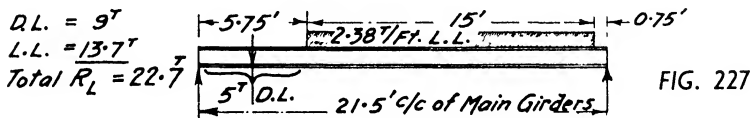

Riveting at 5.75', Fig. 227:—  $F = 0.351S =$   
 $.351(22.7 - 5) = 7$  r/ft. 6.21

Local vertical shear  $V$ , see item 19 = 3

Resulting shear/ft. =  $\sqrt{(6.21^2 + 3^2)} = 6.9$

Reqd. No. of rivets per ft. =  $6.9^r \div 3.52^r = 1.96$   
( $\frac{5}{16}$ " B & D.S.) = 1.96

Rivet pitch required =  $12 \div 1.96 = 6"$

" " given =  $12t = 12 \times \frac{1}{2} = 6"$  20

Flange riveting at first stiffener, 1' 9"  
from reaction.



vides the higher force both sets of wheel loads are shown in position. As these pages are devoted to the practical design of the steelwork the theory of influence lines will not be entered upon, but should further information be desired a reference may be made to "*Influence Lines: Their Practical Use in Bridge Calculation*"; from which both Figs. 228 and 229 and the accompanying three pages of calculations are extracts.

Sometimes it is specified that a bridge shall be designed to withstand the actual wheel loads, and for this reason the forces due to the axle loads are given in addition to those caused by the equivalent uniformly distributed load. Examining the force sheet of Fig. 230 it will be at once apparent that the two sets of results are in remarkably close agreement.

*Chord Members.* The force in  $U_1U_2$  is found by having a section line cut three bars, including the desired bar ( $U_1U_2$ ,  $U_1L_2$ ,  $L_1L_2$ ), and taking moments about the point where the two unwanted bars meet, viz.,  $L_2$ .

The influence line for force, i.e.,  $B.M. \div$  girder depth, is then drawn. Maximum force occurs when the *U.D.L.L.* covers all the span and, numerically, is equal to the area of the figure multiplied by the load per foot on the main truss. The knife-edge load, to cause maximum effect, is placed on the ordinate through the apex, and the resulting force is the height of this ordinate multiplied by the load.

The force due to the axle loads is equal to the sum of the products of the axle loads by their respective ordinates. In  $U_1U_2$  the maximum force occurs when the heaviest wheel is placed at the largest ordinate; but it is not so with  $U_2U_3$ . The rule for maximum force in the case of a triangular shaped influence line may be stated thus:—The load should be so placed on the span that the average load per ft. to the left of the apex equals the average load per ft. to the right of the apex, and, therefore, equals the average load per ft. of span. If a concentrated load lies on the apex ordinate then any desired portion of it may be considered as belonging to the left-hand segment and the remainder to the right-hand segment, in order to get the balance mentioned in the rule.

Thus for  $U_2U_3$  :—

Case (a). Load/ft. of span =  $(8 + 22 + 4 @ 10)^r \div 70'$  = 1 $\frac{1}{2}$ /ft.

On left of apex :— $(8^r + 22^r + 5^r \text{ from apex } 10^r) \div 35'$  = 1 $\frac{1}{2}$ /ft.

On right of apex :— $(5^r \text{ from apex } 10^r + 3 @ 10^r) \div 35'$  = 1 $\frac{1}{2}$ /ft.

Case (b). Load/ft. of span =  $(8 + 22 + 3 @ 10)^r \div 70'$  =  $\frac{9}{7}$ /ft.

On left of apex :— $(8 + \text{all of } 22)^r \div 35'$  =  $\frac{9}{7}$ /ft.

On right of apex :— $(3 @ 10)^r \div 35'$  =  $\frac{9}{7}$ /ft.

With this 1' 9" length unloaded instead of  
 5.75' of Fig. 227,  $R_t$  = 30.6<sup>r</sup>  
 Shear at stiffener = 30.6<sup>r</sup> - *D.L.* of 1.5<sup>r</sup> = 29.1<sup>r</sup>  
 Rivet pitch in flange thereat, reqd. and given = 4"

**Cross Girder Stiffeners. 21**

Outstanding leg =  $(D \div 30) + 2'' = (32'' \div 30) + 2'' = 3'' \text{ or } 3\frac{1}{2}''$   
 Try 2  $\lfloor_s 3\frac{1}{2}'' \times 3'' \times \frac{5}{16}''$ , area = gross sq. in. 3.86  
 Effective length =  $\frac{3}{4}$  girder depth =  $\frac{3}{4}$  of 32" = 24"

Stiffeners at points of concentrated loading carry total shear thereat.  
 Working stress =  $9(1 - 0.0038l/k) = 9(1 - 0.0038 \times 24/1.61) = \tau/\text{sq. in. } 8.5$

Alternatively by the following formula, where  $l$  is now the full depth = 32"

Working stress =  $9(1 - 0.01l/b) = 9(1 - 0.01 \times 32/7\frac{5}{16}) = \tau/\text{sq. in. } 8.6$

Permissible load on each stiffener = 3.86  $\times$  8.5 = 32.8<sup>r</sup>

Satisfactory, since max. end shear, item 17 = 32.8<sup>r</sup>

End cleats, to suit details, 2  $\lfloor_s 4'' \times 3\frac{1}{2}'' \times \frac{5}{16}''$ , area = gross sq. in. 4.50

*Riveting in Stiffeners.*  $\frac{3}{4}''$  dia. rivets,  $\frac{5}{16}'' B = 3.52^r$  (or *D.S.*)

No. given = 10 and permissible load =  $3.52 \times 10 = 35.2^r$

**MAIN TRUSS.**

Dead load of self (including main sections, gusset and batten plates, latticing, diaphragms, packings at cross girders, fascia or ballast channel with shelf angle, hand-railing and rivet heads, etc.) together with an allowance for service mains (not shown on the drawings) = 13<sup>r</sup> 22

Dead load on each cross girder, item 7, = 18<sup>r</sup>

*D.L. per panel point* =  $(13^r \div 6) + (18^r \div 2) = 11.2^r$  23

*D.L. per ft. of Main Truss* =  $11.2^r \div 12'$  panel = 0.94<sup>r</sup> 24

*U.D.L.L. per ft. of Main Truss* = 220 lb./sq. ft.  $\times$  10' width  $\times$  1'  $\div$  2,240 = 0.98<sup>r</sup> 25

*Knife-Edge Load* = 2,700 lb.  $\times$  10' width  $\div$  2,240 = 12.05<sup>r</sup> 26

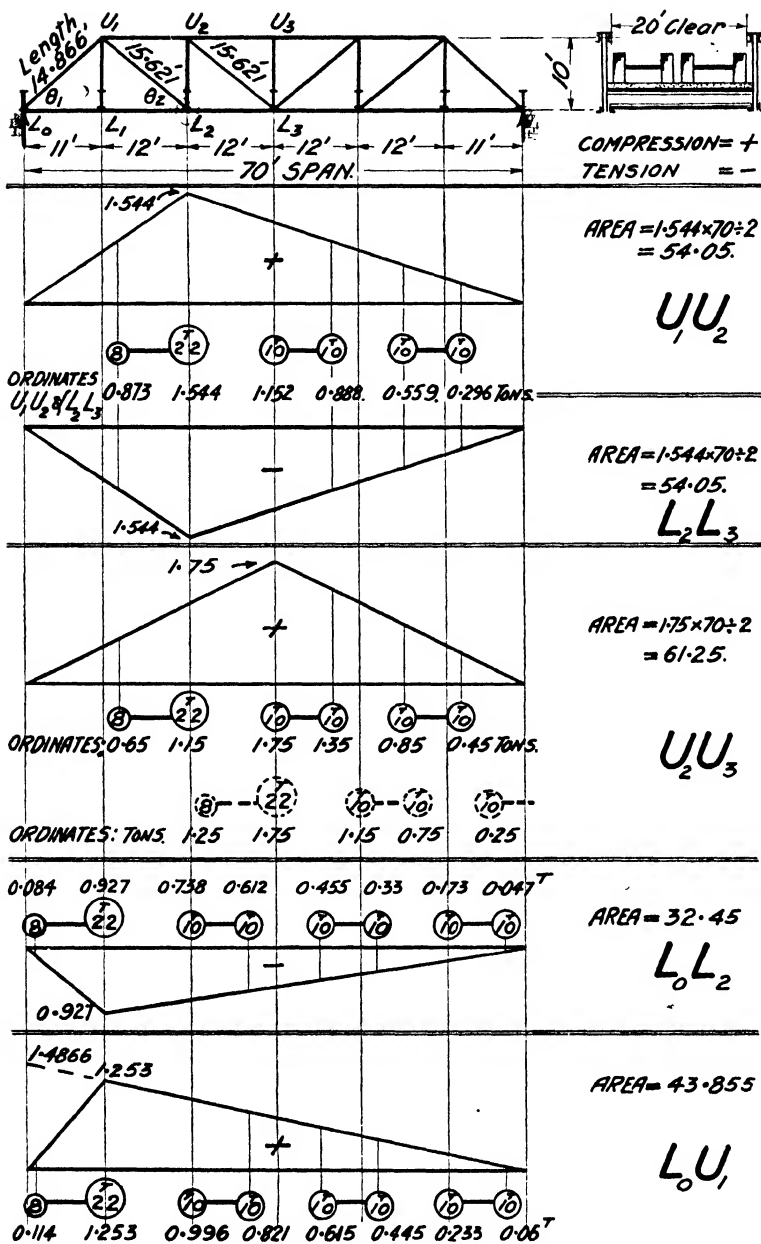

FIG. 228

**MAIN TRUSS FORCES.** Refer to Figs. 228 and 229.

$U_1U_2$ . Moment Centre $L_2$		Tons.
D.L.	$= 54.05 \times 0.94 =$	+ 50.81
U.D.L.L.	$= 54.05 \times 0.98 = 53^r$	
Knife L.	$= 1.544 \times 12.05 = 18.6^r$	
	-----	Total = + 71.6
Axle L.	$= 8 \times 0.873 + 22 \times 1.544 +$ $10(1.152 + 0.888 + 0.559 + 0.296) = + 69.9$	
$U_2U_3$ . Moment Centre $L_3$		
D.L.	$= 61.25 \times 0.94 =$	+ 57.57
U.D.L.L.	$= 61.25 \times 0.98 = 60.03^r$	
Knife L.	$= 1.75 \times 12.05 = 21.09^r$	
	-----	Total = + 81.12
Axle L.	$= 8 \times 0.65 + 22 \times 1.15 +$ $10(1.75 + 1.35 + 0.85 + 0.45) = + 74.5$	
	2nd position = $8 \times 1.25 + 22 \times 1.75 +$ $10(1.15 + 0.75 + 0.25) = + 70.0$	
$L_0L_1$ and $L_1L_2$ . Moment Centre $U_1$		
D.L.	$= 32.45 \times 0.94 =$	- 30.5
U.D.L.L.	$= 32.45 \times 0.98 = 31.8^r$	
Knife L.	$= 0.927 \times 12.05 = 11.17^r$	
	-----	Total = - 42.97
Axle L.	$= 8 \times 0.084 + 22 \times 0.927 +$ $10(0.738 + 0.612 + 0.455$ $+ 0.33 + 0.173 + 0.047) = - 44.62$	
$L_2L_3$ . Moment Centre $U_2$ (same as $L_2$ above)		
D.L.	$=$	- 50.81
U.D.L.L.	$= 53^r$	
Knife L.	$= 18.6^r$	
	-----	Total = - 71.6
Axle L.	$=$ (as for $U_1U_2$ .)	- 69.9
$L_0U_1$ . Vertical shear $\times \text{cosec } \theta_1 = \text{vert. shear}$ $\times (14.866 \div 10)$		
D.L.	$= 43.855 \times 0.94 =$	+ 41.22
U.D.L.L.	$= 43.855 \times 0.98 = 42.98^r$	
Knife L.	$= 1.253 \times 12.05 = 15.10^r$	
	-----	Total = + 58.08
Axle L.	$= 8 \times 0.114 + 22 \times 1.253 +$ $10(0.996 + 0.821 + 0.615$ $+ 0.445 + 0.233 + 0.06) = + 60.17$	

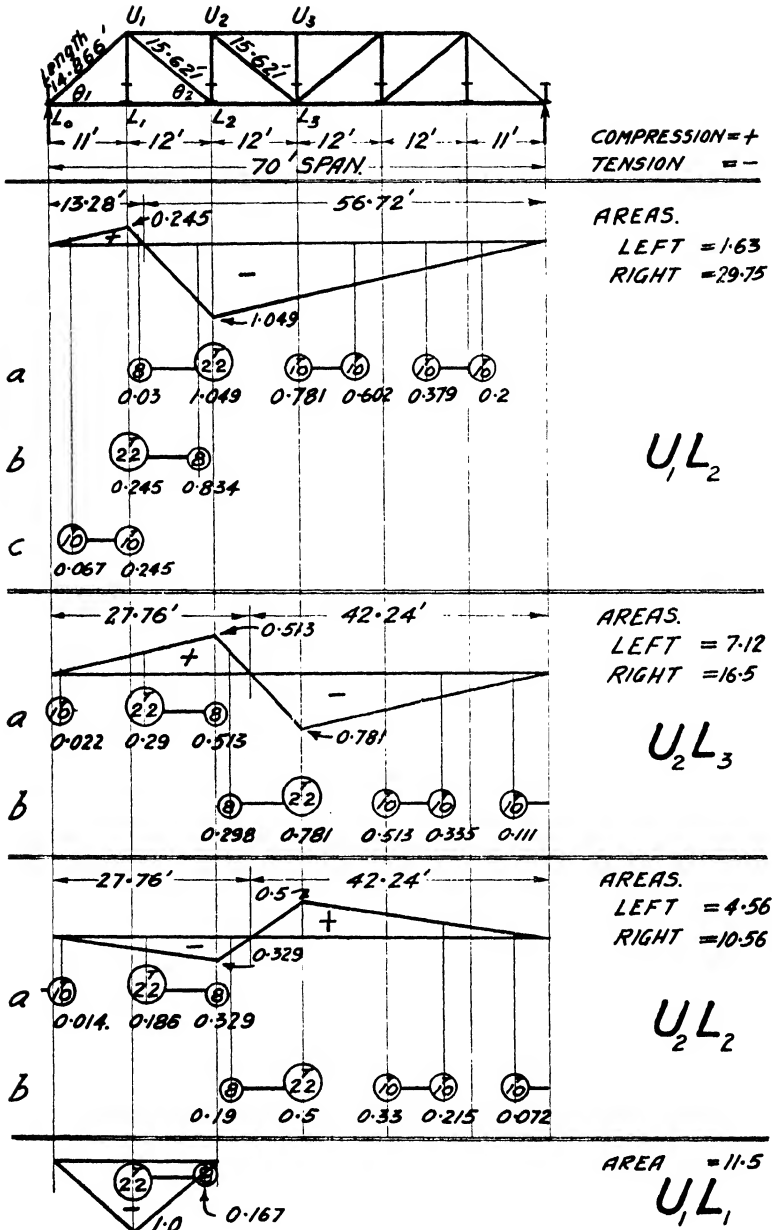

FIG. 229

$U_1L_2$ . Vertical shear  $\times (15.621 \div 10)$

D.L.	$= (+ 1.63 - 29.75) \times 0.94$ (all span loaded)	Tons.	$= - 26.43$
U.D.L.L.	$= - 29.75 \times 0.98 = -29.16^r$ (part span loaded)		
Knife L.	$= - 1.049 \times 12.05 = -12.64^r$		
		Total	$= - 41.80$
Axle L., (a)	$= 8 \times (+ 0.03) - 22 \times 1.049 - 10(0.781 + 0.602 + 0.379 + 0.2)$		$= - 42.46$
	<i>or</i>		
U.D.L.L.	$= + 1.63 \times 0.98 = + 1.60^r$ (part span loaded)		
Knife L.	$= + 0.245 \times 12.05 = + 2.95^r$	Total	$= + 4.55$
Axle L.	Position (c), trailer leaving span, is more severe than position (b), engine entering span from left-hand abutment.		
	(c) $= 10(0.67 + 0.245)$		$= + 3.12$
	(b) $= - 8 \times 0.834 + 22 \times 0.245 = - 1.282^r$ .		

$U_2L_3$ . Vertical shear  $\times (15.621 \div 10)$

D.L.	$= (+ 7.12 - 16.5) \times 0.94$ (all span loaded)	$= - 8.82$	
U.D.L.L.	$= - 16.5 \times 0.98 = - 16.17^r$ (part span loaded)		
Knife L.	$= - 0.781 \times 12.05 = - 9.41^r$	Total	$= - 25.58$
Axle L., (b)	$= + 8 \times 0.298 - 22 \times 0.781 - 10(0.513 + 0.335 \times 0.111)$		$= - 24.39$
	<i>or</i>		
U.D.L.L.	$= + 7.12 \times 0.98 = + 6.98^r$ (part span loaded)		
Knife L.	$= + 0.513 \times 12.05 = + 6.18^r$	Total	$= + 13.16$
Axle L., (a)	$= + 8 \times 0.513 + 22 \times 0.29 + 10 \times 0.022$		$= + 10.71$

$U_1L_1$ . Vertical suspender carrying only the load from cross girder  $L_1$

D.L.	$= - 11.5 \times 0.94$	$= - 10.81$	
U.D.L.L.	$= - 11.5 \times 0.98 = - 11.27^r$		
Knife L.	$= - 1.0 \times 12.05 = - 12.05^r$	Total	$= - 23.32$
Axle L.	$= - 22 \times 1 - 8 \times 0.167$		$= - 23.34$

Both are maximal cases. Case (a) gives the load position for maximum force for six loads on the span while case (b) is that for only five loads on the span. The absolute maximum is, of course, case (a).

*Web Members.*  $U_1L_1$  is a suspender carrying the cross girder. The influence line for this bar is composed of the influence lines for

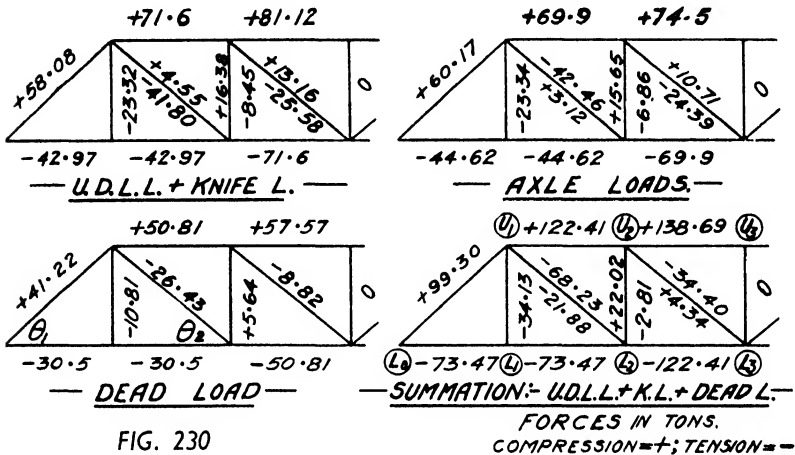

FIG. 230

reaction  $L_1$  in stringer span  $L_1L_0$  and reaction  $L_1$  in stringer span  $L_1L_2$ .

Member  $U_3L_3$  is statically redundant.

The maximum load on  $U_2L_2$  is equal to the maximum shear in panel  $L_2L_3$ .

Force in  $U_2L_3 =$  shear in panel  $L_2L_3 \times \text{cosec } \theta_2$ , where

$$\theta_2 = 15.621' \div 10'$$

,, ,,  $U_1L_2 =$  ,, ,,  $L_1L_2 \times 1.562$ .

,, ,,  $U_1L_0 =$  ,, ,,  $L_0L_1 \times \text{cosec } \theta_1$ , where  $\text{cosec } \theta_1 = 14.866' \div 10'$ .

To obtain maximum compressive force in  $U_1L_2$  or  $U_2L_3$ , load only the left-hand or positive segment ; for maximum tensile force, load only the right-hand, or negative, portion of the span. The wheel loads should be positioned as stated in the rule given above for a triangular shaped influence line. Dead load force is found by summing positive and negative segments, since this loading covers both these portions of the span simultaneously.

$U_2L_2$ carries the vertical shear in panel $L_2L_3$	Tons.
D.L. = $(+ 10.56 - 4.56) \times 0.94$ (all span loaded)	= + 5.64
U.D.L.L. = $(+10.56) \times 0.98$ (part span loaded)	= + 10.35 <sup>r</sup>
Knife L. = $+0.5 \times 12.05$	= + 6.03 <sup>r</sup>
	Total = + 16.38
Axle L., (b) = $- 8 \times 0.19 + 22 \times 0.5 + 10(0.33 + 0.215 + 0.072)$	= + 15.65
	or
U.D.L.L. = $(-4.56) \times 0.98$ (part span loaded)	= - 4.47 <sup>r</sup>
Knife L. = $-0.329 \times 12.05$	= - 3.98 <sup>r</sup>
	Total = - 8.45
Axle L., (a) = $- 8 \times 0.329 - 22 \times 0.186 - 10 \times 0.014$	= - 6.864

**MAIN TRUSS MEMBERS.**

**Web Verticals as "Brackets."**

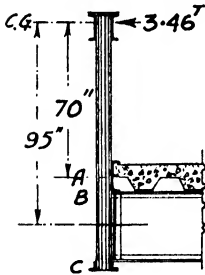

FIG. 231

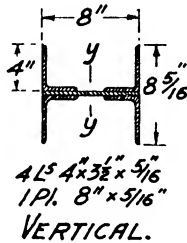

FIG. 232

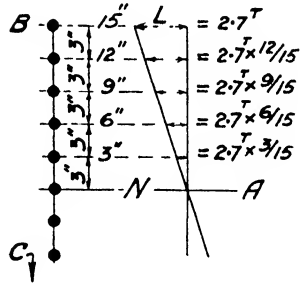

FIG. 233

Unsupported length to C.G. of top chord,

Fig. 231	=	70" 27
Lateral load = $2\frac{1}{2}\%$ of 138.69 <sup>r</sup>	=	3.46 <sup>r</sup>
$B.M._1 = 3.46^r \times 70$ in.	= in. <sup>r</sup>	242.2
$Z_v$ , Figs. 232 and 237 = $I \div y = 108.7 \div 4$	= in. <sup>3</sup>	27.2
Result. extreme fibre stress = $242.2 \div 27.2$	= $\tau$ /sq. in. $\pm$	8.9 28
$B.M.$ at centre of rivet group $B.C. = 3.46^r \times 95$	= in. <sup>r</sup>	329
Working axial load on $\frac{3}{8}$ " dia. site rivet at $\frac{1}{2}F_t$	=	2.71 <sup>r</sup> 29
$\tau$ /sq. in. = $0.601 \times 4.5$	=	2.71 <sup>r</sup> 29
$M$ of $R$ of one row, 30" deep, Fig. 233		



**Main Truss Members.**

**Top Chord "Brackets."** When a through road bridge has deep trusses and ample head room it is a simple matter to reduce the lateral slenderness ratio,  $l/k_y$ , of the upper chord by overhead sway and wind bracing connected to the upper panel points. This construction is impossible with small span shallow trusses and the designer has three courses open to him :—

(a) To make the upper, or compression, chord as wide as possible, or

(b) To use external brackets to support the top chord laterally, as in Fig. 245, or

(c) To design each vertical (and its connection to the cross girder) as a rigid vertical cantilever, thereby giving support at its nose to the upper chord against lateral buckling.

In the design : (a) A relatively wide top chord of 16 in. has been used.

(b) External brackets were discarded because of their clumsy appearance.

(c) The wide upper chord allowed the verticals to be designed as rigid members. Instead of four angles latticed or battened together a continuous  $\frac{5}{16}$  in. web plate was employed to form an  $H$  section, see Figs. 231 and 237. The 4-in. outstanding legs make for easy riveting to the end cleats of the cross girder, while the  $3\frac{1}{2}$ -in. legs to the web plate are the minimum for  $\frac{3}{8}$ -in. dia. rivets.

To obtain a satisfactory section for the verticals, when functioning as cantilevers, the effective lateral thrust at the centre of gravity of the upper chord is usually assumed to be one-fortieth or  $2\frac{1}{2}$  per cent. of the total force in the top chord.

*Item 27.* The free cantilever length commences at the fascia channel.

*Item 28.* The calculated fibre stress is acceptable as it is less than the working stress of  $9\pi$ /sq. in., but it is more or less hypothetical as the "real" stress on the member is the direct stress obtained as a member of the Pratt frame.

*Item 29.* The allowable axial stress on the rivets is taken at  $\frac{1}{2}F_t$  as permitted by some specifications for field rivets. Other bridge specifications, however, forbid the use of rivets in tension ; but the axial stress in these fastenings is conjectural and they carry their definite load from the cross girder end cleats in single shear.

*Item 30.* The adopted rivet pitches in the cross girder end cleats may not exactly conform with those indicated on Fig. 233, but at this stage some approximate estimate had to be made of the probable layout.

$$= 2 \left[ L \times 15 + \frac{12}{15} L \times 12 + \frac{9}{15} L \times 9 + \dots \frac{3}{15} L \times 3 \right]$$

$$= \frac{2}{15} L [15^2 + 12^2 + \dots 3^2] = 66L = 66 \times 2.71 = \text{in.}^2 \quad 179$$

For two rows of rivets in end cleats,  $M$  of  $R = \dots$  358 **30**

The vertical may be considered as a stiffening bracket to upper chord, because the fibre stress  $\pm 8.9^r/\text{sq. in.}$  is less than the working stress of  $9^r/\text{sq. in.}$ , and the riveting provides a resistance of  $358 \text{ in.}^2$  against the required  $329 \text{ in.}^2$ ; (even without allowing for the additional help provided by the troughing being riveted to the fascia channel and thence to the vertical).

**MAIN TRUSS : Top Chord,  $U_2 U_3$ .**

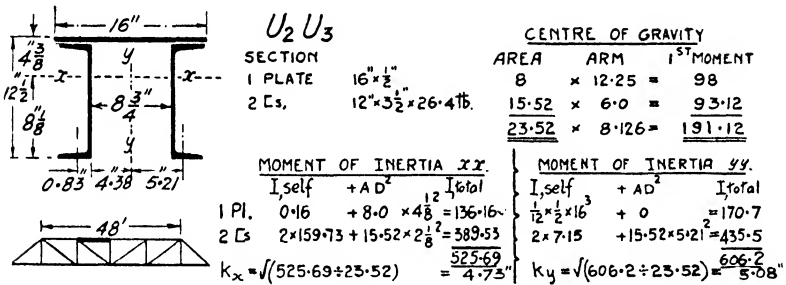

FIG. 234

Total compressive force on member	=	138.69 <sup>r</sup>	
Effective strut lengths, axis $yy$ :—			
(a) $\frac{3}{4}$ of 48'	=	432"	<b>31</b>
(b) between alternate brackets = 24'	=	288"	<b>32</b>
axis $xx$ :—			
(c) between verticals	= 12'	144"	
Slenderness ratios, $l/k_y$ :—			
(a) $432 \div 5.08$	=	85	
(b) $288 \div 5.08$	=	56.7	
Working stress $F_c$ :—			
(a) $9(1 - 0.0038 \times 85)$	= $\tau/\text{sq. in.}$	6.09	<b>33</b>
(b) $9(1 - 0.0038 \times 56.7)$	=	7.06	<b>34</b>
Actual stress = $138.69 \div 23.52$	=	5.90	

**Top Chord,  $U_2U_3$ .** After a preliminary trial the top chord section of Fig. 234 was adopted. If this compression member is given no direct lateral support the effective lateral strut length is usually taken at three-quarters of its overall length of 48 ft., item **31**, so giving a working stress of  $6.09^T$ /sq. in., item **33**.

If side brackets are given at the verticals, or if the verticals themselves are designed as efficient brackets, the effective lateral strut length is variously specified as the distance between brackets, *i.e.*, 12 ft., or as the distance between alternate brackets, *i.e.*, 24 ft. Under the latter and more stringent clause the working stress is  $7.06^T$ /sq. in., items **32** and **34**.

For the  $x$  axis the unsupported strut length is 12 ft., as the top chord is well supported vertically at every panel point, and the corresponding slenderness ratio is the least of all. The top chord will, therefore, not fail in a vertical direction.

The section adopted receives a calculated direct compressive stress of  $5.9^T$ /sq. in. so satisfying the various specifications.

**Top Chord,  $U_1U_2$ .** Most designers would probably keep the thickness of the 16-in. wide cover plate constant throughout the full length of the top chord, and would not thin it down by  $\frac{1}{8}$  in. as in item **35**. This would result in keeping the rivets, connecting the cover plate to the channel flanges, at a constant pitch of  $12t = 12 \times \frac{1}{2}'' = 6$  in. With a  $\frac{3}{8}$ -in. thick cover for  $U_1U_2$  the rivet pitch closes up to  $12 \times \frac{3}{8}''$  or  $4\frac{1}{2}$  in., *i.e.*, the thinner plate requires more riveting and also it necessitates a  $\frac{1}{8}$ -in. thick packing at the splice, as detailed on Sheet 3 of the bridge drawings. It was decided that the use of two thicknesses of cover plates would be more informative to the student than the use of one would be.

The effective truss depth of 10 ft. and the radii of gyration of the top chord are but little altered by the thinning down of the cover plate. The working stress for  $U_1U_2$  is therefore the same as that for  $U_2U_3$ .

**Bottom Chord.** It so happens that the sections used result in the calculated stresses being approximately constant throughout the full length of the bottom chord, items **36** and **37**. Following the usual practice for tensile flanges half the outstanding 4-in. leg is not deducted when calculating the net area.

The centre of gravity line practically coincides with the inner rivet lines, a fact which causes some authorities to specify that the "centre" line of a single angle section with double rivet lines shall be assumed to be the inner rivet line.

Alternative types of bottom chords are (a) two small channels and (b) four angles instead of two, *i.e.*, one angle riveted to each side of each bottom gusset plate ; see Figs. 244 and 245.

**Top Chord  $U_1 U_2$ .**

Total compressive force on member = 122.41<sup>r</sup>  
 Section :— 1 Pl. 16" ×  $\frac{3}{8}$ " = 6 sq. in. 35  
 2 channels, 12" ×  $3\frac{1}{2}$ " × 26.4lb. = 15.52 area, sq. in. 21.52  
 Actual stress = 122.41 ÷ 21.52 = 5.68  $\tau$ /sq. in.

**Lacing of Top Chord.** Refer to the rules given in Chapter IV.

$l/k_y$  for single channel  $\cong L/K_y$  for compound section.  
 i.e.,  $l/0.96$ " " "  $\cong 85$ , Fig. 235, whence  $l \cong 82$ "

With a diaphragm placed at mid-panel the unsupported channel length = 72"

This is satisfactory, but lacing, or latticing, will also be given.

Lateral "shear" on top chord =  $2\frac{1}{2}$  per cent. of total stress 138.69<sup>r</sup> = 3.46<sup>r</sup>

One-half goes to the upper "web" 16" plate; other half to the lower "web" of lacing = 1.73<sup>r</sup>

Single lacing of approximately 60° will be used, see Fig. 235.

Minimum thickness :— rule is  $\frac{1}{10}$  of 12.75" = 0.32"

Adopt  $\frac{3}{8}$ " thickness and a width of  $2\frac{3}{4}$ " (3 rivet dias. =  $3 \times \frac{7}{8}$ ").

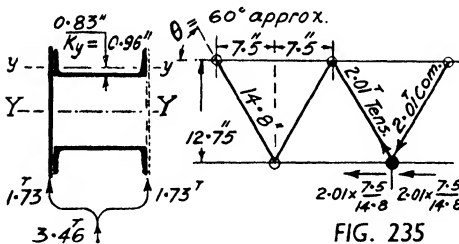

FIG. 235

$2\frac{3}{4}$ "  $\frac{3}{8}$ "  
 Area, gross = 1.031  $\square$   
 Area, net = 0.703  $\square$   
 $I_x = \frac{1}{12} \times 2\frac{3}{4} \times (\frac{3}{8})^3 = 0.0121$   
 $k_x = \sqrt{\frac{I}{A}} = \sqrt{\frac{0.0121}{1.031}} = 0.108$   
 TOP CHORD LATTICING.

Load on lacing bar = shear × cosec  $\theta$  = 1.73<sup>r</sup> × 14.8" ÷ 12.75" = 2.01<sup>r</sup>

$F_c = 9(1 - 0.0038l/k) = 9(1 - 0.0038 \times 14.8 \div 0.108)$  tons/sq. in. = 4.32

Permissible load on one bar, compression, =  $F_c \times$  area  
 = 4.32 × 1.031 = 4.45<sup>r</sup>

" " " tension, =  $F_t \times$  area  
 = 9 × 0.703 = 6.33<sup>r</sup>

Load on one rivet = 2.01<sup>r</sup>, or at flange surface of channel it is the longitud. component of load on compression bar plus ditto tension bar,

= 2(2.01 × 7.5 ÷ 14.8) = 2.04<sup>r</sup>, i.e.,

less than S.S. value per rivet of = 3.91<sup>r</sup>

A three-rivets batten plate will be given at each end of panel as a finish.

**Verticals.** The section for these members was predetermined by the detail at the end cleats of the cross girders and by the necessity for stiffening the upper chord. This explains the large difference between the actual direct loads and the total permissible compressive load of 74 tons, item 39.

*Item 38.* The lesser radius of gyration is that about axis  $x$ .

*Item 40.* Member  $U_1L_1$  is a suspender transferring the cross girder load up to the panel point  $U_1$ . None of the load comes directly into the lower chord at  $L_1$ , which is the reason for the few stitching rivets there.

Member  $U_3L_3$ , on the other hand, acts only as a stool by taking the load from the cross girder and giving it to the main truss at joint  $L_3$  of the lower chord.

*Reversal of Stress.* The nature and value of the force in  $U_2L_2$  change from  $+22.02^T$  to  $-2.81^T$  as the load traverses the span. Fatigue failure, caused by a large number of stress reversals, is a well-known phenomenon, but it hardly applies to a bridge member. Most specifications concur, however, that a little extra area should be given to a member subjected to stress reversal, and they specify that the design load shall be the greater occurring load added to half the lesser; this design load to have the same force sign as the greater. The design load for  $U_2L_2 = + (22.02 + \frac{1}{2} \text{ of } 2.81) = 23.43$  tons, compression. It is always advisable to ensure that the member so designed will carry the lower force of opposite sign, more especially when the two occurring loads are almost equal in value and the compressive one is the lesser. When there is a reversal of stress the connecting rivets at either end of the member are calculated to carry a design load equal to the sum of the occurring loads, *i.e.*,  $22.02 + 2.81$ , or 24.83 tons in the case of  $U_2L_2$ .

**Diagonal  $U_2L_3$ .** Had the adopted section been of two angles cross tied by laticing and batten plates it would have been necessary to deduct half the area of the out-leg from each angle.

By using a continuous web plate, the section, as a complete unit, is symmetrically loaded; there is no free leg and no sacrifice of half the free leg is necessary. The critical transverse section for net area is that which cuts through the two rivets connecting the web plate to the angles, thus causing a loss of two thicknesses of  $\frac{5}{16}$  in. per rivet.

*Item 41.* A reversal of stress occurs; see explanatory text for item 40. Although designed as a tension member the adopted section is also checked for the strut load.

**Diagonal  $U_1L_2$ .** The stress is always tensile; there is no reversal. Here again a continuous web plate is used in preference to lacing, because if the latter were used it would be rather difficult to paint

**Diaphragms to Bottom Chord.** One is placed at the mid-point of each panel to lessen the vibration in the member. The alternative is to use a double or treble riveted batten plate (i.e., 6" or 9" wide by 16 $\frac{3}{4}$ " deep by  $\frac{5}{16}$ " tk.) riveted to the underside of the 4" legs at about 4' pitch.

**Bottom Chord, L<sub>0</sub>L<sub>3</sub>.**

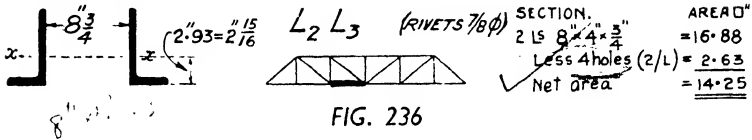

Total tensile force on member = 122.41<sup>T</sup>  
 Actual stress = 122.41 ÷ 14.25 ✓ = <sup>T</sup>/sq. in. 8.59 **36/**  
 Working stress = ,, 9.0

**Bottom Chord, L<sub>0</sub>L<sub>2</sub>.**

Total tensile force on member = 73.47<sup>T</sup>  
 Section :—  
 2 Ls 8" × 4" ×  $\frac{7}{16}$ " = 10.12 sq. in. gross.  
 Less 4 holes (2/L) = 1.53 ,, ,,  
 Total net area = sq. in. 8.59  
 Actual stress = 73.47 ÷ 8.59 = <sup>T</sup>/sq. in. 8.55 **37**  
 Working stress = ,, 9.0 ✓

**Verticals ; U<sub>1</sub>L<sub>1</sub>, U<sub>2</sub>L<sub>2</sub> and U<sub>3</sub>L<sub>3</sub>.**

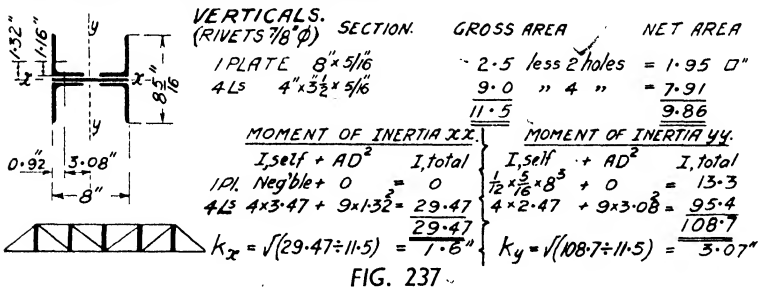

$l/k_x = 120" \div 1.6" = 75$  **38**  
 Working stress  $F_c = 9(1 - 0.0038 \times 75) = 6.44$  = <sup>T</sup>/sq. in. **39**  
 As a compression member permissible load = 11.5 × 6.44 = 74<sup>T</sup>  
 As a tension member permissible load = 9.86 × 9 = 88.74<sup>T</sup>

the inner opposing faces of the angle legs in contact with the lattice bars. The two web rivets penetrate a total of six thicknesses of metal.

**End Post,  $U_1L_0$ .** This important strut is well fixed at the lower end  $L_0$  about both the  $x$  and  $y$  axes and also about the  $x$  axis at the upper end  $U_1$ , where it has the full support of the total length of the upper chord behind it. The weakest end fixing of all is that about the  $y$  axis (*i.e.*, in a direction at right angles to the span) at  $U_1$ , the upper end of the member. But the suspender  $U_1L_1$ , in company with the other verticals, was purposely designed as a cantilever to stiffen the top boom in a lateral direction. The assumed lateral force at top chord level was 3.46 tons, Fig. 231, which now represents 2.8 per cent. of the maximum total direct stress in  $U_1L_1$ .

The slenderness ratios are :— $l/k_x = 14.86 \times 12 \div 2.65 = 67.3$ . Fig. 240, and  $l/k_y = 14.86 \times 12 \div 3.21 = 55.5$ . The latter ratio is that associated with the weaker end fixity, so satisfying the rule that the larger radius of gyration should go with the weaker end fixing. Furthermore, since the calculated stress is 11 per cent. lower than the permissible given by the strut formula the assumption that the effective strut length is equal to the actual length is not unreasonable for the section adopted.

**Riveting.** Most bridge specifications state that when the end of a member is connected to a gusset plate the rivets given thereat should at least develop the calculated load on the member, but when a member is spliced in its length the rivets of the splice should develop the full strength of the member and not only the calculated load.

**Item 42.** Actually 28 rivets are given, *i.e.*, 7 rivets at the end of each of the four angles comprising the section, as will be seen at joint  $L_0$ , Sheet 3.

**Item 43.** The cross girder reaction travels directly up to joint  $U_1$ . Since there are four angles forming the section each angle must be given 3 rivets at the end ; but one pair of the angles is carried further into the upper chord by the distance necessary for one stitching rivet, so as to give as much lateral rigidity as possible to joint  $U_1$ .

The stitching rivets at  $L_1$  carry the weight of the bottom chord into the suspender and prevent the chord sagging and vibrating.

**Item 44.** To prevent eccentricity of loading on the member the same number of rivets is given to each angle, *i.e.*, a total of 20 rivets given as against 18 required.

**Item 45.** The gusset details necessitate more rivets than the bare minimum. Because there is a reversal of stress the rivets at the ends of the member must develop the sum of the forces.

- Force on member  $U_1L_1 =$  tension of 34.13<sup>T</sup> 40  
 ,, ,, ,,  $U_2L_2 =$  comp. of 22.02<sup>T</sup> or  
 tens. of 2.81<sup>T</sup>.  
 ,, ,, ,,  $U_3L_3 = 0$  (redundant)

**Diagonal  $U_2L_3$ .**

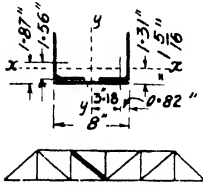

FIG. 238

$U_2L_3$ SECTION 1 PLATE 8" x 5/16" 2 L <sub>s</sub> 5" x 3 1/2" x 5/16" Less holes, 2 @ 2 x 5/16" x 7/8" = 1-1 Total net area 6.52 sq" (RIVETS 7/8" φ) $I_x = 17.9 \text{ in.}^4$ $I_y = 70.3 \text{ in.}^4$	CENTRE OF GRAVITY
	GROSS AREA ARM
	2.5 x 0.15 = 0.375
	5.12 x 1.87 = 9.575
	7.62 x 1.31 = 9.95
	$K_x = \sqrt{17.9 \div 7.62} = 1.53"$ $K_y = \sqrt{70.3 \div 7.62} = 3.04"$

- Total force on member :— tension 34.4<sup>T</sup>  
 compression 4.34<sup>T</sup>  
 As a tension member, permissible load = 6.52 x 9 = 58.68<sup>T</sup>  
 Design load = 34.4 + 1/2(4.34) considered tension 36.57<sup>T</sup> 41

- As a compression member,  
 $F_c = 9(1 - 0.0038l/k)$   
 = 9(1 - 0.0038 x 15.6' x 12 ÷ 1.53") = <sup>T</sup>/sq. in. 4.83  
 As a compression member, actual stress = 4.34 ÷ 7.62 = ,, 0.57

**Diagonal  $U_1L_2$ .**

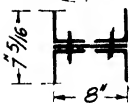

$U_1L_2$

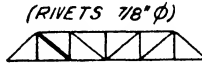
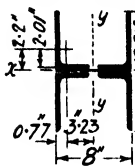

FIG. 239

(RIVETS 7/8" φ)	SECTION.	AREA □
	1 PLATE 8" x 5/16" = 2.5	
	4 L <sub>s</sub> 3 1/2" x 3 1/2" x 5/16" = 8.36	
		10.86
	Less holes, 2 @ 3 x 5/16" x 7/8" = 1.64	
	Total net area = 9.22	

- Total tensile force on member = 68.23<sup>T</sup>  
 Actual stress = 68.23 ÷ 9.22 = <sup>T</sup>/sq. in. 7.4  
 Working stress = ,, 9.0

**End Post,  $U_1L_0$ .**



$U_1L_0$  END POST.

SECTION: 1 PLATE 8" x 3/8" = 3.0" } 16.68 □ Gross.  
 4 L<sub>s</sub> 6" x 3 1/2" x 3/8" = 13.68

-x- MOM. OF INERTIA xx.		MOM. OF INERTIA yy.	
SECT.	$I_{self} + AD^2 = I_{total}$	SECT.	$I_{self} + AD^2 = I_{total}$
1 PL. Neglig'le + 0 = 0	= 0	1/2 x 3/8" x 8" + 0 = 16	= 16
4 L <sub>s</sub> 4 x 12.62 + 13.68 x 2.2^2 = 116.69	116.69	4 x 3.21 + 13.68 x 3.23^2 = 155.52	155.52
	116.69		171.52
	$K_x = \sqrt{116.69 \div 16.68} = 2.65"$		$K_y = \sqrt{171.52 \div 16.68} = 3.21"$

FIG. 240





*Item 46.* By using the reverse angle cleats at joint  $L_3$ , see Sheet 3, it is possible to reduce the size of the gusset plate considerably. It will also be noted that a packing, of the same thickness as the gusset plate, is necessary above the inner gusset plate in contact with the end cleats of the cross girder.

*Item 47.* The cross girder reaction of  $32.83\tau$  is transferred directly into joint  $L_3$  through the lower portion of  $U_3L_3$ . Although statically redundant this member is carried right up and into the top boom, thereby reducing the  $l/k$  value of the upper chord in the vertical plane, and also in the horizontal plane because of the bracket effect previously described. Statically there is no load on the rivets at  $U_3$ .

*Item 48.* The rivets have to abstract all the load in  $U_1U_2$  and transfer it into the gusset plate, there to be balanced by the loads from the other three members at the joint. A similar function is performed by the rivets at  $L_0$  in  $L_0L_1$ .

*Item 49.* Referring to the dead load force sheet of Fig. 230 it will be seen that the flange force difference at  $L_2$  is equal to the horizontal component of the force in diagonal  $U_1L_2$ .

$$\text{Flange force difference at } L_2 = 50.8 - 30.5 = 20.3\tau$$

$$\text{Horiz. comp. of } U_1L_2 = 26.43 \cos \theta_2 = 26.43 \times 0.7682 = 20.3\tau$$

This relationship, however, does not exist with the force summation figure.

$$\text{Flange force difference at } L_2 = 122.41 - 73.47 = 48.94\tau$$

$$\text{Horiz. comp. of } U_1L_2 = 68.23 \cos \theta_2 = 68.23 \times 0.7682 = 52.42\tau$$

The reason for this apparent discrepancy is that the bottom chord receives its maximum force when the live load fully covers the span, whereas  $U_1L_2$  is given its maximum load when the right hand length of 56.72 ft. of the span is loaded as indicated by the influence line—two different cases of loading. The rivets connecting the gusset plate to the chord should therefore develop the horizontal component of the load in the diagonal at that point. The rule that these rivets should develop the chord force difference at the panel point is correct if the load does not vary in position, but if the position alters the rule is only an approximation.

*Item 50.* A similar line of reasoning applies to the chord rivets in gusset  $L_3$ , but in this case more than the necessary number of rivets is given by developing the horizontal component of  $U_2L_3$ . This member receives its maximum load when the 42.24 ft. of the influence line is covered by the *U.D.L.L.* which also causes a lesser load in diagonal  $L_3U_4$ . The horizontal component of the latter does not entirely counteract that of the former in the gusset plate, and the unbalanced amount enters the lower chord through the rivets. The forces are summed because of the stress reversal.

Total compressive force on member = 99.3<sup>T</sup>  
 $F_c = 9(1 - 0.0038l/k)$   
 =  $9(1 - 0.0038 \times 14.866 \times 12 \div 2.65) = \tau/\text{sq. in. } 6.70$   
 Actual stress =  $99.3 \div 16.68 = \text{,, } 5.95$

**Riveting.** Values per  $\frac{7}{8}$ " dia. rivet :— S.S. = 3.91<sup>T</sup> and  $\frac{5}{16}$ " B = 4.1<sup>T</sup>.

Number of S.S. rivets required for the end connection of : —

$U_1L_0$	$= 99.3 \div 3.91$	$= 26$	<b>42</b>
$U_1L_1$	$= 34.13 \div 3.91$	$= 9$	<b>43</b>
$U_1L_2$	$= 68.23 \div 3.91$	$= 18$	<b>44</b>
$U_2L_2$	$= (22.02 + 2.81) \div 3.91$	$= 7$	<b>45</b>
$U_2L_3$	$= (34.4 + 4.34) \div 3.91$	$= 10$	<b>46</b>
$U_3L_3$	$= \text{cross girder reaction } 32.83 \div 3.91$	$= 9$	<b>47</b>
$U_1$ in $U_1U_2$	$= 122.41 \div 3.91$	$= 32$	<b>48</b>
$L_0$ in $L_0L_1$	$= 73.47 \div 3.91$	$= 19$	

*Bottom chord to gusset plate at  $L_2$ .* Cosine of angle  $U_1L_2L_1 = 12' \div 15.621' = .7682$  **49**

No. of rivets = horiz. component of  $U_1L_2 \div 3.91$   
 $= 68.23 \times \cos \theta_2 \div 3.91$   
 $= 68.23 \times .7682 \div 3.91 = 14$

Alternatively = rivets in  $U_1L_2 \times \cos \theta_2$   
 $= 18 \text{ reqd.} \times .7682 = 14$

*Bottom chord to gusset plate at  $L_3$ .* **50**

No. of rivets = horiz. comp. of  $U_2L_3$ ,  
 $= (34.4 + 4.34) \cos \theta_2 \div 3.91$   
 $= 38.74 \times .7682 \div 3.91 = 8$

Alternatively = rivets in  $U_2L_3 \times \cos \theta_2$   
 $= 10 \text{ reqd.} \times .7682 = 8$

*Joint in Upper Chord,  $U_2U_3$ .* **51**

Effective strength = gross area  $\times F_c = 23.52 \times 6.09 = 143.2^T$

No. of S.S. rivets =  $143.2 \div 3.91 = 37$

Proportion these between the elements forming the section, as follows :—

Plate  $16'' \times \frac{1}{2}''$ , area = 8 sq. in. Rivets =  $8 \times 6.09 \div 3.91 = 12.4$   
 Channel web, ,, =  $12'' \times 0.38''$ . ,, =  $4.56 \times 6.09 \div 3.91 = 7.1$

Channel fl., ,, = 1.6. ,, For two webs = 14.2

Channel fl., ,, = 1.6. ,, =  $1.6 \times 6.09 \div 3.91 = 2.5$

For four flanges = 10  
*i.e., total =  $\frac{10}{37}$*

*Item 51.* The top chord splices have been placed at  $U_2$  and  $U_4$  for the purpose of making use of the gusset plates as partial covers to the webs of the channels, and also to make the joints less conspicuous. The rivets and the various covers have been allotted to the different parts of the section proportional to the areas covered. The cross-sectional area of the covers of a splice are always greater than that of the original section by 5 per cent. in the case of a symmetrical joint and 10 per cent. for an unsymmetrical one. The  $16'' \times \frac{9}{16}''$  upper cover plate covers the  $16'' \times \frac{1}{2}''$  flange plate and the two upper flanges of the channels. The lower flanges of the channels are covered by the  $3\frac{1}{2}''$  straps.

*Item 52.* The bottom chord splices have been placed in the end 23-ft. panels and therefore the angles to be developed by the rivets and covers are the  $8'' \times 4'' \times \frac{7}{16}''$  angles and not the  $8'' \times 4'' \times \frac{3}{4}''$  ones.

**Alternative End Post,  $U_1L_0$ .** An alternative to that used in the design is the inverted U section which, when adopted, is usually composed of the top chord scantlings continued down from  $U_1$  to  $L_0$ ; although lighter rollings of the same outline are sometimes used.

Possibly the bridge looks better with this type of end post, but, on the other hand, the H type of section shown on the design drawings makes for simple and straightforward details of  $L_0$  and  $U_1$ .

*Fig. 241.* Because of the dual vertical gussets at  $L_0$  the 16-in. cover plate of the end post must be stopped short at point  $B$  and the problem which arises is that of the transference of the load, carried by this 16-in. cover plate, into the vertical gussets.

The heavier rolling of the 8-in. channel is used as a cleat and is riveted through its web to the 16-in. cover plate. Provided with sufficient area and rivets it lifts the load from this plate and then transfers it into the two vertical gussets through the flange rivets extending from  $A$  to  $B$ . If desired, additional angle cleats, of length  $AB$ , may be used with suitable packings to transfer the load in the upper and lower flanges of the channels directly into the vertical end gussets.

*Fig. 242.* In this alternative detail a bent cover plate is used to abstract the load from the 16-in. cover and deliver it to the two vertical gusset plates through the four angle cleats shown on section  $AB$ .

*Fig. 243.* Bad detailing of this joint was, on one occasion, the cause of a terrible cinema theatre disaster. In consequence many prefer to develop the full compressive strength of the inverted U chord section into the end post, and not simply to transfer the load only.

(Continued on opposite page, under *Fig. 243.*)

Joint in Lower Chord,  $L_1L_2$ .

$$\text{Effective strength} = \text{net area} \times F_t = 8.59 \times 9 = 77.31 \text{ 52}$$

$$\text{No. of } \frac{7}{16} \text{ Rivets} = 77.3 \div 5.74 = 14$$

These rivets are proportioned between the 8" and 4" angle legs in the ratio of 2 to 1.

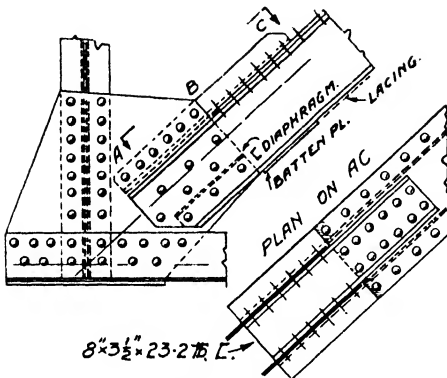

FIG. 241

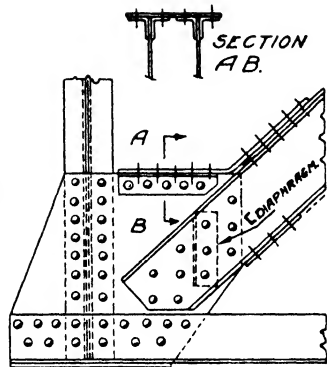

FIG. 242

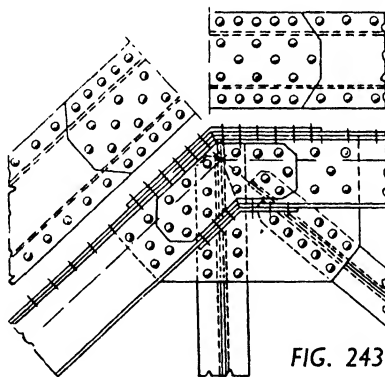

FIG. 243

The bent cover plate on top develops the full strength of the 16-in. cover plate and the two top flanges of the channels; *i.e.*, practically the same detail as at the main chord splice, save that this outer plate is now bent. A bent flat develops the bottom flange of each channel, while the channel webs are covered on the inner faces by the vertical gusset plates. Sometimes shaped plates are also placed on the outer faces of the channel webs as shown on this drawing, thereby causing the attaching rivets to be in double shear and bearing.

**Bridge with Footways.** The cambered plate of Fig. 244 is used

in the form of an arch and is simply laid in position, without riveting, between the two supporting footwalk channels. The adhesion of the concrete provides the necessary attachment; while tie rods,  $\frac{3}{4}$  or  $\frac{7}{8}$  in. dia. with washers at both ends, through the webs of the channels and buried in the concrete at 4 ft. pitch, effectively tie the channels together.

The form of construction outlined by this cross section is a useful one when the live load is small. The top and bottom flange angles on the far side of the cross girder are stopped just short of the main truss vertical, as indicated by the shading, so that the cantilever portion under the foot walk is composed of a web plate with single angles, top and bottom, on the near face. The use of a channel type of main truss vertical (with the outstanding legs on the far side, or an H section with the near angles cut short) permits the cross girder to be riveted through its web to the vertical of the truss. Stiffener angles, not shown, riveted to the near side of the cross girder web plate continue the outline of the two angles of the H type of vertical, which were cut short for constructional reasons.

*Fig. 245.* A continuous cambered plate is again used, but now in the form of a suspension span. It is riveted through a continuous trimming angle to the upper flange of the left-hand vertical channel and directly to the upper flange of the kerb channel. This strong form of construction affords a hidden space of easy access for service mains. Should the 12-ft. span, cross girder to cross girder, be deemed too large for the pipes, then intermediate supports may be given by cross flats or light angles bolted to the undersides of the channel flanges. The arched and cambered plates of both details need only be  $\frac{5}{16}$  in. thick in 6- to 12-ft. lengths.

If, instead of cross supports,  $\frac{1}{4}$ -in. thick steel plating is riveted to the horizontal faces of the bottom flanges of the channels a continuous box is formed. This box can be filled with sand and the service mains and cables buried. These are now better supported and more protected against frost than those of the previous detail. The cambered plate is not now necessary because the walking surface of the footpath is formed of paving stone flags, or pre-cast concrete paving slabs, laid on the sand, thus ensuring easy access to the mains for the full length of the bridge.

A third method is to extend the trough flooring under the footpath and to use sand for the filling,—with the remainder of the detail somewhat similar to that just described. It has the disadvantage, however, of requiring a greater weight of steel and giving much less space for the service mains.

**Bearings.** The same type of bearing is shown on the present drawings as was used for the railway bridge of the previous chapter.

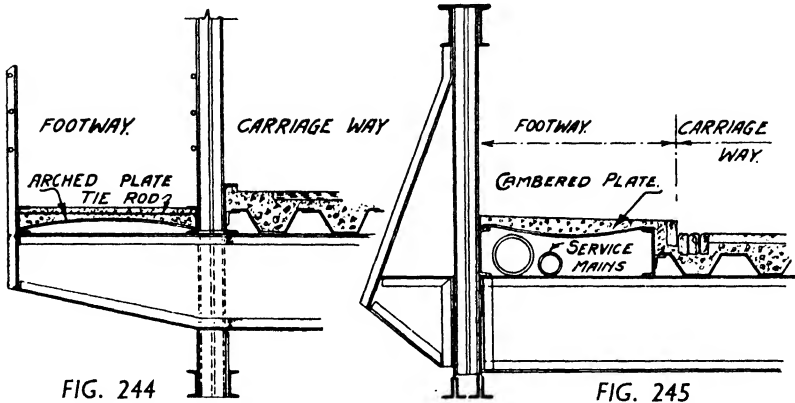

There is, therefore, no necessity to repeat the calculations or the details.

**Expansion.** A common allowance in Great Britain is from  $\frac{3}{4}$  to 1 in. for every 100 ft. of span. Alternatively, if the range of temperature above or below normal be  $x^\circ$  Fahrenheit and the coefficient of liner expansion is 0.0000065 per degree, the change in length above or below the normal length of 70 ft. is  $x \times 0.0000065 \times 70 \times 12$  inches.

**Braking Stresses.** If the bridge is designed for the M. of T. loading no additional allowance need be made for longitudinal forces.

**Wind Pressure.** Because the two main trusses are just a trifle further apart than twice their depth, both trusses are assumed to present their full elevation surface to a wind acting at a slight angle to the normal to the span. The wind intensity for road bridges is usually specified at 50 lb. per sq. ft. of elevation surface of the bridge when clear of traffic, and 20 lb. per sq. ft. of bridge and vehicular surfaces with traffic on the bridge.

For this open truss bridge the wind stresses will be even smaller than those of the 70-ft. span plate girder railway bridge of the previous chapter. A reference to the last article of that chapter on Combined Stresses will justify the statement that the effect of the wind on this road bridge need not be investigated.

## REFERENCES

INFLUENCE LINES, STRESSES, ETC.

DEPT. OF SCIENTIFIC AND INDUSTRIAL RESEARCH. *The Report of the Bridge Stress Committee.* (1929.)

- GRIBBLE, C. *Impact in Railway Bridges with Particular Reference to the Report of the Bridge Stress Committee.* Min. Proc. Inst. C. E., Session 1928-29.
- JOHNSON, BRYAN AND TURNEAURE. *Modern Framed Structures.* Parts I and III. (Wiley & Sons.)
- MORLEY, A. *The Theory of Structures.* (Longmans, Green & Co.)
- REMFRY, D. H. *The Interaction in Bridgework of the Deck System on the Main Girders, etc.* Min. Proc. Inst. C. E., Vol. CCXVIII.
- STEWART, D. S. *Influence Lines. Their Practical Use in Bridge Calculation.* (Constable & Co. Ltd.)
- TIMOSHENKO, S. *Strength of Materials.* (Macmillan & Co.)

#### DETAILS

- KETCHUM, M. S. *Design of Highway Bridges.* (McGraw-Hill.)
- KUNTZ, F. C. *Design of Steel Bridges.* (McGraw-Hill.)
- SKINNER, F. W. *Plate Girders.* (McGraw-Hill.)
- THOMSON, W. C. *Design of Typical Steel Railway Bridges.* (Engineering News.)

#### SPECIFICATIONS

- Girder Bridges, Specification No. 153, Parts I and II, Materials and Workmanship.*
- Girder Bridges, Specification No. 153, Parts III, IV and V, Loads, Stresses, etc.*

Both the foregoing are by the British Standards Institution, and it is advised that reference be made to the current issue.

WADDELL, J. A. L. *Bridge Engineering.* (Wiley & Sons.)

The transactions or journals of the following :—

The Institution of Civil Engineers, The American Society of Civil Engineers, The Engineering Institute of Canada, The Institution of Structural Engineers, etc.

*Code of Practice for Simply Supported Steel Bridges.*

Prepared by the Joint Committee of the Institution of Civil Engineers and the Institution of Structural Engineers.

# INDEX

- A.
- Adhesion, 83, 93
- Alignment charts for—  
angle purlins, 138, 139  
overhang of base-plates, 81  
overhang of concrete found, 87  
stiffener spacing, 23  
working stresses in webs, 22
- Allowance for holes, 3, 4, 147, 212, 285
- Angles, edge, 6, 46, 52  
framing, 159, 161, 189  
net areas, 8, 147, 285, 287  
of repose, 94  
splice of, 255
- Astragals, 133, 165
- Axially loaded columns, 56
- B.
- Ballast, 231, 235, 256
- Base-plates, 31, 79, 81, 95, 254
- Batten-plates, 103, 106-109, 283
- Beam end movement, 110
- Bearings, 31, 216, 255, 292
- Bending, *E.U.D.L.L.*, 221-226, 229, 247, 267-271  
on beams, 12, 89, 122, 125, 146, 188, 203, 237  
on columns, 100, 105, 112-129, 179, 186-193  
on foundations, 126-129, 191-193  
on girders, 3, 43, 207, 228, 237, 241, 244, 269
- Board of Trade, 232
- Bolt values, 75
- Box sections, 6, 99, 102
- Brackets, 113-118, 212, 248, 279, 293
- Braking forces, 41, 256, 293
- Brickwork, 189
- C.
- Camber, 29, 154, 231
- Code of Practice, 6, 10, 19, 27, 67, 68
- Columns, 56-129, 175, 179, 185-201  
base plates, 79-85, 127, 189  
batten plates, 103, 106-109  
bending on. *See* Bending.  
brackets, 113-118
- Columns, design of, 71-97, 105-108, 116-117, 121-122, 125-126, 187-193  
effective length, 59, 67  
end conditions, 57, 71, 77, 98, 175, 182, 188  
formulae, 60-71, 233, 268  
foundations, 80, 86-94, 126-129, 189, 191-193  
lacing, 103-109, 283  
remarks on, 60
- Combined stresses, 27, 120-126, 188, 262
- Contraflexure points, 183, 185, 197-201
- Corrugated sheeting, 133, 135, 138, 158, 162, 195
- Crane, clearance, 102  
girder, 6, 22, 41-55  
rail, 42  
shaft, 100, 196
- Cross girder, 232, 239, 266
- Curtaiment of—  
flange plates, 28, 55, 240, 243, 244  
web plates, 29
- D.
- Deflection, 110, 123, 198, 203
- Depth. *See* Effective depth  
of foundations, 84, 91
- Diaphragms, 100, 283, 291
- Distance washers, 152, 155, 212
- Drainage of roofs, 154
- Duchemin formula, 163
- E.
- Eccentric loading, 109-129, 152
- Edge angles, 6, 46, 52
- Effective depth, 1, 5, 34, 44, 205, 237, 239, 245, 269, 274
- End conditions of struts, 57, 62, 68, 71, 77, 83, 175, 188, 191, 196
- Equivalent loading. *See* *U.D.L.*
- Euler formula, 57, 60
- Expansion, 31, 140, 171, 254, 293
- F.
- Factor of safety, 64-67
- Fidler formula, 63, 64



Flange, rules for, 7  
 plate curtailment, 28, 55, 240, 244  
 stress, 6, 26, 45, 213, 241, 251, 269, 283  
 width, 5, 7, 45, 213, 235, 266, 280  
 Flat ends, 58, 71, 76, 84  
 Floor loads, 134, 202, 264, 265  
 Foot bridge, 202-220  
 Footway, 293  
 Foundations, 80, 85-94, 126-129, 191-193  
 bolts for, 31, 80, 83, 89, 126, 192  
 safe pressure on, 87-94

## G.

Galvanized sheeting. *See* Corrugated.  
 Gantry, girder, 6, 22, 41-55  
 Girder. *See* Plate girder.  
 Glazing, 133, 139, 165  
 Gordon-Rankine formula, 61  
 Grillage foundation, 89  
 Grouting, 31, 88  
 Gusset plates, 154, 219, 286, 288

## H.

Holding-down bolts. *See* Foundation.  
 Holes, allowance for, 3, 4, 147, 215, 285  
 Horizontal deflection, 110  
 framing, 188  
 shear, 11, 35, 43, 83, 93, 203, 239, 241, 251

## I.

Impact, 41, 43, 202, 221, 232, 234, 237, 245, 263  
 formula, 237, 239, 245  
 Inertia, 3, 25, 46  
 Influence lines, 205-211, 246-249, 270-279

## J.

Joggling, 24, 218, 236

## K.

Knee-braces, 174, 180, 187, 189  
 Kneeing, 24, 52, 252  
 Knife-edge load, 263-265, 269, 272-279

## L.

Lacing, 106-109, 283  
 Lateral forces, 45, 110, 122, 212, 279-283  
 Lattice girder, 202-220  
 Louvres, 164

## M.

Main truss, 270, 273-291  
 Ministry of Transport loading, 263-265  
 Moment of inertia, 3, 25-27, 46-49, 253, 283-287  
 Monitor roof, 162-166

## N.

Net areas, 3-5, 8, 47, 147, 237, 244, 251, 283, 285, 287  
 Neutral axis, 2, 12, 46, 92, 279, 281  
 Neutral points, 206-208, 244, 246-248, 276

## P.

Packings, 108, 233, 268, 288  
 Parabola of *B.M.*, 54, 55, 221-226  
 Parabolic formulae, 65  
 Perry formula, 65-68  
 Pin ends, 58-69, 103, 114-117, 125, 175, 182  
 Pitch of rivets, 11, 14, 16, 34-39, 49-51, 76, 239, 241, 251, 269-271  
 Planking, 203  
 Plate girder, bearings, 31, 32, 254-257  
 camber, 29, 154, 231  
 depth, 1, 5, 10, 14, 16, 22, 34, 42, 237, 241, 245, 261, 269  
 flanges, 3-8, 14, 25, 33-39, 45-49, 235, 241, 251, 269  
 inertia, 3, 25-27, 46-49, 253  
 stiffeners. *See* Stiffeners.  
 webs, 3, 9, 27, 29, 35, 47, 96, 237, 251, 269  
 weight of, 33, 42, 239, 245, 269  
 Portals, 174-189  
 Pressure, on concrete, 79, 81  
 of wind. *See* Wind.  
 on soils, 85, 87, 89, 94, 128, 193  
 Punching shear, 93, 94  
 Purlins, 133-137  
 alignment chart, 138, 139

## R.

Radius of gyration, 56-73, 77, 95, 103-108, 116, 117, 121, 147-152, 187, 196, 213-217  
 Rafter design, 72, 73, 149  
 bracing, 161  
 Rail, 42, 229, 235  
 Railway bridge, 224, 231-262  
 Raker, 212, 218, 293  
 Rankine formula, 61-64  
 Redundant bar, 164, 211, 278, 287  
 Reference list, 39, 55, 97, 106, 201, 230, 293

Reinforced concrete, found, 90-94  
 Repose angles, 94  
 Reversal of stress. *See* Stress.  
 Rivet and bolt values, 75, 151, 233, 268  
 Riveting, 16, 35-39, 45, 151, 217, 239, 241, 251, 269, 279, 289  
 Rolling loads, 43, 221-230, 234, 238, 263-265, 274-279  
 Roof, coverings, 133, 159, 165  
   details, 158, 165, 171  
   drainage, 154  
   ridging, 159  
 Roof truss, erection, 171  
   for load lifting, 170  
   knee-braces, 174-187, 189  
   shoes, 140, 171, 172  
   spacing, 168  
   types, 162, 169, 170  
   weights, 133, 157, 162, 168  
   with monitor, 162-166

S.

Safety, factor of, 64-67  
 Section and moments, 140, 164, 178, 204, 272  
 Section modulus, 46, 48, 138, 203, 267, 279  
 Shallow girders, 2  
 Shear, *E.U.D.L.L.*, 227, 247, 269, 275  
   horizontal, 14, 49, 83, 93, 202, 239, 241, 251, 271  
   local, 15, 49, 271  
   on columns, 105, 179, 186  
   vertical, 10, 15, 22, 35, 43, 207, 227, 237, 241, 247-251, 277  
 Shop cross-sections, 101  
 Slenderness ratio, 57, 61-71, 95, 98, 103-108, 116, 147-151, 155, 187, 196, 213-217, 253, 281-289  
 Snow load, 133, 137  
 Soils, pressure on, 85-87, 94, 128, 193  
 Standard loading, 229, 263-265  
 Stiffeners, 17-25, 51, 253, 273  
   rules for, 21  
 Straight-line formula, 65, 213, 233, 268  
 Stress, diagrams, 140, 143, 162, 172, 175, 177, 184, 186, 207, 213  
   reversal, 144, 210, 277, 284, 287  
   ultimate, 66

Stringers, 232, 234-239  
 Struts. *See* Columns, Rafters, etc.

## T.

Temperature expansion, 31, 52, 140, 171, 254, 293  
 Ties, design of, 144, 146-152, 164, 287  
 Timber, 202, 203  
 Tractive forces, 41, 256, 257  
 Troughing, 265-267

## U.

Ultimate stress and load, 66, 67  
 Uniformly distributed loading, 202, 221-230, 247, 263-265

## V.

Vertical shear. *See* Shear.

## W.

Washers, 90, 152, 155, 157, 212  
 Web plate, curtailment, 29  
   girder, 1 55, 231-262, 269-271  
   rules for, 10  
   splice, 29, 53, 259  
 Weight of girders, 32, 42, 205, 235, 238, 245, 269, 273  
   louvres, 164  
   roof trusses, 133, 134, 157, 164, 168  
   soils, 94  
 Wheel loads, 43, 221-230, 238, 263  
 Width of flange plates, 7, 45, 213, 235, 240, 251, 266  
 Wind, bracing, 156, 161, 220  
   pressure, 130-132, 163, 175-188, 218, 256, 293  
 Working stresses, 5, 6, 10, 22, 27, 74, 233, 268  
   columns, 65, 67, 68, 70, 71, 74, 233, 268

## Y.

Yield, stress, 66















