

## PREFACE.

Writing a mere description of Jute Machinery will not be of much assistance to the student, since there is so much detail, and that detail it is of importance to know well before you can expect to get the many wheels and pinions, &c., in your "mind's eye," hence the reason that considerable attention has been bestowed on the illustration of all the parts of the machines. These illustrations being all made to scale, very readily bring before the reader the different proportions and relations of one wheel or roller to another.

Every effort has been made to avoid errors in the calculations. There may be some, however, in the book, but, generally speaking, the figures can be relied upon.

My sincere thanks are due to A. S. Macpherson, Esq., of Messrs Fairbairn, Naylor, Macpherson, & Co., Limited, Leeds; and also to A. Gordon Thomson, Esq., of Messrs Thomson, Son, & Co., Dundee, for valuable assistance rendered.

WILLIAM LEGGATT.

DUNDEE, MAY, 1893.





THE THEORY AND PRACTICE  
OF  
JUTE SPINNING:

BEING A COMPLETE DESCRIPTION  
OF THE MACHINES USED IN THE PREPARATION  
AND SPINNING OF JUTE YARNS.

WITH ILLUSTRATIONS OF THE VARIOUS MACHINES.

SHOWING THE CALCULATIONS, TABLES OF SPEEDS, DRAFTS,  
PRODUCTION, WASTE, ETC.

Including over 140 Diagrams to Scale,  
AND ILLUSTRATIONS BY LAWSON, LEEDS; AND COMBE BARBOUR,  
BELFAST.

677.12  
L52T

BY

WILLIAM LEGGATT,

LATE MANAGER, MANHATTAN WORKS,  
DUNDEE.

*Author of the Second Edition of Art of Weaving.*

DUNDEE: WILLIAM KIDD & SONS, WHITEHALL STREET.  
EDINBURGH AND GLASGOW: JOHN MENZIES & CO.  
LONDON: SIMPKIN, MARSHALL, HAMILTON, KENT, & CO., LIMITED.  
CALCUTTA: THACKER, SPINK, & CO.

1921.

[ALL RIGHTS RESERVED.]

WILLIAM KIDD & SONS, PRINTERS, WHITEHALL STREET  
DUNDEE.

TO  
**Colonel Frank Stewart Sandeman, J.P.,**  
**OF STANLEY, PERTSHIRE.**

THE FOLLOWING PAGES ARE RESPECTFULLY  
INSCRIBED IN RECOGNITION OF MUCH KINDNESS  
AND CONSIDERATION RECEIVED  
DURING THE PAST TWENTY YEARS.

Customer No. ....  
D. 1-7-48  
X

## PREFACE.

---

The author has never forgotten the difficulties he had to contend with in regard to information when learning his business. It is a true saying that too much help is a bad thing, but it is quite as true that a little, just a little at the right time, is a good thing. This is the spirit in which these pages have been written. They contain information which will be found invaluable to those who are seeking with earnestness of purpose to learn their business, but they were not intended to, and will not help those who are not also willing and anxious to help themselves. Any one anxious to do this will, we feel confident, receive from a careful study of these pages a better start than ever the author received.

Nothing has been written in the book with reference to the Jute Fibre or the growth of the plant; that part of the subject the student will find in books already to hand. My endeavour has been to confine myself strictly to the practical manipulation of the fibre and the method of working the machines, explaining as briefly as possible the calculations of speeds, etc.

The man of practical experience will perhaps not find much that is new, but the book may be of service even to him as a reference for figures which are not usually at hand.



## PREFACE.

Writing a mere description of Jute Machinery will not be of much assistance to the student, since there is so much detail, and that detail it is of importance to know well before you can expect to get the many wheels and pinions, &c., in your "mind's eye," hence the reason that considerable attention has been bestowed on the illustration of all the parts of the machines. These illustrations being all made to scale, very readily bring before the reader the different proportions and relations of one wheel or roller to another.

Every effort has been made to avoid errors in the calculations. There may be some, however, in the book, but, generally speaking, the figures can be relied upon.

My sincere thanks are due to A. S. Macpherson, Esq., of Messrs Fairbairn, Naylor, Macpherson, & Co., Limited, Leeds; and also to A. Gordon Thomson, Esq., of Messrs Thomson, Son, & Co., Dundee, for valuable assistance rendered.

WILLIAM LEGGATT.

DUNDEE, MAY, 1893.

# CONTENTS

---

	PAGE
INTRODUCTORY REMARKS, ... ..	1-3
BOILERS AND ENGINES, ... ..	4-17
Description of Boilers—Furnace Apparatus—Economiser—Dimensions of Flues and Arrangement of Dampers, ... ..	4-10
Description of Engines—Abstract of Horse Power—Coals and Water per Horse Power per Hour—Pond Capacity, ... ..	10-12
Engine Diagrams and how to calculate them, ... ..	13-17
SPEED OF SHAFTING, ... ..	18
<b>JUTE BATCHING—</b>	
Description of the Process of Batching, ... ..	19, 20
Selection of Batch for Warp and Weft Yarns for Hessian of Standard quality, .. ..	21, 22
Particulars of Jute Opener and Jute Softener, Speed and Diagrams, ..	23-26
<b>JUTE PREPARING AND PREPARING MACHINERY—</b>	
General Description of Preparing Process, ... ..	27, 28
Explanation of the Working of Breaker and Finisher Cards, ... ..	29-32
Rules for Calculations of Single Doffer Breaker and Finisher Draft, ...	33-35
Double Doffer Breaker and Finisher Draft, ... ..	36, 37
Arrangement of Single Doffer Clock—Calculations for same, with Diagram,	38-40
Specifications and Speed of Single Breaker Card, with Tables of Wheels for Speed of Workers, Drafts, &c. ... ..	41-47
Diagrams and Tables of Wheels and Pulleys for same, ... ..	48-51
Specifications and Speeds of Double Doffer Breakers, with Tables of Wheels for Speeds of Workers, Drafts, &c., ... ..	52-59
Arrangement of Double Doffer Clock, ... ..	60
Diagrams and Tables of Wheels and Pulleys for Double Doffer Breaker, ...	61-64
Diagrams of Upstriker Breaker Card, with Tables of Wheels and Pulleys,	65-68
Diagrams of Single and Double Doffer Finisher Card, with Tables of Wheels and Pulleys for same, ... ..	69-76

	PAGE
Diagrams of Upstriker Finisher Card, with Tables of Wheels and Pulleys for same, ... ..	77-80
Specifications and Speeds of Single Doffer Finisher, with Tables for Speed of Workers, Drafts, &c., ... ..	80-98
Lap Machine—Diagrams and Tables of Wheels and Pulleys for same, ...	99-100
Dimensions of Card Cylinders and Rollers, ... ..	101, 102
Details of Covering for Breakers and Finishers, ... ..	103-106
Specification of Single Doffer Breaker and Finisher Staves, ... ..	107, 108
Specification of Double Doffer Breaker and Finisher Staves, ... ..	109, 110
Details of Covering for Upstriker Breaker and Finisher for West—Covering for Jute Snipper, ... ..	111
Diagrams of Breaker and Finisher Staves, ... ..	112-118
General Instruction as to Setting of Breaker and Finisher Cards for Hessian Yarns, ... ..	119
Particulars of Upstriker Breaker and Finisher Cards—Drafts and Speed of Workers, ... ..	120
Drawing Frames—Description of Drawing Process and different kinds of Drawing Frames, .. ..	121-126
Arrangements of Wheels for Speed, Gill Bars, and Roving, ... ..	128-129
Diagrams of Drawing Frames, with Tables of Wheels and Pulleys for same,	130-143
Diagram—Spiral Drawing Frame, Bend, and Screws, ... ..	144
Diagrams and Particulars of Drawing and Roving Gills, ... ..	145-147
Fluting of Drawing Rollers—Diagrams of Drawing and Pressing Rollers,	148-150
Spiral Roving Frame—The Roving Process—Arrangement of Wheels for Clock Calculations, Drafts, Twists, Speed of Spindles, &c., ...	151-153
Diagrams of Spiral Disc Roving Frame, with Tables of Wheels, Pinions and Pulleys for same, ... ..	154-157
Diagrams—Roving Screws and Gill Bars, ... ..	158
Automatic Motion for Roving Frame Drawing Roller—Diagram and Arrangement of Wheels, ... ..	159, 160
General Instructions as to Working of Roving, ... ..	161
Diagrams—Roving Screws and Gill Bars, showing arrangement of Collar and Pitch Pin, ... ..	162
Diagrams—Differential Motion and Calculations for Speed of Bobbin and Traverse, ... ..	163-168
Diagrams—Rotary Drawings and Rovings, with Tables of Wheels and Pulleys for same, ... ..	169-176
Diagram—Spinning Roving Frame—Table of Wheels and Pinions, ...	176, 177
Speed of Preparing Machinery, ... ..	178

	PAGE
Concluding Remarks on Preparing Machinery, ... ..	179
Diagrams of Barrows for Rove and Spinning Bobbins, ... ..	180
Arrangements of Preparing Machinery Systems to produce Rove from which Hessian Yarns are to be Spun, ... ..	181-187
Sacking, Warp, and Weft arrangements, ... ..	188, 189
<b>JUTE SPINNING,</b> ... ..	<b>190, 191</b>
Instructions as to the Working of Rove Plate, ... ..	192
Explanation of the term "The Rove Running," ... ..	193
Speed of Spinning Frame Spindles, . . . . .	194
Diagram—Spinning, Spindle, and Flyer, ... ..	195
Production from Spinning Frames, .. . . .	196, 197
Twist of Hessian Yarns, .. . . .	198, 199
Spinning Frame—Draft and Twist arrangement of Wheels, for calculation— <i>Fairbairn</i> , ... ..	200-202
Diagrams of End Gables of Spinning Frames, showing Twists and Grist or Draft Arrangement of Wheels, &c.— <i>Fairbairn</i> , ... ..	203-206
Diagram—Heart Motion, ... ..	207
Diagram of Full Bobbin, ... ..	208
Automatic Motion for Drawing Roller— <i>Fairbairn</i> , ... ..	209
Arrangement of Spring and Lever for Pressing Rollers, ... ..	210
Arrangement of Spring and Lever for Pressing Rollers and Retaining Rollers,	211
Automatic Motion for Drawing Roller— <i>Thomson</i> , ... ..	212
Diagram—Rove Plate Arrangement— <i>Fairbairn</i> , ... ..	213
Diagrams—Spinning Frame Gables, showing Twist and Grist or Draft Arrangement of Wheels, &c.— <i>Low, Monifeth</i> , ... ..	214-216
Diagram—Automatic Motion for Drawing Roller— <i>Low, Monifeth</i> , ... ..	217
Particulars of Twist and Grist or Draft Arrangement, showing method of calculation— <i>Low, Monifeth</i> , ... ..	218-227
Diagram of Belt Joint, ... ..	228
The Driving of Spinning Frame, ... ..	229
Instructions for Setting Pulleys for Spinning Frame Belts, .. . . .	230
Diagram showing Setting of Guide Pulleys, ... ..	231
<b>COP WINDING,</b> .. . . .	<b>232</b>
Particulars of Cop Machine Gearing, with Diagrams, .. . . .	233-240
<b>REELING AND BUNDLING,</b> ... ..	<b>241</b>
Diagrams—Power Reel, ... ..	242-243

## CONTENTS.

	PAGE
Instructions and Particulars as to the Reeling of the Yarn, ... ..	244-246
Diagram and Particulars of Warping Mill, ... ..	247
Diagram—Bundling Press, ... ..	248
Diagram—Bundling Stool, ... ..	249
Diagram—Warp Winding Machine, ... ..	250
 <b>CONCLUDING REMARKS—</b>	
Waste, ... ..	251-254
Speed to be put upon the Machinery, ... ..	254, 255
Upkeep of Preparing and Spinning Machinery, ... ..	256
Bobbins, ... ..	256, 257
Accidents to the Machinery, ... ..	257
Finishing the Work for the day, ... ..	258
Arrangement for Extinguishing Fire, ... ..	258
 <b>APPENDIX.</b>	
<b>JUTE SNIPPER—</b>	
Explanation of Machine, with Diagrams, ... ..	261-263
Lathe Attachment for Grinding Spinning Spindles, .. ..	264, 265
 <b>WASTE CLEANER—</b>	
Explanation of Machine, with Diagrams, ... ..	266-268
The Adjustment of the Breaker Shell, ... ..	269, 270
 <b>ADDENDA,</b> ... ..	
Table of Circumference and Areas of Circles, ... ..	271-272
	273-284

# INDEX TO ILLUSTRATIONS.

---

## APPENDIX.

- Patent Centrifugal Flyer Dry Spinning Frame.  
 Spiral Roving Frame. Sectional Elevation showing Pulley End.  
 Spiral Roving Frame. Front Elevation showing Cone Differential and Link Motions.  
 Arrangement of Gearing for Roving Frames.  
 Roll Winding Machine.  
 Traverse Motion for Roll Winding Machine.

---

### PLAN OF JUTE MILL.

Showing arrangement of Machinery and width of Passes.

### PLAN OF JUTE MILL.

Showing Pitch of Columns, Arrangement, Speeds, Dimensions of Shafting.

### BOILERS.

	PAGE
BOILER—Mechanical Stoker for, ... ..	5
Section of Fire Box for, .. .. .	7
Opening above Fire Bridge for, ... .. .	7
Flues, ... .. .	8
Plan of Economiser and Flues for, ... .. .	9

### ENGINES.

DIAGRAMS—Total Load, ... .. .	14
Total Load, ... .. .	15
Friction Load, ... .. .	16
Friction Load, ... .. .	17

### JUTE BATCHING.

CRUSHER—Patent Jute— <i>Butchart</i> , ... .. .	24
SOFTENER—Jute, ... .. .	25
Roller for Jute, ... .. .	26
BARROW—Jute, ... .. .	26
ROOT CUTTER—Jute, ... .. .	259

	PAGE
<b>JUTE PREPARING.</b>	
<b>CARD</b> —Clock for Single Doffer Breaker, ... ..	40
Elevation showing Gearing at end opposite to Driving Pulleys—Single Doffer Breaker, ... ..	49
Elevation of Gearing at Driving End, Single Doffer Breaker, ... ..	51
Elevation showing Gearing at end opposite to Driving Pulleys, Double Doffer Breaker, ... ..	62
Elevation of Gearing at Driving End, Double Doffer Breaker, ... ..	64
Elevation of Gearing at Driving End, Upstriker Breaker, ... ..	66
Elevation of Gearing at end opposite to Driving Pulleys, Upstriker Breaker, ... ..	68
Elevation of Gearing at end opposite to Driving Pulleys, Single Doffer Finisher, ... ..	70
Elevation of Gearing at Driving End, Single Doffer Finisher, ... ..	72
Elevation of Gearing at end opposite to Driving Pulleys, Double Doffer Finisher, ... ..	74
Elevation of Gearing at Driving End, Double Doffer Finisher, ... ..	76
Elevation of Gearing at opposite end to Driving Pulleys, Upstriker Finisher, .. ..	78
Elevation of Gearing at Driving End, Upstriker Finisher, ... ..	80
Covering for Breaker, ... ..	112-114
Covering for Finisher, ... ..	115-118
Lap Machine, ... ..	100
<b>DRAWING FRAME</b> —Circular—Driving End, ... ..	131
Circular—Pass End, ... ..	133
Patent Slide or Push—Driving End, ... ..	135
Patent Slide or Push—Pass End, .. ..	137
Patent Slide or Push—Guide Plate, ... ..	138
Patent Slide or Push—Gill Bars, ... ..	139
Patent Slide or Push—Pressing and Drawing Rollers, ... ..	149, 150
Spiral—Pass End, ... ..	141
Spiral—Driving End, ... ..	143
Spiral—Bend and Screws, — .. ..	144
Gills, ... ..	145, 146
Draft Gearing—Rotary, ... ..	172
Draft Gearing—Double Rotary, ... ..	174
<b>ROVING FRAME</b> —Elevation Pass End (Spiral), ... ..	155
Elevation Driving End (Spiral), ... ..	157
Screw and Gill Bars, ... ..	158

	PAGE
ROVING FRAME—Automatic Motion, Drawing Roller, ... ..	159
Pitch Pin and Collar, ... ..	162
Gills—Spiral, ... ..	146
Differential Motion, ... ..	163, 164
Snail, .. ...	168
Gills—Rotary, ... ..	170
Elevation Rotary “Reach,” ... ..	171
Draft and Twist Gearing—Spinning, ... ..	176
Barrow, ... ..	180

JUTE SPINNING.

SPINNING FRAME—Spindle and Flyer for, ... ..	195
Elevation Pass End— <i>Fairbairn</i> , ... ..	204
Elevation Pulley End— <i>Fairbairn</i> , ... ..	206
Heart Motion for, ... ..	207
Bobbin for, .. ...	208
Automatic Motion, Drawing Roller for, ... ..	209
Bends for, ... ..	210, 211
Automatic Motion, Drawing Roller— <i>Thomson</i> , ... ..	212
Rove Plate for, ... ..	213
Elevation Pass End— <i>Low</i> , ... ..	214, 215
Elevation Driving End— <i>Low</i> , ... ..	216
Automatic Motion, Drawing Roller— <i>Low</i> , ... ..	217
Cotton Belt for, .. ...	228
Belt Fork for, ... ..	230
Belt Guide Pulleys for, ... ..	231
Lathe Attachment for Grinding Spindles, .. ...	264, 265

COP MACHINES.

COP MACHINE—Parker, Sons, & Co., ... ..	234-236
Thomson, Son, & Co., ... ..	237
Combe, Barbour, & Combe, ... ..	238
Lea, Croll, & Co., ... ..	239
Spindle Cone and Cop, ... ..	240



## REELING AND BUNDLING.

	PAGE
REEL—Elevation of Power, .. ... ..	242, 243
BUNDLING—Press, .. ... ..	248
Stool, ... ..	249
WEAVER'S KNOT, ... ..	245

## WARPING.

WARPING MILL, ... ..	247
----------------------	-----

## WARP WINDING.

BOBBIN WARP WINDING, ... ..	250
-----------------------------	-----

## JUTE SNIPPER.

JUTE SNIPPER—Elevation of, ... ..	262
Plan of, ... ..	263

## WASTE CLEANER.

WASTE CLEANER—Elevation and Section, .. ..	266-268
Detail of Radial Bracket carrying Shell, ... ..	269
Arrangement of Radial Bracket for adjusting Shell, ... ..	270

ARRANGEMENT OF GEAR FOR ROVING  
FRAME TRAVERSE.

SCALE,  $\frac{1}{8}$ " TH.

See pages 154-157 for Table of Wheels.

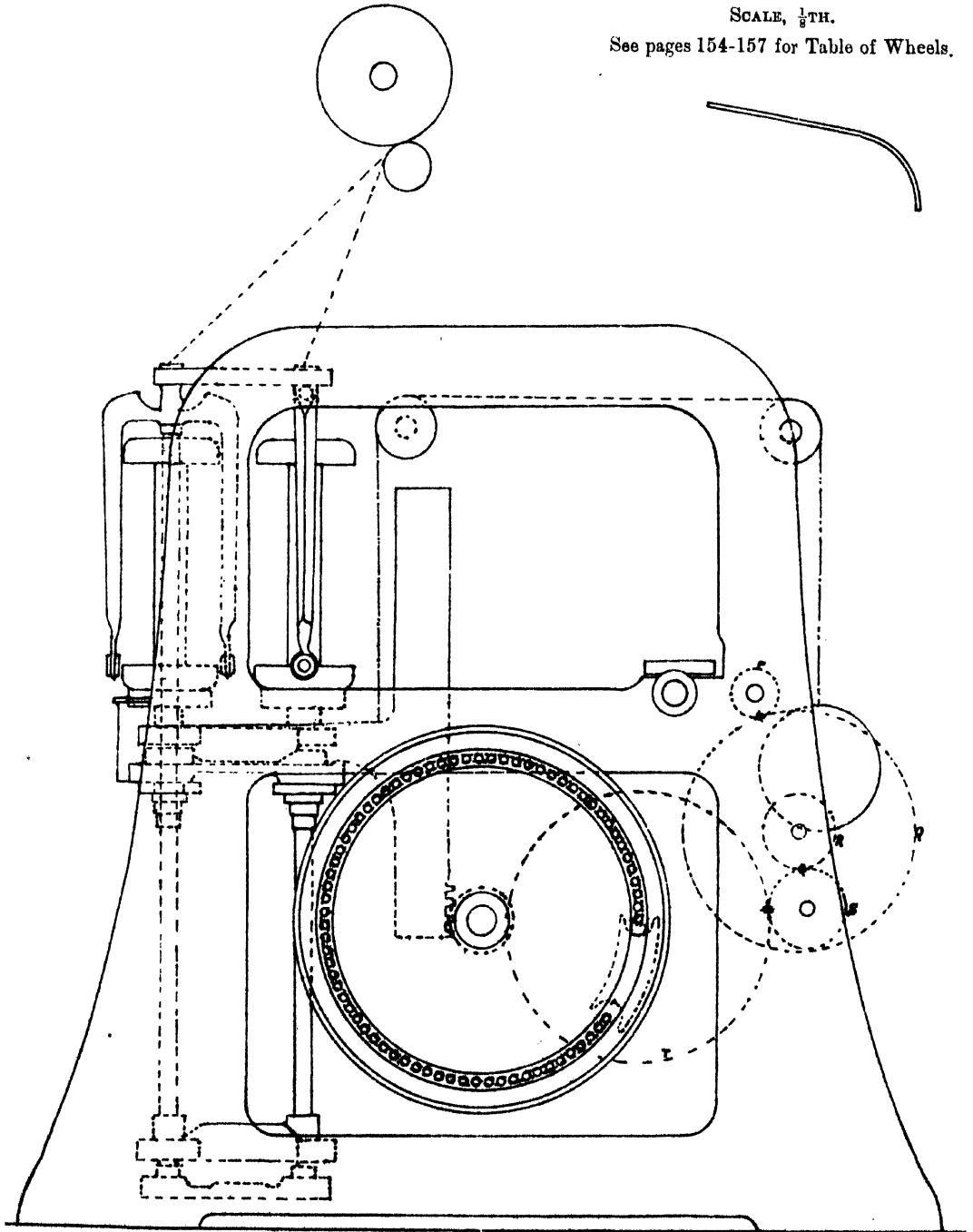



# PATENT CENTRIFUGAL FLYER DRY SPINNING FRAME

The Patent Centrifugal Flyer Spinning Frame is an entirely novel Machine, and has important advantages.

1st.—The yarn is spun on the bare spindle in the form of a “cop” which is put direct into the shuttle of the loom, thus dispensing with the “cop winding” process.

2nd — No bobbins required.

3rd.—Special Doffing Motion controlled by the spinner-girl who doffs the whole side of a machine by one operation, thus doing away with “doffer girls.”

4th.—The time occupied in doffing a whole side of cops is about 20 to 30 seconds.

5th.—A saving of about 20 per cent. in power over the ordinary spinning spindle.

The present standard Machine has  $3\frac{3}{4}$  in pitch of rings (spindles), and is suitable for spinning yarns Nos. 4 to 10 lea (12 to 5 lbs.), and will make cops or rolls any diameter up to  $1\frac{3}{4}$  × 8 in long. It has 144 spindles (72 per side) and occupies a floor space of 26 ft. 0 in. × 8 ft. 4 in.

The accompanying drawings and details will fully explain the working of the Machine

---

## Fairbairn Lawson Combe Barbour

LIMITED.

LEEDS AND BELFAST.

For Details of Working, see inside.

PATENT CENTRIFUGAL FLYER DRY SPINNING FRAME  
 FAIRBAIRN LAWSON COMBE BARBOUR LTD  
 LEEDS AND BELFAST.

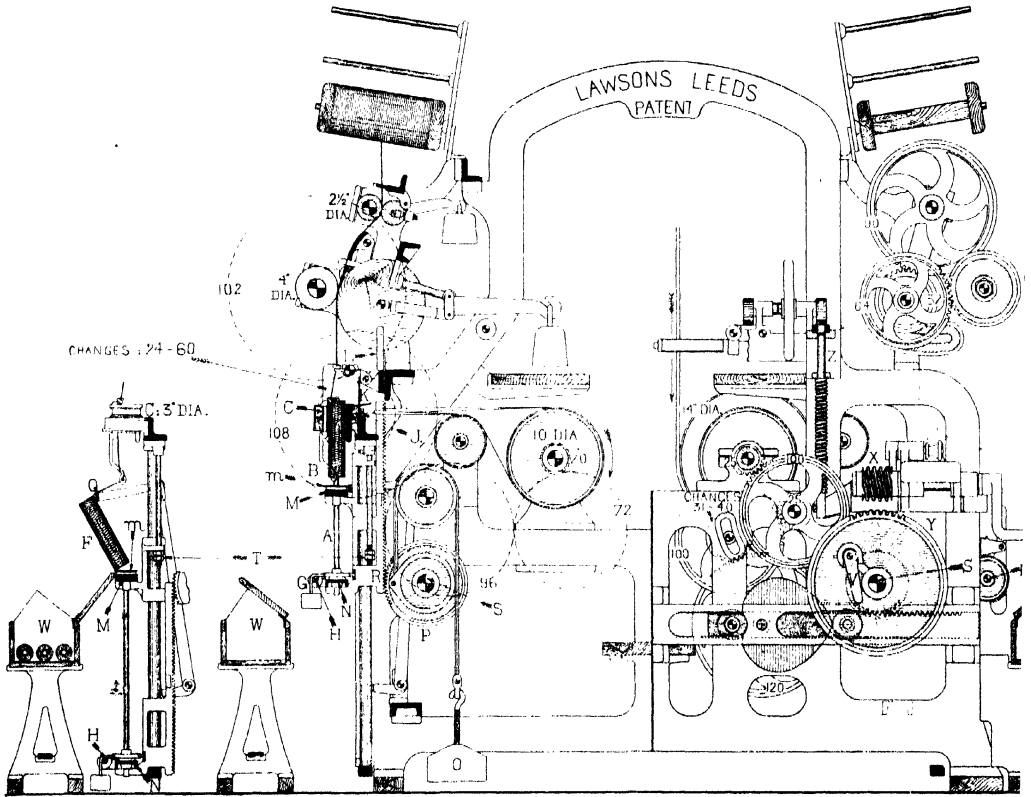

FIG. 1

FIG. 2

FIG. 3



1  
2  
3  
4  
5  
6  
7  
8  
9  
10  
11  
12  
13  
14  
15  
16  
17  
18  
19  
20  
21  
22  
23  
24  
25  
26  
27  
28  
29  
30  
31  
32  
33  
34  
35  
36  
37  
38  
39  
40  
41  
42  
43  
44  
45  
46  
47  
48  
49  
50  
51  
52  
53  
54  
55  
56  
57  
58  
59  
60  
61  
62  
63  
64  
65  
66  
67  
68  
69  
70  
71  
72  
73  
74  
75  
76  
77  
78  
79  
80  
81  
82  
83  
84  
85  
86  
87  
88  
89  
90  
91  
92  
93  
94  
95  
96  
97  
98  
99  
100

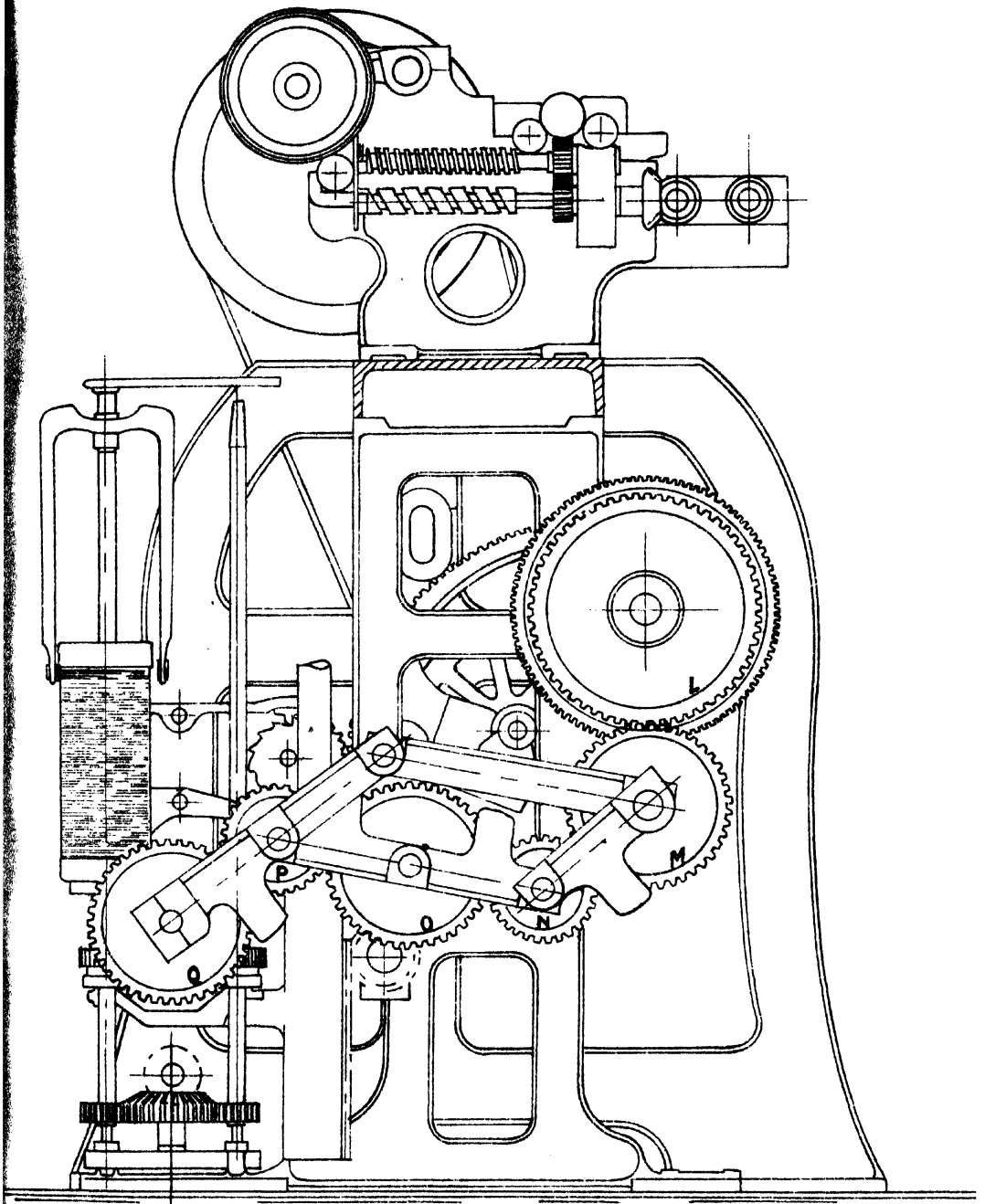

**SPIRAL ROVING FRAME.**

**SECTIONAL ELEVATION SHOWING PULLEY END**

*Scale  $\frac{1}{8}$  full size.*

*COMBE BARBOUR, BELFAST.*



# SPIRAL ROVING FRAME.

## LIST OF GEARING.

A	Diar. of Front Roller, ... ..	2"
B	Do. Cone Pulley, ... ..	16"
C	Do. Cone, ... ..	10·44"
D	Cone Pinion, ... ..	53 Teeth
E	Do. Wheel, ... ..	31 "
F	Differential Pinion, ... ..	32 "
G	Do. Wheel, ... ..	110 "
H	Differential Driving Bevel, ... ..	56 "
I	1st Do. Wheel do. ... ..	60 "
J	2nd Do. do. do. ... ..	45 "
K	Loose Bevel, ... ..	30 "
L	Link Motion Wheel on Loose Bevel, ... ..	60 "
M	Link Motion Wheel, ... ..	42 "
N	1st Intermediate, ... ..	28 "
O	2nd Do. ... ..	42 "
P	3rd Do. ... ..	28 "
Q	Wheel on Builder Shaft, ... ..	42 "
R R <sub>1</sub>	Bevels on Spindle and Builder Shafts, ... ..	15 "
S S <sub>1</sub>	Spur and Bevel Intermediates, ... ..	25 "
T T <sub>1</sub>	Spindle and Bobbin Carrier Pinions, ... ..	13 "
U	Wheel on Driving Shaft, ... ..	64 "
V	1st Spindle Gearing Intermediate, ... ..	64 "
W	2nd Do. do. do. ... ..	64 "
X	Wheel on Spindle Shaft, ... ..	32 "

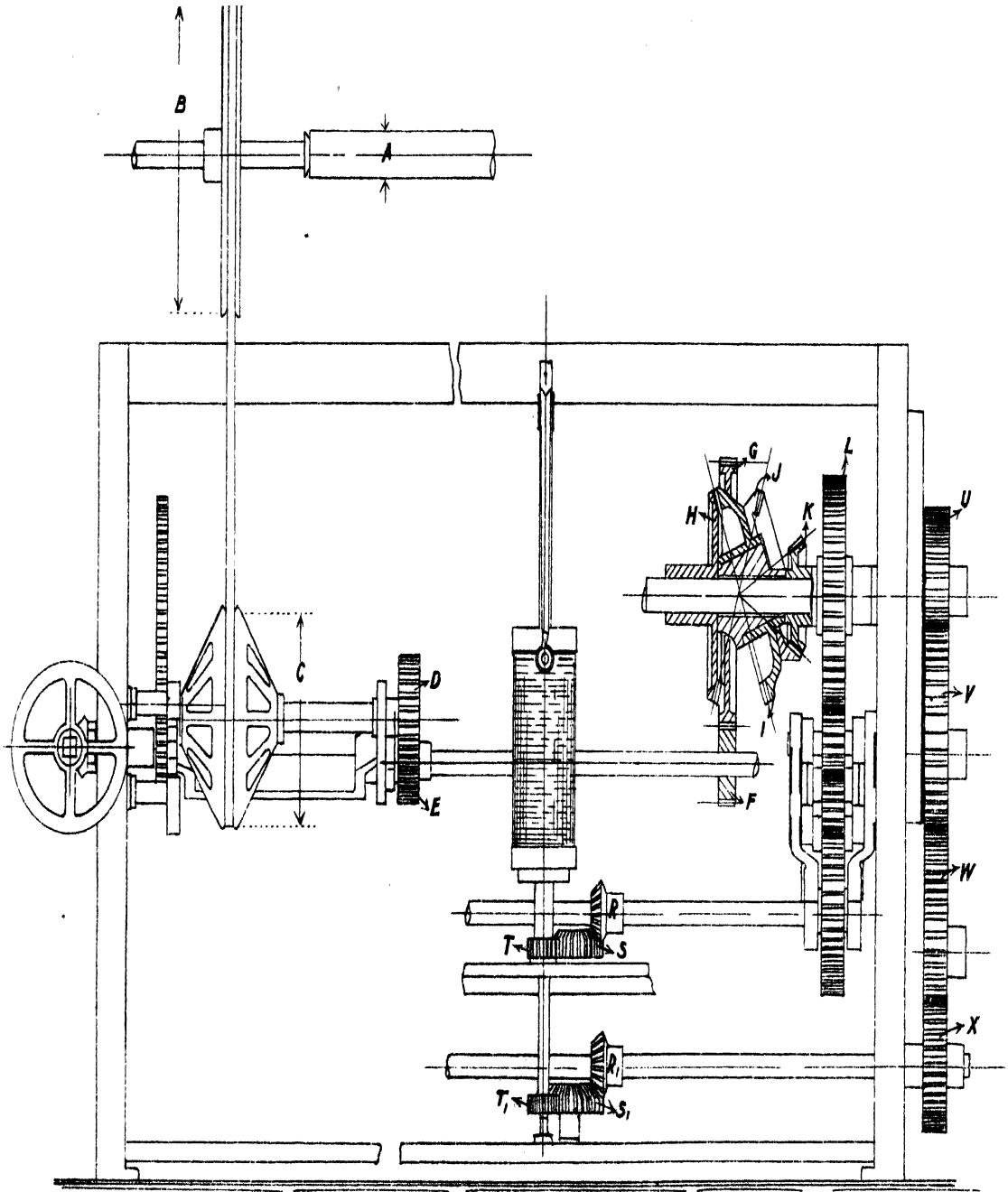

**SPIRAL ROVING FRAME.**

*FRONT ELEVATION SHOWING CONE DIFFERENTIAL AND LINK MOTIONS.*

*Scale  $\frac{1}{8}$ " full size.*

*COMBE BARBOUR, BELFAST.*

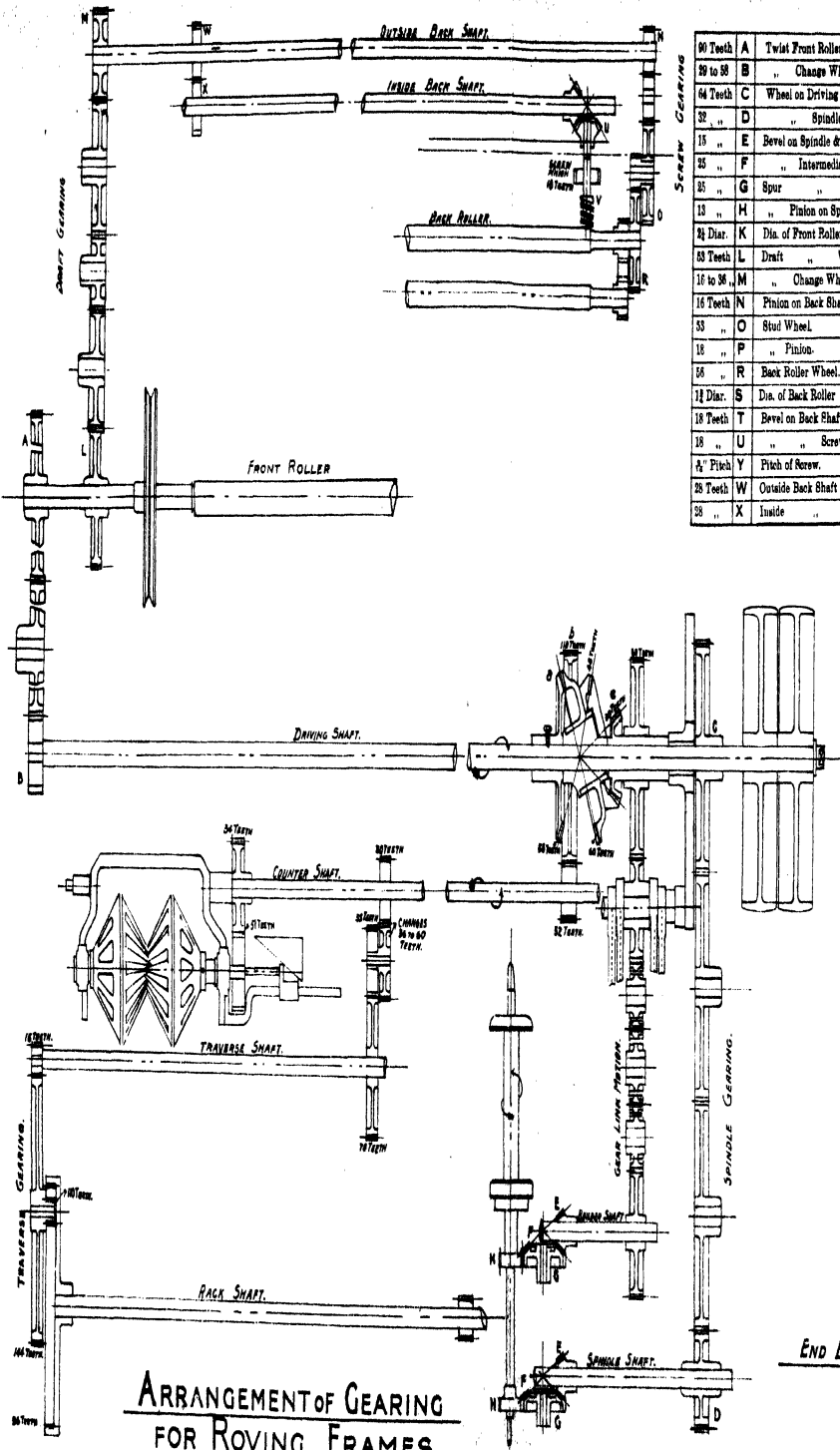

80 Teeth	A	Twist Front Roller Wheel.
29 to 38	B	Change Wheels.
64 Teeth	C	Wheel on Driving Shaft.
32	D	Spindle "
15 "	E	Bevel on Spindle & Builder Shaft
25 "	F	Intermediate on Stud.
25 "	G	Spur "
15 "	H	Pinion on Spindle.
2 1/2 Diam.	K	Dia. of Front Roller.
58 Teeth	L	Draft " Wheel.
16 to 36	M	Change Wheel.
16 Teeth	N	Pinion on Back Shaft.
53 "	O	Stud Wheel.
18 "	P	Pinion.
56 "	R	Back Roller Wheel.
7 1/2 Diam.	S	Dia. of Back Roller.
18 Teeth	T	Bevel on Back Shaft.
18 "	U	" " Screw.
A/ Pitch	Y	Pitch of Screw.
28 Teeth	W	Outside Back Shaft Pinion.
28 "	X	Inside " "

<b>TWIST.</b>	
$\frac{A C E G}{B D F H} = \text{Constant}$ = Circ. of front Roller = Constant Number = Twist.	
<b>DRAFT.</b>	
$\frac{K M O R}{L N P S} = \text{Constant Number}$ $\frac{M}{\text{Constant Number}} = \text{Draft.}$	
<b>LEAD OF FALLERS</b>	
$\frac{R O W T V}{P X U} = \text{Lead of Fallers}$ = Circ. of Back Roller	

— DIFFERENTIAL MOTION. —

(1) Suppose driving shaft with wheel *a* is rotating at 250 revs. per min. then if the differential wheel *b* is stationary we have *c* rotating at 250 × 2 = 500 revs. per min. in the same direction as *a*.

(2) Suppose now that the differential wheel *b* is driven at the same speed and in the same direction as *a* then the whole motion will rotate at the same speed as a clutch that is *a* and *c* will all rotate at 250 revs. per min.

	Revs. of <i>a</i>	Revs. of <i>b</i>	Revs. of <i>c</i>
From (1) we have	250	0	500
" (2) "	250	250	250

Subtracting (1) from (2) we see that as the speed of *b* increases by 250 revs. the speed of *c* decreases 100 revs or 5 revs. of differential wheel *b* means a loss of 2 revs. to *c*.

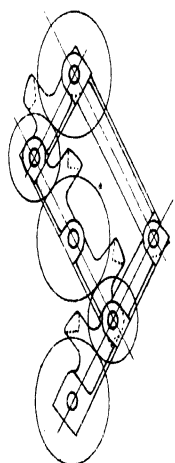

**ARRANGEMENT OF GEARING  
FOR ROVING FRAMES  
COMBE BARBOUR BELFAST.**

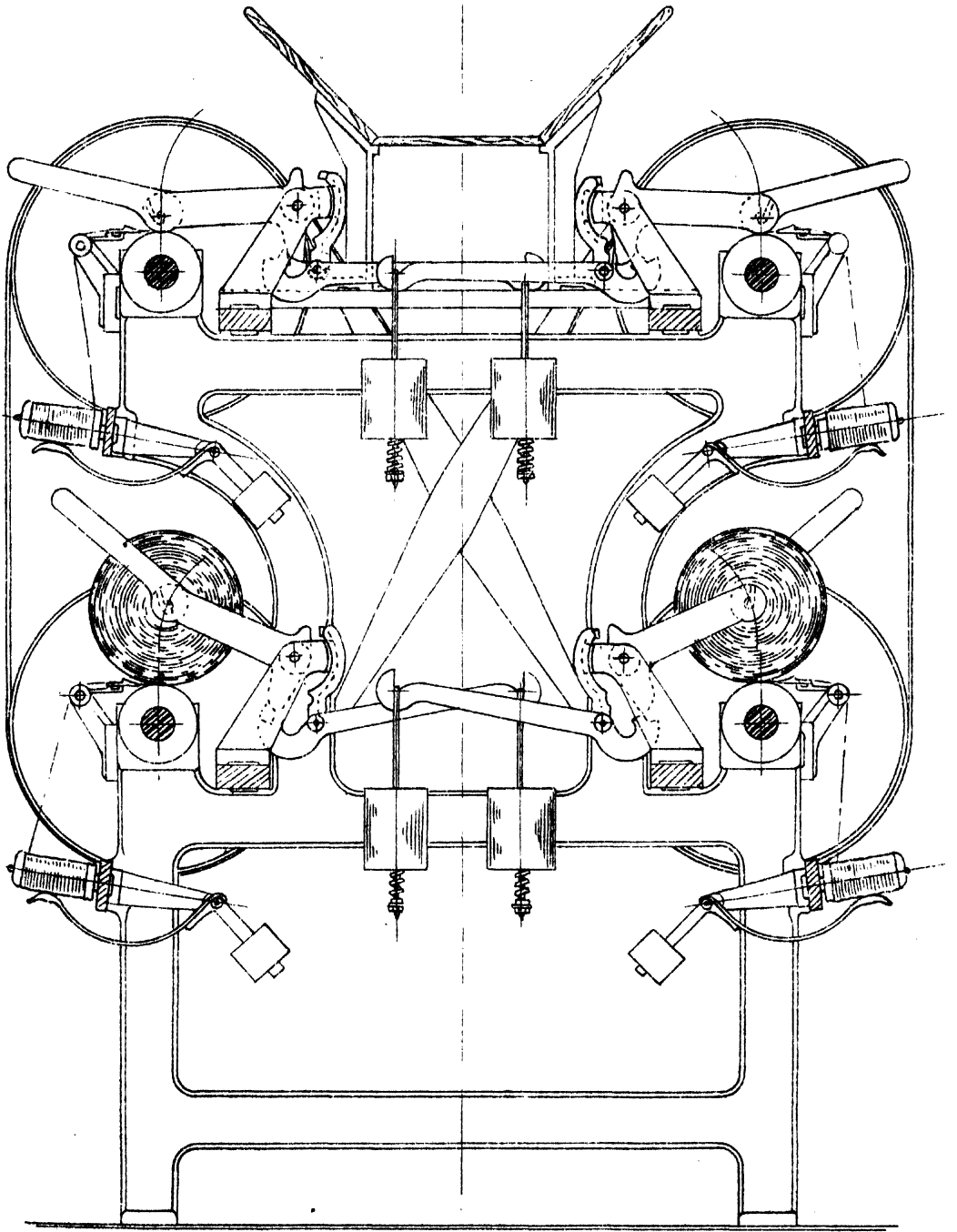

**ROLL WINDING MACHINE.**

*Scale 1/8<sup>th</sup> full size.*

*COMBE BARBOUR, BELFAST.*

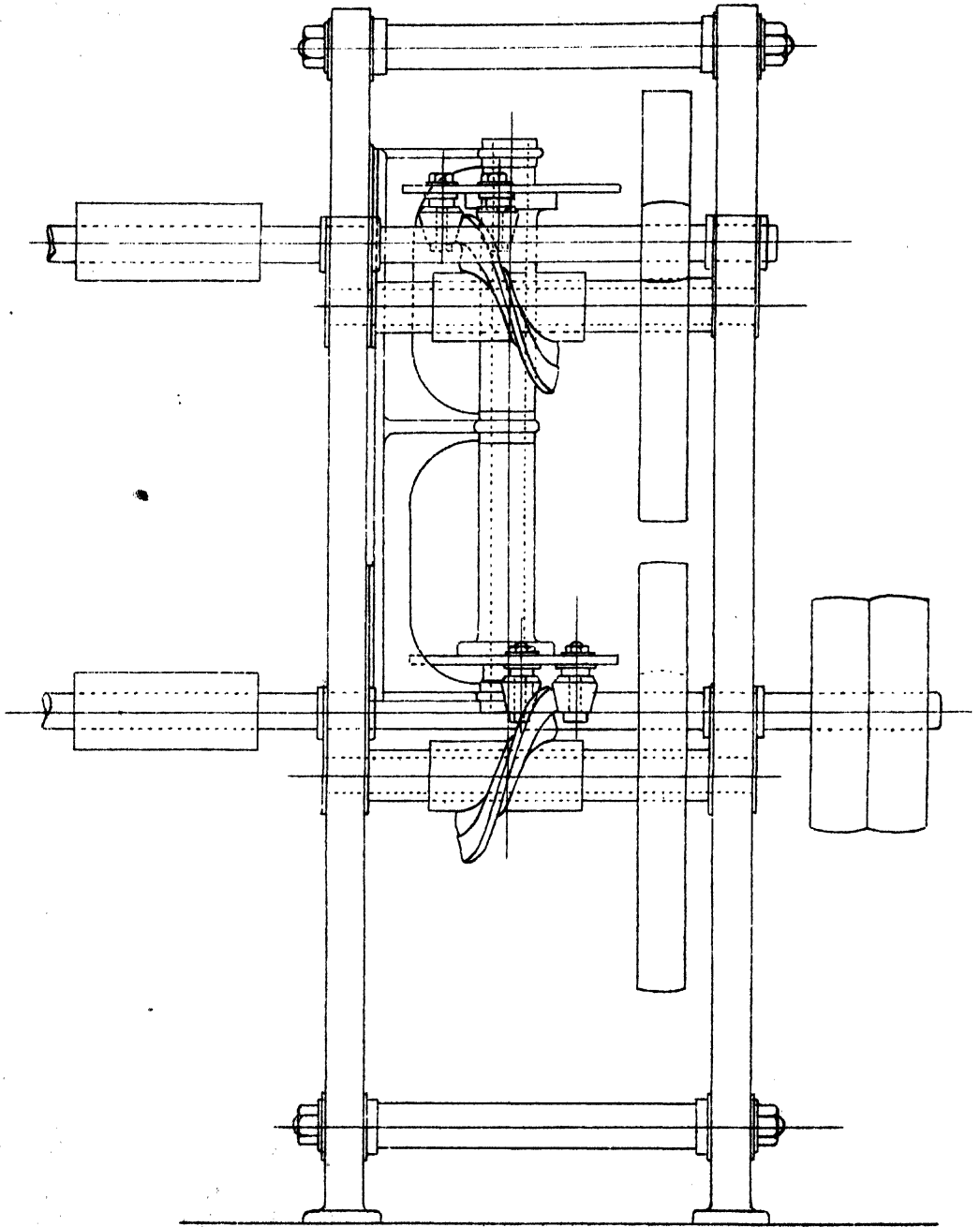

**TRAVERSE MOTION FOR ROLL WINDING MACHINE.**

7

*Scale 1/8<sup>th</sup> full size*

*COMBE BARBOUR, BELFAST.*

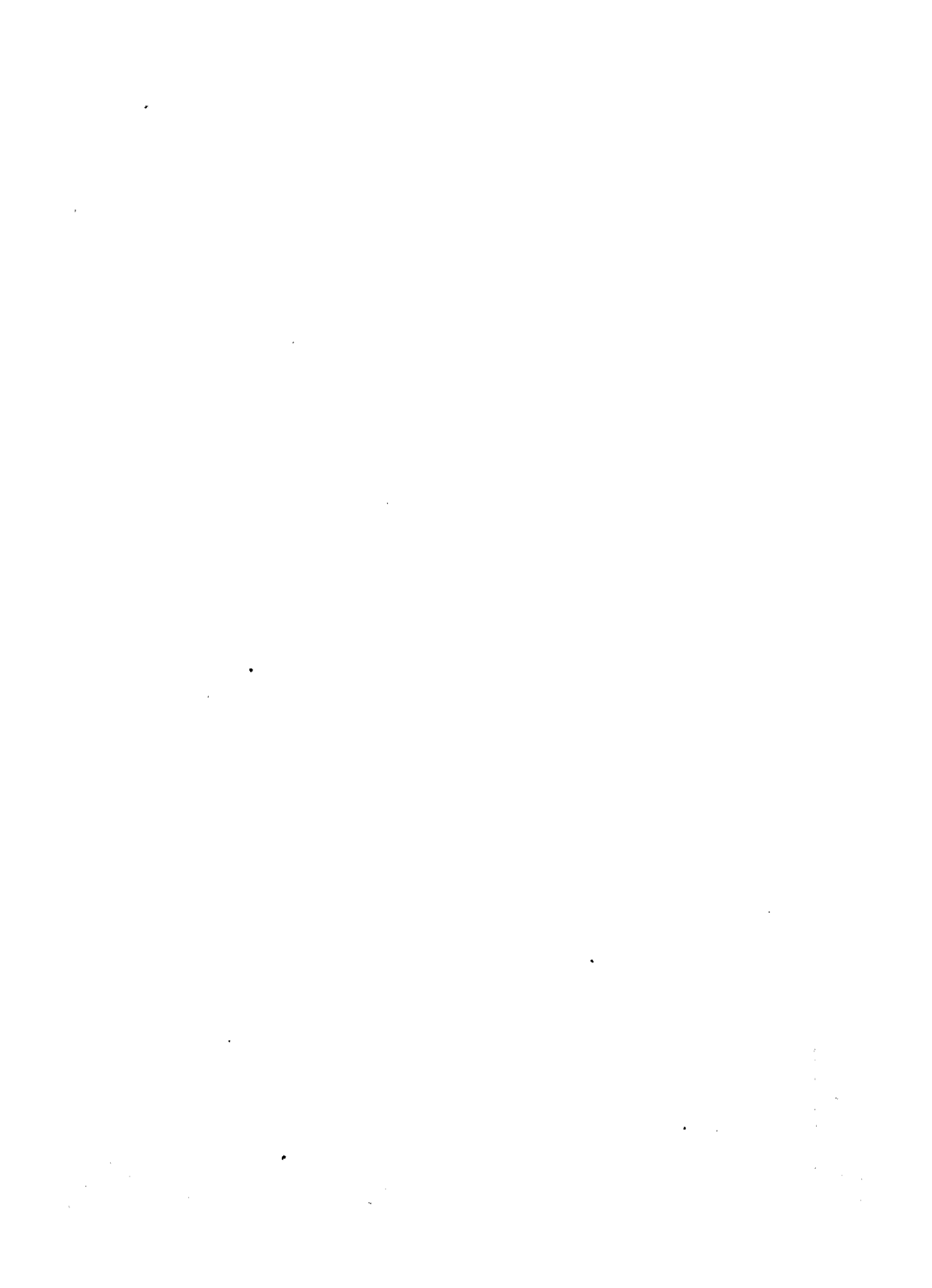

100  
100  
100

100  
100  
100

100

100

100

100

100

100

100

## INTRODUCTORY REMARKS.

TO give in a general way some information that will be of some service to the young mechanics and mill-men anxious to learn their trade, is the object of the following pages, not going too much into detail, but stating in a plain and simple way as much as will help the student to make a start and to persevere in his efforts to learn the theoretical part of his trade, and consequently making the machinery amongst which his daily work is of more interest and attraction to him. No theories or crotchets are discussed, but an attempt has been made to explain the working of the machines, and the calculations pertaining to them, along with their arrangement in the different departments to which they belong.

Two plans of a Jute Mill are given in this book. One of these is a ground plan, and is intended to show the arrangement of machinery, the floor space taken up by each machine, the pitch of columns and roofs, and the width of passes in each direction; the other plan shows the elevation of roof, the lines of shafting, and the diameters of shafting necessary to transmit the horse power required to drive the machinery marked upon the ground plan—the speeds of the different shafts are marked upon this plan for reference. These plans are in no way exhaustive, and are not intended to be so—that is to say, they do not go into details, but they show in a broad and general manner the outstanding arrangement of a Jute Mill built upon the shed principle, and will be found useful as a reference for the information referred to in this paragraph. The reader will note that all the speeds of shafts are given in whole numbers. This has been done merely to avoid fractions, and it will be observed that in the calculations of card cylinder speeds, &c., I have also taken whole numbers for the same reason; but this in no way affects the results, which are near enough for showing the method of working, and also, I may add, for all practical purposes.



It will also be observed from the plan of shafting that wheel-gearing is the method adopted throughout for driving the mill.

In the ground plan all the frames are shown the same size—72 spindles a side, 4" pitch. I will refer to this in the chapter upon spinning and spinning machinery.

The mill as shown by the plan is laid out for the following machinery:—

- 1 Jute Opener.
- 2 „ Softeners of from 47 pairs of rollers each.
- 7 „ Breakers—Cylinder 6' × 4'.
- 14 „ Finishers—Cylinder 6' × 4'.
- 14 „ 1st Drawings—2 heads each—Push Bar.
- 14 „ 2nd „ 2 „ Spiral Bar.
- 14 „ Rovings 10" × 5", 56 spindles each.
- 84 Spinning Frames, 4" pitch, 4" traverse, 72 spindles a side = 6048 spls.
- 12 Cop Machines, 54 spindles a side, 4½" Pitch.
- Warping Mills and Reels.
- Yarn Warehouse Accommodation.

The chapter upon Boilers and Engines gives the information as to coals, water for steam, and horse power required to drive the above; and also shows what part of that H.P. is required to drive each department, and the loss of horse power absorbed by engines, shafting, and pulleys by friction.

Before commencing the description of the several departments and the machinery, the following remarks may not be out of place at the beginning as descriptive of the general arrangements in connection with a Jute Mill.

Punctuality, cleanliness, and organization are the leading points to be kept in mind in the daily routine of a Jute Mill, and the more experience one has of jute spinning the more evident will these points become, as without them, there will not be quantity, quality, or steadiness in the daily output; and these three points are necessary in every department. It is from the study and application of these three points that good results will be obtained, rather than from an undue speed put upon the machinery.

As all the modern mills are built on the shed principle, and with no partition between the departments, every precaution should

be taken against fire—fires occurring on many occasions, the cause of which cannot be very easily explained. Much may be done to localize these small fires by having the departments connected to the mechanics' shop by electric wires, the alarm being sent to the mechanics when a fire occurs, and assistance is then immediately at hand. In most modern mills this plan is now generally adopted, small hose pipes being kept hanging up at various parts of the mill ready for instant action, and these small pipes with spray nozzles will be generally found, if well and properly handled, quite enough for the usual small fires which often occur, particularly in the preparing, spinning, and cop winding departments. A well organised fire brigade, with the necessary equipment, should always form part of the working arrangements of a Jute Mill, and the equipment should be periodically tried and thoroughly examined to see that all the tools are in good order and in their proper place, so that they can be got at once into action in the event of any emergency.

The sanitary arrangements should also have very special attention, and a plan of all the drains should be kept, so that in the event of anything going wrong the lines of drains can at once be traced and repairs made without loss of time and inconvenience to the working arrangements.

Jute spinning, like many other things, cannot be learnt from a book, but the book may be helpful in a way. Spinning can only be learned by steady and persevering hard work and experience.

In every mill many arrangements and adaptations of the machinery have to be made to suit the requirements of the particular branch of the trade in which the mill may happen to be engaged. These arrangements I do not endeavour to describe, as they form no part of the purpose of this book. To describe in a general way the working of the machines, and the method followed in producing yarns suitable for hessian and sacking cloths, is the purpose of this book—with what success I have accomplished my task must be left for the reader to judge. With the above general explanation, I will now describe the various steps in the different departments, commencing with a chapter on boilers and engines.

## THE BOILERS AND ENGINES.

THE BOILERS.—The Boilers most commonly in use in Jute Mills are what are usually called Lancashire Boilers, and the ordinary size in use are 30' × 7', with two flues running right through. Sometimes the flues are what are termed duplex—that is, two flues which run into one at the back end of the firebox. Four boilers are necessary to produce steam for the machinery shown in the plan. The amount of coals and steam required for the work to be done are given in this chapter. The boilers may either be fired by hand or by a furnace-stoking apparatus. Machine firing is, although slowly being adopted, likely to become in a spinning mill the recognised method of firing boilers, as there is more regularity in the pressure of steam and the absence of smoke or dirt. Between the boilers and the chimney is usually placed a series of pipes termed an economiser; through these pipes is passed the feed water on its way to the boilers, and the waste gases are thereby utilised to increase the temperature of the feed water. Eighty pipes per boiler will increase the temperature of the feed water from 120° to 220/230°, if there is a fair draught, say  $\frac{1}{16}$ ths of a column of water in a gauge placed in the flue at back of boilers and in front of the economiser. If machine firing is the plan adopted, the coals are thrown into a large box or hopper, in front of the boilers, and the coals fall through an aperture in the apparatus, and are pushed into the furnace by rams worked by eccentrics or cams. The furnace bars moving at the same time, the coals are carried at the speed required into the furnace. A great many stokers of different construction are now at work, each having their own so-called special advantages. An illustration of a stoker by T. & T. Vicars is given. When working with furnace-stoking apparatus it does not tend to economy to force the consumption of coal, as it leads to unnecessary waste of fuel, but you can consume from 21/22 tons of coal in a working week of 56 hours without over-driving the apparatus, and if a fair quality of Scotch coal is used the waste will not be more than 4/5%. This stoker has been a long time before the public. The illustration is given here to show the principle

upon which the machine works. It is not necessary to comment here upon its comparative merits with other furnace apparatus at present in use.

VICARS' NEW & IMPROVED PATENT MECHANICAL STOKER  
AND  
SELF-CLINKERING SMOKELESS FURNACE.  
INSIDE OR SECTION.

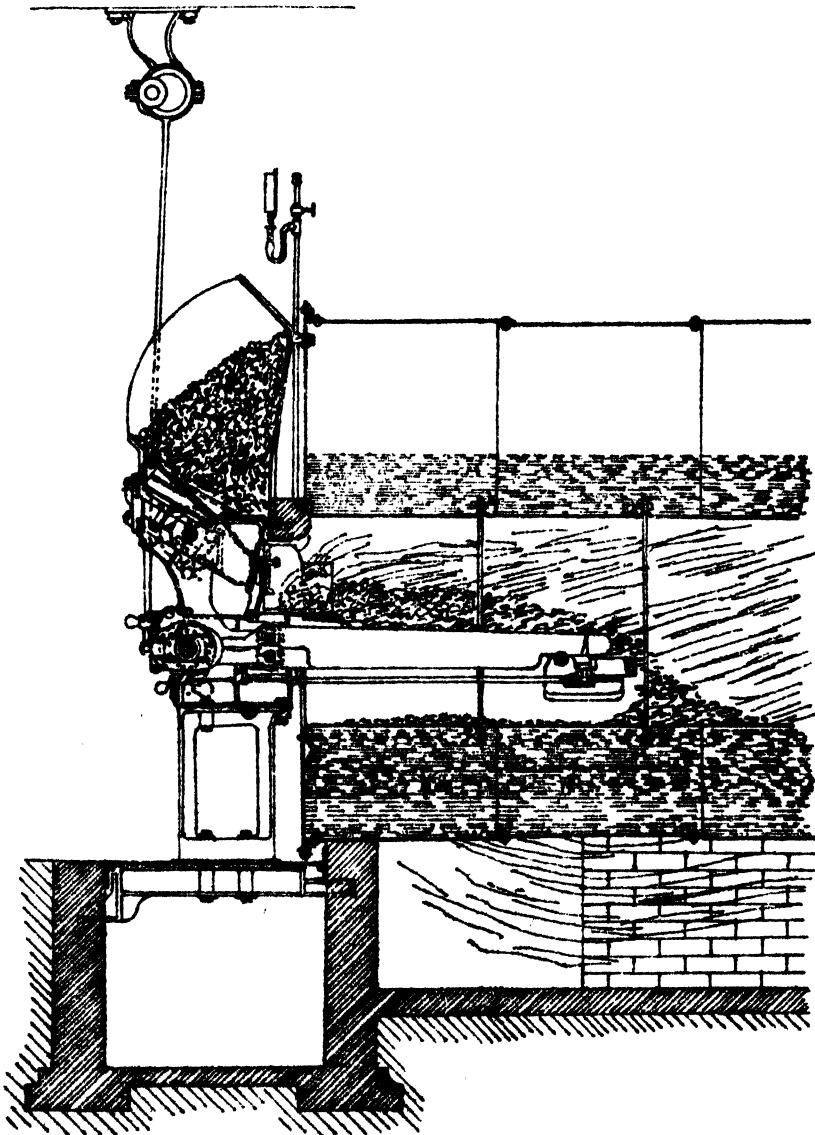

The boilers should be cleaned internally, if the water is of a fair quality, three times a year, and the flues once a year, and the brickwork examined carefully after the annual cleaning is done. The economiser should be "blown through" once a day, and the "soot-chamber" and side flues cleaned out three times a year. If the water is of a fair quality, the pipes will not require to be cleaned internally more than once in ten years.

To get the full benefit of the advantages of the economiser, the boilers should be continually taking water. If the feed valves are not kept open continuously, many of the advantages of the economiser are lost. Care should also be taken to notice that the pressure upon feed water should not be more than 10 lbs. per square inch above the pressure to be carried into the boilers. If more pressure is used, it causes quite an unnecessary strain upon the feed pipes.

---

# SECTION OF FIRE BOX OF BOILERS

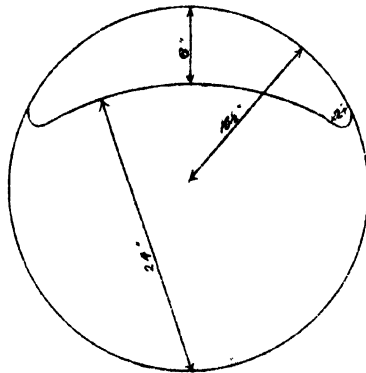

*TO FIND THE AREA OF  
OPENING WANTED ABOVE FIRE  
BRIDGE IN 59 INCHES.*

*TO FIND THE AREA.*

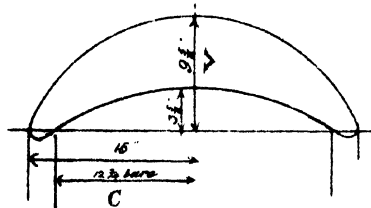

*RULE IN MOLESWORTH*

$$\begin{aligned}
 &= \frac{4 \cdot V}{3} \sqrt{(0.025V)^2 + C^2} \quad \text{Area} \\
 1^{st} \quad &= \frac{4V}{3} \sqrt{(0.025)^2 + C^2} \\
 &= \frac{38.5}{3} \times \sqrt{0.02525^2 + 15^2} \\
 &= 12.833 \times \sqrt{38.28 + 225} \\
 &= 12.833 \times 16.104 = 207.43 \\
 2^{nd} \quad &= \frac{14.5}{3} \times \sqrt{2.25^2 + 12.7^2} \\
 &= 4.833 \times \sqrt{5.06 + 161.3} \\
 &= 4.833 \times 12.9 = 62.34 \\
 &= \begin{array}{r} 207.43 \\ 62.34 \\ \hline \text{Area } 145.09 \text{ Sq. in.} \end{array}
 \end{aligned}$$

## THE BOILERS AND ENGINES.

The following is a sectional elevation to show the form of the boiler flues, and the other diagram is a plan showing position of boilers and economisers, with arrangement of flues and dampers between boiler and chimney.

A boiler  $30' \times 7'$  contains 3500 gals. of water at a temperature of  $60^\circ$ .

Economiser 320 pipes contain 2000 gallons of water at  $60^\circ$ .

### OUTLINE SHEWING AREA OF FLUES.

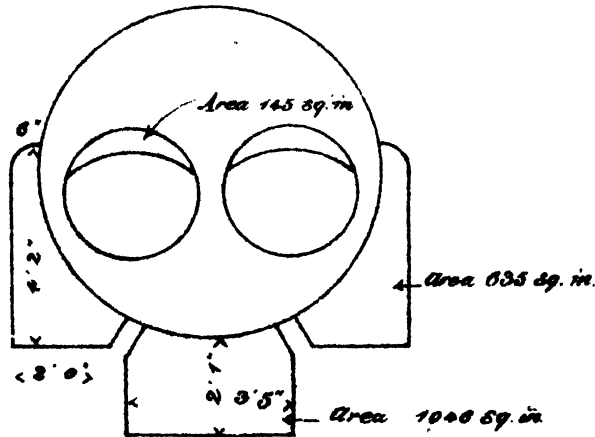

The centre flue is about three feet wide and two feet deep, and the side flues about two feet wide at the bottom, and at the closing-in (which is about three-fourths of a circle) about nine inches wide.

Each boiler has two dampers, which are hung and can be worked independently of each other. When the fires are at rest during the meal hours or at night, these dampers are always shut as close as possible consistent with not sending the smoke out at the furnace doors. When the furnaces are in full operation these dampers are *always full open*; if less draught is required, it is not to be got by closing these dampers, but by closing the damper in the main flue as shown further on. There are two main flues—one goes *direct to the chimney*, the other is the economiser flue through which the smoke passes to the chimney if the economiser is in operation, which it *always is*, unless on very rare occasions and for special purposes.

## THE BOILERS AND ENGINES.

This outline will show the position of the dampers in the main flues.

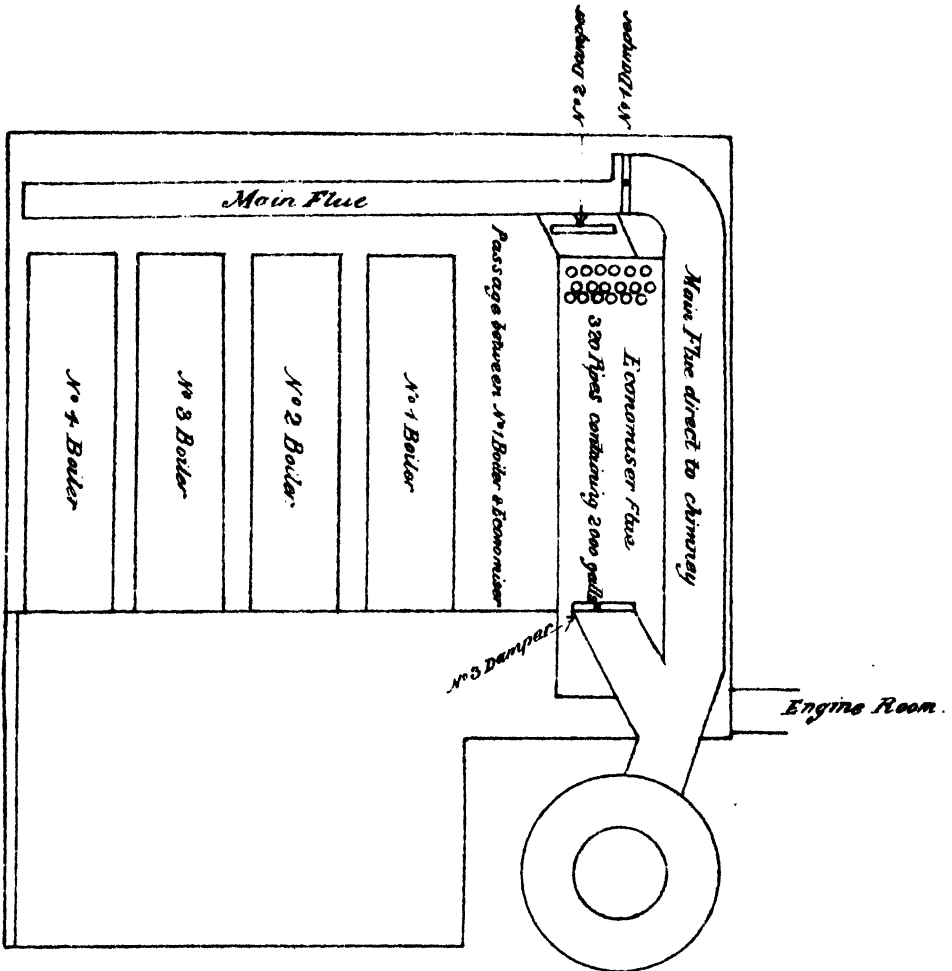

Scale  $\frac{7}{16}$ " = One Foot.

The economiser has 320 pipes 4 inches bore, made up in 40 headers of 8 tubes each. The height of chimney is 160 feet.



## THE BOILERS AND ENGINES.

No 1 damper is on a pivot, and allows the smoke to go direct to the chimney, but is always kept shut when the economiser is working. No. 2 damper is hung on a chain from a pulley, and is opened by pulling it up; it allows the smoke to pass into the economiser and is always full up from 4 a.m. to 5.50 p.m. No. 3 damper is on a pivot, and is always called the round damper; when the economiser is working the draught is regulated by the opening or closing of this damper. Always use No. 3 damper to lessen or increase the draught, never use No. 2.

No. 1 Damper is 8' x 4' with circular top.

No. 2 „ 8' x 4' with square top.

No. 3 „ 8' x 4' with circular top.

**THE ENGINES.**—Much of the success in a spinning mill depends upon the steadiness of the drive, and this can only be attained by having a sufficient margin of power to drive the machinery. Without this margin of power there will be endless trouble and annoyance and continual risk of engine break-down, with all the usual attendant loss of time and money.

Until very lately the form of engines most commonly made for driving Jute Mills was of the type known as compound horizontal, sometimes two cylinders placed tandem, and sometimes two cylinders placed side by side. If the engines were in pairs then the tandem engine would have two pistons on each rod, the low pressure being usually next the connecting rod; if the engine had two cylinders placed side by side, the high pressure would be connected to the one crank, and the low pressure to the other crank. In both types of engines the cranks are usually set at right angles. Corliss type of valves on both cylinders will give the best working results.

The diagrams given here to illustrate the power required to drive the machinery upon the plan are of the compound tandem type, and the data given will be found useful for reference in regard to the horse power required to drive jute machinery.

Triple expansion engines of the marine type are now being introduced, but they have not been long enough in use to be able to compare them with the former types of engines. There is much difference of opinion as to the advantages of triple expansion engines, with high speed and high boiler pressure (say) of 140/150

## THE BOILERS AND ENGINES.

lbs., over compound engines of moderate speed and boiler pressure of 75/80 lbs. per square inch for driving jute mill machinery. The point will be settled by-and-by, as most other things are, by the result of experience, and the comparison of their performance from a commercial point of view.

It will greatly add to the smooth working of the engines and avoid risk of break-down if the "heating-up" arrangements are as complete as possible. If the engines cannot drive the full working load at once on Monday morning at six o'clock, the "heating up" has not been sufficiently attended to. If the heating has been properly done there should be not more than an increase of 7% on the usual total load, and that increase should have disappeared during the first 30 minutes after the engines have been working. Engines driving the load shown on the diagrams will require the heating steam on them not less than five hours before six o'clock on Monday morning in the winter time, and the half of that in the summer time, and the expense of the steam used for this purpose will be repaid by the work done in the mill, owing to the engine going the usual speed, without risk of breakdown.

### ABSTRACT OF POWER.

Engine Friction,	-	-	70 H.P.	}	
Mill	,	,	95.5 H.P.	}	165.5 Friction.
Batching and Preparing,	-	-	150 H.P.	}	
Spinning,	-	-	474.5 H.P.	}	
Cop Winding,	-	-	} 50 H.P.	}	674.5 Effective.
Reeling,	-	-			
				<hr style="width: 20%; margin: 0 auto;"/>	
				840 0	
Total Load,			- - -	840 H.P.	
Friction Load,			- - -	165.5 H.P.	

## THE BOILERS AND ENGINES.

Percentage of Power absorbed by Friction =  $\frac{100 \times 165.5}{840} = 19.7\%$

Coal consumed and water evaporated at 75 lb. pressure in two weeks.

Working hours 56 per week = 112 hours.

Total Revolutions of Engine Index = 307,222

Working hours Engine Time  $\frac{307,222}{45 \times 60} = 113.8$  hours.

Total coals in two weeks = 102.9 tons = 230,496 lbs.

Total Water through Meter in two weeks = 172,043 gallons = 1,720,430 lbs.

Water evaporated per lb. of Coal at 75 lbs. pressure =  $\frac{1,720,430}{230,496} = 7.46$  lbs.

Coal per H.P. per hour =  $\frac{230,496}{113.8 \times 840} = 2.41$  lbs.

Water per H.P. per hour =  $24.1 \times 7.46 = 17.97$  lbs.

The pond capacity for the horse power required for the machinery shown in plan will be—

No. 1 pond from which the water is taken to the engines will require 500,000 gallons.

No. 2 pond into which the water is discharged from the engines is called the cooling pond, and should have a capacity of about 250,000 gallons, and is fitted with troughs about  $3\frac{1}{2}$  feet broad and  $4\frac{1}{5}$ " deep, along which the water is allowed to run about 250 yards before falling into the pond. No special cooler will be necessary.

**ENGINE DIAGRAMS.**—The method adopted for their calculation is as follows:—The high pressure cylinder diagrams in this case have been taken with a  $\frac{1}{32}$ th spring, and the low pressure cylinder with a  $\frac{1}{16}$ th, therefore the scale of diagrams are termed  $\frac{1}{32}$ th and  $\frac{1}{16}$ th

## THE BOILERS AND ENGINES.

### 1.—*The High Pressure Diagram.*

Divide it into ten parts as shown on the illustration, and measure at the centre of these spaces with the scale of the diagram—that is a  $\frac{1}{10}$ th in this case; add together these ten measurements and divide by ten for the average pressure in cylinder, first at the one end, and repeat the working for the other end; then with the average pressure work out the formula for the horse power in each cylinder.

#### *Formula.*

$$\frac{\text{Area of cylinder} \times \text{piston speed per minute} \times \text{average pressure.}}{33,000}$$

$$\frac{572.5 \times 450 \times 32.7}{33,000} = 255.4 \text{ I.H.P.}$$

$$\frac{572.5 \times 450 \times x}{33,000} = 7.8 \text{ Constant Number.}$$

$$\frac{1385.4 \times 450 \times x}{33,000} = 156.2 \text{ I.H.P.}$$

$$\frac{1385.4 \times 450 \times x}{33,000} = 18.89 \text{ Constant Number.}$$

For calculating the diagrams of the engines it is usual to work out the constant number for each cylinder; this constant number multiplied by the average pressure as measured from the diagram equals the indicated horse power, thus :—

$$\text{Average pressure} \times \text{constant} = \text{I.H.P.}$$

In all the calculations required in the machinery throughout the mill, work with the constant number as much as possible and save time.

The friction diagrams are calculated from a piston speed of 395 feet per minute.

Particulars of engines from which diagrams were taken to illustrate the horse power required to drive the machinery upon the plan :—

Pair of Compound Horizontal Engines, cylinders placed tandem, high pressure cylinders 27" diameter = area 57.52 sq. in.; low pressure cylinders 42" diameter = area 1385.4 sq. in.; crank shaft 45 revolutions per minute = 450 feet—speed of piston per minute. High and low pressure cylinders both fitted with Corliss valves.

TOTAL LOAD DIAGRAMS.

TOTAL LOAD DIAGRAMS.

INDICATION OF COMPOUND TANDEM ENGINES.

Cyls. 27" and 42" × 5' 0" Stroke. Boiler Pressure 62 lbs. 45 revs. per min.

Temperature of Injection - - 82°.

Temperature of Hot Well - - 121°.

No. 1 ENGINE.

SCALE  $\frac{1}{30}$

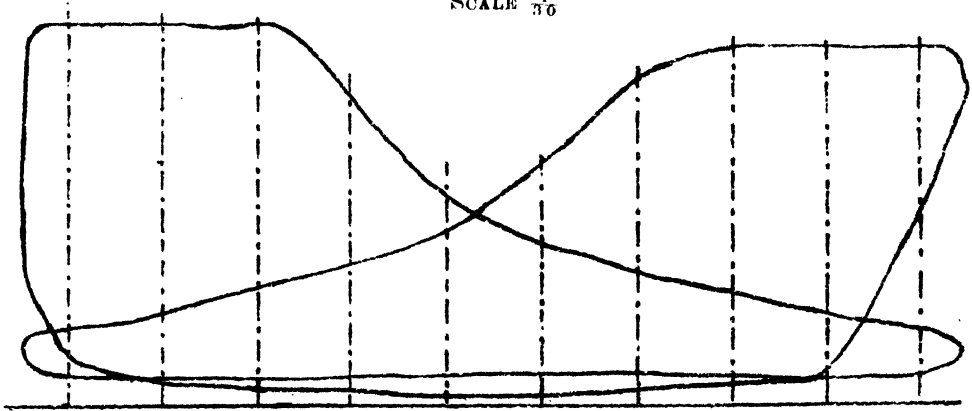

Mean Pressure—Front, 33·7 lbs.

Mean Pressure—Back, 31·7 lbs.

Average Mean Pressure—32·7 lbs. per sq. inch.

I.H.P.—255·4.

SCALE  $\frac{1}{16}$

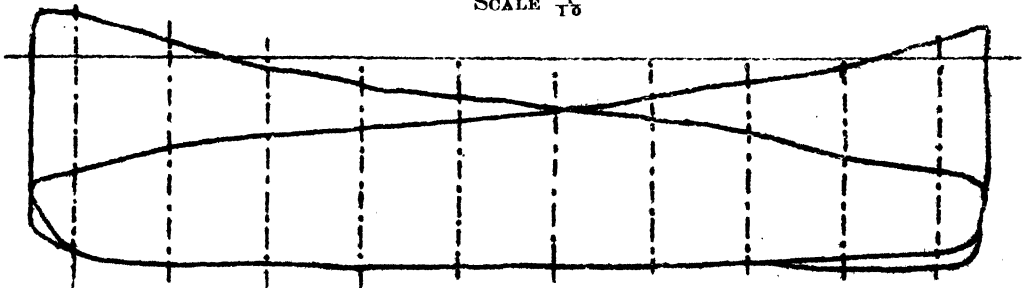

Mean Pressure—Front, 8·4

Mean Pressure—Back, 8·15 lbs.

Average Mean Pressure—8·27 lbs. per sq. inch.

I.H.P.—156·2.

Total I.H.P. No. 1 Engine—411·6.

TOTAL LOAD DIAGRAMS.

TOTAL LOAD DIAGRAMS.

INDICATION OF COMPOUND TANDEM ENGINES.

Cyls. 27" and 42" = 5' 0" Stroke. Boiler Pressure 62 lbs 45 revs. per min.

Temperature of Injection - - 82°.

Temperature of Hot Well - - 121°.

No. 2 ENGINE.

SCALE  $\frac{1}{30}$

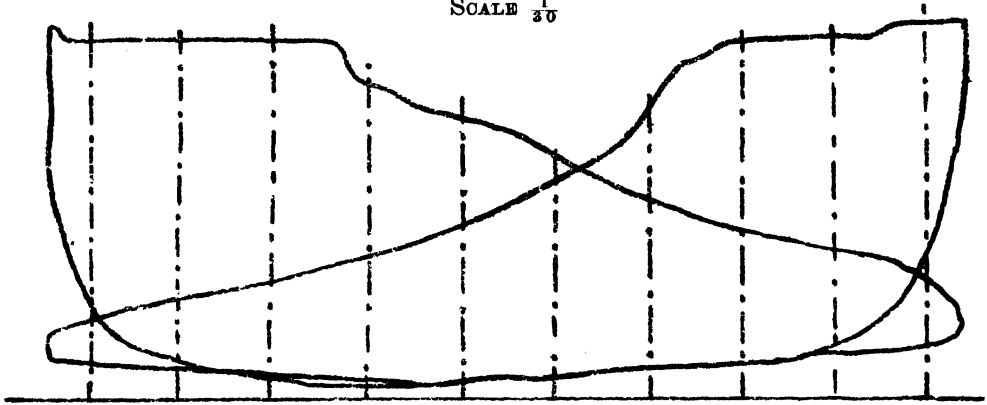

Mean Pressure—Front, 33·6 lbs.

Mean Pressure—Back, 28·35 lbs.

Average Mean Pressure—31·07 lbs. per sq. inch.

I.H.P.—242·4.

SCALE  $\frac{1}{10}$

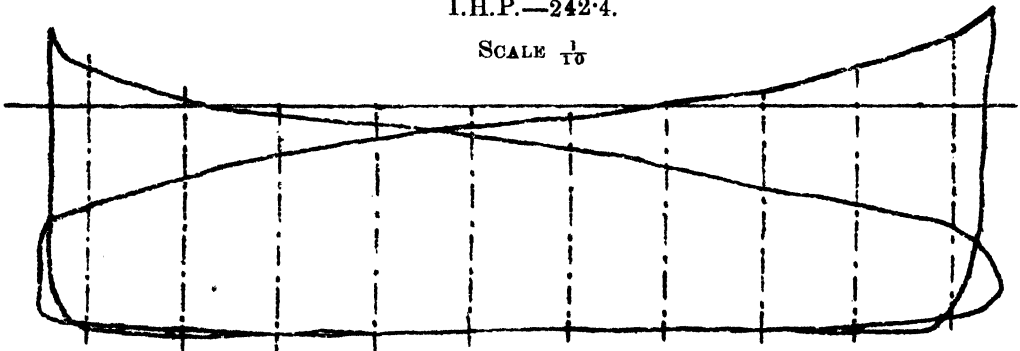

Mean Pressure—Front, 9·2 lbs.

Mean Pressure—Back, 10·5 lbs.

Average Mean Pressure—9·85 lbs. per sq. inch.

I H.P.—186·0.

Total I.H.P.—No. 2 Engine—428·4.

Total Indicated Horse Power—840

FRICION DIAGRAMS.

FRICION DIAGRAMS.

INDICATION OF COMPOUND TANDEM ENGINES.

Cycl. 27" and 42" x 5' 0" Stroke. Boiler Pressure 62 lbs. 39½ revs. per min.

Temperature of Injection . . . 82°.

Temperature of Hot Well . . . 121°.

No. 1 ENGINE.

SCALE,  $\frac{1}{25}$

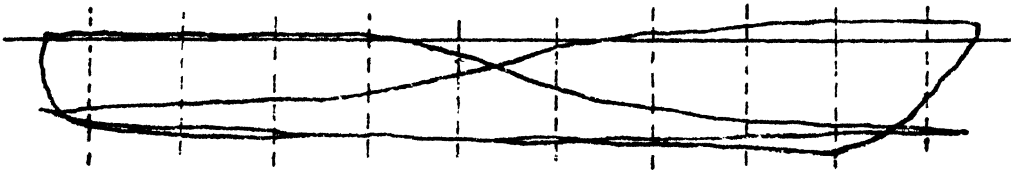

Mean Pressure—Front, 5·8 lbs.

Mean Pressure—Back, 7·374 lbs.

Average Mean Pressure—6·58 lbs per sq. in.

I.H.P.—45·7.

SCALE,  $\frac{1}{15}$

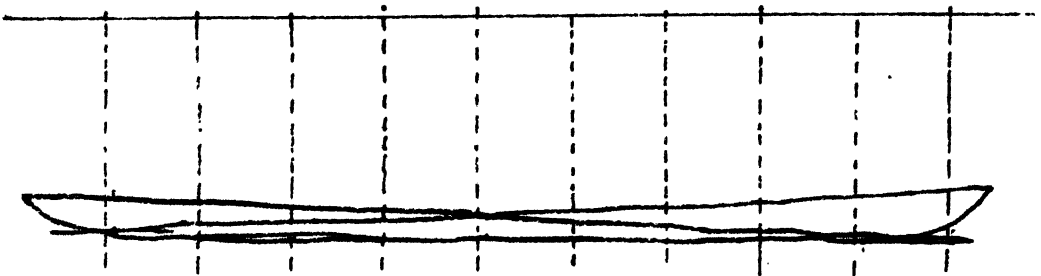

Mean Pressure—Front, 1·0 lbs.

Mean Pressure—Back, 1·37 lbs.

Average Mean Pressure—1·135 lbs. per sq. in.

I.H.P.—19·8.

Total I.H.P. No 1 Engine—65·5.

Total Indicated Horse Power—165·5.

Total Load Indication—840 I.H.P.

Percentage of Power Absorbed by Friction— $\frac{100 \times 165.5}{840} = 19.7\%$ .

FRICION DIAGRAMS.

FRICION DIAGRAMS.

INDICATION OF COMPOUND TANDEM ENGINES.

Cycl. 27" and 42" x 5' 0" Stroke. Boiler Pressure 62 lbs. 39½ revs. per min.

Temperature of Injection - - - 82°.

Temperature of Hot Well - - - 121°.

No. 2 ENGINE.

SCALE,  $\frac{1}{20}$

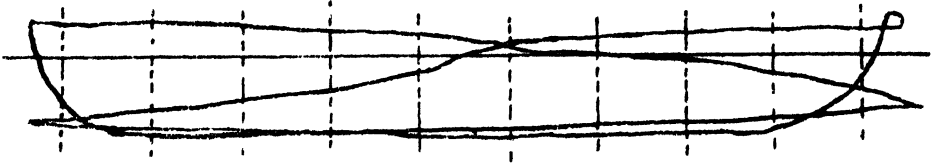

Mean Pressure—Front, 8·0 lbs. Mean Pressure—Back, 6·4 lbs.

Average Mean Pressure—7·2 lbs. per sq. inch.

I.H.P.—50·1.

SCALE,  $\frac{1}{10}$

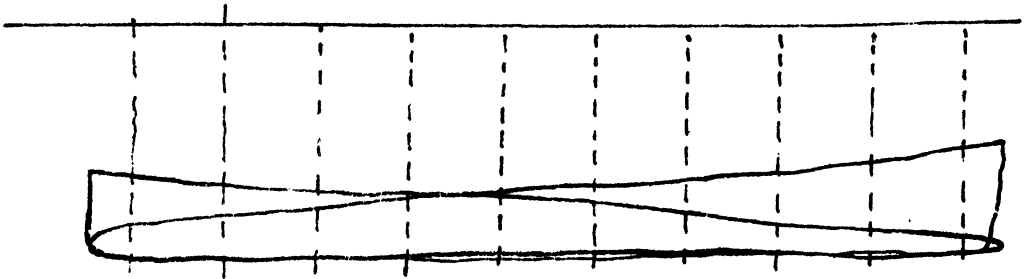

Mean Pressure—Front, 2·5 lbs. Mean Pressure—Back, 3·5 lbs.

Average Mean Pressure—3·0 lbs. per sq. inch.

I.H.P.—49·9.

Total I.H.P.—No. 2 Engine—100·0. Total Indicated Horse Power—165·5.

Total Load Indication—840 I.H.P.

Percentage of Power Absorbed by Friction— $\frac{100 \times 165.5}{840} = 19.7\%$ .



## SPEEDS OF SHAFTING.

### SPEEDS OF SHAFTING.

To find the speeds of the shafting :—

Crank shaft 45 revolutions per minute.

Wheel on crank shaft 130 cogs,  $24\frac{1}{2}$ " broad.

Pinion ,, main ,, 57 teeth,  $24\frac{1}{2}$ " broad.

$$\frac{45 \times 130}{57} = 102.6 \text{ speed of main shaft.}$$

On the plan it will be observed, for reasons given in the introduction, I have marked the speeds.

Crank shaft 45 revolutions per minute.

Main shaft 100 ,, ,,

Batching shaft 160 ,, ,,

Preparing ,, 160 ,, ,,

Spinning ,, 220 ,, ,,

*Example.* —If the main shaft is 100 revolutions per minute, what will be speed of the spinning driving shaft ?

Bevel cog wheel on main shaft 66 cogs.

,, teeth pinion on spinning shaft 30 teeth.

$$100 \times \frac{66}{30} = 220 \text{ revolutions per minute}$$

The above is given by way of example to calculate the speed of the shafting.

Softener Drums,	...	...	30" dia. × 14" broad
Breaker and Finisher Drums,	...	...	28" ,, × 14" ,,
1st Drawing Circular	,,	...	21" ,, × 8" ,,
1st Drawing Drums—Push Bar,			16" ,, × 8" ,,
2nd	,,	Spiral, ...	16" ,, × 8" ,,
Roving Drums,	...	...	24" ,, × 6" ,,
Spinning Drums—Weft Frames,*			32" ,, × 14" ,,
"	,,	Warp	36" ,, × 14" ,,

## JUTE BATCHING.

### JUTE BATCHING.

This is the department in which we commence to handle the material for the first time. The bales of jute are wheeled in from the jute warehouse, which will be seen from a reference to the ground plan to adjoin the batching house, and communicates with it by double iron doors. We will suppose there are six bales in the batch. These bales are set up on their ends three on either side of the feeding end of the jute opener, the ropes by which the bale has been bound together are cut from top to bottom by an axe, the layers of jute are then laid upon the feeding table of the opener, and passed through between the rollers—this softens to a certain extent the layers of jute, and the streaks of jute of which the bale has been made up fall readily apart. These streaks or heads are laid on a low stool or platform about 8 feet long and  $1\frac{1}{2}$  feet broad; the batchers, who are standing in front of this platform, break up the large streaks or heads into streaks of about two pounds each, and lay them upon another platform of the same description, from which they are lifted by the workers who are employed feeding the softener. While the batchers are employed streaking up the jute they may also throw to one side any streak that looks too dark or rotty for the quality wanted from the batch laid down, according to the instructions given them by the overseer in charge of the department, the jute which has been rejected being used in another batch of a lower quality as the case may be. The jute passes through a series of fluted rollers pressed together by springs of either spiral or volute form, and while passing through these rollers a stream of oil and water is running down from pipes upon the fibres. The jute being softened and damped during this operation, is delivered at the other end of the machine, and is taken hold of by the workers, generally termed "twisters," whose work it is to twist the streak and lay it upon a waggon. They build it upon one side of this waggon or jute barrow, as it is usually termed, to the height of 18 inches. The barrow is then turned round, and they build another 18 inches, and so on alternately until the barrow is filled. While it is in process of filling, it should be tramped 3 to 4 times; this presses the jute together, and the barrow is then put aside, and should stand from 18 to 24 hours before being taken to the next

## JUTE BATCHING.

process. While it is standing, the oil and water that has been put upon it is percolating through the fibre and slackening the root and dirt, and making it fit for the carding process which follows. This is what is termed machine batching, and is the form of batching that is most followed in Dundee mills, and it is claimed for this system that it has all the advantages of hand batching, and is accomplished with less trouble and expense. If hand batching is adopted, the jute is put through the softener without oil or water being put upon it; the jute is then put down in a stall in layers, and the oil and water poured upon it from a pitcher, and is allowed to lie as before, and it then has to be carried or lifted into a barrow, and taken to the next process.

Very much of the success of the working of the material in the other departments will depend upon the care and attention given to the material when it is being batched. In the preparing department, if the oil and water has not been evenly put on, and the jute has not been well spread in the softening process, lapping of the jute round the pressing rollers of the different machines will occur, causing needless waste and loss of time, and consequently loss of production. This can always be avoided if sufficient care and attention is given to the material when being batched. The batching house should be kept thoroughly clean, no oil except what is in the tanks above the softener should be kept in the mill, the bulk of the oil should be kept outside and run down through pipes to the softeners as required, and there should be no drain in this department leading from the softeners to the common sewer; a drain here often leads to much loss and carelessness. The softeners should be fitted with trays about 4" deep laid in below the rollers, so that any oil passing through the rollers towards the floor may be caught in them and utilized. There is no valid reason why the batching house should not be as clean as any other department in the mill. Apparatus of different kinds have been fitted to softeners to regulate the fall of the oil upon the jute according to the thickness of the streaks, but I doubt if they are of much practical utility. Adjust the oil and water pipes to deliver at the rate required, and if the softener is fed with fair regularity the end will be attained suitable for all practical purposes without a lot of mechanical nick-nacks, for which there is no time in any department of an ordinary jute mill.

**NOTE.**—The water pipe is next the feeding end of softener, and the oil pipe from 18" to 20" forward from the water pipe.

## JUTE BATCHING.

Mineral oil of various qualities is now mostly used in batching, whale oil being very little used. The mineral, however, should be of *good* quality. As to the quantity required per bale, the quality of the jute and oil being used must be taken into account, and this to a great extent must be determined by one's experience of the yarn wanted. Stated in a general way, a gallon to a gallon and a quarter will be used to a bale of 400 lbs., but this is very often determined by a knowledge on the spot of what is wanted, and this quantity may often be much less and often sometimes more.

As to the quantity of jute put through a softener, this will to a certain extent be determined by the speed of the machine. The speed of the softener given will, with regular feeding, deliver 350 bales per week of 56 hours, and this will allow the streaks to be made about two pounds each, and they should never exceed this if the breaker feeder is to have a chance of making good work when spreading the jute upon the feeding table. One jute opener will pass the quantity (700 bales) in 56 hours at the speed given for this machine.

The batch put down for ordinary hessian warps should be composed of six bales—it is better not to have too many bales in the batch, as the jute will have a better chance to be well mixed, and the different characteristics of the jute in each bale will be better spread through the yarn.

4 bales of  $\frac{2}{3}$  of the batch, second numbers of first marks.  
2    "     $\frac{1}{3}$        "       third       "       "

The jute for warps should be selected as free from dirt and root as possible, and uniformity of colour is desirable to avoid the chance of striping the yarn. If third numbers are being used, they will require to be of early shipment to insure the necessary colour and quality; but this batch will require care and attention, and sometimes a little judicious picking to get rid of any little root will be necessary. The weft for a good standard hessian should be made out of the same batch. My remarks as to the batch given above refer to 11 por. 13 shots  $10\frac{1}{2}$  oz. and heavier. The lighter weights of hessians may be made of a lower quality of weft, the batch for which would be composed entirely of good third numbers.

In the selection of these six bales, it will be found advisable to have, at least as far as possible, a combination of strength, colour, and cleanliness; and to be able to do this, can only be learned from daily study and careful attention to the different parcels of jute as they come before you, and even with all this, and a long experience

## JUTE BATCHING.

in addition, I am afraid more mistakes are often made in this department—unwittingly, of course,—than in any other department in the mill.

In reference to the amount of damp to be put on, from 15 per cent. to 20 per cent. may be given as sufficient, stated in a general way, but this also has, in a great measure, to be determined by the quality of the jute and the state of the atmosphere. The temperature of a mill on the shed principle varies very much with the temperature of the atmosphere, and this reacts upon the material in process; and although 15 per cent. to 20 per cent. may seem to be a large quantity to put in at the first process, if the jute is allowed to lie and become properly moistened, this moisture or damp will pass away in the course of being made into yarn. To put an undue amount of water into the first process is of no practical benefit in the working of the material. The loss of time and waste made if the material is too damp is out of all proportion to any advantage that can otherwise be gained. If proper attention is given to the batching and damping process, the breakers, finishers, drawings, and rovings will work from morning to night without lapping: if they do not, the damping is in all probability being overdone.

The jute opener of which we give an illustration is Messrs Butchart & Skinner's patent, and does its work better than any other machine I have seen, and is now very generally adopted by the trade. As the jute passes through, the knobs on the rollers are pressed into the 'heads' of the jute, making them soft, pliable, and easily handled.

*Speed of Jute Opener as follows:—*

Driving Shaft 160 revolutions per minute.

Drum on Shaft 16" diameter.

Pulley on Opener 20" „

$160 \times \frac{16}{20} \times 118$  revolutions of jute opener pulleys per minute.

$128 \times \frac{3}{8} \times \frac{1}{8} = 7.8$  revolutions of rollers per minute.

The jute softener of which we give an illustration is made by Messrs Urquhart, Lindsay & Co., Ltd., and also by Messrs Thomson, Son, & Co. They are for all practical purposes the same machines.

JUTE BATCHING.

*Speed and Gearing of Messrs Urquhart, Lindsay & Co, Ltd.'s Machine is as follows:—*

Driving Shaft 160 revolutions per minute.

Drum on Shaft 30" diameter.

Pulleys on Softener 36" diameter.

$\frac{160 \times 30}{36} = 133.3$  revolutions per minute—Speed of Pulley Shaft.

Cross Shaft Driving Pinion 18 teeth.

Side „ Wheel 40 teeth.

Shaft Bevel Pinion 16 teeth.

Roller „ Wheel 25 teeth.

$\frac{133.3 \times 18 \times 16}{40 \times 25} = 38.4$  revolutions of rollers per minute.

*Messrs Thomson, Son, & Co.'s Machine.*

Driving Shaft 160 revolutions per minute.

Drum on Shaft 30" diameter.

Pulleys on Softener 36" diameter.

$\frac{160 \times 30}{36} = 133.3$  revolutions per minute—Speed of Pulley Shaft.

Cross Shaft Driving Pinion 19 teeth.

Side „ Wheel 39 teeth.

Shaft Bevel Pinion 16 teeth.

Roller „ Wheel 25 teeth.

$\frac{133.3 \times 19 \times 16}{39 \times 25} = 41.6$  revolutions of rollers per minute.

BUTCHART'S PATENT JUTE CRUSHER.

# BUTCHART'S PATENT JUTE CRUSHER.

Scale  $\frac{1}{4}$ " = One Foot.

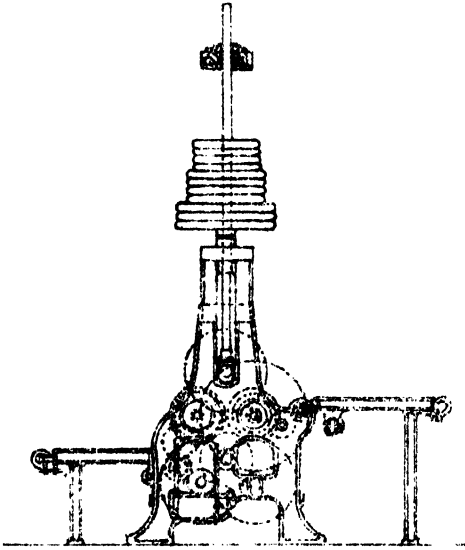

END ELEVATION

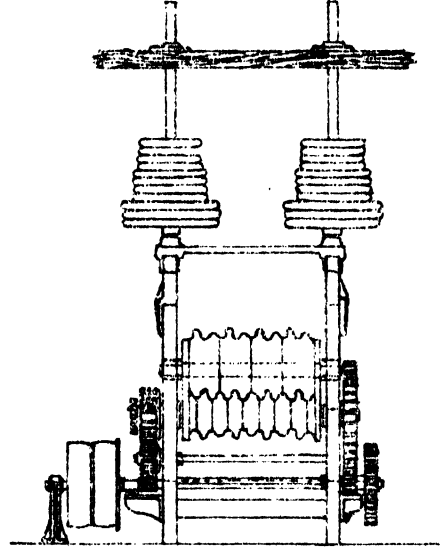

FRONT ELEVATION

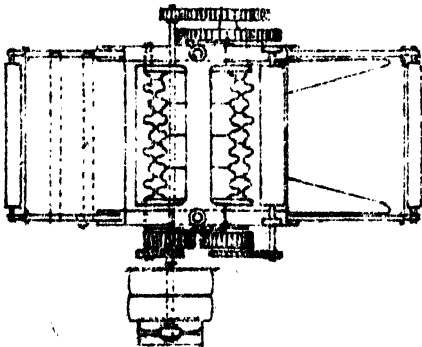

PLAN

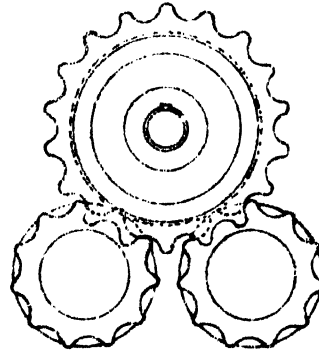

SECTION OF ROLLERS  
SCALE  $\frac{3}{4}$ " = ONE FOOT

# JUTE SOFTENER.

39 Pairs of Rollers.

Scale— $\frac{1}{4}$ " = One Foot.

Belt Pulleys 36" x 6".

	No. of Teeth.	Pitch.	Breadth.
Main Bevel Wheel	39	1.5"	3 $\frac{1}{8}$ "
" Pinion	19	1.5"	3 $\frac{1}{8}$ "
Roller Wheels	25	1.25"	2 $\frac{3}{4}$ "
" Pinions	16	1.25"	2 $\frac{3}{4}$ "

OIL AND WATER TANK

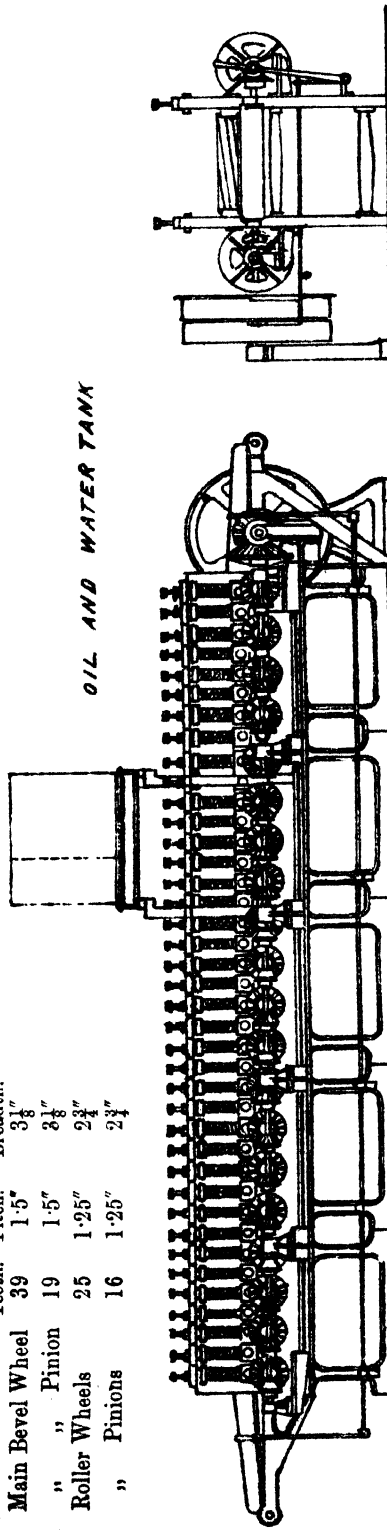

ELEVATION

END ELEVATION

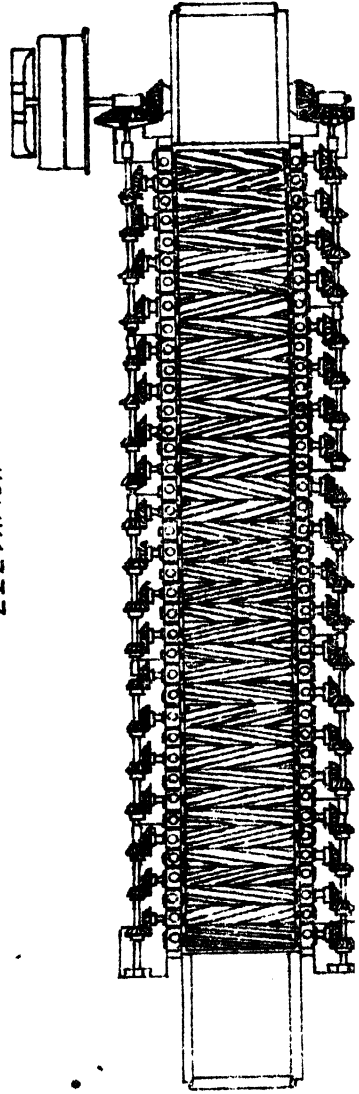



JUTE SOFTENER ROLLERS—JUTE BARROW.

## JUTE SOFTENER ROLLERS.

Scale— $\frac{1}{4}$ " = One Foot.



SPIRAL FLUTES



STRAIGHT FLUTES

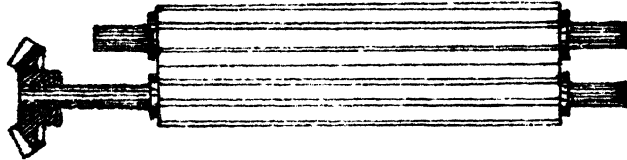

## JUTE BARROW.

USED IN BATCHING.

Scale— $\frac{1}{4}$ " = One Foot.

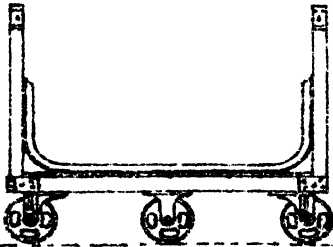

Elevation

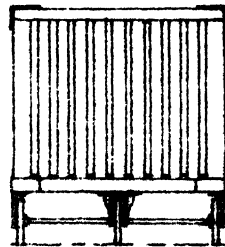

End Elevation

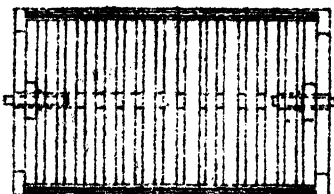

Plan

This barrow will  
contain  $\text{Q} 12$

## JUTE PREPARING.

### JUTE PREPARING.

The process after the jute has been batched and been lying for the necessary time in the jute barrow is termed the preparing. In the preparing department, stated very briefly, the jute is converted from the "streak" into rove yarn in preparation for the spinning process. This conversion is effected by the use of five different machines, sometimes six are used, but not often, at least for ordinary hessian yarns. These machines are named—

- 1st. The Jute Breaker.
- 2nd. „ Finisher.
- 3rd. „ 1st Drawing Frame.
- 4th. „ 2nd „
- 5th. „ Roving Frame.

During its passage through the breaker and finisher the jute is going through what is termed the carding process—that is, it is being cut up into a sort of tow, and during the process it is being drawn to a certain extent at the same time. In the drawings a number of ends or slivers, as they are usually called, are put together and run through the drawing into one at the front, and it is being drawn out still smaller and finer during the process. In the roving frame each end is put through the roving by itself, and when passing through the roving is drawn finer still, and delivered at the front to the weight required for the yarn into which it is to be spun. While it is being delivered at the front of the roving, as it runs on to the bobbin, a certain amount of twist is put on to keep it together while it is being unwound during the spinning process. To give in detail to a certain extent a description of the work done by each of these machines, and also at the same time to show the methods of their arrangement and the calculations of the different speeds involved in each of them, along with one or two arrangements to show the weight of rove produced, will be my object in this chapter.

With reference to the quantity of jute laid on the breaker feed table, two methods are adopted. The first, and I believe the most common method, is to weigh so many pounds of jute and lay it on the

## JUTE PREPARING.

feeding table of breaker during one round of a clock which is attached to the feed roller for the purpose of measurement of the jute as it is passed into the breaker; the other system is to put the jute over the breaker without weighing it, and take the cans to a machine called a balling machine. So many slivers from the breaker are made into a ball or lap, and these laps are made a certain weight for a certain length, and this determines the weight of the slivers delivered from the finisher in a certain number of yards. I give an illustration of a balling machine, and particulars of arrangements, but all the calculations in this chapter are based upon the weight of the "dollop"—that is the weight laid upon the feeding table of breaker for one round of the clock provided for that purpose. It will now be understood that all the measurement of the jute in course of being made into rove is done at the commencement, and in practice there is not found any necessity for more weighing of the material in the process of making rove.

Jute breaker cards and finishing cards are very much of the same construction; they both consist of a cylinder, usually 6 ft long and 4 ft. diam., round which are placed rollers, called first-feeding roller, then stripper roller, worker roller, doffer roller, drawing roller and delivering roller. All these rollers revolve in the same direction as\* the cylinder; the feed roller takes the jute into the cylinder; the jute passing between the feed roller and shell as it is fed in, is retarded by the pins of feed rollers, and as it passes through the shell, it is carded, or combed, by the cylinder. The workers, although revolving in the same direction as the cylinder, from the angle at which the worker pins are set, cards, or combs the fibre still more. The strippers, running in the same direction as the cylinder, and from the angle at which their pins are set, do not card the fibre, but clean the fibre which is on the worker, and pass it on to the cylinder again. After it passes the worker and stripper, it is taken off the cylinder by the doffer, and from the doffer is carried through between the drawing and pressing roller, which are in front of doffer, and passing down a conductor, is passed again through a delivering roller into the can.

In the case of a down-striker breaker, the fibre passes over the top of doffer on to the drawing roller; and in a full circular finisher, the fibre is passed to the drawing roller from the under side of the doffer. A reference to the "set" of the pins in each case will enable the reader to follow this explanation. Much diver-

\*NOTE.—That is, the periphery of rollers and cylinder travel in the same direction at points of contact.

## JUTE PREPARING.

sity of opinion exists as to the best speeds for the cylinders and the different rollers to be driven. It is well known that breaker and finisher cylinders are being run at a speed which varies from 160 to 200 revolutions per minute. This diversity of opinion as to speed proves, I think, very conclusively that there must be a very wide margin, within which it is possible to work; and probably the best speed for breaker and finisher cylinders, working jute for hessian warps and wefts, will be found somewhere between these extremes; and, I believe, these speeds will be found by taking the breaker cylinder at 190 revolutions per minute, and the finisher cylinder at 180 revolutions per minute; and although, as will be seen, I take these speeds for some of the following calculations, I also give some other calculations with other speeds, which have also been found to work on the whole equally as well. The quality of the jute in process must always be taken into consideration in determining the proper speed, and in practice it is not found always convenient to be altering the speed of the breaker or finisher cylinders. It is not a difficult matter to alter the position of the shell to the cylinder, and I am convinced from experience that it is often found to be advantageous to shift the position of the shell to the cylinder, either by putting it closer, or by taking it away from the cylinder when necessary, owing to the hardness or softness of the jute that is being used.

With reference to the quantity that may be put over breaker and finisher in 10 hours there is also some diversity of opinion. This, however, in practice, will, to a considerable extent, be found to be regulated by the sizes that are being spun; and if these sizes are taken—say, from 7 to 12 lbs.—in a general average way over a mill as shown in the plan, the finisher will do about 30/35 cwt. per day of 10 hours. I am, however, well aware that there are many finishers doing less, but I also know that many finishers are doing a great deal more. In passing, I may say that the quantity named—30/35 cwt.—can easily be got over a finisher, with a dollop of moderate weight at the breakers—say 30/33 lbs.—in a single round of the clock—on a single doffer breaker—and for a double doffer breaker, with two deliveries, with rollers 16" diameter, of 40/44 lbs., in one round of clock. And here let me remark, the single delivery breaker and finisher should not be driven faster than what is actually necessary to provide sliver to keep the system fully in motion. This is one of the great points in regard to the speed of the cards and drawings. Their speed should be so adjusted that there will be no long stoppages, which only lead to general interruption of the organiza-

tion of the department. The cards and breakers should also be closed in with sheet iron, doors being made to allow of the dust being swept out as required. If they are closed in thoroughly, it will in a great measure prevent accident; and if a card takes fire, prevent it spreading to the next machine.

As shown in the plan one breaker supplies sliver for two finishers, but if a large production is wanted there is room for 9 breakers to 14 finishers. ✓

As to the position of the breakers and finishers, in the plan given it is intended that the breaker feeding table is next the batching house, and the breaker delivering towards the back of finisher. The cans from the front of breaker will then be taken to the front of finisher by boys usually called "can trailers." These cans—say, 8 or 10 at a time—being fed into the finisher over the feeding cloth, as in the breaker, and delivered at the one side of finisher in front, it will be delivered at the right or left side, according as the finisher is right or left hand, as it is usually termed.

The cylinder lagging, or staves as they are more generally called in this quarter, require periodically to be refilled with new pins. In the case of the breaker this will have to be done twice a year.

The general method is to remove the one half of cylinder cover once every three months, and refill them. Although sometimes the fourth part of the cover is taken off every six weeks and refilled, this method, if adopted, will, of course, ensure a more general average sharpness in the pins of the cylinder cover.

The finisher staves will require to be renewed once in a year, and this is done by removing the half each six months and refilling them. The workers and strippers, &c.; will run on an average, say, the workers 7 years, and the strippers 5 years.

One other point may be mentioned, and that is all the rollers except drawing roller, pressing roller, and delivering roller are covered with wood, and in course of wear they are inclined to go off the 'truth'—this causes trouble when setting the card, as it prevents the rollers from being equally set all the breadth of the card. When they are discovered to be off the truth, the staves should be taken off and the roller put into a turning lathe and made true right across the roller. All the rollers are set to a certain gauge from the cylinder, and also to a certain gauge from one another. Farther on in this chapter a table to which they should be set is given, but in practice it may be sometimes necessary to vary the setting a little in either direction.

## JUTE PREPARING.

With reference to the question as to whether double doffer breakers and finishers are better than single doffer breakers and finishers there is some difference of opinion. Certainly there are not nearly so many double doffer cards working as single doffers, and I don't think they are necessary for producing hessian warps and wefts if you have plenty of single doffer cards; but I believe from my experience that you get more off a double doffer breaker than a single doffer, particularly if you have to work a certain quality of jute, and find it necessary to do this with a fairly heavy dollop. Into the merits of this question it is not necessary to enter here. The student will not find this point trouble him for a considerable time, and by which time he will, both from theory and practice, doubtless be in a position to think it out for himself.

For the changing of the speeds in connection with the working of the breakers and finishers there are four pinions usually called change pinions. These are—first—the pinion on the end of the cylinder arbor, usually called the cylinder pinion; this pinion increases or diminishes the speed of every roller on the breaker or finisher except the stripping rollers, which are driven by a belt passing over a pulley on the opposite end of cylinder arbor, and on the inside of the driving pulleys; the second change pinion is the pinion which lengthens or shortens the draft between the feeding roller and the drawing roller, by the term draft is meant the difference between the surface velocity of the feed roller and drawing roller, the third change pinion is the pinion which increases or diminishes the speed of the workers in their relation to the surface speed of the cylinder; the fourth changes the relative speed between the drawing roller, and the doffer, which lengthens or shortens the draft between doffer and drawing roller, as it is usually termed. The position of all these change pinions are marked on the illustrations of breaker and finisher, and also on all the calculations pertaining to these four points.

When you increase the speed of the workers you reduce the amount of carding being done to the fibre, as there is being less resistance given to the action of the cylinder upon the fibre between the cylinder and worker pins; and when you decrease the speed of the worker the reverse action takes place, and of course more carding is done.\* A reference to the manner in which the pins are set round the cylinder and round the worker will explain this to the reader. The student should also study very carefully how the pins

\*NOTE.—The reader will observe that if the surface velocity of cylinder and worker were equal there would be no carding action.

are set in all the different rollers, so that he can take them out and put them in, understanding very thoroughly the reason in his own mind how the "sets" upon the pins are placed in the different rollers, and the cause for them being so set.

A table of all the diameters of cylinders and the other rollers over the wood over the staves and over the pins is given, and will be found of considerable use as a reference. All the surface speeds referred to in the calculations are taken from the circumference at the *centres of pins*.

Sufficient explanation of the machines has now been given, and we may proceed to show the calculations for surface speed and drafts.

#### SINGLE DOFFER BREAKER.

First, let us try and explain the way to take the draft of a breaker card, and we will try and make it as simple as possible, and we will illustrate this by putting down the letters in their order for a formula, as follows:—

$$\frac{A}{B} \times \frac{C}{D} \times \frac{E}{F} \times \frac{G}{H}$$

In the above—

A = Diameter of Drawing roller.

B = Drawing roller wheel teeth.

C = Wheel of Double intermediate in gear with cylinder pinion.

D = Change or draft pinion on nave of above.

E = Wheel of double intermediate in gear with draft pinion.

F = Pinion on nave of double intermediate in gear with wheel on end of feed roller.

G = Wheel on end of feed roller.

H = Diameter of feed roller.

## SINGLE DOFFER BREAKER.

Thus—

$$\frac{4 \times 80 \times 110 \times 110}{52 \times 26 \times 20 \times 10\frac{1}{2}} = 13.32 \text{ draft between feed and drawing rollers.}$$

$$\frac{4 \times 80 \times 110 \times 110}{52 \times \underset{\text{pinion}}{\text{Change}} \times 20 \times 10\frac{1}{2}} = 346.332 = \text{Constant Number for draft.}$$

It will be observed from above, that commencing with diameter of drawing roller, omitting the single intermediate wheels, you take all the pinions and wheels as they come, one after the other, until you arrive at the feed roller, and you finish the statement of the calculation with the diameter of feed roller. If the student proceeds on these lines, he cannot go wrong if he gives the matter a little consideration and perseverance.

Note the draft of any machine, whether breaker, finisher, drawing, or roving, is the difference between the surface speed of the first and last rollers of the machine.

Next the draft, between the doffer and drawing roller—

$$\begin{array}{ccccc} A & & C & & E \\ \text{---} & \times & \text{---} & \times & \text{---} \\ B & & D & & F \end{array}$$

Then, in this case—

A = Diameter of drawing roller.

B = Pinion on end of drawing roller.

C = Wheel of double intermediate in gear with pinion on end of drawing roller.

D = Pinion on nave of intermediate in gear with doffer wheel.

E = Doffer wheel.

F = Diameter of doffer.

Thus—

$$\frac{4 \quad 54 \quad 88}{\text{---} \times \text{---} \times \text{---}} = 2.05 \text{ draft between doffer and drawing roller.}$$

$$\frac{23 \quad 26 \quad 15\frac{1}{2}}{\text{---} \times \text{---} \times \text{---}}$$

$$\frac{4 \quad 54 \quad 88}{\text{---} \times \text{---} \times \text{---}} = \text{Constant Number}$$

$$\frac{23 \quad \underset{\text{pinion}}{\text{Change}} \quad 15\frac{1}{2}}{\text{---} \times \text{---} \times \text{---}}$$



## SINGLE DOFFER FINISHER.

Note here that, in reference to draft between doffer and drawing roller, taking the diameter of doffer at points of pins against the diameter of drawing roller at 4" diameter, the relative speeds that have been found to work well are:—Drawing roller to revolve at a surface speed of 100 inches for 54 to 57 inches of doffer. Of course, though the diameter of doffer at points of pins is taken, it must be borne in mind that the beard projects, perhaps, 3" to 4" from the points of doffer pins, making a diameter of perhaps 23" to 24" instead of 16" as at pin points. Even then there is a draft between the doffer and the drawing roller, but experience has shown that this difference of speed is best for the effectual clearing of the doffers, and for keeping the fibres straight. The effect I should look for with too slow a speed for the drawing roller would be that the fibre would not be as straight as is desirable, and a more or less lumpy or cloudy appearance would be given to the fleece. On the other hand, if the roller went too fast, I should expect thin parts, or breaks, in the continuity of the fleece.

For the calculations and arrangements of worker wheels, see the specifications of breaker speeds, &c.

## SINGLE DOFFER FINISHER.

Finishers, drafts, &c., are done in the same manner—thus:—

$$\begin{array}{cccc} A & & C & & E & & G \\ - & \times & - & \times & - & \times & - \\ B & & D & & F & & H \end{array}$$

Then in this case—

A = Diameter of drawing roller.

B = Wheel on end of drawing roller.

$\frac{C}{D} = \left. \vphantom{\frac{C}{D}} \right\}$  Double Intermediate.

$\frac{E}{F} = \left. \vphantom{\frac{E}{F}} \right\}$  Double Intermediate.

G = Wheel on end of feed roller.

H = Diameter of ,,

SINGLE DOFFER FINISHER.

Thus—

$$\begin{array}{cccc} 4 & 104 & 96 & 96 \\ \text{---} & \times & \text{---} & \times & \text{---} & \times & \text{---} & = 14.26 = \text{draft between feed and drawing} \\ 75 & & 32 & & 28 & & 4 & \text{rollers.} \\ 4 & 104 & 96 & 96 \\ \text{---} & \times & \text{---} & \times & \text{---} & \times & \text{---} & = 399.3593 = \text{Constant Number for draft.} \\ 75 & & 32 & & \text{Change} & & 4 & \\ & & & & \text{pinion} & & & \end{array}$$

Again, the draft between the doffer and drawing roller—

$$\frac{A}{B} \times \frac{C}{D} \times \frac{E}{F}$$

In this case—

A = Diameter of Drawing roller.

B = Pinion on end of drawing roller.

$\frac{C}{D} = \left. \begin{array}{l} C \\ D \end{array} \right\}$  Double intermediate.

E = Wheel on doffer.

F = Diameter of doffer.

Thus—

$$\begin{array}{cccc} 4 & 60 & 84 & \\ \text{---} & \times & \text{---} & \times & \text{---} & = 2.21 = \text{draft between doffer and drawing roller.} \\ 23 & & 26 & & 15\frac{3}{8} \\ 4 & 60 & 84 & \\ \text{---} & \times & \text{---} & \times & \text{---} & = \text{Constant Number for draft.} \\ 23 & & C. & & 15\frac{3}{8} \end{array}$$

Observe that the note given in reference to draft between doffer and drawing roller applies also to the finisher card.

For the calculation and arrangement of worker wheels and speeds, see the specifications of finisher speeds, etc.

Referring to the delivery of the sliver from the drawing roller into the conductor of finisher, sometimes it is delivered in two distinct slivers, and run into one as it runs into delivering roller, and sometimes it is delivered in one sliver from the drawing roller. This is the better way, as the sliver works much better on the gills of first drawing, and there is less chance of a slack side on the sliver as it passes through the drawing, and it is delivered at the front with much more levelness and regularity than it is when made in two at the finisher.

## DOUBLE DOFFER BREAKER.

## DOUBLE DOFFER BREAKER.

$$\frac{A}{B} \times \frac{C}{D} \times \frac{E}{F} \times \frac{G}{H} = \text{Draft.}$$

Thus in this case—

A = Diameter of drawing roller.

B = Wheel on end of drawing roller.

$\left. \begin{array}{l} C \\ D \end{array} \right\} = \text{Double Intermediate.}$

$\left. \begin{array}{l} E \\ F \end{array} \right\} = \text{Double Intermediate.}$

G = Wheel on end of wheel roller.

H = Diameter.

Thus—

$$\begin{aligned} & 4 \quad 150 \quad 150 \quad 156 \\ & - \times \frac{\quad}{34} \times \frac{\quad}{80} \times \frac{\quad}{20\frac{1}{2}} = 9.7 \text{ draft between feed and drawing} \\ & 70 \quad 150 \quad 150 \quad 153 \quad \text{rollers.} \\ & - \times \frac{\quad}{70} \times \frac{\quad}{30} \times \frac{\quad}{20\frac{1}{2}} = 330.158 \text{ constant number of draft.} \\ & \text{change} \\ & \text{pinion.} \end{aligned}$$

NOTE.—That it is the wheel on end of lower drawing roller that is taken when calculating the draft of Double Doffer Breaker.

In double doffer cards, the wheel on *bottom drawing roller* is 70, and on top roller 74 teeth. This gives a draw to the bottom so as to ensure the sliver from top rollers being taken up properly by the bottom ones.

Again the draft between the doffer and drawing roller—

$$\frac{A}{B} \times \frac{C}{D} \times \frac{E}{F}$$

In this case—

A = Diameter of drawing roller.

B = Pinion on end of ,,

$\left. \begin{array}{l} C \\ D \end{array} \right\} = \text{Double Intermediate.}$

E = Wheel on doffer.

F = Diameter of doffer.

$$\begin{aligned} & 4 \quad 57 \quad 88 \\ & - \times \frac{\quad}{24} \times \frac{\quad}{15\frac{1}{2}} = 1.92 \text{ draft between doffer and drawing roller.} \\ & 24 \quad 57 \quad 88 \\ & - \times \frac{\quad}{24} \times \frac{\quad}{15\frac{1}{2}} = 53.935, \text{ constant number for draft.} \\ & \text{change} \\ & \text{pinion.} \end{aligned}$$

DOUBLE DOFFER FINISHER.

DOUBLE DOFFER FINISHER.

$$\begin{array}{ccccc} \text{A} & & \text{C} & & \text{E} \\ \text{---} & \times & \text{---} & \times & \text{---} = \text{Draft.} \\ \text{B} & & \text{D} & & \text{F} \end{array}$$

Then in this case—

A = Diameter of Drawing Roller.

B = Wheel in end of „

C

— = Double Intermediate.

D

E = Wheel in end of feed roller.

F = Diameter „ „

$$4 \quad 138 \quad 144$$

— × — × — = 12.03 draft between feed and drawing roller.

$$76 \quad 20 \quad 4\frac{1}{4}$$

$$4 \quad 138 \quad 144$$

— × — × — = 246.092 constant number for draft.

$$76 \quad \begin{array}{c} \text{change} \\ \text{pinion.} \end{array} \quad 4\frac{1}{4}$$

Again the Draft between Doffer and Drawing Roller—

$$\begin{array}{ccccc} \text{A} & & \text{C} & & \text{E} \\ \text{---} & \times & \text{---} & \times & \text{---} = \\ \text{B} & & \text{D} & & \text{F} \end{array}$$

Then in this case—

A = Diameter of drawing roller.

B = Pinion on end of „

C = } Double Intermediate.  
D = }

E = Wheel on doffer.

F = Diam. of „

$$4 \quad 54 \quad 88$$

— × — × — = 2.04 draft between doffer and feed roller.

$$24 \quad 25 \quad 15\frac{1}{2}$$

4 54 88 = 51.096 constant number for draft.

$$\text{---} \times \text{---} \times \text{---}$$

$$24 \quad \begin{array}{c} \text{change} \\ \text{pinion.} \end{array} \quad 15\frac{1}{2}$$

NOTE.—Top Drawing Roller Wheel 80 Teeth.

Lower „ „ 76 „

## ARRANGEMENT OF SINGLE DOFFER BREAKER CLOCK.

We will now describe the method followed to produce a certain weight of rove from a certain "dollop." The word dollop is the name applied to the bundles of jute laid on in one round of the clock attached to the feed roller.

Two methods for doing so are adopted --

- 1st. The weight laid on in one round of clock, calculated from the circumference of feed roller at centre of pins.
- 2nd. The weight laid on in one round of clock, calculated from the circumference of the plaiding roller. This roller is 4" in diameter, but the thickness of the feeding cloth must be taken into account, and this makes the diameter  $4\frac{1}{8}$ ", or 11.95 inches in circumference.

Although the first method is preferable, the calculations of both are explained.

Taking the first method—thus:—

$$\begin{array}{r} A \quad C \\ \text{---} \times \text{---} \\ B \quad D \end{array}$$

In this case—

- A = 3 Threaded worm on end of feed roller, and a 3 threaded worm is equal to a pinion of 3 teeth.  
 B = 42 Teeth pinion in gear with worm.  
 C = 36 ,, on nave of 42 teeth pinion.  
 D = 36 ,, on arbour of clock.

Thus—

$\frac{3}{42} \times \frac{36}{36} = \frac{1}{14}$  And a  $\frac{1}{14}$  revolution of the clock is equal to one round of feed roller, and therefore, there are 14 revolutions of feed roller in one round of clock.

Feed roller,  $10\frac{1}{2}$ " diam., according to Messrs Fairbairn, = 32.98 inches circumference.

$$\frac{32.98 \times 14}{36} = 12.82 \text{ yds. in one round of the clock.}$$

## ARRANGEMENT OF SINGLE DOFFER BREAKER CLOCK.

In my own experience I have always found the diameter of feed roller to be  $10\frac{3}{4}$ " , and worked out the length of clock from that diameter—thus :—

$\frac{3}{4} \times \frac{36}{36} = \frac{1}{4}$  And, as above, 14 revolutions of feed roller for one round of clock.

$10\frac{3}{4}$ " diam. = 33.77 circumference.

$\frac{33.77 \times 14}{36} = 13.13$  yds. in one round of clock.

Then the second method—

A	O	E
—	×	—
B	D	F

Then in this case—

A = Pin on end of plaiding roller.

B = Wheel in gear with it.

O = Worm on other end of feed roller.

D = 42 teeth pinion in gear with worm.

E = 36 ,, on nave of 42 teeth pinion.

F = 36 ,, on arbour of clock.

Thus—

$\frac{46}{114} \times \frac{3}{42} \times \frac{36}{36} = \frac{23}{798} = \frac{1}{35}$  Almost, therefore,  $\frac{1}{35}$  of a revolution of the clock equals one round of the plaiding roller.

Plaiding roller,  $4\frac{1}{8}$  diam. = 12.95 circumference.

$\frac{12.95 \times 35}{36} = 12.6$  yards in one round of the clock.

# SINGLE DOFFER BREAKER CLOCK.

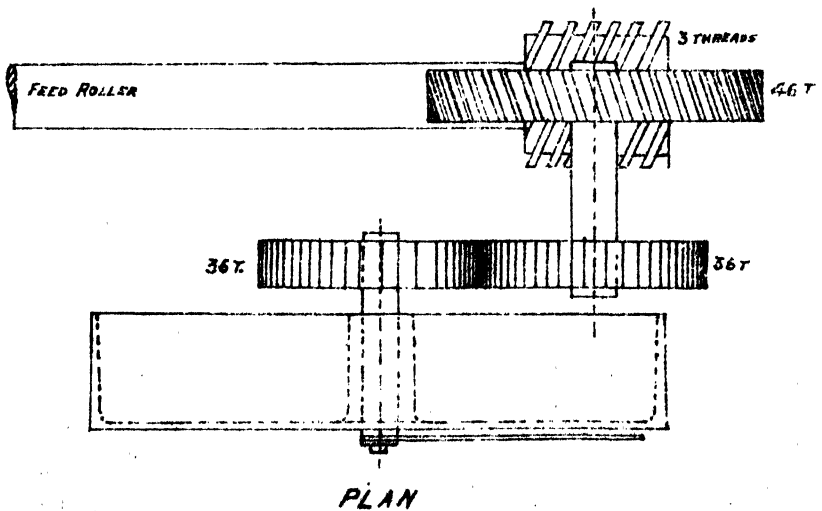
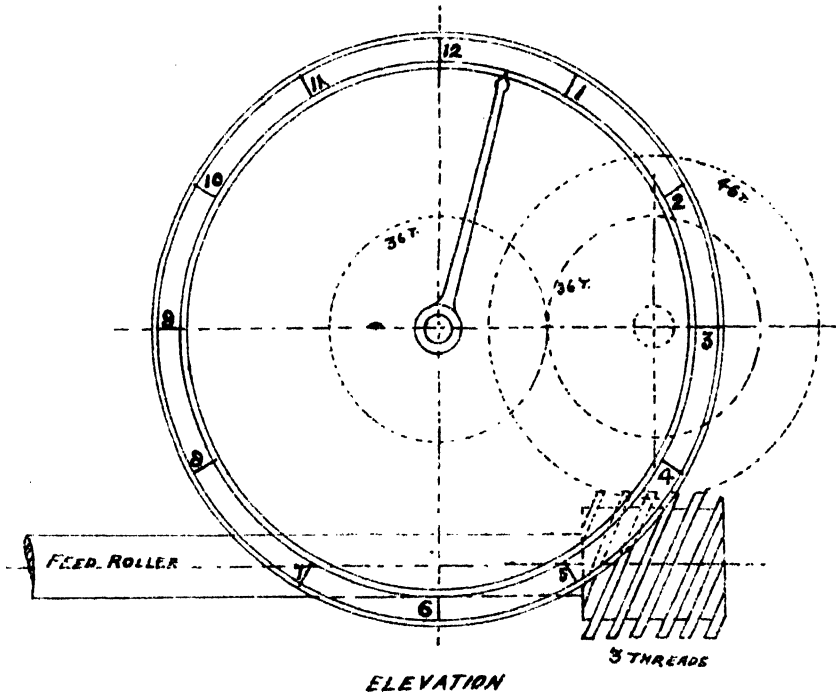

SPECIFICATION AND SPEEDS OF JUTE BREAKERS.

SPECIFICATION AND SPEEDS OF JUTE BREAKER (SINGLE DOFFER).

Cylinder 6' × 4'—2 Workers, 2 Strippers, 1 Doffer, Doffs with iron rollers.

Speed of Cylinder 190 revolutions per minute.

Cylinder Pulleys 24" diameter, 6" broad, 2½" bore.

Pulleys driving Strippers 14" diameter, 3½" broad, 2¼" bore.

Pulley Seats on Strippers 1⅜"

Wheel	,,	workers	1¼"
		doffer	1¼"
		feeder	1¼"
		drawing roller	1¼"
		delivering ,,	1¼"
		tin rollers	1¼"

		Under wood.	Over wood.	Over staves.	Centre to Centre of pins.	Over staves.	Ce Cent.
Cylinder Ring, ...	...	43½" dia.	48" dia.	49⅜" dia.	49½" dia.	155·11" cir.	156
Nos. 1 and 2 Stripper Rings,		8½ "	11 "	12½ "	12⅜ "	38·09 "	38·6
Nos. 1 and 2 Worker	...	4½ "	7 "	8⅞ "	8½ "	25·52 "	26·7
Doffer Rings	... ..	11 "	14 "	15 "	15⅝ "	47·12 "	48·1
Feeder	,, ... ..	6½ "	9 "	10⅞ "	10½ "	31·80 "	32·4



SPECIFICATION AND SPEEDS OF JUTE BREAKERS.

Tin Rollers 10" diameter and 31.41" circumference.

Drawing Rollers 4" dia.      12.56      ,,

Delivering Rollers 4" dia.      12.56      ,,

\*Plaiding Roller 4" dia      12.56      ,,

NOTE.—When this roller is used to calculate the length of breaker clock, the diameter is taken at  $4\frac{1}{8}$ " ; this allows for thickness of feed cloth.

\*Cylinder  $49\frac{11}{16}$  diameter at centre of pins = 156.09" circumference—

$$190 \times 156.09 = 29657.10 \text{ ins.} = 2471.42 \text{ ft.} \text{---the surface speed of cylinder per minute.}$$

Feed roller  $10\frac{1}{2}$ " diameter at centre of pins = 32.98" circumference.

Cylinder Pinion 44 teeth.

$$\frac{190 \times \overset{\text{Cyl. pin}}{44} \times 26 \times 20}{80 \times 110 \times 110} = 4.49 \text{ revolutions of feed roller per minute.}$$

$$4.49 \times 32.98 = 148.08 \text{ ins. or } 12.34 \text{ feet---surface speed of feed roller per minute.}$$

Nos. 1 and 2 Workers  $8\frac{1}{2}$ " diameter at centre of pins = 26.70" circumference.

$$\frac{190 \times \overset{\text{Cyl. pin.}}{44} \times 48}{136 \times 138} = 21.38 \text{ revolutions of workers per minute.}$$

$$21.38 \times 26.70 = 570.84 \text{ ins or } 47.57 \text{ ft.---surface speed of workers per minute.}$$

\*NOTE.—These diameters are taken from a Fairbairn Specification.

Nos. 1 and 2 Strippers  $12\frac{3}{8}$ " diameter at centre of pins = 38.87" circumference.

Pulley driving strippers 14" diameter.      Pulley on end of strippers  $20\frac{1}{2}$ " diameter.

$$\frac{190 \times 14}{20\frac{1}{2}} = 129.75 \text{ revolutions of strippers per minute.}$$

$$129.75 \times 38.87 = 5043.38 \text{ ins. or } 420.28 \text{ feet---surface speed of strippers per minute.} \checkmark$$

SPECIFICATION AND SPEEDS OF JUTE BREAKERS.

Doffer  $15\frac{5}{8}$ " diameter at centre of pins = 48·10" circumference.

$$\frac{\text{Cyl. pin. } 190 \times 44 \times 24 \times 26}{52 \times 54 \times 88} = 21\cdot11 \text{ revolutions of doffer per minute.}$$

$$21\cdot11 \times 48\cdot10 = 1015\cdot39 \text{ ins. or } 84\cdot61 \text{ feet—surface speed of doffer per minute.}$$

Drawing Roller 4" diameter = 12·56 circumference.

$$\frac{\text{Cyl. pin. } 190 \times 44}{52} = 160\cdot76 \text{ revolutions of drawing roller per minute.}$$

$$160\cdot76 \times 12\cdot56 = 2019\cdot14 \text{ ins. or } 168\cdot26 \text{ feet—surface speed of drawing roller per minute.}$$

Delivering Roller 4" diameter = 12·56 circumference.

$$\frac{\text{Cyl. pin. } 90 \times 44 \times 23}{52 \times 24} = 154\cdot07 \text{ revolutions of delivering roller per minute.}$$

$$154\cdot07 \times 12\cdot56 = 1935\cdot11 \text{ ins. or } 161\cdot25 \text{ feet—surface speed of delivering roller per minute.}$$

Nos. 1 and 2 Tin Cylinders 10" diameter = 31·41 circumference.

$$\frac{\text{Cyl. pin. } 190 \times 44 \times 45 \times 75}{136 \times 138 \times 84} = 17\cdot89 \text{ revolutions of tin cylinders per minute.}$$

$$17\cdot89 \times 31\cdot41 = 561\cdot92 \text{ ins. or } 46\cdot82 \text{ feet—surface speed of tin cylinders per minute.}$$

Plaiding Roller 4" diameter = 12·56 circumference.

$$\frac{\text{Cyl. pin. } 190 \times 44 \times 26 \times 20 \times 114}{80 \times 110 \times 110 \times 46} = 11\cdot12 \text{ revolutions of plaiding roller per minute.}$$

$$11\cdot12 \times 12\cdot56 = 139\cdot66 \text{ ins. or } 11\cdot63 \text{ feet—surface speed of plaiding roller per minute.}$$

Speed of Cylinder per min.	Cylinder Pinion 38 T.		Cylinder Pinion 40 T.		Cylinder Pinion 42 T.		Cylinder Pinion 44 T.		Cylinder Pinion 46 T.		Cylinder Pinion 48 T.		Cylinder Pinion 50 T.	
	Surface Speed.	Revs.	Surface Speed.	Revs.	Surface Speed.	Revs.	Surface Speed.	Revs.	Surface Speed.	Revs.	Surface Speed.	Revs.	Surface Speed.	Revs.
	Feet. 2471.42	190	Feet. 2471.42	190	Feet. 2471.42	190	Feet. 2471.42	190	Feet. 2471.42	190	Feet. 2471.42	190	Feet. 2471.42	190
Feed Roller	10.63	3.87	11.21	4.08	11.76	4.28	12.34	4.49	12.88	4.69	13.43	4.89	14.01	5.10
Workers	41.07	18.46	42.23	19.43	45.39	20.40	47.57	21.38	49.72	22.35	51.86	23.32	54.04	24.29
Strippers	420.28	129.75	420.28	129.75	420.28	129.75	420.28	129.75	420.28	129.75	420.28	129.75	420.28	129.75
Doffer	79.07	18.23	76.91	19.19	80.76	20.15	84.61	21.11	88.46	22.07	92.31	23.03	96.11	23.98
Drawing Roller	145.31	138.84	162.97	146.15	160.62	153.46	168.26	160.76	175.91	168.07	183.56	175.38	191.21	182.69
Delivering	139.26	133.06	146.59	140.06	153.92	147.06	161.25	154.07	168.58	161.07	175.91	168.07	183.25	175.98
Tin Cylinders	40.44	15.45	42.58	16.27	44.70	17.08	46.82	17.89	48.97	18.71	51.09	19.52	53.21	20.33
Plaiding Roller	10.05	9.61	10.58	10.11	11.11	10.62	11.63	11.12	12.17	11.63	12.70	12.14	13.22	12.64

Cylinder Pinion 44 teeth.

The Speed of the Feed Roller to the Cylinder is as 1 to 200.27

"	"	Workers	"	1	51.95
"	"	Strippers	"	1	5.88
"	"	Doffers	"	1	29.20
"	"	Drawing Roller	"	1	14.68
"	"	Delivering Roller	"	1	15.32
"	"	Plaiding Roller	"	1	212.50
"	"	Workers to the Strippers is	1	8.83	

SPECIFICATION AND SPEEDS OF JUTE BREAKERS.

Delivering Rollers	$\frac{190 \times \text{Cyl. pin.} \times 23}{52 \times 24}$	..	= 3·501,602	Constant No. for revs. per minute
Feed Roller	$\frac{190 \times \text{Cyl. pin.} \times 26 \times 20}{80 \times 110 \times 110}$	...	= 102·066	" "
Nos. 1 and 2 Workers	$\frac{190 \times \text{Cyl. pin.} \times 48}{136 \times 138}$	...	= 485,938	" "
Doffer	$\frac{190 \times \text{Cyl. pin.} \times 24 \times 26}{52 \times 51 \times 88}$	...	= 479,797	" "
Drawing Roller	$\frac{100 \times \text{Cyl. pin.}}{52}$	...	= 3·653,846	" "
Tin Cylinders	$\frac{190 \times \text{Cyl. pin.} \times 45 \times 75}{136 \times 138 \times 84}$	...	= 406,752	" "
Fluiding Roller	$\frac{190 \times \text{Cyl. pin.} \times 26 \times 26 \times 114}{80 \times 110 \times 110 \times 46}$	...	= 252,946	" "

SETTING OF BREAKER	}	Shell to Cylinder,	...	...	...	...	$\frac{7}{16}$ "
		Feed Roller to Shell,	...	...	...	...	No. 9.
		"    Cylinder,	...	...	...	...	" 16.
		No. 1 Worker to "	...	...	...	...	" 12.
		No. 2 " "	...	...	...	...	" 14.
		Nos. 1 and 2 Strippers,	...	...	...	...	" 14.
		Between Strippers and Workers,	...	...	...	...	" 16.
		Doffer to Cylinder,	...	...	...	...	" 16.
		Drawing Roller to Doffer,	...	...	...	$\frac{3}{16}$ "	

The Speed of the Workers can be changed without affecting the other roller speeds as under:—

Speed of Cyl. Worker.			
$\frac{190 \times 38 \text{ Change pinion.}}{136 \times 138}$	= 38,469	Constant No. with a 38 'T. Cylinder Pinion.	
$\frac{190 \times 40 \times \text{C.P.}}{136 \times 138}$	= 40,494	"	40 "
$\frac{190 \times 42 \times \text{C.P.}}{136 \times 138}$	= 42,519	"	42 "
$\frac{190 \times 44 \times \text{C.P.}}{136 \times 138}$	= 44,543	"	44 "
$\frac{190 \times 46 \times \text{C.P.}}{136 \times 138}$	= 46,568	"	46 "
$\frac{190 \times 48 \times \text{C.P.}}{136 \times 138}$	= 48,593	"	48 "
$\frac{190 \times 50 \times \text{C.P.}}{136 \times 138}$	= 50,618	"	50 "

REVOLUTIONS AND SURFACE SPEEDS UNDER DIFFERENT WORKER AND CYLINDER CHANGE PINIONS.

Cylinder Pinion.	WORKER, CHANGE PINIONS.											60 T	Revolutions.	Surface Speed in feet.
	40	42	44	46	48	50	52	54	56	58	60 T			
38 T	15-3876	16-1569	16-9263	17-6957	18-4651	19-2345	20-0038	20-7732	21-5426	22-3120	23-0814	23-0814	Revolutions.	
	34-23	35-94	37-66	39-37	41-08	42-79	44-50	46-21	47-93	49-64	51-35	51-35	Surface Speed in feet.	
40	16-1976	17-0074	17-8173	18-6272	19-4371	20-2470	21-0568	21-8667	22-6766	23-4865	24-2964	24-2964	Revolutions.	
	36-03	37-84	39-64	41-44	43-24	45-04	46-85	48-65	50-45	52-25	54-05	54-05	Surface Speed in feet.	
42	17-0076	17-8579	18-7083	19-5587	20-4091	21-2595	22-1098	22-9602	23-8106	24-6610	25-5114	25-5114	Revolutions.	
	37-84	39-73	41-62	43-51	45-40	47-30	49-19	51-08	52-97	54-86	56-76	56-76	Surface Speed in feet.	
44	17-8172	18-7080	19-5989	20-4897	21-3806	22-2715	23-1623	24-0532	24-9440	25-8349	26-7258	26-7258	Revolutions.	
	39-64	41-62	43-60	45-58	47-57	49-55	51-53	53-51	55-49	57-48	59-46	59-46	Surface Speed in feet.	
46	18-6272	19-5585	20-4899	21-4212	22-3526	23-2840	24-2153	25-1467	26-0780	27-0094	27-9408	27-9408	Revolutions.	
	41-44	43-51	45-58	47-66	49-78	51-30	53-87	55-95	58-02	60-09	62-16	62-16	Surface Speed in feet.	
48	19-4372	20-4090	21-3809	22-3527	23-3246	24-2965	25-2683	26-2402	27-2120	28-1839	29-1558	29-1558	Revolutions.	
	43-24	45-41	47-57	49-78	51-89	54-05	56-22	58-38	60-54	62-70	64-87	64-87	Surface Speed in feet.	
50	20-2472	21-2595	22-2749	23-2842	24-2966	25-3090	26-3213	27-3337	28-3460	29-3584	30-3708	30-3708	Revolutions.	
	45-05	47-30	49-55	51-80	54-05	56-31	58-56	60-81	63-06	65-32	67-57	67-57	Surface Speed in feet.	

Dollop 32 lbs. Cylinder Pinion 44 teeth. Pulleys 24".

Worm Working Clock, 3 threads, No. 6 pitch, 1 $\frac{1}{4}$ " bore.

$$\frac{1 \times 42 \times 36}{3 \times 36 \times 1} = 14 \text{ revolutions of feed roller for one round of clock.}$$

Circumference of Feed Roller at centre of pins 32.98". Diameter 10 $\frac{1}{2}$ ".

32.98 × 14 = 46.172 inches or 12.82 yards for one round of clock.

$$\frac{4 \times 80 \times 110 \times 110}{52 \times 26 \times 20 \times 10\frac{1}{2}} = 13.63 \text{ draft between feed and drawing roller.}$$

$$\frac{4 \times 80 \times 110 \times 110}{52 \times \text{C.P.} \times 20 \times 10\frac{1}{2}} = 354.578 \text{ Constant Number for draft.}$$

$$\frac{4 \times 54 \times 88}{23 \times 26 \times 15\frac{1}{8}} = 2.07 \text{ draft between doffer and drawing roller.}$$

NOTE.—This draft is only necessary for the delivery of material between the doffer and the drawing roller but is not required in working out the draft between the feed and drawing roller.

13.63 × 12.82 = 174.736 yards delivered at the front of the breaker for one round of the clock.

Change Pinions	20	21	22	23	24	25	26	27	28	29	30 T.
Drafts	17.72	16.88	16.11	15.41	14.77	14.18	13.63	13.18	12.66	12.22	11.81

SPECIFICATION OF PINS.

		Pitch.	Staves.	Rows.	Pins.	Size of Pins.	Length of Pin out.
Cylinder	71" × 48"	$\frac{3}{8}$ " × $\frac{5}{8}$ "	120	7	38	No. 12-1"	$\frac{5}{16}$ "
Feed Roller	71 × 9	$\frac{7}{16}$ × $\frac{7}{16}$	24	6	81	„ 12-1 $\frac{1}{4}$ "	$\frac{3}{8}$
No. 1 Stripper	71 × 12	$\frac{1}{2}$ × $\frac{1}{2}$	30	5	71	„ 13-1 $\frac{1}{4}$ "	$\frac{1}{4}$
No. 2 „	71 × 12	$\frac{1}{2}$ × $\frac{1}{2}$	30	5	71	„ 13 1 $\frac{1}{4}$ "	$\frac{1}{4}$
No. 1 Worker	71 × 7	$\frac{7}{16}$ × $\frac{7}{16}$	30	7	55	„ 13-1 $\frac{1}{2}$ "	$\frac{3}{8}$
No. 2 „	71 × 7	$\frac{7}{16}$ × $\frac{7}{16}$	30	7	55	„ 13-1 $\frac{1}{2}$ "	$\frac{3}{8}$
Doffer	71 × 14	$\frac{3}{8}$ × $\frac{3}{8}$	34	8	81	„ 14-1 $\frac{1}{8}$ "	$\frac{5}{16}$

## SINGLE DOFFER BREAKER CARD.

*Sectional elevation shewing gearing at end opposite to driving pulleys.*

SCALE,  $\frac{1}{16}$

A	Drawing roller wheel, ..	...	...	52 teeth.
B	Intermediate, ...	...	...	108 teeth.
C	Intermediate, ...	..	...	106 teeth.
D	Changes on cylinder end, ..	...	...	20 to 60 teeth.
E	Stud wheel carrying changes, ...	...	...	80 teeth.
F	Changes, ...	...	...	20 to 60 teeth.
G	Stud wheel carrying changes, ...	...	...	80 teeth.
H	Changes, ...	..	...	20 to 60 teeth.
I	Stud wheel, ...	..	...	110 teeth.
J	Stud pinion, ...	...	..	20 teeth.
K	Feeder wheel, ...	...	...	110 teeth.
L	Feeder wheel for driving sheet rollers.	...	...	114 teeth.
M	Sheet roller wheel, ..	...	...	46 teeth.
N	Intermediate for driving workers,	...	...	108 teeth.
OO	Worker wheels, ...	...	...	138 teeth.
P	Intermediate between workers,	..	...	84 teeth.
QQ	Worker wheels for driving tin roller,	...	...	75 teeth.
RR	Tin roller wheels, ...	...	...	84 teeth.

## DRAFT ARRANGEMENT—

$$\frac{4'' \times 80 \times 110 \times 110}{52 \times 26 \times 20 \times 10\frac{1}{2}''} = 13.63 \text{ draft between feed and drawing rollers.}$$

$$\frac{4'' \times 80 \times 110 \times 110}{52 \times \text{C.P.} \times 20 \times 10\frac{1}{2}''} = 354.578 \text{ Constant No. for draft.}$$

NOTE.—This is with feed roller taken  $10\frac{1}{2}''$  diameter (Fairbairn).

Feed roller  $10\frac{3}{4}''$  diameter at centre of pins.

$$\frac{4'' \times 80 \times 110 \times 110}{52 \times 26 \times 20 \times 10\frac{3}{4}''} = 13.32 \text{ draft.}$$

$$\frac{4'' \times 80 \times 110 \times 110}{52 \times \text{C.P.} \times 20 \times 10\frac{3}{4}''} = 346.332 \text{ Constant No. for draft.}$$

NOTE.—C.P.—Change draft pinion.

# SINGLE DOFFER BREAKER CARD.

SECTIONAL ELEVATION SHOWING GEARING

AT END OPPOSITE TO DRIVING PULLEYS.

SCALE,  $\frac{1}{16}$

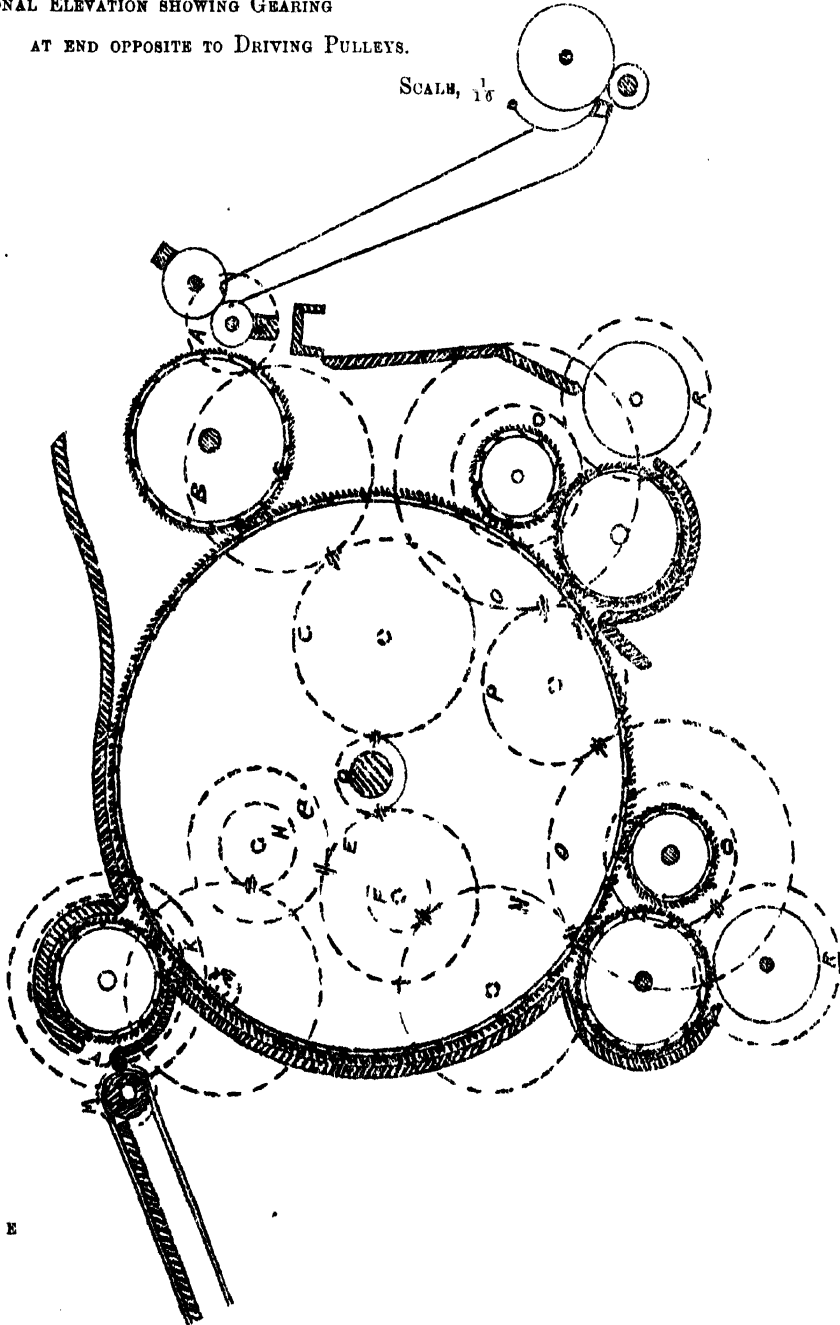

E



## SINGLE DOFFER BREAKER CARD.

*Sectional Elevation showing gearing at driving end.*

SCALE,  $\frac{1}{8}$ "

A	Swift pulley, ..	...	...	...	14" dia.
BB	Stripper pulleys,	...	...	...	20" dia.
C	Stretching pulley,	...	...	...	14" dia.
D	Drawing roller pinion,	...	...	...	24 teeth.
E	Stud wheel, ...	...	...	...	54 teeth.
F	Stud pinion, ...	...	...	...	28 teeth.
G	Doffer wheel,	...	...	...	88 teeth.
H	Intermediate,	...	...	...	110 teeth.
I	Intermediate,	...	...	...	108 teeth.
J	Delivery roller pinion,	...	...	...	22 teeth.

Speed of Cylinder, 190 revolutions per minute.

$$190 \times \frac{14}{8} = 133 \text{ revolutions of strippers per minute.}$$

Length of Feed Cloth, 13 feet.

Breadth, ,, ,, 5 ,, 6 inches.

One Feed Cloth is used for breaker, and it should be made of plaiding,  $\frac{3}{16}$ " thick.

# SINGLE DOFFER BREAKER CARD.

SECTIONAL ELEVATION SHOWING GEARING AT DRIVING END.

SCALE,  $\frac{1}{16}$

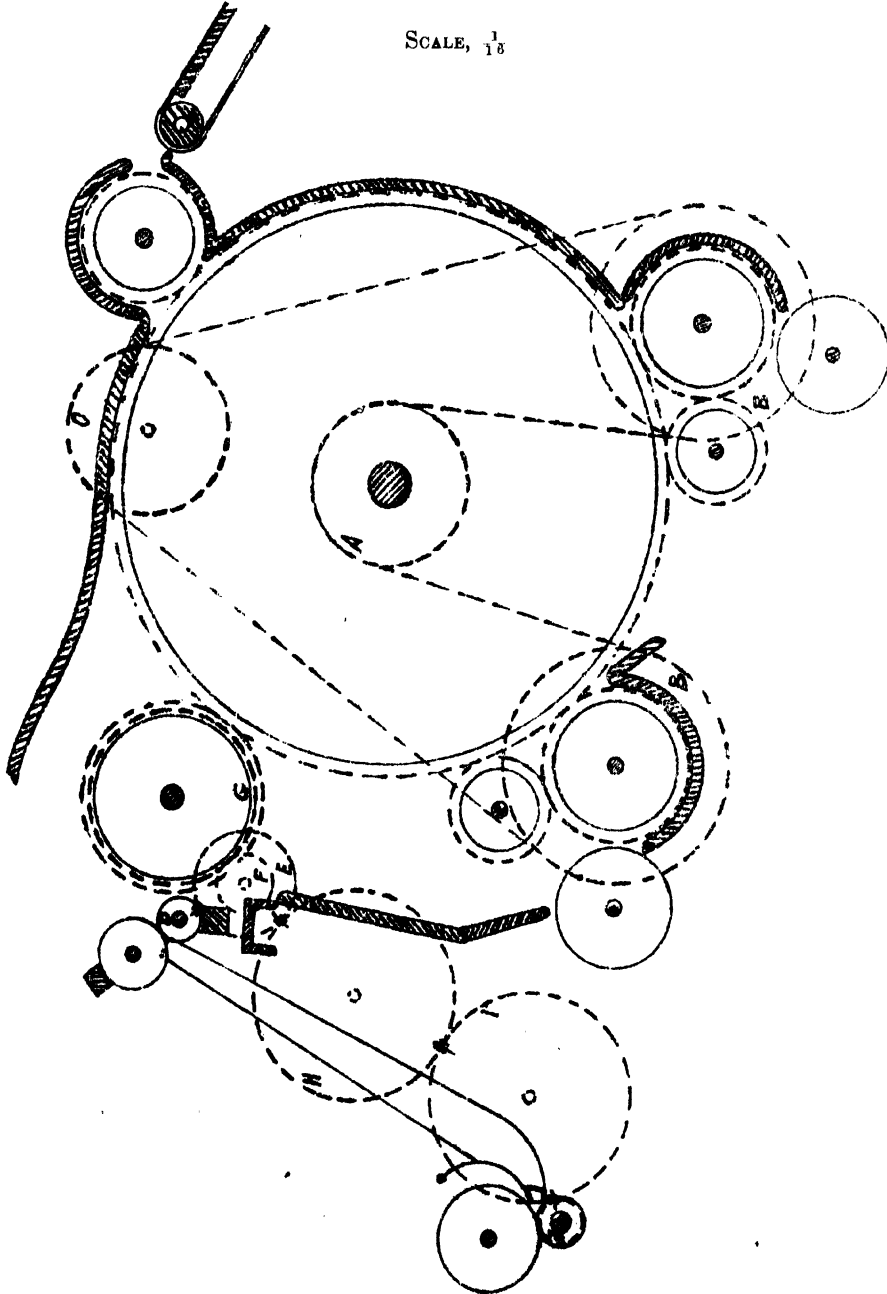

## SPECIFICATION AND SPEEDS OF JUTE BREAKERS (DOUBLE DOFFER).

Cylinder Pinion 44 teeth. Cylinder 184·84 revolutions per minute.

Cylinder 6' × 4' 2 Workers, 2 Strippers, 2 Doffers.

Fast Pulley 30" diameter, 6" broad, 2½" bore.

Loose ,, 30 ,, 6 ,, 3¼ ,, (this pulley works in a bush).

Pulleys driving Strippers 12" diameters, 3½" broad, 3¼" bore.

Pulley Seats on Strippers - 1½"

Wheel ,, Workers - 1½"

,, ,, Doffers - 1¾"

,, ,, Feeder - 1¾"

,, ,, Drawing Roller 1¼"

,, ,, Delivering Roller 1¼"

,, ,, Tin Rollers - 1¼"

	Under Wood.	Over Wood.	Over Staves.	Centre to Centre of pins.	Over Staves.	Over Centre of pins.
Cylinder ring ...	43½" dia,	48" dia.	49½" dia	49½" dia.	154·7 cir.	155·5 cir.
Nos. 1 and 2 Stripper rings	11½ ,,	14 ,,	15½ ,,	15½ ,,	47·516 ,,	48·694 ,,
Nos. 1 and 2 Worker ,,	11½ ,,	14 ,,	15½ ,,	15½ ,,	47·516 ,,	48·694 ,,
Doffers ... ..	11½ ,,	14 ,,	15½ ,,	15½ ,,	47·516 ,,	48·694 ,,
Feeder ... ..	16 ,,	18½ ,,	19¾ ,,	20¼ ,,	62·046 ,,	63·617 ,,

Tin Rollers - - - 16" dia. and 50·265 cir.

Upper and Lower Drawing Rollers 4 ,, 12·56 ,,

Delivering Roller - - 4 ,, 12·56 ,,

184·84 revolutions of cylinder per minute.

Cylinder 49½" diameter at centre of pins = 155·5" circumference.

184·84 × 155·5 = 28,742·62 ins. or 2395·21 feet—the surface speed of cylinder per minute.

Cylinder Pinion 44 T. Cylinder, 184·84 revolutions per minute.

Feed Roller 80½" diameter at centre of pins = 63·617" circumference.

$$\frac{184 \cdot 84 \times 44 \times 34 \times 30}{150 \times 150 \times 156} = 2 \cdot 36 \text{ revolutions of feed roller per minute.}$$

$$2 \cdot 36 \times 63 \cdot 617 = 150 \cdot 13 \text{ ins. or } 12 \cdot 51 \text{ feet the surface speed of feed roller per minute.}$$

Nos. 1 and 2 Workers 15½" diameter at centre of pins = 49·694" circumference.

$$\frac{184 \cdot 84 \times 44 \times 25}{155 \times 144} = 9 \cdot 10 \text{ revolutions of workers per minute.}$$

$$9 \cdot 10 \times 48 \cdot 694 = 443 \cdot 11 \text{ ins. or } 36 \cdot 92 \text{ feet the surface speed of workers per minute.}$$

Nos. 1 and 2 Strippers 15½" diameter at centre of pins = 48·694" circumference.

Pulleys driving strippers 12 ins. diameter.

„ on end of „ 22 „

$$\frac{184 \cdot 84 \times 12}{22} = 100 \cdot 82 \text{ revolutions of strippers per minute.}$$

$$100 \cdot 82 \times 48 \cdot 694 = 4909 \cdot 32 \text{ ins. or } 409 \cdot 11 \text{ feet the surface speed of strippers per minute.}$$

Doffers 15½" diameter at centre of pins = 48·694" circumference.

$$\frac{184 \cdot 84 \times 44 \times 24 \times 28}{74 \times 57 \times 88} = 14 \cdot 72 \text{ revolutions of doffers per minute.}$$

$$14 \cdot 72 \times 48 \cdot 694 = 716 \cdot 77 \text{ ins. or } 59 \cdot 73 \text{ feet the surface speed of doffers per minute.}$$

Lower Drawing Roller 4" diameter = 12·56" circumference.

$$\frac{184 \cdot 84 \times 44}{70} = 116 \cdot 18 \text{ revolutions of lower drawing roller per minute.}$$

$$116 \cdot 18 \times 12 \cdot 56 = 1459 \cdot 22 \text{ ins. or } 121 \cdot 60 \text{ ft. the surface speed of lower drawing roller per minute.}$$

Upper Drawing Roller 4" diameter = 12.56" circumference.

$$\begin{array}{l} \text{Cyl. Fin.} \\ \frac{104.84 \times 44}{74} = 109.90 \text{ revolutions of upper drawing roller per minute.} \end{array}$$

$109.90 \times 12.56 = 1380.34$  ins. or  $115.02$  ft. the surface speed of upper drawing roller per minute.

Delivering Roller 4" diameter = 12.56" circumference.

$$\begin{array}{l} \text{Cyl. Fin.} \\ \frac{184.84 \times 44 \times 23}{70 \times 22} = 121.46 \text{ revolutions of delivering roller per minute.} \end{array}$$

$121.46 \times 12.56 = 1525.53$  ins. or  $127.12$  feet the surface speed of delivering roller per minute.

Tin Cylinder 16" diameter = 50.265" circumference.

$$\begin{array}{l} \text{Cyl. Fin.} \\ \frac{184.84 \times 44 \times 25}{155 \times 72} = 18.21 \text{ revolutions of tin cylinders per minute.} \end{array}$$

$18.21 \times 50.265 = 915.32$  ins. or  $76.27$  feet the surface speed of tin cylinders per minute.

Plaiding Roller 4" diameter = 12.56" circumference.

$$\begin{array}{l} \text{Cyl. Fin.} \\ \frac{184.84 \times 44 \times 34 \times 30 \times 130}{150 \times 150 \times 156 \times 31} = 9.91 \text{ revolutions of plaiding roller per minute.} \end{array}$$

$9.91 \times 12.56 = 124.46$  ins. or  $10.37$  feet the surface speed of plaiding roller per minute

Speed of Cylinder per min.	Cylinder Pinion 38 T.		Cylinder Pinion 40 T.		Cylinder Pinion 42 T.		Cylinder Pinion 44 T.		Cylinder Pinion 46 T.		Cylinder Pinion 48 T.		Cylinder Pinion 50 T.	
	Surface Speed, Feet.	Revs.	Surface Speed, Feet.	Revs.	Surface Speed, Feet.	Revs.	Surface Speed, Feet.	Revs.	Surface Speed, Feet.	Revs.	Surface Speed, Feet.	Revs.	Surface Speed, Feet.	Revs.
" Feed Roller "	2395-21	184-84	2395-21	184-84	2395-21	184-84	2395-21	184-84	2395-21	184-84	2395-21	184-84	2395-21	184-84
" Workers "	10-81	2-04	11-34	2-14	11-92	2-25	12-51	2-36	13-09	2-47	13-62	2-57	14-20	2-68
" Strippers "	31-89	7-86	33-59	8-28	35-26	8-69	36-92	9-10	38-63	9-52	40-29	9-93	41-99	10-35
" Doffers "	409-11	100-82	409-11	100-82	409-11	100-82	409-11	100-82	409-11	100-82	409-11	100-82	409-11	100-82
" Lower Drawing Roller "	51-57	12-71	54-29	13-38	57-01	11-05	59-73	14-72	62-45	15-39	65-16	16-06	67-88	16-73
" Upper "	105-02	100-34	110-54	105-62	116-67	110-90	121-60	116-18	127-12	121-46	132-65	126-74	138-18	132-02
" Delivering Roller "	99-33	94-91	104-57	99-91	109-79	104-90	115-02	109-90	120-26	114-90	125-48	119-89	130-71	124-89
" Tin Cylinders p. min. "	109-79	104-90	115-57	110-42	121-35	115-91	127-12	121-46	132-90	126-98	138-63	132-50	144-46	138-02
" Flaiding Roller "	65-88	15-73	69-36	16-56	72-84	17-39	76-27	18-21	79-75	19-04	83-23	19-87	86-70	20-70
	8-94	8-55	9-43	9-01	9-90	9-46	10-37	9-91	10-84	10-36	11-31	10-81	11-78	11-26

Cylinder Pinion 44 teeth.

The Speed of the Feed Roller to the Cylinder is as 1 to 191-46

" Workers "	1	64-87
" Strippers "	1	5-85
" Doffers "	1	40-10
" Lower Drawing Roller "	1	19-69
" Upper "	1	20-82
" Delivering Roller "	1	18-84
" Workers to the Strippers "	1	11-08

SPECIFICATION AND SPEEDS OF JUTE BREAKERS.

Feed Roller	... $\frac{184 \cdot 84 \times \text{C.P.} \times 34 \times 30}{150 \ 150 \ 156}$	= 053,714 Constant No. for revs. per minute.
Nos. 1 and 2 Workers	$\frac{184 \cdot 84 \times \text{C.P.} \times 25}{155 \ 144}$ ...	= 207,034 " "
Doffer	... $\frac{184 \cdot 84 \times \text{C.P.} \times 24 \times 28}{74 \ 57 \ 88}$	= 334,641 " "
Lower Drawing Roller	$\frac{184 \cdot 84 \times \text{C.P.}}{70}$	= 264,057 " "
Upper Drawing Roller	$\frac{184 \cdot 84 \times \text{C.P.}}{74}$	= 249,783 " "
Delivering Roller	$\frac{184 \cdot 84 \times \text{C.P.} \times 23}{70 \ 22}$	= 276,068 " "
Tin Cylinders	.. $\frac{184 \cdot 84 \times \text{C.P.} \times 25}{155 \ 72}$	= 414,058 " "
Plaiding Rollers	. $\frac{184 \cdot 84 \times \text{C.P.} \times 34 \times 30 \times 130}{150 \ 150 \ 156 \ 31}$	= 225,253 " "

SETTING OF DOUBLE

DOFFER BREAKER

}	Feed Roller to Cylinder,	... ..	No. 16.
	" Shell,	... ..	" 9.
	Shell to Cylinder,	... ..	$\frac{7}{8}$ "
	No. 1 Worker to Cylinder,	... ..	No. 14.
	No. 2 " "	... ..	" 14.
	Nos. 1 and 2 Strippers to Cylinder,	... ..	" 16.
	Between Workers and Strippers,	... ..	" 16.
	Upper Doffer to Cylinder,	... ..	" 16.
	Lower " "	... ..	" 14.
	Upper Drawing Roller to Doffer,	... ..	" 9.
Lower " "	... ..	" 9.	

The Speed of the Workers can be changed without affecting other parts of the breaker as under:—

Speed of Cyl. Worker.		
Cyl. Pin. Change		
$\frac{184 \cdot 84 \times 38 \times \text{Change}}{155 \ 144}$	= 314,691 Constant No. with 38 Teeth Cylinder Pinion.	
$\frac{184 \cdot 84 \times 40 \times}{155 \ 144}$	= 331,254	" 40 "
$\frac{184 \cdot 84 \times 42 \times}{155 \ 144}$	= 347,817	" 42 "
$\frac{184 \cdot 84 \times 44 \times}{155 \ 144}$	= 364,379	" 44 "
$\frac{184 \cdot 84 \times 46 \times}{155 \ 144}$	= 380,942	" 46 "
$\frac{184 \cdot 84 \times 48 \times}{155 \ 144}$	= 397,505	" 48 "
$\frac{184 \cdot 84 \times 50 \times}{155 \ 144}$	= 414,068	" 50 "

Cylinder Pinion.	WORKER, CHANGE PINIONS.										Revolutions. Surface Speed in feet.
	20	22	24	26	28	30	32	34	36 T		
38 T	6-2938	6-9232	7-5525	8-1819	8-8113	9-4407	10-0701	10-6994	11-3288	Revolutions.	
40	25-5391	28 0931	30-6467	33-2007	35-7547	38-3087	40-8627	43-4163	45-9703	Surface Speed in feet.	
42	6-6250	7-2875	7-9500	8-6126	9-2751	9-9376	10-6001	11-2626	11-9251	Revolutions.	
44	26-9664	29-5714	32-2597	34-9484	37-6368	40-5288	43-0134	45-7017	48-3900	Surface Speed in feet.	
46	6-9563	7-6519	8-3476	9-0432	9-7388	10-4345	11-1301	11-8257	12-5214	Revolutions.	
48	28-2275	31 0801	33-8731	36-6957	39-5184	42-3414	45-1640	47-9867	50-8097	Surface Speed in feet.	
50	7-2875	8-0163	8-7450	9-4738	10-2026	10-9313	11-6601	12-3888	13-1176	Revolutions.	
	29-5714	32-5288	35-4857	38-4431	41-4004	44-3573	47-3147	50-2716	53-2290	Surface Speed in feet.	
	7-6188	8-3807	9-1426	9-9044	10-6663	11-4282	12-1901	12-9520	13-7139	Revolutions.	
	30-9158	34-0074	37-0991	40-1904	43-2820	46-3737	49-4653	52-5570	55-6487	Surface Speed in feet.	
	7-9501	8-7451	9-5401	10-3351	11-1301	11-9251	12-7201	13-5151	14-3101	Revolutions.	
	32-2601	35-4861	38-7121	41-9361	45-1640	48-3900	51-6160	54-8420	58-0680	Surface Speed in feet.	
	8-2813	9-1094	9-9376	10-7657	11-5939	12-4220	13-2501	14-0783	14-9064	Revolutions.	
	33-6041	36-9644	40-3251	43-6854	47-0461	50-4064	53-7666	57-1273	60-4876	Surface Speed in feet.	



This Breaker has two deliveries, and each delivery keeps a finisher going. The dolop given here refers to each delivery separately. From the construction of this machine two qualities of material can be wrought at the same time.

Dollop 22 lbs. Cylinder Pinion 44 teeth. Pulleys 30".

Worm Working Clock, 3 threads, No. 6 pitch,  $1\frac{1}{4}$ " bore.

$$\frac{1 \times 22}{3 \times 1} = 7\frac{1}{3} \text{ revolutions of feed roller for one round of clock.}$$

Circumference of Feed Roller at centre of pins 63.61". Diameter  $20\frac{1}{4}$ ".

$7\frac{1}{3} \times 63.61 = 466.26$  inches or 12.95 yards for one round of clock.

$$\frac{4 \times 150 \times 150 \times 156}{70 \times 34c.p. \times 30 \times 20\frac{1}{4}} = 9.71 \text{ draft between feed and upper drawing roller.}$$

$$\frac{4 \times 57 \times 88}{24 \times 28c.p. \times 15\frac{1}{4}} = 1.92 \quad ,, \quad \text{doffer and upper drawing roller.}$$

$$\text{Draft, } 9.71 \times \frac{\text{Yds. per round of clock.}}{12.95} = 125.7 \text{ yards delivered at front of breaker for one round of clock.}$$

$$\frac{4 \times 150 \times 150 \times 156}{70 \times C.P. \times 30 \times 20\frac{1}{4}} = 330.1587 \text{ Constant Number for draft.}$$

$$\frac{4 \times 57 \times 88}{24 \times C.P. \times 15\frac{1}{4}} = 53.9354 \quad ,, \quad \text{between doffer and upper drawing roller.}$$

#### DRAFTS.

Change Pinions	80	31	32	33	34	35	36	37	38	39	40 T.
Drafts	11.00	10.65	10.31	10.09	9.71	9.43	9.17	8.92	8.68	8.46	8.25

#### Drafts between Doffer and Upper Drawing Roller—

Change Pinions	24	25	26	27	28	29	80
Drafts,	2.24	2.15	2.07	1.99	1.92	1.86	1.79

$$\frac{4 \times 74 \times 74 \times 57 \times 88}{70 \times 74 \times 24 \times 28 \times 15\frac{1}{4}} = 2.036 \text{ draft between doffer and lower drawing roller.}$$

If will be observed that there are 4 teeth more draft between the doffer and the lower drawing roller than between the doffer and the upper drawing roller—this is to keep the sliver tight between the top and bottom drawing roller.

The lower doffer is driven direct from the upper doffer, and the lower drawing roller direct from the upper drawing roller.

## SPECIFICATION OF PINS.

Cylinder	...	...	71" × 48"	$\frac{3}{4} \times \frac{3}{4}$	82	5	47	No. 12 $1\frac{1}{8}$
Feeder	...	...	× 18 $\frac{1}{2}$	$\frac{7}{16} \times \frac{3}{8}$	63	8	54	„ 12-1 $\frac{1}{4}$
1st Stripper	...	...	× 14	$\frac{1}{2} \times \frac{1}{2}$	54	5	47	„ 13-1 $\frac{1}{4}$
2nd „	...	...	× 14	$\frac{1}{2} \times \frac{1}{2}$	54	5	47	„ 13-1 $\frac{1}{4}$
1st Worker	...	...	× 14	$\frac{7}{16} \times \frac{3}{8}$	54	7	54	„ 13-1 $\frac{3}{4}$
2nd „	...	...	× 14	$\frac{7}{16} \times \frac{3}{8}$	54	7	54	„ 13-1 $\frac{3}{4}$
1st Doffer	...	...	× 14	$\frac{3}{8} \times \frac{3}{8}$	54	7	63	„ 14-1 $\frac{1}{4}$
2nd „	...	...	× 14	$\frac{3}{8} \times \frac{3}{8}$	54	7	63	„ 14-1 $\frac{1}{4}$

---

## ARRANGEMENT OF DOUBLE DOFFER BREAKER CLOCK.

Length of clock, calculated from diameter of feed roller,  $20\frac{1}{4}$  inches = 63.61 inches circumference.

A  
—  
B

In this case—

A = 3 Threaded worm on end of feed roller.

B = 22 Teeth Pinion on arbor of Clock in gear with worm.

$\frac{3}{2}$ —therefore  $\frac{3}{2}$  of a revolution of clock is equal to one round of a feed roller, and there are therefore  $7\frac{1}{2}$  revolutions of feed roller for one round of clock.

$63.61 \times 7\frac{1}{2} = 466.47$  inches or 12.95 yards in one round of clock.

Length of clock calculated from plaiding roller  $4\frac{1}{4}$ " diameter = 13.35 cir., two thicknesses of feed cloth included in dia. of plaiding roller.

A        C  
— × — =  
B        D

In this case—

A = Pinion on end of plaiding roller.

B = Wheel in gear with it.

C = Worm on end of feed roller.

D = 22 teeth pinion on arbor of clock in gear with worm. .

$\frac{31}{136} \times \frac{3}{32} = \frac{93}{880}$  of a revolution of clock equals one round of the plaiding roller.

$\frac{2860}{93} = 30\frac{3}{4}$  revolutions of plaiding roller in one round of clock.

$\frac{13.35 \times 30.75}{36} = 11.4$  yards in one round of clock.

NOTE.—As to the clock arrangements.—There is a difference between the length of clock when calculated from feed and plaiding-rollers. The method followed is to make the calculation at something between the speed of the feeding cloth and that of the feed roller. We estimate feeding cloth at  $\frac{1}{4}$ " thick; this makes the diameter of plaiding roller equivalent to  $4\frac{1}{4}$ " diameter. Then the feed roller must have a draw on the feeding cloth, so as to ensure that the latter does not tend to choke the shell feeder. Thus, the feeding cloth goes at 11.4, the feeder goes at 12.95; and we estimate that the draw of the feeder in one direction and the resistance of the sheet roller will make the real speed about 12 yards—hence the reason that Messrs Fairbairn, Naylor, Macpherson & Co., Ltd., speak of a 12 yards clock.

## DOUBLE DOFFER BREAKER CARD.

*Sectional elevation shewing gearing at end opposite to driving pulleys.*

SCALE,  $\frac{1}{16}$ th.

(For Diagram see page 62).

A	Feeder wheel,	...	...	...	156 teeth.
B	Changes,	...	...	...	86 to 64 teeth.
C	Stud wheel carrying changes,	...	...	...	150 teeth.
D	Stud pinion,	...	...	...	20 teeth.
E	Stud wheel,	...	...	...	150 teeth.
F	Intermediate,	...	...	...	96 teeth.
G	Changes on cylinder end,	...	...	...	36 to 64 teeth.
H	Intermediate,	...	...	...	102 teeth.
I	Stud wheel,	...	...	...	155 teeth.
J	Stud pinion,	..	...	...	25 teeth.
K	Bottom drawing roller wheel,	...	...	...	70 teeth.
L	Intermediate,	...	..	...	102 teeth.
M	Top drawing roller wheel,	...	...	...	74 teeth.
NN	Worker wheels,	...	...	...	144 teeth.
OO	Tin roller wheels,	...	...	...	72 teeth.
P	Intermediate between workers,	..	..	...	90 teeth.

## DRAFT ARRANGEMENT—

Feed Roller 20" diameter—diameter taken from Fairbairn.

$$\frac{4'' \times 150 \times 150 \times 156}{70 \times 34 \times 30 \times 20''} = 9.83 \text{ draft.}$$

$$\frac{4'' \times 150 \times 150 \times 156}{70 \times \text{C.P.} \times 30 \times 20''} = 334.285 \text{ Constant N. for draft.}$$

Feed roller 20 $\frac{1}{4}$ " diameter (see Specification of Breaker).

$$\frac{4'' \times 150 \times 150 \times 156}{70 \times 34 \times 30 \times 20\frac{1}{4}''} = 9.7 \text{ draft.}$$

$$\frac{4'' \times 150 \times 150 \times 156}{70 \times \text{C.P.} \times 30 \times 20\frac{1}{4}''} = 330.158 \text{ Constant N. for draft.}$$

NOTE.—C.P.—Change on draft pinion.

# DOUBLE DOFFER BREAKER CARD

SECTIONAL ELEVATION SHOWING GEARING

AT END OPPOSITE TO DRIVING PULLEYS.

SCALE  $\frac{1}{8}$  = ONE FOOT.

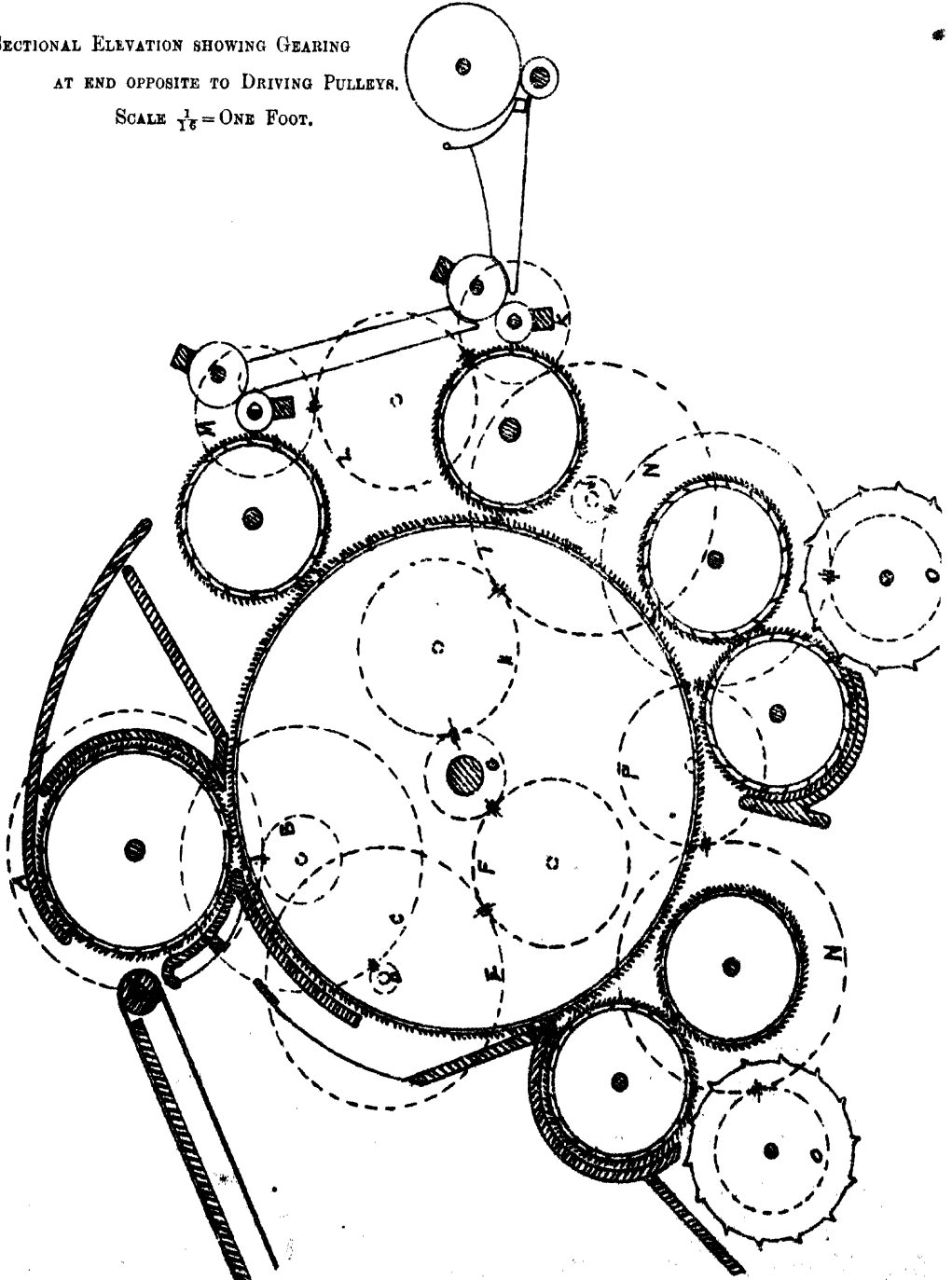

## DOUBLE DOFFER BREAKER CARD.

*Sectional elevation showing gearing at driving end.*SCALE  $\frac{1}{16}$ TH.*(For diagram see page 64).*

A	Swift Pulley, ...	...	...	...	12" dia.
BB	Stripper pulleys,	...	...	...	22" dia.
C	Stretching pulley,	...	...	...	12" dia.
D	Feeder wheel for driving sheet roller,	...	...	...	130 teeth
E	Sheet roller wheel,	...	...	...	31 teeth.
F	Top drawing roller pinion,	...	...	...	24 teeth.
G	Stud wheel, ...	...	...	...	57 teeth.
H	Stud pinion, ...	...	...	...	28 teeth.
II	Doffer wheels,	..	...	...	88 teeth.
J	Intermediate between doffers,	...	...	...	96 teeth.
K	Bottom drawing roller pinions,	...	...	...	24 and 25 teeth.
L	Intermediate,	..	...	...	124 teeth.
M	Delivery roller pinion,	...	...	...	23 teeth.

Speed Cylinder 184·84 revs. per minute.

$$184\cdot84 \times \frac{1\frac{1}{2}}{2} = 100\cdot82 \text{ revs. of Strippers per minute.}$$

Length of Feed Cloth 14 feet.

Breadth „ 2 feet 9 inches.

Two feed cloths are necessary for this breaker, as it delivers two separate slivers.

## DOUBLE DOFFER BREAKER CARD.

SECTIONAL ELEVATION SHOWING GRARING  
AT DRIVING END.

SCALE  $\frac{1}{16}$  = ONE FOOT.

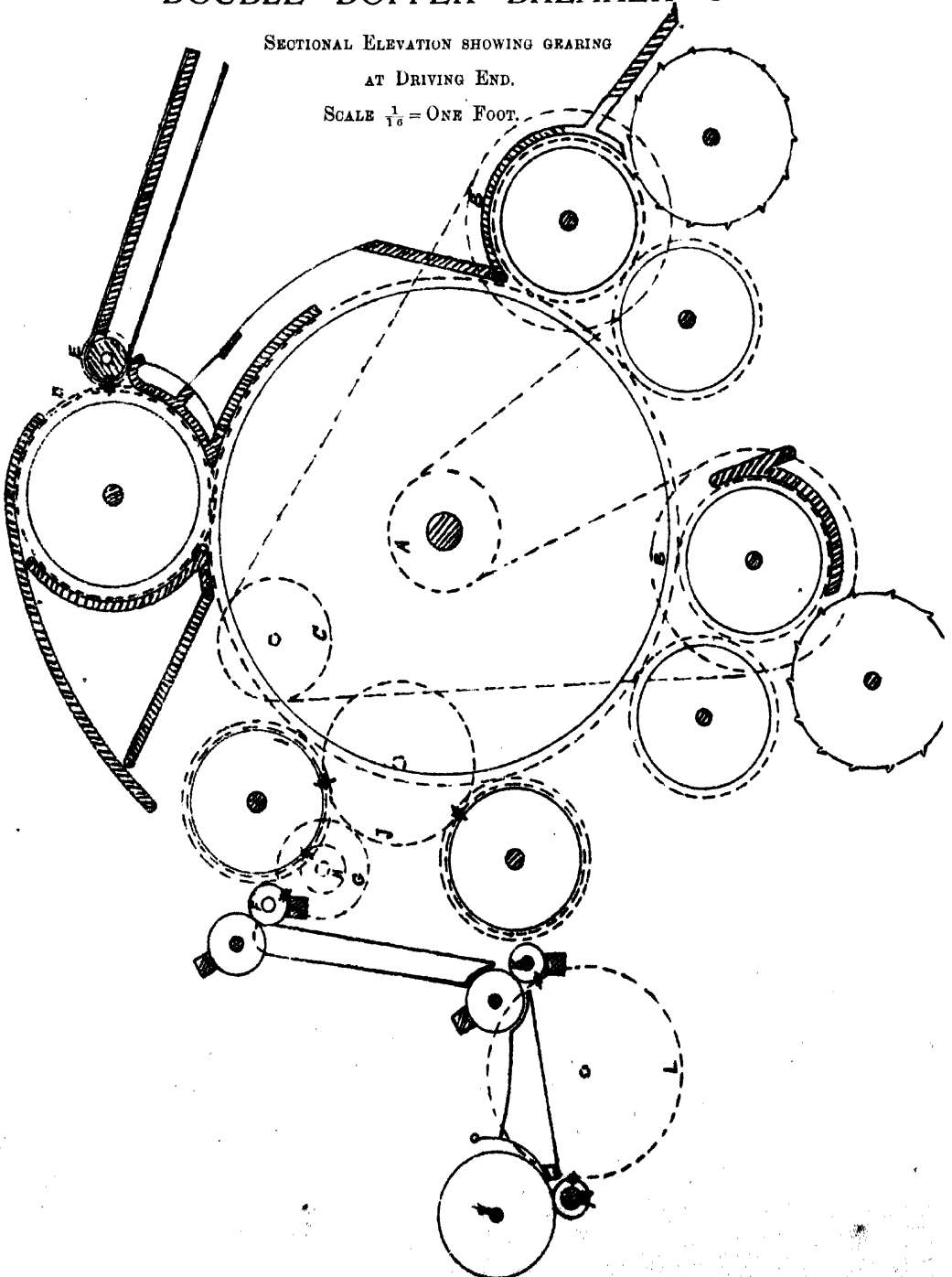

## UP STRIKER BREAKER CARD.

*Sectional elevation showing gearing at driving end.*SCALE  $\frac{1}{8}$ th.*(For Diagram see page 66.)*

A	Swift Pulley, ... ..	14" dia.
BB	Stripper pulleys, ... ..	18" dia.
C	Stretching pulley, ... ..	14" dia.
D	Drawing roller pinion, ... ..	24 teeth.
E	Stud wheel, ... ..	54 teeth.
F	Stud pinion, ... ..	28 teeth.
G	Intermediate, ... ..	42 teeth.
H	Doffer wheel, ... ..	88 teeth.
I	Stud wheel, ... ..	24 teeth.
J	Stud pinion, ... ..	12 teeth.
K	Brush wheel, ... ..	24 teeth.
LL	Intermediate, ... ..	90 teeth.
M	Delivery roller pinion, ... ..	22 teeth.
N	Doffer wheel for driving tin roller, ... ..	104 teeth.
O	Tin roller wheel, ... ..	52 teeth.
P	Feeder wheel for driving sheet roller, ... ..	78 teeth.
Q	Intermediate, ... ..	40 teeth.
R	Sheet roller wheel, ... ..	32 teeth.

Cylinder 190 revolutions per minute.

 $190 \times \frac{14}{8} = 147.7$  revolutions of Strippers per minute.

The illustrations of Up Striker Breakers have been put in for reference. I have not thought it necessary to describe them.

NOTE.—For Particulars of Covering see page 111, and page 120 for Drafts, &c.

F



## UP STRIKER BREAKER CARD.

SECTIONAL ELEVATION SHOWING GEARING AT DRIVING END.

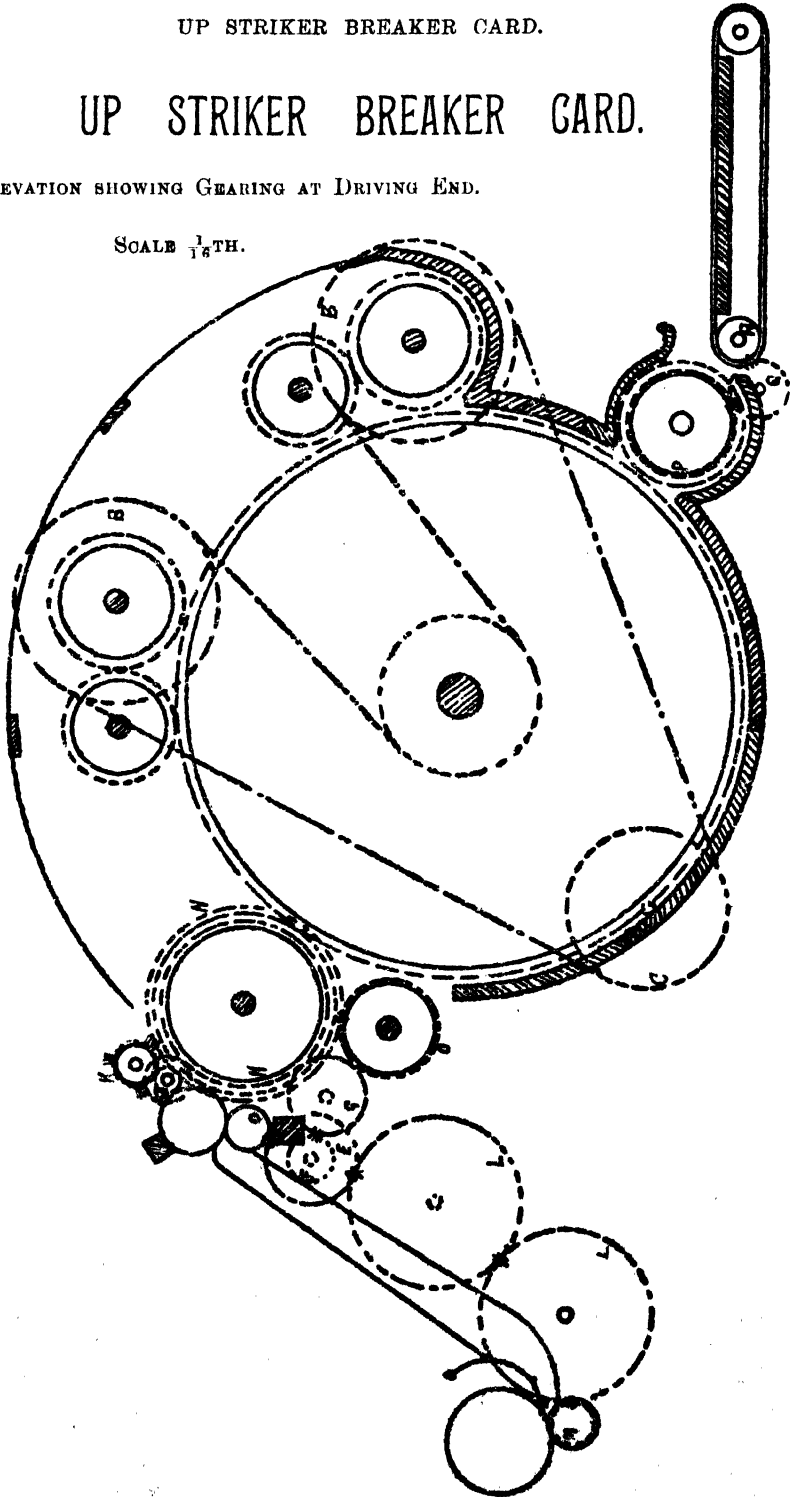
SCALE  $\frac{1}{8}$ TH.

## UP STRIKER BREAKER CARD.

*Sectional elevation showing gearing at opposite end to driving pulleys.*

SCALE  $\frac{1}{8}$ th.

(For Diagram see page 68).

A	Drawing roller wheel,	...	...	...	66 teeth.
BBB	Intermediates,	...	...	...	75 teeth.
C	Changes on cylinder end,	...	...	...	20 to 60 teeth.
D	Intermediate,	...	...	...	54 teeth.
E	Stud wheel,	...	...	...	58 teeth.
F	Stud pinion,	...	...	...	20 teeth.
G	Stud wheel,	...	...	...	120 teeth.
H	Changes,	...	...	...	20 to 60 teeth.
I	Feeder wheel,	...	...	...	120 teeth.
J	Doffer wheel for driving workers,	...	...	...	88 teeth.
K	Stud wheel,	...	...	...	96 teeth.
L	Stud pinion,	...	...	...	64 teeth.
MM	Workers wheel,	...	...	...	92 teeth.
N	Intermediate between workers,	...	...	...	116 teeth.

## DRAFT ARRANGEMENT—

$$\frac{4 \times 58 \times 120 \times 120}{66 \times 20 \times 30 \times 10\frac{1}{2}} = 8.03 \text{ draft.}$$

$$\frac{4}{66} \times \frac{58}{20} \times \frac{120}{\text{O.P.}} \times \frac{120}{10\frac{1}{2}} = 241.089 \text{ Constant No. for draft.}$$

NOTE.—The Breakers are used for Sacking Wefts.

# UP STRIKER BREAKER CARD.

SECTIONAL ELEVATION SHOWING GEARING AT  
OPPOSITE END TO DRIVING PULLEYS.

SCALE  $\frac{1}{16}$  TH.

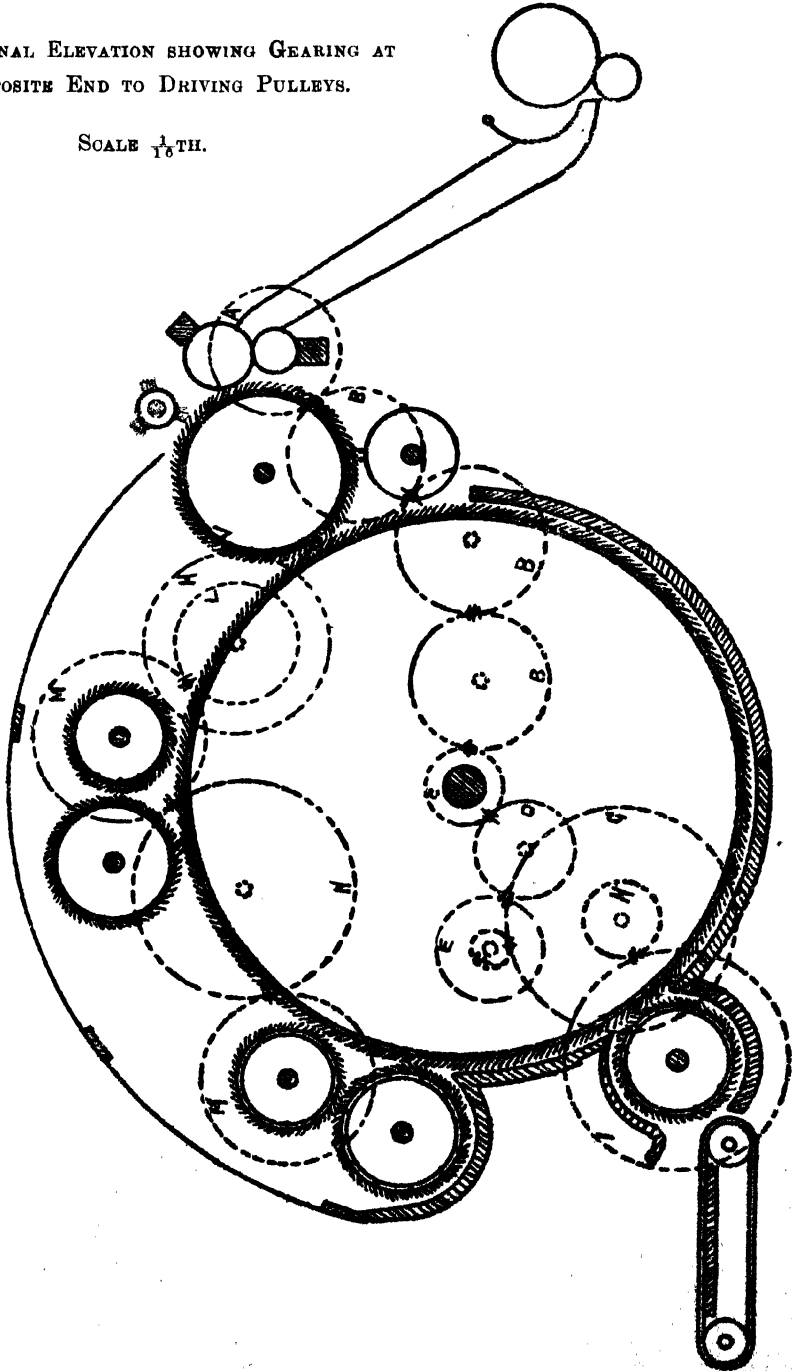

## SINGLE DOFFER FINISHER CARD,

*Sectional elevation showing gearing at end opposite to driving pulleys.*

SCALE  $\frac{1}{16}$ th.

(For diagram see page 70.)

A	Changes on cylinder end,	...	...	20 to 60 teeth
B	Intermediate, ...	...	...	74 teeth.
C	Stud wheel, ...	...	...	104 teeth.
D	Stud pinion, ...	...	...	32 teeth.
E	Intermediate, ...	...	...	66 teeth.
F	Drawing roller wheel, ...	...	...	75 teeth.
G	Stud wheel carrying changes, ...	...	...	96 teeth.
H	Changes, ...	...	...	20 to 60 teeth.
I	Feeder wheel, ...	...	...	96 teeth.
J	Feeder wheel for driving sheet roller, ...	...	...	46 teeth.
K	Sheet roller wheel, ...	...	...	48 teeth.
L	Doffer wheel for driving workers, ...	...	...	84 teeth.
M	Stud pinion, ...	...	...	64 teeth.
N	Stud wheel, ...	...	...	72 teeth.
OOOO	Worker wheels, ...	...	...	90 teeth.
PP	Intermediates between workers, ...	...	...	84 teeth.
Q	Intermediate between workers, ...	...	...	96 teeth,
R	Worker wheel for driving tin roller, ...	...	...	70 teeth.
S	Tin roller wheel, ...	...	...	62 teeth.
T	Worker wheel for driving tin roller, ...	...	...	75 teeth.
U	Tin roller wheel, ...	...	...	84 teeth.
V	Mitre for driving end delivery roller, ...	...	...	30 teeth.
W	Mitre on end delivery roller, ...	...	...	30 teeth.

## DRAFT ARRANGEMENT—

Feed Roller,  $4\frac{1}{8}$ " diameter.

$$\frac{4'' \times 104 \times 96 \times 96}{75 \times 32 \times 28 \times 4\frac{1}{8}''} = 13.83 \text{ draft.}$$

$$\frac{4'' \times 104 \times 96 \times 96}{75 \times 32 \times \text{C.P.} \times 4\frac{1}{8}''} = 387.258 \text{ Constant No. for draft.}$$

Feed Roller, 4" diameter,

$$\frac{4'' \times 104 \times 96 \times 96}{75 \times 32 \times 28 \times 4} = 14.26 \text{ draft.}$$

$$\frac{4'' \times 104 \times 96 \times 96}{75 \times 32 \times \text{C.P.} \times 4} = 999.359 \text{ Constant No. for draft.}$$

## SINGLE DOFFER FINISHER CARD

SECTIONAL ELEVATION SHOWING GEARING AT END OPPOSITE TO

DRIVING PULLEYS.

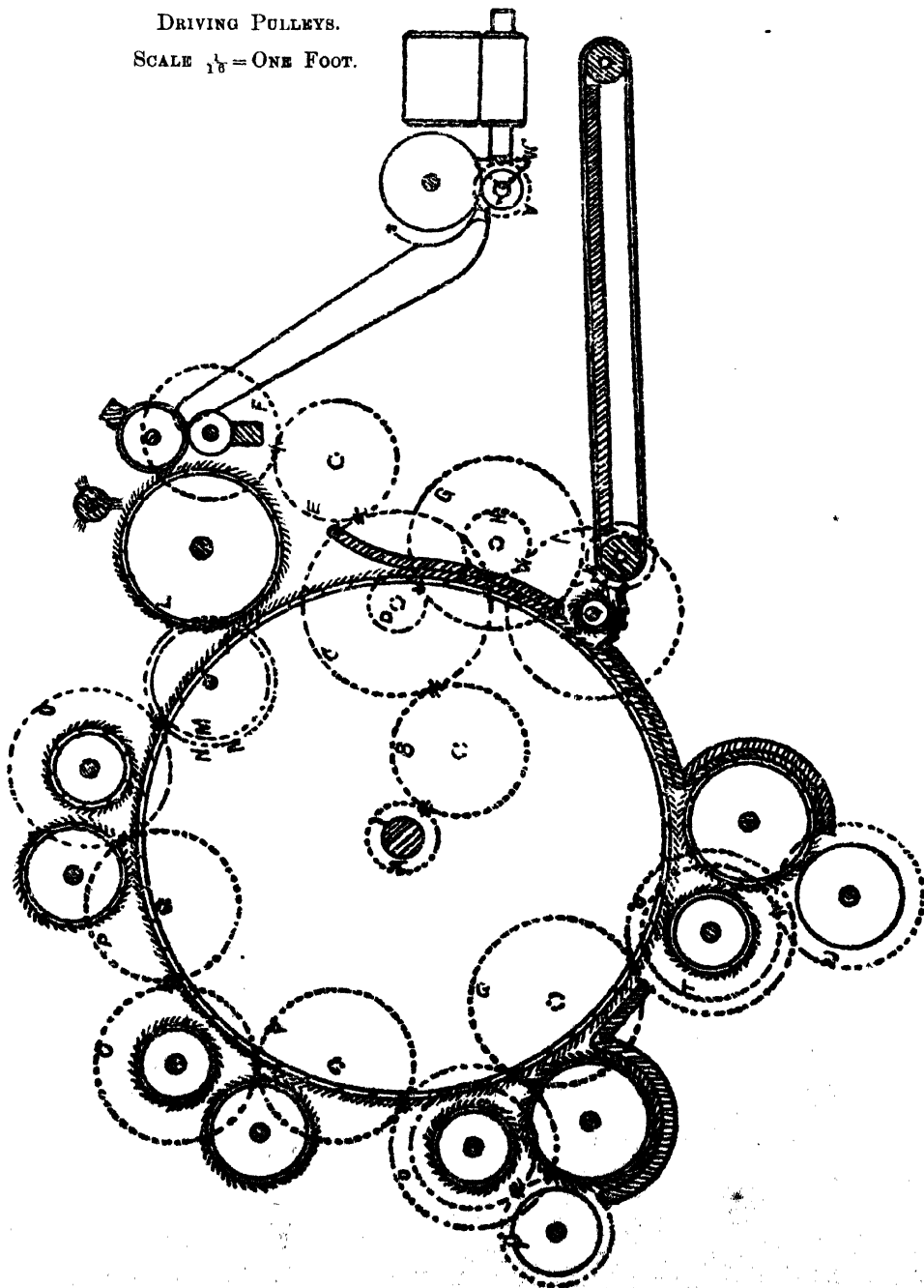
SCALE  $\frac{1}{8}$  = ONE FOOT.

## SINGLE DOFFER FINISHER CARD.

*Sectional elevation showing gearing at driving end.*SCALE  $\frac{1}{8}$ th.

" (For Diagram see page 72.)

A	Swift pulley,	...	...	...	14" dia.
BB	Stripper pulleys,	...	...	...	15" dia.
CC	Stripper pulleys,	...	...	...	18" dia.
D	Stretching pulley,	...	...	...	14" dia.
E	Drawing roller pinion,	...	...	...	24 teeth.
F	Intermediate,	...	...	...	56 teeth.
G	Stud wheel,	...	...	...	60 teeth.
H	Stud pinion,	...	...	...	28 teeth.
II	Intermediate,	...	...	...	84 teeth.
J	Delivery roller pinion,	...	...	...	22 teeth.
K	Doffer wheel,	...	...	...	84 teeth.
L	Stud wheel for driving brush,	...	...	...	24 teeth.
M	Stud pinion,	...	...	...	12 teeth.
N	Brush wheel,	...	...	...	24 teeth.

Speed of Cylinder, 180 revolutions per minute.

$$180 \times \frac{1}{8} = 140 \text{ revolutions of Nos. 1 and 2 strippers per minute.}$$

$$180 \times \frac{1}{8} = 168 \text{ revolutions of Nos. 3 and 4 strippers per minute.}$$

Speed of Cylinder, 193.68 revolutions per minute.

$$193.68 \times \frac{1}{8} = 150.64 \text{ revolutions of Nos. 1 and 2 strippers per minute.}$$

$$193.68 \times \frac{1}{8} = 180.76 \text{ revolutions of Nos. 3 and 4 strippers per minute.}$$

Length of Feed Cloth, 14 feet.

Breadth ,, ,, 2 ,, 9 inches.

Two Feed Cloths are required for one finisher—should be made of plaiding about  $\frac{3}{16}$ " thick.

# SINGLE DOFFER FINISHER CARD.

SECTIONAL ELEVATION SHOWING GEARING  
AT DRIVING END. SCALE  $\frac{1}{8}$  = ONE FOOT.

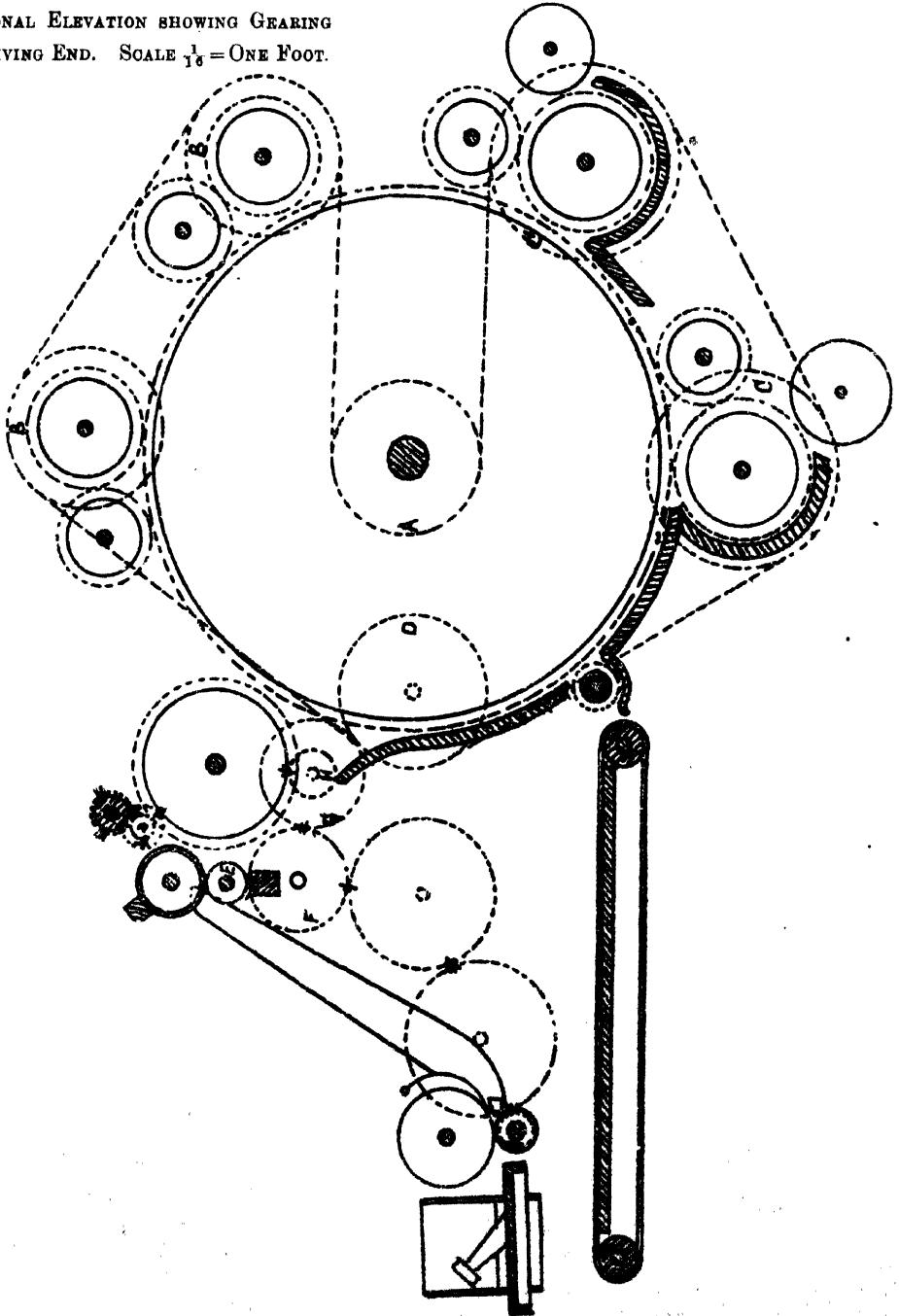

## DOUBLE DOFFER FINISHER CARD.

*Sectional elevation showing gearing at opposite end of driving pulleys.*

SCALE,  $\frac{1}{16}$ TH.

(For Diagram see page 74.)

A	Changes on Cylinder end,	...	...	26 to 42 teeth.
B	Intermediate,...	...	...	72 teeth.
C	Intermediate,...	...	...	90 teeth.
D	Intermediate,...	...	...	63 teeth.
E	Top drawing roller wheel,	...	...	80 teeth.
F	Intermediate between drawing rollers,	...	...	80 teeth.
G	Bottom drawing roller wheel,	...	...	76 teeth.
H	Stud wheel carrying changes,	...	...	138 teeth.
I	Changes,	...	...	26 to 42 teeth.
J	Feeder wheel,	...	...	144 teeth.
K	Feeder wheel for driving sheet roller,	...	...	43 teeth.
L	Sheet roller wheel,	...	...	32 teeth.
M	Doffer wheel for driving workers,	...	...	112 teeth.
N	Intermediate for driving workers,	...	...	72 teeth.
OOO	Worker wheels,	...	...	110 teeth.
P.P	Intermediate between workers,	...	...	180 teeth.
Q	Worker wheel for driving tin roller,	...	...	138 teeth.
R	Tin roller wheel,	..	...	78 teeth.
S	Mitre for driving end delivery roller,	...	...	30 teeth.
T	Mitre on end delivery roller,	...	...	30 teeth.

## DRAFT ARRANGEMENT—

Feed Roller,  $4\frac{1}{4}$ " diameter.

$$\frac{4 \times 138 \times 134}{76 \times 20 \times 4\frac{1}{2}} = 12.03 \text{ draft.}$$

$$\frac{4 \times 138 \times 134}{76 \times \text{C.P.} \times 4\frac{1}{2}} = 246.092 \text{ Constant No. for draft.}$$

NOTE —C.P. = Change or Draft Pinion.



# DOUBLE DOFFER FINISHER CARD

SECTIONAL ELEVATION SHOWING GEARING AT END OPPOSITE  
TO DRIVING PULLEYS.

SCALE,  $\frac{1}{16}$  = ONE FOOT.

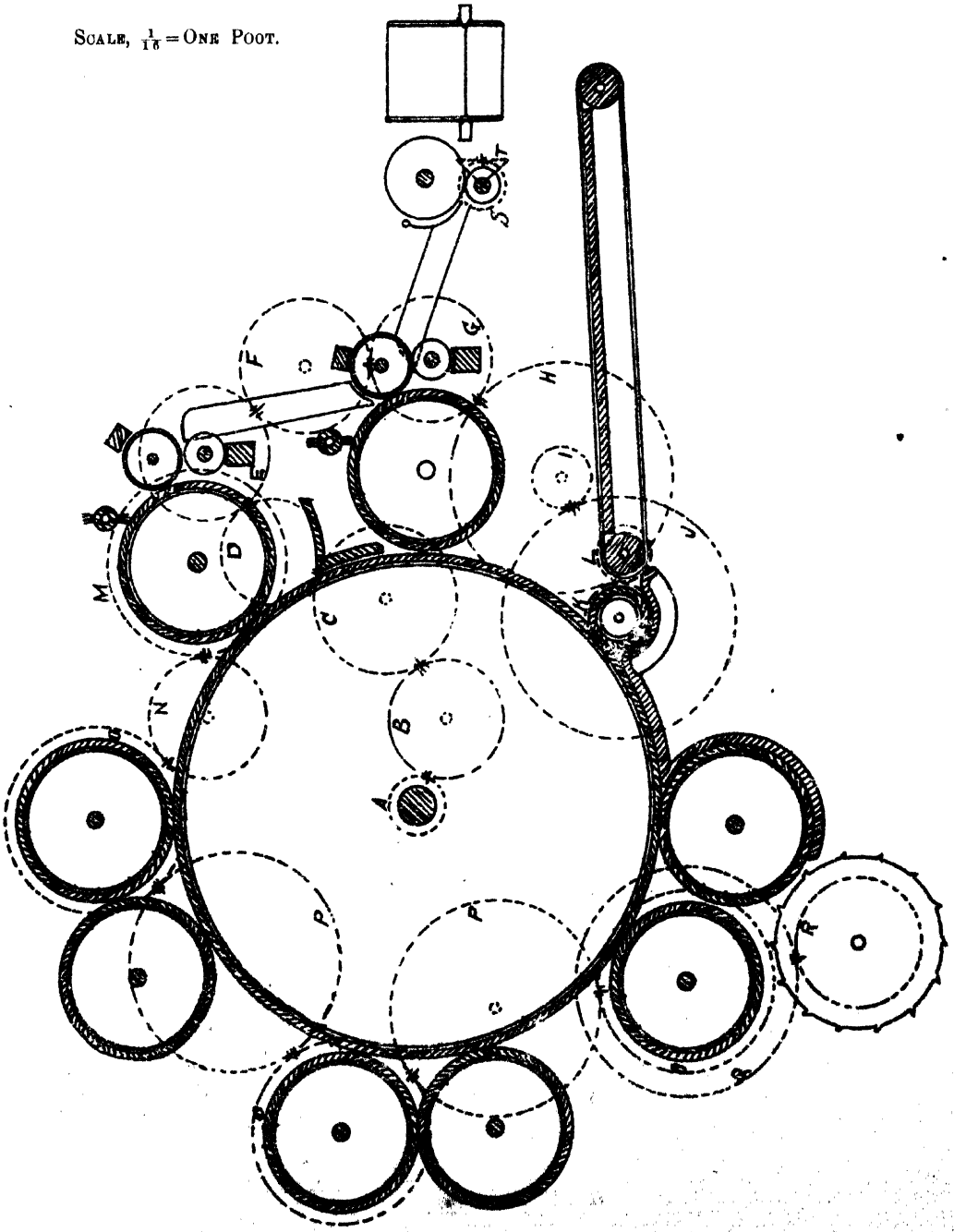

## DOUBLE DOFFER FINISHER CARD.

*Sectional Elevation showing gearing at driving end.*SCALE,  $\frac{1}{16}$ TH.*(For Diagram see page 76.)*

A	Swift pulley, ...	...	...	...	11" dia.
BBB	Stripper pulleys,	...	...	...	24" dia.
C	Stretching pulley,	...	...	...	12" dia.
D	Top drawing roller pinion,	...	...	...	24 teeth.
E	Stud wheel, ...	...	...	...	54 teeth.
F	Stud pinion, ...	...	...	...	25 teeth.
G	Intermediate between doffers,	...	...	...	70 teeth.
HH	Doffer wheels,	...	...	...	88 teeth.
II	Doffer wheels for driving brushes,	..	..	..	44 teeth.
JJ	Intermediates,	...	...	...	30 teeth.
KK	Brush wheels,	...	..	...	24 teeth.
L	Bottom drawing roller pinions,	...	...	...	24 and 25 teeth.
M	Intermediate,	...	...	...	108 teeth.
N	Delivery roller pinion, ...	...	...	...	28 teeth.

Speed of Cylinder, 185 revolutions per minute.

 $185 \times \frac{1}{2} = 84.79$  revolutions of strippers per minute.

Length of Feed Cloth, 7 feet 3 inches.

Breadth, ,, 2 ,, 9 ,,

Two Feed Cloths are required for one finisher.

The Feed Cloths of Double Doffer Breaker and Finisher should also be made of plaiding,  $\frac{3}{16}$ " thick.

# DOUBLE DOFFER FINISHER CARD.

SECTIONAL ELEVATION SHOWING GEARING AT DRIVING END.

SCALE  $\frac{1}{16}$  = ONE FOOT.

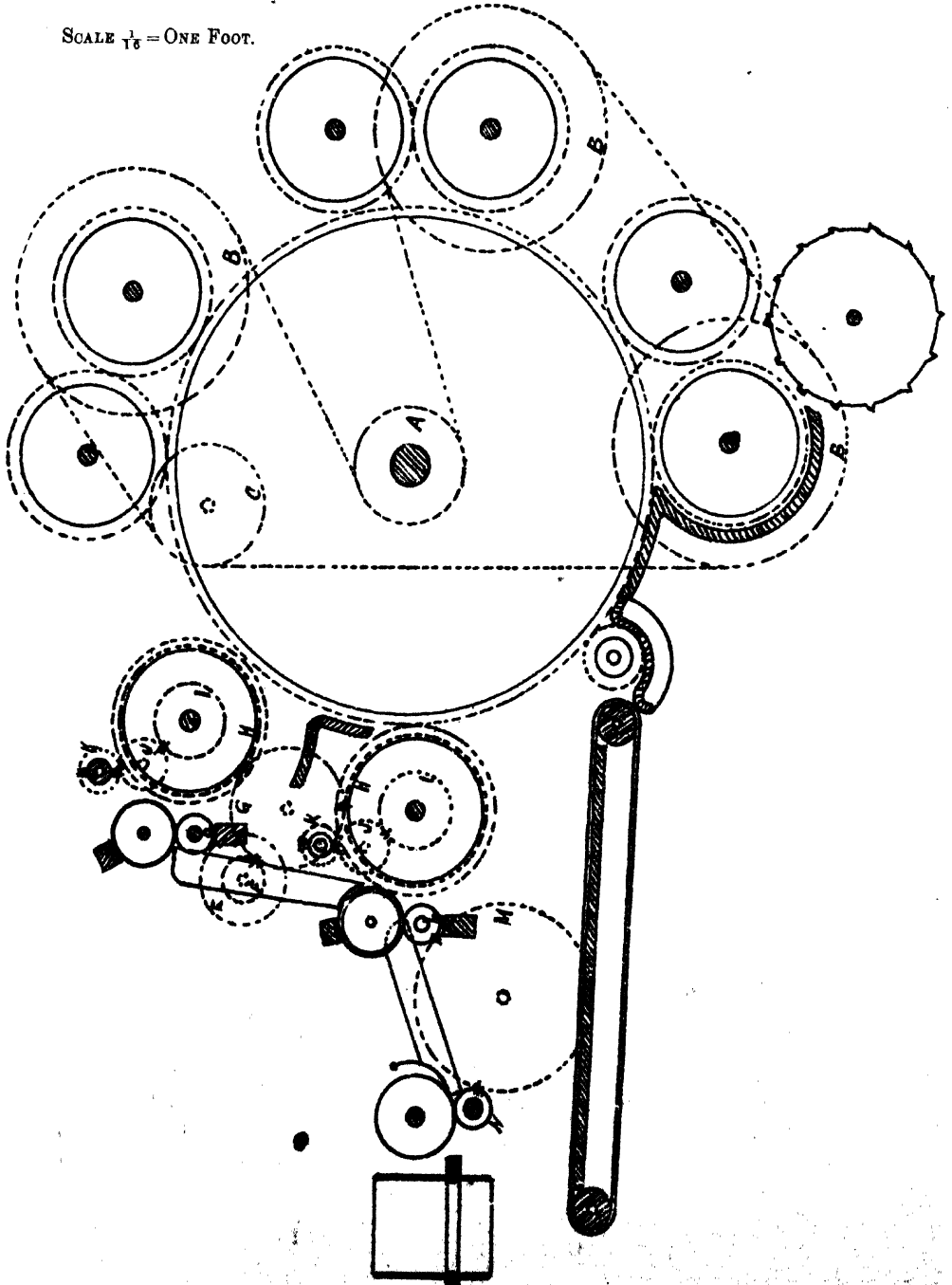

## UP STRIKER FINISHER CARD.

*Sectional elevation showing gearing at opposite end to driving pulleys.*

SCALE  $\frac{1}{16}$ th.

(For Diagram see page 78.)

A	Drawing roller wheel, ... ..	66 teeth.
BBB	Intermediates, ... ..	75 teeth.
C	Changes on cylinder end, ... ..	20 to 60 teeth.
D	Intermediate, .. ... ..	54 teeth.
E	Stud wheel, ... ..	58 teeth.
F	Stud pinion, ... ..	20 teeth.
G	Stud wheel, ... ..	120 teeth.
H	Changes, ... ..	20 to 60 teeth.
I	Feeder wheel, ... ..	120 teeth.
J	Doffer wheel for driving workers, ... ..	88 teeth.
K	Double intermediate, ... ..	60 teeth.
LLL	Worker wheels, ... ..	72 teeth.
MM	Intermediates between workers, ... ..	84 teeth.

## DRAFT ARRANGEMENT—

Feed Roller,  $10\frac{1}{2}$ " diameter.

$$\frac{4 \times 58 \times 120 \times 120}{66 \times 20 \times 80 \times 10\frac{1}{2}} = 8.03 \text{ draft}$$

$$\frac{4 \times 58 \times 120 \times 120}{66 \times 20 \times \text{C.P.} \times 10\frac{1}{2}} = 241.039 \text{ Constant No. for draft.}$$

# UP STRIKER FINISHER CARD

SECTIONAL ELEVATION SHOWING GEARING AT OPPOSITE END  
TO DRIVING PULLEYS

SCALE  $\frac{1}{16}$ .

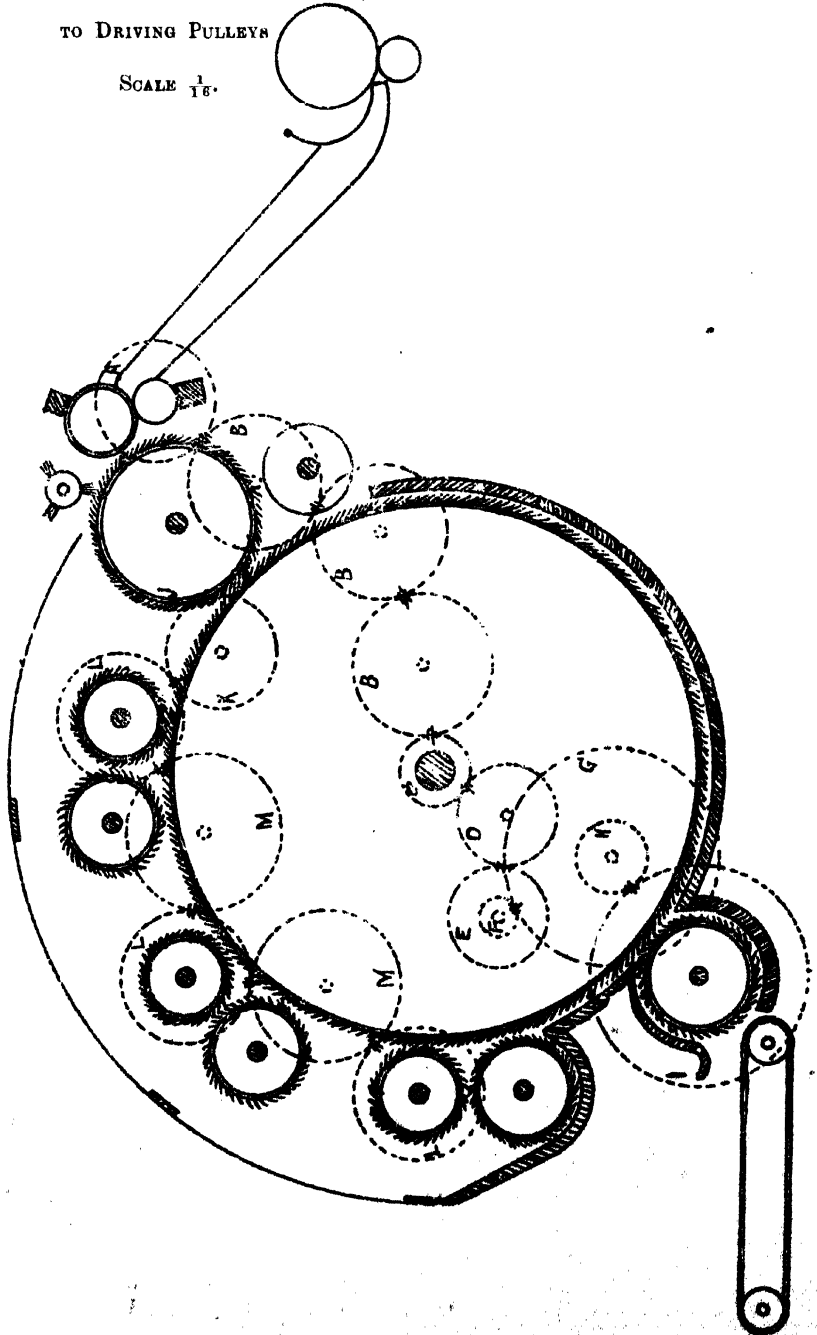

## UP STRIKER FINISHER CARD.

*Sectional elevation showing gearing at driving end.*

SCALE,  $\frac{1}{8}$ "=1".

(For Diagram see page 80).

A	Swift Pulley, ...	...	...	...	16" dia.
BBB	Stripper pulleys,	...	...	...	14" dia.
C	Stretching pulley,	...	...	...	14" dia.
D	Drawing roller pinion,	...	...	...	24 teeth.
E	Stud wheel, ...	...	...	...	54 teeth.
F	Stud pinion, ...	...	...	...	28 teeth.
G	Intermediate,	..	...	...	42 teeth.
H	Doffer wheels,	..	...	...	88 teeth.
I	Stud wheel, ...	...	...	...	24 teeth.
J	Stud pinion, ...	..	...	...	12 teeth.
K	Brush wheel, ...	..	...	...	24 teeth.
LL	Intermediate,	...	...	...	90 teeth.
M	Delivery roller pinion,	...	...	...	22 teeth.
N	Doffer wheel for driving tin roller,	...	...	...	104 teeth.
O	Tin roller wheel, ...	...	...	...	52 teeth.
P	Feeder wheel for driving sheet roller,	...	...	...	78 teeth.
Q	Intermediate,	...	...	...	40 teeth.
R	Sheet roller wheel,	...	...	...	32 teeth.

Cylinder 180 revolutions per minute.

$180 \times \frac{9}{4} = 205.71$  revolutions of stripper per minute.

NOTE.—For particulars of Covering see page 111, and page 120 for drafts, &c.

# UP STRIKER FINISHER CARD.

SECTIONAL ELEVATION SHOWING GEARING AT DRIVING END.

SCALE  $\frac{1}{16}$ .

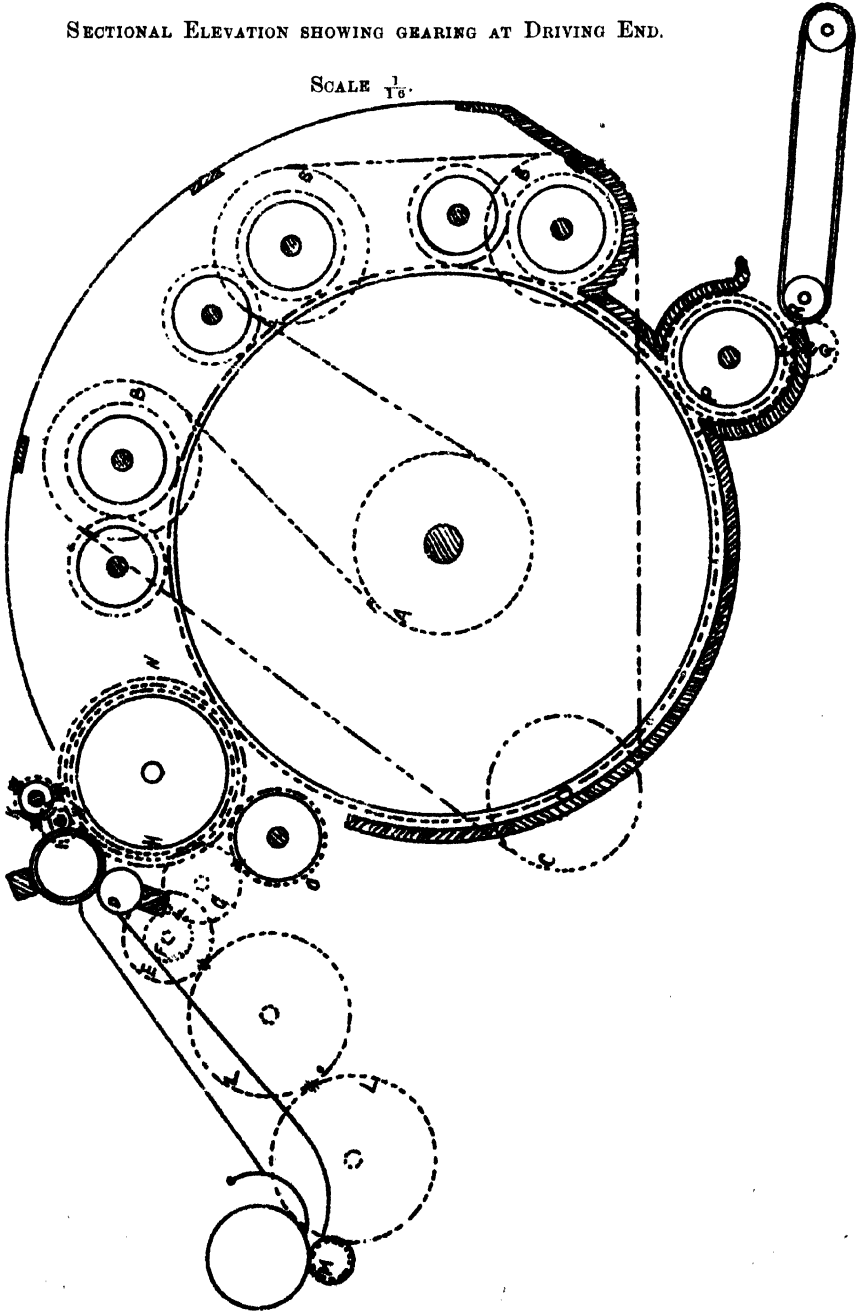

SPECIFICATION AND SPEEDS OF FINISHERS (SINGLE DOFFER).

Cylinder 6' x 4', 4 Workers, 4 Strippers, 1 Doffer, 1 Doffs with leather rollers.

Speed of Cylinder 180 revolutions per minute.

Pulleys, ... ..	...	...	24" diameter, 6" broad, 2½" bore
Pulleys driving Strippers, ...	14	,"	4 " 2½ " "
Pulley Seats on Nos. 1 and 2 Strippers,	1½	,"	
" " " 3 and 4 "	1½	,"	
Wheel Seats on Workers, ...	1½	,"	
" " Doffer, ...	1½	,"	
" " Feeder, ...	1½	,"	
" " Drawing Roller,	1½	,"	
" " Delivery Roller,	1½	,"	
" " Tin Rollers, ...	1½	,"	

NOTE.—These diameters are taken from a Fairbairn Specification.

	Under Wood.	Over Wood.	Over Staves.	Centre to Centre of pins.	Over Staves.	Centre to Centre of pins.
Cylinder Ring, ...	43½" dia.	48" dia.	49½" dia.	49½" dia.	154·33" cir.	155·21" cir.
Nos. 1 and 2 Stripper rings	8½ " "	11 " "	12 " "	12 7/8 " "	37·69 " "	38·38 " "
" 3 and 4 " "	7 " "	9 " "	10 " "	10 7/8 " "	31·41 " "	32·10 " "
Worker, ...	4½ " "	7 " "	8 " "	8 1/8 " "	25·13 " "	26·11 " "
Doffer, ...	11 " "	14 " "	14 7/8 " "	15 6/8 " "	46·73 " "	47·61 " "
Feeder Rings (Iron) ...	2½ " "	—	3½ " "	4½ " "	11·78 " "	12·95 " "
Tin Rollers ...	10 " "	= 81·41 cir. and 8 dia. = 25"·13 cir.				
Drawing Roller, ...	4 " "	= 12·56 " "				
Delivering Roller, ...	4 " "	= 12·56 " "				
Plaiding Roller, ...	4 " "	= 12·56 " "				

\* H



## SPECIFICATION AND SPEEDS OF FINISHERS.

Cylinder Pinion 50 teeth,  $1\frac{1}{2}$ " bore.

Cylinder  $49\frac{1}{2}$ " diameter at centre of pins = 155"·21 circumference

$$180 \times 155 \cdot 21 = 27937 \cdot 80 \text{ inches} = 2328 \cdot 15 \text{ feet, surface speed per minute.}$$

Feed roller  $4\frac{1}{8}$ " diameter at centre of pins = 12"·95 circumference.

$$\frac{180 \times 50 \times 32 \times 32}{104 \times 104 \times 90} = 9 \cdot 46 \text{ revolutions of feed roller per minute.}$$

$$9 \cdot 46 \times 12 \cdot 95 = 122 \cdot 5070 \text{ inches} = 10 \cdot 2089 \text{ feet, surface speed per minute.}$$

Nos. 1, 2, 3, and 4 Workers  $8\frac{5}{8}$ " diameter at centre of pins = 26"·11 circumference

$$\frac{180 \times 50 \times 33 \times 26 \times 84 \times 46}{75 \times 60 \times 84 \times 72 \times 90} = 8 \cdot 49 \text{ revolutions of workers per minute.}$$

$$8 \cdot 49 \times 26 \cdot 11 = 221 \cdot 6739 \text{ inches} = 18 \cdot 4728 \text{ feet, surface speed per minute.}$$

Nos. 1 and 2 Strippers  $12\frac{7}{8}$ " diameter at centre of pins = 38"·38 circumference.

Pulleys driving Strippers, 14" diameter.

„ on end of „ 18 „

$$180 \times \frac{1}{18} = 10 \text{ revolutions of Nos. 1 and 2 Strippers per minute.}$$

$$10 \times 38 \cdot 38 = 383 \cdot 80 \text{ inches} = 31 \cdot 98 \text{ feet, surface speed per minute.}$$

Nos. 3 and 4 Strippers  $10\frac{7}{8}$ " diameter at centre of pins = 32"·10 circumference.

Pulleys driving Strippers, 14" diameter.

„ on end of „ 15 „

$$180 \times \frac{1}{15} = 12 \text{ revolutions of Nos. 3 and 4 Strippers per minute.}$$

$$12 \times 32 \cdot 10 = 385 \cdot 20 \text{ inches} = 32 \cdot 10 \text{ feet, surface speed per minute.}$$

Doffer  $15\frac{5}{8}$ " diameter at centre of pins = 47"·61 circumference.

$$\frac{180 \times 50 \times 23 \times 26}{75 \times 60 \times 84} = 14 \cdot 23 \text{ revolutions of doffer per minute.}$$

$$14 \cdot 23 \times 47 \cdot 61 = 677 \cdot 4903 \text{ inches} = 56 \cdot 4575 \text{ feet, surface speed per minute.}$$

Drawing Roller 4" diameter = 12"·56 circumference.

$$180 \times \frac{\text{Cyl. pin.}}{7 \frac{9}{8}} = 120 \text{ revolutions of drawing roller per minute.}$$

$$120 \times 12 \cdot 56 = 1507 \cdot 2 \text{ inches} = 125 \cdot 6 \text{ feet, surface speed per minute.}$$

Delivering Roller 4" diameter = 12"·56 circumference.

$$\frac{180 \times \text{Cyl. Pin.}}{75 \times 24} = 115 \text{ revolutions of delivering roller per minute.}$$

$$115 \times 12 \cdot 56 = 1444 \cdot 40 \text{ inches} = 120 \cdot 36 \text{ feet, surface speed per minute.}$$

Plaiding Roller 4" diameter = 12"·56 circumference.

$$\frac{180 \times 50 \times 32 \times 32 \times 46}{104 \times 104 \times 90 \times 48} = 9 \cdot 07 \text{ revolutions of plaiding roller per minute.}$$

$$9 \cdot 07 \times 12 \cdot 56 = 113 \cdot 9192 \text{ inches} = 9 \cdot 4932 \text{ feet, surface speed per minute}$$

No. 1 Tin Roller 10" diameter = 31"·41 circumference.

$$\frac{180 \times 50 \times 23 \times 26 \times 84 \times 46 \times 84}{75 \times 60 \times 84 \times 72 \times 90 \times 76} = 9 \cdot 38 \text{ revolutions of No. 1 tin roller per minute.}$$

$$9 \cdot 38 \times 31 \cdot 41 = 294 \cdot 6258 \text{ inches} = 24 \cdot 5521 \text{ feet, surface speed per minute.}$$

No. 2 Tin Roller 8" diameter = 25"·13 circumference.

$$\frac{180 \times 50 \times 23 \times 26 \times 84 \times 46 \times 73}{75 \times 60 \times 84 \times 72 \times 90 \times 60} = 10 \cdot 32 \text{ revolutions of No. 2 tin roller per minute.}$$

$$10 \cdot 32 \times 25 \cdot 13 = 259 \cdot 3416 \text{ inches} = 21 \cdot 6118 \text{ feet, surface speed per minute.}$$

## SPECIFICATION AND SPEEDS OF FINISHERS.

Feed Roller	...	$\frac{180 \times \text{cyl. p.} \times 32 \times 32}{104 \times 104 \times 90}$	=	·189349	Constant No. for revolutions per minute.		
Nos. 1, 2, 3, and 4 Workers		$\frac{180 \times \text{cyl. p.} \times 23 \times 26 \times 84 \times 46}{75 \times 60 \times 84 \times 72 \times 90}$	=	·169802	"	"	"
Nos. 1 and 2 Strippers		$\frac{180 \times \text{cyl. p.}}{18}$	=	10·0	"	"	"
Nos. 3 and 4	"	$\frac{180 \times \text{cyl. p.}}{15}$	=	12·0	"	"	"
Doffer	... ..	$\frac{180 \text{ cyl. p.} \times 23 \times 26}{75 \times 60 \times 84}$	=	·284761	"	"	"
Drawing Roller	...	$\frac{180 \times \text{cyl. p.}}{75}$	=	2·4	"	"	"
Delivering Roller		$\frac{180 \times \text{cyl. p.} \times 23}{75 \times 24}$	=	2·3	"	"	"
Plaiding Roller	---	$\frac{180 \times \text{cyl. p.} \times 32 \times 32 \times 46}{104 \times 104 \times 90 \times 48}$	=	·181459	"	"	"
No. 1 Tin Roller	...	$\frac{180 \times \text{cyl. p.} \times 23 \times 26 \times 84 \times 46 \times 84}{75 \times 60 \times 84 \times 72 \times 90 \times 76}$	=	·187676	"	"	"
No. 2	" " "	$\frac{180 \times \text{cyl. p.} \times 23 \times 26 \times 84 \times 46 \times 73}{75 \times 60 \times 84 \times 72 \times 90 \times 60}$	=	·206593	"	"	"

---



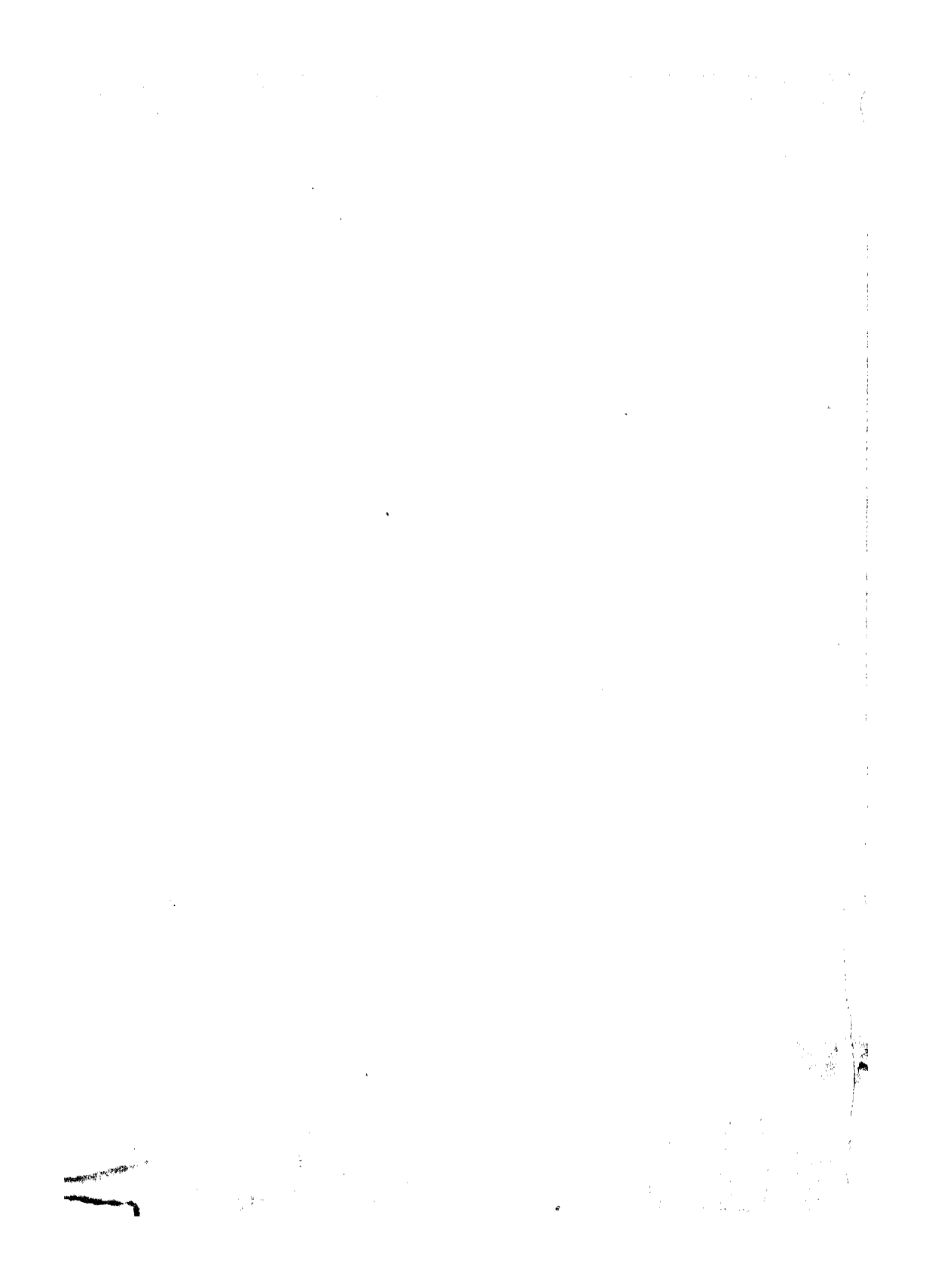

The Speed of the Workers can be changed without affecting the other roller speeds as under :—

Speed of Cylinder.	Cyl. Pin.	Worker			
$\frac{180 \times 40 \times 23 \times 26 \times 84}{75 \times 60 \times 84 \times 72 \times 90}$	change	pinion.	=	.14765	Constant No. with a 40 T. Cylinder Pinion.
$\frac{180 \times 42 \times 23 \times 26 \times 84}{75 \times 60 \times 84 \times 72 \times 90}$		C.P.	=	.15503	„ 42 „
$\frac{180 \times 44 \times 23 \times 26 \times 84}{75 \times 60 \times 84 \times 72 \times 90}$		C.P.	=	.16241	„ 44 „
$\frac{180 \times 46 \times 23 \times 26 \times 84}{75 \times 60 \times 84 \times 72 \times 90}$		C.P.	=	.16980	„ 46 „
$\frac{180 \times 48 \times 23 \times 26 \times 84}{75 \times 60 \times 84 \times 72 \times 90}$		C.P.	=	.17718	„ 48 „
$\frac{180 \times 50 \times 23 \times 26 \times 84}{75 \times 60 \times 84 \times 72 \times 90}$		C.P.	=	.18456	„ 50 „
$\frac{180 \times 52 \times 23 \times 26 \times 84}{75 \times 60 \times 84 \times 72 \times 90}$		C.P.	=	.19195	„ 52 „
$\frac{180 \times 54 \times 23 \times 26 \times 84}{75 \times 60 \times 84 \times 72 \times 90}$		C.P.	=	.19938	„ 54 „
$\frac{180 \times 56 \times 23 \times 26 \times 84}{75 \times 60 \times 84 \times 72 \times 90}$		C.P.	=	.20671	„ 56 „
$\frac{180 \times 58 \times 23 \times 26 \times 84}{75 \times 60 \times 84 \times 72 \times 90}$		C.P.	=	.21409	„ 58 „
$\frac{180 \times 60 \times 23 \times 26 \times 84}{75 \times 60 \times 84 \times 72 \times 90}$		C.P.	=	.22148	„ 60 „

## SPECIFICATION AND SPEEDS OF FINISHERS.

SETTING OF FINISHER ...	Shell to Cylinder,	...	...	...	...	$\frac{1}{4}$ "
	Feed Roller to Shell,	...	...	...	...	$\frac{3}{16}$
	,, Cylinder,	...	...	...	...	No. 16
	No. 1 Worker to Cylinder,	...	...	...	...	,, 14
	,, 2 ,, ,,	...	...	...	...	,, 16
	,, 3 ,, ,,	...	...	...	...	,, 16
	,, 4 ,, ,,	...	...	...	...	,, 16
	,, 1 Stripper	..	...	...	...	,, 16
	,, 1 ,, ,,	...	...	...	...	,, 16
	,, 3 ,, ,,	...	...	...	...	,, 16
	,, 4 ,, ,,	...	...	...	...	,, 16
	Between Workers and Strippers,	...	...	...	...	,, 16
	Doffer to Cylinder,	...	...	...	...	,, 10
	,, Drawing Roller,	...	...	...	...	,, 10

## SPECIFICATION OF PINS.

			Pitch.	Staves.	Rows.	Pins.	Size of Pins.	Length of Pins out.
Cylinder	... ..	71" x 48"	$\frac{7}{16} \times \frac{7}{16}$	120	9	55	No. 15, $\frac{7}{8}$ "	$\frac{9}{32}$ "
Feed Roller,	...	71 x 2 $\frac{1}{2}$	$\frac{3}{8} \times \frac{3}{8}$	4	8	186	,, 14, 1 $\frac{1}{8}$	$\frac{3}{8}$
No. 1 and 2 Strippers,		71 x 11	$\frac{7}{16} \times \frac{7}{16}$	30	7	82	,, 14, 1 $\frac{1}{8}$	$\frac{7}{32}$
,, 3 and 4 ,,		71 x 9	$\frac{3}{8} \times \frac{3}{8}$	36	7	63	,, 15, 1 $\frac{1}{8}$	$\frac{7}{32}$
,, 1 and 2 Workers,		71 x 7	$\frac{3}{8} \times \frac{3}{8}$	30	7	63	,, 14, 1 $\frac{1}{2}$	$\frac{5}{16}$
,, 3 and 4 ,,		71 x 7	$\frac{5}{16} \times \frac{5}{16}$	30	8	75	,, 15, 1 $\frac{1}{2}$	$\frac{1}{16}$
Doffer,	... ..	71 x 14	$\frac{5}{16} \times \frac{1}{4}$	34	11	140	,, 16, 1	$\frac{9}{32}$

Pulleys, 24", Cylinder Pinion, 50 Teeth, Stripper Driving Pulley, 14" diameter, 10 ends into 1.

$$\frac{4 \times 104 \times 96 \times 96}{75 \times 32 \times 28 \times 4\frac{1}{8}} = 13.8306 \text{ draft.}$$

C.P. C.P.

$\frac{4 \times 60 \times 84}{23 \times 26 \times 15\frac{3}{4}} = 2.2243$  draft between doffer and drawing roller. This draft is only necessary for the delivery of material between doffer and drawing roller, but is not required in working out the draft between the feed and drawing rollers

Change Pinions	20	22	24	26	28	30 T.
Drafts	2.8916	2.3287	2.4096	2.2243	2.0654	1.9277

$$\frac{4 \times 104 \times 96 \times 96}{75 \times 30 \times - \times 4\frac{3}{8}} = 413.08095 \text{ Constant No. for draft with a 30 T. change pinion on}$$

C.P. C.P.

$$\frac{4 \times 104 \times 96 \times 96}{75 \times 32 \times - \times 4\frac{3}{8}} = 387.25818 \quad \text{''} \quad \text{''} \quad 32 \quad \text{''}$$

C.P. C.P.

$$\frac{4 \times 104 \times 96 \times 96}{75 \times 34 \times - \times 4\frac{3}{8}} = 364.47828 \quad \text{''} \quad \text{''} \quad 34 \quad \text{''}$$

C.P. C.P.

$$\frac{4 \times 104 \times 96 \times 96}{75 \times 36 \times - \times 4\frac{3}{8}} = 344.22949 \quad \text{''} \quad \text{''} \quad 36 \quad \text{''}$$

C.P. C.P.

$$\frac{4 \times 104 \times 96 \times 96}{75 \times 38 \times - \times 4\frac{3}{8}} = 326.11215 \quad \text{''} \quad \text{''} \quad 38 \quad \text{''}$$

C.P. C.P.

$$\frac{4 \times 104 \times 96 \times 96}{75 \times 40 \times - \times 4\frac{3}{8}} = 309.80654 \quad \text{''} \quad \text{''} \quad 40 \quad \text{''}$$

C.P. C.P.

DRAFTS.

Change Pinion on	CHANGE PINIONS ON										
	20	22	24	26	28	30	32	34	36	38	40 T.
30 Teeth	20.6540	18.7764	17.2117	15.8877	14.7528	13.7693	12.9087	12.1494	11.4744	10.8705	10.3270
32 "	19.3629	17.6028	16.1357	14.8945	13.8306	12.9086	12.1018	11.3899	10.7571	10.1910	9.6814
34 "	18.2239	16.5671	15.1865	14.0183	13.0170	12.1492	11.3899	10.7199	10.1243	9.5915	9.1119
36 "	17.2114	15.6467	14.3428	13.2395	12.2939	11.4743	10.7571	10.1243	9.5619	9.0586	8.6057
38 "	16.3056	14.8232	13.5880	12.5427	11.6468	10.8704	10.1910	9.5915	9.0586	8.5816	8.1528
40 "	15.4903	14.0821	12.9086	11.9156	11.0645	10.3268	9.6814	9.1119	8.6057	8.1528	7.7451



SPECIFICATION AND SPEEDS OF FINISHERS (SINGLE DOFFER).

Cylinder 6' x 4'—4 Workers, 4 Strippers, 1 Doffer, Doffs with leather rollers.

Pulleys,	...	...	...	...	24" diameter, 6" broad, 2 $\frac{1}{4}$ " bore.
"	...	..	...	...	" " "
"	...	...	...	...	" " "
Pulleys driving Strippers,	...	...	14	,"	4 " 2 $\frac{1}{4}$ "
Pulley Seats on Strippers,	1 $\frac{1}{2}$ " dia. *				
Wheel	,"	Workers,	1 $\frac{1}{4}$		
"	,"	Doffer,	1 $\frac{1}{4}$		
"	,"	Feeder,	1 $\frac{1}{4}$		
"	,"	Drawing Roller,	1 $\frac{1}{4}$ "		
"	,"	Delivering "	1 $\frac{1}{4}$		
"	,"	Tin Rollers,	1 $\frac{1}{4}$		

*		Under wood.	Over wood.	Over staves.	Centre to Centre of pins.	Over staves.	Centre to Centre of pins.
Cylinder Ring,	...	43 $\frac{1}{2}$ " dia.	45" dia.	49" dia.	49 $\frac{3}{8}$ " dia.	153.50" cir.	154.90" cir.
Nos. 1 and 2 Stripper Rings	...	8 $\frac{1}{2}$ "	11 "	11 $\frac{7}{8}$ "	12 $\frac{1}{8}$ "	37.30 "	38.09 "
Nos. 3 and 4	,"	7 "	9 "	9 $\frac{7}{8}$ "	10 $\frac{1}{8}$ "	31.02 "	31.80 "
Worker	,"	4 $\frac{1}{2}$ "	7 "	8 "	8 $\frac{5}{8}$ "	25.13 "	26.11 "
Doffer Rings	,"	11 "	14 "	14 $\frac{7}{8}$ "	15 $\frac{3}{8}$ "	46.73 "	48.10 "
Feeder	,"	2 $\frac{1}{2}$ "	— "	3 $\frac{5}{8}$ "	4 "	11.38 "	12.56 "

Tin Rollers 10" diameter, 31.41" circumference, and 8" diameter = 25.13" circumference.

Drawing Rollers 4" dia. = 12.56 "

Delivering Rollers 4" = 12.56 "

Plaiding Roller 4" = 12.56 "

\*NOTE.—These diameters are from my own measurements. They differ, however, very little from a Fairbairn Specification.

SPECIFICATION AND SPEEDS OF FINISHERS.

Cylinder Pinion 50 teeth,  $1\frac{1}{2}$ " bore.

$$\frac{163.1 \times 28\frac{1}{2}}{24} = 193.68 \text{ revolutions of cylinder per minute.}$$

Cylinder  $49\frac{5}{8}$ " diameter at centre of pins = 154.9" circumference.

$$193.68 \times 154.9 = 30001.032 \text{ ins.} = 2500.086 \text{ ft.} \text{---surface speed per minute.}$$

Feed Roller 4" diameter at centre of pins = 12.56" circumference.

$$\frac{193.68 \times 50 \times 32 \times 32}{104 \times 104 \times 90} = 10.18 \text{ revolutions of feed roller per minute.}$$

$$10.18 \times 12.56 = 127.8608 \text{ ins.} = 10.65 \text{ feet} \text{---surface speed per minute.}$$

Nos. 1, 2, 3, and 4 Workers,  $8\frac{5}{8}$ " diameter at centre of pins = 26.11" circumference.

$$\frac{193.68 \times 50 \times 23 \times 26 \times 84 \times 46}{75 \times 60 \times 84 \times 72 \times 90} = 9.13 \text{ revolutions of workers per minute.}$$

$$9.13 \times 26.11 = 238.3843 \text{ ins.} = 19.86 \text{ ft.} \text{---surface speed per minute.}$$

Nos. 1 and 2 Strippers  $12\frac{1}{8}$ " diameter at centre of pins = 38.09" circumference.

Pulleys driving strippers 14" diameter. Pulley on end of strippers 18" diameter.

$$\frac{193.68 \times 14}{18} = 150.64 \text{ revolutions of Nos. 1 and 2 strippers per minute.}$$

$$150.64 \times 38.09 = 5737.8776 \text{ ins.} = 478.1564 \text{ ft.} \text{---surface speed per minute.}$$

Nos. 3 and 4 Strippers  $10\frac{1}{8}$ " diameter at centre of pins = 31.80" circumference.

Pulleys driving strippers 14" diameter. Pulleys on end of strippers 15" diameter.

$$\frac{193.68 \times 14}{15} = 180.76 \text{ revolutions of Nos. 3 and 4 strippers per minute.}$$

$$180.76 \times 31.80 = 5748.168 \text{ ins.} = 479.014 \text{ ft.} \text{---the surface speed per minute.}$$

Doffer  $15\frac{3}{8}$ " diameter at centre of pins = 48.10 circumference.

$$\frac{193.68 \times 50 \times 23 \times 26}{75 \times 60 \times 84} = 15.32 \text{ revolutions of doffer per minute.}$$

$$15.32 \times 48.10 = 736.8920 \text{ ins.} = 61.4076 \text{ feet} \text{---surface speed per minute.}$$

Drawing Roller 4" diameter = 12.56" circumference

$$\frac{\text{Cyl. Pin. } 193.68 \times 50}{75} = 129.12 \text{ revolutions of drawing roller per minute.}$$

$$129.12 \times 12.56 = 1621.7472 \text{ ins.} = 135.1456 \text{ feet—surface speed per minute.}$$

Delivering Roller 4" diameter = 12.56" circumference.

$$\frac{\text{Cyl. Pin. } 193.68 \times 50 \times 23}{75 \times 24} = 123.74 \text{ revolutions of delivering roller per minute.}$$

$$123.74 \times 12.56 = 1554.1744 \text{ ins.} = 129.5145 \text{ feet—surface speed per minute}$$

Plaiding Roller 4" diameter = 12.56" circumference

$$\frac{\text{Cyl. Pin. } 193.68 \times 50 \times 32 \times 32 \times 46}{104 \times 104 \times 90 \times 48} = 9.76 \text{ revolutions of plaiding roller per minute.}$$

$$9.76 \times 12.56 = 122.5856 \text{ ins.} = 10.2154 \text{ feet—surface speed per minute.}$$

No. 1 Tin Roller 10" diameter = 31.41" circumference.

$$\frac{\text{Cyl. Pin. } 193.68 \times 50 \times 23 \times 26 \times 84 \times 46 \times 84}{75 \times 60 \times 84 \times 72 \times 90 \times 76} = 10.09 \text{ revolutions of No. 1 tin roller per minute.}$$

$$10.09 \times 31.41 = 316.9269 \text{ ins.} = 26.4105 \text{ feet—surface speed per minute.}$$

No. 2 Tin Roller 8" diameter = 25.13" circumference.

$$\frac{\text{Cyl. Pin. } 193.68 \times 50 \times 23 \times 26 \times 84 \times 46 \times 73}{75 \times 60 \times 84 \times 72 \times 90 \times 60} = 11.11 \text{ revolutions of No. 2 tin roller per minute.}$$

$$11.11 \times 25.13 = 279.1943 \text{ ins.} = 23.2661 \text{ feet—the surface speed per minute.}$$

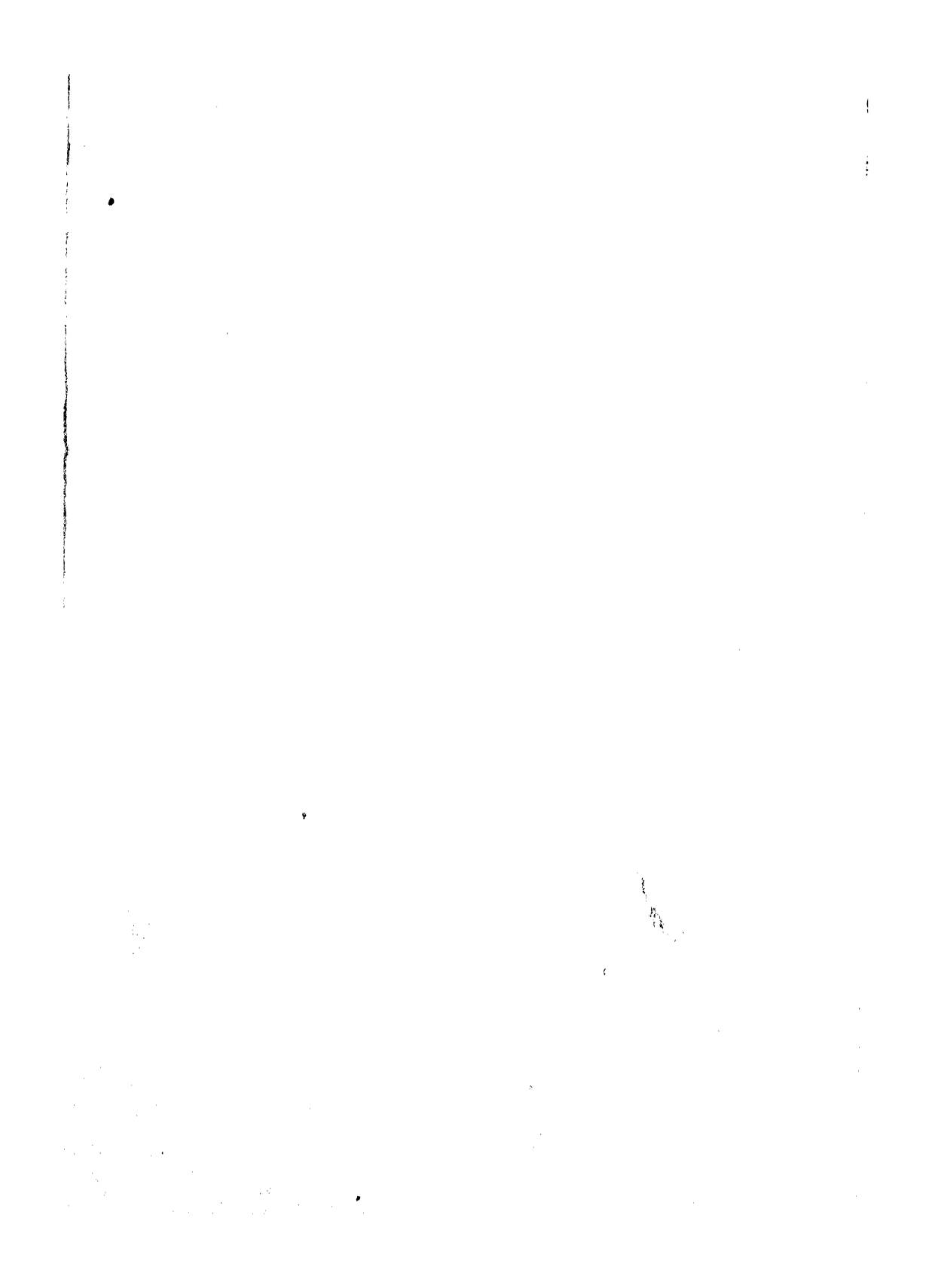



SPECIFICATION AND SPEEDS OF FINISHERS.

Feed Roller	...	...	$\frac{193.68 \times \text{cyl. pin.} \times 32 \times 32}{104 \times 104 \times 90}$	=	20.373	Constant No. for revs. p	
						minute.	
Nos. 1, 2, 3, and 4 Workers			$\frac{193.68 \times \text{c.p.} \times 23 \times 26 \times 84 \times 46}{75 \times 60 \times 84 \times 72 \times 90}$	=	18.270	"	"
Nos. 1 and 2 Strippers			$\frac{193.68 \times \text{C. pin.}}{18}$	=	10.76	"	"
Nos. 3 and 4	„		$\frac{193.68 \times \text{C. pin.}}{15}$	=	12.912	"	"
Doffer	...	...	$\frac{193.68 \times \text{C. pin.} \times 23 \times 26}{75 \times 60 \times 84}$	=	3.064	"	"
Drawing Roller	...		$\frac{193.68 \times \text{C. pin.}}{75}$	=	2.5824	"	"
Delivering Roller	...		$\frac{193.68 \times \text{C. pin.} \times 23}{75 \times 24}$	=	2.4748	"	"
Plaiding Roller	...		$\frac{193.68 \times \text{C. pin.} \times 32 \times 32 \times 46}{104 \times 104 \times 90 \times 48}$	=	19.525	"	"
No. 1 Tin Roller	...		$\frac{193.68 \times \text{C.p.} \times 23 \times 26 \times 84 \times 46 \times 84}{75 \times 60 \times 84 \times 72 \times 90 \times 76}$	=	20.187	"	"
No. 2	„	„	$\frac{193.68 \times \text{C.p.} \times 23 \times 26 \times 84 \times 46 \times 73}{75 \times 60 \times 84 \times 72 \times 90 \times 60}$	=	22.229	"	"

The Speed of the Workers can be changed without affecting the other parts of the Finisher as under:—

$$\frac{\text{Speed of Cyl. Worker.} \\ \text{Cylinder. Pin.} \\ 193.68 \times 40 \times 23 \times 26 \times 84 \times \text{Change} \\ 75 \times 60 \times 84 \times 72 \times 90 \text{ pinion.}}{=} = 16,887 \text{ Constant No. with a 40 T. Cylinder Pinion.}$$

$$\frac{193.68 \times 42 \times 23 \times 26 \times 84 \times \text{C.P.}}{75 \times 60 \times 84 \times 72 \times 90} = 15,681 \quad \text{,,} \quad 42 \quad \text{,,}$$

$$\frac{193.68 \times 44 \times 23 \times 26 \times 84 \times \text{C.P.}}{75 \times 60 \times 84 \times 72 \times 90} = 17,476 \quad \text{,,} \quad 44 \quad \text{,,}$$

$$\frac{193.68 \times 46 \times 23 \times 26 \times 84 \times \text{C.P.}}{75 \times 60 \times 84 \times 72 \times 90} = 18,270 \quad \text{,,} \quad 46 \quad \text{,,}$$

$$\frac{193.68 \times 48 \times 23 \times 26 \times 84 \times \text{C.P.}}{75 \times 60 \times 84 \times 72 \times 90} = 19,064 \quad \text{,,} \quad 48 \quad \text{,,}$$

$$\frac{193.68 \times 50 \times 23 \times 26 \times 84 \times \text{C.P.}}{75 \times 60 \times 84 \times 72 \times 90} = 19,859 \quad \text{,,} \quad 50 \quad \text{,,}$$

$$\frac{193.68 \times 52 \times 23 \times 26 \times 84 \times \text{C.P.}}{75 \times 60 \times 84 \times 72 \times 90} = 20,653 \quad \text{,,} \quad 52 \quad \text{,,}$$

$$\frac{193.68 \times 54 \times 23 \times 26 \times 84 \times \text{C.P.}}{75 \times 60 \times 84 \times 72 \times 90} = 21,447 \quad \text{,,} \quad 54 \quad \text{,,}$$

$$\frac{193.68 \times 56 \times 23 \times 26 \times 84 \times \text{C.P.}}{* \quad 75 \times 60 \times 84 \times 72 \times 90} = 22,242 \quad \text{,,} \quad 56 \quad \text{,,}$$

$$\frac{193.68 \times 58 \times 23 \times 26 \times 84 \times \text{C.P.}}{75 \times 60 \times 84 \times 72 \times 90} = 23,036 \quad \text{,,} \quad 58 \quad \text{,,}$$

$$\frac{193.68 \times 60 \times 23 \times 26 \times 84 \times \text{C.P.}}{75 \times 60 \times 84 \times 72 \times 90} = 23,880 \quad \text{,,} \quad 60 \quad \text{,,}$$







SETTING OF FINISHER ...

Shell to Cylinder,	...	...	...	...	...	$\frac{1}{4}$ "
Feed Roller to Shell,	...	...	...	...	...	$\frac{1}{18}$
,,    Cylinder,	...	...	...	...	No. 16	
No. 1 Worker to Cylinder,	...	...	...	...	,,	14
No. 2    ,,    ,,	...	...	...	...	,,	14
No. 3    ,,    ,,	...	...	...	...	,,	16
No. 4    ,,    ,,	...	...	...	...	,,	16
No. 1 Stripper.	,,	...	...	...	,,	14
No. 2    ,,    ,,	...	...	...	...	,,	16
No. 3    ,,    ,,	...	...	...	...	,,	16
No. 4    ,,    ,,	...	...	...	...	,,	16
Between Strippers and Workers,	...	...	...	...	,,	16
Doffer to Cylinder,	...	...	...	...	,,	14
Doffer to Drawing Roller,	...	...	...	...	,,	10

SPECIFICATION OF PINS.

Cylinder,	...	71" × 48"	$\frac{7}{16}$ " × $\frac{7}{16}$ "	120	9	55	No. 14	$\frac{7}{8}$ "
Feed Roller,	...	71 × 2 $\frac{1}{2}$	$\frac{3}{8}$ × $\frac{3}{8}$	4	8	186	,, 14	1 $\frac{1}{8}$
No. 1 Stripper	...	71 × 11	$\frac{7}{16}$ × $\frac{3}{8}$	30	7	82	,, 14	$\frac{7}{8}$
No. 2    ,,	...	71 × 11	$\frac{7}{16}$ × $\frac{3}{8}$	30	7	82	,, 14	$\frac{7}{8}$
No. 3    ,,	...	71 × 9	$\frac{3}{8}$ × $\frac{3}{8}$	36	7	63	,, 15	$\frac{7}{8}$
No. 4    ,,	...	71 × 9	$\frac{3}{8}$ × $\frac{3}{8}$	36	7	63	,, 15	$\frac{7}{8}$
No. 1 Worker	...	71 × 7	$\frac{3}{8}$ × $\frac{3}{8}$	30	7	63	,, 13	1 $\frac{3}{8}$
No. 2    ,,	...	71 × 7	$\frac{5}{16}$ × $\frac{5}{16}$	30	8	75	,, 14	1 $\frac{1}{4}$
No. 3    ,,	...	71 × 7	$\frac{5}{16}$ × $\frac{5}{16}$	30	8	75	,, 14	1 $\frac{1}{4}$
No. 4    ,,	...	71 × 7	$\frac{5}{16}$ × $\frac{5}{16}$	30	8	75	,, 14	1 $\frac{1}{4}$
Doffer,	...	71 × 14	$\frac{1}{4}$ × $\frac{1}{4}$	34	11	140	,, 16	1

FINISHER.

Pulleys 24", Cylinder Pinion 50 Teeth, Stripper Driving Pulley 94" diameter, 10 ends into 1.

$$\frac{4 \times 104 \times 104 \times 90}{75 \times 32 \times 32 \times 4} = 12.675 \text{ draft.}$$

C.P. C.P.

$$\frac{4 \times 60 \times 84}{23 \times 26 \times 15 \frac{1}{8} \text{ dia. of doffer}} = 2.2197 \text{ draft between doffer and drawing roller.}$$

C.P.

This draft is only necessary for the delivery of material between doffer and drawing roller, but is not required in working out the draft between the feed and drawing roller.

Change Pinions	20	22	24	26	28	30 T.
Drafts	2.8856	2.6233	2.4047	2.2197	2.0611	1.9237

$$\frac{4 \times 104 \times 104 \times 90}{75 \times 30} = 432.64 \text{ Constant No. for draft with a 30 T Change Pinion.}$$

C.P. C.P.

$$\frac{4 \times 104 \times 104 \times 90}{75 \times 32} = 405.6 \quad \text{''} \quad \text{''} \quad 32 \quad \text{''}$$

C.P. C.P.

$$\frac{4 \times 104 \times 104 \times 90}{75 \times 34} = 381.741 \quad \text{''} \quad \text{''} \quad 34 \quad \text{''}$$

C.P. C.P.

$$\frac{4 \times 104 \times 104 \times 90}{75 \times 36} = 360.533 \quad \text{''} \quad \text{''} \quad 36 \quad \text{''}$$

C.P. C.P.

$$\frac{4 \times 104 \times 104 \times 90}{75 \times 38} = 341.557 \quad \text{''} \quad \text{''} \quad 38 \quad \text{''}$$

C.P. C.P.

$$\frac{4 \times 104 \times 104 \times 90}{75 \times 40} = 324.48 \quad \text{''} \quad \text{''} \quad 40 \quad \text{''}$$

C.P. C.P.

DRAFTS.

Change Pinions on	CHANGE PINIONS ON										
	20	22	24	26	28	30	32	34	36	38	40 T.
30 Teeth	21.632	19.6636	18.0266	16.64	15.4514	14.4213	13.52	12.7247	12.0177	11.3852	10.816
32 "	20.28	18.4363	16.9	15.6	14.4857	13.52	12.675	11.9294	11.2666	10.6736	10.14
34 "	19.087	17.3518	15.9058	14.6823	13.6336	12.7247	11.9294	11.2276	10.6039	10.0458	9.5435
36 "	18.0266	16.3878	15.0222	13.8666	12.8761	12.0177	11.2666	10.6039	10.0148	9.4876	9.0133
38 "	17.0778	15.5253	14.2315	13.1368	12.1984	11.3852	10.6736	10.0457	9.4876	8.9883	8.5389
40 "	16.224	14.749	13.52	12.48	11.5585	10.816	10.14	9.5435	9.0133	8.5389	8.112

## LAP MACHINE.

*End elevation showing driving end.*SCALE,  $\frac{1}{8}$ th.*(For Diagram see page 100.)*

A	Friction disc for driving bowl, ... ..	28" dia.
B	Bowl sliding on vertical shaft, ... ..	6 $\frac{1}{2}$ " dia.
C	Bevel pinion on vertical shaft, ... ..	16 teeth.
D	Bevel wheel on stud pinion, ... ..	60 teeth.
E	Stud pinion, ... ..	12 teeth.
F	Wheel for driving bobbin, ... ..	84 teeth.
G	Rack pinion, ... ..	11 teeth.

## LAP MACHINE.

*End elevation showing end opposite to driving pulleys.*SCALE,  $\frac{1}{8}$ th.*(For Diagram see page 100.)*

A	Rack pinion, ... ..	11 teeth.
B	Wheel on rack pinion shaft, ... ..	100 teeth.
C	Pinion on hand wheel, ... ..	14 teeth.
D	Worm wheel for ringing bell, .. ..	90 to 100 teeth.
	Speed Pulleys, ... ..	300 revolutions.
	Friction Plate, ... ..	28" dia.
	„ Ball, ... ..	7" „
	Bevel Pinion, ... ..	16 teeth.
	„ Wheel, ... ..	60 teeth.
	Spur pinion, ... ..	12 teeth.
	„ Wheel, ... ..	84 „ on ball.

LAP MACHINE.

LAP MACHINE.

END ELEVATION SHOWING DRIVING END.

SCALE  $\frac{1}{8}$ TH.

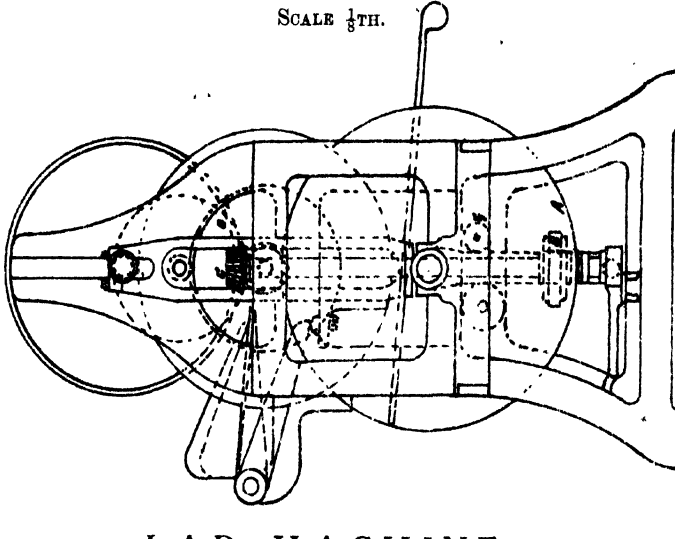

LAP MACHINE.

END ELEVATION SHOWING END OPPOSITE

TO DRIVING PULLEYS.

SCALE,  $\frac{1}{8}$ TH.

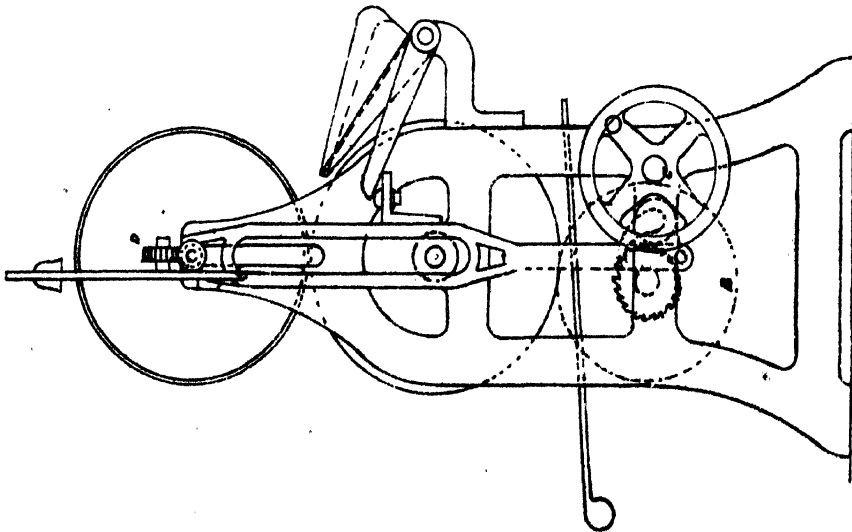

DIMENSIONS OF CARD CYLINDERS AND ROLLERS.

DIMENSIONS OF CARD CYLINDERS AND ROLLERS.

*According to a Fairbairn Specification.*

SINGLE DOFFER BREAKER CARD.

NAME OF ROLLER.	Dia. over the wood.	Dia. over the staves.	Dia. to centre of pins.
Cylinder ... ..	4 ft.	4— $1\frac{3}{8}$	4— $11\frac{1}{16}$
Feeder ... ..	9 ins.	$10\frac{1}{8}$	$10\frac{1}{2}$
2 Workers ... ..	7 ins.	$8\frac{1}{8}$	$8\frac{1}{2}$
2 Strippers ... ..	11 ins.	$12\frac{1}{8}$	$12\frac{3}{8}$
Doffer ... ..	14 ins.	15	$5\frac{5}{16}$

SINGLE DOFFER FINISHING CARD.

Cylinder ... ..	4 ft.	4— $1\frac{1}{8}$	4— $1\frac{3}{32}$
Feeder ... ..	$2\frac{1}{2}$ ins.	$3\frac{3}{4}$	$4\frac{1}{8}$
1st and 2nd Workers ...	7 ins.	8	$8\frac{5}{16}$
1st and 2nd Strippers ...	11 ins.	12	$12\frac{7}{32}$
3rd and 4th Workers ...	7 ins.	8	$8\frac{5}{16}$
3rd and 4th Strippers ...	9 ins.	10	$10\frac{7}{32}$
Doffer ... ..	14 ins.	$14\frac{7}{8}$	$15\frac{5}{32}$

## DOUBLE DOFFER BREAKER CARD.

Cylinder . . . . .	4 ft.	4—1 $\frac{3}{8}$	4—1 $\frac{11}{16}$
Feeder ... ..	18 $\frac{1}{2}$ ins.	19 $\frac{5}{8}$	20
Workers ... ..	14 ins.	15 $\frac{1}{8}$	15 $\frac{1}{2}$
Strippers .. . . .	14 ins.	15 $\frac{1}{8}$	15 $\frac{3}{8}$
1st Doffer ... ..	14 ins.	15	15 $\frac{5}{16}$
2nd Doffer ... ..	14 ins.	14 $\frac{7}{8}$	15 $\frac{5}{32}$

## DOUBLE DOFFER FINISHER CARD.

Cylinder ... ..	4 ft.	4—1 $\frac{1}{8}$	4—1 $\frac{3}{32}$
Feeder ... ..	4 ins.	5 $\frac{1}{4}$	5 $\frac{5}{8}$
1st Worker ... ..	14 ins.	15	15 $\frac{5}{16}$
1st Stripper ... ..	14 ins.	15	15 $\frac{7}{32}$
2nd and 3rd Workers ...	14 ins.	15	15 $\frac{5}{16}$
2nd and 3rd Strippers ...	14 ins.	15	15 $\frac{7}{32}$
1st Doffer ... ..	14 ins.	14 $\frac{7}{8}$	15 $\frac{5}{32}$
2nd Doffer ... ..	14 ins.	14 $\frac{7}{8}$	15 $\frac{1}{8}$

DETAILS OF COVERING.

DETAILS OF COVERING.

(Recommended by Fairbairn).

SINGLE DOFFER BREAKER CARD FOR WARPS.

NAME OF ROLLER.	No. of w.g.	Total length of pins.	Pitch of Pins.	Length of pins out.
Cylinder ... ..	12	1	$\frac{5}{8}$ and $\frac{5}{8}$	$\frac{5}{16}$
Feeder ... ..	12	$1\frac{1}{2}$	$\frac{7}{16}$ and $\frac{7}{16}$	$\frac{3}{8}$
2 Workers ... ..	13	$1\frac{1}{2}$	$\frac{7}{16}$ and $\frac{7}{16}$	$\frac{3}{8}$
2 Strippers ... ..	13	$1\frac{1}{4}$	$\frac{1}{2}$ and $\frac{1}{2}$	$\frac{1}{4}$
Doffer ... ..	14	$1\frac{1}{8}$	$\frac{3}{8}$ and $\frac{3}{8}$	$\frac{5}{16}$

SINGLE DOFFER FINISHER FOR WARPS.

Cylinder ... ..	14	$\frac{7}{8}$	$\frac{15}{32}$ and $\frac{15}{32}$	$\frac{9}{32}$
Feeder ... ..	13	$1\frac{1}{8}$	$\frac{13}{32}$ and $\frac{13}{32}$	$\frac{3}{8}$
1st and 2nd Workers ...	13	$1\frac{1}{2}$	$\frac{13}{32}$ and $\frac{13}{32}$	$\frac{5}{16}$
1st and 2nd Strippers ...	13	$1\frac{1}{4}$	$\frac{5}{8}$ and $\frac{5}{8}$	$\frac{7}{32}$
3rd and 4th Workers ...	14	$1\frac{1}{2}$	$\frac{3}{8}$ and $\frac{3}{8}$	$\frac{5}{16}$
3rd and 4th Strippers ...	14	$1\frac{1}{8}$	$\frac{7}{16}$ and $\frac{7}{16}$	$\frac{7}{32}$
Doffer ... ..	15	1	$\frac{11}{32}$ and $\frac{11}{32}$	$\frac{9}{32}$



## SINGLE DOFFER FINISHER FOR WARPS.

Cylinder ... ..	15	" $\frac{7}{8}$	"    " $\frac{7}{16}$ and $\frac{7}{16}$	" $\frac{9}{32}$
Feeder ... ..	14	$1\frac{1}{8}$	$\frac{3}{8}$ and $\frac{3}{8}$	$\frac{3}{8}$
1st and 2nd Workers ...	14	$1\frac{1}{2}$	$\frac{3}{8}$ and $\frac{3}{8}$	$\frac{5}{16}$
1st and 2nd Strippers ...	14	$1\frac{1}{8}$	$\frac{7}{16}$ and $\frac{7}{16}$	$\frac{7}{32}$
3rd and 4th Workers ...	15	$1\frac{1}{2}$	$\frac{5}{16}$ and $\frac{5}{16}$	$\frac{5}{16}$
3rd and 4th Strippers ...	15	$1\frac{1}{8}$	$\frac{3}{8}$ and $\frac{3}{8}$	$\frac{7}{32}$
Doffer ... ..	16	1	$\frac{5}{16}$ and $\frac{1}{4}$	$\frac{9}{32}$

## SINGLE DOFFER BREAKER FOR WEFTS

Cylinder ... ..	11	" $1\frac{1}{8}$	"    " $\frac{3}{4}$ and $\frac{3}{4}$	" $\frac{11}{32}$
Feeder ... ..	11	$1\frac{1}{4}$	$\frac{1}{2}$ and $\frac{1}{2}$	$\frac{13}{32}$
2 Workers ... ..	12	$1\frac{5}{8}$	$\frac{1}{2}$ and $\frac{1}{2}$	$\frac{13}{32}$
2 Strippers ... ..	12	$1\frac{1}{4}$	$\frac{1}{2}$ and $\frac{1}{2}$	$\frac{9}{32}$
Doffer ... ..	13	$1\frac{1}{8}$	$\frac{7}{16}$ and $\frac{7}{16}$	$\frac{11}{32}$

SINGLE DOFFER FINISHER FOR WEFTS.

Cylinder ... ..	13	1	$\frac{1}{2}$ and $\frac{1}{2}$	$\frac{9}{32}$
Feeder ... ..	12	$1\frac{1}{4}$	$\frac{7}{16}$ and $\frac{7}{16}$	$\frac{3}{8}$
1st and 2nd Workers ..	12	$1\frac{1}{2}$	$\frac{7}{16}$ and $\frac{7}{16}$	$\frac{5}{16}$
1st and 2nd Strippers ...	13	$1\frac{1}{4}$	$\frac{15}{32}$ and $\frac{15}{32}$	$\frac{7}{32}$
3rd Worker ... ..	13	$1\frac{1}{2}$	$\frac{3}{8}$ and $\frac{3}{8}$	$\frac{5}{16}$
3rd Stripper ... ..	14	$1\frac{1}{8}$	$\frac{7}{16}$ and $\frac{7}{16}$	$\frac{7}{32}$
Doffer ... ..	15	1	$\frac{3}{8}$ and $\frac{3}{8}$	$\frac{9}{32}$

DETAILS OF COVERING

DOUBLE DOFFER BREAKER CARD FOR WEFTS.

NAME OF ROLLER.	No. of w.g.	Total length of pins.	Pitch of Pins.	Length of pins out.
Cylinder ... ..	12	1	$\frac{5}{8}$ and $\frac{5}{8}$	$\frac{5}{16}$
Feeder ... ..	12	$1\frac{1}{4}$	$\frac{7}{16}$ and $\frac{7}{16}$	$\frac{3}{8}$
2 Workers ... ..	13	$1\frac{1}{2}$	$\frac{7}{16}$ and $\frac{7}{16}$	$\frac{3}{8}$
2 Strippers ... ..	13	$1\frac{1}{4}$	$\frac{1}{2}$ and $\frac{1}{2}$	$\frac{1}{4}$
1st Doffer ... ..	14	$1\frac{1}{8}$	$\frac{3}{8}$ and $\frac{3}{8}$	$\frac{5}{16}$
2nd Doffer ... ..	15	1	$\frac{11}{32}$ and $\frac{11}{32}$	$\frac{9}{32}$

## DOUBLE DOFFER FINISHER FOR WARPS

Cylinder ... ..	14	"	" "	"
Feeder ... ..	13	1 $\frac{1}{11}$	$\frac{1^5}{3^2}$ and $\frac{1^5}{3^2}$	$\frac{9}{3^2}$
1st Worker ... ..	13	1 $\frac{1}{2}$	$\frac{1^3}{3^2}$ and $\frac{1^3}{3^2}$	$\frac{3}{8}$
1st Stripper ... ..	13	1 $\frac{1}{4}$	$\frac{1^5}{3^2}$ and $\frac{1^5}{3^2}$	$\frac{5}{16}$
2nd and 3rd Workers ...	14	1 $\frac{1}{2}$	$\frac{3}{8}$ and $\frac{3}{8}$	$\frac{7}{3^2}$
2nd and 3rd Strippers ...	14	1 $\frac{1}{8}$	$\frac{7}{16}$ and $\frac{7}{16}$	$\frac{5}{16}$
1st Doffer ... ..	15	1	$\frac{1^1}{3^2}$ and $\frac{1^1}{3^2}$	$\frac{7}{3^2}$
2nd Doffer ... ..	16	1	$\frac{5}{16}$ and $\frac{5}{16}$	$\frac{9}{3^2}$
			$\frac{1}{4}$	

## DOUBLE DOFFER FINISHER FOR WEFTS.

Cylinder ... ..	15	"	" "	"
Feeder ... ..	14	1 $\frac{1}{8}$	$\frac{7}{16}$ and $\frac{7}{16}$	$\frac{9}{3^2}$
1st Worker ... ..	14	1 $\frac{1}{2}$	$\frac{3}{8}$ and $\frac{3}{8}$	$\frac{3}{8}$
1st Stripper ... ..	14	1 $\frac{1}{8}$	$\frac{3}{8}$ and $\frac{3}{8}$	$\frac{5}{16}$
2nd and 3rd Workers ...	15	1 $\frac{1}{2}$	$\frac{7}{16}$ and $\frac{7}{16}$	$\frac{5}{16}$
2nd and 3rd Strippers ...	15	1 $\frac{1}{8}$	$\frac{5}{16}$ and $\frac{5}{16}$	$\frac{7}{3^2}$
1st Doffer .. ..	16	1	$\frac{3}{8}$ and $\frac{3}{8}$	$\frac{7}{3^2}$
2nd Doffer ... ..	17	1	$\frac{5}{16}$ and $\frac{1}{4}$	$\frac{9}{3^2}$
			$\frac{1}{4}$ and $\frac{1}{4}$	$\frac{1}{4}$

SINGLE DOFFER BREAKER AND FINISHER STAVES.

SPECIFICATION OF SINGLE DOFFER BREAKER AND  
FINISHER STAVES.

The following specifications of single doffer breaker and finisher staves are given as an example of what is actually working, and also to show the student the *correct manner* in which to state the particulars of breaker and finisher covering.

It will be observed that this covering is not quite so fine as that shown on the previous pages, which is recommended by Messrs Fairbairn, Naylor, Macpherson & Co., Ltd. My experience, however, is that it is fine enough for breaker and finisher producing sliver for hessian warps and wefts.

Breaker, 6' × 4' cylinder.

Cylinder cover, 71" × 48";  $\frac{5}{8}$ " ×  $\frac{9}{16}$ " pitch.

3 rounds of 41 staves each.

123 staves, 7 rows, 38 pins, No. 12—1".

Feed cover, 71" × 9";  $\frac{7}{16}$ " ×  $\frac{7}{16}$ " pitch.

3 rounds of 12 staves each.

36 staves, 6 rows, 54 pins, No. 12—1 $\frac{1}{4}$ ".

(2) Stripper covers, 71" × 11";  $\frac{1}{2}$ " ×  $\frac{1}{2}$ " pitch.

3 rounds of 15 staves each.

45 staves, 5 rows, 47 pins, No. 13—1".

(2) Worker covers, 71" × 7";  $\frac{1}{2}$ " ×  $\frac{3}{8}$ " pitch.

3 rounds of 10 staves each.

30 staves, 7 rows, 47 pins, No. 12—1 $\frac{5}{8}$ ".

Doffer cover, 71" × 14";  $\frac{3}{8}$ " ×  $\frac{5}{16}$ " full, pitch.

3 rounds of 17 staves each.

51 staves, 8 rows, 63 pins, No. 14—1 $\frac{3}{8}$ ".

Finisher, 6' × 4' cylinder.

Cylinder cover, 71" × 48";  $\frac{7}{16}$ " ×  $\frac{7}{16}$ " pitch.

3 rounds of 41 staves each.

123 staves, 9 rows, 54 pins, No. 14— $\frac{7}{8}$ ".

Feeder cover, 71" × 2 $\frac{7}{8}$ ";  $\frac{3}{8}$ " ×  $\frac{3}{8}$ " pitch.

3 rounds of 4 staves each.

12 staves, 8 rows, 63 pins, No. 14—1 $\frac{1}{8}$ ".

## DOUBLE DOFFER BREAKER AND FINISHER STAVES.

- (2) Stripper covers,  $71'' \times 11''$ ;  $\frac{7}{16}'' \times \frac{7}{16}''$  pitch.  
 3 rounds of 15 staves each.  
 45 staves, 6 rows, 54 pins, No. 14— $\frac{7}{8}''$ .
- (2) Stripper covers,  $71'' \times 9''$ ;  $\frac{7}{16}'' \times \frac{7}{16}''$  pitch.  
 3 rounds of 12 staves each.  
 36 staves, 6 rows, 54 pins, No. 14— $\frac{7}{8}''$ .
- (2) Worker covers,  $71'' \times 7''$ ;  $\frac{7}{16}'' \times \frac{3}{8}''$  pitch.  
 3 rounds of 10 staves each.  
 30 staves, 7 rows, 54 pins, No. 13— $1\frac{3}{8}''$ .
- (2) Worker covers,  $71'' \times 7''$ ;  $\frac{3}{8}'' \times \frac{5}{16}''$  pitch.  
 3 rounds of 10 staves each.  
 30 staves, 8 rows, 63 pins, No. 14— $1\frac{1}{4}''$ .
- Doffer cover,  $71'' \times 14''$ ;  $\frac{5}{16}'' \times \frac{1}{4}''$  pitch.  
 3 rounds of 17 staves each.  
 51 staves, 11 rows, 75 pins, No. 16— $1''$ .
- 

SPECIFICATION OF DOUBLE DOFFER BREAKER AND  
FINISHER STAVES.

- Breaker, 6'  $\times$  4' cylinder.  
 Cylinder cover,  $71'' \times 48''$ ;  $\frac{3}{4}'' \times \frac{3}{4}''$  pitch.  
 3 rounds of 41 staves each.  
 123 staves, 5 rows, 31 pins, No. 12— $1\frac{1}{16}''$ .
- Feeder cover,  $71'' \times 18\frac{1}{2}''$ ;  $\frac{7}{16}'' \times \frac{7}{16}''$  pitch.  
 3 rounds of 23 staves each.  
 69 staves, 6 rows, 54 pins, No. 12— $1\frac{1}{4}''$ .
- (2) Stripper covers,  $71'' \times 14''$ ;  $\frac{1}{2}'' \times \frac{1}{2}''$  pitch.  
 3 rounds of 17 staves each.  
 51 staves, 5 rows, 47 pins, No. 13— $1''$ .
- (2) Worker covers,  $71'' \times 14''$ ;  $\frac{3}{8}'' \times \frac{3}{8}''$  pitch.  
 3 rounds of 17 staves each.  
 51 staves, 64 rows, 13 pins, No. 13— $1\frac{3}{4}''$ .

## DOUBLE DOFFER BREAKER AND FINISHER STAVES.

Doffer cover, 71" × 14";  $\frac{3}{8}$ " ×  $\frac{3}{8}$ " pitch.

3 rounds of 21 staves each.

51 staves, 7 rows, 63 pins, No. 14— $1\frac{1}{8}$ ".

Finisher, 6' × 4' cylinder.

Cylinder, 71" × 48";  $\frac{5}{8}$ " ×  $\frac{5}{8}$ " pitch.

3 rounds of 41 staves each.

123 staves, 6 rows, 38 pins, No. 14— $\frac{7}{8}$ ".

Feeder cover, 71" × 14";  $\frac{3}{8}$ " ×  $\frac{3}{8}$ " pitch.

3 rounds of 5 staves each.

15 staves, 8 rows, 63 pins, No. 14— $1\frac{1}{8}$ ".

(3) Stripper covers, 71" × 14";  $\frac{3}{4}$ " ×  $\frac{3}{4}$ " pitch.

3 rounds of 17 staves each.

51 staves, 4 rows, 32 pins, No. 14— $\frac{3}{4}$ ".

(3) Worker covers, 71" × 14";  $\frac{3}{8}$ " ×  $\frac{3}{8}$ " pitch.

3 rounds of 17 staves each.

51 staves, 9 rows, 94 pins, No. 16—1".

(2) Doffer covers, 71" × 14";  $\frac{1}{4}$ " ×  $\frac{5}{16}$ " pitch.

3 rounds of 17 staves each.

51 staves, 9 rows, 94 pins, No. 16—1".

NOTE.—All the rollers are 71" long over the staves, the cylinder cover is also 71" over the staves; this is owing to the flange of cylinder ends being  $\frac{1}{2}$ " thick.

The staves are all made in three lengths. This is more convenient than when they are made in two. If any accident happens to the covering, it can often be repaired with much less trouble.

It is of the utmost importance that the covering of cards should be well and carefully screwed on to the cylinder and the other rollers. If a staff gets loose, much damage may and often is done when this happens.

All the staves should be made of the very best beech that can be had, thoroughly clean, free from knots, and well seasoned; should be in stock at least three years.

All the rollers of breakers and finishers should be picked and brushed thoroughly with a steel reenge once a week.

The "shrouding," that is the cast iron plate at both ends of cylinder, should always be kept as close as possible, say barely  $\frac{1}{16}$ th clear; this also helps to keep the ends of all the roller covers clean.

## DOUBLE DOFFER BREAKER AND FINISHER STAVES.

Dimensions of screws used to fix on staves—screws for wood—

Cylinder staves, No. 16— $1\frac{3}{4}$ ".

Feeder „ No. 16— $1\frac{1}{2}$ ".

Stripper „ No. 16— $1\frac{1}{2}$ ".

Worker „ No. 16— $1\frac{1}{2}$ ".

Doffer „ No. 16— $1\frac{1}{2}$ ".

Finisher feed roller screws are  $1\frac{1}{2}$ "  $\times$   $\frac{3}{8}$ " for iron.

As the staves on the covering of the breakers and finishers is a matter of great importance, and is not very easily understood by the beginner, I have thought it best to explain this by an illustration of the different staves. This will very readily bring before the eye of the student the pitch of pin, the angle to pitch, &c., of the staves, the specification of staves in each case being marked upon the illustration. It must be borne in mind, however, that a great many different opinions are held by men of experience as to what is the best specification for breaker and finisher covering, and on this subject we will not attempt to dogmatize. Without doubt there is a great difference of opinion on this as well as upon many other points in connection with jute machinery; and so little has been written upon the subject that it has not been possible to gather up practical men's opinions as to what has been generally found to be best, and thereby form a general rule for the course to be adopted; and if more had been written on jute machinery it would have been better for the general good of all concerned—better for the man of experience, as well as for the young men engaged in learning their business.

---

DETAILS OF COVERING.

DETAILS OF COVERING.

UP STRIKER SINGLE DOFFER BREAKER FOR WEFTS.

NAME OF ROLLER.	No. of w.g.	Total length of pins.	Pitch of Pins.	Length of pins out.
Cylinder ... ..	11	$1\frac{1}{8}$ "	$\frac{3}{4} \times \frac{3}{4}$ "	$\frac{11}{32}$ "
Feeder ... ..	11	$1\frac{1}{4}$	$\frac{1}{2} \times \frac{1}{2}$	$\frac{13}{32}$
2 Workers ... ..	12	$1\frac{5}{8}$	$\frac{1}{2} \times \frac{1}{2}$	$\frac{11}{32}$
2 Strippers ... ..	12	$1\frac{1}{4}$	$\frac{1}{2} \times \frac{1}{2}$	$\frac{9}{32}$
Doffer ... ..	13	$1\frac{1}{8}$	$\frac{7}{16} \times \frac{7}{16}$	$\frac{11}{32}$

UP STRIKER SINGLE DOFFER FINISHER FOR WEFTS.

Cylinder ... ..	13	1"	$\frac{1}{2} \times \frac{1}{2}$ "	$\frac{9}{32}$
Feeder ... ..	12	$1\frac{1}{4}$	$\frac{7}{16} \times \frac{7}{16}$	$\frac{3}{8}$
1st and 2nd Workers ...	12	$1\frac{1}{2}$	$\frac{7}{16} \times \frac{7}{16}$	$\frac{5}{16}$
1st and 2nd Strippers ...	13	$1\frac{1}{4}$	$\frac{15}{32} \times \frac{15}{32}$	$\frac{7}{32}$
3rd Workers ... ..	13	$1\frac{1}{2}$	$\frac{3}{8} \times \frac{3}{8}$	$\frac{5}{16}$
3rd Strippers ... ..	14	$1\frac{1}{8}$	$\frac{7}{16} \times \frac{7}{16}$	$\frac{7}{32}$
Doffer ... ..	15	1	$\frac{3}{8} \times \frac{3}{8}$	$\frac{9}{32}$

COVERING FOR JUTE SNIPPER.

Two Cylinders (Upper and Lower) with 4 Sheets of Staves each.

1st Sheet ...	38 staves, 2 rows, 8 pins, No. 9—	$1\frac{3}{8}$ .
2nd " {	30 " 3 " 7 "	$10-1\frac{3}{8}$ .
	3 " 11 "	$12-1\frac{3}{8}$ .
3rd " {	30 " 10 " 22 "	$14-1\frac{3}{8}$ .
	15 " 21 "	$16-1\frac{3}{8}$ .
4th " ...	30 " 20 " 78 "	$18-\frac{7}{8}$ .



## BREAKER COVERING.

## BREAKER COVERING.

Stripper Cover 71" × 11";  $\frac{1}{2}$ " ×  $\frac{1}{2}$ " pitch.

Three rounds of 15 staves each, 45 staves, 5 rows, 47 pins—No. 13, 1".

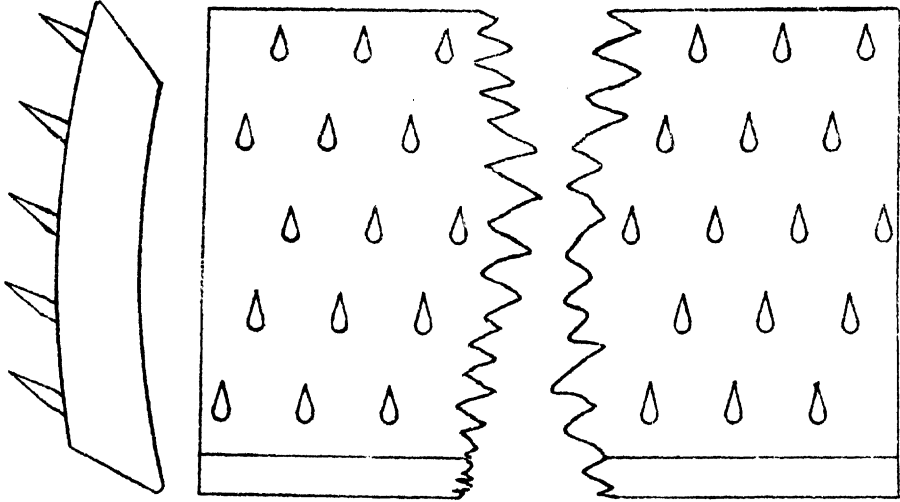

## BREAKER.

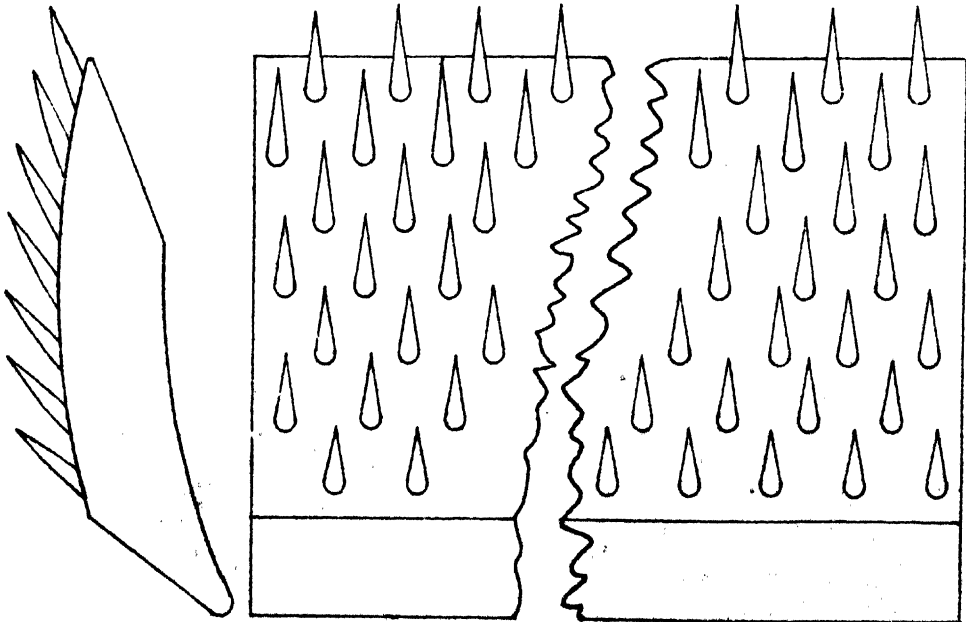
Worker Cover 71" × 7";  $\frac{1}{2}$ " ×  $\frac{3}{8}$ " pitch.Three rounds of 10 staves each, 30 staves, 7 rows, 47 pins—No. 12, 1 $\frac{1}{8}$ ".

BREAKER COVERING.

BREAKER.

Cylinder Cover 71" × 48";  $\frac{5}{8}$ " ×  $\frac{9}{16}$ " pitch.

Three rounds of 41 staves each, 123 staves, 7 rows, 38 pins—No. 12, 1".

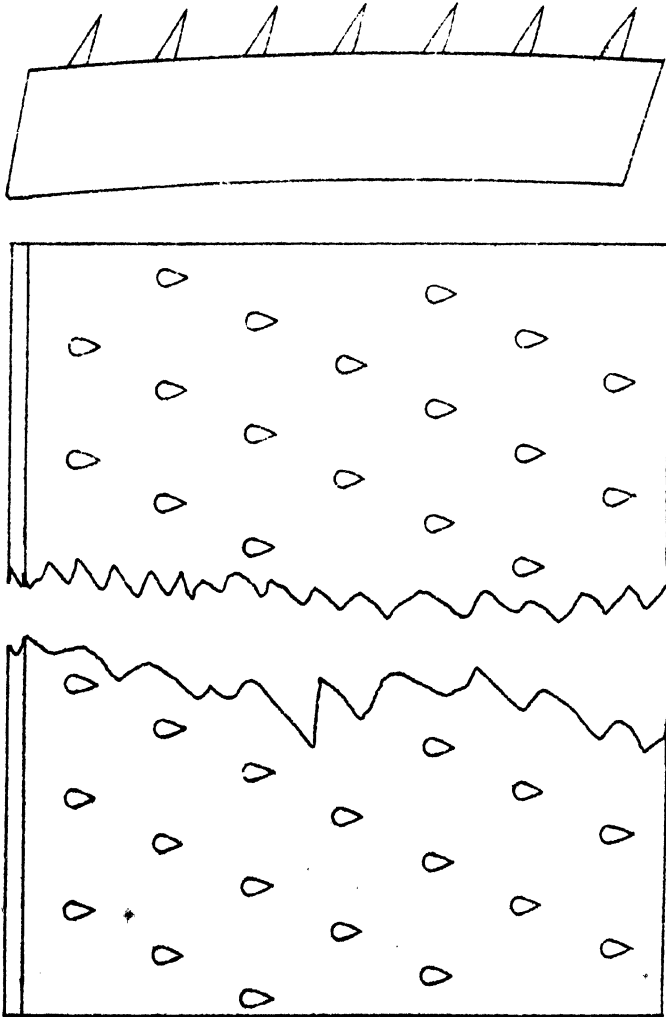

BREAKER COVERING.

BREAKER.

Feeder Cover 71" x 9";  $\frac{1}{16}$ " x  $\frac{1}{16}$ " pitch.

Three rounds of 12 staves each, 36 staves, 6 rows, 54 pins—No. 12, 1 $\frac{1}{4}$ ".

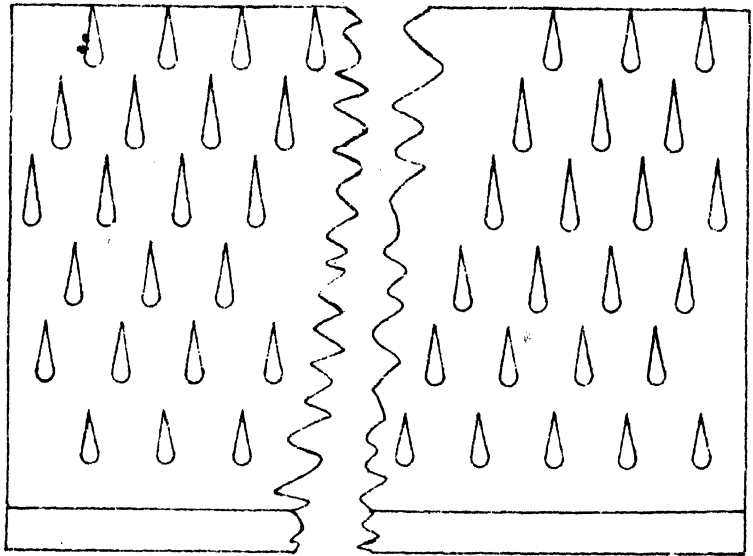
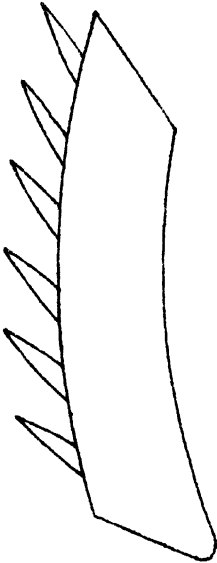

BREAKER.

Doffer Cover 71" x 14";  $\frac{3}{16}$ " x  $\frac{5}{16}$ ".

Three rounds of 17 staves each, 51 staves, 8 rows, 63 pins—No. 14, 1 $\frac{1}{2}$ ".

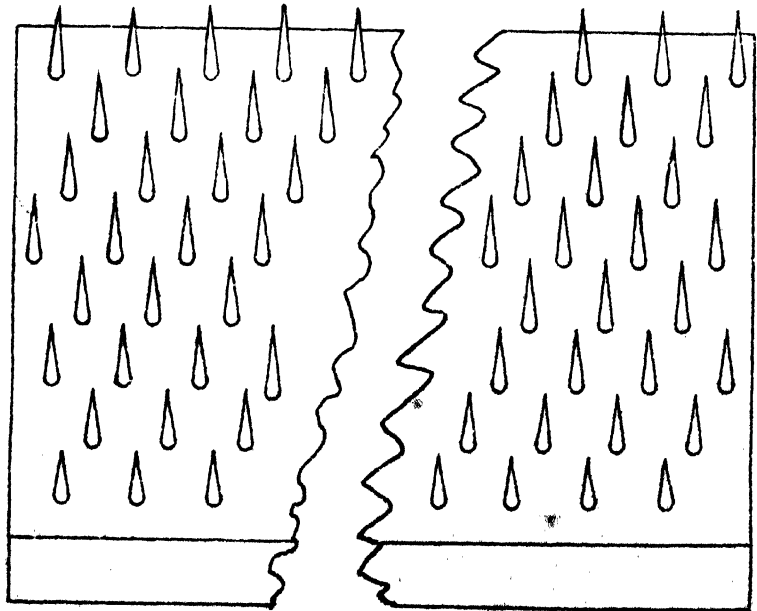
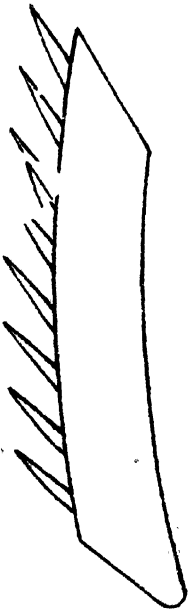

## FINISHER

Cylinder Cover (Single Doffer) 71" × 48";  $\frac{1}{16}$ " ×  $\frac{7}{16}$ " pitch.

Three rounds of 41 staves each, 123 staves, 9 rows. 54 pins—No. 14,  $\frac{7}{8}$ ".

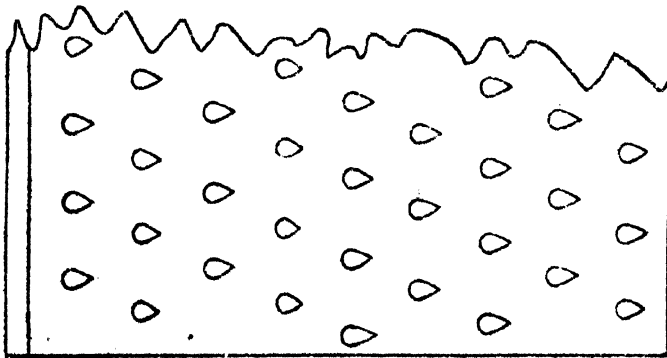
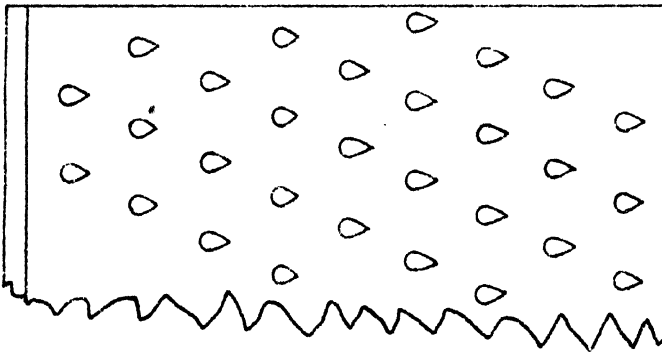
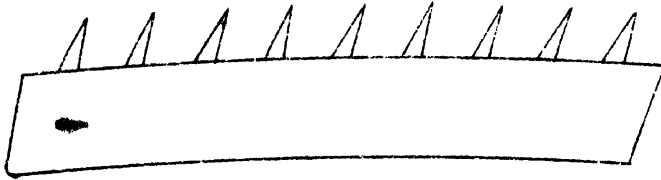

FINISHER COVERING.

FINISHER.

Feed Cover  $71'' \times 2\frac{7}{16}''$ ;  $\frac{3}{8}'' \times \frac{3}{8}''$  pitch.

Three rounds of 4 staves each, 12 staves, 8 rows, 68 pins—No. 13,  $1\frac{1}{8}''$ .

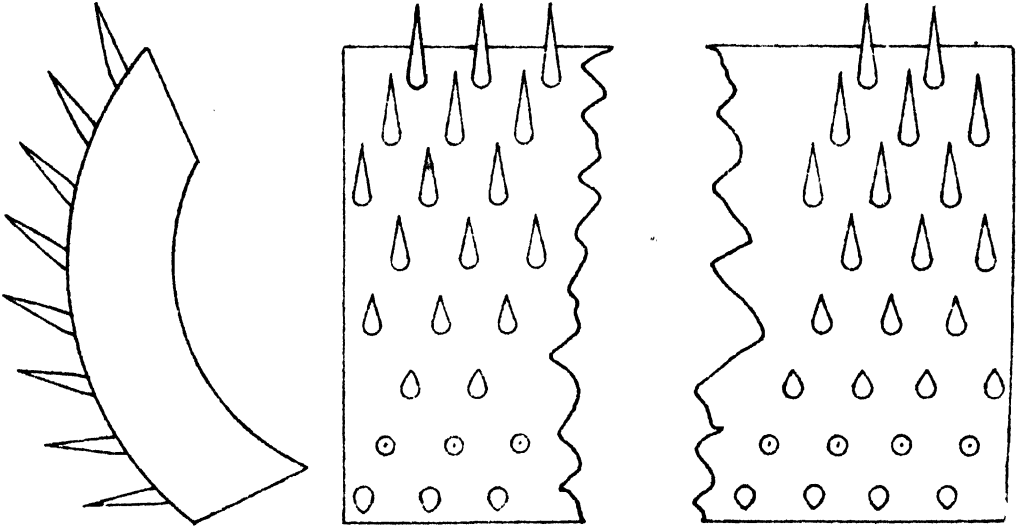

FINISHER.

Stripper Cover  $71'' \times 11''$ ;  $1\frac{7}{8}'' \times 1\frac{7}{8}''$  pitch.

Three rounds of 15 staves each, 45 staves, 6 rows, 54 pins—No. 14,  $\frac{7}{8}''$ .

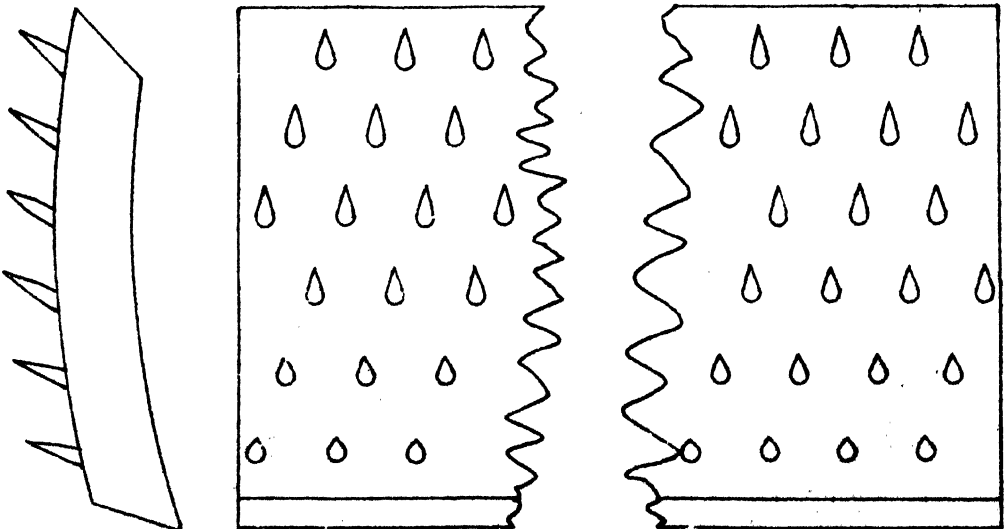

FINISHER COVERING.

FINISHER.

Stripper Cover  $71'' \times 9''$ ;  $\frac{1}{16}'' \times \frac{1}{16}''$  pitch.

Three rounds of 12 staves each, 36 staves, 6 rows, 54 pins—No. 14,  $\frac{7}{8}''$ .

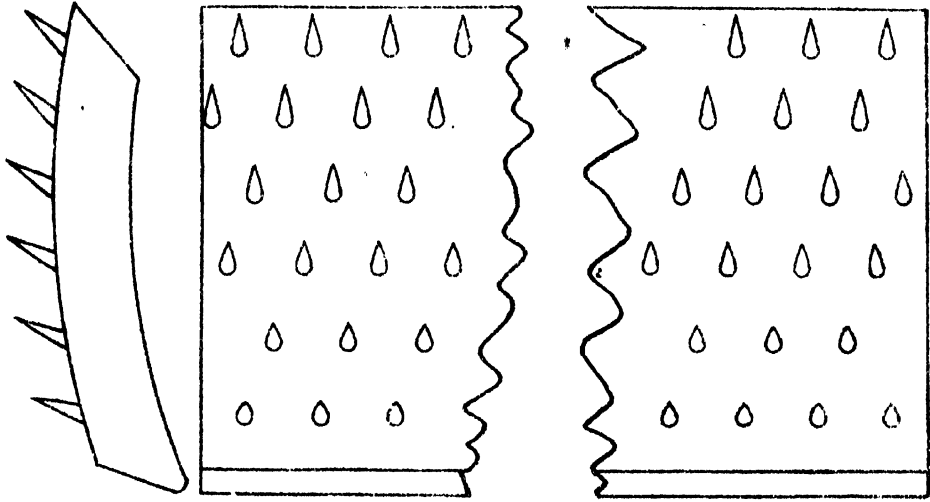

FINISHER.

Worker Cover  $71'' \times 7''$ ;  $\frac{1}{16}'' \times \frac{3}{8}''$  pitch.

Three rounds of 10 staves each, 80 staves, 7 rows, 54 pins—No. 13,  $1\frac{3}{8}''$ .

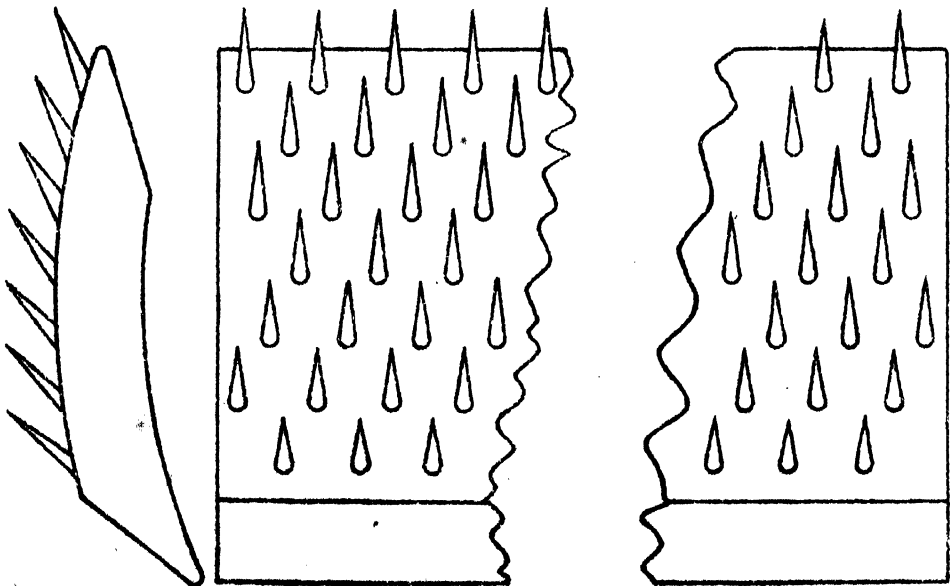

FINISHER COVERING.

FINISHER.

Worker Cover 71" x 7";  $\frac{3}{8}$ " x  $\frac{5}{16}$ " pitch.

Three rounds of 10 staves each, 30 staves, 8 rows, 68 pins—No. 14, 1 $\frac{1}{4}$ ".

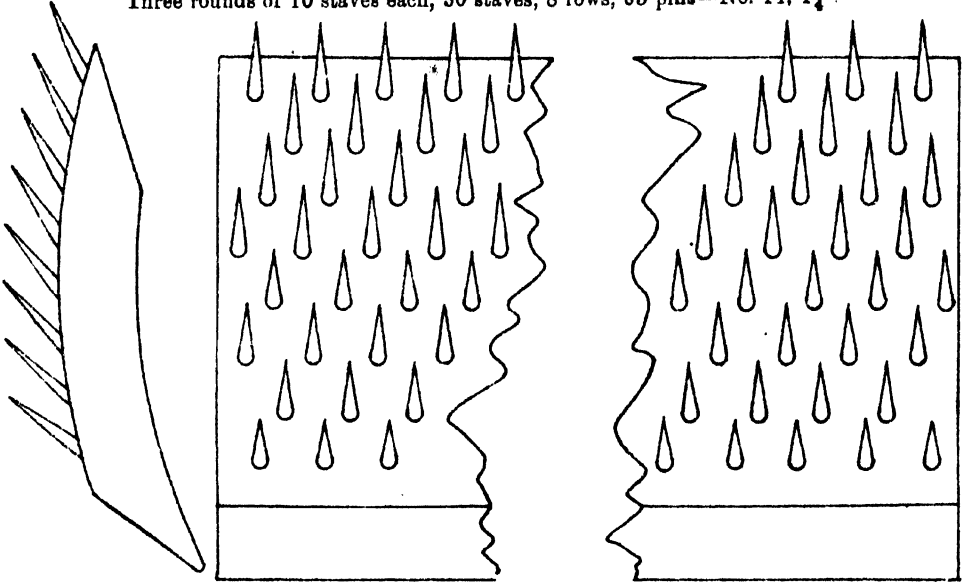

FINISHER.

Doffer Cover 71" x 14";  $\frac{5}{16}$ " x  $\frac{1}{4}$ " pitch.

Three rounds of 17 staves each, 51 staves, 11 rows, 75 pins—No. 16, 1".

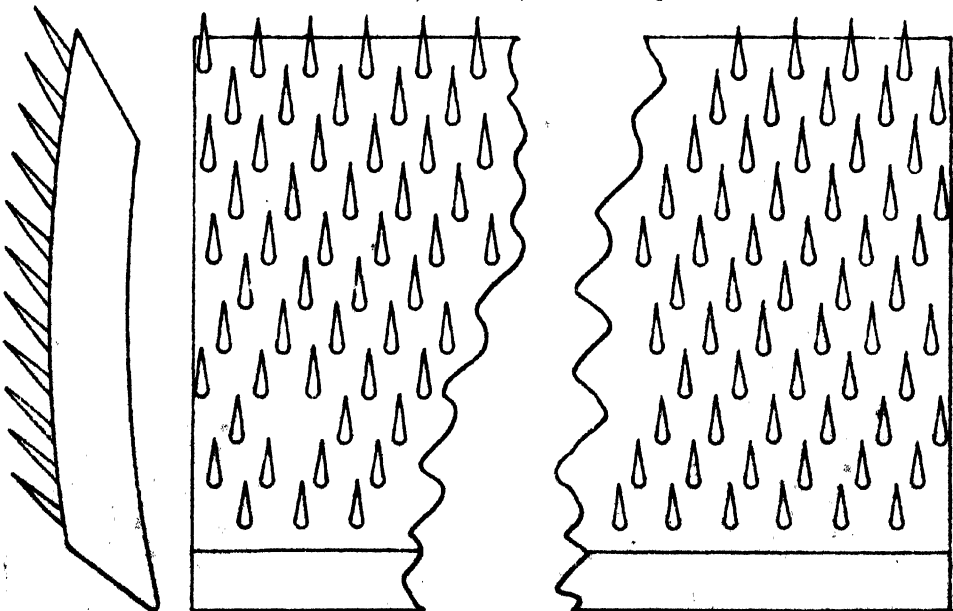

SETTING OF BREAKER AND FINISHER CARDS.

GENERAL INSTRUCTIONS AS TO SETTING\* OF BREAKER  
AND FINISHER CARDS FOR HESSIAN YARNS.

*Breaker.*

Distance between feed worker and shell	...	No. 15 W.G.
Shell of cylinder, $\frac{3}{8}$ "		
Feed roller cylinder	... ..	" 14 "
1st worker	... ..	" 11 "
2nd worker	... ..	" 12 "
2 strippers	... ..	" 16 "
Doffer	... ..	" 15 "
Drawing roller	... ..	" 10 "
Pressing roller, 1" off cylinder.		

*Finisher.*

Shell—the usual distance is  $\frac{3}{16}$ " to  $\frac{1}{4}$ " off cylinder.

Feed roller from cylinder and shell	...	No. 15 W.G.
2 workers	... ..	" 12 "
2 "	... ..	" 14 "
4 strippers	... ..	" 16 "
Doffer	... ..	" 17 "
Drawing roller, 1" off cylinder.		
Leather roller	... ..	" 10 "

In the case of double doffer cards, the only difference would be that on the breaker the bottom doffer would be No. 14 W.G., and top doffer No. 15; and on the finisher card the top doffer No. 16, and bottom doffer No. 17. When the quantity passed over a breaker is more than 12 tons, and over a finisher more than 6 tons, per week, the distance of pin points of rollers from cylinder should be rather greater than indicated.

\*NOTE.—Card "Sets" are pieces of steel plate usually about 12 inches long and 3 inches broad, and should be stamped No. 10, 12, 14, 16, &c, according to their thickness B.W.G.; if Worker and Stripper are to be set No. 16 between, use No. 16 set, and so on.



## UP STRIKER BREAKER CARD.

## DRAFTS.

$$\begin{array}{l}
 120 \text{ feeder wheel} \times 120 \text{ stud wheel} \times 58 \text{ stud wheel} \times 4'' \text{ dia.} \\
 \text{of drawing roller} \quad \dots \quad \dots \quad \dots \quad \dots \quad \dots \\
 20 \text{ change} \times 20 \text{ stud pinion} \times 66 \text{ drawing roller wheel} \times 10\frac{1}{2}'' \\
 \text{working diameter of feeder} \quad \dots \quad \dots \quad \dots \quad \dots
 \end{array}
 \left. \vphantom{\begin{array}{l} 120 \text{ feeder wheel} \\ 20 \text{ change} \end{array}} \right\} = 12$$

## SPEEDS OF WORKERS.

$$\begin{array}{l}
 52 \text{ change} \times 24 \text{ drawing roller pinion} \times 28 \text{ stud pinion} \times 88 \\
 \text{doffer wheel} \times 64 \text{ stud pinion} \times 190 \text{ revs. of cylinder} \quad \dots \\
 66 \text{ drawing roller wheel} \times 54 \text{ stud wheel} \times 88 \text{ doffer wheel} \\
 \times 96 \text{ stud wheel} \times 92 \text{ worker wheel} \quad \dots \quad \dots \quad \dots
 \end{array}
 \left. \vphantom{\begin{array}{l} 52 \text{ change} \\ 66 \text{ drawing roller wheel} \end{array}} \right\} = 13.5$$

13.5 revs. per min.  $\times$  29.8" working circumference = 33.5 ft. per min.

## UP STRIKER FINISHER CARD.

## DRAFTS.

$$\begin{array}{l}
 120 \text{ feeder wheel} \times 120 \text{ stud wheel} \times 58 \text{ stud wheel} \times 4'' \text{ dia.} \\
 \text{of drawing roller} \quad \dots \quad \dots \quad \dots \quad \dots \quad \dots \\
 20 \text{ change} \times 20 \text{ stud pinion} \times 66 \text{ drawing roller wheel} \times 10\frac{1}{2}'' \\
 \text{working diameter of feeder} \quad \dots \quad \dots \quad \dots \quad \dots
 \end{array}
 \left. \vphantom{\begin{array}{l} 120 \text{ feeder wheel} \\ 20 \text{ change} \end{array}} \right\} = 12$$

## SPEEDS OF WORKERS.

$$\begin{array}{l}
 40 \text{ change} \times 24 \text{ drawing roller pinion} \times 28 \text{ stud pinion} \times 88 \\
 \text{doffer wheel} \times 190 \text{ revs. of cylinder} \quad \dots \quad \dots \quad \dots \\
 66 \text{ drawing roller wheel} \times 54 \text{ stud wheel} \times 88 \text{ doffer wheel} \times 72 \\
 \text{worker wheel} \quad \dots \quad \dots \quad \dots \quad \dots \quad \dots
 \end{array}
 \left. \vphantom{\begin{array}{l} 40 \text{ change} \\ 66 \text{ drawing roller wheel} \end{array}} \right\} = 19.9$$

19.9 revs. per min.  $\times$  26.7" working circumference = 44.3 ft. per min.

## DRAWING FRAMES.

### DRAWING FRAMES.

DRAWING FRAMES.—After the carding processes comes the drawing. In an ordinary hessian yarn system there are two drawings, usually called first and second drawings. The cans taken from the finishers are put up at the back of the first drawing, and so many of them are run into one at the front of the first drawing—usually four ends are run into one. The cans from the front of the first drawing are put up at the back of the second drawing, and so many are again run into one at the front of the second drawing—usually two ends are run into one here, but at both drawings more are often put up, never less for the making of hessian yarns.

So far as the material passing over the drawings, the most important point is to see that the gills are not overloaded—that is, that the sliver is well down through the gill pins. You should always see the points of the gill pins if you wish a level sliver at the front of the drawing, and this will also ensure a level and regular spun rove. No matter how well the jute has been carded, if the drawing gills are overloaded, irregular and lumpy spun rove will follow. Two kinds of first drawings are illustrated, and the particulars of gear and speed are given. The circular first drawing is not very much used now in Dundee at least; why it has been laid aside I have never been able exactly to understand, as it could do a large amount of work, and do it well, without much mechanical attention, and was a machine easily managed by the worker. From its general compactness and the small space occupied by it, I have an impression it will come back again.

The First Drawing, now most in use, is the push bar drawing, and there is no doubt it has been a great success. It may be driven at any speed within reason; but it must not be too heavily laden, or the fibre will incline to slide over the points of the pins. With a light load, so that the gill pins will go well up through the material, it will make a thorough job, and do a fair quantity per day of 10 hours—say from 30 cwt. to 35 cwt.—with two heads. It works best with a single end over each gill, and the four ends run

into one at the front. This, however, is of course a matter of opinion, and sometimes of convenience in the arrangement of the work to be done. Two heads are sufficient for a 56 spindle roving.

The gill bars of the push bar drawing are actuated by pinions. When the bars are working, so many of them are in the teeth of these pinions, the others both above and below not actually into the wheels, are being pushed along by the others as they pass out of the teeth, hence the name push or slide drawing. To keep the bars tight upon the top is imperative, and a pinion and coupling has been arranged for on this machine, so that if the bars wear a little slack this slackness can be taken off. The success of the push drawing has been owing to the bars rising up straight at the back, and they do this nearer to a spiral drawing than any other drawing we have had before, consequently the less slackness you allow to get upon the bars the nearer the perpendicular will the gill bar pins rise through the sliver at the back end, which is the great point to be desired.

As there is no intricate work about the arrangement for actuating the gill bars, simply four pinions with teeth into which the end of the bars move, it only requires to be kept *clean*. It has become very popular.

The Second Drawing, or, as it is sometimes called, the finishing drawing, is usually a spiral drawing—so called from the gill bars being actuated by screws. To the speed of a spiral drawing or roving there is a limit beyond which it is impossible to go. No finishing drawing will make such a level sliver as a spiral drawing—that is the result of my experience; many others hold a different opinion, however. The push bar drawing is being adopted as a second drawing, but as I have not worked them as such, would rather not express an opinion of its merits as a finishing drawing. The screws, wipers, slides, &c., require careful attention, so that the heads of gill bars are kept upon the “pitch.” To possess a thorough knowledge of the screws of spiral drawings and rovings, and to be able to keep them running on the “pitch” without any tampering with the “pitch pin,” is about the best test of fitness of a mill mechanic for his work; and all apprentice mill mechanics should make it their business to thoroughly master this, as without a thorough knowledge of this they will never be the master of their trade.

## DRAWING FRAMES.

Two heads of a spiral drawing are sufficient for a 56 spindle roving 10" × 5" pitch, but many people prefer three heads to a roving. If you have three heads in your second drawing to each roving, this will necessitate the second drawings being at right angles to the first drawings, and, of course, in line with the rovings, and this means you will have to drive the second drawings with belts over a universal guide. The arrangement, either as regards the floor space or driving arrangement, never seems so direct and complete as when the breakers, finishers, and drawings are in parallel lines, and the rovings at right angles to the second drawings.

A second drawing of two heads is able to produce sliver for a 56 spindle roving, 10" × 5" pitch, making 30 cwt. to 35 cwt. of rove, in 10 hours.

Here we may explain what is meant by the gill bars going off the "pitch." The gill bars of any drawing or roving, except, of course, rotary drawings and rovings, are driven by a small pin, called the "pitch" pin. If the bars do not move easily, either from some mechanical defect or from the gill bars getting jammed by a lump of jute, or a "choke," as it is termed, this pitch pin will break; the gill bars of the head which has gone out of order will cease to move, while the other head or heads will continue to work as before. The head which has ceased working, owing to the breakage of the "pitch pin," will not work until this pin has been renewed, and the obstruction removed; and the smaller the pitch pin is in diameter the better, as it will do the less damage to the gill bars when it breaks easily than if it requires an unnecessary amount of obstruction to break it, and the smaller the pin you can work with is the real guarantee that the screws, wipers, slides, &c., are mechanically in good order, and also thoroughly clean.

PITCH PIN FOR PUSH BAR DRAWING.—This pin works both heads of the drawing, and should not be more than No. 8 Birmingham wire gauge; second drawing pitch pin, which works only one of the drawing heads, should not be more than No. 10 B.W.G., and the roving pitch pins No. 15 B.W.G. If you work with these pins there will not be much wrong with the gill bars before you will know it.

\*See page 162 for illustration of "pitch pin" arrangement.

The number of gill bars in circular drawings is	-	52	
"	"	one head of push bar is	32
"	"	„ spiral second drawing is	21
"	"	„ roving is	- 22

The "cans" from the second drawings should be put up in sets of eight at a time at the back of the roving.

DRAWINGS.—Sometimes the drawing rollers and pressing rollers are made "hard to hard"—by that term is meant that both surfaces of the rollers are metal—but the most common method employed is that the pressing roller is covered with leather. If the rollers are hard to hard, they are both fluted with a round top and bottom flute, and the flutes work into one another; and we may remark here, in passing, that, for the purpose of calculation, a round top and bottom fluted roller  $2\frac{1}{2}$  in. diameter is always taken at 3 in. diameter. This, as will be readily understood, is owing to the depth of flutes making the circumference of roller longer than if with plain flutes. Leather-covered pressing rollers on a round top and bottom fluted roller are often used in first drawings; but usually leather pressing rollers, either in drawings or rovings, work upon a drawing roller with V flutes, or scratch flutes, as they are sometimes called.

DRAFT PLATE WITH DRAFT PINION AND DRAFT ATTACHED TO MACHINE.

Push Bar Drawing—

Draft.	Pinion.
$2\frac{1}{2}$	96
3	80
$3\frac{1}{2}$	68
4	60
$4\frac{1}{2}$	53
5	48
$5\frac{1}{2}$	44
6	40
$6\frac{1}{2}$	37

Circular Drawing—

Draft.	Pinion.
3	60
$3\frac{1}{2}$	52
4	45
$4\frac{1}{2}$	40
5	36
6	30
$6\frac{1}{2}$	28
7	26

Second Drawing Spiral—

Draft.	Pinion.
5	64
$5\frac{1}{2}$	58
6	53
$6\frac{1}{2}$	49
7	46
$7\frac{1}{2}$	43
8	40
$8\frac{1}{2}$	38
9	36
$9\frac{1}{2}$	34
10	32

DRAWING DRAFT ARRANGEMENTS.

DRAWING DRAFT ARRANGEMENTS.

*First Drawing—Push Bar.*

Speed Pulleys 180 revolutions per minute ; pulley pinion 34 teeth.

Draft arrangement—hard-to-hard rollers—

$$*(3'') \frac{2\frac{1}{2} \times 56 \times 74 \times 50 \times 23 \times 32}{80 \times 20 \times 34 \times 39 \times 40 \times 1\frac{1}{8}} = 3.3 \text{ draft.}$$

$$*(3'') \frac{\text{Change}}{\text{pinion}} \frac{2\frac{1}{2} \times 56 \times 74 \times 50 \times 23 \times 32}{\times 20 \times 34 \times 39 \times 40 \times 1\frac{1}{8}} = 264.9 \text{ Constant Number for draft.}$$

*First Drawing—Push Bar.*

Speed Pulleys 180 revolutions per minute.

Draft arrangement—Leather rollers on round fluted roller or plain fluted roller.

$$\frac{2\frac{1}{2} \times 76 \times 74 \times 50 \times 28 \times 32}{56 \times 19 \times 34 \times 39 \times 40 \times 1\frac{1}{8}} = 3.9 \text{ draft.}$$

$$\frac{\text{Change}}{\text{pinion}} \frac{2\frac{1}{2} \times 76 \times 74 \times 50 \times 28 \times 32}{\times 19 \times 34 \times 39 \times 40 \times 1\frac{1}{8}} = 222.5 \text{ Constant Number for draft.}$$

\*In the calculations remember remarks as to round top and bottom fluted rollers *versus* plain or V fluted rollers.

*First Drawing Circular.*

Speed Pulleys 240 revolutions per minute ; pulley pinion 28 teeth.

Draft arrangement—hard-to-hard rollers—

$$(3\frac{1}{2}'') \frac{3'' \times 18 \times 120 \times 27 \times 15}{22 \times 18 \times 52 \times 15 \times 3''} = 3.30 \text{ draft between drawing roller and retaining roller.}$$

$$(3\frac{1}{2}'') \frac{3'' \times 18 \times 120 \times 27 \times 15}{22 \times 18 \times \text{c.p.} \times 15 \times 3''} = 171.8 \text{ Constant Number for draft.}$$

*First Drawing—Circular.*

Speed pulleys 240 revolutions per minute.

Draft arrangement—Leather rollers on round fluted roller or plain fluted roller.

$$\begin{array}{cccccc}
 3'' & 18 & 120 & 27 & 15 & \\
 \text{---} \times \text{---} \times \text{---} \times \text{---} \times \text{---} & = 3.46 \text{ draft between drawing roller} \\
 18 & 18 & 52 & 15 & 3'' & \text{and retaining roller.} \\
 3'' & 18 & 120 & 27 & 15 & \\
 \text{---} \times \text{---} \times \text{---} \times \text{---} \times \text{---} & = 180 \text{ Constant Number for draft.} \\
 18 & 18 & \text{Change} & 15 & 3'' & \\
 & & \text{pinion} & & & 
 \end{array}$$

*Second Drawing—Spiral.*

Speed pulleys 170 revolutions per minute ; pulley pinion 28 teeth.

Draft arrangement—Leather pressing roller on a plain or V fluted roller.

$$\frac{2\frac{1}{2} \times 35 \times 68 \times 69}{43 \times 25 \times 25 \times 1\frac{1}{8}} = 7.88 \text{ draft.}$$

$$\frac{2\frac{1}{2} \times 35 \times 68 \times 69}{\text{Change pinion} \times 25 \times 25 \times 1\frac{1}{8}} = 339.08 \text{—Constant Number for draft.}$$

---

ARRANGEMENTS OF WHEELS FOR CALCULATION OF SPEED.

ARRANGEMENTS OF WHEELS FOR CALCULATION OF SPEED OF GILL BARS IN DRAWINGS AND ROVINGS.

Driving Shaft 160 revolutions per minute—see plan.

Drum Push Bar Drawing, 16"	
Pulleys „ „ 14"	
Drum Circular „ „ 21"	
Pulleys „ „ 14"	
Drum Spiral „ „ 16"	
Pulleys „ „ 16"	

Thus—

1st Push Bar Drawing Pulley Pinion, 34 teeth.

$$160 \times \frac{6}{14} = 182\frac{2}{7}, \text{ say } 180 \text{ speed of pulleys.}$$

$180 \times \frac{34}{36} = \frac{29}{74} \times \frac{34}{36} = 20.08$  revolutions per minute = speed of Gill Bar Shaft, upon which is Gill Bar Wheel, into which the bars work. This wheel has 17 teeth.

$$180 \times \frac{6}{55} \times \frac{29}{74} \times \frac{34}{36} = 590 \text{ constant number for speed of Gill Bars.}$$

$$17 \times 20.08 = 341.36, \text{ speed of Gill Bars per minute,}$$

This is a fair speed. With this speed this drawing will take sliver from a finisher producing 35 cwt per 10 hours.

Breaker Draft, say, about 13/13½.

Finisher „ „ 14/14½.

Dollop, 32/33 lbs.

1st Circular Drawing Pulley Pinion, 32 teeth.

$$160 \times \frac{3}{4} = 240 \text{ revolutions of pulleys per minute.}$$

$$240 \times \frac{32}{78} \times \frac{18}{120} \times \frac{52}{110} = \text{almost } 7 \text{ revolutions of Gill Bar Wheel per minute.}$$

$$240 \times \frac{32}{78} \times \frac{18}{120} \times \frac{52}{110} = 134 \text{ constant number.}$$

Number of teeth or spaces for bars in Gill Bar Wheel, 52.

$$52 \times 7 = 364 \text{ drops of Gill Bars per minute.}$$

With same arrangement as to Breaker, Finisher, Dollop, &c., this drawing will take from a finisher producing 35 cwt. per day.

Then—

2nd Spiral Drawing—pulley pinion 30 teeth.

$$160 \times \frac{6}{10} = 160 \text{ revolutions of pulleys per minute.}$$

$$160 \times \frac{30}{33} \times \frac{18}{10} \times \frac{21}{14} = 205\frac{2}{7} \text{ speed of Gill Bars per minute.}$$

$$160 \times \frac{\text{Change}}{35} \times \frac{18}{10} \times \frac{21}{14} = 6.85 \text{ constant number.}$$

This drawing, with two heads at this speed on bars, and with a 7½ draft, will take the production from either of the 1st drawings, Push Bar or Circular.

NOTE.—The relations of speed between the retaining roller and gill bars on a Screw Gill Roving are the same for 200/250 lbs. rove as for 60/70 lbs. rove.



Then—

Roving—Drum, 25" ; Pulleys, 18".  
 Twist pinion, 35" on 2¼" rollers.  
 Grist " 35".  
 Rack " 17".  
 Traverse " 28".  
 Weight of rove, 72½/75 lbs. per spindle.

With this arrangement roving will produce 28/30 shifts = 35 cwt. in 10 hours.

In this case particulars are given previous to working out speed of gill bars, as the speed of bars depend on these particulars.

$$160 \times \frac{25}{18} = 222.2. \text{ Say 225 revolutions of main shaft of roving per minute.}$$

$$225 \times \frac{35}{60} \times \frac{38}{35} \times \frac{22}{22} \times \frac{24}{16} = 213.5 \text{ speed of gill bars per minute.}$$

$$225 \times \frac{\text{Twist pinion}}{60} \times \frac{38}{35} \times \frac{22}{22} \times \frac{24}{16} = 6.10 \text{ constant number.}$$

$$225 \times \frac{44}{22} \times \frac{21}{14} = 675 \text{ speed of spindles per minute.}$$

#### SPEED OF DRAWING ROLLER BY SPEED FROM SHAFT DRIVING ROVING PULLEYS.

$$160 \times \frac{25}{18} \times \frac{35}{60} = 129.6 \text{ revolutions of drawing roller per minute.}$$

Engine, 10 hours = 600 minutes.

$$129.6 \times 600 = 77760.0 \text{ revolutions of drawing roller in 10 hours.}$$

$$77760 \times 7.06 = 548985.60 \text{ inches in 10 hours.}$$

$$\frac{548985.60}{36} = 15249.6 \text{ yds.}$$

$$\frac{15249.6}{14400} = 1.05 \text{ spyndles per spindle in 10 hours by engine.}$$

This roving arrangement produces 35 cwt. of rove at 72½/75 lbs. per spynkle, by 56 spindles, 10" × 5" pitch.

$$35 \text{ cwt.} = 3920 \text{ lbs.}$$

$$\frac{3920}{75} = 52.26 \text{ spyndles of rove at 75 lbs. per spindle from 56 spindles.}$$

$$\frac{52.26}{56} = .933 \text{ spyndles per spindle actual in 10 hours.}$$

ARRANGEMENTS OF WHEELS FOR CALCULATION OF SPEED.

11.1 per cent. difference between engine and actual production.

Engine production, 1.05

Actual „ .933

„ Difference, .117

---

1.05 : 100 : : .117 : Answer, 11.1.

*Pitch of Gill Bar Screws for Second Spiral Drawings and also Spiral Rovings.*

The screws for these drawings and rovings, made by Messrs Fairbairn, Naylor, & Macpherson, are always cut a certain number of threads per inch, so that they are not always measurable by an  $\frac{1}{8}$ th or  $\frac{1}{16}$ th.

In the Second Drawings—

Top screws have  $1\frac{3}{4}$  threads per inch.

Bottom „, 0.8 „ „

Rovings—

Top screws have 2 threads per inch.

Bottom „, 0.8 „ „

If you observe the working of gill bars in the second spiral drawing, you will notice that there are most frequently 14 gill bars in the top screws of drawing and 7 in the bottom screws; sometimes there will be 15 in the top and 6 in the bottom; and frequently one will be half-way between. The distance from where the gill bar rises to where it descends is  $8\frac{1}{2}$  inches.

Pitch of top screws,  $1\frac{3}{4}$  per inch.

Top screw,  $8.25 \times 1.75 = 14.43$

Bottom „,  $8.25 \times 0.8 = 6.6$

---

Total, 21 gill bars in a head of 2nd drawing.

Roving,  $10' \times 5''$  spiral.

Top screw,  $7.875 \times 2 = 15.75$

Bottom „,  $7.875 \times 0.8 = 6.3$

---

Total, 22.0 gill bars in one head of roving.

NOTE—For illustrations of Drawing and Roving Screws, see pages 144 and 158

# PATENT CIRCULAR DRAWING FRAME.

SECTIONAL ELEVATION SHOWING  
GEARING AT DRIVING END.  
SCALE,  $\frac{1}{8}$ TH = ONE FOOT.

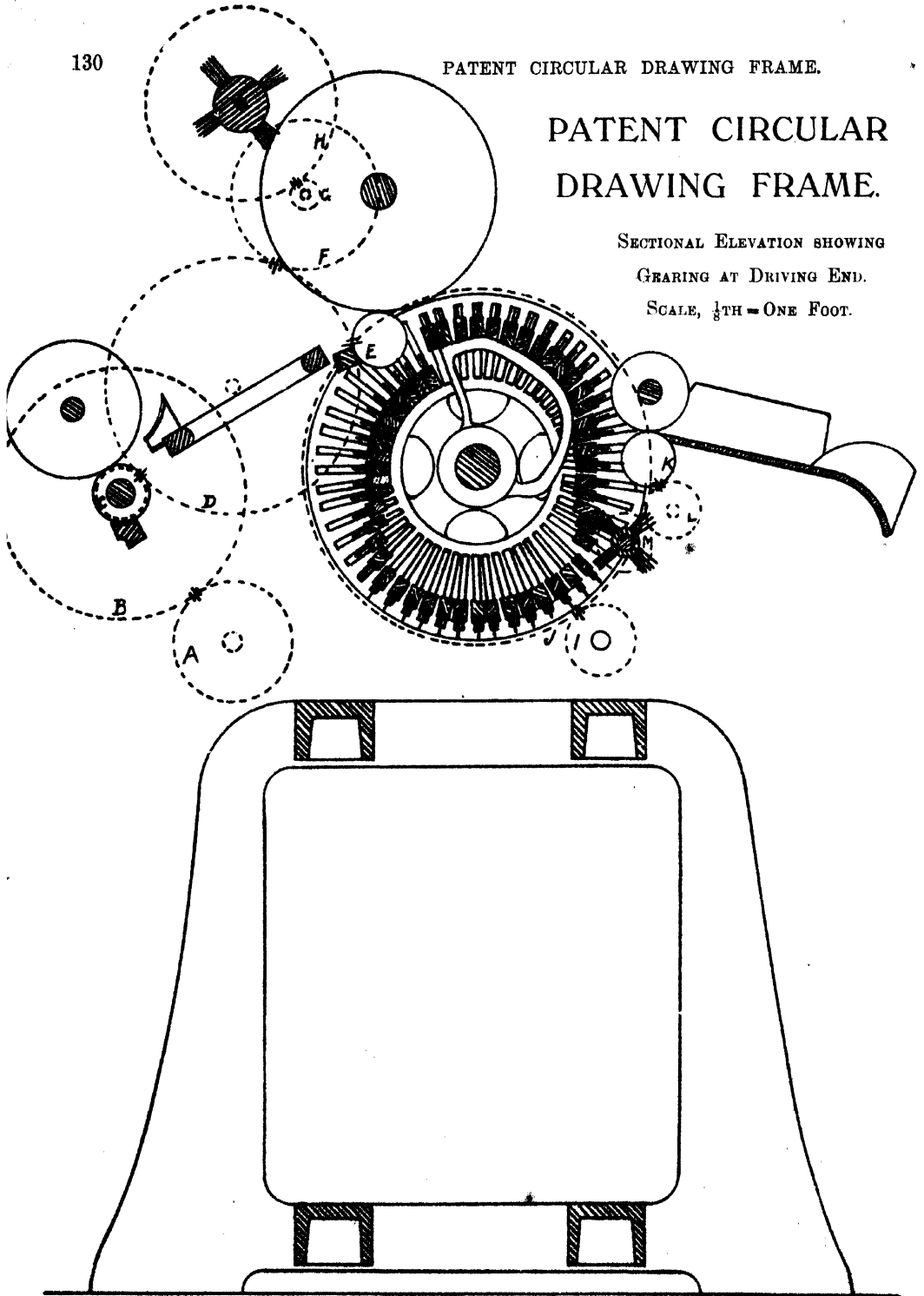

PATENT CIRCULAR DRAWING FRAME.

PATENT CIRCULAR DRAWING FRAME.

*Sectional elevation showing gearing at driving end.*

SCALE,  $\frac{1}{8}$ TH.

A	Driving pinions,	...	...	...	36, 39, and 42 teeth.
B	Delivery roller wheel,	...	...	..	78 teeth.
C	Delivery roller pinion,	...	...	...	17 teeth.
D	Intermediate,	...	...	...	80 teeth.
E	Drawing roller pinion,	...	...	...	18 teeth.
F	Stud wheel for driving brush,	...	...	...	46 teeth
G	Stud pinion for do.,	...	...	...	12 teeth.
H	Brush wheel,	...	...	...	80 teeth.
I	Wheel on shaft for driving circle,	...	...	...	24 teeth.
J	Wheel on circle,	...	...	...	110 teeth.
K	Retaining roller wheel for driving brush,	...	...	...	18 teeth.
L	Intermediate for do.,	...	...	...	18 teeth.
M	Brush wheel,	...	..	...	18 teeth.

Arrangement of Wheels for calculation of speed of gill bars—

$$\frac{240 \times 32 \times 18 \times 52}{78 \times 120 \times 110} = 7 \text{ revolutions of gill bar wheel per minute.}$$

$$\frac{240 \times 32 \times 18 \times \text{C.P.}}{78 \times 120 \times 110} = 134 \text{ constant number for speed gill bars.}$$

Number of spaces for gill bars in gill bar wheel, 52 ; therefore,  $52 \times 7 =$   
**364 drops of gill bars per minute.**

## PATENT CIRCULAR DRAWING FRAME.

*Sectional elevation showing gearing at end opposite to driving pulleys.*

SCALE,  $\frac{1}{8}$ TH.

A	Delivery roller pinion,	...	...	17 teeth.
B	Stud wheel,	...	...	120 teeth.
C	Draught changes,	..	...	26 to 60 teeth.
D	Wheel on circle for driving fallers,	...	...	110 teeth.
E	Wheel on shaft for driving circle at pulley end,	...	...	24 teeth.
F	Stud wheel for driving retaining roller,	...	...	27 teeth.
G	Stud pinion for do.,	..	...	15 teeth.
H	Retaining roller wheel,	...	...	15 teeth.

## DRAFT ARRANGEMENT—

Pressing rollers hard to hard.

$$\frac{(3\frac{1}{2}) 3 \times 18 \times 120 \times 27 \times 15}{22 \times 18 \times 52 \times 15 \times 3} = 3.30 \text{ draft.}$$

$$\frac{3 \times 18 \times 120 \times 27 \times 15}{22 \times 18 \times \text{C.P.} \times 25 \times 3} = 171.8 \text{ constant No. for draft.}$$

Pressing rollers—leather covered on a plain or V fluted roller.

$$\frac{3 \times 18 \times 120 \times 27 \times 15}{18 \times 18 \times 52 \times 15 \times 3} = 3.46 \text{ draft.}$$

$$\frac{3 \times 18 \times 120 \times 27 \times 15}{18 \times 18 \times \text{C.P.} \times 15 \times 3} = 180 \text{ constant No. for draft.}$$

PATENT CIRCULAR DRAWING FRAME.

# PATENT CIRCULAR DRAWING FRAME.

SECTIONAL ELEVATION SHOWING GEARING  
AT END OPPOSITE TO DRIVING PULLEYS.

SCALE  $\frac{1}{8}$ TH.

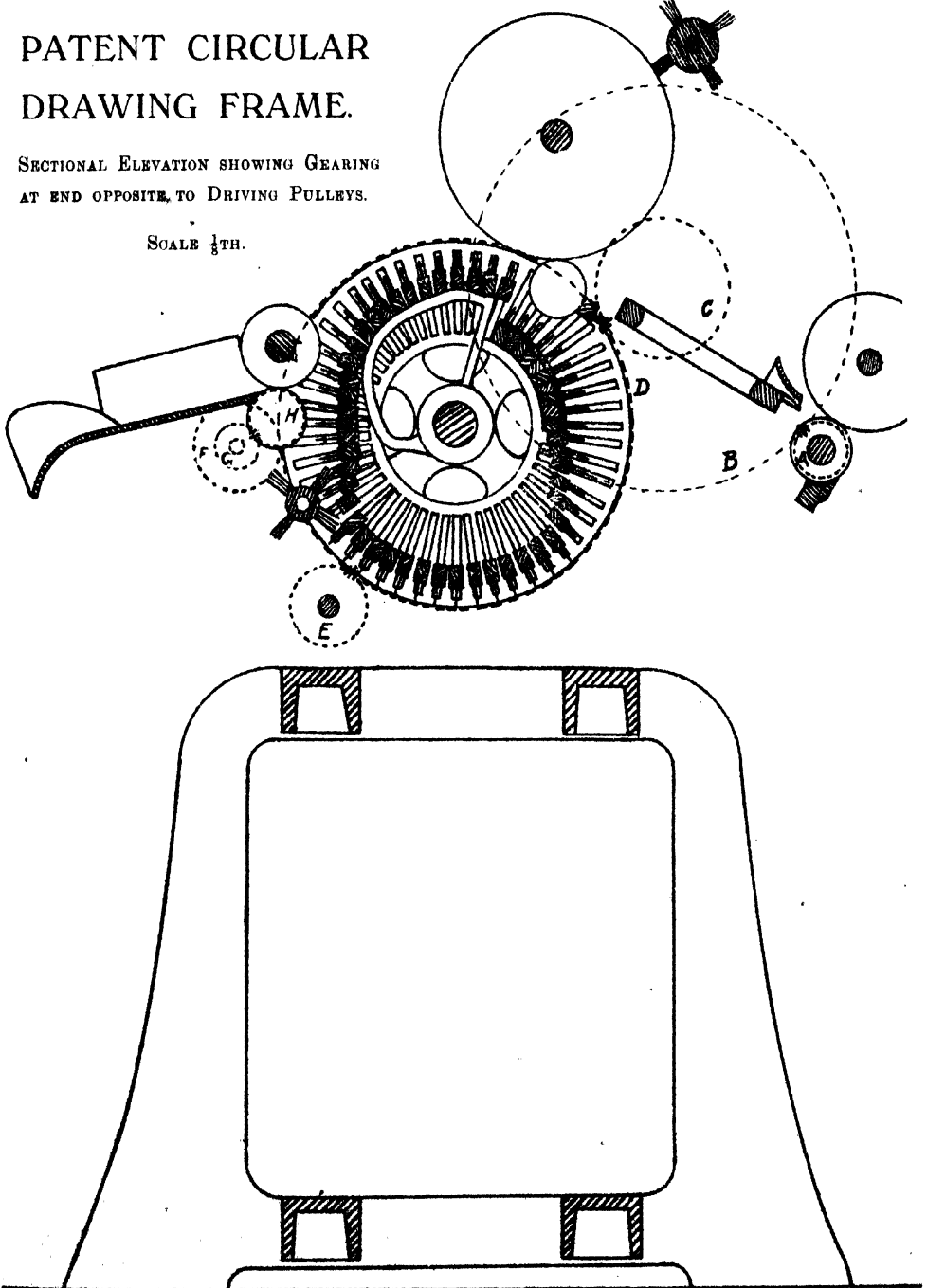

## PATENT PUSH OR SLIDE DRAWING FRAME.

*Sectional elevation showing gearing at driving end.*SCALE  $\frac{1}{8}$ TH.

A	Driving pinions,	...	...	...	30, 34 & 38 <sup>6</sup> teeth.
B	Stud wheel,	...	...	...	70 teeth.
C	Stud pinion,	...	...	...	19 teeth.
D	Short shaft wheel,	...	...	...	78 teeth.
E	Short shaft pinion,	...	...	...	34 teeth.
FF	Faller shaft wheels,	...	...	...	50 teeth.
G	Intermediate,	...	..	...	62 teeth.
H	Draught changes,	...	...	...	34 to 80 teeth.
I	Stripping roller pinion,	...	...	...	26 teeth.
J	Intermediate,	...	...	...	100 teeth.
K	Delivery roller pinion for driving stripping roller,	...	...	...	38 teeth.
LL	Retaining roller pinions,	...	...	...	22 teeth.
M	Intermediate,	...	...	...	24 teeth.

## DRAFT ARRANGEMENT—

Hard to hard pressing rollers—

$$(3'')$$

$$\frac{2\frac{1}{2} \times 56 \times 74 \times 50 \times 23 \times 32}{56 \times 20 \times 34 \times 39 \times 40 \times 1\frac{1}{8}} = 3.9 \text{ draft.}$$

$$(3'')$$

$$\frac{2\frac{1}{2} \times 56 \times 74 \times 50 \times 23 \times 32}{\text{C.P.} \times 20 \times 34 \times 39 \times 40 \times 1\frac{1}{8}} = 222.5 \text{ constant No. for draft}$$

Pressing Rollers—Leather covered on a plain or a V fluted roller—

$$\frac{2\frac{1}{2} \times 76 \times 74 \times 50 \times 23 \times 32}{80 \times 19 \times 34 \times 39 \times 40 \times 1\frac{1}{8}} = 3.3 \text{ draft.}$$

$$\frac{2\frac{1}{2} \times 76 \times 74 \times 50 \times 23 \times 32}{\text{C.P.} \times 19 \times 34 \times 39 \times 40 \times 1\frac{1}{8}} = 264.9 \text{ constant for draft.}$$

PATENT SLIDE DRAWING FRAME.

# PATENT SLIDE DRAWING FRAME.

SECTIONAL ELEVATION SHOWING GEARING AT DRIVING END.

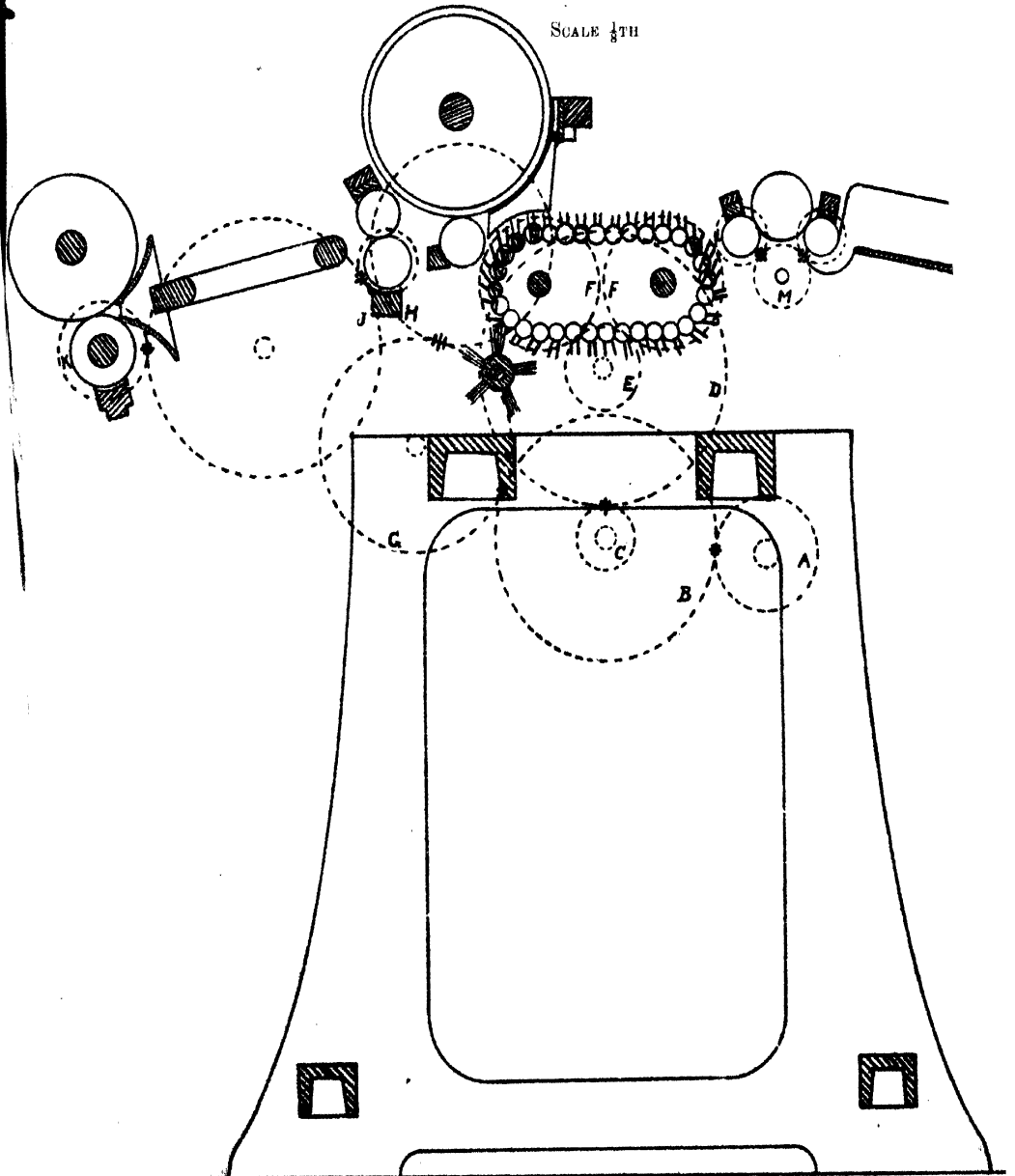



## PATENT PUSH OR SLIDE DRAWING FRAME.

*Sectional elevation showing gearing at end opposite to driving pulleys.*

SCALE  $\frac{1}{8}$ th.

A	Retaining roller wheels,	...	...	32 and 33 teeth.
B	Stud wheel,	...	...	40 teeth.
C	Stud pinion,	...	...	23 teeth.
D	Intermediate,	...	...	64 teeth.
E	Faller shaft pinion,	...	...	39 teeth.
F	Stud wheel,	...	...	33 teeth.
G	Stud pinion,	...	...	23 teeth.
H	Brush wheel,	...	...	36 teeth.
I	Drawing roller pinion,	...	...	28 teeth.
J	Intermediate,	...	...	130 teeth.
K	Delivery roller pinions,	...	...	37 and 38 teeth.

Arrangements of Wheels for calculation of speed of gill bars—

$$\frac{*180 \times 34 \times 20 \times 34}{56 \times 74 \times 50} = 20.08 \text{ revolutions of gill bar shaft upon which is gill bar wheel 17 teeth into which bars work.}$$

Then  $17 \times 20.08 = 341.36$  speed of gill bars per minute.

$$\frac{180 \times C. \times 20 \times 34}{56 \times 74 \times 50} = .590 \text{ Constant Number for gill bar shaft.}$$

\*NOTE.—Speed Pulleys 180 revolutions per minute.

PATENT SLIDE DRAWING FRAME.

# PATENT SLIDE DRAWING FRAME.

SECTIONAL ELEVATION SHOWING GEARING AT END  
OPPOSITE TO DRIVING PULLEYS.

SCALE  $\frac{1}{8}$ TH.

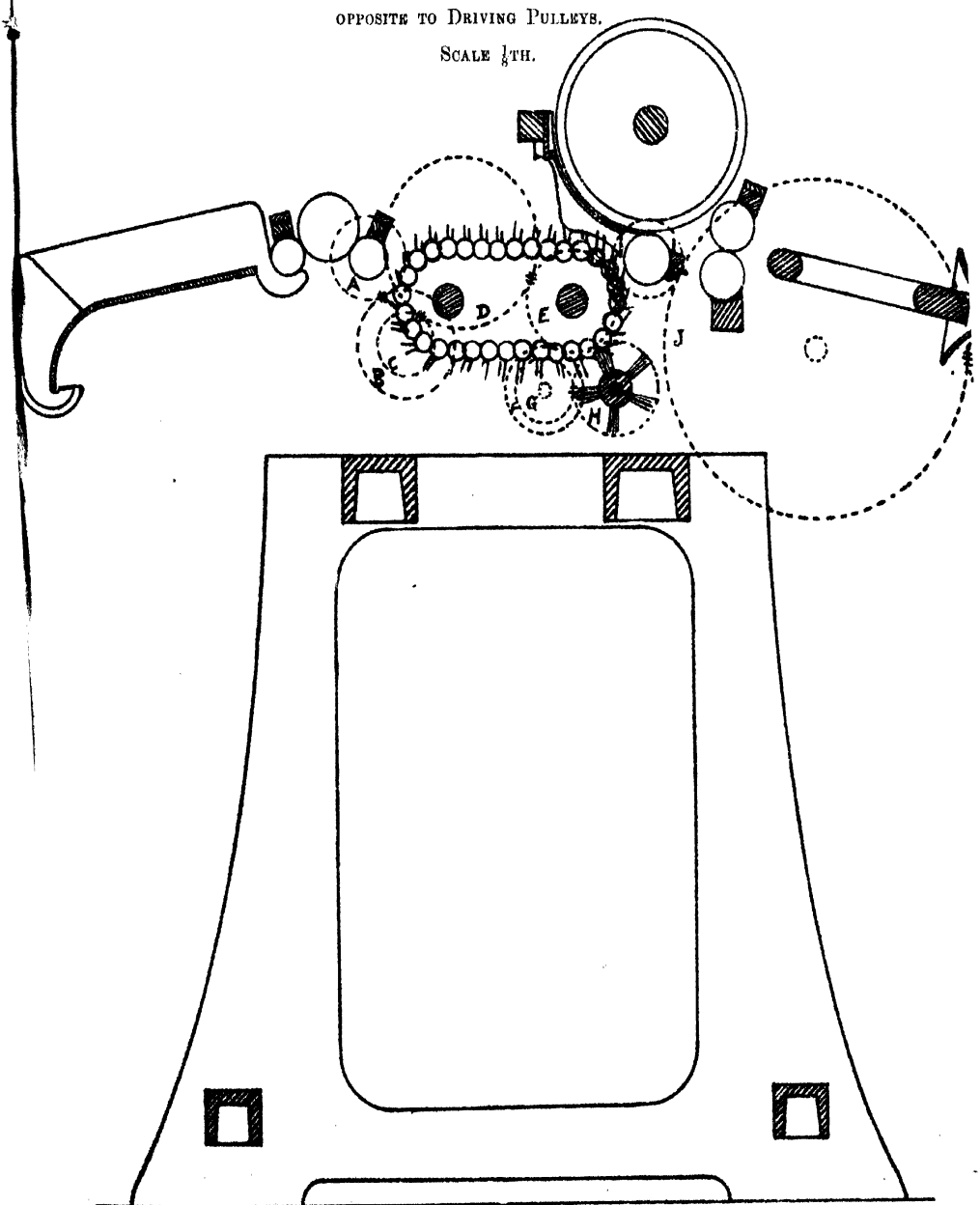

# SLIDE FOR PUSH BAR DRAWING.

SCALE 3" TO ONE FOOT.

Elevation of Guide Plate "A" for pins on gill bar cranks.

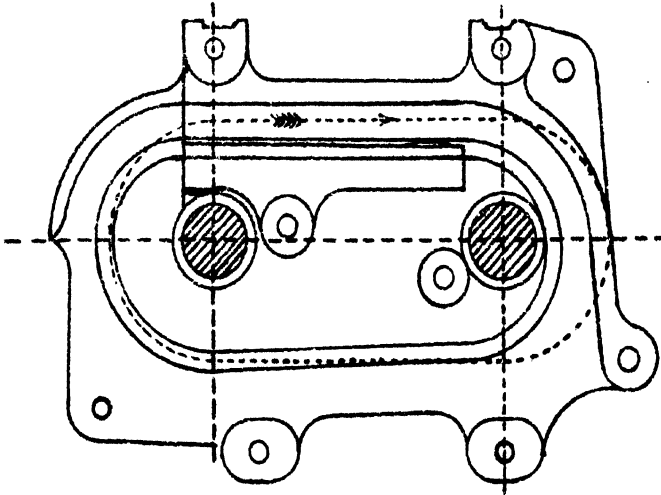

Elevation of Guide Plate "B" for gill bars.

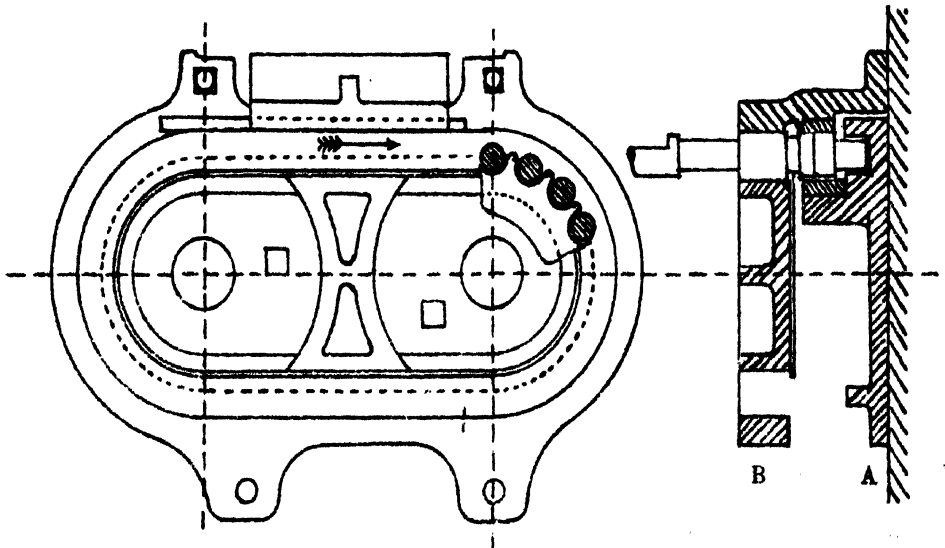

Sectional Elevation.

GILL BARS FOR PUSH BAR DRAWING.

# GILL BARS FOR PUSH BAR DRAWING.

SCALE  $\frac{1}{8}$ TH.

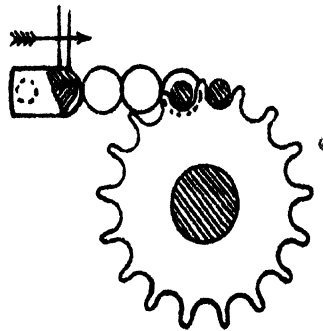
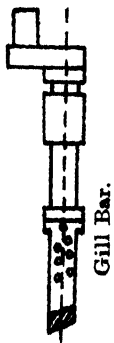
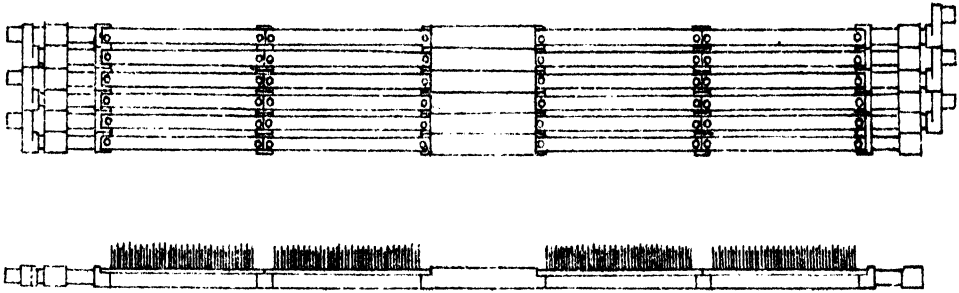

Elevation of Pinion and Cross Section of gill bar.

## SPIRAL DRAWING FRAME.

*Sectional elevation showing gearing at end opposite to driving pulleys.*

SCALE  $\frac{1}{8}$ TH.

A	Back shaft pinion,	...	...	...	25 teeth.
B	Intermediate,	...	...	...	25 teeth.
C	Stud wheel,	...	...	...	68 teeth.
D	Stud pinion,	...	...	...	25 teeth.
E	Retaining roller wheel,	...	...	...	69 teeth.
FF	Retaining roller pinions,	...	...	...	24 teeth.
G	Intermediate,	...	...	...	24 teeth.
H	Wheel for driving single back shaft (separate for each head),	...	...	...	19 teeth.
I	Wheel on single back shaft,	...	...	...	19 teeth.
J	Bevil for driving screws,	...	...	...	21 teeth.
K	Bevil pinion on bottom screw,	...	...	...	14 teeth.
L	Drawing roller pinion for driving delivery roller,	...	...	...	41 teeth.
M	Intermediate,	...	...	...	88 teeth.
N	Delivery roller pinion,	...	...	...	56 teeth.

**DRAFT ARRANGEMENT—**

Pressing Rollers— Leather covered on a plain or V fluted roller—

$$\frac{2\frac{1}{2} \times 35 \times 68 \times 69}{43 \times 25 \times 25 \times 1\frac{1}{8}} = 7.88 \text{ draft.}$$

$$\frac{2\frac{1}{2} \times 35^* \times 68 \times 69}{C.P. \times 25 \times 25 \times 1\frac{1}{8}} = 339.03 \text{ constant for draft.}$$

\*If this pinion is a 34, 329.606 will be constant No.

SPIRAL DRAWING FRAME.

SPIRAL DRAWING FRAME.

SECTIONAL ELEVATION SHOWING GEARING AT END OPPOSITE TO DRIVING PULLEYS.

SCALE  $\frac{1}{8}$ TH = ONE FOOT.

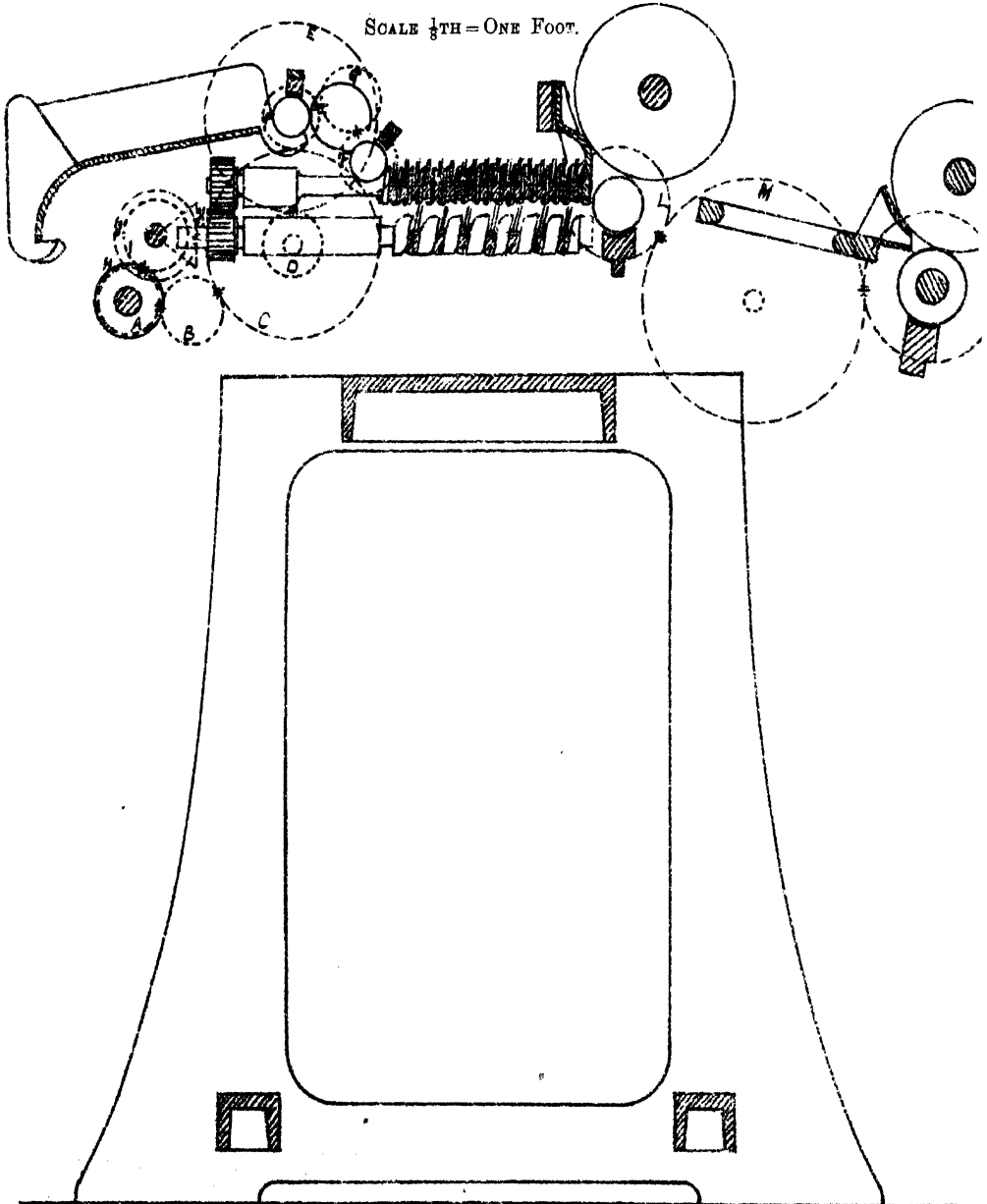

## SPIRAL DRAWING FRAME.

*Sectional Elevation showing gearing at driving end.*SCALE  $\frac{1}{8}$  IN.

A	Draught changes,	...	...	...	32 to 64 teeth.
B	Intermediate,	...	...	...	80 teeth.
C	Driving pinion,	...	...	...	24 teeth.
D	Intermediate,	...	...	...	32 teeth.
E	Back shaft pinion,	...	...	...	34 teeth.
F	Wheel for driving single back shaft (separate for each head),	...	...	...	19 teeth.
G	Wheel on single back shaft,	...	...	...	19 teeth.
H	Bevil wheel for driving screws,	...	...	...	21 teeth.
I	Bevil pinion on bottom screw,	...	...	...	14 teeth

Arrangement of Wheels for calculation of speed of gill bars—

$$\frac{*160 \times 30 \times 19 \times 21}{35 \times 19 \times 14} = 205 \text{ speed gill bars per minute.}$$

$$\frac{160 \times \text{C.P.} \times 19 \times 21}{35^* \times 19 \times 14} = 6.85 \text{ constant number for gill bars.}$$

\*If this pinion is a 34, 7.05 will be constant No.

\*NOTE.—Speed of Pulleys 160 revolutions per minute.

SPIRAL DRAWING FRAME.

# SPIRAL DRAWING FRAME.

SECTIONAL ELEVATION SHOWING GEARING AT DRIVING END.

SCALE  $\frac{1}{8}$  = ONE FOOT.

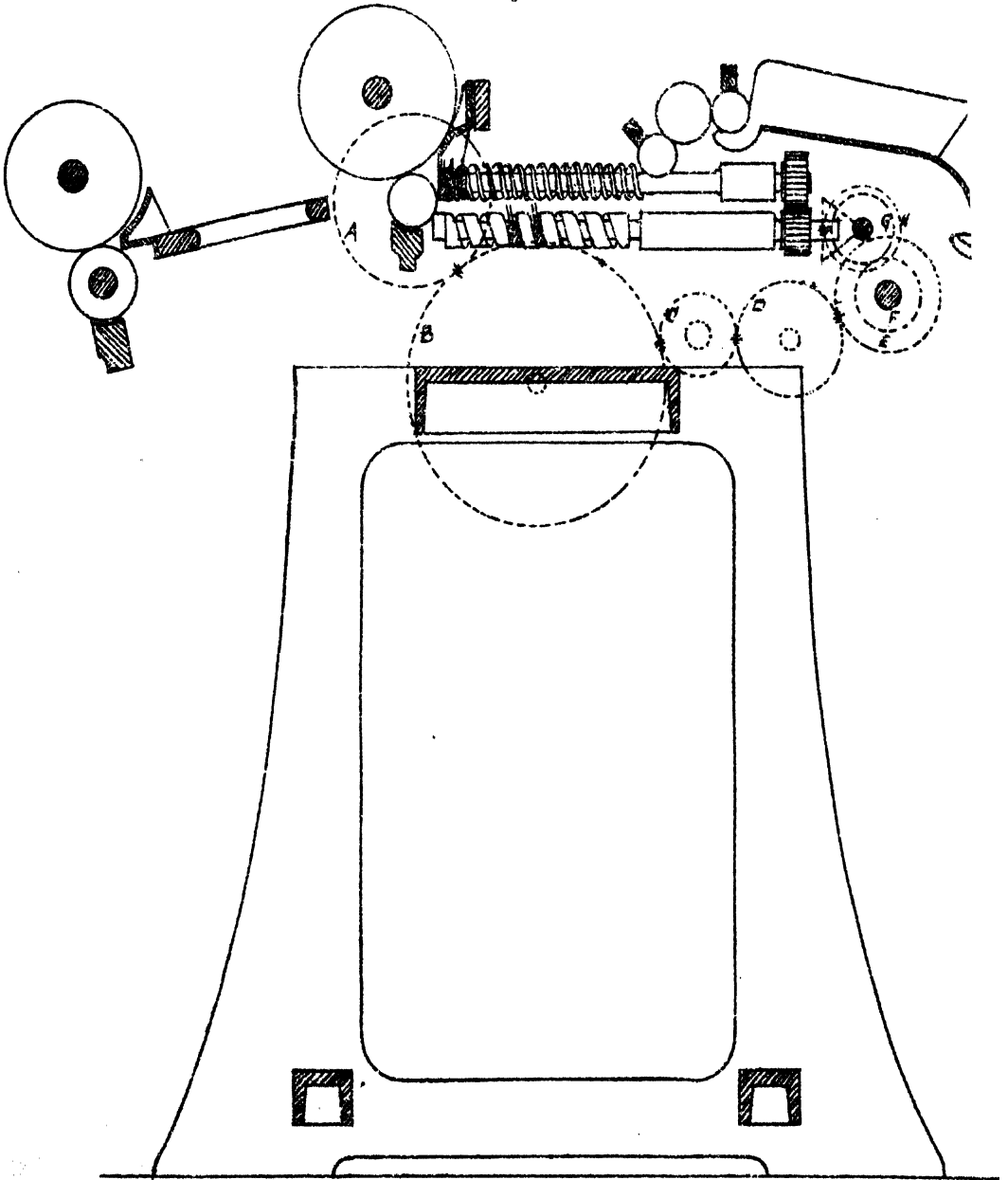



# BEND AND SCREWS.

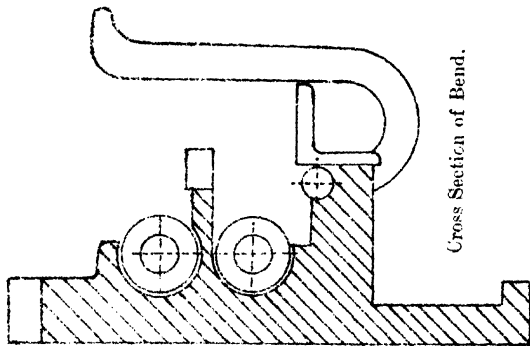

Cross Section of Bend.

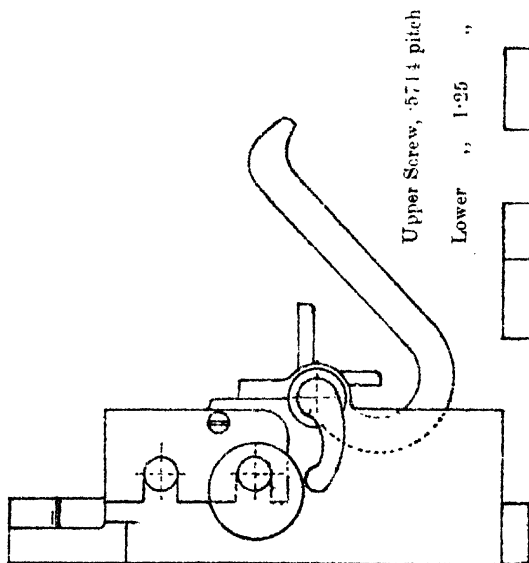

End Elevation of Bend.

Upper Screw,  $.571\frac{1}{4}$  pitch  
 Lower " 1.25 "

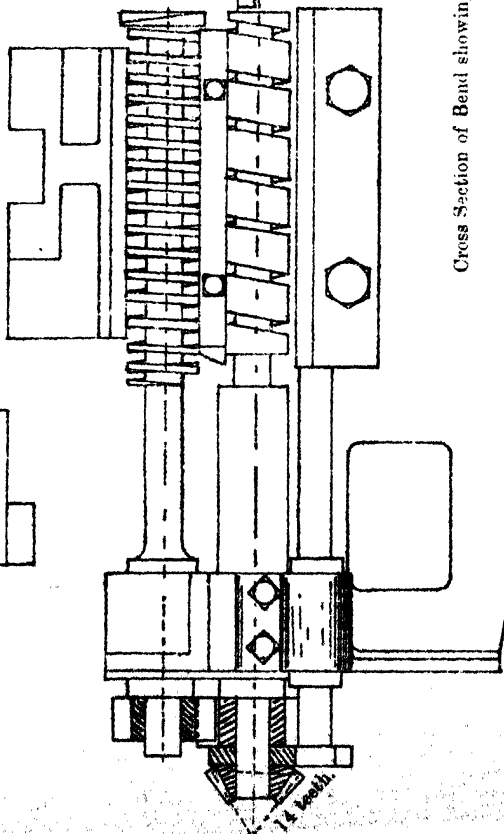

Gill Bars in one head = 21

Cross Section of Bend showing Screws for oil bars

1/4 inch.

DRAWING GILLS.

DRAWING GILLS.

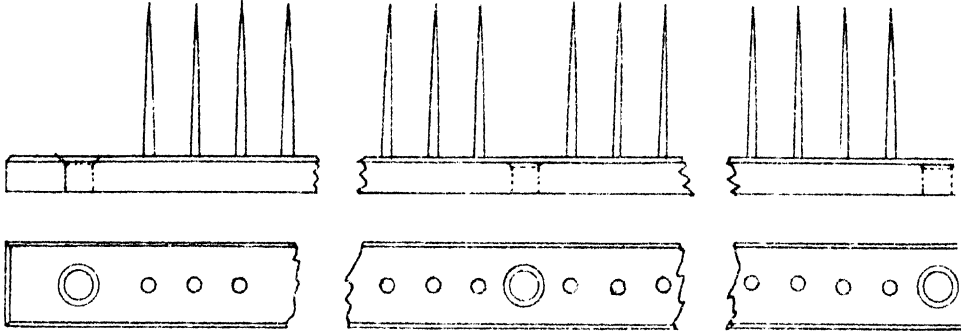

CIRCULAR DRAWING GILL.

$18\frac{1}{2}'' \times \frac{1}{2}'' \times \frac{1}{4}''$  Brass.

$3\frac{1}{2}''$  pins per inch.

$17\frac{1}{4} - 1 - 60 - \text{No. 15, } 1\frac{1}{8}''$ . Rivet No. 8,  $1\frac{1}{4}''$ .

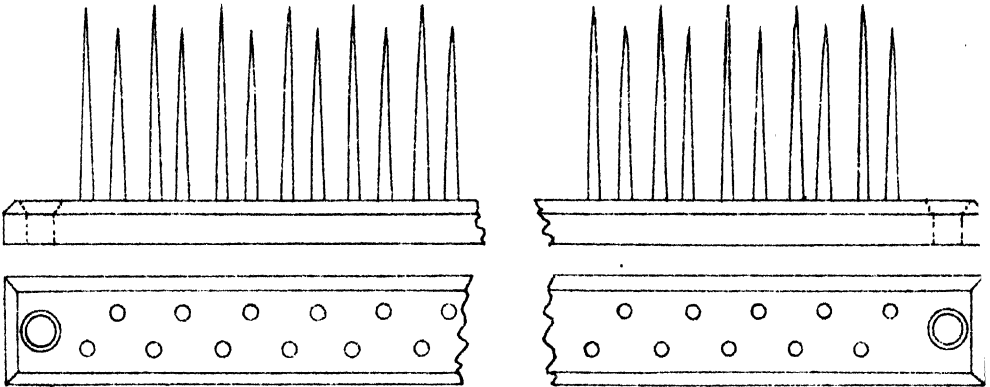

FIRST PUSH BAR DRAWING GILL

$8'' \times \frac{5}{8}'' \times \frac{1}{4}''$  Brass.

$2\frac{1}{2}''$  pins per inch.

$7'' - 2 - 18 - \text{No. 14, } 1\frac{3}{8}''$  and  $1\frac{1}{4}''$ . Rivet No. 8,  $1''$ .

## DRAWING GILLS.

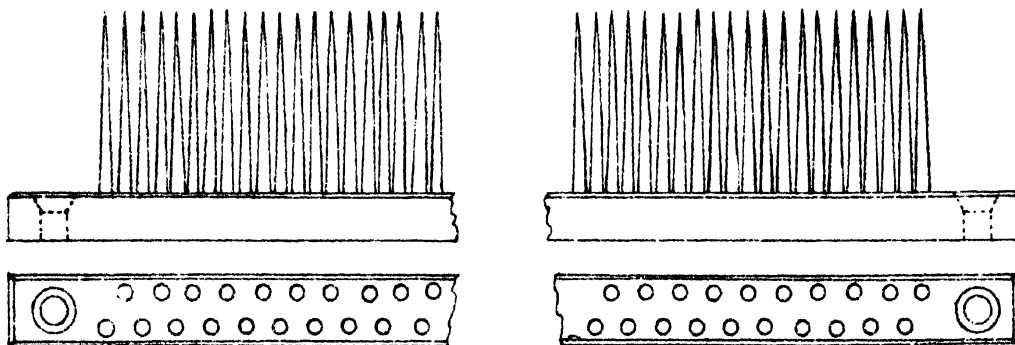

## SECOND DRAWING SPIRAL.

$7'' \times \frac{1}{3}'' \times \frac{1}{4}''$  Brass.

5 pins per inch.

6''—2—30. No. 16— $1\frac{1}{4}''$ . Rivet No. 10,  $1\frac{1}{8}''$

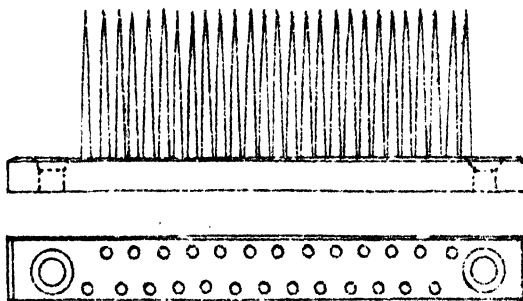

$10'' \times 5''$  Roving Gill.

$2\frac{7}{8}'' \times \frac{3}{8}'' \times \frac{7}{8}''$  Brass.

6 pins per inch.

$2\frac{1}{8}''$ —2—13. No. 16— $1''$ .

Gill Rivet,  $1''$ , No. 11.

DRAWING AND ROVING GILLS.

SPECIFICATIONS AND PARTICULARS OF DRAWING AND ROVING GILLS FOR HESSIAN YARNS.

The student will note as to the arrangement of the dimension.

*Push Bar Drawing Gills.*

8" ×  $\frac{5}{8}$ " ×  $\frac{1}{4}$ " brass.

rows. pins.  
7", 2, 18, No. 14,  $1\frac{3}{8}$  and  $1\frac{1}{4}$ — $2\frac{1}{2}$  pins per inch.

NOTE.—That front row of pins are  $\frac{1}{8}$ th shorter than back row.

*Circular Drawing.*

$18\frac{1}{2}$ " ×  $\frac{1}{2}$ " ×  $\frac{1}{4}$ " brass.

rows. pins.  
 $17\frac{1}{4}$ ", 1, 60, No. 15,  $1\frac{1}{8}$ ",  $3\frac{1}{2}$  pins per inch.

*Second Drawing Spiral.*

7" ×  $\frac{13}{32}$ " ×  $\frac{1}{4}$ " brass.

rows. pins.  
6", 2, 30, No. 16,  $1\frac{1}{2}$ , 5 pins per inch.

*Roving 10" × 5" Pitch.*

$27\frac{7}{8}$ " ×  $\frac{3}{8}$ " ×  $\frac{7}{32}$ " brass.

rows. pins.  
 $2\frac{1}{8}$ ", 2, 13, No. 16—1", 6 pins per inch.

Gill Rivets Push Bar—No. 8, 1".

" " Circular Bar—No.  $1\frac{1}{4}$ ".

" " Second Spiral—No. 10,  $1\frac{1}{8}$ ".

" " Rovings 10" × 5"—No. 11, 1".

GILLS FOR HESSIANS.

(Recommended by Fairbairn).

1st Push Bar Drawing, No. 15 w.g., 21 pins per row of 7 ins.

2nd Spiral " No. 15 w.g., 30 " " 6 ins.

Spiral Roving No. 16 w.g., 14 " "  $2\frac{1}{2}$  ins.

GILLS FOR WARPS.

1st Push Bar Drawing, No. 15 w.g., 18 pins per row of 7 ins.

2nd Push Bar Drawing, No. 15 w.g., 25 " " 7 ins.

Spiral Roving, No. 16 w.g., 12 " "  $2\frac{1}{2}$  ins.

GILLS FOR WEFTS.

1st Push Bar Drawing, No. 14 w.g., 16 per row of 7 ins.

2nd " " No. 15 w.g., 22 " " 7 ins.

Spiral Roving, No. 15 w.g., 11 " "  $2\frac{1}{2}$  ins.

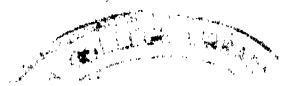

## FLUTING OF DRAWING ROLLERS.

The Drawing Rollers of first and second drawings and also the rovings are fluted to a certain pitch, so many flutes in the circumference. These are not all of the same pitch, hence the term irregular fluted roller. The reason for making the flutes irregular in the pitch is that when made so this irregularity of flute prevents the pressing roller becoming fluted by the pressure of the pressing roller. If the pressing roller is allowed to work until it is fluted and working into the flutes of drawing roller, this makes the sliver smaller than is intended, and for the same reason if this takes place at the roving small rove will be the result. Automatic motions are fitted on the drawing rollers of rovings and spinning frames to move the drawing rollers on end; this prevents the drawing rollers getting grooved at one part of the roller, and of course makes the drawing rollers last out much longer.

32 Flutes in 2"	Roller	} Preparing Drawing Rollers.
34	" 2 $\frac{1}{8}$ " "	
36	" 2 $\frac{1}{4}$ " "	
38	" 2 $\frac{3}{8}$ " "	
40	" 2 $\frac{1}{2}$ " "	
48	" 3" "	} Spinning Drawing Rollers.
64	" 4" "	
66	" 4 $\frac{1}{8}$ " "	

16 flutes per inch diameter.

DIAGRAMS OF PUSH BAR DRAWINGS.

DIAGRAM OF PUSH BAR DRAWING.

Pressing and Drawing Roller—hard-to-hard. SCALE 3" TO ONE FOOT.

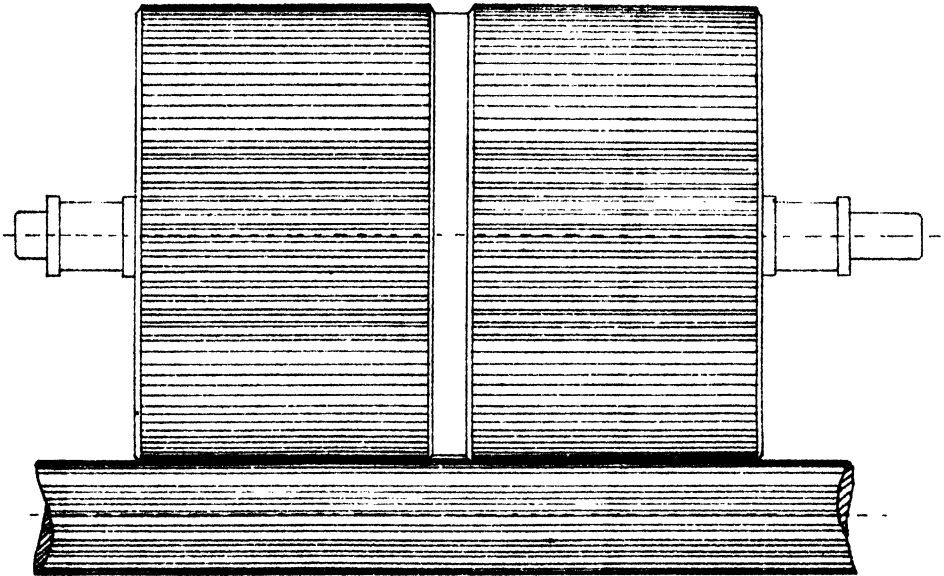

Drawing Roller.  
2 1/4" diameter.

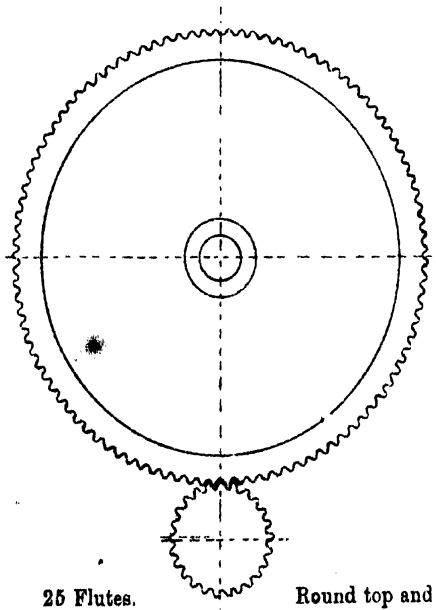

25 Flutes.

Round top and bottom fluted roller.

DIAGRAMS OF PUSH BAR DRAWINGS.

DIAGRAM OF PUSH BAR DRAWING.

Pressing and Drawing—Leather covered Pressing Roller.

SCALE 3" TO ONE FOOT.

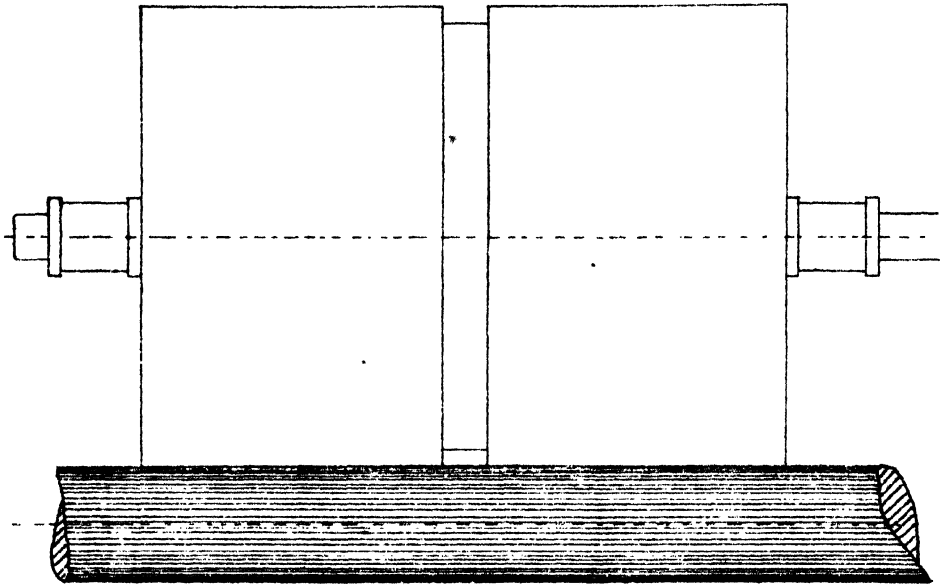

Drawing Rolle  
2½" diameter.

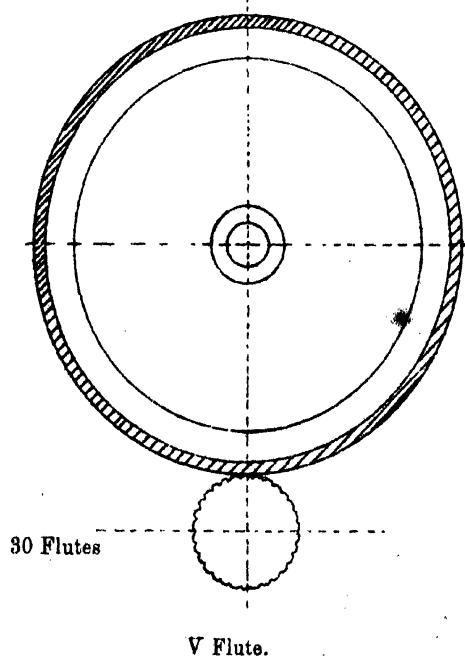

## ROVING.

### ROVING.

ROVING.—The cans being taken in setts of eight each from the second drawing, are put up at the back of the roving, one end over each gill, and are delivered on to the rove bobbin in front of roving. On the roving there are four change pinions—first, the twist pinion; second, the draft or grist pinion; third, the traverse pinion; and, fourth, the rack pinion. For a rove of 70/75 lbs. per spindle, the twist pinion is 35, with  $2\frac{1}{2}$  drawing roller; rack pinion, 15; and traverse pinion, 28 teeth.

*Note.*—*Roving Rack Pinion.*—A mark on the side of one of the teeth in the pinion is put there for a guide. When you put on a rack pinion, the top catch should be into the marked tooth, after the rack is wound up.

*Arrangement of Clock, which is driven from Drawing Roller.*  
—This Clock shows the quantity taken off on a day or week.

Drawing roller =  $2\frac{1}{4}$ " diam = 7.06 circumference.  
 $1 \times 59 \times 60 \times 60 \times 60 \times 60 \times 60 \times 46 = 732780 =$  revolutions of roller for  

---

 $1 \times 10 \times 10 \times 10 \times 10 \times 12 \times 24 \times 1$  one round of clock.  
 $732780 \times 7.06 = 5173426.60$  inches, and  
 $5173426.60 \div 36 = 143706.3$  yds.  
 $143706.3 \div 14400 = 9.97$  spindles per spindle, and  
 $9.97 \times 56 = 558.32$  spindles in one round of clock.

*Note.*—That the dial of roving clock is marked off in 40 points 10 parts marked 4, 8, 10, 16, 20, 24, 28, 32, 36, and 40.

*The following are the Roving, Twist, and Draft arrangements*

Draft arrangement—

A	C	E	G
—	x	—	x
—	—	x	—
B	D	F	H



In this case—

- A = Diameter of Drawing Roller.  
 B = Pinion on „  
 C = „ on back shaft.  
 E } = Double intermediate at opposite end of roving.  
 F }  
 G = Wheel on retaining roller in gear with F.  
 H = Diameter of drawing roller.

Thus—

$$\frac{2\frac{1}{2} \times 36 \times 70 \times 70}{38 \times 24 \times 24 \times 1\frac{1}{8}} = 9.35 \text{ draft between drawing roller and retaining roller.}$$

$$\text{Grist or Change pinion C. } \frac{2\frac{1}{2} \times 36 \times 70 \times 70}{24 \times 24 \times 1\frac{1}{8}} = 2599 = \text{constant number.}$$

TWIST ARRANGEMENT.—Drawing roller,  $2\frac{1}{4}$  in. dia. = 7.06 circumference.

$$\frac{A}{B} \times \frac{C}{D} \times \frac{E}{F} \times \frac{G}{H} = \text{twist per inch.}$$

In this case—

- A = Drawing roller wheel.  
 B = Twist pinion.  
 C = Pinion on driving shaft of roving, driving D, the pinion on end of spindle driver shaft.  
 D = Pinion of end of spindle driver shaft.  
 E = Bevel pinion on spindle shaft, driving G, the pinion in spindle.  
 F = Pinion on spindle  
 G = Circumference of drawing roller.

Thus—

$$\frac{60 \times 44 \times 21}{36 \times 22 \times 14 \times 7.06} = .75 \text{ twists per inch.}$$

$$\frac{60 \times 44 \times 21}{\text{Twist } 22 \times 14 \times 7.06} = 25.4 = \text{constant number for twists per inch.}$$

pinion

ROVING.

SPEED SPINDLES.—Roving shaft, 215 revolutions per minute ;  
Preparing shaft, 160 ; Drum, 24" diameter ; Pulleys, 18" diameter.

$$\frac{160 \times 24}{18} = 213.33. \text{ Say } 215 \text{ revs. per minute of Main Shaft Roving.}$$

In this case—

$$\frac{A}{—} \times \frac{B}{C} \times \frac{D}{E} = \text{speed spindles.}$$

- A = Speed, main shaft of roving.
- B = Pinion on „ „
- C = Pinion on end of spindle shaft of roving.
- D = Bevel pinion on spindle „
- E = Pinion on spindle.

Thus—

$$\frac{215 \times 44 \times 21}{22 \times 14} = 645 \text{ revolutions of spindle per minute.}$$

With the above arrangement of draft, twist, and speed of spindles the roving will make 28/30 shifts in 10 hours, or 21/22 points on the clock dial, in a week of 56 hours. This, by the clock, means rather more than five spindles per spindle per week of 56 hours.

Draft and Twist Plate attached to 10" × 5" spiral roving, with drawing roller 2½" diameter.

Draft.	Pinion.	Twist.	Pinion.
5	... 20	1.5	... 17
5½	... 22	1.25	... 21
6	... 24	1	... 26
6½	... 26	.9	... 29
7	... 28	.8	... 52
7½	... 30	.7	... 37
8	... 32	.6	... 43
8½	... 34	.5	... 52
9	... 36		
9½	... 38		
10	... 40		

\*When changing a roller from 2½ to 2⅝" diameter, put on a 37 pinion on drawing roller, and for every ⅛th smaller the roller wears. When it is turned up, allow one-tenth less on the drawing roller pinion. This will keep the draft plate correct. Example:—

Teeth.

$$2\frac{1}{4} : 2\frac{5}{16} : : 38 : 37 \text{ almost.}$$

\*NOTE.—A full-sized Drawing Roller, that is 2½" diameter, has on it a 38 teeth pinion.

## SPIRAL DISC ROVING FRAME, 10" × 5" BOBBIN.

*Sectional elevation showing gearing at end opposite to the driving pulleys.*SCALE  $\frac{1}{8}$ TH.

A	Twist Changes (on driving shaft),	...	...	17 to 52 teeth.
B	Intermediate,	...	...	150 teeth.
C	Twist Wheel (on drawing rollers),	...	...	60 teeth.
D	Drawing roller wheel,	...	...	38 teeth.
EE	Intermediates,	...	...	36 teeth.
F	Intermediate,	...	...	40 teeth.
G	Draught changes (on back shaft),	...	...	20 to 40 teeth.
H	Wheel for driving single back shaft (separate for each head),	...	...	22 teeth.
I	Wheel on single back shaft,	...	...	22 teeth.
J	Bevel wheel for driving screws,	...	...	24 teeth.
K	Bevel pinion on bottom screw,	...	...	16 teeth.
LL	Wheels for driving top screw,	...	...	14 teeth.
M	Intermediate,	...	...	54 teeth.
N	Wheel on countershaft for driving discs,	...	...	30 teeth.
OOO	Mitres for driving discs,	...	...	28 teeth.
P	Pinion on end of bowl shaft,	...	...	20 teeth.
Q	Wheel on short countershaft,	...	...	96 teeth.
R	Traverse Changes,	...	...	20 to 40 teeth.
S	Intermediate,	...	...	32 teeth.
T	Wheel on mangle wheel pinion shaft,	...	...	108 teeth.
U	Pinion for driving differential wheel,	...	...	12 teeth.
V	Intermediate,	...	...	27 teeth.
W	Differential Wheel,	...	...	78 teeth.
XXX	Differential bevels,	...	...	30 teeth.
Y	Wheel on pap of differential bevel,	...	...	30 teeth.
Z	Wheel on countershaft,	...	...	24 teeth.
a	Wheel on countershaft,	...	...	48 teeth.
b	Intermediate,	...	...	96 teeth.
c	Intermediate,	...	...	92 teeth.
d	Wheel on bobbin shaft,	...	...	30 teeth.
e	Bevel wheel on bobbin shaft (one for every two spindles),	...	...	21 teeth.
f	Spur and bevel intermediate,	...	...	28 teeth.
gg	Bobbin pinions,	...	...	14 teeth.
h	Bevel wheel on pinion shaft (one for every two spindles),	...	...	21 teeth.
i	Spur and bevel intermediate,	...	...	28 teeth.
j	Spindle pinions,	...	...	14 teeth.
k	Rack pinion (for traversing bobbins),	...	...	20 teeth.

# SPIRAL DISC ROVING FRAME. SPIRAL DISC ROVING FRAME.

SECTIONAL ELEVATION SHOWING GEARING AT END OPPOSITE  
TO DRIVING PULLEYS.

SCALE  $\frac{1}{8}$ TH.

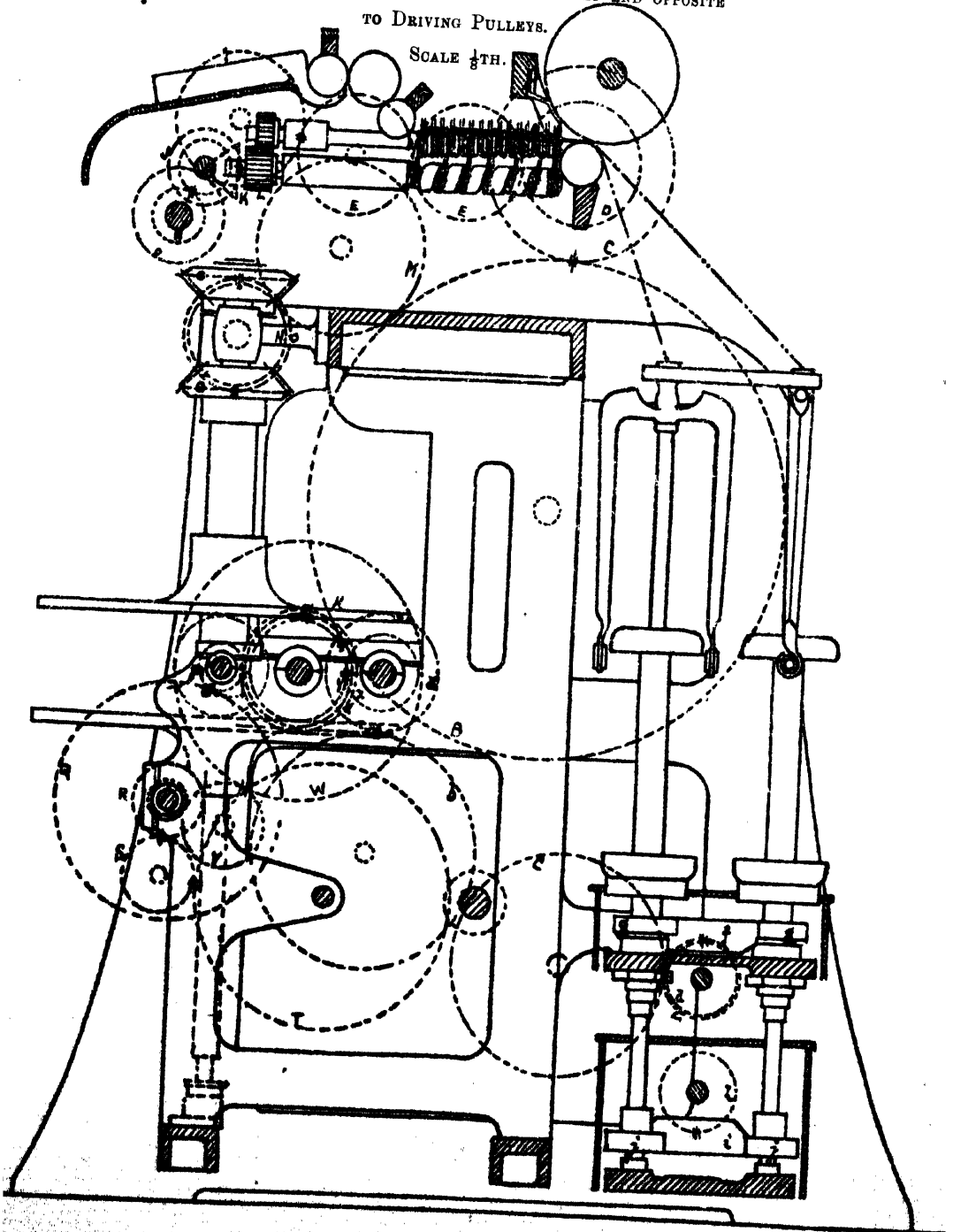

## SPIRAL DISC ROVING FRAME.

## SPIRAL DISC ROVING FRAME. 10" × 5" BOBBIN.

*Sectional elevation showing gearing at pulley end.*SCALE  $\frac{1}{8}$ TH.

A	Wheel for driving single back shaft (separate for each head),	...	...	...	22 teeth.
B	Wheel on single back shaft,	...	...	...	22 teeth.
C	Bevel wheel for driving screws,	...	...	...	24 teeth.
D	Bevel pinion on bottom screw,	...	...	...	16 teeth.
EE	Wheels for driving top screw,	...	...	...	14 teeth.
F	Back shaft pinion,	...	...	...	24 teeth.
G	Intermediate,	...	...	...	30 teeth.
H	Stud wheel,	...	...	...	70 teeth.
I	Stud pinion,	...	...	...	24 teeth.
J	Retaining roller wheel,	...	...	...	70 teeth.
KKK	Wheels for driving lower retaining roller,	...	...	...	24 teeth.
L	Wheel on driving shaft,	...	...	...	44 teeth.
MM	Intermediates,	...	...	...	84 teeth.
N	Wheel on spindle shaft,	...	...	...	22 teeth.
O	Bevel wheel on spindle shaft,	...	...	...	21 teeth.
P	Spur and bevel intermediate,	...	...	...	28 teeth.
QQ	Spindle pinions,	...	...	...	14 teeth.
R	Bevel wheel on bobbin shaft,	...	...	...	21 teeth.
S	Spur and bevel intermediate,	...	...	...	28 teeth.
TT	Bobbin pinions,	...	...	...	14 teeth.
U	Mangle wheel pinion,	...	...	...	5 teeth.
V	Mangle wheel,	...	...	...	73 teeth.
W	Rack pinion (for traversing bobbins),	...	...	...	20 teeth.

## DRAFT ARRANGEMENT—

$$\frac{2\frac{1}{2} \times 36 \times 70 \times 70}{38 \times 24 \times 14 \times 1\frac{1}{4}} = 9.35 \text{ draft.}$$

$$\frac{2\frac{1}{2} \times \text{C.P.} \times 70 \times 70}{38 \times 24 \times 24 \times 1\frac{1}{4}} = .2599 \text{ constant No. for draft.}$$

## TWIST ARRANGEMENT—

$$\frac{60 \times 44 \times 21}{36 \times 22 \times 14 \times 7.06} = .75 \text{ twists per inch.}$$

$$\frac{60 \times 44 \times 21}{\text{C.P.} \times 22 \times 14 \times 7.06} = 25.495 \text{ constant No. for twist.}$$

Speed Spindle = Speed Main Shaft Roving × 3. Main Shaft Roving  
215 revolutions per minute.

$$\frac{44 \times 21}{22 \times 14} = 3. \text{ Thus } 215 \times 3 = 645 \text{ revolutions per minute.}$$

SPIRAL DISC ROVING FRAME.  
 SPIRAL DISC ROVING FRAME.

SECTIONAL ELEVATION SHOWING GEARING AT PULLEY END.

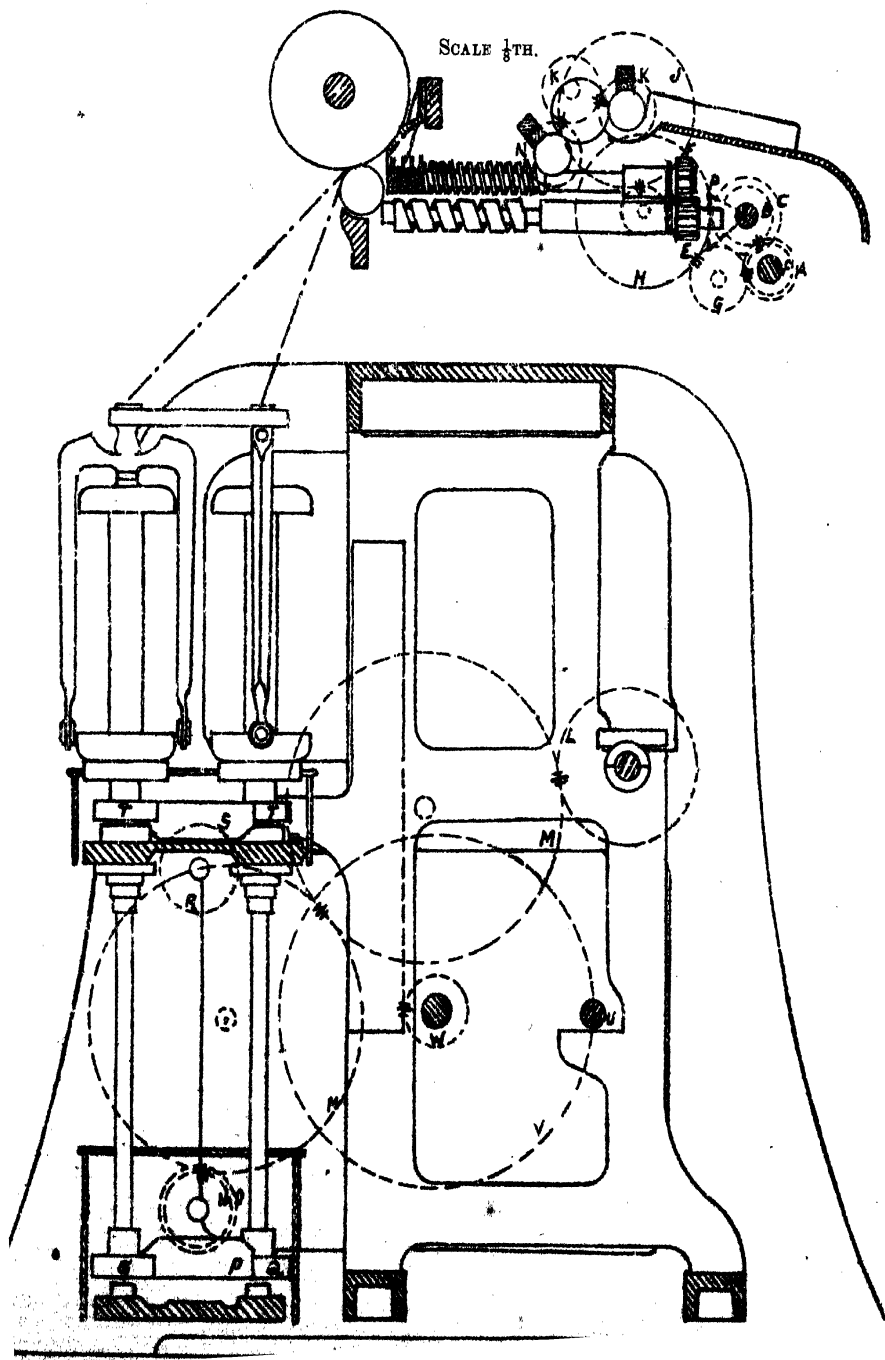

ROVING SCREWS AND GILL BARS.

SCALE 3" TO ONE FOOT.

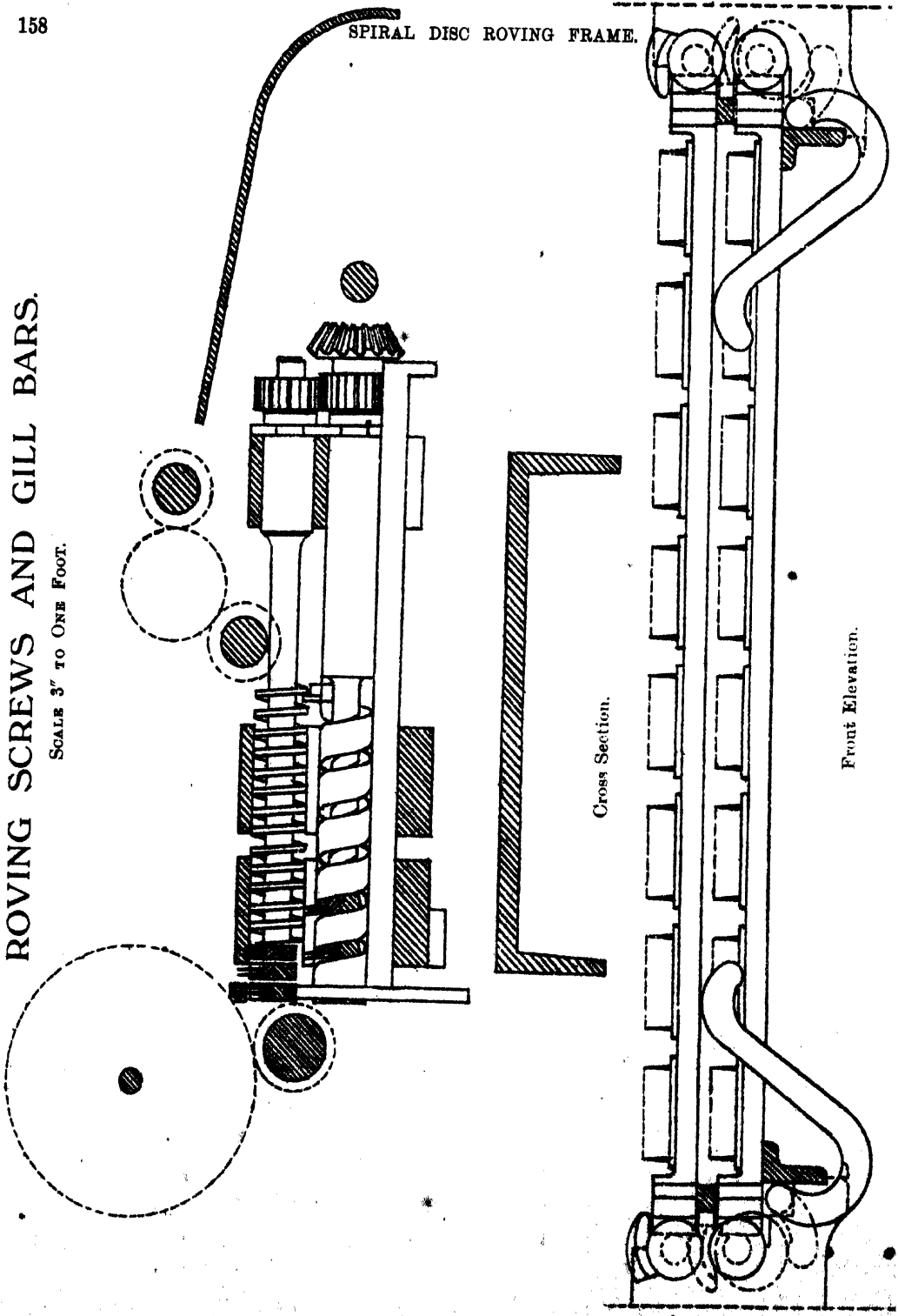

SPIRAL DISC ROVING FRAME.

Cross Section.

Front Elevation.

# Automatic Motion for Roving Frame Drawing Roller.

SCALE 3" TO ONE FOOT.

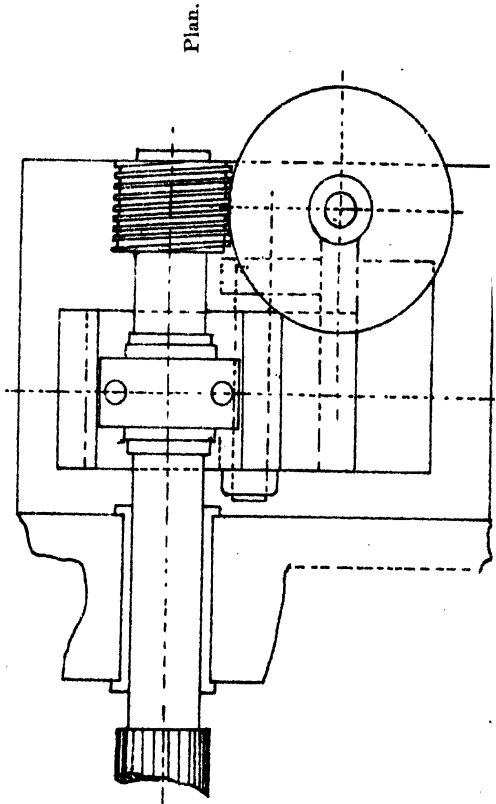
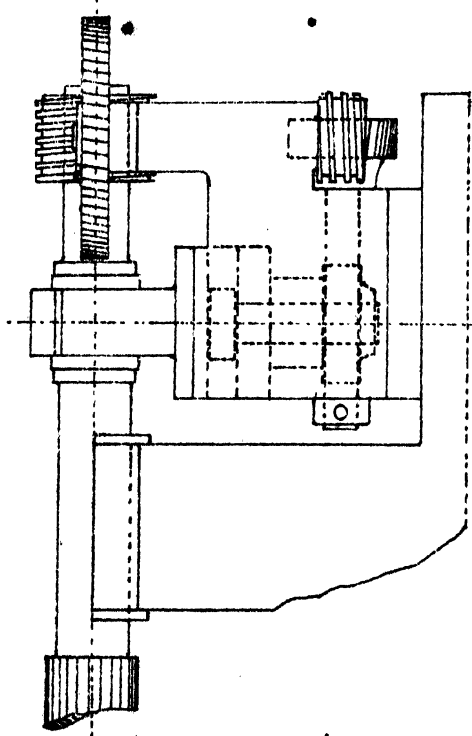
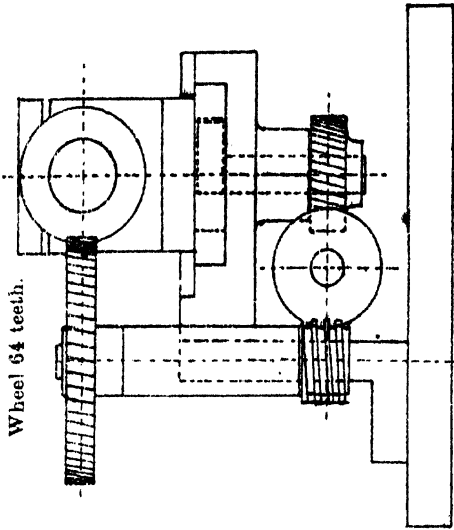



PARTICULARS OF AUTOMATIC MOTION FOR ROVING  
DRAWING ROLLER.

(For Diagram see page 159).

Wheel in gear with worm (single thread) on Drawing Roller, 64 teeth.

Two pinions each 36 teeth in gear, with single thread worms, as shown on diagram. Thus—

$$\frac{1}{64} \times \frac{1}{36} \times \frac{1}{36} = \frac{1}{82944}$$

Movement of eccentric  $1\frac{1}{2}$  inches—that is  $\frac{3}{4}$ " to the right and  $\frac{3}{4}$ " to left side.

Then—

$$\frac{1\frac{1}{2}}{82944} = \frac{\frac{3}{4}}{82944} = \frac{3}{2} \times \frac{1}{82944} = \frac{3}{165888} = \frac{1}{55296} \text{ of an inch}$$

of travel of the eccentric for each revolution of the drawing roller.

## GENERAL INSTRUCTIONS AS TO WORKING OF ROVING.

There is no doubt that the roving is one of the most important machines in a jute mill. Two parts of this machine require continual attention—namely, the differential motion and traverse gear, and the screws working the gill bars.

First, in reference to the differential motion, a description of this having been given by Mr Joseph Hovell, which has been much appreciated by those interested in jute machinery, it is not necessary to go into this in detail; only a diagram of this part of the roving frame is therefore given, and the calculations stated, so that the student will have the particulars ready to hand as a reference.

The second part of the machine which is of importance is the gill bars and screws actuating same. If a large and steady production is wanted of the roving, this part of it will require constant and careful attention by those in charge. I have already stated my opinion as to their repair and upkeep, and can only repeat here that the importance of this part of the roving cannot be overstated—the gill bars must be kept thoroughly clean, the gill pins sharp and well set up. All this can only be done by so many heads of bars being taken out each day and cleaned, the screws also cleaned and picked, the collar for pitch pin being carefully kept in order. Never allow the hole in collar for pitch pin to become wide at the edge next the pinion, or the pin will bend round between the collar and pinion, instead of breaking clean off, and when this occurs, will sometimes drive the carriage or head of bars in a jerky way, thus making thin parts on the rove, may not be noticed until the roves are on the spinning frame—small rove and small yarn being the result. All this may be avoided by care and attention combined with a knowledge of the proper working of the gill bars and the screws actuating them.

One other point may be mentioned, and that is never allow the crown wheels, as they are usually called, that drive the bobbin driver to be too much worn and round in the teeth, as this also tends to make the rove soft and irregular, and consequently unfit for spinning purposes.

Make sure that the mangle wheel is in good order at the turning pins and the bracket-carrying mangle wheel pinion is kept firm. With due attention to these details, there will not be much wrong with the roves, and you will have a chance to get a fair quantity of them from the roving.

162

# ROVING SCREWS AND GILL BARS.

SHOWING ARRANGEMENT OF COLLAR AND PINION  
WITH "PITCH PIN."

SCALE 3" TO ONE FOOT.

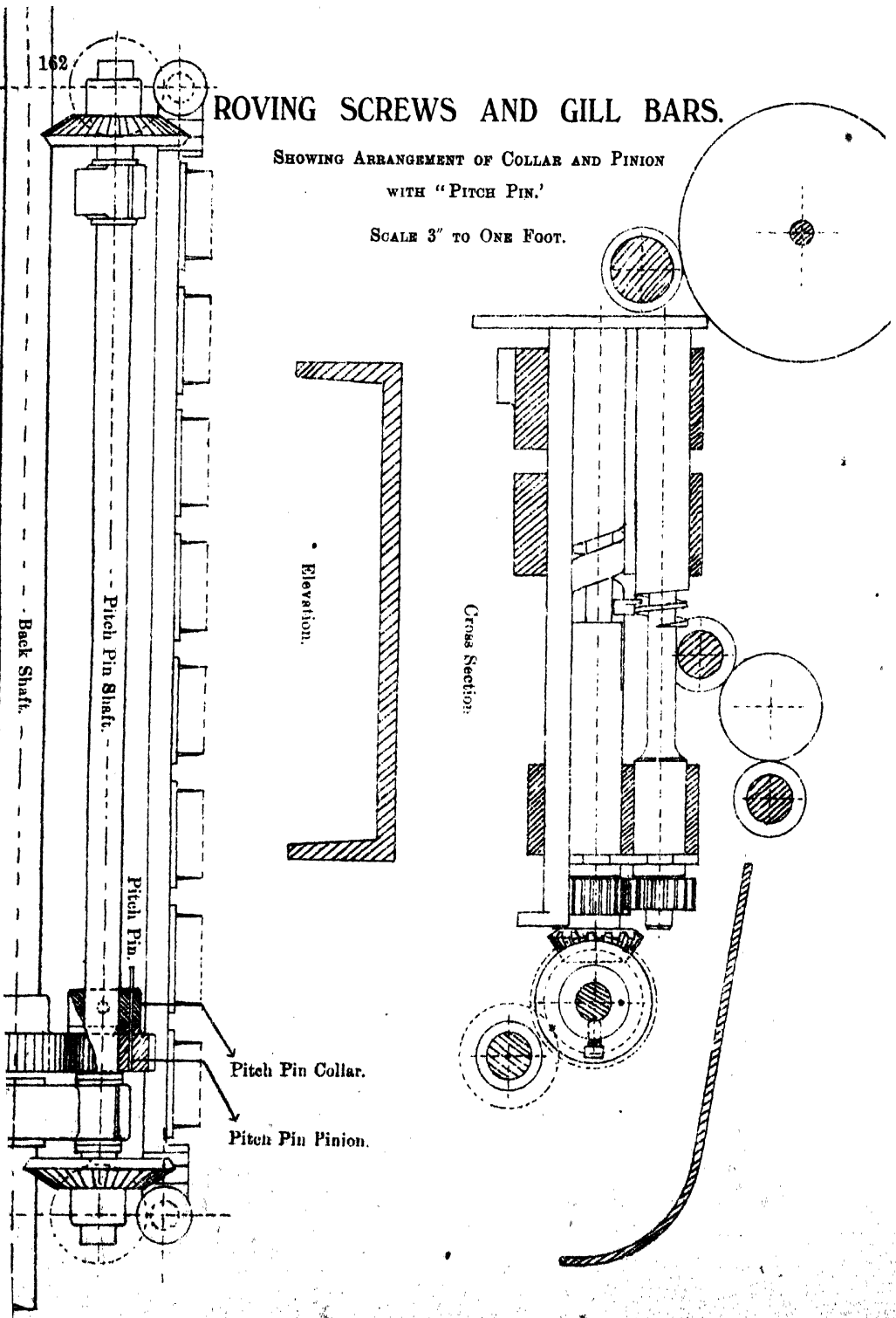

DIFFERENTIAL MOTION.

SCALE 1 1/2" TO ONE FOOT.

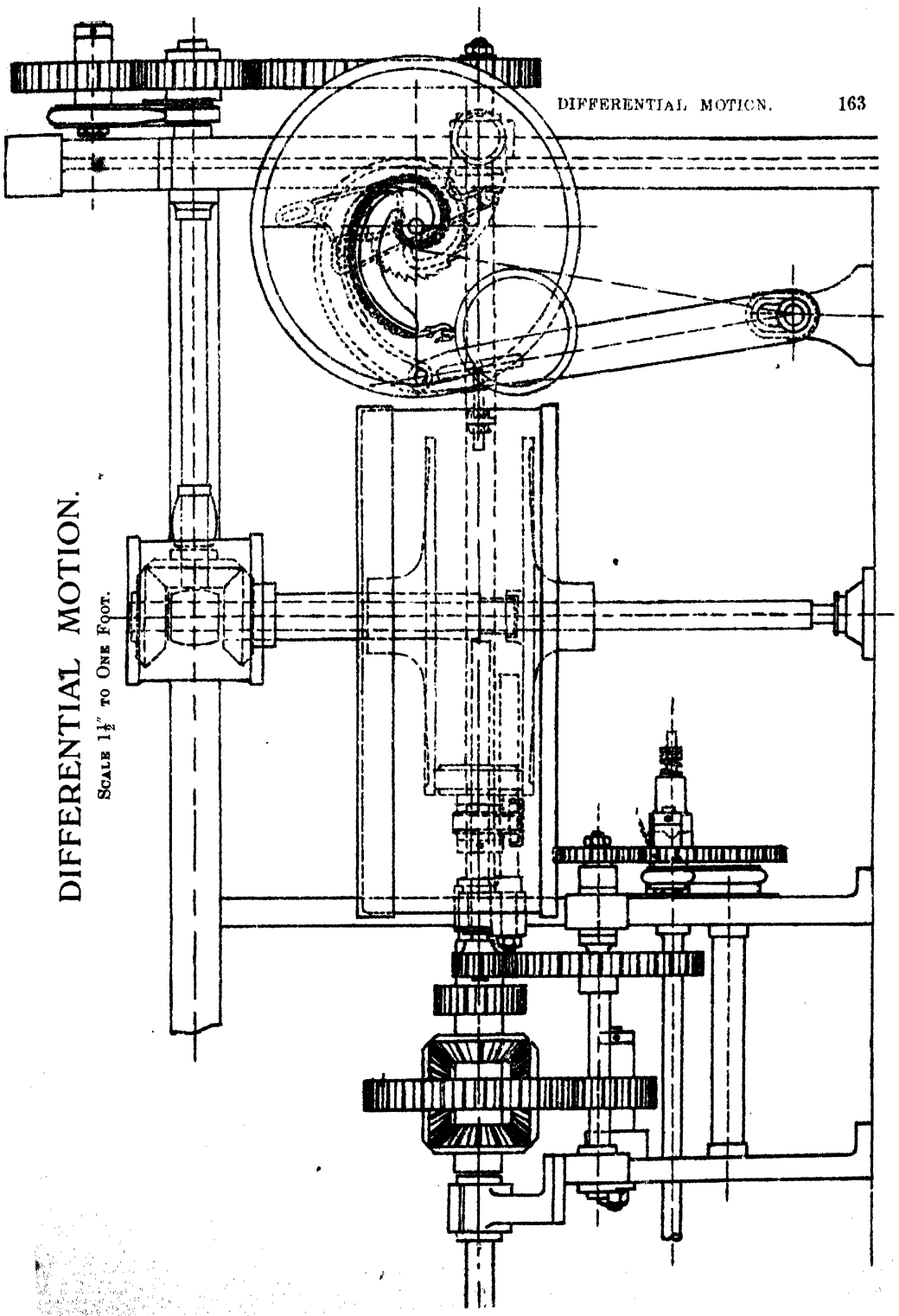

DIFFERENTIAL MOTION.

DIFFERENTIAL MOTION.

SCALE 1 1/4" TO ONE FOOT.

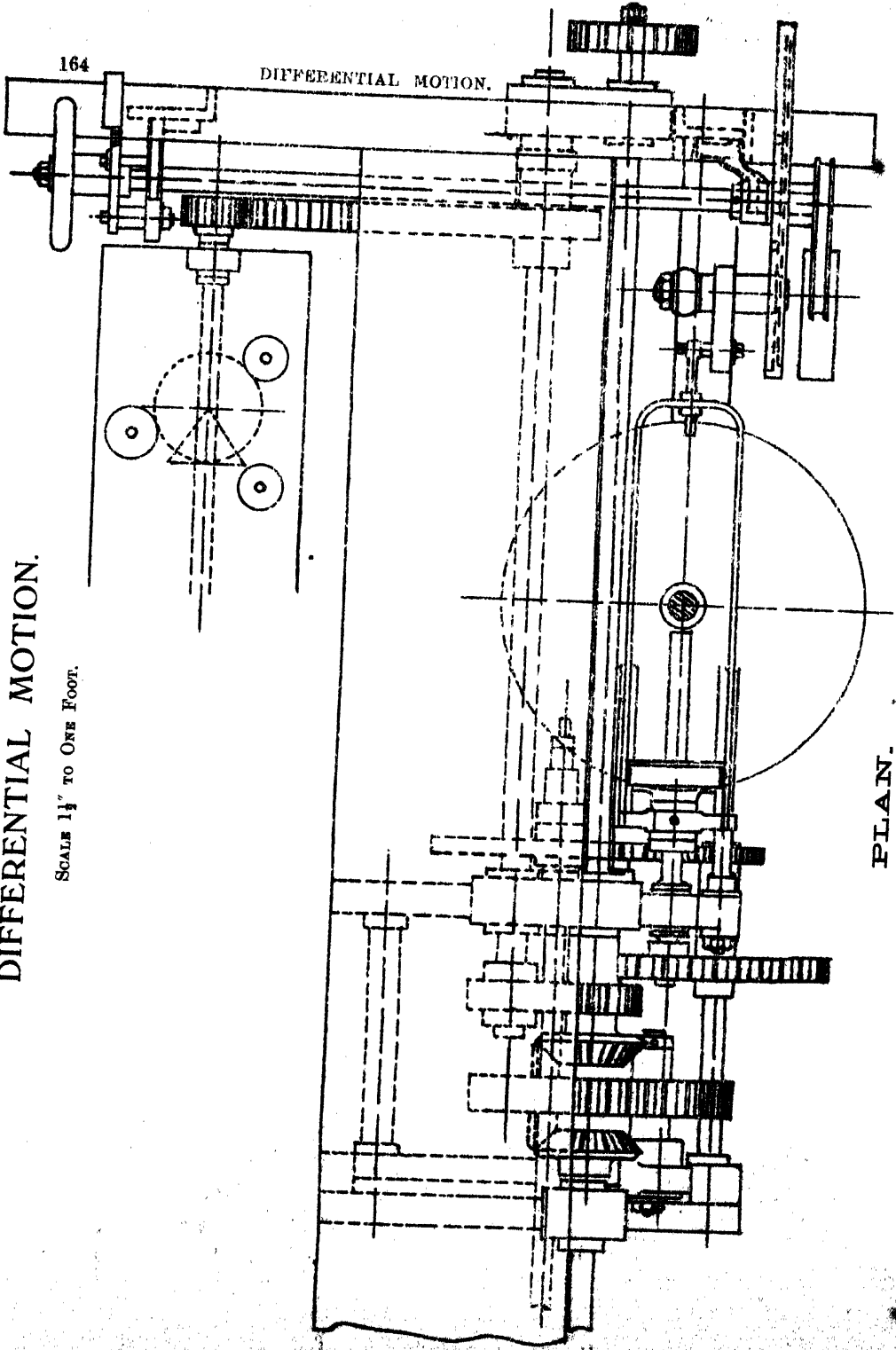

PLAN.

DESCRIPTION OF THE DISC AND DIFFERENTIAL MOTION ON A ROVING FRAME

The following formula shows how to calculate the position of the bowl between the disc plates for any diameter of bobbin or drawing roller, but *note* that in the calculation the number of teeth in the differential wheel is taken at *half of the actual number* for the reason that one revolution of the differential wheel has a double effect on the wheel which it controls.

Working dia. on discs for full bobbin—5·85.	Diameter of full bobbin—5".
" " empty " 19·5.	" empty bobbin shank—1½".
Drawing Roller Wheel × Diameter on disc × Pinion on end of bowl shaft × Pinion on short shaft × 3* × Diameter of bobbin shank ... .. .	} = 1.
Wheel on end of counter shaft for driving disc plates × Diameter of Bowl × Wheel on end of short shaft × differential wheel × 1* × Diameter of drawing roller	

\*The figures here 3 to 1 express shortly the net result of the train of wheels from driving shaft to spindles, and also from the loose running bevel wheel controlled by the differential motion wheel to bobbin.

Wheel upon shaft driving spindle driver shaft ... .. .	44 teeth	} $\frac{44 \times 21 \times 3}{22 \times 14 \times 1} =$
Pinion upon spindle shaft ... .. .	22 "	
Bevel pinion upon spindle driver shaft ... .. .	21 "	
Spur pinion upon spindle ... .. .	14 "	

Formula for full bobbin  $\frac{60 \times 5.85 \times 20 \times 12 \times 3 \times 5}{80 \times 5 \times 96 \times (\frac{1}{2}) \times 39 \times 1 \times 2\frac{1}{2}} = 1.$

" empty "  $\frac{60 \times 19.5 \times 20 \times 12 \times 3 \times 1\frac{1}{2}}{30 \times 5 \times 96 \times (\frac{1}{2}) \times 39 \times 1 \times 2\frac{1}{2}} = 1.$

$\frac{60 \times A \times 20 \times 12 \times 3 \times B}{80 \times 5 \times 96 \times (\frac{1}{2}) \times 39 \times 1 \times 2\frac{1}{2}} = 29.25 \text{ Constant No.}$

From this Constant No. you can find the diameter of bobbin, and the working diameter for friction ball upon the disc plate as follows:—

- A Working diameter of friction ball upon disc plate.
- B Diameter of bobbin.

Full bobbin 5" diameter  $\frac{29.25}{5} = 5.85" \text{ working dia. of ball upon disc.}$

Working dia. of ball upon plate  $\frac{29.25}{5.85} = 5" \text{ dia. of bobbin when ball is working 19.5" disc plate.}$

The position of the bowl between the discs will not practically be quite the same as the calculation because an allowance must be made for contraction of the rove by the twist.

The figures used in above calculations are taken from the rovings made by Messrs Fairbair Naylor, Macpherson, & Co., Leeds, at the present day.

To find the speed of the empty bobbin  $1\frac{1}{2}$ " diameter, and say  $2\frac{1}{4}$ " diameter, the same diameter as the drawing roller, and also when full, say 5" diameter.

Speed of roving main shaft 218 revolutions per minute.

" " spindles 654 " "

" " drawing roller 127·16 " "

Twist pinion 35 teeth.

Bobbin Shank  $1\frac{1}{2}$ " diameter = 4·71" circumference.

"  $2\frac{1}{4}$  " = 7·06 "

Bobbin when full 5 " = 15·70 "

$$\frac{127\cdot16 \times 60 \times 19\cdot5 \times 20 \times 12}{30 \times 5 \times 96 \times (\frac{1}{2}) 39} = 63\cdot58 \text{ revolutions of differential wheel,}$$

which subtract from the speed of the roving shaft 218—63·58 = 154·42 and

$$\frac{154\cdot42 \times 30 \times 48 \times 21}{24 \times 30 \times 14} = 463\cdot26 \text{ revolutions of bobbin,}$$

which subtract from the speed of the spindles 654—463·26 = 190·74 and

190·74 × 4·71 = 898·38 inches of rove laid on per minute.

Again when the bobbin is say  $2\frac{1}{4}$ " diameter the same as the drawing roller,

$$\frac{127\cdot16 \times 60 \times 13 \times 20 \times 12}{30 \times 5 \times 96 \times (\frac{1}{2}) 39} = 42\cdot38 \text{ revolutions of the differential wheel,}$$

which subtract from the speed of the roving shaft 218—42·38 = 175·62 and

$$\frac{175\cdot62 \times 30 \times 48 \times 21}{24 \times 30 \times 14} = 526\cdot86 \text{ revolutions of bobbin,}$$

which subtract from the speed of the spindles 654—526·86 = 127·14 and

127·14 × 7·06 = 897·60 inches of rove laid on per minute.

Again when the bobbin is full say 5" diameter,

$$\frac{127\cdot16 \times 60 \times 5\cdot85 \times 20 \times 12}{30 \times 5 \times 96 \times (\frac{1}{2}) 39} = 19\cdot07 \text{ revolutions of differential wheel,}$$

which subtract from the speed of the roving shaft 218—19·07 = 198·93 and

$$\frac{198\cdot93 \times 30 \times 48 \times 21}{24 \times 30 \times 14} = 596\cdot79 \text{ revolutions of bobbin,}$$

which subtract from the speed of the spindles 654—596·79 = 57·21 and

57·21 × 15·70 = 898·19 inches of rove laid on per minute.

*Arrangement to find the speed of Roving Traverse when the bobbin is empty and full, that is 1½" and 5" diameter, or 4·71 and 15·70 inches in circumference.*

Speed of Drawing Roller 127·16 revolutions per minute; Traverse Pinion 22 teeth for 75/80 lb. rove.

$$\text{when empty } \frac{127\cdot16 \times 60 \times 19\cdot5 \times 20 \times 22 \times 5}{30 \times 5 \times 96 \times 108 \times 73} = 2\cdot88 \text{ speed of traverse.}$$

$$\text{when full } \frac{127\cdot16 \times 60 \times 5\cdot85 \times 20 \times 22 \times 5}{30 \times 5 \times 96 \times 108 \times 73} = \cdot864 \quad "$$

$$\frac{127\cdot16 \times 60 \times C \times 20 \times 22 \times 5}{30 \times 5 \times 96 \times 108 \times 73} = \cdot1478 \text{ Constant No.}$$

There is no method of calculating what traverse pinion should be used. This is not a question of length, but a question of the thickness of each size of rove; on this roving we find a 22" teeth pinion gives the proper build for a 75 lb. rove.

When the bobbin is empty (that is 4·71 inches in circumference), the drawing roller moves 127·16 revolutions per minute, and the traverse 2·88 per minute, which is equal to 44 to 1, and the circumference of the roller 7"; therefore 308 inches are delivered for each up and down movement of traverse, and

$$\frac{308}{4\cdot71} = 65\cdot39 \text{ layers of rove.}$$

For a thicker rove the traverse would have to go faster, and for a finer a little slower.

When the rove is full (that is 15·70 inches-circumference), the drawing roller moves 127·16 revolutions per minute, and the traverse ·864 per minute, which is equal to 147·17 to 1, and the circumference of the roller being 7"; therefore 1030·19 inches are delivered in each up and down of the traverse.

$$\frac{1030\cdot19}{15\cdot70} = 65\cdot6 \text{ layers of rove,}$$

The pinions upon the traverse shaft of this roving are 20 teeth, No. 6 pitch, and therefore equal to  $3\frac{1}{8}$ " diameter at pitch lines. One revolution of this pinion is 10·40 inches, but the pinion, owing to the shape of the turning points of the mangle wheel, only moves the traverse of the bobbin board 10" up and 10" down.

You will therefore observe that when the bobbin is empty it goes slower and the traverse faster, and *vice versa* when the bobbin is full; the speed of the bobbin is always opposite to the speed of the traverse.



## SNAIL

(OLD STYLE).

SCALE 3" TO ONE FOOT.

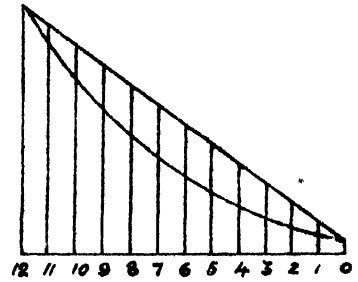
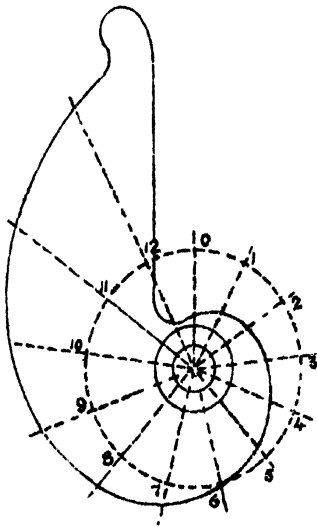

## ROTARY DRAWING AND ROVINGS.

I do not feel called upon to say much about these machines. Their use for hessian yarn is limited to a small portion of the trade. The gills are fixed upon a shaft placed close up to the drawing roller. An illustration is given of drawing and also of roving showing the arrangement and the relation of the speed of gill to retaining and drawing roller. All the other parts of the machines are much the same as in spiral machinery. For heavy wefts, a rotary roving will be found very convenient—you can take off a good production of rove, and make a good job, as sliver is right; but you can make up the weight, owing to the shortness of the draft required in a rotary roving. \*I have given an arrangement with rotary roving, and have also given an example for hessian wefts—say from 8/12 lbs. per spindle. As in the case of spiral machinery, it is important that the gills be kept clean, and the gill pins sharp and carefully set up. If this is not done, the tendency is for the rotary gill to “lap,” and this causes irregularity in the rove. If this roving is, however, kept clean and in good order, not much trouble will be experienced in doing the work of an arrangement such as is given in a few pages further on.

ROTARY ROVING.—For heavy rove, 200 to 250 lbs., if made from poor stuff, and from which sacking wefts are to be spun, rotary rovings are generally employed. An illustration on page 170 shows the centres of gills and rollers; three different sets of wheels and pinions are given. This allows of the reach between centre of gill shaft and retaining rollers being set in three different positions, according to the rove being made. If the material is weak, the retaining roller should be closer upon the gill than when it is strong. When the jute is strong the retaining roller must not be too near the gills, or the sliver will not draw at the pressing roller.

\*See page 185 for arrangement of Machinery Making Rove 105 lbs. per spindle, from which is to be spun 20 lbs. Weft.

*The following are particulars of two arrangements of Rotary Gills.*

First drawing rotary,  $7\frac{1}{2}'' \times 3'' \times \frac{1}{4}''$  brass,  $3\frac{1}{2}$  pins per inch, set over  $6\frac{5}{8}''$ , 80 rows, 24 pins, No. 14— $\frac{3}{4}''$ ,  $\frac{1}{2}''$  out; or,

Second drawing rotary,  $6'' \times 3'' \times \frac{1}{4}''$  brass,  $3\frac{1}{2}$  pins per inch, 30 rows, 21 pins, No. 14— $\frac{3}{4}''$ ,  $\frac{1}{2}''$  out;

Rotary roving gill,  $2'' \times 3''$  dia. brass, 28 rows, 8 pins, No. 14— $\frac{3}{4}''$ , set over  $1\frac{1}{2}''$ , 5 pins per inch, and  $\frac{1}{2}''$  out;

First drawing rotary,  $7'' \times 3'' \times \frac{1}{4}''$  brass, 5 pins per inch, 30 rows, 30 pins, No. 15— $\frac{3}{4}''$ ,  $\frac{1}{2}''$  out; to work with

Roving rotary,  $1\frac{5}{8}'' \times 2\frac{1}{4}'' \times \frac{1}{4}''$  brass,  $5\frac{1}{2}$  pins per inch, 26 rows, 7 pins, No. 16— $\frac{5}{8}''$ ,  $\frac{3}{8}''$  out.

## ROTARY ROVING GILLS

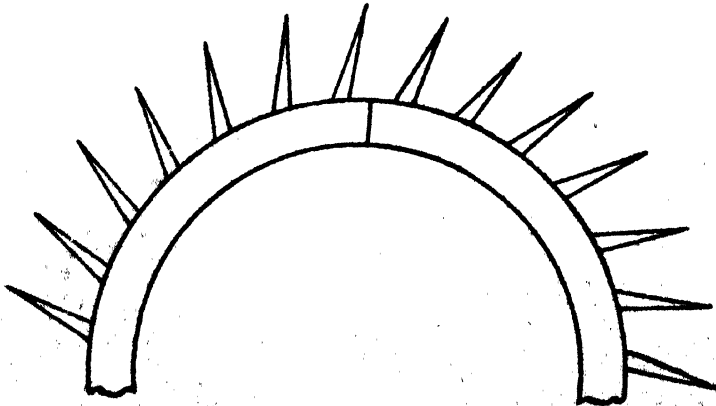
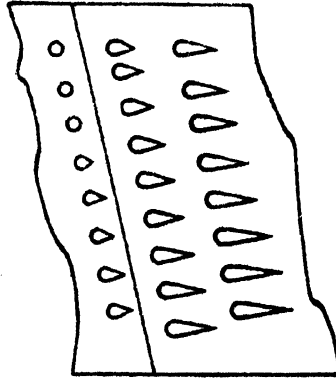

# ROTARY ROVING FRAME

SCALE,  $\frac{1}{8}$ TH.

*Diagrams showing Three Sets of Wheels and Pinions for altering "Reach" between Retaining Roller and Gill Shaft.*

- |                     |                              |
|---------------------|------------------------------|
| A = Drawing Roller. | C = Gill Shaft.              |
| B = Pressing " "    | D and E = Retaining Rollers. |

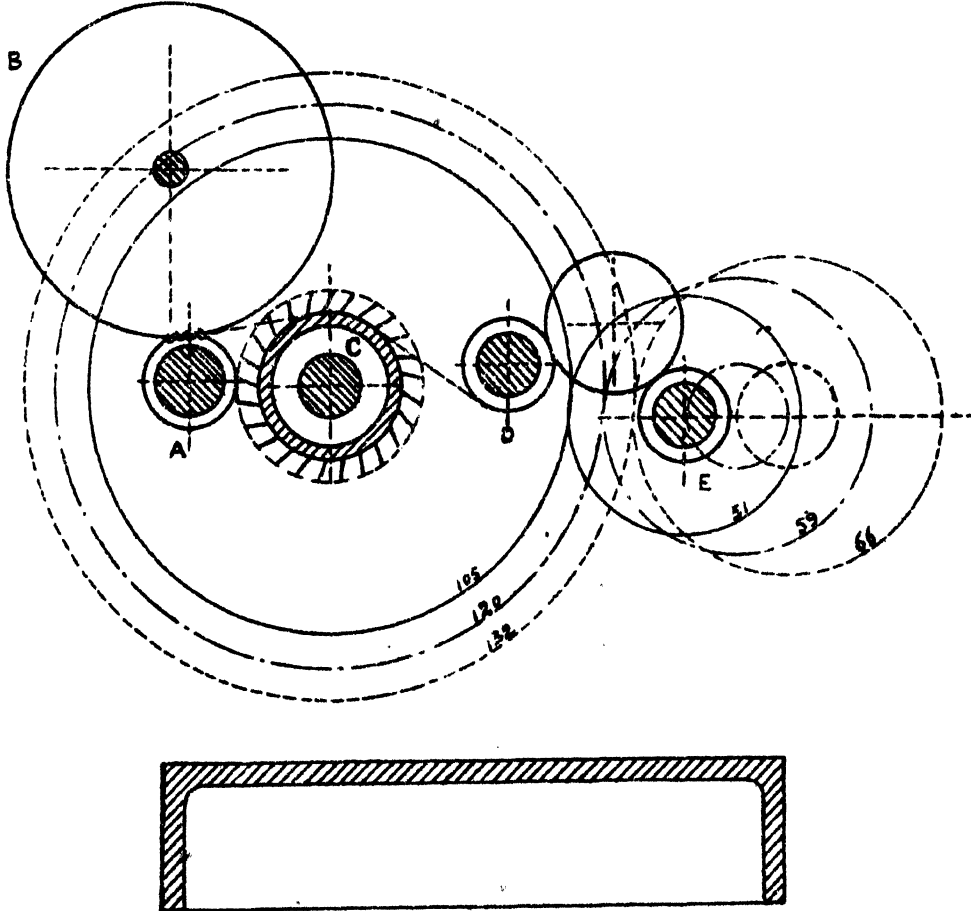

**NOTE.**—The surface speed of the Rotary Gill at the point of the pin is almost equal to the surface speed of the Retaining Roller.

# ROTARY DRAWING FRAME ROTARY DRAWING FRAME

ARRANGEMENT OF DRAFT GEARING.

SCALE  $\frac{1}{8}$ TH.

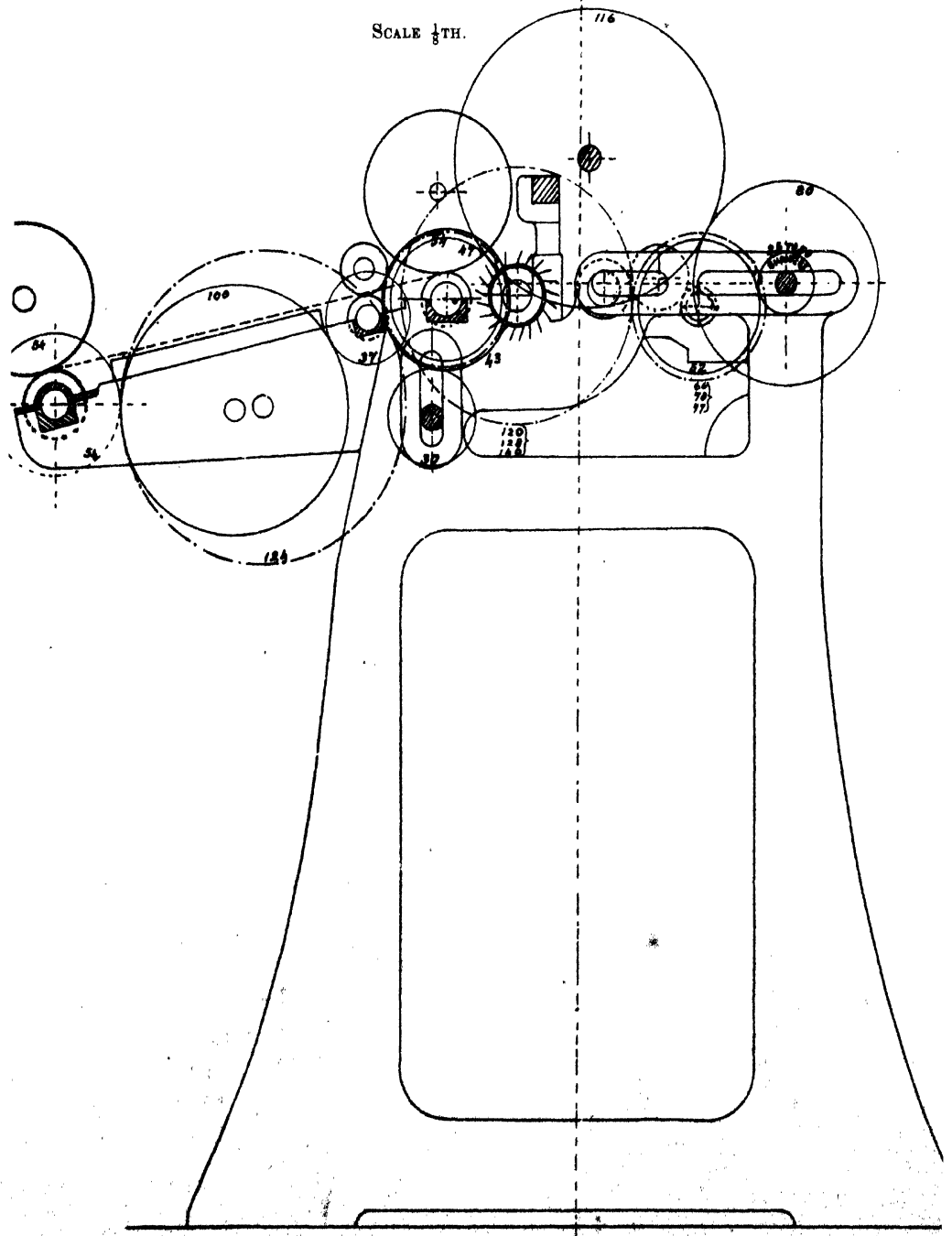

ROTARY DRAWING FRAME.

DRAFT ARRANGEMENT.

Back Roller Wheel,	...	...	...	...	52 teeth.
Change Pinion,	...	..	...	...	25 teeth.
Stud Wheel,	...	...	...	...	80 teeth.
Front Roller Wheel,	...	...	...	...	47 teeth.
Working diameter of Front Roller,			...	...	3·4 inches.
"    "    Back Roller,			...	...	2    "

$$\frac{52 \times 80 \times 3\cdot4}{25 \times 47 \times 2} = 6 \text{ draft.}$$

# DOUBLE ROTARY DRAWING FRAME.

ARRANGEMENT OF DRAFT GEARING.

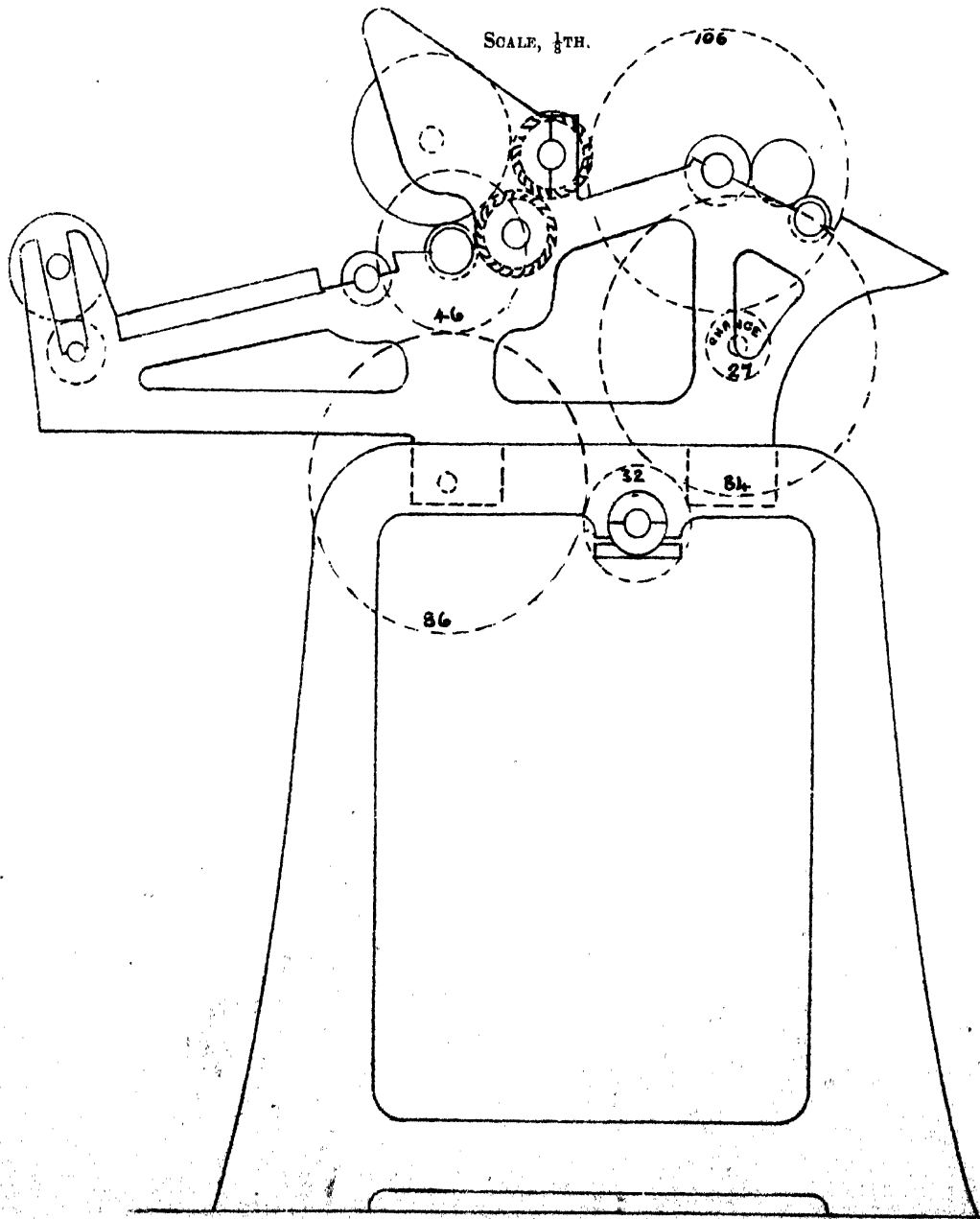

DRAFT GEARING FOR DOUBLE ROTARY FRAME.

Back Roller Wheel,	...	...	...	...	106 teeth.
Draft Pinion,	...	..	...	...	27 ,,
Stud Wheel,	...	...	...	...	84 ,,
Drawing Roller Wheel,	..	...	...	...	46 ,,
Diameter of Drawing Roller,	...	...	...	...	2½"
,, Retaining Roller,	...	...	...	...	3"

$$\frac{106 \times 84 \times 2\frac{1}{2}}{27 \times 46 \times 3} = 6 \text{ draft.}$$



## SPINNING ROVING FRAME.

ARRANGEMENT OF DRAFT AND TWIST GEARING FOR ROVING, BOBBIN 8" x 4"

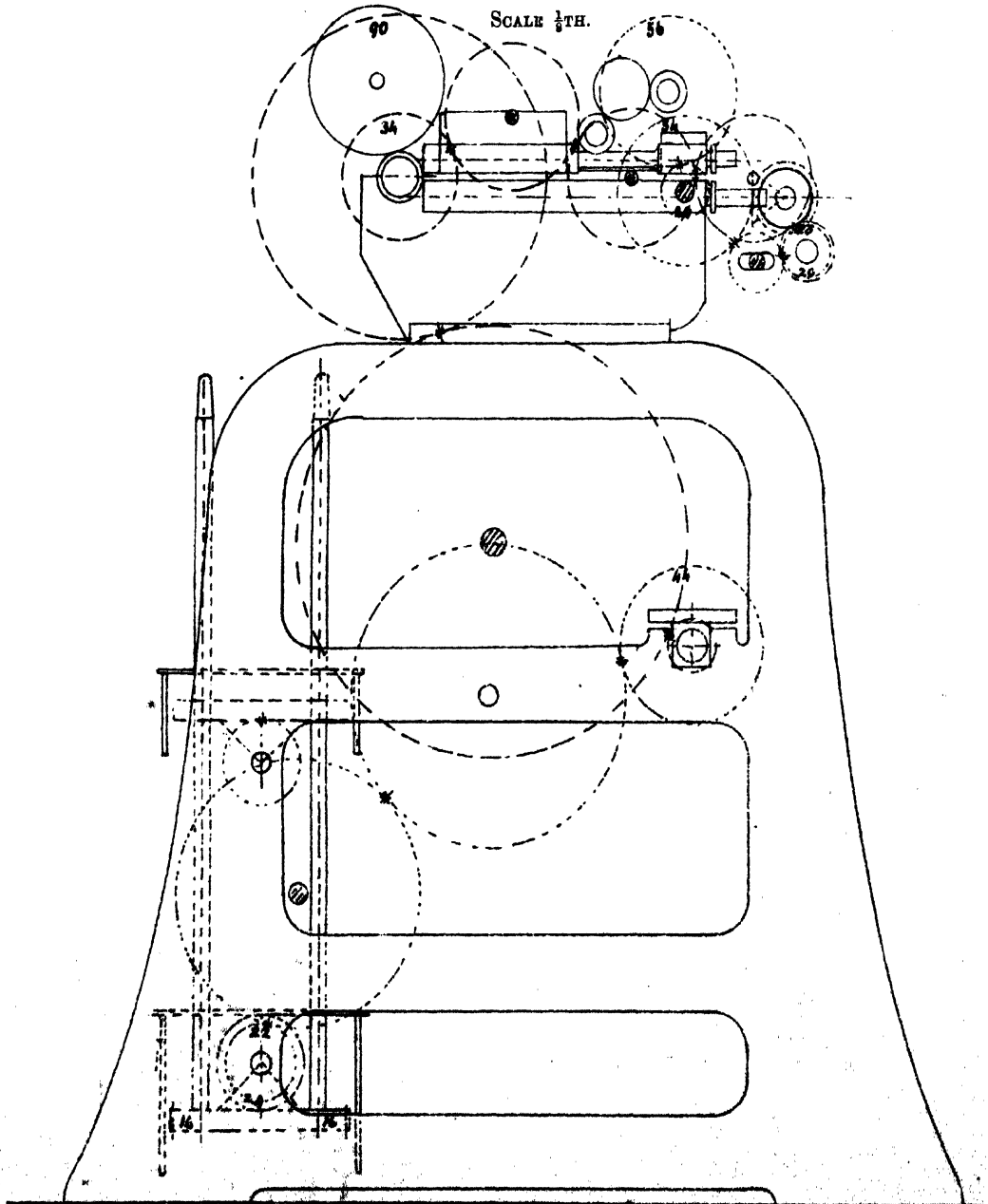

SPINNING ROVING FRAME, 8" TRAVERSE.

DRAFT ARRANGEMENT—

Retaining Roller Wheel,	...	...	...	56 teeth.
Drawing Roller Pinion,	...	...	...	34 ,,
Double Intermediate,	...	...	...	54 and 20 ,,
Back Shaft Pinion,	...	...	...	20 ,,
,,      ,,      Change,	...	...	...	20 ,,

Diameter of Drawing Roller and Retaining Roller, 2" and 1 $\frac{3}{4}$ ".

$$\frac{56 \times 54 \times 20 \times 2''}{20 \times 20 \times 34 \times 1\frac{3}{4}''} = 5 \text{ draft.}$$

$$\frac{56 \times 54 \times \text{C.P.} \times 2''}{20 \times 20 \times 34 \times 1\frac{3}{4}''} = 254 \text{ Constant for draft,}$$

TWIST ARRANGEMENT—

Drawing Roller Wheel,	...	...	...	90 teeth.
Wheel on Main Shaft of Roving,	...	...	...	44 ,,
Bevel Pinion on Spindle Shaft, ..	...	...	...	24 ,,
Twist Pinion,	...	...	...	14 ,,
Pinion on end of Spindle Shaft, ...	...	...	...	22 ,,
,,      on Spindle,	...	...	...	16 ,,

Diameter of Drawing Roller, 2" = 6.28 circumference.

$$\frac{90 \times 44 \times 24}{14 \times 22 \times 16 \times 6.28} = 3 \text{ Twist per inch.}$$

$$\frac{90 \times 44 \times 24}{\text{Twist Pinion} \times 22 \times 16 \times 6.28} = 43 \text{ Constant Number.}$$

$$\text{Speed Roving Spindles, } \frac{44}{22} \times \frac{24}{16} = 3.$$

Speed Spindles = Speed Main Shaft of Roving  $\times$  3.

The Speed of Spindles of Roving Spinning 48/60 lbs. weft yarn is about 1050 revolutions per minute.

## SPEEDS OF JUTE SPINNING MACHINERY.

(Recommended by Fairbairn, Naylor, Macpherson & Co., Ltd., Leeds).

## 4 ft. x 6 ft. SHELL BREAKER CARD

Cylinder, 190 revolutions per minute; Surface Speed, 2485 ft. over points of pins.

7" Workers, 24 revolutions per minute; Surface Speed, 54 ft. over points of pins.

11" Strippers, 133 revolutions per minute; Surface Speed, 443 ft. over points of pins.

Change pinion on Cylinder, 48 teeth.

## 4 ft. x 6 ft. CIRCULAR FINISHER CARD.

Cylinder, 190 revolutions per minute; Surface Speed, 2470 ft. over points of pins.

7" Workers, 15 revolutions per minute; Surface Speed, 33 ft. over points of pins.

11" Strippers, 147 revolutions per minute; Surface Speed, 490 ft. over points of pins.

Change pinion on Cylinder, 56 teeth.

## 1ST AND 2ND SPIRAL DRAWINGS.

150 to 160 Drops of Gill Bars per minute.

## PUSH BAR OR SLIDE DRAWING.

350 Drops of Gill Bars per minute.

## 1ST CIRCULAR DRAWING.

306 Drops of Gill Bars per minute.

## SPIRAL ROVINGS, 10" x 5" BOBBINS.

Speed of Spindles, 540 revolutions per minute.

Drops of Gill Bars will vary with the Twists and Drafts, but the bars can be run at the same speed as for Spiral Drawing.

## SPEED OF SPINNING FRAME SPINDLES.

6" Traverse, 1500 revolutions per minute.

5½"	"	1600	"	"
5"	"	1800	"	"
4½"	"	2000	"	"
4¼"	"	2200	"	"
4"	"	2600	"	"
3¾"	"	2800	"	"
3½"	"	3000	"	"
3¼"	"	3200	"	"
3"	"	3400	"	"
2¾"	"	3400	"	"

## REMARKS ON PREPARING MACHINERY.

Before finishing this chapter upon preparing machinery, let me make a few general remarks. If work of a fair quality and quantity is to be made, the machinery must be kept clean and in good mechanical order; the breaker and finisher workers, strippers, &c., should be regularly picked and cleaned in a thorough manner during the meal hours; and once every three months the setting of the rollers should be tried, to see if they are correct, and adjusted where necessary; all the pins in cylinder, &c., kept in good order; the drawings and rovings cleaned thoroughly once every six weeks or two months at least, and the cleaning should be done as much as possible in the day time, so that the condition of the machines can be thoroughly seen and examined, and little things can then be put right—wheels and pinions, &c., renewed where necessary. If all this is done in an orderly and systematic manner, the machinery will run without much trouble or annoyance to the workers, and quality and quantity will be ensured; without this there will neither be the one nor the other, but continual worry and annoyance will be the daily result.

*Dimensions of Sliver Cans in use for Preparing Machinery.*

Breaker Cans,	13" × 11" × 36".	Oval.
Finisher	„ 12" × 9" × 36".	„
Drawing	„ 12" × 9" × 36".	„
Roving	„ 10" × 7" × 36".	„

NOTE—Sometimes the breaker, finisher, and drawing cans are made oblong; the roving cans are always made oval.

---

All the calculations and illustrations in this chapter are of machines made by Messrs Fairbairn, Naylor, Macpherson, & Co., Limited, Leeds, who stand first as makers of jute machinery, their attention to the many intricate details, as well as to the general finish and fitting up of this class of machinery, having secured for them a world wide reputation. Without their kind assistance and permission it would have been impossible to illustrate the various machines. The calculations for machines by other makers are worked out by the same methods.

BARROWS.

ROVE BARROW. SCALE  $\frac{3}{4}$ " TO ONE FOOT

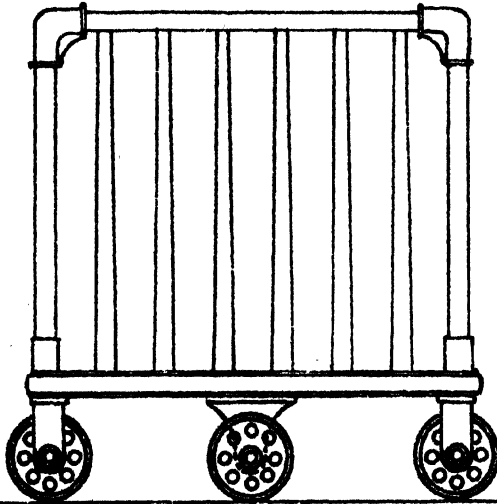

Front Elevation.

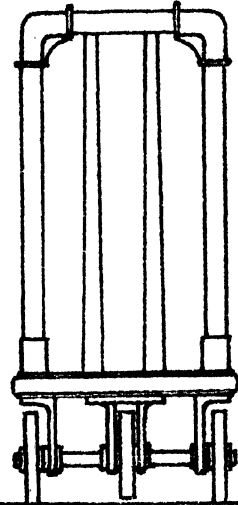

End Elevation.

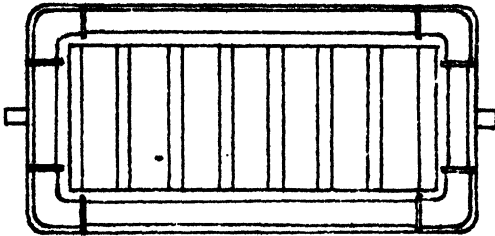

This Barrow holds one shift—  
56 roves x 10" x 5" roving.

BARROW FOR BOXES WITH SPINNING BOBBINS.

SCALE  $\frac{3}{4}$ " TO ONE FOOT.

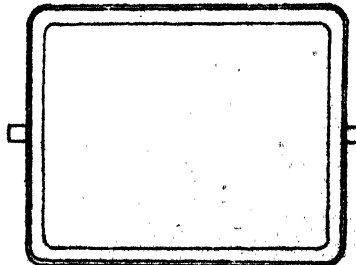
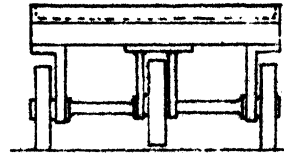
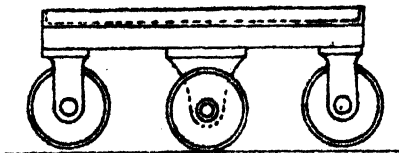

ARRANGEMENT TO PRODUCE ROVE FOR 9/12 LBS. WEFT  
AND WARP HESSIAN QUALITY.WEIGHT OF ROVE WANTED  $72\frac{1}{2}/75$  LBS. PER SPYNDLE.

Breaker Single Doffer—Cylinder, 190 revolutions per minute; cylinder pinion, 46 teeth.

Dollop, 33 lbs.; clock, 13·13, calculated from feed roller  $10\frac{3}{4}$ " diameter = 33·77 inches circumference.

Draft between feed and drawing roller—

$$\frac{4 \times 80 \times 110 \times 110}{52 \times 26 \times 20 \times 10\frac{3}{4}} = 13\cdot32 \text{ draft.}$$

Finisher, 10 ends into 1; Cylinder, 190 revolutions per minute; cylinder pinion, 56 teeth.

Draft between feed and drawing roller—

$$\frac{4 \times 104 \times 96 \times 96}{75 \times 32 \times 28 \times 4} = 14\cdot26 \text{ draft.}$$

Speed pulleys, 180 revolutions per minute.

Push bar drawing, 4 ends into 1; pulley pinion, 34 teeth.

Leather pressing roller—

$$\frac{160 \times 16}{14} = 182\frac{2}{7} \text{ revolutions pulley per minute.}$$

$$\frac{2\frac{1}{2} \times 56 \times 74 \times 50 \times 23 \times 32}{52 \times 20 \times 34 \times 39 \times 40 \times 1\frac{1}{8}} = 3\cdot5.$$

Pulleys, 160 revolutions per minute.

Second drawing spiral, 2 ends into 1; pulley pinion, 30 teeth—

$$\frac{160 \times 16}{16} = 160 \text{ revolutions of pulleys per minute.}$$

$$\frac{2\frac{1}{2} \times 34 \times 68 \times 69}{43 \times 25 \times 25 \times 1\frac{1}{8}} = 7\cdot65 \text{ draft.}$$

Roving, 1 end into 1; speed pulleys, 225 revolutions per minute.

$$\frac{2\frac{1}{2} \times 32 \times 70 \times 70}{38 \times 24 \times 24 \times 1\frac{1}{8}} = 8\cdot31 \text{ draft.}$$

The following example will show arrangement and weight of rove in this system :—

Breaker dollop, 38 lbs.

,, clock, 13·13 yards.

,, draft, 13·82.

## ARRANGEMENT TO PRODUCE ROVE OF A GIVEN WEIGHT.

$13.32 \times 13.13 = 174.89$  yards delivered at front of breaker, weighs 33 lbs.

Finisher, 10 ends into 1.

Draft, 13.32.

$$\frac{33 \times 10}{13.32} = 24.77 \text{ lbs. weight of } 174.89 \text{ yards at front of finisher.}$$

Push bar drawing, 4 ends into 1.

Draft, 3.5.

$$\frac{24.77 \times 4}{3.5} = 28.31 \text{ lbs. weight of } 174.89 \text{ yards at front of 1st drawing.}$$

Second drawing spiral, 2 ends into 1.

Draft.

$$\frac{28.31 \times 2}{7.65} = 7.40 \text{ lbs. weight of } 174.89 \text{ yards at front of 2nd drawing.}$$

Roving Spiral—56 spindles, 10" × 5" pitch—675 revs. of spindles per minute.

Draft, 8.31.

$$\frac{7.40}{8.31} = .890 \text{ lbs. weight of } 174.89 \text{ yards at front of roving.}$$

$174.89 : 14400 : : .890 : 73.2$  lbs. per spynkle.

The actual weight of this rove was  $72\frac{1}{2}$  lbs.

ARRANGEMENT TO PRODUCE ROVE FOR  $\frac{7}{8}$  LBS. WARP.

WEIGHT OF ROVE WANTED,  $67\frac{1}{2}$  LBS.

Breaker Double Doffer—cylinder, 190 revolutions per minute; cylinder pinion, 44 teeth.

„ clock, calculated from feed roller  $20\frac{1}{4}$ " diameter = 12.95 yards

„ draft, 9.7; dollop, 22 lbs.

$12.95 \times 9.7 = 125.6$  yards delivered at front of breaker in one round of clock.

Finisher single doffer—10 ends into 1; cylinder, 190 revs. per minute.

Draft cylinder pinion, 56 teeth.

$$\frac{22 \times 10}{14.26} = 15.42 \text{ lbs. weight of } 125.6 \text{ yards at front of finisher.}$$

Push Bar Drawing, 4 ends into 1; draft,  $3\frac{1}{2}$ ; leather pressing rollers; pulley pinion, 34 teeth.

$$\frac{160 \times 16}{14} = 182\frac{6}{7} \text{ revolutions pulleys per minute.}$$

$$\frac{15 \cdot 42 \times 4}{3\frac{1}{2}} = 17 \cdot 62 \text{ lbs. weight of 125 \cdot 6 yards at front of 1st drawing.}$$

Second Drawing Spiral, 2 ends into 1.

Draft, 7 \cdot 65.

$$\frac{17 \cdot 62 \times 2}{7 \cdot 65} = 4 \cdot 60 \text{ lbs. weight of 125 \cdot 6 yards at front of 2nd drawing.}$$

Roving Spiral, 1 end into 1—Speed spindles 675 revs. per minute.

Draft, 8.

$$\frac{4 \cdot 60}{8} = \cdot 575 \text{ lbs. weight of 125 \cdot 6 yards at front of roving.}$$

125 \cdot 6 : 14400 : : \cdot 575 : 65 \cdot 9 \text{ lbs. per spyndle.}

Actual weight of this rove, 65/67\frac{1}{2} lbs.

Roving,	-	-	-	-
Twist Pinion,	-	-	-	32
Grist, ,,	-	-	-	31
Traverse ,,	-	-	-	28
Rack ,,	-	-	-	17

These three examples are sufficient for the explanation of this part of the subject. Different arrangements are in operation to do the same thing. Many of them are based upon the opinion and experience of those in charge, others are in a measure based upon convenience. The production required from the system also determines to a certain extent the arrangement. Theory in this matter has often—within limits, of course—to give way to what is best in practice.

#### ARRANGEMENT TO PRODUCE ROVE FOR 16/24 LBS. WEFT OF ORDINARY HESSIAN QUALITY.

ROVE TO BE 105/110 LBS.

Breaker Single Doffer—cylinder, 195 revolutions per minute; cylinder pinion, 46 teeth.

Dollop, 33 lbs.; clock—13 \cdot 16 yds., calculated from feed roller 10\frac{3}{4}" dia.  
= 33 \cdot 77 inches.

4\frac{1}{2}\frac{6}{10}



## ARRANGEMENT TO PRODUCE ROVE OF A GIVEN WEIGHT.

Draft between feed and drawing roller—

$$\frac{4 \times 80 \times 110 \times 110}{52 \times 26 \times 20 \times 10\frac{1}{2}} = 13.32 \text{ draft.}$$

Draft between doffer and drawing roller—

$$\frac{4}{23} \times \frac{54}{26} \times \frac{88}{15\frac{1}{2}} = 2.05 \text{ draft.}$$

This is only shown as a draft that is necessary for delivery of material from doffer to drawing roller. This draft is not necessary in working out the total draft of breaker.

Finisher single doffer—cylinder, 195 revolutions per minute; cylinder pinion, 64 teeth.

Finisher, 10 ends into 1.

Draft between feed and drawing roller—

$$\frac{4}{75} \times \frac{104}{32} \times \frac{96}{32} \times \frac{96}{4} = 12.48 \text{ draft.}$$

CIRCULAR DRAWING—Pulley pinion, 32 teeth.

$$160 \times \frac{21}{14} = 240 \text{ revolutions per minute.}$$

Pressing and drawing roller, hard to hard ( $3\frac{1}{2}$ " )—

$$\frac{3}{22} \times \frac{120}{50} \times \frac{27}{15} \times \frac{15}{3} = 3.43 \text{ draft.}$$

4 ends into 1.

Second drawing spiral—pulley pinion, 80 teeth.

Leather pressing rollers—

$$160 \times \frac{16}{16} = 160 \text{ revolutions per minute.}$$

$$\frac{2\frac{1}{2} \times 34 \times 68 \times 69}{82 \times 25 \times 25 \times 1\frac{1}{4}} = 10.32 \text{ draft.}$$

2 ends into 1.

Roving—Rotary, 48 spindles; 10" × 5" pitch.

Speed spindles—

$$160 \times \frac{25}{18} \times \frac{44}{22} \times \frac{21}{14} = 666\frac{2}{3} \text{ revolutions of spindles per minute.}$$

Twist arrangement—

$$\frac{60 \times 44 \times 21}{42 \times 22 \times 14 \times 7.06} = .60 \text{ twist on rove.}$$

$$\frac{60 \times 44 \times 21}{C. \times 22 \times 14 \times 7.06} = 25.495.$$

Grist arrangement—

$$\begin{array}{r} 2\frac{1}{4} \quad 80 \quad 60 \\ - \times - \times - \\ 44 \quad 25 \quad 1\frac{5}{16} \end{array} = 4.69 \text{ draft between retaining drawing roller.}$$

$$\frac{2\frac{1}{4} \times 80 \times 60}{44 \times C. \times 1\frac{5}{16}} = 126.686 \text{ constant number.}$$

The following example will show the way to find weight of rove in this system:—

Breaker dollop, 38 lbs.

„ clock, 13.13 yds.

„ draft, 13.32 „

$13.32 \times 13.13 = 174.89$  delivered at front of breaker, weighs 33 lbs.

Finisher, 10 ends into 1.

Draft, 12.48.

$$\frac{33 \times 10}{12.48} = 27.24 \text{ lbs. weight of } 174.89 \text{ yds. delivered at front of finisher.}$$

Circular—1st drawing, 4 ends into 1.

Draft—

$$\frac{27.24 \times 4}{3.43} = 31.76 \text{ lbs. weight of } 174.89 \text{ yards delivered at front of } 1^{\text{st}} \text{ drawing.}$$

Second drawing—spiral, 2 ends to 1.

Draft, 10.32.

$$\frac{31.76 \times 2}{10.32} = 6.15 \text{ lbs., weight of } 174.89 \text{ yards delivered at front of } 2^{\text{nd}} \text{ drawing.}$$

Roving rotary, 1 end into 1—draft.

Draft—4.69.

$$\frac{6.15}{4.69} = 31 \text{ lbs., weight of } 174.89 \text{ yards delivered at front of roving.}$$

$174.89 : 14400 : : 1.31 : 107.8$  lbs. per spynkle.

The actual weight of this rove was 105/106 lbs.

Roving twist pinion, 42 teeth.

„	grist	„	25	„
„	rack	„	11	„
„	traverse	„	86	„

This roving made 44 shifts in 10 hours, and produced rove at 105 lbs. per spynkle, and kept three frames 72 spindles each, 4 in. pitch, 5 in. traverse, spinning 20 lbs. weft. The production from these three frames was 242 spynkles in 10 hours, this average being taken over a period of three months,

	Tons.	Cwts.	Qrs.	Lbs.
242 × 20 = 4840 lbs. =	2	3	1	6

Spinning frame—Particulars of speed spindle.

$$\frac{220 \times 28 \times 10}{14 \times 1\frac{1}{4}} = 2514.2 \text{ revs. of spindles per minute.}$$

To find speed of spindle—

$$\frac{A \times B \times D}{C \times E}$$

A = Speed Driving Shaft.

B = Drum upon Driving Shaft.

C = Pulleys on Cylinder Arbor of Frame.

D = Diameter of Cylinder.

E = Diameter of Spindle Wove.

Cylinder, 10" diameter; Drawing Roller Wheel, 120 teeth.

Twist Wheel and Pinion, 90 and 76 teeth.

Spindle Werve, 1 $\frac{3}{4}$ " diameter.

Drawing Roller, 4 $\frac{1}{8}$ " diameter.

Retaining „ 1 $\frac{1}{2}$ " diameter.

„ „ Wheel, 75 teeth.

Double Intermediate, 80/86. Draft arrangement.

Twist arrangement—Cylinder pinion, 34 teeth; drawing roller, 4 $\frac{1}{2}$ " dia.—12.95 circumference.

$$\frac{10 \times 90 \times 120}{1\frac{1}{2} \times 34 \times 76 \times 12.95} = 1.84 \text{ twist per inch upon this yarn.}$$

Grist arrangement—Drawing roller pinion or grist pinion, 35 teeth.

$$\frac{4\frac{1}{2} \times 80 \times 75}{35 \times 86 \times 1\frac{1}{4}} = 5.4 \text{ draft.}$$

80 spynkles from 72 spindles =

80

— = 1 $\frac{1}{3}$  spynkles per spindle in 10 hours.

72

## DOUBLINGS AND DRAFTS.

7 TO 12 LBS.

Breaker 30 lbs. dollop—to 12 yards clock—draft 12.  
 Finisher—10 ends into 1—circular—draft 16.  
 1st drawing—4 ends into 1—push bar—draft 4.  
 2nd drawing—2 ends into 1—spiral—draft  $6\frac{1}{2}$ .  
 Roving, - - - - - ,, draft 8.  
 Will give 72 lbs. rove—exclusive of allowance for waste.

## DOUBLE DOFFER CARDS.

Breaker 22 lbs. dollop—to 12 yards clock—draft 10.  
 Finisher 10 ends into 1—circular—draft 14.  
 1st drawing—4 ends into 1—push bar—draft 4.  
 2nd drawing—2 ends into 1—spiral—draft  $6\frac{1}{2}$ .  
 Roving, - - - - - ,, draft 8.  
 Will give  $72\frac{1}{2}$  lbs. rove—exclusive of allowance for waste.

## DOUBLINGS AND DRAFTS.

7 TO 12 LBS.

*Rotary System.*

Breaker 30 lbs dollop to 12 yards clock,	...	...	Draft 14.
Finisher, 10 ends into 1—circular,	...	..	,, 21.
1st Drawing, 4 ends into 1,	...	...	,, $4\frac{1}{4}$ .
2nd ,, 2 ,, 1,	...	...	,, $5\frac{1}{4}$ .
Roving, ... ..	..	...	,, 6.

Will give  $73\frac{1}{2}$  lbs. rove—exclusive of allowance for waste.

## SACKING WEFT—AVERAGE 32 LBS.

Breaker 28 lbs. dollop to 12 yards clock,	...	...	Draft 13.
Finisher, 10 ends into 1—half circular,	...	...	,, 16.
1st Drawing, 4 ends into 1—push bar,	...	...	,, $3\frac{1}{2}$ .
2nd ,, 2 ,, 1 ,,	...	...	,, $4\frac{1}{4}$ .
Roving—spiral,	...	...	,, 7.

Will give 126 lbs. rove—exclusive of waste allowance.

The results given above will be the same whether the finisher card be fed from laps or cans, provided the same number of ends be put up in each case.

The machines and draft arrangements for Sacking Warps are precisely the same as for Hessian Yarns, the only difference being that the quality of jute is lower in the former case, and the yarn is frequently harder twisted.

## SACKING WARP ARRANGEMENT.

Dollop, 32 lbs. ... Breaker Clock = 10 yds.

*Breaker Draft Arrangement.*

$$\frac{4'' \times 72 \times 120 \times 120}{72 \times 18 \times 24 \times 9\frac{1}{2}''} = 14 \text{ draft.}$$

$14 \times 10 = 140$  yds. at front of breaker.

*Finisher—10 ends into 1.*

$$\frac{4'' \times 72 \times 120 \times 120}{72 \times 18 \times 22 \times 9\frac{1}{2}''} = 15.31 \text{ draft.}$$

$32 \times 10 \div 15.31 = 20.9$  lbs. weight of 140 yards at front of finisher.

*1st Drawing (Lawson) 8 ends into 1.*

$$\frac{3\frac{3}{8}'' \times 40 \times 70 \times 28}{23 \times 20 \times 53 \times 2''} = 4 \text{ draft.}$$

$15.31 \times 8 \div 4 = 30.62$  lbs. at 1st Drawing.

*2nd Drawing (Push Bar) one into one.*

$$\frac{2\frac{1}{2}'' \times 56 \times 74 \times 50 \times 23 \times 35}{60 \times 20 \times 34 \times 39 \times 40 \times 1\frac{1}{8}''} = 4\frac{1}{2} \text{ draft.}$$

$30.62 \div 4.5 = 6.8$  lbs. at 2nd Drawing.

*Roving (Lawson Spiral) one into one.*

$$\frac{2\frac{1}{4}'' \times 36 \times 56 \times 63}{48 \times 24 \times 24 \times 1\frac{3}{4}''} = 5.9 \text{ draft.}$$

$6.8 \div 5.9 = 1.15$  lbs. at roving.

$140 : 14,400 :: 1.15 : 118$  lbs. weight of rove.

Rove actually weighs 115/120 lbs.

4% fluctuation

From this is spun 10/14 lbs. Warp.

## SACKING WEFT ARRANGEMENT.

Dollop 32 lbs.

Breaker Clock = 10 yds.

*Breaker Draft Arrangement.*

$$\frac{4'' \times 72 \times 120 \times 120}{72 \times 18 \times 28 \times 9\frac{1}{2}''} = 12.03 \text{ draft.}$$

12.03 × 10 = 120.30 yds. at front of breaker.

*Finisher 10 ends into 1.*

$$\frac{4'' \times 72 \times 120 \times 120}{72 \times 18 \times 26 \times 9\frac{1}{2}''} = 12.95 \text{ draft.}$$

32 = 10 ÷ 12.95 = 24.71 lbs. weight of 120.30 yds. at front of finisher.

*1st Drawing (Lawson's Link Gill) 8 ends into 1.*

$$\frac{3\frac{1}{8}'' \times 40 \times 70 \times 23}{23 \times 20 \times 53 \times 2''} = 4 \text{ draft.}$$

24.71 × 8 ÷ 4 = 49.42 lbs. at 1st Drawing.

*2nd Drawing (Push Bar) one end into one.*

$$\frac{2\frac{1}{2}'' \times 56 \times 74 \times 50 \times 23 \times 35}{67 \times 20 \times 34 \times 39 \times 40 \times 1\frac{1}{8}''} = 4 \text{ draft.}$$

49.42 ÷ 4 = 12.35 at 2nd Drawing.

*Roving (Rotary) one into one (Lawson Roving).*

$$\frac{2\frac{1}{2}'' \times 144 \times 74}{72 \times 20 \times 3''} = 5.55 \text{ draft.}$$

12.35 ÷ 5.55 = 2.22 lbs. at roving.

120.30 : 14,400 :: 2.22 : 265 lbs. weight of rove.

Actual weight of rove is 240 lbs. From this we spin from 32 lbs. up to 44 lbs.

## JUTE SPINNING.

When the rove bobbins are filled at the roving, they are taken off and put into a rove barrow. They are then taken to the spinning department, put upon the spinning frames, and it is here that the operation of spinning commences.

The spinning operation is performed by one machine. This machine is called a spinning frame. Spinning frames are very much of the same construction, they only vary in the size of the spindle and the pitch of the spindles. By the pitch of the spindle is meant the distance between the centre of each spindle; and in speaking of a spinning frame, we usually speak of the frame as being of 4 inch pitch, 4 inch traverse,  $4\frac{1}{2}$  inch pitch,  $4\frac{1}{2}$  traverse, and so on as the case may be. As already mentioned, the pitch of the frame is the distance between the centre of the spindles; and by the traverse is meant the length of the bobbin which is to be filled upon the frame. In the spinning of hessian warps and wefts three sizes of bobbins are commonly in use— $3\frac{3}{4}$  inch, 4 inch, and 5 inch. The  $3\frac{3}{4}$  inch bobbin is used to spin from 7 to 8 pounds warp; the 4 inch bobbin, from 9 to 12 pounds, and sometimes 16 pounds. The 5 inch bobbin is used to spin from 16 to 24 pounds per spindle. In the plan of the mill in this book the frames are all given 72 spindles, 4 inch pitch; but in a mill of from 5000 to 6000 spindles it is better to have a certain proportion of the spindles  $3\frac{3}{4}$  inch, 4 inch, and 5 inch traverse; when this is the case, care should be taken to have all the frames made the same length, or nearly so, over all. This will keep up the uniform width of the passes from north to south, and to a considerable extent facilitate the regular traffic as well as add to the general appearance of this part of the mill.

The successful production of the yarn from a spinning frame depends more upon the worker in attendance (called a spinner) than any other machine in the mill. The frame may be in perfect order and mechanically correct, but everything will depend upon the ability of the spinner to produce good work, and a fair quantity of it. This ability can only be attained by long experience at this class of work.

There are three motions on the spinning frame:—

- |         |   |   |                           |
|---------|---|---|---------------------------|
| First,  | - | - | The twist arrangement.    |
| Second, | - | - | The grist arrangement.    |
| Third,  | - | - | The traverse arrangement. |

The twist arrangement of wheels fixes the amount of turns or twists per inch to be put upon the yarn being spun. The grist arrangement of wheels fixes the weight of the yarn—say 7, 8, 9, or 10 pounds per spyndle of 14,400 yards, usually termed a spyndle. Whatever the size of yarn may be given, it is always understood that the spyndle contains 14,400 yards (see yarn table in reeling chapter). The traverse arrangement, consisting of heart and heart motion wheel and pinion on the end of retaining roller, by the action of the lever from the heart (which is a form of eccentric or cam) to the traverse pulleys, which are fixed upon the traverse shaft, chains attached to these pulleys, and also to lever which is actuated by the eccentric or cam—commonly termed the heart motion—moves the bobbin board up and down. If the frame is for 4" bobbins, that means the traverse of the bobbin up and down will be 4 inches up and 4 inches down, and so on alternately. The form of the heart determines the shape of the bobbin. The usual practice is to shape the heart so that the bobbin will be thickest in the centre, and this makes the bobbin build better while filling. An illustration of the heart motion and arrangement of the traverse pulleys and chains is given, and also the calculation for the traverse.\* The same heart or eccentric is used for 3½", 4", 4½", and 5" traverse, the difference being made in the lever and pulleys for each of these sizes. In the spinning frame it is of the utmost importance that the bands, or lists, as they are commonly termed, be kept in good order. If this band which drives the spindle is not kept uniformly tight, slack-twisted yarn will be the result. The broader the band you can work with the better; for 3½ inch spindles the band should be 1½ in. broad, 4 inch spindles 2 inches broad, and 4½ to 5 ins. 2½ in. bands; the length of band required in an ordinary frame, 4 inch pitch, 4 inch traverse, is 65 inches. The pressing rollers should also have great care and attention bestowed upon them; and the frames in a large mill should be systematically gone over day by day, and the rollers carefully examined, and the bad ones—that is, those that are chipped or "off the truth"—taken out and turned in a turning lathe. The remaining point of importance to be mentioned is the adjustment of the rove plate over which the rove passes as it comes from the retaining roller to the drawing roller.

\*See page 207 for illustration of Heart Motion and Traverse Arrangement.



INSTRUCTIONS AS TO THE WORKING OF ROVE PLATE  
ON JUTE SPINNING FRAME (SEE PAGE 213).

First, let it be understood that the movement backward and forward of the rove plate and conductor in a spinning frame is intended either to open out the twist of the rove or to keep it in for a certain length of time while the rove is passing between the retaining and drawing rollers. The slower the rove passes down from the retaining roller the longer time will be taken for the twist to come out of the rove; hence the reason for keeping the rove forward by the plate, and keeping the top half of conductor well back when the rove is passing quickly between retaining and drawing rollers, as in a heavy size more freedom is required by the rove to allow the twist to come out of it quickly, otherwise the rove "will run."

Again, when spinning a light size of yarn, 7 to 8 lbs. per spynkle, you wish to keep the twist on the rove while passing between retaining and drawing rollers as long as you possibly can—within limits, of course—as in a light size, if you open up the twist of the rove too quickly as it comes off the rove plate to the bite of pressing and drawing rollers, it will tend to breakage of the yard—particularly weft yarn.

Thus, for yarn, say, 8 lbs. weft, to allow the twist being kept on the rove, set the rove plate so that rove will rest easy on the front of conductor. This eases the strain down to the bite of pressing and drawing rollers, and saves the yarn from breaking where there is not much twist being put on, as in weft of the lighter weights.

Then, for 8 lbs. warp yarn, bring forward the plate a little, to allow the twist to come off the rove a little quicker than in the previous case. This will allow the yarn to draw more equally, and it will take on the twist better; and there is not so much danger of the yarn breaking with the twist that is put on warp yarns.

Then, for, say, from 12/14 lbs. warp and weft yarns, bring forward the rove plate about a  $\frac{1}{4}$  of an inch from the position referred to in above instructions for 8 lbs. weft and warp, and let the rove touch the plate across its whole breadth. This putting forward the plate is intended to make the rove tighter between the retaining roller and conductor, and tends to keep the rove from "running," as it is termed. Then put back the rod from which the conductor is hung, so that the rove while passing through the conductor will only touch the back of

its lower half, the upper half of the length of conductor being kept about  $1\frac{3}{8}$ " clear of the rove as it comes over the rove plate. This position of rove plate, conductor rod, and conductor, allows the twist to come out of the rove in sufficient time to allow the drawing roller to put on the proper draft without breakage to the yarn or the "running" of the rove. Then, say, for 16/24 lbs. yarn, as the rove will in these sizes be heavier, and also be passing still faster through between retaining roller and drawing roller the distance forward of rove plate will have to be slightly increased, and the conductor rod also put a little further back, than in the case of the 12/14 lbs. yarn.

A new arrangement of gear attached to the rove plate of spinning frames made by Messrs Fairbairn, Naylor, Macpherson & Co., Ltd., saves much time. All the rove plates are fixed upon one rod, and by the movement of a handle placed at driving end of frame the rove plates across the whole length of frame are moved at one time, and can be readily set to the position required for the yarn being spun. An illustration is given (see page 213).

\*With reference to the pressure on the pressing rollers, you will require more pressure on the rollers for 24 lbs. than for 8/12 lbs. ; but one cannot be too careful as to the pressure put upon the pressing rollers. If more pressure is being put on the rollers than is absolutely necessary, this means more horse-power, which, in a mill of 5/6000 spindles, might be—and, I believe, often is—a very serious thing in regard to consumpt of coal, oil, &c. This pressing of the rollers is one of the things that must be learned by care, attention, and experience.

#### EXPLANATION OF THE TERM THE ROVE "RUNNING."

If the twist is not entirely out of the rove by the time it is actually at the bite of the drawing and pressing rollers, the rove will "run"—that is, the rove will be caught by the pressing and drawing rollers and dragged down at the surface speed of the drawing roller. The pressure on the retaining roller will not keep it back. This, of course, is owing to the strength of the rove, the twist not being out of it. By the time the rove is in the bite, it must be in the form of a thin sliver. The causes for this "running" may be various. If the pressing roller against the retaining roller gets out of order this would cause it ; but it mostly happens when the rove plate and conductor are not properly set for the size of the yarn being spun. For example, if you attempted to spin, say, 20 lbs. with rove plate and conductor set to spin 8 lbs., the rove would certainly "run."

\*See pages 210 and 211 for illustrations of the methods adopted to apply pressure to pressing rollers.

This, of course, will be readily gathered from what has been said as to the setting of the rove plate and conductor for the different sizes; and in the extreme case which we have taken as an example the running of the rove would in that case be caused by the increased speed of the rollers drawing the rove down before the twist was properly out; and this, in a certain degree, is more or less always the cause of the rove "running"—always, of course, making certain that the pressing roller, drawing roller, &c., are in proper working order.

### SPEED OF SPINNING FRAME SPINDLES.

So far as the speed of the spindles is concerned, very much depends upon the size of them if a fair speed is to be kept upon the frame without damage to the spindles. Very many of the spindles are made too light both in the haft and in the blade. A heavy collar or neck, fitted tight into the spindle rail, will also conduce very much to the life of the spindle if a fair speed is being put upon it, and if that speed is to be kept on continuously without damage. Whenever any lift is noticed upon the spindle, the neck should be knocked down, to take the lift off. Nothing will damage the spindles more than the neck slack in the neck rail, or the cone of the spindle being allowed to wear in the neck until the spindle has a lift between the neck and the step. It is imperative that the neck be kept close down on the cone—this is the secret of the life of the spindle. The following speeds are given to show what is the regular speed to be put upon the different sizes of spindles for the different sizes and twists of yarn being spun.

3 $\frac{3}{4}$ " spindle, spinning 8 lbs. hard warp, say, 5 $\frac{1}{2}$  to 6 turns per inch, speed spindle = 3,300 revolutions per minute.

3 $\frac{1}{2}$ " spindles, spinning 8 lbs. starching warp, say, 4 $\frac{3}{4}$  turns per inch = 3,100 revolutions per minute.

4" spindles, spinning 8 to 10 lbs. weft = 2,700 revolutions per minute.

12 to 16 lbs. = 2,600 revolutions per minute.

18 to 24 lbs. weft = 2,500 revolutions per minute.

SPINNING SPINDLE AND FLYER.

SPINNING SPINDLE  
AND FLYER.

4" TRAVERSE—HALF SIZE.

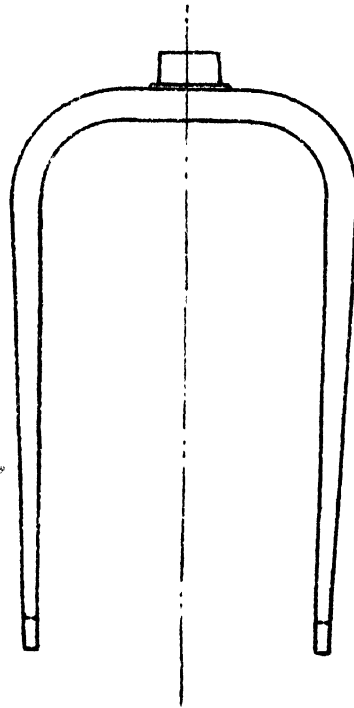
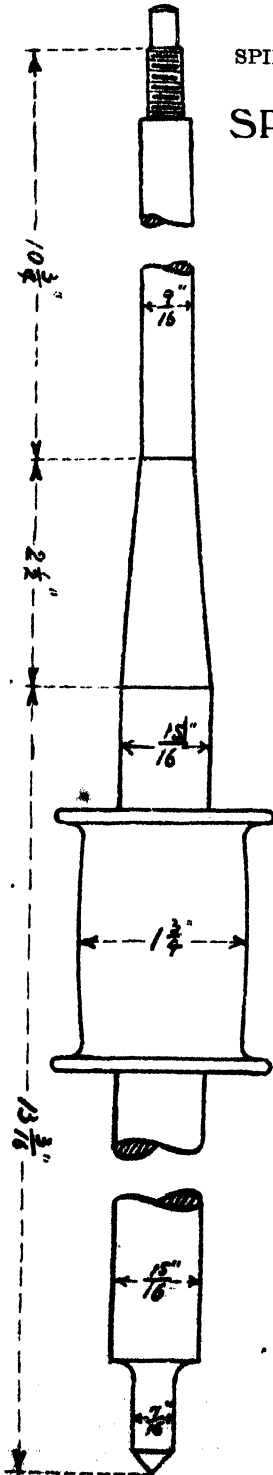

4" Bobbin.

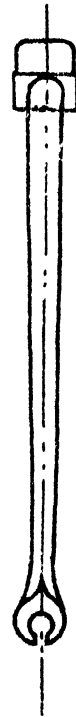

## THE PRODUCTION FROM THE SPINNING FRAMES.

So far as the production of the spinning frames is concerned, everything here, as in the roving in the preparing flat, depends upon the organization, steadiness, care, and attention of the workers, from the overseer onwards. Without organization, perseverance, and the individual attention of the workers, the production will suffer. As in every department of the mill, cleanliness here is of the utmost importance. Without cleanliness you cannot be doing much good in the spinning department. If you are clean in this department you may not be doing all that you might desire to do; but if you are dirty you may rely upon it, you cannot be doing very much good.

The question of production in this department is considered by many the most important in the mill. I think, however, that the production from the preparing machinery is quite as important as the production from the spinning machinery. We very seldom hear anything of what the production of the preparing machinery is. The production from a roving frame is of quite as much importance as the production of a spinning frame. Many things go to decide the question of production in the spinning department. First, the question of twist is an important factor in the production. If a mill be spinning a large proportion of weft yarns, the result will, or ought to be, a much larger production than from a mill working a large proportion of warp yarn. The cause of this difference of production is, of course, owing to the difference between weft and warp twist. A frame which would do 60 spyndles of 8 or 9 lbs. hessian weft, the same frame spinning warps of the same quality would not do much more than 50 spyndles. While it is perfectly true that the twist plays an important part in the question of production, there are other causes which will add to it, and the want of which will just as readily tend to the less of production. In speaking of production in this department, it is great folly to speak of what is the best that can be done in the course of a day, a week, or even a month. The only correct average for the production of a spinning department is to take the average over a year. We very seldom hear what the production for a year is, but we often hear of what we have done in a day—shall we say a very fine day, with the weather and everything else in favour of a good result. Strangely enough, we never hear how much production has been taken off in the morning. If a fair production is being made—say, 4 to 4½ spyndles per spindle, in a mill spinning warps and wefts, the whole of which

is to be woven in a factory which may be a part of the same works an average of 4 to 4½ spindles per spindle for all the year round will be a fair production; and to do this, will require the jute not only to be of the quality indicated in the chapter upon batching, but it will require all the points which the reader's attention was directed to in the introductory chapter—namely, punctuality, cleanliness, and organisation. Without determination to be punctual the production suffers, and without the same determination to be clean you will not have much chance to get this production; and without organisation, which should be the constant care and attention of those in charge of this department, you will not have very much chance of the daily and weekly output being of any regularity worthy of the name. But given these points, and if attention and consideration be bestowed upon them by all those interested, a very fair and reasonable production day by day may be looked for; and will, with perseverance, give to a mill an average for a year which will compare favourably with the ordinary run of a jute spinning mill. While we have said all this on the question of production, no one, not even an expert, can very well speak upon the production of a jute mill without thoroughly understanding the kind of work that is being done. The production of a spinning department might seem to an outsider fairly good, and if investigated by an expert there would be nothing special about it. This, you will see, might be the case from what has already been said as to the twist being put upon the yarn; while it is also true that the production of a mill might seem to an outsider a very ordinary one—they might say it was very poor—but which, upon investigation, might be very good; this being also to some extent depending upon the class of yarn being spun. The real success, so far as production is concerned, will be found by every one who is personally interested doing every day their very best, and if all do this, the best results will be sure to follow.

When the bobbins have been filled they are put into boxes and wheeled away on a bobbin barrow to either the cop-winding, the warp-winding, or the reeling departments. To see that the empty bobbins are kept steadily on the road back from these departments to the spinning frames is not the least important point to be kept before the people in charge of the spinning department. Every empty bobbin should be set up in its place ready to be handled by the shifters when they come to shift the frames. If this is not done endless annoyance and confusion, not to say anything of loss of time, will be the result.

Illustrations are given of spinning frames by two makers. The Messrs Low, of Monifieth, made almost a speciality of this machine, and as makers of frames they stand in the front rank. I am indebted to them for their kindness in giving me permission to illustrate their spinning frame. The following pages give the particulars of gearing for twist, and draft calculations by both makers. There is also given the heart and traverse motion arrangement by both firms. The diagrams will be of much service in showing the whole arrangement of this part of a spinning frame, which is so important to the proper filling of the bobbin.

---

### TWIST OF HESSIAN YARNS.

The twist of these yarns may vary according to the quality of the jute and the quality of the hessian being made; but for a good standard hessian, in a mill where it is the aim and intention to produce the same all the year round, there should be no necessity for varying the twist; and I am convinced from experience that it is unnecessary, and should never be permitted on any consideration. Twist is money, and this should never be lost sight of. But apart from that, tampering with the twist of the yarn, either warp or weft, means tampering with the quality and appearance of the cloth. You will not have any suggestion as to softening the twist; it will always be the other way—"harden it up." This, of course, reacts upon the finish of the cloth, and may lead to serious trouble on the delivery of the goods. But, as has been already said, if there is an effort all round to keep the quality of the batch as equal as possible, there will not be any necessity to tamper with the twist, which can only lead to loss of production in the first place, and trouble as to the quality of the goods manufactured from the same.

The following twists are given as an illustration of the twist put upon these yarns when they are to be worked into cops and wound on a bobbin warp winding machine, and woven at once in a factory adjoining a mill. If the yarns, weft and warp, are to be reeled and bundled, they must be copped and wound again; a little more twist may sometimes be necessary, but not much—say, not more than 3 per cent. on the weft and 2 per cent. on the warp pinion.

Weft	Twists per inch.	Starving Warp.	Twists per inch.	Hard Warp.	Twists per inch.
7	3.80	7	4.49	8	5½ to 6
8	3.44	8	4.23	10	4.87
9	3.14	9	4.	14	3.81
10	2.89	10	3.81		
12	2.58	12	3.65		
14	2.40	14	3.13		
16	2.19				
20	1.90				
24	1.68				

Usual weft sizes for hessians, 7/14 lbs.

„ warp „ 7/9 lbs.

Spinning frame, 4" pitch, 4" traverse (Fairbairn).

Twist arrangement and calculations—

Diameter of drawing roller, 4".

Cylinder pinion, 28 teeth.

A C E

— × — × — = twist per inch.

B D F × G

In this case—

A = diameter of cylinder.

B = „ spindle werve.

C = wheel of double intermediate, on which is twist pinion.

D = cylinder pinion.

E = drawing roller wheel.

F = twist pinion.

G = circumference of drawing roller.

Diameter.  
D Roller.

$$4'' \quad \frac{10}{1\frac{3}{4}} \times \frac{90}{28} \times \frac{120}{60 \times 12.56} = 2.92 \text{ twists per inch.}$$

$$\frac{10}{1\frac{3}{4}} \times \frac{90}{28} \times \frac{120}{\text{Twist pinion} \times 12.56} = 175.484 \text{ constant number for twist.}$$

$$3\frac{1}{8}'' \quad \frac{10}{1\frac{3}{4}} \times \frac{90}{28} \times \frac{120}{\text{Twist pinion} \times 12.37} = 178.179 \text{ constant number.}$$

$$3\frac{7}{8}'' \quad \frac{10}{1\frac{3}{4}} \times \frac{90}{28} \times \frac{120}{\text{Twist pinion} \times 12.17} = 181.107 \text{ constant number.}$$

$$3\frac{1}{2}'' \quad \frac{10}{1\frac{3}{4}} \times \frac{90}{28} \times \frac{120}{\text{Twist pinion} \times 11.97} = 184.133 \text{ constant number.}$$



Diameter. D. Roller.	10	90	120	
$3\frac{3}{4}$ "	—	—	—	= 187·103 constant number.
	$1\frac{3}{4}$	28	$\frac{\text{Twist pinion}}{11\cdot78}$	
	10	90	120	
$3\frac{11}{16}$ "	—	—	—	= 190·335 constant number.
	$1\frac{3}{4}$	28	$\frac{\text{Twist pinion}}{11\cdot58}$	
	10	90	120	
$3\frac{5}{8}$ "	—	—	—	= 193·680 constant number.
	$1\frac{3}{4}$	28	$\frac{\text{Twist pinion}}{11\cdot38}$	
	10	90	120	
$3\frac{9}{16}$ "	—	—	—	= 196·968 constant number.
	$1\frac{3}{4}$	28	$\frac{\text{Twist pinion}}{11\cdot19}$	
	10	90	120	
$3\frac{1}{2}$ "	—	—	—	= 200·553 constant number.
	$1\frac{3}{4}$	28	$\frac{\text{Twist pinion}}{10\cdot96}$	

Spinning frame 4" pitch, 4" traverse (Fairbairn).

## Twist arrangement and calculations—

Diameter of drawing roller, 4".

Cylinder pinion, 34 teeth.

Diameter. D. Roller.	10	90	120	
4"	—	—	—	= 144·516 constant number.
	$1\frac{3}{4}$	34	$\frac{\text{Twist pinion}}{12\cdot56}$	
	10	90	120	
$3\frac{15}{16}$ "	—	—	—	= 146·734 constant number
	$1\frac{3}{4}$	34	$\frac{\text{Twist pinion}}{12\cdot37}$	
	10	90	120	
$3\frac{7}{8}$ "	—	—	—	= 149·147 constant number.
	$1\frac{3}{4}$	34	$\frac{\text{Twist pinion}}{12\cdot17}$	
	10	90	120	
$3\frac{13}{16}$ "	—	—	—	= 151·639 constant number.
	$1\frac{3}{4}$	34	$\frac{\text{Twist pinion}}{11\cdot97}$	
	10	90	120	
$3\frac{3}{4}$ "	—	—	—	= 154·085 constant number.
	$1\frac{3}{4}$	34	$\frac{\text{Twist pinion}}{11\cdot78}$	
	10	90	120	
$3\frac{11}{16}$ "	—	—	—	= 156·746 constant number.
	$1\frac{3}{4}$	34	$\frac{\text{Twist pinion}}{11\cdot58}$	
	10	90	120	
$3\frac{5}{8}$ "	—	—	—	= 159·501 constant number.
	$1\frac{3}{4}$	34	$\frac{\text{Twist pinion}}{11\cdot38}$	
	10	90	120	
$3\frac{9}{16}$ "	—	—	—	= 162·209 constant number.
	$1\frac{3}{4}$	34	$\frac{\text{Twist pinion}}{11\cdot19}$	

Diameter.  
D. Roller.

$$3\frac{1}{2}'' \quad 10 \quad 90 \quad 120$$

$$\frac{1\frac{3}{4}}{34} \times \frac{34}{34} \times \frac{120}{\text{Twist pinion} \times 10 \cdot 99} = 165 \cdot 161 \text{ constant number.}$$

Spinning frame, 4" pitch, 4" traverse (Fairbairn).

Draft arrangement—

Diameter of drawing roller, 4".

„ retaining roller, 2½".

Double intermediate, ¾".

$$\begin{matrix} A & C & E \\ - & \times & - & \times & - & = \text{draft.} \\ B & D & F \end{matrix}$$

In this case—

- A = diameter of drawing roller.
- B = drawing roller pinion or grist pinion.
- C } = double intermediate.
- D }
- E = retaining roller wheel.
- F = diameter of retaining roller.

Thus—

Diameter.  
D. Roller.

$$4'' \quad \frac{4}{45} \times \frac{90}{44} \times \frac{111}{2\frac{1}{2}} = 9 \cdot 08 \text{ draft between drawing roller and retaining roller.}$$

$$\frac{4}{3\frac{1}{8}} \times \frac{90}{44} \times \frac{111}{2\frac{1}{2}} = 363 \cdot 272 \text{ constant number for draft.}$$

$$3\frac{1}{8}'' \quad \frac{\text{Grist pinion}}{3\frac{1}{8}} \times \frac{90}{44} \times \frac{111}{2\frac{1}{2}} = 357 \cdot 596 \text{ constant number.}$$

$$3\frac{7}{8}'' \quad \frac{\text{G.p.}}{3\frac{7}{8}} \times \frac{90}{44} \times \frac{111}{2\frac{1}{2}} = 351 \cdot 920 \text{ constant number.}$$

$$3\frac{1}{2}'' \quad \frac{\text{G.p.}}{3\frac{1}{2}} \times \frac{90}{44} \times \frac{111}{2\frac{1}{2}} = 346 \cdot 244 \text{ constant number.}$$

$$3\frac{3}{4}'' \quad \frac{\text{G.p.}}{3\frac{3}{4}} \times \frac{90}{44} \times \frac{111}{2\frac{1}{2}} = 340 \cdot 568 \text{ constant number.}$$

$$3\frac{1}{4}'' \quad \frac{\text{G.p.}}{3\frac{1}{4}} \times \frac{90}{44} \times \frac{111}{2\frac{1}{2}} = 334 \cdot 892 \text{ constant number.}$$

Diameter.  
D. Roller.

$$3\frac{5}{8}'' \frac{3\frac{5}{8}}{\text{G.p.}} \times \frac{90}{44} \times \frac{111}{2\frac{1}{2}} = 329.215 \text{ constant number.}$$

$$3\frac{9}{16}'' \frac{3\frac{9}{16}}{\text{G.p.}} \times \frac{90}{44} \times \frac{111}{2\frac{1}{2}} = 328.539 \text{ constant number.}$$

$$3\frac{1}{2}'' \frac{3\frac{1}{2}}{\text{G.p.}} \times \frac{90}{44} \times \frac{111}{2\frac{1}{2}} = 317.863 \text{ constant number.}$$

Spinning frame, 4" pitch, 4" traverse (Fairbairn).

Draft arrangement—

Diameter of drawing roller, 4".

„ retaining roller, 2½".

Double intermediate,  $\frac{9 \cdot 07}{8 \cdot 0}$ .

Diameter.  
D. Roller.

$$4'' \frac{4}{\text{G.p.}} \times \frac{90}{60} \times \frac{111}{2\frac{1}{2}} = 266.4 \text{ constant number.}$$

$$3\frac{1}{4}'' \frac{3\frac{1}{4}}{\text{G.p.}} \times \frac{90}{60} \times \frac{111}{2\frac{1}{2}} = 262.237 \text{ constant number.}$$

$$3\frac{7}{8}'' \frac{3\frac{7}{8}}{\text{G.p.}} \times \frac{90}{60} \times \frac{111}{2\frac{1}{2}} = 258.075 \text{ constant number.}$$

$$3\frac{1}{2}'' \frac{3\frac{1}{2}}{\text{G.p.}} \times \frac{90}{60} \times \frac{111}{2\frac{1}{2}} = 253.912 \text{ constant number.}$$

$$3\frac{3}{4}'' \frac{3\frac{3}{4}}{\text{G.p.}} \times \frac{90}{60} \times \frac{111}{2\frac{1}{2}} = 249.750 \text{ constant number.}$$

$$3\frac{11}{16}'' \frac{3\frac{11}{16}}{\text{G.p.}} \times \frac{90}{60} \times \frac{111}{2\frac{1}{2}} = 245.587 \text{ constant number.}$$

$$3\frac{5}{8}'' \frac{3\frac{5}{8}}{\text{G.p.}} \times \frac{90}{60} \times \frac{111}{2\frac{1}{2}} = 241.425 \text{ constant number.}$$

$$3\frac{9}{16}'' \frac{3\frac{9}{16}}{\text{G.p.}} \times \frac{90}{60} \times \frac{111}{2\frac{1}{2}} = 237.262 \text{ constant number.}$$

$$3\frac{1}{2}'' \frac{3\frac{1}{2}}{\text{G.p.}} \times \frac{90}{60} \times \frac{111}{2\frac{1}{2}} = 233.1 \text{ constant number.}$$

DRY SPINNING FRAME.

*Sectional elevation showing gearing at end opposite to the driving pulleys.*

SCALE  $\frac{1}{8}$ TH.

*(For Diagram see page 204).*

A A	Drawing roller wheels,	...	...	44 teeth.
B B	Stud wheels,	...	...	90 teeth.
C C	Draught changes,	...	...	33 to 60 teeth.
D D	Retaining roller wheels,	...	...	111 teeth.
E E	Pinions on retaining rollers for driving			
	heart wheels,	...	...	11 teeth.
F F	Heart wheels,	...	...	120 teeth.

# DRY SPINNING FRAME.

SECTIONAL ELEVATION SHOWING GEARING AT END OPPOSITE TO THE DRIVING PULLEYS.

SCALE  $\frac{1}{16}$  TH.

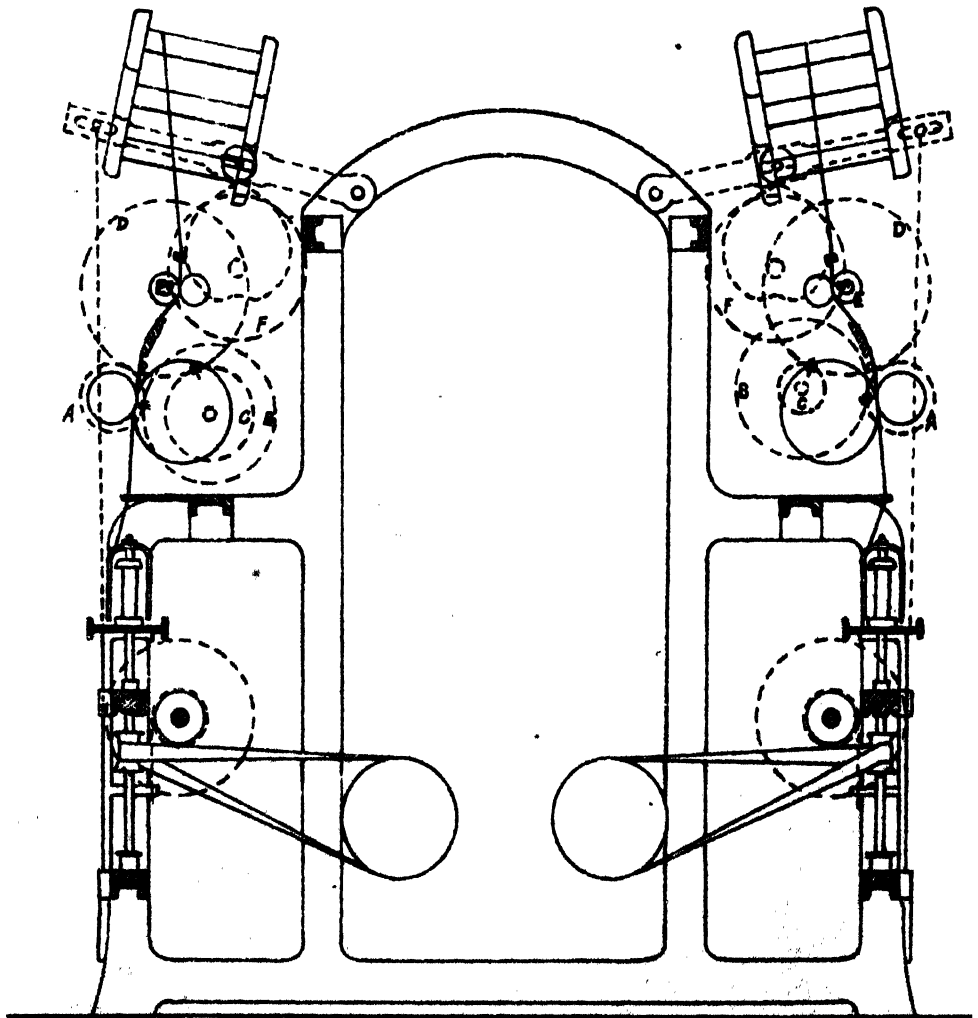

DRY SPINNING FRAME.

*Sectional elevation showing gearing at pulley end.*

SCALE  $\frac{1}{16}$  TH.

*(For Diagram see page 206.)*

A A	Cylinder pinions,	...	...	...	28 teeth.
B B	Intermediates,	...	...	...	144 teeth.
C C	Twist wheels,	...	...	...	90 teeth.
D D	Twist changes,	...	...	...	• 26 to 60 teeth.
E E	Drawing roller wheels,	...	...	...	120 teeth.

# DRY SPINNING FRAME.

SECTIONAL ELEVATION SHOWING GEARING AT PULLEY END.

SCALE  $\frac{1}{18}$ TH.

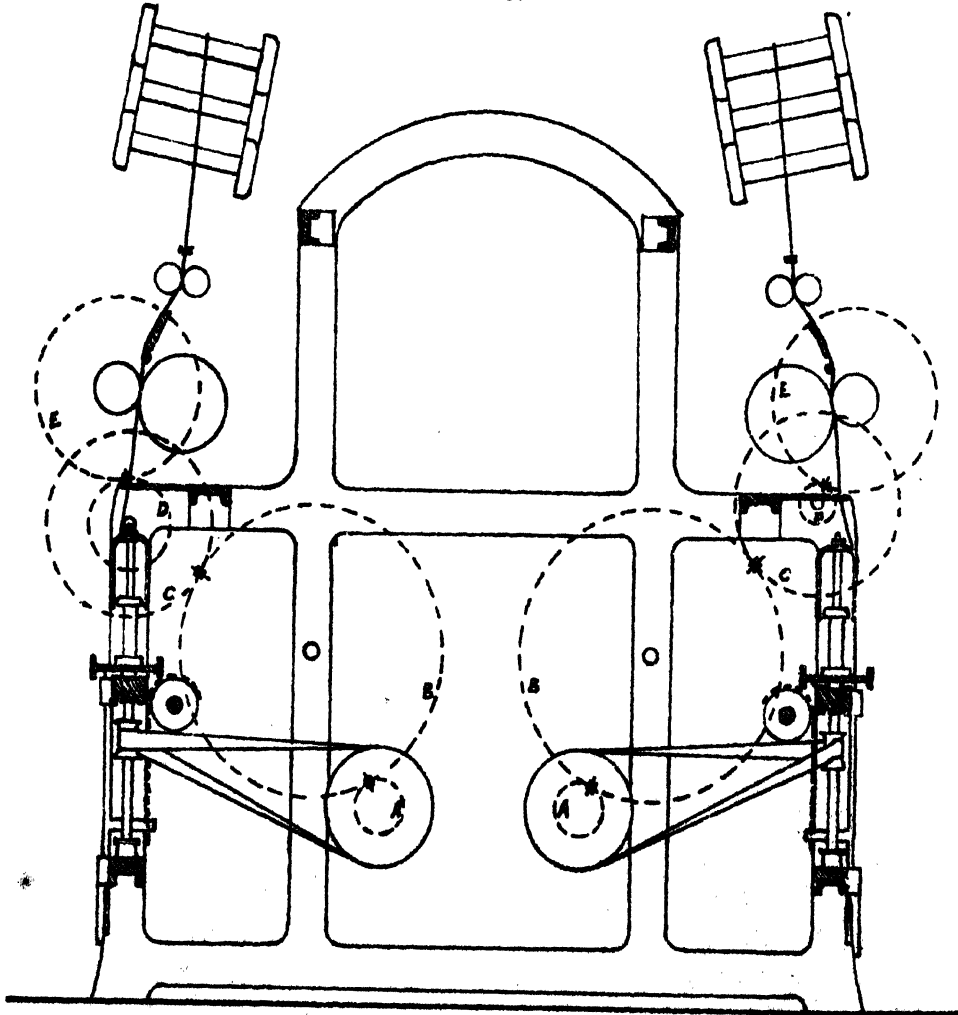

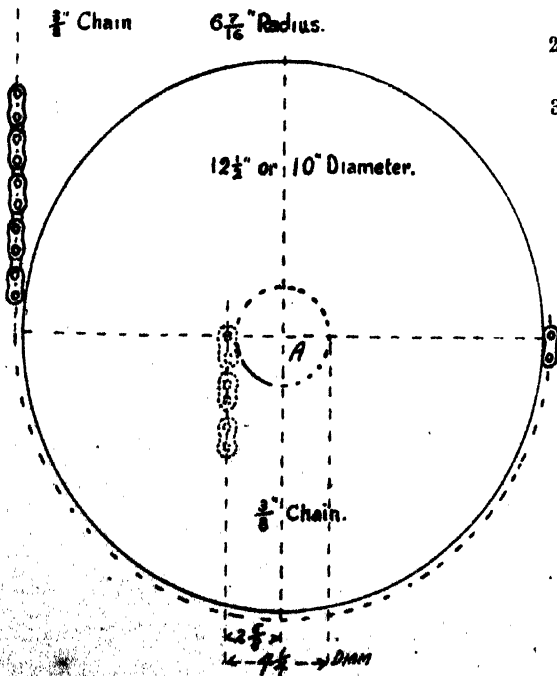
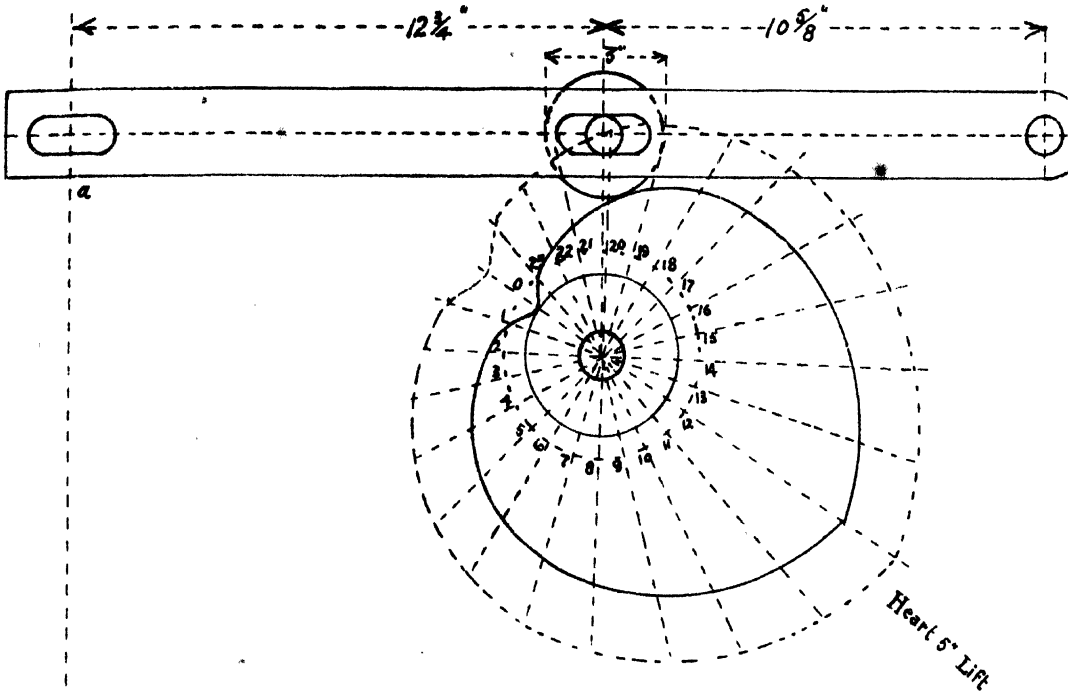

- 1st. Traverse of Lever at A—  
 $10\frac{5}{8}'' : (12\frac{3}{4} \times 10\frac{5}{8}) :: 5'' : 11''$  at A.
- 2nd. Traverse of Lever at B—  
 $6\frac{7}{16}'' : 2\frac{5}{16}'' :: 11'' : 3.9514$ —say 4".
- 3rd. With pulley 10" diameter, traverse at B—  
 $5\frac{3}{16}'' : 2\frac{5}{16}'' :: 11'' : 4.9$ —say 5".

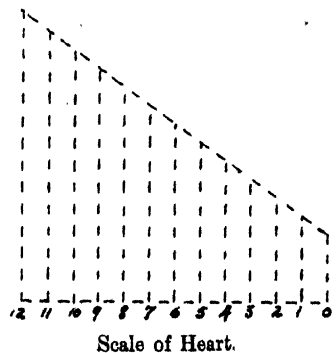



# BOBBIN.

4" TRAVERSE (FULL SIZE)—SHOWING SHAPE OF BOBBIN WHEN FULL.

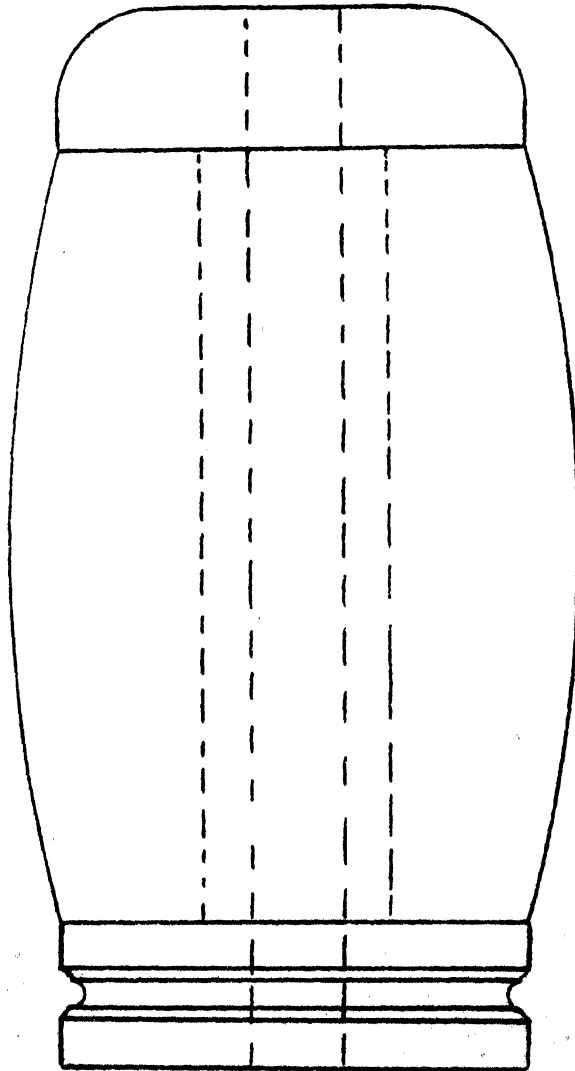

AUTOMATIC MOTION FOR  
DRAWING ROLLERS OF DRY SPINNING FRAMES.

(Fairbairn.)

SCALE 3" TO ONE FOOT.

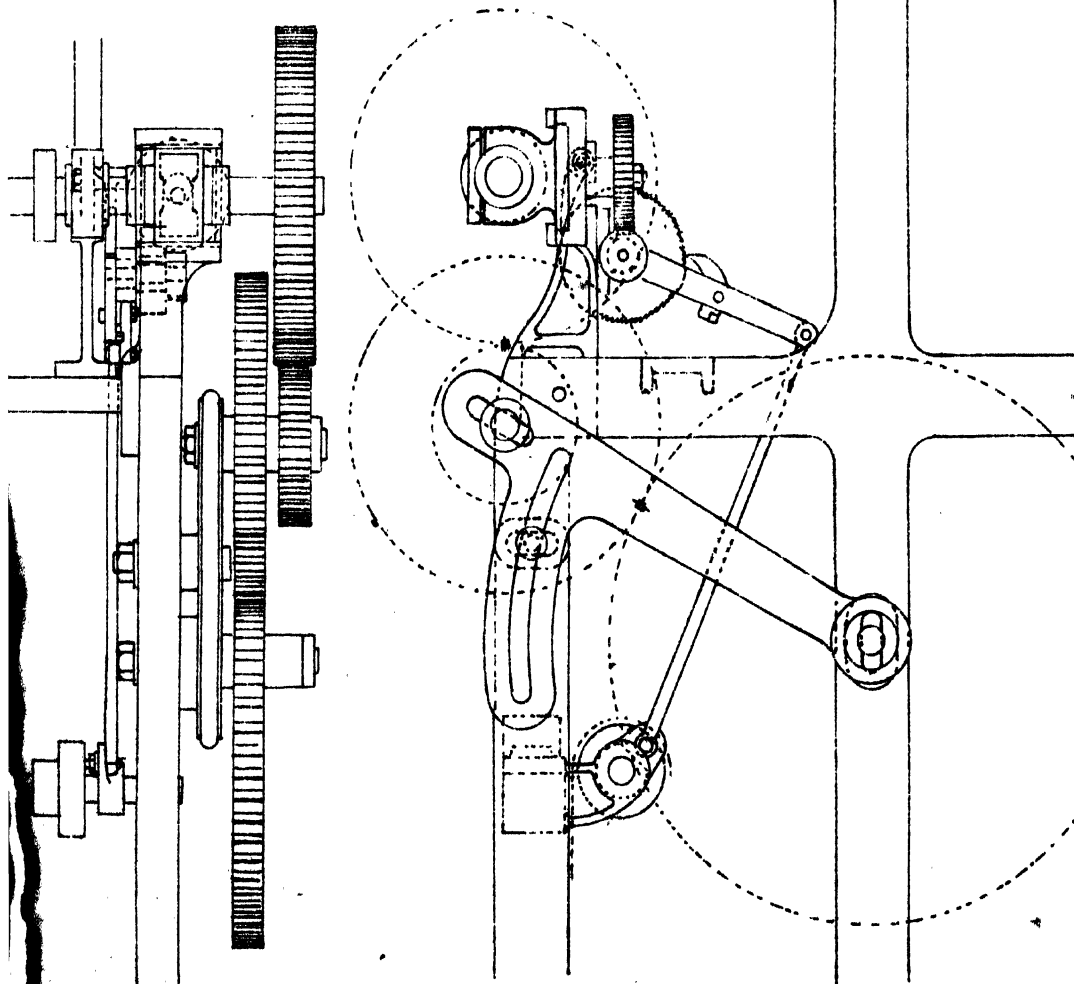

NOTE.—The movement of drawing roller end ways is  $\frac{1}{4}$ " in each direction

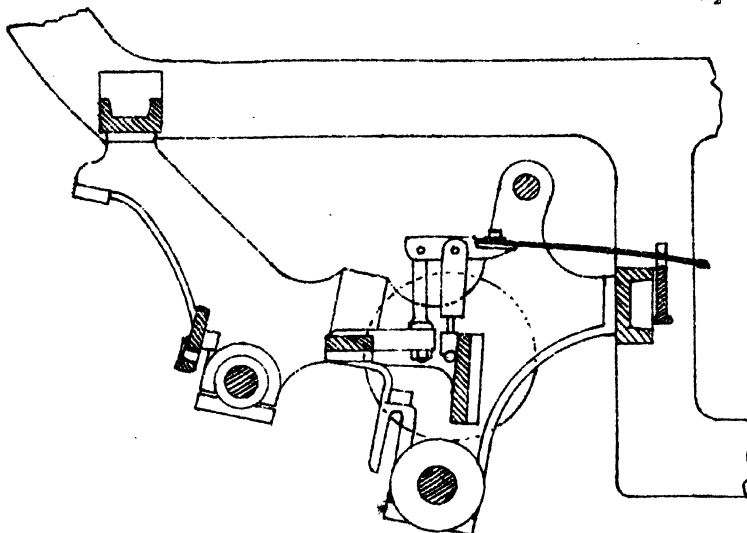
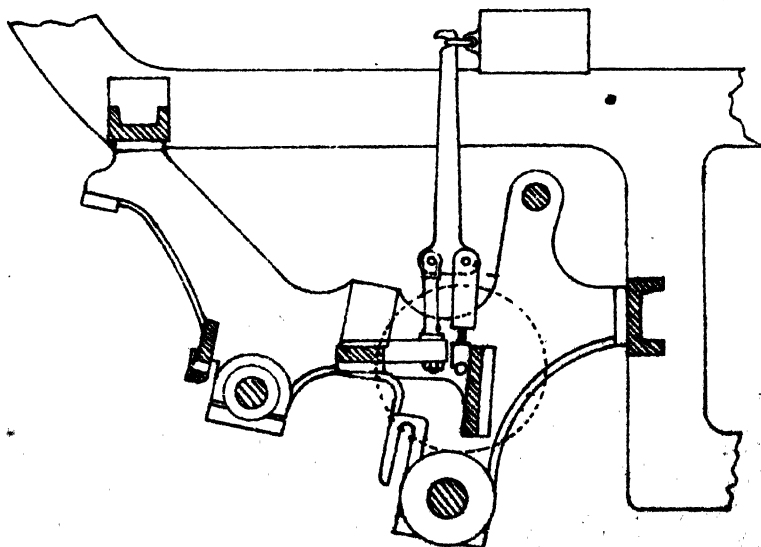
ARRANGEMENT OF SPRING FOR PRESSING ROLLER  
SPINNING FRAME.SCALE  $1\frac{1}{2}$ " TO ONE FOOT.ARRANGEMENT OF LEVER AND WEIGHT FOR PRESSING  
ROLLER OF SPINNING FRAME.SCALE  $1\frac{1}{2}$ " TO ONE FOOT.

For pressure on pressing roller. Proportion of levers—  
Arm of pressing roller =  $1\frac{1}{2}$ ". Arm of weight = 10".

$$\text{Ratio } \frac{1\frac{1}{2}}{10} = \frac{1}{6.6} \text{ and if weight is 12 lbs. then—}$$

$$12 \times 6.6 = 79.2 \text{ lbs. = pressure upon two balls.}$$

ELEVATION OF SPINNING FRAME BEND.

Showing Drawing Roller and Pressing Roller with Lever and Spiral Spring.

SCALE  $1\frac{1}{2}$ " TO ONE FOOT.

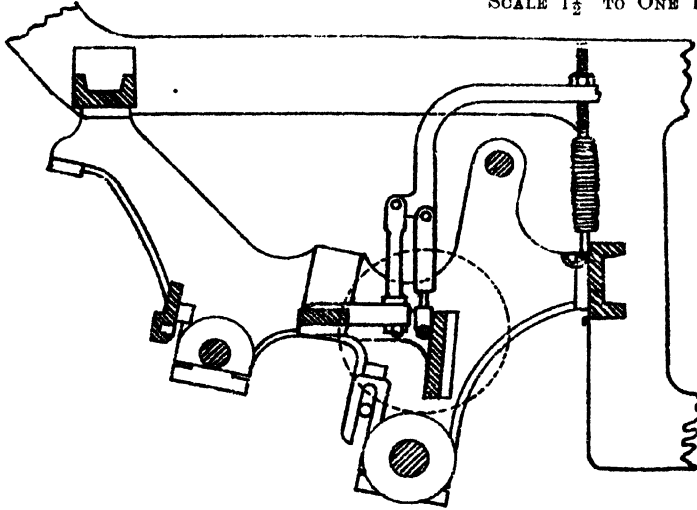

For pressure on pressing roller. Proportion of levers—  
 Arm of pressing roller =  $1\frac{1}{2}$ ". Arm of spring =  $8\frac{1}{2}$ ".  
 $\frac{1\frac{1}{2}}{8\frac{1}{2}} = \frac{1}{5.6}$  and if pull of spring = 12 lbs. then—  
 $12 \times 5.6 = 67.2$  lbs. = pressure upon two balls.

ELEVATION OF SPINNING FRAME BEND.

Showing Retaining Roller and Slip Roller with Lever and Weight.

SCALE  $1\frac{1}{2}$ " TO ONE FOOT.

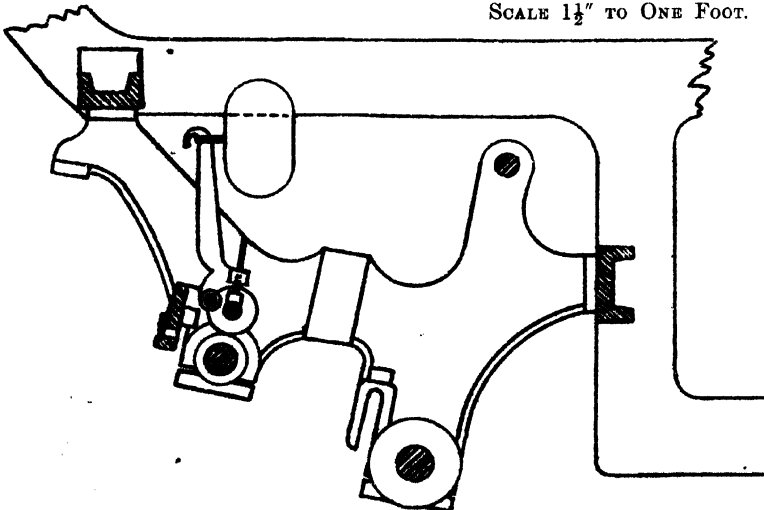

For pressure on slip roller. Proportion of levers—  
 Arm of slip roller =  $1\frac{1}{8}$ ". Arm of weight =  $7\frac{1}{2}$ ".  
 $\frac{1\frac{1}{8}}{7\frac{1}{2}} = \frac{1}{6.6}$  and if weight is 6 lbs. then—  
 $6 \times 6.6 = 39.6$  lbs. = pressure upon two balls.

AUTOMATIC MOTION FOR SPINNING FRAME DRAWING ROLLERS.

AUTOMATIC MOTION FOR SPINNING FRAME DRAWING ROLLERS.

SCALE 3" TO ONE FOOT.

(Messrs Thomson, Son, & Co.)

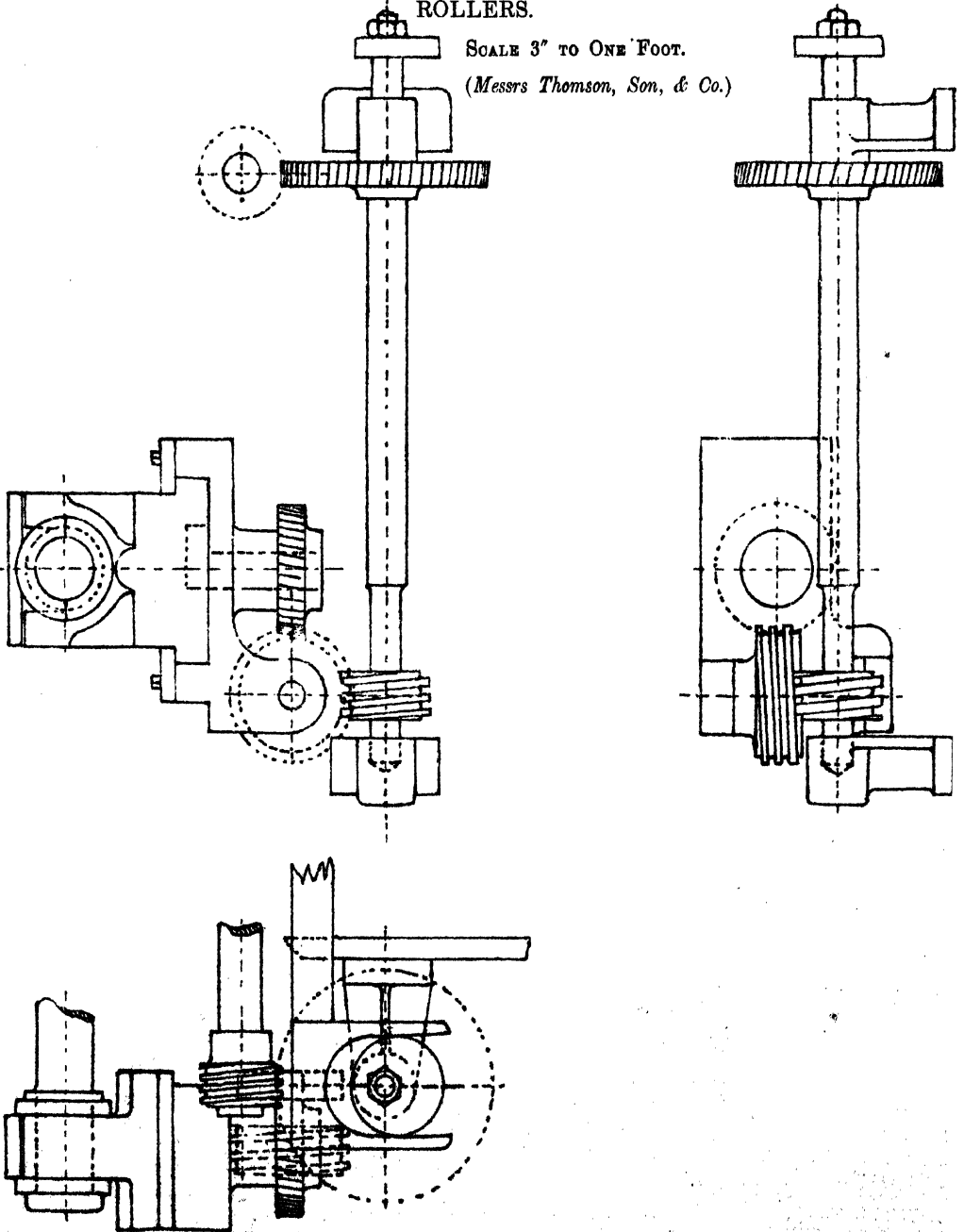

# ROVE PLATE ARRANGEMENT.

SCALE 3" TO ONE FOOT.

(Fairbairn.)

- A - Drawing Roller
- B = Pressing "
- C = Retaining "
- D = Slip "

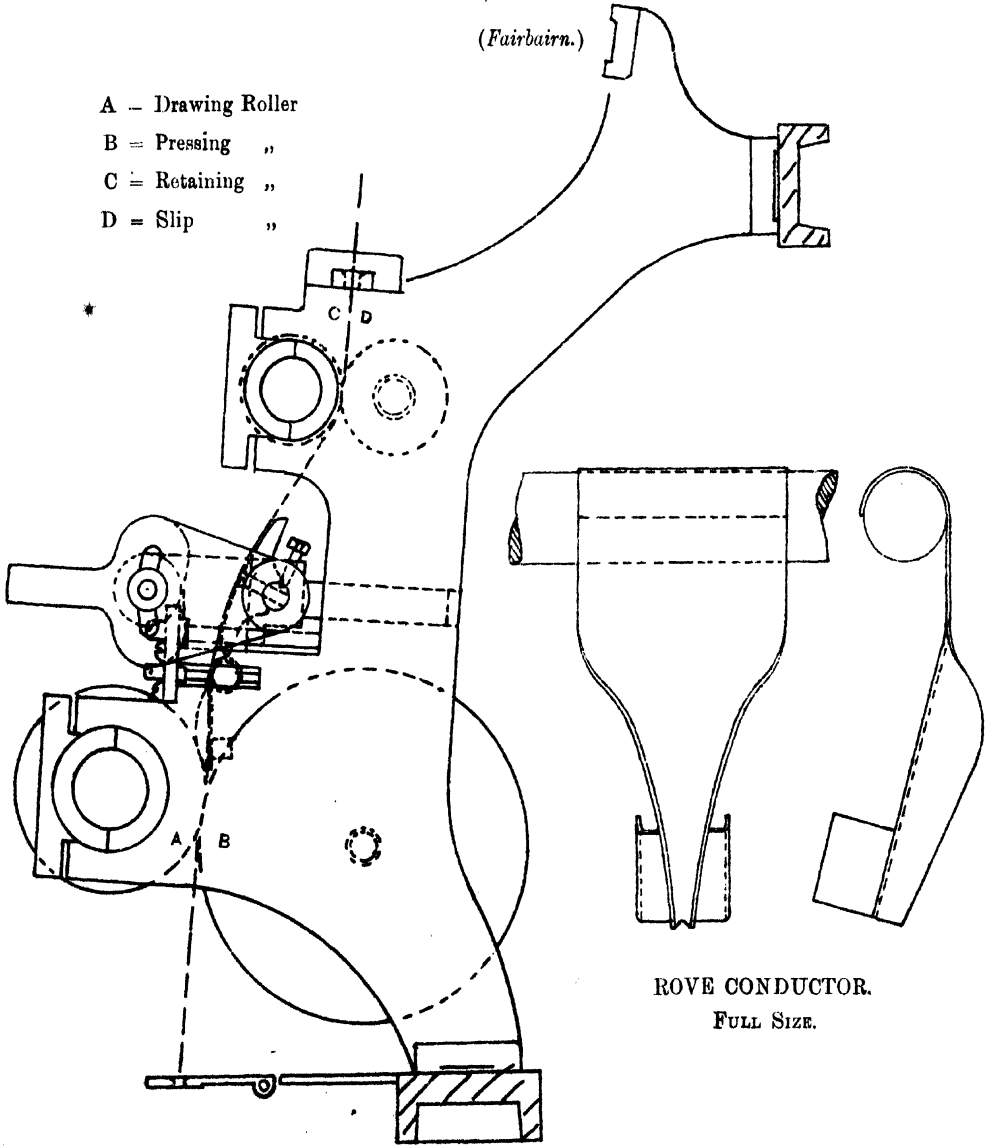

ROVE CONDUCTOR.  
FULL SIZE.

For explanation of the working of Rove Plate see page 192.

# SPINNING FRAME.

4" TRAVERSE—(Low, *Monifeth*).

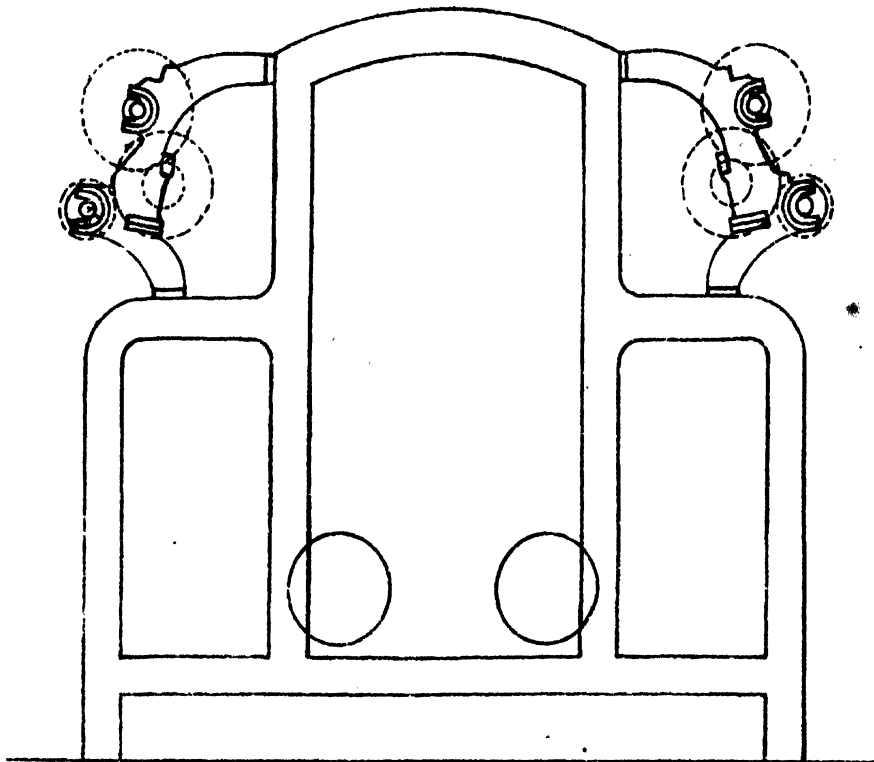

ELEVATION PASS END SHOWING GRIST GEARING.

SCALE  $\frac{1}{16}$  TH.

Diameter of Drawing Roller, ...	...	...	4".
„ Retaining Roller, ...	...	...	2 $\frac{1}{2}$ ".
Pinion on Drawing Roller, ...	...	...	30 teeth.
Wheel on Retaining Roller, ...	...	...	80 teeth.
Double Intermediate, ...	...	...	70/35 teeth.

# SPINNING FRAME

4" TRAVERSE—(*Low, Monifeth*).

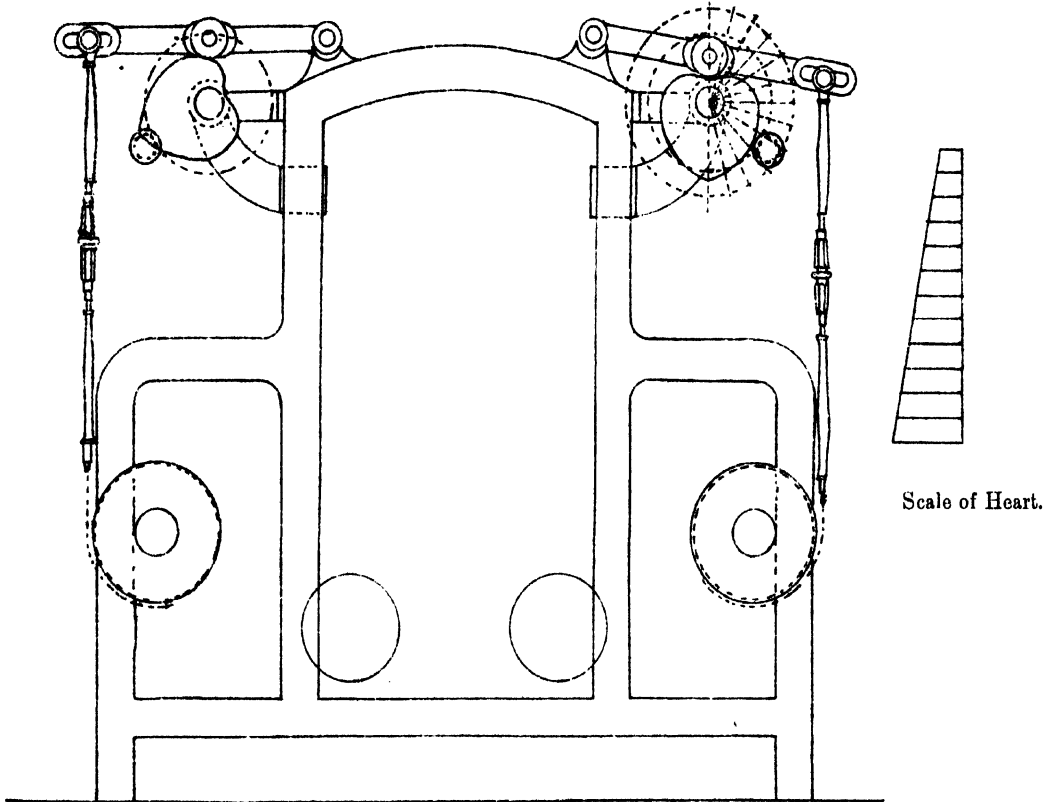

ELEVATION PASS END SHOWING HEART MOTION ARRANGEMENT FOR TRAVERSE OF BOBBIN.

SCALE  $\frac{1}{8}$  TH.



# SPINNING FRAME

4" TRAVERSE—(Low, *Monisteth*).

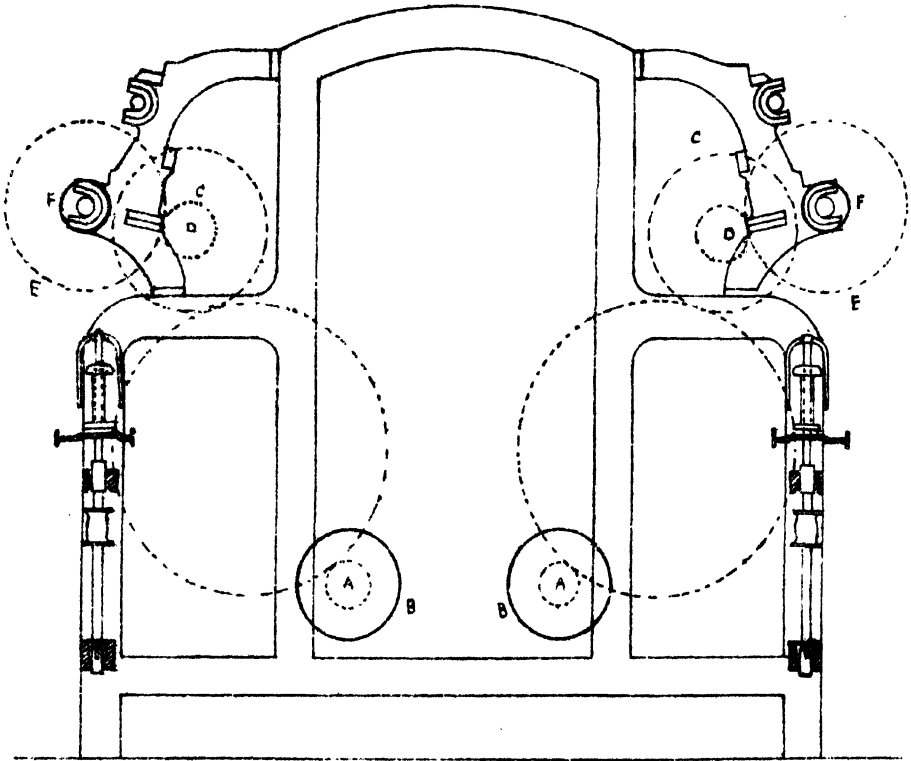

ELEVATION DRIVING END SHOWING TWIST GEARING.\*

SCALE  $\frac{1}{16}$  TH.

- A = Cylinder Pinion.
- B = Diameter of Cylinder.
- C = Wheel of double intermediate.
- D = Twist Pinion.
- E = Drawing Roller Wheel.
- F = Diameter of Drawing Roller.

\*See page 220.

# SPINNING FRAME

SCALE 3" TO ONE FOOT.

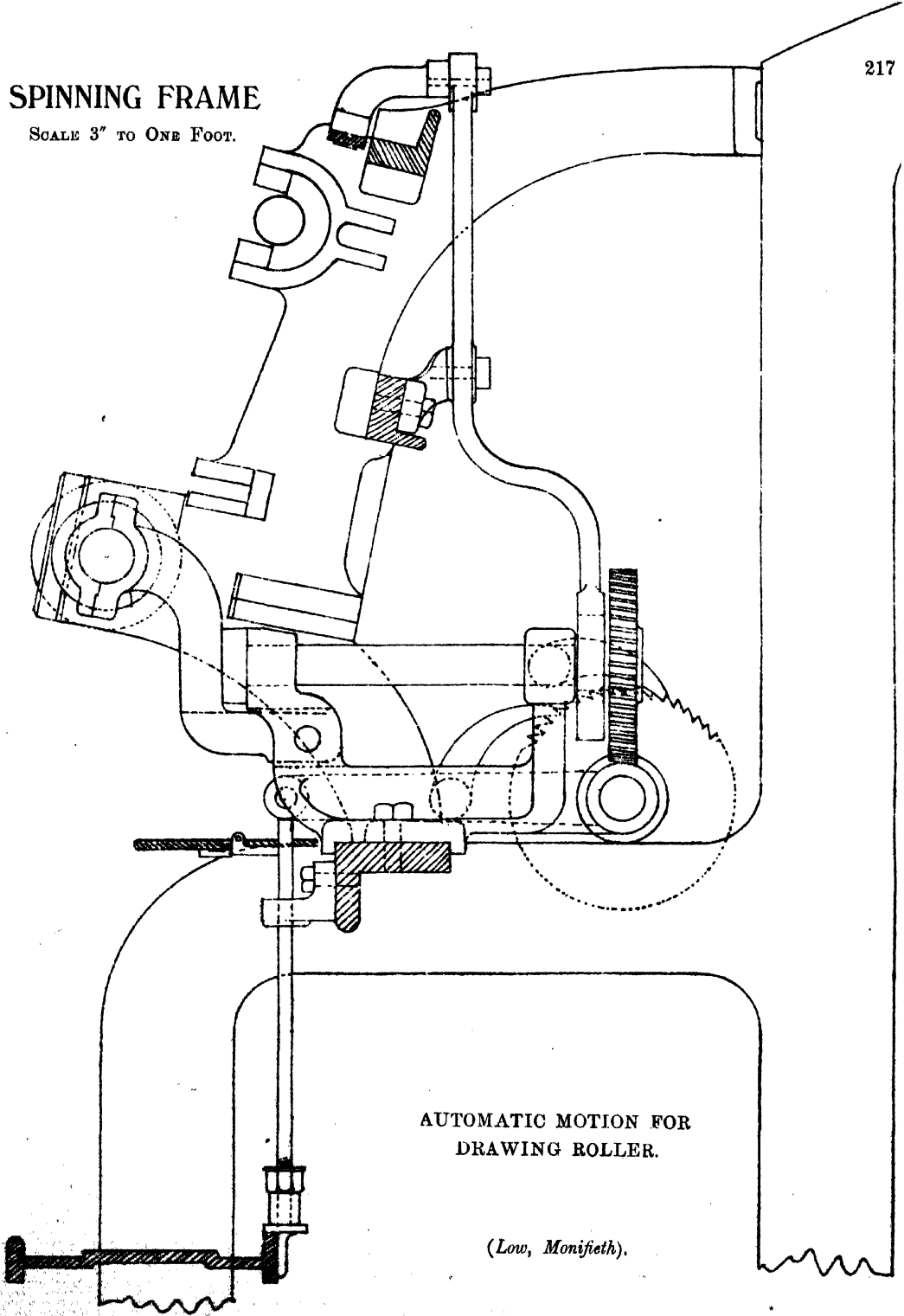

## SPINNING FRAME.

The following particulars show the general practice as to gearing, &c., followed by Messrs Low, Monfieth, in the construction of their Spinning Frames:—

For 4" traverse frames they have to vary some of the parts considerably, to meet different requirements, and they have gable patterns 5' 3"—5' 6" and 5' 8" wide.

Then for Twist—The Spindle Werve is  $1\frac{5}{8}$ " and sometimes  $1\frac{3}{4}$ " diameter.

Cylinder, 9" or 10" diameter.

Cylinder Pinions, 24—28—30 teeth.

Intermediate Stud Wheel, 150 or 156 teeth.

Twist Wheel, 80 teeth.

Changes, from 25 to 50 teeth.

Drawing Roller Wheel, 114 teeth.

Drawing Roller Boss, 4" diameter.

The above is their ordinary practice, and the drawings are made to it—but they sometimes make the Twist Wheel 90 teeth, and Drawing Roller Wheel 120 teeth, which increases the size of the Cylinder Pinion somewhat, and this is on the right side.

For the Draft—Drawing Roller Boss, 4".

Changes at pass end, 25 to 50 teeth.

Stud Wheel, 70 teeth.

Changes on nave of do., 25 to 50 teeth.

Retaining Roller Wheel, 80 teeth.

Retaining Roller Boss,  $2\frac{1}{2}$ " diameter.

The above is for 10" Reach Bend, but when 9" reach is used, they generally put in the Stud Wheel 60 teeth instead of 70, as the latter fills up the shorter space rather too much.

For the Heart or Lifter Motion—Pinion of 11 teeth on Retaining Roller, with 128 or 132 teeth on nave of Heart.

The Chain Pulley on Lifter Shaft is  $11\frac{1}{4}$ " diameter, and the Bosses on this Shaft are  $3\frac{1}{4}$ " to 4" diameter.

DRAFT ARRANGEMENT.

Spinning Frame, 4" pitch, 4" traverse. Low, Moufieth.

Frame 10" reach.

Diameter of drawing roller, 4".

" " retaining " 2½".

Pinion on drawing " change.

Wheel on retaining " 80 teeth.

Double Intermediate " 70 or 70/45.

$$\frac{A}{B} \times \frac{C}{D} \times \frac{E}{F} = \text{draft.}$$

A = Diameter of Drawing Roller.

B = Grist or Change Pinion.

C }  
D } = Double Intermediate.

F = Wheel on Retaining Roller.

4	70	80			
—	×	—	×	—	= 6.68 draft.
30	45	2½			
4	70	80			
—	×	—	×	—	= 199.1 constant number for draft.
C	45	2½			
31½	70	80			
—	×	—	×	—	= 196 " " "
C	45	2½			
37	70	80			
—	×	—	×	—	= 192.88 " " "
C	45	2½			
31½	70	80			
—	×	—	×	—	= 189.77 " " "
C	45	2½			
3½	70	80			
—	×	—	×	—	= 186.6 " " "
C	45	2½			
31½	70	80			
—	×	—	×	—	= 183.55 " " "
C	45	2½			
3½	70	80			
—	×	—	×	—	= 180.44 " " "
C	45	2½			

$$\begin{array}{r}
 3\frac{9}{16} \quad 70 \quad 80 \\
 - \times - \times - = 177.33 \text{ constant number for draft.} \\
 C \quad 45 \quad 2\frac{1}{2} \\
 3\frac{1}{2} \quad 70 \quad 80 \\
 - \times - \times - = 174.22 \quad ,, \quad ,, \quad ,, \\
 C \quad 45 \quad 2\frac{1}{2}
 \end{array}$$

Double intermediate,  $\frac{7}{3}\frac{9}{8}$ .

$$\begin{array}{r}
 4 \quad 70 \quad 80 \\
 - \times - \times - = 256 \text{ constant number for draft.} \\
 C \quad 35 \quad 2\frac{1}{2} \\
 3\frac{1}{8}\frac{5}{8} \quad 70 \quad 80 \\
 - \times - \times - = 252 \quad ,, \quad ,, \quad ,, \\
 C \quad 35 \quad 2\frac{1}{2} \\
 3\frac{7}{8} \quad 70 \quad 80 \\
 - \times - \times - = 248 \quad ,, \quad ,, \quad ,, \\
 C \quad 35 \quad 2\frac{1}{2} \\
 3\frac{1}{8}\frac{3}{8} \quad 70 \quad 80 \\
 - \times - \times - = 244 \quad ,, \quad ,, \quad ,, \\
 C \quad 35 \quad 2\frac{1}{2} \\
 3\frac{3}{4} \quad 70 \quad 80 \\
 - \times - \times - = 240 \quad ,, \quad ,, \quad ,, \\
 C \quad 35 \quad 2\frac{1}{2} \\
 3\frac{1}{16}\frac{1}{16} \quad 70 \quad 80 \\
 - \times - \times - = 236 \quad ,, \quad ,, \quad ,, \\
 C \quad 35 \quad 2\frac{1}{2} \\
 3\frac{5}{8} \quad 70 \quad 80 \\
 - \times - \times - = 232 \quad ,, \quad ,, \quad ,, \\
 C \quad 35 \quad 2\frac{1}{2} \\
 3\frac{9}{16} \quad 70 \quad 80 \\
 - \times - \times - = 228 \quad ,, \quad ,, \quad ,, \\
 C \quad 35 \quad 2\frac{1}{2} \\
 3\frac{1}{2} \quad 70 \quad 80 \\
 - \times - \times - = 224 \quad ,, \quad ,, \quad ,, \\
 C \quad 35 \quad 2\frac{1}{2}
 \end{array}$$

### TWIST ARRANGEMENTS.

Spinning Frame, 4" pitch, 4" traverse. Low, Monifeth.

Cylinder, 10" diameter.

Spindle Werve,  $1\frac{1}{2}$ ".

Cylinder Pinions, 24—28—30 teeth.

Twist Wheel, 80 teeth, or Double Intermediate.

Drawing Roller Wheel, 114 teeth.

Diameter of Drawing Roller, 4".

- A C E  
 — × — × — = Twists per inch.  
 B D F × G  
 A = Diameter of Cylinder.  
 B = " Spindle Werve.  
 C = Twist Wheel.  
 D = Cylinder Pinion.  
 E = Drawing Roller Wheel.  
 F = Twist Pinion.  
 G = Circumference of Drawing Roller.

Diameter of  
 Drawing Roller.

	10"	80	114		
4"	—	×	—	×	————— = 3·45 Twists per inch.
	1 $\frac{3}{4}$	24	50	×	12·56"
	10	80	114		
4"	—	×	—	×	————— = 172·88 Constant No. for Twist.
	1 $\frac{3}{4}$	24	Twist Pinion	×	12·56
	10	80	114		
3 $\frac{15}{16}$ "	—	×	—	×	————— = 175·54 " "
	1 $\frac{3}{4}$	24		×	12·37
	10	80	114		
3 $\frac{7}{8}$ "	—	×	—	×	————— = 178·42 " "
	1 $\frac{3}{4}$	24		×	12·17
	10	80	114		
3 $\frac{13}{16}$ "	—	×	—	×	————— = 181·40 " "
	1 $\frac{3}{4}$	24		×	11·97
	10	80	114		
3 $\frac{3}{4}$ "	—	×	—	×	————— = 184·17 " "
	1 $\frac{3}{4}$	24		×	11·79
	10	80	114		
3 $\frac{11}{16}$ "	—	×	—	×	————— = 187·51 " "
	1 $\frac{3}{4}$	24		×	11·58
	10	80	114		
3 $\frac{5}{8}$ "	—	×	—	×	————— = 190·81 " "
	1 $\frac{3}{4}$	24		×	11·38
	10	80	114		
3 $\frac{9}{16}$ "	—	×	—	×	————— = 194·04 " "
	1 $\frac{3}{4}$	24		×	11·19
	10	80	114		
3 $\frac{1}{2}$ "	—	×	—	×	————— = 195·76 " "
	1 $\frac{3}{4}$	24		×	10·99

## SPINNING FRAMES.

Twist Arrangement—Cylinder Pinion, 28 teeth.

Diameter of  
Drawing Roller.

4"	10	80	114		= 148.18	Constant No. for Twist.
	$1\frac{3}{4}$	28		Twist Pinion	$\times 12.56$	
	10	80	114			
$3\frac{1}{8}$ "	—	—	—		= 150.45	" "
	$1\frac{3}{4}$	28			$\times 12.37$	
	10	80	114			
$3\frac{7}{8}$ "	—	—	—		= 152.93	" "
	$1\frac{3}{4}$	28			$\times 12.17$	
	10	80	114			
$3\frac{1}{2}$ "	—	—	—		= 155.49	" "
	$1\frac{3}{4}$	28			$\times 11.97$	
	10	80	114			
$3\frac{3}{4}$ "	—	—	—		= 158.03	" "
	$1\frac{3}{4}$	28			$\times 11.79$	
	10	80	114			
$3\frac{11}{16}$ "	—	—	—		= 160.72	" "
	$1\frac{3}{4}$	28			$\times 11.58$	
	10	80	114			
$3\frac{5}{8}$ "	—	—	—		= 163.55	" "
	$1\frac{3}{4}$	28			$\times 11.38$	
	10	80	114			
$3\frac{9}{16}$ "	—	—	—		= 166.32	" "
	$1\frac{3}{4}$	28			$\times 11.19$	
	10	80	114			
$3\frac{1}{2}$ "	—	—	—		= 169.35	" "
	$1\frac{3}{4}$	28			$\times 10.99$	

Twist Arrangement—Cylinder Pinion, 30 teeth.

Diameter of  
Drawing Roller.

4"	10"	80	114		= 138.30	Constant No. for Twist.
	$1\frac{3}{4}$	30			$\times 12.56$	
	10	80	114			
$3\frac{1}{8}$ "	—	—	—		= 140.43	" "
	$1\frac{3}{4}$	30			$\times 12.37$	
	10	80	114			
$3\frac{7}{8}$ "	—	—	—		= 142.73	" "
	$1\frac{3}{4}$	30			$\times 12.17$	

Diameter of  
Drawing Roller.

$3\frac{13}{16}$ "	10	80	114		
	—	×	—	×	—————
	$1\frac{3}{4}$	30		×	11.97
	10	80	114		
	= 145.12 Constant No. for Twist.				
$3\frac{3}{4}$ "	—	×	—	×	—————
	$1\frac{3}{4}$	30		×	11.79
	10	80	114		
	= 147.34     "     "				
$3\frac{11}{16}$ "	—	×	—	×	—————
	$1\frac{3}{4}$	30		×	11.58
	10	80	114		
	= 150.01     "     "				
$3\frac{5}{8}$ "	—	×	—	×	—————
	$1\frac{3}{4}$	80		×	11.38
	10	80	114		
	= 151.77     "     "				
$3\frac{9}{16}$ "	—	×	—	×	—————
	$1\frac{3}{4}$	30		×	11.19
	10	80	114		
	= 155.24     "     "				
$3\frac{1}{2}$ "	—	×	—	×	—————
	$1\frac{3}{4}$	30		×	10.99
	10	80	114		
	= 158.06     "     "				

TWIST ARRANGEMENT.

Spinning Frame, 4" pitch, 4" traverse. Low, Monifieth.

Cylinder, 10" diameter.

Spindle Werve,  $1\frac{3}{4}$ " diameter.

Cylinder Pinions, 28—30 teeth.

Twist Wheel, 90 teeth.

Drawing Roller Wheel, 120 teeth.

Diameter of Drawing Roller, 4".

Diameter of  
Drawing Roller.

4"	10	90	120		
	—	×	—	×	—————
	$1\frac{3}{4}$	28		×	12.56
	10	90	120		
	= 175.48 Constant No. for Twist.				
$3\frac{15}{16}$ "	—	×	—	×	—————
	$1\frac{3}{4}$	28		×	12.37
	10	90	120		
	= 178.17     "     "				
$3\frac{7}{8}$ "	—	×	—	×	—————
	$1\frac{3}{4}$	28		×	12.17
	10	90	120		
	= 181.10     "     "				
$3\frac{13}{16}$ "	—	×	—	×	—————
	$1\frac{3}{4}$	28		×	11.97
	10	90	120		
	= 184.13     "     "				



Diameter of  
Drawing Roller.

	10	90	120		
$3\frac{3}{4}$ "	—	×	—	×	————— = 187·10 Constant No. for Twist.
	$1\frac{3}{4}$	28		×	11·79
	10	90	120		
$3\frac{11}{16}$ "	—	×	—	×	————— = 190·33    "    "
	$1\frac{3}{4}$	28		×	11·58
	10	90	120		
$3\frac{5}{8}$ "	—	×	—	×	————— = 193·68    "    "
	$1\frac{3}{4}$	28		×	11·38
	10	90	120		
$3\frac{9}{16}$ "	—	×	—	×	————— = 196·96    "    "
	$1\frac{3}{4}$	28		×	11·19
	10	90	120		
$3\frac{1}{2}$ "	—	×	—	×	————— = 200·55    "    "
	$1\frac{3}{4}$	28		×	10·99

Twist Arrangement—Cylinder Pinion, 30 teeth.

Diameter of  
Drawing Roller.

	10	90	120		
4"	—	×	—	×	————— = 163·78 Constant No. for Twist.
	$1\frac{3}{4}$	30		×	12·56
	10	90	120		
$3\frac{15}{16}$ "	—	×	—	×	————— = 166·30    "    "
	$1\frac{3}{4}$	30		×	12·37
	10	90	120		
$3\frac{7}{8}$ "	—	×	—	×	————— = 169·03    "    "
	$1\frac{3}{4}$	30		×	12·17
	10	90	120		
$3\frac{13}{16}$ "	—	×	—	×	————— = 171·85    "    "
	$1\frac{3}{4}$	30		×	11·97
	10	90	120		
$3\frac{3}{4}$ "	—	×	—	×	————— = 174·48    "    "
	$1\frac{3}{4}$	30		×	11·79
	10	90	120		
$3\frac{11}{16}$ "	—	×	—	×	————— = 177·64    "    "
	$1\frac{3}{4}$	30		×	11·58
	10	90	120		
$3\frac{5}{8}$ "	—	×	—	×	————— = 180·76    "    "
	$1\frac{3}{4}$	30		×	11·38

Diameter of Drawing Roller.

	10	90	120	
$3\frac{9}{16}$ "	—	×	—	×
	$1\frac{3}{4}$	30		×
	10	90	120	
	—	×	—	×
$3\frac{1}{2}$ "	—	×	—	×
	$1\frac{3}{4}$	30		×

= 183.83 Constant No. for Twist.

= 187.18 " " "

Twist Arrangement—Cylinder Pinion, 24—28—30 teeth.

Cylinder, 9" diameter.

Spindle Werve,  $1\frac{5}{8}$ " diameter.

Cylinder Pinions, 24—28—30 teeth.

Twist Wheel, 80 teeth.

Drawing Roller Wheel, 114 teeth.

Diameter of Drawing Roller, 4".

Diameter of Drawing Roller.

	9	80	114	
4"	—	×	—	×
	$1\frac{5}{8}$	24		×
	9	80	114	
	—	×	—	×
$3\frac{5}{16}$ "	—	×	—	×
	$1\frac{5}{8}$	24		×
	9	80	114	
	—	×	—	×
$3\frac{7}{8}$ "	—	×	—	×
	$1\frac{5}{8}$	24		×
	9	80	114	
	—	×	—	×
$3\frac{13}{16}$ "	—	×	—	×
	$1\frac{5}{8}$	24		×
	9	80	114	
	—	×	—	×
$3\frac{3}{4}$ "	—	×	—	×
	$1\frac{5}{8}$	24		×
	9	80	114	
	—	×	—	×
$3\frac{11}{8}$ "	—	×	—	×
	$1\frac{5}{8}$	24		×
	9	80	114	
	—	×	—	×
$3\frac{5}{8}$ "	—	×	—	×
	$1\frac{5}{8}$	24		×
	9	80	114	
	—	×	—	×
$3\frac{9}{16}$ "	—	×	—	×
	$1\frac{5}{8}$	24		×

= 167.56 Constant No. for Twist.

= 170.13 " "

= 172.93 " "

= 175.82 " "

= 178.50 " "

= 181.74 " "

= 184.93 " "

= 188.07 " "

= 11.19 " "

Diameter of  
Drawing Roller.

$$3\frac{1}{8}'' \quad \begin{array}{ccc} 9 & 80 & 114 \\ \hline 1\frac{5}{8} & 24 & \end{array} \times \frac{\quad}{\quad} \times \frac{\quad}{\quad} = 191.50 \text{ Constant No. for Twist.} \\ \times 10.99$$

Twist Pinion—Cylinder Pinion, 28 teeth.

Diameter of  
Drawing Roller.

4"	$\frac{9}{1\frac{5}{8}} \times \frac{80}{28} \times \frac{114}{\quad} = 143.62$	Constant No. for Twist,
	$\times 12.56$	
$3\frac{1}{8}''$	$\frac{9}{1\frac{5}{8}} \times \frac{80}{28} \times \frac{114}{\quad} = 145.83$	" "
	$\times 12.37$	
$3\frac{7}{8}''$	$\frac{9}{1\frac{5}{8}} \times \frac{80}{28} \times \frac{114}{\quad} = 148.22$	" "
	$\times 12.17$	
$3\frac{1}{2}''$	$\frac{9}{1\frac{5}{8}} \times \frac{80}{28} \times \frac{114}{\quad} = 150.70$	" "
	$\times 11.97$	
$3\frac{3}{4}''$	$\frac{9}{1\frac{5}{8}} \times \frac{80}{28} \times \frac{114}{\quad} = 153.00$	" "
	$\times 11.79$	
$3\frac{11}{16}''$	$\frac{9}{1\frac{5}{8}} \times \frac{80}{28} \times \frac{114}{\quad} = 155.78$	" "
	$\times 11.58$	
$3\frac{5}{8}''$	$\frac{9}{1\frac{5}{8}} \times \frac{80}{28} \times \frac{114}{\quad} = 158.51$	" "
	$\times 11.38$	
$3\frac{9}{8}''$	$\frac{9}{1\frac{5}{8}} \times \frac{80}{28} \times \frac{114}{\quad} = 161.21$	" "
	$\times 11.19$	
$3\frac{1}{2}''$	$\frac{9}{1\frac{5}{8}} \times \frac{80}{28} \times \frac{114}{\quad} = 164.14$	" "
	$\times 10.99$	

Twist Pinion—Cylinder Pinion, 30 teeth.

Diameter of  
Drawing Roller.

$$4'' \quad \begin{array}{ccc} 9 & 80 & 114 \\ \hline 1\frac{5}{8} & 30 & \end{array} \times \frac{\quad}{\quad} \times \frac{\quad}{\quad} = 134.05 \quad " \quad " \\ \times 12.56$$

Diameter of  
Drawing Roller.

	9	80	114		
$3\frac{1}{8}$ "	—	×	—	×	$\frac{9 \times 80 \times 114}{15 \times 80 \times 9} = 136.11$ Constant No. for Twist.
	$1\frac{5}{8}$	80		×	12.37
	9	80	114		
$3\frac{7}{8}$ "	—	×	—	×	$\frac{9 \times 80 \times 114}{15 \times 80 \times 9} = 138.34$ " "
	$1\frac{5}{8}$	80		×	12.17
	9	80	114		
$3\frac{11}{8}$ "	—	×	—	×	$\frac{9 \times 80 \times 114}{15 \times 30 \times 9} = 140.48$ " "
	$1\frac{5}{8}$	30		×	11.97
	9	80	114		
$3\frac{3}{4}$ "	—	×	—	×	$\frac{9 \times 80 \times 114}{15 \times 30 \times 9} = 142.80$ " "
	$1\frac{5}{8}$	30		×	11.79
	9	80	114		
$3\frac{11}{10}$ "	—	×	—	×	$\frac{9 \times 80 \times 114}{15 \times 30 \times 9} = 145.39$ " "
	$1\frac{5}{8}$	30		×	11.58
	9	80	114		
$3\frac{5}{8}$ "	—	×	—	×	$\frac{9 \times 80 \times 114}{15 \times 30 \times 9} = 147.95$ " "
	$1\frac{5}{8}$	30		×	11.38
	9	80	114		
$3\frac{9}{10}$ "	—	×	—	×	$\frac{9 \times 80 \times 114}{15 \times 30 \times 9} = 150.46$ " "
	$1\frac{5}{8}$	30		×	11.19
	9	80	114		
$8\frac{1}{2}$ "	—	×	—	×	$\frac{9 \times 80 \times 114}{15 \times 30 \times 9} = 153.20$ " "
	$1\frac{5}{8}$	30		×	10.99

# COTTON BELT JOINT.

SHOWING METHOD ADOPTED FOR FIXING—Rivets used  $\frac{5}{8}$ " No. 6.

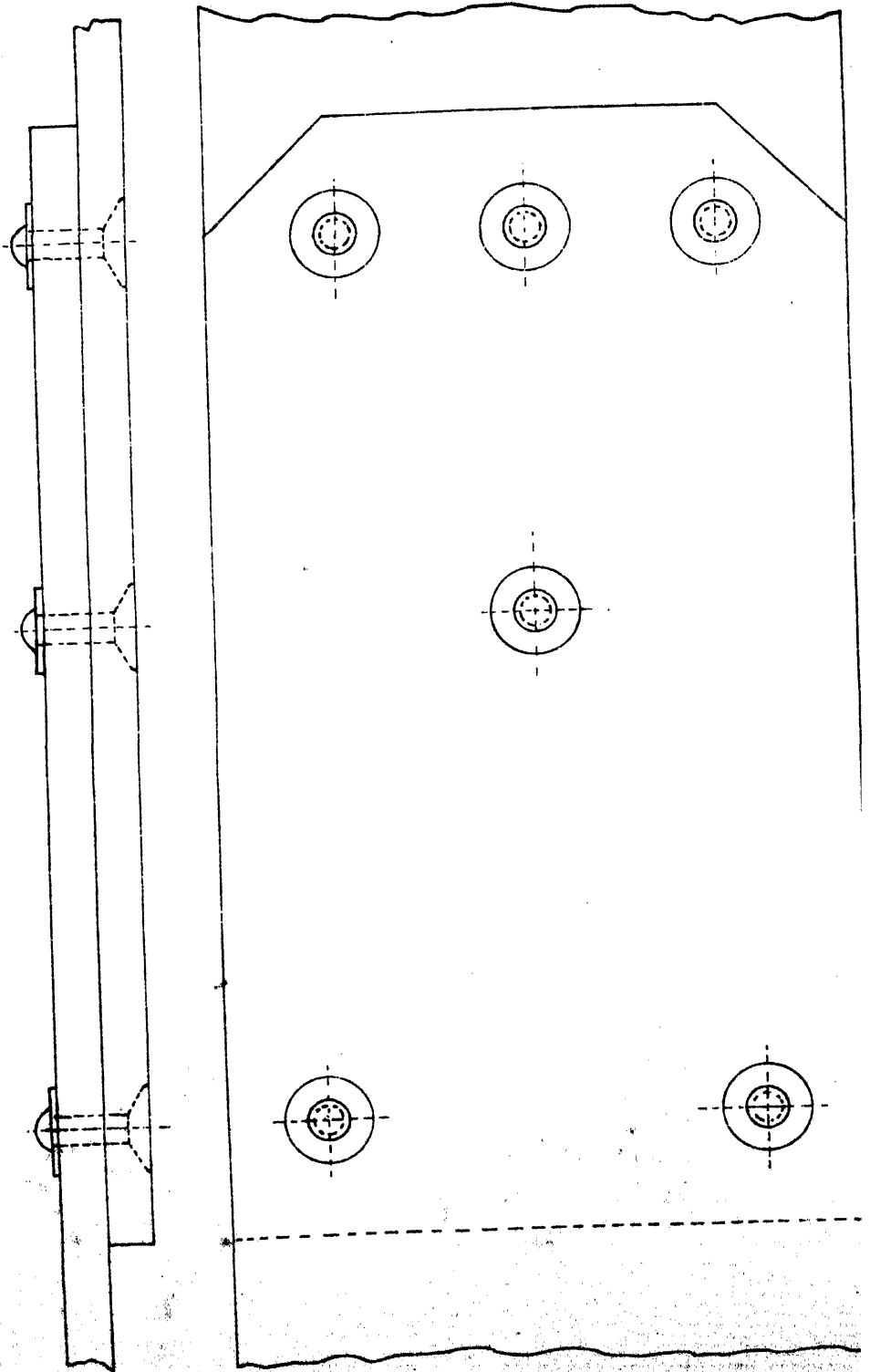

## THE DRIVING OF THE SPINNING FRAME.

The steadiness of the drive to the Spinning Frame Spindles is of much importance, and it will always be observed that when a pair of engines are working together driving a mill, the driving will be much steadier than when working with a single engine. A 72 Spindle Frame, 4 inch pitch, 4 inch traverse, will require a belt 4 ins. broad and 80 feet long, according to the plan of mill given in this book. At one time all the belts used in jute mills were made of leather, but this is not now the case. Many mills work cotton belting. This belt has many advantages over leather for driving jute mill machinery; not only is it cheaper, but it runs much smoother, owing to the absence of joints. There is only one joint in the belt. This joint is made very easily, and in a much shorter time than you can make a sewed joint. The cost of the six copper rivets and washers is trifling compared with the price of belt laces. This is a diagram showing the form of joint used largely for Spinning Frame Belts made of cotton, solid woven (*see diagram page 228*).

These belts will drive the Frame, and not require to be kept so tight as leather belts. They do not require nearly so much attention and upkeep as leather belts do, the laces for which are a serious matter, as the average life of a belt lace of good quality is only about  $2\frac{1}{3}$  months. A cotton belt will run for about  $\frac{6}{8}$  months without anything being done to the joint, and it will run from  $\frac{4}{5}$  years with very little trouble and without much expense. At the end of that time there will not be more than two or three joints in the belt. During that period a leather belt will have cost *something*, if it is *still running*, in the shape of laces, and there will be *rather more* than two or three joints in it. It should be always borne in mind, whether the belt is made of leather or cotton, that the guide pulleys should be properly set to the driving drum and to the driving pulleys of frame. On this depends in a great measure the life of a belt. Much destruction is caused to belts by the guides being improperly set, throwing an unnecessary strain and consequent wear upon the edges. This, of course, ruins the belt, whether of leather or cotton. If the guide pulleys are correctly set to the driving pulley the "belt fork" will never touch the belt except when required to shift it from one pulley to another. When the belt is running on either pulley it should be quite free, and should not press against the side of belt fork. This can be easily accomplished if the guide is set as described.

## INSTRUCTIONS FOR SETTING GUIDE PULLEYS FOR SPINNING FRAME BELTS.

*(See Diagram page 231.)*

In this diagram the arrow at A shows the direction the belt is running on the drum D. This is called the "leading side" of the belt. The edges of the guide pulley from which the belt is running on the drum should be set in line with the edge of the drum. If the guide is 4" broad and the drum 6" broad, the edge of pulley should be set to throw belt one inch from edge of drum, and when the belt is running on drum it will be one inch within each side of it. Second, the guide pulley should be set so that a plumb line from the circumference of guide pulley should fall between the two pulleys at P as dotted line. This insures that the fork will have the same pressure on the belt edge when putting on as when you put it off. Third, a line from the edge of each guide pulley to a point at a distance equal to half the width of guide pulley from the circumference of cylinder pulley will set the guide pulley to the angle required to keep the belt running fair. If attention be given to these three points, and the guide pulley frame is set parallel to the driving shaft, there is no fear but the belt will run without damage to its edges. Belt forks are often made of round iron  $\frac{1}{2}$  inches or  $\frac{3}{4}$  inches diameter. This is not a good thing for any kind of belt. This diagram shows a fork which will be found very easy upon the belts and is supplied by Fairbairn to all their Spinning Frames.

### DIAGRAM OF BELT FORK FOR SPINNING FRAME.

SCALE, 3" TO ONE FOOT.

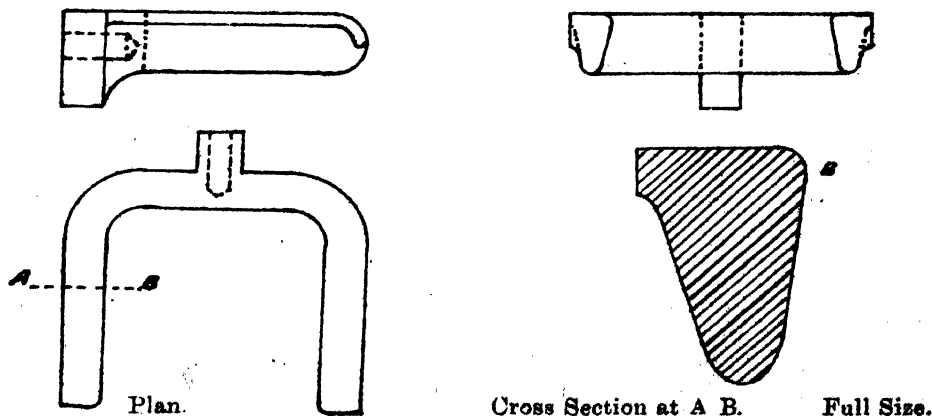

ARRANGEMENT OF GUIDE PULLEYS FOR DRIVING  
SPINNING FRAME

SCALE  $\frac{1}{4}$ " TO ONE FOOT.

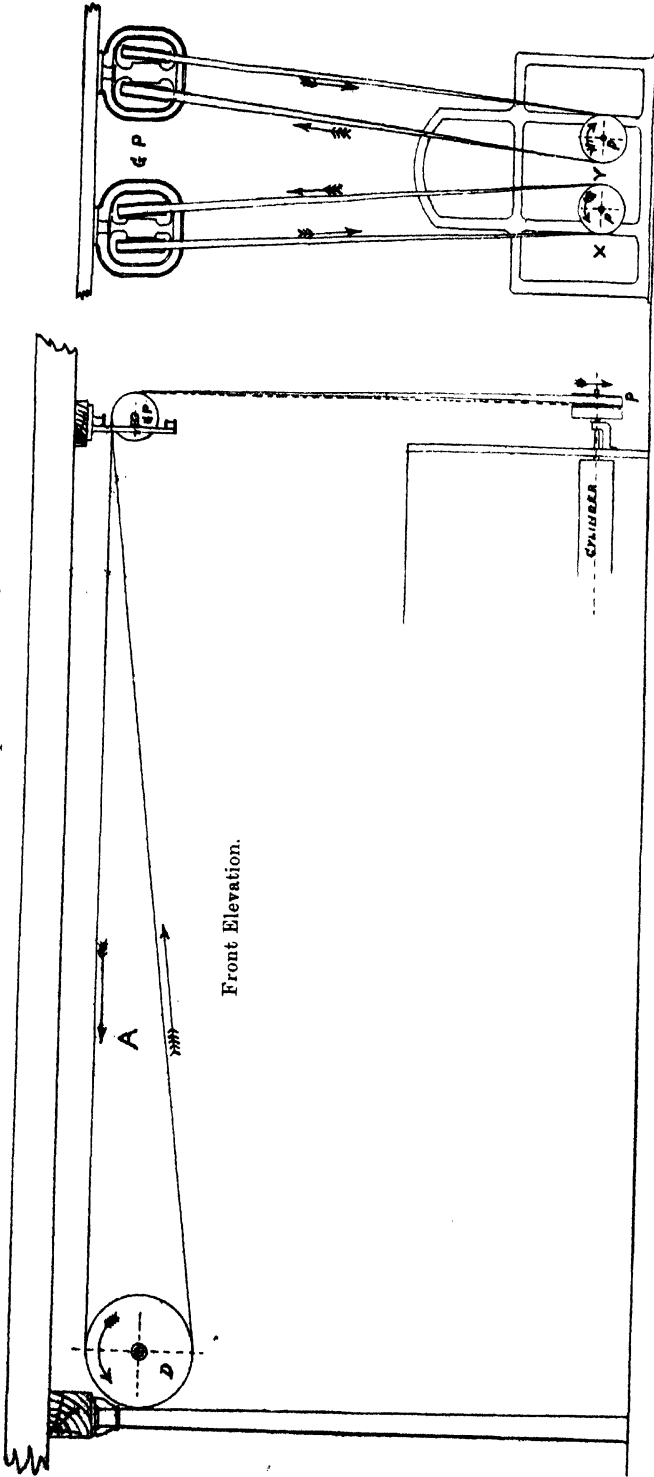

End Elevation.

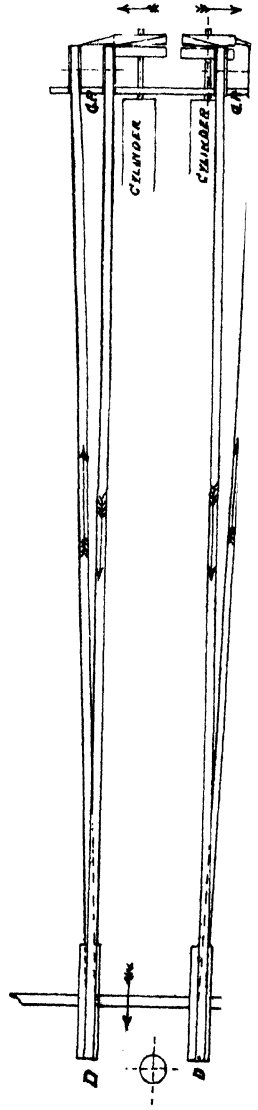



## COP WINDING.

If the weft which has been spun upon the frames is to be made into cops, it is taken to the cop-winding department. Here it is wound upon the cop machines into cops, according to the size of the shuttles in which the weft is to be used in the process of weaving. Usually, hessian cops are made 9 inches long, and  $1\frac{1}{2}$  inches in diameter. Sometimes they are made 9 inches by  $1\frac{5}{8}$  inches; but if the looms are being driven fast, I think a 9 inch by  $1\frac{1}{2}$  inch cop is preferable, as there is less tendency to make waste. Illustrations of three different types of cop machines are given—the original machine of Combe, Barbour & Company; Messrs Lee, Croll & Company; and Messrs Charles Parker, Son & Company. The last two mentioned are very much of the same construction. The cop cone in these two machines is in an inverted position from the former machine. This will be readily understood from a reference to the diagrams given. All the machines do their work equally well. My experience has, however, been confined to the machine of Messrs Combe, Barbour & Company. It is sometimes said of this machine that it is difficult to keep up—that is to say, that it is difficult to keep in mechanical order. I cannot, however, say I have found it very much trouble; that, however, is a matter of opinion. I am inclined to think that Messrs Combe, Barbour & Company's machine can be driven at a greater speed than the others mentioned. In a mill the workers get accustomed to either of them; and, of course, both employers and employees make use of what they have been accustomed to. Particulars, arrangements of speeds, &c., are given. The cops when taken off the spindles are either put into pans or bags. If they are to be used at once in a factory, they are very often put into pans; if they are to be sent a distance, they are always put into bags. It is of importance that the pan or bag be made the exact breadth of the length of cop. This is not to allow the cops to shift about and get broken; as, if they are in any way knocked about, they are apt to become soft, and this will always lead to unnecessary waste in the weaving department. The cop pan is usually made 16 inches long, 11 inches deep, and  $9\frac{1}{2}$  inches broad. The bag—to hold about 56 to 60 pounds weight—is made 22 inches broad, 10 inches wide, and 22 inches deep. The waste in this department is a matter which requires continual attention. My experience is, that for

ordinary hessian wefts the waste will average about 4 per cent., the cop machine of 54 spindles will require three winders, and they will wind into cops, on an average, 60 spindles of 8 or 9 lbs. in 10 hours. When the size is from 10 to 12 lbs., it will depend to some extent upon the ability of the winder as to whether she will be able to wind the production of a 72 spindle frame. This, of course, is a matter of arrangement when it happens in the department.

#### PARTICULARS OF COP MACHINE GEARING.

*(Parker, Son & Co.)*

Spindle driving wheel (a), 46 teeth.

„ „ pinion (b), 16 teeth.

Travelling cloth pulley (c and d), each  $7\frac{1}{2}$ " dia.

Worm, single thread, right hand (e).

Worm wheel, 24 teeth, right hand (f).

Cloth roller,  $4\frac{1}{2}$ " dia. (g).

Driving pulleys (P), generally 15" dia.  $\times$   $3\frac{1}{2}$ " and run 260 revolutions for ordinary jute hessian cops.

# COP MACHINE.

SCALE, 1½" TO ONE FOOT.

(Charles Parker, Son, & Co.)

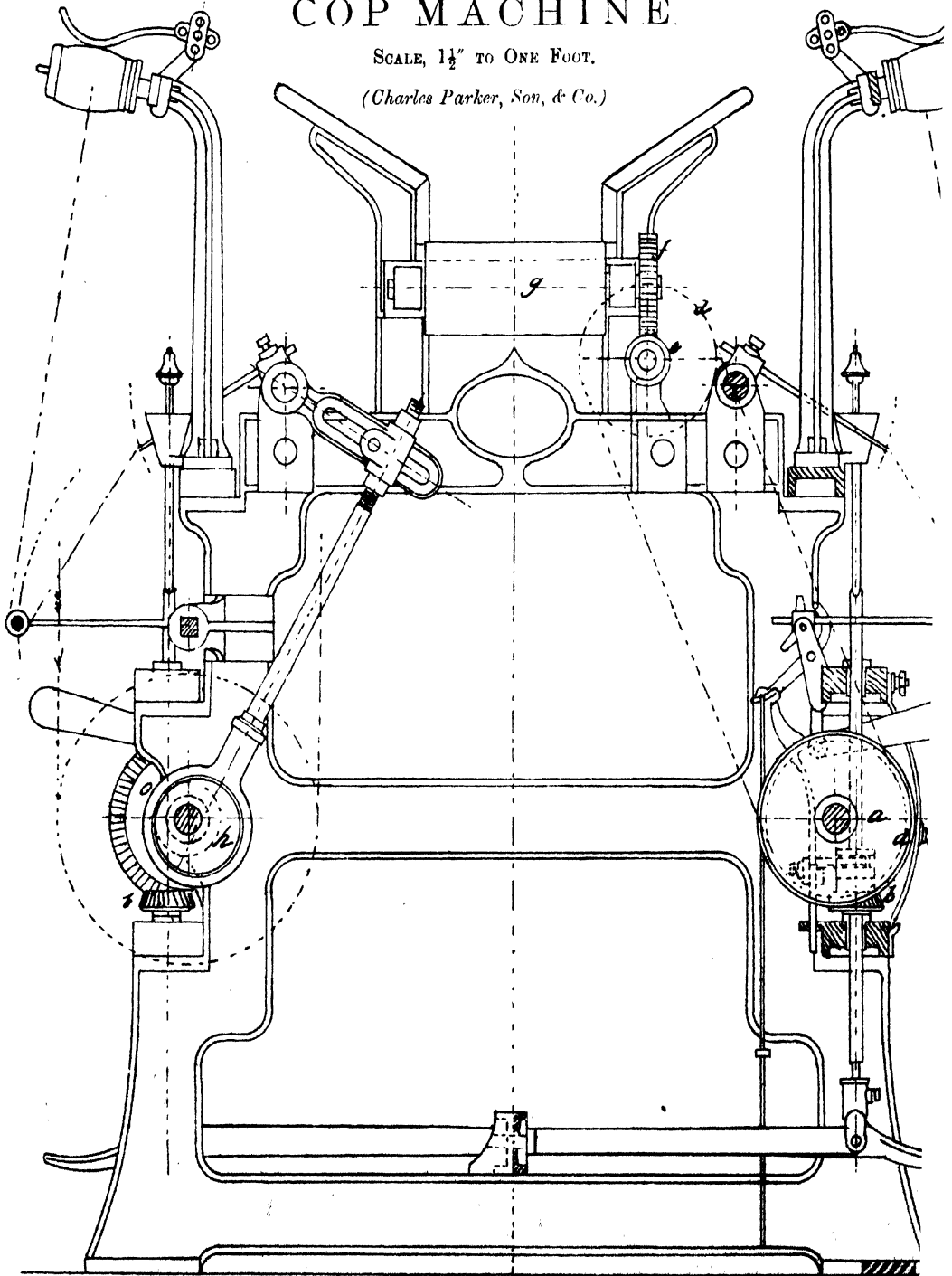

HALF SECTIONAL ELEVATION

# COP MACHINE.

SCALE, 1½" TO ONE FOOT.

(Charles Parker, Son, & Co.)

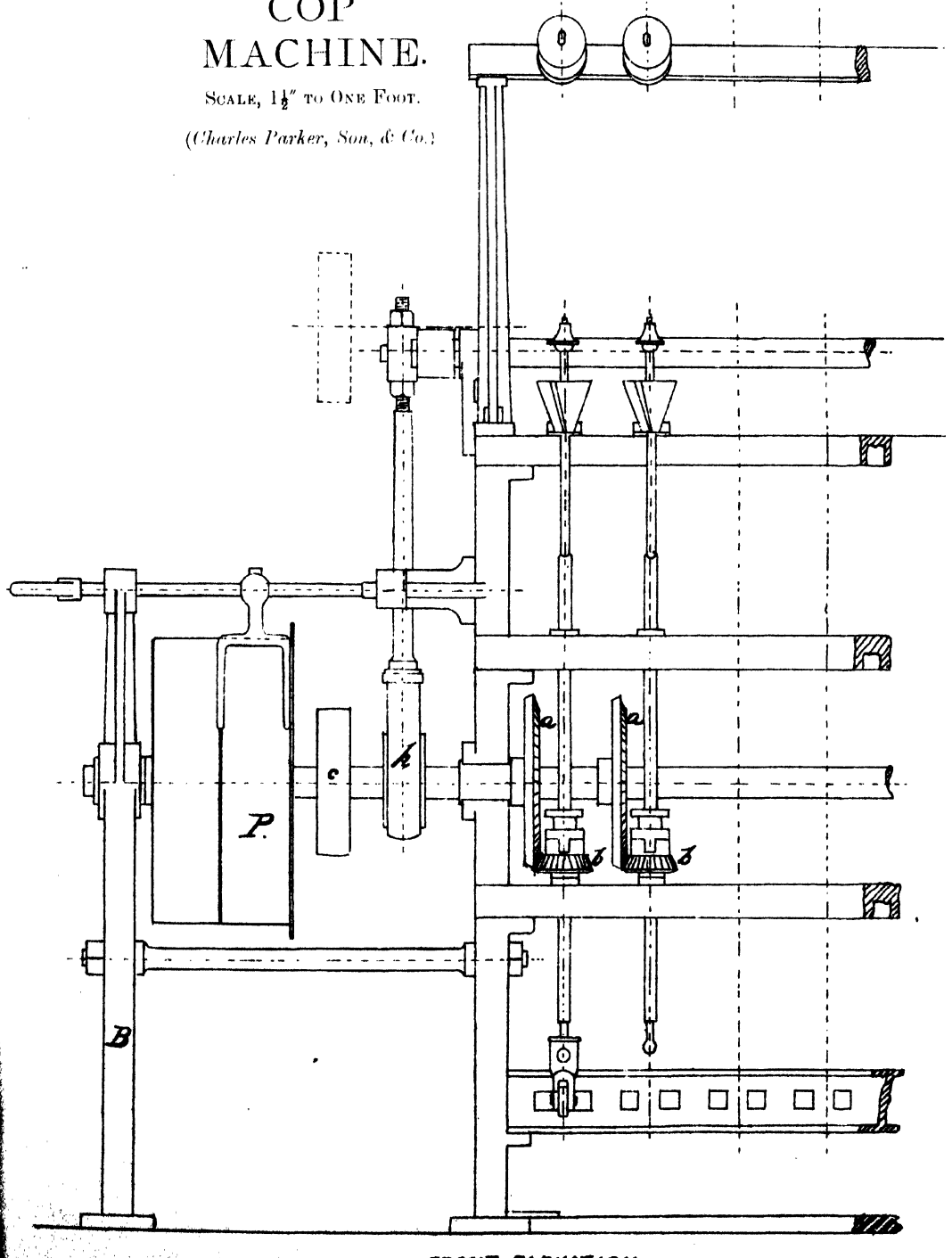

## COP MACHINE

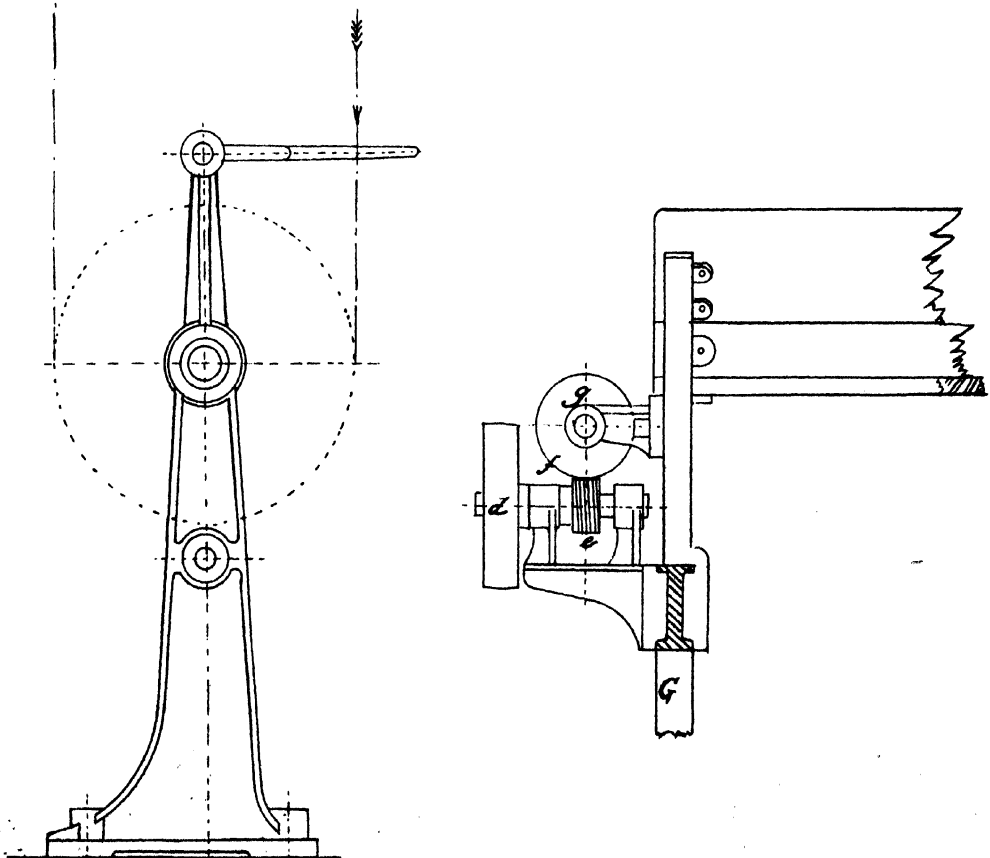
SCALE,  $1\frac{1}{2}$ " TO ONE FOOT*(Charles Parker, Son & Co.)*

SIDE VIEW OF  
OUTER CARRIER B.

COP MACHINE.

2:

# COP MACHINE

SCALE,  $\frac{1}{2}$ " TO ONE FOOT.

(Thomson, Son, & Co.)

Speed pulleys 528 revolutions per minute.

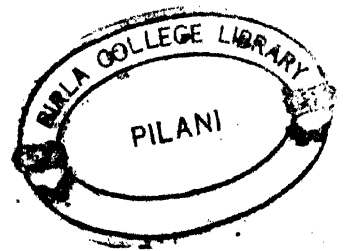
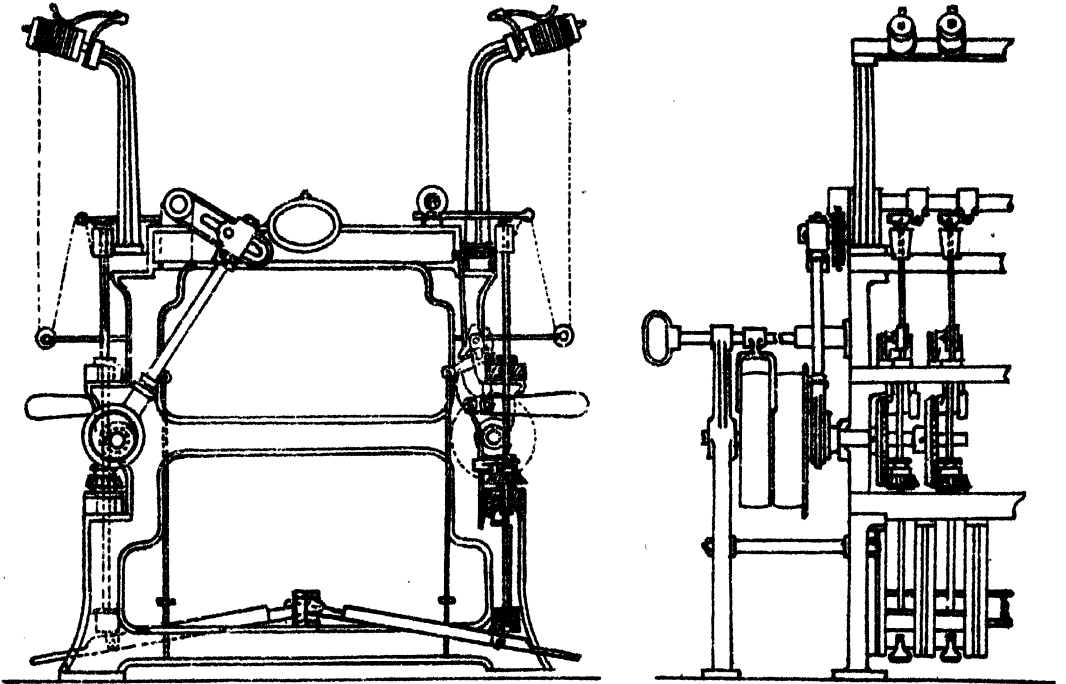

# COP MACHINE

SCALE,  $\frac{3}{4}$ " TO ONE FOOT.

(Combe, Barbour, & Combe.)

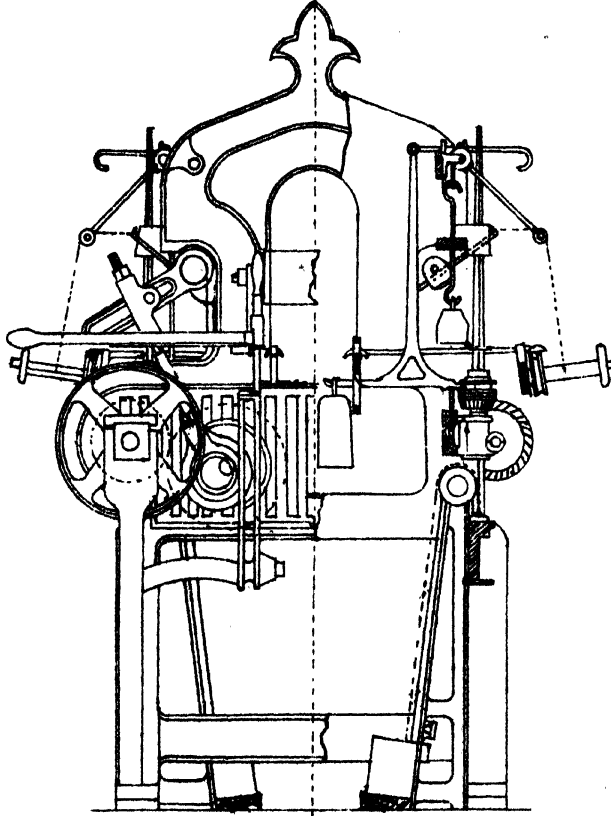

## COP PAN

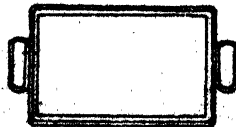
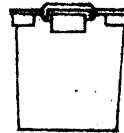
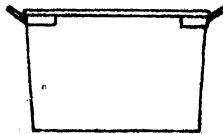

COP MACHINE.

# COP MACHINE

SCALE  $\frac{3}{4}$ " TO ONE FOOT.

(*Lee, Croll, & Co.*)

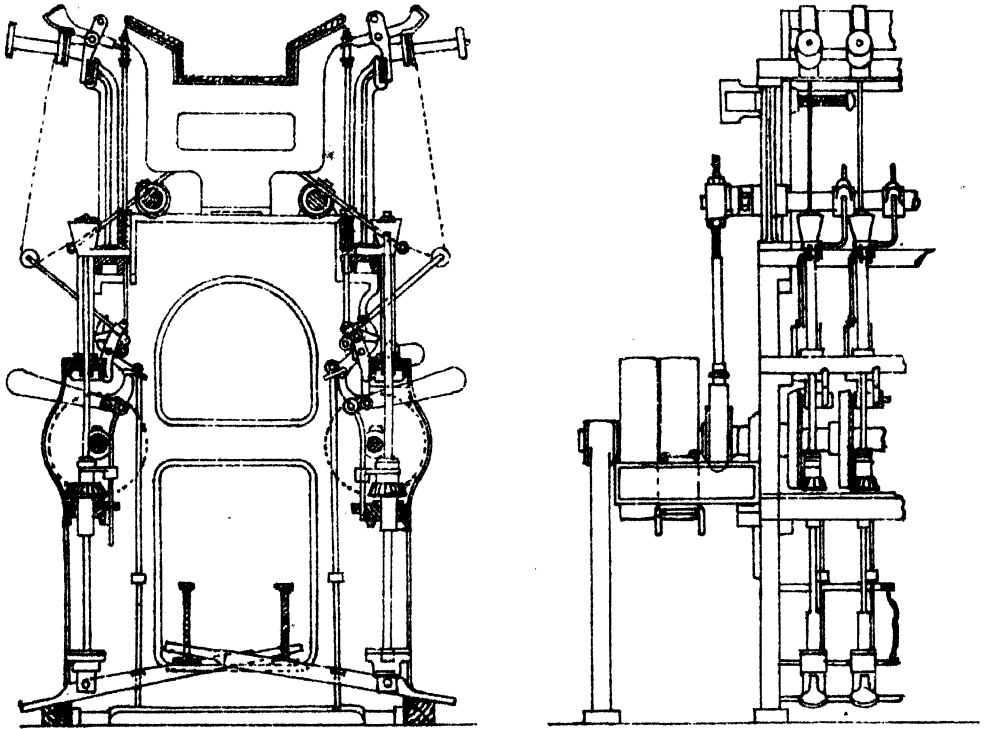

COP MACHINE.

Spindle Pinion, 16 teeth.

Wheel on Driving Shaft, 46 teeth.

Pulleys, usually about 16" diameter.

Speed of Spindles, from 800 to 1000 revolutions per minute.



# SPINDLE AND COP WITH CONE FOR COP WINDING MACHINE

(Combe, Barbour, & Combe). SCALE, HALF SIZE. Usual Size of Cop, 9" x 1 1/2".

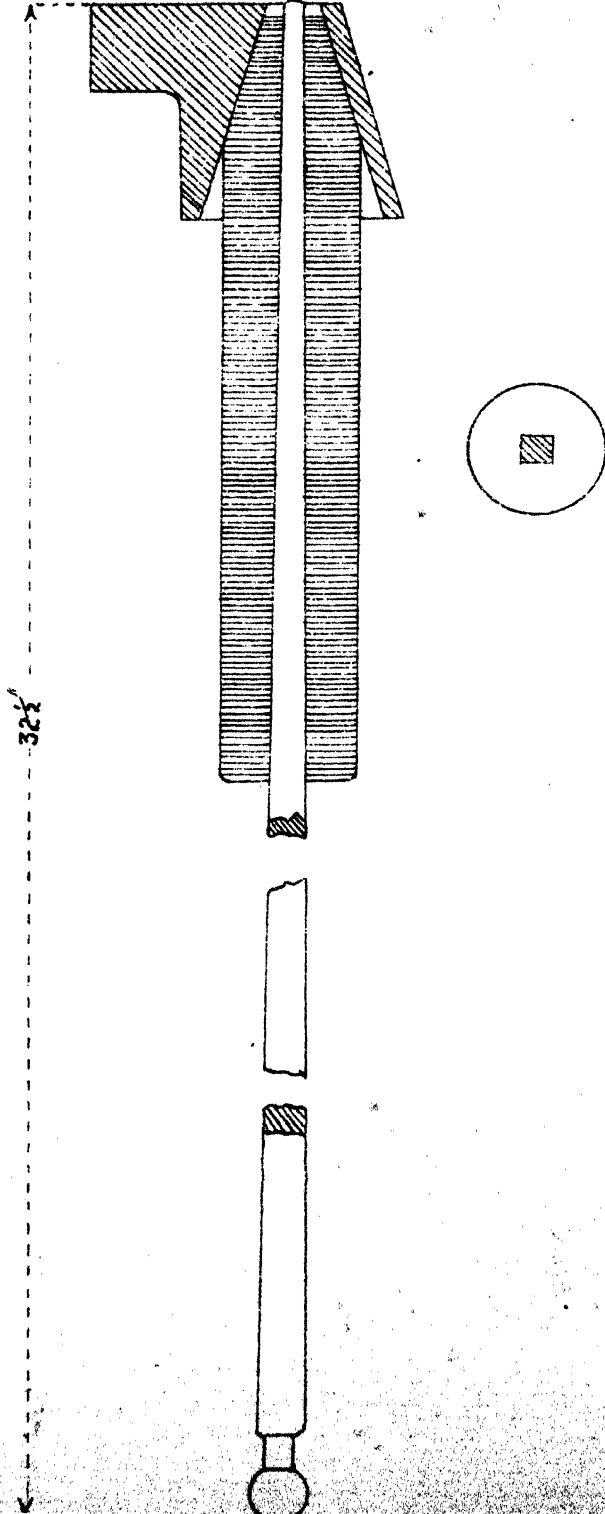

## REELING AND BUNDLING.

Here the yarn which has been spun, either warp or weft, which is to be delivered in the bundle, is brought to be reeled—that is, that the yarn is reeled round the barrel, or swift, as it is more usually termed. Upon this barrel or swift a certain number of threads are tied up into cuts, heers, hanks, and spyndles (see yarn table). When the yarn is taken off the reels, it is taken and weighed, or sized is the term generally in use. So many spyndles are put into a bundle, according to the size of the yarn. In this department much care and attention is necessary by the workers and by those in charge. It is of much importance that the tell of the yarn should be correct. By the term “tell” is meant the number of threads and yards in a “cut.” 120 threads are in each “cut,” the tell wheel for 7 to 9 lbs. will have 125 teeth; and for 10 to 20 lbs., 123 teeth. This enables the reeler, with ordinary care, to put in the correct number—120 threads into each cut. By care and attention in the reeling department, very much can be done to keep the yarn regular upon the weight. After the yarn is reeled and sized, it is handed over to the bundlers, who lay first one hank and then another upon a bundling stool (see illustration), so many bands being put round it. The bands are tied round, and knotted up with a “bundling pin,” and the yarn is then laid in the yarn warehouse to wait such time as required to deliver it. It is essential to the look of the yarn, while it is being bundled, that the bundlers display taste and some degree of pride in the making up of the bundles. No matter how well the yarn may have been spun and reeled, if it is carelessly and slovenly bundled, this will tend to detract from its appearance; and I almost venture to say, from the market value of the yarn.

## POWER REEL

END ELEVATION SHOWING DRIVING END—SCALE,  $\frac{1}{8}$ TH

90" Circumference.

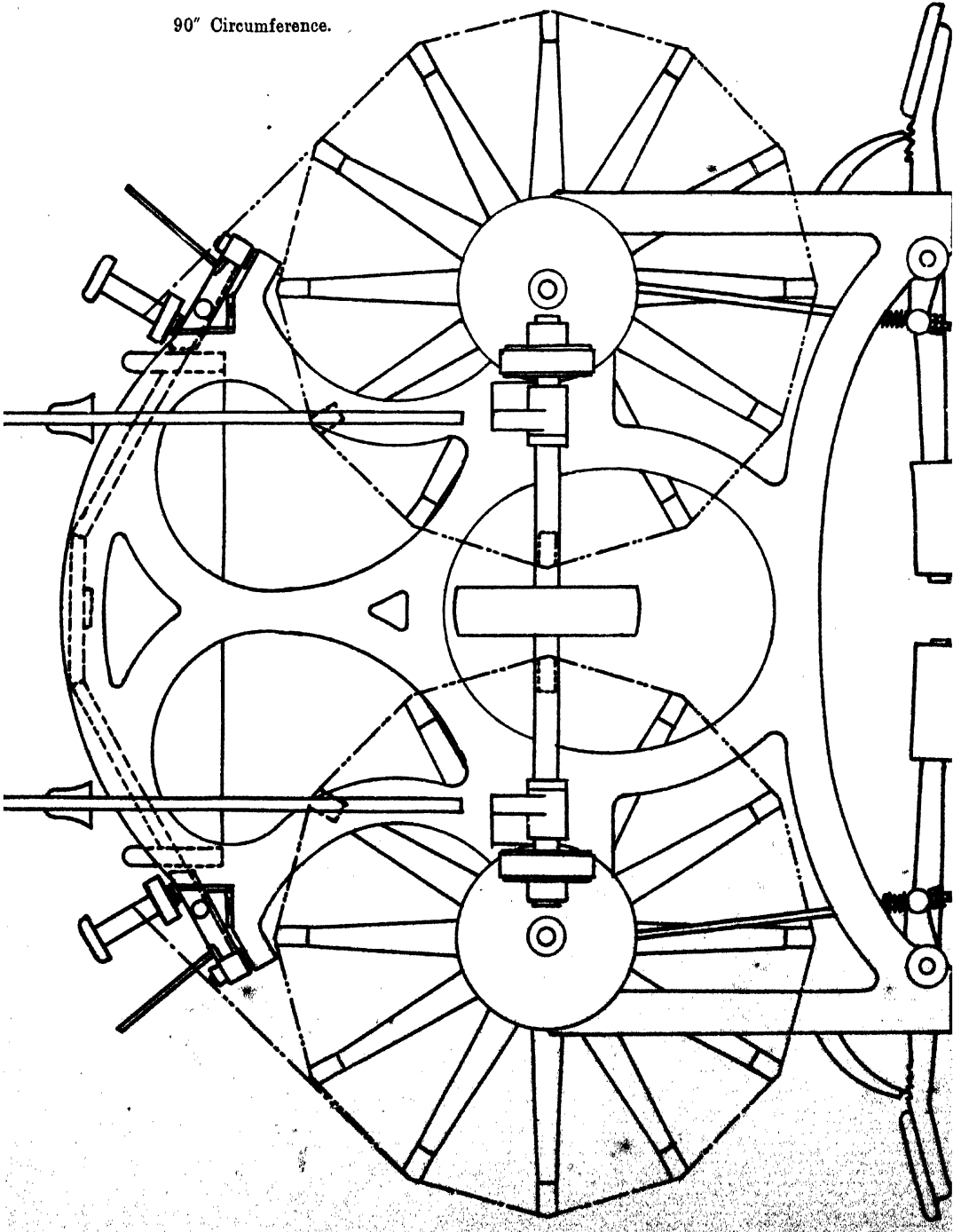

# POWER REEL

END ELEVATION SHOWING DOFFING END—SCALE,  $\frac{1}{8}$  TH.

90" Circumference.

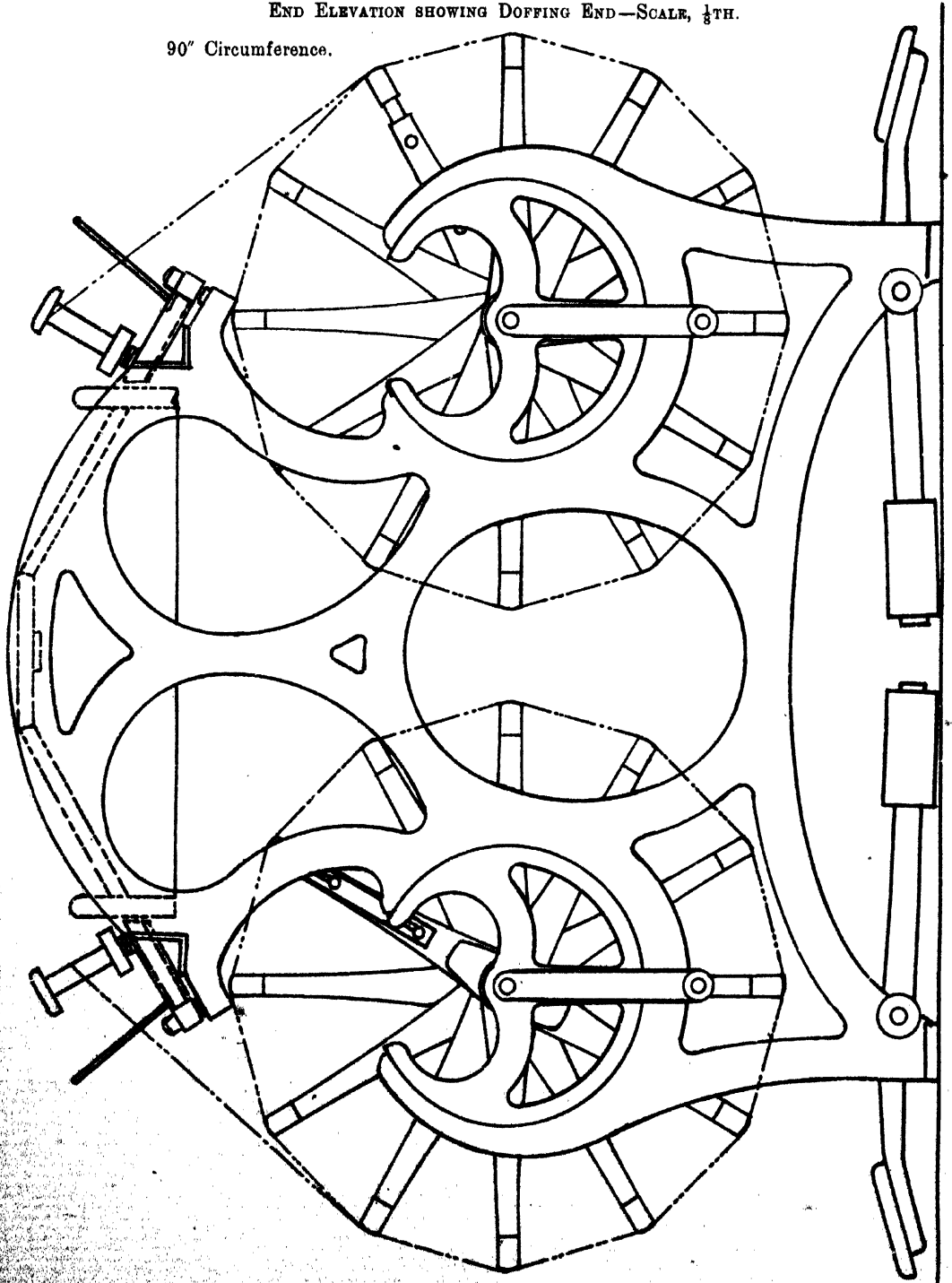

### INSTRUCTIONS AND PARTICULARS AS TO THE REELING OF THE YARNS.

The reel is 12 ft. 4 in. long, and 90 in. in circumference; and the rails upon which the yarns are reeled are attached to spokes. In a Fairbairn reel there are 12 spokes in the swift, as the reel is sometimes called. By a reference to the illustration, it will be seen that these spokes make the yarn, when on the reel, in the form of a 12 sided figure. This is to allow the yarn to come off without trouble. And when the reel or swift has been filled, an arrangement is provided to make part of the swift or barrel collapse; and the reeler has then to draw the yarn all to the one end, and by turning the wheel provided for the purpose, she can lift off the yarn and hang it on the hook at the end of her reel. From thence it is taken to the bundling department, when it is made into the size of bundles required. These bundles are commonly made a certain size for a certain weight of yarn (see table); but sometimes special sizes of bundles are made, according to the order in hands.

7/12 lbs. yarn is reeled in hanks of 6 cuts each.  
 13/24   "   "   "   4   "  
 25/82   "   "   "   3   "

### TABLE SHOWING THE NUMBER OF SPYNDLES IN A BUNDLE OF THE DIFFERENT SIZES OF YARN.

Lbs.	Spls.	Weight of Bdl.	Bundles are made up in hanks of half a spl.			
7	8	55 lbs.				
8	7	56 "	"	"	"	"
9	6	54 "	"	"	"	"
9½	6	57 "	"	"	"	"
10	6	60 "	"	"	"	"
11	5	55 "	"	"	"	"
12	5	60 "	"	"	"	"
13	4	52 "	"	"	"	" of a third of a spl.
14	4	56 "	"	"	"	"
15	4	60 "	"	"	"	"
15½	3½	58½ "	Bdls. are made up in 11 hanks and 4 cuts.			
16	3½	56 "	"                                   10 hanks and 8 cuts.			
19	3½	59½ "	"	"	"	"

Lbs.	Spls.	Weight of Bdl.	
18	3	54 lbs.	Bdls. are made up in 9 hanks of a third of a spl. each.
19	3	57 "	" " " "
20	3	60 "	18 hanks of a $\frac{1}{8}$ of a spl. each.
21	$2\frac{3}{4}$	$57\frac{3}{4}$ "	16 hanks of a $\frac{1}{8}$ of a spl. and 4 cuts
22	$2\frac{1}{2}$	55 "	15 hanks of a $\frac{1}{8}$ of a spl.
24	$2\frac{1}{2}$	60 "	15 " "
28	2	56 "	12 " "
29	2	58 "	12 " "
80	2	60 "	12 " "
32	$1\frac{3}{4}$	56 "	14 " of an $\frac{1}{8}$ of a spl.

The "bands" of the bundles are included in the quantity given in above particulars of hanks. The bands are usually reeled to a size that will make them manageable for the tying up of the bundle. In 7 lbs. yarn the bands are reeled in 6 cuts; and for 20 lbs., are reeled in 2 cuts This is a matter of convenience to some extent.

An illustration of an ordinary bundling stool, and also a small bundling press, is given. This press is used for making small bundles, generally twisted yarns—that is, yarn in the ply.

Every attention should be given by the reelers, and by those in charge of the reeling department, to see that the proper knot is made on the yarn. This knot is usually termed a "weaver's knot." This is a representation of it—



SCOTTISH YARN TABLE.

$2\frac{1}{2}$ yards	=	1 thread.
120 threads	=	1 cut.
300 yards	=	1 cut or lea.
600 "	=	1 heer.
3,600 "	=	1 hank.
7,200 "	=	1 hesp.
14,400 "	=	1 spyndle.

ENGLISH YARN TABLE.

$2\frac{1}{2}$ yards	=	1 thread.
300 "	=	1 lea.
3,000 "	=	1 hank.
60,000 "	=	1 bundle.

The grist or fineness of the heavy linen and jute yarns is estimated by the weight of a spyndle per lb. avoirdupois—the finer qualities by leas, of which the following is the table and the rule for finding the same:—

TABLE.

Leas per Lb.	Weight per Spindle.			Leas per Lb.	Weight per Spindle.		
	Lbs.	Oz.	Dr.		Lbs.	Oz.	Dr.
1	48	0	0	50	0	15	5 $\frac{3}{4}$
2	24	0	0	55	0	13	5 $\frac{1}{2}$
3	16	0	0	60	0	12	12 $\frac{1}{2}$
4	12	0	0	65	0	11	13
5	9	9	9 $\frac{1}{2}$	70	0	10	15 $\frac{1}{2}$
6	8	0	0	75	0	10	3 $\frac{1}{2}$
7	6	13	11 $\frac{1}{2}$	80	0	9	9 $\frac{1}{2}$
8	6	0	0	85	0	9	0 $\frac{1}{2}$
10	4	12	12 $\frac{3}{4}$	90	0	8	8 $\frac{1}{2}$
12	4	0	0	95	0	8	1 $\frac{1}{2}$
14	3	6	13 $\frac{3}{4}$	100	0	7	10 $\frac{3}{4}$
16	3	0	0	110	0	6	15 $\frac{1}{2}$
18	2	10	10 $\frac{1}{2}$	120	0	6	6 $\frac{1}{2}$
20	2	6	6 $\frac{1}{2}$	130	0	5	14 $\frac{1}{2}$
22	2	2	14 $\frac{1}{2}$	140	0	5	7 $\frac{1}{2}$
25	1	14	11 $\frac{1}{2}$	150	0	5	1 $\frac{1}{2}$
28	1	11	6 $\frac{3}{4}$	160	0	4	12 $\frac{1}{2}$
30	1	9	9 $\frac{1}{2}$	170	0	4	8 $\frac{1}{2}$
35	1	5	15	180	0	4	4 $\frac{1}{2}$
40	1	3	3	190	0	4	0 $\frac{7}{8}$
45	1	1	1	200	0	3	13 $\frac{1}{2}$

*Rule.*—Divide the leas in a spyndle by the number of the lea yarn. Thus, for 16 lea yarn—

$$16 \overline{)48} (3 \text{ lb. yarn}$$

48

# WARPING MILL\*

SCALE,  $1\frac{1}{2}$ " TO ONE FOOT. Circumference = 13 yards.

ELEVATION SHOWING DRIVING WHEEL, HAKES, GUIDES, AND TRAVERSE MOTION.

Worm, single thread,  $\frac{5}{8}$ " pitch,  $3\frac{1}{2}$ " diameter.

Worm wheel, 46 teeth,  $\frac{5}{8}$ " pitch. Chain wheel, 25" diameter.

Revs. of chain wheel for one rev. of Warp Mill =  $\frac{1}{46} \times 1 = \frac{1}{46}$  of a rev.

Traverse of hake per rev. of Warp Mill =  $\frac{1}{46} \times 25 \times 3.1416 = 1.707$ ".

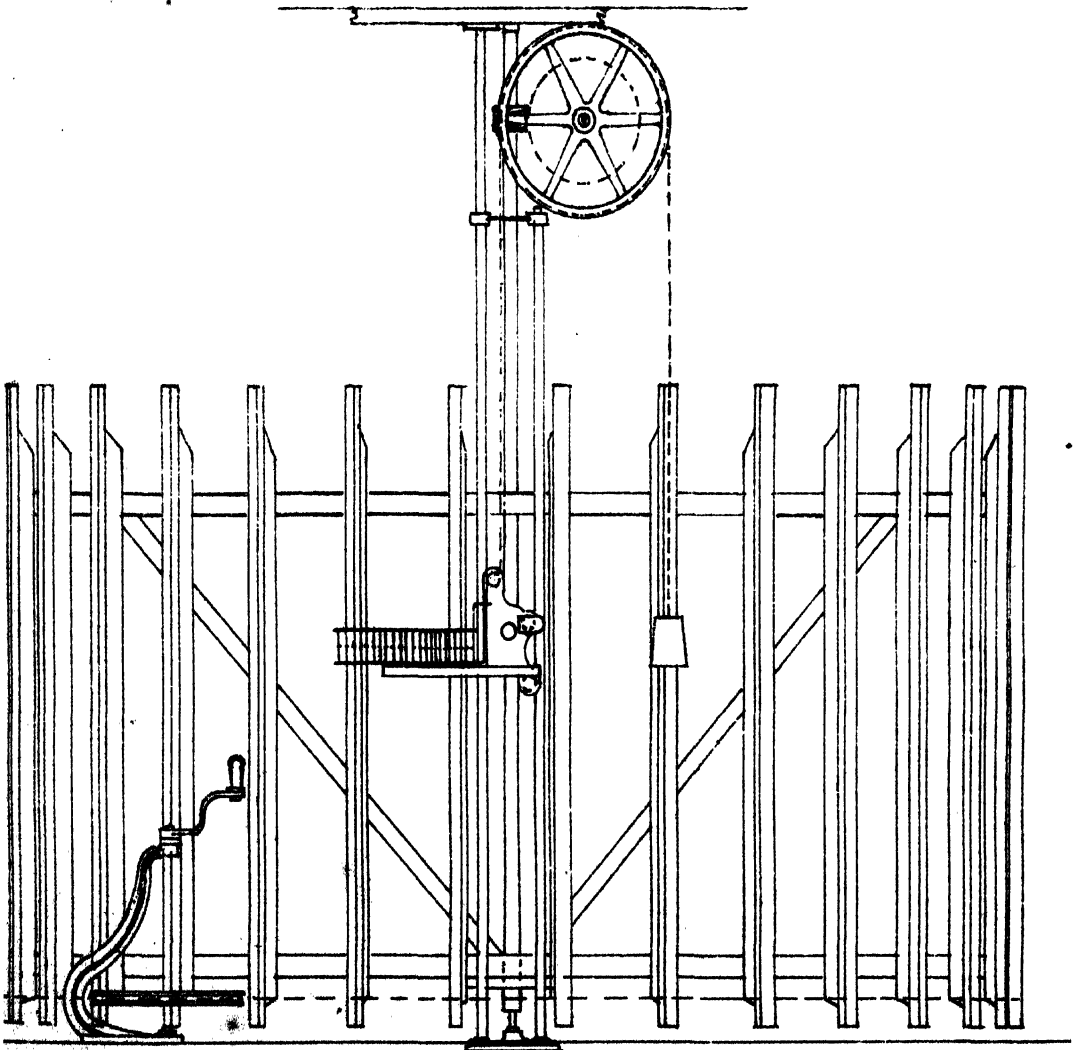

\*For description of the process of Warping see "Art of Weaving."



BUNDLING PRESS.

# BUNDLING PRESS\*

SCALE,  $\frac{3}{4}$ " TO ONE FOOT.

Hand wheel, 36" diameter.

Pinion, 13 teeth.

Wheel, 32 teeth.

Pinion, 10 teeth.

Break wheel, 66 teeth.

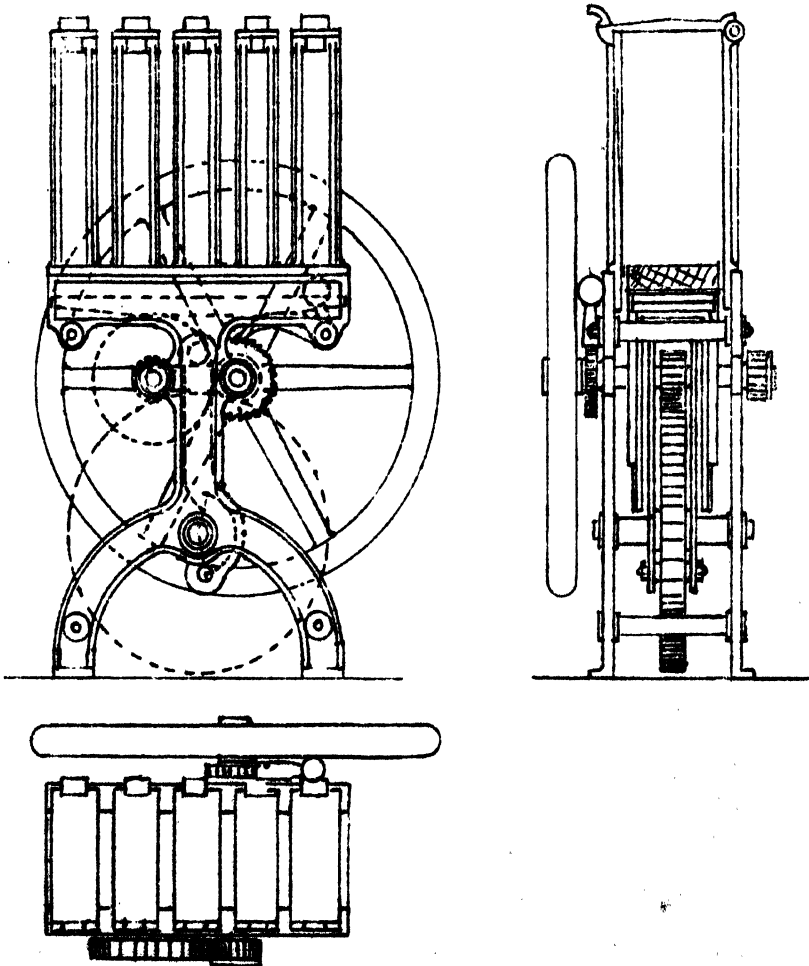

This Press is used for making small bundles—say from 8/16 lbs each.

# BUNDLING STOOL

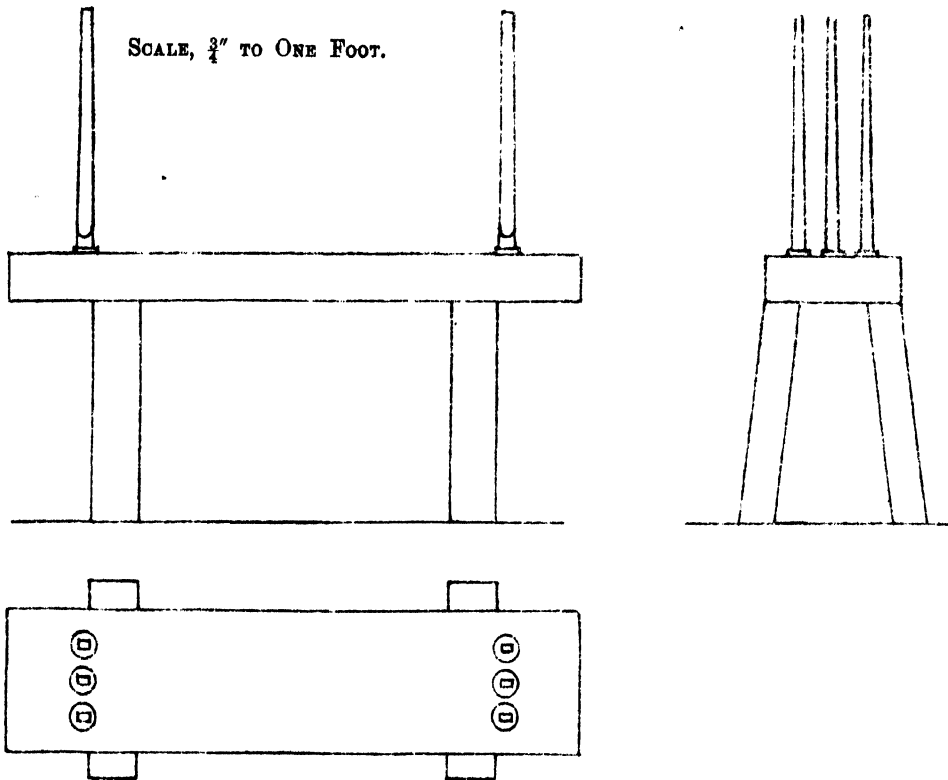

## WARP WINDING.

If the warp yarn which has been spun is to be sent into the factory, it is taken to the warp-winding department. Here the spinning bobbins are wound upon a large bobbin—usually 8 inch by 5 inch—preparatory to being sent to the dressing machines. The machine illustrated is made by Messrs Thomson, Son & Co. Three winders are usually employed upon each side; and one machine of the description illustrated will wind about 2,000 spyndles per week. The particulars of speed, &c., of this machine are also given. Here I may say that the yarns, both weft and warp, being winded from the spinning frames, should be carefully sampled three times each day, to ensure that the yarn is being kept to the weight required.

In the Cop and Warp Winding departments the cops and warp bobbins are weighed when taken from the winders—this should always be done with care and attention, as the winders in these departments are paid according to the weight of yarns wound by them.

# BOBBIN WARP WINDING MACHINE

## WARP WINDING.

(Messrs Thomson, Son, & Co.)

SCALE,  $\frac{3}{4}$ " TO ONE FOOT.

8" TRAVERSE.

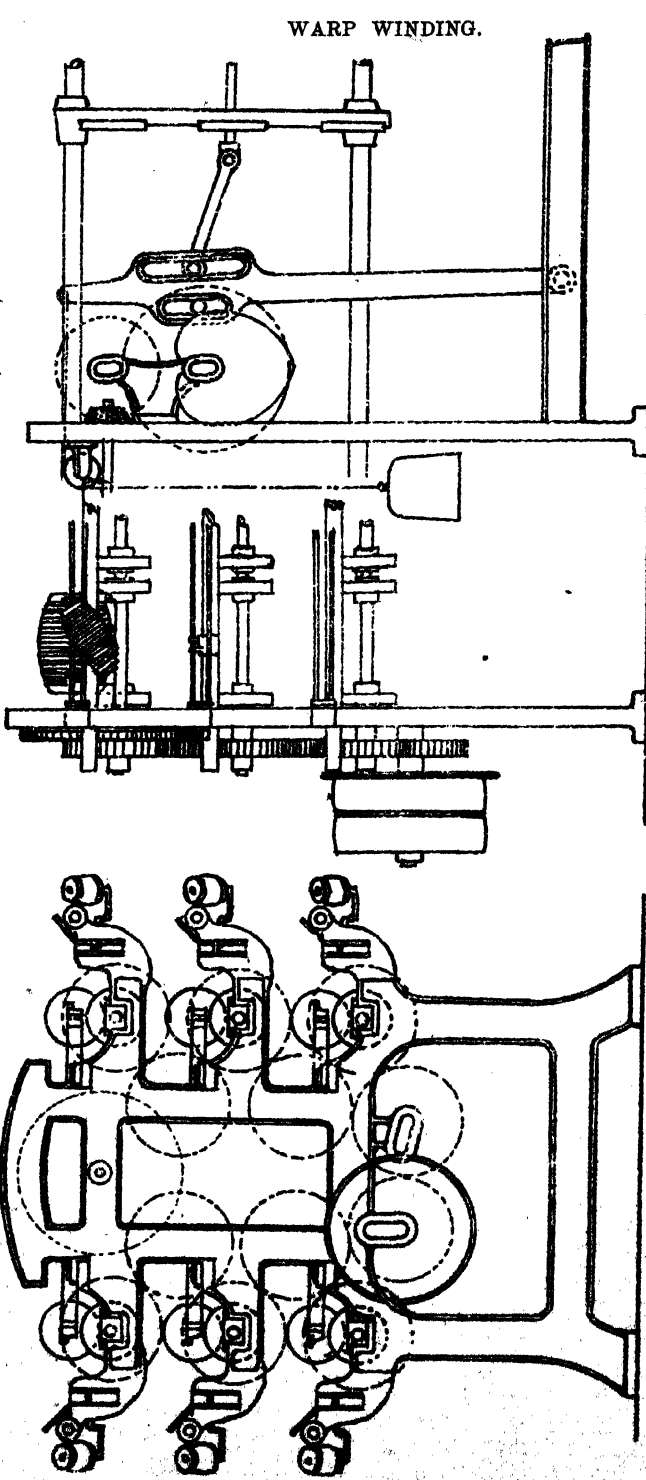

Pulleys, 14" diameter. Pulleys Pinion, 48 teeth. Pinion on end of Bobbin Drum Shaft, 48 teeth.  
 $220 \times \frac{1}{11} = 267$  speed pulleys.  $267 \times \frac{48}{18} = 267$  revs. of bobbin drum per minute.  
 Traverse Arrangement—Heart, 6" lift.  $267 \times \frac{48}{18} \times \frac{30}{130} \times \frac{18}{8} \times \frac{18}{8} =$  speed of heart for traverse.

## CONCLUDING REMARKS.

WASTE.—These pages would not be complete and would not fulfil their purpose if the author said nothing as to the question of the quantity of waste made, or that may be expected to be made, in the different departments during the various operations from batching to reeling, &c. Waste and dirt always tend to make more waste and dirt, hence the necessity to do all that can be done to make as little dirt and waste as possible. It is the attention that is bestowed upon the seemingly small details that go to make the whole arrangement and organization complete, and in reference to this question of waste too much attention can hardly be given to it until you have been able to impress every one in charge with the importance of the matter. When the making of waste is tolerated you may be sure the tendency to make waste will always be on the increase, followed in every case by indifference and neglect. The waste in the batching—that is, the dirt and root—as it falls through the softener rollers to the floor will be found to be about '3052%, but it is waste you want to get rid of, and you can only minimize this by as much care and attention as possible to the selection of the jute suitable for the yarn required.

The waste or droppings from the breakers and finishers to a certain extent is also what you wish to be rid of, but if there is inattention to the staves, if they are not kept sharp and regularly set in their proper relation to one another, you will make for a certainty more waste than is necessary, and the more waste you make here than is absolutely necessary, you are, of course, always adding to the cost of the batch you have laid down at the commencement. If the drawings and rovings are thoroughly swept out *every day* this will keep steadily before your eye what is being done in the matter of waste—from this the following is about the proportion of waste that will be made: 1st. From breaker about 1'36%, from finishers about '696%. Of course the droppings from breaker and finishers will require to be shaken in a waste cleaner, and there will be 1'25% of dust and '5% of pickings, the latter of which may be used for some of the coarser qualities of yarn. The waste from the drawing and rovings will be about '435% of the quantity of rove made.

The waste from the spinning department, taking the average size at 9 lbs. per spynkle, two-thirds of which will be weft and one-third warp, will be about 2'10% on the yarn produced, and the reader will

bear in mind that on this question of waste I am referring to the class of jute described in the chapter upon Batching as necessary for the production of Hessian cloth of good standard quality, the jute for which has been carefully selected for the purpose intended.

To speak in a general way as to the total waste made during the manipulation of jute into yarn would not have much value. A statement, therefore, as to the quantity of jute put over the machinery involved in the process, showing at the same time the per cent. of waste made at each class of machinery, is necessary:—

#### BATCHING.

60 bales of jute (400 lbs, each), to which is added 3% of oil and 15% damp, was put over the softener in ten hours—a fair day's work, based upon the speed of the machine given in the chapter on Batching.

60 bales, 400 lbs. each =	...	...	...	cwt.	214	1	4
+ 3% of oil	...	...	...	„	6	1	20
<hr style="width: 100%;"/>							
				„	220	2	24
—Ropes taken from bales	...	•	„	2	3	7	
<hr style="width: 100%;"/>							
„ 217 3 17							

From this was got 62½ lbs. dry and 35 lbs. wet refuse—say altogether 74½ lbs dry—equivalent to 3052%.

#### PREPARING.

The following is based on the results of two working days, or 20 hours, producing 140 cwt. rove and 3 cwt. 2 qrs. 10 lbs. waste:—

##### 1 Double Doffer Breaker—

Dollop 22 lbs., 2 deliveries of 22 lbs. each for one round of clock.

Cylinder making 185 revolutions per minute.

Cylinder Pinion, 44 teeth.

Worker „ 33 „

Draft „ 34 „

3½ tons can be put over this breaker in 10 hours, supplying

##### 2 Single Doffer Finishers—

Cylinder making 198 revolutions per minute.

Cylinder Pinion, 60 teeth.

Worker „ 58 „

Draft „ 31 „

Each finisher supplies 1 push bar drawing.

2 Push Bar Drawings of 2 heads each—

Speed of Pulleys, 145 revolutions per minute.

Pulley Pinion, 32 teeth.

Draft „ 54 „

Each push bar drawing supplies 1 spiral 2nd drawing.

2 Spiral 2nd Drawings of 2 heads each—

Speed of Pulleys, 170 revolutions per minute.

Pulley Pinion, 28 teeth.

Draft „ 43 „

Each 2nd drawing supplies 1 roving of 56 spindles.

2 Roving of 56 spindles, 10" × 5" bobbin, make 35 cwt. of rove, 72½/75 lbs. per spindle each, in 10 hours—say 140 cwt. in 20 hours—

Speed of Pulleys, 220 revolutions per minute.

Twist pinion, 35 teeth.

Grist „ 36 „

Traverse „ 28 „

Rack „ 15 „

The waste made ... cwt. 3 2 10

The rove made ... „ 140 0 0

---

„ 143 2 10

The waste made at each class of machine was as follows :—

1 Breaker—

Dust ... 210 lbs.

Pickings 10 „

---

220 „ = 1·3680 %.

2 Finishers—

Dust ... 28 „

Pickings 84 „

---

112 „ = ·6964 %.

4 Drawings and 2 Rovings—

Dust ... 30 lbs.

Pickings 40 „

---

70 „ = ·4352 %.

Total Dust ... 268 „ = 1·6664 %.

„ Pickings 134 „ = ·8332 „

---

402 „ = 2·4996 %.

## SPINNING.

The yarn spun from this rove was  $\frac{2}{3}$  weft and  $\frac{1}{3}$  warp, and the average weight per spyndle 9 lbs.; waste = 2·1069 per cent. in the spinning process.

## REELING AND COPPING.

The percentage of waste made in the reeling and copping departments are ·5853 and ·8809 per cent. respectively; and if the production of the mill is to be two-thirds reeled and one-third copped, the overhead rate would be ·5172.

$$\begin{array}{r} \frac{2}{3} \\ \frac{1}{3} \end{array} \begin{array}{l} \cdot 5853 \\ \cdot 8809 \end{array} = \begin{array}{l} \cdot 3902 \\ \cdot 1270 \end{array}$$

---

$$\cdot 5172 \%$$

## SUMMARY OF WASTE PERCENTAGE.

Batching and Softening, ... ..	·3052%
Preparing, Breakers, and Finishers, ... ..	2·0644
,, Drawings and Rovings, ... ..	·4352
Spinning, ... ..	2·1069
Reeling and Copping, ... ..	·5172
Total, ... ..	5·4289%

These results are borne out by experience over a whole year, and can therefore be relied on.

The value of the different kinds of waste made in relation to the value of the raw material will be found to be as follows:—

The value of dust is equal to 4·1% of the original cost of the raw material.

,, pickings	25·0	,,	,,	,,	,,
,, spinners' waste	29·1	,,	,,	,,	,,
,, reellers'	58·3	,,	,,	,,	,,
,, copping	58·3	,,	,,	,,	,,

**SPEED TO BE PUT UPON THE MACHINERY.**—I have in the chapter upon Preparing Machinery alluded to this as a question upon which there is much difference of opinion. While this is so as to the surface speed of Card Cylinders, the speed of a breaker or finisher or any other of the machines in the various processes is in a great measure a question of production. If a large production is wanted, the speed must be put upon the machines to bring it off; it is sometimes said that too much speed upon the machines will destroy the material, but if the speed put upon the machinery is

beyond the possible limit, you will destroy the machines long before you spoil the material. In the case of the preparing machinery it is not the speed put upon the machines that will make rove to produce bad yarn, it is the *overloading* of the different machines—that is, the putting on the Breaker in one round of the clock more weight of jute than the length of the Cylinder or other Roller pins will come up through, and also the overloading of the other machines in the same direction. If a moderate quantity is put on the machines the speed, although on the fast side, will do no harm to the material; and to the machinery the speed, if on the quick side, of course means more mechanical expense and attention on the part of those in charge of it, and the same remarks apply to the other machines in the preparing department. The question of speed is, therefore, in a great measure to be determined by the amount of mechanical attention and expense you are prepared to give for the utmost production that can be taken out of the machine. Of course, the reader will see at a glance that if the machinery is being kept on the fast side more expense in the shape of oil and all other furnishings will be incurred. Against this, of course, you have the larger production than if you drive the machinery on the slow side. It is a question that need not be pursued further here. I merely wish to bring to the notice of the reader that increased speed of the preparing machinery is done at the expense of the machine and not at the expense of the material, as is often supposed. Experience will often prove that where the machinery is being driven slow it is no guarantee that it is being kept in better order than when it is being driven on the fast side. Rather the opposite will, as a rule, be found to be the case. If the limit of speed is being attained on the machinery experience will also prove that the machinery is being kept in good order; in fact, it must be so, if you are to keep it going.

The above remarks will only apply, to a limited extent, to the spinning frame. Here the spindles and flyers will only stand a certain speed, and they determine the speed of the other parts of the frame. If the flyers are driven beyond this speed by the centrifugal force, the legs of the flyer will fly out and break one another; but all the same, there may be a good speed upon the spindle without going to the extreme alluded to in the above remarks. Here again it is a question of upkeep. More oil, spindle bands, &c., will be necessary. To put it shortly, instead of oiling the spindle necks twice a day, you will require to oil them three times a day. To oil 6,000 necks twice a day will require about three-quarters of a gallon of oil, and a



half more of this quantity means an extra cost of about 4d per 10 hours day—not a large item if you are taking the production out of the machine.

**UPKEEP OF JUTE PREPARING AND SPINNING MACHINERY.**—Jute Preparing and Spinning Machinery, owing to the sandy and gritty nature of the jute fibre, is liable to much wear. The dirt and sand finds its way in every direction through the machinery; the consequence is that the mechanical attention required to keep the machinery in good order is considerable, and on the mechanical energy displayed in the mill will greatly depend the general production and the working conditions of the different machines. All the details of the machinery must be kept as near as possible the same as when the machine was new. When a wheel or pinion is broken it should be replaced by a new one, and the new one should be a casting from the maker of the machine; if not from the maker, at least of the same pattern. In the case of wheels and pinions this is of great importance. To repair wheels and pinions by putting pins in them for teeth, or to repair brackets and other parts of the machines by patches of plates, is perfect folly, and nothing will in the end lead so much to the total deterioration of a mill than to pursue a course such as described. To give force, spirit, and éclat to the whole mill is to keep the machinery in the very best order, and you thereby will have at your command effective tools for the work to be done. The same remarks apply to all the smaller details, furnishings, as they are generally called, belts, spindle bands, and many other small things which we need not specify further.

**BOBBINS.**—Bobbins in large quantities should always be kept in hand; if this is done you will have them well seasoned and in good working order. A very important point in the preparing and spinning departments—sometimes the full bobbins accumulate in the cop, reeling, and winding departments, and this will happen occasionally no matter how well you try to avoid it, but while this is so there should always be enough bobbins at hand to cope with the emergency. There should on no account be a stoppage of the flow of full bobbins either from the preparing or spinning departments. In a mill, owing to the number of people employed, any stoppage of the flow of production very quickly increases the cost, hence the absolute necessity of removing every obstacle that will in any way impede the steady run of the

work in every department. Each department should be conducted on such lines as will make those who are responsible feel they themselves have the making of the production in their own hands. But while saying all this as to the general benefits to be derived from keeping everything in good mechanical order, and also the details up to the mark in every way, there is no necessity for extravagance, and no countenance should be given to it. Experience will prove that when those in charge know that it is necessary to keep everything in effective condition ready for immediate use, the result is always to strive to keep everything in order without unnecessary waste or extravagance. Nothing will sooner utterly destroy the production of a jute mill more thoroughly than the knowledge creeping into the minds of those in authority that the necessary repairs will not be allowed to be made upon the machinery for the making of good work—paralysis sure and certain will take possession of the spirit and working energy of the people.

**ACCIDENTS TO THE MACHINERY.**—Accidents to the machinery do happen, and will continue to happen, no matter how much care and attention has been taken to avoid them, but you can expect no spirit nor heart in those who are responsible if the machinery is allowed to run until it stops through sheer mechanical neglect. Inferior production; inferior everything in fact, can only be the result.

When the machinery is in want of repairs get the trained mechanic to do it, and on no account let others who have neither the mechanical knowledge nor the training necessary for this class of work attempt it. The "handy" man amongst machinery is very often the "expensive" man in the end. He should be kept strictly at the work which he has been engaged to perform. As a rule, he will have enough to do, and sometimes more than enough, if he tries to do it well.

**TEMPERATURE OF THE MILL**—This is a matter that should engage the attention of those in charge. For a mill, as shown on the plan, four lines of heating pipes will be necessary—one line of pipes in batching house, one line in front of finisher cards, one line between first and second line of spinning, and the fourth line of pipes between the end of third line of spinning and the cop and warp winding machinery. These pipes should all be run into a receiver at the north side of mill, and as near the centre of that side as possible, and the waste water or condensed steam, should then be returned to the boilers.

It is of great importance that the mill be made comfortable for the workers in the cold mornings. If the temperature be below 70° the material will not work well, neither will the workers be able to work with freedom the different machines at which they are engaged; but the temperature should not be over 70°, and there should always be care taken to provide fresh air and plenty of ventilation.

When the mill is built on the shed principle, the temperature varies very much, and if attention is not given to this question of heating arrangement, much loss of production and waste will ensue.

**SAMPLING THE YARN.**—This is a matter of great importance. The yarn that is to be wound into cops or upon warp bobbins for Dressing or Beaming Machines should be sampled three times a day. This is done by reeling 12 cuts upon a 90" reel, with 120 teeth "tell" wheel that is a quarter spyndle. If a number of frames are spinning the same size of yarn, more than one sample should be taken—no allowance for loss of weight should be made on the yarn when sampled. The correct weight of yarn as it comes from the frame should be written into the book kept for the purpose. If the making of an allowance upon the yarn when sampled is encouraged, it only leads to the yarn being spun above the weight. The yarn should be spun and should weigh the size it is, namely—if you are spinning 8 lbs. yarn it should weigh 8 lbs. in the sample, neither more nor less—to make it so it should be the aim of all interested. It will help very much to keep the yarn upon the weight if the same frames are always supplied from the same rovings. This will sometimes require a little attention and arrangement to enable this to be carried out, but the result will be worth any trouble that may be taken to ensure this being done.

**NOTE.**—That the reel upon which the samples are reeled should be kept for sample purposes.

**FINISHING THE WORK FOR THE DAY.**—When the work for the day is finished, the mill should be left clean and tidy, and everything in perfect order. When this is done, it will be found of great service to the making of a good start in the morning. The floor should be cleaned up thoroughly, no roves nor rove bobbins, boxes, or anything of the kind left lying about—in short, the cleaner and smarter you leave everything, the better able are you to cope with the work at the start; and these remarks apply with equal force all through the works—boiler shed, engine-room, &c., &c.

ARRANGEMENTS FOR EXTINGUISHING FIRE.—All the tools in connection with the apparatus kept for the extinguishing of fire should be seen to every night when the works are stopped. The fire-cocks should have bends and keys fitted on, and everything left so that in an emergency it can be used without fuss or trouble, and when those in charge arrive at the works, everything will be found in readiness to cope with whatever may happen. It is the unexpected that always happens, and everything that can be done to provide against accident should always be attended to as fully as the resources of the works will allow.

I have now described the various machines, and the operations that are gone through during the conversion of jute in the bale into yarn; and we have followed it to each of the departments, to be made into cops, wound in warp bobbin for dressing machine, and also reeled in the bundle. While this may have been done somewhat imperfectly, enough has been said to enable the student to follow the different processes. The author of these pages has found the writing and preparation of them congenial work; and now that the work is done, he can only hope that they will supply what he believes to be a want in connection with the jute trade; and also that they will prove of interest, stimulate and encourage the young men to learn their business with thoroughness and with some degree of interest in the working of the machinery in whatever department of the mill they may be employed. In this book the writer does not for one moment pretend to have told everything; he has, however, explained many things which, from his own experience while learning his business, he is sure will be very helpful to those anxious to know something of their work, and the proper way to set about the doing of it. The reader by this time will fully understand my motive in publishing these pages; and in offering them to the general public, however imperfectly they have been written, they will, I trust, be of service, and fulfil the purpose for which they were intended.

# APPENDIX.

## JUTE SNIPPER.

This machine, which we have illustrated by a plan and elevation, is not so much used now as it was some years ago. It is used to snip or comb off the root ends of the jute, and it did this, without doubt, very well, but the cost was too great. It not only took off the roots, but also made a great amount of tow, the very least taken off the streak of jute after it came through the machine being about 15%. This tow was very inferior, and, of course, when you deducted the value of the 15% lost (or nearly so, comparatively speaking) this increased the cost of the jute left, and the machine is now not much used. It is found by the trade to be much better to cut the roots off with a knife or blade of steel, about 36" long by 6" broad, fixed to a wood frame. This is often done when a yarn is wanted of fine quality and free from root. When the roots are taken off this way there is not nearly the same loss as with the snipper, and the roots can always be used without making the loss that was done by the snipper, the tow from which it was impossible to use up profitably without damage to the yarn it was put in. The following is an illustration of steel blade showing attachment to wood frame (Scale  $\frac{3}{4}$ " to One Foot).

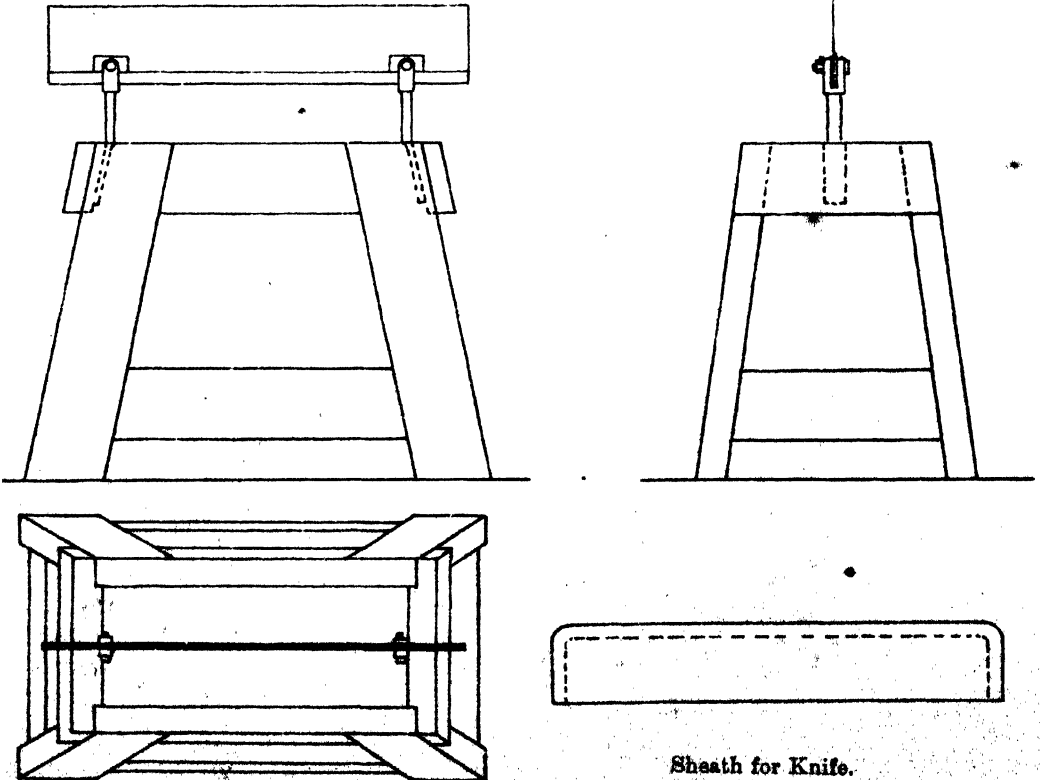

Sheath for Knife.

SNIPPING MACHINE FOR JUTE.

SCALE,  $\frac{1}{12}$ TH.

(For Diagram see Page 262.)

AA	Driving Pulleys, ... ..	20" dia.
BB	Pulleys for driving top cylinder, ... ..	18" dia.
C	Pulley for driving chain wheel, ... ..	6" dia.
D	Pulley carrying spur pinion, ... ..	18" dia.
E	Spur pinion, ... ..	35 teeth
F	Spur wheel on driving shaft, ... ..	144 teeth
G	Bevel pinion on driving shaft, ... ..	18 teeth.
H	Bevel wheel on intermediate shaft, ... ..	64 teeth.
I	Bevel pinion on intermediate shaft, ... ..	18 teeth.
J	Bevel wheel on chain wheel shaft, ... ..	64 teeth.
K	Pulley on driving shaft, ... ..	18" dia.
L	Pulley on sheet roller shaft, ... ..	5" dia.
MM	Endless chains for holding the jute.	

JUTE SNIPPER.

# JUTE SNIPPER

SCALE,  $\frac{1}{2}$ " TO ONE FOOT.

Chain Wheel

Feeding Table carrying end of Jute Strick into Cylinder.

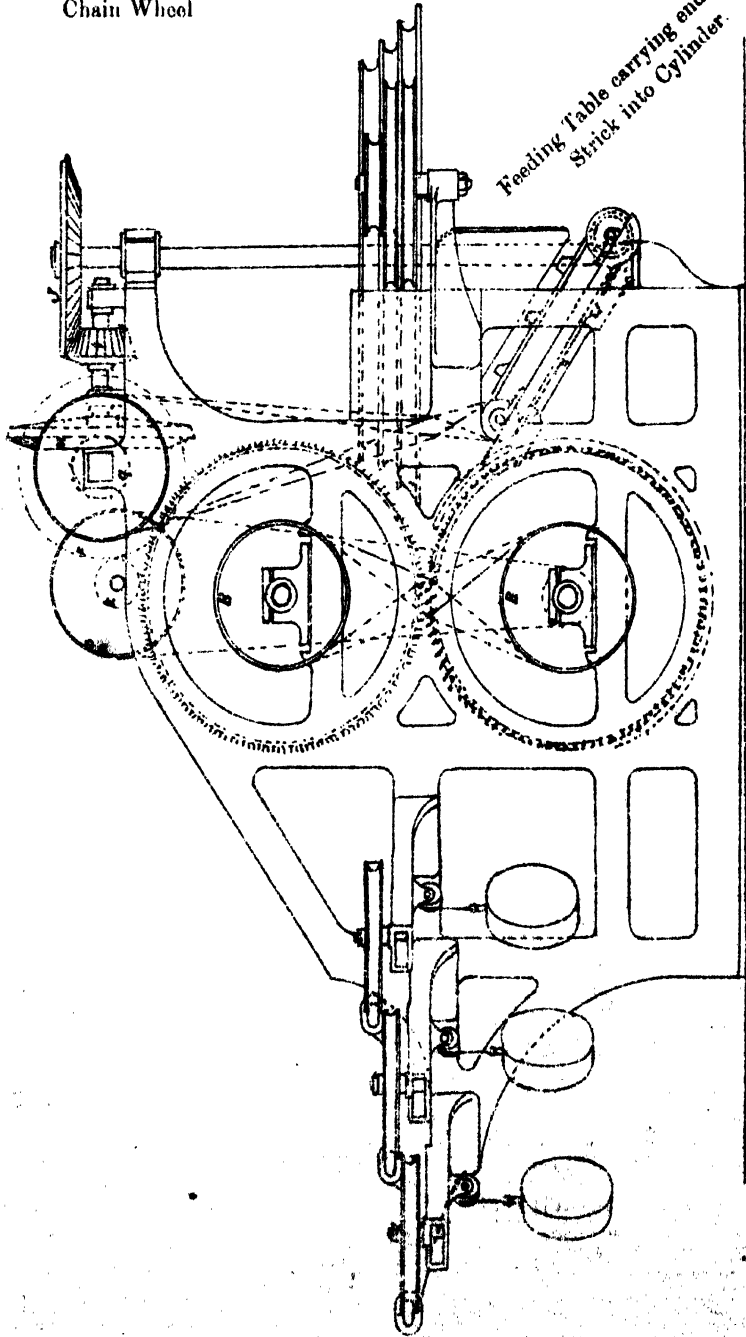

Elevation.

# JUTE SNIPPER

SCALE,  $\frac{1}{2}$ " TO ONE FOOT.

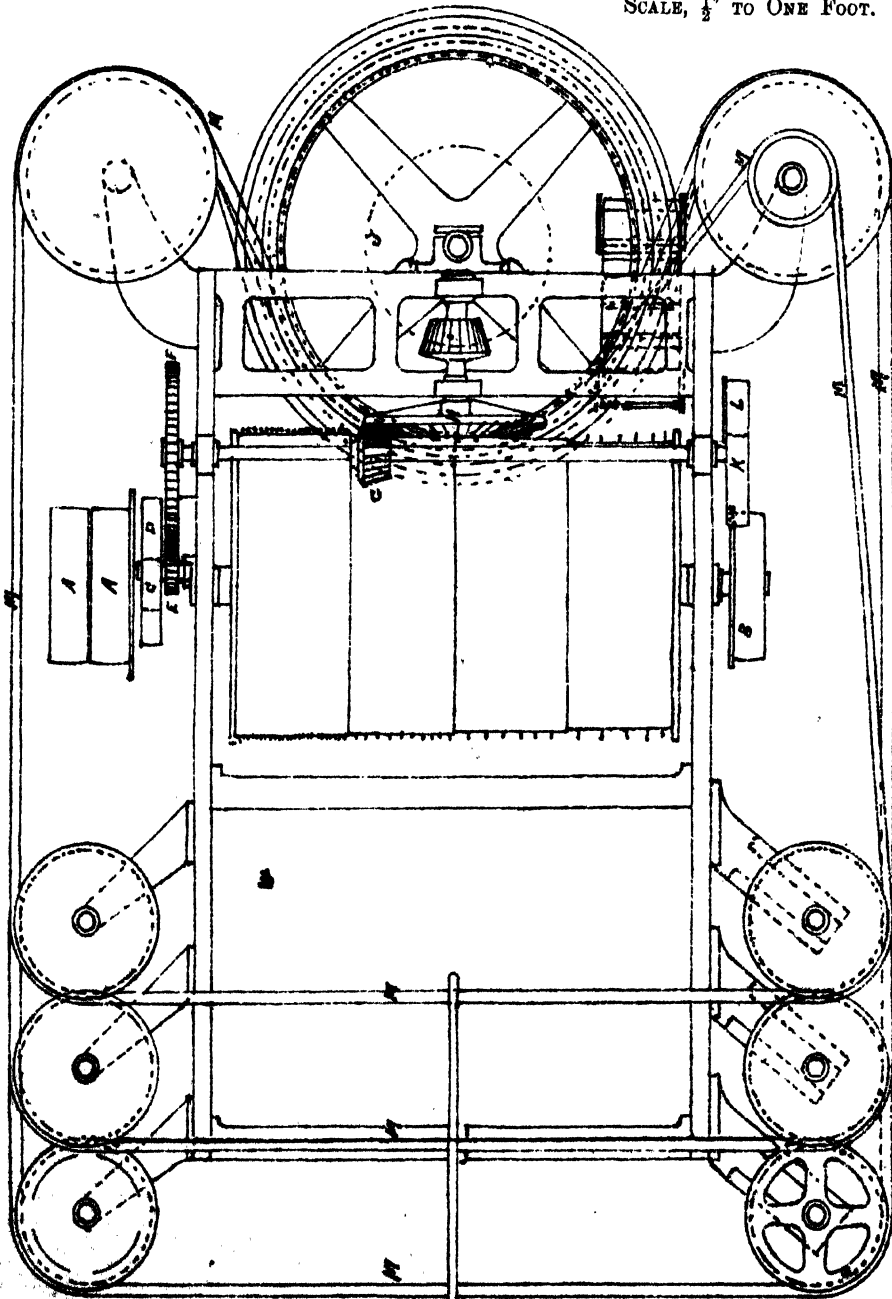

For particulars of Staves for Snipper Cylinder on page 111



# Lathe Attachment for Grinding Spinning Spindles.

SCALE,  $1\frac{1}{2}$ " TO ONE FOOT.

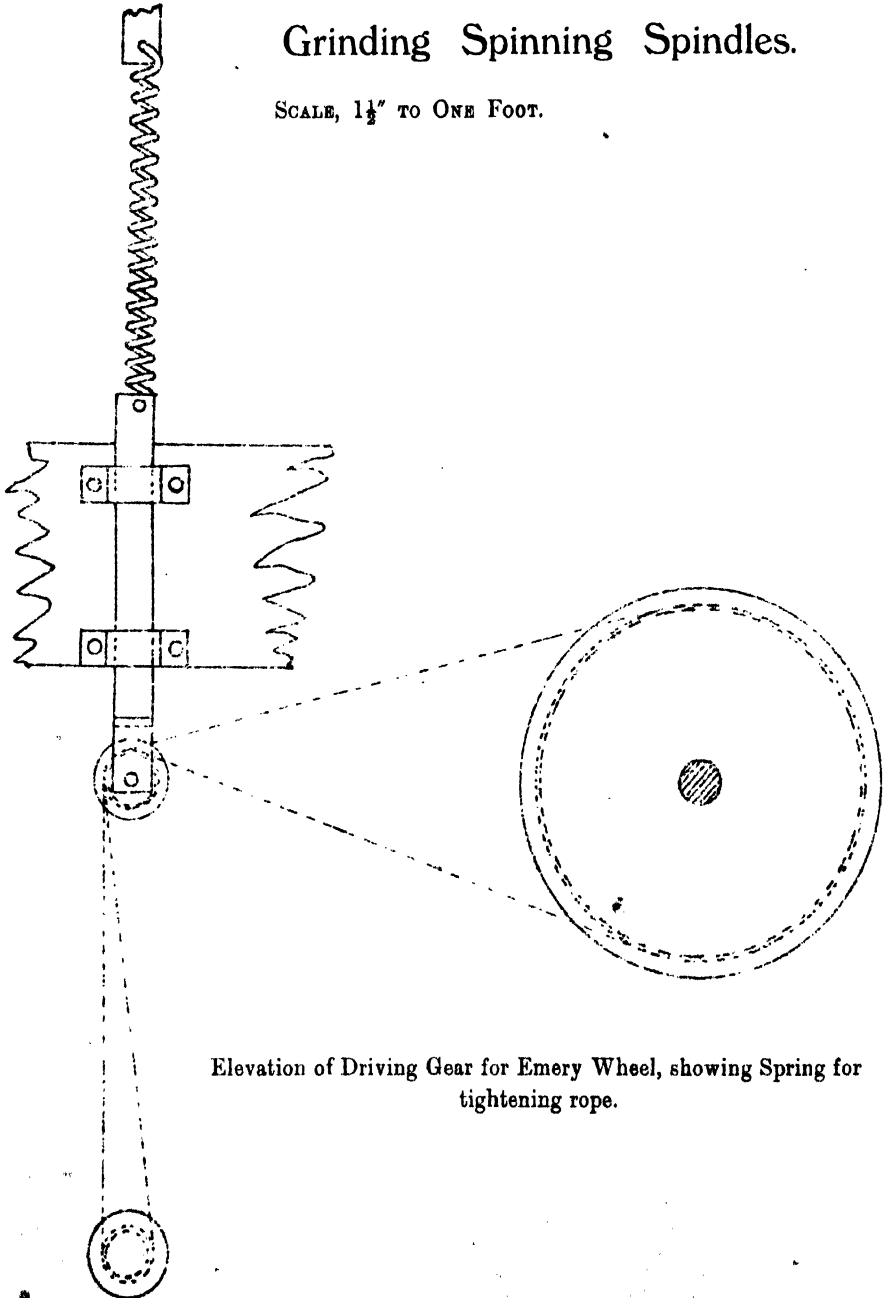

Elevation of Driving Gear for Emery Wheel, showing Spring for tightening rope.

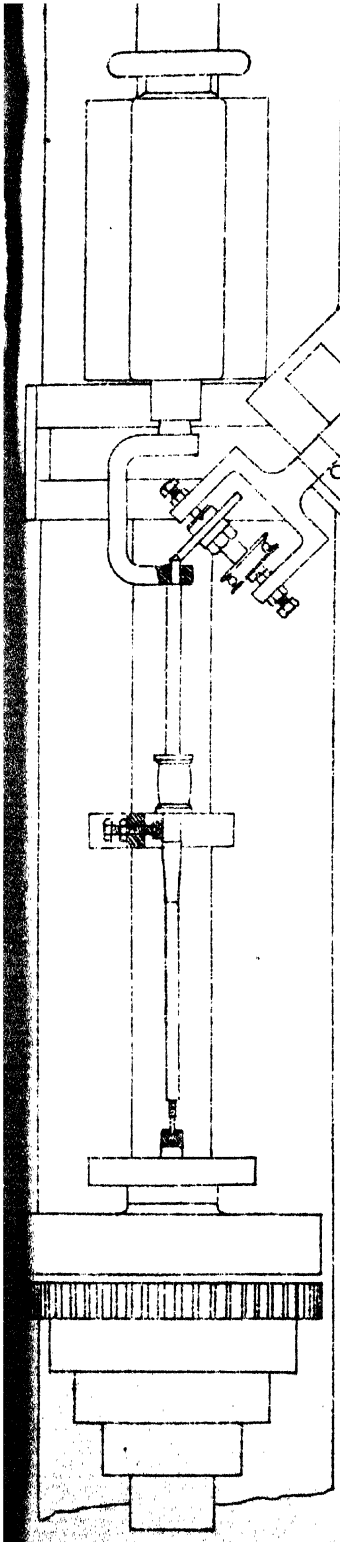

Plan

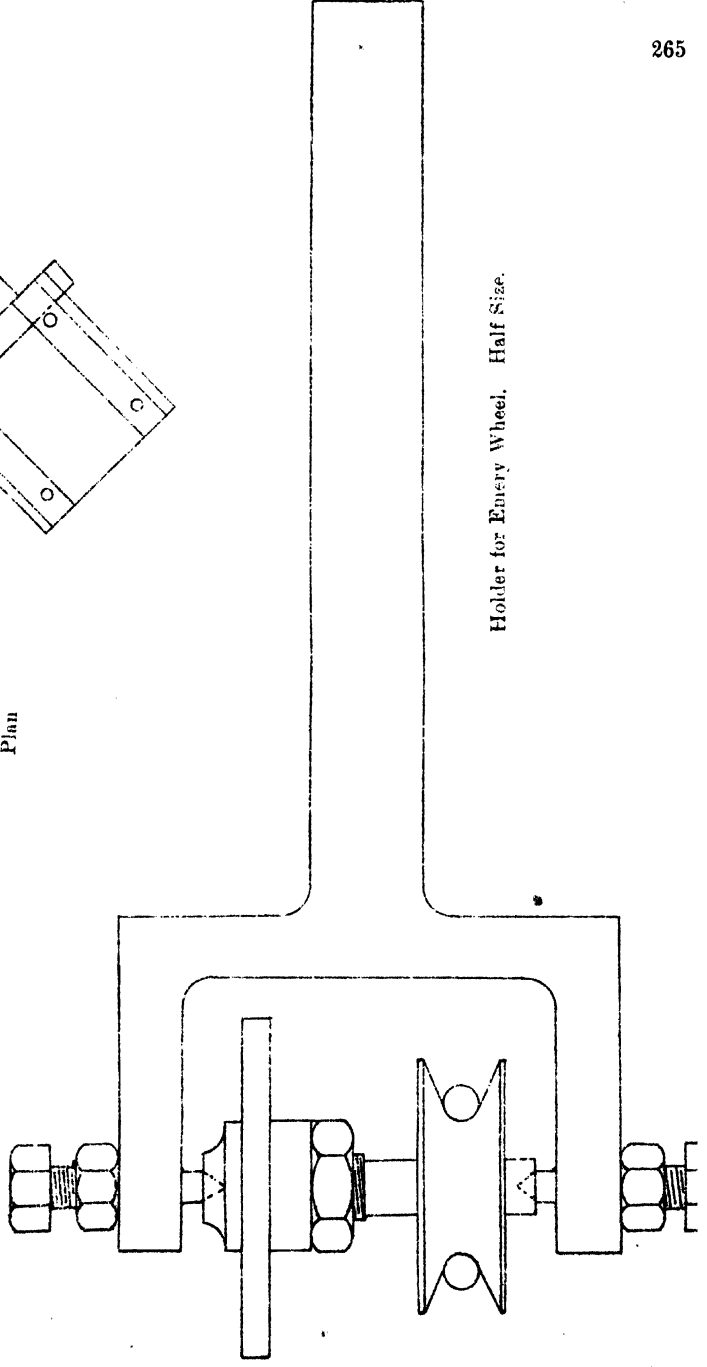

Holder for Energy Wheel, Half Size.

## WASTE CLEANER.

This machine is used for cleaning the waste made at Breaker and Finisher Cards.\* The waste is laid upon the feed cloth A and a quantity fed into the machine—this is allowed to remain in from a minute to a minute and a half, the dust falling through a circular grating below cylinder. The waste fibre is allowed to pass out of the machine by the lifting of a flap cover at B, the dust drops into a bag at C, and the waste into a bag at D. The machine cleans the waste thoroughly, and the fibre or pickings, as previously explained in the chapter on Waste, can be utilised for the coarser qualities of yarn.

SCALE,  $\frac{3}{4}$ " TO ONE FOOT.

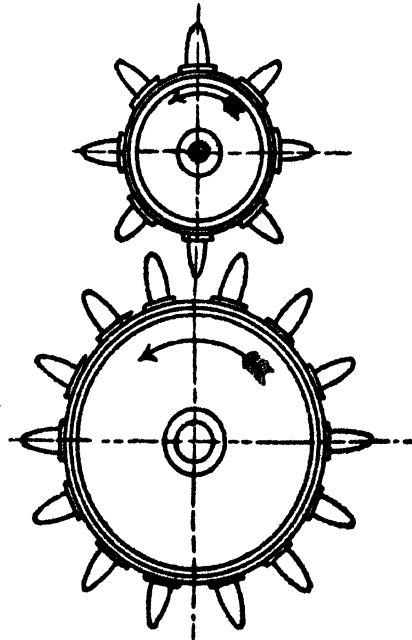

Section of Cylinder.

\*The Waste made at Drawings and Rovings may also be cleaned in this Machine.

# WASTE CLEANER

SCALE  $\frac{1}{4}$ " TO ONE FOOT.

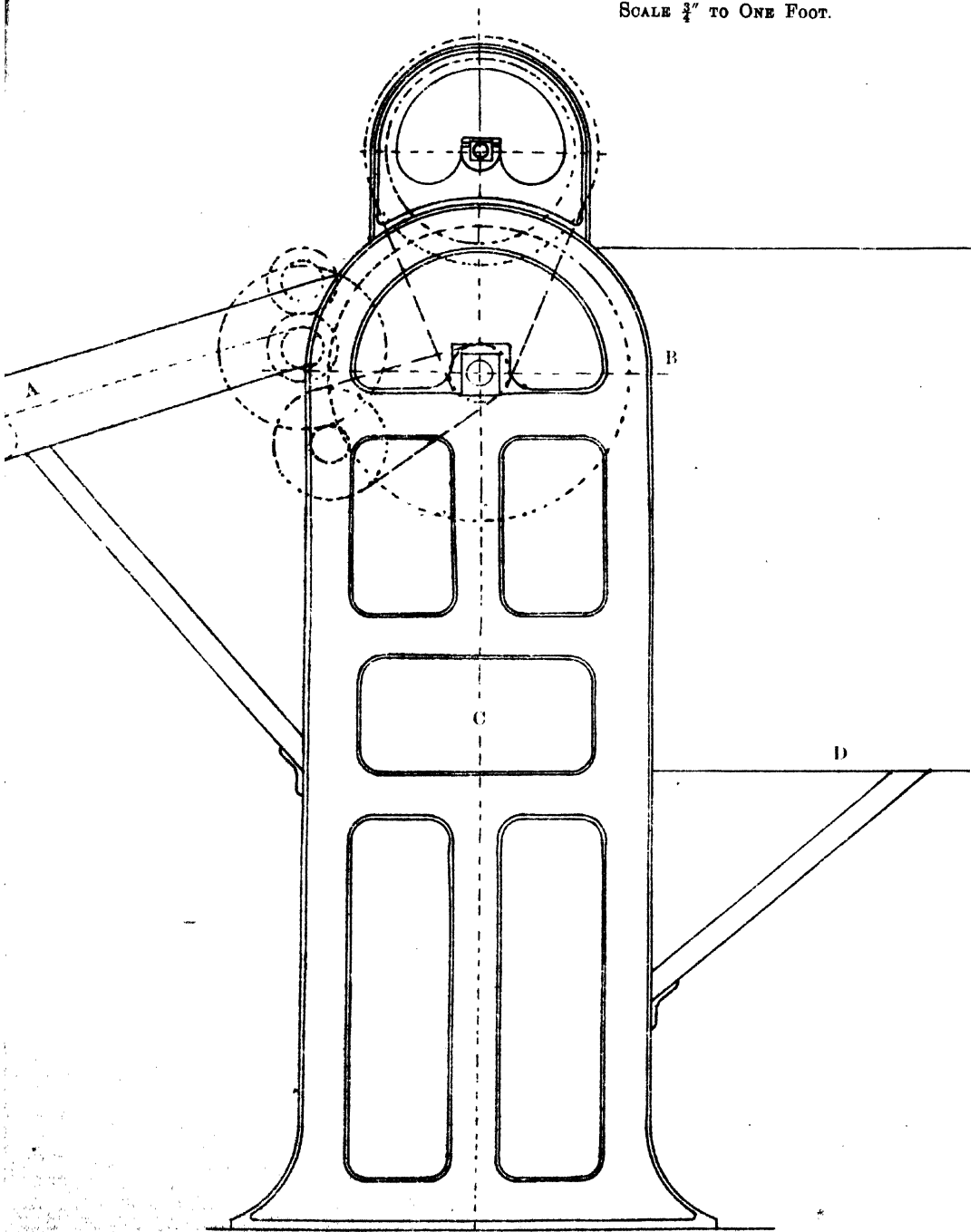

End Elevation.

# WASTE CLEANER

SCALE,  $\frac{3}{4}$ " TO ONE FOOT.

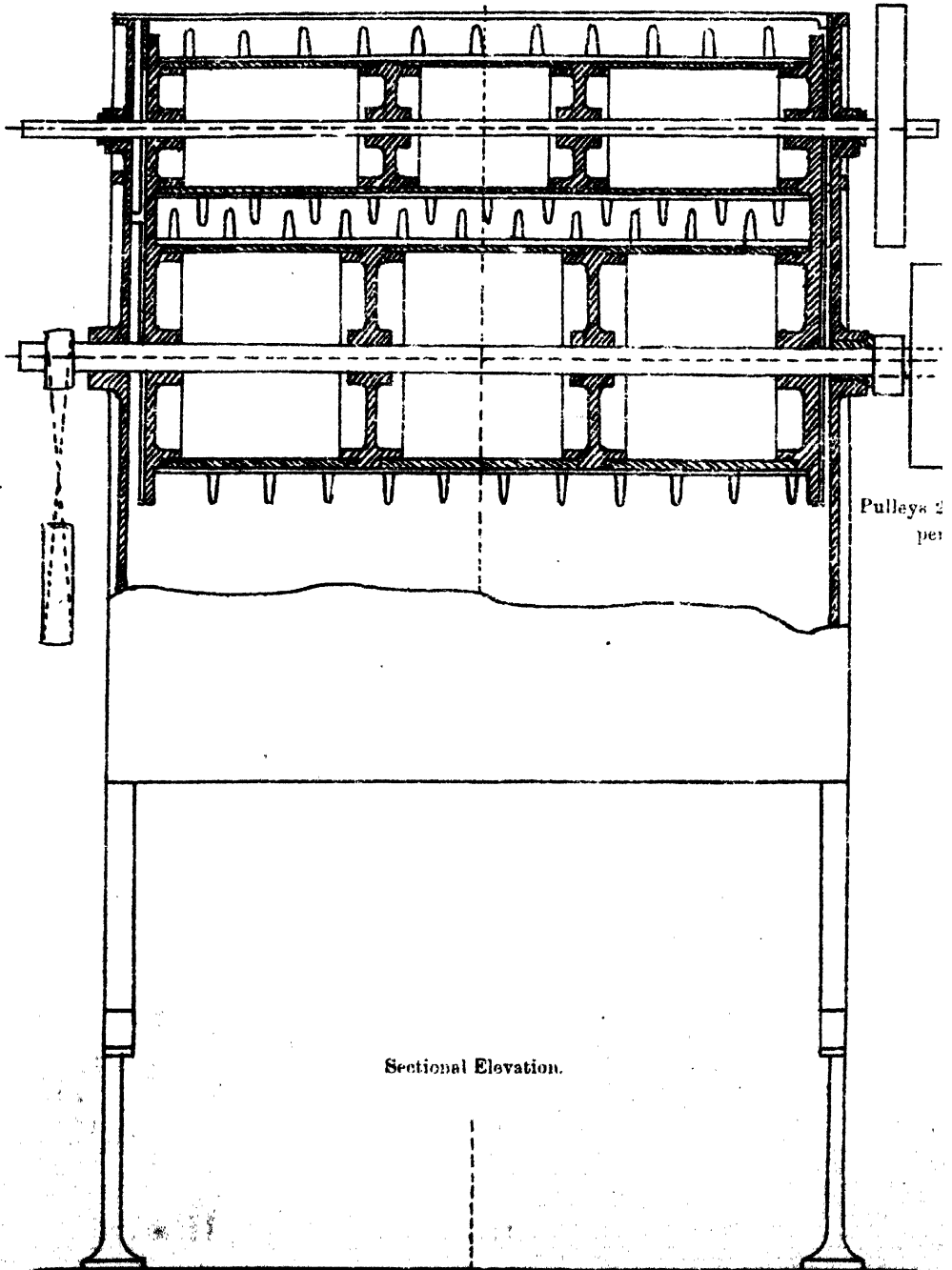

Sectional Elevation.

## THE ADJUSTMENT OF THE BREAKER SHELL.

This illustration is given to show how the shell is hung from the feed roller arbor, it being often necessary to move the shell either closer to, or farther away from the cylinder, according to the jute being used. This can be done in a few minutes when required if the fixing of the shell is properly understood.

A radial bracket A is hung from feed roller arbor B, a sett screw C is provided for adjusting the distance of front of shell D from cylinder pins, two bolts E and F fix the shell to the radial bracket. In a breaker the shell is usually set  $\frac{1}{8}$ " from feed roller, and is seldom moved from that position. The position of front of shell to cylinder pins is usually about  $\frac{3}{8}$ ", but may be varied, and often is so, from a  $\frac{1}{4}$ " to a  $\frac{1}{2}$ ", according to the quality and weight of material being put over a breaker in one round of breaker clock.

In illustration the fixing of one end only of the shell is shown, both ends being alike.

## DETAIL OF RADIAL BRACKET CARRYING SHELL.

SCALE 3" TO ONE FOOT.

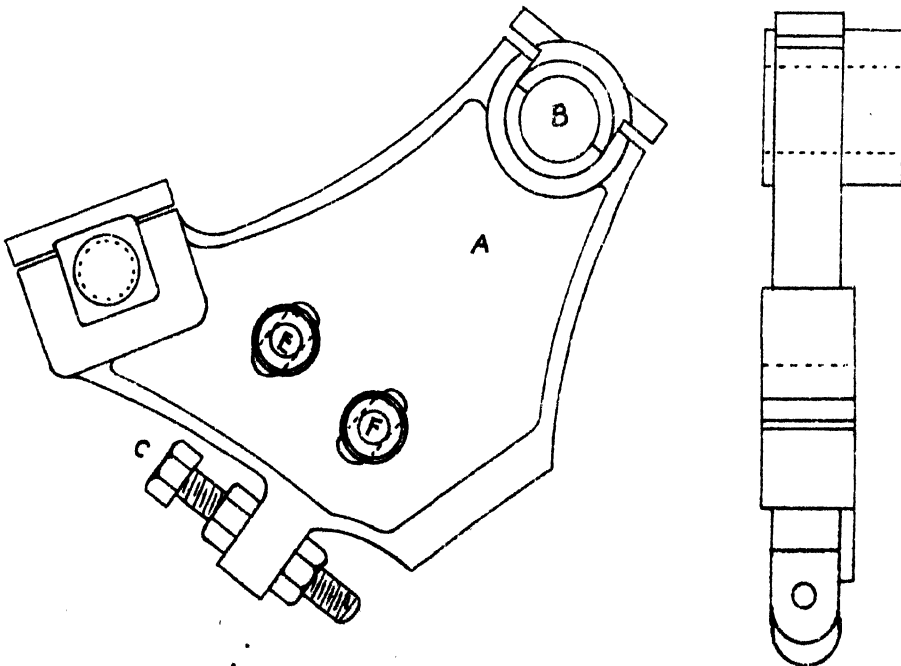

ARRANGEMENT OF RADIAL BRACKET FOR  
ADJUSTING SHELL TO CYLINDER.

SCALE  $1\frac{1}{2}$ " TO ONE FOOT.

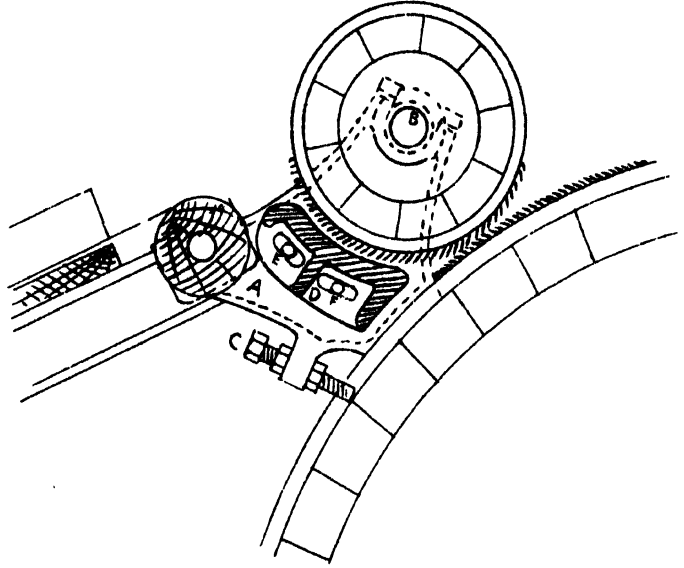

Cross Section.

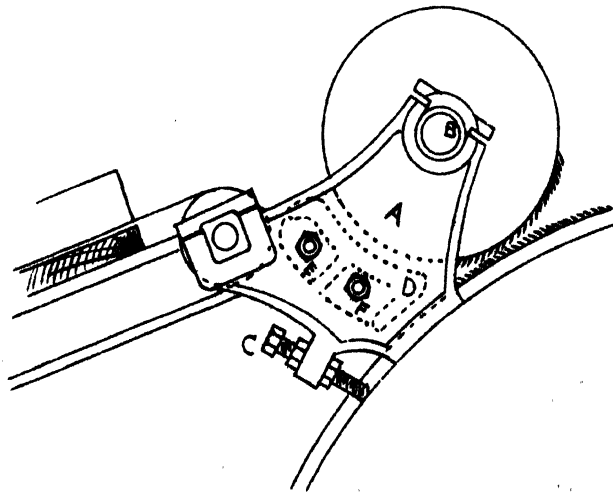

End Elevation.

ADDENDA.

SEE PAGES 181 TO 186.

Single Doffer Breaker Worker Pinion,	...	...	60 teeth.
Double „ „ „ „	...	...	32 „
Single „ „ Finisher, „	...	...	46 „
Single Doffer Breaker Change Pinion for Draft between			
Doffer and Drawing Roller,	...	...	26 „
Ditto for Double Doffer Breaker,	...	...	28 „
„ Single „ Finisher,	...	...	28 „

PAGE 194.

To find the speed of Spinning Frame Spindles :—

Driving Shaft,	...	220 revolutions per minute.
Drum on Shaft,	...	32" diameter.
Pulleys on Cylinder ...	15" „	
Cylinder, ...	10" „	
Spindle Werve.	...	1 $\frac{3}{4}$ " „
220 × 32	10	
————— × —	=	2681·9 revolutions of spindles per minute.
15	1 $\frac{3}{4}$	

PAGE 201.

If the grist pinion on end of drawing roller is 36 teeth, and is producing 9 lbs. yard, what pinion will be required to produce 10 lbs. or 12 lbs. ?

Then—9 : 10 :: 36 : 40 the pinion required ; or

9 : 12 :: 36 : 48 „ „



## SAMPLING WEIGHT OF ROVE.

The rove should be sampled once every week to insure that the weight of rove wanted is being produced. This may be done as follows :—

Take one rove of each head of roving, reel 30 threads off each rove (90" reel)— $8 \times 30 = 240$  threads in sample, weigh this, and, for example, say it weighs 3 lbs. (that is 48 ounces)—then  $48 \times 3$  and  $\div 2$  will equal the weight of rove in lbs. per spindle.

**NOTE.**—You take 8 roves and 30 threads off each, multiply the weight of sample in ounces by 3, and divide by 2, and the answer will always be weight of rove being produced in lbs. per spindle of 14,440 yards.

To prove this—5760 threads in one spindle of 14,400 yards—

Threads.	Threads	Ozs.
240	:	5760
1	:	24
		48
		<hr/>
		192
		96
		<hr/>
16	)	1152
		<hr/>

72 lbs. per spindle = weight of rove ; or

16	:	24	:	:	48
2	:	3	:	:	48
					3
					<hr/>
		2	)		144
					<hr/>

72 lbs, per spindle = weight of rove.

If the rove weighs 70 lbs. per spindle, and you wish to spin 10 lbs. yarn this means a draft of 7 will be required on the Spinning Frame.

A TABLE CONTAINING  
THE CIRCUMFERENCES AND AREAS OF CIRCLES.

Circumferences and Areas of Circles from  $\frac{1}{16}$  of an inch to 10 inches, advancing by  $\frac{1}{16}$  of an inch; and by an  $\frac{1}{8}$  of an inch, from 10 inches to 100 inches Diameter.

Diameter.	Circum.	Area.	Diameter.	Circum.	Area.
$\frac{1}{16}$	·1963	·0030	2 in.	6·2832	3·1416
$\frac{1}{8}$	·3927	·0122	$\frac{1}{16}$	6·4795	3·3411
$\frac{3}{16}$	·5890	·0276	$\frac{1}{8}$	6·6759	3·5465
$\frac{1}{4}$	·7854	·0490	$\frac{3}{16}$	6·8722	3·7582
$\frac{5}{16}$	·9817	·0767	$\frac{1}{2}$	7·0686	3·9760
$\frac{3}{8}$	1·1781	·1104	$\frac{5}{16}$	7·2649	4·2001
$\frac{7}{16}$	1·3744	·1503	$\frac{3}{4}$	7·4613	4·4302
$\frac{1}{2}$	1·5708	·1963	$\frac{7}{16}$	7·6576	4·6664
$\frac{9}{16}$	1·7671	·2485	$\frac{1}{2}$	7·8540	4·9087
$\frac{5}{8}$	1·9635	·3068	$\frac{9}{16}$	8·0503	5·1573
$\frac{11}{16}$	2·1598	·3712	$\frac{5}{8}$	8·2467	5·4119
$\frac{3}{4}$	2·3562	·4417	$\frac{11}{16}$	8·4430	5·6727
$\frac{13}{16}$	2·5525	·5185	$\frac{3}{4}$	8·6394	5·9395
$\frac{7}{8}$	2·7489	·6013	$\frac{13}{16}$	8·8357	6·2126
$\frac{15}{16}$	2·9452	·6903	$\frac{1}{2}$	9·0321	6·4918
1 in.	3·1416	·7854	$\frac{15}{16}$	9·2284	6·7772
$\frac{1}{16}$	3·3379	·8861	3 in.	9·4248	7·0686
$\frac{1}{8}$	3·5343	·9940	$\frac{1}{16}$	9·6211	7·3662
$\frac{3}{16}$	3·7306	1·1075	$\frac{1}{8}$	9·8175	7·6699
$\frac{1}{4}$	3·9270	1·2271	$\frac{3}{16}$	10·0138	7·9798
$\frac{5}{16}$	4·1233	1·3529	$\frac{1}{2}$	10·2102	8·2957
$\frac{3}{8}$	4·3197	1·4848	$\frac{5}{16}$	10·4065	8·6179
$\frac{7}{16}$	4·5160	1·6229	$\frac{3}{8}$	10·6029	8·9462
$\frac{1}{2}$	4·7124	1·7671	$\frac{7}{16}$	10·7992	9·2806
$\frac{9}{16}$	4·9087	1·9175	$\frac{1}{2}$	10·9956	9·6211
$\frac{5}{8}$	5·1051	2·0739	$\frac{9}{16}$	11·1919	9·9678
$\frac{11}{16}$	5·3014	2·2365	$\frac{5}{8}$	11·3883	10·3206
$\frac{3}{4}$	5·4978	2·4052	$\frac{11}{16}$	11·5846	10·6796
$\frac{13}{16}$	5·6941	2·5801	$\frac{3}{4}$	11·7810	11·0446
$\frac{7}{8}$	5·8905	2·7611	$\frac{13}{16}$	11·9773	11·4159
$\frac{15}{16}$	6·0868	2·9483	$\frac{1}{2}$	12·1737	11·7932

CIRCUMFERENCES AND AREAS OF CIRCLES.

Diameter.	Circum.	Area.	Diameter.	Circum.	Area.
$\frac{15}{16}$	12·3700	12·1768	$\frac{1}{8}$	20·4204	33·1831
4 in.	12·5664	12·5664	$\frac{9}{16}$	20·6167	33·8244
$\frac{1}{16}$	12·7627	12·9622	$\frac{5}{8}$	20·8131	34·4717
$\frac{3}{8}$	12·9591	13·3640	$\frac{11}{16}$	21·0094	35·1252
$\frac{1}{8}$	13·1554	13·7721	$\frac{3}{4}$	21·2058	35·7847
$\frac{1}{4}$	13·3518	14·1862	$\frac{7}{8}$	21·4021	36·4505
$\frac{3}{16}$	13·5481	14·6066	$\frac{1}{2}$	21·5985	37·1224
$\frac{1}{2}$	13·7445	15·0331	$\frac{13}{16}$	21·7948	37·8005
$\frac{5}{8}$	13·9408	15·4657	7 in.	21·9912	38·4846
$\frac{3}{4}$	14·1372	15·9043	$\frac{1}{16}$	22·1875	39·1749
$\frac{7}{8}$	14·3335	16·3492	$\frac{1}{8}$	22·3839	39·8713
$\frac{15}{16}$	14·5299	16·8001	$\frac{3}{16}$	22·5802	40·5469
$\frac{1}{10}$	14·7262	17·2573	$\frac{1}{4}$	22·7766	41·2825
$\frac{3}{10}$	14·9226	17·7205	$\frac{5}{16}$	22·9729	41·9974
$\frac{2}{5}$	15·1189	18·1900	$\frac{3}{8}$	23·1693	42·7184
$\frac{1}{5}$	15·3153	18·6655	$\frac{1}{2}$	23·3656	43·4455
$\frac{15}{16}$	15·5116	19·1472	$\frac{5}{8}$	23·5620	44·1787
5 in.	15·7080	19·6350	$\frac{9}{16}$	23·7583	44·9181
$\frac{1}{16}$	15·9043	20·1290	$\frac{5}{8}$	23·9547	45·6636
$\frac{1}{8}$	16·1007	20·6290	$\frac{11}{16}$	24·1510	46·4153
$\frac{3}{16}$	16·2970	21·1252	$\frac{3}{4}$	24·3474	47·1730
$\frac{1}{4}$	16·4934	21·6475	$\frac{7}{8}$	24·5437	47·9370
$\frac{5}{16}$	16·6897	22·1661	$\frac{1}{2}$	24·7401	48·7070
$\frac{3}{8}$	16·8861	22·6907	$\frac{13}{16}$	24·9364	49·4833
$\frac{1}{2}$	17·0824	23·2215	8 in.	25·1328	50·2656
$\frac{5}{8}$	17·2788	23·7583	$\frac{1}{16}$	25·3291	51·0541
$\frac{3}{4}$	17·4751	24·3014	$\frac{1}{8}$	25·5255	51·8486
$\frac{7}{8}$	17·6715	24·8505	$\frac{3}{16}$	25·7218	52·8994
$\frac{15}{16}$	17·8678	25·4058	$\frac{1}{4}$	25·9182	53·4562
$\frac{1}{10}$	18·0642	25·9672	$\frac{5}{16}$	26·1145	54·2748
$\frac{3}{10}$	18·2605	26·5348	$\frac{3}{8}$	26·3109	55·0885
$\frac{2}{5}$	18·4569	27·1085	$\frac{1}{2}$	26·5072	55·9138
$\frac{15}{16}$	18·6532	27·6884	$\frac{5}{8}$	26·7036	56·7451
6 in.	18·8496	28·2744	$\frac{9}{16}$	26·8999	57·5887
$\frac{1}{16}$	19·0459	28·8665	$\frac{5}{8}$	27·0963	58·4264
$\frac{1}{8}$	19·2423	29·4647	$\frac{11}{16}$	27·2926	59·2762
$\frac{3}{16}$	19·4386	30·0798	$\frac{3}{4}$	27·4890	60·1321
$\frac{1}{4}$	19·6350	30·6796	$\frac{7}{8}$	27·6853	60·9943
$\frac{5}{16}$	19·8313	31·2964	$\frac{1}{2}$	27·8817	61·8625
$\frac{3}{8}$	20·0277	31·9192	$\frac{13}{16}$	27·0780	62·7369
$\frac{1}{2}$	20·2240	32·5481	9 in.	28·2744	63·6174

CIRCUMFERENCES AND AREAS OF CIRCLES.

Diameter.	Circum.	Area.	Diameter.	Circum.	Area.
$\frac{1}{16}$	28·4707	64·5041	$\frac{1}{8}$	41·2338	135·2974
$\frac{1}{8}$	28·6671	65·3968	$\frac{1}{4}$	41·6262	137·8867
$\frac{3}{16}$	28·8634	66·2957	$\frac{1}{2}$	42·0189	140·5007
$\frac{1}{4}$	29·0598	67·2007	$\frac{3}{8}$	42·4116	143·1391
$\frac{5}{16}$	29·2561	68·1120	$\frac{1}{2}$	42·8043	145·8021
$\frac{3}{8}$	29·4525	69·0293	$\frac{5}{8}$	43·1970	148·4896
$\frac{7}{16}$	29·6488	69·9528	$\frac{3}{4}$	43·5897	151·2017
$\frac{1}{2}$	29·8452	70·8823			
$\frac{9}{16}$	30·0415	71·8181	14 in.	43·9824	153·9384
$\frac{5}{8}$	30·2379	72·7599	$\frac{1}{2}$	44·3751	156·6995
$\frac{11}{16}$	30·4342	73·7079	$\frac{3}{4}$	44·7676	159·4852
$\frac{3}{4}$	30·6306	74·6620	$\frac{1}{2}$	45·1605	162·2956
$\frac{13}{16}$	30·8269	75·6223	$\frac{5}{8}$	45·5532	165·1303
$\frac{7}{8}$	31·0233	76·5887	$\frac{3}{4}$	45·9459	167·9896
$\frac{15}{16}$	31·2196	77·5613	$\frac{7}{8}$	46·3386	170·8735
			$\frac{1}{2}$	46·7313	173·7820
10 in.	31·4160	78·5400			
$\frac{1}{8}$	31·8087	80·5157	15 in.	47·1240	176·7150
$\frac{1}{4}$	32·2014	82·5160	$\frac{1}{8}$	47·5167	179·6725
$\frac{3}{8}$	32·5941	84·5409	$\frac{1}{4}$	47·9094	182·6545
$\frac{1}{2}$	32·9868	86·5903	$\frac{3}{8}$	48·3021	185·6612
$\frac{5}{8}$	33·3795	88·6643	$\frac{1}{2}$	48·6948	188·6923
$\frac{3}{4}$	33·7722	90·7627	$\frac{5}{8}$	49·0875	191·7480
$\frac{7}{8}$	34·1649	92·8858	$\frac{3}{4}$	49·4802	194·8282
			$\frac{7}{8}$	49·8729	197·9330
11 in.	34·5576	95·0334			
$\frac{1}{8}$	34·9503	97·2053	16 in.	50·2656	201·0624
$\frac{1}{4}$	35·3430	99·4021	$\frac{1}{8}$	50·6583	204·2162
$\frac{3}{8}$	35·7357	101·6234	$\frac{1}{4}$	51·0510	207·3946
$\frac{1}{2}$	36·1284	103·8691	$\frac{3}{8}$	51·4437	210·5976
$\frac{5}{8}$	36·5211	106·1394	$\frac{1}{2}$	51·8364	213·8251
$\frac{3}{4}$	36·9138	108·4342	$\frac{5}{8}$	52·2291	217·0772
$\frac{7}{8}$	37·3065	110·7536	$\frac{3}{4}$	52·6218	220·3537
			$\frac{7}{8}$	53·0145	223·6549
12 in.	37·6992	113·0976			
$\frac{1}{8}$	38·0919	115·4660	17 in.	53·4072	226·9806
$\frac{1}{4}$	38·4846	117·8590	$\frac{1}{8}$	53·7999	230·3308
$\frac{3}{8}$	38·8773	120·2766	$\frac{1}{4}$	54·1926	233·7055
$\frac{1}{2}$	39·2700	122·7187	$\frac{3}{8}$	54·5853	237·1049
$\frac{5}{8}$	39·6627	125·1854	$\frac{1}{2}$	54·9780	240·5287
$\frac{3}{4}$	40·0554	127·6765	$\frac{5}{8}$	55·3707	243·9771
$\frac{7}{8}$	40·4481	130·1923	$\frac{3}{4}$	55·7634	247·4500
			$\frac{7}{8}$	56·1561	250·9475
13 in.	40·8408	132·7326			

## CIRCUMFERENCES AND AREAS OF CIRCLES.

Diameter.	Circum.	Area.	Diameter.	Circum.	Area.
18 in.	56·5488	254·4696	23 in.	72·2568	415·4766
$\frac{1}{8}$	56·9415	258·0161	$\frac{1}{8}$	72·6495	420·0049
$\frac{1}{4}$	57·8342	261·5872	$\frac{1}{4}$	73·0422	424·5577
$\frac{3}{8}$	57·7269	265·1829	$\frac{3}{8}$	73·4349	429·1352
$\frac{1}{2}$	58·1196	268·8031	$\frac{1}{2}$	73·8276	433·7371
$\frac{5}{8}$	58·5123	272·4479	$\frac{5}{8}$	74·2203	438·3636
$\frac{3}{4}$	58·9056	276·1171	$\frac{3}{4}$	74·6130	443·0146
$\frac{7}{8}$	59·2977	279·8110	$\frac{7}{8}$	75·0057	447·6992
19 in.	59·6904	283·5294	24 in.	75·3984	452·3904
$\frac{1}{8}$	60·0831	287·2723	$\frac{1}{8}$	75·7911	457·1150
$\frac{1}{4}$	60·4758	291·0397	$\frac{1}{4}$	76·1838	461·8642
$\frac{3}{8}$	60·8685	294·8312	$\frac{3}{8}$	76·5765	466·6380
$\frac{1}{2}$	61·2612	298·6483	$\frac{1}{2}$	76·9692	471·4363
$\frac{5}{8}$	61·6539	302·4894	$\frac{5}{8}$	77·3619	476·2592
$\frac{3}{4}$	62·0466	306·3550	$\frac{3}{4}$	77·7546	481·1065
$\frac{7}{8}$	62·4393	310·2452	$\frac{7}{8}$	78·1473	485·9785
20 in.	62·8320	314·1600	25 in.	78·5400	490·8750
$\frac{1}{8}$	63·2247	318·0992	$\frac{1}{8}$	78·9327	495·7960
$\frac{1}{4}$	63·6174	322·0630	$\frac{1}{4}$	79·3254	500·7415
$\frac{3}{8}$	64·0101	326·0514	$\frac{3}{8}$	79·7181	505·7117
$\frac{1}{2}$	64·4028	330·0643	$\frac{1}{2}$	80·1108	510·7063
$\frac{5}{8}$	64·7955	334·1018	$\frac{5}{8}$	80·5035	515·7255
$\frac{3}{4}$	65·1882	338·1637	$\frac{3}{4}$	80·8962	520·7692
$\frac{7}{8}$	65·5809	342·2503	$\frac{7}{8}$	81·2889	525·8375
21 in.	65·9736	346·3614	26 in.	81·6816	530·9304
$\frac{1}{8}$	66·3663	350·4970	$\frac{1}{8}$	82·0743	536·0477
$\frac{1}{4}$	66·7590	354·6571	$\frac{1}{4}$	82·4670	541·1896
$\frac{3}{8}$	67·1517	358·8419	$\frac{3}{8}$	82·8597	546·3561
$\frac{1}{2}$	67·5444	363·0511	$\frac{1}{2}$	83·2524	551·5471
$\frac{5}{8}$	67·9371	367·2849	$\frac{5}{8}$	83·6451	556·7627
$\frac{3}{4}$	68·3298	371·5432	$\frac{3}{4}$	84·0378	562·0027
$\frac{7}{8}$	68·7225	375·8261	$\frac{7}{8}$	84·4305	567·2674
22 in.	69·1152	380·1336	27 in.	84·8232	572·5566
$\frac{1}{8}$	69·5079	384·4655	$\frac{1}{8}$	85·2159	577·8703
$\frac{1}{4}$	69·9006	388·8220	$\frac{1}{4}$	85·6086	583·2085
$\frac{3}{8}$	70·2933	393·2031	$\frac{3}{8}$	86·0013	588·5714
$\frac{1}{2}$	70·6860	397·6087	$\frac{1}{2}$	86·3940	593·9587
$\frac{5}{8}$	71·0787	402·0388	$\frac{5}{8}$	86·7867	599·3706
$\frac{3}{4}$	71·4714	406·4935	$\frac{3}{4}$	87·1794	604·8070
$\frac{7}{8}$	71·8641	410·9728	$\frac{7}{8}$	87·5721	610·2680

CIRCUMFERENCES AND AREAS OF CIRCLES.

Diameter.	Circum.	Area.	Diameter.	Circum.	Area.
28 in.	87·9648	615·7536	33 in.	103·6728	855·3006
1	88·3575	621·2636	1	104·0655	861·7924
2	88·7502	626·7982	2	104·4582	868·3087
3	89·1429	632·3574	3	104·8509	874·8497
4	89·5356	637·9411	4	105·2436	881·4151
5	89·9283	643·5494	5	105·6363	888·0051
6	90·3210	649·1821	6	106·0290	894·6196
7	90·7137	654·8395	7	106·4217	901·2587
8			8		
29 in.	91·1064	660·5214	34 in.	106·8144	907·9224
1	91·4991	666·2278	1	107·2071	914·6105
2	91·8918	671·9587	2	107·5998	921·3232
3	92·2845	677·7143	3	107·9925	928·0605
4	92·6772	683·4943	4	108·3852	934·8223
5	93·0699	689·2989	5	108·7779	941·6086
6	93·4626	695·1280	6	109·1706	948·4195
7	93·8553	700·9817	7	109·5633	955·2550
8			8		
30 in.	94·2480	706·8600	35 in.	109·9560	962·1150
1	94·6407	712·7627	1	110·3487	968·9995
2	95·0334	718·6900	2	110·7414	975·9085
3	95·4261	724·6419	3	111·1341	982·8422
4	95·8188	730·6183	4	111·5268	989·8003
5	96·2115	736·6193	5	111·9195	996·7830
6	96·6042	742·6447	6	112·3122	1003·7902
7	96·9969	748·6948	7	112·7049	1010·8220
8			8		
31 in.	97·3896	754·7694	36 in.	113·0976	1017·8784
1	97·7823	760·8685	1	113·4903	1024·9592
2	98·1750	766·9921	2	113·8830	1032·0646
3	98·5677	773·1404	3	114·2757	1039·1946
4	98·9604	779·3131	4	114·6684	1046·3941
5	99·3531	785·5104	5	115·0611	1053·5281
6	99·7458	791·7322	6	115·4538	1060·7317
7	100·1385	797·9786	7	115·8465	1067·9599
8			8		
32 in.	100·5312	804·2496	37 in.	116·2392	1075·2126
1	100·9240	810·5450	1	116·6319	1082·4898
2	101·3166	816·8650	2	117·0246	1089·7915
3	101·7093	823·2096	3	117·4173	1097·1179
4	102·1020	829·5787	4	117·8100	1104·4687
5	102·4947	835·9724	5	118·2027	1111·8441
6	102·8874	842·3905	6	118·5954	1119·2440
7	103·2801	848·8333	7	118·9881	1126·6685
8			8		

## CIRCUMFERENCES AND AREAS OF CIRCLES.

Diameter.	Circum.	Area.	Diameter.	Circum.	Area.
38 in.	119·3808	1134·1176	43 in.	135·0888	1452·2046
1	119·7735	1141·5911	1	135·4815	1460·6599
2	120·1662	1149·0892	2	135·8742	1469·1397
3	120·5589	1156·6119	3	136·2669	1477·6342
4	120·9516	1164·1591	4	136·6596	1486·1731
5	121·3443	1171·7309	5	137·0523	1494·7266
6	121·7370	1179·3271	6	137·4450	1503·3046
7	122·1297	1186·9480	7	137·8377	1511·9072
39 in.	122·5224	1194·5934	44 in.	138·2304	1520·5344
1	122·9151	1202·2633	1	138·6231	1529·1860
2	123·3078	1209·9577	2	139·0158	1537·8622
3	123·7005	1217·6768	3	139·4085	1546·5530
4	124·0932	1225·4203	4	139·8012	1555·2883
5	124·4859	1233·1884	5	140·1939	1564·0382
6	124·9787	1240·9810	6	140·5866	1572·8125
7	125·2713	1248·7982	7	140·9793	1581·6115
40 in.	125·6640	1256·6400	45 in.	141·3720	1590·4350
1	126·0567	1264·5062	1	141·7647	1599·2830
2	126·4494	1272·3970	2	142·1574	1608·1555
3	126·8421	1280·3124	3	142·5501	1617·0427
4	127·2348	1288·2523	4	142·9428	1625·9743
5	127·6275	1296·2168	5	143·3355	1634·9205
6	128·0202	1304·2057	6	143·7382	1643·8912
7	128·4129	1312·2193	7	144·1209	1652·8865
41 in.	128·8056	1320·2574	46 in.	144·5136	1661·9064
1	129·1983	1328·3200	1	144·9063	1670·9507
2	129·5910	1336·4071	2	145·2990	1680·0196
3	129·9837	1344·5189	3	145·6917	1689·1031
4	130·3764	1352·6551	4	146·0844	1698·2311
5	130·7691	1360·8159	5	146·4771	1707·3787
6	131·1618	1369·0012	6	146·8698	1716·5407
7	131·5545	1377·2111	7	147·2625	1725·7324
42 in.	131·9472	1335·4456	47 in.	147·6552	1734·9486
1	132·3399	1393·7045	1	148·0479	1744·1893
2	132·7326	1401·9880	2	148·4406	1753·4545
3	133·1253	1470·2961	3	148·8333	1762·7344
4	133·5180	1418·6287	4	149·2260	1772·0587
5	133·9107	1426·9859	5	149·6187	1781·3976
6	134·3034	1435·3675	6	150·0114	1790·7610
7	134·6961	1443·7738	7	150·4041	1800·1490

Diameter.	Circum.	Area.	Diameter.	Circum.	Area.
48 in.	150·7968	1809·5615	53 in.	166·5048	2206·1886
↓	151·1895	1818·9986	↓	166·8975	2216·6074
↓	151·5822	1828·4602	↓	167·2902	2227·0507
↓	151·9749	1837·9364	↓	167·6829	2237·5187
↓	152·3676	1847·4571	↓	168·0756	2248·0111
↓	152·7603	1856·9924	↓	168·4683	2258·5281
↓	153·1530	1868·5521	↓	168·8610	2269·0696
↓	153·5457	1876·1365	↓	169·2537	2279·6357
49 in.	153·9384	1885·7454	54 in.	169·6464	2290·2264
↓	154·3311	1895·3788	↓	170·0391	2300·8415
↓	154·7238	1905·0367	↓	170·4318	2311·4812
↓	155·1165	1914·7093	↓	170·8245	2322·1455
↓	155·5092	1924·4263	↓	171·2172	2332·8343
↓	155·9010	1934·1579	↓	171·6099	2343·5477
↓	156·2946	1943·9140	↓	172·0026	2354·2855
↓	156·6873	1953·6947	↓	172·3953	2365·0480
50 in.	157·0800	1963·5000	55 in.	172·7880	2375·8350
↓	157·4727	1973·3297	↓	173·1807	2386·6465
↓	157·8654	1983·1840	↓	173·5734	2397·4825
↓	158·2581	1993·0529	↓	173·9661	2408·3432
↓	158·6508	2002·9663	↓	174·3588	2419·2283
↓	159·0435	2012·8943	↓	174·7515	2430·1833
↓	159·4362	2022·8467	↓	175·1442	2441·0772
↓	159·8289	2032·8238	↓	175·5369	2452·0301
51 in.	160·2216	2042·8254	56 in.	175·9296	2463·0144
↓	160·6143	2052·8515	↓	176·3323	2474·0222
↓	161·0070	2062·9021	↓	176·7150	2485·3546
↓	161·3997	2072·9764	↓	177·1077	2496·1116
↓	161·7924	2083·0771	↓	177·5004	2507·1931
↓	162·1851	2093·2014	↓	177·8931	2518·2992
↓	162·5778	2103·3502	↓	178·2858	2529·4297
↓	162·9705	2113·5236	↓	178·6785	2543·5849
52 in.	163·3632	2123·7216	57 in.	179·0712	2551·7646
↓	163·7559	2133·9440	↓	179·4639	2562·9688
↓	164·1486	2144·1910	↓	179·8566	2574·1975
↓	164·5413	2154·4626	↓	180·2493	2585·4509
↓	164·9340	2164·7587	↓	180·6423	2596·7287
↓	165·3267	2175·0794	↓	181·0347	2608·0311
↓	165·7194	2185·4245	↓	181·4274	2619·3580
↓	166·1121	2195·7943	↓	181·8201	2630·7095



CIRCUMFERENCES AND AREAS OF CIRCLES.

Diameter.	Circum.	Area.	Diameter.	Circum.	Area.
58 in.	182·2128	2642·0856	63 in.	197·9208	3117·2526
1/8	182·6055	2653·4861	1/8	198·3135	3129·6349
1/4	182·9982	2664·9112	1/4	198·7062	3142·0417
3/8	183·3909	2676·3609	3/8	199·0989	3154·4732
1/2	183·7836	2687·8351	1/2	199·4916	3166·9291
5/8	184·1763	2699·3338	5/8	199·8843	3179·4096
3/4	184·5690	2710·8571	3/4	200·2770	3191·9146
7/8	184·9617	2722·4050	7/8	200·6697	3204·4449
59 in.	185·3544	2733·9774	64 in.	201·0624	3216·9984
1/8	185·7471	2745·5743	1/8	201·4551	3229·5770
1/4	186·1398	2757·1957	1/4	201·8478	3242·1782
3/8	186·5325	2768·8418	3/8	202·2405	3254·8080
1/2	186·9252	2780·5123	1/2	202·6332	3267·4603
5/8	187·3179	2792·2074	5/8	203·0259	3280·1372
3/4	187·7106	2803·9270	3/4	203·4186	3292·8385
7/8	188·1033	2815·6712	7/8	203·8113	3306·5645
60 in.	188·4960	2827·4400	65 in.	204·2040	3318·3151
1/8	188·8887	2839·2332	1/8	204·5917	3331·0900
1/4	189·2814	2851·0510	1/4	204·9894	3343·8875
3/8	189·6741	2862·8934	3/8	205·3821	3356·7136
1/2	190·0668	2874·7603	1/2	205·7748	3369·5623
5/8	190·4595	2886·6517	5/8	206·1675	3382·4355
3/4	190·8522	2898·5677	3/4	206·5602	3395·3332
7/8	191·2419	2910·5083	7/8	206·9529	3408·2555
61 in.	191·6376	2922·4734	66 in.	207·3456	3421·2024
1/8	192·0303	2934·4630	1/8	207·7383	3434·1737
1/4	192·4230	2946·4771	1/4	208·1310	3447·1676
3/8	192·8157	2958·5159	3/8	208·5237	3460·1901
1/2	193·2084	2970·5791	1/2	208·9164	3473·2351
5/8	193·6011	2982·6669	5/8	209·3091	3486·3047
3/4	193·9931	2994·7792	3/4	209·7018	3499·3987
7/8	194·3865	3006·9161	7/8	210·0945	3512·5174
62 in.	194·7792	3019·0776	67 in.	210·4872	3525·6606
1/8	195·1719	3031·2835	1/8	210·8799	3538·8283
1/4	195·5646	3043·4740	1/4	211·2726	3552·0185
3/8	195·9573	3055·7091	3/8	211·6653	3565·2374
1/2	196·3500	3067·9687	1/2	212·0500	3578·4787
5/8	196·7427	3080·2529	5/8	212·4507	3591·7446
3/4	197·1354	3092·5615	3/4	212·8434	3605·0350
7/8	197·5281	3104·8948	7/8	213·2361	3618·3300

Diameter.	Circum.	Area.	Diameter.	Circum.	Area.
68 in.	213·6288	3631·6896	73 in.	229·3368	4185·3966
1 8 1 4 3 8	214·0215	3645·0536	1 8 1 4 3 8	229·7295	4199·7424
1 8 1 4 3 8	214·4142	3658·4402	1 8 1 4 3 8	230·1222	4214·1107
1 8 1 4 3 8	214·8069	3671·8554	1 8 1 4 3 8	230·5149	4228·5077
1 8 1 4 3 8	215·1996	3685·2931	1 8 1 4 3 8	230·9076	4242·9271
1 8 1 4 3 8	215·5923	3698·7554	1 8 1 4 3 8	231·3003	4257·3711
1 8 1 4 3 8	215·9850	3712·2421	1 8 1 4 3 8	231·6930	4271·8396
1 8 1 4 3 8	216·3777	3725·7535	1 8 1 4 3 8	232·0857	4286·3327
69 in.	216·7704	3739·2894	74 in.	232·4784	4300·8504
1 8 1 4 3 8	217·1631	3752·8498	1 8 1 4 3 8	232·8711	4315·3926
1 8 1 4 3 8	217·5558	3766·4327	1 8 1 4 3 8	233·2638	4329·9572
1 8 1 4 3 8	217·9485	3780·0443	1 8 1 4 3 8	233·6565	4344·5505
1 8 1 4 3 8	218·3412	3793·6783	1 8 1 4 3 8	234·0492	4359·1663
1 8 1 4 3 8	218·7339	3807·3369	1 8 1 4 3 8	234·4419	4373·8067
1 8 1 4 3 8	219·1266	3821·0200	1 8 1 4 3 8	234·8346	4388·4715
1 8 1 4 3 8	219·5193	3834·7277	1 8 1 4 3 8	235·2273	4403·1610
70 in.	219·9120	3848·4600	75 in.	235·6200	4417·8750
1 8 1 4 3 8	220·3047	3862·2167	1 8 1 4 3 8	236·0127	4432·6135
1 8 1 4 3 8	220·6974	3875·9960	1 8 1 4 3 8	236·4054	4447·3745
1 8 1 4 3 8	221·0901	3889·8039	1 8 1 4 3 8	236·7981	4462·1642
1 8 1 4 3 8	221·4828	3903·6343	1 8 1 4 3 8	237·1908	4476·9763
1 8 1 4 3 8	221·8755	3917·4893	1 8 1 4 3 8	237·5835	4491·8130
1 8 1 4 3 8	222·2682	3931·3687	1 8 1 4 3 8	237·9762	4506·6742
1 8 1 4 3 8	222·6609	3745·2728	1 8 1 4 3 8	238·3689	4521·5600
71 in.	223·0536	3959·2014	76 in.	238·7616	4536·4707
1 8 1 4 3 8	223·4463	3973·1545	1 8 1 4 3 8	239·1543	4551·4023
1 8 1 4 3 8	223·8390	3987·1301	1 8 1 4 3 8	239·5470	4566·3626
1 8 1 4 3 8	224·2317	4001·1344	1 8 1 4 3 8	239·9397	4581·3486
1 8 1 4 3 8	224·6244	4015·1611	1 8 1 4 3 8	240·3324	4596·3571
1 8 1 4 3 8	225·0171	4029·2124	1 8 1 4 3 8	240·7251	4611·3902
1 8 1 4 3 8	225·4098	4043·2882	1 8 1 4 3 8	241·1178	4626·4477
1 8 1 4 3 8	225·8025	4057·3886	1 8 1 4 3 8	241·5105	4641·5299
72 in.	226·1952	4071·5136	77 in.	241·9032	4656·6366
1 8 1 4 3 8	226·5879	4085·6631	1 8 1 4 3 8	242·2959	4671·7678
1 8 1 4 3 8	226·9806	4099·8350	1 8 1 4 3 8	242·6886	4686·9215
1 8 1 4 3 8	227·3733	4114·0356	1 8 1 4 3 8	243·0813	4702·1039
1 8 1 4 3 8	227·7660	4128·2587	1 8 1 4 3 8	243·4740	4717·3087
1 8 1 4 3 8	228·1587	4142·5064	1 8 1 4 3 8	243·8667	4732·5381
1 8 1 4 3 8	228·5514	4156·7785	1 8 1 4 3 8	244·2594	4747·7920
1 8 1 4 3 8	228·9441	4171·0753	1 8 1 4 3 8	244·6521	4763·0705

CIRCUMFERENCES AND AREAS OF CIRCLES.

Diameter.	Circum.	Area.	Diameter.	Circum.	Area.
78 in.	245·0448	4778·3736	83 in.	260·7528	5410·6206
1 2 3 4 5 6 7 8	245·4375	4793·7012	1 2 3 4 5 6 7 8	261·1455	5426·9299
	245·8302	4809·0512		261·5382	5443·2617
	246·2229	4824·4299		261·9309	5459·6222
	246·6156	4839·8311		262·3236	5476·0051
	247·0083	4855·2568		262·7163	5492·4118
	247·4010	4870·7071		263·1090	5508·8446
	247·7937	4886·1820		263·5017	5525·3012
79 in.	248·1864	4901·6814	84 in.	263·8944	5541·7824
1 2 3 4 5 6 7 8	248·5791	4917·2053	1 2 3 4 5 6 7 8	264·2871	5558·2881
	248·9718	4932·7517		264·7698	5574·8162
	249·3645	4948·3268		265·0725	5591·3730
	249·7572	4963·9243		265·4652	5607·9523
	250·1499	4979·5456		265·8579	5624·5554
	250·5426	4995·1930		266·2506	5641·1845
	250·9353	5010·8642		266·6433	5657·8357
80 in.	251·3280	5026·5600	85 in.	267·0360	5674·1500
1 2 3 4 5 6 7 8	251·7207	5042·2803	1 2 3 4 5 6 7 8	267·4287	5691·2517
	252·1134	5058·0230		267·8214	5707·9415
	252·5061	5073·7944		268·2141	5724·6947
	252·8988	5089·5883		268·6068	5741·4703
	253·2915	5106·4060		268·9997	5758·2697
	253·6842	5121·2497		269·3922	5775·0952
	254·0769	5137·1173		269·7849	5791·9445
81 in.	254·4696	5153·0094	86 in.	270·1776	5808·8184
1 2 3 4 5 6 7 8	254·8623	5168·9260	1 2 3 4 5 6 7 8	270·5703	5825·7168
	255·2550	5184·8651		270·9630	5842·6376
	255·6477	5200·8329		271·3557	5859·5871
	256·0404	5216·8231		271·7484	5876·5591
	256·4331	5232·8371		272·1411	5893·5549
	256·8258	5248·8772		272·5338	5910·5767
	257·2105	5264·9411		272·9265	5927·6224
82 in.	257·6112	5281·0296	87 in.	273·3192	5955·6926
1 2 3 4 5 6 7 8	258·0039	5297·1426	1 2 3 4 5 6 7 8	273·7119	5961·7873
	258·3966	5313·2780		274·1046	5978·9045
	258·7893	5329·4421		274·4973	5996·0504
	259·1820	5345·6287		274·8900	6013·2187
	259·5747	5361·8391		275·2827	6030·4108
	259·9674	5378·0755		275·6754	6047·6290
	260·3601	5394·3358		276·0681	6064·8710

CIRCUMFERENCES AND AREAS OF CIRCLES.

Diameter.	Circum.	Area.	Diameter.	Circum.	Area.
88 in.	276·4608	6082·1376	93 in.	292·1688	6792·9248
1/8	276·8535	6099·4287	1/8	292·5615	6811·1974
1/4	277·2462	6116·7422	1/4	292·9542	6829·4927
1/2	277·6389	6134·0844	1/2	293·3469	6847·8167
3/4	278·0316	6151·4491	3/4	293·7396	6866·1631
1	278·4243	6169·8376	1	294·1323	6884·5338
1 1/8	278·8170	6186·2591	1 1/8	294·5350	6902·9296
1 1/4	279·2097	6203·6905	1 1/4	294·9177	6921·3497
89 in.	279·6024	6221·1534	94 in.	295·3104	6939·7946
1/8	279·9951	6238·6408	1/8	295·7031	6958·2636
1/4	280·3878	6256·1507	1/4	296·0958	6976·7552
1/2	280·7805	6273·6893	1/2	296·4885	6995·2755
3/4	281·1732	6291·2503	3/4	296·8812	7013·8183
1	281·5659	6308·8351	1	297·2739	7032·3853
1 1/8	281·9586	6326·4460	1 1/8	297·6666	7050·9775
1 1/4	282·3513	6344·0807	1 1/4	298·0593	7069·5940
90 in.	282·7440	6361·7400	95 in.	298·4520	7088·2352
1/8	283·1367	6379·4238	1/8	298·8447	7106·9005
1/4	283·5294	6397·1300	1/4	299·2374	7125·5885
1/2	283·9221	6424·8649	1/2	299·6301	7144·3052
3/4	284·3148	6432·6223	3/4	300·0228	7163·0443
1	284·7075	6450·4039	1	300·4155	7181·8077
1 1/8	285·1002	6468·2107	1 1/8	300·8082	7200·5962
1 1/4	285·4929	6486·0418	1 1/4	301·2009	7219·4090
91 in.	285·8856	6503·8974	96 in.	301·5936	7238·2466
1/8	286·2783	6521·7772	1/8	301·9863	7257·1083
1/4	286·6710	6539·6801	1/4	302·3790	7275·9926
1/2	287·0637	6557·6114	1/2	302·7717	7294·9056
3/4	287·4564	6573·5651	3/4	303·1644	7313·8411
1	287·8491	6589·5431	1	303·5571	7332·8088
1 1/8	288·2418	6611·5462	1 1/8	303·9490	7351·7857
1 1/4	288·6345	6629·5736	1 1/4	304·3425	7370·7949
92 in.	289·0272	6647·6258	97 in.	304·7352	7389·8288
1/8	289·4199	6665·7021	1/8	305·1279	7408·8868
1/4	289·8125	6683·8010	1/4	305·5206	7427·9675
1/2	290·2053	6701·9286	1/2	305·9133	7447·0769
3/4	290·5980	6720·0787	3/4	306·3060	7466·2087
1	290·9907	6738·2530	1	306·6987	7485·3648
1 1/8	291·3834	6756·4525	1 1/8	307·0914	7504·5460
1 1/4	291·7661	6774·6763	1 1/4	309·4841	7523·7515

## CIRCUMFERENCES AND AREAS OF CIRCLES.

Diameter.	Circum.	Area.	Diameter.	Circum.	Area.
98 in.	307·8768	7542·9818	$\frac{1}{8}$	311·4111	7717·1563
$\frac{1}{8}$	308·2695	7562·2362	$\frac{1}{4}$	311·8038	7736·6297
$\frac{1}{4}$	308·6622	7581·5132	$\frac{3}{8}$	312·1965	7756·1318
$\frac{3}{8}$	309·0549	7600·8189	$\frac{1}{2}$	312·5892	7775·6563
$\frac{1}{2}$	309·4476	7620·1471	$\frac{5}{8}$	312·9819	7795·2051
$\frac{5}{8}$	309·8403	7639·4995	$\frac{3}{4}$	313·3746	7814·7790
$\frac{3}{4}$	310·2330	7658·8771	$\frac{7}{8}$	313·7673	7834·3772
$\frac{7}{8}$	310·6257	7678·2790	100 in.	314·1600	7854·0000
99 in.	311·0184	7697·7056			

*Established 50 Years.*

Telegrams: "LORD, DUNDEE," A B C Code.  
Telephone: 1252, Dundee.

# George H. Lord & Son

ENGINEERS AND MACHINE MERCHANTS,  
MILL AND FACTORY FURNISHERS,

**PARK MACHINE WORKS, DUNDEE.**

---

## LICENSED VALUERS.

Mill, Factory, and Rope Work  
Property and Plant Valued (for  
Insurance, Partnership, and other  
purposes); also arranged for dis-  
posal by Private Sale.

## FIRE ASSESSORS.

Fire Claims prepared and ad-  
justed on behalf of the assured  
or others.

## A LARGE STOCK

always on hand of Second-Hand

**Preparing, Spinning,  
Winding, Weaving &  
Finishing Machinery,**

suitable for Hemp, Flax, & Jute;  
also for Manilla, Russian, Italian,  
and other Hemps for Binder  
Twines, Ropes, Cords, &c.

---

## **DEALERS IN ENGINEERS' TOOLS.**

---

**Makers of ALL-STEEL BOBBINS for Twisting Rope Yarn, Binder, Twine, &c.**

*Estimates given for Machinery Overhauled and put into Good Working Order.*

---

**Postal Address, - CHAMBERS, 11 Ward Road, Dundee, Scotland.**

Telephone No. 1970.

# R. C. STIVEN & CO.

OIL MERCHANTS,

MILL AND FACTORY FURNISHERS,

22 & 24 WARD ROAD, DUNDEE.

Agents for D. ANDERSON & SON, Belfast.

“SIDEROLEUM” WOOD PRESERVATIVE.

“SIDEROSTHEN” ANTICORROSIVE PAINT

---

# JAS. CARMICHAEL & SONS,

*Tanners, Curriers, and Leather Merchants,*

DUNDEE.

---

MANUFACTURERS of LEATHER BELTING; CHROME PICKING BANDS;

CHROME, WHITE, and BROWN LACES;

ROLLER COVERS; MARTINGALE TRAPPINGS, &c.

---

All descriptions of LEATHER used in the Jute Manufacturing Trade

Gold Medal of Honour, Paris, 1885.  
Bronze Medal, London, 1851.

Council Medal, London, 1851.  
Silver Medal, Paris, 1865.

# CHAS. PARKER SONS, & CO.,

*Engineers,*  
*Machine Makers,*  
*and*  
*Ironfounders.*

**VICTORIA**  
**FOUNDRY,**  
**DUNDEE.**

MAKERS OF ALL KINDS  
OF

PREPARING,  
WEAVING,

AND

FINISHING  
MACHINERY

(from Latest and Most  
Improved Models),

For Jute, Flax  
and

Hemp Textiles

Improved Jute Opening and Jute Softening Machines.

Roll, Warp, and Weft (Cop) Winding Machines, with all the Latest Improvements.

Improved Yarn Dressing and Beaming Machines.

Special Power Looms for Hessians, Sackings, Tarpaulings, etc.

Do.	do	Linoleum Cloth
Do.	do.	Jute Carpetings, Matting, etc.
Do.	do.	Checked Goods, with 2, 3, and 4 Shuttles.
Do.	do.	all kinds of Canvas and Sailcloth, up to the heaviest Nos.

Improved Cropping Machines, Spray and Brush Damping Machines, Calenders (with 3, 4, and 5 Bowls), Measuring Machines, Folding Machines, Crisping Machines, Rolling Machines, Sackcutters, Hydraulic Pumps and Presses, etc.

Also Transmission, consisting of Grooved Wheels, Shafting with Bearings, Couplings, etc.

Shafting, Drums, Wall Boxes, Hangers, Brackets, etc.

PLANS, SPECIFICATIONS, AND ESTIMATES FURNISHED.



# THOMAS C. KEAY, Ltd.

MILL FURNISHERS,

SHUTTLE, PICKER, AND BOBBIN MAKERS,

ENGINEERS AND MACHINE MERCHANTS,

## BALTIC STREET, DUNDEE.

MAKERS OF

Sack Cutting Machines. Tarring Machines.

Sewing Machine Spare Parts. Planetree Pressing Rollers. Shuttles.

Pickers. Bobbins. Buffalo Skips. Fibre Sliver Cans.

Every Requisite in Furnishings for Jute and Flax Mills.

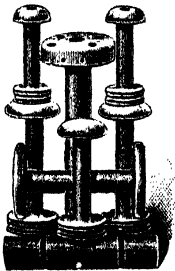

BOBBINS, ALL SIZES.



BEECH AND PERSIMMON  
WOOD SHUTTLES.

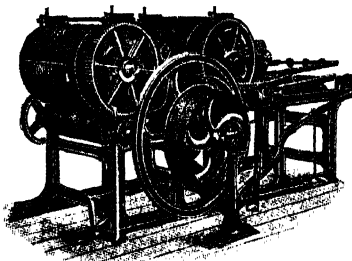

SINGLE AND MULTI COLOUR SACK  
PRINTING MACHINES.

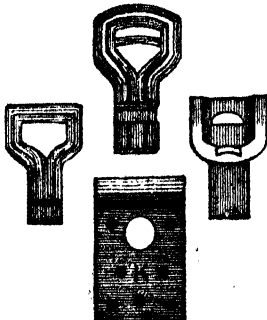

BUFFALO PICKERS.



"GOVERNMENT"  
WATERPROOF  
BELT DRESSING.

CATALOGUES ON APPLICATION.

# “UNION SPECIAL”

## The World's Best Bag Sewing Machine

Years ago the “Union Special”  
Machine revolutionised the Bag  
Sewing Trade.  
To-day it holds the first place  
among Sewing Machines.

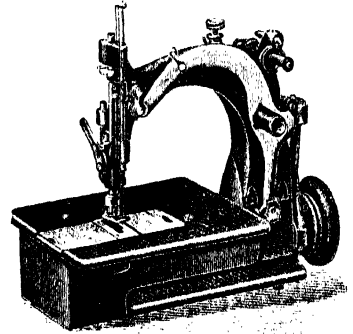

Style 1,900a.

### CLASSES.

1,900.      30,100.  
80,000 (ANTAEUS).  
81,000 (HERAKLES).

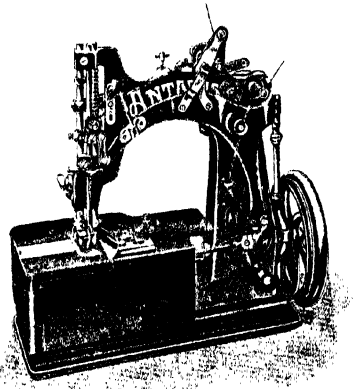

Style 80,000a.

Large Stock of Machines and  
Spare Parts always on hand.

Sole Agents for the United Kingdom and India:—

# **THOMAS C. KEAY, Ltd.**

**BALTIC STREET, DUNDEE.**

Telegraphic Address—"ENGINEERS, DUNDEE."

"A.B.C." Code Used.

**URQUHART, LINDSAY & CO., LIMITED,**  
**BLACKNESS FOUNDRY, DUNDEE,**  
**Engineers, Millwrights, & Ironfounders.**

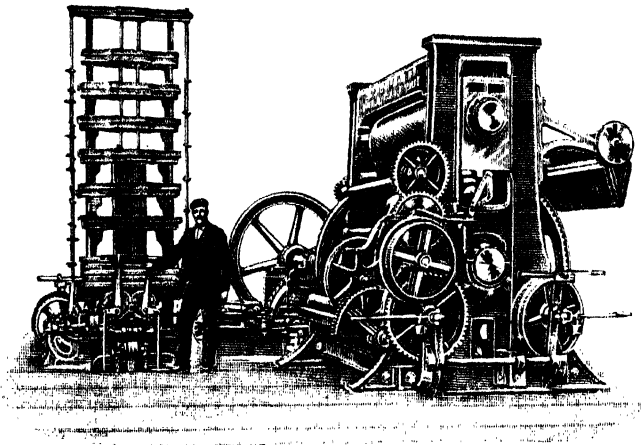

**Machine-Moulded and Machine-Cut Wheels of all Descriptions.**

**JUTE OPENERS AND SOFTENERS.**

**Warp Winding, Cop Winding, Dressing and Beaming Machines.**

**POWER LOOMS, AND ALL WEAVING MACHINERY.**

**PATENT CROPPING MACHINES.**

**CLOTH FINISHING MACHINERY,**

**And all descriptions of General Engineering Work.**

Telegraphic Address--"FOUNDERS," Dundee.

Telephone No. 652.

# **ROBERTSON & ORCHAR, LTD.,**

## **WALLACE FOUNDRY, DUNDEE.**

---

**ENGINEERS, MILLWRIGHTS, MACHINE MAKERS, & FOUNDERS.**

**MAKERS OF PREPARING, WEAVING, AND FINISHING MACHINERY**

**for all classes of Linen, Hemp, Tow and Jute Fabrics.**

---

*PATENTEES and MAKERS of the following Machines :--*

WARP WINDING MACHINES.

WEFT WINDING MACHINES.

WEFT SOFTENING MACHINES.

PATENT YARN DRESSING MACHINES with  
Two to Eight Cylinders.

DRY YARN BEAMING MACHINES.

POWER LOOMS.

DOUBLE AND SINGLE CLOTH DAMPING  
MACHINES.

CLOTH STARCHING MACHINES.

CLOTH MEASURING MACHINES.

PATENT HYDRAULIC AND LEVER PRESSER  
ROLLER MANGLES of all widths.

IMPROVED CALENDERS of Three, Four,  
and Five Rollers, with Special Lever  
Pressure.

CLOTH CRISPING MACHINES.

CANDROYS FOR ROLLING CLOTH.

**HYDRAULIC PACKING PRESSES AND PUMPS.**

### **SPECIALITY.**

**PATENT OVERHEAD HAND-STITCH AND SACK SEWING MACHINES,**

**CHAIN STITCH AND PLAIN STITCH SEWING MACHINES.**

---

**Every description of Millwright and General Engineering Work  
carefully executed.**

# DAVID KEAY & LESLIE, HILLBANK IRON WORKS, DUNDEE.

ON GOVERNMENT LIST OF CONTRACTORS.

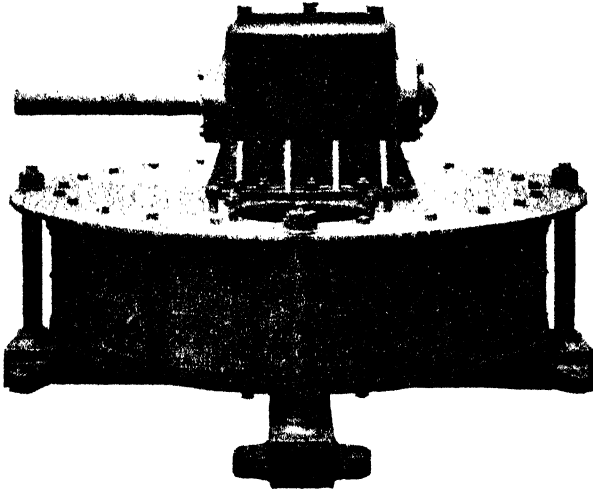

Patentees and Sole Makers of the  
**DUNDEE PATENT WATER COOLER**  
FOR CONDENSING ENGINES.

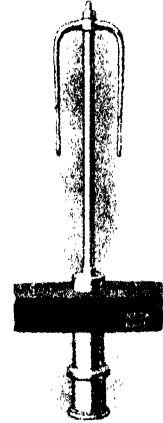

Patentees and Sole Makers of the  
**LESLIE PATENT**  
**SPINNING SPINDLE.**

## **TEXTILE MACHINERY Made and Repaired.**

**Shafting with Ball Bearings. Machine Forgings.**

**Iron and Steel Flue Proofing. Steel Guides.**

**Iron and Steel Sheds, Roofs, Doors, and Windows.**

**Wheel Covers in Steel.**

**Complete System of WATER SUPPLY in Cast & Wrot Iron Piping.**

**STEAM TRAPS, VALVES, and all Fittings in Stock.**

**HEATING APPARATUS—Steam & Hot Water, with Ventilation.**

**Sole Agents and Erectors for Dundee and District for the Associated Auto Sprinkler Coy.**

Telegrams—"POWER."

Telephone No. 1934.

# MILL, FACTORY & ENGINEERING SUPPLIES

**Enquiries and Orders invited for**

**SPINNING FRAME REQUIREMENTS.**

**LOOM FITTINGS. STEAM VALVES AND PIPES.**

**ALL CLASSES OF TOOLS, ETC., ETC.**

**LARGE STOCKS KEPT.**

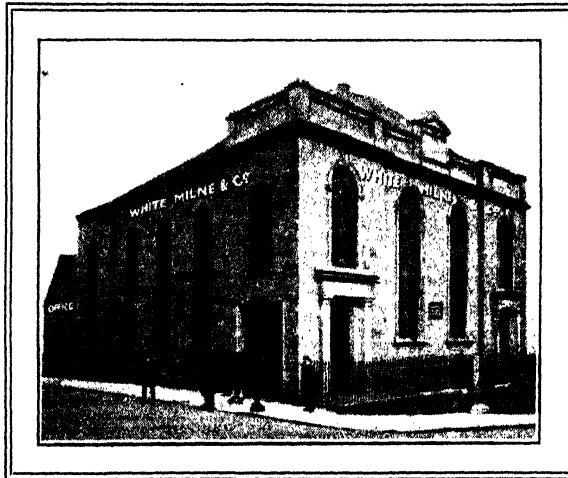

Telegrams:  
"Tools, Dundee."  
Telephone 2059.

CODES:  
A. B. C. 5th Edition,  
Bentley's, Lieber's,  
and Private.

# WHITE, MILNE, & Co.

*OFFICE AND WAREHOUSE:*

**No. 1, BELL STREET, DUNDEE.**

**OUR MOTTO: SERVICE.**

Telegrams—"Pulleys, Dundee."

Telephone 2183.

# **ROBERT STIVEN & CO.**

**TEMPLE MILLS,  
TAY STREET, DUNDEE.**

---

**ESTABLISHED 1840.**

---

**MILL AND FACTORY FURNISHERS.  
*EXPORT MERCHANTS.***

---

---

**Large and Well Selected Stock of Plane Tree  
PRESSING ROLLERS.**

---

---

*Agents for Scotland for*

**JONATHAN HATTERSLEY & SON, LIMITED,  
LEEDS,**

**Manufacturers of Spindles and Flyers for the Preparing  
and Spinning of Flax, Tow, Jute, Silk,  
and Worsted.**

**Established 1874.**

# WM. R. STEWART & SONS,

MANUFACTURERS OF ALL KINDS OF  
Wood Card Covering, Hackles, Gills, &c.

For Preparing Flax, Hemp, and Jute.

---

STEELFACED CARD COVERING A SPECIALITY.

HACKLE, GILL, AND CARD PINS, GILL RIVETS, &c.

---

Hillbank Hackle Works, Dens Road, Dundee

Telephone No. 1024.

Telegraphic Address:—"CARDING, DUNDEE."

---

# JOHN GALLOWAY & SONS,

Ironmongers, Plumbers, Tinsmiths and Gasfitters,

HILLTOWN AND FAIRMUIR SHEET METAL WORKS, DUNDEE.

TELEPHONE No. 434

ESTABLISHED 1870

## MANUFACTURERS OF

OBLONG



**MACHINE MADE SLIVER OANS.**—Oblong, Oval, or Round--made from Patent Coated, Black or Tinned Steel, or Best Fibre Sheets.

**IMPROVED SPIN CONDUCTORS,** any Size and Shape.

**SPINNING FRAME AND OTHER CYLINDERS.**

**OOP PANS,** in Patent Coated Black Steel, Tinplate, or Best Fibre Sheets.

**PIRN TRAYS**—any Make or Size.

**PICKER GROOVES,** any Length up to 32 inches long.

*Quotations given for any quantity, and Deliveries as arranged.*

**GAS, WATER, AND STEAM PIPES FITTED, AND PLUMBER WORK DONE IN ALL ITS BRANCHES.**

All kinds of Mill and Factory Work done. Prompt attention given.

Van sent to any Local Mills for Repairs, &c.

OVAL

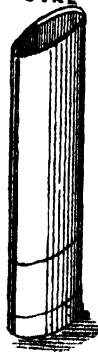

Estimates given for Covering Engine Cylinders, &c., with Blue Planished Steel; also for Lubricators, Pipes, Drip Pans, and other Engine Fittings in Brass, Copper, Zinc, &c.



# **JOHN COOPER & SONS**

**Mill, Factory, and Engineers' Furnishers,**

**52 TO 56 BELL STREET, DUNDEE.**

---

**EXPORTERS TO ALL MARKETS.**

---

## **GENERAL MILL STORES.**

Bolts, Setscrews, Files, Wire, Rubber, and Asbestos Goods, Engine Packings Jointings, Pulleys, Belting, Buckets, Scythestones, . . . Engineers' Tools all kinds, &c.

## **JUTE MACHINERY PARTS.**

Wipers, Fallers, Chains (all kinds), Bobbins, Skips, Flier Eyes, Spindle Tops, Guides Arbors, Drag Springs, Spool Pins, Dectors, Neck Washers, Casehardened Setscrews, &c.

## **LOOMS.**

Shuttles, Spindles and Studs, Pickers, Picking Arms, Box End and Protector Springs, Picking Springs, Beam Flange Screws, all kinds of Special Bolts, Screws, and Studs for Jute Machinery, &c.

---

**Every Requisite for Softeners, Preparing Machinery, Spinning, Cop and Roll Winding, Looms, &c.**

**SPECIAL ATTENTION TO FOREIGN INDENTS.**

---

## **Sole Distributors of THE 'PARAGON' FALLERS.**

These Fallers are Composite Bars, having Soft Steel Centres and Nickel Chrome Steel Ends.

\* **THE FINEST GILL BARS MADE.**

# Thos. Ferguson & Co.

Textile Engineers,

Mill, Factory, and Engineers' Furnishers,

35 COWGATE, DUNDEE.

Gills and  
Fallers . .

Steel and  
Files . . .

Leather. .  
Asbestos.  
Rubber . .

## LIST OF GOODS.

All kinds of Fallers and Gills for Jute and Flax Machinery, made from best Solid Steel, and fitted with Gills made from best drawn gill metal or drilled and pinned through the steel bar if required. Best quality of Gill Pins, Card Pins, and Gill Rivets always in stock.

Firth's Speedicut Steel Twist Drills, Steel Forgings, Files, and Tools.

**ANGUS BELTINGS.**—Leather, Cotton, Hair, and Balata. English and Foreign Butts, Camb and Martingale Straps, Picking Bands and Laces, Buffalo Skips and Pickers, Woven Hose, Packings and Asbestos.

**LUBRICANTS.**—Batching, Cylinder, Spindle, Loom, and Shafting Oils. Solid Lubricants. Lubricators and Oil Cans.

Bobbins, Shuttles, and Planetree Rollers, Picking Arms, Bank Pins and Spools, Cotton Banding, Temper Bands, &c., &c.

## SUNDRIES

Oils (Batching and Lubricating); Wheel, Rope, and Belt Dressing; Planetree Rollers; Roves; Bobbins; Spools; Electric Lamps; Batching and other Soaps; Tallow; Rosin; Glue; Cotton Waste; Sponge Cloths; Tying Twines; Hemp Temper Bands, &c.

# D. J. MACDONALD

C.E., M.I.MECH.E.,

MILL, FACTORY & ENGINEERS'  
FURNISHER AND EXPORTER,

15 CONSTABLE STREET, DUNDEE.

*Supplier of  
all classes of  
Mill Stores.*

Bobbins, Shuttles, Planetree Rollers,  
Pickers, Bale Hoops, Buckles and Rods,  
Grind Stones, Picking Arms,  
Scythe Stones, Jute Cutting Knives,  
Spinners', Reelers', and Weavers' Knives.  
Hook Knives, Leather Belting and Laces,  
Springs, Cylinder and Lubricating Oils,  
&c., &c.

Sole Agent for Scotland and British India  
for

**Walrus Fibre Sliver Cans**

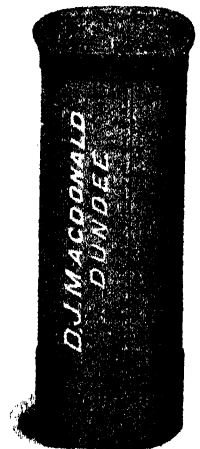

# D. J. MACDONALD

C.E., M.I.MECH.E.,

ENGINEER AND MACHINE MAKER,

South Saint Roque's Works, DUNDEE.

---

## **MAKER of** —

**SACK CUTTING MACHINES.**

**SACK HEMMING MACHINES (Straight Stitch).**

**SACK HEMMING MACHINES (Union Special System).**

**Overhead Hand-Stitch SACK SEWING MACHINES.**

**Single and Multi-Colour SACK PRINTING MACHINES.**

**TWINE TARRING MACHINES.**

**DYEING MACHINERY.**

**BLEACHING MACHINERY.**

**PITCHING and PROOFING MACHINERY.**

**RUBBER Grinding Mills.**

**Washing Mills.**

**Refining Mills.**

**Vulcanising Presses.**

**Spreading Machines.**

**Calenders.**

## **SOLE MAKER of** —

**Kinmond & Kidd Patent Multi-Colour Printing Machines.**

**M. & M. Patent Model Z Overhead Sewing Machine.**

**Hill's Patent Yarn Tester.**

**MacDonald Patent Consecutive Bag Numbering Machine.**

**Chilton & MacDonald Patent High-Speed Engine.**

Tel. No. 412

# BEATH & KEAY,

Tel No. 412

Engineers and Ironfounders,

## ALBION FOUNDRY, DUNDEE.

CASTINGS OF ALL DESCRIPTIONS FOR MILLS AND FACTORIES.  
PIPES AND BENDS UP TO 24 INS. DIA.

SHAFTING PULLEYS, WALL BRACKETS, HANGER BRACKETS, ETC.  
ROLLED STEEL JOISTS, GIRDERS, ROOFING, AND GENERAL ENGINEERING WORK.

Tel. Address: "FERGUSON."

ESTABLISHED 1875.

Telephone No. 94

# ROBERT FERGUSON & SONS,

Tool Specialists, Mill, Factory, and Engineers' Furnishers,

OFFICE AND SHOWROOMS: 15 BELL ST., DUNDEE.

WAREHOUSES: ROYAL EXCHANGE LANE.

### SPECIALITIES.

MACHINE AND HAND TOOLS OF ALL DESCRIPTIONS.  
PLANE TREE ROLLERS.  
WOOD AND PAPER SPOOLS.  
WOOD AND STEEL SPLIT PULLEYS.  
BALATA, COTTON AND HAIR BELTINGS.  
WHALE AND LUBRICATING OILS.

### AGENCIES.

"UNIVERSAL" WINDING MACHINES.  
CROPPING MACHINES.  
"BUCKEYE" WHITEWASH AND PAINT SPRAYERS.  
"BUFFALO" AUTOMATIC INJECTORS.  
HART'S PATENT DUPLEX DIESTOCKS.  
"MINIMAX" FIRE EXTINGUISHERS.  
METAL FILAMENT ELECTRIC LAMPS.

Foreign Indents carefully attended to.

Shippers to all parts of the World.

Telephone No. 2231.

Telegraphic Address:—"Ammoniac," Dundee.

# DAVID T. DEWAR, Ltd.,

THE DUNDEE HACKLE WORKS,  
OLD GLAMIS ROAD, DUNDEE.

Manufacturers of Wood Card Covering, Hackles, Gill and Card Pine,  
Rivets, etc. Cast Steel Wire Drawers.

# **JAMES F. LOW & CO.,**

**MONIFIETH FOUNDRY,** **Ltd.,**

**MONIFIETH, SCOTLAND.**

---

**Makers of**

**PREPARING AND SPINNING MACHINERY**

**FOR**

**Flax, Hemp, Jute, and Tow.**

---

**IRON AND BRASS FOUNDERS.**

---

Wheel Gearing of all kinds, both moulded and machine-cut, also Brass  
Necks and Steps for all classes of Textile Machinery a Speciality.

---

**SOLE MAKERS OF**

**Orr's Patent Jute Root Opener,**

**Spences' Patent Jute Root Comber,**

**AND**

**The Prause Patent Mechanical Doffing  
Spinning Frame.**

---

**Complete Plans and Estimates supplied for Mills.**

Telegrams: "Low, Monifieth."  
Telephone: No. 1, Monifieth.

Codes { A, B, C (5th),  
Marconi.

Telephone No. 1173.

# **DIXON'S**

# **Sheffield Warehouse**

FAMED FOR ALL KINDS OF  
CUTLERY.

---

---

**Small Tools.**    **Mill Scissors.**

**ELECTRIC BELL SUNDRIES.**

**Porter Gauges.**    **Linen Provers.**

---

---

You will find us quite useful for many Lines.

**DIXON'S**    **41 High Street**  
**DUNDEE**

# HUNTER, DOIG, & PALMER,

Brassfounders and Brassfinishers,  
Mill, Factory, and Engineers'  
Furnishers,

RATTRAY STREET, WARD ROAD,  
DUNDEE,  
SCOTLAND.

---

MANUFACTURERS

of Every Description of

GUN METAL FITTINGS

for

Spinning and Weaving.

---

MILL STORES

of all kinds kept in Stock.

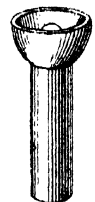
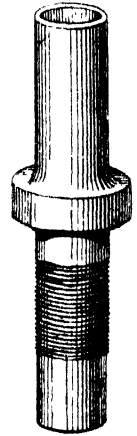
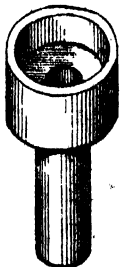
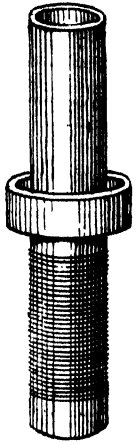



WALKER &  
THOMSON,  
DUNDEE.

Jute Batching Oils

— and —

Lubricating Oils

*Advertisements*

**Established 1814.**

# George Stephen & Son

29 CASTLE STREET, DUNDEE.

WAREHOUSES:—EXCHANGE STREET & COMMERCIAL STREET.

**Iron, Steel & Metal Merchants, Mill & Factory Furnishers,  
General Household Furnishings.**

## Hand Screwing Machines.

For Screwing Bolts, etc.,  $\frac{1}{4}$ " to 1"  
Gas Thread,  $\frac{1}{4}$ " to 1".

**Special Dies, B.S.F., Left Hand,  
Metric.**

**Electric Conduit  
Thread Dies.**

Suitable for Engineers.  
Mills, Blacksmiths, &c.

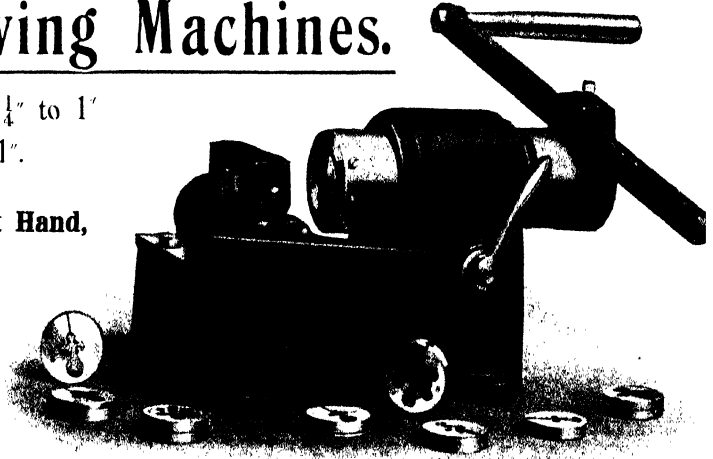

**PRICE LOW.**

SOLE AGENTS FROM FORTH TO NORTH OF SCOTLAND.

**Garden Utensils      Garden Rollers      Garden Sprinklers**

**KITCHEN RANGES to any Size a Speciality.**

**BOLTS & NUTS—Most Varied Stock in Scotland.**

**FOREIGN INDENTS Carefully Attended To.**

# GEORGE STEPHEN & SON, 29 Castle St., Dundee

Telegraphic Address: "Rae, Dundee."

Telephone Nos. 199 and 299.

TELEPHONE No. 647.

# HALLEY BROTHERS, LTD.

MANUFACTURERS OF

Wood Card Covering and Steelfaced Card Covering,  
Gills, Machine and Hand Hackles,

FOR PREPARING FLAX, HEMP, AND JUTE.

ALSO

HACKLE, GILL, AND CARD PINS, GILL RIVETS, Etc.,

FOR THE JUTE, FLAX, AND HEMP TRADES.

---

SOUTH WARD ROAD, DUNDEE.

---

## THE WILL MOTOR TRANSPORT COY., LTD.,

Telephone { 2258  
Nos. { 631  
282

MOTOR HAULAGE CONTRACTORS  
AND STEAM WAGON OWNERS,

GEO. WILL,  
Manager.

Office & Garage: **200 STRATHMARTINE ROAD, DUNDEE.**

---

CHAR - A - BANCS FOR HIRE (Up-to-Date Vehicles).

---

**PETROL AND STEAM LORRIES for LOADS of 2/10 TONS.**

GOODS TRANSPORTED ANY DISTANCE.

REMOVALS UNDERTAKEN IN TOWN & COUNTRY.

---

GOODS DELIVERED TO ALL PARTS OF TOWN.

Receiving Office: 43 YEAMAN SHORE.

# PRINTING

with Promptitude

**HOME AND EXPORT**

- ¶ Up-to-Date Plant.  
Type Setting by Hand and Machine.
- ¶ We can print everything from Highest-class Three-Colour Work to a Visiting Card.
- ¶ We guarantee the rapid production of Prospectuses, Statements, Balance Sheets, Billheads, Pamphlets, Memorandums, Booklets, Circulars, Show Cards, Catalogues, Textile Stationery of every description, &c., &c.
- ¶ Our Work is of the Best, and Our Prices are very Moderate.

• • • •

**WILLIAM KIDD & SONS**

**Whitehall Street :: :: :: Dundee**

# Fairbairn Lawson Combe Barbour

Limited.



And at CALCUTTA, India; and LILLE, France.

Makers of Machinery for Preparing and Spinning

## FLAX, HEMP, TOW, and JUTE.

SOLE MAKERS OF

PATENT DRY SPINNING FRAME for SPINNING COPS on the BARE SPINDLE.

Machinery for the Manufacture of

## TWINES and ROPE YARNS.

TUBING TWISTERS AND CABLERS.

## BINDER TWINE, TRAWL TWINE, HOUSE and ROPE WALK MACHINERY.

Also Makers of

ENGINEERS' GENERAL TOOLS for RAILWAY & ORDNANCE Purposes.

STEAM ENGINES, GROOVED ROPE PULLEYS, SHAFTING, &c.

COMPLETE PLANS AND ESTIMATES FOR SPINNING AND WEAVING MILLS SUPPLIED

