

BIRLA CENTRAL LIBRARY
PILANI [RAJASTHAN]

Class No.

Book No.

Accession No.

THE FIBRO MANUAL

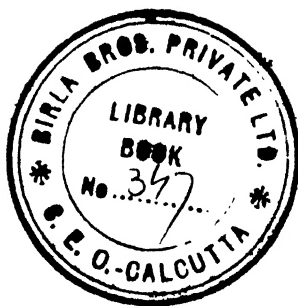

*Witness, all ye realms
Of either hemisphere, where commerce flows:
The important truth is stamped on every bale.*

THE FLEECE, JOHN DYER, 1700-1758

THE FIBRO MANUAL

A treatise on the characteristics and application of viscose rayon staple produced by Courtaulds, Limited. By a group of specialists under the editorship of C. M. WHITTAKER, D.Sc., F.T.I.

Copyright by Courtaulds, Limited

SET BY CLARE, SON & CO. LTD., WELLS, SOMERSET; PRINTED AND BOUND BY NOVELLO &
CO. LTD., LONDON. PAPER: JOHN GALPIN LTD. CLOTH: TEXTUFF LTD., LONDON.
MADE IN GREAT BRITAIN

NAMES OF CONTRIBUTORS

- H. ASHTON, F.T.I.
J. K. BERRY, M.SC., A.INST.P.
H. W. BEST-GORDON
J. BOULTON, M.SC. TECH., F.R.I.C., F.T.I.
A. S. CLULEY, A.T.I.
A. GLOVER, F.T.I.
R. S. GREENWOOD, M.SC. TECH.
W. HARDACRE, F.T.I.
C. HOWDEN, A.T.I.
J. A. KIRBY, M.SC. TECH.
R. A. MCFARLANE
S. PEARSON, M.SC., A.R.I.C.
W. PENN, F.T.I.
S. POTTS, B.SC. TECH.
J. PROCTER
C. P. TATTERSFIELD, A.T.I.
H. A. THOMAS, B.SC., PH.D., F.R.I.C., F.T.I.
S. D. WEAVER, B.SC., PH.D., A.R.C.S., D.I.C.
C. C. WILCOCK

SHORT GLOSSARY OF TERMS

DENIER	The term used to denote the size of rayon or silk yarns. The denier is the weight in grammes of 9,000 metres of yarn.
<i>FIBRANDA</i>	Viscose rayon staple produced by Courtaulds, Limited, and chemically modified to reduce its water imbibition and thus its swelling properties.
<i>FIBRO</i>	Viscose rayon staple produced by Courtaulds, Limited.
<i>FIBROCETA</i>	Cellulose-acetate rayon staple produced by Courtaulds, Limited.
<i>FIBROFIX</i>	Product manufactured by Courtaulds, Limited, used chiefly in improving the fastness to washing of selected direct cotton dyes.
<i>FIBROLANE</i>	Protein rayon staple produced by Courtaulds, Limited.
"GREENFIELD TOP"	<i>Fibro</i> top or sliver produced directly from continuous filament tow by the Courtauld "Greenfield" patent method.
<i>RAYOLANDA</i>	Viscose rayon staple produced by Courtaulds, Limited, with special properties, the most important of which are fullness of handle and an affinity for wool dyes.
RAYON	Generic term applied to all fibres for textile use which are not of natural occurrence (Textile Institute definition).

CONTENTS

	<i>Page</i>
Names of Contributors	5
Short Glossary of Terms	7
Preface	11
Introduction	14

SECTION I—PRODUCTION AND PROPERTIES

CHAPTER 1.	Production	19
CHAPTER 2.	Physical and Chemical Properties	22

SECTION II—SPINNING

CHAPTER 3.	Tinting	37
CHAPTER 4.	“Greenfield Top”—Rayon Tow-to Top Conversion	40
CHAPTER 5.	<i>Fibro</i> for Cotton Spinning Machinery	46
CHAPTER 6.	Spinning on Cotton Machinery	63
CHAPTER 7.	Spinning on Cotton Condenser Machinery	75
CHAPTER 8.	Spinning on Woollen Machinery	76
CHAPTER 9.	<i>Fibro</i> for Worsted Machinery	80
CHAPTER 10.	Spinning on Worsted Machinery	100
CHAPTER 11.	Spinning on Flax Machinery	105
CHAPTER 12.	<i>Fibro</i> in the Spun Silk Industry	106
CHAPTER 13.	Spinning on Jute Machinery	108

SECTION III—FABRIC PRODUCTION

CHAPTER 14.	Fabric Construction	113
CHAPTER 15.	Warp Sizing	121
CHAPTER 16.	Weaving	124
CHAPTER 17.	Knitted Fabrics	128

SECTION IV.—PREPARING, DYEING, PRINTING AND FINISHING

CHAPTER 18.	Staple and Yarn Dyeing	133
CHAPTER 19.	Narrow-Fabric Dyeing	164
CHAPTER 20.	Preparing and Dyeing <i>Fibro</i> Fabrics	171
CHAPTER 21.	Printing of <i>Fibro</i> Fabrics	185
CHAPTER 22.	Finishing of <i>Fibro</i> Fabrics	213
CHAPTER 23.	Preparing and Dyeing <i>Fibro</i> /Wool Blends	244
CHAPTER 24.	Preparing and Dyeing <i>Fibro</i> /Rayolanda Blends	258
CHAPTER 25.	Preparing and Dyeing <i>Fibro</i> /Fibroceta Blends	268
CHAPTER 26.	Preparing and Dyeing <i>Fibro</i> /Fibrolane Blends	273
	Appendices	279
	Index	301

PREFACE

THE widening use of *Fibro* over the past twenty-five years has brought with it an increasing literature on the subject, composed chiefly of patent specifications, scientific lectures and papers, publications issued by Courtaulds, Limited (its sole producers), and articles in the technical press. Its development has been so rapid that much of this literature is out-dated and is, moreover, not easily found as it is widely dispersed. These considerations, and the demand for guidance on the subject by textile technologists, demonstrated a need to assemble into one volume a comprehensive body of information on *Fibro* and its applications; and I was invited by my co-directors to arrange for this.

It was obvious from the outset that no one individual could provide even a large part of what the textile trades would expect to find in a book on a fibre that has opened up entirely new fields, and to-day plays no mean part in the national economy. I therefore invited a number of my colleagues in Courtaulds, Limited, to prepare chapters on those fields in which they were most experienced. They and their staffs tackled the job with enthusiasm, and the present manual is the outcome.

It is hoped that this book will enable all those interested to form a true estimate of the manifold applications of *Fibro* and to achieve the best results with it in producing fabrics for a necessitous world. In meeting the long-term need for quality, which must not be sacrificed to the short-term call for quantity, the technical "know-how" is of paramount importance. Far-sighted users have long since recognised that *Fibro* is no mere substitute material but is distinctive,

has its own intrinsic qualities, and calls for special techniques at various stages of its handling if the best results are to be achieved.

Moreover, the fact that *Fibro* may be spun on every known system places at the disposal of the textile technologist a range of yarns unsurpassed in scope by any other fibre—yarns which demonstrate in use that *Fibro* is complementary to as well as competitive with other textile materials. So no longer can (say) the woollen or worsted manufacturer afford to think in terms alone of wool, or the linen weaver alone of flax; all textile technologists to-day must think in terms of all available fibres and use them much as an architect does his materials—to achieve the desired result in terms of public satisfaction.

Therefore, the maximum value from this book may best be obtained by reading it all, thereby obtaining from it an over-all picture, rather than by confining attention to those chapters dealing with machinery or methods in which the reader may have special interest. Yet, while comprehensive, this manual is not of course complete. My colleagues lay no claim to a monopoly of knowledge on their subjects and are learning all the time. Furthermore, what might be impossible with *Fibro* to-day may well be possible to-morrow, and a limited knowledge at present exists on some uses which remain only partially explored. Because this or that chapter is brief or sketchy, it should not therefore be assumed that the application with which it deals is necessarily unsuitable; only that time and circumstances have not yet permitted it to be investigated so thoroughly as others and difficulties surmounted.

As to the form in which the manual is presented, all concerned have aimed at as high a standard as is permitted by to-day's production limitations. Apart from comprehensiveness, the aims have been accuracy, clarity, ease of reference, and durability. On the score of clarity it should be mentioned here that where registered names of Courtaulds' rayon staples and yarns occur in the text they are distinguished by italics. Some of these productions, it should be borne in mind, are only in the development stages at the time of writing and they may not be available in commercial quantities.

I am happy to acknowledge the suggestions made by Mr. A. H. Wilson, F.R.S., and the technical editorial assistance of Mr. G. S. Heaven. I must also thank the British Launderers' Research Association for the informative appendix on "Laundering".

C. M. WHITTAKER

INTRODUCTION

TOWARDS the end of the last century the outstanding and desirable feature of all the early rayons, or "artificial silks" as they were then called, was their production in continuous threads of high lustre. They were readily sold at high prices, rivalling those of silk; and, after the successful manufacture of a marketable product in 1894, the quantity produced steadily increased and so did their selling price, until from about 1906 they met the competition of the newer viscose rayons. These in their turn were even more successful, technically and commercially, and the expansion in their production was enormous.

Rayon was first used in continuous filament form as a substitute for silk; then, in addition, in the form of discontinuous waste, for mixing with wool and cotton on wool and cotton machinery; and later in the form of staple specially produced for spinning on the standard textile spinning systems into 100% spun rayon or mixture yarn.

In order to spin rayon with the natural discontinuous fibres on machinery designed for the latter, the continuous filaments had to be cut into small pieces of staple length. A. Pellerin in France proposed in his patent of 1907 to spin a kind of discontinuous rayon waste, to be worked up with the "natural" fibres; but the time was not ripe for such productions.

However, the late Mr. H. G. Tetley of Courtaulds, Limited, was led to consider the alternative of rayon specially produced in staple lengths for spinning on cotton and worsted machinery.

During the First World War the Germans were short of wool and cotton, and made great use of cut rayon in the manufacture of mixed fabrics; their technicians anticipated large scale manufacture after the war. These expectations were not realised as it was not yet economical to replace the relatively low priced cotton and wool, and factories turned back to continuous filament rayon production. Such progress as was made in most countries was in the direction of using rayon waste necessarily made in the normal textile processes.

Viscose rayon staple, under the registered trade-mark of *Fibro*, was manufactured on a commercial scale by Courtaulds at their Wolverhampton and Flint factories early in 1925, and a modern factory for the sole production of *Fibro* was soon envisaged and built at Greenfield in North Wales.

The ambiguity of the customs classification of rayon waste with rayon staple gave rise to a good deal of unfortunate misapprehension as to the real status of the latter specialised material, which had been designed from first to last to perform a specific textile function.

However, the *Fibro* production of the Greenfield factory, with a capacity of over one million pounds weight per week, and the acquisition by Courtaulds of a typical Lancashire cotton spinning mill (Arrow Mill) to demonstrate the ease with which *Fibro* could be spun on normal cotton mill equipment, finally established this rayon staple in industry.

In 1937 another step forward was taken by the purchase of a Bradford mill, now named Westcroft Mill, to serve the interests of the Yorkshire worsted trade in the same way that Arrow Mill served the Lancashire cotton trade. The equipment installed gave the maximum flexibility in order to perform a useful service to the whole of the Yorkshire trade by demonstrating the simplicity of processing rayon staple blended with wool, and by assisting in the development of new types of staples and their introduction to the trade.

During the past few years special factories have been erected by many companies in different parts of the world for the sole purpose of producing rayon staple.

Thus this new industry is the natural outcome of the older

rayon industry of continuous filaments, and its product is uniform in length, denier, and dyeing affinity.

Rayon staple is a new material with its own intrinsic merits; it is not a substitute but a fibre which is complementary to the older ones, and its development has been made on the basis of experience in manufacture and utilisation.

SECTION I
PRODUCTION AND PROPERTIES

FIGURE 1

FLOW GRAPH

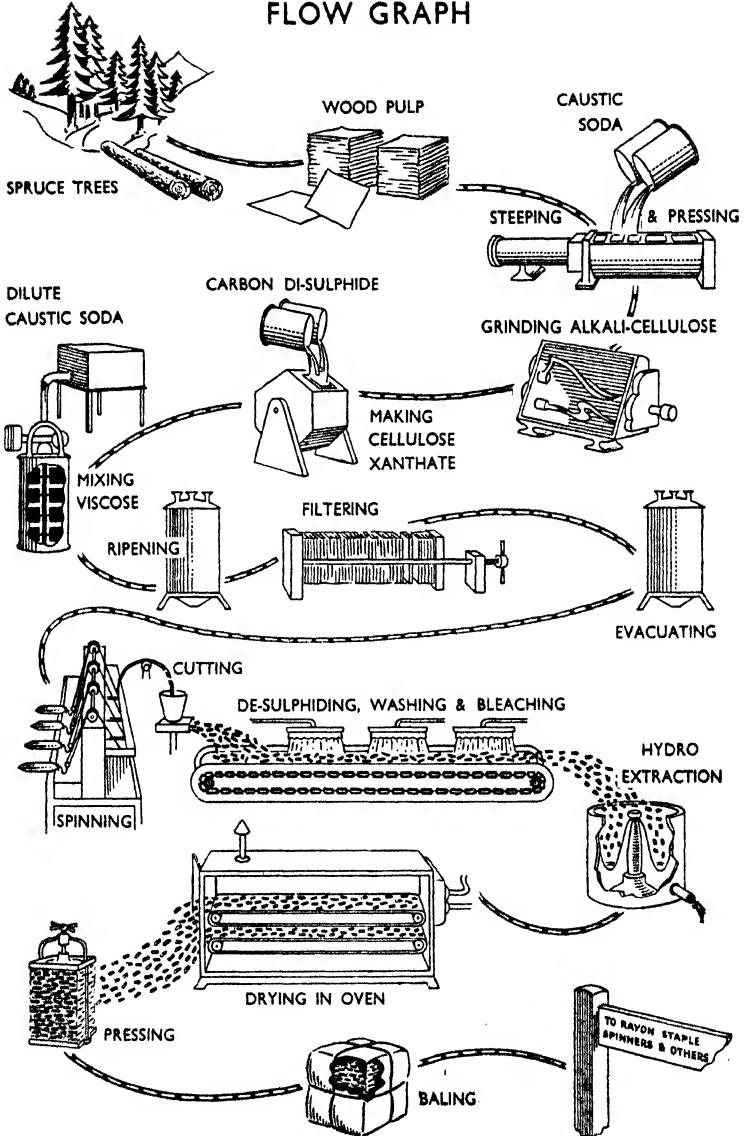

CHAPTER I

PRODUCTION

THE progress and use of rayon staple in the past twenty years or so have been little short of phenomenal, as the figures in Appendix Four show, and few would challenge the view that its place in the textile industries is now permanent.

It may be produced from viscose, cellulose-acetate, casein or other materials, each type of staple having its own particular merits and suitable applications; but this book is concerned mainly with viscose, which hitherto has accounted for the great bulk of the world and United Kingdom outputs of rayon staple, and more especially with Courtaulds' own brand of this—*Fibro*. This chapter is therefore confined to the production of that staple.

Although it is hardly necessary for the textile technologist to have a scientific knowledge of the processes involved in producing *Fibro*, it is advisable for him to know these in broad outline. To some people who have become acquainted with *Fibro* at one or more stages on its road to the consumer, this chapter may therefore be confirmation of knowledge already possessed. Nevertheless, it is included because to some it may be new and is, in any case, an essential and initial part of a manual laying claim to comprehensiveness on its subject.

The following may be read in conjunction with the flow graph at Figure 1.

Fibro is made from regenerated cellulose—that is, the natural cellulose of plant life, dissolved and then reprecipitated in a different form. The starting material is a sulphite wood pulp usually manufactured from Canadian or Norwegian spruce.

Wood Pulp. The first process in the pulp manufacture is the washing of the logs and the removal of the bark by rolling them together. They are then cut up into small chips which are placed in digesters and cooked by steam in

the presence of an acid bisulphite liquor. This removes practically all unwanted material. The cooked cellulose, after bleaching, is then washed and small solid impurities that remain in it are removed in "riffers".

Pulp for rayon manufacture has to be prepared for economical transport, so it is next screened to remove water and then run over about forty large steam-heated cylinders; leaving this machine, it is cut into convenient sizes of sheet, in which form it is shipped.

On receipt at Greenfield Works, Holywell, Flintshire, North Wales, where they are manufactured into *Fibro*, the cellulose sheets are sampled, tested and stored in a special warehouse to condition them.

Steeping and Pressing. In a press the cellulose sheets are then steeped in a caustic soda solution of approximately mercerising strength, immersed in an upright position. Next the soda solution is allowed to drain off, and part of the soda retained by the sheets is squeezed out by means of hydraulic rams fitted to the steeping tanks.

Grinding. The sheets are then taken out and ground in a shredder. This has a set of powerful spiral knives which revolve, tearing the sheets to pieces against another set of knives fixed to the bottom of the shredder. At this stage the alkali-cellulose material is called "crumbs" because of its resemblance to breadcrumbs. On completion of this stage the product contains approximately one part cellulose and two parts soda.

The crumbs are then stored in large boxes for a few days at a constant temperature; this period is known as mercerising, as the time and temperature control the amount of oxygen absorbed by the crumbs, which determines the viscosity of the final solution.

Making Cellulose Xanthate—After mercerising, the crumbs are taken to the churn room where they are placed in a large hexagonal churn and treated with carbon di-sulphide, the effect of which is to change the cellulose from a white insoluble material to an orange-red sticky substance, soluble in water, named "cellulose xanthate".

Mixing. The cellulose xanthate is emptied from the churns into large mixers where it is dissolved in water or a weak solution of caustic soda; this action is assisted by an agitator

which keeps the solvent in continuous circulation. When the xanthate has been dissolved the solution is run off and passed through a series of filters to remove impurities.

Ripening. After filtration and de-aeration under vacuum to remove any bubbles of air which would interfere with the spinning operation, the solution is kept in large storage tanks, where it undergoes a process known as "ageing". Actually this is a reversal of the xanthation process, for, instead of the carbon di-sulphide combining with the cellulose, it now detaches itself and forms other compounds or by-products. If it were left long enough the viscose would set to a solid jelly of regenerated cellulose. The selection of the best condition for spinning is ascertained by reference to time and temperature. When ready for spinning, the solution is a clear sticky liquid, in appearance like treacle. It is this distinctive viscosity which gives it its name "viscose".

Viscose Spinning. After the final filtration, the viscose is now ready to spin (the word is used here, of course, in the sense of *extrude into filament form*) and is conveyed to the spinning machine through pipes under pressure; it is then squirted or extruded through a spinning nozzle or jet called a spinneret, the flow being controlled by a pump, into a spinning bath containing dilute sulphuric acid and other chemicals. The cellulose is thus precipitated and can be extruded as filaments.

Cutting. It is at this point that the manufacture of *Fibro* varies from that of continuous filament. With the latter the filaments are twisted into a thread and go through subsequent operations in that form, i.e., yarn. With *Fibro* the spinnerets are much larger with hundreds instead of dozens of holes; and the spinning machine is constructed differently to allow for the collection of the thousands of filaments coming from the jets to be drawn together in the form of a "tow" instead of threads. A few moments after coagulation has taken place, this tow of continuous filaments is cut up into staples of predetermined length by an automatic device of great accuracy. In the course of this process the fibres acquire a "crinkle" which makes for inter-fibre cohesion when in loose form and greatly facilitates their treatment in the processes prior to their conversion into yarn.

De-sulphurising, Washing, Hydro-extracting, Drying. What is

now viscose rayon staple is still wet with liquor from the spinning bath, so it is now washed free from acid, desulphurised, washed and given a final treatment with soap solution. Then it is dried and opened out carefully before being conditioned to a uniform moisture content of 10%.

Pressing and Baling. It is now pressed into bales, and is ready for shipment as *Fibro* to the mills for conversion into yarn on one or other of the standard textile spinning systems. The fact that it has been brought to a 10% moisture content makes it highly desirable when it arrives at the mill to store it in an atmosphere of the same relative humidity. In this way irregularities in processing may be avoided.

Of course, a strict control of chemicals, conditions and times has to be unfailingly maintained all along the line of manufacture. At crucial points, tests are made regularly and nothing is left undone to assure a product of high standard.

Fibro can be spun to any degree of "dullness" by incorporating a dulling agent into the viscose solution before it is spun (i.e., *extruded*). The dullness is therefore actually inherent in the fibre and cannot of course be removed by any subsequent treatment. Viscose can also be extruded as a coloured filament, pigment being incorporated in the viscose before extrusion. "Spun-dyed *Fibro*" is available in several standard shades. (See Appendix Six).

Fibro is also produced and supplied in top or sliver form, known as "Greenfield Top," which is dealt with at length in Chapter IV.

CHAPTER II

PHYSICAL AND CHEMICAL PROPERTIES

Molecular Structure. All fibres manufactured by the viscose process are of the regenerated cellulose type, and a controlled stretch is applied to them during the spinning process. Their physical properties and degree of orientation depend

upon the physico-chemical condition of the material during the stretching process, and on the magnitude of the applied stretch. During the production process as described in Chapter I, cellulose xanthate is brought into solution and, according to the theory of molecular convolution, proposed by Mark, Meyer, Kuhn^{1, 2, 3} and others, these xanthate chain molecules relax due to thermal agitation to a coiled configuration by free rotation at the oxygen bridges between successive glucose units. The object of the spinning process is to extend these chains to their maximum length and to orient them parallel to the fibre axis so that crystallisation is promoted and the resulting high lattice energy confers physical and chemical stability on the product. This object is achieved in part only, and the fibres contain non-crystalline regions where the chains are less closely packed and have a lower degree of orientation along the fibre axis than in the crystallites; thus they retain some of the randomness of configuration which they possessed in solution. In such regions the lateral adhesion of adjacent chains is reduced and their presence as an appreciable volume fraction of the fibre provides an explanation of some of the differences between regenerated and natural cellulose fibres.

In the production of the regenerated cellulose fibres, it is possible by altering the physico-chemical conditions of precipitation and stretching to obtain a range of fibres from those of a high strength and low extensibility to those of a low strength and high extensibility. Examination of the cross sections of the more oriented fibres by polarised light or suitable staining technique shows that this orientation is not uniform throughout the section but appears to be greatest at the surface of the filaments and least in the central core. This structure is a natural consequence of the viscose spinning process and, as would be expected, the tensile strength is increased within limits by reduction in filament denier.

Mark and Meyer⁴ have calculated the theoretical tensile strength of a fully oriented crystalline cellulose breaking by chain rupture to be 850 kgs/mm.² and for an ideal system of parallel chains of degree of polymerisation of 400 breaking by slippage as 130 kgs/mm.². Since the estimate due to Svedberg⁵ gives the degree of polymerisation of cotton cellulose between 6,000 and 10,000, neither of these

mechanisms represents the true picture of rupture as they suggest strengths considerably in excess of the highest measured values. It would appear, therefore, that in common with most other crystalline substances, the tensile strength realised by the most perfectly oriented natural cellulose is limited by structural imperfections.

Regenerated cellulose fibres may be considered to consist of primary valence chains of limited length which form crystalline regions linked to regions of lower order, and X-ray photographs show that increasing orientation is in general accompanied by improved crystallinity. The regions of lower order in the structure sometimes known as amorphous are, of course, regions of low lateral adhesion and the value of this lateral adhesion will determine whether a fibre is ruptured by slippage or chain fracture. It is probable, for the more highly oriented fibres, that the rupture process is a small initial slippage resulting in uneven load distribution and finally successive rupture of the chains. If the lateral adhesion which depends on chain length and orientation is low, then rupture may occur largely by slippage alone—as, for example, when the fibres are swollen with water. X-ray evidence shows that water does not penetrate the fully crystalline regions, but it does penetrate the regions of lower order and therefore reduces the lateral adhesion which promotes slippage under load, causing a reduction in strength. In contrast to this, the strengths of cotton and other natural celluloses are not decreased by wetting since these fibres consist of very long highly oriented primary valence chains and are ruptured by chain fracture. The swelling of such fibres by water appears to produce stress equalisation which may even confer improved mechanical strength.

Mechanical Properties. Stress-Strain Relationships. The measurement of breaking loads and extensions gives a very limited amount of information about the properties of a substance, but it is possible to amplify this information if the relationship between stress and strain is obtained throughout the loading cycle. It is very desirable that such studies of behaviour should be made under controlled and measured conditions of rate of loading, temperature and relative humidity. Since all these factors have an influence on the load extension behaviour, it is not possible to ascribe to a

FIGURE 2

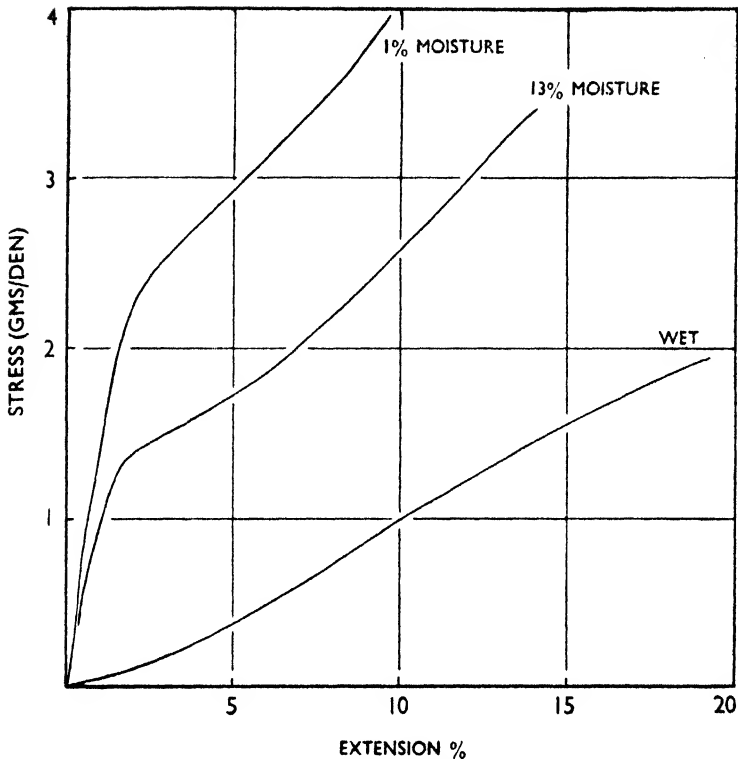

fibre a particular stress-strain relationship without describing the conditions and history of the sample and the dynamics of the measurement, but the general form of the stress-strain curve is common to all regenerated cellulose fibres, and can be related to the molecular structure outlined above.⁶

One of the curves shown in *Figure 2* is a typical stress-strain diagram of Strong *Fibro* 1½ denier per filament measured at adsorption equilibrium with an atmosphere of 65% R.H. 20°C. with a sample length of two centimetres and rate of loading of 10 grams per denier per minute. It will be seen that there is an initial region of high modulus up to the yield point of the secondary valence forces in the "amorphous" regions. This yield point occurs at about 1% extension, and deformations within this limit are approximately elastic. The value of the initial modulus, and the

FIGURE 3

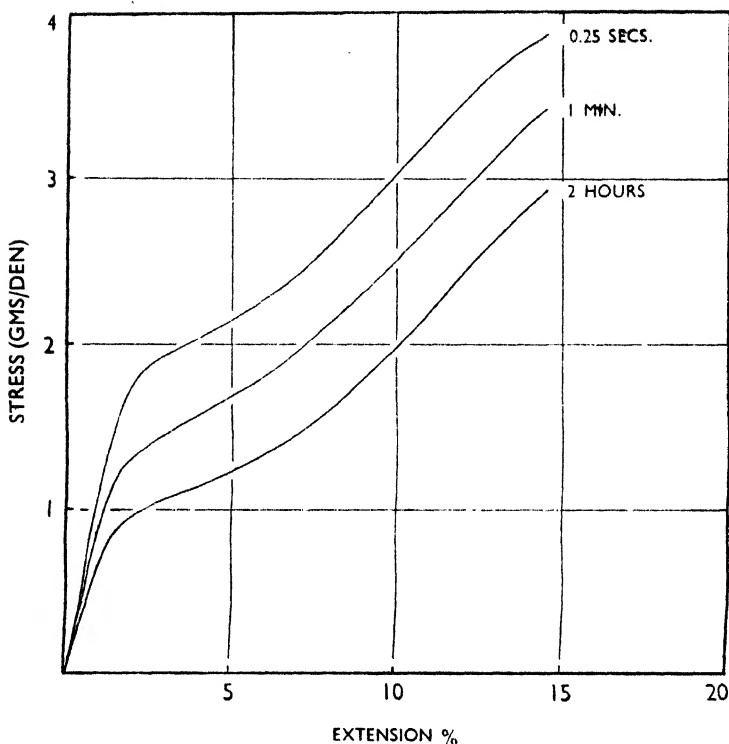

co-ordinates of the yield point, are dependent on the degree of orientation of the material, its moisture content and on the rate of loading. Beyond the yield point there is a region of lower modulus which corresponds to structural rearrangement in the non-crystalline regions, by the straightening out of non-linear cellulose chains by internal rotation and slippage. Deformation in this region is largely permanent in the dry state, but up to about 4% extension is fully recoverable by swelling in water and drying freely. Increasing extension produces increased orientation and the modulus increases again. Further deformation appears to be mainly a continuation of the chain uncoiling process which, however, is not fully recoverable by swelling in water, due probably to steric hindrance. Finally breakage occurs, partially by chain slippage and partially by successive chain

rupture due to uneven load distribution over the internal structure of the fibre.

The influence of moisture content on the stress-strain relationship is also illustrated in *Figure 2* which shows that a decreasing moisture content increases the initial modulus and raises the yield point and breaking load while the extensibility is reduced. The lower curve in the figure shows the effect of saturating the fibre with water which results in a decreased breaking load and an increase in extensibility. In this case the yield point and initial modulus have disappeared due to the reduced lateral adhesion in the amorphous regions which are penetrated by water. The magnitude of the effect of wetting on the mechanical properties depends upon the extent to which the water can penetrate the structure, and thus the effect of wetting is related to the degree of crystallinity.

In *Figure 3* the effect of rate of loading on the stress-strain relationship is illustrated, and this shows that the modulus of elasticity, the yield point and the breaking load increase as the rate of loading increases. The general shape of the curve and the extensibility at breaking point remain constant, however. Over a considerable range there is an almost linear relationship between the breaking load and the logarithm of the time of break.

The effect of spinning conditions on the shape of the stress-strain curve is illustrated in *Figure 4*, and it will be seen that strong *Fibro* is stronger and less extensible than normal *Fibro* and also has a higher initial modulus and yield point. This is the result of the effect of different spinning conditions on the structures of the two fibres which confer an increased orientation and an improved crystallinity of the strong *Fibro* with consequent modification of the mechanical properties.

Elasticity. Elastic behaviour of fibres is important at many stages of their processing and subsequent use as either yarn or fabric. The recovery of fibres from an imposed strain depends upon such factors as the rate of loading to produce the strain, the duration of the strain, rate of unloading and the duration of recovery. In comparing the elastic behaviour of fibres, it is therefore necessary to adopt arbitrary standards of time for each of the above influences. Meredith⁷ has

FIGURE 4

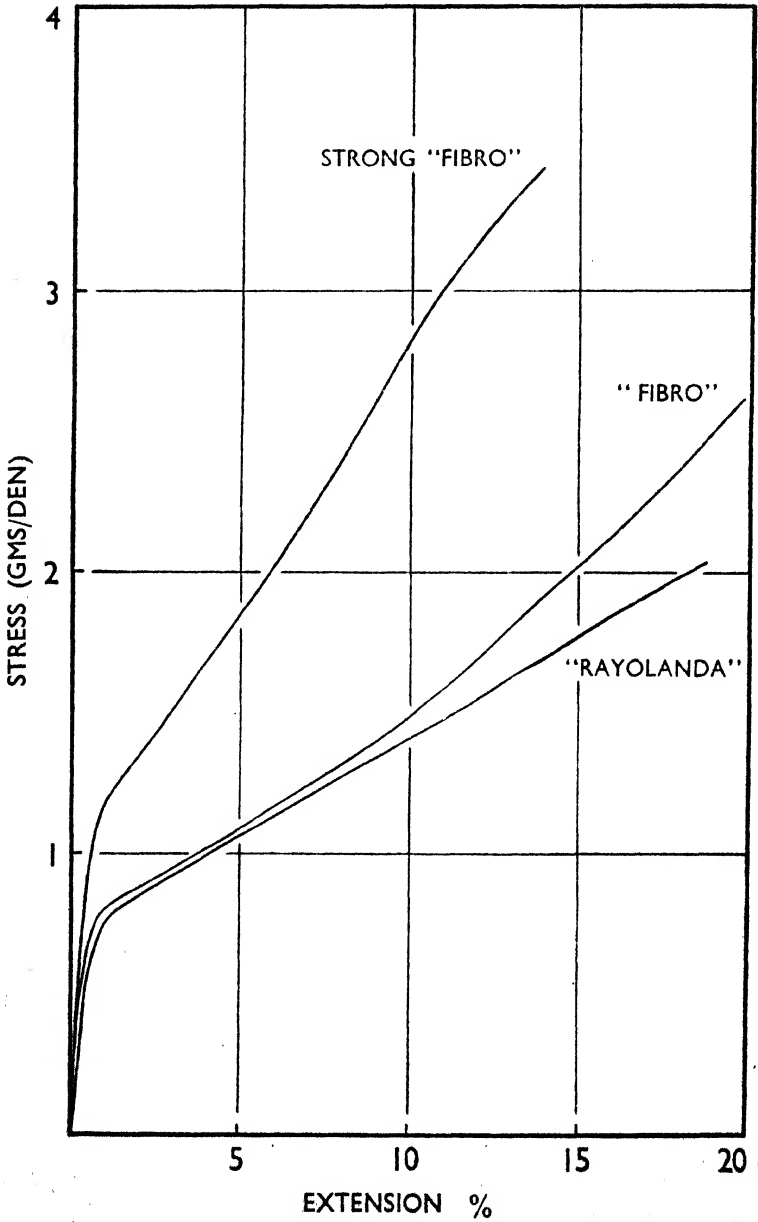
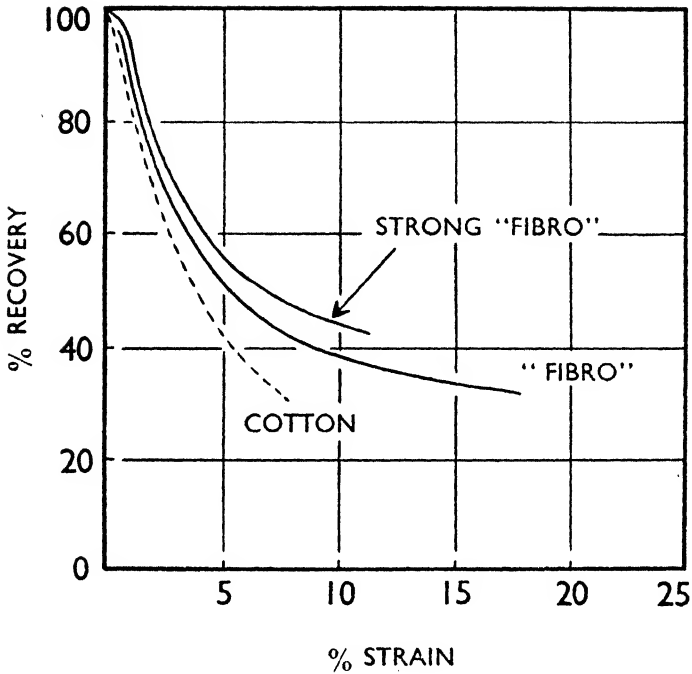
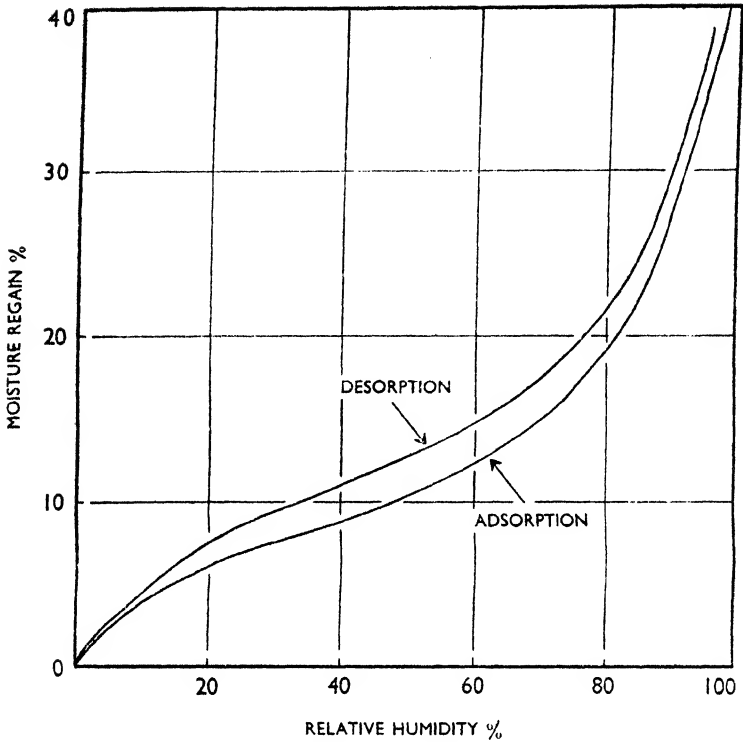

FIGURE 5



investigated the tensile elasticity of a considerable range of fibres and expressed his results as percentage recoverable extension of the total extension plotted against total percentage strain. Some of these results reproduced in *Figure 5* show that all cellulosic fibres have a low elastic recovery when strained beyond their yield point. This is due to rearrangement in the "amorphous" regions and stabilisation of the structure in the more extended state, which means that such fibres have a permanent internal strain which time alone does not completely remove. This delayed elasticity can, however, be converted into true elasticity by a swelling treatment which releases the internal strain. If, for example, a viscose fibre is strained 10%, then on removal of the load it will not recover more than about one-third of this strain even after a considerable time. If, however, the fibre is

FIGURE 6



swollen with water or dilute soda and allowed to dry freely, then recovery will be considerably increased by an amount dependent on the degree of swelling. If the swelling is sufficient the recovery may be complete and the fibre may even contract to less than its original length.⁸ In such a case the swelling has produced a decrease in lateral adhesion in the "amorphous" regions of the fibre sufficient to enable sections of the chain molecules, several glucose units in length, to behave independently of their neighbours, and rotation of the glucose units at the oxygen bridges is therefore possible.

Before leaving the subject of mechanical properties it is desirable to mention that the behaviour of fibres in practice is subject to the influence of the structure into which the fibre is formed whether it be yarn, rope, cord or fabric; and

further by the ability of the fibres to withstand a series of successive loads and strains which may be much below their breaking points. Such behaviour is conditioned by time effects, relaxation and flow properties: ultimate breakdown may be caused by irreversible flow due to the cumulative effects of stresses of short duration.

Moisture Relationships. Moisture Regain. In common with many other textile fibres, *Fibro* shows an adsorption and desorption hysteresis, and the dependence of moisture regain on relative humidity is shown in *Figure 6*. For example, *Fibro* conditioned from the dry side to equilibrium with an atmosphere of 65% R.H., 20°C. will have a moisture regain of approximately 13.3%, while a similar sample conditioned from the wet side to equilibrium with the same atmosphere will have a regain of 15.9%. The actual value of the equilibrium regain and the time taken to reach such equilibrium is dependent upon a number of factors such as the previous history of the sample and the presence of oil or other substances, which may hinder the adsorption or desorption of moisture. A sample of normal *Fibro* which does not contain any such oil would take approximately two weeks to reach full equilibrium with a controlled atmosphere of 65% R.H. 20° C., even in a well open form with the air in movement, although it would probably approach within 0.5% of its final equilibrium moisture regain after about two days.

The moisture regain figures related to equilibrium conditions in particular atmospheres should not be confused with the commercial regain figure known as Standard Regain, which is 11% for regenerated cellulose fibres; and it should be emphasised that this is a purely arbitrary figure chosen as the most useful for commercial purposes and that such standard regains for *Fibro* and other materials bear no consistent relationship to equilibrium regains in a particular atmospheric humidity.

Water Imbibition. The water imbibition of a textile material is defined as the weight of water imbibed after centrifuging at a particular acceleration as a percentage of the dry weight of the sample, and of course should be always quoted in conjunction with the acceleration at which it was measured. The property of water imbibition is of obvious importance in all textile wet processes such as dyeing,

laundering, drying and ironing; for example, fabrics made from fibres with a high water imbibition will be heavier when wet and take longer to dry than similar fabrics made from fibres of a low water imbibition. A reasonably high water imbibition, however, may provide a safety factor for time of safe contact during ironing, since a fabric with a very low water imbibition will quickly attain the temperature of the iron as there will be very little water to evaporate.

Typical values of water imbibition of *Fibro* obtained at an acceleration of 1000 g are as follows:

Standard *Fibro*

As received	100%–105%
After scouring and drying	90%–95%

Note: It may have lower imbibition value after steaming treatments.

Strong <i>Fibro</i>	95%–100%
<i>Rayolanda</i>	circa 50%

General Properties. Appearance. Normally *Fibro* is white and lustrous with a soft handle but, in common with other rayon fibres, one of its characteristics is that its properties can be modified to suit a particular purpose, not only by after-treatment of the finished yarn or fabric, but also by chemical or physical changes brought about during the manufacture of the fibres. For example, the lustre may be subdued by incorporating dispersed pigments such as titanium dioxide in the spinning solution, and it is by this means that dull or matt *Fibro* is made. Similarly, coloured fibres known as “spun-dyed” may be produced by the use of suitable coloured pigments, and it is possible by exercising a proper choice of pigments to achieve very good fastness properties which are in many cases superior to those obtained by normal methods of dyeing and much cheaper to produce.

The fineness of the individual fibres and the length to which they are cut may also be varied within fairly wide limits by suitable adjustments of the spinning process; therefore a very considerable variety of yarns may be spun from *Fibro*, in which considerable advantage may be gained by exercising the freedom of choice available regarding fibre characteristics such as length and fineness. In the

subsequent application of such yarns in fabrics, for example, it is possible to take advantage of the versatility of the manufacturing process to achieve an improved product such as a stronger fabric or one with a firmer handle.

The shape of the cross-section of regenerated cellulose fibres is quite characteristic and very often provides a means of identification. Normally the sections are considerably serrated and indented and it should be noted that the presence of included particles whether for dulling or colouring may be detected by microscopic examination particularly of the longitudinal view.

Specific Gravity. The specific gravity of *Fibro* is normally 1.53 but it is possible to produce it with a specific gravity down to 0.80 by causing the filaments to become inflated during production. Complete or partial collapse subsequent to spinning gives such fibres an elongated section with a hollow interior, and they therefore have a very considerable bulk and a very high surface/volume ratio, while their handle is extremely soft.

Thermal Properties. *Fibro* is very resistant to heat and, apart from glass and asbestos, is at least as good as any other textile fibre whether natural or rayon. Exposure to elevated temperatures over a period of time results in a degradation of mechanical properties in a manner almost identical to cotton. After prolonged exposure (24 hours) at 150° C. signs of charring are apparent, but the fibres will withstand higher temperatures for a shorter period without suffering appreciable damage, although thermal decomposition becomes increasingly rapid as the temperature is raised.

Effect of Exposure. When *Fibro* is stored under proper conditions without exposure to sunlight, fumes, high humidities and temperatures, it can be stored indefinitely with very little effect on its properties. Proper storage conditions may be considered to be within the range 55 % to 65 % R.H. 15° to 20° C. Exposure to sunlight results in a loss of strength by an amount dependent on the type of fibre and the conditions of exposure such as temperature, humidity and time. For example, pigment-dulled fibres degrade more rapidly than bright and thus, in general, bright, not matt *Fibro* should be used where conditions of service include prolonged exposure to sunlight. *Fibro* is completely resistant to attack

by moths, but may be subjected to attack by mildew if stored in conditions favourable to its growth.

Effect of Chemicals. In this respect *Fibro* is very similar to cotton, being disintegrated completely by hot dilute or cold concentrated acids, and attacked to a greater or lesser degree by acids of other concentrations and temperatures. In the presence of alkalis, *Fibro* becomes swollen to a greater extent than cotton, and its mechanical properties are impaired. If sufficiently concentrated, alkalis may cause complete disintegration.

The majority of organic solvents have no effect on *Fibro* and it may therefore be subjected to the usual dry cleaning process without harmful results. In common with other regenerated cellulose fibres, *Fibro* is completely soluble in cuprammonium solution and is attacked by strong oxidising agents. However, it is not damaged by hypochlorite or peroxide solutions, providing the strength of these is controlled similarly to the strengths used for cotton.

In the following *Table 1* the properties of *Fibro* are summarised where it is possible to present them in such a form.

TABLE 1

	(65% R.H., 20° C.)	<i>Strong Fibro</i>	<i>Fibro</i>	<i>Rayolanda</i>
Tenacity, gms./den.		3.4	2.6	2.0
Extensibility, %	..	14.0	20.0	18.0
Breaking stress K, gms./mm. ²	..	46.0	35.0	28.0
Breaking length K, m.	..	31.0	23.0	18.0
Work of rupture, gms./cm./den./m.	..	32.0	32.0	26.0
Young's modulus, gms./den.	..	83.0	74.0	60.0
Loss of strength on wetting, %	40.0	42.0	43.0
Water imbibition, %	95-100	90-95	50 circa.
Specific gravity	1.5	1.53	1.53

The table includes the properties already mentioned, and also others which are included for the sake of completeness.

References

¹ Mark and Meyer, *Cellulose and Cellulose Derivatives* (Ed. Ott, Interscience Publishers, 1943).

²Kuhn, *Kolloid-Z.*, (1934), 68, 2 ; (1936), 76, 258 ; *Naturwiss* (1936), 24, 346.

³Guth and Mark, *Monatsh.*, (1934), 65, 93.

⁴Mark and Meyer, *loc. cit.*

⁵Svedberg, *Nature*, (November, 1943).

⁶Berry, J., *J. Roy. Soc. Arts.*, (1946), 94, 403.

⁷Meredith, J., *J. Text. Inst.*, (1945), 36, T. 147.

⁸Entwistle, D., *J. Soc. Dyers and Colourists*, (1946), 62, 269.

SECTION II

SPINNING

CHAPTER III

TINTING

WITH the increasing use of blends of various types of rayon staple, and of these with natural fibres, it has become essential to have some means of identifying the different blends during the various stages of processing if mistakes due to mixing are to be avoided. The most effective means of identification is by the application of fugitive tints to the materials, thereby imparting to each blend a distinctive coloration. For obvious reasons this tinting should be done at the earliest convenient point, which will usually be in the stages preparatory to spinning.

Methods of Application. When lubricants are to be applied to fibres, as in the woollen and cotton waste systems of spinning, it is usually convenient to apply the tint at the same time as the lubricant. If emulsions are being used the tint can be introduced into the emulsion itself; otherwise the oil and tint can be sprayed on the material from separate containers either in a floor mix or at the teaser.

In cotton spinning, where lubricants are not generally used, tinting is usually done at the first hopper, the apparatus consisting of a tank containing the aqueous solution of tint conveniently situated to give a slight head of pressure on an atomising nozzle. The tint solution flows by gravity from the tank to the atomising nozzle, to which is connected an air pressure line of 20 to 40 lb. per square inch. The nozzle is directed straight into the hopper, spraying the tint on the circulating materials inside. The supply of tint is automatically cut off when the hopper is not feeding. Where a wide range of blends is being processed it is often found desirable to use several tanks containing differently coloured tint solutions, any one of which may be brought into action as required, thus avoiding the necessity of cleaning out whenever a change of colour is made.

An alternative method which is now being used in some

works is to spray the tint by means of an atomising nozzle situated at the air entry to the pipe line which conveys the fibres to the openers or mixing stacks. It is claimed that in this way a very even tinting is obtained and the machinery kept much cleaner.

In a further system known as "Texspray" (Texaco Oil Company), the tint is stored in a drum from which it is drawn by a small suction pump to a constant head tank above the level of the opener in which the tint is to be applied. From the tank it is led down by a pipe line to the applicator located immediately beneath the feed rollers of the beater. The applicator consists of a bar stretching the entire width of the machine; the face of this bar is kept permanently wetted by tint which is transferred to the fibres as they brush past it on being struck downwards from the feed rollers by the beater.

It is claimed that a very even application is obtained in this way as every fibre in the thin fringe of lap receives its share of tint. The flow of tint solution to the applicator is cut off when the feed to the beater is stopped.

Owing to the division of the worsted industry into top-making and spinning it is not usually desirable to tint the material until it is in the hands of the spinner.

The can gill box at the beginning of the drawing would be a suitable place for tinting 100% *Fibro*. The usual oiling or tinting motions in use for 100% wool in the drawing section of the worsted industry are not entirely suitable for 100% *Fibro*, and some form of atomiser should be used if faulty slivers are to be avoided.

Yarn may be tinted in the form of warp during sizing, or as weft by impregnation with tinting liquor, or more usually by dipping the ends of cones, cops, etc., in a tinting liquor, or by spraying or splashing such liquor on to the yarn package.

When blends are being prepared, it should first be decided whether it is necessary to tint the *Fibro*. For example, *Fibro*ceta is tinted pink by the producer, and in a blend with *Fibro* this may be sufficient.

Again, on the worsted system, from the point of view of ease of processing it is desirable where possible to tint the wool rather than the *Fibro* element of the blend.

Dyes Recommended. Where the *Fibro* must be tinted, many acid dyes are suitable. In particular the following may be used.

Xylene Light Yellow 2G	(C.I. 639)
Acid Orange 2G	(C.I. 27)
Acid Violet 6BN	(C.I. 732)
Indigo Carmine	(C.I. 1180)
Kiton Blue VS	(C.I. 712)
Lissamine Green SF or V	(C.I. 735)

As *Fibro* is always tinted pink, no red dye has been included in the above list, although Azo Geranine 2G (C.I. 31), which is in use for this purpose, is suitable for *Fibro* from other points of view.

All these are well-known dyes and, under different names, may be obtained from most makers.

Where the textile manufacturer or spinner wishes to prepare his own tinting solution, it should be borne in mind that since these dyes are very fine powders and of high tinctorial value they should be kept well away from textile materials until dissolved. The following procedure should be adopted: First the powders should be pasted with water, and then more water added to give a 5% solution. This should be boiled, allowed to cool, and filtered; then it may be diluted for use. While the final concentration can only be decided by experiment, since the method of application will influence it, dilutions of 1 lb. dye in 100 gallons will probably be suitable. This is equal to 2 gallons of the 5% solution in 100 gallons. The minimum concentration compatible with the production of a distinctive coloration should be used to facilitate subsequent removal of tint.

The tints listed above may be applied to blends of *Fibro* and *Fibro*, but for the tinting of blends containing *Fibrolane* or *Rayolanda* the following tints are preferred:

Blends containing Rayolanda

Acid Violet	6 BN
Kiton Green	V
Acid Violet	4 BN

Blends containing Fibrolane

Acid Violet	6 BN
Kiton Green	V
Azo Geranine 2 G	Acid Orange 2 G

If tinted *Fibro* is to be used in admixture with animal fibres, or rayon fibres with affinity for wool dyes, e.g., *Rayolanda* and *Fibrolane*, care must be taken to avoid acid conditions prior to or during scouring.

For the same reason steaming or hot water treatment (as is used to "set" fibres such as wool, nylon and cellulose-acetate) should be avoided or minimised where possible until the tint has been removed.

Removal of Tints. Scouring will readily remove these tints from *Fibro* and, where no other fibres are present, normal scouring procedures, as detailed elsewhere in this manual, may be adopted without hesitation.

Where other fibres are present which under some conditions have an affinity for acid dyes, some modification of scouring method may be desirable. For example, when scouring tinted *Fibro*/*Rayolanda* or *Fibro*/*Fibrolane* blends it has on occasion been found necessary to render the scouring liquor slightly alkaline with small additions of ammonia or soda ash. A further useful procedure has been to run the blend in a scouring liquor at a low temperature for a short time until the major part of the tint has been removed from the *Fibro*, but has not tinted the *Rayolanda* (or *Fibrolane*). This liquor is run off and the fabric then scoured in the normal manner.

CHAPTER IV

"GREENFIELD TOP"—RAYON TOW-TO-TOP CONVERSION

DURING the past ten years, in discussion on the use of rayon staple on existing textile spinning machinery, the question has frequently been asked: *Rayon staple, being a virgin product (not waste fibre), exists at some stage of its manufacture in the form of continuous and perfectly regular filaments without nep or other entanglements; why cut them up into little pieces to be crushed into bales, so that spinners have the task of straightening them out again before they are able to spin yarn?* In other words, cannot the rope of continuous filaments be converted directly to a sliver

of stapled fibres? The question is not quite as naive as some people may imagine, but, in fact, carries within it the seeds of a revolution in textile technology. Because of this, it has never been far from the thoughts of those concerned with the development of yarns spun from rayon staple of any kind.

It is not necessary to enter here into the many reasons why it is desirable to produce yarns from rayon staple as distinct from continuous filament yarns, as the complementary functions and economics of these productions are now more clearly understood than they were. It was at first found expedient to make rayon staple in forms suitable for processing on existing spinning systems. It does not follow that these were the only possibilities, or that one can for ever rest content with the limitations of orthodox processing. As one looks back over rayon staple developments of the past fifteen years to consider whether it would have been better to develop spun rayon yarns through and by the building of new and revolutionary processing equipment as distinct from the way of evolutionary development from its first use on existing machines, it is now clear that the latter course was inevitable. It is only through the persevering efforts of those who first fitted the material to existing practice that the versatility and far-reaching possibilities of rayon staple have become evident. It is in consequence of the wide appreciation of the latent possibilities of the material thereby aroused that interest and activity in the development of new techniques have been stimulated.

It has for some years been recognised by research workers in the industry that the elimination of the carding operation and the substitution of the "rayon tow-to-top" process would probably mark the first major advance. While the impact of this development is likely to be felt in some sections of the spinning trades before others, it is only a question of time before all are involved.

In the case of natural staple fibres, the problem of preparing material for spinning a yarn resolves itself first into separating and cleaning the individual fibres and then aggregating them into a sliver or top for subsequent drafting operations which straighten and parallelise the fibres and attenuate the ribbon to the chosen size. Successful drafting depends

on the disposition of the separate fibres in the sliver so that each fibre in turn may be selected and pulled ahead at a rate faster than its neighbours. It is therefore essential that, in the sliver, the ends of fibres must be staggered relative to each other, to provide cohesion by overlap and to allow selective drafting action to take place.

Problem of Cutting or Breaking. The operations so far found necessary to form a sliver from an entangled mass of individual fibres usually involve some degree of fibre breakage and nep formation. In certain cases, the nep and short fibre must be removed by expensive combing operations before yarns of high quality can be made. As this applies to rayon staple now in volume production as well as to the natural fibres, it follows that if means could be developed for producing sliver direct from continuous filaments before such entanglement has taken place, in some cases expensive processes could be eliminated, and in others materials could be provided in sliver form, which are at the moment beyond the capacity of conventional sliver-making processes.

Drafting (in the sense meant in spinning fibres) cannot be applied to continuous filaments, which would and can only be stretched as in wire drawing, and then only to the limit of the extensibility of the rayon filament, beyond which limit the filaments will break. The task of providing a sliver composed of individual fibres direct from continuous filaments without carding therefore resolves itself into one of converting filaments into fibres either by breaking, abrading or cutting them in such a way that the fibres can be separated easily from each other yet retain good cohesion in sliver form, without which it would scarcely be possible to handle the material. Merely to cut across the rope of filaments would not produce a sliver but would be equivalent to a sliver breakage for each cut. There must also be good control of staple length produced, otherwise much of the advantage of the process is lost, though this is less important in some types of spinning than in others. Most of the earlier attempts to produce rayon staple slivers direct from continuous filaments have relied upon breaking methods as distinct from cutting methods, as the very difficulty of controlling staple length by breaking has provided the easiest way of securing the

staggered or random disposition of the fibres essential for drafting and sliver cohesion.

In comparing cutting, breaking and/or abrading methods, it will be appreciated that the disadvantage of breaking as applied to continuous material lies in the destruction of some of the intrinsic qualities of the filaments such as extensibility, as well as the very large variation in staple length which this method tends to produce. While in some spinning systems this variation in staple is not very important, providing there is not too large a proportion of very short filaments, other systems of spinning, such as cotton, have precise requirements of staple length, particularly so far as excess length is concerned.

Although abrading and breaking methods can be applied to continuous filament yarns and relatively light and continuous tows, it has so far been impracticable to deal with very heavy total denier tows. As it happens, the rayon manufacturer can produce coarse total denier continuous tows at less cost than fine tows.

Of late years, therefore, various attempts have been made to replace breaking or abrading by cutting methods, using tows of very heavy total denier, thus retaining the cost advantage together with the preservation of the properties of the material and with a better chance of obtaining control of the resulting staple length.

A Sliver Stapling Method. Development work initiated by Courtaulds in 1937 led to the working out of a method of cutting filaments in a number of rayon ropes or tows of heavy denier, simultaneously subjecting the cut fibres to a drafting operation to secure fibre separation and cohesion. The process was covered by a series of British patents, the numbers of which are: 511867, 518995, 523579, 535793 and 537742. In brief, the process consists first of providing ropes or tows of continuous rayon filaments each of a total denier ranging up to and beyond 300,000 denier. These tows are fed in parallel form from a creel capable of carrying a number of packages of tow, each weighing some 100 lb., to a pair of cutting rollers, so designed as to cut the mass of filaments within a chosen angle of 5° to 15° to the tow length while using the pair of cutting rollers to carry forward the

sheet of cut fibres in an undisturbed manner, so as to deposit them on an endless feed apron. This apron, in turn, feeds direct to an intersecting gill box of standard design for worsted processing, which is so set as to give sufficient draft and pin action to deliver a sliver or top into a can, or ball, in the usual way. It has been found advantageous to pass the resulting sliver through two succeeding stages of gilling, to produce a final top having the desired fibre displacement, regularity and cohesion to render following operations trouble-free. The accompanying photographs (*Figures 7 and 8*) illustrate the machines and methods used.

As the tops were first made for commercial purposes in Courtauld's Greenfield factory in June 1939, they were given the name of "Greenfield Top" a name which has since become well known. The following qualities have been in production since that time:

- 8-inch staple 8 denier bright viscose
- 4-inch staple $4\frac{1}{2}$ denier bright and matt viscose
- 4-inch staple $1\frac{1}{2}$ denier bright and matt viscose
- 4-inch staple $1\frac{1}{4}$ denier bright strong viscose

Worsted Spinning. It will not surprise those acquainted with the worsted process to learn that the new production was first directed to this industry. There are two reasons for this. It must be obvious that, in a process of this kind (depending as it does for success on cutting and staggering of fibre ends by relative displacement), the difficulty of the operation will vary with the length of staple to be produced, and the thickness or denier of the filament in the continuous tow—the longer the staple and the coarser the filament denier, the more easily is the top-making process carried out.

As worsted machinery normally uses staples of 3 inches upwards and deniers in rayon staple of 3.0, 4.5 and 8.0, it was natural that attention should be given to this range before applying the process to the shorter staples and deniers. More important than this, however, are the economics of the industry. Unlike a cotton spinner, the worsted spinner who buys a bale of material and completes the operations to yarn, is the exception rather than the rule. The industry divides naturally into two main divisions: combing or sliver production, and drawing and spinning. The top or

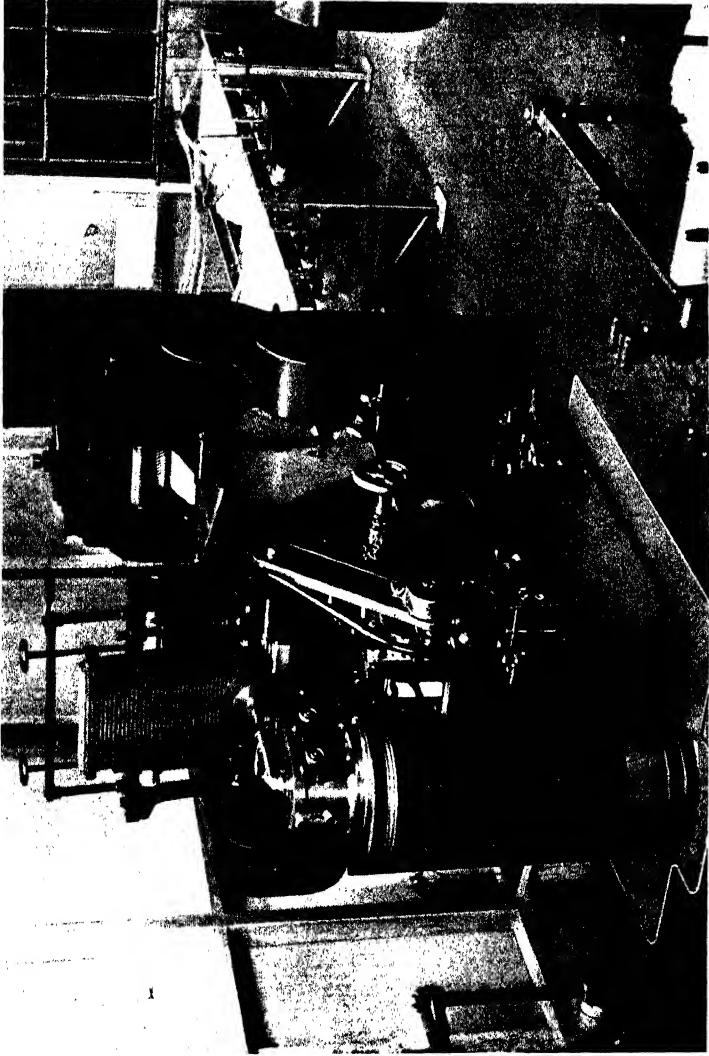

FIGURE 7 STAPLE CUTTING OF TOW WITH BRADFORD OPEN-DRAWING INTERSECTING GILL BOX

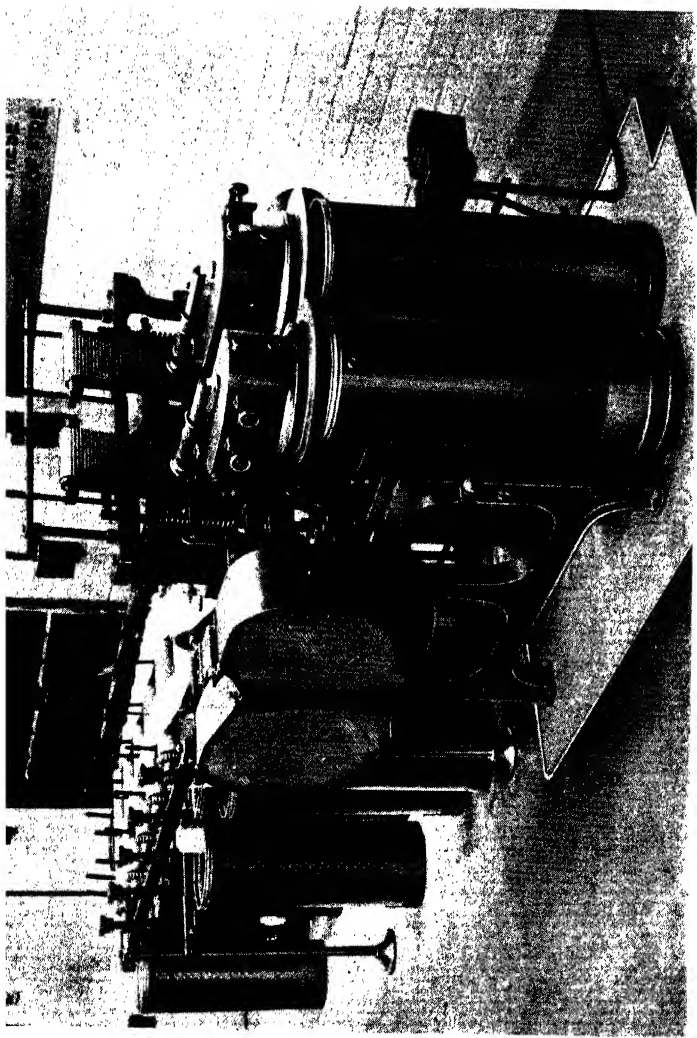

FIGURE 8 BRADFORD OPEN-DRAWING INTERSECTING GILL BOX

sliver is the finished product of the first, but the raw material of the second. This specialisation has been mainly due to the variety and scope of the operations necessary to reduce raw wool to top or sliver ready for drawing.

When rayon staple was introduced to the trade in bale form, at first for top production there was no alternative to the existing carding and combing process. Combing after carding is just as essential for rayon staple as for wool, owing to the necessity for clearing nep and broken fibre, the result of the worsted carding operation. Rayon staple must therefore carry the full cost of the carding and combing operation which, as a separate section of the industry, must also include the usual charges for sales and distribution and profit. The result at time of writing is that bales of rayon staple are sold to combers at $16\frac{1}{2}$ pence per pound, whereas the price of the finished top ready for drawing is 25 pence, a difference of $8\frac{1}{2}$ pence per pound. This, therefore, immediately contrasts with a difference of 2 pence per pound between baled rayon staple and "Greenfield Top".

Flax, Jute, and Silk Spinning. Apart from the obvious effect on the supply of rayon staple in the worsted industry, "Greenfield Top" will also be subject to development for the supply of rayon staple for flax, jute, and silk spinning. In flax and jute spinning the lengths and deniers will be fairly comparable with those used in worsted spinning; in silk spinning the staple length will be approximately 6 inches, but finer deniers will be required, possibly ranging down to one denier.

Cotton Spinning. As is well known, cotton spinning has consumed by far the largest proportion of rayon staple produced, not only in the United Kingdom but in the world. This has been due mainly to the relatively low cost and versatility of its yarn producing methods and the comparative ease with which rayon staple can be fitted to existing machinery. Within its range of length and denier (from $1\frac{3}{8}$ inches downwards and in deniers from $1\frac{1}{4}$ up to $4\frac{1}{2}$, with certain other combinations of length and denier), the sliver-making means employed are lower in cost than any other, "Greenfield Top" included.

It will be appreciated that the difficulty of "Greenfield Top" manufacture will tend to rise with decreasing

length and denier, unless experience gained in dealing with the longer staples and coarser deniers leads to a simplification of methods when dealing with shorter lengths and finer deniers. On the other hand, it must be remembered that the present limitations of the cotton carding process have so far prevented the fullest use being made of the properties of rayon staple. The optimum staple length for yarn strength lies about $2\frac{1}{2}$ inches, and obviously the greatest benefit would accrue where this length or longer could be used with fine deniers of the order of 1 or $1\frac{1}{4}$, within the present spinning costs. Progress has already been made in modifying cotton sliver making machinery to deal satisfactorily with lengths of $2\frac{1}{2}$ inches and 3 inches but only for deniers of 3 and above. We are still a long way from producing satisfactory all-purpose slivers from these lengths in deniers of $1\frac{1}{2}$ and below. Once a satisfactory sliver is available in the required length and denier, only relatively simple modifications of cotton spinning drafting technique are required to bring these materials within the scope of cotton spinning operations and costs. It is here that "Greenfield Top" may find its opening in the cotton spinning trade, i.e., in the provision of the ideal length and denier in sliver form ready for drafting, at a cost equal to or only slightly higher than that under present practice.

CHAPTER V

FIBRO FOR COTTON SPINNING MACHINERY

Types of Rayon Staple. Table 2 gives the principal staple lengths and deniers of the varieties of rayon staple made for cotton spinning by Courtaulds. For convenient reference the spinning limit of each variety is given except when they are used only in mixture with other varieties. It is seen that a wide range of staple lengths and deniers is available in both bright and matt lustre. Of these $1\frac{1}{2}$ denier $1\frac{1}{16}$ -inch staple is the commonest in bulk and application, and is the type from which the great majority of rayon staple yarns are at present made in the United Kingdom. It is historically interesting

because it is the pioneer type of rayon staple and led the way in quantity for the development of rayon staple spinning in Lancashire. The length and denier were chosen to compare closely with Egyptian type cottons and therefore to have ready application to a large part of standard Lancashire machinery.

The 3 denier $1\frac{7}{16}$ -inch staple type has been in wide use for coarse to medium type yarns both alone and in mixtures.

The $4\frac{1}{2}$ denier $1\frac{7}{16}$ -inch staple has not been widely applied yet, but its use will almost certainly be extended for coarser yarns particularly of the irregular type to give stiff, firm handling cloths.

The $2\frac{1}{2}$ -inch staple is of particular interest. It has been introduced to obtain a higher strength and a finer count than are possible from a shorter length, and therefore the advantage of a coarse denier filament in medium count yarns. It is of great value for mixture yarn purposes, to which reference will be made later.

TABLE 2

Name	Type	Lustre	Staple ins.	Denier and Cotton Count Limit (Brackets)		
<i>Fibro</i>	Viscose	Bright	$1\frac{7}{16}$	$1\frac{1}{2}$ (72)	3 (20)	$4\frac{1}{2}$ (16)
<i>Fibro</i>	Viscose	Matt	$1\frac{7}{16}$	$1\frac{1}{2}$ (50)	3 (20)	$4\frac{1}{2}$ (16)
<i>Fibro</i>	Viscose	Bright & Matt	$2\frac{1}{2}$		3 (30)	$4\frac{1}{2}$ (24)
<i>Strong Fibro</i>	Viscose	Bright	$1\frac{7}{8}$	$1\frac{1}{4}$ (92)		
<i>Rayolanda</i>	Modified Viscose	Matt	$1\frac{7}{16}$	$1\frac{1}{2}$ (40)		
<i>Rayolanda</i>	Modified Viscose	Matt	$2\frac{1}{2}$		3 (24)	
<i>Fibroceta</i>	Cellulose-Acetate	Bright & Matt	$1\frac{7}{16}$		$2\frac{1}{2}$ (20)	
<i>Fibroceta</i>	Cellulose-Acetate	Bright & Matt	$2\frac{1}{2}$		$2\frac{1}{2}$ (30)	$4\frac{1}{2}$ (20)
<i>Fibrolane</i>	Protein	Medium	$2\frac{1}{2}$			$3\frac{1}{2}$ for blending

Table 3 shows for comparison the hair weight per centimetre and corresponding filament denier of many types of natural fibres. In the natural fibres there is a large variation between different growths but these figures are fairly representative of each type. The figures for the bast fibres must be considered as representing only the particular samples from which they have been taken.

FIGURE 9

THE EFFECT OF FILAMENT DENIER ON THE LEA STRENGTH AND SINGLE THREAD STRENGTH OF
 1/16'S COTTON COUNT "FIBRO" YARN $1\frac{7}{8}$ " STAPLE

RING SPUN YARNS

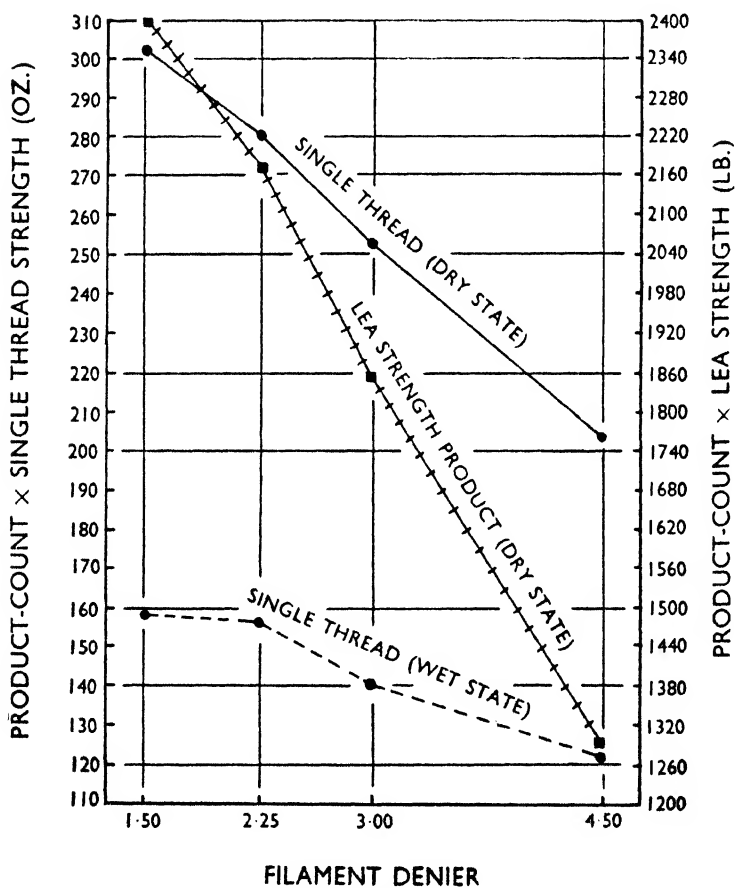

TABLE 3

						Hair Weight Centimetre	Corresponding Filament Denier
<i>Fibro</i>	0·00138 mgm.	1·25
<i>Fibro</i>	0·00167 mgm.	1·5
<i>Fibro</i>	0·00333 mgm.	3·0
<i>Fibro</i>	0·00500 mgm.	4·5
Sea Island Cotton	0·00120 mgm.	1·08
Egyptian Cotton	0·00140 mgm.	1·26
American Cotton	0·00200 mgm.	1·8
Indian Cotton	0·00250 mgm.	2·25
70s Merino Wool	0·00481 mgm.	4·33
64s Merino Wool	0·00557 mgm.	5·02
58s Crossbred Wool	0·00832 mgm.	7·5
46s Crossbred Wool	0·01264 mgm.	11·39
Silk	0·00101 mgm.	0·91
Ramie	0·00595 mgm.	5·36
Irish Flax	0·00626 mgm.	5·64
Flax (treated to reduce to ultimate fibre)	0·00195 mgm.	1·76
Jute	0·01540 mgm.	14·0

Effect of Filament Denier on Yarn Properties. The fineness of the filaments used to spin a rayon staple yarn has a considerable effect on its strength and a knowledge of this is essential to appraise the strength of yarns spun from the different deniers of rayon staple available. Other things being equal, yarns spun from fine deniers are stronger than yarns spun from coarser deniers.

Figure 9 shows the strength obtained by spinning yarns of 1/16s cotton counts from filaments of four different deniers of the standard quality of *Fibro*. The dry single-thread strength falls 33% in changing from the finest to the coarsest denier. It is on this account that the coarse deniers cannot be used for spinning fine counts. Rather less change takes place in wet single-thread strength, the corresponding fall being about 25%. It is interesting to note that there is a linear fall of strength with increasing denier in this count.

Figures 10 and 11 show the effect of spinning yarns of different count from filaments of different denier. As the count is increased there is an approximately linear fall in strength which is sharper in the coarser deniers than in the finer, as one would expect. The curves of wet strength do not show the same rate of fall as do the curves of dry strength, due presumably to a greater tendency for filaments to lose

FIGURE 11

SHOWING THE SINGLE THREAD STRENGTHS OF SEVERAL COUNTS USING FILAMENTS OF DIFFERENT DENIER

- — ● "FIBRO" 1 $\frac{7}{8}$ " STAPLE 1.50 DENIER
- — ○ " " " 2.25 "
- × — × " " " 3.00 "
- + — + " " " 4.50 "

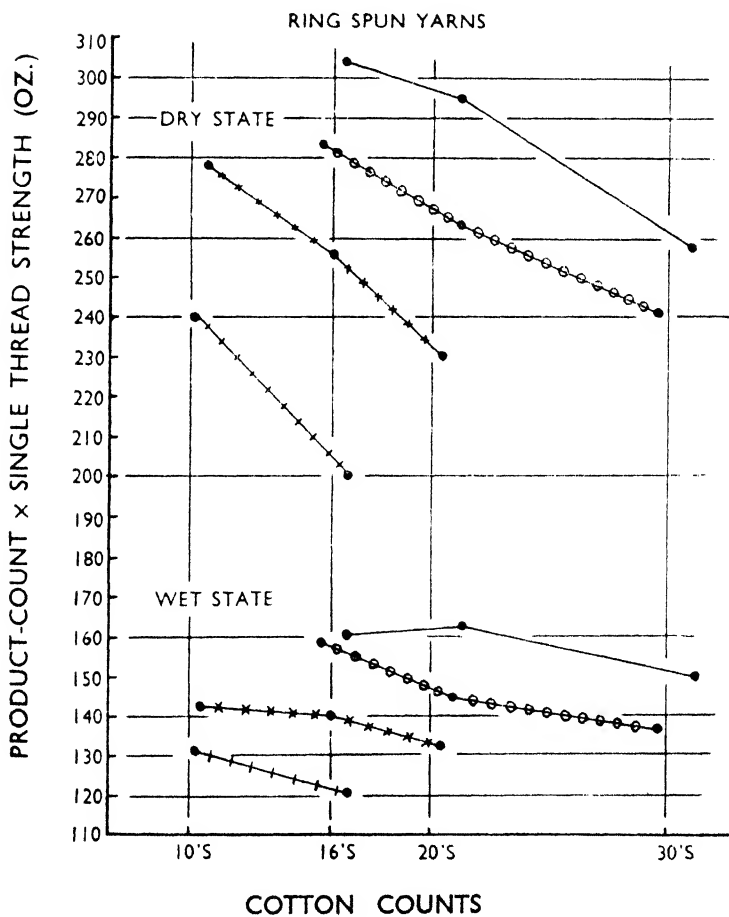

their individuality when wet. The same trend is well known when spinning wool or cotton, although there are complicating factors of length and fineness with these fibres.

Effect of Filament Length on Yarn Properties. An increase of yarn strength results from an increase of filament length within those limits which it is possible to process on cotton machinery. At some length beyond the maximum generally used in cotton spinning, the greatest strength is reached that it is possible to obtain by increasing the filament length. Other systems of spinning can make use of these longer filaments, notably the spun silk system.

Figure 12 illustrates this point. It shows that with a staple length of $2\frac{1}{8}$ inches, the maximum strength has not been reached. It is possible to compare the strengths of rayon staple yarns, with the ideal strength provided by regular continuous filament yarn, in a way not possible when dealing with yarns made from natural fibres. But until spun threads can be made to equal continuous filament yarns in regularity, it is clear that they cannot match the latter in strength when made in equal counts from the same material. Being irregular, spun threads differ in strength compared with continuous filament yarn, and it is not possible to bridge that difference by increasing the staple length. Strength comparisons of *Fibro* yarns with continuous filament yarns of the same filament denier and total counts, both equally twisted (e.g., *Fibro*, $1\frac{7}{16}$ -inch, 1.5 denier, 36s cotton counts; continuous filament 150 denier 100 filaments) reveal that the latter is some 35% stronger than the former.

As will be seen from *Figure 12* *Fibro* yarns made with a staple of $2\frac{1}{8}$ inches are some 13% stronger than yarns made with a staple of $1\frac{7}{16}$ inches and the strength is still rising with increasing staple length.

Effect of Twist on Yarn Properties. The character of a yarn depends greatly on the twist factor used in spinning. Although the majority of *Fibro* warp yarns are spun to maximum strength, many special effects are obtained by using higher twists than are necessary for that purpose. Of particular interest is the use of semi-voile or voile twists in plain yarns to obtain pleasing sheer finishes, and in slub and nep yarns to produce a crisp, springy feel without harshness, obtainable at such twists because of the natural softness of

FIGURE 12

EFFECT OF STAPLE LENGTH ON YARN STRENGTH
MATERIAL-"FIBRO" 1.5 FILAMENT DENIER

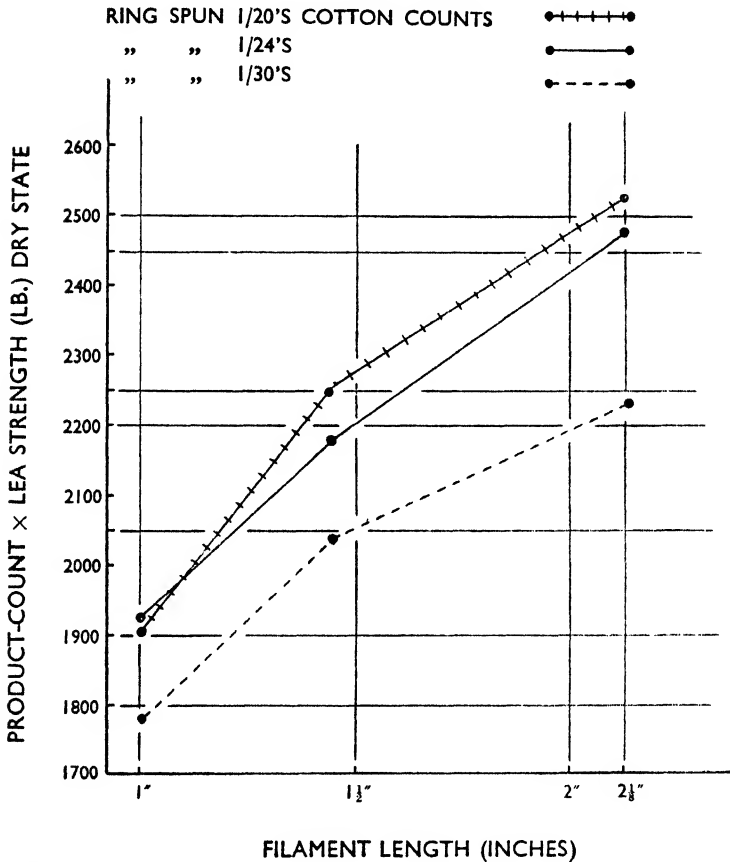

Fibro. It is of interest to note that with *Fibro* the twist factor for maximum strength is lower than that required for cotton. The approximate twist factors required to give the maximum strength in cotton yarns are:

Indian Cotton	4.5 to 5.5
American Cotton	3.75 to 4.25
Egyptian Uppers	3.5 to 4.0
Egyptian Sakel	3.5 to 3.75

FIGURE 13

EFFECT OF CHANGES IN FILAMENT LENGTH ON THE COUNT LEA STRENGTH PRODUCT OF 20'S COTTON COUNTS "FIBRO" YARNS AT DIFFERENT TWISTS

- 1" STAPLE 1.5 DENIER
- ++++● 1 ⁷/₁₆" " 1.5 "
- 2" " 1.5 "

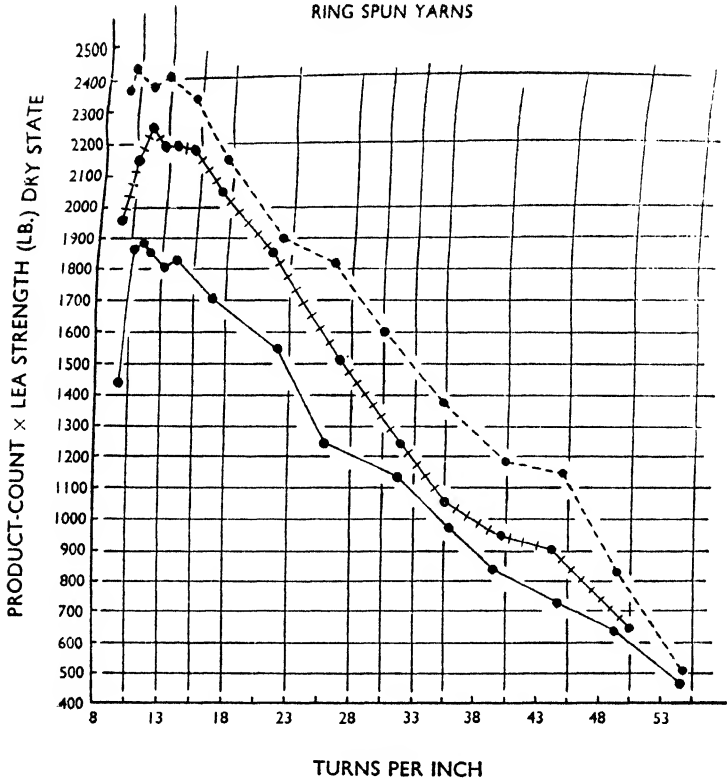

as opposed to 2.7 when using *Fibro* of 1.5 denier, 1 ⁷/₁₆ inches.

The twist curves for *Fibro* yarns are similar to those for natural fibres, in that the strength increases to a maximum as twist is increased up to a critical point and then steadily declines as twist is increased beyond this point.

Figure 13 shows the relation of strength to twist for 1/20s yarns spun from three types of *Fibro*, the only difference

between them being in staple length. Thus the *figure* shows also the effect of staple length on yarn strength over a range of twists. It is seen that in all cases the maximum strength is reached at a twist factor of 2.7, and that the twists required for maximum strength are higher as the staple length decreases. The effect of this is more clearly shown in the graph for 60s cotton counts (*Figure 14*). At this count the twist factor required to obtain maximum strength with the 1-inch staple is about 3.2, but that for the $1 \frac{7}{16}$ -inch is about 2.7,

FIGURE 14

EFFECT OF CHANGES IN FILAMENT LENGTH ON THE COUNT LEA STRENGTH PRODUCT OF 60'S COTTON COUNTS "FIBRO" YARNS AT DIFFERENT TWISTS

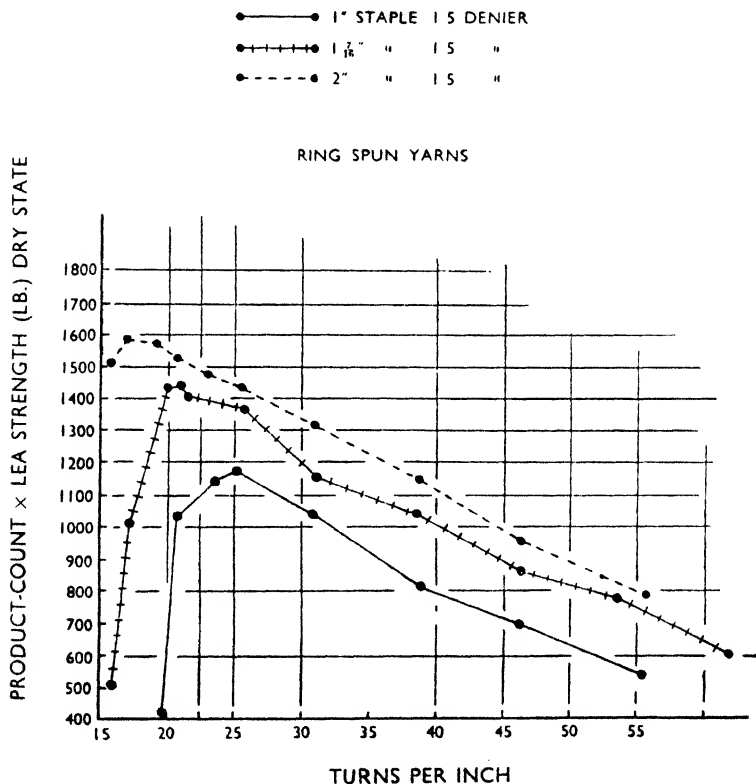

FIGURE 15

SHOWING LEA STRENGTH PRODUCTS OF SINGLE
AND TWO-FOLD YARNS

STRONG "FIBRO" $1\frac{1}{4}$ " STAPLE 1.25 DENIER

- +-+-+● 1/20'S Z TWIST SINGLE
- - - -● 2/40'S S/Z
- - - -● 2/40'S Z/Z

TWIST FACTOR IN SINGLE YARN = 2.5

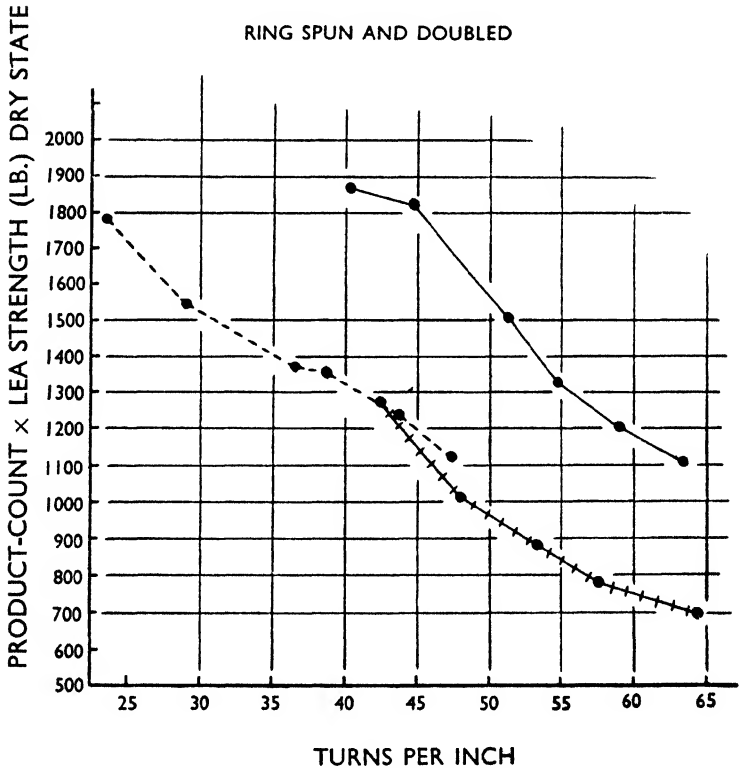

and for the 2-inch about 2.4. This illustrates the value of using the longest possible staple length where the softest twisted yarns are required; an effect that is already well known in cotton spinning.

FIGURE 16

SHOWING THE COUNT LEA STRENGTH PRODUCTS
OF YARNS SPUN FROM—

- STANDARD "FIBRO" $1\frac{7}{16}$ " STAPLE 1.5 DENIER
- - -● STRONG "FIBRO" " " " "
- + + +● STRONG "FIBRO" $1\frac{7}{8}$ " " 1.25 "

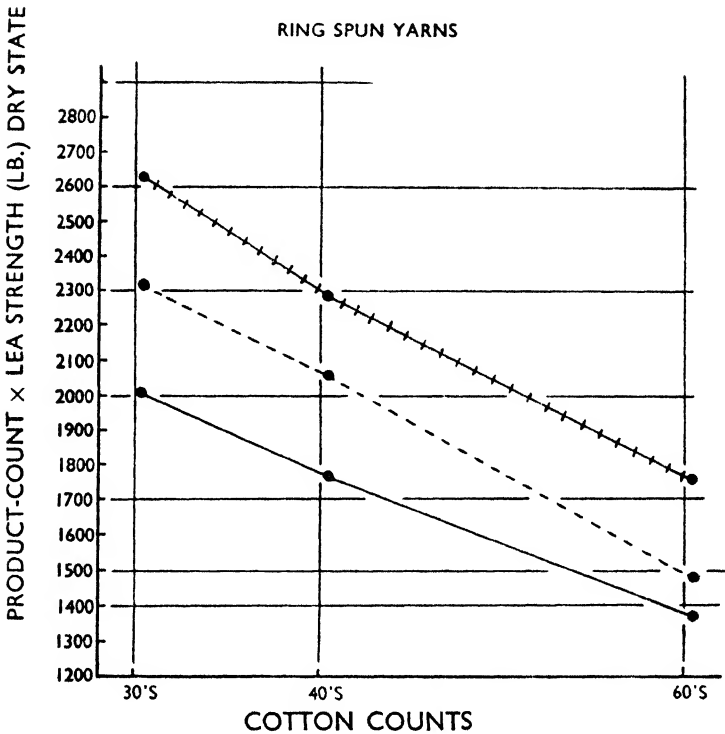

Figure 15 shows the effect of twist on single and twofold yarns spun from *Fibro* 1.25 denier $1\frac{7}{8}$ inches Strong.

Strong Fibro. Strong *Fibro* in $1\frac{7}{8}$ denier, $1\frac{7}{8}$ -inch staple, can be spun into yarns appreciably stronger than can be spun from $1\frac{1}{2}$ denier $1\frac{7}{16}$ -inch staple standard *Fibro* and is thus the type to use where extra yarn and cloth strength is desirable. Because of its longer staple, finer denier, and higher intrinsic strength, it can be spun into finer yarns than other types of

FIGURE 17

SHOWING THE SINGLE THREAD STRENGTH
OF YARNS SPUN FROM—

- STANDARD "FIBRO" $1\frac{7}{8}$ " STAPLE 1.5 DENIER
- - -● STRONG "FIBRO" " " " "
- + + +● STRONG "FIBRO" $1\frac{7}{8}$ " " 1.25 "

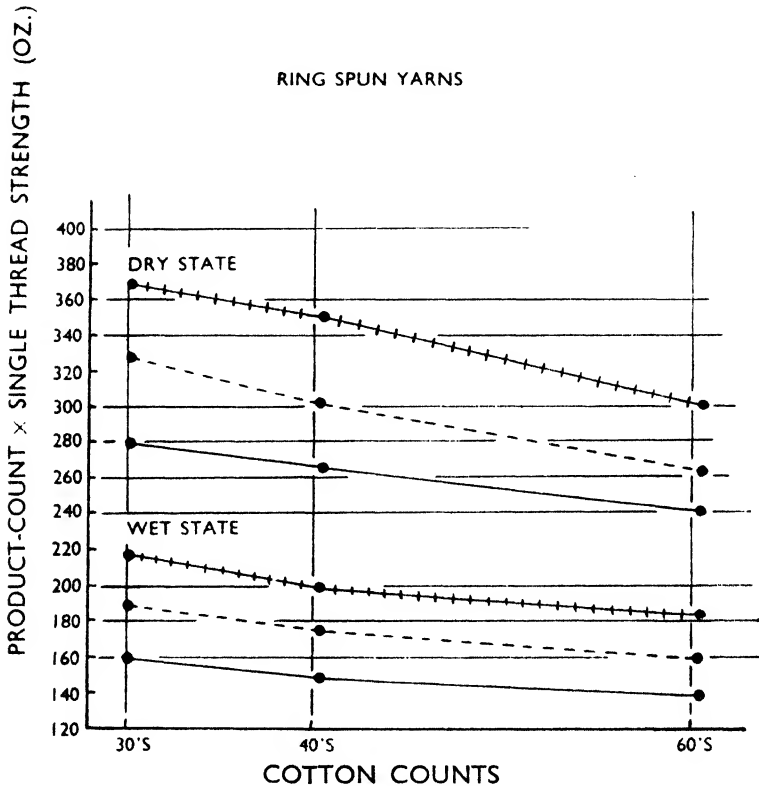

Fibro, and 80s/2 warp gassed and 100s/2 weft gassed are within the spinning limits of this quality.

A comparison of relative strengths of strong and standard *Fibro* types is shown in *Figures 16 and 17*, where the count/lea strength products and dry and wet single-thread strengths of the three types of yarn are given for 30s/1, 40s/1 and 60s/1 cotton counts. In *Table 4* opposite are given the percentage

increases actually obtained. It will be seen that there is an appreciable advantage in the use of strong *Fibro*, particularly of $1\frac{7}{8}$ -inch staple $1\frac{1}{2}$ denier.

In *Figure 18* is shown the extension per cent at break for these yarns. It is seen that no reduction of this value has resulted from the increase of strength and that the figure is appreciably higher wet than dry.

TABLE 4

COMPARATIVE PERCENTAGE INCREASES OF STRENGTH BY USING STRONG *Fibro* AS COMPARED WITH STANDARD *Fibro*

		$1\frac{7}{8}$ inches Strong $1\frac{7}{8}$ inches Standard	$1\frac{1}{2}$ inches Strong $1\frac{7}{8}$ inches Strong	$1\frac{1}{8}$ inches Strong $1\frac{1}{8}$ inches Standard
DRY	30s	17.0	11.0	30.0
	40s	13.5	14.5	30.0
	60s	8.0	13.5	22.5
WET	30s	21.0	12.5	36.0
	40s	16.0	16.0	35.0
	60s	17.0	14.5	34.0

Fibroceta. One of the special attributes of *Fibroceta* is that owing to its distinctive behaviour towards dyes it can be dyed independently of viscose, and vice-versa, and thus cross-dyed effects can be readily produced by using *Fibroceta* yarns in conjunction with *Fibro* yarns, or by mixing *Fibroceta* and *Fibro* together in the yarns.

Fibrolane. The distinctive dyeing properties of *Fibrolane* enable it to be dyed with a large range of dyes including those used for wool and viscose. Thus many colour effects are possible from blends of *Fibrolane* and *Fibro* and *Fibrolane* with wool. Its handle is soft, warm and resilient, and this texturally enhances the properties of cloths containing this new fibre. While *Fibrolane* can be spun by itself, it is mainly used blended with wool, or with *Fibro*, *Rayolanda*, or *Fibroceta*. Wool acquires increased felting properties when blended with *Fibrolane*. *Fibrolane* is made for cotton spinning, in $2\frac{1}{2}$ -inch staple length, for blending with 3 denier and $4\frac{1}{2}$ denier $2\frac{1}{2}$ -inch staple.

Blend Yarns and Special Effect Yarns. Blends of *Fibroceta* with 3 denier $1\frac{7}{8}$ -inch *Fibro* have been made in large volume in the past and probably will continue to be made, but it is likely that many blends of *Fibroceta* of $2\frac{1}{2}$ denier will be made with $1\frac{1}{2}$ denier *Fibro*, both bright and matt, since the count range of such blends is appreciably greater than

FIGURE 18
EXTENSION-AT-BREAK OF YARNS SPUN FROM—

○——○ Standard "Fibro" 1½" Staple 1.5 Denier Dry State.
 ○- - - -○ Strong "Fibro" " " " " " "
 ○- - - -○ Strong "Fibro" 1½" " " 1.25 " " " "

RING SPUN YARNS

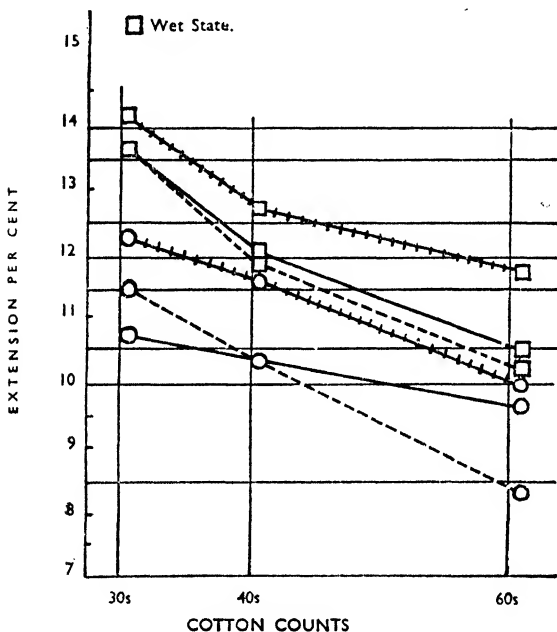

with 3 denier *Fibro*. With blends of 40% *Fibroceta*/60% 1½ denier *Fibro*, counts up to 50s can be spun for doubling, and 36s/1 for use as single. The yarns are very suitable for soft, warm-handling fabrics, and have good resistance to creasing. *Fibro* 3 denier 2½-inch and *Fibroceta* 2½ denier 2½-inch would be chosen for *Fibro*/*Fibroceta* yarns up to 30s and 4½ denier 2½-inch *Fibro* and *Fibroceta* where *Fibro*/*Fibroceta* blends up to 20s are wanted.

For hosiery yarns, blends of *Fibro* and cotton have been in favour, particularly when either Peruvian or East African cottons have been chosen. Similar blends will be used for weaving firm style fabrics as the *Fibro* component of such yarns is more reactive than cotton to many finishing treatments; in particular the anti-crease finish confers firmness as well as crease resistance to the cloth. One advantage

FIGURE 19

BLENDS OF "FIBRO" $1\frac{1}{8}$ " 1.5 DENIER BRIGHT

TANGUIS COTTON 36'S COTTON COUNTS

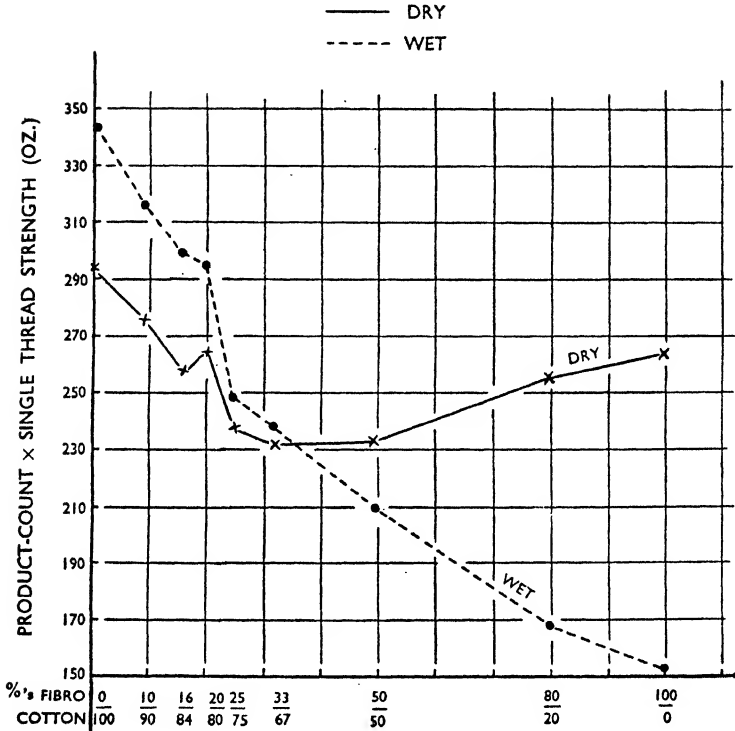

of blending cotton with *Fibro* is that a yarn can be made with some of the virtues of *Fibro*, such as whiteness, cleanness and good draping qualities, together with a wet yarn strength equal to the dry strength. This is illustrated in *Figure 19* which gives the dry and wet single-thread strength products of various blends of standard *Fibro*, $1\frac{1}{2}$ denier $1\frac{1}{8}$ -inch staple, and Tanguis cotton. It is seen that with about two-thirds cotton, one-third *Fibro*, the dry and wet strengths are equal. Strong *Fibro* $1\frac{1}{4}$ denier, $1\frac{1}{8}$ -inch staple, is suitable for blending with super-quality cottons for making fine count yarns for dress and shantung fabrics.

It is likely that two principal classes of *Fibro* and wool

blends will be spun on cotton spinning machinery, namely blends of $1\frac{1}{2}$ denier $1\frac{7}{8}$ -inch staple *Fibro* and/or *Rayolanda* with cut wool; and blends of 3 denier $2\frac{1}{2}$ -inch staple *Fibro* and/or *Rayolanda* with uncut wool of the Cape-top type where the staple has an average length of about 2 inches. The short staple class will be spun into the finer count because of the fine denier of *Fibro* that is used, whereas the medium and coarser counts will be spun from the 3 denier *Fibro*. The wool chosen for cotton spinning is usually between 64s and 70s quality. This can readily be spun in blends containing up to 50% wool with minor changes of machinery.

Fibrolane and *Fibro* blends are usually made from $4\frac{1}{2}$ denier $2\frac{1}{2}$ -inch *Fibrolane* and 3 denier $2\frac{1}{2}$ -inch *Fibro* and blends up to 33% *Fibrolane* have already been made in bulk.

Two types of *Fibro*/silk blends can be made. By using short silk noils in combination with *Fibro* of any staple length and denier, neppy and somewhat irregular yarns will be obtained. Another way would be to cut combed silk slivers to the staple of the *Fibro* and blend the silk with the *Fibro* at the opener, and thus make almost nep-free yarns. By the use of strong *Fibro* $1\frac{1}{4}$ denier $1\frac{7}{8}$ -inch staple, fine yarns can be made. These yarns will be capable of cross-dyeing or solid dyeing according to the dyes chosen.

Nep yarns, slub yarns, and irregular yarns are a very popular class. Nep and irregular yarns can be made by producing a neppy, lumpy sliver at the card by open settings (Doffer-cylinder principally) and then processing this in the ordinary way. Owing to the ease with which bright *Fibro* is carded, the neps are better made from matt *Fibro* as its higher fibre friction is more conducive to nep production. Probably the best way to make nep yarns is to make fine pinhead neps of matt *Fibro* or cotton and to blend these with the stock. The card should then preferably be worked with flat settings wider than normal, otherwise the neps will be opened.

Irregular yarns can readily be made by mixing short staple with longer staple; for example, up to 50% of $\frac{1}{2}$ -inch staple with $1\frac{7}{8}$ -inch staple. The short staple must be appreciably different in length from the longer, otherwise the resulting yarn will not be sufficiently irregular; thus, 1-inch staple will

probably be too close to $1\frac{7}{16}$ -inch. In a blend where the main component is $2\frac{1}{2}$ -inch staple, a shorter staple of $1\frac{7}{16}$ -inch would again probably not enable sufficiently irregular yarns to be made, and lengths of 1 inch or less should be used. The blend should be processed with settings to suit the long component and any artifices that will produce drafting waves are obviously advantageous.

Slub yarns are also conveniently produced by using slubbing motions at the speed or spinning frames. Extra ornamentation of these yarns can readily be achieved by mixing two or more types of rayon staple or by introducing natural fibres.

CHAPTER VI

SPINNING ON COTTON MACHINERY

It is proposed in this chapter to discuss the machines stage by stage in their normal sequence, bringing out the main points of difference from normal cotton spinning practice. Tabulated details will be given of equipment that has been found satisfactory. All the machines referred to are of the standard, conventional types, and nowhere will reference be made to modern systems of high drafting or to any other practices that differ substantially from the traditional methods of cotton spinning. This is to show that rayon staple can be spun on such machinery with a minimum of conversion and expense. It is, however, recognised that rayon staple and its blends with natural fibres respond to high-drafting and to shortened and speedier methods of processing, and it is expected that it will be spun and processed increasingly on this type of equipment.

Rayon staple can be spun satisfactorily on normal cotton spinning machines with no more than minor changes of setting, etc., as are in keeping with such physical attributes of rayon staple as staple length, fineness, and bulkiness in the mass.

Mixing, Blending and Opening. As rayon staple is supplied in a partly opened state (it being opened prior to baling) and free from impurities, cleaning is not needed, and the whole

object of the treatment in the opening combination is to make even and well-opened laps, with a minimum of waste. Where blends are being made there is the extra object of even blending. A combination that has been found satisfactory is :

TABLE 5

		<i>Cylinder Diameter</i>	<i>R.P.M.</i>
Hopper opener :			
Lattice feeder and striker cylinder	..	24 inches	600
Hopper feeder :			
Striker cylinder	18 inches	700
Striker cylinder lap end	41 inches	360
Finisher scutcher with striker cylinder	..	18 inches	1000

Conveying is conveniently done by air trunking, but dust trunks should be by-passed. Suitable lap weights are :

Opener	17 ounces/yard per 40-inch width
Finisher	14 ounces/yard per 40-inch width

It is common to feed the hopper opener from a mixing of six to eight bales, as might be done in cotton feeding, by stripping layers off each bale in turn and throwing them on the feed lattice or in the hopper. The purpose of this is not to blend variations in the fibres, but solely to eliminate variations in the moisture content of the bales, as, no matter what care is taken in drying and conditioning prior to baling, variations may arise in manufacture and storage.

This point is considered to be the most satisfactory stage for blending *Fibro* with *Fibroceta*, *Fibrolane*, *Rayolanda* and cut wool (for cotton see later), the blend being made by weighing out the required proportions of stock and spreading these on the feed lattice preferably in superimposed layers. The quantities weighed out should not be so large as to make reasonable hand mixing impossible. Thus the unit of the blend should be of the order of 50 pounds, say $7\frac{1}{2}$ pounds *Fibroceta* and $42\frac{1}{2}$ pounds *Fibro* for a blend of 15% *Fibroceta*/85% *Fibro*. The figures given here are for illustration only and take no account of the different moisture content of the materials as they should for strictly correct blending.

In the hoppers the evener roller speed and setting should be adjusted, as usual, to regulate the weights of stock required to flow forward. An alteration may be required when changing to rayon staple, depending on the bulkiness of

FIGURE 20

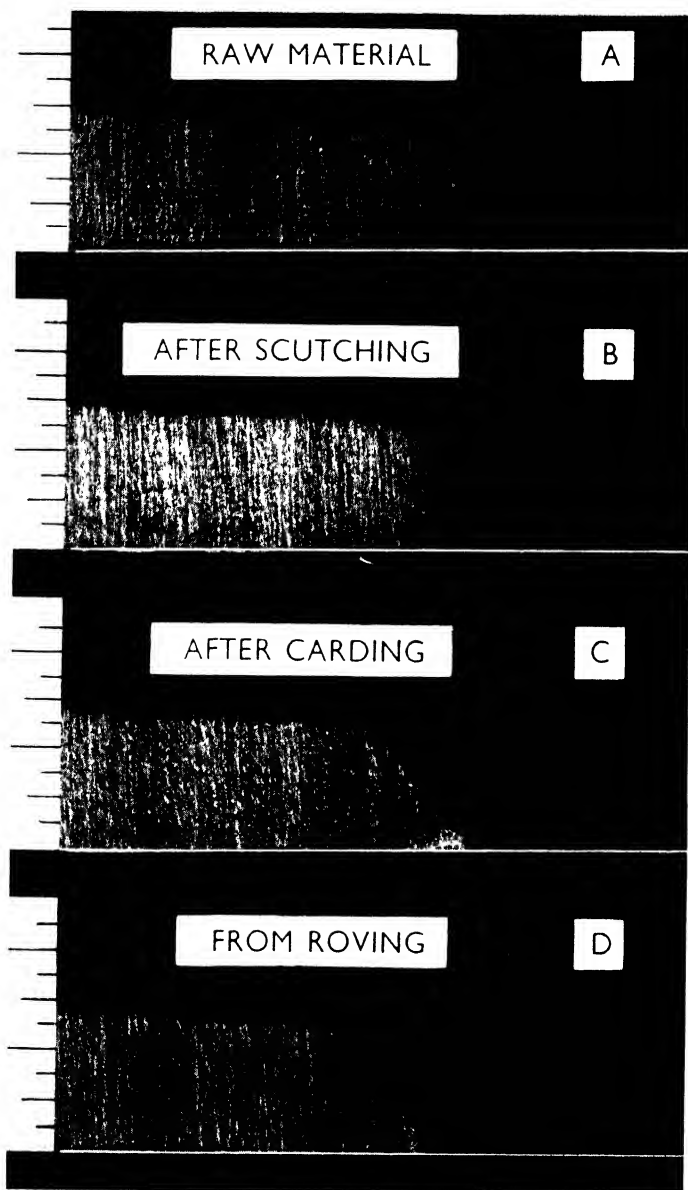

fibres previously processed, and may even be required when changing from, say, *Fibro* to *Rayolanda*, since *Rayolanda*, as taken from the bale, may be more compact than *Fibro*, and would be overfed if adjustments were not made. At the openers all parts of the machine at which rayon staple is likely to drop to the floor should be sealed in; also the beater bars can be reversed to prevent fibres being thrown out, which obviates the need for the bars to be blanked in. A satisfactory arrangement for the lead bars is to cover them with a metal sheet and arrange for an air inlet between the leading edge of this and the beater bars.

It may be found essential to speed-up the calender rollers in relation to the cage feed rollers in processing *Rayolanda* or *Fibro*/wool, to prevent folds in the lap. With the normal weightings of the racks as used for cotton, the lap rollers are often difficult to remove from rayon staple laps. Friction on the brake block at the lap end should be reduced by sliding the weights on the weight lever. The difficulty can also be lessened by making the lap rollers slightly tapered. The unwinding of laps at the scutcher and card can be improved by the use of lap felters behind the calender rollers of both the opener and scutcher.

With attention paid to the rate of flow of the material through the machine, rayon staple can be satisfactorily processed on the combination given. The staple diagrams in *Figure 20* show that the amount of breakage that takes place in opening is slight.

Carding. The standard cotton card has been largely used for carding of rayon staple of the types enumerated as being available for cotton spinning, though no doubt there will be developments as new machines are produced.

Only a minimum of re-adjustment is needed to obtain satisfactory results on the standard card. Suitable settings are given in *Table 6*.

TABLE 6

PARTICULARS OF CARD AND SETTINGS				
		Counts of Wire	Speed per Minute	Diameter
Cylinder	110S	160 revs.	50 inches
Doffer	120S	10-11 revs.	27 inches
Flats	110S	1½ inches	

	<i>Staple</i>		
	$1\frac{7}{16}$ inches	$1\frac{1}{8}$ inches	$2\frac{1}{2}$ inches
Feed plate/taker-in (1/1000 inches)	12	18	36
Taker-in/cylinder	..	7	
Flats/cylinder	..	10	
Doffer/cylinder	..	5	
Comb/doffer	..	12	

For good carding of rayon staple, as for the natural fibres, it is of course essential that the clothing should be well ground and in good condition though rayon staple needs no better conditions than other fibres. With such cards it is a commonplace that strong, clean, well-carded webs are readily obtained, as rayon staple cards easily. With the longer staple lengths and with laps that are too heavy it may be found that some plucking is met at the feed rollers, but this can be stopped by extra weighting of these rollers. A setting that is too close may do the same, but this would not be expected to arise with the settings given in the table. Of these settings the most important is considered to be the doffer/cylinder setting with the taker-in/cylinder next, the others being less critical probably than in cotton spinning owing to the relative freedom from entanglement of rayon staple and its regularity of staple and filament cross-section.

With $1\frac{1}{2}$ denier $1\frac{7}{16}$ -inch *Fibro*, stripping three times a day is a generous frequency, though more frequent stripping may be necessary when carding *Rayolanda*, *Fibrocta* or wool mixtures.

It may be found that with certain qualities there is a tendency for the web to sag overmuch, but this can be corrected by a change of one tooth on the calender block pinion. The breakage of rayon staple after opening and carding is very small as can be seen by the traces in *Figure 20* which show the staple lengths of the main types of rayon staple as taken from the bale and after carding.

TABLE 7

	<i>Fibro</i> $1\frac{1}{2}$ denier, $1\frac{7}{16}$ inches staple, Bright	<i>Fibro</i> $1\frac{1}{4}$ denier, $1\frac{1}{8}$ inches staple, Strong	<i>Fibro</i> 3 denier, $2\frac{1}{2}$ inches staple, Matt
	%	%	%
Sliver produced ..	98.0	96.2	97.4
Cylinder strips ..	0.6	0.6	0.8
Doffer strips ..	0.2	0.5	0.3
Flat strips ..	0.6	1.9	0.5
Droppings ..	0.2	0.2	0.2
Invisible loss ..	0.4	0.6	0.8

Table 7 shows the results of waste tests at the card, when carding three types of *Fibro*.

Drawing. It is customary to give the slivers three passages of drawing as in this way maximum lustre is achieved in the yarn and the regularity of the drawn sliver is higher than would be obtained by only two passages. Six slivers are commonly fed at each stage, though this is not essential; in fact, five may often be used when blending in ratios of tenths or fifths.

Settings. For all three stages of drawing with roller weightings of 20 pounds at each end of the rollers, suitable settings are:

TABLE 8

Roller Settings—Draw Frame	Centres, inches		
	Front—2nd	2nd—3rd	3rd—Back
1 $\frac{7}{8}$ inches	1 $\frac{5}{8}$	1 $\frac{3}{4}$	1 $\frac{7}{8}$
1 $\frac{7}{8}$ inches	2 $\frac{1}{8}$	2 $\frac{1}{4}$	2 $\frac{3}{8}$
2 $\frac{1}{2}$ inches (4 lines)	2 $\frac{3}{8}$	2 $\frac{7}{8}$	3 $\frac{1}{8}$
2 $\frac{1}{2}$ inches (3 lines)	2 $\frac{5}{8}$	3 $\frac{1}{8}$	—

Front roller diameter, 1 $\frac{1}{2}$ inches
 Front roller R.P.M., 390-400

Three lines would be used when the stands are not long enough to permit four lines to be used.

Drafts. The draft is usually approximately equal to the number of slivers fed, and therefore follows the common practice in drawing.

Blending of Cotton. Because of the cleaning required and the relatively high waste loss of cotton in opening and carding, it is considered that the draw-frame is the most suitable stage at which to make cotton blends. Thus for a mixture of one-third cotton, two-thirds *Fibro*, two card slivers of cotton would be blended at the card box with four slivers of *Fibro* of the same hank. Three passages of drawing should be used.

Table 8 shows the front roller size and speed in revolutions per minute that are in use when drawing *Fibro* and blends of *Fibro* of 1 $\frac{7}{8}$ inches, 1 $\frac{7}{8}$ inches and 2 $\frac{1}{2}$ inches staple length. They show that the productive rate is as high as would be obtained on cotton.

Roller Coverings. Unvarnished leather-covered top rollers at each line except front give satisfactory working. The front roller should be varnished.

FIGURE 21

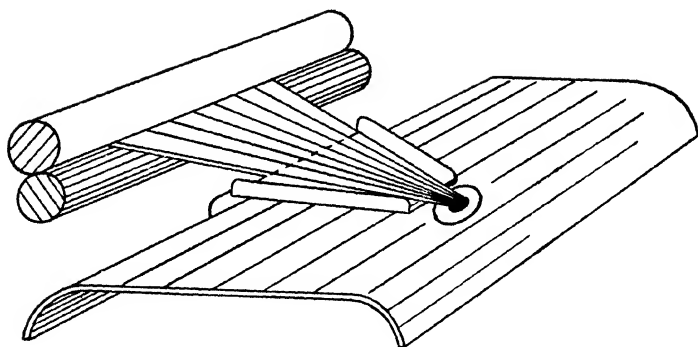

Web Tension. The front roller calender pinion should be such that the web sags just slightly, thus ensuring that it is not being ratched. In the case of *Fibro*/wool blends it may be found advantageous to fit a thin metal trough to the draw-frame as shown in *Figure 21*. This will prevent fibres from straying from the web and falling on the trumpet plate.

It is advisable also to use a selvage guide, which may conveniently be of thin plastic sheet or fibre board, in which case it would rest on the sliver between the front and second rollers and be supported by it, or alternatively may be in the form of thin fingers, one at each side of the sliver, again between the first and second rollers, and fixed by bolts to a bracket which passes under the rollers from the traverse motion. (See *Figure 22*.)

Relative Humidity and Temperature. In processing rayon staple it is desirable to keep the temperature of the room above 21° C., as at low temperatures, particularly first thing in the morning, the fibres are liable to lick on the front rollers and trumpet plate. For *Fibro* a relative humidity of about 50% is satisfactory and at this relative humidity other materials are workable, though for *Rayolanda* a relative humidity of about 55% is preferable and for *Fibro*ceta and *Fibro*/wool 60%–65% is better.

When drawing frames have been running cotton, the deposits of wax on plates, spoons, trumpets, etc., should be removed by cleaning with solvent.

FIGURE 22

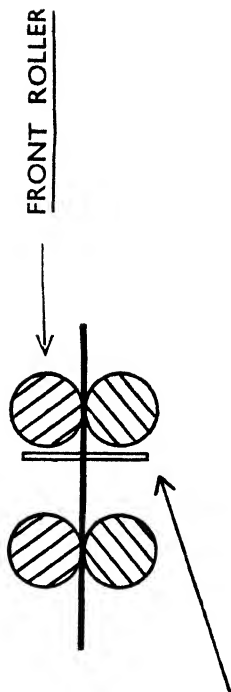
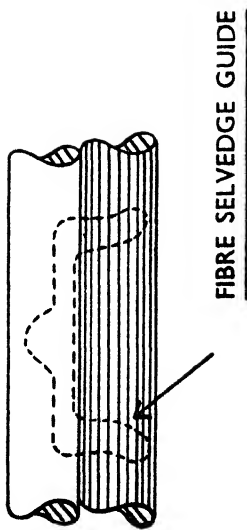
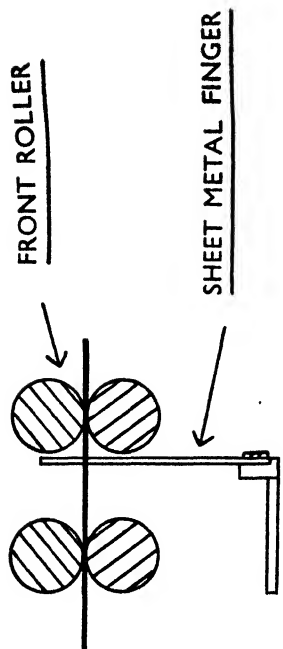
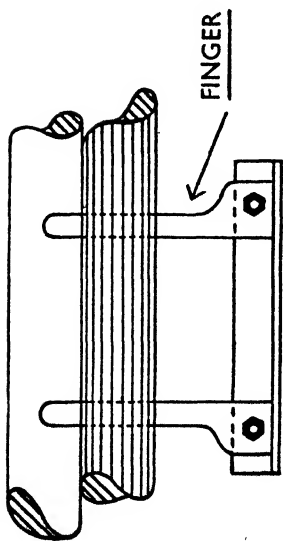

Speed Frames. At this stage in processing rayon staple as compared with cotton a few points of difference arise in manipulation because rayon staple of a given hank lies in less space than cotton. They are noted later. Special attention should also be paid to the twist in the roving (used here in a general sense to cover the product of each frame) which must be changed to suit the particular staple length, filament, denier and type of *Fibro*, *Fibroreta*, *Fibrolane*, *Rayolanda* and blend to ensure that the twist is just sufficient to prevent ratching in drawing-off but no more. An indication of these is given below in *Table 9*:

TABLE 9

	<i>Slubbing</i> 0.7 Hank	<i>Intermediate</i> 1.7 Hank	<i>Roving</i> 5.0 Hank
<i>Fibro</i> 1½ denier, 1 7/8 inches, Bright ..	0.7-0.8	0.8-0.9	1.0-1.15
<i>Rayolanda</i> 1½ denier, 1 7/8 inches ..	0.9	1.0	1.25
<i>Fibro</i> 3 denier, 1 7/8 inches ..	0.9	1.0	1.25
3 denier, 2½-inches staple <i>Fibro</i> , <i>Rayolanda</i> and Mixtures, 3-line ..	0.6	0.7	0.7
2-line ..	0.7	0.7	0.8
<i>Fibro</i> 1½ denier, 1 7/8-inches Strong ..	0.6	0.7	0.8
<i>Fibroreta</i> 2½ denier, 1 7/8 inches, Matt ..	0.9	0.95	1.25

When using old bobbins there may be a liability to oil-staining of the layers of roving near the bobbin, due to oil seeping through the bobbin. This can be cured by covering the bobbins with varnished paper sleeves. Alternatively it can be prevented by using resin-impregnated paper bobbins.

It is necessary to increase the taper of the cone at the top and bottom of the bobbins, as compared with cotton, to prevent the coils of roving slipping out of position. This would be effected by a change in the tapering bevel.

It will generally be found that slight changes are also needed in the sizes of the rack and lifter wheels. The rack wheel is generally required to be of a higher number of teeth and the lifter wheel of a smaller number of teeth than for cotton, the roving behaving as if it is finer than the nominal hank.

The speed of the front roller and the theoretical maximum production will depend on the twist factor being put in the roving. The list above, together with *Table 10* of suggested spindle speeds, will enable one to calculate these productions.

TABLE 10

SPINDLE SPEEDS AT SPEED FRAMES			
Slubber	500 R.P.M.
Intermediate	750 R.P.M.
Rover	1150 R.P.M.

Suitable settings and roller weightings, which have been in bulk practice over many years, for several principal staple lengths are given in *Table 11*. These settings would, of course, need some modification if weightings other than those stated were used.

TABLE 11

ROLLER WEIGHTS			
	<i>Front</i>	<i>Middle</i>	<i>Back</i>
Slubber 20 pounds	—	24 pounds (saddled)
Intermediate 17 pounds	—	20 pounds (saddled)
Rover 9 pounds	14 ounces	2½ pounds

SETTINGS—ROLLER CENTRES

<i>Slubber</i>		<i>Front—Middle</i>	<i>Middle—Back</i>
<i>Fibro</i> , 1½ denier, 1⅞-inch, Bright	1⅞ inches	2⅞ inches
<i>Fibro</i> , 1¼ denier, 1⅝-inch, Strong	2 inches	2⅞ inches
<i>Fibro</i> , 2½-inch, staple	—	2⅞ inches (2 lines, middle removed)
<i>Intermediate</i>			
<i>Fibro</i> , 1½ denier, 1⅞-inch, Bright	1½ inches	2 inches
<i>Fibro</i> , 1¼ denier, 1⅝-inch, Strong	1⅞ inches	2½ inches
<i>Fibro</i> , 2½-inch, staple	—	2⅞ inches (2 lines, middle removed)
<i>Rover</i>			
<i>Fibro</i> , 1½ denier, 1⅞-inch, Bright	1⅞ inches	1⅞ inches
<i>Fibro</i> , 1¼ denier, 1⅝-inch, Strong	1⅞ inches	2½ inches
<i>Fibro</i> , 2½-inch, staple	—	2⅞ inches (2 lines, middle removed)

At slubbing and intermediate frames it is recommended that selvage guides should be suspended between the front and middle rollers of the type illustrated in *Figure 22*. For 2½-inch staples it is better to use a condenser of the type shown in *Figure 23* overleaf.

Roller coverings of the usual unvarnished leather are quite satisfactory. Also it may be necessary when changing from cotton to remove wax from the flyer top and inside the hollow leg and paddle. Further, it is an advantage to use a flyer with the slits in the hollow leg finer than would normally be used for cotton of the same hank so as to

FIGURE 23

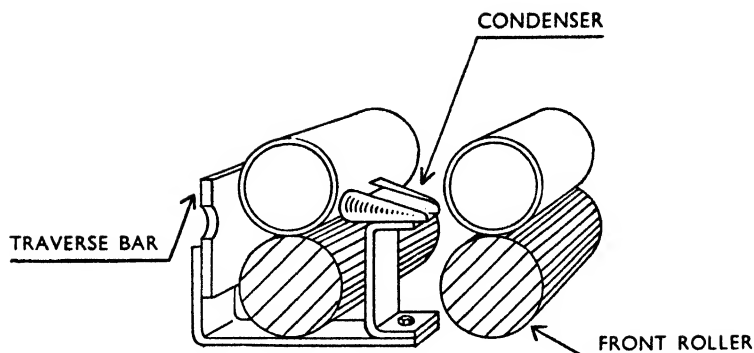

prevent any liability for the more slippery rayon staple roving from flying out of the leg.

Ring Spinning. This system of spinning is eminently satisfactory for spinning all counts of yarn from coarse to fine. Again only minor changes as compared with spinning cotton are necessary.

It will be found that rayon staple can be spun to approximately maximum strength and processed with much lower twist factors than are customary for cotton. *Table 12* shows a comparison. However, it should be noted that, though this is the case, the twist factor should be decided entirely by reference to the textural requirements of the cloth and not from such considerations of maximum strength, etc., as only in this way can the maximum benefit be obtained from rayon staple. It is not possible to lay down these twist factors didactically.

TABLE 12
MINIMUM TWIST FACTORS FOR RAYON STAPLE YARNS, RING SPUN

	Counts			
	Coarse	Medium	Fine	
	10s	20s-30s	60s-80s	
<i>Fibro</i> , 1½ denier, 1⅞-inch, Bright ..	2.7	2.9	3.25	
<i>Fibrocta</i> , 2½ denier, 1⅞-inch, Matt ..	3.0	3.5		
<i>Rayolanda</i> , 1½ denier, 1⅞-inch ..	3.0	3.25		
<i>Fibro</i> , 3 denier, 1⅞-inch ..	3.0	3.25		
<i>Fibro</i> , 1½ denier, 1⅞-inch, Strong ..	2.7	2.9	3.25	3.5
<i>Fibro</i> , 3 denier, 2¼-inch ..	2.8	3.0		

The spindle speed will be adjusted to maintain a suitable front roller speed, having in mind the twist factor, but in general the front roller speed is at least as high as would be used in spinning good class cottons. It follows, therefore, that productions are at least similar to what would be obtained in spinning such cottons.

Using the standard three line rollers system (details of an example of which are given in *Table 13*), drafts of the order of twelve are in common use. For most qualities single roving can be used up to 20s cotton counts but double rovings are better for all counts above 20s. Settings are also given in *Table 13*.

Roller coverings are the normal leather-covered front rollers with self-weighted middle and back rollers and the settings apply to these. A high draft system can be used, in which event the behaviour on rayon staple would be similar to that on cotton.

The traveller weights should generally be slightly heavier by, say, two sizes, than those for cotton. The rack wheel can contain 20% more teeth than for cotton of comparative count. In order to prevent sloughing-off at the bottom of the tube the "pig's foot" should be removed from the builder motion.

TABLE 13
SETTINGS AND WEIGHTS OF RING FRAME ROLLERS

Settings	Front Middle		Middle Back
	<i>Fibro</i> , 1½ denier, 1⅞-inch, Bright	1 ⅝ inches	
<i>Fibro</i> , 1½ denier, 1⅞-inch, Strong	1 ⅞ inches		2½ inches
<i>Fibro</i> , 3 denier, 2½-inch	1 ⅞ inches		2 inches

ROLLER SETTINGS AND WEIGHTS—MULE

Roller Weights	Front	Middle	Back
<i>Fibro</i> , 1½ denier, 1⅞-inch, Bright	5½ pounds	10 ounces	2½ pounds
<i>Fibro</i> , 1½ denier, 1⅞-inch, Strong	5½ pounds	10 ounces	2½ pounds
<i>Fibro</i> , 3 denier, 2½-inch	5½ pounds	1 ounce	2½ pounds

Mule Spinning. When spinning on the mule, it is desirable that the mule should be in good alignment; rollers, fallers and spindle points should be parallel as far as practicable to reduce yarn strain to a minimum. It will usually be preferable to increase the spindle bevel to a ratio of 1:3.4. The topping of the spindles should be 2⅝ inches out and 2⅝ inches down, which is generally slightly greater than for cotton spinning.

Owing to the greater liability of rayon staple to slough off, it will usually be found necessary to finish the cops lower down the spindle than would be necessary with cotton; otherwise the coils of yarn will slip off the spindle blade to the detriment of the cop nose and the winding. Further, it might be found better to use an anti-snarling motion and to set the unlocking bracket as late as possible without unduly straining the yarn.

To prevent sloughing off, the cop chase should be slightly longer and the cop bottom rather steeper than for cotton. The builder wheel can be larger, as suggested for ring spinning.

Because the twist factors are lower than for cotton, the maintenance of the spindle bands must receive the best attention. A slack string in rayon staple spinning, with the use of low twist factors, would soon lead to dangerously low twists. Twist factors in common use for mule spun yarns of *Fibro*, $1\frac{1}{2}$ denier $1\frac{7}{16}$ inches are:

 Weft: 2.6. Doubling Weft: 2.75. Warp: 2.9

TABLE 14

ROLLER SETTINGS AND WEIGHTS—MULE

<i>Settings (Centres)</i>	<i>Front—Middle</i>	<i>Middle—Back</i>
<i>Fibro</i> , $1\frac{1}{2}$ denier, $1\frac{7}{16}$ -inch, Bright ..	$1\frac{3}{8}$ inches	$1\frac{3}{4}$
	<i>Front</i>	<i>Middle</i> <i>Back</i>
<i>Fibro</i> , $1\frac{1}{2}$ denier, $1\frac{7}{16}$ -inch, Bright ..	$\frac{6}{2}$ pounds	$4\frac{1}{2}$ ounces $1\frac{3}{4}$ pounds

Yarn Processing. *Fibro* yarns are commonly processed on standard preparatory machinery similar to the processing of cotton yarns in all forms of package, cone, cheese, pirn, ball warp, back beam, and hank.

CHAPTER VII

SPINNING ON COTTON CONDENSER
MACHINERY

TABLE 15

<i>Name</i>	<i>Type</i>	<i>Lustre</i>	<i>Staple ins.</i>	<i>Denier</i>	<i>and Count Limit (Cotton Counts in Brackets)</i>
<i>Fibro</i>	Viscose	Bright & Matt	$1\frac{1}{8}$	$1\frac{1}{2}$	(6)
<i>Fibro</i>	Viscose	Bright & Matt	$1\frac{7}{8}$	$1\frac{1}{2}$	(8) 3 (6)
<i>Fibro</i>	Viscose	Bright & Matt	$2\frac{1}{2}$		3 (10) $4\frac{1}{2}$ (8)
<i>Rayolanda</i>	Modified Viscose	Bright & Matt	$1\frac{7}{8}$	$1\frac{1}{2}$	(8)
<i>Rayolanda</i>	Modified Viscose	Bright & Matt	$2\frac{1}{2}$		3 (10) $4\frac{1}{2}$ (8)
<i>Fibroceta</i>	Cellulose- Acetate	Bright & Matt	$1\frac{7}{8}$		$2\frac{1}{2}$ (8) $4\frac{1}{2}$ (8)
<i>Fibroceta</i>	Cellulose- Acetate	Bright & Matt	$2\frac{1}{2}$		$2\frac{1}{2}$ (10) $4\frac{1}{2}$ (8)
<i>Fibrolane</i>	Protein	Medium	$2\frac{1}{2}$		$4\frac{1}{2}$ (6)

THE above rayon staples are suitable for processing on most types of cotton condenser machinery. The chief point to note is that the staple length should be chosen so as to suit the condensing mechanism. If ring doffers are used the staple length must not be too long to prevent clear separation of adjacent tapes of fibres at the dividing rollers. On tape condensers there is much more latitude in the upper length of fibre than can be used with good splitting.

The limits of count given in the table are conservative for each fibre processed in the pure state without admixture and, as a rough guide, it will be found that mixtures of fibres can be spun to limits at least as high as would be calculated from the proportions of several components of a blend and the count limits of the separate components. Blending takes place before breaker carding, as generally little or no long range blending takes place during carding. As for cotton, it is desirable to lubricate rayon staple for cotton condenser carding with small quantities, 1%–2% of light oils, preferably readily emulsifiable, or with a soap solution.

At the breaker card it may be found necessary to increase the draft between the side drawing motion and the doffer and between the side drawing calenders and the coiler.

The remarks on woollen and cotton spinning apply almost equally to cotton condenser spinning and therefore also cover the ground of the system of yarn preparation.

CHAPTER VIII

SPINNING ON WOOLLEN MACHINERY

ALL the types of rayon staple recommended in Chapter V as suitable for cotton spinning can be used in appropriate circumstances for woollen spinning, but the coarser deniers, longer staple length types, are generally preferable to others. By using these the full advantage of the effect of length on yarn strength is gained together with the relative ease of working of the coarser denier filament, as, if the filament denier is too fine, extra care is needed to prevent neps being made in carding. Reference may also be made to pages 22-34, where some of the properties of the principal types of rayon staple are briefly described.

For most yarns 3 denier is the finest recommended and, in the staple lengths given, can be processed into nep-free blends. It is the denier to choose when the finer skeins of yarn are required and, where possible, 2½-inch staple should be used in preference to 2-inch.

Table 16 states the principal types of Courtaulds' rayon staple suitable for woollen spinning, and the counts given indicate the approximate spinning limits of each type when used alone. Where blends with natural fibres are being made, the denier of the rayon staple chosen will often be determined by reference to the kind and quality of the natural fibres. Thus when blending with 70s wool, 2½ inch 3 denier would be chosen for yarns of about 30s skeins, and 2½ inch 4.5 denier for yarns for 20s-24s skeins. For blending with 56s qualities, 2½ inches, 4.5 denier or even 8 denier might be chosen according to the handle required and type of fabric being made. For carpet yarns very coarse deniers are desirable (18 or 30 denier) and the staple length should be as long as can be processed on the card.

TABLE 16

Name	Type	Lustre	Staple ins.	Denier and Skein Limit (Skeins in Brackets)		
<i>Fibro</i>	Viscose	Bright & Matt	2	3(26s)	4.5(20s)	
<i>Fibro</i>	Viscose	Bright & Matt	2½	3(30s)	4.5(24s)	8(16s)
<i>Fibro</i>	Viscose	Bright & Matt	4			18(8s)
<i>Rayolanda</i>	Modified Viscose	Bright & Matt	2½	3(30s)	4.5(24s)	
<i>Fibrometa</i>	Cellulose- Acetate	Bright & Matt	2½	2½(30s)	4.5(24s)	
<i>Fibrolane</i>	Protein	Medium	2½		4.5(20s)	

(SKEINS = number of lengths each of 256 yards in 1 pound)

As all the types of rayon staple can readily be spun on woollen machinery either alone or in mixture with the natural fibres, the many combinations possible offer very wide scope for yarn construction and fabric design. In blending fibres it is essential to have in mind the particular dyeing and finishing properties of the fibres, as otherwise the fibres would not be blended to their best advantage.

One obvious use of rayon staple is in union yarns in blends of wool and *Fibro* or *Fibrometa* where advantage can be taken of the different dyeing properties to obtain piece-dyeing effects. By using rayon staple, good quality yarns can be obtained since the rayon staples are not contaminated with impurities and can be chosen of long staple length and of filament denier to suit the particular handle required in the cloth, whether soft and supple, or rough and stiff.

Where coloured yarns are required, spun-dyed *Fibro* is an obvious choice for union yarns, as in addition to the advantages of rayon staple mentioned above, only the wool component need be dyed.

It is essential for the wool to be clean as it will not be possible to remove burrs in finishing, and for this reason worsted laps, broken tops, garnetted thread waste or cloth clippings, carbonised pieces or noil, are suitable types of wool to use with *Fibro*, particularly when spinning yarns for dress cloths.

Blending and Oiling. In view of the different dyeing properties and physical characteristics of *Fibro* as compared with wool, it is essential that blending should be carried out

carefully. Particular care must be taken to ensure that the different fibres are not separated by variations in their flotation propensities, or by the selective action of pins on one component of the blend.

With all types of rayon staple it is generally advisable to oil them for carding and spinning whether they are blended with wool or not. The oiling could be done in the stack before teasing, or at the fearnought. If the wool (e.g., carbonised pieces and noils, or broken tops) does not contain oil, it would be satisfactory to oil the blend of fibres. If the wool contains oil, as would worsted spinners' laps, then the *Fibro* could be oiled separately, leaving the wool unoiled, when making the stack from layers of each component of the blend. It is very desirable to spread the oil evenly on the material and in a finely divided state, and for this some form of spraying device is needed. The oil can be conveniently applied as an emulsion with water (say 50% oil/50% water); and about 5% oil on the blend, or on the *Fibro* where only the *Fibro* is oiled, will usually be sufficient for all types of blends excepting those containing a large proportion of *Fibro* of extremely coarse denier. In the latter case (for example, with *Fibro* of 18 denier and 30 denier for carpet and rug yarns) it will generally be better to use two to four times this quantity of oil.

Carding. Rayon staple is processed on woollen cards under conditions very similar to those for carding wools. There are some points of difference, however, which will be of interest to woollen spinners who contemplate changing their cards from wool to rayon staple.

Rayon staple cards easily on all systems of carding because of its cleanness and the readiness with which its fibres separate. On this account high rates of carding are possible and it will probably be found that the limit is set by the speed at which the slubbings can be condensed. To obtain maximum production it may therefore be found necessary to vibrate the rubbers at speeds appreciably higher than would be used for most wools. When running rayon staple on cards previously set for wool, it will probably be found that the web is liable to sag too much between the doffer and the tape rollers, and that the slubbings come from the rubbers with "steps" or kinks at very frequent intervals.

The sagging can be easily corrected by a draft change between the condenser and the doffer. The kinks are readily removed by increasing the draft (by perhaps as much as 20%) between the tapes and the rubbers, as the kinks are formed by the strips of fibres running slack and forming loops as they leave the tapes before passing between the rubbers.

These considerations do not apply where ring doffers are used, but even here, as well as with tape condensers, it might also be found advantageous to set the rubbers progressively more open from front to back. Though it could not be advanced as a likely general rule for wide application, in some cases it has been found better to decrease the pressure on the rubbers and to vibrate the rubbers at compensatingly higher speeds.

It will probably be found that the swifts and workers keep clean much longer when carding rayon staple, and therefore that much less waste is made and less fettling needed. Rayon staple is much more prone to fly off the swift and workers than is wool, and covers and undergrids are usually preferable. For a similar reason it is more likely than wool to wrap around stripper ends, particularly when they pass through holes in top covers where the outward draft aggravates the trouble. The shaft ends should be suitably enclosed, and stripper speeds should be reduced so that they just strip the workers.

Fancy speeds will usually be of the order used for good quality wools of average staple, but it is not possible to be more precise than to say that large quantities of rayon staple of widely different types have been satisfactorily carded with fancy leads in the neighbourhood of 16%. In general it will probably be found that only light fancy actions are needed and that conditions that facilitate this are desirable.

Where they arise—and it is probable that they would not all arise in all machines—the above changes can be readily accomplished on woollen cards, and it will then be found that rayon staple gives good carding at satisfactory rates of production.

Mule Spinning. Rayon staple can be spun without difficulty on both the woollen and cotton condenser mules when the spinning and drafting conditions are modified to suit the

fibre. The first and main point to note is that rayon staple cannot be satisfactorily drafted with the proportion of twist during drawing-out that would be used for wool or cotton, and, as a rough guide, it might be taken that about half the drawing-out twist will be needed. Thus it will generally be necessary to use a small slow speed rim, and larger drawing-out wheels and drag-wheels, so that the twist is reduced by appreciably faster carriage speeds, particularly at the beginning of the draw. Because of the reduction of twist and the fast carriage speed, care must be taken to have the drive to the carriage steady, as a jerky motion would pull thin places in the yarn; and it will be obvious to practical spinners that it is desirable that the rollers and carriage should be in good alignment.

In general, the remarks regarding the building of the cop discussed under *Mule Spinning* in Chapter VI apply here. Three speed motions are not essential but, where available, they would facilitate a steady building up of the twist during the draw.

The drafts that can be used will usually be found to be of the order of $1\frac{1}{4}$ – $1\frac{1}{3}$, depending on the staple length, denier and the count being spun.

It is advisable to alter the topping and the bevel of the spindles and, as a guide to these, the following dimensions have been found satisfactory and have been extensively used:

TABLE 17

<i>System</i>	<i>Bevel</i>	<i>Topping</i>
Woollen Mule	5 in $19\frac{1}{2}$ inches	$2\frac{1}{8}$ inches down, $2\frac{1}{4}$ inches out
Cotton Condenser Mule . .	5 in 19 inches	2 inches down, $2\frac{1}{4}$ inches out

CHAPTER IX

FIBRO FOR WORSTED MACHINERY

CERTAIN staple lengths and filament deniers of *Fibro* have been selected for satisfactory blending with the principal qualities of wool. For example, *Fibro* of 4-inch staple in both 3.0 and 4.5 deniers is used to blend with merino types of wool in 64s quality; whereas 6-inch, 4.5 denier, is used with fine crossbred wool in qualities 50s to 58s. For

FIGURE 24

EFFECT OF STAPLE LENGTH ON YARN STRENGTH
OF "FIBRO" YARNS

1/30'S WORSTED COUNT

CAP SPUN YARNS

DENIER PER FILAMENT 4.5

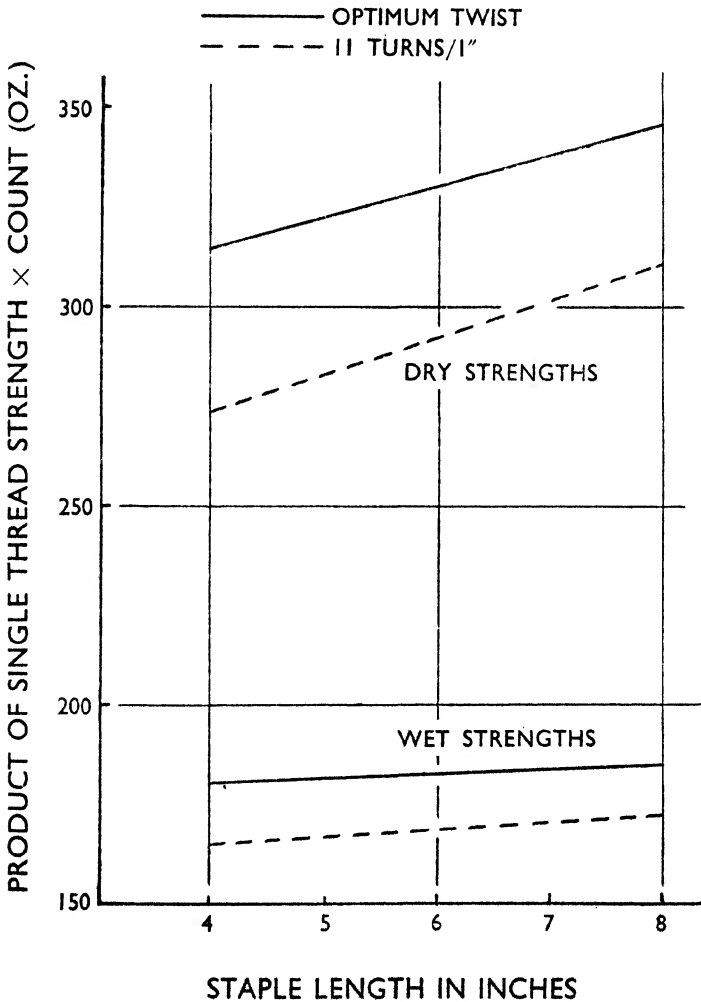

FIGURE 25

EFFECT OF STAPLE LENGTH ON THE
EXTENSION-AT-BREAK OF " FIBRO " YARNS

1/30'S WORSTED COUNT

CAP SPUN YARNS

DENIER PER FILAMENT 4.5

——— OPTIMUM TWIST
 - - - - - 11 TURNS/1"
 * * * * *
 ——— DRY
 - - - - - WET

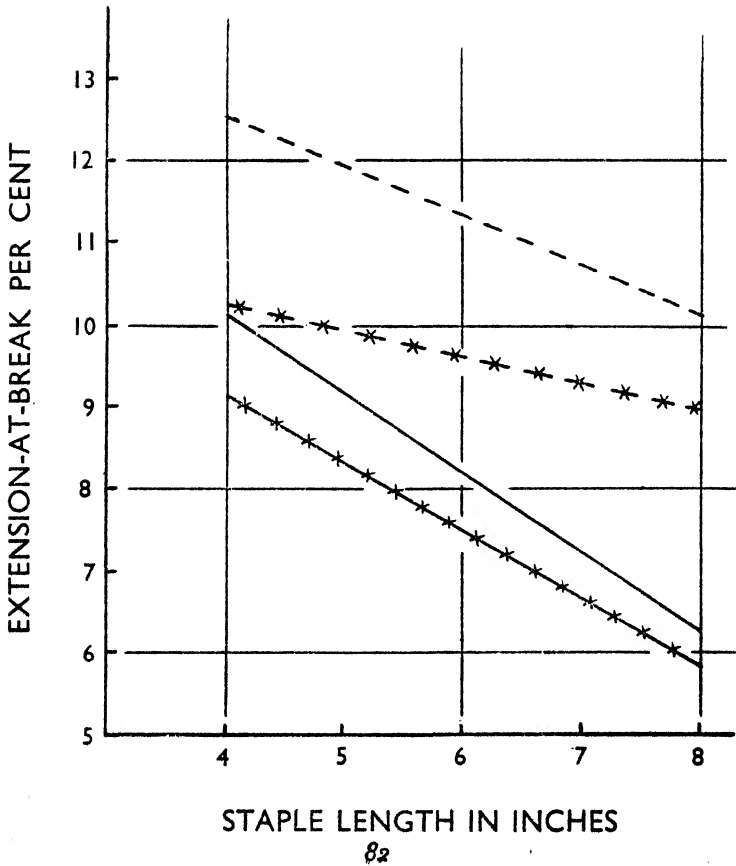

FIGURE 26

EFFECT OF FILAMENT DENIER ON THE STRENGTH OF "FIBRO" YARNS

1/30'S WORSTED COUNT

CAP SPUN YARNS

**	**	**	"FIBRO" 4" STAPLE	11 TURNS/1"
-x-x-x-x-	..	4"	..	OPTIMUM TWIST (16 T/1")
-x-x-x-x-	..	8"	..	11 TURNS/1"
- - - - -	..	8"	..	OPTIMUM TWIST (14 T/1")

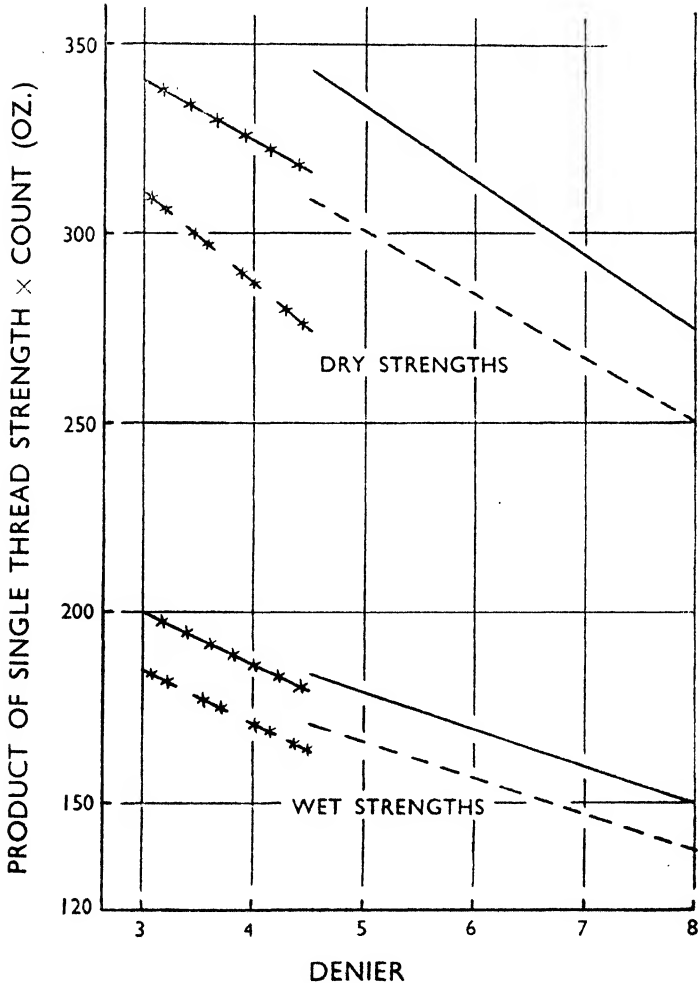

firm-handling yarns in coarse counts, 8-inch staple and 8 denier in bright lustre is supplied, and is suitable for blending with crossbred wools, such as 40s to 48s quality.

The effect of staple lengths on *Fibro* yarns spun from 4.5 denier filaments is shown in *Figures 24* and *25*; the greatest increase produced by a longer staple results when the twist is low, while the extensions decrease as the staple lengths increase.

In *Table 18* the fineness of *Fibro* filaments is shown, as well as that of natural fibres of interest to woollen and worsted spinners. The values in the first column are expressed in deniers, the standard of measurement for all rayon and silk yarns. The second column gives the mean fibre width in microns, i.e., in thousandths of 1 millimetre, as this is a convenient method of measuring the fineness of wools. The fifth column expresses fineness in terms of the weight in milligrams of 1 centimetre lengths of the fibres.

The relative orders in the second column are not the same as in the first and fifth columns, since the thickness of filaments of a given weight per centimetre varies according to their cross-sectional shape and density. However, a comparison can be made by the method which best suits the user of the table.

It is common knowledge that with natural fibres the finest spin the strongest yarns; this is also true of rayon staple, and it is an easy matter to isolate the effect of denier. *Figure 26* (page 83) gives the strength of 1/30s worsted counts, spun from *Fibro* staples of different deniers, and illustrates the above general law. As the denier is increased, the strength of the yarn decreases, the staple and twist being constant.

It may be noted that since the denier is the weight of a given length, and the yarn count is the length of a given weight, a high denier denotes a heavy yarn, while a high count denotes a fine yarn. The yarn spun from 4-inch staple, 3.0 denier is nearly as strong as the yarn spun from 8-inch staple, 4.5 denier.

Figure 27 shows the extension at break of the yarns and it will be seen that, as the denier increases and strength decreases, the extension also decreases in approximate proportions to the change in strength.

TABLE 18

AVERAGE FINENESS OF FIBRES

Material	Filament Denier	Average Fibre Diameter in Microns	Standard Deviation of Diameter	Co-efficient of Variation of Diameter	Mean Hair Wt. per Centimetre in Milligrams
<i>Fibro</i>	3.00	21.5	3.60	16.7	0.00333
<i>Fibro</i>	4.50	24.9	3.10	12.5	0.00500
<i>Fibro</i>	8.00	37.6	6.14	16.3	0.00888
70s Qual. Wool	4.33	19.7	4.03	20.4	0.00481
64s Qual. Wool	5.02	20.9	4.23	20.2	0.00557
56s Qual. Wool	7.50	26.4	6.92	26.2	0.00832
46s Qual. Wool	11.39	34.0	9.17	26.9	0.01264
4s Turkey Mohair	12.70	40.7	10.90	26.7	0.01410
Medium Alpaca	5.76	27.1	9.24	34.1	0.00639
Fine Camel Hair	3.40	17.9	4.30	24.0	0.00377

Note.—All rayon staple samples were mounted in alpha-bromo-naphthalene; while the wool, mohair, alpaca, and camel-hair were mounted in cedar-wood oil.

Effect of Twist on Yarn Strength. It is well known that the strength of a yarn is very largely dependent on the twist factor used in the spinning operation. The strength of all types of spun yarns rises to a maximum as the twist is increased from zero to some value that is mainly determined by the nature of the material being spun. When the twist is increased further, the strength of the yarn drops and continues to drop as the increase of twist continues.

The amount of twist required to give the maximum strength in any yarn of given count is often called the "optimum" twist for that count. A comparison of the twist/strength relationships of yarns spun from *Fibro*, blends of *Fibro* and wool, and from 100% wool is therefore interesting.

The curves in *Figures 28 and 29* show the twist/strength relationships of *Fibro* 4-inch 3.0 denier, 64s merino wool, and blends of these, and of *Fibro* 4-inch 4.5 denier, from 8–38 turns per inch.

In the dry state with the 4-inch, 3.0 denier, and wool blends, the yarn strength increases with increasing *Fibro* content over the twist range shown. The twist factor required for maximum strength is practically the same for all the yarns, though there is a suggestion that it increases slightly as the percentage of wool in the yarn increases.

As the twist is decreased below the optimum, then, the greater the wool content of the yarn, the quicker does the

FIGURE 27

EFFECT OF FILAMENT DENIER ON THE
EXTENSION-AT-BREAK OF "FIBRO" YARNS

1/30'S WORSTED COUNT

CAP SPUN YARNS

OPTIMUM TWIST

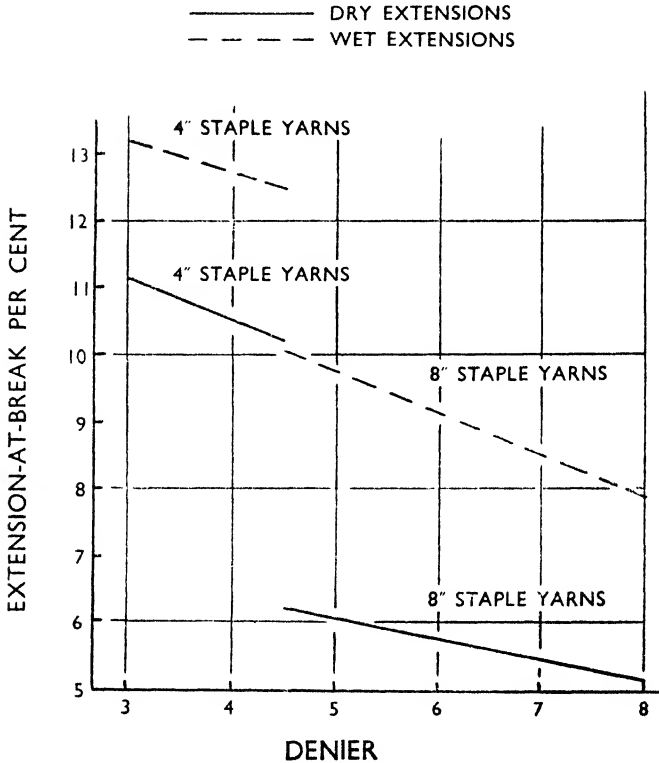

yarn lose strength. As twist is increased above the optimum the reverse is true. These statements apply to both the dry and wet strengths.

As the upper limit of twist is increased, the differences between yarn strengths disappear. This is more clearly shown by the wet curves.

FIGURE 28

EFFECT OF TWIST ON "FIBRO" AND WOOL BLENDS

DRY SINGLE THREAD STRENGTHS

- +++++ 100% "FIBRO" 4" STAPLE 3.0 DENIER
- 100% "FIBRO" 4" STAPLE 4.5 DENIER
- *-*-*-* { 75% "FIBRO" 4" STAPLE 3.0 DENIER
25% WOOL 64'S MERINO
- - - - { 50% "FIBRO" 4" STAPLE 3.0 DENIER
50% WOOL 64'S MERINO
- 100% WOOL 64'S MERINO

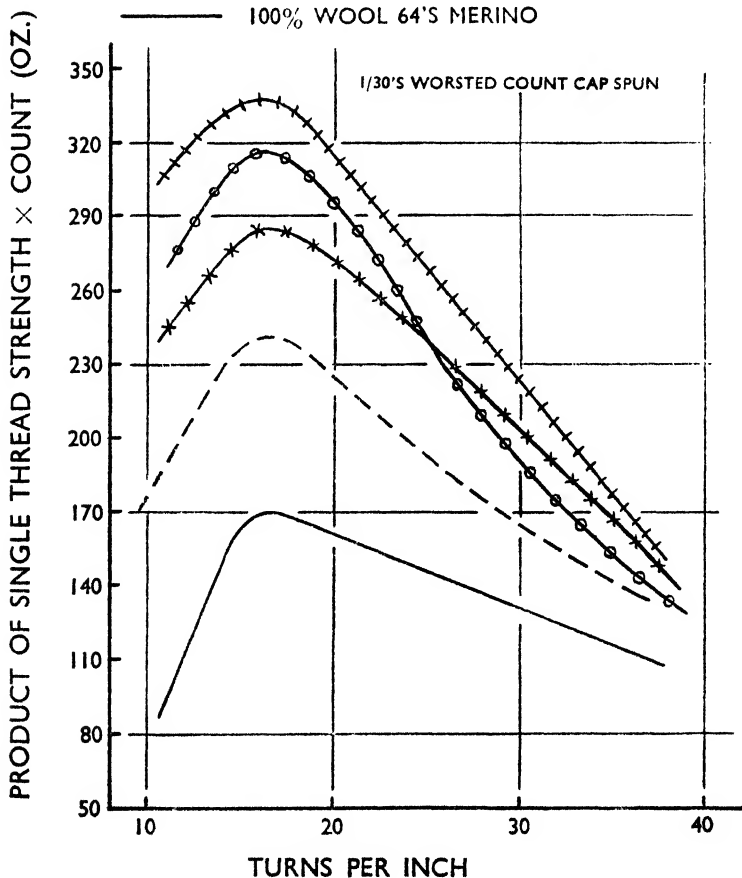

FIGURE 29

EFFECT OF TWIST ON "FIBRO"/WOOL BLENDS

WET SINGLE THREAD STRENGTHS

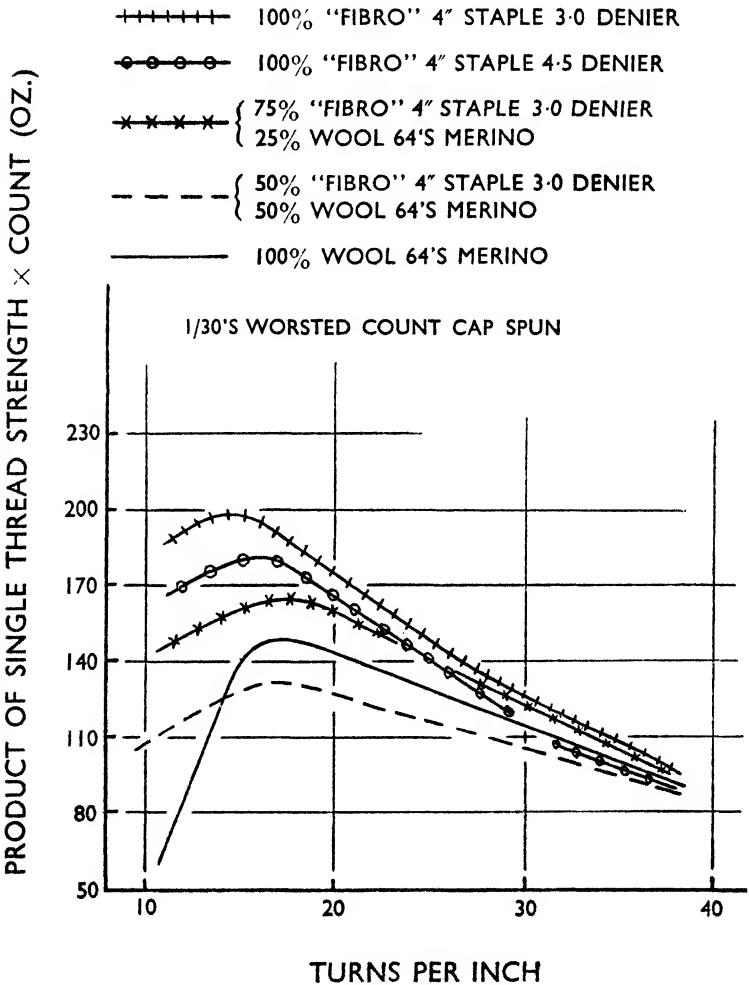

FIGURE 30

EFFECT OF TWIST ON "FIBRO" AND WOOL YARNS

DRY SINGLE THREAD STRENGTHS

1/30'S WORSTED COUNT

CAP SPUN

- "FIBRO" 8" STAPLE 4.5 DENIER
- ××××× "FIBRO" 8" STAPLE 8.0 DENIER
- +++++ WOOL 58'S QUALITY CROSS-BRED
- WOOL 46'S QUALITY CROSS-BRED

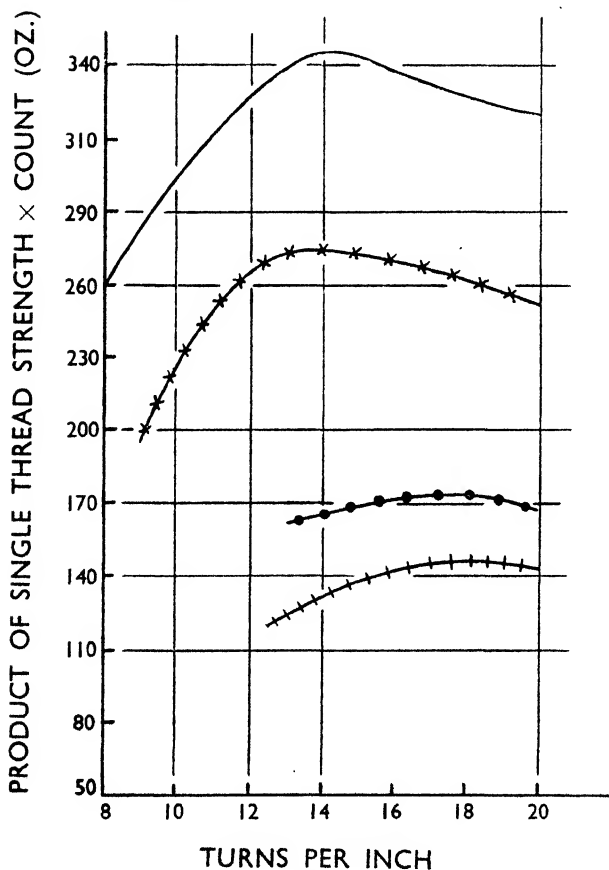

In the wet state, the 100% wool yarn is stronger than the 50% *Fibro*/50% wool yarn after a twist factor of about 2.6. The 4-inch, 4.5 denier *Fibro* yarn loses strength faster than the *Fibro*/wool blends after passing the optimum twist, and falls below their strength above a twist factor of about 5.

Figures 30 and 31 show the strengths of yarns spun from *Fibro*, 8-inch, 4.5 denier, and 8-inch, 8.0 denier, and 58s and 46s crossbred wool over a range of twists. The 4.5 and 8.0 denier yarns reach their maximum strength at a twist factor of about 2.6–2.7. The wool yarns change very little in strength over the range shown and there is a suggestion, from the curves for wet strength, that the optimum twist factor for the wool is about 3.

Fibro and Fibro/wool Blends. Some of the most interesting details of *Fibro* yarn properties are those that arise in the comparison of different blends of *Fibro* and wool. In Figure 32 the dry and wet single thread strengths are shown for a range of blends of *Fibro*, 4-inch, 3.0 denier, and 64s quality wool.

Yarn strength drops steadily as the percentage of wool in the yarn is increased. The dry strength of the 100% wool yarn is about 40% of the dry strength of the *Fibro* yarn, while the wet strength of the former is about 55% of the wet strength of the *Fibro* yarn. The relative strengths of the blends can be considered for practical purposes as having a linear relation to the above terminals. It should be noted that even the wet strengths of the *Fibro* yarns (both counts) are greater than the dry wool yarn strengths. This can perhaps be best expressed in this manner: the percentage excess of wet *Fibro* strength over dry wool strength, based on dry wool strength is, in the case of 30s, 28%, and in the case of 48s, 29%.

With reference to these yarns in Figure 33, the curves for extension-at-break show that, in the dry state, the differences between the blends are small; in the wet state no significant change takes place from 100% *Fibro* to 50/50—but, beyond that point the final extension-at-break increases very rapidly.

Figure 34 shows the strengths and extensions for 6-inch, 4.5 denier *Fibro* and 58s wool, and blends of these. The dry strength of the 100% wool yarn is about 40% of the strength of the *Fibro*, while the wet strength of the wool is about 50%

FIGURE 31

EFFECT OF TWIST ON "FIBRO" AND WOOL YARNS

WET SINGLE THREAD STRENGTHS

1/30'S WORSTED COUNT

CAP SPUN

PRODUCT OF SINGLE THREAD STRENGTH \times COUNT (OZ.)

- "FIBRO" 8" STAPLE 4.5 DENIER
- * * * * * "FIBRO" 8" STAPLE 8.0 DENIER
- + + + + + WOOL 58'S QUALITY CROSS-BRED
- ● ● ● ● WOOL 46'S QUALITY CROSS-BRED

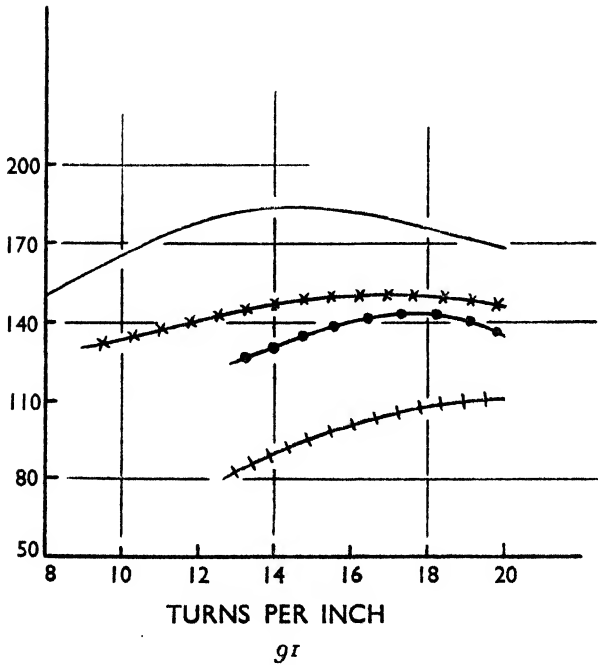

FIGURE 32

THE STRENGTH OF YARNS SPUN FROM
 "FIBRO"—4" STAPLE 3 DENIER/FIL.
 AND WOOL—64'S MERINO

○ ——— ○ ——— ○ 1/30'S DRY
 x ——— x ——— x 1/48'S DRY
 ○ - - - - ○ - - - - ○ 1/30'S WET
 x - - - - x - - - - x 1/48'S WET

RING SPUN YARNS

11 TURNS/1" FOR 1/30'S WORSTED COUNT
 14 TURNS/1" FOR 1/48'S WORSTED COUNT

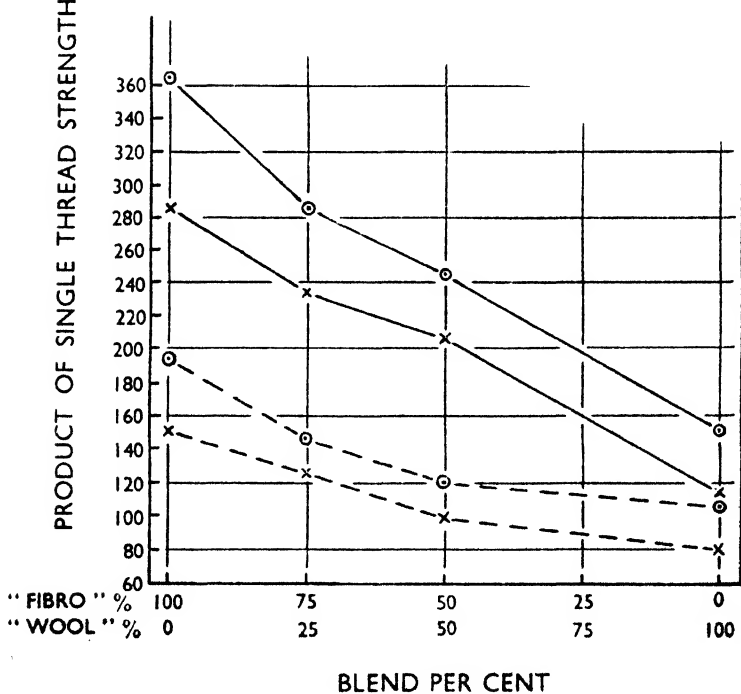

FIGURE 33

THE EXTENSION AT BREAK OF YARNS SPUN FROM
 "FIBRO"—4" STAPLE 3 DENIER/FIL.
 AND WOOL—64'S MERINO

○ ——— ○ ——— ○ 1/30'S DRY
 x ——— x ——— x 1/48'S DRY
 ○ - - - ○ - - - ○ 1/30'S WET
 x - - - x - - - x 1/48'S WET

RING SPUN YARNS

11 TURNS/1" FOR 1/30'S WORSTED COUNT
 14 TURNS/1" FOR 1/48'S WORSTED COUNT

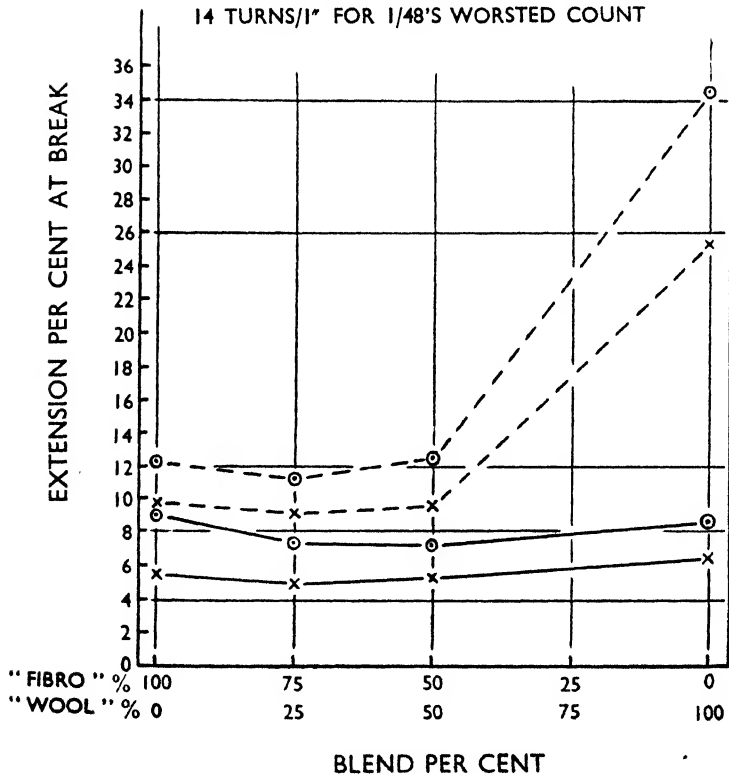
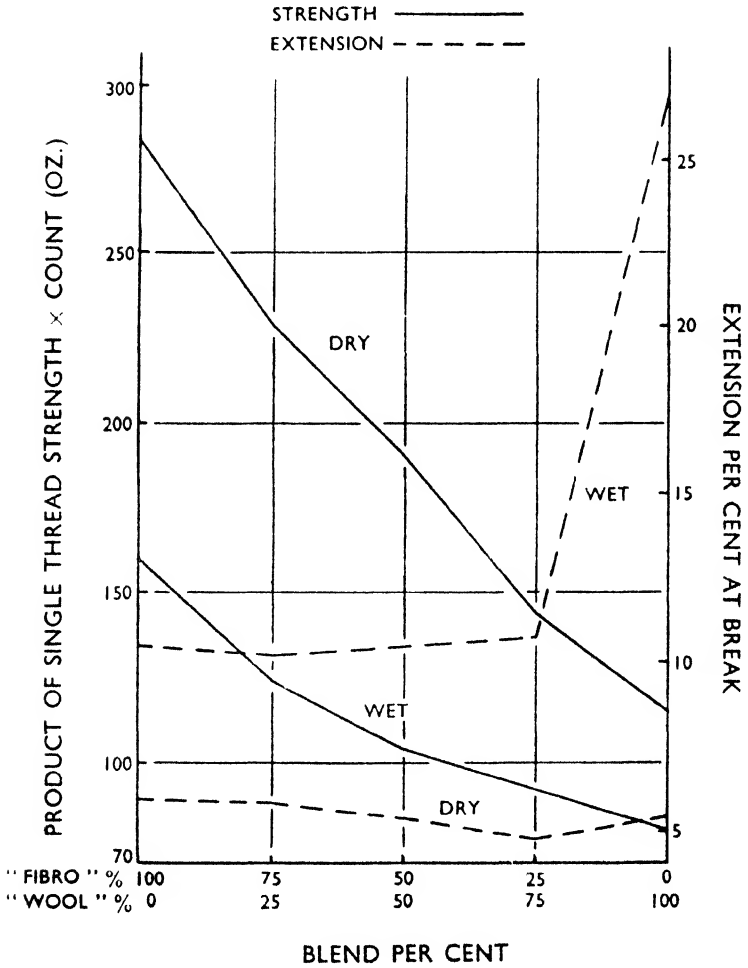

FIGURE 34

SINGLE THREAD STRENGTHS OF BLENDS OF
 "FIBRO" 6" STAPLE 4.5 DENIER
 WOOL 58'S QUALITY CROSSBRED

1/30'S WORSTED COUNT CAP SPUN 11 T./1"



of the wet strength of the *Fibro*. The wet strength of the *Fibro* yarn is about 40% higher than the dry wool strengths. The blends take up intermediate values between the strengths of the 100% *Fibro* and wool yarns.

The dry extensions *per cent* are practically the same for both 100% yarns and the blends, and the wet extensions are very nearly equal for the 100% *Fibro* yarn and blends, the *Fibro* apparently dominating the behaviour. The 100% wet wool yarn is very much more extensible, as is seen in the *Figure* under discussion.

Similarly, *Figure 35* and *Figure 36* show the strength and extension of yarns spun from *Fibro* 8-inch, 8.0 denier, and blends with 58s crossbred wool, and from *Fibro* 8-inch, 8.0 denier, and blends with 46s crossbred wool.

For these yarns, a similar relation is seen to exist between the pure yarns and the blends. The dry strength of the 100% 58s wool is about 45% of the dry strength of the 8-inch, 8.0 denier *Fibro*, and the wet strength of the wool is about 50% of that of the *Fibro*. The wet strength of the *Fibro* yarn is slightly higher than the strength of the dry wool. All the strengths fall practically on a straight line connecting the strengths of the two 100% yarns. It is interesting to note that the dry extensions are practically equal for all the yarns.

As the proportion of wool is increased in the blend yarns, their wet extension increases slightly. The 100% wool yarn has a very high wet extension. Again the *Fibro* dominates the extension of the wet yarn.

In the case of the 8-inch, 8 denier and 46s wool, the dry wool strength is about 60% of the dry *Fibro* strength; the wet *Fibro* yarn strength, though slightly higher than the wet wool strength, is slightly less than the dry wool strength. The wet wool strength in this case is higher than the strengths of the two blend yarns. The dry extensions for the pure yarns and blends are not much different from each other, though the differences are greater than seen in the previous cases. With the present yarns the wet extensions show a greater effect from the wool component, and the wet extensions of the pure wool are very high.

Absorption of Water. *Fibro* wets out readily, resembling bleached cotton in this respect. It has a greater capacity

FIGURE 35

SINGLE THREAD STRENGTHS OF BLENDS
OF "FIBRO" 8" STAPLE 8 DENIER
AND WOOL 58'S CROSSBRED

1/30'S WORSTED COUNT CAP SPUN 12 T/1"

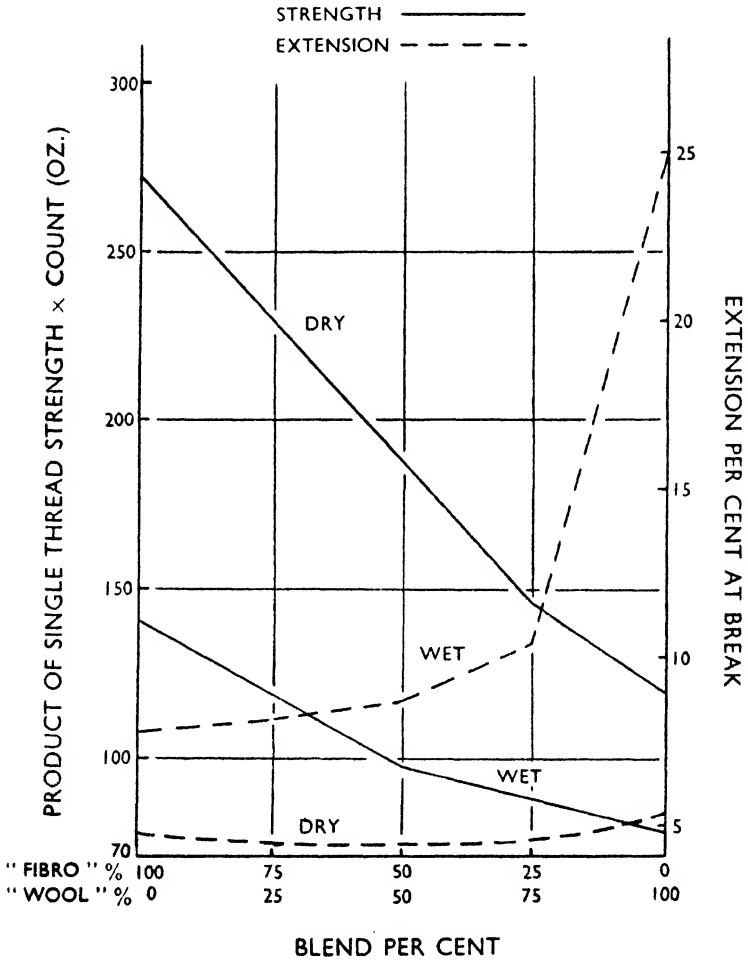
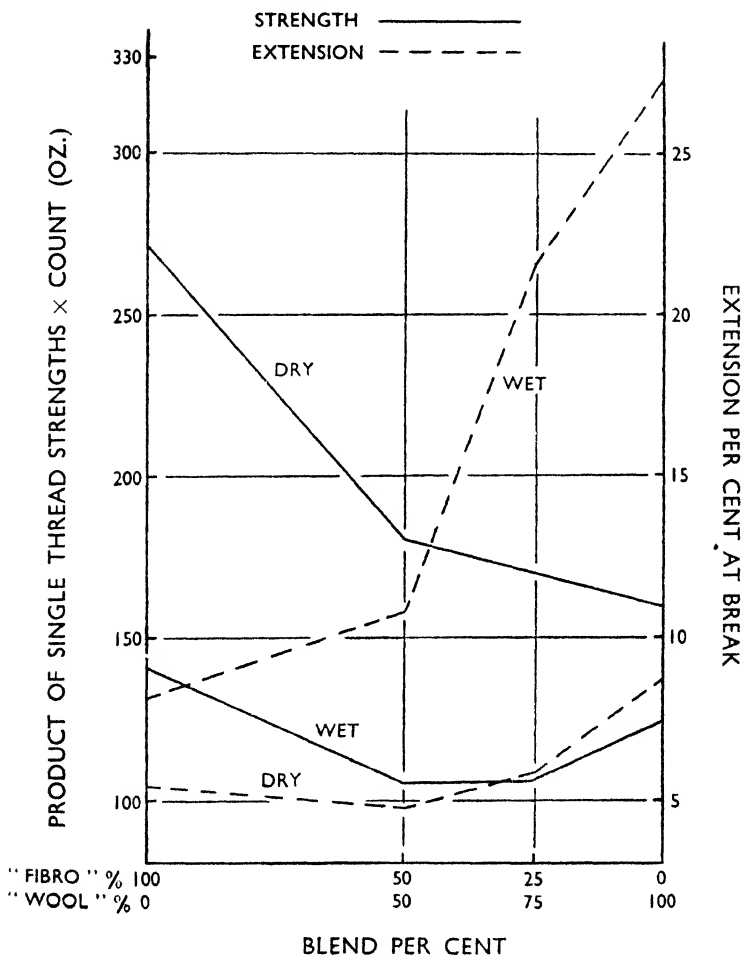

FIGURE 36

SINGLE THREAD STRENGTHS OF BLENDS OF
 "FIBRO" 8" STAPLE 8 DENIER
 AND WOOL 46'S QUALITY CROSSBRED

1/30's WORSTED COUNT CAP SPUN 12 T/1"



for absorbing moisture than has cotton at all relative humidities. For this reason the agreed regain, 11.1%, corresponding to a moisture content of 9.9%, is higher than that for cotton materials, where it is 8.5%. *Fibroceta*, which also wets out readily, has a much lower capacity for absorbing moisture than either cotton or *Fibro*, and its regain allowance for purposes of conditioned weight is 9% (moisture + oil).

The commercial moisture regain is, of course, an arbitrary figure adopted as the regain to be used in calculating weights for the delivery or shipment of any specific textile material. At the present time the following are accepted as the regain figures for commercial purposes:

Wool Tops combed in oil	.. .	19%
Wool Tops combed without oil		18.25%
Worsted Yarn	18.25%
Viscose and Cuprammonium continuous filament and staple	..	11.1%
Cellulose-acetate continuous filament and staple	9% (moisture + oil)

The standard regains for blends are calculated on a proportionate basis from the standard regains of the fibres present, e.g., if 50% *Fibro* and 50% wool are present in a yarn its standard regain figure is:

$$\frac{(50 \times 18.25) + (50 \times 11)}{100} = 14.63\%$$

Figure 37 shows the proportionate regain figures of *Fibro*/wool and *Fibroceta*/wool blends calculated from the standard regains.

Care should be taken in blending fibres, such as *Fibro* and wool, which have a different capacity for holding moisture. In illustration of this, a 64s quality wool top and 100% *Fibro* top were exposed under controlled conditions in an atmosphere of 65% relative humidity at 20°C., and weighed at intervals until they reached a constant weight. Conditioning tests were carried out when this equilibrium position was attained, and they showed that the actual regain figure for the wool was 13.5% and for the *Fibro*

FIGURE 37

MOISTURE REGAIN OF RAYON STAPLE/WOOL BLENDS

- "FIBRO" & OILCOMBED WOOL IN TOP FORM -----
- "FIBRO" & DRYCOMBED WOOL IN TOP FORM } -----
- "FIBRO" & WOOL IN YARN FORM } -----
- "FIBROCETA" & OILCOMBED WOOL IN TOP FORM -----
- "FIBROCETA" & DRYCOMBED WOOL IN TOP FORM } -----
- "FIBROCETA" & WOOL IN YARN FORM } -----

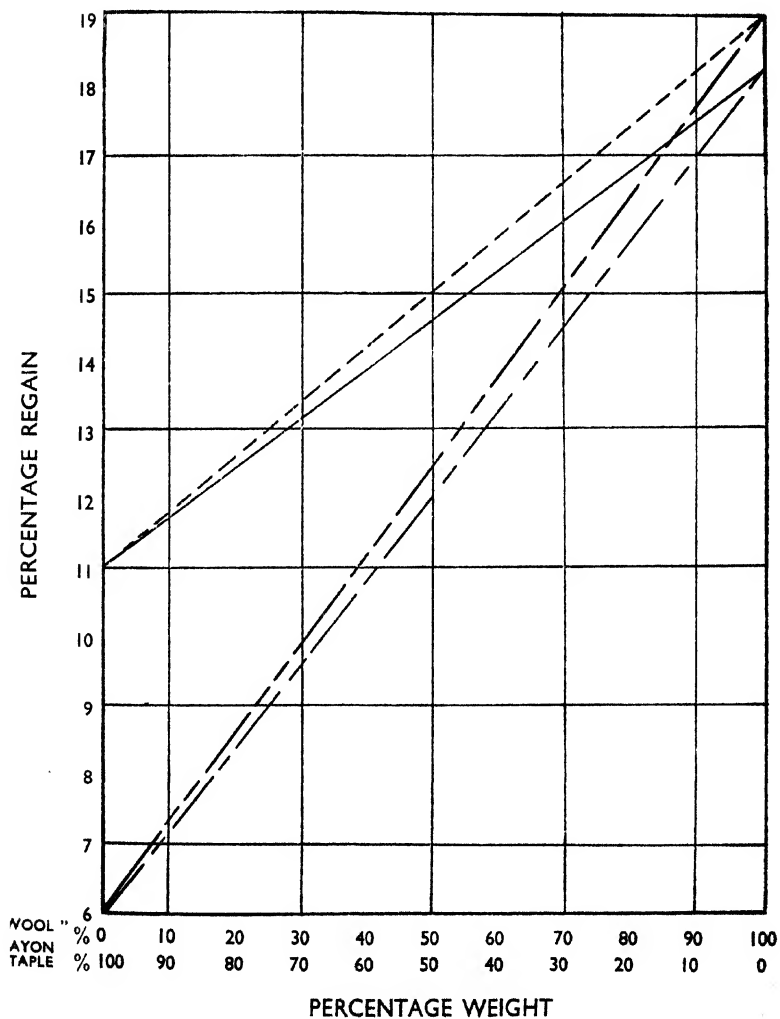

was 11.7%. This shows that, in order to produce an accurate blend of different fibres, a determination of their moisture contents should first be made. No condition of any kind should be added to blends of *Fibro* and wool containing over 75% of *Fibro*. *Fibro* possesses a large elongation when in a wet state; therefore, uneven yarn might result from any tension applied in further processing.

CHAPTER X

SPINNING ON WORSTED MACHINERY

As delivered from the production factory, *Fibro* requires no initial opening before entering the card hopper, for the mild opening given by this mechanism is sufficient to meet the requirements of satisfactory carding. Table 19 illustrates the economies effected by the use of *Fibro* in the initial stages of processing, compared with standard practice when processing 100% wool.

TABLE 19

<i>Stages of Processing necessary for:</i>	
100% Wool, 64s Quality	100% Fibro
Sorting	—
Scouring	—
Drying	—
Carding	Carding
Back Washing	—
Gilling	Gilling
Combing	Combing

Carding. *Fibro* may be processed on the standard worsted or woollen 60-inch carding engine in general use in the trade, at a production rate equal to that of wool of a similar staple length, but with less waste than is usual when carding 100% wool. Waste loss in carding *Fibro* is only 0.4% of the weight fed into the hopper, there being no foreign matter to remove.

Intergilling. This operation does not differ from normal processing, as standard intersecting gill boxes are used. However, it is advisable before combing to work with slightly larger drafts than would be used for 100% wool. This is due to the fact that, generally speaking, the average relative

FIGURE 38

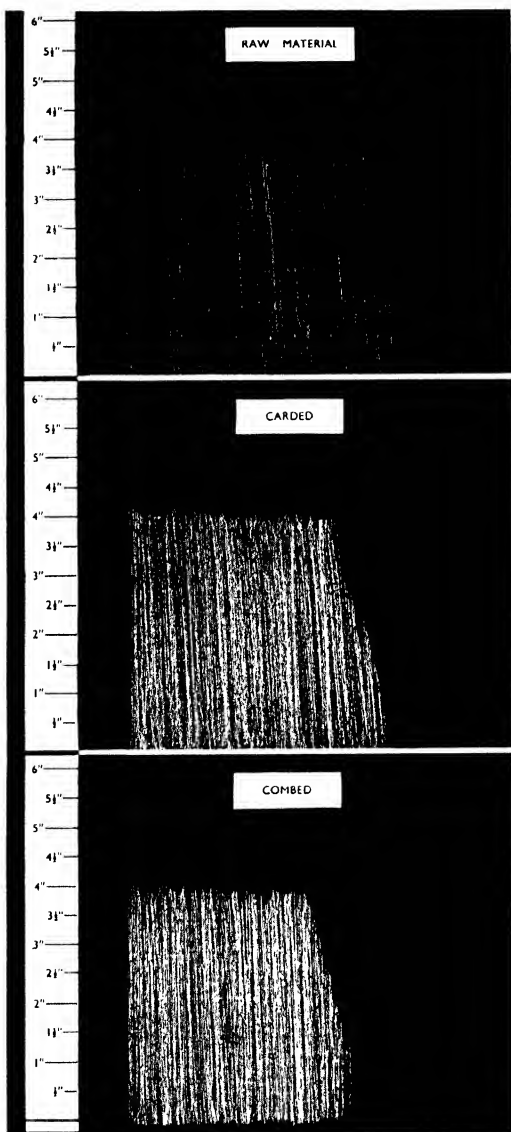

length of the *Fibro* after carding is slightly higher than the average length of the carded wool.

Punch Box. This machine requires little comment except that it is advisable to build the punch ball a little softer than when working wool, so that there should be no "licking" when unwinding at the Noble comb.

Combing. Either the Noble or Rectilinear type of comb may be used with success; 100% *Fibro* can be combed satisfactorily on either comb, giving a production equal to that of 100% wool. It is advisable to use chrome leathers to prevent "licking" of the *Fibro*. The Noble comb is ideal for blends of wool and *Fibro*, giving results which show no streakiness in the resultant yarn or fabric. The Baer diagrams (*Figure 38*) illustrate the amount of breakage which takes place, and the resultant length after the carding and combing processes.

Recombing. Recombing of *Fibro* and wool is essential for producing yarns for the high-class suiting and dress goods trade. There is no necessity to recomb when producing yarns for hosiery purposes, as mixing on gill boxes gives quite a satisfactory blend for hand and machine knitting yarns.

Drawing. In this operation there is no deviation from standard practice, though higher drafts can be used with *Fibro*/wool blends than with 100% wool. When processing 100% *Fibro*, the draft can be increased 20% without affecting the regularity of the roving. When processing *Fibro*/wool blends, the drafts used vary according to the percentage of *Fibro* in the blend, and drafts approximating to those used in the worsted trade are necessary when only small percentages of *Fibro* are used. All types of drawing can be used, whether Open, Cone, Continental or Anglo.

Spinning. All types of spinning machines can be used, mule, ring, cap or fly, depending on the type of yarn required. Resultant yarns from all these systems give good commercial results and require less twist than would be used with 100% wool and this, incidentally, means more production and lower costs. Better spinning is obtained with *Fibro*/wool blends than is normal with the same count in 100% wool.

An example of the advantage to be gained by using *Fibro*

is the increased spinning properties which result from blending with crossbred wools. A blend of 50% 56s quality wool and 50% 4.5 denier, 6-inch bright *Fibro* will spin to 1/50s, using 18 turns per inch; a blend of 50% 46s quality wool and 50% 4.5 denier, 6-inch bright *Fibro* will spin to 1/40s, using 16 turns per inch; and a blend of 50% 40s quality wool and 50% 4.5 denier, 6-inch bright *Fibro* will spin to 1/36s, using 13 turns per inch. This means that an entirely new kind of fabric can be produced, a cloth made from fine yarns but having crossbred quality, thus bringing low-quality wools into a finer type of fabric. In spinning, less twist is needed with *Fibro*/wool blend yarns than with 100% wool yarns of the same counts.

75% *Fibro*/25% wool can be spun with 10 to 15% less twist; 50% *Fibro*/50% wool can be spun with 5 to 10% less twist; and 25% *Fibro*/75% wool can be spun with up to 5% less twist than 100% wool of the same counts.

These two factors, the increase of drafts in drawing, and the decrease of spinning twist, are due to the regularity of staple length and fibre diameter of the *Fibro*. Their results are increased production and a consequent reduction in conversion costs.

Other Production Details. Twisting, reeling and winding machines call for no comment, as all types can be employed satisfactorily.

It is advisable that excessive weighting of rollers in drawing and spinning should be avoided, as this tends to cause breakage of the filaments, and may cause bars in the resultant cloth, due to the short fibres working to the surface during finishing.

Some production details are shown in *Tables 20-23*, and are given as guides which can be modified to suit the varying needs of worsted combers and spinners.

TABLE 20

CARDING

<i>Standard Worsted Carding Engine, 60 inches wide, clothed for Average 58s-64s Quality</i>	<i>Counts of Card Clothing</i>	
	<i>1st</i>	<i>2nd</i>
Swifts	125/12	140/13½
Worker	130/12	140/13½
Doffer	130/12	150/14
Stripper	90/9	110/9
Fancy	70/7	70/7

Speed of Swift—120 revs. per minute. Setting: initial—20: final—32. Actual production on 100% *Fibro* 4-inch staple, 3 denier—50 pounds per hour.

Note.—As the *Fibro* has been suitably lubricated, there is no need to use an emulsion when carding. No steam is required in the cannon.

TABLE 21

INTER-GILLING AND COMBING

	<i>Doubling</i>	<i>Draft</i>	<i>Pins per Inch</i>	<i>Weight per 5 Yards ounces</i>	<i>Material</i>
1st Single Head ..	24	5	8	10	100% <i>Fibro</i>
2nd Single Head ..	5	6	9	8½	4-inch staple
Punch Box ..	—	—	—	8½	3·0 denier

Noble comb with suitable circle for combing fine crossbred 58s-64s wools, 38/42 circle.

	<i>Doubling</i>	<i>Draft</i>	<i>Pins per Inch</i>	<i>Weight per 5 Yards ounces</i>	<i>Material</i>
Single Head Inter-sector Gill Box, 1st Finisher	15	4	9	4	100% <i>Fibro</i> 4-inch staple
Double Head Inter-sector Gill Box, 2nd Finisher	3	5	10	2·4	

The production of the Noble Comb will vary according to length of staple and denier in the same way that it would in combing 100% wool.

Tearage: 100% *Fibro* 4-inch staple, 3 denier, 18/1.

Tearage: 100% *Fibro* 3-inch staple, 3 denier, 14/1.

Production: 100% *Fibro* 4-inch staple, 3 denier, 50 pounds per hour.

TABLE 22

ACTUAL SPEED AND PRODUCTION OF OPEN DRAWING. MATERIAL 50% Fibro 4-INCH STAPLE, 3·0 DENIER; 50% 64s WOOL.

Machine	Doubling	Draft	Ratch ins.	Weight per 40 Yards. Drams	Turns 1 inch	Diameter		Actual		Faller Drop per min.	Pins per inch
						of Back Roller ins.	Front Roller ins.	Speed of Spindle per min.	Revs. F.R.		
2, Double Headed Can Inter Gill	7	5·3	—	334	—	3	2	—	—	500	10
2, 2-Spindle Gill Box	..	5·3	—	315	0·21	3	2	—	—	500	10
1, 6-Spindle Draw Box	..	6·3	7½	200	0·22	2½	4	230	83	—	—
1, 8-Spindle Weigh Box	..	4	7½	126	0·31	2½	4	445	114	—	—
3, 8-Spindle Finisher	..	4	7½	80	0·45	2½	4	524	93	—	—
2, 24-Spindle Dandy Finisher	..	2	7	22	0·78	2	4	800	82	—	—
4, 32-Spindle Dandy Reducer	..	2	6½	6	1·6	2	4	1490	74	—	—

The above set should produce approximately 5,000 pounds per 48-hour week, making 6 drams per 40 yards.
These operations may be omitted when processing 100% Fibro.

TABLE 23

CALCULATED SPEED AND PRODUCTION PER SPINDLE PER 48 HOURS WHEN SPINNING 100% Fibro 4-INCH STAPLE, 3·0 DENIER

Type of Frame	Calculated Speed of Spindles	Calculated Revs. of F.R. per Min.	Diameter of F.R. in Inches	Draft	Actual Counts	Actual Twist	Pitch of Spindle inches	Ratch in inches	Rev. Wt. 40 Yards Drams	Product lb.	
										Twist Multiplier	per Spindle per 48 Hours
Fly	2800	23·3	4	10·0	30·0	9·6	3½	5½	6·0	1·7	1·38
Ring	6000	34·2	4	8·0	48·0	14·0	3½	5½	3·0	2·0	1·28
Cap	7000	28·0	4	7·5	60·0	18·0	3½	5½	2·3	2·3	0·92

SPINNING ON FLAX MACHINERY

Fibro is usually processed on Flax Tow processing and spinning machinery, although it can also be processed on line machinery. If any blending is required it is done before carding, on the same lines as the blending of flax is carried out. The staples used are usually:

- 4.5 denier, 4-inch Bright or Matt *Fibro*
- 4.5 denier, 6-inch Bright or Matt *Fibro*
- 3 denier, 4-inch Bright or Matt *Fibro* (to a small extent)

Carding on the Standard Flax Card. As *Fibro* is supplied free from impurities, carding can begin at the finisher card and, providing setting and speeds are suitable, a satisfactory sliver can be produced. An automatic feeding mechanism is desirable if maximum regularity of sliver is desired. The following settings have been found satisfactory:

Initial 16	Final 22 B.W.G.
Cylinder speed	160 revs. per minute
Production	70 lb. per hour

Combing. If a combed sliver is required the rayon staple card sliver can be combed on the standard type of machine in use in the flax trade, i.e., Prince-Smith & Stells, Delleste or Schlumberga type. All these machines will produce a satisfactory combed sliver.

Drawing. All types of flax drawing, Line or Tow, are suitable for processing 4.5 denier, 4-inch Matt or Bright *Fibro*, and 4.5 denier, 6-inch Matt or Bright *Fibro*, and drawing can be carried out without any difficulty.

Spinning. *Fibro* is being spun on all types of standard flax spinning machines at normal speeds and productions. The dry spinning machine has been found very suitable for spinning 1.5, 3 and 4.5 deniers in 4-inch and 6-inch staple lengths. The wet spinning frame has limitations due to the reach being too short even for 4-inch staple; this has resulted in excessive breakage, although various modifications have been adopted and the difficulty thus overcome with a certain amount of success. However, the wet spinning frame is

gradually being superseded by the improved new type of semi-automatic doffing frame with adjustable reach which enables the flax spinner to spin rayon staple with the minimum fibre breakage. Various types of yarns are being produced in all qualities and counts from 8s to 60s linen lea which are finding a ready outlet in the furnishing and dress goods trade.

Care should be taken not to mix yarns spun at different reaches even if they are of the same quality and count, as this tends to produce barriness in the woven fabric.

Because flax is a much cheaper and dirtier fibre than *Fibro*, the flax-spinning industry has not been accustomed to taking any special precautions in handling and storing it subsequent to spinning. *Fibro* is delivered to the spinners in a clean condition, free from impurities, and therefore calls for different methods of handling and storing to avoid its being unnecessarily soiled before passing to the weaver and dyer.

CHAPTER XII

FIBRO IN THE SPUN SILK INDUSTRY

FOR many years the English spun silk industry and the schappe spinning industry of the Continent have displayed interest in rayon staple for yarn production, both alone and in blend with silk, on their standard machinery. This interest was first awakened by the possibilities revealed by the use of rayon wastes which arise as a by-product of the production and processing of continuous filament rayon yarns. Rayon wastes, being usually in a physical form fairly comparable with silk waste, presented little difficulty in the sliver-making and subsequent processes of the silk spinning industries, though the yarns when spun left much to be desired owing to the coarse filament denier of the wastes and the large variation both in filament denier and dyeing affinities normally associated with rayon wastes.

When rayon staple, produced specifically for the production of spun rayon yarns, replaced rayon wastes, problems arose for silk spinners as the new material was already in

staple form and thus not amenable to combing, flat or circular dressing, or sliver-making processes of the silk spinning industries. Endeavours were therefore made to overcome the difficulties by eliminating the long and costly processes of dressing and sliver-making so far as rayon staple was concerned. The methods first used took the form of making slivers by hand at the spreaders, using about 7-inch hand-cut continuous rayon tow having a heavy total denier but with filaments of relatively fine denier to compare with silk; deniers of $1\frac{1}{4}$ and $1\frac{1}{2}$ were normally used, the resulting slivers being passed through the normal silk drawing and spinning processes to produce some very attractive yarns ranging upward in counts to 50s/2.

The character and physical properties of these long staple fine denier yarns were so attractive, when compared in cloth with the products of other spinning systems using rayon staple, as to draw attention to the necessity of presenting the material to the silk spinner in a much more satisfactory form. On the Continent before the war slivers were made by breaking continuous filament material from a rope or tow, using the sliver thus produced in the drawing and subsequent operations. Unfortunately, slivers of this kind, provided by breaking continuous rayon material, gave rise to other difficulties due to the large irregularity in staple length and the destruction of the extensibility and other physical properties of the fibres, resulting in yarns of low quality. As a result, "Greenfield Top" (see Chapter IV) was evolved in this country in the form of a sliver made after cutting continuous rayon material into staples of 4- to 6-inch lengths in fine or coarse deniers as required.

Unfortunately, due to the war, with its attendant shortages and lack of development facilities, it has not yet proved possible to provide the silk industry with a top of sufficient high quality in fine filament deniers to render combing entirely unnecessary. Therefore, present procedure is for "Greenfield Tops" to be made in a staple length of 4 to 6 inches with a filament denier of $1\frac{1}{2}$ or $1\frac{1}{4}$, and to comb these on rectilinear combs before presenting to the silk drawing and spinning operations for spinning into yarn either alone or in blend with silk. In this way, high-quality yarns ranging up to 50s/2 are being made from 100% *Fibro*.

SPINNING ON JUTE MACHINERY

THE types of *Fibro* processed on jute machinery are almost entirely of 8-inch staple length, as this suits most kinds of equipment. The filament denier generally used is 18, though occasionally higher deniers up to about 50 have been tried for special purposes. "Greenfield Top" is also commonly worked on jute machinery, where it is invariably 8 denier, 8-inch staple Bright, whereas *Fibro* from the bale is processed in both Bright and Matt. It is customary to despatch the *Fibro* in 400-lb. bales in a semi-opened state.

The spinner usually feeds direct from the bale to the card, it being customary to use the standard jute cards. Two distinct carding practices are adopted: in one case two cards are used, the breaker and finisher; in the other only the finisher is used. Opinion differs on which is the better method. Where blends are made it is probable that the double carding method is desirable, as it is preferable to start blending at as early a stage as possible, and the breaker card can be used to make the first blend by systematically feeding weighed portions of *Fibro* to it. It is recommended that the fibre should be admixed before feeding to the breaker card rather than fed in successive dollops of different material. When two cards are used the finisher card is of course fed by a series of slivers and a great deal of mixing occurs at this stage. The finisher card offers a facility for improving the regularity of the final card sliver owing to its being fed by a multiplicity of breaker card slivers. It is the common practice to collect the sliver in cans, though the roll-batching method is also being used. Where difficulty is experienced, due to the stiffness of the fibre, improvement has been obtained by spraying the sliver with a fine spray of water. The water is applied to the sliver as it leaves the final card before entering the can or passing on to the batching roller, though care is necessary with the quantity that is added, only 2% or 3% being used.

It is customary to pass the slivers, after carding, through two or three passages of drawing frame of the standard type, followed by one roving frame and the spinning frame.

At all stages *Fibro* processes well and the spinning conditions are particularly good.

A wide range of counts are made, varying from 4 to 36 lb. jute count, though the bulk of yarns are of about 8 to 10 lb. count.

When "Greenfield Top" is processed two methods are used. In one the sliver is fed direct to the roving frame, whereas in the other one or two stages of drawing may be used before the roving frame, the choice depending on the degree of levelness required in the ultimate yarn.

One of the advantages of *Fibro* to the jute industry is its purity and constancy of quality. The staple and denier are fixed, and regular dimensions and composition and finish of the fibre are constant. The bales are, of course, free from dirt and impurities.

It is considered that *Fibro* offers wide scope to the jute industry for furnishing fabric and carpet pile yarns; and a great deal of development work in these fields is in progress and contemplated.

Because jute is a much cheaper and dirtier fibre than *Fibro*, the jute-spinning industry has not been accustomed to taking any special precautions in handling and storing it subsequent to spinning. *Fibro* is delivered to the spinners in a clean condition, free from impurities, and therefore calls for different methods of handling and storing to avoid its being unnecessarily soiled before passing to the weaver and dyer.

SECTION III
FABRIC PRODUCTION

FABRIC CONSTRUCTION

WHEN he starts his study of the construction of fabrics from *Fibro* and other rayon staples, the fabric technologist should have an open mind uninfluenced by preconceived ideas.

Of course, a knowledge of the technique of fabric construction from the natural fibres is useful, but it should not be assumed that *Fibro* will behave in a similar way to them. Experience of fabric structure from yarns spun from natural fibres has been acquired over a great number of years, whereas *Fibro* and its congeners are comparatively new and are continually being developed in fresh forms. Unexpected results occur which may surprise those immersed in the subject; hence the technologist should proceed with caution, take little for granted and rely in the main on personal experience gained by trial and error. What may appear at first sight to be a weakness, may frequently be converted to an advantage.

It would be difficult to produce woven materials from *Fibro* which do not bear some resemblance to one or other of the textiles made by similar processes from the natural fibres. Nevertheless, it is quite the wrong approach to the study of *Fibro* to aim at simulating a natural fibre fabric. Fabrics from all fibres have their own specific uses and fabrics made with *Fibro* have established a claim to their place in the textile world by virtue of their own intrinsic merits.

In designing a fabric to be made wholly or partly of rayon staples decisions have to be taken on several points. The first is to select the type of rayon staple to be used; then follow the filament denier, the method of spinning (since *Fibro* can be spun by every system of spinning), the length of staple, the lustre; and finally, should more than one type be envisaged, the blend.

Filament Denier. The fineness of the fibre in *Fibro* and other rayon staples is of course measured by the denier of the individual filament, and since the denier denotes the weight of a given length, the lower the denier the finer the filament. The general characteristics of a fabric are influenced more by the filament denier than by an other single factor.

It is difficult to formulate rules regarding the precise effect of filament denier, as the effect varies with the method of spinning and the staple length, but in a broad sense the thicker the fibre the greater is the flexural rigidity of the fabric.

Staple Length. While certain limitations are imposed by bulk production, a wide choice of staple length is available with any given filament denier, although this frequently involves different systems of spinning.

Greater staple lengths enable finer counts to be spun with any filament denier and with a correspondingly less twist, while the length of filament undoubtedly influences the handle, sheerness and draping qualities of the fabric, although to a lesser extent than might be considered possible.

System of Spinning. It must be noticed that there is a close relationship between the count of yarn, staple length, filament denier and the method of spinning, and that fabric characteristics are influenced by the combination of these factors.

Fibro can be spun on most of the plant devised for spinning natural fibres. Special spinning machinery will doubtless be created, and already a modified type of cotton equipment is in use to take up to a 3-inch staple. The following comments on the use of yarns spun by the different spinning systems are made from the point of view of a fabric technologist.

Cotton Spinning. The fabric designer will normally consider cotton-spun yarn as his first choice for any particular purpose, unless fabric characteristics or count limitations call for a yarn spun by one of the other available spinning systems. Cotton-spun yarns are usually associated with a *Fibro* of filament denier 1.5, but 1.0, 3.0 and even heavier deniers are also spun. The filament lengths of from 1 inch to 2 inches are spun on the standard system, and from 2½ inches to 3 inches on the modified system.

Condenser Spinning. As with cotton, fabrics made from *Fibro* yarns spun on the condenser system have distinct individual characteristics compared with fabrics made from yarns spun on the cotton systems. Where counts of 9s or coarser are needed, and a fabric with a bulky handle or feel is desired, the condenser-spun type of yarn has advantages.

Silk Spinning. The class of yarn usually produced by this system of spinning is fine two-fold gassed yarn, in counts up to 50s/2, although for certain fabrics coarser yarns are used to produce textures of different character.

In general terms, it may be said that tissues made from silk-spun yarns have excellent draping quality and possess a delicate pleasing lustre.

The staple length of *Fibro* is from 4 to 6 inches; the filament denier is usually, but not exclusively, 1.5.

Bradford Worsted System. The filament denier used is 3.0, 4.5 and coarser, while the staple length is from 4 inches to 8 inches. The features which call for consideration are: (1) The extra length of staple influences the handle as well as the draping qualities of the fabric; (2) The count limit of yarns with the greater staple length and with a filament denier of 3-4½, is much finer than that of yarns with the same filament denier but with the shorter staple needed for the cotton spinning system; (3) The versatility of this system is shown in the production of blends, since relatively small quantities of quite intricate blends can be spun commercially.

French Worsted. The strong point of this system lies in the production of blends of *Fibro* with short fine wools as, with the drawing machinery employed, shorter fibres can be used than with other worsted systems. A hybrid system for wool-and-*Fibro* blends makes use of some cotton system machinery.

Woollen. This system has some likeness to the cotton condenser system, and generally it is preferable to the latter system where blends are needed.

Flax Tow. This system produces yarns somewhat akin to those made by the worsted system, and uses similar *Fibro* of similar dimensions. One difference is that the yarns have

a natural irregularity which produces a typical attractiveness in the fabric.

Jute. Only very coarse yarns from long staple and for special purposes can be produced by this system.

Further Variations. It should be noted that with all systems of spinning, further variations of the yarn are possible, since for example, the ring, mule, flyer, cap and other frames produce yarns with certain differences, slight in themselves but which affect the ultimate fabric. This should therefore be duly considered and not ignored. Other yarn considerations of importance to the fabric technologist are as follows:

Colour and Lustre. Bright and matt or dull varieties of rayon staple are available, hence the selection of the one or the other is determined by the appearance which is desired in the fabric. Intermediate degrees of lustre are obtainable by a suitable blending of bright and dull types. *Fibro* is also produced in a range of colours by the introduction of pigments into the spinning solution prior to the spinning of the filaments. The term "spun-dyed" is used for this type of coloured *Fibro* which is marketed in "S.D." colours (see Appendix Six). These colours have very good fastness and are equally as attractive as standard *Fibro* in spinning and weaving, as they have not been subjected to the extra handling necessary in the various methods for dyeing. Spun-dyed *Fibro* therefore spins and weaves equally as well as standard undyed *Fibro*.

Blends. The technique of blending has not as yet been fully appreciated, although it is a study in its own right. Such fabric features as handle, touch, draping quality, resistance to wear, shrinkage, lustre, crush resistance, and the response to special finishing treatments, are greatly influenced by the proportion of fibres with different characteristics there are in a blend.

Blending possibilities are wide since *Fibro* can be mixed with the natural fibres, wool, linen, cotton, silk, etc., and also with the other rayons such as *Rayolanda*, *Fibroseta* and *Fibrolane*.

In such blendings special effects may be produced by using fibres of different filament denier in the same yarn or again by making use of bright and matt filaments in varying proportions.

A simple calculation shows that by selecting two fibres at a time from the 13 natural and rayon fibres which are available, 78 blends can be produced, and that 286 combinations are possible with three fibres at a time.

These figures draw attention to the great possibilities of blending yet to be developed by the intelligent fabric designer working in conjunction with spinners, dyers and finishers.

A very important aspect of blending is that of associating in the same yarn fibres of different dyeing affinity in order to produce mixture effects by dyeing either the yarn or the woven piece. Examples of such blends are those of *Fibro* and *Fibroseta*, *Fibro* and wool, *Fibro* and *Rayolanda*, *Fibro* and *Fibrolane*.

Spun-dyed black or other dark spun-dyed shades can be introduced to add depth to such blends and to provide additional tones for stripe and check effects, thus enabling a wide range of shades to be produced from the grey cloth by piece dyeing.

It has been found that, apart from certain mass-produced general-purpose fabrics, in general the most interesting and attractive fabrics are made from yarns containing more than one fibre.

For example, one such cotton-spun yarn used in bulk was composed of 70% 3 denier matt *Fibroseta* and 30% 1½ denier bright *Fibro*. This blend could be spun to a finer count than 100% 3 denier matt *Fibro*, and it had acquired additional features in that it contained bright and matt fibres differing in filament denier.

A blended yarn spun on the modified cotton system which gained popularity in the U.S.A. contains:

12½%	2 denier matt <i>Fibroseta</i>	2½ inch
12½%	64s quality wool	
37½%	3 denier matt <i>Fibro</i>	2½ inch
37½%	bright <i>Fibro</i>	2½ inch

It will be seen that this yarn contains three fibres of different affinity for different classes of dyes, so that either three-colour or two-colour-and-white effects can be produced by piece-dyeing the material in the same loom state.

Also, the different appearance of the bright and matt dyed *Fibro* adds a further subtle feature. The *Fibro* provides the bulk and backbone, acetate the soft handle, and wool the loft; thus, because of its heterogeneous composition, the fabric has attractive and distinctive features, and these may be increased by variations in the deniers and staple lengths of the bright and matt rayons employed.

Yarn Features. *Fibro* yarns can be obtained in all the variations usual with natural fibres. Such features as folded, spiral, gimp, nep, slub, gassed, crêpe and voile are readily available. A special feature of *Fibro* is the facility with which irregular yarns of the thick and thin type can be spun, such yarns producing fabrics of distinctive character.

Rayon Combinations. Many pleasing fabrics may be made by associating spun rayons with continuous filament; such textures differ from those of 100% rayon fabrics and 100% spun rayon fabrics respectively. One can associate the yarns by using rayon warp and spun rayon weft or *vice versa*, or by using folded yarns made of rayon and spun rayon single yarns.

The possibilities of rayon and spun rayon have not yet been fully explored, and the scope of the combinations is widened by the inclusion of blended yarns of spun rayon.

Shrinkage. The shrinkage in width and in length of *Fibro* fabrics, from the loom to the finished state, is possibly the most important single feature calling for the concentrated co-operation of all engaged in the production of these fabrics.

It will be realised, after a consideration of the immense amount of thought and study which has been put into the development of these new materials, that it is very unwise to decide arbitrarily the width allowance on a fabric from a mere consideration of the reed space of looms which are available, or the length allowance to fit in with a pre-determined selling price. Similarly it is unwise to use dyeing and finishing machines which do not allow adequate shrinkage being given to rayon staple fabrics.

To secure dimensional stability in a fabric, it is most important to obtain a correct shrinkage balance between the warp and weft directions of the fabric. For example, it

may be preferable in a given case to have a 3-inch contraction in the width, and a 10% shrinkage in the length, rather than shrinkages of 2 inches and 12½% respectively.

It is difficult to generalise on shrinkage but in fabric with a plain weave, from "grey cloth on the table" to a finished state, a contraction is desirable of from 8% to 12% in both directions of the finished cloth. Few constructions are at their best below this and many will need a still greater allowance.

Fabrics demonstrating the various points mentioned are constantly being produced by Courtaulds to assist the trade, and may be examined on application.

Dyeing and Finishing Considerations. The intrinsic beauty of *Fibro* and the satisfaction and pleasure of the ultimate user call for adequate shrinkage, and the nature of *Fibro* is such that with a suitable cloth and yarn construction it is capable of considerable shrinkage from loom to finished state without the aid of highly twisted yarn. Numerous factors affect the shrinkage capacity of cloths, among which are method of spinning, type of *Fibro*, composition of blend, yarn count, cloth construction, weave, etc.

In woven fabric form, *Fibro* in many cases has not been presented to the buying public in such a manner as to do full justice to its intrinsic merits. Millions of yards have been treated by weavers, dyers and finishers as though they were cotton goods. It is true that there is a chemical resemblance between cotton and *Fibro*, but in their physical properties and reactions to various treatments they differ considerably. One result of the susceptibility of *Fibro* fabrics to stretching, is that *Fibro* yarn has often been overstretched in sizing and in weaving, while *Fibro* fabrics have been similarly overstretched during the dyeing and finishing operations.

For example, prior to 1940 large quantities of such fabrics, capable of a shrinkage of at least 12½%, were finished from a loom state of 36½ to 36 inches and stretched 4% in length—an obvious error in treatment; the fabric must have given little satisfaction to its wearers.

When fabrics made from *Fibro* were introduced to the Utility range, even the specified allowance for shrinkage

was inadequate and failed to do justice to the merits of *Fibro* in the particular cloth.

No general rule can be given for adequate shrinkage; with some fabrics 2% may be adequate while in other cases 25% may be necessary. Some factors which influence the final shrinkage figure are: (a) The blend of *Fibro* used, whether with cellulose-acetate, wool, cotton, flax, silk or other fibres. (b) Method of spinning, including staple lengths, e.g., whether cotton, condenser, worsted, woollen, schappe, flax or jute systems. (c) Filament denier, including mixed deniers in the same yarn. (d) Degree of twist in the yarn. (e) The build of the cloth, i.e., count of yarn, number of ends and picks per inch, balance of warp and weft. (f) Degree of mishandling in warp sizing by stretching or by over-drying. (g) Stretch of yarn by being over-weighted in the loom during weaving.

Thus it follows that each fabric must be considered individually, and that no arbitrary decision should be made in office or designing room on the finishing instructions for any particular cloth.

As soon as the first pattern piece comes off the loom the dyer and finisher should be consulted, and the necessary shrinkage decided after laboratory tests; the decision made and finishing instructions issued, no alteration in the construction should be permitted.

These recommendations apply equally to fabrics that are to have an anti-crease, synthetic resin treatment. There has been a marked tendency to market cloths which in the finishing have been stretched to "grey" width and length, and temporarily set to these dimensions by the application of a synthetic resin finish. The permanence of the setting depends on the degree of scientific control of the anti-crease process. Tests of fabrics on the market show that the degree of control varies very widely. Fabrics so treated can never give lasting satisfaction to the user, and must hinder the growth of the industry.

Finally, in Appendix Two, construction details are given of 20 fabrics which demonstrate some of the variations that are possible with *Fibro*. Fabrics produced by Courtaulds to demonstrate the uses to which yarns may be put may be examined on application to the Company.

CHAPTER XV

WARP SIZING

Fibro is a viscose rayon, and although warps can be sized on machines similar to those used for continuous filament yarns, there is usually insufficient room on these machines to separate the warp ends adequately after drying. Better results will be obtained on a cotton slashing machine, either the cylinder or hot air drying type, where proper provision is made for separating the sized ends. Certain essential precautions should, however, be observed.

Two-fold yarns do not usually require sizing, except in the case of 60s/2 cotton counts or finer, where a light starch size has been found advantageous. For dyed yarns of these counts, ball warp sizing, applied as a final stage in the dyeing process, has given good results.

Yarns which have to be sized may be divided into two classes, according to their composition, viz. (i) Yarns composed wholly of *Fibro* or mixture yarns containing not less than 85% *Fibro*; (ii) Mixture yarns containing less than 85% *Fibro* and more than 15% of other fibres, such as *Fibroceta*, *Rayolanda*, wool, etc.

There has been a tendency in the past to oversize *Fibro* warps, making them stiff and brittle. This cannot be too strongly deprecated; all that is needed for yarns in class (i) is a "pure" light size. Mixtures containing china clay and other mineral fillers such as are sometimes used on cotton warps, should not be used on *Fibro*, where the sole object is to protect the filaments during weaving, and not to add weight to the yarn.

For all size mixing the old secret rule of thumb methods, handed down from generation to generation of slashers, should be discarded, and modern methods adopted. All ingredients of the size should be carefully weighed and the final mixture made up to a definite volume.

Following are some typical mixtures suitable for warps containing 85% to 100% *Fibro*:

- | | |
|-------------------------------|-------------------------------------|
| (a) 150 lb. Sago | (b) 100 lb. Sago |
| 11 $\frac{3}{4}$ lb. Tallow | 6 $\frac{3}{4}$ lb. Tallow |
| 200 galls. Water | 6 $\frac{3}{4}$ lb. Soft soap |
| | 3 $\frac{1}{4}$ lb. Glycerine |
| | 200 galls. Water |
| (c) 27 lb. Sago | (d) 12 $\frac{1}{2}$ lb. Gum Tragon |
| 17 lb. Gum Tragon | 12 $\frac{1}{2}$ lb. Glycerine |
| 6 $\frac{3}{4}$ lb. Tallow | 200 galls. Water |
| 3 $\frac{1}{4}$ lb. Glycerine | |
| 200 galls. Water | |
| (e) 25 lb. Sago | (f) 40 lb. Sago |
| 25 lb. Gum Tragon | 17 lb. Gum Tragon |
| 200 galls. Water | 6 $\frac{3}{4}$ lb. Tallow |
| | 200 galls. Water |

These mixtures are used at the boil, more in order to prevent the size skinning over, than to help penetration into the yarn, since *Fibro* does not contain the waxy impurities found in raw cotton.

Warps sized with any of these recipes except (e) will require enzymase desizing treatment before the cloth is dyed. It is most important that the size should be completely removed before the cloth is dyed, or streakiness will result. Soluble starches, which are easily removable by a light scour, are in limited use in the trade, from 3 to 8 ozs. per gallon being employed, together with a small proportion of oleine oil emulsion. More precise information can be obtained from the suppliers of these starches, which are always proprietary products.

The sizing of yarns in class (ii), containing more than 15% of fibres other than viscose, is a much more difficult problem, owing to the fact that these other fibres tend to resist wetting by the size. So far no satisfactory mixture has been found, and the best that can be recommended at present is to use the heaviest of those mentioned above.

Fibro is supplied to customers on back-beams, the required number of these being used as in cotton slashing. The normal practice is followed of immersing the combined sheet of ends beneath the surface of the size, by means of a dipping roller, and squeezing between steel rollers of which the top

is felt-covered. After drying on steam-heated cylinders the sheets of yarn are separated in the usual way with rods and comb before being run on to the weaver's beam. The drying cylinders should be only as hot as is necessary to dry the warp; overbaking should be avoided, as it tends to embrittle the yarn. It is advantageous to fit a moisture meter to the machine, so that the speed and cylinder temperatures can be adjusted to give a correctly dried warp (10% to 11% moisture content).

One of the most important points to watch in *Fibro* sizing is the stretch, which should not exceed 4%, if the desirable characteristics of the yarn are to be retained. To achieve this the tension on the back-beams and on the draw-rollers at the take-up end of the machine should be only just sufficient to ensure adequate control of the warp. In slashing cotton warps it is customary to pass the warp over the top of the large drying drum, and back over the small drum, the warp then passing along the bottom of the machine under both drums and out to the conditioning fan. In sizing *Fibro* warps, better results and lower stretch will be obtained by fitting extra guide rollers so that the warp can first be passed under the small drum, up over the large drum, down under another guide roller and out to the conditioning fan. Admittedly this makes less efficient use of the drying capacity of the drums, but it avoids the long spans of unsupported yarn which would result from the normal method of threading-up, and is well worth the slight sacrifice of speed which results.

In an attempt to reduce the amount of dusting off in loom, promising results have been obtained by sizing *Fibro* warps on a linen-dressing machine. The features of this method are:

1. The warps are run from both ends of the machine, and combined on to the weaver's beam, at the middle. Each set of quetsch rollers therefore deals with only half the number of ends which a cotton slasher set of rollers would have to handle for the same weaver's beam. This ensures a better coating of size being applied to each individual thread.
2. The sized threads are brushed while still wet. This lays the protruding hairs, and the ends are then separated

with rods and combs before they have dried and stuck together.

3. Drying is effected with hot air, except with dense warps, when an auxiliary steam-heated cylinder is used. Even in this case the bulk of the moisture is removed by air, and the plucking up of the hairs by the cylinder is minimized.

4. An external lubricant is brushed on to the dried yarn. This materially assists it in its passage through the loom.

The method is, however, slow, and some modification of the system, to combine its advantages with the speed of production of a cotton slasher, may have to be developed in the trade.

CHAPTER XVI

WEAVING

THE manufacture of fabrics from *Fibro* involves a series of operations which, although separately performed, are so co-related that each influences subsequent operations. Though obvious in the successive stages of a manufacturing process carried out in any one factory, it is not so apparent with the individual operations performed by the allied branches of an industry; it is therefore essential that *all* processes prior to weaving should be performed with the requirements of the weaver well in mind.

It is absolutely necessary for the designer to know the properties of the yarns he contemplates using; otherwise the weaver may have trouble in producing a satisfactory fabric. Also any imperfections in the spinning of *Fibro*, if not discovered and removed, will lead to an unsatisfactory fabric, and during weaving it is no uncommon thing to discover faults directly traceable to one or other of the spinning processes.

In its broad sense the term "weaving" embraces the entire series of operations involved in the preparation of warp and weft and in their use in the loom. In its most

limited sense the term means the operation of combining two sets of threads, warp and weft, by crossing them in a loom and interlacing them at right angles in such a manner as to produce a fabric.

The preliminary weaving operations may be performed in various ways each of which comprises a series of operations. The character of these operations and the machines used in them depend, in the main, on the class of fabric to be manufactured, since certain methods of preparation and types of machines are more suitable, efficient and economical than others for a given class of fabric.

Among the necessary items of a loom are healds, reeds, temples, take-up rollers, cloth rollers, shuttles, shuttleboxes, shedding motions, beam control mechanisms, back rests, lease rods, raceboards, picking and pickers; with these it is proposed to deal in so far as *Fibro* weaving is concerned.

Several types of heald can be used for *Fibro*, such as cotton healds, slider wire healds and knit wire healds. When cotton healds are used the eyes should be as smooth and as small as possible. Flexibility and smoothness of the healds must be considered. Knit wire healds can be used and slider wire healds of 34 guage, 12 to 13 inches deep; the advantage of the latter over knit wire healds is that they are more adaptable, hence a manufacturer does not require to carry such a large stock of healds.

Reeds. Reeds for *Fibro* weaving are usually of the pitch baulk type and if correctly made give good results. Reeds vary in depth according to the types of cloth to be produced. The dents of the reed should be highly polished with rounded edges; sharp edges are to be avoided; it is advisable to have dent for dent spacing to enable knots to pass through the reed during weaving; badly made reeds may give rise to much trouble. The dents of the reeds must be flexible.

The function of the reed is to divide the yarn, to beat up the weft into its final position in the cloth, and to form a guide for the shuttle in its passage from box to box. Great care must be taken of the reed and every endeavour made to prevent it being damaged by the temple or other loom parts. The dents must be kept free from rust or dirt and the reed maintained in good condition for weaving *Fibro*.

Temples. Good temples are necessary; much cloth has

been damaged through temple plucking. Sometimes it is difficult to hold out a cloth sufficiently well to prevent the ends fraying, without getting temple plucking, but a skilled overlooker will be able to overcome the difficulty by the use of rubber covered rollers set in the temple box.

The temples must be set as near to the reed as possible when the crank is on its front centre; they must not touch the raceboard nor be set too high and cause the shuttle to lift, or to tilt the shuttle on its passage from shuttlebox to shuttlebox.

Rollers. Take-up rollers must also be kept in good condition and be covered with a material of sufficient holding power for the fabric without damaging or unduly weakening the fabric. Covering materials may be either rubber, emery or tin, according to the type of cloth to be produced.

During recent years the periodic irregularity of pick spacing has become a serious fault in high-grade fabrics, with the result that considerable attention has been given to the regularity of the drawing forward of the woven cloth performed by the take-up motion. The most precise system of cloth control by the take-up motion must be considered to be an essential part of the modern power loom. Uneven cloth may be traced to an eccentricity of the wheels in the take-up motion, and it is advisable to use cut teeth in the take-up motion.

Shuttles. Shuttles play a very important part in the successful weaving of fabrics from *Fibro*. They should be well made; the points at the tips of the shuttles should be kept sharp and highly polished. The shuttle tongs must maintain the weft package firmly in its position inside the shuttle. Large packages of *Fibro* weft can be used and these must be carefully prepared. *Fibro* which is rewound from ring bobbins on to maximum-sized weft spools, will give good weaving results, the size of the spool being decided by the counts of *Fibro* used.

The cost of rewinding on to wooden spools will be amply repaid by the greater loom efficiency and lessening of waste.

The weft must be nicely controlled as it leaves the eye of the shuttle; the shuttle fronts should be tooled out to form a good groove so that the weft may be protected from damage caused by the yarn being squeezed between the

shuttle and the box front. The weavers must be convinced that "care pays", and trained to keep the shuttles in good condition. Loom overlookers have many problems and perhaps their most complex is that of the traverse of the shuttle from box to box. The shuttle is a fly shuttle which requires a suitable length of box to check and control it.

The shape and position of the box swell plays an important part in controlling and assisting the correct traverse of the shuttle. Should the shuttle be not picked or checked correctly, the *Fibro* weft cops may break, the waste be excessive, or the shuttle may fly out of the loom. The correct alignment of the reed and box backs is essential; also of the plates at the back and bottom of the shuttleboxes and raceboard; this helps to obtain a good shuttle traverse.

Shedding Motions. Shedding motions are of great importance in the successful weaving of *Fibro*. They may consist of plain tappets under the loom with revolving doll heads above the healds, of various kinds of under tappets, side tappets, dobbies and jacquards.

Whatever shedding motion is used, it is essential to obtain uniformity in each shed; the shed must be large enough to allow the shuttle to pass freely yet not so large as to put an excessive strain on the warp threads.

The top and bottom sheds should have equal tension and should be so set that the *Fibro* warp threads only just touch the raceboards when the cranks are on their back centres.

The timing of the shedding varies according to the type of cloth and the shedding motion employed. Should a plain *Fibro* cloth be woven, then it is advisable to cross the healds with the cranks at top centres in order to get cover on the fabric. For dobby or jacquard fabrics the ends may be made to cross when the cranks are between the top and the front centre. The setting of the picking of the shuttle has to be worked in conjunction with the timing of the shedding.

Back Rests. For weaving *Fibro* warps either a fluted wooden revolving back rest can be used or an iron vibrating back rest, according to the type of cloth to be made. The revolving fluted wooden roller can be used for dobby or jacquard weaves, while for plain cloths, where cover is essential, the iron vibrating back rest can be used.

Fibro warps can be satisfactorily woven without the slay

being covered with swansdown. When weaving crêpe wefts the centre-weft fork mechanism with instant stop gives good results. These mechanisms have been introduced to detect the absence of weft instantly and also to stop the loom in such a position that the fell of the cloth is not influenced by the reed beating up while the cloth is not being woven.

Humidity. *Fibro* warps and wefts can be satisfactorily woven in weaving sheds having a relative humidity of from 60% to 70%.

Fluff. In weaving *Fibro* warps, there has been a tendency for small lengths of filaments to be broken by the dents of the reeds, owing to protruding filaments from the warp threads being snapped off as they come into contact with the dents of the reeds. This not only results in a loss of weight in the woven fabric, but causes fluff to collect on the healds, the working parts of the loom and under the loom. This formation of fluff can be considerably lessened by sizing the warp yarn in such a way that the protruding filaments will be stuck to the sized thread, and yarn so sized lends itself admirably to automatic loom weaving.

CHAPTER XVII

KNITTED FABRICS

THE versatility of *Fibro*—derived from the facility with which it is possible to control its staple length, filament denier and lustre—has enabled the knitter to make many and varied uses of it both by itself and in blends with other fibres. All those properties of *Fibro* and its allied staples which have been described elsewhere, the individual merit of each fibre as well as all the possibilities of producing effect fabrics by combining them with each other and with cotton and wool, can be used most effectively in knitting.

A softer, silkier handle and improved whiteness are very desirable characteristics of *Fibro* which, either alone or in blends with cotton, is being used to produce knitted garments formerly made entirely from cotton. Cellular lock-nit for underwear is one fabric in which 100% *Fibro* has become popular. A similar cloth made with coarser

counts on Raschel looms is very successful as a sports shirting. This type of loom, with its weft insertion which improves shape stability, is of great value when knitting 100% *Fibro*; because in some types of knitted garments there are still difficulties to surmount in achieving good shape stability, particularly those in which the shape depends on the elasticity of plain rib.

Much can be done by both the knitter and the finisher to make or mar the shape stability of a fabric, as was evident when *Fibro* was first introduced into the interlock trade. In the early days the interlock manufacturers were attracted by the whiteness and softness of *Fibro*, and put on to their machines counts equivalent to those of the cotton they had been using. Unfortunately when the resulting garments were washed they usually decreased in length and increased in width. Some of the manufacturers were immediately discouraged and condemned *Fibro* as unsuitable for their use. A few of the more enterprising knitters persevered and produced garments which passed stringent tests and proved themselves in sale and use. These knitters succeeded because they found that it was not enough to replace cotton with *Fibro* on their machines without taking into account the possible need for variation of method. *Fibro*, they found, was slightly more compact than cotton and needed to be of a lower count to give the same fabric density. Alternatively, if the count was kept the same as for cotton, it was necessary to improve the knitting quality by increasing the courses per inch. In any case, for shape stability, they found it was advisable to knit a good stiff quality so that the fabric was both firm and soft after washing.

The finisher also had to make alterations to his standard cotton procedure. In steam calendering he had to board out to more than the machine width and, by plaiting instead of rolling, to avoid tensioning while the cloth was in the damp state.

These changes were small but necessary to obtain the correct final result. In this way *Fibro* made its place in one section of the knitting industry where it had at first been rejected as unsuitable.

Research work is in progress on the treatment needed for *Fibro* in other types of knitted fabric, and there is little

doubt that in time equally satisfactory techniques in these fields will be devised.

There is a fair demand for *Fibro* in plain circular knit, in which it is used both alone and as a machine blend with natural fibres; also on loop wheel machines it is being used to produce pleasing effects as a laying-in thread in woollen outerwear fabric.

Lace stitch machines, making shaped garments by alternation of open stitch fabric with plain rib, usually have to knit blends of *Fibro* with wool or cotton, this being a type of fabric in which 100% *Fibro* has not yet proved entirely satisfactory.

Fibro imparts a degree of shrinkage-resistance to wool of suitable length when blended with it; this is important in half hose and even more so in the manufacture of baby clothes. The need for frequency of washing makes this a valuable property in both cases but in baby wear there is an additional advantage: it is possible to keep the full, soft handle of the wool which otherwise might be partly destroyed by a "non-shrink" finish. Also the excellent brushing quality of *Fibro* is another good reason for its use in this field.

When the versatility of *Fibro* is combined with the versatility of the Raschel loom there seems to be unlimited scope. In addition to cellular sports wear cloths already mentioned, dress fabrics, curtains and blankets are applications that have proved satisfactory and capable of development. On Simplex machines, in fine counts spun from one denier staple, *Fibro* has been found to make an exceptionally good glove fabric.

These are a few of the uses to which *Fibro* is being put by knitters. As experience is gained and techniques developed, more and more qualities are being knitted into more and more types of garments: solid dyed blends with merino wools for underwear; cross dyed styles, as well as solids, in crossbred wool blends for outerwear; cotton blends and 100% *Fibro* yarns—these are all being used for their own intrinsic merits and advantages. They have greatly increased the scope of the knitting manufacturer; yet so much research and development work remains to be done and proved in actual commercial practice that, it can be safely said, *Fibro* is capable of far wider and more effective use in knitting than at present.

SECTION IV
PREPARING, DYEING,
PRINTING AND FINISHING

STAPLE AND YARN DYEING

In order to reduce the list of dyes to a reasonable size, no synonyms have been included. Many of these may be found in the Colour Index.

Fibro may be dyed as loose staple, sliver, roving, yarn or fabric, the form and method selected depending on the purpose for which it is subsequently to be used.

Stress must be laid on the basic fact that the filament denier of *Fibro* has a considerable influence on the depth of shade obtainable with a definite quantity of dyes, the amount of dye required to give any shade being greater on a fine filament than on a coarse filament. Thus with Diphenyl Blue M2B 300% with 30% salt, a liquor ratio of 20 to 1 and 30 minutes dyeing at 90° C., the following amounts of dye are required to give approximately the same depth of shade on *Fibro* of different filament deniers.

<i>Filament Denier</i>	<i>Diphenyl Blue M2B</i>
	300%
1.25%	0.63%
1.5%	0.57%
3.0%	0.40%
4.5%	0.33%

From this it will be seen that 1.5 filament denier *Fibro* requires over 70% more dye than does 4.5 filament denier.

It is possible to calculate the relative percentages of dye giving the same depth of shade on two different denier rayons, either *Fibro* or continuous filament rayon, by dividing the square root of one denier by the square root of the other. To illustrate this, 150 denier, 72 filament rayon has a filament denier of 2.08, and 150 denier, 27 filament rayon has a filament denier of 5.55, and the relative weights of dye are:

$$\frac{\sqrt{5.55}}{\sqrt{2.08}} = \frac{2.36}{1.44}$$

Thus, 2.36% of a direct cotton dye on 150/72 denier viscose rayon will give the same depth of shade as 1.44% of the same direct dye on 150/27 denier viscose rayon provided

complete exhaustion of the dye liquors is attained and dyeing is continued to equilibrium, i.e., complete diffusion or penetration into the filament has occurred.

To save such calculations, Fothergill (*J. Soc. Dyers and Colourists*, 1944, p. 93) has published a nomogram which is reproduced opposite (*Figure 39*), where:

D_1 = filament denier of yarn already dyed

D_2 = filament denier of yarn to be dyed

M = multiplying factor

As an example of the use of the nomogram, suppose that a batch of 150/72 viscose rayon yarn has to be dyed to the same shade as a batch of 150/27 viscose rayon yarn which has already been dyed in a 40 vol. bath containing 2% dye on the weight of yarn. The denier per filament of the yarn already dyed is $150/27 = 5.55$; that of the yarn to be dyed is $150/72 = 2.08$. Laying a straight edge (or better a fine taut thread) across the nomogram so that it crosses the D^1 scale at 5.55 and the D^2 scale at 2.08, it is found that it crosses the M scale at 1.63. The dye concentration required in the bath is, therefore, 1.63 times that used for the yarn with the coarser filament, i.e., $1.63 \times 2 = 3.26\%$ of dye on the finer filament yarn.

If it is the finer filament yarn which has already been dyed, the concentration of dye required to match the coarser filament yarn against it will be found by laying the taut thread across the nomogram so that it cuts the D_1 scale at 2.08 and the D_2 scale at 5.55. It will then cut the M scale at 0.62 showing that the 150/27 yarn requires 0.62 times as much dye as the 150/72, if the two yarns are to match each other. The multiplier M , viz., 1.63, is, of course, the reciprocal of the multiplier 0.62.

It must be appreciated that ratios and multiplier only apply when there is equal exhaustion of the dye liquor.

As most *Fibro* supplied to the cotton trade has a filament denier of 1.5 compared with 5.5 for 150 denier, 27 filament yarn, it follows that dyeings on 1.5 filament denier *Fibro* will be less fast to washing than the same shade in 150 denier, 27 filament rayon, whereas dyeings on 4.5 filament denier *Fibro* are practically of equal fastness.

It is also interesting to note that the Shirley Institute has shown that cottons of different hair weight yield different

FIGURE 39

A NOMOGRAM TO HELP IN THE DYEING OF FINE AND COARSE FILAMENT RAYONS AND SPUN RAYONS TO THE SAME SHADE.

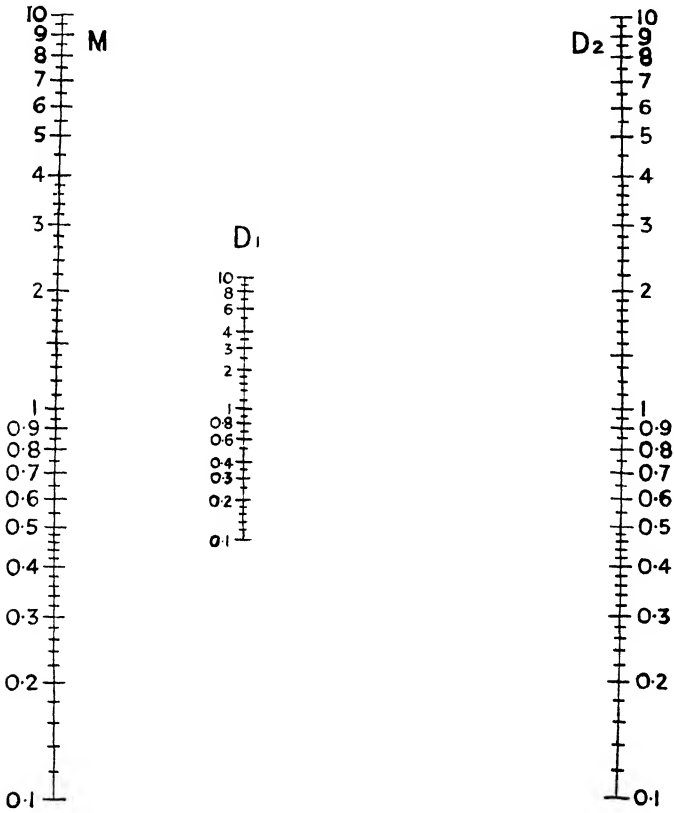

shades when dyed under equal conditions, while it is also known that coarse wools require less dye than do finer wools to reach a given depth of shade.

Since the hair denier of Egyptian cotton is approximately 1.34 and that of American cotton 1.69, it follows that 1.5 filament denier *Fibro* will dye in a similar way to cotton whereas *Fibro* with a filament denier of 4.5 will require less dye to give the same depth of shade.

These considerations of the effect of filament denier on depth of shade should therefore be borne in mind when the relative fastness to washing of dyed *Fibro* and cotton is being considered.

When dyeing compound shades on *Fibro*, the golden rule is that for such shades dyes of similar dyeing properties should as far as possible be selected. Fastness and shade considerations frequently render impossible the observance of this principle, but its wider application will become possible when the necessary dyes are obtainable.

Direct Cotton Dyes. Laboratory work has shown, and large scale practice over twenty years has confirmed, that direct cotton dyes can be divided according to their dyeing properties into three classes, namely:

Class A. Dyes which show a good exhaustion at 90° C. in the absence of added salt, and have good levelling properties. These dyes can be dyed throughout at 90° C. since, if the shade is poor in the initial stages of dyeing, they level up rapidly as dyeing proceeds. Typical examples are as follows:

Benzanil Fast Bordeaux 4BLN	(Y.D.C.)
Chlorazol Fast Black BKS	(I.C.I.)
Chlorazol Fast Bordeaux LKS	(I.C.I.)
Chlorazol Fast Helio BKS	(I.C.I.)
Chlorazol Fast Orange GS	(I.C.I.)
Chlorazol Fast Yellow 5GKS	(I.C.I.)
Icyl Orange RS	(I.C.I.)
Diazol Lt. Yellow N ₄ J	(F.)
Paramine Fast Red F	(L.B.H.)
Rigan Blue R	(C.A.C.)
Rigan Sky Blue G	(C.A.C.)
Viscose Blue Grey NB	(F.)
Viscose Navy Blue NB	(F.)

Class B. Dyes which show poor exhaustion at 90° C. in the absence of added salt, and have poor levelling properties. These dyes can be dyed throughout at 90° C., since so little dyeing takes place in the absence of added salt that any initial unevenness at this stage will not affect the final dyeing. Subsequent salt additions must be carefully made or unsatisfactory dyeings will result. For example, with *Fibro* hanks on the rotating roller type of machine, if 10% salt has to be added it should not be added in one or two lots, but in 7 equal lots at 5- to 7-minute intervals. With loose material in the Obermaier type of machine, this precaution is unnecessary providing there is an adequate rate of flow of liquor through the material. Typical examples are:

Benzanil Fast Brown 3 RL	(Y.D.C.)
Benzanil Fast Orange ER	(Y.D.C.)
Chlorantine Fast Blue 3GLL	(C.A.C.)
Chlorantine Fast Blue GLN200	(C.A.C.)
Chlorazol Blue B525	(I.C.I.)
Chlorazol Fast Blue 4GKS	(I.C.I.)
Chlorazol Fast Orange AGS	(I.C.I.)
Chlorazol Fast Pink BKS	(I.C.I.)
Diphenyl Blue M2B 300	(Gy)
Diphenyl Fast Blue 10 GL	(Gy)
Diphenyl Fast Blue 3RL	(Gy)
Diphenyl Fast Blue Green BL	(Gy)
Diphenyl Fast Rubine RL	(Gy)
Durazol Violet 2BS	(I.C.I.)
Solophenyl Red Brown	(Gy)
Solar Orange RGL	(S)
Solar Red 2BL	(S)
Solar Rubinole B	(S)
Solar Yellow 2R	(S)

Class C. Dyes which show good exhaustion at 90° C. in the absence of added salt, and also have poor levelling properties. Examples are:

Benzopurpurine 4B	(S)
Chloramine Purple 10BC	(S)
Chlorazol Black E extra	(I.C.I.)
Chlorazol Blue BS	(I.C.I.)

Chlorazol Brown BS	(I.C.I.)
Chlorazol Brown MS	(I.C.I.)
Diphenyl Brilliant Blue FF	(Gy)
Diphenyl Fast Bordeaux B conc	(Gy)
Formic Black MTG	(Gy)
Paramine Black BH	(L.B.H.)
Rigan Sky Blue 4G	(C.A.C.)

Satisfactory application of the *Class C* dyes may be obtained by one of the following two methods of controlling the dyeing :

Method 1. By the use of highly concentrated dyes which, in the absence of added salt, show a lower exhaustion than do the corresponding standard brands. This is shown by the following table, the dyeing being made for $\frac{1}{2}$ -hour at 90° C. in a dye liquor where the liquor to material ratio of 10 : 1 is observed.

% of Common Salt added	0	0.1	0.3	0.5	1	5	10
% Exhaustion of $\frac{1}{4}$ %							
Chlorazol Blue B525 ..	0	5	23	42	68	94	100
% Exhaustion of $\frac{1}{2}$ % Di-							
phenyl Blue M2B 300	30	45	55	66	84	94	100

If the above figures are examined, it is seen that Chlorazol Blue B 525 has no affinity at 90° C. when dyed without salt. Thus the use of concentrated dyes enables the dyer to control the initial dyeing affinity, and also, by carefully regulating the additions of common salt, the rate of exhaustion of the dye liquor. If the equivalent amount of actual dye had been used in the form of Chlorazol Blue BS, such control would not have been possible as the dye liquor would have contained at the beginning 1% of salt, which amount will exhaust 68% of $\frac{1}{4}$ % Chlorazol Blue 525. The difference in the salt content between $\frac{1}{2}$ % Diphenyl Blue M2B 300 and $\frac{1}{4}$ % Chlorazol Blue B 525, is approximately $\frac{1}{4}$ % of salt, (the percentage being here calculated on the weight of material), yet the salt present in the Diphenyl Blue M2B 300 would by itself have caused a 30% exhaustion of the dye in the absence of salt added to the dye liquor.

Another conclusion to be drawn from the above table is that the danger of salting on the dye too quickly is greatest in the initial stages of dyeing, since 60% of the Chlorazol

Blue B 525 is exhausted when 1% of common salt is added, whereas the addition of a further 4% of salt increases the exhaustion by only 26%.

These concentrated dyes may be applied by the method used for Class B dyes, whereas the standard brand would fall in Class C.

It should be noted that some waters have such a high content of electrolyte as to nullify completely the advantage of the highly concentrated dyes.

Method 2. By controlling the temperature of dyeing by starting dyeing at a lower temperature, so reducing the rate of exhaustion and then gradually raising the temperature to 90° C.

Careful salt additions may then be made at 90° C. should this be necessary to complete the exhaustion of the dye liquor.

Figures obtained by the temperature control method are given for Benzopurpurine 4B in the following table:

EXHAUSTION OF BENZOPURPURINE 4B STANDARD AND 180 PER CENT CONG.
 $\frac{1}{2}$ HOUR DYEINGS WITHOUT SALT.

Temperature	1% Standard Dyes % Exhaustion	.05% Concentrated Dyes % Exhaustion
30° C.	74%	43%
40° C.	94%	74%
50° C.	96%	87%
60° C.	96%	93%
70° C.	96%	96%
80° C.	96%	92%
90° C.	94%	89%

Liquor ratio 1 to 10; 1/248 Fibro, 4.5 filament denier.

The very wide control obtainable by the use of temperature is clearly shown when the degree of exhaustion of the concentrated dye at such temperatures as 90° C. and 30° C. are compared. No such control is obtained by temperature adjustment when using the standard dye, and this clearly shows the necessity for the highly concentrated "C" class dyes.

For the dyeing of Fibro in staple form the Obermaier type of machine is eminently suitable. Dyeing by poling in an open vessel is totally unsuitable, as it causes considerable entanglement which is more pronounced with a long dyeing time, and the waste during the subsequent carding is excessive.

With the Obermaier machine, dry *Fibro* should be packed into the container; when wet *Fibro* is used the packing is too solid, the liquor flow is reduced and uneven penetration may result. With direct dyes, and the easy flow made possible with a dry pack of *Fibro*, it is possible to obtain uniform penetration in 5 minutes. The following examples, taken from works practice, illustrate this point:

Example 1. 82 pounds of $1\frac{1}{2}$ filament denier *Fibro* were dyed with 0.2% Pyrazol Orange GH 250%, 0.02% Diphenyl Fast Red 7BL 180%, and 0.05% Chlorazol Fast Black BK 135%, in 94 gallons of water. The dye liquor was brought to the boil, $1\frac{1}{4}$ % of salt added, the material entered and dyeing continued for 2 to 3 minutes. A further $1\frac{1}{4}$ % of salt was added and the dyeing continued for a further 2 minutes, making the total dyeing time 5 minutes. The dye liquor was run off and the dyed material rinsed in cold water containing 5% of salt calculated on the weight of the material, thus cooling the material without excessive loss of dye.

A cold soap bath containing 0.15% of soap was then given for the purpose of lubricating the *Fibro* for spinning, and the mass hydro-extracted and dried.

Example 2. A similar procedure was adopted with 3% of Direct Blue 5B, and 5% of salt was added at the commencement of dyeing.

In both cases the material was thoroughly penetrated and was suitable for commercial use.

Example 3. 25 pounds of $1\frac{1}{2}$ denier *Fibro* were dyed at 90° C. with 1% Chlorazol Fast Orange AG in 44 gallons of liquor; 15% salt was added at the commencement of dyeing, the duration of which was 1 to 2 minutes. The dye liquor was run off and the dyed material rinsed with water containing 5% of the *Fibro* weight of salt. A soaping with 0.15% of soap was followed by hydro-extraction and drying. Excellent penetration was obtained.

It is therefore clear that adequate penetration can be obtained in short dyeing times although, of course, the exhaustion of the dye liquor is poor. More complete exhaustion, however, can be obtained either by extending the dyeing time or by increasing the salt addition. The further salt need not be added slowly as there is an adequate

flow of liquor through the material. This is not the case with "cheese" dyeing where the flow of liquor is less than in the machine dyeing of loose *Fibro*. Again, the acceptable standard of dyeing for loose staple is not as high as the standard for yarn or pieces.

From a detailed study of pack-dyeing over a period of more than 8 years, it can be stated that even shades can be produced provided that there is a uniform flow of dye liquor at a rate greater than the rate of dye absorption by the package of *Fibro*.

Fibro sliver in the form of tops can be dyed on the Long-close cheese or cake dyeing type of machine.

The tops are dressed by drawing out their centres so as to leave a 2-inch hole through the middle and then dressing them on the perforated spindles of the machine. The length of sliver from the centre is laid round the upper surface of the top. The tops are then wrapped with an openwork cloth to prevent damage from the swirling of the dye liquor during dyeing; a metal plate is placed in position on the top of the spindle and held in position by means of a wing screw bolt.

The dye liquor is prepared at 90° C. and contains, in addition to the dye, 2 ounces per 100 gallons of Lissapol LS paste or some similar product.

The liquor is circulated from inside to outside for 30 minutes at approximately 15 pounds per square inch gauge pressure. Salting is carried out slowly until the required shade is obtained. The following are examples of two bulk dyeings:

Example 1. 100 pounds of 4½ denier, 4-inch *Fibro* sliver in top form was dyed with 0.18% Chlorazol Dark Green PL 145% and 0.27% Diphenyl Fast Yellow 4GL in a liquor to material ratio of 22 to 1. After dyeing for 30 minutes at 15 pounds pressure with inside to outside circulation, the following amounts of salt were added at 10-minute intervals: ½ ounce, 1 ounce, 1½ ounces, 2 ounces, 2½ ounces and 3 ounces. The dye liquor was then let off and the tops softened by giving a cold soap containing 0.15% solution soap, 0.0125% solution Lissapol LS paste, 0.3% solution salt for 10 minutes; the latter being added to prevent washing off and migration of dye during drying.

Example 2. 200 pounds of 4½ filament denier, 4-inch

Fibro was similarly dyed with 0.95 % Chlorazol Blue B525, 0.03 % Pyrazol Orange GH 250 in a liquor to material ratio of 25 to 1, salt being added as follows: 1 ounce, 2 ounces, 3 ounces, 4 ounces, at 10-minute intervals after an initial 30 minutes' dyeing without salt. The dye liquor was then let off, and the tops softened by giving a cold soap containing 0.15 % solution soap, 0.0125 % solution Lissapol LS paste, and 0.3 % solution salt for 10 minutes.

Fibro in hank form may be dyed on a variety of machines; the rotating roller, Hussong, Longclose or Obermaier types are all satisfactory machines.

With the rotating roller machine either a crank or straight shaft motion of the rollers can be used, but the latter type is recommended. The dry yarn is entered into the dye liquor at 90°–95° C. (excepting with those dyes which require to be temperature controlled) and kept well opened out during the dyeing by hand turning on the rollers. The opening of the yarn is done by turning in the direction in which the rollers rotate, thus avoiding damage of the yarn by dragging on the rollers. The method of making salt additions depends essentially upon the amount of salt to be used in the dye liquor; thus, when up to 10 % salt is to be used it is added in seven equal lots at 5- to 7-minute intervals, after an initial dyeing without salt for 10 minutes. When more than 10 % salt is to be used this is added in 10 equal lots at 5- to 7-minute intervals.

Since *Fibro* yarns have a tendency to float to the surface of the dye liquor when dyed on this type of machine, it is advisable not to use soap or auxiliary products of the sulphated fatty alcohol type in the dye liquor at the start of dyeing, as such products increase this tendency to float. When soap and like substances are required for softening purposes, they should be added to the dye liquor during the last few minutes of dyeing. This tendency to float is worse with worsted spun yarns than with cotton spun yarns, owing to the more lofty nature of the former yarns which causes more air to be entrained during the dyeing process. After dyeing, it is advisable not to leave the dyed yarn hanging on the rollers for any length of time; unless the machine is unloaded quickly, there is a tendency to unevenness due to exhaustion of the residual dye liquor draining to

the lower end of the skeins hanging on the rollers. If unevenness is obtained by this cause, it can readily be corrected by giving the yarn a further short period of dyeing, for example, 10 minutes in the boiling dye liquor.

Example 1. 500 pounds 1/10s worsted counts, $4\frac{1}{2}$ filament denier *Fibro* was dyed on an 80-roller machine in a liquor to material ratio of 20 to 1, with 2.7% Chlorazol Blue G 150%. The yarn was entered into the dye liquor at 90° C. to 95° C. and dyed for 10 minutes without addition of salt; 20% of salt was then added in 10 equal lots of 2%, 5 to 7 minutes' dyeing being allowed between each salt addition. After each salt addition the temperature of the dye liquor was brought to 90°–95° C. The yarn was then taken from the machine, hydro-extracted and dried.

Example 2. 500 pounds 1/10s worsted counts, $4\frac{1}{2}$ filament denier *Fibro* was similarly dyed using 0.8% Diphenyl Fast Red 7BL 180%, 0.08% Chlorazol Fast Black BK 125%. In this case 10% only of salt was used, and was added in 7 equal lots at 5 to 7 minute intervals.

Fibro yarns which float badly on the rotating roller type of machine can be dyed advantageously either on the Hussong or Obermaier type machine. Experience with the former has shown that, to keep the yarn in the best condition, one way circulation (namely, over the yarn) is desirable. With fine counts *Fibro* yarn, experience has shown that entanglement is considerably reduced if the yarn hung on the frame of this machine is curtained with calico before dyeing. This precaution is unnecessary with coarse counts *Fibro* yarns. When dyeing *Fibro* on a Hussong machine the dry yarn is dressed on to the rods which are then placed on the frame; the frame is then lifted into position in the machine; the dye liquor (excepting with those dyes requiring to be temperature controlled), having been previously brought to the boil, is circulated over the hanks. Salt is added as described for dyeings on the rotating roller machine through the stuffing box.

Example 1. 250 pounds 2/30s cotton counts, *Fibro* yarn was dyed in a liquor to material ratio of 22 to 1 with 25% Pyralon Orange G, 0.33% Diphenyl Fast Red 7BL 180%.

After 10 minutes' dyeing, salt was added in ten $1\frac{1}{2}\%$ portions, each at 5 minute intervals.

Example 2. 250 pounds 1/10s worsted counts, $4\frac{1}{2}$ filament denier *Fibro* was similarly dyed with: 0.4% Benzopurpurine 10B, 0.5% Chlorazol Fast Black BK 125%, 0.4% Chlorazol Fast Helio BK 235%.

The methods of dyeing of *Fibro* hanks and warps in the Obermaier type of machine are so similar that they can be described together. The main essential for satisfactory dyeings when using this machine is that the yarns shall be suitably packed in the perforated container. With *Fibro* warps the yarn is, therefore, uniformly plaited down into the container which has been first lined with a cotton net fabric to prevent threads from the warp being forced into the holes of the container during dyeing and hydro-extraction. Formerly *Fibro* hanks were made into slack noddles, each containing two hanks, which were then laid brickwise in the container. As more uniform penetration was obtained with warps than with hanks packed in the latter way, the cause of this was investigated, and as a result the *Fibro* hanks are now packed into the container singly, by plaiting down loosely and evenly in the same way as the *Fibro* warps.

After packing the container with the dry *Fibro* it is then placed in the machine and dyeing carried out by the methods already described. The dyed *Fibro* is then given a light soap in a cold liquor containing 0.15% solution soap, 0.0125% solution Lissapol LS paste, 0.3% salt for 10 minutes. The container is then transferred to the hydro-extractor.

Dyeing warps in this type of machine eliminates any danger of producing broken ends by cutting, such as occurs when the lease bands or cut marks of a warp pass between the rollers of the usual type chain warp dyeing machine. If warps have to be dyed on the latter type of machine the nip rollers should be of soft rubber and, to avoid cutting of the warps at the lease bands and cut marks, great care should be exercised to ensure that the weight on the rollers, when such places pass through, is reduced to a minimum.

Roving on bobbins and yarn on cheeses call for no special comment if the dyes used are chosen as already described, and the necessary dyeing precautions are taken. However

it is essential that the packages be wound suitably soft to facilitate penetration.

Fibrofix. The variation in washing fastness of the individual direct cotton dyes made it desirable to find some treatment for improving the fastness-to-washing of direct cotton dyes, particularly on the $1\frac{1}{2}$ filament denier *Fibro* materials. Examination of a large number of auxiliary products on the market showed that none improved the fastness to washing, although many of the cation active products imparted satisfactory fastness to water and to acid cross dyeing. Further investigation resulted in the discovery of a product which has been named *Fibrofix*, although its use is not confined to *Fibro*, as it is equally applicable to direct cotton dyes on, e.g., silk and casein fibres. The use of this product has been patented, and its name is a registered trade mark.

Fibrofix is a cream coloured powder which is insoluble in water, but may be dissolved in acetic acid. It is dissolved by pasting with its own weight of acetic acid 80% in about 10 volumes of water, heating to the boil, and boiling for about 1 minute. This solution is then diluted for use, whereupon a clear solution is obtained. Where copper acetate is used, it should be mixed with the *Fibrofix* before solution, as it increases the solubility of the latter. Soft water should be used because salts throw *Fibrofix* out of solution. Since an after-treatment with *Fibrofix* decreases the light fastness of certain direct cotton dyes, it has been found necessary to make an addition of copper acetate to the *Fibrofix* solution in order to minimise this drawback in cases where light fastness is a major consideration. To obtain dyeings of direct cotton dyes fast to washing at 40° C., an after-treatment with 2% *Fibrofix* and 1.4% copper acetate (both on the weight of material) applied in a liquor ratio of 20 to 1 for 20 minutes at 40° C. is usually sufficient. As the after-treatment liquor is not exhausted a standing bath may be used and replenished with approximately one-third of the *Fibrofix* when it will be ready again for subsequent use. When using copper acetate the amount of acetic acid may be reduced to $\frac{1}{4}$ of the *Fibrofix* used; by using this reduced amount of acetic acid a further increase

in washing fastness is obtained. A still further increase in washing fastness is also obtained by treatment at 90° C. instead of 40° C. By taking advantage of these improvements and using more *Fibrofix* it is possible to obtain a number of direct cotton dyeings which are fast to soaping at 90° C. This is well illustrated by the fact that dyeings of 3% Chlorazol Black BK, 3% Durazol Fast Violet 2BS, 2% Chlorantine Fast Blue GLL 200%, 4% Paramine Fast Red F, 3% Chlorazol Fast Yellow FS, 1% Chlorantine Fast Green 5GLL, 5% Chlorazol Brown BS, when after-treated at 90° C. for 20 minutes with 5% *Fibrofix* and 2% copper acetate using $\frac{1}{4}$ of the weight of *Fibrofix* of acetic acid are fast to a washing for 20 minutes in $\frac{1}{2}$ % solution soap at 90° C.

The marked improvement in washing fastness obtained by after-treatment with *Fibrofix* has made it possible in practice to dye many shades with direct cotton dyes which formerly had to be dyed with developed, sulphur, or even vat dyes to obtain the desired fastness. The consequent economy in dye and labour costs is obvious.

Sulphur Dyes. The sulphur dyes have only been used to a limited extent for continuous filament viscose rayon dyeing. However, in recent years they have been widely used on *Fibro* for the production of fast to washing shades, and also for the dyeing of many shades which require to be de-sized by treatment in boiling soap, prior to such finishing treatments as anti-creasing. As a class these dyes produce rather dull shades but are very useful in supplementing the vat dyes in heavy shades when the use of the latter is prohibitive on price grounds. From the standpoint of the dyer, matching to shade is difficult with sulphur dyes owing to the gradual change of shade (ageing) which occurs with sulphur dyeings on storing. This difficulty, due to progressive oxidation in the air, can be minimised by treating the patterning swatch or sample with either perborate or chrome and acetic acid which assists in obtaining a shade more nearly like that of an aged dyeing.

Fibro may be dyed in all forms with sulphur dyes, in loose staple, top, cheese, cone, cop or warp form in one of the many forms of package dyeing machines; in hank form in the Hussong, Klauder Weldon, rotating roller, or other

hank dyeing machine. The use of sodium sulphide crystals rather than rock sodium sulphide is generally to be preferred, but the use of crystal sulphide is absolutely essential in any form of package dyeing, owing to the high percentage of insoluble impurities present in fused (or rock) sodium sulphide, as these, during dyeing, would be filtered out and adhere to the *Fibro*. It must be realised that sodium sulphide crystals also contain impurities and that, even after filtering a solution, further precipitation occurs on allowing to stand for some time. It has been suggested that this is due to the slow oxidation of ferrous sulphide contained in sodium sulphide crystals to ferric sulphide, which is less soluble than the ferrous sulphide. It is advisable, therefore, to dissolve sodium sulphide crystals the day before using them, to allow the insoluble matter to settle out, and to syphon or run off the clear solution. This method is preferable to filtering, as the precipitate is in such a fine state of division that some will inevitably pass through the ordinary type of filter used in the dyehouse. With a large number of sulphur dyes reduction with $\frac{1}{2}$ cc./100 caustic soda 70° Tw. and 10% sodium hydro-sulphite can be employed, so eliminating the use of sodium sulphide. Some of the redder type sulphur dyes, Sulphol Claret RL, Thionol Red Brown 4R and 6R, are destroyed by this method of reduction; this has been shown to be due to the alkalinity of the solution, since the addition of caustic soda to a dye liquor prepared with sodium sulphide also produces destruction of these particular types.

Like all other classes of dyes the sulphur dyes exhibit individual dyeing characteristics. It has already been shown that the direct cotton dyes can be classified into three classes (see page 135), according to their dyeing behaviour, and that such a classification not only enables the dyer to decide on the best method for the application of individual dyes, but also to choose those which will work well together in compound shades. Examination of the dyeing properties of the sulphur dyes has shown that a similar classification may be made. With a few exceptions the sulphur dyes fall into the same class, irrespective of whether they are dyed with sodium sulphide or with caustic soda and sodium hydro-sulphite. As the use of sodium sulphide is the more common

practice, the following classified list of sulphur dyes is based on the results when sodium sulphide is used :

Class A. Sulphur dyes which can be dyed throughout at 95° C. and do not require as careful salting as the Class B dyes since they show good levelling properties :

Sulphol Brilliant Green 8G	(J.R.)
Sulphol Green B. Conc.	(J.R.)
Thionol Sky Blue FFS	(I.C.I.)
Thionol Sky Blue BNS	(I.C.I.)
Thionol Indigo Blue 2RS	(I.C.I.)
Thionol Ultra Green BS	(I.C.I.)

Class B. Sulphur dyes which can be dyed throughout at 95° C. but which require careful salting since they show poor levelling properties :

Thionol Brown P. 200	(I.C.I.)
Thionol Brown O.W.	(I.C.I.)
Thionol Black Brown 200	(I.C.I.)
Sulphol Dark Brown FRW 200	(J.R.)
Sulphol Dark Brown B. Spec. 200	(J.R.)
Immedial Fast Dark Brown B	(I.G.)
Sulphol Dark Brown RWN	(R.N.)
Thionol Olive R.200	(I.C.I.)
Sulphol Claret RL.300	(J.R.)
Thionol Red Brown 6RS	(J.R.)
Sulphol Prune B	(J.R.)
Thionol Grey 6R	(I.C.I.)
Thionol Grey 2G.200	(I.C.I.)
Thionol Brown PR.200	(I.C.I.)
Pyrogene Direct Blue RL.	(C.A.C.)

Class C. Sulphur dyes which dye rapidly at 95° C. and show poor levelling properties. These dyes require to be dyed by the temperature control method, namely, by starting at a low temperature, and as dyeing proceeds gradually raising the temperature to 95° C., any necessary salting being done at the high temperature. It follows that the dyes in this class are the most difficult to apply in practice :

Sulphol Yellow JR.300	(J.R.)	
Thionol Yellow R.150	(I.C.I.)	
Sulphol Orange CG.200	(J.R.)	
Sulphol Orange 6R	(J.R.)	
Thionol Orange L	(I.C.I.)	
Thionol Brown GDR.200	(I.C.I.)	
Thionol Black B.200	(I.C.I.)	In pale shades as greys.
Sulphol Black PXR.	(J.R.)	
Sulphol Brown GD.	(J.R.)	

The quantity of sodium sulphide required for dissolving the sulphur dyes depends on the dye under consideration, and on its strength; for details of the recommended amount of sodium sulphide reference to the makers' pattern cards should be made. When dyeing pale shades, unless sufficient sodium sulphide is present, the dye will fall out of solution; to avoid this the concentration should never be less than 0.25% solution of sodium sulphide (fused) or 0.5% solution of sodium sulphide crystals. In all cases the sulphur dye should be pasted with a little soda ash, the requisite amount of sodium sulphide added and dissolved by pouring on boiling water while stirring, and boiling until dissolved. Dyeing is usually carried out near the boil, excepting with those sulphur dyes in Class C which require to be temperature controlled. With some dyes fuller and brighter shades are obtained by dyeing at lower temperatures; for example, Sulphol Red Browns at 50° C., Sulphol Bordeaux, Pyrogene Green 3G and GK at 70° to 75° C. After dyeing the goods are well washed with cold water, hydro-extracted and dried. With some of the more soluble sulphur dyes a treatment in a liquor containing 1% to 2% sodium perborate or a similar oxidising agent before washing off, gives fuller and more level results.

The fastness to soaping at 90° C. and to cross-wool dyeing, of dyeings of the Sulphol Brilliant Green 8G and Sulphol Green B conc. types are considerably improved by after-treatment with *Fibrofix*, thus: 10% Sulphol Brilliant Green 8GS shows considerable bleeding on to white viscose material on treating in 0.5% soap solution for 30 minutes at the boil, while the same dyeing after-treated with 3% *Fibrofix* at

60° C. for 20 minutes, shows no bleeding when treated in a similar manner.

Vat Dyes. The vat dyes can be applied to *Fibro* in all its forms from loose staple to piece goods, the actual stage at which it is dyed depending upon the purpose for which it is required. For blending purposes it may be dyed either as loose staple or in top form, and for stripings as yarn, either in hank, cheese or warp form. In whatever form the *Fibro* is dyed it is essential to remember that it is a viscose rayon for which vat dyes have a much greater affinity than for cotton. Consequently it is highly important that compound shades should, as far as possible, be dyed with dyes which dye at the same rate. Observance of this rule precludes strongly alkaline and weakly alkaline vat dyes being used together for compound shades on *Fibro*. Inferior results will be obtained if the two classes are mixed.

Detailed examinations of the vat dyes has shown how widely they differ in dyeing properties. A test which is within the scope of any dyehouse laboratory is the "1 minute strike test". In making this a series of 40 volume dye liquors (200 cc.) is prepared, each to accommodate two small hanks of yarn or slips of fabric (2.5 grams each) taken from the same commercial hank or piece of fabric respectively. The dye liquors are then brought to 60° C., one hank, or slip, entered into the dye liquor exactly 1 minute before the other and dyeing continued for 5, 20, 40, 60 and 80 minutes. After similarly oxidising, soaping and drying, the dyed hanks (or slips) are examined. In the case of hanks the two hanks taken from each dye liquor are knitted in alternate broad panels on a single thread circular stocking knitting machine before examination. From the 5-minute dyeings the "strike" difference is assessed and designated by a letter, namely:

A. There is no appreciable difference in depth of shade between the two hanks (or slips).

B. There is appreciable difference.

C. There is very marked difference.

D. There is gross difference, as between full dyeing and light staining.

The remaining dyeings are taken, examined, and to the letter indicating the original "strike" difference is now

appended the time required for the two hanks (or slips) to attain the same depth of shade. Examples of complete strike indexes are:

- A₅ Level after 5 minutes.
 A/B₄₀ Very slight difference strike; level after 40 minutes.
 C ∞ Marked difference strike; not level after 80 minutes.
 D ∞ Gross strike difference; not level after 80 minutes.

A finer classification of the rapidly exhausting "strong alkali" dyes is obtained by the "modified" or "10 second strike test". This only differs from the "1 minute strike test" in that one hank (or slip) is entered into the dye liquor 10 seconds before the second hank (or slip) instead of after 1 minute. The results of the strike test with a number of vat dyes is given in *Table 24*:

TABLE 24
 STRIKE INDEX CLASSIFICATION

"Weak Alkali" Vat		Strike	"Weak Alkali" Vat		Strike
No.	Dyes	Test	No.	Dyes	Test
1	Indanthren Yellow GK	A ₅	26	Caledon Dark Brown 4RBS	C ₈₀
2	Indanthren Yellow 4GK	A ₅	27	Caledon Brown RS	C∞
3	Caledon Yellow 3G	A/B ₄₀	28	Indanthren Olive GN	C∞
4	Indanthren Orange 2RK	B ₂₀	29	Caledon Olive RS	C∞
5	Indanthren Red BK	B ₂₀	30	Indanthren Brown BR	C∞
6	Indanthren Olive 3G	B ₂₀	31	Indanthren Red Brown	
7	Caledon Red 5G	B ₂₀		5RF	C∞
8	Indanthren Yellow FFRK	B ₂₀	32	Indanthren Bordeaux B	C∞
9	Caledon Red Violet 2RN	B ₂₀	33	Indanthren Red FBB	C∞
10	Paradone Yellow 5 GK	B ₂₀	34	Caledon Red BN	D ₄₀
11	Indanthren Yellow 7GK	B ₂₀	35	Ciba Violet B	D ₄₀
12	Indanthren Corinth RK	B ₄₀	36	Indanthren Brilliant	
13	Indanthren Orange 3G	B ₄₀		Orange RK	D ₄₀
14	Indanthren Yellow Brown		37	Indanthren Orange F3R	D ₈₀
	3G	B ₈₀	38	Caledon Red 2G	D ₈₀
15	Caledon Red X5BS	C ₂₀	39	Indanthren Printing Violet	
16	Hydron Orange RF	C ₂₀		RF	D ₈₀
17	Hydron Violet 2BF	C ₂₀	40	Caledon Gold Orange G	D ₈₀
18	Caledon Brilliant Violet		41	Hydron Scarlet 2B	D ₈₀
	R	C ₂₀	42	Indanthren Brown RRD	D ₈₀
19	Caledon Red 5B	C ₂₀	43	Indanthren Orange 2R	D∞
20	Caledon Brilliant Violet		44	Hydron Bordeaux	D∞
	2BS	C ₂₀	45	Indanthren Rubine B	D∞
21	Indanthren Pink B	C ₄₀	46	Indanthren Magenta B	D∞
22	Indanthren Yellow RK	C ₈₀	47	Ciba Brown 2R	D∞
23	Indanthren Brown FFR	C ₈₀	48	Ciba Blue 2B	D∞
24	Caledon Brown G	C ₈₀	49	Hydron Blue G	D∞
25	Hydron Blue R	C ₈₀	50	Durindon Pink FFS	D∞
			51	Durindon Pink FB	D∞

No.	"Strong Alkali" Vat Dyes	Strike Test (1 minute)	Modified Strike Test (10 seconds)
1	Indanthren Khaki 2G	.. A5	5
2	Cibanone Yellow 2GR	.. B20	5
3	Hydron Yellow NF B20	10
4	Cibanone Red 4B B40	5
5	Cibanone Blue 2G B40	5/10
6	Indanthren Yellow 3RT	.. B40	10
7	Paradone Yellow GC B00	20
8	Paradone Yellow G C40	60
9	Indanthren Scarlet GK	.. C80	5
10	Indanthren Brown GR	.. D80	20
11	Paradone Violet 2R D00	20
12	Indanthren Grey M D00	20
13	Caledon Green RC D00	60
14	Indanthren Direct Black RB	D00	60
15	Indanthren Blue 5G D00	60
16	Caledon Orange 4R D00	60
17	Indanthren Olive Green 2G ..	D00	60
18	Alizanthrene Navy Blue	.. D00	80
19	Caledon Orange RRT	.. D00	80
20	Caledon Jade Green X	.. D00	80
21	Cibanone Black 2B D00	∞
22	Paradone Dark Blue D00	∞
23	Indanthren Brilliant Violet 3B	D00	∞
24	Caledon Blue RC D00	∞
25	Indanthren Olive Green B	.. D00	—
26	Paradone Black 2B D00	∞
27	Caledon Blue RS D00	—
28	Indanthren Grey 3B D00	—
29	Indanthren Grey MG	.. D00	∞
30	Indanthren Scarlet 2G	.. D00	∞

It will be seen from the original strike difference in the above table, that most of the vat dyes (C and D) give poor strikes at 60° C., namely, they dye so rapidly that in the first few minutes of dyeing the material is unevenly dyed. This, coupled with the fact that a large number of the vat dyes do not readily migrate or level (as is shown by the number requiring 80 or more minutes to level), indicates the methods of control necessary to obtain satisfactory results in practice.

With the weak alkali vat dyes experience has shown that :

(a) The strike can be improved considerably by starting dyeing at a low temperature whereby the rate of dyeing is reduced, and then raising the temperature to take advantage of any levelling which occurs at this higher temperature; thus with *Fibro* hanks dyeing is commenced at 35° C. and the temperature raised to 60° C. This method has been shown to be satisfactory with both the cold and hot dyeing weak alkali vat dyes.

(b) With some hot dyeing weak alkali vat dyes, better results are obtained by dyeing at 80° C. throughout, using twice the amount of caustic soda (namely, 1 cc. 70° Tw. caustic soda for 100 cc. liquor), since there is appreciably greater migration at 80° C. than at 60° C. Caledon Gold Orange 3G is typical of dyes which can be applied by this method.

When dyeing cellulosic fibres with vat dyes there is always a tendency for the fibre to be tendered somewhat, due to the cycles of oxidation and reduction occurring during the dyeing process. With most weak alkali vat dyes this tendering is negligible, but with others (for example, Indanthren Corinth RK, Indanthren Bordeaux B) it can be very marked. Experience has shown that such degradation can be very simply prevented by the use of sufficient sulphite cellulose waste liquor in the dyeliquor to give a 0.15%–0.25% solution, or by the addition of tannic acid sufficient to give 0.2 gm. per litre of dyeliquor, or 0.4 gm. per litre when dyeing at 80° C.

The strong alkali vat dyes in general exhaust more rapidly and have poorer migration properties than have the weak alkali vat dyes, so that although some help is obtained in controlling their exhaustion by starting dyeing at 35° C. this is insufficient to give good results in practice. For this reason it is advisable to add a restraining agent to the dye liquor when dyeing *Fibro* with these dyes. Albatex PO, Dispersol VL, certain sulphite cellulose waste liquors, etc., are used for this purpose. When using these products the vat dyes are vatted in the usual manner, the dye liquor prepared and the requisite quantity of the well-diluted auxiliary product added immediately before use. It must be remembered that the use of these products usually requires more vat dye to obtain the same depth of shade than in their absence. One of the main practical difficulties is that vat dyes are not all equally restrained; one dye may be considerably restrained, while another may not be restrained at all. This difficulty has been accepted by most of the makers who issue lists showing the extent to which the various vat dyes are restrained. When comparing the relative merits of the vat restraining agents, the strike tests described above will be found of value.

With *Fibro*, many of the so-called cold dyeing weak alkali vat dyes are the most difficult to finish satisfactorily as owing to their ready solubility in the leuco form they are liable to run or to be washed off during the oxidation and soaping processes. To overcome this difficulty oxidising agents may be used. Practical experience has shown that in most cases the best method is to oxidise with dilute sodium hypochlorite; 0.25 cc. NaOCl (15% available chlorine) per 100 cc. liquor in presence of sufficient common salt to give a 2% solution has proved satisfactory for *Fibro* staple, hanks and warps. This is followed by a cold water wash, hot water wash and finally soaping at the boil. The strong alkali vat dyes show much less tendency to wash off during the finishing treatment since their leuco compounds oxidise more readily than the leuco compounds of the weak alkali vat dyes, and are therefore, easier to manipulate when finishing off.

Example 1. 50 lb. 2/12s cotton counts *Fibro* in hank form dyed on rotating roller type machine in 46 volumes.

5%	<i>Caledon Red BN. paste</i>
3.8%	<i>Caledon Brown R. paste</i>
0.2%	<i>Caledon Olive R. powder</i>
0.5 cc./100	<i>Caustic soda 70° Tw.</i>
10%	<i>Hydrosulphite</i>
0.2 gm./litre	<i>Tannic acid</i>

The dyeing is run 15 minutes at 35° C. with 6% hydrosulphite present, and the dye liquor is then raised to 60° C., 2% hydrosulphite is added and dyeing continued for 15 minutes. The salt and 2% hydrosulphite is then added in two lots, dyeing for 15 minutes after each addition. The dye liquor is then run off and the yarn plunged as quickly as possible into a cold 2% solution of salt. After cooling for 5 minutes the yarn is then treated in a fresh cold 2% solution salt containing 0.25 cc./100 sodium hypochlorite (15% available chlorine) until oxidation is complete (15–20 minutes). The yarn is given two cold washes and one at 50° C. each of 10 minutes' duration, followed by a finishing treatment for 10 minutes at 90° C. with 0.2% solution soap, and 0.0125% solution Lissapol LS paste.

Example 2. 80 lb. 2/50s cotton counts *Fibro* warp, dyed in the Obermaier type of machine in 12 volumes.

2.5%	<i>Caledon Olive Green B.200 paste</i>
0.32%	<i>Paradone Yellow G.200 paste</i>
1.25 cc./100	<i>Caustic soda 70° Tw.</i>
10%	<i>Hydrosulphite</i>
0.2 gm./litre	<i>Tannic acid</i>
5%	<i>Dispersol VL.</i>

The dyeing and finishing method was as in *Example 1* except that no salt was added during dyeing to obtain exhaustion.

Example 3. 100 lb. 2/36s cotton counts *Fibro* yarn dyed in hank form on the rotating roller type of machine in 60 volumes.

20%	<i>Caledon Red BN. paste</i>
1%	<i>Caledon Olive RS. paste</i>
4%	<i>Solution salt</i>
0.5 cc./100	<i>Caustic soda 70° Tw.</i>
10.0%	<i>Hydrosulphite</i>
0.2 gm./litre	<i>Tannic acid</i>

The dyeing and finishing methods were as in *Example 1*.

Example 4. 80 lb. 1/20s cotton counts *Fibro* warp dyed in the Obermaier type of container in 12 volumes.

2.7%	<i>Caledon Brown RS. paste</i>
0.16%	<i>Paradone Red Brown 5RD. paste</i>
0.35%	<i>Caledon Olive R. powder</i>
1 cc./100	<i>Caustic soda 70° Tw.</i>
10.00%	<i>Hydrosulphite</i>
0.4 gm./litre	<i>Tannic acid</i>

Dyeing was commenced at 80° C. and this temperature was maintained for 1 hour. The development and finishing were carried out as in *Example 1*.

The Solubilised Vat Dyes. These dyes, the Soledons and Indigosols, are naturally more expensive than the corresponding vat dye, but they have many virtues which compensate for their higher price. Experience with *Fibro* yarns, for example, has shown that the dyeing time is shorter than with vat dyes; there is less difficulty in obtaining levelness; there is no danger of oxidation streaks, and the use of

caustic soda is avoided. With many shades the use of common salt makes it possible to reduce the total dyeing cost to the level of that of vat dyes, while with certain pale shades the costs are actually less than for vat dyeings.

The affinity of the Soledon and Indigosol dyes for cellulosic fibres is, in general, poor, but as with all classes of dyes, they vary widely in their rate of exhaustion, salt sensitivity, and temperature of maximum affinity, as is shown by the table overleaf.

The solubilised vat dyes are applied to *Fibro* either in the form of yarn or piece.

Yarn may be dyed either as hanks, cheese or warps in suitable package machines, while hanks may also be dyed on sticks in the ordinary hand dyebeck or on machines of the rotating roller type. The method of dyeing naturally depends upon the type of machine used, on the depth of shade desired and on the dye to be used, so that no hard and fast rules can be given. In general, the dyebath is set with the dye and Glauber's or common salt, and dyeing continued for $\frac{1}{2}$ to $\frac{3}{4}$ hour at room temperature. For pale shades on hard spun yarns, no salt should be added at the commencement of dyeing, and the salt should then be added in small portions during the dyeing. This is particularly essential when dyeing mixtures of, for example, Soledon Jade Green XS and Soledon Yellow GS., on viscose rayon, since as shown in *Table 24* Soledon Jade Green XS requires much less salt to give maximum exhaustion than does Soledon Yellow GS, so that, unless the salt is carefully added, unlevel dyeings will be obtained owing to the strong affinity of the Soledon Jade Green XS. Similarly, the temperature of dyeing has to be regulated. For example, viscose rayon is in general more evenly dyed at 50° to 60° C. than by dyeing at lower temperatures.

After dyeing, the solubilised vat dyes require to be "developed", by which is understood a hydrolysis of the dye by an acid in presence of an oxidising agent. The speed of hydrolysis depends mainly on the temperature and concentration of the acid in the developing bath and is only influenced to a certain extent by the amount of oxidising agent used. Several methods are used for developing, most of which are recommended for printing, but the method

TABLE 25

TEMPERATURE AND SALT ADDITIONS RECOMMENDED FOR USE WITH THE FOLLOWING INDIGOSOL AND SOLEDON DYES ON *Fibro* (1½ FIL. DENIER) IN 1 : 40 DYE LIQUOR RATIO

	<i>Dye</i>	<i>Dyeing Affinity</i>	<i>Temperature giving Maximum Affinity</i>	<i>Percentage of Common Salt giving Maximum Depth in Percentage Stated</i>
10%	Indigosol Blue AGG Powder	C	20° C.	200
10%	" Blue AZG Powder ..	C	20° C.	160
10%	" Blue IBC Paste ..	C	20°-90° C.	200
9%	" Brown IBR Powder	A	60°-90° C.	120
10%	" Brown IRRD Powder	C	20° C.	40
2%	" Grey IBL Powder	C	20° C.	160
5%	" OExtra Powder ..	C	20° C.	200
5%	" O4 B Powder ..	A	30°-40° C.	120
5%	" O6 B Powder ..	A	40° C.	120
6%	" Olive Green 1B Powder	A	60° C.	80
5%	" Orange HR Powder	B	20° C.	200
10%	" Pink IR Powder ..	C	20° C.	200
3%	" Red IFBB Powder	A	50° C.	120
10%	" Scarlet HB Powder	C	20° C.	200
6%	" Violet ABBF Powder	B	20° C.	160
6%	" Violet ARR Powder	B	20° C.	200
10%	" Red Violet IRH Powder	C	20° C.	200
2%	" Golden Yellow IGK Powder	C	20° C.	160
2%	" Golden Yellow IRK Powder	B	20°-40° C.	80
5%	" Yellow V. Powder ..	C	20° C.	200
10%	Soledon Black 2B 50 Paste ..	A	90° C.	80
10%	" Blue RCS Paste ..	C	20°-90° C.	200
10%	" Blue 4GS Powder ..	C	20° C.	160
5%	" Blue 4BCS Powder ..	A	30°-40° C.	120
10%	" Dark Blue BS Paste ..	A	90° C.	40
10%	" Dark Blue 2RS Paste	A	90° C.	40
10%	" Dark Blue GS Paste	A	50°-90° C.	80
10%	" Brown GS Powder ..	C	20° C.	40
9%	" Dark Brown 3RS Paste	A	60°-90° C.	120
2%	" Golden Yellow GKS Powder	C	20° C.	160
2%	" Golden Yellow RKS Powder	B	20°-40° C.	80
6%	" Green GS Powder ..	A	60° C.	80
2%	" Grey BS Powder ..	C	20° C.	160
5%	" Indigo LLS Powder	C	20° C.	200
2%	" Jade Green XS Powder	A	60° C.	10
5%	" Orange RS Powder	B	20° C.	200
10%	" Orange 4RS Paste ..	A	70°-80° C.	120
10%	" Pink FFS Powder ..	C	20° C.	200
4%	" Brilliant Purple 2RS Paste	A	50°-60° C.	20
3%	" Red 2BS Powder ..	A	50° C.	120
10%	" Red 3 BS Powder ..	C	20° C.	200
10%	" Scarlet BS Powder ..	C	20° C.	200
6%	" Violet BS Powder ..	B	20° C.	160
5%	" Yellow GS Paste ..	A	50° C.	120
2%	" Yellow 5GS Powder	C	20° C.	200

Class A has maximum dyeing affinity; Class C minimum dyeing affinity; Class B is intermediate between A and C.

chiefly used in dyeing involves the use of sulphuric acid and sodium nitrite. Individual members vary considerably in their ease of development; thus, Indigosol Red IRH is difficult to develop, while Soledon Jade Green XS is very easy. The fact that Soledon and Indigosol dyeings fluoresce strongly in ultra-violet light has led us to examine all shades under this light source when development of bulk dyeings is thought to be complete. If the shades fluoresce it is evident that they are not fully developed and require a longer treatment in the developing bath. Certain members (for example, Indigosol Olive Green IB), are prone to over-oxidation, the shade becoming flatter and yellower, so that as this dye is easy to develop, developing should be carried out cold. If over-oxidation has occurred the correct shade can usually be recovered by the addition of 5% glucose and 2% soda ash to the soaping bath.

Example 1. 95 lb. 2/30s cotton counts *Fibro* in warp form dyed in 10 volumes in Obermaier type of machine.

0.27%	<i>Soldedon Dark Brown 3RS. powder</i>
0.3%	<i>Soledon Yellow G. paste</i>
1.0%	<i>Soda ash</i>
5.0%	<i>Salt</i>

Dyeing is commenced at 60° C. without salt, and this temperature is maintained until dyeing is completed. The salt is added in five lots, $\frac{1}{4}\%$, $\frac{1}{2}\%$, $\frac{3}{4}\%$, $1\frac{1}{2}\%$, and 2% at 10 minute intervals. The yarn is then developed with 0.5% sodium nitrite, 1 cc./100 sulphuric acid 140° Tw. and 2% solution salt for 20 minutes at 30° C. The yarn is then washed off in cold water, followed by 1% soda ash, then washed at 40° and 60° C. and finally soaped with 0.2% solution soap, 0.0125% solution Lissapol LS. paste for 15 minutes at 95° C.

Example 2. 100 lb. 2/36s cotton counts *Fibro* in hank form dyed in 40 volumes in a rotating roller type machine.

1.8%	<i>Soledon Orange 4R. powder</i>
1.6%	<i>Soledon Yellow G. paste</i>
0.15%	<i>Soledon Dark Brown 3 RS. powder</i>
1.00%	<i>Soda ash</i>
1.00%	<i>Solution salt</i>

Dyeing is commenced at 60° C. and maintained throughout, salt being added in 1½ lb., 3 lb., 6 lb., 12 lb., and 18 lb. lots at 10 minute intervals. The yarn is then developed in 30 volumes with 0.5% sodium nitrite and 1 cc./100 sulphuric acid 140° Tw. and 2% solution salt at 30° C. The yarn is washed off in cold water followed by 1% soda ash, then with water at 40° C. and 60° C. and finally soaped with 2% soap on weight of yarn at 95° C. for 15 minutes.

Azoic Dyes. These dyes are used on *Fibro* which is required to be fast to light, boiling, washing, bleaching and cross-dyeing. The general method for their application is similar to that employed for cotton, but acetic acid, not aluminium sulphate, should be used as the alkali binding agent to prevent precipitation of aluminium hydroxide in the dye liquor, which would result in dulling of the lustre of the rayon. Again, it is obvious that the padding and wringing process employed for cotton yarns cannot be used for *Fibro* hanks owing to the mechanical damage which would result. Advantage is therefore taken of the superior substantivity of *Fibro* over that of cotton for the Naphtol, which makes possible the economical application of the Naphtol from a salt bath. Common salt should also be added to the developing baths to prevent the bleeding of Naphtol from the yarn into the developing liquor during this process, which, if allowed to occur, would result in the production of unlevel and dirty dyeings. This method has the further advantage of dispensing with any elaborate calculations as to the feeding of the liquor, because the batch of yarn, particularly when using the roller type of machine, is dyed to the same shade owing to the whole of the batch being impregnated simultaneously with the Naphtol solution in the same liquor. It has been proposed to hydro-extract the rayon after impregnating with the Naphtol, but this requires very special precautions in order to avoid white marks caused by the handling necessary during the wrapping of the yarn into cloths and the loading and unloading of the hydro-extractor. Again, as a hydro-extractor has yet to be built which will extract evenly the liquor from a batch of rayon skeins, this method is not recommended.

No difficulties arise in dyeing the azoic dyes on *Fibro* providing the coupling is very rapid, but with slow-coupling

combinations the insides of the skeins are liable to be almost undyed. On the roller type of machine this difficulty can be minimised by hand turning the yarn whilst the rollers are rotating so as to open out the yarn and allow the developing solution to come rapidly into contact with all parts of the Naphtolated skeins.

Skeins may be dyed either in the open beck, in a liquoring machine, such as the Spencer padding machine, or in machines on the pack system, the choice of method depending on the quantity of yarn to be dyed and on the available equipment. Warps may be dyed in the ordinary warp dyeing machine, care being taken to give an efficient nip to the Naphtolated material before passing it into the developing bath. Alternatively, they may be dyed in a pack dyeing machine of the Obermaier type. With the latter it is advantageous if the Obermaier cage can be removed from the liquor and hydro-extracted. For pieces, the padding machines with a double nip is the ideal method for their application, although the jigger can also be used if followed by an efficient squeeze on the mangle. In many cases it is found advisable to dry warps and pieces after impregnation with the Naphtol in order to give a better rubbing fastness; drying may be carried out either in a hot-flue or on other suitable drying machinery, care being taken that the cylinders are not excessively heated. In all cases the method of application of these dyes is first to impregnate with the Naphtol solution, remove excess of liquor from the material, then to develop in a solution of either a diazotised base or a Fast Colour salt.

After the dyeings have been developed, the diazo solutions still adhering to the material must be removed by rinsing with cold water (when the developing bath contains aluminium sulphate the use of a mildly acid rinse is to be recommended), and the material soaped as hot as possible with soap and soda. This after-soaping must be very thorough as it serves to develop the true shade of the combination used, to increase the fastness to rubbing by removing loose pigment adhering to the surface of the material, and to increase the fastness of the dyeing, particularly to chlorine and light (*see Bean and Rowe, J. Soc. Dyers and Colourists* 1929, 45, page 67). With combinations which show a tendency to

rub, steeping overnight in a 0.5% soap solution may be used. The material is entered into the 60° C. soap solution and allowed to cool overnight. Although this method, apart from its cost, may have certain objections, in practice it deserves serious consideration. Excellent results on yarn have been obtained by steeping overnight in hot soap solution of this strength, hydro-extracting, washing in hot water, and then giving a normal soaping with 5% soap (on the weight of yarn) to remove any dirty soap liquor and loose pigment left in the yarn from the steeping treatment.

Lacing of Hanks. If *Fibro* hanks are not laced satisfactorily the dyer will have difficulty in producing level shades, and the hanks will also be in an unsatisfactory condition for winding after dyeing. Hanks other than of carpet or hand-knitting yarn should contain two lacings, preferably of continuous filament viscose, since this does not cling to the *Fibro* yarn. These two lacings should be disposed at opposite ends of the hank, one of the lacings serving as a tieband, the ends of the yarn being tied to it. Each lacing should divide the hank into three equal portions, to form three loops in such a way that the hank is not "throttled". There should be sufficient length of lacing to enable the hank to be spread out on the rollers of the dyeing machine, but there should not be an excessive length of lacing, which is liable to catch up with threads of adjacent hanks. The ends of the tieband should be tied in a double twist knot to prevent the lacing from coming undone during dyeing; *Figure 40* illustrates the type of lacing and the double twist knot.

For carpet and hand-knitting yarns, one triple loop lacing and a single loop tieband disposed at opposite ends of the hank should be used. The single loop tieband facilitates freer handling of these relatively large hanks. The Gerber type of rotating roller hank dyeing machine is not suitable for dyeing hanks of *Fibro* carpet yarn owing to their bulk, and the consequent risk of uneven "draining" of dye liquor and difficulty in penetration.

Spun Rayon Yarns in Cake Form for Dyeing. Courtaulds have developed the dyeing of spun viscose rayon yarns in the form of a special package which, because of its similarity in build to the viscose rayon cake produced in the Topham Box, is referred to as a *Fibro* cake.

Winding of Spun Rayon Yarns into Cake Form for Dyeing. Winding is normally conducted overend from such packages as ring tube, mule cop, doubler bobbin or cone. In general it will be found that it is preferable to use a spindle winding machine as distinct from the drum winding types. A machine which has proved satisfactory for the job is the Style 50 "Universal" Spindle Cheese Winder.

FIGURE 40

TRIPLE-LOOP LACING BAND

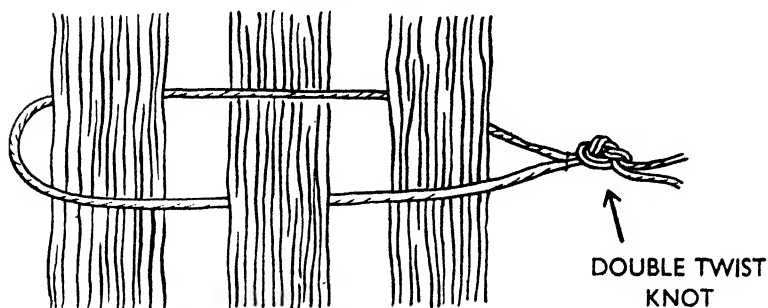

DOUBLE TWIST KNOT

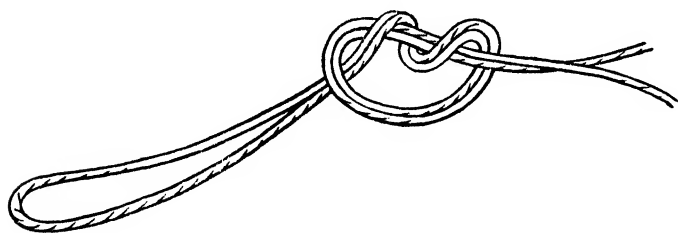

Using the standard 6-spindle machine, it is possible to wind cakes having a total net weight of about $1\frac{1}{4}$ lb. using all 6 spindles, with an internal bore of $4\frac{1}{2}$ inches, and an external diameter of $6\frac{1}{2}$ inches, with a traverse of 5 inches. To do this, the normal spindle is removed and replaced by a metal former, held in place by an expanding spindle. To protect the yarn cake during transport and the dyeing operations, a piece of stockinette approximately 28 inches long, is pulled over the former before winding begins; when the cake of yarn is complete and doffed, the stockinette can

then be wrapped round each end of the cake, thus completely enclosing the yarn in stockinette.

When winding spun rayon yarn cakes in this way at an average speed of 300 yards per minute, a production of some 20 lb. per spindle in 48 hours is obtained with a yarn count of single 20s. Higher or lower average winding speeds may be used, depending on the quality and count of the yarn being wound. Yarn tensioning arrangements are not used during this cake winding operation, as the natural tension developed during winding is quite sufficient to ensure the building of a soft cake suitable for dyeing.

Dyeing in this form completely eliminates the necessity for reeling yarn into hanks and, as there is considerably less handling of the yarn in cake compared with hank, this results in a marked improvement in the winding and weaving quality of the dyed yarn.

Fibro cakes can be dyed either on the Courtauld Horizontal Arm Cake Dyeing machine (reference *Textile Institute* 1947 *Conference paper "A new machine for the dyeing of viscose rayon cakes"*, by C. M. Whittaker. *J. Text. Inst.* 38, page 273, 1947) or on the Longclose Vertical Spindle Cake Dyeing Machine, using either vat, azoic, sulphur, or direct cotton dyes, with or without a *Fibrofix* after-treatment, to give the usual fastness properties required commercially. The largest *Fibro* cake dyed up to the present weighed $3\frac{1}{4}$ lb. but it is evident that, should a demand arise for still larger packages, the limit has not yet been reached. For general bulk production $1\frac{1}{4}$ lb. cakes are found to be a convenient size for the spinner and winder.

The following are examples of recipes used for bulk lots of *Fibro* cakes.

Vat Dyes

Green.

- 0.6% *Caledon Jade Green X300 paste*
 - 0.7% *Paradone Yellow G200 paste*
 - 7.0% *Caledon Green RC. paste*
 - 1.25 cc. *Caustic soda 72° Tw. per 100 cc. liquor*
 - 5% *Dispersol VL. 10% Hydrosulphite*
- Pigment padded and dyed at 75° C.*
20 volumes, in the presence of 0.4 gm. tannic acid/litre

Gold.

- 1.2% Caledon Golden Orange 3G. 200 paste
- 0.7% Caledon Brown R. powder
- 1.4% Caledon Brown G. powder
- 1.0 cc. Caustic soda 72° Tw. per 100 cc. liquor
- 5.0% Dispersol VL.
- 10% Hydrosulphite

Pigment padded and dyed at 75° C. 20 volumes, in the presence of 0.4 gm. tannic acid/litre.

Brown BCC.68.

- 9% Caledon Brown RS. paste
- 18% Caledon Brown G. paste
- 0.4% Caledon Brown 3G. 200 paste
- 1 cc. Caustic soda 72° Tw. per 100 cc. liquor
- 4% Solution salt
- 2% Dispersol VL.
- 0.4 gm. Tannic acid per litre, dyed from the reduced vat at 75° C. 20 volumes liquor ratio.

Tulip Leaf Green.

- 3% Caledon Jade Green X300 paste
- 2.5% Caledon Olive Green B200 paste
- 0.55% Paradone Yellow GC.750 powder
- 1.25 cc. Caustic soda 72° Tw. per 100 cc. liquor
- 2% Dispersol VL.
- 0.4 gm. Tannic acid per litre, dyed from the reduced vat at 75° C. in 20 volumes liquor ratio.

The vat shades were developed on the *Fibro* cakes by first washing in cold water for the strong alkali vat dyes, and in cold 2% salt solution for weak alkali vat dyes: then in cold sodium hypochlorite solution (0.25 cc. sodium hypochlorite (15%) in 100 cc. water) for strong alkali vat dyes, or in 100 cc. 2% salt solution for weak alkali vat dyes, circulated for 20 minutes, followed by a cold water wash, then in 4 oz. Calgon per 100 gallons hot water at 60° C., followed by the usual boiling soap solution, 4 oz. soap, 4 oz. Lissapol, and 4 oz. Calgon per 100 gallons liquor.

Fast to Light and Washing Navy.

- 3.3% Chlorantine Fast Blue GLN.200
- 0.25% Chlorazol Fast Orange AG.125
- 0.9% Benzanil Fast Brown 5RL.
- 30% Salt
- 90° C. 20 volumes.

The dyeing was done without salt for 30 minutes, 20 minutes flow inside to outside, 10 minutes flow outside to inside, and the salt added at 10 minute intervals, the flow being reversed every 10 minutes.

Salt Additions.

3	additions of	0.25 %	salt.
3	„	0.5 %	„
3	„	1.0 %	„
3	„	2.0 %	„
3	„	2.5 %	„

Patterned off, found to be correct to shade before after-treatment.

After-treatment with :

2 %	<i>Fibrofix</i>
1.4 %	<i>Copper acetate</i>
1 %	<i>Acetic acid 80 %</i>
0.1 %	<i>part glue per 1,000 of liquor, and dissolved in the manner recommended.</i>

The solution was filtered into the dye vessel containing cold water, the cakes entered and the solution heated to 60° C. during 20 minutes, and kept at 60° C. for 20 minutes, followed by washing in water and finally treating with 0.1 % Alcamine in 20 volumes (i.e. 0.005 % solution of Alcamine) cold for 20 minutes to impart a soft handle, hydro-extracted and dried.

CHAPTER XIX

NARROW-FABRIC DYEING

THE term "narrow fabric" is applied to a woven, knitted or braided fabric, plastic strip or webless tape of a width no greater than 18 inches. It therefore includes tapes, webbings or webs, either flat or tubular; ribbons, braids, trimmings, chevrons, galloons and shalloons.

Fibro yarns are being used in increasingly large quantities in such materials, as, for example, tapes for furnishing fabrics where *Fibro* is more attractive than cotton webbing.

The higher absorptive capacity of *Fibro* compared with cotton for water and for aqueous solutions, makes it specially suitable for treatment with special finishes—for example, smoulder-proofing and stiffening. Smoulder-proofed tape made from *Fibro* was found to have an important wartime application.

An all-rayon Petersham ribbon has been made possible by the use of spun *Fibro* yarn as weft with a continuous filament yarn as warp, the deniers being of the same order, facilitating solid dyed shades on warp and weft. (The production of solid shades on continuous filament warp and cotton weft in the usual construction of Petershams is a difficult dyeing problem.)

Firms manufacturing narrow fabrics usually purchase yarn on cheese, cone, doubler bobbin or ring tube, reel it into hanks and send them to the dyer. On their return the webbing manufacturer winds the yarn into a suitable package (cheeses for warping creels or braiding machines, pirns for the shuttle, or cones for the knitting machines) and proceeds to weave, knit or braid the narrow fabric.

The warehouses of many webbing manufacturers are littered with odd weights of dyed yarns of different shades, for which there is no immediate use, and the remedy for this uneconomic practice is to have standard constructions of narrow fabrics, in the grey state, kept in stock and then dyed as required, enabling orders to be executed much more rapidly.

Package Dyeing. Wet processing of narrow fabrics in package form has been developed, and fabrics made of *Fibro* are particularly suitable for the package dyeing process.

Dyeing narrow fabrics in hank form usually causes distortion which has to be corrected in the subsequent finishing. The package dyeing process evolved by Courtaulds uses the existing Longclose rayon cake dyeing machines for dyeing rolls or cheeses of narrow fabrics, and the process can be regarded as a logical development of viscose rayon cake dyeing.

The smoulder-proofing process was applied successfully to blocks or rolls of *Fibro* tape in various widths, by packing them in a cage inserted in the dyeing machine, in which the impregnating solution was circulated under pressure. The

packages were then hydro-extracted in the cage and dried in circulating hot air, at a temperature no higher than 65° C.

An analysis of cuttings taken from different parts of the rolls shewed the distribution of the chemical employed (mon-ammonium phosphate) to be remarkably constant throughout the roll, from the inside to the outside. Moreover, the treated tape was flat, free from curl and kinks, and in excellent condition to run through a stitching machine. These results prompted experiments on the dyeing of *Fibro* tape in roll form.

The first trial was made by dyeing *Fibro* shoulder-strap ribbons in roll form with direct cotton dyes. Subsequently, single-faced and double-faced viscose rayon satin ribbons were similarly dyed after de-sizing in the roll with caustic soda and soap to remove the oil size.

Webbings and ribbons dyed or otherwise treated in roll form do not show creep or relaxation shrinkage, even in lengths cut from the rolls which have been subsequently wetted. Thus "set" or stability of the web is achieved by this package dyeing process and, moreover, the edges of the web or ribbon are straight and flat provided they have been so woven—the hall-mark of the craftsman. Webbing can also be satisfactorily bleached in roll form.

Petersham ribbons gave rise to difficulties when dyed in roll form, as moiré effects were produced by the shrinkage of the ribbon in the roll; this fault was obviated by blocking the previously wetted-out ribbon in a sufficiently slack roll.

Loosely knitted tubular webbing and loosely braided ribbons extend and become narrower when dyed in any form, so if a predetermined width is needed with such loose constructions, the braid or webbing should be made from dyed yarn.

Rolls of fabric for dyeing or other wet treatments are blocked, direct from the loom box, with as little tension as possible. Pins should not be used for joining or fixing the ends of the roll owing to the risk of corrosion and the formation of rust marks in the outer laps of webbing to the depth of the roll penetrated by the pin. The end of the roll should be stitched down with suitable thread, either of *Fibro* or cotton.

If the rolls are uniformly slack the relaxation shrinkage which occurs during dyeing will not tighten up the rolls and hinder the penetration of dyeliquor.

On drying, the rolls slacken somewhat but on re-wetting they do not "tighten up" appreciably. This indicates the removal of weaving and other strains; in consequence the rolls, after this treatment, do not exhibit creep or relaxation shrinkage.

Should the roll be considered too slack, the end of the tape may be pulled and the roll allowed to screw up on its centre. This tightening should be done on a smooth and clean table by the packer, but is unnecessary with cotton rolls or tightly woven rayon ribbons.

Should the rolls be too tight for dyeing, the reverse operation of unscrewing about the centre can be performed to give the required slackness of roll.

The aim should be to produce a sufficiently slack roll in the operation of blocking from the loom box.

The manufacturer wraps ribbon or webbing either directly on the metal spindle (of either square or round section, but preferably square sectioned for easier removal of the roll), or alternatively on to a perforated tube fitted on to the spindle. In the first case the tape fills up the hole in the centre when the roll is removed, the hole being $\frac{1}{2}$ -inch circular or $\frac{3}{4}$ -inch or 1-inch square; this class of roll can be termed *a solid roll*. In the second case the perforated centre remains in the roll; this can be termed *an annular roll*.

A supply of perforated tubes of approximately 1½-inches diameter can be obtained in various lengths from ½-inch upwards to be used for different widths of webbing. These perforated cardboard centres have been impregnated with synthetic resin and baked in order that they withstand dyeing conditions with direct and vat dyes; thus the tubes can be used repeatedly. Used tubes are boiled to remove dye stains before re-use. Boiling in 8 oz. sulphated fatty alcohol and 8 oz. sodium hydrosulphite per 100 gallons of water, followed by two changes of boiling water, is very effective. For new tubes this procedure is recommended to remove any excess of synthetic resin which might discolour the webbing or ribbon. Tubes washed off in boiling water dry readily in the atmosphere.

Bleaching and Dyeing Solid Rolls. Solid rolls are suitable for the treatment and dyeing of spun *Fibro* tape, which is sponge-like in its absorbency, and for rayon ribbons and laces (not containing oil sized warp) which have an open weave. It is preferable to bleach soft rolls of cotton tape in the solid roll form.

The rolls are packed end upon end in the annular space between the two perforated walls forming the cage of the package dyeing machine. The liquor is pumped across the packed space, the perforated container being immersed in the liquor in the cylindrical tank, the circulation pressure being from 5 to 10 pounds per square inch.

There is, of course, some channelling because of the spaces between the rolls; this is advantageous when bleaching cotton rolls, as the pectins and waxes are washed away through these spaces.

Dyeing of Annular Rolls. This process can be more widely applied than the former as, unless the webbing is very absorbent, or of open construction, the solid rolls are not penetrated satisfactorily, whereas the thickest cotton equipment webbing and linen firehose have been satisfactorily dyed throughout in annular roll form.

The rolls are dressed in columns on the perforated metal spindles of the Longclose machine, and the dye or other liquor is pumped from the expansion tank through the rolls, either from inside to outside or *vice versa*. The circulation pressure varies according to the size of the roll and the type of webbing, but in general it is from 20–25 pounds per square inch at its maximum, dropping to 6–8 pounds per square inch according to the pressure gradient across the rolls. Thus, when circulating the liquor from the inside to the outside, the pressure on the inside of the rolls is 20–25 pounds per square inch, which drops to 6–8 pounds per square inch on the outside of the rolls.

It is recommended that the flow of liquor is reversed every 10 minutes.

Rolls of thick or wide webbing can be wound satisfactorily stable without a perforated tube. The webbing is slackly blocked on a 2-inch circular sectioned spindle, the roll is removed, two loops of string are passed through the centre and round the outside of the roll, and the rolls are

then dressed on the perforated spindle of the dyeing machine. Perforated centres must be used for thin cotton tapes, worsted tapes and elastic webs, and may be used for *Fibro* tapes, or rayon ribbons.

The length of the perforated tube should be equal to, or slightly less than, the width of the webbing and not larger, otherwise the rolls will collapse or distort.

Slightly more than 1,000 pounds of webbing can be dyed in one set on the 36 and 42 spindled Longclose machines, and it is possible to dye 250,000 yards of $\frac{1}{2}$ -inch tape in 72-yard rolls on a 42 spindle machine in one operation.

Preparation for Dyeing. When oil sized warp is present in the narrow fabric, de-sizing is satisfactorily effected in roll form in the package dyeing machine, by treatment at the boil with circulating caustic soda and soap solution. A suitable liquor contains 100 gallons of $\frac{1}{2}$ % soap solution and $\frac{1}{2}$ gallon of caustic soda 70° Tw. The fabric is rinsed in water prior to dyeing.

If the tape is woven from a gelatine-sized warp, scouring is not necessary, as the gelatine is removed in the dye liquor without influencing the dyeing operation.

Where starch-sized warps have been used, as in the wider fabrics, it is recommended that a malt treatment (followed by scouring) should be given to the fabric in the loose state prior to blocking it into a slack roll for dyeing.

Dyeing Solid Rolls. As an example, 80 pounds of *Fibro* tape of $5\frac{1}{2}$ "lignes" and 7 "lignes" width were dyed to a red shade in 95 gallons of dye liquor, containing 9 ounces of Calgon and 1.8% Benzopurpurine 4B. 210%, and 1.5% glue (% calculated on weight of tape), the latter being used to give the required stiff finish. The rolls were packed on end in the perforated cage and dyed with a circulation pressure of 5 pounds per square inch. Dyeing was commenced at a temperature of 35° C. increased to 100° C. during one hour, and then continued for one hour at the boil. The rolls were hydro-extracted in the cage and dried at 65° C. The outer laps of tape on the rolls were slack and were therefore pulled to tighten the rolls.

Annular Rolls.—Example 1. $37\frac{1}{2}$ lb. of Petersham ribbon woven from continuous filament viscose rayon warp and *Fibro* weft. These rolls, slackly blocked wet on perforated

tubes, were dressed on the perforated spindles of the dyeing machine and dyed to a brown shade in 50 gallons of dye liquor made up as follows :

0.5%	<i>Pyrazol Orange GH.</i> 250%
0.35%	<i>Diphenyl Fast Red 7BL.</i> 180%
0.8%	<i>Viscose Blue Grey NB.</i>
6.0%	<i>Salt</i>
0.1%	<i>Calsolene Oil HS.</i>

The dyeing was done at 90° C. for 3 hours, the salt being added in twelve portions during the operation.

Example 2. 217 lb. of tape, 1½-inches wide, woven with *Fibro* warp and weft, and containing no size, were dyed Royal Blue in 500 gallons with:

2.2%	<i>Chlorazol Blue G.</i> 150%
0.04%	<i>Chlorazol Fast Helio BK.</i> 235%
0.1%	<i>Calsolene Oil HS.</i>
7.0%	<i>Salt.</i>

The dry rolls were entered into the dye liquor, the temperature being 90° C. After dyeing for 40 minutes the salt was added in six portions until the correct shade was obtained. The temperature of the dye liquor was allowed to fall to 65° C. (to obtain better exhaustion) and the flow of liquor was reversed every 10 minutes. The rolls were then washed in a 0.25% salt solution to prevent the migration of the dye during drying.

Although tapes may be given a stiff finish by incorporating glue or gelatine in the dye liquor, it is more economical to keep a standing bath of glue for an after-treatment of several dyed lots.

An alternative method for a stiff finish is to use Tragon "A" in a 0.25% solution and to impregnate the tapes in this bath at 30° C.

Wide Fabrics Dyed in Roll Form. The roll form dyeing process is also applicable to wide fabrics made of *Fibro*, which method is helpful in obtaining a full soft handle, providing the cloth is adequately shrunk.

The following is an example of the procedure to be used with wide fabrics :

A dress fabric containing 85% *Fibro* and 15% *Fibroceta*, and having a loom width of 40 inches (length 74 yards and weight 75 pounds) was scoured. It was rolled slackly on the perforated cylinder and then dyed in 220 lb. of dye liquor containing:

1 lb.	<i>Soap and 4 oz. Calgon per 100 gallons</i>
2.8%	<i>Chlorazol Fast Helio 2RK.200%</i>
0.2%	<i>Chlorazol Fast Helio BK.260%</i>
0.12%	<i>Pyrazol Orange GH.250%</i>

10% of salt being added in twelve portions at 10-minute intervals. Dyeing was commenced at 90° C. and the liquor allowed to cool to 80° C. After dyeing, the roll was treated with 0.2% of salt to prevent dye migration during extraction and drying. The extraction was by suction and the drying was done on an overfeed pin stenter to allow adequate shrinkage in length and width, which in this instance was 7%.

CHAPTER XX

PREPARING AND DYEING *FIBRO* FABRICS

Although *Fibro* has an affinity for all dyes normally used for the dyeing of other cellulosic fibres, most *Fibro* fabrics are still piece dyed with the direct cotton dyes. Consequently, although there appears to be an increasing demand for faster dyeings involving the use of azoic and vat dyes, it is natural that there is not the same accumulated experience in the application of these dyes as there is with the direct cotton dyes; in fact, some of the application problems are still under investigation. This demand for faster dyeings is undoubtedly greater in America than in this country mainly because of the more stringent requirements in America for colours having excellent fastness to light coupled with good fastness to severe laundering and to perspiration.

In Chapter 18 the very important questions of the selection of suitable dyes, their classification and their method of application to *Fibro* staples and yarns have been dealt with at some length. Experience has also shown that in general

the same principles equally apply when dyeing *Fibro* fabrics. There is, however, one important difference in the application of the direct cotton dyes to fabrics, namely, that whereas in staple and yarn dyeing the preferred method of application with most of these dyes is to dye throughout at high temperatures, e.g., 90° C., fabric dyeing is usually begun at lower temperatures and the temperature gradually raised to or near to the boil irrespective of the actual direct cotton dyes which are used.

Preparing Fibro Fabrics. A vital point which requires to be stressed in piece dyeing is the great importance of the preparation of the fabric for dyeing. This cannot be over-emphasised, as the ultimate properties and appearance of the finished fabric depend very largely upon an adequate and effectively controlled fabric preparation technique. This is true no matter which class of dyes is being applied, and is consequently dealt with at length in this Chapter.

1.—*Examination of Grey Fabrics.* Grey fabrics as received for dyeing and finishing should be examined for faults at open width on one of the many forms of examining machines. For this purpose good illumination is important, and use can be made of fluorescent tube lighting with advantage; such lighting will be found particularly useful in winter time. Some of the faults to be noted are water spots, oil and grease spots, iron stains, dirty ends and knots, and any mechanically damaged places. In the case of gross faults a string should be put in the selvedge to mark these faults and left in throughout the dyeing and finishing process. This is necessary to ensure that the processer is not blamed for faults initially present in the grey fabric. Oil and grease stains, which are not likely to be removed in the subsequent scouring process, should be hand spotted with one of the many proprietary products supplied for this purpose. The basis of these products is emulsified trichlorethylene, solvent naphtha, etc. Soap may be used to clean the fabrics of dirt marks. Care should be taken during hand spotting not to raise a nap on the fabrics by excessive rubbing, and if the fabrics are to be stored for any length of time prior to scouring the use of dry-cleaning agents which may develop acidity is to be avoided. Cleaning agents which swell the

fibre appreciably more than water, e.g., caustic soda, should not be used for local or spot cleaning since this may result in "patchy" dyeings. Rust marks can be removed by the use of ammonium oxalate (6-7 gms. per litre) applied at 40°-50° C., followed by rinsing with water. Water spots are liable to show up in the dyed and finished fabric as light coloured patches: such faults cannot be easily corrected. On no account should grey crêpe fabrics be spotted with aqueous liquors for cleaning purposes.

2.—*Singeing*. The object of singeing is to burn off the hairs that protrude from the surface of fabrics and so obtain a smooth, non-hairy fabric. This is obtained by rapidly drawing the fabric at open width over a red-hot plate or roller (plate singeing) or through controlled gas flames (gas singeing). The singed fabric is then usually quenched with water in a light mangle to extinguish any sparks and so reduce the fire hazards of this process.

When a full handle is required singeing can usually be omitted with advantage. With some fabrics there is a decided and definite "face" and therefore it is necessary to singe only one side of the fabric. This is often an advantage because the back or unsinged side of the fabric (which is left hairy) adds to the thick feeling and fullness of the cloth. On the other hand when a smooth surface is required, as with tropical suitings, damasks and printers fabrics, it is, of course, necessary to singe both sides. Heavy singes are not usually necessary as neps and similar impurities found in cotton are not present in *Fibro* yarns. After singeing, the *Fibro* fabrics are sent forward for desizing and scouring.

3.—*Pre-treatment of Fibro fabrics prior to desizing and scouring*. *Fibro* fabrics may, if desired, be treated in the grey state in order to modify the appearance and handle of the fabric in the finished state.

Fabrics may be calendered in order to obtain more cover and more uniform cover. In most cases the fabric also tends to have a slightly thinner and smoother handle. If a thinner and flatter handle is undesirable, an embossing calender may be used. In such cases a fine pattern should be selected of the crêpe figure type. It should be noted that very little embossed figure will be retained in the finished state, but greater uniformity of cover will be obtained without making

the fabric unduly flat in appearance or thin in handle.

If cellulose-acetate is present more figure will be retained on embossing according to the proportion of cellulose-acetate to *Fibro*. Fabrics made from a cellulose-acetate warp and crêpe *Fibro* weft will retain an embossed effect or pattern if pre-embossed at 75°–95° C.

If improved cover is only required on one side in order to retain a hairy appearance on the other, a heavy polishing process may be used, such as can be obtained on the Conway machine. This may be useful for fabrics which are to be raised on the opposite side after finishing.

In order to obtain the maximum effects from these pre-treatments the fabrics should be lightly steamed immediately before the pre-treatment; to retain the effect in some cases it may be necessary to employ a milder form of scour.

Many *Fibro* warps are sized with a mixture containing tallow or a wax-type substance. If pre-calendering or embossing is employed, a layer of the tallow or wax-type substance will be pressed into the soft bowl. In such cases the bowl may need washing more frequently with water at a higher temperature than is normally used.

4.—*Desizing and Scouring*. The yarn as supplied to the textile manufacturer contains only a lubricant which is easily removed by a light scour; consequently the desizing and scouring processes required by a given fabric will mainly depend upon:

- (a) The type of size used on the warp and weft.
- (b) Any contamination during processing, weaving and transit.
- (c) Whether other fibres are present.
- (d) Fabric characteristics which require developing in the scouring bath—as in the case of crêpe fabrics.

Most dress fabrics and similar qualities made wholly from *Fibro* are made from warps sized with a starch-tallow type mixture. Many of the heavier qualities and qualities made from doubled yarns are not warp sized. Most *Fibro* weft yarns are unsized unless special properties are required. The desizing of *Fibro* fabrics usually involves the use of enzyme preparations such as malt extract (Diastafor), pancreatic enzymes (Novo-Fermasol) or bacterial diastases (Rapidade).

These may be applied by padding the fabric at open width with the enzyme solution followed by piling overnight, by steeping the fabric in the solution overnight, or by treatment in the winch machine (see below). Temperatures exceeding 50°–60° C. should generally be avoided since at high temperatures most enzymes are destroyed; Rapidase, however, can be safely used at 70°–75° C. The activity of these enzymes is also greatly influenced by the pH of the solution, alkali being particularly detrimental, so that neutral or faintly acid liquors should be used.

The desized goods are then scoured at or near the boil in a liquor containing soap and caustic soda solution (see below). Soft water should be used if possible, but if this is not available an addition of 0.05–0.25 gm. per litre Calgon T or other lime soap dispersing agent should be added. Very hard water may also require the addition of sulphated fatty alcohol, the amount used depending on the hardness of the water.

After scouring, the fabric should be free from starch, tallow, or other sizing materials, and should show no trace of the blue colour reaction for starch when spotted with iodine solution.

The following methods for removing starch from *Fibro* fabrics have been employed in practice.

(a) Undesized *Fibro* fabric was padded with an enzyme solution at 40° C. containing 20 lb. Brimal (malt) extract (British Malt Products Co.), in 25 gallons of soft water, plaited down, and allowed to remain in the wet condition overnight. The pieces were then scoured at 95° C. by passing through a Spooner internal pressure washing machine, using 20 lb. soap and 1½ gallons caustic soda solution 70° Tw. in 300 gallons of water, followed by thorough washing in cold water. After each 1,000 yards had passed through the machine the liquor was strengthened by the addition of 4 lb. of soap and ½ gallon of caustic soda solution.

(b) 30 lb. Brimal (malt) Extract were dissolved in 600 gallons of soft water at 40° C. entered in a stainless steel lined wooden tank.

Pieces of undesized *Fibro* fabric were stitched end to end and placed in the desizing solution whilst in folds, and allowed to stand overnight. The pieces were then removed

at open width and scoured as described at (a) above, using the Spooner washing machine.

(c) 30 pieces of undesized *Fibro* fabric were entered into a winch machine containing 800 gallons of soft water, the temperature raised to 45° C., 8 lb. Entlein E (B. Keegan and Co.) and 16 lb. common salt added, the goods run for 2 hours, and then washed in cold water. They were then scoured for 1 hour at the boil in 800 gallons of water containing 8 lb. soap and 1 gallon caustic soda solution 70° Tw. followed by washing off in cold water.

In the case of fabrics containing oil stains, an oil solvent, e.g., solvent naphtha, can with advantage be dispersed in the scouring liquor. A suitable preparation for this purpose is prepared as follows:

2 lb. of gelatine are dissolved in water at 60° C. containing 4 gallons of Teepol X. 8 gallons of naphtha are slowly added with stirring so that at no time is there any large amount of undispersed naphtha in the preparation. The amount of the above solvent dispersion required as an addition to the scour bath will depend upon the type and quantity of oil and grease to be removed. Normally sufficient naphtha dispersion to give 1.25–5 gms. per litre is sufficient for ordinary requirements.

As this product contains a dispersing agent of the sulphated fatty alcohol type, the addition of Calgon or other lime soap dispersing agent to the scouring liquor is unnecessary.

It cannot be over-emphasised that these preliminary desizing and scouring processes must not be skimped.

For the scouring of *Fibro* blended with other rayons such as *Fibro-ceta*, *Fibrolane*, and *Rayolanda*, the Chapters on blends should be consulted.

Modified Scouring Treatments. As with other fibres, the finish given to a fabric made from *Fibro* can be controlled or modified by varying the scouring conditions. The handle may be made fuller by allowing the fabric to shrink during scouring and drying; tension should be avoided at all costs. The handle can be varied from one which is soft to one which is firm and cordy by padding the grey fabric through a caustic soda or potash solution of the order of 1% to 8% followed by washing carefully at open width in water.

The controlling factors are:

- (a) tension during processing,
- (b) concentration of caustic soda,
- (c) temperature of the wash-off liquor.

Fibro fabrics with a softer handle can be obtained by passing the fabric through caustic soda solution 8° Tw. at 22° C. using a pad giving a double immersion and double nip to the fabric. After padding, the fabric is allowed to swell in a scray for some 2 minutes. It is then washed off in open width in water at 70° C. If a firm handle is required padding should be done with caustic soda 72° Tw. at room temperature (25° C.) again giving a double immersion and double nip, plaiting down and allowing the fabric to lie for two minutes. The fabric is then washed off at open width in cold water.

It will be appreciated that as a result of an alkaline treatment the *Fibro* will have an increased affinity for most dyes.

Modified Scouring Treatments for Crêpe Fabrics. A large number of crêpe fabrics are now being made either from 100% *Fibro* or else containing *Fibro* in warp or weft. *Fibro* crêpe yarns are usually spun on the cotton system from staples of 1½ or 3 denier per filament. In order to obtain adequate swelling of the fibres of fabrics made from crêpe *Fibro* weft it may be necessary in some cases to employ a more severe crêping procedure than is generally used in this country for fabrics containing continuous filament crêpe weft. The actual methods used will differ according to the yarns present in the fabric, the fabric construction, the finish required, and the equipment available in a particular works. The following are examples of practical methods:

Crêpe Fabrics made wholly of Fibro. Fabrics of this type may be processed by a number of methods. An example of a suitable method is as follows:

Fabrics are put into book or hank form, and strings passed through the selvedge to form loops for suspending the fabrics from sticks which are in turn supported by the sides of the beck. The dimensions of the beck should be such as to allow the fabric to be processed free of creases and without touching the bottom or sides of the beck. It is important that the strings do not cut the weft in the selvedge otherwise the fabric may be creased or distorted. Precautions

should be taken to avoid "ballooning" in the crêping bath and if necessary strings should also be placed in the opposite selvedge.

The books or hanks are entered into a liquor consisting of 1-2.5 gms. olive oil soap or other good quality soap per litre at 60° C. The liquor is gradually raised to the boil and is maintained at this temperature for $\frac{1}{2}$ to 1 hour by means of a stainless steel steam coil situated under a false bottom fitted in the beck. The fabric is then cooled and washed.

The main points to be observed are:

(a) full contraction required must be obtained during the crêping process as further contraction in rope form during subsequent scouring or dyeing will cause cracks and creases in the fabric;

(b) the rate of shrinkage should be controlled and must not be too rapid, otherwise uneven pobble, "rained on" or "birds' eye" type of defects may be caused.

In some cases prior to crêping it may be necessary to give the fabric an enzyme treatment in book or hank form in order to ensure the removal of a starch type size from the warp. After crêping, many fabrics will require scouring in soap and caustic soda on the winch prior to dyeing. In some cases, particularly when an enzyme treatment has been included in the crêping process, further treatment before dyeing may be unnecessary. Fabrics may also be crêped by the caustic soda treatment detailed below.

Crêpe fabrics made from a viscose rayon continuous filament warp and Fibro crêpe weft. Fabrics of this type may be treated as crêpe fabrics made wholly of *Fibro*.

A further method is as follows:

Pad through a solution containing 35 gms. caustic soda, 70° Tw. per litre at 25° C. Collect in a scray without forming creases and allow to stand until full contraction has taken place—usually of the order of 15 mins. In some cases full contraction may be obtained by re-padding.

The fabric is then washed thoroughly with cold water, either in an open width machine or winch, and scoured on the same machine.

Crêpe fabrics made from cellulose-acetate rayon continuous filament warp and Fibro crêpe weft. Many crêpe fabrics made from a cellulose-acetate warp and *Fibro* crêpe weft are

designed and constructed to shrink less than the crêpe fabrics already discussed. It is practicable therefore to process them by methods used in the bulk processing of crêpe fabrics made entirely of continuous filament yarns, excluding strong alkali methods.

Contract at open width in soap solution at 75°–100° C. to obtain full contraction, and follow by scouring on the winch in a solution of 2 to 5 grams of soap per litre.

The temperature of the crêping and scouring liquors will depend on whether a bright or dull finish is required on the cellulose-acetate warp yarn. In the former case the temperature should not exceed 75° C., whilst for dull finishes the liquor must be at or near the boil, with an addition of 1 to 2 grams phenol per litre if necessary.

It is essential that the crêping temperature be higher than that of any subsequent wet process.

Bleaching Fibro Fabrics. *Fibro* fabrics rarely require to be bleached if they are intended for dyeing, but in some cases when a "dead" white or a particularly bright shade is required, bleaching may be necessary. It must be remembered that natural impurities are almost non-existent in *Fibro* fabrics and that consequently milder bleaching conditions may be employed than are normally used for bleaching cotton fabrics. No matter whether sodium hypochlorite or hydrogen peroxide is used as the bleaching agent, careful control is essential to avoid damage to the fabric. Bleaching should be carried out in wooden, stainless steel or earthenware vessels and never in vessels containing iron or copper parts. The following are practical examples of suitable procedures.

(a) *Sodium Hypochlorite.* 20 pieces of desized and scoured fabric were treated for 1 hour in a winch machine in a cold liquor containing 1.5 gms. available chlorine per litre which had been adjusted to pH 10–11 by the addition of soda ash (liquor to goods ratio 30 : 1). The fabric was then thoroughly washed in cold water, soured in a cold liquor containing 2 cc. hydrochloric acid (20%) per litre, and again well washed until free from acid. Alternatively, 0.5 gm. per litre sodium bisulphite may be used as an anti-chlor instead of souring with hydrochloric acid.

(b) *Hydrogen Peroxide.* 20 pieces of desized and scoured fabric were treated in a winch machine (liquor to goods ratio 1 : 20) for one hour in a liquor containing 3 cc. hydrogen peroxide (100 vols.) per litre, adjusted to pH 9 with sodium silicate at a temperature of 50°–60° C. The goods were then well washed off in water.

It is possible that in future sodium chlorite may be used for bleaching *Fibro* fabrics. It is claimed that high temperatures may be used without risk of tendering the fabrics and that the desizing, scouring and bleaching may be carried out simultaneously.

Dyeing Fibro Fabrics. 1.—*Direct Cotton Dyes.* *Fibro* fabrics are almost invariably dyed with the direct cotton dyes in the winch machine. Both the deep and shallow types of winch machines may be used, but the dyebath should either be made of, or lined with, stainless steel. The vessel should be constructed to give the fabric a long draw—approximately 4 ft.—through the dye liquor whilst a minimum lift from the liquor to the front roller should be employed. Totally enclosed winches are to be recommended in preference to the open type since not only is there an economy in steam coupled with improved working conditions, but penetration of the dye into the fibre is facilitated so that shorter dyeing times are required. This is because of the higher dye liquor temperatures which are attainable in enclosed winches. Thus in the open type of winch there is a usual drop of 4°–5° C. in the temperature at the back of the machine as compared with the front; this is mainly due to cooling of the fabric as it travels over the winch reel. Such variations in temperature are absent in totally enclosed winch machines. Practical experience with enclosed winches has shown that it is essential to control the pH of the water used in dyeing, since with a slightly alkaline water coupled with the higher temperatures attainable in such winches, destruction of certain dyes is more likely to occur than when open winches are used. This may be achieved quite simply by the addition of ammonium sulphate. Thus one particular water with a pH of 8 (and a pH of 10 after boiling for one hour, due to decomposition of bicarbonates) is corrected by an addition of sufficient ammonium sulphate to give a 0.125% solution.

Dyes such as Viscose Blue Grey N.B., Durazol Fast Blue GS and Chlorantine Fast Green BLL when used in the uncorrected water are fairly rapidly destroyed. With the corrected water no difficulties of this nature are encountered.

The choice of dyes for application to *Fibro* fabrics depends (a) upon their dyeing characteristics, and (b) upon the fastness to various agents required of the dyed fabric. As regards (a) it can very briefly be stated that dyes having similar dyeing properties should as far as possible be used for compound shades; help in this direction can be obtained from the classified lists of direct cotton dyes in Chapter 18, page 135. Fastness to washing, light and the anti-crease process are the main fastness requirements required of *Fibro* fabrics dyed with this class of dyes. Suitable dyes to meet these requirements can be obtained from dyemakers' pattern cards, but the following list of dyes which withstand the Courtauld patented anti-crease process have been found useful in works practice.

Chloramine New Blue 5B	S.
Chlorantine Fast Green 5GLL 100%	C.A.C.
Chlorantine Fast Yellow S.L.	C.A.C.
Chlorazol Fast Helio 2RK. 200%	I.C.I.
Chlorazol Fast Scarlet G.S.	I.C.I.
Chlorazol Fast Scarlet 4B 150%	I.C.I.
Diazo Fast Green G.L.	C.A.C.
Diazo Fast Green B.L.	C.A.C.
Diazo Indigo Blue B.R.	C.A.C.
Diazo Navy Blue Z.6086	C.A.C.
Diazol Fast Bordeaux N.R.M.	Francolor
Diphenyl Brown B.B.N. Extra	G.
Direct Fast Scarlet S.E.	C.A.C.
Durazol Blue 2 GN. 200	I.C.I.
Durazol Fast Blue 3RS	I.C.I.
Durazol Fast Helio B.S.	I.C.I.
Durazol Fast Helio 2RK, 200%	I.C.I.
Durazol Fast Yellow 3R	I.C.I.
Durazol Red 6BS	I.C.I.
Melantherine Black BH. 180%	C.A.C.
Rosanthere Bordeaux 2 BL	C.A.C.

Rosanthere Red 7BL
Rosanthere Violet 5R
Viscose Blue Grey NB

C.A.C.
C.A.C.
Francolor

The following are examples taken from practice of the application of direct cotton dyes to *Fibro* fabrics:

(a) 860 lb. *Fibro* fabric were dyed to a biscuit shade in 900 gallons of liquor with 0.022% Pyralon Orange G 200%, 0.01 % Durazol Red 6BS, 0.016% Viscose Blue Grey NB and 1.25 % common salt (percentages on weight of fabric).

The desized and scoured goods were placed in the winch and the machine filled with cold water. 4 lb. soap flakes, 4 pints Calgon T (4 lb. per gallon) and 8 oz. sulphated fatty alcohol were added to the stuffing box whilst the goods were running. The dyes were then dissolved in boiling water, passed through a fine stainless steel filter gauze into the stuffing box of the winch and the goods allowed to run for 10 minutes in the cold liquor. The dye liquor was then brought to the boil and maintained at the boil for 2 hours.

Half the salt (previously dissolved in 2 gallons of the dye liquor) was added, and dyeing continued for 30 minutes. The remaining salt was then added and dyeing continued for a further 1 hour.

After dyeing, the dye liquor was run off, and the goods washed in cold water for 5 minutes. The wash liquor was then run off, the goods washed in a 1 gm. per litre salt solution for 10 minutes, followed by a second similar wash for 5 minutes. The ends of each piece were then unstitched and the goods run into bags for hydro-extraction.

This general procedure is used for the dyeing of *Fibro* fabrics in all shades with the direct cotton dyes, the only variation being in the salting procedure and in the strength of the salt washes used after dyeing.

(b) 860 lb. of *Fibro* fabric were dyed to a myrtle shade using 3.8% Durazol Blue 2GN200, 0.34% Durazol Red 6BS, 1.7% Chlorantine Fast Yellow SL, and 10% common salt (liquor to goods ratio 10.5 : 1).

In this case the salt was added in eight equal portions at 30-minute intervals after dyeing without salt for 1 hour at the boil. The salt wash liquors contained 3 grams common salt per litre.

The washing fastness of a number of direct cotton dyes may be improved by an after-treatment with *Fibrofix*. The method of application is described in Chapter 18, "Staple and Yarn Dyeing".

After dyeing with direct cotton dyes, particularly if the dyeings are not of the higher grades of washing fastness or have not even been treated to improve their washing fastness, *Fibro* fabrics should not be allowed to stand before drying, otherwise dye migration, causing unlevelness, may occur.

Direct dyes which require subsequently to be diazotised and developed are similarly applied to *Fibro* fabrics excepting that the final two salt washes are omitted, the goods only being given the cold water wash before diazotising. Thus 860 lb. *Fibro* fabric were dyed to a navy blue shade using 2.7% Diazo Black OT, 0.9% Rosanthrene Red 7BL, 15% common salt (liquor to goods ratio 10.5 : 1). After dyeing the goods were washed in cold water, diazotised in a cold 900 gallon liquor containing 10 lb. sodium nitrite and 2 gallons hydrochloric acid (20%) for 30 minutes, followed by developing in a cold 900 gallon liquor containing 4 lb. β -naphthol previously dissolved in 3 pints caustic soda 72° Tw. After developing, the goods were soaped twice for $\frac{3}{4}$ hour at 60° C. in a 900 gallon liquor containing 6 lb. soap flakes. After the second soaping a cutting from the goods was tested in the laboratory for the amount of residual β -naphthol in the fabric. The maximum quantity allowable is 120 parts per million. Any goods containing more than this are further soaped until passed by the laboratory.

2.—*Vat Dyes*. Vat dyes may be applied to *Fibro* fabrics by padding in pigment form, followed by jig reduction and oxidation. The pad mangle and the jigger should be in line, and the pigmented fabric should pass from the pad mangle over the first roller of the jigger through the reduction liquor and be batched on the second roller. The fabric is then given sufficient ends on the jigger until the required shade is obtained. During the jigger operation the roll must be perfectly straight, otherwise the selvages will be unevenly dyed. After reduction the fabric is washed in cold water followed by oxidation of the dye with chrome or perborate.

The many disadvantages of the pad/jig system have prompted intensive development work on the continuous high speed vat dyeing of spun rayon fabrics by means of special machines such as the DuPont "Pad Steam" and "Multilap" units, and also the Williams Box machine.

Fibro Knitted Fabrics. The bulk of *Fibro* knitted fabrics are made on circular machines, although a number of "cellular" fabrics for shirtings, etc., are made on warp looms.

Knitted fabrics, as received by the dyer, contain dirt and lubricating oil. In cases where needle dirt is particularly pronounced its removal can be assisted by "spotting" with a suitable preparation prior to scouring.

Whilst in a wet condition *Fibro* knitted fabrics are easily distorted, so that pressure and tension must be avoided. For this reason the scouring operation should *not* be carried out on a dolly or similar machine as used in the ordinary routine of wet processing of cotton or wool knitted fabrics, but on a winch machine of the type described for the dyeing of woven fabrics.

A suitable scouring liquor consists of: 2.5 grams soap flakes per litre, 2.5 grams soda ash per litre (with the addition of a suitable solvent emulsion, if necessary). This should be used for 30 minutes at the boil.

The bulk of *Fibro* knitted fabric wet-processed today is for underwear, and is not dyed, whereas the remainder, which is used for dress goods, etc., is normally dyed with direct cotton dyes. With the increasing use of *Fibro* knitted fabrics for week-end shirts suitable methods will have to be devised for the dyeing of knitted fabrics with vat dyes on winch machines. Very little experience has been obtained on this method of dyeing, but Wiltshire (*J. Soc. Dyers and Colourists* (1946) 62, 313-318) has given useful data on the subject of dyeing knitted cotton fabrics.

After dyeing, the fabrics are centrifuged at a speed of not more than 500 r.p.m. and, in the case of circular fabrics, either finished on a tubular finishing machine or slack dried (festoon or brattice) and pressed. Drag on the fabric and length tension must be reduced to a minimum. Warp knitted fabrics can be dried and finished on the pin stenter. If vertical presses are used for finishing, care must be exercised to prevent the steam from contaminating the batching roll

which is usually situated above the bed. *Fibro* duplex glove fabrics are usually sueded and cropped after drying. The application of an anti-crease finish to *Fibro* knitted fabrics materially improves the shape stability to subsequent laundering, but this finish is not advocated purely for this purpose and attention is drawn to the procedure outlined in Chapter 17. An anti-crease finish, however, considerably improves fabrics which are to be used for outerwear, in as much as apart from the lower susceptibility of the fabric to creasing, the handle of the fabric is improved, as is also the appearance—particularly in respect of regularity of stitch. Owing to the limitation of the plant used for finishing circular knitted fabrics, the anti-crease finish has to be applied by a “batch” process using an ammonium thiocyanate–Calgon catalyst. The procedure for anti-crease finishing is similar to that outlined in Chapter 22.

CHAPTER XXI

PRINTING OF *FIBRO* FABRICS

FABRICS made from *Fibro* have been printed for many years in a great variety of styles, and it is probable that nearly every block, machine and screen printer in Great Britain now includes examples in his range. There is, however, scope for further development, particularly in view of the many types of fabrics which can be constructed not only from *Fibro* yarns alone, but from the various blends with other yarns in various deniers and staple lengths. Examples of some of the printers’ styles into which *Fibro* yarns and blends may be profitably introduced are: casements, covers, dress and dressing gown fabrics, handkerchiefs, ladies’ overalls, table covers, ties, scarves, tropical suitings and export styles for the African, Indian and South American markets.

Until the introduction of rayon, most printers could be classified as either cotton or silk printers. To obtain the best prints on fabrics made from *Fibro* the procedure in the main should be—colour recipes as for cotton and technique of

handling as for silk. There are recipe and processing variations, however, and one of the purposes of this Chapter is to describe as many of these as possible.

Preparation of Fabrics for Printing. A number of *Fibro* fabrics will require singeing, particularly lower quality fabrics, those made with yarn spun on the flax or jute systems, and when it is intended to print a fine design or when a definite outline is required. Either a burner or plate machine may be used, but a heavy singe should not be necessary and the fabric should not be run over the brush roller. It may be advantageous when printing fine lines on some fabrics to singe or calender after scouring and drying, and before printing.

The conditions of desizing, scouring and bleaching will be much the same as for preparing fabrics for dyeing, but it is even more important that the printer's fabric should be free from all sizing agents such as starch, tallow and oils.

After scouring, care should be taken to remove traces of lime soaps, as they are a frequent source of trouble, particularly when printing blotches.

After scouring, *Fibro* fabrics for printing should be hydro-extracted or run over the suction machine, but should not be run over the scutcher roller, otherwise a slight nap may be formed. Drying should be carried out on the normal machines, but fabrics for printing should not be baked or stretched on drying tins. It is preferable when drying compact fabrics to use a pin stenter; tin drying sometimes leaves the fabric surface difficult to penetrate with the printing paste. Fabrics made from *Fibro* should not be brushed prior to printing, but run up on a white room stenter to width and stored in a dry room until required.

The dimensions of the fabric when forwarded to the printer should in most cases be identical with the dimensions of the finished fabric. If in order to print effectively it is essential to apply tension to the fabric which will alter the dimensions, the fabric should be returned to the white room and re-stentered in the presence of steam to dimensions which will allow for the alteration taking place on the machine or table. If these points are not observed the pattern obtained on the printed fabric will not be a true one, but a distorted version of the true pattern.

Printing Process. The actual printing should present little difficulty, but to obtain first-class prints there are a few points which should be noted. *Fibro* absorbs appreciably more moisture than either cotton or silk, so it is advantageous to carry out all printing operations in a room which is always dry. As *Fibro* has both a high moisture take-up and wet extensibility, excessive tension should not be applied during printing or drying; otherwise stretching will take place, and this may result in the distortion of the pattern during final stentering. In view of the importance of eliminating any unnecessary tension, tin drying should be avoided if possible and modern festoon dryers or tower system drying introduced.

“Push through” and heavy blotch patterns can be printed on most fabrics with relative ease, but fabric structure must be taken into account. With very closely woven fabrics, particularly of the heavy tapestry type, the swelling of the fibres when brought into contact with an aqueous or alkaline printing paste may in some instances produce a very compact fabric which is difficult to penetrate. In such cases the type of thickener, the viscosity of the print paste, the wrapping of the cylinder, and the blanket, should be selected carefully.

Excellent definition can be obtained on suitable fabrics when printing the average peg and blotch patterns. The blanket may be of the normal or rubber-proofed variety, but should not be too “springy” or “spongy”.

Duplex and surface prints can be obtained on all but the low open weave qualities but, with the exception of the very closely woven fabrics, a slightly more viscous printing paste may be required as compared with cotton fabrics of similar structure.

Border patterns for both home and export trade can be printed in the ordinary way, using normal thickening agents. The tendency is usually for the *Fibro* to print fuller than a corresponding cotton fabric.

Outstanding block prints can be obtained on fabrics of suitable construction, particularly for the dressing gown, scarf, tapestry and tie trades. The absorbent nature of most fabrics of *Fibro* when properly scoured and washed, makes them eminently suitable for screen printing. When printing

by either method, care should be taken to avoid overpasting and overstretching the fabric on the table prior to printing. If particularly smart outline is required when screen printing it is sometimes advantageous to use a higher number bolting silk than when printing a similar cotton fabric.

Fabrics made from *Fibro* blended with cotton, wool, *Fibroceta*, *Fibrolane* and *Rayolanda* can be printed to give novel and pleasing effects by both the print-on and the discharge methods. Patterns designed to bring out check, heather, shadow and speckled effects are particularly suitable. A wide range of fabrics can be constructed from blends of this type, and there should be a possibility of developing new printing styles, especially in the heavy dress goods trade which formerly had only a limited market in prints.

Discharge Styles. Fabrics made from *Fibro* can be dyed in solid shades using azoic, basic, direct or vat dyes. As far as possible compound shades should be dyed with dyes which dye at approximately the same rate. The methods of application of dyes, and their fastness, are in the main the same as when the same dyes are dyed on continuous filament viscose rayon fabrics. The tendency is for dyes to be faster to washing and light when dyed on *Fibro* than when dyed on cotton, particularly direct cotton dyes. Fabrics made from blends of *Fibro* and other staples can be piece-dyed to give reserved, tone-in-tone, solid, or two-colour effects, according to the dyeing properties of the other staple present.

A jigger, winch or continuous machine may be used for the dyeing process, providing of course the fabric structure is suitable for a given machine. Whatever machine is used, the fabric should not be worked unnecessarily, friction should be avoided, and tension minimised. It is often advantageous to add soap or a sulphated fatty alcohol to the dye liquor to ensure smooth running of the fabric. Care should be taken when washing after dyeing, to remove any loose dye or lime soaps; otherwise an inferior discharge will be obtained.

At present the white and coloured discharges on direct dyed grounds are the most popular of this type of print. The tin method is seldom employed now and usually one of

the sulphoxylate-formaldehyde compounds is used, such as Erasol (L. B. Holliday), Formosul (Brotherton), Rongalite C. etc. A full range of dischargeable direct dyed ground shades can be obtained on fabrics made of *Fibro*, using either neutral or alkaline print pastes.

Neutral White Discharge. The discharge recipe will depend upon the particular dyes used in dyeing the ground, the depth of shade, the weight and construction of the fabric, the type of pattern and the ageing or steaming plant available. Depending on these conditions the amount of sodium sulphoxylate formaldehyde compound required in the discharge paste may vary between say 4% and 16%. A typical recipe, however, would be:

100 gms. *Sodium sulphoxylate formaldehyde compound*
300 gms. *Water*
600 gms. *Starch-Tragacanth thickening*

In some cases, to obtain a full pure white discharge, zinc oxide may be added to the print paste. The zinc oxide not only improves the white by virtue of being a white insoluble metal oxide with good covering properties, but keeps the discharge paste on the surface of the fabric, so giving the maximum discharge effect on the face side of the fabric. A good fine quality zinc oxide should be used, free from iron and lead impurities.

100 gms. *Sodium sulphoxylate formaldehyde compound*
150 gms. *Water*
550 gms. *Starch-Tragacanth thickening*
100 gms. *Zinc oxide; Water 1 : 1*
20 gms. *Glycerine*
80 gms. *Water*

Other additions which may be made to the discharge mixture are Ultramarine for the purpose of "blueing" the white, and compounds of the anthraquinone, Leucotrope W, and ammonium citrate types to increase the effectiveness of the sulphoxylate formaldehyde compounds.

100 gms. *Sodium sulphoxylate formaldehyde compound*
118 gms. *Water*
500 gms. *Starch-Tragacanth thickening*
60 gms. *Zinc oxide—Water 1 : 1*

60 gms. Water
25 gms. *Leucotrope W* (*Brotherton*)
17 gms. *Anthraquinone paste*

When discharging pale shades the precaution may be taken of padding the fabric through $\frac{1}{8}\%$ – $\frac{1}{4}\%$ sodium chlorate solution and drying prior to printing to prevent doctor streaks from showing on the fabric after ageing.

After printing and drying, the fabric should be steamed in a Mather & Platt type ager free from air, using moist steam and maintaining a temperature of 101°–105° C. The washing and soaping after ageing may be carried out in rope form in a winch, or in an open width machine, providing the fabric is not pulling the rollers round and is generally free from warp tension. The actual conditions of washing and soaping (such as time, temperature and concentration of soap solution) must largely depend upon the wash fastness of the dyed ground; consequently specific guidance cannot be given. However, it should be noted that, if the ground shade will not withstand a washing and soaping treatment at a temperature of the order of 38°–50° C., the print should not be sold for any purpose which may necessitate washing after purchase. Further, the washing treatment should be sufficient to remove the print thickening in order to obtain the natural handle of *Fibro* in the finished state. The system of running a fabric out of a winch after washing or other process, passing through a pot eye, pad mangling in rope form, and opening out on a fast revolving scutcher roller, should not be adopted with fabrics made of *Fibro*. Preferably the fabric should be run into bags, hydro-extracted, and dried either in a stove without applying warp tension, or on a pin stenter fitted with overfeed mechanism.

Alkaline White Discharge on Direct Dyed Ground. Alkaline discharge pastes may be used to obtain a white discharge on a direct dyed ground. In the main the procedure is the same as for a neutral discharge, and the recipes similar to those used for vat colour discharges on direct grounds, but in most cases the "white" obtained is inferior to that obtained by the use of a neutral discharge mixture. Catalytic substances, such as anthraquinone paste, may be added

to the printing mixture to increase the effectiveness of the discharge. A suitable recipe is :

100-160 gms. *Sodium sulfoxylate formaldehyde compound*
120 gms. *Water*
520 gms. *Gum thickening*
30 gms. *Zinc oxide* }
30 gms. *Water* }
20 gms. *Titanium oxide* }
20 gms. *Water* }
35 gms. *Potassium carbonate* }
30 gms. *Water* }
35 gms. *Anthraquinone 30% paste*

Up to 1000 gms.

After printing and drying, the fabric should be aged for 5 minutes at 101°-105° C. in an air-free ager and then washed thoroughly, but within the limits of the wash fastness of the dyes used on the ground.

Improving Fastness of Direct Dyed Grounds. Many methods of improving the fastness of direct dyed grounds have been used over a number of years. They are of particular interest to the printer of discharge styles. It is common practice to treat suitable direct dyes immediately after dyeing, to improve the wash fastness, by such methods as :

- (a) diazotising, and developing with compounds such as β -naphthol, m-phenylene diamine, etc. ;
- (b) coupling with diazotised p-nitraniline or other diazotised bases.

There are proprietary products for improving the fastness of direct dyed grounds, and below is a description of the application of one of interest to discharge printers.

It is possible to improve the light fastness of some dischargeable direct dyes by employing a *Fibrofix* or *Fibrofix* and copper acetate treatment. Certain precautions need to be taken, however, otherwise a poor discharge may be obtained.

The method consists of:

(a) Normal dyeing process followed by treatment in:

3% *Fibrofix* on weight of fabric

30 : 1 *Liquor-fabric ratio*

Temperature 45°–50° C.

Time—20 minutes

Rinse and dry ready for printing.

The *Fibrofix* is prepared by boiling together:

1 part *Fibrofix*

1 part *Acetic acid* 80%

8 parts *Water*

(b) Print 50–150 gms. *Sodium sulfoxylate formaldehyde compound* (according to requirements)

600 gms. *Starch-Tragacanth thickening*

Water to dissolve sodium sulfoxylate formaldehyde compound and bulk to 100 gms.

Dry and age in the normal way.

(c) Treat in 0.25% *Acetic acid* (80%) at 40° C. for 20 minutes—wash well.

(d) Treat in 3% *Fibrofix* on weight of fabric
2% *Copper acetate* on weight of fabric
30 : 1 *Liquor-fabric ratio*

Starting cold and raising temperature to 40° C. or higher according to fastness of dye.

(e) Dry and finish in the normal way.

Examples of some of the dyes which can be improved by treating in this way are:

Chlorantine F Red 5 GLL

Chlorazol F Yellow 5 GKS

Chlorantine F Blue 3 GLL

Diphenyl F Blue 3 RL

If the wash fastness of the original dyeing is such that bleeding of the ground into the discharge is not likely to take place during the washing process after ageing, the first *Fibrofix* treatment may be omitted.

Zinc oxide must not be added to the discharge paste; otherwise discoloration will take place, probably due to the formation of zinc sulphide during the ageing process and the subsequent formation of copper sulphide in the copper acetate bath. Most of the sulfoxylate formaldehyde

compounds contain zinc, but normally the quantity is not large enough to cause trouble.

The acid and washing treatment after ageing is recommended to remove sulphur which, if left on the fabric, will give a brown discoloration in place of a white discharge.

The method is applicable to alkaline white and vat colour discharge styles and should be useful to printers for the purpose of obtaining faster ground shades.

Coloured Discharges on Direct Dyed Grounds. Basic and vat colour discharges can be obtained on direct dyed fabrics of *Fibro* in much the same way as on those of cotton. The chief virtue of the basic discharge prints is the brightness of the colour discharge and the relative cheapness of the dyes. The light fastness, however, is mainly poor. A suitable discharge paste would be :

- 35- 45 gms. *Dye*
- 25 gms. *Glycerine*
- 115 gms. *Water*
- 450 gms. *Starch-Tragacanth thickening*
- 75 gms. *Methylated spirits*
- 50 gms. *Phenol*
- 120 gms. *Tannic acid solution 50%*
- 70 gms. *Sodium sulphoxylate formaldehyde compound*

After drying and ageing, the dyes are fixed in a tartar emetic bath, washed and soaped. In some cases it is necessary to include an oxidising treatment in the washing-off operations in order to oxidise the reduced dye. Examples of suitable dyes are :

Rhodamine B
Acridine Orange DH
Auramine O
Methylene Blue S, etc.

A method such as the one described depends upon the use of a solvent (such as phenol or resorcinol) to prevent the formation of a basic dye—tannic acid lake in the printing colour. Another method depends upon the use of aniline oil and methylated spirits for dissolving the tannic acid and keeping it in solution, but tends to give poor colour value. The Resistone or Tanninol method has the advantage of not having a precipitating mordant present

in the print colour, and less sulphoxylate formaldehyde compound is required to obtain a discharge. Furthermore, the print colour is more stable and less liable to scum during printing.

The Resistone or Tanninol may be added to the dye liquor at the rate of 2% to 4% on the weight of goods and the quantity of Glauber's salt should be increased 25% to 40%. Alternatively the fabric may be padded after squeezing or extracting, through

1.5% to 2.5% *Resistone O.P.*
(*Glovers (Chemicals) Ltd.*)
0.15% to 2.5% *Soda ash*

If the fabric is dry before padding the amounts may be reduced to 1% Resistone O.P. and 0.1% soda ash. Drying should be carried out in the stove and the following print recipe can be used:

20-35 gms. *Dye*
40 gms. *Thiodiglycol*
375 gms. *Water*
450 gms. *Starch-Tragacanth*
40-100 gms. *Sodium sulphoxylate formaldehyde compound*

After printing and drying, the fabric should be aged, oxidised if necessary, rinsed in:

0.1% *Resistone O.P.*
0.01% *Soda ash*

washed, and given a light soap.

Vat Colour Discharge on a Direct Colour Dyed Ground. The vat colour discharge on a direct dyed ground style has been extensively used over a number of years on fabrics made of *Fibro*. Both the Indigoid and Anthraquinone types are used, mostly the latter. The usual recipes for the straight printing of vat colours can be used for discharge work, although for dark shades the amount of sulphoxylate formaldehyde compound may have to be increased in some cases. A typical recipe is:

200 gms. *Vat dye paste (printing quality)*
80 gms. *Glycerine*
450 gms. *Starch-Tragacanth*

95 gms. *Potassium carbonate*
 85 gms. *Water*
 90 gms. *Sodium sulphonylate formaldehyde compound*

After printing and drying, the fabric should be aged and washed off as soon as possible. The conditions of washing and oxidising are generally the same as for straight vat prints, but the temperature of the soaping treatment will have to be reduced in accordance with the fastness of the direct dyed ground. Note should be made that the presence of alkali in the discharge paste will limit the number of direct dyes which can be used for this class of work.

Other Discharge Styles. Discharges on azoic, basic and vat dyed grounds are obtained on *Fibro* in much the same way as on cotton. The most important of these are probably those obtained on azoic dyed grounds. The normal procedure for applying:

Brenthol (I.C.I.)
Solunaptol (J. W. Leitch and Co.)
Ciba naphthol (Ciba)
 or *Naphtol*
 and *diazotised base*
Brentamine Fast Salts and bases (I.C.I.)
Fast Colour Salts and bases

should be adopted, but it is preferable not to dry on drying tins after the Brentholating process. The discharge recipe required will depend upon the particular combination used and the ageing or steaming equipment available. The following general guidance; however, can be given.

Most of the Brenthol AS (Naphtol AS) combinations can be discharged white, using sulphonylate formaldehyde compounds. Additions to the discharge paste may be made, such as anthraquinone paste, zinc oxide, potassium carbonate, etc. Examples of suitable combinations are:

<i>Brenthol OT</i>	<i>Fast Red KB Base</i>
„ <i>FR</i>	„ „ <i>KB</i> „
„ <i>CT</i>	„ „ <i>TR</i> „
„ <i>OT</i>	„ „ <i>TR</i> „
„ <i>FR</i>	„ „ <i>RC</i> „
„ <i>OT</i>	„ „ <i>GR</i> „

<i>Brenthol AS</i>	<i>Fast Scarlet Salt GG</i>
" <i>OT</i>	" " " <i>GG</i>
" <i>CT</i>	" " <i>TR Base</i>
" <i>AS</i>	" " <i>TR</i> "
<i>Brenthol OT</i>	<i>Fast Scarlet G Base</i>
" <i>MN</i>	" " <i>G</i> "
" "	" <i>Red ITR</i> ,"
" <i>MN</i>	" <i>Scarlet RC</i> "
" <i>AS</i>	" <i>Red RC</i> "
" <i>PA</i>	" " <i>RL</i> "
<i>Brenthol FR</i>	<i>Fast Orange GC Base</i>
" <i>OT</i>	" " <i>GC</i> "
" <i>OT</i>	" <i>Yellow GC</i> "
" <i>OT</i>	" <i>Scarlet TR</i> "
" <i>CT</i>	" " <i>RD</i> "
<i>Brenthol AS</i>	<i>Fast Blue Salt RR</i>
" <i>OT</i>	" " " <i>RR</i>
" <i>CT</i>	" " " <i>RR</i>
<i>Brenthol OT</i>	<i>Fast Violet B Base</i>
<i>Brenthol AS</i>	<i>Fast Black Salt K</i>
" <i>OT</i>	" " " <i>K</i>
" <i>AS</i>	" " " <i>G</i>

A suitable discharge recipe is :

- 100-250 gms. *Sodium sulphoxylate formaldehyde compound*
- 75-100 gms. *Zinc oxide*
- 115 gms. *Water*
- 20-55 gms. *Potassium carbonate*
- 10-30 gms. *Anthraquinone paste*
- 450 gms. *Starch-Tragacanth*

For combinations which are difficult to discharge, the potassium carbonate may be replaced with caustic soda. The Leucotrope products may also be used.

After printing, the fabric should be aged for 4, 5 or 8 minutes, according to the combination, fabric, and design, in an ager free from air and maintained at 105°-107° C. It should then be treated for 5-10 minutes in:

0.25% Soap solution

0.001% Soda ash

at the boil (or other suitable temperature according to the particular combination) and washed well. The fabric must not be allowed to lie between the ageing and the washing treatment.

Coloured discharges are obtained mostly with vat dyes, using a similar recipe as for the straight vat print and in some cases adding anthraquinone paste and extra sulfoxylate formaldehyde compound. After printing and drying, the fabric should be aged for 5 minutes in moist steam at 100°–101° C., oxidised in acidified peroxide or perborate and soaped at the boil.

Discharge Prints on Fabrics made from Fibro Blends. Fabrics, made from blends of *Fibro* with other staples (such as cotton, wool, *Fibrometa*, *Fibrolane*, nylon, *Rayolanda*, etc.) should offer an excellent opportunity to the discharge printer, providing he is supplied with fabrics suitable for the purpose.

The dyed and printed effects which can be obtained on such fabrics will depend on which particular staple is blended with *Fibro*. In some cases solid shades, tone-in-tone effects and two-colour effects will be possible on the same grey fabric by selecting suitable dyes. A further selection of dyes will permit the fabric to be discharge printed to give:

- (a) complete discharge on both yarns;
- (b) discharge of the dyes on one yarn only;
- (c) discharge of one only of the two or more dyes used on one yarn;
- (d) colour discharge, the print colour having an affinity for one or both of the yarns present.

It is important to select suitable patterns; for instance, in the last example (d) it would be futile to print a lot of colour over a wide area on a yarn on which it could not be fixed. Trouble would undoubtedly be experienced in the washing-off process.

Discharge prints of the types described, printed in the quieter patterns or checks, should be suitable for the heavier weight dress fabrics for everyday winter wear. Other outlets would be in the casement and tapestry styles; also dressing gown fabrics raised after printing.

Resist Styles. Probably the most popular resists with the exception of certain export styles are those under aniline black, azoic, Indigosol and Soledon dyes. The methods and recipes used for cotton fabrics are applicable to those of *Fibro*, but certain precautions should be taken. *Fibro* has a greater affinity for many dyes than has cotton; consequently care must be taken not to "swamp" the resist during padding after printing. Oxidation processes for the purpose of developing colours on the fibre should be controlled rigidly, otherwise serious tendering may occur. The over-printed rather than the "first printed" style should be used when printing resists under Indigosols.

"*Straight*" *Prints: Acid Dyes.* Acid dye-prints on fabrics made from cellulosic fibres have been popular for many years. The prints are outstandingly bright, easy to produce, and the dyes are relatively cheap.

Originally the recipes used were much the same as those used in the printing of mordant colours on oiled and unoled fabrics. Dyes (such as Brilliant Croceine B, Brilliant Scarlet G, Croceine Scarlet 3B, Orange II, Quinoline Yellow, Brilliant Acid Green 6B, Brilliant Acid Blue B, Brilliant Indocyanine 6B, Acid Violet 7BN, etc.) were printed with a mixture of the following type:

5-40 gms. *Dye*
200 gms. *Water*
90 gms. *Acetic acid (30%)*
490 gms. *Starch-Tragacanth thickening*
180 gms. *Aluminium acetate 15° Tw. added to mixture*
when cold

After printing, the fabrics were dried and steamed for 1 hour at 0-2 pounds pressure. They were sold without washing.

A number of acid dyes, including Alkali Violet LR and Soluble Blue TB, may be printed as basic dyes using tannic acid.

Resorcine dyes (Rose Bengal G, Phloxine BBN conc.) are printed with a recipe similar to the above but using chrome in place of aluminium acetate.

More recently the urea method has been widely adopted. Because of their absorbent nature and naturally clear grounds, fabrics made with *Fibro* are eminently suitable for

this class of work. Highly decorative prints in bright colours can be obtained in floral and similar designs. Note should be made, however, that all acid dyes are not suitable for printing by this method, and in any case many of the printed fabrics should not be sold for purposes which demand frequent washing at medium temperatures.

It has been shown that the amount of urea required is to a large extent dependent upon the amount of moisture present during the subsequent steaming process. Using dry steam no fixation is obtained without the addition of urea; conversely, if a suitable amount of moisture is present in the steam, selected dyes can be fixed without the addition of urea. It is concluded that, at least in part, the function of the urea is to have a solubilising or dispersing effect on the dye in the thickener, making it more mobile and enabling it to penetrate the fibre. It is also concluded that the acid dyes with the smallest particle size cannot be fixed on viscose, and that the acid dyes which can be fixed have a large particle size in aqueous solution; and, further, that the fastness to washing of the printed colour increases with the particle size. Another observation is that acid dyes possessing no affinity for viscose should be printed only in full or medium shades and that the use of highly concentrated brands is to be preferred.

Recipe.

30 parts Dye
320 parts Water
150 parts Urea
500 parts Industrial Gum 1 : 2
—
1000
—

Reduction.

550 parts Gum 1 : 2
375 parts Water
75 parts Urea
—
1000
—

Print, steam for 1 hour, wash off and dry.

The urea formaldehyde process, patented by Ciba is also recommended. The process is applicable to the following three classes of dyes—Chlorantine Fast and Direct dyes, Neolan, and Acid and Cloth Fast dyes. In the case of the Neolan dyes ammonium phosphate is used as catalyst, whereas ammonium phosphate or sulphate may be employed for the other classes.

Recipe.

5	15	30 gms.	<i>Dye are mixed with</i>
200	200	200 gms.	<i>Urea and dissolved in</i>
195	210	220 cc.	<i>Hot water. The solution is pasted into</i>
550	525	500 gms.	<i>Crystal gum thickening 1 : 2.</i>
			<i>Finally,</i>
10	10	10 gms.	<i>Catalyst, dissolved in</i>
40	40	40 cc.	<i>Water are added.</i>
<hr/>			
1000 gms.			
<hr/>			

After printing, the fabric is dried, steamed twice for 7 minutes at 102° to 104° C. in an ager into which formaldehyde is sprayed, and rinsed. Softening is recommended with Sapamine KW (Clayton Aniline Co.).

Many direct dyes made by various firms are suitable for printing by the urea method, but it must be emphasised that all acid and direct dyes are not suitable. A number of the dyes recommended have reasonable to good fastness to light and washing. Generally, however, the main virtue of the prints is the brightness of the colours, and they should be offered to the public as such.

Basic Dyes. Basic dyes are printed on fabrics made with *Fibro*, chiefly for the overall and scarf trades. Their main characteristics are brightness, good colour value, and a certain degree of wash fastness. The methods of application and recipes required are fundamentally the same as for cotton fabrics. Excellent definition can be obtained providing a number of factors are observed, such as: (1) Suitable thickenings should be used, gums from locust beans and seaweed should be avoided, and if starch is used it should be fully boiled and made acid with an organic acid; (2) an adequate amount of tannic acid should be employed;

(3) the dyes should be properly dissolved, this being very important with such dyes as Auramine O, Victoria Blue, etc.; (4) sufficient organic acid, such as acetic acid, should be present in the print paste to prevent premature lake formation; (5) old printing colours should not be used if lake formation has taken place, unless the lake can be effectively re-dissolved before use; (6) if dyes containing zinc chloride are used, sodium acetate should be added to the print mixture to prevent the tendering of the fabric during steaming; (7) after steaming, the dyes should be properly fixed.

Recipes (the amounts in the printing recipe will have to be varied for some dyes).

Thickening 1

110 gms. *Wheat starch*
330 gms. *Water*
300 gms. *Gum Tragacanth* 5 %
260 gms. *Acetic acid* 40 %

1000

Reducing Thickening (pale shades)

750 gms. *Thickening 1*
164 gms. *Water*
80 gms. *Acetic acid* 40 %
6 gms. *Tannic-acetic* 1 : 1

1000

Tannic and Acetic 1 : 1

500 gms. *Tannic acid*
312 gms. *Acetic acid* 40 %
188 gms. *Water*

1000

Printing Recipe

25 gms. *Dye*
55 gms. *Acetic acid* 40 %
100 gms. *Water*

10 gms. <i>Tartaric acid</i>
710 gms. <i>Thickening 1</i>
<i>cool and add</i>
100 gms. <i>Tannic-acetic 1 : 1</i>
—
1000
—

After printing, the fabric should be dried, steamed for 1 hour in a cottage steamer and fixed in a bath containing 10 gms. Tartar Emetic per litre for $\frac{1}{2}$ -minute at 49° C. It should be given a light soaping treatment to remove residual thickening; if starch has been used a diastase treatment may be given prior to soaping.

Mordant and Chrome Dyes. Mordant dyes are generally printed in the same way as on cotton fabrics. They are very useful in many ways, giving good colour value, but in most cases they lack the brightness of acid and basic dyes. They have average fastness to light and washing, and are often printed along with acid and basic dyes to give depth and contrast to the colouring of the pattern, particularly for scarf work. Other uses are in the printing of overalls and non-guaranteed cretonne styles.

The printing of mordant dyes of one type or another is more or less as old as the textile printing trade; consequently there is a wide range of recipes and methods, and it is only proposed to give one example here:

25 gms. <i>Dye powder</i>
165 gms. <i>Water</i>
650 gms. <i>Starch-tragacanth thickening made acid with acetic acid</i>
45 gms. <i>Acetic acid 40%</i>
15 gms. <i>Olive oil, and after cooling</i>
100 gms. <i>Acetate of chrome 32° Tw.</i>
—
1000
—

After printing and drying, the fabric should be steamed for 1 hour in the cottage steamer, washed and soaped at 50° C.

The alizarin dyes with alumina and other mordants on

oiled and unoled fabrics are applicable, and prints of good depth and bloom are obtained.

Vat Dyes. Generally speaking, the vat dyes have the best fastness properties of the various dye classes. It is therefore appropriate that they are used for printing most of the *Fibro* dress and tapestry qualities. The range of fabrics covered is very wide, including light-weight dress fabrics of 2 to 3 ounces per square yard, and the heavier casement qualities of 8 to 10 ounces per square yard.

All vat dyes are not suitable for printing, although most are, but wherever possible the specially prepared printing brands should be used. A specific recipe cannot be given for the printing of all vat dyes; allowance must be made for the type of vat dye, the particular style being printed, and the plant available in a given works. The essential constituents of most recipes are—dye, sulphonyl-formaldehyde compound, an alkaline carbonate (usually potassium carbonate) and a suitable thickener.

In some recipes soda ash and in others caustic soda are used as the alkaline medium, and in many recipes glycerine is included for the purpose of accelerating the reduction of the dyes and improving fixation. Compounds such as sodium benzyl sulphanilate

Solution Salt BN (I.C.I.)

Solution Salt SV (I.C.I.)

Dissolving Salt B

are used to accelerate reduction and assist in obtaining a level print, but are not recommended for use with some vat dyes. Caledon Yellow G thickens up on the addition of sodium benzyl sulphanilate, while other vat dyes which already contain this compound at the time of purchase tend to give specky prints if a further addition is made and the printing mixture stored for some time.

The thickening medium should be selected carefully; the fullest and clearest prints are often obtained using starch-tragacanth, but for pale shades and large blotches more level shades are sometimes obtained with British gum, gum arabic or gum senegal. If caustic soda is included in the recipe, British gum or calcined starch should be used as thickening agents. Calcined starch should be used and the printing

mixture warmed slightly if trouble due to crystal formation is met with during printing.

A suitable recipe for many vat dyes is:

100	300 gms. <i>Vat dye paste (printing grade)</i>
90	110 gms. <i>Glycerine</i>
480	360 gms. <i>Starch-Tragacanth</i>
175	15 gms. <i>Water</i>
70	100 gms. <i>Sodium sulfoxylate formaldehyde compound</i>
85	115 gms. <i>Potassium carbonate</i>
<hr/>	<hr/>
1000	1000 gms.
<hr/>	<hr/>

Reduction thickening.

60 gms. <i>Glycerine</i>
700 gms. <i>Gum senegal</i>
145 gms. <i>Water</i>
45 gms. <i>Sodium sulfoxylate formaldehyde compound</i>
50 gms. <i>Potassium carbonate</i>
<hr/>
1000
<hr/>

After printing, the fabric should be dried quickly but not at too high a temperature, nor should it be allowed to bake in the stove. Tin drying should be avoided if possible, not only because of the effect of tension, but because of the danger of colour cracks in heavily coloured patterns, particularly if an oil has not been included in the printing recipe. A further danger in tin drying is the marking off and flattening of the dye on the tin surface. Care should be taken to prevent the premature decomposition of the sulfoxylate formaldehyde compound; otherwise uneven prints and poor colour values will result.

After drying, the fabric should be aged as soon as possible; if stored for only a short time, care should be taken to protect it from acid-vapour, heat, moisture and sunlight. If storage is unavoidable, the printed fabric should be wrapped in a cloth and placed in a dry, dark and warm place. The average vat print will require 4 to 6 minutes' ageing in saturated steam at 100° C. Heavy blotch patterns

may require two runs through the ager (8 to 10 minutes) or one run through the continuous steamer. Every effort should be made to keep the conditions inside the ager or steamer as uniform as possible at a temperature of the order of 100°–101° C. One method of doing this is to feed the steam from the main into a conditioning chamber situated next to the ager and from there to the ager. This precaution will not, of course, take care of the heat which is developed due to the physical and chemical changes taking place. If, during a run, the temperature inside the ager is found to be rising, the safest procedure is to adopt the old established method of breaking off at the first stitching, and running a damp grey through in order to bring the printed piece out of the machine. Wet greys are then run through the machine until the temperature is normal. (*The Rise in Temperature of the Ager*, A. B. Meggy, *J. Soc. Dyers and Colourists*, September, 1943).

The fabric should not be stored after ageing, but treated in:

2 gms. *Sodium perborate (or hydrogen peroxide)*

4 cc. *Acetic acid 40%*

Up to 1000 cc.

then washed and soaped at the boil in a winch.

Screen printing has been developed to a considerable extent over the past few years, and this is likely to continue, particularly in view of the fact that bolting silk of the required quality will be available from British manufacturers. The normal potassium carbonate–sodium sulfoxylate formaldehyde compound recipe is too alkaline for the purpose of printing vat dyes through silk screens and, until bolting cloth made from alkali-resistant fibres is available in bulk quantities, a modified recipe will have to be used. An example is:

100 gms. *Vat dye paste (printing grade)*

110 gms. *Glycerine*

70 gms. *Water*

95 gms. *Sodium sulfoxylate formaldehyde compound*

190 gms. *Potassium bicarbonate*

435 gms. *Gum tragacanth*

Up to 1000 gms.

The Colloresin Process, named after Colloresin DK thickener, but applicable to other thickeners, such as gum arabic and gum senegal, can be used. Colloresin DK is soluble in cold water but insoluble at high temperatures and in concentrated salt solutions and fixed alkalis. The process consists of printing the dye and thickener, drying, and at some subsequent time treating in a reducing bath, ageing, etc.

Example. 100 gms. *Dye paste*
 Print 220 gms. *Water*
 400 gms. *Starch 8%*
 280 gms. *Colloresin thickening*

1000 gms.

Colloresin thickening

45 gms. *Colloresin DK* are covered with water at 80° C. and stirred until cool

Dry, and when convenient, pad through

80 gms. *Glycerine*
 100 gms. *Potassium carbonate*
 660 gms. *Water*
 100 gms. *Sodium sulphoxylate formaldehyde compound*
 60 gms. *Glauber's salt*

1000 gms. at 28° C.

Dry in stove (not drum type), age and wash off as soon as possible, employing the same conditions as the potassium carbonate method. This method is applicable to machine, screen or block printing.

Indigosol and Soledon dyes are applicable, giving level prints, although in some cases they fix more slowly than on cotton. These dyes, which are leuco ester compounds of vat dyes, are soluble in water and are printed "direct" on to the fabric. They are converted into the insoluble vat dye by hydrolysis and oxidation on the fibre. Careful control must be adopted when using processes of this type, otherwise tendering of the fibre will take place.

It should be noted that certain vat dyes accelerate the

photo-degradation of the fibre, consequently only those dyes should be used for printing which are known to be safe.

Azoic Dyes. Excellent prints are obtained by use of azoic dyes. As on cotton fabrics, most combinations in full shades have good fastness to light and washing, and give moderately bright to bright shades.

The fabric may be prepared with either Brenthol or Naphtol and printed with a diazotised base, or Fast Colour salt. Normally Brenthols or Naphtols with little or no affinity are used in order that the uncombined Brenthol or Naphtol may be removed during washing-off and soaping treatments.

Example.

Pad through 15 gms. Brenthol AS
 20 gms. Oleine Oil
 19 cc. Caustic soda 70° Tw.

Up to 1000 gms.

Dry carefully and uniformly in the stove, white room stenter and print with:

10 gms. Fast Orange GR Base are made into a paste with
20 gms. Hot water and
5.5 gms. Sodium nitrite. The paste is cooled down, and whilst stirring quickly, poured into a mixture of
21.5 gms. Hydrochloric acid 32° Tw. and
200 gms. Cold water. Allow to stand for 15 minutes with frequent stirring. Stir into
500 gms. Neutral starch-tragacanth. Add
22 gms. Sodium acetate 1 : 1

Up to 1000 gms.

Dry, treat in a cold dilute solution of sodium bisulphite, wash and soap.

The process may be reversed; that is, the Brenthol or Naphtol may be printed and the fabric developed by passing through a bath containing a diazotised base or Fast Colour

Salt, providing of course the particular base or salt does not stain the white ground. Using either method, note should be made that *Fibro* takes up more of some of the Brenthols and Naphtols than cotton; consequently allowance should be made, particularly in the padding process. In the printing of Fast Colour Salts on *Fibro*, claim has been made that in many cases the addition of zinc sulphate and urea to the printing recipe improves the colour yield and brightness of the print.

A simpler method of printing azoic dyes is to use the Rapid Fast dyes, which are mixtures of the sodium salt of a Naphtol and a diazotised amine in the form of its nitrosamine. The mixture is stable, but coupling of the components takes place on acidification. In preparing the Rapid Fast Dyes for printing, caustic soda is added to the powder brands but not to the pastes.

Examples.

50-80 gms. *Rapid Fast Powder pasted up with*
 17-25 gms. *Caustic soda 70° Tw.*
 20-30 gms. *Turkey red oil and*
 333-275 gms. *Water at 27° C. and*
 30-50 gms. *Neutral chromate solution, and stirred in*
 550 gms. *Neutral starch-tragacanth*

1000 gms.

100-150 gms. *Rapid Fast Paste are mixed with*
 270-220 gms. *Cold water*
 30 gms. *Turkey red oil*
 50 gms. *Neutral chromate solution into*
 550 gms. *Neutral starch-tragacanth*

1000 gms.

Neutral chromate solution

150 gms. *Sodium bichromate dissolved in*
 720 gms. *Water and*
 130 gms. *Caustic soda 70° Tw. added*

1000 gms. *Cooled before use*

After printing and dyeing the Rapid Fast dyes may be developed by:

1. Airing (storage in a moist warm atmosphere overnight and then developed in a bath of 40 cc. acetic acid (60%) and 50 grams Glauber's Salts per litre at 70° to 75° C.)

2. Steaming without acid (3 minutes in a rapid ager followed by a treatment in an acetic and Glauber's bath).

3. The acid steaming developing method (3 to 5 minutes in the rapid ager in the presence of acetic or formic acid).

After developing, the printed fabric should be soaped as for azoic dyes.

The Rapidogen dyes may also be used. They consist of mixtures of a sodium salt of a Naphtol and a diazotised amine; the latter is stabilised by combining it with an amino fatty acid, such as methylamino-acetic acid. The colour is developed by steaming and acidification. The acid destroys the compound between the diazotised amine and the amino fatty acid and normal coupling takes place between the Naphtol and the diazotised amine.

A typical printing recipe is:

80 gms. *Rapidogen Yellow G*

20 gms. *Caustic soda 70° Tw.*

30 gms. *Methylated spirits*

100 gms. *Water at 49° C.*

670 gms. *Gum tragacanth*

100 gms. *Water*

1000 gms.

The colour may be developed in a number of ways, such as:

1. Acetic and formic acid vapour in the ager.

2. Padding through acetic-formic acid-Glauber's Salt mixture and drying on tins.

3. Passing open width through a bath containing acetic-formic acid-Glauber's Salt at the boil.

After developing, the fabric should be washed and soaped.

Pigment Fixation. Much attention has been given in recent years to the fixation of dye pigments on fabrics, using synthetic resins and similar products as binding agents. The process in most cases consists of the application of dye and synthetic resin, followed by drying, heat treatment and, where necessary, soaping or softening.

The natural soft handle of most fabrics made with *Fibro* is a decided asset in this class of printing. Cover, dressing gown, overall, table-cloth and scarf fabrics can be printed and finished to give distinctive prints with a pleasing handle.

The Aridye (Interchemical Corporation) process depends on the fixation of specially prepared dye pigments with synthetic resins. The printing mixture consists essentially of a dispersion of water and dye in an organic solution of the dope or resin. To dilute the mixture or remove it from the printing roller, a mixture of solvent and water should be used.

In the case of Orema (Clayton Aniline Co.), specially prepared dye pigments are also used and the printing mixture consists of a water dispersion of synthetic resins, protein, solvent and pigment. Water may be used for cleaning the rollers after printing. The method of application for machine and screen printing recommended is:

450 gms. *Orema Fixer* are stirred with
50-150 gms. *Orema dye*. The fixer is added gradually and the bulk added only when the dye has been mixed thoroughly and evenly with a small quantity of *Orema Fixer*. The homogeneous mass is then added to
500-400 gms. *Orema Thickener*, and stirring is continued until a completely homogeneous printing colour is obtained

1000 gms.

Reduction Paste 500 gms. *Orema Fixer* are mixed thoroughly by stirring with
500 gms. *Orema Thickener*

1000 gms.

The fabric is dried after printing and baked for 2 minutes at 150° C. (For every 10° C. above or below this temperature the time must be halved or doubled respectively.)

The makers state that the dyes have a wash fastness comparable with that of the fastest known dyes, that the fastness to light is between 7 and 8 medium and full shades, and that the fastness to rubbing depends to a large extent on the nature of the material in question.

Finishing. The treatment given during the washing-off and finishing processes is important and one should complement the other. It is pointless to wash off and squeeze under severe warp tension and then attempt to correct the resulting extension with overfeed on the stenter. Similarly it is useless to avoid warp strain during the scouring, printing, and washing-off processes and then finally to dry the fabric under tension on tins.

The actual method of washing off will depend upon the type and weight of fabric being processed. Printed fabrics liable to mark off or bleed, or too heavy to put into rope form, should be treated in an open width on a "tensionless" continuous soaper. They should then be suctioned or mangled, running from one slide to another, or plaiting may be used if the dyes are sufficiently fast; but running from one batching roller to another should be avoided unless the tension can be controlled. The average fabric is best washed off in a winch, run out of the machine into bags, hydro-extracted, and opened out by hand prior to drying. Variations of this procedure may have to be adopted, according to the type of fabric and equipment, but opening out on a scutcher should be avoided if possible, particularly the old type used for cotton fabrics.

Fibro absorbs and retains (inside the fibre) approximately twice as much moisture as cotton and consequently swells to an appreciable extent. In this state it is liable to be damaged by unintelligent handling, rough surfaces or abrasion. Operatives should be discouraged from poking at fabrics with sticks; roller and other surfaces along which the fabric travels should be smooth, and the skidding of pad mangle bowls should be prevented.

When washing off, every effort should be made to remove the thickener used in the printing mixture in order to obtain

the natural handle of the fabric. This applies particularly to fabrics to be treated by the anti-crease or anti-shrink processes, otherwise residual gum or starch will be fixed on the fabric. The anti-crease and anti-shrink processes are described in Chapter 22, but a number of factors are particularly important with reference to printed fabrics.

The processes should be controlled rigidly, mechanically as well as chemically. Special care should be taken during stentering after padding and the polymerisation processes; the fabric should not be used to drive rollers, but should be free from warp tension. If the fabric is polymerised whilst distorted, it is probable that the printed pattern will be distorted on the finished fabric. The washing off after the anti-crease process can be used to some extent to control the handle of finished printed fabric. The essential function of the washing process is to remove residual formaldehyde, acid, and any resin which has formed on the surface of the fibre. It should, however, be modified according to the style and type of printed fabric. If a springy handle is required, such as for tie and certain dress qualities, the fabric should be washed in open width in water and dilute alkali (caustic soda), followed by a thorough water wash. Most dress fabrics will require to have a softer handle than is obtained by this method and a softener (1 lb. Brilliant Avirol per 100 gallons) should be added to the final water treatment. To obtain a very soft handle, such as for light-weight dress fabrics, the washing off treatment should be carried out in the winch, and a softener added to the final wash. A moderately soft, smooth finish suitable for some casements, dress fabrics and tropical suitings can be obtained by calendering after polymerising and prior to washing off in dilute alkali and water.

The general finishing methods applicable to printed *Fibro* fabrics are, in the main, similar to those applied to dyed fabrics and described in Chapter 22. In most cases a softening agent, if required, will be added to the final rinse bath of the washing process carried out after printing and ageing or steaming.

FINISHING OF *FIBRO* FABRICS

THE finish of a fabric is a primary sales factor and may broadly be described as the appearance, handle and to some extent the performance of the fabric. Factors other than the finishing processes affect these properties, such as the fabric construction and the method of preparing and dyeing. The fabric properties, however, may be modified during the finishing processes, and providing the methods employed are sound the beauty and value of the fabric will be enhanced. *Fibro* fabrics are regarded as highly adaptable in that a variety of finishes can be obtained on a given fabric. In order to obtain the best finishes a number of precautions should be taken which are based on the properties of the fibre and the fabric construction. All processes carried out on a fabric after weaving will probably affect the finish, but the actual finishing processes may be taken as those carried out subsequent to dyeing.

If *Fibro* fabrics require softening, an addition of a suitable softener may be made to the final rinse water after dyeing. Scoured *Fibro* has a characteristic soft handle; consequently casement and similar fabrics generally will not require softening. Most dress fabrics will require softening, but the type of softener to be used and the amount required may vary according to the type of dress fabric. For most fabrics, however, cation-active softeners will be found suitable such as Alcamine (Allied Colloids), Gemex Z6 (General Metallurgical Co.), Sapamine KW (Clayton Aniline). These softeners are to some extent substantive to the fibre, but not equally so; consequently the amount of softener to be used and the time of treatment will vary according to the particular softener employed. In many cases the amount will be of the order of 2 lb. per 100 gallons, and the time of running sufficient to give uniform softening throughout the piece and to take up a reasonable amount of softener (processing in a winch, this is of the order of 20 minutes). In order to obtain maximum value when using a cation-active softener the fabric should be free from soap as the latter is anion-active and if present in quantity will appreciably

modify the handle. A different type of handle can be obtained using an anion-active softener such as Brilliant Avirol (Gardinol Chemical Co.). The tendency with this type of softener is to obtain a smooth rather than a soft handle.

A further point with reference to the final rinse water after dyeing is that the water used should be neutral or only slightly alkaline. An acid water is obviously undesirable in that the fabric in the finished state may tend to have a harsh handle and the yarn may tend to be brittle. It is also undesirable for the wearer to have next to the skin a fabric which is either decidedly acid or alkaline. If the last rinse water is alkaline there is also a danger that the dyed and finished fabric will be changed in shade on being given a steaming treatment, such as decatizing, as some dyes are reduced under these conditions. Examples are Chlorantine Green BLL and Durazol F. Blue GS. In order to avoid these troubles the last rinse water should be neutralised by the addition of the requisite amount of formic or acetic acid.

Fabrics which have been dyed and softened in a winch, or only dyed, should be run over the winch wheel and opened out by hand or run over the winch wheel into bags. If the winch wheel has not a smooth surface it should be covered with a soft cotton or *Fibro* fabric in order to prevent the fabric becoming hairy due to friction. Scutcher rollers, particularly the older types, should be avoided for opening out purposes unless a light nap or hairy appearance is required on the finished fabric. After taking out of the winch the fabric should not be allowed to lie about, but should be uniformly packed in the basket of an hydro-extractor and excess water removed; otherwise, if the dyes are not particularly fast to water, migration may take place. The basket of the hydro-extractor should contain no rough surfaces, and preferably should be covered with a soft open weave cotton or *Fibro* fabric. The suction machine may be used in place of the hydro-extractor, but in order to avoid unnecessary warp tension the fabric should not be run from a batch roll. A pad mangle should not be used unless a compact heavy weight fabric is being processed and no other machine is available for removing excess water.

Fabrics which have been dyed in open width on a jigger

or continuous machine, should be run on to a wood block and hydro-extracted in open width. If a hydro-extractor designed for treating fabrics in open width is not available, the suction machine may be used providing warp tension is kept down to a minimum.

After the removal of excess water, the fabric should be dried and not allowed to lie, otherwise migration of dyes may take place causing "standing" places. An appreciable percentage of returns for retreatment are caused at this stage of processing, either through "standing" places or creases. If it is impossible to dry the fabric within a reasonably short time, it should be stored for the minimum time in a conditioned room.

The drying process is important; an otherwise excellent finish can be ruined by treating the drying of textile fabrics as a mere matter of driving off water in any convenient way. Immediately before drying, the water content throughout a piece and from piece to piece should be uniform. *Fibro* absorbs more water than most fibres and takes a longer time to dry. Examples of water imbibition figures are:

Standard *Fibro*

As received 100%–105%

After scouring and drying 90%–95%

Note: It may have lower imbibition value after steaming treatments.

Strong *Fibro* 95%–100%

Rayolanda circa 50%

Owing to the relatively high water content and the consequent highly swollen state, plus the high extensibility of the wet yarn, *Fibro* fabrics are in most cases not suitable for tin drying, particularly in the final finishing operations. The resulting finish tends to be boardy to the hand, and to have a surface sheen. If it is necessary to dry on the tins certain of the heavier types of casement and similar fabrics which may require to have a slightly firm handle, precautions should be taken, such as (a) the first one or two tins should be covered with a soft cotton fabric, (b) none of the tins should be allowed to reach a high temperature—80°–85° C. should be the maximum temperature, (c) the warp

tension should be kept to a minimum, and (d) the fabric should not be allowed to stand on the tins.

Fibro fabrics may be stove dried and clip stentered in the presence of steam. There are a number of types of stove drying machines. The festoon type drier, such as the most recent Haas machine, dries the fabric in loop form with the minimum amount of warp tension. There is a tendency to apply slightly more warp tension on the conveyor type of machine, such as the Tomlinson machine. In this machine the fabric is carried along on a wood brattice type conveyor, but if precautions are taken the warp tension may be reduced to the order of that obtained in a festoon drier. A further type consists of a drum approximately 8 feet in diameter, the frame of which is made of metal, but in place of the usual metal sheet cylinder a covering of two fabrics is used, first a leno weave fabric and then a muslin fabric. The drum is driven and revolves inside a box enclosure. The fabric enters and leaves the enclosure through a slit and is carried round the revolving drum. Hot air is sucked through the fabric into the inside of the drum. A machine of this type is made by Weisbach and has the advantage of taking up less space than the festoon and conveyor machines, but more warp tension is applied to the fabric during drying.

Using any of these machines, the minimum warp tension is applied to the fabric by running from a loose batch and plaiting down the dry fabric. The tension applied to the fabric should be based on the dimensions required in the finished fabric and should usually be either the minimum or only slight tension. Machines of this type are usually operated at a temperature of the order of 80° C., but the temperature should be regulated in order not to dry too quickly or overdry.

In America the air flow type of drier is used; it is claimed that the warm air virtually supports or carries the fabric as it is dried.

Stove dried fabrics are normally clip stentered in the presence of steam. Steam is necessary to re-set the fabric in order to remove the small creases or distortions developed during processing or drying. The minimum amount of warp tension is applied by running from a loose batch and

plaiting down at the delivery end of the stenter. Clip stenters of this type are usually housed or enclosed and the space within the enclosure is heated with hot air to give a temperature of 60°–70° C. The enclosure is fitted with doors and when necessary it is possible to walk from one end to the other to inspect the fabric on the machine. Many *Fibro* dress fabrics are stove dried and clip stentered in order to obtain a full soft handle. The stenter speed for treating a 4 oz. fabric may be from 60–100 yards per minute depending upon the condition of the clips, the rigidity of the frame work of the stenter and the type of fabric. A plain weave *Fibro* fabric which only requires straightening or pulling out in width $\frac{1}{2}$ -inch and is uniform in width may be run at a much faster speed than a crêpe fabric made from *Fibro* or a *Fibro* warp, which prior to stentering may be non-uniform in width within the piece.

Some clip stenters are enclosed in the minimum amount of space necessary for practicable running and are operated at temperatures of the order of 120° C., in order to stenter fabrics without pre-drying in a stove. *Fibro* fabrics of the casement and lining types may be wet stentered, i.e., after hydro-extraction, in order to obtain a flat appearance, and a slightly firm handle. Taking a medium weight *Fibro* casement fabric as an example, the stenter speed for drying and stentering in one operation will be of the order of 20 yards per minute.

Care should be taken to avoid overdrying when clip stentering *Fibro* fabrics, otherwise the handle may be affected. The danger of overdrying is greater when pre-drying is omitted, owing to the higher temperature at which the stenter is operated. The control of the speed of the stenter according to the moisture content of the fabric may be adopted by fitting moisture measuring and speed control devices. Mechanisms for this purpose are discussed later in the Chapter in connection with pin stenters. The majority of clip stenters are not fitted with an overfeed device, consequently it is important to avoid warp tension, particularly when stentering without pre-drying.

Fibro fabrics may be processed on a Palmer stretcher and drier, or on a drier only followed by clip stentering. In the latter case a better handle is obtained if the fabric is allowed

to condition before stentering. Dress fabrics treated on the Palmer range tend to have a soft but slightly thinner and smoother handle than comparable fabrics stove dried and clip stentered or pin stentered with overfeed. Precautions should be taken when treating *Fibro* fabrics on the Palmer range. The fabric should have been uniformly hydro-extracted, the temperature of the tin should be of the order of 70°–80° C., and the warp tension kept down to a minimum.

Many *Fibro* fabrics, particularly dress fabrics, are finished on a pin stenter. Most modern pin stenters are enclosed and are 20–30 yards long and when used for drying and stentering medium weight *Fibro* dress fabrics, operate at an average speed of the order of 25–30 yards per minute. A strong hot air current is utilised and operates from the direction of the delivery to the feed end of the machine and the temperature inside the enclosed part of the machine is of the order of 115°–135° C. The draught is obtained by using electrically driven fans situated at both sides of the machine and the air is heated by passing over steam-heated fluted gilled pipes. Recently the advantage of the fluted gilled pipes over the smooth surface variety has been put in doubt, as it is suspected that when processing *Fibro* fabrics the advantage of the greater heating surface obtained with the fluted gilled pipe is offset owing to a greater quantity of fly or fluff collecting on the pipes.

Most modern pin stenters are fitted with automatic width control and warp overfeed mechanisms. The former greatly facilitates the running of the machine and consequently increases production. The latter is used to control the length of the fabric and to remove warp strain which may have been introduced in previous processes or in running from a batch roll on to the stenter. Owing to the relatively high temperature at which pin stenters are operated the step from the “just dry” to overdrying is a short one. The tendency is for the operative to avoid the more obvious trouble by overdrying. The ideal would be to control the stenter speed according to the moisture content of the fabric. Progress has been made along these lines. The Dalglish Control and the Fielden Drimeter are two devices which are being developed for this purpose. The former is dependent

on the fact that the electrical resistance of fabrics increases with decreasing moisture content whilst the latter depends on the increase in dielectric constant of fabrics when the moisture content increases. Each of these methods has virtues, but also limitations, particularly when long runs of the same quality or similar qualities are not available. An alternative method of finishing the fabric to the required moisture content depends upon the use of a conditioning plant either in the last section or at the end of the stenter. This method has met with a certain amount of success, but it is obviously a less economic proposition.

A further development is the use of specially designed drying stoves situated immediately in front of the stenter for the purpose of removing some of the moisture prior to stentering and so permitting the expensive stenter machine to run at a faster rate. In some cases the ordinary steam heated drying stove type is used, but the modern tendency is to use gas heated infra-red equipment working at temperatures of the order of 315° – 540° C., according to whether a black or red type emitter is used. It is claimed that using infra-red drying equipment to remove part of the moisture prior to stentering, the stenter speeds have been increased to 80–120 yards per minute and in some cases higher. In countries where electrical power is relatively cheap, such as some parts of Canada, high frequency radiation is used in place of gas. In Great Britain, owing to the price per unit of electricity, drying by means of high frequency radiation is expensive.

The drying and stentering processes may be regarded as the backbone of the finish, but there are many ancillary mechanical processes which may be employed to modify the finish to an appreciable extent. It is sometimes required to give the fabric a breaking treatment in order to obtain a softer, fuller handle and improved draping qualities. There are a number of types of machines used for breaking down the firm handle of fabrics and their effect on the fabric varies to some extent. The spiral breaker consists of a number of smooth surface metal spiral shaped rollers arranged in circular fashion and revolving in the opposite direction to the fabric. Providing the spiral rollers are well polished, *Fibro* fabrics which tend to be too firm in handle may be treated

on a machine of this type. It is essential, however, to keep the warp tension down to a minimum. Under suitable conditions the handle obtained is softer and tends to be slightly fuller than before pre-treatment. A variation of this machine consists of a single-bladed roller made of metal or wood and revolving at a relatively high speed in the opposite direction to the passage of the fabric. The machine may be used as a separate entity or may be fitted at the delivery end of the stenter. Machines of this type tend to cause a small amount of hairiness which may be desirable on some dress fabrics where such a handle is required. If, however, a sheer surface is preferred, the fabric may be given a light cold calender running from a loose batch and plaiting down after calendering. In order to avoid obtaining a glazed surface the moisture content of the fabric should be kept low. A further method of breaking without causing hairiness consists of jiggging on the stenter. This method slows down the speed of the stenter and consequently is expensive due to loss of production. If softness, fullness and a slightly raised or hairy appearance is required, such as may be suitable for dressing gowns and some types of sheetings, a pin breaker may be employed. This machine consists of a series of rollers working in pairs. Each roller is covered with fine straight wire carding. Each pair of rollers may be set so that the pins may just touch one another or may mesh to any required degree. The rollers revolve and the fabric passes between each pair.

A fully raised effect along with a soft handle can be obtained by running the fabric through a raising machine. This machine consists of rollers similar to the pin breaker, but the wire is more rigid and bent at an angle. Raising machines are usually constructed on the basis of a cylinder on which are mounted small rollers covered with wire carding or filleting. There are a number of variants, but there are two main types, Single Action and Double Action raising. In the former the pile or cover is raised only in one direction. In the latter, two sets of rollers known as pile and counter pile rollers are fitted, which run in the same direction, but the points of the card wire are set in opposite directions to each other consequently the pile or cover is raised in two directions. In order to obtain the most solid

raised effect from a given number of runs through the breaking machine, the fabric should be treated with a softener after dyeing. Turkey red oil is suitable for this purpose. The fabric should then be dried on the pin stenter with the maximum amount of overfeed and, after raising, re-stentered to the required dimensions.

If lustre or glaze is required, such as may be the case with lining fabrics made from or containing *Fibro*, the fabric may be calendered. A certain amount of warp tension will be necessary and the fabric should be conditioned prior to calendering. Generally a three-bowl calender will be employed, the centre bowl being made from a metal and heated through the centre by gas. The other two bowls will be made from compressed paper or cotton. In most cases only a light glaze will be required which will be obtained by employing a slight amount of warp tension and heating the metal bowl to 80°–90° C. A thin papery handle will be obtained by first running the fabric through a fine spray of water such as is obtained on a damping machine and running the fabric through the calender whilst applying appreciable warp tension. It should be noted that although the application of appreciable warp tension is discouraged when processing *Fibro* fabrics, it is necessary in this case in order to obtain the desired effect. A more highly glazed effect is obtained if the fabric is conditioned and then friction calendered, i.e., one bowl, usually the metal bowl, run at a greater speed than the others.

A flat dense finish with a degree of lustre and uniform cover suitable for high-class dress fabrics and some types of sheetings, can be obtained by beetling. This consists of closing the interstices of the fabric by pounding the fabric with a series of heavy wooden hammers which fall on the beam of fabric directly beneath them. The beam revolves and moves laterally during the hammering. The time of beetling is usually of the order of 8 hours.

Fibro dress fabrics may be treated on a decatizing machine in order to obtain a soft, full, mellow handle. The fabric with an interlayer of blanket is run on to a perforated cylinder. Dry steam is blown through the fabric and blanket from the perforated cylinder. It should be noted that if the fabric is subjected to warp strain during decatizing a thin

flat finish will be obtained, consequently the minimum amount of warp tension should be applied when running the fabric into the machine.

Wet Finishes. *Fibro* fabrics may be treated during the finishing processes to impart special properties such as anti-crease, waterproofing, etc. Processes of this type are usually carried out after drying and before final stentering, and frequently involve the use of a pad mangle. The padding of wet fabric is not advocated owing to the tendency to impart warp strain and to dilute the bath, thus causing non-uniform treatment.

Showerproof Finishes. Showerproof or water repellent finishes, which leave the fabric porous to air, may be applied to *Fibro* fabrics. There are a number of methods, including:

1. Treating the fabrics with aluminium compounds, such as aluminium acetate or formate and drying. A variant is the formation of aluminium soaps on the fibre, usually obtained by treating the fabric with a soluble metallic soap, i.e. sodium, and converting to the insoluble aluminium soap by treating in a solution of alum.
2. Treating the fabric in a solution of an organic solvent or an aqueous emulsion of a suitable fat, oil, or wax. Aqueous wax emulsions are mainly used in conjunction with aluminium acetate. In some cases the wax and the aluminium acetate are applied separately owing to the instability of the wax in the presence of aluminium acetate. With other wax emulsions the aluminium acetate may be added to the bath immediately before treating the fabric. Stable wax emulsions may be bought or prepared, which already contain aluminium acetate and only require diluting with water prior to use. Examples of trade products of this type which are on the market are Cerol T (Sandoz), Waxol W (I.C.I.) and Migasol PJ (Clayton Aniline). The process of application of the aqueous type, taking Waxol W as an example, consists of diluting the product to give 1%–4% emulsion and padding the fabric through the bath at 50°–60° C., followed by drying. Aluminium may be replaced with other metals. The

German product Persistol Salt concentrated consists of zirconium oxychloride and is applied in a single bath process with Persistol Base B. The latter consists of:

- 24 parts *Hard paraffin wax*
- 24 parts *Ceresin*
- 13 parts *IG Wax BT (ethylene ester of montan acid)*
- 8 parts *Sodium oleate*
- 5.5 parts *Sodium Oleyl Sarcosin bulked to 1 gallon with water.*

3. Treating the fabric in the bath containing a protein and usually an aluminium salt. Products of this type are made by the Catomance Company under the brand name Mystolene.
4. Treating the fabric in a bath containing synthetic compounds of high molecular weight or long chain of fatty compounds which combine chemically with the fibre. The German product Persistol VS (octadecyl-ethylene-urea) is of this type and the process of application consists in padding through a water dispersion of 3%–5% and drying at a temperature above 80° C. A further example is Velan PF (I.C.I.) which dissolves in water at 35°–45° C. to give a slightly opalescent solution. An addition of 4½ oz. of crystalline sodium acetate per 10 lb. of Velan PF is added to the bath. The amount of Velan PF required varies according to the type of fabric, but for *Fibro* dress fabrics it is usually of the order of a 2%–4% solution. The fabric is padded, dried in a stove or hot air stenter and then treated at a temperature of 120° C. for 3 minutes. It is finally washed in a bath containing:

- 1 lb. *Soda ash/per 100 gallons at 35° C.*
- 2 lb. *Soap/ for 5–10 minutes,*

followed by thorough washing to remove all traces of soap, and then finishing in the usual way, i.e., by stove drying and clip stentering, or drying direct on the stenter range.

Fireproofing. *Fibro* fabrics intended for cinema or theatre curtains, war purposes, or similar uses, may be treated with

what are commonly called fireproofing agents. The effect of such agents is not to make the fabric actually fireproof. This is true whether the fabric is made from *Fibro* or other fibres. Treated fabrics will still char and decompose, but do not propagate flame beyond the charred area and in some cases only glow for a very short time.

Examples of substances which may be used in order to obtain what is sometimes called a flame- or glow-proof finish, are ammonium phosphate, borax and boric acid, sodium silicate and sodium tungstate.

Various mixtures are used. Examples are:

7-10 oz. per gallon of the following mixture:

50 parts Borax

35 parts Boric acid

15 parts Sodium phosphate

The fabric is padded, dried and stentered.

The U.S. Bureau of Standards recommend:

29.5 oz. Sodium tungstate

7.5 oz. Diammonium phosphate,

bulked to 1 gallon with water.

The mixture is applied by padding.

No substance or mixture introduced up to the present has been found entirely satisfactory. Two of the defects commonly associated with finishes of this type are lack of fastness to washing or laundering and stiffening of the handle of the fabric. In many cases owing to poor wash-fastness fabrics are re-treated after washing or laundering in order to comply with by-laws or Government specifications.

Many methods have been introduced using insoluble substances in order to overcome the lack of fastness to washing, laundering and outdoor exposure. These have varied considerably in their effectiveness, but in every case the handle of the fabric has been adversely affected, and in most cases the treated fabric has only been suitable for outdoor coverings and similar purposes. An example of a method of this type is the use of ferric oxide with vinyl chloride as a binding agent.

Ammonium sulphamate has recently been put forward as a fireproofing agent, particularly in America. It is claimed that it does not adversely affect the handle of the fabric, nor

effloresce on storage, and is not removed by the common solvents used in the dry-cleaning industry. It does not effectively stop after-glow, but an addition of ammonium phosphate will correct this deficiency. It is stated, however, that ammonium sulphamate tenders rayon fabrics.

There are many other fireproofing agents and mixtures of various types, all of which have virtues and limitations. The number of patents taken out is a strong indication of the importance of the subject and the interest taken in it. The examples quoted will serve as an indication of the type of substances used and the limitations of the finishes at present available.

Filling. In the main *Fibro* fabrics should not require filling in order to add weight to the fabric. The practice of filling fabrics with large quantities of Epsom salts, china clay and similar weighting agents is a bad one. It is advantageous in some instances to finish *Fibro* with agents which either modify the handle or modify the properties in order to make the fabric more suitable for a specific purpose.

A fuller and firmer handle may be obtained by the use of cellulose derivatives. A number of trade products are available for this purpose, such as Cellofas TWL (I.C.I.), which is water soluble, and Cellofas TAF (I.C.I.), which is alkali soluble.

Cellofas TWL is sold in the form of flocks and is prepared for use by placing 14 oz. in a double walled vessel fitted with an automatic stirrer and adding 14 oz. of boiling water. The mixture is stirred slowly until the Cellofas TWL is thoroughly soaked, when cold water is circulated in the outer vessel to cool the mixture. When cold, 132 oz. of cold water are added whilst stirring in order to obtain a uniform mixture. The standard mixture thus prepared may be diluted to the required strength which will be dependent on the purpose for which it is required. A typical finish for dress fabrics requiring a firmer handle would be—after scouring, dyeing and drying, pad through $\frac{1}{2}$ – $1\frac{1}{2}$ oz. Cellofas TWL per gallon and dry on a pin stenter employing sufficient overfeed to balance the tension applied during padding.

If a fuller but only slightly firmer handle is required a softener should be included in the mixture, such as Cirrasol LC (I.C.I.) or Velan PF (I.C.I.). The amount of softener

required will be of the order of $\frac{1}{4}$ -1 oz. per gallon of the mixture.

Cellofas TAF is applied from an alkaline solution and is insolubilised by precipitation with acid. It may be applied to *Fibro* fabrics in order to obtain, for example, a fuller and firmer handle on sheeting fabrics, or to prevent hairiness developing on casement fabrics during use. The method of application is similar to that used with the alkali soluble type cyanoethyl cellulose ether, an example being described below.

The application of water soluble, and water insoluble but alkali soluble, cyanoethyl cellulose ethers is described in B.P. 588,751 (Courtaulds, Limited). These compounds are not at present commercially available. The water soluble type may be used to obtain a fuller and firmer handle on *Fibro* fabrics. The method of application is similar to that used for Cellofas TWL.

The alkali soluble type may be applied to the grey, or scoured, dyed and dried fabric. An example of a method of application to a dyed *Fibro* fabric intended for casements, is to pad through:

4 oz. *Cyanoethyl cellulose ether (alkali soluble)*
12 oz. *Caustic soda 72° Tw.*
per gallon.

and run straight into a tensionless type jigger and given four ends in 3 oz. sulphuric acid 168° Tw. per gallon.

Followed by:

2 ends *Cold water*
2 ends $\frac{1}{2}$ oz. *Soda ash per gallon at 20° C.*
2 ends *Water at 40° C.*
2 ends $\frac{1}{4}$ oz. *Soap per gallon*
2 ends *Water at 20° C.*

Hydro-extract in open width and clip stenter. Hydrochloric acid or acid salts such as ammonium chloride and sulphate may be used in place of sulphuric acid for precipitation purposes.

An alternative method of applying cyanoethyl cellulose ether (alkali soluble) is to use the mercerising range, using ammonium sulphate in place of water in the spray, sour in the pit, and soap on a jigger or winch according to the type of

fabric. A softer handle is obtained than by the method mentioned previously.

A further method is to pad, partially dry on the stenter to leave 20% moisture in the fabric and then treat on jigger as above example, but using 40% weaker acid. Fabrics treated by this method have a firmer and more wiry handle than those treated entirely on the jigger after padding.

The same methods may be used when treating *Fibro* fabrics in the grey state, but whilst it is important to obtain uniform treatment when treating dyed fabrics, it is even more important in the case of grey fabrics as otherwise uneven results may be obtained during subsequent dyeing.

A number of interesting finishes can be obtained by applying cyanoethyl cellulose ether (alkali soluble) to *Fibro* fabrics. A fuller and firmer handle can be obtained on Utility qualities such as 1005, whilst on fabrics of suitable construction in coarser counts, a stiff finish may be obtained. Table cloth and sheeting type fabrics may be given firm durable finishes which will stand many laundering treatments. The resistance to wearing and the formation of loose fibres on casement fabrics can be appreciably increased and the draping properties of the lighter type of curtain fabric can be improved.

The handle of *Fibro* fabrics may be modified—usually made firmer—by the use of synthetic resins. Special finishes may also be obtained, such as embossed, glazed and abrasion resistant finishes. For these purposes the resins usually employed are those which remain on the outside of the fibre. The chemical types which have been most used up to the present are alkyd, urea-formaldehyde and vinyl resins.

The alkyd resins are condensation products of polybasic acids and polyhydric alcohols. The Bedafin range of I.C.I. includes a number of resins of this class. The one most commonly applied to *Fibro* fabrics is probably Bedafin 2001, which is a thermo-setting resin of the urea-formaldehyde-castor oil-modified-glycerol-phthalic anhydride type. It may be applied from a methylated spirit-benzene or toluene solution, but is generally applied from an aqueous bath with the addition of ammonia or sodium carbonate or triethanolamine. An example of the application of Bedafin

2001 to a *Fibro* casement fabric in order to obtain a firmer handle, is:

After scouring, dyeing and drying, the fabric is padded through

2 oz. *Bedafin* 2001

$\frac{1}{2}$ oz. *Ammonia*

6 oz. *Water*,

stirred into solution, and then bulked to 1 gallon with water. The fabric is dried on a pin stenter with sufficient overfeed to compensate for warp tension applied during padding, after which it is treated in festoon form for 3 minutes at 130° C. and re-stentered.

The urea-formaldehyde resins are more important when produced inside the *Fibro* fibre in order to obtain anti-crease and similar finishes. Urea-formaldehyde resins which remain on the outside or surface of the fibre are also used, mainly to obtain firm or glazed finishes. It is also claimed that urea-formaldehyde in the intermediate polymer stage and applied in colloidal solution, or a very high polymer in dispersion, increases the resistance of *Fibro* fabrics to abrasion.

Vinyl resins are also applied to *Fibro* fabrics. Polyvinyl chloride and plasticiser mixtures may be used for coating purposes, or polyvinyl chloride may be hot calendered on to the fabric. Treated fabrics of this type may be used for coverings, book-backs and similar purposes. Fine suspensions or dispersions of polyvinyl chloride may be used for imparting a fuller handle to *Fibro* fabrics, such as dress fabrics. An example of such treatment is:

After scouring, dyeing and drying, the fabric is padded through a 1-oz. per gallon polyvinyl chloride dispersion and dried on a pin stenter employing sufficient overfeed to compensate for the warp tension applied during the padding process.

After a breaking treatment the fabric has a full and pleasing handle.

Polyvinyl acetate may be applied to *Fibro* fabrics either from an organic solution or in emulsion form. The latter form is mostly used on the grounds of cheapness. For example, a closely woven plain weave *Fibro* fabric of 3-4 oz. per square yard, after scouring, dyeing and drying, is padded through an emulsion containing 3-5 oz. polyvinyl acetate

per gallon and dried on the pin stenter. After conditioning the fabric is run through an embossing calender. The metal bowl should be finely engraved and operated at a temperature of 70°–100° C. The dimensions of the fabric in the embossed state should be such that on wetting a test sample in cold water, the fabric does not contract or extend to any appreciable extent. A fabric finished in this way should be suitable for book-backs and similar purposes.

Methacrylate type synthetic resins may be prepared as emulsion-polymers, and used in textile finishing. An example is Bedafin CM (I.C.I.) which is a cellosolve methacrylate type compound. These products may be applied to *Fibro* fabrics for the purpose of obtaining a full, firm handle, or as a pre-treatment prior to calendaring with the object of obtaining more cover or a glazed effect.

Special Finishes. A number of special finishes may be applied to *Fibro* fabrics, such as those commonly referred to as “anti-shrink” and “anti-crease” finishes.

The anti-shrink type of finish has not been developed commercially to the same extent as the anti-crease finish, partly because the latter imparts to dress and similar fabrics some anti-shrink properties.

A more effective anti-shrink finish for shirtings and similar fabrics which are sometimes subjected to high temperature alkaline treatments during laundering, is obtained by reducing the swelling of the cellulose by the use of formaldehyde in the presence of an acid catalyst. The reaction was described originally by Eschaliér in 1906, but the amounts used and the conditions of processing must be controlled carefully, otherwise appreciable acid tendering will take place.

An effective treatment based on B.P. 510,199 is:

A *Fibro* shirting fabric after scouring, dyeing if necessary, and drying, is padded through:

28 oz. *Formaldehyde* 34%–35%
2.8 oz. *Thiourea*
1.1 oz. *Potassium tetroxalate*
128 oz. *Water*,

leaving 90%–110% of padding liquor in the fabric (based on the weight of fabric). The fabric is dried on a pin

stenter at 80°–90° C. to dimensions equal to or slightly greater than those required in the finished state. It is then heated for 8 minutes at 140° C. without appreciably altering the dimensions obtained on the stenter. Free formaldehyde and acid left in the fabric are removed and the final finish obtained by treating as follows:

5 minutes in Water at 40° C.

15 minutes in $\frac{1}{4}$ oz. Soap per gallon at 60° C.

5 minutes in Water at 30° C.

5 minutes in Cold water

hydro-extract or suction and finish on the pin stenter.

The final dimensions of the fabric should be ascertained experimentally, and should be based on minimum shrinkage on domestic washing whilst avoiding extension on domestic washing and ironing.

Anti-Crease Finish. The object of applying this process to fabrics made of *Fibro* is to give them a greater ability to recover after they have been crumpled, and to reduce the tendency to crease. The treatment also confers some degree of stabilisation.

The process is performed in three stages: (1) impregnation with a solution of a partially condensed water-soluble urea-formaldehyde and a catalyst; (2) drying to width; (3) polymerisation of the resin by baking. The fabric is then lightly scoured and dried to width on a stenter. Avoidance of undue tension during the preparatory dyeing and drying process is of the utmost importance.

The stabilisation induced by the process will set the material so that any tension effects produced prior to the treatment will be retained, thus impoverishing the handle of the finished fabric in proportion to their severity. Garments made from anti-creased fabrics are stabilised from shrinkage during the effective life of the resin. Correct polymerisation is essential, as insufficient polymerisation lowers the resistance to washing of the treated fabric. The best results can be obtained only by careful control of the process based on practical experience.

Details of the processes, as applied under the patents of Courtaulds, Limited (B.P. 562,790 and 579,709) are as follows:

Preparation of Fabric. De-sizing should be done by any approved process such as that described on page 174.

It is essential that the fabric should be thoroughly scoured prior to dyeing so that it is clean and free from extraneous matter before applying the anti-crease process.

Scouring is best effected in a soap and caustic soda solution containing 1 lb. soap and one-third of a pint of caustic soda 72° Tw. per 100 gallons at 85° C. Dyeing should be followed by extraction and drying.

The fabric should be examined immediately after dyeing so that any dyeing faults may be corrected prior to giving the anti-crease treatment.

Re-processing cannot be satisfactory without first removing the resin once it has been applied and polymerised.

Preparation of Precondensate. A perfectly clear water-soluble solution must be prepared; this cannot be kept for a long time, and the best and most economical practice is to prepare sufficient solution for one day's use.

The following instructions are based upon the preparation of sufficient solution to treat 10,000 yards of fabric, on the basis of the expression on the padding mangle of 90% to 100%. The most suitable vessel is a tank of wood or stainless steel, fitted with a mechanical stirrer and covered by a tightly-fitting lid in which there is a suitable air condenser. The tank must be fitted with a coil for heating, and provision also made for cooling. The most convenient arrangement is to have a single coil with a two-way valve, through which steam and cold water may be passed.

Seventy-nine gallons of commercial formaldehyde is neutralised with caustic soda, cleared by heating to 60°-70° C., and then again cooled; 333 lb. urea and 0.5 lb. borax are added and the whole stirred until dissolved. This solution is accurately adjusted to pH 10.0-10.1 (glass electrode measurements) by means of additions of caustic soda 72° Tw., about 1-1½ pints generally being required. It has been found that the use of an alcoholic solution of thymol phthalein is a suitable indicator for controlling the addition of caustic soda. The solution is then heated to 60° C. and immediately cooled to 25°-30° C. Heating and cooling are such that heating from 50°-60° C. takes about 5 minutes and cooling from 60°-50° C. about 10 minutes.

Further cooling should be complete in about another 30 minutes. The cooled precondensate is now a thin, clear syrup which is immediately diluted. If kept in the undiluted form it will within 24 hours set to a white paste which, on dissolving in water, gives a precondensate of inferior stability. Water should be added in sufficient amounts to give the desired amount of resin to the fabric—a ratio of 30 parts precondensate to 70 parts of water, should give approximately 12%–15% resin on the fabric, with an expression during padding of 90%–100%.

Catalysing the Precondensate. The catalyst is water-soluble and should be added in solution form. Hence a convenient quantity of the water necessary for dilution should be reserved for this solution. When boro-tartaric acid is used (as under B.P. 562,790) it is recommended that the solution should have a maximum concentration of 0.525% and a minimum of 0.4% on the total volume of impregnating liquor.

The boro-tartaric acid is prepared by dissolving together 1 part by weight of boric acid and 4 parts by weight of tartaric acid.

Under B.P. 579,709 a catalyst of ammonium thiocyanate plus Calgon is used. In this case the maximum concentration of ammonium thiocyanate is 0.9% and the minimum 0.75% on the volume of concentrated precondensate. Sufficient Calgon is used to make 0.025% on the total volume of impregnating liquor. Again the catalyst is added immediately before the impregnation stage. The stability of the solution varies with the ratio of precondensate to water and with the catalyst used. For example, the stability of the boro-tartaric acid catalysed precondensate is from 6 to 10 minutes, while that of the ammonium thiocyanate and Calgon catalysed precondensate is 40–60 minutes.

Impregnation. A double or single nip padding mangle is employed, with pressure applied either hydraulically or by means of compressed air; these types are preferred to the lever system of weighting, as they give the finer control needed for the production of standard finishes.

The pressure on the nip rolls is adjusted to leave 90%–100% by weight of the solution on the dry cloth, by means of a trial using a piece of dry fabric of known weight, which is

wetted out with water, passed through the nip and weighed again. The pad is fitted with a stainless steel trough of about 20 pints capacity, and a small reserve measuring and mixing tank is so placed that the diluted precondensate and catalyst mixture can be run into the trough. The procedure is as follows:

The precondensate is run from the first mixer into a tank large enough for its dilution to the necessary volume. The catalyst is dissolved in a separate tank, using the remainder of the diluting water. As an example, 17 pints of the diluted precondensate is run into the measuring tank and 3 pints of the catalyst solution are added. After mixing, the solution is run into the trough; this is repeated throughout the run in order to keep the pad trough filled to a constant level. A tray is fitted underneath the pad rolls at such an angle that the liquor squeezed out of the fabric may run back into the trough. The padding temperature should be 20°-25° C. More detailed examples are as follows:

Process according to B.P. 562,790:

Solution "A" 100 gallons precondensate
180 gallons water

Solution "B" Catalyst:

	<i>Minimum Quantity</i>	<i>Maximum Quantity</i>
Tartaric acid	10 lb. 10 oz.	13 lb. 5 oz.
Boric acid	2 lb. 11 oz.	3 lb. 5½ oz.

These are dissolved in water to make 50 gallons of solution. Three pints of Solution "B" are used with 17 pints of Solution "A".

Process according to B.P. 579,709:

Solution "A" 100 gallons precondensate
180 gallons water containing 13½ oz. of

Calgon T.

Solution "B" Catalyst:

	<i>Minimum Quantity</i>	<i>Maximum Quantity</i>
Ammonium thiocyanate	7lb.	9 lb.

Dissolved in water and made up to 50 gallons.

Three pints of Solution "B" are used with 17 pints of Solution "A".

Drying the Impregnated Fabric. The fabric is passed direct from the padding mangle to the stenter for drying, which should be done evenly at a low temperature (80° – 90° C.), and should be completed on the stenter. Owing to the stabilising effect of the resin on the fabric, undue warp stretch should be avoided during stentering by the use (for example) of an overfeed device. The width of the fabric should be the same or approximately half an inch greater than the desired finished width.

Polymerisation by Baking at High Temperature. The machine for polymerisation should be of the festoon type with a suitable means of heating and with a good ventilation and air circulation for the removal of formaldehyde fumes.

For the boro-tartaric acid treatment the fabric should be kept at 145° C. for 3 minutes or at 160° C. for 2–2½ minutes. When ammonium thiocyanate and Calgon T are used the temperature should be held at 135° C. for 2–3 minutes and should not vary more than 5° C. during the polymerisation; the impregnated fabric itself must attain the recommended temperature for the stated period, since washing fastness is seriously impaired by incomplete polymerisation.

Washing and Finishing. Washing is necessary to remove any free formaldehyde or surface resin; it is essential for any acid in the cloth to be neutralised by the wash liquor.

A continuous open width washer of the tensionless type is strongly recommended and the wash liquor may contain either 0.25% soap and 0.25% soda ash or 0.1% caustic soda 72° Tw. Washing temperature should be 50° C., and the time 1–2 minutes. The fabric should be washed in water after the above treatment.

Ammonia should not be added to the wash liquor, as it gives rise to objectionable vapours when garments receive their ultimate pressing. The final finish will depend mainly on the type of fabric.

Decatizing is not advisable owing to the possible breakdown of the resin in this treatment.

Testing for anti-crease should be delayed, as improvement in this property continues for about 3–7 days.

Analysis of Chemicals. Quantitative estimation of formaldehyde in the commercial product may be ascertained as follows:

(a) Dilute 10 cc. of the commercial formaldehyde to 1 litre with distilled water; 10 cc. of this solution are added to 250 cc. of distilled water in a 1-litre beaker.

(b) 50 cc. of a mixture of 2 volumes of N sodium acetate solution and 1 volume of N hydrochloric acid is then added to the formaldehyde in the beaker, and this addition is followed by a solution of 0.5 gm. dimedone in 95% ethyl alcohol. The mixture is allowed to stand for at least 2 hours and if heated prior to standing the precipitate is in a better condition for filtering through a tared sintered glass crucible (Grade 3 porosity). The precipitate, after washing with distilled water, is dried for 1 hour at 110° C. The weight of the precipitate multiplied by 103 is equal to the percentage of formaldehyde.

It is sometimes necessary to determine the formaldehyde in anti-crease fabrics. The method is as follows:

A suitable weight of material is placed in a distillation flask with 25 cc. of concentrated hydrochloric acid and 50 cc. distilled water. The mixture is steam distilled until 250 cc. of distillate has been collected. The distillate is neutralised with caustic soda in the presence of B.D.H. Universal Indicator. The method is then as in (b) above. The weight of precipitate multiplied by 0.103 equals the weight of formaldehyde.

A suitable weight of material is one which gives 0.3 to 0.4 gm. of precipitate. The amount of formaldehyde is based on the dry weight of material as determined by drying a separate sample at 110° C.

Analysis of Technically Pure Urea. This is analysed for nitrogen by the Kjeldahl flask, and for water.

To 0.1 gm. urea in a 500 cc. Kjeldahl flask add 20 cc. of concentrated sulphuric acid. Place a small funnel in the top of the flask and boil gently for 15 minutes; allow to cool and add 10 gms. potassium sulphate and 0.5 gm. copper sulphate crystals. Boil till the solution is pale green; allow to cool; dilute to 200 cc.; add 100 cc. of 30% caustic soda and distil into 50 cc. N/10 hydrochloric acid (the tube should dip below the surface of the acid) until 300 cc. distillate has been collected. A few pieces of porous pot in the flask will assist uniform distillation.

The distillate is then titrated with N/10 caustic soda with either methyl orange or methyl red as indicator. A blank determination should also be performed.

One cc. N/10 HCl = 0.0014 gm. Nitrogen = 0.0030 gm. urea. The nitrogen content of the fabric may be determined in a similar way using 0.8 gm. of treated fabric. Multiplication of the percentage of nitrogen by the factor 2.74 gives the percentage of resin on the fabric.

Owing to moisture variations it has been found better to dry the fabric at 105° C. for 1½ hours and then to base the calculation on the bone dry weight of the fabric.

Boric acid and tartaric acid are analysed in the usual way with standard alkali.

Ammonium thiocyanate is analysed by direct titration against silver nitrate (Volhard's method). Pipette 25 cc. of standard N/10 silver nitrate into a 250 cc. conical flask, add 5 cc. of 6N nitric acid and 1 cc. of saturated A.R. ferric ammonium sulphate solution. Titrate this with a solution of ammonium thiocyanate (made by dissolving 10 gms. ammonium thiocyanate in one litre of water). As each drop of ammonium thiocyanate is added, a reddish brown coloration is obtained which disappears less rapidly until the end point is reached, when one drop causes permanent reddish coloration. It is essential to shake vigorously during titration to ensure correct results. One cc. N/10 AgNO_3 = 0.007612 gm. ammonium thiocyanate.

Stability of Catalysed Precondensate. This is measured as the length of time taken for the catalysed precondensate to precipitate at room temperature. The test is made by filling a test tube with the catalysed precondensate immediately the catalyst is added, and noting the time elapsing from the instant the catalyst is added to the development of cloudiness. In practice, the impregnated fabric should be completely dried before precipitation has had time to take place. The test therefore indicates how quickly the fabric should be dried.

Examination of the Finished Fabric. The fabric should be examined in the usual way for dyeing and finishing faults, uniformity in handle, appearance, etc. In addition, for each preparation of precondensate and for each fabric quality, examination of the fabric should be made for recovery from creasing, resin content, and free formaldehyde.

Methods of Testing the Finished Fabric—Recovery from Creasing.

Four test pieces are cut, each 2 inches \times $\frac{3}{4}$ inch, two parallel to the warp and two to the weft. Each strip is taken in turn, folded across the centre and placed between plane surfaces under $2\frac{1}{4}$ lb. (1 Kg.) weight for 1 minute. The folded strip is then lifted with forceps and the angle measured on the *Shirley Crease Recovery and Stiffness Tester*. The sample is permitted to recover 1 minute before measuring. The angle is then calculated as a percentage of 180° , this figure being the percentage recovery from creasing:

$$\frac{X}{180} \times 100 = \% \text{ recovery}$$

X = degree of angle measured.

Resin Content of the Fabric. Resin is estimated by extraction with acid. The following method, using a solution buffered at pH 4.6 is a modification of a suggestion by Shirley Institute.

Preparation of Buffered Solution. 50 cc. of 2N acetic acid are neutralised with sodium hydroxide solution, using phenolphthalein as indicator, a further 50 cc. of 2N acetic acid added and the mixture diluted to 1 litre with distilled water. The correctness of the pH of the solution can be verified with the glass electrode or "4.5" indicator (B.D.H.).

Method of Resin Removal. 5 gms. of the conditioned material to be examined are weighed out accurately into a conical flask and 180 cc. of the prepared buffer solution added. The mouth of the flask is loosely closed with a pear-shaped bulb or a small condenser. The flask is then immersed in an oil bath at 105° C. for one hour. After the treatment the sample is washed carefully first by the addition of a little of the buffer solution and then with distilled water until free from acid. The sample is transferred to a weighing bottle, dried to bone dry, cooled and weighed. A separate sample is used for moisture determination. The loss in weight may be calculated as a percentage on the original moisture-free weight of the resinified fabric and described as resin content or, alternatively, on the bone dry weight of the extracted sample, and the result described as added resin.

Testing for Formaldehyde. It is undesirable to market fabrics which contain free or uncombined formaldehyde. The test is most readily done colorimetrically by the use of Schiff's reagent. Two gms. of the fabric are soaked in 20 cc. of boiled distilled water for 20 minutes at 25° C. Ten cc. of the extract are then pipetted out for comparison with standard formaldehyde solutions, which are prepared with 10, 20, 40, 60, 80 and 100 parts per 100,000. To the 10 cc. of each extract, 10 cc. of Schiff's reagent are added, and 5 cc. of 2.5 N. hydrochloric acid. The solutions are heated to 80° C. for 5 minutes and the depth of colour is matched either in a colorimeter or in Nessler glasses, using the standard nearest to the colour of the extract. The suggested permissible limit is 20 parts formaldehyde per 100,000. Schiff's reagent is prepared from :

0.2 gm. *Magenta crystals*
10.0 gms. *Sodium bisulphite*
11.0 cc. *Concentrated hydrochloric acid*
Made up with Water to 2000 cc.

The pH of the fabric extract is determined by adding 30 cc. of boiled distilled water to the remaining 10 cc. of the extract obtained in the above test (making a 40 : 1 liquor to fabric ratio) and measuring on the glass electrode in the usual way.

Efficiency of Plant. Examination of the finished fabric often reveals faults sometimes detrimental to both the finished handle and appearance. A method which has proved suitable for the detection of such faults, and many others which may otherwise remain undetected, is as follows :

A sample of the dyed and finished fabric of any convenient size (preferably full width) is impregnated cold in a 40-volume bath containing 4% Brenthol AS, on weight of material, for 20-30 minutes and then washed in a 2% common salt solution. Coupling is carried out with 20% on weight of fabric of Fast Red 3GL Salt in 40 volumes for a further 20 minutes followed by washing off and soaping. The sample should then be pressed carefully in a dry cloth to remove surplus moisture, and hung to dry in a drying chamber at 60°-70° C., with a good air circulation to prevent migration of the colour. A fabric which has been

insufficiently baked, or has a low resin content is stained to a full red shade. Where there has been excessive or irregular heat in drying, and the resin has migrated or polymerised unevenly, these portions are left unstained. The fully polymerised resin has no affinity for the Brenthol and, therefore, the depth of red is in inverse proportion to the amount of completely polymerised resin.

A further positive test for a urea-formaldehyde resin-treated fabric is provided by acetate rayon dyes. A sample of the fabric is stained using 20% on fabric weight of Duranol Violet 2R in 40 volumes of a 2% salt solution for 30 minutes at 95° C. and then washed. Non-uniform polymerisation is revealed by variations in the depth of shade. The heavier the stain the higher is the degree of polymerisation, or the greater the resin content. This test, however, is not considered as sensitive as the Naphtol test.

Careful examination of the stained fabric often reveals mechanical faults which can be readily traced and appropriately corrected. For example, winch or running creases, uneven expression during padding, uneven or differential drying (where the excessive heat on one side of the fabric has caused the non-substantive resin to migrate to the hot side of the fabric), finger or hand marks caused by operatives handling the fabric between impregnation and drying, water or condensation drops, all show as faults.

Dimensional Stability. The application of urea-formaldehyde to fabric imparts a degree of "set" in the dimensional stability which is, of course, of great importance to the ultimate consumer. The following test has been devised to show the stability.

A piece of fabric at least 14 inches square is taken and an area 10 inches × 10 inches is marked out by template in indelible ink. The fabric is relaxed two hours by steeping in a 0.25% solution of soft soap at 37° C., and laid flat in a shallow trough containing water about 1 inch deep. Measurements are taken along the warp and weft directions; these are the wet relaxed dimensions. The fabric is then laid flat, without stretching, on a smooth surface and dried out at a temperature not exceeding 60° C. After the fabric has been allowed to condition for three hours, it is again measured to give the dry relaxed dimensions. Washing shrinkage

is determined by taking the relaxed fabric and washing it at 37° C. in a 0.25% solution of soap for 20 minutes, and after rinsing taking the wet and dry measurements as described for the relaxation shrinkage.

Pressing is done by laying the fabric on a flat ironing pad and pressing without any sideways movement, using a domestic electric iron.

The above test may also be used to determine shrinkage of grey fabrics, or of comparative untreated fabrics when an addition of 0.2% enzyme per litre may be added to the bath to remove the size, and the sample left in the solution overnight.

Removal of Resin from Fabrics. It is not advisable to re-dye fabrics that have been given an anti-crease finish, without first removing the resin. This is done by treating the fabric on the winch in 10 parts commercial hydrochloric acid per litre of water for one hour at 60° C., or 1 part formic acid 80% per litre of water for 60–90 minutes at 80° C. These treatments are followed by a thorough washing to clear the fabric of acid; the goods may then require the dye to be stripped before re-dyeing to the desired shade. It is not considered advisable to re-treat the fabric with a resin, which should be avoided where possible.

Blends and Mixtures. There are many fabrics made from blend yarns containing *Fibro*, and others from *Fibro* and other yarns woven together in the same fabric. The object of producing blend and mixture fabrics should not merely be the dilution of one yarn with another for economic reasons, but to utilise the special properties of the fibres. This may be done for a number of reasons, such as to obtain effects in weaving or dyeing, or to obtain a particular appearance, handle, and fabric performance. Taking into account the number of fibres available it is apparent that a large number of types of fabrics may be produced. The selection of the finishing processes necessary for each fabric will, to some extent, be based on the fibre and fabric properties and purpose for which the fabric is required. The following are examples:

Many dress fabrics are made from blend yarns consisting of *Fibro* and *Fibrometa*; usually the proportion of each is of the order of 85 : 15. These fabrics may be dyed to give a

solid shade, two colour, or reserved effect, and the handle of the fabric has a little more bite than a corresponding fabric made from 100% *Fibro* yarn. Fabrics of this type are usually softened by treating in the winch after dyeing in a bath containing 1 lb. of sulphonated oil per 100 gallons. They are then run into bags, hydro-extracted, pulled over to straighten, and pin stentered with sufficient overfeed to leave 2% to 4% residual shrinkage, depending upon the type of fabric. Care should be taken to avoid drying too quickly or over-drying, otherwise a relatively harsh handle will be obtained. Fabrics made from *Fibro* and *Fibrometa* blend yarns may be given an anti-crease finish providing the *Fibrometa* content is not appreciably higher than 30%. After an anti-crease finish the handle of the fabric tends to be firmer than a corresponding fabric made from 100% *Fibro*; if, however, the *Fibrometa* content is appreciably above 30%, the handle tends to be harsh due to the presence of resin on the surface of the *Fibrometa* fibre.

A number of fabrics have been developed using blend yarns consisting of *Fibro* and *Rayolanda* in various proportions. There are a number of advantages which may be gained by using *Rayolanda*, including dyed effects, and the warm resilient handle and good raising properties of *Rayolanda*. As an example, a dress fabric made from a blend yarn consisting of 60% *Fibro*, 40% *Rayolanda*, after dyeing and treating in the winch in $\frac{1}{2}$ lb. Brilliant Avirol (Gardinol Chemical Co.) per 100 gallons, is run into bags and hydro-extracted. It is then pin stentered with overfeed to leave no residual shrinkage in the fabric, conditioned, and run over the raising machine a sufficient number of times to give a uniform pile. The fabric is then re-stentered with steam to leave 2% residual shrinkage. The stenter during the stentering treatments should be at a temperature of the order of 80° C. The fabric in the finished state should have a warm, soft handle and good draping properties. Fabrics of this type may be given an anti-crease finish, but such a finish should not be necessary, and if employed will give a harsher handle than previously.

Many fabrics of various types are made from *Fibro* and cotton, both in blend and mixture form. Examples of fabrics made from blend yarns are dress fabrics and sheet-

ings, while among the mixture fabrics are casements and tropical suitings.

Many casement fabrics are made from cotton warps and *Fibro* weft. The object may be to bring out the pattern weave or to obtain a fuller and softer handle and better draping properties than are obtained on a corresponding fabric made from 100% cotton. Fabrics of this type are usually jigger dyed or dyed by a continuous method, in either case employing minimum warp tension, after which they are hydro-extracted in open width. If the fabric is of the closely woven heavy type, tin drying may be employed, taking the precautions of wrapping the first tin (maintaining the temperature of the tins between 80°-90° C.) and applying minimum warp tension to the fabric. The fabric should then be straightened on a clip stenter with steam running from a loose batch. Lighter type fabrics may be dried direct on the clip stenter. If the handle of the fabrics is too firm, one run through a light cold calender will be sufficient to break it down.

A number of dress and other fabrics are made using nylon warp ways and *Fibro* weft ways. The object in most cases is to obtain a type of soft handle peculiar to nylon/*Fibro* mixtures, but other advantages may be gained, such as cross-dyed and rib effects. In fabrics of this type the setting treatments must be regarded as part of the finish, owing to the fact that effective setting to a large extent controls the final appearance and dimensions of the fabric. Nylon yarn shrinks about 9% in boiling water. This shrinkage may be prevented or partially prevented and controlled by employing a setting treatment. For this purpose boiling water, steam or high temperature heating may be employed. It is apparent that taking a given fabric in grey state, according to whether full contraction, partial contraction, or contraction is prevented entirely, a vastly different type of finished fabric will be obtained. In the case of a fabric made from a nylon warp and a highly twisted *Fibro* weft, full contraction would be allowed in order to obtain a crêpe-like effect. The fabric may be pre-embossed if a more controlled or deeper figure or a pattern effect is required. After dyeing in the winch, a fabric of this type would be softened in 1 lb. Brilliant Avirol (or similar softening agent)

per 100 gallons, run into bags, hydro-extracted and pin stentered with overfeed.

In the case of a fabric made from a nylon warp and *Fibro* weft with normal twist and where some but not full contraction is required in order to obtain cover and fullness of handle, a light scour at a low temperature will be given prior to setting. As an example, a blouse type fabric, after scouring in hank form at 45° C., is run on to a perforated tube employing only sufficient warp tension to remove creases. It is then steamed in an enclosed vessel for 15-30 minutes at 20 lb. pressure, and, if possible, scoured and dyed in the same vessel. After hydro-extraction in open width, the fabric is dried on the clip stenter to the same or slightly less dimensions than those obtained during the setting treatment.

For fabrics in which it is desired to prevent or permit only a small amount of contraction, a number of alternative methods are available. If a flat, glazed finish with good cover is required such as may be suitable for some umbrella fabrics, a high temperature (170°-180° C.) calendering treatment may be employed. The fabric is then wetted out, scoured and dyed on the jigger, followed by open width hydro-extraction and clip stentering. Other methods of pre-setting nylon/*Fibro* fabrics are steaming at 30-40 lb. pressure on a perforated tube in a kier or an enclosed decatizer, or running through boiling water in an enclosed jigger. In the latter case the warp tension applied to the fabric will control the dimensions of the set fabric.

There are many other types of fabrics made from *Fibro* yarns, or *Fibro* and other yarns in the same fabric; some are made from the yarns already mentioned, e.g., crêpe fabric made from a *Fibro* warp and crêpe viscose weft, and others are made with fibres not mentioned, e.g., blend and mixture fabrics made from *Fibro* with *Fibrolane* or wool or silk—particularly spun silk. The examples already given will, however, indicate the type of processes required, modifications having to be made according to the type of other fibre present, such as a crabbing treatment for fabrics containing wool and a de-gumming treatment for those containing silk.

General Finishing. At various stages of the description of finishing and other processes, mention has been made of

the care that should be exercised to prevent stretching of fabrics during processing. Stretched fabrics do not give consumer satisfaction nor do they reveal the intrinsic merits of *Fibro*. A reasonable control maintained in making and processing fabrics will ensure a serviceable finished fabric. Fabrics made from or containing *Fibro* do not require nursing through every process, nor is it necessary in every case to obtain full relaxation shrinkage. It is essential that the fabric should be adequately shrunk so that any further shrinkage which may take place in natural use is within commercial limits. It is undesirable that a process such as the anti-crease process should be used to stabilise temporarily a fabric in a stretched condition. Providing a fabric is of sound construction and is processed intelligently it will not shrink unduly nor suffer from bagging, but will have the full, mellow handle characteristic of *Fibro*.

CHAPTER XXIII

PREPARING AND DYEING *FIBRO*/WOOL BLENDS

THE wet processing of *Fibro* blended with wool will depend on whether it is spun on the worsted or woollen system; a woollen-spun yarn will probably contain a large percentage of oil which is in the main saponifiable, while worsted-spun yarn will contain a small amount of an emulsifiable oil.

Processes involving the use of concentrated mineral acids as in the carbonising process must not be used, neither must hypochlorite bleaching be performed owing to the adverse effect of this reagent on wool.

Yarns, fabrics, etc. constructed from wool, felt under the influence of moisture and mechanical action, while *Fibro* materials do not. In general, blends of *Fibro* and wool will felt to an intermediate extent, which will depend both upon the structure and upon the relative amounts of the fibres in the mixture. In certain cases a blend containing a small amount of *Fibro* may shrink more than wool.

Yarn. Should it be desirable to set the yarn before scouring, it is put under tension upon frames which are immersed in boiling water in the normal manner for all-wool yarns.

Scouring is usually carried out on continuous tape machines, and as the original *Fibro* is clean, less difficulty is experienced in cleansing the blend than with an all-wool yarn. Alternatively, the scouring can be performed in the dye-vessel, and this is especially so of worsted spun yarn, the yarn being dressed as for dyeing; after scouring in the dyeing machine it is thoroughly rinsed.

Bleaching. When it contains more wool than *Fibro*, it is often necessary to bleach the yarn especially if white and bright shades are needed, and in such cases the peroxide bleach is recommended. For bulk work it has been generally found that steeping overnight in a cold bath containing 2 volumes of hydrogen peroxide adjusted to pH 9 with 5 cc. of ammonia (.880), and 5 grams of sodium silicate (specific gravity 1.7) per litre is satisfactory. Sulphur stoving, after the peroxide treatment, is often used to give a "bloomy" white, although the usual precautions needed with this process are of course necessary. Peroxide bleaching should on no account be carried out in vessels containing iron, copper or monel metal; vessels of wood, earthenware or stainless steel are satisfactory.

Half Hose. Scouring and bleaching processes are performed in the same plant as is used for wool. Although the presence of *Fibro* in hosiery usually tends to lessen the shrinkage during subsequent washing, it is often advisable to impart a shrink resistant finish. For this the normal chlorination processes can be used to obtain satisfactory results, provided strict control is exercised during the operations. Experience has shown that such processes as Drisol, W.I.R.A., dry chlorination, Negafel, Epilox, Papain, N.S., are quite effective, and that the results obtained from their use on *Fibro*/wool fabrics compare very favourably with those on corresponding wool fabrics. Mineral acids must not, of course, be allowed to dry on the material.

Fabrics. Processes necessary to the required finish of all-wool fabrics are in general applicable to *Fibro*/wool fabrics of similar construction, the final finish being always determined by the procedures adopted more especially in the preparatory treatments.

Setting or Crabbing. The above general remarks apply to this process, but it is desirable to determine by laboratory

trials whether it is essential to give the desired "set" so that distortion or "cockled" effects may be avoided; fabrics made from *Fibro*/wool blends usually shrink less than similar fabrics made from wool.

Many wool fabrics need to be set by a prolonged treatment with hot water in a crabbing machine and, although this process may be used successfully with the *Fibro* blend, sufficient stability in some fabrics can be obtained by subjecting them to a steaming operation. The steam may be passed through the fabric, either in roll or batch form, and standard machines can be used. As with wool fabrics it is advisable to re-roll and re-steam the fabric to obtain even results and level shades in the subsequent dyeing operations.

Scouring. The standard dolly scouring process can be used to give good results, but with light-weight fabrics and those in which *Fibro* preponderates, it is advantageous to use one of the newer types of machine in which the roller weight can be controlled, as by this means longitudinal cracks can be avoided.

If care is taken to keep the grey fabric reasonably clean, a modified procedure can often be adopted which will secure a better handle than would otherwise be so.

It cannot be too greatly emphasised that a suitable soft water aids scouring, and with it the following treatment will give satisfaction: Scour the worsted-spun fabric for 15 minutes at a temperature not exceeding 40° C. in a bath consisting of 30 gallons soda ash solution of 2° Tw. and 5% soap on weight of goods per 100 lb. of fabric, and finally wash off thoroughly with water at the same temperature.

Milling. This process is essential to the production of characteristic finishes—"milled finish"—on *Fibro*/wool fabrics. The amount of milling shrinkage produced by a standard treatment generally decreases with the *Fibro* content, and this must be taken into consideration in the milling procedure.

The effect of cloth construction, the degree of milling required and many other factors must be taken into account, and Whewell and others (*J. Soc. Dyers and Colourists*, 1943, 59, page 233) have shown that in some instances a limited amount of *Fibro* added to wool will slightly increase the degree of shrinkage obtained in subsequent milling.

Experience has shown that in *Fibro*/wool fabrics the length of cellulose fibre is of no consequence so far as milling shrinkage is concerned; therefore the independence of milling shrinkage on staple length has considerable value, as it is possible to increase the yarn strength by increasing the staple length without altering the milling properties of the fabric; so that, to produce the strongest milled cloth, the longest staple length of *Fibro* should be used consistent with the construction of the fabric. With the exception of special constructions and those containing a high proportion of *Fibro*, *Fibro*/wool fabrics can be handled in the same way as corresponding all-wools. The standard procedures used for "grease milling" and "soap milling" can be adopted and under certain conditions dilute organic acids can be used in the milling. The following method of soap milling exemplifies a suitable treatment for *Fibro*/wool coating fabrics:

100 lb. of fabric is run wet into the milling machine and 2 gallons of a 5% solution of soap added. Milling is continued for the time necessary to obtain the required dimensions, further soap being added at intervals.

In acid milling it is advisable, as mentioned, to use formic or acetic acid rather than the sulphuric acid more usual for wool, and it is essential that washing off after milling should be complete.

Combined Scouring and Milling. The processes of scouring and milling for *Fibro*/wool fabrics are often carried out in one operation on a machine designed for this purpose, which usually gives better results through better control.

Washing-off Process. As indicated, a thorough washing-off process, using a suitable soft water after scouring and milling treatments, ensures against subsequent dyeing and finishing faults.

Peroxide Bleaching. Peroxide bleaching of *Fibro*/wool fabrics is usually carried out on a winch machine as follows:

2 volumes solution Hydrogen peroxide.

5 cc. per litre Ammonia .880.

5 gms. per litre Sodium silicate 1.7 sp. gr. to give pH 9.
for 2 hours at 50° C.

Drying. While it is possible to dry *Fibro*/wool fabrics by

methods normal with all-wools, it is as well to bear in mind that the recommendations already made for the drying of fabrics made entirely from *Fibro* can be introduced with advantage to the subsequent handle of *Fibro*/wool fabrics, and especially of those containing a high proportion of *Fibro*.

Finishing. Finishing processes similar to those used for all-wools can be adopted for *Fibro*/wool fabrics, although again consideration should be given to the fact that some modification in procedure will be necessary according to the *Fibro* content.

As already stated, the final finish required is determined in the preparatory treatments so that dyed fabrics can be raised and cropped where required. Steaming processes such as decatizing can be used advantageously with many *Fibro*/wool fabrics; like that of other similar ones, their handle responds appreciably to conditioning treatments.

Dyeing. *Fibro*/wool blends are normally dyed, not in the staple, but in yarn or fabric form; and in general the machinery normally used for dyeing similar all-wool materials is suitable.

Hussong machines are largely used for yarn dyeing although with certain fine yarns package dyeing methods are preferable. Half hose can be dyed in the usual types of injector or paddle machines employed for 100% wool. Winch dyeing machines are generally employed for both knitted and woven fabrics.

As the direct cotton dyes often used in union dyeings stain wooden vessels, thus causing difficulties with the next batch of material to be dyed, it is advisable that all machines be made of stainless steel.

It may be desired that one fibre only should be dyed and the other reserved white, or again that the two fibres may be required to be dyed the same shade, or occasionally contrasting shades. The fastness requirements also vary with the use to which the mixture is ultimately to be put. For women's knitted wear, knitting yarns etc., fastness to light, washing and perspiration only are expected, whereas for suitings a high all-round standard of fastness is required. A large number of methods of dyeing have therefore been used, some of which are referred to below.

Stress has been placed on the importance of filament denier on the apparent depth of shade obtained from a given amount of dye; it applies equally in union dyeing as in dyeing 100% *Fibro*. A further factor to be kept in mind is the proportion of *Fibro* to wool, and it will be readily appreciated that a dye mixture which gives a solid shade on a 50/50 blend will not give the same result where only 10% *Fibro* is present.

Dyeing Wool and Reserving Fibro—Acid Dyes. The level-dyeing acid dyes are usually suitable for this purpose, whereas some of the fast to milling acid dyes stain *Fibro* to some extent. The use of sulphuric acid is not recommended on account of the possibility of tendering the *Fibro* during the subsequent drying. Only a minimum of Glauber's salt is used to obtain levelness and typical additions to the dye liquor are:

4% *Formic acid*.

10% *Glauber's salt crystals*.

Dyeing is usually commenced at 40°–50° C., the dye liquor being heated to the boil and then boiled for $\frac{3}{4}$ hour, or until the required shade is obtained. The dyeing may then be washed off in warm water, hydro-extracted and dried. The material should not be left lying in a wet condition, or the dye may bleed on to the white *Fibro*.

Green

9 lb. 1/36s worsted counts 50% 4 $\frac{1}{2}$ denier 6-inch *Fibro*; 50% wool in cheese form, dyed in 130 gallons in enclosed machine.

Scoured with:

0.2% *Solution soap*

0.05% *Solution ammonia*

4 oz./100 gallons *Calgon T*

50° C. $\frac{1}{2}$ hour

Washed off at 40° C. with:

2 oz./100 gallons *Lissapol LS*

4 oz./100 gallons *Calgon T*

Dyed with:

0.35% *Alizarine Brilliant Green G*

0.1% *Coomassie Yellow R.200*

1% *Acetic acid* 80%

Dyeing commenced at 40° C., the temperature of the dye liquor raised to the boil in $\frac{1}{4}$ hour, and maintained $\frac{1}{4}$ hour.

Dyeing Wool and Reserving Fibro—Neolan Dyes. These may be used where good fastness to light and washing are required. It is recommended that dyeing should commence with 10% Glauber's salt and 3%–4% sulphuric acid for a 50/50 *Fibro*/wool mixture. The dye liquor is then heated to the boil in $\frac{1}{2}$ – $\frac{3}{4}$ hour and this temperature maintained for 1 $\frac{1}{4}$ hours. The sulphuric acid may be increased or decreased to maintain 6%–8% acid on the total weight of wool present. After dyeing, the goods should be well rinsed and a little ammonia or soda ash added to one of the rinse waters so that no free acid is dried in the material. If formic acid is used in place of sulphuric acid, there is some loss in levelness and penetration, but the possibility of tendering on drying is removed.

Combination shades are usually produced with mixtures of the following dyes :

Neolan Blue GG.
Neolan Blue 2R.
Neolan Bordeaux B.
Neolan Green BG.
Neolan Pink BA.
Neolan Orange GRE.
Neolan Red BRE.
Neolan Yellow BE.

The other members of the Neolan series are also suitable for dyeing the wool in wool/*Fibro* mixtures.

Mid Brown

80 lb. 50/50 *Fibro*/wool serge in 25 volumes scoured with :

0.2% *Solution soap*
0.05% *Solution ammonia*
4 oz./100 gallons *Calgon T*
50° C. for 1 hour

Washed off at 40° C. with :

2 oz./100 gallons *Lissapol LS.*
4 oz./100 gallons *Calgon T*

Dyed with:

0.55% *Neolan Yellow BE.*

0.5% *Neolan Red BRE.*

0.38% *Neolan Blue 2G.*

8% *Formic acid*

10% *Glauber's salts*

Dyeing commenced at 40° C., the dye liquor heated to the boil and maintained 1½ hours.

Dyeing Wool and Reserving Fibro—Chrome Dyes. Of the three chief methods of applying chrome dyes to wool—chrome mordant, metachrome, and afterchrome—the last-named is the most important for reserving the *Fibro* in wool/*Fibro* mixtures. The following is typical of this method of dyeing. The material is entered into the dye liquor containing the dissolved dye and 1%–2% acetic acid 80%. The addition of Glauber's salts is of doubtful value with many chrome dyes. The dye liquor is heated from 40° C. to the boil in ½ to ¾ hour and this temperature is maintained for ¾ hour. Additional acetic or formic acid may be added during this period to ensure exhaustion of the dye. The liquor is then cooled and the requisite bichrome added, after which the dye liquor is brought to the boil and this temperature again maintained ½ to ¾ hour. The material is then rinsed in warm water and dried.

It is essential for the dye liquor to be exhausted before the bichrome is added; a safer alternative is to run the dye liquor away and chrome in a fresh liquor containing bichrome and acid. As the dye on the wool is now fast, a mild clearing process can be applied if necessary.

Grey

20 lb. 1/36s worsted counts 50% wool 50% 4½ denier
6-inch *Fibro* in cheese form, dyed in 80 gallons in
enclosed machine.

Scoured with:

0.2% *Solution soap*

0.05% *Solution ammonia*

4 oz./100 gallons *Calgon T*

Washed off at 40° C. with:

2 oz./100 gallons *Lissapol LS.*

4 oz./100 gallons *Calgon T*

Dyed with :

- 0.7% *Eriochrome Brown R.*
- 0.45% *Solway Blue Black B.150.*
- 0.04% *Chrome Fast Yellow O.*
- 1% *Acetic acid 80%*

Dyeing was commenced at 40° C. the temperature of the dye liquor raised to the boil in $\frac{1}{2}$ hour and maintained 40 minutes. The dyeing was then chromed in a fresh liquor at the boil for $\frac{1}{2}$ hour with :

- 0.5% *Bichrome*
- 2% *Formic acid*

Dyeing Fibro and Reserving Wool—Direct Dyes. The majority of direct cotton dyes will dye or stain wool at high temperatures, in fact a few such as Chlorazol Fast Red F. are applied to wool. At lower temperatures the affinity is much reduced and there is a wide range of dyes which will reserve wool. A further precaution is to add a small amount of alkali (for example, 1% soda ash to the dye liquor) or alternatively one of the proprietary products sold for this purpose, such as :

- Tanninol WR.
- Resistone W.
- Thiotan RS.
- Erional L and CL.

One per cent to 6% of one of these products is added to the dye liquor after the dye and before entering the material. Three per cent is the usual addition.

The most important factors in reserving the wool are the use of low temperatures and the correct selection of dyes. The usual method, therefore, is to set the cold dye liquor with the selected mixing of direct cotton dyes, and salt may be added. A resist agent or a little alkali may be added and the material is entered. The temperature is then raised to 40°–50° C. and maintained for the duration of dyeing. Lists of suitable dyes are published by the dye makers, and the makers of wool-resist agents also publish lists showing the maximum temperatures at which the dye still reserves the wool in the presence of their products. It will be appreciated that the nature and proportion of the wool is important and that conditions satisfactory for virgin wool

may not be satisfactory for carbonised, chlorinated or re-worked wool.

Amethyst on Fibro, wool reserved

40 lb. knitted fabric of 50% wool 50% *Fibro* dyed in winch machine in 100 gallons.

2.4% *Chlorazol Fast Pink BKS.*

0.2% *Chlorantine Fast Blue GLL.*

0.08% *Chlorazol Fast Orange AGS.*

3% *Tanninol WR.*

20% *Salt.*

Dyeing commenced at 40° C. without salt, the temperature raised to 70° C. and maintained 1 hour, during which time the salt was added slowly.

Dyeing Fibro and Wool—Solid Shades—Two-bath Dyeing.

By first dyeing the wool and then the *Fibro* by suitable methods chosen from those outlined, solid shades can be obtained. By the employment of such methods a better handle and brighter shades can be obtained than by the usual one-bath method.

The most common procedure is to dye the wool content of the union first with wool dyes of the requisite fastness, usually level-dyeing acid dyes, though, if desirable, fast to milling, Neolan or chrome dyes may be used. When the desired shade is obtained on the wool, the material is well washed off to remove, as far as possible, traces of acid which would interfere with the next stage. The material is then dyed with a selection of the dyes which will dye the *Fibro* while reserving the wool. To get the best value from the cotton dyes the ratio of liquor to material should be as low as possible.

On the market are products (for example, *Fibrofix* and "Fixanol") which improve the fastness of direct cotton dyes to water and to acid conditions. It is therefore possible to dye the *Fibro* at a low temperature with selected direct cotton dyes, to treat with one of these products and then dye the wool with acid dyes. The direct dyed material, after rinsing well, is treated in the cold for 20 to 30 minutes with 1% to 2% "Fixanol" or 3% *Fibrofix*, or else *Fibrofix* and copper acetate, as recommended in Chapter 18. After rinsing, the wool is then dyed with acid dyes.

Two-tone Effects. The above two-bath methods of dyeing solid shades on *Fibro*/wool unions can be used to produce two-tone or contrasting tone effects. In some cases, however, sullyng of one fibre may take place during the dyeing of the other fibre, and allowance will have to be made for this.

Solid Shades—One-bath Dyeing. *Fibro*/wool unions are usually dyed with mixtures of direct cotton and acid dyes by the one-bath method. The method is cheap and quick, but requires considerable skill in controlling the solidity and matching to shade. Two distinct approaches may be made. Either direct cotton dyes should be used which dye the wool and *Fibro* equally under suitable conditions, if necessary bringing to shade with direct cotton or neutral dyeing acid dyes; or, alternatively, direct cotton dyes which stain wool as little as possible, together with neutral dyeing acid dyes which stain the *Fibro* only slightly.

The former method is useful either where only straight shades of a dye are required, or for some heavy shades. However, where compound shades are required it is difficult to obtain dyes which will distribute themselves in the same proportions on the wool and *Fibro* throughout the whole time of dyeing. Furthermore, there are few direct blues or navy-blues which will dye wool as heavily as *Fibro*.

The temperature or other conditions of dyeing will also have to be altered when changing from one blend to another; for example, when changing from virgin wool to shoddy or chlorinated wool or from one denier of *Fibro* to another.

Bright Yellow

Worsted Counts

150 lb. 3/12s 50/% *Fibro* 50/% wool, knitting yarn in
Hussong machine 550 gallons.

Scoured with:

0.02% *Solution soap*
0.05% *Solution ammonia*
4 oz./100 gallons *Calgon T*
50° C. for 1 hour

Washed off at 40° C. with:

2 oz./100 gallons *Lissapol LS.*
4 oz./100 gallons *Calgon T*

Dyed with :

1.3% *Chlorazol Fast Yellow 5GK.150.*

20% *Salt*

Dyeing commenced at 40° C., the dye liquor was heated to 95° C. and maintained 1 hour at that temperature.

When dyes with affinity for one fibre only are used, the recipe may appear cumbersome, often containing six dyes, three for the wool and three for the *Fibro*. Greater control is available, however, since additions can be made to the bath which will change the shade of one fibre, leaving the other substantially unaffected.

The fastness obtainable by this procedure is also better than where direct dyes (which dye both fibres equally) are used, since these are usually only of medium fastness to light and often have poor fastness to washing. The range of direct dyes which do not greatly dye wool at high temperatures is large, including some of the members of the series fastest to light and to washing.

All the neutral dyeing members of the acid dyes range may be used.

Dyeing is commenced at a low temperature and the dye liquor is slowly heated to the boil. For heavy shades salt may be added at the commencement of dyeing, particularly as by doing so the direct dye is fixed on the *Fibro* and so cannot stain the wool at the high temperature. The temperature is maintained just below the boil and dye additions are made to bring the two fibres to the correct shade. When this point is approached the temperature should be allowed to fall to ensure that no direct cotton dye boils off the *Fibro* on to the wool.

The *Fibro* can be brought to shade by the further additions of direct cotton dye and, if necessary, salt. A suitable wool-resist agent may be added to the cooling bath to ensure that the wool does not become further stained. Should the wool require a slight shading the following dyes have a reasonable affinity and are level dyeing at reduced temperatures in neutral dye liquors.

Citronine R.

Orange II.

Alizarine Light Red R.

Disulphine Blue A.

Kiton Fast Green V.

The dyeing should be well washed off.

Some direct cotton dyes, especially blues and greens, reduce readily; and, as wool in a boiling neutral liquor has reducing properties, there is the possibility of some destruction of dyes in union dyeing, but an addition of ammonium sulphate will prevent this.

Solid Brown

120 lb. 2/24s 50% 4½ denier 6-inch *Fibro* 50% 64s wool,
dyed in hank form in Hussong machine, 550 gallons.

Scoured with:

0.2% *Solution soap*
0.05% *Solution ammonia* .880
4 oz./100 gallons *Calgon T*
50° C. ½ hour

Washed off at 40° C. with:

2 oz./100 gallons *Lissapol LS*.
4 oz./100 gallons *Calgon T*

Dyed with:

0.22% *Coomassie Yellow R*.200%
0.2% *Coomassie Red PGS*.
0.14% *Cloth Fast Blue RN*.112½%
1.0% *Chlorazol Fast Orange AG*.125%
0.32% *Direct Fast Scarlet SE*.170%
0.35% *Chlorantine Fast Blue GLL*.200%
10% *Salt*

Dyeing was commenced cold, the dye liquor raised in 1 hour to 90° C. and maintained 1 hour at 90° C.

Where still better wet fastness is required than is obtainable by the foregoing one bath-dyeing, the neutral dyeing acid dyes may be replaced by metachrome dyes, and the direct cotton dyes selected must be of the best fastness to wet processing and also withstand chrome.

The dye liquor is set with 3% to 8% *Metachrome mordant* or 2% to 4% *Ammonium sulphate*.

1% to 2% *Potassium or sodium chromate*—

and the dyes. The material is entered at a low temperature and the dye liquor heated to the boil in ½ to 1 hour. Dyeing must be continued for at least 1 hour to ensure full development of the chrome dyes. Suitable chrome dyes are as follows:

Chrome Fast Brown R.
Chrome Fast Yellow G.
Cloth Fast Blue RN.
Cyanine Fast Black B and 2B.
Eriochrome Brilliant Violet B.
Eriochrome Orange 2RL.
Eriochrome Verdone G.
Metachrome Brown B.
Metachrome Brown R.
Metachrome Olive Brown G.
Omega Chrome Brilliant Blue B.
Monochrome Green B.
Solochrome Black F.
Solochrome Brown RS.
Solway Green G.

Direct cotton dyes may be chosen from :

Chlorantine Fast Blue GLL.
Chlorantine Fast Green 5GLL.
Chlorantine Fast Violet 5BLL.
Chlorazol Fast Orange AG.
Chlorazol Fast Scarlet 8BS.
Chlorazol Fast Yellow FGS.
Diphenyl Brilliant Blue FF. †
Diphenyl Chlorine Yellow FF.
Diphenyl Fast Blue Green BL.
Direct Fast Scarlet SE.
Formic Black MTG.
Paramine Black BH.
Solar Orange RGL.

Fibro dyed by this method is not so fast as wool to washing, and in certain shades is much inferior. This can be overcome by after-treatment with *Fibrofix*, or, where the light fastness is also of importance, by *Fibrofix* and copper acetate.

The dyed material is after-treated with :

3 % *Fibrofix*, or
3 % *Fibrofix*, 2 % Copper acetate.

The treatment is carried out at 40° C. for 20 minutes, and a little change in shade is obtained with most dyes. To obtain the maximum improvement the bath containing the

material may be raised to 80°–90° C., but this is accompanied by a greater shade change.

Most dye makers supply ranges of mixed acid and direct dyes and chrome and direct dyes. The former type are usually divided into two classes, one of medium to good fastness to light and the other of no particular fastness.

All these ready-made mixtures are dyed by the methods outlined earlier. While they offer advantage in convenience and simplicity for dyeing certain shades or certain blends, it will be appreciated that in general such is the variety of materials passing through the dyer's hands that no mixture of dyes can be expected to give solid shades on them all; therefore, the intelligent dyer should make his own mixings of wool and cotton dyes.

For pale, bright shades the Soledon dyes may be applied by the one-bath method to give shades of excellent solidity. The material is entered at 60° C. in a bath containing the dye, ammonium thiocyanate, diethyl tartrate and a penetrating agent, and this is dried and steamed in moist steam at 100° C. for $\frac{1}{2}$ hour. Development of the shade is completed by immersing the fabric for 3 minutes in a solution comprising 10 parts ammonium persulphate, 3 parts acetic acid (30%) and 1,000 parts water.

CHAPTER XXIV

PREPARING AND DYEING *FIBRO/RAYOLANDA* BLENDS

Fibro and *Rayolanda* combined facilitate the production of colour effects which, for the most part, are otherwise possible only by blending wool with *Fibro* or with cotton.

All the classes of dyes used for *Fibro* may be used for *Rayolanda*. Thus *Rayolanda/Fibro* blends may be dyed with direct cotton, sulphur, vat, Soledon, and azoic dyes; in addition the *Rayolanda* may also be dyed with dyes used for wool.

Using selected wool dyes it is possible to dye the *Rayolanda* only and leave the *Fibro* white or slightly tinted, providing the depth of shade on the *Rayolanda* is not too heavy.

FIGURE 41

0.5% CHLORAZOL FAST BLACK BK 200. 1/24's "FIBRO",
1/24's "RAYOLANDA", BOTH 4.5 FIL. DEN.
DYED IN 40 VOLS. FOR 30 MINS.

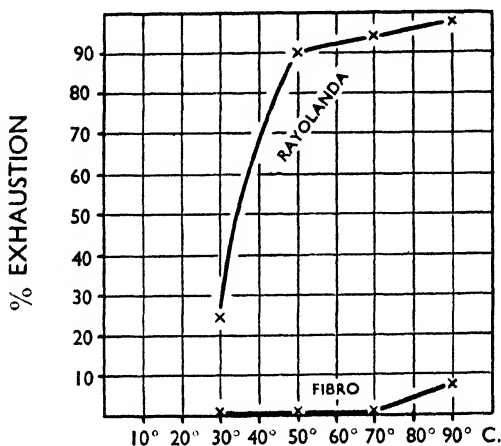

EFFECT OF TEMPERATURE WITHOUT SALT

Preparation. Yarn or fabrics consisting of *Rayolanda* and *Fibro* do not require a kier boiling; a light scour is sufficient. As the dyeing affinity of *Rayolanda* is reduced by severe scouring at high temperatures the scour should be carried out at as low a temperature as will give the required result, while full use should be made of the newer detergents. On no account must *Rayolanda* be submitted to a hypochlorite bleaching process, which destroys its special affinity for dyes, though not its full resilient handle. It may be bleached with peroxide.

Dyeing—Direct Cotton Dyes. This class of dye is capable of giving tone-in-tone or solid effects by control of the temperature of the dye liquor and the amount of common salt used.

The wide degree of control possible is shown by the

FIGURE 42

0.5% CHLORAZOL FAST BLACK BK 200. 1/24's "FIBRO
1/24's "RAYOLANDA", BOTH 4.5 FIL. DEN.
DYED IN 40 VOLS. FOR 30 MINS.

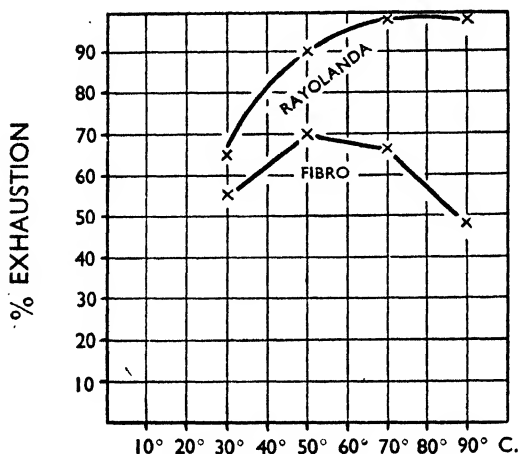

EFFECT OF TEMPERATURE WITH 5% SALT

curves in *Figures 41 to 47*, dealing with Chlorazol Fast Black BK 200% and Chlorantine Fast Blue GLL 200%.

Comparative dyeings were made under the same conditions on 1/24s worsted counts *Fibro* and *Rayolanda* both of $4\frac{1}{2}$ filament denier.

Figures 41 and 42 show the difference in relative exhaustion of Chlorazol Fast Black BK 200% at different temperatures with and without common salt addition.

Figures 43, 44 and 45 show the different exhaustion of Chlorantine Fast Blue GLL 200%, with and without common salt at different temperatures.

Figures 46 and 47 show the effect of time on the rate of exhaustion of Chlorantine Fast Blue GLL 200%, and Chlorazol Fast Black BK 200% at 90° C.

These curves show once more the marked individualism

FIGURE 43

0.5% CHLORANTINE FAST BLUE GLL 200. 1/24's "FIBRO"
1/24's "RAYOLANDA", BOTH 4.5 FIL. DEN.
DYED IN 40 VOLS. FOR 30 MINS.

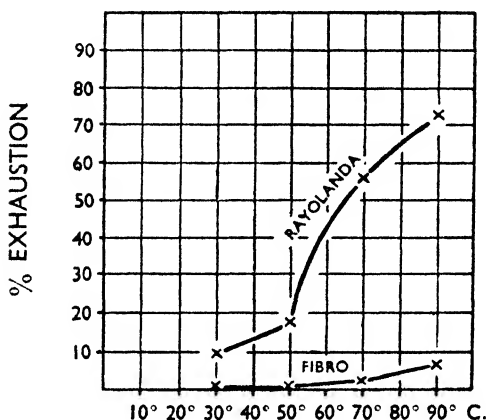

EFFECT OF TEMPERATURE WITHOUT SALT

of dyes of the same class. They show clearly the influence of common salt on the relative depth of shade on the *Rayolanda* and *Fibro*, thereby indicating that the greatest contrast between the two fibres is obtained in the absence of salt.

It has to be understood that the direct cotton dyes have to be carefully selected to give the desired effects. For compound shades the golden rule of choosing dyes which dye on at the same rate must be observed as far as possible.

Tone-in-tone Effects. Tone-in-tone effects may be produced with the direct cotton dyes by working at high temperatures and making only small or even no salt additions. In general, the lower the amount of salt and the higher the temperature, the greater the contrast obtained with all direct cotton dyes—the heavier shade being on the *Rayolanda*. For example, using $\frac{1}{2}$ % Benzanil Fast Orange ER and $\frac{1}{2}$ % Chlorantine Fast Blue GLL with 10% salt and

FIGURE 44

0.5% CHLORANTINE FAST BLUE GLL 200. 1/24's "FIBRO"
1/24's "RAYOLANDA", BOTH 4.5 FIL. DEN.
DYED IN 40 VOLS. FOR 30 MINS.

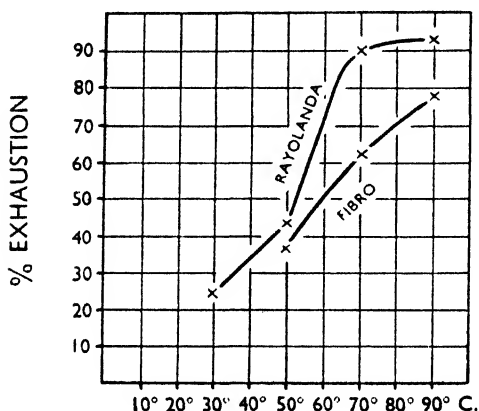

EFFECT OF TEMPERATURE WITH 10% SALT

dyeing for $\frac{1}{2}$ hour at 90° C. a very attractive tone-in-tone grey is obtained, the *Rayolanda* being dyed much heavier than the *Fibro*.

As in dyeing *Rayolanda*/wool blends, however, dyeing should be started at room temperature and the salt added in portions at the maximum temperature.

Solid Shades. Many of the most satisfactory direct cotton dyes for producing solid shades on *Rayolanda*/*Fibro* blends are those which dye slowly, such as Chlorazol Fast Orange AG. These dyes may be found at the lower end of the list of dyes given by Boulton and Reading (see *J. Soc. Dyers and Colourists* 1944, page 14). It will be found that, in general, a more solid effect is obtained by increasing the amount of added salt, since the shade on the *Fibro* increases with increasing amounts of salt, whereas the shade on the *Rayolanda* is less dependent on salt addition. Again, the lower the temperature of dyeing the more solid the effect, since

FIGURE 45

0.5% CHLORANTINE FAST BLUE GLL 200. 1/24's "FIBRO"
1/24's "RAYOLANDA", BOTH 4.5 FIL. DEN.
DYED IN 40 VOLS. FOR 30 MINS.

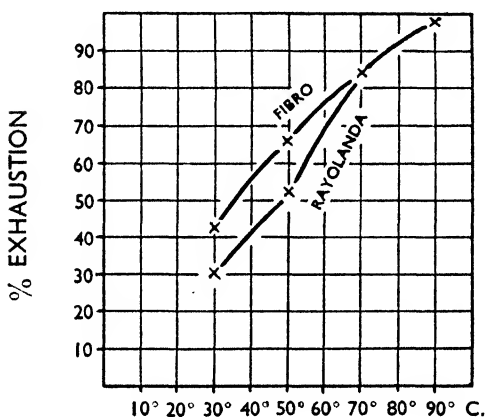

EFFECT OF TEMPERATURE WITH 20% SALT

the dyeing of *Rayolanda* is relatively more affected by lowering the temperature than is that of *Fibro*; it should be understood that with the direct cotton dyes the tendency is for *Rayolanda* to be dyed a heavier shade than *Fibro*. As the depth of shade on *Fibro* increases with decreasing liquor volume, whereas the affinity of *Rayolanda* is relatively independent of liquor volume, it follows that the smaller the volume the more readily is a solid shade obtained.

For example, the slow-dyeing Chlorantine Fast Blue GLL and Chlorazol Fast Orange AG give a solid shade on *Rayolanda/Fibro* if dyed at 60° C. with 20% salt, whereas with the more rapid-dyeing Pyralon Orange G a solid shade is obtained at 30° C. using 20% salt. With Pyralon Orange G smaller quantities of salt make little difference at 30° C., but by using a higher temperature with 20% salt the *Rayolanda* is dyed much more heavily than the *Fibro*.

FIGURE 46

0.5% CHLORANTINE FAST BLUE GLL 200. 1/24's "FIBRO"
1/24's "RAYOLANDA", BOTH 4.5 FIL. DEN.
DYED IN 40 VOLS. AT 90° C.

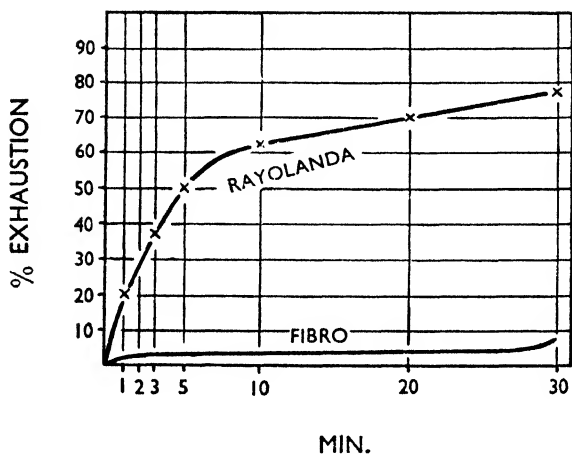

EFFECT OF TIME WITHOUT SALT

Fastness. The direct cotton dyes are distinctly better in washing fastness when dyed on *Rayolanda* than when dyed on *Fibro* of the same filament denier or on cotton, an advantage which enables the dyer in many cases to use dyes for washing shades which normally could only be obtained either by suitable after-treatment or in some cases by the use of faster and more expensive dyes. On the other hand, the light fastness of some of the direct cotton dyes is adversely affected, but a sufficient number are available to produce the wide variety of shades demanded.

The following is a list of dyes whose light fastness is not seriously reduced:

Benzanil Fast Orange ER.	Diphenyl Fast Brown 8GL.
Benzopurpurine 4B	Diphenyl Chlorine Yellow FF.
Chloramine Purple 10BC.	Durazol Fast Blue 8GS.

Chlorantine Fast Blue GLL.	Durazol Fast Grey VG.
Chlorantine Fast Blue 3GLL.	Durazol Fast Violet 2BS.
Chlorantine Fast Brown BRLL.	Formic Black MTG
Chlorantine Fast Rubine RNLL.	Neolan Green BL
Chlorazol Fast Black BK.	Paramine Black BH.
Chlorazol Fast Orange AG.	Pyralon Orange G
Chlorazol Fast Pink BK	Rigan Blue G.
Chlorazol Fast Red FS	Rigan Green G.
Chrysophenine G	Solar Orange RGL.
Diazol Lt. Bordeaux N6B.	Solar Rubinole B.
Diazol Lt. Yellow N ₄ J.	Solar Yellow 2R.
Diphenyl Brilliant Blue FF.	Solophenyl Red Brown.
Diphenyl Fast Blue Green BL.	Trisulphon Violet B

A combination of Chlorantine Fast Blue GLL, Durazol Grey VGL, Chlorazol Fast Orange AG, and Benzanil Fast Orange ER enables a wide range of fawns, greys, etc., of good light fastness to be obtained.

In addition to the dyes given in the above list it is possible to use a number of other dyes in heavy shades, their use being precluded only for light and medium shades. They can also be used where light fastness is unimportant.

Sulphur Dyes. Sulphur dyes can be used for the production of solid shades on *Rayolanda* and *Fibro* where a greater degree of fastness to washing is required than is obtained with the direct cotton dyes.

In general solid shades are obtained at 90° C. with the addition of 20% salt to the dye liquor. Thionol Black B, Pyrogene Direct Blue RL, and Pyrogene Brown 6R give solid shades.

Tone-in-tone effects may be obtained with these dyes by working at low temperatures, for example 40° C. at which temperature a heavier shade is obtained on the *Fibro*. The greater relative depth of shade on *Fibro* becomes more pronounced with increased salt additions.

Vat Dyes. The vat dyes may be used to produce solid

FIGURE 47

0.5% CHLORAZOL FAST BLACK BK 200. 1/24's "FIBRO"
 1/24's "RAYOLANDA", BOTH 4.5 FIL. DEN.
 DYED IN 40 VOLS. AT 90° C.

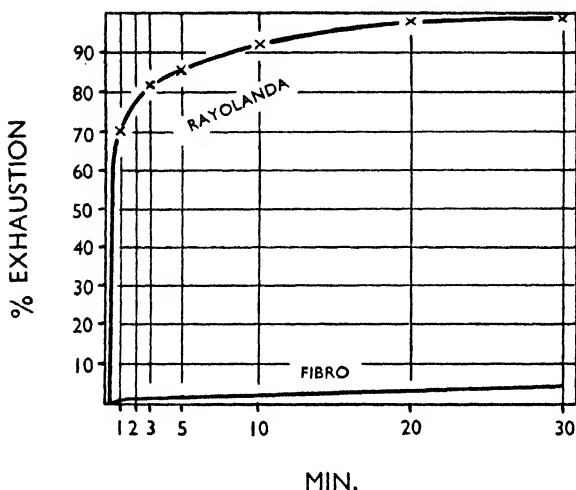

EFFECT OF TIME WITHOUT SALT

shades. When dyed with the usually recommended quantities of caustic soda and sodium hydrosulphite the *Fibro* is dyed slightly heavier than the *Rayolanda* at low temperatures, but the *Rayolanda* dyes to the same depth or to a slightly heavier shade as the temperature is raised, depending on the actual dyes used.

For example, Caledon Jade Green when dyed at 30° C. dyes the *Fibro* slightly heavier than the *Rayolanda*, whereas at 80° C. the two fibres are dyed to a solid shade.

Solubilised Vat Dyes. These dyes give tone-in-tone or, in some cases, dyed-and-white effects on *Rayolanda*/*Fibro* fabrics; the *Rayolanda* is always more heavily dyed.

Fabrics so dyed are suitable for shirtings, pyjamas and other articles which must be fast to power laundering. The fastness to light varies and corresponds to that of the vat

dyes, from which the solubilised vat dye is made, and, on *Rayolanda*, is equal to the fastness on *Fibro*.

To obtain the maximum contrasts between the shade of the *Rayolanda* and *Fibro*, no salt should be used in the dye liquor, the final temperature of which should be as high as possible. However, it is recommended, as with direct acid and chrome dyes, to start dyeing at room temperature. No advantage is gained by dyeing in an acid or potentially acid liquor, such as is used when dyeing these dyes on wool. The depth of shade on the *Fibro* is controlled by the addition of salt, but even the use of the maximum amounts of salt recommended in the accompanying table does not result in the *Fibro* being dyed equally in depth to the *Rayolanda* when high temperatures are used.

The following dyes will give approximately solid shades when dyed at low temperatures in the presence of salt:

Soledon Blue 2RCS.	Soledon Brilliant Orange
Soledon Gold Yellow GKS.	Soledon Pink FFS. [6RS
Soledon Gold Yellow RKS.	Soledon Brilliant Purple
Soledon Grey BS.	Soledon Red 2BS. [2RS.
Soledon Orange RS.	Soledon Scarlet BS.

It is to be noted that Soledon dyes develop more slowly on *Rayolanda* than on *Fibro*. This applies especially to the following:

Soledon Blue 4BCS.	Soledon Brilliant Orange 6RS.
Soledon Blue 4GS.	Soledon Pink FFS.
Soledon Grey BS.	Soledon Red 2BS.
Soledon Orange RS.	Soledon Red 3BS.
Soledon Orange 4RS.	Soledon Scarlet BS.

It is therefore recommended to develop these dyes on *Rayolanda* with 2% sodium nitrite calculated on the weight of material, 2 parts sulphuric acid per 100 parts liquor for 15 minutes at 35–75° C. Salt should be added to the developing bath in order to prevent bleeding of the dyes during fixation. After developing, neutralise cold in 2 gms. per litre soda ash solution followed by soaping with 3% soap on weight of yarn at 90° C. for 10 minutes.

A Table showing the dyeing characteristics of Soledon dyes on *Fibro* is included in Chapter 18, page 156, and with its aid, dyes may be selected that are suitable for leaving

Fibro white or for dyeing *Fibro* to a lighter shade than the *Rayolanda*. For example, Soledon Blue 2RCS which has a very low affinity and requires a very large amount of salt to force it on to the *Fibro*, when dyed in the absence of salt on combinations of *Rayolanda* and *Fibro* will reserve the *Fibro*. Soledon Jade Green XS paste, having a much greater affinity for *Fibro*, will under the same conditions dye the *Fibro* to an appreciable extent.

Azoic Dyes. When applied by normal methods, the azoic dyes in general dye *Rayolanda* as heavily as *Fibro*. While the distribution of dye between the two fibres in a blend can be controlled somewhat by the conditions of impregnation, marked differences in depth of shade have not been obtained. The method therefore lends itself to the production of solid shades rather than tone-in-tone effects. The fastness to light and boiling soap of azoic dyes is the same on *Rayolanda* as on *Fibro*.

CHAPTER XXV

PREPARING AND DYEING *FIBRO*/*FIBROCETA* BLENDS

THE presence of *Fibroceta* in unions necessitates the taking of a number of precautions during wet processing, such as:

(1) The use of caustic alkalis must be avoided owing to the likelihood of saponification of the *Fibroceta* with consequent loss of strength, dyeing affinity, and other desirable characteristics, such as handle and warmth. (2) When bright *Fibroceta* is treated in liquors above 75° C. de-lustering takes place; it is therefore essential, if bright finishes are desired, to avoid exceeding this temperature. If matt *Fibroceta* has been employed it is not essential to control the temperature quite so strictly. The property of sensitivity to temperature can, of course, be used to give dull finishes on bright *Fibroceta*; the degree of dullness obtained can be controlled by varying the temperature of the liquor used for this purpose. This usually consists of 2 to 5 grams of soap per litre, to which small additions of phenol (1 to 2 grams per litre)

may be added to increase dullness. As *Fibroceta* is a thermo-plastic fibre it must be handled carefully during wet processing, particularly when high temperatures are used, to avoid the formation of permanent creases. It is also important that temperature changes do not take place too suddenly, and in particular it is essential that liquors are cooled down slowly while fabrics are running on the machine, and before they are removed for hydro-extraction.

Yarn. *Fibro/Fibroceta* blend yarn can be scoured on a continuous tape scouring machine, or on a Hussong or Gerber, prior to dyeing. A suitable scouring recipe is as follows:

2.5 grams Soap flakes per litre
1-2 grams Ammonia .880
for 30 minutes at 75° C.

In most cases it is not necessary to bleach *Fibro/Fibroceta* blends, but should this be desirable bleaching can be carried out with Sodium Hypochlorite (2 to 3 grams per litre available chlorine), the pH value of the liquor being adjusted to a minimum of 10, for 30 minutes at room temperature. The yarn should be washed thoroughly and soured at room temperature with hydrochloric acid (one gram per litre), and again washed to remove all traces of acid. If the goods are to be finished white it is desirable to give a suitable antichlor.

Fabrics—Knitted and Woven. Fabrics are handled on either the jig or winch machine, depending on the construction. Knitted goods, crêpes and the softer types of dress goods are winch treated, while some linings, satin crêpes, and tropical suitings of certain constructions, are processed on the jig.

Owing to the plasticising action of hot liquors, care must be exercised during the handling of fabrics. Pieces running in the rope on a winch machine must not be subjected to excessive tension or pressure, or permanent cracks will result; also it is advisable to have a short lift from the liquor to the front roller to minimise drag, and a long draft through the liquor in order to ensure a continuous displacement of the folds. If too much tension is applied to pieces on the jig, causing them to roll too tightly, a flattening of the fabric will take place with a consequent papery handle. The

adverse effects of plasticity can be minimised by gradually raising the temperature of the liquor to the maximum required for the process, and gradually cooling off before the pieces are hydro-extracted.

Fibro warps are usually sized with starch, which necessitates an enzyme treatment to remove it. A suitable process has been described in Chapter 20, "Preparing and Dyeing *Fibro* Fabrics", page 174, and the only modification necessary is to keep the washing temperature below 70° C. when bright *Fibro* is present.

A suitable scouring process is as follows :

2.5 grams Soap flakes per litre
2.5 grams Ammonia .880 per litre
for 30 minutes at 75° C.

The fabric is washed thoroughly at 70° C. If matt *Fibro* is present, or a dull finish is required, scouring and washing can be carried out at a higher temperature.

Dyeing. One of the main advantages derived from the use of *Fibro* with *Fibro* is that novelty effects, such as two-colour, and dyed and white effects, can be obtained by cross dyeing, which enables manufacturers to carry stocks of grey goods to be dyed to seasonal shades as required.

Fibro Dyed, Fibro Reserved. The *Fibro* component can be dyed with either direct cotton or vat dyes, depending on the fastness required. For many purposes direct cotton dyes give a sufficiently high degree of fastness, although in the case of soft furnishing fabrics, tropical suitings and certain classes of sportswear, vat dyes are often required.

All direct cotton dyes do not reserve *Fibro*, but specially purified brands for this purpose can be obtained. In addition a number of the standard brands are suitable.

Direct cotton dyes are dyed from a dye liquor containing either soap or a synthetic auxiliary product (1 gram per litre) at 75° C. or (if in a dull finish) at the boil, with the addition of common salt if necessary, according to the depth of shade.

If perfect reserves are required it is inadvisable to allow the dyeing temperature to exceed 85° C. (even though matt *Fibro* has been employed), as a small amount of hydrolysis of the *Fibro* may take place and result in sullyng the

white owing to the imparted affinity for the direct cotton dyes.

For more detailed information on the selection of direct cotton dyes, for dyeing properties, and fastness, etc., reference should be made to Chapter 18, page 135.

Vat dyes cannot be applied by the usual methods for cellulose fibres, owing to the *Fibrometa* saponifying; but they can be applied by a modified process in which the excess caustic soda is buffered with sodium bi-carbonate, β -naphthol, phenol, etc.

Example A.

Fibro Dyed, Fibrometa Reserved.

80 lb. 2/32s Worsted Spun, 50% *Fibro* 50% Matt *Fibrometa*.

Dyed on the Hussong machine. Volume 200 gallons.

Fibro dyed blue *Fibrometa* reserved.

1 lb. 8 oz. C.R. Durazol Blue 3RS.

Dyed for 2 hours at 85° C.

4 lb. of common salt was added in four portions of $\frac{1}{2}$ lb. each, and 2 portions of 1 lb. each, at intervals of 10 minutes, commencing 30 minutes after the beginning of dyeing.

Fibrometa Dyed, Fibro Reserved. The *Fibrometa* is dyed with dispersed acetate dyes from an aqueous dye liquor. It is often desirable, to obtain maximum dispersion of the dye, to paste it with Turkey red oil, or other suitable wetting agent, prior to the addition of hot water; and to dye it in a liquor containing sufficient dispersing agent to prevent aggregation of the particles of dye. The need for thorough dispersion of the dye cannot be over-emphasised, as poor dispersion can be responsible for colour spots developing on the material during storage. Dyeing is usually commenced at 40°–50° C., and the temperature gradually raised (during 15 to 30 minutes) to 75° C. or the boil (depending on the finish desired) and there maintained until dyeing is complete.

The main difficulty in the dyeing of blends with dispersed cellulose-acetate dyes, is that they stain *Fibro* somewhat except in pale shades; to counteract this it is necessary to give a clearing process after dyeing, which is sometimes

liable to affect the shade. A suitable clearing procedure is to treat in a liquor consisting of:

2 grams Soap per litre
1.25 grams Sodium hydrosulphite per litre

Sufficient ammonia is added to prevent "cracking" of the soap solution. The material is treated for 20 minutes at 45° C. (or for such time as is required for giving the necessary degree of whiteness on the *Fibro*).

Black-and-white effects produced with a diazotisable black require this clearing treatment, both after dyeing and after developing.

Example B.

*Fibro*ceta Dyed, *Fibro* Reserved.

150 lb. 40% matt *Fibro*ceta, 60% *Fibro* Dress Fabric.
Dyed in 10 ropes on a winch vessel of 450 gallons' capacity.

*Fibro*ceta dyed Navy, *Fibro* reserved.

4½ lb. Duranol Brilliant Blue B300%

1½ lb. Duranol Red 2 B300

12 oz. Duranol Orange G300

2 lb. Soap flakes

2 pints Turkey red oil

Dyed for 1½ hours at 90° C.

The dye liquor was gradually cooled to 40° C. by the addition of cold water before running to waste.

The *Fibro* was cleared by running the fabric in a fresh liquor containing:

2 lb. Soap flakes

1¼ lb. Sodium hydrosulphite

½ pint Ammonia .880

for 10 minutes at 45° C.

Followed by thorough washing.

Two-colour Effects and Solid Shades. Solid shades can be produced by combining the two previous methods into a one-bath process. In some cases better fastness to washing can be obtained with a two-bath process by dyeing the *Fibro* component with direct cotton dyes and after-treating with *Fibro*fix or using the diazotising and developing process, followed by dyeing of the *Fibro*ceta.

Example C.

Matt Fibro and Matt Fibroceta Dyed Solid Shade.

100 lb. 50% matt *Fibro*, 50% matt *Fibroceta* Carpet Yarn.

Dyed to a solid green shade on a Hussong machine, volume 250 gallons.

3 lb. 8 oz.	<i>Dispersol Yellow 2GS</i>
13 oz.	<i>Duranol Brilliant Blue B300</i>
1 oz.	<i>Duranol Red G300</i>
2 lb.	<i>Chlorantine Green BLL 175%</i>
8 oz.	<i>Chlorantine Green 5 GLL</i>
1½ oz.	<i>Durazol Red 6BS</i>

Dyed for 2½ hours at 95° C.

Common salt. 8 lb. was added in four portions of ½ lb. each, and four portions of 1¼ lb. each, at 10-minute intervals, commencing 30 minutes after the beginning of dyeing.

The majority of two-colour effects can be produced by a single bath method. The staining of the *Fibro* by the dispersed dyes is often covered by cross-dyeing, though, where extreme purity of shade is desired, a modified process should be used in which the *Fibroceta* is dyed first, the *Fibro* is cleared of staining and then dyed with direct cotton dyes.

CHAPTER XXVI

PREPARING AND DYEING *FIBRO/FIBROLANE* BLENDS

Preparing. *Fibro* and *Fibrolane* come on to the market as clean fibres free from extraneous matter; mixtures therefore require only a mild treatment sufficient to remove oil, size, etc., added during processing.

Free alkali must not be used in the preparing process, and bleaching with sodium hypochlorite must be avoided.

If needed, de-sizing should be done with a malt extract,

the temperature not to exceed 60° C., and soap scouring should be carried out for a minimum time at about 40° C. Suggested concentrations are 0.1 % soap and 0.02 % sulphated fatty alcohol. Alternatively, soap may be dispensed with and use made of an 0.1 % solution of the sulphated fatty alcohol, either with or without the further addition of 2 % acetic acid on the weight of the goods. The temperature of 40° C. is again recommended.

The material must be washed free from soap or acid before drying.

Care in handling during wet processing is necessary, and fabrics should not be allowed to lie under heavy pressure while wet.

Bleaching. Hydrogen peroxide is the most satisfactory material for bleaching mixtures of the two fibres, which should be steeped overnight in a 2 volume solution of hydrogen peroxide adjusted to pH 9 by solution of ammonia and sodium silicate, the strength of the former being 5 cc. per litre of ammonia .880, and of the latter 5 cc. per litre of sodium silicate 1.7 specific gravity.

Dyeing. *Fibrolane* can be dyed with all types of dyes. Therefore either solid shades, or shades in which the *Fibrolane* is dyed and the *Fibro* reserved, can be obtained on the blends. Difficulty is found in dyeing the *Fibro* whilst completely reserving the *Fibrolane*.

Solid Shades. These are most conveniently obtained by the use of direct cotton dyes which have an affinity for both fibres under normal dyeing conditions. Several factors control the distribution of dye between the two fibres, the most important being the pH of the material and the dye-liquor. It cannot be over-emphasised that *Fibrolane* readily absorbs acids and alkalis; that all pre-dyeing processes should be carried out as close to neutrality as possible; and that washing off should be thorough.

The following figures show the importance of the neutrality of the dye liquor, as they indicate the relative degree of exhaustion of a direct dye by *Fibrolane* from liquors containing in one case 4 % ammonium acetate and in the other 4 % of sodium bicarbonate, the percentages being based on the weight of the *Fibrolane*.

Dyeing conditions: 1% Chlorazol Fast Orange AG 40 volumes for 1 hour at 95° C.

Dye liquor containing:	No	10%
	Salt	Common Salt
<i>Additions to dye liquor</i>	<i>Exhaustion</i>	<i>percentages</i>
None	37	86
4% Ammonium acetate	85	89
4% Sodium bicarbonate	4	45

To stabilise the pH of the dye liquor, such additions may be made as 1 gram per litre ammonium acetate or 0.6 gram/litre sodium dihydrogen phosphate.

The relative depth of shade is also strongly influenced by the properties of the dye.

Dyes which are rapid dyeing on viscose are readily absorbed and retained by *Fibrolane* which, under neutral conditions, is always more heavily dyed than *Fibro*, both at low and high temperatures if normal amounts of salt are present in the liquor. However, many other direct cotton dyes will dye *Fibro* more fully than *Fibrolane* at low temperatures in the presence of normal amounts of salt.

With all dyes the effect of raising the temperatures of dyeing is to increase the depth of shade of the *Fibrolane* relative to the *Fibro*.

Salt additions increase the depth of shade obtained by direct cotton dyes on both *Fibro* and *Fibrolane* when dyed separately; but when they are dyed together the general effect is to increase the depth of shade on *Fibro* to a more marked degree than on *Fibrolane*.

If necessary the shade on *Fibrolane* can be modified by the addition to the dye liquor of "fast to milling" acid or Neolan dyes, which have a good affinity for *Fibrolane* in a neutral liquor.

Example:

Solid Shade. Scarlet.

45 lb. Dress Fabric containing $\frac{2}{3}$ matt *Fibro* $\frac{1}{3}$ *Fibrolane* length 180 yards.

Dyed in three ropes on a winch, bath volume 225 gallons.

3.05% Chlorazol Fast Scarlet 4BS.

0.2% Solophenyl Yellow FFL.

2.0% *Polar Red G.*

20.0% *Glauber's salt (added in portions).*

Dyed at 3 hours at 80° C.

Dyes which are improved by after-treatment with formaldehyde, or copper sulphate and sodium bichromate may be given such treatments. All direct dyes on *Fibrolane* (as on *Fibro*) are improved in fastness to washing and other wet processing, by after-treatment with *Fibrofix* or *Fibrofix* and copper acetate as previously recommended.

Diazotisable direct cotton dyes may be applied to these mixed fibres, but the shade developed on the *Fibrolane* is often quite different from that on the *Fibro*.

Dyed and White Effect. Many types of wool dyes may be used to reserve the *Fibro* while dyeing the *Fibrolane*. The level dyeing acid dyes are not advised for this effect as the washing fastness of such dyeings is very low. The fast-to-milling acid dyes give a better washing fastness on *Fibrolane* and therefore a more satisfactory range, particularly as they are more level dyeing than on wool.

Dyeing is commenced cold in the liquor containing the dyes, and ammonium acetate or sulphate or acetic acid; the temperature is slowly raised to 90° C. and so maintained until dyeing is completed. Further acid may be added during dyeing, if it is necessary to obtain exhaustion.

Example:

Fibro Reserved, Fibrolane Fawn.

70 lb. Dress Fabric containing $\frac{2}{3}$ matt *Fibro*, $\frac{1}{3}$ *Fibrolane* length 220 yards.

Dyed in four ropes on a winch, bath volume 350 gallons.

1.4% *Cloth Fast Yellow R.*

0.24% *Acid Light Scarlet GL.*

0.17% *Coomassie Blue BLS.*

10.00% *Glauber's salt.*

Dyeing commenced cold, liquor gradually heated to 90° C. and this temperature maintained throughout. After 1 hour's dyeing 1.5% acetic acid 40% added and dyeing continued a further hour.

The Neolan dyes are very suitable for these mixed fibres.

The most satisfactory dyeing assistant is ammonium sulphate, as this gives a slower rate of dyeing than with free organic acids or sulphuric acid; also it avoids the tendering which may occur if sulphuric acid is used.

Dyeing should be commenced at a low temperature in a dye liquor containing the dye and 4% of ammonium sulphate. The liquor temperature is slowly raised to 90°–95° C. and there maintained during the dyeing periods. Good exhaustion is obtained and the fastness appears to be equal in every way to that obtained where free organic or mineral acids are used as dyeing assistants.

Care is needed in the selection of chrome dyes for *Fibro/ Fibrolane* mixtures, since a few do not develop their true shades (especially by the after-chrome method) and some others, while giving a true shade, are of inferior milling fastness. Very many, however, give shades of good fastness to milling and throughout the range the light fastness is similar to that obtained on wool.

The methods of dyeing are:

1. *Afterchrome*. The cold liquor is prepared with the dye and 1% acetic acid. After entering the material the liquor is raised to 90°–100° C. and there maintained for $\frac{1}{2}$ hour, further acid being added if necessary to exhaust the bath. 0.5% to 1.5% of bichrome is added and the chroming continued for $\frac{1}{2}$ hour.

2. *Metachrome*. The material is entered into the cold dye liquor containing the dyes, 1% to 2% sodium chromate and 2% to 4% ammonium sulphate. The dye liquor is slowly raised to 90°–100° C. and the temperature maintained for 1 hour.

With some chrome dyes full development and milling fastness may be obtained by chroming at 70° C., while with others a temperature of 95° C. is needed.

Fibrolane reserved. A limited number of shades may be obtained by applying a careful selection of direct cotton dyes in alkaline solution, pH 8 to 9, to the blend of fibres. The dyeing temperature should be as low as possible and salt should be added as an assistant.

Two-colour Effects. However, a number of neutral-dyeing acid dyes will dye *Fibrolane* under mildly alkaline conditions

(pH 8–9) whilst reserving *Fibro* and may therefore be applied with such direct cotton dyes as reserve the *Fibrolane* but dye the *Fibro* under these conditions. In this way a limited range of two-colour effects can be obtained.

Example:

A fabric composed of equal parts of the two fibres was scoured and then dyed with:

1% *Solar Orange GA.*

2% *Lanasol Violet R.*

30% *Salt*

10% *Soap.*

Dyeing was commenced cold. The dye liquor was gradually heated to 80° C. and this temperature was maintained for $\frac{1}{2}$ hour. The fabric was well rinsed in warm water and dried. The *Fibro* was dyed orange and the *Fibrolane* purple.

APPENDICES

1

Some Productions made with *FIBRO*

2

Construction Details of 20 Typical Fabrics made with
FIBRO

3

The Laundering of Fabrics made with *FIBRO*

4

World Production of Rayon Staple

5

Designation of Twist in Single Yarns, Folded Yarns
and Cables

6

The Fastness of Spun-Dyed *FIBRO* Shades

APPENDIX ONE

SOME PRODUCTIONS MADE WITH *FIBRO*

(a) WOMEN'S WEAR

Blouses	Linings
Coats	Overalls
Corsets	Roll-ons
Dresses	Scarves and Squares
Dressing Gowns	Sportswear
Gloves	Suits
Hats	Swimsuits
Knitted Underwear and Outerwear	

(b) MEN'S WEAR

Carpet Slippers	Pyjamas
Dressing Gowns	Sports Shirts
Hats	Suitings
Hose	Ties
Knitted Underwear and Outerwear	Tropical Suitings Underwear
Linings	

(c) CHILDREN'S WEAR

Half Hose	Outerwear
-----------	-----------

(d) HOUSEHOLD ARTICLES

Blankets	Rugs
Carpets	Sheets
Chair Stuffing	Tablecloths
Curtains and Coverings	Towels
Napkins	Underfelts
Upholstery materials	

(e) OTHER ARTICLES

Book Cloths	Lace
Braids	Mattress Fillings and Wadding
Cigarette Filter Tips	Motor-car Head Linings
Cords	Narrow Fabrics
Cut Pile Fabrics	Pram Hoods and Aprons
Embroidery Yarns	Ribbons
Facial and Cosmetic Tissues	Sanitary Towels
Felting Materials	Sewing Thread
Flock	Shoe Laces
Gas Mantles	Shoe Linings
Hand Knitting Yarns	Tapes
Insulating Materials for the Electrical Trades	Trimmings
	Tyre Cord Fabrics

APPENDIX TWO

CONSTRUCTION DETAILS OF TWENTY TYPICAL FABRICS MADE WITH *FIBRO*

EXAMPLE 1	Cotton-spun yarn.
TYPE	Poplinette. 100% <i>Fibro</i> .
PURPOSE	Dress, lingerie, children's wear, etc.
LOOM	Width on reed: 40-41 inches.
SPECIFICATION	Ends per inch on reed: 84. Warp: 30's/1 1.5 den. $1\frac{7}{16}$ inch Bright <i>Fibro</i> 16/17 turns per inch. Picks per inch: 60. Weft: As warp. Weave: 1 × 1.
FINISHED DETAILS	Width: 36 inches. Warp shrinkage: 10%/12%. Finish: Adequately shrunk or anti-creased piece dye, print or coloured woven.
REMARKS	A popular general purpose fabric.



EXAMPLE 2	Cotton-spun yarn.
TYPE	Plain slub. 100% <i>Fibro</i> .
PURPOSE	Dress.
LOOM	Width on reed: 40-41 inches.
SPECIFICATION	Ends per inch on reed: 40. Warp: 14's/1 1.5 den. $1\frac{7}{16}$ inch Bright <i>Fibro</i> slub yarn. Picks per inch: 42. Weft: As warp. Weave: 1 × 1.
FINISHED DETAILS	Width: 36 inches. Warp shrinkage. 8%. Finish: Adequately shrunk or anti-creased piece dye or print.
REMARKS	A good summer dress material particularly for prints.

EXAMPLE 3	Cotton-spun yarn.
TYPE	Mixture effect dress material 100% spun rayon.
PURPOSE	Dress, sports shirts, children's wear.
LOOM SPECIFICATION	Width on reed: $39\frac{1}{2}$ inches. Ends per inch on reed: 48. Warp 12's/1: 25% $2\frac{1}{2}$ den. $1\frac{7}{16}$ inch Matt <i>Fibroceta</i> . 75% 3·0 den. $1\frac{7}{16}$ inch Bright <i>Fibro</i> .
FINISHED DETAILS	Picks per inch: 42. Weft: As warp. Weave: 1 × 1. Width: 36 inches. Warp shrinkage: 8%. Finish: Adequately shrunk piece-dye, <i>Fibro</i> dyed and <i>Fibroceta</i> reserved.
REMARKS	This fabric can be used as a ground for a stripe or check fabric with cellulose-acetate or dyed or spun-dyed <i>Fibro</i> for the decoration yarn.



EXAMPLE 4	Cotton-spun yarn.
TYPE	Coarse toile. 100% <i>Fibro</i> .
PURPOSE	Dress, shorts, slacks, 2-piece suits, furnishings.
LOOM SPECIFICATION	Width on reed: 42 inches. Ends per inch on reed: 26. Warp: 4's 3 den. $1\frac{7}{16}$ inch or $2\frac{1}{2}$ inch Matt <i>Fibro</i> . Picks per inch: 26. Weft: As warp. Weave: Plain 1 × 1.
FINISHED DETAILS	Width: 36 inches. Warp shrinkage: 8%. Finish: Plain dye or print, adequately shrunk or anti-creased
REMARKS	This construction is useful for yarns spun in equivalent counts on other systems.

EXAMPLE 5	Cotton-spun yarn.
TYPE	Grey mixture light-weight flannel 100% <i>Fibro</i> .
PURPOSE	Dress.
LOOM	Width on reed: 41 inches.
SPECIFICATION	Ends per inch on reed: 78/3/52. Warp 22's/1: 80% 3 den. 1 $\frac{7}{8}$ inch Matt <i>Fibro</i> . 20% 1.5 den. 1 $\frac{7}{8}$ inch S.D. Black <i>Fibro</i> .
FINISHED DETAILS	Picks per inch: 64.
	Weft: As warp.
	Weave: 2 x 2 twill.
	Width: 36 inches.
REMARKS	Warp shrinkage: 6%-8%.
	Finish: Adequately shrunk or anti-creased.
REMARKS	This is a useful ground fabric for coloured stripes and checks.



EXAMPLE 6	Cotton-spun yarns.
TYPE	Flannel. <i>Fibro</i> and <i>Fibrolane</i> mix- ture.
PURPOSE	Dress.
LOOM	Width on reed: 41 inches.
SPECIFICATION	Ends per inch on reed: 62. Warp 18's: 66.2% 3 den. 2 $\frac{1}{2}$ inch Matt <i>Fibro</i> . 33 $\frac{1}{2}$ % 4 den. 2 $\frac{1}{2}$ inch <i>Fibrolane</i> .
FINISHED DETAILS	Picks per inch: 58.
	Weft: As warp.
	Weave: 2 x 2 twill or dobby.
	Width: 36 inches.
REMARKS	Warp shrinkage: 6%-8%.
	Finish: Adequately shrunk.
REMARKS	Alternative ways of dyeing are either, solid colour by the use of carefully selected dyes, or mix- ture, with the <i>Fibrolane</i> dyed with wool colours and the <i>Fibro</i> reserved.

EXAMPLE 7	Cotton-spun yarn.
TYPE	Georgette. 100% <i>Fibro</i> .
PURPOSE	Dress or blouse.
LOOM	Width on reed: 45 inches.
SPECIFICATION	Ends per inch on reed: 56. Warp: 16's/1 1.5 den. 1 $\frac{7}{18}$ inch Bright <i>Fibro</i> 40 turns 2 "S" 2 "Z".
	Picks per inch: 48.
	Weft: As warp.
	Weave: 6 shaft special draft.
FINISHED DETAILS	Width: 36 inches. Warp shrinkage: 16%. Finish: Adequately shrunk.
REMARKS	A basic construction for lighter or heavier crêpe fabrics.



EXAMPLE 8	Cotton-spun yarns.
TYPE	Grey mixture flannel. <i>Fibro</i> and wool.
PURPOSE	2-piece suits, slacks, etc.
LOOM	Width on reed: 42 inches or 64 inches.
SPECIFICATION	Ends per inch on reed: 56. Warp 2/24's: 20% 3 den. 2 $\frac{1}{2}$ inch Bright <i>Fibro</i> Stock-dyed black fast to milling and scouring, 65% 3 den. 2 $\frac{1}{2}$ inch Matt <i>Fibro</i> . 15% 64's quality wool. 20 turns "Z" singles. 10 turns "S" folding.
	Picks per inch: 60.
	Weft: As warp.
	Weave: 2 × 2 twill.
FINISHED DETAILS	Width: 36 inches or 54 inches. Warp shrinkage: 5%. Finish: Semi-milled.

REMARKS

Note high twist of single to prevent wool working out in milling.



EXAMPLE 9

Cotton-spun yarn.

TYPE

Light flannel: 100% *Rayolanda*.

PURPOSE

Blouse, dress and children's wear.

LOOM

Width on reed: 41 inches.

SPECIFICATION

Ends per inch on reed: 96.

Warp: 30's/1 1.5 den. $1\frac{7}{16}$ inch
Rayolanda.

Picks per inch: 82.

Weft: As warp.

Weave: 2 × 2 twill.

FINISHED DETAILS

Width: 36 inches.

Warp shrinkage: 5%.

Finish: Adequately shrunk, piece-dyed or printed.

REMARKS

A soft handling fabric.



EXAMPLE 10

Cotton-spun yarn.

TYPE

Cavalry twill. *Rayolanda*/wool mixture.

PURPOSE

Dress, 2-piece suits, slacks, etc.

LOOM

Width on reed: 42 inches.

SPECIFICATION

Ends per inch on reed: 120.

Warp: 24's/1 $66\frac{2}{3}\%$ 3 den. $2\frac{1}{2}$ inch
Rayolanda. $33\frac{1}{3}\%$ 64's wool
(cut tops).

Picks: 68.

Weft: As warp.

Weave: Fancy twill.

FINISHED DETAILS

Width: 36 inches.

Warp shrinkage: 5%.

Finish: Adequately shrunk.

REMARKS

May be dyed solid or *Rayolanda*-dyed with cotton, colour wool reserved.

EXAMPLE 11	Cotton-spun yarn.
TYPE	Batiste.
PURPOSE	Blouse and dress.
LOOM	Width on reed: 42 inches.
SPECIFICATION	Ends per inch on reed: 100. Warp: 50's/1 1.25 den. $1\frac{7}{8}$ inch strong <i>Fibro</i> .
	Picks per inch: 100.
	Weft: As warp.
	Weave: Plain 1 × 1.
FINISHED DETAILS	Width: 36 inches. Warp shrinkage: 8%. Finish: Adequately shrunk.



EXAMPLE 12	Cotton-condenser spun.
TYPE	Toile.
PURPOSE	Dress or sports blouse.
LOOM	Width on reed: 41 inches.
SPECIFICATION	Ends per inch on reed: 28. Warp: $7\frac{1}{2}$'s 100% 3 den. Bright <i>Fibro</i> .
	Picks per inch: 30.
	Weft: As warp.
	Weave: Plain.
FINISHED DETAILS	Width: 35-36 inches. Warp shrinkage: 7%. Finish: Adequately shrunk.
REMARKS	This construction is also suitable for various blends of fibres.



EXAMPLE 13	Worsted-spun.
TYPE	Diaper mixture. <i>Fibro</i> and wool.
PURPOSE	Tailored frocks.
LOOM	Width on reed: 63 inches.
SPECIFICATION	Ends per inch on reed: 58. Warp: 48's/2 50% 3 den. 4 inch Matt <i>Fibro</i> .
	50% 64's wool.
	Picks per inch: 60.
	Weft: As warp.
	Weave: 2-float dobby pattern.

FINISHED DETAILS Width: 54 inches.
 Warp shrinkage: 5%.
 Finish: Adequately shrunk, wool dyed, *Fibro* reserved.

REMARKS A useful construction.



EXAMPLE 14 Worsted-spun.
TYPE Tropical suiting.
PURPOSE Men's wear, tropical and women's wear 2-piece suits.

LOOM Width on reed: 63 inches.
SPECIFICATION Ends per inch on reed: 42.
 Warp: 30's/2 50% 3 den. 4 inch
Matt Fibro.
 50% 64's quality
 wool.

Picks per inch: 40.

Weft: As warp.

Weave: Plain.

FINISHED DETAILS Width: 54-55 inches.
 Warp shrinkage: Nominal 5%.
 Weight: 9½-10 ounces per linear yard.

REMARKS This construction is equally suitable, if the proportion of wool to *Fibro* is altered to 75%/25% or *vice versa*.



EXAMPLE 15 Flax-tow spun.
TYPE Toile.
PURPOSE Dress, 2-piece suits, play suits, etc.
LOOM Width on reed: 44-42 inches.
SPECIFICATION Ends per inch in loom: 35.
 Warp: 25's/1 Linen Lea 6 inch
 4.5 den. Bright *Fibro*.

Picks per inch: 35.

Weft: As warp.

Weave: 1 × 1.

FINISHED DETAILS Width: 36 inches.
 Warp shrinkage: 8%.
 Finish: Adequately shrunk or anti-creased.

EXAMPLE 16	Jute-spun yarn.
TYPE	Heavy toile.
PURPOSE	Soft furnishing.
LOOM	Width on reed: 55 inches.
SPECIFICATION	Ends per inch on reed: 28.
	Warp: 4 lb. per spindle 6 inch 4½ den. Bright <i>Fibro</i> .
	Picks per inch: 28.
	Weft: As warp.
	Weave: 1 × 1.
FINISHED DETAILS	Width: 48 inches.
	Warp shrinkage: 7%–8%.
REMARKS	Finish: For dyeing or printing.
	With suitable modification this fabric can be made in diagonal and other weaves.



EXAMPLE 17	Silk-spun yarn.
TYPE	Fine poplin.
PURPOSE	Lingerie, blouse, dress, etc.
LOOM	Width on reed: 41–42 inches.
SPECIFICATION	Ends per inch on reed: 104.
	Warp: 40s/2 6 inch 1.5 den. Bright <i>Fibro</i> .
	Picks per inch: 76.
	Weft: As warp.
	Weave: 1 × 1.
FINISHED DETAILS	Width: 36 inches.
	Length shrinkage: 8%–10%.
	Finish: For dyeing or printing, adequately shrunk.



EXAMPLE 18	Woollen-spun.
TYPE AND PURPOSE	Dress fabric.
LOOM	Width on reed: 65 inches.
SPECIFICATION	Ends per inch on reed: 32.
	Warp: 28 skeins 66⅔% 4.5 den. 2 inch Matt <i>Fibro</i> .
	33⅓% 70's qual. wool.

Warped 1 "S" 1 "Z".
 Picks per inch: 32.
 Weft: As warp but all "S".
 Weave: 1 × 1.
 FINISHED DETAILS Width: 54 inches.
 Warp shrinkage: 8%.
 Finish: Dye solid or *Fibro* dyed
 and wool reserved. Ade-
 quately shrunk.
 REMARKS *Rayolanda* can be used instead of
Fibro.

★

EXAMPLE 19 Woollen-spun yarns.
 TYPE AND PURPOSE Dress fabric.
 LOOM Width on reed: 64 inches.
 SPECIFICATION Ends per inch on reed: 34.
 Warp: 28 skeins.
Light 1 50% 4·5 den. 2 inch
 Matt White *Fibro*.
 50% 70's wool noils.
Medium 2 25% 4·5 den. 2 inch
 Matt White *Fibro*.
 25% 4·5 den. 2 inch
 S.D. Black *Fibro*.
 50% 70's wool noils.
Dark 3 50% 4·5 den. 2 inch
 S.D. Black *Fibro*.
 50% 70's wool noils.
Coloured 4 50% 4·5 den. 2 inch
 S.D. Red *Fibro*.
 50% 70's wool noils.
 Warped to a pattern with yarns 1,
 2 and 3, with yarn 4 as a coloured
 overcheck.
 Picks per inch: 36.
 Weft: As warp.
 Weave: Fancy.
 FINISHED DETAILS Width: 54 inches.
 Warp shrinkage: 5%.
 Dye and finish: Wool dyed in the
 piece, *Fibro* re-
 served.

REMARKS	An example of elaborate pattern adapted for piece-dyeing.
	★
EXAMPLE 20	Woollen-spun yarns.
TYPE AND PURPOSE	Ladies coating in a bird's eye spot design.
LOOM	Width on reed: 66 inches.
SPECIFICATION	Ends per inch on reed: 24. Warp: 14 skeins. <i>Light yarn:</i> 75% 4·5 den. 2 inch Matt White <i>Fibro</i> . 25% 58's white laps. <i>Dark yarn:</i> 25% 4·5 den. 2 inch S.D. Black <i>Fibro</i> . 75% 58's white wool laps. Picks per inch: 24. Weft: 40% 4·5 den. 2 inch Matt White <i>Fibro</i> . 60% 58's white wool laps. Design: Bird's eye spot.
FINISHED DETAILS	Width: 54-55 inches. Warp shrinkage: 5%. Dye: Wool dyed. <i>Fibro</i> reserved, in the piece.

APPENDIX THREE

THE LAUNDERING OF FABRICS MADE WITH *FIBRO*

Contributed by the
British Launderers' Research Association

The principal characteristic of *FIBRO* which is important in laundering is its loss in strength on wetting. This necessitates care in the handling of wet articles and the use of mild washing processes. *FIBRO* is not an exception in this respect, for the commercial launderer recognises the need for the use of mild processes for other types of textile fibres, e.g. the other rayons, woollens and silks. *FIBRO* articles are not difficult to cleanse, and it has been found that laundering processes suitable for silks are also appropriate for many fabrics made with *FIBRO*. Although such fabrics as are anti-creased do not suffer the same loss of strength on wetting as others they must, from the laundering point of view, be treated in the same manner.

The use of mild processes is also rendered necessary by the susceptibility of some fabrics made with *FIBRO* to fray very readily at raw edges, in the course of washing. The breakdown of seams and hems which results from the allowance of inadequate turnings could be avoided by the more careful making-up of garments.

TYPES OF LAUNDERABLE ARTICLE. While the applications of *FIBRO* are extending it may be taken that, of the many types of article which are normally laundered, *FIBRO* is only likely to be met with in dresses, sports shirts and other items of personal clothing, in sheets—either alone or with cotton—and in soft furnishings.

SORTING. The identification of *FIBRO* should not present any difficulty to the experienced sorter who will classify it as rayon. The inexperienced sorter should be trained not so much in the recognition of *FIBRO* as such (for that is not necessary) but in the recognition of rayons in general, for it is the correct classification of *FIBRO* with rayons that is essential. *FIBRO* in both the bright (lustrous) and matt (delustred) finishes is readily recognisable when used alone in dress goods and in sheets or other flatwork. Difficulty does arise with certain articles such as *FIBRO*/cotton sheets: even experienced sorters may not appreciate the presence of the *FIBRO*, and such articles are likely to be included in the normal sheets classification. The only solution to this problem is the marking of these articles by the maker-up with a label "Wash as Rayon," but this is not yet possible. It must be stated that the washing of *FIBRO* or *FIBRO*/cotton sheets by the normal sheets process is not appropriate; the *FIBRO* will stand up

to such laundering but it will not give such satisfactory service as when a more suitable process is employed.

Dresses made of *FIBRO* materials should be carefully inspected by the sorter or classifier to ascertain whether the fabric has been made up in a satisfactory manner. Unless really good turnings have been allowed and have been well finished off to minimise fraying, trouble may arise in washing. If turnings are narrow and have not been double stitched or otherwise finished off, it is a risk to undertake washing; fraying may be sufficiently serious as to lead to a breaking away at the seams. Badly made garments should not be accepted for washing: well made garments will wash entirely satisfactorily.

WASHING. Fabrics made with *FIBRO* are readily cleansed and it is therefore possible to use a mild low temperature process and obtain good results. In view of the fall in strength on wetting, the washing process should be designed to reduce mechanical action to the minimum consistent with adequate cleansing. The goods can, of course, be washed very successfully by hand, but when a machine process is employed it is preferable to wash fairly small loads in a small machine at moderately high dips and for a short time. It is advisable to sub-sort the articles so that the more substantial fabrics, such as sheets, are not washed with the more delicate items, such as personal wear.

Light Garments. In commercial laundry practice the smaller, lighter weight *FIBRO* articles are certain to be included with a mixed silks-and-rayons classification for which the following process is suitable, the pre-soak being necessary for the silk articles.

For use with water of 0° hardness. Machine size: 24" × 36"
Degree of loading: 2½ lb. per cu. ft. Weight of load: 25 lb.

Soak

Run down cold water from last rinse of previous load to a standing dip of	8 in.
Add crystal borax or sodium bicarbonate	10 oz.
Mix well, load machine, shut doors and turn cage over two or three times.		
Soak, with machine stopped, for not less than 5 minutes.		
Run off, allow time to drain, and close run-off valve.		

Wash

1 Cold water to a running dip of	8 in.
Add low titre soap	4 oz.
Run cold for 10 minutes in all.		
Run off, allow time to drain and close run-off valve.		

Wash

- | | | | |
|---|---|--------|-------|
| 2 | Warm water (38°C.) to a running dip of | ... | 8 in. |
| | Add low titre soap | | 2 oz. |
| | Keep at 38° C. and run 10 minutes in all. | | |
| | Run off, allow time to drain and close run-off valve. | | |

Rinses

Four, each to run 4 minutes after all the water is in.

- | | | |
|---|--|--------|
| 1 | Warm water (not over 38° C.) to a running dip of | 8 in. |
| 2 | Warm water (not over 38° C.) to a running dip of | 10 in. |
| 3 | Warm water (not over 38° C.) to a running dip of | 10 in. |
| 4 | Cold water to fill machine | Full |

Note:

For lightly soiled work, Wash 2 may be omitted and the temperature of Wash 1 increased to not more than 38° C.

Flatwork, etc. The above process will not always be entirely adequate for all articles and this is especially so with flatwork, such as sheets, for which the under noted process is more appropriate. It should be noted that larger loads are permissible since flatwork may be rather heavily soiled and is unlikely to include the light-weight fabrics which may be found in personal wear. The process is, however, suitable for some items of personal wear, e.g. shirts, which may require more vigorous washing but it is recommended that large and small items should not be included in the same load. White articles may be bleached but only when such treatment is essential and then only under carefully controlled conditions.

For use with water of 0° hardness. Machine size: 34" × 54"
Degree of loading: 3½ lb. per cu. ft. Weight of load: 100 lb.

Wash

- | | | | |
|----|---|--------|-----------|
| 1. | Run down cold water from last rinse of previous load to a standing dip of | ... | 10 in. |
| | Add low titre soap | | 12-14 oz. |
| | Add modified alkali | | 3 oz. |
| | Mix well, load machine, shut doors and start. | | |
| | Warm slowly to 38°C. and run 10 minutes in all. | | |
| | Run off, allow time to drain and close run-off valve. | | |

Wash

- | | | | |
|---|---|--------|---------|
| 2 | Warm water (38° C.) to a running dip of | ... | 6 in. |
| | Add low titre soap | | 4-6 oz. |
| | Add modified alkali | | 1 oz. |
| | Keep at 38° C., and run 10 minutes in all. | | |
| | Run off, allow time to drain and close run-off valve. | | |

Rinses

Four, each to be run 4 minutes after all the water is in.

- | | | | |
|---|--|--------|--------|
| 1 | Warm water (38°C.) to a running dip of | ... | 9 in. |
| 2 | Warm water (38°C.) to a running dip of | ... | 9 in. |
| 3 | Warm water (38°C.) to a running dip of | ... | 14 in. |
| 4 | Cold water to fill machine | | Full |

Notes:

- 1 With heavily soiled *FIBRO* and cotton/*FIBRO* flatwork, Wash 1 may be run at 43° C. and Wash 2 at 60° C.
- 2 With stained white work, bleach may be applied in Wash 2 at 60° C., at the rate of 200 grains per 100 lb. load.

Bleaching must be strictly controlled.

If *FIBRO* articles should be so heavily soiled and stained that satisfactory cleansing can only be achieved by a more vigorous process than the flatwork process, it is suggested that the customer be advised accordingly, for it is not to be expected that these or any other article will give such good service when repeatedly washed by a process which is more vigorous than that really appropriate to the fabric.

BLEACHING AND STAIN REMOVAL. Bleaching for removal of stains will sometimes be necessary and the need is more likely to arise with white articles. When general bleaching is required sodium hypochlorite (chlorine bleach) may be used at the rate of 2 grains available chlorine per pound weight of load. If coloured goods are concerned, hydrogen peroxide, sodium perborate or sodium percarbonate may be used at the rate of 6 oz. of 20 Vol. hydrogen peroxide per 100 lb. load or 2 oz. of either sodium perborate or sodium percarbonate per 100 lb. load. At these rates, bleaching should not lead to any difficulty provided (as always) careful temperature control is exercised, the bleach being used in the second wash of the flatwork process.

The normal methods of stain removal can be applied provided that the usual precautions, which apply to all stain removal processes on all types of fabric, are observed. A warning is, however, necessary regarding the use of sodium hypochlorite (chlorine bleach) at concentrations greater than the 2 grains available chlorine per pound of load which is quoted above. For particularly resistant stains bleach may be used cold at concentrations up to 100 grains per gallon or even more; and normally, when due care is exercised, the procedure is not attended by undue risk. With anti-creased fabrics made with *FIBRO* chlorine may be retained by the fabric and will give rise to serious tendering in the course of subsequent finishing. It is therefore essential when using bleach at these higher concentrations to include an antichlor in the rinses, and this should be done no matter whether the fabric is or is not known to have been

anti-creased. It is convenient to apply the antichlor in the second rinse of a four rinse procedure and sodium thiosulphate (photographers' hypo) or sodium bisulphite are suitable for the purpose. The fabric will have been given an effective antichlor if it does not retain any chlorine-like odour.

HYDROING. In handling fabrics made with *FIBRO* from the unloading of the washing machine to finishing, due care should be observed to avoid unnecessary straining. The hydro should be properly packed and, for sheets, it should be run for the usual time of about 7 minutes, after attaining full speed. For dresses, the total run should not exceed five minutes, i.e., the usual procedure for silks and rayons should be observed.

Fabrics made with *FIBRO* (if not anti-creased), will retain proportionately more water after hydroing than will either cotton or linen.

FINISHING. Sheets and other flatwork should be finished by calendering in the usual manner but it may be found necessary to give an additional passage through the calender (compared with the normal requirements of cotton and linen sheets) because of the higher moisture retention of the hydroed articles. Curtains may be finished by the appropriate means such as calendering or gladironing.

The principal difficulty that arises in the finishing of fabrics made with *FIBRO* is a tendency to glaze, which is most troublesome with dress goods, particularly in the darker shades. Glazing occurs wherever there is some increase in finishing pressure, such as at seams and hems, and it can therefore be substantially eliminated by using methods of finishing in which little or no pressure is applied to the fabric. The use of garment finishers of the steam-air type and of puff irons, when practicable, will avoid glazing difficulties. Hand-ironing and pressing are often the only available methods of finishing and, with these, glazing is influenced not solely by pressure but also by finishing temperature and the degree of dampness of the fabric. The glazing may be minimised by finishing garments as dry as possible, by the use of a cool light weight iron, and by finishing in single, not double, thickness.

DOMESTIC LAUNDERING. Domestic laundering does not present any difficulties other than those already mentioned. The articles should be squeezed in lukewarm soapy water and vigorous local rubbing should be avoided. Washing should be followed by thorough rinsing, the articles being squeezed out and not wrung out by twisting: the use of a wringer—at light pressure—is permissible with articles that can be conveniently handled in this way. If articles are completely dried, they should be re-dampened in the usual manner, rolled and set aside for a short time; they should then be hand-ironed in the manner detailed above.

APPENDIX FOUR

DEVELOPMENT OF RAYON STAPLE PRODUCTION IN PRINCIPAL COUNTRIES

(Figures in thousands of lb.)

Source RAYON ORGANON

	1930	1933	1936	1937	1938	1939	Peak war prod'n	1946	1947
Germany ..	4,350	8,750	94,800	220,000	340,000	440,000	689,000 (1942)	89,300	73,000
Japan ..	—	965	45,850	175,495	327,210	301,265	296,605 (1941)	20,625	19,250
Italy ..	705	11,025	110,105	156,355	166,850	189,595	291,670 (1941)	29,465	47,620
U.S.A. ..	350	2,100	12,300	20,245	29,860	51,315	168,740 (1944)	176,375	228,435
U.K. ..	850	2,440	24,600	30,500	29,700	55,800	55,800 (1940)	68,100	80,600
France ..	—	2,200	6,600	11,300	10,800	15,490	64,535 (1943)	34,215	42,590
Austria ..	—	—	—	—	—	10,000	65,000 (1941)	3,890	6,925
Sweden ..	—	—	485	2,930	3,825	4,390	33,500 (1944)	28,950	25,395
Poland ..	—	440	1,200	2,270	8,750	10,000	30,000 (1943)	11,500	15,800
Belgium ..	—	—	290	755	1,535	2,080	13,430 (1943)	27,165	25,655
Switzerland ..	—	—	—	—	75	10	24,690 (1944)	23,200	20,900
Czechoslovakia ..	—	—	—	660	660	2,000	22,610 (1944)	20,690	31,285
Spain ..	—	—	—	—	—	—	1,590 (1944)	14,795	18,610
Finland ..	—	—	—	—	45	640	10,860 (1944)	10,420	10,980
Norway ..	—	—	—	150	70	—	—	4,500	6,500
WORLD TOTAL	6,255	27,920	300,330	625,880	927,895	1,094,710	1,552,095 (1941)	572,720	679,875

APPENDIX FIVE

DESIGNATION OF TWIST IN SINGLE YARNS, FOLDED YARNS AND CABLES

SINGLE YARNS

A yarn has "S" twist if, when it is held in the vertical position, the spirals conform in direction of slope to that of the central portion of the letter "S." Similarly, the yarn has "Z" twist if the spirals conform in direction of slope to that of the central portion of the letter "Z." These are illustrated below.

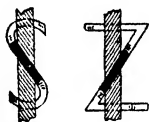

FOLDED YARNS AND CABLES

If in the successive operations twist is applied in the same direction the twist in the folded yarns or cables is designated "S/S/S....." or "Z/Z/Z.....". If twist is applied in opposite directions in successive operations the designation is "S/Z/S....." or "Z/S/Z.....". In all cases the first letter gives the direction of twist in the first folding operation.

APPENDIX SIX

THE FASTNESS OF SPUN DYED *FIBRO* SHADES

All the Spun Dyed *Fibro* shades, as listed below, are fast to the *Society of Dyers and Colourists'* Washing Test No. 4, and therefore of course to the less strenuous Washing Tests Nos. 1, 2, 3. They are also fast to Perspiration, Acid Cross Dyeing, Enzyme Desizing, Sulphur Stoving and Peroxide Bleaching.

The fastness to light is as follows:

	$1\frac{1}{2}$ Den.		$4\frac{1}{2}$ Den.	Light S.D.C.
Sulphur	S.D.F. 19	and	S.D.F. 33	6
Indian Yellow	S.D.F. 20	,,	S.D.F. 32	6
Pink	S.D.F. 21	,,	S.D.F. 39	5-6
Red	S.D.F. 14	,,	S.D.F. 31	6-7
Light Blue	S.D.F. 12	,,	S.D.F. 34	5-6
Medium Blue	S.D.F. 15	,,	S.D.F. 35	6-7
Dark Blue	S.D.F. 16	,,	S.D.F. 36	(Navy) 6-7
Apple Green	S.D.F. 17	,,	S.D.F. 37	5-6
Malachite Green	S.D.F. 18	,,	S.D.F. 38	6-7
Black S.D.F.				8

The Light Standards used are those of the *Society of Dyers and Colourists* and published by the *British Standards Institution* (B.S. 1006, Part 1, 1942).

COMBINED SODA BOILING (OPEN KIER) AND HYPOCHLORITE BLEACH

With the exception of Apple Green, Malachite Green, Sulphur and Indian Yellow, Spun Dyed *Fibro* shades are fast. With the normal precautions taken by bleachers accustomed to colour work, these four shades may also be treated successfully. The same four shades together with Pink and Red are not suitable for cross-dyeing or over-printing with vat dyes.

*S.D.F.=Spun Dyed *Fibro*.

INDEX

- ABRASION-RESISTANT FINISHES**, 227
ACETATE
 dyes, 271
 rayon staple (see *Fibrometa*)
ACID DYES, 39, 198, 249, 275
ADEQUATE SHRINKAGE, 118-120, 244
"AGEING" OF VISCOSE, 21
AGER, MATHER AND PLATT TYPE, 190
ALKALI-CELLULOSE, 20
ALPACA FIBRES, FINENESS OF, 85
AMERICAN COTTON, 53, 135
ANGLO DRAWING, 101
ANNULAR ROLL, 167, 168, 169
ANTI-CREASE PROCESS, 60, 181, 185,
 230-237, 244
ANTI-SHRINK FINISH, 229-230
APPEARANCE
 of *Fibro*, 32
 of fabrics modified by finishing, 220,
 221
"ARIDYE" PROCESS, 210
ARROW MILL, 15
AZOIC DYES, 158, 188, 198, 207, 258,
 268
BACK RESTS, 127
**BAER DIAGRAMS ILLUSTRATING BREAK-
 AGE OF *Fibro***, 65, 101
BALING, 22
"BALLOONING", 178
BASIC DYES, 188, 200
BEETLING, 221
BLEACHING
 Fibro blends, 245, 247, 259, 269,
 273, 274
 Fibro fabrics (dyeing) 179-180
 (laundering) 295
 (printing) 186
BLENDING, 37, 63, 64, (WITH COTTON)
 67, 75, 77, 78, 105, 108
BLENDS (STAPLE AND YARN):
 dyeing, 59, 117, 244, 259, 269, 273
 number of different combinations,
 117
 tinting for identification, 37-38
 yarns, 59-63, 76, 80, 84, 85-100,
 101, 102, 107, 116, 117
BLENDS AND MIXTURES (FABRICS):
 construction, 113, 116, 117
 dyeing, 244, 259, 269, 273
 finishing, 240-243, 248
 printing, 188, 197
BOLTING SILK, 205
BRADFORD, WESTCROFT MILL, 15
**BRADFORD OPEN-DRAWING INTER-
 SECTING GILL BOX, ILLUS., FACING**
 44 AND 45
BRAIDS, 164
BREAKAGE OF *Fibro* IN OPENING ETC.,
 65, 66, 101
BREAKING TREATMENTS, 219-220
BRIGHT *Fibro*, 47, 75, 77, 105, 108
BRITISH LAUNDERERS' RESEARCH
 ASSOCIATION, 13, 292
CAKE DYEING, 160-164
CALENDERING, 221
CAMEL HAIR, FINENESS OF, 85
CAPE-TOP WOOL, 62
CAP SPINNING, 101, 104
CARBON DISULPHIDE, 20, 21
CARDING
 on cotton condenser machinery, 75
 cotton machinery, 46, 65-66
 flax machinery, 105
 jute machinery, 108
 woollen machinery, 78
 worsted machinery, 100, 103
 eliminating, 41
CARPET YARNS, 76, 109, 160, 273
CASEIN, 19, 144
CASEMENTS, 185
CELLULOSE
 -acetate, 19
 -acetate rayon staple (see *Fibrometa*)
 alkali, 20
 regenerated, 19, 21, 22
 -xanthate, 20, 23
CHAINS, PRIMARY VALENCE, 24
CHEMICAL PROPERTIES, 22-34
CHEMICALS, EFFECT OF, 34
CHEVRONS, 164
CHILDREN'S WEAR, 281
CHROME DYES, 202, 251, 257, 277
CHURNS, 20
CLIP STENTERING, 216-218
"COLLORESIN" PROCESS, 206
COMBING (WORSTED), 100, 101, 103
 (FILAX), 105
COMPOUND SHADES, DYEING OF, 135,
 149, 181
CONDITIONING OF *Fibro*
 after manufacture, 22
 unnecessary for certain blends, 100
CONE DRAWING, 101
CONSTRUCTION OF FABRICS, 113-120,
 282-291
CONTINENTAL DRAWING, 101
CONTINUOUS FILAMENT
 comparison of spun yarns with, 52
 difference in manufacture of, 21
 used with *Fibro* for fabrics, 118, 178
COST, COMPARISON OF BETWEEN BALED
 Fibro, TOP, AND "GREENFIELD
 TOP", 45
COTTON
 American, 53, 135
 blending with *Fibro*, 60, 61, 67
 East African, 60
 Egyptian, 47, 53, 135

COTTON—cont.,
 Indian, 53
 Peruvian, 60
 shortage of in Germany, 15
 Tanguis, 61
COTTON CARD, STANDARD, 65
COTTON DYES, DIRECT, 135-138, 144,
 145, 180-182, 188, 252, 257,
 258-259, 264, 270, 274
COTTON CONDENSER MACHINERY
Fibro for, 75
 count limits, 75
 types of staple suitable, 75
 spinning *Fibro* on, 75
 blending, 75
 drafts, 75
 lubricating, 75
COTTON MACHINERY,
Fibro for, 46-63
 blend and special effect yarns, 59-63
 blends with cotton, 60, 61
 blends with silk, 62
 blends with wool, 61, 62
 carding limitations, 46
 comparison of spun and continuous
 filament yarns, 52
 count limits, 47
 effect of filament denier on yarn pro-
 perties, 49
 effect of filament length on yarn
 properties, 52, 55
 effect of twist on yarn properties,
 52-57
 fancy yarns, 62, 63
 hair weights and corresponding fila-
 ment deniers, 47, 49
 hosiery yarns, 60
 ornamentation of yarns, 63
 range of staple lengths and deniers,
 46-47
 strong *Fibro*, 47, 57-59
Fibroceta for, 47, 59, 60
Fibrolane for, 47, 59, 62
 "Greenfield Top" for, 45-46
Rayolanda for, 47, 59, 62
 spinning *Fibro* on, 14, 15, 45,
 63-74
 blending, 64, 67
 carding, 65-66
 combination details, 64
 condenser (speed frame), 71
 drafts, 67, 73
 drawing, 67
 feeding, 64
 lap weights, 64
 machinery requirements, 63
 metal trough (draw frame), 68
 mixing, 64
 mule spinning, 73
 opening, 63-65
 relative humidity and temperature, 68

COTTON MACHINERY—cont.,
 ring spinning, 72
 roller coverings (draw frame), 67
 roller coverings (ring frames), 73
 roller coverings (speed frames), 71
 roller settings (draw frame), 67
 roller settings (mule), 74
 roller settings (ring frames), 73
 roller settings (speed frames), 71
 roller weightings (draw frame), 67
 roller weightings (mule), 74
 roller weightings (ring frames), 71
 selvage guides (draw frame), 68
 selvage guides (speed frames), 71
 speed frames, 70
 spindle speeds, 71, 73
 stripping, 66
 sloughing off, 74
 three line rollers system, 73
 twist factors, 52-57, 70, 72, 74
 twist in the roving, 70
 waste tests, 66
 wax deposits (draw frames), 68
 web-tension, 68
 yarn processing, 74
COUNT
 definition of yarn, 84
 limits for spinning, 47, 75, 77, 102
COURTAULD CAKE DYEING MACHINE,
 162
CRABBING, 243, 245-246
CREASE-RESISTING PROCESS, 60, 181,
 185, 230-237, 244
CREASING, TEST FOR RECOVERY FROM,
 237
CREPE FABRICS, 177-179, 269
CROSS-DYEING, 59, 117, 197, 244, 258,
 268, 273
CROSS SECTION OF *Fibro*, 33
 "CRUMBS", ALKALI-CELLULOSE, 20
CUPRAMMONIUM RAYON, 98
CUSTOMS CLASSIFICATION OF RAYON
 WASTE, 15
CUT RAYON, 15
CUTTING INTO STAPLE, 21
CUTTING OF TOW, 43-44
CYANOETHYL CELLULOSE ETHERS,
 APPLICATION OF, 226
DALGLISH CONTROL, 218
DE-AERATION OF VISCOSE, 21
DECATIZING, 221, 248
DEFINITION OF *Fibro* AND OTHER RAYON
 STAPLES, 7
DEGUMMING, 243
DELETTE FLAX COMBING MACHINE, 105
DENIER
 definition of, 7, 84
 filament, choice of in fabric con-
 struction, 114
 filament, influence of in dyeing,
 133-135, 249

- DENIER—cont.**,
 filament, effect of on yarn properties, 49, 84
 hair weights and corresponding filament, 47, 49
- DENSITY (SEE SPECIFIC GRAVITY)**
- DE-SIZING**
 blends (see Dyeing), 270, 273
Fibro fabrics for dyeing, 122, 174
Fibro fabrics for printing, 186
- DESULPHURISING**, 22
- DIGESTERS**, 19
- DIMENSIONAL STABILITY**
 of fabrics, 118
 test for, 239-240
- DIRECT COTTON DYES**, 135-138, 144-145, 180-182, 188, 252, 257-259, 264, 270, 274
- DISCHARGE STYLES**, 188-197
- DISCONTINUOUS RAYON WASTE**, 14
- DISPERSED ACETATE DYES**, 271
- DOBBY WEAVES, BACK RESTS FOR**, 127
- DOFFING FRAME, SEMI-AUTOMATIC**, 106
- DOLLY SCOURING**, 246
- DOUBLE TWIST KNOT, ILLUS.**, 161
- DRAFTS (COTTON MACHINERY)**, 67, 73;
 (WOOLLEN MACHINERY) 80;
 (WORSTED MACHINERY), 103, 104
- DRAWING**
 Anglo, 101
 Cone, 101
 Continental, 101
 cotton system, 67-68
 Open, 101
 worsted system, 101, 102, 104
- DRESSING GOWN FABRICS**, 185
- DRISOL PROCESS**, 245
- DRY-CLEANING OF *Fibro***, 34
- DU PONT "PAD STREAM" AND "MULTILAP" UNITS**, 184
- DULL *Fibro* (SEE MATT *Fibro*)**
- DYEING**
 blends (*Fibro*/*Fibro*ceta), 39, 59, 268-273
 avoidance of caustic alkalis, 268
 de-sizing, 270
 fabrics, 269
Fibro reserved, 271-272
*Fibro*ceta reserved, 270
 solid shades, 272-273
 temperature control, 268-269
 tinting, 39
 two-colour effects, 272-273
 yarn, 269
 blends (*Fibro*/*Fibrolane*), 39-40, 59, 273-278
 bleaching, 274
 de-sizing, 273
 effect of temperature, 275
 effect of salt additions, 275
Fibro reserved, 276-277
- DYEING—cont.**,
Fibrolane reserved, 277
 dyes suitable, 274, 275
 solid shades, 274-276
 tinting, 39-40
 two-colour effects, 277
 blends (*Fibro*/*Rayolanda*), 39-40, 258-268
 bleaching, 259
 dyes suitable, 258
 effect of temperature and salt additions, 259-263
 fabrics, 259
 solid shades, 262-263, 265, 266, 267, 268
 tinting, 39-40
 tone-in-tone effects, 261-262, 265
 washing fastness, 264
 yarn, 259
 blends (*Fibro*/*Wool*), 244-258
 bleaching, 245, 247
 crabbing, 245
 fabrics, 245
Fibro reserved, 249-251
 finishing, 248
 half hose, 245
 milling, 246-247
 scouring, 245, 246, 247
 solid shades, 253-257
 washing off, 247
 wool reserved, 252
 yarn, 244-245
 compound shades, 135, 149, 181
 fabrics (*Fibro*), 170-171, 171-185
 bleaching, 179
 centrifuging, 184
 choice of dyes, 181
 crêpe fabrics, 177-179
 de-sizing and scouring, 174-179
 direct cotton dyes, 180-183
 dyeing for printing, 188
 examination of grey fabrics, 172
 finishing, 184-185 (see also Finishing)
 knitted fabrics, 184
 pad-jig system, 183
 pre-treatment, 173
 roll-form dyeing, 170-171
 singeing, 173
 vat dyes, 183
 winch machines, 180
 narrow fabrics, 164-171
 package dyeing, 165
 roll-form dyeing, 165-170
 staple and yarn (*Fibro*), 37-40, 133-164
 azoic dyes, 158
 cake-dyeing, 160-164
 compound shades, 135, 149
 direct cotton dyes, 135-138
 fastness to washing of cotton dyes, improvement in, 144

DYEING—cont.,

- fastness of spun-dyed Fibro*, 299
- Fibrofix*, use of, 144-145, 148
- hank dyeing*, 141-143, 145, 149, 158, 159, 160
- influence of filament denier*, 133-135
- lacing of hanks*, 160, and *illus.*, 161
- nomogram to help in dyeing rayons of different filament denier to same depth of shade*, 133-134
- sliver in top-form dyeing*, 140-141, 145, 149
- solubilized vat dyes*, 154-158
- spun-dyed Fibro (q.v.)*
- staple dyeing*, 136-140, 145, 149
- sulphur dyes*, 145-149
- tinting*, 37-40
- vat dyes*, 149-154
- warp dyeing*, 143, 145, 149, 159
- winding spun yarns into cake-form*, 161
- wide fabrics in roll form, 170-171

DYES

- acetate, 271
- acid, 39; (for prints), 198; (for blends), 249, 275
- azoic, 158; (for prints) 188, 198, 207; (for blends), 258, 268
- basic, (for prints), 188, 200
- chrome, 202, 251, 256-257, 277
- direct cotton, 135-138, 180-182; (for prints), 188; (for blends), 252, 257-259, 264, 270, 274
- classification of*, 135
- improvement in fastness to washing of*, 144-145
- fugitive (see Tints)
- Indigosol (see Solubilized vat dyes)
- mordant, 202
- Neolan, 250, 275, 276
- Soledon (see Solubilized vat dyes)
- Solubilized vat, 154-158; (for prints) 198; (for blends), 258, 266, 267
- classification of*, 155-156
- sulphur, 145-149; (for blends), 258, 265
- classification of*, 147
- use of Fibrofix with*, 148
- vat, 149-154, 162-163, 183; (for prints) 188, 197, 203; (for blends) 258, 265, 270, 271
- classification of*, 149 *et seq.*
- strike test for*, 149
- washing fastness of, improvement to, 7, 144-145, 253, 264

EAST AFRICAN COTTON, 60**EGYPTIAN COTTON**, 47, 53, 135**ELASTICITY**, 27**ENZYME**

- preparations, 174
- treatment, 178

EPILOX PROCESS, 245**ESCHALIER**, 229**EXTRUSION OF FILAMENTS**, 21**EXTENSIBILITY**, 27**FABRICS**

- cut pile, 281
- construction details for, 282-291
- construction of from *Fibro*, 113-120
- blends*, 116-117
- colour and lustre*, 116-117
- filament denier*, 114
- shrinkage*, 118-120
- staple length*, 114
- spinning of yarns*, 114-116
- use of continuous filaments*, 118
- dyeing and finishing*, 119
- dyeing of (see Dyeing)
- filling of, 225
- furnishing, 106, 109, 164
- knitted, 128-130
- tyre cord, 281

FANCY YARNS, 62, 63**FASTNESS**

- of direct dyes, improving, 7, 144-145, 253
- of dyes on *Rayolanda*, 264
- of spun-dyed *Fibro*, 299

FEEDING, 64**FESTOON TYPE DRYING MACHINE**, 216**FIBRANDA**, 7**FIBRO**

- bright, 47, 75, 77, 105, 108
- complementary to other textiles, 12
- definition of, 7
- fineness of, 84, 85
- for cotton condenser machinery, 75
- for cotton machinery, 46
- for flax machinery, 105
- for jute machinery, 108
- for woollen machinery, 77
- for worsted machinery, 44, 80 (see also "Greenfield Top")
- history of, 14-16
- in cake-form, 160
- mat, 22, 32, 47, 75, 77, 105, 108
- manufacture of, 19-22
- moisture regain of, 31, 98
- registered trade mark, 7, 15
- strong, 32, 47, 57, 59, 215
- spun-dyed, 22, 32, 77, 116, 299
- water imbibition of, 31, 32, 95, 98, 100, 215

FIBROCETA

- for cotton condenser machinery, 75
- for cotton machinery, 47, 59
- for woollen machinery, 77
- definition of, 7

FIBROCETA—cont.,

- in blend with *Fibro*, 59, 64
- finishing of fabrics containing, 240-241
- temperature control during wet processing of, 269
- moisture regain of, 98
- dyeing of in blend with *Fibro*, 59, 268-273

FIBROFIX

- definition of, 7
- description and use of, 144-145
- miscellaneous uses of, 148, 162, 183, 191, 192, 253, 257, 272, 276

FIBROLANE

- for cotton condenser machinery, 75
- for cotton machinery, 47, 59
- for woollen machinery, 77
- in blend with *Fibro*, 59, 62
- definition of, 7
- dyeing of in blend with *Fibro*, 273-278

FIELDEN DRIMETER, 218**FILAMENT DENIER (SEE DENIER)****FILAMENT LENGTH**

- choice of in fabric construction, 114
- effect of on yarn properties, 52, 55, 84

FILAMENTS, EXTRUSION OF, 21**FILLING, 225****FILTERING VISCOSE, 21****FINENESS OF *Fibro* AND OTHER FIBRES, 84, 85****FINISHING, 165, 181, 184, 185, 211-212, 213-244, 248, 296**

- abrasion-resistant finishes, 227
- anti-crease finish, 60, 181, 185, 230-240
 - analysis of chemicals, 234
 - B.P.s.*, 562, 790, and 579, 709: 230, 232
 - determination of formaldehyde, 235, 238
 - drying, 234
 - detection of faults, 238-239
 - dimensional stability, test for, 239
 - examination of fabric, 236
 - estimating resin content, 237
 - impregnation, 232
 - precondensate, 231, 236
 - polymerization, 234
 - removal of resins, 240
 - shrinkage tests, 239-240
 - testing for recovery from creasing, 237
 - washing and finishing, 234
- anti-shrink finish, 229-230
 - B.P. 510*, 199: 229
- adequate shrinkage, 118, 120, 244
- blends and mixture fabrics of
 - Fibro* and cotton, 241
 - Fibro* and *Fibroceta*, 240

FINISHING—cont.,

- Fibro* and *Fibrolane*, 243
 - Fibro* and nylon, 242-243
 - Fibro* and *Rayolanda*, 241
 - Fibro* and wool, 248
 - Fibro* and silk, 243
 - breaking treatments, 219-220
 - beetling, 221
 - calendering, 221
 - clip-stentering, 216-217
 - cyanoeethyl cellulose ethers, application of, 226-227
 - decatizing, 221, 248
 - drying stoves, 219
 - embossed and glazed finishes, 227
 - filling, 225
 - fireproofing, 165, 223-225
 - flat finishes, 221
 - glazed effects, 221
 - handle and appearance, modification of, 219, 220, 221, 225-228
 - hydro-extracting and drying, 215-216
 - infra-red drying equipment, 219
 - laundering, 296
 - pin-stentering, 218
 - printed fabrics, 211-212
 - Palmer stretcher, 217
 - removal of fabrics from drying machine, 214-215
 - resins, for special finishes, 227-228
 - rinsing after dyeing, 214
 - shower-proofing, 222-223
 - shrinkage, 118-120, 229-230, 244
 - slack drying, 184
 - smoulder proofing narrow fabrics, 165
 - softening, 213
 - stiff finishes, 227
 - stove drying machines, 216
 - stretching, 244
 - tubular finishing machine, 184
 - vertical presses, 184
 - water repellent finishes, 222-223
 - wet finishes, 222
- FIREPROOFING, 165, 223-225**
- "FIXANOL", 253
- FLAME-PROOFING, 224**
- FLAT FINISHES, 221**
- FLAX CARD, STANDARD, 105**
- FLAX LINE PROCESSING, 105**
- FLAX MACHINERY**
- "Greenfield Top" for, 45
 - spinning *Fibro* on, 45, 105-106
 - blending, 105
 - carding, 105
 - combing, 105
 - drawing, 105
 - dry and wet spinning, 105
 - doffing frames, 106

- FLAX MACHINERY**—*cont.*
types of staple used, 105
yarns 106, 115
 handling and storing *Fibro* for, 106
- FLAX TOW PROCESSING, 105, 115**
- FLOWGRAPH ILLUSTRATING *Fibro* MANUFACTURE, 18**
- FLUFF, 128**
- FLYER-SPINNING, 101, 104**
- FORMALDEHYDE**
 analysis of, 234
 determination of in fabrics, 235, 238
- FRENCH WORSTED SYSTEM, 115**
- FUGITIVE TINTS (SEE TINTS)**
- FURNISHING FABRICS, 106, 109, 164**
- GALLOONS, 164**
- GAS-HEATED INFRA-RED DRYING EQUIPMENT, 219**
- GERBER DYEING MACHINE, 160, 269**
- GLAZED EFFECTS, 221**
- GLOVE FABRIC, 130, 185**
- GLOWPROOF FINISH, 224**
- "GREENFIELD TOP", 7, 22, 40-46, 107-109:**
 bearing of length and denier on manufacture of, 45-46
 cutting of tow, illus., facing 44
 cost, 45
 definition of, 7
 first made commercially, 44
 for cotton machinery, 45
 for flax machinery, 45
 for jute machinery, 45, 108, 109
 for silk machinery, 45, 107
 for worsted machinery, 44
 qualities produced, 44
 sliver stapling method, 43
 tow-to-top conversion, 40-46
- GREENFIELD WORKS, 15, 20, 44**
- GREY FABRIC, EXAMINATION OF, 172**
- GRINDING, 20**
- HAAS DRYING MACHINE, 216**
- HAIR WEIGHTS, 47, 49**
- HANDKERCHIEFS, 185**
- HANDLE OF FABRICS, MODIFIED BY FINISHING, 219, 220, 221, 225-228**
- HANK DYEING, 141-143, 145, 149, 158, 159, 160**
- HANKS, LACING OF, 160**
- HEALDS, 125**
- HEAVEN, G.S., 13**
- HIGH FREQUENCY RADIATION, 219**
- HISTORY OF *Fibro*, 14-16**
- HOSE, HALF, 130, 245**
- HOSIERY**
Fibro in, 245
 yarns, 60
- HOUSEHOLD ARTICLES, 281**
- HUMIDITY, 68, 128**
- HUSSONG DYEING MACHINE, 141, 142, 145, 248, 256, 269, 273**
- HYDRO-EXTRACTING, 18, 21, 215-216, 296**
- IMPREGNATION, 232**
- INDIAN COTTON, 53**
- INDIGOSOL DYES (SEE DYES—SOLUBILIZED VAT)**
- INFRA-RED DRYING EQUIPMENT, 219**
- INTERGILLING, 100, 103**
- INTERLOCK TRADE, 129 (SEE ALSO KNITTED FABRICS)**
- JACQUARD WEAVES, BACK RESTS FOR, 127**
- JET, SPINNING, 21**
- JUTE CARDS, 108**
- JUTE MACHINERY**
 "Greenfield Top" for, 45, 108, 109
Fibro for, 108
 spinning *Fibro* on, 45, 108, 109
 blending, 108
 carding, 108
 drawing, roving and spinning, 108
 water application to sliver, 108
 yarns, 109, 116
 advantages of *Fibro* for, 109
 storing and handling *Fibro* for, 109
- KLAUDER WELDON DYEING MACHINE, 145**
- KNITTED FABRICS**
 application of anti-crease finish to, 185
 dyeing *Fibro*, 184
 dyeing *Fibro/Fibrocta*, 269
 use of *Fibro* for, 128-130
 adjustments and variations of method, 129
 cellular locknit, 128
 circular knit, 130
 interlock trade, 129
 lace-stitch, 130
 laying-in-thread, 130
 range of productions, 130
 Raschel looms, 129, 130
 shrinkage, 130
 Simplex looms, 130
 sports shirting, 128
 yarn qualities and blends, 130
- LACE, 281**
- LACE-STITCH, 130**
- LAP WEIGHTS, 64**
- LAUNDERING**
 of *Fibro* fabrics, 292-296
 domestic, 296
- LAYING-IN-THREAD, 130**
- LIGHT STANDARDS, 299**
- LINE PROCESSING, 105**
- LINEN DRESSING MACHINE 123**
- LINING FABRICS, 221**
- LOCKNIT, CELLULAR, 128 (SEE ALSO KNITTED FABRICS)**

- LONGCLOSE DYEING MACHINE, 140,
141, 162, 165
- LOOMS (SEE ALSO WEAVING)
Raschel, 128, 130
Simplex, 130
- LUBRICATION OF *Fibro*, 75, 78
- MANUFACTURE OF *Fibro*, 19-22
- MATT *Fibro*, 22, 32, 47, 75, 77, 105,
108
- MECHANICAL PROPERTIES, 24
- MEN'S WEAR, 281
- MERCERISING ALKALI-CELLULOSE, 20
- METAL TROUGH (COTTON DRAW-
FRAME), 68
- MILDEW, RESISTANCE OF *Fibro* TO, 34
- MILLING, 246-247
- MILLS
Arrow Mill, 15
Westcroft Mill, 15
- MIXING
Fibro, 64
viscose, 20
- MIXTURE FABRICS (SEE BLENDS AND
MIXTURES)
- MOHAIR, FINENESS OF, 85
- MOISTURE CONTENT, 22
influence of on mechanical pro-
perties, 27
variation of between bales—
method of eliminating, 64
- MOISTURE REGAIN, 31, 98
- MOISTURE RELATIONSHIPS, 31
- MORDANT DYES, 202
- MOTHS, RESISTANCE OF *Fibro* TO, 34
- MULE SPINNING
on cotton machinery, 73
on woollen machinery, 79
on worsted machinery, 101
- "MULTILAP" UNIT, DU PONT, 184
- "MYSTOLENE", 223
- N.S. PROCESS, 245
- NARROW FABRICS
the term, 164
dyeing of, 164-171
suitability of *Fibro* for, 165
- NEGAFEL PROCESS, 245
- NEOLAN DYES, 250, 275, 276
- NOBLE COMB, 101, 103
- NOMOGRAM TO HELP IN DYEING
RAYONS OF DIFFERENT FILAMENT
DENIER TO SAME DEPTH OF SHADE,
134
- NYLON, 197
finishing of fabrics containing, 242,
243
- OBERMAIER DYEING MACHINE, 136,
138, 139, 141, 142, 143, 159
- OIL STAINS, 70, 176
- OILING, 75, 78
- OPEN DRAWING (WORSTED), 101, 103
- OPENING OF *Fibro*
after manufacture, 22
for cotton spinning, 63-65
for worsted spinning, 100
- ORIENTATION, 22-24
- OVERALLS, 185
- PAD/JIG SYSTEM, 183-184
- "PAD STEAM" UNIT (DU PONT), 184
- PALMER STRETCHER, 217-218
- PAPAIN PROCESS, 245
- PATENTS:
anti-shrink process, 229
anti-crease process (Courtaulds,
Ltd.), 181, 230
application of cyanoethyl cellulose
ethers (Courtaulds, Ltd.), 226
"Fibrofix", 144
"Greenfield Top" sliver stapling
method, 43
Pellerin's discontinuous waste, 14
urea formaldehyde process (Ciba),
200
- PELLERIN, A, 14
- PERUVIAN COTTON, 60
- PETERSHAM RIBBON, 165, 166, 169
- PHOTO-DEGRADATION, 207
- PHYSICAL PROPERTIES, 22-34
- PIGMENT, 22, 32
fixation, 210
- PIN STENTER, 186, 218
- PLAIN CLOTHS, BACK RESTS FOR
WEAVING, 127
- POLYMERISATION, 234
- POLYVINYL ACETATE, 228
- PRECONDENSATE, 231
stability of, 236
- PREPARING *Fibro* FABRICS
for dyeing, 172 *et seq.*
for printing, 186
(for preparing blends, see Dyeing)
- PRESSING OF *Fibro* INTO BALES, 22
- PRE-TREATMENT OF *Fibro* FABRICS, 173
- PRINTING, 185-212:
blend fabrics, 188, 197
conditions for printing, 186-187
colour recipes and technique, 185,
186
"Colloresin" process, 206
discharge styles, 188-197
desizing, scouring and bleaching,
186
finishing, 211-212 (see also 213 *et
seq.*)
hydro-extracting and drying, 186
improving fastness of direct dyed
grounds, 191
pigment fixation, 210
preparation of fabrics, 186
printers' styles, 185
resist styles, 198
screen prints, 187, 188, 205

- PRINTING—cont.**
 "straight prints", 198-209
 types of print, 187
 urea method, 198
 urea formaldehyde process, 200
- PROCESSING**
 cotton-spun yarns, 74
 worsted-spun yarns, 102
 spun yarns for dyeing in cake-form, 161
- PRODUCTION OF *Fibro***, 19-22
- PRODUCTION OF RAYON STAPLE, WORLD**
 297
- PROPERTIES, PHYSICAL AND CHEMICAL**, 22-34
- PROTEIN RAYON STAPLE**, 7 (SEE ALSO *Fibrolane*)
- PUNCH BOX**, 101
- RAISED EFFECTS**, 220
- RASGHEL LOOMS**, 129, 130
- RAYON**
 definition of, 7
 discontinuous waste, 14
 first used as substitute for silk, 14
 waste, 14, 15, 106
- RAYON STAPLE (SEE ALSO *Fibro*, *Fibroseta*, *Fibranda*, *Fibrolane* AND *Rayolanda*)**
 cost of, 45
 development of world production of, 297
 for cotton-, cotton condenser-, flax-, jute-, silk-, woollen-, and worsted-machinery (see Cotton etc. machinery)
 history of, 14-16
 manufacture of, 19-22
 properties of, 22-34
 productions in development stage, 12
- RAYOLANDA**
 definition of, 7
 dyeing of, in blend with *Fibro*, 258-268
 finishing of fabrics containing, 241
 for cotton condenser machinery, 75
 for cotton machinery, 47, 59
 for woollen machinery, 77
- RECTILINEAR COMB**, 101
- REGAIN, MOISTURE AND STANDARD**, 31, 98
- REGISTERED TRADE MARKS, COURTAULDS'**, 7, 15, 144
- RELATIVE HUMIDITY**
 for processing on cotton machinery, 68
 for weaving sheds, 128
- RESINS**
 application of, 227-229
 estimation of in fabrics, 237
 removal of from fabrics, 240
- RESIST STYLES**, 198
- RIBBONS**, 164
- "RIFFLERS"**, 20
- RING SPINNING**
 on cotton machinery, 72-73
 on worsted machinery, 101, 104
- RIPENING OF VISCOSE**, 21
- ROLL**
 annular, 167-169
 solid, 167-169
- ROLL-FORM, DYEING FABRICS IN**, 165-171
- ROLLER COVERINGS (COTTON MACHINERY)**
 draw frame, 67
 ring frame, 73
 speed frame, 71
- ROLLER SETTINGS (COTTON MACHINERY)**
 draw frame, 67
 mule, 74
 ring frame, 73
 speed frame, 71
- ROLLER WEIGHTINGS (COTTON MACHINERY)**
 draw frame, 67
 mule, 74
 speed frame, 71
- ROLLERS, TAKE-UP**, 126
- SCARVES**, 185
- SCHAPPE SPINNING INDUSTRY**, 106
- SCHLUMBERGA FLAX COMBING MACHINE**
 105
- SCOURING**
Fibro fabrics (for dyeing) 174-179;
 (for printing), 186
 blends, 40, 245, 246, 247, 259, 270, 274
 dolly, 246
 (tinting), 40
- SCREEN PRINTS**, 187, 188, 205
- SELVEDGE GUIDES**, 68, 71
- SHALLOONS**, 164
- SHANTUNG FABRICS**, 61
- SHEDDING MOTIONS**, 127
- SHIRLEY CREASE RECOVERY AND STIFFNESS TESTER**, 237
- SHIRTING, KNITTED SPORTS**, 128
- SHOWER-PROOF FINISHES**, 222-223
- SHREDDER**, 20
- SHRINK RESISTING FINISH**, 229-230
- SHRINKAGE**
 adequate, 118-120, 244
 in fabric construction, 118-120
 of *Fibro* fabrics, 118
 of grey fabrics, test to determine, 240
 -resistance imparted by *Fibro* to wool, 130
- SHUTTLES**, 126
- SIMPLEX MACHINES**, 130
- SINGEING**, 173, 186

- SILK**
 application of *Fibrofix* to, 144
 bolting, 205
 degumming *Fibro* fabrics containing, 243
 finishing of *Fibro* fabrics containing, 243
 for blending with *Fibro*, 62
 industry, 106
 machinery, spinning *Fibro* on, 45, 107
- SIZING, WARP, 121-124, 128 :**
 avoiding excessive stretch, 123
 classification of yarns, 121
 extra guide rollers, 123
 lessening fluff formation, 128
 linen-dressing machine, 123
 machines used, 121
 methods, 121-123
 recipes, 121-122
 starches, 122
- SKEIN LIMITS, 77**
- SLIVER OR TOP, *Fibro***
 dyeing, 140-141, 145, 149
 producing direct from tow, 40-46
- SLIVER STAPLING METHOD, 43**
- SMOULDER-PROOFING NARROW FABRICS, 165**
- SOFTENERS, 213**
- SOLEDON DYES (SEE SOLUBILIZED VAT DYES)**
- SOLID ROLLS, 167-169**
- SOLUBILIZED VAT DYES, 154-158, 198, 258, 266, 267**
- SPECIFIC GRAVITY OF *Fibro*, 33, 34**
- SPEED FRAMES, 70**
- SPENCER PADDING MACHINE, 159**
- SPINNERET, 21**
- SPINNING**
 on cotton machinery, 14, 15, 45, 63-74 (for detail see Cotton machinery)
 on cotton condenser machinery, 75-76 (for detail see Cotton condenser machinery)
 on flax machinery, 45, 105-106 (for detail see Flax machinery)
 on jute machinery, 45, 108-109 (for detail see Jute machinery)
 on silk machinery, 45, 107 (for detail see Silk machinery)
 on woollen machinery, 76-80 (for detail see Woollen machinery)
 on worsted machinery, 14, 44, 100-104 (for detail see Worsted machinery)
 from "Greenfield Top", 44-46, 107, 109 (for detail see "Greenfield Top")
- SPINNING MACHINE, 21**
- SPIRAL BREAKER, 219**
- SPORTS SHIRTING, 129**
- SPUN DYED *Fibro*, 22, 32, 77, 116, 299**
- SPUN SILK INDUSTRY, 106-107**
- STABILITY, DIMENSIONAL, 118, (TEST FOR) 239-240**
- STANDARD MOISTURE REGAIN, 31, 98**
- STAPLE**
 dyeing, 37-40, 138-140, 145, 149
 length,
choice of in fabric construction, 114
effect of on yarn properties, 52, 55, 84
- STARCH**
 for warp-sizing, 122
 removal from *Fibro* fabrics, 175
- STEPPING, 20**
- STENTERING**
 clip, 216-218
 pin, 186, 218
 white room, 186, 219
- STORING *Fibro*, 22, 33, 106, 109**
- STOVES, DRYING, 216-219**
- STRESS-STRAIN RELATIONSHIPS, 24-27**
- STRETCH**
 avoidance of in warp sizing, 123
 in *Fibro* manufacture, 22
 avoidance of in finishing, 244
- STRONG *Fibro***
 comparison with ordinary *Fibro*, 27, 58, 59
 for cotton spinning, 47, 57
 properties of, 25, 34
 water imbibition of, 32, 215
- STRUCTURE OF *Fibro*, 23**
- SULPHUR DYES, 145-149, 258, 265**
- TANGUIS COTTON, 61**
- TAPES, 164**
- TEMPERATURE**
 effect of in dyeing, 138, 179, 259-263, 268-269, 275
 for processing on cotton machinery, 68
- TEMPLES, 125**
- TENSILE STRENGTH, 23, 24**
- TETLEY, H.G., 14**
- "TEXSPRAY", 38**
- THERMAL PROPERTIES, 33**
- TIES, 185**
- TIN DRYING, 215**
- TINTS**
 application of, 37-38
 list of, 39
 preparation of own, 39
 removal of, 40
- TOMLINSON DRYING MACHINE, 216**
- TOP OR SLIVER, RAYON STAPLE**
 dyeing, 140-141, 145, 149
 producing direct from tow, 40-46
- TOPHAM BOX, 160**
- TOW, RAYON, 21, 43, 44**

- TOW-TO-TOP CONVERSION, 40-46
 TRADE MARKS, COURTAULDS' REGISTERED, 7, 15, 144
 TRIMMINGS, 164
 TRIPLE-LOOP LACING BAND, ILLUS., 161
 TROPICAL SUITINGS, 185
 TUBULAR FINISHING MACHINE, 184
 TWIST
 designation of 'S' and 'Z', 298
 factors
 (cotton spinning), 52-57, 70, 72, 74
 (worsted spinning), 85-90, 102, 104
 knot, double, illus., 161
 semi-voile or voile, 52
 TYRE CORD FABRICS, 281
 UNIONS, DYEING OF (SEE DYEING-BLENDS)
 UNITED KINGDOM, OUTPUT OF RAYON STAPLE IN, 19, 297
 "UNIVERSAL" SPINDLE CHEESE WINDER, STYLE 50, 161
 UREA, ANALYSIS OF TECHNICALLY PURE 235
 UREA FORMALDEHYDE PROCESS (CIBA) 200
 UREA METHOD, 198
 USES OF *Fibro*, 281
 VALENCE CHAINS, 24
 VAT DYES, 149-158, 162-163, 183, 188, 197, 203, 258, 265-267, 270, 271
 VISCOSE
 manufacture of, 19-21
 rayon staple (see also *Fibranda*, *Fibro* and *Rayolanda*)
 manufacture, 19-21
 moisture regain, 98
 with special properties, 7
 top or sliver, 40-46
 WARP DYEING, 143, 145, 149, 159
 WARP SIZING, 121-124, 128
 WASHING FASTNESS OF DYES
 improving, 144-145, 253
 on *Rayolanda*, 264
 WASHING OF FABRICS, 292-296
 WASTE
 customs classification of, 15
 discontinuous rayon, 14
 rayon, 106
 tests, 66
 WATER
 imbibition, 31, 32, 95, 98, 100, 215
 repellent finishes, 222-223
 WEAVING, 124-128 :
 back rests, 127
 crepe wefts, 128
 fluff, 128
 humidity in sheds, 128
 healds, 125
 pick spacing, 126
 WEAVING—cont.
 position of box swell, 127
 preliminary operations, 125
 reeds, 125
 rollers, 126
 shedding motions, 127
 shuttles, 126
 temples, 125
 WEBBINGS, 164
 WEISBACH DRYING MACHINE, 216
 WESTCROFT MILL, 15
 WET FINISHES, 222 *et seq.*
 W.I.R.A. PROCESS, 245
 WIDE FABRICS, DYEING IN ROLL FORM, 170-171
 WILSON, A.H., 13
 WINCH DYEING MACHINES, 180, 214
 WINDING SPUN YARNS INTO CAKES, 161-162
 WOMEN'S WEAR, 281
 WOOD-PULP, 19-20
 WOOL
 cape-top, 62
 crabbing *Fibro* fabrics containing, 243, 245-246
 fibres, fineness of, 85
 in blend with *Fibro*, dyeing of, 248-258
 in blend with *Fibro* for cotton machinery, 61, 62, 68
 in blend with *Fibro* for woollen machinery, 76 *et seq.*
 in blend with *Fibro* for worsted machinery, 80 *et seq.*
 in blend with *Fibrolane*, 59
 moisture regain of, 98
 WOOLLEN MACHINERY
Fibro for, 76-77
 skein limits, 77
 blending with wool, 76
 carpet yarns, 76
 other blends, 77
 spinning *Fibro* on, 76-80
 blending and oiling, 77-78
 carding, 78
 drafts, 80
 mule spinning, 79
 topping and bevel of spindles, 80
 WORSTED MACHINERY
Fibro for, 80-100
 effect of filament denier on yarn properties, 84
 effect of staple length on yarn properties, 84
 effect of twist on yarn properties, 85-90
 fineness of *Fibro* and other fibres, 84
 blends with wool, 80, 84-86, 90, 95, 98, 100, 102
 wet and dry strengths and extensions, 85, 86, 90, 95

WORSTED MACHINERY—cont.

- water absorption, 95, 98, 100*
- types of staple suitable, 80, 84*
- "Greenfield Top" for, 44-45
- spinning Fibro on, 14, 44, 100-104
 - breakage after carding and combing, 101*
 - carding, 100, 103*
 - combing, 100, 101, 103*
 - drawing, 101, 102, 104*
 - economies in initial processing, 100*
 - intergilling, 100, 103*
 - opening, 100*
 - Noble comb, 101, 103*
 - punch box, 101*
 - recombing, 101*
 - Rectilinear comb, 101*
 - spinning, 101, 102, 104*
 - twist factors, 85-90, 102, 104*
 - twisting, reeling and winding, 102*
 - settings, drafts, speeds and other production details, 103, 104*

YARN

- count, 84
- dyeing, 141-143, 145, 149, 158, 159, 160-164, 244-245, 259, 269
(see also Dyeing)

YARNS

- blend, 59-63, 76, 80, 84, 85-100, 101, 102, 107, 116, 117
- carpet, 76, 109, 160, 273
- cotton-spun, 46-63, 114, 117
- cotton condenser-spun, 75, 115
- designation of 'S' and 'Z' twist in, 298
- fancy, 62, 63
- flax-spun, 106, 115
- hosiery, 60
- jute-spun, 109, 116
- processing of, 74, 102, 161
- silk-spun, 107, 115
- woollen-spun, 76, 77, 115
- worsted-spun, 80-100, 102, 115

