

BIRLA CENTRAL LIBRARY
PILANI (Rajasthan)

Class No

661.2

R

Book No

L93M V.1

Accession No.

59535

THE MANUFACTURE OF ACIDS AND ALKALIS
BY GEORGE LUNGE, PH.D., DR.ING.
Emeritus Professor of Technical Chemistry, Zurich.

Completely Revised and Rewritten under the Editorship of
ALEXANDER CHARLES CUMMING
O.B.E., D.Sc., F.I.C.

VOLUME I

Raw Materials for the Manufacture of
Sulphuric Acid and Sulphur Dioxide

RAW MATERIALS FOR
THE MANUFACTURE OF
SULPHURIC ACID
AND THE
MANUFACTURE OF
SULPHUR DIOXIDE

BY

WILFRID WYLD

CONSULTING CHEMIST

FORMERLY GENERAL TECHNICAL MANAGER OF MESSRS NICHOLSON AND SONS, LTD.

FORMERLY CHIEF ENGINEER OF MESSRS BROTHERTON AND CO. LTD.

FORMERLY MANAGER THE DHARAMSI MOPARJI CHEMICAL CO., LTD., BOMBAY



GURNEY AND JACKSON
LONDON: 33 PATERNOSTER ROW
EDINBURGH: TWEEDDALE COURT

1923

PRINTED IN GREAT BRITAIN BY
OLIVER AND BOYD, EDINBURGH

EDITOR'S PREFACE

THE first English edition of Lunge's *Sulphuric Acid and Alkali* appeared in 1879. Since that date the book has been revised and extended in subsequent editions until, with the companion volumes on *Coal Tar and Ammonia*, it extended to nine volumes, covering most of the heavy chemical industries of Britain. A supplementary volume on Sulphuric and Nitric Acids by Dr Lunge in 1917 marked the end of his long labours in this field, and he informed the publishers that he could no longer undertake the preparation of new editions. The mere compilation of the volumes which he wrote would be in itself a wonderful achievement, but Dr Lunge's place in the history of chemical industry is due still more to the fact that he played a leading part in the discoveries and improvements which built up the industries of which he wrote.

By a curious coincidence, the end of Dr Lunge's long literary labours came just as the processes which he originally described died out. The Hargreaves process has gone, in this country at least; the Leblanc process is dying, if not actually dead already; even the chamber process for sulphuric acid has now a competitor that threatens to become a rival.

The volumes written by Dr Lunge have escaped a common criticism of factory managers that books give only an outline of a manufacturing process; indeed, the only criticism has been that Dr Lunge's books gave almost too much detail. It may, however, be realised how important is a detail relating to a matter involving a possible saving of only one-tenth of one per cent., when it is pointed out that this small economy in the

manufacture of sulphuric acid would mean a saving of thousands of pounds, since the value of the sulphuric acid manufactured annually in Great Britain alone amounts to several million pounds.

Each new edition of this series has been an expansion and extension of that which preceded it, fuller treatment being accorded to subsidiary manufactures as they increased in commercial importance, until the name *Sulphuric Acid and Alkali* became a cover for what was practically an encyclopedia of the heavy chemical industries.

The last arrangement into volumes and parts was largely fortuitous, having arisen from uneven growth of knowledge and commercial development in different branches; and as this appeared to be a favourable opportunity for instituting a new arrangement, it was decided to subdivide the work into sections more in accord with modern developments. The last few years have brought with them many changes in the chemical industries, and the revision required in most of the volumes has involved such drastic recasting that the new edition will be more a new book than a revised edition.

It is doubtful if any one man could take up Dr Lunge's task of describing adequately all the industries now dealt with in these volumes, and it is certain that few would care to attempt it. Each volume will therefore be on a special subject and dealt with by a separate author, who is responsible for that volume, and is given a wide discretion in his treatment of the subject.

It is hoped that these united efforts will produce a new edition worthy of the great tradition which Dr Lunge has established.

The editor will be pleased to consider for publication in this series any manuscripts or original work on this, or allied subjects.

A. C. C.

AUTHOR'S PREFACE

THE last edition of Lunge appeared in the year 1913, and his supplementary volume a few years later.

Since that period, however, many changes and advances have been made in the methods of construction of plant and in the process of manufacture, and new inventions have been brought out, so that no apology is needed for another edition of so important a work.

The task of revising Dr Lunge's treatise has been a formidable one, and I trust the reader will excuse the errors and omissions inevitable when dealing with so vast a subject.

Free use has been made of Dr Lunge's very important investigations on the theory of the various reactions appertaining to this manufacture.

New matter has been introduced in relation to the disposal of the by-products, mechanical furnaces, etc., together with many new illustrations.

I have thought it inadvisable to give many details of the cost of production and erection of plant, for at this period of transition from War to Peace the markets fluctuate from week to week, and any such figures would be of little value.

Unless otherwise mentioned, all temperatures throughout this volume are on the Centigrade scale.

W. W.

LEEDS, *February* 1923.

CONTENTS

INTRODUCTION	PAGE I
------------------------	-----------

CHAPTER I

HISTORICAL AND GENERAL NOTES ON THE MANUFACTURE OF SULPHURIC ACID

History of the Manufacture	3
General Principles	6

CHAPTER II

THE RAW MATERIALS OF THE SULPHURIC ACID MANUFACTURE

1. <i>Natural Sulphur (Brimstone)</i>	8
Properties of Sulphur	8
Colloidal Sulphur	12
Allotropic Modifications	14
Chemical Compounds of Sulphur	16
Vegetable Physiological Action	17
Commercial Descriptions	18
Natural Occurrence of Sulphur	20
Manufacture of Sulphur from Native Crude Brimstone	28
The Frasch Process	29
Other Processes	32
Sulphur obtained from various materials	34
1. From Spent Oxide	34
2. From Pyrites	36
3. From Sulphur Dioxide	38
4. From Gases containing SO_2 (Smeltry Fumes)	41
5. From Sulphuretted Hydrogen	43
6. From Sulphites	45
7. From Sulphides of Alkaline Earth Metals	46
8. From Sulphates of the Alkaline Earths	46

	PAGE
Reducing Sulphur to Fine Powder	50
Estimating the Degrees of Fineness	51
Refining of Sulphur	53
Roll and Block Sulphur	53
Flowers of Sulphur	53
Technical Forms of Sulphur	56
Technical Analysis of Commercial Sulphur	57
2. <i>Pyrites</i>	68
Properties of Iron Pyrites	68
Of Marcasite	69
Of Pyrrhotite	71
Of Copper-Pyrites	73
Sources of Pyrites	76
Price of Pyrites	97
Value of Poor and Rich Pyrites	97
Analysis of Pyrites	98
Volumetric Estimation	103
Analysis of Burnt Pyrites (Cinders)	107
Estimation of other Constituents of Pyrites	111
2A. <i>Coal-Pyrites</i>	122
3. <i>Zinc-blende</i>	125
Analysis of Zinc-blende	126
Presence of Impurities	129
Statistics	133
4. <i>By-products of other Manufacture</i>	137
<i>a.</i> Spent Oxide from Gasworks	137
Analysis of Spent Oxide	139
<i>b.</i> Sulphuretted Hydrogen	142
<i>c.</i> Copper-pyrites, etc.	143
5. <i>Other Metallic Sulphides—Noxious Vapours</i>	145
Abatement of the Nuisance	151
6. <i>Supplying Nitrogen Oxides to the Sulphuric Acid Process</i>	156
<i>a.</i> Introduction of Nitric Acid as Vapour	157
<i>b.</i> As Liquid Nitric Acid	160
<i>c.</i> Introduction of Nitre as an Aqueous Solution of Sodium Nitrate	162
<i>d.</i> With Nitrous Gases obtained as By-products	165
<i>e.</i> By Oxidation of Ammonia	166

CHAPTER III

THE PROPERTIES AND ANALYSIS OF THE TECHNICALLY
EMPLOYED OXIDES OF SULPHUR

	PAGE
<i>Sesquioxide</i>	176
<i>Sulphur Dioxide</i>	176
Properties of Gaseous Sulphur Dioxide	176
Detection and Estimation of Sulphurous Acid and Sulphur Dioxide	184
Applications of Sulphurous Acid (Sulphur Dioxide)	190
<i>Sulphur Trioxide</i> (Sulphuric Anhydride)	191
<i>Sulphuric Acid</i>	194
Properties of "Monohydrated" Sulphuric Acid	194
Sulphuric Acid containing Water	196
Hydrometers	199
Specific Gravities of Sulphuric Acid	203
Influence of Impurities on the Density	207
Physiological Action of Sulphuric Acid	217
Chemical Behaviour of Sulphuric Acid	218
Action on Metals	222
On Platinum	223
On Lead	224
On Cast-iron	239
On Iron Alloys	242
On Wrought-iron and Steel	243
Behaviour of Sulphurous and Sulphuric Acid towards the Oxides of Nitrogen	249
Nitrous Oxide	250
Nitric Oxide	250
Nitrous Acid	252
Nitrogen Trioxide	253
Nitrogen Peroxide	260
Specific Gravities of Nitrous Vitriol	268
Analysis of Sulphuric Acid	274
Estimation of Impurities of Sulphuric Acid	278
Estimation of Nitrogen Compounds in Sulphuric Acid	288

CHAPTER IV

THE PRODUCTION OF SULPHUR DIOXIDE

A. <i>From Sulphur</i>	306
B. <i>From Pyrites</i>	319
1. <i>Breaking the Pyrites</i>	319

	PAGE
2. Pyrites-burners for Lumps	326
Explosive Pyrites	339
Working of the Pyrites-burners for Lumps	341
3. Burning Pyrites-smalls	352
Hand-fired Burners	357
Mechanical Burners	367
C. <i>Sulphur Dioxide from Zinc-blende and other Sulphides</i>	396
Mechanical Roasting Furnaces	399
Treatment of Complex Ores containing Blende	411
D. <i>Sulphur Dioxide from various other Materials</i>	418
1. Burners for the Spent Oxide of Gasworks	418
2. Burners for Sulphuretted Hydrogen	422
E. <i>Sulphur Dioxide from Noxious Vapours</i>	424
F. <i>Sulphur Dioxide from Blast-furnace Slag</i>	429
G. <i>By other Methods</i>	431
H. <i>Preparation of Sulphur Dioxide in the Pure or Liquid State</i>	432
Carriage of Liquid Sulphur Dioxide	436
Uses of Sulphur Dioxide	437
I. <i>Draught-pipes and Flues</i>	439
Dust-chambers	440
The Electrical Precipitation of Dust	443
Other Methods of removing Dust	447
Purification of Burner-gases from Liquid and Gaseous Con- taminations	452
J. <i>Composition of the Burner-gas</i>	457
1. From Burning Brimstone	457
2. From Burning Pyrites	458
3. Comparison of Brimstone and Pyrites as Material for the Manufacture of Sulphuric Acid, etc.	461
4. Composition of the Gas from Blende-furnaces	462
5. Sulphuric Anhydride in Burner-gas	463
6. Actual Percentage of Sulphur Dioxide in Burner-gas	468
7. The Quantitative Estimation of Sulphur Dioxide	471
8. Lunge's Test for Total Acids	476
9. Estimation of Oxygen	479
10. Of Oxides and Acids of Nitrogen	482
K. <i>Composition of Flue-dust and Chamber Deposits</i>	484
Recovery of Thallium and Selenium	487

CHAPTER V

BY-PRODUCTS IN THE MANUFACTURE OF SULPHURIC ACID

	PAGE
I. <i>Disposal of the Cinders</i>	491
<i>a. Briquetting</i>	491
Types of Presses	495
Drying	495
Furnaces	496
<i>b. Sintering</i>	498
II. <i>Extraction of Copper from Pyrites-cinders</i>	500
Grinding	504
Hand Furnaces	507
Mechanical Furnaces	507
Condensation of the Calcination-gas	513
Lixiviation of the Calcined Charge	514
Pre-leaching	515
The Residue from Lixiviation	520
Copper-liquor obtained by Lixiviation	522
Precipitation of the Copper from the Liquors	522
III. <i>Working up the Copper Precipitate</i>	525
IV. <i>Extraction of the Silver</i>	526
V. <i>Extraction of Zinc</i>	529
Electrolytic Methods	532
VI. <i>Recovery of the Sodium Sulphate</i>	534
VII. <i>Treatment of Ores poor in Copper</i>	536
<i>General Remarks</i>	541
INDEX OF NAMES	543
INDEX OF SUBJECTS	555

RAW MATERIALS AND MANUFACTURE OF SULPHURIC ACID AND SULPHUR DIOXIDE

INTRODUCTION

IT can be truly said that the manufacture of acids and alkali is the foundation upon which the whole chemical industry of our times is built up, and that this industry cannot be much developed in any country not possessing a flourishing alkali trade unless it is specially well situated for buying these products. It is thus evident how great is the importance of the alkali trade in its wider meaning to the civilisation of mankind, though we should certainly be going too far if we measured, as some have done, the civilisation of a country by the development of this special industry.

The manufacture of *sulphuric acid* is a very large and important industry. Enormous quantities of it are required for the manufacture of artificial manures (fertilisers), and therefore every large manure factory makes its own sulphuric acid. This is done also by the largest sulphate-of-ammonia works, petroleum refiners, coke oven works, explosives factories, and in a few other cases. Some works in England, and many on the Continent, make sulphuric acid to a great extent, or even entirely, not for their own use, but for sale. Since this acid is no longer sent out in any considerable quantity in glass carboys, but in iron tank-waggon, it can be carried to considerable distances at moderate cost.

As sulphuric acid is mostly made from pyrites, its manu-

acture is intimately connected with the recovery of *copper* from the cinders, in which process silver, zinc, and other by-products are obtained, leaving the iron as ferric oxide to be subsequently converted into iron.

A large quantity of sulphuric acid is used for the manufacture of *sulphate of soda* (*salt-cake*) and *sulphate of potash*, in which *hydrochloric acid* is a necessary by-product. The electrolytical method for the manufacture of soda caustic has practically replaced the Leblanc process, and the demand for sulphuric acid in this direction is consequently reduced proportionately.

Other demands for sulphuric acid are, however, springing up, such as in the extraction of grease from town sewage, the sulphonation of tar products for the preparation of "intermediates," and the like, so that we need not fear any immediate falling off in the demand for sulphuric acid.

CHAPTER I

HISTORICAL AND GENERAL NOTES ON THE MANUFACTURE OF SULPHURIC ACID,

History of the Manufacture of Sulphuric Acid.

ACCORDING to Rodwell (*Birth of Chemistry*) it is very probable that sulphuric acid was already known to the ancients; but usually its first, although indistinct, mention is ascribed to the Arab Geber, who speaks of the "spirit" which can be expelled from alum and which possesses solvent powers. Geber is, however, a mythical personage, and many of his alleged numerous discoveries have wrongfully crept into the Latin "translations" of his pretended writings, as proved by Berthelot and Steinschneider,¹ who show that sulphuric acid was unknown to the Arabian writers about A.D. 975. Others give the honour of its discovery to the Persian alchemist Abu-Bekr-Alrhases, who is said to have died in 940. Vincentius de Beauvais (about 1250) alludes to it; and Albertus Magnus (1193-1280) speaks of a *spiritus vitrioli Romani*, which can only have been sulphuric acid; his "sulphur philosophorum" is the same thing.

Basil Valentine, who probably lived in the second half of the fifteenth century, in his *Revelation of the Hidden Manipulations*, clearly described its preparation from calcined copperas and silica, and, in his *Triumphal Car of Antimony*, its preparation by burning sulphur with saltpetre;² but he took the two to be different substances.

Gerhard Dornæus (1570) described its properties accurately; Libavius (1595) recognised the identity of the acids from different processes of preparation; this was done also by

¹ Cf. Lippmann, *Z. angew. Chem.*, 1901, p. 646.

² Kopp, *Geschichte der Chemie*, 3, p. 303.

Angelus Sala (1613), who pointed out the fact, which had sunk into oblivion since Basilus, that sulphuric acid can be obtained by burning sulphur in moist vessels (of course with access of air); after that time it was prepared by the apothecaries in this way. An essential improvement, the addition of a little saltpetre, was introduced in 1666 by Nicolas le Fèvre and Nicolas Lémery. This started a sort of manufacture of vitriol which is said to have been introduced into England by Cornelius Drebbel; a quack doctor of the name of Ward first carried on sulphuric-acid making, on what was then a large scale, at Richmond, near London, probably a little before 1740. Ward employed large glass vessels up to 66 gallons capacity, which stood in two rows in a sand-bath, and which were provided with horizontally projecting necks; at the bottom they contained a little water. In each neck there was placed an earthenware pot, and on this a small red-hot iron dish, into which a mixture of one part saltpetre and eight parts of brimstone was put. The neck of the bottle was then closed with a wooden plug until the combustion was finished. Fresh air was allowed to enter the vessel, and the operation was repeated till the acid had become strong enough to pay for concentrating in glass retorts.

Ward called the product "oil of vitriol made by the bell" (already Basil Valentine had used the expression "per campanam" in this sense), in order to distinguish the spirit of vitriol made from brimstone from that distilled from sulphate of iron, the latter having been already before Ward's time made on a kind of manufacturing scale in England. Ward's process, troublesome as it was, reduced the price of the acid from 2s. 6d. per oz. (the price of the acid from copperas or from burning brimstone under a moist glass jar) to 2s. per lb.

An extremely important improvement in this process was the introduction of the *lead chambers*, which by general consent is ascribed to Roebuck of Birmingham,¹ who in 1746 erected such a chamber 6 ft. square, and in 1749, in partnership with Mr Garbett, built a factory with lead chambers at Prestonpans in Scotland, in order to supply acid for bleaching linen. The mixture of brimstone and saltpetre in the proportion employed by Ward was put into small iron waggons

¹ Guttman, *J. Soc. Chem. Ind.*, 1901, p. 5.

which were run into the chamber on a railway: the chamber was closed, and the process carried on intermittently in this way.

Soon other works followed at Bridgnorth, and at Dowles in Worcestershire, where the chambers were made 10 ft. square; in 1772 a factory was erected in London with 71 cylindrical lead chambers, each 6 ft. in diameter and 6 ft. high. In 1797 there were already six or eight works in Glasgow alone. In Radcliffe there were six chambers 12 ft. long, 10 ft. wide, and 10 ft. high, with roofs like those of cottages, and valves which were opened between each operation; on their bottom there was 8 or 9 in. of water; every four hours a mixture of 1 lb. saltpetre and 7 lb. brimstone was burned in each chamber on iron shelves, of which each chamber contained four, 4 in. distant one from another. The shelves were made of very thin iron, in order to obtain quick heating, and rested on iron frames, by means of which they could be slid in and out; a quarter of an hour before each operation, the valves and doors were opened in order to allow air to enter. In six weeks the strength of the acid attained only 1.250 sp. gr.; it was then run off and concentrated up to 1.375 sp. gr., in which state it was used and sold. At Prestonpans, in 1800, a yield of only 111 per cent. on the sulphur was attained, with a consumption of 13 per cent. saltpetre on the brimstone; in 1813 there were in that place 108 chambers of 14 ft. length, 10 ft. height, and 4 ft. width. In 1805 there was at Burntisland a factory with 360 chambers of a capacity of 192 cub. ft. each.

R. Forbes Carpenter and W. F. Reid also give some interesting notes on the early manufacture of sulphuric acid (*loc. cit.*). The former mentions acid-chambers erected in Cornwall from dressed granite, with lead top and bottom.

In the meantime, the first lead chamber in France had been erected at Rouen by Holker in 1766. In 1774, in that place, on the advice of De la Follie, an important improvement was introduced, viz. the introduction of steam into the chambers during the combustion of brimstone. In 1793 Clément and Désormes showed that the acid-chambers could be fed by a *continuous* current of air, by which a great deal of saltpetre could be saved. They showed that the oxidation of sulphurous

acid takes place to the extent of nine-tenths at the expense of atmospheric oxygen, and that the saltpetre plays only the part of intermediary between the air and the sulphurous acid. By this demonstration, the essential part of the modern theory of sulphuric acid manufacture was established; but it took a remarkably long time before the difficulties were overcome which stood in the way of introducing the continuous system into practice. Usually the introduction of the continuous burning of brimstone is ascribed to Jean Holker (a grandson of the first Holker), in 1810; but, according to Mactear, a continuous system had been introduced at St Rollox, at least partially, by 1807; steam was first introduced there in 1813 or 1814.

Kestner, of Thann in Alsace, was the first to collect the products of condensation at the chamber-sides in order to regulate the working of the chambers thereby. This innovation was at once considered of such importance that Kestner was called to Glasgow in order to introduce his plan into Tennant's works.

Gay-Lussac's apparatus for condensing the oxides of nitrogen escaping from the chambers was invented in 1827: at Chauny this apparatus was erected in 1842, at Glasgow in 1844. But we have now come so near the present time that we may conclude the historical part of our task.

General Principles of the Manufacture of Sulphuric Acid.

Sulphuric acid can be obtained on a large scale in two ways—viz. either by burning sulphur or sulphides into sulphur dioxide and further oxidising the latter, or by decomposing natural or artificially prepared sulphates.

By the *combustion of sulphur*, either free (as brimstone, gas-sulphur, etc.) or combined with metals or with hydrogen, *sulphur dioxide* (SO_2) is always formed at first. Sulphuretted hydrogen, even when mixed with as much as 70 per cent. of inert gases (carbon dioxide, nitrogen), can be lighted like coal-gas and continues burning without any difficulty, aqueous vapour being formed at the same time as SO_2 . Brimstone ignites in the air at a temperature below 300° ; and when once it has begun to burn, the heat generated raises the whole of the sulphur to

the point of ignition, provided that sufficient air be present. A number of metallic sulphides behave similarly: the most important of these for our purpose is iron disulphide, FeS_2 (pyrites); but here special precautions must be taken, so that the whole mass may be completely burned (roasted). In both cases, besides sulphur dioxide, SO_2 , a little trioxide (sulphuric anhydride), SO_3 , is always formed, and, in the presence of water or steam, also sulphuric acid, H_2SO_4 , more or less diluted with water. Moreover, an aqueous solution of sulphurous acid in contact with air gradually changes into sulphuric acid. In both cases it is, of course, the oxygen of the air which converts the SO_2 into SO_3 or H_2SO_4 ; but this reaction at the ordinary or only moderately elevated temperature goes on far too slowly to be applicable for technical purposes.

There are two ways of increasing the velocity of the oxidation of sulphur dioxide. One of these, which is principally applicable to dry gases and therefore leads to the preparation of sulphur trioxide in the anhydrous state, is the employment of *catalytic* or *contact* substances.

The second way, which is exclusively applicable to the production of real sulphuric acid, H_2SO_4 , is founded on the property of the acids of nitrogen to serve as carriers of oxygen from atmospheric air upon sulphur dioxide and water, the original nitrogen oxide being always reformed. This process will be explained in detail when we treat of the theory of the formation of sulphuric acid; it is commonly called the *lead-chamber process*.

The reaction between nitrogen acids and sulphur dioxide goes on only in the presence of water; and, in practice, much more water is needed than suffices for the formation of H_2SO_4 ; the sulphuric acid formed is therefore always *dilute*, and must be *concentrated* for many purposes.

For some purposes, the acid must also be deprived of certain foreign substances which get into it from the raw materials and the apparatus; and in these cases the acid has to be purified.

CHAPTER II

THE RAW MATERIALS OF THE SULPHURIC ACID MANUFACTURE

I. SULPHUR (BRIMSTONE).

BRIMSTONE, owing to its being found in nature in the free state, has been known to mankind since ancient times. The Romans evidently obtained it in the same way as is done now, by melting it out of its mixture with marl, etc.

Properties of Sulphur.

Sulphur is an element having an atomic weight of 32.065 (oxygen = 16), Richards and Hoover.¹ It is very brittle, its hardness is from 1.5 to 2.5 of the ordinary mineralogical scale; its specific gravity is 2.0748. As usually occurring, it is semi-transparent at the edges and of the well-known bright yellow colour; at -50° it is nearly devoid of colour. Its taste and smell are very slight. It is a bad conductor of electricity, but becomes electric by friction, and is therefore difficult to powder finely, as it adheres to the mortar and pestle.

Solubility.—The behaviour of sulphur to water and aqueous solutions of acids and salts, in which "colloidal" sulphur is soluble to some extent, has been studied by several chemists, among whom we mention Ruff and Graf.²

Under ordinary circumstances sulphur is insoluble in water, very slightly soluble in alcohol or in glycerine, a little more so in essential oils.

¹ *J. Amer. Chem. Soc.*, 1915, 37, 108.

² *Berl. Ber.*, 1907, p. 4199; Raffo, *J. Soc. Chem. Ind.*, 1908, p. 747; Odén, *ibid.*, 1911, p. 941; Raffo and Mancini, *Chem. Zentr.*, 1910, 2, 1129; 1911, 2, 1305.

Volatility.—Jones¹ states that sulphur volatilises very slowly at 100° in the absence of water, and is subsequently deposited in aggregations of octahedral crystals elongated so as to appear needle-shaped, together with smaller quantities of β -sulphur which, however, remain transparent indefinitely. Even the purest forms of sulphur appear to possess sensible volatility at the ordinary temperature, since silver foil suspended over them becomes blackened, especially in the presence of water.

Molecular Complexity.—The molecular complexity of liquid sulphur is given by Alexander Mitchell Kellas.² He states that sulphur has a greater molecular complexity in solution, and also throughout a considerable range of temperature in the gaseous condition, than any other element. Its complexity in the liquid state would therefore seem to be of special interest. Several years ago, he carried out the usual lecture experiment of preparing the plastic modification of sulphur, and drew the conclusion that viscosity could not be the cause of the failure to obtain definite results, as sulphur is quite mobile from its melting point at 115° up to about 160°, when an abrupt increase of viscosity occurs. This evidently gave a range of about 45° for the determination of the variation of molecular surface energy with temperature, which is larger than that generally used by Ramsay and Shields.

Preliminary experiments showed that it was easy to get liquid sulphur to rise from 4 to 8 cm. in capillary tubes, but also—as was to be expected from the difficulties as those above mentioned—that it was impossible to obtain concordant results. As, however, great volatility—which at this stage was regarded as an almost insurmountable factor—was evidently not the cause of the discrepancy observed, the author started a series of experiments in order to determine the actual disturbing agents, and, after that difficulty, was able to devise a course of procedure which allows of the determination of the surface tension of sulphur at any temperature from its melting-point to its boiling-point (that is, from 115° to 445°).

When sulphur is melted it forms a mobile, light brown

¹ *Mem. Manchester Phil. Soc.*, 1856, No. xiv., 1-5.

² *J. Chem. Soc.*, December 1911, 903-909.

10 MATERIALS OF SULPHURIC ACID MANUFACTURE

liquid. On raising the temperature the liquid becomes viscous, so much so, indeed, that the vessel containing it can be inverted without spilling the contents. At a still higher temperature it again becomes mobile, changing to a deep brown colour. On cooling, these changes are reversed.

If viscous sulphur be poured into water it hardens to a substance resembling india-rubber; this form, if kept for some hours, falls into minute octahedral crystals. Von Weimarn¹ prepared an elastic sulphur by heating ordinary sulphur at above 400° and pouring it in a thin stream into liquid air, the sulphur being obtained in the form of a thin thread of a diameter of 0.5-1 mm. When removed from the liquid air this thread was quite hard and brittle, but when the temperature was raised somewhat it assumed extraordinary elasticity. The sulphur had a polished surface, and appeared pale grey in reflected light, being completely transparent and without sign of opalescence. The elasticity was lost in about half an hour after the thread was removed from the liquid air, the sulphur then becoming plastic and remaining so for twenty-four hours.

According to T. Iredale,² elastic sulphur is prepared by treating powdered sodium thiosulphate with one-half its weight of concentrated nitric acid, and, after the reaction is complete, adding water and washing the product. A yellow transparent mass is obtained which, after distension to four times its length, will regain its original form. Cooling to 0° makes it opaque and brittle, but heating in water at 100° reproduces the elastic characteristics. After twenty-four hours, it passes completely into the crystalline form.

Boiling-point.—Chappuis³ determined the boiling-point of sulphur at normal pressure at constant volume, which was found to be 444.60 on the thermodynamic scale.

Mueller and Burgess⁴ do not agree with the above, and state that the boiling-point of pure sulphur is 421.73 at 760 mm. pressure.

¹ *J. Russ. Phys. Chem. Soc.*, 1910, 42, 474-476; *J. Chem. Soc.*, 1910, 2, 603.

² *Kolloid-Zeits.*, 1921, 28, 126-127; *J. Soc. Chem. Ind.*, 1921, p. 258A.

³ *Bur. Int. Poids et Mes.*, 1917, Man. 16, p. 44; *J. Chem. Soc.*, 1920, 2, 306-307.

⁴ *J. Amer. Chem. Soc.*, 1919, 41, 745-763.

Callendar and Moss¹ give the boiling-point at 444·53, and Eumorphopulos² as 444·55°.

Heat of Combustion.—Sulphur burns with a purplish-blue flame. In forming sulphur dioxide it gives out the following heat units :—

S (Rhombic)	+ O ₂ = SO ₂ = 71,080 cals.,	Favre & Silberman.
S	„ + O ₂ = SO ₂ = 69,300	Berthelot.
S (Monoclinic)	+ O ₂ = SO ₂ = 71,720	Thomsen.
(In calories applied to 32 grams of sulphur.)		

The specific heat of sulphur at 0° is :—

Rhombic S	·166 (Thomsen)
Monoclinic S	·174 do.

Vapour and Vapour Pressure.—Watson³ states that the phosphorescent glow which is exhibited by sulphur under certain conditions is readily obtained when a current of air is passed over it heated to a temperature below its ignition point, and then through a tube which is maintained at an appreciably lower temperature. Under these conditions, the air becomes charged with sulphur vapour, which separates out in the form of a cloud of very small particles when the temperature falls. The oxidation of this finely divided sulphur is the cause of the phosphorescence. There is no evidence of the formation of any oxide other than sulphur dioxide at any stage of the process.

Researches on this point have also been made by Herrmann, Baker, Moissan and Block.⁴ At a recent meeting of the Royal Society, a paper on the subject of the constitution of sulphur vapour was communicated by Sir James Dobbie and J. J. Fox.⁵

Investigations based on the determination of the vapour density, said the authors, leave unsettled the question of the existence of the sulphur molecules intermediate in complexity between S₈ and S₂. The paper contains an account of an attempt to solve the problem by the study of the absorptive

¹ *Proc. Roy. Soc.*, 1909, A 83, 106-108; *J. Chem. Soc.*, 1910, 2, 28.

² *Proc. Roy. Soc.*, 96, 189.

³ *Chem. News*, 108, 187-188; *J. Chem. Soc.*, 1913, 2, 946.

⁴ *Comptes rend.*, 1909, pp. 148 and 782; *Ann. Chim. Phys.*, 1911, 22, 460.

⁵ *Chem. Trade J.*, 1919, p. 209.

12 MATERIALS OF SULPHURIC ACID MANUFACTURE

power of the vapour of sulphur for light under various conditions of temperature.

The vapour pressure of sulphur at temperatures below its boiling-point have been studied by Matthies,¹ H. Gruener,² later by the same chemist,³ Ruff and Graf.⁴ According to the last-mentioned chemists, the vapour pressure of sulphur is:—

° C.	78	104	135	181	245
mm.	0.002	0.01	0.1	1	10

Further determinations given by Ruff, Matthies, and Bodenstein are as follows:—

° C.	49.7	131.9	211.3	306.5	374	427	444.6
mm.	.00034	.081	3.14	53.5	240	580	760

The vapour pressure over the range 700 mm. to 800 mm. has been redetermined by Mueller and Burgess,⁵ and from these values an equation for calculating the boiling-point at various pressures is deduced. This has the form $t = 444.60 + 0.0910(p - 760) - 0.000049(p - 760)^2$. A résumé of the conditions to be observed in determining the boiling-point of sulphur for standardisation purposes is appended to the paper.

Colloidal Sulphur.

Sulphur is a typical allocolloid. The soft, plastic, translucent to transparent form of sulphur, obtained by cooling rapidly, has long been called colloid or "colloidally amorphous."

A colloidal form of sulphur is obtained by adding a solution of sodium thiosulphate to cold sulphuric acid. The liquid is then diluted, heated, and filtered through glass wool. The result is that a thick cloudy yellow mass is left, which, upon the application of warmth, becomes quite clear and transparent, but, as it cools again, becomes turbid.

In regard to the conditions which are favourable to the formation of colloidal sulphur, the most important fact appears

¹ *Phys. Ztsch.*, 7, 395.

² *Science*, 1905, p. 74; *Z. angew. Chem.*, 1905, p. 107.

³ In *J. Amer. Chem. Soc.*, 1907, pp. 1396-1402; *Z. anorg. Chem.*, 56, 145-152.

⁴ *Berl. Ber.*, 1907, pp. 4199-4205.

⁵ *J. Amer. Chem. Soc.*, 1919, 41, 745-763; *J. Chem. Soc.*, 1919, 2, 446.

to be a high concentration of the substance. Experiments on the interaction of 3N-sodium thiosulphate with concentrated sulphuric acid, at temperatures between -5° and 35° are said to show a maximum yield of colloidal sulphur at 25° .

Colloidal sulphur can be produced by the decomposition of sulphur chloride by water, or by the action of sulphur dioxide on hydrogen sulphide; the sulphur does not separate, but remains in the state of "pseudo-solution" in the water; it can be precipitated on addition of salts such as calcium chloride.

Rudolph Auerbach¹ states that colloidal sulphur is capable of exhibiting various colours depending on the degree of dispersion. The colour changes can be shown by adding phosphoric acid to sodium thiosulphate solution, when first a weak turbidity appears, which is followed by a yellowish-blue opalescence, and then the colour observed by transmitted light passes slowly through yellow, green, red, violet, and blue, and finally the sulphur is precipitated. The whole process occupies twenty minutes. The following quantities are recommended for demonstration of the process:—(i.) For demonstration in a test-glass: 10 c.c. of N/20-sodium thiosulphate are treated with 0.1 c.c. of phosphoric acid ($D = 1.70$) in 9.9 c.c. of water. (ii.) For demonstration by lantern projection on a white screen: 15 c.c. of N/20-sodium thiosulphate solution are treated with 0.1 c.c. of phosphoric acid ($D = 1.70$) in 4.9 c.c. of water. It follows, therefore, that disperse systems of dielectric substances can show polychromatic colours just in the same way as metallic disperse systems.

Sarason (Ger. Ps. 216824 and 216825) prepares solutions of colloidal sulphur by acidulating solutions of thiosulphates in glycerine, with addition of thickening substances, *e.g.* gelatine.

The same (Ger. P. 242467) prepares colloidal sulphur (or selenium), soluble in water, by decomposing SO_2 with H_2S (or SeO_2 with H_2Se) in volatile solvents not miscible with water, *e.g.* carbon disulphide, benzene, carbon tetrachloride.

The Aktiebolaget Kolloid in Stockholm (B. P. 7238 of 1913; Fr. P. 456058) passes a mixture of $\text{SO}_2 + \text{H}_2\text{S}$ through decinormal acid, and precipitates the colloidal sulphur formed

¹ *Kolloid-Zeitsch.*, 1920, 27, 223-225; *J. Chem. Soc.*, 1921, 2, 40.

14 MATERIALS OF SULPHURIC ACID MANUFACTURE

by the addition of sodium chloride ; it may be redissolved in a colloidal way.

Julius Meyer¹ prepares colloidal solutions of sulphur (or selenium) by dissolving ground sulphur (or selenium) in a few cubic centimetres of hydrazin sulphate up to saturation, by shaking, and pouring a few drops of the solution, rapidly shaking, into several litres of water. In the case of sulphur this proceeding yields a solution which has at first a lemon-yellow, later on through formation of colloidal sulphur a yellowish-white colour, which is not very stable nor dialysable.

Application of Colloidal Sulphur.—Lumière and Seyewetz² apply it for "toning" solutions of silver bromide for photographic purposes. The photographs are soaked in a solution of 125 grams "fixing soda" in 1 litre water, to which had been added 250 c.c. 50-per-cent. dextrine solution and, shortly before use, 50 c.c. hydrochloric acid. The photographs remain in this solution for twenty to twenty-five minutes, and are then washed for one and a half hours, whereby the toning process is completed. In this treatment the white places remain quite intact.

Allotropic Modifications.

In the allotropy of sulphur, there are two or more solid phases, the rhombic "*a*" and the monoclinic "*β*," besides several in the liquid phase. If sulphur be allowed to crystallise from fusion, or slowly from a solution of sulphur in CS₂, it assumes a monoclinic form of long prisms. These crystals, however, change spontaneously at the ordinary temperature, and soon fall into minute rhombic octahedra.

The monoclinic crystals are brownish yellow and of a sp. gr. 1.982. The native or natural sulphur exists in the rhombic form. Besides the better-known forms just mentioned, a nacreous form of sulphur S_γ can be obtained by heating sulphur to 150°, then cooling it to 90°, and the crystals initiated by rubbing the inside of the tube with a glass rod, the sulphur crystallising in lustrous needles. A comparatively mobile and stable sulphur S_λ of bright yellow colour can be obtained by heating sulphur in the pure form above 160°,

¹ *Berl. Ber.*, 1913, p. 3089.

² *Bull. Soc. franc. Min.*, 1912, p. 375.

which is soluble in carbon bisulphide. When this soluble sulphur ($S\lambda$) is exposed to light, it changes slowly into insoluble sulphur, the rate of change depending on a number of factors, such as the temperature, rate of stirring, nature of solvent, extent of surface exposed to light, etc. (Aten¹). A viscous and dark sulphur $S\mu$ which has the property of being dissolved in $S\lambda$ is also known, but is in itself insoluble in carbon bisulphide.

For each of these modifications there is a freezing-point curve, depending on the relative proportions of $S\lambda$ and $S\mu$ in the liquid with which the respective solids are in equilibrium. The respective freezing-points when no $S\mu$ is present are known as "ideal" freezing-points, and are obtained by extrapolation.

Solid Sulphur.	Natural Freezing-point.	Ideal Freezing-point.
$S\alpha$	114.6° (3.6 per cent. $S\mu$, amorphous)	119.3° (Smith)
$S\beta$	110.2° (3.4 per cent. $S\mu$)	112.8° and
$S\gamma$	103.4° (3.1 per cent. $S\mu$)	106.8° Carson.)

When a strong solution of hydrochloric acid at 0° is added to a cold solution of sodium thiosulphate and the solution shaken with toluene, $S\phi$ crystallises out after a short time, the colour being orange-yellow. These crystals are fairly stable in the dark whilst in the solid state, but when in the liquid state in the presence of light they rapidly change into $S\mu$ and $S\lambda$.

Sulphur of a strong yellow colour $S\pi$ is obtained by warming solutions of $S\lambda$ in sulphur chloride. This form of sulphur is stable in the dark.

Other information upon these modifications of sulphur are dealt with in various Journals, and the reader is referred to the following:—

Beckmann, Paul, and Liesche (*Z. anorg. Chem.*, 1918, **103**, 189-206).

Smits and De Leemo (*Proc. K. Akad. Wetensch.*, Amsterdam, 1911, **14**, 461-468).

Gaubert (*Comptes rend.*, 1916, **162**, 554; *J. Soc. Chem. Ind.*, 1916, p. 600).

Scott (*Chem. Trade J.*, 1919, p. 443).

¹ *Z. physik. Chem.*, 1913, **83**, 442.

16 MATERIALS OF SULPHURIC ACID MANUFACTURE

Allen (*Z. physik. Chem.*, 1912, p. 257).

Leeuw (*J. Chem. Soc. Abstr.*, 1913, ii. p. 40).

The "dynamic allotropy" of sulphur is treated by Kruyt (*Z. physik. Chem.*, 1908, pp. 513-561); the changes in the viscosity of "liquid" sulphur by Protinjanz (*ibid.*, 1908, pp. 609-621); colloidal sulphur by Raffo (*Z. Chem. Ind. v. Colloide*, 1908, p. 358).

Chemical Compounds of Sulphur.

Combination with Oxygen.—On heating in the presence of oxygen or gaseous mixtures containing it (air), sulphur inflames. According to Moissan,¹ solid or liquid sulphur inflames at ordinary atmospheric pressure in oxygen at 282°, in air at 363°. A mixture of sulphur vapour and air inflames at 285°. If the air contains SO₂, the flaming-point is much higher; with 5 per cent. SO₂ it is 445°, with 10 per cent. SO₂, 465°. The slow combination of S with O commences at a much lower temperature; it is quite sensible at 100° within twelve hours, but goes on very slowly at ordinary temperatures.

Friedrich² found the inflaming-point of sulphur in oxygen = 270°, in air = 348°.

M'Crea and Wilson³ found the inflaming-point of sulphur = 265°.

Kastle and M'Hargue⁴ found that when sulphur burns in oxygen at atmospheric pressure, about 2.73 per cent. is converted into SO₃; when burning in air, about 5.7 per cent. of the S forms SO₃. The humidity and the presence of CO₂ have little influence on the proportion of SO₃ formed, but nitrogen acts considerably, probably as a carrier of O to SO₂, evidently being itself oxidised in the first instance.

Hydrogen combines with sulphur very slightly at a temperature of 120°, very sensibly so at 200°. On boiling sulphur with water, hydrogen sulphide is evolved and sulphuric acid is found in the residu.⁵

¹ *Comptes rend.*, 1903, 137, 547.

² *Chem. Cbl.*, 1909, 2, 316.

³ *Chem. News*, 95, 169; 96, 25.

⁴ *Amer. Chem. J.*, 1907, 38, 466-475.

⁵ Cross and Higgin, *J. Chem. Soc.*, 35, 249; cf. also Colson, *Bull. Soc. chim.* (2), 34, 66.

Vegetable Physiological Action.

The action of sulphur on the fungus (*Oidium Tuckeri*) which causes the grape disease, is, by Marcille,¹ ascribed to the sulphurous and sulphuric acid adhering to various forms of sulphur. This explains why the action of resublimed brimstone in that respect is strongest, whilst the ordinary descriptions of sublimed and ground brimstone contain only 0.01-0.02 per cent. H_2SO_4 and are less efficient. Marcille, therefore, recommends introducing gaseous SO_2 into the condensation chambers for sulphur intended to be employed against the *Oidium*.

The use of sulphur in connection with the grape disease is the only important use of sulphur in agriculture, though many experiments have been tried to determine its value as a fertilising agent.

It has been found that it can act as a useful addition to farmyard manure, but this beneficial action diminishes and eventually vanishes in the presence of a large amount of organic and mineral fertilisers.

Statements in the literature regarding the effect of direct addition of sulphur to the soil are somewhat conflicting, and it is probable that, while its action is beneficial with certain soils and certain crops, it is equally injurious in other cases. It is unlikely that its use would prove advantageous on an acid soil or a soil on which liming was found to have a beneficial effect, and it is stated that on light lands it has an injurious action on the growth of cereals. On the other hand, the addition of small quantities of flowers of sulphur to soil is said to improve the yield of such plants as carrots, haricots, and potatoes. As this improvement is more marked with ordinary soil than when using sterilised material, it would seem that sulphur acts, in part at least, by modifying the development or activity of the bacterial flora, but the general action in manuring is so slow that it is doubtful whether it is of any economic advantage. According to Demolon,² the judicious use of sulphur is advantageous, since it supplies the plant by bacterial oxidation in the soil with sulphuric acid which is

¹ *Ac. des Sciences*, March 20, 1911; *Chem. Zeit.*, 1911, Rep., p. 426.

² *Comptes rend.*, 156, 725 *et seq.*

18 MATERIALS OF SULPHURIC ACID MANUFACTURE

directly assimilable, and this sulphuric acid, especially in non-calcareous soils, facilitates the absorption of certain mineral elements (potash, iron oxide, alumina, and even manganese); in addition, it also facilitates the work of nitrifying and ammonifying bacteria, and thus places larger quantities of nitrogen at the disposal of the plant.

It has been thought that sulphur favours the development of the root nodules of leguminous plants. With a view to obtaining exact information on this point, Mr G. Nicolas¹ experimented on this subject in 1918 in Algiers, and in 1920 at the Jardin des Plantes at Nancy with peas, *Phaseolus Lathyris Ochrus*, and *Lupinus albus* grown in pots, to which sulphur was added in amounts corresponding to 100, 200, and 300 kilos per hectare. No very definite result was obtained, possibly on account of the high nitrogen-content of the substratum (garden soil). The experiments, however, showed that sulphur in suitable amounts helps the carbonaceous nutrition of the plants. In amounts suited to each species (200 kg. per hectare for *Phaseolus* and 300 kg. for peas) sulphur favours the formation of starch and photosynthesis. Maze and Demolon have shown that sulphur is necessary for the development of chlorophyll, that its absence causes chlorosis.

Spraying with a colloidal sulphur prepared, for example, by leading hydrogen sulphide and sulphur dioxide simultaneously into a solution of glue is said to be particularly effective against *Peronospora* (Ger. Ps. 290610 and 290240, 1915).

Commercial Descriptions.

The sulphur occurring in commerce, as refined sulphur, in rolls, or as rock-sulphur, is frequently almost chemically pure.

Flowers of sulphur always contains some free sulphurous acid, and cannot be completely freed from it even by washing for days with cold or hot water. If cotton is impregnated with sulphur which has been precipitated from alkaline solutions, and then repeatedly dried at 140°-160° and

¹ *Comptes rend.*, 172, 85-86; *Int. Agr. Rev.*, April 1921. According to *Chem. Trade J.*, 1922, 70, 176.

exposed to the air between these operations, it becomes superficially carbonised. The presence of a trace of sulphuric acid in sulphur accelerates the formation of further quantities.¹

Uses of Sulphur.—The burning of sulphur was a religious rite of the ancients, who also employed it for its disinfecting properties.

In modern times, it is used for the above purposes, and for many others; but we are concerned with its use for the manufacture of sulphuric acid.

Sulphur is undoubtedly the most convenient raw material for this manufacture, and for a long time all the sulphuric acid of commerce, apart from Nordhausen acid, was made from it, but it has been displaced to a great extent by iron-pyrites and zinc blende.

A considerable quantity of sulphur is also consumed in the manufacture of sulphurous acid, principally in order to prepare bisulphite of lime for the manufacture of wood pulp. But the introduction of the pyrites process has been progressing rapidly, especially among Norwegian sulphite mills, since 1904, and it is reported that the greater number of mills are now so equipped, and hence, normally, use pyrites instead of sulphur.

Although some of the sulphur required for this purpose is derived from the burning of sulphide ores, most of the pulp manufactured in U.S.A. is prepared by the agency of native sulphur.

Besides having insulating qualities, sulphur is inert towards most chemicals. As a cement, either alone or combined with sand, it is used for many purposes, such as the setting of brick linings in acid towers, in constructing large storage tanks, and for paving floors.

When melting large quantities of sulphur for industrial use, precautions have to be taken, for unless the material be well stirred, its temperature will increase rapidly so that it becomes viscous, and may even take fire, especially if large open vessels be used for the purpose.

In order to overcome these objectionable features, steam-jacketed pans are used with steam at about 30 lb. pressure.

¹ Znäker and Färber, *Färber-Zeit.*, 1914, 25, 343, 361; *Chem. Zeit.*, 1915, 39, Rep. 110; *J. Soc. Chem. Ind.*, 1915, p. 659.

20 MATERIALS OF SULPHURIC ACID MANUFACTURE

Molten sulphur can also be conveyed a considerable distance in a pipe line having a steam pipe threaded through its centre.

The tensile strengths of sulphur-sand mixtures are given by Wolf and Larison.¹

Percentage of sulphur by weight.	Tensile strength in lb. per sq. inch.
25	90
35	310
40	400
45	310
50	110
100	250

Weight per cub. ft. of the 40-60, 154 lb.

Weight of sulphur required per cub. ft, 62 lb.

Weight of sulphur required per cub. yard, 1670 lb.

Specific gravity, 2.46.

Natural Occurrence of Sulphur.

Sulphur occurs in nature in very large quantities, both in the free state and in combination with other bodies as sulphides and sulphates. Deposits of sulphur are forming at the present day, especially in volcanic countries, by decomposition of sulphuretted hydrogen and sulphur dioxide. But of far more importance are the beds of sulphur deposited in former geological periods.

In the United States practically all the native sulphur produced is mined by melting it with superheated water in the rocks in which it occurs and forcing it to the surface. Most of the sulphur produced by this method is very nearly pure, being, in current commercial practice, guaranteed to be 99.5 per cent.

A fuller description of the method adopted in Louisiana is given *infra*.

In Sicily.—A very important deposit is that in Sicily, and it is stated in the U.S. Reps., February 28, 1919, that there is a total possible sulphur-bearing area of some 2,000,000 square miles, one per cent. only having been explored.

The industry is threatened with a severe crisis due to American competition, says the *Financier*.² The Italian output (annual) is about 300,000 tons, as compared with 1½ million tons produced in America, and the introduction of American

¹ *American Sulphuric Acid Manufacture*, 1921, p. 37.

² *Chem. Trade J.*, 48, 13.

sulphur into markets hitherto supplied by Sicily is to be anticipated. In addition, the American industry possesses a much more up-to-date equipment than the Italian, which enables it to extract the sulphur with greater economy. In the vast American deposits, where the sulphur is near the surface, it is extracted in the liquid state, and is purer than that dug from the ground, as in Sicily. This method might be adopted in Sicily, but the American mines, owing to their proximity to oil wells, which facilitate the supply of aqueous steam, enjoy a natural advantage. The situation is further aggravated by the peculiar condition of Sicilian labour, and the relations between the industry and the owners of the soil. The Government is considering a bill which would reduce, in due proportion, profits and wages.

According to the *Chemical Trade Journal*, vol. lxxi. (1922), p. 761, the Italian exports of sulphur declined from 454,000 tons in 1903 to 293,000 in 1907, but advanced to 324,000 tons in 1909, and were fairly stable at about 354,000 tons annually from 1909 to 1913. Shipments were lower during the War. Production, which reached a maximum of 560,000 in 1905, averaged 398,000 tons from 1909 to 1913, fell as low as 208,000 tons in 1917, but advanced to 280,000 tons in 1921. About 10 per cent. of the Italian production of sulphur is obtained from the mainland, but the bulk of the output is in Sicily, where the sulphur-bearing belt extends about 100 miles, from Mount Etna on the east to Girgenti on the west.¹

In United States.—The production of sulphur in U.S.A. was in 1918 carried out by nine mines, one each in Louisiana, Wyoming, Colorado, and California, two in Nevada, and three in Texas.

Some of these deposits are of immense size, the largest being probably that worked by the Texas Gulf Co., which contains upwards of 10 million tons, and in 1920 produced approximately 1,000,000 tons.

¹ Descriptions of the Sicilian sulphur industry are given by Jungfleisch (*Monit. Scient.*, 1901, p. 511); in *Chem. Trade J.*, 35, 92; by Bruhn (*Chem. Ind.*, 1910, p. 64).

Probably the most exhaustive description of the modern Italian sulphur industry is that given by Aichino, in *Mineral Industry*, 8, 592, and by Phelen, in *Min. Res. Unit. States*, 1910, 2, 785.

22 MATERIALS OF SULPHURIC ACID MANUFACTURE

Mining operations began in 1919 and have been continuous ever since. The plant was designed to have a capacity of 1000 tons per day, but the output can be forced to three or four times that amount, using the present equipment.¹

As a result of the drilling of deep test-holes at Hoskins Mound, Texas, the Texas Co. has proved what is said to be one of the largest known deposits of that product in the world. The proposed plant will cost 5,000,000 dollars, and will be in operation by the end of 1922.²

The *Min. Res. U.S.*, 1918, states that many of the Aleutian Islands, which stretch westward from Alaska Peninsula towards Asia, bear deposits of sulphur of the type called solfatras. Sulphur claims have been located at three places on these islands, and on the peninsula, one of them in the crater of Makuhin Volcano, on Unalaska Island. The sulphur deposit is the only part of the crater that is permanently free from snow and ice, being kept so by subterranean heat, and by the discharge of hot sulphurous vapour. In this crater 10,000 to 15,000 tons of sulphur may be available for mining.

Another deposit is on the Akun Island, 1300 to 1500 feet above sea-level. The sulphur-bearing area contains about 1200 tons to the acre. The sulphur in this deposit consists chiefly of crystalline incrustations, $\frac{1}{16}$ to $\frac{1}{8}$ " thick, on the walls of narrow crevices and small cavities in the porous earthy zone.

At other sulphur-producing deposits, the sulphur occurs, in part at least, at the surface, and is mined by stripping or by subsurface drifting. The ore is then taken to retorts or furnaces, where it is heated so that the sulphur liquefies and runs out of the rock. It usually constitutes 10 to 50 per cent. of the ore, and, although the ore can be mined at these places rather cheaply, the handling and further treatment required to free the sulphur from the worthless material is expensive. Furthermore, a good deal of the sulphur is not extracted by this rather crude method of treatment, hence the difference between the original sulphur content of the ore and the quantity recovered in practice is often very great.

An interesting description is also given of the sulphur found at Sulphur Springs, which occurs as rhyolite, a volcanic

¹ *Chem. Trade J.*, 1921, 69, 524.

² *Ibid.*, 1922, 70, 182.

rock being apparently deposited in vents, cracks, and pores within a few feet or a few inches of the surface.

Sulphur in U.S.A. is used for many different purposes, but normally the greatest consumption is in the manufacture of paper and in the preparation of chemicals.

Under normal conditions not much native sulphur, except that of the best quality, is used for the manufacture of sulphuric acid, but lately, owing to the heavy demand for large quantities of all grades of acid, the quantity so used has increased notably. According to the reports of the producers of acid, 463,364 long tons of domestic and 20,463 tons of foreign sulphur were used by them in 1917.

Some of the native sulphur is used in various agricultural activities in addition to the direct use for acid manufacture in production of fertilisers. The quantity used for these purposes, including spraying, dipping, and dusting (sulphurising), is roughly estimated as between 35,000 and 40,000 tons per annum.

According to the *Chemical Trade Journal*, vol. lxxi., p. 762, the exports of sulphur from the United States are as follows :

Country.	1910-14, 5-year average.	1919.	1920.	1921.	1922, 9 months.
France	26,086	77,206	105,381	55,304	80,749
Canada	17,742	41,136	124,301	59,487	93,840
Germany	7,121	...	13,946	23,049	48,323
Netherlands	3,003	42	317	4,200	9,812
Newfoundland and Labrador	2,180	2,801	3,500
French Africa	800	3,200	2,400	...	2,200
Mexico	323	4,970	8,860	8,321	5,235
Argentina	10	6,072	5,074	7,011	...
United Kingdom	1	706	15,578	14,897	29,268
Sweden	28,902	57,721	13,331	39,125
Finland	12,424	12,590	6,901	12,650
Greece	10,943
Portugal	9,505	15,374	3,335	3,003
Australia	8,985	63,251	54,938	38,225
Belgium	4,286	2,211	5,586	3,008
British South Africa	3,822	4,200	...	8,550
Spain	627	12,056	5,514	11,171
Norway	466	12,481	3,134	6,000
Other Countries	337	8,619	18,209	20,154	15,385
	57,603	224,712	477,450	285,762	406,550

24 MATERIALS OF SULPHURIC ACID MANUFACTURE

The *production* and *imports* for U.S.A. are given below :-

Year.	Production.	Imports.
1903	25,000	?
1911	265,664	30,000 about
1912	303,412	29,927
1913	311,590	22,605
1914	327,634	26,135
1915	520,582	25,910
1916	649,683	22,235
1917	1,134,412	1,015
1918	1,353,525	82
1919	1,190,575	101
1920	1,255,249	136
1921	1,879,150	50

In many other parts of the world deposits have been found, but, with the exception of those just described, they have, as yet, made no impression on the sulphur trade.

The more important of these sulphur mines are the following :—

In United Kingdom.—The United Kingdom produces no native brimstone, but only sulphur recovered from alkali waste, with which we are not concerned here.

The following quantities were imported by the Government during the past few years :—

1915, 5700 tons ; 1916, 34,200 tons ; 1917, 52,600 tons ; 1918, 67,800 tons ; 1920, 15,687 tons ; and 1921, 9637 tons.

In Japan.—Japan possesses very large stores of sulphur. According to the *J. Soc. Chem. Ind.*, 1919, p. 329R, the chief deposits occur on the island of Hokkaido, those on the islands of Hondo and Kyusshyu being less extensive. The output diminished considerably in 1918 owing to the cessation of demand consequent on the conclusion of the armistice.

The geological formation of the sulphur districts is not uniform. In some localities large masses of sulphur are found covered with volcanic lava, in others the mineral occurs mixed with clay.

At Iwaoto there is a deposit of precipitated sulphur, and another consisting of intrusions of fused sulphur in a sandy bed.

The deposit at Horobetsu shows a continuous vein of pure

sulphur in the form of irregular granules. Speaking generally, the crude material contains 30 to 60 per cent. of sulphur, and this is refined up to 99-100 per cent. quality by the operations of crushing, drying, distilling, and moulding.

The distillation is carried out in cast-iron stills of 3 feet diameter, connected with a condensing chamber measuring 20 feet long by 2 feet 5 inches diameter. In the past these have been heated by direct firing, but recently steam heating has been resorted to with successful results.

The *production* of sulphur in Japan :—

	1914.	1915.	1916.	1917.	1919.
Refined Sulphur	74,115	72,206	106,387
Crude Sulphur	8,835	17,172	21,475
Total	<u>82,950</u>	<u>89,378</u>	<u>127,862</u>	<u>116,120</u>	<u>66,314</u>

and in 1921, 33,539 tons.

The *exports* are as follows :—

1914	29,008
1915	42,118
1916	46,513
1917	48,062
1918	30,431
1919	16,126
1920	39,600

According to the report of the Government Trade Commissioner in 1912,¹ a company, with a capital of £100,000, has purchased White Island, in the Bay of Plenty, with the object of working the sulphur deposits there. It is said that there are 40 acres of rock sulphur ore containing about 84 per cent., as well as hot sulphur springs, which pour out thick streams containing about 94 per cent. of pure sulphur.

The company proposes to make borings to reach the source of these springs.

Later information is to the effect that, owing to the distance from the markets, labour troubles, and inadequate machinery, the mines have been abandoned.

In Canada.—Canada imports a considerable quantity of sulphur, there being only a few scattered deposits.

¹ *Chem. Trade J.*, 53, 464.

26 MATERIALS OF SULPHURIC ACID MANUFACTURE

According to the Annual Reports the imports are as shown in table below :—

	1914.	1915.	1916.	1917.	1918.
	lb.	lb.	lb.	lb.	lb.
United Kingdom	222,104	149,711	29,389	5,602	112
New Zealand	2,520
Germany . . .	35,800
Italy . . .	1,455,536	2,013,370
Japan . . .	5,791,910	6,418,463	205,991	199,808	...
Spain . . .	30,000	92,944	5,875,039	9,314,475	1,079,678
Switzerland . . .	1,500
U.S.A. . .	52,175,570	68,187,401	69,730,678	158,424,825	147,603,524
Totals . . .	59,712,420	76,864,409	75,841,097	167,944,710	148,683,314

In Cyprus.—The *Cyprus Agricultural Journal* states that sulphur has been found in the mines at Skouriotissa. A moderate deposit has already been located, and steps are now being taken to extract and refine the sulphur, and to prepare therefrom flowers of sulphur of a quality which, it is believed, will be suited for the treatment of vines.

In Chili.—In Chili, brimstone is found at a height of from 12,000 to 13,000 feet above the sea. The mines, which were started in September 1900, by an Iquique company, are 54 miles from the nearest railway station. The product is said to be of very good quality; it is used in the provinces of Atacama and Tarapaca for the recovery of iodine, and for making blasting-powder for the nitrate works. This seems to be the Taltal deposit mentioned in the Consular Report, quoted *J. Soc. Chem. Ind.*, 1901, p. 1039. In 1901 the working was stopped as being unremunerative (*Z. anorg. Chem.*, 1901, p. 1243).

The production of sulphur in Chili during recent years is as follows: in 1918, 19,557; in 1919, 18,910; and in 1920, 13,340 tons.

In Africa.—Mr G. T. Trevor, Inspector of Mines, Pretoria,¹ has recently emphasised the significance of the chemical industries, and, in particular, the industrial importance of sulphur. He explains the various forms in which pyrites occur, and shows that South African conditions in this respect are such as to render it possible for the country to meet all its sulphur requirements for an indefinite time to come.

¹ *Chem. Trade J.*, 1921, p. 212.

South Africa has abundant supplies of coal, iron, and sulphur, and these, he shows, are the three great essentials for industrial improvement.

In Spain.—There are in the province of Murcia, according to a writer in the *Boletín Oficial de Mines Metalurgia*, a number of sulphur deposits, one of the most important of them being that of La Surata de Lorca, near the town of Lorca. This bed extends over a length of 10 kiloms. and a width of 1 to 2 kiloms. Three companies are working these deposits in a somewhat primitive manner by highly inclined galleries of reduced cross-section. A few pits have also been sunk to a shallow depth. Ventilation is very unsatisfactory. The sulphur is treated in the Sicilian calcarone furnaces, though efforts are being made to introduce an improved type of furnace. The fused sulphur is refined in two sets of pots, the necks of which are set into two iron tubes which lead into a large brick chamber. Retorts are also used of similar type to those used in gasworks.

In Mexico.—Bernhard Neumann's investigations¹ upon some black sulphur found in Mexico led him to the conclusion that the black sulphur of Magnus and Knapp is not a special modification of sulphur, but ordinary yellow sulphur which has been coloured black by small quantities of carbon or of metallic sulphides (iron and platinum).

In the New Hebrides.—According to the *Chem. Trade J.*, vol. lxix. (1921), p. 311, a considerable quantity of sulphur is found on the mountain and island of Vanua Lava in the New Hebrides, in one vast mass containing 99 per cent. sulphur and the balance ash. The height of the mountain, which forms an island in itself, is 1600 ft., the area of the island being 100 sq. miles.

Vanua Lava, as part of Banks group, is included in the administration of the Condominium Government of the New Hebrides. The Banks group lies between the 15th and 20th degrees of south latitude, and is about 900 miles from the Queensland coast.

According to Mr T. J. McMahon, writing in the *Times Trade Supplement*, twenty-five years ago a French company

¹ *Z. angew. Chem.*, 1917, **11**, 165-166; *J. Chem. Soc.*, 1917, **2**, 465.

began operations on the mountain, employing competent engineers. The company built a long, substantial coral concrete wharf and storehouse in a small bay at the foot of the mountain, and constructed an aerial railway up the mountain for nearly 900 ft. Hundreds of natives were employed in digging out the sulphur from the mountain side, and hundreds more in carrying 50-lb. bags of sulphur to the railway terminus, whence carriers were sent rapidly to the storehouse on the bay. The first shipment of sulphur sent to France paid handsomely, but the company suddenly abandoned the field, giving as a reason that malarial fever of a malignant type made it impossible for white men to live on the mountain island. It was eventually stated, however, that the company had discovered that the administration of the New Hebrides was not in a position to guarantee the company a monopoly, a prior right from an Australian engineer, the original discoverer of the commercial possibilities of the island, being in existence. To-day this claim holds good, but Condominium law prevents any prompt commercial activities on the island. A British-Australian company is now endeavouring to begin operations, and has opened up negotiations with the Condominium Government, the British side of the Condominium being favourable to the enterprise.

Manufacture of Commercial Sulphur from Native Crude Brimstone.

The old Sicilian "calcarone" method, described in all older text-books, need not be described here, as it is now obsolete. On p. 21 we have quoted the books in which the former Sicilian methods are described in detail; here we shall treat only of the more recent apparatus used for the purpose of obtaining commercial sulphur from the raw ore by fusing.

In recent years the "Gill kilns" have rapidly gained ground in replacing the calcarone methods, and they increase the output of sulphur by 50 per cent. These kilns consist of an oven covered by a cupola, called a "cell"; inside there is a smaller cupola, within which a coke fire is burning. Each cell holds from 5 to 30 cub. metres of ore. There are generally six cells working in an angular battery. The gases generated in the first cell pass by lateral channels into the next; by the time

the fusion is completed in the first cell, the contents of the second cell are already heated up to the igniting-point by the gases, and so on. The gases heavily charged with sulphur are not lost as in the calcarone method; the yield is much larger, the time shorter (three or four days for each cell), and, as the quantity of smoke is much less, the work can be continued almost all the year round without danger to the crops.

The Frasch Process.

A complete revolution in the production of commercial sulphur from hitherto unavailable crude ores has been brought about by the ingenious process of Herman Frasch. Prior to this development of sulphur mining, nine-tenths of the world's supply was produced in Sicily by extremely primitive methods, which involved shafting and other ordinary methods used in mining. In 1869, an enormous deposit of sulphur was discovered in Louisiana when a well was being drilled for oil. All methods to mine this proved unsuccessful for twenty-five years, until Herman Frasch took up the problem.

The character of these deposits is described in *Mineral Resources of the U.S.* for 1918, p. 365, as follows:—From the surface to a depth of several hundred feet are unconsolidated sands and muds. Beneath the unconsolidated deposits is a limestone, in places as much as 100 feet thick, locally known as the cap rock, because it covers the sulphur deposits. Next beneath the cap rock is limestone, with some gypsum and large quantities of sulphur. Lower down the proportion of the limestone decreases, and in the next few hundred feet the beds are mainly gypsum, with some sulphur and a little limestone. Still lower down the rock is massive gypsum. This gypsum member is said to rest on beds of salt of unknown thickness. The rocks below the unconsolidated deposits are apparently folded so that the rock surface forms a dome. In fact, the slopes of the sides of the rock dome are, in places, more than 45°. The sulphur does not occur in massive beds, but in stringers and lenses, which traverse the adjacent rocks irregularly.

Briefly, the process of extraction is as follows:—Holes, nearly a foot in diameter, are bored to the deposit by rigs and drills similar to those used in boring for oil, and the

30 MATERIALS OF SULPHURIC ACID MANUFACTURE

sulphur, which liquefies at about 116° , is melted by the introduction of superheated water. After the sulphur has melted and collected at the bottom of the hole, it is raised to the surface by the use of compressed air. The sulphur in the liquid state is piped to large bins, where, on cooling, it consolidates. The solid sulphur in the bins is blasted down by powder, picked up by steam shovels, and loaded into box cars for railroad shipment, or on open gondola cars for transportation to the loading dock for ocean shipment.

The sulphur obtained is not further refined at the mines, but is sold with the guarantee that it is at least 99.5 per cent. pure. It contains no arsenic or selenium. Usually not all the sulphur in the adjacent rocks is melted out by one well, and consequently the practice has been to abandon a well after a certain length of time, and later to go back and sink another well in the neighbourhood. The distance to which the steaming affects the rocks varies greatly according to local conditions. In some places, wells less than 50 feet apart show no interrelation; whereas in other places, wells more than 1000 feet apart show distinct intercommunication. Already, several hundred wells have been sunk at each mine, but of these only four or five yield sulphur at a time. The number of wells in operation at a time is limited, not only by the equipment required to furnish the necessary hot water, but also by the necessity of avoiding the setting up of excessive pressures underground. The quantity of sulphur derived from individual wells differs considerably. The most productive wells are said to have yielded more than 100,000 tons of sulphur.

The following is the history of the Frasch Patents.¹ Frasch's first patents granted were 461429 and 461430, which covered the apparatus.

These patents being granted in 1891 and having now expired, the same general process is being used both at the original locality and at Freeport, Texas.

The first patent was useful for sulphur deposits which were overlaid with beds of quicksand, which therefore prevented shafting. The method disclosed in this patent required that an ordinary well should be drilled through the limestone above

¹ *Chem. and Met. Eng.*, 1919, p. 637.

the sulphur, a casing being forced through this limestone and through the quicksand by the ordinary methods used in drilling oil-wells and the like. This shut off the water and the quicksand. When the casing reached the sulphur, a hole of smaller diameter was continued to the bottom of the deposit. A suitable tubing was then passed down in a central position, and continued upwards above the surface, to a casing head. Water at about 133° to 138° was then forced down the annular space to the bottom, whereby the sulphur was melted and forced up through the tubing to proper separators.

The second patent also showed a pump at the bottom of the tubing, which could be used to raise the molten sulphur. Thus the mine could be filled with hot water to melt the sulphur, and the sulphur could be periodically removed by this pump. A modification of this apparatus showed a bleed pipe extending from the surface of the ground to the hole in the mine, the bottom of the bleed being higher than the bottom of the casing and tubing. This bleed pipe could be used to draw off the hot water, while the sulphur was pumped up by the pump before mentioned.

Frasch's first well was drilled in the fall of 1894, and was worked for four or five hours, producing about 500 bbls. of sulphur, when mechanical difficulties, due to the sulphur corroding the iron working parts of the valve and pump, and the weakness of the boiler to supply hot water, caused the stoppage of operations.

Various reasons delayed complete commercial success until 1903, but such delay was not caused by defect in Frasc's original conception, or in means to utilise it. He was occupied in other work, his visits were infrequent, and operations were often suspended for as long as a year at a time.

In the meantime, and before commercial success had been secured, Frasc filed another specification, in 1897, two patents being granted, Nos. 799642 and 800127. In addition he was granted No. 1008319 in 1911.

In U.S. P. 799642 he stated that the earlier patents were unsatisfactory because, since the sulphur had been found to be porous, he could not develop sufficient pressure with the water pump to raise the column of molten sulphur, and a lifting pump gave trouble with its valves. In addition, the

32 MATERIALS OF SULPHURIC ACID MANUFACTURE

water with which the deposit of sulphur was saturated, cooled the superheated water so that the yield was small. The novelty of this patent consisted in not returning the water to the surface, but forcing it out through the porous rock, so as to heat it even when the temperature of the water was below the melting-point of sulphur. The water was now forced at about 147° to counteract the effect of the cold water in the porous deposit.

Later, Frasch took out another patent in which further modifications were described, air being injected from an air pipe until the density of the sulphur was lowered to about that of water, so that it could be easily raised by the column of water in the hot-water pipe.

Patent 800127 had about the same disclosure as 799642, and mentioned that no provision was made for the return of the hot water, which was forced through the walls of the cavity of the sulphur and into the walls of the surrounding rock. Patent 1008319 covered the idea of injecting the hot water into the mine through a strainer so as to divide the stream of hot water over a wider zone to prevent clogging.

In December 1911, Herman Frasch¹ received for his immense technical achievements the great distinction of the Perkin medal. The speech of Professor C. F. Chandler and the reply of Frasch, which are recorded in *J. Soc. Chem. Ind.*, 1912, pp. 168-176, give a most interesting account of his inventions and their practical application.

Other Processes for the Extraction of Sulphur from Raw Ores.

There are many other processes for the extraction of sulphur from ore, but we propose dealing only with those of recent date.

Becraft and Genter (U.S. P. 1332537) and Clifford and Green (1332542) use two retorts somewhat resembling a Kelly filter press in design. They consist essentially of a cage into which the sulphur-bearing rock is introduced, and a housing into which the cage moves when charged. Steam is admitted and the cage rotated. The molten sulphur collects in the shell, from which it is discharged by a valve.

¹ H. Frasch, died in 1914 at the age of 63.

Sedgwick (U.S. P. 1318051) heats the ore and centrifuges it to separate the liquid sulphur, which is then solidified by cooling the material before the centrifugal motion is stopped.

Huff and Connolly (U.S. P. 1137625) claim an apparatus, the efficiency of which is dependent upon the melting of the sulphur in the absence of air, and the conservation of a large portion of the heat imparted to the gangue and the parts of the apparatus which carry the sulphur-bearing material, through the melting-chamber. The sulphur ore is fed automatically to a series of buckets attached to rollers formed into a continuous chain by means of links. This bucket conveyer dips beneath water contained in a tank, rises from the tank, passes through a melting-chamber, and is again immersed in water in a second tank, passing over a sprocket wheel at the discharge end of the apparatus, where the gangue is dumped into cars for disposal. The two tanks containing water act as water seals for the melting-chamber, thereby preventing the entrance of air thereto. The air is removed from the ore which is heated in the first tank. The heat of the gangue from which the sulphur has been removed in the melting-chamber, and of the buckets, rollers, and links, is absorbed in the second tank. The water is circulated through the tanks by a pump. Heat is provided to the melting-chamber by means of a furnace.

Perry (U.S. P. 1285358) fuses the sulphur *in situ* by means of superheated water, and the molten sulphur is injected in the form of a spray into a cooling medium, by which it is solidified in the form of small globules.

Lucas and Tait (U.S. P. 1259536 A and 1259537 B).
A. The sulphur in the deposit is ignited and partly burnt in a mixture of air and CO_2 , in such proportions that sufficient heat is generated to melt a further quantity of sulphur. The molten sulphur is forced to the surface by the gas pressure.

B. Two concentric vertical passages are provided in the deposit, and hot air, diluted with combustion products, is passed down through the outer passage and back through the central passage, so as to heat the central to 450° . A limited combustion of sulphur is permitted and a further quantity is volatilised. The sulphur vapour and combustion products are

withdrawn through the central passage, the former being then condensed and removed.

E. F. White (*Eng. and Min. J.*, lxii, p. 536) extracts sulphur from ores by passing the latter downwards between two conical steam-heated vessels, where the sulphur is fused and runs out at the bottom.

De la Tour Breuil¹ employs a 66 per cent. solution of calcium chloride for the same process. C. Vincent recommends this method.²

Huff (Assignor to Moss, U.S. P. 1184649) employs a well-casing, closed at the top, with perforations near the bottom, near to which electrical heaters are mounted. Water supplied to the casing is heated therein, and passes through the perforations into the sulphur-bearing strata. The molten sulphur is raised through an inner pipe, which passes down and projects beyond the bottom of the casing.

Fleming (U.S. P. 945926) melts the ore by any means desired, and afterwards maintains it in fusion by electrical means out of communication with the atmosphere, forcing currents of steam, with or without air, through the molten mass and condensing the vapours evolved in cooled receivers.

G. A. Bragg, Assr. to Texas Gulf Sulphur Co. (U.S. P. 1374422 of 1921), divides the ore into a fine pulp in water, and the mass is heated to the melting-point of sulphur by means of steam, and upon agitation the sulphur coalesces and is thus separated.

SULPHUR OBTAINED FROM VARIOUS MATERIALS

1. Sulphur from Spent Oxide.

Free sulphur is produced in large quantities in the manufacture of coal-gas, and is contained in the oxide of iron after use in its purification. We shall treat of this later on as material for producing sulphur dioxide; in this place we mention it only as a source of free sulphur.

The sulphur obtained from this source is mostly of a dark colour, owing to the presence of tarry substances, and this

¹ *Comptes rend.*, 93, 456.

² *Bull. Soc. chim.*, 40, 528.

makes it very difficult to sell, so that it is nearly always burned without extracting it, as we shall see later.

In order to remove this dark colour, Bécignoul (Ger. P. 178020) filters the benzene or toluene solution through animal charcoal. He describes an extracting apparatus in the form of an autoclave, a charcoal filter, a cooler, and a filter for collecting the sulphur, of such a construction that the benzol may be recovered. The desulphurised mass is treated with lime in a high-pressure apparatus, in order to recover the cyanogen compounds. His B. P. 8530 of 1905 describes extracting the sulphur by hot toluol, allowing it to separate by cooling, and using the solvent over and over again. In his Austr. P. 27298 he describes mixing the toluol with carbon tetrachloride.

Vaton and Zuaznavar (Fr. P. 336661) distil the spent oxide in retorts, with a condensing chamber of such dimensions that the temperature is maintained between 150° and 440° , so that only pure sulphur is condensed therein.

Günther and Franke (B. P. 11187 of 1907; Fr. P. 377827) extract sulphur from gangue or other material, especially spent oxide of gasworks, by boiling acetylene tetrachloride or a mixture of it with xylol; on cooling, all the sulphur separates except 1 per cent. remaining in solution. The ferric oxide remaining behind may be used over and over again, and thus accumulates a greater amount of cyanogen compounds than is possible with other sulphur-extracting methods.

Derome (Fr. P. 372099) heats the material to redness, with or without the addition of a hydrated base, with injection of steam into the retort, to assist in decomposing cyanides. Sulphur, ammonia, etc, escape and are condensed in a cooling-chamber by water sprays.

P. E. Williams (B. P. 596 of 1909) treats the spent oxide with liquor ammonia, and filters the solution of ammonium polysulphide from the ferrous sulphide, which is converted into oxide by exposure to the air and again treated with NH_3 . Sulphur is precipitated from the ammonium polysulphide solution by boiling, the escaping NH_3 being recovered in any suitable manner.

It is not possible to obtain the sulphur derived from

spent gas oxides entirely free from the solvent, *e.g.* petroleum, aniline, tar oils, and especially carbon disulphide, by mere distillation. The Chemische Fabrik Phönix, Rohleder & Co. (Ger. P. 182820, and B. P. 23957 of 1906; Fr. P. 370893) attain this object by running the solution, in a finely divided form, into water heated above the boiling-point of solvent; in case of CS₂ say to 70°, at such a rate that no large quantity of the solvent can collect there. The small quantities gradually flowing in quickly give up the CS₂ by evaporation, and the S collecting at the bottom of the vessel in the form of leaflet does not retain any CS₂. When enough sulphur has collected, the supply of solution is stopped and the boiler is heated to about 85° for $\frac{1}{4}$ hour, then allowed to cool and emptied; the sulphur remains on a sieve placed below.

Hunt and Gidden (B. P. 8097 of 1912; U.S. P. 1059996; Chance and Hunt, Fr. P. 452034 and Ger. P. 263389) heat the mass above the fusing-point of sulphur, then treat with sulphuric acid of sp. gr. 1.60, and extract the sulphur from the residue by means of a solvent. Or, the spent oxide is first treated with a solvent for sulphur, and the impure product treated as above.

The Société d'Éclairage, Chauffage et Force motrice (Fr. P. 454990) extract the sulphur by means of light tar-oils (boiling between 150° and 190°) at 100° which dissolve 35 to 40 per cent. The sulphur remaining behind is converted into sulphocyanides.

2. Sulphur from Pyrites.

A certain quantity of sulphur is obtained by the *distillation of pyrites*. This, however, only pays in very few instances.

Walter (Ger. P. 192518) obtains sulphur in the roasting of pyrites smalls, by a furnace similar to the Herreshoff burner but fitted in a special way, so that the condensing sulphur remains in a melted state and can be run off through one or more lateral pipes. Or else the roasting takes place in slightly inclined revolving cylinders.

W. A. Hall (B. P. 20759 of 1912; U.S. P. 1083248; Fr. Ps. 455005 and 458028) submits the gases produced in a mechanical pyrites burner of his own construction in turns to the action of steam and to that of a reducing flame, whereby

hydrogen sulphide and free sulphur are formed. His B. P. 20760 of 1912 describes the conversion of the hydrogen sulphide into free sulphur. According to a report, quoted in *Z. angew. Chem.*, 1913, iii., p. 573, from *Mining Science*, the first National Copper Co. at Coram (Cal.) decided to introduce this process, heating sulphide ores in a neutral or reducing atmosphere, whereby the sulphur is volatilised in the free form and collected in water, or precipitated by a Cottrell electrical precipitator, whilst the metal remains in the form of oxide. According to the reports given in *Eng. and Min. J.*, 5th July 1913, and *J. Ind. Eng. Chem.*, 1913, p. 955, all the sulphur down to one per cent. remaining in the residue can be removed and recovered by submitting the ore to a flame of non-oxidising or reducing character, together with the water formed by burning hydrogen, or of steam which is decomposed by the hot ore. The oxygen formed thereby combines with the metal, and the nascent hydrogen combines with any free oxygen getting into the "atomiser," which serves for decomposing the gases, so that a circular process of decomposing and reforming H_2O is brought about. If the burners are properly regulated, all the hydrogen escapes in the form of H_2O , and, in the exit-gases, no SO_2 , SO_3 , COS , or H_2S is found. This process has been applied to all sorts of ores: pyrites, pyrrhotite, copper concentrates, crude blende and zinc concentrates, also pure FeS . In all cases pure sulphur vapour, with no SO_2 or H_2S , escaped. The residues consisted of a mixture of Fe_2O_3 and Fe_3O_4 .

Further patents of W. A. Hall (B. Ps. 26370 and 26595 of 1912; 8279 of 1913; U.S. P. 1133626) contain further rules for carrying out the process. Other patents (U.S. Ps. 1083249 to 1083253) refer to the application of his process to other metallic sulphides, such as zinc-blende, copper pyrites, and galena, and give further details of his process. He (U.S. Ps. 1133637 and 1134846) introduces the ores continuously into the furnace, and maintains the top layer at a temperature below the ignition-point of free sulphur by spraying with water, avoiding the introduction of air.

Hall's processes are fully described in detail by Wierum in *U.S. Min. Res.* for 1914, p. 138.

The British Sulphur Co., Ltd. (Aust. P. appl. 6907), obtain

the total sulphur of ores in the free state by means of a reducing flame, containing an excess of hydrogen, with just enough oxygen to burn the hydrogen and to convert any H_2S formed, into water and free sulphur.

The New Jersey Zinc Company, New York (U.S. Ps. 1103081 and 1103082), obtain sulphur by heating pyrites, with exclusion of air, to 600° to 800° , until it has passed over into pyrrhotite or magnetic sulphide. When treating blende in this way, the iron sulphide formed can be extracted by magnetic means.

L. P. Wright (B. P. 26128 of 1911) heats pyrites by means of an electric retort-furnace to a very high temperature, whereby most of the sulphur is set free and is collected in the distillate; the residue consists of iron containing some sulphur, and may be refined by any well-known means.

Birkeland (U.S. P. 1121606) obtains sulphur from blende or other sulphides by passing superheated steam through them.

Kingsley (U.S. P. 1144480) heats sulphides with dilute nitric acid (containing at most 5 per cent HNO_3), whereby, together with metallic nitrates, free sulphur is obtained.

Hoffman (U.S. P. 1273370) drives off the sulphur from pyrites or similar ores, and passes the gas into a heated container along with a gaseous hydrocarbon, producing sulphur, carbon dioxide, and water. The catalyst used may be a mixture of calcium sulphite and sulphide.

H. C. Pedersen (B. P. 152887) mixes ordinary pyrites with coke and roasts with the usual quantity of air.

3. Sulphur from Sulphur Dioxide.

It has often been proposed to prepare sulphur by *passing gases containing sulphur dioxide through red-hot coke*. The first mention of this process is made in a pamphlet of Vivian in 1833; Reich describes experiments made with it at Frankfort in 1858.

F. R. Carpenter (Amer. Ps. 871912 and 925751) obtains sulphur from the roasting-gases of sulphide ores (especially in the Colorado district). The gases are purified from flue-dust in chambers, where they are also saturated with water introduced as spray; they are then cooled in large chambers by means of water-coils, which causes all the SO_2 to condense as

an aqueous solution ; the residual gases are taken away by an exhauster. The solution of SO_2 is freed from flue-dust, and the SO_2 boiled out of it by means of coils containing water superheated in the flue-dust chambers. The SO_2 is conducted into towers containing red-hot coke, where both SO_2 and H_2O are reduced as follows, with formation of CO_2 or CO :—

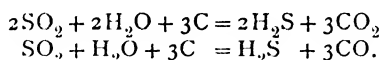

This gaseous mixture, after admitting the necessary amount of air, is worked in Claus-kilns¹ for sulphur :—

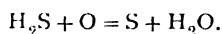

A modification of the process, which is, however, less advantageous, consists in taking the roasting-gases, without concentrating the SO_2 in the above-described manner, with addition of steam directly into the reducing-kilns, or else they are further heated to decompose the "subsidiary sulphides."

Lamoureux and Renwick (B. P. 2834, 1915 ; U.S. Ps. 1140310 and 1182915 ; Fr. P. 477795) reduce SO_2 contained in gases, mixed with atmospheric oxygen, to elemental sulphur by contact with incandescent coke to which the necessary heat is supplied electrically. Lamoureux (U.S. P. 1169726) in that process utilises the heat of the outflowing gases for heating the inflow gases before passing them into the reaction chamber. The sulphur may be obtained almost quantitatively by keeping the gases in contact with the coke for five seconds at a temperature of 1300° . In order to ensure complete reduction of the SO_2 to S, heat is applied by passing an electric current through the bed of coke.

Ruthenburg (B. P. 29030, 1912) also passes the gases first through an electrically heated coke column, then through a chamber where sulphur is precipitated, and ultimately through a sealing liquid into the chimney.

Basset (B. P. 20716, 1913 ; Fr. P. 472957) passes the gases, previously purified from dust, through a tower filled with red-hot coke, where a mixture of carbon dioxide, oxysulphide, and monosulphide is formed. This is oxidised to sulphur and carbon dioxide in another tower, heated by the first, into

¹ *Vide* Lunge, [3], 2, 972 *et seq.*

40 MATERIALS OF SULPHURIC ACID MANUFACTURE

which, through a special pipe, an excess of carbon dioxide is introduced.

Vadner (Ger. P. 276568) removes from the gases the solid impurities, mixes them with reducing-gases, and passes them first through red-hot coke, then into the space where the sulphur is condensed, and ultimately again through a purifier, for which purpose apparatus is described.

The American Smelting and Refining Co., New York (B. P. 144306; Convention date Sept. 9, 1918), also recover the sulphur dioxide by means of air and incandescent coke.

Jacob Papish¹ states that sulphur dioxide is reduced to sulphur by methane at an elevated temperature. The author suggests that sulphur occurring in volcanic regions may, in part, be formed by reduction of sulphur dioxide by methane, carbon monoxide, or hydrogen, all of which occur in volcanic exhalations.

Teed, Sulman, and Picard (B. P. 14628 of 1911) mix gases containing SO_2 with reducing-gases, like producer-gases or water-gas, and carry the mixture over a heated contact mass consisting of magnesia, or calcium sulphate, or ferric oxide, *e.g.* magnesia bricks heated to a red heat, which produces the reactions,

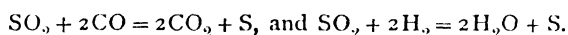

P. S. Smith, Assignor to the Pont de Nemours Powder Co. (Amer. P. 878569), forms producer-gas and water-gas successively, and mixes the water-gas with the SO_2 contained in sulphur-bearing gases. This mixture is highly heated by the producer-gas; the sulphur vapour, set free by the reaction between the SO_2 and the water-gas, is condensed and collected. The same inventor (U.S. Ps. 945111 and 945112) describes special constructions of apparatus for this purpose, which allow of working the process in a continuous manner.

Sanborn, McMahan, Overbury, and Young (B. P. 18202, 1911; U.S. P. 1062120) pass the SO_2 containing gases through a tower in which calcium sulphide solution is sprayed. The mixed solution of calcium sulphide and sulphate collecting at the bottom together with precipitated sulphur, passes through a vessel where the solids are deposited, and then

¹ *Proc. Indiana Acad. Sci.*, 1918, pp. 170-171.

through a funnel into a furnace where the sulphur is distilled off and condensed; the residue remaining in the furnace is mixed with coal, and from this mixture calcium sulphide is regenerated.

The Chemische Fabrik Griesheim-Electron (B. P. 1550 of 1914) reduces sulphur dioxide or sulphites to sulphur by means of spongy zinc.

4. Sulphur from Gases containing SO₂ (Smeltry Fumes).

The "Thiogen process" of the Pennsylvania Manufacturing Co., described by S. W. Young,¹ depends upon the reduction of sulphur dioxide by ethylenic hydrocarbons according to the reaction,

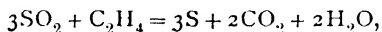

which, however, is very slow and incomplete. This is avoided by employing as catalyst, ferric oxide or calcium sulphide containing it, which brings about the cyclic reaction,

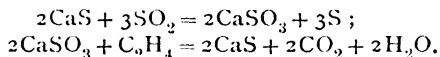

The roaster-gases containing about 8 per cent. of SO₂ are passed first through a dust-settler to a combustion-chamber, where a certain amount of oil is introduced, and in which the excess of oxygen in the gases is burnt out. Thence the gases pass to the contact-chamber, where more oil is introduced, the total amount being that which is necessary to burn out the oxygen and reduce the sulphur dioxide. The contact material is made up from plaster of Paris, which is mixed with water containing iron salts, allowed to set, and broken into lumps. The chief chemical difficulty is that the contact-mass is rendered inactive, either by the presence of flue-dust, or by the destruction of its porosity by too high a temperature in the contact-chamber. In a series of trials in one unit of a battery of eight six-hearth M'Dougall roasters, the same charge of contact material was run for periods of from ten to twelve days without loss of activity, the exit-gases containing

¹ *J. Soc. Chem. Ind.*, 1913, p. 293.

practically no SO_2 . The exit-gases from the contact-chamber pass through a cooling and condensing apparatus, where the sulphur is deposited. The combustion-chamber is filled with a network of bricks, heated to about 800° by oil introduced in the form of spray by means of steam injectors. The contact-chamber also contains a network of bricks, the interstices being to a great extent filled with a mixture of equal parts of plaster of Paris and moistened sawdust with a little iron salt; the CaSO_4 is quickly reduced to CaS , and the mass shrinks to half of its first volume. The sulphur set free is collected in a tube formed like an inverted U, provided with slanting bottoms and outlets. In order to prevent the condensation of compounds of selenium, arsenic, and antimony together with sulphur, the gas may be, in a previous chamber, cooled down to about 500° by means of water sprays. By this process, the contents of the gases may be reduced down to 0.2 per cent. of S. An experimental plant has been built at Campo Seco, California.

For this process Young, for the Thiogen Company, has obtained the U.S. Ps. 1094656/7, Fr. P. 450786, and the Ger. P. 271002. His processes are described in detail in the *U.S. Min. Res.* for 1914, p. 139.

Later, Young obtained U.S. P. 1262295 of 1918. In a cyclic process for treating sulphurous fumes, the latter are brought into contact with water and the solution is treated with an alkali-earth (barium) sulphide to produce a mixture of sulphur and oxygen-sulphur compounds. This mixture is heated to expel the free sulphur and then reduced with carbon to regenerate the alkaline-earth sulphide.

C. G. Collins, New York (B. P. 152447 of 1919), recovers sulphur from gases obtained in the roasting and smelting of sulphur-bearing ores by passing the gases in a dry state into a cooling-chamber maintained at a temperature slightly above the condensation-point of sulphur, and then into a condensing-chamber at a lower temperature, the sulphur depositing on collecting material placed therein. This material may consist of asbestos screens supported upon removable frames. The temperature of the cooling-chamber is controlled by varying the speed of the gases by a fan or other equivalent device, the speed of which can be adjusted.

5. Sulphur from Sulphuretted Hydrogen.

Sulphuretted hydrogen has frequently been proposed as a material for the production of free sulphur. Its use has become an economical possibility through the Claus process for the recovery of sulphur from Leblanc tank-waste (*Sulphuric Acid and Alkali*, vol. ii., p. 967 *et seq.*, edition of 1909).

For gases containing more than 15 per cent. of sulphuretted hydrogen, the Chemische Fabrik Rhenania and F. Projahn (Ger. P. 298884; B. P. No. 169467 of 1920) claim an improvement upon the Claus process. This process, they state, only yields 80 to 85 per cent. of the sulphur, the remainder reacting with the steam, producing a mixture of H_2S and SO_2 , which escapes.

They therefore proceed in the following way:—The gases, after mixing them with air, are passed downwards through a layer of bauxite in a cupola at about 330° , the thickness of the contact material being of about 30 cm. in order to cool the gases to a minimum temperature of approximately 200° .

The main reaction,

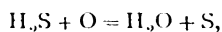

proceeds most favourably at 300° . The injurious secondary reaction,

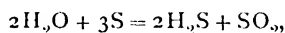

is only feeble at 200° , and, in the lower layer of the contact material, is largely replaced by the reaction,

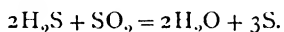

It is claimed that a yield of 97 per cent. may be obtained.

The *Chem. Zeit.*, 1908, p. 247, states that, by the application of bauxite as contact-mass, in this manner, on the large scale sulphur up to 5 per cent. could be recovered, whilst an experiment on the larger scale with titanite iron ore (B. P. 25976 of 1906) did not confirm the good results obtained in the preliminary experiments.

Tyers, Hedley, and the United Alkali Co. (B. P. 25976 of 1906) use a salt or ore of titanium as the catalytic agent in the recovery of sulphur from H_2S .

Hellsing (Fr. P. 376534; Ger. P. 209960; B. P. 8164 of 1907) brings the gases containing H_2S into contact with a

44 MATERIALS OF SULPHURIC ACID MANUFACTURE

strong solution of SO_2 ; after the precipitated sulphur has been deposited, the liquor is again treated with SO_2 . In order to prevent formation of a colloidal solution of the sulphur set free, sulphuric or hydrochloric acid, or a suitable salt, is added to the solution of SO_2 .

The *47th Inspectors' Report on Alkali Works* (for 1910), pp. 23-26, contains a paper by Linder on the oxidation of H_2S by MnO_2 in absence of CO_2 and presence of air, the result of which is that the presence of free lime (Ca(OH)_2) is favourable to a high yield of free sulphur; the yield of thio-sulphate in this case is low, and there is an entire absence of MnS and polysulphide.

Feld (B. P. 3061 of 1909; Amer. P. 985667) produces sulphur from H_2S and SO_2 , by treating them with compounds of a metal (Zn, Mn, or Fe), the sulphide of which is insoluble and is decomposed by SO_2 , either alone or in the presence of air or oxidising agents, with formation of free S. The process is specially adapted for the purification of coal-gas, and apparatus is described for that purpose. The same inventor's Ger. P. 192533 describes several processes for washing H_2S out of gases, with recovery of the washing-agent. His Ger. P. 237607 describes bringing H_2S and SO_2 , mixed with each other or one after the other, into contact with moist or dissolved sulphides, thiosulphates, or polythionates of zinc, manganese, or iron.

The same inventor (B. P. 2719 of 1908; Amer. P. 927342 of Feld and Jahl; Ger. P. 202349; Fr. P. 387438) performs the interaction of H_2S and SO_2 in the presence of a substance capable of dissolving the liberated sulphur, preferably heavy coal-tar oils heated up to 40° . The temperature rises above this by the reaction. When the amount of free sulphur reaches 50 to 60 per cent., the bath is allowed to cool, the crystallised sulphur is separated centrifugally, washed with steam, and the precipitated sodium sulphate dissolved out by the condensation water. Pure sulphur is thus obtained. The liquid is kept acid, in order to avoid the formation of thio-sulphates and polythionic acids.

New patents of his are: B. Ps. 157 of 1912, 10147 of 1912; Fr. Ps. 432590, 457853; Ger. Ps. 272474, 272475; U.S. Ps. 1079291, 1127219. They describe obtaining sulphur

and sulphates by the alternating treatment of solutions of polythionates by gases, vapours, or liquids containing reducing substances (ammonia or sulphur dioxide, or both together), and by a quantity of sulphur dioxide insufficient for a complete oxidation of the thiosulphate into polythionate, so that unchanged thiosulphate is always present.

Fritzsche (B. P. 25454 of 1911) treats SO_2 and H_2S simultaneously, or in succession, at a temperature of 60° to 70° with a liquid in which aluminium hydroxide or basic aluminium sulphide is suspended. Soluble acid sulphites are formed, which with H_2S give a precipitate of sulphur and basic sulphate, which latter is regenerated to acid sulphite by means of SO_2 .

Bémelmans (Ger. P. 77335) reduces the SO_2 by carbon and hydrogen to H_2S , dries the latter, mixes it with dry SO_2 , and causes the decomposition into H_2O and S.

Farbenfabriken vorm. F. Bayer & Co., Leverkusen, Germany (B. P. 146141 of 1917), obtain sulphur from hydrogen sulphide, or from gases — such as illuminating gas — which contain hydrogen sulphide, by mixing with air or oxygen or sulphur dioxide and bringing the mixture into contact with porous carbon, for example, vegetable or animal charcoal. The reaction does not require any external heat. The sulphur is precipitated upon the carbon in the fused state or as *flowers of sulphur*, and is removed by sublimation or by extraction with a solvent.

Nordin (Swed. P. 35040) promotes the reaction between H_2S , SO_2 , and water by adding an acid, cooling, and precipitating the sulphur by an electrolyte.

R. von Walther (Ger. P. 262468) treats waste liquids from the manufacture of sulphite-cellulose with a quantity of H_2S sufficient for decomposing the SO_2 present. The sulphur is nearly completely precipitated in the colloid state; after removing it, the liquid may be utilised for other purposes.

6. Sulphur from Sulphites.

The Farbenfabriken vorm. Friedr. Bayer & Co. (Ger. Ps. 263167, 264920, 265167; Fr. P. 459713) obtain sulphur and sulphates from solutions containing sulphites and thiosulphates, by adding (3 or 4 per cent. of the weight of the salts) poly-

thionates, and heating in open vessels; e.g. a liquid containing 100 parts sodium tetrathionate, 77 sodium bisulphite, and 140 sodium sulphate. This remains at first clear when being heated to boiling, but suddenly a strong separation of sulphur takes place, whereupon the decomposition is quickly completed, and the liquid now contains only sulphate. In order to avoid explosions, they prefer converting 2 mol. bisulphate and 1 mol. normal sulphite, by heating under pressure, into sulphate and sulphur, through the quantitatively occurring reaction,

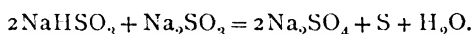

Hansen (U.S. P. 1101740) obtains free sulphur and sodium sulphate by heating a mixed solution of bisulphate and sulphite, in exactly the same manner.

7. Sulphur from the Sulphides of Alkaline Earth Metals.

The Nürnberg Consortium für elektroch. Industrie (Ger. P. 162913) obtains sulphur by treating alkaline earth sulphides with chlorine at high temperatures, until the chlorine contained in the distillate in the form of sulphuryl chloride suffices for chlorinating the polysulphide formed, whereupon this is decomposed by the sulphuryl chloride in aqueous solutions to chlorides and free sulphur.

Deutsch Petroleum-A.-G. (Ger. P. 339610 of 1918) pass steam at 1200° or above, over the sulphides, which may be mixed with carbon. The steam may be mixed in varying proportions with a reducing-gas such as methane or hydrogen.

8. Sulphur from Sulphates of the Alkaline Earths.

E. H. Riesenfeld¹ gives a résumé on the preparation of sulphur from sulphates:—

I. *Reduction of Kieserite by Carbon* (with Alfred Faber).—A review of the literature on the utilisation of magnesium sulphate leads to preference being given to the proposal of Precht² to reduce kieserite by means of charcoal according to the equation $2\text{MgSO}_4 + \text{C} = 2\text{MgO} + 2\text{SO}_2 + \text{CO}_2$. Experiments showed that, at least in part, reaction occurs according to

¹ *J. pr. Chem.*, 1920, 2, 100, 115-158; *J. Chem. Soc.*, 1921, 2, 40-42.

² *Chem. Ind.*, 1881, 4, 350.

the equation $\text{MgSO}_4 + \text{C} = \text{MgO} + \text{SO}_2 + \text{CO}$. Thus the solid residue always contained sulphur when less than one atomic proportion of carbon to magnesium was employed, the best results being obtained with the proportion 1 : 1 at $750\text{--}850^\circ$ or 1.5 : 1 at 950° . Under these conditions, the sulphur was obtained almost entirely as sulphur dioxide, with a little free sulphur. Contrary to what might be expected, reduction was not complete when greater proportions of carbon were used, probably because the molten sulphide then produced surrounded the sulphate and protected it from further action.

II. *Reduction of Gypsum and Anhydrite by Carbon* (with Hans Feld).—The reaction between gypsum and carbon sets in below 500° , but very slowly, and is fairly rapid from about 700° upwards. Under suitable conditions, pure calcium sulphide was obtained, approximately according to the equation $\text{CaSO}_4 + 3\text{C} = \text{CaS} + \text{CO}_2 + 2\text{CO}$. Similarly, from strontium and barium sulphates, the sulphides were produced, the different behaviour of magnesium sulphate being accounted for by a consideration of the heats of reaction. The composition of the gaseous phase in the former cases is controlled by the C : CO : CO_2 equilibrium, but in the case of magnesium sulphate this is disturbed by the action of sulphur dioxide on carbon monoxide.

III. *The Calcium Sulphate-Carbonate Equilibrium* (with (Fr.) Italiener and (Fr.) M. Hesse).—The equilibrium $\text{CaS} + \text{H}_2\text{O} + \text{CO}_2 \rightleftharpoons \text{CaCO}_3 + \text{H}_2\text{S}$ cannot be utilised for the disposal of calcium sulphide obtained by the above reduction, since at temperatures, for example 700° , at which it is sufficiently rapidly attained, it favours the formation of calcium sulphide to a very considerable extent.

IV. *Reduction of Gypsum and Anhydrite by Gases* (with Margarete Hesse).—Gypsum was reduced by methane according to the equation $\text{CaSO}_4 + \text{CH}_4 = \text{CaS} + \text{CO}_2 + 2\text{H}_2\text{O}$. Below 800° , dehydration of the gypsum alone occurred, but at $800\text{--}1000^\circ$ quantitative reduction appears possible if the action be sufficiently prolonged. Above 1100° , some calcium oxide was produced, probably as a result of the reaction $\text{CaS} + \text{H}_2\text{O} = \text{CaO} + \text{H}_2\text{S}$. The deduction from this equation—that excess of steam would favour complete removal of sulphur—was confirmed by experiments at 1200° and 1300° . Partly

in consequence, however, of dissociation of hydrogen sulphide and partly by its reaction with water vapour,¹ the sulphur was obtained almost entirely as sulphur dioxide or elementary sulphur, the latter predominating when only a slight excess of water was employed.

V. *Decomposition of Calcium Sulphide by Steam and the Direct Conversion of Gypsum and Anhydrite into Oxide* (with Margarete Hesse).—Experiments on the action of steam on calcium sulphide justified the above assumption of its intermediate formation, the amounts of sulphur dioxide and elementary sulphur produced being in agreement with the previous results. It must therefore be possible to convert calcium sulphate directly into the oxide by treatment with carbon and steam, and experiment showed this to occur at 1200°, but more than six times as rapidly at 1300°. Owing to the reducing action of carbon monoxide and hydrogen on sulphur dioxide, elementary sulphur predominated in the product, only 50 per cent. being obtained as the dioxide, even when 850 times the theoretical proportion of steam was employed.

Sulphur dioxide is produced from calcium sulphate by Chem. Fabr. vorm. Weiler-ter Meer, Ger. P. 307772. A mixture of calcium sulphate and calcium sulphide is heated above 1000°, whereby sulphur dioxide is formed in accordance with the equation

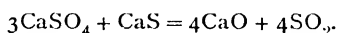

Palaschowski (Russ. Ps. 5464 and 5477 of 1901; *Chem. Zeit.*, 1902, p. 15) describes the following modifications of the process of Baranoff and Hildt for obtaining S and SO₂ from sulphates. Instead of simply mixing the sulphates with coke, he moulds them into briquettes by means of coal-tar, etc., which shortens the time of reduction. The sulphide is decomposed by CO₂ at a pressure of 2 or 3 atmospheres. The H₂S is best not passed at once through red-hot sulphates, but first through a solution of the sulphides, which forms Ca(SH)₂ and NaHS. The former is converted by means of Na₂SO₄ into NaHS, which with CO₂ gives H₂S and NaHCO₃. Only this H₂S is employed for being oxidised by sulphates to S and SO₂.

¹ Compare Randell and Bichowsky, *J. Chem. Soc.*, 1918, 2, 159.

The Verein Chemischer Fabriken Mannheim (B. P. 149662, 1919)¹ states that sulphur dioxide is volatilised when sulphates of the alkaline earth and magnesium and iron sulphates are heated at a comparatively low temperature in the presence of certain reducing-agents. Preferably, the latter are added only in sufficient quantities for the sulphates to be reduced to the sulphite stage; the reduction being effected by means of metallic iron, other metals capable of being obtained by reduction with hydrogen, the lower oxides of these metals, or coal. Excess reducing-agent, or sufficient to form sulphides, may be employed, however, but the process is then performed in two stages. The reduction is first effected at about 600°, and then the sulphur is volatilised as sulphur dioxide and sulphuric acid, at 900°, in a current of steam and air. When excess is used, coal, water-gas, or other reducing-gas may partly replace the metals or their low oxides, and the latter may be produced during the actual process from higher oxides. The reduction may be carried out in an atmosphere of nitrogen or other inert gas, or in a vacuum, and the metal can be recovered from the residual mass by removal of the lime after reduction. In examples gypsum, hepatite, and magnesium sulphate are reduced by the methods given above by means of iron powder, and iron protoxide with evolution of sulphur dioxide.

Bambach (B. P. 3174, 1914; Ger. P. appl. P30692; Fr. P. 470652) makes sulphurous acid from alkaline-earth sulphates by heating them to redness by contact with a burning mixture of gas and air, and further heating the residue, either by a flame containing an excess of air, or by the successive action of a reducing flame and oxygen (preferably as air). The process may be applied to sulphides, the heated material being decomposed by an oxidising flame or by air.

The preparation of sulphur from calcium sulphate was one of the German war-time chemical processes, and it is said that it is still being carried out with advantage because it yields a sulphur of 99.95 per cent. and at a cost smaller than the imported material.

The raw materials of the process are anhydrous calcium

¹ *Chem. Trade J.*, 1920, p. 652.

sulphate and magnesium chloride, both occurring in the potash salt deposits.

The sulphate is mixed with coal and heated in revolving furnaces to 1100° ; the resulting calcium sulphide is ground up and treated with a solution of magnesium chloride and live steam; the sulphuretted hydrogen passes through Claus furnaces (bauxite being used as a catalyser), and the sulphur is deposited there and in the subliming chambers.

The Badische Anilin- und Soda-Fabrik Ger. Ps. (A) 301682, (B) 302471, 18.11.16, (C) 306312, 24.12.16, are for the production of sulphur from calcium sulphate.

(A) The gases containing sulphur dioxide derived from the decomposition of calcium sulphate are mixed with carbon monoxide, or gases containing carbon monoxide, in presence of red-hot coal or coke.

(B) Instead of, or in addition to, carbon monoxide, oxygen or air may be introduced in such excess that the gases, after leaving the combustion zone and on entering the reduction-chamber, contain an appreciable proportion of oxygen.

(C) When gypsum is employed for the production of the gases, it may be first dehydrated, the air introduced into the process being also completely dried. The yield of sulphur is practically doubled by this means.

Reducing Sulphur to Fine Powder.

Apart from sublimed sulphur (see below) very much sulphur is reduced to a fine powder by mere grinding and sifting, which operation, if performed in the ordinary way, need not be described here. We shall merely mention some special processes for this purpose.

A. Walter (Ger. P. 136547) performs the grinding and sifting of sulphur in an atmosphere of inert gas, which is made to circulate through the apparatus. In this way the formation of sparks is avoided, and the sulphur can be reduced to such a degree of fineness that it passes through a sieve of 5000 meshes per square centimetre.

Köhler (Ger. P. 192815; Amer. P. 898378) obtains sulphur in a state of great fineness by dissolving it in its own weight of fused naphthalene, and after cooling, removing the naphthalene by gentle heating or by extraction with a solvent.

Estimation of the Degree of Fineness of Ground Sulphur.

Since, for the purpose of preventing the grape-disease (the *Oidium*), the degree of fineness of ground sulphur is very important, in France this is ascertained by Chancel's *sulphurimeter*, shown in Fig. 1 on a scale of 1 : 2. This is a glass tube sealed at the bottom and closed at the top by a ground-in glass stopper. It is 23 cm. long and 15 mm. wide, and divided into 100° of $\frac{1}{4}$ c.c. each, beginning from the bottom; the 100° occupy a space of 100 mm.

If ground sulphur is shaken up with anhydrous ether it forms, after settling down, a layer, the height of which corresponds to the fineness of the powder. The sulphur to be tested is passed through a sieve; 5 grams of it are put in the tube, together with ether, filling half the tube. The tube is well shaken to break up all small lumps, more ether is poured in up to 1 cm. above the degree 100, the tube is again shaken and placed in a vertical position. When the layer of sulphur ceases to subside, its height is read off and stated as "degrees Chancel."

Ordinary ground and sifted sulphur shows 50° to 55° Chancel, finer grades 70° to 75°. The finest grade is obtained not by sifting, but by "fanning." This "zolfo ventilato" shows 90° to 91° Chancel (Walter, *Chem. Zeit.*, 1901, 539). For use in vineyards the "flowers" ought to show at least 60° Chancel; some demand as much as 75° Chancel.

H. Fresenius and P. Beck (*Z. anal. Chem.*, xlii, p. 21) draw attention to some points necessary to observe. They recommend the sulphurimeter sold by Joh. Greiner of Munich, which deviates in its dimensions from the instruments supplied by French firms. These instruments have been officially adopted by the Swiss Union of Analytical Chemists,¹ who recommend the following way of proceeding for testing the degree of fineness of the sulphur intended for viticultural purposes. Five grams taken from a larger sample of brimstone, passed through a



FIG. 1.

¹ *Z. anal. Chem.*, 1906, 45, 760.

2-mm. wire sieve, are introduced into the sulphurimeter. After the air has been driven out of the apparatus, it is filled up to the 100 mark by ether, closed by its glass stopper, and placed for a short time into water of 17.5° . Now the contents of the tube (which is best wrapped in a woollen cloth) are thoroughly mixed during one minute by vigorous, long pushes in the longitudinal direction; the sulphurimeter is then quickly placed in a stand in a vertical position, any further shaking is avoided, and the place up to which the sulphur reaches is read off. This operation is repeated ten times, and the mean result taken. The following points are observed for a judgment of the quality:—

1. Sulphur samples with more than 2 per mille of mineral admixtures are to be designated as impure.

2. For sublimed sulphur 40° , for ground sulphur 60° , for blown sulphur 70° Chancel, must be demanded.

3. Under the microscope the particles of the ground or blown sulphur appear angular and sharp-edged, those of sublimed sulphur rounded, smooth, and frequently cohering by fusion in rows. In polarised light the former are translucent, the latter transparent. Pure ground sulphur is entirely soluble in carbon disulphide, sublimed sulphur only partially so. The following prescription, founded on Dusserre's proposals, serves for an approximate estimation of the percentage of both of these modifications in a mixture: 5 grams of the sulphur are introduced into a Chancel sulphurimeter, which is then filled with pure carbon disulphide up to the mark. After shaking up two or three times and settling, the volume of the undissolved sulphur is read off. Pure ground sulphur, owing to its complete solubility in carbon disulphide, shows no sediment; but sublimed sulphur leaves a residue of amorphous sulphur, whose volume varies between 24 and 40, and on the average is = 33 Chancel. In mixtures of sublimed and ground sulphur the volume of the residue insoluble in carbon disulphide is between 8 and 21, and averages 13 Chancel.

The same Union recommend the following rules for estimating the sulphur in mixtures, especially those intended for dusting on grape-vines. If the sulphur is ground, and there are no other substances present which are soluble in carbon disulphide, the sample is extracted by carbon disulphide in a Soxhlet

apparatus. If the sample contains sublimed sulphur, the following method (worked out by Dusserre) usually yields the desired result, on the supposition that there are no substances present which are insoluble in water, alcohol, and ether, and which are also volatile. Ten grams of the powder are mixed with so much hydrochloric acid that the copper salts, lime, sodium carbonate, etc., are dissolved. It is then filtered through asbestos, washed several times with cold water, then with alcohol, and lastly with a little ether, whereby soap, resin, etc., are removed. The residue remaining on the asbestos filter, which contains only sulphur and the insoluble portions of the powder (talcum, china clay, etc.), is placed in a platinum crucible, dried in a water oven, weighed, ignited, and reweighed. The difference between the two weighings indicates the percentage of sulphur.

Refining of Sulphur; Roll and Block Sulphur.

A few modern improvements of these well-known operations may be mentioned.

Boude et fils (Fr. P. 408512) describe the manufacture of sulphur cast into moulds, by distilling the crude sulphur from a cast-iron retort into a cast-iron condenser, surrounded by a fire-space, and connected with a second condenser. The condensed sulphur flows from the first into the second condenser, and from this into the moulds.

The purification of sulphur is claimed by J. J. Hood (B. P. 140844), the sulphur being melted and filtered through precipitated and ignited tri-hydrate of alumina, or precipitated and ignited magnesia. Alternatively, bauxite or magnesite may be used as a starting material. The filtering material may be regenerated by passing steam or a sulphur solvent through it and then igniting the residue. Spent oxide may be treated with carbon bisulphide or other sulphur solvent, and the sulphur solution then filtered through ignited bauxite or magnesite. The filtering material may be regenerated as above.

Flowers of Sulphur.

It is unnecessary to describe the well-known operation of obtaining flowers of sulphur by the process of sublimation in its old form, but we must mention recent improvements in this line.

Walter (Ger. P. 177281; Amer. P. 873812) manufactures flowers of sulphur, not in the ordinary way of aspirating the vapours from the retort by an inert gas and allowing them to condense in cooling-chambers (which yields various degrees of fineness, according to the distance from the retort), but by driving on the gases, by means of a fan, through the coolers so that the gases and vapours are thoroughly mixed, and the sulphur vapour is ultimately condensed in the state of uniform fineness, without drops and stalactites, of which, by the old process, sometimes 30 or 40 per cent. of the sulphur are found near the retorts. This product is sold as "zolfo ventilato."

The same inventor (Ger. P. 192472) obtains both melted sulphur and flowers of sulphur directly from the ore by passing it continuously through a vertical cylinder, together with hot inert gases (*i.e.* smoke gases), and drawing off the vapours. The inert gases may have a temperature of only 150° in the upper part, but about 350° in the lower part of the cylinder.

Boude et fils (Fr. P. 361874), in the production of flowers of sulphur, arrange, for each subliming furnace, two cooling-chambers, so that each of them can be emptied without interrupting the work.

The same firm (Fr. P. 369089) provide the sublimation chambers with arches, ranged perpendicularly to the breadth of the chamber, rising to the right and left of the inlet opening for the sulphur vapour.

Basse-Courbet (Fr. P. 366280), in working sulphur minerals containing arsenic for flowers of sulphur, continually draws the non-condensing gas away from the chamber by means of a fan.

Dementieff (Fr. P. 351981) introduces sulphur vapours, together with steam or sprayed water, under pressure, into a chamber where the sulphur is at once condensed in a very fine state of division.

Consoli (B. P. 8757 of 1902; Fr. P. 316226) sublimes sulphur by a continuous process in a battery of several retorts, fed with melted sulphur.

Bert (Fr. P. 401023) effects the continuous sublimation of sulphur by means of an apparatus comprising a hopper, from which the crude material is automatically fed into a vessel, heated by waste heat, in which it is melted, the impurities

being deposited and removed, the liquid sulphur rising through a filtering device immersed in the liquid. The nearly pure sulphur then passes to tubular retorts of thin steel or iron, the surface of which may be suitably protected, from which the sulphur vapour passes to the collecting chambers through condensers cooled by water.

A. R. Scott and A. Meyer (Fr. P. 439258) prevent the formation of crystallised or solid sulphur upon the floor of the chamber by subjecting the sulphur vapours, before being admitted to the condensing chamber, to a vigorous atomisation by a suitable apparatus.

Fronzes-Diacon¹ describes the adulteration and grading of sublimed sulphur. The material from the collecting chamber is graded into grésil, éponges, grapillons, and candi, according to its degree of fineness. A sample taken from the floor of a chamber contained 32.7 per cent. of sulphur insoluble in carbon bisulphide, whilst another of equal fineness taken from the wall at the height of about 1 m. contained 30 per cent. of insoluble sulphur. A third sample, taken at about 2.5 m. from one of the vapour inlets, was much coarser, and consisted of a mixture of the first three grades. A fourth sample, collected about 2 m. from a vapour inlet, was still coarser, and consisted of éponges containing only 0.3 per cent. of insoluble sulphur; whilst a sample of candi collected directly above an inlet consisted of large fused masses which were practically free from insoluble sulphur. The proportion of insoluble sulphur stood in direct relationship to the degree of fineness, and this also applied to commercial sublimed sulphur. The very pure sublimed product collected from the middle of the floor to the chamber passed through a 100-mesh and (with prolonged shaking) through a 240-mesh sieve, and, when fractionated by partial sifting, yielded three fractions containing 30.3, 30.5, and 30.3 per cent. of insoluble sulphur respectively. In the case of the second sample the grésil retained by a 100-mesh sieve contained 10.4 per cent., the coarse flowers retained by a 240-mesh sieve contained 12.5 per cent., and the fine flowers which passes through that sieve contained 15.5 per cent. of insoluble sulphur. A very pure commercial sample as used in vineyards contained 28.2 per cent. insoluble

¹ *Ann. falsif.*, 1916, 9, 333-339; *J. Soc. Chem. Ind.*, 1917, p. 338.

sulphur. It passed through a 100-mesh sieve, but by treatment on a 240-mesh sieve was separated into coarse and fine flowers containing respectively 27.3 and 29.5 per cent. of insoluble sulphur. A coarser commercial product was separated into grésil (retained by a 100-mesh sieve), and coarse and fine flowers, containing 16.1, 19.6, and 26.3 per cent. of insoluble sulphur respectively; whilst a badly-made product of poor quality yielded grésil with 2.3 per cent., coarse flowers with 4.8 per cent., and fine flowers with 18.7 per cent. of insoluble sulphur. In every instance of pure sublimed samples the ratio of the insoluble sulphur in the grésil to that in the coarse flowers was less than unity. Any decrease in the proportion of insoluble sulphur on keeping is immaterial, since it affects all the fractions of the sulphur. The addition of 20 to 25 per cent. of ordinary powdered sulphur to sublimed sulphur causes this ratio to exceed unity. The insoluble sulphur is determined by treating 1 to 2 grams of the sample with three successive portions of carbon bisulphide for thirty minutes each time, separating the extracts by centrifuging, and drying the insoluble residue in the water oven.

Special Technical Forms of Sulphur (Colloidal, etc.).

Sulphur or selenium in a colloidal form is obtained by Chemische Fabrik von Heyden (Ger. P. 167664) by precipitating the sulphur from its solutions in the well-known way in the presence of albuminoid substances, redissolving in a weak solution of alkali and precipitating by alcohol, alcohol-ether, or acetone. Their Ger. P. 201371 describes dissolving the sulphur in physical solvents, and precipitating it again by dilution with weak solutions of albumen, or removing the solvent by dialysis or decomposition. The sulphur thus obtained is soluble in water and is valuable for medicinal purposes, *e.g.* against skin diseases. Himmelbauer¹ prepares colloidal sulphur by the action of gelatine or of colloid silica on a solution of sulphuretted hydrogen. Sarason (Ger. Ps. 216824 and 216825) makes such solutions by acidulating solutions of thiosulphates in glycerine with addition of thickening agents, *e.g.* gelatine. The Thomsen Chemical Company (Ger. P. 273761) prepare sulphur in such a form that, when

¹ *Chem. Zentr.*, 1909, 2, 790.

suspended in water or other liquids, it is not coagulated by sulphuric acid. This is done by grinding it to an extremely fine state, together with a colloid, *e.g.* 50 parts sulphur with a solution of 5 parts glue in 50 water. Other suitable colloids are: extract of soap-bark, Irish moss, gum tragacanth or gum-arabic; or by grinding the sulphur in the dry state with the colloid and then with water. The product thus obtained serves for wetting shrubs, for destroying fungi, and (with addition of plumbic arseniate) for destroying insects.

Ducancel et Gouthière et Cie. (Fr. P. 401067) incorporate finely divided sulphur with barium, strontium, or calcium saccharate, and thereby render it miscible with water, for the treatment of the vine-disease.

"*Plastic*" sulphur, for employment in agriculture and viticulture, is made by Imbert (Fr. P. 459534) by adding 0.5 part ox-gall to 999.5 sulphur.

"*Precipitated*" sulphur, as sold for dealing with the vine-disease, according to Kulisch,¹ has nothing to do with the precipitated sulphur used in pharmacy, and evidently comes from the coal-gas manufacture. It is a brown or black powder, containing 50 per cent. ashes (20 per cent. of which is ferric oxide), and only 33 per cent. real sulphur.

Leather-tanning by Precipitated Sulphur.—According to Apostolo,² instead of precipitating the sulphur on the leather from sodium thiosulphate by the addition of acids, the leather may be dipped in a liquid holding in suspension the sulphur precipitated from thiosulphate by the gradual addition of an acid. After ten or twelve hours' treatment, white, very soft leather is obtained, holding for 100 parts from 2.5 to 3.5 parts of sulphur in a state of adsorption, and stable in warm, but not in cold water.

Technical Analysis of Commercial Sulphur.

Cf. the tests for the degree of fineness, supra, p. 51.

Estimation of Moisture.

In the case of unground brimstone it is seldom necessary to estimate the moisture; but where water has been added purposely, or by accidental exposure to rain, it is then necessary to do so. It is not so simple an operation as it looks, since it

¹ *Z. angew. Chem.*, 1914, 2, 415. ² *Ann. Chim. anal.*, 1914, 1, 124.

is hardly possible to preserve the sample without loss of moisture. In the case of coarse sulphur, the sample must be crushed as quickly as possible, only quite coarsely, and at least 100 grams must be employed for the estimation of moisture. In case of ground sulphur it is, of course, much easier to obtain an average sample, even of less size.

According to Fresenius and Beck,¹ the drying should be performed only during a short time, and at not more than 70°.

Estimation of the Total Sulphur.

Macagno² proposed the *direct estimation of sulphur* by means of its solubility in carbon disulphide.³ Pfeiffer⁴ has re-investigated this matter and given the following prescriptions for this method:—Shake a weighed sample of powdered sulphur with exactly four times the quantity of pure carbon disulphide, filter, reduce the temperature to 15°, and ascertain the specific gravity of the solution. The following table (abridged from the original) shows the number of parts of sulphur dissolved by 100 parts by weight of CS₂ at 15° for various specific gravities found:—

Specific gravity.	Sulphur dissolved.	Specific gravity.	Sulphur dissolved.	Specific gravity.	Sulphur dissolved.
1.2708	0	1.3087	8.5	1.3426	17.0
1.2731	0.5	1.3108	9.0	1.3445	17.5
1.2754	1.0	1.3129	9.5	1.3463	18.0
1.2779	1.5	1.3150	10.0	1.3481	18.5
1.2800	2.0	1.3170	10.5	1.3500	19.0
1.2833	2.5	1.3190	11.0	1.3517	19.5
1.2857	3.0	1.3211	11.5	1.3536	20.0
1.2870	3.5	1.3231	12.0	1.3553	20.5
1.2894	4.0	1.3251	12.5	1.3571	21.0
1.2916	4.5	1.3271	13.0	1.3587	21.5
1.2938	5.0	1.3291	13.5	1.3605	22.0
1.2960	5.5	1.3311	14.0	1.3622	22.5
1.2982	6.0	1.3330	14.5	1.3640	23.0
1.3003	6.5	1.3350	15.0	1.3657	23.5
1.3024	7.0	1.3369	15.5	1.3674	24.0
1.3045	7.5	1.3388	16.0	1.3692	24.5
1.3066	8.0	1.3408	16.5	1.3709	25.0

¹ *Z. anal. Chem.*, 42, 21.

² *Chem. News*, 43, 192.

³ F. B. Carpenter (*J. Soc. Chem. Ind.*, 1902, p. 832) points out that crude sulphur sometimes contains a large quantity of gypsum, which interferes with the carbon-disulphide treatment. In such cases the calcium sulphate must be previously removed by boiling with hydrochloric acid.

⁴ *Z. anorg. Chem.*, 15, 194, and Lunge, *Chem. techn. Untersuchungs-methoden*, 1, 240.

The same subject is again treated by P. Fuchs.¹ His figures are slightly different from those obtained by Pfeiffer in Lunge's laboratory.

Ceruti² places 1 or 2 grams of the commercial sulphur on a filter, dries at 100° and weighs, gradually adds 50 c.c. of aniline (boiling-point 180° to 185°) heated to 120° to 130°, and collects the filtrate. The filter is washed with aniline, dried at 100° and reweighed, thus showing the amount of impurities insoluble in aniline. The filtrate is mixed with hydrochloric acid, allowed to cool, the precipitate then forming is washed on a weighed filter, dried in a vacuum over concentrated sulphuric acid, and thus the real S present is found.

Giuseppe Anelli³ states that the various methods for estimating sulphur in the crude products containing bitumen consist in oxidising the sulphur to sulphuric acid, the bitumen being estimated by difference. He has investigated the method in which the oxidation is effected by means of fuming nitric acid in sealed tubes, and finds that this procedure always gives results in excess of the theoretical values, the divergence varying with the nature of the glass of the sealed tubes, and amounting, in some cases, to 6 per cent. These results are found to be due to action of the sulphuric acid formed on the glass, but no satisfactory correction could be applied for the silicic acid dissolved. When an organic compound containing a limited proportion of sulphur is being analysed, the error produced in the above manner is negligible, although somewhat high values are usually obtained. With sulphur itself or with compounds containing much sulphur, barium nitrate in slight excess over the theoretical amount must be introduced into the Carius tubes with the nitric acid.

M. G. Levi⁴ examined the methods proposed for estimating the sulphur in crude brimstone, especially in Sicilian sulphur containing bituminous impurities.

The method of Carius did not yield exact results, nor did combustion in a current of oxygen, which is quite suitable for purer forms of sulphur. Better results were obtained by

¹ *Z. angew. Chem.*, 1898, p. 1189.

² *Chem. Zentr.*, 1904, p. 615.

³ *Gazzetta*, 1911, 41, 334-341; *J. Chem. Soc.*, 1911, 2, 533.

⁴ *Ann. Chim.*, 1915, pp. 9-31; *J. Soc. Chem. Ind.*, 1915, p. 282.

the method of Fresenius and Beck,¹ viz. heating 10 grams a little over 200° in order to volatilise the sulphur, weighing the residue and estimating the bitumen contained therein by reducing it to ashes. Exact results are obtained by means of nitric acid and bromine when proceeding in the following way:— Place 2 grams of sulphur in a 100 c.c. flask connected by a ground-glass stopper with a reflux cooler. Place the flask in an inclined position in cold water, and introduce 10 c.c. fuming sulphuric acid, and then 5 drops of bromine through the reflux tube. Shake the flask from time to time until most of the sulphur and of the bromine is dissolved. Add another 5 c.c. nitric acid, heat on the water-bath for half an hour, dip the flask into cold water, add 50 c.c. of water in small portions through the reflux tube, and precipitate the sulphuric acid formed as barium sulphate in the well-known way. In the case of low-grade sulphur, the sulphur must be extracted from the sample by carbon disulphide and then tested as above.

Berger² pours 10 c.c. of fuming nitric acid over 0.1 to 0.2 gram of the substance, adds 0.5 to 1.0 gram potassium bromide, allows to stand for a few minutes, evaporates to dryness, treats the residue a few times with hydrochloric acid, takes it up with water, and estimates the sulphuric acid formed by precipitation with barium chloride.

Estimation of the Impurities of Sulphur.—*Bituminous* substances are most easily recognised by the colour of the sulphur; they occur chiefly in sulphur made from spent oxide of gasworks, which is sometimes coloured quite black. Peratoner³ found in ordinary crude Sicilian brimstone 0.03 to 2.44 per cent., but even in so-called "dark brimstone" not above 5 to 8 per cent. bitumen.

Durier⁴ describes an adulterant employed for ground sulphur, consisting of infusorial earth, which can be easily detected by chemical or microscopical methods. It contains about 75 per cent. silica, and yields at least 80 per cent. ash. As sulphur contains at most 2 per cent. ash, its incineration will reveal the adulteration; also microscopical examination of

¹ *Z. anal. Chem.*, 42, 21.

² *Comptes rend.*, 143, 1160.

³ *Chem. Zentr.*, 1909, 2, 479.

⁴ *Ann. falsif.*, 37, 584; *Abstr. Amer. Chem. Soc.*, 1912, 535.

the original material or the ash will show the presence of diatoms.

R. V. Hasslinger¹ states that all commercial sulphur, whether distilled or recrystallised, deposits, on boiling, a black precipitate, which contains only carbon and iron. This precipitate is insoluble in sulphur and all solvents for sulphur, is not identical with so-called "black sulphur," and can be artificially prepared by distilling pure sulphur—obtained from sulphuretted hydrogen—with iron and hydrocarbons.

Estimation of Arsenic.

Arsenic in brimstone occurs mostly as As_2S_3 , but sometimes also partly as As_2O_3 , or, exceptionally, as calcium or ferric arsenite; it occurs more especially in that recovered from alkali-works, in the form of arsenious sulphide. On extracting the brimstone with disulphide of carbon, the As_2S_3 remains behind and can be estimated.

A qualitative reaction for arsenic consists in agitating 1 gram sulphur with 15 drops liquor ammonia and 2 c.c. water for half an hour, filtering, adding to the filtrate 30 drops of hydrochloric acid and 15 drops solution of oxalic acid, placing a bright piece of brass in the solution and heating to from 60° to 100° ; in the presence of arsenic the brass is stained grey or black.²

Steel³ proceeds as follows:—He extracts 200 grams of the sample during two hours in a paper filter in the Soxhlet apparatus with carbon disulphide, withdraws the paper filter, allows the CS_2 to evaporate, scrapes out the residue, heats this with 50 c.c. strong nitric acid till all acid is driven off, adds 1 c.c. strong hydrochloric acid and, after a few minutes, 5 c.c. warm water, filters into a test-tube, washes the insoluble residue with a little water, adds to the solution 20 c.c. strong hydrochloric acid, 1 or 2 c.c. of a fairly concentrated solution of stannous chloride in hydrochloric acid, and, lastly, 3 c.c. of strong sulphuric acid, heats gently and allows to stand over-night. If As or Se

¹ *Monatsh. f. Chem.*, 1903, **24** (9), 729-736; *J. Soc. Chem. Ind.*, 1903, p. 1291.

² Hager, *Pharm. Zentralk.*, 1884, pp. 263 and 443.

³ *Chem. News*, **86**, 135.

(insoluble in CS_2) is present, a dark-brown precipitate is formed. This is filtered through asbestos (purified by aqua regia), washed and dried at 100° , transferred to a hard-glass tube, 7 mm. bore, closed at one end; the tube is then drawn out immediately above the contents to 1.5 mm. bore for a length of about 80 mm. The bulb portion, containing the asbestos, etc., is heated to redness in a Bunsen flame. As and Se are driven off and condense in the narrow part of the tube. Se appears in both the black and the red modification, and is at once identified by its characteristic odour; As is found by heating the sublimate in a current of air, when As_2O_3 forms a ring of glistening crystals, or, in the presence of traces of water, globules of a solution of oxide. If no selenium is found here, it may be sought for in the CS_2 solution, by distilling off the CS_2 , oxidising the mass of sulphur by means of fuming nitric acid [no mean task with 200 grams sulphur!], filtering through asbestos, evaporating the filtrate till strong white fumes of sulphuric acid appear, and then reducing with SnCl_2 , etc., as above.

Brand¹ prefers the method of Gutzzeit, which he carries out as follows:—He digests 5 grams sulphur, etc., with 25 c.c. dilute ammoniacal liquor (1 : 3) during a quarter of an hour, filters, washes the filter with a little water, evaporates the solution to dryness, pours a few drops of nitric acid over the residue, dries in a porcelain dish, dissolves in 8 to 10 c.c. dilute sulphuric acid, pours into a large test-tube, containing a few pieces of pure zinc, puts a loose plug of cotton-wool into the neck of the tube and on this a piece of filter-paper, moistened with a drop of concentrated silver-nitrate solution (1 : 1). The moistened spot is coloured lemon-yellow, more or less quickly, according to the quantity of arsenic present, and on addition of water turns black. In the case of brimstone rolls, intended for sulphurising hops, no sensible coloration ought to take place within a quarter of an hour. He suggests testing, by this method, all samples of sulphur intended for preserving articles of food.

In a communication to the *J. of Eng. Chem.*, 1920, **12**, pp. 479-480, *Chem. Trade J.*, 1920, p. 411, H. S. and M. D. Davis discuss the various methods proposed for the detection of small quantities of arsenic in sulphur. The method as

¹ *Chem. Zentr.*, 1908, p. 762.

described by Schäppi,¹ which rests upon the assumption that any arsenic in sulphur is present as sulphide, consists essentially in first digesting the sulphur with dilute nitric acid for the purpose of removing calcium chloride, sulphate, and sulphide. The sulphur washed free from acid is now treated with dilute ammonia solution for fifteen minutes at 70° to 80°. The arsenic is then estimated indirectly through determination of the amount of sulphide by precipitation with silver nitrate in neutral solution.

Schäppi endeavoured to test the accuracy of his method by dissolving known amounts of pure arsenious sulphide in ammonia solution, carefully neutralising with nitric acid, and titrating with decinormal silver nitrate, using chromate as indicator. His results showed fairly good agreement between the quantities of arsenic taken and those found. However, his results would have been conclusive only if the arsenious sulphide had been added to the sulphur and the mixture tested by his method. Any other sulphide, if present in the ammonia solution, would also be precipitated by the silver nitrate. It is now found that sulphur continuously reacts with dilute ammonia at 70° to 80° to form sulphides, so that even arsenic-free sulphur will give a qualitative test for arsenic by this method.

The sulphur used in the present experiments was obtained from Texas deposits, and was found to be absolutely free from arsenic when tested by the Gutzeit method, as described later in this paper. Ten grams of a representative sample, powdered to pass a 160 mesh, were digested with 25 c.c. of hot water, to which 0.4 c.c. concentrated nitric acid was added. It was then washed free from acid and sulphides and digested with 25 c.c. water and 0.5 c.c. ammonium hydroxide (specific gravity 0.90) at a temperature of 70° to 80° for fifteen minutes. The filtrate was somewhat tinged with a bright yellow colour, and gave a heavy dark-brown precipitate on the addition of silver nitrate. The sulphur was now washed free from alkali and sulphides, and the extraction repeated with ammonia solution as before. Again, the filtrate gave a heavy precipitate on the addition of silver nitrate. The extraction was repeated a third and a fourth time, washing the sulphur

¹ *Chem. Ind.*, 1881, p. 409.

free from alkali and sulphur in each case, and the same results were obtained. The precipitate with silver nitrate in the last extract seemed as heavy as that in the first.

A sample of *flowers of sulphur* was tested in the same way, the extraction with dilute ammonium hydroxide being repeated three times. The results were the same as in the case of the crude sulphur.

To determine whether or not the ammonium hydroxide solution really contained arsenic, the first extract from 10 grams of crude sulphur was acidified with hydrochloric acid, a crystal of potassium chlorate added, and the solution boiled until all the chlorate was decomposed. This solution was then tested by Gutzeit's method for arsenic and none was detected. Further, 8 grams of crude sulphur were extracted with dilute ammonia at 70° to 80° . The extract was acidified with strong nitric acid and evaporated to dryness on a water-bath. A few cubic centimetres of concentrated nitric acid were added, and it was again evaporated to dryness. The residue was dissolved in water and tested by Gutzeit's method for arsenic with negative results. In a check test, 0.00004 gram of arsenic under similar conditions in the Gutzeit apparatus gave a well-marked arsenic stain.

These experiments indicate that sulphur reacts with dilute ammonium hydroxide at 70° to 80° to form ammonium sulphides. This is substantiated by the well-known fact that sulphur readily dissolves in hot solutions of the strong alkalies to form polysulphides. A sample of arsenic-free sulphur would, therefore, continue indefinitely to give a test for arsenic by Schäppi's method.

In testing the sulphur for arsenic by Gutzeit's method, 10 grams of the material were treated with 30 c.c. of carbon tetrachloride mixture (3 parts CCl_4 + 2 parts Br), and after standing for ten minutes 40 c.c. strong nitric acid were added in small portions (a watch-glass covering the beaker during the intervals of addition). The mixture was taken to dryness on a steam bath, water was added, and the evaporation repeated. Arsenic was now determined on the residue by the Gutzeit method. It was found advisable to warm the sulphur bromide slightly before adding the nitric acid from a dropping pipette. The final evaporations were carried out directly over a flame,

instead of on a water-bath, until sulphur trioxide fumes appeared. By the action of the bromine and nitric acid the sulphur was completely oxidised to sulphuric acid. The carbon tetrachloride was added to moderate the violence of the reaction and to prevent the precipitation of sulphur. Any excess of these reagents was expelled by the final evaporations. The acid solution remaining in the flask was now tested for arsenic by Gutzeit's method.

The conclusions arrived at are that Schäppi's method is unreliable, owing to the reaction of sulphur with dilute ammonia at 70° to 80° ; but, that the method of testing for arsenic in sulphur which consists in oxidising the sulphur with bromine and nitric acid and then testing the residue by Gutzeit's method is reliable.

Estimation of Selenium.

Apart from the methods already described, *selenium* is also detected by deflagrating the sulphur with nitrate of potash, dissolving in hydrochloric acid, and treating with SO_2 , which precipitates the selenium as a red powder.

Klason¹ states that even 0.5 mg. selenium per litre makes sulphuric acid useless for the treatment of materials in paper-making. Sicilian brimstone contains about 0.9 gram Se, Japanese brimstone 1 to 20 grams Se per ton. The selenium passes over partly into the burner-gases and partly into the cinders. The higher the temperature, the more Se passes into the burner-gases, but the cinders contain at least 30 per cent. of the total selenium, and in the case of cuprous pyrites more than that. Falun pyrites contains on an average 10 grams Se per ton, but sometimes three or four times as much. By his hydriodic process, Klason was able to find 92 per cent. of the selenium in the boiling acid, even with quantities of 0.25 mg. per litre.

To estimate the selenium in crude brimstone, this is burned in a current of oxygen, in a porcelain boat placed in a glass tube, 1 m. long, between two asbestos plugs, which retain the SeO_2 formed almost completely. The SeO_2 is several times sublimed backwards and forwards, till it has turned perfectly

¹ *Chem. Zeit.*, 1911, p. 1345; *J. Chem. Soc. Abstr.*, 1912, 2, 201; fully in *Z. angew. Chem.*, 1912, p. 514 *et seq.*

white; it is then dissolved out of the tube and the asbestos plugs by water. The solution is diluted to 100 to 300 c.c. in a flask, and then 2 to 10 drops of hydrochloric acid (sp. gr. 1.19) are added. The flask and its contents are heated on a water-bath, the air is replaced by CO_2 , and 2 to 5 grams of potassium iodide is added. After well corking the flask, it is shaken to dissolve the iodide, cooled, and then kept in the dark for one hour. The iodine liberated by the reaction,

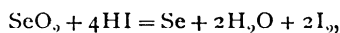

is titrated with standard thiosulphate. Care must be taken that the hydrochloric acid used is free from chlorine, and that the potassium iodide contains no iodate.

W. Smith¹ gives the following method based on the fact that the bromides of sulphur and selenium are decomposed by excess of cold water according to the equations $2\text{S}_2\text{Br}_2 + 3\text{H}_2\text{O} = \text{H}_2\text{SO}_3 + 3\text{S} + 4\text{HBr}$, and $\text{SeBr}_4 + 3\text{H}_2\text{O} = \text{H}_2\text{SeO}_3 + 4\text{HBr}$, and on the fact that the selenium compound decomposes very rapidly as compared with the sulphur compound. When the selenium acids (small amounts of selenic acid are formed by oxidation) are heated with an excess of hydriodic acid they are reduced to selenium, $\text{H}_2\text{SeO}_4 + 6\text{HI} = 4\text{H}_2\text{O} + 3\text{I}_2 + \text{Se}$ and $\text{H}_2\text{SeO}_3 + 4\text{HI} = 3\text{H}_2\text{O} + 2\text{I}_2 + \text{Se}$. Fifty grams of the powdered sulphur are mixed with about 55 c.c. of bromine, and after fifteen minutes the mixture is shaken for one minute, with 40 c.c. of bromine water, the aqueous solution separated and filtered, and the sulphur bromide extracted with four further quantities of 40 c.c. of bromine water, 2 c.c. of bromine being also added each time. The last extract is heated with hydrochloric acid and potassium iodide; if selenium is still present the extraction with bromine water is continued. The united extracts are now boiled, treated with potassium sulphite to remove bromine, diluted to about 250 c.c., 15 c.c. of hydrochloric acid and 5 grams of potassium iodide are added, the mixture is boiled, liberated iodine is removed by the addition of potassium sulphite solution, and after twenty minutes' boiling the selenium is collected, dried at 100° , and weighed. Four samples of Japanese sulphur were found to contain:—

¹ *J. Ind. Eng. Chem.*, 1915, 7, 849-850; *J. Chem. Soc.*, 1915, 2, 839.

(1) 0.8 per cent. As, 0.152 per cent. Se; (2) 0.7 per cent. As, 0.085 per cent. Se; (3) 0.5 per cent. As, 0.055 per cent. Se; and (4) 0.3 per cent. As, 0.045 per cent. Se. Tellurium, if present in the sulphur, is estimated with the selenium, and may be separated by the method described by Browning and Flint.¹

Analysis of Refined Sulphur.—Sulphur in blocks or rolls is almost always practically pure; it may be tested for ash, arsenic, and selenium as above.

Flowers of Sulphur is never quite pure unless specially washed; it always contains some acid. Ianda² found up to 0.283 per cent. ash; the average of thirty samples was 0.063 per cent. He also tested the solubility in boiling solution of caustic soda of sp. gr. 1.2. This varied from 88 per cent. (in one case 68 per cent.) to 99.99 per cent., average 98.04 per cent.

Domergue³ acknowledges only as "flowers of sulphur" that which contains at least 25 per cent. of sulphur insoluble in carbon disulphide. Heckel⁴ agrees to this. But the French Agricultural Society⁵ is of different opinion. On the one hand, the percentage of sulphur insoluble in CS₂ in flowers of sulphur gradually decreases on keeping, and may sink from 30 or 35 per cent. to 12 per cent., without being less efficacious against vine-disease. On the other hand, mixtures of sublimed sulphur and ground sulphur, containing but 13 to 15 per cent. insoluble in CS₂, would pass as the proper article for the vine-grower, although they are not so. Domergue⁶ replies that he asked merely for a *minimum* of 12 per cent. S insoluble in CS₂ in unadulterated flowers of sulphur, but an excess over that proportion is admissible.

Marcille⁷ tests the commercial value of sublimed sulphur by shaking up 5 grams in a Chancel tube with carbon disulphide free from water and reading off the volume of the insoluble matter on the division of the tube; the Chancel degrees answer pretty nearly to the percentage of S insoluble in CS₂.

¹ *J. Chem. Soc.*, 1909, 2, 934; *Amer. J. Sci.*, 1909, 28, 112.

² *Fischer's Jahresber.*, 1898, p. 421.

³ *Chem. Zeit. Rep.*, 1905, p. 19.

⁴ *Chem. Zentr.*, 1905, 1, 205.

⁵ *Ibid.*, 1905, 2, 1482.

⁶ *Chem. Zentr.*, 1906, 1, 8.

⁷ *Ann. Chim. appl.*, 10, 101; *Z. angew. Chem.*, 1906, p. 99.

Taurel and Griffet¹ treat commercial mixtures of sublimed sulphur and other forms of sulphur with carbon bisulphide,

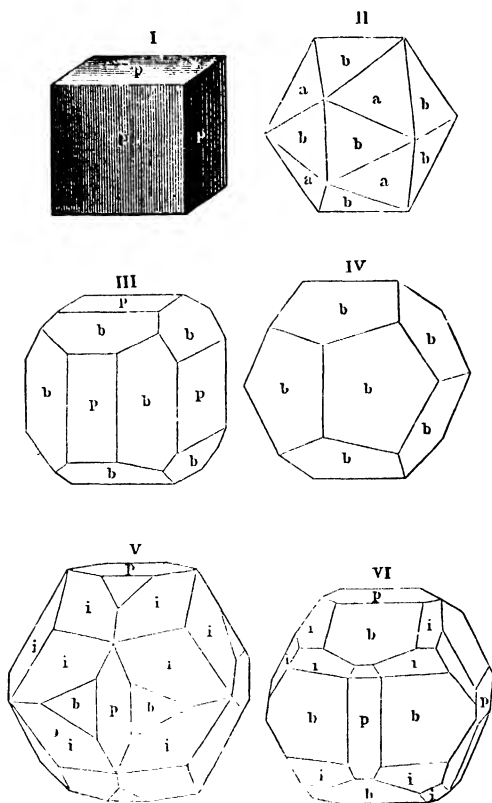

FIG. 2.

which dissolves the ground or precipitated sulphur, whilst the amorphous coatings of the sublimed sulphur globules (which constitute from 12 to 33 per cent. of the sublimed sulphur) remain insoluble; they retain their form and the apparent volume of sublimed sulphur is not altered. Weigh 15 grams of the sample into each of two graduated tubes of equal diameter, one of which contains 35 c.c. of petroleum spirit and the other 35 c.c. of carbon disulphide. Shake gently and submit both tubes to centrifugal action. The volume of the sediment in the CS_2 tube gives the volume of the sublimed S present, the volume in the other tube showing the total volume of the mixed sulphurs.

2. PYRITES²

Pyrites is the indefinite trade name for any iron sulphide. What is called iron-pyrites, in a technical sense, is hardly

¹ *Comptes rend.*, 152, 1182-1183; *J. Chem. Soc.*, 1911, p. 533.

² A very complete treatise on pyrites was published in 1907 by P. Truchot: *Les Pyrites, Pyrites de Fer, Pyrites de Cuivre*, Paris, chez Dunod et Pinat.

ever pure iron disulphide, FeS_2 , but either a mixture of this with gangue, or more frequently at the same time with other sulphuretted ores, as shown by numerous analyses. The iron disulphide may be present either as iron-pyrites proper or as marcasite. The *iron-pyrites proper* crystallises in the regular system, with parallel hemihedry, proved even on the faces of the cube by striation (Fig. 2 (I)).

Besides the cube, the octahedron is frequently found, often modified by the pyritohedron, and, if both are equally developed, forming the icosahedron. The combined forms IV, V, VI, as well as twin crystals, frequently occur. The crystals are often well developed; but in the pyrites used on the large scale they are mostly quite indistinct. The colour of pure pyrites is greyish yellow, and easily distinguished from that of copper-pyrites. The micro-crystalline pyrites of trade often shows other colours, even a slate-grey; the powder is brownish black. Its cleavage parallel to the faces of the cube is not very pronounced; the fracture is conchoidal or irregular. Hardness 6 to $6\frac{1}{2}$, sp. gr. 4.83 to 5.2. Pure FeS_2 contains 46.55 per cent. of iron and 53.45 per cent. of sulphur.

According to Mène, the pyrites from volcanic formations contains no water, but that from sedimentary strata both water and clay. Among the first he classes the yellow octahedral pyrites, which is stable in the air; among the latter the grey cubical pyrites, which is easily transformed into ferric sulphate.¹ Some descriptions of pyrites, in consequence of their content of water, fly asunder on roasting, with the force of an explosion; this is attributed by Klason² to the presence of zeolites.

Feld,³ on the strength of experiments, explains the formation of the natural pyrites beds by the action of thiosulphate, in the presence of hydrogen sulphide, on FeS and S . Only a very small quantity of thiosulphate need be present if the conditions are favourable for its continuous reformation.

Marcasite crystallises in the rhombic system, in rhombical prisms $m = 106^\circ 2'$ with longitudinal faces $l = 100^\circ$ and r , and the end face p inclined to r at an angle of $158^\circ 20'$. It frequently occurs in twin crystals, partially united along one of the faces m , also in triplets and quadruplets, etc. (Fig. 3), in fibrous,

¹ *Comptes rend.*, 29th April 1867. ² *Chem. Zeit.*, 1911, p. 1334.

³ *Z. angew. Chem.*, 1910, p. 971.

70 MATERIALS OF SULPHURIC ACID MANUFACTURE

bulbous, etc., varieties; cleavage indistinct; hardness 6 to 6.5; sp. gr. 4.65 to 4.88; colour grey to yellow or greenish yellow, lighter than iron-pyrites proper; powder greenish dark grey. Marcasite is most frequently found in bituminous slate and coal, and decomposes even more quickly than pyrites, with the formation of ferrous sulphate and basic ferric sulphate.

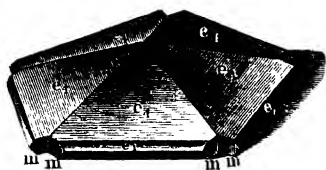

FIG. 3.

According to G. W. Plummer,¹ the behaviour of marcasite and pyrites towards bismuth chloride proves that both minerals contain their iron wholly in the ferrous state, and that their

formula must hence be : $\text{Fe} \begin{matrix} \text{S} \\ | \\ \text{S} \end{matrix}$.

Iron-pyrites and marcasite are produced artificially by the action of hydrogen sulphide on ferric sulphate solution, the latter being first reduced to ferrous sulphate with the separation of free sulphur ($\text{FeSO}_4 + \text{H}_2\text{S} + \text{S} = \text{FeS}_2 + \text{H}_2\text{SO}_4$). This reaction takes place at the ordinary temperature, and the dark precipitate is minutely crystalline; at higher temperature (about 200°), in a sealed tube, distinct crystals are produced.²

Marcasite when heated at 450° changes into iron-pyrites with development of heat; but this change is not reversible, and iron-pyrites cannot be changed directly into marcasite.

Descriptions are given of the surface characters of crystals of pyrites and marcasite, as seen under a metallographic microscope, by Viktor Pöschl.³

The characters of the faces and form of orientation of the artificially produced etched figures suggest that the symmetry of pyrites is tetrahedral-pentagonal-dodecahedral rather than pentagonal-dodecahedral.

Numerous determinations were made of the hardness of natural and of artificially cut faces. Different crystals, however, differ slightly in hardness, and it is noticed that those which are softer are at the same time less dense. The specifically

¹ *J. Amer. Chem. Soc.*, 1911, 33, 1487 *et seq.*

² Allen, *J. Washington Acad. Sci.*, 1911, 1, 170-177; *J. Chem. Soc.*, 1911, 2, 1093.

³ *Z. Kryst. Min.*, 1911, 48, 572-618.

lightest and heaviest crystals of each lot experimented on were analysed, with the following results, but no essential differences are shown in chemical composition :—

	Fe.	Ni.	Co.	Cu.	S.	As.	Total.	Sp. Gr.
I.	46.02	0.04	...	0.59	51.70	0.93	99.28	5.098*
II.	46.19	0.07	...	0.63	51.55	0.78	99.22	5.153*
III.	46.32	trace	0.06	0.09	51.78	1.52	99.77	5.078
IV.	46.18	trace	0.09	0.04	51.90	1.73	99.94	5.113
V.	46.07	0.03	0.16	0.26	51.83	1.28	99.63	5.068†
VI.	45.98	0.02	0.18	0.29	51.95	1.19	99.61	5.101†

* Trace Ag.

† Trace Mn.

I. and II., pentagonal-dodecahedral crystals {210} of pyrites from Elba; II. and IV., ditto, from Hüttenberg, Carinthia; V. and VI., ditto, from Seegraben, near Leoben, Styria.

G. Sirovich¹ describes marcasite obtained from Castelnovo di Porto, of the following composition :—

Fe.	S.	As.	SiO ₂ .	Total.
46.20	53.25	0.32	0.24	100.01

It occurs in crusts and also in stalactites in the neighbourhood of ferruginous springs and natural hydrogen sulphide, and is thus still being formed by the method of Allen, Crenshaw, and Johnstone, which these authors suggested was responsible for the natural production of this material.

Detailed investigations on the different behaviour of pyrites and marcasite have been published by A. P. Brown² and by Stokes³ and Oknow.⁴

Pyrrhotite—magnetic pyrites—occurs occasionally as six-sided crystals belonging to the hexagonal system, but is usually found in globular or compact masses with a platy structure. It is softer and tarnishes more readily than ordinary pyrites, and is distinguished by its colour, which is a bronze-yellow to copper-red. It has magnetic properties, whereas the other minerals have not such characteristics.

Pyrrhotite does not correspond with any definite chemical

¹ *Atti R. Accad. Lincei*, 1912 [5], 21, 352-354; *J. Chem. Soc.*, 1912, 2, 1061.

² *Chem. News*, 1895, 71, 139, and following numbers.

³ *Bulletin U.S. Geol. Surv.*, No. 186, 1901.

⁴ *Metallurgie*, 8, 539.

formula. That derived from meteorites approximately corresponds with FeS ; probably the excess of sulphur has been lost during the heating of the meteorite. Pyrrhotite is regarded as a solid solution of FeS with a higher iron sulphide, probably one of low density, thus generally suggesting Fe_6S_7 .¹

Allen (*loc. cit.*) explains variation in compounds by a solid solution of sulphur in ferrous sulphide giving $(\text{FeS})\text{S}$; but Arbeiter² does not agree with this statement, and says that lower sulphides are not present.

Habermehl gives Fe_7S_8 as the formula for the variety from Bodenmais; whilst Lindström regards Fe_8S_9 as representing the commonest type.

In the ores of commerce it is often present, of the formula Fe_7S_8 , with 60.5 iron and 39.5 sulphur; colour between brass-yellow and copper-red; hardness 3.5 to 4.5; sp. gr. 4.4 to 4.7.

It is notable that nickel is very often present in magnetic pyrites, in some cases up to 5 or 6 per cent. According to *Mineral Resources of United States*, there has been a marked tendency on the part of manufacturers of sulphuric acid to avoid experimenting with pyrrhotite ores. Experiments by McDowell have shown that, if ground fine, this material is quite suitable for manufacture of acid, and that in most cases it can now be obtained at less price per unit of sulphur than is paid for pyrites. Enormous deposits of this material are known in the Eastern United States.

A new mineral of the pyrites group containing both nickel and cobalt, described by M. Henglein,³ is found in Müsen, Siegen, Westphalia. It occurs as confused aggregates of small cubic crystals, together with quartz, chalybite, pyrites, and copper-pyrites. The colour is steel-grey with a metallic lustre, and the streak is greyish-black. The analysis is as follows:—

Fe	21-22 per cent.
Ni	11-17 "
Co	6-10 "
Sulphur	53 "
Insol	$\frac{3}{4}$ -1 "

¹ *J. Chem. Soc.*, 1913, 2, 781.

² *Chem. Zentr.*, 1913, 1, 1933.

³ *Zentr. Min.*, 1914, pp. 129-134; *J. Chem. Soc.*, 1914, 2, 282.

A new iron disulphide has been described by Doss under the name of "melnikowite."¹

The *copper-pyrites* so often mixed with iron-pyrites is distinguished from it by its colour, yellow as brass, sometimes as gold; this colour modifies that of the iron-pyrites according to the degree of admixture. It crystallises in the tetragonal system, but in the ores which concern us always occurs in a microcrystalline form. Its hardness is 3.5 to 4.0, sp. gr. 4.15 to 4.3. Pure copper-pyrites of the formula FeCuS_2 should contain 30.42 per cent. iron, 34.64 per cent. copper, and 34.94 per cent. sulphur; but the ores serving for the manufacture of sulphuric acid rarely contain beyond 4 per cent. of copper.

An investigation of the *calorific value* of pyrites has been made by Somermeier.² For pure pyrites (53.45 per cent. S) the calorific value of the sulphur contained therein is 4957 cal. per gram in the calorimeter, where $\text{Fe}_3\text{O}_4 + 6\text{SO}_3$ *aq* are formed, but only 2915 cal. per gram of sulphur on burning in the air under ordinary circumstances where $\text{Fe}_2\text{O}_3 + 4\text{SO}_2$ are formed. From this we may calculate the calorific value per gram of pyrites = 1557 cal. [This determination and calculations cannot be considered as quite exact, but only as approximately correct.]

H. Kamura³ states that iron-pyrites is decomposed at different temperatures ranging from 400° to 700°, according to the decomposition pressure at which the sulphur vapour is given off. From the decomposition pressure curve the heat absorbed in the decomposition was deduced thermodynamically, giving *Q*, the heat of decomposition per molecule volume of sulphur vapour formed, as 37,223 cal., corresponding to the heat value of the equation

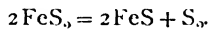

The value of the heat absorbed per atom of sulphur, or conversely the heat evolved in the combination, can therefore be expressed thermochemically as $(\text{FeS}, \text{S gas}) = 18,611$ cal.

The first application of pyrites for sulphuric-acid making is

¹ *Z. f. prakt. Geol.*, 20, 453-482; *Chem. Zentr.*, 1913, p. 737.

² *J. Amer. Chem. Soc.*, 1904, 26, 555 *et seq.*

³ *Chem. and Met. Eng.*, 1921, 24, 437; *J. Soc. Chem. Ind.*, 1921, p. 262A.

generally ascribed to a Mr Hill, of Deptford, who in 1818 took out a patent for it.¹ In France, Clément-Désormes seems to have made the first proposals and experiments. His trials did not, however, succeed, because he believed it necessary to increase the combustibility of pyrites by an addition of coal. This is both unnecessary, with properly constructed kilns, and injurious to the process, owing to the dilution of the gases by the carbon dioxide getting into the chambers. Great difficulty was experienced in lighting the kilns, as it was attempted to do this from below, like an ordinary fire. According to a communication from Mr Todd (Government Inspector of Alkali Works), a workman of his father's in Cornwall, in 1830, accidentally discovered the way of lighting the kilns from the top, which is practised to this day. The principal merit of introducing pyrites is, however, due to Perret & Son, of Chessy, who were led to it by the necessity of desulphurising their cuprous pyrites previous to getting the copper, and of condensing the gas evolved. There was no question then of supplanting the Sicilian sulphur generally. Perret & Son, with the greatest care, inquired into all the conditions necessary for a proper combustion of the ore; and to them the honour is due of having overcome all the difficulties of this problem, and of having rendered the process technically useful. As early as 1833 they had burnt iron-pyrites successfully; and in a patent dated 20th November 1835 they described their process, to which their partner, Olivier, is said to have given the first impulse.

These trials at making sulphuric acid from pyrites possessed, however, only local interest; and probably for a long time no general attempt to do away with Sicilian brimstone would have been made, but for the Neapolitan Government, in 1838, being induced to grant a monopoly for the exportation of Sicilian sulphur to the Marseilles firm of Taix & Co. This firm at once raised the price of brimstone from £5 to £14 per ton, and thus would have given a fatal blow to the manufacture of artificial soda-ash, just then beginning to take a firm hold, if no other source of sulphur had been known, and if such an unnatural measure could have been carried out at all. But the attempt came too late—just after Perret & Son had proved that the pyrites occurring in most industrial countries could be used for

¹ Sorel attributes this honour to his countryman, d'Artigues, in 1793.

vitriol-making without any difficulty. The result was to be foreseen. Once the discovery of a new source of sulphur had become a matter of necessity, there were, within twelve months from the rise in the price of brimstone, fifteen patents taken out in England for burning pyrites for the purpose of making sulphurous acid, and an even larger number for making sulphur from pyrites, gypsum, etc.

According to Muspratt's *Chemistry*,¹ Thomas Thomson was the first in England to point to pyrites in this crisis; but most probably many others at the same time turned to it. So much is proved—that Thomas Farmer, of London, was the first in England who employed pyrites on a large scale (in 1839) for the manufacture of sulphuric acid.²

E. K. Muspratt states that his father, in 1839 and 1840, used large quantities of Wicklow and Welsh pyrites at Liverpool and Newton, the cuprous cinders being sent to the Sutton Copper Company at St Helens.

The Sicilian brimstone monopoly certainly did not last long; diplomatic pressure on the part of England soon led to its abolition; and with the lowering of the price of brimstone most works at first returned to its employment. But the ice was now broken; it was known that it was possible to make acid without Sicilian brimstone; the owners of pyrites-mines took pains to advance the use of pyrites by low prices; and thus, in the course of the next twenty years, brimstone was gradually, but steadily, driven from its place in sulphuric-acid making, in proportion as it became dearer. In 1852 brimstone was no longer used in Lancashire, but on the Tyne 7580 tons of it were still burned. About 1860, or a little after, this process ceased, and since that time no alkali has been manufactured in Great Britain with the employment of brimstone, although it is employed a good deal even now for the manufacture of sulphuric acid.

The decisive point in favour of the use of pyrites was that continually increasing quantities of *cupriferosus iron-pyrites* came into the market, from Spain especially (first in 1859), but also from other countries. These had in any case to be

¹ Vol. ii., p. 1023.

² Hofman, *Report by the Juries*, International Exhibition, 1862, Class II., Section A, p. 12.

burned and their sulphur expelled before they could be worked for copper. Already with Perret & Son this had been the stimulus for their efforts; but the use of such pyrites has increased on a colossal scale in consequence of the opening out of the cuprous-pyrites mines in the south of Spain, in Portugal, and in Norway. In 1867 pyrites had almost entirely supplanted brimstone in France as a raw material for acid-making in the large industrial centres.¹

Thus, starting from the use of the ordinary iron-pyrites, that of cupriferous iron-pyrites followed; and to this was added the employment of other sulphurous ores and of the intermediate products of smelting—for instance, copper-regulus (“coarse metal”) at Mansfield and Swansea.

Sources of Pyrites.

The *principal sources of pyrites* will now be enumerated, including the cuprous and non-cuprous.

Some kinds of pyrites contain so little copper (below one per cent.) that it cannot be utilised; and these are included with the non-cuprous ores.

In Great Britain.

Great Britain possesses several deposits of pyrites, but none of very great importance. In Cornwall and Devonshire pyrites of the following composition is found:—

	Pattinson.	Clapham (8 analyses).
Sulphur	27.00	24.013 to 34.880
Iron	22.69	27.076 „ 60.676
Copper	2.00	0.400 „ 4.600
Lead	trace	0. „ 7.446
Zinc	1.23	0. „ 9.086
Lime	0.22	Gypsum 0. „ 0.596
Carbonate of Lime	0. „ 3.579
Magnesia	0.12	...
Arsenic	0.32	0. „ 1.160
Insoluble (silica).	45.60	2.000 „ 38.676
Oxygen as Fe ₂ O ₃	0.13	...
Moisture	0.64	...
	<hr/>	
	<u>99.95</u>	

¹ *Rapport du Jury International, Expos. Univ. de 1867*, 7, 19.

In *Ireland* there are large beds of pyrites, especially in the county of Wicklow; and up to about 1862 this Irish ore supplied a very large portion of the pyrites used in England. In 1860, 40,000 tons of it were imported into the Tyne district; but in 1863 the importation had fallen to 4000 tons, and the production in 1912 was only 1328 tons. It is found in beds from 6 to 50 ft. in thickness, which overlie siliceous clay-slate. The beds go down to depths of 80 to 100 fathoms. The bulk of the ore contains only 30 to 35 per cent. of sulphur. A small quantity of richer ore has been found in the valley of Ovoca. The Irish ore is too hard and slaty and does not burn well; it requires a great heat, and consequently deep kilns. It nearly always contains copper, but rarely sufficient to pay for extracting it.

In Wales (in the Cae Coch Mine) pyrites is found containing very little arsenic, and the following are analyses of consignments burned at Widnes during the War (Duly):—

Sulphur	31.94	30.61
Iron	31.26	30.69
Silica	22.54	21.68
Alumina	3.20	4.02
Copper01	.01
Lead03	.07
Arsenic02	.03
Antimony01	...
Tin02	...
Bismuth	trace	nil
Zinc13	.09
Cobalt and Nickel06	.12
Manganese08	.06
Lime	2.82	3.98
Barium Oxide56	.11
Magnesia80	.70
CO ₂	3.58	4.25
P ₂ O ₅	trace	.01
Oxygen	2.94	3.57
	<hr/> <hr/>	<hr/> <hr/>
	100.00	100.00

From the writer's experience in the burning of this quality of ore, there was no trouble in reducing the sulphur to a low figure, in Herreshoff burners. It is extremely doubtful, however, whether such ore will compete with the Spanish or Norwegian pyrites in normal times.

78 MATERIALS OF SULPHURIC ACID MANUFACTURE

The production of pyrites in the United Kingdom, in 1912, was 10,552; in 1913, 11,427; in 1914, 11,654; in 1915, 10,535; in 1916, 10,481; in 1917, 8515; in 1919, 7336; in 1920, 6659; in 1921, 3945.

The *importations of foreign pyrites* into Great Britain for the years 1914 to 1918, from the Bluebook (Annual Statement of the Trade, etc.) for 1918, pages 31 and 161, were as follows :—

	1914.		1915.	
	Tons.	£.	Tons.	£.
Norway	106,672	168,345	78,281	125,244
France	2,056	1,042	9,700	11,399
Portugal	73,219	100,446	59,143	98,769
Spain	604,367	1,025,172	751,978	1,325,780
Italy	7,557	9,467
Other Foreign Countries	1,100	1,350	4,365	6,592
Total	794,971	1,305,822	903,467	1,567,784
Newfoundland and Coast Labrador	8,168	14,260
Other British Possessions	10	32
Total from	8,178	14,292
Total	803,149	1,320,114	903,467	1,567,784

	1916.		1917.	
	Tons.	£.	Tons.	£.
Norway	24,639	56,214	49,960	159,421
France	7,422	11,228
Portugal	83,506	228,768	31,096	96,795
Spain	819,465	1,880,795	772,585	2,077,340
Italy	11,923	30,031	600	4,470
Other Foreign Countries	3,041	6,055
Total	949,996	2,213,091	854,241	2,338,026

	1918.	
	Tons.	£.
Norway	112,889	371,719
France
Portugal	28,003	111,173
Spain	695,811	2,230,516
Italy
Other Foreign Countries
Total	836,703	2,713,408

In 1919 the importation was 344,457 tons; for 1920 and 1921 the quantities were 630,564 (value £2,141,951) and 288,440 (value £818,781) tons respectively.

In Germany.

The most important *German* pyrites-bed is that of *Meggcn* in the Siegen district, in Westphalia. The ore has not an attractive outward appearance; its colour is slate-grey; but it burns very well in the kilns, and it would be even more valuable if the zinc contained in it did not prevent its burning completely. Here are analyses made at the Rhenania Chemical Works, as furnished to Lunge by R. Hasenclever in 1902:—

	a.	b.	Average.
Gangue	12·02	12·96	12·0
Sulphur	41·94	43·42	40·0 to 43·0
Iron	34·92	35·56	35·0
Zinc	7·56	5·81	7·0
Lead	0·38	not estimated	0·3 to 0·5
Lime	0·50	„	0·1 „ 0·5
Arsenic	trace	0·05	trace „ 0·05
Total	97·32	97·80	...

The average represents 12 per cent. gangue, 75 per cent. iron-pyrites (FeS_2), 10·5 per cent. zinc-blende (ZnS), together 97·5.

Jurisch¹ quotes a number of analyses of Westphalian pyrites, by F. Quincke, for the year 1892. In these the

¹ *Schwefelsäure-fabrikation*, p. 14 et seq.

80 MATERIALS OF SULPHURIC ACID MANUFACTURE

sulphur varied from 41 to 46.75 per cent., iron from 29.55 to 36.16 per cent., zinc from 8.2 to 19.41 per cent., lead from 0.3 to 1.7 per cent., arsenic from 0.1 to 0.2 per cent., besides silica, alumina, lime, magnesia, manganese, alkalis, and small quantities of other substances.

The same source quotes analyses of pyrites from Bensberg (46.86 per cent. S), Aachen (46.0 per cent.), Rammelsberg (44.65 to 48.4 per cent.), Freiberg (52.20 per cent.).

The following is a complete analysis by Fresenius of ore from the Philippine pit belonging to the Sicilia Mining Company at Meggen, made in 1898:—

Iron	34.89
Zinc	8.38
Manganese	0.155
Cobalt and Nickel	0.024
Lead	0.298
Alumina	trace
Lime	1.41
Magnesia	0.75
Sulphur	44.55
Arsenic	0.07
Carbon dioxide	1.90
Phosphorus peroxide	trace
Gangue	5.83
Oxygen as Sulphate, Thiosulphate, etc., and traces of other substances	1.743
	<hr/> <u>100.000</u>

The bed of Schwelm in Westphalia, in the Devonian formation, has a thickness of from 10 to 33 ft, over a surface of nearly 150 acres, and is covered by rich iron-ore; the pyrites itself consists of two-thirds powder mixed with well-crystallised pieces. The ore contains about 40 per cent. sulphur, and more or less clay, which is removed by washing; after this it is sold to the vitriol-makers, who like it on account of its freedom from arsenic;¹ Hjelt, however, found more arsenic in it than in Meggen pyrites.

The production of pyrites in Germany in 1913 was 268,600 tons; in 1917, 803,700 tons; in 1919, 381,400 tons; and in 1920, 436,300 tons.

¹ *Dingl. polyt. J.*, 228, 283.

In Austria-Hungary.

Austria-Hungary possesses large beds of pyrites at Schemnitz and Schmölnitz in Hungary, in Styria, and Tyrol. The pyrites from Schemnitz contains on an average 47 to 48 per cent. S, 39 to 40 per cent. Fe, 0.58 per cent. Cu, 1.5 to 2 per cent. Zn, besides lead, silver (81 grams per ton), and gold (2.2 grams per ton). Schmölnitz ore contains 44 to 48 per cent. S, 0.4 to 0.6 per cent. Cu, 2 to 3 per cent. Zn. Jurisch (from whose *Schwefelsäure-fabrikation*, p. 18, the above is taken) quotes an analysis of Schmölnitz pyrites with 48.89 per cent. S, 0.32 per cent. Cu, 0.14 per cent. As; 70,000 or 80,000 tons of this pyrites are obtained per annum.

At Davidsthal, in Bohemia, pyrites is found containing 49 per cent. of S with 6 per cent. carbon. It is used for manufacturing SO_3 by the contact process.

A. Liffa¹ gives crystallographic descriptions of iron-pyrites from various Hungarian localities. Crystals (penetrated by quartz) from Caungány on analysis by K. Emszt gave:—

Fe.	As.	Ni.	S.	SiO.	Total.
45.36	trace	0.05	51.61	2.84	99.86

In Tyrol pyrites is found testing 40.5 to 41.3 per cent. S.

In Styria,² in the Saun valley, a number of beds of very pure but easily decomposable pyrites occur in the clay porphyry, with a percentage of 48 to 52 of sulphur. It is used in the chemical works at Hrastnigg and in Bohemia.

In Belgium.

In *Belgium* a rich pyrites is met with, the great friability and softness of which do not tell in its favour. The following are analyses of this pyrites:—

¹ *Z. Kryst. Min.*, 1910, 48, 441-442; from *Földtani Közlem.*, 1908, 38, 276-294, 405-423; *J. Chem. Soc.*, 1911, 2, 46.

² Riedl, *Z. f. d. chem. Grossgewerbe*, 2, 567.

	a.	b.	c.	d.	e.	f.
Sulphur	42.80	35.50	46.20	45.01	50.00	45.60
Iron	36.70	38.60	40.50	39.68	43.61	38.52
Ferric oxide	7.23	4.24	2.20
Oxygen in ferric oxide	0.32	0.18	6.00
Lead	0.92	0.65	0.41	0.37
Zinc	0.40	5.26	0.22	1.80	1.75	...
Arsenic	0.20	0.31	0.41	trace	trace	trace
Thallium	trace
Alumina	trace
Silica	8.86	14.90	9.10	12.23	2.85	9.00
Carbonic acid	0.73	...
Calcium carbonate	0.84	trace	0.11
Lime	0.25	0.92	...
Water	1.46	0.56	0.42	0.25	0.10	0.36
Total	99.41	100.02	99.46	99.91	100.14	99.59

(*a*, *b*, and *c* by Clapham in Richardson and Watts' *Chemical Technology*, vol. i., part iii., p. 14; *d*, pyrites from Rodieux near Spa; *e*, from Santon's pit on the Meuse, both by Pattinson, *loc. cit.*; *f*, by MacCulloch, *Chem. News*, xxvii., p. 125.)

The Belgian pyrites is usually only got as a by-product in obtaining lead- and zinc-ores in the provinces of Liège and Namur; it is either microcrystalline or crystalline, or in bulbous pieces with a concentrically fibrous structure. Its quality varies very much. It is mostly used locally and in the north of France.

In France.

In *France* the principal deposits of pyrites are those of the Rhone (Chessey and Sain-Bel) and of the South (Gard and Ardèche). The Rhone beds exist on both banks of the Brevenne, a tributary of the Saone, on a width of 4 or 5 miles. The bed on the left bank is that of Chessey, about 6 miles long and several yards thick. This pyrites is bright yellow, very crystalline and friable. When first got it contained 4 or 5 per cent. of copper; but the cuprous vein has run out, and the non-cuprous ore on this side has nearly ceased to be worked. The beds on the right bank are those of Sain-Bel or Sourcieux. The northern part furnishes a more compact ore than that from Chessey. Most of it is non-cuprous, but there is also a vein with 4 or 5 per cent. copper; the gangue is mostly sulphate

of baryta. Much more important is the southern part of this bed, the "masse de Bibost." The ore is here very rich in sulphur, green with yellow reflection, and very friable, so that there is almost as much smalls as lumps; the gangue is almost entirely siliceous. The beds in the south of France are more numerous, but much less important. The most considerable mine is that of Saint-Julien-de-Valgalgues, in the Département du Gard; there is another mine at Soyons, in the Ardèche. The other French mines are of little importance. A detailed description of the French pyrites-mines has been given by Girard and Morin.¹

According to Scheurer-Kestner,² the pyrites from Chessy and Sain-Bel contains 45 to 48 per cent. of sulphur with very little arsenic and selenium; that from Chessy also 1 or 2 per cent. of copper and zinc. The copper is obtained from the cinders, at least at the Chessy works, by allowing them to lie for a time and moistening them: the liquid running off contains copper and zinc sulphates; and the copper is got from it by cementation. Nearly all French works, as well as those in Alsace and Switzerland, obtain their ore from those two pits; only the works at Gard and Marseilles get it from Alais, where the pyrites contains 38 to 42 per cent. of sulphur; a few factories in the north of France use Belgian pyrites, those in the south use Spanish pyrites.

The production of pyrites in France was:—In 1910, 250,432 tons; in 1911, 240,000 tons; in 1919, 118,703 tons; in 1920, 132,443 tons.

The importation into France:—1900, 92,000 tons; 1905, 251,000; 1906, 364,000; 1907, 331,000; 1908, 307,000; 1909, 235,000; 1910, 270,000; 1911, 450,000.

The exportation since 1900 has been nil.

In Italy.

Italy possesses beds of pyrites in several places. Those occurring in the province of Bergamo, tested in Vienna,³ are composed as follows:—

¹ *Comptes rend.*, 1875, 81, 190; *Ann. Chim. Phys.* [5], 7, 229.

² *Wurst. Dict. de Chimie*, 2, 138.

³ *Wagner's Jahresber.*, 1879, p. 272.

84 MATERIALS OF SULPHURIC ACID MANUFACTURE

	Redolta quarry.	Passevra quarry.	S. Giuseppe pit.	Vallantica pit.
Iron	36.29	41.72	48.35	36.79
Copper	trace	trace	0.07	1.69
Zinc	trace	...	0.18	...
Lead	trace
Silver	0.014
Sulphur	39.32	44.36	30.97	41.56
Arsenic	0.53	0.14	...	0.18
Alumina	2.37	1.28	1.86	1.25
Lime	5.89	0.88	1.70	0.37
Magnesia	0.66	0.39	0.14	0.10
Silica	7.16	9.68	10.45	16.40
CO ₂ , O and H ₂ O (by diff.)	7.78	1.55	6.28	1.646
Total	100.00	100.00	100.00	100.00

In the Val d' Aosta there are several mines, some of which contain a strongly arsenical pyrites.

Those at Brosso, near Ivrea, belonging to Messrs Sclopis & Co., yield pyrites containing very little arsenic: present output about 20,000 tons per annum. One quality contains 48 or 49 per cent. of sulphur and 0.2 of arsenic, the other nearly 50 of sulphur and only traces of arsenic. It is too explosive for burning in lumps, but excellent for burning as smalls. Another mine is at Pré St Didier in the same valley. This Aosta pyrites mostly requires special contrivances for getting rid of the arsenic in burning; the cinders are worked for copper, silver, and gold.

Pyrites in quantity is also found at Agordo (Cadore), Sestri Levante, and of very good quality in Sicily.

The quantity of iron- and copper-pyrites produced in Italy for the years 1915 to 1921 is as follows:—

1915.	1916.	1917.	1918.	1919.	1920.	1921.
369,320	410,290	500,782	482,060	372,474	321,589	448,600 tons.

In Sweden.

Swedish pyrites, from Fahlun, varies between 43 and 48 per cent. of sulphur. This ore is obtained as a by-product in the getting of copper-ores, and is said to exist in enormous quantity; but, owing to the difficulty of transit, its exportation does not pay. It is said to burn well.

Analyses of Swedish Pyrites.

	Pattinson.	Browell and Marreco.
Sulphur	43·70	38·05
Iron	39·01	42·80
Copper	0·60	1·50
Lead	0·12	...
Zinc	2·57	...
Lime	0·85	...
Magnesia	0·69	...
Arsenic	trace	...
Insoluble	11·66	12·16
Oxygen, as Fe ₂ O ₃	0·22	{ Oxygen and loss } 5·49
Water	0·20	
	<u>99·62</u>	<u>100·00</u>

Production of Pyrites in Sweden.

1912.	1918.	1914.	1915.	1916.	1917.	1918.	1919.	1920.
35,000	34,320	33,313	76,324	97,850	142,660	141,180	108,770	107,326 tons.

In Norway.

In *Norway* there exist very large beds of pyrites, many of them containing copper, and the mineral constitutes one of the leading exports of the country. Of the many pits formerly worked there, all those had to stop which produced ores with only from 35 to 40 per cent. of sulphur. The richer ores, even those free from copper, have maintained their position to some extent, because they burn well, are easily lighted, keep the heat well, do not "scar," etc. They are mostly hard and difficult to break. The most considerable pits are those of Ytteröen, which export *við* Drontheim; they supply 6000 to 8000 tons per annum. Norwegian pyrites contains very little arsenic. Other pits exist thirty miles from Drontheim, on the Hardanger Fjord, near Bergen, etc. The Norwegian pyrites is more in favour as a sulphur-ore (although troublesome to break) than as a copper-ore.

Analyses of Norwegian Pyrites.

	Pattinson.		MacCulloch.	
	Ytteroer ore.	Drontheim ore.	I.	II.
Sulphur	44.50	50.60	46.15	38.17
Iron	39.22	44.62	44.20	32.80
Copper	1.80	trace	1.20	1.10
Zinc	1.18	1.34	2.10	2.32
Lead	trace
Lime	2.10	trace
Calcium carbonate	2.55	11.90
Magnesia	0.01	trace
Magnesium carbonate	1.08
Carbonic acid	1.65
Arsenic	trace
Insoluble	9.08	3.15	3.20	12.20
Oxygen, as Fe ₂ O ₃	0.45
Moisture	0.17	0.20	0.40	0.25
Total	100.16	99.91	99.80	99.82

The following information is due to Mr Knudsen, manager of the Sulitjelma mine (through Hasenclever). Norway exported in 1901 about 90,000 tons pyrites from the following pits:—

Sulitjelma, near Bodoer	35 to 36,000 tons with 45 p.c. sulphur.
Killingdal	25,000 ,, 43 to 44 p.c. sulphur.
Röros, near Trondhjem	15,000 ,, 43 ,, 44 ,,
Bossmo ,,	15,000 ,, 48 ,, 50 ,,

By far the largest mine is the first mentioned, which has sufficient ore reserves to last for centuries. It contains very little arsenic. Much ore, richer in copper and poorer in sulphur, is also smelted on the spot. The ore from Killingdal and Röros is also cuprous; and that from Bossmo is free from copper, with traces of arsenic.

The following mines, Foldal, Vaarteigen, and Nudal, give a pyrites containing 43 to 44 per cent. S, and at most 2.5 per cent. Cu.

The deposits in the Orong district are estimated at 16 to 18 million tons, but they have not been utilised owing to absence of railway facilities, and several years must elapse before they can be worked.

Rich deposits have been found in Kongswold Hjerkin, in West Norway, which extend over 1600 metres, and are estimated to contain eight million tons of good ore.

Sebelien¹ makes detailed statements on the pyrites industry of Norway, of which we give a short abstract. The Foldalens Verk produces pyrites containing on an average 1.85 per cent. copper and 46 per cent. sulphur. The Orong-Grube has pyrites beds north of Trondhjem, at Ogersviken, and near the Swedish frontier at Joma; the latter yields an ore containing little copper, but 44 per cent. sulphur. The Orkla Company possesses pyrites beds in Meldalen, some of which have been worked since the 17th century for copper, of which the washed pyrites contains from 5 to 8 per cent. The Röstvangen Co. has pits at a height of 950 to 1300 metres above the sea-level; the pyrites has been worked since 1908. That which is exported contains 2.4 to 3.4 per cent. copper, 42 to 46 per cent. sulphur; and, per ton, 0.3 to 2.0 grams Au and 10 to 80 grams Ag.

Falkenberg² discusses in detail the geology and petrography of the pyrites beds in South Norway.

Total Production of Pyrites in Norway.

1912.	1913.	1914.	1915.	1917.	1918.	1919.
464,326	441,291	414,886	513,335	295,354	332,240	312,930 tons.

Production of Cuprous Pyrites in Norway.

1914.	1915.	1916.	1917.	1918.	1919.
407,000	462,400	257,300	269,350	275,850	267,750 tons.

Exports of Cuprous and Non-cuprous Pyrites from Norway.

	1913.	1914.	1915.	1916.	1917.	1918.	1919.	1920.
Belgium	26,251	8,750	3,200
Germany	40,892	60,730	210,450	84,500	4,100	...	4,450	107,000
Netherlands	46,773	40,220	7,450	10,900	8,900	1,320
Sweden	89,518	112,350	154,440	115,500	101,700	103,700	42,250	73,700
U. K.	138,134	91,700	75,250	21,850	50,800	94,000	11,400	4,950

¹ *Chem. Zeit.*, 1914, p. 1119.

² *Z. prakt. Geol.*, 1914, p. 105.

88 MATERIALS OF SULPHURIC ACID MANUFACTURE

The figures for 1913 to 1917 include both cuprous and non-cuprous pyrites. The figures for 1918 to 1920 include only cuprous pyrites. Of non-cuprous pyrites, 37,175 tons were exported in 1918, and 39,850 tons were exported in 1919.

In Russia.

In *Russia* a good many beds of pyrites exist, some of which are utilised for the manufacture of sulphuric acid, especially those in the Ural. The Russian pyrites beds are enumerated in *Chem. Trade J.*, 1911, xlix., p. 29, and l., p. 71; and in *Eng. and Min. World*, 14th October 1911. Pyrites is found in Central and South Russia, and in the Caucasus, but most of it in the Ural districts, far from the centres of chemical industry. It contains about 30 per cent. S and much carbon, which makes it unsuitable for the production of sulphuric acid by the contact process. The Ural pyrites splits in roasting and gives off much dust. In 1908 the production in the Ural was 50,000 tons, in Central Russia 2500 tons, in the Caucasus about 5000 tons: total, 57,500 tons.

The productions, etc., are:—

	Production.	Importation.	Consumption.
1908	. . .	90,000	...
1910	. . . 50,000	110,000	...
1911	. . .	115,000	...
1912	. . . 130,000	145,000	256,000

According to the *Chem. Trade J.*, 1915, p. 489, two beds of cuprous pyrites have been discovered 18 miles from Elisavetpol, one of which is already worked and yields per day 16 tons ore of 48 to 53 per cent. sulphur, which goes to the factories at Baku.

In Greece.

According to the *Chem. Trade J.*, vol. xlvii., 1921, p. 453, the Greek pyrites mines near Kassandra on the Chalcidice Peninsula are again in full swing, and may attain an annual output of 200,000 tons. Since Greece herself requires barely 500 tons, large quantities will be available for export. The pyrites is said to be entirely free from arsenic and to have a guaranteed sulphur content of between 48 and 51 per cent.

In Spain and Portugal.

Spain and Portugal possess the largest known beds of pyrites. Much of it is cupriferous, and all of it is distinguished by its very good behaviour in burners; so that the burners have been built very much lower for it, and much labour is saved. This pyrites has only been worked again since 1855; but the Romans, and before them the Phœnicians and Carthaginians, knew it very well, as is shown by many traces. The bed, however, was at that time only worked where it was richest in copper. According to Schönichen¹ all the beds are within a belt of 5 leagues width, reaching, parallel to the Sierra Morena, from the western frontier of the province of Seville, across the hilly country situated to the south of this, right through Portugal to the Atlantic Ocean—a distance of 30 leagues. The prevailing rocks in that country are clay-slate and crystalline slates; but parallel to the granitic tract of the Sierra Morena, felsite-porphry and quartzite have broken through the slate, and only in the neighbourhood of such dykes are the pyrites-beds found. Their shape is that of large lenticular pockets in the metamorphic clay-slate, from 20 to 36 fathoms thick, and extending to a length of 170 to 260 fathoms. The whole bed is filled with pure pyrites, without any visible gangue. The ore is in a few places found at only 1 or 2 fathoms below the surface, undecomposed, and in a sandy state, so that it can be got by daylight work. In other places the zone of decomposition reaches from 10 to 50 fathoms downwards. The percentage of copper varies from $2\frac{1}{2}$ to 40; but ores with more than 10 per cent. of copper are only contained in small vertical zones within the large masses. Only these "black" ores were the object of the mining operations on the part of the Phœnicians and Romans. The quantity of pyrites existing there is almost inexhaustible, and can certainly supply the world's requirements of both copper and sulphur for thousands of years to come.

Special highways, and latterly also railways, have been made in order to facilitate communication with the ports of Huelva, San Lucar du Guadiana, and Pomaron; but a

¹ *Dingl. polyt. J.*, 170, 448.

great deal of the ore is still conveyed for some distance by mules.

Of the various companies which had been formed for working this ore, most have ceased to exist; and only four or five remain, all of them in English and French hands. The smallest of these is the Buitron Pyrites Company, which works the mines of Buitron and Poderosa. The Tharsis Sulphur and Copper Company possesses much more extensive mines, a railway of its own, a wharf at Huelva, and also a number of works in England and Scotland for the wet extraction of the copper from the cinders returned to them. The Tharsis ore is very good, but very soft, and makes much dust in breaking. The San Domingo mine lies in Portuguese territory; its ore is known as Mason's ore, and is considered superior to all others, so that it commands a better price. The last, but largest, of these companies is the Rio Tinto Company, which has thrown such large quantities of pyrites into the English market that, from 1875 to 1876, prices receded by more than one-third. Its ore is also of excellent quality. The mines of Carpio and Lagunazo, in the province of Huelva, are not yet worked for exportation.

The Spanish (and Portuguese) pyrites never contains less than 46 and up to 50 per cent. of sulphur, besides 3 to 4½ per cent. of copper, which, however, by most of the English buyers, is not bought, but returned in kind to the seller in the shape of cinders from the pyrites-burners. The value of the copper (if bought) is still fixed by the so-called "Cornish assay"—that is, a process of dry assaying known only to a few assayers living at Redruth and other places in Cornwall, the great inaccuracy of which is perfectly well known to all parties concerned: it shows, for instance, only 2 per cent. if 4 per cent. is actually present; and from this difference the buyer must pay the cost of extracting the copper and his own profit, since the price to be paid for the copper *in the ore* by Cornish assay is sometimes higher than the value of a similar quantity of copper *metal*. This remarkably irrational system has not hitherto been done away with for sales.

The ore of three principal companies is very similar in composition; its analysis is as follows:—

	Pattinson.				Claudet (San Domingo ore).	MacCulloch (San Domingo ore).
	48.00	49.60	44.60	49.30		
Sulphur . . .	48.00	49.60	44.60	49.30	49.00	49.80
Iron . . .	40.74	42.88	38.70	41.41	43.55	42.88
Copper . . .	3.42	2.26	3.80	5.81	3.20	2.26
Lead . . .	0.82	0.52	0.58	0.66	0.93	...
Zinc . . .	trace	0.10	0.30	trace	0.35	0.10
Lime . . .	0.21	0.18	0.14	0.14	0.10	0.18
Magnesia . . .	0.08	trace	trace	trace
Thallium . . .	trace	trace	trace	trace
Arsenic . . .	0.21	0.28	0.26	0.31	0.47	0.28
Insoluble . . .	5.67	2.94	11.10	2.00	0.63	2.94
Oxygen, as Fe ₂ O ₃	0.09	0.15	0.23	0.25	1.07	...
Moisture . . .	0.91	0.95	0.17	0.05	0.70	0.95
Total . . .	100.15	99.86	99.88	99.93	100.00	99.39

The following analyses represent the average quality:—

	Rio Tinto.			S. Domingo.		Thars.s. Bartlett.
	Cumenge.	Caron.	Rivista Min. 23.	Pattinson.	Bartlett.	
Sulphur . . .	48.00	50.7	49.00	49.90	49.80	47.50
Iron . . .	40.00	41.3	43.55	41.41	43.55	41.92
Copper . . .	3.42	3.5	3.20	2.46	3.20	4.21
Lead . . .	0.82	...	0.93	0.98	0.93	1.52
Zinc . . .	trace	...	0.35	0.44	0.35	0.22
Arsenic . . .	0.21	...	0.47	0.55	0.47	0.38

A pyrites-mine has been opened in Spain, called St Mardy Tinto Santarossa. Its product has been found by Lunge and Bänziger¹ to contain 0.85 per cent. moisture, 5.20 insoluble, 43.87 sulphur, 42.12 iron, 1.09 arsenic, 2.15 antimony, 3.17 copper.

Some kinds of Spanish pyrites are in bad repute with the manufacturers as "explosive," or "detonating," because they decrepitate in the kilns shortly after lighting, with loud detonations, and thereby make so much fine powder that the burners are stopped up and "scars" are formed. The reason of this detonating property is probably to be sought in the presence of hydrated silicates (zeolites) in the ore. Best and the United Alkali Co. (B. P. 7915 of 1905) subject such pyrites to a preliminary heating by means of an apparatus, shown in the specification, before charging it in the pyrites-burners.

¹ *Z. angew. Chem.*, 1896, p. 421.

Recently hundreds of thousands of tons of "leached ores" have come into the market from Spain, especially Rio Tinto and Pomaron. These ores are exposed to the weather and then washed with water, in order to extract the copper, of which they retain only 0.3 to 0.5 per cent. They test 49 or 50 per cent. sulphur in the dry state, but they generally contain about 5 per cent. water. In the pyrites-burners they make very much dust, as they are very porous and friable.

According to Hjelt the average percentage of arsenic in Spanish ores is 0.91.

Pyrites with very little or no copper is also found in Spain. One of the best descriptions is that of the Aguas Teñidas mine, containing iron 46.60 per cent., sulphur 53.15 per cent., silica 0.20 per cent., arsenic, copper, selenium, silver and gold traces. It is sold in the state of lumps and smalls. It burns very easily down to 1.0 or 0.5 per cent. of sulphur, so that the cinders, which contain 68.5 per cent. of metallic iron, and no copper, phosphorus, lead, or zinc, are very valuable for blast-furnaces. The annual sales have exceeded 200,000 tons, but for some time very little has come into the market owing to an accident at the mine.

H. J. Davis of New York, one of the principal importers of pyrites to the United States, gives the following analyses of very good, hard Spanish ores containing but little copper:—

	Aracena.	Balmecca.	San Tolmo.
S	51.77	50.19	46.40
Fe	45.53	45.61	40.11
Cu	0.29	0.20	1.90
Si	1.90	3.00	11.27
As	?	?	none

The following figures show the output of unwashed iron-pyrites and copper-pyrites in the district of Huelva in 1915 and 1916:—¹

	1915.	1916.
Rio Tinto	1,023,951	1,477,726
Tharsis	669,642	676,285
Société des Pyrites	160,773	238,255
United Alkali	114,020	208,058

¹ *Chem. Trade J.*, 1917, p. 323.

	1915.	1916.
Peña Copper	120,594	159,268
Esperanza Copper	81,055	107,558
San Platon	41,797	62,044
Huelva Copper	51,059	49,276
Other concerns	62,337	110,580
Total	<u>2,325,228</u>	<u>3,089,050</u>

According to the *J. Soc. Chem. Ind.*, 1922, p. 226R, the sales of pyrites produced in the Spanish province of Huelva amounted to 671,645 metric tons, compared with 754,713 t. and 1,698,972 t. in the same period of 1920 and 1913 respectively; sales fell from 3,937,945 in 1913 to 1,509,426 t. in 1920. This decline of roughly 60 per cent. in the exports is due to the economic situation in Europe, and to the development of domestic resources of sulphur in the United States. Germany, although buying smaller quantities, is still the chief consumer. The distribution of the exports in 1913 and 1920 is as follows:—

	1913.	1920.
Germany and Holland	1,051,885	326,816
France	487,212	269,539
England	627,229	504,814
United States	783,504	229,850
Belgium	182,201	66,201
Denmark	12,083	20,465
Australia	10,158	...
Scandinavia	31,338	31,187
Other countries	138,964	7,329

The consumption in Spain represents only about 5 per cent. of the total sales, viz. 73,371 t. in 1913, and 53,225 t. in 1920.

The following is the analysis of ordinary Peña washed fines:—

S	45.38	Mn	trace
Fe	40.09	CaO	„
Cu24	Pb22
BaSO ₄	8.70	Pi002
SiO ₂	2.55	Ni and Co07
Fe, MgO, and C24	H ₂ O20
As061	Soluble Sulphates (Oxygen)	1.23
Zn80		

Owing to the high content of barium sulphate the burnt cinders from this class of ore are of rather inferior quality; the arsenic content is, however, fairly low.

The Esperanza Copper and Sulphur Co., Ltd., for the year

94 MATERIALS OF SULPHURIC ACID MANUFACTURE

1920 mined 71,176 tons of pyrites against 34,729 in 1919; the shipments at Huelva being 82,970 tons for 1920 against 33,996 in 1919.

Enormous quantities of cuprous pyrites are roasted and worked for copper in Spain, without utilising the sulphur.

The total export from Spain in 1913 was 2,858,000 tons, and the production 3,120,000 tons.

In the *Z. angew. Chem.*, 1905, p. 759, the following statements are made on Spanish pyrites. New facilities for shipping ore have been provided at Huelva and at some new railway stations. At Huelva in 1904 about two million tons of pyrites have been shipped. The Tharsis Co., the Rio Tinto Co., and the Buitron Co. have opened out new mines. The Rio Tinto Co. was erecting superphosphate works to utilise the excess of their ore.

According to Reusch¹ the Rio Tinto Co. has discovered new beds of pyrites which allow it to maintain the present production for another hundred years; so also has the Tharsis Co., which will be able to supply several millions of tons of pyrites in excess of what it had counted upon four years previously.

In the United States of America.

The *United States of America* are very rich in pyrites, and the following information is taken from the *Mineral Resources* for 1917 and 1918:—

PRODUCTION AND VALUE IN \$ OF PYRITES IN 1917-18 (IN LONG TONS).

	1917.		1918.	
	Tons.	\$.	Tons.	\$.
California . . .	115,817	333,501	111,861	501,541
Georgia . . .	23,242	155,560	31,315	268,797
Illinois . . .	24,596	89,998	24,369	85,659
Ohio . . .	13,218	29,557	9,845	40,215
Virginia . . .	170,382	1,378,043	143,427	841,177
Other States . . .	115,407	498,776 (a)	53,204 (b)	299,254
New York	63,982	422,958
Missouri	7,674	69,202
Colorado	18,817	115,712
Totals . . .	462,662	2,485,435	464,494	2,644,515

(a) Includes Alabama, Indiana, Kentucky, Missouri, New York, Pennsylvania, South Dakota, Tennessee, and Wisconsin.

(b) Includes Alabama, Kentucky, Pennsylvania, South Carolina, South Dakota, Tennessee, and Wisconsin.

¹ *Chem. Zeit.*, 1906, p. 326.

The United States Geological Survey has made, and is making, investigations of the many deposits, and the reader is referred to the record *loc. cit.*

The States are divided into four main areas. These are: from east to west, the Appalachian Mountain region; the interior States; the Rocky Mountain States; and the Coast ranges.

Full particulars are given of the deposits in the various States, with the names of the companies working them.

Ektel¹ describes a new occurrence of pyrites, the Chestatee lode, in Lumpkin County, Gainsville, Ga., 30 ft. thick, and proved for 250 ft. Composition: 43.52 per cent. S, 39.70 Fe, 3.09 Cu, 0.72 Zn, 2.53 Al, 0.43 MgO, 110 As, 9.26 sand, etc., 0.36 moisture.

The absence of arsenic in most American pyrites (as far as it is now worked) is a remarkable feature.

K. F. Stahl² quotes analyses of American pyrites. No. 1 is from Tallapoosa Mine, Georgia, 1882; No. 2 from Rogers Mine, Paulding County, Dallas, Ga.; No. 3 from Sulphur Mines Co. of Virginia, Louisa County, 1884; No. 4, Peru Zinc Co., La Salle, Ill.; No. 5 from Dodgeville, Wis.; No. 6, from the same mine as No. 3, 1891; No. 7, Davis Sulphur Ore Co., Franklin County, Mass., 1891.

	1.	2.	3.	4.	5.	6.	7.
Water	2.9	1.3	0.8
Sulphur . . .	45.1	37.6	37.1	50.2	43.7	40.6	42.4
Iron	40.6	41.5	37.3	35.4
Copper . . .	3.1	5.2	0.6	1.0	1.4
Zinc . . .	3.0	4.5	0.8	1.9	5.5
Cadmium . . .	0.1	0.01	?	?	?
Insoluble . . .	2.9	9.5	14.7	...	1.4	10.5	5.1
Arsenic . . .	?	?	0.02	trace	trace

We quote from the volumes of the *U.S. Geological Survey* the production and imports of pyrites in the United States, in long tons of 2240 lb. :—

¹ *U.S. Geol. Survey Bull.*, No. 213, p. 62.

² *Z. angew. Chem.*, 1893, p. 54.

A special pamphlet on pyrites in Canada has been published by A. W. G. Wilson, in 1912, at Ottawa.

The world's pre-war annual consumption of pyrites was about 7,000,000 tons :—

United States	1,300,000
Germany	1,200,000
Great Britain and Ireland	810,000
France	700,000
Other Countries	2,990,000
Total	<u>7,000,000</u>

Price of Pyrites.

The price paid for pyrites in the English trade is usually based on the actual sulphur content as found by analysis of the ore. Each one per cent. of sulphur is taken as a unit, and the price being fixed per unit, the price per ton of pyrites is the product of the two. Thus, if the sulphur content be 48.5 per cent. and the basis price 6d. per unit, the price per ton of ore is $48.5 \times 6d. = 24s. 3d.$

Another method is for the price per ton to be paid for a given sulphur content, subject to adjustment at so much per unit above or below this figure.

Unless there is a copper extraction plant at the sulphuric acid works, the copper value in the case of cuprous ore does not concern the acid manufacturer; he would usually be required under the purchase terms to put the resulting cinders on rails at his own expense, to the order of the supplier. This would also hold good in the case of non-cuprous or washed pyrites, unless otherwise agreed between buyer and seller.

Value of Poor and Rich Pyrites.

To the acid manufacturer the important consideration in buying pyrites is the ultimate cost of the "useful sulphur" which it is possible to obtain from the ore. The "useful sulphur" may be taken as the total sulphur originally present, less the amount left in the cinders resulting from the roasting. The bulk weight of pyrites determines such costs as freightage or carriage to the works, unloading, crushing (in the case of

lump ore), storing, transport from store to burners, and feeding into the burners. It therefore follows that the lower the percentage of sulphur in the ore, the higher will be the cost per unit of the "useful sulphur." In addition, some allowance would have to be made for any reduction of output arising out of the smaller amount of sulphur which could be liberated per square foot of kiln available. A discussion on the relative merits of poor and rich ores has been carried on in *Chem. Zeit.* (1912, p. 1219; 1913, pp. 2, 59, 318; 1914, pp. 597, 816) by Keppeler, Nemes, and Uhlman.

Keppeler describes trials with Spanish pyrites smalls containing 48.4 per cent. sulphur and Norwegian smalls containing 43.28 per cent. and more copper and zinc than the former. The roasting was done in mechanical dust burners with three floors. Less sulphur could be burned in the same time with the poor ore than with the rich ore, the same chamber system yielding only 21.2 tons of sulphuric acid against 28 tons.

Nemes, however, contends that with modern burners it is more economical to work a poor ore rather than a richer ore, and in this he is supported by Uhlman, who states that in the long run the same quantity of acid can be made in the ordinary chambers whether Norwegian or Spanish ores are used. The temperature of the third floor of the burners must be kept high, the fourth and fifth floors being used for cooling the cinders, with hardly any combustion taking place therein. Norwegian ore is considered more valuable than Spanish ores on account of its easy working, freedom from arsenic, and small production of dust. Albrecht contends it is superior in burning qualities to most known descriptions of pyrites, being equalled only by an ore of Turkish origin.

ANALYSIS OF PYRITES

It is usually necessary to analyse the pyrites for the constituents which form the basis of purchase price, namely sulphur, and also copper, if this is to be extracted by the buyer. Should the ore be bought at a fixed rate per ton irrespective of the sulphur content, it might be regarded as essential to ascertain the amount present for the purpose of regulating the process and ascertaining data as to the efficiency

thereof. Beyond this—and perhaps the arsenic content—it is not general practice to carry the analysis, particularly where the ore is obtained from certain localities and its general composition and properties are well known. Each cargo is sampled at the port of discharge in the presence of the representatives of both buyer and seller, the sample being drawn as the ore is weighed over the ship's side. The bulk sample is broken up, reduced, put into bottles which are afterwards sealed—one each for the buyer and seller and a third for reference in case of dispute. The analysis, as ascertained by each party, is exchanged simultaneously; and should the two results be within certain limits, the mean is accepted, otherwise the tests of an independent assayer form the basis of settlement. The procedure as regards sampling and settlement of assays is usually fully prescribed in the Form of Contract. Should it be agreed to allow the moisture as a deduction from the weight of ore, this is usually ascertained jointly at the time of completion of sampling at the port.

The usual method for analyses is by the *wet* way, by fuming nitric acid or aqua regia, the directions differing in details.

Lunge recommends aqua regia prepared from 1 part of fuming hydrochloric acid and 3 or 4 parts of nitric acid of 1.36 to 1.4 sp. gr.

A very large amount of work has recently been done by a great number of chemists. That which has been published up to 1908 is embodied in the respective chapters of Lunge's *Technical Methods of Chemical Analysis*, edited by C. A. Keane, vol. i., p. 272 *et seq.*; and more briefly, in Lunge's *Technical Chemists' Handbook*, 1916, p. 108 *et seq.*

Estimation of Moisture.

Dry the coarse ground sample at 105° until the weight remains constant. For the other tests the pyrites is not employed in the dry state, but directly in the finely ground sample, kept in a well-sealed bottle. The analytical results are calculated for dry pyrites, for which reason a special moisture determination of the finely ground sample must be made.

Estimation of Sulphur.

The ore should be converted into an impalpable powder and passed through the finest silk gauze; the triturating ought to be done first in a steel mortar, and then in an agate mortar, *not* in a porcelain one.

Lunge's Method.—In view of the great desirability of retaining the decomposition of pyrites in the *wet* way, Lunge worked out a method for doing so without incurring the error caused by the presence of iron.

About 0.5 gram of pyrites is heated with about 10 c.c. of a mixture of 3 vols. nitric acid (sp. gr. 1.4) and 1 vol. strong hydrochloric acid, both ascertained to be absolutely free from sulphuric acid. The mixture is heated up now and then, till the decomposition is complete, and is then evaporated to dryness in a water-bath. Now add 5 c.c. hydrochloric acid, evaporate once more (no nitrous fumes ought to escape now), add 1 c.c. concentrated hydrochloric acid and 100 c.c. hot water; filter and wash with hot water.¹ The insoluble residue may be dried, ignited, and weighed. It may contain, besides silicic acid and silicates, the sulphates of barium, lead, and even calcium, whose sulphur, as being useless, is purposely neglected. (If this residue is not to be estimated, it need not be filtered off, and the next step, the elimination of the iron, may be performed without removing the silica, etc.) The filtrate and washings are saturated with ammonia, avoiding a very large excess of it; the mixture is kept at a moderately warm temperature for about ten minutes (at the expiration of which time it ought still to smell of ammonia very distinctly, not merely faintly), and the precipitated ferric hydrate—after several decantations with hot water—is filtered off while hot, employing a filter pump in the operation. The whole operation can be performed in from half to one hour, and no trace of sulphuric acid is retained in the precipitate. The total bulk of the filtrate and washings need not exceed

¹ G. Chaudron and G. Juge-Boirard (*Comptes rend.*, 1922, 174, 683-685; *J. Chem. Soc.*, 1922, 2, 311) state that during the dissolution of pyrites in nitric acid or aqua regia, there is always a separation of free sulphur if the temperature exceeds 60° in the case of marcasite or pyrites containing other metallic sulphides. If, however, the acid is allowed to act at the room temperature, there is no separation of sulphur, but the time required is much longer.

200 or 250 c.c., which saves concentrating the liquid by evaporation.

The clear liquid, which now contains all the sulphuric acid combined with ammonia, is acidulated with pure hydrochloric acid in very slight excess, heated to boiling, the burner removed, and 20 c.c. of a 10 per cent. solution of barium chloride, previously heated, put in *all at once* (not drop by drop). The error introduced by carrying down a little barium chloride with the sulphate is just compensated by the opposite error, caused by the slight solubility of barium sulphate in the hot solution, containing free HCl and ammonium chloride. (This disposes of the objection made by H. C. Moore in *J. Ind. Eng. Chem.*, 1915, p. 634.) This quantity, which suffices in any case for 0.5 gram pyrites, is roughly measured off in a test-tube provided with a mark, and is heated in the same tube. After precipitation, the liquid is left to stand for half an hour, when the precipitate should be completely settled. The clear portion is now decanted, and the washing continued by decantation with boiling water.

L. Gadais¹ gives a critical view of Lunge's method and certain suggested modifications. For accurate work, the original method without alteration is to be preferred, care being taken to adhere strictly to all details of the operations. A variation of this method, in which the insoluble gangue is not filtered off before the precipitation of the iron with ammonia, is not recommended, as this gangue contains substances such as the sulphates of barium, strontium, calcium, and lead, which may be partly dissolved by ammonia and reprecipitated on subsequent acidification and addition of barium chloride. A second modification of Lunge's procedure, which obviates the washing of the gangue, consists in making up the solution in aqua regia to 100 c.c., filtering off 50 c.c., and proceeding with this aliquot portion as in the original method. This is free from serious objection provided the insoluble residue is comparatively small in amount. Finally, a rapid control method, not suitable for accurate work, consists in diluting the original solution to about 800 c.c., adding ammonia directly to this, digesting for two hours at a moderate temperature, cooling, making up the volume to 1000 c.c., and filtering off 500 c.c. in which sulphate is estimated in the usual way.

¹ *Ann. Chim. anal.*, 1921, 3, 330-335; *J. Chem. Soc.*, 1922, 2, 79.

Z. Karaoglanow (with P. and M. Dimitrow)¹ makes the following remarks in dealing with the estimation of sulphur in pyrites:—After the sulphur has been oxidised to sulphuric acid by heating with a mixture of nitric and hydrochloric acids, or by fusion with sodium carbonate and potassium nitrate, the sulphuric acid may be precipitated directly from the hydrochloric acid solution obtained after separating the silica, previous removal of the iron being unnecessary if the precipitation is carried out under the following conditions. The solution (from 0.5 gram of pyrites), which should contain from 30 to 50 c.c. of 6N-hydrochloric acid, is diluted to 700 c.c., heated to boiling, and 40 c.c. of hot 10 per cent. barium chloride solution, previously diluted with 100 c.c. of hot water, are added gradually while the mixture is stirred. The precipitated barium sulphate is collected after fifteen hours, washed first with water containing hydrochloric acid and barium chloride, then with hot water, dried, ignited, and weighed.

C. Zay² takes 1 gram of the finely powdered pyrites and treats in the usual way with a mixture of nitric and hydrochloric acids, but recommends redissolving the ferric hydrate on the filter-paper with hydrochloric acid, again adding ammonia and filtering off. Mixes the two filtrates and estimates the sulphur in the usual way as barium sulphate.

The results of co-operative work on the determination of sulphur in pyrites are given by H. C. Moore.³

The results obtained in a great number of laboratories by three different methods are tabulated and discussed. Allen and Bishop's method (oxidation with bromine in carbon tetrachloride solution, followed by treatment with nitric acid, and precipitation of the sulphuric acid as barium sulphate after removal of silica and reduction of ferric salts) gives more concordant results than Lunge's method and is recommended as accurate. The method has, however, been modified as follows to allow of using a smaller sample: 0.5495 gram of

¹ *Z. anal. Chem.*, 1917, 56, 561-568; *J. Chem. Soc.*, 1918, 2, 126.

² *Stat. sperim. agrar. ital.*, 1916, 49, 530-536; *J. Chem. Soc.*, 1917, 2, 328.

³ *J. Ind. Eng. Chem.*, 1916, 8, 1167-1170, and 1919, 45, 33-34; *J. Soc. Chem. Ind.*, 1917, p. 29, and 1919, p. 171A.

the powdered sample, dried at 100° , is treated with 6-8 c.c. of a mixture of 2 parts of bromine and 3 parts of carbon tetrachloride by volume, and left for fifteen minutes in a tall covered beaker, with occasional shaking; 10 c.c. of concentrated nitric acid is then added, and after standing for fifteen minutes with occasional shaking, the mixture is heated below 100° until most of the bromine has been expelled, and then evaporated to dryness on a steam plate. The residue is treated with 10 c.c. of concentrated hydrochloric acid, the mixture evaporated to dryness, and the residue heated at 100° for $\frac{1}{2}$ -1 hour to dehydrate the silica, then moistened with 1 c.c. of concentrated hydrochloric acid and heated with 50 c.c. or more of water until solution is complete. After cooling for 3-5 minutes, 0.1 gram of powdered aluminium is added, and when reduction is complete the solution is filtered and the residue washed nine times with hot water. The solution is treated with 2.5 c.c. of concentrated hydrochloric acid, then diluted to 650 c.c., and 50 c.c. of cold 5 per cent. barium chloride solution added slowly, without stirring, preferably in single drops at the rate of about 5 c.c. per minute. The mixture is stirred, allowed to stand for at least two hours, and the precipitate collected on a thick layer of asbestos in a Gooch crucible, using suction. After washing with cold water, the precipitate is dried and ignited.

Having examined the precipitates of barium sulphate obtained by this method in the presence of various salts, the authors are of the opinion that no correction for the presence of occluded salts in the precipitate is necessary when the analysis is conducted as described.

Volumetrical Estimation.

In lieu of the estimation of sulphuric acid by weight, some chemists prefer *titration* by means of a standard solution of barium chloride. This was first proposed by Wildenstein,¹ and afterwards, especially for the analysis of pyrites, by Teschemacher and Smith.² Although this process, notwith-

¹ *Z. anal. Chem.*, **1**, 432.

² *Chem. News*, **24**, 61, 66; cf. also Glendinning and Edgar, *ibid.*, 140.

standing some assertions to the contrary, is most certainly no more accurate than the gravimetric process, and in most hands is less so, and is not used by many chemists in important cases, we shall take this opportunity of describing the estimation of sulphates by titration with barium chloride in its simplest form, such as is used at some works in testing black-ash, etc. It is sometimes used in testing pyrites, blende, burnt-ore, etc., for purposes where no great accuracy is required.

The liquid is brought to the boil in a porcelain dish, barium-chloride solution is added from a burette; from time to time a few drops are taken out with a glass tube, passed through a miniature filter on to a glass plate resting on a black background, upon which a number of drops both of dilute sulphuric acid and of barium chloride have been put. If the filtrate still gives a cloudiness with a barium-chloride drop, easily visible on the black ground, the little filter is thrown back into the dish, more barium-chloride solution is added from the burette, another test is made, and so forth. The end is attained when a filtered drop gives an extremely slight cloudiness both with a drop of barium chloride and with one of sulphuric acid.

C. and J. Beringer effect the titration by barium chloride after addition of sodium acetate and acetic acid.¹

Various other volumetric methods for the estimation of sulphates, by Carl Mohr, Ad. Clemm, Wildenstein (2nd method), Schwarz, and Pappenheim, are described in the treatises of Fresenius and Mohr; but they are more complicated and not more accurate than the direct titration with barium chloride as just described.

Harcourt Phillips² gives a description of a rapid method for its estimation, based on the use of a standard solution of barium chloride, of which 1 c.c. is equivalent to 0.01 gram of sulphur. A deficient quantity of barium-chloride solution is added to the oxidised pyrites solution which has been freed from nitric acid and has been adjusted to a definite bulk; the titration is completed by making further additions of 0.5 c.c., boiling the liquid, and filtering off 5 c.c. after each addition, until the end-point is reached.

¹ *Chem. News*, 59, 41.

² *Chem. News*, 1917, 115, 312; *J. Chem. Soc.*, 2, 379.

Ernest Martin¹ treats the pyrites with aqua regia, the solution evaporated to dryness, and the residue redissolved in dilute hydrochloric acid. The solution is diluted, and sodium carbonate added. The assay may also be opened out by fusion with sodium peroxide or a mixture of sodium carbonate and potassium nitrate, dissolved in water, and carbon dioxide passed through to precipitate lead. After filtration, methyl-orange is added, and the solution exactly neutralised with hydrochloric acid. The carbon dioxide is boiled off, and to the lukewarm solution a known volume of standard barium hydroxide and phenolphthalein is added. Carbon dioxide is bubbled through until the colour just changes, when the solution is cooled and titrated with N/2-hydrochloric acid.

T. J. I. Craig² describes a method for the volumetric estimation based on oxidation to sulphuric acid by means of aqua regia, or preferably by nitric acid and bromine, and titration with standard alkali hydroxide after the removal of all the other acid ions from the solution. It is shown that nitric acid is completely eliminated from the aqua regia solution of pyrites by evaporating to dryness twice with hydrochloric acid, and finally drying for an hour at 110°, whilst from the nitric acid-bromine solution two evaporations to dryness, followed by an hour's heating at 110°, are sufficient to remove both nitric acid and bromine. Where hydrochloric acid is present, it can only be completely eliminated by treating the solution with silver oxide, the alternative being to estimate it with standard silver nitrate and make the requisite allowance in the subsequent titration of the sulphuric acid. When arsenic acid is present, it is shown to be practically all eliminated by the precipitated ferric hydroxide, and hence does not interfere with the titration. The procedure recommended is briefly as follows:—10 grams of pyrites are treated with 30 per cent. nitric acid, the reaction mixture cooled to 50°, treated with 5 c.c. of bromine, and boiled until no more brown fumes are liberated. Nitric acid is eliminated as above described, the residue dissolved in water and made up to 250 c.c. Of this solution 25 c.c. are boiled with a known excess of N-sodium hydroxide and the solution made

¹ *Monit. Scient.*, 1918 [5], 8, 149-150; *J. Chem. Soc.*, 1918, 2, 330.

² *Chem. News*, 1917, 115, 253-255, 265-268; *J. Chem. Soc.*, 1917, 2, 420.

up to 200·25 c.c. (0·25 c.c. to allow for the volume occupied by the ferric hydroxide). After filtration, an aliquot portion is titrated to neutrality with phenolphthalein as indicator. The results obtained are claimed to be closely in accord with those obtained by the more elaborate gravimetric method. The paper includes a short historical summary of the various methods suggested for the estimation of sulphur in pyrites.

Available Sulphur.

Several methods have been proposed for estimating the *available sulphur* of sulphur-ores—that is, that portion of it which passes into the chambers in the form of SO_2 and SO_3 . Thus W. G. Mixer¹ burns the pyrites in a current of oxygen, and passes the vapours into bromine-water containing some hydrochloric acid and an excess of bromine.² This method is very suitable for testing spent oxide, for this material is always contaminated with sawdust, tarry matters, and variable

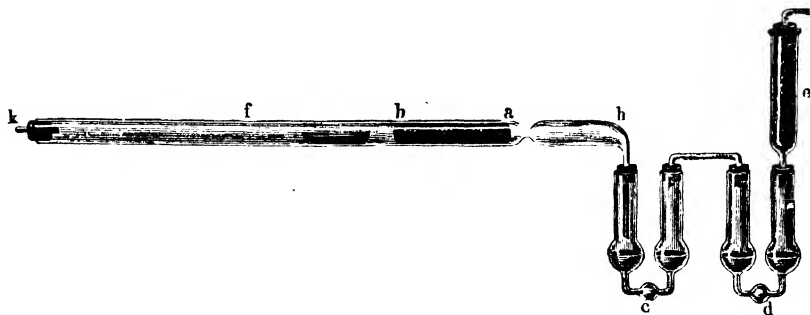

FIG. 4.

quantities of lime which retains part of the sulphur in burning, whence an estimation of the total sulphur is quite useless for practical purposes. The process takes place in a combustion-tube (Fig. 4), 2 ft. long, narrowed at *a*, and drawn out at the end into a long tube, not too thin, and bent downwards. Between *a* and *b* there is a layer of platinised asbestos (see below), 8 to 10 in. long, and at a distance of 3 or 4 in. from this a porcelain boat with about 0·4 gram of spent oxide or pyrites. The end of the tube at *k* is connected with an oxygen gas-

¹ *Amer. Chem. J.*, 2, 396.

² Zulkowsky, *Wagners Jahresh.*, 1881, p. 160, recommends a similar process.

holder. The absorption of the vapours takes place in the two 3-bulb tubes *c* and *d* ($5\frac{1}{2}$ in. high) and the tube *e*, filled with glass-wool. The absorbing-liquid is made by dissolving 180 grams caustic potash (purified with alcohol from sulphate) in water, adding 100 grams bromine, taking care to keep the mixture cool, and diluting to 1000 c.c. Thirty c.c. of this suffice for estimating 0.5 gram sulphur. The tube *e* ought also to be moistened with it. First heat the portion of the tube between *a* and *b*, passing moist oxygen through it at the same time; then heat the boat from the right to the left; lastly the tube, up to the place *f*. The current of gas must be much stronger than for an organic analysis, lest any sulphur should escape unburnt, but not strong enough to draw off any SO_2 unabsorbed. So long as any dew appears at *h*, it must be driven into the receiver with a Bunsen burner. When this ceases (usually in about an hour), the experiment is finished. The receivers are then taken off, washed out, and the acid remaining in *h* is recovered by aspirating water several times through it. All the liquids are united, saturated with hydrochloric acid in order to decompose the potassium hypobromite, heated, concentrated if necessary, and the sulphuric acid is precipitated by barium chloride in the usual manner (or, more conveniently, the receivers are charged with hydrogen peroxide, free from sulphuric acid, and are retitrated after the end of the operation.

Expeditious assays of pyrites have been proposed in many ways, but none of them is sufficiently accurate to be employed for estimating the sulphur in fresh pyrites, and some of them are not even accurate enough for testing the sulphur remaining in *burnt ore* (pyrites cinders).

The so-called *mechanical pyrites assay* of Anthon¹ is too rough and unreliable even for very simple purposes.²

ANALYSIS OF BURNT CINDERS

Estimation of Sulphur.

This can be done, of course, by the wet methods described in our text, p. 100 *et seq.* But at the factories these methods are only exceptionally employed, because they are even more

¹ *Dingl. polyt. J.*, 161, 115.

² *Cf.* 1st ed. of Lunge, 1, 108.

troublesome and lengthy for testing burnt ore than for fresh pyrites, and because dry methods exist which are both rapid and sufficiently accurate. Indeed, Jene¹ maintains that the wet methods are altogether unsuitable for testing pyrites cinders intended for being worked up in blast-furnaces, as they do not give the total, but only the "available" sulphur; and this has been confirmed by Gottlieb.² Jene also estimates the sulphur of the sulphates, soluble in water; so does Mennicke.³

Not all the dry methods are sufficiently accurate or convenient for daily use at vitriol-works. More suitable are the methods now to be described.

Böckmann proceeds as follows:—

A sample of the burnt ore is taken every twelve hours, every kiln being provided with a large and a small sample-box. The samples are, in the first instance, collected in the small boxes and brought in these to the laboratory, where they are transferred to the corresponding larger boxes. At the end of a week an average sample is taken from the latter and broken down in an iron mortar; the coarsely ground sample so obtained is divided by quartering on a piece of stout paper, and one of the quarters is finely ground and sieved. Finally, several grams of every sample are ground in successive small portions in an agate mortar until no grittiness is felt on rubbing between the fingers; 1.5 to 2.0 grams of the very finely ground material are weighed off, and mixed with about 25 grams of a mixture of 6 parts sodium carbonate and 1 part potassium chlorate; this mixing is done in a large platinum dish with the aid of an agate pestle. The mixture is then fused over the blowpipe. The melt is allowed to cool till only just lukewarm, then covered with hot water, heated to boiling, and both this solution and the insoluble residue are washed into a 250 c.c. flask. The contents are cooled under a water-tap, made up to the 250 c.c. mark, and four-fifths of the solution filtered through a pleated filter paper into a 200 c.c. flask. The insoluble portion of the melt (oxides of iron, copper, etc.) only occupies a small volume. The solution is acidulated with hydrochloric acid, and the sulphuric acid estimated in the usual manner.

¹ *Chem. Zeit.*, 1905, p. 362.

² *Ibid.*, 1905, p. 688.

³ *Ibid.*, p. 495.

The following process is employed in one of the largest French works for the regular daily control of the working of the burners ; it enables a large number of sulphur tests in burnt ore to be carried out simultaneously, and in comparatively short time. It is founded upon the fact that at a red heat hydrogen decomposes all sulphur compounds of iron with the formation of hydrogen sulphide, which is passed into a standard solution of silver nitrate, estimating the excess of this by titrating back according to Volhard's method. It is carried out as follows :—Several porcelain tubes, closed at both ends by non-vulcanised rubber stoppers carrying glass tubes, are arranged in a furnace heated by a six-flamed Bunsen burner. The glass tubes are connected at the inlet end with a hydrogen generator by means of a corresponding number of lengths of rubber tubing furnished with screw clips ; the outlet pieces are connected with vertically bent tubes which dip into small test-glasses. The hydrogen used must be freed from any accompanying hydrogen sulphide by washing with silver nitrate solution. Each set is numbered, and the porcelain tubes, stoppers, inlet- and outlet-tubes and test-glasses are marked to correspond. A preliminary test is first made to ensure that no precipitate results when the hydrogen is passed into the silver nitrate solution in the test-glasses. When this has been ascertained, exactly 1 gram of the finely ground cinders is weighed into a numbered porcelain boat, the boat pushed to the marked position in the porcelain tube by means of a glass rod, and 25 c.c. of silver nitrate solution (containing 10.604 grams AgNO_3 , corresponding to 3.65 grams NaCl , per litre) is placed in each test-glass. When all the weighed samples are in position, a current of hydrogen is passed through the tubes, and regulated by means of the screw clips to two or three bubbles per minute. After ten minutes, when all the air has been expelled, the furnace is heated, at first gently, and then gradually raised to a red heat. After one and a half hours' heating the elimination of the sulphur is complete. This is shown by no further cloudiness appearing in the silver nitrate solution, and by the improved and satisfactory settling out of the black precipitate of silver sulphide. The gas supply to the furnace is then gradually reduced, and the hydrogen current interrupted. The test-glasses are removed in turn, and without filtering off

the precipitate 1 c.c. of iron-indicator (2.5 grams ferric nitrate dissolved in 100 c.c. nitric acid of sp. gr. 1.38) is added, and the solution immediately titrated with ammonium thiocyanate solution up to permanent redness. The thiocyanate solution contains 4.752 grams per litre, and should correspond exactly with the silver nitrate solution. If the number of cubic centimetres of ammonium thiocyanate be denoted by a , then the percentage of sulphur in the pyrites cinders is $\frac{25 - a}{10}$.

For rapid control in the estimation of sulphur in burnt cinders, H. C. Moore¹ recommends the following sodium peroxide fusion method. About 1.5 gram of the finely powdered sample is fused in a wrought-iron or nickel crucible with 7 grams of sodium peroxide, the cooled mass is dissolved in water and slightly acidified with hydrochloric acid. About 0.5 gram of aluminium powder is now added, and, when the ferric salts have been reduced, the solution is heated to boiling, diluted to 500 c.c., and filtered. Two hundred c.c. of the filtrate are diluted to 450 c.c., 1 c.c. of concentrated hydrochloric acid is added, and the sulphuric acid is precipitated by treating the cold solution with barium chloride solution. After one hour, the barium sulphate is collected, washed with cold water, ignited, and weighed. The presence of considerable quantities of barium sulphate and silica in the cinder does not have an appreciable influence on the results obtained.

O. Binder² recommends (for thoroughly mixing the sodium carbonate and potassium nitrate in preparing a stock of fusion mixture) that the carbonate be suitably coloured and the mixing continued until the colour of the whole mixture is uniform.

For further methods for testing burnt pyrites we refer the reader to Lunge's *Technical Chemist's Handbook* (1910) and Lunge's *Technical Methods of Chemical Analysis*.

Other methods have been proposed by:—

Nikaido (*J. Amer. Chem. Soc.*, 1902, p. 774).

Riegler (*Z. anal. Chem.*, 1902, p. 17).

Mohnhaupt (*Chem. Zeit.*, 1904, p. 1125).

¹ *J. Ind. Eng. Chem.*, 1916, 8, 26-28; *J. Chem. Soc.*, 1916, 2, 263.

² *Chem. Zeit.*, 1918, 42, 503.

Blacher and Koerber (*ibid.*, 1905, p. 722).

Martin (*Monit. Scient.*, 1914, p. 866).

Scholtz (*Arch. Pharm.*, 1905, p. 667).

W. J. Müller (*Ber.*, 1902, p. 1587).

Müller and Dürkes (*Z. anal. Chem.*, 1903, p. 477).

Raschig (*Z. angew. Chem.*, 1903, p. 617 and 818; 1906, p. 332).

Knorre (*Chem. Ind.*, 1905, p. 2).

Friedheim and Nydegger (*Z. angew. Chem.*, 1907, p. 9).

Nickel (*ibid.*, 1910, p. 1560).

Zehetmayr (*ibid.*, 1910, p. 1359).

Hassreidter and van Zuylen (*Chem. Zentr.*, 1905, i., p. 1433).

F. Chio (*Giorn. Chim. Ind. Appl.*, 1921, 3453).

Estimation of other Constituents of Pyrites.—Usually it is sufficient to estimate the sulphur in a pyrites whose nature is otherwise known. If, however, the pyrites is of unknown composition, its value for acid-making can only be estimated by a complete determination of all its constituents according to the rules of mineral analysis. If it contains, for instance, *calcium carbonate*, this on burning will retain its equivalent of sulphuric acid equal to 0.32 per cent. S for each per cent. CaCO_3 ; if *calcium sulphate* is present, its sulphuric acid has to be deducted from the whole quantity of sulphur found. If *lead* has been found, its equivalent of sulphur must be considered as practically lost; and the same is the case with *zinc*—because the sulphates of both metals are hardly or not at all decomposed at the temperature of a pyrites burner. In France half of the S combined with Zn is considered as lost, = 0.245 per cent. S per 1 per cent. Zn (for copper they reckon 0.505 per cent. S per 1 per cent. Cu as lost). *Arsenic* will also have to be sought for; and even *silica* may be of importance—firstly, because in the presence of much silica “explosive” properties of the pyrites must be feared (see p. 339), and secondly, in the case of cuprous pyrites, because silica lessens the value of the cinders. Even *silver* and *gold* are sometimes sought for,¹ but it cannot be said that the quantities hitherto found have any influence on the commercial value of pyrites.

¹ Cf. *Chem. News*, 26, 63; 34, 94, 132, 152, 172.

The estimation of *carbon* in pyrites, especially the "coal brasses," can be done by the ordinary method of elementary analysis, but better by the method of Corleis (dissolving in chromic acid, and absorbing the CO_2 formed by soda-lime). Treadwell and Koch¹ give some details of their method. They oxidise the pyrites by a mixture of chromic and sulphuric acids, and pass the gas liberated through a 10 cm. layer of glowing copper oxide, followed by 10 cm. of glowing chromium trioxide, and after this through two small U-tubes, each containing 3 c.c. of a solution of chromium trioxide in concentrated sulphuric acid. After leaving the U-tubes, the gas is passed through a tube filled with glass beads moistened with sulphuric acid, then through two calcium-chloride tubes, and is finally absorbed in two soda-lime tubes.

Carbonates of the alkaline earths are occasionally estimated in pyrites as they retain sulphur, owing to the formation of the corresponding sulphates. Since their quantity is very small, the CO_2 cannot be accurately estimated by loss, and consequently a direct method must be used. The CO_2 is liberated by addition of strong acid and absorbed in soda-lime, taking care to retain moisture and any acid carried forward. For this purpose the well-known apparatus of Fresenius or of Classen may be employed, but greater rapidity and accuracy are attained by the gas-volumetric method of Lunge and Marchlewski² or the apparatus of Lunge and Rittener.³

Estimation of Arsenic.

The process employed at Freiberg is that used by Reich, and is as follows:—Digest about 0.5 gram of finely pulverised pyrites in a porcelain crucible, covered with a watch-glass, with concentrated nitric acid at a gentle heat, until the residue assumes a lighter colour and the separated sulphur has turned a pure yellow. After decomposition, heat the crucible on a sand-bath to get rid of the excess of acid, but not to dryness. Add 4 grams of sodium carbonate, dry completely on the sand-bath, add 4 grams of potassium nitrate, and heat the mass until the contents of the crucible have been in quiet fusion for ten

¹ *Z. angew. Chem.*, 1903, p. 173.

² Lunge-Keane's *Tech. Meth. of Chem. Anal.*, I, 149.

³ *Z. angew. Chem.*, 1906, p. 1849.

minutes. Extract the cooled mass with hot water, and filter; the filtrate contains all the arsenic as sodium arseniate. Acidify with a little nitric acid, keep for two hours on a sand-bath to get rid of the carbon dioxide, add a sufficient quantity of a solution of silver nitrate, and neutralise carefully with dilute ammonia. The reddish-brown precipitate of silver arseniate is filtered, washed, dried, taken off the filter as well as possible, the filter is incinerated in a muffle, the precipitate put to it, a sufficient quantity of assay lead is added, and the silver estimated by cupellation. One hundred parts of silver correspond to 23.15 of arsenic.

Leroy M. M'Cay has modified and greatly simplified this method¹ by estimating the excess of silver used by Volhard's method. Later on² the same author recommends as preferable another plan, namely, dissolving the Ag_3AsO_4 in dilute ammonia, and either estimating the silver by Volhard's volumetric method (precipitation with ammonium thiocyanate), or evaporating, drying, and weighing the total in a thin platinum dish. If the arsenic is to be precipitated as pentasulphide, which is otherwise a tedious operation, M'Cay recommends³ placing the solution in a flask with a well-fitting stopper, acidifying with HCl , and diluting with freshly boiled water till the flask is nearly full, passing in H_2S to saturation, inserting and fastening down the stopper, and placing the whole in a water-bath for an hour. At the end of that time all the arsenic will be precipitated as pentasulphide, As_2S_5 , containing no free sulphur.

Vilstrup⁴ estimates in pyrites the sulphur and iron by Lunge's method. For the estimation of arsenic he moistens 12.5 grams of the powdered ore in a large beaker with 10 c.c. of water and 1 c.c. of sulphuric acid, adds strong nitric acid until there is no further effervescence, boils the liquid to a paste, and treats the residue with boiling water. If the residue is not white, the liquid is decanted and the insoluble mass boiled with aqua regia. This is then evaporated and the residue transferred to the main solution, and the whole is diluted to 250 c.c.

¹ *Chem. News*, 48, 7.

² *Amer. Chem. J.*, 8, No. 2.

³ *Ibid.*, 9, No. 3, and 10, No. 6.

⁴ *Chem. Zeit.*, 1910, 350; *J. Chem. Soc. Abstr.*, 1910, 2, p. 458.

The solution is then passed through a dry filter; the residue is washed and tested for lead by boiling with ammonium acetate; excess of sulphuric acid reprecipitates the lead. Two hundred grams of the filtrate (= 10 grams of the sample) are treated with hydrogen sulphide. The precipitate, consisting of copper and arsenious sulphide, is treated with ammonium carbonate; this dissolves the arsenic, which is then reprecipitated by adding dilute sulphuric acid and passing H_2S in. The As_2S_3 is collected in a Gooch crucible, washed with alcohol and carbon disulphide, dried at 100° and weighed. The copper sulphide is freed from admixed sulphur and traces of antimony sulphide by boiling with sodium sulphide, and then washed and burned to oxide. The filtrate from the copper arsenic precipitate is diluted to 500 c.c., 50 c.c. (= 1 gram sample) are boiled, oxidised with nitric acid and, after adding an excess of ammonium chloride, precipitated with ammonia. As the iron precipitate retains zinc, it should, after washing, be redissolved in hydrochloric acid and, after neutralisation, boiled with ammonium acetate or nitrite. The united filtrates then contain all the zinc. After adding ammonia and heating to boiling, any Ca and Mg are precipitated by ammonium carbonate and phosphate; the liquid should then be stirred for half an hour. From the filtrate, the zinc-ammonium phosphate is recovered by boiling off the NH_3 , and finally converted by ignition into zinc pyrophosphate and weighed as such. If the colour should not be pure white, traces of Ni or Co phosphate may be present. In such cases the filtrate from the iron is acidified with acetic acid and treated with H_2S . After twenty-four hours the precipitate is collected and treated with cold *N*-hydrochloric acid; the zinc dissolves, and the Ni and Co are not affected. From the filtrate the zinc is then recovered as pyrophosphate in the usual way. Hattensaur¹ recommends this process.

Blattner and Brasseur² quote an instance in which different analysts found from 0.19 to 0.57 per cent. arsenic in the same sample of pyrites, and another in which the figures varied from 0.05 to 0.39 per cent. They recommend the following two processes for the estimation of arsenic:—

1. *Wet Treatment.*—10 grams pyrites are added gradually

¹ *Chem. Zentr.*, 1911, 1, 1373.

² *Bull. Soc. chim.*, 1897, 17, 13.

with gentle warming to aqua regia, prepared from 125 c.c. nitric acid (sp. gr. 1.37), 250 c.c. hydrochloric acid (sp. gr. 1.15 to 1.17), and 100 c.c. water, in a litre flask. The bulk of the nitric acid is driven off by evaporation after addition of hydrochloric acid; since all the arsenic is present as As_2O_5 , no loss through evolution of AsCl_3 can take place. After adding 100 c.c. water, the solution is cooled and filtered, ammonia is added until a slight precipitate of ferric hydroxide is formed, SO_2 passed through the cold solution until the reduction of the iron to the ferrous state is complete, the excess of SO_2 is removed by warming, and after cooling to 60° to 70° the arsenic is precipitated by passing in H_2S for six or seven hours. The solution is then allowed to stand for twelve hours, and filtered. The precipitate is washed by water containing HCl and H_2S , until all the iron has been removed, and then by distilled water. It is then dissolved by digesting the precipitate and filter paper with ammonium carbonate, and the solution is filtered. The solution is strongly acidified by hydrochloric acid warmed to 50° to 70° , and the arsenic is precipitated as As_2S_3 by passing in H_2S for an hour. The arsenic in the precipitate may be determined either as magnesium-ammonium arsenate or as silver arsenate. In the former case the precipitate is dissolved in strong ammonia, evaporated to dryness on the water-bath, taken up with 10 c.c. nitric acid, and, after a slight evaporation, rendered ammoniacal, and a small quantity of alcohol, followed by magnesia mixture, is added. After standing for twelve hours, the precipitate is collected on an ash-free filter paper, washed by a solution of one part of ammonium chloride and one part of alcohol in three of water, dried, and ignited after separation from the filter paper. The filter paper is ignited separately after addition of a small quantity of ammonium nitrate. One hundred parts $\text{Mg}_2\text{As}_2\text{O}_7$ correspond to 48.28 parts As.

2. *Dry Treatment.*—Two grams pyrites are thoroughly mixed in a platinum crucible of 30 c.c. capacity with 10 to 12 grams of equal parts of potassium nitrate and sodium carbonate, and covered by a layer of 2 grams of the same mixture. The crucible is then covered, and heated over a Bunsen flame 3 cm. high. When the reaction is complete, the mass is allowed to cool, the contents of the crucible are placed in 70 c.c. of boiling

water, and, after solution, the whole is filtered and the residue washed with boiling water. All the arsenic is then in the filtrate in the shape of arsenate. The solution is acidified with nitric acid, heated to boiling, allowed to cool, rendered exactly neutral by ammonia, and, after the addition of one drop of nitric acid, again neutralised, until a drop of the solution produces a blue tint on red litmus paper only after some seconds. Silver nitrate is then added, drop by drop, until no further precipitation takes place; the silver arsenate is collected on a filter and washed with cold water, until the filtrate no longer gives a turbidity with hydrochloric acid. The silver arsenate is dissolved on the filter in very dilute nitric acid, 5 c.c. of an iron solution in sulphuric and nitric acid is added as indicator, and the solution titrated by $N/10$ ammonium-thiocyanate solution up to the appearance of a pink colour. Each c.c. of the thiocyanate solution corresponds to 0.0025 gram As. The second method is preferable to the first, since in this, arsenic may be lost by volatilisation of its chloride.

List¹ heats 2 grams pyrites with sodium peroxide, which transforms the arsenic into arsenic acid; this is estimated by the method of Blattner and Brasseur, described above. Parr² also employs a sodium peroxide mixture.

Ebough and Sprague³ fuse pyrites with sodium carbonate and zinc oxide, acidulate the aqueous extract with acetic acid, precipitate the arsenic acid by silver nitrate, dissolve the silver arsenate in dilute nitric acid, and titrate it with ammonium or potassium sulphocyanate.

Low⁴ heats the ore with potassium bisulphate, tartaric acid, and concentrated sulphuric acid, precipitates from the solution the arsenic (and antimony) by H_2S , dissolves the sulphides in ammonium sulphide, and titrates by iodine solution, for which detailed instructions are given. This titration is also employed by Platten.⁵

Other methods are described by Guedrias⁶ and Hattensaur.⁷

¹ *Z. angew. Chem.*, 1903, p. 415.

² *J. Amer. Chem. Soc.*, 1908, p. 764.

³ *Ibid.*, p. 1475.

⁵ *J. Soc. Chem. Ind.*, 1894, p. 524.

⁶ *Rev. gén. chim. pure et appl.*, 1908, p. 251.

⁷ *Chem. Zeit. Rep.*, 1911, p. 391.

⁴ *Ibid.*, 1906, p. 1715.

Schürmann and Böttcher¹ discuss the former methods for estimating arsenic in pyrites, and give their own method.

Estimation of Zinc.

This is sometimes estimated in pyrites, because the sulphur combined with zinc is lost in the ordinary process of burning. The method of Schaffner, described in Lunge's *Technical Methods of Chemical Analysis*, ii, p. 291, is not available in this case in its original form, owing to the large preponderance of iron, but it can be employed if the iron is first removed by Rothe's ether process.

Zinc can be estimated by gravimetric analysis. Dissolve 1 gram pyrites in aqua regia, as described on p. 100 of the text, evaporate off the excess of nitric acid, treat the residue with 5 c.c. strong hydrochloric acid, add water, and saturate with hydrogen sulphide to remove any metals yielding sulphides insoluble in the acid solution. Any precipitate formed is filtered off, the filtrate freed from H_2S by boiling, and oxidised by aqua regia. The oxidised solution, after cooling, is treated with ammonium carbonate until the resulting precipitate redissolves very slowly; ammonium acetate is then added, the solution boiled for a short time, and filtered. The basic ferric acetate so precipitated carries down some of the zinc, and must therefore be dissolved in hydrochloric acid and again precipitated; the operation is repeated so long as any zinc can be detected in the filtrate. The combined filtrates are concentrated if necessary, and the zinc is precipitated in the warm solution by H_2S ; the whole is then allowed to stand for twenty-four hours, the clear liquor is decanted, and the ZnS filtered off and washed. The precipitate and filter are treated with dilute hydrochloric acid, and the resulting solution, after boiling until free from H_2S , filtered, precipitated with carbonate, and the zinc carbonate well washed, dried, and converted by ignition into ZnO , of which one part = 0.8034 Zn. For very exact determinations any silica, oxide of iron, and alumina precipitated with the zinc oxide must be estimated and allowed for; this, however, is seldom necessary.

¹ *Chem. Zeit.*, 1913, 37, 49-51; *J. Chem. Soc.*, 1913, 2, 152.

Rubricius¹ estimates small quantities of zinc in ores and pyrites cinders as follows:—

Dissolve 5 grams of the ore in 15 c.c. concentrated hydrochloric acid, with application of heat, add a few c.c. of concentrated nitric acid, evaporate to a small bulk (but not to dryness). Allow to cool, and stir up with 30 c.c. concentrated ammonia solution. The precipitate is twice or three times treated with ammonia, filtered and washed with hot water. If the filtrate does not, by a blue coloration, indicate the presence of copper, add a little cupric sulphate, heat to boiling, add a little sodium sulphide, filter off the precipitated sulphides, wash with hot water, dissolve the ZnS by hot dilute hydrochloric acid, precipitate the zinc from the boiling solution, and weigh it as ZnO. If any manganese is present, this is removed from the mixture of sulphides by treatment with dilute acetic acid, previously to the treatment by hydrochloric acid.

Estimation of Selenium.

The detection and estimation of selenium is described by Klason and Melliquist.² According to them, both the acid from the Glover tower and the chamber acid may show a red colour, caused by colloidal selenium. Some of the selenium dust contained in the pyrites burner-gases is retained in the Glover tower, but most of it passes through the tower and is found in the chamber acid.

Their method for estimation of selenium is as follows:—20 to 30 grams of the ore are dissolved in hydrochloric acid (sp. gr. 1.19) and potassium chlorate. After filtering from gangue, the iron is reduced to the ferrous state, by means of zinc, more hydrochloric acid is added, the solution boiled and the selenium precipitated by stannous chloride. Since it may contain arsenic, it is collected on an asbestos filter, dissolved in potassium iodide, and again precipitated by hydrochloric acid and sulphur dioxide. The further treatment is similar to that described under sulphur.

A simple roasting of the pyrites in a current of oxygen

¹ *Chem. Zeit.*, 1915, p. 198. See also Urbasch, *Abstr. Soc. Chem. Ind.*, 1922, p. 218.

² *Arkiv. Kem. Min. Geol. (J. Chem. Soc. Abstr., 1912, 2, 201)*; *Z. angew. Chem.*, 1912, p. 514; *J. Chem. Soc.*, 1912, 2, 201 and 990.

does not convert all the selenium into dioxide. Examination of fourteen samples of pyrites showed great variations in the proportions between the selenium going away with the roasting-gases and that remaining in the pyrites cinders. If the pyrites contains copper or lead, much more selenium remains in the cinders than otherwise.

J. Meyer and W. von Gaon¹ describe a colorimetric method for estimating minute quantities of selenium, and a method of titrating with thiosulphate for the estimation of more considerable quantities of selenium. J. Meyer² describes improvements in the gravimetric estimation of selenium. Gutbier and Engeloff³ describe the results that have been obtained by these methods.⁴

Estimation of Copper.

Koelsch⁵ reduces the difficultly soluble ferric sesquioxide to protoxide by heating 10 grams of the burnt ore with 5 to 7 grams solid sodium hypophosphite and 40 c.c. hydrochloric acid (sp. gr. 1.16) to boiling, dilutes (without filtration) with 100 c.c. hot water, precipitates the copper by sodium sulphide solution, filters, ignites, adds a little nitric acid and sulphuric acid, drives the acids off by heating, and estimates the copper by electrolysis. For less accurate work, the filter and precipitate are heated with 10 c.c. nitric acid (sp. gr. 1.4), a little urea is added, the solution is cooled, rendered faintly ammoniacal, then acidified with acetic acid and titrated with thiosulphate, after adding potassium iodide. The treatment with hypophosphite and hydrochloric acid can be applied wherever highly ignited ferric oxide is to be brought into solution.

The Duisburg copper-works employ the following process:— Five grams of pyrites, ground and dried at 100°, are gradually dissolved in 50 c.c. nitric acid (sp. gr. 1.2) in an inclined Erlenmeyer flask. As soon as the violence of the reaction is over, the flask is warmed and evaporation allowed to proceed until sulphuric acid vapours are given off. The dry residue is dissolved in 50 c.c. hydrochloric acid (sp. gr. 1.19), and after the addition of sodium hypophosphite (2 grams NaH_2PO_2

¹ *Z. anal. Chem.*, 53, 29.

² *Ibid.*, 145.

³ *Ibid.*, 4, 193.

⁴ Compare also Meunier, *Comptes rend.*, 1916, 163, 332.

⁵ *Chem. Zeit.*, 1913, p. 753.

dissolved in 5 c.c. water) the solution is boiled for a time to remove arsenic, and to reduce the ferric to ferrous chloride. An excess of strong hydrochloric acid is then added, the solution diluted with about 300 c.c. hot water, hydrogen sulphide passed in, and the precipitate filtered off and thoroughly washed. A hole is made in the filter by means of a glass rod, the precipitate is washed back into the precipitating flask, and the metallic sulphides adhering to the filter paper, as well as the main bulk of precipitate, are brought into solution by treatment with nitric acid. The solution in the flask is then evaporated to dryness on the water-bath; the residue is again taken up by nitric acid and water, neutralised by ammonia, and dilute sulphuric acid is added in slight excess. When cold, the solution is filtered in order to remove any lead sulphate and other insoluble matter; the flask and the filter are washed by water containing sulphuric acid; 3 to 8 c.c. of nitric acid of sp. gr. 1.4 are added to the filtrate, and the copper is deposited electrolytically. From the weight of copper found, 0.01 per cent. is deducted for the simultaneously deposited bismuth and antimony.

List¹ burns the pyrites in a porcelain crucible of special shape, extracts the product by hydrochloric acid, neutralises with ammonia, adds sulphurous acid, and precipitates the copper as cuprous thiocyanate; this is oxidised by a mixture of sulphuric and nitric acids to sulphate, and the copper determined by electrolysis. Electrolytic methods for the estimation of copper in ores are also employed by Heidenreich² and Treadwell.³

For the electrolytic estimation in presence of arsenic, antimony, or bismuth, D. J. Demorest⁴ states that copper is entirely precipitated as cuprous thiocyanate from a solution containing ammonium sulphate, ammonium tartrate, and tartaric acid. The ore (1 gram, or more if the sample is low in copper) is treated according to the method given in the preceding abstract, using, however, 7 c.c. each of hydrochloric acid and nitric acid, 5 c.c. of sulphuric acid, 30 c.c. of water, and 2 grams of sodium sulphite. The precipitate of cuprous thiocyanate, after being

¹ *Z. angew. Chem.*, 1903, p. 416. ² *Z. anal. Chem.*, 1901, p. 15.

³ *Chem. Zeit.*, 1912, p. 961; *J. Chem. Soc. Abstr.*, 1912, 2, 998.

⁴ *J. Ind. Eng. Chem.*, 1913, 5, 216; *J. Chem. Soc. Abstr.*, 1913, 2, 342.

collected on a dense filter, is washed several times with a solution containing about 1 per cent. of potassium thiocyanate, and the same amount of tartaric acid. The precipitate is then dissolved in nitric acid (1 : 2), using as little as possible, the solution boiled to destroy all the thiocyanate, the volume made up to 125 c.c., and the copper estimated electrolytically.

A new modification of the electrolytic estimation of copper is given by F. G. Hawley.¹

The thiocyanate permanganate method is given by D. J. Demorest,² who modifies Guess's method of Grossmann and Hölter³ by oxidising most of the thiocyanate with alkaline permanganate and completing the oxidation with acid permanganate; a correction factor is thereby avoided.

The weight of ore taken should contain 0.05-0.3 gram of copper. It is heated for several minutes with 5 c.c. of concentrated hydrochloric acid, after which 10 c.c. of nitric acid are added, and the ore digested until completely decomposed; 10 c.c. of sulphuric acid (1 : 1) are added, and the whole evaporated until sulphuric acid fumes appear. It is then cooled, 50 c.c. of water containing 3 grams of tartaric acid added, and heated until all soluble salts are dissolved; again cooled, ammonia added until the liquid is a deep blue, and then acidified with sulphuric acid. After the addition of 1 gram of sodium sulphite, dissolved in 20 c.c. of water, the solution is heated nearly to boiling, and then a solution of 1 gram of potassium thiocyanate in 20 c.c. of water added, with vigorous stirring, to precipitate the copper. It is heated for some time to coagulate the precipitate and dissolve the tartaric acid, filtered through a Gooch crucible, washed well, and then 30 c.c. of a hot 10-per-cent. solution of sodium hydroxide run through the crucible in order to decompose the cuprous thiocyanate; and again washed well. The filtrate is warmed to 50°, and the thiocyanate present titrated with permanganate, spot-testing it from time to time with ferric chloride and hydrochloric acid. When the red colour in the spot-test becomes very faint, 30 c.c. of sulphuric acid (1 : 1) are added, all the man-

¹ *Eng. and Min. J.*, 1920, 110, 162-165; *J. Chem. Soc. Abstr.*, 1921, 2, 216.

² *J. Ind. Eng. Chem.*, 1913, 5, 215-216; *J. Chem. Soc. Abstr.*, 1913, 2, 341.

³ *J. Chem. Soc. Abstr.*, 1909, 2, 449.

ganese dioxide allowed to dissolve, and the titration finished with permanganate.

No elements interfere with the method except silver; any lead present is collected as sulphate after evaporating with sulphuric acid. The results are accurate.

A rapid process for the estimation of copper in roasted pyrites is given by Hermann Koelsch.¹

Estimation of Iron.

The ferric oxide of 0.5 gram pyrites cinders is dissolved by heating the burnt ore for some time with concentrated hydrochloric acid; the boiling solution is reduced by zinc, or preferably by stannous chloride, the excess of which is removed by addition of a little mercuric chloride; the solution of ferrous chloride thus obtained is poured into $\frac{1}{2}$ litre water, to which about 2 grams manganous sulphate and a drop or two of permanganate solution have been added. In this solution the iron is estimated by titrating with decinormal permanganate solution.

Estimation of Lead.

The lead remains in the shape of sulphate in the residue from treating pyrites with aqua regia.² It is extracted from this residue by heating with a concentrated solution of ammonium acetate; this solution is finally evaporated, with the addition of a little pure sulphuric acid, in a porcelain capsule, dried, and ignited.

Koch³ titrates the lead by sodium sulphide solution. Low⁴ dissolves the lead sulphate in sodium-acetate solution, converts it by addition of potassium bichromate into lead chromate, converts this by digestion with a hot solution of oxalic acid into oxalate, and titrates this by potassium permanganate.

2A. COAL-PYRITES

A certain quantity of pyrites is picked from coal, and is known as coal-pyrites or coal-brasses. If quite free from coal it is usually very rich in sulphur, and there are many firms

¹ *Chem. Zeit.*, 1913, 37, 735; *J. Chem. Soc. Abstr.*, 1913, 2, 729.

² *Vide text*, p. 115 *et seq.* ³ *Chem. Zeit.*, 1908, p. 124.

⁴ *J. Amer. Chem. Soc.*, 1908, p. 587.

in this country using such material in the manufacture of sulphuric acid, and a very good quality of acid is produced therefrom.

Owing to the great demand for pyrites during the War considerable quantities of coal-pyrites were recovered in America, and an article in the *Chemical Trade Journal* for 1917, p. 240, on the utilisation of pyrites in coal, states that the results of experiments on this subject have been published in Bulletin 51 of the University of Illinois. The cutting off, to a large extent, of the supplies of Spanish pyrites created new conditions in the American market, and experimental work was conducted with a view to obtaining pyrites clean enough for industrial utilisation, and also coal as a by-product. To meet the demands of purchasers of pyrites, a certain degree of purity is necessary. Perfectly pure pyrites should contain 53.45 per cent. of sulphur and 46.55 per cent. of iron. The pyrites found in Illinois coal, even when appearing perfectly clean, does not contain 53.45 per cent. of sulphur, as there is some impurity, probably carbon, generally combined or intimately mixed with it; thus a sample of apparently absolute purity would probably show by analysis about 50 per cent. of sulphur. In 1917, the demand was so great that some mines were shipping hand-picked pyrites without further cleaning, even though its content of sulphur was not so high as 40 per cent. Certain mines in Illinois have been abandoned owing to the high pyrites content of the coal.

The best sample showed 48.5 per cent. Samples from other States contained on an average 44 to 48 per cent. It is generally assumed that carbon dioxide exercises an injurious action in the lead-chambers, and for this reason coal-brasses have not been considered good raw material for the manufacture of sulphuric acid until quite recently. The statement that carbon dioxide is injurious arises either from inaccurate information, or from difficulties encountered in making sulphuric acid from roughly hand-cleaned coal-pyrites ore containing from 10 to 25 per cent. coal with its accompanying volatile matter. The maximum amount of carbon in pyrites concentrates allowed without penalty is generally 8 per cent. The total carbon content of several samples varied from 2.9 to 6.76 per cent.

In connection with storage, the tendency of coal-pyrites to fire spontaneously must be considered. It is well known that

hand-picked pyrites, containing, as it does, generous amounts of coal, takes fire quite readily during storage. Information covering storage, for long periods of time, of washed pyrites concentrates, which ordinarily contain less than 5 per cent. of carbon, are not available.

Spanish pyrites from Rio Tinto district contains an average of .91 per cent. arsenic. Pyrites recovered from coal-mining operations showed much less arsenic in six samples examined, the lowest being 0.005 per cent. and the highest 0.056 per cent. The results on these samples can be taken as fairly representative of coal-pyrites concentrates, and show that the arsenic content of this material is negligible.

The clinker or cinder remaining after burning off the sulphur from pyrites has been utilised as an iron-ore. The material is generally so fine that it requires agglomeration or nodulising, as well as roasting, to remove the remaining sulphur.

Several other factors determine its suitability for use as an ore of iron, but because of the present low phosphorus iron-ore situation, it was considered advisable to determine the amount of phosphorus present in coal-pyrites. Ten samples of coal-pyrites concentrates were obtained at pyrites washeries, and, from milling tests on half-ton lots of coal-pyrites ore, the analyses were made. The percentage of phosphorus found to be present in the pyrites varied from 0.003 to 0.083 in these concentrates. Seven of the samples contained less than 0.015 per cent. phosphorus, while four showed less than 0.008 per cent. phosphorus. It is apparent that a considerable portion of the burnt coal-pyrites cinders could be used for the production of low-phosphorus iron.

The results of the test made led to the conclusion that the practical separation of pyrites from Illinois coal for the purpose of obtaining a commercial grade, with coal as a by-product, presents no difficulties when performed by crushers, screens, and concentrating machines adapted to ordinary ore-dressing work. The chief problem is to secure a plant of the greatest simplicity and lowest cost. At the same time it should be of good capacity, and should yield a high percentage of recovery of the pyrites. The experiments indicate that a simple plant will recover about 81 per cent. of the pyrites in the coal, and that, if the middlings product from the jig is crushed and re-

treated, this recovery can be increased to about 87 per cent. This pyrites will average more than 40 per cent. of sulphur, and may be sold directly to chemical or fertiliser manufacturers. The coal recovered as a by-product is not greatly inferior to ordinary screenings.

The following extracts are from another article on the use of coal-pyrites, by H. F. Yancy, Assistant Chemist, Bureau of Mines.¹

A survey indicated that about 1,500,000 short tons of pyrites concentrates could be recovered from the coal-mining operations in the Eastern and Central coal-fields of the United States.

The preparation of samples for analysis and the determination of sulphur by various methods are fully dealt with, and very many were analysed.

The State of Ohio was represented by 47 samples, 24 of which contained less than 40 per cent. of sulphur. Only 4 per cent. of them contained less than 35 per cent. The best sample had a content of 51.2 per cent., which was the highest met with during the entire investigation. Thirty-six samples were collected in Missouri coal-mines; 22 per cent. of those examined contained less than 40 per cent., whilst only 5 per cent. contained less than 35 per cent.

3. ZINC-BLENDE

This mineral is now the principal zinc-ore. Previously to reducing the zinc, the blende must be roasted in order to convert it into ZnO, and this process was formerly carried out without attempting to deal with the enormous quantities of SO₂ formed. Legislation at last interfered with this procedure, which of course laid waste all the country round the zinc-works, and compelled measures to be taken for dealing with the noxious gases. Part of these are now used for the production of liquid sulphur dioxide;² mostly, however, they serve for the manufacture of sulphuric acid, so that blende has now become one of the more important raw materials for this purpose. The historical development of this industry will be related in Chapter IV.

¹ *Chem. and Met. Eng.*, **22**, 105-109; *J. Soc. Chem. Ind.*, 1920, p. 186A.

² *Cf.* Chapter IV.

Blende occurs in large quantities, for instance, in Silesia, Westphalia, Rhineland, Austria, Wales, the Isle of Man, Spain, Italy, France, New South Wales, the United States, in nearly all of which localities it is utilised for the manufacture of sulphuric acid.

Pure zinc-blende is a white transparent mineral ZnS , and contains 32.9 per cent. S and 67.1 per cent. Zn. The commercial ore is, of course, always impure and generally black or brown, and contains several per cent. of iron as amorphous FeS , and frequently some manganese.

If pyrites, FeS_2 , is present the sulphur assay rises.

Drasche analysed a blende from Carinthia: ZnS , 68.41 per cent.; PbS , 4.55; FeS_2 , 2.05; $ZnCO_3$, 2.40; $CaCO_3$, 8.93; $MgCO_3$, 10.62; Al_2O_3 , 0.63; gangue (principally quartz), 2.32 per cent.

Pennsylvanian blende, according to F. A. Genth: Sulphur, 32.69 to 33.06 per cent.; Zinc, 66.47; Iron, 0.38; Cobalt, 0.34.

Analysis of Zinc-blende.

The sulphur is estimated by the wet method as described, p. 100. In the roasted blende the same method must be employed, since the dry methods, *e.g.* Watson-Lunge's,¹ in this case give quite wrong results.

The estimation of the zinc contents of the blende does not concern us here; the methods used for that purpose are described in Lunge-Keane's *Technical Methods of Chemical Analysis*, 1908, vol. i., p. 289 *et seq.*, and *J. Soc. Chem. Ind.*, 1916, pp. 543 and 1094.

For the estimation of sulphur in zinc-blende and roasted blende, Koelsch² fuses 0.625 gram of blende, or 1.25 gram of roasted blende, with 15 grams sodium peroxide in an iron crucible. The cooled mass is dissolved in about 150 c.c. of water, the solution nearly neutralised by hydrochloric acid, diluted to 250 c.c., filtered, and the sulphuric acid estimated in 200 c.c. of the filtrate by precipitation as barium sulphate. The presence of a small quantity of silica in the ore does not appreciably affect the results. This process yields results coinciding with those obtained by fusing with potassium chlorate and sodium carbonates, and better results than dissolving in aqua regia, which

¹ Lunge, 4th ed., p. 104.

² *Chem. Zeit.*, 1916, 40, 174.

cannot be recommended, least of all for crude blende. The iron crucibles employed for the process above described, of 2 mm. thickness of plate and a capacity of 25 c.c., stand about twenty-five fusions. They are best placed in iron triangles, those of stoneware being quickly destroyed.

A rapid method for the *determination of sulphur in roasted blende* is described by Nitchie in *J. Soc. Chem. Ind.*, 1912, p. 30 *et seq.* It consists in heating the sample, preferably in a boat, by means of an electric tube furnace, in a current of air to about 1000° , absorbing the resulting oxides of sulphur in an excess of standard alkali solution and titrating the excess, phenolphthalein being used as an indicator. This method (which, according to Nitchie, does not answer for raw ores) occupies less than ten minutes from taking the sample to completing the titration, and may be entrusted to boys with but little training in chemical manipulation.

Hassreidter¹ tests roasted blende (1) for zinc sulphate, by extracting with warm water and estimating the zinc in the solution by Schaffner's method; (2) for sulphides, by boiling with a solution of 39 grams tin in 1 litre concentrated hydrochloric acid, and passing the gases containing H_2S through a ten-bulb tube charged with a solution of bromine in hydrochloric acid, where all the sulphur is retained as H_2SO_4 ; the latter is found by precipitation with barium chloride, after previously removing the excess of bromine and approximately neutralising with sodium carbonate.

F. Meyer² describes methods of analysis for sulphur in the cinders. As a quick method for checking the work, the foreman makes the following test:—he heats the cinders with 10 c.c. dilute hydrochloric acid (1 : 2) in a small flask, and places into the neck of this a slip of paper, moistened with neutral or faintly alkaline solution of lead acetate; from the depth of the brown colour produced on the paper he judges the state of roasting.

Max Liebig³ dissolves 2 grams of the cinders in aqua regia, by slowly heating in a flask, placed on a sand-bath in a slanting position. He then evaporates to dryness, dissolves in water acidulated with hydrochloric acid, filters, dilutes to

¹ *Z. angew. Chem.*, 1906, p. 137.

² *Ibid.*, 1894, p. 392.

³ *Zink und Cadmium*, p. 34.

200 c.c., places all the samples on a dark surface, adds an excess of 5/16 normal barium-chloride solution (of which, when working on 2 grams of cinders, each c.c. indicates $\frac{1}{2}$ per cent. S), and notes the number of seconds elapsing until the appearance of an opacity which admits of judging on the sulphur contents.

In samples containing 2 per cent. S or upwards the same author estimates the sulphur by the method of Wildenstein,¹ which consists in running in a solution of barium chloride, with application of a bell-jar filter. The solution contains 76.25 grams $\text{BaCl}_2 \cdot 2\text{H}_2\text{O}$ per litre; and 1 c.c. of it when working on a 2 grams substance indicates 0.5 per cent. sulphur.

Accurate Methods.—The estimation of the sulphur is carried out volumetrically by the method of Lunge and Stierlin (p. 103). In the presence of very much zinc it may happen that, in consequence of the precipitation of zinc oxide and carbonate during the titration, an opacity is produced which makes it difficult to recognise the exact point at which the colour of the methyl-orange is changed to the "intermediate" point. In such cases it is preferable to carry on the titration, both of the pure bicarbonate and of the solution finally obtained, until the indicator shows a decided *red* colour.

In the case of cinders containing upwards of 6 per cent. sulphur, the mixture is made as follows:—1.603 gram cinders, 2.000 grams sodium bicarbonate, 4 grams potassium chlorate, 2 or 3 grams ferric oxide, free from sulphur. If we designate the consumption of acid for the original bicarbonate = A, that for retitration = B, the per cent. of S in the cinders is $A - B$.

In many cases there is an understanding, binding both on the sellers and the buyers, that by "injurious" or "removable" sulphur the difference between the total percentage of sulphur (*a*), and that combined in the cinders with lead, calcium, magnesium, or barium to sulphates (*b*), is to be understood. The difference $a - b = c$ shows the sulphur still present in the cinders in the shape of zinc sulphate (*d*) and zinc sulphide (*e*). Since it is uncertain whether these metals are really present in the cinders in the shape of sulphides, Hassreidter² recommends the direct estimation of the "injurious" sulphur, *c*,

¹ Lunge-Keane's *Technical Methods of Chemical Analysis*, 1, 278.

² *Z. angew. Chem.*, 1906, p. 137.

by estimating the sulphur of zinc sulphate, d , and zinc sulphide, e ; therefore the sum $d + e$, in the following manner:—

Sulphur of Zinc Sulphate (d).—Extract in a $\frac{1}{4}$ -litre flask 25 grams of the cinders with water, fill up with water after cooling, filter, and estimate in 200 c.c. the zinc (+ any cadmium present) by the method of Schaffner. 65.37 parts of zinc correspond to 32.07 parts of sulphur present as zinc sulphate.

Sulphur of Zinc Sulphide (e).—Extract 2 or 3 grams cinders with a solution of 30 grams pure zinc in 1 litre of hydrochloric acid of sp. gr. 1.19, in a flask with reflux cooler at boiling-heat, and pass the H_2S thereby quantitatively liberated into a test-bulb, charged with 30 to 40 c.c. of a solution of bromine in hydrochloric acid, which causes the conversion of the H_2S into sulphuric acid. Brominated hydrochloric acid is, for this purpose, preferable to hydrogen peroxide, because it admits of following the progress of the reaction in the test-bulb by the gradual decolorisation of the reagent, so that it is always possible to recognise whether the oxidising agent had been employed in the necessary excess. After removing the excess of bromine and approximately neutralising the hydrochloric acid with sodium carbonate, the sulphuric acid is precipitated by barium chloride.

Some descriptions of blende contain aluminates and silicates of zinc, which pertinaciously resist the action of aqua regia.

Lindt¹ describes the injurious effect of sulphur, whether as sulphide or sulphate, in roasted blende on the manufacture of zinc, which makes it necessary to test for it.

Presence of Impurities.

In some ores the presence of substances which interfere with the desulphurising is important: lime, magnesia, strontia, and baryta, if combined with sulphur, retain it in the roasting-furnace; if combined with carbonic acid, this is driven off, and in some cases the lime, etc., will take up sulphur from the ore. In considering the sulphur contents of roasted blende, allowance must be made for this combined sulphur. Lead becomes a nuisance in hand-rabbles furnaces, but Ridge² says that he

¹ *Metall und Erz*, 1915, p. 335; *Z. angew. Chem.*, 1915, 2, 613.

² *J. Soc. Chem. Ind.*, 1917, p. 676.

found no trouble in properly designed furnaces, for if ore high in lead is treated continually, an accretion will form on the hearths, but the rabblies can be made to remove this. High iron content is found in some Spanish and German ores and makes complete roasting in hand furnaces almost impossible; in Germany, he was able, in a mechanical furnace, to reduce the sulphur left in the roasted ore more than 1 per cent. below that possible in hand furnaces.

Most zinc-ores offer the advantage of being free from arsenic, but on the other hand they frequently contain fluorine, of which even as little as 0.01 to 0.02 per cent. becomes noticeable. Fluorine occurs with the ore as calcium fluoride, which is decomposed in the roasting-furnace in the presence of silica and forms silicon fluoride. If this gas passes into the Glover tower it is decomposed and hydrofluosilicic acid is formed; this, in turn, appears to split up. As it is usual, when treating zinc-ores, to circulate the tower acids, the fluorine contents seem to remain in the circuit, so that the attack on the packing of the towers gradually increases, but, contrary to expectation, Ridge found no increased corrosion of the lead-work of the chambers by fluorine. Many efforts have been made to overcome the trouble with the packing. Glover towers have been built entirely of lead, and with lead sheets as a packing, so as to avoid the use of silicious material; but it is found necessary in this case to use two Glover towers in series, the first one being an empty tower followed by a tower filled with suspended lead sheets. Ridge found it preferable to overcome the trouble by passing the whole of the chamber acid through the towers instead of only circulating the tower acids, and by this means keeping down the fluorine contents of the acid; and at the same time to pack the towers with a well-burnt brick packing of a suitable composition which would offer the maximum possible resistance to the attack of hydrofluoric acid. Glover towers built in this way, and properly operated, have been worked continuously for twelve months and longer without trouble.

Other important impurities affecting sulphuric acid manufacture are antimony, mercury, and chlorine.

Some years ago Ridge experienced trouble in consequence of the unexpected presence of chlorine, and on investigation

he found that this was due to the ore having been left lying for several months on the wharf at Port Pirie, and sprayed with sea-water in order to avoid loss by windage.

Mercury is found in some Spanish blendes. It collects at the outer parts of the dish of the lead-chamber where unprotected by lead sulphate, and causes rapid corrosion of the lead. This can be overcome by lining the sides of the dish with thin brickwork.

Antimony occurs frequently in small quantities with zinc-blende, and at the high temperature of the roasting furnace some of this is volatilised and passes into the acid. On one occasion Ridge received serious complaints about the presence of arsenic, but found, on examination, that antimony was the cause of the trouble. Antimony was found in the zinc concentrates from Broken Hill when treating ore from the upper levels in one of the mines, but the quantity present was less than 0.03 per cent.

Most zinc-ores have lead associated with them, and some of this is generally driven off with the sulphur in the roasting-furnace together with the silver which is combined with the lead; but both the lead and the silver are deposited in the chamber sludge.

The lead-chamber process, when working with hand furnaces, has to be carefully watched because of the intermittent evolution of sulphur dioxide in consequence of intermittent rabbling of the ore. In Germany it has been usual to reduce this difficulty by arranging for the furnace hands, working on the different furnaces, to start their shifts at different times; but, in spite of this, it is not possible to obtain a continuous current of uniform gas throughout the twenty-four hours, and, unless the process is watched carefully, loss of nitre is the result. With modern mechanical furnaces this trouble does not occur.

The design of the chamber plant does not call for special comment. It is in every way similar to that used when burning pyrites.

The nitre composition, and working cost of the plant, are not higher than with pyrites.

Eugene Prost¹ states that it is generally admitted that

¹ *Bull. Soc. chim. Belg.*, 1911, 25, 103-115; *J. Chem. Soc.*, 1911, 2, 283.

lime contained in zinc-blende is converted into sulphate during the roasting, but some metallurgists have maintained that during the operation the sulphate thus formed is decomposed for the most part, and that the sulphate existing in the roasted blende is present as zinc sulphate. The latter view is contrary to what would be expected from a knowledge of the behaviour of the sulphates of calcium and zinc at different temperatures, but it is impossible to disprove it by analysis of the roasted ore, since on extraction with water any zinc sulphate which may be present would react with the lime, forming calcium sulphate. The author has therefore carried out a series of experiments with a pure Transvaal blende containing only 0.74 per cent. of lime.

Two experiments were generally carried out side by side, the one consisting of roasting the pure ore, the other of roasting the ore mixed with a certain proportion of pure lime, or of lime mixed with known quantities of silica, lead oxide, or iron oxide. From the analyses of the resulting products, conclusions could be drawn as to the amount of calcium sulphate present.

In the first set of experiments, the roasting was done in a muffle at a temperature of 1025-1050°, that is, 100-250° higher than the temperature in a zinc furnace. The results show that at least 71-85 per cent. of the lime is present as sulphate. Similar results were obtained in a second series of experiments, in which the mixtures were heated in a Delplace zinc-blende furnace.

Attempts to find a method for analysing a mixture of lime and zinc sulphate were unsuccessful.

In Lunge's fourth edition it is stated that the sulphuric-acid works recently refused to accept blende containing *fluorides*. Truchot¹ states that blende nearly always contains calcium fluoride, ranging from a few grams to 250 to 300 grams per 100 kg. Lead is attacked notably by sulphuric acid of 53° B. containing small quantities of hydrofluoric or hydrofluosilicic acids, and it appears certain that the life of the chambers and more so that of the first tower, and that of the Glover tower, must be considerably shortened by the use of blende containing fluorine.

¹ *J. Soc. Chem. Ind.*, 1911, p. 207.

Delplace (Ger. P. 200747) removes the fluorides from blende by heating the ground mineral with sulphuric acid, if necessary with additions of silica in the form of powdered glass or quartz; the fluorine compounds are recovered and utilised.

Jensch¹ shows by analyses that the sulphur in *roasted blende* is mostly contained therein in the shape of ferrous sulphide; when roasting down to 2 per cent. S, no ZnS is present, and it is therefore quite unnecessary to drive the roasting down to 0.5 per cent. S, as is sometimes demanded.

Statistics.

Ridge² made the following statement: "In America 14 zinc smelters make sulphuric acid, but they mainly use the contact process."

Calculated at 60° B. acid, the American production from zinc-blende was:

In the year 1911	.	.	.	230,643 short tons.
„ 1912	.	.	.	292,917 „
„ 1913	.	.	.	296,218 „
„ 1914	.	.	.	411,911 „
„ 1915	.	.	.	484,942 „

The use of the contact process for fumes from zinc-ore made the biggest strides in the United States, because there the smelters are largely able to rely for their ore supplies upon the produce of one or more mines, and are not dependent upon small parcels of ore shipped from various parts of the world, as has been the case here and on the Continent. They have consequently been able to make provision for eliminating any harmful ingredients which may be present in the raw material which they expect to be treating over a long period. The American smelters also have the advantage of having practically no hand-rabbed furnaces.

In England, acid has only been made from zinc-ore in three plants, and Ridge estimates that their output does not exceed 25,000 tons a year of 140° Tw. acid. This tonnage corresponds to a production of about 10,000 tons of spelter. In 1913, 31,290 tons of virgin spelter was made in the country. Part of this was made from calamine, but the

¹ *Z. angew. Chem.*, 1894, p. 50.

² *J. Soc. Chem. Ind.*, 1917, p. 676.

134 MATERIALS OF SULPHURIC ACID MANUFACTURE

available supplies of this ore are steadily decreasing, and it is only a question of a short time when the whole of the metal will have to be smelted from zinc-blende. The position is really worse than is indicated by these figures, because it has been customary to roast the sulphide ore in reverberatory furnaces from which the fumes cannot be used, so that sulphur is wasted and the atmosphere polluted.

To illustrate the importance of the utilisation of the sulphur of zinc-ores, Ridge refers to the figures for Upper Silesia. The district produces about 60 per cent. of the spelter made in Germany, but a good deal of calamine is still available there, so that the maximum production of sulphuric acid from blende has not been reached ; the tonnage of *calamine* treated steadily decreases, but the increased amount of blende compensates for this, and allows a steady increase in spelter and acid production. The last figures available are for 1911, and the accompanying table shows the result for every fourth year since 1887.

Statistics from Upper Silesia.

Year.	Raw Blende roasted. Metric tons.	Sulphuric Acid reduced to 50° B. Metric tons.
1887	53,882	21,013
1891	66,236	32,676
1895	84,857	33,229
1899	123,602	64,029
1903	187,596	104,268
1907	421,006	139,840
1911	411,352	213,317
1912	...	254,008

Six works still used their old reverberatory furnaces, so that all the sulphur could not be utilised, but for some years factory legislation has prohibited the emission of noxious fumes, and as the plants become worn out they have to be replaced by modern installations. The fumes of the reverberatory furnaces are scrubbed with milk of lime, which is sent to waste.

In 1913 in Germany 554,760 metric tons of blende was roasted for making sulphuric acid ; of this 87,439 tons was imported from Australia and 56,181 tons from other countries.

In Belgium, blende is mainly roasted by the chemical

manufacturers, who retain the sulphur and receive from the zinc smelter in addition a payment per 1000 kilos. for roasting the ore.

The most important and serious factor for consideration here in England is the shortage of zinc-smelting capacity in the country. In 1913 our consumption of spelter amounted to no less than 224,000 tons, of which 74 per cent. was imported. After allowing for the metal made by the refiners, we imported about 166,000 tons of spelter and zinc in other forms. If this quantity were all made from blende, the roasting-fumes could be used to produce annually 400,000 tons of 140° Tw. acid. There is no reason why this should not be done and the corresponding quantity of brimstone and non-cuprous pyrites displaced, as well as a portion of the pyrites which is low in copper.

Zinc-ore must be treated because spelter is required, and if the work is not done here it will have to be done elsewhere. Cheap sulphuric acid has always been an important factor in the chemical industries, and unless we use the resources of the Empire others will do it for us, and we shall be obliged to look on while the foreign subsidiary industries using the acid go ahead.

According to the *Bull. Imp. Inst.*, 1915, 13, 611-634, after the outbreak of war the demand for zinc increased enormously, whereas the British supply, most of which had previously come from Germany and Belgium, was considerably reduced.

In the United Kingdom little zinc is found, and the quantity of sulphuric acid made from blende is insignificant in comparison with that produced from pyrites or spent oxide. About 20,000 tons of zinc-ore is produced per annum, chiefly in Cumberland, Northumberland, Isle of Man, Wales, and Dumfriesshire and Lanarkshire. Deposits of zinc-ores occur in various parts of Canada, and efforts are now being made to develop the zinc-smelting industry. Zinc-ore is also found in Queensland, Tasmania, New Zealand, Newfoundland, Egypt, Nigeria, Rhodesia, and S. Africa, and, associated with copper-ore and galena, at Tsumeb in the former German colony of South-west Africa. The most important deposits in the British Empire are those at Broken Hill, N.S.W., where, by

136 MATERIALS OF SULPHURIC ACID MANUFACTURE

concentration and separation processes, two chief products are obtained, viz. zinc-ore containing about 45 per cent. Zn and 5 per cent. Pb, and lead-ore containing 65 per cent. Pb, 6 per cent. Zn, and varying quantities of silver. Except for the small quantity of ore smelted at the plant of the Broken Hill Associated Smelters at Port Pirie, S. Australia, and about 20,000 tons exported to England and smelted at the Sulphide Corporation's works at Seaton Carew, the whole of the Broken Hill production was formerly shipped to the Continent.

The imports of zinc-ore into the United Kingdom during 1912-14 were as under:—

From	1912.	1913.	1914.
	Tons.	Tons.	Tons.
Australia	20,611	16,772	78,503
Italy	13,963	13,801	23,280
Algeria	8,707	9,302	6,929
Germany	5,004	7,169	5,190
France	3,408	4,337	3,175
Spain	8,417	6,348	6,474
Russia	21	315	6,436
Japan	1,190	5,191
Other countries	7,208	5,346	9,073
Totals	67,339	64,580	144,251

The increase of imports to Great Britain in 1914 is due to shipments being diverted or captured at the outbreak of war, and only part of the ore was treated in the country.

In Germany the quantity of acid produced from blende does not suffer sensibly from that produced from pyrites. In Belgium, on the other hand, 65 per cent. of the total production of sulphuric acid was made from blende, explainable by the fact that Belgium produced annually nearly 200,000 tons of zinc, representing a quantity of blende to be desulphurised of about 450,000 tons. So considerable a production would be possible only with difficulty, if the Belgian zinc-works were obliged themselves to desulphurise all the blende treated in the zinc furnaces. That is why these factories have working arrangements with the acid-works, more or less in their vicinity. The latter receive the raw blende, extract the sulphur, and then return the roasted blende to the zinc works.

Uses of Zinc.—About 80 per cent. of the world's output

is consumed in the process of galvanising, other important uses being the manufacture of alloys, pigments, the de-silverisation of lead, and precipitation of gold from cyanide solutions.

4. BY-PRODUCTS OF OTHER MANUFACTURERS

a. Spent Oxide from Gasworks.

We have already (*supra*, p. 34) treated of this oxide as a material for obtaining free sulphur. We shall now describe it in respect of its application for the manufacture of sulphuric acid, which is carried on in many places.

Coal-gas is universally purified from sulphuretted hydrogen by passing it over hydrated ferric oxide. The H_2S of coal-gas is due to the presence of pyrites, contained in the coal, the S of which appears in the gas mostly as sulphuretted hydrogen. Most works remove this from the gas by a mixture of hydrated iron oxide and sawdust. In this case sulphide of iron and sulphur are formed, according to the equation

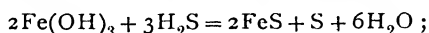

and when the mass, having become inactive, is exposed to the air, it again passes over into ferric hydroxide, more sulphur being precipitated, thus :

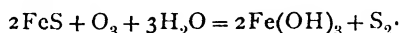

The hydroxide thus reproduced and mixed with sawdust is again used in the purifiers, and is regenerated about thirty or forty times over before the sulphur has accumulated therein to such an extent that the mixture does not work any longer ; it is then replaced by fresh oxide, and the spent material is passed over to vitriol-makers.

Phipson states the composition of such a mass to be :—

Water	14 per cent.
Sulphur	60 "
Organic substance insoluble in alcohol .	3 "
Organic substance soluble in alcohol (calcium ferrocyanide and sulphocyanide, ammonium sulphocyanide, ammonium chloride, hydrocarbons)	1.5 "
Clay and sand	8 "
Calcium carbonate, ferric oxide, etc.	13.5 "

If the oxide contains considerable quantities of cyanides, it

may cause great trouble in the manufacture of sulphuric acid (31st *Alkali Report*, p. 89).

Hot water extracts the ferrocyanides and sulphocyanides, together with ammonium chloride; the solution can be evaporated to dryness, and the residue separated by alcohol into insoluble calcium ferrocyanide and soluble sulphocyanide and chloride.

The following table gives the composition of spent oxide, proceeding from different raw materials:—

	Precipitated Fe(OH) ₃ .	Bog-iron- ore.	Copperas.	Bad oxides.
Ferric hydroxide	17.74 to 19.36	15.96 to 26.42	5.04 to 6.84	8.72 to 20.40
Sawdust . . .	1.98 ,, 4.72	1.14 ,, 3.72	1.04 ,, 3.24	2.16 ,, 9.76
Calcium carbonate	0. ,, 1.04	0. ,, 1.73	0.	0. ,, 10.36
Ammonium sul- phocyanide . .	1.99 ,, 2.74	0.94 ,, 1.93	1.98 ,, 3.41	1.18 ,, 4.72
Ammonium ferro- cyanide . . .	trace	trace ,, 0.21	0.27 ,, 0.64	trace ,, 0.44
Tarry matters .	0.72 to 1.22	0.92 ,, 1.14	0.72 ,, 1.18	0.55 ,, 1.04
Sulphur . . .	62.44 ,, 67.18	48.76 ,, 57.44	48.76 ,, 55.74	32.42 ,, 42.16
Insoluble in di- lute HCl . . .	3.66 ,, 5.47	9.74 ,, 11.42	7.82 ,, 12.68	12.12 ,, 20.71
Prussian blue	trace ,, 0.17	trace ,, 1.74	trace ,, 0.64
Calcium sulphate	trace ,, 1.43	0. ,, 3.23
Ammonium sul- phate	12.78 ,, 16.72	0. ,, 1.14
Moisture (by diff.)	4.72 ,, 5.76	7.22 ,, 10.82	7.98 ,, 9.22	7.49 ,, 33.41

From these analyses it can be seen, first, that it is decidedly best to extract the mass at first with water, in order to remove the ammonia compounds, which are in themselves valuable, and which, if they get into the chambers, destroy a good deal of nitre (their value is certainly greatly lessened by the sulphocyanide); secondly, that sometimes a considerable quantity of calcium carbonate is present, which may get into it at the gasworks by lime being added, on purpose or by mistake, and which, of course, retains an equivalent quantity of sulphur in the shape of gypsum. In fact, a sample of the residue left after burning contained:

Insoluble . . .	33.386	Calcium sulphate . . .	13.315
Ferric oxide . . .	52.399	Sulphur . . .	0.200

These impurities (which cause a loss by retaining sulphuric acid) and the sulphates present from the first (which are not available) must be allowed for in *analysing* the gas-oxide.

The *burning* of gas-oxide is usually performed in shelf-furnaces similar to those used for pyrites-smalls. They will be described in detail in Chapter IV.

The rational treatment of spent oxides for the purpose of obtaining ammonium salts, ferrocyanides, and sulphocyanides is described in Lunge's *Coal-Tar and Ammonia*, 5th edition (1916), p. 1206.

According to the *41st Alkali Report*, p. 105, the manufacture of sulphuric acid from spent oxide requires very close watching, on account of the variation in the nitrate-consuming compounds which it contains. Certain kinds of spent oxide cannot be burnt without seriously disorganising the chamber-process, unless the oxide is first washed.

Messel¹ states that so far he had not been successful in working with the spent oxide of gasworks (referring to the catalytic process). It has the advantage of relative freedom from arsenic, but the drawback of producing an acid which is not so bright and colourless as that made from pyrites. The colour is due to the organic matter in the raw material, and to the formation of nitric oxide from its nitrogenous constituents.

Koppers (B. P. 21385, 1913) exposes the spent oxide to the action of steam and gases at a temperature below that of the volatilisation of sulphur, in order to destroy the organic substance. The ammonia contained in the escaping gases is absorbed; the gases are superheated and conveyed back into the apparatus.

Other processes: Burkheiser (Ger. P. 235870); Feld (described by Lepsius, *Z. angew. Chem.*, 1914, i., p. 234); Fritzsche (Ger. Ps. 250243, 251353); Soc. H. Gouthrière (Ger. P. 245570); Akt.-Ges. f. chem. Industrie and Wolf (Ger. P. 248001).

Ciselet and Deguide (Ger. P. 288767) dissolve the ferric hydrate by sulphuric or hydrochloric acid, leaving the free sulphur and the ferrocyanides behind and separating these in the well-known manner.

Analysis of Spent Oxide.

Sulphur.—This, according to Davis, was formerly done by extracting by means of carbon disulphide, evaporating the

¹ *J. Soc. Chem. Ind.*, 1912, p. 856.

140 MATERIALS OF SULPHURIC ACID MANUFACTURE

solution, and weighing the sulphur; but, as the presence of tarry matters causes an error, Davis now makes the analysis by burning the sulphur in a current of air in a combustion-tube of Bohemian glass, conducting the SO_2 formed into an absorbing-apparatus filled with iodine solution, and retitrating the unaffected iodine by a solution of sodium thiosulphate.¹

Pfeiffer² estimates the S in spent gas-oxide by burning 1 gram in a bottle filled with oxygen, containing 25 to 50 cm. normal NaOH solution. If the sample should not take fire, it is taken out, glycerine is poured over it, a priming-match is put in, which is lighted and the sample put back into the bottle. When the combustion is completed, 1 c.c. of neutral hydrogen peroxide is put in, and the NaOH in excess titrated with acid and methyl-orange.

Myhill³ points out that errors may arise in the estimation of the sulphur by extraction with carbon disulphide, if a little CS_2 remains with the sulphur, which may enter into the reaction

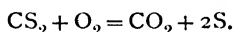

Davis and Foucar estimate the free sulphur by converting it into thiocyanate by means of an alcoholic solution of sodium cyanide, and titrating the thiocyanate with silver nitrate in the well-known manner.⁴

The Spent Oxide Association advise the following procedure:—

SAMPLING

Samples sent for quotation purposes are often assumed to represent bulk deliveries. This is almost impossible to be the case, as the bulk of the oxide may subsequently dry further or become damper owing to exposure. It is also possible that portions of the heap of oxide which contain more or less sulphur may have become covered up and not included in the sample, however carefully taken. The spent oxide should, therefore, for invoicing purposes, be again sampled during loading and the greatest care taken to obtain correct proportions

¹ *Chem. News*, 36, 190; cf. also Zulkowsky's process, p. 106.

² *J. Gasbeleucht.*, 1905, p. 977.

³ *J. Chem. Soc. Abstr.*, 1914, p. 234.

⁴ *J. Soc. Chem. Ind.*, 1912, p. 100.

of lumps and fines, as these may contain different percentages of sulphur.

When deliveries are being made, daily samples are to be taken from every cart or wagon and collected in an air-tight receptacle. It cannot be too strongly emphasised that samples *must not* be allowed to lie about exposed to the risk of drying, but must be mixed, ground, and bottled each day. When the delivery of the parcel is completed all the daily samples are to be *at once* mixed and broken down, and for this purpose coning and quartering is the best method. The well-mixed oxide is poured several times on to a given centre ; this ensures an even distribution of both lumps and fines in the form of a cone. The cone is then flattened and quartered. Two opposite quarters are discarded and the remainder again mixed, coned, and quartered until the quantity is reduced to a convenient amount. This is now crushed until it will *all* pass through a $\frac{1}{4}$ -in. mesh sieve, and *at once* bottled.

The above operation must be carried out as quickly as possible to avoid alteration in the moisture content of the sample.

Samples should be of at least $\frac{1}{2}$ lb., and must be packed in air-tight bottles or tins ; no other receptacle may be used. In taking the necessary samples, one must always be sealed and retained for reference.

Before carrying out the analysis, the *whole* of the sample is further intimately mixed and broken down and reduced to about 100 grams, which is ground so that the whole quantity passes through a 20-mesh sieve.

ANALYSIS

Moisture.—Five grams are dried for three hours at 100° in a water oven. The loss of weight found on cooling and re-weighing represents the moisture.

Sulphur and Tar.—The dried residue from the moisture determination is to be extracted for two hours in a Soxhlet's apparatus with freshly distilled carbon bisulphide. The carbon bisulphide is then distilled off, the flask cautiously blown out with air and dried for two hours at 100° in the water oven. The flask is then placed on a hot sand-bath until the sulphur

has just fused, care being taken that no loss by overheating and volatilisation takes place. After the flask has cooled completely it is again carefully blown out with dry air and again weighed.

Estimation of the Sulphur.—15 c.c. of concentrated (95 per cent.) sulphuric acid are poured on to the sulphur and tar in the flask, and the whole is heated for two hours at 100° in a water oven. After cooling, the contents of the flask are diluted with water, filtered, washed free from acid, and dried. The dried filter paper with contents is placed in a Soxhlet's tube and again extracted with carbon bisulphide. The bisulphide is distilled off, and the residue fused exactly as described above.

(In order to expedite the extraction by CS_2 , the following alternative method gives reliable results:—Place the 5 grams of dried spent oxide in a beaker with 25 c.c. of strong sulphuric acid and heat for four hours at 100° . Carefully dilute with distilled water, filter and wash free from acid, dry and extract with CS_2 in the usual way. Only one extraction with the solvent is necessary.—W. W.)

b. Sulphuretted Hydrogen.

The sulphur contained in Leblanc *alkali-waste*, in the form of calcium sulphide, has been frequently proposed for the manufacture of sulphuric acid, nearly always after having first converted it into *sulphuretted hydrogen*. The only successful process in this line (the Chance process of treating alkali-waste) belongs to the domain of alkali-manufacture, and cannot be treated in this volume; it is described in Lunge's third edition, vol. ii., pp. 945 *et seq.* (1909). Only the contrivances for *burning* the hydrogen sulphide will be described in Chapter IV.

*The sulphuretted hydrogen given off in the manufacture of sulphate of ammonia*¹ is sometimes used for the manufacture of sulphuric acid. Here the H_2S is not merely diluted with a large quantity of inert gases, but is also of very unequal concentration.

The utilisation of such H_2S for the manufacture of sulphuric acid has, however, been greatly improved, and is now no longer a rare exception, but is practised in a good many English works. If the gas is properly introduced

¹ Cf. Lunge's *Coal-Tar and Ammonia*, 5th edition, p. 1499.

into the burner,¹ the consumption of nitre is not excessive, and it is even possible to increase the heat by this means, if the spent oxides should not suffice for this purpose. The effect of the large quantity of carbon dioxide accompanying the H_2S in the case of sulphate-of-ammonia works would seem to consist only in requiring a certain amount of chamber-space, contrary to the opinion reported in Chapter IX.

Pintsch, Strache, and Hiller (Ger. P. 283601) cause the oxidation of hydrogen sulphide into sulphuric acid without any separation of free sulphur, by passing the gases containing H_2S into a hot solution of ferric sulphate, containing an excess of sulphuric acid, in which the regeneration of the ferric sulphate from the ferrous sulphate formed is brought about by air or oxygen, either at the same time or turn by turn. The sulphur separated in the first instance dissolves in the hot sulphuric acid, which is thereby partially reduced to sulphurous acid; the latter again reduces the ferric ion, being oxidised into sulphuric acid. The sulphuric acid made in this way contains iron; it can be used for most purposes, including the absorption of ammonia, in which case, on reaching the point of neutralisation, the ferrous sulphide, which is now stable, is separated from the solution of ammonium sulphate, and is regenerated into sulphate by being again introduced into the oxidising solution.

c. Copper-pyrites, etc.

Copper-pyrites and mixtures of this with blende, galena, etc., are roasted in several places in kilns so as to utilise the SO_2 in acid-chambers—at Chessy near Lyons, at Oker in the Harz, at Mansfield, and at Swansea. At Freiberg the Mulden and Halsbrücke works proceed in the same way; but they only utilise ores and products pretty rich in sulphur for vitriol-making.

The following particulars respecting the materials burned at the Government works at Oker in 1901 were communicated to Lunge from an official source. The ores are:—

¹ Cf. Chapter IV.

144 MATERIALS OF SULPHURIC ACID MANUFACTURE

	Lumps.	Other forms.	Total.
	Tons.	Tons.	Tons.
Copper-ores, No. 1 . . .	1,205	895	2,100
" 2 . . .	4,095	88	4,183
" 3 . . .	1,417	73	1,490
Mixed ores . . .	7,916	3,770	11,686
Pyritic lead-ore . . .	805	64	869
Copper-matte . . .	6,288	...	6,288
Lead-matte . . .	3,377	...	3,377
"Spurstein" (regulus)	1,620	1,620
Total . . .	25,103	6,510	31,613

Composition of these materials :—

	Copper-ore.			Mixed ore.	Pyritic lead-ore.	Copper-matte.	Lead-matte.	Refr.
	1.	2.	3.					
Cu .	17.70	9.70	4.75	4.60	1.05	30.47	18.20	64.38
Fe .	23.00	30.40	33.50	12.40	24.50	21.40	21.70	8.93
Zn .	9.50	5.80	4.90	21.50	15.50	8.75	15.00	1.34
Pb .	3.70	2.40	1.75	10.05	6.75	5.80	7.10	2.95
S .	32.00	36.00	40.50	24.00	34.00	18.70	17.00	20.70

Apart from pure pyrites, the "ordinary ores" are best adapted for vitriol-making, because they contain their sulphur mostly as FeS_2 ; the "mixed ores" are less favourable, on account of their galena, and the rich copper-ores on account of their large percentage of copper. Of the lead-ores only those amply permeated by pyrites are fit for vitriol-making. The sulphur in the ores worked at Oker varies from 20 to 40 per cent.; on an average it is 30 per cent.; but it must be noticed that the sulphur of the galena is altogether unavailable for vitriol-making. The case is not much better when copper-pyrites with a high percentage of copper predominates, because this furnishes too poor a gas, and, moreover, decrepitates and falls to powder in roasting. If no more than 35 per cent. of copper-pyrites is mixed with iron-pyrites, it does no harm. Blende behaves in a similar way, but rather more favourably; ores containing 35 per cent. blende along with 25 per cent. pyrites yield gas quite adapted for vitriol-making.

In the *Eng. and Min. J.*, 1904, lxxviii., p. 216, there is a report on the utilisation of the sulphur contained in the Broken

Hill ore, as treated by the Carmichael-Bradford process. The raw material is mixed with 15 to 25 per cent. gypsum, the mixture is broken up to the size of marbles and roasted in converters in such manner that the temperature in the lower part reaches 400° to 500° . When air is passed through it, SO_2 is given off, partly also from the gypsum, and the gases are passed into lead chambers, where about 350 kg. of sulphuric acid is recovered from 1 ton of ore, containing 14 per cent. sulphur. The plant at that time yielded 35 tons chamber acid per week, and it was to be enlarged.

"*Coarse metal*" of copper-smelting is roasted for the manufacture of sulphuric acid at Mansfield. A product containing 34 per cent. Cu, 28 per cent. Fe, and 28 per cent. S, according to Bode, yields gas with $5\frac{1}{2}$ per cent. by volume of SO_2 , and at a sufficiently high temperature to work with the Glover tower. In most cases, up to the present, coarse metal cannot be roasted so as to utilise the SO_2 .

Galena is of little use as a raw material for sulphuric acid manufacture. The purest galena contains only 13.4 per cent. of sulphur; it is transformed into lead sulphate on roasting, and only at the strongest white heat gives off a portion of its sulphur as SO_2 ; moreover, the metallurgical processes to which it is subjected are of such a nature that only poor gas can be produced from it.

Lead-matte is used for the manufacture of sulphuric acid—for instance, at Freiberg and in the Lower Harz; it is there roasted in large kilns of $12\frac{1}{2}$ tons capacity. The matte loses half its sulphur, and yields gas with 4 to 6 per cent. of SO_2 ; the temperature, according to Bode, is high enough for the Glover tower. In the Upper Harz the utilisation of its sulphur in metallurgy has in general not been found practicable.

5. OTHER METALLIC SULPHIDES—NOXIOUS VAPOURS

Pyrites proper has hardly any other application than that for sulphuric-acid making, and it is obtained almost exclusively for this purpose. In the case of cuprififerous pyrites, the sulphur constitutes only a portion, but a very considerable one, of its value. The working of poor copper-ores would not pay, apart from the noxious effect of the gas produced in calcining

the ore, unless the price of the ore were very moderate; and this is only possible by the acid-makers paying on their part for the ore, which they can well afford, as most kinds of cuprous pyrites behave very well in the burners, and yield quite as much acid in proportion to their percentage of copper as the non-cuprous ores. The case of zinc-blende is now similar to that of cuprous pyrites.

The case is different with most other sulphuretted ores occurring in smelting operations, such as *galena*, the many *mixed ores* containing blende and galena, besides iron- and copper-pyrites; the richer *copper-pyrites* themselves, and, lastly, the intermediate products, "*coarse metal*," "*matte*," etc. These, for their metallurgical utilisation, equally require a calcination evolving sulphur dioxide; but the matter is very different here from what it is with a good pyrites, whether it be pure iron-pyrites or containing a few per cent. of copper. On the whole, all those ores and metallurgical products are much poorer in sulphur than ordinary good pyrites; and for this reason they are less easily calcined in such a manner as to allow of utilising the gas, because the evolution of heat by the combustion of their own sulphur is not sufficient to maintain the process energetically. An external stimulus was required before smelting-works would seriously attempt to utilise the sulphur dioxide contained in the gas from calcining the ores; and this proved to be the damage and nuisance caused by the *noxious vapours* all round the works. The claims for damages, the law-suits, and the measures taken by the authorities at last made it impossible in many places for the works to go on in the old way; and although it appeared at first as if the sulphurous acid could not be condensed at all in this case, or only at a loss, practice has now succeeded in fulfilling the task in most (but not in all) cases, principally by the construction of improved burners, which will be described in Chapter IV. It would undoubtedly be too much to say that the task has been solved in all its parts; the success has mostly been only partial. In many cases where an ore could not possibly have been calcined so as to utilise the gas, mixing others with it has been resorted to. Thus the Halsbrücke works, near Freiberg, roast galena and blende mixed with pyrites; and in 1870 they made 8000 tons of sulphuric acid from the gas.

In reference to the sulphur dioxide escaping as noxious vapour, Leplay¹ mentions that in South Wales annually 46,000 tons of sulphur escaped into the air as sulphur dioxide, together with arsenic, fluorine, lead, and zinc compounds, in spite of the condensing-chambers. In fact, the country round Swansea was stripped of all vegetation. At Freiberg the works in 1864 paid upwards of £2750 damages on account of their vapours; in 1870, after better condensation had been effected, only £239. It should not be forgotten that sulphur dioxide occurs in very large quantity, although in a much more dilute state, in all coal-smoke, and consequently in the atmosphere and the rain-water of all large towns, and that the most perfect "smoke-combustion" cannot do away with this. Much more injurious than the vapours escaping through high chimneys, which are soon diluted with air, is the smoke from brick-works, coke-ovens, and other fires which emit their smoke at a low height above the ground. Fletcher calculated that at St Helens the acids escaping amounted :

From fire-gases	.	.	.	to 800 tons per week.
„ copper-works	.	.	.	„ 380 „ „
„ glass-works	.	.	.	„ 180 „ „
„ alkali-works	.	.	.	„ 25 „ „

Similar calculations have been made by Hasenclever,² who has given strong proof of the damage done by coal-smoke alone.

In Chapter IV. we shall deal with the various attempts at utilising, or at least rendering innocuous, the acid gases given out in calcining ores.

According to the *Bull. U.S. Geol. Surv.* for 1911, in the year 1911, 400,000 tons of various sulphide ores were roasted at Ducktown, Tenn., in seven large blast-furnaces, and thereby daily 160 tons, exceptionally 200 tons, sulphuric acid of 60° Bé. was obtained.

The Amer. P. of J. Parke Channing, 962498 (Ger. P. 253492), protects a special treatment in the "pyritic smelting" of sulphide ores, by which gases for working up in lead-chambers are obtained. He adds in the smelting 1 per cent. carbon for every 4 per cent. of "available" sulphur, and works

¹ Cf. Percy, *Metallurgy*, 1862, 1, 337.

² *Chem. Ind.*, 1879, p. 225.

with so much air, that there is 4 or 5 per cent. oxygen present in the gases over and above that which is required for the formation of sulphur trioxide.

An opinion has been given in a case arising in the Salt Lake Valley, Utah, upon the effect of noxious fumes, and the following is abstracted from the articles in the *Chem. and Met. Eng.*, 1920, pp. 917 and 1145 *et seq.*:—

The opinion regarding the real nature of the smoke damage is of considerable interest. Accepting the fact of plant injury by sulphur dioxide, the decision was that it was immaterial whether sulphur dioxide was oxidised to SO_3 in the ground, in the air, or in the plant tissue itself. The main fact was, that under such conditions, it actually caused harm to plant life, if in sufficient concentration.

Analyses showing the sulphur content of the ground, the plants growing on the ground, and momentary quantities in the air were too meagre for much weight to be attached thereto, and sulphur contents in plants might not affect their vitality or their proper use.

It was agreed that one part of sulphur dioxide to one million parts of air, under certain favourable conditions, would mark, dry up, or bleach foliage of certain non-resistant crops; the skin or bark of growing plants being much more resistant, while young fruit, blossoms, and grain while it is heading out, were less resistant than the bark, but more resistant than foliage. The effect seemed to be that sulphur dioxide passes from the air to the leaf structure through the stomata, destroying cell life and drying up the structure in a way which is visibly evident.

The appearance of SO_2 injury in the foliage of plants and its extent depended upon certain conditions:

1. The sensitiveness of the plant to SO_2 injury.
2. The concentration of SO_2 in the atmosphere.
3. The length of time during which the plant was subjected to SO_2 .
4. The humidity of the atmosphere.
5. The presence or absence of those conditions which affected or controlled the opening or closing of the stomata, as light, darkness, heat and cold.

As a rule, SO_2 appeared to attack the leaves at their points

and edges, extending into the leaf in proportion to the severity of the injury. The effect of SO_2 injury—that is to say, the markings of the foliage—was observable practically at once. The appearance of the markings of the leaf tended to change somewhat with the lapse of time. The discoloration of the leaves or the appearance of the markings on them resulting from SO_2 injury was not the same in all plants, and was not distinguishable from discoloration and markings resulting from many other causes, whether examined by the eye alone or under a microscope, and so far as the evidence disclosed there were no structural or chemical characteristics of SO_2 injury which distinguished it from injury by many other causes. Injury caused by frost, sunburn, sun-scald, and alkali were among the causes producing leaf injury in every characteristic similar to that caused by SO_2 —that is, relatively sudden deterioration, disintegration, and breaking down of the internal cell tissues of the leaf.

Leaf injury occasioned by insects directly attacking the leaf of the plant was ordinarily readily distinguishable from SO_2 injury.

Fungous diseases of plants, in many cases, cause leaf deterioration identical with SO_2 injury. These bacterial diseases have each their several characteristics other than leaf deterioration common to them all and to SO_2 injury, and the presence of the characteristics of disease will ordinarily classify the leaf injury as injury resulting from disease and not from the presence of SO_2 .

For instance, frost effect was observed over a relatively large area of country; sun-scald was accompanied by hot sunshine preceded by irrigation or rain; sunburn by lack of moisture. Alkali injury showed on crops in soils containing alkali. Similarly, SO_2 had its accompanying factors—namely, injury from SO_2 always occurred in the path of the wind blowing over and from smelting plant, or the stacks from which sulphur dioxide was discharged.

In conclusion, there was little doubt that SO_2 injury, when occurring at a critical period in plant development, resulted in economic loss, that is, substantial diminution of crop yield. The tendency of growing crops was to throw off or overcome the injury inflicted by SO_2 , or injury caused by any other

agent, and the observations upon the matter were that markings caused by SO_2 would cease to be noticeable, during the season of rapid growth and development, within a short time, the length of time in any case depending upon the species of the plant affected, the time of year, and, generally, upon every factor that promoted or retarded plant growth and development.

Further papers on noxious vapours, with details as to their action, are those by Sorauer and Ramann (*Bied. Zentr.*, 1900, 29, 678), Wislicenus (*Z. angew. Chem.*, 1901, p. 689), Ost (*ibid.*, 1907, p. 1689), Wieler (*Fischer's Jahresber.*, 1905, p. 394, and *Chem. Zeit.*, 1908, p. 868), Sorauer (*ibid.*, p. 395), Baskerville (*Chem. Zeit.*, 1908, p. 54a).

A book, covering the whole of this subject, was published in 1903 by Haselhoff and Lindau, under the title *Die Beschädigung der Vegetation durch Rauch*, another by Professor A. Wieler, *Einwirkung von schwefliger Säure auf Pflanzen*, in 1905 (Berlin, Bornträger). See also Lunge, fourth edition, p. 269 *et seq.*

A paper on atmospheric pollution and its measurement was given before the Chemistry Section of the British Association on 27th August 1920, by Mr S. Owens, who dealt with the work of the Advisory Committee to the Meteorological Office on Atmospheric Pollution.¹ This investigation, it was explained, has been carried on for five or six years, records being taken at some twenty-five or thirty stations in different parts of the country.

The important matter from the chemical point of view has been the work of measuring the atmospheric acidity. This had to be dealt with in two ways: first, the gaseous acidity, and secondly, the acidity which might be held in the suspended solid impurities. The first difficulty met with was that the quantities to be measured were so excessively minute, and it became necessary to devise some method of measurement. The Committee had not altogether succeeded in doing that, and it was in the hope that the members of the Section might be able to assist, that the paper was read. Indigo-carmin and methyl-orange have been used as the indicators. It was suggested, at one time, that Congo-red should be used instead

¹ *Chem. Trade J.*, 1920, p. 347.

of methyl-orange as being more sensitive, but it was found that Congo-red was sensitive to CO_2 , and as there was always CO_2 in the air its use had to be abandoned. At the same time, in dealing with gaseous acidity in the atmosphere with the instruments which have so far been devised, a considerable degree of accuracy has been attained, such as one part by volume in 20 millions, for instance. Even better results were suggested as possible with the same apparatus.

Still greater difficulties, however, have been encountered in the efforts to measure the acidity of the suspended impurities. An instrument was devised for getting out the suspended impurities and measuring the acidity, but difficulties arose and it had to be abandoned. Other methods were adopted, including an electrical conductivity method, without much greater success; and the present position was, said Mr Owens, that whilst he believed they had got a satisfactory instrument for measuring the gaseous acidity of the atmosphere with a considerable degree of accuracy, they had not got a satisfactory method for measuring the acidity of the suspended solid impurities. One of the difficulties encountered with the electrical conductivity method was the provision of a suitable filtering medium, which would be free from electrolytes, and therefore would have no influence on the conductivity. All the materials tried, however, were found to affect the conductivity to a greater or less degree, the most favourable being lactose.

Abatement of the Nuisance.

The abatement of the nuisance caused by the acid-smoke given off in metallurgical and other operations presents special difficulties where the percentage of acids is so slight that their utilisation by condensation or by conversion into sulphuric acid is out of the question; that is, if less than 4 per cent. SO_2 by volume is present.

The problem of dealing with the enormous quantity of sulphur dioxide contained in *ordinary coal-smoke* has hardly ever been attacked in a serious manner, as the expense and inconvenience of any imaginable measures for this purpose have hitherto appeared to be quite unbearable; and it does not

seem as if this would be different in the near future. The only practicable remedy in this case, as well as in some cases of metallurgical smoke, is to dilute the gases with a large quantity of air, by erecting very tall chimneys for carrying them up to a considerable height above the surface of the earth. Such chimneys have been made up to 450 ft. in height. Freytag certainly estimates (somewhat arbitrarily) that smoke is harmless only when it does not contain beyond 0.003 per cent. SO_2 by volume; but since, for instance, in lead-works the percentage of SO_2 in the main flues, where all the smoke and fire-gases are mixed, rarely exceeds 0.1 per cent., it is very likely that, if these gases are allowed to escape only 200 ft. or more above any vegetation, they get sufficiently diluted with air in their descent to become harmless. This is owing to the fact that sulphur dioxide diffuses pretty equally in the air, whilst hydrochloric acid, sulphuric anhydride, acid salts, etc., which form visible fumes, generally reach the ground in a very little-divided stream, and cannot therefore be made innocuous by very tall chimney-shafts. In fact, this is the only explanation why the scores of tons of sulphur dioxide daily belched forth in certain localities by lead-works, zinc-works, glass-works, etc., have not ere now destroyed all vegetable life around the works, as is notoriously the case in a few isolated instances. But as such instances do occur, and as altogether the requirements of sanitary authorities are constantly becoming stricter, the removal of the acid-smoke to a high level by means of chimneys cannot be pronounced a final solution of the difficulty, even where SO_2 is the only acid concerned, all the more as in moist weather the acids escaping from the very tallest chimneys are brought to the ground in a somewhat concentrated state.

H. Wislicenus¹ asserts that sensitive plants, like pine-trees, are damaged if there is as little as 1 part SO_2 (or total acids calculated as SO_2) in 500,000 parts of air, and if they are exposed to such air during a whole period of vegetation. That limit is far exceeded by the air of industrial regions in spite of all remedies hitherto tried, and even the giant chimneys built in some places have not had any success, whilst he claims this for his "dissipators" (see below). The injury done by acid gases extends principally to the chemical processes of

¹ *Die Abgasfrage*, 1912.

assimilation; chlorophyll is destroyed even by minimal quantities of SO_2 , and the protoplasma is also acted upon.

In the special catalogue of the group, "Injury by Smoke," of the International Hygienic Exhibition at Dresden in 1911, Wislicenus enumerates the literature on this subject, which is enormous, and whereof his own publications form an important share. He also discusses the causes of the damage done by the smoke, and the measures or proposals for its prevention. In his pamphlet on the foundations for technical and legal measures for the prevention of damage by smoke (Berlin, 1908), he had already come to the conclusion that the removal of SO_2 , strongly diluted with combustion-gases by washing with water alone, has no prospect of success. The combination of this washing and sprinkling with lime in towers or chambers is more promising. He enters fully into this matter, but he considers it too expensive. He treats especially of the prevention of damage through smoke-gases by diluting them with air or other indifferent gases.

Wislicenus claims to have attained full success by his invention of the "dissipator," an apparatus for diluting the smoke-gases on new principles. He states that the natural principle for dealing with the smoke-gases is their dilution with air. But, wherever this has been tried on the large scale, it has been found that blowing air into the chimneys is not suitable, since even the best apparatus for this purpose work too expensively. Apparatus for blowing or aspirating air work uneconomically even if they have only to provide the air indispensable for combustion. The modern installations for "artificial draught" introduce air only to the extent of one-half, or at most three-quarters, of the volume of the smoke-gases, and therefore dilute these only by 50 up to 75 per cent., which is not sufficient. When the gases get into the free air, undoubtedly at first a further manifold dilution takes place, as long as the gases are still in a whirling condition, *i.e.* as long as their temperature and movement are different from the air. But if the air-current moves on evenly, the air and the smoke-gases will soon come to equal velocity, temperature, and direction. Where there is no interruption by differences of level, houses, trees, etc., the smoke-gases will travel on without being sufficiently diluted, and, after

a long way through the air, will still descend as poisonous fumes upon the soil and the vegetation.

This uniform motion, without whirling, must be especially avoided. We know from experience, *e.g.* from the observations of aeronauts, that all valleys cause strong whirls in the air-currents above them. Higher up, the air-current generally proceeds evenly. It is, therefore, a mistake to introduce the smoke-gases into these high, non-whirling air-currents. Chimneys, which from hygienic considerations are built much higher than required by their function of producing draught, are therefore inoperative; they protect at most their immediate surroundings. The remedy is, therefore, to produce at the source of the smoke itself, a sufficient dilution and formation of a whirling movement. That is the principle of the "dissipators," which are constructed as follows:—

The walls of the upper part of the chimney-shaft contain conical air-channels, the number of which increases from below upwards. This prevents the gases from flowing out in a compact stream from the furnace, but provides for gradually supplying them during their progress with as much air as possible, in such a way that the particles of smoke-gas and air acquire a great variety of directions and speeds. At first some practical men called it nonsense to build a chimney with holes. To this Wislicenus remarks that, as a matter of course, there must be a sufficiently high draught-producing shaft, if the chimney has to provide the draught. But there are some cases where there is no aspirating work required from the chimney, but where this is performed by artificial means, such as fan blasts, exhausters, etc. Only the "hygienic" part of the chimney, which has frequently caused it to be made much higher, is to be replaced by a lower, but more efficient dissipator, which causes the formation of whirls and the admixture of air during the *outflow* of the gases. Through the variously directed channels in the wall, the diluting air is introduced at the windward side with various velocities and in various directions. On the other, the "lee" side, the wind will act in an aspirating way. In cases where there are not tall chimneys, but gas outlets, from dehydrating plants, flue-dust chambers, etc., the outgoing gases are still more diluted with air by a "multi-dissipator." The gases are gradually divided and diluted.

Since from the lowest series of wind-channels only a small fraction of the gases escapes, with which from the opposite side more wind is mixed, the main body of the gas must rise higher, and gradually mix with more air. Consequently there is both a mechanical and a temporary dissolving action. Into iron chimneys, the wind-channels may be introduced tangentially.

At first the chimneys were built in such a manner that the holes were produced by leaving interstices between the bricks. This has certain drawbacks, especially an excessive contact of the joints with acid gases. Therefore, later on, perforated stones have been employed, in which the air-channel goes through the body of the stone, and the joints are as little as possible in contact with the smoke-gases. But the mortar joints may also be protected against the acids in the gases by a coating of tar, or of tar and clay, or of gypsum. The perforated stones have the further advantage that the fine sieve formed by the numerous small holes produces a greater division of the gas-current.

The stones might also be provided with air-channels in a somewhat tangential direction, in order to produce a still better spiral whirl motion. But such stones are not easily manufactured and are very expensive.

The inventor has recently, in connection with the Metallbank und Metallurgische Gesellschaft at Frankfurt a.M., applied a very fine sieve-grating, made of perforated stones.

After the lecture given by Wislicenus in 1911, a practical chimney-builder made the objection that the numerous holes in the upper part of the chimney-shaft are strongly exposed to frost, rain, etc., so that the material must greatly suffer, and frequent repairs will be required, about which point further experience must be collected.

According to Reuss,¹ it is true that, in the case of faintly acid gases and small quantities of smoke, the gases going out from high chimneys may be diluted up to being quite innocuous, but, under certain circumstances, high chimneys may have an injurious action, by carrying the gases to much greater distances and affecting a much greater extent of forest.

Reports on the damage done by coal-smoke in the Rhenish-

¹ *Rauch und Staub*, 1914, p. 162.

Westphalian industrial district have been made by Eicke¹ and Rippert.²

Wislicenus discusses the damage caused by smoke-gases and his process for preventing it in a pamphlet, *Über die Abgasfrage*, etc., in 1912, and several papers published in 1910 and 1911. His apparatus, called "dissipator," is protected by B. P. 16609 of 1908; Amer. P. 988920; Ger. Ps. 228922 and 229070; Swiss P. 44774; Fr. P. 397953; Belg. P. 212930; Norw. P. 19003; Austr. P. 45391.

6. SUPPLYING NITROGEN OXIDES TO THE SULPHURIC ACID PROCESS

An important item in the manufacture of sulphuric acid is the supply of nitrogen oxides to the chamber process.

There are many methods in use, the most important being the following:—

(a) Decomposition of nitrate of soda with sulphuric acid in pots placed in the path of the burner gases.

(b) Feeding the Glover tower with nitric acid or liquid nitrate of soda.

(c) Spraying nitrate of soda solution or nitric acid into the first chamber.

(d) Oxidation of ammonia and conveying the nitre compounds into the Glover flue, or to the first chamber.

Opinions differ as to which of the methods is the best.

In the first, it is necessary to employ much more sulphuric acid for the decomposition of the nitrate than in the regular manufacture of nitric acid, but there is a saving of fuel, the heat of the burners being usually sufficient for the purpose.

In the case of there being a supply of waste or weak nitric acid available, the second method is the cheaper.

As to the oxidation of ammonia, it is chiefly a question of the relative costs of ammonia and nitrate of soda.

The advantages of introducing nitric acid in the *liquid* form are the following:—avoiding the entrance of false air into the chambers and the escape of burner-gas into the atmosphere, both of which occur in many (not all) systems of employment

¹ *Rauch und Staub*, 1913, p. 162.

² *Glückauf*, 1912, pp. 1992 and 2026.

of gaseous acid ; the possibility of employing as much nitric acid and as quickly as desired, whilst in the second case this depends on the heat of the burner-gas, which during irregularities in the working of the process, just when most nitric acid is needed, sometimes proves insufficient ; lastly, and most of all, the exact regulation possible with liquid nitric acid and its continuous supply, whilst gaseous acid is always given off very unequally from the nitre-mixture. These advantages have induced most Continental and, later on, many English and American manufacturers to employ liquid nitric acid.

It is claimed as an advantage for introducing the nitre by "potting," that the chambers are not exposed to the damage possible in the case of incautious handling of nitric acid, whilst, on the other hand, the irregular evolution of gas from the nitre-mixture is equalised by employing several decomposing apparatus, and charging them in turns, say once every hour, just after a fresh burner has been charged ; thus the stronger evolution of nitre-gas runs parallel with that of sulphur dioxide. Some prefer a contrivance for supplying gradually, and not all at once, the sulphuric acid serving for decomposing the nitre. It was formerly contended that the best English works, all of which employed at that time solid nitre, worked with as small a consumption of it and as good a yield of vitriol as the best of the Continental works employing liquid nitric acid ; also on the Continent some manufacturers work quite as well with solid nitre as their neighbours with nitric acid ; but it is extremely difficult to check such statements, as few manufacturers divulge their *real* working results to outsiders, and, moreover, very many of them do not even know these results themselves with that degree of accuracy which is required to decide this question.

There is no doubt whatever that the chamber-process can be worked more regularly by the continuous supply of nitric acid in the liquid form.

(a) *Introduction of Nitric Acid as Vapour ("Potting").*

The old style of apparatus for this purpose is by means of small pots placed in a special *nitre-oven* constructed by enlarging a suitable place in the gas-flue. It is situated either

above or, preferably, just behind the burners, and provided with the necessary working-doors and a cast-iron saucer for collecting what boils over. The nitre-pots themselves have

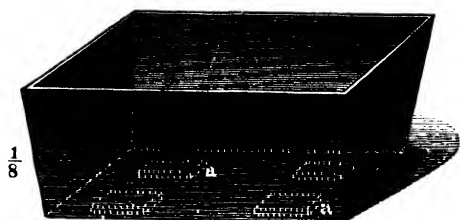

FIG. 5.

various shapes—for instance, that shown in Fig. 5; at *a a* ledges are cast on the bottom, which facilitate pushing the pots backwards and forwards. They hold from 8 to 12 lb. of nitre.

The “potting” with these pots, which are still met with in some English works, is very troublesome and imperfect.

A much more perfect plan is that of decomposing the nitre in a *fixed apparatus*, and running off the acid sodium sulphate (nitre-cake) in a liquid form. This apparatus consists of a

semicylinder of cast iron, *a* (Figs. 6 and 7), with a cast-on tube, *b*, bored somewhat conically. The latter projects out of the nitre-oven, and during the working is closed by an iron plug with a long handle. Outside there is a cast-iron tray for holding the nitre-cake, which at once solidifies. The internal saucer, *c*, catches any material boiling over. The nitre is introduced by the hopper *d*, also provided with a plug;

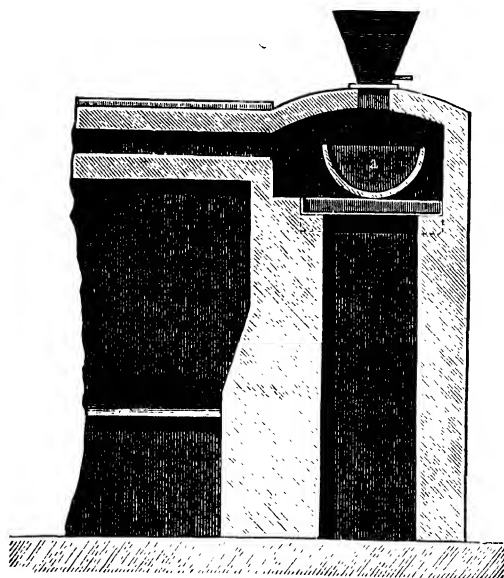

FIG. 6.

and after putting it in, it is made gas-tight by filling up with the next charge of nitre. For running in the sulphuric acid, it is best to provide a small tank with a siphon or stopcock.

This tank is preferably kept supplied with hot Glover acid taken direct from the tower bottom by a self-acting siphon. An apparatus holding 56 lb. of nitre can be easily decomposed in two hours. In any case, there should be two or more of these apparatus, so as to make the current of nitre-gas more regular by charging them in turns.

Even preferable to the arrangement here shown is that of placing the nitre-trough in such a way that the burner-gas can play round the bottom as well. The tray for the boiling-over material, which forms the bottom of the nitre-oven, must then be placed somewhat lower.

A contrivance which has been in operation for many years past, is that of putting the nitre-oven between the burners and the Glover tower in such a way that, by means of dampers, the burner-gas can be made to travel either through the oven or directly into the chambers.

An intermediate process between the "potting" system and the application of liquid nitric acid is the generation of nitric acid in the ordinary retorts, fired with coals, but without condensing the vapours to liquid nitric acid by passing them straight into the chambers. This system is still followed in several English works, and is a much more cleanly method than "potting" in the ovens built in the burner-flues.

The Soc. anon L. Vogel (B. P. 6846 of 1904; Ger. P. 171088) passes the vapours evolved in the ordinary nitric acid retorts from sodium nitrate and sulphuric acid, without condensing

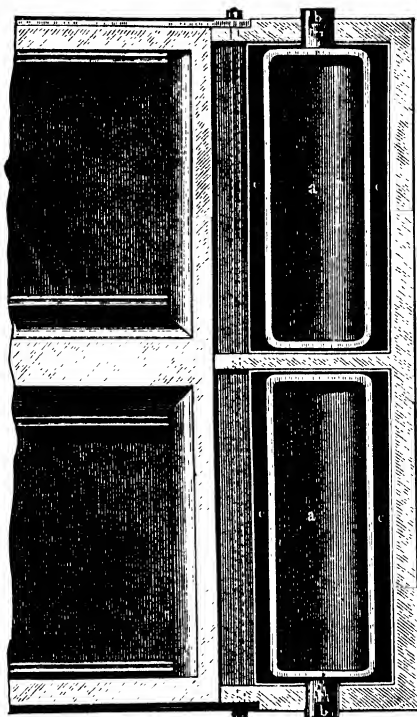

FIG. 7.

them to liquid acid, into the Gay-Lussac tower, where they are absorbed and later on utilised in the Glover towers. Thus large quantities of nitric acid can be supplied to the chambers in a continuous manner, assisted by a fan interposed. The cylinders, where the nitric acid is evolved, are set in the dust-chamber behind the kilns and heated by the burner-gases.

Howard (U.S. P. 115103) interposes in the flue leading from the burners to the Glover tower a closed vessel, provided with an agitating arrangement, for decomposing the mixture of nitre and sulphuric acid. This mixture is first introduced into a second apparatus, placed above the first, also provided with an agitator, and runs out of this through a pipe, containing a screw-carrier, which delivers it in an even manner to the lower apparatus, in which ultimately remains neutral sodium sulphate of commercial quality.

(b) Introduction of Liquid Nitric Acid.

Any of the apparatus for the manufacture of nitric acid may be employed for use in connection with acid-chambers, but no special precautions are in this case needed for obtaining the acid in a concentrated state or free from lower nitrogen oxides. On the contrary, any low-strength and impure acid obtained in the manufacture of commercial nitric acid may be turned to use in the vitriol-chambers.

It is, however, of the greatest importance for the process to supply the acid in an even, continuous way, and to regulate the supply to a nicety.

Lunge¹ describes several methods of feeding nitric acid on to the Glover tower, and into the chamber, to which the reader is referred.

Two or more earthenware vessels (or carboys) with several small-bore glass siphons form quite a satisfactory arrangement, each vessel being filled in turn, in order to compensate somewhat for the variation in head of liquid. Precautions should of course be taken to prevent blockage of the siphons by foreign substances.

The simplest way of introducing the nitric acid through the Glover tower is to run a suitable quantity of it into the nitrous-vitriol tank at the bottom of the tower, and pump up the

¹ Fourth edition, p. 709 *et seq.*

mixture in the usual manner. It is sometimes preferred to carry the nitric acid to the top of the chambers or the tower, and to run it into one of the lutes of the tower as required.

The Société Nitrogène (Fr. P. 404071) employs for the chambers a solution of dilute nitrous gases in concentrated sulphuric acid, thus producing a mixture of nitrosyl-sulphuric acid and nitric acid.

The storing of nitric acid on the top of the chambers or of the Glover tower is generally effected in large stoneware

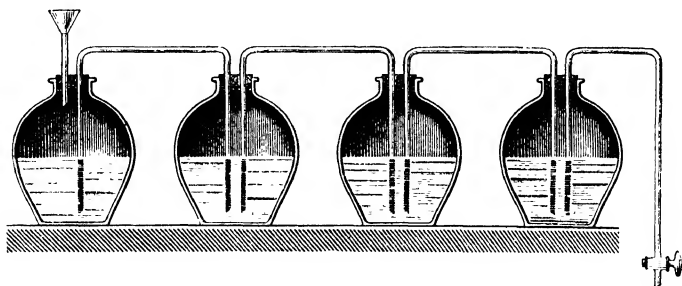

FIG. 8.

receivers, or else in a number of smaller stoneware jars or ordinary glass carboys, all of which are connected by glass siphons, so that the running off by means of a tap-siphon need take place only from the last vessel of the set (Fig. 8). Vessels proof against nitric acid may also be composed of single pieces of stone joined together by a cement made of finely-ground asbestos and a dilute solution of silicate of soda, kneaded into a putty and preferably mixed with ground sulphate of baryta.

E. Pohl (Ger. P. 30188) employs iron vessels lined inside with asbestos cloth soaked in paraffin. The riveting of the iron shell is effected in the manner shown in Fig. 9, so that the acid nowhere comes into contact with the iron.



FIG. 9.

Lutgens (B. P. 6617, 1914) regulates the supply of nitric acid to the Glover tower by connecting the apparatus with the chamber thermometer in such a way that on the rise of temperature in the chamber the feeding-apparatus is automatically throttled, and on the falling of the temperature again opened.

G. P. Adamson (Amer. P. 846541) stores acids in bottles of glass, ceresin, or other suitable material, whose sides and bottoms are strengthened by a cylinder and plate of wire-gauze, embedded in the material of the bottle. The lower edge of the gauze cylinder has a head formed on it which projects below the edge of the gauze plate.

(c) *Introducing Nitre as an Aqueous Solution of Sodium Nitrate.*

There is yet another way of introducing the nitre. Many years ago several works ran their nitre as a *solution in water* into the chambers. This has long since been discontinued, both because all the sodium sulphate formed gets into the acid, which is not allowable for many purposes, and because the lead always wears away very quickly at the point where the solution enters. This method was patented by Burnard (14th August 1875). The solution of nitre was to be injected into the chamber in a thin jet, or, better still, at once mixed with sulphuric acid by means of a steam-jet, exactly similar to Sprengel's water-spray (*vide infra*). The chief object sought to be attained in this process was an imaginary saving of nitric acid, which in the decomposition of nitre by the burner-gas was supposed to be reduced to N_2O and N . As mentioned, *infra*, p. 257, no sensible decomposition of this kind takes place at all; and any advantage accruing therefrom would be far more than counterbalanced by the difficulty of keeping the nitrate solution long enough in suspension to completely decompose it and to prevent liquid nitric acid from getting at the chamber-bottom. The process also takes so much steam that the acid in the first chamber gets too weak. This is certainly contradicted by the patentees;¹ but no independent favourable testimony has yet been published, and a saving of nitre appears out of the question. It would, however, seem feasible to run a solution of nitre through the Glover tower together with chamber-acid and nitrous vitriol, so that the nitre would be decomposed in the tower itself, sodium sulphate and nitrous vapours being formed. Of course this plan, as well as that mentioned before, is restricted to the case

¹ *Chem. News*, 37, 203.

of the sulphuric acid not being intended for sale, but employed for decomposing salt, or for the manufacture of superphosphates, etc.

The introduction of the nitre in the form of an aqueous solution of sodium nitrate is undoubtedly the simplest imaginable plan for supplying it to the chambers, uniting the advantages of both solid nitre and nitric acid—easy regulation, introduction of any quantity at a time, dispensing with all apparatus for introducing the nitre or manufacturing nitric acid, saving of labour and coals (in the case of nitric acid), avoiding the handling of nitric-acid carboys or of fluxed nitre-cake, the latter being an article difficult to utilise to any extent. Unfortunately, these advantages are counterbalanced by a drawback, which has induced most manufacturers who have tried this process to give it up: it is found that sodium sulphate crystallises in the towers, tanks, and connecting-pipes and causes obstructions. It would be necessary to have two Glover towers for each set, and to run the nitre solution down only one of these, using this acid for the salt-cake pans or for superphosphate only and not for the Gay-Lussac tower. This would be very inconvenient, and for smaller works not at all feasible.

Potut (B. P. 7710 of 1900) injects a solution of sodium nitrate between the Glover tower and the first chamber.

R. Vetterlein, Schöningen (Ger. P. 303557, Feb. 26, 1916), claims passing the burner-gases to the Glover tower, which are made to act upon nitrate or nitrite of soda, preferably by spraying aqueous solutions of the salts into a tower through which the gases are passed. The resulting nitrous gases pass into the lead-chamber, whilst the non-volatile constituents of the salts subside in the reaction chamber, but it is advisable to interpose a dust-catcher to prevent solid particles entering the Glover tower.

Dervig (Amer. P. 850820), in lieu of the ordinary nitre-ovens, employs a column, packed with quartz or coke, through which a solution of sodium nitrate in sulphuric acid is run; it is placed either between the pyrites-burners and the Glover tower, or between this and the first lead-chamber. In the first case, part of the hot burner-gases, in the second, the whole of the Glover exit-gases, are passed through this column (which

has about one-fifth of the diameter of the Glover), in order to supply the necessary heat for driving off the nitric acid. [The reporter in *Chem. Zeit. Rep.*, 1907, p. 272, justly remarks that this column will be easily stopped up by sodium sulphate crystallising out.]

H. Lemaitre¹ deals with the subject of the use of a solution of nitrate of soda in the Glover, stating that the continuous introduction of sodium nitrate in solution through the Glover tower produces saturation of the acid with sodium bisulphate and consequent choking of pipes. Dilution of the Glover acid with chamber-acid to prevent saturation is rendered impracticable by the limited concentration capacity of the Glover. Alternate introduction of nitric acid and liquid sodium nitrate may be suitable, provided that the supply of nitrate is arrested before saturation is reached, this stage being determined by calculation or by control analysis of the bisulphate content of the acid. To avoid saturation entirely, it is preferable to introduce the nitre as a mixture of nitric acid (36° B., sp. gr. 1.33) and sodium nitrate solution. Loss of nitric acid resulting from imperfect working of the Glover seldom exceeds 5-10 per cent.; in the Gay-Lussac tower it amounts to 50-75 per cent. of the total, but these losses may be considerably reduced, and the economy achieved may equal or exceed that attained by use of sodium nitrate. The reactions which take place in the Gay-Lussac towers are indicated by the author, and the control of the chamber-process by the use of graphs is advised.

According to the 50th Report of the Alkali Inspector (for 1913), p. 133, the application of a solution of nitrate of soda in the form of a spray to the first chamber has answered very well, especially owing to the regularity and rapid adjusting of the feed. The drawback caused by some sodium sulphate dissolving in the chamber-acid is of no importance, if the acid is used for the manufacture of fertilisers.

E. W. Kauffmann found the supply of nitre to the chambers in this form at various French works, and applies this himself in those cases where a slight contamination by sodium sulphate is of no consequence.

¹ *Monit. Scient.*, 1920, 10, 145-157; *J. Soc. Chem. Ind.*, 1920, p. 655A.

(d) *Feeding the Chambers with Nitrous Gases obtained as By-products.*

An ingenious process, invented by Dunlop, was for many years carried out by Messrs Tennant at St Rollox, and had become very famous, but it was not introduced at the new works at Hebburn erected by the same firm. A mixture of common salt, nitrate of soda, and sulphuric acid is heated in large iron cylinders; the principal reaction setting in is as follows:—

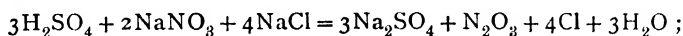

but any further deoxidation of nitric acid must be prevented by keeping within certain limits of temperature. Thus there remains a soluble residue of sodium sulphate, whilst chlorine and nitrous acid are given off in a gaseous state. The two gases are separated by passing them through a series of leaden Woulfe's bottles filled with sulphuric acid of 1.75 sp. gr., which retains the nitre-gas, being converted into "nitrous vitriol" and used as such (*vide infra*); the chlorine passes through without absorption and is utilised for bleaching-powder. The advantage of this process is, that chlorine is obtained direct from salt without making any hydrochloric acid and without employing peroxide of manganese. The drawbacks are:— that the nitre-gas has to be evolved again from the nitrous vitriol, which at that time could only be done by diluting with hot water, necessitating a reconcentration of the vitriol; that there is a danger of losing nitrogen compounds; and that the apparatus is very complicated. This process consequently did not obtain permanent success, and we abstain from giving a fuller description of it here.

In many works the nitre supply for the chambers is obtained in the manufacture of ferric sulphate. This is made by treating ferrous sulphate with nitric acid, and thus oxidising the ferrous salt to ferric. The nitric acid is thereby reduced mostly to lower oxides of nitrogen; these gases are conveyed into the vitriol-chambers, and there do exactly the same duty as if the nitric acid had been directly supplied to the chambers. Recently the manufacture of *cupric sulphate* from metallic copper, sulphuric and nitric acid has been introduced

at some works, the nitrous vapours being led into the vitriol-chambers.

(c) *By Oxidation of Ammonia.*

During the War the Ministry of Munitions found it imperative that the strictest economy should be practised in the consumption of nitrate of soda in all industries; and as the chamber-process required by no means inconsiderable amounts of oxides of nitrogen to replace losses in the nitrogen cycle, it claimed their serious attention.

They therefore devised a small converter for the oxidation of ammonia to oxides of nitrogen, this being accomplished by passing a suitable mixture of air and ammonia through the converter. During its passage, the mixture is forced through two or more pieces of fine platinum gauze stretched close together at right angles to the gas flow; these gauzes being maintained at a dull red heat by the combustion of the ammonia to oxides of nitrogen.

As regards the working capacity of these converters, it may be taken that the efficiency of conversion is about 90 to 95 per cent., with an output equal to 1.5 ton of nitric acid per square foot of single gauze per twenty-four hours.

The converter devised by the writer consists of a cast-iron box with inlet at the bottom, through which the mixture of air and ammonia enters (Fig. 10).

The catalyst frame *a* containing two or more gauzes made of pure platinum wire, of diameter 0.065 mm., evenly woven in square mesh, 80 meshes per linear inch, is fixed just above the said inlet.

An outlet *b* is provided at the upper part of the box for conveying the oxides of nitrogen to a condenser, and thence into the chamber or Glover tower flue.

The catalyst unit should be an air-tight fit in the converter body in order that the ammonia and air must pass through the gauze.

Great care has to be taken to keep the platinum gauzes absolutely clean. They should be boiled with pure concentrated hydrochloric acid, and rinsed in distilled water before fixing, and should on no account be touched with the fingers or otherwise soiled.

The mixture of air and ammonia, filtered and purified as described below, in the proportion of one vol. of ammonia to

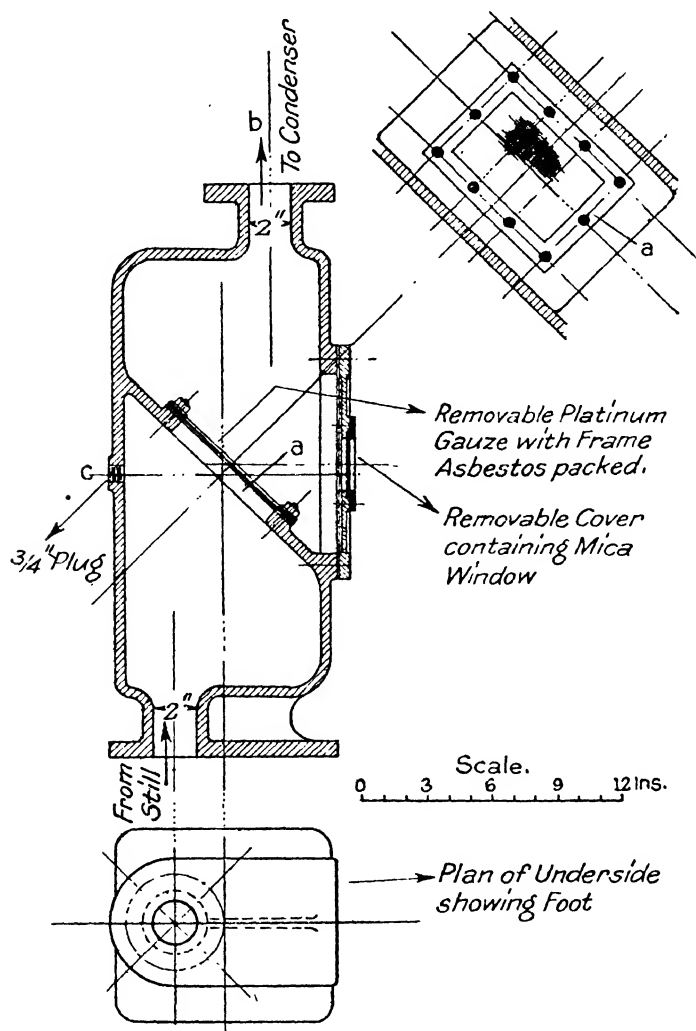

FIG. 10.

7.5 vols. of air, is passed to the base of the converter at a suitable rate, *i.e.* approximately 6 lb. of ammonia, or about 1100 cub. ft. of mixture, per square inch of catalyst net per twenty-four hours.

The apparatus is started by heating up the gauzes by inserting a flame of non-luminous gas (arsenic-free hydrogen, for example) through the hole *c* provided in the side of the converter box for this purpose, or by squirting a small quantity of alcohol on to the gauze, igniting it, and then turning on the ammonia and air mixture.

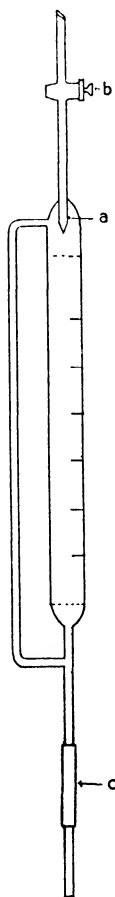

FIG. 11.

New platinum gauzes may be somewhat inactive for a time, but can be "activated" by passing, at fairly slow rate, a mixture with an excess of oxygen, say 1 vol. NH_3 to 10 vols. of air.

After an hour or two the platinum becomes activated, and white fumes of ammonium nitrate and nitrite, leaving the converter (after cooling), change into clear red fumes of oxides of nitrogen.

When this occurs, the ammonia is brought up to the ratio of 1 vol. NH_3 to 7.5 vols. of air.

If spots are observed on the heated gauze in working, and these do not rapidly disappear, the catalyst unit should be removed and the gauzes again cleaned in the manner described above.

For feeding the distillation column with a regular supply of liquor ammonia, the burette principle appears to be generally adopted. The liquid from an overhead supply gravitates to the burette, which is fitted with a control tap *b* (Fig. 11), attached to a finely-drawn-out tube *a* inserted in the upper portion.

The amount of flow is ascertained by pinching the rubber connection *c* and timing by means of the seconds hand of a watch or clock, the volume of liquid (previously marked on the burette) corresponding to the amount required by the chamber plant.

It is advisable to use connection pipes of lead for conveying the ammonia to the apparatus just described, otherwise, if iron be used, any rust may cause a blockage of the finely-drawn-out tubing.

The filter usually provided for the ammonia liquor flowing to the burette should also be of lead, and fitted for easy access to the sponge or other media used therein.

The gases leaving the pipe at the top of the converter have a temperature of about 400° . They consist of nitric oxide (NO), steam, nitrogen, and a slight excess of air. The reaction in the converter is as follows:—

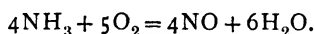

At this temperature the gases are still quite colourless, since secondary oxidation of NO to NO_2 has not begun on account of the high temperature.

The mixture of air and ammonia supplied to the apparatus may be produced in two different ways:—

(1) By producing air and ammonia gas separately, and then mixing the same in the proper proportion in a suitable mixing chamber.

(2) By producing directly a mixture of air and ammonia gas.

The supply of ammonia may be obtained from ordinary commercial liquid ammonia containing 25 per cent. NH_3 , from ordinary gas liquor, or by the distillation of various salts of ammonia with an alkali. In the case of distillation of ammoniacal liquor it is necessary to remove the bulk of the sulphuretted hydrogen by any well-known means; it is, however, better to start the oxidation plant with liquid ammonia, which is flowing down a small column with the supply of air and steam entering at the bottom in sufficient quantity to reduce the ammonia content of the effluent leaving the column to 0.015 per cent. NH_3 .

Where several converters are at work, it is preferable to have one distillation plant with condensers, coolers, etc., and to collect the ammonia gas in a gasometer; by this arrangement the pressure of the gas is equalised and thereby more easily regulated.

The air supply is also of importance, and in order to ensure a regular supply, a blower, capable of giving an amount above that normally required, is advisable, and should be capable of maintaining a regular pressure of 5 lb. per square inch. The inlet to the blower should be connected to a filter (Fig. 12) packed with coke, shavings, pyrites in lump form, or any other material of a like nature, these media being coated over with waste oil, but not in sufficient quantity to clog up the interstices.

In the handling and storage of ammonia liquor in bulk, the following precautions should be taken :—

(a) The storage reservoir should be an overhead, lead-lined, air-tight vessel, or constructed from a boiler shell.

(b) The ammonia liquor should be preferably delivered to the sulphuric-acid works in railway tanks, these being provided

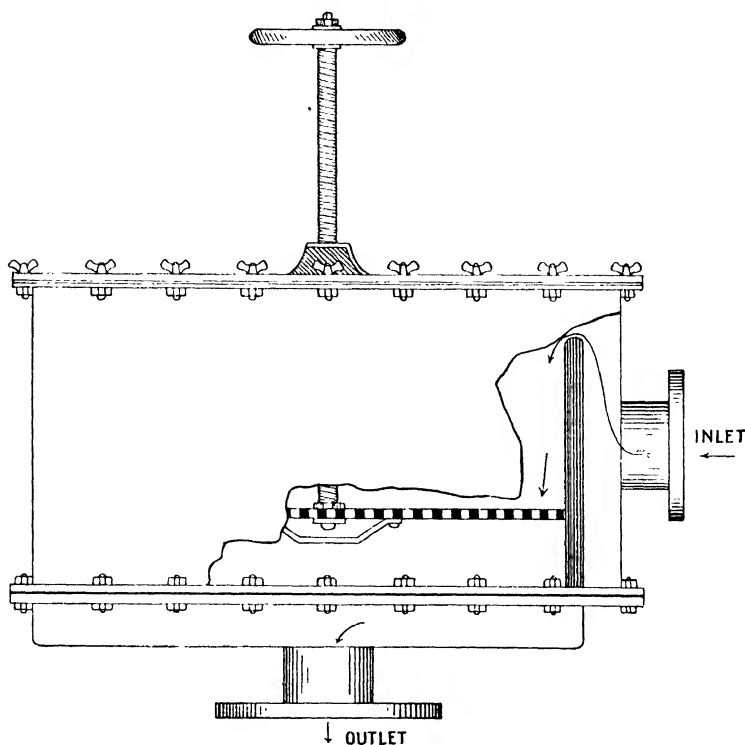

FIG. 12.

with facilities for discharging their contents by means of compressed air.

(c) The vent of the storage reservoir should be connected to a small water-fed wash-column, which should be so constructed that, when pressure takes place, there is a washing effect, and, when vacuum occurs, the contents of the scrubber are not drawn into the store. It is only necessary to supply the scrubber with a small amount of water from time to time.

A quantitative yield of nitric oxide is attainable, but in practice it is never obtained, for the following reasons:—

(1) The time of contact of the air and ammonia mixture with the platinum may be too long, and the nitric oxide formed will commence to dissociate according to the equation:

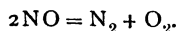

This reaction may also be brought about by incorrect temperature; a dull red heat giving the most efficient results.

(2) Part of the ammonia may escape contact with the catalyst. Undecomposed ammonia present in the effluent gases will react with the nitrous acid formed on the condensation of the nitrogen oxide with water, with the liberation of nitrogen:

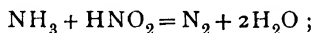

thus, twice the amount of nitrogen present with the ammonia will be lost.

(3) The absorption of the oxides of nitrogen may not be complete.

The gases coming from the outlet pipe of the converter can either be passed direct to the Glover tower, burner pipe, or other suitable point of entry to the chamber plant, or they may be passed through a series of silica condensing coils, or of acid-resisting iron, where about 70 per cent. of the water produced in the reaction is separated. If the cooling is performed sufficiently rapidly, the condensate will contain only 0.1 to 0.5 per cent. of the total oxide of nitrogen as nitrous and nitric acid, and any trace of ammonia which may have escaped oxidation.

For a 4-inch by 6-inch converter, three lengths of 6 feet by 6 inch diameter tubing is ample.

The water separated in this coil should be drained into a small receiver constructed so as to form a trap to prevent the burner-gases passing back to the platinum gauze, otherwise the catalyst becomes poisoned.

If the consumption varies in the working of the chamber plant, it may be adjusted by running the converter 20 per cent. under or over the usual output without affecting the efficiency greatly.

By maintaining a regular supply of air and ammonia after the platinum gauze has become activated there are no further

difficulties, and the gauzes should run at least six months without disturbance.

By means of an interchanger, the air-ammonia mixture was pre-heated, passing, on its way to the platinum gauze, round tubes conveying the hot oxides of nitrogen to the chambers. Without a pre-heater, a four-ply gauze of 6" x 4" was capable of oxidising ammonia equivalent to 35 cwts. of NaNO_3 per week. Using a pre-heater, the gauze could give the equivalent of 50 cwts. NaNO_3 per week with a considerably increased efficiency (40 per cent. increase).

Under the conditions prevailing in a heat-exchanger, experiments showed that most common metals caused the decomposition of ammonia to nitrogen to a certain extent, so that care was necessary in selecting the material of which the tubes were made. Silica was least active in this respect, but, on account of its low conductivity and the difficulty of making the apparatus, this material was not readily adaptable. Enamelled iron had been used successfully, and, later still, steel tubes coated with a mixture of barium sulphate and silicate of soda.

The chemical control of an oxidation plant is dealt with very fully in an article by P. F. Fox.¹

For the determination of the ammonia in the entering gas, the Cumming Absorber, described by Edwards (Bureau of Standards, Techn. Paper 34, 1914), effects complete absorption, and by its use it is possible to determine the ammonia without making a titration. A measured quantity of standard acid is placed in the absorber and coloured with an indicator, and the gas is made to bubble through the liquid until the colour changes. The theoretical dry air-ammonia mixture should contain 14.33 per cent. of ammonia. The method of absorption by means of standard alkali of the acid formed from the nitrogen peroxide (NO_2) is not applicable to the exit-gas from the oxidation, owing to a large amount of condensed water from the hot gas interfering with the measurement of the volume, and also to the possibility that sufficient oxygen may not be present to oxidise all the nitric oxide to nitrogen peroxide. To obviate these difficulties, the following method is

¹ *J. Ind. Eng. Chem.*, 1917, pp. 737-742; *J. Soc. Chem. Ind.*, 1917, p. 1005.

suggested:—The gas is aspirated from the outlet pipe, but before reaching the absorption apparatus it is mixed with a measured quantity of oxygen or air in sufficient quantity to convert all the nitric oxide into nitrogen peroxide. The mixture is drawn through two absorption vessels, the first of which contains standard alkali solution, and the second standard alkali solution containing 1 per cent. of hydrogen peroxide. By this arrangement, ammonium nitrate remains in the first vessel, where there is no hydrogen peroxide to oxidise it. To prevent condensation of water, the sample of gas should be taken through a capillary tube as close to the catalyst as possible. Test experiments showed that the alkaline 1 per cent. hydrogen peroxide yielded about 6 c.c. of oxygen in the determination, and it is therefore advisable to make a correction for this amount. As an alternative efficient absorbent agent, sulphuric acid may be used, the gases being previously mixed with oxygen as described above. For the determination of very small amounts of ammonia in the exit-gases, the best method is that of oxidation by means of sodium hypobromite, and measurement of the resulting nitrogen in a gas burette. The author has worked out the following formula for calculating the efficiency of the process:—

$$\text{Efficiency} = \frac{Vno}{Vnh_3} = \frac{Vno(1/b - 1.25)}{fc + Vno},$$

where Vno is the volume of nitric oxide, Vnh_3 is the volume of ammonia in the entering gas, b is the ratio of ammonia to the volume of the entering gas mixture, and fc is the volume of the residual gas collected in the aspirator bottle of the testing apparatus, corrected as described below. If the hypobromite test shows that the ammonia has passed through the catalyst unchanged, the equation must be modified as follows:—

$$\text{Efficiency} = \frac{Vno + V_1}{Vnh_3} = \frac{(Vno + V_1)(1/b - 1.25)}{Vno + 0.75V_1 + fc},$$

where V_1 is the volume of the unoxidised ammonia. The correction to be applied to the volume of gas in the aspirator bottle reduced to standard pressure and temperature f is:

$$fc = f + 0.5(Vno + V_1) - Vox,$$

where Vox represents the volume of oxygen added.

B. Neumann and H. Rose¹ give an extensive survey of the numerous processes and researches in connection with catalytic oxidation of ammonia, and contribute some results of their own investigations. Special attention has been directed to the influence of the ammonia concentration, the velocity of the gas stream, and the temperature.

The highest yields are obtainable with platinum at 500° (96 per cent.). From curves plotted to show the gas composition at approximately 300-700° with the various catalysts, it is apparent that, under fixed conditions, the oxidation will proceed continuously without extraneous heat. With platinum gauze of 300 meshes per sq. cm. as catalyst, the best yield (96 per cent.) was obtained with a velocity of gas current of 20 litres per hour, and the yield was not greatly affected by increase of the ammonia concentration from about 3 to 9 per cent. by volume.

Another very interesting paper is given by G. A. Perley.² The starting and stability phenomena of the same subject are dealt with by F. G. Liljenroth.³

In the 56th Annual Report, p. 17, and the 57th, p. 17, it is stated that the ammonia oxidation method appears to be definitely established, and its use extending. In one or two cases difficulty was found in obtaining the best results, and in maintaining at a maximum the efficiency of the catalytic material.

This process has now replaced "potting" at all the works of the United Alkali Co., and there has been a saving of 30 to 40 per cent. in the cost of materials.⁴

In coming to a decision regarding the introduction of an oxidation unit in lieu of "potting," the question naturally arises, what advantage will accrue from such procedure?

Of course the first point is the relative price of ammonia and nitrate of soda plus the acid used for decomposing the latter, also the wear and tear of the apparatus and flues.

Then regarding the supervision—the oxidation process, being a continuous one, requires attention from time to time,

¹ *Z. angew. Chem.*, 1920, 33, 41-44, 45-48, 51-55; *J. Soc. Chem. Ind.*, 1920, p. 264A.

² *Chem. and Met. Eng.*, 1920, pp. 125-129.

³ *Ibid.*, 1918, 19, 287-293; *J. Chem. Soc.*, 1919, 2, 23.

⁴ *Chem. Trade J.*, 1922, 70, 113.

and it cannot be worked at very low output with full efficiency.

In large works there is usually chemical supervision available; or the tower man could give the necessary attention. But in small works, where the burner man is the sole attendant, one can hardly recommend the introduction of such an apparatus.

An interesting paper on the subject of ammonia oxidation is given by C. Cooper (*Chem. Age*, 1922, p. 826) with graphs showing the relative costs of the nitrate of soda and ammonia oxidation systems.

CHAPTER III

THE PROPERTIES AND ANALYSIS OF THE TECHNICALLY EMPLOYED OXIDES OF SULPHUR

Sulphur Sesquioxide, S_2O_3 .

BUCHHOLZ was the first to observe the formation of a blue solution when *flowers of sulphur* was dissolved in Nordhausen sulphuric acid. Vogel found that the same colour was produced with S and SO_3 , but Weber was the first to show that it was due to the formation of a new oxide of sulphur.¹

Sulphur sesquioxide is obtained by dissolving flowers of sulphur in an excess of sulphur trioxide, cooled to 15° , when it forms bluish-green crusts resembling *malachite*.

It forms a crystalline mass, which easily decomposes, especially on heating, into S and SO_2 .

In moist air it absorbs water, giving a brown liquid which soon decomposes with precipitation of sulphur. It is soluble in fuming sulphuric acid, producing a blue solution which is comparatively stable and may be kept in a sealed tube, but eventually decomposes giving a brown solution with liberation of SO_2 and a proportion of sulphur.

The solution is used in the manufacture of certain colours.

Sulphur Dioxide, SO_2

(*Sulphurous Anhydride*).

Sulphur dioxide is, at the ordinary temperature and pressure, a colourless gas of suffocating smell, neither supporting combustion nor being itself combustible. Even when greatly diluted with air it has a very injurious action upon plants and animals. It contains 50.05 per cent. by weight of sulphur and

¹ *Pogg. Ann.*, 1875, pp. 156-531.

49.95 per cent. oxygen. Molecular weight 64.06 (O = 16). Its specific gravity has been found by various observers, 2.222-2.247 (air = 1); calculated from the molecular weight 2.2136. A litre of the gas at 0° and 760 mm. pressure weighs 2.8608 grams. Its coefficient of expansion is not exactly equal to that of air, but rather larger, especially at lower temperatures, namely for each 1°, according to Amagat:—

Degrees.				
Between	0 and 10	.	.	0.004233
"	10 " 20	.	.	0.004005
	At 50	.	.	0.003846
"	100	.	.	0.003757
"	150	.	.	0.003718
"	200	.	.	0.003695
"	250	.	.	0.003685

Its *specific heat*, compared with an equal weight of water, is = 0.1544; compared with an equal weight of air = 0.3414. Mathias¹ gives it between -20° and +130° as:

$$0.31712 + 0.0003507t + 0.000006762t^2.$$

Ratio of sp. ht. at constant pressure to sp. ht. at constant vol. = 1.26.

Formation.—Sulphur dioxide is produced by burning brimstone, and by heating (roasting) many metallic sulphides, in the presence of air; by the action of strong mineral acids, on the sulphites, the thiosulphates, and all polythionic acids; by heating sulphuric anhydride with sulphur, or by heating oil of vitriol with brimstone, coal, organic substances, or certain metals; by strongly heating the vapour of sulphuric anhydride, or sulphuric acid, with simultaneous formation of oxygen and water; and by igniting many sulphates, whereby the sulphuric anhydride first liberated at once splits up into sulphur dioxide and oxygen.

According to Scott, when sulphur dioxide (mixed with CO₂) is to be made by the process mostly used on the small or moderately small scale, viz. that of heating sulphuric acid with charcoal, it is best to employ acid of 74 per cent. SO₃ = 165° Tw. If stronger acid be used, a portion of it is reduced to sulphur, which may produce iron sulphide with the iron of the apparatus; with weaker acid sulphuretted hydrogen is formed.

¹ *Comptes rend.*, 119, 404.

178 TECHNICALLY EMPLOYED OXIDES OF SULPHUR

In order to obtain the gas as pure as possible, the washing-water should be mixed with lead sulphate or coarsely powdered charcoal.

Thus sulphur dioxide is produced from sulphuric acid or anhydride in many ways by processes of reduction. On the other hand, the sulphur dioxide passes over, even more easily, into sulphuric acid by oxidation processes; and it is accordingly one of the most frequently used and potent reducing agents.

Edward Hart¹ prepares sulphurous acid in the following manner:—

Fuming sulphuric acid containing 30 per cent. SO_3 is warmed with lump sulphur. The sulphur dissolves, forming a blue solution, from which, on warming, sulphur dioxide is given off mixed with some sulphur trioxide. Evolution of sulphur dioxide ceases when all the sulphur trioxide has been acted on and the sulphur melts.

The *density* of saturated vapour of SO_2 (that is, in contact with liquid SO_2) at various temperatures (water of $0^\circ = 1$) is, according to Cailletet and Mathias²:—

* Cent.	Density.		* Cent.	Density.
At 7.3	0.00624		At 100.6	0.0786
„ 16.5	0.00858		„ 123	0.1340
„ 24.7	0.0112		„ 130	0.1607
„ 37.5	0.0169		„ 135	0.1888
„ 45.4	0.0218		„ 144	0.2195
„ 58.2	0.0310		„ 152.5	0.3426
„ 78.7	0.0464		„ 154.9	0.4017
„ 91.0	0.0626		„ 156	critical point.

The *heat of formation* of 1 gram-mol. of SO_2 (= 64.06 grams) from ordinary (rhombical) sulphur is = 71,080 cal. (Thomsen), or 69,260 cal. (Berthelot).

By cooling with ice and salt, sulphur dioxide can be condensed to a liquid, even without application of pressure. Liquid SO_2 is a colourless mobile fluid, of about the same refractive power as water, boiling at -11° ; but on drawing it off at the ordinary temperature from a reservoir it remains liquid for some time, the evaporation cooling it down below

¹ *J. Amer. Chem. Soc.*, 1917, 39, 376; *J. Chem. Soc.*, June 1917, 2, 256.

² *Comptes rend.*, 104, 1536.

its boiling-point. Its *latent heat* at 0° is 91·2, at 10° 88·7, at 20° 84·7, at 30° 80·5.

Its *vapour-tension* is:—

At - 11° = 0	atmosphere overpressure.
„ 0 = 0·53	„ „
„ 10 = 1·26	„ „
„ 20 = 2·24	atmospheres „
„ 30 = 3·51	„ „
„ 40 = 5·15	„ „

The *specific gravity* of liquid sulphur dioxide at various temperatures has been accurately determined by A. Lange¹ as follows:—

Temperature. C.	Specific gravity.	Temperature. C.	Specific gravity.
- 20°	1·4846	+ 20°	1·3831
- 10°	1·4601	25°	1·3695
- 5°	1·4476	30°	1·3556
0°	1·4350	35°	1·3441
+ 5°	1·4223	40°	1·3264
10°	1·4095	50°	1·2957
15°	1·3964	60°	1·2633

Action of Light.—The action of light on the formation of SO₃ from SO₂ and O has been studied by Coehn and Becker.²

Action with Oxygen.—According to Berthelot, the combination of dry gaseous sulphur dioxide with dry oxygen under the influence of strong electric currents produces the crystallised anhydride of persulphuric acid S₂O₇.

Action on Metals and Oxides.—Many metals are attacked when heated in the gas; potassium burns with formation of potassium sulphate and sulphite. Reduced iron or other iron ores with little or no carbon is used in a finely divided form for the preparation of hydrosulphites and sulphonyl-sulphides (German Pat., von Heyden, 304107.)

By passing metallic oxides such as cupric oxide, bismuth oxide, mercuric oxide, manganese dioxide, selenium dioxide, and telluric oxide in a current of the gas, sulphur dioxide undergoes oxidation. Although the sulphate of the metal is

¹ *Z. angew. Chem.*, 1899, p. 275.

² *Z. physik. Chem.*, 1909, 70, 88-115.

one of the products of the reaction in most of the cases, the actual change varies with the nature of the metal.

Stannous oxide, lead monoxide, ferrous oxide, and manganese oxide behave similarly to the alkaline earth oxides in that sulphites appear to be formed as the primary product, which is subsequently transformed into a mixture of sulphides and sulphates. These oxides also have a reducing effect on the sulphur dioxide.

Under certain conditions, by the action of light, of the electric current, or of a very high temperature and pressure combined, sulphur dioxide splits up into sulphur and sulphuric anhydride. A very important reaction is that between SO_2 and sulphuretted hydrogen. When completely dry the two gases do not seem to act upon each other. Even in the presence of moisture no action takes place at temperatures above 400° (E. Mulder). At the ordinary temperature water and sulphur are produced, but at the same time also pentathionic acid, according to the equation :

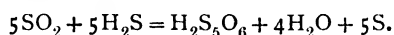

This action occurs simultaneously with the simple reaction :

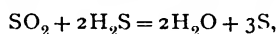

one or other of these prevailing, according to the proportion of the two gases in the mixture.

Behaviour towards Water. — Sulphur dioxide does not interact with exactly 1 mol. of H_2O to form sulphurous acid proper, H_2SO_3 , but under certain conditions it yields a solid compound with much more water (9, 11, or 15 H_2O to SO_2), which has not yet been definitely investigated. Sulphur dioxide dissolves pretty freely in water; and this solution behaves in every way as if it contained the real acid H_2SO_3 , but, even at the ordinary temperature, the dioxide evaporates constantly from it. One volume of SO_2 under 760 mm. pressure and at 0° , nearly 8 volumes of water, coefficient of absorption, according to H_2 and Schlegel, at temperatures ranging between 0° and 40° , is,

$$79.789 - 2.6077t + 0.029349t^2;$$

at temperatures between 21° and 40° ,

$$75.182 - 2.1716t + 0.01903t^2.$$

The absorbed gas does not escape on freezing ; on boiling for a long time it is driven off completely.

According to Jungfleisch and Brunel,¹ the final products of the reaction of SO₂ on water at temperatures up to 160° are sulphur and sulphuric acid. The reaction is slower the more concentrated the solution of the SO₂ and the lower the temperature. At low temperatures first hydrosulphurous acid and sulphuric acid are formed :

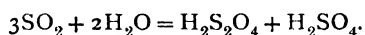

Later on, the hydrosulphurous acid decomposes into sulphur and sulphuric acid :

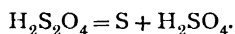

These two phases of the reaction set in also at the ordinary temperature, but very slowly. All their experiments were made in closed tubes, with exclusion of air. The decompositions described are accompanied by secondary reactions. Forster² investigated the stability of aqueous solutions of sulphur dioxide.

From Bunsen and Schönfeld's determinations, the following table is calculated by Harpf³ for the solubility in water at normal atmospheric pressure :—

Temperature. ° C.	1 lit. water dissolves lit. SO ₂ .	1 lit. water dissolves grams SO ₂ .	1 lit. satur- ated aqueous solution con- tains lit. SO ₂ .	Specific gravity of aqueous solution.	Per cent. SO ₂ by weight in aqueous solution.
0	79.8	228.3	68.86	1.0609	18.58
5	67.5	193.1	59.82	1.059	16.19
10	56.6	161.9	51.38	1.0547	13.93
15	47.3	135.3	43.56	1.042	11.92
20	39.4	112.7	36.21	1.0239	10.12

Freese⁴ has determined the solubility of sulphur dioxide in water between 0° and 40°, and the results are given in grams and in litres of gas dissolved per litre of water. At 0° the solubility is 228.29, at 10° 162.09, at 20° 112.90, at 25°

¹ *Comptes rend.*, 9th June 1913.

² *Arch. d. Kais. Gesundheitsamts*, 1914, p. 468 ; *Chem. Zeit.*, 1915, 1, 447.

³ *Chem. Zeit.*, 1905, p. 136.

⁴ *Ibid.*, 1920, 44, 294 ; *J. Chem. Soc. Abstr.*, June 1920, 2, 370.

94.08, at 30° 78.67, and at 40° 54.11 grams per litre, which agree with Bunsen and Schönfeld's table given above.

Another table for the percentage of sulphur dioxide in solutions of various sp. gr. at 15° is given by Scott¹:—

Per cent. SO ₂ .	Specific gravity.	Per cent. SO ₂ .	Specific gravity.
0.5	1.0028	5.5	1.0302
1.0	1.0056	6.0	1.0328
1.5	1.0085	6.5	1.0353
2.0	1.0113	7.0	1.0377
2.5	1.0141	7.5	1.0401
3.0	1.0168	8.0	1.0426
3.5	1.0194	8.5	1.0450
4.0	1.0221	9.0	1.0474
4.5	1.0248	9.5	1.0497
5.0	1.0275	10.0	1.0520

H. Pellett² determined the specific gravity of different solutions, and has obtained results differing greatly from those given above. He gives the following table of specific gravities of sulphurous acid solutions at 15° to 17°:—

Sulphurous Acid in 100 c.c.	Specific gravity.	Sulphurous Acid in 100 c.c.	Specific gravity.
1	1.0075	4	1.0300
2	1.0150	5	1.0375
3	1.0225	6	1.0450

He stated that he has rarely met with a solution having a greater specific gravity than 1.045 at 15° to 17°.

He shows that the maximum strength of aqueous solutions varies with the quality of the gas from which they are prepared, and that the purer the gas the stronger the solution. This explains the difference in the specific gravity of different solutions, each supposed to be saturated with sulphur dioxide. Moreover, the strength of a solution saturated with sulphurous acid obtained from a gas rich in sulphur dioxide can be reduced by the introduction of a gas containing less sulphur dioxide.

Sulphur Dioxide and Alcohol.—Alcohol absorbs considerably greater quantities of sulphur dioxide than does water,

¹ *Pharm. Soc. J. and Trans.*, 11, 217.

² *Bull. Assoc. chim. Sucri.*, 1901, 19 (6), 732-736; *J. Soc. Chem. Ind.*, 1902, p. 171.

and the table below gives the vol. calculated at N.T.P. absorbed by 1 vol. alcohol (Bunsen).

° C.	SO ₂	° C.	SO ₂	° C.	SO ₂
0	326.62	9	201.33	18	124.58
1	311.98	10	190.31	19	119.17
2	295.97	11	179.91	20	114.48
3	280.58	12	170.13	21	110.22
4	265.81	13	160.98	22	106.68
5	251.67	14	152.45	23	103.77
6	238.16	15	144.55	24	101.47
7	225.25	16	137.27	25	99.81
8	212.98	17	130.61		

Sulphur Dioxide and Ammonia.—Divers and Ogawa¹ state that, with excess of SO₂, ammosulphinic acid NH₂SO₂H is always formed, a pale-yellow-coloured compound, but with excess of ammonia the ammonium salt NH₂·SO₂NH₄ of this acid is formed as a white substance; but other investigators do not agree with the above: see Ephraim and Piotrowski.² The first named therefore made further investigations, and confirmed their findings.³

The oxidising properties of sulphur dioxide are fully dealt with in an article by Wardlaw and Clews.⁴

An investigation of the decomposing action of sulphurous acid on some rock-forming minerals has been made by Lotz.⁵

Physiological Action of Sulphur Dioxide.

In an investigation on the injurious action of sulphur dioxide on animal and vegetable organisms, Ogata⁶ found that 0.04 per cent. SO₂ caused difficulty in breathing after a few hours, and that he could not take a single full breath of air containing 0.05 per cent. SO₂. It is an acute blood poison.

¹ *Chem. Soc. Trans.*, 1901, **79**, 1102.

² *Ber.*, 1911, **44**, 379-386; *J. Chem. Soc.*, 1911, **2**, 275.

³ *Sci. Reports Tôhoku Imp. Univ.*, 1913, **2**, 121-129; *J. Chem. Soc.*, 1914, **2**, 264.

⁴ *J. Chem. Soc.*, 1920, pp. 1093, 1099, 1101; 1245.

⁵ *Rauch und Staub*, 1913, p. 279; abstracted in *Chem. Zeit. Rep.*, 1913, p. 568.

⁶ *Arch. f. Hygiene*, 1884, p. 223.

A number of investigations on the bactericidal properties of sulphur dioxide and sulphides has been made by the German Imperial Board of Trade; abstracted in *Z. angew. Chem.*, 1913, 2, 589.

Tatlock and Thomson, in a lecture given before the Society of Public Analysts,¹ point out that the mere fact of the presence of sulphates in plants in excess of those which have grown in a pure atmosphere is no proof of any damage having been caused to the plants by the acids of sulphur; this they prove by the results of the analysis of plants from various localities. They conclude that such damage can be assumed to have taken place only if, firstly, the percentage of SO_3 is considerably in excess of that which normally occurs in the plants; and if, secondly, on wetting its surface with water and litmus, a leaf or other part of the plant shows an acid reaction (phenolphthalein is not to be used as indicator).

DETECTION AND ESTIMATION OF SULPHUROUS ACID AND SULPHUR DIOXIDE

Qualitative Reactions of Sulphurous Acid.—The sense of smell is a very good means for detecting the presence of SO_2 , when other odorous acids are absent. Gaseous mixtures containing SO_2 together with such acids are best passed through an absorbent, e.g. sodium carbonate, with which afterwards the ordinary tests for SO_2 are made. When such gaseous mixtures are passed through a solution of potassium permanganate, or of iodine in potassium iodide, these liquids are decolorised. A test-paper, soaked in a solution prepared by boiling 2 grams wheat-starch with 100 c.c. of water, and adding 0.2 gram of potassium iodate dissolved in 5 c.c. water, is turned blue by SO_2 . These reactions may also be utilised for recognising the presence of SO_2 when set free from its salts by the action of sulphuric acid. One of the best reactions, specially adapted for discovering SO_2 in sulphuric acid itself, is its conversion into H_2S by means of pure zinc, or, preferably, aluminium in an acid solution. The H_2S is then recognised by its reaction on lead paper, or by the purple colour produced in an ammoniacal solution of sodium nitroprusside.

¹ Abstracted in *Chem. Trade J.*, 1914, 54, 390.

A solution of a sulphite, either neutral or with addition of some sodium bicarbonate (*just* acidulated with acetic acid), when poured into a solution of zinc sulphate containing a little sodium nitroprusside, produces a red colour or precipitate, either at once or, if very little SO_2 is present, after adding some potassium ferricyanide. This reaction is not given by thio-sulphates, which are, moreover, distinguished from sulphites by their giving (generally only after a little time) a precipitate of sulphur on being treated with a stronger acid. According to Reinsch, SO_2 can be detected by boiling the acid solution with a strip of clean copper, which is thereby blackened. This is caused by the formation of cupric sulphide, and the colour is not changed by heating the strip in a glass tube; but when the colour is produced by arsenic, there is a sublimate of white arsenious acid formed in the tube.

According to Schützenberger, sulphurous acid contained in a solution can be recognised by adding a drop of indigo solution and agitating with a zinc rod; owing to the formation of hypo-sulphurous acid (Schützenberger's "hydrosulphuric" acid), HSO_2 , the blue colour will be destroyed, but will quickly reappear in contact with the air.

Very small quantities of sulphurous acid, *e.g.* in parts of plants damaged by acid smoke, can be detected¹ by digesting the very finely cut-up material during two days with cold water, with exclusion of air, adding to the extract thus obtained iodic acid, and shaking up with chloroform, which if SO_2 is present acquires a purple colour.

Seidell and Meserve² find extremely small quantities of SO_2 in gases as follows:— $2\frac{1}{2}$ litres of the gas are mixed in a bottle with starch solution, with which the walls of the bottle are moistened all over; then $1/1000$ normal iodine solution is run in, until a blue colour appears. If the gas contains four to ten vols. SO_2 in a million vols., the colour appears when 70 to 80 per cent. of the SO_2 has been consumed.

Denigès³ dips a glass rod into a solution of mercuric sulphate, and exposes it to the air to be tested. If any

¹ Stefano, *Chem. Zentr.*, 1914, 1, 516.

² *J. Ind. Eng. Chem.*, 1914, p. 298.

³ *Bull. Soc. Pharm. Bordeaux*, 54, 145; *J. Soc. Chem. Ind.*, 1915, p. 149.

SO_2 is present, characteristic crystals of mercurous sulphate are formed.

The *quantitative estimation* of sulphurous acid in the free state can be performed either as will be described in the case of sulphites, or by titration with standard sodium hydroxide. In the latter case, however, it must be noted that the point of neutrality is reached with phenolphthalein as indicator when the normal salt, Na_2SO_3 , has been formed, so that each cubic centimetre of normal alkali (containing 0.031 NaOH) indicates 0.003203 gram SO_2 . But when employing methyl-orange as indicator, the point of neutrality is reached exactly at the formation of NaHSO_3 , so that each cubic centimetre of normal alkali indicates 0.06406 SO_2 . Litmus gives uncertain results, and is therefore useless as an indicator. It is therefore possible to estimate free SO_2 in the presence of stronger free acids in the following way: one portion of the liquid is titrated with methyl-orange, and another with phenolphthalein as indicator; in the latter case more alkali will be used, and the difference of cubic centimetres of normal alkali, multiplied by 0.06406, shows the quantity of free SO_2 present.

The acid sulphites are neutral to methyl-orange, which consequently enables us to estimate any SO_2 present over and above NaHSO_3 . The SO_2 present in the NaHSO_3 itself can be titrated with normal soda and phenolphthalein, each cubic centimetre of normal alkali indicating 0.06406 SO_2 . Normal sulphites, like Na_2SO_3 , can be titrated by means of methyl-orange and standard hydrochloric or sulphuric acid, the red colour appearing when NaHSO_3 has been formed, so that each cubic centimetre of standard acid indicates 0.06406 SO_2 .

Other methods of estimating SO_2 either in the free state or in its salts are based on its reducing properties. The reagents serving for this purpose are either a standard solution of iodine or one of potassium permanganate. A decinormal solution of either indicates per cubic centimetre 0.003203 gram SO_2 . The method to be recommended for testing gaseous SO_2 in burner-gas will be described when treating of that gas in Chapter IV. Special attention must be drawn to the necessity of employing water *free from air* in estimating SO_2 . This is not necessary if the solution of the sulphite or sulphurous acid is run into the solution of iodine.

Victor Copetti¹ states that the gravimetric method of Haas for the estimation of sulphurous acid, which consists in expelling the sulphur dioxide from the solution under examination by distilling in an atmosphere of carbon dioxide, absorbing the gas in a solution of iodine, and weighing the resulting sulphuric acid as barium sulphate, gives accurate results volumetrically if means are taken to prevent loss of iodine by volatilisation in the current of carbon dioxide. For this purpose, an apparatus is described consisting essentially of a 300 c.c. flask to contain the iodine solution, to the bottom of which extends the gas delivery tube from the distillation flask. Surmounting the flask is a spherical absorption vessel containing N/10 thiosulphate solution, through which the carbon dioxide and iodine vapours leaving the flask must pass. When distillation is complete, the thiosulphate solution containing all the volatilised iodine is allowed to run back into the flask and the excess of iodine in the latter is titrated back with standard thiosulphate solution.

Kolthoff² also states that the accuracy of the iodine method for estimating sulphurous acid depends on adding the sulphurous acid to the iodine solution and not *vice versa*. Errors are caused by oxidation by the air; sodium carbonate and hydrochloric acid increase these errors. Potassium iodide acts similarly, owing to its being a catalyst in the oxidation process. Mannitol, sucrose, and alcohol do not increase the accuracy of the determination.

Kedesdy³ confirms Lunge's statement *supra*, that methyl-orange changes its colour exactly at the point where the bisulphite has been formed :

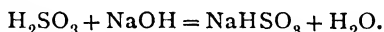

When employing phenolphthalein for titrating free sulphuric acid, the red colour appears only when all the sulphurous acid has passed over into the normal salt, Na_2SO_3 ; but in this case the change of colour is quite gradual, and the titration with this indicator is not exact. He, therefore, prefers oxidising the sulphurous acid by hydrogen peroxide into sulphuric

¹ *Ann. Chim. anal.*, 1921, 3, 327-330; *J. Chem. Soc.*, 1922, 2, 80.

² *Pharm. Weekblad*, 1919, 56, 1366-1373; *J. Soc. Chem. Ind.*, 1919, p. 815A.

³ *Chem. Zeit.*, 1914, p. 601.

acid, which proceeds readily at the ordinary temperature, and then titrating with normal caustic-soda solution and methyl-orange. This method is especially suitable for estimating the sulphurous acid in fuming oil of vitriol.

The reaction between iodine and sulphurous acid has been studied by Robert Milroy Macaulay,¹ and his conclusions are as follows :

Sulphurous acid is quantitatively oxidised to sulphuric acid by N/10 iodine, without separation of sulphur. The intermediate formation of the yellow compound SO_2HI which occurs in solutions of moderate concentration, has no influence on the final result.

The low results obtained when sulphurous acid is exposed to the air during the titration are due entirely to evaporation of sulphur dioxide, the amount of atmospheric oxidation being negligible.

Sodium sulphite solution is more readily oxidised than sulphurous acid ; consequently atmospheric oxidation is a disturbing factor when sodium sulphite solution is titrated with iodine. Since the reaction between sulphurous acid and iodine is not reversed under the state of dilution obtaining in volumetric analysis, the addition of sodium hydrogen carbonate to neutralise hydriodic acid, as when solutions of arsenious compounds are being titrated, is unnecessary ; and since a sulphite solution is so quickly oxidised it is not necessary to allow a time interval for such oxidation by iodine to be completed.

Liquid sulphur dioxide, according to *Papier-Zeitung*, 1892, No. 62, sometimes contains up to 20 per cent. sulphuric acid. It can be tested in exactly the same manner as solutions of sulphur dioxide. A special apparatus for the analysis of liquid sulphur dioxide is described in Fr. P. 435763 of the Comp. ind. d. proc. R. Pictet.²

Sander,³ on titrating sulphurous acid with decinormal caustic-soda solution, found that the values obtained with methyl-orange as indicator agree very well with those obtained by titrating with iodine, but the application of phenolphthalein as

¹ *J. Chem. Soc.*, 1922, pp. 552-6.

² *J. Soc. Chem. Ind.*, 1913, p. 412.

³ *Chem. Zeit.*, 1914, p. 1057.

indicator gave no good results. But since even with methyl-orange the change of colour is not so sharp as in the case of other acids, he prefers oxidising the SO_2 by perfectly neutral hydrogen peroxide, and titrating the sulphuric acid formed. This can be done with the utmost accuracy. In *Z. angew. Chem.*, 1915, p. 10, he recommends oxidising the SO_2 by boiling with a solution of mercuric chloride in very dilute solution.

Jamieson¹ titrates sulphurous acid with potassium iodate in the presence of hydrochloric acid and a little chloroform (method of Andrews).

Craig² gives the following method for determining sulphurous acid volumetrically, which depends upon the following reactions:—

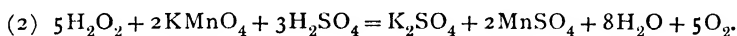
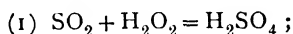

A solution of the sulphurous acid, sulphite or bisulphite, is added to a known excess of acidified hydrogen peroxide, and the residual hydrogen peroxide is determined by titration with standard permanganate.

Samples of sodium sulphite, potassium metabisulphite, and commercial sodium bisulphite liquor were employed to test the method. It was found that the action of hydrogen peroxide on sulphur dioxide is best carried out in a solution which is not too dilute; afterwards the liquid may be diluted before titrating back with permanganate.

Proposed Method.—One gram of the sample is dissolved in from 25 c.c. to 50 c.c. of distilled water and gradually added to a decided excess of standardised hydrogen peroxide—an excess equal to about 10 c.c. of N/2 permanganate should suffice. The amount of hydrogen peroxide taken is noted and stated as its equivalent in c.c. N/2 solution—say x c.c. 10 c.c. of dilute (1 : 3) sulphuric acid is now gradually run in and the whole well mixed. The mixture is cooled to the ordinary temperature and the residual hydrogen peroxide determined by titration with N/2 permanganate. The volume of the permanganate used is noted = y c.c. Then $x - y =$ c.c. of N/2 permanganate

¹ *Amer. J. Sci.*, 1914, 38, 166.

² *J. Soc. Chem. Ind.*, 1919, p. 96T.

equivalent to the sulphur dioxide present in the portion taken for analysis.

Since sulphites and bisulphites in dilute neutral or acid solution rapidly deteriorate, as short a time as possible should be allowed to elapse between dissolving the sample in water and adding it to the hydrogen peroxide. Alkaline sulphite solutions do not deteriorate so quickly. The hydrogen peroxide solution is standardised by titrating 10 c.c. (of "10 volume" solution) with $N/2$ permanganate under conditions similar to those in which the analysis is made. The method was tested with samples of sulphite, metabisulphite, and bisulphate, and in all cases the results agreed excellently with those found by the iodine method.

Instead of oxidising with hydrogen peroxide, other oxidising agents, such as chlorine, bromine, and iodine, have been employed.

Sulphur dioxide may be present in a gaseous mixture along with hydrogen sulphide provided that these gases are very greatly diluted by inert gases (as in the exit-gases from the "Claus kilns"). In such cases, it can be estimated by passing the gases through a solution of I in KI, followed by a solution of caustic soda or, preferably, sodium thiosulphate. The iodine oxidises H_2S into $H_2O + S$, and SO_2 into H_2SO_4 ; hence the acidity of the solution is not affected by H_2S , merely by SO_2 . On the other hand, each cubic centimetre of decinormal iodine indicates 0.003203 gram of sulphur in either case, so that the difference between the iodometrical and the alkalimetric test gives the H_2S present. The addition of a tube with sodium thiosulphate solution is necessary, because the gaseous current carries away some iodine which is retained in that solution; the latter, before titrating the iodine solution back, is added to it.¹

Applications of Sulphurous Acid (Sulphur Dioxide).

The greatest quantity of SO_2 is produced for the manufacture of sulphuric acid. Next to this in importance comes its use for the manufacture of wood-pulp, mostly in the state of calcium bisulphite (or a solution of $CaSO_3$ in an excess of sulphurous acid). One of the oldest uses of sulphur dioxide, obtained by

¹ Details in Lunge's paper, *J. Soc. Chem. Ind.*, November 1890.

burning sulphur, is that of a disinfecting and antiseptic agent. For the former purpose it is not so much valued now as formerly, since it has been shown that many disease-germs resist the action of SO_2 for a long time. The antiseptic function of SO_2 comes into play in the fumigation of wine-casks, in the manufacture of glue (where it acts also as a bleaching agent), and in many other cases.

In the textile industries sulphurous acid is largely used as a bleaching agent, especially for wool, silk, straw, etc. It is not quite certain in which way it acts in this case, possibly by forming a compound with the colouring matters contained in the fibres. Formerly it was generally assumed that the SO_2 in bleaching acted as a reducing agent, which indeed must be true in some cases, although probably not in all.

The reducing functions of SO_2 are utilised in chemical and metallurgical operations in too many cases to be enumerated here.

The use of SO_2 in any form is said to be advantageous in wine-making, and metabisulphite gives somewhat better results than the other preparations used.

∩

Sulphur Trioxide SO_3

(*Sulphuric Anhydride*).

Properties.—Consists of 40.05 parts by weight of sulphur, and 59.95 of oxygen.

It is a white, silky-looking, crystalline substance melting at 14.8° and boiling at 46.2° . It is very volatile and gives off dense white fumes in contact with air, owing to the combination of its vapour with atmospheric moisture to form sulphuric acid. It combines with water with great energy to form sulphuric acid; a fragment of the compound dropped into water dissolves with a hissing sound resembling the quenching of red-hot iron.

When brought into contact with the skin or other organic matter containing hydrogen and oxygen, it abstracts these elements and produces a burnt or charred effect upon the substance. Sulphur trioxide unites directly with barium oxide, yielding barium sulphate, and if the baryta be dry the mass becomes incandescent, owing to the heat of the union.

When the vapour of sulphur trioxide is passed through a red-hot tube, it decomposes into sulphur dioxide and oxygen.

The rate of decomposition at 809° has been determined by Bodenstein and Kranendieck.¹

When sulphur trioxide is heated, it melts to a colourless liquid, which exhibits a remarkably high rate of expansion by heat; between 25° and 45° its mean coefficient of expansion is 0.0027—nearly three-fourths of the expansion coefficient of a gas.

Several investigators have come to the conclusion that there are two different modifications, whilst Weber ascribes formation of the modification resembling asbestos to a minute trace of water.

Litchy² agrees that two modifications are known, "a" which has a definite melting-point, and the "β" form which volatilises without melting. The "a" modification, prepared by repeated distillation over phosphorus pentoxide *in vacuo*, fuses at 16.79° ; its boiling-point at pressures of 740.7 to 744.5 mm. is 44.23° to 44.36° , corresponding to a boiling-point of 44.88° at a pressure of 760 mm. The sp. gr. was 1.9457 at 11.8° , and 1.7921 at 48° ; the coefficient of expansion 0.000676 at 11.5° , and 0.002805 at 40° to 48° . Nowhere between 11° and 45° was the volume contraction observed which Schenck³ asserts to take place at 35° . The other modification of SO_3 , designated as the "β" form, is the ordinary product, whose molecular weight is the same as the liquid "a" modification, viz. = 80.

Weber describes his preparation as absolutely pure and free from water. At the summer temperature it is a very mobile, colourless liquid, which, on gradually cooling, solidifies to long, transparent, prismatic crystals. These crystals melt at 14.8° and boil at 46.2° .

The structural formula for sulphur trioxide is $\text{O}=\text{S}\begin{matrix} \text{O} \\ \diagup \\ \text{O} \end{matrix}$.

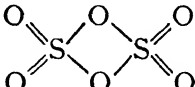
Oddo suggests for S_2O_6 

¹ *Z. physik. Chem.*, 1912, 80, 148-158; *J. Chem. Soc.*, 1912, 2, 747.

² *J. Amer. Chem. Soc.*, 1912, 34, 1440-1448.

³ *Annalen*, 316, 1.

Sulphur trioxide is said to volatilise at about 50°, being converted into "α" modification by distillation.

According to Giraud,¹ the vapour of sulphuric anhydride at the moment of its being formed has the simple formula SO₃.

The heat of formation of 1 mol. of SO₃ (= 80.06 parts by weight) from S and O₃ is = 103,230 cal. (Thomsen); from SO₂ + O = 34,400 cal. in the solid state, or = 22,600 cal. in the gaseous state (Berthelot). The heat of vaporising 1 mol. SO₃ is = 11,800 cal.; that produced by dissolving 1 mol. SO₃ in a large quantity of water = 39,170 cal. (Thomsen). 1 kilogram SO₃ liberates 500 cal. when dissolved in water, 300 cal. when dissolved in 66° B. S/Acid.

The thermal properties of liquid SO₃ are fully dealt with in a paper by Porter.²

The sp. gr. of pure sulphur trioxide is given by Litchy as follows:—

° C.	Sp. gr.	° C.	Sp. gr.
11.8	1.9457	30	1.8798
15.0	1.9422	35	1.8569
20.0	1.9229	40	1.8324
25.0	1.9020	45	1.7921

The coefficient of expansion was determined for several intervals of temperature between 11.8° and 45°; it was found to be 0.002005 at 15-20°, and 0.002671 at 35-40°.

Formation of Sulphur Trioxide.—This compound is produced when a mixture of sulphur dioxide and oxygen (or atmospheric air) is passed over spongy platinum or platinised asbestos. On leading the product through a well-cooled receiver, the sulphur trioxide condenses in white silky needles. This method is now successfully employed on a commercial scale.

A process for making sulphur trioxide is described by W. H. Seamon, Texas (U.S. P. 1292089), the compound being produced by fusing a mixture of sodium sulphate, calcium sulphate, and silica in the absence of a reducing environment to avoid excessive decomposition of the sulphur trioxide formed.

¹ *Comptes rend.*, 1913, p. 395. ² *Trans. Faraday Soc.*, 1918, 13, 373.

Pure "Monohydrated" Sulphuric Acid, H_2SO_4 .

Properties of Pure Sulphuric Acid.—Sulphuric acid containing 81.63 per cent. SO_3 and 18.37 per cent. of water has the rational formula,

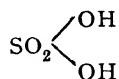

It is a limpid, colourless, oily liquid. The sp. gr. at 0° is 1.854; at 15° (compared with water at 4°) 1.8384 (Lunge and Naef), 1.8378 (Schertel), 1.8372 (Marignac, F. Kohlrausch, Mendelejeff).

The sp. gr. changes per degree as follows:—

1.000-1.170 = .0006
1.170-1.450 = .0007
1.450-1.580 = .0008
1.580-1.750 = .0009
1.750-1.820 = .0010
1.820-1.840 = .0008

The addition of very little SO_3 or of a small amount of water causes the specific gravity to increase.

The pure monohydrate solidifies when cooled to 0° and forms large, plate-shaped crystals, which melt at 10.5° ; they remain liquid much below that temperature, but solidify on agitation, or even better when a fragment of the solid hydrate is introduced.

The acid begins to boil at 290° , but the boiling-point rises to 338° (Marignac). This shows that it does not distil unchanged; in fact, a mixture of hydrated acid, anhydride, and water passes over. This dissociation begins much earlier; the pure monohydrate produces fumes giving off SO_3 , very slightly even at the ordinary summer temperature, distinctly at 30° or 40° . Accordingly it cannot be obtained by boiling down or distilling the dilute acid, but only by adding an exactly sufficient quantity of anhydride to the strongest acid obtainable by concentration, as is often done on a commercial scale in large quantities.

The vapour of sulphuric acid consists for the most part, or even entirely (according to the temperature), not of molecules of H_2SO_4 , but of isolated molecules of SO_3 and H_2O ; theory would give to H_2SO_4 (2 vols.) a vapour-density of 3.3862,

for separated molecules of SO_3 and H_2O (4 vols.) a vapour-density of 1.6931, whilst Deville and Troost at 440° found it actually = 1.74. The dissociation is therefore nearly complete in the state of vapour.¹

Oddo and Anelli² found the vapour-density of absolutely pure H_2SO_4 rather higher than calculated for this formula, which proves that some molecules of $(\text{H}_2\text{SO}_4)_2$ are present, as well as H_2SO_4 , SO_3 , and H_2O . In solutions they assume the sulphuric acid to be always present as the dimeric molecule $(\text{H}_2\text{SO}_4)_2$, but nitric acid as the simple molecule HNO_3 .

Further detailed investigations on the properties of absolutely pure H_2SO_4 have been made by Litchy³ and by Hantzsch.⁴

The *heat of formation* of 98 parts of H_2SO_4 is:—

	Liquid.	In diluted solutions.
From SO_2 , O, H_2O . . .	54,400	72,000 calories
„ S, O_3 , H_2O . . .	124,000	141,000 „
„ S, O_4 , H_2 . . .	193,000	210,000 „

Formation.—It has been asserted that sulphuric acid is formed in damp flowers of sulphur, even at the ordinary temperature; this is certainly the case on heating sulphur with water, or by applying the electric current. Sulphur is easily oxidised to sulphuric acid by chlorine, hypochlorous acid, nitric acid, aqua regia, etc. It is produced, together with sulphurous acid and sulphur, from tri-, tetra-, and pentathionic acids—from the former by merely heating, from all three by the action of chlorine or bromine, or even on the prolonged action of stronger acids, which set the thionic acids free; also the thiosulphates are decomposed by most acids into SO_2 and S.

Mostly sulphuric acid is produced from sulphur dioxide. The aqueous solution of the latter is gradually transformed into sulphuric acid by the action of the air alone, and it is also transformed at once by chlorine, bromine, iodine, hypochlorous acid, nitric acid, and several metallic salts such as manganic

¹ Dittmar, *Chem. News*, 20, 258.

² *Gazz. Chim. Ital.*, 1911, p. 552; *Chem. Zeit.*, 1911, p. 846.

³ *J. Amer. Chem. Soc.*, 1908, 30, 1834-1846.

⁴ *Z. physik. Chem.*, 1907, 61, 257-312; *Chem. Zeit.*, 1908, 1, 1240-1242.

sulphate, mercurous nitrate, etc. Sulphur dioxide and oxygen conducted through a red-hot tube containing platinum, platinised asbestos, ferric oxide, and a number of other substances, yield sulphuric anhydride, or in the presence of water sulphuric acid. This reaction, which was formerly only of scientific interest, has become of the greatest technical importance, and is, according to some opinions, destined to supersede the formerly universal and, up to this, most general process of making sulphuric acid from sulphur dioxide, air, and water by means of nitrogen oxides as oxygen carriers.

Sulphuric Acid containing Water.

Sulphuric acid combines with water in various proportions, forming a number of hydrates of a more or less definite character. The best known are those represented by the formulæ H_2SO_4 , H_2O , and $H_2SO_4 \cdot 2H_2O$. These compounds may be regarded as respectively tetrabasic and hexabasic sulphuric acid, and their relation to the ordinary dibasic acid may be expressed by the following formulæ:—

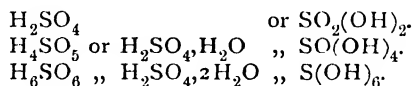

The double hydrate, $H_2SO_4 \cdot 2H_2O$ crystallises from rather more dilute acid—for instance, acid of 144° Tw. in the cold. It contains 84.48 monohydrate + 15.52 water (or 68.97 anhydride + 31.03 water), melts at $+8^\circ$, but owing to supercooling generally only solidifies below this temperature (for instance, in the depth of winter); at 205° to 210° it already loses 1 mol. H_2O and leaves ordinary oil of vitriol behind. The crystals form large, clear, hexagonal columns with six-pointed end-faces. Sp. gr. 1.78 to 1.79. By the crystallisation of this hydrate carboys are often cracked in winter; acid of 144° Tw. and the like ought, therefore, only to be warehoused in places where the temperature will not sink too low, for instance under the acid-chambers. Stronger or weaker acid can be exposed to the cold of winter without any danger.

Another hydrate, $H_2SO_4 \cdot 2H_2O$, is assumed, because, on diluting strong vitriol with water down to this point (that is, corresponding to 73.13 per cent. monohydrate, or 59.70 per

cent. anhydride), the largest contraction, viz. from 100 vols. to 92.14 vols., takes place. Bourgoïn¹ infers the same from observations on electrolysing dilute vitriol. The density of this mixture is variously stated by different observers:—by Graham at 1.6321; by Bineau, 1.665; by Kolb, 1.652; by Jacquelain, 1.6746. According to Liebig it boils at 163° to 170°; between 193° and 199° it loses 1 mol. of water, and is changed into H_2SO_4, H_2O (Graham).

Pickering² has obtained a hydrate of the formula $H_2SO_4, 4H_2O$, containing 57.67 per cent. real sulphuric acid. It fuses at -25° . By adding a little water or sulphuric acid the fusing-point is at once lowered to -70° .

The work of Pickering on the solidifying-points of mixtures of water and sulphuric acid has been extended by Giran.³ He established the solidifying-points of mixtures containing from 68 to 70 per cent. H_2SO_4 , and found a hydrate, $H_2SO_4, 2H_2O$, as well as two eutectic points.

Donk⁴ has obtained crystalline sulphuric-acid monohydrate, H_2SO_4, H_2O , by mixing 40 parts of lead or barium sulphate with 60 parts of 85 per cent. sulphuric acid, and setting the mixture away at 0° overnight. A portion of the crystallised mass thus obtained is then used for seeding or inoculating a new portion of 85 per cent. sulphuric acid, which has also been kept overnight at 0° , when the acid rapidly crystallises. The crystals are monoclinic. Crystallised H_2SO_4 is similarly obtained by seeding 99.9 per cent. sulphuric acid with a portion of a solidified mixture of 60 grams 99.9 per cent. sulphuric acid and 40 grams of lead sulphate. Crystallised H_2SO_4 is more difficult to obtain than crystallised H_2SO_4, H_2O , and is not formed if the acid is weaker than 99.50 per cent.

Jorissen⁵ states that he prepared crystallised H_2SO_4, H_2O (85 per cent. H_2SO_4) by cooling 84.0 per cent. and 83.3 per cent. solutions in melting ice. Nearly 100 per cent. H_2SO_4 may be made to crystallise by cooling 200 c.c. fuming oil of vitriol (containing 7.5 per cent. SO_3), mixed with 50 c.c. 93 per cent. sulphuric acid, in ice.

¹ *Bull. Soc. Chim.* [2], 12, 433.

² *Chem. News*, 60, 68.

³ *Bull. Soc. Chim.*, 1913, 13, 1049.

⁴ *Chem. Weekblad*, 10, 956; *Abstr. Am. Chem. Soc.*, 1914, 2, 1926.

⁵ *Chem. Weekblad*, 10, 962; *Am. Abstr.*, p. 3540.

A series of curves illustrating the properties of sulphuric acid of various degrees of concentration as given by Knietsch¹ is shown below, Fig. 13. The boiling-point curve shows a sharp apex at 98.3° per cent.; below this, water or dilute sulphuric acid; whilst above this, sulphuric anhydride is volatilised until in either case the constantly-boiling acid of 98.3 per cent. is reached. The vapour-tension at that critical concentration is zero, measured at 100° in a vacuum; the specific gravity of hydrated acid here reaches its maximum, from which it descends in both directions; the electrical resistance at this point begins to increase suddenly towards a maximum reached at nearly 100 per cent. H₂SO₄. In connection with this, it may be mentioned that the action upon iron decreases, which is of great importance for the durability of apparatus (*cf.* below).

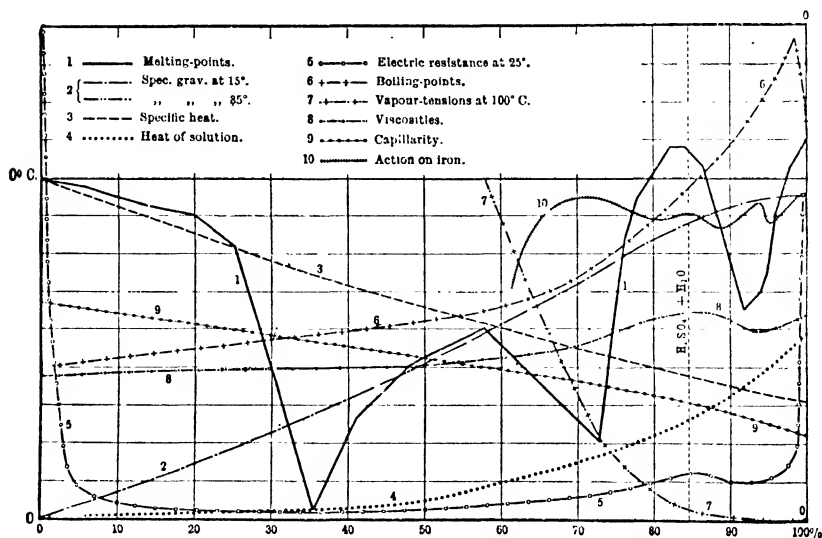

FIG. 13.

In Fig. 13, curve 1, marked ———, shows the melting-points; curve 2, - - - - - the specific gravities at 15°, - · - · - · at 35°; curve 3, - - - - -, the specific heats; curve 4, ·····, the heat of solution; curve 5, o-o-o-o, the electric resistance at 25°; curve 6, + - + -, the boiling-points; curve 7,

¹ *Ber.*, 1901, p. 4089.

· + · - · + · - , the vapour-tensions at 100°; curve 8, - · 0 - · 0 - , the viscosities (times of outflow); curve 9, - · - · - · - · , the capillarity; curve 10, - | - | - | - | - | - | - | - , the action upon iron.

The specific gravity of commercial acids, owing to the presence of impurities, is always higher than that of the pure acid; but, apart from this, the correctness of ordinary hydrometers is rarely of a very high order. Still, it must be conceded that in England, at least, there is a possibility of making the hydrometers all alike, the basis of Twaddell's system being plain and unmistakable, since every degree is equal to a difference of 0.005. But matters are far worse on the Continent and in America, where Baumé's hydrometer is almost universally used; unfortunately, the degrees of this instrument, as stated by various authorities, answer to very different specific gravities, and those of the instruments found in trade often show even far greater deviations. The only rational hydrometer on Baumé's system which rests on a mathematical basis, and which should therefore be always obtainable with a uniform scale, is that graduated according to the formula

$$d = \frac{144.3}{144.3 - n}$$

where d signifies any special density (specific gravity), and n the degree of the scale corresponding to it. (The mathematical deduction of this formula is given in the first edition of Lunge's work, pp. 20 and 21.) This scale is now also generally accepted in Germany and France. According to the *U.S. Bur. Stand.*, No. 69, quoted in *Chem. Abst. Chem. Soc.*, 1916, p. 1720, the Bureau in 1904 adopted for liquids heavier than water the formula

$$\text{Degrees Bé.} = 145 \text{ to } 145/d \text{ at } 60/60^\circ \text{ F.}$$

This was confirmed in 1916.

We therefore give, herewith, a table showing the value of a degree Baumé according to the rational scale, to Gerlach's, and to the American scale:—

[TABLE

*Comparison of Baumé's Hydrometers with the
Specific Gravities.*

Degrees.	Rational Hydrometer, $d = \frac{144.3}{144.3 - n}$	Baumé's Hydrometer (Gerlach).	American Hydrometer.	Degrees.	Rational Hydrometer, $d = \frac{144.3}{144.3 - n}$	Baumé's Hydrometer (Gerlach).	American Hydrometer.
1	1.007	1.0068	1.005	36	1.332	1.3250	1.334
2	1.014	1.0138	1.011	37	1.345	1.3370	1.342
3	1.022	1.0208	1.023	38	1.357	1.3494	1.359
4	1.029	1.0280	1.029	39	1.370	1.3619	1.368
5	1.037	1.0353	1.036	40	1.383	1.3746	1.386
6	1.045	1.0426	1.043	41	1.397	1.3876	1.395
7	1.052	1.0501	1.050	42	1.410	1.4009	1.413
8	1.060	1.0576	1.057	43	1.424	1.4143	1.422
9	1.067	1.0653	1.064	44	1.438	1.4281	1.441
10	1.075	1.0731	1.071	45	1.453	1.4421	1.451
11	1.083	1.0810	1.086	46	1.468	1.4564	1.470
12	1.091	1.0890	1.093	47	1.483	1.4710	1.480
13	1.100	1.0972	1.100	48	1.498	1.4860	1.500
14	1.108	1.1054	1.107	49	1.514	1.5012	1.510
15	1.116	1.1138	1.114	50	1.530	1.5167	1.531
16	1.125	1.1224	1.122	51	1.547	1.5325	1.541
17	1.134	1.1310	1.136	52	1.563	1.5487	1.561
18	1.142	1.1398	1.143	53	1.580	1.5652	1.573
19	1.152	1.1487	1.150	54	1.597	1.5820	1.594
20	1.162	1.1578	1.158	55	1.615	1.5993	1.616
21	1.171	1.1670	1.172	56	1.634	1.6169	1.627
22	1.180	1.1763	1.179	57	1.652	1.6349	1.650
23	1.190	1.1858	1.186	58	1.671	1.6533	1.661
24	1.200	1.1955	1.201	59	1.691	1.6721	1.683
25	1.210	1.2053	1.203	60	1.711	1.6914	1.705
26	1.220	1.2153	1.216	61	1.732	1.7111	1.727
27	1.231	1.2254	1.231	62	1.753	1.7313	1.747
28	1.241	1.2357	1.238	63	1.775	1.7520	1.767
29	1.252	1.2462	1.254	64	1.797	1.7731	1.793
30	1.263	1.2569	1.262	65	1.820	1.7948	1.814
31	1.274	1.2677	1.269	66	1.843	1.8171	1.835
32	1.285	1.2788	1.285				
33	1.297	1.2901	1.293				
34	1.308	1.3015	1.309				
35	1.320	1.3131	1.317				

Comparison between the Degrees of Twaddell's Hydrometer and Specific Gravities.

Degrees, Tw.	Specific gravity.	Degrees, Tw.	Specific gravity.	Degrees, Tw.	Specific gravity.	Degrees, Tw.	Specific gravity.
1	1.005	44	1.220	87	1.435	130	1.650
2	1.010	45	1.225	88	1.440	131	1.655
3	1.015	46	1.230	89	1.445	132	1.660
4	1.020	47	1.235	90	1.450	133	1.665
5	1.025	48	1.240	91	1.455	134	1.670
6	1.030	49	1.245	92	1.460	135	1.675
7	1.035	50	1.250	93	1.465	136	1.680
8	1.040	51	1.255	94	1.470	137	1.685
9	1.045	52	1.260	95	1.475	138	1.690
10	1.050	53	1.265	96	1.480	139	1.695
11	1.055	54	1.270	97	1.485	140	1.700
12	1.060	55	1.275	98	1.490	141	1.705
13	1.065	56	1.280	99	1.495	142	1.710
14	1.070	57	1.285	100	1.500	143	1.715
15	1.075	58	1.290	101	1.505	144	1.720
16	1.080	59	1.295	102	1.510	145	1.725
17	1.085	60	1.300	103	1.515	146	1.730
18	1.090	61	1.305	104	1.520	147	1.735
19	1.095	62	1.310	105	1.525	148	1.740
20	1.100	63	1.315	106	1.530	149	1.745
21	1.105	64	1.320	107	1.535	150	1.750
22	1.110	65	1.325	108	1.540	151	1.755
23	1.115	66	1.330	109	1.545	152	1.760
24	1.120	67	1.335	110	1.550	153	1.765
25	1.125	68	1.340	111	1.555	154	1.770
26	1.130	69	1.345	112	1.560	155	1.775
27	1.135	70	1.350	113	1.565	156	1.780
28	1.140	71	1.355	114	1.570	157	1.785
29	1.145	72	1.360	115	1.575	158	1.790
30	1.150	73	1.365	116	1.580	159	1.795
31	1.155	74	1.370	117	1.585	160	1.800
32	1.160	75	1.375	118	1.590	161	1.805
33	1.165	76	1.380	119	1.595	162	1.810
34	1.170	77	1.385	120	1.600	163	1.815
35	1.175	78	1.390	121	1.605	164	1.820
36	1.180	79	1.395	122	1.610	165	1.825
37	1.185	80	1.400	123	1.615	166	1.830
38	1.190	81	1.405	124	1.620	167	1.835
39	1.195	82	1.410	125	1.625	168	1.840
40	1.200	83	1.415	126	1.630	169	1.845
41	1.205	84	1.420	127	1.635	170	1.850
42	1.210	85	1.425	128	1.640		
43	1.215	86	1.430	129	1.645		

The percentage of mixtures of sulphuric acid and water is, in the great majority of cases, tested by the hydrometer only, and many tables have been constructed for this purpose. It would be very desirable, as Hasenclever points out,¹ if all sulphuric-acid makers used the same reduction-tables for their calculations; for in the statements on the yield of acid, and in many other cases, frequently different tables are used; so that the working results of different factories are not always comparable with each other.

Special attention should be drawn to the point that all tables indicate the specific gravities only for chemically pure acids; the figures for commercial impure acids are always higher; we shall return to this subject further on.

A very extended study of the specific gravities of sulphuric-acid solutions has been published by Pickering.²

Perhaps the most elaborate investigations on the density and expansion of aqueous solutions of sulphuric acid, the formation of hydrates, etc., have been made by Domke and Bein, on behalf of the *Normaleichungskommission* at Berlin.³

The tables given in previous editions have been recalculated by Dr A. C. Cumming from the data of Domke and Bein, and are given on pp. 203-206.

Worden and Motion⁴ have made very accurate determinations of the density of very dilute sulphuric acid, for the purpose of preparing standard solutions for volumetric purposes. Their work has no application for technical purposes.

A paper by Mendelejeff⁵ on the specific gravities of the mixtures of sulphuric acid and water has only theoretical interest.

¹ *Hofmann's Report*, I, 181.

² *J. Chem. Soc.*, 57, 64 *et seq.*

³ *Z. anorg. Chem.*, 1905, 43, 125-181.

⁴ *J. Soc. Chem. Ind.*, 1905, p. 178 *et seq.*

⁵ *Z. physik. Chem.*, I, 273.

Specific Gravities of Sulphuric Acid.

Degrees Twaddell.	Specific gravity $d\ 15^{\circ}/4^{\circ}$.	100 parts by weight contain		Kilos H_2SO_4 per litre.	1 cubic foot of acid	
		SO_3 .	H_2SO_4 .		weighs lb. avoird.	contains lb. H_2SO_4 .
1	1.005	0.69	0.84	0.0084	62.74	0.53
2	1.010	1.28	1.57	0.0159	63.05	0.99
3	1.015	1.89	2.31	0.0234	63.37	1.46
4	1.020	2.48	3.04	0.0310	63.68	1.94
5	1.025	3.10	3.79	0.0388	63.99	2.42
6	1.030	3.70	4.53	0.0467	64.30	2.91
7	1.035	4.31	5.27	0.0546	64.61	3.40
8	1.040	4.90	6.00	0.0624	64.93	3.90
9	1.045	5.49	6.72	0.0702	65.24	4.38
10	1.050	6.08	7.44	0.0781	65.55	4.88
11	1.055	6.66	8.15	0.0860	65.86	5.37
12	1.060	7.24	8.86	0.0939	66.18	5.86
13	1.065	7.81	9.56	0.1018	66.49	6.36
14	1.070	8.39	10.26	0.1098	66.80	6.86
15	1.075	8.96	10.96	0.1178	67.11	7.36
16	1.080	9.53	11.66	0.1259	67.42	7.86
17	1.085	10.09	12.35	0.1340	67.74	8.37
18	1.090	10.65	13.03	0.1420	68.05	8.87
19	1.095	11.21	13.71	0.1501	68.36	9.37
20	1.100	11.76	14.39	0.1583	68.67	9.88
21	1.105	12.32	15.07	0.1665	68.98	10.40
22	1.110	12.86	15.73	0.1746	69.30	10.90
23	1.115	13.40	16.40	0.1829	69.61	11.42
24	1.120	13.95	17.07	0.1912	69.92	11.93
25	1.125	14.49	17.73	0.1995	70.23	12.45
26	1.130	15.03	18.39	0.2078	70.55	12.97
27	1.135	15.56	19.04	0.2161	70.86	13.49
28	1.140	16.09	19.69	0.2245	71.17	14.01
29	1.145	16.62	20.34	0.2329	71.48	14.54
30	1.150	17.15	20.98	0.2413	71.79	15.06
31	1.155	17.67	21.62	0.2497	72.11	15.59
32	1.160	18.19	22.26	0.2582	72.42	16.12
33	1.165	18.72	22.90	0.2668	72.73	16.66
34	1.170	19.24	23.54	0.2754	73.04	17.19
35	1.175	19.75	24.17	0.2840	73.35	17.73
36	1.180	20.27	24.80	0.2926	73.67	18.27
37	1.185	20.78	25.43	0.3013	73.98	18.81
38	1.190	21.29	26.05	0.3100	74.29	19.35
39	1.195	21.81	26.68	0.3188	74.60	19.90
40	1.200	22.31	27.30	0.3278	74.92	20.45
41	1.205	22.82	27.92	0.3364	75.23	21.00
42	1.210	23.17	28.53	0.3452	75.54	21.55
43	1.215	23.82	29.15	0.3542	75.85	22.11
44	1.220	24.32	29.76	0.3631	76.16	22.67
45	1.225	24.82	30.37	0.3720	76.48	23.23
46	1.230	25.32	30.98	0.3810	76.79	23.79
47	1.235	25.81	31.58	0.3900	77.10	24.35
48	1.240	26.30	32.18	0.3990	77.41	24.91
49	1.245	26.79	32.78	0.4081	77.72	25.48
50	1.250	27.28	33.38	0.4172	78.04	26.05
51	1.255	27.77	33.98	0.4264	78.35	26.62

204 TECHNICALLY EMPLOYED OXIDES OF SULPHUR

Specific Gravities of Sulphuric Acid—continued.

Degrees Twaddell.	Specific gravity d_{15}^{15} .	100 parts by weight contain		Kilos H_2SO_4 per litre.	1 cubic foot of acid	
		SO_3 .	H_2SO_4 .		weighs lb. avoird.	contains lb. H_2SO_4 .
52	1.260	28.25	34.57	0.4356	78.66	27.19
53	1.265	28.74	35.17	0.4449	78.97	27.77
54	1.270	29.23	35.76	0.4515	79.29	28.35
55	1.275	29.71	36.35	0.4635	79.60	28.93
56	1.280	30.19	36.94	0.4728	79.91	29.52
57	1.285	30.67	37.52	0.4821	80.22	30.10
58	1.290	31.14	38.10	0.4919	80.53	30.68
59	1.295	31.61	38.68	0.5009	80.85	31.27
60	1.300	32.08	39.25	0.5102	81.16	31.85
61	1.305	32.56	39.83	0.5198	81.47	32.45
62	1.310	33.02	40.40	0.5292	81.78	33.04
63	1.315	33.48	40.97	0.5388	82.09	33.63
64	1.320	33.94	41.53	0.5482	82.41	34.22
65	1.325	34.40	42.09	0.5577	82.72	34.82
66	1.330	34.86	42.65	0.5672	83.03	35.41
67	1.335	35.31	43.20	0.5767	83.34	36.00
68	1.340	35.76	43.75	0.5862	83.66	36.60
69	1.345	36.21	44.30	0.5958	83.97	37.20
70	1.350	36.66	44.85	0.6055	84.28	37.80
71	1.355	37.10	45.39	0.6150	84.59	38.40
72	1.360	37.54	45.93	0.6246	84.90	39.00
73	1.365	37.97	46.46	0.6342	85.22	39.59
74	1.370	38.40	46.99	0.6438	85.53	40.19
75	1.375	38.84	47.52	0.6534	85.84	40.79
76	1.380	39.26	48.04	0.6629	86.15	41.39
77	1.385	39.69	48.56	0.6726	86.47	41.99
78	1.390	40.10	49.07	0.6821	86.78	42.58
79	1.395	40.53	49.59	0.6918	87.09	43.19
80	1.400	40.95	50.10	0.7014	87.40	43.79
81	1.405	41.36	50.61	0.7111	87.71	44.39
82	1.410	41.78	51.12	0.7208	88.03	45.00
83	1.415	42.89	51.62	0.7304	88.34	45.60
84	1.420	42.60	52.12	0.7401	88.65	46.20
85	1.425	43.01	52.62	0.7498	88.96	46.81
86	1.430	43.41	53.11	0.7595	89.27	47.41
87	1.435	43.81	53.60	0.7692	89.59	48.02
88	1.440	44.21	54.09	0.7789	89.90	48.63
89	1.445	44.61	54.58	0.7887	90.21	49.24
90	1.450	45.00	55.06	0.7984	90.52	49.84
91	1.455	45.39	55.54	0.8081	90.84	50.45
92	1.460	45.79	56.02	0.8179	91.15	51.06
93	1.465	46.18	56.50	0.8277	91.46	51.67
94	1.470	46.56	56.97	0.8375	91.77	52.28
95	1.475	46.95	57.44	0.8472	92.08	52.89
96	1.480	47.33	57.91	0.8571	92.40	53.51
97	1.485	47.71	58.38	0.8669	92.71	54.12
98	1.490	48.10	58.85	0.8769	93.02	54.74
99	1.495	48.48	59.32	0.8868	93.33	55.36
100	1.500	48.86	59.78	0.8967	93.64	55.98
101	1.505	49.23	60.24	0.9066	93.96	56.60
102	1.510	49.61	60.70	0.9166	94.27	57.22

Specific Gravities of Sulphuric Acid—continued.

Degrees Twaddell.	Specific gravity $d\ 15^{\circ}/4^{\circ}$.	100 parts by weight contain		Kilos H_2SO_4 per litre.	1 cubic foot of acid	
		SO_3 .	H_2SO_4 .		weighs lb. avoird.	contains lb. H_2SO_4 .
103	1.515	49.99	61.16	0.9266	94.58	57.85
104	1.520	50.35	61.61	0.9365	94.89	58.46
105	1.525	50.73	62.07	0.9466	95.21	59.09
106	1.530	51.10	62.52	0.9566	95.52	59.72
107	1.535	51.47	62.97	0.9666	95.83	60.34
108	1.540	51.83	63.42	0.9767	96.14	60.97
109	1.545	52.20	63.87	0.9868	96.45	61.60
110	1.550	52.56	64.31	0.9968	96.77	62.23
111	1.555	52.92	64.75	1.0069	97.08	62.86
112	1.560	53.28	65.19	1.0170	97.39	63.49
113	1.565	53.64	65.63	1.0271	97.70	64.12
114	1.570	54.01	66.08	1.0375	98.01	64.77
115	1.575	54.37	66.52	1.0477	98.33	65.41
116	1.580	54.73	66.96	1.0580	98.64	66.05
117	1.585	55.09	67.40	1.0683	98.95	66.69
118	1.590	55.44	67.83	1.0785	99.26	67.33
119	1.595	55.79	68.26	1.0887	99.58	67.97
120	1.600	56.14	68.69	1.0990	99.89	68.61
121	1.605	56.49	69.12	1.1094	100.20	69.26
122	1.610	56.84	69.55	1.1198	100.51	69.91
123	1.615	57.19	69.98	1.1302	100.82	70.56
124	1.620	57.46	70.41	1.1406	101.14	71.21
125	1.625	57.89	70.83	1.1510	101.45	71.86
126	1.630	58.25	71.27	1.1617	101.76	72.52
127	1.635	58.60	71.70	1.1723	102.07	73.19
128	1.640	58.95	72.13	1.1829	102.38	73.85
129	1.645	59.30	72.55	1.1934	102.70	74.51
130	1.650	59.64	72.97	1.2040	103.01	75.17
131	1.655	59.99	73.40	1.2148	103.32	75.84
132	1.660	60.33	73.82	1.2254	103.63	76.50
133	1.665	60.68	74.24	1.2361	103.95	77.17
134	1.670	61.02	74.66	1.2468	104.26	77.84
135	1.675	61.37	75.09	1.2578	104.57	78.52
136	1.680	61.71	75.51	1.2686	104.88	79.20
137	1.685	62.06	75.93	1.2794	105.19	79.87
138	1.690	62.41	76.36	1.2905	105.51	80.56
139	1.695	62.75	76.78	1.3014	105.82	81.25
140	1.700	63.10	77.21	1.3126	106.13	81.94
141	1.705	63.45	77.63	1.3236	106.44	82.63
142	1.710	63.80	78.06	1.3348	106.75	83.33
143	1.715	64.15	78.49	1.3461	107.07	84.04
144	1.720	64.50	78.92	1.3574	107.38	84.74
145	1.725	64.85	79.35	1.3688	107.69	85.45
146	1.730	65.21	79.79	1.3804	108.00	86.18
147	1.735	65.57	80.23	1.3920	108.32	86.90
148	1.740	65.94	80.68	1.4038	108.63	87.64
149	1.745	66.31	81.14	1.4159	108.94	88.39
150	1.750	66.69	81.60	1.4280	109.25	89.15
151	1.755	67.08	82.07	1.4403	109.56	89.92
152	1.760	67.46	82.54	1.4527	109.88	90.69
153	1.765	67.85	83.02	1.4653	110.19	91.48

Specific Gravities of Sulphuric Acid—continued.

Degrees Twaddell.	Specific gravity d 15°/4°.	100 parts by weight contain		Kilos H ₂ SO ₄ per litre.	1 cubic foot of acid	
		SO ₃ .	H ₂ SO ₄ .		weighs lb. avoird.	contains lb. H ₂ SO ₄ .
154	1.770	68.24	83.50	1.4779	110.50	92.27
155	1.775	68.68	84.03	1.4915	110.81	93.12
156	1.780	69.11	84.56	1.5052	111.12	93.97
157	1.785	69.57	85.12	1.5194	111.44	94.86
158	1.790	70.03	85.69	1.5338	111.75	95.76
159	1.795	70.53	86.30	1.5491	112.06	96.71
160	1.800	71.04	86.92	1.5646	112.37	97.67
161	1.805	71.60	87.61	1.5814	112.69	98.72
162	1.810	72.21	88.35	1.5991	113.00	99.83
163	1.815	72.87	89.16	1.6182	113.310	101.03
164	1.820	73.59	90.04	1.6387	113.62	102.31

Specific Gravities of Solutions containing above 90 per cent. of Sulphuric Acid.

Per cent. H ₂ SO ₄	91	92	93	94	95
Density d 15°/4°	1.8248	1.8293	1.8331	1.8363	1.8388
Per cent. H ₂ SO ₄	96	97	98	99	100
Density d 15°/4°	1.8406	1.8466	1.8411	1.8393	1.8357

A correction for any deviation of the temperature from 15° must be made, whenever the acid tested by the hydrometer is above or below that temperature. Bineau has given a small table for this purpose, which, however, is wrong for the more dilute acids. From a very large number of observations made in Lunge's laboratory, a table has been constructed showing the alterations to be made in the specific gravities observed for all strengths of acid, and for all temperatures from 0° to 100°, in order to reduce them to 15°. This table is found in Lunge's

Technical Chemists' Handbook (1910), pp. 126-129. In this place we only give the average figures. For each degree above or below 15° you should add to or deduct from the specific gravity observed :

0.0006	with acids up to	1.170.
0.0007	„ „	from 1.170 to 1.450.
0.0008	„ „	1.450 „ 1.580.
0.0009	„ „	1.580 „ 1.750.
0.0010	„ „	1.750 „ 1.840.

H. C. Moore¹ describes a slide-rule for reducing the specific gravities of sulphuric acids of various densities and temperatures to the density of 50° Bé. at 60° F.

Influence of Impurities on the Density of Aqueous Sulphuric Acid.

The specific gravities given in all the tables refer only to pure acid, and cannot be accepted as quite correct for the ordinary acid of trade, which always contains impurities. Kolb has examined this matter, and has determined the influence of the common impurities upon the density of sulphuric acid, viz. that of lead sulphate, of the oxygen compounds, of nitrogen, and of sulphurous acid. Arsenic, and perhaps iron, usually occur in too small a quantity in sulphuric acid to influence its density ; but certainly there may be cases, not mentioned by Kolb, in which sulphuric acid is strongly contaminated with salts of iron, aluminium, sodium, etc. The iron, for instance, may come from pyrites-dust ; aluminium from the packing of the Glover tower, or from the fireclay frequently employed for stopping leaks ; sodium from solutions of nitrate or sulphate of soda, which sometimes inadvertently get into the chambers.

With respect to *lead sulphate*, Kolb found that, at the ordinary temperature, there was dissolved up to

0.039	part in 100 parts vitriol of	1.841 sp. gr.
0.011	„ „ 100 „ „	1.793 „ „
0.003	„ „ 100 „ „	1.540 „ „

In more dilute acids the lead can hardly be estimated. Nitric acid, which, in any case, occurs in very small quantities, does

¹ *J. Ind. and Eng. Chem.*, 1912, p. 677.

not strongly influence the solubility of lead sulphate in sulphuric acid ; nitrous acid not at all. The effect of lead sulphate on the density of vitriol can accordingly be neglected for the ordinary temperature ; at most it would influence the fourth place of decimals.

Marshall¹ gives the following table showing the effect of impurities on the specific gravity of sulphuric acid :—

	100 per cent.	98 per cent.	94 per cent.	80 per cent.	70 per cent.
Na ₂ SO ₄ ·	0·0011	0·0010	0·0007	0·0008	0·0007
CaSO ₄ ·	0·0012	0·0011	0·0009	0·0007	0·0006
Al ₂ (SO ₄) ₃ ·	Insoluble	Insoluble	Insoluble	0·0012 ?	0·0011
Fe ₂ (SO ₄) ₃ ·	”	”	0·0006 ?	0·0008	0·0007
PbSO ₄ ·	0·0017	0·0014	0·0015	Insoluble	Insoluble
As ₂ O ₃ ·	...	0·0013	...	0·001	...

These figures show the increase in density caused by the actual addition of the impurities in question.

The sulphates of aluminium and iron are practically insoluble. With concentrated sulphuric acid, aluminium sulphate forms the compound Al₂(SO₄)₃H₂SO₄·3H₂O, the mixture solidifying after a few hours.

Solubility of SO₂ in Sulphuric Acid.

Miles and Fenton² state that 95 per cent. acid dissolves more SO₂ than 85 per cent. The solubility in more dilute acid diminishes in the usual manner as the concentration increases, and the graph *infra* shows grams SO₂ dissolved in grams acid.

To obtain rapid saturation of sulphuric acid, especially when concentrated, and therefore viscous, was by no means easy, but the authors explain how they overcame the difficulties.

The solubility reaches a minimum value at 86 per cent., and from that point the curve inclines very sharply upward for either increase or decrease in the concentration of sulphuric acid.

It is significant that acid of 84·48 per cent. has the composition of the hydrate H₂SO₄·H₂O, and that in the neighbourhood of this point the temperature of melting and other physical properties pass through critical values.

¹ *J. Soc. Chem. Ind.*, 1902, p. 1508.

² *J. Chem. Soc.*, 1920, p. 59.

The experiments were carried out at 20° , and corrections made for the barometer readings.

Sulphurous acid certainly never occurs in commercial sulphuric acid in quantities commensurate with those possible from its solubility. It is rarely that more than traces of it are found therein. It cannot, of course, coexist in quantity

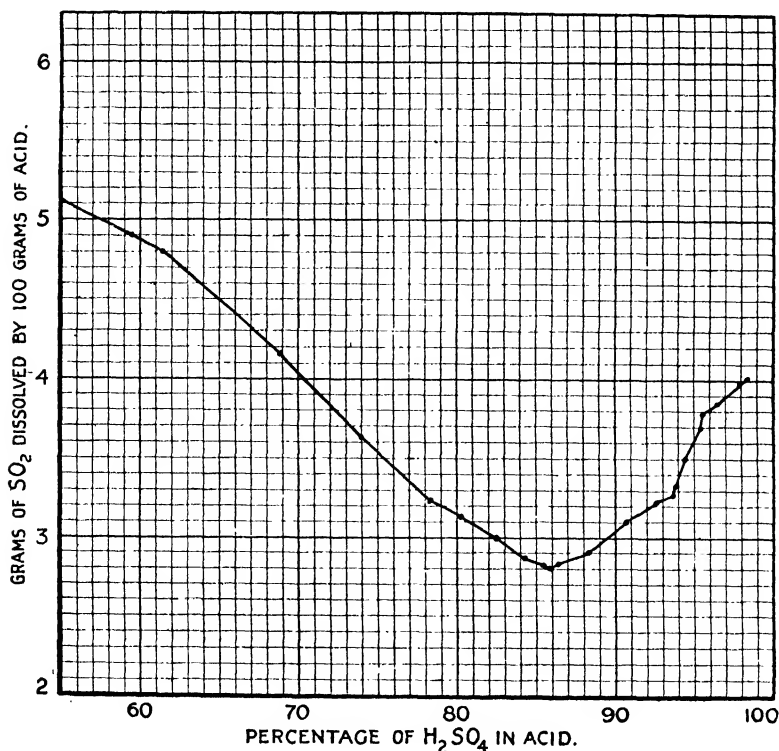

with the nitrogen oxides which are most frequently found in commercial vitriol. Nitric acid is, if at all, only present in extremely small quantities in the sulphuric acid of trade, and therefore does not modify its density to a sensible extent; especially it will not be found in sulphuric acid of more than 144° Tw., except perhaps in the nitrous vitriol from the Gay-Lussac towers; but even this, according to Lunge's analyses, under normal conditions contains only slight traces of HNO_3 . Nitric oxide can also be neglected; neither con-

210 TECHNICALLY EMPLOYED OXIDES OF SULPHUR

centrated nor diluted sulphuric acid dissolves more than mere traces of it. Nitrous acid certainly has a very marked effect on the apparent percentage of sulphuric acid, according to the hydrometrical test, although it is only in "nitrous vitriol" that such large proportions of nitrous acid occur as to influence the specific gravity of the sulphuric acid.

Although, as we see, the impurities of ordinary sulphuric acid, excepting "nitrous vitriol," have very little effect on its density, it must be remembered that the density is not a trustworthy means of estimating the percentage of real H_2SO_4 in concentrated acid, even when the correction for temperature mentioned on p. 206 is applied, because at high concentrations a small difference in density corresponds to a very large difference in percentage. Many factories use special hydrometers, in which the last few degrees are spread over a large area and are further subdivided; but any determination of density for estimating the percentage of the very strongest acids must be rejected, after what we have seen on p. 206. The acids from 92 per cent. upwards ought therefore always to be estimated alkalimetrically.

a.	b.	a.	b.	a.	b.
1	1.009	130	1.456	370	1.723
2	1.015	140	1.473	380	1.727
5	1.035	150	1.490	390	1.730
10	1.060	160	1.510	400	1.733
15	1.090	170	1.530	410	1.737
20	1.113	180	1.543	420	1.740
25	1.140	190	1.556	430	1.743
30	1.165	200	1.568	440	1.746
35	1.187	210	1.580	450	1.750
40	1.210	220	1.593	460	1.754
45	1.229	230	1.606	470	1.757
50	1.248	240	1.620	480	1.760
55	1.265	250	1.630	490	1.763
60	1.280	260	1.640	500	1.766
65	1.297	270	1.648	510	1.768
70	1.312	280	1.654	520	1.770
75	1.326	290	1.667	530	1.772
80	1.340	300	1.678	540	1.774
85	1.357	310	1.689	550	1.776
90	1.372	320	1.700	560	1.777
95	1.386	330	1.705	580	1.778
100	1.398	340	1.710	590	1.780
110	1.420	350	1.714	600	1.782
120	1.438	360	1.719		

Obtaining Acid of any desired Strength by mixing O.V. with Water.—The above table of Anthon's will be of practical

value. It shows in column *a* how many parts of oil of vitriol of 168° Tw. must be mixed with 100 parts water at 15° or 20° in order to obtain an acid of the specific gravity *b*.

The *freezing-* and *melting-points* of sulphuric acids of different degrees of concentration are given by Payen in a table quoted in Lunge's second edition, p. 133.

A new determination by Lunge¹ gave the following results :—

Spec. grav. of acid at 15° C.	Freezing-point.	Melting-point.	Spec. grav. of acid at 15° C.	Freezing-point.	Melting-point.
1.671	liquid at -20° C.	liquid.	1.767	+1°.6	+6°.5
1.691	do.	do.	1.790	+4°.5	+8°.0
1.712	do.	do.	1.807	-9°.0	-6°.8
1.727	-7°.5	-7°.5	1.822	liquid at -20° C.	liquid.
1.732	-8°.5	-8°.5	1.840	do.	do.
1.749	-0°.2	+4°.5			

Pickering² has published an extensive memoir on the freezing-points of sulphuric acid and its solutions. Thilo³ gives very extended tables as to the results obtained by him in R. Pictet's laboratory. Pictet subsequently supplies the following table :—

Formula.	H ₂ SO ₄ per cent.	Specific gravity.	Freezing-point.
			Degrees.
H ₂ SO ₄	100.00	1.842	+10.5
„ + H ₂ O	84.48	1.777	+ 3.5
„ 2H ₂ O	73.08	1.650	- 7.0
„ 4 „	57.65	1.476	- 4.0
„ 6 „	47.57	1.376	- 5.0
„ 8 „	40.50	1.311	- 6.5
„ 10 „	35.25	1.268	- 8.8
„ 11 „	33.11	1.249	- 7.5
„ 12 „	31.21	1.233	- 5.5
„ 13 „	29.52	1.219	- 4.5
„ 14 „	28.00	1.207	- 4.0
„ 15 „	26.63	1.196	- 3.4
„ 16 „	25.39	1.187	- 26.5
„ 18 „	23.22	1.170	- 1.9
„ 20 „	21.40	1.157	- 1.7
„ 25 „	17.88	1.129	- 8.5
„ 30 „	15.36	1.109	- 6.5
„ 40 „	11.08	1.084	- 4.5
„ 50 „	9.82	1.067	- 3.5
„ 75 „	6.77	1.045	0
„ 100 „	5.16	1.032	+ 2.5
„ 200 „	2.65	1.013	+ 4.0
„ 300 „	1.78	1.007	+ 4.5
„ 1000 „	0.54	1.001	+ 0.5

¹ Berl. Ber., 1881, p. 2649.

² J. Chem. Soc., 1890, 57, 331 et seq.

³ J. Soc. Chem. Ind., 1893, p. 837.

By "melting-point" we understand the temperature at which the cooled acids in which crystals had commenced to form remained constant when the vessel was taken out of the cooling medium during the process of solidification.

On *boiling* dilute sulphuric acid, at first nothing but aqueous vapour escapes; according to Graham, acid vapour is mixed with the steam only when no more than 2 mol. of water are present to 1 of SO_3 —that is, with a percentage of 84.48 H_2SO_4 or a sp. gr. of 1.78. From several discussions about the loss of sulphuric acid in concentrating it, by Lunge, Bode, Walter, etc., it may be assumed that in manufacturing practice no sensible loss of acid takes place by real *volatilisation* up to a strength of 144° or even of 152° Tw.; but from violently boiling acid there is always a little acid carried away mechanically in the shape of small drops, especially in pans fired from the top and also in the Glover tower, or in a "vesicular state." When the evaporation up to that point takes place quietly at a moderate heat, there is probably no loss of acid at all.

At the request of Dr A. C. Cumming this point was specially investigated by Webster and MacDonald in the Technical Chemical Laboratory, University of Edinburgh. It was found that when precautions were taken to prevent acid being carried over mechanically, sulphuric acid could be distilled so that there was no sulphuric acid in the distillate from even 90 per cent. acid; only after the concentration of the liquid being distilled exceeded 96 per cent. did that of the distillate exceed 5 per cent.

The boiling-points of sulphuric acid containing water were examined by Dalton in the beginning of this century. His table, which was obviously wrong, has been replaced by another, founded upon Lunge's investigations,¹ which is herewith reproduced:—

¹ *Berl. Ber.*, 11, 370.

Specific gravity.	Temperature. °C.	Spec. grav. reduced to 15° C.	Percentage of H ₂ SO ₄ .	Boiling-point. °C.	Barometer reduced to 0°. Millims.
1.8380	17	1.8400	95.3	297	718.8
1.8325	16.5	1.8334	92.8	280	723.9
1.8240	15.5	1.8242	90.4	264	720.6
1.8130	16	1.8140	88.7	257	726.0
1.7985	15.5	1.7990	86.6	241.5	720.1
1.7800	15	1.7800	84.3	228	720.5
1.7545	16	1.7554	81.8	218	726.0
1.7400	15	1.7400	80.6	209	720.6
1.7185	17	1.7203	78.9	203.5	725.9
1.7010	18	1.7037	77.5	197	725.2
1.6750	19	1.6786	75.3	183.5	725.2
1.6590	16	1.6599	73.9	180	725.2
1.6310	17	1.6328	71.5	173	725.2
1.6055	17	1.6072	69.5	169	730.1
1.5825	15	1.5825	67.2	160	728.8
1.5600	17	1.5617	65.4	158.5	730.1
1.5420	17	1.5437	64.3	151.5	730.1
1.4935	18	1.4960	59.4	143	730.1
1.4620	17	1.4635	56.4	133	730.1
1.4000	17	1.4015	50.3	124	730.1
1.3540	17	1.3554	45.3	118.5	730.1
1.3180	17	1.3194	41.5	115	730.1
1.2620	17	1.2633	34.7	110	732.9
1.2030	17	1.2042	27.6	107	732.9
1.1120	17	1.1128	15.8	103.5	732.9
1.0575	17	1.0580	8.5	101.5	735.0

(Calculated by graphical interpolation.)

Per cent. H ₂ SO ₄ .	Boiling-point.	Per cent. H ₂ SO ₄ .	Boiling-point.	Per cent. H ₂ SO ₄ .	Boiling-point.	Per cent. H ₂ SO ₄ .	Boiling-point.
	Degrees.		Degrees.		Degrees.		Degrees.
5	101	45	118.5	70	170	86	238.5
10	102	50	124	72	174.5	88	251.5
15	103.5	53	128.5	74	180.5	90	262.5
20	105	56	133	76	189	91	268
25	106.5	60	141.5	78	199	92	274.5
30	108	62.5	147	80	207	93	281.5
35	110	65	153.5	82	218.5	94	288.5
40	114	67.5	161	84	227	95	295

The *tension of aqueous vapour* in sulphuric-acid solutions of various strengths was determined by Regnault in 1845¹ for temperatures from 5° to 35°. We here give his table (for every second degree), adding to the hydrates quoted by him the percentage composition and specific gravities. We also subjoin Sorel's table (p. 215), computed for a wider interval

¹ *Ann. Chim. anal.* [3], 15, 179.

214 TECHNICALLY EMPLOYED OXIDES OF SULPHUR

of temperatures, better suited for the wants of sulphuric-acid manufacture. The tensions are stated in millimetres of mercurial pressure.

Regnault's Table of the Aqueous-Vapour Tensions of Dilute Sulphuric Acid.

C.	H ₂ SO ₄ +H ₂ O 84·5% 1·780.	H ₂ SO ₄ +2 H ₂ O 78·1% 1·654.	H ₂ SO ₄ +3 H ₂ O 64·5% 1·564.	H ₂ SO ₄ +4 H ₂ O 57·6% 1·477.	H ₂ SO ₄ +5 H ₂ O 52·1% 1·420.	H ₂ SO ₄ +7 H ₂ O 43·7% 1·340.	H ₂ SO ₄ +9 H ₂ O 37·7% 1·287.	H ₂ SO ₄ +11 H ₂ O 33·1% 1·247.	H ₂ SO ₄ +17 H ₂ O 24·8% 1·176.
	mm.	mm.	mm.	mm.	mm.	mm.	mm.	mm.	mm.
5	0·105	0·388	0·861	1·294	2·137	3·168	4·120	4·428	5·478
7	0·108	0·430	0·985	1·510	2·464	3·643	4·728	5·164	6·300
9	0·112	0·476	1·125	1·753	2·829	4·176	5·408	5·980	7·216
11	0·118	0·527	1·280	2·025	3·240	4·773	6·166	6·883	8·237
13	0·124	0·586	1·454	2·331	3·699	5·443	7·013	7·885	9·374
15	0·131	0·651	1·648	2·674	4·215	6·194	7·958	8·995	10·641
17	0·139	0·725	1·865	3·059	4·793	7·036	9·014	10·222	12·054
19	0·149	0·808	2·108	3·492	5·440	7·980	10·191	11·583	13·628
21	0·159	0·901	2·380	3·977	6·166	9·039	11·506	13·090	15·383
23	0·171	1·006	2·684	4·523	6·979	10·226	12·974	14·760	17·338
25	0·184	1·125	3·024	5·135	7·892	11·557	14·613	16·610	19·516
27	0·199	1·258	3·405	5·822	8·914	13·050	16·443	18·659	21·944
29	0·216	1·408	3·830	6·594	10·060	14·723	18·485	20·929	24·650
31	0·235	1·557	4·305	7·459	11·345	16·600	20·765	23·443	27·666
33	0·256	1·767	4·838	8·432	12·785	18·704	23·311	26·228	31·025
35	0·280	1·981	5·432	9·524	14·400	21·063	26·152	29·314	34·770

Knietsch¹ has also determined the vapour-tensions of sulphuric acid, both ordinary and fuming, at various temperatures up to 100°. As may be imagined, the aqueous-vapour pressures decline rapidly with the concentration of the ordinary acid, and for acids from 90 to 98·6 per cent. they are = 0 even at 100°.

¹ *Berl. Ber.*, 1901, p. 4111.

Tension of Aqueous Vapour in Mixtures of Sulphuric Acid and Water (Sorel).

Spec. grav. of Acid.	Approx. degree. Twad. deil.	Per. cent. of H ₂ SO ₄ .	Temperatures (° C.).																		
			10	15	20	25	30	35	40	45	50	55	60	65	70	75	80	85	90	95	
1.342	68½	44	4.4	6.1	8.5	11.5	15.5	20.9	28.1	37.4	48.3
1.361	72	46	4.0	5.5	7.7	10.5	14.5	19.7	26.3	33.6	44.4	59.6	76.5	96.4
1.380	76	48	3.7	5.0	7.1	9.6	13.4	18.1	23.9	30.5	40.1	53.5	69.0	86.8	107.2	132.1
1.399	80	50	3.3	4.5	6.5	8.8	12.0	16.4	21.4	27.4	35.9	47.4	61.3	77.0	95.6	118.1	132.0	166.5	207.9	251.5	...
1.418	83½	52	3.0	4.0	5.8	7.9	10.9	14.5	18.9	24.1	31.5	41.5	54.0	67.9	84.5	104.5	131.2	166.5	207.9	251.5	...
1.439	88	54	2.6	3.6	5.0	7.0	9.5	12.5	16.5	21.3	27.8	36.2	47.2	59.9	74.8	92.6	116.1	146.8	183.5	222.0	...
1.459	92	56	2.2	3.1	4.3	6.0	8.1	11.0	14.2	18.5	24.1	31.0	41.6	51.6	65.0	80.6	100.9	128.2	160.0	195.0	...
1.480	96	58	1.9	2.6	3.5	5.1	7.2	9.1	12.0	15.8	20.4	26.1	34.5	44.0	55.4	68.4	86.2	110.6	138.5	169.5	...
1.502	100½	60	1.6	2.1	3.0	4.3	6.1	7.5	10.0	13.0	16.9	21.6	28.7	36.7	46.1	56.7	72.3	94.0	118.7	146.0	...
1.525	105	62	1.4	1.8	2.6	3.6	5.0	6.5	8.1	10.5	13.9	17.7	23.9	30.0	37.7	46.2	59.7	78.2	100.7	125.0	...
1.547	109½	64	1.2	1.6	2.2	3.0	4.0	5.5	6.5	8.2	10.9	14.0	18.7	23.9	30.3	37.4	48.0	63.8	83.7	105.0	...
1.569	114	66	1.1	1.4	1.8	2.5	3.5	4.5	5.4	6.5	8.9	11.5	15.2	19.1	24.2	30.3	39.0	52.5	70.0	88.0	...
1.592	118½	68	0.9	1.2	1.5	2.1	3.0	3.8	4.5	5.4	7.2	9.5	12.3	15.4	19.4	24.4	31.4	42.5	56.0	72.0	...
1.615	123	70	0.8	1.0	1.3	1.8	2.5	3.3	3.8	4.4	5.9	7.5	9.5	12.1	15.5	19.8	25.5	33.9	44.4	57.0	...
1.638	127½	72	0.7	0.8	1.0	1.4	2.0	2.8	3.2	3.6	4.8	6.0	7.5	9.5	12.0	15.4	20.0	26.2	33.7	43.4	...
1.662	132½	74	0.5	0.6	0.6	1.2	1.7	2.1	2.6	3.1	3.9	4.9	6.0	7.5	9.5	12.1	15.4	19.5	24.5	31.5	...
1.687	137½	76	0.4	0.4	0.5	1.0	1.4	1.8	2.1	2.5	3.0	4.0	4.8	5.9	7.5	9.5	11.8	15.0	18.5	22.0	...
1.710	142	78	0.3	0.3	0.4	0.8	1.1	1.4	1.7	2.1	2.4	3.0	3.5	4.0	5.7	7.0	8.5	10.5	13.0	15.8	...
1.733	146½	80	0.2	0.2	0.3	0.6	0.8	1.1	1.3	1.6	1.9	2.4	2.9	3.3	4.1	5.0	6.2	7.5	9.3	11.0	...
1.755	151	82	0.1	0.1	0.2	0.4	0.5	0.5	0.9	1.1	1.4	1.7	2.0	2.3	2.7	3.2	3.9	4.7	5.6	6.8	...

216 TECHNICALLY EMPLOYED OXIDES OF SULPHUR

Hacker¹ gives a mathematical derivation of the variations of the vapour-tensions of dilute sulphuric acids by the temperature, the results of which agree very well with the observed pressures.

The viscosity of sulphuric acid has been examined by Dunstan and Wilson ;² Kremann and Ehrlich ;³ and Dunstan.⁴

The surface tension of mixtures of sulphuric acid and water at various temperatures has been determined by Morgan and Davis.⁵

E. Briggs⁶ describes his experiments on the vapour-tensions of mixtures of sulphuric acid and water, which he applies to the construction of the following table, the figures denoting millimetres of mercury :—

Percentage of H ₂ SO ₄ .	Temperature (° C.).												
	100	110	120	125	130	140	150	160	170	175	180	190	200
77·51	20·2	42·5	71·0	90·8	112·5	168·5	300·0
79·17	14·3	33·8	56·2	67·5	86·2	132·0	210·0	335·0
81·81	8·5	18·8	32·5	40·0	51·0	75·7	126·5	207·5	322·5	400
84·26	5·3	11·1	18·5	23·1	29·5	46·0	76·5	118·5	180·0	230	282·5
87·32	2·4	5·0	8·7	10·5	15·0	26·3	43·5	63·8	92·5	113	132·5	191·0	367
91·22	5·0	6·9	10·0	15·0	25·0	40·6	51	62·0	92·5	149

B. C. Burt⁷ describes his experiments on the vapour-pressure of sulphuric-acid solutions, carried on by means of a specially designed apparatus, for concentrations ranging between 24·92 and 95·94 per cent. H₂SO₄, and he also reviews all the earlier work on this subject. His conclusion is that, in solution, combination ensues between sulphuric acid and water with the formation of new compounds. There is no evidence to show that definite hydrates exist in the solutions ; in fact, several attempts to calculate molecular weights, presupposing the existence of certain hydrates, led to very contradictory results.

¹ *Ann. Physik*, 1912 [4], 39, 1338.

² *Trans. Chem. Soc.*, 1907, 91, 85.

³ *Monatsh.*, 1907, 28, 831.

⁴ *Proc. Chem. Soc.*, 1914, 30, 104.

⁵ *J. Amer. Chem. Soc.*, 1916, p. 855.

⁶ *J. Soc. Chem. Ind.*, 1903, p. 1275.

⁷ *J. Chem. Soc.*, 1904, 85, 1339 *et seq.*

The *specific heat* of monohydrated sulphuric acid at 16° to 20° C. is 0.3315 (water = 1). Marignac states the specific heat of acid diluted with water as follows :—

H ₂ SO ₄ +	5 aq.	=	0.5764
„	+ 10 „	=	0.7212
„	+ 15 „	=	0.7919
„	+ 25 „	=	0.8537
„	+ 50 „	=	0.9155
„	+ 100 „	=	0.9545
„	+ 200 „	=	0.9747
„	+ 400 „	=	0.9878

The following table, by Bode, is more convenient for practical use¹ :—

Spec. grav.	Spec. heat.	Spec. grav.	Spec. heat.
1.842	0.3315	1.320	0.67
1.774	0.38	1.263	0.73
1.711	0.41	1.210	0.78
1.615	0.45	1.162	0.82
1.530	0.49	1.116	0.87
1.442	0.55	1.075	0.90
1.383	0.60	1.037	0.95

Physiological Action of Sulphuric Acid.

Sulphuric acid is recommended as a typhoid disinfectant by S. Rideal in a paper read before the British Association (Section B) Glasgow meeting, 1901.² Allowing for the alkalinity of the sewage, an addition of 4 grams of sulphuric acid per gallon would be sufficient to ensure the death of typhoid organisms in an infected drainage water. The free acidity produced would be speedily neutralised when the treated water became mixed with any fresh sewage which had not been similarly treated, and, as the infected sewage must always represent a very small proportion of the total drainage to be dealt with, this method of ensuring the absence of typhoid organisms in drainage waters would be satisfactory in practice.

K. Andrlík³ states that the addition of sulphuric acid to soil affects the growth of beet, and he thought it worth while to try

¹ *Z. angew. Chem.*, 1889, p. 244. Cf. also Pickering, *J. Chem. Soc.*, 57, 90.

² *J. Soc. Chem. Ind.*, 1901, p. 1133.

³ *Z. Zuckerind. Böhm.*, 1917, 4, 685-688; *Chem. Soc. Abst.*, 1917, 1, 620.

the effect of mineral acids in rendering the natural constituents of the soil more available to the plant. He compared the growth of sugar beet on field plots sprinkled before seed-time with dilute sulphuric acid (2-4 kilos. per acre) and on untreated plots, and finds indications that the weights of root and leaves are less, but the quantity and quality of the sugar slightly greater on the treated ground.

CHEMICAL BEHAVIOUR OF SULPHURIC ACID

On mixing oil of vitriol with water, a considerable rise of temperature takes place, certain hydrates being formed, as described above. On mixing concentrated acid with water, a not inconsiderable contraction takes place, which must equally lead to an evolution of heat. But on mixing strong sulphuric acid with *snow*, excessive cold is produced by the heat becoming latent on the liquefaction of snow, which considerably exceeds that becoming free in consequence of the chemical combination. This cold, however, is only produced when the proportion between acid and ice does not exceed certain limits: for 1 part of sulphuric acid there must be $1\frac{1}{4}$ part of snow present; with less snow, there is a rise of temperature.

Even when sulphuric acid is more strongly diluted much heat is liberated. Many observers have worked upon this subject; but we quote here only a few. Thomsen¹ states that 1 gram-mol. (that is, 98 gram) H_2SO_4 gives the following amounts of heat when combining with x molecules of water:—

x .		
1	6,272 metrical heat-units.
2	9,364 " "
3	11,108 " "
5	13,082 " "
9	14,940 " "
19	16,248 " "
49	16,676 " "
99	16,850 " "
199	17,056 " "
499	17,304 " "
799	17,632 " "
1599	17,848 " "

Somewhat higher results were obtained by Pickering.²

¹ *Ber.*, 3, 496.

² *J. Chem. Soc.*, 57, 94.

Knietsch¹ gives the following figures for the heat of solution, found both in the laboratory and by large-scale experiments with 400 kg. water :—

SO ₃ per cent.	H ₂ SO ₄ per cent.	Calories.	SO ₃ per cent.	H ₂ SO ₄ per cent.	Calories.
50	61.25	39	67	82.08	93
51	62.48	41	68	83.30	98
52	63.70	44	69	84.53	103
53	64.93	46.5	70	85.75	108
54	66.15	49	71	86.98	113
55	67.38	51.5	72	88.20	119
56	68.60	54	73	89.43	126
57	69.83	57	74	90.65	133
58	71.05	59.5	75	91.88	139
59	72.28	62	76	93.10	146
60	73.50	65	77	94.33	152
61	74.73	68	78	95.55	160
62	75.95	72	79	96.78	168
63	77.18	75	80	98.00	178
64	78.40	79	81	99.23	188
65	79.63	83.5	81.63	100.00	193
66	80.85	88			

The curve runs on quite steadily, without any breaks.

On account of this considerable evolution of heat, concentrated sulphuric acid and water must always be mixed with care: the water ought never to be poured into the acid, but the acid run in a thin jet into the water with constant stirring. In case of sudden mixture, so much heat is liberated at once that the acid may be raised to the boiling-point, and glass vessels are easily cracked thereby.

The affinity of sulphuric acid for water is also proved by its great hygroscopicity. Concentrated sulphuric acid is one of the best agents for drying gases; and it is not only used in this way for innumerable scientific, but also for some technical purposes—for instance, in the manufacture of oleum, where air or SO₃ gas is passed through a tower fed with sulphuric acid, in order to remove moisture. On the large scale, acid of about 96 per cent. H₂SO₄ is usually employed for such purposes, but care must be taken lest its concentration during the work does not fall below sp. gr. 1.72, or it will no longer act as a dehydrator.

Concentrated sulphuric acid acts upon many liquid and solid

¹ *Ber.*, 1901, p. 4103.

bodies by depriving them of water or even splitting off the elements of the same. Upon this action a host of scientific and technical applications of sulphuric acid are founded. Frequently the so-called *sulphonic acids* are formed, which are generally compounds easily lending themselves to further reactions. Instances of this are:—the formation of ether by the dehydration of alcohol, with the intermediate formation of sulphovinic acid; that of ethylene by the further splitting off of water; the preparation of nitrobenzene, picric acid, nitronaphthalene; the manufacture of resorcine and alizarine by the alkaline fusion of the sulphonic acids of benzene and anthraquinone; and many other cases.

The charring of many organic substances, such as wood, sugar, etc., by contact with strong sulphuric acid, proceeds from the same source. Necessarily this acid, in its concentrated form, must have an extremely prejudicial effect on the animal body. The remedy usually applied, burnt magnesia, cannot do much good when the epithelium of the œsophagus and the stomach has been destroyed.

The affinity of concentrated sulphuric acid for water is also shown by the fact that it easily runs over, when kept in open vessels, by attracting moisture from the air—a fact to be remembered when employing it for keeping balances, etc., dry.

The heat of neutralisation of 1 mol. (98 parts) H_2SO_4 by 2 mols. (80 parts) NaOH in the presence of 400 mols. of water is given by Thomsen = 31,380 cal. Pickering¹ states it is only = 28,197 cal.

Enklaar² has studied the step-by-step neutralisation of sulphuric acid, effected by addition of successive quantities of N/10-sodium hydroxide to 10 c.c. of N-sulphuric acid and dilution of the mixture to 100 c.c. at 18°.

Decompositions of Sulphuric Acid.—Some of these have been mentioned already—for instance, that into anhydride and water by evaporation. The mixed vapour, on account of the unequal velocity of diffusion of the two vapours, can be separated to a great extent into its two constituents, so that at 520°, within an hour, a residue of 60 per cent. monohydrate and 40 per cent. anhydride, at 445° 75 per cent. monohydrate and 25 per cent.

¹ *J. Chem. Soc.*, 1889, p. 323.

² *Chem. Weekblad*, 1912, 9, 28-31; *J. Chem. Soc.*, 1912, 2, 239.

anhydride was obtained.¹ Perhaps a process for preparing fuming acid could be founded upon this fact. Even far below the boiling-point the dissociation begins in the liquid acid. It has been pointed out that even at 30° to 40° C. the monohydrate begins to give off vapours of anhydride (Marignac), which fact has been confirmed by the exact researches of Dittmar² and Pfaundler and Pölt.³

A more thorough decomposition into sulphur dioxide, oxygen, and water takes place on conducting the vapour of sulphuric acid through porcelain or platinum tubes filled with chips of porcelain and heated to a bright red heat. This mode of decomposition has been recommended by Deville and Debray as a "cheap" plan for making oxygen; but it does not seem to have answered, owing to the insufficient sale of sulphurous acid or its salts; it was expected to play a great part in the manufacture of anhydride by Winkler's process, but even for this purpose it has not been found economical.

On heating with charcoal to 100°-150°, sulphuric acid yields carbon dioxide and sulphur dioxide; on boiling with phosphorus, sulphur; on boiling with sulphur, sulphur dioxide; by the action of the electric current, hydrogen, oxygen, sulphur, etc. (in dilute sulphuric acid the electric current merely causes the decomposition of water).

Sulphuric acid at temperatures below its boiling-point expels other acids from their salts when the solubilities, etc., allow this; but, inversely, sodium sulphate is also decomposed by hydrochloric acid. In fact, the "avidity" of hydrochloric and nitric acid at ordinary temperatures much exceeds that of sulphuric acid. Boussingault⁴ has shown that dry hydrochloric acid gas at a red heat decomposes the sulphates of sodium, potassium, barium, strontium, and calcium (see further on). More refractory acids, for instance, boric acid, silica, and phosphoric acid, expel sulphuric acid at higher temperatures.

With the bases, sulphuric acid forms two principal series of salts, viz. acid salts, of the formula $\text{SO}_2 \begin{matrix} \diagup \text{OH} \\ \diagdown \text{OM} \end{matrix}$, and neutral salts, of the formula $\text{SO}_2 \begin{matrix} \diagup \text{OM} \\ \diagdown \text{OM} \end{matrix}$. There is also definite evidence of

¹ Wanklyn and Robinson, *Roy. Soc. Proc.*, **12**, 507.

² *J. Chem. Soc.* [2], **7**, 446.

³ *Z. f. Chemie*, **13**, 66.

⁴ *Ann. Chim. Phys.* [5], **2**, 120.

the existence of other acid salts, such as $K_3H(SO_4)_2$ and $KH_3(SO_4)_2$. Very frequently it also forms basic salts, rarely hyperacid salts.

The sulphates form an important group of salts. Amongst the best known are: Sodium sulphate, or "Glauber's Salt"; calcium sulphate as "Gypsum," "Alabaster," "Plaster of Paris"; barium sulphate as "Heavy Spar," or "Barytes"; magnesium sulphate as "Epsom Salts."

The acid and neutral sulphates are soluble in water, excepting the neutral salts of barium, strontium, lead, silver, and mercury (in the state of protoxide), which are little or not at all soluble in water and dilute acids. Calcium sulphate is sparingly soluble in water. Most sulphates are insoluble in alcohol. The basic sulphates are mostly insoluble in water, but soluble in acids. The sulphates readily yield double salts, of which those are called *alums* which contain a combination of univalent and trivalent (corresponding to a double atom of quadrivalent) metals.

The neutral salts of the alkali-metals, of calcium, magnesium, silver, manganese, and ferrous, the last only if entirely free from acid and ferric salt (a condition very rarely realised), do not redden blue litmus-paper, whilst all other soluble sulphates are acid in reaction.

On heating to a red heat, only the neutral sulphates of the alkalies, of the alkaline earths, and of lead remain unchanged. At a still higher temperature (that of melting iron) the two latter classes are also decomposed, but the alkaline sulphates are volatilised without change. Even zinc sulphate and manganous sulphate are not easily decomposed. This explains the difficulty of completely converting blende into oxide of zinc.

On roasting, the decomposable sulphates yield metallic oxides, sulphur dioxide, and oxygen. They are much more easily split up on heating with certain additions, such as coal, iron, etc.

ACTION OF SULPHURIC ACID ON METALS

On the *metals*, sulphuric acid acts in very different ways. The water-decomposing metals in the cold yield nothing but hydrogen with it; at high temperatures, zinc and iron yield

sulphurous acid ; and zinc, if certain conditions are observed, can even yield sulphuretted hydrogen (Fordos and Gélis).

Most of the heavy metals do not act upon dilute sulphuric acid in the cold. Arsenic, antimony, bismuth, tin, lead, copper, mercury, silver, and some other metals are acted on by hot concentrated sulphuric acid with formation of sulphates and evolution of sulphur dioxide. Gold, iridium, and rhodium do not act on sulphuric acid at any temperature.

Action on Platinum.—Le Roy W. McCay¹ found that boiling sulphuric acid dissolves platinum in considerable amounts (in one experiment when boiling 10 c.c. of acid in a covered dish for one hour, 0.0038 of Pt was dissolved). The attack is not due to atmospheric oxygen, for the same thing happens when heating in a current of an inert gas. Excess of sulphur dioxide, which may be conveniently generated by introducing a piece of sulphur into the hot acid, or may be passed in the form of a current, prevents almost entirely the solvent action.

If it is assumed that at the temperature of attack there is a slight dissociation of the acid, thus liberating oxygen which would cause the action, this would account for the protective power of such reducing substances as excess of sulphur dioxide, arsenious and antimonious oxides.

According to Marie,² in the presence of oxidising substances, like persulphate, bichromate, permanganate, or chlorate, platinum is sensibly dissolved, even at ordinary temperatures, by dilute or concentrated sulphuric acid.

Impure platinum is more or less acted upon by sulphuric acid than pure platinum, according to the nature of the impurity. According to experiments made by Heraeus,³ an alloy of 90 per cent. platinum with 10 per cent. iridium, on boiling for forty days with sulphuric acid, lost only half as much weight as pure platinum ; an alloy of 95 per cent. platinum + 5 per cent. iridium lost three-quarters as much as pure platinum. According to Délépine,⁴ the advantage of the alloy of 90 per cent. platinum with 10 per cent. iridium over pure platinum decreases after boiling for eight to ten hours.

¹ *Eighth Inter. Cong. App. Chem.*, 1912, 1, 351-359; *J. Chem. Soc.*, 1913, 2, 713.

² *Comptes rend.*, 1907, p. 145 ; 1908, p. 475.

³ *Chem. Zeit. Rep.*, 1891, p. 36.

⁴ *Comptes rend.*, 142, 631.

About the behaviour of *zinc* towards sulphuric acid, we will only quote the fact that concentrated acid yields hydrogen, together with hydrogen sulphide, down to acid of the formula $\text{H}_2\text{SO}_4, 5\text{H}_2\text{O}$. Acid of the composition $\text{H}_2\text{SO}_4, 6\text{H}_2\text{O}$ yields pure hydrogen.¹

Tin is not acted upon by acid of the composition $\text{H}_2\text{SO}_4, 3\text{H}_2\text{O}$.

Fluorides sometimes occur in blende, and they may cause trouble, as they are converted into HF in the Glover tower, and this acid contaminates the sulphuric acid. Prost² asserts that even a very slight quantity of HF in sulphuric acid causes great wear and tear of the lead of Glover towers and chambers, not only directly, but by facilitating the corrosion by sulphuric acid and the nitrogen acids. Most descriptions of blende contain only traces of fluorine, but once he found 7 per cent. (The experiments quoted in the original do not show any essential difference between pure acids and those containing up to 2 per cent. HF in their action on lead. Gaseous HF seems to act much more than that contained in sulphuric acid.)

Action of Sulphuric Acid on Lead.

Calvert and Johnson³ came to the conclusion that lead is all the more acted upon the purer it is, and that an energetic action only takes place by acid above the sp. gr. of 140° Tw.

According to experiments made by J. Glover,⁴ pure lead is less acted upon when suspended in a vitriol chamber than lead containing 0.1 to 0.75 per cent. copper, or 0.1 to 0.5 per cent. antimony. N. Cookson⁵ found that strong acids at a high temperature act more upon lead containing antimony than upon pure lead, whilst weaker acid at a lower temperature acts the other way.⁶

In the north of England those rolling-mills which sell the sheet-lead to the vitriol-works supply a special kind of "chemical lead" which is made from the melted-up old chamber-lead, pipes, etc.; in this case many impurities, especially antimony, from "regulus"-valves, etc., get into the lead,

¹ Muir and Robb, *Chem. News*, 45, 70.

² *Chem. Zeit.*, 1902, p. 12.

⁴ *Chem. News*, 45, 105.

⁶ Cf. also Mactear, *Chem. News*, 41, 236.

³ *Comptes rend.*, 56, 140.

⁵ *Ibid.*, 106.

which are supposed to improve its quality for acid-chambers.

Napier and Tatlock¹ found that the action of sulphuric acid on lead at the ordinary temperature is accompanied by an evolution of hydrogen, which may cause bulging out of the closed lead vessels in which the acid is sometimes sent out for sale.

An extensive investigation on the action of sulphuric acid on lead made by Lunge together with E. Schmid has been published in *Z. angew. Chem.*, 1892, p. 642, also partly in *J. Soc. Chem. Ind.*, 1891, p. 146. We here give a very brief summary of their results, some of which are of great practical importance.

1. *At higher temperatures* the purest lead in all cases resists both pure and nitrous sulphuric acid, with or without access of air, much better than "regulus metal" (82 Pb, 18 Sb) or "hard lead" (1.8 per cent. Sb), or even soft lead with only 0.2 per cent. Sb. *In the cold*, lead with 0.2 per cent. Sb is very slightly superior to the purest lead; regulus metal behaves much worse, and hard lead worst of all.

2. *Concentrated nitrous vitriol* is always more active than pure acid. In the case of somewhat dilute acid (sp. gr. 1.72 to 1.76), nitrous vitriol acts less than pure acid on soft lead and hard lead, owing to a protective coating of lead sulphate being formed. If the acid is more dilute, the action is again stronger (*cf.* below). In all cases nitrous vitriol acts more in the presence than in the absence of air.

3. Comparing two samples of soft lead, the purer sample was found decidedly better; even a very slight proportion of bismuth (0.044 per cent.) acts injuriously.

4. It is altogether inadmissible to judge of the resistance of lead to sulphuric acid from the quantity of the *gas* (hydrogen) evolved. Soft lead gives off at the ordinary temperature, after a week's contact, much gas; hard lead, although losing much more weight, gives very little gas ($\frac{1}{200}$ of the theoretical quantity), probably owing to galvanic action. On this account, if sulphuric acid is to be sent out in tightly-closed or soldered-up leaden boxes, they should not be made of soft, but of hard lead, since otherwise the hydrogen may bulge or burst the vessels.

¹ *Chem. News*, 42, 314.

5. (a) Lead containing up to 0.2 per cent. *copper* (alloys containing more copper cannot be homogeneously rolled) is *in the cold* acted upon by strong sulphuric acid more than pure lead; with nitrous acid there is not much difference. At 100° all kinds of acid act in the same way on pure lead and on lead containing copper; concentrated pure acid rather less than concentrated nitrous vitriol, but more than nitrous vitriol of sp. gr. 1.72 (*cf.* No. 2). At 200° concentrated acid acts alike on pure lead and on lead containing 0.02 per cent. Cu; lead containing more copper is slightly less acted upon by pure acid, but rather more by nitrous vitriol.

(b) Above 200° (225° to 255°) lead alloyed with 1 per cent. *antimony* is far more strongly acted upon than pure lead (in the proportion of 26.5 to 1 at 225°); but lead containing 0.2 per cent. *copper* resists the acid at 235° much *better* than pure lead in the proportion of 1 : 17, and at 255° in the proportion of 1 : 26.5.

6. (a) Pure soft lead gives no visible evolution of gas with pure concentrated sulphuric acid up to 220°. From this point gas-bubbles are continually given off, and at 260° the lead is rapidly dissolved with strong frothing, evolution of SO₂, and precipitation of sulphur, the temperature rising to 275°.

(b) The same lead, alloyed with 0.2 per cent. of copper, shows a visible evolution of gas only at 260°, regularly increasing up to the boiling-point (310°), at which the lead is very gradually dissolved.

(c) Soft lead, alloyed with 1 per cent. Sb, gives with sulphuric acid the first visible gas at 175°, more strongly at 225°, and between 275° and 280° there is the same turbulent, sudden solution as in the case of pure soft lead.¹

Hence the purest lead is subject to instantaneous solution by sulphuric acid at 260°. An addition of 1 per cent. Sb raises this temperature only about 20°, but 0.2 per cent. Cu completely destroys this liability to sudden decomposition.

7. The percentage of *oxygen* in lead is very slight even in extreme cases, and does not seem to have any connection with its liability to be acted upon by acid. But that liability, as may be imagined, is less when the *density of the surface* is *mechanically* increased.

¹ See Barrs, *infra*.

8. The final considerations in selecting the kind of lead best suited for constructing apparatus for the manufacture of sulphuric acid are as follows :—

For vitriol-chambers, towers, tanks, pipes, and all other instances where the temperature can rise but moderately, and certainly never up to 200°, the purest soft lead is preferable to every other description of lead, being least acted upon by hot acid, whether dilute or concentrated, pure or nitrous.

Any sensible proportion of *antimony* is in nearly all cases *injurious*; *copper* causes at least no improvement. This, of course, does not apply to those cases where the lead requires an addition to its tensile strength, nor to that mentioned of packages for acid to be closed air-tight. Hence an addition of about 0.2 per cent. antimony may be useful in the case of apparatus which is only in contact with *cold acid*; but with *warm acid* even this percentage is to be avoided.

For *very high temperatures*, e.g. *the hottest boiling-down pans*, which ought not to be heated above 200°, but may sometimes be raised to that point, *an addition of 0.1 to 0.2 per cent. copper* is *advantageous*, whilst antimony should be avoided here under all circumstances (*cf.* No. 6*b*). This percentage of copper has no action at 200°, but only above 220°; and in the presence of bismuth it protects the lead from the sudden destruction sometimes observed.

9. *Nitric acid* of sp. gr. 1.37 to 1.42 may be brought into contact with lead *at the ordinary temperature*, but no acid of less strength. Stronger acid than the above acts more powerfully upon lead, but no more than concentrated sulphuric acid. *Mixtures of concentrated sulphuric acid and strong nitric acid* act very little indeed upon lead, much less than either strong sulphuric acid or strong nitric acid by themselves; such mixtures can be treated in lead vessels, at *ordinary temperatures*, if no moisture can be attracted from the air. *Hot mixed acids* act strongly on lead.

10. Mixtures of *sulphuric acid and nitroso-sulphuric acid*, partly also containing *nitric acid*, all of them originally containing 0.1 per cent. N, but by heating to 65° brought to the state in which they can really exist in vitriol-chambers, give the following results :—If a little nitric acid is added to dilute sulphuric acid, and the mixture is heated, a little HNO₃ is

volatilised, but no nitrosyl-sulphuric acid is formed until the concentration has reached sp. gr. 1.5. From this point oxygen escapes, and at sp. gr. 1.768 the whole of the HNO_3 has vanished, SO_5NH appearing in its stead. Inversely, nitric acid is formed from nitrous sulphuric acid on diluting it; in the case of prolonged heating, this evidently takes place not by splitting up into HNO_2 and NO , but by absorption of oxygen from the air.

The action of the acid on lead is least just about the lowest point where the nitrosyl-sulphuric acid is still capable of existing. It increases with its dilution, and in proportion to this, evidently through the formation of nitric acid, equally with its concentration, and later on rapidly so, the action of stronger sulphuric acid combining with that of nitrosyl-sulphuric acid and nitric acid. *The minimum action is between sp. gr. 1.5 and 1.6—that is, just at that concentration above or below which the acid ought not to be kept in vitriol-chambers.* This proves that it is not rational to keep the acid in the first chamber too strong (*cf.* Chapter III, Vol. II).

Hart¹ found the formation of easily fusible alloys of lead with aluminium, tin, or zinc to be the most frequent cause of the leaking of lead pans; bismuth has a similar but slower action; antimony acts injuriously, but copper, arsenic, and silver very little, and copper, under certain circumstances, may even act as a protective agent. The physical condition of the lead is also of importance.

C. E. Barrs,² in giving the results of his investigation of the action of sulphuric acid upon lead, states that two brands of lead, supplied for chemical use, proved to be very different in their power of resistance to the action of concentrated sulphuric acid. When a small portion of each was heated with concentrated acid it was noticed that one brand (A) containing 0.002 per cent. copper was rapidly attacked by the acid at about 250°, whereas the other (B) containing 0.02 per cent. copper resisted the attack until a temperature of 296° was reached.

A further series of tests made on lead from various sources showed that those in which copper was the predominating impurity were most resistant when heated with sulphuric acid.

¹ *J. Soc. Chem. Ind.*, 1907, p. 668.

² *Ibid. (Review)*, 1919, 407.

Lead of the same composition as "A" was then alloyed separately with approximately 0.2 per cent. of each of the following metals:—copper, bismuth, arsenic, antimony, zinc, tin, and silver, and also with tellurium and sulphur. Small portions of each were then heated with concentrated sulphuric acid, with the results tabulated below:—

	First action.	Action vigorous.
Lead alone (A)	150° C.	220° C.
„ plus 0.2% copper	210° „	315° „
„ „ bismuth	70° „	135° „
„ „ arsenic	213° „	260° „
„ „ antimony	150° „	220° „
„ „ zinc	160° „	200° „
„ „ tin	156° „	232° „
„ „ silver	200° „	262° „
„ „ tellurium	190° „	316° „
„ „ sulphur	142° „	238° „

The temperature of the "first action" was taken when a continuous stream of bubbles was seen to rise from the metal or alloy. The final temperature, "vigorous action," was noted when excessive frothing of the acid took place; and although the heat was removed at this point, it was noticed with those metals or alloys attacked at the lower temperature that the action still continued very vigorously for some time afterwards, whilst with the copper and tellurium alloys the action soon ceased when the heat was removed.

Subsequent research has shown that, by subjecting the lead to refining heat treatment in order still further to eliminate impurities, it is possible to obtain a metal which will resist attack up to 280°. In other words, an increase in the purity of lead renders it more resistant to attack by acid. It has, however, been found desirable in most cases to add a small percentage of copper (0.02-0.05 per cent.) to ensure obtaining the maximum resistance.

D. W. Jones,¹ in giving his conclusion upon the subject, says "that at higher temperatures the purest lead resists both pure and nitrous sulphurous acid much better than regulus metal or hard lead."

¹ *J. Soc. Chem. Ind. (Trans.)*, 1920, 39, 221.

He also recommends the addition of copper to ensure obtaining the maximum resistance.

To determine the quality of chemical lead he states that it is customary to make examinations by all or any of the following methods :—

1. Heat in 96 per cent. sulphuric acid up to 290° in five minutes, cool to 100° , and observe loss in weight.

2. Heat in 91-92 per cent. nitric acid. No appreciable action should occur in fifteen minutes.

3. Heat in a mixture of 40 per cent. of nitric acid, 52 per cent. of sulphuric acid, and 8 per cent. of water. No appreciable action should take place between 93° and 109° .

4. Heat a filed surface in a mixture of 1 vol. of hydrochloric acid, sp. gr. 1.14, 2 vols. of nitric acid, sp. gr. 1.50, and 3 vols. of water. The time required for spots of lead chloride to appear, and the time at which vigorous action takes place after boiling, are noted.

5. Heat in concentrated sulphuric acid and observe the temperatures at which bubbles of gas are first evolved and at which the lead decomposes.

Of these methods No. 5 is the one most generally favoured. When under observation by this method, in some cases the decomposition of lead is sudden, total, and violent, and is attended by a rise of temperature up to 27° after removing the source of heat. With a good quality lead, decomposition proceeds slowly, and is arrested when the source of heat is removed. The temperature recorded is that at which the solution becomes slightly turbid owing to the formation of lead sulphate. Since it has been found that 96 per cent. sulphuric acid (by wt.) gives figures comparable with those obtained when chamber-acid is used, all observations refer to trials conducted with pure acid of this concentration.

The tests described *infra* were carried out under the following conditions :—A test piece of rolled lead 1 sq. in. in area and $\frac{1}{16}$ in. thick (corresponding approximately to sheet 4 lb. per sq. ft.) is heated with 30 c.c. of 96 per cent. sulphuric acid at such a rate that the temperature of the acid reaches 300° in five minutes.

A suitable chemical lead when tested in this way evolves bubbles of gas at 190° - 200° and decomposes at 300° - 312° .

The following figures have been obtained from the examination of many hundreds of samples of lead refined by the Parkes process, including English, Spanish, Australian, and American supplies :—Bubbles of gas evolved : average, 187°; maximum, 212°; minimum, 146°. Lead decomposes : average, 235°; max., 280°; min., 183°.

Thus Parkes lead without further treatment is unsuitable for use in many operations (see *supra*). To test the effect of impurities on the chemical properties of lead, additions of pure metal were made to a Parkes lead containing Cu 0.003 per cent., Bi 0.007, Fe 0.0018, Ag 0.0005, Sb 0.006, Zn 0.0018, Sn, Ni, Co, *nil*, As, Mn, traces, Pb (by diff.) 99.9799 per cent. The results of these additions are shown in the following table :—

I. *Behaviour of Parkes Lead when heated in Sulphuric Acid.*

a. Gas evolved. b. Lead decomposes.

Percentage of metal added.	Cu.		Sb.		Cu and Sb. Equal quantities of each of these, in the amounts stated, were added.	
	a.	b.	a.	b.	a.	b.
<i>Nil.</i>	191°	254°	191°	254°	191°	254°
0.005	190°	277°	179°	205°	186°	259°
0.01	198°	281°	180°	210°	190°	275°
0.02	195°	288°	179°	212°	189°	284°
0.03	190°	291°	180°	206°	203°	289°
0.04	176°	290°	179°	202°	196°	286°
0.05	175°	295°	182°	203°	197°	277°
0.06	185°	296°	192°	220°	190°	284°
...

With *copper* alone, and with copper and antimony together, partial decomposition occurred. At 0.06 per cent. Cu and Sb local action was observed, streams of lead sulphate being formed, which dissolved 20° below the recorded decomposition temperature.

It is of interest to note how the addition of a number of elements affects the resistance to attack by sulphuric acid upon a lead known to possess this property. For this purpose the lead used was prepared from Parkes lead on a commercial scale by a process which is the subject of a patent granted to his firm in 1920. It contained Cu 0.0009 per cent., Bi 0.0007, Fe 0.0003, Ag 0.0005, Sb 0.0002, Zn 0.0019, Sn, As, Cd, Ni,

232 TECHNICALLY EMPLOYED OXIDES OF SULPHUR

Co, *nil*, Mn traces, Pb (by diff.) 99.9955 per cent. The results of these additions are shown in the following table :—

II. *Behaviour of Chemical Lead when heated in Sulphuric Acid.*

a. Gas evolved. b. Lead decomposes (° C.).

Percentage of addition.	Cu.		Sb.		Cu and Sb.		Zn.		P.	
	a.	b.	a.	b.	a.	b.	a.	b.	a.	b.
<i>Nil.</i>	202°	314°	202°	314°	202°	314°	202°	314°	202°	314°
0.005	211°	314°	208°	295°	197°	309°
0.01	209°	314°	198°	244°	204°	299°	180°	314°
0.02	205°	314°	201°	212°	211°	300°	180°	316°	219°	277°
0.03	196°	314°	203°	219°	207°	305°	200°	312°
0.04	193°	318°	203°	216°	192°	307°	197°	309°
0.05	209°	314°	201°	222°	202°	304°	176°	314°
0.06	207°	316°	205°	215°	193°	314°
0.08	219°	290°

Percentage of addition.	Hg.		Sn.		Bi.		Bi and Sb.*	
	a.	b.	a.	b.	a.	b.	a.	b.
<i>Nil.</i>	202°	314°	202°	314°	202°	314°	202°	314°
0.005	205°	314°	204°	314°
0.01	197°	314°	198°	314°	210°	300°
0.02	189°	308°	314°	188°	200°
0.03	200°	305°	199°	308°
0.04	198°	302°
0.05	198°	273°
0.06	197°	314°	198°	276°
0.08	189°	283°

* With 0.04 per cent. Bi and 0.005 per cent. Sb a = 199°, b = 270° ; with 0.04 per cent. Bi and 0.01 per cent. Sb a = 198°, b = 283°.

Remarks.—With the original metal, and also when copper was added, partial decomposition occurred, the action soon ceasing when the source of heat was removed. With 0.005 per cent. Sb total decomposition was observed, lead sulphate being formed at 270°; with higher percentages total and violent decompositions occurred. With Cu and Sb there was partial decomposition, with indication of lead sulphate about 10° below decomposition point. With zinc partial decomposition occurred; no indication of lead sulphate except with 0.02 per cent. and 0.05 per cent. With phosphorus and mercury, total decomposition was observed. With tin, partial decomposition occurred, with slight indication of sulphate at

260°. With 0.005 per cent. and 0.01 per cent. Bi decomposition was partial, with 0.02-0.04 per cent. total, and 0.05-0.06 per cent. sudden, total, and violent. With 0.005 per cent. Bi and Sb decomposition was partial, with 0.01 per cent. total, and with 0.02 per cent. more sudden, violent, and total.

This work has been confined to the addition of comparatively small amounts of impurities, many of which are known to exist in commercial lead, with the object of devising methods of eliminating those impurities found to possess a deleterious effect.

From the above tables it is evident that the presence of antimony in lead to the extent of 0.01 per cent. renders it unfit for use in the manufacture of chemical plant.

With 0.06 per cent. of added antimony the temperature of initial attack is restored; but as this amount is never found in commercial lead (which is usually of a purity of 99.98 per cent.), and it is not conceivable that an addition of 0.06 per cent. antimony would materially lead to additional strength, there can be little or no advantage derived from the fact.

Hard lead sheet and pipe containing 0.75-5.25 per cent. Sb in no case gave a higher decomposition temperature than 244°, but at temperatures above 220° signs of gas bubbles are first observed when this type of lead is heated in concentrated sulphuric acid.

Antimony, therefore, if present in lead in practically any proportion above the most minute, will, in the absence of a known corrective agent, be the cause of immediate breakdown if temperatures much over 200° are employed.

Copper also has a marked effect in reducing the temperature of initial attack by sulphuric acid. The figures in the tables point to the fact that there is a danger zone lying beyond 0.03 per cent. in lead of the Parkes type, and in the "chemical" lead clearly defined between 0.03 and 0.045 per cent. If copper be introduced, due consideration must be given to the above-mentioned factors.

The effect upon the decomposition temperature of the addition of copper upon a Parkes lead is most beneficial; 0.005 per cent. introduced shows a rise of as much as 23°, and at the same time is sufficient to prevent the vigorous action which causes the whole of the lead to be converted into sulphate

and consequent total destruction. The gain achieved by introducing 0.03 per cent. is 37°, and brings an ordinary lead within measurable distance of chemical lead. No remarkable effect ensues from the addition of copper to a pure chemical lead; a gain of 4° by 0.04 per cent. addition is all that calls for comment.

Most probably the reason for the statement previously quoted from Percy is, that the soft lead derived from pure ores contained about 0.01 per cent. Cu; similar lead to-day approximates to that amount and compares very nearly in all respects with Parkes lead when 0.01 per cent. Cu has been added. Such lead may have been more resistant to acid than desilverised lead manufactured at that period, especially when it is remembered that pan concentration of sulphuric acid was more universally in use. Pure lead is, however, manufactured to-day which withstands the action of hot concentrated sulphuric acid without being instantaneously dissolved when heated beyond 300°.

The effect of copper in counteracting the harmful influence of antimony in lead is evident from the tables. In no case is total decomposition brought about, which, with antimony only present to the same extent, would result in every instance. With between 0.02 and 0.03 per cent. of antimony and copper there seems to be a rise in the temperature of initial attack; this fact may be of some value if lead, containing these amounts of antimony and copper, is used for purposes dealing with concentrated acid at comparatively low temperatures.

Zinc, when present in lead even in very small amounts, is generally supposed to destroy in a marked degree the power to withstand the corrosive action of acid; this is not borne out by any work undertaken by the author, which embraces the examination of chemical lead, prepared by different methods, to which additions of zinc have been made. The temperature at which the first action is discernible is lowered in all cases. At 0.02 and 0.05 per cent. a degradation of resistivity is evidenced by the formation of lead sulphate much below the temperature of complete solution. At 0.03-0.04 per cent. Zn a critical stage exists where this injurious effect is not operative.

Mercury when alloyed with lead has a deleterious effect upon its "chemical" properties. By amalgamation this effect

is more serious. If 1 per cent. of mercury is rubbed over the surface of a piece of chemical lead until amalgamation appears to be completed, allowing one hour as contact time, the product is very sensitive to the action of hot concentrated sulphuric acid. At 170° lead sulphate is formed copiously. If the heating be discontinued at this stage the action of the acid will cease on cooling to 70° . After washing the lead sulphate from the trial piece it will be observed that pitting has proceeded over the entire surface, and minute globules of mercury can be seen under the microscope. If this piece of lead be again heated with sulphuric acid, action will commence at 180° , and sudden, total, and violent decomposition will take place at 220° . Repeating the above, but allowing contact over-night between the lead and the mercury for more complete amalgamation, a distinct action is noticeable on heating to 50° . At 100° total decomposition accompanied by the usual phenomena takes place. Using 0.1 per cent. of mercury on the weight of lead of standard size (*i.e.* just sufficient to cover one-third of the area), and allowing two hours for amalgamation, a distinct vigorous action commences at 100° , and total solution takes place at 215° .

Tin has a degrading influence upon lead intended for chemical purposes, though not to the extent generally believed. Since it is easily removed by refining methods of to-day, it is not usually found in lead in more than minute traces.

Bismuth, so frequently associated with lead of American origin, is decidedly injurious if present above 0.04 per cent., and even at 0.02 per cent. it causes total decomposition in an otherwise resistant lead. The addition of 0.02 per cent. of copper to lead containing 0.05 per cent. bismuth will be sufficient to raise the temperature of decomposition from 273° to over 300° .

The combined effect of antimony and bismuth is noteworthy. The addition of 0.005 per cent. of each metal leaves chemical lead practically unaltered, but when 0.02 per cent. antimony and 0.02 per cent. bismuth are present there is a difference of only 12° between the temperatures of first action and of violent decomposition.

Doubtless the poor chemical quality of Parkes lead in some instances is due to its containing antimony and bismuth in

some peculiar proportions, as singly their effect when added to a pure lead is not so pronounced.

Investigating the cause of the breakdown of lead concentrating pans, Hart¹ stated that 200° is never exceeded in this class of work, and that the trouble occurs when the acid has reached a sp. gr. of 1.65-1.675, and may occur at sp. gr. 1.63 after constant use for a long period. A possible explanation of these defects might lie in the peculiar behaviour of pure lead to which antimony and bismuth have been added. Though these metals may not originally be present in lead in the exact proportion which leads to decomposition at or even below 200°, a selective action of sulphuric acid upon lead known to contain bismuth and antimony may ultimately bring about conditions resulting in breakdown in pan concentration.

A practical method favoured by acid manufacturers of testing lead intended for chambers is to expose a sheet, previously weighed and measured, to the exit-gases of a No. 1 chamber (the gases at this point are considered most corrosive), and note the loss per unit of area exposed over a given period, usually not less than three months.

The following are the details of a trial, as described, upon four different samples of sheet lead exposed to the action of chamber-gases for 130 days:—

Description.	Behaviour when heated in sulphuric acid.		Area, sq. in.	Loss per sq. in., gms.
	Gas evolved. °C.	Lead decomposes. °C.		
Pattinson lead	200	316	19.500	1.274
Do. + 0.38 per cent. Cu	215	325	19.132	1.323
Pattinson lead (old sheet from the side of a No. 4 chamber)	210	300	26.800	0.749
Chemical lead prepared from Parkes lead	202	314	19.750	1.254

The behaviour of sheet lead which had seen previous service is remarkable; this had a fine coating of lead sulphate on its surface, which was not removed before beginning the trial. It is possible that, not being an immersion test, a protective action is exercised by this coating of lead sulphate. Apart

¹ *J. Soc. Chem. Ind.*, 1907, p. 504.

from this result pure lead shows the smallest loss, and a Pattinson lead shows a smaller loss than the same lead to which copper has been added.

Assuming the loss of pure lead to be unity, and that lead of 7 lb. per sq. ft. is under consideration, the increased loss suffered by Pattinson lead in chamber work as compared with pure lead would be 5.7 lb. per ton of lead per annum; and for Pattinson lead containing 0.38 per cent. added copper, 19.6 lb. per ton per annum.

Of the whole of the elements used for additive purposes, there are only two which consistently exert a beneficial influence upon the chemical properties of lead, viz. copper and sodium; this is most marked with non-chemical lead, and in the case of copper does not apply to any extent to additions made to a pure chemical lead. Avoiding those quantities which produce a fall in the temperature at which the first action is discernible, something may be said in favour of lead containing copper on account of a gain in strength and rigidity thereby secured. It is by fatigue, produced by constant use above normal temperature, that lead often becomes unreliable; here again the introduction of copper should prove advantageous.

Of other additions it may be said that they are injurious in their effect, though in most cases not to the extent generally supposed. There is one outstanding instance, viz. antimony, which, if present in lead in quantities which a commercial metal may contain, will effectively debar its use as "chemical" lead.

Chemical lead is sometimes subject to local action, attributed to oxides which in places become rolled out into the sheet. By a careful control of casting temperature alone this source of danger can be largely eliminated.

Reference to the table *supra* will show that local action is most pronounced when copper and antimony are together present in lead.

In spite of the fact that copper can function as a corrective agent and will counteract the injurious effect of antimony and bismuth in lead, the author is yet in agreement with Rhead,¹ who has emphasised the importance of using pure lead in connection with acid plant.

¹ *J. Soc. Chem. Ind.*, 1920, p. 128R.

William G. McKellar¹ gives a very interesting account of his investigations into the action of sulphuric acid upon samples of lead sheet, and concludes as follows :—

“Analysis alone is of no value in disclosing the source of trouble in lead, but if used in conjunction with micrographic work progress would be made.”

He states that he is satisfied that there is no alloy of copper with lead at the end of the scale where lead predominates, or, in other words, it is not possible to produce a solid solution of copper in lead, and continues :—

“The varied results obtained with different leads which had been treated with copper, lead to the conclusion that the protective value of the copper is mythical. There might be some value in treating lead at the last stage of refining with a proportion of liquid copper, which, after thoroughly stirring through the molten charge, should be allowed to settle off. It should not be poured along with the lead. In this case the copper might act beneficially as a scour by alloying itself with certain prejudicial metals which are likely to be present with the lead, but great care would be required to see that all the copper was actually settled out, otherwise in the atmosphere of an acid-chamber there is every probability that the destructive galvanic action would be set up by the presence of copper.”²

Action of Sulphuric Acid on Reinforced Lead.—A method for reinforcing lead for use in chemical plant is described by Messrs C. Baskerville and C. M. Wales.³ When lead is suspended in large sheets or pipes it creeps or sags, so that it must be held in position, and frequent supports are necessary to hold the lead in place.

Many of the troubles in the use of lead have been entirely overcome and others materially diminished by reinforcing it with iron- or steel-wire gauze or perforated sheets, which are embedded within the lead (U.S. P. 1280098 and 1280909). The elastic limit has in this way been increased four- to five-fold, and the tensile strength has been increased two- to three-fold. The variations observed were due to differences of gauge of wire and mesh of gauze used. Both may be materially increased by increasing (within limits) the gauge and looseness

¹ *J. Soc. Chem. Ind.*, 1921, pp. 137-141T.

² See Jones, *supra*.

³ *Chem. and Met. Eng.*, New York; *Chem. Trade J.*, 1920, p. 150.

of weaving the gauze. When manufactured, the lead or lead alloy may be somewhat rough on the surface and unnecessarily thick. Both faults are easily remedied by rolling, as in making sheet lead. Lateral extension of 20 per cent. and elongation of 30 per cent. have been obtained, the main care being against tearing the reinforcing wire gauze. Sheets 4 ft. 6 in. by 5 ft. 6 in. have been made. For obvious reasons, smoothing the surface is advisable only when the reinforcing member is perforated sheet iron or steel.

The reinforced sheets may be bent or shaped almost at will, as the lead does not fracture when bent. They may be cut, and the joints are easily burned together in the same manner as ordinary sheet lead is burned. The edges may be overlapped to form a pipe and burned in position. A pipe 8 in. in diameter, made up of reinforced lead 0.2 in. thick, collapsed at 85 lb. per square inch pressure.

Action of Sulphuric Acid on Cast-iron.

The behaviour of *cast-iron* towards sulphuric acid is of great technical importance. It has been known for many years that concentrated oil of vitriol acts very little indeed upon cast-iron, whether hot or cold, provided that air is excluded, the moisture from which would dilute the acid and cause it to act more strongly.

During the War manufacturers obtained considerable experience in the storage of acid in metallic containers, in the mixing of nitric and sulphuric acids, and innumerable other purposes where strong acids have to be manipulated either hot or cold, and even for the last concentration of sulphuric acid itself. Dilute sulphuric acid, if the dilution be not too strong, acts very little on cast-iron in the cold or at a gentle heat, if air be excluded; it can therefore be employed for "acid eggs," in which chamber-acid is forced up, in lieu of pumps, and for similar purposes.

It is usually assumed that some descriptions of cast-iron resist the attack of acids more than others. This point, together with some others of importance, has been the subject of experiments by Lunge and his collaborators.¹

¹ *Chem. Ind.*, 1886, p. 74. A full report is also given in the second edition of Lunge, pp. 141-143.

These experiments lead to the following conclusions:—

1. At the ordinary temperature all acids down to 106° Tw. act very little on all descriptions of cast-iron, if the access of air is prevented.

2. At 100° , the action is much stronger. It is least in the case of acid of 168° Tw., $1\frac{1}{2}$ times stronger with acid 142° Tw., and 3 times stronger with acid 106° Tw.

3. At the boiling-point of the acids the differences are far more pronounced. Acid of 168° Tw. acts very little even then (*i.e.* at 295°), either in the pure state, or as commercial acid (containing a little N_2O_3), or when containing a little SO_2 . But acid of 142° Tw. acts (on an average) 14 times stronger at its boiling-point (200°) than the same acid at 100° , and 20 times stronger than acid of 168° Tw. At 200° commercial acid of 142° Tw. does not act very differently from pure acid of the same strength. Hence it is not feasible to concentrate acid of 142° Tw. to higher strengths in iron vessels. Acid of 106° Tw. at its boiling-point ($= 147^{\circ}$) acts rather less than acid of 142° Tw. at 200° , but still 14 times as much as acid of 168° Tw. at 295° . There is no difference between pure and commercial acid in this case.

4. The differences between various mixtures of cast-iron are of no importance against acid of 168° Tw. in all cases, and against the weaker acids at 20° and 100° . But the latter acids at their boiling-point act decidedly less on charcoal-pig and on chilled cast-iron than on all other kinds. A difference between hot and cold casting could not be found. The strongest attack took place on Scotch pig and on mixtures containing this.

In another series of tests, the action of *monohydrated sulphuric acid* on various metals was examined, both on standing six days at 20° and on heating two hours to 100° , always with exclusion of air. The loss of weight was:—

	Loss per cent.		Loss in grams per square centimetre of surface.	
	6 days at 20°.	2 hours at 100°.	6 days at 20°.	2 hours at 100°.
Cast-iron . .	0.041	0.071	0.062	0.015
Wrought-iron . .	0.175	0.313	0.056	0.095
Copper	2.630	excessive	1.115	excessive
Lead	3.480	3.650	1.790	1.847

Knietsch¹ gives the following table respecting the action of sulphuric acid of various strengths on cast-iron, mild steel ("Flusseisen"), and puddled iron. The cast-iron contained 2.787 per cent. graphite and 3.55 per cent. total carbon, the mild steel 0.115 per cent. carbon, and the puddled iron 0.076 per cent. The figures denote the loss of the metal per superficial metre and hour in grams, after treating with acid for seventy-two hours at 18° to 20°, with exclusion of air.

H ₂ SO ₄ per cent.	SO ₃ per cent.	Cast-iron.	Mild steel.	Puddled iron.
48.8	39.9	0.2177
61.2	50.0	0.1510	...	0.3032
67.7	55.3	0.0847	...	0.0789
73.4	59.9	0.0662	...	0.0623
79.7	65.0	0.1560	...	0.1159
83.7	68.4	0.1388	...	0.1052
85.1	69.5	0.1306	...	0.1034
88.2	72.0	0.1636	...	0.1417
90.6	73.9	0.1760	...	0.1339
92.0	75.2	0.0983	...	0.1040
93.0	75.9	0.0736	0.0987	0.0855
94.3	77.0	0.0723	0.0987	0.0708
95.4	77.9	0.1274	0.0933	0.1209
96.8	79.0	0.1013	0.0815	0.0988
98.4	80.3	0.0681	0.0533	0.0655
98.7	80.6	0.0589	0.0509	0.0570
99.2	81.0	0.0568	0.0418	0.0504
99.30	81.07	0.057	0.042	0.050
99.50	81.25	0.060	0.038	0.049
99.77	81.45	0.066	0.042	0.049
100.00	81.63	0.087	0.088	0.076

Ricevuto² found a cast-iron dish, which resisted the action of acids particularly well, to contain 9.24 per cent. Si, 0.526 per cent. P, 0.080 S.

¹ *Ber.*, 1901, p. 4109.

² *Chem. Zeit.*, 1907, p. 960.

Action of Sulphuric Acid on Iron Alloys.

If heated clean iron be exposed to hydrogen containing about 5 per cent. of silicon hydride (the gas evolved on treating magnesium silicide, SiMg_2 , with dilute hydrochloric acid), silicon is deposited upon it as an even coating, and the protected metal will completely withstand the action of hydrochloric acid for at least two weeks. Silicon is not deposited in this manner on copper, nickel, or aluminium.¹ The resistance of alloys containing nickel has been investigated by Roland Irmann.²

A Bulletin recording the results of "A Preliminary Study of the Alloys of Chromium, Copper, and Nickel," by Messrs D. F. McFarland and O. E. Harder, has been issued by the University of Illinois Engineer Experiments Station,³ and analyses are given of the various copper and nickel alloys.

The growing interest in special acid-resisting alloys and the many uses found for them, say the authors, has stimulated both the search for efficient materials of this nature and the study of the causes underlying their merits.

The writer made some exhaustive tests on the action of acids on "Monel" metal, which consists of—

Cu . . .	25.83	28.90
Ni . . .	68.40	67.02
Fe . . .	3.10	1.75
Al30	.27
Mn . . .	2.10	1.74
C25	.30
Si02	.02
	<u>100.00</u>	<u>100.00</u>

and found great resistance to the action of acids, even at high temperatures.

Duriron metal contains approximately: silicon 14 per cent., manganese about 0.35 per cent., total carbon 0.20 to 0.60 per cent., phosphorus 0.16 to 0.20 per cent., and sulphur under 0.5 per cent.

¹ *Z. Verein. deutsch. Ingen.*, Dec. 7, 1918.

² *Metall und Erz*, 1917, 14, 21-30, 37-42; from *Chem. Zentr.*, 1917, 1, 1069-1070; *J. Chem. Soc.*, 1917, 2, 478, to which the reader is referred.

³ *Chem. Trade J.*, 1917, p. 404.

Its coefficient of expansion is about three times that of cast-iron, so that the initiation of a special foundry technique was found necessary.¹

The silicon-iron alloys on the market, such as Tant-iron, Ironac, Narki, and others, have their respective qualifications.

According to *Chemical Age*, 1921, p. 121, corrosion tests have been made with pieces taken from large vessels constructed of "Ironac," and these showed results of a convincing character. With sulphuric acid of 65 per cent., which had been boiled at 150° for 72 hours, no corrosive effect was perceptible. With mixed acid, 65 per cent. sulphuric acid, 2 per cent. nitric, 33 per cent. water, subjected for 24 hours to a temperature of 150°, no corrosive effect was discernible.

Aitchison² investigated the action of 10 per cent. sulphuric acid on steels alloyed with vanadium, chromium, tungsten, nickel, cobalt, and manganese. Vanadium does not pass into solution until the steel contains 5.4 per cent. of the metal, showing that up to that point the whole of the vanadium is present in the state of carbide, which is not attacked by sulphuric acid under the conditions of the experiment. Chromium is present both in solid solution and in the carbide, and the latter is slightly attacked. Alloys containing large percentages of chromium, however, give up very little to the acid. Tungsten is entirely present as carbide up to 11.5 per cent., and this is not attacked by acid. Nickel, on the other hand, is present only in solid solution until high percentages are reached, whilst cobalt is contained only as carbide. Manganese is present both in solid solution and in the carbide, the latter being partly attacked owing to its fine state of division in the sorbitic pearlite. Double carbides are much less susceptible to attack by acid than pure iron carbide.

Action of Sulphuric Acid on Wrought-Iron and Steel.

Wrought-iron is much more acted upon than cast-iron by weaker acids, as appears from some of the above-quoted investigations, but at the ordinary temperature it resists the action of strong sulphuric acid down to 140° Tw., and probably even a little below that strength. Where, however, through the action

¹ *Chem. Trade J.*, 69, 703.

² *Trans. Chem. Soc.*, 1916, 109, 288.

of moist atmospheric air, the acid gets more diluted, a very strong action sets in. Hence the wrought-iron vessels in which sulphuric acid is now very generally carried must be protected inside against any access of air when empty; and at the manholes, etc., where temporary access of air is unavoidable, they are best protected by a sheet of lead.

Fawsitt and Powell¹ have made a very extensive study of the action of sulphuric acid upon iron and steel, the results of which they summarise as follows:—

1. Concentrated sulphuric acid acts at the ordinary temperature on steel and on some kinds of cast-iron, the products being ferrous sulphate and hydrogen with a small quantity of sulphur dioxide.
2. The reaction proceeds more rapidly with rise of temperature, and the gaseous products at 180° are sulphur dioxide, with occasional small quantities of sulphuretted hydrogen, but no hydrogen.
3. The rate is increased on the average about three times for each 10° rise of temperature.
4. The rate of reaction depends on the concentration of the acid, but for small dilutions the ratio of hydrogen to sulphur dioxide in the mixture of gases evolved remains almost unchanged.
5. Although the rate of reaction depends to a certain extent on the composition of the sample of iron, as indicated by the large difference between steel wire and pig-iron, an important factor governing the reaction with any one sample appears to be the condition of the surface of the iron.
6. Laboratory experiments on the rate of reaction were found to give results similar to those obtained on the large scale.
7. For the carriage of iron drums containing sulphuric acid, it is possible to calculate the conditions for safe carriage in any particular instance.

Further investigations have been made by C. E. Fawsitt,² who states that there exists some uncertainty as to the safety of transporting concentrated acid in iron or steel drums, and

¹ *J. Soc. Chem. Ind.*, 1914, 33, 234-237.

² *Ibid. (Trans.)*, 1920, p. 147.

much more investigation is required on the action of sulphuric acid on iron on account of the importance of the matter in chemical industry.

Some of the factors which influence the action are :—(a) the kind of iron used—this depends on the chemical composition and also on the structure of the metal; (b) the nature of the surface of the iron, *i.e.* whether rough or smooth, or covered by any film of solid, liquid, or gaseous substance; (c) the concentration of the acid; (d) the temperature; (e) the presence of impurities, or additions of foreign substances to acid or iron; (f) mechanical influences, such as shaking.

The factors under headings (a) and (d) were to some extent discussed in the earlier article. Some work under heading (c) has been done by Knietsch.¹

The manner in which the addition of water increases the rate of action on iron depends apparently on the kind of iron used. Using steel wire containing C 0.51, P 0.046, Si 0.083, S 0.058, Mn 0.48 per cent., the velocity of action, found by Fawsitt and Pain, is as indicated in the table *infra*. When the acid and steel were shaken together, the rate of action was measured by weighing the steel before and after action, but these results are also calculated to show the average volume of gas evolved.

Weight of steel used, 5 grams; surface, 36 sq. cm.; temperature, 30°; time, 28 days.

Concentration of sulphuric acid (per cent. of H ₂ SO ₄).	Steel and acid unshaken. Average vol. (for 28 days) of gas evolved in c.c. per hour per sq. dem. of steel surface.	Steel and acid shaken together.	
		Loss of weight of, in (28 days grams).	Calc. average vol. of gas evolved during 28 days (c.c. per hour per sq. dem.).
97.4	...	0.099	0.17
94.0	0.27	0.861	1.46
90.9	0.31	1.222	2.07
89.3	0.06	0.140	0.24
87.9	0.28	0.523	0.89
85.0	0.30	0.526	0.89
80.0	2.5	2.915	4.94

With the particular class of steel used here, the velocity increases as the acid is diluted from 97 per cent. to 90.9 per

¹ *J. Soc. Chem. Ind.*, 1902, p. 343.

cent. H_2SO_4 ; it then appears to drop rather suddenly at the next concentration (89.3 per cent.). After the concentration has dropped to 85 per cent. the velocity increases very decidedly. It would be of interest to examine more exactly the effect on strengths between 91 per cent. and 88 per cent. H_2SO_4 .

Further experiments under heading (*f*), carried out recently, all show that shaking has an important effect in increasing the velocity of action.

Experiments would indicate that, with commercial acid and any particular kind of iron, a certain maximum rate of action is sometimes capable of being realised. When a drum of acid is being transported it is safer to assume that the maximum rate of action may take place, and the maximum pressure of gas, after a given time, could be calculated from the dimensions of the drum, the volume of the air space above the acid, the temperature, by laboratory experiments with the same iron and the same acid. The maximum rate of action is, however, not always attained.

It has sometimes been found that, although there may be a pressure of gas in one drum of acid, there is little or no pressure in other drums of the same kind, filled with the same acid, and exposed to exactly the same conditions, as far as can be judged. So long as calculations are based on the maximum rate of action, no harm can result from a smaller rate being actually observed, but it is disconcerting to find this great difference in behaviour between different drums.

Among other considerations, it is possible that the reason why the iron is not always acted on at the maximum rate is, that the iron may sometimes go into a passive state, and so not be acted on by the sulphuric acid. There may be more than one kind of passive iron, but the readiest means of producing a passive iron is to leave iron for a few moments in nitric acid of sp. gr. 1.4. It may easily be shown by E.M.F. measurements that iron, lying in concentrated sulphuric acid, and apparently not being acted upon by the acid, is not usually in a passive state. On the other hand, passivity is recorded¹ as being produced on iron sometimes simply by exposing iron to air. Fawsitt says he never came across a case where a

¹ Heathcote, *J. Soc. Chem. Ind.*, 1907, pp. 899-917.

piece of iron or steel, that has been lying in the air (and otherwise untreated), showed passivity towards concentrated sulphuric acid; but if the iron of a drum could become wholly (or perhaps even partially) converted into passive iron, by lying in the air or otherwise, it is quite possible that such iron might retain its passivity after the sulphuric acid has been put in.

Many experiments have been carried out by the above investigator, where steel that had been wholly treated by nitric acid of sp. gr. 1.4 was passive towards concentrated sulphuric acid. The passivity is detectable both by E.M.F. measurements, and by the observation that little or no solution of the steel takes place. Every case tried did not succeed.

A curious effect has been noticed. If a piece of steel is dipped for only part (say half) of its length into nitric acid of sp. gr. 1.4 and then dipped wholly into concentrated sulphuric acid, in many cases no action on the steel is apparent for several days at least,¹ either on the lower (passivified) part or on the upper part. This might be thought to be due to a "wave of passivification" passing over the whole iron (just as the activity proceeds by propagation from one part of the iron to the other. This is not the real explanation, however, as the upper portion originally not acted on by the nitric acid becomes immediately coated with a white film of ferrous sulphate, while the lower portion, which has been acted upon, is unaffected. The upper part, although originally of a greater solution pressure than the lower, probably becomes polarised and will no longer dissolve.

Experiments were also carried out with the addition of certain substances to the acid in the hope that the action might be decreased by certain additions. Unfortunately, no experiment has yet shown that any addition to the acid is decidedly helpful in preventing action. In these experiments the tubes containing 40 c.c. of acid and 3.5 grams of steel were not shaken. The steel was weighed before and after each experiment. On lifting the tube from the thermostat, the acid was poured off as completely as possible and the steel washed twice with alcohol, then with water, and finally with alcohol; it was then dried and weighed. The surface of the steel

¹ A momentary action takes place on the untreated portion.

exposed to the acid in each case was approximately 25 sq. cm. Before using fresh steel wire in these experiments, it was first treated with sodium hydroxide solution, and then with water. In many cases, however, the steel was used in a second experiment; it was then used exactly as it came from the first experiment (after washing with alcohol and drying).

The same steel wire was used in all the experiments as in those described on p. 245.

It will be noticed that although preliminary treatment with concentrated nitric acid may to a certain extent preserve the steel from being afterwards attacked by the concentrated sulphuric acid, putting nitric acid or nitrates into the sulphuric acid increases the rate of action very much.

While dipping iron into concentrated nitric acid either wholly or partially and then placing in concentrated sulphuric acid may bring about a passive state which persists for some considerable time, this is not by any means always the case.

When the iron is not passive or when the passivification is only effective for a few hours or days, the small quantity of nitric acid in the solution enormously increases the rate of action of the acid on the iron. This is shown by the results of several experiments at 30° for 44 days with 96.3 per cent. H_2SO_4 , using 3.5 grams of steel in each case. In the first two experiments, in which the steel received no preliminary treatment, the loss of weight was 0.132 gram and 0.238 gram respectively. In another experiment one-third of the steel was covered with concentrated nitric acid; this was poured off and concentrated sulphuric acid added to cover (the same) one-third of the steel and poured off. Then 40 c.c. of concentrated sulphuric acid was added. In this case the loss of weight was 0.047 gram. In a further experiment with the same treatment as the last, but with only one-quarter of the steel treated with nitric acid, the loss of weight was 1.37 grams, whilst when the whole steel was treated with concentrated nitric acid the loss was 1.52 gram. It appears, then, that although preliminary treatment of the steel with concentrated nitric acid cannot yet be recommended as a means to be generally used in preventing subsequent action of the sulphuric acid, this is a not unpromising line for further experiment.

A record of further work has appeared in a recent paper,¹ which stated that differences in electrochemical behaviour showed that no real similarity existed between iron which is slowly dissolving in concentrated sulphuric acid and iron rendered "passive" by dipping into nitric acid. The slowing down or cessation of the reaction was due apparently to the formation of a form of ferrous sulphate monohydrate on the surface of the iron. Although, generally speaking, increased dilution of the acid with water results in greater reactivity, certain anomalies were observed in this respect, notably that 89.3 per cent. acid has considerably less solvent action than either weaker or stronger acid of 94 per cent., 90.9 per cent., 87.9 per cent., or 85 per cent. strength. The solvent effect is in all cases noticeably increased by shaking the containing vessel.

BEHAVIOUR OF SULPHUROUS AND SULPHURIC ACID TOWARDS THE OXIDES OF NITROGEN

The reactions between the oxides and acids of sulphur and nitrogen are of extreme importance for the theory of the sulphuric-acid process in general, and for the recovery of the nitrogen compounds in particular.

The older researches in this field, of Clément-Désormes, Dalton, Davy, Berzelius, Gay-Lussac, W. Henry, Gaultier de Claubry, De la Provostaye, A. Rose, Koene, Weltzien, Rebling, and Müller, have now merely an historical interest. The modern literature of this subject begins with the labours of R. Weber, during the years 1862 to 1867, published in the *J. prakt. Chem.*, lxxxv., p. 423, and c., p. 37; *Poggendorff's Annalen*, cxxiii., p. 341, cxxvii., p. 543, cxxx., p. 277; and partly in *Dingl. polyt. J.*, clxvii., p. 453. Other very important papers have been published by Cl. A. Winkler ("Researches on the Chemical Processes going on in the Gay-Lussac Towers," Freiberg, 1867), by Rammelsberg (*Ber.*, 1872, p. 310), by Michaelis and Schumann (*ibid.*, 1874, p. 1075).

Lunge's researches referring to this subject are found in the following publications:—1877: *Berl. Ber.*, x., pp. 1073 and

¹ Fawsitt and Pain, *Proc. Roy. Soc. N.S.W.*, 1918, 52, p. 396; *J. Soc. Chem. Ind.*, 1920, p. 193A.

1432. 1878: *Berl. Ber.*, xi, pp. 434 and 1229; *Dingl. polyt. J.*, ccxxviii, pp. 70, 548, and 553. 1879: *Dingl. polyt. J.*, ccxxxiii, p. 63; *Berl. Ber.*, xii, pp. 357 and 1058. 1881: *Berl. Ber.*, xiv, pp. 2188 and 2196. 1882: *Berl. Ber.*, xv, pp. 488 and 495. 1884: *Chem. Ind.*, 1884, p. 5. 1885: *J. Soc. Chem. Ind.*, pp. 31 and 447; *Berl. Ber.*, xviii, pp. 1376, 1384, 1391; *J. Chem. Soc.*, xlvii, pp. 457 and 465. 1888: *Berl. Ber.*, xxi, pp. 67 and 3223. 1889: *Z. angew. Chem.*, pp. 265 and 385. 1890: *ibid.*, p. 195. 1899: *ibid.*, p. 393.

Nitrous Oxide N_2O .

(*Hyponitrous Anhydride*).

Of the different oxides of nitrogen, *nitrous oxide* need only be dealt with briefly. It is slightly soluble in sulphuric acid, much less so than in pure water, as, once formed, it is not oxidised again into NO or higher nitrogen oxides; it is altogether lost for the manufacture of sulphuric acid, nor does it form any chemical compound with that acid. The solubility rapidly decreases as the temperature rises, as will be seen by the following table (Carius):—

1 c.c. water at 760 mm. dissolves	c.c. N_2O at 0° and 760 mm.
At 0°	1.3052
„ 10°	0.9196
„ 20°	0.6700
„ 25°	0.5962

Nitric Oxide, NO.

Nitric oxide is a colourless gas, having a specific gravity of 1.039. When brought into the air, it combines with atmospheric oxygen, forming red-brown vapours, consisting of nitrogen peroxide, the combination being attended by a rise of temperature. The formation of these red fumes in contact with oxygen is characteristic of this gas, thereby distinguishing it from all other gases. Nitric oxide is only very sparingly soluble in water. It is the most stable of all the oxides of nitrogen, being able to stand a dull red heat without decomposition. It is soluble in a solution of ferrous sulphate, forming a dark-brown solution, containing an unstable compound of

ferrous sulphate and nitric oxide, $2\text{FeSO}_4\cdot\text{NO}$. This compound is readily decomposed by heat, nitric oxide being evolved. By means of this reaction, nitric oxide may be separated from other gases. Nitric oxide is a difficultly liquefiable gas, its critical temperature being -93.5° ; at this temperature a pressure of 71.2 atmospheres is required to liquefy it.

In the presence of water, nitric oxide is oxidised to nitrogen trioxide, the trioxide then being decomposed by the water, with formation of nitric acid and partial regeneration of nitric oxide.

According to P. Jolibois and A. Sanfourche,¹ when nitric oxide and oxygen are mixed in the proportion of 4 : 1 by volume, combination is instantaneous at the ordinary temperature, nitrogen trioxide, N_2O_3 , being formed and remaining stable. If the gases are mixed in the proportion of 2 : 1 the combination very rapidly reaches the stage N_2O_3 , and subsequently the peroxide is formed to the extent of 34 per cent. in 20 seconds, the transformation being complete after 100 seconds; even if oxygen is supplied in excess the time required for the formation of the peroxide is of the same order. If the nitrous vapours are submitted to a temperature of 400° , the equilibrium tends towards N_2O_3 .

Nitric oxide was stated by Henry and Plisson to be absorbed by oil of vitriol, if left a long time in contact with it, with formation of nitrous pyrosulphuric anhydride (see below); but Berzelius, Gay-Lussac, and many others have long ago refuted this statement. In fact, the sulphuric acid of the absorbing-apparatus cannot retain that portion of the nitrogen oxides which have been reduced to the state of nitric oxide; and from this follows the necessity of an excess of oxygen in the gas issuing from the chambers, since only this prevents the existence of nitric oxide in the same. Small quantities of nitric oxide may, however, escape oxidation even in the presence of oxygen, and hence be found in the chamber exit-gases.

The solubility of NO in sulphuric acid, although not *nil*, is extremely slight. Kolb made experiments with acids of varying concentration,² and found that acid of 1.841 does not

¹ *Comptes rend.*, 1919, 168, 235-237; *J. Soc. Chem. Ind.*, 1919, p. 132A.

² *Bull. Soc. Ind. Mulhouse*, 1872, p. 225.

absorb even traces of NO; acid of 1.749 to 1.621 merely traces (2 to 6 mg. to 100 grams acid); acid of 1.426 absorbs 0.017 gram NO; acid of 1.327, 0.020 gram NO to 100 grams. Lunge's experiments¹ show that concentrated O.V. absorbs per c.c. only 0.0000593 gram = 0.035 c.c. NO, and acid of sp. gr. 1.500 only half that quantity.

In the presence of oxygen nitric oxide is absorbed by sulphuric acid (Bussy, Winkler); but then it is really nitrous acid which is absorbed; and Winkler was the first to prove that it is precisely the presence of sulphuric acid which causes the oxidation not to proceed beyond the formation of nitrous acid, the latter combining with the sulphuric acid to form nitroso-sulphuric acid and water:

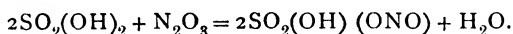

In several of his papers (*cf.* p. 249) Lunge gave proofs of the same fact, viz. that on passing nitric oxide, together with a very large excess of free oxygen, through strong sulphuric acid, nothing but nitroso-sulphuric acid is formed, which means that two NO take up only one O; but once out of the range of the acid, immediately above it, the reaction $2\text{NO} + \text{O}_2 = \text{N}_2\text{O}_4$ sets in, and this compound, when afterwards meeting sulphuric acid, yields equal molecules of nitric acid and of nitroso-sulphuric acid (*vide infra*).

Nitrous Acid, HNO_2 .

Real nitrous acid, HNO_2 , is not known in the pure state, only in that of dilute solutions. When dissolving nitrous anhydride, N_2O_3 , in water, some nitrous acid is formed and remains dissolved in the excess of water, but much of it splits up according to the formula:

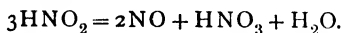

The velocity of decomposition of nitrous acid in aqueous solution, according to the above equation, depends on the velocity with which the nitric oxide is removed from the solution, and also on the pressure of nitric oxide above the solution. The direct decomposition of nitrous acid is

¹ *J. Soc. Chem. Ind.*, 1885, p. 447, and 1886, p. 82; also *Berl. Ber.*, 1885, p. 1391, and 1886, p. 111. Webb and Taylor (*J. Soc. Chem. Ind.*, 1922, p. 364T) state that Lunge's figures are too high.

spontaneous and immeasurably rapid, its transitory existence in aqueous solution depending upon a mutual action between it and the solvent.¹

Nitrogen Trioxide, N_2O_3
(*Nitrous Anhydride*).

There is considerable doubt as to the existence of this compound. It has been shown by the determination of the vapour density that in the gaseous state the compound N_2O_3 does not exist, but that the gas is a mixture of molecules of NO and NO_2 . Others regard it as merely a solution of the difficultly liquefied gas, NO, in liquid nitrogen peroxide, NO_2 . If the two oxides are in a state of combination, it would appear to be at best a feeble union, for it has been shown that at temperatures as low as -90° the liquid slowly evolves NO, while at this temperature no nitrogen peroxide is given off.

The most recent work on the subject, however, based upon minute changes of volume which result when NO and NO_2 are mixed,² points to the conclusion that the reaction, which may be expressed $N_2O_3 = NO + NO_2$, is to a slight extent a reversible one; and that therefore a mixture of the two gases NO and NO_2 at ordinary temperatures actually does contain a small percentage of N_2O_3 molecules.

We shall not here enter upon the much-debated question concerning the existence of N_2O_3 in the gaseous state, but merely quote the literature: Luck (*Berl. Ber.*, 1878, pp. 1232 and 1643), Witt (*ibid.*, p. 2188), Ramsay and Cundall (*J. Chem. Soc.*, xlvii., pp. 187, 672), Lunge (*ibid.*, p. 457; *Z. anorg. Chem.*, vii., p. 209). H. Brereton Baker and Muriel Baker (*Trans. Chem. Soc.*, 1907, xci., p. 1862) have shown that in the dried condition gaseous N_2O_3 can be most certainly obtained.

Although there is no doubt about the fact that the "nitrous vapours," formerly considered as N_2O_3 in the state of gas or vapour, are in reality principally a mixture of nitric oxide and peroxide, with very little N_2O_3 , we must bear in mind the equally undoubted fact that a mixture of equal molecules of NO and NO_2 behaves in all its reactions towards other

¹ A. K. Klemen and F. Pollak, *Z. physik. Chem.*, 1922, 101, 150-171; *J. Soc. Chem. Ind.*, 1922, p. 412A.

² Dixon and Peterkin, *Proc. Chem. Soc.*, June 1899, p. 115.

chemical compounds exactly as if it were N_2O_3 . When passed into an alkaline solution, it quantitatively yields a nitrite :

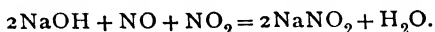

We have, therefore, the right to assume that such a mixture of equal molecules of NO and NO_2 *chemically* comes to the same thing as gaseous N_2O_3 ; and we shall throughout this book simplify many of our explanations and discussions by speaking of the above mixture as N_2O_3 , although *physically* it is only a mixture of NO and NO_2 . We are all the more entitled to do this, since there is no doubt that *some* N_2O_3 exists in the gaseous state as such, and since, according to the law of mass action, this N_2O_3 must be constantly reformed when taken away by any chemical reaction.

Nitrogen trioxide dissolves in sulphuric acid, more easily when the acid is concentrated, but also when it contains a certain amount of water. The reaction taking place is :

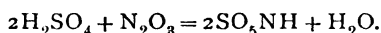

Rammelsberg asserts that when nitrous anhydride is employed in excess, nitric acid and nitric oxide are also formed :



but this reaction only takes place in presence of water, and the formation of nitric acid and nitric oxide must be regarded as a secondary reaction, owing to the well-known action of free nitrous acid on an excess of water. Where there is enough sulphuric acid and no excess of water, Rammelsberg's reaction does not come into play.

The compound formed by the action of nitrous acid on sulphuric acid possessing the empirical formula SO_5NH has long been known, both in the solid state, as "chamber-crystals," and dissolved in an excess of sulphuric acid, as "nitrous-vitriol"; but its true composition as *nitroso-sulphuric acid* has only comparatively recently been elucidated.

The easiest way of preparing the *chamber-crystals* in a state of purity is by conducting sulphur dioxide into well-cooled fuming nitric acid until the whole mass has been converted into a magma, but not until the nitric acid has been entirely decomposed, and drying the crystallised mass on a porous slab under

a bell-jar over some oil of vitriol. Obtained in this way, or collected in the connecting-pipes of vitriol-chambers or other places where there is a deficiency of steam, they consist of four-sided prisms or orthorhombic crystals; but generally, when prepared on the small scale, they appear as a scaly, feather-like, or granular mass, colourless and transparent. Their fusing-point is stated by Weltzien = 73° , by Gaultier de Claubry = 120° to 130° ; but they are partly decomposed before fusing, with evolution of red fumes.

The composition of chamber-crystals was formerly uncertain; the question was, in the language of the older chemists, whether they were a compound of sulphuric acid with nitrogen peroxide or with nitrous acid (nitrogen trioxide). Müller¹ pronounced for the former; but R. Weber proved in 1862, and more rigorously in the following year, by estimating all their constituents according to unexceptionable methods, that their formula must be constructed on the second supposition.

This formula has also been confirmed by Michaelis and Schumann,² who at the same time maintained, from the products of the decomposition of chamber-crystals by phosphorus pentachloride, that the compound must be regarded as *nitro-sulphonic acid*, $\text{SO}_2 \begin{matrix} \text{OH} \\ \text{NO}_2 \end{matrix}$; that is, as sulphuric acid, one of whose hydroxyls is replaced by the nitro group, or as nitric acid, for whose hydroxyl is substituted the sulpho group. This mode of explaining the constitution of that substance cannot, however, be strictly maintained. Both from its formation and the decomposition, it is certain that it does not contain the nitro group NO_2 , but the nitroso group NO . Its formula must therefore be written:

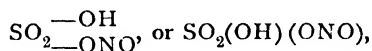

and it must be called nitrosyl sulphate, or nitrosyl-sulphuric acid, or nitroso-sulphuric acid, which means sulphuric acid, one of whose hydrogen atoms is replaced by the nitroso group, that is the radical of nitrous acid, $\text{NO}(\text{OH})$. It is a mixed anhydride of sulphuric and nitrous acid, as is proved both by its formation and its decomposition by water.

¹ *Ann. Chim. anal.*, 122, 1.

² *Ber.*, 1874, p. 1075.

Jurisch gives to the chamber-crystals ("Weber's acid") the formula: H_2O , O_3S , SO_3 , O_3N_2 .

The constitution of chamber-crystals is discussed by Biehringer in *Z. anorg. Chem.*, 1916, iii., p. 532; *Ber.*, 1916, 49, 1402. At temperatures from 19° to 15° their formula approaches most to nitroso-sulphuric acid, at 28° to 30° to nitro-sulphonic acid.

There exists also a complete anhydride of nitroso-sulphuric acid, of the empirical formula, $\text{N}_2\text{O}_3, 2\text{SO}_3$, which is rationally written :

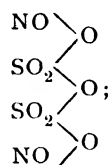

but this is only formed by mixing liquid sulphur dioxide and nitrogen tetroxide in the cold under pressure (Provostaye), or sulphuric anhydride with dry nitric oxide (H. Rose), or by heating sulphuric anhydride with nitrogen tetroxide (Weber), none of which reactions are possible in the manufacture of sulphuric acid.

Similarly, the compound produced by R. Weber¹ by conducting sulphuric anhydride into the most highly concentrated nitric acid, with empirical formula $\text{N}_2\text{O}_5, 4\text{SO}_3, 3\text{H}_2\text{O}$, will never be met with in practice.

Nitroso-sulphuric acid is formed not merely as above indicated, but in many other ways. We have already mentioned its formation from sulphur dioxide and nitric acid :

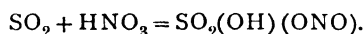

It is also formed when a mixture of strong sulphuric and nitric acids is heated, oxygen being evolved (A. Rose, and *infra*, p. 265):

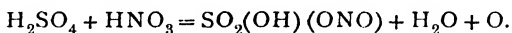

Sulphur dioxide can form this compound even with the lower oxides of nitrogen, if there is water and (except with N_2O_4 , where this is unnecessary) oxygen present. In the perfectly dry state sulphur dioxide does not act on the dry nitrogen

¹ *Poggend. Annalen*, 162, 602.

oxides ; but in presence of the smallest quantity of water "chamber-crystals" are formed, if SO_2 meets with N_2O_4 , or with NO or N_2O_3 and oxygen. Winkler has shown that, in an atmosphere of moist carbon dioxide, nitrogen trioxide does not form chamber-crystals with sulphur dioxide, but nitrogen peroxide does so, and he distinguishes N_2O_3 and N_2O_4 in this manner. The fumes of N_2O_3 , with an excess of SO_2 and H_2O , but in the absence of oxygen, give no chamber-crystals at all ; they are decolorised, nitric oxide and sulphuric acid being formed. If oxygen or air is admitted, chamber-crystals instantly appear, and this is also the case when nitrogen peroxide meets sulphurous acid in the presence of water. These observations of Winkler's have been repeatedly confirmed ; but we must now add that what he called "fumes of N_2O_3 " is in reality mostly a mixture of equal molecules of NO and NO_2 , behaving *chemically* like N_2O_3 .

As some points had not been entirely cleared up by previous investigators, and there were partial contradictions among their results, Lunge undertook an investigation on the *interaction of sulphur dioxide and nitric oxide, with or without the presence of water*,¹ which led to the following results :—

1. Dry NO and SO_2 have no action upon one another, be it at the ordinary temperature, or at 50° or at 100° , provided that air and moisture are rigorously excluded.

2. NO , SO_2 , and water act in such a way that as much N_2O is formed as corresponds to the quantity of SO_2 originally present. A reduction down to N could not be established.

3. If NO and SO_2 meet in the presence of dilute sulphuric acid, of sp. gr. 1.455, no reduction of NO to N_2O takes place, even when there is a very large excess of SO_2 present, whether the digestion be carried on for many hours at ordinary temperature or at 60° . Even with acid of sp. gr. 1.32 no reduction of NO by SO_2 could be established.

4. If NO , SO_2 , and oxygen meet in the presence of water, a slight but distinct reduction down to N_2O takes place. If, however, in lieu of water, dilute acid of sp. gr. 1.32 is employed, no such reduction can be observed.

The bearing of these results on the theory of the chamber-process will be discussed later on (Chapter III in Volume II).

¹ *Ber.*, 14, 2196 *et seq.*

A further investigation by Lunge¹ confirmed the above results. It was shown that in the dry state nitric oxide combines with an excess of oxygen to form N_2O_4 exclusively, or nearly so; dry nitric oxide in excess with oxygen yields N_2O_3 along with N_2O_4 ; in the presence of water, NO with an excess of oxygen is altogether converted into nitric acid. If, however, NO meets O in immediate contact with concentrated sulphuric acid, there is no formation of either N_2O_4 or HNO_3 , even with the greatest excess of oxygen; oxidation proceeds only to the stage of N_2O_3 , which, however, is not formed in the free state, but is at once converted into nitroso-sulphuric acid:

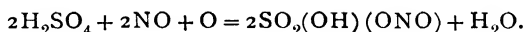

Outside the immediate contact with the acid the reaction is again as before with dry gases, viz. $2NO + O_2 = N_2O_4$; that is, here NO is oxidised to a higher state than within the sulphuric acid.

A very elaborate investigation of the interaction between nitrous and sulphurous acid was published by Raschig.² He found a number of new compounds, and rectified some of the statements of Frémy and Claus concerning compounds formerly described by them. He also discovered a very convenient method of preparing hydroxylamine. But as nearly all Raschig's experiments were made with alkaline solutions, and those which were performed with acid solutions were made under conditions utterly different from those of a lead chamber, namely at the freezing-point, we must refer* to his papers for details. Under these circumstances, apart from N_2O and NO, amidosulphonic acid, hydroxylamine, and ammonia are observed, but only in small quantities; and above the low temperatures employed by Raschig the occurrence of those substances is altogether too uncertain and minimal to be taken into consideration for our purposes.

Action of Water on Chamber-crystals.—These crystals are very deliquescent; they absorb water rapidly from ordinary air. In contact with a little more water, they dissolve quickly with evolution of heat, much nitric oxide being given off. When introduced into a large quantity of water, they dissolve without

¹ *Ber.*, 18, 1384; *J. Chem. Soc.*, 47, 465.

² *Lieb. Ann.*, 241, 161 et seq.

visible evolution of gas ; but in point of fact nitric oxide is formed as well as nitric acid and nitrous acid. This has led to many attempts at explanations, and Rammelsberg and Philipp have asserted that exactly $\frac{1}{4}$ of the nitrogen appears as NO, $\frac{5}{8}$ as nitrous acid, and $\frac{1}{8}$ as nitric acid :

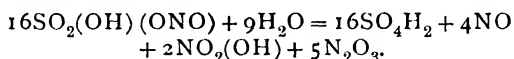

But this complicated and very unlikely reaction need not be assumed at all. Every fact observed in this connection can be quite simply explained by the following reaction :

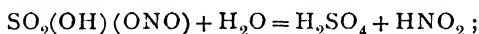

that is, nitroso-sulphuric acid takes up the elements of water, to form sulphuric acid and nitrous acid ; the latter, as is well known, is unstable in the presence of an excess of water, and hence partly splits up into nitric oxide and nitric acid :

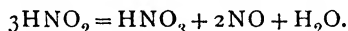

In the presence of less water, nitrous anhydride can be formed from chamber-crystals, and escapes in the form of brown fumes (of course mostly dissociated into nitric oxide and peroxide) :

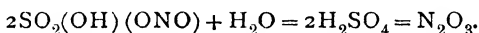

For nearly every purpose nitroso-sulphuric acid or its solution in sulphuric acid may be regarded as a solution of nitrous acid in sulphuric acid.

The behaviour of nitroso-sulphuric acid towards sulphuric acid of various concentrations is of great interest for our purposes. In concentrated oil of vitriol the crystals dissolve easily and without decomposition. This solution is stable enough to be distilled without losing any nitrous acid, whilst the isolated crystals are decomposed on being gently heated. Lunge showed¹ that on distilling such a solution for four hours, when 40 per cent. of the sulphuric acid had passed over, the distillate contained only 5 per cent., the residue 95 per cent. of the nitrous acid, none of it having been destroyed. It is possible to obtain solutions of 1.9 sp. gr. ; they evolve nitric oxide with water, inflame phosphorus at 62°, oxidise sulphur and many metals on distillation with evolution of NO ; heated with ammonium sulphate to 160° they evolve nitrogen gas.

¹ *Z. angew. Chem.*, 1888, p. 661, and 1890, p. 447.

Sulphur dioxide evolves nitric oxide ; but a solution of nitroso-sulphuric acid in strong oil of vitriol (of 168° Tw.), even on long-continued treatment with dry sulphur dioxide, is only incompletely decomposed, and on addition of water still shows the presence of nitrous acid by the evolution of brown vapours. This explains the fact (well known to manufacturers) that *concentrated* sulphuric acid contaminated by nitrous acid is only with difficulty purified by sulphur dioxide. At a higher temperature, sulphur dioxide decomposes chamber-crystals with evolution of nitrous oxide (Frémy). Further statements respecting the behaviour of sulphur dioxide towards the solution of chamber-crystals in sulphuric acid, the so-called "nitrous vitriol," will be made when examining the process going on within the Glover tower. It is remarkable, and of great importance for the practice of sulphuric-acid making, that even dilute acids of 1.70 down to 1.55 sp. gr. dissolve the crystals in the cold without decomposition ; the decomposition only commences when the specific gravity of the dilute acid has fallen below 1.55—that is, below the density of ordinary chamber-acid.

Nitrogen Peroxide, NO_2 , and N_2O_4 .

At low temperatures nitrogen peroxide is a colourless crystalline compound. It melts at -9° , but requires a temperature as low as -30° to solidify it. At a temperature slightly above its melting-point the liquid begins to acquire a pale yellowish tint, which rapidly deepens until at the ordinary temperature it is a full orange colour. The liquid boils at 22° , and gives a vapour having a reddish-brown colour. The colour of the vapour also becomes deeper as its temperature is raised, until at 140° it is a dark chocolate brown, and almost opaque. On allowing the vapour to cool the reverse changes take place. This change of colour, as the temperature rises, is accompanied by a steady change in the density of the gas.

It is believed that at low temperatures nitrogen peroxide has the composition represented by the formula N_2O_4 , but that dissociation begins to take place even in the liquid state, as indicated by the gradual change of colour. At temperatures between the boiling-point of the liquid, viz. 22° , and 140° , the gas therefore consists of mixtures of molecules of NO_2 and N_2O_4 . The calculated percentage of NO_2 molecules, which the

gas contains at the temperatures at which the above densities are taken, are given in the third column.

° C.	Per cent. N ₂ O ₄ .	Per cent. NO ₂ .
At 26.7	80	20
„ 39.8	71	29
„ 60.2	47	53
„ 80.6	23	77
„ 135	1	99

Nitrogen peroxide is decomposed by water. At low temperatures, and with small quantities of water, nitric and nitrous acids are the products of the action, thus :

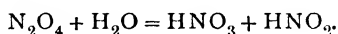

At the ordinary temperature, and with an excess of water, the following reaction takes place :

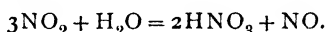

Nitrogen peroxide, whether in the state of liquid or of gas, acts strongly on sulphuric acid. According to Weber, if nitrogen peroxide, made by gently heating fuming nitric acid [and therefore not quite free from nitric acid], be added to sulphuric acid of different degrees of concentration, the following is observed :—The strongest oil of vitriol, down to 1.7 sp. gr., absorbs the nitrogen peroxide without coloration. Acid of 1.55 turns yellow ; here the nitrogen peroxide is probably absorbed to a large extent similarly as by nitric acid, and no decomposition, as represented by the equation on p. 263, has taken place, while this has to be assumed in the case of the stronger acids. Acid of 1.49 turns greenish-yellow ; of 1.41 intensely green ; acid of 1.31 turns blue and evolves nitric oxide, which on applying a gentle heat escapes with violent effervescence. Weak acids are only coloured for a short time. From this Weber inferred :—that acids of 1.8 to 1.7 combine with nitrogen peroxide with formation of nitroso-sulphuric acid ; weaker acids simply absorb it ; and the more dilute acids decompose it with formation of nitric oxide, nitrous acid, and nitric acid. The action of sulphurous acid on these mixtures is different according to their concentration. As mentioned above, the solution of chamber-crystals in concentrated sulphuric acid is but incompletely decomposed even by

prolonged action of sulphurous acid ; but the yellow mixture of 1.55 sp. gr. and the coloured, more dilute, acids are decomposed with strong effervescence of nitric oxide. It will be shown afterwards what part all these reactions play in the recovery of the nitrous gas in the manufacture, where the object is first to absorb the gas in sulphuric acid of 1.7, and then again to liberate it from that solution.

Winkler gave a different account of the behaviour of liquid nitrogen peroxide from that of Weber. He stated that it may be mixed with sulphuric acids down to 142° Tw., but that it yields a solution totally different from that of chamber-crystals in sulphuric acid, viz. a liquid of yellow colour and constantly evolving red fumes. On heating, it effervesces and gives off streams of gaseous nitrogen peroxide ; if the mixture is made with sulphuric acid of 142° Tw., the NO₂ completely volatilises far below the boiling-point of sulphuric acid, so that the residue on dilution with water does not decolorise potassium permanganate. If, however, acid of 168° Tw. has been employed, the liquid on heating certainly yields up the larger portion of its NO₂ ; but the residue behaves like a solution of chamber-crystals in sulphuric acid, and on being mixed with water it evolves red fumes which can be proved to be N₂O₃, not NO₂, by their not forming any chamber-crystals with moist SO₂.

If concentrated sulphuric acid is mixed with a little concentrated *nitric acid*, and sulphur dioxide is passed into the mixture, the nitric acid in the cold is only reduced to nitrous acid, which remains combined with the sulphuric acid : this compound resists the further action of the sulphur dioxide in the same way as the solution prepared from concentrated oil of vitriol and chamber-crystals. On the other hand, more dilute mixtures of sulphuric and nitric acid, below 1.7 sp. gr., are more or less easily decomposed by SO₂, in the ratio of their dilution.

Since the labours of Weber and Winkler did not in all points agree with one another, and the subject seemed to call for another investigation, Lunge undertook a long research,¹ the conclusions of which² are as follows :—

1. Nitrogen peroxide, under ordinary circumstances, cannot

¹ *Dingl. polyt. J.*, 233, 63.

² Also published in the *Ber.*, 12, 1058.

exist in contact with sulphuric acid, but at once splits up into nitrous acid, which, with a portion of the sulphuric acid, yields nitroso-sulphuric acid and nitric acid (dissolving as such) thus :

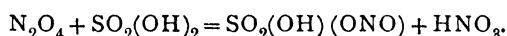

2. Nitroso-sulphuric acid, on dissolving in an excess of sulphuric acid, forms a colourless liquid, but only up to a certain limit of saturation, which is higher the more concentrated the sulphuric acid. This limit for acid of sp. gr. 1.84 is not yet reached at 55.34 mg. $\text{N}_2\text{O}_3 = 185$ mg. $\text{SO}_2(\text{OH})(\text{ONO})$ in 1 c.c. of acid.

3. Beyond that limit at first a yellowish tint appears, of course with stronger acids only when more nitroso-sulphuric acid is present than with weaker acids. This took place with a mixture of sp. gr. 1.887 (made from pure sulphuric acid of sp. gr. 1.84), containing in 1 c.c. 147 mg. $\text{N}_2\text{O}_3 = 372$ mg. $\text{SO}_3(\text{OH})(\text{ONO})$, and also with acid of sp. gr. 1.706, containing in 1 c.c. only 56.7 mg. $\text{N}_2\text{O}_3 = 190$ mg. $\text{SO}_2(\text{OH})(\text{ONO})$. Since these acids also are rendered colourless by prolonged boiling, the excess of nitroso-sulphuric acid seems to be rather loosely held; but the temperature of the water-bath is not sufficient to affect it.

4. The phenomenon observed by Winkler, a mixture of strong vitriol and nitrogen peroxide showing an orange-colour even when cold, emitting red vapours, and exhibiting a tempestuous evolution of nitrogen peroxide on being gently heated (which proves the existence of unchanged nitrogen peroxide), can evidently take place only when the mixture contains *far* more N_2O_4 than the strongest mentioned above, or the strongest ever occurring in sulphuric-acid works under any circumstances. Many experiments of heating in the water-bath for a prolonged period demonstrate the absence of free N_2O_4 in all cases observed. Still less can the presence of nitrogen peroxide be assumed in more dilute acids; it is therefore inadmissible to cite it as such in analyses.

5. All nitrous vitriols, *i.e.* solutions of nitroso-sulphuric acid in sulphuric acid, whether they contain nitric acid at the same time or not, on being heated far below their boiling-point assume a golden-yellow or even darker yellow colour, but

entirely lose it again on cooling. This change of colours may be repeated any number of times.

6. The stability of nitroso-sulphuric acid in its solution in sulphuric acid is very great, even at the boiling-point, providing the sp. gr. is not below 1.70. It is true that on boiling it some nitrogen is always lost, and all the more the less concentrated the acid is; but if the boiling takes place so that the vapour cannot condense and flow back, there is some nitroso-sulphuric acid found in the residue, even from acid of sp. gr. 1.65 (*cf.* p. 259). But if the vapour is condensed and the condensing liquid (which, in the case of vitriol of sp. gr. 1.80 or below, consists of very dilute acid or almost pure water) is allowed to flow back, a considerable loss is caused by denitration.

7. Down to a concentration of sp. gr. 1.65 the affinity of sulphuric acid for nitrous acid, *i.e.* the tendency to the formation of nitroso-sulphuric acid, is so great that any nitric acid present at the same time, whether added as such or formed by the decomposition of nitrogen peroxide, is reduced with loss of oxygen, and employed to form nitroso-sulphuric acid. In the case of acid of sp. gr. 1.71 and upwards, this transformation takes place almost completely after a brief boiling, but at sp. gr. 1.65 only incompletely. This is a further argument against the existence of N_2O_4 in the solution.

8. Below sp. gr. 1.65 the nitroso-sulphuric acid possesses so little stability that, for instance, from acid of sp. gr. 1.60 some nitrogen oxides (but only a very small percentage) are expelled in the water-bath, and nearly all of them by boiling for a short time. In the case of acid of sp. gr. 1.5, it is evident that, even without heating, the nitrous acid added is partly decomposed into nitric acid and nitric oxide; but after heating for an hour in the water-bath a considerable quantity of nitroso-sulphuric acid remains undecomposed, whilst another portion has been converted into sulphuric acid. In the case of still weaker acids, of course these phenomena occur even to a greater extent; but it is very probable that even very dilute sulphuric acid may contain, while cold, a little nitroso-sulphuric acid if reducing-agents are absent.

9. Most of the nitric acid present together with nitroso-sulphuric acid in dilute acids (of sp. gr. 1.5 and below) remains behind in the liquid even after prolonged boiling. If, therefore,

the nitrous vitriol of acid-works, in consequence of a faulty process, contains nitric together with nitrous acid, it cannot possibly be completely denitrated by hot water or steam, in which case a lower strength than sp. gr. 1.5 is never reached; the denitration can only be effected by reducing-agents, such as sulphur dioxide in the Glover tower or mercury in the nitrometer. In the latter it can be very clearly seen with how much more difficulty and slowness the denitration goes on in the presence of nitric acid.

10. The tendency to form nitroso-sulphuric acid is so strong that even on passing a large quantity of air (oxygen) through sulphuric acid together with nitrous acid, no oxidation of N_2O_4 or N_2O_5 takes place, just as in the case of oxygen and NO.

11. Nitrous acid cannot be absorbed by caustic-soda solution without loss, because a portion of it is decomposed into nitric acid and nitric oxide.

12. The purple colour which is developed in nitrous vitriol by the action of reducing-agents is caused by a solution of nitric oxide in such acids, and is possibly produced by a very unstable compound of nitrogen and oxygen, midway between NO and N_2O_3 .

Although Lunge's experiments had definitely proved (*cf.* Nos. 1 and 4 of his conclusions) that nitrogen peroxide does not dissolve as such in sulphuric acid, with formation of an unstable solution from which the N_2O_4 can be drawn off by heating, the former erroneous assertion of Winkler (since that time recognised as such by himself) did not vanish from chemical literature, and, for instance, gave rise to a decidedly erroneous explanation of the process of Lasne and Benker for carrying on the work in the Gay-Lussac tower. This caused Lunge to investigate the subject once more,¹ and he pointed out that mixtures of pure nitrogen peroxide with even somewhat dilute sulphuric acid, down to sp. gr. 1.65, behave quantitatively like mixed solutions of equal molecules of nitroso-sulphuric acid and nitric acids; that on prolonged heating in a water-bath such solutions in acid of sp. gr. 1.75 do not lose any, and in acid of sp. gr. 1.65 only very little, of their nitrogen compounds. On prolonged boiling, part of the latter escapes, but a large quantity of nitroso-sulphuric acid remains behind,

¹ *Ber.*, 15, 488.

more than that originally present, part of the nitric acid having passed into it with loss of oxygen. The idea of a "loose" union between N_2O_4 and sulphuric acid must therefore be entirely abandoned; and from this follows the fallacy of the idea held by some manufacturers that N_2O_4 is less easily absorbed by sulphuric acid than N_2O_3 , and that therefore much N_2O_4 is lost in the Gay-Lussac tower. Lunge directly disproved this idea by showing that vapours of nitrogen peroxide are most easily, quickly, and completely absorbed by sulphuric acid of sp. gr. 1.71, such as is used in the Gay-Lussac tower, and that this (colourless) solution is not changed either by long heating to 100° or by passing a current of air for a long time through it.

A concluding investigation on the behaviour of nitrogen peroxide towards sulphuric acid has been made by Lunge together with Weintraub,¹ of which we here give merely a summary of the results.

1. The reaction between sulphuric acid and nitrogen peroxide is reversible, since the nitric acid formed has some action on nitroso-sulphuric acid, forming sulphuric acid and nitrogen peroxide:

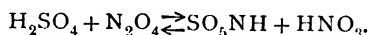

In mixtures of sulphuric acid and nitrogen peroxide an equilibrium is formed, all four substances—sulphuric acid, nitrogen peroxide, nitroso-sulphuric acid, and nitric acid—being present at the same time. 2. In contact with concentrated sulphuric acid (95 per cent. H_2SO_4) nearly all the nitrogen peroxide is converted into nitroso-sulphuric and nitric acid. The inverse reaction sets in to a sensible extent only when very little sulphuric acid is present in comparison with nitric acid. 3. The affinity of sulphuric acid for nitrogen peroxide quickly decreases with the increase of water, so that in the case of sulphuric acid of sp. gr. 1.65 the action of nitric acid on nitroso-sulphuric acid begins to prevail; therefore very much of the nitrogen peroxide added remains in the free state, although the quantity of HNO_3 , which is only formed by the reaction itself, is but small. 4. In the practice of sulphuric acid manufacture, the quantity of sulphuric acid in the con-

¹ *Z. angew. Chem.*, 1899, p. 393.

centrated state so largely prevails over that of the nitric acid, that all nitrogen peroxide may be practically regarded as quantitatively changed into SO_5NH and HNO_3 . This, of course, also holds good when absorbing nitrous gases in concentrated sulphuric acid for analytical purposes. Therefore the conclusions No. 1 and No. 4 (pp. 262 and 263), although not mathematically exact, are to all intents and purposes valid.

The tension of nitrous acid in presence of dilute sulphuric acid at different temperatures is a matter of great importance for the theory of the formation of sulphuric acid in the lead-chambers. The first observations on this point were published by Sorel;¹ but these have been superseded by the far more extended observations published by Lunge.² The following tables (Nos. 1, 2, 3, and 4, see pp. 268-271) constructed from these indicate the loss of N_2O_3 suffered by acids of four different concentrations, containing quantities of N_2O_3 varying from 1 gram per litre upwards, in a current of air at temperatures from 50° to 90° .

The behaviour of nitroso-sulphuric acid towards reducing agents is of the greatest importance, both for the chamber-process in general and for the recovery of nitrogen compounds. The most important of these agents is *sulphur dioxide*, which acts as follows :

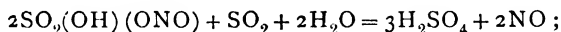

that is, it forms with nitroso-sulphuric acid both sulphuric acid and nitric oxide. This is the leading reaction of the Glover tower, as we shall see hereafter ; and it must also occur within the chambers, more especially in the first part of the set.

Sorel³ has shown that if a mixture of SO_2 and O is made to react upon nitrous sulphuric acid and NO, there may be either a reduction of nitrous acid to NO, or an oxidation of NO to N_2O_3 (in the shape of SO_5NH), according to variations in the following conditions : temperature, dilution of the acid, proportion between SO_2 and O, percentage of NO. The extreme cases were well known before : a reduction takes place at high temperatures, in case of scarcity of oxygen and excess of water ; an oxidation in case of excess of oxygen, concentrated acid, and low temperatures. For the intermediate cases

¹ *Z. angew. Chem.*, 1889, p. 272.

² *Ibid.*, 1891, p. 37 *et seq.*

³ *Ibid.*, 1889, p. 273.

I. Nitrous Vitriol of Sp. Gr. 1.720 (say, 78 per cent. H_2SO_4).

N ₂ O ₃ originally present, Grams in 1 litre.	Loss of N ₂ O ₃ in grams per litre at				
	50°.	60°.	70°.	80°.	90°.
1	0.006
2	0.018
3	0.025
4	0.031
5	0.037
6	0.043
7	0.006	0.056
8	0.010	0.068
9	0.012	0.081
10	0.018	0.093
11	0.025	0.112
12	0.030	0.125
13	0.031	0.143
14	0.043	0.168
15	0.006	0.056	0.193
16	0.010	0.068	0.218
17	0.006	0.087	0.250
18	0.012	0.106	0.281
19	0.025	0.125	0.318
20	0.031	0.150	0.356
21	0.043	0.175	0.400
22	0.064	0.200	0.450
23	...	0.006	0.081	0.237	0.500
24	0.006	0.018	0.100	0.275	0.550
25	0.012	0.031	0.125	0.312	0.600
26	0.018	0.043	0.150	0.356	0.662
27	0.031	0.062	0.181	0.400	0.725
28	0.043	0.081	0.212	0.450	0.800
29	0.062	0.100	0.256	0.500	0.850
30	0.081	0.125	0.293	0.550	0.956
31	0.093	0.162	0.337	0.612	1.043
32	0.112	0.200	0.387	0.641	1.125
33	0.125	0.237	0.391	0.743	1.206
34	0.143	0.275	0.475	0.806	1.287
35	0.156	0.312	0.525	0.868	1.375
36	0.175	0.350	0.575	0.931	1.456
37	0.193	0.381	0.618	1.000	1.543
38	0.206	0.418	0.662	1.062	1.625
39	0.237	0.456	0.718	1.125	1.712
40	0.268	0.500	0.775	1.193	1.800
41	0.293	0.543	0.831	1.256	1.890
42	0.325	0.587	0.887	1.331	1.975
43	0.350	0.631	0.937	1.400	2.062
44	0.376	0.675	0.993	1.468	2.150
45	0.406	0.712	1.050	1.537	2.237
46	0.437	0.756	1.106	1.606	2.325
47	0.462	0.800	1.162	1.675	2.392
48	0.493	0.837	1.218	1.743	2.500
49	0.518	0.881	1.268	1.806	2.587
50	0.550	0.931	1.325	1.875	2.675

Sorel made some special experiments, from the results of which it followed that in identical mixtures an increase of the

2. Acid of Sp. Gr. 1.686 (say, 76 per cent. H_2SO_4).

N_2O_3 originally present. Grams in 1 litre.	Loss of N_2O_3 in grams per litre at				
	50°.	60°.	70°.	80°.	90°.
8	0.025
9	0.036
10	0.012	0.050
11	0.018	0.062
12	0.025	0.086
13	0.010	0.050	0.125
14	0.012	0.075	0.162
15	0.025	0.100	0.225
16	0.050	0.150	0.286
17	...	0.010	0.062	0.200	0.350
18	...	0.012	0.100	0.262	0.436
19	...	0.025	0.150	0.350	0.525
20	...	0.050	0.186	0.425	0.625
21	...	0.075	0.250	0.525	0.750
22	...	0.112	0.300	0.650	0.975
23	...	0.136	0.350	0.775	1.200
24	...	0.175	0.400	0.900	1.436
25	0.010	0.200	0.462	1.025	1.662
26	0.012	0.236	0.512	1.175	1.900
27	0.025	0.262	0.562	1.300	2.125
28	0.036	0.300	0.612	1.436	2.350
29	0.050	0.336	0.675	1.575	2.600
30	0.062	0.362	0.750	1.700	2.812
31	0.100	0.412	0.850	1.812	3.086
32	0.136	0.462	0.950	1.975	3.350
33	0.186	0.512	1.050	2.100	3.625
34	0.225	0.575	1.150	2.236	3.900
35	0.275	0.625	1.250	2.362	4.175
36	0.312	0.675	1.336	2.500	4.450
37	0.350	0.725	1.436	2.625	4.736
38	0.400	0.825	1.536	2.762	5.000
39	0.436	0.836	1.636	2.900	5.275
40	0.486	0.886	1.736	3.025	5.550
41	0.550	0.950	1.850	3.150	5.850
42	0.612	1.050	1.986	3.275	6.125
43	0.686	1.125	2.112	3.412	6.400
44	0.750	1.212	2.250	3.525	6.700
45	0.825	1.300	2.325	3.736	6.975
46	0.886	1.386	2.500	3.825	7.250
47	0.962	1.475	2.636	3.962	7.536
48	1.025	1.512	2.762	4.100	7.825
49	1.100	1.650	2.886	4.236	8.100

temperature from 70° to 80° was sufficient to change the oxidation into reduction. At equal temperatures a reduction took place when the gaseous mixture contained 31 per cent.

SO₂, 10 per cent. O, 59 per cent. N, but an oxidation with a mixture of 21 SO₂, 12·1 O, 66·9 N, etc. The reaction of SO₂ on nitrous sulphuric acid is nothing like so simple as previously assumed. If the acid exceeds the strength of 1·630, the SO₂ does not reduce the N₂O₃ to NO, but forms with it and sulphuric

3. *Acid of Sp. Gr. 1·633 (say, 71·5 per cent. H₂SO₄).*

N ₂ O ₃ originally present. Grains in 1 litre.	Loss of N ₂ O ₃ in grams per litre at				
	50°.	60°.	70°.	80°.	90°.
1	0·012	0·025	0·036	0·100	0·150
2	0·050	0·075	0·086	0·225	0·300
3	0·100	0·150	0·186	0·350	0·436
4	0·162	0·212	0·300	0·536	0·612
5	0·212	0·300	0·436	0·736	0·825
6	0·300	0·425	0·636	1·000	1·112
7	0·400	0·562	0·836	1·275	1·425
8	0·500	0·712	1·036	1·550	1·750
9	0·600	0·835	1·236	1·812	2·062
10	0·700	0·936	1·436	2·086	2·375
11	0·800	1·125	1·636	2·350	2·712
12	0·871	1·262	1·825	2·636	3·075
13	0·986	1·400	2·036	2·900	3·436
14	1·086	1·536	2·225	3·175	3·800
15	1·186	1·675	2·412	3·450	4·162
16	1·275	1·800	2·612	3·725	4·512
17	1·375	1·936	2·786	4·000	4·886
18	1·475	2·036	2·975	4·262	5·236
19	1·562	2·250	3·186	4·550	5·600
20	1·662	2·412	3·400	4·850	5·986
21	1·812	2·612	3·650	5·162	6·400
22	1·975	2·812	3·912	5·512	6·862
23	2·186	3·062	4·250	5·912	7·425
24	2·436	3·336	4·612	6·350	8·036
25	2·700	3·636	5·000	6·800	8·662
26	3·000	3·950	5·412	7·300	9·362
27	3·312	4·300	5·850	7·812	10·150
28	3·662	4·636	6·325	8·400	11·000
29	4·025	5·012	6·812	8·025	11·986
30	4·412	5·412	7·350	9·675	13·125
31	4·800	5·836	7·950	10·386	14·500
32	5·236	6·325	8·575	11·175	16·362

acid nitroso-sulphuric acid, so long as there is oxygen in excess and the atmosphere contains more N₂O₃ than corresponds to the tension of the acid in question at that special temperature (*cf.* above). Otherwise reduction to NO takes place. Acids below sp. gr. 1·600 are able to fix N₂O₃ under the same conditions, but only at comparatively low temperatures ; at higher

temperatures there is reduction even in the presence of an excess of O and N_2O_3 .

The previously mentioned *blue or purple acid*, formed by the action of reducing substances on nitroso-sulphuric acid, and sometimes occurring in vitriol chambers, is, according to Buraczewski and Zbijewski, a product of the reduction of nitrous vitriol by SO_2 , which they call "nitrosylic acid." It can be

4. *Acid of Sp. Gr. 1.60 (say, 69 per cent. H_2SO_4).*

N ₂ O ₃ originally present. Grams in 1 litre.	Loss of N ₂ O ₃ in grams per litre at				
	50°.	60°.	70°.	80°.	90°.
1	0.050	0.086	0.175	0.336	0.412
2	0.100	0.236	0.436	0.725	0.912
3	0.325	0.525	0.775	1.150	1.500
4	0.562	0.836	1.250	1.910	2.100
5	0.812	1.150	1.500	2.120	2.700
6	1.050	1.450	1.900	2.500	3.350
7	1.286	1.800	2.350	3.100	4.112
8	1.512	2.150	2.800	3.725	4.900
9	1.750	2.425	3.250	4.336	5.686
10	1.975	2.812	3.712	4.900	6.475
11	2.250	3.162	4.436	5.265	7.300
12	2.512	3.536	4.675	6.325	8.125
13	2.786	3.936	5.150	7.012	8.962
14	3.065	4.250	5.650	7.700	9.750
15	3.360	4.612	6.125	8.400	10.625
16	3.600	4.975	6.612	9.125	11.462
17	3.862	5.350	7.100	9.525	12.250
18	4.150	5.712	7.600	10.462	13.136
19	4.425	6.075	8.086	11.350	13.975
20	4.700	6.425	8.562	11.850	14.800

reduced still further by SO_2 , as first asserted by Wentzki and then revoked by him.¹ This product would be "hyponitrosylic acid."²

On this point Manchot has made a number of investigations.³ Contrary to Raschig, who on passing nitric oxide into sulphuric acid had observed a reddish colour and a much greater solubility than that stated by Lunge (*cf.* p. 252), Manchot could not, even at the temperature of liquid air, find that colour, nor a greater solubility of NO than that observed by Lunge. Manchot has no doubt that the sulphuric acid employed in

¹ *Z. angew. Chem.*, 1911, p. 392.

² *Oesterr. Chem. Zeit.*, 14, 235; *Chem. Zentr.*, 1911, 2, 1558.

³ *Z. angew. Chem.*, 1910, p. 2112; 1911, p. 13; 1912, p. 1055.

Raschig's experiments contained a trace of iron, which would explain the red colour; in this case, according to Manchot and Huttner,¹ a crystallising compound of equal molecules of FeSO_4 and NO is formed, whilst a solution of NO in the presence of ferric sulphate in sulphuric acid contains 2 mols. NO to 1 mol. Fe in chemical combination. Manchot also objects to the theory of Sabatier,² according to which the coloured solutions of nitric oxide and copper or iron sulphate contain salts of "blue acid," to which Sabatier gives the formula: $\text{ON}(\text{SO}_3\text{H})_2$, nitroso-disulphuric acid. According to Manchot, the compounds of NO with copper and iron salts have nothing to do with the "blue acid."

To these views Raschig³ made several objections, which Manchot⁴ proved to be unfounded in all cases. Later on⁵ he made further communications anent the "blue acid." If the deeply indigo-blue solution is immersed in a mixture of solid carbon dioxide and acetone, it quickly turns intensely carmine red; on being allowed to reach the ordinary temperature, it turns again blue; and these changes can be indefinitely repeated. The first reddish tint appears at -40° ; at -80° the colour is intensely carmine red and does not any more change if the temperature is further lowered. By this play of colours the blue acid can be much more easily discovered than had been hitherto possible. The question arose whether the blue acid contains any sulphur at all; but it was not possible to obtain a blue solution in the absence of sulphuric acid. Further experiments showed that sulphurous acid is not required for the formation of the blue acid; this acid is formed from sulphuric acid by every other reducing agent, and therefore cannot be a derivative of sulphurous acid, but probably it contains in its molecule sulphuric acid, probably also water, since no very high concentration of sulphuric acid is required for its formation. Nor is it formed by bringing nitric oxide into contact with concentrated sulphuric acid, as shown before. The reducing agent does not act on the oxygen combined with sulphur, but on that combined with nitrogen. In any case the blue acid is

¹ *Liéb. Ann.*, 372, 152.

² *Comptes rend.*, 122, 1417, 1479, 1537; 123, 255.

³ *Z. angew. Chem.*, 1910, p. 2248.

⁴ *Ibid.*, 1911, p. 13.

⁵ *Ibid.*, 1912, p. 1055.

a compound of H_2SO_4 with an oxide of nitrogen, probably with one in which the proportion between N and O is intermediate between $1 : 1\frac{1}{2}$ (as in nitrous acid) and $1 : 1$ (as in nitric oxide).¹ In any case, it is a complicated compound in which more than one molecule of NO is present for every molecule of NO_2 , and in which, therefore, the proportion between NO and NO_2 is much more complicated than in N_2O_3 . The change of colour on strong cooling, which accompanies phenomena of dissociation and polymerisation, supports this assumption. Moreover, Manchot refutes Raschig's assertions concerning a nitric-oxide compound of cupric sulphate ;² but this controversy has no direct interest for the chamber-process.

Another reducing agent whose action had formerly been overlooked is *carbon*, in the shape of the *coke* employed for packing the Gay-Lussac tower. Lunge has shown³ that coke has a very strong reducing action on nitric acid dissolved in sulphuric acid, which goes far towards explaining the fact that the "nitrous vitriol" from the Gay-Lussac towers never, except under altogether exceptional circumstances, contains any nitric acid, even when considerable quantities of N_2O_4 had been present in the exit-gases. But the reduction goes further ; some N_2O_3 itself, in the shape of nitroso-sulphuric acid, is reduced by the coke to lower nitrogen oxides and is thus lost. This has been proved by Lunge in his laboratory ;⁴ and as it is a matter of importance, we give the results obtained in the following table :—

¹ Lunge mentioned this in a paper of 1879 (*Ber.*, 12, 1058) as a probable fact.

² *Loc. cit.*, 1911, p. 160.

³ *J. Soc. Chem. Ind.*, 1885, p. 31.

⁴ *Z. angew. Chem.*, 1890, p. 195.

274 TECHNICALLY EMPLOYED OXIDES OF SULPHUR

Material used.	Temperature. ° C.	Time (hours).	Original percentage in N_2O_3 , grams.	Percentage decrease.	
				In grams N_2O_3 .	Of the N_2O_3 originally present.
1. Nitrous Vitriol of sp. gr. 1·8375.					
Gas Coke in lumps .	15	24	18·93	0·330	1·71
" " " .	14	2	18·92	0·539	2·86
" " " .	70	2	19·30	0·742	3·84
Oven Coke in lumps .	15	24	19·30	0·285	1·48
" " " .	40	2	18·92	0·362	1·91
" " " .	70	2	19·30	0·452	2·34
Gas Coke in powder .	15	24	19·30	0·790	4·09
" " " .	40	2	18·92	0·858	4·54
" " " .	70	2	16·22	0·903	5·57
" " " .	100	2	16·22	4·611	28·43
Oven Coke in powder .	15	24	19·30	0·379	1·96
" " " .	40	2	18·92	0·451	2·38
" " " .	70	2	16·22	0·527	3·25
" " " .	100	2	16·22	2·770	17·08
2. Nitrous Vitriol of sp. gr. 1·725.					
Gas Coke in powder .	15	24	19·50	0·333	1·98
" " " .	40	2	19·50	0·574	2·94
" " " .	70	2	19·50	0·891	4·57
" " " .	100	2	19·50	3·410	17·49

We see from it that at 40° two hours' contact reduced the percentage of N_2O_3 by 2·4 to 4·5 per cent.; at 70° the reduction sometimes went as far as 28 per cent. The latter temperature ought never to occur in a Gay-Lussac tower, but it does occur regularly in Glover towers up to the top. The conclusion is that coke-packing should be entirely avoided in Glover towers, and that it is not advisable even for Gay-Lussac towers.¹

ANALYSIS OF SULPHURIC ACID

Qualitatively sulphuric acid is always best recognised by the white precipitate of barium sulphate which it gives with barium chloride, both in the free state and in the solutions of its salts, even when very much diluted. This precipitate mostly settles

¹ Cf. Chapter II of Vol. II.

down as a heavy powder, but in extremely dilute liquids occasionally appears only after some little time as a white cloud. Barium sulphate is practically insoluble in water, solutions of salts, and dilute acids; in concentrated acids it is a little soluble, especially on heating, also in concentrated sulphuric acid itself and in solutions of ferric chloride. On the other hand, in a very concentrated liquid free from sulphuric acid, but containing much hydrochloric or, especially, nitric acid, the addition of barium chloride may cause a precipitate of barium chloride itself or of barium nitrate, which, however, is distinguished from barium sulphate by its crystalline appearance, and more readily by vanishing on dilution of the liquid; barium selenate is distinguished from barium sulphate by its solubility on boiling with concentrated hydrochloric acid, and by its behaviour before the blowpipe. The barium chloride reaction proves the presence of sulphuric acid either in its free state or in its salts. In order to find sulphuric acid in the *free* state in the presence of sulphates of acid reaction, either the alcoholic solution of the substances can be tested with barium chloride (the free acid being soluble, but all sulphates insoluble in absolute alcohol), or the charring properties of concentrated oil of vitriol are made use of by evaporating the solution mixed with a little cane-sugar in a small porcelain capsule on the water-bath, and observing whether a blackening of the sugar takes place. This reaction, however, also takes place with the sulphates of very weak bases, such as alumina or ferric oxide; nor can sulphuric acid be distinguished with certainty in this way from hydrochloric or nitric acid; but in phosphoric, acetic, tartaric acid, etc., a very small proportion of sulphuric acid can be proved by this reaction. Another reaction for free sulphuric acid, as well as for any other strong free acid, is that with methyl-orange: the latter does not change colour by adding metallic salts, but is changed by the smallest quantity of free sulphuric acid.

In insoluble sulphates the acid is recognised by fusing them with alkaline carbonates, or by boiling with concentrated solutions of the same and filtering the solution of the alkaline sulphate formed thereby from the insoluble carbonates, or with the blowpipe, on charcoal, by the formation of sodium sulphide, according to well-known methods.

The *quantitative estimation* of free sulphuric acid for technical purposes is almost exclusively effected by volumetric methods or by the hydrometer. In both cases, of course, impurities will have a disturbing action; but for technical purposes their influence on the estimation of sulphuric acid may nearly always be neglected.¹ The hydrometric estimation of sulphuric acid has been already described in detail on pp. 199 *et seq.*; and we shall here only point out again that the temperature correction must not be neglected.

The *volumetrical estimation* of free acid generally takes place by means of a standard solution of potash, soda, or ammonia. According to the degree of accuracy required, either a normal solution is used, or a semi- or decinormal solution, etc.

Formerly tincture of litmus was most frequently used as indicator. Litmus is not well adapted for working in artificial light; and has, moreover, the disadvantage that it is sensitive to all weak acids as well, and that it is destroyed by sulphuretted hydrogen.

Phenolphthalein has in many cases taken the place of litmus. It is one of the most sensitive indicators known, and the change from no colour in acid solutions to a decided pink when the faintest trace of free alkali is present, is easily noticed even in artificial light. But this indicator has two drawbacks: it is too sensitive even towards the weakest acids (*e.g.* CO_2), and it fails in the presence of ammonia.

The indicator which in alkali- and acid-works is now universally employed is *methyl-orange*, which is employed in an aqueous solution of 1 in 2000 water, or even more dilute, and a very small quantity of the solution is used for each test. Methyl-orange is not acted upon by weak acids, such as CO_2 , H_2S , acetic acid, etc.; and this is undoubtedly one of its most valuable properties, since the trouble and loss of time in boiling the liquids, and the error introduced in the case of glass vessels (which easily give up some alkali to the hot liquid), are thereby avoided. Sulphurous acid behaves in the manner explained *supra* (p. 186); that is, Na_2SO_3 is alkaline, whilst NaHSO_3 is neutral, to methyl-orange. Oxalic acid, as well as other strong organic acids, come in between sulphurous acid and the strong mineral acids; no sharp results can be obtained

¹ Cf. pp. 207, 208 *et seq.*

with them, and hence oxalic acid cannot serve as standard acid with methyl-orange. On the other hand, ammonia, which cannot be titrated with phenolphthalein, behaves quite normally towards methyl-orange, just like potash and soda. The normal sulphates of ferric iron, alumina, etc., which give an acid reaction with litmus, are neutral towards methyl-orange, so that any free acid present with them can be estimated by means of this indicator.

Methyl-orange is destroyed by nitrous acid. Nevertheless it can be easily employed in titrating sulphuric or nitric acid containing nitrous acid, in two ways: either by adding the indicator shortly before neutralisation and quickly finishing the titration, or by supersaturating the acid with caustic soda and titrating back with standard acid.

Nitrous acid acts upon methyl-orange like a strong mineral acid, and is therefore completely saturated before the pink colour has changed to yellow, if there is not time for the colouring matter to be destroyed.

The tropæolins, formerly recommended as indicators, are nothing like so sensitive as methyl-orange, and are best not used at all as indicators, especially since several totally distinct compounds are comprised under this name, and the dealers do not always supply that which is really wanted.

In the titration of sulphuric acid recovered from the "*vitriol-tar*" produced in refining petroleum, etc., all indicators yield erroneous (too high) results, as they are affected also by the sulphonic acids present.¹

Free sulphuric acid (including that contained in commercial ferric or aluminium sulphate, or any other sulphate) is estimated by adding a drop of methyl-orange solution, which produces a pink colour, and then adding a standard solution of alkali, till the pink tint has changed into pure light yellow. It is best to check this by reproducing the faint pink shade by means of a drop of standard acid.

H. Howard² describes a method for estimating the strength of fuming (and ordinary) sulphuric acid by means of the heat of reaction produced on dilution with water (*supra*, p. 218).

A rapid method for estimating the strength of sulphuric

¹ Hausmann, in *Petroleum*, 1911, p. 2301.

² *J. Soc. Chem. Ind.*, 1910, p. 3.

acid by its thermal properties is given by H. Droop Richmond and J. E. Merreywether.¹

The Detection and Estimation of Impurities of Sulphuric Acid.

The impurities of sulphuric acid are recognisable qualitatively in the following manner:—A residue found on evaporating the acid in a platinum crucible may contain sulphates of sodium (more rarely of potassium), of calcium, aluminium, iron or lead. Copper, zinc, or other metals rarely occur in sensible quantity. *Iron* is already betrayed by the colour of the residue after ignition, and can also be detected in the acid itself, without evaporating it, by the ordinary reagents such as potassium ferrocyanide. Boil the acid with a drop of pure nitric acid, dilute a little, allow to cool, and add a solution of potassium sulphocyanide in excess. To make sure that any red colour is not caused by the nitric acid, a controlling test must be made with the latter.

Venables² employs a mixture of cobalt nitrate with strong hydrochloric acid; the blue colour of this solution is changed into green by traces of ferric salts, but not by ferrous. Iron is estimated by reducing with pure zinc and titrating with potassium permanganate; not leaving out of sight its action upon SO_2 , N_2O_3 , etc. A very convenient method for estimating traces of iron has been described by Lunge in *Z. angew. Chem.*, 1896, p. 3; reprinted in his *Technical Methods of Chemical Analysis*, 1908, vol. i., p. 381.

Lead is often found as a white precipitate of sulphate on diluting concentrated vitriol with water—further, by adding one or two drops of hydrochloric acid, by which white clouds are formed, which vanish on addition of more hydrochloric acid or on heating; with more certainty it is shown by diluting the acid with three or four times its volume of strong alcohol. The precipitate must, of course, be examined further—for instance, with the blowpipe, by reduction on charcoal to metallic lead, by moistening with ammonium sulphide (which blackens it). *Lead* is estimated by diluting the acid, if concentrated, with its own volume of water and twice the volume of absolute alcohol, whereby all the lead is precipitated as PbSO_4 .

¹ *Analyst*, 1917, 42, 273-274; *J. Chem. Soc.*, 1917, 2, 503.

² *Z. anal. Chem.*, 28, p. 699.

Ammonia.—Dilute 2 grams acid with 30 c.c. water, add excess of potassium hydrate (3 or 4 grams), and 10 to 15 drops of Nessler's reagent; this ought not to produce a yellow or brown-red colour. Krauch found by this test a distinctly yellow colour and opacity, when adding 1 mg. NH_3 to 100 grams concentrated sulphuric acid.

Hydrochloric acid (from the common salt present in the nitrate of soda) can be detected by nitrate of silver, but considerable dilution is necessary, as silver sulphate is sparingly soluble.

For the estimation of chloride, 10 c.c. of the acid is boiled in a flask, the vapours are conducted over the surface of a little water contained in a flask, which absorbs the HCl, and in this solution it is estimated by titration with decinormal silver nitrate solution.

Hydrofluoric acid is found by heating in a platinum dish covered by a glass plate coated with wax, and containing scratched-in figures.

The estimation of hydrofluoric acid is given by Ehrenfeld,¹ who precipitates both acids.

The *volatile impurities* of sulphuric acid are estimated as follows:—Two kg. of the acid (undiluted) are shaken up in a bottle half filled with it, whereby the air contained in the bottle is saturated with the gases dissolved in the acid. They are tested: 1st, for sulphur dioxide by iodide-starch paper; 2nd, for the gaseous oxides of nitrogen by potassium-iodide starch paper. Only a great excess of SO_2 would decolorise the paper, turned blue by nitrous gases.

Sulphur dioxide is found by the discharge of the blue colour of faintly blue iodine-starch solution. Or, the SO_2 is converted by zinc or aluminium into hydrogen sulphide, and this is tested with lead paper, or with an alkaline solution of sodium nitroprusside.

Arsenic is recognised in dilute sulphuric acid by sulphuretted hydrogen; more delicate than this is Reinsch's test—diluting with equal volumes of water and pure hydrochloric acid, and immersing a bright copper foil, which, after gentle heating, is covered with a fast-adhering slate-grey precipitate, consisting of a compound of copper and arsenic, Cu_5As_2 (if the arsenic is present as arsenic acid, the reaction only sets in after

¹ *Chem. Zeit.*, 1915, p. 440.

longer heating). Most delicate is the detection of arsenic by Marsh's apparatus, in which, on addition of pure zinc and water, the arsenic is given off as arseniuretted hydrogen, and is found by reduction in a red-hot tube (Berzelius) or by lighting the gas and holding a piece of porcelain in the flame, on which any arsenic appears as spots. Since it is difficult to procure zinc absolutely free from arsenic, it is well to substitute aluminium foil for it. This test shows arsenic acid as well as arsenious acid; they can be distinguished by neutralising with ammonia and adding magnesia mixture: any precipitate thus formed must contain the arsenic acid, the filtrate the arsenious acid. Marsh's reaction is interfered with by the presence of sulphurous acid, nitrous acid, nitric acid, etc.

Selmi¹ asserts that arsenic can be detected in acids which give no reaction by Marsh's test, by adding to 1000 grams of the acid 300 grams water and some lead chloride, distilling and testing the first portions of the distillate with sulphuretted hydrogen.

Seybel and Wikander² prove the presence of arsenic in sulphuric or hydrochloric acid by the yellow precipitate of AsI_3 , produced by the addition of a solution of potassium iodide. Sulphuric acid should be diluted to 45°B ., hydrochloric acid should be employed in the concentrated state. The reaction is interfered with by free chlorine, ferric salts, nitrous acid (which equally cause a yellow coloration by the formation of free iodine), and by lead, which forms yellow PbI_2 . (Unfortunately, commercial acids mostly contain one or the other of these impurities.)

According to Dawdow,³ Rosenheim,⁴ and Berry,⁵ selenium interferes with the Marsh test. Schindelmeiser⁶ found that no AsH_3 is given off until all selenium has been precipitated by zinc or aluminium in the Marsh apparatus. Selenium also forms precipitates with potassium iodide very similar to AsI_3 , so that Seybel and Wikander's test is also interfered with.

Although the minute rules laid down by the Arsenic Committee of the London Section of the Society of Chemical Industry⁷ refer to the examination of beer, brewing-materials,

¹ *Gazz. Chim. Ital.*, 10, 40.

³ *Chem. Zentr.*, 1895, 1, 811.

⁵ *J. Soc. Chem. Ind.*, 20, 322.

⁷ *J. Soc. Chem. Ind.*, 1902, p. 94.

² *Chem. Zeit.*, 1902, p. 50.

⁴ *Chem. News*, 83, 277.

⁶ *Chem. Zentr.*, 1902, 2, 960.

food-stuffs, and fuels for arsenic, we shall reproduce here that portion of them which can be applied also to the examination of sulphuric acid. The Committee recommend the use of the Marsh-Berzelius test.

1. *Pure Reagents.*—To half a litre of "pure" sulphuric acid a few grammes of sodium chloride are added and the mixture is distilled from a non-tubulated retort, the first portion of about 50 c.c. being rejected. One volume of the distilled acid is diluted with 4 vols. of water. Zinc, free from arsenic, can be obtained from the dealers in fine chemicals. It should be regranulated by melting it and pouring it from some height into cold water. A. H. Allen holds it to be essential that the zinc should contain a trace of iron.

2. *Apparatus.*—A bottle or flask, holding about 200 c.c., is fitted with a doubly-bored cork, india-rubber stopper, or with a ground-in glass connection, carrying a tapped funnel holding about 50 c.c. and an exit-tube. The latter is connected with a horizontal drying-tube, containing, first a roll of blotting-paper soaked in lead-acetate solution and dried, or a layer of cotton-wool prepared in a similar way, then a wad of cotton-wool, then a layer of granulated calcium chloride, and finally a thick wad of cotton-wool. To this tube is fitted a hard-glass tube, drawn out into a thin tube of such external diameter that at the place where the arsenic mirror is expected the tube just passes through a No. 13 Birmingham wire-gauge (= 0.092 in.). A good Bunsen flame is used to heat the wider part of the hard-glass tube close to the constriction. About 1 in. of tube, including the shoulder, ought to be red-hot. A piece of moderately fine copper gauze (about 1 in. square), wrapped round the portion of the tube to be heated, assists in ensuring an equal distribution of heat.

3. *Mode of Testing.*—About 20 grams of zinc are placed in the bottle and washed with water to clean the surface; all parts of the apparatus are connected and sufficient acid is allowed to flow from the funnel so as to cause a fairly brisk evolution of hydrogen. When the hydrogen flame (which during the heating of the tube should be kept as uniformly as possible $\frac{1}{4}$ in. high) burns with a round (not pointed) top, all air has been removed from the apparatus. The Bunsen burner should then be placed under the hard-glass tube, as described, and

more acid (10 to 20 c.c.) run in as required. With good materials no trace of a mirror is obtained within half an hour. Great care must be taken that, when additions of acid are made to the zinc, no bubble of air is introduced, since in presence of air the arsenic mirror may become black and uneven, whilst it should be brown.

Should the blank experiment not be satisfactory, it must be ascertained, by changing the materials methodically, whether the fault lies with the acid, the zinc, or the apparatus.

4. *Preparation of Standard Mirrors.*—A hydrochloric-acid solution of arsenious oxide, containing 0.001 mg. As_2O_3 per cubic centimetre, is prepared by diluting a stronger solution with distilled water. Two c.c. of this solution are introduced into the apparatus. If the zinc is "sensitive," a distinct brown mirror is obtained within twenty minutes. (Some "pure" zinc is, from a cause at present unknown, not sensitive.) The portion of the tube containing the arsenic should be sealed off while still filled with hydrogen. Mirrors are similarly made with 0.004, 0.006, 0.008, and 0.01 mg. of arsenious oxides. The first stage of every test must be blank for at least twenty minutes.

Arsenic in both states of oxidation can be detected and estimated by the procedure described.

The proof that the mirrors are arsenical is obtained as follows:—The narrow portion of the tube containing the mirror is cut off, the hydrogen replaced by air, and the ends sealed up. The tube is then repeatedly drawn through a Bunsen flame until the mirror has disappeared. On cooling, minute sparkling crystals of arsenious oxide deposit, which can be readily identified under the microscope. With this test, quantities of 20 c.c. will give an indication in the presence of 0.000015 per cent., or 1 part arsenious oxide in 7,000,000.

We have thought it right to quote this method; but (as is the case with some which follow) it is really *too* delicate for the ordinary purposes of the acid-maker. The limit allowed by the British Pharmacopœia is 5 parts As per million. It is acknowledged on most sides that acid containing such a minimum of arsenic can be employed even for the purpose of manufacturing glucose, tartaric acid, and other substances intended for human consumption.

Bertrand¹ concentrates the arsenic in not more than 30 to 60 c.c. of liquid in the hydrogen apparatus. The oxygen is entirely driven out of the apparatus, after putting in the zinc, by pure CO₂ taken from a bottle of liquid CO₂; this takes only a few minutes. Then one or two drops of dilute platinum chloride in 10 c.c. of dilute sulphuric acid (1 : 5) are added, and after ten minutes the arsenical solution is introduced. The gas is dried by cotton-wool, previously heated to 120°. It is passed through perfectly clean glass tubes, which are chosen all the narrower the smaller the quantity of arsenic expected; *e.g.* only 1 mm. wide, if less than $\frac{1}{300}$ mg. is present. The end is drawn out very fine for several centimetres, about 10 or 15 cms. from the place where the ring is to be formed. A space of about 20 cms. length of this tube is heated to nascent redness. If the tube is thin, nothing else need be done; if it is of thick glass, a space of the above length should be confined on both sides by a band of filtering-paper kept moist, so as to prevent the ring from spreading too fast. In this way one-thousandth of a milligram or even less can be detected; but of course the greatest care must be taken not to introduce it by the reagents. Such exceedingly slight mirrors must be kept from oxidising by sealing the tube while filled with hydrogen.

Parsons and Stewart² show that in the presence of iron some arsenic is retained in the Marsh-Berzelius flask, and hence iron should be avoided if quantitative results are required. This contradicts Allen's views *supra*, p. 281.

The test proposed by Gutzeit is frequently preferred on account of its simplicity. It consists in allowing hydrogen, containing arsenic, cooled as in the Marsh test, to act upon solid silver nitrate, deposited by drying on a piece of blotting-paper. Convenient forms of apparatus for this test have been constructed by Kirkby,³ by Tyrer,⁴ and by Dowzard.⁵ *Cf.* also Hehner,⁶ Bird,⁷ Richardson,⁸ and Gottself.⁹

For sulphuric acid specially Bettendorf's test is also employed, in which a solution of stannous chloride in its own

¹ *Bull. Soc. Chim.* [3], 27, No. 16; *Chem. News*, 86, 191.

² *J. Amer. Chem. Soc.*, 1902, 24, 1005.

³ *J. Soc. Chem. Ind.*, 1901, p. 281.

⁴ *Ibid.*, p. 281.

⁵ *Ibid.*, 1900, p. 1145.

⁶ *Ibid.*, 1901, p. 194.

⁷ *Ibid.*, 1901, p. 390.

⁸ *Ibid.*, 1902, p. 902.

⁹ *Ibid.*, 1903, p. 191.

weight of strong hydrochloric acid is added to the solution to be tested. In the presence of arsenic a brown colour and, later on, a black precipitate are formed much more quickly when heating. According to Messel,¹ 0.01 mg. As_4O_6 can be detected in 1 c.c. sulphuric acid by this test.

The detection of arsenic has been most thoroughly treated in a Report of a Committee appointed by the Commissioners of Inland Revenue, of which Professor T. E. Thorpe was Chairman. They recommend, in the first instance, Bloxam's electrolytic method for the reduction of the arsenic to arsenuretted hydrogen, as worked in the Government Laboratory. The apparatus serving for this is illustrated and minutely described in the Report. It is somewhat costly, and of course only applicable where an electric current is available. Therefore in many cases the zinc method will be preferred, in spite of its drawbacks. This latter method, as described in the Report, agrees in most respects with the prescriptions laid down by the Arsenic Committee of the Society of Chemical Industry;² the deviations comprise only some certainly not unimportant details. The size of the apparatus employed and the amount of zinc and acid are much smaller, the rate of evolution of the gas is less, and the arsenic is deposited over a smaller area of glass.³

In the *J. Soc. Chem. Ind.*, 1917, p. 576, the application of the Gutzeit test to works determinations of arsenic is given by C. Hollins.

The chemistry of the Marsh-Berzelius process for the estimating of arsenic is given by B. S. Evans in the *Analyst*, for 1920, 45, pp. 8-17; *Chem. Soc. Abst.*, 1920, ii., p. 125.

Arsenic is estimated by reducing any arsenic acid to arsenious acid by a stream of SO_2 , expelling this by CO_2 , and precipitating by H_2S . The presence of lead, antimony, copper, platinum, etc., makes this process very complicated.⁴ If the quantity of As is somewhat considerable, it can be reduced to As_2O_3 by SO_2 , followed by CO_2 ; the liquid is then neutralised by soda, and the As_2O_3 titrated by iodine solution.⁵ Further

¹ *J. Soc. Chem. Ind.*, 1901, p. 192.

² *Supra*, p. 280.

³ *J. Chem. Soc.*, 83, 974; *J. Soc. Chem. Ind.*, 1903, p. 965.

⁴ Cf. thereon McCay, *Amer. Chem. J.*, 7, No. 6.

⁵ Kislring, *Chem. Ind.*, 1886, p. 137.

particulars are given in Lunge-Keane's *Technical Methods of Chemical Analysis*, vol. i., pp. 383-384.

This method of Lunge's is criticised by Peregin.¹ By this method the results were trustworthy, but had a tendency to be too low; a correcting factor, however, may be found and applied in practice.

Twenty c.c. of the sulphuric acid are diluted to about 50 c.c. and treated for ten minutes with a current of sulphur dioxide; the mixture is then heated, and a current of carbon dioxide is passed through it until all the sulphur dioxide has been expelled. After further dilution the solution is neutralised with sodium hydrogen carbonate and titrated with N/20-iodine solution.

In the iodometric estimation of arsenic acid, I. M. Kolthoff² states that the reaction :



proceeds from left to right only in acid solution. In order to obtain satisfactory results by titration of the liberated iodine with thiosulphate, hydrochloric acid must be present as 4N acid in the mixture if the solution of arsenate is N/5 to N/10. If the arsenate is more dilute (N/50) a minimum concentration of 4.5 N hydrochloric acid is necessary. The reaction mixture must stand for five minutes before titration with thiosulphate.

Kohr³ gives a rapid method for the quantitative determination of arsenic in commercial sulphuric acid. After examination of the literature on the subject, and having examined the various methods, the following was finally devised:—

Arsenious Form.—Weigh out 20 grams of acid and dilute with a small amount of distilled water, and add a few drops of methyl-orange. Carefully neutralise with a solution of sodium carbonate until the methyl-orange shows very faint pink, and add about 2 grams of sodium bicarbonate powder in excess. Make up the solution to about 250 c.c. with distilled water, if necessary, and titrate with N/10-iodine solution, using starch as an indicator. A blank determination should be made on the reagents and suitable corrections made. C.c. N/10 iodine $\times 0.00495 =$ grams As_2O_3 in the arsenious form.

¹ *Ann. Chim. anal.*, 1917, 22, pp. 24-25; *J. Chem. Soc.*, 1917, 2, 180.

² *Pharm. Weekblad*, 1919, 56, 1322-1326; *J. Soc. Chem. Ind.*, 1919, p. 762A.

³ *J. Ind. Eng. Chem.*, 1920, p. 580.

Arsenic Form.—Weigh out 20 grams of the acid to be tested into a small beaker and place in an oven regulated at 105° - 110° for about one hour. Dilute with a small amount of distilled water, and add a saturated solution of sodium carbonate until just in excess (phenolphthalein). Boil and filter into an Erlenmeyer flask, wash thoroughly, and add about 3 grams sodium bicarbonate powder. Add 150 c.c. strong HCl slowly with occasional agitation, then add about 1 gram of potassium iodide crystals, cover the flask in order to keep out the air, agitate and then allow to stand five minutes. Titrate the iodine liberated with N/10 thiosulphate with starch as indicator.

C.c. N/10 thiosulphate \times .00495 = grams As_2O_3 in arsenic form. Arsenic in arsenic form + arsenic in arsenious form = total As_2O_3 . Total $\text{As}_2\text{O}_3 \times 5$ = per cent. As_2O_3 . Per cent. total $\text{As}_2\text{O}_3 \times .7575$ = per cent. total As.

Copper interferes with the estimation of the arsenic acid, and if an appreciable quantity of this metal is present it should be estimated and an allowance made for its amount; 1 molecule of copper liberates 1 molecule of iodine from potassium iodide.

Selenium.—According to E. Schmidt,¹ a solution of a few milligrams of codein phosphate in 10 c.c. sulphuric acid in the presence of only 1 part of SeO_2 in a million parts of sulphuric acid produces a distinctly green colour, which after standing for a quarter of an hour is changed into deep blue-green. Selenic acid (SeO_3) is not indicated by this or the other reagents, but (as well as SeO_2) by acetylene, which with 0.001 per cent. selenium gives a red colour. The addition of a little hydrochloric acid accelerates the secretion of the selenium, which dissolves in the hot sulphuric acid with a green colour. The *red* colour of sulphuric acid sometimes observed is usually caused by a very slight percentage of selenium, in cases where in the denitration of Gay-Lussac acid an excess of SO_2 has been applied.

Orlow² rejects codein and prefers SO_2 , especially on heating. Five parts H_2SO_4 + 10 parts water + 10 parts SO_2 solution give a red precipitate at once with 0.3 per cent. H_2SeO_3 , but also with 0.03 per cent. after standing a few days or heating

¹ *Arch. Pharm.*, 1914, p. 16.

² *Chem. Zentr.*, 1901, 1, 480.

a few hours. Even 0.003 per cent. gives a rose-colour. Rosenheim¹ discusses at length the influence of selenium on the ordinary tests for arsenic.

Meyer and Tannek² prove the presence of small quantities of selenium by sodium hydrosulphite, which reduces it to the colloidal state, producing a deep red colour of the liquid. 0.1 gram of the hydrosulphite is added to 1 c.c. of the faintly acid solution; the colour appears after a few seconds. The solution is then neutralised by solid sodium carbonate, in order to prevent the liberation of yellow hydrosulphuric acid. Neutral salts do not interfere with the reaction, which appears up to 1 part in 160,000, and which can be also used for quantitative colorimetric estimations. If hydrosulphite is added to concentrated sulphuric acid, a milky precipitate of free sulphur is formed, which in the presence of 0.002 per cent. SeO_2 has a yellow colour.

According to J. Meyer,³ solutions containing selenium, when evaporated on a water-bath, lose sensible quantities of SeO_2 by volatilisation. This loss is very considerable in the presence of free hydrogen chloride, and on repeated evaporation with HCl may go up to 80 per cent. of the selenium; it is not reduced by the presence of potassium or sodium chloride.

J. Meyer and W. von Gaon⁴ carry out the quantitative estimation of selenium colorimetrically by measuring the intensity of the colour of iodine, liberated from an acidulated solution of potassium iodide by the selenium dioxide; this colour in dilute solutions is yellow, in concentrated solutions yellowish brown up to blackish brown. The reaction is:

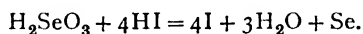

In order to obtain the liberated selenium in a colloidal solution, a few drops of a solution of gum arabic are added; otherwise the selenium would be separated in red flakes, very much interfering with the reaction. The comparative measurements of the intensity of colour were made by a Krüss colorimeter with a Lummer-Brodhuhn prism at daylight. In this way selenious acid can be estimated in dilutions of one in a million.

¹ *Chem. Zentr.*, 1901, 2, 234.

² *Z. anal. Chem.*, 1913, p. 534.

³ *Ibid.*, 1914, p. 145.

⁴ *Ibid.*, p. 29.

Denigès¹ detects selenium by boiling the substance with a few drops of concentrated hydrochloric acid, diluting with the same volume of water, and adding a dilute solution of mercurous nitrate, which produces a characteristic precipitate of mercurous selenite. In case of very small traces, the reaction can be carried out on a microscope-glass.

Meunier² detects selenium by means of Marsh's apparatus. For the detection of very small quantities of *selenious acid* in sulphuric acid see Ernst Schmidt, *Arch. Pharm.*, 1914, **252**, 161-165.; *J. Chem. Soc.*, 1914, ii., 672.

Luciano P. J. Palet³ states that selenium in sulphuric acid gives an intense violet coloration with aspidospermine. The pure acid does not give this reaction, but in the presence of an oxidiser, such as potassium chlorate or lead peroxide, it develops a rose-red coloration.

Oxygen Compounds of Nitrogen.—These are nearly always present in the sulphuric acid of trade. They are recognised in the simplest manner, and with nearly as much precision as by any other test, either by the decolorisation of a drop of dilute solution of indigo on heating, or by carefully pouring a solution of ferrous sulphate on the acid contained in a test-tube, so that the liquids do not get mixed. In the presence of traces of nitrous acid or of higher nitrogen oxides a brown ring will be formed at the point of contact; if more be present, the iron solution is coloured brown or black; but after some time it loses colour again, especially if it has become warm by the reaction. Selenium also gives a red ring similar to that produced by traces of nitrogen oxides; but the colour, instead of gradually vanishing, after standing for some time turns into a red precipitate at the bottom of the test-tube. Nitrous and hyponitric acids are also recognised by turning blue a solution of starch containing potassium iodide. The most sensitive reagent for nitrogen acids is *diphenylamine*.

Lunge has shown⁴ that the diphenylamine reaction is best employed in the following manner: 0.5 gram white diphenylamine is dissolved in 100 c.c. pure strong sulphuric

¹ *Ann. Chim. anal.*, 1915, pp. 57 and 59.

² *Comptes rend.*, 1916, p. 332.

³ *Anal. Soc. Quim. Argentina*, 1917, 5, 121-123; *J. Chem. Soc.*, 1918, 2, 127.

⁴ *Z. angew. Chem.*, 1894, p. 345.

acid, adding 20 c.c. water ; the heat assists in dissolving the substance, and the reagent keeps in well-stoppered bottles a long time without turning brown. When testing for nitrogen acids, pour a few cubic centimetres of the heavier liquid into a test-tube and carefully pour the lighter liquid on the top, so that the layers only gradually mix. The presence of as little as $\frac{1}{20}$ mg. nitrogen in the shape of nitrogen acids per litre is indicated by a blue ring forming at the surface of contact of both liquids, most easily perceived by holding the glass sideways against a white background. Both nitric and nitrous acid are indicated in this way.

Withers and Ray¹ describe the test just in the same manner ; according to them, the blue ring appears in the presence of $\frac{1}{25}$ millionth of nitrous nitrogen or $\frac{1}{35}$ millionth nitric nitrogen, and when heating for an hour even with $\frac{1}{32}$ millionth nitrous or $\frac{1}{44}$ nitric nitrogen.

Brucine indicates only nitric acid if there is a great excess of strong sulphuric acid present ; neither selenium nor nitrous acid interferes with this test, but nitrous acid reacts with brucine if there is but little sulphuric acid and much water present, say 1 : 2. In order to detect nitric acid, an aqueous solution to be tested should contain at least $\frac{2}{3}$ of its volume of strong sulphuric acid. The brucine can be added either as powder or dissolved in pure strong sulphuric acid, say 1 c.c. of a solution of 0.2 gram brucine in 100 c.c. strong acid, for 50 c.c. of the solution to be tested, of which $\frac{2}{3}$ must consist of strong sulphuric acid. If as little as $\frac{1}{100}$ mg. nitric nitrogen be present, a pink colour is produced which gradually, on heating very quickly, passes through orange into yellow. Lunge has shown how this test can be utilised for a quantitative colorimetric estimation of small quantities of nitric acid.²

Most reagents, like diphenylamine, ferrous sulphate, and indigo, indicate both nitric and nitrous acid. There are other reagents which prove the presence of *nitrous acid* (or nitrites) *alone*, not that of nitric acid : for instance, a mixture of starch solution with a solution of iodide of zinc (a blue colour being produced), and of various organic amines, which with nitrous

¹ *J. Amer. Chem. Soc.*, 1911, p. 708.

² *Z. angew. Chem.*, 1894, p. 347. Cf. also *ibid.*, 1902, pp. 1, 170, and 241.

acid form corresponding azo-colours.¹ Of these the most frequently used are : metaphenylene diamine, which produces a yellow colour with 0.1 mg. nitrous acid in a litre, or else a combination of sulphanilic acid and α -naphthylamine (reagent of Griess). Lunge² states that it is best to mix both substances, dissolved in dilute acetic acid, at once, and to keep this solution ready for use ; any nitrous acid getting in from the laboratory air is thus betrayed by the reagent turning pink. This colour can be removed by shaking up with zinc dust and filtering. In order to carry out the test for nitrous acid, the solution is heated up to about 80°, and a few cubic centimetres of the mixed reagent added to it, when a rose colour will be developed with less than $\frac{1}{1000}$ mg. N_2O_3 in one or two minutes. Solutions containing too much nitrous acid give only a yellow colour. In order to obtain a reagent which is not discoloured on keeping, a little of the α -naphthylamine is boiled with a few cubic centimetres of water, the hot solution is poured off, and only this is used, mixing it with dilute acetic acid and a dilute solution of sulphanilic acid.

If any nitrous acid present is carefully destroyed by treatment with urea, the ordinary reagents like diphenylamine, ferrous sulphate, and indigo, will indicate any nitric acid present, this not being acted upon by urea.

The *acids of nitrogen* (nitrous, hyponitric, and nitric) cannot easily be present together with sulphurous acid in sensible quantity ; but they occur in very considerable proportions in certain intermediate manufacturing products ("nitrous vitriol") ; and the methods for estimating them are therefore of great importance. Also in chamber-acid and in more concentrated products there is more often nitrous or even nitric acid present than sulphurous acid ; and in this case the estimation of even minute quantities is sometimes of importance, because they exert a very injurious action during the concentration of the acid in platinum.

Nitric oxide, as shown on p. 251, is soluble in sulphuric acid only in extremely slight quantities, inappreciable in any ordinary mode of testing. In practice, accordingly, no account need be taken of nitric oxide, especially in the case of the stronger acids, since in any case it cannot be present in sufficient quantity for

¹ Griess, *Ber.*, 11, 624.

² *Z. angew. Chem.*, 1889, p. 666.

estimation; and the analytical methods can only refer to the higher oxides and acids of nitrogen. Of these, again, only nitric and nitrous acid need to be taken into account. Nitrogen peroxide, N_2O_4 , when dissolved in sulphuric acid behaves exactly like a mixture of equal molecules of nitric and nitrous acid (p. 263). Nitrous acid itself does not exist in any but rather dilute sulphuric acid; in somewhat concentrated acid it exists as nitroso-sulphuric acid, $SO_2(OH)(ONO)$. The solution of this compound in sulphuric acid behaves, however, towards oxidising agents and in most other respects exactly like a solution of nitrous acid, which, in fact, is formed from it by dilution with water. Ordinarily in doing this, part of the HNO_2 is decomposed into NO and HNO_3 (p. 259), but this decomposition, which would interfere with the analysis, can be prevented by proper precautions, as we shall see later on.

First of all we must describe the methods for estimating *the total nitrogen acids*, that is, *nitrous and nitric acids together*, in which case the result can be calculated as N_2O_3 , N_2O_5 , HNO_3 , etc. Frequently, for technical purposes, the N is calculated as $NaNO_3$.

Of the numerous methods proposed for this end we only mention those which are employed for technical purposes.

The method of Pelouze, modified by Fresenius and others, is only adapted for the estimation of nitric acid; it is, however, sometimes used for estimating a mixture of this and of nitrous acid, after the latter has been converted into nitric acid; for instance, by chlorine, potassium bichromate, permanganate, etc. It is founded upon the fact that free nitric acid oxidises ferrous chloride or sulphate, according to the equation:

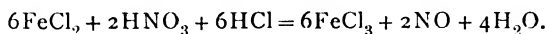

By means of potassium permanganate the ferrous salt, 1.0t oxidised by nitric acid, is estimated, and the quantity of the latter is calculated from that of the ferrous salt consumed.

This method is described in great detail in Lunge's first edition, vol. i., pp. 54 to 58, and second edition, vol. i., pp. 173 to 176; it is not repeated here, as the much handier nitrometer method has made it obsolete.

The process which is mostly used for *the estimation of the total nitrogen acids* in sulphuric acids (as well as for that of nitrate of soda, of nitroglycerine, and for many analogous

purposes) is the *nitrometer* method, founded upon a reaction discovered by Walter Crum.¹ Nitrometers are made in various

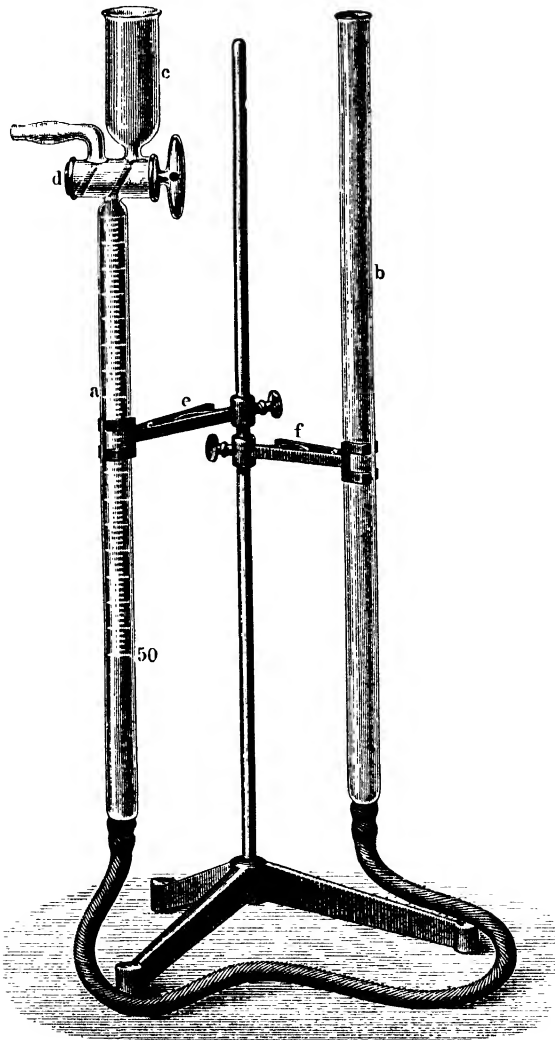

FIG. 14.

forms for various purposes ; that which is used in testing nitrous vitriol is shown in Fig. 14.

Its principal portion is a glass tube, *a*, a little over 50 c.c.

¹ *Phil. Mag.*, 1840, 30, 426.

capacity, divided into tenths of a cubic centimetre. At the bottom it tapers to fit a rubber tube; at the top it ends in a funnel, *c*, communicating with the inner part of the tube by a three-way tap. Its plug has one bore through which the measuring-tube communicates with the funnel, and another bore through which the contents of the funnel can be run off. The division of the measuring-tube *a* begins from the tap itself, and goes from the top downwards. The tube *a* hangs in a clamp, *e*, which can be instantaneously opened by a spring, so that the tube can be taken out. Another clamp, *f*, sliding on the same stand, carries a plain cylindrical glass tube, *b*, tapering below, of the same contents and about the same diameter as the measuring-tube. The lower ends of the two tubes are connected by a thick rubber tube. The tube *b* slides up and down in its clamp with friction. In order to use the apparatus, *b* is placed so that its lower end is rather higher than the tap *d*, and, the latter being opened, mercury is poured in through *b* till it just comes up to the funnel *c*. As it flows into *a* from below, it will not allow any air-bubbles to remain in the tube. The tap *d* is now closed; *b* is lowered; and the acid to be tested is run into the funnel *c* by means of a measuring-pipette. Of course it is necessary to have an idea of the maximum quantity of NO which may be given off without expelling the mercury from the tube altogether, and the quantity of sulphuric acid must be chosen accordingly. By carefully opening the tap *d*, the acid is run into *a* without any air being allowed to enter; in a similar way the funnel *c* is washed out twice by means of successive small quantities of pure concentrated sulphuric acid. It is not advisable to put more than 4 to 5 c.c. into the apparatus altogether, but in any case there must be an excess of strong sulphuric acid present. Now the tube *a* is taken out of the spring clamp and well shaken up. The evolution of gas in the case of nitrous acid commences at once—the acid taking a purple colour, in the case of nitric acid, after a minute or so. The reaction is ended by violent shaking for one or two minutes. Sometimes it takes a long while before the acid clears and the froth subsides, but generally this is effected in a very short time; in any case it is necessary to wait a little, so that the apparatus may assume the temperature of the air. Now, by sliding *b* up or down, the

level of the mercury in this tube is so placed that it is as much higher than that of *a* as corresponds to the vitriol ; say, for each 7 mm. of acid 1 mm. of mercury ; or else the level of the mercury is made the same in both tubes, and the height of mercury corresponding to the layer of vitriol in the tube is deducted from the barometrical pressure. In the former case, it is easy to ascertain after reading off whether the proper compensation for the height of the acid column has been made or not. It is only necessary to open cautiously the tap *d*, over which a drop of acid has been left standing. If this is sucked in, and the level of the acid falls, there has been too little pressure, and *vice versa*. The volume of the nitric oxide can be read off to $\frac{1}{20}$ c.c. and reduced to N.T.P. Each cubic centimetre of NO, measured at 0° and 760 mm., corresponds to 1.3402 mg. NO, or 1.6975 mg. N₂O₃, or 2.8144 mg. HNO₃, or 4.5176 mg. KNO₃, or 3.7986 mg. NaNO₃.¹ By this process, of course, nitric and nitrous acids cannot be distinguished, but are always estimated together.

After reading off, *b* is again placed higher, the tap *d* is opened so that tube *a* communicates with the small outlet tube, and thus first the nitric oxide and then the sulphuric acid, muddy with mercuric sulphate, is driven out. When the mercury begins to run out as well, the tap is closed, and everything is again ready for a new test. If any sensible quantities of sulphurous acid are present in the acid to be tested (as proved by the smell), it is best to add a very little powdered potassium permanganate to the sulphuric acid, avoiding any considerable excess.

It has been stated by T. Bayley that it is necessary to dilute the acid contained in the nitrometer at the close of the experiment, in order to expel the nitric oxide dissolved by the sulphuric acid. But for ordinary purposes there is no appreciable error caused by the solubility of NO in sulphuric acid, as Lunge showed in *J. Soc. Chem. Ind.*, 1885, p. 447, and 1886, p. 82. This could not be contradicted by Bayley, who, however, contended that the iron contained in the acid as ferrous sulphate acted as solvent for NO. Lunge replied to this² that the quantity of iron found in any commercial

¹ Multiples of these figures from 2 to 9 are given in Lunge's *Technical Chemists' Handbook*, 1916, 15.

² *Chem. News*, 1886, 53, 289.

acid would never lead to any appreciable error of this kind, more particularly as it would be present as ferric sulphate.

For very exact purposes the solubility of NO in strong sulphuric acid, which amounts to 0.35 c.c. NO in 100 c.c. acid, must be taken into consideration. Nor must the acid employed be stronger than 94 to 94.5° per cent., to avoid the reduction of NO to N₂O or N.¹

In spite of the very great convenience, speed, and accuracy of the nitrometric estimation of the nitrogen acids, many chemists might have abstained from using it, because the unavoidable reduction of the volume of NO to 0° and 760 mm. pressure appeared too tedious to them. In order to overcome this objection, Lunge calculated tables which admit of reducing any volume of gas from 1 to 100 from any given temperature to 0°, and from any given pressure to 760 mm., by simple reading off. These tables were given in the Appendix to his first edition; they are also contained in Lunge's *Technical Chemists' Handbook* (1916), p. 48 *et seq.* Other tables, requiring very little more time for use, are found in Winkler-Lunge's *Handbook of Gas-Analysis*, 2nd edition, p. 177 *et seq.*

These tables are not required if one uses an instrument invented by Lunge, and called the *gas-volumeter*.² This renders unnecessary all calculations and tables in connection with the reduction of volumes of gases to 0° and 760 mm. This instrument, as shown in Fig. 15, consists of three glass tubes, all joined by rubber "pressure" tubes to a three-way pipe, D, and sliding upwards or downwards in strong clips. Tube A is the measuring-tube, B the reduction-tube, C the level-tube. A is divided into tenths of a cubic centimetre, and generally holds 50 c.c.; where larger volumes of gases are to be measured it is shaped like B, and holds 60 or 100 c.c. in the upper, wider portion, and another 40 c.c. (divided into $\frac{1}{10}$ c.c.) in the lower, narrower portion. The "reduction-tube" B holds 100 c.c. in the upper part, and another 30 c.c. (divided into $\frac{1}{10}$ c.c.) in the lower part. This tube is set once for all in the following way:—After putting the apparatus together and partly filling it with mercury, the temperature close to B and the barometric pressure are taken, and it is calculated, by the

¹ Cf. p. 252.

² *Z. angew. Chem.*, 1890, p. 139; *Berl. Ber.*, 1890, p. 440.

well-known formula

$$\frac{(273 + t)760}{273 \times b}$$

(where t denotes the temperature in $^{\circ}$ C., b the height of the barometer in millimetres), what would be the volume of 100 c.c.

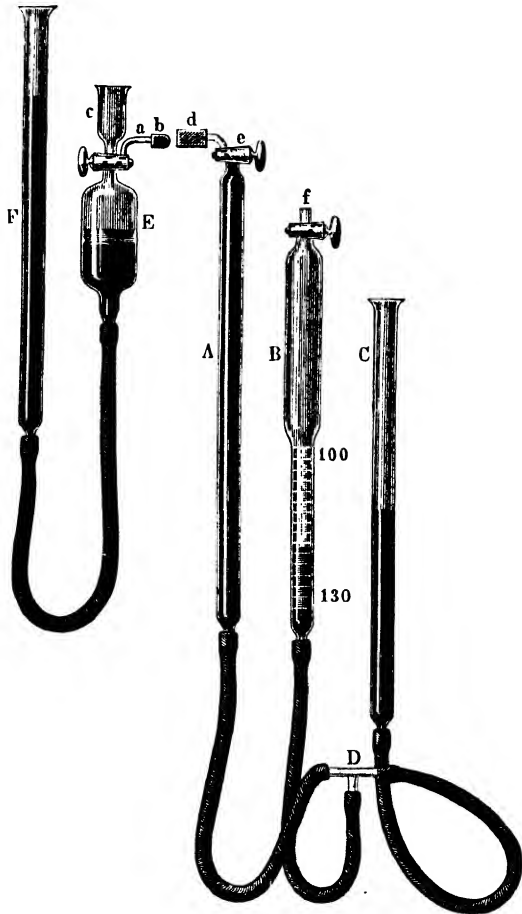

FIG. 15.

dry air under the existing atmospheric conditions. (This calculation can be abridged by using any of the above-mentioned tables, if they are at hand.) Suppose $t = 20^{\circ}$, $b = 750$ mm. In this case 100 c.c. of dry air would occupy the volume 108.8 c.c. We now move B and C so that, tap f

being open, the level of the mercury in B is at 108.8, whilst the mercury in C is, of course, at the same level. Previously to this we have introduced a drop of strong sulphuric acid into B, but not sufficient to reach over the meniscus of the quicksilver, which would be an impediment to taking the readings; this is done because gases have afterwards to be measured in the *dry* state. (In the more frequent case in which this instrument is employed for measuring *moist* gases, in lieu of sulphuric acid a drop of water is introduced into B, and the calculation is made by deducting from the barometric pressure the tension of aqueous vapour corresponding to the existing temperature.) Now tap *f* is closed, and is secured so that no air can enter or escape through it. In lieu of this tap a capillary tube may be provided which is sealed by a small flame, after having put a perforated piece of asbestos cardboard over the top of tube B, to prevent its temperature rising during the sealing-operation. The best way of closing tube B is by means of a mercury-sealed tap, as described by Lunge.¹

It is quite evident that every time level-tube C is raised so that the mercury in B rises to the point 100, the air within B is compressed to the volume it would occupy at 0° and 760 mm. independent of the temperature and barometric pressure actually existing. Now suppose we have evolved or carried over into tube A a certain volume of gas, and we adjust the position of the three tubes so that the mercury in B stands at 100°, and that in A exactly at the same level, it is evident that the gas in A is under the same pressure as in B; and, supposing its temperature to be the same (which will be the case if the two tubes are close together), the gas in A (equally with that in B) will be compressed to the volume it would occupy at 0° and 760 mm. barometric pressure. The reading taken in A thus yields at once the corrected volume without the need for looking at a thermometer or barometer or using any calculations or tables.

Tube A might be an ordinary nitrometer; but it is far preferable to use it only as a measuring-tube, and thus to keep it always clean and dry, whilst the nitrometric operation proper is carried out in the auxiliary "agitating-vessel" E.

¹ *Ber.*, 1892, p. 3158.

This is a non-graduated vessel, holding 100 to 150 c.c., and connected by a strong rubber tube with the level-tube F. The vessel E bears at the top the usual three-way tap and cup *c*. The side-tube *a* can be closed by a small ground-on cap, *b*, or else by an indiarubber cap. Before commencing the analytical operation, the tube F is raised so that the mercury just issues out of *a*; cap *b* is now put on and tap *c* is closed. Now the nitrous vitriol (or solution of nitrate of soda) is introduced through *c*, by carefully lowering F, so that only the liquid, but no air, enters into E; strong sulphuric acid follows, to rinse out cup *c*; the tap is now entirely closed, and E is violently shaken till the decomposition is complete and no more NO is given off. The cap *b* prevents the mercury in tube *a* from being thrown out in the shaking. The instrument is allowed to cool down, and is then put in the position shown in the diagram, so that the small tubes *a* and *d* are on the same level. Previously a short piece of indiarubber tube has been slipped over *d*, and by raising C the mercury has been forced right to the end of *d*. Now cap *b* is taken off, and *a* is introduced into the short rubber tube, till the glass tubes *a* and *d* touch. Now tube C is lowered and F raised (as shown in the diagram), and tap *c* is cautiously opened (*e* having been left open before). The gas will thus be transferred from E into A; at the moment when the sulphuric acid has entered into the bore of *e*, but before it has got inside of A, tap *e* is closed. Now the reading is taken as described above; the apparatus EF may be detached at any time and cleaned as occasion requires.

The readings of the volume of NO taken in tube A may be converted into grams of N_2O_3 or $NaNO_3$, etc., by means of the table mentioned on p. 294. If nitrate of soda has to be analysed, each cubic centimetre will indicate 3.7986 mg. $NaNO_3$; hence, if 0.3799 gram of nitrate were employed for the test, the number of cubic centimetres of NO would at once indicate the percentage of $NaNO_3$. In the case of nitrous vitriol the quantity will usually not be weighed, but measured by means of a pipette, and the results obtained must then be divided by the specific gravity of the acid, to reduce them to weight percentage. If the acid is near 140° Tw., this is unnecessary; for in this case a 1 c.c. pipette will deliver 1.70

gram acid, and as each cubic centimetre of NO indicates 0.0017 N₂O₃, this means that the number of cubic centimetres read off is exactly = tenths of a per cent. of N₂O₃ by weight of the nitrous vitriol.

Japp¹ showed that by suitably placing the "reduction-tube" of the gas-volumeter, the readings can be made in such manner that they indicate immediately the *weight* of the gas in question. If, *e.g.*, in a cylindrical reduction-tube the point 25 is taken as unit, the gases must be compressed to 25.0, in order to be reduced to 0° and 760 mm. pressure. Since 1 c.c. nitrogen under these circumstances weighs 0.0012505 gram, 25 c.c. mean 0.0012505 × 25 = 0.03126 gram. If, before reading off, the reduction-tube is placed at 31.3 c.c., each cubic centimetre in the measuring-tube will immediately indicate 1 mg. nitrogen.

Lunge has shown² that this procedure, owing to the employment of the small quantity of 25 c.c., has not a sufficient degree of accuracy. But Japp's proposal can be carried out more accurately, if an ordinary reduction-tube, divided from 90 to 150 c.c., is used and placed at 100. If in the measuring-tube the cubic centimetres read off are to indicate milligrams, the mercury in the reduction-tube must be placed at 100 times the litre weight of the gas in question, *e.g.* for nitric oxide at 134.02. But Japp's proposal, even in this improved shape, rarely has an advantage over that made by Lunge, *viz.* employing for the test such a weight of the substance that, on placing the reduction-tube at 100, the readings of the measuring-tube indicate immediately the percentage sought.

Later on, other authors constructed apparatus by which gases can be measured without the aid of a thermometer and barometer, *e.g.* Hempel,³ Bleier,⁴ and Bodländer.⁵ The barothermoscope of Salomon⁶ is rather too complicated for practical use.

Planchon⁷ describes a modification of the nitrometer, which he calls "manonitrometer."

¹ *J. Soc. Chem. Ind.*, 1891, 59, 894.

² *Ber.*, 1892, p. 3162.

³ *Z. angew. Chem.*, 1894, p. 92. ⁴ *Ber.*, 1897, p. 2733; 1898, p. 236.

⁵ *Z. angew. Chem.*, 1895, p. 49. ⁶ *Ibid.*, 1893, p. 376; 1894, p. 686.

⁷ *Ann. Chim. anal.*, 1915, p. 189; *J. Soc. Chem. Ind.*, 1915, p. 1031.

Estimation of Nitrous Acid or Nitroso-sulphuric Acid in the "Nitrous Vitriol" from the Gay-Lussac Tower.—Among all the analytical methods founded upon the oxidation of nitrous acid, the most convenient and accurate is that employing *potassium permanganate*. Even for scientific purposes we do not possess a more accurate method for estimating nitrous acid in an acid solution than this, if other oxidisable bodies be absent.

Nitric oxide is oxidised by this reagent, according to this equation :



Accordingly each cubic centimetre of the seminormal solution of permanganate corresponds to 0.005 gram NO. Thus, on the one hand, nitric oxide can be estimated quantitatively by this reagent : on the other hand, the nitric oxide would make the estimation of nitrous acid inaccurate if it were present at the same time, which, fortunately, is not the case in sulphuric acid to an appreciable extent.

Nitrous acid itself is oxidised by permanganate, according to the equation :

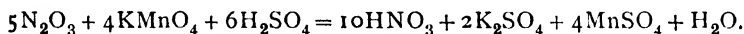

Here every cubic centimetre of seminormal permanganate solution corresponds to 0.009502 gram N_2O_3 .

The process formerly in use, where the permanganate solution was run into the nitrous vitriol, has been shown to be quite inaccurate by Lunge's investigations (owing to the formation of NO and HNO_3), and has been replaced by the following :—The permanganate is not run into the acid, but, on the contrary, a certain volume of permanganate solution is taken, and the nitrous vitriol is run in from a burette, slowly and with constant shaking, till the liquid is just decolorised. In the cold this takes some time, since the very dilute solution of permanganate is no longer acted upon instantaneously. This loss of time can be avoided by working at 30° to 40° , but *no higher*. When working with concentrated sulphuric acid, this temperature is attained through the heat of dilution ; otherwise the permanganate solution is heated up beforehand. If seminormal solution is employed, it is diluted with about 100 c.c. of tepid water. Sometimes a brown precipitate (of hydrated manganese peroxide) is formed in the operation ; but this dissolves later

on, and the final result is quite as correct in these as in any other cases.

In testing chamber-acid, at most 5 c.c. of seminormal permanganate should be employed ; otherwise the quantity of sulphuric acid required for decolorising it will be inconveniently large. For proper "nitrous vitriol" from the Gay-Lussac tower up to 50 c.c. permanganate may be taken. If the number of cubic centimetres of permanganate is called x , and that of the acid required for decolorising it y , the quantity of N_2O_3 present in

grammes per litre of acid is $\frac{9 \cdot 502x}{y}$

calculated as $HNO_3 = \frac{15 \cdot 75x}{y}$,

or as $NaNO_3 = \frac{21 \cdot 258x}{y}$.

A table given in Lunge's *Technical Chemists' Handbook*, 1916, p. 136, saves the calculation in all cases in which $x = 50$.

In the presence of *other oxidisable substances*, such as sulphurous acid, ferrous salts, organic substances, etc., all oxidation methods are of course inexact—whether the bleaching-powder, or the bichromate, or the permanganate process. Generally those impurities are too insignificant to do any harm ; and, especially where large quantities of nitrous acid are present, as in the nitrous vitriol from the Gay-Lussac towers, the permanganate process is quite sufficient for the purpose of checking the course of manufacture. Of the oxidisable substances only arsenious acid sometimes occurs in sufficient quantities to affect the results sensibly, but to a small extent only, in nitrous vitriol, where it is mostly changed into arsenic acid.

Minute quantities of nitrogen acids cannot be quantitatively estimated by the above methods, but the *colorimetric estimation of slight quantities of nitrous acid*¹ can be performed by Griess's reagent, modified as follows :—0.1 gram white α -naphthylamine is dissolved by boiling in 100 c.c. water for a quarter of an hour ; then 5 c.c. glacial acetic acid (or its equivalent in ordinary acetic acid) and a solution of 1 gram sulphanilic acid in 100 c.c. water are added. The solution is kept in a well-

¹ G. Lunge, *Z. angew. Chem.*, 1894, p. 348.

stopped bottle ; if it turns pink it is decolorised by shaking with zinc-dust and filtering. A very slight colour does not interfere with its use, as only 1 c.c. is employed for 50 c.c. of the solution to be tested. One c.c. of the reagent indicates $\frac{1}{1000}$ mg. nitrous nitrogen in 100 c.c. water by turning the water pink in ten minutes. Strong mineral acids retard or stop the reaction, but this can be remedied by adding a large excess of pure sodium acetate.

For quantitative use a standard solution is prepared as follows :—0.0493 gram pure sodium nitrite, containing 0.010 gram nitrogen, is dissolved in 100 c.c. water, and 10 c.c. of this solution is added drop by drop to 90 c.c. pure sulphuric acid ; the resulting mixture contains $\frac{1}{100}$ mg. of nitrous nitrogen in a perfectly stable form. Two colorimeter cylinders are charged as follows :—Each of them receives 1 c.c. of the Griess-Lunge reagent, 40 c.c. of water, and about 5 grams of solid sodium acetate. To one of these is added 1 c.c. of the standard solution, to the other 1 c.c. of the acid to be tested. The contents of each cylinder are at once thoroughly mixed, and after five or ten minutes the colours are compared. If they do not correspond, the more strongly coloured liquid is diluted up to the point where layers of equal thickness show the same depth of colour in both solutions, and the percentage of nitrous nitrogen is calculated from the amount of dilution.

Very minute quantities of *nitric acid* are best estimated by the *colorimetric brucine process*,¹ the principle of which consists of comparing the yellow colour obtained by heating to about 70° with brucine with a standard solution of nitric acid. As a rule, nitric acid is not estimated by itself in sulphuric acid, but indirectly, by estimating the total nitrogen acids by means of the nitrometer (p. 292) and deducting the nitrous acid found by the permanganate method (p. 300).

Finch² discusses the volumetric methods for estimating sulphuric, nitric, and nitrous acid in mixed acids for nitrating purposes, and in the waste acids produced in those operations.

The detection and estimation of small quantities of nitrous acid is described by E. Holl Miller.³

¹ G. Lunge, *Z. angew. Chem.*, 1894, p. 347.

² *Z. f. Schiess-u. Sprengstoffwesen*, 1912, 7, 113 and 337.

³ *Analyst*, 1912, 37, p. 345 ; *J. Chem. Soc.*, 1912, 2, 992.

A solution is prepared containing 8 grams of dimethylaniline and 4 grams of hydrochloric acid per 100 c.c., and also a solution of sodium nitrite representing 1 part of nitrous acid per 100,000. The estimation is performed in Nessler tubes or a colorimeter. Fifty c.c. of the solution under examination are acidified with 1 drop of hydrochloric acid, and, after adding 5 drops of the dimethylaniline solution, allowed to remain for fifteen minutes, or longer if necessary. The yellow colour is then matched in the usual manner against the standard solution, which is acidified with 1 drop of acid and mixed with 3 drops of the reagent. Nitrates do not interfere.

Three Nitrogen Acids occurring together.— N_2O_3 , N_2O_4 , and HNO_3 in a mixture of all three acids absorbed by sulphuric acid can be derived from the results of the permanganate titration, combined with estimation of the total nitrogen as NO in the nitrometer, by the following formulæ:—

a = c.c. NO, found in the nitrometer.

b = c.c. O, calculated from the permanganate titration 1 c.c. O
= 1.429 mg.; therefore, 1 c.c. seminormal permanganate
= 0.004 gram = 2.798 c.c. oxygen.

x = vol. NO, corresponding to the N_2O_3 present in the mixture.

y = " " " N_2O_4 " "

z = " " " HNO_3 " "

If $4b > a$, the amounts sought are:—

$$x = 4b - a.$$

$$y = 2(a - b) \text{ or } a - x.$$

If $4b < a$, the amounts are:—

$$y = 4b$$

$$z = a - 4b.$$

That means: if the oxygen is sufficient for assuming all nitrogen acids to consist of N_2O_4 , they are calculated as such; if more oxygen is present, the excess is calculated as HNO_3 ; if less oxygen is present, the excess is calculated as N_2O_3 . In reality the ordinary nitrous vitriols do not contain any nitrogen peroxide, so that it is best to calculate the whole consumption of oxygen found by the permanganate titration as N_2O_3 or nitroso-sulphuric acid, and the remainder of the nitrogen as HNO_3 .

In Lunge-Keane's *Technical Methods of Chemical Analysis*, vol. i, p. 345, and in Lunge's *Technical Chemists' Handbook*,

2nd edition, p. 14, tables are given showing the amounts of milligrams of N, NO, N_2O_3 , HNO_3 , and $NaNO_3$ corresponding to 1 to 9 c.c. NO.

Analysis of Mixtures of Sulphuric and Nitric Acid as employed for Nitrating Processes.—Lunge and Berl¹ perform this as follows:—

1. The total acidity is found by titrating 1 gram weighed off in a "bulb-tap" pipette with normal caustic-soda solution, employing methyl-orange as indicator, but adding this only at the close of the operation, or renewing it when destroyed. Or else a known volume of standard soda is added, the methyl-orange is then added, and the excess of soda found with normal acid.
2. The nitrous acid (or nitrogen peroxide) is found as described on p. 300, viz. running the mixed acids slowly into a measured volume of seminormal permanganate solution of which 1 c.c. indicates 0.023005 gram N_2O_4 .
3. The total nitrogen acids are found by means of the nitrometer as described on pp. 291 *et seq.* From the NO found is deducted the amount corresponding to N_2O_4 , as ascertained under No. 2; the remainder is = HNO_3 .
4. The sulphuric acid is found by deducting the nitrogen acids as found under No. 3 from the total acidity found in No. 1.

Another process for the analysis of acid mixtures for nitrating processes and of waste acids is described by Finch.² He adds to the acid mixture an excess of precipitated barium carbonate, boils for five minutes, washes the mixed precipitate of barium sulphate and carbonate, boils the filtrate with standard sodium carbonate solution, washes the precipitate until neutral, and titrates the sodium carbonate still present. He thus finds the nitric acid, from which the nitrous acid found by the permanganate titration must be deducted. The amount of total nitrogen found by the nitrometer is rather higher than that found by this method, probably owing to the presence of esters of glycerin-nitrates.

¹ *Z. angew. Chem.*, 1905, p. 1681.

² *Z. f. Schiess- u. Sprengstoffwesen*, 1912, p. 113; *Chem. Zentr.*, 1912, 1, 1862.

Busvold¹ states that sometimes erroneous results are obtained by Lunge's permanganate method. This is not the fault of the method itself, but of the fact that the permanganate solution employed in those cases contained finely divided particles of manganese dioxide. He therefore controls the results by his silver bromate method described in *Chem. Zeit.*, 1914, 38, 28.

Raschig² recommends for the titration of nitrous vitriol and of nitrite the process of Volhard, in which permanganate solution is added in excess (about 20 per cent.), then after two minutes a solution of potassium iodide, and after a few minutes the free iodine formed is titrated with thiosulphate solution. This method is right in principle, but its drawbacks are the necessity of employing several standard solutions, and the use of expensive potassium iodide.³

Rupp⁴ oxidises the solution of nitrites (which must not contain upwards of 1 per cent.) by an excess of permanganate solution, with heating, dilutes with water after cooling, acidulates with sulphuric acid, and determines the excess of permanganate by Volhard's method.

B. S. Davison⁵ employs the iodometric method, previously driving out the air by carbon dioxide.

¹ *Chem. Zeit.*, 1915, p. 214.

² *Z. Chem.*, 1905, p. 1286; *Ber.*, 1905, 38, 3911.

³ Cf. Lunge and Berl, *Z. angew. Chem.*, 1906, 19, 809.

⁴ *Z. anal. Chem.*, 1906, p. 687.

⁵ *J. Amer. Chem. Soc.*, 1916, 38, 1683.

CHAPTER IV

THE PRODUCTION OF SULPHUR DIOXIDE

A. FROM SULPHUR

THE simplest sulphur-burners such as were formerly employed in England consisted of a brick chamber covered with an arch, the bottom being formed by a cast- or wrought-iron tray, about 4' x 6' or 8', the two long sides and back having vertical sides 3" high, but the front flange at an angle of 45° for removing the ashes easily. The door had a slide or a chain and balance-weight arrangement for regulating the amount of air entering.

Sulphur was burned at the rate of 1½ lb. per sq. ft. per hour.

Davis¹ states that up to 2 lb. of sulphur can be burned per sq. ft. per hour, but Lunge in his fourth edition, p. 393, says that this is more than the maximum he ever found in practice. The writer, however, was able to burn much greater quantities by charging the sulphur at frequent intervals and in small quantity, with occasional stirring. It is advisable not to reckon upon more than the latter amount unless there be considerable agitation of the molten mass by mechanical or other means.

Later, sets of these burners were placed together in the form of the "smalls" pyrites burners described elsewhere, and these are still in use in this country (1922).

Lunge mentions the fact that nitre pots were inserted amidst the burning sulphur by means of large tongs, and the nitre and acid added by guesswork. He also describes burners covered with evaporating pans, but the reader is referred to his fourth edition for the interesting development of

¹ *Chem. Eng.*, 2, 123.

the sulphur furnaces, for we shall confine our attention to the more modern plant.

A type of sulphur-burner is described by Miles and Sarginson¹ which was used at Queensferry during the War.

Fig. 16 is a vertical section of the burners which were built side by side in a block of twelve.

The sulphur was charged into the iron pan, P, in sheet-iron

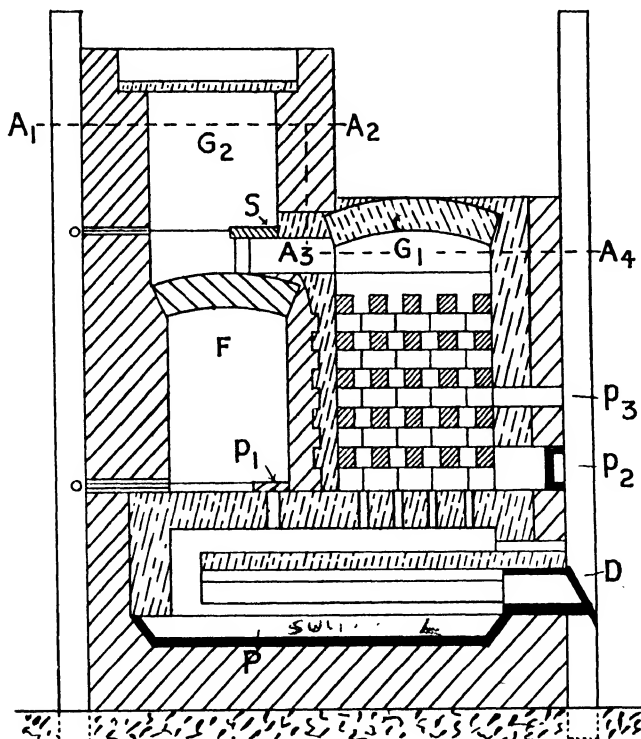

FIG. 16.

scoops, once an hour, the sliding door, D, being opened and closed as quickly as possible. Air was drawn through a small adjustable orifice in the door in amount just sufficient to cause, by its combustion, the regular boiling of the sulphur (the burners were of course worked under suction). Air which had been to some extent pre-heated in the flue, F, was supplied by the port p_1 , always fully opened, and additional air could be

¹ *J. Soc. Chem. Ind.*, 1922, p. 183T *et seq.*

admitted, if sublimation was feared, by the ports p_2 and p_3 , in front of the block. The sulphur vapour and air were thoroughly mixed by passing through the fire-brick chequer-work. Each burner had its own stack of chequer-work, divided from those on either side by a partition wall, but the flue G_1 , above the stacks, was common to them all. Between the flues G_1 and G_2 were arranged adjustable slides, S_1 , S_2 , etc., in order that the suction should be equal on all fires. The relation of these two flues was found to be an important feature of the burners, and can be more clearly seen from

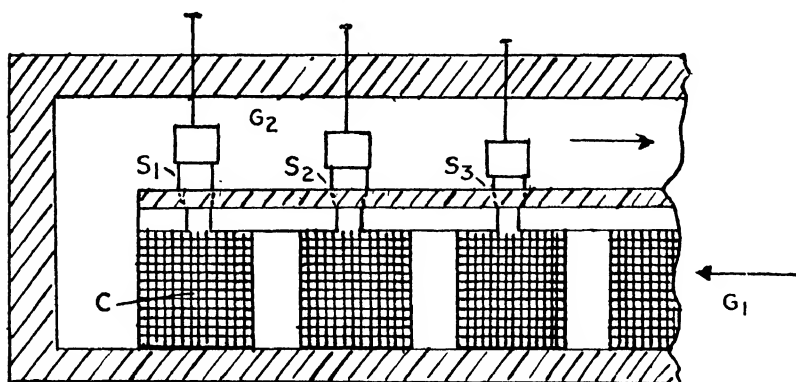

FIG. 17.

Fig. 17, which is a diagram of a horizontal section taken along A_1, A_2, A_3, A_4 of Fig. 16. The suction along the main flue, G_2 , will increase in the direction of the arrow, and it is easy to see that to have the same suction on each fire the ports, S_1, S_2 , etc., must be less and less open as we pass in the direction of the arrow. The slides were adjusted accordingly and the adjustment tested by applying a delicate manometer to the air-vent of each door in succession. With sulphur charges of 65 lbs. per burner the suction was about 0.170 in. of water, and did not vary from one pan to another more than 0.01 in. unless a fire was at a period of maximum burning, when the suction at the door was always lessened.

Graphs are also shown giving the percentage of SO_2 at various periods after charging, and details of the precautions taken to obtain a gas of regular composition.

Humphries' Sulphur-Burner.—It is claimed that this burner gives complete combustion of the sulphur and has a high capacity with an elastic range. It is made in metal in sizes for burning from 1 to 100 lb. per hour. Facilities are provided for withdrawing the grate or tray for cleaning, and a sight-hole for inspection purposes is fitted.

The maker is H. P. P. Humphries, 14 Old Queen Street, S.W.1, who has supplied a considerable number of these burners. For large burning capacities the same principle is adopted in furnaces constructed of suitable refractory materials.

Humphries (B. P. 11750 of 1912) divides the burner by means of a plate into an upper and lower chamber, connected by a narrow passage in the plate. The latter may be made hollow to permit of the circulation of cooling water or air. The sulphur is burnt in a tray in the bottom chamber, the air for this purpose being heated up by circulating round the tray. The sulphur is charged by means of a hopper and an extension passing through the upper chamber and the plate into the bottom chamber.

The sulphur-burner of Hinske, Rothschild, Assignor to Valley Iron Works (U.S. P. 1149765), is made in capacities of from 250 lb. to 12 tons per twenty-four hours, and the following is a description of the 9-ton burner:—

It is of the round vertical type, the top forming a dome or cupola, on the top of which, and partly entering the burner, is a melting-kettle. The casing of the burner is of steel and the inner lining of firebrick.

The inside is provided with a number of iron trays or shelves, each of the chambers being provided with a door of an upward swinging type, admitting the air from the lowest part of the doors. Each door is provided with a damper hole through which the flow of sulphur and the colour of the flame can be observed. The air moving against the flow of sulphur makes it burn very rapidly. From the burner, the gases pass through a so-called combustion chamber, which consists of a slotted pipe with a damper arrangement, wherein the sulphur fumes undergo a final combustion.

The gas outlet consists of two parts: the first is an elbow, extending into the burner and forming an arch for the brick lining; and the second consists of a round iron pipe,

oblong-shaped at one end, to conform with the shape of the elbow.

The sulphur is placed in the melting-pot at the top of the furnace and a fire started on the uppermost of the series of trays. A handful of oiled waste is all that is necessary to start the process of melting the sulphur. The needle-point valve in the bottom of the melting-pot is opened slightly, releasing the molten sulphur on to the flame below. As the sulphur begins to burn the heat increases, and as the melting-pot is located in the hottest part of the burner the sulphur melts very rapidly. Gradually the valve is opened and the burning molten sulphur drips downward from tray to tray, backwards and forwards, until it enters the bottom chamber, where the ashes and impurities collect.

Although the sulphur fumes may leave the burning-chamber in a state of semi-combustion, complete oxidation will take place in the combustion-chamber. When the sulphur-gas reaches the outlet pipe, the air rushes in from all sides, mingling with the gas thoroughly and oxidising it with a bright blue flame.

The floor space occupied by the burner is very small, and no auxiliary combustion-chamber, steam, or power is required.

The percentage of the gas leaving the burner is said to reach 18 per cent. without sublimation taking place.

The revolving sulphur-burner of *Tromblee and Paull* (U.S. P. No. 749311) (supplied by the Glens Falls Machine Works, Glens Falls, New York) is recommended in advertisements of the technical journals as one of the best for this purpose. It consists of a horizontal cylindrical iron shell 8 feet long and 3 feet in diameter, with conical ends, revolving on its axis once in two minutes. At one end is a hopper and worm feed with sliding dampers. The other end connects with a rectangular cast-iron box of 37 cub. ft. capacity, provided with sliding damper and vertical cast-iron uptake pipe. This pipe leads to a brick dust-catcher, such as is ordinarily used with pyrites-burners. The dust-catcher merely cools the gas, as no appreciable amount of sulphur is carried beyond the combustion-box.

The burner is rated at 5500 lb. per day, but there has been no difficulty in burning 6000 lb. per day. Before feeding

to the hopper, the sulphur needs no other preparation than breaking up large lumps with a shovel. When forced along by the worm, the sulphur melts just before it drops into the body of the burner, and a sufficient amount of melted sulphur is always present to form a complete liquid coating on the inside of the shell as it revolves. The combustion-box and vertical uptake complete the combustion of any sulphur which is volatilised from the cylinder.

The special advantages of this burner are ease in controlling composition of gas, low cost of upkeep, and freedom from losses. Once in about two months it is necessary to clean out the dross which collects in the cylinder. To do this, or to prepare for a shut-down for repairs in any other part of the plant, the sulphur charge is allowed to burn out completely. Any residue in the cylinder is then easily removed by a hoe. Starting the burner after cleaning, or even when it is cold, is a simple operation, and no losses occur.

The best results are obtained under a constant sulphur feed and proper regulation of dampers, which allows a very persistent and complete combustion, forming a uniform gas, free from sublimation, being easily controlled between 5 per cent. and 17 per cent. SO_2 .

T. A. Clayton, Paris (B. P. 141661), describes a burner in which secondary air is delivered into the space between baffles arranged above the hearth or pan for the sulphur, and a box-like baffle or deflector is provided at the secondary air-inlet to prevent a back flow of gases into the combustion-chamber.

His further patent, No. 166961, describes a burner in which the complete combustion of the sulphur is effected without a risk of choking the conduits with uncombined sulphur. The air is directed upwards and downwards by means of a tubular element having openings or nozzles. The hopper feed is arranged in the crown of the furnace, the downward passage of the sulphur being uninterrupted by any baffle plates as is usual in similar apparatus.

Ellis (U.S. P. 1289417).¹ The burning-chamber for sulphur is of firebrick, and has an inlet and outlet, being supported on a bed of reinforced concrete which is enclosed by

¹ *J. Soc. Chem. Ind.*, 1919, p. 135A.

a brick structure having a roof of reinforced concrete. The two structures are spaced apart to effect insulation and permit expansion of the inner chamber, and the roof and bed of the reinforced concrete are connected by vertical tie-rods extended through the outer walls.

Hurt (U.S. P. 1289783)¹ describes an apparatus for burning sulphur. An upward spray of molten sulphur is produced within the burning-chamber, at the bottom of which a pool of the liquid material is maintained, and the gaseous products, containing a larger proportion of sulphur-vapour, are conducted into the spacious channels, to which sufficient air to effect complete oxidation of the sulphur is supplied.

Pintsch (Ger. P. 295747 of 1915)² uses a vessel shaped like a filter funnel, which is fitted into a cylindrical oven divided laterally into two parts, the cone of the funnel being in the upper and the stem in the lower compartment. The sulphur is melted in the conical part, which is surrounded by a hot oil-jacket, and falls on to the hearth of the lower compartment, where it is burnt, the gases which enter the upper part serving to keep the sulphur melted. There is an exit pipe in each compartment, and, by adjusting the draught, the sulphur can be regulated at the requisite temperature.

McIntyre (U.S. P. 1303348) describes a down-draught sulphur-burner consisting of four chambers, the uppermost serving as a supply-chamber for sulphur which is melted by the heat below. Liquid sulphur is run into the lower shelves, which are connected by openings at opposite ends. A layer of melted sulphur is retained in the second and third by a rim at the opening, while the excess of sulphur will collect on the lowest shelf. Air is supplied through the six adjustable dampers, and the SO₂ is drawn through the pipes at the bottom bed. The whole furnace is surrounded by a jacket having sliding dampers, through which the air-supply must pass while the burner is in operation, thus pre-heating the air by contact with the hot walls. Numerous sight-holes are provided so that the colour of the flame can be observed and the air regulated accordingly. It is claimed that sublimation is avoided by this construction.

Krotoff (B. P. 128549 of 1918) claims the following:— Sulphur in a finely powdered form is passed through a pipe

¹ *J. Soc. Chem. Ind.*, 1919, p. 135A.

² *Ibid.*, 1917, p. 646.

into the furnace, and burned to sulphur dioxide by air-blast injected through another pipe. The burning gases pass backward and forward through a series of concentric tubes, placed horizontally, and a gas high in sulphur dioxide is finally discharged through an outlet provided at the opposite end of the furnace.

Coombs (U.S. P. 1147376) burns sulphur in a chamber containing a retort into which molten sulphur is run continuously; a jet nozzle, supplied with a regulated air-current, and in open communication with the retort and chamber, directs a flame jet on to the bottom of the retort.

Descamps (B. P. 100939 of 1916) describes a furnace for obtaining a mixture of SO_2 and N by means of dry air.¹

Hunt (B. P. 18895 of 1911) provides a self-acting contrivance for the introduction of air. From the main air-pipe a pipe is branched off leading directly into the combustion-chamber, which contains a thermostat for regulating the air-valve.

Rossiter (Amer. Ps. 1038442 and 1039812) employs a revolving drum, with a gas outlet at one of the ends, connected with an aspirator. Within the drum there is an inner drum connected with it for revolving; here the sulphur is burned. The annular space between the drums receives the heat radiated from the inner drum. The latter is provided with air-inlets and with gas-outlets, passing into the annular space, where more air is introduced in order to burn the subliming sulphur.

Brochon (Fr. P. 355252)² burns sulphur (or pyrites) with an excess of air under such pressure that the product consists partly of strong sulphuric acid, and even, under favourable conditions, of SO_3 , at least in the early stage of the process. The powdered sulphur (or pyrites) is blown through a vertical tube into a horizontal tube, narrowed to a small aperture, and removably fitted to the wall of a chamber. Air under pressure, say 10 atmos., is forced in through the horizontal tube, both from its bottom and from the end, supplying an excess of air. The vapours escape through a narrow channel at the farther end of the combustion-tube into condensing vessels, or into ordinary lead-chambers.

¹ *J. Soc. Chem. Ind.*, 1916, p. 963.

² *Ibid.*, 1905, p. 1171.

The *Schutte and Koerting Co.* in Philadelphia supplies a sulphur-furnace, shown in Fig. 18, made entirely of cast-iron. The lower part contains a pan in which the sulphur burns. A steam-jet exhauster *a* draws the gas through the cooler *b*, placed above the pan, and discharges it under pressure of about

10 lb. of water through the outlet pipe *c*. As the exhauster creates an inward suction, there is no escape of smelling gases from the furnace. The object of cooling the gas (*d* shows the water-inlet) is to protect the exhauster (which is partly made of lead) and to prevent the gas from reaching the saturating-tanks at too high a temperature. By taking off the top cap, the exhauster and the whole apparatus is accessible for cleaning and renewals. This furnace is made in three sizes for burning 10, 20, or 40 lb. of sulphur per hour, and is specially intended for the manufacture of sulphites.

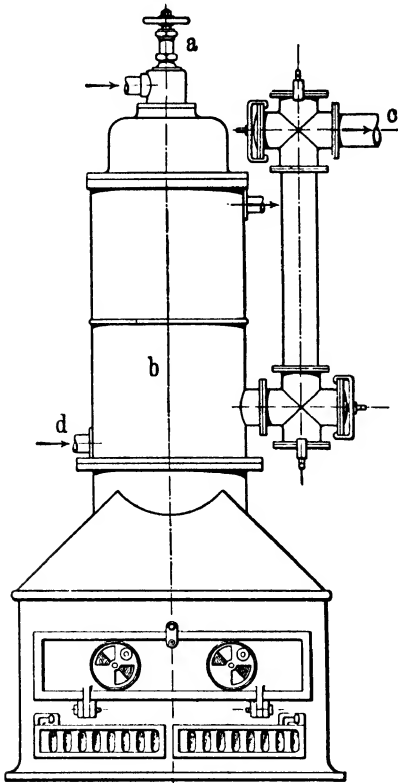

FIG. 18.

the S is converted into spray and intimately mixed with the air.

The *Sachsenburger Maschinenfabrik* (Ger. P. 196371) describe the sulphur-burner shown in Fig. 19. The sulphur is introduced at *i*, and ignited through the opening *n*, air being supplied by pipe *a*. The SO_2 escapes by pipe *b*, and molten sulphur collects at the bottom of the furnace. Fresh sulphur is introduced through *e* into the funnel *f*, the lower end of which is luted by the molten sulphur in *c*. The upper portion of the

Lyman (Amer. P. 911735) attains the complete combustion of brimstone by running the melted S, together with air, into a chamber, so that

funnel is water-cooled by the tank *o*. Compressed air may be introduced into the pipe *b*, to burn any sulphur sublimed there.

Clark (Amer. Ps. 952098, 952099, 952100) admits hot air into the sulphur-burner, in order to effect the combustion of any vaporised sulphur, and keeps the gases at about 1100° , in order to decompose any SO_3 that may have been formed. His furnace comprises a preliminary combustion-chamber, and a second combustion-chamber into which the products from the first chamber are directed. Means are provided for the admission of hot and cold air, and for the regulation of the furnace temperature.

Grimm's sulphur-burner (B. P. 10774 of 1909; Amer. P. 957418) consists of a combustion-chamber suspended in the upper part of a metal jacket, through which water is made to flow. The sulphur is contained in a loose tray, slightly raised above the floor of the chamber, and air is supplied under

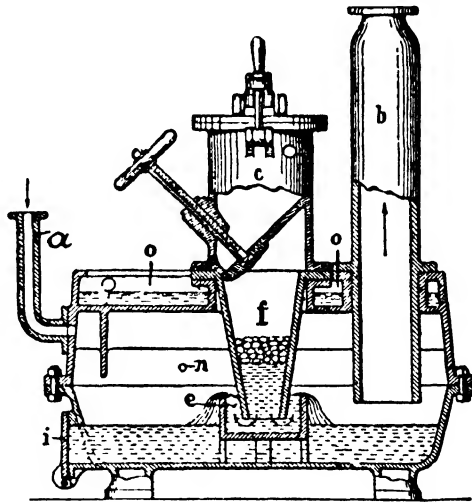

FIG. 19.

pressure. The gas passes out of the furnace and then back through a number of cooling-pipes situated in the lower part of the jacket; any proportion of air may be mixed with it by means of a valved by-pass from the air-supply pipe. Molten sulphur may be supplied as required from above by means of a screw valve. The supplies of air and sulphur are thus under perfect control, and any desired temperature may be maintained, gas of any desired concentration being continuously produced.

Westgate's burner (B. P. 17348 of 1909) is very similar to the preceding.

Contamin (Amer. P. 996215) employs for the production of SO_2 for fumigating, etc., a combustion-chamber containing

superposed plates to hold the burning sulphur and baffle-plates to give the gases a zigzag course through the chamber; then follows a chamber with cooling-pipes around which the gas flows; from this the gases pass through a pipe with reticulated terminus into a dust-chamber, provided with baffle-plates, from which they are taken by means of a pump into a refrigerating-chamber containing baffle-plates and cooling-pipes.

Oddo (B. P. 21255 of 1908; Ger. P. 225321; Fr. P. 397450) describes brimstone-burners, similar to the Malétra and Herreshoff burners for pyrites smalls, both for operation by hand, and in circular mechanical furnaces with four stories, provided with a vertical spindle with radial rotating arms.

He discusses his processes for utilising raw brimstone ores directly for the manufacture of sulphuric acid in *Chem. Zeit.*, 1910, pp. 505-507, 514-515.

Stebbins (Amer. P. 934700) supplies fused sulphur to the burner automatically and continuously, without opening the front door, which always causes irregularities in the entrance of air. The proper quantity of air is constantly introduced, and a mixture of SO_2 and air of perfectly constant composition is produced.

Thalin (Norw. P. 20450) burns sulphur-vapour with the requisite quantity of air in a revolving drum; the non-oxidised sulphur-vapour is precipitated in a special chamber and burned.

G. E. Miller (Amer. P. 1018255) provides brimstone-burners with an automatic feeding arrangement, and with a mechanical agitator operating beneath the surface of the burning sulphur.

Feld (B. P. 21996 of 1911; Ger. P. 262326) describes an apparatus in which the sulphur is burned in two stages, the sulphur being volatilised in a horizontal bottom chamber, where part of it is already burned; the vapours go into another, perpendicular chamber, placed above the bottom chamber, where they are burned. The top chamber is surrounded by a pipe; the air serving for the combustion of the sulphur passes through the concentric space thus formed, where it is pre-heated, and enters below into the chamber by a slot. In the centre of this chamber there is a perpendicular pipe for supplying the brimstone.

Whalen (U.S. P. 1065750) passes the gases from the sulphur-burners through a chamber provided with interchangeable partitions, where they meet air, so that any sulphur carried along is here burned.

Temperatures in Sulphur-Burners.

Stefano Pagliani¹ states that the theoretical temperature at which sulphur burns in the calculated proportion of air is found to be 1616° at constant pressure, and 2000° at constant volume.

The calculated maximum temperature attainable by the combustion of sulphur in the quantity of air required to yield burner-gases containing about 10 per cent. SO_2 is 900° . The author measured, by means of a Le Chatelier platinum-rhodium thermocouple, the temperature in different parts of the interior of a sulphur-burning furnace of simple construction in a sulphuric-acid works. In one case the temperature in the space above the burner pan or plate was found to be 340° 10 minutes after charging, and 495° after 85 minutes; in another case it was 370° after 15 minutes, and 420° after 25 minutes; and in a third case 520° after 90 minutes. The highest temperature observed, viz. 550° , was in the discharge conduit leading from the furnace to a dust-chamber. In furnaces for the extraction of sulphur from crude native sulphur by the heat developed by combustion of a part of the sulphur itself, the most suitable temperature is about 330° - 340° . The low efficiency of such furnaces is due to the need for using a large excess of air that the ignition temperature of the sulphur does not exceed about 340° ; the ignition temperature is about 250° with a large excess of air, 445° in air containing 5 per cent. SO_2 , and 465° in air containing 10 per cent. SO_2 .

Some interesting tests were made on the Vesuvius sulphur-burner (*infra*, p. 309) installed at Marathon Paper Co., Rothschild, Wis., for the temperatures of the burner-gas in the combustion-chamber, and the pyrometer tests were made in the following manner:—One hole was drilled in the gas-outlet pipe twelve inches below the oxidiser, and another about twelve inches above the oxidiser.

¹ *Ann. Chim. applicata*, 1915, 4, 75-81; *J. Chem. Soc.*, 1915, 2, 766.

Six Tests made on the Lower Hole.

	Outside Temperature.	Inside Temperature.
1st	74°	730°
2nd	64	470
3rd	64	430
4th	67	440
5th	72	460
6th	72	470

Three Tests made in Upper Hole.

1st	62°	460°
2nd	85	690
3rd	85	685

The tests of SO_2 by volume during the pyrometer tests were 17 per cent., 17.5 per cent., 18 per cent., and 18.5 per cent. However, when the percentage of SO_2 increased above 18 it would show sublimation of sulphur.

Residue from Sulphur-Burners.

The following analysis of the residue from the sulphur-burners has been made by Richardson¹:—

Sodium sulphate ²	13.77
Calcium sulphate ³	28.49
Calcium silicate ³	15.91
Sodium silicate	1.10
Ferric oxide and alumina	2.80
Water and sulphuric acid ²	13.05
Insoluble	24.29
	<hr/>
	99.41
	<hr/> <hr/>

The amount of residue being very small, it is quite possible to judge by mere inspection whether the combustion has been perfect or not. In doubtful cases a sample is tested for free sulphur by heating in a porcelain capsule, or by oxidation with aqua regia.

Cooling the Gas from Sulphur-Burners.

If these gases are to be employed for the production of

¹ Richardson and Watts, *Chemical Technology*, I (5), 198.

² The sodium sulphate and the free sulphuric acid (or rather the acid sulphate) evidently come from the nitre-pots boiling over.

³ The lime no doubt comes partly from the brickwork of the furnace.

calcium-bisulphite liquor for the manufacture of wood-pulp, they must be not merely cooled, but also purified from sulphur trioxide.

A special cooling of the gas from sulphur-burners for manufacturing sulphuric acid (as distinct from that of bisulphite of lime) is, as a rule, unnecessary. Even where no cooling takes place by water-pans, steam-boilers, etc., the gas gets into the draught-pipe sometimes at only about 100° or 120° , which is just sufficient to prevent the nitric acid condensing before it gets into the chambers, a contingency decidedly to be avoided. Where water-tanks, acid-pans, etc., are used, the temperature of the gas is said to come down as low as 40° ; in this case only liquid nitric acid can be used for the chambers. In Blair's or Glover's continuous burner the temperature certainly rises much higher; and in this case a cooling arrangement was formerly thought indispensable, before means had been found of utilising the heat of the gases in a Glover tower or otherwise.

B. SULPHUR DIOXIDE FROM PYRITES

1. Breaking the Pyrites.

The pyrites imported into this country is of such a size as can be conveniently fed into the ordinary jaw crusher, and is of sufficient purity to render a previous separation from gangue quite unnecessary.

Several firms known to the writer still crush by hand, using heavy sledge-hammers to bring down to 6-inch pieces, and then finishing with the light knapping hammers. The mechanical method produces much more "fines," in some cases at least double the amount of that formed by hand-breaking, the explanation being that, in the latter case, the fracture follows a certain natural cleavage, which leaves the ore otherwise intact, whilst in the former method the machine tends to shatter the ore by starting fractures in several directions where it does not actually produce a cleavage.

Jaw Crushers.

The Blake Crusher appears to be the earliest machine of the jaw type, being introduced over fifty years ago by an

American of that name. This type has been the standard ever since, and is generally used for the rough breaking of ore, reducing it down to pieces from 2-inch to as low as $\frac{1}{2}$ -inch according to the adjustment of the jaws.

The sizes of the jaw openings range from 10" \times 6" in the smallest commercial machine to 84" \times 60" in the largest.

The larger breakers are not, however, suitable for making so fine a product as the smaller machines, their function being

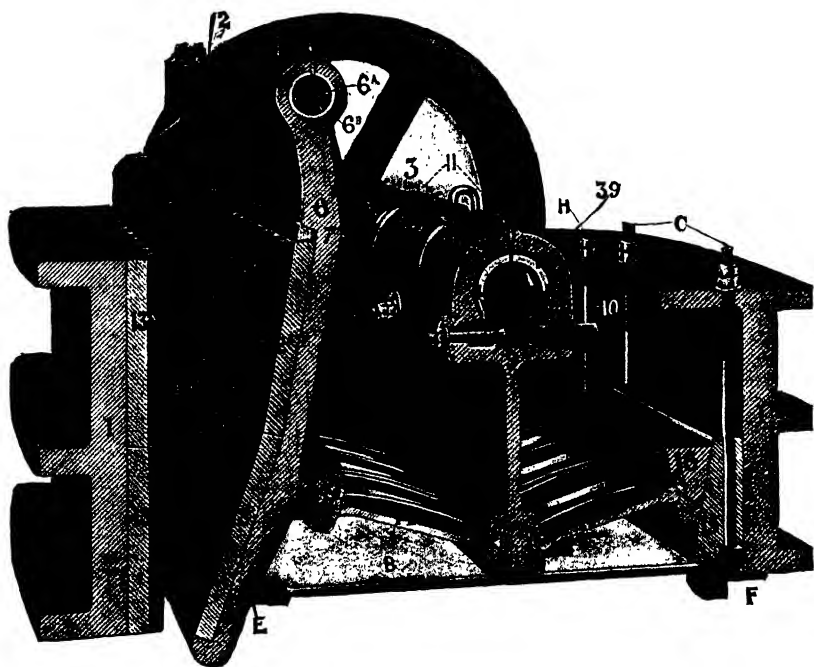

FIG. 20.—Blake Crusher.

that of sledging the material preparatory to feeding the breakers that carry out the secondary reduction.

The growing adoption of steam shovels and mechanical diggers calls for these "sledgers," so as to maintain continuity of operation in the mechanical handling of material to the exclusion, so far as is practical, of manual labour.

Fig. 20 illustrates one of Messrs Hadfield's machines with a jaw opening of 30" \times 18". This is capable of crushing 40 tons of Spanish ore per hour down to 2", the product being in the

proportion of 34 tons of the larger size, with "fines" equal to 6 tons passing through $\frac{1}{2}$ " mesh; on some of the Norwegian, such as Orkla ores, however, the output would probably be half the amount mentioned.

Other makers of this type of machine are: Broadbent; Marsden; Pluver Crusher Co.

Gyratory Crushers.

About thirty years later a type of gyratory crusher was introduced, consisting of a vertical spindle with a conical head attached, which is set inside a very massive frame, circular in plan. The shaft is set up into an eccentric bushing or bearing, to which the gearing is attached, the effect being to give the spindle a gyratory motion varying in stroke with the size of the machine, from $1\frac{1}{8}$ " to 3" at the bottom of the spindle. The ore is brought directly into the hopper, the circular head serving to distribute the material. The crushing movement commences at the top, the ore being gradually reduced in size until it reaches the narrowest point between the crushing head and concaves, and then passes out. The crushing faces of the machine are lined in segments made of manganese steel. Several sizes are on the market, varying in capacity from 150 tons down to 4 tons per hour. A typical machine is illustrated in Fig. 21, and is made by Hadfield's Ltd.

This machine has the advantage of large capacity with small consumption of power.

The Blake type of crusher is superior so far as concerns the size and shape of the feed opening, and the ease with which it may be repaired and overhauled.

Symon's Disc Crusher.—This machine is also constructed by Hadfield, Ltd., and is known by the name of "Hecla" (Fig. 22).

A new crushing principle is embodied in the design. As the name implies, the operation is performed between the two discs, saucer-shape, and set with their hollow or concave sides facing each other, thus forming a cavity between. They rotate in the same direction, at the same speed, and are supported at an angle to each other. The ore is fed through the central feed-spout and is thrown by centrifugal force into the opening

where the discs are widest apart. It is carried round by these to where they are closer together and is crushed in the operation. The smaller particles fly out from between the discs into the encircling chute, whilst the larger ones are caught again until the requisite fineness is attained.

There are several advantages in this machine over other

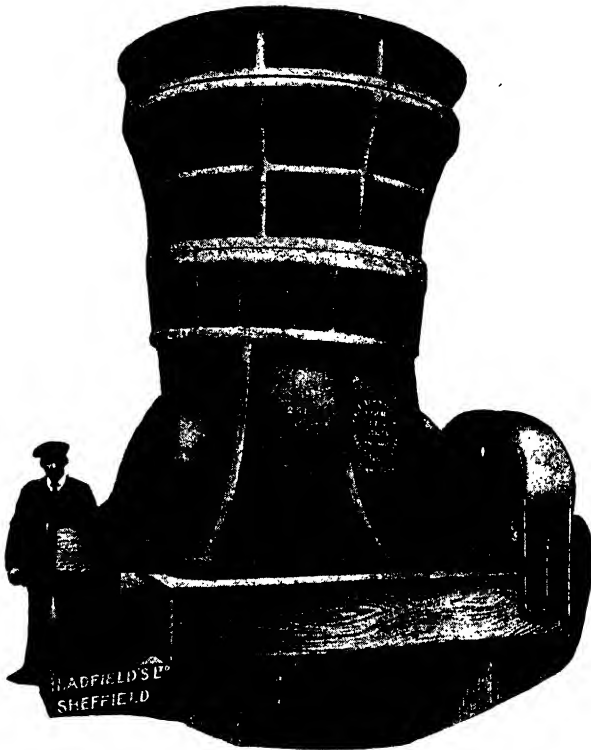

FIG. 21.—Gyratory Crusher.

types. The particles are quickly separated and no congestion takes place; the wearing parts can be easily renewed, and the size of particles regulated by adjustment.

This machine differs from those just described, in that its principal use is in connection with ore-mining as a secondary machine, or a medium-size crusher, the feed being limited to a definite size according to the particular machine used. Its output is high and the material discharged is very regular, and

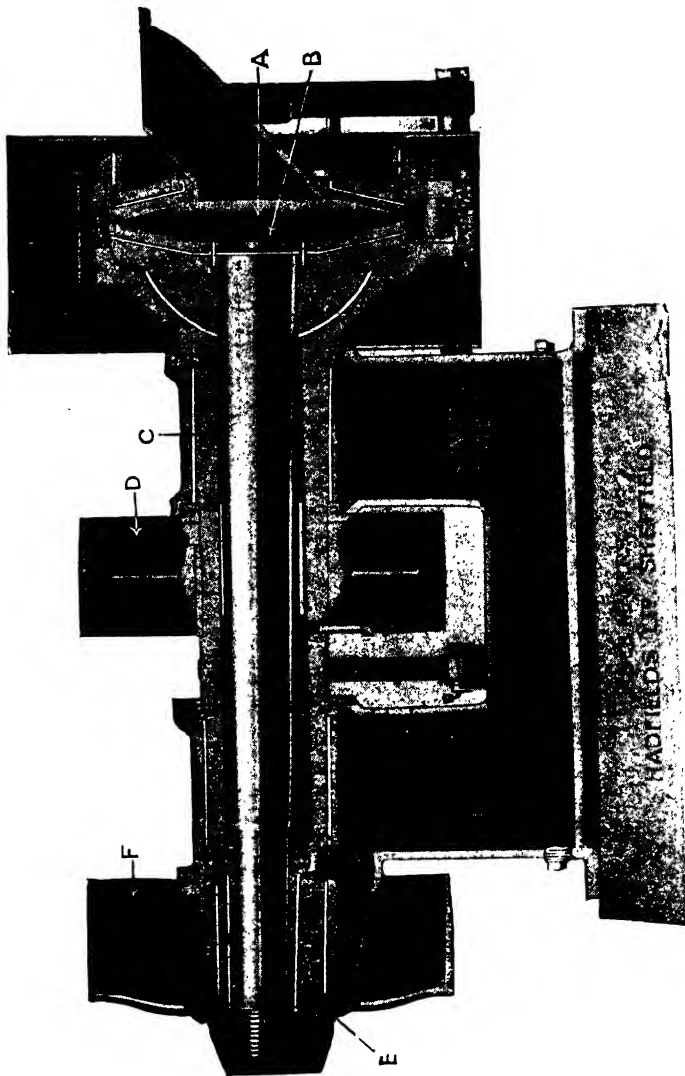

FIG. 22.—Disc Crusher (sectional view).

where the feed, size, and product desired are suitable for this machine, its regularity in output is very satisfactory.

Roll Mills.

Another class of machines for reducing ore is by the well-known rolls, two such being used, of an average size of

30 in. diameter by 15 in. to 30 in. wide on the face. The faces revolve towards each other at a distance apart, varying with the size of the material required. This type is chiefly used where the product is desired to be from $\frac{3}{8}$ in. to $\frac{1}{16}$ in., and one advantage of this kind of mill is that it produces a minimum of "fines."

The faces become worn and then allow a certain amount of material to pass through which has to be returned for recrushing. This drawback, however, is easily overcome, as the faces can be turned down and made true again. Rolls are very suitable for grinding the burnt cinders (*cf. infra*).

Other Crushers.

Mansfield Granulator.—This machine has been designed for the purpose of reducing all kinds of ore to powder, or it can be adjusted to give varying-sized pieces. The construction is such that it is almost impossible for it to get out of order. The renewal of the wearing parts is very easily accomplished. Figs. 23 and 24 show what is termed the No. 2 size.

The heavy wedge-shaped hammers hang loosely at their extremities on the steel spindles. The screens or grids are made of segments of special alloy steel. The speed of the mill is regulated according to the material to be dealt with and degree of fineness required.

When the mill is in motion, the hammers (notwithstanding the fact that they hang loosely on their shafts) fly out by centrifugal action and make a complete circle in the chamber.

The material is projected against the plates, and the action repeated until it is fine enough to pass the screen.

Should impulverisable material by unforeseen circumstances enter the granulator, no harm is done, an easy means being provided for extracting it without undue delay.

The experience on hard pyrites, such as Orkla, has shown that this machine will pulverise so as to pass $\frac{1}{2}$ " mesh with ease.

The hammers, however, have to be changed for every few hundred tons put through, but this operation does not occupy above half an hour.

The "Dodge" Crusher has a jaw, the moving force of which

is attached to a lever worked from an eccentric shaft by means of a pitman, and the action is to oscillate the lever upon a

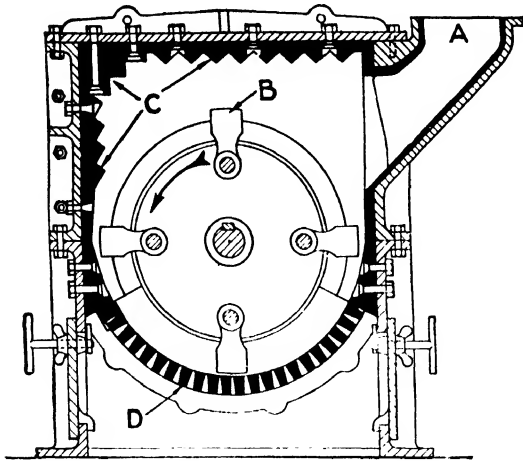

FIG. 23.

fulcrum pin, so that the greater part of the movement is upon the upper part of the jaw.

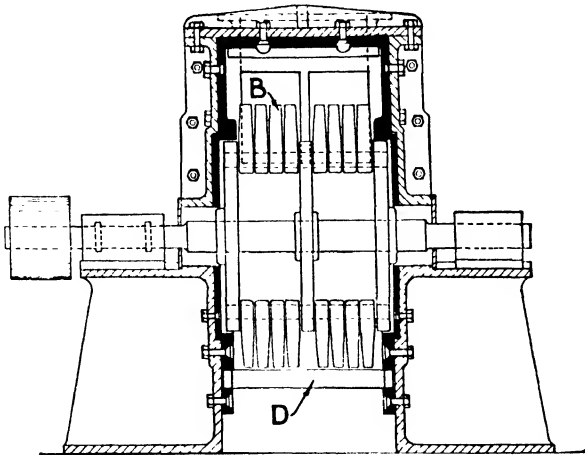

FIG. 24.

This is a departure from accepted practice, but the type possesses certain advantages. The product is of more uniform size and can be easily determined by adjustment.

2. Pyrites-burners for Lumps.

Among the apparatus for burning pyrites in the manufacture of sulphuric acid, a distinction has to be made between those intended for lumps and those intended for smalls. It is indispensable to keep both kinds apart, and to employ different

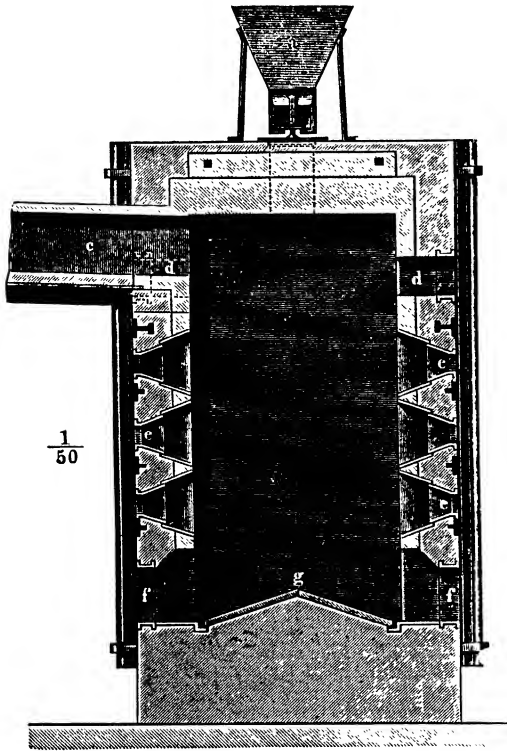

FIG. 25.

apparatus for them; for if the broken ore is put into the burner without separating the smalls, the air-channels, which ought to remain between the pieces, are soon partly stopped up with powder, and the access of air becomes irregular, and proper work is impossible. Apart from the coarser and finer powder obtained on breaking, a great deal of smalls comes into the trade direct from the mines, obtained there by separating the ore from the gangue.

Where cuprous pyrites is roasted without any regard to the utilisation of the sulphur, the only object being the extraction of the copper, usually no regular kilns are employed at all, but the ore is burnt in "heaps." This was formerly done on an enormous scale in the south of Spain; but the damage to health and vegetation was so great that a law was passed compelling manufacturers to abate this nuisance.

The burning of pyrites in lumps for the manufacture of

sulphuric acid is always done in such a way that the combustion heat of the pyrites is utilised for maintaining the process without employing any extraneous fuel. The furnaces are called "kilns" or "burners."

For poor ores and intermediate products which must be treated at metallurgical works (p. 146 *et seq.*), furnaces are required of a different kind from the grate-burners now universally employed for good pyrites in lumps. The style of kilns used at the Muldenhütten near Freiberg is shown in Figs. 25, 26. They serve for poor iron-pyrites containing

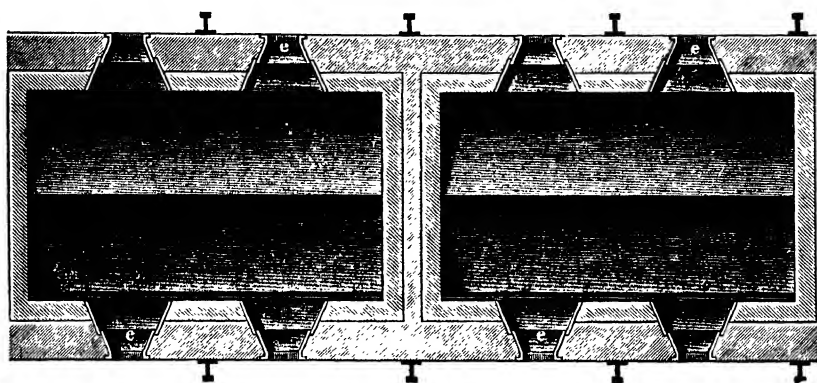

FIG. 26.

blende and arsenical pyrites, as well as for lead- and coppermatte.

The grate formerly employed at Freiberg has been replaced by slanting cast-iron plates, *g*. The air does not now enter through special channels, but through the discharging and working holes. *a* shows the charging hopper, *c* the exit channel for the roasting-gases, *d* openings for spreading out the charge, *e* working-holes, *f* discharging-holes. Each kiln roasts about 25 cwt. of pyrites per twenty-four hours; 5 kilns are combined in a set. The sulphur is roasted off to 4 or 5 per cent. left in the cinders.

For richer and purer pyrites, grate-burners are employed at Freiberg consisting of 3 kilns, with 25 sq. ft. grate surface each, and a distance of 4 ft. from the movable grates to

the crown of the arch. Each set roasts about 36 cwt. pyrites per twenty-four hours down to 2 or 3 per cent. S.

The kilns used at Oker are exactly like the Freiberg kilns just described. They are of two different sizes—deeper kilns (with a layer of ore 9 ft. deep) serve for the poorer ores, shallower kilns (the ore lying 6 ft. deep) for the richer ores. The English grate-burners, formerly employed at Oker, have not been found suitable for this class of ores.

The kilns described above have been found indispensable for roasting poor ores, matte, etc., where the sulphuric acid is a by-product and where the heat generated in the process is less than when roasting ordinary pyrites, containing at least 40 per cent. sulphur, usually a good deal more, such as is now universally employed for the manufacture of sulphuric acid as a principal product. For such richer ores the kilns or burners ought always to be constructed with *grates and ash-pits*. This causes a considerable improvement in the working of the furnaces. Where the air has merely to pass through a mass of burnt ore, its quantity cannot possibly be regulated at the inlet, but only by dampers at the other end of the furnace. It is even a more serious disadvantage that in this case the subdivision of the air inside the burner must be very irregular. According to the greater or smaller resistance offered by the individual portions of the layer of pyrites, the air will pass through very unequally, and in less quantity at the places where most pyrites is lying and where it is most required. The introduction of a grate and a closed ash-pit alters the case at once, as only a definite quantity of air need be admitted into the ash-pit, and this air must first spread equally underneath the grate and rise all over the area of the burner. Thus the ore is much more completely burnt, and at the same time richer gas is obtained, which leads to a better working of the chamber-process, higher yield of acid, and smaller consumption of nitre; the operation of drawing out the burnt ore becomes much more regular and offers a greater guarantee against raw ore getting into it; lastly, it does not happen so often that fused masses ("scars") are formed in the burner, although in the case of grates this easily happens if the method of working is faulty.

The introduction of grates led to a diminution of the

height of the burners, which made them much handier for working.

The different descriptions of grate-burners which were introduced into England about 1860, and have been employed

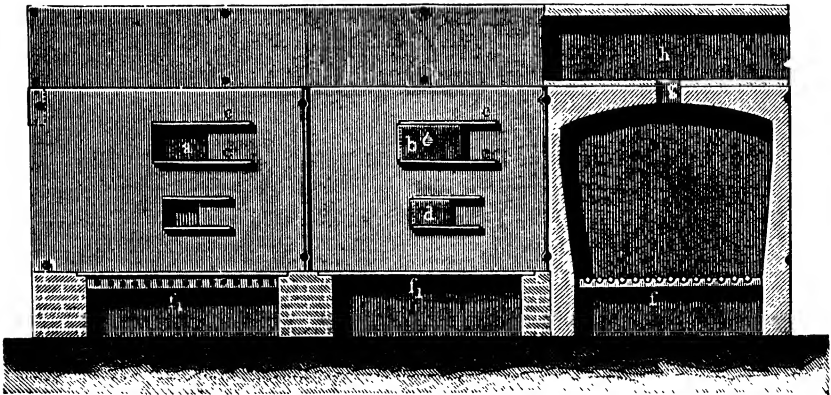

FIG. 27.

up to this day both there and in many factories abroad, are shown in Figs. 27-31.

Figs. 27, 28, 29 show a somewhat simple construction,

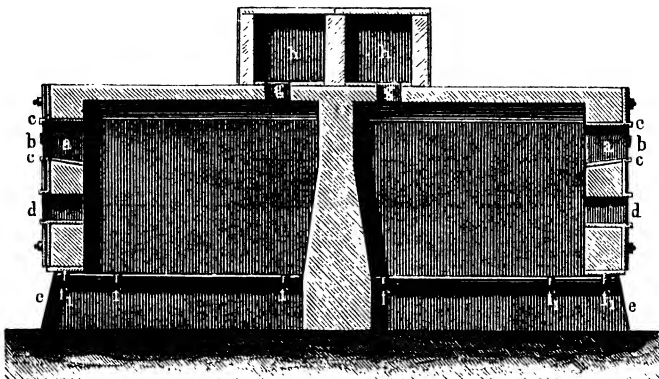

FIG. 28.

which can be made with open sand-castings; Figs. 30 and 31 a more expensive kind of front plates, requiring planing, etc.: the latter are much neater and cleaner, because no jointing is required for the doors. Sometimes these front plates,

however, become a little warped, and then the doors are not tight without claying up.

Fig. 27 shows two burners in front elevation and one in section, the first burner without doors. Fig. 28 is a cross section, showing two rows back to back; Fig. 29 a sectional plan, half taken just over the grate, half through the middle of a door. *a* is the charging-opening, with the door *b*, which slides in the grooved ledges, *c c*, provided on the front plate. The small door *d*, only to be used exceptionally, is arranged in precisely the same way. The openings of the brickwork inside are protected by small metal plates; *e* is the movable cover

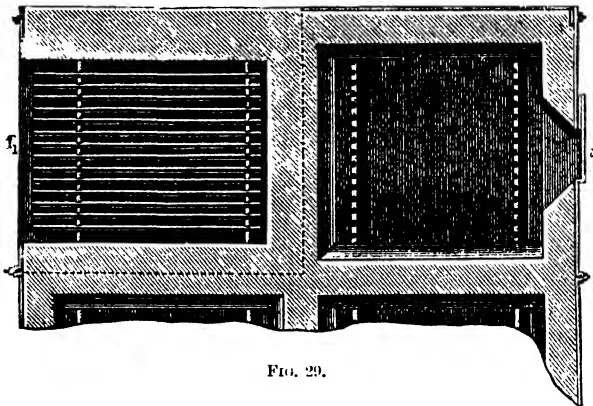

FIG. 29.

of the ash-pit, provided with air-holes; *f f* are the grate-bearers; the front bearers are perforated with round holes, while the back bearers are cut out in semicircles. The arches are sprung parallel with the working-doors, and by the draught-holes, *g g*, are in connection with the gas-flues, *h h*. The latter, like the burners, are cased in metal plates; they are covered with fire-tiles.

A somewhat more costly but better arrangement is shown in Figs. 30 and 31, in front elevation and two sectional elevations. *a* is the working-door, with the small slide *b* for observing the interior of the burner; all the metal parts coming into contact are machined, so as to close air-tight. The doors *c c* for the grate bars and *d* for the ash-pit are constructed in the same way, whilst the rarely-used doors *e* and *f* (the latter for the gas-flue) are made in a similar manner

(Fig. 30). The burners are supposed to be, the last of the row; so that the nitre-oven *g*, with the semi-cylindrical trough

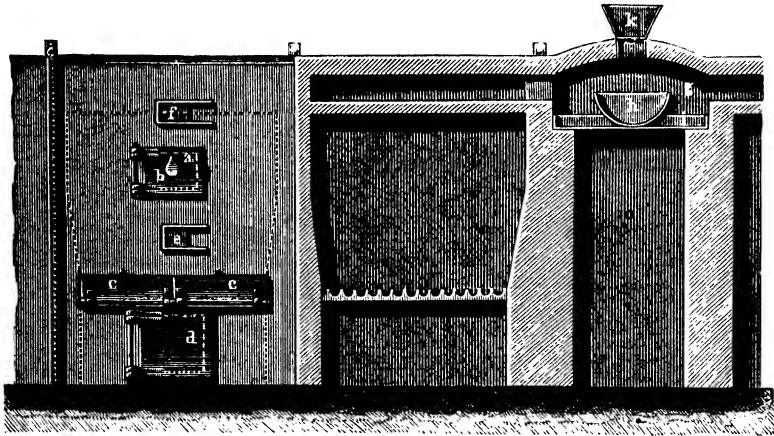

FIG. 30.

h, the saucer *i*, and the hopper *k* adjoin them. The diagrams are all on a scale of 1 to 50.

English pyrites-burners generally have grates of moderate area, about 4 or 5 ft. wide, and $4\frac{1}{2}$ to 6 ft. from front to back. The inner walls sometimes rise quite perpendicularly; more frequently the two sides and the back slant a little outwards, up to the level of the working-door, to the extent of 6 or 9 in. in width, and half as much in the back; from that level the walls rise again perpendicularly up to the roof. The front wall, which is only 9 in. thick, and mostly protected by a 1-in. or $1\frac{1}{2}$ -in. metal plate, rises perpendicularly, and has several working-holes. The ash-pit has either vertical sides or, preferably, sides converging towards the bottom, in order to facilitate the removal of the cinders. Its depth varies from 16 to 24 in. The level of

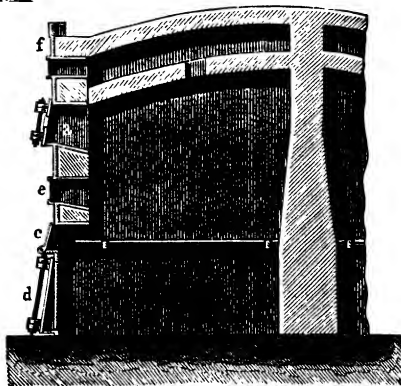

FIG. 31.

the working-doors, which determines the depth of the layer of pyrites, varies from 1 ft. to 2 ft. The height from the upper level of the ore or to the abutment of the arch is usually about equal to that of the working-door, say $9\frac{1}{2}$ to 12 in., and from there up to the crown of the arch another 8 or 9 in. The arch itself is either sprung from side to side, as is the custom on the Tyne (whereby the walls are made to bear the weight more equally and the working through the doors is facilitated), or, as is usual in Lancashire, from front to back (which is more advisable in the case of two rows of burners being built back to back, in which case the arch is sprung over both burners together, with a supporting wall in the centre). In any case it is advisable to build the burners back to back, even with arches sprung from side to side, wherever it is locally possible; thus one back wall is saved, the heat is kept up better, and a common gas-flue can be employed.

The *gas-flue* of the English burners is always at the top, each burner-arch having a hole of 4 to 5 in. square leading into it. These holes are not always provided with dampers; but by gradually increasing the size of the holes as the distance from the main shaft becomes greater, regularity of draught is produced. The flue itself can be made of bricks, and covered with fire-tiles. Most modern works prefer forming it by a second arch, about 6 or 12 in. above the burner-roof, reaching right across the whole burner, and supported by the front plate being made high enough.

The principal feature of the English pyrites-burners, which is found in all Continental works as well, except in some burners for metallurgical purposes (Mansfeld or Freiberg kilns), is the



FIG. 32.

employment of *grate-bars* of square section, movable in bearings, and leaving larger or smaller spaces between them, according to their position. Fig. 32 represents such a grate-bar, showing also the parts which are forged or machined with a circular section, so that they can easily turn in the respective bearers. Bars 2 in. square are usually made of wrought-iron; the

oblong bars, 2 by 3 in., which, being turned on edge, leave a larger space, and therefore only suit larger pieces, are mostly of cast-iron. The grate-bars rest on cast-iron bearers, as shown in Fig. 33; in the shallower kilns ($4\frac{1}{2}$ to 5 ft. from front to

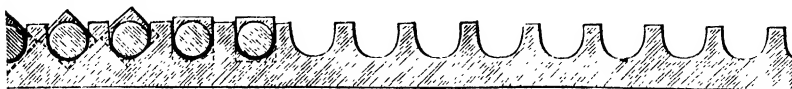

FIG. 33.

back) there are two such, in the deeper kilns (5 ft. 3 in. to 6 ft. from front to back inside) three. According to this, of course, two or three rounded places must be provided on the bars themselves. Lest these should be weakened too much, the diameter of the round parts in the square bars is made equal to the side of the square, in the oblong ones equal to the smaller side. In any case the front piece of each bar, where it projects beyond the bearing-bar, has a square or oblong section, so that it can be turned by means of a suitable key or spanner (Fig. 34). The spaces between the grate-bars are mostly arranged so that with 2-in. bars they are about 2 in. when the

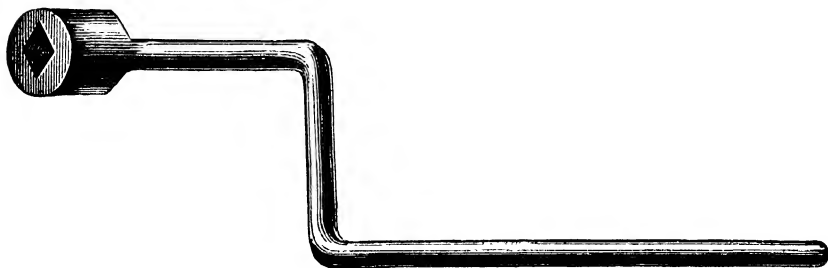

FIG. 34.

bars are in the situation shown at *a* in Fig. 35; but if they are turned 90° , as at *b*, the intervals will only amount to $1\frac{1}{4}$ in. In another actual instance the diameter of the bars was $1\frac{1}{4}$ in., the clear distance in the straight position $1\frac{1}{2}$ in., in the diagonal position 1 in. If, lastly, the situation is as at *c*, where half of the bars are turned, the intervals will be between the two above limits; and as each bar can be turned separately, many combinations can be produced. Usually the bars stand as at *b*—that is, all with their diagonals in a horizontal plane, or with the smallest possible intervals, so that the pieces of ore cannot

fall through. As soon as a portion of the ore has to be removed, the attendant takes hold of the front end of the bar with his key, and moves it a few times from side to side. Thus a kind of crushing action will be exercised on the cinders getting between the two bars, the spaces are momentarily enlarged, and the cinders jammed between the bars are forced downwards. At the same time, by the action of the key, the pyrites is loosened up to a certain height. The workman now goes from one bar to another and shakes them, according to his judgment, so far that an equal quantity of burnt ore is drawn out all over the area of the grate. That which has fallen through is allowed to

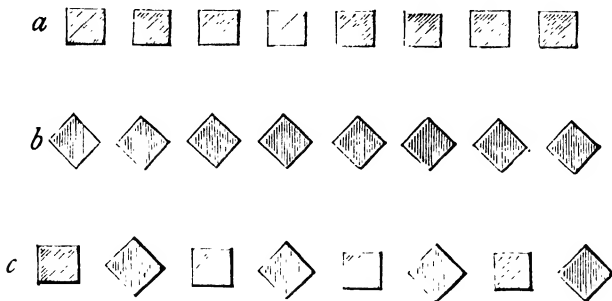

FIG. 35.

lie in the ash-pit till the time comes, once every twenty-four hours, for opening the bottom door and taking away the cinders.

A shape of bars which was said to possess great advantages over the ordinary angular ones was patented by W. Helbig,¹ and is shown on p. 222 of Lunge's second edition, but omitted here, as it seems to have found no practical application. It was a cast-iron bar with a worm-thread round it.

A burner patented by Harlan & Grenshaw (Ger. P. 100243) contains hollow grate-bars, with tapering, narrow chambers, rising vertically nearly to the top of the layer of pyrites, so that the air enters not merely at the bottom above the grate, but also higher up, nearly to the top of the pyrites.

It is a great improvement if the *ash-pit* is deep enough for introducing an iron bogie below the grate whose top equals the whole surface of the grate in size; the ash-pit door, of

¹ *Dingl. polyt. J.*, 227, 67.

course, must be correspondingly large. The cinders in that case fall direct into the bogie, and can be wheeled out in a few moments; otherwise they have to be raked out by hand, during which time the door must stand open and much false air gets into the burner. Where there are not two rows of burners built back to back, it is possible to charge on one side and discharge on the other; but there is not much advantage in this arrangement, which takes a great deal of space.

The best and most easily worked arrangement is obtained by sloping both sides of the ash-pit, and providing a hopper large enough to contain the cinders produced in forty-eight hours, so as to avoid their removal on Sundays and holidays; the bottom of the hopper has only a small gate, air being admitted above the hopper through special openings.

The discharging of the cinders is then expedited by iron bogies running on tramways, which are in the ash-pits, and into which the cinders fall when the gates are opened. This very good plan necessitates a system of tramways and turn-tables, as well as the construction of a lower floor-level.

The capital outlay is a good deal greater, but several plants of this type have been built in England and Germany with good results.

The tilting-boxes described in Lunge's fourth edition, p. 432, offer a poor substitute, being very cumbersome and difficult to handle; they are now rarely used in this country, the workmen preferring to use the ordinary hand-barrow, where bogies on rails are not provided.

In order to avoid opening the whole ash-pit when shaking the bars, all the best furnaces are provided with a slot in the front plate, through which the ends of the bars are accessible; except whilst the bars are being shaken this is closed by a door.

Special Arrangements for preventing the blowing out of the Sulphurous Gases.—According to a communication from Mr K. Walter, a simple means of preventing the blowing out of gas at the working-door during charging is this: to arrange a flue underneath the burners, in connection with the chimney, which is opened during the charging just sufficiently to prevent any blowing out at the working-door. Less gas is lost and less nuisance is produced in this way than is otherwise the case

from the working-doors. With this arrangement, the ash-pits require only loosely put-on wrought-iron doors.

In England it would not be permissible to discharge the gas into the chimney, even for a short time.

In properly constructed pyrites-kilns, all *doors* for charging, working, shaking of the bars, and getting out the cinders either run horizontally in grooves, or, still better, they are hung on hinges; and the door-frame, cast upon the front plate, is made to slant forwards below, sometimes also sideways, so that the door lies fast upon it by its own weight. As both the door-frame and the edges of the door touching it are planed, the doors close tight without any luting, whilst those running in grooves must be made tight with luting clay.

All *brickwork*, so far as it is affected by the heat (that is, the walls above the grates, the arch, and the gas-flue), is lined with firebricks; the total thickness in front is one brick, behind (or in case of a partition between two rows of burners) two bricks. The side walls dividing each two burners of a row are $1\frac{1}{2}$ or 2 bricks thick, but they diminish upwards to 1 brick. The roof should be 9 in. thick. Fireclay should be used for the internal lining, and ordinary lime mortar is quite suitable for the outside brickwork.

F. J. Falding¹ constructs the first layer behind the cast-iron front plates of hollow bricks, so that air-channels are formed from the grates upwards to the top of the burner. This keeps the burner-room cool and easier to work in, at the same time obtaining heat for concentration in acid pans on the top of the burners, or for increasing the efficiency of the Glover tower, or for supplying the burners themselves with hot air, which is an advantage in some cases. The whole outside of the structure is preferably coated with tar, and in some cases non-conducting composition is of advantage.

Of course, the burners are well bound together, either by special uprights and tension-bars, or by flanges cast to the front plates, provided with holes for the cross-bars (Fig. 29, p. 330).

Opinions as to what *size* the burners are to be made vary a good deal. Frequently smaller burners are met with, about 4 ft. 6 in. to 5 ft. from the outside to the inside of the back

¹ *Min. Ind.*, 7, 666.

wall. The reason given for this is that longer grates cannot be served so well, and that in a larger burner the newly-charged ore forms too shallow a layer (the depth of the whole layer of pyrites, including the partially burnt ore, is not in question here).

Lunge in his fourth edition, p. 437, mentions having employed burners 6 ft. from back to front and obtained better results than most people. He, however, found it necessary to charge 7 cwt. at a time, and concludes: "As a result of long experience, I am inclined to consider a grate-surface of 4 ft. 6 in. by 5 ft. 8 in., and a depth of pyrites of 2 ft. 3 in., very favourable for burning 7 cwt. of 48 per cent. Spanish ore, changing once every twenty-four hours.

"The rate of burning just mentioned equals 30 lb. of 48 per cent. pyrites per superficial foot of grate in twenty-four hours. With poorer ore (40 to 42 per cent.) I have certainly burnt in the same grate 8 cwt. (= 35 lb. per sq. ft.), and with 38 or 40 per cent. ore even 9 cwt. (= nearly 40 lb. per sq. ft.)." In England the maximum quantity of pyrites burnt per square foot of grate will very rarely exceed 40 lb. of 48 per cent. pyrites.

From the writer's experience with burners¹ 4 ft. 3 in. long by 4 ft. wide, charges of 3½ cwt. were made every twelve hours (42·8 lb. per sq. ft. per twenty-four hours), with Orkla ore rather less (39·5 lb. per sq. ft. per twenty-four hours). With the Mannheim type of burner, using Peña ore, upwards of 52 lb. was possible.²

Such high rates should not, however, be reckoned upon in designing a plant, unless of course cuprous ore has to be used, where the sulphur content in the cinders need not be reduced below 4 per cent.

Sets of Burners.—It is hardly necessary to say that the pyrites-burners are always built in *sets*. Usually twelve to twenty-four burners are served by the same set of men; and they must be worked so that every one gets its regular turn, as is evident from the necessity of a regular evolution of gas. Frequently the burners are built underneath the acid-chambers. Not only must they in any case be protected by a roof against rain (if not placed underneath the chambers), but they must not stand in a space open at the sides, since strong winds would interfere with the draught, and cause them either to go too fast

¹ English type.

² Continental type. Cf. *J. Soc. Chem. Ind.*, 1922, p. 101T.

or to blow out at the doors. It is best to protect them by light walls or by a brattice with shutters adjustable according to the direction of the wind.

As the drawings of the English burners (p. 329 *et seq.*) show, each burner is independent of the other, and they do not communicate one with another, but only with the common gas-flue. Each burner, then, ought to have its own damper, which is not always the case. On the Continent, frequently the single burners are separated merely by low walls; the ore in this case lies only about 18 or 20 in. deep on the grates, and the whole set is like one large burner with a divided grate. It is, of course, in this case not possible, as on the English system, to treat each burner individually, to give it more or less draught, to isolate it for repairs, etc. Nevertheless, this system is in favour with some of the more experienced Continental manufacturers, who say that 18 in. depth is quite sufficient for the rich ores, now universally employed, and that the connection of the gas-space of all burners into one whole is preferable to the English system, because one burner can aid another and the whole is visible at a glance. Evidently this system answers its purpose as well as the English, but, from the writer's experience with both types, he favours the English method. In the Continental arrangement the burner nearest the Glover tower usually obtained the most draught, thus causing the burner farthest away to burn badly.

In Continental works possessing no Glover tower it is usual to concentrate the chamber-acid up to 144° Tw. in leaden *acid-pans*, which are mounted on the top of the burners, and are heated by their waste heat. The Glover tower having, however, made the use of lead pans superfluous, it is hardly necessary to employ pans on the top of the burners, such space being usefully employed for drying purposes.

A charging arrangement for pyrites-burners is described in the B. P. 2367 of 1912, and in the U.S. P. 1089304, of Battaille and Piperaut.

Buddeus (Ger. P. 285888) describes a kiln for roasting pyrites, in which the ore gets a preliminary roasting in an upper compartment, and descends through a grating, capable of being closed, to the lower compartment, where air is introduced under pressure.

Explosive pyrites is treated by the United Alkali Co. (B. P. 7915 of 1905) by previously heating for twelve hours on hearths, placed below the gas-flue near to the pyrites-burners, on a higher level, so that the pre-heated ore, which has now lost its explosive property, can be shifted downwards into the burners.

The explosive property of certain varieties of pyrites interferes with the burning of the ore in lumps, since the dust produced by the decrepitation of the lumps fills up interstices and prevents free access of air.

Gyander¹ determines the "explosibility" of pyrites by heating the sample in a covered dish at a high temperature until no further change is observed, and then cooling, screening, and weighing the material which remains on a screen of a certain size, whilst passing through a next larger size. It has been claimed that a gradual pre-heating of the ore will minimise the effect of "explosion," but in the author's experiments twenty-four hours' pre-heating at 120° to 340° had no apparent effect in diminishing the "explosive" quality. But even in the case of non-crumbling ores, the sulphur may be given up slowly during the combustion, so that to find the available sulphur content of an ore it is necessary to determine the rate of change compared with that of some other ore which behaves normally and contains a known amount of available sulphur. For this purpose 2 grms. of the ore, crushed to pass a 50-mesh sieve, is placed in a thin-walled silica dish. Three such dishes, of uniform size and thickness of wall, each containing a charge of ore, are heated at 538° in a sheet-iron rack in an electric furnace. After successive intervals of fifteen minutes, or longer if necessary, the dishes are separately withdrawn, and the reaction stopped by placing 5 grams of sodium carbonate on the top of the ore. The sulphur in each is then determined by breaking up the mass, fusing it with 5 grams of sodium nitrate, dissolving the melt in hydrochloric acid, separating the silica, and precipitating with barium chloride. From the amounts of sulphur found the rate of change may be calculated.

Burners for Roasting Copper-matte.—Haeger² describes the

¹ *J. Ind. Eng. Chem.*, 1917, 9, pp. 776-780; *J. Soc. Chem. Ind.*, 1917, p. 1004.

² *Berg- u. Hütten-Zeit.*, 1893, p. 383.

process introduced by him at Briton Ferry, near Swansea. The copper-matte produced there could not be roasted in Mansfeld kilns, nor in ordinary pyrites-burners. The desired result was obtained by increasing the heat, in the first instance by a suitable treatment of the matte, and in addition to this by improving the construction of the burners. The matte was rendered porous by tapping it on to a sand-bed slightly moistened and dusted over with fine coal. It was then crushed by a Blake's stone-breaker, in which one of the corrugated faces had been substituted by a smooth one, so that flat, more tightly lying pieces were obtained, which were separated from the smalls by a riddle with openings of $\frac{3}{8}$ in. width. The burners were of the ordinary shape of English pyrites-burners, described above, but of slightly different dimensions:—Grate-surface 4 ft. 3 in. by 4 ft. 4 in.; area at the level of the upper working-surface 5 ft. by 4 ft. 9 in.; height from grate-bars to the upper working-surface 2 ft., to spring of the arch 3 ft. 4 in., to the crown of the arch 3 ft. 8 in.; smoke-flue at the lowest point 6 in., at the highest 1 ft. 4 in.; total outside height 7 feet 10 in. The heating-up takes place from the top, exactly as described in the text; the burners are ready for work in two or three days. Each burner then receives a charge of from 6 to $7\frac{1}{2}$ cwt. of crude matte every twelve hours. The draught must be well regulated; there should be a slight plus-pressure within the burner. In this way mattes containing from 20 to 47 per cent. copper are treated. The poorer matte yields rather hotter and better gas and more sulphuric acid than the richer. With 20 per cent. matte the roasted product contains 9 per cent. sulphur, with rich matte it contains 11 per cent. sulphur; both are at once ready for the concentrating work. From 40 per cent. matte about 47 or 48 per cent. of the weight of roasted matte is obtained in the shape of chamber-acid of 110° Tw., with consumption of 0.8 to 1.0 nitre per cent. of chamber-acid. The gases are hot enough to thoroughly decompose the mixture of nitre and sulphuric acid in the nitre-oven and to denitrate the acid in the Glover tower; the acid flows from this with a temperature of 140° to 155° .

Working of the Pyrites-burners for Lumps.

In order to *start a burner* it is first, if newly built, dried by a slow fire in the usual way, and then filled with burnt ore to within 3 in. below the working-door. If no burnt ore can be procured, ordinary road-metal, etc., may be taken, broken sufficiently to pass between the grate-bars when they are turned. It is advantageous to open out the flue leading to the Glover tower in order to ensure sufficient draught on all the burners; fires are then made in each unit by means of wood, followed later by coke.

After twelve or twenty-four hours the burner and the uppermost layer of the ore will have reached a dull red heat; the rougher parts of the fuel still present are then drawn out and an ordinary charge of green pyrites is put on. By the heat of the burner walls, that of the ore below, and the fuel still present, the fresh ore will soon be lighted; when it is fully burning, the opening in the gas-flue is closed and the gas allowed to go to the acid-chambers. Care must be taken in lighting up not to go too far, which would damage the burners.

Thus the process is started; and it is now continued regularly and uninterruptedly till it has to be stopped for external reasons. Repairs are very rarely necessary in pyrites-kilns; but those of other parts of the acid-making apparatus may compel their stoppage. At some English works the dampers are put in every Saturday at midnight, and are opened only on Sunday at midnight; in the meantime all other openings are well closed; and the burner thus keeps its heat so well that the new charges at once take fire when brought in. If any temporary interruption of work does not last beyond four to six days, usually the burners can be kept hot enough in this way to be started without any fresh lighting-up by means of fuel.

The regular burning process has a double object, from which follow all the precautions to be observed. In the first place, the sulphur contained in the ore is to be burnt as far as possible; and, secondly, the quantity of air must be no more and no less than is required for the chamber-process. This means, besides the air necessary for burning the sulphur to sulphur dioxide,

introducing as much more *air* as is required for oxidising the latter to sulphuric acid, and, moreover, a certain excess of air found necessary in practical work.

The sulphates of iron, which are always partly formed as intermediate products, are decomposed again at a comparatively low temperature into Fe_2O_3 , O, and SO_2 , or into Fe_2O_3 and SO_3 , for which the heat of the burners is quite sufficient. This reaction does not go on quite so easily in the case of the sulphides of copper; but the temperature of decomposition of CuSO_4 is also within a red heat. Moreover, the copper-extraction works do not want all the sulphur to be burnt, but allow a residue of from four to at most six per cent. sulphur in the cinders. If, however, the ores contain blende or galena, which on burning are transformed into zinc and lead sulphates, the burner cannot possibly effect a total desulphurisation; for these sulphates are only decomposed at a temperature which is not allowable in a pyrites-burner, and they must thus remain as such in the cinders. Furthermore, if the pyrites contains calcium sulphate or carbonate, a corresponding quantity of CaSO_4 will remain in the residue. Any barium sulphate present would be missed in the testing of the pyrites or the cinders, being classed among the "insoluble."

In the case of the usual descriptions of pyrites, not containing any considerable quantity of zinc or lead, the burning of ore in lumps will reduce the sulphur in the cinders with good work to 3 or 4 per cent. Less than 3 per cent. of sulphur rarely occurs on an average of the whole year; but with very good ores it may go down to $2\frac{1}{2}$ per cent. Most frequently the limit stated above for good work is exceeded; some works leave 6 or 8 per cent. of sulphur, and even more, in their cinders, whilst their neighbours only leave 4 or 5 per cent. in the same ore. The fault of this may be due either to the description of burner employed or to bad work. If, by the construction of the burner, the pyrites forms too shallow a layer, and this is let down too soon on shaking the bars, it will easily come out badly burnt. But even if the burner is correctly built, much still depends upon the skill and care of the burner-men.

Excellent results are obtained with some of the very rich descriptions of Spanish non-cuprous pyrites which have for

some time past come into the market (p. 91). These pyrites can be burnt down to 0.5 per cent. of sulphur in the cinders, so that the latter can generally be sent straight to the blast-furnaces. But if this degree of purity is to be obtained, the place in front of the kilns, where the burnt ore is drawn out, must be kept perfectly clean, so that no green ore can get mixed with the cinders; and any portions of these which have been spilt from the discharging bogies on to the ground must not be shovelled back into them, as they will have some admixture of dust from green ore, but they must be put back into the kilns.

Much depends upon employing the ore in *neither too large nor too small pieces*, and upon keeping the pieces of as *uniform a size* as possible; only then will it be possible to regulate both the depth of layer and the draught in a satisfactory way.

Whether pyrites is properly burnt or not can be recognised to a great extent by the eye. By the burning-process the pieces swell out and burst; they become light and porous, and assume the red colour of ferric oxide, or, in the case of cuprous pyrites, a more blackish-red colour. The burnt ore ought therefore to consist of light porous pieces of the proper colour, apart from the powder always present in quantity, which is generally sufficiently burnt. On taking up the larger pieces, their weight will allow at once a rough judgment of the state of the burning; and this can be more distinctly recognised by breaking the pieces and observing whether they contain a raw core in the centre. The presence of many slags (scars) on the cinder-heap is another proof of bad burning.

Important as these empirical signs are, no well-managed factory will be satisfied with them, but will have the cinders tested daily, after having drawn a large sample and reduced it properly. In any case, the above-mentioned empirical signs have hardly any value for small ore.

The scientific principles of roasting processes are treated by Schenk,¹ especially with respect to the roasting of ores containing less sulphur than iron pyrites, such as copper pyrites and blende.

Keppeler² describes comparative trials on the burning of Norwegian and Spanish pyrites.

¹ *Z. angew. Chem.*, 1913, p. 641.

² *Chem. Zeit.*, 1913, p. 1219.

Channing (Ger. P. 250772) roasts pyrites in such a way that, apart from gases suitable for the manufacture of sulphuric acid, a residue (cinders) is obtained fit for the manufacture of iron. For this purpose he carries on the process in such a manner that the sulphur goes away as SO_2 , together with an excess of oxygen, and that all the iron present is converted into ferric oxide.

Debusch (Ger. P. 269774) carries out the burning of pyrites completely, in such a manner that the metals present, apart from the iron, viz. copper, zinc, and lead, are completely converted into sulphates. Since this, especially in the case of cupric sulphate, takes place at 600° to 650° , this temperature is attained by transferring part of the ore from the first to the third, from the second to the fourth burner, and so forth, with the result that in none of the burners is there such an amount of sulphur present as would cause an increase of the temperature beyond the above-indicated limit.

Koppers (Ger. P. 288322) burns pyrites in a kiln provided with a revolving conical grate, into which air is introduced by a central pipe and passes by fine openings into the kiln. The kiln is closed at the top by a dome, with central outlet for the gases; this dome is surrounded by a jacket, and the fresh ore is charged into the annular space thus formed. In order to prevent any sintering of the charge, by the temperature rising too high, steam is blown in along with the air.

The Nichols Copper Co. (Ger. P. 288013) provides, apart from the outside charging arrangement, an inside charger, consisting of a funnel and a periodically moved scraper.

The chemical testing of pyrites cinders (burnt ore) can take place by exactly the same methods as described in Chapter II for the analysis of pyrites.

The *sulphur* contained in the burnt ore is no longer in the form of FeS_2 , apart from any quite raw cores in large pieces. But even fine or quite porous cinders, burnt as well as possible, also those from pure pyrites free from lead, zinc, and lime, always contain sulphur; and as this cannot be present in the shape of FeS_2 , the question can only be whether the cinders contain FeS or sulphates of iron (most probably basic ferric sulphates), or both.

According to Troost, the first reaction in the burners is

$3\text{FeS}_2 = 2\text{S} + \text{Fe}_3\text{S}_4$. Regnault holds that the sulphide formed has the formula Fe_5S_6 . Lemoine,¹ from observations made in a Malétra shelf-burner, believes that in the upper layers there is always a distillation of sulphur, which afterwards burns with a blue flame. Lower down this is no longer the case, either because here most of the pyrites is already reduced to FeS , or because the temperature is too low and the supply of oxygen too great for the formation of free S . Ferric oxide appears only after roasting for two and a half hours. The action on pyrites seems to commence from the outside, where there is combustion into Fe_2O_3 , and the action of the heat thereby produced on the inner part brings about a decomposition into FeS and S . The S distils and burns outside, the FeS is oxidised by the Fe_2O_3 , which is again reformed by the outer air.

All that has been said (*cf.* p. 342) respecting the maximum of sulphur in the cinders to be aimed at, only refers to the burning of pyrites proper—that is to say, of ores containing essentially FeS_2 , and employed exclusively as a raw material for vitriol-making. Just in the same line are those *cuprous pyrites* (with less than 4 per cent. of copper) whose copper can only be extracted by the wet process; for these the above-mentioned rules for the sulphur in the cinders are equally valid. But the case is quite different with a number of ores where the residue from the burning is regarded as by far the most important product, and where the gas is only a by-product, often only converted into sulphuric acid in order to get rid of it. To this category belong blende, coarse metal, etc. Here the burning-down to the above-mentioned minimum of sulphur is hardly possible, nor even desirable (as for copper-pyrites); and there exist for each case definite rules, which, however, do not belong to the domain of acid-making, but to that of metallurgy. Even where a larger percentage of sulphur is required for further metallurgical operations, it is more rational, so far as concerns the acid-maker, in order to save labour, burner-space, etc., to burn the material as well as possible, and to supply the necessary sulphur afterwards by adding a little green ore; this is done, for instance, by the copper-extraction works when they receive the cinders too far

¹ *Fischer's Jahresber.*, 1899, p. 355.

desulphurised. The case of zinc-blende is special, and will be dealt with later on.

We now pass on to the second fundamental condition of proper work in the pyrites-burners, viz. *that neither too little nor too much air be employed*. At this stage we leave out of consideration the absolute quantity of air required, and only treat of the practical rules and of the appearances observed in the burners themselves. If too little air is admitted, whether because too few holes in the bottom door have been opened, or the damper in the draught-hole has not been enough drawn, or because the pipes are stopped up with dust, or the draught in the whole chamber system is insufficient from one cause or another, the same thing will happen as in the case of sulphur-burners when they get too hot: *sulphur will sublime* as such, and will be deposited in the flues, the dust-chambers, the Glover tower, or the chambers themselves. It is, however, a more frequent and serious consequence that, in the case of insufficient draught, the often-mentioned *slags* or *scars* are formed. The scars mostly enclose some green pyrites, and in this way cause a further loss of sulphur. A much greater loss is occasioned by their stopping the passage of air, so that the ore above and below a scar is very incompletely burnt. The heat is locally increased and driven further down than it ought to be; the zone of combustion is removed further downwards; and on letting down the ore part of the pyrites comes out incompletely burnt. If scars have formed in the burner, they naturally descend as the cinders are let down, and they would ultimately lie immediately on the grates and entirely stop them up. This, however, must be prevented by every means. A careful workman always breaks up the surface of the old ore before putting in a fresh charge; and thus he finds out whether any scars have formed, which mostly takes place near the surface: they can then be easily brought to the surface by means of hooks and pulled out at the door. But if they had been overlooked at first and have got lower down, in doing which they constantly increase in size, their removal is more difficult. Then a very large and heavy *poker* of the best tough iron (these are made up to 12 ft. long and 2 in. thick), bent in the way shown in Fig. 36, is introduced into the burner through the charging-hole, and the men work it till they have got the point *a*

underneath the scar. Several men, working at the end *b*, then try to lift up the scar, in spite of the resistance of the superjacent mass of pyrites. This labour is very disagreeable, exhausting, and difficult. The middle doors, between the charging-door and the grate, found in all pyrites-burners, are only used in extreme cases.

In the burners mentioned above, where the ore lies only to a depth of 20 in., scarring is next to unknown, at least if the ore is very carefully sized, so that all passing through a $\frac{1}{2}$ -in. riddle is kept out. This agrees with the facts which will now be explained.

Apart from other causes, the supply of air in a burner may be insufficient because the ore lies too deep. As the depth of the ore depends upon the vertical distance between the grate and the working-door, it follows that for ores behaving very differently in this respect differently-built burners must be used.

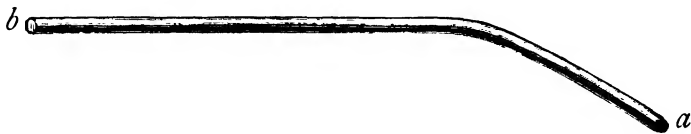

FIG. 36.

Thus the deep burners built for Irish pyrites had at once to be given up when Spanish pyrites began to be used. With the same height of pyrites which was just right for the poor ore, in order to keep the heat better together, the rich cuprous ore, in itself more fusible, became far too hot, and, moreover, the air could not pass through quickly enough to make a *complete* burning of the ore possible at every point; from both causes combined, it followed that the scarring became excessive. It is always much more feasible to burn poor ore in a shallow than rich ore in a deep burner.

Insufficiency of draught, if very considerable, will be easily recognised by the gas blowing out of all the joints of the burners, and especially coming out in force whenever the working-doors or the bottom door are opened. On the other hand, the draught should not be so strong that too much air will get into the chambers; the gas ought to be kept as rich as possible, as will be shown hereafter. It may be assumed that the draught is just right, if, on opening the small slide in the

working-door, neither gas nor flame issues from it, nor if, on the other hand, the flames inside the burner perceptibly tend towards the draught-hole. They ought to rise up perpendicularly and quite steadily; and on opening the door they may even tend slightly towards it. As, however, the exact regulation of the draught can only be effected by regulating the holes in the bottom door, and as on each opening of the doors above or below the grate much more air must get in than is necessary, of course the periods during which the doors are opened should be restricted as much as possible, and the charging, shaking of the grates, and discharging managed as quickly as possible. It is very advisable to close the holes in the bottom door completely while the top door is open. If the draught is not sufficient whenever the door is opened, the gas will rush out and get into the burner-house; this is both a loss and a nuisance.

For regulating the supply of air several plans are possible. The regulation takes place either *before* the grate, by the holes in the bottom door, or *behind* the grate, by means of the damper in the draught-hole or that in the large chimney behind the chambers, or else by fan (*cf.* Chapter I, Vol. II). Regulation behind the burners is only available where all the burners have a common gas-space; otherwise the draught through the chimney or fan must be equal to the maximum amount required for all the burners, and must be changed according to the atmospheric conditions, each burner being regulated separately. This would be done best and most safely by the dampers in the draught-holes connecting each burner with the gas-flue; but these are rarely used for this purpose: they would have to be made very tight-fitting, and then would easily get fast by flue-dust. Therefore here also the draught is made sufficient for all eventualities. The real regulation of the air, at least generally in England, takes place by means of the holes in the ash-pit door, of which a sufficient number are closed by plugs or otherwise.

The supply of air is usually regulated by the following practical rules:—At the beginning (that is, immediately after making a fresh charge) the burner does not require very much air, till the ore has caught fire, which will take half an hour to an hour. Then more air must be admitted, always with the

above-mentioned restriction : that the flames rise perpendicularly, and tend slightly towards the slide when this is opened. When, however, the principal portion of the sulphur is burnt and the flames become scarce, the air is shut off altogether, and further action is left to the heat of the burner. About two hours before it is time for recharging, the working-door is opened and the ore is well raked and turned over by means of a hook to a depth of 3 or 4 in., and any small scars are removed. If now blue flames appear to any extent, this proves that the burning has not been sufficient, and a little air must be admitted. When the whole time is up, be it a twelve hours' or a twenty-four hours' turn, the air is entirely shut off at the bottom, the small doors covering the grate-bars are opened, and the latter are turned two or three times, leaving each alternate one out. During this the workman must look through the working-door, to see whether the layer of ore is let down evenly all over ; he can easily manage, determining by the eye, not to let the ore down too much or too little. Then, as quickly as possible, the new charge of ore in pieces (usually with a little dust), which must have been lying ready in front of the burner, is put in, and the process begins again. It is evident that there must be a regular rotation, so that a fresh burner comes in turn every hour or so ; this is both indispensable for a regular evolution of gas, and convenient for distributing the labour over the day.

The burner-men ought to shake the grates quite evenly for the purpose of discharging, so that the ore does not come down more quickly in one place than in another, and to take care that only cold, thoroughly exhausted cinders, but no red-hot ore, come down. They ought then to work up the ore on the top through the doorway with their pokers, and rake the surface so as to make it even again. Then they must charge the new ore equally all over, starting about 2 in. towards the door from the back and the sides.

The interior of a burner, after the throwing-in of a fresh charge, is, of course, at first black. Gradually small blue flames appear, which become larger and more lively and cover the whole mass. After a few hours they become scarcer again ; but the mass in the meantime has become red-hot. Later on it cools again ; and towards the end of the period there is no

glowing visible at the surface; but as soon as the mass is stirred up the glowing appears again.

Frequently it is necessary to wait a short time, even for a few hours, after shaking the grate-bars and letting down the burnt ore, in order that the burner may cool down a little before recharging it; this has the advantage that the top layer can be turned over, and its sulphur is therefore burned more thoroughly than if cold pyrites has been thrown in.

Generally it takes some time before the men get used to a new kind of burner or of pyrites. Even if skilled men are taken from other places, they require special supervision, and still more if a new kind of pyrites has to be tried. If at all possible, one kind of ore should be adhered to for some time, because only in this way do the men get used to a proper treatment of the burner. Each kind of pyrites requires a little different treatment as to supply of air, breaking up, etc.

An extremely great help in regulating the burning process is the *analysis of the gas*, which, however, is nearly always made for a whole set of burners together in their common flue. We shall enter into the details of this later on.

If a pyrites-burner is working properly, it will, if touched outside, be so hot in its upper part (say 6 in. below the working-door) that the hand cannot be borne upon it; farther down it must be cooler; and immediately above the grates it ought to be cold, or at most hand-warm. *This is one of the most important practical signs of the proper working of the burner.* If a burner is too hot below, this may be due to insufficient draught, or (which in the end comes to the same thing) there has either been too much pyrites charged, or there is too much dust in the burner, which has stopped up the interstices. Too much dust may come from bad riddling, from too much having been added on purpose, from the falling of the "balls" inside the burners, or from the decrepitation of "explosive" ores.¹

In any case, the first thing to be done, apart from removing the cause of the evil, is to again *cool* the excessively hot burner. Above all, *more air* must be admitted: and, in order to drive up the heat more certainly, the new charge must be kept back a little, and no fresh ore put in the middle, but only along the sides and the back of the burner. It sometimes takes one or

¹ Cf. p. 339.

two days before a burner has recovered its normal temperature. In specially obstinate cases there is nothing for it but making very small charges for a day or two, till matters have come right again. Some prefer taking out the ignited top layer, allowing it to cool a little, and putting it back into the burner, which in the meantime has received more draught, owing to the lower depth of ore, and thus has become cooled.

If a kiln is allowed to go too hot for any length of time, whatever may be the cause (want of air, too large charges, stopping up by dust, bad breaking up), the consequence will always be the same, viz. increased *scarring*, with all its unpleasant accompaniments.

Of course, it also sometimes happens that a burner goes *too cold* and the fresh charges take fire too slowly. This may be caused either by insufficient draught or by too small charges, and can be easily remedied in either case. If it has, however, got so far that the new pyrites will not take fire at all, nothing remains but to put in very hot ore from some of the other working-burners; in this way the matter may always be put right with some patience, unless large scars are lying on the grates, or there are other serious faults which must be removed before the burner can be expected to work properly. A frequently employed, but objectionable, remedy against cold burners is to put live coals on the pyrites; the carbon dioxide produced thereby thus entering the chamber process.

A pyrites-burner may also go too cold if there is *too much draught*—if, therefore, besides the air required for its intense working there is an excess, which only acts as inert cooling gas. This is a very great fault; for in this case the consumption of nitre is increased and the yield of sulphuric acid diminished. Long before the burners cool from this cause, an excess of air may become injurious in this way; and by observing the flames in the burners (much better, however, by the analysis of the gas), it must be ascertained whether the proper proportion of air is present or not.

Objection has been made by some to the employment of *damp* pyrites,¹ because in this case, on burning, more sulphates are formed, which give off sulphur trioxide; this takes up moisture, and condenses as sulphuric acid before getting into

¹ Kerl-Stohmann's *Chemie*, [3], 6, 197.

the chambers, destroying the flues and so forth. Even with dry ore in damp weather similar phenomena are said to be observed, and a smaller yield is alleged to be the consequence of the moisture in the air. It is very desirable that this point should be specially examined. The formation of sulphur trioxide, as well as the occurrence of liquid sulphuric acid, in the connecting-tubes has certainly been established; but it has not yet been proved that the moisture of the air acts so as to increase that formation, and the contrary is more than likely to promote the formation of sulphur trioxide.

People who have no practical acquaintance with the matter, looking at these numerous sources of mishaps, may be inclined to think that the working of a set of pyrites-burners is a most difficult task. But it is far from that. If once the burners are in order, they remain very long so if the burner-men know and perform their duty, and if proper supervision is exercised over them; the pyrites-burners then give even less trouble than sulphur-burners. Certainly, when they do get wrong, it takes energetic and experienced management to put them right again.

It will now hardly be necessary to explain in detail why there are only narrow limits for each given burner and style of charging, within which the *quantity* of pyrites charged may vary.¹ If too much is charged, the burner scars; if too little is taken, it gets cold. When, therefore, for any reason the daily quantity of pyrites has to be cut down, it is necessary to put out a corresponding number of kilns and to work the remainder fully. Only in the case of brief temporary interruptions is it advisable to charge rather less than usual for a few days.

Employment of Brimstone together with Pyrites.—Westergren² prepares SO₂ for the manufacture of sulphite pulp by roasting pyrites with an excess of air, and passing the gases produced through flues in which brimstone is burned, if necessary with admission of more air.

3. Burning Pyrites-smalls.

We have seen above (p. 347) that the fine powder which passes, say, through a $\frac{1}{2}$ -in. or at most a $\frac{1}{4}$ -in. riddle must be kept out of the ore going into the ordinary pyrites-kilns. The

¹ Cf. pp. 337 and 340.

² Swed. P. 31999; *Chem. Zeit. Rep.*, 1912, p. 170.

“smalls,” “fines,” or “dust” produced in this way, whether it be on breaking the ore at the works or at the mine, must be dealt with separately.

This can be done in very different ways, according to circumstances. Where pyrites-smalls are not bought as such, the question is only about the dust arriving along with the bulk of the ore, and also that made in breaking. Much more dust is produced when breaking by machine than by hand—viz. 10 to 15 per cent. in the case of middling hard ores, and even more in that of soft ores. Formerly, before rational and really satisfactory contrivances for the burning of smalls were known, some large factories, which had already mounted stone-breaking machines, went back to hand-breaking, in spite of its costing many times as much, merely in order to avoid the excess of dust. This was especially the case in factories using soft ores, such as the Tharsis ore; with Norwegian ores the advantage was always on the side of the mechanical breaking, because these are much harder and make less dust. If the quantity of dust going through the smaller riddle does not exceed $1\frac{1}{2}$ cwt. to the ton, it can be got rid of, without any special contrivance, in the following way:—The dust is sifted off as usual, and a certain quantity of it is laid down for each burner alongside the pieces. If, for instance, the whole charge is 7 cwt., $6\frac{1}{2}$ cwt. of pieces are used and $\frac{1}{2}$ cwt. of dust (if more dust than this is used, the burner easily gets out of order). First the coarse ore is charged as usual; and then the man throws the dust with his shovel along the *sides* and the *back* of the burner, leaving the whole central part free. Anyhow, the ore ought to be levelled after throwing in the charge, in such a way as to make it lie higher along the sides and back than in the centre of the burner. The reason is this: the air entering from below meets with much less resistance at the comparatively smooth walls than in the centre of the layer of ore, and it will preferably rise along the former; the centre thus will get less air than the parts next to the walls. If, however, the ore is lying near the walls at a higher level, and especially if the passage of air is obstructed by the dust lying at those places, the draught will be more nearly equalised, and the burning will take place evenly all over the area of the burner. Of course, it will not do to proceed too far in this

way ; nor can it be expected that the result is as good as when lumps and smalls are each treated in the best way suited for them.

Dust made into Balls.

The arrangement just described does not answer if more than $1\frac{1}{2}$ cwt. of smalls to the ton of pyrites has to be dealt with ; and special arrangements must then be resorted to. Probably the oldest method, now almost obsolete, is that of mixing the small ore with sufficient clay to make it plastic, forming into *balls*, and drying on a steam boiler or pyrites-burner. Rarely less than 10 per cent. of clay will be required for this, often more, up to 25 per cent. The balls are then charged together with lumps into the ordinary burners, but never too many at a time (at most one-sixth part of the whole charge), because they fall to powder in the burner after a time, and if used in a greater proportion would stop the draught.

Robeson (B.P. 1639 of 1908 ; Ger. P. 238119 ; Fr. P. 386695) makes briquettes from pyrites-smalls by means of spent sulphite liquor from the manufacture of paper pulp as binding agent. The liquor is first neutralised by caustic soda or lime, and concentrated *in vacuo* to 30° B. The briquettes obtained are hard and not hygroscopic, and the organic matter, introduced with the sulphite, aids in the combustion [but emits injurious carbon dioxide].

Utley Wedge (Amer. Ps. 804690, 804691, 804785, all of November 1905 ; Ger. P. 181516) employs, as binding agent for pyrites-smalls, ferrous sulphate, by itself or mixed with sodium sulphate and nitrate, and subjects the mixture to heat, insufficient to expel the S from the pyrites, but sufficient to bind the mass.

Ricketts and King (Amer. P. 894799) mix the pyrites fines with a fusible sulphide or other sulphur compound, and subject the mixture, under reducing conditions, to sufficient heat to liquefy the sulphur compounds. The now coherent mass is compressed into any desired shape.

A. G. Anderson (Fr. P. 458442 ; Belg. P. 256447) moulds small ores ground down to 1 mm. in the moist state in revolving cylinders into porous balls, passing hot gases through the mass,

Gröndal (Ger. P. 277895) employs a tunnel-shaped furnace with flues in the walls, arranged lengthway, connected with a supply of air at the discharging end of the furnace, and possessing in several places inside the furnace openings provided with regulators; if necessary, also with flues near the outlet, connected with a gas-generator and with a chimney. Porous ore-balls are easily permeable for gas. There is no formation of dust, which is a great advantage over the ordinary burners for smalls, and even over lump-burners, and allows of dispensing with dust-chambers. The burnt ore is obtained in a very easily managed form, and can be immediately utilised for the production of iron. If necessary, it can be further treated in an ordinary burner for smalls.

Buddæus (U.S. P. 1079897) burns small ore containing less than 30 per cent. sulphur, without any supply of heat from without, in kilns provided with a porous bottom through which air is blown in.

G. H. Benjamin (Ger. P. 274663) provides the shelf-burners with electrodes, in order to produce a higher temperature.

Bracklesberg¹ described the preparation of "agglomerated" balls of pyrites or blende smalls.

Burning Pyrites-smalls without making them into Balls.

The making up of pyrites into balls with clay is attended by so many drawbacks that something else was soon looked for. This was found indispensable where nothing but pyrites-smalls could be obtained, or where these could be procured so cheaply that acid-makers wished to dispense entirely or partially with using lump ore. At the pyrites-mines there were formerly enormous heaps of smalls, which were not saleable at all and would sometimes have been given away for nothing, just to make room. In other places pyrites only occurs in a loose, roughly crystalline shape; and, again, in others it is obtained by wet preparation altogether in the state of smalls. Thus there was great encouragement for constructing apparatus for burning small pyrites in large quantities.

The contrivances for burning pyrites-smalls may be divided into three classes, namely, those working by external heat, those

¹ *Z. angew. Chem.*, 1916, 1, 281 *et seq.*

utilising the heat of ordinary burners for pyrites in lumps, and those arranged for burning the smalls by themselves without any extraneous apparatus.

(a) *Burning Pyrites-smalls in Coal-fire Furnaces.*

Apart from the use of "balls," the oldest plan of dealing with pyrites-smalls is that of spreading them on the bed of a furnace, heated by flues underneath, the fireplace being arranged at one end and the pyrites-dust being introduced at the other, and being gradually moved forward towards the fire end, as room is made for it by drawing out the burnt ore. Since the ore is thus turned over many times on its way from one end of the furnace to the other, the sulphur was supposed to be thoroughly burnt. The burning is, however, imperfect, even if the furnaces are made 100 ft. long. Moreover, the cost of fuel is very heavy (at least 10 cwt. of coal is consumed for a ton of pyrites, usually much more), so is the cost of labour; the continuous opening of the working-doors causes very much false air to get into the chambers, even fire-gases sometimes leak through the furnace-bottom, and therefore the consumption of nitre and the yield of acid are very bad. We shall, consequently, not go into any details respecting these "muffle-furnaces," but refer to the first edition of Lunge's *Sulphuric Acid*, where, on pp. 186 to 190, the Belgian furnaces, and those of Spence, of Godin, of Imeary and Richardson, are described and partly illustrated by diagrams. Since it has been recognised that no extraneous heat is necessary for burning pyrites-smalls, such furnaces must be looked upon as altogether irrational, and they are practically obsolete now. This, of course, has nothing to do with the fact that similar furnaces are in use for roasting galena and other ores which require external heat for the purpose.

(b) *Burning Pyrites-dust by the Heat of Burners for Lumps.*

This was considered a great improvement upon the older methods, but it must also be pronounced obsolete now, at all events in the case of ordinary pyrites. We shall therefore treat these processes very briefly, referring for details to the first edition of Lunge.

The first furnace for burning pyrites-smalls by means of the heat from lump-burners seems to have been that patented in France by Usiglio and Dony, in 1852, which, however, did very imperfect work. Much more important is the furnace constructed by Olivier and Perret, which was introduced into the majority of French works and was in use there for many years, until replaced by the Malétra burner (*vide* p. 359). Olivier and Perret placed above an ordinary lump-burner a number of shelves made of fireclay, and charged with a thin layer (not above $\frac{3}{4}$ in.) of pyrites-dust (for exact description and diagrams, *vide* first edition, pp. 193-196). In this way it is possible to burn about 1 cwt. of dust to each 2 cwt. of lumps, the sulphur in the cinders being reduced down to 4 or 5 per cent. The whole furnace was originally about 20 ft. high, which necessitated a second working-stage above the ground. There is, of course, a good deal of labour connected with this system. Later on it was made lower, and so arranged that all the doors were on one side, so that a number of furnaces could be grouped into a set.

In a simpler form, namely, that of a single cast-iron plate above ordinary lump-burners, this system was introduced into some Tyneside works, first by MacCulloch, but was soon abandoned again.¹

Another way of carrying out the same principle was the furnace of Hasenclever and Helbig.² Here, at the end of a set of lump-burners, a tower-like apparatus was arranged with eight inclined shelves of fireclay, over which the dust was gradually to slide down and to be burnt on its way. Thus from 10 to 16 cwt. of smalls were to be burnt for each 48 cwt. of lumps; but the principle of automatic sliding-down did not answer; the motion of the dust had to be aided by hand-work, with much introduction of false air.

(c) *Burning Pyrites-smalls without External Heat.*

We must, in the first place, mention a plan which does without any special dust-burners, and only represents an improvement in making "balls." It is based upon the fact that pyrites, if it is in the form of very fine powder mixed with

¹ Cf. Lunge's first edition, pp. 191-193.

² *Ibid.*, pp. 196-201.

water, coheres to a solid mass *without the aid of any plastic substance*. The fine pyrites-dust, in the presence of water and air, begins to oxidise very soon, even at the ordinary temperature; thus basic ferric sulphate is formed, which firmly cements together the separate grains of dust. This only takes place to a sufficient extent if the grains of dust are very fine and the mixture with water very perfect; and it can never be attained by merely sifting and moistening the fine ore. The ore must therefore be ground finely with water in a mill, and the mass dried in layers of $\frac{1}{2}$ in. thickness on the top of the pyrites-burners, in cakes about 18 in. square. After twenty-four or thirty-six hours it has hardened sufficiently for use. It is broken up into pieces of the same size as the lump ore, and charged together with this into ordinary pyrites-burners. In this case it is not necessary to observe a fixed proportion; for the balls made in this way are so hard that they can be thrown to the ground without being broken; they do not fall to powder in the burners, and they burn out as well as lumps; their cinders are, of course, of the same value as those from lump ore, whilst those mixed with clay make the utilisation of the ferric oxide, produced at the copper-extraction works, very difficult.

The principal drawback of the process is that the mills suffer very much wear and tear from the hard pyrites. In spite of this, it was formerly the most usual plan in the large English factories. The cost of labour for grinding, carrying to the top of the burners, for drying, taking down, breaking up, and laying down in front of the burners, is heavy, and to this must be added the power for working the mill, and wear and tear of the same.

The process just described is not applicable in cases where the great bulk or the whole of the pyrites employed is in the form of dust. In such cases at one time the only available contrivance was the muffle-furnace (p. 356), with all its great drawbacks. The first who proved that the heat generated by the combustion of ferrous bisulphide is sufficient to keep the process going without any external aid, quite as well in the case of pyrites-smalls as in that of lumps, was Moritz Gerstenhöfer, whose furnace is described at length and shown in several diagrams in Lunge's first edition, pp. 205-215.

The two great drawbacks of the Gerstenhöfer burner are : the very large amount of flue-dust produced in it, and the very incomplete desulphurisation of the ore (8 or 10 per cent. S in the cinders). Principally for these reasons this ingenious furnace has been abandoned again nearly everywhere, and is now only used for roasting "coarse metal" in a few copper-works. At the Freiberg works, where it was used for a variety of mixed ores (25 to 36 per cent. S), it has been replaced by the Rhenania furnace, to be described below.

According to Scheurer-Kestner,¹ Perret later on constructed a furnace resembling Gerstenhöfer's. As nothing more has been heard of it, its success cannot have been so great as anticipated.

The object but imperfectly attained by Gerstenhöfer's invention has been realised by a very simple plan—so simple, indeed, that it was not thought worth patenting at the time, although it has subsequently proved to be of immense importance. Malétra, owner of the works of Petit Quevilly, near Rouen, after having for some time burnt his smalls by means of an Olivier-Perret furnace, conceived the idea of separating the upper part of this furnace from the lower, and working the dust by its own heat of combustion without any aid from a lump-burner. This idea, which was worked out about 1867 with the aid of Tinel, proved entirely successful ; but in spite of this, and also of the "*shelf-burner*" being the simplest and cheapest of all dust-burners, it became comparatively slowly known ; but after 1873, when it became better known through the Vienna Exhibition, it spread on the Continent with extraordinary rapidity, whilst for a long time it attracted little attention in England. The first burner out of France seems to have been erected at the works of Schnorf Brothers, at Uetikon, near Zürich, in 1870 ; in Germany, the first was erected at Kunheim's works in Berlin. Even if, as it would seem, some form of these simple shelf-burners had been previously in use here and there, their *successful* application for burning pyrites-smalls seems first to have been effected by Malétra's works.

Fig. 37 gives a longitudinal, Fig. 38 a cross section, the latter through two furnaces. Usually a whole set is built in a row. In order to start it, a coal-grate, *a*, and fire-door, *b*, are

¹ *Bull. Soc. Chim.*, 45, 228.

provided, which are walled up when the burner has got up to the necessary heat.¹ During this time the top working-door remains open. The air enters through *l*, and is regulated at will. The gas travels over all the shelves in series, as indicated by the arrows, escapes through *m* into the dust-chamber, *n*, and through *o* into the acid-chamber or into another dust-chamber. The chamber *n* is covered by a metal plate, *p*, upon which

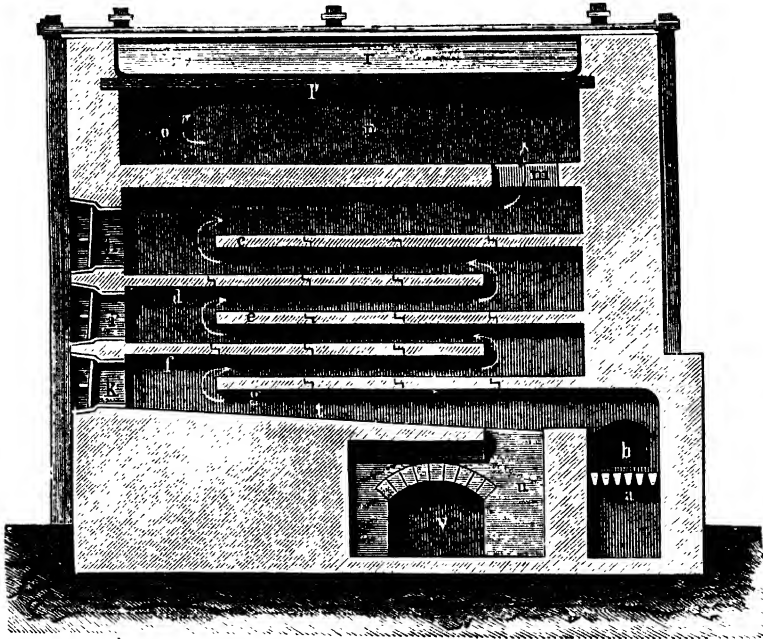

FIG. 37.

lead pans, *r*, *r*, are placed, in which chamber-acid can be concentrated from 112° to 144° Tw. The acid of one pan communicates with that of another (as usual) by siphons or by simple overflows. The shelves are 8 ft. long and 5 ft. wide; they are not equidistant, as can be seen in the drawing; the upper shelves, where more gas is evolved, are wider apart than the lower ones, where the radiant heat of the shelves is all the more useful. The best distance for the upper shelves is $4\frac{1}{2}$ in. In order to burn a larger quantity of pyrites, it is not possible to leave the ore lying quietly, as in Olivier-Perret's burner:

¹ This arrangement is now hardly ever used.—W. W.

since here the external heating by the lump ore is missing, the combustion would be too incomplete, and the heat would soon get so low that the burning would cease. The mass must therefore be turned over, which is done in the following way:—Every four hours the contents of the lowest shelf, *g*, are drawn through the door *k* on to the arch *t* (which is level at the top, but slopes behind), after the burnt ore lying on the

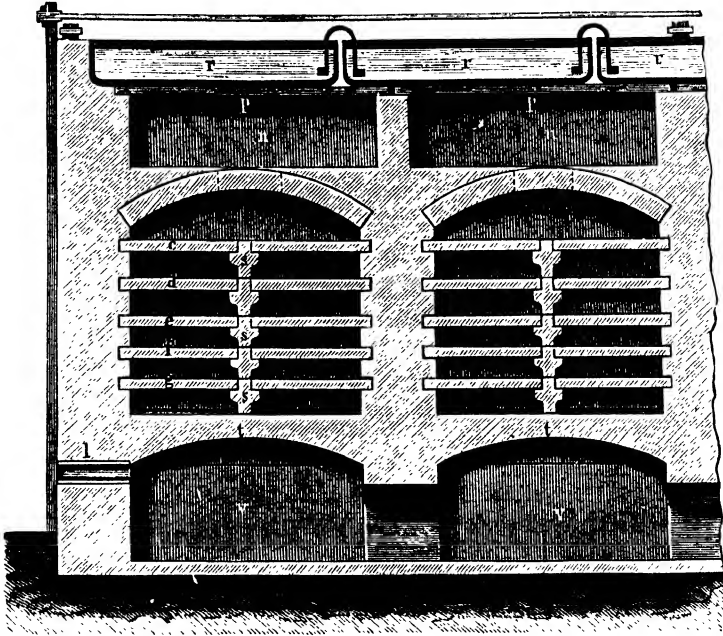

FIG. 38.

arch has first been pushed through the door *k* to the opening into the pit *u*. Then through the door *i* the contents of *f* are pushed down to the plate *g*, and there levelled again. Thus the higher shelves are successively treated, till the highest one, *c*, is emptied and can be charged with fresh ore. The contents of the pit *u* are removed once a day by the door *v*. The movement of the ore by removal from one shelf to another causes its thorough combustion, and thus also raises the heat. Four furnaces of the above dimensions burn daily 3 tons of pyrites. From $6\frac{1}{2}$ to 7 lb. of ore are calculated for each superficial foot of shelving per twenty-four hours.

Sometimes the shelves are made in the shape of a very flat arch, for the sake of greater stability; or at least the bottom is arched, especially in the case of wide shelves.

The burners are now generally built as shown in Figs. 39

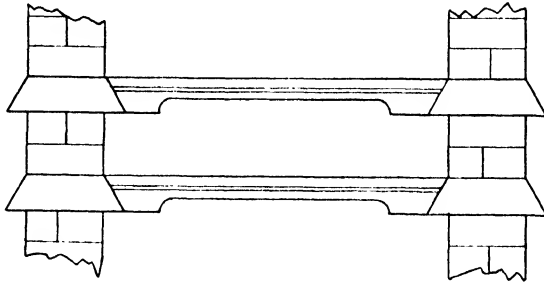

FIG. 39.

and 40, so that the shelves can be easily replaced when broken.

The firebrick of the shelves should be as thin as possible, consistent with stability, and the spacing of the shelves should be considered in each case, because while the distance should be as small as possible the spacing must depend on the quality

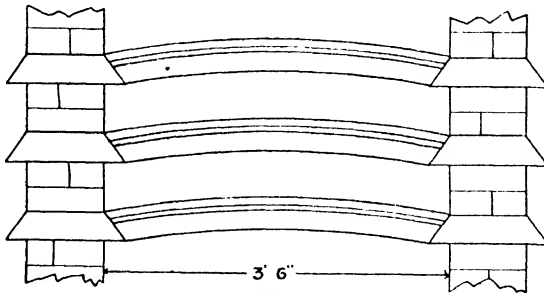

FIG. 40.

of the ore which is to be burnt, if the best results are to be obtained.

In Lunge's second edition, pp. 255-256, a furnace is described having seven shelves, each served through its own door—three on one side, four on the other. On the first side there is also the ash-pit door, 18 in. square, for drawing out the cinders, which is thus done in the usual way, not by the rather inaccessible pit of Malétra. The doors all slide with their planed

margins on equally planed ledges cast on the front plates, so that luting or plastering is not necessary. There are no special openings for the air, as, in spite of the planed surfaces, sufficient air enters to support the combustion. The regulation of the draught is here effected entirely by the chimney or fan damper.

In this burner *dust and peas* are burnt *together*, and the sulphur is burnt down to 1 per cent.; thus the grinding of the smalls, which is still practised at some works, is done away with.

Most manufacturers now consider that burners worked from both sides allow too much false air to enter, and therefore prefer arranging two rows back to back.

Lunge¹ describes and illustrates the burner of H. H. Niedenführ, which overcomes this objection, but we only here give an illustration of a cross section of this (Fig. 41).

One of the principal advantages of the shelf-burners is that the ore is burnt out to a much larger extent, not merely than with any of the older forms of dust-burners, but even with the best lump-burners. Even without grinding the smalls it is quite easy to keep the sulphur in the cinders down to 1.5 per cent. At many works, *e.g.* at Uetikon, the average amount of sulphur in the cinders never exceeds 1 per cent., and frequently it is below. At Malétra's own works they get down to 0.6 or 0.8 per cent., but this can be done only by crushing the smalls down to an almost uniform fine powder. The amount passed through the burner also influences this. Sorel states that a set of burners, charged with about 7 lb. per sq. ft. of ore every twenty-four hours, was regularly burnt down to 0.75 per cent.

Such results can, of course, be obtained only with pure ores free from zinc, lead, etc. Hence the cinders from shelf-burners are readily bought by ironworks, both for blast-furnaces and for other purposes.

The Malétra burner is particularly adapted to rich ores. With a 50 per cent. ore good results are obtained, if from 5.8 to 6.6 lb. per sq. ft. per twenty-four hours is burned. The lowest limit is 5.0 lb., and this should be only exceptional, because otherwise the burners cool down. The shelf-burner is not well adapted for poor ores—that is, below 38 per cent. sulphur.

In a six-shelf burner there ought to be scarcely any purple

¹ Fourth edition, p. 469.

flame visible when pulling the charge down from the top shelf to the second shelf. The second shelf is at a bright red heat, the third one less so, and so forth ; the back part of the fifth

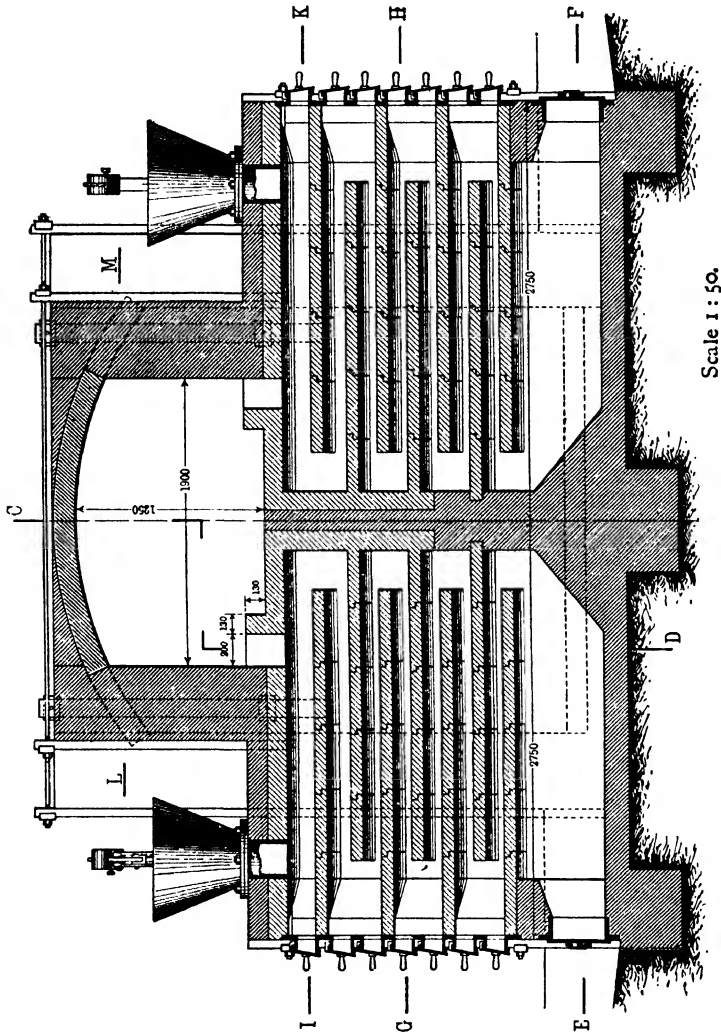

ought to be visible only at night by the light radiated downwards from the fourth, and the sixth ought to be perfectly black.

Sorel found the following percentages of sulphur on the different shelves :—

Sulphur in green ore	.	.	50 per cent.
First shelf	.	.	32 "
Second "	.	.	17 "
Third "	.	.	7 "
Fourth "	.	.	5 "
Fifth "	.	.	2 "
Sixth "	.	.	0·75 "

He regularly found half of the sulphur in the cinders to be in the form of FeS, the other half in that of ferric sulphate.

Crowder,¹ in working with shelf-burners containing seven beds, charged once every eight hours (so that the charge takes $7 \times 8 = 56$ hours to complete the course), found the following percentages of sulphur on the different shelves (nearly agreeing with Sorel's results mentioned above):—

Ore charged	Average of 23 trials.		Ditto of 26 trials.	
No. 1 shelf	.	.	50	per cent. S.
1 shelf	.	.	32·27	32·81 "
2 "	.	.	21·41	17·55 "
3 "	.	.	12·77	11·09 "
4 "	.	.	6·39	5·05 "
5 "	.	.	4·08	3·42 "
6 "	.	.	2·35	2·56 "
7 "	.	.	2·27	1·96 "

If there is too much draught, the lower shelves cool down and the upper ones get hotter. This may cause the process to appear as going on very well; but it soon turns out bad. If, on the contrary, there is too little air, the bottom shelf becomes luminous and the sulphur in the cinders rises rapidly. In both cases there is incipient fusion on the second shelf, which prevents the roasting from being carried through. This can be remedied by admitting a little air at the door of the second shelf, or even mixing a little dead ore with the charge. The admission of air to the intermediate shelves serves also for bringing forward any burners which have got behind, and to burn any sulphur subliming from the first shelf, in case the burners are too hot, or from damp pyrites giving off sulphuretted hydrogen; but this expedient, useful as it is when properly handled, must be employed with caution lest the bottom shelves get too cold from want of air.

In the normal style of working, all the air required for

¹ *J. Soc. Chem. Ind.*, 1891, p. 298.

converting the sulphur into sulphuric acid enters at the bottom shelf, and this large quantity of cold air may lower the temperature of the nearly burnt-out mass to such an extent that no more ferric sulphate is decomposed. It was at first attempted at Malétra's works to avoid this by leading the burner-gas downwards underneath the bottom shelf, thus heating the latter and employing the ground-space as a dust-chamber; but this plan did not answer and was soon given up again. It has even been tried to utilise the heat of the burner-gases for a previous heating of the air serving* for the burning process. But evidently this must most seriously interfere with the draught, and will hardly answer in the long run. The same advantage would be secured more easily by admitting at the bottom only the quantity of air absolutely necessary for completing the roasting of the ore, and allowing the remaining air to enter by a regulating-slide in the top working-door. In this case the bottom shelf will be visibly red-hot in the dark. This plan can be carried out where the draught is very good—for instance, by making the gas rise to a considerable height before entering the chambers, and never leading it downwards in any part of its course. Where a fan is used, there is no difficulty in regulating the admission of air as required.

The management of shelf-burners is really easier than that of lump-burners, but it involves a little more labour. The working-doors must never be left open any longer than is absolutely necessary for the work; in this case both the yield of acid and the consumption of nitre are just as favourable when working dust on a shelf-burner as with the best lump-burners.

In order to start a new burner (which, of course, must have been thoroughly dried in the ordinary manner), the communication with the chambers is stopped and a fire is lighted on the shelves, beginning with the bottom. Sometimes the necessary draught is obtained by means of a temporary chimney. After three or four days, when the burner is moderately red-hot (it is unnecessary and even injurious to get it up to a *bright* red heat), the remainder of the fuel is cleared away, pyrites is charged on the three top shelves, and communication made with the chambers, whereupon the regular service is started as previously described.

(d) *Combination of Lump-burners and Dust-burners for the same Set of Chambers.*—Such a combination is generally avoided, as the conditions of draught are very different in each case. The writer, however, found little difficulty in such instances if frequent tests were made of the burner-gas leaving the respective burners.

(e) *Mechanical Furnaces.*—The necessity of frequently opening the doors in Malétra's and all similar furnaces is certainly a drawback; it necessitates much labour, and cannot but introduce some false air. These drawbacks have been overcome in a most ingenious way in the mechanical pyrites-dust burners now on the market.

M'Dougall Furnace.—A full description is given of the original type of M'Dougall burner in Lunge's fourth edition, pp. 474-478. The burner then consisted of cast-iron rings 6 ft. in diameter, bolted together, and forming seven hearths, the top one being used for drying purposes. Air was supplied by an air-pump to facilitate combustion, but this method is now dispensed with. The capacity of such a furnace was $3\frac{1}{2}$ tons of ore per twenty-four hours; one with eight closed shelves, 5 tons per twenty-four hours. Mention was made of the great amount of dust given off in the early type of burner, amounting to 16 per cent., whereas in the later type it is approximately 4 per cent., depending upon the degree of fineness to which the ore is crushed before roasting.

The shell of the burner is now made of steel plates riveted together without any rings or flanges. The driving machinery for revolving the centre shelf and arms may be applied from either the top or bottom, as desired. Fig. 42 illustrates the Z-122 size, and is 18 ft. outside diameter, has six hearths, and is water-cooled.

With regard to the capacity of the improved burner, this has been increased considerably, and burners up to 25 ft. have been made, consisting of six or seven hearths and one drying-floor.

The centre shaft and arms are cooled by water carried in pipes inside the centre shaft and arms, or are air-cooled by means of air forced in by a fan. The amount of water required for cooling the shaft and arms of the 18-ft. furnace would be approximately 20 to 25 gall. per minute,

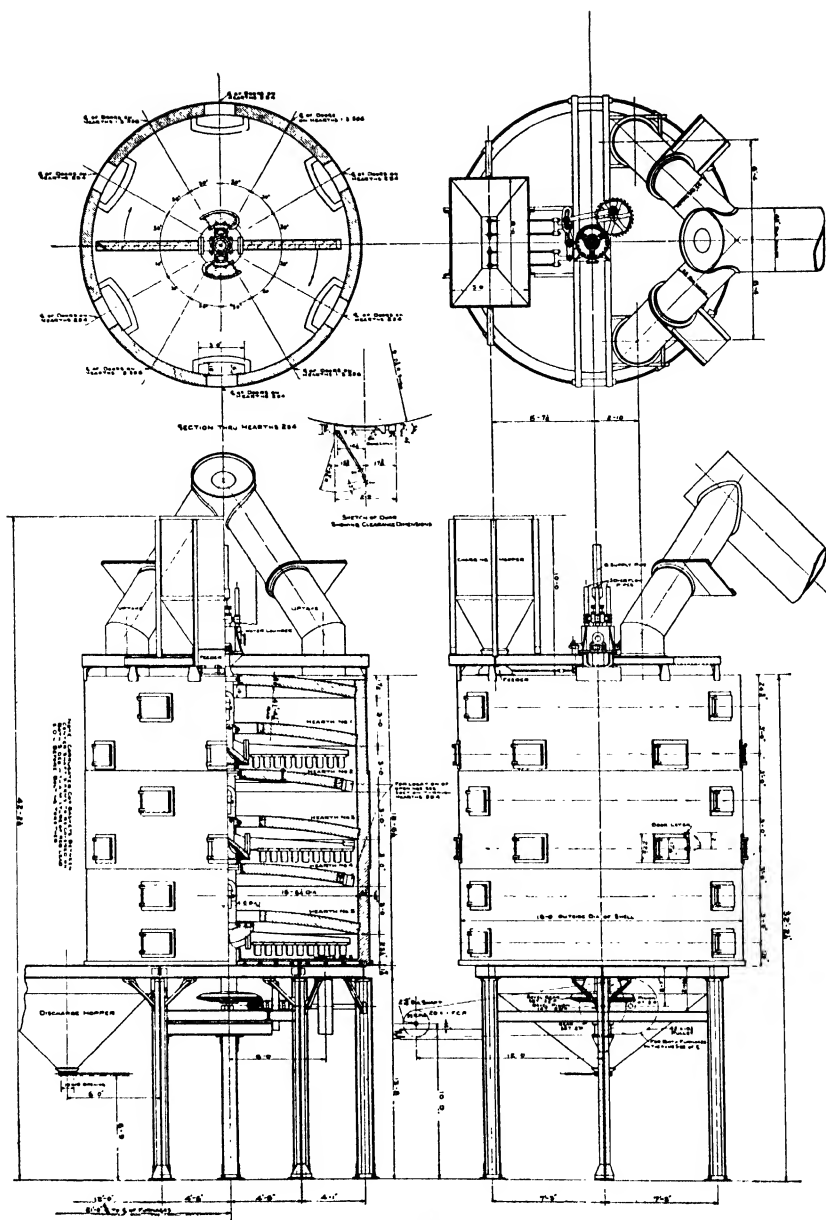

FIG. 42.

with the feed water entering at 21° , discharging at 54° to 66° . The horse-power required for driving a M'Dougall furnace is comparatively small. For instance, a furnace 18 ft. diameter having six hearths only requires 2 to 3 h.p. However, a 5-h.p. motor or engine is generally provided in case any foreign substance happens to get in the furnace by accident.

There are several methods used for feeding the ore into the furnace: the plunger feeder, cam feeder, and scraper feeder, also chute and gate feed. The plunger feeder is the type most commonly used.

Ramén Furnace.—A large number of different types of mechanical roasting-furnaces have been constructed and put on the market, but the principal, which is characterised by the so-called M'Dougall type, has for several reasons proved itself to give good results economically as well as technically. Several furnaces of this type have appeared under the names of the respective inventors. A new furnace of this class has recently been designed by Arthur Ramén, and is worthy of notice.

At some industrial plants the prevailing opinion seems to be that there is some advantage in having a battery of a large number of furnaces of low capacity rather than a small number of large furnaces. The reason for this is, that these small furnaces are easily manipulated, and if one or two only of them for some reason should get out of order or break down, the plant would be guarded against a total shut-down, as there still would be a number of furnaces operating. One great disadvantage with the small-size furnaces is, however, that they quickly lose their heat and cool down in case of a stoppage. One will readily realise that a plant using large furnaces, specially designed to meet the exigencies that tend to cause a shut-down, but which, if requiring repairs, can quickly be put in order again, must be of a great advantage as against the small-unit plant. Such large furnaces can be stopped for several hours without losing much of their heat, and the cost of operation, also the cost of repairs per ton of ore roasted, becomes lower than with the small units. The first cost per unit of roasting area is also lower with the large-capacity units. Besides, they produce a more evenly roasted calcine and a

more even furnace gas (SO_2). Another advantage of the larger furnaces is that lean sulphide ores can be roasted without using any extraneous heat. These ores cannot be roasted in small furnaces on account of the difficulty of preserving the heat in these.

The Ramén furnace about to be described is made of three different types :

- Type RI., uncooled arms.
- „ RII., air-cooled arms.
- „ RIII., water-cooled arms.

Type RI. is made in sizes having capacities of 3 to 10 tons of ore per 24 hours, and contains five or more hearths according to their capacity. The arms are made as short as possible in order to eliminate the risk of breaking. This is accomplished by making the central shaft of large diameter, the roasting area being only decreased a very small amount thereby.

Type RII. is for capacities of 10 to 15 tons of ore per twenty-four hours. The central shaft is made slightly over 3 ft. in diameter, and the arms are fastened in a special manner, to be described later.

Type RIII. is made in sizes from 15 to 25 tons of ore per twenty-four hours, and has water-cooled arms.

In case of ores containing insufficient sulphur for self-roasting, Ramén supplies a furnace with extraneous firing, using either coal, gas, or oil, etc.

The above capacities are all based upon a sulphur content of 48 per cent.

In the types RII. and RIII., the arms are carried by a central shaft made out of cast-iron or steel plate, which is large enough to allow a man to enter it from below or above. It rests on a ball-bearing of special construction, and the top part is supported by roller-bearings. The largest unit of this furnace has a power consumption of about 2 h.p.

The outside of the central shaft is covered by specially made bricks which protect it against the heat of the furnace, at the same time preventing loss of heat through this iron shaft. In order to prevent the ore falling from one floor to another along the central shaft, there are iron rings, so-called umbrellas, fastened to the shaft. It is well known that the brick arches in a furnace of this type will rise with the

increase in temperature, which might cause serious trouble, if the distance of the rakes above the arches is not carefully observed. In order to adjust this quickly and without necessitating the exchange of rabbles, the central shaft is so constructed that it can be raised or lowered, according to prevailing conditions. One readily realises that this is an important detail in a furnace of this type.

In the case of any obstruction getting in the way of an arm there is a safety device which will snap off in preference to the arm, causing the central shaft to stop, thus protecting the furnace against serious breakdown.

One of the most important details in a furnace of this type is the construction of the arms. These must be so arranged that they can easily be exchanged without allowing the furnace to lose its heat. In Ramén furnaces having water-cooled arms, the water connections can be undone from the outside of the furnace, thus avoiding the necessity of a man entering the central shaft. The water-pipe having been thus disconnected, the arm is pulled out and a new one put in in a short time. Each arm has its own water connections. The construction of the arm is such, that it also acts as a holder for the rakes, an arrangement which is well known.

Special attention has been given to the speed of the central shaft and to the stirring of the ore, in order to secure a satisfactory roasting. In cases where the conditions of the roasting process are such that air-cooled arms are preferred, this type is supplied, and these arms can be exchanged in the same manner as the water-cooled ones.

The ore is fed to the furnace in conjunction with the running of the central shaft, and can be adjusted according to the tonnage that is to be roasted. The top arch acts also as a dryer, so that the ore is dry as it enters the furnace. This feeding arrangement is very simple, and requires little attention after having once been adjusted.

The Ramén furnace has a drive of similar construction to the Ramén-Beskow chloridising furnaces. Some of these have been in continuous operation for more than eight years without requiring any repairs. All the principal bearings are of the ball-bearing type, and, as mentioned above, the power consumption is low, and so is the consumption of lubricating oils.

The arches are also constructed as in the Ramen-Beskow furnaces.

In order to facilitate erection a new method is adopted. Up to recently, it has been the custom to erect mechanical furnaces by first putting up the iron parts. On account of this the erection was often delayed, because the iron parts required longer time for delivery than the bricks. In erecting the Ramén furnace, the following is the procedure:—

Having finished the foundation, the outside shell, which is made of reinforced concrete, is built next. Then follows the brickwork, including the arches. Having completed this, the iron parts are placed in position, and the furnace finished. By this method of construction considerable time is saved.

Furnaces erected according to this method, and after being in use for a number of years, have been proved to work quite successfully.

Ramén (B. P. 118812) claims the method of fixing the arms in the water-cooled type, there being an arrangement in the shaft of a movable and detachable water-supply pipe for each stirring arm, the pipe at its outlet being removable, or permanently connected to a hollow valve body which corresponds to a valve seat, surrounding the water-inlet of the circulating channel of the arm, and adapted to be tightly pressed against the seat either by moving the pipe itself, or independently thereof, by a member manipulated from outside the furnace.

B. P. 12214 of 1911 describes the method of fixing the uncooled arms to the central shaft of either the chloridising or pyrites roasting furnaces.

B. P. 23641 of 1909 describes the automatic feeding arrangement, which is well known to users of the Ramén-Beskow chloridising furnaces, and therefore need not be described here.

The feeding device in the Ramén pyrites furnace is a modified application of the Ramén-Beskow feeding arrangement.

K. Walter has constructed a special burner for "*peas*," that is, small pieces of ore between the size of a hazel-nut and such as pass through a sieve with eight holes to the linear inch. This apparatus is described and figured in Lunge's first edition, pp. 225-229.

Walter's burners require a strong draught, and must be worked for a separate set of chambers; with insufficient draught

very large scars are at once formed. As they are only adapted for a special size of ore, they have not met with any extended application.

An important modification is the burner constructed by Herman Frasch, which avoids most of the difficulties of the above system by the introduction of water-cooling. The Frasch burner has been described in *Z. angew. Chem.*, 1894, p. 15, and in Lunge's fourth edition, p. 480.

Lunge mentions (*ibid.*) that he was convinced by personal observation of the excellent working of this apparatus, especially also of the fact that the protective water circulation between the hollow shaft and the hollow side-arms is quite sufficiently effected by the steam formed in the latter.

According to a report received from Mr Frasch, his furnaces, which are now regularly made 16 ft. wide, have done perfect work ever since; many of them are in operation at different works of the Standard Oil Co. for the purpose of roasting metallic-sulphides. The heat produced in the interior of the shaft and arms is utilised by attaching a steam-drum to the highest portion of the water circulation, and the steam is used under 2 atmospheres' pressure for distilling benzine out of light petroleum oils.

Ridge Furnace.—Fig. 43 shows a longitudinal section, and Fig. 44 a horizontal section on line B B of Fig. 43, of this furnace.

The ore is fed continuously on to the top roasting-hearth near to and behind the shaft, where the gas is practically stationary, and is stirred in a gradually increasing spiral until it reaches the periphery of the rabbled zone, and then passes into the zone rabbled by the second shaft. Here it is stirred in the gradually decreasing spiral towards the centre, and passes on to the second hearth. The same travel of ore takes place on this, and also on the third, fourth, and fifth hearths. From the latter is a discharge through a special arrangement which prevents any inrush of cold air into a trunk or conveyor. The rabbles which come into direct contact with the ore are the only wearing parts. These have renewable feet, which are easily and quickly replaced. The shafts and arms are strongly made, and experience shows that they last many years without renewal. The height between each hearth and the underside

of the arch above is small, and the gas space appreciably less than in other types of furnaces. Owing to a special design, the underside of the arch is made nearly horizontal, so that the air and gas are forced down into close contact with the ore. In consequence of the straight-line travel of the gases in the furnace, and the position where the ore drops from one

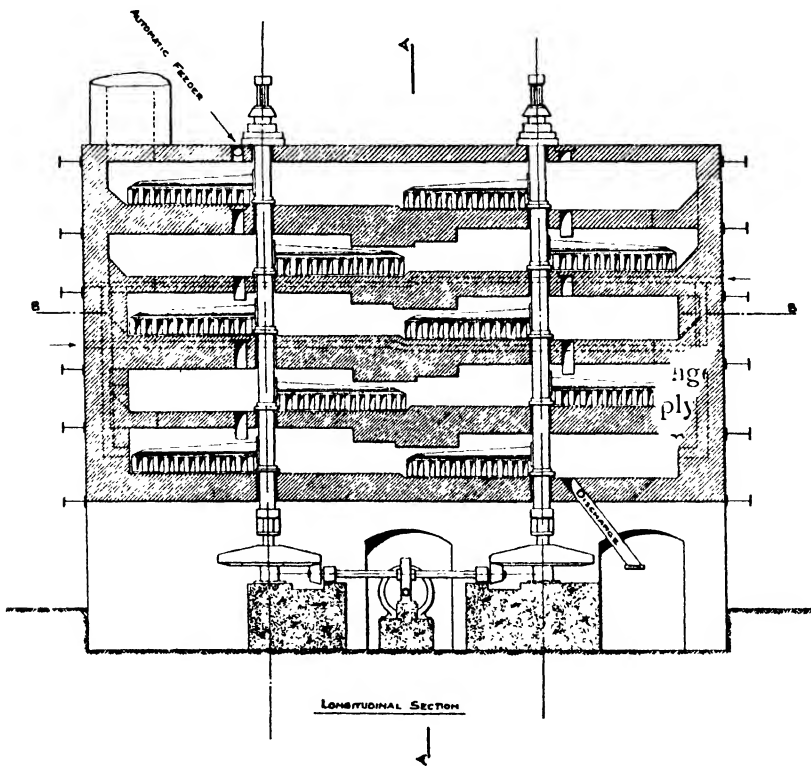
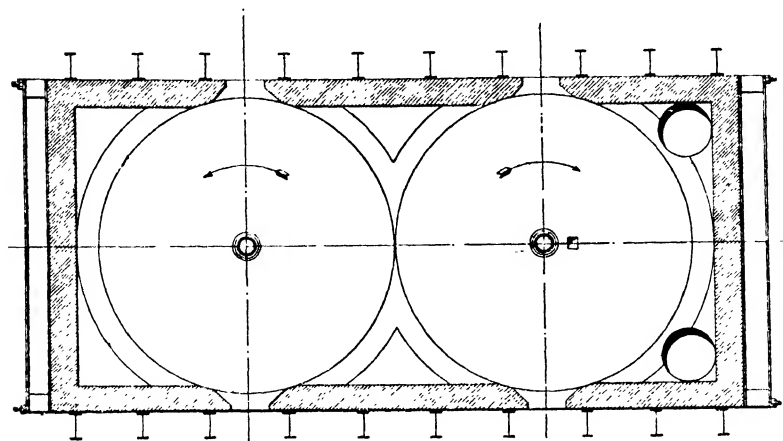

FIG. 43.

hearth to the next, the gas leaves the furnace remarkably free from dust. Careful determinations of the dust loss, extending over several months, were made on a furnace treating very finely crushed ore, which would all pass a screen with 40 mesh to the linear inch, and included a considerable proportion finer than 120 mesh; the result showed that only about $\frac{1}{4}$ per cent. of the material was carried forward with the gas.

The centre hearths of the furnace are cooled by means

of small passages, and the air (which is pre-heated in these passages) passes continuously to the bottom hearth of the furnace, where hot air is required to oxidise the last trace of sulphur. By this means the sulphur can be more completely removed than is possible in the older types of the furnaces, and low-grade ores can be treated without extraneous heating. Ordinary firebrick, and for the arches wedge bricks, are used, so that only a limited quantity of special bricks is necessary. The thick walls provided avoid loss of heat. Dust loss is prevented because the ore is fed into the furnacc, where there



HORIZONTAL SECTION ON LINE B B

FIG. 44.

is practically no travel of gas, whilst the dust from the partially burnt ore settles very completely on the ore in the upper hearths in consequence of the straight-line travel. To allow for expansion of the brickwork, each shaft can be raised or lowered independently.

The gas is remarkably rich, 11 per cent. SO_2 being easily maintained in regular working, and, if desired, it can be increased to 12 per cent. SO_2 by regulation of the draught. If the gas is used for making acid by the contact process, air is admitted behind the furnace so as to reduce the SO_2 content to the desired amount. The capacity of the furnace is 15 tons of ordinary pyrites fines in twenty-four hours for the large standard size, decreasing to 6 tons for the smallest.

The furnace is very flexible in use, and the capacity rises noticeably when finer crushed ore is fed. When an ore requiring a longer or shorter time in the furnace is to be treated, adjustment is quickly and easily made by a few of the rabbles on each or some of the arms with other rabbles having a slightly different angle. By this means an existing furnace can be immediately adapted to varying conditions, and the best results obtained in spite of large variations in the ore.

Harris Furnace.—John B. Harris (B. Ps. 23331 of 1910, 28078 of 1911, 21897 of 1913; Ger. Ps. 247695 and 259208; Fr. P. 432121) describes a mechanical burner, divided into vertical compartments, with arrangements at the flues and slides permitting repairs. The lower coils are placed in a cooling-channel. Above the arched bottom of the lowest roasting-bed there is a partition with zigzag channels for introducing external heat for the purpose of completing the roasting. The ore is supplied in successive portions; every charge is removed from the neighbourhood of the entrance-plane previous to the arrival of the next charge, and the ore is moved over the furnace-bed in such a way that every charge is kept separated from those preceding and following it, up to the time that it has approximately attained the proper temperature. According to *Chem. Trade J.*, 1914, p. 182, several Harris burners have been erected in England and on the Continent. Each compartment is said to roast off 7 tons pyrites-smalls in twenty-four hours; the cinders are automatically removed, with a minimum of manual labour. The cast-iron vertical shafts and the blades are cooled by water. Separate channels are provided for the ascending roasting-gases, and for the ore dust, descending from bed to bed, which reduces the formation of dust to such an extent that no cooling-chamber is required, and the gas can be passed from the gas-flue straight into the Glover tower. For each compartment one horse-power is required to do the work. The Harris Furnace Company contend that their furnace is cheaper than all other mechanical burners, and equally well adapted for rich and small ores; for the roasting of zinc-blende and other sulphides it may be provided with an auxiliary heating arrangement.

The same inventor (Ger. P. 273045) describes an agitating-

shaft for mechanical ore-burners, provided with water- and air-cooling, with water-cooled, rake-shaped stirring-blades for the higher outside compartments, and air-cooled blades for the central, lower compartments, which travel mostly within the roasting material; this admits of greatly reducing the height of these central compartments and of working economically.

The Herreshoff Furnace.—The Herreshoff furnace is sold by the General Chemical Company of New York, the Pacific Foundry Company of San Francisco, and is covered by many American and other patents.

The former shape of this furnace and its working are described in Lunge (fourth edition), Part I, pp. 482-488, figures 117-118. In the place of this we shall now describe and illustrate the latest type of this furnace showing air not only used, as heretofore, as a cooling medium for the shaft and arms, but also utilising the same air for temperature control through the medium of the so-called temperature flues, incorporated in the brick lining of the shell, which supplements combustion in the various hearths and measurably increases the capacity of the furnace.

There were in 1921 over 2200 of various sizes of the Herreshoff furnace in practical and economical operation in the following fields:—

1. Roasting pyrites for manufacture of sulphuric acid.
2. Roasting pyrites for manufacture of sulphite pulp.
3. Roasting pyrrhotite.
4. Roasting of mixed sulphides for magnetic separation.
5. Preliminary roasting of simple or complex sulphides for metallurgical work.
6. Calcining of materials where specific temperatures must be maintained for a given period of time.
7. Drying.

The new Herreshoff furnace (also covered by a number of American and other patents) is the direct result of an extended and intensive study in roasting the fines of ore. The irregularities in operation of many "fines" burners have sprung to a considerable extent from two causes. First, slagging and sintering of the roasting ore, which caught the arms and rables, sometimes breaking them; and second, excessive dust production,

which necessitated cleaning of flues and consequent interruptions. The latter will be dealt with in a later part of this chapter, where the flue-dust is specially treated.

It was soon discovered that slagging and sintering was in reality a fusion of the FeS resulting from the oxidation of half of the sulphur in FeS_2 , that the fusion did not occur until after that sulphur was driven off, and that it did not occur when there was a quantity of Fe_2O_3 present.

The problem immediately resolved itself into a regulation of the temperature of the roasting-ore between the points where the first atom of sulphur had been oxidised, and where sufficient iron existed as sesquioxide to prevent fusion.

This is accomplished by means of the cooling, by air, of the central shaft and arms and by the introduction of this air into the temperature control flues, thereby equalising the temperatures on the various hearths, and thus controlling the temperature of the roasting ore between the proper limits. It was found, when water was used as a cooling medium, that it was necessary to run through the shaft and arms sufficient water to prevent the temperature from reaching the boiling-point (otherwise it will form incrustations in the pipes), and, moreover, water was found to be a cooling medium of insufficient elasticity. One might imagine that the slagging of ore could be prevented by cooling the entire furnace by means of decreasing the thickness of the brick lining of the shell, but here again the difficulty was encountered that with ores of lower sulphur contents the temperature of the furnace as a whole dropped below the combustion-point, and that the cinders resulting ran too high in sulphur.

The inventor finally settled on air as a cooling medium, claiming that it is elastic and that the quantity of heat extracted can be regulated. He also found that the lower hearth should be operated at as high a temperature as possible, for the presence of an excess of Fe_2O_3 prevents fusion, and the higher temperature will oxidise the remaining sulphur in the cinders more completely. In other words, instead of having, as formerly, the maximum temperature in the upper hearths of the furnace, through the agency of the temperature control flues the heat is equalised on all the hearths, which completely oxidises the ore and allows the furnace to be operated at

its highest efficiency. The life of the central shaft and arms, as well as of the teeth, is prolonged by internal cooling. This cooling is accomplished by air, which is forced into the bottom of the shaft, as shown in the illustration, Fig. 45, and then delivered through the central shaft, from which it passes in multiple at once into all the arms. After cooling the arms and shaft, the air is conveyed to the annular bustle pipe surmounting the vertical temperature flues, through which it passes to the bottom shelf, thus fulfilling a twofold purpose: first, the equalisation of temperatures on the hearths; secondly, additional oxidation for combustion by the admixture of pre-heated air. The general principles of the construction employed to accomplish this appear in U.S. P. 1181183 (1916), 1181184 (1916), and elsewhere.

In the manufacture of acid, when burning pyrites containing above 24 per cent. sulphur to a dead roast, the roasting capacity may be estimated to be about 13 lb. of sulphur per sq. ft. of hearth area in twenty-four hours.

No accurate statement as to the capacities of furnaces in pounds of sulphur or tons of pyrites per twenty-four hours can be made without a knowledge of the chemical composition or physical character of the ore to be roasted. In general, these furnaces will oxidise 0.5 to 1.0 lb. of sulphur per hour per sq. ft. of hearth area from pyrites ore 40 per cent. or higher in sulphur, to 2.5 or 3 per cent. sulphur in the roasted

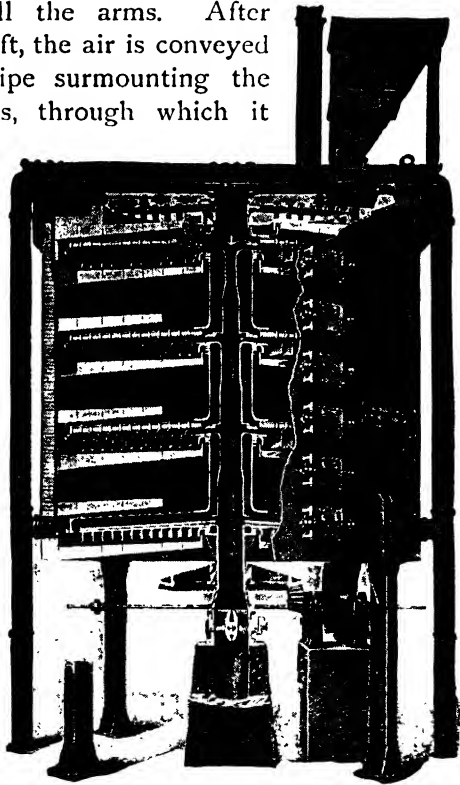

FIG. 45.

ore. It can be assumed that capacities are lowest for dead roasting and greatest in metallurgical work.

The repairs on these furnaces are insignificant. The design is such that the temperatures of the cast-iron shaft and arms are maintained at about 427° , at which point there is no condensation of acid, and the cast-iron is at the point of maximum strength.

The new Herreshoff furnace has a cylindrical steel shell placed vertically, lined with red- or fire-brick, and in this shell brick hearths are placed horizontally one above the other. Utilisation of the top (or roof) of the first hearth has been made so that it acts as a pre-heater. The ore drops from the hopper to the hearth and is rabbled across it, thereby freeing itself of a great portion of its moisture content. Passing down through the centre of these hearths is a double vertical hollow shaft. Attached to this shaft are one or two removable arms at each shelf, and replaceable rabbles, or teeth. On the first hearth they are placed at such an angle that the revolving arms plough and turn over the roasting ore in a regular way, making it travel from the centre of the hearth outward. From there it discharges through proper openings on to the hearth below, where the teeth are placed at an opposite angle to the one above, so as to turn and plough the ore from the outside toward the centre of the furnace, where it again drops to the hearth below, as shown in the vertical section. This operation is repeated until the ore finally discharges through an opening placed at the outer edge of the bottom hearth. The rabble teeth are so arranged, in regard to their pitch and progression, that the movable ore body maintains a regular form of furrows equal in depth, from the centre to the circumference on all hearths.

The hearths are of specially moulded arch firebrick. The openings in the hearths for the passage of the gas and discharge of ore are carefully calculated to prevent dust nuisance.

The shaft, of close-grained special cast-iron, is made in sections bolted together to facilitate manufacture and erection. It consists of an inner chamber into which the cooling air is forced, and an outer chamber which carries away the air which has cooled the arms. The shaft is provided with sockets in which the arms are placed. It is mounted on a special button-bearing, on which it revolves.

The arms are made in two types—either of cast-iron, bolted directly to the shaft, or of removable steel pipes (this type may be renewed without appreciable interruption to the operation), which fit into machined arm-sockets bolted to the shaft. In each case the arms contain two passages, the one for receiving the cool air from the inner chamber of the shaft, the other for expelling it to the outer shaft-chamber.

The rabbles, of close-grained special cast-iron, are of two types, depending upon the kind of arm used. In either case they are removable. In the bolted type of arm they are attached by means of a button held in a groove which runs the entire length of the arm. These rabble sections are identical in pattern, automatically adjusting themselves to the proper angle for most effective rabbling. In the removable steel-pipe type of arm the rabble sections are attached to the outer pipe by bands which are cast as an integral part of the rabble sections.

The shaft is driven from the bottom by means of a cast-iron gear and pinion, and makes one revolution in from 20 to 150 seconds, depending upon the kind of roast. Speed reductions are made by spur gear, reducing worm gear, or variable-speed pulley with belt drive.

The Herreshoff furnace is built in diameters of 11 ft. 7½ in., 15 ft. 9¾ in., 18 ft. 0 in., 19 ft. 6 in., 21 ft. 6 in., with from 5 to 9 hearths as required. In addition a laboratory size has been developed for experimental purposes. This has a diameter of 4 ft. 6 in., with 6 to 10 hearths as required.

Ores containing more than 20 per cent. sulphur can usually be roasted without the use of extraneous fuel. In roasting ores where extraneous fuel is required, such as zinc blende, ores for chlorination, in the decomposition of telluride, or for calcination, a fire-box can be added.

Mechanically, the operation of a Herreshoff burner is extremely simple, as it consists merely of regulating the amount of material fed to the furnace and controlling the admission of pre-heated air to the bottom hearths to obtain a proper temperature and gas concentration. By the installation of the temperature-control flues the most effective distribution of heat is secured, and the maximum capacity of the furnace obtained.

Thorba Furnace.—Another furnace is the “Thorba”

mechanical furnace, supplied by F. W. Bakema, Hilversum, nr. Amsterdam. The furnace is cylindrical in shape and built of fire-proof bricks, the interior being divided into several hearths by means of fire-proof shelves or beds, all the movable parts being constructed of iron. For each hearth there are two diametrically opposed hollow stirring arms, fixed on the hollow central shaft.

In the top of the furnace there is a special feeding apparatus, through which the pyrites is fed automatically in regulated quantities, on to the upper bed, where they are spread out by the slanting teeth of the arms. By means of these teeth the pyrites is guided downwards in a radial direction from the periphery to the centre of the furnace, and *vice versa* from bed to bed, the burnt ore being removed through a closed conveyor at the bottom of the furnace, and the air for combustion passes through the furnace in an opposite direction.

The feeding apparatus may, without stoppage, be regulated from 0 to about 40 tons.

These furnace arms are cooled by means of water, in consequence of which they are kept cooled so effectually that they keep their original shape and strength and do not break. The teeth, which are connected to the arms in a simple way, are said to show hardly any signs of wear, and only in the very hottest beds require now and then to be replaced.

The cooling water runs freely in and out, so that no stuffing-boxes are required.

As mentioned above, the iron parts, viz. the arms and the shaft, are cooled by water. This water cooling is arranged simply and practically, in such a manner that the quantity of cooling water flowing to each of the arms may be separately regulated. Water is saved and the arms may always be kept under control. This arrangement also renders possible the cleaning of any arm by rinsing in opposite directions, should there be any obstruction to the passage of water. The teeth are connected to the arms in such a way that they may be very easily removed, and do not stick so fast as to cause a stoppage.

The writer was informed that these furnaces had been in operation for several years without any stoppage occurring.

After passing through the furnace, the cooling water serves

as a feed for the steam boiler. The quantity is regulated in such a way as to maintain the temperature of the water running away at from 60° to 80°. The arms through which it runs are therefore never heated above the latter temperature, and this is a favourable point as regards the durability of the arms.

The generation of dust, caused by the falling of the pyrites from shelf to shelf, is, in these large furnaces, proportionately less than in smaller ones. The number of falls in this larger furnace is only a fraction of what it would be in a corresponding number of smaller ones, and consequently the dust is reduced in proportion. The driving mechanism is simple and the power consumption low, being 3 h.p. at the starting and only 1½ h.p. when in operation.

In the larger types a screw-thread is introduced into the bottom, so that the entire mechanism (shaft and arms) can be lifted or lowered. This is very practical, as of course there comes some movement in the masonry of shelves in dimensions of 20 ft. in diameter.

The upper shelf acts as a kind of kiln-dryer, which prevents the caking of the pyrites in the furnace.

The Thorba furnaces are built in three sizes :—

Capacity per 24 hours.	Inner Diameter.	Weight of Iron Parts.
8 to 11 tons.	14 ft. 9 in.	17 tons.
12 „ 15 „	17 „ 0 „	23 „
16 „ 20 „	20 „ 2 „	27 „

Wedge Furnace.—The Wedge furnace is built in various diameters, up to 25 ft., and with varying numbers of hearths—3, 5, 7, etc.

The central vertical shaft is 5 ft. in diameter, and is insulated from the heat and destructive gases of the furnace by special fire-tiles and insulating material, which are attached to and revolve with the shaft; therefore no air or water is required for the cooling of the central shaft, thus eliminating the disturbing factor which is present where cast-iron shafts are used, since these must be cooled by either air or water, which introduces a cooling element into the heart of the furnace. The shaft, being 5 ft. in diameter and open top and bottom, forms a natural stack, and allows the arms to be locked on the inside of the shaft, where the arm-locking device is accessible.

Further, it permits of a separate pipe for air or water to each arm or tandem arms, or any combination desired ; or air-cooling part of the arms and water-cooling remainder, with control over the quantity of air or water circulated through each arm. Where air is used for cooling, butterfly valves are located in the air-feed pipe to each arm, permitting regulation of the quantity of air circulated. There are also valves so that the hot air can be used for feeding the furnace, or otherwise dealt with. Thus full control over draught conditions is possible, with a consequent uniform gas for the production of acid.

When it becomes necessary to change an arm, a workman enters the central shaft, and the only tool required is a wrench to loosen one small nut, in order to release a dog, which in its turn releases the arm, which may then be withdrawn by workmen outside the furnace and a new arm inserted ; the dog is then thrown into position and the arm held by tightening one nut. On account of the insulation around the shaft it is not much hotter inside the shaft than immediately adjacent to the outer shell of the furnace, and an arm can be changed in a hot furnace in less than an hour's time. In fact, one of the advantages of the furnace is that all ordinary repairs incident to the operation of a roasting-furnace can be made in the furnace while hot.

Fig. 46 shows the construction of the Wedge furnace. In this type the material to be roasted is fed from a bin or hopper, to the top of the furnace at the periphery. From this point it is rabbled towards the centre, and enters a luted feed. This feed is adjustable and rejects oversize material, and works on the principle of a sand lute, thus preventing the inlet of false air or the discharge of gases. From this point the ore is rabbled to the periphery, then dropped to the next hearth and rabbled to the centre, and so on until finally discharged through drop-holes arranged at the periphery of the bottom hearth.

The furnace arches may be built of straight nine-inch brick and levelled with inert material, or may be built of special bricks, giving a level working hearth. In the larger-diameter furnaces, and especially for high-temperature roasting, a high-grade firebrick is used in the construction of the arches, reducing to a minimum the rise and fall of these caused by expansion and contraction.

There are two types of bearing used for the central shaft.

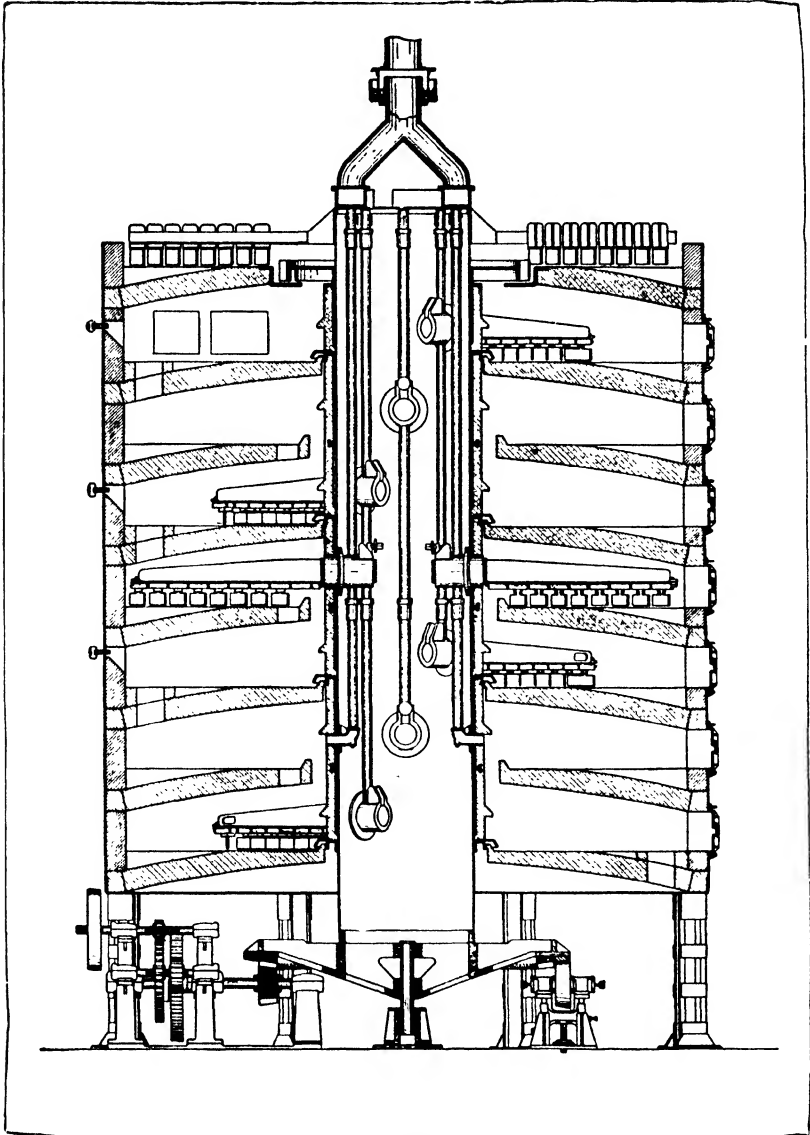

FIG. 46.

With the bearing shown, a wide base is formed by the master-gear, which is carried on supporting rollers, there being no

weight on the centre, the pin at this point being simply a guide pin. Each supporting roller has a screw-jack, permitting its adjustment to keep the master-gear level and the shaft vertical. In this type no bearing is required at the top of the shaft. Furnaces are also built with a step button-bearing, also a step roller-bearing, in which construction a centre bearing is required at the top of the shaft, which is carried by beams supported on the shell of the furnace.

Various types of arms are used, depending on whether they are air- or water-cooled, and whether it is desired to admit into the furnace a certain amount of air from the arms on various hearths, or have a closed circulation through the arms. These are cast with a diaphragm through the centre, extending close to the outer end of the arm, thus making positive circulation of the cooling medium.

Various types of rabblers are also used, with different angles and length, according to circumstances ; and also various designs for carrying the rabblers on the arm, some being made rigid, and carried on the under-side of the arm, as shown. There is also the overhanging type of rabble, which rides on the hearth and will rise or fall with any obstruction.

For zinc, two different types of furnace are in commercial use, one where the gases are utilised for the production of acid, and the other where the gases are wasted. The principle observed is that most zinc blendes will auto-roast down to 5 per cent. or 6 per cent. sulphur, thus making possible the production of acid from the gases. These furnaces are 25 ft. in diameter, and have seven roasting-hearth and a dryer or pre-heater hearth. Between the fifth and sixth hearths there is a semi-muffle, and the furnace is subdivided at this point by luted drop-holes, the roasting material filling the drop-hole and sliding from the fifth to the sixth hearth. The two lower hearths and the muffle may be fired, with damper-controlled inlets, and the two lower hearths are down-drafted, the combustion-gases being taken off at the bottom hearth. By this means, muffle-firing effect is secured under the fifth hearth. The hot combustion-gases passing under the tile hearth are drawn down through the arch, giving a burner effect over the hearth below, plus the direct-firing on the two hearths, thus securing a dead roast. This type of furnace has been used

within city limits, without causing fume trouble. The percentage of sulphur eliminated on the two lower hearths is small in proportion to the volume of combustion-gases passing into the stack and out into the atmosphere. Gas analyses made at the foot of the stack connected with furnaces of this type showed ($\text{SO}_2 + \text{SO}_3$) 0.16 per cent. Gas analyses made at the top of the stack showed ($\text{SO}_2 + \text{SO}_3$) 0.13 per cent. Where the gases are wasted, no muffle is used between the fifth and sixth hearths. This furnace has well-insulated outer walls and central shaft, and is fired on the lower hearths. Oil, gas, or coal can be used as fuel. This type of furnace is generally used at plants where they are leaching and producing electrolytic zinc.

According to Hasenclever¹ there were, in Germany, Wedge furnaces working satisfactorily in five chemical works and another fifteen furnaces in course of construction. The largest type of them gets through about 20 tons of pyrites in twenty-four hours each, that is, six or seven times as much as the Herreshoff furnace, and their design is more compact and simple than that of the latter; but there seems to be no particular economy in cost of construction or working expenses. The main feature of the Wedge furnace is that it permits of repairs being made without interrupting the working.

The Wedge burners (Ger. P. 255648) can be worked from beginning to end of the roasting in an uninterrupted way, by employing a mechanical burner with several shelves; the upper shelves perform the pre-roasting, and the lower ones finish the process, after mixing a reducing agent, such as coal, with the product.

L. D. Anderson² reports that the Wedge furnaces have given excellent results for roasting lead matte at Midvale, Utah.

Prior to development of the Wedge lead-roaster, it was common practice to roast lead ores and matte in hand reverberatory furnaces or mechanical furnaces of the single-hearth type. In roasting lead matte, carrying about 25 per cent. sulphur, in hand reverberatories, as high as 25 per cent. extraneous fuel was required. In the mechanical single-hearth

¹ *J. Soc. Chem. Ind.*, 1911, p. 1291.

² *Eng. and Min. J.*, 1914, p. 51.

furnaces, approximately 12 per cent. fuel was considered good practice. In the Wedge roaster, lead matte is roasted without the use of any extraneous fuel. In roasting this material and the like, there is a tendency in the early stages, where the temperatures are excessive, to cause fusion of the matte. This is overcome in the Wedge furnace by having dampered gas outlets to the upper hearths of the furnace. The hot gases from the lower hearths therefore do not pass over the upper ones. By opening or closing these dampers it has been found possible in actual commercial practice to secure a variation of temperature ranging from 100° to 150° F. in about an hour's time. When once set for the roasting of lead matte, no further attention is required.

For further details regarding the Wedge roaster, see Hofman's *Metallurgy of Lead*, last edition.

In these lead-roasters, provision is made for firing the bottom hearth, in case of cleaning the furnace and shifting from roasting matte to other material, where fuel might be required to heat up the furnace properly for further use, or where the material being roasted is so low in sulphur that auto-roasting is impossible. These combustion-inlets are provided with dampers or doors, so that they may be closed when not in use.

Kauffmann Furnace (Ger. P. 161200 of 1903).—Kauffmann describes a mechanical stirrer, with a hollow shaft with a cooling agent flowing through it, provided with perforations for putting in the stirring-blades. These blades are of a special shape which allows the cooling agent to pass through them as well. Fig. 47 shows this arrangement in vertical, and Fig. 48 in horizontal, section. 1 is the hollow shaft, which for each of the shelves of the furnace is provided with a rectangular channel, 2, of such a height that the hollow stirring-blade, 3, with its teeth, 4, can be put through; the width of the channel corresponds to the thickness of the blades. When in use, the arm, 3, rests in its central part upon the bottom plane, 5, of channel, 2, and is secured against shifting by the lugs, 6. A perforation, 7, is provided in the bottom plane, 5, of the channel, and a perforation, 8, in the plane of the blade resting upon it, so that the cooling agent, introduced under pressure, also penetrates into the hollow blades and gets out through the openings, 9,

into the furnace. In this way, also, those parts of the blades which are at some distance from the cooling places, *e.g.* the teeth, 4, are protected against damage by heating. The cooling agent is cold air, which is blown in by a fan-blast into the hollow footsteps of the shaft, in such quantity that it protects the blades against overheating, without interfering with the

FIG. 47.

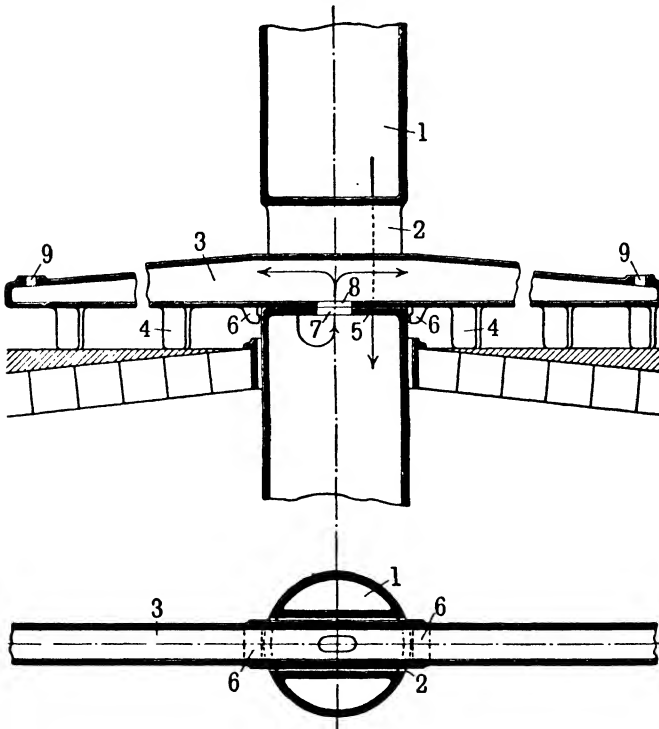

FIG. 48.

roasting process. Each furnace roasts $2\frac{1}{2}$ to 3 tons of 50 per cent. pyrites in twenty-seven hours, down to 1 or 2 per cent., with an expenditure of only $\frac{1}{2}$ h.p., and requires no manual labour except for carting the ore and taking away again the cinders.

The other patents of Kauffmann are: Ger. Ps. 161624, 163914, 165270, 186314, 186315, 205215, 227621.

The Erzröstgesellschaft in Cologne (Austr. P. 51096) states

that the amount of work done by these furnaces can be largely increased by frequently turning over the ore, and gradually moving it forward in a radial direction. For this purpose the teeth of the stirring-arms stand alternately in opposite directions, so that the ore, moved forward by one half of the arm, is brought back through part of the way already made.

Reusch¹ states that in the beginning of 1912 about 600 such furnaces were working in Europe, America, and Australia.

Hartmann and Benker² assert that the asbestos screens in the Kauffmann burners are destroyed after a short time.

Truchot³ states that these furnaces are an essential improvement over the original Kauffmann burner; they save 28 per cent. of space and 50 per cent. of power, and do 10 per cent. more work. In this type the revolving axis and the stirring-blades are cooled by air blown in by a fan-blast. The ore slides from one shelf to another by laterally inclined cast-iron plates, which greatly reduce the production of dust. The teeth of the stirring-blades are exchangeable. Their Ger. Ps. are 246067, 250310, 262002, 267374, 268649.

Keppeler⁴ makes critical remarks on the modern burners for pyrites-smalls. He points out that many so-called improvements have not stood the trial of practical experience. Thus, *e.g.*, the shortening of the way which the ore has to travel by increasing the stirring-up of the material, whereby the velocity of the roasting process is increased, has the drawback that it is less easy to adapt oneself to changes in the conditions of working. More success for the increase of the working capacity of the burners may be expected from increasing their size. Against this conclusion, Nemes⁵ urges that in case of the very large burners, going through 25 tons, difficulties arise when they have to be laid off for repairs; he therefore prefers burners for 8 to 10 tons duty. Keppeler⁶ makes further remarks on this subject.

Lüty⁷ quotes results from actual practice, according to which, under European conditions, mechanical burners work less economically than hand-worked burners; but he thinks that

¹ *Chem. Zeit.*, 1912, p. 213.

² *Z. angew. Chem.*, 1906, p. 1188.

³ *Rev. gén. chim. pure et appl.*, 1914, p. 169.

⁴ *Chem. Zeit.*, 1913, p. 1220.

⁵ *Ibid.*, 1914, p. 2.

⁶ *Ibid.*, 1914, p. 318.

⁷ *Z. angew. Chem.*, 1905, p. 1253.

with higher wages the cost may be the same, and then mechanical furnaces have the advantages of requiring fewer men and being less dependent upon them.

E. W. Kauffmann¹ contradicts these conclusions, and maintains that mechanical pyrites-roasting with modern furnaces, quite apart from the better result, is considerably cheaper than roasting by hand-work. At all events he claims this for his furnaces.

Furnaces built by the Humboldt Engineering Works at Cologne are very similar, although they embody some improvement.

Other Mechanical Dust-burners.

The O'Brien furnace, built by the American Coke and Gas Construction Co., very much resembles the Herreshoff furnace (p. 377). In this furnace the arms are put in and taken out horizontally and without raising. It is claimed that it requires less power than any other furnace of similar capacity, and is equally efficient for "fines" and for "granular ore"; the feed can be exactly regulated and the depth of the ore can be maintained differently on the different shelves, a shallow bed being used where the combustion is most active, and a deeper bed where the sulphur is partially burnt out. The central shaft is hollow, and no stack is required to create a draught through it; it can be withdrawn and replaced. The driving-mechanism is placed near the circumference of the furnace, where it can be easily reached for oiling and repairing.

Legge (B. P. 21160 of 1905) describes furnaces containing two or more superposed series of roasting-chambers, with horizontal or slightly inclined hearths; rubble shafts with arms passing through them convey the ore through all the chambers of a series, and means are provided for discharging the ore.

The Maschinenbau-Anstalt Humboldt at Kalk (B. P. 27061 of 1906) forms each stirring-arm as a two-armed lever, and supports it on the shaft in such manner that it can be easily disengaged.

Greenaway (Ger. P. 182409) describes a mechanical pyrites-burner, consisting of a long hearth, with a stirring-carriage over it, the hearth being formed by a porous layer of ore,

¹ *Z. angew. Chem.*, 1905, p. 1628.

divided by intermediate walls into several compartments, corresponding to the varying quantities of air required for the successive stages of the roasting process. Each compartment possesses an opening leading to a vault in front, by which air is introduced and from which the porous layer may be renewed.

A mechanical dust-burner, with scrapers travelling backwards and forwards, has been constructed by Hegeler,¹ and is employed in a few factories, both for lead-chambers and for the Schroeder-Grillo contact process. Here the stirrers are always conveyed to one side, are turned round there and conveyed to the other side again. The ore is dropped gradually from one shelf to the other once per hour.

Ducco's furnace² (Ger. P. 185809) consists of a horizontal wrought-iron cylinder, lined with bricks, with screw-shaped grooves for turning over the material and shifting it gradually to one end of the cylinder, where it is discharged.

Warren (B. P. 17457 of 1905; Amer. P. 864816) divides a rotary kiln into compartments by a hollow lateral partition, communicating with the air at diametrically opposite points. The hollow space diverges at opposite ends, where it communicates with the air. The other portion of the kiln forms a common chamber, the flame from which passes simultaneously into the compartments of the first portion.

Falding (B. P. 6931 of 1905) provides for the stirring-arms means of being readily removed without removing the central shaft; both this and the arms are provided with an arrangement for cooling by air.

Daniel and Römer (Ger. P. 208354) describe a roaster consisting of revolving drums superposed over one another, through which the ore is automatically propelled.

Zelewski (Ger. P. 195724 and Ger. P. appl. Z5379) describes a modification of the Herreshoff mechanical roaster (p. 377) in which the stirrers of the bottom compartment are placed in a special socket, surrounding the perpendicular shaft, so that a certain portion of the ore can be completely roasted off, while another portion lies still.

J. L. Tafto (Amer. P. 891116; Ger. P. 207760) equalises

¹ *Min. Ind.*, 1905, p. 246.

² Described by Hartmann and Benker in *Z. angew. Chem.*, 1906, p. 1194.

the SO_2 contents of pyrites-kiln gases, to obtain a product with 6 per cent. SO_2 and about 816° , by passing them through an iron-cased brick dust-chamber and then through a similar chamber, packed with bricks, which is large enough to contain the gases for some time and to equalise the variations of composition and temperature. Between these two chambers air can be introduced by means of a regulating-valve, and the gases containing too little SO_2 and too much O can be enriched in SO_2 by passing them to a layer of hot pyrites, where more SO_2 is generated.

St Beuve and E. Marconnet (Fr. P. 390323) blow finely-ground pyrites by a current of air continuously into a combustion-chamber, provided with an exit opening for the SO_2 , and a discharge opening for the removal of the residue. The pyrites, which may be mixed with substances for accelerating the combustion, or fuses, is delivered by a screw-conveyer into a chamber, and taken out by a fan, delivering it into the combustion-chamber by a tangential pipe.

Olga Niedenführ (Ger. Ps. 239702 and 239703) provides mechanical roasting-furnaces in their hottest parts with cooling-channels; cold roasting-gases are conveyed through the shaft and the stirring-arms. Easily and badly roasting ores can be worked in the same furnace by putting them alternately into successive roasting-compartments.

The mechanical pyrites-burner of P. Spence is a shelf-burner provided with mechanical stirring arrangement.

It is very fully described in Lunge's fourth edition, pp. 488 *et seq.*

Düron (Ger. P. 275751) describes special shapes of stirring-blades. The same (Ger. P. appl. D28657) describes a charging apparatus for mechanical burners, allowing of very exact regulation, consisting of a helix causing a continuous agitation, avoiding any intermediate machinery (such as levers, toothed wheels, ropes, etc.), and loosening and drying the material, without requiring any supervision.

Zelewski (U.S. P. 1097500) heats briquettes, made from sulphide ores, in a closed chamber, first by fire-gases, igniting the gas given off; the fire-gases are then cut off, and air is passed round the briquettes under pressure up to their complete combustion.

Spinzig and Hommel (Ger. Ps. 272097 and 290835; Fr. P. 460128; Austr. P. 67690) employ an arrangement for moving the ore in a direction perpendicular to the motion of the stirrers by moving these backwards and forwards. At one end, arranged transversely to the longitudinal axis of the furnace, rods are placed which are made to travel backwards and forwards; to them a number of stirring-blades is attached, moving in the longitudinal direction, with V-shaped or plough-share-like stirrers. The patent specification describes a number of ways of carrying out this system. These burners are reported to be working at the zincworks at Neuss. Hommel's Ger. P. 292487 describes various forms of stirring-blades for mechanical roasters.

The mechanical dust-burner of Bracq and Moritz is described in detail by Barth.¹ According to *Chem. Zeit.*, 1914, p. 816, forty such burners had been built during the last four years. According to *Chem. Zeit. Rep.*, 1914, p. 336, this burner roasts the sulphur in pyrites from 50 per cent. down to less than 1 per cent.; each burner requires 0.1 to 0.25 h.p. The cinders in the bottom compartments are nearly cold, which in the case of cupriferous ores greatly facilitates the extraction of copper.

Barth (Ger. P. 289259 and 291886) describes a mechanical dust-burner containing a number of hearths which are in turn fixed and moving; they revolve upon a common hollow axis, consisting of two concentric tubes, one of which serves for introducing cold air into the single compartments, the other taking away heated air.

Wagner & Co.'s burner (Ger. P. 290534 of 1914) consists of a series of superposed shelves with the usual rabblés attached to a vertical central shaft. The ore is carried downwards between successive chambers by endless screws, through channels in the walls of the furnace, and falls through funnels near the centre, alternately. Separate channels are provided for the gases. This arrangement is said to cause the ore to move forward in a regular manner, and prevents formation of lumps and consequent blocking of the passages.

J. L. Fairrie (B. P. 144412 of 1919) describes a pyrites-burner having a number of chambers in a circle round a

¹ *Chemische Apparatur*, 1915, pp. 95 and 105.

common discharge-pit, such chambers being in the form of a truncated sector of a circle. It is provided with the usual grate bars and doors. The ash-pit floors slope downwards to a common central pit, and the gases are discharged above into a common central flue. The pit and flue can be put into communication through a conduit controlled by a damper. The burnt cinders are removed from the pit by an endless conveyor.

The Svovlsyre- og Superphosphat-Fabrik, Copenhagen (B. P. 28703 of 1911), describe a mechanical pyrites-roaster, provided with complete water-cooling of the shaft and all the stirring-arms, worked by a water-tank at the top, into which the exit-water pipes from the shaft and the arms are conducted back.

Other modifications are patented by Scherfenberg and Prager (Ger. Ps. 329759 and 332056); Lütgens (Ger. P. 358443); Hommel (Fr. P. 384350); Aktiengesellschaft für Bergbau, Blei- und Zinkfabrikation (Ger. P. 202377); Merton (Ger. P. 185506); Bracq-Laurent (Ger. P. appl. B52846); Grünewald and Welsch (Ger. P. 232044); Bracq and Moritz (Ger. P. appl. B52486); Parent (Fr. P. 424269); de Spirlet (Ger. P. 236089); Scherfenberg (Ger. Ps. 236090 and 237215); Hübner (Ger. P. 236669); Renwick (Amer. P. 981880); Hardingham (B. P. 19314 of 1911).

Special contrivances for charging the ore into the furnace in a regular way are described by the Metallbank und Metallurgische Gesellschaft (Ger. Ps. 263939 and 243913, that of the Maschinenbau-Anstalt Humboldt 243613). Other patents:—Société minière et métallurgique de Peñarroya (Ger. P. 275908); Bracq (Ger. Ps. 250623 and 257424; B. P. 20108 of 1912); Wagenmann, Seybel & Co. (Austr. P. 54964); John G. Jones (Ger. P. 263393; U.S. P. 1098177); Kirsch and Mausser (Ger. P. 263851); Gottlieb (Ger. P. 268330); Thorsell (Norw. P. 34440); Gaillard (Fr. P. 458413); Helsingborgs Kopparwerks A. B. (Ger. P. 261608); Kalinowsky and Roth (Ger. P. appl. K29006); Dohet (Ger. Ps. 258261 and 265075, Austr. P. 67180); Scherfenberg (Ger. P. 258766); Stout (B. Ps. 3581 and 15463 of 1914); Parent (Ger. P. 264709); Wocke (Ger. P. 216657); Fowler (B. P. 7471 of 1914); Claude (Fr. P.

468968); Renwick (Ger. P. 246180); Herzig (U.S. P. 1108906); Timm (Austr. P. appl. 9226 of 1913); Edwards (Ger. Ps. 242888, 250774, and 255747); Ernest (Austr. P. appl. 2496); Chemische Industrie Akt.-Ges. and Singer (Ger. P. 262610); S. et G. Dumont et Frères (Ger. P. 262183); Bousse (Ger. P. 280523); W. A. Hall (B. P. 20759 of 1912; U.S. P. 1076763); Zetsche (Ger. P. 280430); Saccharinfabrik A.-G. vorm. Fahlberg, List & Co. (Ger. P. 257537); Zavelberg (U.S. P. 1107006; Fr. P. 468685; Ger. Ps. 284607 and 292809); Sarrasin (B. P. 26915 of 1913; Fr. P. 451182); Aktiengesellschaft für Zinkindustrie vorm. W. Grillo and Schefczik (Ger. Ps. 280427 and 280429); Selas (Ger. P. 285913); Lütgens and Ludewich (Ger. P. 262128; Fr. P. 449144; U.S. P. 1176070); Nichols Copper Company (Ger. Ps. 276570, 284586, 286381, 287079, 288013, 289998, and appl. 15180); Nichols Copper Company and Stout (B. P. 9958 of 1915); Hildebrandt (Ger. P. 290733); Maschinenfabrik A.-G. vorm. Wagner & Co. (Ger. Ps. 290534 and 291239); Jenks (U.S. P. 1179928); Mount (U.S. P. 1179952); Hommel (Ger. P. 292794).

C. SULPHUR DIOXIDE FROM ZINC-BLENDE AND OTHER SULPHIDES

Zinc-blende is now the most important of all zinc-ores, and must be always converted into zinc-oxide by a thorough roasting. This is much more difficult than with pyrites, since blende contains at best only about 33 per cent., sometimes down to 18 per cent., of sulphur.

The heats of formation are:—

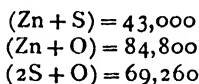

Thus the formation of 81 kg. $\text{ZnO} = 84,800$ calories.

And the " " 64 " $\text{SO}_2 = 69,260$ "

Total . . . 154,060

Decomposition of 97 kg. ZnS requires 43,000 "

Nett heat evolution . . . 111,060 "

This result is borne out in practice, and it is possible to roast zinc-ore without extraneous fuel, but in this case the

sulphur fumes are discharged at comparatively low temperature. In the great majority of works the fumes are treated by the chamber-process, and this requires the SO_2 to be delivered at a high temperature, for which purpose fuel has to be used.

In the muffled zinc-blende roasting-furnaces mainly used in Germany, the fire-gases passed under each of three hearths. It was necessary to supply heat to the bottom muffle, but when the fire-gases passed under the middle muffle their temperature was lower than that of the ore in the muffle where rapid oxidation took place. As a consequence, the fire-gases in this part of the furnace were heated from the ore and the roasting operation was retarded by loss of heat.

Roasting in open heaps was formerly practised to a large extent, but the removal of sulphur was always incomplete and the loss of metal considerable, while the sulphur fumes were allowed to pass out of the top of the heap only a few feet above the ground-level, so that the atmosphere was polluted and all vegetation destroyed. This method is still used on copper and lead ores to obtain a preliminary partial roast.

At Broken Hill this method was adopted to a considerable extent for sintering and partly desulphurising lead-zinc slimes, but the fumes were such a nuisance that the operation had to be carried out some miles away from the town, far from human habitation. The individual heaps contained 4000 to 5000 tons of slimes.

Reverberatory furnaces rabbled by hand were in use in many works, and a single-hearth furnace as used for lead or copper ore was about 60 ft. long and the hearth 44 ft. long by 10 ft. wide. Given efficient labour, good results were obtained; but as the work was most arduous, hand-rabbed reverberatories are now only built for temporary purposes or under special conditions. Such furnaces were wasteful in fuel and required an enormous amount of labour. The furnace arch was usually much too high, and a large volume of unnecessary air passed through the furnace, and much heat was thereby lost.

Sulphur Fumes.—In consequence of the effects of passing large quantities of sulphur fumes into the air, efforts were made in Germany and Belgium to make a more concentrated gas from roasting zinc-sulphide ore, and to avoid the dilution with the fire-gases, so that the SO_2 could be used for making

sulphuric acid. About 1855, Hasenclever built a partially muffled furnace and tried to use the fumes given off on the upper hearth for making acid, while the last of the sulphur was drawn off in contact with the fire-gases on the lower hearth. The arches were built too high, and the SO_2 contents of the fumes was low.

Godin constructed a muffled furnace for the same purpose in 1865. The results were better, but the output was small and the concentration of the gas insufficient. This furnace showed a marked improvement, as the designer realised that extraneous heat was only necessary for the final oxidation.

In order to reduce hand labour, Hasenclever and Helbig, in 1862, attempted to use an inclined plane for the first stage of the operation, followed by a horizontal hearth in contact with the fire-gases. Labour costs were not reduced because of the irregular manner in which the ore travelled down the incline, partly on account of the iron and lead, which caused caking, so that the accretions had to be barred down. The furnace produced about 3 tons of roasted ore per twenty-four hours, and six men, each working twelve-hour shifts, were required, so that the output per shift per man was only 10 cwt.

Delplace Furnace.—This is composed of a series of units, and is furnished with grates heating the lower shelf, the flame from the grates circulating under the lower shelf. A battery of Delplace furnaces is generally composed of nine, twelve, or fifteen units, each dealing with 1 ton of blende per twenty-four hours. Every group of three units is furnished with two fire-places, each of which has a muffle, heated by radiation from the fire, and in which the coal distils, giving up its volatile matter and forming coke. When the evolution of volatile matter is completed, the coke is pushed on to the fire-grate, where it burns. Air heated by the waste fire-gases is brought in small passages, leading in several directions, to burn the gases liberated by the coal. This permits of distributing the heat in a regular manner. The air used for the combustion of the sulphur in the blende is also heated before being introduced into the furnace. This disposition of the burners, together with the recovery of the waste heat, enables the blende to be roasted with a reduced quantity of fuel ; several works employing

this furnace have a consumption of fuel of 14 per cent. of the weight of the raw blende charged. The height of the roasting-compartments of the furnaces (that is to say, the distance between the upper side of one slab and the lower side of the following one) is $6\frac{1}{2}$ in. The operating doors on each shelf are very small, and exactly proportioned to enable the introduction of a rake the section of which is about 12 in. to $1\frac{1}{2}$ in. All this results in a great concentration of heat as well as a good utilisation of the air in the furnace. Sulphurous gases are obtained containing on an average 6.5 to 7 per cent. of SO_2 . This is rarely possible to attain with any other type of hand-rabbléd blende furnace. The fact that the operating doors are very small permits of working the furnace without its cooling in a sensible manner. The operation is the same as with a Malétra furnace. Each unit is worked with four or six hours' interval. The workman commences by emptying the lower floor containing blende completely roasted, then bringing down successively the contents of the furnace. When the uppermost floor has been emptied, he charges it with from 180 to 250 lb. of raw blende. Every hour or every two hours during the four or six hours' interval between the working of a unit, the operator rakes each floor of the unit so as to stir the blende and renew the layer on top. He thus works in a compartment of restricted dimensions, and has only to stir a minimum quantity of blende; he gets through 1000 to 1200 kg. Every time the furnace is operated to lower the blende from one floor to another, the ore is vigorously stirred and brought into contact with the air. The furnaces being built side by side, so that the two short ends of each unit are accessible, each compartment is always worked at the same time as the corresponding compartment on the opposite side. The blende which falls from the front is piled on the immediately lower floor of the rear. By this method the operators mutually control one another. The consumption of fuel is low (16 per cent.), and with the low roasting-compartments a gas rich in SO_2 is possible.

Mechanical Roasting Furnaces.

The main essential conditions for a mechanical furnace for the roasting of blende are:—

- (a) The stirring-arms should be easily accessible.
- (b) The ore must be continuously stirred.
- (c) The roasted ore should be free from lumps and low in sulphur.
- (d) The emanating gas should be uniform in composition, and high in sulphur dioxide.
- (e) A minimum of dust to be generated.
- (f) The heat of the different hearths to be easily controlled.
- (g) The air-supply should be pre-heated by passing over the ore.

Of course, no furnace fully covers all these conditions, but the number of furnaces on the market is legion, and we need only deal with the most important. Readers are therefore referred to Lunge's fourth edition, p. 501 *et seq.*, for the historical data regarding the early attempts to solve the many difficulties of blende-roasting.¹

Buddæus (B. P. 29042, 1913; Ger. P. 278443; Fr. P. 466397) converts the blende into briquettes, applying calcium silicate as a cementing material, in case of necessity with addition of a combustible substance. Owing to the porosity of these briquettes the sulphur can be roasted off without fuel till below 1 or 2 per cent. His U.S. Ps. are 1079897 and 1121226.

Saulles (U.S. P. 1183172) roasts blende (with the addition of carbon near the end of the roasting) with a regulated supply of air, so as to prevent the temperature of the charge from exceeding 1000°. This effects the decomposition and reduction of sulphates without volatilising much of the metal.

Schütz, who describes the various apparatus for roasting blende,² also comes to the conclusion that up to that time none of the mechanical blende-roasting furnaces had had a full success, and that the mechanical roasting of blende was at that time still in the experimental stage, at least in Germany. In *Metall und Erz*, 1915, p. 109, he makes a report on the progress in the roasting of blende up to that time.

Enumerations of the various descriptions of such furnaces are given by him in *Metallurgie*, 1911, p. 635 *et seq.*; and by Hommel, *loc. cit.*, p. 290 *et seq.* The latter divides them into

¹ See also Ridge, *J. Soc. Chem. Ind.*, 1917, p. 676 *et seq.*; and *supra*, p. 129.

² *Metallurgie*, 1911, pp. 637-645.

two classes, viz. those where the hearth itself is moving, and those provided with moving stirrers. The first class comprises (1) horizontal revolving drums, (2) vertical revolving furnaces; the second class, (3) long furnaces with one or more floors in which the stirrers travel horizontally lengthways, (4) furnaces with revolving stirrers. A combination of these two classes is Hommel's furnace (Ger. P. 204423), in which the first roasting of the ore takes place in a revolving hearth, and the desulphurisation is to be completed on a fixed annular hearth in which the ore is moved forward by stirrers attached to the periphery of the revolving hearth.

A detailed discussion of the principles of blende-roasting is published by W. Hommel in *Metallurgie*, 1912, pp. 281-296.

Spirlet Furnace (F. P. 415338; Ger. Ps. 236089, 292371).—The principle of this furnace is original, and entirely distinct from what has previously been tried. The characteristic of the apparatus is that it has no metallic parts in the interior of the furnace. This is composed of a number of platforms of fireclay material, superposed and alternately fixed and movable. The fixed ones are carried on six columns arranged round the furnace, the movable ones turning about an imaginary axis. They are fitted with rollers, which move on a rail carried by columns. Into the interior face of each hearth are built a number of fireclay bricks arranged like teeth, and displacing the blende towards either the interior or the exterior. The space between two consecutive plates forms a shelf of the furnace, and is closed by a sand joint. Generally the furnace comprises three shelves, of which the lowest is heated. The advantages of such construction are apparent. By suppressing the metallic parts, the height of the shelves is very slight, hardly greater than that of the shelves of the Delplace furnaces. The consumption of fuel is low, never exceeding 10 per cent. As the shelves are low, the production of dust is not important. The weak point of the furnace is evidently the employment of teeth of fireclay material, which must necessitate the stoppage of the furnace when the number broken becomes too great, or when they become worn.

The capacity is from 3 to 5 tons per day, and the horsepower is stated to be 1. Australian blende can be worked off to 1 per cent. S, Algerian blende to 2 per cent.

The newer designs of furnace are constructed with four hearths, alternate hearths being rotated.

The gas is said to be from 5 to 7 per cent. SO_2 .

Hegeler Furnace.—Of the Hegeler furnace, Lummen gives the following account. This mechanical furnace is employed in the United States by all the zincworks which transform the SO_2 gases produced in roasting blende into sulphuric acid. Introduced in 1882, it has scarcely been modified since. The furnace has two compartments, about 75 ft. long. Each compartment has seven shelves, the two lowest being fitted with muffles for the purpose of heating. The movement of the blende across the furnace is carried out by means of rabble arms dragged by a chain. The rake enters at one end of a shelf and leaves at the opposite end; then, after being cooled, it enters the furnace again. Every shelf is fitted at its two extremities with movable doors, permitting the entry and exit of the rakes. The height of the shelves is relatively great (about 2 ft.), which causes a deficiency in the use of the air and produces gases very poor in SO_2 (3 to $4\frac{1}{2}$ per cent.). The blende is stirred at intervals varying from one and a half to two hours, which is little for a mechanical furnace. The capacity of a Hegeler furnace is about 40 tons of blende per twenty-four hours; and although the furnace is mechanical, the number of workers varies from thirteen to fifteen. The consumption of coal is very high, viz. 25 per cent. of the weight of the raw ore charged. The necessary power is about 40 h.p. In view of its dimensions, a Hegeler furnace cannot be constructed in an existing building. Besides the disadvantages of getting an imperfectly roasted ore and gases very poor in SO_2 , the cost of roasting a ton of ore is the same as with a Hasenclever furnace, and is much higher than with a Delplace furnace (*cf.* p. 398).

Ridge Furnace.—According to B. P. 3981 of 1911, the heating-gases are led along a flue situated entirely below the floor of one hearth, and pass from the end of the flue along another in the opposite direction, this flue being confined between the roof of this hearth and the floor of that next above it, the arrangement being such that the flow of the heating-gases under each hearth is opposite in direction to the progression of the ore along that hearth. In the later modifica-

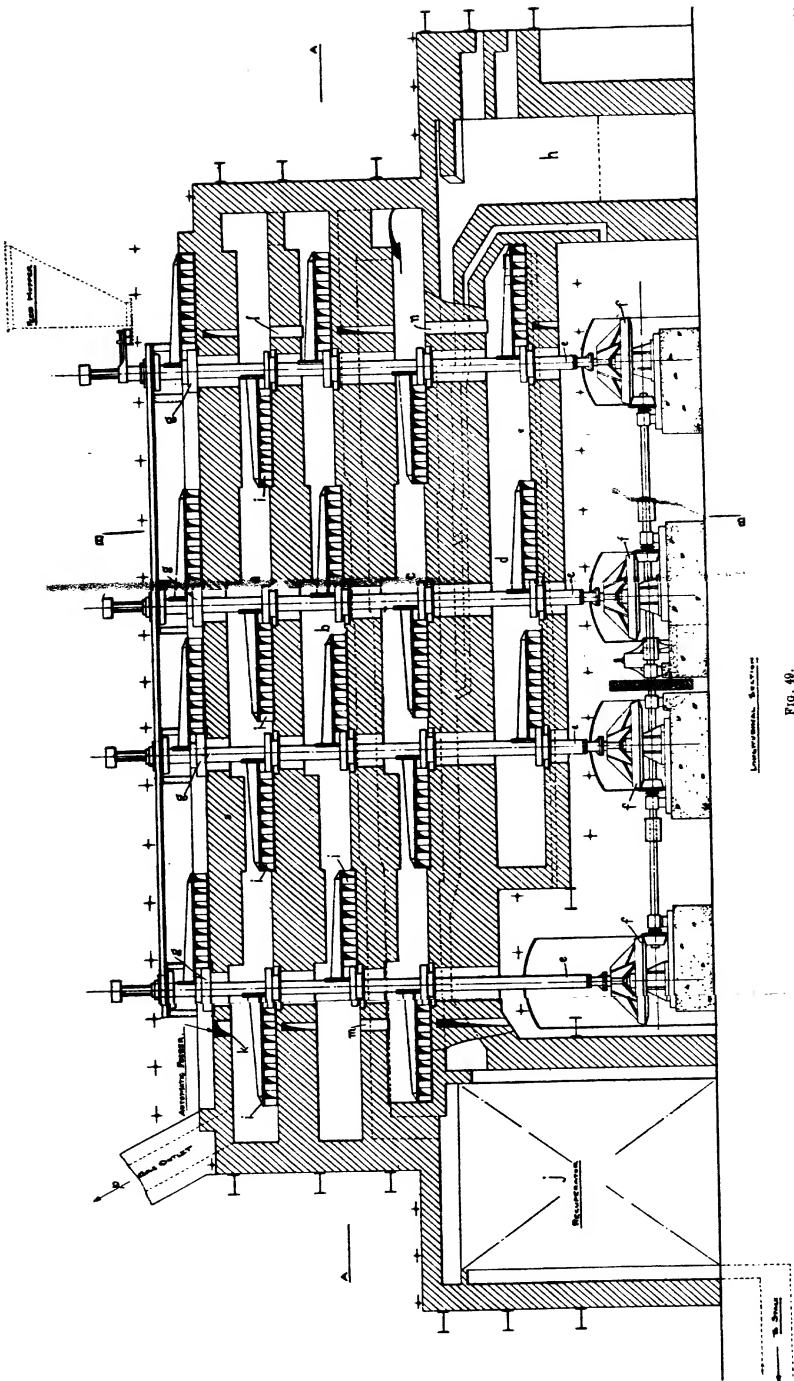

Fig. 40.

tion, the fire-gases pass only under the bottom roasting-hearth, and are then used for pre-heating the air required for oxidising the ore. The air is pre-heated to about 900° in a recuperator, and travels through passages under the middle roasting-hearth to the other end of the furnace, dropping there into the bottom one.

Fig. 49 is a longitudinal section of this furnace on the centre line of Fig. 50, which is a horizontal section on line A A of Fig. 49.

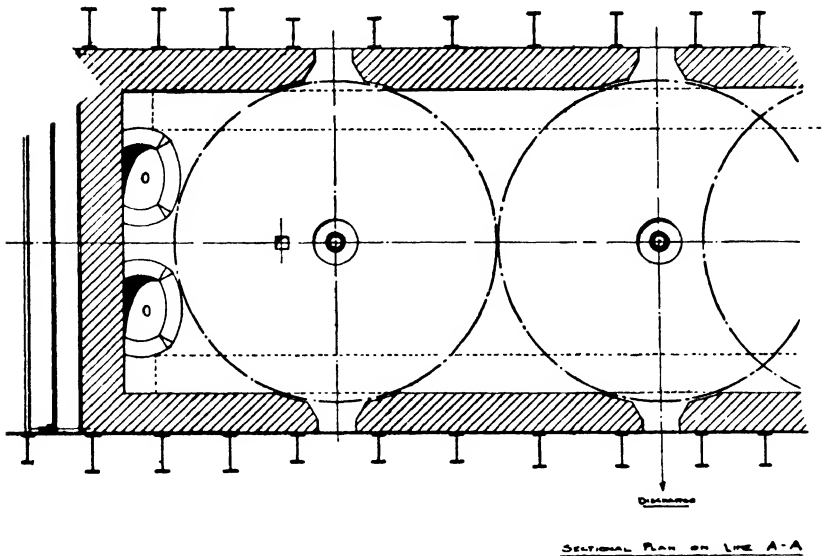

FIG. 50.

The furnace has three superimposed muffles, *a*, *b*, *c*, which are heated by the flue *d*, which first passes beneath the hearth of the bottom muffle *c*. On the longitudinal centre line of the muffles is a series of four vertical shafts *e*, each of which except the one at the right-hand end passes through all three muffles, while three of them also pass through the cooling-hearths *d*. Each shaft is supported beneath the furnace in a footstep bearing, and is adjusted separately for height. The shafts are revolved in the usual manner by means of gearing *f*, and gas-tight joints are made at the top of the furnace by means of water seals *g*, at the points where the vertical shafts pass through the top arch. Where these shafts

pass through the heating-flue they are insulated by rings of firebrick, which serve the double purpose of preventing transference of heat to the shafts and leakage of the furnace gases into the muffles. The shafts are fitted with rabble arms *i*, and are arranged at varying distances apart so that the paths of the stirrers or rabbles in some cases only tangentially touch the zone of the adjacent rabble, whilst in other cases the two zones overlap to a very considerable extent so as to ensure a thorough mixing of the ore. Where the rabble path only touches the adjoining zone, the rabbles are so designed that the passage of the ore from the one zone to the other can take place only in one direction. By this means the material, while being roasted, passes gradually along the furnace until it reaches the last rabbling-zone of a given hearth, where it is stirred in gradually decreasing spirals until it reaches an opening, for example *l* or *m*, near the shaft, from which it drops to the muffle below it. There are, in all, nine separate roasting-zones and two cooling-zones.

Zinc-ore as delivered to the furnace is usually wet, having 4 to 6 per cent. of moisture, and sometimes more. If such wet ore is fed directly into a hot furnace, lumps are formed which in many cases are very hard, and these can only be oxidised on the surface. By heating the ore gradually while being stirred continuously the formation of lumps is prevented, and at the same time nodules already present are broken up by the steam, which causes decrepitation. To effect this result the Ridge blende-roasters have a pre-heating and drying hearth on the top, heated by the heat transmitted through the top arch. The ore is gradually dried, heated usually to about 120° , and then passes, free from lumps, into the top roasting-hearth.

The warm ore is introduced into the top muffle through the opening *k*, and passes successively through the three rabbling-zones in the top muffle, or hearth, *a*, until it reaches the last zone. From there it passes through the drop-hole *l* on to the hearth of the next muffle *b*, which it traverses in the opposite direction until it reaches the drop-hole *m*, through which it passes to the lowest muffle *c*, traversing it, and eventually leaving this through the drop-hole *n*.

Many highly ferruginous blendes, or such material high in lead, have a remarkable tendency to cake together if put hot

into trucks or stacked, and when this happens the roasted ore has to be crushed before further treatment. As the ore reaches a temperature of 1000° or 1200° on the bottom roasting-hearth, a good deal of heat would be lost if the hot ore was discharged at such a temperature. Caking is prevented by cooling the ore whilst being continuously rabbled; this is done on the cooling-hearth *d*, where the temperature is brought down to 60° to 80° , whilst the part of the air required in the furnace passes over the ore and is pre-heated so as to recover the heat units. Air also passes through small channels in the brickwork under the cooling-hearth, so that the bottom of the furnace is kept cool.

The fire-gases travel in the opposite direction to the ore from the furnace *h*, under the bottom muffle *c*, and through the recuperator *j* to the chimney. The gases from the ore pass through the flues *o* connecting the muffles with the uppermost hearth *a*, and thence out of the furnace through the flue *p*.

The number of superimposed muffles may vary according to circumstances and the nature of the material to be treated, and similarly the number of vertical shafts and the arrangement of the rabbling-zones may likewise be varied to suit particular requirements.

According¹ to the inventor's statement,¹ in the Ridge mechanical zinc-blende furnace the mechanical arrangements have been so far worked out that reasonable freedom from difficulties is assured, while the whole furnace is easily accessible. The shafts are each made in one piece and are water-cooled, about 15,000 gall. of cooling water being passed through the shafts in twenty-four hours. The rabbles are easily and quickly renewed, and the part to be replaced weighs only 5 lb. The mechanism of each furnace is driven by a separate electric motor which takes 6 to 8 horse-power. The motor and all the gearing are on a solid foundation beneath the furnace, and quite accessible. The discharge opening is separated from the gearing by a brick wall to keep out all dust.

Broken Hill zinc concentrates are roasted down to 2 per cent. total sulphur with a feed of 14 to 15 tons of ore per day of twenty-four hours, and a coal consumption of 10 per cent. The

¹ *J. Soc. Chem. Ind.*, 1917, p. 676.

sulphur fumes leave the furnace with $6\frac{1}{2}$ to $8\frac{1}{4}$ per cent. sulphur dioxide, and in addition a good deal of SO_3 or H_2SO_4 , at a temperature of 380° to 450° , so that they can be used satisfactorily in the lead-chamber process. One man per shift can attend to the furnace and the producer.

Zinc concentrates with 14 per cent. of lead have been satisfactorily treated, and also concentrates with 17 per cent. iron. When roasting an ore high in lead or iron, it is essential that a mechanical furnace be kept working continuously, because half an hour's stoppage means that the ore on the hearths sets hard and forms lumps, which have to be broken up. It has been found possible in this furnace to use the rabbles for breaking up the lumps, and the gearing is arranged for running alternately backwards and forwards till the hearths are free.

A furnace constructed by Zellweger and described in *Eng. and Min. J.*, 1900, p. 261, shows a roller-shaped stirrer. It turns out 30 tons in twenty-four hours.

The burner patented by J. Haas (Ger. P. 23080) is very similar to M'Dougall's (*cf.* p. 367), but the single chambers, in lieu of having simple brick bottoms, are separated by flues through which pass the fire-gases from a coal-fire. Mechanical stirrers move the ore from the top shelf over three others and ultimately into an open hearth, where the last roasting takes place.

The burners patented by the Société Vieille Montagne (Ger. Ps. 24155 and 36609) are mechanical burners in which the flame of the coal-fire is not separated from the roasting-gases. These burners have been continuously at work at Oberhausen since 1883. Their construction is shown in Fig. 51. There are several superposed circular calcining-hearths A, A, to which is attached a square calciner B. The ground ore is charged through hopper *a* by means of feeding-rollers and flues on to the top chamber and gradually finds its way downwards and into B. The fire of the fuel burning on grate T first passes over B, then over the circular hearths A, A, into the dust-chamber C and into the flue S. The agitation is procured by the vertical shaft *b* and arms *e*, *e*, the stuffing-boxes being packed with asbestos. Shaft *p* is contained in an outer pipe *g*, and the air rising between them acts as a cooling medium. The arms carry tooth-rakes *m*, in a radial position for the purpose

of stirring, and slanting solid rakes *f*, which move the ore from the circumference to the centre, or the other way, as is required for the purpose of gradually transporting the ore downwards and ultimately on to hearth B. [These furnaces, which had to be frequently repaired and made much flue-dust, are being gradually replaced by hand-worked muffle-furnaces, although according to Pierron¹ they consume only 18 parts coal for 100 blende.]

The O'Brien mechanical furnace has also been adapted to the roasting of zinc-blende. It is for this purpose surrounded

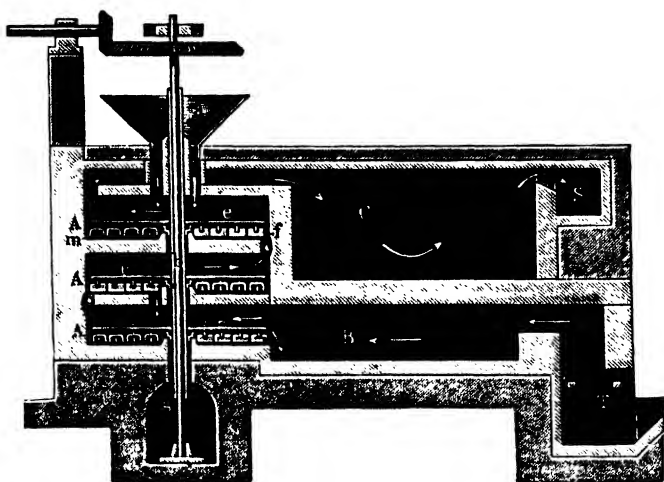

FIG. 51.

by a muffle, and is supplied with additional heat under three shelves, either by gaseous fuel, or by pulverised fuel, or from an outside combustion-furnace. This furnace is shown in Fig. 52.

Schmieder (Ger. P. 244131) describes a revolving tube closed at both ends, with air-channels in the walls of the tube, where the air gets heated and issues into the zinc-ore through holes protected by slanting pieces or by segment tubes against the entrance of ore dust.

Olga Niedenführ (Ger. P. appl. 10070) describes a mechanical roasting-furnace with special cooling-channels in the hottest spaces; on the top a covering of roasted ore in a

¹ *Monit. Scient.*, 1900, p. 562.

granular form is spread, which at the same time serves as a filter for the dust.

Felix Thomas (Ger. P. 212312)¹ roasts blende at a low temperature in order to obtain zinc sulphate, and decomposes this by air containing much steam, according to the equation : $\text{ZnSO}_4 + \text{H}_2\text{O} = \text{ZnO} + \text{H}_2\text{SO}_4$. In order to produce steam

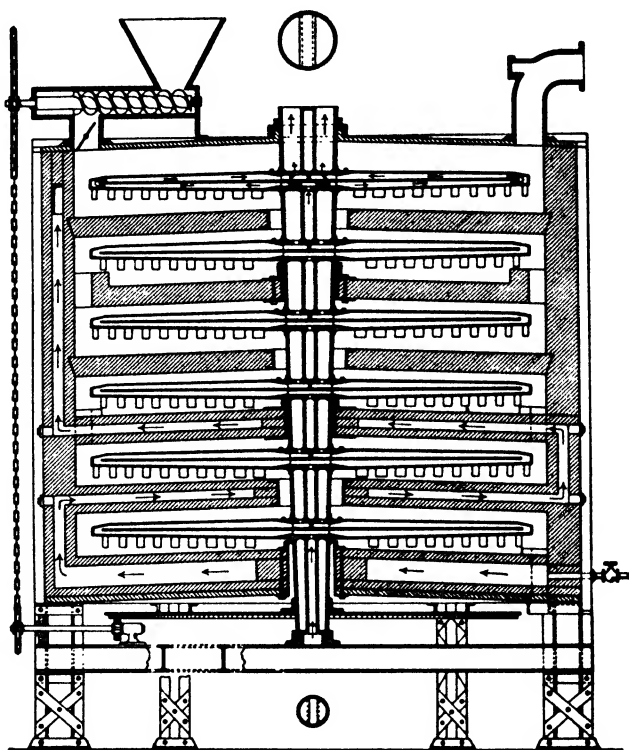

FIG. 52.

and heat from within as well as from without, the roasted ore is made into briquettes with fuel. The decomposition of zinc sulphate in this case begins at 600° and is finished at about 820° ; it can therefore be carried on with damp air at 100° lower than when working with dry air. He recommends briquetting the zinc-ore with tar, pitch, caking-coal, etc., roasting the briquettes in the oxidising flame of a gas-producer at 700° to 750° and in the end going up to 820° ,

¹ *Chem. Zeit. Rep.*, 1910, p. 576.

preferably in revolving furnaces. By this he expects to economise time, fuel, and loss of ZnO by volatilisation, to facilitate the application of mechanical roasting, and to improve the result of roasting.

According to Hasenclever,¹ the use of mechanical furnaces for roasting zinc-blende has made very slow progress in Germany. Many German zincworks have spent large sums of money on experimental furnaces of their own construction. The main difficulty in that respect seems to be the fact that most of the zincworks are obliged to work with blende containing some lead, which ores sinter on roasting, and stick to the rods and moving parts.

In 1914 over thirty furnaces similar to the Ridge mechanical furnaces were working in Germany.

Rules for roasting Blende and similar poor Ores, and for treating the Cinders.—Hassreidter² maintains that roasted blende should contain as little sulphur as possible in the shape of zinc sulphide and sulphate, whilst other sulphates have no injurious action in the utilisation of the cinders.

Doeltz and Graumann³ made an investigation on the decomposition and formation of ZnSO₄ during the roasting of blende.

Prost⁴ proves that in the cinders from blende containing lime the sulphur is in the state of calcium sulphate, not in that of zinc sulphate.

Juretzka (Ger. P. appl. J12275) makes the sulphates, contained in cinders from blende, harmless for the subsequent distillation process by mixing them with dry lime and covering with water. The roasting process remains in the usual form, and the whole of the sulphide-sulphur is obtained as sulphuric acid. The calcium sulphate is left in the cinders without interfering with the distilling process for zinc.

Pape (Ger. P. appl. P26589) removes the sulphur from zinc sulphate by adding zinc oxide before the ignition. Thereby the SO₂ is split off completely on ignition and at comparatively low temperatures.

¹ *J. Soc. Chem. Ind.*, 1911, p. 1291.

² *Z. angew. Chem.*, 1906, p. 522.

³ *Chem. Zentr.*, 1907, 1, 1467.

⁴ *Bull. Soc. chim. Belg.*, 1911, p. 103.

Jensch¹ shows by analyses that the sulphur in roasted blende is mostly in the state of iron sulphide; even when roasting down to 2 per cent. S there is no more ZnS in the cinders. It is therefore unnecessary to carry the roasting down to 0.5 per cent. S in the cinders, as is frequently demanded.

Nemes (Fr. P. 426851) blows finely powdered pyrites, blende, etc., into a furnace where they slide downwards on an inclined plane. The hot roasting-gases travel underneath that plane. For roasting blende, a special heating contrivance is provided.

Hübner (Ger. P. 236669) roasts blende in a vacuum in several superposed chambers.

According to H. O. Hoffman,² when roasting blende in the ordinary way very little zinc sulphate remains in the cinders. To this Hommel³ remarks that Hoffman in his experiments had exceeded the temperature of decomposing zinc sulphate. If the temperature is kept purposely low, 60 to 70 per cent. of the zinc contained in the blende may be obtained as sulphate. This sulphate begins to decompose between 800° and 850°. Therefore Hommel prescribes pre-heating the air before it enters the bottom muffle. Mistakes in the way of heating cause the formation of matte and of ferrite in the cinders. A strong formation of zinc ferrite also takes place if blende containing much iron is heated strongly from the outside and is vigorously worked without much excess of air. The temperature of the formation of the ferrite is above 1200°. Mistakes in heating may be caused both by overdoing and by underdoing it. From his experiments Hommel draws the following conclusions:—(1) The ore must be rapidly brought to the temperature of ignition, either by external heating or by the hot roasting-gases. (2) The ignited blende must be deprived of the greater part of its sulphur by thorough stirring and moderate supply of air, but without external heating. (3) The nearly desulphurised blende must be brought into contact, at a temperature which need not exceed 800°, and with thorough stirring, with a strong current of air, but in such a way that it is not cooled thereby. (4) The space occupied by the ore in

¹ *Z. angew. Chem.*, 1894, p. 50.

² *Trans. Amer. Inst. Min. Eng.*, 1904, p. 834.

³ *Loc. cit.*

the muffle ought to be as nearly as possible equal to the free space. Hommel finds that most of the furnaces now used do not satisfy these conditions, more especially those built on the Hasenclever principle. Much better than these are the old Eichhorn-Liebig furnaces (Lunge, 4th edition, p. 504) in a slightly modified form; also the Delplace furnaces, which, however, have an unduly complicated firing arrangement. Modern roasting-furnaces ought to be in any case worked with producer-gas.

Max Liebig treats of the same matter in his *Zink und Cadmium*, 1913, p. 222 *et seq.*

Reed (U.S. P. 1069178) mixes the blende with part of the cinders from a previous operation.

Titus and Barescheer (U.S. P. 1069498) mix blende with sodium chloride, heat it, and treat the cinders with chlorine.

The Ger. P. 272918 of Martin also belongs to this domain.

Mostowitch¹ describes the behaviour of zinc sulphate at high temperatures. He knows of cases where the sellers of roasted blende have been obliged to allow deductions from the selling price, owing to bad roasting.

Nemes² writes on the roasting of blende in shelf-furnaces. According to him, the decomposition of the sulphate is not merely dependent upon the temperature, which is nearly identical with various samples of blende in the same furnace, but also upon their composition, especially on the percentage of iron. Lead sulphate is not decomposed by heat in the blende furnaces, but by a secondary reaction thiosulphate is transformed into silicate by quartz or by the silica of fireclay; therefore blende containing much lead acts more strongly on the material of the furnaces than that containing but little lead. According to this author, the Rhenania furnaces have been almost entirely replaced in Belgium by the Delplace furnace; see p. 398.

Treatment of Complex Ores containing Blende, Copper Ores, and of other Ores yielding poor Gases.—Hart³ proposes treating such ores with sulphuric acid in a salt-cake pot, and, when the mass has become pasty, transferring it to a blind roaster

¹ *Z. angew. Chem.*, 1911, p. 763.

² *Metallurgie*, 1912, p. 516; *Z. angew. Chem.*, 1913, 2, 55.

³ *J. Soc. Chem. Ind.*, 1895, p. 544.

and finishing it there, all the gases going into vitriol-chambers. The zinc remains behind as sulphate, which can be obtained by lixiviation and crystallisation ; or else it is mixed with poor zinc-ore and roasted, in which case the oxygen of the sulphate combines with the sulphur of the blende. The reaction seems to be :

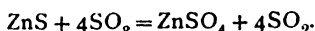

The Maschinenbau-Anstalt Humboldt (Ger. P. 160694) treats ores composed of pyrites and blende as follows :—The ore is at first but slightly roasted, so that on the surface the FeS_2 is converted into FeS . It then passes a magnetic separator, and after leaving this, FeS and ZnS , now separated, are roasted in separate furnaces. Here FeS is completely roasted, and the gases, which are superheated and contain SO_2 , are passed into the furnace, where the ZnS is completely roasted, employing so much air that the gases leaving this furnace can be employed for the superficial roasting of FeS_2 mentioned in the beginning ; hence there is no fuel required for this, and the gases passing out of the first furnace contain all the sulphur of the ore as SO_2 in such concentration that it can be advantageously worked up. Another patent of this firm (Ger. P. 161154) treats of the case of ores containing but little pyrites, not sufficient for yielding enough heat on burning to roast the blende. This drawback is remedied by mixing such ores with enough fresh pyrites to yield sufficient heat on roasting for the roasting of the blende.

In order to enrich the SO_2 gases from ores not yielding sufficiently good gases, J. G. Jones (Amer. P. 872822) burns raw brimstone in a horizontal furnace and passes the heated gases into a horizontal revolving furnace, in which the poor sulphur ores travel in the opposite direction ; thus both sources of sulphur are utilised for producing gas rich in SO_2 . The coke produced is continuously removed from the revolving furnace.

O. Niedenführ (Ger. P. appl. N10069) effects the simultaneous roasting of easily burning and more difficultly treated ores (only of pyrites and zinc-blende) by preventing the ores from getting mixed. On each shelf of the burner there is only one ore, in turns ; or one furnace is arranged inside the other, with special stirrers.

In England spent oxide has been burnt to give a rich gas and to enrich the gases from Rhenania furnaces.

Channing and Falding (Amer. P. 962498)¹ utilise the gases from the "*pyritic smelting*" of copper ores, which hitherto were wasted on account of the irregularity of their composition and the small percentage of SO₂ contained therein, in the following manner. The addition of coke in the fusing process is kept as low as possible, in order to avoid unnecessary dilution of the gases with CO₂ and N; say, 1 part coke to 4 parts of available sulphur in the sulphides. The air-blast is regulated in such manner that, after the oxidising processes have been accomplished, an excess of 4 or 5 per cent. O remains in the gases. In order to keep the percentage of SO₂ in the roasting-gases between 5 and 8 per cent., as is the rule both for the chamber- and the contact-process, and to obtain gases of uniform quality, they are conducted from the single furnaces into a large mixing-chamber; if they are too rich in SO₂, air is introduced in some suitable place; if too poor, some of the furnaces are charged with richer ore.

Reverberatory furnaces applicable to the production of blister copper, together with SO₂ in a state in which it can be used in vitriol-chambers, are described by T. Walker in B. P. 9918 of 1909.

The recovery of sulphur trioxide and sulphuric acid from the gases of "pyritic" copper-smelting, containing 3½ per cent. SO₂, is described in detail by Freeland and Renwick.² This is done by the Ducktown Sulphur, Copper, and Iron Co. in Tennessee to the extent of 160 tons acid of 60° Bé. per diem.

Carmichael (Ger. P. 175436, U.S. P. 1124696) roasts ores and metallurgical products containing sulphides in a converter, with addition of calcium sulphate or sulphide, in such manner as to obtain, on one side, the metals as such, and, on the other side, gases rich enough in SO₂ to be worked for sulphuric acid.

Sweeting (Fr. P. 361808) utilises the SO₂ given up in the roasting of *antimony ores* by absorbing them in water; the

¹ Described by Redepinning in *Berg- und Hüttenw. Rundschau*, 1911, pp. 1-19; extr. in *Z. angew. Chem.*, 1912, p. 860.

² *Eng. and Min. J.*, 1910, pp. 1116-1120.

antimony oxide carried along with the gases is filtered or decanted off.

The furnaces or kilns for roasting ordinary copper-ores, lead-ores, and so forth, so far as they are not mentioned in previous places, cannot be described in this book, as they belong to the domain of metallurgy proper, and in these cases if the roasting-gases are sent into vitriol-chambers it is merely to get rid of them, with no expectation of profitable work.

We merely mention a few modern attempts to obtain workable roasting-gases from such ores by new methods.

Hybinette (Ger. P. 275204) adds to cupric-sulphide ores from 2 to 5 per cent. sodium-sulphide before roasting; this prevents the formation of hard lumps of cupric sulphide, which are not dissolved in the succeeding treatment with ferric salts.

Sébillot (B. P. of 21616, 1898) charges cuprous or other sulphur ores, mixed with fuel, into a furnace provided with air-blast. The gases are led into a chamber containing coke, pumice, or a suitable metallic oxide, where they are treated with air and steam, and where sulphuric acid is formed (*cf.* Chapter IV, Vol. II).

The ordinary *wad ores* smelted in Europe contain but 11 to 15 per cent. sulphur, and by the old roasting processes yield burner-gases containing about 1 per cent. of sulphur, which are, of course, quite useless for the manufacture of sulphuric acid. Richer gases are obtained by the process of Huntington and Heberlein (B. Ps. 8064 of 1896, 3795 of 1897), in which air is blown in a "converter" through a layer of lead ore 3 ft. deep. In the beginning and at the end of the roasting, gases very poor in SO_2 are obtained; but during the most active stage the gases contain up to 15 per cent. SO_2 , and by working a large number of converters charged at different times, a fairly continuous gas current can be obtained, which is sufficiently rich in SO_2 for conversion into sulphuric acid. According to Hasenclever,¹ the manufacture of sulphuric acid by this process was first introduced at the Muldenhütte at Freiberg, Winkler's contact-process being used; at the Friedrichshütte at Tarnowitz in Silesia the roaster-gases are treated by the chamber-process after being reheated in firebrick pipes which are externally heated.

¹ *J. Soc. Chem. Ind.*, 1911, p. 1291.

Whilst the Huntington-Heberlein converters work intermittently, the work of the Dwight-Lloyd furnace, improved by Schlippenbach, is continuous. In this apparatus¹ the air is not blown through the material from underneath, but sucked down through it from the top to the bottom. This furnace delivers a regular gas-current of 4 to 6 per cent. SO_2 by separating continuously the rich from the poor gases. Probably about 90 per cent. of the sulphur of the lead sulphide can be utilised for the manufacture of sulphuric acid, so that 4 tons of lead ore will yield 1 ton of sulphuric acid of 142° Tw. A large plant for the manufacture of sulphuric acid by the contact-process combined with furnaces of this design was erected at Stolberg in October 1911. Considerable difficulties were experienced, as the gases contain 5 or 6 per cent. CO_2 and much dust, and are low in SO_2 owing to false air being drawn in.

If all the lead-ores smelted in Germany were to be treated in this way, they would yield about 40,000 tons sulphuric acid of 142° Tw. *per annum*. The production of acid from this source in England would be about 6000 tons; in Belgium, 18,000 tons; in France, 12,000 tons; in Spain, 75,000 tons.

Offerhaus² describes the "pyritic process" for smelting copper ores in kilns, in which ferrous sulphide, FeS , serves as fuel; in the "semipyritic process," coke is used at the same time. At Copperhill factory, part of the furnaces is connected with a sulphuric-acid plant, consisting of twenty-four large and eighty small chambers and eleven Gay-Lussac towers, with a daily production of 600 tons sulphuric acid of 60° Bé.

According to Dempwolff,³ on heating lead sulphide up to 450° lead sulphate is the principal product; at higher temperatures more SO_2 is formed, but no SO_3 . When all the lead has been converted into sulphate, all stages in the proportion of SO_2 : SO_3 are gone through, until at 760° the proportion 65 SO_2 : 35 SO_3 has been attained. If the temperature is raised still higher, besides the oxidation, reduction also sets in. By the admixture of indifferent substances the limit of the reaction can be moved to even higher temperatures.

G. de Bechi (B. Ps. 9939, 1906, and 4246, 1912) separates

¹ Mentioned by Hasenclever, *loc. cit.*

² *Metall und Erz*, 10, 863; *Z. angew. Chem.*, 1914, 2, 442.

³ *Metall und Erz*, 1914, p. 619; *Chem. Zeit. Rep.*, 1915, p. 127.

the lead and zinc in mixed sulphide ores by converting the sulphides into sulphates. The finely ground ore is treated with a hot solution of ferric sulphate, containing free sulphuric and nitric acid, whereby PbS and ZnS are converted into sulphates, the ferric sulphate being reduced to ferrous sulphate :

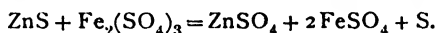

The ferrous sulphate is reconverted by the sulphuric and nitric acid into ferric sulphate. The solution contains zinc sulphate, whilst lead sulphate and free sulphur remain behind and are filtered off. From the solution, on cooling, zinc sulphate crystallises out ; the mother-liquor goes back into the process. The zinc sulphate is roasted, whereby the sulphuric acid required for the process is regenerated ; the residual ZnO is converted into metallic zinc. The free sulphur is obtained by distillation or extraction by means of a suitable solvent, and the final residue, which contains all the lead, is smelted for silver-lead bullion.

Reinders¹ describes the reactions taking place in the roasting of lead sulphide.

Estelle (Ger. P. 293908) treats the sulphide ores with hydrochloric acid ; the iron is dissolved in the ferrous state and the sulphur escapes as H₂S. The ferrous chloride is lixiviated out and electrolysed, whereby part of the iron is separated in the metallic state, and the remainder, is brought into contact with the H₂S, whereby the sulphur is precipitated and the ferric salt reduced to the ferrous state.

Debusch (Ger. P. 269774) treats pyrites containing copper, zinc, and lead sulphides as follows. The roasting process is interrupted, for part of the material, and the product mixed with the other part to be finished at a later stage. In order to moderate the excessive heat caused by the roasting, other materials may be mixed with the pyrites which do not participate in the roasting. In this way the metals accompanying the iron are converted into easily soluble salts, *e.g.* into sulphates. The roasting is effected at 600° to 650° by moving part of the ore from the first shelf to the third, from the second to the fourth, and so on.

¹ *Z. anorg. Chem.*, 1915, 93, 213 ; *J. Soc. Chem. Ind. Abstr.*, 1916, p. 847.

According to Wade (B. P. 14295 of 1914) (a communication from *Carmichael and Montgomery*), sulphide ores of low sulphur content are roasted so as to convert one or more of the metals present into sulphate, and at the same time to produce a furnace-gas rich in sulphur dioxide. The ore is heated to the required temperature in a muffled hearth, and then discharged into an oxidising hearth of a furnace of the superposed chamber type.

W. W. Norton¹ compares the results obtained with several descriptions of roasting-furnaces which are working side by side at the Murray Works of the American Smelting and Refining Co., viz. the furnaces of Huntington and Heberlein (p. 415), of Dwight and Lloyd (p. 415), of Godfrey and of Wedge (p. 383). The last two systems work with ores containing a good deal of sulphur (25 to 35 per cent.), the Dwight-Lloyd furnaces with poor ores (15 to 18 per cent.) which cannot be used for the furnaces of Godfrey and Wedge. For the Dwight-Lloyd and the Huntington-Heberlein furnaces the ores must go through a preliminary roasting, or the sulphur contents of the ore must be reduced by admixtures; these two furnaces are therefore finishing roasters, the other two preliminary roasters. The Dwight-Lloyd plant roasts per day 220 tons ore of 15 to 16 per cent. S down to 4 per cent.; the Huntington-Heberlein plant, 400 tons of 17 to 19 per cent. S down to 5 per cent. The cost of roasting of the last-mentioned works is lower by 3 to 4 per cent., but the cost of plant is higher. At the former there was 0.93 per cent. lead in the scoria, and 14.96 per cent. in the matte; at the second, 0.63 per cent. lead in the scoria, and 10.7 per cent. in the matte. As to the physical properties, the Huntington-Heberlein product is superior.

The theory of this process is discussed by Bannister in *Inst. Min. and Metall.*, 1912, 8th February; abstracted in *J. Soc. Chem. Ind.*, 1912, p. 285. Further processes for this purpose have been proposed by Nemes (Fr. P. 426851); Renwick (Amer. P. 981880); Grünewald and Welsch (Ger. Ps. 232044 and 238293; Aktiengesellschaft für Bergbau, Blei- und Zinkfabrikation zu Stolberg (Ger. P. 253492).

¹ *Eng. and Min. J.*, 1914, 93, 299.

D. SULPHUR DIOXIDE FROM VARIOUS OTHER MATERIALS

1. Burners for the Spent Oxide of Gasworks.

The spent oxide of gasworks is now generally washed, so as to obtain ammonia salts therefrom, and is also frequently treated for the ferrocyanide or sulphocyanide. At all events the sulphur, which it contains in the free state up to 50 per cent. and over, is ultimately burnt for the manufacture of sulphuric acid. This is sometimes done in ordinary brimstone-burners, as shown above, p. 306 *et seq.*; but in this case it is difficult to burn it out completely, and there is loss of sulphur in the residue. Ordinarily it is burnt in apparatus very similar to "shelf-burners," as shown in Fig. 53 (Hill's burner).

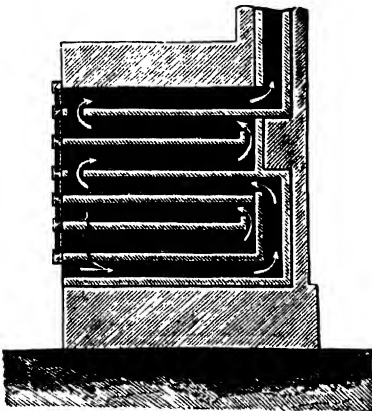

FIG. 53.

Each chamber in this case is about 10 ft. long, 20 in. wide, and 9 in. high. M'Dougall's, Harris's, and Herreshoff's mechanical furnaces have also been used for this purpose (*cf.* above).

Where the Herreshoff furnace has been adopted, it is constructed with only four hearths.

A modified form of Hill's burner is shown in Figs. 53 and 54. Fig. 53 is a sectional longitudinal elevation. In Fig. 55, D is a plan on line A A" of Fig. 54, E a plan on line B B", and F a plan on line C C". H is the nitre potting oven and G the main flue to the Glover tower.

There are only three working beds, *a*, *b*, and *c*, the gases travelling along the top and bottom flues as shown by the arrows.

Sometimes the oxide is moulded into bricks and put into lump-burners: it burns off very well, and the cinders fall through the grate-bars by themselves; in fact, the bars must be touched as little as possible. This process does not answer so well as shelf-burners.

The 38th *Alkali Report*, p. 97, recommends not to discharge

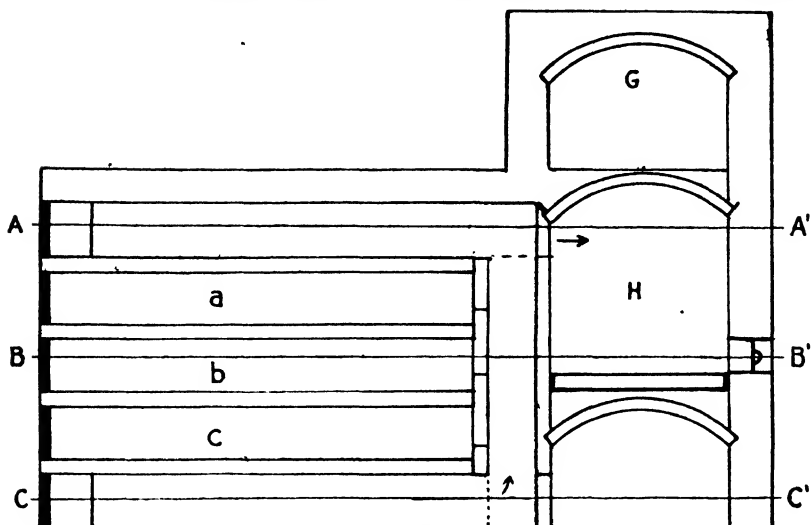

FIG. 54.

the hot residue from oxide-burners through the front working-doors, as this causes a nuisance, but to push it into chambers

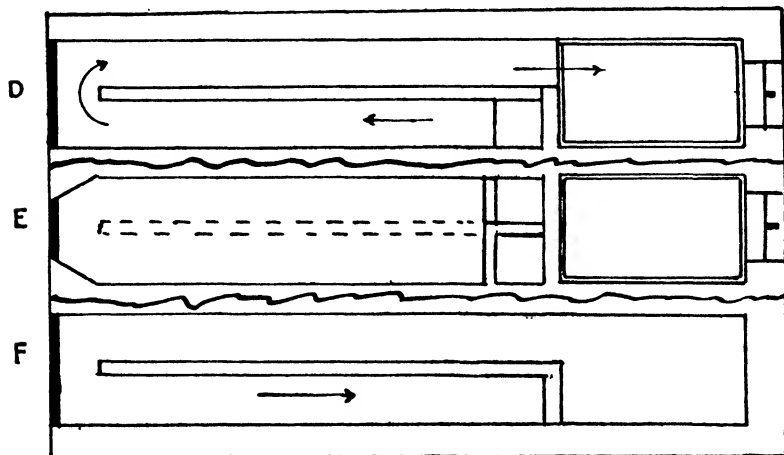

FIG. 55.

placed at the back, where they can cool off. The gases should be taken through long, heated flues, in order to burn the tarry substances and ammonia which destroy nitre.

Wilfrid Wyld, Assignor to *J. F. Carmichael & Co., Ltd.* (B. P. 5751 of 1911), describes a mechanical furnace for the combustion of spent oxide or sulphur, having two hearths provided with stirrers.

The material is fed from a hopper, 1, Fig. 56, the lower portion of which consists of a cylindrical casing, 2, in which a shaft containing radial blades is rotated by means of an eccentric rod connected on the shaft, 6.

The material falling on to the upper hearth is carried forward by means of rakes, 15, attached to an endless chain, 8, and carried over sprocket wheels, 7, and upon reaching

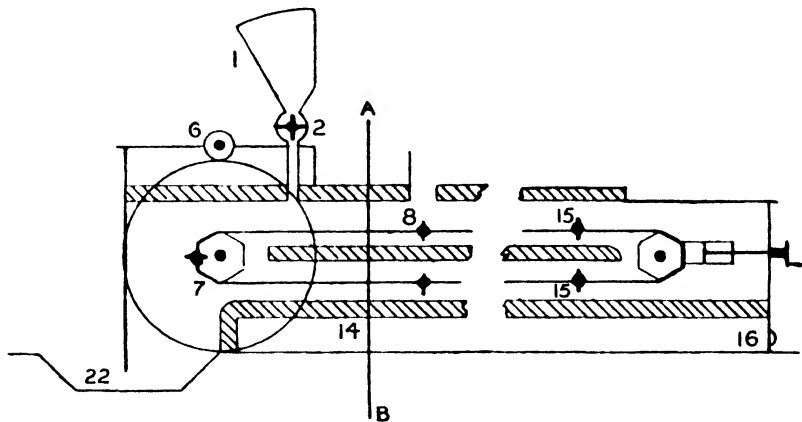

FIG. 56.

the end of the hearth falls on to the lower one, the rakes finally carrying the burnt material into the pit, 22.

Air is admitted at the back of the burner at 16, and is pre-heated by travelling along flues, 14.

A burner 3 ft. wide \times 18 ft. long is capable of burning $1\frac{1}{2}$ to $1\frac{3}{4}$ cwt. of spent oxide per twenty-four hours.

These furnaces are in use in many parts of the country, and by all the principal Gas Companies and Corporations, and have proved very satisfactory.

Fig. 57 shows a sectional elevation of two burners built side by side.

Kershaw (B. P. 108986) describes a furnace consisting of one or more inclined flues, each provided with a device for feeding and discharging at the upper and lower ends

respectively. The flues may be arranged one above the other, in spiral form, around a central column, the inclination being such that the spent oxide remains in repose upon the floor of each until the sulphur is expelled, when the residue travels downwards by gravity to the place of discharge.

In the 56th Report on Alkali Works, p. 18, it is stated that the "Kershaw" gravitation furnace has been reconstructed. It is now provided with three spiral flues, instead of one, and the capacity has been increased fourfold. It was in intermittent use under adverse local conditions as regards draught.

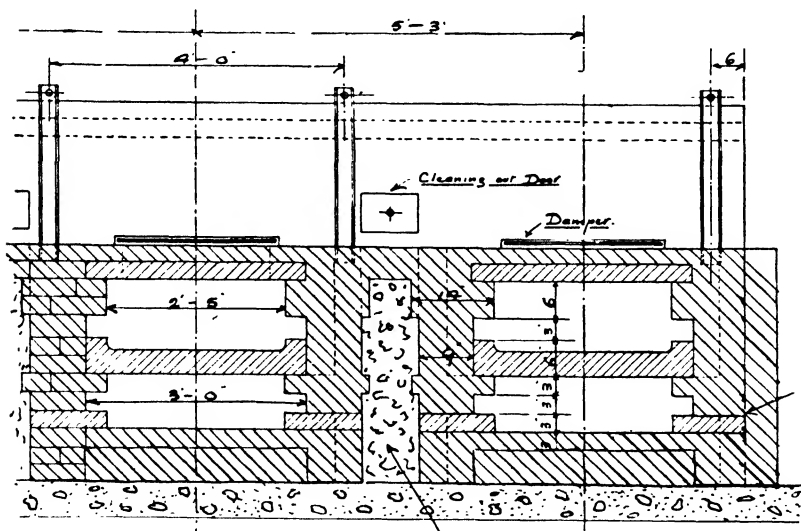

FIG. 57.

It is anticipated that the use of a fan to increase and control the draught will materially improve working results.

A furnace for burning spent oxide is claimed by W. Crowther (B. P. 145366).¹ A number of superposed burning compartments are arranged in a setting, each being provided with an arched roof, leaving a space between the roof and the floor next above. The burner-gas passes through a square hole in the arch of the roof into the space above and thence through side openings into a common vertical flue. The material on each floor is thus pre-heated by the gas from the chamber below. The burnt oxide is pushed out of the burning-

¹ *J. Soc. Chem. Ind.*, 1920, p. 570A.

chambers into a receiver at the back, and the light dust is deposited in the outlet flues.

A damper is pushed in to prevent excess of air entering the kiln before the receiver door is removed, and the burnt oxide withdrawn. Each shelf is 3 ft. 8 in. wide and 10 ft. 6 in. long, and said to be capable of burning 10 cwt. per shelf in eighteen hours.

The *Chemische Industrie Aktiengesellschaft and F. Wolf* (Ger. P. 248001) recover all the sulphur liberated in the distillation of coal, by mixing the SO_2 gas obtained by burning the spent oxide, with the waste gases of the furnace, whereby the sulphur dioxide contained in these latter gases is equally utilised.

2. Burners for Sulphuretted Hydrogen.

These are usually of a very simple description. That shown in Fig. 58 consists of a brick chamber provided with some baffling-walls *a, a*. The sulphuretted hydrogen gas (which is nearly always mixed with a large quantity of inert gas, chiefly nitrogen) is introduced through the cast-iron pipe *b*, the supply being regulated by an inlet-valve *c*. Air is admitted partly round the pipe *b*, and partly by a special opening *d*, which ought to be provided with a slide or other means of regulating the amount of air. The heat produced by the combustion of the sulphuretted hydrogen is quite sufficient for keeping the temperature of the chamber at a red heat, so that the gas is always lighted again if by chance the flame has been extinguished. This is aided by the baffling-walls *a, a*, which provide a reservoir of heat and at the same time mix the gases so as to ensure perfect combustion. The grate *e* is required only for relighting the gas after stoppages where gas of irregular composition is used. With gases of regular composition and comparatively rich in sulphuretted hydrogen, like those given off in Chance's sulphur-recovering process, the grate *e* is unnecessary, as these gases are as easily lighted and kept burning as coal-gas. The doors *f, f* serve for "potting" the nitre, where it is not preferred to employ more rationally constructed apparatus for this purpose.¹ The size of the whole chamber may be about 10 to 12 ft.

¹ Cf. Chapter II.

long, 4 or 5 ft. wide, and 3 ft. high. Pans for concentrating sulphuric acid may be placed upon it, and even in this case the gases will issue hot enough to do full work in a Glover tower. Sublimation of sulphur is never observed with ordinary care in admitting the air. One very great advantage in burning sulphuretted hydrogen is this: that, in contrast with the variations in the amount of SO_2 in burning brimstone or pyrites, even when keeping up a regular rotation of the burners, the process in this case is perfectly continuous, as the supply

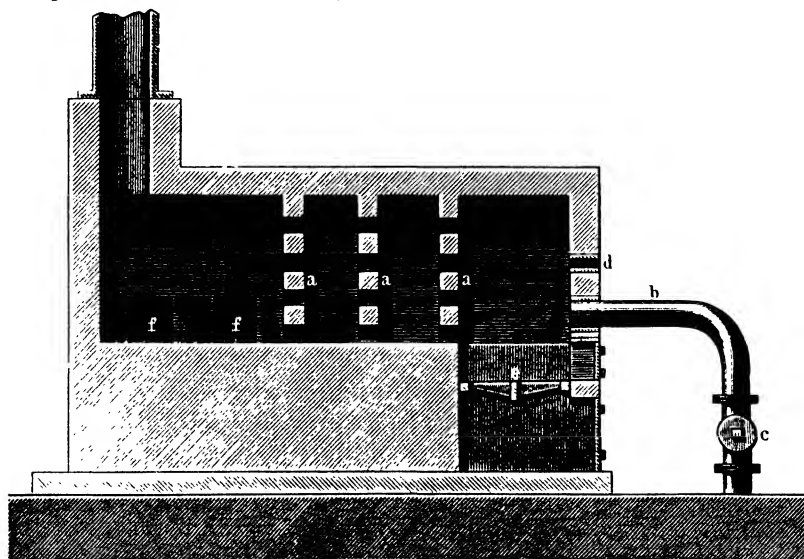

FIG. 58.

of H_2S from the gas-holder is continuous; the amount of air need never be varied when once regulated; the percentage of SO_2 in the burner-gas is altogether uniform; the chamber-process is consequently much more regular than with brimstone or pyrites, and the consumption of nitre is correspondingly smaller. All this, however, holds good only if the percentage of H_2S in the gas is practically constant, whilst with gases of very varying composition, such as those evolved in ammonia-works, the contrary is the case.

It must be remarked that at some works, in burning the sulphuretted hydrogen from the Chance process, an increased consumption of nitre has been noticed, whilst at others a saving

in nitre in comparison with the burning of pyrites has been effected. Evidently in the former case the quality of the sulphuretted hydrogen has not been as it ought to be ; it has no doubt varied in percentage, and may even have contained a notable quantity of carbon dioxide, so that the chamber-process would not be so regular as desirable. Sometimes it has been noticed that the combustion has not been quite perfect, so that sublimed sulphur has been found in the Glover tower or even in the chambers ; but this is evidently owing to mistakes and careless work, and should not occur with ordinary care.

Koppers (B. P. 21385) treats the spent oxide with gases, with or without steam, and separates the SO_2 and NH_3 from those gases. This, he asserts, avoids the excessive amount of nitric acid required in the manufacture of sulphuric acid by roasting spent oxide.

E. SULPHUR DIOXIDE FROM NOXIOUS VAPOURS

Sulphur dioxide is very injurious to vegetation, and is one of the chief constituents of the "noxious vapours" so much complained of in most manufacturing districts. It is true that these vapours contain other injurious constituents, chiefly of an acid character, viz. sulphuric anhydride, hydrogen chloride, and sometimes even the acids of nitrogen.

Processes for absorbing Sulphur Dioxide contained in Acid-Smoke, and the like.

We will now give a synopsis of the various methods for treating ordinary acid-smoke, with special reference to the removal of SO_2 and SO_3 . For details we must refer to the sources quoted in this work, to a special treatise by C. A. Hering, *Die Verdichtung des Hüttenrauches* (Stuttgart, 1888), and to one by Schnabel, *Metallhüttenkunde*, ii. p. 58 *et seq.*

Condensing by water seems to be the simplest and most obvious process, looking at the great solubility of sulphurous and sulphuric acid in water. But this process is in reality only practicable where the percentage of acids is not too slight ; dilute acid-smoke cannot be sufficiently washed without employing a comparatively enormous quantity of water ; and, surprising as it is, SO_3 is even more difficult to condense in this way than

SO₂. It is quite certain that condensation by water can be made to *pay* only where the gases are sufficiently concentrated to convert them into sulphuric acid in lead-chambers; it is therefore to the interest of smelting-works, etc., to conduct their processes in such a manner that the acids are diluted with as little inert gases as possible. If the percentage of SO₂ reaches 4 per cent. by volume, they may be submitted to the Schroeder and Haenisch process (*vide infra*), or they may even be converted into sulphuric acid, although this will leave hardly any profit at that percentage; but it is enough to have removed the nuisance. Where, however, there is less than 4 per cent. of SO₂ in the gases, any *utilisation* is out of the question—the dilute acid liquids obtained by washing the smoke must be run to waste (which in most cases means a fresh nuisance, and is not permitted by the authorities); nor is the SO₂ and SO₃ anything like completely taken out of the gases, and the nuisance is at best only diminished, but not remedied.

At all events, the contact of the absorbing-water with the acid gases must be made as intimate as possible. The condensing apparatus used for hydrochloric acid is suitable only for somewhat strong gases; the weak gases require special means, such as paddle-wheels or similar spray-producing apparatus, costly to work and to keep in repair, and generally imperfect in their action.

Moscicki (Ger. P. 256595) employs, for absorbing the acids from large quantities of diluent gases by liquids, a space in which the liquid flows through a packing, contained in a single space, through which the gases travel in the horizontal direction. The packing is divided into layers, perpendicular to the direction of the gas-current, some of which are sprayed with water. This division is produced by a number of partitions pervious to the gases, which prevent the descending liquid getting from one layer to the next, so that the liquid gets more concentrated in the places near the entrance of the gases.

Flasche (Ger. P. 271786) describes an absorbing-vessel with tangentially arranged tubes for introducing the gas.

Zschokke (Ger. P. 282088) describes an apparatus for purifying gases and vapours from suspended dust by water sprayed on by centrifugal action.

Babé and Pape (Ger. P. 187381; B. P. 19973 of 1906) pass

the gases, previously cooled and washed, through a second chamber, *cooled* down below 0° , *e.g.* by lumps of ice, or on the outside by the evaporation of liquid ammonia or sulphur dioxide. Here the aqueous vapour is condensed and retains all the SO_2 present in the form of a saturated solution. If necessary, a little more water is introduced, or else an aqueous solution of salts not decomposable by SO_2 .

H. Howard (Amer. P. 889132) absorbs the SO_2 from dilute gas by water, drives it out by heating, cools the concentrated gas and absorbs it by a sulphite solution.

Borchers¹ obtains technically available solutions of SO_2 from dilute gases by repeated automatic supply of water or weak solutions of SO_2 to absorbing-towers.

Drewsen (Amer. P. 981625) utilises gases poor in SO_2 by absorbing this in water, and driving it out of the solution by the heat of the burner-gases.

Edmunds (B. P. 8006 of 1910) describes an apparatus for this purpose.

Burbury (Fr. P. 420596 and additions) atomises water in apparatus for the absorption of SO_2 , and injects it into the tube through which the gas is passing on its way from the furnace to the absorbing vessel.

Absorbing the acids by caustic lime, generally in the form of a cream of lime, is one of the oldest and, if properly carried out, still one of the most efficient ways of removing the acid-smoke nuisance. Where the quantity of acids is but slight, and the manufacture in question is sufficiently profitable otherwise, this process is even now applicable, and if properly applied it does remove practically all the acids. The cream of lime should meet the gases in a finely divided state, either by flowing down properly constructed towers, or, still better, by being converted into a spray by means of paddle-wheels or the like. That this leads to the desired effect, even with the large quantity of SO_2 emitted in roasting blende, has been proved by working on the large scale in Upper Silesia.² But unfortunately the expense of this process, where large volumes of acid gases are concerned, is very serious, more especially as nothing like the whole of the lime can be utilised for absorption,

¹ *Chem. Zentr.*, 1909, 2, 1177.

² *Cf. Bernoulli, Fischer's Jahresber.*, 1880, p. 184.

and the attempt to sell the product as bisulphite of lime (Hasenclever, Ger. P. 10710) has failed.¹

According to Jensch,² the deposit forming in the milk-of-lime towers contains so much lime that it can be used over again, and at least a product is obtained containing 37.7 per cent. lime, 38.4 SO₂, 2.8 SO₃, 4.1 CO₂, etc., which is very useful as an addition to animal manure for the purpose of fixing the ammonia, in which respect it is equal to gypsum.

It has been found by Cl. Winkler and other observers that the SO₂ in smoke is much more injurious to vegetation if accompanied by much steam, *e.g.* in smoke-gases from brick-kilns. Spitta (Ger. P. 110388) proposes to absorb SO₂ and steam at the same time by passing the gases up and down several flues, into which slaked lime in the shape of dust is injected from the top. The bisulphite of lime formed is removed from the bottom of the flues by means of special doors.

Limestone is very much cheaper than caustic lime, and is almost equally efficient if employed in the proper way; that is, if a very large surface of limestone is exposed to the acid gases, and if this surface is kept from being covered with a crust of sulphite by being constantly washed with a stream of water. Cl. Winkler has constructed a special arrangement for this purpose (Ger. P. 7174) which completely fulfilled its object at the Schneeberg ultramarine-works. It consists of three brick chambers filled with large pieces of limestone, the roof being formed by plank covers perforated with many holes, through which water is kept running on to the limestone. The gases pass through these chambers successively and in regular rotation. The absorption of SO₂ is excellent, but as each cwt. of sulphur requires 3 cwt. of limestone, it is still too dear for most metallurgical purposes, especially as any utilisation of the sulphur is out of the question.

The gases going out of the limestone-towers mostly still contain from 1 to 2 per cent. SO₂, corresponding to a loss of 10 per cent. of the SO₂; in case of the application of a fan for producing the draught, the loss of SO₂ may go up to 15 or 20 per cent. This is, according to de Cew's U.S. P. 1077243, avoided by filling the top part of the limestone-tower

¹ Cf. Schroeder and Haenisch, *Chem. Ind.*, 1884, p. 118.

² *Fischer's Jahresber.*, 1889, p. 321.

with moistened blocks of calcined magnesia. The magnesia is not, like the lime, converted into hydrate, and absorbs SO_2 even in the most highly diluted form much more easily than lime, with formation of magnesium sulphite and bisulphite.

The limestone treatment is frequently employed at sulphate-of-ammonia works for getting rid of the SO_2 formed by combustion of the H_2S escaping from the saturators. This treatment is frequently mentioned in the Alkali Inspectors' Reports, and in the *36th Report* (for 1899), pp. 25 and 26, Mr R. Forbes Carpenter, the Chief Inspector, states the following conditions as being absolutely necessary for success:—(1st) There must be sufficient draught at the furnace, and the suction at the condenser outlet must be adequate to supply this at all times, to avoid sublimation of sulphur. Such draught might be supplied by injecting air under slight pressure in the furnaces. (2nd) The gases must be completely cooled before and behind the furnace. If they enter the limestone-tower above 38° much calcium sulphate is produced, which forms a protective crust on the limestone. The hot gases are to be cooled first by cast-iron pipes until some condensation takes place, when leaden pipes must be substituted for them. (3rd) The limestone-tower should be made of wood planks, tongued and grooved, or of brick and cement. (4th) The supply of water is best made in two forms, one constant, the other intermittent (by flushes), especially in the case of limestone; but with hard chalk the intermittent flush only may be used, at not too long intervals.

Bauxite, or a similar substance, is employed by Peniakoff (B. P. 21476 of 1912; Fr. P. 459926). The acid gases, preferably still hot, are brought into contact with the purifying materials, which are best moved forward in a direction opposite to that of the gases. The sulphur acids contained in these are thereby fixed in the form of sulphate of alumina and iron, which are obtained by lixiviation, and are either worked up into a marketable state, or decomposed by heating into sulphuric acid, the residue again serving as absorbent.

Fleitmann (Ger. P. 17397) passes the sulphurous gases, together with some air, through a kiln containing a mixture of *ferric oxide* and coal. The latter, in burning, yields the necessary heat, and at the same time reduces the Fe_2O_3 and SO_2 , so that FeS collects at the bottom.

SULPHUR DIOXIDE FROM BLAST-FURNACE SLAG 429

In Salt Lake City the SO_2 contained in the smoke of the copper-works is retained by the bases of scoria blown into a kind of glass-wool.

Calcium sulphide, proposed many years ago by Dumas, forms the absorbing substance in Kosmann's process (Ger. P. 13123).

Barium sulphide, which was experimentally tried at Freiberg, proved much too costly.

Vegetable charcoal was proposed by A. H. Allen (B. P. 189 of 1879), who passes the gases, freed from dust, through drying-towers fed with sulphuric acid and then through columns filled with charcoal, previously ignited in a stream of nitrogen, where the SO_2 is retained, whilst the nitrogen passes on. By a vacuum or by heating to 300° to 400° , or by a combination of both, the SO_2 is to be driven out and utilised.

A similar process to that of Allen is claimed, according to U.S. P. 1145579,¹ by passing the gases at room temperature over charcoal, when the SO_2 is absorbed, and later the charcoal is heated to from 130° to 180° , when the SO_2 is expelled. The enriched gas, which may occasionally carry even 98 to 99 per cent. SO_2 , is recovered and used. Various charcoals have different affinities for sulphur dioxide, boxwood being recommended.

Garner and Clayton (U.S. P. 1173566, assigned to the Metals Research Co.) treat SO_2 with a gaseous fuel containing carbon monoxide and hydrogen, in presence of wood charcoal at a temperature of 500° to 600° , whereby H_2S is formed.

Farbenfabr. vorm. F. Bayer und Co. (G. P. 304262, 24·11·16)² prepare sulphurous gases in a concentrated form as follows: Gases containing a low percentage of sulphur are passed over porous charcoal moving in the opposite direction, and the sulphurous acid absorbed by the charcoal is then recovered by careful heating. By keeping the charcoal in motion during the heat treatment the formation of carbon oxy-sulphide is prevented, and the sulphur dioxide content of the gases may be raised from 0·3 per cent. to 70 per cent.

F. SULPHUR DIOXIDE FROM BLAST-FURNACE SLAG

According to the *Chem. Tr. J.*, vol. lxix. (1921), p. 217, when the imports of pyrites into Germany were stopped by

¹ *Chem. Trade J.*, 1915, p. 57.

² *J. Soc. Chem. Ind.*, 1920, p. 570A.

the war, various processes were worked out for recovering the sulphur from the natural calcium sulphate (gypsum and anhydrite) and also from blast-furnace slag. The annual slag production of the country amounted to 20,000,000 tons, and the slag contains an average 1.5 per cent. of sulphur; some 300,000 tons of sulphur were therefore dumped with the slag every year. The recovery process which L. H. Diehl developed in the Gutehoffnungshütte promises to survive the war period.

Slag contains sulphur mostly in the form of calcium sulphide, and this sulphur can be oxidised by air and also by sulphates such as gypsum. The meta-silicate of the slag is then converted into calcium ortho-silicate Ca_2SiO_4 , while the sulphur is liberated as such, or as SO_2 . Calcium sulphate and calcium sulphide can co-exist in the solid condition, but not in the molten state; when gypsum is added to fused slag, SO_2 is liberated. Though the reactions are not quite so simple as they may appear, the Diehl process consists simply in blowing hot air through the fused slag as it is tapped from the blast-furnace and before it enters the granulation tanks or is otherwise treated. The oxidation-chambers used are firebrick tanks 3.5 m. long, 0.6 m. wide, 1.7 m. high, partly covered by a vault, but overtopped by a shaft for charging in the anhydrite; the slag itself is dumped in at the open end, where the bottom slopes upward, and discharged through a tap-hole at the other end. The air is injected at a pressure of about 15 cm. of mercury through slots in the bottom. At first, nozzles were tried, projecting into the slag; but they were easily clogged with slag and corroded, and it was observed that narrow slots, 5 mm. wide, were far less likely to get clogged than round holes; the air vents now used are blocks of hematite iron, cast with ducts for cold water, and fixed flush in the bottom of the tank. The treatment takes from ten to twenty-five minutes.

The hotter the slag, the more complete is the recovery of the sulphur, which averages 50 per cent., and may be complete when anhydrite has been added to the slag. The air escapes very hot, near 950° , and contains about 10 per cent. by volume of SO_2 . A white salt settles in the iron pipe used for the hot gases; this salt is essentially potassium disulphate KHSO_4 , and

contains only a small percentage of NaHSO_4 ; the salt volatilised from ferro-manganese furnaces is also essentially an acid potassium sulphate.

G. PROCESSES FOR OBTAINING SULPHUR DIOXIDE BY OTHER METHODS

From nitre-cake (acid sodium sulphate) Bottée (B. P. 6898 of 1904) obtains neutral sulphate and SO_2 by mixing the nitre-cake with 12 per cent. wood-shavings and 2 per cent. coke, and heating in a retort provided with a stirring arrangement.

Llewellyn and Spence (B. P. 103689 of 1917) treat nitre-cake with a suitable reducing agent, as for instance 25 per cent. of pyrites, in a ground condition in a closed iron vessel provided with a mechanical agitator. Sulphur dioxide is evolved, together with some sulphur which is readily condensed, and a residue of normal sodium sulphate and iron oxide remains.

If finely divided iron be substituted for the pyrites, no free sulphur is liberated, but a steady evolution of sulphur dioxide occurs.

Garroway (B. P. 11986 of 1905) decomposes a solution of sodium bisulphite under pressure by sodium bisulphate or free sulphuric acid; most of the SO_2 is driven out in the cold, the remainder by injection of steam.

Elworthy (Fr. P. 352254) oxidises a mixture of sodium sulphide with calcium or sodium sulphate in a Bessemer converter by air, thus obtaining all the S as SO_2 .

Basset (Fr. P. 428019) heats a mixture of calcium sulphate and alumina, preferably with addition of powdered coal, to a high temperature. The reaction is:

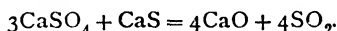

Schildhaus and Condrea (Amer. P. 956184) obtain SO_2 from acid-tar or sludge by heating it to 200° to 300° in a retort and passing into this air pre-heated to the same degree; the liquid hydrocarbons contained in the vapours produced are condensed and the remaining gases are washed, first with heavy hydrocarbon oil and finally with sulphuric acid; the coke formed is continuously removed from the retort.

J. S. and A. A. Blowski (Amer. P. 1010221) obtain SO_2 from petroleum sludge by means of water, so as to obtain a

dilute acid containing sufficient organic matter to decompose the acid on subsequent heating. The SO_2 thus obtained is purified and reoxidised to attain sulphuric acid.

H. PREPARATION OF SULPHUR DIOXIDE IN THE PURE OR LIQUID STATE¹

Formerly pure sulphur dioxide, free from nitrogen and excess of oxygen, was required only in very few cases for industrial purposes. The methods employed for preparing it were various, one of the commonest being the action of concentrated sulphuric acid upon copper at a higher temperature. This is, of course, only applicable where there is a sale for the cupric sulphate formed, and is, moreover, hardly workable on a large scale. Cheaper and easier is the process of heating strong sulphuric acid with charcoal, when a mixture of SO_2 with CO_2 (and CO) is obtained :



The CO and CO_2 are harmless in many applications of SO_2 .

Sulphur dioxide, quite free from other gases, is made by heating concentrated sulphuric acid with sulphur :

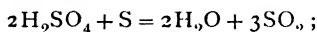

this can be done by running a slow stream of sulphuric acid on sulphur, heated to about 400° in an iron retort. It should, however, be noticed that melted sulphur acts very strongly upon cast-iron; hence the operation should be performed in a cast-iron pan widening out at the top so that a lining of acid-resisting bricks can be put in it. Concentrated sulphuric acid is boiled with sulphur, which floats on the top and is kept by the brick lining from coming into immediate contact with the iron, whilst the lower part of the pan is fully exposed to the heating action of the fire.

Cast-iron pans are, however, used at the present time without such linings, but in this case they are made from 3 in. in thickness, and require rather frequent renewal.

Sulphur dioxide was made by the Compagnie industrielle des procédés Raoul Pictet (Ger. P. 22365), and was purified in

¹ A special treatise on the preparation, properties, and application of pure sulphur dioxide is *Flüssiges Schwefeldioxyd*, by A. Harpf (Stuttgart, 1900).

a special apparatus, utilising the fact that the hydrates of SO_2 all crystallise at -11° and that gaseous SO_2 at this temperature loses all its aqueous vapour. It is unnecessary to describe this (somewhat complicated) apparatus, which is described in the *J. Soc. Chem. Ind.*, 1883, p. 413.

An old and well-known process for obtaining pure SO_2 is to heat ferrous sulphate with sulphur, in the presence of sufficient air, the reaction being :

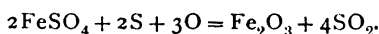

This process was made the subject of a new patent by Terrell (B. P. 5930 of 1884), who draws special attention to the value of the ferric oxide remaining behind, which furnishes a good paint.

Bergmann and Berliner (Ger. P. 160940) prepare pure SO_2 by a reaction observed by Gerland, viz. the absorption by calcium diphosphate, which, on heating to 100° , liberates the SO_2 again. Dicalciumphosphate absorbs SO_2 even from very dilute mixtures, like fuel-gases and exit-gases of acid-works, which may thus be utilised, the absorbent being always recovered. The reactions are :

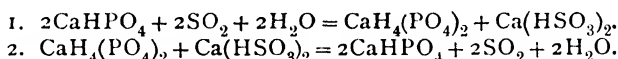

Carpenter (Amer. P. 829765) obtains pure SO_2 from burner-gases by gradual cooling, moistening with water, thus separating the mechanical impurities, and cooling down to 0° , whereby the SO_2 condenses as a solution in water, while the other gases go away.

Hegeler and Heinz (Amer. P. 931868) mix hot SO_2 gases from a sulphur-burner with about the same quantity of cooled gases, to reduce the temperature below 100° , pass the mixture through a tower fed with water, dry and filter the gases.

Moulin and Vandoni (Fr. P. 432431) describe an apparatus consisting of a sulphur-burner, working preferably under pressure, followed by a heat-interchanger, a cooling apparatus, and a series of compressors, where the gas is compressed to about 30 kg., after which it is cooled to about 0° and passed to the liquefier. The residual gases from this, after allowing them to expand to about 5.5 kg. pressure, are at a temperature

of -70° , and are used for cooling the tubes of the liquefier and in the heat-interchangers.

The Comp. ind. des Alcools de l'Ardèche (B. P. 9145 of 1909), in order to recover SO_2 from solution, heat the solution and project it violently in the form of a jet against the walls of a case. The SO_2 goes out at the top, and the water flows out at the bottom.

The best-known process for preparing pure liquid sulphur dioxide on the large scale is that of Schroeder and Haenisch, by which it can be prepared in a cheap way from gases containing down to 4 per cent. SO_2 . It is hardly necessary to say that richer gases are better for this purpose. This process has made liquid sulphur dioxide a cheap article, manufactured on a large scale, and has rendered it possible to employ that substance for many purposes for which formerly only the ordinary impure gaseous SO_2 was available.

The gases, testing 6 per cent. SO_2 , were taken from a novel kind of blende-roasting furnace, similar to the Rhenania furnace.

The process consists in absorbing the SO_2 gas in water in an ordinary coke-tower, and expelling it again from the resulting weak solution by the action of heat, in such manner that the latent heat of the steam carried along is fully utilised, and ultimately a very small amount of coal is required. It is described in Lunge's fourth edition, p. 534.

The manufacture of liquid SO_2 from SO_2 diluted with other gases is described in Ger. P. 325473, 23/11/19, Manufactures des Produits Chim. du Nord, Établ. Kuhlmann.

The gases containing a small percentage of SO_2 , *e.g.* those obtained from roasting blende or pyrites, are compressed and then agitated with heavy tar-oil free from anthracene, which absorbs the SO_2 . The latter is removed in the usual way. Coal-tar oil of sp. gr. 1 dissolves at atmospheric pressure and ordinary temperature about a quarter of its weight of SO_2 .

Liquid sulphurous acid is also prepared from dilute gases by P. Pascal (B. P. 159337) by absorbing the sulphur dioxide in carbolic oil distilled from coal-tar at a temperature range of 175° - 225° and having a density of about 1. The dilute gas from a compressor is passed into the bottom of an absorption-tower filled with packing material over which coal-tar oil trickles downwards and absorbs the sulphur dioxide,

which is eliminated by heat and the oil thus prepared for re-use.

A. H. Eustis, Mass. (B. P. 168627), recovers SO_2 from furnace-gases by passing them through a tower, where it is cleaned and cooled, and thence to scrubbing-towers packed with coke over which the absorbing liquor flows. After leaving the first series of scrubbers, it passes into another series containing limestone. The SO_2 in the solution leaving these scrubbers is then liberated by steam, and after removing the bulk of the moisture the gas is passed to refrigerators for further drying and then compressed into liquid (see also B. P. 167725).

Nonnet (B. P. 26999, 1912; Fr. P. 450804) adds to a mixture of equal parts of alkaline bisulphite and sodium thio-sulphate, fused in its water of crystallisation, 5 per cent. of gum arabic, and then the equivalent quantity of anhydrous sodium thiosulphate. He granulates the mass, which forms a stable powder, yielding all the SO_2 on contact with water.

Bassets (B. P. 20667, 1913) passes the gases through a dust-collector, a heat-exchanging apparatus, and a tower sprayed with water or a solution of potassium carbonate. The liquid running out of this, after heating up, goes through a heat-exchanger into a boiler.

An apparatus for preparing solutions of sulphurous acid or of sulphites is described by F. E. Coombs (U.S. P. 1147376). It comprises, first, a brimstone-furnace with a shallow bottom tray, fired from below, and over this a funnel for the brimstone to be burned, provided with a steam mantle by which the brimstone can be fused and run down into the furnace, regulated by a tap. The SO_2 gases pass into the lower part of an absorbing-cylinder, filled with suitable packing material, over which water, milk of lime, a solution of sodium carbonate, etc., are run. At the bottom it is funnel-shaped, and the solutions obtained run into a receiver. This contains a float by which the pumps for feeding the absorber with liquid and for carrying away the solution formed therein are automatically regulated.

Moore and Wolf (U.S. P. 1091689) pass SO_2 gas, produced in any suitable way, containing air and nitrogen, into a cooled solution of calcium chloride, which retains the SO_2 , and from which it can be obtained in the pure state by heating with application of a vacuum. The advantage of employing a

solution of calcium chloride instead of pure water is this, that it can be cooled down below 0° without solidifying, and that its boiling-point is higher than that of water. Since the boiling-point of the dissolved SO_2 in both cases is the same, less water is carried away with it when driving it out of the solution of calcium chloride than when driving it out of a solution in water.

Babe and Pape (B. P. 19937 of 1916) separate sulphurous acid as a saturated solution from combustion-gases by cooling them to below 0° to condense the water vapour. If necessary, a certain quantity of water in the form of a spray or as steam, or else a solution of a salt that is not affected by sulphurous acid, may be added to absorb the whole of the sulphur dioxide and form a saturated solution or condensate which will not freeze to ice. The process may be effected by passing the gases through a chamber filled with ice, or over a surface flooded by a cooling-liquid or kept cool by the evaporation of ammonia or sulphur dioxide.

Carriage of Liquid Sulphur Dioxide.

The liquid sulphur dioxide is sent out in iron cylinders (bottles) holding 1 or 2 cwt. each, or in tank-waggons of 10 tons capacity. The bottles are tested to 50 atm. pressure, so that there is no danger whatever in their transit. The vapour-tension of SO_2 is given on p. 179.

It is not advisable to keep the liquid in a place where the temperature may rise above 40° .

Boake and Roberts (B. P. 19789 of 1892) find that liquid SO_2 does not act on tin or soft solder, and that therefore these can be employed in the manufacture of carrying-vessels.

Lange¹ found that absolutely anhydrous liquid sulphur dioxide did not act upon iron up to 100° . Technical sulphur dioxide has a slight action, owing to the presence of a little water. The temperature at which this takes place increases with the purity of the acid; *e.g.*, it is 70° in the case of acid containing 0.7 per cent. H_2O . Since liquid SO_2 cannot dissolve more than 1 per cent. water, even the more impure product cannot act on the iron vessels in which it is transported at ordinary temperatures. The mixture of ferrous sulphite and thiosulphate

¹ *J. angew. Chem.*, 1899, p. 275.

formed, moreover, acts as a protecting crust. In ice-machines where SO_2 is the active agent, and where the temperature in the pumps may rise considerably, only absolutely anhydrous SO_2 should be employed.¹

Carrier (Fr. P. 402810) describes a pump specially adapted for the compression of sulphur dioxide.

Pacottet (Fr. P. 365224) describes an apparatus for measuring liquid SO_2 , which he calls sulphitometer.

The Heylands Company (Ger. P. 250263) construct vessels for keeping and carrying liquefied gases, consisting of two concentrically arranged metallic vessels, the thin neck of the inside vessel being of a special shape.

The regulations for the carriage of liquid sulphur dioxide are given in the *Chem. Trade J.* for 1920, p. 531:—Sulphur dioxide, being neither combustible nor explosive, and not corrosive (in the sense in which nitric and sulphuric acids are), is not classed as "Dangerous Goods" within the meaning of section 446 of the Merchant Shipping Act, 1894. Its usual condition is liquid when stored in glass siphons or in metal cylinders. As the pressure of *liquid* rises rapidly with increasing temperature, vessels containing it should not be carried if more than seven-eighths filled. Siphons and cylinders containing sulphur dioxide must be kept in a cool place, away from boilers, and protected from the direct action of the sun's rays. The cylinders used for transporting this substance may be of wrought-iron instead of steel.

It may not be carried on emigrant or passenger steamers without special permission from the Board of Trade. On cargo vessels the carriage of siphons should be confined to deck cargo, and the siphons should be packed in a case and embedded in powdered chalk. Metal cylinders should be enclosed in stout rope mat or in wooden cases to prevent concussion, and should be kept cool and away from the living-quarters; they should be readily accessible, but may be stowed either on deck or under deck.

Uses of Sulphur Dioxide.

The principal uses for liquid sulphur dioxide are for refrigerating-machines (Pictet's and others), for wood-pulp manufacture

¹ Cf., on this subject also, *Z. angew. Chem.*, 1899, pp. 300 and 595.

(to bring the calcium bisulphite liquors up to strength), for the purification of beetroot juice, for disinfecting, for bleaching, and for the manufacture of glue and gelatine.

Liquid sulphur dioxide has been applied by Behrend and Zimmermann as a means for increasing the efficiency of steam-engines by utilising the heat of the exhaust steam for evaporating SO_2 . The high-pressure vapours thus produced are utilised in an auxiliary cylinder for generating motive power, and are afterwards again condensed to liquid SO_2 . Hitherto this system does not seem to have fulfilled its expectations.

The formerly rather extensive use of liquid SO_2 for bringing calcium bisulphite liquor (for the manufacture of wood-pulp) up to strength has very much decreased, since the factories have improved their plant for the direct preparation of strong sulphite liquor.

According to Edelenau,¹ liquid sulphur dioxide is employed in the refining of petroleum. It dissolves the non-saturated hydrocarbons which cause the bad burning or the characteristic smell of some lighting-oils, and leaves unchanged the saturated hydrocarbons which are the valuable constituents of petroleum. Frasch applies spirit of wine to the same purpose: but sulphur dioxide has over this the twofold advantage that it is cheaper and that it can be completely recovered. The process is made clearer by illustrations, and the paper also contains practical results, yields, and calculations of costs.

Galaine and Hulbert² describe an apparatus for mixing liquid sulphur dioxide with air for disinfecting purposes.

Fischer and Glund³ employ liquid SO_2 for extracting organic substance from coal.

In Eastern Borneo there is a factory for producing 4 tons of sulphur dioxide per month, for use in the manufacture of ice.⁴

Olga Niedenfür (Ger. Ps. 254044 and 254362) evaporates part of the already liquefied sulphur dioxide, and employs the gaseous SO_2 thereby formed for producing sulphur dioxide in the concentrated state.

¹ *Bull. Amer. Min. Eng.*, 1914, p. 2313.

² *Comptes rend.*, 162, 363.

³ *Berl. Ber.*, 1916, p. 1469.

⁴ *Chem. Zeit.*, 1916, p. 80.

I. DRAUGHT-PIPES AND FLUES. REMOVAL OF FLUE-DUST AND OTHER IMPURITIES

The flues conveying the burner-gases from the kilns into the chambers or into the Glover towers may be constructed of brickwork only so far as the gases keep hot enough to prevent any moisture condensing—that is, especially in upright flues and flue-dust chambers. From this point they must be made of cast-iron, and further on, when they have cooled down, of lead.

The gas, which goes away red-hot from the burners, must necessarily be *cooled down* to the temperature of the chambers, say 50° – 60° ; otherwise the first chamber would be very quickly destroyed. This cooling was formerly effected by conveying the burner-gas in very long flues of cast-iron, or

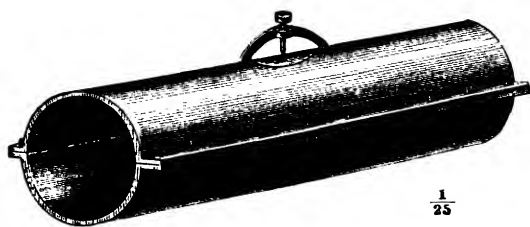

FIG. 59.

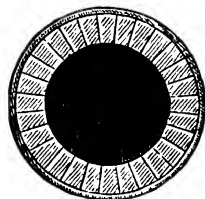

FIG. 60.

partly of cast-iron, and, when partially cooled, of lead. Such cooling-flues were made up to 300 ft. long.

The cast-iron pipes are suitably shaped, as shown in Fig. 59, in order that the upper half may be replaced independently of the lower, or taken away for cleaning; the latter can also be done by means of manholes. For a set of from 12 to 18 burners a pipe of 2 ft. diameter is sufficient; but they are now and then made upwards of 3 ft. in diameter. Sometimes they are lined with fire-bricks, as shown in Fig. 60; the cooling in this case is very imperfect and the cost higher. Occasionally, in very large works, square or oblong flues of wrought- or cast-iron are found. Brick flues (for perpendicular shafts or for flue-dust chambers) are made of bricks boiled in tar, and set with tar and sand. Earthenware pipes mostly crack too quickly.

Perpendicular stacks and pipes act as a sort of chimney,

and they are therefore carried up nearly to the top of the chambers where there is no Glover tower. These pipes were sometimes cooled by water, and even very complicated contrivances were met with for this purpose. It has long been recognised that the only rational way of cooling the burner-gas is to take away its heat for some useful purpose, and this is done almost everywhere in the Glover tower (Chapter II, Vol. II).

Dust-chambers.—Where the quantity of flue-dust is very large, as is generally the case with arsenical ores, and with some of the burners for pyrites-smalls, the ordinary dust-chambers, which form simply enlargements of the gas-flue, are not sufficient, and special contrivances must be adopted. This matter has been thoroughly worked out in the lead-smelting works and other metallurgical establishments, and a large number of apparatus have been constructed for this purpose. Many of the contrivances employed at lead-works, etc., are unsuitable for pyrites, on account of being made of iron. But the general principles remain the same: the flue-dust must be made to deposit by cooling, by retarding the speed of the gaseous current, and by offering to it large surfaces to which it can attach itself. All these conditions are more or less fulfilled by making the gas-flues adequately long and wide, but this is not sufficient in many cases, especially for arsenical ores. The case is here complicated by the fact that the cooling of the gas may be injurious to the chamber-process, and that the long flues, especially those carried in a zigzag way or provided with "baffle-walls," interfere very seriously with the draught. The latter disadvantage has been greatly lessened, since it has been recognised that it is unnecessary to carry the gases in flues like those sketched in Figs. 61 and 62 (in the former the diagram may be taken either as plan or elevation), where the current of gas is constantly checked by meeting solid surfaces, but that the surfaces may be disposed in the direction of the current itself, where they cause the dust to be deposited on them without interfering with the draught. Fig. 63 shows how this can be done in such a way that the flue-dust can be removed without interfering with the process. The gases arriving through *a* are, by means of dampers, sent through either chamber A or B. In the present case, the dampers *b*, *b* being closed, the gases travel through A. Each chamber

is divided into several longitudinal channels by thin partitions *d, d*, made of masonry, fireclay slabs, lead, or other suitable

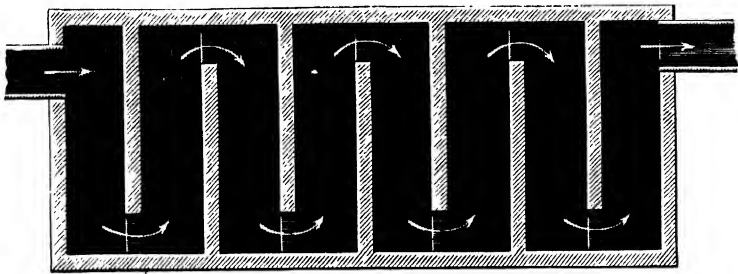

FIG. 61.

material. The gas thus travels in parallel streams through

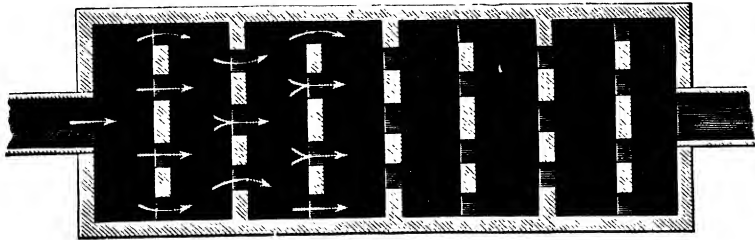

FIG. 62.

narrow channels and the streams collect again into one, issuing

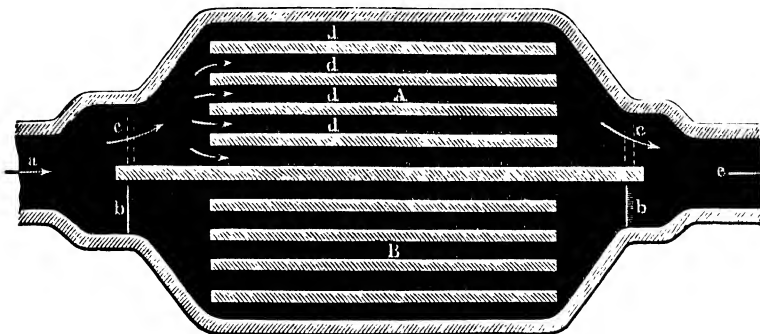

FIG. 63.

at *e*. When chamber A is too much choked up by dust, the dampers *b, b* are opened, the dampers *c, c* are shut, and the gases now travel through B, giving an opportunity to clean out chamber A by means of suitable manholes.

In very bad cases, as, for instance, with mechanical dust-burners, longitudinal partitions are not sufficient, and real baffle-plates must be employed, as shown in Figs. 61 and 62.

Bauer¹ states that the nine sets of chambers connected with the Freiberg smelting-works (containing thirty lead-chambers) possess 26,368 ft. of flues, of 41 sq. ft. section. The flue-dust in 1893 contained 1137 kg. silver, 1656 tons lead, and 917 tons arsenic, valued at £13,600. In 1893 80 per cent. of the dust was recovered, and 20 per cent. lost. The damages to be paid had diminished from £3050 to £180. In that year, new flues on the Monier-Freudenberg system were built for recovering the last 20 per cent. of dust. The rate of cooling of the gases was 1° per 27 ft. length in closed-in Monier flues, per 15 ft. in freely exposed Monier flues, per 10 ft. in leaden flues, and per 19.6 ft. in brick flues.

In 1902 Lunge was informed that the water-covered flues had been abandoned at Freiberg as being too costly, and had been replaced by simple lead tunnels. Where the heat is too great for the stability of the latter, brick flues are employed.

Falding² describes a dust-catcher, constructed by A. P. O'Brien, of Richmond, Va., on the well-known centrifugal principle. It works in connection with the cast-iron fan of the same inventor, described in Chapter II, Vol. II, and receives the gas from five Herreshoff fines-furnaces, retaining 75 per cent. of the dust. At the same time it does very efficient service as a metre-oven. As shown in Figs. 64 and 65, it consists of a tapering, hopper-shaped iron shell, 8 ft. wide in the cylindrical part and 12 ft. high, with a 6-in. opening in the bottom for the discharge of flue-dust. It is lined with 4-in. firebrick. The gas enters through the top pipe at a high rate of speed from the fan and strikes the cylinder tangentially; it leaves the apparatus through a central pipe. The gas takes a rotary motion and deposits all the heavy dust, which is automatically discharged through the 6-in. opening. Six tubular nitre-pots are arranged in the manner shown, so that they can be charged from the top and discharged sideways.

¹ *Jahresber. f. Berg- u. Hüttenw.*, 1894, p. 39.

² *Min. Ind.*, 9, 623.

Morton and the United Alkali Co. (B. P. 17461 of 1906) remove flue-dust, *e.g.* from Herreshoff furnaces, which consists chiefly of magnetic oxide of iron, by means of a number of plates of magnetic metal, placed side by side in the flue, on either side of which there is a pole of an electro-magnet. From time to time the electric current is interrupted, where-upon the dust collected on the plates falls into a hopper below.

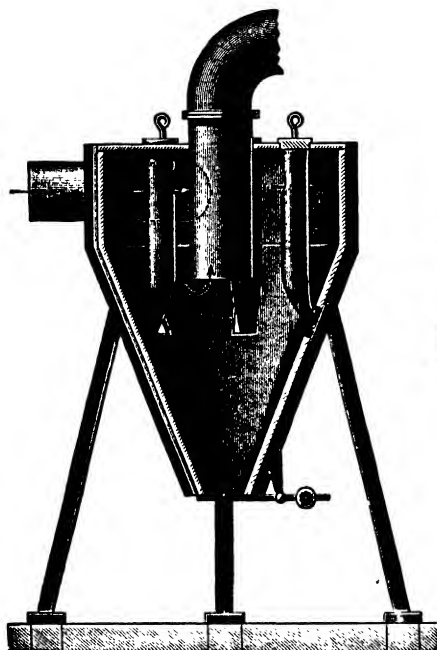

FIG. 64.

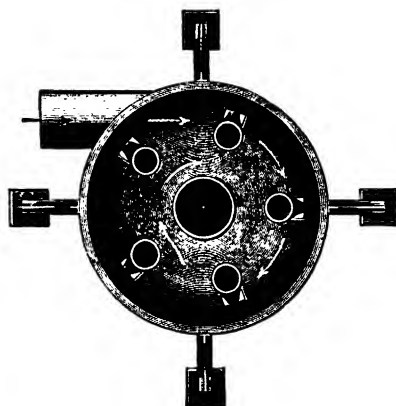

FIG. 65.

Electrical Precipitation of Dust.

The first systematic investigation of the influence of electric fields on the removal of suspended particles from gases or vapours was made in the years 1884–1886 by Sir Oliver Lodge, although isolated observations of the precipitating effect of an electrified insulated wire surrounded by gas containing suspended particles had been made independently, so long previously as 1824, by Hohfield in Leipzig, and about 1850 by Guitard in London.

Until 1906, practically no serious study of the matter was attempted until F. G. Cottrell had occasion to repeat Lodge's work, and applied his methods to the removal of acid mists in the contact sulphuric process.¹

The Cottrell system is represented by Huntington, Heberlein & Co., and the writer understands that the American agent has erected over thirty sets in that country, but in England there appears none yet at work.

The over-all efficiency is said to have been proved to be 99 per cent., and the plant is cheaper than many dust-chambers and very much more efficient.

The gas enters at 500° or thereabouts, and must fall below 350°, especially if moisture be present. When the current is turned off, the dust falls and is easily removed. Mechanical pyrites-burners in U.S.A. burning 70 tons of ore per twenty-four hours recovered 6 tons of dust per week, the efficiency being 98 per cent.

Heimrod and Egbert² give some details regarding the efficiency of the above apparatus, stating that the temperature of the gases and character of the suspended matter are governing factors. At temperatures of 540° and over, and for the removal of dust rather than fume, precipitators of the plate type are preferable, in which the gases pass horizontally between collecting and discharge electrodes. With gases cooled to about 320° for the removal of fume, the pipe type of precipitator is preferable. In a Wisconsin plant for roasting zinc-ore, 17,500 cub. ft. of gas per minute is cleansed at about 260° by an installation of two units, each containing 36 steel pipes as collecting electrodes, 12 in. in diameter and 15 ft. high, with discharge electrodes in the form of chains arranged axially. The electrical equipment consists of a 200 to 65/70/75/80/85000 volt transformer, and the power consumption is about 18 kilowatts; 7600 lb. of material containing 22 per cent. zinc and 30 per cent. sulphur is collected every twenty-four hours. In a precipitator at Baltimore working at 590°–760°, 17,500 cub. ft. of gas per minute at 590° is treated, and 900 to 1200 lb. of dust per day is

¹ *Chem. Age*, 5, 592.

² *Chem. and Met. Eng.*, 1918, 19, 309-314; *J. Soc. Chem. Ind.*, 1918, p. 729A.

obtained from the roasting of 40 to 50 tons of pyrites. The installation is made in two sections, each of which may be shut off by dampers. The electrodes are heavy steel plates, suitably reinforced, suspended, and insulated, and a voltage of about 50,000 volts is used, the power consumed being not over 2 kilowatts.

A modified arrangement of the Cottrell precipitator is the one which has been developed by R. B. Rathbun, of the American Smelting and Refining Co. The main feature of this is the use of sheets of iron screen instead of the iron plates of the Cottrell precipitator. These screens have diamond-shaped or square meshes of about 2 in. wide, and are placed transversely to the direction of the flow of the gases and parallel to each other, having intervening spaces of about 6 in. between the adjacent screens.

The advantage of the screen type of apparatus is that the grounded electrodes are placed transversely to the direction of the gas flow instead of parallel, and the screens themselves, without any electrical equipment, are of a form adapted for the precipitation of dust.

While the screens are being shaken for the removal of the dust adhering thereto, the gases are turned into another flue. So far, this apparatus has only been used for the removal of dust from lead-smelting furnaces, and has not yet been used on the gases emanating from pyrites burners.

Efficiency tests on the plate type of precipitator are given by A. W. Fairlie :—¹

Dust and elements in the dust.	Weights precipitated, lbs.	Percentage precipitated.	Weight unprecipitated, lbs.	Percentage unprecipitated.
Dust	1700.00	98.94	18.25	1.06
Soluble Iron	14.45	83.24	2.95	16.76
Arsenic	70.00	24.21	218.00*	75.79
Lead	262.00	81.59	59.00*	18.41

¹ *Chem. and Met. Eng.*, 1921, 25, 864.

* This weight is evidently considered to be present in the hot gas as volatilised metallic fume, not as dust. During the above test the amount of sulphur burned in the form of pyrites was 56,100 lbs. per day.

It is interesting to note that the arsenic was the least efficiently precipitated, due, no doubt, to the fact that it was present in the gas chiefly as uncondensed fume, and not as dust.

The partial analysis of the precipitated dust was as follows :—

Sulphur	4.17 per cent.
Soluble Iron85 „
Lead	15.40 „
Arsenic	4.11 „
Acidity	5.98 „
	<hr/>
Total	<u>30.51</u>

The remainder was assumed to be chiefly oxide of iron.

L. B. Skinner¹ states that : “ The Cottrell process has failed to work satisfactorily under very severe practical conditions of acid plants where it has been tried on plants using fine concentrates.”

Precipitation of dust or other impurities from vapours by means of high tension, direct or alternating currents, is described by F. Schultz (Ger. P. 312049 of 1918),² the apparatus being provided with tubular electrodes composed of non-conducting material, the appropriate surfaces of which are made conducting by means of a layer of metal ; the tubes should be made of materials possessing different di-electric constants, that of the inner being the greater. The outer electrode tube, through which the gas is passed, is vertical, and the inner tube is suspended in this with its axis horizontal. It may be desirable to use two or more of these short inner electrodes.

Another device for the precipitation of solids electrically is patented by Bradley (U.S. P. 1284175),³ who describes an apparatus for the precipitation of the solid particles from gases containing SO₂ and sulphuric acid, consisting of two electrical precipitators arranged in series in the line of the flow of the gas, and between them a heat-interchanger by means of which the precipitation may be carried out either above or below the condensing temperature of sulphuric acid.

An apparatus for the electrical precipitation of suspended matter in gas⁴ consists of (A) an electrode frame arranged between

¹ *Chem. and Met. Eng.*, 1918, 18, 82-85 ; *J. Soc. Chem. Ind.*, 1918, p. 147A.

² *J. Soc. Chem. Ind.*, 1919, p. 752A.

³ *J. Soc. Chem. Ind.*, 1919, p. 74A.

⁴ A. F. Nesbit, Assr. to International Precipitation Co. (U.S. P. (A) 1356462, 19/10/20, (B) 1357201, and (C) 1357202, 26/10/20 appl., (A, B) 17/11/14, (C) 16/5/15).

spaced plate-like receiving electrodes forming a gas passage. A series of parallel, flexible discharge members extending longitudinally through the passage are held rigidly by the frame. (B) The discharge system of opposing electrode systems comprises a number of wires arranged spirally in the direction of the length of the system, each wire having its axis out of the axis of symmetry of the opposing electrode system, whereby an unsymmetrical field is produced in the various cross-sections of the system, through which the fluid stream tends to flow spirally. (C) The discharge system of opposing electrode systems comprises a frame carrying rigidly a number of electrode elements arranged parallel to one another and to one side of the frame.

A very interesting article on the removal of dust from gases is given in the *J. Soc. Chem. Ind.*, 1922, p. 211 *et seq.*, to which the reader is referred.

Other Methods of removing Dust.

Shields (B. Ps. 16353 and 16354 of 1904; Ger. Ps. 180070 and 180071) conducts the burner-gases beneath or into a constantly replenished heap of porous or granular material, such as coke, crushed slag, or the like, which, as it collects the dust, is drawn away from the bottom of the heap by a conveyer, and is elevated to pass into a separator for the removal of the dust, and then restored through a funnel hopper in a clean, hot state to the top of the heap. The receptacle for the filtering material is of conical shape, with its apex downwards, and about the centre of the heap the gases are passed in through a pipe immediately under a horizontal disc, beneath which a cavity is thus maintained. Another form of apparatus is also shown, in which the filtering material descends slowly between sets of inclined shelves arranged in a cylindrical or rectangular form.

Cellarius (B. P. 22080 of 1905) purifies the burner-gases from dust and from nitrous oxides by producing in them, both before entering and after leaving the chambers, a whirling motion and throwing them against a damp clay wall, or against damp coke.

The same inventor (Ger. P. 263941) obtains steam for working purposes by utilising the heat of the gases of pyrites-

and blende-burners. In the gas-flue a closed vessel is placed into which, from outside, water is sprayed by means of a spray-producer, the steam thereby formed being carried away by a pipe from the top of that vessel. Two or more such vessels may be placed in the flue, the steam-pipes of which are connected with a common collector. Behind these vessels another vessel may be placed, into which no water is sprayed, for the purpose of superheating the vapour passing through it. The vessels may consist of cast-iron, with a suitable lining and a layer of fireclay lumps at the bottom. By this means the steam for producing the power required for driving the mechanical burners, fan-blasts, air-compressors, etc., may be partially or entirely obtained.

Gayer and Witter (Ger. P. 227387) employ a box with a horizontal shaft, provided with beating-arms, revolving several hundred times per minute, and moistened by water-sprays. The beaters are placed on the shaft in a screw-line. The gases enter at the bottom and go out at the top.

Heine (Ger. P. 230182) arranges in the dust-chamber slanting plates, reaching a little more than half way through, and leaving a distance of 3 or 4 mm. from the side free for a small portion of the gases to pass through, so that whirls are formed.

Krowatschek (Ger. P. appl. K45381 of 1911) describes a very similar arrangement.

Howard (Amer. P. 896111; re-issue 8th March and 13th September 1910; this patent is held by the General Chemical Co. of New York) describes a dust-separator containing a great number of horizontal steel plates between which the gases pass from one side to the other. It is shown in Fig. 66, and consists of: A, brick entrance flue; B, cast-iron damper, operated from without by winches; C, cast-iron ring-plate over which B closes; D, vestibule from which the gas enters between the horizontal steel plates E, $2\frac{1}{2}$ in. apart from one another, and gets into space F. They strike against the baffle-wall G, and leave through the flue H, covered by the cast-iron plate I, provided with an opening for the damper J; K is the outlet; L, cleaning-holes with covers. The outside brick walls are 19 in. thick, with a 1-in. insulating space. The interior walls are 12-in. red brick.

The velocity of the gas in passing between the steel plates is checked by the large area of cross-section, and, since these plates are only $2\frac{1}{2}$ in. apart, each dust particle needs to fall only $2\frac{1}{2}$ in. (instead of 6 or 8 ft. as in the old-fashioned practice) before finding a surface to which it adheres. Under ordinary circumstances the plates need not be cleaned any oftener than once in thirty or forty days. For that purpose

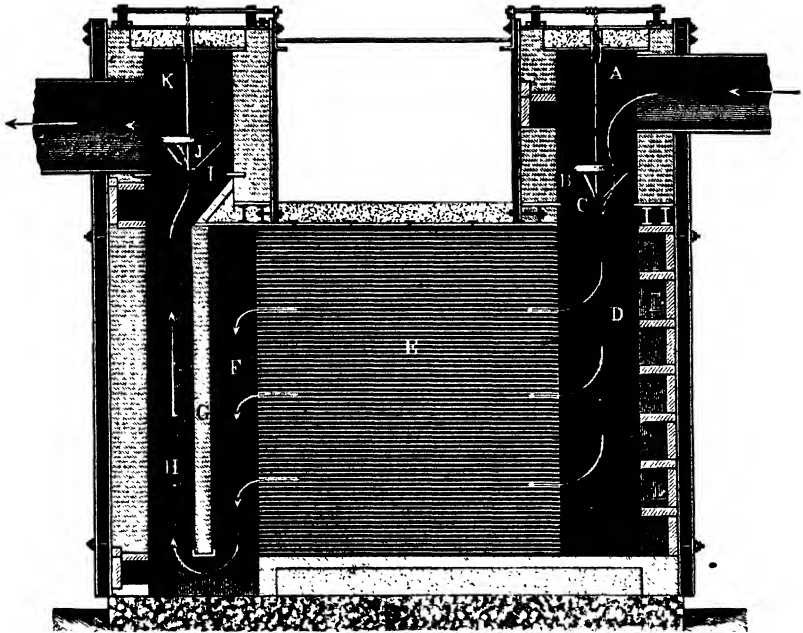

FIG. 66.

the covers are removed from the cleaning-holes L, and the dust is taken out.

These separators are made for a capacity of 24,000 to 60,000 lb. of ore per day in two compartments, or from 72,000 to 80,000 lb. in four compartments. There are five sizes, with from 6540 to 18,700 superficial ft. of plate area, and a vertical height of from 27 to 31 ft.; ground space required, 17 to 31 × 27 ft.

Huntington, Heberlein & Co., Ltd.'s patent dust-catcher consists of a brick chamber supported on either brick piers or cast-iron columns. The chamber is supported on a strong

R.S.J. frame, to which the discharge hoppers are fixed, and is divided by a partition wall into two or three compartments ; according to capacity of furnace installation, either of them can be cut off for cleaning purposes, so that the working of the plant is not interrupted.

Each compartment is provided with the necessary C.I. dampers, discharge arresting-gear, charging and discharging hoppers, etc. The compartments are filled in with broken bricks or burned pyrites lumps. The working of the dust-catcher is simple, and requires little attention beyond the changing of the filter media.

Benker and Hartmann (Fr. P. 387456) also pass the burner-gases horizontally through vertical filters composed of pieces of firebricks or stones, contained between vertical perforated walls. The bottom of the filtering column rests on a vertical rotating roller, which continually carries away a small quantity of the filtering-material to a rotating drum, in which it is deprived of the dust with which it is laden. It then falls into a receptacle, from which a conveyer returns it to the top of the filtering-column.

Scherfenberg and Prager (Ger. P. 203948) employ dust-chambers with baffling-walls, all inner surfaces being corrugated.

Brandenburg¹ describes a centrifugal dust-catcher similar to those which have been found very efficient in connection with blast-furnaces.

Wright² found that the gases from mechanical dust-burners, after they had traversed a small dust-chamber with a velocity of 1 ft. per second, still contained 0.28 gram dust per cubic metre ; and, after passing through a washing-tower and a long tube, still 0.11 gram.

The Metallic Compounds Separation Syndicate (Ger. P. 153641) combine a number of burners with a common chamber, in which the dust is precipitated by serpentine channels.

A very complete plant for purifying burner-gases (from mechanical furnaces) from dust is that built by Gilchrist and described by Hartmann and Benker in *Z. angew. Chem.*, 1906, p. 1188 *et seq.*

¹ *Z. angew. Chem.*, 1909, pp. 2490-2492.

² *Eng. and Min. J.*, 1910, p. 111.

The Metallbank und Metallurgische Gesellschaft A.-G. (Fr. P. 456524) employ for the filtration of burner-gases, etc., an acid-proof material, prepared by gradually heating cotton tissue, weighing 350 grams per superficial metre, in closed vessels to 300° to 350° for some minutes, or to 200° to 250° for several days, and subsequently cooling. The tissue loses 68 to 76 per cent. of its weight, and its tensile strength falls from 2300 kg. to 30 to 35 kg. per metre, but this still leaves sufficient flexibility to the fibre. The carbonised product contains considerable proportions of chemically combined hydrogen and oxygen, and is a good conductor for electricity.

Else Heine (Ger. P. 280088) passes the gases through the mixing tuyere of a steam- or water-spray-producer, whereby the solid particles are moistened and partly compressed, partly torn up; on the water-spray striking against a wall, they adhere to this, or are taken away by the water running out. Behind this wall a contrivance for separating liquids may be placed.

The Gewerkschaft Messel, Adolf Spiegel und Paul Meltzer (Ger. P. 260415), pass the gases through wires, extended between the two perforated ends of a cylinder, revolving in a fixed case. At the gas-outlet of the non-perforated part of the cylinder bottom a revolving fan produces between the casing and the revolving cylinder a plus-pressure, thus compelling the gas to travel through the wires.

Reichling (Ger. P. 279819) describes an apparatus for separating solid and liquid particles from gases and vapours, containing adjustable longitudinal partitions.

Moore (U.S. P. 1184006) filters the gases through a series of fabrics which are periodically cleared of dust; the last filtering-fabric is allowed to remain filled with dust, whereby the last traces of dust are removed from the gases.

Brunner & Co. (Ger. P. 269539) remove liquids from gases and vapours by passing them through a series of rods.

Herreshoff (Ger. P. 143740 of the Nichols Chemical Company, New York) prevents the carrying away of ore-dust by the gases in mechanical pyrites-burners by making the ore descend from one stage to another through special openings, separately from those serving for the gases, or by mechanically-moved sliding laths.

Lütgens (Ger. P. 255535) provides the flue-dust chambers with filters made of perforated tubes, open at both sides, and lateral gas inlets and outlets. The perforated tubes are suspended from the roof of the chamber, and are accessible to the gases on all sides. If their perforations are blocked up, so that the draught is interfered with, the gases can take their way from below through the tubes, at whose walls some dust always adheres.

Asbrand (Ger. P. 243787) describes a centrifugal apparatus for the removal of flue-dust.

Other patents in this direction: Beth (Ger. P. 245569); Michaelis (Ger. P. 244206); Maschinenfabrik Buckau (Ger. P. 245319); Gerdts and Strauch (Ger. P. 257368); C. S. Watson (B. P. 17384, 1912); Neumark (Ger. P. 263285); Greding (Ger. P. 263201); Püning (Ger. P. 262882); A. Müller (Ger. Ps. 216483, 265638); Kirschner (Ger. P. 268880); Krowatschek (Ger. P. appl. K45381); Wedge (B. P. 16617, 1915); Aicher (Ger. P. 289569); Egestorff's Salzwerke (Ger. P. 70396); Vadner (U.S. P. 1110660); Hommel and Durant (B. P. 28611 of 1909); Rehmann and Mirbach (Ger. P. 292004).

The Purification of Burner-gases from Liquid and Gaseous Contaminations.

This is very necessary where the gases are to serve for the manufacture of SO_3 by contact-processes, but in this chapter we only treat of the purification of burner-gases for ordinary purposes (lead-chambers, manufacture of liquid sulphur dioxide, of sulphites, etc.). The *mechanical* impurities are frequently mentioned in other places, especially in connection with the Glover tower, and are dealt with, in the first instance, by dust-chambers (p. 440). But for some purposes this is not sufficient, and, moreover, a *chemical* purification is necessary for various uses of the burner-gases. The Metallurgische Gesellschaft, Frankfort (Ger. P. 161017), describe a process for the uninterrupted simultaneous mechanical and chemical purification and cooling of burner-gases. They employ a water-fed tower, provided with inside shelves, with a vessel placed about midways, where there is not yet much sulphuric acid dissolved in the water run in at the top. Up to that point the water has

principally performed a cooling action and a mechanical purification upon the gases; it runs out from the above-mentioned vessel through an overflow, and part of it, after cooling, is used over again in the upper part of the tower, another portion being sprayed into the lower part, for the purpose of chemical purification of the gas. The quantity of water used here is regulated in such manner that it comes to about 70° , at which temperature it absorbs hardly any SO_2 , and carries away merely sulphuric acid and ferric-oxide mud.

The Tentelewsche Chemische Fabrik (Ger. P. 194176) purifies the burner-gases from *chlorine*, etc., by first applying a dust-chamber and a water-cooler, then taking out the sulphuric-acid fog and the last portions of dust by a coke filter,¹ and ultimately removing the chlorine by a solution of alkali or milk of lime.

The same firm (Fr. P. 431067) purifies gases from pyrites-burners as follows. A circular tower, built in sections, is surrounded by an annular space for cooling-water, which connects with hollow vertical partitions crossing each section, the whole being built of lead and supported over a circular trough in which it is sealed by sulphuric acid. The gases from the burners enter from the top and leave at the bottom, whilst the cooling-water passes in the opposite direction through the cylindrical jacket and the hollow partitions. The burner-gases can be cooled from 500° to the ordinary temperature, and all the sulphuric-acid fog they contain separated as a liquid. The lid of the apparatus is removable, and easy access is thus afforded for cleaning, which, however, is only necessary at long intervals.

Sulphur dioxide gases for the manufacture of wood-pulp ought to be as free as possible, not merely from flue-dust but also from *sulphuric acid* (or *sulphur trioxide*). For this purpose dust-chambers must be provided; the gas must also be cooled, e.g. by perpendicular cast-iron pipes, 2 ft. 6 in. diameter, running up for a height of 50 or 60 ft. and down again. A more efficient removal of the SO_3 and H_2SO_4 is effected by the apparatus of Némethy (Ger. P. 48285 of 1889), in which the gases from the burner pass through a large box containing iron borings, etc., before entering the cooling-apparatus.

¹ Ger. P. 230585.

Collett and Eckardt (Ger. P. 244841) purify the burner-gases, after properly regulating their oxygen contents, by allowing them to act upon ammonium sulphite at a higher temperature, whereby all the ammonium sulphite can be transformed into practically pure sulphate.

Projahn (Ger. P. 221847) purifies burner-gases from *arsenic* by passing them at a high temperature over a porous mass of aluminium sulphate, as it is obtained by heating such sulphate containing water. This mass is placed behind the pyrites- or blende-roasters, and retains not merely arsenic, but also *selenium* and flue-dust, practically at no expense.

Herreshoff and the General Chemical Co. (Amer. P. 969868) cool and purify pyrites burner-gases by producing between the wall and the gases a pellicle of liquid which also protects the metallic walls against destruction.

Duron (B. P. 9869 of 1910) first takes out the coarsest impurities, especially Fe and As, by filtration through a suitable substance containing ferric sulphate, cooling down in the meantime, then heating and cooling with sprayed sulphuric acid of about 30° Bé., then passing upwards through a scrubbing-tower sprinkled with water, then through filter-chambers charged with inert materials, and then raising to the temperature required for the lead-chamber or the contact-process by means of a heater arranged within the ordinary purifier and heated by the hot gases to be purified.

Moore¹ describes the system of Messrs Simon Carves: "The gases from the burners are led into the dust-chamber, where a preliminary settling is effected. They afterwards pass to the wash-tower (instead of the Glover tower), where the dust is removed, together with most of the arsenic, by a copious flood of acid. By this means they are cooled down to little above atmospheric temperature. Final cooling, necessary for the elimination of arsenic, takes place in the filters placed in the open air. These are small leaden chambers packed with selected coke. The gas, now perfectly clean, only requires heating to be ready for the chamber-process. Heat exchange is effected by passing it back through the dust-chamber in contact with the hot gases from the burners, after which it traverses a gas heater, where a temperature of 350°–400° is

¹ *J. Soc. Chem. Ind.*, 1918, p. 69T.

imparted to it by a coke-fire. In a works where waste gas is available this operation is most conveniently and economically conducted by that agency, the need of a fireman being dispensed with. The hot gas now enters the potting-oven, similar in most respects to established practice. From this point the course through the Glover, chambers, and Gay-Lussac towers is precisely similar to other chamber plants, but the gas possesses the great advantage of being absolutely free from dust."

Girod (B. P. 17157 of 1910) removes arsenic, etc., by thorough filtration of the gases between the burners and the Glover through several boxes, packed with granite, or lava, or other acid-resisting materials in pieces of various degrees of fineness, and then passing the gases through washing-towers fed with sulphuric acid of 30° to 40° Bé. The nitrous vitriol coming from the Glover tower is treated with nitric acid, in order to oxidise the arsenious acid to arsenic acid which is partly retained in the Glover, and completely in washing-towers following upon this. The acid from the latter goes through the Glover.

Herreshoff (Amer. Ps. 940595 and 940596) passes burner-gases through scrubbing-towers, sprayed with weak acid containing SO_2 , and then through filters.

The same inventor (U.S. P. 1113437) washes the burner-gases by means of sulphuric acid and rapidly cooling from 93° to 38°, and removing the condensate formed.

Reese (Amer. P. 989801) cools the gases, scrubs them with sulphuric acid, and passes them through a dry lime filter.

The Gräflich von Landsberg-Velen und Gemensche Chemische Fabrik (Ger. P. 256237) pass the burner-gases first through a dry filter, then through a denitrating Glover tower and through a series of wash-towers, fed with acid as free as possible from arsenic. That acid, after having taken up a sufficient quantity of impurities, is employed for feeding the Glover tower. The dry filter has a slanting bottom on which the granular filtering material slides forward; the gases pass into it from below and from the side.

Boubon (B. P. 15209 of 1911) passes the gases under pressure into a revolving cylinder, containing plates at whose circumference they escape through holes. The dust is here washed out by water or some other liquid.

Liebrecht (Ger. P. 265584) passes the gases through pieces formed from crystalline materials, together with steam.

Fr. Curtius & Co. (Ger. P. appl. C23027) wash and filter the gases in towers, regulating their temperature in such a way that they take up a quantity of water or acid, sufficient for dissolving the impurities or keeping them in suspension, before they get on to the dry filter. This filter may be filled with cylinders, rhomboeders, balls, pebbles, lumps of fireclay, or left quite empty; it need not be sprinkled with water. Sometimes it is useful to employ a second filter with a finely grained filling.

Fluorine may get into gases through the presence of fluor-spar in the pyrites, and may do damage to the towers and chambers. Klencke (Fr. P. 408417) removes it by treating the gases with denitrated sulphuric acid in an empty tower, and afterwards by nitrous vitriol in another tower fitted with perforated lead shelves.¹

Selenium was formerly considered as a non-essential impurity of sulphuric acid, on account of its small quantity. Klason and Mellquist,² however, state that selenium not merely causes the red coloration of Glover- and chamber-acid, but acts in a much more serious way in the manufacture of sulphite cellulose, as has been manifested in the application of Falun pyrites. As little as 1 mg. selenium per litre of acid may, by catalytic action, completely convert the SO_2 into H_2SO_4 and S .³ Tellurium acts in a similar way, but hardly comes into question, owing to the high boiling-point of the free metal and its oxides. This injurious action of the Falun pyrites has caused some of the Swedish sulphite-cellulose makers to abandon it in favour of Sicilian brimstone.

Klason and Mellquist remove the selenium by a tight filter, made of asbestos and the like, and recover it from this by heating or by means of a solvent.

Sublimed sulphur contained in burner-gases is removed, according to H. H. Niedenfür's Ger. P. 249330, by passing the gases, together with an excess of heated air, through hot

¹ See Chapter II.

² *Papier-Zeit.*, 1912, p. 767.

³ This reaction is claimed by P. C. Haesler as a new method for producing sulphuric acid (*cf.* Chapter VI, Vol. II).

metallic pipes. It is also suggested to construct the grates of the pyrites-burners of pipes through which the mixture of burner-gases and air is passed.

J. COMPOSITION OF THE BURNER-GAS

1. *Composition of the Burner-gas from Burning Brimstone.*

Atmospheric air contains, roughly speaking, 21 per cent. by volume of oxygen, and 79 per cent. nitrogen or other inert gas. If it were possible to convert all the oxygen into sulphur dioxide, the volume would not be changed, since 1 mol. O_2 furnishes 1 mol. SO_2 .

In the case of making sulphur dioxide for the manufacture of wood-pulp, we want to render it as free as possible from uncombined oxygen. But for the manufacture of sulphuric acid we must introduce into the burner sufficient oxygen for the subsequent formation of sulphuric acid, and a certain excess is practically necessary in the process. For the former object we must at once increase the oxygen by 50 per cent., as $2SO_2$ require O_2 for the formation of SO_3 , and the theoretical maximum of SO_2 in the burner-gas would therefore be 14 per cent., together with 7 per cent. oxygen and 79 per cent. nitrogen. Practically we must have an excess of oxygen equal to 5 per cent. of the exit-gases from the system, together with 95 per cent. N.

If we call the unknown volume in the burner-gas of this excess oxygen = x , it must carry along $\frac{79}{21}x$ vols. N. To this are added 79 vols. N, entering together with the 21 vols. O required for forming 14 vols. of SO_2 and converting them into SO_3 . The volume of the total N and of the excess oxygen required in practice for each 14 vols. of SO_2 introduced into the chambers thus amounts to

$$79 + \frac{79}{21}x + x = 79 + \frac{100}{21}x.$$

x was stated to form 5 per cent. = $\frac{1}{20}$ of this volume.

We have thus the equation :

$$x = \frac{1}{20} \left(79 + \frac{100}{21}x \right) = \frac{79}{20} + \frac{5}{21}x.$$

From this follows:

$$x = \frac{5}{21}x \text{ or } \frac{16}{21}x = \frac{79}{20},$$

$$x = \frac{79 \times 21}{20 \times 16} = 5.18 \text{ vols. ;}$$

that is, besides the theoretical quantities of gas mentioned above, another 5.18 vols. of oxygen, along with the corresponding $5.18 \times \frac{79}{21} = 19.50$ vols. of nitrogen, are necessary. The gaseous mixture formed in the sulphur-burner accordingly ought to contain upon each

	14	vols. of SO ₂ ,
7 +	5.18 =	12.18 ,, O,
and 79 +	19.50 =	98.50 ,, N.
	<hr style="width: 50%; margin: 0 auto;"/>	
	124.68	vols.

From this the following composition for 1 l. of this gaseous mixture is computed :

0.1123	litre SO ₂
0.0977	,, O
0.7900	,, N
<hr style="width: 50%; margin: 0 auto;"/>	
1.0000	,,

That is to say : *The normal quantity of SO₂ in burner-gas from brimstone-burners is 11.23 per cent. by volume.*

This normal quantity can be attained by proper care, but is very rarely reached in practice.

2. Composition of the Burner-gas from Burning Pyrites.

The proportion of air required in this case differs very much from the preceding. We shall calculate this for pure iron disulphide. This body consists of 46.66 per cent. Fe and 53.33 per cent. S.

Although in the combustion of dense pyrites sometimes the iron is not all oxidised up to Fe₂O₃, and a little magnetic oxide, Fe₃O₄, is formed, we must suppose the complete conversion of iron into Fe₂O₃ as the normal state to be aimed at for complete utilisation of the sulphur. Consequently 2 mols. or 240 parts of FeS₂ require 3 atoms = 48 parts O for oxidising the iron, and another 8 atoms = 128 parts O for burning the S into SO₂. Altogether 11 atoms = 176 parts oxygen are necessary for

burning, and another 4 atoms of oxygen = 64 parts for changing the formed 4 mols. = 256 parts of SO_2 into SO_3 . From this we calculate that for each thousand parts of FeS_2 ,

200 parts oxygen are required for oxidising the iron,			
$533\frac{1}{3}$	"	"	forming SO_2 ,
$266\frac{2}{3}$	"	"	oxidising this to SO_3 ,
1000	"	"	in all.

Now, here also an excess of oxygen must be used, even larger than in the case of brimstone, which we will assume to amount to 6.4 per cent. by volume in the gas leaving the chambers. If we call the unknown volume of oxygen in excess to be introduced for each kilogram of S employed as FeS_2 , x litre, the volume of nitrogen accompanying it is $\frac{79}{21} x$ litre.

Both together and the 4933.3 l. N, introduced along with the O requisite for combustion and formation of SO_3 , form the gaseous mixture escaping at the end, the volume of which is therefore

$$4933.3 \times x + \frac{79}{21}x = 4933.3 + \frac{100}{21}x.$$

As x is $\frac{6.4}{100}$ of this volume, we have

$$x = \frac{6.4}{100} \left(4933.3 + \frac{100}{21}x \right),$$

$$x = 454.1.$$

Accordingly, for each kilogram of S burnt as FeS_2 , apart from the theoretical 6244.7 l. air, another 454.1 l. oxygen, together with $\frac{454.1 \times 79}{21} = 1708.4$ l. nitrogen—that is, 2162.5 l. air—altogether 8407.2 l. air at 0° and 760 mm. pressure, have to be introduced.

Now, each kilogram of free sulphur (brimstone) requires 6199 l. air at 0° and 760 mm.; consequently a certain quantity of sulphur, burnt as FeS_2 , requires

$$\frac{8407.2}{6199} = 1.356 \text{ times}$$

as much air as if burnt in the free state.

This is not quite the proportion of the gas *as it enters the chambers*. For on burning FeS_2 a portion of the oxygen

remains behind with the iron, whilst on burning brimstone the whole quantity of air gets into the chambers, and at equal temperature and pressure retains its volume, since oxygen on combining with S to SO_2 does not change its volume.

The 8407.2 l. air entering the burner for each kilogram of sulphur burnt as FeS_2 produce the following quantities of gas, calculated for 0° and 760 mm. :—

699.4 l. SO_2 generated from the same volume of O,
349.7 ,, O required for transforming SO_2 into SO_3 ,
454.1 ,, O as excess,
4933.3 ,, N accompanying the theoretically necessary oxygen,
1708.4 ,, N ,, ,, excess of oxygen.
8144.9 ,, containing 699.4 l. SO_2 ,
830.9 ,, O,
6641.7 ,, N.

For a certain quantity of sulphur, burnt as FeS_2 , $\frac{8144.9}{6199}$ times = 1.314 times as much gas must enter the chambers as if the sulphur were burnt in the free state.

Consequently, in the case of burning pyrites, 100 vols. of the normal gaseous mixture on entering the chamber ought to consist of

8.59 vols. SO_2 ,
9.87 ,, O,
81.54 ,, N.

In most factories the sulphur dioxide is much below 8.59 per cent., sometimes not above 6 per cent., of the volume of the gas. In that case correspondingly less acid is made in the same chamber-space, unless the formation of sulphuric acid is increased by a larger consumption of nitre. We shall return to this subject in Chapter III, Vol. II.

Sulphur Dioxide for manufacturing Calcium Bisulphite (in the manufacture of Wood-pulp, etc.).—In this case the conditions are different from those just described. There is no question of having to provide the oxygen for forming H_2SO_4 from SO_2 and the excess of oxygen practically necessary in the lead-chambers; and the formation of SO_3 in the burners should be avoided as much as possible. The operation should be conducted so as to exceed as little as possible the amount of oxygen demanded by the equation $2\text{FeS}_2 + 11\text{O} = \text{Fe}_2\text{O}_3 + 4\text{SO}_2$, which corresponds to a theoretical maximum of 16 per cent. SO_2 by volume in the burner-gas. Practically, however, 11 per cent.

should not be exceeded, because otherwise the burners get too hot, which causes the sublimation of sulphur and the formation of scoria in the burners.

Harpf¹ gives some calculations referring to this special case, containing nothing of importance.

3. *Comparison of Brimstone and Pyrites as Material for the Manufacture of Sulphuric, etc.*

We have seen above that the burner-gas from brimstone is richer than that from pyrites in the proportion of 1 : 1.314; that is to say, under equal conditions, the gas generated in burning pyrites occupies 1.314 times as much space as if the same quantity of sulphur had been employed as brimstone. From this it directly follows that the gas will also require much more chamber-space; thus, for an equal production of sulphuric acid, the chambers must be about one-third larger if working with pyrites than if working with brimstone. Usually it is assumed that the consumption of nitre has to be increased in a similar ratio; this, however, is not the case, as a properly constructed Gay-Lussac tower retains almost the whole of the nitre-gas, and the excess volume of air is not of great importance.

Leaving the nitre out of consideration, the advantages of using brimstone are:—A somewhat higher yield of acid;² rather smaller cost of plant; and less trouble with the burners if anything goes wrong; and, above all, much greater purity of the sulphuric acid, especially from iron and arsenic (this is important only for sale acid, not for use in manure-works, alkali-works, etc.).³ If brimstone could be had at the same price as the sulphur in pyrites, nobody would hesitate for a moment to employ the former; and even a moderately higher price would not deter from this.

The manufacture of acid from brimstone in Europe, until recently, was confined to small factories producing a specially pure article. A number of manufacturers now find the use of

¹ *Wochenbl. für Papierfabr.*, Biberach, 1901, Nos. 23, 25, and 27.

² See Chapter V.

³ Steele (*J. Soc. Chem. Ind.*, 1910, p. 1142) found in a brimstone-burner a deposit of crystallised arsenic sulphate, which, however, will be quite an exceptional case.

brimstone more profitable than pyrites as the source of sulphur. But it should be noticed that sometimes acid is sold in England as "brimstone acid," which is in reality made from pyrites and purified from arsenic, or else acid made from spent oxide of gasworks, which is also practically free from arsenic.

It is frequently asserted that sulphuric-acid chambers worked with brimstone last very much longer than with pyrites. It is not impossible that there is *some* difference in this respect; but even this is not certain, and at all events the difference in the life of the chambers is nothing like so great as was formerly supposed, and forms no item in the comparison of costs.¹

4. *Composition of the Gas from Blende-furnaces.*

For burner-gas from *zinc-blende* the following calculation has been made by Hasenclever²:—Zinc-blende (in the pure state), ZnS, consists of 65 parts Zn + 32 parts S. For burning it into ZnO + SO₂, 3 × 16 = 48 parts O are required, for converting the SO₂ into SO₃ another 16 O; therefore for 97 ZnS, containing 32 S, altogether 64 O. This means that each kilogram S in zinc-blende requires 2 kg. O, or 1398·7 l. at 0° and 760 mm., together with 5258·0 l. nitrogen = 6656 l. air. In order to make allowance for the 6·4 vols. per cent. of oxygen required to be in excess in the exit-gas, we find this by the formula:

$$n = \frac{6.4}{100} \left(5258 + \frac{100}{21} n \right),$$

$$\begin{aligned} n &= 484.0 \text{ l. oxygen, corresponding to} \\ &\quad \underline{1820.7 \text{ ,, nitrogen}} \\ &\quad 2304.7 \text{ ,, air.} \end{aligned}$$

Consequently the normal gaseous mixture in roasting 1 kg. blende consists of:

699.4 l. SO ₂ ,	
349.7 ,, O for forming SO ₃ ,	
484.0 ,, O in excess,	
5288.0 ,, N entering with the theoretically necessary oxygen,	
1820.7 ,, N ,, ,, excess oxygen.	
<u>8641.8</u> ,, of gases.	

¹ Cf. Chapter I, Vol. II.

² *Chem. Ind.*, 1884, p. 79.

This means that 100 vols. of the gas should contain :

8.12 vols. SO_2 ,
 9.69 „ O,
 82.19 „ N.

So far, as we see from Hasenclever's calculation, theory would show that the strongest obtainable burner-gas from blende is not much inferior to that obtainable from pyrites (p 458). But apart from the fact that here, as well as in the case of pyrites and to some extent even of brimstone, the theoretical figures are undoubtedly interfered with by the formation of sulphuric anhydride, there is, at least in the case of all the older blende furnaces, a far more potent reason why the practical percentage of SO_2 in blende-gases should be far below the theoretical one. Seeing that in those older furnaces only half, or at most two-thirds, of the sulphur was liberated as SO_2 [and SO_3], that the other half or third remained behind in the state of ZnSO_4 , and that the nitrogen corresponding to the four atoms of oxygen contained in ZnSO_4 dilutes the burner-gas, it is easily understood why formerly it was considered *good* work if blende-gases contained 5, or at most 6, per cent. of SO_2 . The modern furnaces (p. 399 *et seq.*) undoubtedly yield better gases, not much inferior to the burner-gas from pyrites.

5. Sulphuric Anhydride in Burner-gas.

In the pyrites-burner, besides sulphur dioxide, there is always some sulphuric anhydride formed during the burning. This fact has long been known, and was explained in 1852 by Woehler and Mahla, and again in 1856 by Plattner.¹ Many substances, one of which (ferric oxide) is present in large quantity in the pyrites-burner, cause sulphur dioxide to combine with the oxygen of the air to form sulphuric anhydride by "catalytic action." Another plausible explanation is, that in the cooler parts of the pyrites-burners sulphates of iron are formed, which in the hotter parts again split up into Fe_2O_3 and SO_3 . This explanation, however, is not sufficient for Fortman's experiments,² according to which the

¹ *Die metallurgischen Röstprocesse.*

² *Dingl. polyt. J.*, 187, 155.

whole of the fumes of anhydride appear the moment the pyrites take fire. Scheurer-Kestner¹ explained the matter by the well-known fact that ferric oxide can act as an oxidising agent by successively giving up and absorbing oxygen. It is, however, established that even on burning pure sulphur a little sulphur trioxide is formed, as we shall see.

In Fortmann's experiments, made on a small scale, on burning pyrites far more SO_3 than SO_2 was formed, viz. in one experiment 4 times as much, in another as 5 : 3. His results were evidently altogether wrong, in consequence of a faulty analytical method. Scheurer-Kestner² only found 2 or 3 per cent. of all the SO_2 converted into SO_3 , but a larger deficiency of oxygen in the gas than corresponds to this amount; and the subsequent discussion between Bode³ and Scheurer-Kestner⁴ did not clear up the matter.

In order to decide the question of the formation of SO_3 on burning pyrites by more exact methods than those hitherto used, especially by Fortmann, Lunge made, together with Salathé, a series of experiments.⁵ It was found that SO_2 cannot, as Scheurer-Kestner had supposed, be absorbed and estimated by barium chloride, because even chemically pure SO_2 with BaCl_2 in the presence of O or atmospheric air at once gives a precipitate of BaSO_4 . Check tests proved that exact results were obtained by conducting the gas through an excess of standard iodine solution, retitrating the latter by sodium arsenite, and estimating the total sulphuric acid formed in another portion of the liquid by precipitation with BaCl_2 .⁶ By retitration the quantity of SO_2 absorbed was found, and by subtracting this from the total sulphuric acid that of the SO_2 was obtained. Two experiments with burning Spanish cuprous pyrites, containing 48.62 per cent. of sulphur, in a glass tube in a current of air gave :

¹ *Bull. Soc. Chim.*, 1875, 23, 437.

² *Loc. cit.*

³ *Dingl. polyt. J.*, 218, 325.

⁴ *Ibid.*, 219, 512.

⁵ *Ber.*, 10, 1824.

⁶ Eugen Richter (*Z. angew. Chem.*, 1913, p. 132) does not, however, consider the above method sufficiently accurate, and proposes, in lieu of this, cooling the gases in tubes to the ordinary temperature, whereby the SO_2 is condensed; it is then washed out of the tubes, and the sulphuric acid is estimated by precipitation with barium chloride.

	I.	II.
Sulphur obtained as SO ₂	. 88.02	88.78 per cent.
„ „ SO ₃	. 5.80	6.05 „
„ in the residue	. 3.43 }	
„ lost 2.75 }	5.17 „

Hawley¹ removes the SO₃ by filtering the gases through two glass funnels, placed so that their broad sides touch each other, a piece of damp filter-paper being put in between; here the SO₃ is retained, which is then washed out of the paper and titrated with decinormal soda solution and methyl-orange.

Of the sulphur of the burner-gas itself there was present :

	I.	II.
As SO ₂ 93.83	93.63 per cent.
„ SO ₃ 6.17	6.37 „

Two other experiments were made in this way: In a glass tube 50 grams of cinders from the same pyrites, in pieces about the size of a pea, were completely freed from sulphur by ignition, and fresh pyrites was burnt as before, the gas passing through the cinders. Found :

	III.	IV.
Sulphur as SO ₂ 79.25	76.90 per cent.
„ SO ₃ 16.02	16.84 „
Residue and loss 4.73	6.26 „

Of the sulphur of the burner-gas itself there was present :

	III.	IV.
As SO ₂ 83.18	82.00 per cent.
„ SO ₃ 16.82	18.00 „

On the large scale the formation of SO₃ will hardly be as considerable as in the last two experiments, because in the burners the gas passes through much less ignited ferric oxide than in their experiments.

Lunge by later experiments² found that in roasting pyrites by itself 5.05 per cent., but when passing the gases through a layer of red-hot pyrites-cinders 15.8 per cent., of the total sulphur reappeared as SO₃, which entirely confirms the above results. On burning *brimstone* it was found that even

¹ *Eng. and Min. J.*, 94, 987.

² *Chem. Zeit.*, 1883, p. 29.

then 2.48 to 2.80 per cent. of the sulphur was converted into SO_3 ; and this quantity was increased to 9.5 to 13.1 per cent. if the gases were passed through red-hot pyrites-cinders.

Hempel¹ found that, on burning brimstone in oxygen at the ordinary atmospheric pressure, about 2 per cent. of it was converted into SO_3 (which agrees with Lunge's results, as given above); but when effecting the combustion under a pressure of 40 or 50 atm., about 50 per cent. of the sulphur was converted into SO_3 .

Further experiments were made by Scheurer-Kestner² with the gases from pyrites-kilns as given off in actual manufacturing. We quote here a series of his results, obtained with samples of burner-gas taken at various times—A, from a lump-burner; B, from a Malétra dust-burner.

	Volume per cent. of SO_2 .	Sulphur converted into SO_3 per cent. of total S.	
A. <i>Lump-burner.</i>	7.3	2.8	Average 3.1
	7.5	5.8	
	6.5	1.2	
	6.6	1.0	
	8.3	0.0	
	9.9	2.8	
	6.2	8.4	
B. <i>Dust-burner.</i>	8.2	3.0	Average 3.5
	9.0	6.8	
	7.6	0.4	
	11.3	0.8	
	7.7	1.0	
	8.7	2.5	
	8.7	9.3	
	7.6	4.1	

The quantity of SO_3 formed is here found to be very irregular, varying from 0 to 9.3 per cent. of the SO_2 ; the average is decidedly less than in their laboratory experiments with pyrites.

F. Fischer³ obtained the following results, which at the same time give an idea of the difference in the composition of the gases on the various shelves of a Malétra dust-burner:—

¹ *Ber.*, 1890, p. 1455.

² *Bull. Soc. Chim.*, 43, 9; 44, 98.

³ *Dingl. polyt. J.*, 258, 28.

	SO ₂ per cent.	SO ₃ per cent.	O per cent.
A. <i>First test</i> (shelf-burner):			
Second shelf from below	0.96	0.44	18.4
Fourth " "	1.52	0.68	16.6
Sixth " "	3.81	0.97	12.5
Main flue	8.26	1.34	5.9
" "	7.53	1.27	7.5
B. <i>Second test</i> (shelf-burner):			
Sixth shelf from below	8.43	3.17	3.9
" "	4.92	0.68	10.7
Second shelf from below	2.48	1.42	14.8
Fourth " "	2.62	0.78	16.0
Main flue	5.80	0.65	10.6
C. <i>Lump-burner</i> up to	9.3	2.1	5.0

These tests were made by an expeditious method which cannot compete in respect of accuracy with that employed by Lunge or by Scheurer-Kestner. The much larger quantity of SO₃ in proportion to SO₂ is perhaps explicable in this way.¹

Blende-roasting gases, when tested by Lunge's method at the Rhenania works at Stolberg, yielded up to 25 per cent. of the total S as SO₃.

If the burner-gases are not passed hot into a Glover tower, but are cooled in the old way, most of the SO₃ condenses in the shape of sulphuric acid, more than enough water for this purpose being contained in the air and the pyrites. Where the gases go into a Glover tower, this, of course, retains all the SO₃ previously formed, also in the shape of H₂SO₄.² We shall further on consider this fact in detail when speaking of the Glover tower and the formation of sulphuric acid generally.

The constant presence of sulphuric anhydride in various proportions in the burner-gas is, of course, a source of inaccuracy in the testing process according to Reich (see below), which indicates only the sulphur dioxide, as we shall see later on; it causes, moreover, a deficiency of oxygen and an excess of nitrogen in the composition of the gases. Hitherto no satisfactory relation has been found between the amount of SO₂, SO₃, O, and N in the many analyses of burner-gases, as is apparent from the disputes between Scheurer-Kestner and Bode³, as well as from Fischer's tests just quoted.

¹ Harpf (*Dingl. polyt. J.*, 301, Part 2) has grossly misinterpreted Scheurer-Kestner's results, as shown by Lunge, *ibid.*, part 4.

² Scheurer-Kestner, *loc. cit.*

³ *Vide supra*, p. 464; cf. also *Berl. Ber.*, 7, 1665.

The above-mentioned results have led to the following attempt at increasing the formation of sulphur trioxide in the roasting process. Collett and Eckardt (Norw. P. 20273) increase the percentage of SO_3 in burner-gases by passing them, mixed with air in excess, over the hottest part of the burnt ore, whereby a great part of the SO_2 is converted into SO_3 . Pyrites and air enter the burner, not, as otherwise usual, in opposite directions, but in parallel currents, and the gas and the hot cinders are allowed to act upon each other for a sufficiently long time. The burner-gases in that case contain so much SO_3 that they can be employed directly for the manufacture of ammonium sulphate.

6. *Actual Percentage of Sulphur Dioxide in Burner-gas.*

A source of dilution of the burner-gas, not easily traceable quantitatively, is that the burnt ore contains not only pure Fe_2O_3 , but also sulphates of iron, which must always retain more oxygen than Fe_2O_3 , and the nitrogen corresponding to this excess of oxygen must be found in the burner-gas. On the other hand, a little nitrogen will have to be deducted if in the burnt ore FeS is present; but this amounts to very little indeed.

Moreover, in the factories working with nitrate of soda decomposed immediately behind the burners, the dilution of gas caused thereby must be accounted for. The calculated density of HNO_3 is 2.17823; we need only take this into account, as the HNO_3 forms the largest portion of the gas given off by the nitre mixture. It differs so little from that of SO_2 (viz. 2.2109) that, looking at the small quantities in question, we can take the two as equal without any sensible error. Now, in normal working order, and using a Gay-Lussac tower, certainly not above 5 per cent. of nitre on the burnt sulphur is consumed (corresponding to 3.7 per cent. of HNO_3), or 1.85 upon the SO_2 . Thus a gaseous mixture which, without the nitric acid, contains 8.59 per cent. of SO_2 , contains besides $\frac{1.85 \times 8.59}{100}$ nitric acid

vapour, which increases its volume to 100.16 and diminishes the percentage of SO_2 in the total volume to 8.576—a diminution too slight to be traceable by analysis. Also, if the nitric

acid is not calculated as such, but as NO_2 or N_2O_3 , it has no sensible influence upon the analyses, even if the sample of gas is taken in a place where the nitrous vapours coming from the Gay-Lussac tower have already entered into the process.

Still, all the above-mentioned causes unite in somewhat diminishing the percentage of SO_2 in the burner-gases: so that the percentages stated above:

11.23	per cent.	by volume	in burning	sulphur,
8.59	"	"	"	pyrites,

must be looked upon as the *maximum*, which in practice can only be approached, but hardly ever reached.

According to L. T. Wright,¹ the deficiency of oxygen noticed by Scheurer-Kestner, Bode, and Lunge, in their analyses of pyrites-burner gases, is all the greater the more strongly the gas is diluted; this, he considers, points to the fact that, apart from the well-known absorption of oxygen by the formation of sulphur trioxide and of metallic sulphates, there must be another cause for that deficiency, perhaps a constant error in the methods of analysis. In any case, even when the oxygen is completely consumed, the percentage of SO_2 in the burner-gases cannot exceed a maximum of 12 per cent., as his own practical trials have proved.

If the sulphur dioxide in the burner-gas be estimated, this will sufficiently test the style of burning, since the oxygen of the gas must necessarily be in inverse proportion to its sulphur dioxide—although not exactly, as the sulphuric anhydride comes into play. In practice, usually from 11 to 13 per cent. of oxygen is found in good burner-gas.

The innumerable observations made upon the percentage of burner-gas in chemical works have proved that with very good pyrites the above maximum figures can be very nearly approached, whilst with other ores, badly burning or containing unfavourable metallic sulphides, only 7 to $7\frac{1}{2}$ per cent. SO_2 in the burner-gas is attained.² Of course, looking at the difficulty of keeping the evolution of gas exactly uniform, the different observations made in the course of a day will

¹ *J. Soc. Chem. Ind.*, 1914, p. 111.

² *E.g.*, Büchner, *Dingl. polyt. J.*, 215, 557.

frequently yield less than the above figures¹; and they only signify the *average* percentage of the burner-gas. As a *minimum*, below which the gas of real pyrites ought never to fall, 6 per cent.—as ordinary *average*, 7 to 8 per cent. SO₂ by volume can be assumed. If less is found, the draught should be cut off; if more, more air should be admitted.

Crowder² quotes the following observations on the volume-percentage of burner-gas (details in the original; no account is taken of the SO₃ present):—

	from	SO ₂	to	O.
Lump-kilns	4.97	6.33	9.60	11.21
Old dust-kilns (shelf-burners) „	6.03	7.02	9.10	10.00
„ with another ore „	6.34	7.43	7.78	8.82
New dust-kilns	4.86	7.03	8.98	10.68

The *temperature* of the gas, where it enters the Glover tower, in the case of lump-burners is between the melting-points of zinc (419°) and antimony (630°). The gas from dust-burners, which has first to traverse a series of dust-chambers, is generally hot enough to melt lead (= 327°), but it is sometimes rather less.

All the above calculations refer only to pyrites proper—that is, such as contains merely a few per cent. of other metallic sulphides. If the latter have to be roasted by themselves (for instance, preparatory to their metallurgical utilisation), only poor gas can be obtained, partly because more sulphates remain in the residue, for which the corresponding nitrogen is found in the gas, partly because they must be roasted with a larger excess of air.

Bode states³ that at Oker poor ores with 27 per cent. sulphur, of which only 22 per cent. was combined with iron, the remainder being present as blende and barium sulphate, yielded gas with 5.5 per cent. SO₂. Lead-matte yields gas with 5 to 5.5 per cent.; coarse copper metal (with 34 per cent. Cu, 28 per cent. Fe, and 28 per cent. S), 5.5 per cent. SO₂.

According to Wunderlich,⁴ the gas at Oker contains 5 to 7

¹ E.g., Scheurer-Kestner, *Dingl. polyt. J.*, 219, 117, in one day found 6.5, 6.5, 6.0, 8.0, 9.0, 8.7; even greater differences occur in his tests quoted *supra*, p. 464.

² *J. Soc. Chem. Ind.*, 1891, p. 298.

³ *Gloverthurm*, p. 88.

⁴ *Z. f. d. chem. Grossgew.*, 1, 74.

per cent. SO_2 ; its temperature in the case of ores rich in sulphur reaches 360° , in the case of poorer ores about 230° .

Attention must be drawn to a circumstance frequently overlooked in analyses—that for technical purposes very rarely a reduction of the volumes of gases to 0° and 760 mm. is effected. This matters less in ordinary gas-analysis than in tests like that of Reich, where the gases are compared with a fixed quantity of SO_2 assumed to be at 0° and 760 mm. This causes most tests made by Reich's method to indicate less than the real percentage of SO_2 present.

Usually 4 per cent. SO_2 in the gases entering the chambers is considered the minimum at which it is possible to make sulphuric acid without actually losing money by the process. Locally, of course, this may be modified to some little extent. The average at those works where a great variety of poor ores, all arsenical, and "matte" is roasted, preparatory to the smelting process, is from 5 to 7 per cent. SO_2 in the burner-gas.

In the case where coal pyrites is the source of sulphur, and the ore has not been well "dressed," the average per cent. of SO_2 in the burner-gas rarely exceeds 5, otherwise a deficiency of oxygen frequently occurs.

7. The Quantitative Estimation of Sulphur Dioxide.

This is usually effected by Reich's process, which consists in aspirating the gas through a measured quantity of a solution of iodine, to which a little starch has been added. This is carried on till the blue colour of the solution disappears; the amount of gas aspirated in proportion to the constant quantity of iodine employed admits of calculating the percentage of SO_2 in the gas.

The reaction taking place is as follows:—

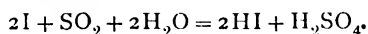

The operation is carried out with an apparatus consisting of a wash-bottle (similar to the one illustrated by Fig. 68), an aspirator of about 2000 c.c. capacity for drawing the burner-gas through the solution of standard iodine (which is placed in the absorption-bottle, along with a small

amount of starch solution and water) and a 250 c.c. graduated cylinder for measuring the amount of water run from the aspirator.

For taking the test for SO_2 in the gaseous mixture, connection is made with the burner pipe and wash-bottle, the latter being charged usually with 10 c.c. of the standard iodine, and the aspirator tap opened.

The amount of water run out is read off in the cylinder and the calculation made as described below.

Of course, precautions must be taken to remove the air from the connecting tubes leading to the wash-bottle, before commencing the measurement of the water run into the cylinder.

It is advisable to add a little sodium bicarbonate to the iodine in order to neutralise free HI formed, and this will facilitate absorption of SO_2 .

For further details we refer to Lunge's fourth edition, pp. 571 *et seq.*

If a second test is to be made, a fresh quantity of iodine solution can be added and the process recommenced. When this has been repeated a few times, the decolorised liquid, after a short time, again turns blue, because then its percentage of HI has become so large that it decomposes on standing and liberates iodine. This liquid must then be poured away, and replaced by fresh water and a little starch solution.

The calculation is as follows:—The n c.c. of iodine solution by its decolorisation shows 0.0032 gram SO_2 , which, at 0° and 760 mm., occupies a volume of $1.114 \times n$ c.c. If the barometer shows b mm., and the thermometer t° , and the difference of water-level in the aspirator is $=h$ mm. equal to $\frac{h}{13.6}$ mm. of mercury, the exact volume of $0.0032 \times n$ gram SO_2 is

$$1.114 \times n \times \frac{760}{b - \frac{h}{13.6}} \times (1 + 0.003665 t) \text{ c.c.}$$

As the water run out, and thus also the gas aspirated through A, amounts to m c.c., the volume of the aspirated gaseous mixture, before the absorption of the SO_2 contained therein, must have been

$$m + 1.114 \times n \times \frac{760}{b - \frac{760}{13.6}} \times (1 + 0.003665 \times t) \text{ c.c.,}$$

and the percentage of SO₂ in volumes of the gaseous mixture

$$\frac{100 \times 1.114 \times n \times \frac{760}{b - \frac{760}{13.6}} \times (1 + 0.003665 \times t)}{m + 1.114 \times n \times \frac{760}{b - \frac{760}{13.6}} \times (1 + 0.003665 \times t)}$$

In many cases a correction for the barometrical and thermometrical changes will not be required ; and the formula is then simply

$$\frac{111.4 \times n}{m + 1.114 \times n} \text{ per cent. SO}_2.$$

If the percentage of SO₂ in the gas is very small, and thus m very large in proportion to n , the formula may be simplified into

$$\frac{111.4 \times n}{m}.$$

If 10 c.c. of a decinormal iodine solution have been used, this quantity, according to the above-given formula, will correspond to 0.032 gram, or 11.14 c.c. SO₂, at 0° and 760 mm. ; and this number need only be multiplied by 100, and divided by the number of cubic centimetres of water collected in C, *plus* 11, in order to find the percentage of SO₂ in the gas. The barometrical and thermometrical corrections are in this case, of course, neglected. The subjoined table will save this calculation. On employing 10 c.c. of decinormal iodine solution, the following number of cubic centimetres collected in the graduated cylinder, C, show :—

Cubic centimetres.	Volume percentage of SO ₂ .
82	12.0
86	11.5
90	11.0
95	10.5
100	10.0
106	9.5
113	9.0
120	8.5

Cubic centimetres.	Volume percentage of SO ₂ .
128	8.0
138	7.5
148	7.0
160	6.5
175	6.0
192	5.5
212	5.0
237	4.5
268	4.0

Even if the gas to be examined is taken at a point where it is already mixed with nitre gas, this will not exercise any practically important influence upon the result. We have already seen that, in ordinary work, for each 100 parts of SO₂ only 1.85 NHO₃, or its equivalent as N₂O₃ or NO₂, exists in the gas. In such dilute aqueous solutions nitric acid hardly oxidises sulphurous acid at all; this, however, is done by nitrous and hyponitric acids. Even if we assume that only NO₂ is formed (which is going much too far), this could at most oxidise its equivalent in SO₂, according to the formula

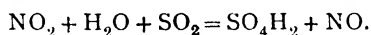

46 NO₂ thus oxidises 64 SO₃, or 1.35 NO₂ (the equivalent of 1.85 NO₃H) only 1.88 SO₂; in other words, in the worst case, never happening in practical work, of 100 parts SO₂, 1.88 parts would be oxidised by nitrogen acids instead of iodine. Even this maximum error would, say at 10 per cent., only amount to a deficiency of 0.188 per cent.; but this is certainly reckoning it much too high.

Raschig¹ points out an inaccuracy connected with this method in consequence of the presence of nitrous gases, and the uncertainty of recognising the end of the reaction, owing to the fact that the iodine solution, after being decolorised, again takes a blue colour through the action of nitrous acid. This fault is, however, avoided if sodium acetate is added, say for each 10 c.c. decinormal iodine solution about 10 c.c. of a cold saturated solution of sodium acetate, and the chamber gases are filtered through glass-wool before reaching the iodine solution; thus only acetic acid is present in the free state, which prevents any action of nitrous acid. This acid, in fact, or its equivalent of NO + NO₂, can be estimated, after perform-

¹ *Z. angew. Chem.*, 1909, p. 1182.

ing the Reich test, by adding a drop of phenolphthalein and titrating with decinormal NaOH solution till the red colour appears. From the volume of soda solution consumed must be deducted 10 c.c. for the HI formed from the 10 c.c. $\frac{1}{10}$ normal iodine, and 10 c.c. for the H_2SO_4 formed by the reaction : $SO_2 + 2I + 2H_2O = 2HI + H_2SO_4$; the decinormal soda solution used beyond those 20 c.c. indicates nitric and nitrous acid. [This estimation is not quite correct, because the CO_2 of air (and of that contained as impurity in the NaOH solution) also acts on phenolphthalein, and no boiling out can be allowed here, because then the nitrous acid would be driven out as well.]

The analysis of burner-gas is described by F. M. Williams,¹ who states that better results are obtained by the direct analysis of a measured volume of the gas than by aspirating a current of the gas through a series of absorption vessels containing iodine solution. Apparatus of the Orsat type is most convenient for the purpose, and a slightly modified form, in which the fragile U-tube or goose-neck reagent vessels are replaced by straight pipettes inverted in cylindrical containers, is described. The author employs an apparatus with three vessels, which can be used either for sulphur burner-gases or for flue-gases. In the case of sulphur burner-gases the sulphur dioxide is absorbed by caustic potash solution, and the result may be verified by a determination of the oxygen in the residue. With this method of operation it is easy to confirm the fact that the absorption of the sulphur dioxide is complete, thus avoiding a source of uncertainty which always attends the use of the aspiration method.

Ljungh² describes a useful modification of the Reich apparatus, by means of which any requisite corrections of pressure can be effected in a simple manner. This apparatus is shown in Fig. 67. The running-off tube *b* of bottle B is turned in an angle, and is connected by an indiarubber tube with the tap *i* fixed at the bottom end of the perpendicular metal rod *s*. The top end of *s* is turned in a right angle, the point of which serves for adjusting the rod to the changing level of water in B, by means of the clamp-screw *k*. A test

¹ *Tech. Assoc. Pulp and Paper Ind.*, 1918, pp. 26-27 ; *J. Soc. Chem. Ind.*, 1919, p. 572A.

² *Chem. Zeit.*, 1909, 33, 143.

for SO_2 is made as follows:—By opening tap *h* on bottle A, the tube is filled with fresh gas, and at the same time a measured quantity of iodine solution is put into A. After closing A, tap *i* is opened and the point of rod *s* is adjusted to the level of water in B. Now, by turning tap *h*, the gas is passed through *a* into the iodine solution contained in A. The non-absorbed portion of the gas passes into the bottle B; the water displaced by it is caught in the cylinder below *i*. At the moment when the iodine solution in A is decolorised, *h* is shut, and the running out of the water from B soon ceases. Now point *s* is again adjusted to the water-level in B, whereby a little more water runs out, and the total volume of the

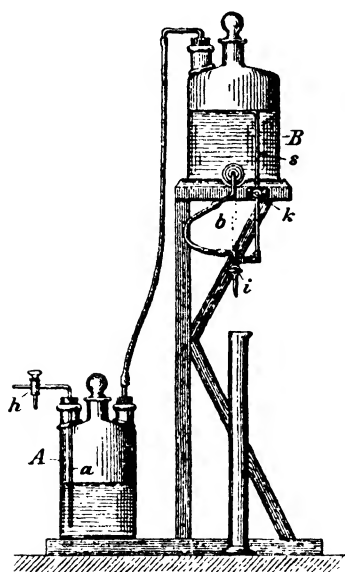

FIG. 67.

displaced water is measured in the cylinder below.

Another improvement of Reich's apparatus has been made by Rabe.

8. Lunge's Test for Total Acids.

Considering the inaccuracy inherent in Reich's test, owing to the constant presence of sulphuric anhydride in the burner-gas,¹ the question arises whether it would not be better to substitute for it a test showing the *total acidity* of the burner-gases. There is no difficulty in doing this, either by the method indicated for testing the exit-gases, or in a more expeditious way by employing the apparatus shown in Fig. 68. Lunge has shown this method to be quite practicable and accurate, and it is carried out at many works for the regular control of the process. A decinormal solution of caustic soda is employed, of which 10 c.c. are tinged red with phenolphthalein and diluted to about 100 or 200 c.c. The gas is

¹ Cf. *supra*, p. 467 et seq.

aspirated through it slowly, exactly as in Reich's test, with continuous shaking. Especially towards the end the shaking must be continued for a while (say half a minute), each time aspirating a few cubic centimetres of gas through the liquid, till the colour has been completely discharged, which is best ascertained by putting a white piece of paper or the like underneath the bottle. The calculation is made exactly as with the iodine test, counting all the acids as SO_2 . A large number of practical tests made in this manner have shown that the percentage of total acids calculated as SO_2 is always larger than the figures found by the iodine test, owing to the presence of SO_3 , and that the results of the former test agree with those of gravimetric estimations.

The absorption-bottle used by Lunge differs from Reich's in having an inlet-tube for the gas, closed at the bottom, and perforated by many pin-holes, through which the gas rises in many minute bubbles, instead of one large bubble, as shown.

The otherwise excellent absorbing-bottle described in No. 34 of the *Alkali Inspector's Reports*, p. 22, is not available in this case, as it contains indiarubber rings, which act upon iodine, but it gives good results in the Lunge test for total acids, and in other very difficult cases, such as the absorption of acid fog. The flask is fitted with a rubber stopper provided with inlet- and exit-tubes. The former is 8 mm. wide, closed at the bottom, and pierced with a number of small holes, through which the gas passes to a double bulb, attached to the tube by means of a rubber stopper. The upper bulb is filled with small cuttings of rubber tubing, kept in motion by the stream of gas, which is thus brought into very intimate contact with the absorbing solution; the lower bulb is open at the bottom. The success of the operation depends largely on the correct dimensions being adhered to. The lower opening of the

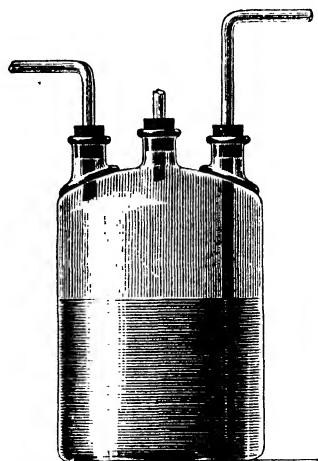

FIG. 68.

double bulb is 6 mm., the lower bulb 15 mm., and the upper bulb 18 mm. in diameter respectively; the upper opening, through which the inlet-tube passes, is 13 mm. wide. The gas passes from the bulb into the flask through several small holes, and finally leaves it through the exit-tube, which is narrowed below, and widened above, to form a cylindrical chamber; the lower, narrow portion is filled with rubber rings, and the upper, wider portion with glass-wool. When used for the absorption of acid vapours, the exit-tube is moistened with water coloured with methyl-orange, which serves to indicate whether complete absorption is being effected in the bottle.

Lunge¹ has also proposed to determine the acidity of burner-gases by measuring their specific gravity, a method which might be used for giving a continuous graphic record of the operation of the burners. Differences of 1 per cent. of SO₂ by volume affect the value of the specific gravity in the second decimal place; differences of 0.1 per cent. do this in the third decimal place. Such measurements might be made, *e.g.*, by a modification of the Lux gas-balance, which, as at present constructed, is not suitable for use with acid gases.

Nestell and Anderson² absorb the acids in flue-gases by sodium carbonate solution, and retitrate this, using methyl-orange as indicator. The residual Na₂SO₃ is oxidised by hydrogen peroxide.

A. Sander³ gives a method of estimating SO₂:—10 c.c. of N/10 sodium hydroxide is introduced, together with some methyl-orange as indicator, into an absorption-flask, provided with a bottom run-off tap. By means of an aspirator, the burner-gases are slowly drawn in until neutralisation takes place, and from the known volume of the gases the total sulphur (dioxide and trioxide) is calculated. The solution is then drawn off, treated with a saturated solution of mercuric chloride, and titrated with N/10 sodium hydroxide, the result enabling the amount of sulphur dioxide to be determined; sulphur trioxide is calculated by difference.

B. C. Stuer and W. Grob⁴ discuss the above method, and

¹ *Z. angew. Chem.*, 1890, p. 567.

² *J. Ind. Eng. Chem.*, 1916, p. 258.

³ *Chem. Zeit.*, 1921, 45, 261-263; *J. Soc. Chem. Ind.*, 1921, p. 256A.

⁴ *Chem. Zeit.*, 1921, 45, 553-554; *J. Soc. Chem. Ind.*, 1921, p. 506A.

dispute Sander's contention that mercury has a strong catalytic action on mixtures of air and sulphur dioxide; the high percentage of sulphur trioxide found by him in burner-gases is more probably due to oxidation when sulphur dioxide is absorbed by sodium hydroxide. In a reply, Sander contends that if the sulphur dioxide is introduced into the alkali in a fine stream, and agitation is avoided, appreciable oxidation of the sodium bisulphite will not take place. He further maintains that his results for sulphur dioxide are given in close agreement with those obtained by Reich's method, and that therefore the sulphur trioxide value, which is derived from the difference between total acidity and sulphur dioxide figures, must also be correct.

Later, Stuer and Grob¹ continue the discussion, stating that if oxidation of sulphur dioxide during absorption in alkali is caused by agitation in presence of air, as contended by Sander, it will not be prevented by excluding contact with air, as burner-gases contain oxygen. In reply (*ibid.* p. 771), Sander gives a series of comparative analyses by his method and the Reich-Lunge method, the former giving a lower sulphur trioxide content in all cases.

E. Berl² states that the absorption of sulphur dioxide in the presence of oxygen, by means of caustic soda, yields low results, especially if the liquid is shaken vigorously or contains positive catalysts, such as copper sulphate. Good results are obtained, on the other hand, by addition of small quantities of negative catalysts, especially stannous chloride. It is recommended to add to each assay 10 c.c. of a $\frac{1}{1000}$ solution of stannous chloride (0.23 gram $\text{SnCl}_2 \cdot 2\text{H}_2\text{O}$ per l.) before absorption. The gases are passed through the liquid, which is then acidified and titrated with iodine in the usual way. It is unnecessary to make allowance for the stannous chloride added.

9. Estimation of Oxygen in Burner and Chamber Gases.

Although burner-gas is not generally tested for oxygen, this test being reserved for the exit-gases, we will here describe

¹ *Chem. Zeit.*, 1921, 45, 770; *J. Soc. Chem. Ind.*, 1921, p. 656A.

² *Chem. Zeit.*, 1921, 45, 693; *J. Soc. Chem. Ind.*, 1921, p. 580A.

the methods employed for estimating oxygen in any of the gases occurring in the manufacture of sulphuric acid.

Oxygen is, for technical purposes, always estimated by means of an absorbent, observing the contraction of volume produced. Cuprous chloride in ammoniacal solution, or copper gauze in ammonium chloride solution with ammonia present, may be employed, but have little advantage over pyrogallol or phosphorus.

Of these, *pyrogallol* must also be in an alkaline solution, and it acts very promptly. Its use for this purpose was proposed by Chevreul as early as 1820, but it became general only through Liebig many years after. It is true that this reagent in the presence of pure oxygen forms some carbon monoxide;¹ but this never happens with gaseous mixtures containing no more oxygen than atmospheric air.² It is therefore reliable and very much employed. Unfortunately, the solution (25 grams potassium hydrate and 10 grams pyrogallol to 400 c.c. water) gradually thickens and becomes useless long before this somewhat expensive reagent has been used up. The absorption of oxygen by pyrogallol can be carried out by a Winkler gas-burette, or by an Orsat apparatus, etc. Very convenient for this purpose is the apparatus constructed by M. Liebig,³ which allows of making an estimation in three minutes. This apparatus may also be used with other absorbing agents for other gases, *e.g.*, with caustic-potash solution for carbon dioxide. It works more quickly than Winkler's gas-burette, but does not, like this, allow of making a full analysis of gases with the same sample. For this purpose Liebig has constructed another apparatus, about which we must refer to his paper.⁴

It has been proposed to purify the gas from any sulphur dioxide and nitrogen oxides present, which would be also absorbed by the alkaline pyrogallol solution, by prolonged contact with a solution of potassium dichromate, over mercury, or at least by washing with water. But the error caused by the acid gases is very slight when testing the gases going out of the chamber for oxygen.

¹ Crace Calvert, *Proc. Manch. Lit. and Phil. Soc.*, 1863, p. 184.

² Poleck, *Z. anal. Chem.*, 1869, p. 451.

³ *Dingl. polyt. J.*, 207, 37.

⁴ *Loc. cit.*, p. 44.

Phosphorus is one of the oldest absorbents for oxygen, and it has again come into use, since the manner of employing it has been properly studied, and as it is now found in trade in very thin sticks, offering a great surface. Of course, it must be kept under water, and must be exposed only to the gas to be analysed. It acts only at a temperature of at least 16° , better a little above; this is the first condition to be observed in its use, but it is easy to attain if the apparatus is kept in a somewhat warm place (near an acid chamber). The action of phosphorus on oxygen is interfered with by traces of tarry matters and the like; but such do not occur in chamber-gas. As it is, the gases, both for the pyrogallol and the phosphorus test, are often previously washed and freed from acids by passing them through a solution of caustic potash; but there is generally no great error caused by omitting this treatment. The action of the oxygen on the phosphorus is at once indicated by the formation of a white cloud, and it is necessary to

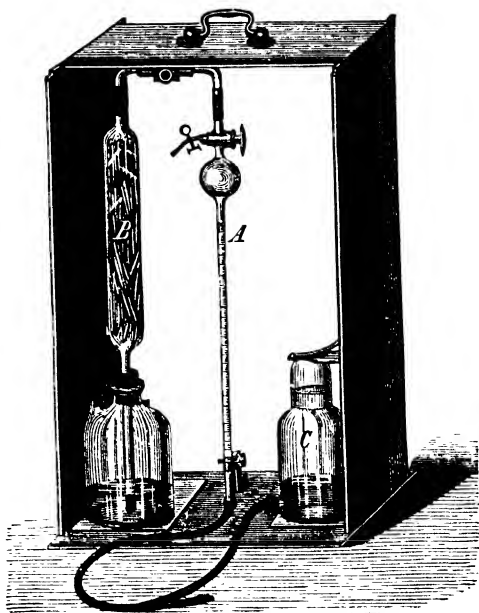

FIG. 69.

wait a few minutes till that cloud has completely disappeared, when the absorption of oxygen will be complete. Once charged, such an apparatus may serve for hundreds of tests, but it should be kept protected from daylight.

Of course, Hempel's, Bunte's, or any other apparatus for general technical gas-analysis may be employed as well.

Lindemann's apparatus, which is specially intended for the estimation of oxygen by *phosphorus*, is shown in Fig. 69. The measuring-tube A has a three-way cock at the top, but

no tap at the bottom. It contains 100 c.c., 75 c.c. of this in the globular and 25 c.c. in the cylindrical part, which is divided into tenths of a cubic centimetre. The level-bottle C contains water, the absorbing-vessel B thin sticks of phosphorus and water up to the mark. The manipulation is exactly as with Orsat's apparatus.

Instead of taking only single samples of the escaping gas, it is advisable, apart from these, to collect an average sample (say, for twenty-four hours) by aspirating a certain quantity (say, about 50 l.) by means of a large aspirator with the outlet-cock very slightly opened. Owing to the slowness of the aspiration, the gas standing over the water in the aspirator will be thoroughly mixed up, and by taking a sample from the aspirator the *average* percentage of oxygen can be estimated with some degree of accuracy. We shall treat this matter more in detail in Chapter III, Vol. II, when describing the testing of the exit-gases.

10. *Estimation of the Oxides and Acids of Nitrogen.*

Burner-gas will contain the above acids if the "potting" has been done either within or close to the burners, as is usual in England. The acids and oxides of nitrogen are, however, but exceptionally estimated in burner-gas, and not very often even in chamber-gas; the latter is not indispensable, because the colour of the chamber-gas on the one hand, and the testing of the "drips" on the other, which we shall describe in Chapter I, Vol. II, are sufficient for guiding the manufacturer in his work.

In well-conducted works, however, the chamber-exits are tested not merely for total acidity, but also for nitrogen acids separately. For this purpose the prescriptions formulated by the British Alkali-Makers' Association may be observed, which we shall give in detail later on (Chapter III, Vol. II). These do not extend to nitric oxide, but we shall see that it is easy to estimate this at the same time. In this place we shall give a short outline of the methods employed by Lunge and Naef for their extended experimental investigation of the vitriol-chamber process¹ for *estimating nitrogen oxides and sulphur dioxide at the same time*. The pipe bringing the gas from

¹ *Chem. Ind.*, 1884, p. 5.

the chambers is continued into a Y-pipe, both branches of which are connected with sets of absorbing-tubes. One branch is connected with three U-tubes containing concentrated pure sulphuric acid (for retaining N_2O_3 and N_2O_4) and a fourth tube containing an acidulated solution of potassium permanganate (for retaining NO). The other branch of the Y-pipe first leads into a long glass tube filled with cotton-wool or glass-wool, where any drops of mechanically carried-over sulphuric acid are retained, and then into two U-tubes containing pure caustic-soda solution (for estimating SO_2). At the end of both sets of tubes there is an aspirator, consisting of a large glass bottle, holding about 20 l., divided into single litres, with a tap or tap-siphon leading into a similar bottle, so that the quantity of water run out indicates the quantity of gas passed through each set of tubes. The gas remaining in the aspirators is tested for *oxygen* by absorption; for *nitrogen* by difference. *Sulphur dioxide* is found by oxidising the caustic-soda solution with bromine water, and precipitating the sulphuric acid formed by barium chloride. In the sulphuric acid *nitrogen trioxide* and *tetroxide* are estimated in the way indicated in Chapter III (p. 291 *et seq.*), by testing both with permanganate and with the nitrometer. The tube filled with potassium permanganate will retain the *nitric oxide* which is found by adding titrated ferrous sulphate solution and retitrating with permanganate. Where the quantity of SO_2 in the gas is considerable, this method cannot be employed; in this case it is not possible to separate the N_2O_3 and N_2O_4 , and the method otherwise used for the chamber-exits must be employed (Chapter III, Vol. II).

Nitrogen protoxide, N_2O , may occur in chamber-gases in very slight quantities. The former methods of its detection and estimation were very inadequate, and failed entirely in the presence of other nitrogen oxides. It may be possible to apply the method proposed by Knorre,¹ viz. burning with excess of hydrogen in a Drehschmidt's platinum capillary,² or else Pollak's method³ of burning in a bright red-hot Drehschmidt's

¹ *Berl. Ber.*, 33, 2136.

² Cf. Winkler-Lunge's *Technical Gas-Analysis*, 2nd edition, p. 162.

³ Described in his inaugural dissertation, Prag, 1902, p. 52, and in Treadwell's *Lehrbuch der anal. Chem.* [2], 2, 538.

capillary with pure carbon monoxide, measuring the contraction and estimating the CO_2 formed. The contraction in burning for NO is $\frac{\text{NO}}{2}$; for N_2O there is no contraction at all; the volume of the absorbed CO_2 is equal to $\text{NO} + \text{N}_2\text{O}$. Hence the volume of N_2O is obtained by deducting twice the volume of the first contraction from the volume of CO_2 found. This is made clear by the following equations:—

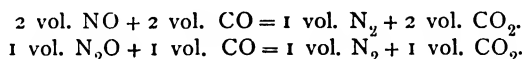

Hempel¹ estimates very slight quantities of nitrogen protoxide, such as may be suspected in chamber-gases, by cooling the gases by means of liquid air, which causes the N_2O to condense to a liquid, adding to it electrolytic fulminating-gas ($\text{H}_2 + \text{O}$) and exploding in an explosion-pipette. The increase of the volume of the gas thus produced corresponds to half the N_2O originally present. He thus found in the exit-gases from the Freiberg factory, 0.063 to 0.073 per cent.; from the Aussig factory, 0.11 to 0.14 per cent.; in a very bad chamber-gas, 0.25 per cent. N_2O .

K. COMPOSITION OF FLUE-DUST AND CHAMBER-DEPOSITS

In the gas-flues and draught-pipes flue-dust is always deposited, much more when smalls are burnt than with lump ore, especially in furnaces where the small ore is used. In such cases special dust-chambers are indispensable, as has been remarked in the description of those furnaces. Even when burning ore in large lumps the flues and pipes must be cleaned out from time to time, as they would otherwise be stopped up entirely. At some factories this is done monthly, at others more rarely. If the deposit is allowed to remain too long, it hardens into a stone-like mass, which cannot be got out without stopping the process.

The composition of this deposit varies, of course, very much; and even its external aspect varies from that of a dry, light dust to that of a thick, strongly acid mud. It generally

¹ *Z. f. Elektrochem.*, 1906, p. 600 *et seq.*

contains a large proportion of *arsenic*. Clapham analysed such a deposit, from a source not mentioned,¹ and found:

Sand, etc.	2.333
Lead oxide	1.683
Ferric oxide	3.700
Cupric oxide	trace
Zinc oxide	trace
Arsenious acid	58.777
Sulphuric acid	25.266
Nitric acid	trace
Water	8.000
		<hr/>
		99.759

D. Playfair² examined flue-dust from pyrites-kilns, in which he found chiefly arsenic, antimony, lead, copper, and iron; of thallium 0.002 to 0.05, of tellurium and selenium 0.001 per cent. was present. He describes in detail the analytical methods employed.

Reich³ found in the Mulden Works a crystallised deposit consisting of equal molecules of arsenious and sulphuric anhydride. Similar deposits have been frequently observed since.

In other cases the deposit is dry dust, consisting mostly of mechanically conveyed pyrites-dust, better burnt than that within the burner itself,⁴ and nearly always containing so much arsenic that its crystals can be seen with the naked eye.

H. A. Smith⁵ found in the dust 46.36 per cent. of As_2O_3 , together with a large quantity of sulphur in the pasty condition—the latter, of course, formed by sublimation from pyrites.

The flue-dust is also a principal source of *thallium*, and when *selenium* occurs in the pyrites it is found in the flue-dust.

Bismuth, to the extent of 3.5 to 4.0 per cent., has been found in the flue-dust from Rio Tinto ore by E. Gibbon,⁶ who proposes to recover it by extracting the dust with hydrochloric acid sp. gr. 1.07, allowing the solution to clear, precipitating the bismuth as oxychloride, $BiOCl$, by dilution with water,

¹ Richardson and Watts, *Chem. Techn.*, 1 (3), p. 70.

² *Chem. News*, 39, 245.

³ *Erdmann's Journal*, 90, 176.

⁴ Bode, *Beiträge*, p. 41.

⁵ *Chemistry of Sulphuric-Acid-making*.

⁶ *Chem. Trade J.*, 1905, 36, 88.

heating and agitating, and at last filter-pressing and washing the precipitate.

A. Hoffmann¹ states that the flue-dust from blende-roasting furnaces is not merely the principal source of the impurities in the chamber-acid, but also causes trouble in the working of the chambers through the stopping up of towers and pipe-conduits. The quantity of dust depends upon the kind of burners, and upon the fineness of grain of the blende. An average sample of the flue-dust showed: 6.54 per cent. ZnO; 24.29 ZnSO₄; 6.75 Fe₂O₃; 6.80 FeSO₄; 5.37 Fe₂(SO₄)₃; 11.61 PbSO₄; 12.84 CaSO₄; 7.18 MgSO₄; 0.25 As₂O₃; 8.16 SiO₂; 0.40 Ti₂O. The proportion of sulphates to the oxides, especially of iron and zinc, seems to be greatly dependent upon the temperature reigning in the dust-chamber, and the composition of the gases. The flue-dust not retained in the dust-chambers gets into the Glover towers; here the oxides are completely converted into sulphates, and these are partly deposited on the packing of the tower in constantly increasing crusts, but mostly carried away by the Glover acid, and deposited in the acid reservoirs, coolers, and spreading apparatus, whence they must be removed from time to time. With the Glover acid the sulphates get into the Gay-Lussac tower, and here also gradually obstruct the packing. Crusts of sulphate are also deposited in the lead tubes for pumping the acid. A small portion of the flue-dust gets into the vitriol chambers, where it is precipitated together with the acid fog, and saturates the chamber-acid with sulphates; the insoluble lead sulphate accumulates in the chambers as mud. A muddy sulphate formed in an iron acid reservoir had the composition

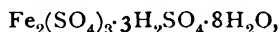

whilst crystalline crusts had the composition

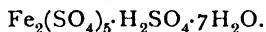

The lead sulphate is less inclined to form acid sulphate; that contained in the chamber mud is normal sulphate. Aluminium sulphate mostly occurs only in traces, if the packing of the towers consists of good material.

The ZnSO₄ remains mostly dissolved in the hot Glover-

¹ *Metall und Erz*, 1915, 12, 290 and 310; *J. Soc. Chem. Ind.*, 1916, p. 358.

tower acid, but crystallises on cooling in the Gay-Lussac tower.

Recovery of Thallium and Selenium.

In the flue-dust and the chamber-deposit of many descriptions of pyrites the rare metals *selenium* and *thallium* have been found. The former has hitherto had no industrial application, apart from the employment of crystalline selenium in photometry, as its electrical conductivity changes in proportion to the intensity of the light that falls upon it.

Thallium, however, is manufactured on a comparatively large scale at Aussig and Mannheim; and it might possibly be found useful for optical glass, replacing the alkali: owing to its very high atomic weight (204) it gives, together with red-lead and quartz, the specifically heaviest and consequently the most refractive glass hitherto known (Lamy).

The preparation of thallium from the flue-dust of Westphalian pyrites has been described by Schaffner,¹ and in Lunge's fourth edition, p. 1465.

Selenium was discovered (in 1817) by Berzelius in the chamber-deposit of the sulphuric-acid works at Gripsholm, at which Fahlun sulphur (obtained in roasting ores) was used. It also occurs in volcanic sulphur, e.g. 0.264 per cent. in the solfataras of Naples, according to Phipson²—principally, however, in many descriptions of pyrites; so that the chamber-deposit of the Mansfeld and Oker works is the best source of it. Selenium occurs in several allotropic modifications, in regard to which we must refer our readers to the chemical treatises. Its specific gravity is given as 4.8, melting-point 217°, boiling-point about 690°. Selenium always occurs in very small quantities; but its characteristic reactions cause it to be easily discovered, and it becomes very much concentrated in the deposit of flue-dust.

The deposit contains free selenium, as the selenious acid formed by burning is reduced by sulphurous acid. Otto³ digests the deposit, previously washed with water, with aqua regia to oxidise the selenium, adds sulphuric acid, evaporates to dryness, driving off the other acids, treats the residue with

¹ *Wagner's Jahresber.*, 1871, p. 1.

² *Chem. News*, 5, 337.

³ *Lehrbuch d. Chem.* [4], 1, 633.

water, and from the solution, by cautious addition of ammonium sulphite, first precipitates white mercurial chloro-seleniate, then from the filtrate, by more ammonium sulphite and sulphuric acid, the selenium itself. From the mercurial precipitate the selenium can be obtained by oxidising with nitric acid, evaporating, neutralising with sodium carbonate, fluxing with potassium nitrate, boiling with hydrochloric acid in order to reduce SeO_3 to SeO_2 , and precipitating the selenium from the solution by SO_2 .

Böttger¹ extracts the selenium from the chamber-deposit washed with water by means of a concentrated solution of neutral sodium sulphite, and filters it into dilute hydrochloric acid, which at once precipitates the selenium.

Nilson² describes the working-up of the Fahlun chamber-deposit for selenium. This cannot well be done by Otto's process: it is better to employ potassium cyanide, 2 parts of which yield 1 part of selenium. The washed deposit only needs to be digested with a concentrated solution of potassium cyanide at 80° to 100° C. till its red colour has just been turned into pure grey; the residue is washed with boiling water, filtered, and hydrochloric acid added to the solution; selenium at once precipitates in cherry-red flakes, as the liberated selenocyanic acid is almost instantaneously decomposed into selenium and hydrocyanic acid; the sulphur dissolved at the same time remains in solution as sulphocyanic acid. The selenium thus obtained contains only a little copper, iron, and perhaps traces of mercury; it is obtained quite pure by dissolving in nitric acid, evaporating to dryness in a water-bath, subliming the anhydride in a current of dry air, and treating its solution with sulphurous and hydrochloric acids.

Kienlen³ showed that the selenium, being reduced by SO_2 in the Glover tower, is dissolved in the sulphuric acid, to which it sometimes imparts a blood-red colour. When diluting the acid with three times its bulk of water, the selenium is precipitated. Glover acid contains up to 17.3 mg., chamber-acid 22.3 mg. per kilogram. If such sulphuric acid is employed for the manufacture of hydrochloric acid, the selenium is

¹ *Dingl. polyt. J.*, 176, 405.

³ *Bull. Soc. Chem.* [2], 24, 404.

² *Ber.*, 7, 1719.

volatilised together with HCl and is deposited in the first receivers as a reddish mud containing 41 to 45 per cent. Se, whilst the hydrochloric acid holds up to 21·4 mg. Se per kilogram. The selenium is extracted from the mud by chlorine, which forms selenious and selenic acid. When the red colour has been destroyed the mass is filtered, the filtrate is boiled with hydrochloric acid, and the selenium precipitated by sodium sulphite.

Bornträger¹ found in the red mud from Glover-tower acid (made from Rio Tinto pyrites), after washing and drying, 12·60 per cent. Se (with 76·30 PbSO₄, etc.). He obtains the selenium from it by heating it in fireclay retorts at a red heat, with exclusion of air, as a black metallic sublimate, which is freed from As₂O₃ and SeO₂ by washing with strong caustic soda.

Divers and Shimosé² found in sulphuric acid made from Japanese brimstone 0·37 gram tellurium and 0·15 gram selenium per litre, and in the sediment from the same acid 10·5 per cent. selenium and 1·2 per cent. tellurium. Shimosé³ further describes the process employed by him for separating selenium and tellurium, viz. neutralising the sediment with sodium carbonate, removing the selenium by digesting with concentrated solution of potassium cyanide at a gentle heat (at first cold), diluting the mixture with water, and heating 'nearly to boiling. The solution, containing the selenium, is treated with hydrochloric acid in order to separate the Se; on the other hand, the sediment from which the cyanide solution has been decanted yields tellurium by a treatment with sulphuric acid and a little nitric acid, and passing H₂S through the solution obtained.

Koch (Ger. P. 167457) recovers selenium from the deposits of the lead-chambers by treating it with sulphuric acid of moderate concentration (50° Bé.) and potassium permanganate at 50° to 60°, adding NaCl, diluting the liquid, filtering and precipitating the selenium from the filtrate by reducing-agents.

Threlfall⁴ purifies selenium by dissolving in nitric acid, boiling off the excess of the latter, subliming the SeO₂, dissolving it in water and filtering, precipitating free Se by

¹ *Dingl. polyt. J.*, 247, 505.

² *Chem. News*, No. 1256.

³ *Ibid.*, No. 1260.

⁴ *Roy. Soc. Proc.*, 79, A, 167.

reduction with HCl and SO_2 , washing with water, again converting into SeO_2 , and subliming this in a current of air in order to remove any traces of tellurium. Selenium after this treatment shows absolutely no Hg, only 0.00038 per cent. As, and less than 0.01 per cent. SeO_2 .

CHAPTER V

BY-PRODUCTS IN THE MANUFACTURE OF SULPHURIC ACID

THE extraction of the metals contained in the cuprous cinders is of importance, and we shall now deal with this subject in detail.

From non-cuprous pyrites cinders, recovery of metals other than iron is rarely attempted. Non-cuprous cinders containing usually over 2 per cent. of sulphur are not suitable for the manufacture of iron unless mixed with a larger proportion of better class of ore, such as the "purple ore" obtained from the cuprous cinders after wet extraction of the copper, or after briquetting or sintering, as described lower.

Attempts to employ the cinders of "smalls" pyrites fail unless they are conglomerated, as otherwise the fine particles are blown out of the blast furnace.

I. Disposal of the Cinders.

a. Briquetting.

Various patents have been taken out during the past thirty years, in which it is suggested to admix clay, tar, peat, or limestone, but in England such admixtures are rarely, if ever, used.¹

The possibility of making briquettes without a binder was shown by Henry Bird (B. P. 10420 of 1891). When ground in a Chilian mill the mass became as plastic as clay. It was then filled into moulds and dried, and the briquettes burned without disintegrating. On this line the first briquetting furnace was built at Doncaster, England.

¹ See Lunge's fourth edition, p. 1457 *et seq.*

The cause of this plasticity when grinding might be that part of the iron oxide was in a colloidal state, and constantly retained water. Bird found that about 17 per cent. moisture in the purple ore was necessary for briquetting (see *infra*). The discovery that roasted ore can be briquetted without any other binder than water is therefore due to Bird. Gröndal and Dellvik found in 1896 that moistened ore dust from a stamp-mill could be pressed into briquettes, which after burning became very solid, showing that iron-ore acted in the same way as purple ore.

Ramén¹ states that the fundamental point of great importance which is often overlooked is the deleterious effect of the binder used in making the briquettes. The iron content of the ore being lowered, the cost of production per ton of metal is increased, whether the binder is of acid or neutral character. Attention has to be paid not only to the cost of the slagging of these binders, which is a matter of considerable importance, but also to the fact that the quantity of iron produced per unit weight of briquettes is reduced in a corresponding degree. In contrast with this, the cost of producing pig-iron from a briquette made without a binder entails a saving of coal, and gives a greater output, and the commercial aspects of the smelting operations are improved correspondingly.

In Swedish furnaces using charcoal it has been proved that by smelting briquettes, which are easily reduced, an increased output and a considerable saving in fuel have resulted. With regard to blast-furnaces using coke, an experiment has recently been made at a German plant. In this experiment 2000 tons of purple-ore briquettes from Helsingborg's copper plant were smelted with coke in a blast-furnace, and the experience gained by the Swedish furnaces was fully verified. This test showed a considerable reduction in the coke consumption as well as an increase in the output of pig-iron, also an increase of 25 to 30 per cent. in the capacity of the furnace. The saving in coke amounted to 8 per cent., and would be still higher in the case of a more regular operation during a longer period. When figuring the saving which accrues from smelting briquettes of good quality, as against smelting unbriquetted ore,

¹ Lecture given at the meeting of the Verein Deutscher Eisenhütteleute, 1st December 1912.

one has, of course, to consider the higher price of the briquettes. As the blast-furnace man, in most cases, is able to make his own comparative calculation, it is evident that this higher price is being paid because of some advantages being connected with smelting of these briquettes.

Attention should be drawn to the fact that only a small proportion of the briquettes now made answers the above-given requirements. Amongst the good briquettes are those made in furnaces of the tunnel type. These not only answer the physical but also the chemical and metallurgical requirements, as they contain no detrimental constituents, such as sulphur, and are also free from any binder. The briquettes are, moreover, characterised by being easily reduced and by their uniform composition. In the table below a number of analyses are given, made in connection with large-scale operations, showing the composition of the briquettes, their percentage of ferric and ferrous oxide of iron as well as the percentage of sulphur in the purple ore. Two per cent. of sulphur in the ore can be reduced as low as 0.09 per cent. in the finished briquettes without interfering with their other good qualities.

Iron ore.	Tons of briquettes in 24 hours.	Sulphur in purple ore.	Sulphur in briquettes.	In briquettes.		
				Total iron.	Iron as ferrous oxide.	Iron as ferric oxide.
		Per cent.	Per cent.	Per cent.	Per cent.	Per cent.
Siltelma (purple ore)	72	0.15	0.03	61.80	1.35	60.45
Foldalen (purple ore)	72	0.26	0.02	60.43	0.70	59.73
Rio Tinto (purple ore)	72	0.25	0.06	64.38	0.90	63.48
Pomaron (purple ore)	72	0.32	0.02	61.98	0.75	61.23
Orkla (purple ore)	72	...	0.055	62.98	1.05	61.93
Bismarckhütte (Rio Tinto ore residues)	60	2.22	0.039	64.34	1.05	63.29
Bismarckhütte (zinc-ore residues)	60	2.06	0.087	52.20	1.00	51.20

These good results were secured in large-scale operations with briquettes made from magnetic ore, purple ore, and pyrites cinders, limonite, and siderite. One can therefore say that the above conclusions regarding the manufacture of briquettes from iron-ores containing 50 per cent. of iron, or over, are justified, and most metallurgists acknowledge the advantage

claimed for this briquetting process and the benefits derived from it.

The ordinary purple ore obtained from the sulphuric acid works can usually be made into briquettes by a pressure of 2 to 10 tons per square inch, 2 tons being usually sufficient.

The sizes of briquettes vary in the different machines, and are 6 in. \times 6 in. \times 3 in. ; 10 in. \times 5 in. \times 3½ in. ; or 7 in. \times 7 in. \times 3 in.

The following conditions of the burned briquette should be attained :—

(a) When dropped from a height of 10 ft. on a hard surface, the bricks should not break into dust.

(b) They should resist a temperature of about 900° without disintegrating.

(c) The porosity should be such that the carbon monoxide of the furnace-gas can easily penetrate the mass.

(d) They should withstand the action of water for a reasonable time without disintegrating.

(e) They should resist the action of the steam usually present in the blast-furnace.

(f) If a binder be used, it must not contain such quantity of objectionable material as would be prejudicial to the quality of the iron.

(g) The cost of production should be less than the increased value of the resultant product.

(h) The sulphur content should not exceed 0·15 per cent.

In the briquetting of ores, especially those of a fine nature, such as dust, it is very important that the moisture content be correct, and also that the air contained in the ore be eliminated, which is effected by applying the pressure slowly and sometimes in two separate stages.

In many cases it is advisable, before passing the ore through the presses, to mix the material thoroughly in pug or edge runner pan mills, in order to prepare an ore of uniform composition.

Ramén says (*ibid.*) from his experience at Helsingborg Kopperverk: "The explanation of the fact that better briquettes are made in a compression press is that this works slower. The air in the ore has not time to escape when using the blow from a falling weight. During the blow the air is

compressed, and when the pressure is released by the rebound of the hammer the air expands, causing the formation of cracks and lessening the adhesion in the mass, so that they do not stand subsequent handling. If a sufficient pressure and adequate moisture are used when making the briquettes, the formation of cracks can be altogether avoided and very strong briquettes produced."

From experience on the Continent and in England, the maximum moisture content has been found to be 17 per cent.

A well-made briquette, when placed on edge, should support the weight of a man. Another good test is, that when the bricks are stacked 6 ft. high, the lower courses should not crumble.

Types of Presses.

There are very many types of briquette presses on the market, and mention need only be made of the following:—

Bradley & Craven, Ltd., Wakefield, produce a machine of the horizontal table type, the briquette being pressed from both sides simultaneously.

The press of T. C. Fawcett, Ltd., Leeds, has a cylinder fitted with four moulds arranged symmetrically about its circumference and rotated by suitable pawl-gear to bring each mould successively into the required position for filling, pressing, and extraction of the briquette. The capacity of this machine is about 50 tons per ten-hour shift.

The machine of Sutcliffe, Speakman & Co., Ltd., of Leigh, is also designed to press the briquettes from both sides, and at the same time to relieve the frame entirely from the greater stresses due to the operation.

Johnson, Ltd., of Leeds, make a machine which has given great satisfaction.

Drying.

When the bricks are to be placed in the ordinary Staffordshire brick-kilns, it is necessary to dry them previously, and this can be accomplished by passing the bogies, carrying them from the presses, into tunnel-shaped flues heated by the waste heat from the kilns, or by exhaust-steam pipes laid the length of the tunnel. There are ovens in use exceeding 150 ft. in length. They are 6 ft. wide by 6 ft. high.

Furnaces.

In the case of the continuous type of briquette-kiln it is, however, not necessary to dry the briquettes before burning. Anderson appears to be the first inventor to use tunnel furnaces (U.S.A. P. 379927 of 1888). The Gröndal process has been widely adopted, and is probably able to treat almost any ore which can be compressed sufficiently solid to withstand the subsequent handling.

When treating pyrites residues in the mechanical furnaces, the action of the acid gases on the cars and the walls of the kilns is very serious, and it is important to keep this in mind when deciding upon the type of furnace to be installed. Generally, tunnel furnaces consist of a number of trucks running on a track in a lower channel, and having their side edges plunging into sand-grooves, thus separating the upper and lower channels from each other.

The combustion-chamber has to be provided with a steady hot and oxidising flame, which is preferably effected by introducing pre-heated air and gas, under pressure through suitable nozzles. The usual drawback is that the brick lining on the top of the cars has a tendency to crack from the repeated heating and cooling, and to fall off when the iron side-plates for keeping the bricks in position have been burnt away, which causes high costs for repairs and frequent closing down of the plant.

Ramén (B. P. 20240 of 1910, and 4386 of 1912) describes an ingenious arrangement for overcoming the difficulties cited. He arranges the tunnel above the cars, considerably narrower than the cars, so that there are projecting parts of the brick-work adjacent, and such portions may be carried on water-cooled iron boxes, shown in Figs. 70 and 71 below.

He has patented a tunnel kiln or furnace with a movable hearth in which the cooling-chamber is connected to the combustion-chamber by one or more channels which may be water-cooled, and which receive pipes for the introduction of gas or air, which may be pre-heated. These pipes are adjustable and water-cooled, and arranged in the channels in such manner as to act as injectors, in order to draw air from the cooling-chamber into the combustion-chamber, to mix

the same simultaneously with the combustible gas introduced through the said or other pipes, and also to regulate the introduction of air over the whole width of the furnace.

A special advantage in this construction of the tunnel is, that it allows an even distribution of the gas and air, resulting in a uniform burning of the briquettes. This arrangement makes it possible to use kilns of large dimensions, up to 3 metres in width. One such tunnel has a capacity of up to 100 tons of briquettes per twenty-four hours.

The use of extending side-walls allows the sides of the cars to be well protected. The Ramén cars are built with a body made of a mass cast between the iron side-frames, the ends

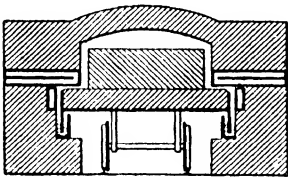

Fig. 70.

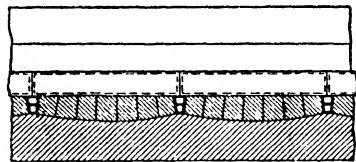

Fig. 71.

being protected by briquettes. This manner of construction gives the cars a much longer life than when made of the narrower type, where the sides of the cars are more directly exposed to the heat. Ramén has invented an ingenious arrangement for unloading the briquettes mechanically without spoiling the fireproof body of the cars. This was not possible with the old cars, as the firebrick lining thereby was destroyed. The mechanical unloading is carried out with the aid of an electrical locomotive, provided with a platform for the briquette car, also a table which can be lifted and tipped to either side. The briquette car is placed on the platform, and then taken to an arrangement which scrapes the briquettes over the table. This table is then tipped over, dumping the briquettes into a bucket, car, or other suitable carrier.

According to Ramén (B. P. 134387, 1919), moulds containing the briquetted material in a more or less liquid condition are introduced into a furnace, dried by means of the furnace-gases, the moulds turned over by magnets or other devices, then removed from the furnace, leaving the briquette within to be burnt.

b. Sintering.

In order to avoid the cost of briquetting, attempts have recently been made to agglomerate the fine-grained ore in rotary and other types of kilns, and with considerable success; and plants dealing with 4000 tons and upwards of material per week are now at work. The fine-grained ore is mixed with coke-dust and heated by producer-gas or oil-flame.

The Dwight Lloyd process is fully described in *Iron Age*, vol. lxxxviii., p. 422. The machine consists of a travelling band of fire-bars upon which the material is spread automatically from a hopper. Blast-furnace gas, or other heating medium, is supplied in order to ignite the combustible matter added, and in a very short travel the mass forms in nodules or sinters, and is in a very convenient form for transport and subsequent use in the blast-furnaces.

The Greenwalt system (B. P. 14805 of 1912) appears to have found favour in America, but plants have been erected in this country, and there are installations actually at work. The mixture of ore and fuel, suitably moistened, is fed by an overhead charging car to give a layer of correct depth, on a grate surface suitably protected by crushed limestone. After the charge is in position, the pan is enclosed with a cover on which is attached the heating device, which consists of an oil-burner. Suction is applied by a fan giving 20 in. suction, and the charge is said to be completely sintered in 25 min. The pan which contains the grate-bars is fitted with trunnions to facilitate discharge of the sintered material. After the cover is removed, the contents are dropped upon breaking-bars by simply revolving the pan on its trunnions. The dusty particles formed by the above procedure are returned again; anything above $\frac{1}{4}$ -in. mesh need not, however, be rejected. The average size of the sinters would be about 3 in. For a plant to deal with 200 tons daily, thirteen men are necessary, and the cost of fuel, labour, etc., is said to be far below that of briquetting.

In the making of agglomerates for smelting from finely divided ores, flue-dust, and other residues, K. Endell¹ states that the aim should be to produce a body which is porous and

¹ *Metall u. Erz*, 1921, 18, 163-177; *J. S. Chem. Ind.*, 1921, p. 394A.

mechanically strong at 1000° , has the greatest possible surface, and requires the minimum of fuel in the subsequent smelting process. Sintering of the mass is usually brought about either by an increase in the grain size of one or more of the constituents, with consequent intercrystallisation of the particles, in most cases accompanied by an increase in the specific gravity, or by reactions between the solid constituents of the mass resulting in an evolution of heat and partial fusion of the particles, or in the formation throughout the mass of interlocked crystals of a new compound. The course of the changes that take place during sintering may be followed by the construction of a heating curve and by direct observation through a microscope in conjunction with a small electric heating furnace fitted with a thermo-couple. Such an instrument is described in the paper in detail, together with some results obtained by its use.

M. Guédras¹ completely dries the burnt cinders, then almost frees them from sulphur, and agglomerates in a continuous furnace of the Breuillé type, heated by lignite gas or blast-furnace gas; in this way the percentage of sulphur is reduced from 2.3 to 0.1-0.2, and the resulting product is hard yet highly permeable to gases. After introduction into an electric furnace and treatment with dry calcium chloride, the resultant iron only contains 0.01 to 0.03 per cent. of sulphur.

Pyrites-cinders produced :	1917.	1918.
Cuprous	386,000
Non-cuprous	609,000	130,000
Total	<u>609,000</u>	<u>516,000</u>
Pyrites-cinders delivered for use in blast furnaces—		
From copper extraction plants :		
Briquettes	208,000	208,000
" Blue Billy "	272,000	211,000
	<u>480,000</u>	<u>419,000</u>
Non-cuprous pyrites-cinders delivered direct to ironworks	45,000	66,000
Total to ironworks	<u>525,000</u>	<u>485,000</u>

¹ *Giorn. Chim. Ind., Appl.* 1921, 3, 58-61; *J. Soc. Chem. Ind.*, 1921, p. 261A.

According to H. J. Bailey,¹ the foregoing table gives the production and use of pyrites-cinders in the United Kingdom during the year 1917-1918.

Cinders from non-cuprous pyrites have been used as ballast for making roads, for absorption of sulphuretted hydrogen, for manufacture of copperas, ferric chloride, and the like; for decomposition of sulphides, for paint, and many other purposes.²

II. Extraction of Copper from Pyrites-cinders.

This process is rarely carried out in the smaller factories, but there is no reason why those firms dealing with 40 tons of cinders daily should not do so, for by so doing considerable transport charges are saved.

One of the largest pyrites-mining companies, the Tharsis Sulphur & Copper Extracting Co., supplies its ore to the consumers only on condition of returning the burnt cinders to their works. Their mines in South Spain generally forward the pyrites direct to the consumer, and the cinders are returned to the company's works at Glasgow, Cardiff, Willington Quay, or Hebburn-on-Tyne; the last works smelt the precipitate produced at the other works. Similar arrangements are also carried out by the Rhenish manufacturers.

The percentage of copper in the ores is generally low, rarely above 4 per cent., so that its extraction by smelting would hardly pay. In any case, the sulphur would have to be burned and the sulphur dioxide conveyed into the lead-chambers for the manufacture of sulphuric acid.

Since 1865 the usual method of extracting copper has been by the wet way, and the process as carried out at the present time will be described below. The precipitation of the copper by metallic iron is most generally in use in England and on the Continent.

The first attempts in this way seem to be referable to Hunt (B. P. 8356 of 21st January 1840), and especially to Longmaid (B. Ps. 9496 of 20th October 1842, and 10004 of 1844). The latter exactly described the principles of the process, as it is carried out at the present day, certainly with a view to

¹ *J. Soc. Chem. Ind.*, 1921, p. 246R.

² See Lunge, fourth edition, p. 1454 *et seq.*

making salt-cake and chlorine as the chief products; and he also worked it out on a large scale; so that he must be regarded as the founder of the wet extraction of copper. Certain small improvements were patented at different times.¹

The most important ores employed in the English sulphuric-acid factories contain from 40 to 49 per cent. of sulphur, and the following quantities of copper and silver:—

	Copper.	Silver.
	Per cent.	Ounces (troy) per ton.
Rio-Tinto . . .	3.80	1.20
Tharsis . . .	3.50	0.75
San-Domingo . . .	3.70	0.75
Sulitelema . . .	2.70 to 3.5	0.96
Orkla . . .	2.25 to 3.50	0.96

The percentage of sulphur in the cinders as they are supplied by the acid-works varies extremely; hardly ever falling below 2 per cent., but sometimes rising above 10 per cent. The latter, however, results from very bad working of pyrites-burners, but 4 to 5 per cent. is considered fairly good work, this amount being often required for the wet copper-extraction.

The analyses by Gibb on the following page show the composition of the pyrites-cinders as the copper-works receive them.

¹ Spongy iron was first employed by Gossage (B. P. 13177, 1850); it was again patented by Aas in 1861, and by G. Bischof in 1862 (*Wagner's Jahresber.*, 1862, p. 133, and 1863, p. 153).

The process now generally employed in England has been principally described by Clapham (*Chem. News*, 23, 26), Gibb (*Chem. News*, 31, 156, and several publications of the Tyne Chemical Society), and Lunge (*Dingl. polyt. J.*, 204, 288; 214, 466; 215, 54 and 229; 219, 323). A paper by Bode (*Dingl. polyt. J.*, 226, 254, 357, and 428) gives a very complete survey of all the previous ones. The notes of E. A. Mebus, published by Jurisch, are also of interest, especially concerning the recovery of silver (*Chem. Ind.*, 1894, p. 378). The process and plant used at Natrona, near Pittsburg, are described by Clemmer (*Min. Ind.*, 7, 197, and 9, 283). Kothny (*Metallurgie*, 1911, 8, 389 to 399) describes his investigations on the chemical processes going on in the roasting of burnt pyrites with salt.

502 BY-PRODUCTS IN SULPHURIC ACID MANUFACTURE

	Rio Tinto.	Tharsis.	San-Domingo.	Ytteren (Norway).
Copper*	1.65	1.50	1.55	1.01
Iron*	3.64	3.23	3.76	3.33
Sulphur*	3.53	3.15	3.62	3.10
Cupric oxide	2.75	2.56	2.70	0.39
Zinc oxide	2.02	0.55	0.47	6.46
Lead oxide	0.47	0.70	0.84	0.06
Silver	0.0037	0.0023	0.0023	...
Cobaltic oxide	0.007	0.032	0.033	...
Bismuth oxide	0.013	0.010	0.013	...
Calcium oxide	0.20	0.25	0.28	2.30
Ferric oxide	77.40	77.00	78.15	68.06
Sulphuric acid	6.10	5.25	5.80	6.56
Arsenic acid	0.24	0.17	0.25	0.05
Insoluble residue	1.45	5.85	1.85	8.74
Total	99.47	100.25	99.31	100.06

* Calculated as Cu_2S and Fe_2S_3 .

Phillips states the following as the composition of cinders from San-Domingo ore :—

Sulphur	3.66
Arsenic	0.25
Iron	58.25 = 83.0 Fe_2O_3
Copper	4.14
Zinc	0.37
Cobalt	trace
Lead	1.24
Lime	0.25
Insoluble	1.06
Moisture	3.85
Oxygen and loss	26.93

Phipson gives the following analysis of residue from Irish pyrites¹ :—

Zinc oxide	5.50
Cupric oxide	2.86
Manganese oxide	1.60
Nickel and cobalt oxide	0.12
Cadmium oxide	0.01
Lead oxide	1.67
Antimony oxide	0.04
Ferrous oxide	1.17

Carry forward 12.97

¹ *Chem. News*, 18, 29.

EXTRACTION OF COPPER FROM PYRITES-CINDERS 503

	Brought forward	12.97
Alumina		3.25
Sulphur		2.60
Thallium		traces
Indium		traces
Gangue		15.00
Ferric oxide		65.99
Lime		0.11
Magnesia		0.08
		100.00

Wedding and Ulrich found in samples from Widnes (*a*) and Hebburn (*b*):—

	Sulphur.		Copper.	
	<i>a.</i>	<i>b.</i>	<i>a.</i>	<i>b.</i>
Altogether	4.12	3.75	4.08	5.75
Of this soluble in water	Per cent. 43.0	Per cent. 37.0	Per cent. 46.0	Per cent. 26.1
" " HCl	55.0	59.0	22.2	13.3
In the residue	2.0	4.0	31.8	60.6
	100.0	100.0	100.0	100.0

The cinders from Sulitelma pyrites and those from Orkla pyrites show the following:—

SULITELMA.

Ferric oxide	75.70 (Fe - 53 per cent.)
Copper	3.50
Zinc	2.50
Al ₂ O ₃	2.50
CaO	0.20
SiO ₂	8.00
Sulphur	4.00
Arsenic	0.035
Cobalt	0.07
Oxygen and undetermined	3.49
	99.995

ORKLA.

Copper	2.25 to 3.50 per cent.
Zinc	3.50
Iron	50.00
SiO ₂	14.00

Grinding.

The mixture of cinders and salt must be carefully controlled, and it is advisable to grind after mixing in order to ensure a mass of uniform composition. A suitable grading is as follows:—

100 per cent.	passing through	$\frac{1}{4}$ in.
80-90 "	" "	$\frac{1}{8}$ in.
50-60 "	" "	$\frac{1}{16}$ in.
20 "	" "	$\frac{1}{40}$ in.

If ground too fine, a slimy mass will be formed in the subsequent leaching process. If too coarse, the chloridising process and time of leaching are too much prolonged.

For grinding the cinders there are many types of machines on the market, and many of those described in Chapter IV. for grinding pyrites may be used. The Kent mill is particularly suitable for grinding cinders and is largely used for Orkla; the machine having a capacity of 150 tons in eight hours.

Rock-salt has advantages over the fine qualities due to smaller loss by volatilisation, and also to decrepitation of the larger pieces bringing about better distribution throughout the charge.

The sulphur content of the cinders should be at least equal to the percentage of copper + zinc + lead present in the ore; excessive use of salt would cause the calcination to be prolonged.

Should the pyrites be too thoroughly burnt, it is necessary to add a portion of raw pyrites to the cinders to bring the sulphur content sufficiently high for the chloridising process.

On the Continent it is the practice to use automatic weighing hoppers for both cinders and salt, the mixture being then conveyed to the grinding and sieving machinery in a floor above, thence into overhead bunkers for subsequently feeding the furnaces.

Before proceeding to describe the various types of furnaces,

it will be advisable to consider the reactions taking place in the chloridising process.

Professor Peter Klason gives the results of his investigations in an article in the *Mining Magazine* for December 1918, in which he quotes Ramén's theory of the decomposition taking place in the Ramén-Beskow chloridising furnace: Ramén's statement being:—

“The process, in my opinion, depends principally upon gaseous reactions. One must assume an oxidising of the sulphides with air in which the iron pyrites plays the greatest part, decomposing these into metal oxides and oxygen radicals, which again drive the chlorine out of the common salt. The chlorine then acts, chloridising as free chlorine.

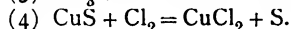
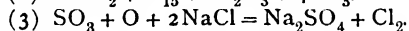
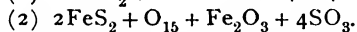
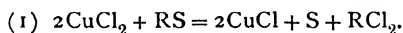

“It is evident that these reactions are theoretical, so that the intermediate stages must be imagined, SO_2 forming first, which, owing to the effect of the furnace mass as a contact substance, is oxidised to sulphuric acid. But even assuming a direct conversion:

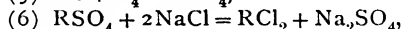
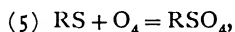

between the salt and the oxidised sulphides, one has clearly to deal with a gas reaction, and oxidising with the aid of the oxygen in the air. It is possible that the reactions (5) and (6) take place, although I consider that (2), (3), and (4) are especially important for a complete roasting of the copper to chloride.

“The theories I advanced a few years ago on chloridising roasting, which at the present time is performed in most metallurgical works in the well-known Ramén-Beskow mechanical furnaces, seem for the greater part to have been confirmed by experience. It has been proved with certainty that the mass acts as a contact substance in the forming of the chlorine necessary for the reaction, and I consider it proved that this reaction takes place principally by alternate oxidising and reduction of the iron compound present in the

506 BY-PRODUCTS IN SULPHURIC ACID MANUFACTURE

mass. It is also shown that the roasting is more complete in cases where the ore contains iron than where it is poor in iron."

Professor Klason goes on to say that, from the large number of investigations he made, he confirms Ramén's statement that the formation of chlorine takes place according to formula (3):

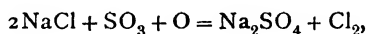

whereby the ferric oxide introduces oxygen from the air into the reaction by catalytic action, SO_3 and NaCl acting on each other according to the formula



forming sulphur pentoxydichloride and sodium pyrosulphate, these products being intermediate ones.

The $\text{SO}_2\text{O}_5\text{Cl}_2$ decomposes into chlorine, sulphur dioxide, and sulphur trioxide, and the pyrosulphate into neutral sulphate and sulphur trioxide.

The HCl formed during roasting naturally gets its hydrogen from the moisture in the air and the cinders, and is formed partly according to the reaction

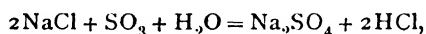

and also

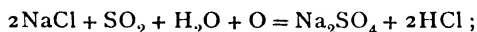

these reactions being important not only because they produce the acid necessary in the leaching, but also on account of both being exothermic.

This evolution of heat, together with that generated in roasting the added pyrites, is utilised in the Ramén-Beskow furnace by shortening the time of reaction by diligent stirring, thus getting better practical results, lower fuel consumption, and the copper more soluble in the leaching process.

If the contents of sulphur are increased by adding ferric sulphate (pyrites probably would be just as good), the experiments showed that Cu became equally soluble as in common cinders, thus showing that copper ores can be treated by chloridising roasting without having been previously subjected to sulphurising roasting. In this case, however, iron will probably go into solution.

Further experiments went to prove that cupric chloride is more or less decomposed into cuprous chloride and chlorine; for by heating a quantity of anhydrous cupric chloride in a current of dry air to 500° for three hours, 83 per cent. was converted into cuprous chloride. By heating the resultant cuprous salt for a longer period, cupric oxide was formed, but when moisture was present the following reaction took place:

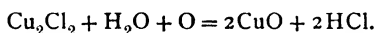

It is quite evident from the foregoing extracts from Prof. Klason's exceedingly interesting paper, that every care should be taken in using the correct amount of salt, in controlling the temperature, and in taking analyses of the calcination gases at frequent periods.

Hand Furnaces.

The first attempts at chloridising cuprous cinders appears to have been made in reverberatory furnaces, but these have been given up and muffle-furnaces substituted. In the former, the material was subjected to very uneven temperature and local overheating. About 1870 the muffle-furnace was introduced, and better control of the heat was possible; later, a combination of the two types was constructed, having two or more hearths, and the charge removed from the higher one to the lower.

The essential conditions for a satisfactory hand-furnace are, that the brickwork should be tight, and the whole structure built of bricks of acid- and heat-resisting quality and having as little porosity as possible. Facilities for cleaning the various flue connections should of course be provided.

For descriptions of the various hand-fired furnaces, the reader is referred to Lunge's fourth edition, pp. 1476 *et seq.*, for such furnaces are now rarely used, the principal copper firms having replaced the whole of them by mechanical furnaces.

Mechanical Furnaces.

The chief work in the development of mechanically operated furnaces has been carried out by Ramén and Beskow of Helsingborg, Sweden, and a description of their mechanical

furnace will be of interest. Up to 1920 there were between thirty and forty Ramén furnaces in use in Great Britain, sixteen of which were installed by the Tharsis Co., Ltd., and three by the United Alkali Co., Ltd. There are about seventy at work on the Continent.

Before Ramén and Beskow perfected their invention, Ramén undertook many investigations at the Helsingborgs Kopparverk, where he proved that the roasting of cuprous cinders could be done in a very short time if given the necessary amount of air and suitable admixture of salt.

He also proved that after pre-heating the mixture in one compartment, the chloridising could be completed in a second one without the use of external heat.

Ramén and Beskow's conditions for effective chloridising are :

- (1) An even temperature in all parts of the mass.
- (2) A regular supply of air without undue dilution of the gases leaving the furnace.

There are two sizes of the Ramén-Beskow furnaces on the market, one with a capacity of 40-50 tons of cinders and salt per twenty-four hours, and another of 80 tons. The smaller size consists of five hearths, circular in section and about 21 ft. 6 in. in diam., the internal lining being circular and built of special firebricks, the outside structure square and carried on piers and archways about 7 ft. above the ground, thus allowing for discharge into bogies or other transporting devices. Under the furnace proper the motor and gearing are arranged, these being enclosed in order to prevent ingress of dust. The various hearths have a camber arch rising about 10 in., special blocks being used throughout, and very substantially built into the sides of the furnace. Steel joists are used extensively to take all thrusts, but during the war reinforced concrete was substituted and found to be very satisfactory.

Fig. 72 shows a sectional plan of the second hearth of their furnace. Four flues are provided, one at each corner of the structure, three of which are connected to the bottom four beds for conveying the acid gases to the condensers, and the fourth flue for the products of combustion emanating from the top bed. The mixture of cinders and salt is fed into the top hearth by means of a hopper feed and the producer-gas applied

at the circumference thereof. Rabblers fixed to a central shaft carry the material from hearth to hearth.

The chloridising does not take place at the top hearth, therefore these gases may be taken direct to the chimney. The air necessary for burning the producer-gas is usually

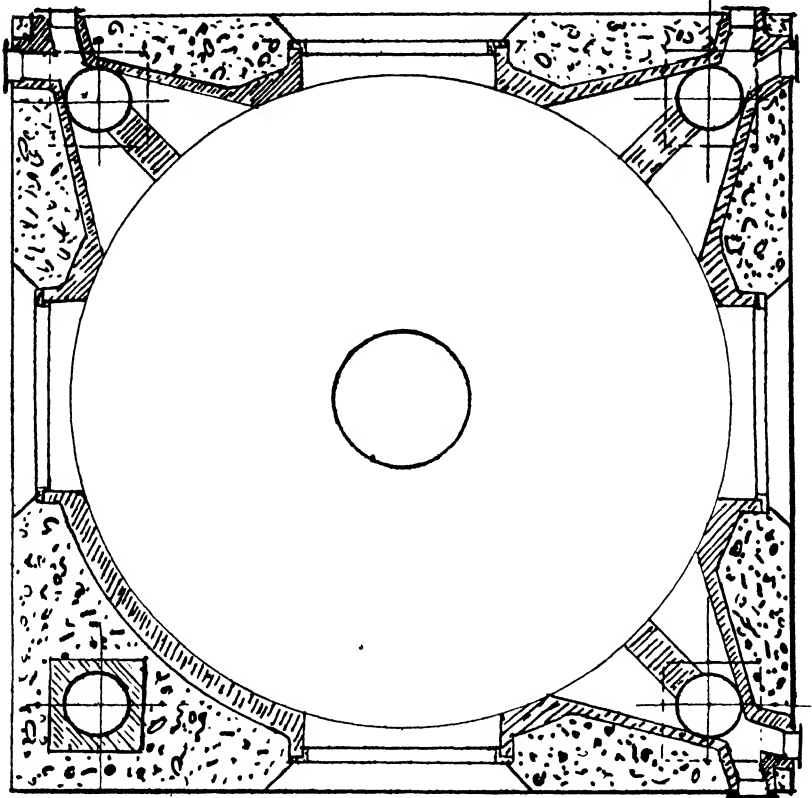

FIG. 72.

supplied by a small fan, and that required for roasting by openings provided in the lowest bed.

The temperatures of the various beds should be as follows :

Top	.	.	250-300°
2nd	.	.	450°
3rd	.	.	500° max.
4th	.	.	500° „
5th	.	.	440° „

Of course, a great deal depends upon the sulphur content of

the cinders and the amount of air added at the top and bottom beds, but the figures given can be taken as those giving the best results.

Compared with the hand muffle furnaces mentioned above, the saving in fuel is very marked, the reduction being from 10 per cent. of fuel on the cinders to under 2 per cent. The cost of upkeep is remarkably low. The power required to operate a 40-ton-capacity furnace does not exceed 2 h.p., but the type of motor should be such that it can be regulated for speeds varying from 300 to 900 revolutions per minute, for at the commencement of charging of the furnace it may be necessary to run at the lowest speed, and at the period in which the furnace charge has to be "sliced," or the scars removed, the speed should also be regulated.

With some class of ores it may be necessary to "slice" the contents of middle hearths every alternate day, but only experience can guide the operator in this respect.

Another important point in obtaining a satisfactory output of cinders is the regulation of the draft on the various parts of the furnace and flues. An iron fan of convenient capacity is usually installed between the furnaces and condensing-towers.

Working of Furnaces.—For pre-heating the cinders on the first hearth an ordinary Mond producer with forced draught is suitable, and for a furnace dealing with 80 tons of cinders per twenty-four hours a 6 ft. diam. producer is ample.

The furnace, when started up cold, should be heated very gradually by means of wood fires on each hearth, followed in a day or two by coke. Four or five days should be occupied in this process, and the ore may be charged when the brickwork of the middle beds is at dull red-heat.

It is advisable that daily samples of cinders and salt entering the furnace be obtained, and a sieve test taken; also an analysis of the percentage of salt present and the amount of copper, as a check on the process-worker. Each bed should be examined daily by stopping the furnace mechanism and running a slice through the contents of each hearth. If a considerable amount of scars is found, it is then necessary to remove the ordinary rabbles and to substitute the special ploughing ones, and after the furnace is again put to work the scars can easily be removed through the doors. As pointed

out previously, temperature control is very important; the draught readings ought also to be recorded several times during the twenty-four hours. The vacuum usually found on the upper hearths is 0.75 down to .02 in. of water, but practical experience in the actual plant is essential because of varying arrangements of flues and capacity of the plant.

Since the chlorides of copper are both unstable and volatile at high temperature the control of temperature is of importance, for considerable loss of the metal occurs in many works, and it is with difficulty that profit is realised even with the high returning charge demanded when purchasing cuprous ores.

It is quite evident that considerable saving can be effected by the use of mechanical furnaces over hand-manipulated. Not only is the consumption of salt halved, but labour, wear and tear, fuel, etc., are reduced in a marked manner.

Other mechanically-operated furnaces used for the chloridising of cuprous ore are of interest, and the "Wedge," described in another chapter, is one of the successful type. In fact, the furnaces used for "fines" pyrites can be easily adapted for calcining such ores, and *vice versa*.

Ramén-Beskow (B. P. 23108 of 1909)¹ describe a method of heating the ore by itself in the upper compartment, and then, without the gases being permitted to mingle with each other, the ore is conveyed to the lower compartment, into which the salt is separately introduced; or a mixture of the ore and chloride of sodium is introduced into the upper compartment, and the gases developed in the second compartment are led away separately from the combustion-gases which are leaving the upper compartment. Figs. 73 and 74 illustrate the apparatus.

The tests for ascertaining the completion of the calcination are of a very simple character, which is the more necessary

¹ Swedish P. 34215 of 1911 describes a furnace having a central vertical shaft with stirring-arms and with flues for gases to or from the furnace, or to and from the different compartments; B. Ps. 31047, 32642, 34513, and 35543 being for furnace details only. B. P. 11515 of 1912 claims the method of pre-heating the air-supply by means of a separate heating apparatus and then introducing it into the material to be roasted. B. P. 29235 of 1912 describes a device for effecting a downward gas-tight feeding of roasting material from one compartment to another in a furnace provided with a number of shelves.

512 BY-PRODUCTS IN SULPHURIC ACID MANUFACTURE
 as they must be made very quickly. A certain measure of

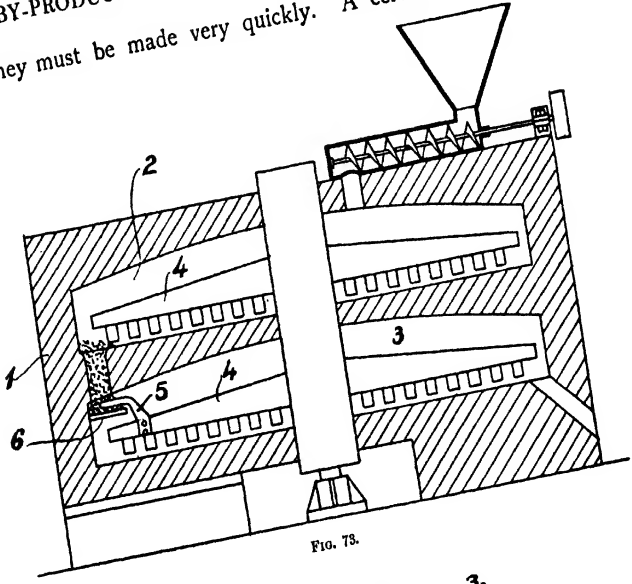

FIG. 73.

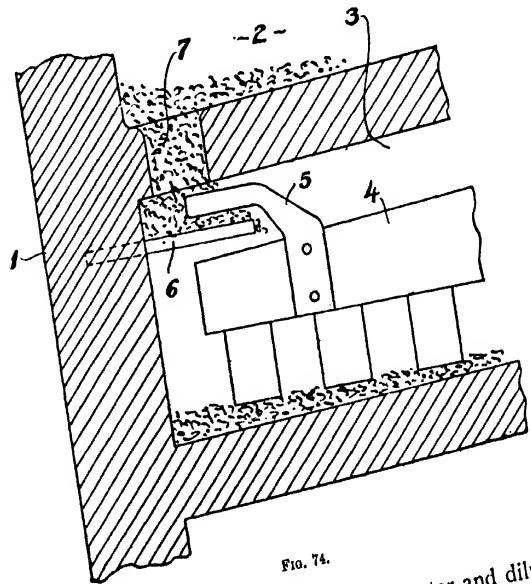

FIG. 74.

the charge, not weighed, is lixiviated by water and dilute HCl,

just as on the large scale ; the residue is boiled with aqua regia, supersaturated with ammonia, and allowed to settle ; the more or less blue colour of the solution of ammonio-cupric salt gives a sufficient indication of the percentage of insoluble copper.

Condensation of the Calcination-gas.—The condensers are constructed of stoneware slabs similar to the towers used in the manufacture of hydrochloric acid. Those made of timber are less serviceable. They are sometimes packed with coke, but, better still, with any of the acid-resisting packings described in Chapter II, Vol. II. Those packed with coke are quickly blocked by the dust which is carried forward by the suction of the fan, with subsequent disturbance of the process.

Another method of condensing the gases is by means of a water-spray in an empty column of similar construction ; but this can hardly be recommended, although a plant of this type was under the writer's supervision for a period, but several feet in depth of earthenware packers were introduced with beneficial results, the strength of the condensed acid increasing considerably. Further investigations proved that a considerable amount of copper was still escaping into the chimney, and it was found advisable to supplement the packing area still further.

There is little doubt but that, on this score alone, the subject should receive careful attention by any one interested in the design or control of copper-recovery plants.

The strength of the acid leaving the condensers should show 3·7 per cent. of HCl and about $\frac{1}{2}$ per cent. of sulphuric acid, but the strength depends entirely upon the efficiency of the condensers, for sufficient wash-water has to be circulated to reduce the escape of the deleterious vapours to comply with the Alkali Act.

The total condensed liquid is usually sufficient for the succeeding operation of lixiviating the calcined mass. If not, additional acid has to be added ; but many works have weak acid of 10° or 20° Tw., which is of little value, and this can be used for the purpose.

The condensed acid should be examined for content of gold, and, if in sufficient quantity to precipitate as sulphide,

this is accomplished by allowing the liquor leaving the towers to percolate through a layer of sulphide of iron.

Lixiviation of the Calcined Charge.—This is usually carried in bogies running on tram-lines over each of the lixiviating-tanks, into which it is tipped. The material of the tanks is generally wood; most metals are excluded by the nature of the lixiviating liquid. As such wooden vessels cannot well be kept tight on account of the unavoidable rough treatment and the hot liquor, the whole floor of the lixiviating-shed is covered

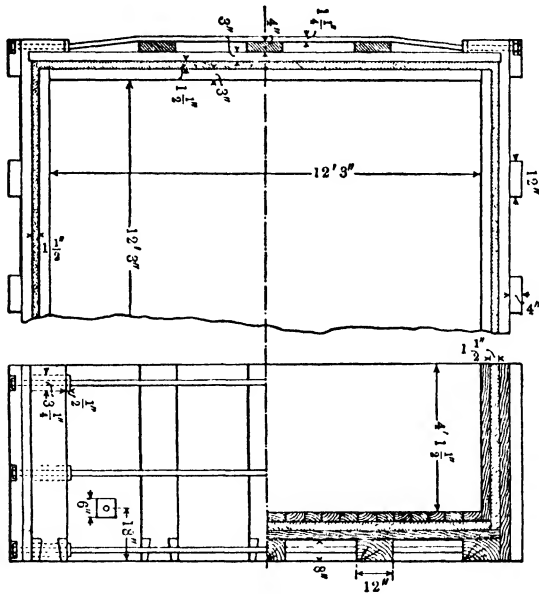

FIG. 75.

with a layer of asphalt and slopes to one point, so that all the liquors leaking out run to a catch-well, into which are fixed earthenware or wooden spouts for carrying the strong copper-liquors. Fig. 75 shows their construction.

Many of the lixiviating-tanks are square, about 11 × 11 ft. wide and 4 ft. to 5 ft. deep, made of well-seasoned 3-in. to 4-in. planks kept together by corner-pieces, screw-bolts, etc. The joints are painted and caulked in the usual manner; afterwards the whole of the inside of the tank is given a coating of hot coal-tar. Lead-lined vessels have been used, but these are expensive and frequently need repairing. On

the bottom, laths on end are placed ; upon these, perforated fire-tiles or boards ; upon this false bottom, a layer of sifted furnace cinders or coal is spread ; and on the top is put a layer of heather or coke 3 in. to 6 in. deep. The liquors are conveyed in earthenware or lead and indiarubber tubes of 3 in. to 4 in. diameter, the latter provided with iron pinch-clamps. In order to force the liquors from one tank to the other, or from the catch-well into the tanks, simple metal or stoneware injectors are provided.

Into every tank about 10 tons of calcined ore are put, quite hot from the furnaces, and covered with weak liquor from a previous operation, which gets heated by the heat of the mass itself. After one or two hours the now concentrated liquor is run off by a plug-hole below the false bottom, and is now ready for precipitation. Then follow several (three or four) washes with the weak condenser-acid, or, if this does not suffice, with sulphuric or hydrochloric acid bought for the purpose and much diluted. This is scarcely necessary in the case of mechanical furnaces, because the copper-salts from these are mostly soluble in water ; but it is usually necessary with hand-furnaces. Even when no acid need be bought, but sufficient condenser-acid is obtainable, a saving of acid is important, since the condenser-acid conveys arsenic and bismuth into the copper. This treatment is succeeded by three or four washings with water, preferably at 85° to 90° , the attendant making the necessary tests of the washings for copper content, in order to guide him as to the washing required.

The plant necessary for leaching a given quantity of ore calcined in hand-worked muffle furnaces is based on the time occupied in charging, washing, and refilling, which may be taken as from forty-eight to sixty hours when dealing with the above-mentioned quantity. Under similar conditions it will be advisable to provide plant on the basis of seventy hours for leaching ores calcined in mechanical furnaces, with a few tanks in reserve.

Pre-leaching.—In the ordinary system of lixiviation, described above, the custom of dumping the hot calcined ore into the tanks and then covering with the solution from a previous batch, lumps frequently form owing to the difficulty in getting the bulk evenly wetted on account of the tendency of the

sodium sulphate to absorb water of crystallisation. Thus channels are formed, with a resultant retardation of the process of leaching. The lumps have to be removed, and considerable manual labour expended.

Ramén and Beskow¹ invented a method of overcoming this

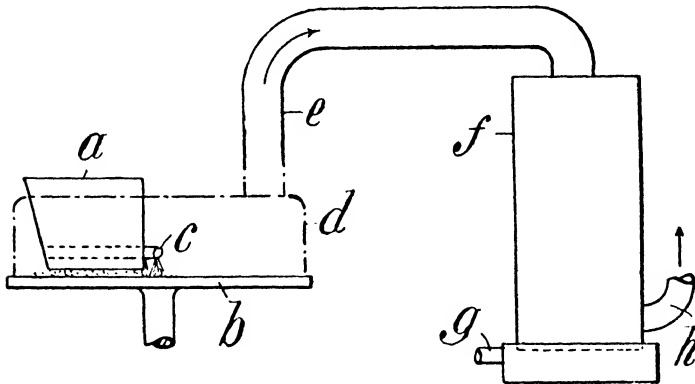

FIG. 76.

difficulty, by spraying water on the hot ore before taking it to the leaching vats. Ramén afterwards introduced an apparatus called a "Pre-leacher,"² illustrated by Figs. 76 and 77.

The hot roasted ore leaving the chloridising furnace, instead

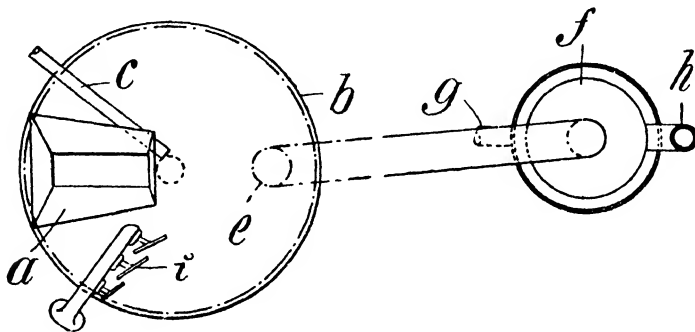

FIG. 77.

of being taken direct to the leaching-tanks, is carried to the hopper feeding the pre-leacher. The hopper *a*, placed eccentrically, commands a revolving table *b*, and can be regulated in height in order to increase or decrease the amount and depth spread evenly over the surface of the table.

¹ Swedish P. 35572.

² B. P. 15254 of 1914.

Water-spray pipes *c* are fixed above, and use is made of the vapours by condensation in a small column *f*, erected adjacent thereto, the water thus formed being used for the spray supply.

A fixed arm with rables *i* removes the moistened material to the discharge-hole; the moisture content being maintained at about 10 per cent. By this procedure it is possible to expedite very considerably the process of leaching proper; moreover, according to the inventor's claims, the zinc chloride and copper chloride may be more readily obtained in separate solutions in a more concentrated form, thus facilitating recovery of these metals and subsequent recovery of the sodium sulphate.

As the ore will have a temperature not over 100° , when put into the leaching-tanks, these will not be damaged by it, and thus will require less repairs than when charged with hot ore, as is often the case in plants not using the Ramón pre-leacher.

The pre-leacher is so constructed that the ore is treated in a closed apparatus, whereby the dust and fumes, which form when the hot ore is wetted, are condensed and taken care of, instead of being allowed to blow off into the air, inside of the building. This fact has the good effect that machines and iron in general, also the inside walls of the building, are not corroded by the action of fumes and dust so characteristic of the old chloridising leaching-plants. This system, therefore, saves machinery and woodwork in the leaching department, and also creates better working conditions for the men.

At present the purple ore is the best-paying product from extraction plants, and the price of the same is considerably influenced by its percentage of sulphur and copper. The leaching process determines to a certain degree these percentages in the purple ore, and by this system of leaching a purple ore free from all soluble matter can be secured.

With large leaching-tanks, to be shortly described, it is possible to reduce the leaching time to twenty to twenty-four hours, whereas, in the ordinary methods of washing, the operations usually extend over sixty to seventy hours, as mentioned above.

Experiments undertaken by the writer in the pre-leaching of ore gave the following results:—

518 BY-PRODUCTS IN SULPHURIC ACID MANUFACTURE

Two batches of calcined ore were sprayed while hot with water and then transferred to the washing-tank and covered with weak liquor. After twelve hours this was run off, and three washings of condensed tower acid put on, followed by two washings of water.

The weight of ore treated was 11 tons 9 cwts. and 10 tons 17 cwts. respectively, and after being sprayed it contained 13-14 per cent. of water.

The washings tested as follows :—

No. of Wash.	° Tw.		Final ° Tw.		Grams Cu per litre.		Grams Ag per litre.	
	a	b	a	b	a	b	a	b
1 Weak liquor .	29	36	60	67	42.82	52.44	.0146	.0205
2 Tower acid .	3	1	45	49	32.55	38.67	.0100	.0158
3 " " .	3	2	28	35	21.41	29.06	.0061	.0034
4 " " .	3	2	18	10	11.79	6.11	.0053	.0021
5 Water " .	0	0	12	3	6.99	1.87	.0038	.0007
6 " " .	0	0	4	1	3.27	.54	.0016	nil.

During these experiments the process of washing by the ordinary method was still being carried out, and the material lumped considerably, whereas the batches which were wetted previously to leaching showed no signs of lumping whatever. Moreover, the period occupied in completing the charges was reduced considerably, and much stronger liquors resulted.

The material dealt with was a conglomerate of various ores, and contained a large proportion of fines, so much so that "slimes" were formed by the ordinary procedure of lixiviation.

The tanks in use at the various works where Ramón has introduced his system are five or six times the capacity of those just described. They are built of reinforced concrete, measuring internally about 25 ft. long × 18 ft. wide and 5 ft. deep, and are built with rounded corners, so that a grab-bucket can easily remove the ore. They are lined with a layer of asphalt, this being protected by timber boarding, the joints being caulked in the manner already mentioned. The usual capacity is 70-90 tons of cinders. There need only be one man per day shift for the handling of the ore from the pre-leacher dump to the tanks, and from the tanks to the outside store for purple ore. There is no digging by hand, and the

labour is reduced very considerably. A series of four tanks is all that is necessary for an output of 100 tons of cinders per twenty-four hours. The bottom filtering medium is usually graded pebbles, which are protected by several lengths of timber laid on the top of them to prevent disturbance by the action of the grab.

Braumuller (Ger. P. 307175) leaches roasted ore in the following manner:—The hot material containing copper, zinc, silver, etc., obtained by the chloridising roasting of burnt pyrites, is mixed with the leaching solution and the mixture passed to a perforated distributing-plate arranged above a washing-tank, where the solids are deposited and from which the solution is tapped off.

E. C. Vigeon and J. M'Conway (B. P. 161375) sprinkle the hot cinders with a liquid while in a conveyer, preferably of the screw type.

The Dorr system of leaching (B. P. No. 154512 of 1920) in America is accomplished by means of classifiers.

These are placed in series, the first two or three being used for treatment with the condensed acid and the remaining ones for the wash-water.

The troughs are inclined to the horizontal, with overflows at the lower end and an outlet at the upper end. A conveyer travels over the floor by gearing, and it is lifted periodically above the surface of the settling material. The material is fed into the trough, and water or other fluid is supplied from a main above, the coarser portion being discharged by buckets into a launder. The level of the solution is maintained in the trough, and the finer portion which settles to the bottom of the trough is moved by the conveyer to the overflow. The lighter portion which remains in suspension in the solution is discharged at the other overflow. The operation is a continuous one, and it is claimed that great output can be obtained in a small ground area.

The writer is informed that the Dorr system has been tried for a period of several months in the year 1916 at a copper-works in America, but the tests were not very satisfactory. The purple ore produced was no better than that produced in the ordinary system of leaching, and the copper solution was very dilute. The greatest difficulty appeared to be in the

construction of the working parts, and the separation of the coarse from the fines also gave considerable trouble.

The Residue from Lixiviation.—It is the value of this residue which makes the wet process in this case more profitable than the dry process, as the residue is a valuable iron-ore, going by the name of *purple ore* or *blue billy*. The following is the composition of two average samples :—

Ferric oxide	90.61	95.10
Copper	0.15	0.18 ¹
Sulphur	0.08	0.07
Phosphorus
Lead sulphate	1.46	1.29
Calcium sulphate	0.37	0.49
Sodium sulphate	0.37	0.29
Sodium chloride	0.28	...
Insoluble	6.30	2.13
	<hr/>	<hr/>
	99.62	99.55
Metallic iron	63.42	66.57

This ore is thus shown to be very rich in iron, entirely free from phosphorus, and to contain very little sulphur; its slight percentage of copper does no harm. The only drawback is its fine state of division. It can be to some extent employed directly in its pulverulent state as a mixture with five or even only three parts of lump iron-ore in blast-furnaces; using limestone in addition, both grey and white pig can be made from it. Much inferior ores are, however, generally met with, the sulphur often reaching 0.6 per cent., phosphorus 0.02 per cent., and insoluble exceeding 10 per cent., beyond which many ironworks will refuse to accept without considerable allowance off the price.

Purple ore is more valued the freer it is from this siliceous gangue; and for this reason, that made from Spanish and Portuguese is preferred to that from Norwegian pyrites.

Cf. p. 491 as to briquetting and agglomerating pyrites-cinders, all of which of course apply also to purple ore.

The *lead* contained in the pyrites is found in the cinders as sulphate. Part of this is carried away with the leaching-liquors in the form of mud, and is removed by settling out;

¹ In well-conducted works the copper content is usually reduced to 0.05 to 0.10 per cent.

this mud contains some gold. Another portion remains behind in the lixivated residue, mixed with the purple ore and injuring its quality as an iron-ore. Schaffner¹ removed and utilised the lead in the following simple and cheap manner:—After roasting the ore with common salt as usual, and washing out all soluble chlorides and sulphates, the residue is drenched with chloride-of-calcium liquor (from the Weldon chlorine process) of 9° to 12° Tw., heated to about 40° and acidulated with hydrochloric acid. By mutual decomposition gypsum and lead chloride are at once formed, which remain dissolved in the acid liquor. This is run off and brought into contact with metallic iron, which precipitates the lead in the metallic state. After washing, the purple ore is quite free from lead sulphate. At the same time the CaCl₂ dissolves the last traces of copper and silver present as Cu₂Cl₂ and AgCl; these are precipitated together with the lead. It

	Mechanical Furnace Ore.		Hand-worked Furnace Ore.	
		Copper.		Copper.
<i>Soluble in water:</i>	Per cent.	Per cent.	Per cent.	Per cent.
Cupric chloride	4·16	1·96	3·81	1·82
Cuprous chloride	0·19	0·12
Cupric sulphate	1·83	0·81
Ferrous sulphate	0·15
Ferric sulphate	0·75
Zinc sulphate	2·01	...	1·95	...
Calcium sulphate	1·29	...	1·39	...
Sodium sulphate	9·17	...	11·13	...
Sodium chloride	2·64	...
<i>Soluble in dilute hydrochloric acid:</i>				
Cuprous chloride	0·015	0·01	0·33	0·21
Cupric oxide	0·225	0·18	1·01	0·81
Lead sulphate	} not determined		not determined	
Ferric oxide	}			
<i>Residue (by difference):</i>				
“Purple iron-ore”	80·40	0·08	77·55	0·11
	100·00	3·04	100·00	3·07
Sodium chloride equivalent to sodium salts as above	7·56		11·81	

¹ Fischer's Jahresber., 1880, p. 136.

should be noticed that sulphuretted hydrogen fails to indicate the lead in a solution of $PbCl_2$ in $CaCl_2$ acidulated with HCl.

Where the copper is precipitated by spongy iron, a portion of the purple ore is employed for preparing the latter.

Copper-liquor obtained by Lixiviation.—The effect of the lixiviation is best seen from the analyses by Gibb, *cf.* p. 521, which at the same time illustrate the great difference of work between mechanical and hand-worked furnaces.

The composition of the copper-liquor, according to Gibb, is in grammes per litre:—

	From hand-worked Furnaces.		From mechanical Furnaces.
Sodium sulphate	144.1	Sodium sulphate	110.9
Sodium chloride	63.9	Sodium chloride	4.1
Chlorine in combination with heavy metals	67.1
Copper	53.0	Cuprous chloride	53.2
Zinc	6.9	Cupric chloride	0.8
Lead	0.6	Zinc sulphate	10.1
Iron	0.5	Lead sulphate	0.8
Calcium	0.7	Ferrous sulphate	4.3
Silver	0.047	Calcium sulphate	5.0
		Silver	not estimated

Precipitation of the Copper from the Liquors.

This is sometimes preceded by special treatment for obtaining the silver, which will be described. The precipitation of the copper now takes place by means of metallic iron. Lunge in his last edition describes fully the preparation of "spongy iron" used for the precipitation of copper; but seeing the cost of scrap-iron is so low, it hardly pays to use the more expensive material, the reaction taking place according to one of the following formulæ:—

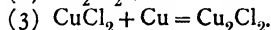
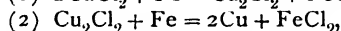
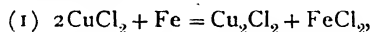

Regarding the application of these seemingly simple reactions, which, however, in practice meets with several difficulties, Ramén says:

"The cuprous chloride formed according to reaction (1) is insoluble in water and certain solutions, but to a certain

degree soluble in chlorides—for instance, sodium chloride and ferric (ferrous) chloride. Under certain conditions the cuprous chloride dissolves, or rather is prevented from being precipitated by the ferrous chloride formed; but if these conditions do not prevail, cuprous chloride may be precipitated as a very fine powder, difficult to remove from the cement copper. The cuprous chloride forms specially if cupric chloride comes in contact with already precipitated copper (reaction 3), in which case ferrous chloride is not formed to keep the cuprous chloride in solution. This chloride being very volatile, causes copper losses in the smelting of the cement copper for refining."

Ramén (B. P. 100588) describes an apparatus which is working very satisfactorily on the Continent, and is about to be introduced into this country. It consists of a cylindrical drum mounted on trunnions. The inside is lined with lead, then a protective layer of acid-resisting brickwork.

The strong solution is run in by gravity from overhead store-tanks, and the necessary quantity of light scrap-iron thrown in through the manhole. The manhole lid is then fixed, and the vessel rotated. A suitable valve is fitted to allow escape of the hydrogen generated. Air thus being excluded, there is practically no iron compound thrown down with the copper, the result being a purer cement copper than is obtained otherwise.

Samples obtained by the writer from the works in Sweden showed a copper content of 90 per cent., whereas the best produced in the old system hardly averaged 70 per cent. Cu. No steam is used in the Ramén precipitation, and the loss of copper is infinitesimal. Arsenic and chlorine are very much lower than is usual in the older methods of precipitation.

The writer devised an apparatus for precipitation of copper, and found it gave very satisfactory results. A number of tanks were arranged so that the solution entered at one side and left at the opposite by suitable conduits. These vessels were square and constructed of wood, their lower portion being conical, and at the lowest point an outlet was provided for removal of the deposited copper by a sluice valve. Into these vessels containers were placed, half-cylindrical in section, with their horizontal axes parallel with the top side of the vessel.

The containers were perforated by numerous holes to allow

ingress of the solution and egress of the precipitate. Into these containers the requisite scrap-iron was thrown, and in order to cause movement of the liquid through the interstices of the metal the containers were fitted with trunnions, on which they were oscillated. The precipitated copper was thus washed through the perforations of the containers, and, falling into the bottom of the vessel, was removed from time to time.

Fig. 78 is a sectional elevation of two vessels in series

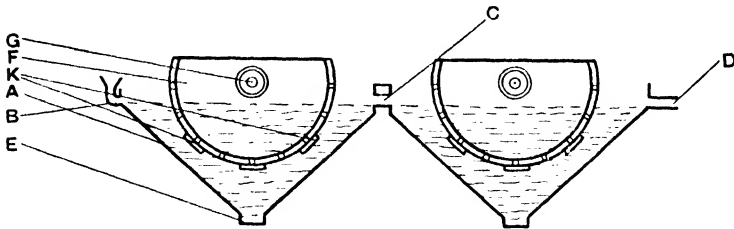

FIG. 78.

with their respective containers; and Fig. 79 a plan of a vessel with a pair of containers.

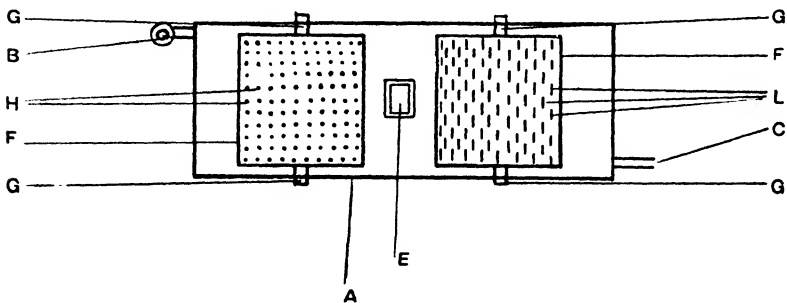

FIG. 79.

Fig. 78 represents two vessels which were constructed of wood, and connected together by conduit C with inlet B and outlet D at opposite sides.

On the sides of the vessel A the containers F were carried by means of trunnions G fixed to the sides of such vessels, and were oscillated by gear.

The vessels F were perforated as shown at H and L (Fig. 79).

The liquid requiring treatment was fed into A, through the inlet B, and scrap-iron thrown in the containers F; when the

containers were oscillated the movement of the metal scrap allowed quick reaction to take place, the copper in solution being deposited and washed through the interstices H, L of the container.

The extraction of the copper was very rapid, at least 80 per cent. being recovered in the first vessel and the remainder in the following. The precipitate analysed 80-90 per cent. of copper.

The whole process was continuous, and no steam was required.

The following is an analysis of copper precipitate (dried at 100°) from pyrites cinders at a works in the north of England:—

Copper	Per cent.
Zinc	68.00
Metallic iron	2.50
Insoluble	1.50
Arsenic	9.00
Sodium chloride and sulphate	1.50
Iron sulphate	1.00
Lead sulphate	3.50
Undetermined	2.00
Alumina	7.50
	3.50
	<u>100.00</u>

This shows a very impure material, and is considerably inferior to that produced by the newer methods of precipitation, described above, of Ramén and Wyld.

III. Working up the Copper Precipitate.

The copper precipitate can be taken direct to the smelting department, but it is of course preferable to dry down to 10 per cent. on heated flues in case of transporting to a distance.

Excessive heat should be avoided, otherwise some of the copper will be converted into oxide. With the better quality of precipitate produced by the Ramén system it is not necessary to dry, the subsequent smelting operations are very much simplified, and finished copper of high quality can be produced by a less number of furnacings, whereas with the inferior precipitates considerable costs are entailed.

In the earlier process of smelting, the object was to obtain a blister copper containing a minimum of 95 per cent.; the

charges for the roasting-furnace consisted of precipitate, a quantity of raw pyrites, with the white metal and the refinery slag produced in the other furnaces. The blister copper was then transferred to the refinery with a portion of lime, anthracite, etc. The slag produced in this furnace usually contained about 35 per cent. Cu. That from the roaster, containing 20 per cent. of copper, was worked up with coarse metal from the cleaning-off furnace, with pyrites, etc., giving the white metal referred to above. The residual slag from this process was worked down to coarse metal (15 per cent.) and ordinary slag (0.7 per cent.).

Now, with a richer precipitate containing 90 per cent. of copper three operations only are necessary. The precipitate is roasted and the blister copper transferred while hot to the adjoining furnace, where it is refined to 99½ per cent. quality at little cost. For the slags, a small cupola is all that is necessary. The *returning charge* for the improved quality of material is thus reduced considerably. The ordinary furnaces used in England are of the well-known reverberatory type, but considerable advancements have been made in recent years by introducing the gas-producer-fired furnaces.

Hall (U.S. P. 1290024) treats the cement copper by compression, using the "waste liquor" as a binder, the bricks being afterwards dried, and the copper recovered in melting in the usual way, or by electrical means.

IV. Extraction of the Silver.

According to Phillips, the cuprous pyrites-cinders contain on the average 0.0027 per cent. silver and 0.0001 per cent. gold. These metals, on calcining with salt, are converted into chlorides; and, owing to the solubility of AgCl in NaCl, the silver is found mostly, the gold at least partly, in the liquors obtained by lixiviating the calcined ore. In order to further this, Phillips adds some more common salt in the lixiviating-tanks. These metals are now recovered in most works usually by the process of Claudet (B. P. 282 of 1870). This process consists in precipitating by a soluble iodide the silver from the liquors in the state of AgI, which is quite insoluble in solutions of chlorides. Usually a recovery of 90 to 95 per cent. of silver is attained, with a loss of 15 to 30 per cent. of iodine.

For the treatment of the copper liquors by Claudet's process it is necessary to provide storage capacity sufficient for two days' production, in order to allow for ample cooling and settlement of the lead sulphate. This separation gives a much better quality than would otherwise be obtained. These tanks are preferably lead-lined, and placed below the level of the lixiviating ones. They are provided with steam ejectors or pumps for removal of the liquor to the precipitation tanks, which are of similar capacity but fixed at a higher level. Samples from each vessel are taken and the silver content estimated, the necessary amount of iodine being calculated. The liquor is then pumped to the precipitating tanks, the iodine added, and after agitation it is allowed to settle twenty-four hours. The clear liquor is then decanted and the tanks used for further batches until sufficient mud accumulates to warrant removal. The precipitate is washed to free it from copper, and is then decomposed with scrap zinc or sodium sulphide with regeneration of zinc iodide and sodium iodide respectively. The liquor leaving the precipitation tanks is filtered through a layer of 18 in. sawdust before passing to the copper-precipitators.

The mud obtained usually contains 25 to 45 per cent. of silver, and from 0.1 to 0.2 per cent. of gold, the remainder being principally lead and zinc.

Ramén (B. P. 15378 of 1914) claims a more scientific method of obtaining the silver in a concentrated form, and the following statement occurs:—

“It is known that chloride of silver, which is not soluble in water, is soluble to a certain extent in solutions of salts, as for instance in a solution of common salt. An ore containing copper and silver, which has been subjected to a chloridising roasting, according to the present invention is fed to the pre-leacher and sprayed with a solution of common salt in such quantity that it is absorbed by all particles of the ore, whereby the chloride of silver becomes dissolved, while the copper to a great extent remains undissolved.

“At a subsequent lixiviation of the ore thus treated, for instance with a solution of chlorides, it will now not become necessary to use this solution in excess, as otherwise would be the case for obtaining a complete lixiviation of the silver.

A more concentrated silver solution is thus obtained, which contains a smaller quantity of copper than if the ore after the roasting were directly lixiviated as heretofore. If this solution of silver and a little copper is precipitated upon iron, a product of cement copper is obtained which in most cases contains so much silver that it will be economical to precipitate the copper electrolytically, whereby the silver is obtained without loss. In the lixiviation directly after roasting, as hitherto used, it would be necessary to use quantities of the solution of chlorides for the lixiviation of the silver so great that a relatively great quantity of copper also becomes dissolved, the quantity of silver in the solution and also in the cement copper for that reason becoming relatively small. It has been a practice to precipitate this small quantity of silver by means of salts of iodine, which method, however, is costly and also involves loss of silver.

“An ore, containing copper and zinc, which has been subjected to a chloridising roasting, may be treated in the same manner. It is first sprinkled with a liquid, consisting for instance of a solution of chlorides of copper and zinc, obtained when lixiviating the roasted ore. The zinc salts absorbing the liquid more rapidly than the copper salts, the quantity of the sprinkling liquid is limited so that especially the zinc salts of the ore are converted into a solution retained in admixture with the copper salts which remain undissolved. For that reason, at a subsequent lixiviation of the sprinkled ore the zinc salts are first obtained in the solution together with a little quantity of copper, while the main part of the copper may be extracted by a continued lixiviation of longer duration. The copper contained in the zinc solution is for economical reasons generally precipitated by means of iron, which thereby is dissolved, so that the solution obtained will contain the zinc mixed with iron, which must be removed in order to obtain the zinc in a pure state. This removal of the iron heretofore has been very costly, for which reason it has been preferred not to extract the zinc from the so-called spent liquors, obtained in the extraction copper. It is evident that the treatment of these liquors will become cheaper and simpler when the liquors which principally contain the zinc contain only small quantities of iron, as will be the case when the ore is treated in the above-described manner, viz. uniformly sprinkled

or sprayed with a liquid in such a quantity that preferably the zinc salts are made to dissolve. In the first washing some copper will be present, but in so small a quantity that a very small quantity of iron will be required for its precipitation. For that reason very small quantities of iron will be present in the zinc solution as compared with the quantities of iron appearing in the liquor in the usual extraction process. These small quantities of iron can be easily removed as compared with the large quantities of iron appearing in the solutions after the precipitation of the copper by iron from solutions containing zinc according to the usual process. In a similar manner the method may be used for the extraction of other metals from the roasted ore."

V. Extraction of Zinc.

Pyrites containing zinc, such as the Westphalian ore from Meggen, cannot possibly be desulphurised in the burners so well as purer ore, owing to the great heat required for decomposing the zinc sulphate. The cinders from such ores contain both too much sulphur and too much zinc to be useful for the manufacture of iron without a special treatment for removing these impurities.

P. W. Hofmann¹ proposed the following process for utilising the cinders from Westphalian pyrites, which sometimes contain 6 per cent. of zinc:—The cinders contain the zinc as sulphate, which is only decomposed at a much higher temperature than is attainable in a pyrites-burner. The zinc sulphate can be washed out by water at 40°; but it contains too much iron sulphate to be saleable. If, however, a solution of 1.25 sp. gr. be mixed with a proportion of NaCl equivalent to the sulphuric acid contained in it, and heated to 30°, a liquor of 1.38 sp. gr. is obtained, from which, on cooling, such a quantity of Glauber's salt crystallises that this alone pays all expenses. The mother-liquor contains chloride of zinc, with more or less common salt and the sulphates of iron, zinc, and sodium. If evaporated to 1.60 sp. gr., all foreign salts are separated, and a solution of zinc chloride, with mere traces of sulphates and of iron, remains behind, which can be employed directly for pickling railway-sleepers. The residue from lixiviating the sulphates is allowed

¹ *Z. Verein. deutsch. Ingen.*, 18, 521.

to lie a few days in the air to dry: most of it then falls to powder. When this is passed through a sieve, the fine dust is found to be almost free from sulphur, the rougher particles containing nearly all the sulphur in the shape of FeS. The dust might be employed in a blast-furnace after briquetting or sintering.

At the Aussig works the crude zinc sulphate obtained in just the same way was formerly worked up by the addition of calcium chloride (waste lye from the recovery of sulphur) into "pearl-hardening" and zinc chloride. Owing to the want of a sufficient market, this manufacture has been discontinued.

Creutz¹ remarks that Hofmann's process has not been much used, because the reactions are not so smooth as he represented. The sodium sulphate remaining in the zinc-chloride liquor is prejudicial to its employment for pickling timber. Nor were better results obtained by mixing the solutions of sodium chloride and zinc sulphate in the cold, as recommended (Amer. P. 236051). The formation of double salts of zinc and sodium is the cause of this difficulty. It is therefore best to employ calcium chloride in the following manner:—The pyrites-cinders are exposed to the weather as long as possible to oxidise the iron and manganese compounds and the sulphurous acid. They are then lixiviated with cinders containing 3 per cent. zinc; a solution of zinc sulphate is obtained of sp. gr. 1.016, containing next to no iron and only traces of manganese and cobalt. This liquor is mixed with waste calcium-chloride liquor from the Weldon process, of sp. gr. 1.116, leaving a small excess of zinc sulphate. Calcium sulphate is precipitated and is filtered off. The clear liquor, of sp. gr. 1.075, is boiled down in an iron pan with top heat, and a little bleaching-powder is added to precipitate manganese and cobalt as peroxides. At a concentration of 1.5, the last traces of calcium sulphate are precipitated, and the clear liquor now contains only zinc chloride with a little zinc sulphate, no more than is contained in the liquor obtained by dissolving scrap-zinc in commercial hydrochloric acid. This process has the drawback of requiring fuel for boiling down the liquor, but it furnishes a liquor entirely fit for pickling wood. The expense of boiling

¹ *Chem. Ind.*, 1883, p. 258.

down is saved when the crude solution of zinc chloride is treated for the preparation of zinc hydrate (for purifying soda-liquors from sulphides) by addition of lime, and filtering through a sand filter.

The Königshütte Berg- und Hüttenverwaltung (Ger. P. 28465) roast pyrites-cinders, containing zinc, with common salt, and lixivate with weak hydrochloric acid. The liquor in case of need is freed from copper and is cooled down to such a temperature that sodium sulphate crystallises out. The zinc remains in the mother-liquor, and is recovered in the usual manner, probably chiefly in the shape of crystallised zinc sulphate.

Kosmann¹ regards all the processes hitherto employed for the above purposes as of doubtful economic value.

From the zinc solution, obtained by roasting the cinders with salt and lixiviating, a valuable *paint* can be obtained by precipitating, with a solution of barium chloride, a mixture of barium sulphate and zinc sulphide. This mixture is called *lithopone*, and is largely employed as a non-poisonous substitute for white lead.

Wikander (Ger. P. 158087 of 1903) passes through the cinders, at a temperature of about 550°, HCl gas or a mixture of this with air, thus converting the zinc into chloride, which is recovered by lixiviation.

Thwaites (B. P. 27515 of 1906) lixiviates the cinders and uses the liquid over and over again for the same purpose until sufficiently concentrated, oxidising by air if desirable, and taking out the copper by scrap-iron. From the solution of zinc thus obtained most of the sulphate of iron may be removed by crystallisation; the remainder of the iron may be precipitated by zinc oxide, or by caustic or carbonated alkali. The same inventor (B. Ps. 24847 and 27426 of 1907) first adds to the liquor, from which the copper may or may not have been removed, zinc oxide or carbonate, or both; then oxidises by air or by a suitable oxidising compound, separates the precipitate formed, adds a suitable sulphide to precipitate Cu, Pb, As, and Cd, removes the precipitate and adds a soluble sulphide in proportion insufficient to precipitate the whole of the Zn as ZnS. As a final step, after removing the white ZnS, the rest

¹ *Fischer's Jahresber.*, 1886, p. 268.

of the ZnS and any Mn, Ni, and Co may be precipitated by a soluble sulphide. A later patent (Ger. P. 218870) provides for the recovery of cobalt from the liquid filtered from the zinc precipitate, by treating it with an oxidising agent.

Siemens and Halske (Ger. P. 233252) add common salt to the cinders, remove the sodium sulphate by freezing out of the solution, precipitate the Zn by means of calcium carbonate, collect the $ZnCO_3$, convert this into sulphate by addition of sulphuric acid, and obtain from this the zinc by electrolysis.

The Metals Extraction Corporation (Ger. P. 22492) extracts the zinc from pyrites-cinders, etc., by an aqueous solution of SO_2 , saturated under the pressure of at least 1 atm.

Ramén (B. P. 9064 of 1913) treats the zinc solution by blowing in air, after heating or boiling, and adding the necessary amount of finely divided alkaline earth carbonate, thus removing the iron without notable precipitation of zinc. This process is very similar to that of Egestorff's Salzwerke (Ger. P. 23712) described in Lunge, fourth edition, p. 1461.

Recovery by Electrolytic Methods.

The extraction of this metal from the waste liquors is worked upon a large scale, especially in America, but the profit derived therefrom depends so much upon the market price of the metal that it is hardly a process to be recommended without serious consideration.

In an instance which came under the writer's notice in 1918, the liquor leaving the precipitation-tanks was treated with lime to just near neutralisation-point in special wooden vessels, having a shaft and stirrers of the same material. The resultant precipitate of calcium sulphate and iron was filter-pressed and the filtrate passed into another set of agitators, where it was treated with sulphuretted hydrogen, the zinc being thus obtained as sulphide. This precipitate was then dried and afterwards roasted in mechanical furnaces. The calcine was then treated with the residual liquor leaving the electrolytic cells, or by addition of weak sulphuric acid, in order to dissolve the ZnO, and the solution after purification was electrolysed in a series of cells. These cells were constructed of timber and were lead-lined.

As it was very essential to produce an electrolyte of great purity, all metals more electro-negative than zinc had to be removed (nickel, copper, cadmium). The deposited zinc was obtained of exceptional purity, usually containing about 0.02 per cent. of cadmium, 0.02 per cent. of lead, and 0.01 per cent. of iron.

Aluminium plates were found to be most suitable for the cathode, and lead for the anode. The former, after being in use a considerable period, appeared to be just as good as when first put into use.

A serious drawback was in the loss of zinc in the unconverted sulphide due to difficulties in roasting material with a low content of this metal.

Special attention ought to be given to the application of heat to the roasting-furnace. The producer-gas should be applied in such a way that a maximum temperature is obtained in the third hearth, but in the plant which the writer inspected the flame was applied on the top hearth and considerable unoxidised zinc was subsequently found in the calcine.

For a description of the process as carried out in America, the reader is referred to an article in the *Chem. Trade J.*, lxxvii., 1921, pp. 44-45.

S. Field and Metals Extraction Corporation (B. P. 138946 of 1918)¹ describe a method for purifying zinc solutions which are to be subjected to electrolysis. Such solutions, as zinc sulphate, are purified by treatment with ozonised air in presence of a metallic oxide hydrate or carbonate; manganese dioxide, manganese hydrate, lead and zinc oxide and carbonates, and zinc hydrate being mentioned as suitable. The treatment is preferably effected at a raised temperature and with agitation. If the zinc solution contains manganese, an added reagent is not necessary, and the manganese compound may be caused to precipitate by adding a reagent such as chalk or zinc oxide. Any manganese remaining in the solution after purification is recovered as peroxide mixed with lead peroxide at the anode in the electrolysis, and this mixture may be used as the catalyst. The treatment described removes iron, cobalt, arsenic, and antimony; but copper, nickel, and cadmium are not completely precipitated. These metals

¹ *Chem. Trade J.*, 1920, 46, 578.

are finally removed by treatment with zinc-dust as described in Specification 138,947, or with zinc-dust in presence of acid as described in Specification 138,954.

Farbenfabr. vorm. F. Bayer und Co. (Ger. P. (A) 312384 and (B) 320066, 11/5/18) claim the following process for extracting zinc from burnt pyrites:—

(A) Burnt pyrites is leached with hydrochloric acid or sulphuric acid and sodium chloride, while chlorine is simultaneously introduced.

(B) By first mixing the burnt pyrites with manganese ore the zinc content is reduced below 1 per cent., and the extracted material may then be smelted to obtain the iron.

VI. Recovery of the Sodium Sulphate.

Utilisation of the Sodium Sulphate contained in the Mother-liquors from the Precipitation of Copper.—At present the liquors are almost everywhere allowed to run into the rivers, and the sodium sulphate contained in them is lost. At a large copper-works for a time a process was employed by which ferric oxide was simultaneously obtained of great purity and fineness, so that it could be sold on the large scale for red paint. The acid liquors were boiled down to dryness in a brick furnace; the residual mass of sodium sulphate and chloride and iron salts was ignited, and ground very fine under edge-rollers; it was then carefully calcined in an ordinary calciner until all the iron salts were peroxidised. The mass was treated with hot water and allowed to settle; the ferric oxide deposited only required washing in order to become marketable as Venetian red. The solution (containing chiefly Na_2SO_4 and NaCl) was concentrated in pans by means of steam circulating in a worm, an agitator preventing the salt from adhering in crusts to the bottom and sides of the pan and to the worm. At a concentration of 1.37 to 1.40 sp. gr. nearly all the sulphate was found to be separated; the liquor with the suspended salt was drained off the precipitate, which was washed with a little hot water and dried in a furnace. It contained only about $\frac{1}{4}$ per cent. of NaCl , and not a trace of iron; so that it was very well adapted for glass-making. The high price of coal caused this process to be given up at the

time; and it does not seem to have been taken up again. Probably the first step, viz. the evaporation of the acid liquors in a brick furnace, would present the same difficulties as in Gibb's process.

Ellis¹ proposed, in lieu of concentrating the liquors by heat, to do so only partially, and then to promote the crystallisation of sodium sulphate by cooling. He mentions no trials made on the large scale.

E. de Cuyper (Ger. Ps. 53261 and 54131) cools the liquor down to -3° , at which temperature all the sulphate of soda crystallises out, whilst the chlorides of iron, zinc, sodium, etc., remain in solution even at -10° . After removing the Glauber's salts, the liquor is boiled down to dryness and the residue is calcined; pure ferric oxide is formed, and is freed from the zinc chloride by lixiviation.

Jurisch (Ger. P. 41737) seeks to utilise the waste liquors after extracting the copper in the following manner:—They are almost neutralised, in tubs provided with mechanical agitators, by means of calcium carbonate; air and steam are blown through, and in the same ratio as ferric sulphate is formed milk of lime is added, without, however, allowing all the acid to be saturated. When all the iron has been precipitated the mud is run into the settlers, the clear liquor is drawn off, and the deposit is passed through a filter-press. It contains some zinc salt, calcium sulphate, and carbonate, and can be made richer in iron by employing it the next time for the saturation of fresh liquor. — The basic sulphate of iron thus formed can be employed for making sulphuric anhydride, oxide of iron, paint, etc. The liquor drawn off from it is mixed in an agitator with enough milk of lime to produce basic reaction; the zinc hydroxide precipitated contains some basic ferric sulphate, manganese, and calcium carbonate, and can be utilised in a suitable manner.

According to a communication of the inventor in the *Chem. Ind.*, 1888, p. 3, 50 cb.m. of waste liquor, containing 40 grams $ZnCl_2$ per litre (from pyrites containing 1.5 to 3 per cent. Zn), would yield by his process 806 kg. ferric oxide mixed with calcium carbonate, 3600 kg. ammonium sulphate, 1444 kg. zinc oxide (50 per cent. Zn), 3245 kg. common salt, and a little

¹ *J. Soc. Chem. Ind.*, 1884, p. 613.

536 BY-PRODUCTS IN SULPHURIC ACID MANUFACTURE

potassium chloride. This statement is, however, only derived from analyses and laboratory trials, as Jurisch's process has not found any practical application. It will be interesting, though, to quote from his paper the composition of the liquor he worked with, obtained from the Witkowitz iron- and copper-works, with Hungarian pyrites.

One litre contained :—

8.6	grams free HCl,
73.0	„ Na ₂ SO ₄ ,
3.6	„ K ₂ SO ₄ ,
16.9	„ NaCl,
40.3	„ ZnCl ₂ ,
25.9	„ FeCl ₂ ,
3.1	„ FeCl ₃ ,
6.4	„ other matters.

He also gives a table of the copper and zinc percentages of a great many descriptions of pyrites.

Grabowski (Ger. P. 71917) concentrates the liquor by evaporation and crystallisation of Glauber's salt to sp. gr. 1.56; he then applies to them an electric current of great intensity, with lead and copper electrodes, by which arsenic and antimony are precipitated as metals at the cathode.

Brewer (B. P. 1348 of 1895) adds to the liquor a sufficient quantity of calcium-chloride solution, separates the resulting solution from the precipitated calcium sulphate (pearl-hardening), removes the silver, and afterwards the iron by calcium carbonate (in the shape of "caustic mud"), then nickel, cobalt, and manganese by bleaching-powder. This treatment practically leaves only the chlorides of zinc and calcium in the solution, which is electrolysed in order to obtain metallic zinc and free chlorine.

VII. Treatment of Ores poor in Copper.

The case now occurs much more frequently than formerly, that ores containing only 1 or 2 per cent. of copper are burned. In such cases the cinders are too poor to apply the treatment described above, p. 500 *et seq.*, beginning with roasting the ground cinders with salt; on the other hand, there is too much copper left in them to meet the demand of the iron-smelter. To overcome this difficulty the acid treatment,

mentioned in some of the processes described, is applied. Frequently the cinders are previously exposed to the air for some time, in order to render some of the copper soluble in water; sometimes they are put in the leaching-vats quite fresh and warm. It depends upon the nature of the ore which of these two ways is preferable, and it must be found by experience in practice.

The acid treatment takes place in lead-lined wooden boxes, provided with a false bottom, and is carried on as described, p. 514 *et seq.*, beginning with weak liquor from a previous operation, to which is added a little sulphuric acid, 2 or 3 per cent. of the weight of the cinders. This acid liquor is left in contact with the cinders for two days; the strong liquor thus formed is then run off into the precipitating-tank and is replaced by weaker washings and ultimately by fresh water, so that the operation is finished in seven or eight days. The weak washings formed are pumped back into other leaching-tanks by means of injectors. The copper is precipitated in lead-lined vats by means of scrap-iron, suspended in wicker baskets or otherwise, at a temperature of 50° or 60° . The precipitated copper mud is sold to iron-smelters, or is roasted into oxide in reverberatory furnaces and dissolved in hot weak sulphuric acid, to manufacture cupric sulphate.

By this treatment it is hardly possible to extract all the copper, but sufficiently so to render the cinders fit for the blast-furnace.

The manufacture of cupric sulphate from pyrites-cinders and low-grade copper ores is described by Millberg.¹ The liquor obtained by lixiviation is treated with air, whereby the iron is precipitated in the form of ferric oxide and the copper remains in solution as sulphate. If manganese is present, it is removed by precipitating the copper with milk of lime at a high temperature. Alumina is precipitated before the copper, and is thus kept out as well.

Mastbaum² reports a case where the shifting about of wet lixiviated pyrites-cinders in a steamer nearly caused it to founder.

¹ *Chem. Zeit.*, 1906, p. 511.

² *Ibid.*, 1912, p. 30.

VIII. Other Processes for Extraction of Copper, etc.

Richard¹ discusses the way of roasting cuprous ores and cinders so as to obtain the maximum yield of soluble copper salt. This coincides with increase of the ferric sulphate; hence the roasting should be performed at a temperature where this is possible. The finer the grain of the ore, the better for this purpose; 2 mm. should not be exceeded. It is most useful to treat the roasted ore in the furnace itself with a few per cent. of sulphuric acid. During the last period of roasting, the traces of Au and Ag present can be made soluble by suitable additions, and the liquors can be worked directly for cupric sulphate. Or else, by precipitating the Cu by Fe, final liquors can be obtained which can be worked for red and black iron paint. The residue from lixiviation goes to the iron-smelting establishments.

Parent (Fr. P. 411863) calcines pyrites-cinders in a special hearth on the top of the burner, or on the uppermost shelf of the burner, after mixing them with dilute sulphuric acid or finely powdered pyrites; in one or two hours the copper is completely soluble. In a later patent he claims the employment of ferrous and ferric sulphate and sulphuric acid for mixing with the cinders, and the employment of two charging-hoppers, one for feeding the sulphating hearth on the top and the other for delivering material to be desulphurised to the hearth below.

Kothny² finds temperatures between 500° and 600° most suitable for the calcining of pyrites-cinders with salt; *cf. supra*.

Evans (U.S. P. 1297670) treats the ore containing copper with an aqueous solution of nitre cake, the proportion of this latter being 50 per cent. of the copper content of the ore. The metal is subsequently recovered in the usual way.

Christensen (U.S. P. A1316351; B1316352). (A) Copper ore is lixiviated with a solution of sulphur dioxide. The leaching solution is kept free from sulphates by exclusion of air, and the formation of CaSO₄ is prevented by adding metallic copper to the solution, which is boiled to expel excess of sulphur dioxide, this being used again. A precipitate of cupro-cupric sulphite separates during the boiling process. (B) The ore is treated to convert the copper into cupro-cupric

¹ *Chem. Zeit.*, 1908, pp. 5-7.

² *Chem. Zeit. Rep.*, 1911, p. 457.

sulphite, which is separated from the remainder of the ore by a flotation process. The accumulation of iron in the solution is prevented by the addition of lime or limestone.

Leaver (U.S. P. 1312488 of 1919) uses a rotary drum of special construction and sulphurous acid for the leaching agent, the temperature being maintained so that the SO_2 is only slightly soluble in water. The presence of oxygen converts the sulphite into sulphate, the copper being recovered as such.

Wm. E. Greenwalt (U.S. P. 1328666) also uses sulphurous and sulphuric acid as a solvent for copper, and electrolyses the solution thus obtained, the sulphurous acid liberated being of advantage to the process. Sulphuric acid is also formed, making the process self-sustaining.

At Anaconda, tailings containing only 0.60 per cent. of copper are dealt with in huge quantities. They are firstly oxidised by roasting, then leached successively with

- (a) Weak liquors and common salt.
- (b) A weak liquor and sulphuric acid and salt.
- (c) Another similar solution.
- (d) Hot water.

The silver is also recovered along with the copper, by use of scrap-iron. The cement copper, containing 70 per cent. of the metal, is briquetted and then furnaced.

E. R. Weidlein (Assignor to Metals Research Co., U.S. P. 1089096; B. P. 101339 of 1914) leaches copper-ores with sulphuric acid giving a solution containing not more than 1 per cent. of free acid and preferably 1.5 per cent. of copper. The solution is then neutralised and the copper precipitated almost quantitatively with sulphur dioxide under pressure. After separating the copper, the residual liquor is used to extract a further quantity of copper from the ore.

Höpfner (Ger. P. 66096) adds to the copper-liquor so much NaCl or CuSO_4 that the proportion $\text{Na}_2\text{SO}_4 + \text{CuCl}_2$ is attained; then he adds metallic copper, whereby all the copper is precipitated as cuprous chloride, together with the silver as metal. From the mother-liquor, sulphate of soda is recoverable. Other modifications of the process are also proposed.

P. Spence¹ burns the pyrites (finely ground) in a furnace

¹ Cf. *Alkali Inspector's Report*, 1877-1878, p. 48.

provided with mechanical stirrers that plough up the ore into ridges, making a change of surface every two and a half minutes. He asserts that in this way he burns 3 tons of ore in a furnace in a day, and renders all the copper soluble to 0.24 per cent. ; thus he is able to wash out the copper salt and avoid the subsequent roasting with common salt. As much as 4.6 per cent. of sulphuric acid is left in the ore, rendering the copper soluble.

H. and Ch. H. Hills (B. P. 1621 of 1878) separate the coarse and fine portions of pyrites-cinders by sifting. The fine portions are calcined with salt in the usual manner ; the coarse portions are lixiviated with dilute hydrochloric or sulphuric acid, and the copper is precipitated from the liquor by means of iron.

Another process was patented (in 1873) by Baron Leithner in Austria.¹ The burnt ore (in this case containing about 1 per cent. of copper) was to be smelted with 36 per cent. calcium hydrate in a kiln heated by the waste gas of a blast-furnace ; the product was to be smelted for pig-iron, which now contains 2.09 per cent. Cu, and this was to be used for precipitating copper ; so that its own copper was utilised as well.

Some British patents of Mason's (2984, 2992, and 2993 of 1877) seem to contain nothing new of any importance.

The whole of the processes connected with the wet extraction of copper, as far as published up to the end of 1878, and including many proposals or actually employed processes not mentioned here (because they do not refer specially to the treatment of pyrites-cinders from sulphuric-acid works), are described in a condensed form by Bode.²

Hargreaves and Robinson (B. Ps. 5601 of 1886 and 3704 of 1887) treat the pyrites-cinders, obtained in the usual manner, in a closed chamber with fire-gases and excess of air, in order to burn all the residual sulphur ; the mass is allowed to cool down to the point where no cupric chloride can be volatilised, and is then treated with gaseous HCl till it is sufficiently decomposed. It is then lixiviated with water in tanks, after being moistened with strong hydrochloric acid ; the residual ferric oxide is obtained in lumps, which are immediately ready for the blast-furnace.

¹ *Dingl. polyt. J.*, 211, 349.

² *Ibid.*, 231, 254, 357, 428.

Pezzolato (Austr. P. 3882) mixes the cinders with 2 per cent. coal, and heats them with exclusion of air. The cooled and ground product is brought under the action of a magnetic ore-separator which takes out the iron compounds, together with the copper; from the acid solution the copper is precipitated by metallic iron, and ferrous sulphate is recovered from the solution left behind.

Tixier (Ger. P. 209508) extracts copper and other metals, except gold, from pyrites-cinders by treating them with chlorine *in statu nascendi* in an acid solution at 70° to 80°, e.g. by mixing them with 2 to 5 per cent. bleaching-powder or adding sulphuric acid or tepid hydrochloric acid.

General Remarks.

In laying out a copper-extraction works the levels must be carefully attended to, so that the very large quantities of solid and liquids may be easily transported.

At several of the copper-works in Sweden which the writer visited in 1919, the following arrangement of the Raménia system was inspected:—

Electrically controlled bucket-grabs (on overhead platform with rails, on which the crane could travel) unloaded the cinders from boats or trucks, and conveyed them to large silos holding several thousand tons of ore. In this way a uniform mixture was possible.

The stores were under cover, thus keeping the ore dry and preventing the loss of copper.

From the lowest portion of the store the cinders gravitated to a bucket elevator, which carried them to the grinding-mill, which in eight hours ground sufficient to keep the furnaces going for twenty-four hours.

After screening, the material was conveyed to a weighing-machine, and the salt (also weighed automatically) was mixed with it, and thence it was carried by another bucket elevator to the hoppers commanding the calcining furnaces.

After calcination the hot ore was taken direct to the Ramén pre-leacher, and from this it gravitated to a storage bin, from which it was conveyed to the lixiviation tanks by a travelling crane with grab-bucket arrangement.

These tanks were built of reinforced concrete, and held about 80 tons of furnaced ore, as described p. 518. In this department only one man was employed per shift for an output of 150 tons of cinders per twenty-four hours. The crane also removed the finished product, and was only operated during the sixteen hours out of the twenty-four, whilst only one man per shift was necessary for the process of leaching.

The liquor from the leaching-vats was then pumped into the store-tanks commanding the revolving precipitator (described *supra*, p. 523).

The precipitated copper, after being filter-pressed and washed, was dropped into bogies below on tram-lines, the precipitate being conveyed direct to the smelting department, or to the drying-sheds when the material was required for sale or for transporting to a distance.

INDEX OF NAMES

- AAS, 501
 Abu-Bekr-Alrhases, 3
 Adamson, G. P., 162
 Aicher, 452
 Aichino, 21
 Aitchison, 243
 Aktiebolaget Kolloid, 13
 Aktiengesellschaft für Bergbau,
 Blei- und Zinkfabrikation zu Stol-
 berg, 417
 Aktiengesellschaft für Zinkindustrie
 vorm. W. Grillo and Schefczik, 396
 Aktiengesellschaft für Bergbau, Blei-
 und Zinkfabrikation, 395
 Albrecht, 98
 Allen, 16, 70, 71, 72, 102
 Allen, A. H., 281, 429
 American Smelting and Refining Co.,
 40
 Anderson, 496
 Anderson, A. G., 354
 Anderson, L. D., 387
 Andrews, 189
 Andrlik, K., 217
 Anelli, 195
 Anelli, G., 59
 Anthon, 107, 210
 Apostolo, 57
 Arbeiter, 72
 Asbrand, 452
 Aten, 15
 Auerbach, R., 13

BABÉ AND PAPE, 425, 436
 Badische Anilin- und Soda-Fabrik, 50
 Bailey, H. J., 500
 Bakema, F. W., 382
 Baker, 11
 Baker, H. B. and M., 253
 Bambach, 49
 Bannister, 417
 Bänziger, 91
 Baranoff, 48
 Barrs, C. E., 226

 Barth, 394
 Bartlett, 91
 Baskerville, 150, 238
 Basse-Courbet, 54
 Basset, 39, 431
 Bassets, 435
 Bataille, 338
 Bauer, 442
 Bayer, F., und Co., 534
 Bayley, T., 294
 Beauvais, V. de, 3
 Bechi, G. de, 415
 Becigneul, 35
 Beck, P., 51, 58, 60
 Becker, 179
 Beckmann, 15
 Beckmann, Paull and Liesche, 15
 Becraft and Genter, 32
 Behrend and Zimmermann, 438
 Bein, 202
 Bémelmans, 45
 Benjamin, G. H., 355
 Benker, 265
 Benker and Hartmann, 390, 392, 450
 Berger, 60
 Bergmann and Berliner, 433
 Beringer, C. and J., 104
 Berl, 304, 305
 Berl, E., 479
 Bernoulli, 426
 Berry, 280
 Bert, 54
 Berthelot, 3, 11, 178, 179, 193
 Bertrand, 283
 Berzelius, 249, 251, 280, 281, 487
 Best and United Alkali Co., 91
 Beth, 452
 Bettendorf, 283
 Beuve, St, and Marconnet, E., 393
 Biberach, 461
 Bichowsky, 48
 Biehringer, 256
 Binder, O., 110
 Bineau, 197, 206

Bird, 283
 Bird, H., 491, 452
 Birkeland, 38
 Bischof, G., 501
 Bishop, 102
 Blacher and Koerber, 111
 Blair, 319
 Blake, 319
 Blattner, 114, 116
 Bleier, 299
 Block, 11
 Blouski, J. S. and A. A., 431
 Bloxam, 284
 Boake and Roberts, 436
 Böckmann, 108
 Bode, 212, 217, 464, 467, 469, 470,
 485, 501, 540
 Bodenstein, 12
 Bodenstein and Kranendieck, 192
 Bodländer, 299
 Borchers, 426
 Bornträger, 489
 Böttcher, 117
 Bottée, 431
 Böttger, 488
 Boubon, 455
 Boude et fils, 53, 54
 Bourgoin, 197
 Bousse, 396
 Boussingault, 221
 Bracklesberg, 355
 Bracq, 395
 Bracq-Laurent, 395
 Bracq and Moritz, 394, 395
 Bradley, 446
 Bradley & Craven, Ltd., 495
 Bragg, G. A., 34
 Brand, 62
 Brandenburg, 450
 Brasseur, 114, 116
 Braumuller, 519
 Breuil, De la Tour, 34
 Brewer, 536
 Briggs, E., 216
 British Sulphur Co., Ltd., 37
 Broadbent, 321
 Brochon, 313
 Browell, 85
 Brown, A. P., 71
 Browning, 67
 Bruhn, 21
 Brunel, 181
 Brunner & Co., 451
 Büchner, 469
 Buchholz, 176
 Buddæus, 355, 400
 Buddeus, 338

Buitron Pyrites Co., 90
 Bunsen, 180, 181, 182, 183
 Bunte, 481
 Buraczewski and Zbijewski, 271
 Burbury, 426
 Burgess, 10, 12
 Burkheiser, 139
 Burnard, 162
 Burt, B. C., 216
 Bussy, 252
 Busvold, 305

 CAILLETET AND MATHIAS, 178
 Callendar, 11
 Callendar and Moss, 11
 Calvert, G., 480
 Calvert and Johnson, 224
 Carieus, 59
 Carmichael, 413
 Carmichael-Bradford, 145
 Carmichael, J. F., & Co., 420
 Carmichael and Montgomery, 417
 Caron, 91
 Carpenter, 433
 Carpenter, F. B., 58
 Carpenter, F. R., 38
 Carpenter, R. F., 5, 428
 Carrier, 437
 Carson, 15
 Cellarius, 447
 Ceruti, 59
 Chance and Hunt, 36
 Chancel, 51
 Chandler, C. F., 32
 Channing and Falding, 413
 Channing, J. Parke, 147, 344
 Chappuis, 10
 Chaudron, G., 100
 Chemische Fabrik Greisheim-Elec-
 tron, 41
 Chemische Fabrik von Heyden, 56
 Chemische Fabrik Phœnix, Rohleder
 & Co., 36
 Chemische Fabrik Rhenania, 43
 Chem. Fabr. vorm. Weiler-ter-Meer,
 48
 Chemische Industrie Akt.-Ges. and
 Singer, 396
 Chemische Industrie Aktiengesell-
 schaft and F. Wolf, 422
 Chevreul, 480
 Chio, F., 111
 Christensen, 538
 Ciselet and Deguide, 139
 Clapham, 76, 82, 485, 501
 Clark, 315
 Claubry, G. de, 249, 255

- Claude, 395
 Claudet, 91, 526, 527
 Claus, 258
 Clayton, 311
 Clément, 5
 Clément-Désormes, 5, 74, 249
 Clemm, A., 104
 Clemmer, 501
 Clifford and Green, 32
 Coehn, 179
 Collett and Eckhardt, 454, 468
 Collins, C. G., 42
 Colson, 16
 Comp. ind. des Alcools de l'Ardèche,
 434
 Connolly, 33
 Consoli, 54
 Contamin, 315
 Cookson, N., 224
 Coombs, 313
 Coombs, F. E., 435
 Cooper, C., 175
 Copetti, V., 187
 Corleis, 112
 Cottrell, F. G., 444
 Craig, 189
 Craig, T. J. T., 105
 Crenshaw, 71
 Creutz, 530
 Cross and Higgin, 16
 Crowder, 365, 470
 Crowther, W., 421
 Crum, W., 292
 Cumenge, 91
 Cumming, A. C., 202, 212
 Cuyper, E. de, 535
- D'ARTIGUES, 74
 Dalton, 212, 249
 Daniel and Römer, 392
 Davis, 139, 140, 306
 Davis, H. J., 92
 Davis, H. S. and M. D., 62
 Davison, B. S., 305
 Davy, 249
 Dawdow, 280
 Debray, 221
 Debusch, 344, 416
 De Bechl, G., 415
 De Claubry, 249, 255
 De Cuyper, E., 535
 De Leemo, 15
 De Spirlet, 395
 De la Follie, 5
 De la Provostaye, 249, 256
 De la Tour Breuil, 34
 Délépine, 223
- Delplace, 133
 Dementieff, 54
 Demolen, 17, 18
 Demorest, D. J., 120, 121
 Dempwolff, 415
 Denigès, 185, 288
 Derome, 35
 Dervig, 163
 Descamps, 313
 Désormes, 5
 Deutsch Petroleum-A.-G., 46
 Deville, 195, 221
 Diehl, L. H., 430
 Dimitrow, P. and M., 102
 Dittmar, 195, 221
 Divers, 183, 489
 Dixon and Peterkin, 253
 Dobbie, J., 11
 Doeltz and Graumann, 409
 Dohet, 395
 Domergue, 67
 Domke, 202
 Donk, 197
 Dornæus, G., 3
 Dorr, 519
 Doss, 73
 Dowzard, 283
 Drasche, 126
 Drebbel, C., 4
 Drehschmidt, 483
 Drewsen, 426
 Ducancel, 57
 Ducco, 392
 Dumas, 429
 Dumont, S. et G., et Frères, 396
 Dunstan, 216
 Dunstan and Wilson, 216
 Durier, 60
 Düron, 393, 454
 Dusserre, 52
 Dwight and Lloyd, 417, 498
- EBOUGH, 116
 Edelenau, 438
 Edgen, 103
 Edmunds, 426
 Edwards, 172, 396
 Egestorff's Salzwärke, 452, 532
 Ehrenfeld, 279
 Eicke, 156
 Ektel, 95
 Ellis, 311, 535
 Elworthy, 431
 Emszt, K., 81
 Endell, K., 498
 Engeloff, 119
 Enklaar, 220

- Ephraim, 183
 Ernest, 396
 Erzröstgesellschaft, 389
 Esperanza Copper and Silver Co.,
 93
 Estelle, 416
 Eumorphopulos, 11
 Eustis, A. H., 435
 Evans, 538

 FABER, A., 46
 Fairlie, A. W., 445
 Fairrie, J. L., 394
 Falding, F. J., 336, 392, 442
 Falkenberg, 87
 Farbenfabriken vorm. F. Bayer & Co.,
 45, 429, 534
 Farmer, T., 75
 Fawcett, T. C., Ltd., 495
 Fawsitt, C. E., 244, 246
 Fawsitt and Pain, 245, 249
 Fawsitt and Powell, 244
 Favre and Silberman, 11
 Feld, 44, 69, 139, 316
 Feld, H., 47
 Fenton, 208
 Fèvre, N. le, 4
 Field, S., and Metals Extraction Cor-
 poration, 533
 Finch, 302, 304
 Fischer, F., 466, 467
 Fischer and Glund, 438
 Flasche, 425
 Fleitmann, 428
 Fleming, 34
 Fletcher, 147
 Flint, 67
 Foldalens Verk, 87
 Follie, De la, 5
 Fordos and Gélis, 223
 Forster, 181
 Fortmann, 463, 464
 Foucar, 140
 Fowler, 395
 Fox, J. J., 11
 Fox, P. F., 172
 Franke, 35
 Fräsche, H., 29, 373, 438
 Freeland and Renwick, 413
 Freese, 181
 Frémy, 258, 260
 Fresenius, H., 51, 58, 60, 80, 104,
 291
 Freytag, 152
 Friedheim and Nydegger, 111
 Friedrich, 16
 Fritzsche, 45, 139

 Fronzes-Diacon, 55
 Fuchs, P., 59

 GADIAS, L., 101
 Gaillard, 395
 Galaine and Hulbert, 438
 Gaon, W. von, 119, 287
 Garbett, 4
 Garner and Clayton, 429
 Garroway, 431
 Gaubert, 15
 Gayer and Witter, 448
 Gay-Lussac, 249, 251
 Geber, A., 3
 Genth, F. A., 126
 Gerdts and Strauch, 452
 Gerlach, 199
 Gerland, 433
 Gerstenhöfer, M., 358, 359
 Gewerkschaft Messel, A. Spiegel und
 P. Meltzer, 451
 Gibb, 501, 522
 Gibbon, E., 485
 Gilchrist, 450
 Giran, 197
 Girard, 83
 Giraud, 193
 Girod, 455
 Glendinning, 103
 Glover, J., 224, 319
 Glückauf, 156
 Godfrey, 417
 Godin, 356, 398
 Gossage, 501
 Gotthelf, 283
 Gottlieb, 108, 395
 Gouthière et Cie., 57
 Gouthrière, H., 139
 Grabowski, 536
 Graf, 8, 12
 Graffich von Landsberg-Velen und
 Gemensche Chemische Fabrik, 455
 Graham, 197, 212
 Greding, 452
 Greenaway, 391
 Greenwalt, W. E., 498, 539
 Greiner, J., 51
 Griess, 290
 Griffet, 68
 Grimm, 315
 Gröndal, 355
 Gröndal and Dellvik, 492
 Grossmann and Hölter, 121
 Gruener, H., 12
 Grünwald and Welsch, 395, 417
 Guédras, M., 499
 Guedrias, 116

- Guess, 121
 Guitard, 443
 Günther, 35
 Gutbier, 119
 Guttman, 4
 Gutzeit, 62, 64, 65, 283
 Gyander, 339

 HAAS, 187, 406
 Habermehl, 72
 Hacker, 216
 Hadfield, 320, 321
 Haege, 339
 Haesler, P. C., 456
 Hall, 526
 Hall, W. A., 36, 37, 396
 Hansen, 46
 Hantzsch, 195
 Harder, O. E., 242
 Hardingham, 395
 Hargreaves and Robinson, 540
 Harlan and Grenshaw, 334
 Harpf, 181
 Harpf, A., 432, 461, 467
 Harris, J. B., 376, 418
 Hart, E., 178, 228, 236, 411
 Hartmann and Benker, 390, 392, 450
 Haselhoff and Lindau, 150
 Hasenclever, 79, 147, 202, 387, 398,
 409, 414, 427, 462, 463
 Hasslinger, R. V., 61
 Hassreidter, 127, 128, 409
 Hassreidter and Van Zuylen, 111
 Hattensaur, 114, 116
 Hausmann, 277
 Hawley, 465
 Hawley, F. G., 121
 Heathcote, 246
 Heckel, 67
 Hegeler, 392
 Hegeler and Heinz, 433
 Hehner, 283
 Heidenreich, 120
 Heimrod and Egbert, 444
 Heine, 448, 451
 Helbig, W., 334, 357, 398
 Hellsing, 43
 Helsingborgs Kopparwerks A. B.,
 395, 508
 Hempel, 299, 466, 481, 484
 Henglein, 72
 Henry, W., 249, 251
 Henzke, 309
 Heraeus, 223
 Hering, C. A., 424
 Herrmann, 11
 Herreshoff, 377, 418, 451, 454, 455

 Herzig, 396
 Hesse, M., 47, 48
 Heyden, von, 179
 Heylands Co., 437
 Hildebrandt, 396
 Hildt, 48
 Hill, 74, 418
 Hiller, 143
 Hills, H. and Ch. H., 540
 Himmelbauer, 56
 Hjelt, 80, 92
 Hoffman, 38
 Hoffman, H. O., 410
 Hoffmann, A., 486
 Hofman, 75
 Hofmann, P. W., 529, 530
 Hohfield, 443
 Holker, 5
 Holker, Jean, 5, 6
 Hollins, C., 284
 Hommel, 394, 395, 396, 400, 401, 410,
 411
 Hommel and Durant, 452
 Hood, J. J., 53
 Hoover, 8
 Höpfner, 539
 Howard, 160, 448
 Howard, H., 277, 427
 Hübner, 395, 410
 Huff, 33, 34
 Humboldt Eng. Works, 391
 Humphries, H. P. P., 309
 Hunt, 313, 500
 Hunt and Gidden, 36
 Huntington and Heberlein, 414, 417,
 444, 449
 Hurt, 312
 Hybinette, 414

 IANDA, 67
 Imbert, 57
 Imeary, 356
 Iredale, T., 10
 Irmann, R., 242
 Italiener, 47

 JACQUELAIN, 197
 Jahl, 44
 Jamieson, 189
 Japp, 299
 Jene, 108
 Jenks, 396
 Jensch, 133, 410, 427
 Johnson, Ltd., 495
 Johnstone, 71
 Jolibois, P., 251
 Jones, 9

- Jones, D. W., 229
 Jones, J. G., 395, 412
 Jorissen, 197
 Juge-Goirard, G., 100
 Jungfleisch, 21, 181
 Jurisch, 79, 81, 256, 501, 535
 Juritzka, 409

KALINOWSKY AND ROTH, 395
 Kamura, H., 73
 Karaoglanow, Z., 102
 Kastle, 16
 Kauffmann, E. W., 164, 388, 389, 391
 Keane, C. A., 99
 Kedesdy, 187
 Kellas, A. M., 9
 Keppeler, 98, 343, 390
 Kerl-Stohmann, 351
 Kershaw, 420
 Kestner, 6
 Kienlen, 488
 Kingsley, 38
 Kirkby, 283
 Kirsch and Mausser, 395
 Kirschner, 452
 Kisling, 284
 Klason, 65, 69, 118
 Klason, P., 505, 506, 507
 Klason and Mellquist, 456
 Klemmer, G. K., and F. Pollak, 253
 Klencke, 456
 Knietsch, 198, 214, 219, 241, 245
 Knorre, 11, 483
 Knudsen, 86
 Koch, 112, 122, 489
 Koelsch, 119, 122, 126
 Koene, 249
 Köhler, 50
 Kohlrausch, F., 194
 Kohr, 285
 Kolb, 197, 207, 251
 Kolthoff, T. M., 187, 285
 Königshütte Berg- und Hüttenver-
 waltung, 531
 Kopp, 3
 Koppas, 139, 344, 424
 Kosmann, 429, 531
 Kothny, 501, 538
 Krauch, 279
 Kremann and Ehrlich, 216
 Krotoff, 312
 Krowatschek, 448, 452
 Kruyt, 16
 Kulisch, 57

LAMOUREUX, 39
 Lamy, 487

 Lange, A., 179, 436
 Larison, 20
 Lasne, 265
 Leaver, 539
 Leemo, De, 15
 Leeuw, 16
 Le Fèvre, N., 4
 Legge, 391
 Leithner, 540
 Lemaitre, H., 164
 Lémercy, N., 4
 Lemoine, 345
 Leplay, 147
 Lepsius, 139
 Levi, M. G., 59
 Libavius, 3
 Liebig, M., 127, 197, 411, 480
 Liebrecht, 456
 Liesche, 15
 Liffa, A., 81
 Liljenroth, F. G., 174
 Lindemann, 481
 Linder, 44
 Lindström, 72
 Lindt, 129
 Lippmann, 3
 List, 116, 120
 Litchy, 192, 193, 195
 Ljungh, 475
 Llewellyn and Spence, 431
 Lodge, O., 443
 Longmaid, 500
 Lotz, 183
 Low, 116, 122
 Lucas, 33
 Luck, 253
 Lumière, 14
 Lumière and Seyewetz, 14
 Lummen, 402
 Lunge, 58, 79, 91, 99, 101, 102, 110,
 117, 132, 139, 142, 161, 187, 190,
 252, 253, 257, 262, 263, 265, 267,
 275, 290, 291, 297, 299, 301, 303,
 304, 306, 334, 337, 356, 357, 358,
 362, 367, 434, 464, 465, 469, 476,
 478, 501, 522
 Lunge-Keane, 126, 285, 303
 Lunge and Naef, 194, 482
 Lunge and Stierlin, 128
 Lütgens, 161, 395, 452
 Lütgens and Ludewick, 396
 Lüty, 390
 Lyman, 314

 M'CAY, L. M., 113
 M'Crea, 16
 M'Dougall, 367, 406, 418

- M'Hargue, 16
 McCay, 223, 284
 McDowell, 72
 McFarland, D. F., 242
 McIntyre, 312
 McKellar, W. G., 238
 McMahan, T. J., 27, 40
 Macagno, 58
 Macaulay, R. M., 188
 MacCulloch, 82, 86, 91, 357
 MacDonald, 212
 Mactear, 6, 224
 Magnus, A., 3
 Magnus and Knapp, 27
 Malétra, 359, 363, 366
 Manchot, 271, 273
 Manchot and Huttner, 272
 Mansfield, 324
 Manufactures des Produits Chim. du
 Nord, Établ. Kuhlmann, 434
 Marchlewski, 112
 Marcille, 17, 67
 Marie, 223
 Marignac, 194, 217, 221
 Marreco, 85
 Marsden, 321
 Marsh, 280, 281, 288
 Marshall, 208
 Martin, 111, 411
 Martin, E., 105
 Maschinenbau - Anstalt Humboldt,
 391, 395, 412
 Maschinenfabrik Buckau, 452
 Maschinenfabrik A.-G. vorm. Wag-
 ner & Co., 396
 Mason, 540
 Mastbaum, 537
 Matthies, 12
 Maze, 18
 Mebus, E. A., 501
 Melliquist, 118
 Mendelejeff, 194, 202
 Mène, 69
 Mennicke, 108
 Merreywether, J. E., 278
 Merton, 395
 Meserve, 185
 Messel, 139, 284
 Metallbank und Metallurgische Ge-
 sellschaft, 395, 451
 Metallic Compounds Separation
 Syndicate, 450
 Metallurgische Gesellschaft, 452
 Metals Extraction Corporation, 532,
 533
 Meunier, 288
 Meyer, A., 55
 Meyer, F., 127
 Meyer, J., 14, 119, 287
 Meyer and Tannek, 287
 Michaelis, 452
 Michaelis and Schumann, 249, 255
 Miles, 208
 Miles and Sarginson, 307
 Millberg, 537
 Miller, E. Holl, 302
 Miller, G. E., 316
 Mixer, W. G., 106
 Mohnhaupt, 110
 Mohr, C., 104
 Moissan, 11, 16
 Moore, 451, 454
 Moore, H. C., 101, 102, 110, 207
 Moore and Wolf, 435
 Morgan and Davis, 216
 Morin, 83
 Morton and United Alkali Co.,
 443
 Moscicki, 425
 Moss, 11
 Mostowitch, 411
 Moulin and Vandoni, 433
 Mount, 396
 Mueller and Burgess, 10, 12
 Muer and Robb, 224
 Mulder, E., 180
 Müller, 249, 255
 Müller, A., 452
 Müller, W. J., 111
 Müller and Dürkes, 111
 Muspratt, E. K., 75
 Myhill, 140
 NAPIER AND TATLOCK, 225
 Nemes, 98, 390, 410, 411, 417
 Némethy, 453
 Nesbit, A. F., 446
 Nessler, 279
 Nestell and Anderson, 478
 Neumann, B., 27, 174
 Neumark, 452
 New Jersey Zinc Co., 38
 Nichols Copper Co., 344
 Nichols Copper Co. and Stout, 396
 Nickel, 111
 Nicolas, G., 18
 Nidenführ, H. H., 363, 456
 Nidenführ, O., 393, 407, 412, 438
 Nikaido, 110
 Nilson, 488
 Nitchie, 127
 Nonnet, 435
 Nordin, 45
 Norton, W. W., 417

- Nürnberg Consortium für elektroch.
Industrie, 46
- O'BRIEN, A. P., 442
- Oddo, 192, 195, 316
- Offerhaus, 415
- Ogata, 183
- Ogawa, 183
- Oknow, 71
- Olivier, 74
- Olivier and Perret, 357, 359, 360, 363
- Orkla Co., 87
- Orlow, 286
- Orong-Grube, 87
- Ost, 150
- Otto, 487, 488
- Overbury, 40
- Owens, S., 150
- PACOTTET, 437
- Pagliani, S., 317
- Palaschowski, 48
- Palet, L. P. J., 288
- Pape, 409
- Papish, J., 40
- Pappenheim, 104
- Parent, 395, 538
- Parr, 116
- Parsons and Stewart, 283
- Pascal, P., 434
- Pattinson, 76, 82, 85, 86, 91
- Paul, 15
- Pedersen, H. C., 38
- Pellet, H., 182
- Pelouze, 291
- Peniakoff, 428
- Peratoner, 60
- Peregrin, 285
- Perley, G. A., 174
- Perret and Son, 74, 76, 359
- Perry, 33
- Pezzolato, 541
- Pfaundler, 221
- Pfeiffer, 58, 140
- Phelen, 21
- Philipp, 259
- Phillips, 502, 526
- Phillips, H., 104
- Phipson, 137, 487, 502
- Pickering, 197, 202, 211, 217, 218, 220
- Pictet, R., 188, 211, 432, 437
- Pierron, 407
- Pintsch, 143, 312
- Piotrowski, 183
- Piperaut, 338
- Planchon, 299
- Platten, 116
- Plattner, 463
- Playfair, D., 485
- Plisson, 251
- Plummer, G. W., 70
- Pluver Crusher Co., 321
- Pohl, E., 161
- Poleck, 480
- Pollak, 483
- Pölt, 221
- Porter, 193
- Pöschl, V., 70
- Potut, 163
- Projahn, 454
- Projahn, F., 43
- Prost, E., 131, 224, 409
- Protinjanz, 16
- Provostaye, De la, 249, 256
- Püning, 452
- QUINCKE, F., 79
- RABE, 476
- Raffo, 8, 16
- Raffo and Mancini, 8
- Ramén, A., 369, 370, 371, 372, 492, 494, 496, 497, 505, 506, 508, 518, 522, 523, 525, 527, 532
- Ramén-Beskow, 507, 508, 511, 516
- Rammelsberg, 249, 254, 259
- Ramsay, 9
- Ramsay and Cundall, 253
- Randell, 48
- Raschig, 111, 258, 271, 273, 305, 474
- Rathbun, R. B., 445
- Rauch and Staub, 156, 183
- Rebling, 249
- Reed, 411
- Reese, 455
- Regnault, 213, 214, 345
- Rehmann and Mirbach, 452
- Reich, 38, 112, 467, 475, 476, 479, 485
- Reich-Lunge, 479
- Reichling, 451
- Reid, W. F., 5
- Reinders, 416
- Reinsch, 185, 279
- Renwick, 39, 395, 396, 417
- Reusch, 94, 390
- Reuss, 155
- Ricevuto, 241
- Richard, 538
- Richards and Hoover, 8
- Richardson, 283, 318, 356
- Richardson and Watts, 485
- Richmond, H. D., 278
- Richter, E., 464

- Ricketts and King, 354
 Rideal, S., 217
 Ridge, 129, 133, 375, 376, 400, 402
 Riegler, 110
 Riesenfeld, E. H., 46
 Rio Tinto Co., 90, 92
 Rippert, 156
 Rittener, 112
 Rivista, 91
 Robeson, 354
 Rodwell, 3
 Roebuck, 4
 Rose, A., 249, 256
 Rose, H., 174, 256
 Rosenheim, 280, 287
 Rossiter, 313
 Röstvangen Co., 87
 Rothe, 117
 Rubricius, 118
 Ruff and Graf, 8, 12
 Rupp, 305
 Ruthenburg, 39
- SABATIER, 272
 Saccharinfabrik A.-G. vorm. Fahl-
 berg, List & Co., 396
 Sachsenburger Maschinenfabrik, 314
 Sala, A., 4
 Salathé, 464
 Salomon, 299
 Sanborn, 40
 Sander, A., 188, 478, 479
 Sanfourche, A., 251
 Sarason, 13, 56
 Sarrasin, 396
 Saulles, 400
 Schaffner, 117, 487, 521
 Schäppi, 63, 65
 Schildhaus and Condrea, 431
 Schenck, 192
 Schenk, 343
 Scherfenberg, 395
 Scherfenberg and Prager, 395, 450
 Schertel, 194
 Scheurer-Kestner, 83, 171, 359, 464,
 466, 467, 469, 470
 Schindelmeiser, 280
 Schlippenbach, 415
 Schmidt, E., 225, 286, 288
 Schmieder, 407
 Schnabel, 424
 Schnorf, 359
 Scholtz, 111
 Schönfeld, 180, 181, 182
 Schönichen, 89
 Schroeder-Grillo, 392
 Schroeder and Haenisch, 425, 427, 434
- Schultz, F., 446
 Schürmann, 117
 Schutte and Koerting Co., 314
 Schütz, 400
 Schützenberger, 185
 Schwarz, 104
 Sclopis & Co., 84
 Scott, 177, 182
 Scott, A. R., 15, 55
 Seamon, W. H., 193
 Sebelien, 87
 Sébillot, 414
 Sedgwsek, 33
 Seidell, 185
 Selas, 396
 Selmi, 280
 Seybel and Wikander, 280
 Seyewetz, 14
 Shields, 9, 447
 Shimosé, 489
 Siemens and Halske, 532
 Simon-Carves, 454
 Singer, 396
 Sirovich, G., 71
 Skinner, L. B., 446
 Smith, 15, 103
 Smith, H. A., 485
 Smith, P. S., 40
 Smith, W., 66
 Smith and Carson, 15
 Smits, 15
 Smits and De Leemo, 15
 Société d'Éclairage, Chauffage et
 Force motrice, 36
 Société Nitrogène, 161
 Société minière et métallurgique de
 Peñarroya, 395
 Société Vieille Montagne, 406
 Somermeier, 73
 Sorauer, 150
 Sorauer and Ramann, 150
 Sorel, 74, 213, 215, 267, 269, 363,
 364, 365
 Spence, 356
 Spence, P., 539
 Spent Oxide Association, 140
 Spinzig and Hommel, 394
 Spirlet, De, 395
 Spitta, 427
 Sprague, 116
 Stahl, K. F., 95
 St Beuve and E. Marconnet, 393
 Stebbins, 316
 Steel, 61
 Steele, 461
 Stefano, 185
 Steinschneider, 3

- Stokes, 71
 Stout, 395
 Strache, 143
 Stuer, B. C., and W. Grob, 478, 479
 Sutcliffe, Speakman & Co., Ltd., 495
 Svovlsyre- og Superphosphat-Fabrik, 395
 Sweeting, 413
 Symon, 321

 TAFTO, J. L., 392
 Tait, 33
 Taix & Co., 74
 Tatlock, 184
 Taurel, 68
 Teed, Sulman, and Picard, 40
 Tennant, 165
 Tentelewsche Chemische Fabrik, 453
 Teschemacher, 103
 Thalin, 316
 Tharsis Sulphur and Copper Co., 90, 500, 508
 Thilo, 211
 Thomas, F., 408
 Thomsen, 11, 178, 193, 218, 220
 Thomsen Chemical Co., 56
 Thomson, 184
 Thomson, T., 75
 Thorp, T. E., 284
 Thorsell, 395
 Threlfall, 489
 Thwaites, 531
 Timm, 396
 Titus and Barenscheer, 411
 Tixier, 541
 Todd, 74
 Treadwell, 112, 120
 Trevor, G. T., 26
 Tromblee and Paull, 310
 Troost, 195, 344
 Truchot, 132, 390
 Tyers, Hedley, and United Alkali Co., 43
 Tyrer, 283

 UHL, 98
 United Alkali Co., 43, 71, 174, 339, 443, 508
 Usiglio and Dony, 357

 VADNER, 40, 452
 Valentine, B., 3, 4
 Van Zuylen, 111
 Vaton and Zuaznavar, 35

 Venables, 278
 Verein Chemischer Fabriken Mannheim, 49
 Vetterlein, R., 163
 Vigeon, E. C., and J. M'Conway, 519
 Vilstrup, 113
 Vincent, C., 34
 Vivian, 38
 Vogel, L., 159, 176
 Volhard, 109, 113, 305
 Von Gaon, W., 119, 287
 Von Heyden, 179
 Von Walther, R., 45
 Von Weimarn, 10

 WADE, 417
 Wagenmann, Seybel & Co., 395
 Wagner & Co., 394
 Wales, C. M., 238
 Walker, T., 413
 Walter, 212, 335
 Walter, A., 36, 50, 51, 54
 Walter, K., 372
 Walther, R. von, 45
 Wanklyn and Robinson, 221
 Ward, 4
 Wardlaw and Clews, 183
 Warren, 392
 Watson, 11
 Watson, C. S., 452
 Watson-Lunge, 126
 Watts, 318
 Webb and Taylor, 252
 Weber, 176, 192, 249, 255, 256, 261, 262
 Webster, 212
 Wedding and Ulrich, 503
 Wedge, U., 354, 417, 452
 Weidlein, E. R., 539
 Weimarn, Von, 10
 Weintraub, 266
 Weltzien, 249, 255
 Wentzki, 271
 Westergren, 352
 Westgate, 315
 Whalen, 316
 White, E. F., 34
 Wieler, 150
 Wikander, 531
 Wildenstein, 103, 104, 128
 Williams, F. M., 475
 Williams, P. E., 35
 Wilson, A. W. G., 16, 97
 Winkler, C. A., 221, 249, 252, 257, 262, 263, 265, 427
 Winkler-Lunge, 483

- Wislicenus, 150, 152, 153, 154,
156
Withers and Ray, 289
Witt, 253
Wocke, 395
Woehler and Mahla, 463
Wolf, 20, 139, 422
Worden and Motion, 202
Wright, 450
Wright, L. P., 38
Wright, L. T., 469
Wunderlich, 470
Wyld, W., 420, 525
- YANCY, H. F., 125
Young, S. W., 40, 41, 42
- ZAVELBERG, 396
Zay, C., 102
Zehetmayr, 111
Zelewski, 392, 393
Zellweger, 406
Zetsche, 396
Zschokke, 425
Zuaznavar, 35
Zulkowsky, 106
Zuylen, Van, 111

INDEX OF SUBJECTS

- ADULTERATION of sulphur, 55
 Allotropic modifications of sulphur, 14
 Ammonia oxidation, 166
 Analysis of commercial sulphur, 57
 Analysis of sulphuric acid, 274
 Arsenic, determination of, in sulphuric acid, 280
 estimation of, in sulphur, 61
 Available sulphur in pyrites, estimation of, 106
- BAUME'S hydrometer, 199
 Blake crusher, 319
 Brimstone. *See under* Sulphur
 Briquetting of cinders, 491
 Burner-gases, analysis of, 471
 composition of, 457, 466
 purification of, 452
 Burnt cinders, analysis of, 107
- CALCARONE method of sulphur manufacture, 28
 Calorific value of pyrites, 73
 Cast-iron, action of sulphuric acid on, 239
 Catalyst unit for oxidation of ammonia, 166
 Chamber crystals, 254
 Chloridising cinders, 507
 Coal-pyrites, 122
 Colloidal sulphur, 12
 Copper, extraction from cinders, 500
 Copper-matte, roaster for, 339
 Copper ores, smelting of, 413
 Copper-pyrites, 73
 as source of sulphur, 143
 Costs of ammonia oxidation, 173, 175
 Cottrell precipitator, 444
 Crushers for pyrites, 319
 Crushers, disc, 321
 gyratory, 321
 roll mills, 323
 Crystalline forms of sulphur, 68
- Cumming absorber for determining ammonia, 172
 Cyclone extractor for dust, 442
- DELPLACE furnace, 398
 Densities of sulphuric acid, 203
 Discovery of sulphuric acid, 3
 Dorr system of leaching, 519
 Dust-chambers, 440
 Dust, electrical precipitation of, 443
 settling of, 440
- ELASTIC sulphur, 10
 Estimation of fineness of sulphur, 51
 Estimation of moisture in sulphur, 57
 Estimation of sulphur in commercial sulphur, 58
 Explosive pyrites, 339
- FINENESS of sulphur, estimation of, 51
 Fire precautions with sulphur, 19
 Flowers of sulphur, 18
 examination of, 67
 manufacture of, 53
 Flue-dust, composition of, 484
 Fluorides in sulphuric acid, 224
 Frasch process of sulphur production, 29
 Fumes from acid-works, 151
 Furnaces for briquettes, 496
- GAS-VOLUMETER, 295
 Gill kilns, 28
 Gypsum as source of sulphur, 47
- HARRIS furnace, 376
 Hegeler furnace, 402
 Herreshoff furnace, 377
 Hydrogen sulphide as source of sulphur, 43
- IRON alloys, acid-resisting, 242

- JAW crushers for pyrites, 319
- KAUFFMANN furnace, 388
- Kilns for briquettes, 496
- LEACHING of cinders, 514, 519
- Lead, action of sulphuric acid on, 224
 chemical, 224
 effect of impurities, 226
 influence of, on specific gravity, 207
 Parkes, 231
 testing of, 225
- Lead chambers, introduction of, 4
- Lead ores, smelting of, 414
- Lead sulphate, solubility of, in sulphuric acid, 207
- Leather-tanning, use of sulphur for, 57
- M'DOUGAL furnace, 367
- Magnetic pyrites, 71
- Mansfield granulator, 324
- Marcasite, 69
- Mechanical burners for pyrites, 367
- Mercury, occurrence in blends, 131
- Monohydrated sulphuric acid. *See* under Sulphuric acid, pure
- NICKEL, occurrence in pyrites, 72
- Nitre, direct use of nitre for chambers, 162
- Nitre-oven, 157
- Nitric acid, use of liquid, for chambers, 160
- Nitric oxide, absorption by vitriol, 251
 properties of, 250
- Nitrogen oxides, supply to the chambers, 156
 for chambers obtained from ammonia, 166
- Nitrogen peroxide, 260
- Nitrogen trioxide, 253
- Nitrometer, use of, 292
- Nitrosyl-sulphuric acid, 255, 263
- Nitrous acid, 252
- Nitrous gases obtained as by-products fed to chambers, 165
- Nitrous oxide, properties of, 250
- Nitrous vitriol, analysis of, 300
 properties of, 266
- Noxious vapour containing sulphur, 149
- OXIDATION of ammonia to obtain nitrogen oxides, 166
- Oxygen in burner-gases, estimation of, 479
- PHYSIOLOGICAL action of sulphur dioxide, 183
- "Plastic" sulphur, 57
- Potting process of supply nitric acid, 157
- Price of pyrites, 97
- Pyrites, analyses of, 76 *et seq.*
 analysis of, 98
 as source of sulphur, 36
 calorific value of, 73
 commercial, 68
 crushers, 319
 estimation of arsenic in, 112
 estimation of carbon in, 112
 estimation of copper in, 119
 estimation of iron in, 122
 estimation of lead in, 122
 estimation of selenium in, 118
 estimation of zinc in, 117
 explosive, 339
 moisture in, 99
 price of, 97
 sources of, 76
 statistics relating to, 76
 "useful sulphur" in, 97
- Pyrites-burners, Harris furnace, 376
 Herreshoff furnace, 377
 Kauffmann furnace, 388
 Ramón furnace, 369
 Ridge furnace, 373
 Thorba furnace, 381
 Wedge furnace, 383
- Pyrites-burners, for lumps, 326
 for smalls, 352
 mechanical, 367
 working of, 341
- Pyrites-kilns, 326
- Pyrites-smalls, burning of, 352
- Pyrrhotite, 71
- RAMÓN furnace, 369
- Ramón & Beskow chloridising furnace, 508
- Refining of sulphur, 53
- Regulus metal, 225
- Ridge furnace, 373
- Roll mills for pyrites, 323
- SELENIUM in sulphur, estimation of, 65
- Selenium in sulphuric acid, estimation of, 286
- Selenium, recovery from chamber deposit, 487

- Silver recovery, 526
 Smelting fumes, utilisation of, 41
 Sodium sulphate, utilisation of, 534
 Specific gravities of sulphuric acid, 203
 Spent oxide as source of sulphur, 34
 Spent oxide, burners for, 418
 Spent oxide from gasworks, 137
 analysis of, 139
 composition of, 138
 sampling of, 140
 Spirlet furnace, 401
 Statistics of sulphur production, 20
 Statistics relating to pyrites, 76
 Statistics relating to zinc-blende, 133
 Storage of sulphuric acid in cast-iron vessels, 239
 Sulphites as source of sulphur, 45
 Sulphur, allotropic modifications of, 14
 boiling-point of, 10
 chemical compounds of, 16
 colloidal, 12
 commercial forms of, 18
 estimation of impurities in, 60
 from alkaline earth sulphides, 46
 from copper-pyrites, 143
 from gypsum, 47
 from hydrogen sulphide, 43, 142
 from kieserite, 46
 from Leblanc alkali-waste, 142
 from pyrites, 36
 from spent oxide, 34
 from smelting fumes, 41
 from sulphates, 46
 from sulphites, 45
 from sulphur dioxide, 29
 heat of combustion of, 11
 manufacture of commercial, 28
 molecular complexity of, 9
 natural occurrence of, 20
 properties of, 8
 refining of, 53
 solubility of, 8
 statistics of production, 20
 uses of, 19
 vapour pressures of, 11
 vegetable physiological action of, 17
 viscous, 10
 volatility of, 9
 Sulphur burners, cooling gas from, 318
 Hinzke's, 309
 Humphries', 309
 Queensferry, 307
 residue from, 318
 Sulphur burners (*contd.*)—
 temperature in, 317
 various, 310
 Sulphur dioxide, action on metals, 179
 as source of sulphur, 29
 carriage of, 436
 density of, 178
 density of solutions of, 179
 detection of, 184
 estimation of, 185
 flues for, 439
 formation of, 177
 heat of formation of, 178
 interaction with ammonia, 183
 interaction with oxygen, 179
 manufacture of, 306
 preparation of liquid, 432
 properties of, 176
 solubility in alcohol, 182
 solubility in sulphuric acid, 208
 solubility of, 180
 specific heat, 177
 uses of, 190, 437
 Sulphur sesquioxide, properties of, 176
 Sulphur trioxide, properties of, 191
 formation of, 193
 heat of formation, 193
 modifications of, 192
 specific gravity of liquid, 193
 Sulphuretted hydrogen as source of sulphur, 142
 Sulphuretted hydrogen, burners for, 422
 Sulphuric acid, action on cast iron, 239
 action on metals, 222
 action on steel, 243
 analysis of, 274
 aqueous tension of, 213
 chemical reactions of, 221
 decompositions of, 220
 densities of, 203
 freezing-points of, 211
 heat of dilution of, 218
 historical notes, 3
 hydrates of, 196
 influence of impurities, 208
 melting-points of, 211
 monohydrate of, 196
 physiological action of, 217
 properties of, 198
 specific gravities of, 203
 specific heat of, 217
 viscosity of, 216
 volatilisation of, 212

- sulphuric acid, pure, formation of, 195
 heat of formation of, 195
 properties of, 194
 specific gravity of, 194
 sulphuric anhydride. *See* Sulphur trioxide
 sulphurous acid, formation of, 180
 density of, 182
 sulphurous anhydride. *See under* Sulphur dioxide

 TEMPERATURE, effect on specific gravity, 206
 Thallium, recovery from flue-dust, 487
 Thiogen process, 41

 Thorba furnace, 381
 Twaddell degrees, relation to specific gravities, 201

 VEGETATION, action of sulphur on, 17
 action of sulphur dioxide on, 148, 183

 WEDGE furnace, 383

 ZINC-BLENDE, 125
 analysis of, 126
 furnaces for, 396
 statistics relating to, 133
 Zinc recovery, 529

THE END

LUNGE'S
SULPHURIC ACID AND ALKALI

NEW EDITION

*Forming a series of volumes greatly extended, completely
revised, and rewritten under the general title of*

THE MANUFACTURE OF ACIDS
AND ALKALIS

EDITED BY

ALEXANDER CHARLES CUMMING

O.B.E., D.Sc., F.I.C.

*A detailed list of the volumes already published or in course
of publication will be found on the following pages.*

Medium 8vo. 79 Illustrations and Diagrams. xvi + 542 pp.

RAW MATERIALS FOR
THE MANUFACTURE OF
SULPHURIC ACID
AND THE
MANUFACTURE OF
SULPHUR DIOXIDE

BY
WILFRID WYLD

CONSULTING CHEMIST

FORMERLY GENERAL TECHNICAL MANAGER OF MESSRS NICHOLSON AND SONS, LTD.
FORMERLY CHIEF ENGINEER OF MESSRS BROTHERTON AND CO. LTD.

CONTENTS

- Historical and General Notes on the Manufacture of Sulphuric Acid.
- Raw Materials of the Sulphuric Acid Manufacture.
- Properties and Analyses of the Technically employed Oxides of Sulphur.
- Production of Sulphur Dioxide.
- By-products in the Manufacture of Sulphuric Acid.

GURNEY AND JACKSON
LONDON: 33 PATERNOSTER ROW
EDINBURGH: TWEEDDALE COURT

THE MANUFACTURE
OF
SULPHURIC ACID
(CHAMBER PROCESS)

BY
WILFRID WYLD

CONSULTING CHEMIST
FORMERLY GENERAL TECHNICAL MANAGER OF MESSRS NICHOLSON AND SONS, LTD.
FORMERLY CHIEF ENGINEER OF MESSRS BROTHERTON AND CO. LTD.

CONTENTS

- Construction of the Lead Chambers.
- Recovery of the Nitrogen Compounds.
- Chamber Process (Starting the Chambers).
- Purification of Sulphuric Acid.
- Arrangement of a Sulphuric-Acid Works on the Chamber Plan; Yields and Costs.
- Other Processes for Manufacturing Sulphuric Acid.
- Applications of Sulphuric Acid.

GURNEY AND JACKSON
LONDON: 33 PATERNOSTER ROW
EDINBURGH: TWEEDDALE COURT

THE CONCENTRATION OF SULPHURIC ACID

BY
JOHN WILFRID PARKES

M.Sc. (Birmingham), A.I.C.

TECHNICAL SUPERINTENDENT, W. AND H. M. GOULDING LTD.
LATE CHEMICAL WORKS MANAGER, MESSRS KYNOCH LTD, EXPLOSIVES MANUFACTURERS,
ARKLOW, CO. WICKLOW

CONTENTS

- Introduction. Reasons for Concentration. Outline of Processes of Concentration.
- The Properties of Ordinary Concentrated Sulphuric Acid and of Anhydrous Sulphuric Acid.
- Concentration in Heated Pans or Retorts :—
Lead Pans heated from Above, Lead Pans heated from Below, Lead Pans fired by Waste Heat, Concentration in Steam-heated Pans, Glass Retorts, Platinum Stills, Porcelain Dishes and Beakers, Fused Silica Ware, Acid-resisting Iron, Cascade Plants, Iron Vessels.
- Concentration of Sulphuric Acid in a current of Hot Gases :—
In a Kessler Plant, Gaillard Plant, Gilchrist Plant.
- Various Methods of Concentration :—
In Vacuum Retorts, Tube Systems, by Electricity.
- Condensation of Sulphuric Acid Vapours :—
By Electrical Means, High-speed Scrubber.
- Recovery of Sulphuric Acid from Waste Acids :—
The Refining of Mineral Oils, Benzol Manufacture, Explosives and Nitration Processes.
- Concentration Costs.
- The Transport of Sulphuric Acid :—
Carboys, Tank Wagons, Acid Boats, Storage Vessels.
- Applications of Sulphuric Acid, and Statistics.

GURNEY AND JACKSON
LONDON: 33 PATERNOSTER ROW
EDINBURGH: TWEEDDALE COURT

THE MANUFACTURE
OF
Hydrochloric Acid
and Saltcake

BY
ALEXANDER CHARLES CUMMING, O.B.E.
D.Sc., F.I.C.

CONTENTS

- Properties of the Raw Materials and Products of the Hydrochloric Acid and Saltcake Industry.
- The Raw Materials and Products of the Manufacture of Saltcake and Hydrochloric Acid and their Analysis.
- The Manufacture of Saltcake and Hydrochloric Acid from Sulphuric Acid and Salt.
- Various Processes for the Manufacture of Sulphate of Soda Saltcake as a Principal Product from Common Salt.
- Manufacture of Sulphate of Soda by the Process of Hargreaves and Robinson.
- Manufacture of Pure Sodium Sulphate and Glauber's Salt.
- Absorption of Hydrochloric Acid.
- Manufacture of Hydrochloric Acid from Chlorine.
- Manufacture of Hydrochloric Acid by other than the Ordinary Methods.
- Weak Acid; Control of Condensation; Yields, Costs, Purification, Pumping and Conveyance of Hydrochloric Acid.

GURNEY AND JACKSON
LONDON: 33 PATERNOSTER ROW
EDINBURGH: TWEEDDALE COURT

THE MANUFACTURE
OF
Nitric Acid and
Nitrates

BY

ALLIN COTTRELL, M.Sc., F.I.C., M.I.CHEM. E.

LECTURER IN TECHNICAL CHEMISTRY, UNIVERSITY OF EDINBURGH
LATELY ACIDS MANAGER, H.M. FACTORY, GRKINA

CONTENTS

- Raw Materials for the Manufacture of Nitric Acid by the Retort Process.
- The Manufacture of Nitric Acid from Chili Saltpetre and Sulphuric Acid.
- Nitric Acid Manufacture—Analytical.
- Denitration of Waste or Spent Mixed Acids.
- Mixed Acids.
- Physical and Chemical Properties of Nitric Acid.
- Industrially Important Nitrates.
- An Acid and Water Balance.

GURNEY AND JACKSON
LONDON: 33 PATERNOSTER ROW
EDINBURGH: TWEEDDALE COURT

Medium 8vo.—Illustrations and Diagrams.

THE MANUFACTURE
OF
SULPHURIC ACID
(CONTACT PROCESS)

BY

F. D. MILES, M.Sc. (LOND.), A.R.C.Sc., F.I.C.

CONTENTS

- Historical Account of the Contact Process.
- Sulphur Trioxide and Oleum (Properties and Analysis).
- Gas-equilibrium and Velocity of Reaction.
- Catalysts and Contact Mass.
- Purification of Burner Gas.
- Converters and Conversion.
- Absorption of Sulphur Trioxide.
- Descriptions of Plants and their Operations :—
 - Grillo Plants of D.E.S., U.S. Government Plants,
 - U.S. Naval Proving Ground, Mannheim, Tentelew,
 - Simon-Carves, German Plants.
- Production and Costs.

GURNEY AND JACKSON
LONDON: 33 PATERNOSTER ROW
EDINBURGH: TWEEDDALE COURT

Medium 8vo.—Illustrations and Diagrams.

THE FIXATION OF Atmospheric Nitrogen

THE MANUFACTURE OF AMMONIA, NITRATES
AND OTHER NITROGEN COMPOUNDS FROM
ATMOSPHERIC NITROGEN

BY

JOSEPH KNOX, D.Sc.

LECTURER IN CHEMISTRY, UNIVERSITY OF GLASGOW

CONTENTS

- Fixation of Nitrogen as Nitric Oxide :—
 - The Nitric Oxide Equilibrium. The Oxidation and Absorption of Nitric Oxide.
- Technical Processes for Fixation of Nitrogen :—
 - The Birkeland-Eyde Process. The Schonherr Process. The Pauling Process. Other Arc Processes. The Hausser and other Combustion Processes.
- Fixation of Nitrogen as Ammonia :—
 - The Ammonia Equilibrium. The Haber Process. The Claude Process. Other Processes for the Synthesis of Ammonia and Ammonium and Ammonium Compounds.
- The Oxidation of Ammonia to Nitric Acid :—
 - Theory of the Oxidation of Ammonia to Nitric Acid. Technical Processes for Ammonia Oxidation.
- Fixation of Nitrogen as Calcium Cyanamide :—
 - Theory of Calcium Cyanamide Formation. Technical Production of Calcium Cyanamide and its Conversion to Ammonia.
- Fixation of Nitrogen as Cyanide.
- Other Processes for the Fixation of Nitrogen.

GURNEY AND JACKSON
LONDON: 33 PATERNOSTER ROW
EDINBURGH: TWEEDDALE COURT

DATE OF ISSUE

This book must be returned within 3/7/14 days of its issue. A fine of ONE ANNA per day will be charged if the book is overdue.

--	--	--	--

For Reference



NOT TO BE TAKEN FROM THIS ROOM.