

Birla Central Library

PILANI (Jaipur State)

Class No :- 1744-0623

Book No :- G292 I v.2

Accession No :- 2057

AN INTRODUCTION TO
ELECTRICAL DRAWING

IN TWO PARTS

BY

E. H. H. GIBBINS

B.Sc.(Hons.) (Lond.)

PART II

BLACKIE & SON LIMITED

LONDON AND GLASGOW

BLACKIE & SON LIMITED
50 Old Bailey, London
17 Stanhope Street, Glasgow

BLACKIE & SON (INDIA) LIMITED
Warwick House, Fort Street, Bombay

BLACKIE & SON (CANADA) LIMITED
Toronto

PREFACE

This book is a continuation of Part I without any introductory matter. The exercises in the first part are taken principally from distribution and switchgear whilst those in the second part deal with transformers, motors, and generators. The drawings have been grouped under subjects, and the exercises, taken generally, are of increasing difficulty.

By the time a student reaches this stage he will have acquired a knowledge of the underlying principles of motors and generators and be in a position to benefit by the notes opposite the drawings. Whilst this work is not intended to deal with electrical design it seemed desirable that the notes should give, not only a brief account of the parts represented, but also, in many instances, the factors which determine form and size.

For the assistance of those who have difficulty in visualizing an object from its orthographic projections the method of isometric projection has been adopted for many of the drawings, as in Part I.

The source of each drawing is acknowledged in the text and the author is deeply indebted to the firms mentioned for the information supplied and for permission to publish details.

The author again desires to thank Mr. B. J. Chubb, F.C.P., and Mr. W. Abbott, B.Sc., A.M.I.M.E., for their kindness in undertaking the arduous task of reading the proofs and checking the drawings.

E. H. H. G.

H. M. DOCKYARD SCHOOL,
DEVONPORT, 1928

First published 1928
Reprinted 1931, 1942, 1944

CONTENTS OF PART II

Transformers	Pages
Instrument Transformers - - - - -	4-7
Power Transformers - - - - -	8-11
 Motors and Generators	
General Details	
Keys and Shafts - - - - -	12-13
End plate and Bearing - - - - -	14-15
Pedestal Bearing - - - - -	16-17
Bearing Bushes - - - - -	18-19
 D.C. Machines	
Field Poles and Shoes - - - - -	20-21
Field Magnet Frames - - - - -	22-27
Brush Rocker Ring - - - - -	28-29
Brush Holder Bracket - - - - -	30-31
Brush Rockers - - - - -	32-33
Brush Holders - - - - -	34-35
Armatures - - - - -	36-41
Commutators - - - - -	42-45
 A.C. Machines	
Slip-ring Brush-holder Bracket - - - - -	46-47
Slip-rings - - - - -	48-49
Short-circuiting and Brush-lifting Device - - - - -	50-51
Rotors - - - - -	52-53
Rotor for Induction Motor - - - - -	54-55
Rotor for Turbo-alternator - - - - -	56-57
Stator Frames - - - - -	58-61
*Bracing for Ends of Stator Coils - - - - -	62-63

TRANSFORMERS

Modern generators in large power stations give heavy outputs and much of the current is often transmitted over long distances. It is the usual practice to generate alternating current at high tension or extra high tension. The pressure is reduced by means of step-down transformers before the current is passed into the feeders. These transformers are called **Power Transformers** (see pages 8-11). The instruments and automatic relays on the generating station switchboards are operated by low-pressure circuits from **Instrument Transformers**. This avoids supplying high-tension currents to voltmeters, ammeters, &c., and enables the whole of the high-tension circuit to be effectively enclosed and kept out of reach.

Transformers consist of two or more coils wound over an iron *core*, or within an iron shell; the coils to which current is supplied are called **primary coils**, those from which current is taken are called **secondary coils**. A variable current in the primary coil tends to cause a change of flux in the iron core, and because this flux passes through the secondary coil, a change in the primary current causes an E.M.F. to be set up in the secondary circuit. Generally, the ratio between the pressure in the primary, and the pressure in the secondary is approximately equal to the ratio between the number of turns in the primary and the number of turns in the secondary. Both coils, but especially the high-tension, must be efficiently insulated. A short-circuit across the secondary terminals may produce very high pressures in the primary windings and may cause electromagnetic forces sufficient to damage the winding. The cores are built up of laminations of soft iron or of special alloy which are held together by suitable *core clamps*. Laminated cores are essential in order to reduce to a minimum the eddy currents which are always produced in a core surrounded by a wire conveying a variable current. The laminations or stampings are from 10 to 20 mils thick and they are separated by insulation. The size of the wire for power transformer coils must be such that the maximum current can be carried continuously without overheating, and they should be able to carry an overload for a short time. Both power transformers and instrument

transformers are often oil-immersed, especially if the pressure exceeds 6600 volts. The drawings of transformers on pages 5 to 11 represent parts of plant manufactured by Messrs. Johnson & Phillips, Ltd.

Instrument Transformers are of two kinds: **Current Transformers** and **Pressure Transformers**. The former are used in connexion with ammeters and trip-coils; the latter are used for operating voltmeters and relays. For accurate ammeter readings, the secondary current in current transformers must always be proportional to the primary current, although the pressure will be much lower. The whole of the high-tension current passes through the primary coil, and the secondary of standard transformers is designed to give 5 amps. at full load. For ordinary switchboard instruments there are about 400 ampere-turns on the primary. When the primary current exceeds 400 or 500 amps. the primary coil may be reduced to a single rod or bar which passes through the cores. The primary of a current transformer acts as a choke coil, and may be subjected to very high pressures due to surges; the insulation of the coil must, therefore, be much heavier than that necessary for normal working conditions.

Fig. 1 on opposite page is an isometric view of a current transformer suitable for pressures up to 6600 volts. If this transformer is placed in an oil tank provided with suitable insulators it can be used for pressures up to 11,000 volts. Details of the windings are not shown, and the number of turns and size of the primary winding will depend upon the current; the primary is wound over the secondary and the coils are insulated by bakelite tubes and washers. The core is built up of stampings somewhat similar to those shown in fig. 4, p. 7. The two core clamps are castings and they are identical in shape and size. The terminal block and the leads to the secondary terminals have been omitted from the isometric view, but full details of the block and terminals are shown in plan and elevation, figs. 2 and 3.

The re-entrant angles formed by the webs and flanges of the core clamps represented on pp. 5 and 7, are not actually sharp angles as shown, but are somewhat rounded by the provision of fillets.

TRANSFORMERS

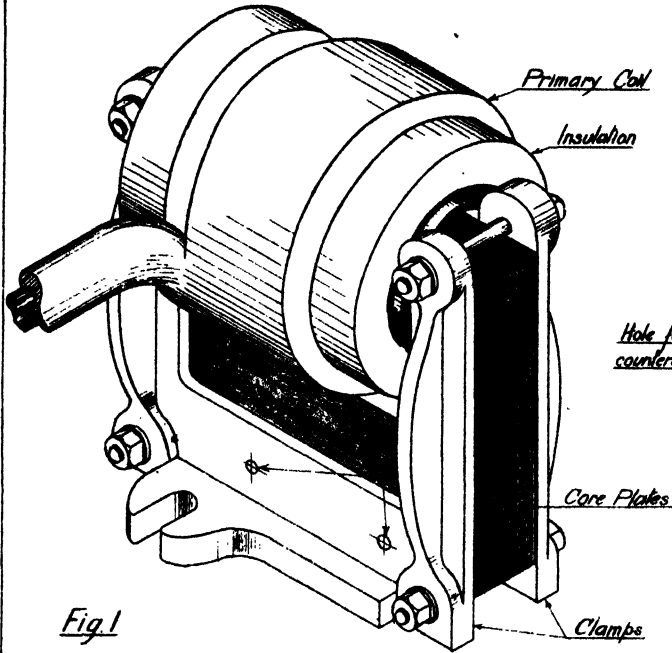

Fig. 1

Terminal Block
Elevation

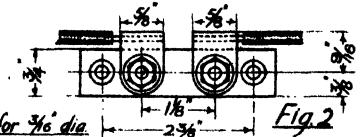

Fig. 2

Plan

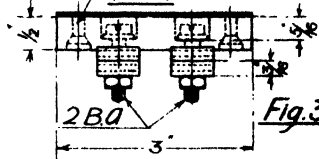

Fig. 3

Side Elevation (coils in section)

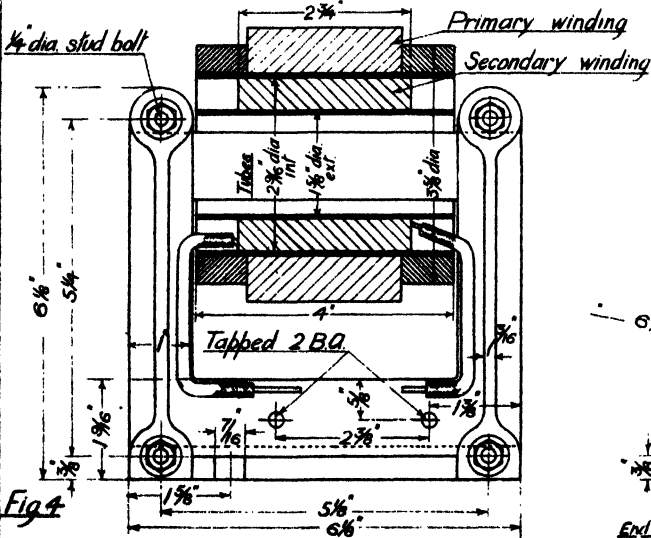

Fig. 4

End Elevation

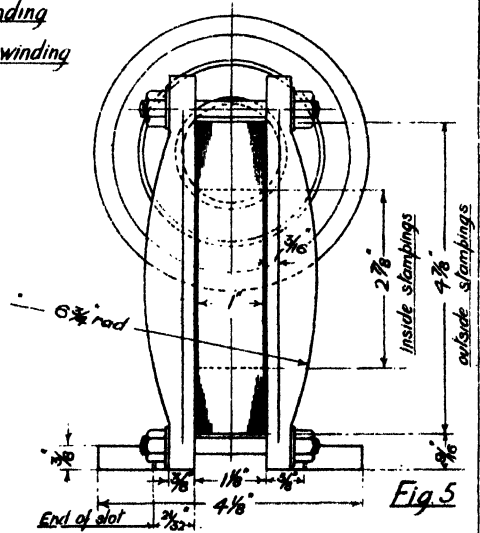

Fig. 5

TRANSFORMERS (Continued)

A **Bus-bar or Straight Through** type transformer is shown on opposite page. It is a current transformer suitable for heavy primary currents; the bus-bar passes through the core and takes the place of the primary coil. The core plates are held together by four core clamps and the transformer is secured by four bus-bar clamps. The form of the core clamps is shown in figs. 2 and 3, and a section is seen in fig. 1. Each clamp has a bolt hole at either end and a strengthening web on one side. Two bent plate bridges connect the ends of the clamps; on the right the bridge is above the secondary coil, on the left the bridge is below the coil. The short clamps which secure the transformer in position are seen most clearly in figs. 1 and 3. They project slightly beyond the inside edges of the core clamps (see fig. 1), whilst projections at the middle of each core clamp extend into the space between the bus-bar clamps (see fig. 3). The assembly of the core plates is shown in fig. 4. A break of joint is made by arranging for the joints in alternate plates to be as shown by the dotted lines. The secondary winding consists of two coils joined in series as shown in the plan. The bus-bar is insulated from the transformer by layers of tape, micanite or other suitable material, extending beyond the clamps far

enough to prevent surface leakage. The bus-bar consists of two copper plates separated by three distance pieces which are held in place by countersunk rivets (not shown in figs.). The main bus-bar is cut where this transformer is to be fitted, and the ends fitted into the spaces between the transformer bus-bar plates. Holes near the ends are for clamping into position. Transformers of this type are not suitable for immersion in oil, but if it is necessary to protect the windings they can be enclosed in a case filled with compound, and this is desirable in tropical climates where the windings are liable to be attacked by insects.

Potential transformers for the operation of voltmeters, &c., are similar to power transformers, but very much smaller. They are designed to give a standard secondary pressure of 110 volts, and special insulated terminals are provided on the H.T. side.

Instrument transformers which have to operate measuring instruments are designed so that the current ratio or voltage ratio, as the case may be, remains constant at all loads, and to do this it is necessary to keep the magnetic leakage as low as possible, and to use material for the core which will give low hysteresis and eddy current losses.

EXERCISES

(1) Draw a side elevation, an end elevation, and a plan of the current transformer illustrated on p. 5. In your views show the terminal block in position. Show the coils in section in the side elevation, as in fig. 4, using your judgment for approximate dimensions. Scale: full size.

(2) Draw a sectional end view of the transformer on p. 5, taking a vertical section plane at the centre of the transformer. Scale: full size.

(3) Draw an elevation, end view and plan of the core plate assembly for the bus-bar trans-

former on opposite page, with core clamps and bridge plates in position, but omitting all other details. Scale: full size.

(4) Copy the plan of the bus-bar transformer and project an end view. Scale: full size.

Note.—Many of the drawings on the following pages illustrate assemblies in which cores are built of stampings or laminations. It is not necessary to show these stampings as is done on the opposite page. Much time is saved by using the method on p. 21, where the fine lines are drawn only in the corners of the figures.

TRANSFORMERS (Continued)

Power Transformers.—In power transformers there are exactly the same essential parts as in instrument transformers, namely, core and core clamps, primary and secondary windings. When a transformer is in use, heat is produced in the windings and in the core, and in large transformers with heavy loads the heat produced may be so great that special means must be taken to dissipate it. The production of heat is a waste of energy and to obtain high efficiencies, transformers are designed so that as little heat as possible is produced. The losses are classed as: (a) copper losses in the windings; (b) hysteresis and eddy losses in the core.

If t is the thickness of plates in mm.

f the frequency of alternations;

B the maximum flux density;

F the form factor, (1.11 for sine curve);

s the specific resistance of core,

the eddy current losses in a transformer are

$\frac{.785(tfBF)^2}{s \times 10^{-8}}$ watts. The formula of Steinmetz

for hysteresis loss is $\eta f B^{1.6} \times 10^{-7}$ watts, where η varies from .001 to .002. It is therefore necessary to keep the value of B as low as possible. A flux density of 4000 to 10,000 lines per square centimetre is used. The coils are made as short as possible, and the cross section of the yoke parts of the stampings is made larger than the cross section of the core parts, as this tends to reduce the copper and iron losses to a minimum.

Power transformers may be for either single-phase, two-phase, or three-phase circuits with separate high-tension and low-tension coils for each phase.

The drawings on pp. 9 and 11 show a three-phase, oil-immersed, self-cooled transformer for 400 k.v.a. at 6500 volts primary, 443 volts secondary, at 25 cycles. The general arrangement of core, clamps, and windings is shown in the isometric view, fig. 1 on opposite page. The core assembly is shown in fig. 4. On the

left-hand side of this figure, part of the core clamps are shown; these consist of four 11" channel bars, and the upper and lower clamps are connected by eight 1" diameter bolts. The arrangement of the core plates can be seen from the sectional view, fig. 5; the core plates are stepped so that the core shall lie inside a circle 9½" diameter. The yoke portions at the top and bottom are stepped in one direction only (see fig. 2 on opposite page, and fig. 2, p. 11). Eighteen insulated bolts, ½" diameter, pass through the core plates. Below the bottom yoke and above the top yoke the spaces formed are filled in with wood. Two 5" channel bars connect the bottom clamps and three similar bars connect the top clamps. Another 5" channel bar extends over the whole length of the transformer, and is long enough to reach into the guides at the ends of the oil tank, p. 11. The eyebolt for lifting the transformer passes through two channel bars.

There are three vertical cores and a primary and secondary coil are wound over each, one pair for each phase. The primary coils are outside, the secondary inside. Each primary coil is made in one length but each secondary is made up of 18 sections joined in series. Special care is taken to provide effective insulation between the primary and secondary windings especially near the ends of the primary as these parts are liable to be subject, not only to considerable mechanical force, but also to very high potentials when switching operations take place.

The various sections of the primary windings are separated by fullerboard sectors; these are shown in figs. 2 and 3 on opposite page. Ducts are formed between the sectors so that the oil in which the transformer is immersed can circulate freely round the coils and help to carry away the heat produced.

Clamping arrangements are provided for holding down the coils. These are attached to the upper core clamps, but they are not shown in the figures.

TRANSFORMERS

Part Assembly

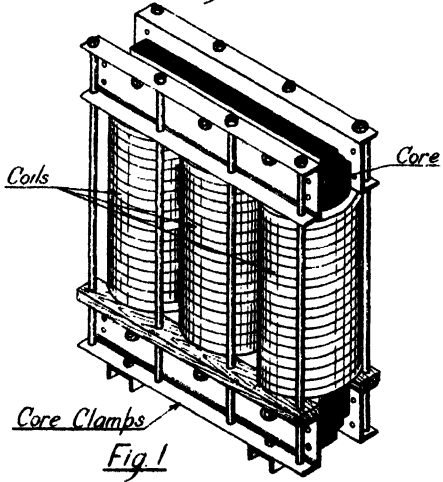

Fig. 1

Coils and Spacing Sectors

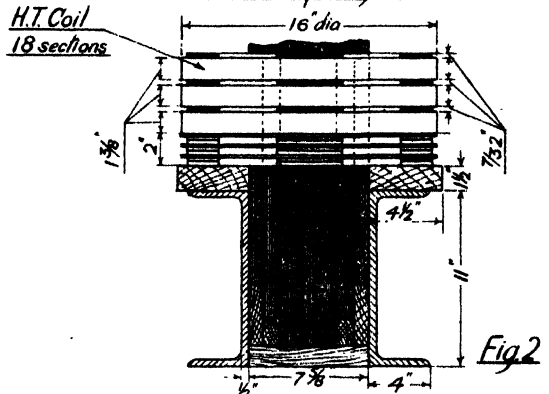

Fig. 2

Secl. Plan of Fullerboard Sectors

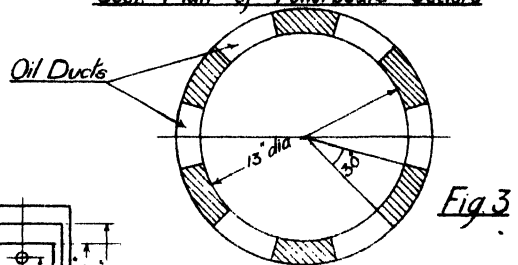

Fig. 3

Core Assembly

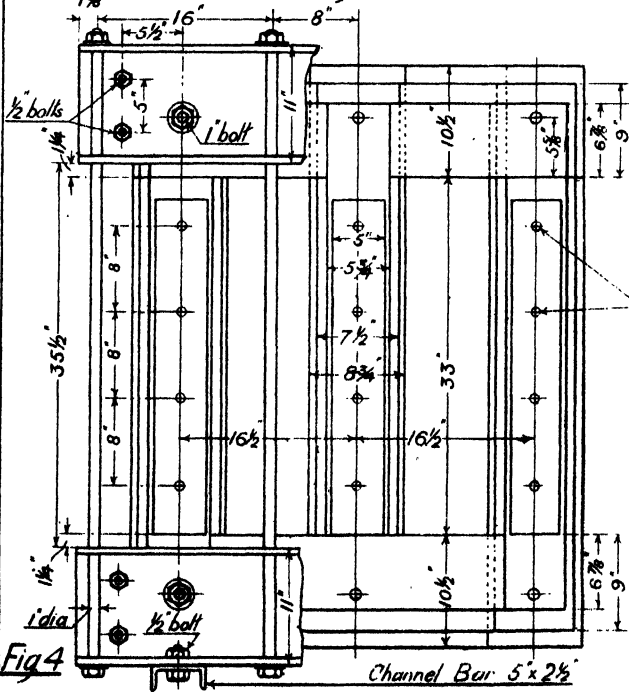

Fig. 4

Channel Bar 5 x 2 1/2"

Section through Core Plates

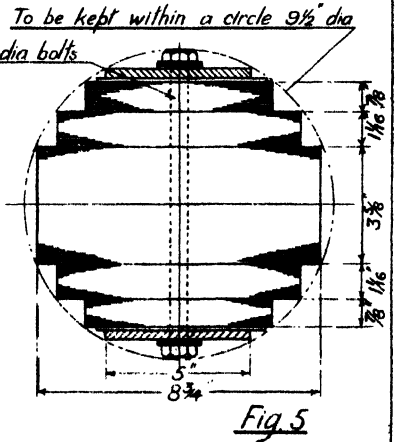

Fig. 5

TRANSFORMERS (Continued)

Oil Tank.—In large power transformers the losses, although only a very small percentage of the total power transformed, may produce considerable rise in temperature unless special methods are adopted to dissipate the heat. Cooling is effected by immersing the whole transformer in a tank of oil and causing the oil to circulate. The hot oil may be passed through air-cooled or water-cooled pipes. Figs. 3 and 4 on opposite page represent an oil tank for the transformer shown in the previous figures. It is built of steel plates and stiffened with angle bars. One of the structural difficulties in connexion with oil tanks is to secure oil-tightness and the joints are often welded. In the tank shown, the oil is cooled by air, the heat passing not only through the sides of the tank but also through the walls of a number of pipes in which the oil circulates. There are 80 pipes in all, 30 on each side and 10 on each end, and the circulation of oil is maintained by convection currents. Guides are fitted inside the tank at each end to hold the transformer

in place. The tank is entirely closed by a cover plate which is bolted to a flange round the top of the tank. It is very essential that moisture should be excluded, and therefore calcium chloride breathers are fitted so that air which enters owing to change of temperature may be perfectly dry. The lifting arrangements consist of two plates at each end with holes near the top for 2" diameter pins. Various other details not shown in the drawings are usually fitted. These include a vertical stand pipe in one corner, a short tube at one end to form a thermometer pocket and an oil gauge.

Connexions.—Terminals are fitted to the sides of the tank; the high-tension terminals on one side, the low-tension terminals on the other. Suitable porcelain insulators must be used on the high tension side. Some of the sections of the primary windings are connected to terminals near the top of the transformer and, by short circuiting certain sections with links, the transformer may be used for a range of primary pressures.

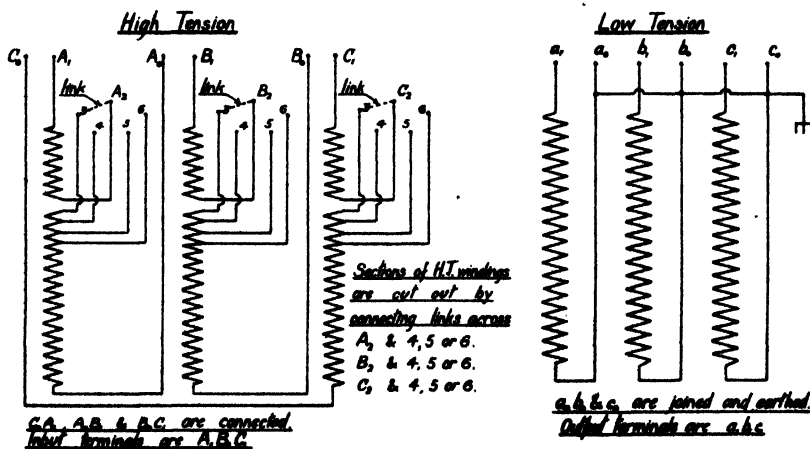

EXERCISES

- (1) Draw an elevation of the complete core assembly for the power transformer and add a plan and end view. Scale: 1" = 1 foot.
- (2) Make a horizontal section through the centre of the core assembly. Scale: 2" = 1 foot.
- (3) Draw an end view of the complete trans-

former (without the oil tank). Scale: 1½" = 1 foot.

(4) Copy the sectional elevation of the oil tank and add a plan. Scale: ½" = 1 foot.

(5) Make a wiring diagram for the transformer similar to that shown.

TRANSFORMERS

Arrangements for lifting

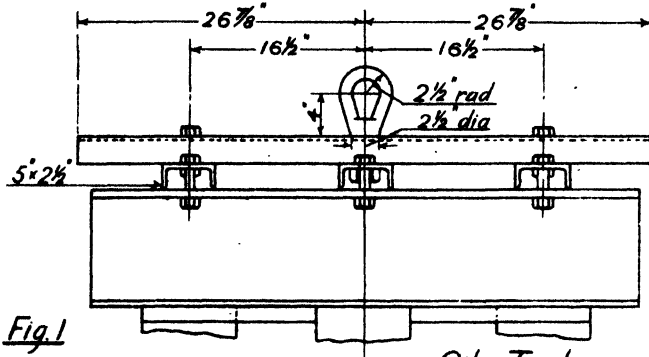

Oil Tank

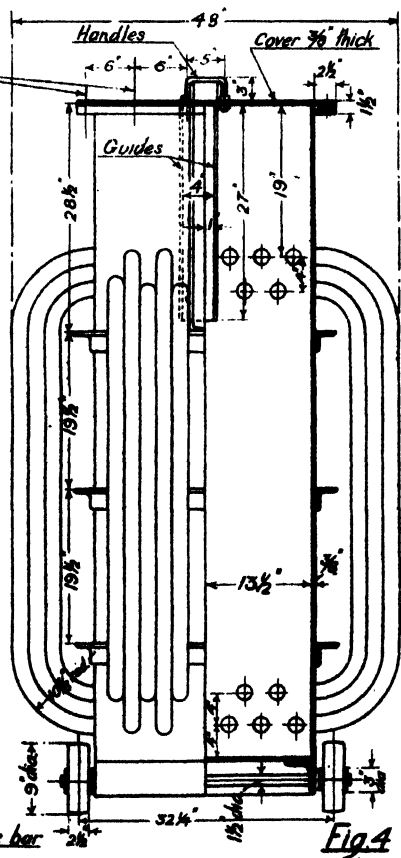
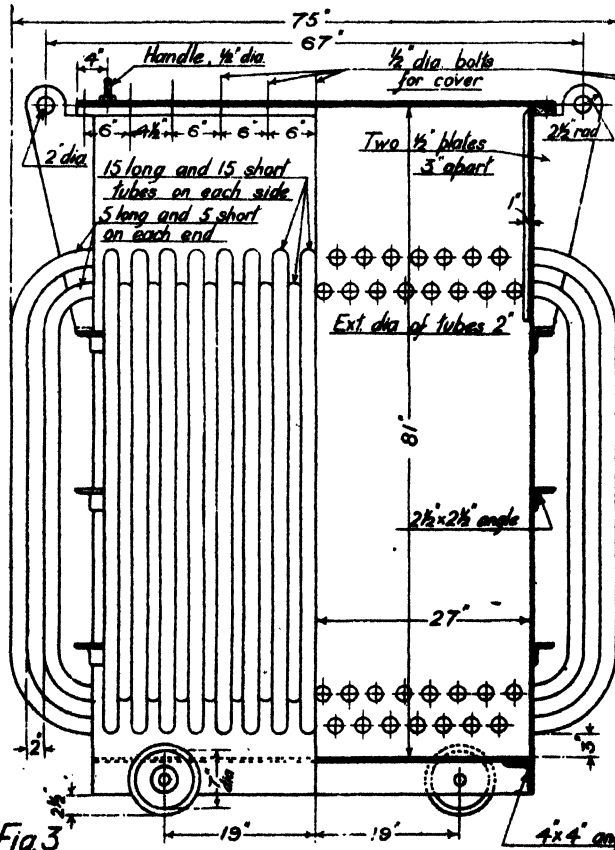
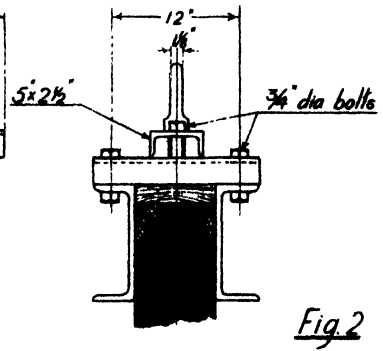

KEYS AND SHAFTS

Shafts are made from either mild steel or high carbon steel; they are turned to size from shaft steel bars or from forgings. The diameter of a shaft may vary considerably from point to point along its length, and in order to provide the necessary stiffness the diameter at the middle is greater than the diameter at the ends. Rotor spiders or armature and commutator spiders are keyed to the shafts between the bearings and these contribute to the stiffness. The spiders are fitted tightly against shoulders which are turned on the shaft at suitable points and are thus prevented from slipping out of place. Sometimes set-screws are used to secure the spiders, holes being drilled in the shaft to take the points. The diameter of a shaft has to be determined from considerations of strength and stiffness. The shaft has to transmit a torque from pulley to armature in a dynamo, and from armature to pulley in a motor, but it has to resist also a bending moment due to the weight of the various parts, and the pulls in the driving belt. But in addition to this, further bending moments may be produced by unequal magnetic forces in the fields. If the shaft bends appreciably the field intensity between armature and field pole will increase and cause further bending. It is therefore necessary to make a shaft very stiff especially when the clearance between armature and field poles is very small. If a shaft is not sufficiently stiff excessive vibration may occur when running near the critical speed, and shafts are designed so that the critical speed shall be as far as possible from the normal running speed. Usually, if a shaft is sufficiently stiff it will be capable of transmitting the maximum torque.

Keys and Keyways.—There are several forms of keys; saddle keys, sunk keys, keys on a flattened part of a shaft, &c., but only the sunk keys are commonly used in electrical engineering.

Fig. 1 shows a sunk key. This type of key is used for pulleys, armature spiders and rotors. The key is recessed into the shaft as shown in fig. 2.

Fig. 3 represents a feather key. This type of key is used when the part is free to slide along the shaft but must rotate with it. Both key and keyway have semicircular ends. Ordinary sunk keys have parallel sides with a slight taper of about 1 in 100 in the thickness, but feather keys have no taper. Feather keys are often secured to the shaft or to the sliding part with countersunk screws.

Fig. 4 shows a taper key with a head for driving it back; headed keys are often used for pulleys, and in positions where it would be difficult to drive the key back from the thin end.

The dimensions of a sunk key may be taken to be approximately as follows: Width = $\frac{1}{2}$ diameter + $\frac{1}{8}$ ". Depth = $\frac{1}{3}$ diameter.

The dimensions of keys recommended by the British Engineering Standards Association are given in their Report No. 46 (1909).

Fig. 5 represents a motor shaft; the positions of the armature laminations, commutator, &c., are indicated. There are two keyways, one for the armature and one for the pulley.

Fig. 6 represents a motor shaft. Ball bearings are used in this machine and the screw threads are for nuts which hold the inner races.

The shaft shown in fig. 7 is for a machine made by Messrs. W. H. Allen, Sons & Co., Ltd., for direct coupling to another shaft. The shaft is forged with a flange on one end with six bolt holes, and the bolts pass through corresponding holes in a similar flange on the other shaft. *Oil-throwers* or *flirts* are turned on the shaft near the bearings to prevent oil creeping along the shaft and coming into contact with the insulation.

EXERCISES

(1) On a length of shafting 3" diameter, turned down to 2½" diameter for a distance of 7" from one end, show two keyways, one for an ordinary sunk key, the other for a feather key. Each keyway to be 5" long. Make sections through the keyways showing the keys in place.

(2) Copy fig. 5. Give the overall dimension

and add end views and a section through the centre. Scale: half full size.

(3) Draw the elevation of the shaft shown in fig. 6. Add end views and a section through the centre keyway. Scale: 2" = 1 foot.

(4) Draw an elevation and end views of the shaft shown in fig. 6. Scale: 2" = 1 foot.

KEYS AND SHAFTS

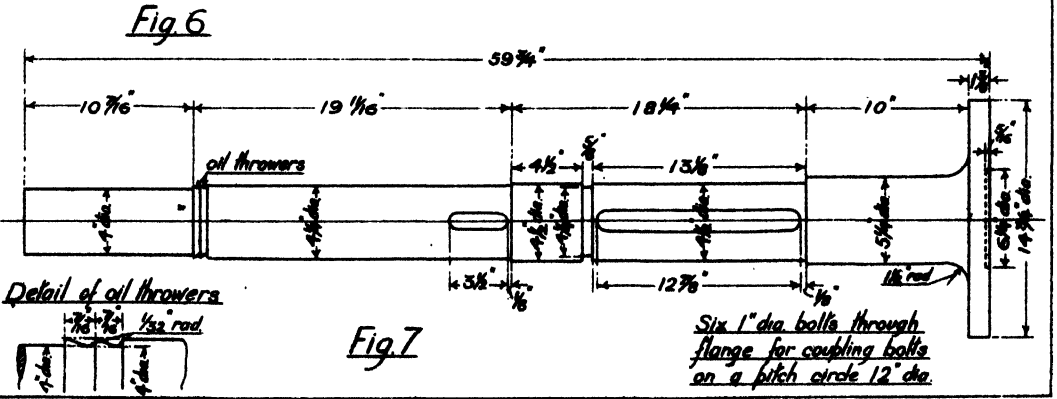
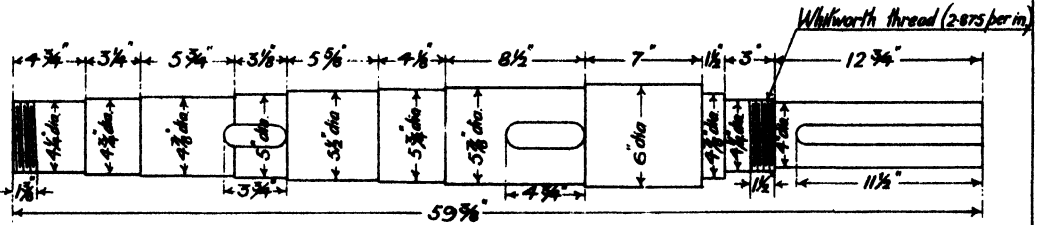
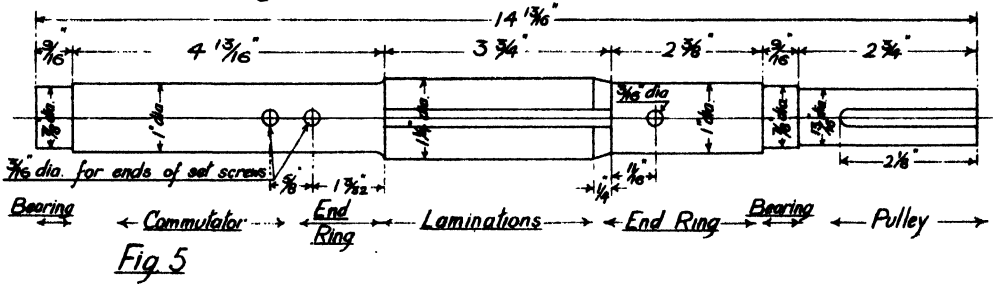
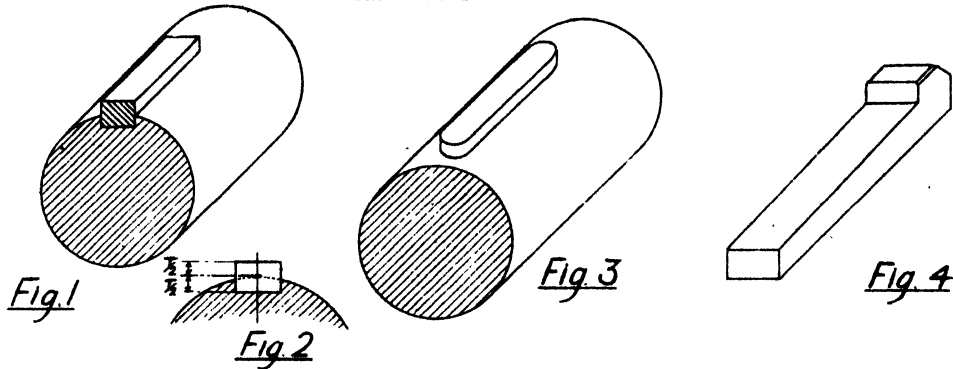

END PLATE AND BEARING

End plates are castings which are bolted to the field magnet frame so as to enclose most of the rotating parts and, in small machines, they carry the bearing bushes. The shape and dimensions depend upon the type of machine and the size of the field magnet frame. In some motors the end plates are solid so that the motor is totally enclosed. This is desirable in mill motors and traction motors where dirt or water would be liable to get into the machine, but otherwise the end plates have two or more arms, the space between the arms being left open or filled with expanded metal. The yoke and end plates are machined where they come together and connexion is made by bolts. The two end plates are sometimes almost identical, but in some motors the plate at the commutator end is much deeper than that at the pulley end in order that the brush gear may be reached through the space between the arms.

The figures on the opposite page show an end plate for a 3-h.p., protected, squirrel cage, induction motor made by Messrs. Metropolitan Vickers, Ltd. The end plate is bolted to the stator frame by four bolts and there are four radial arms. The sectional elevation is taken along a line ABC. This method of showing a section is often used when an object is symmetrical about a centre line as it really gives two sections in one view. It is only necessary to show a small part of the end elevation; from this the complete elevation is obvious.

Bearing.—End plates can be arranged to

carry the ordinary bearing bushes (either plain or with oil ring lubrication), or they may be designed for ball or roller bearings. Many machines are now fitted with the latter. For small motors a single ball bearing at each end is sufficient but for heavy loads roller bearings are to be preferred. If rollers are used a ball bearing must be fitted in addition at one end (location bearing) to prevent any lateral motion. Ball and roller bearings are manufactured by specialists and the electrical engineer designs the housing to fit a standard bearing. The makers of the bearing specify the inner diameter of the inner race, i.e. the shaft diameter, and the outer diameter of the outer race, i.e. the diameter of the hole in the end plate. They also specify what tolerances can be permitted in these dimensions.

Fig. 1 shows a section through a single ball bearing. The bearing consists of an inner race, an outer race and the cage containing the balls. The outer race is stationary and should be a tight fit. It is held in position by spigots on the cover plates. The inner race abuts against a collar on the shaft. In many instances the inner race is held in place by a nut on the shaft; fig. 6 on p. 13 shows a shaft with threads cut on it for this purpose. The cover plate through which the shaft passes has a groove cut in it so that when filled with grease an effective dust seal for the bearing is formed. Four long $\frac{3}{8}$ " diameter bolts hold the cover plates in position.

EXERCISES

(1) Draw a complete end elevation of the end plate (fig. 2) and project a plan. Scale: half full size.

(2) Draw a complete vertical section through the centre of the bearing. Scale: half full size.

(3) Draw an end elevation of the end plate without the bearing or cover plates and add a section through one of the arms. Scale: half full size.

END PLATE AND BEARING

Part Sectl. Elevn. at ABC

End Elevation

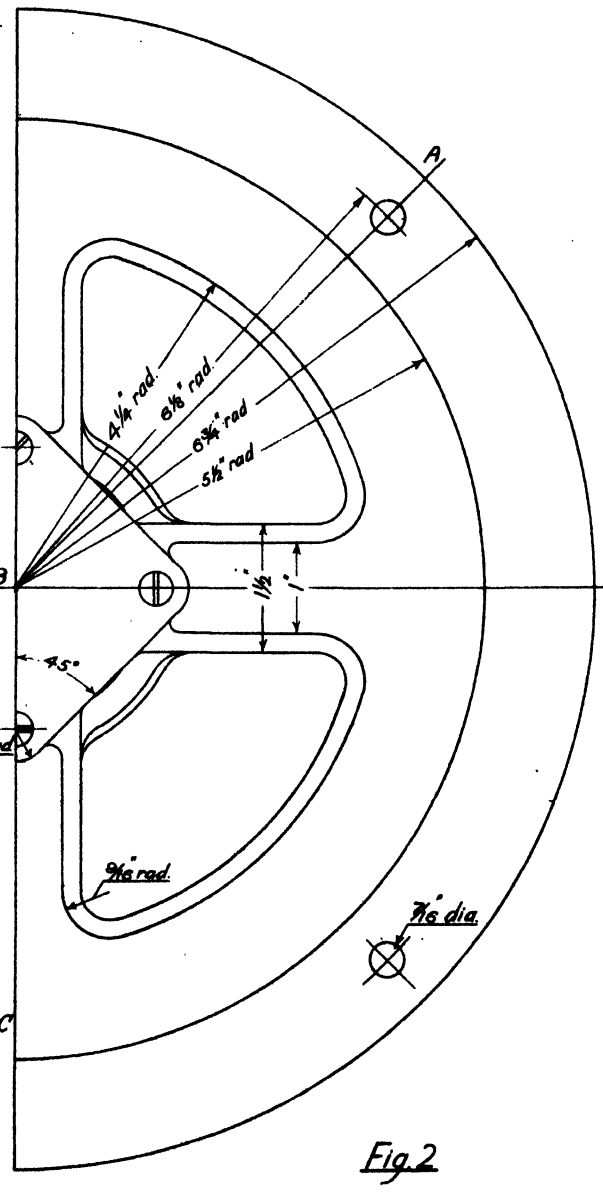
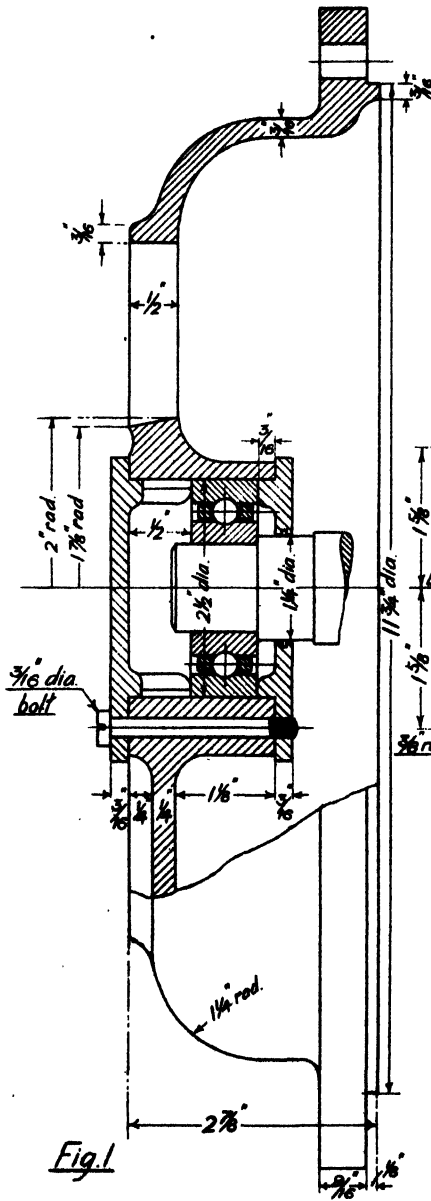

Fig. 1

Fig. 2

PEDESTAL BEARING

The bearings for large machines are not carried on the end plates but on pedestals, the field magnet frame and the pedestals being bolted to a steel base frame. Whilst the pedestal must be quite rigid it should be as light as possible and it is therefore formed of a hollow casting, wider at the bottom than at the top with an enlarged part at the top for holding the bearing bushes. The shape of the casting must depend to some extent upon the type of bearing. With roller bearings a plain hole is drilled for the races, and cover plates are fitted to keep the races in position. With ring oiled bearings a reservoir is formed below the bearing bush to contain the oil into which the rings dip, and a cap must be provided so that the bearing bush can be put in place and secured.

Pedestal.—Fig. 3 on the opposite page represents a pedestal for a machine made by Messrs. W. H. Allen, Sons & Co., Ltd. One corner of the figure is cut away to show the interior. The casting is hollow with a horizontal web to form the bottom of the oil reservoir below the bearing. The bush rests on three fitting strips, and the upper part of the casting is extended beyond the outer fitting strips to form pockets. The bush is entirely within the casting, and oil which drains from the ends of the bush, drops into the pockets and returns to the oil reservoir through slots $1\frac{1}{2}$ " wide. The oil rings hang in the spaces between the fitting strips. Feet are cast on the pedestal for bolting down and the bolt holes are *cuttered* or slightly recessed to form good surfaces for

the holding down bolts. Lightening holes are formed in the lower part and these give access to the oil drain which is screwed into the horizontal web. The top of the pedestal is slightly enlarged to give sufficient material for drilling and tapping the $\frac{3}{4}$ " diameter holes for the cap bolts.

The **Cap** is shown in figs. 2 and 4. It is cast in one piece and fits the top of the pedestal accurately, the surfaces which come into contact being machined. The isometric view (fig. 2) shows only one half; the front part is cut away so that the inside may be seen. The cap and pedestal are bored to receive the bearing bush. An oil hole $5\frac{1}{2}$ " long is cast in the cap and the sectional elevation (fig. 4) is taken through the oil hole, about 1" from the centre. The cap bolt holes are drilled through bosses but to make room for the bolt heads pockets have to be formed in the cap; these are shown in the sectional elevation. A hole $\frac{9}{16}$ " diameter in the centre of the cap is for a projection on the bush which prevents rotation with the shaft.

Oil Hole Cover.—Details of the cover are shown in fig. 1. It is a rectangular casting which just fits over the oil hole. The top is curved to a radius of 11", and the under side is recessed to fit over the projecting rim on the cap. The hinge block is drilled with two countersunk holes for the screws which secure it to the flat part of the cap. Holes for these screws are not shown in the figures.

Pedestal, cap and cover are made of cast iron.

EXERCISES

(1) Draw an end elevation and plan of the pedestal without the cap.

(2) Draw the sectional elevation of the pedestal taking the section plane through the axis of the shaft.

(3) Make a vertical section of the pedestal at right angles to the shaft. Take the section plane at the centre.

(4) Draw a sectional side elevation of the cap and project a view looking from below.

(5) Draw a side elevation and plan of the complete pedestal with cap and cover in place. Show the cap bolts.

(6) Make a sectional elevation of the complete pedestal at right angles to the shaft taking the section plane 5" from the centre.

Scale for the exercises: 3" = 1 foot.

PEDESTAL BEARING

Oil Hole Cover

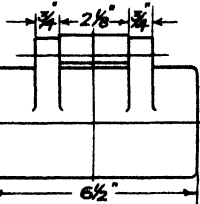

Fig. 1

Hinge block 7/8 sq.

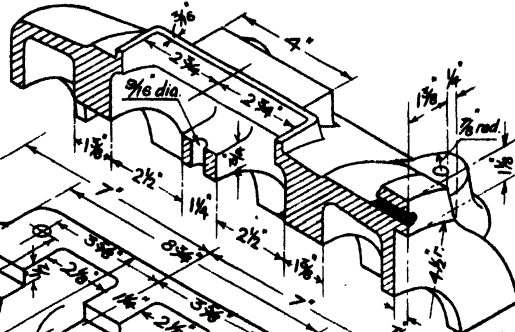
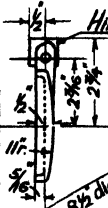
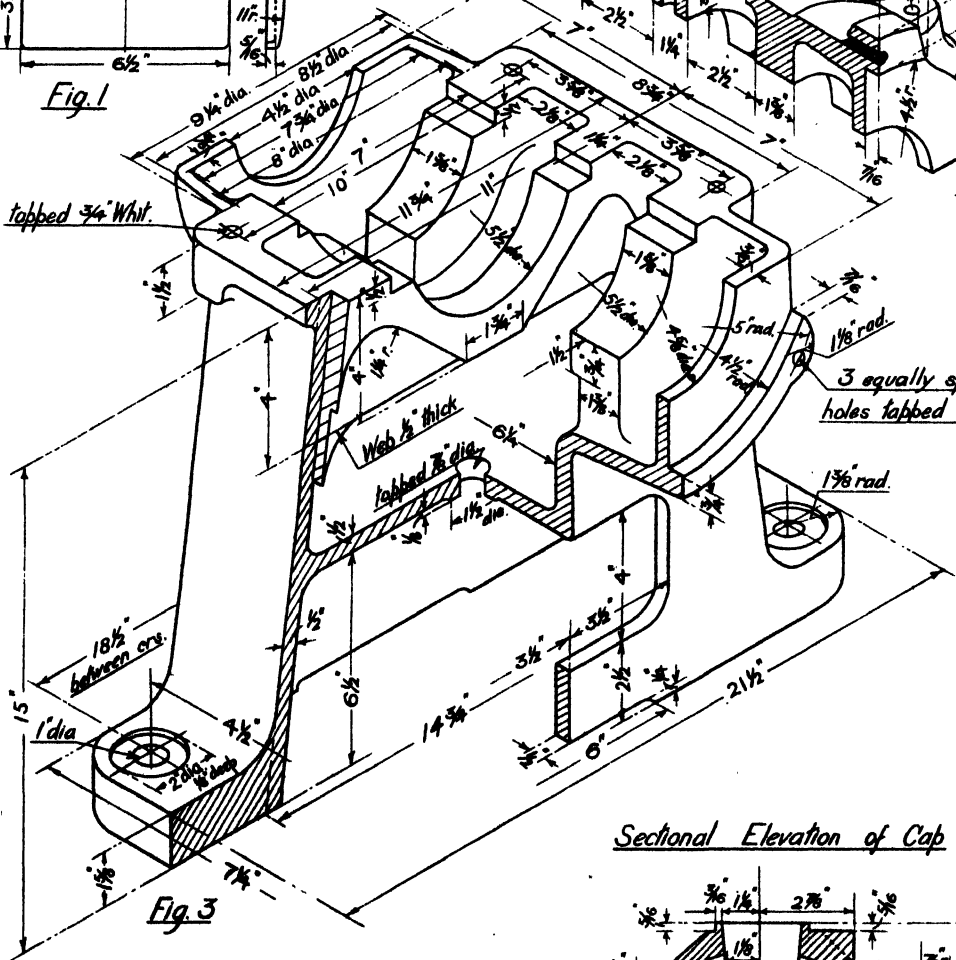

Fig. 2

tabbed $3/4$ Whit.



3 equally spaced
holes tabbed $1/2$ Whit.

Web $1/2$ thick

tabbed $7/8$ dia.

Fig. 3

Sectional Elevation of Cap

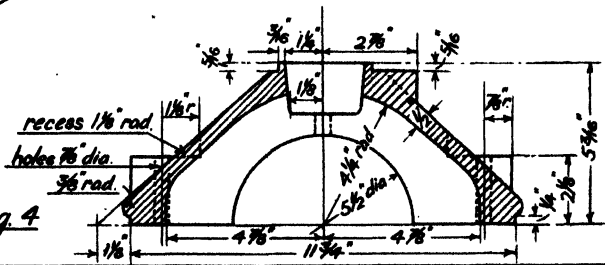

Fig. 4

BEARING BUSHES

Motor and dynamo shafts run in bearing bushes, except in machines where ball or roller bearings are fitted. For small motors the bearing bushes may be plain but for large machines they are lined with a special white metal alloy. The diameter is determined by the dimensions of the shaft, and the length is such that the bearing pressure shall not exceed a certain value. Some bushes have oil holes through which the oil is frequently introduced, but many have slots in the upper half for oil rings. The rings rest on the shaft and rotate with it, and, as the bottom of each ring dips into oil, a continuous supply is carried to the bearing. Efficient lubrication lengthens the life of a bearing and oil-ring lubrication is very satisfactory. The bushes are frequently called *brasses* or *steps* and are made of cast iron, brass, gunmetal or phosphor bronze. Sometimes they are made in one piece and slipped over the end of the shaft but this is not always possible. Divided bushes are made in two parts, the division being made by a horizontal plane through the axis of the shaft, and they have the advantage that they can be adjusted for wear. The bushes are cast with fitting strips on the outer surface and these are turned to fit the pedestal or end plate. In old pattern bushes the fitting strips may be octagonal instead of circular; this prevents the bush rotating with the shaft. When the fitting strips are circular, rotation is prevented by a pin which projects into the bush and the cap. Bushes which are lined with white metal have grooves cut on the inside and the white metal is poured in when molten. The grooves are cut so as to form dovetails which hold the lining in place. Two types of bush are shown on the opposite page, a fixed bush which is clamped rigidly by the fitting strips, and a self-aligning bush which is capable of slight rotation about the centre of the bearing.

The **Fixed Bush** (figs. 1 and 2) is made by Messrs. W. H. Allen & Sons, Ltd., and is

to fit the pedestal bearing on p. 17. It is divided and slots are cut in the upper half for the oil rings. Fig. 2 is a section through the slot for one of the rings. Fig. 1 is a sectional elevation and shows how the material is cut away at the sides for nearly the whole length, so that the bearing surface is only at the top and bottom. The white metal lining in this bush extends right to the end. Grooves are cut on the inside of the bush near the end and three vertical holes are drilled through the bottom of the bush into each of the grooves. The oil flows down the grooves and passes through the holes into the reservoir below.

A **Self-Aligning Bush** for a machine made by The British Thomson-Houston Co., Ltd., is shown in figs. 3, 4, 5, and 6. There are no fitting strips but there is a single bearing surface at the middle of the bush. This surface is spherical and is fitted to a corresponding surface in the end plate or pedestal so that the bush is free to revolve to a limited degree in any direction about its centre. Any unevenness of bearing pressure which would occur due to a slight error in alignment of the bearings is avoided. Fig. 3 is a side elevation of the bush. Fig. 4 is an end elevation with the right-hand half in section. This figure shows how the upper part is fitted into the lower so that there can be no relative motion; a single pin on one side prevents one part slipping over the other in the direction of the axis. Fig. 5 is a section through the axis and fig. 6 is a section through one of the slots for the oil rings. These figures show how the white metal lining is fitted. A pin projects from the cap into the slot at the top of the upper bush (see figs. 4 and 5) and prevents rotation with the shaft.

Sections through white metal in these figures are shown by two sets of lines inclined at 45° . This is the method of showing white metal in engineering drawings, although sometimes the lines are inclined at 60° or 30° .

EXERCISES

(1) Draw a side elevation of the bush shown in figs. 1 and 2. Add an end elevation and a plan.

(2) Make a sectional side elevation and a plan of the lower bearing bush (fig. 1).

(3) Copy the side elevation of the self-aligning bush and add a plan.

(4) Draw a sectional side elevation of the self-aligning bush and add a plan of the lower part.

Scale for the above exercises: half full size.

BEARING BUSHES

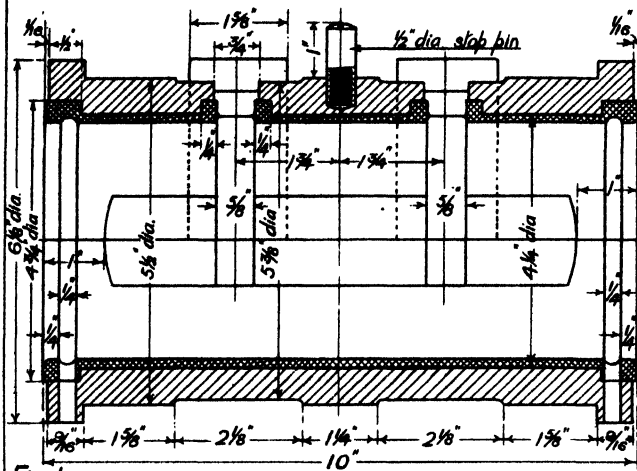

Fig 1

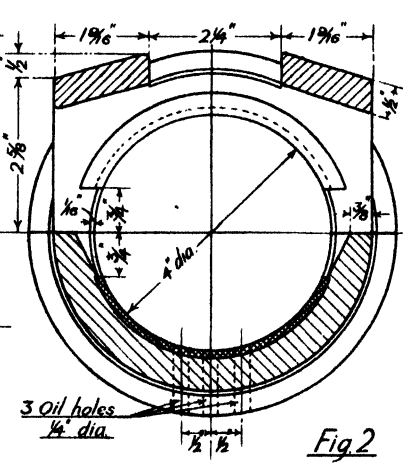

Fig 2

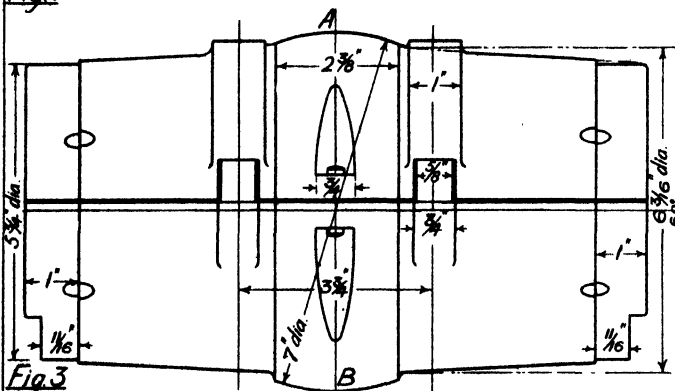

Fig 3

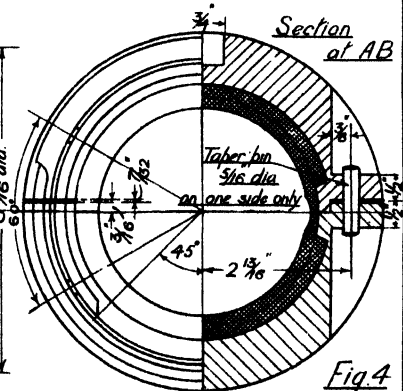

Fig 4

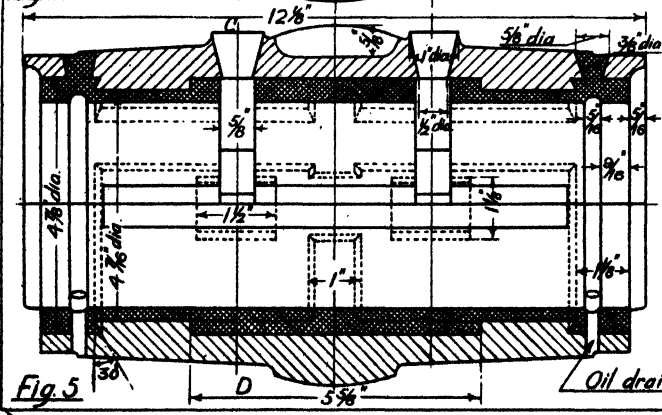

Fig 5

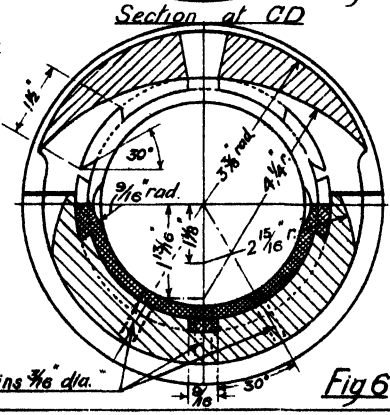

Fig 6

FIELD POLES AND SHOES

Field poles are frequently cast with the *frame or yoke* but in some machines they are cast separately and bolted in place. Some poles are built of laminations, riveted between side plates and secured to the yoke. Various methods are used for connecting the poles to the magnet frame. The field cores are surrounded by the field windings, and connexions are made so that the poles shall be in pairs, a north pole and a south pole alternately. The yoke and field poles are carefully machined so that the surfaces fit well together. The inner ends of the poles are machined to take *pole pieces* or *pole shoes*, the shoes being secured by countersunk screws or by dovetails. The inside surfaces of the pole shoes form the *armature tunnel*, and as the air space between the armature and the pole shoes is always small, varying in different machines from .5 to 1.5 cm., these surfaces also must be accurately machined. Many small machines have cast-iron poles but for large machines the poles are made of cast steel or wrought-iron stampings. The pole shoes for large machines may be cast with the poles, but for large machines they are always made of wrought-iron stampings on account of the eddy currents which are induced in them. As the armature teeth pass the poles the flux density varies and the effect is more marked in the pole shoes than elsewhere. If the shoes are not laminated the eddy current losses may be considerable and excessive heating will result. The current density in the field poles varies between 14,000 and 16,000 lines per square centimetre; in the air gap the density is from 6000 to 10,000 lines per square centimetre. The polar arc is about .7 of the polar pitch but if interpoles are fitted this ratio is reduced to about .6. The pole face extends the whole length of the armature.

Laminated Pole.—The field pole shown in fig. 1 is built up of stampings riveted together between side plates, each 17 mm. thick. These

plates give rigidity to the assembly and the rivet holes can be easily countersunk. The pole and shoe are made in one piece when they are both laminated. The inner surface of the shoe is machined to a radius of 317 mm., but it is cut back at the tips so as to increase the air gap by 5 mm. Each pole is attached to the frame by two 1" diameter bolts. Six poles similar to this are fitted to the field frame shown on p. 23.

Pole Shoe. A laminated pole shoe is shown in fig. 4. Two rivets and two bolts pass through the assembly and hold it together. Two $\frac{1}{4}$ " Whitworth countersunk screws hold the shoe to the field pole. The field coils are secured by brackets attached to the shoe. Four brackets are used for each pole, one is shown in place in fig. 4, and details are shown in fig. 5. Two brackets are similar to that shown in fig. 5, but the other two are bent in the opposite direction.

Commutating Pole or Interpole.—Machines that have to carry heavy overloads or loads varying between wide limits are usually fitted with commutating poles or interpoles midway between the main field poles. The magnetic fields produced by these poles assist commutation by inducing a reversed E.M.F. in the field coils short-circuited by the brushes. The poles have a much smaller cross section than the main poles and the polar arc is about 30 per cent more than the pitch of the armature slots. When the space between the main poles permits, a polar arc equal to twice the slot pitch has been recommended. Commutating poles are made of cast-steel or wrought-iron laminations. Figs. 2 and 3 show a cast-steel interpole having steel and micanite brackets for holding the interpole coil.

The field-pole shoe and the commutating pole are for the field-magnet frame on p. 25; suitable surfaces for the interpoles are machined on the frame.

EXERCISES

(1) Make a side elevation and end view of the pole shoe shown in fig. 4. Also make detail sketches of all the parts. Scale: half full size.

(2) Make working drawings of the commutating pole shown together with the coil brackets. Scale: half full size.

FIELD POLES AND SHOES

*Dimensions for Fig. 1
are in m.m.s*

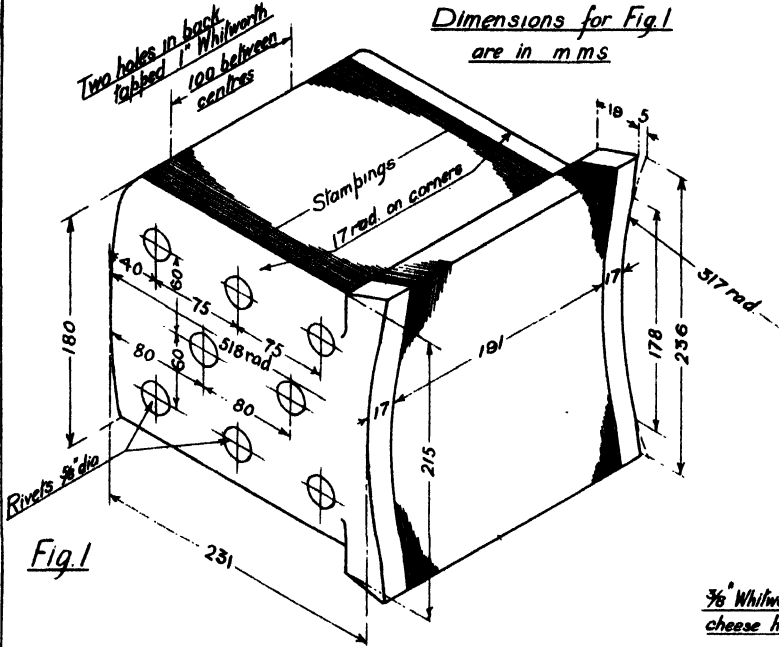

Fig. 1

Commutating Pole Elevation

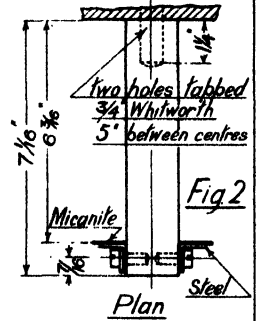

Fig. 2

Pole Shoe

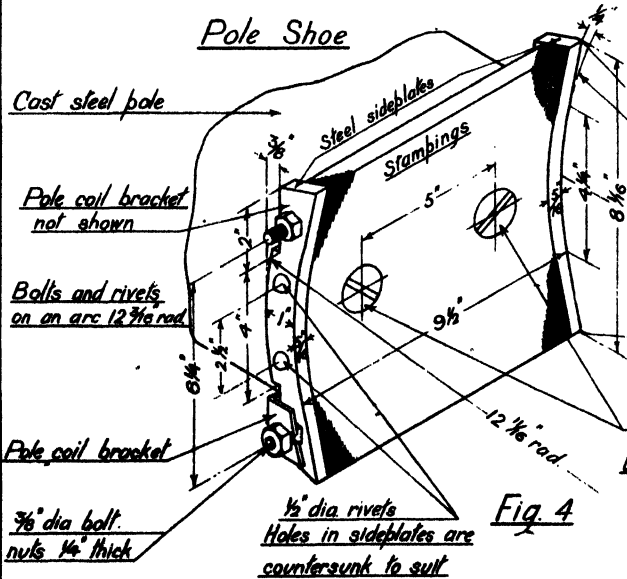

Fig. 4

3/8" Whitworth cheese head

Steel bracket 1/8" thick

Micanile bracket

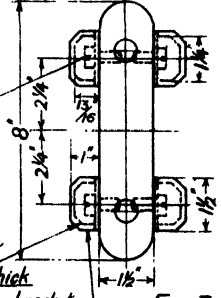

Fig. 3

Pole Coil Bracket

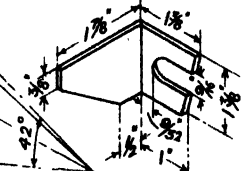

Fig. 5

3/4" Whitworth, 2" long countersunk

Back of stampings 12 1/2" rad throughout



FIELD-MAGNET FRAMES

Field-magnet poles are bolted into castings called **field-magnet frames** or **field-magnet cases**. In modern dynamos and motors these frames are cylindrical in form, except in some special instances such as mill motors, where they are octagonal in section. The poles may be cast with the frame or made separately (see fig. 1, p. 21) and bolted into the frame. It is sometimes necessary to remove a field coil, and if the poles are bolted into the frame the pole and coil can be taken out without removing the armature, the coil then being free to slip over the end of the pole. Small field-magnet frames are made in one piece but large ones are split horizontally. The surfaces where they meet are carefully machined and the two parts are bolted together, suitable lugs being cast on the frames to take the bolts. The difficulty of removing a large armature without damage is avoided by having a split frame so that when the upper half of the frame is removed the armature may be lifted vertically.

Feet are cast on the lower part in suitable positions. They are spread as far apart as possible to give a stable and rigid support, and webs connect the feet to the frame. The under side of each foot is machined, and the frame is secured to a base-plate by dowels and bolts.

Field-magnet frames are made of cast iron or mild steel. Mild-steel poles are sometimes cast into an iron frame by fixing the poles in place in the mould before running in the iron. The edges are welded to ensure good contact. Frames of large machines are usually made of mild steel because a much higher flux density can be allowed in mild steel and hence

the sectional area of the frame can be reduced.

The dimensions of a frame are determined from considerations of armature diameter and the magnetic flux required in the poles. In addition to providing the necessary cross section for the lines of force, the yoke must be strong enough to withstand the magnetic attraction between the poles and the armature.

The field-magnet frame shown on p. 23 is made by Messrs. Bruce Peebles, & Co., Ltd. It is made of cast steel and is split horizontally, lugs being cast on the sides for the four $\frac{3}{4}$ " diameter stud bolts which hold the parts together. Fig. 2 shows the two parts slightly separated, and fig. 1 shows a part section through the frame. The inner part of the frame is machined for a width of 245 mm. to form a surface for the field poles; this part is machined accurately to a diameter of 1100 mm. Six pairs of $1\frac{1}{8}$ " diameter holes are drilled through the frame for the field poles and midway between them are six pairs of $\frac{1}{2}$ " diameter holes for the commutating poles. The type of field pole fitted to this magnet case is shown in fig. 1, p. 21. It is not necessary to machine the casting all over, but in addition to the surface for the field poles one edge of the frame is machined to the dimensions shown in the sectional view (fig. 1) to take the brush rocker ring. Bosses are cast on the upper part and these are drilled and tapped for the lifting eye-bolts. Fig. 3 is a part section of the frame at right angles to the axis of the shaft and gives details of the web connecting the feet. The flat part shown at the bottom of the frame is cast on one side only.

EXERCISES

(1) Draw a complete vertical section through the axis of the magnet case. Scale: one-eighth full size.

(2) Make a vertical section through the centre of the magnet case, taking the section

plane at right angles to the axis. Add a plan. Scale: one-eighth full size.

(3) Draw an elevation of the frame showing the field poles in place. Project an end view. Refer to fig. 1 on p. 21 for details of the field poles. Scale: one-eighth full size.

FIELD MAGNET FRAME

Dimensions are in millimetres except where otherwise stated

Section through frame

Tabbed 1 1/8" Whit for eye-ball

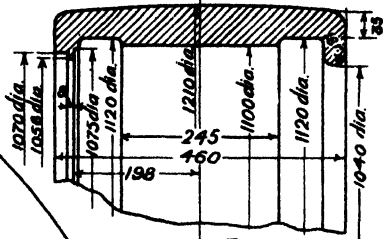

Fig. 1

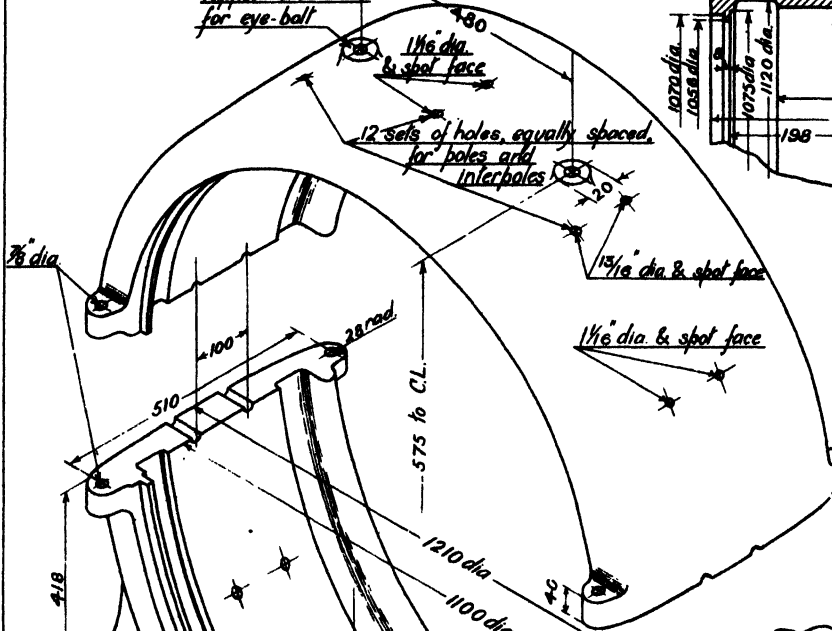
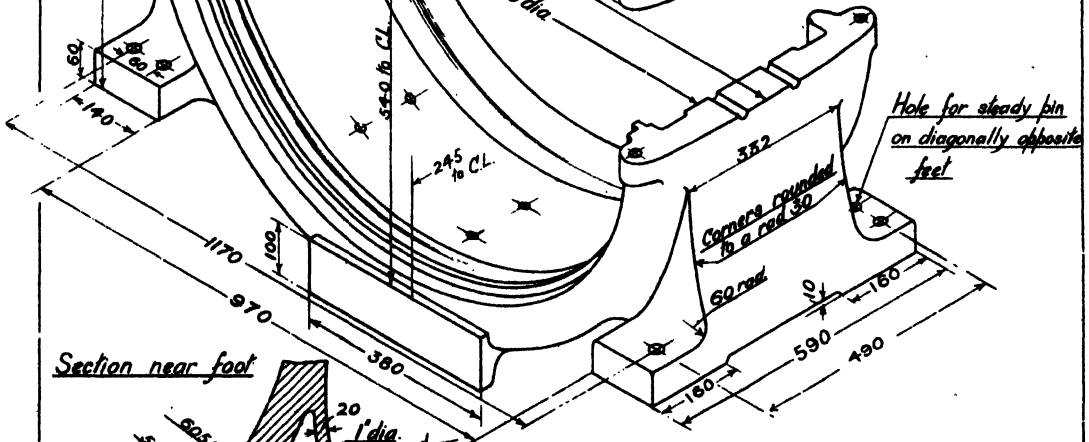

Fig. 2



Hole for steady pin on diagonally opposite feet

Section near foot

Fig. 3

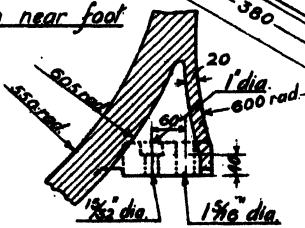

FIELD MAGNET FRAMES (Continued)

The diagram below indicates the paths of the lines of force in a field magnet frame in which there are four poles. Each magnetic circuit consists of the following parts: two pole cores, two pole shoes, two air gaps, a portion of the armature core and a part of the yoke. The diagram shows that the number of lines of force in the pole cores is approximately twice as many as in the yoke or armature core. The

ratio $\frac{\text{Length}}{\text{cross section} \times \text{permeability}}$ for any part is called the *reluctance* of that part and the total reluctance of a magnetic circuit is the sum of the reluctances of the separate parts. Between the total magnetic flux and the reluctance there is the well-known relation: $\text{Flux} = \frac{4\pi NC}{\text{reluctance}}$, where N and C are respectively the number of turns on the magnetizing coil and the current in the coil. The product of N and C is called the number of *ampere-turns*. The total reluctance of one of the field-magnet circuits can be represented in symbols:

$$\frac{2l_g}{a_g} + \frac{2l_p}{\mu_p a_p} + \frac{2l_s}{\mu_s a_s} + \frac{l_y}{\mu_y a_y} + \frac{l_c}{\mu_c a_c}$$

where μ is the permeability and the suffixes stand for air-gap, poles, &c.

The lines of force generated in the field coils do not all complete the magnetic circuit in the iron; some pass from one pole to another, or from a pole to the yoke through the air and not through the armature core. These useless lines are called *leakage lines* and the ratio $\frac{\text{total lines generated}}{\text{lines in armature core}}$ is called the *coefficient of magnetic leakage*. Its value varies with different machines from about 1.1 in large machines to 1.25 in small machines. Care is taken in designing machines that the end plates and pedestal bearings shall be so far from the poles that they will not appreciably increase the magnetic leakage. In practice, the flux densities allowed

in the various parts are, very approximately, 16,000 lines per square centimetre in cast-steel cores, 12,000 lines per square centimetre in cast-steel yokes, but up to 20,000 or more lines per square centimetre in the armature teeth.

Fig. 1 on p. 25 represents a field-magnet frame made by Messrs. W. H. Allen, Sons & Co., Ltd. This frame differs in several respects from the one shown on the previous page. The main poles are cast with the frame, surfaces being machined for the interpoles. The frame is split; the plane of section does not pass through the axis but is 3" above it. This brings the joint in the frame between a main pole and an interpole. The lugs for the connecting bolts are placed in a different position and the feet are shaped differently. Instead of the eye-bolts being screwed into the frame they are cast with it; fig. 2 shows the position and dimensions. The part elevation (fig. 3) gives dimensions which could not be represented conveniently on the isometric view.

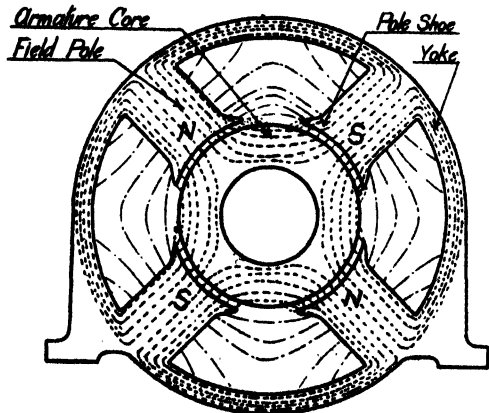

EXERCISES

(1) Draw an elevation of the magnet frame shown on opposite page, looking in the direction of the shaft, and add a plan. Scale: one-eighth full size.

(2) Make two sectional elevations of the

magnet frame. Take the section planes at right angles to each other and through the centre. Show the interpoles in place. Dimensions of interpoles may be taken from figs. 2 and 3, p. 21.

FIELD MAGNET FRAME

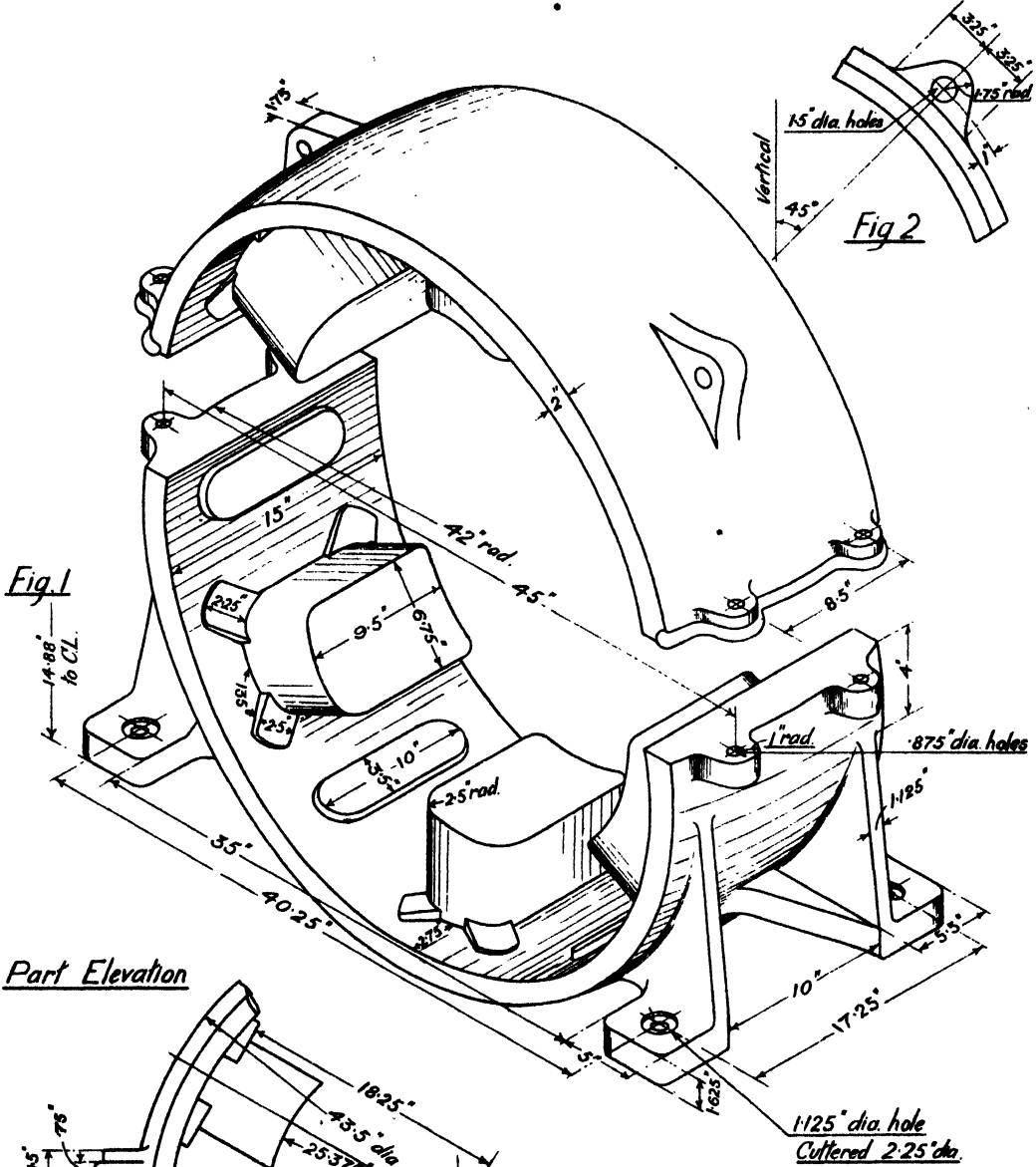

FIELD MAGNET FRAMES (Continued)

The field-magnet frame shown on the opposite page is for a small motor made by Messrs. Mawdsley, Ltd. The frame is in one piece and the field magnets are cast with the frame. Fig. 1 is an isometric view of the frame, representing it as being divided vertically through the centre, and the two parts separated so that the form may be seen more clearly. There are really two field poles each of which is divided into two separate poles and provided with separate windings. The sectional view (fig. 4) shows the arrangement of a pole and field windings. A lifting eye-bolt is screwed into the top of the frame and is placed so that it is over the centre of gravity of the complete machine.

Interpoles.—These are fitted separately into the frame. Slots $1\frac{1}{4}$ " wide and $\frac{1}{4}$ " deep are cut at the top and bottom of the frame to receive them and each pole is held in place by a single bolt. The pole is shown to be of rectangular section, although in practice the edges are slightly rounded, and a projection at the inner end serves to hold the coil in place. The coil is well insulated and brass flanges are fitted at top and bottom. Fig. 2 shows an interpole with a portion of the coil cut away.

Slide Rails.—Small motors are very often fitted on slide rails bolted to a concrete floor. This allows the position of the motor to be adjusted and is very convenient when using a belt drive. A slide rail is illustrated in fig. 3, and the motor is mounted on two such rails fixed parallel to each other and the correct distance apart. As the slide rail is rather long only the ends and middle portion are shown; the parts broken out are of uniform section and can therefore be omitted. Each slide rail

is a casting with a slot running the greater part of its length and having a square hole in the middle to enable the heads of the holding-down bolts to be placed under the slots. When the motor is placed on the rails and whilst the holding-down bolts are still slack, its position is adjusted by means of the forcing screws.

Field Coils.—Motors and dynamos are classified according to the manner of connecting the field coils. They may be *series wound*, *shunt wound*, or *compound wound*. Series machines have the field coils in series with the armature, shunt machines have the field coils connected across the brushes, and compound machines have both series and shunt coils.

The coils may be wound in spools or on formers. Spools are made of metal or fibre and metal spools are carefully insulated before winding. Former-wound coils are made on a wooden former and after winding is completed they are removed from the former and well taped and varnished. Field coils are made so that they shall have a large surface exposed to the air and frequently the number of turns on successive layers is reduced so as to pile up the winding; this increases the surface area and assists the dissipation of heat. In small compound wound motors the series coil is often placed over the shunt coil as in fig. 4, but in larger machines the coils are wound side by side. The pole and shoe are cast solid with the frame in the machine shown on the opposite page, and the shunt coil has to be made large enough to slip over the shoe. Special clips are used to hold the coils in place. Details of these clips and the bolts which hold them are shown in figs. 4 and 5, but the holes for the bolts are omitted from fig. 1.

EXERCISES

(1) Make an elevation, plan and end view of the magnet frame shown in fig. 1. Scale: one-quarter full size.

(2) Draw a sectional elevation of the field-magnet frame looking in the direction of the axis. Show the interpole and field coils. Scale: one-quarter full size.

(3) Make a detailed drawing of the slide rail. Portions may be broken out as shown in fig. 3. Scale: half full size.

(4) Draw a side elevation of the motor frame in position on the slide rails showing the field coils and interpoles. Scale: one-quarter full size.

FIELD MAGNET FRAME

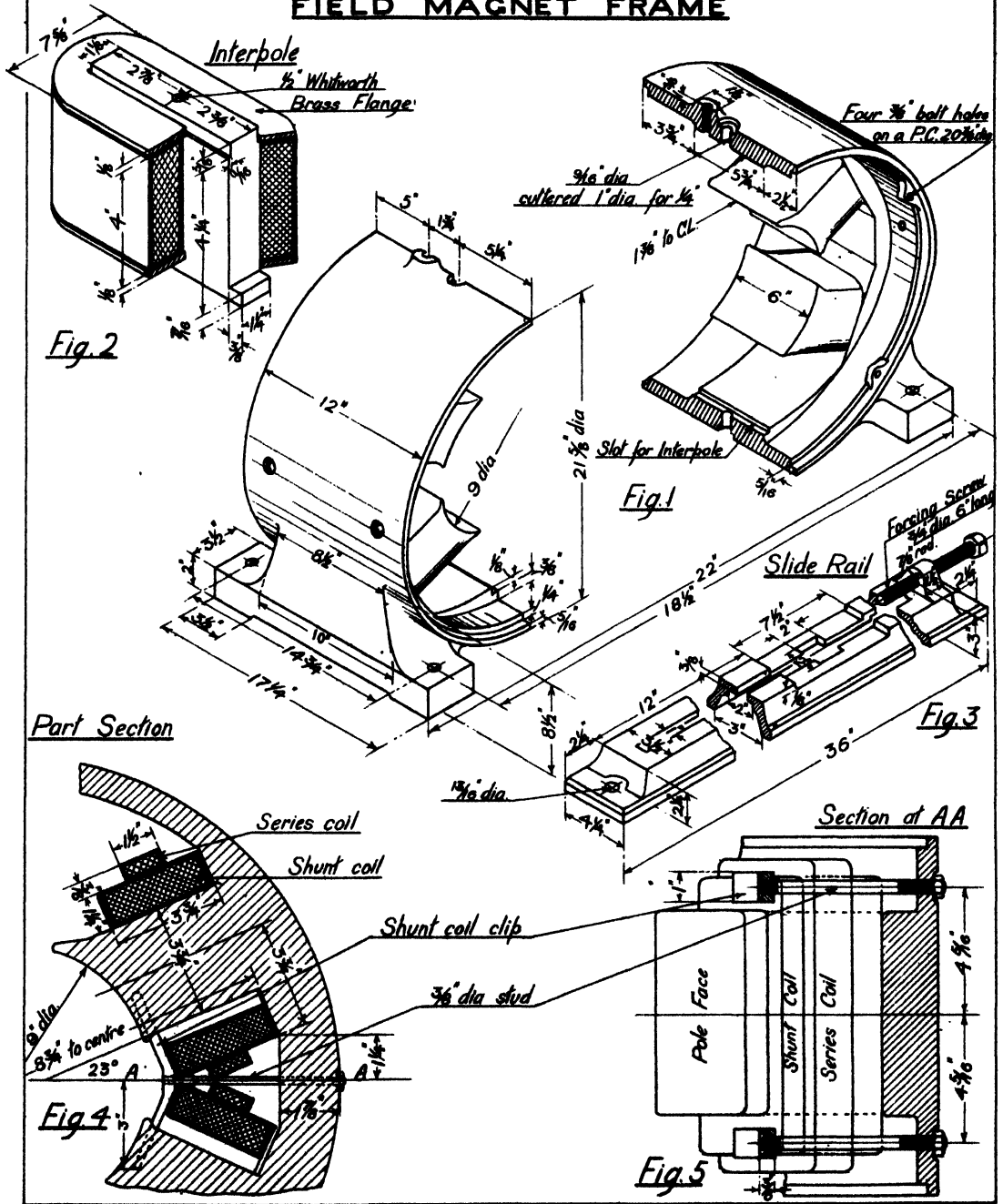

BRUSH ROCKER RING

Current enters or leaves the armature of a dynamo or motor by way of the brushes which are fixed rigidly just over the commutator surface. A very firm support is essential to prevent the brushes vibrating and thus causing sparking. Brush boxes are mounted on spindles or brackets, bolted or clamped to a brush rocker. In small machines the brush rocker is fitted over an extension of the bearing, but in machines with large diameter commutators it is fitted into the magnet frame.

The drawings on the opposite page represent a rocker ring made by Messrs. Bruce Peebles & Co., Ltd., which is suitable for fitting to the magnet frame on p. 23. It is composed of two steel castings fastened together by two $\frac{3}{8}$ " diameter stud bolts. The plane of division of the parts passes through the centre and the castings are accurately machined on the surfaces where they meet.

When the parts are bolted together they may be considered to form two rings, an inner and an outer, connected by twelve arms. The outer ring is solid, but the inner ring and the arms are lightened by removing material near the centre to form channel bar sections; in this way the maximum strength is obtained with the minimum weight of material. Rigidity and lightness are essential features of the design and material is removed wherever possible without unduly reducing the strength. To reduce the weight still further, twelve lightening holes are formed round the inner part of the ring as shown in the elevation (fig. 1). The general shape of the section of the ring can be seen from the plan of the lower ring at BB, although the enlarged part for the bolt hole appears in this view. Fig. 2 is a section through one of the arms.

The number of brush holder brackets varies with different machines, and depends upon the number of circuits into which the armature winding is divided, but they are all alike and equally spaced around the commutator. The ring shown is arranged for six brackets and two bolt holes are drilled for each bracket. The shape of the section of the inner part of the ring necessitates bosses being formed for these holes; the section at CC (fig. 4) is taken through one of these holes and shows two bosses.

The ring is machined on the outer edge to be a sliding fit in the magnet frame and is retained in place by four guides. The positions of these clips are shown in fig. 1, and their dimensions are given in fig. 3. Two $\frac{3}{8}$ " diameter Whitworth holes are tapped in each guide and the sectional view (fig. 4) shows how the guide is bolted to the back of the ring. The guides project into a groove on the inside of the magnet frame (see the sectional view, fig. 1, p. 23). This method of holding the rocker ring permits it to be rotated, and therefore the brushes can be moved around the periphery of the commutator as desired. In the older machines any considerable change in the load made it necessary to adjust the position of the brushes to prevent sparking, but modern machines are designed to run with sparkless commutation at all loads. It is still the practice, however, to fit adjustable brush rockers to most machines and frequently a worm and worm-wheel or pinion gearing is fitted to give a fine adjustment. In fig. 1 two $\frac{1}{8}$ " holes are shown in the lower frame; either of these can be used for the attachment of this gearing.

EXERCISES

(1) Draw a plan and elevation of the lower half of the brush rocker ring. Scale: one-sixth full size.

(2) Draw a complete vertical section through the centre of the ring. Scale: one-sixth full size.

(3) Draw an elevation of the complete ring

looking from the back. Scale: one-sixth full size.

(4) Copy the section at CC (fig. 4) and add a section of the magnet frame in its correct position. Take dimensions from fig. 1, p. 23. Scale: half full size.

BRUSH ROCKER RING

Dimensions are in m.m.

The detail drawings are made to a scale four times that of fig. 1

Elevation

Section at AA

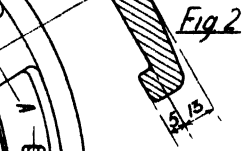
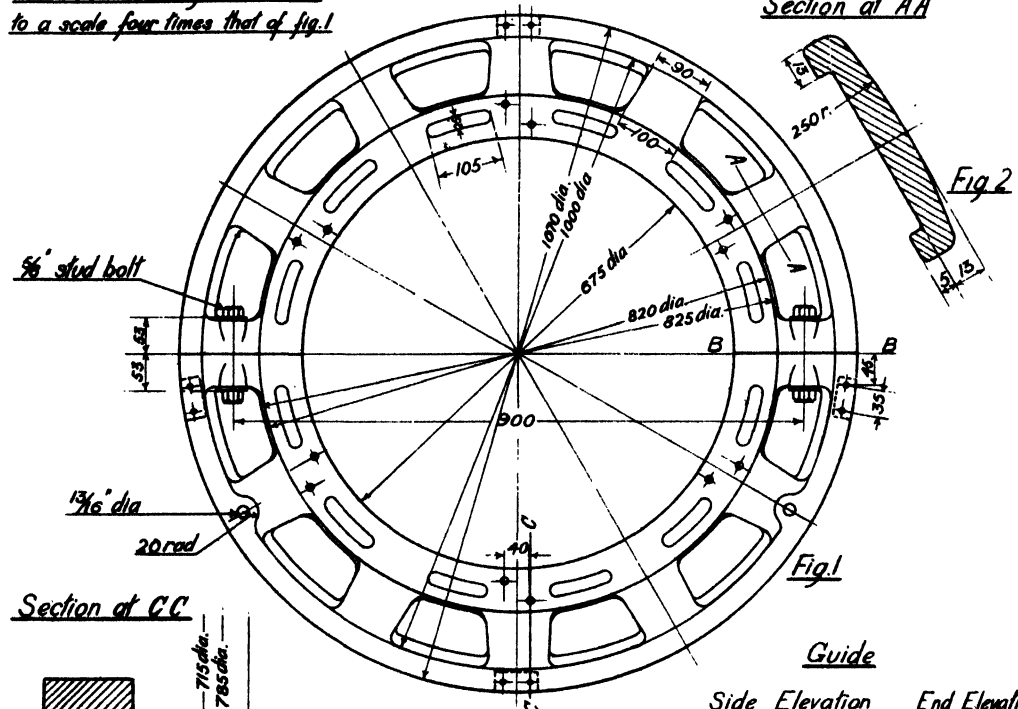

5/8" stud bolt

1 3/16" dia

20 rod

Fig. 1

Section at CC

Guide

Side Elevation

End Elevation

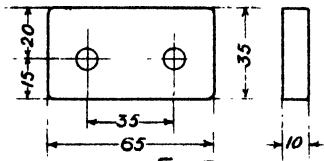
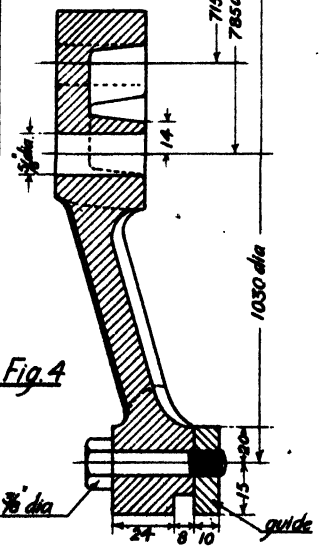

Fig. 3

Plan of Lower Ring at BB

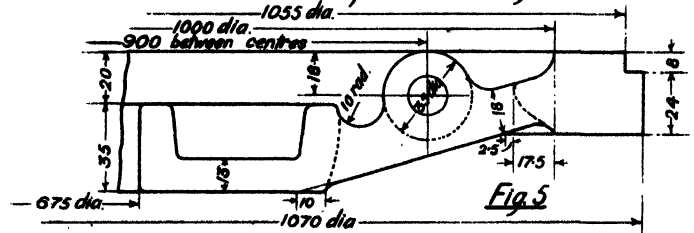

Fig. 5

BRUSH-HOLDER BRACKET

The drawings on p. 31 give particulars of a **Brush-Holder Bracket** and the arrangements for clamping it to a brush-rocker ring. Six brush-holder brackets similar to this are bolted to the rocker ring on p. 29, their function being to give rigid support to the brush boxes. The size of a bracket depends upon the number of brush boxes it has to carry, and this is determined by the current-carrying capacity of each armature circuit. The bracket shown carries five brush boxes; for details of the brush boxes fitted to this bracket see figs. 8 and 9, p. 35. The brush box has a groove 27 mm. wide cut across it so that it fits the bracket, and when bolted in place can neither slip nor turn. The end elevation is symmetrical about the centre line, the lower part being such that the brush boxes can be clamped on either side. The central part consists of a web varying in thickness from 10 to 15 mm. bounded at the ends by flanges 10 mm. thick; this form is chosen so that the bracket shall be both light and rigid. The upper part is enlarged to a sufficient width to allow a slot to be cast in it for a $\frac{1}{4}$ " diameter bolt. A section through the upper part of the bracket, along the line XX, is given in fig. 3, and this shows how one side is still further expanded where it fits against the clamping plate. Projections on the sides fit into recesses on the edges of the clamp and prevent the bracket rotating about the bolt. The width of the surface which bears against the clamping plate is 64 mm.; the increased

width has the effect of reducing the stress in the clamping bolt due to bending moments on the bracket, and it consequently affords a more rigid connexion.

Clamp.—This is a plate of suitable shape tapped with two $\frac{1}{4}$ " diameter holes for studs which pass through the rocker ring, and one $\frac{1}{4}$ " diameter hole for the bolt which holds the bracket. It is necessary to insulate each clamp from the rocker since they are in electrical contact with the brushes through the brackets. Details of the clamping arrangements and insulation are shown in figs. 4 and 5. Bakelite washers and pertinax tubes are used for insulation, the bakelite washers being placed between steel or metal washers. Alternate clamps are connected by copper bars or strips, and the ends of these strips are placed between the clamps and the bakelite washers. The slot at the top of the bracket permits the bracket to be adjusted radially by turning back the clamping bolt. This adjustment may be required if the commutator becomes so badly worn that it is necessary to turn it down. The normal position of the commutator face with respect to the bracket is shown by chain lines in the side elevation.

In order to distribute the wear over the commutator face the position of the brush boxes is changed on alternate pairs of brackets; thus the distance of the first bolt hole on the next two brackets is 49.5 mm. instead of 24.5 mm.

EXERCISES

(1) Draw a side elevation of the bracket and clamp, showing part of the rocker ring near the clamp. Place the bracket so that the bolt is in the centre of the slot. Scale: half full size.

(2) Make a sectional end elevation looking towards the clamp. Take the section through

the centre of the slotted part. Scale: half full size.

(3) Six equally spaced brackets are mounted on a rocker ring which is placed so that two brackets are vertical. Draw an end view of one of the upper inclined brackets, and project an elevation looking from the centre of the machine. Scale: half full size. .

BRUSH-HOLDER BRACKET

Scale. $\frac{1}{2}$ full size

Dimensions are in millimetres

Side Elevation

End Elevation

Section at X X

Taper 1 in 30 on rod

Fig. 3

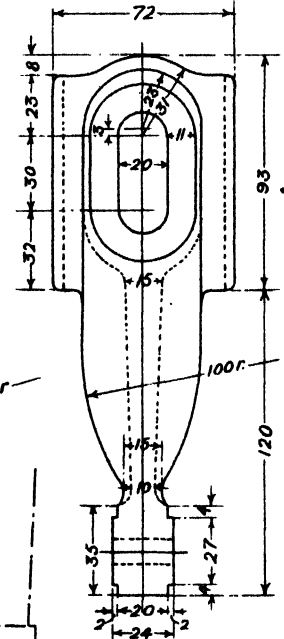
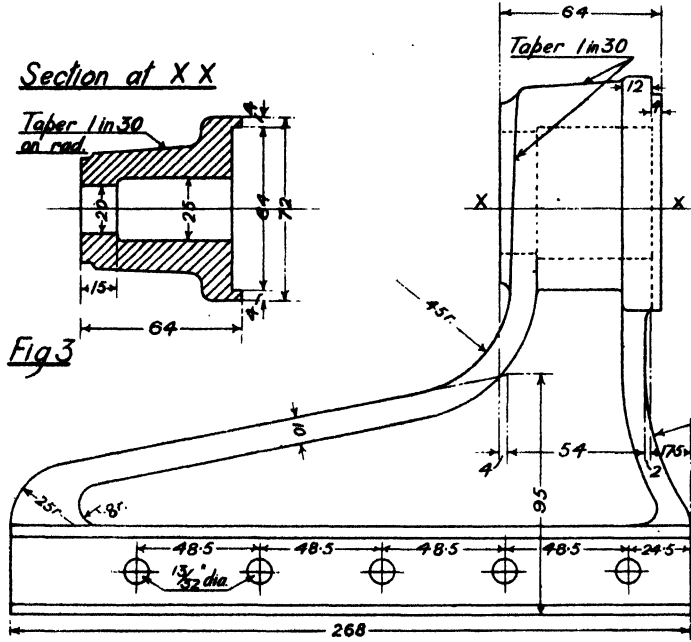

Fig. 1

Fig. 2

Details of Arrangements for Clamping

End Elevation

Section

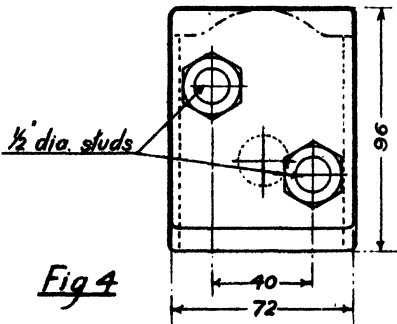

Fig. 4

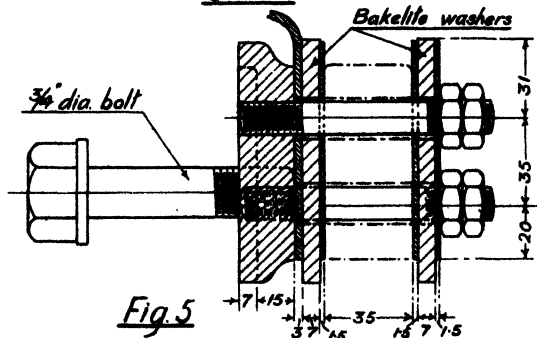

Fig. 5

BRUSH ROCKERS

The brush rockers illustrated on the opposite page are mounted on projections of the bearings, and they differ in this respect from the rocker ring on p. 29, which is fitted to the field-magnet frame, but they serve the same purpose in supporting the brushes. All rockers of this type have much the same form, that is, a ring to fit the bearing with radial arms to hold the spindles on which the brush boxes are mounted.

Figs. 1 and 2 represent a brush rocker made by Messrs W. H. Allen & Son, Ltd. It is made of two almost similar castings bolted together to form the complete rocker. Fig. 1 is an isometric drawing showing the castings slightly separated. The rocker has six equidistant and similar arms long enough to hold the brushes in their correct position over the commutator surface. Each arm is expanded at the outer end so that, with a cap, it forms a clamp for the brush-box spindle or bar. All the caps are the same; only one is shown and it is represented as being raised from its place on the arm. Each cap is held down by two $\frac{3}{8}$ " diameter hexagonal bolts with spring washers. Fig. 2 gives details of one of the arms and shows a part of the rocker on a larger scale; the section of the rocker is also shown. The latter shows the rim on the inner edge which fits into the projections on the end of the pedestal bearing, p. 17. Three 2" by $\frac{3}{8}$ " slots are cast in the rocker, one in the upper part and two in the

lower. $\frac{1}{2}$ " diameter bolts are passed through the slots and screwed into holes tapped into the end of the bearing. The angle through which this rocker can be rotated is limited by the length of the slots, but only a slight adjustment is necessary, and once this is made the bolts can be tightened up and the rocker fixed in place.

Figs. 3 and 4 show a brush rocker made by The British Thomson-Houston Co., Ltd. Fig. 4 is a sectional elevation through the centre. The rocker is split and has eight equally spaced radial arms. These arms taper in the side elevation and in the section, and terminate in forks for the brush box spindles. Washers and tubes are used to insulate the spindles which are screwed at the ends and fitted with nuts for clamping. Although the two castings are identical the holes in them are drilled differently. Two adjacent forks in each casting are connected by a curved arm and a hole 1" diameter is drilled in one of these arms, a boss being cast in the centre of each arm for this purpose. At a distance of $1\frac{1}{4}$ " from the hole and near the bottom of the rocker is another 1" diameter hole. These are drilled to take supports for a worm wheel spindle. A worm is fitted to the spindle to gear with a fixed rack, and a hand-wheel is pinned to the outer end of the spindle by means of which the position of the brushes can be adjusted.

EXERCISES

(1) Draw a side elevation and plan of the complete brush rocker shown in figs. 1 and 2. Scale: one-third full size.

(2) Draw a vertical section through the centre of the brush rocker (fig. 1); add a small part of a section through the pedestal bearing

on p. 17, in the correct position against the rocker. Scale: one-third full size.

(3) Draw an elevation of the rocker shown in figs. 3 and 4. Make the elevation similar to fig. 3, but turned through 20° in an anti-clockwise direction. Add an end view. Scale: one-sixth full size.

BRUSH-HOLDERS

There are two kinds of brush-holders, the **Hammer type** and the **Box type**; in the former the carbon brush is firmly held at one end of a lever; in the latter the brush is free to slide in a metal box; in both, the brush is held against the commutator surface by a spring. The examples on the opposite page are all of the box type, the type much more frequently used. All brush-holders have some device for altering the pressure exerted by the spring on the brush, and it is found that a satisfactory pressure between the brush and the commutator is between 1 and $1\frac{1}{2}$ lb. per square inch. Many different varieties of carbon are used for brushes, and sometimes mixtures of copper and carbon are used. There are brushes suitable for all kinds of working conditions, and for current densities varying from 40 to 150 amps. per square inch. It is most important that the brushes should slide freely in the brush boxes, but they should not be loose enough to chatter. On account of the poor electrical contact between the brush and the sides of the brush-holder, **Pigtail Connections** of copper braid are used; these are fastened at one end to the brush, and at the other end to the brush-holder or clamp.

Three different brush-holders are shown on the opposite page. Figs. 1 to 7 illustrate a brush-holder made by Messrs. W. H. Allen, Sons & Co., Ltd. Fig. 1 is an isometric view of the complete fitting. The essential parts are the **Brush-Holder Casting**, the **Pressure Arm**, and the **Spring**. Fig. 2 is a plan of the brush-holder casting; it is made of brass and has brackets for the pressure arm on one side and a clamping device on the other. The two racks cut on this casting engage with a corresponding rack on the clamping plate, and the head of a bolt is passed into the slot behind the racks. This enables the holder to be adjusted by steps equal to the pitch of the teeth on the

racks. The pressure arm is a brass casting made to the form and dimensions shown in figs. 6 and 7, and it is mounted on a brass pin between the brackets. One end of the bronze spring is secured by turning a hook on that end and slipping it under the bracket; the other end has a straight part that is put into the slots on the pressure arm. The pressure exerted on the brush can be varied by altering the position of the end of the spring from one slot to another. The distance piece is used to keep the pressure arm in its proper place on the pin.

Figs. 8 and 9 show the elevation and plan of a brush-holder made by Messrs Bruce Peebles & Co., Ltd. The principal differences between this brush-holder and the former one is in the method of clamping, and the manner of adjusting the pressure on the spring. No pressure arm is used but one end of a flat spring presses on the top of the brush, the other end is turned round a drum. The drum is mounted on a pin between arms on one side of the brush-holder, and it can be rotated by a worm and worm-wheel gearing. On the other side of the brush box a hole is drilled for a $\frac{3}{8}$ " diameter bolt and a groove is cut to fit the brush-holder bracket on p. 31. The position of the brush-holder is therefore fixed with reference to the bracket, but provision is made for the radial adjustment of the bracket itself.

Figs. 10 and 11 represent a brush-holder made by Messrs. Mawdsley, Ltd. This brush-holder is clamped to an arm near its centre, and not on one side as in the previous examples. Pressure on the top of the brush is exerted by one end of a stiffened steel spring and the other end of the spring is coiled round a drum. A pin attached to the drum can be placed in any one of a number of slots, and so the spring can be wound or unwound and the pressure on the brush adjusted.

EXERCISES

(1) Make a side elevation and plan of the pressure arm and insert all the necessary dimensions. Scale: twice full size.

(2) Make a side elevation, end elevation and plan of the complete brush-holder shown in figs. 1 to 7. Show the top of the carbon brush $\frac{1}{4}$ " above the top of the brush-holder. Total depth of brush, $1\frac{1}{4}$ ". Scale: full size.

(3) Use the scale to insert the principal dimensions in a side elevation of the brush-holder shown in figs. 8 and 9, and project an end view looking from the right. Scale: full size.

(4) Copy the side elevation (fig. 10) and project an end view looking from the right. Scale: full size.

BRUSH-HOLDERS

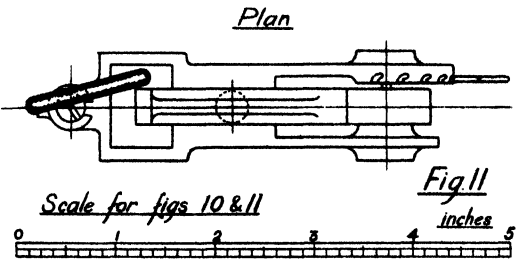
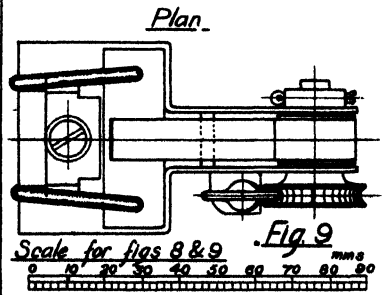
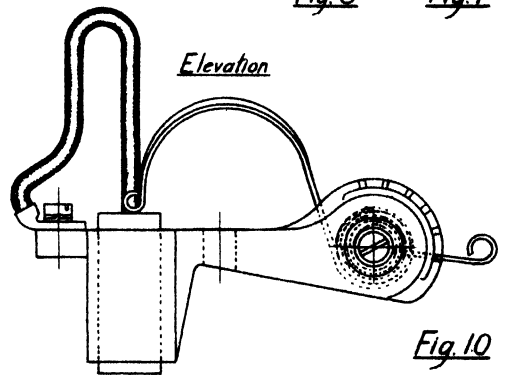
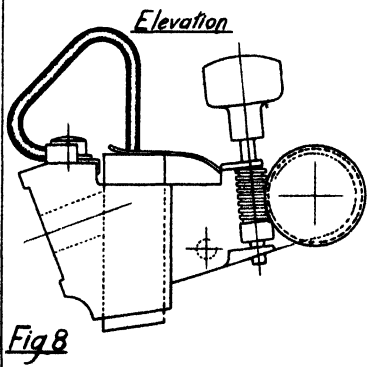
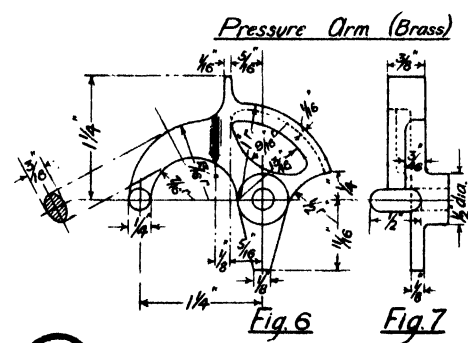
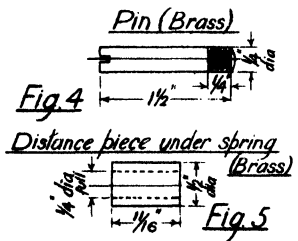
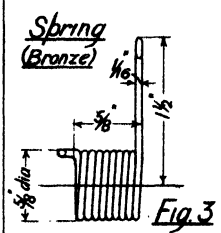
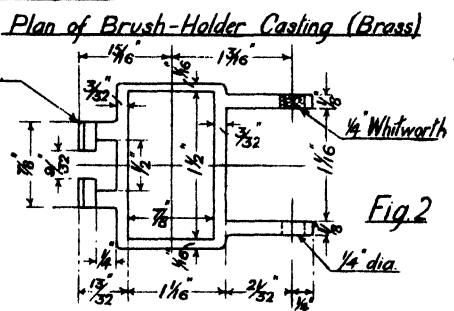
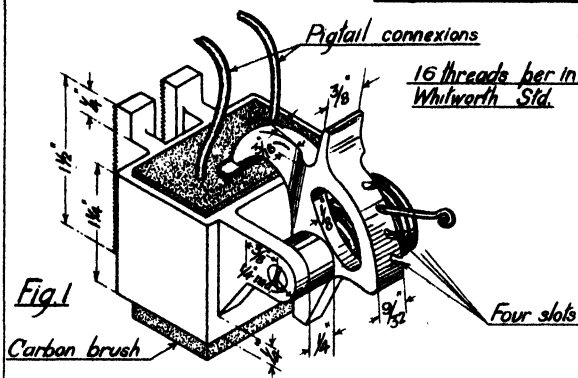

ARMATURES

Armatures are built up of **Core Plates** or **Stampings** held in place on the shaft between **End Plates**. In small motors they may be keyed directly to the shaft, but in larger machines they are assembled on an **Armature Spider**. If the diameter of the armature does not exceed three feet the stampings are in the form of complete rings, but in larger armatures the stampings are fitted in sectors arranged to break joint in adjacent layers. The stampings are from 22 to 25 mils thick and insulated from each other by thin paper or varnish so that the length of the iron is about 90 per cent of the total length of the core.

The stampings are shaped so that when correctly assembled, **Slots** are formed along the armature core, and in these slots the armature windings are laid. In very many armatures the slots are parallel sided, but sometimes the slots are partly closed at the top and the latter type is often used when, due to the high speed or large diameter of the armature, the centrifugal force on the conductors is considerable. When parallel-sided slots are used the windings are kept in the slots by binding wires, but when partly closed slots are used hard wooden wedges are driven into the top of the slots above the windings. The relative widths of slot and tooth vary in different machines, but the ratio of the width of a slot to the mean width of a tooth is always between 1 and 2.

Owing to the heat produced in an armature it is important that efficient means for ventilation should be provided. Ducts are formed at certain intervals by placing distance pieces between the core plates so that air currents pass into the core axially and outwards radially. A fan is fitted to some motor armatures, on the end remote from the commutator, to induce a draught.

The figures on p. 37 illustrate two armatures in each of which the core plates are keyed directly to the shaft.

Fig. 1 is an isometric view representing a small armature cut vertically through the centre, the shaft being removed. This armature is made by Messrs. Mawdsley, Ltd. The stampings are assembled on the shaft and clamped between cast-iron End Rings or Armature Carriers, the latter being held in place by shrink rings not shown in the figure. The commutator is mounted on the shaft against the smaller armature carrier, and a fan is bolted to a flange on the other carrier, the five bolt holes being drilled and tapped for this purpose. Two slots can be seen in the figure round the circumference of the core; these are for wire bindings to hold the armature windings in the slots, and they are formed by using core plates $\frac{1}{4}$ " smaller in diameter. Further bindings are used to lash the ends of the windings down to the armature carriers.

Figs. 2 and 3 give details of an armature made by Messrs. W. H. Allen, Sons & Co., Ltd. Fig. 2 is the upper half of a sectional elevation, and fig 3 is an end view of one quarter of a core plate. Four lightening holes are punched in each core plate, and three vent ducts are formed in the core assembly. The holes in the core plates serve not only to lighten the armature, but also to provide a passage for the air through the core and into the vent ducts. Corresponding holes are formed in the cast-iron end rings. Fig. 3 shows how the steel strips are secured to the core plates to form the vent ducts. The end rings are shown in the sectional elevation; one ring is fitted against a collar on the shaft, the other is retained by a shrink ring. Forming part of the end rings and cast with them are rings to support the ends of the armature windings. They are covered with insulation, and the coil ends are pressed down to them and covered with binding wire.

EXERCISES

(1) Make a drawing of a core plate for the armature shown in fig. 1. Scale: full size.

(2) Draw an end view of the armature (fig. 1) looking from the commutator end. Scale: full size.

(3) Make a complete sectional elevation through the centre of the armature as shown in the isometric view. Scale: full size.

(4) Draw an end view of the armature shown in figs. 2 and 3. Show the left-hand side only. Scale: one-quarter full size.

(5) Copy fig. 2 and add the lower half of the armature in elevation. Scale: one-quarter full size.

ARMATURES

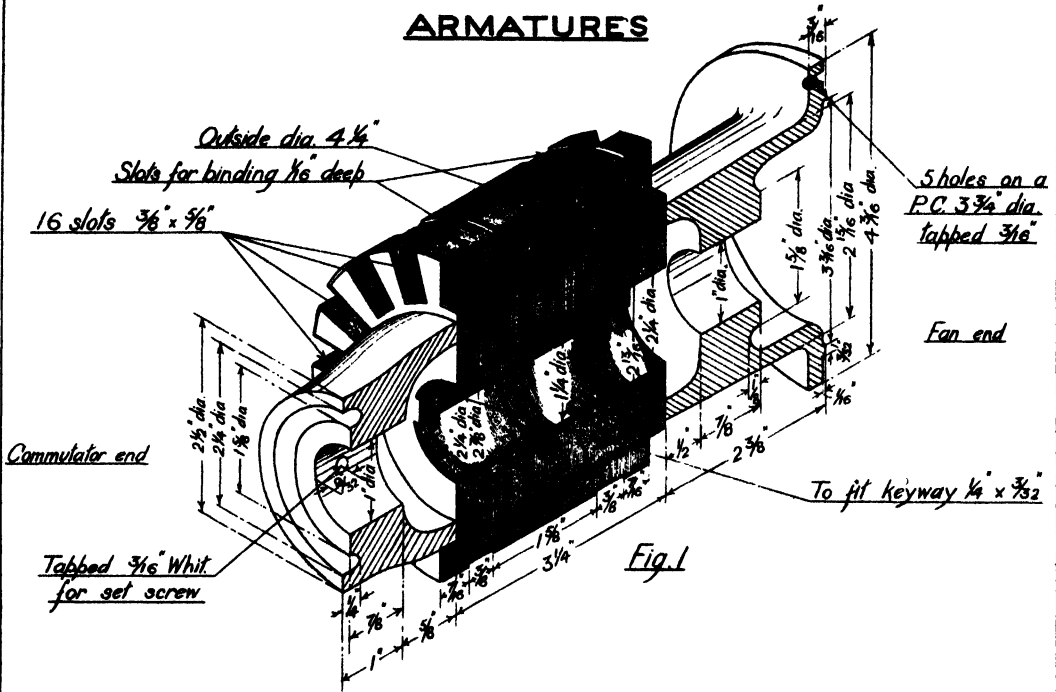

Fig. 1

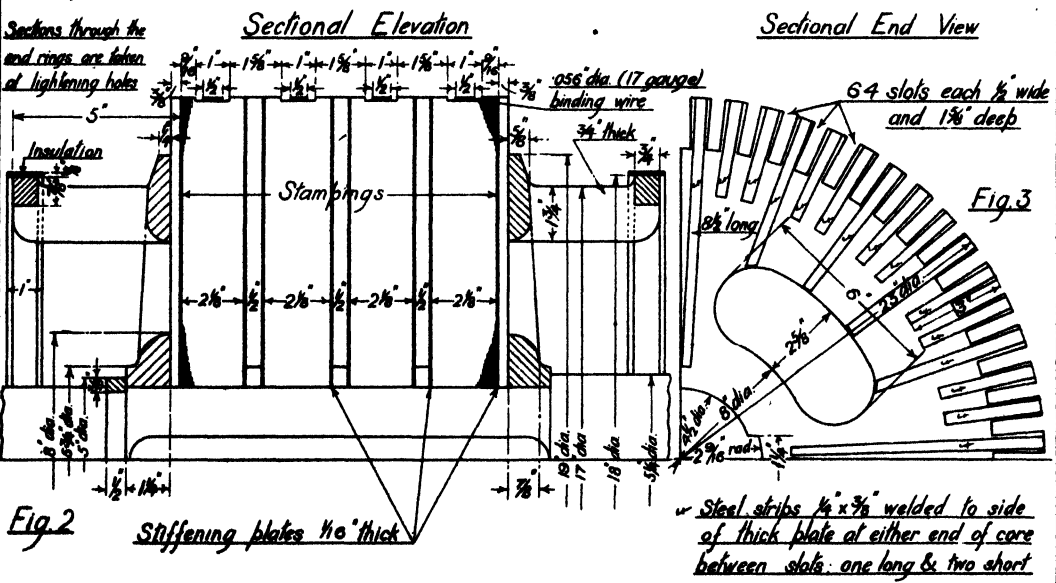

Fig. 2

Fig. 3

Steel strips $\frac{1}{4} \times \frac{3}{8}$ " welded to side of thick plate at either end of core between slots, one long & two short

ARMATURES (Continued)

The drawings on p. 39 show an armature made by Messrs. Mawdsley, Ltd. The core plates are assembled on a cast-iron spider and clamped between retaining rings bolted to the ends of the spider. If necessary the whole assembly can be removed from the shaft without disturbing the core or windings.

Fig. 1 is an isometric sectional view of the complete assembly representing the appearance of the armature, without windings or slot insulation, removed from the shaft and cut vertically through the centre.

Spider.—In addition to the sectional view (fig. 1) an end view of the spider is given in fig. 2. The casting is in the form of a hub with five equal radiating arms strengthened by webs at the centre. It is drilled at the ends to fit the shaft, but the central part is cast out somewhat larger than the shaft diameter. A keyway is cut at one end and part of this can just be seen in the isometric view. The ends of the arms are machined to fit keyways on the core plates.

Core Plates.—These are complete rings and two different diameters are used, the smaller ones forming the five slots for the binding wires. The core is divided into five parts by four vent ducts. Air is drawn into the spaces between the arms of the spider and through the vent ducts to carry away the heat produced in the armature coils and core. Fig. 5 shows the upper half of a core plate with strips riveted to it between the teeth to form the air duct. The core plates adjacent to an air duct are somewhat thicker than the others.

End Rings.—Figs. 3 and 4 show sections through the end rings or retaining rings. Each

ring is fastened by five bolts, holes for the bolts being tapped into the spider arms. The ring at the commutator end is the smaller; the other ring is continued to form a flange and eight holes are tapped into this to secure the fan for circulating air in the machine. The outer surface of each ring is covered with insulation, and the coil ends are held down by wire binding.

Armature Windings.—Insulated wires or bars are laid in the armature slots and inter-connected at the ends to form a closed winding, equidistant points at one end of the winding being connected to the commutator bars. Two methods are commonly used for winding armatures: *Wave Winding*, in which the current travels continuously round the armature in the same direction, and *Lap Winding* where it travels backwards and forwards alternately in unequal steps. In wave winding the armature is divided into two parallel paths no matter how many poles are used in the field-magnet frame, but in lap winding there are as many parallel paths as there are poles.

When small wires of circular cross section are used the armature is *Former Wound*, i.e. a wooden former is made to the correct shape, the coil is wound on it and then taped and varnished. Bars of rectangular section instead of circular wires are used for heavy currents, and when these are used the armature is said to be *Bar Wound*. Two or more conductors are put in each slot, usually in two layers. Each conductor is separately insulated and, in addition, the slots are lined with presspahn or other insulating material.

EXERCISES

(1) Make sectional elevations and end views of the retaining rings. Take the end view of each ring as seen from their respective ends of the armature when in place. Scale: one-quarter full size.

(2) Copy the end view of the spider (fig. 2) and add a side elevation. Scale: one-quarter full size.

(3) Make a complete sectional view through the armature assembly. Scale: one-quarter full size.

ARMATURES

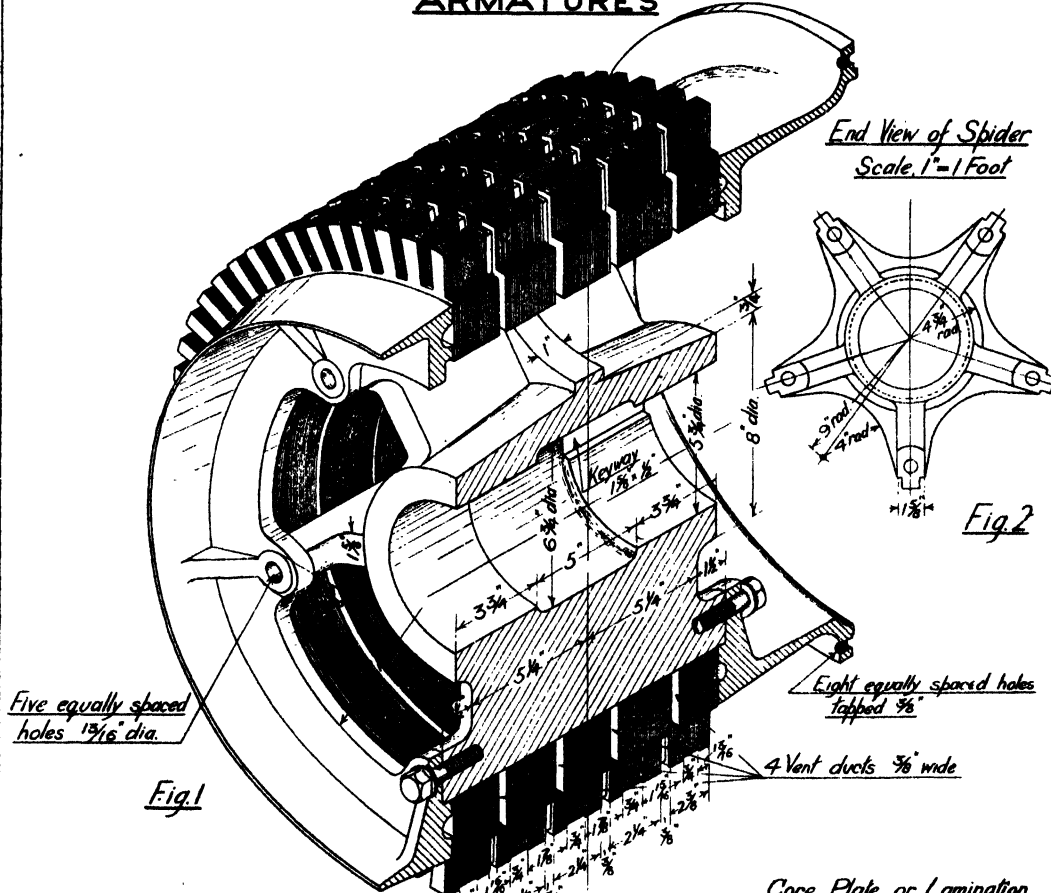

*End View of Spider
Scale, 1"=1 Foot*

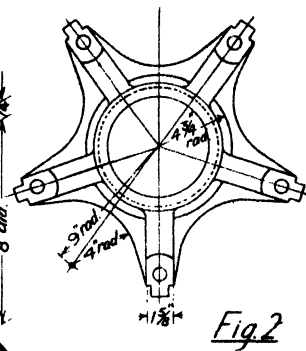

Fig. 2

Five equally spaced holes 1 3/16\"/>

Eight equally spaced holes tapped 7/8\"/>

4 Vent ducts 7/8\"/>

Fig. 1

*Sections through Retaining Rings
Scale, 2"=1 Foot.*

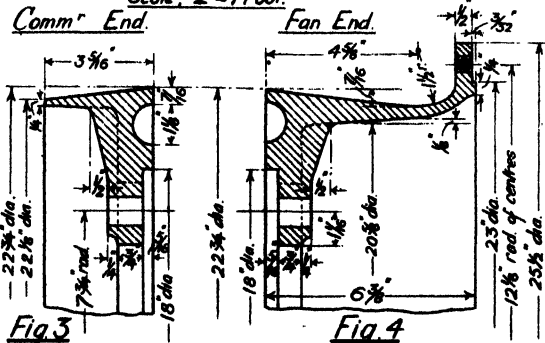

Fig. 3

Fig. 4

Core Plate or Lamination

Scale 1"=1 Foot

66 slots per plate

Spacers riveted between each tooth

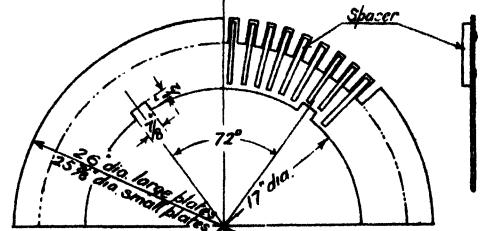

12 thick plates, 2 of each end of core and 2 of each vent duct

Fig. 5

ARMATURES (Continued)

On the opposite page are drawings showing details of an armature made by Messrs. Bruce Peebles & Co., Ltd. This armature resembles the last example in that the core plates are assembled on a spider between end plates, but there are several differences in points of detail.

Fig. 1 is a sectional isometric view of the complete assembly.

Spider.—Details of the spider are shown in figs. 2 and 3. Each arm is enlarged at the outer end to give a greater bearing surface for the core plates and end rings, and a collar is turned on the spider against which one of the end plates abuts. Keyways are cut round the outside of each arm to retain the other end plate.

End Plates.—Figs. 4 and 5 are sections through the end plates. Rings for supporting the end connexions of the armature windings form part of the end plates. The ring shown in fig. 5 has a recess turned on the inside for balance weights (not shown). This ring is seen clearly in fig. 1. Thirty-six bolt holes are drilled and tapped round the ring so that the balance weights can be placed where required.

Equalizing Rings.—In a lap winding, slight differences of pressure in the various circuits due to unequal flux from each pole may cause local currents to be set up in the coils with consequent heating and loss of energy. To prevent these currents, equalizing rings or bucking rings are fitted in some lap wound armatures. They are heavy copper rings connected to points on the winding, twice the polar pitch apart; such points should be at the same potential. To be effective at least eight of these rings should be fitted; in the armature

shown on the opposite page there are fourteen. The method of securing them is shown in the section, fig. 5. Wooden chocks are fitted to the edge of the spider and the rings are held against the chocks by six metal clamps. Each clamp is fastened by two stud bolts one of which is tapped into the spider arm and the other into the end plate.

Armature Wiring Diagrams.—Two kinds of wiring diagrams are commonly used: the *radial diagram* and the *developed diagram*. One of each kind is shown below. The radial diagram is for a four pole, simple, wave wound armature. The inductors, as the bars or wires in the armature slots are called, are represented by the numbered radial lines. The developed diagram is for a six - pole lap wound armature with 72 inductors and 12 equalizing rings.

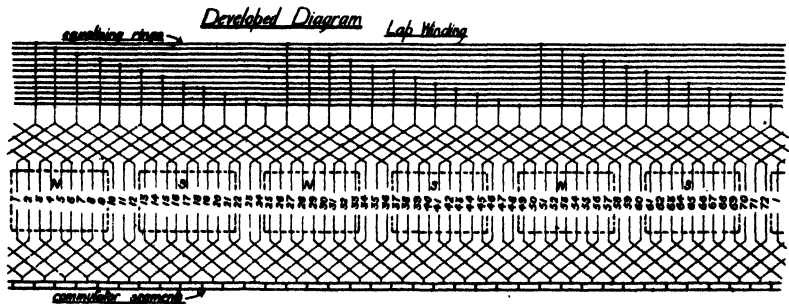
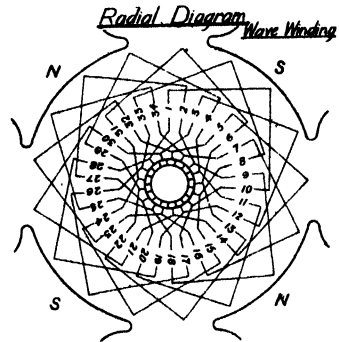

EXERCISES

(1) Copy the sectional views of the end plates and project enough of the end elevation of each of the end plates and spider to show two of the arms. Scale: half full size.

(2) Make a side elevation of the complete

armature showing the top half in section. Scale: half full size.

(3) Convert the wave wound armature radial diagram into a developed diagram.

ARMATURES

Dimensions are in m.m.s.

Details of Spider

Part Sectl. End Elevation

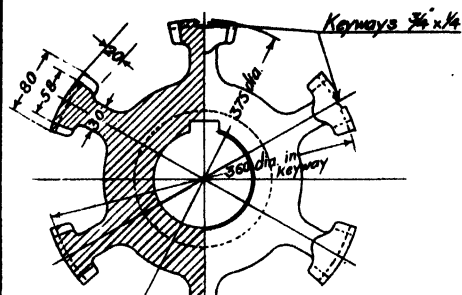

Fig 2

Part Sectl. Plan

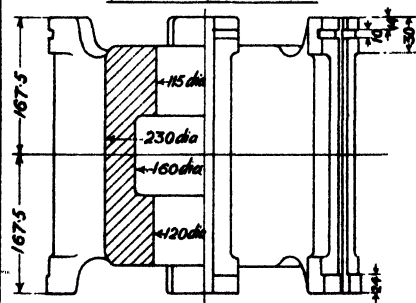

Fig 3

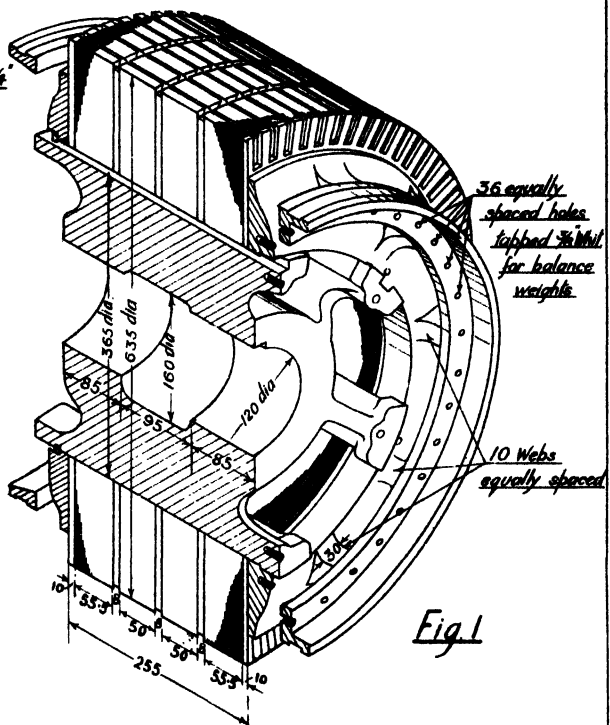

Fig 1

Details of End Plates

Section

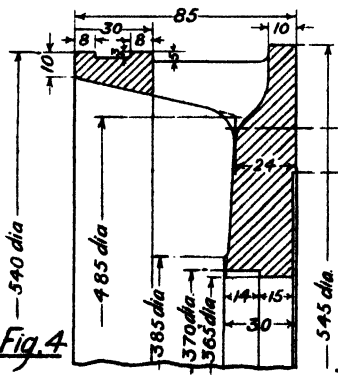

Fig 4

Section

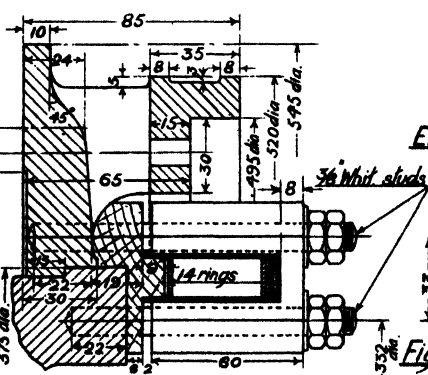

Fig 5

End Elevation of Clamp

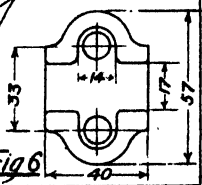

Fig 6

COMMUTATORS

Commutators are generally cylindrical and are built up of copper segments insulated from each other and built up between cone-shaped end rings. In another form of commutator, however, the segments are fitted together to form a circular flat surface and the brushes make contact along radial lines. Commutators are mounted on the shaft as near the armature as convenient. The connexion between a commutator and the shaft is by a key, but in some cases the commutator is, in addition, bolted to the armature so that there can be no relative motion between the two parts. The diameter of a commutator with relation to other parts of a machine varies considerably, but generally it may be taken as approximately three-quarters the armature diameter.

The **Segments** are made of high conductivity hard-drawn copper of the correct tapering section, usually drop-forged. The length of the commutator surface depends upon the number and size of the brushes, and this, of course, depends upon the current in the armature. Better commutation can be obtained by increasing the number of segments, but the cross section of a segment is limited by electrical and mechanical considerations. A segment must have a cross section large enough to carry the current and it must be sufficiently strong mechanically to withstand the stress due to centrifugal force. At the end of a segment a saw cut is made for the *riser*, and to provide sufficient material for this the minimum width allowed is 4 or 5 mm. Hence it is not possible to have more than a certain number of segments on a commutator of a specified diameter.

Small commutators are often made by clamping the segments between two end rings, but most commutators are built on cast-iron

Spiders. One end ring is often cast on the spider the other being loose. The copper segments are assembled temporarily inside steel rings, and the V-shaped grooves are turned in the ends. The wedge-shaped end rings are forced into the grooves and retained by bolts before the steel rings are removed. It is found from experience that the angle of the wedges should be about 35°; the inner face makes an angle of about 30° with the axis. The inner edges are slightly rounded to provide draw.

Figs. 1 and 2 represent commutators made by Messrs. Mawdsley, Ltd.

Fig. 1 is an isometric view of a small commutator with the front upper portion removed to show the construction. The segments are clamped between end rings, one of which is keyed to the shaft, and the rings are held together by five stud bolts. Each bolt is covered with a micanite tube between the end rings to insulate it from the segments and the segments are insulated from the end rings by micanite rings.

Fig. 2 shows a much larger commutator. The spider is lightened as much as possible and is keyed to the shaft at one end only. At one end of the spider a ring is cast on it, and at the other end it is turned down for a distance of 1½" to receive the loose ring. Dimensions of the latter are shown in fig. 3.

Figs. 5 to 8 give details of a commutator made by Messrs. Bruce Peebles & Co., Ltd. Both end rings are cast separately, and they are retained by bolts which pass right through the spider. The heads of these bolts are eccentric so that they will not turn when the nuts are tightened.

The separate commutator bars are not shown in fig. 8.

EXERCISES

(1) Draw a sectional elevation and an end elevation of the commutator shown in fig. 1. Scale: full size.

(2) Make a side elevation of the spider and end ring shown in fig. 2. Show the loose end ring in place, and make the upper half of the drawing in section. Scale: one-quarter full size.

(3) Make an end elevation of the commutator shown in fig. 5. Draw the right-hand side in section. Scale: one-quarter full size.

(4) Draw a side sectional elevation of the commutator (fig. 5). Scale: one-quarter full size.

COMMUTATORS

Dimensions for figs 5 to 8 are in mms.

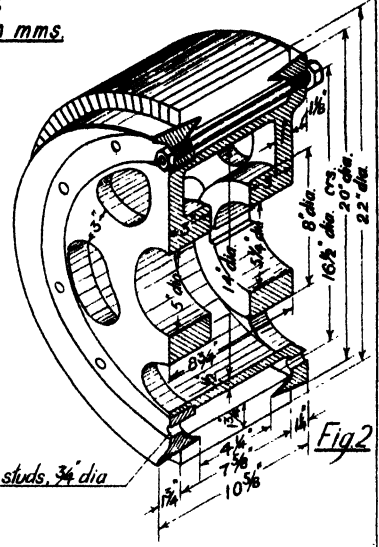
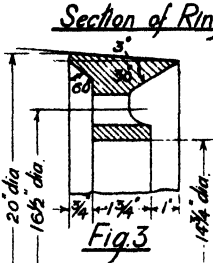
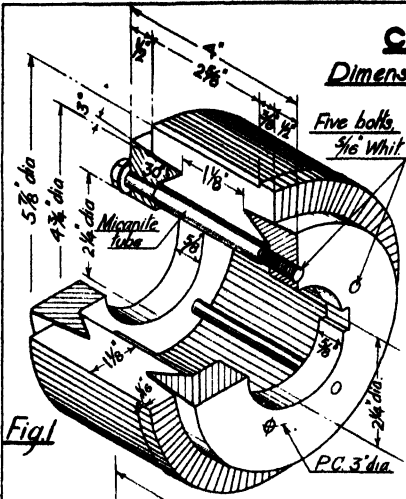

Commutator Bar

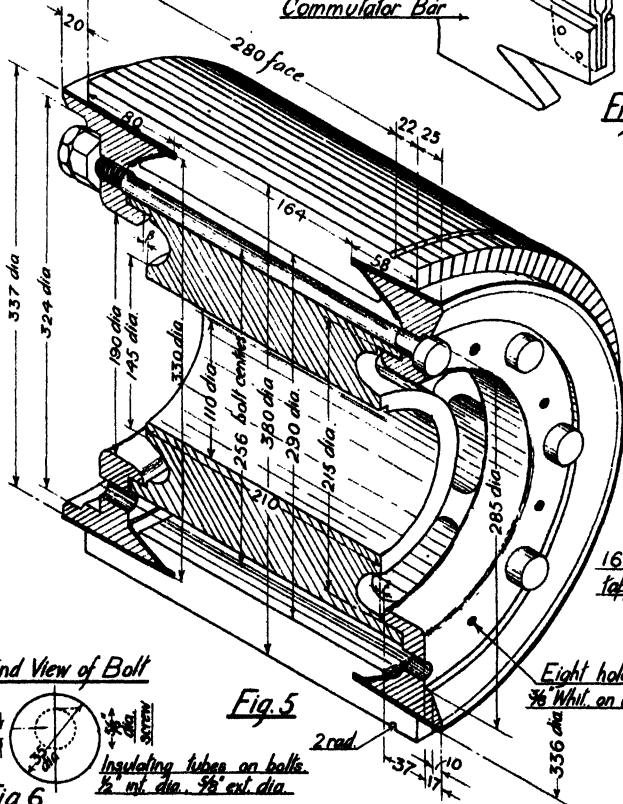
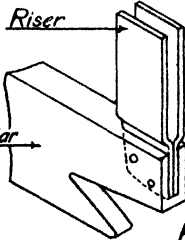

Section of Front End Ring

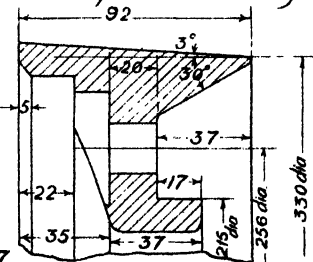

Part End Elevation

16 holes for Balance Weights,
tapped 3/16 Whit, on a
P.C. 290 dia.

Eight holes, tapped
3/16 Whit, on a P.C. 230 dia.

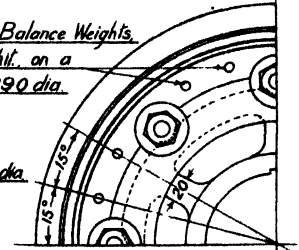

End View of Bolt

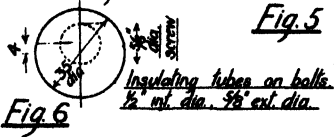

COMMUTATORS (Continued)

The ends of the armature coils are connected to the commutator segments by short copper strips called **Risers**. There are many different forms of risers and methods of connecting them; some are made of a single copper strip turned over at one end to enclose the coil ends; others are made of two copper strips riveted together. The inner ends of the risers are riveted and sweated into saw-cuts in the ends of the commutator bars. Fig. 4 on p. 43 is an isometric view of one form of riser fitted to the end of a commutator segment.

Insulation.—The only material which is really suitable for the insulation of adjacent segments is mica. This material possesses all the necessary properties; it will not burn, it cannot be carbonized and it does not absorb moisture. As some degree of sparking may occur at the brushes, a material which carbonized might cause the insulation between the segments to break down; if the material absorbed moisture its insulating properties would be seriously reduced.

The continuous rubbing of the brushes causes the commutator to wear down, but the copper segments and the mica insulation should wear at the same rate, otherwise the projecting mica will cause the brushes to jump and chatter. The best Canadian mica is used for insulation, and is selected so that it shall wear at the same rate as the copper. As it is not possible to obtain sheets of mica sufficiently large they have to be built up from very thin strips and shellac is used to fasten the strips together.

The strips of mica are usually about .03" thick; that is more than is required on account of the few volts difference of pressure between adjacent segments, but with very thin insulation, and any slight sparking at the brushes, particles of melted copper from the trailing

edges of the bars might be able to bridge across the spaces and short-circuit the commutator.

When a commutator wears unevenly the brushes jump and cause sparking and this makes the surface worse. To obtain a truly cylindrical surface again, the commutator is turned down to a slightly smaller diameter, and to allow for this the segments are made about twice as deep as required from mechanical and electrical considerations.

The end rings and spider are covered with mica or micanite, shaped to the correct form where necessary.

Fig. 1 shows a commutator made by Messrs. W. H. Allen, Son & Co., Ltd. The spider has three radial arms and the loose end ring is held by six bolts all of which pass right through the spider. The insulating rings are made of micanite. The saw-cuts at the ends of the bars are shown in the figure but not the risers; of course, the risers must be riveted into the bars before the commutator is assembled.

Commutator for Exciter.—In some machines the commutator is not mounted separately on the shaft, but is an extension of the armature. Very large commutators and small commutators forming part of the exciters of turbo-alternators are often made in this way. Figs. 3 and 4 show a commutator for the exciter of a turbo-alternator made by the English Electric Co. The construction of the commutator and the method of attaching the end rings is shown in the sectional elevation. The nuts are prevented from slacking back by locking washers. Pieces of tinned sheet, .02" thick, are cut as shown in fig. 3 so that each piece passes under two nuts: the edges of the plates are turned up against the nuts after they have been tightened.

EXERCISES

(1) Draw a side elevation and an end elevation of the spider for the commutator shown in fig. 1. Scale: half full size.

(2) Draw a sectional side elevation through the complete commutator (fig. 1). Scale: half full size.

(3) Make a side elevation of the commutator for the exciter with the upper half in section as in fig. 4. Complete the end view. Scale: half full size.

Do not show the separate commutator bars or risers.

SLIP-RING BRUSH-HOLDER BRACKET

Alternating currents are conveyed to and from rotating coils by way of slip rings and brush gear. The ends of the coils are connected to the rings which rotate with the shaft, and the brushes are fitted into a brush-box holder attached to some suitable form of fixed bracket corresponding to the brush holder casting for direct current machines. There may be one or more brushes per ring according to the magnitude of the current, but whereas the brushes for a direct current machine must be arranged side by side on an axial line, slip-ring brushes can be arranged in any positions round the ring.

Brushes.—Various types of graphite and copper-graphite brushes are made for the various conditions of work. The choice of brush depends upon the material of the ring, the speed of the ring and the current density. Graphite brushes of different grades can be used for current densities between 50 and 100 or even 120 amps. per square inch of contact surface, whilst copper-graphite brushes will work with densities between 150 and 180 amps. per square inch. Adjustable springs are fitted to maintain a uniform pressure between the brushes and the slip-rings, and pigtail connexions are used on account of the poor electrical contact between the brushes and the holders.

A **Brush-Holder Bracket** for an Induction Motor is shown on p. 47. The main part of the bracket is curved to follow the form of the slip-ring, but the ends are extended to take

clamps. The bracket is made of cast brass, and the six slots for the brushes in the curved part are cast out. Although the webs connecting the sides of the brackets are inclined to each other and thus form tapering slots, the full width of a slot (25 mm.) is maintained for a distance of only 35 mm. in each. The slot is machined so that a brush 25 mm. × 35 mm. will just fit with sufficient ease to slide freely but not chatter in use. The form of the slot can be seen clearly from the section.

Two-phase motors have two slip-rings, and three-phase motors have three slip-rings, and one brush-holder bracket is fitted to each slip-ring. The brackets are clamped side by side to two parallel bars, one immediately over the slip-rings and one at the side. Two clamps are fitted to each bracket and they are shown bolted in place in fig. 1. They are alike and are made of cast brass; the bolts are made of mild steel. As each bracket is in electrical contact with its respective slip-ring it must be insulated from its support; insulation is therefore fitted under the clamps. The cables are connected to the flat parts at the bottom of the brackets; the two $\frac{7}{16}$ " holes are for bolting a gun-metal cable socket to each bracket.

Any number of brushes, from two to six, can be used in a bracket. Only the slots which are to be used for brushes need to be machined, and the table below the drawings shows which slots are used for various numbers of brushes.

EXERCISES

(1) Copy the side elevation of the brush-holder bracket and project the end elevation looking from the left. Show the outline of the

slip-ring in the elevation. Scale: one-quarter full size.

(2) Draw a plan of the bracket to a scale half full size.

SLIP-RING BRUSH-HOLDER BRACKET

Dimensions are in mms.

Section at XX

Side Elevation

End Elevation

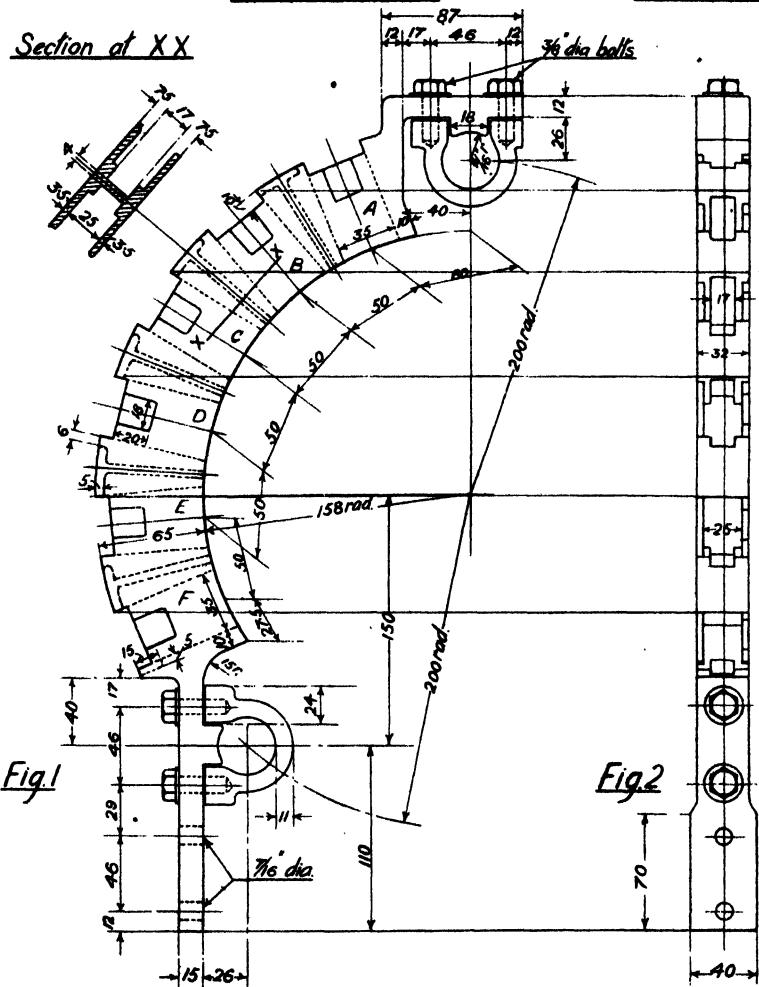

Dia of slip rings 310 mms.
 Brushes 25x35 mms.
 2 to 6 brushes per ring

No. of Brushes	Slots					
2	A					F
3	A		C			F
4	A	B			E	F
5	A	B		D	E	F
6	A	B	C	D	E	F

SLIP-RINGS

The rotor windings of many induction motors are connected to slip-rings so that the rotor currents can be controlled. Squirrel-cage motors have their rotor windings permanently connected and therefore have no slip-rings. Slip-rings are fitted to alternating current generators to convey the direct current from the exciter leads to the rotor windings. Most slip-rings are made of a bronze alloy, but copper, brass, and cast-iron rings are used. They are mounted over a layer of insulation on a cast-iron hub or bush. Generally, the number of slip-rings fitted to a machine is equal to the number of phases.

A set of **Slip-rings for a High Voltage three-phase Induction Motor** made by Messrs. Bruce Peebles & Co., Ltd., is shown in fig. 1. The bush on which they are mounted is made of cast iron and covered with mica. It is keyed to the shaft between the rotor and the bearing. The slip-rings are made of cast bronze, turned to size and shrunk on to the hub over the mica. A string binding is put on over the mica where it is not covered by the rings and this is covered with shellac. The rings are connected to the rotor leads by three bolts, one for each ring, and each bolt is covered with a tube of insulating material. The longest bolt is shown in the sectional view at the top; it passes through two rings and is screwed into the third; the next bolt passes through the first ring and is screwed into the second. The small figures on the right (figs. 2, 3, and 4) show how the holes are drilled and tapped. This

assembly forms a complete unit and can be removed from the shaft as a whole.

Figs. 5 to 8 give the details of a **Slip-ring Assembly for the Brush-raising and Short-circuiting Device** shown on p. 51. The slip-rings are made of phosphor bronze and are shrunk on to a cast-iron sleeve covered with mica. There are three lightening holes in each ring, and in addition three bolt holes; two of the bolt holes are parallel and one is tapered. The studs which connect the ends of the rotor leads to the respective slip-rings are made of hard-drawn brass and are fastened to the rings with brass cone nuts. These nuts fit the tapered holes in the slip rings. The longest stud is shown at the top in the sectional elevation, and dimensions of a cone nut are given in fig. 8. Two fibre bushes are fitted to the left-hand slip-ring to secure the ends of the longer bolts. The left-hand end of each stud is screwed into a contact so that by connecting the three contacts the rotor becomes short-circuited. A cap is screwed to the side of each contact to clamp the ends of the rotor leads.

The cast-iron sleeve is fixed in its proper position on the shaft by a set screw, and after being secured, the head of the screw is covered with shellac. The exposed part of the mica covering is bound over with cord and then covered with varnish. Four slots are cut in the sleeve; three are $\frac{1}{4}$ " long and one is $1\frac{1}{4}$ " long. The shaft is hollow, and the rotor leads pass through it and out through the short slots to the contacts. The long slot is for a pin which drives the short-circuiting clips.

EXERCISES

(1) Draw a side elevation of the slip-ring assembly (fig. 1). Show the outside elevation of the lower half and the sectional elevation of the upper half. Project an end view looking from the right. Scale: one-quarter full size.

(2) Make a sectional elevation and an end elevation of one of the slip-rings shown in figs. 5 and 6. Scale: full size.

(3) Make a plan and an elevation of the longest stud with the contact, cone nut and fibre washer for the slip-ring assembly (figs. 5 and 6). Scale: full size.

(4) Draw a side elevation of the assembly shown in fig. 5, and project an end view looking from the left. Scale: half full size.

SLIP RINGS

Dimensions for fig.1 are in mms.

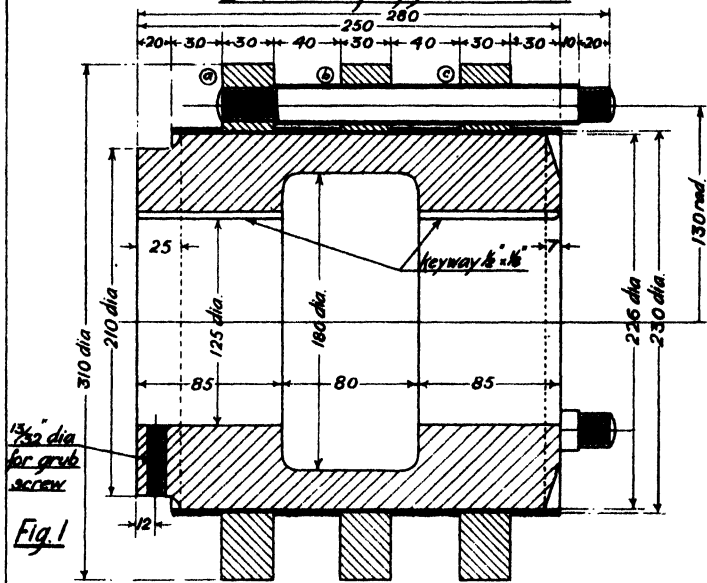

Fig.1

Details of holes in rings

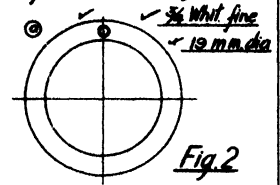

Fig.2

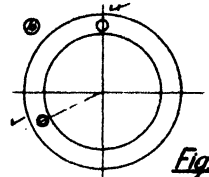

Fig.3

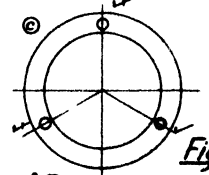

Fig.4

Sectional Elevation

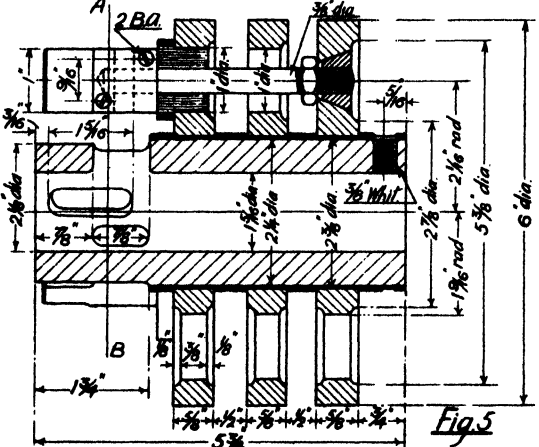

Fig.5

Section at AB

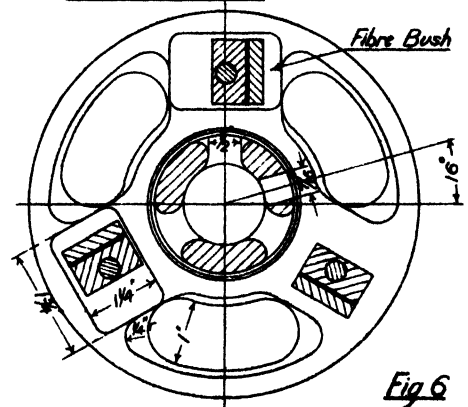

Fig.6

Plan of Contact



Fig.7

Cone Nut



Fig.8

SHORT-CIRCUITING AND BRUSH-LIFTING DEVICE

The great advantage of slip-ring induction motors is their power to give a maximum starting torque with the minimum line disturbance, and with little more than full-load current. The advantage is gained by putting resistance in the rotor circuit; points on the rotor winding are connected through the slip-rings and brushes to variable resistances which are gradually cut out as the motor increases speed. When the motor attains full speed and all the external resistances have been cut out there will still be a certain amount of resistance in the rotor circuit due to the leads and brushes. This is objectionable as it causes increased slip and loss of power, and to avoid it in many machines provision is made to short-circuit the slip-rings, and at the same time raise the brushes from the rings.

The figures on the opposite page show a short-circuiting device made by The British Thomson-Houston Co., Ltd. Fig. 1 is a part sectional elevation of the device which is fitted to the motor outside the bearing and is enclosed in a steel casing. Details of the slip-rings and the sleeve on which they are mounted are given on p. 49.

The rotor is short-circuited by the spring contacts on the plunger being forced over the fixed contacts on the studs. The plunger is made to slide easily in the end of the sleeve carrying the slip-rings, but is caused to rotate with the rings by the pin on the stop-plate projecting into the slot in the sleeve. A horizontal shaft through the bottom of the casing has two levers keyed to it, one outside with a handle at the upper end, the other inside, branched, with two projecting pins engaging with a groove; this determines the position of the plunger.

The brushes are not shown in the side elevation, but a brush-holder is shown in the side elevation (fig. 2). It is of the lever type, the free end extending over the horizontal bar above the slip-rings and it is held down by an adjustable spring. The bar is connected to a short lever at one end and to a slotted plate at the other end, so that by swinging the plate in one direction or the other the bar is slightly raised or lowered. The extensions on the brush-holders project so that by raising the bar the brushes are lifted off the slip-rings. A pin on the end of the lever inside the casing is arranged to engage the slot in the plate and the dimensions of the various parts are designed so that a single motion of the handle first short-circuits the rotor and then raises the brushes.

Details of the short-circuiting plunger, &c., are given in the lower figures. The plunger is made of brass, cast to the required shape and machined where necessary. The spring contacts are made of phosphor bronze and are held by cheese-head screws. The stop-plate is made of mild steel and is fastened to the plunger by two pins and one o.B.A. cheese-head screw. It will be seen that the elevation of the stop-plate must be turned end for end to be in its correct relative position with reference to the plunger.

The motor is stopped by opening the main switch without moving the short-circuiting gear, but the plunger must be withdrawn and all the resistance inserted in the rotor circuit before the motor is restarted. In some motors interlocking devices are fitted to prevent the main switch being closed whilst the rotor is short-circuited.

EXERCISES

(1) Draw a plan, a side elevation and an end elevation of the short-circuiting plunger. Take the plunger in the position with one arm vertical and below the centre. Scale: full size.

(2) Draw a side elevation of the plunger with the contact spring and stop plate. Take the

plunger in the position shown in fig. 3. Scale: full size.

(3) Draw a sectional elevation through the plunger and slip-rings with the plunger in the position for the contacts to be closed. The dimensions of the slip-rings may be taken from p. 49. Scale: half full size.

SHORT-CIRCUITING AND BRUSH-LIFTING DEVICE

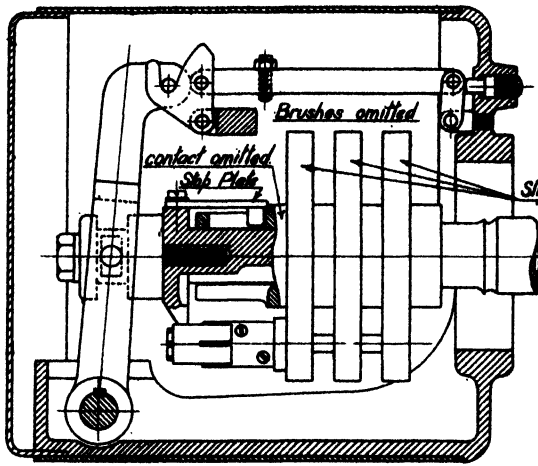

Fig. 1

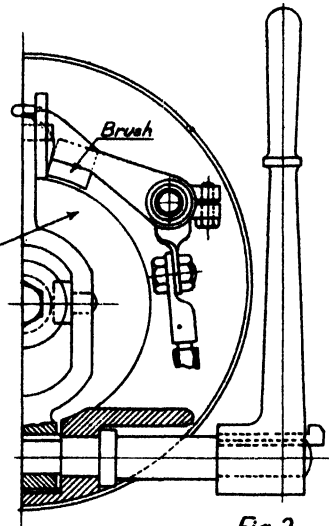

Fig. 2

Short Circuiting Plunger

Section at AB

Sectional Elevation

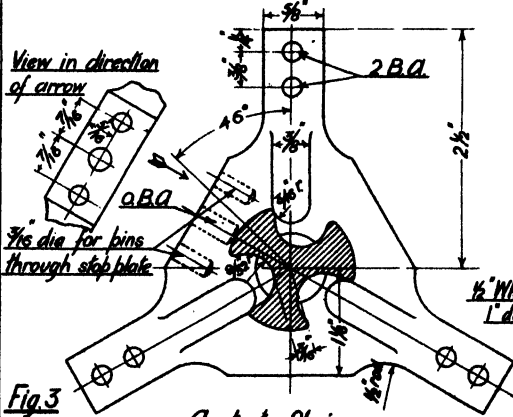

Fig. 3

Contact Spring

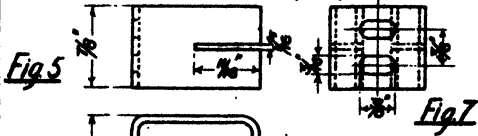

Fig. 5

Fig. 7

Fig. 6

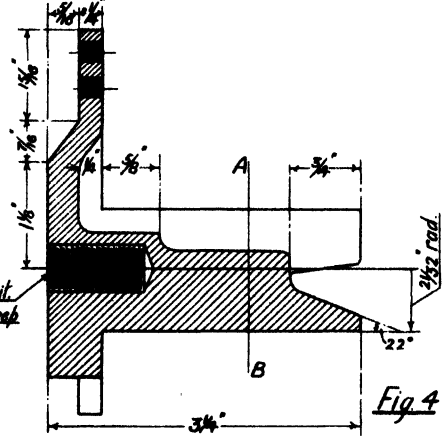
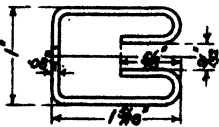

Fig. 4

Stop Plate

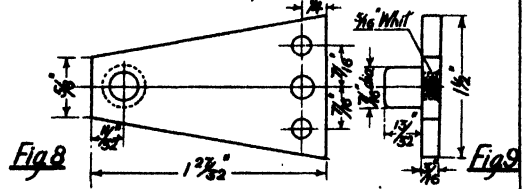

Fig. 8

Fig. 9

ROTORS

The rotating core of an alternating current generator or motor, together with its windings, form the rotor. There are different types of rotors and, in general, those for generators differ from those for motors. For generators they consist of two or more poles energized by direct current: for motors they consist of a laminated core with a winding which is closed either in the rotor itself or through an external resistance.

Alternating current motors may be divided into two classes, squirrel-cage motors and slip-ring motors, the latter class including the various kinds of synchronous motors. In squirrel-cage motors and ordinary slip-ring motors the rotor winding acts as the secondary of a transformer of which the stator winding is the primary. The squirrel-cage motor has a very robust construction, but has inherent defects; it will give only a small starting torque, and will take a momentary heavy current at a low power factor. It has, however, no rubbing contacts and no bare wires, and when running at full speed it has high efficiency and high power factor.

Fig. 1 is an isometric sectional view of a **Squirrel-cage Rotor** made by Messrs. Metropolitan Vickers, Ltd. Its construction is simple; it consists of annealed steel stampings held between end plates and mounted directly on the shaft. One end of the rotor is forced against a collar on the shaft and the other end is held by a ring sprung into a groove. There is no key, but the shaft under the rotor is knurled. Fig. 2 shows one half of a rotor stamping. Thirty-eight copper bars pass through semi-

enclosed holes in the stampings and through corresponding holes in two copper rings at the ends of the core. The holes in the rings are countersunk and the ends of the copper bars are riveted over and welded to the rings. The copper bars are not insulated from the core plates. Four fan plates are fitted to each end of the motor; one plate is shown in the figure.

Figs. 3 to 6 show details of a **Rotor for a Generator** made by The British Thomson-Houston Co., Ltd. It is for a slow-speed machine and it consists of eighteen poles bolted to a cast-iron spider. Fig. 3 is a view of the spider cut vertically through the centre. An inner hub which is keyed to the shaft is connected to an outer rim by a central web. Thirty-six holes are drilled through the outer rim for the bolts holding the poles, and the holes are slightly cuttered on the inside to give a flat surface for the heads of the bolts. Lightning holes and balancing holes are drilled in the web; the former are tapered in both directions towards the centre and details are given in fig. 4. A rotor pole is shown in figs. 5 and 6. It is a mild-steel casting with a flange at the top, and the top and bottom are machined to the correct radii. All the poles are alike, and they are fitted to the spider on *shims* or thin plates cut to the same size as the base of a pole. Hard-wood flanges, $\frac{1}{8}$ " thick in the thinnest part are made to fit over the bottoms of the poles. A coil is wound over each pole and the coils are joined in series in such a manner that the outer ends of alternate poles have opposite polarity. The ends of the winding are taken through the two $\frac{1}{8}$ " holes in the rim of the spider to the slip-rings.

EXERCISES

(1) Draw an end elevation of the squirrel-cage rotor with the left-hand side in section to show the rotor punchings. Scale: full size.

(2) Draw a side elevation of the squirrel-cage rotor with the upper half in section. Scale: full size.

(3) Make whatever drawings you consider necessary to show completely the form of the

spider represented in fig. 3. Scale: one-quarter full size.

(4) Make a side elevation of the rotor for the alternating current generator with the upper half in section and showing the poles on the rotor. Project an end view. Scale: one-eighth full size.

ROTORS

Squirrel Cage Rotor

Rotor Stamping

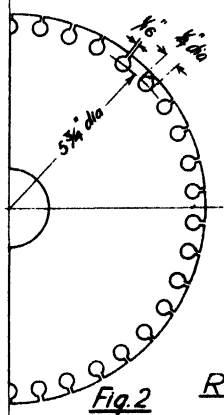

Fig. 2

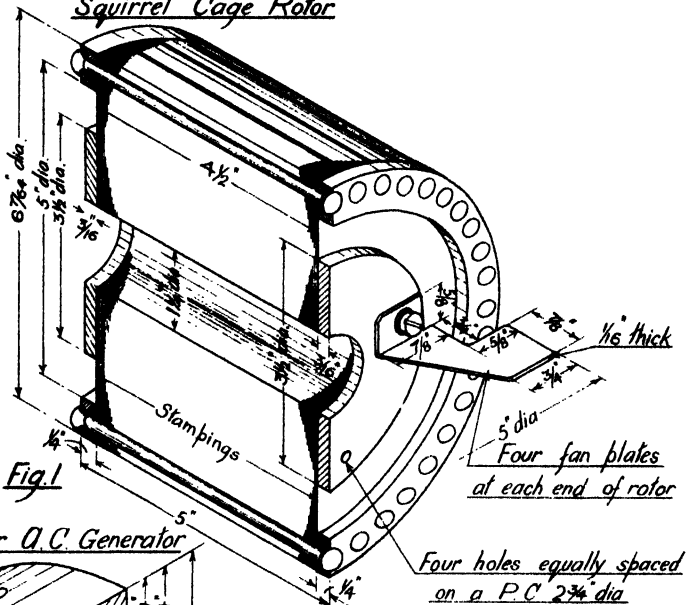

Fig. 1

Four fan blades at each end of rotor

Four holes equally spaced on a P.C. 2 3/4\"/>

tapped 7/16 Whit.

Rotor for D.C. Generator

18 pairs of holes 1 3/16\"/>

equally spaced

7/16\"/>

dia holes for leads

4 holes 3\"/>

dia equally spaced

8 holes for balancing equally spaced between

Holes for balancing



Fig. 4

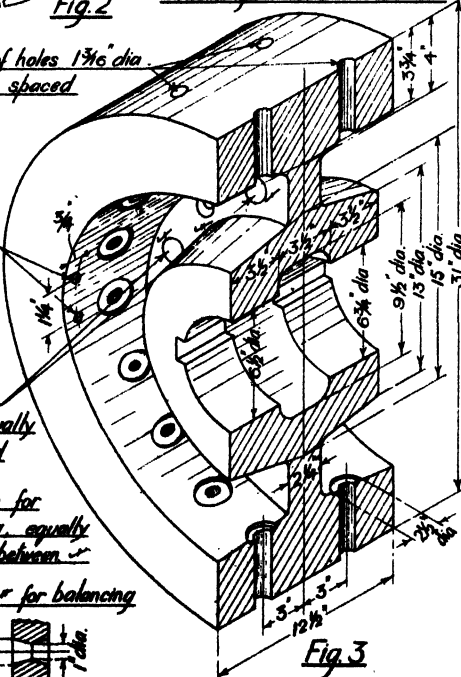

Fig. 3

Rotor Pole Elevation

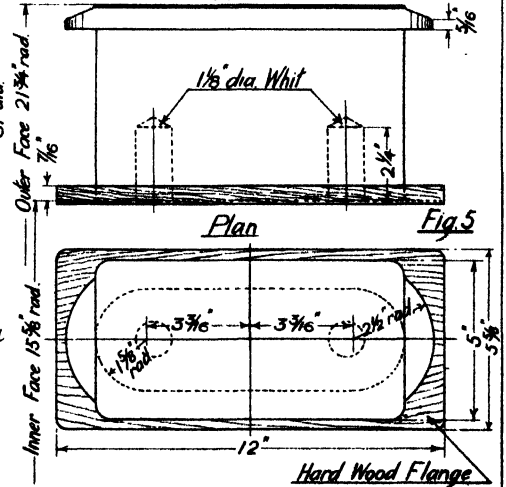

Fig. 5

Hard Wood Flange

Two shims are fitted between each pole and rotor

Fig. 6

ROTORS (Continued)

Although the squirrel-cage motor is of very simple construction, is cheap to instal, has very little to get out of order, has no moving contacts, and has a high efficiency under full load conditions, its inability to start under load without taking an exceptionally heavy starting current is a distinct disadvantage. The average squirrel-cage motor when starting takes about four or five times full load current to give the full load torque and serious line disturbance may be caused by switching in a large motor of this type. By inserting resistance in the rotor circuit, however, full load torque can be obtained on starting with little more than full load current, but the resistance must be cut out as the motor gains speed. This means that slip-rings and brush gear must be used to connect the rotor windings to the external resistances; in fact, the squirrel-cage motor becomes the slip-ring motor. The addition of an exciter for supplying continuous current to the rotor windings converts the slip-ring motor into the synchronous motor—a constant speed machine.

Whereas the windings of a squirrel-cage motor consist of uninsulated thick copper bars welded to end-rings, slip-ring rotor windings are made of insulated strips or wires with their ends connected in a particular way. There are two methods commonly used for making the end connexions in a three-phase motor; one forms a coil winding (used on small motors), and the other forms a bar winding (used on large motors) and corresponds to the wave winding on a direct current armature. The rotor is wound for the same number of poles as there are on the stator.

The drawings on p. 55 give details for a

Rotor for a Slip-ring Induction Motor made by Messrs. Bruce Peebles & Co., Ltd. It consists of a cast-iron spider upon which the rotor stampings are assembled and clamped between end-rings.

The **Spider** is shown in figs. 5 and 6. Fig. 5 is the upper half of a sectional side elevation on a line midway between the arms, and fig. 6 is a part elevation and part section at AB. The outer rim is connected to the hub by eight equal arms of the section shown in the small figure. Keyways are cut on the spider; one in the hub for the shaft; twelve on the rim for keys through the stampings; and twelve for short keys round the rim to retain the end-rings in place. Most of the axial keys extend only through the stampings, but one is long enough to pass through the end-rings as well. Its section can be seen from the shape of the stampings, fig. 4 and the section of the keyways in fig. 6. The dovetail section is only maintained in the stampings; in the end-rings it is rectangular.

Owing to the size of the rotor the **Stampings** are not in the form of complete rings but are made in sectors—six sectors per circle. Details of one sector are shown in fig. 4. They are assembled so that the joints come opposite in alternate layers. The slots are semi-enclosed and only three are shown in the figure.

Sections through the **End-rings** are shown in figs. 1 and 2 in their correct relative positions with regard to the sectional elevation of the rotor spider (fig. 5), but, of course, on a much larger scale. The grooves round the outside of these rings are for insulation and the ends of the windings are bound down on this with steel wire.

EXERCISES

(1) Draw a sectional elevation and an end elevation of each end ring. Scale: one-fifth full size.

(2) Copy the end elevation of the spider (fig. 6) and add a plan. Scale: one-fifth full size.

(3) Make separate drawings of each type of key used in this rotor. Scale: one-third full size.

(4) Make a sectional side elevation of the complete rotor. Only the upper half need be drawn. Scale: one-fifth full size.

ROTOR FOR INDUCTION MOTOR

Dimensions are in m.m.s.

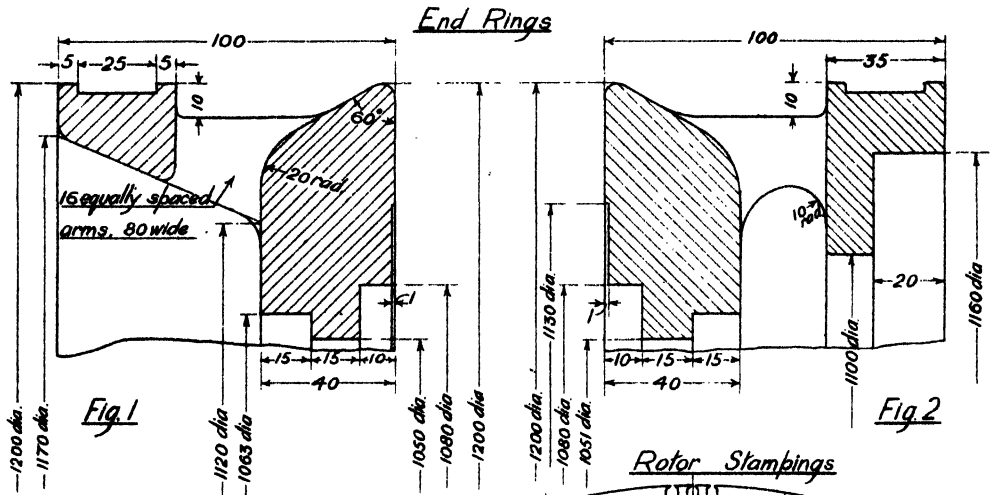

Detail at edge of Rotor Spider

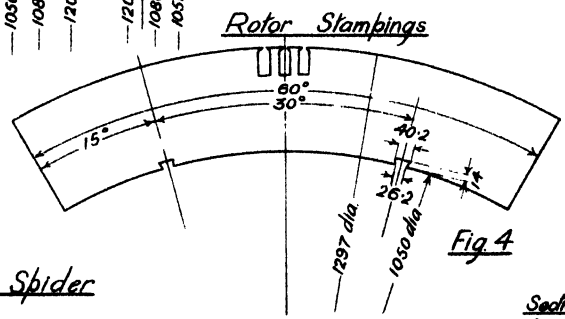
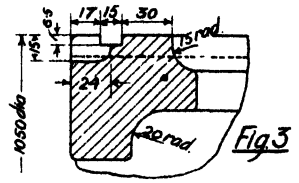

Rotor Spider

Sectional Elevation

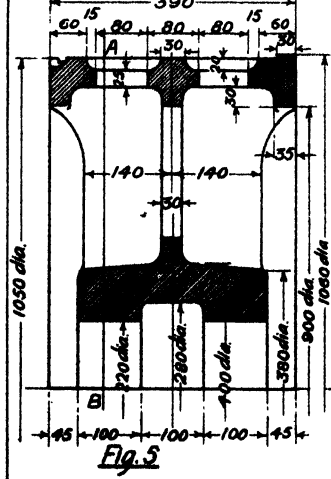

Section through AB

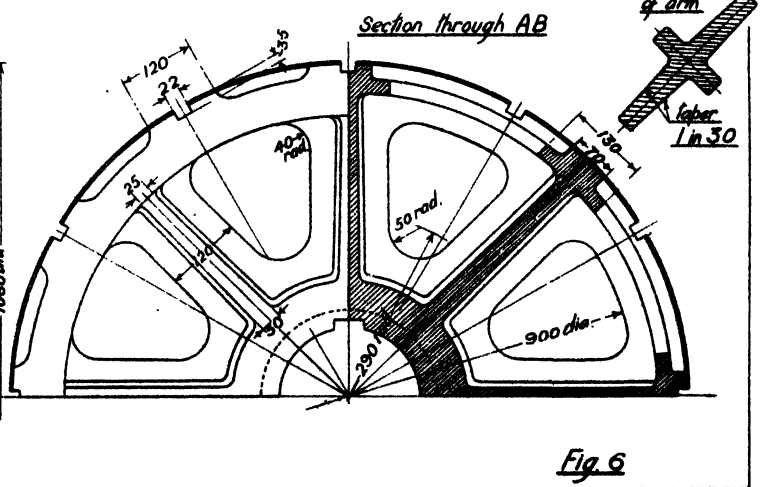

Fig. 6

ROTOR FOR TURBO-ALTERNATOR

Most modern generators of large output are of the turbo-alternator type. This machine has been developed so that to give a certain output a much smaller plant is needed now than was formerly required. Perhaps the greatest difficulty in connexion with the manufacture of high-speed alternators is the construction of a satisfactory rotor. These machines are in quite a different class from those driven by slow-speed engines or water-wheels making from 200 to 600 revolutions per minute, and having large diameter rotors as fig. 3, p. 53. Turbine driven rotors make from 1500 to 3000 revolutions per minute, and at these high speeds considerable stresses are set up in the rotor and its windings. Special care must be taken to ensure accurate balancing and adequate clamping for the end connexions of the windings. To reduce the centrifugal forces to a minimum the ratio of the diameter to the length is made as small as possible.

The rotors for turbo alternators are usually of the smooth core type, forged solid in one piece with the shaft, the slots for the windings being cut out after forging has been completed. In certain circumstances, however, it is desirable to build up the rotor core of boiler-plate stampings.

The drawings on the opposite page show a rotor for a turbo-generator made by the Brush Electrical Engineering Co. It is made of steel and forged in one piece. Fig. 6 is an elevation of the rotor with the central portion and the bearings taken out to save space. The turbine shaft is coupled to the right-hand end and the exciter to the left. Three screw threads are cut on the rotor; the one on the left is for a nut to hold slip-rings on the adjacent tapered part; the others are for screwing on bell-shaped covers to enclose the end connexions of the

rotor windings. Two grooves are cut along the shaft for the leads from the windings to the slip-rings; the position of the grooves are shown by dotted lines in the elevation and a section is shown in fig. 3. The leads are covered by hard-wood wedges.

Details of the slots for the winding are given in the section (fig. 4). These are milled out in two groups to form a two-pole rotor.

The bearings are shown separately on a large scale in figs. 7 and 8. The hole through the shaft near the turbine end is for balancing. To prevent oil creeping along the rotor, *throwers* and *pins* are fitted as shown. The fins are made of hard copper strip and they are caulked in with soft copper.

A wiring diagram for a two-pole rotor is given below.

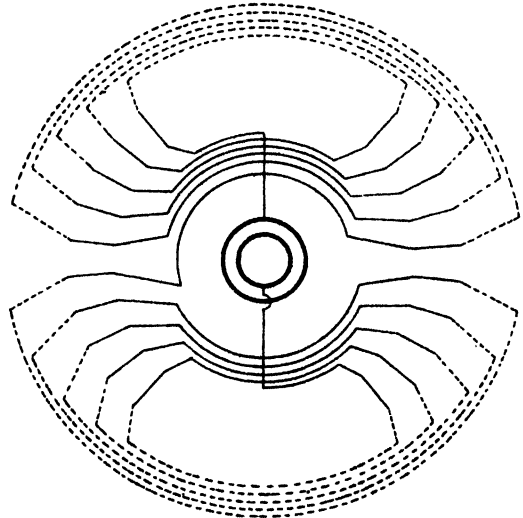

EXERCISES

(1) Draw an end elevation of the rotor looking from the left. Scale: one-quarter full size.

(2) Make an elevation of the rotor, similar

to fig. 6, but with the upper half in section. Scale: one-quarter full size.

(3) Draw a side elevation of the turbine end of the rotor, and give details of a fin. Scale: half full size.

ROTOR FOR TURBO-ALTERNATOR

Section at AB looking to the right

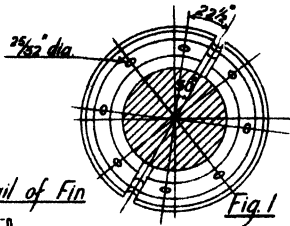

Section through C of Rotor

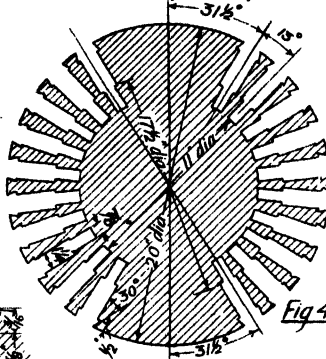

View of turbine end

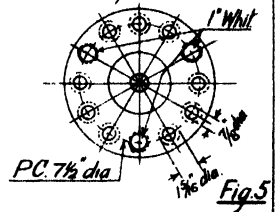

Detail of Fin

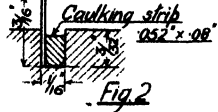
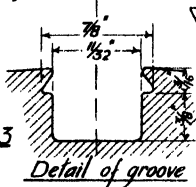

Fig 2



Detail of groove

6 holes tapped 7/8 Whit on a P.C. 5 3/8 dia.

Fig 3

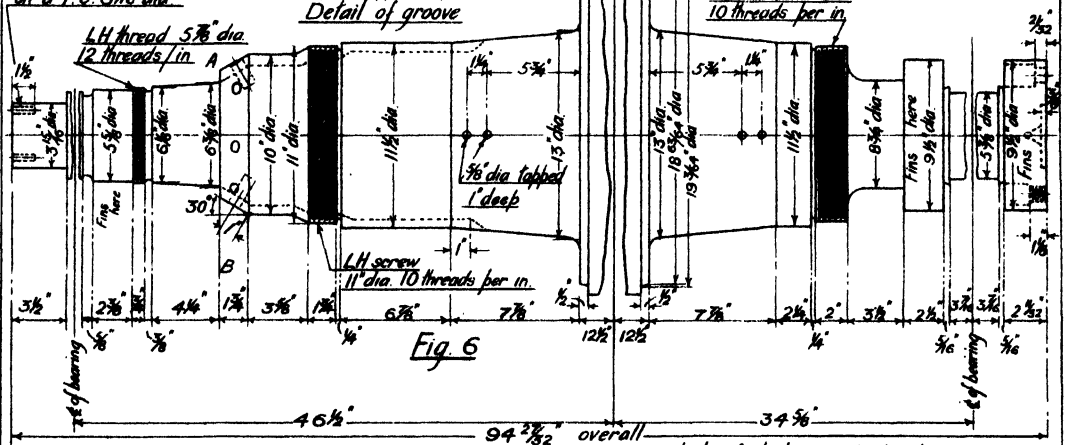

Fig 6

Detail near exciter end of rotor

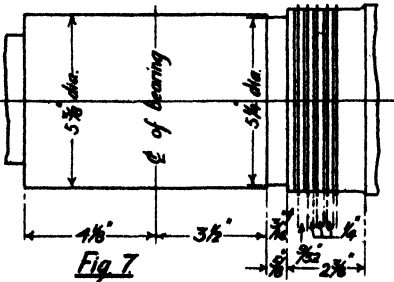

Fig 7

Detail of turbine end of rotor

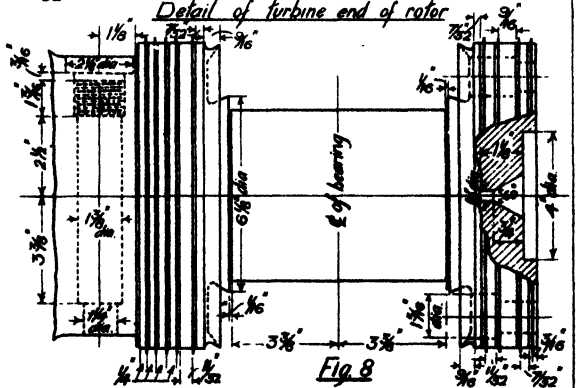

Fig 8

STATOR FRAMES

Stator frames are cast-iron frames which hold the armature punchings and windings. They are usually made in one piece and are of girder form with lightening and ventilation holes. The punchings are made of annealed steel and, as they are too large to fit in complete rings, are made in sectors arranged to break joint in alternate layers, and clamped between end-rings. When complete the assembly forms a hollow cylinder with slots for the armature windings on the inside. The great advantage of the alternator with a fixed armature is that there are no moving contacts for the main current.

The stator frame illustrated on the opposite page is made by the British Thomson-Houston Co., Ltd. The rotor for this frame is shown on p. 53. In form it is a cylinder stiffened inside with three circular girders, one on each end and one in the centre. Feet are cast on the frame so that it can be bolted down to a base-plate. Twelve bars connect the inner edges of the girders and a keyway is cut in each bar.

Fig. 1 is an isometric view of the frame with the upper nearer quarter removed, and, in addition, some of the lower part broken away. This enables the form of the central girder and the construction of the feet to be seen. Webs similar to that shown in fig. 3 are formed between five of the keyways and the outside of the casting. The keyways are all similar to the section shown in fig. 2.

The edges of the frame, the feet, and the key-

ways are carefully machined. Circular flanges or end-rings are bolted to the edges of the frame to clamp the stampings. Twelve $\frac{1}{2}$ " diameter holes are drilled and tapped for each flange; these holes are not shown in the figure.

The punchings are made of annealed sheets; they are made in sectors, six to each ring, and the joints come on the keyways. Dovetailed keyways on the punchings correspond to the parallel keyways on the frame. When the punchings are assembled the diameter of the gap is 46". Semi-enclosed slots, about $1\frac{1}{4}$ " deep, are formed in the punchings for the stator windings. It is usual to arrange for six slots per pole in a machine of this type on account of the ease with which the winding may be made for single, two or three phase.

The axial length of the stator in this type of machine is small in comparison with its diameter, and the difficulty of keeping the frame from reaching too high a temperature is not so great as it is in turbo-alternators. Nevertheless, heavy currents flow in the armature windings, and it is necessary to arrange for a satisfactory system of ventilation so that by a free circulation of air the armature may be kept cool. Vent ducts are formed where required by inserting spacer plates between the punchings. The ducts are $\frac{3}{4}$ " wide and any number from one to six may be formed in the assembly according to the output of the machine. The heated air passes through the ducts into the annular space outside the punchings.

EXERCISES

(1) Draw an end elevation of the stator frame with the right-hand side in section. Take the section plane about two inches from the centre of the frame so that it will not pass through the central girder. Show the outline of the stampings and the position of the joints.

The internal diameter of the core is 46", and the joints are at the keyways. Scale: one-eighth full size.

(2) Draw a side elevation of the stator frame with the upper half in section. Scale: one-eighth full size.

STATOR FRAME

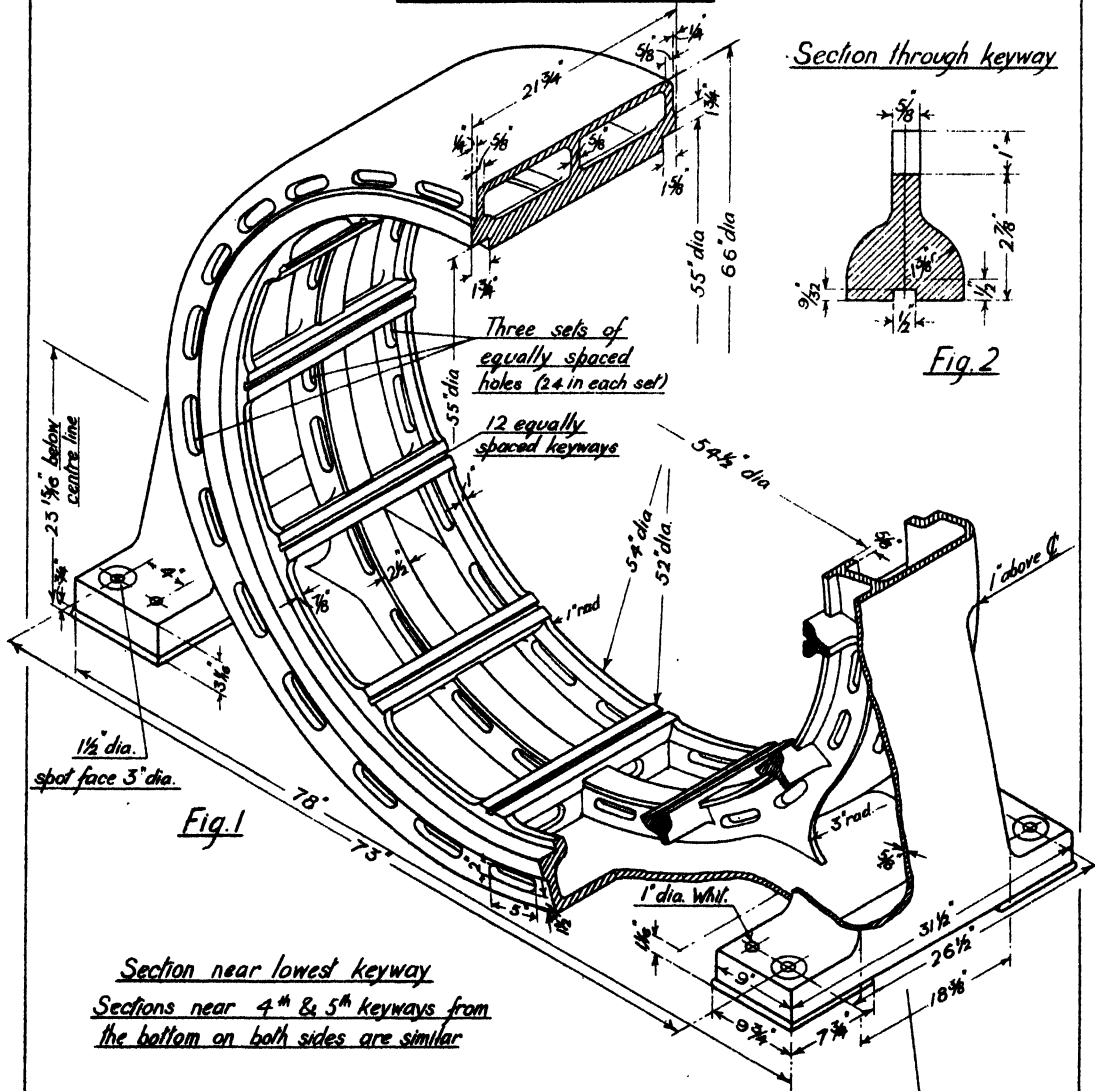

Section through keyway

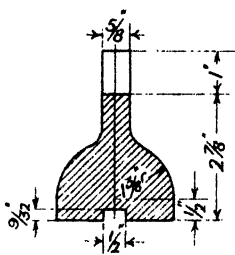

Fig. 2

Fig. 1

Section near lowest keyway
Sections near 4th & 5th keyways from
the bottom on both sides are similar

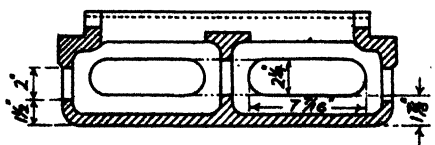

Fig. 3

Rectangular Opening 17 x 6 1/2" (under)

STATOR FRAMES (Continued)

The figures on p. 61 show a stator frame for a turbo-alternator made by Messrs. Metropolitan Vickers & Co., Ltd. It consists of a cylindrical box stiffened by two intermediate circular girders, in addition to the circular ends. The core is composed of punchings and is fitted into the frame. Keyways for the core plates are cut along twelve bars which connect the ends of the frame. At the top of the frame is a large flanged rectangular opening, and at the bottom of the frame is another opening of exactly the same size. Feet are cast on the sides of the frame at suitable positions to form supports and to afford means for securing the frame to a base plate. The right-hand side of fig. 1 is an end elevation and the frame is symmetrical about the centre line. The left-hand side of fig. 1 is a section through the centre and shows one of the circular girders. A boss is cast in the frame on each side to take the lifting gear.

Fig. 2 is a section through one of the bars in which the keyways are cut.

The right-hand side of fig. 3 is a half plan and the frame is symmetrical about both centre lines. One quarter of the rectangular opening at the top of the frame is shown in this figure, and inside the opening the girders can be seen. The left-hand side of this figure is a half-sectional plan.

The punchings are made of annealed steel and fitted in sectors. Dovetails are formed on the outside edges to fit the keyways in the frame and the joints are broken in alternate layers. The punchings are clamped between steel end-plates or flanges, and a section through an end-plate can be seen in fig. 2, p. 63. They

are held in position by twelve short keys at each end of the frame, suitable keyways are cut on the frame and corresponding keyways on the end rings. On the inner edge of the stampings the correct number of slots are formed for the armature winding. The slots are semi-enclosed, and the conductors are held in place by hard-wood wedges. In large machines each conductor is formed of a number of parallel copper strips, the conductors being insulated with mica and other suitable insulating material before being placed in the slots.

Ventilation.—The stators of modern turbo-alternators are comparatively small whilst their current output is large, therefore special care must be taken to prevent any part reaching too high a temperature. The method of doing this is to drive cold air through the machine either by fans on the rotor or by separate fans outside the machines. Vent ducts are provided in stator cores; sometimes radial ducts are used, sometimes axial ducts are used, and some stator cores have both radial and axial ducts. Radial ducts are formed by inserting spacer plates where required; twenty-six ducts, each $\frac{1}{8}$ " wide, are made in the core for the frame shown on the opposite page. These ducts are not equally spaced but are closer together at the centre and wider apart at the ends. The air is forced through the ducts into the annular space between the core and the frame, and is then discharged either into the engine-room or through pipes into the open air. The annular space in the frame is closed by bolting covering plates over the rectangular openings at the top and bottom of the frame.

EXERCISES

(1) Draw the left-hand half of a side elevation of the stator frame and project the left-hand half of a plan. Scale: 1" = 1 foot.

(2) Draw a side elevation of the stator frame

showing the upper half in section. Indicate the position of the core plates in the section, but do not show any vent ducts. Scale: one-eighth full size.

STATOR FRAME

*End Elevation
(half in Section)*

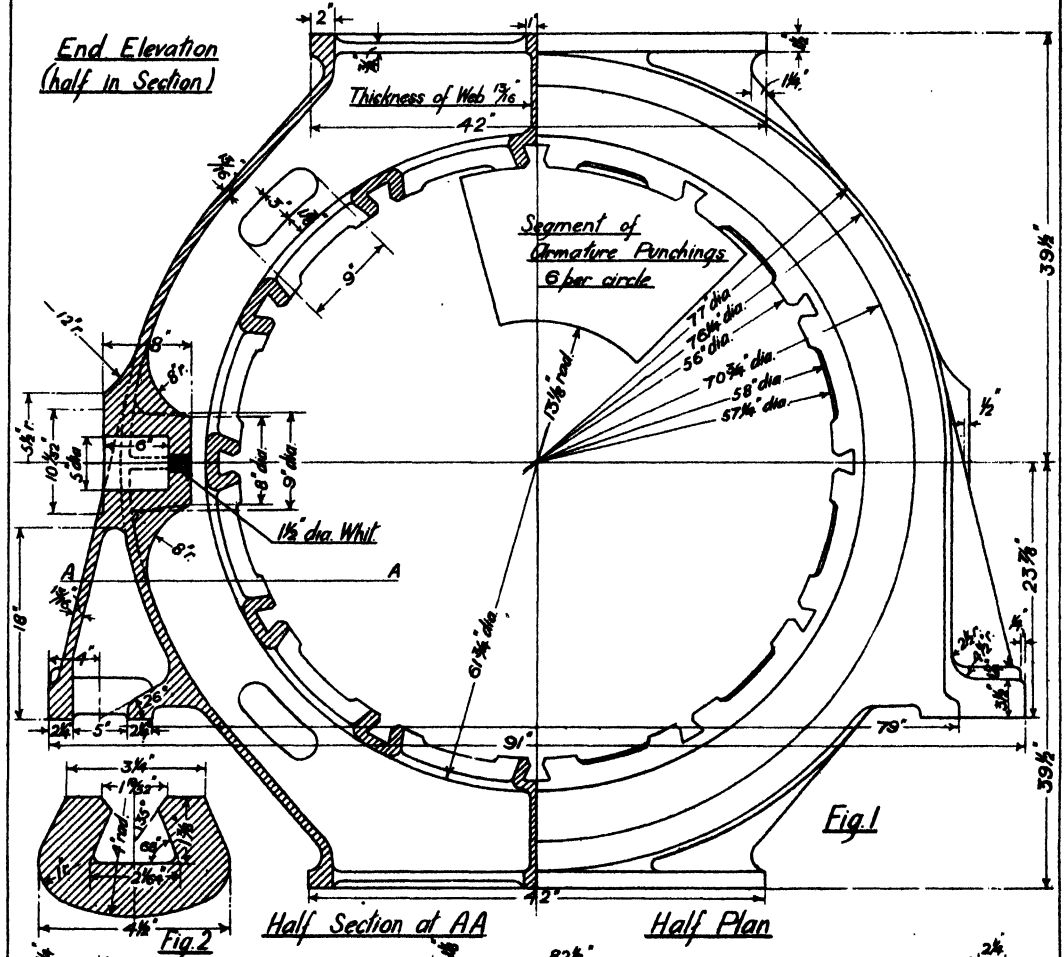

Half Section at AA

Half Plan

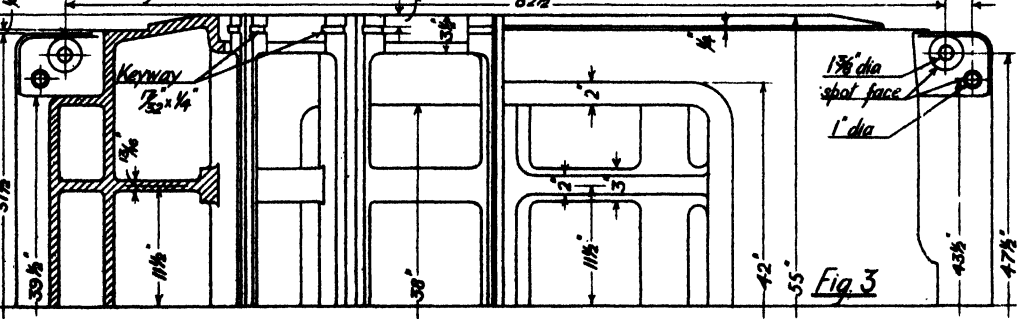

BRACING FOR ENDS OF STATOR COILS

A **Wiring Diagram** is given below for the stator frame shown on p. 61. The winding is for three phases, the different phases being shown by continuous lines, dotted lines and chain lines respectively. All the conductors are shown in one phase only; the other phases are similar. The two separate windings for each phase are connected in parallel and the ends brought to terminals, AA for one phase, BB for the second, and CC for the third.

An armature winding consists of (a) the inductors in the slots, and (b) the end connexions. The former are well secured in the slots by wedges, but the end connexions are in strong magnetic fields and are subject to mechanical forces depending upon the armature current, forces that are liable to become exceptionally heavy especially if the machine happens to be short-circuited. Very strong clamping is necessary to secure the end connexions so that they cannot be bent or torn out of place.

The drawings on p. 63 show the scheme for bracing the ends of the armature windings for

the turbo-alternator frame on p. 61. The end connexions are braced against the end rings by eighteen clamps, each clamp being bolted to the end ring by two gun-metal stud bolts, and additional rigidity is obtained by fitting two rings over the studs. These rings are fitted outside the clamps and parts of them are shown in the end elevation (fig. 1). Hard-wood chocks are fitted between the conductors and the end-rings, these are shown in the sectional elevation through the bottom of the stator (fig. 2). This figure shows only the ends of the core, the middle part has been omitted. The separate conductors in one phase are shown sectioned, and the single conductor which connects one set of coils to the other in each phase is also shown. These single conductors are secured by another smaller set of clamps, ten in number, shown in both figures. As these coil connexions are all made at the exciter end, the clamps are required at that end only. Further the space occupied by the bracing at the exciter end is slightly greater than that required at the turbine end.

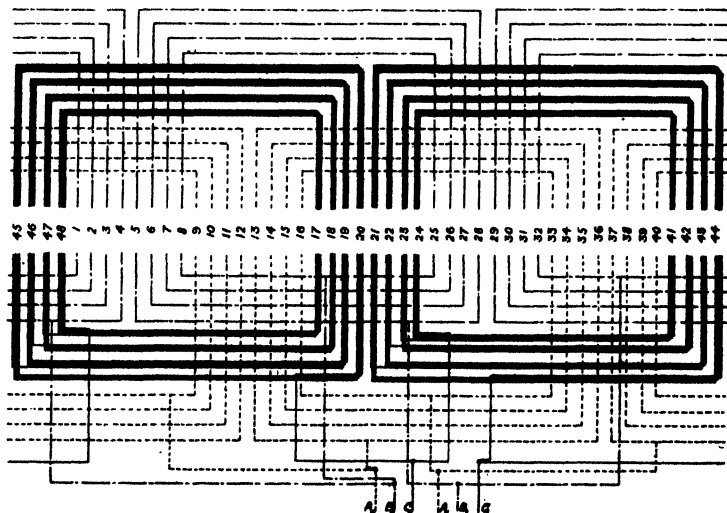

EXERCISE

Copy fig. 1 to a scale of 1" to 1 foot and, by the aid of the wiring diagram, indicate the positions of the connexions between the coils and the

terminals. Dimensions not given may be taken from the figures on p. 61.

BRACING FOR ENDS OF STATOR COILS

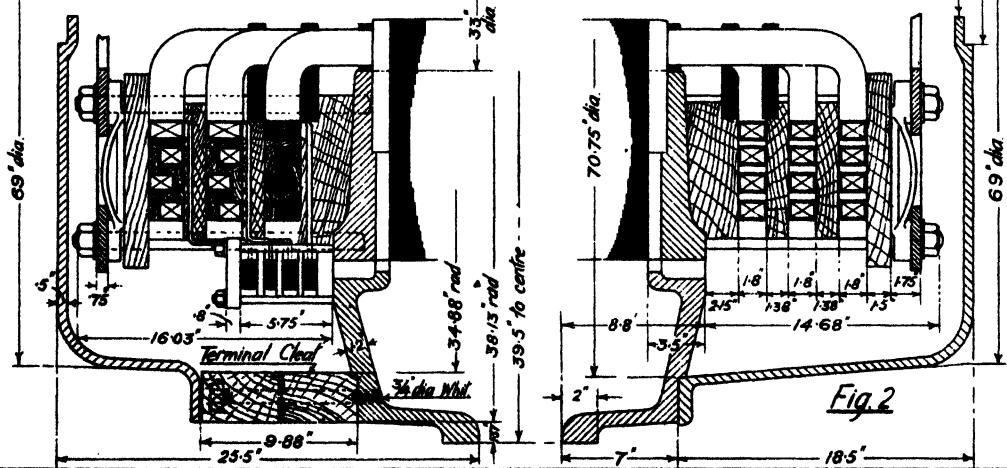
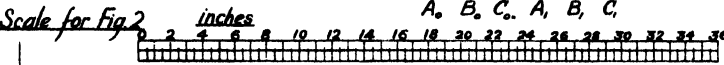
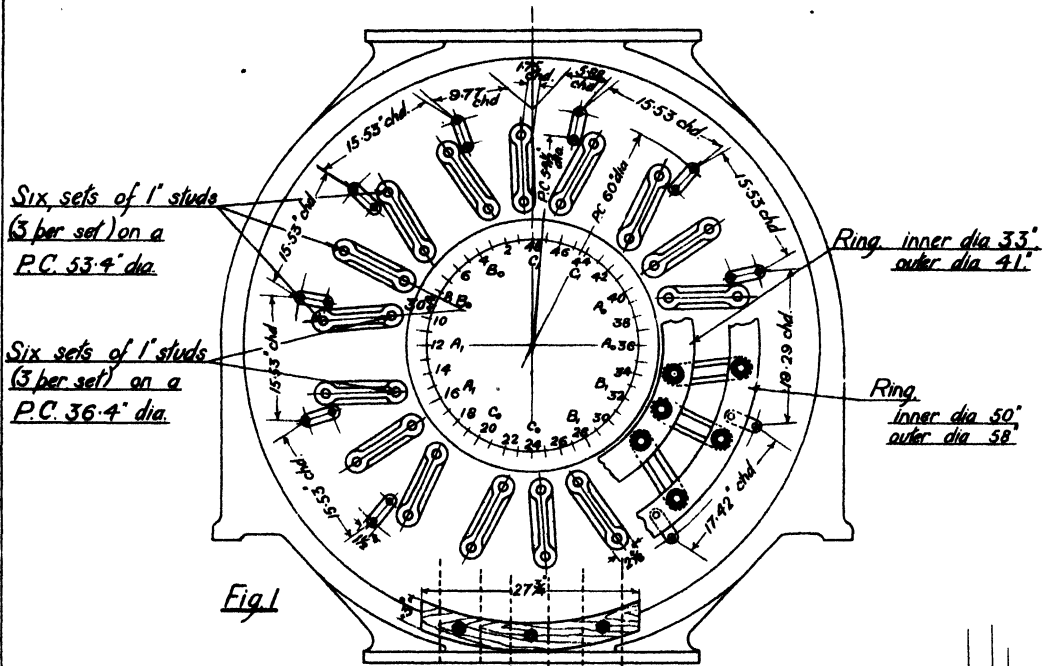

DATE OF ISSUE

This book must be returned
within 3, 7, 14 days of its issue. A
fine of ONE ANNA per day will
be charged if the book is overdue.

27 AUG

1911

1911

1911 *TD*

14/6

21 to 87

1. The first part of the document is a list of names and addresses, which appears to be a directory or a list of contacts. The names are listed in a column, and the addresses are listed in a column to the right.