

BIRLA CENTRAL LIBRARY  
PILANI [RAJASTHAN]

Class No. 444

Book No. 1015

Accession No. 1015





ELEMENTARY METALLURGY  
FOR ENGINEERS

A Selection of  
**CONSTABLE'S TEXT BOOKS**

*Metal Airplane Structures.* By Major F. E. Loudy. A practical treatise on the design and construction of the major component parts of various aeroplanes. Fully illustrated. 24/- net.

*Diesel Engine Design.* By H. F. P. Purday, B.Sc., A.M.I.Mech.E. A text-book for the student and engineer. Fourth edition. 24/- net.

*Mechanical Technology.* By G. F. Charnock, M.Inst.C.E. A treatise for Engineering Students. New and revised edition. 15/- net.

*Hydraulics and its Applications.* By A. H. Gibson, D.Sc., M.Inst.C.E. A text-book for Engineering Students. Fourth Edition. 16/- net.

*Problems in Electrical Engineering (with Answers).* By S. Parker Smith, D.Sc., M.I.E.E. Specially written for Engineering Colleges and Schools. New and revised edition. 6/- net.

*Elementary Plane Trigonometry.* By H. E. Piggott, M.A., Head of Mathematical Department, R.N. College, Dartmouth. A book well adapted for preparation for most examinations on the subject. Third Edition. 7/6 net.

*The Practical Design of Simple Steel Structures.* By D. S. Stewart, B.Sc., A.M.Inst.C.E. Complete in three volumes. Vol. I., 12/- net. Vol. II., 16/- net. Vol. III., 5/- net.

*Plane and Geodetic Surveying.* By David Clark, M.A., B.Sc., M.Inst.C.E., Professor of Civil Engineering, University of Dublin. New Edition. Revised. Vol. I. Plane Surveying. 360 Illustrations and Diagrams. 24/- net. Vol. II. Higher Surveying. 114 Illustrations and Diagrams. 25/- net.

*Physical Chemistry.* By Dr. John Eggert, Professor at the University of Berlin. Revised in collaboration with Dr. Lothar Hock, Professor in the University of Giessen. Translated by S. J. Gregg, Ph.D., A.R.C.Sc. With an Introduction by W. A. Caspari, D.Sc. 128 Illustrations. Price 24/- net.

*Atomic Theory:* An Elementary Exposition. By Dr. Arthur Haas. New Edition with author's summary of recent advances. 15/- net.

*Introduction to the Study of Physical Metallurgy.* By Walter Rosenhain, D.Sc., F.R.S. Third Edition, revised and partly re-written by John L. Haughton, D.Sc., F.Inst.P. 20/- net.

*Surveying from Air Photographs.* By Major M. Hotine, R.E. With 102 line drawings and seven plates in collotype. 30/- net.



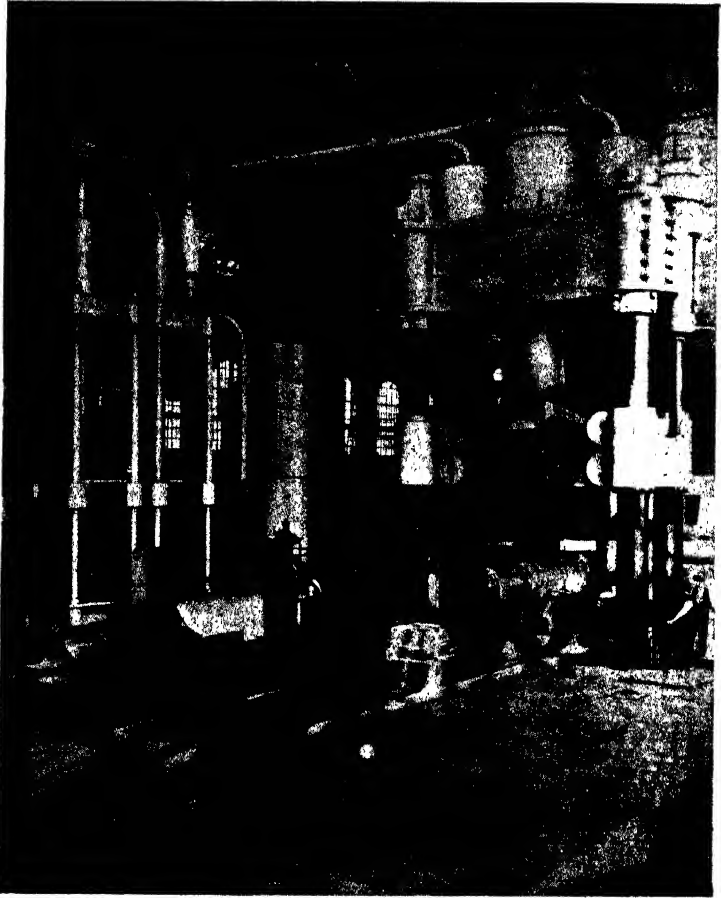

*(John Brown & Co. Ltd., Sheffield).*

**Six-thousand-ton hydraulic forging press with twin cylinders,  
central guide and steam intensifiers.**

**ELEMENTARY METALLURGY**  
**FOR**  
**ENGINEERS**

**BY**

**G. F. C. GORDON**

**M.A. A.M.I.C.E. M.E. I.E.**

**LECTURER IN ENGINEERING MATERIALS AND SUPERINTENDENT OF  
ENGINEERING WORKSHOPS IN THE UNIVERSITY OF CAMBRIDGE**

**SECOND EDITION**  
**REVISED AND ENLARGED**

**LONDON**  
**CONSTABLE & COMPANY LTD**  
**10 ORANGE STREET WC2**



PUBLISHED BY  
*Constable and Company Ltd.*  
LONDON

*The Macmillan Company*  
*of Canada, Limited*  
TORONTO

First published 1932  
Second edition 1936  
Reprinted 1938

PRINTED IN GREAT BRITAIN BY THE WHITEFRIARS PRESS LTD.  
LONDON AND TONBRIDGE

## PREFACE

THE young engineer of the present day has so much to learn in a comparatively short time that he is liable to become confused by the masses of information he is required to store in his brain. This volume is an attempt to present in simple language a general outline of the subject in elementary form. I have to acknowledge much help and constructive criticism from colleagues and others, and, in particular, from Mr. H. Quinney, of Cambridge.

G. F. C. G.

## PREFACE TO THE SECOND EDITION

I WISH to record my thanks to my colleague Dr. Elam (Mrs. G. H. Tipper) for much valuable help in revising this volume.

G. F. C. G.



# CONTENTS

CHAPTER	PAGE
PREFACE . . . . .	v
LIST OF ILLUSTRATIONS . . . . .	ix
I. TESTING OF MATERIALS . . . . .	1
II. METALLOGRAPHY AND MACROGRAPHY . . . . .	19
III. IRON . . . . .	21
IV. WROUGHT IRON. . . . .	52
V. TOOL-STEEL . . . . .	58
VI. PRODUCTION OF STRUCTURAL STEELS . . . . .	72
VII. PRODUCTION OF FORGINGS . . . . .	93
VIII. ALLOY STEELS . . . . .	99
IX. THERMAL CHANGES IN METALS . . . . .	107
X. NON-FERROUS METALS . . . . .	140
XI. SELECTION OF MATERIALS . . . . .	158
INDEX . . . . .	163



## LIST OF ILLUSTRATIONS

Fig.		PAGE
	SIX THOUSAND TON PRESS . . . . .	<i>Frontispiece</i>
1.	ROTARY BEND TEST . . . . .	12
2.	STRESS-ENDURANCE CURVE . . . . .	14
3.	CREEPING CRACKS . . . . .	<i>facing</i> 18
4.	CREEPING CRACKS . . . . .	" 18
5.	DRAW HOOKS . . . . .	" 19
6.	BLAST FURNACE . . . . .	27
7.	POUMAY CUPOLA . . . . .	35
8.	STRUCTURES OF CAST IRONS . . . . .	<i>facing</i> 40
9.	TEMPERATURE-SHRINKAGE CURVES . . . . .	44
10.	CRACKED BELT PULLEY . . . . .	<i>facing</i> 46
11.	ABRUPT CHANGE OF SECTION . . . . .	" 46
12.	SOLIDIFICATION OF CASTINGS . . . . .	47
13.	MALLEABLE CASTINGS . . . . .	<i>facing</i> 50
14.	PUDDLING FURNACE . . . . .	54
15.	STRUCTURES OF WROUGHT IRON . . . . .	<i>facing</i> 54
16.	SIEMENS FURNACE . . . . .	77
17.	COAL-DUST FURNACE . . . . .	<i>facing</i> 80
18.	SHAPES OF INGOTS . . . . .	87
19.	DEFECTIVE FORGINGS . . . . .	<i>facing</i> 94
20.	AERO ENGINE CRANK . . . . .	96
21.	LEAD-TIN ALLOYS . . . . .	111
22.	IRON-CARBON DIAGRAM . . . . .	113
23.	STRUCTURES OF STEELS . . . . .	<i>facing</i> 114
24.	ARREST POINTS . . . . .	116
25.	THERMAL CURVES FOR STEEL . . . . .	118
26.	MARTENSITIC STRUCTURE . . . . .	<i>facing</i> 130
27.	CRYSTAL GROWTH . . . . .	" 136
28.	CRYSTAL GROWTH . . . . .	" 136



# ELEMENTARY METALLURGY FOR ENGINEERS

## CHAPTER I

### TESTING OF MATERIALS

FOR many purposes the engineer is content to buy his material from some reputable source, but where there is some element of doubt as to what he is purchasing or producing, it may be necessary to test this material, especially where life and limb are at stake. Since good material can be ruined by careless mechanical and thermal treatment it is customary in some works to test the material both in the raw and finished state, so that if the component is not up to the mark, the blame may be apportioned. In some cases the purchaser has the tests on the material carried out before delivery in order to save carriage should it prove defective.

The tests selected depend partly on the purpose for which the material is to be used, and partly on the opinion of the engineer. One well-known engineer has stated that he can derive all the information he requires from a tensile test while another neglects the tensile test and insists on Brinell and impact tests. In the writer's view the second engineer has made, possibly, the better choice. Many trades have special tests in connection with their work, such as the repeated sharp bend test used in wire works to measure brittleness. Some tests, such as the "rams' horn" (a drifting and bending test) applied to wrought iron, depend on the personal skill of the man carrying them out.



### Commercial Testing

**Tensile Test.**—Of the various mechanical tests applied to metals, the oldest and still one of the most important is the tensile test. Originally the test was carried out mainly in order to determine the stress required to fracture the specimen. To-day this is so when we are dealing with brittle materials such as grey cast iron, but, so far as ductile materials are concerned, the breaking load is now considered as being of secondary importance only, and there is a tendency for engineers of to-day to look upon it merely as a confirmation of the yield point. For instance, if the piston rod of a steam engine is stressed beyond the yield point during one stroke, it will be permanently elongated and knock out the cylinder cover on the return stroke. If a member of a lattice girder bridge is stressed beyond its yield point, the elongation which takes place redistributes the load on other members which in turn become overloaded. A gun barrel stressed beyond its yield point becomes permanently inaccurate and useless. If we regard the breaking load in this light only, it proves quite useful, especially when through some accident the yield point of a costly test-piece inadvertently has been missed, and much expense and delay would be involved if a fresh specimen were prepared. In such a case it is absolutely necessary that the engineer should possess the requisite knowledge of the ratio of the yield point to the breaking load. He must know the material he is testing and its previous history, *i.e.* the thermal and mechanical treatment it has received. The ratio of the yield point to the breaking load not only depends upon the composition of the material under test, but also upon the mechanical and heat treatment it has undergone, and all these factors must be taken into account when an estimate of the yield point is based on the breaking load. Thus a forging which has been overheated may show a nearly normal breaking load, but the reduced elongation

and contraction of area will indicate that the yield point is almost certainly below normal.

**Length of Test-Piece.**—During the age of wrought iron it was customary to use test-pieces which were very long in comparison with the cross-section. Such long pieces had the advantage that they increased the possibility of including a weak place in a material which was by no means homogeneous. Long test-pieces are still used when testing steel plates, and they possess the advantage of reducing the effects of non-axial loading. It is still customary to machine the sides of test-pieces sheared from plate, but it appears very doubtful whether the extra accuracy resulting from such procedure always justifies the expense involved, except in research work. Modern steel plates are of such high quality that there is usually a very ample margin between test results on a sheared strip and the specified figures. In fact, test-pieces might with advantage be machined if preliminary tests showed that the material was of doubtful quality rather than reject the material on the results obtained from the sheared specimen. At the present time a very much shorter test-piece is almost universally used for materials other than wrought iron bars and mild steel plates. Several factors have contributed to the present practice, viz., the absolute necessity for similarity of test specimens if the results obtained with different sized specimens are to be compared, the impossibility of obtaining long test-pieces from small but important components and the ease and relatively low cost of preparing and treating small samples in the research laboratory.

Consider tests made with a thick and a thin bar of the same material and length. The thick bar will exhibit a distinctly higher elongation than the thin one. If we measure the elongation for a given bar on 8 in. and also on 2 in., we find an enormous difference as shown below :—

TABLE I

Material	Per cent. Elongation on 8 in.	Elongation on 2 in.
Wrought iron . . . . .	30	43
Mild steel . . . . .	27	43
Nickel chrome steel . . . . .	8·8	18
Aluminium rod . . . . .	13·7	38

If the ratio of square root of the area to length is kept constant, the result will be nearly independent of the size of the test specimens.

Approximate similarity of test-pieces can be attained by making

$$\frac{\text{length between marks}}{\sqrt{\text{area of cross-section}}} = \text{constant}$$

and the constant most usually adopted is 4.

The formula is then stated as

$$\text{Length between marks} = 4 \sqrt{\text{area.}}$$

Unfortunately the importance of similarity of test-pieces has not been fully realised, and many figures published in text-books and scientific papers are very difficult, if not impossible, to interpret. The usual method of determining the yield point by means of a pair of compasses may lead to disputes between the contractor and purchaser in cases where the yield point of the specimen is nearly but not quite up to specification. With a view to eliminating all possibility of argument, many Government specifications are drawn up in the following manner. The minimum yield point permissible is stated and the inspector is instructed to scribe a line on the test-piece, apply the corresponding load, remove the load, and scribe again. Then if two lines occur on the test-piece, it has failed.

Some metallurgists, especially those dealing with non-

ferrous metals, prefer to use what is known as the "proof test." In such cases they determine the minimum stress which will produce a permanent elongation 0.5 per cent. of the gauge length after fifteen seconds, *i.e.* 0.01 in. on 2 in. Many metals do not yield suddenly, like mild steel, and have not a clearly defined yield point.

The breaking load is usually found for all test-pieces, and mention of it is made in almost all specifications. The chief use of observing the breaking load in connection with ductile material, as mentioned before, is that it acts as a check on the determination of the yield point of the material if its previous thermal and mechanical histories are known.

When dealing with the four main features of the tensile test, *viz.* : the yield point, elongation, contraction of area and appearance of the fracture, we find that all four are very closely related to one another, at any rate in commercial steels. Consequently, by making use of all four observations, we can ascertain a good deal of the history of the test-piece, even without resorting to the microscope. With forgings, etc. (using the term in the widest sense), the two main causes of abnormality are due to (a) the work on the metal being completed at too high a temperature, (b) the work being completed at a low or even atmospheric temperature.

(a) The test-piece will exhibit a low yield point, small elongation, negligible contraction of area and coarsely crystalline fracture if the initial and finishing temperatures have been very high as in the case of some drop forgings which have not undergone any subsequent heat treatment. If, on the other hand, the temperature conditions have not been quite so high but still excessive, we may find a more nearly normal yield point, about normal elongation, very small contraction of area, and a finely crystalline fracture.

As illustrating the effect of forging temperature, let us consider two test-pieces. Both were forged from the

same steel, but the second one was too hot from start to finish. Both showed approximately the same yield point and elongation per cent., but in No. 1 there was a large contraction of area and fibrous fracture, whereas in No. 2 the fracture was finely crystalline and the contraction small. In service under severe working conditions No. 1 would stand up well, whereas No. 2 would be liable to fracture. We are therefore led to the conclusion that contraction of area and not elongation is the true indication of toughness, and that this property is associated with a metal which exhibits a fibrous fracture. Such conclusions are supported by the results obtained from impact and fatigue tests. Copper, heat-treated nickel steel, and other metals exhibiting a large contraction of area and fibrous fracture are selected by engineers for purposes where toughness is the first consideration.

(b) The general characteristics of cold working are an abnormally high yield point, rather low elongation, rather low contraction of area and a fibrous fracture. When testing specimens of cold drawn bars, it should be noted that quite an appreciable amount of the abnormality occurs in the neighbourhood of the surface, and it may or may not be a fair test if the bar is turned down for testing.

It is possible that in the near future users of materials may specify the rate at which the load must be applied when tests are carried out. At Cambridge and elsewhere, recent researches have established the fact that when very ductile materials are tested, the stress at the yield point is greatly influenced by the rate of loading. Without going into details, it has been proved that with very rapid loading a ductile specimen will exhibit an abnormally high yield point, whereas in the case of a very slowly loaded specimen of the same material, the yield point is greatly depressed and the point of discontinuity associated with the yield point in ferrous metals, though still distinct, is much less prominent. The changes in the breaking load, though similar in character, are much less in magni-

tude. From this we see that a ductile material resists strain to an abnormal degree when the load on a structure is applied suddenly, but for gradually applied loads a greater margin of safety may be desirable. Experiments of this kind show that further research is required, especially as some of the results which have been obtained are difficult to explain at this stage, *e.g.*, a mild steel rivet fractured in a very small fraction of a second by Hopkinson (who used gun-cotton) showed a contraction of area *exceeding 80 per cent.*, whereas the average engineer would expect little or no contraction of area under such circumstances.

The majority of tensile tests are carried out at atmospheric temperature, but tests carried out at higher temperatures are necessary for metals used for certain parts of steam and internal combustion engines and chemical plants. Some twenty-five years ago a very serious accident occurred in connection with a locomotive boiler, the firebox of which was stayed with a special bronze. At atmospheric temperature the tensile tests proved ideal, but it was subsequently discovered that at the temperature of the steam used (about 200° C.) the material was absolutely worthless.

**Creep Tests.**—In the case of materials severely stressed at elevated temperatures, it is now customary to perform what are termed “creep tests.” Special machines have been designed for the purpose and these measure the very gradual strain which occurs as a result of prolonged stress when a certain temperature is exceeded. In certain cases creep tests are sometimes performed even at atmospheric temperature.

**Testing of Cast Iron.**—The tensile testing of cast iron presents several difficulties. Even the usual form of collared test-piece gives most unreliable results, but consistent results may be obtained by using test-pieces with screwed ends (1 in. diameter, 12 threads per inch) if the machine is capable of exerting a perfectly axial pull.

As such test-pieces are costly to produce, many foundries adhere to a bend test which can be performed quickly and cheaply with simple apparatus. The chief difficulty, however, is to obtain a test-piece which is truly representative of the metal in the casting. Even when test bars of large section are cast close to and even attached to large castings, the difference of rate of cooling may produce quite different properties in the specimens from those in the casting. In repetition work, however, it is always possible to compile a tabular comparison between the results obtained from sample test bars and from pieces cut from waster castings.

**Hardness Testing.**—A commercial test of considerable importance is the Brinell test (called after the Swedish metallurgist who developed it). It is an indentation test applied by means of a hard steel ball of 10 mm. diameter under a load of 3,000 kg. (when applied to ferrous metals). It is usually described as a hardness test, since it is found that, in general, the reciprocal of the spherical area of the depression produced multiplied by a constant agrees very closely with the hardness as measured by other means. Though of much use in testing the hardness of softer materials, it cannot be applied to glass hard or nearly glass hard material. Even with fairly hard steels there is a tendency for the ball to flatten. From the point of view of testing the machinability of forgings, etc., it is quite useless. Many black forgings exhibit such marked decarburisation of the surface that it is, in some cases, necessary to machine off an appreciable layer before the test is performed.

The action of the ball upon the surface of the metal is one of displacement, and time should be allowed for the flow of metal to take place. As we should expect, the amount of flow which takes place and therefore the size of the depression is dependent on the ultimate strength of the material. Hence it is possible in many cases to find a constant = tensile strength  $\times$  area of the depression,

but this constant depends not only on chemical composition but on the heat treatment and crystal size.

The same constant does not even apply to all physical states of the same metal, let alone different metals, but if this limit is recognised, the test becomes one of very great use in repetition work. The test can be applied very quickly to finished components, thereby checking whether they all possess the requisite yield point, the yield point bearing a definite relationship in a given material in a given state to the breaking load. By means of the Brinell test it is possible to determine in a few seconds whether a particular bar of material is of mild steel or, say, of nickel steel, and hence it forms a valuable check in works where both materials are in use, not only in the stores but also in the inspection department.

**Vickers' Diamond Hardness Tester.**—This instrument is a modification of the Brinell method. The indentation is performed with the apex of a pyramidal diamond. Several refinements are provided for ensuring a constant time of application and for measuring accurately the size of the indentation. The test is applicable to very hard metals and can be applied to, say, every tooth of a hacksaw to ascertain whether the heat treatment has been carried out uniformly.

**Turner's Sclerometer.**—In this test a diamond is drawn across a smooth surface under test and is successively weighted until a scratch which can be felt with the fingernail or quill pen is produced. The weight necessary to produce such a scratch is taken as a measure of the hardness. We have already noted that the Brinell test gives no indication of the machinability of a given specimen, but it appears highly probable that the Sclerometer is one of the best tests yet devised in this respect. The Sclerometer would appear to be a simple and cheap hardness test which can be applied to glass hard material such as the white cast iron castings used for milling cereals.



**Shore Scleroscope.**—With this instrument a small hard steel pellet of cylindrical form is allowed to fall a fixed height on to a smooth surface and the height of the rebound is taken as a measure of the hardness. The extent of the rebound does not depend upon the coefficient of elasticity of the metal, but upon the energy absorbed during the impact. There is no doubt that a portion of the energy is dissipated during the distortion of the surface since softer metals such as brass exhibit signs of hammer hardening, the rebound becoming larger and larger if the test is repeated on the same spot. If we accept this point of view, it is easy to understand why the results are in many cases in very close agreement with those obtained by the Brinell indentation test.

There is no doubt that within certain limits the test has a certain range of usefulness, but many of the claims for it must be accepted with great caution. In fact, anomalies are extremely frequent even when dealing with metals. When applied to non-metallic substances the tests are even more erratic. Thus a piece of soft yellow pine will produce a very much greater rebound than will a piece of elm.

**The Izod Test.**—In this test a small square or round bar, slightly notched, is held in a vice and struck by a falling pendulum of known kinetic energy. After fracture the pendulum continues its motion, and finally comes to rest. The extent of the swing beyond the vertical depends on the amount of energy absorbed in fracturing the test-piece, and this is read off directly on a dial. The test bars are not only similar in dimensions, but the notches must be of standard depth and radius at the root. At first sight it would appear that providing the notch is not mathematically sharp at the bottom, its form does not matter much, since commercial notches are distinctly blunt compared with the size of crystal grain. On the whole this idea is in accordance with actual facts, but there is no doubt that fine scratches produced during

notching are frequently the cause of very erratic results. This trouble can be quickly eliminated by polishing all notches before the test is performed. Unfortunately, in the past, most workers have adhered to the square test-piece, usually notched in the milling machine. If the round test-piece were substituted for the square one and the notch carried right round, perfect test-pieces could be produced very much more cheaply and with less delay.

Impact tests such as the Izod were introduced with a view to detecting brittleness more accurately than by measuring the contraction of area in a tensile test. In this respect they succeed admirably. For instance, two samples of steel of which one contains rather more phosphorus than the other will show the same contraction of area under a static tensile test, but a marked difference in behaviour is exhibited by an impact test such as the Izod. The tensile test gives a general idea as to whether a given material is tough or brittle, but the Izod test gives us much more accurate information on the subject. The Izod test, when applied to heat-treated nickel steel, shows at once whether the very best temperatures have been used, or whether there is laxity in the works requiring immediate attention.

In addition to the Izod impact test, others, such as the Charpey, are in daily use.

### Fatigue Testing

The reader who wishes to acquire a good working knowledge of this subject is referred to such works as H. J. Gough's "Fatigue in Metals," and the scientific papers cited in such volumes. The subject is by no means new and has exercised the minds of engineers and metallurgists for nearly a hundred years. Many important points have been cleared up, but many other phenomena are worthy of further research.

An outstanding pioneer of research in fatigue of metals

was Sir Wm. Fairbairn, who in 1860 published the results of experiments performed on built-up wrought iron beams 22 ft. long and 16 in. deep. Ten years later Wöhler published the results of experiments carried out upon small laboratory specimens which had been subjected to alternating tension, compression, bending and torsional stresses. Such work is still being carried out to-day. Many varieties of machines have been devised and used, and the following is a brief description of a type which is not only simple in construction, but uses specimens which

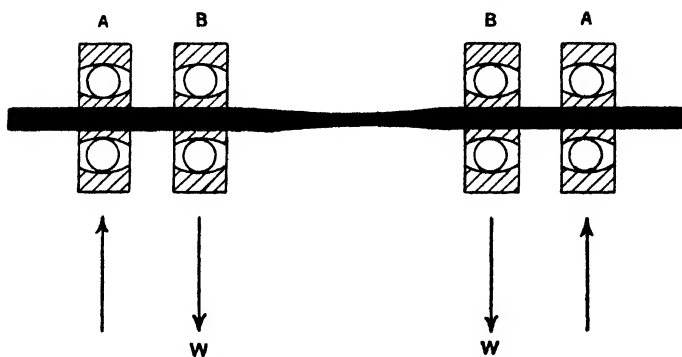

FIG. 1.—Rotary Bend Test.

are free from shear and “end effect,” and are produced in about twenty minutes on an ordinary workshop grinding machine to which a simple accessory has been added.

The prepared bar revolves in a pair of spherical ball bearings, AA, and is stressed by the weights, W, suspended from the spherical bearings BB. The machine is provided with a revolution counter and switch which stops the motor when the specimen breaks. The speed of rotation is 1,500 r.p.m.

The following explanation of the test is copied almost verbatim from Gough’s book already mentioned.

“A specimen is placed in the machine and reversals of stress of a certain magnitude are applied. The specimens fail after

a certain number of reversals. A second specimen is placed in the machine and subjected to a range of stress less than that used for the first experiment. Again failure results after a certain endurance. The process is now repeated, the applied range of stress being reduced with each succeeding specimen. Finally a stress is reached which does not cause failure on the application of a number of reversals previously fixed. It is obvious that a test to determine the resistance to an *infinite* number of reversals cannot be made. Accordingly, the tests are carried out until failure does not occur after a certain number of millions of reversals. Suppose, for example, that 10 millions of reversals have been chosen, then such an endurance test is said to have been carried out on a '10 million reversals basis.' Data obtained from such a test are given in Table II.

TABLE II.—*Results of Typical Endurance Tests*  
(Stanton and Pannell)

Limits of stress cycle (tons/inch) <sup>a</sup>	Range of stress (tons/inch) <sup>a</sup>	Reversals to fracture (millions)
± 16.3	32.6	0.050
± 15.0	30.0	0.164
± 14.0	28.0	0.481
± 13.7	27.4	0.878
± 13.4	26.8	1.394
± 13.4	26.8	1.264
± 13.1	26.2	1.684
± 12.8	25.6	2.630
± 12.8	25.6	4.537
± 12.7	25.4	10.000
		(unbroken)

“ Either the maximum applied stress of the cycle or the range of stress can now be plotted against the corresponding number of reversals to failure. The curve obtained is termed an S/N curve, and the above results are shown, thus plotted, in Fig. 2. It will be seen that the observations lie more or less evenly about a regular curve which tends to become parallel to the N axis when the number of reversals to fracture is large. The importance of this latter feature is obvious, because, if the curve does actually become horizontal and

continues so, then a limiting value of stress is indicated below which fracture will not occur for an infinite, or an indefinitely large number of reversals. Attention is drawn to the irregularity of some of the points. This irregularity is a feature of repeated stress testing, and is due to lack of homogeneity in the specimens, but is not surprising when one considers that differences of 5 per cent. in ultimate tensile stress often occur among specimens of steel cut from the same bar. It is unfortunate, however, that such differences will be made most apparent at those stresses which are in the neighbourhood of the flatter portion of the S/N curve, the portion which, from the designer's point of view, affords the most useful informa-

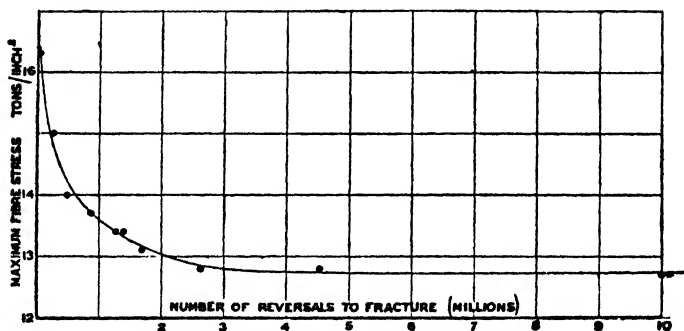

FIG. 2.—Stress Endurance (S/N) Curve.

tion. In order to avoid serious error, it would be advisable to test two new specimens, at stress limits of  $\pm 12.8$  and  $\pm 12.7$  tons/inch<sup>2</sup>, respectively. If the former broke at a number of reversals less than 10 millions, and the latter remained unbroken after the same number, the test could be said to be satisfactory.

“The following four phrases are used to describe the result of the test :—

For the material used—

(a) The Endurance Limits of Stress, on a 10-million reversals basis, are  $\pm 12.75$  tons/inch<sup>2</sup>; or

(b) the Limiting Range of Stress, on a 10-million reversals basis, is 25.5 tons/inch<sup>2</sup>, using reversed stresses; or

(c) the Limiting Range of Stress, on a 10-million reversals basis, is  $\pm 12.75$  tons/inch<sup>2</sup>; or

(d) the Limiting Stress, on a 10-million reversals basis, is 12.75 tons/inch<sup>2</sup>.

“The same general type of S/N curve is obtained if direct,

bending, torsional, combined or impact stresses are employed, and whether the mean stress of the cycle is zero or has any other value."

From the above it will be noted that the last specimen was unbroken after 10 million reversals and the curve is now so flat that there appears to be no reason for going further. That this view is probably correct for ferrous metals is shown by the fact that specimens which have stood up to 10 million reversals showed no signs of distress after 200 million. The reader may suggest that a single test-piece might suffice if the test were carried out in a different order, viz., by starting with low stresses and periodically increasing them until rupture takes place. Unfortunately such procedure produces figures which are abnormally high. Just as the physical endurance of a human being can be increased by a period of training, so ferrous metals exhibit greater resistance to fatigue if they undergo a similar process. It is also worthy of note that just as an athlete may partially incapacitate himself by straining a muscle, so a test-piece subjected to an excessive stress for comparatively few revolutions will show lower endurance by breaking under a comparatively low stress later on. Several experimenters have stated that the range of stress which a specimen can endure is a function of the speed of the machine. Thus Hopkinson, the first designer of an electro-magnetic fatigue tester, found that very greatly increased speeds increased the endurance limit of steel, though his results have been questioned by subsequent investigators. It is therefore very desirable that the number of cycles per minute should be stated whenever endurance figures are quoted. Since each test on a 10 million reversals basis occupies about 100 hours at 1,500 r.p.m., attempts have been made to reduce this period. The results, however, show that not only do the methods proposed call for the highest possible experimental technique, but they rather lack accuracy. So far we have considered stresses, the mean of which is zero,

but many components of structures are subjected to initial constant stresses upon which are superimposed alternating ones. In such cases the problem becomes distinctly complicated, and up to the present time no law has been propounded which enables the designer to compute with accuracy the fatigue limit of his component from considerations of the constant stress and endurance limits of his material under reversed stresses, the mean of which is zero.

Attempts have naturally been made to connect the property of endurance to fatigue with the results obtained by means of simple tensile and impact tests. Investigation shows that there is no general connection between fatigue limits and the yield point, elongation, contraction of area or impact figure, but that in NORMAL FORGED steel they are related to the breaking load. The statement that the limiting fatigue stress is  $0.46 \times$  ultimate tensile stress is accurate within  $\pm 10$  per cent. On the other hand, the state of the steel has profound influence on the factor (0.46). Thus Moore and Kommers found that a 0.93 per cent. carbon steel showed an increased endurance of 84 per cent. in the sorbitic and 221 per cent. in the troostitic state compared with the figure for the pearlitic state. The corresponding increase in ultimate tensile strength would be very much smaller.

In the case of non-ferrous metals the subject is very much complicated by various factors. We have seen that 10 million cycles appear to suffice for ferrous metals, but non-ferrous metals do not exhibit the same constancy, and discontinuities in the curve (Fig. 2) occur above the 10 million limit. Duralumin in particular shows no signs of "settling down" at any number of cycles yet used.

When a metallic crystal is subjected to the influence of a certain stress at atmospheric temperature it assumes a banded appearance due to slight slip along certain planes. This slip increases the strength and hardness of the crystal, and as a rule, within certain limits, is not

detrimental to the material. The crystals of hard drawn wire and cold rolled steel exhibit this banded appearance, and the metal is entirely reliable under static stress. The production of banded crystals under alternating stresses may, however, be a sign that we are in the neighbourhood of an unsafe range of stress if continued over a considerable period, and by the aid of the microscope we are able to watch developments. Apparently the soft banded crystals undergo further embrittlement, and after a time they actually break up. When a group of crystals have become definitely fissured they are incapable of bearing their fair share of the stress, and others adjacent to them, becoming overloaded, are unable to stand the racket and crack up too. By this process we have crack following crack progressively and a state of "creeping crack" established. The microscope further reveals the fact that the cracking-up process is not accompanied by any marked distortion of the crystal boundaries as in static tensile tests.

Fractures in ductile steels which have succumbed to the influence of creeping cracks present many characteristics of brittle materials. Fatigue, tensile and bending cracks assume a flat or conchoidal form, as in Fig. 3, and those due to torsion a spiral form, as in Fig. 4. The reader should note that the process is a progressive one, and as a rule only the crystals actually adjacent to the crack have suffered badly and the rest of the material is less distressed except for a short distance in advance of the crack. Since local damage to few crystals may be regarded as the birth place of a creeping crack, it is not surprising that a particle of hard grit in a bearing may tear certain crystals in the shaft and induce it. Even a centre punch mark or the depression formed during a Brinell test may originate a creeping crack, if stress conditions are favourable. Very heavy roughing cuts when applied to axles may rack certain crystals below the finished surface so severely that creeping crack may



follow. Tool marks, and even emery scratches on a specimen, lower the endurance of the metal very considerably. It has long been known that in the case of steel plates which have been drilled with blunt drills or punched, the local hardening which results is a frequent and recognised cause of subsequent cracking. In those cases in which creeping cracks are associated with very sharp angles and abrupt changes of section, we may attribute them to the fact that the local concentrations of stress have exceeded the endurance limit. Such a crack, once started, usually extends with increasing rapidity as the effective cross-section of the metal is reduced, but this does not always occur. It is common experience that cracks which develop in locomotive crank axles frequently attain a maximum within a comparatively short period, and then cease to extend. Possibly in such cases the crack relieves certain excessive local stresses, and equalises the stress over the remainder of the section so that no portion is stressed beyond the endurance limit. The breaking of an abnormally highly stressed strand in a wire rope does not necessarily imply that the rope is unfit for further use.

The old notion that a piece of iron or steel was rendered coarsely crystalline by vibration or alternating stresses has been definitely disproved by means of the microscope. It is easily proved, however, that if a piece of material is rendered coarsely crystalline by subjecting it to a high temperature or by an excess of phosphorus, its endurance is enormously reduced.

The embrittlement which van tyres undergo after a period of use on cobbled streets is possibly partially due to repeated bending, but more probably due to a form of hammer hardening as a result of hundreds of millions of blows which they receive.

**Corrosion and Fatigue.**—Recent research has proved, beyond all doubt, that metals subject to corrosion exhibit far less resistance to fatigue.

## CHAPTER II

### METALLOGRAPHY AND MACROGRAPHY

DURING the last forty years the microscope has contributed enormously to our knowledge of metals and their properties. Owing to the opacity of metals it is only possible to examine the surface of a given sample, but nevertheless such examinations tell us much regarding the chemical constitution, physical structure, and mechanical properties. In fact, it has been found that in the case of cranks an estimate of their probable life in service can be more accurately gauged by microscopic examination than from results of tensile tests. It will be seen in another part of this volume that we can gauge very closely, not only the composition of the metal or alloy, but its thermal history. The reader must realise, however, that the cause of comparatively few failures can be ascertained by means of the microscope, unless the metal is in a radically wrong physical state or dirty. It frequently occurs that first-class material fails owing to bad design or improper use or both.

In the case of "Macrography" large areas are prepared for examination by the naked eye or with the help of a hand lens. By very deeply etching a large surface of rolled or forged material we obtain a surface like that of a piece of deal which has been partially weathered. The apparent wood-like structure produced by the differential etching of the various ingredients in the metal may prove a valuable source of information. Thus Fig. 5 from Travener's translation of Guillet and Portevin's treatise on Metallography and Macrography show clearly that the cracked railway draw-hook had, contrary to specification, been cut from a straight piece instead of

being formed by bending. Fig. 20 of part of an aero-crank is another example of macrography.

Macrography, when applied to cast metals, has taught us much concerning the mechanism of crystallisation, and shows very clearly the influences of varying casting temperatures.

### Sulphur Prints

Another macrographic process of great simplicity but considerable usefulness consists of applying a sheet of bromide photographic paper moistened with dilute sulphuric acid (3 per cent.) to a polished surface for about half a minute. The  $H_2S$  and  $PH_3$  set free from the segregations in the metal darken the paper and produce a pictorial record which can be rendered fairly permanent by rinsing and fixing in hypo.

This test is generally applied to determine the location of the sulphides only. Sulphides are immediately attacked by dilute acids, but phosphides require a considerable time.

## CHAPTER III

### IRON

It is a popular belief that following the Stone Age, another known as the Bronze Age preceded the Iron Age. In certain localities this was so, but many archæologists are of the opinion that over huge tracts of Europe, Asia and Africa, the Bronze Age never existed. The bright blue colour of copper ores enabling them to be identified, certainly must have contributed to the ease of production of bronze implements, and the relative resistance of bronze to corrosion has resulted in large collections of all manner of articles made from it finding their way into our museums. There is no doubt, however, that the smelting of copper or copper-plus-tin ores must have presented a good deal of difficulty to the ancients.

Iron ores are, as a rule, less easy to identify than those of copper, but reduction to the metallic state is almost as easy. Unfortunately the rapid corrosion of iron by moist air or humic acid has resulted in fewer pieces of very early work surviving till to-day.

The ease with which an ore may be reduced to the metallic state varies enormously, and, in general, the first operation consists of preparing an oxide of the metal if the ore is not one already. Thus, by calcining a carbonate, the oxide is readily produced, and if the ore is a sulphide such as sulphide of zinc, the sulphur is utilised in the manufacture of sulphuric acid, and zinc oxide is subsequently reduced.

Many oxides, such as those of lead, zinc and iron, when heated in contact with carbon, are very readily reduced at a low temperature. Others such as silica and lime are only reduced in quantity at the highest temperatures

possible in a smelting furnace using carbon fuel. On the other hand, aluminium oxide is not reduced at all by carbon, and the commercial production of this metal to-day is carried out by electrolysis of a fused electrolyte of high melting-point. Other metals, such as molybdenum and vanadium, are frequently prepared by reducing their oxides by means of aluminium powder. The "Thermit" process takes advantage of the fact that aluminium has a far greater affinity for oxygen than carbon or any other commercial agent. Obviously the use of aluminium as a reducing agent is only justified when the resulting metal commands a high price, say £300 or more per ton.

In general, it may be said that metals are almost universally prepared commercially in the liquid state, but there are exceptions. Thus zinc and cadmium, etc., are distilled, and tungsten is reduced as a powder from the oxide.

If we melt a few pounds of lead in a ladle we find that almost immediately a film of yellow lead oxide forms on the surface, but if after allowing this crust to accumulate for a short time we sprinkle some powdered charcoal on the surface, rapid reduction to the metallic state takes place, even though the temperature is well below a red heat. In the case of ferric oxide, reduction commences at a low red heat if the atmospheric conditions are favourable. We usually speak of carbon as a reducing agent, but, strictly speaking, this is seldom true, at any rate on the large scale. Thus if carbon and copper oxide (both pure) were heated together in an atmosphere of nitrogen, little or no metallic copper would be formed. The usual link between the carbon and the metallic oxide is the gas carbon monoxide. If any trace of it (or oxygen to form it) exists in the furnace atmosphere, we have, taking copper as an example, a reaction shown by the equation

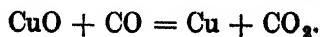

The carbon dioxide formed then reacts with the carbon present, thus :

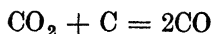

We see that as fast as the carbon monoxide is used up it is re-formed so that there is no cessation of the reduction of the copper oxide, and the solid carbon becomes used up. We therefore regard carbon monoxide as the active agent working backwards and forwards between the solid oxide and solid carbon. In fact, reduction of the metallic oxide by carbon may take place in a closed vessel even though the two solids are not in actual contact with one another.

### Smelting of Iron

The early method of producing iron from its ores was in all probability almost identical to that carried on to-day by certain tribes in Africa and India.

In 1918 Professor McWilliam\* witnessed the smelting of iron by the ancient process in the Indian jungle. The ironworks staff consisted of the owner, two sons and a daughter. Timber was felled locally and converted into charcoal, and the ore was obtained on the spot. The furnace used had a height of 3 ft. 10 in., the internal diameter being, at the base 15 in., and at the top 4½ in. Near the base was an arched opening for the removal of the iron, temporarily closed during the smelting operation. The blast was produced by a double set of hand and foot manipulated bellows which the staff worked in turns. The heat lasted five and a half hours, after which the archway was opened up and the spongy mass of iron weighing 14½ lb. was withdrawn, hacked in two with an axe, and then re-heated and consolidated by forging. Including the preparation of the charcoal and digging the ore, it appears that the process requires the labour of four persons for two days to prepare about sixteen pence worth of iron !

\* *Jour. I. and S.I.*, No. II., 1920, Vol. C. II.

The iron produced was found to have a composition and physical properties very similar to the wrought iron of to-day produced in this country by the puddling process.

The resulting product involved an extravagant expenditure of labour and fuel for a remarkably small result, and the metal produced was not only identical with much of the early wrought iron, but also with that produced to-day by a more modern method.

The Romans smelted iron on such a large scale that enormous deposits of cinder rich in iron are found in various parts of the country such as the Forest of Dean, and these have subsequently been treated in more modern furnaces for the extraction of the metal.

During Norman times the production of wrought iron in Great Britain was somewhat limited, and much was imported from Germany. The Germans, having established an export trade, wished to increase production and save fuel and labour by using larger furnaces. Anyone who sees a large evolution of carbon monoxide flame from the top or chimney of a furnace naturally asks whether the heat cannot be conserved for some useful purpose. The short primitive furnace described by Professor McWilliam must, on the face of it, be extremely uneconomical. Accordingly the Germans enlarged their furnaces in diameter to increase production, and in height to save fuel. Their furnace then took the form of a double cone, and was some 15 ft. high and 5 ft. in diameter. It was called a "Stückofen."

This increase of height of the furnace resulted, however, in a remarkable phenomenon which changed the whole character of the product.

In the short furnace the burden does not take long to pass down from the reducing zone at the top to the lower portion where air is being blown in very vigorously. In the higher furnace, however, some time elapses while the metal descends, and it passes through a zone which is very

hot and very highly charged with carbon and carbon monoxide. In this zone carbon is greedily absorbed by the iron which is capable of taking about  $3\frac{1}{2}$  or 4 per cent. into solution. It is this absorption of carbon which changes everything. Whereas pure iron melts at  $1,532^{\circ}\text{C}$ ., a highly carburised iron melts at  $1,150^{\circ}\text{C}$ ., and hence liquid iron is produced from the spongy mass. The subsequent passage of the metal to the bottom of the furnace takes but a few seconds, so it is not "bessemerised" (a term which will be understood later) during its passage past the blast orifice. Hence we see that the higher furnace did not produce more wrought iron, but produced a liquid metal which, when cast in moulds, produced brittle castings.

The reader must not suppose that the early smelters understood the process and used high or low furnaces according to what they had in view. Excavations of the sites of ancient ironworks in England, Scotland and Wales demonstrate conclusively, not only that there was always a risk of producing cast iron by accident, but also that the cast iron was regarded as useless.

Iron-founding in Britain does not appear to have commenced until about 1500, and even then its spread was very slow. This may, in part, be attributed to the fact that most of the early cast iron was white and glass hard, so that it was impossible to touch it with drill or file, and even chisel work to remove runners, fins, etc., would present very great difficulties.

### Production of Pig Iron

The principal iron ores may be classified under the following headings:—

(1) **Hæmatites.**—These are ferric oxides. In Britain deposits of this ore are confined to small areas, which is unfortunate, as they are very low in phosphorus. In fact, the trade uses the expression hæmatite-pig or simply



hæmatite in place of the more cumbersome one : pig iron low in phosphorus.

(2) **Magnetites.**—These are nearly pure magnetic oxide of iron,  $\text{Fe}_3\text{O}_4$ . They are practically non-existent in Britain. In the Lake Superior district huge deposits are found, and stony matter is removed from the ore by magnetic separation.

(3) **Carbonates.**—Most of the ores found in this country are of this type. They have a high phosphorus content and require calcining before use. By calcining ferrous carbonate it is converted into ferric oxide, which is not only easier to smelt, but, unlike ferrous oxide, does not combine with the silica lining of the blast furnace and cause it to melt away in the form of a fusible silicate. Some sulphur is eliminated during the process.

(4) **Sulphides.**—Large quantities of iron pyrites,  $\text{FeS}_2$ , are imported annually for the manufacture of sulphuric acid, with the result that the oxide produced in the process is available for smelting. It is in a more or less powdered form, which is bad from the smelters' point of view, and may contain an excess of residual sulphur which is highly objectionable.

The economical production of iron demands the greatest possible chemical and metallurgical skill combined with first-class organisation and freedom from stoppage through breakdown of plant or labour troubles.

A modern furnace not only calls for 480 tons of ore, 230 tons of coke, 100 tons of limestone, 1,000 tons of heated air under pressure every twenty-four hours, but a market must be found to absorb 200 tons of pig iron, if possible 400 tons of slag, and the excess of valuable blast furnace gas must be turned to useful account. Every possible by-product in the manufacture of the coke must be recovered and sold. In fact, the difference between profit and loss on a given plant is more than accounted for by the sale of by-products.

The figures given above for a single furnace are fre-

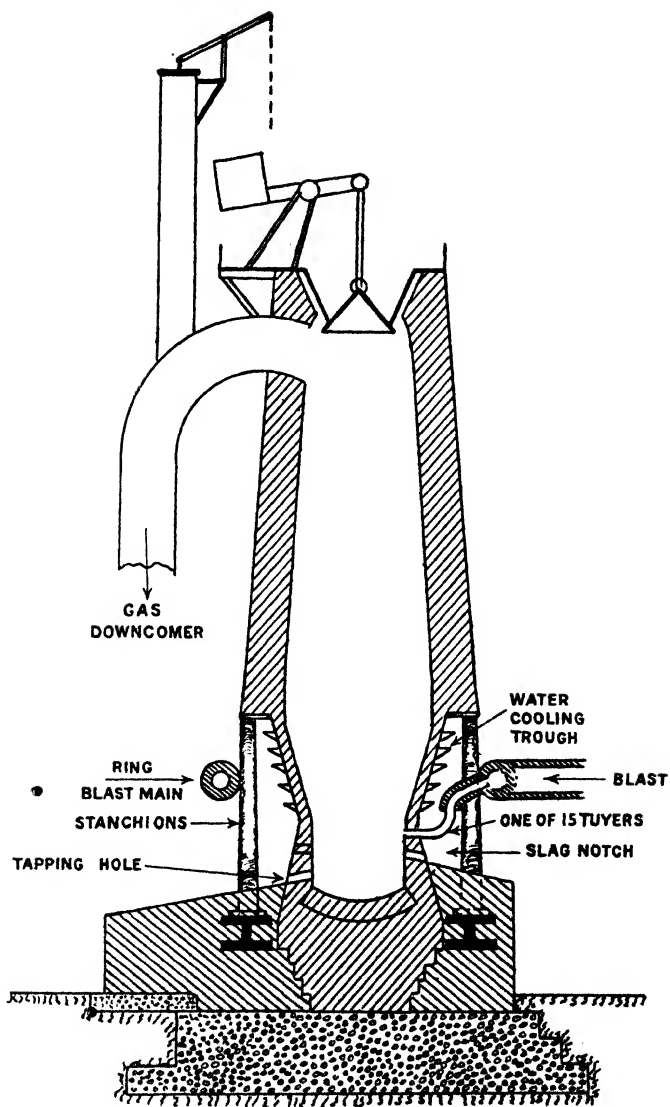

FIG. 6.—Blast Furnace (Vertical Section).

quently doubled by more intensive working, and it is customary to erect furnaces in groups, thereby reducing the overhead charges per ton and maintaining production when they are blown out, one by one, for relining or other extensive repairs.

Fig. 6 represents the cross-section of a modern blast furnace. The height is about 85 ft. and maximum internal diameter about 22 ft. The top is closed by a large conical casting, the "bell," which prevents the escape of the gases into the atmosphere and acts as an inlet valve for the raw material.

The blast under pressure from 7 to 15 lb. per square inch is provided by large reciprocating blowing engines or more compact turbine blowers. In practically all blast furnaces the blast is pre-heated to 600° or 800° C. before entering the furnace by passing it through the stoves. The stoves are large steel towers about the height of the furnace, and are not only fire-brick lined, but are partially filled with a chequer-work of refractory material. Blast furnace gas is burnt in these stoves until they reach about 1,000° C., after which the blast passes through them for a short period. By using two or more stoves alternately for periods of about half an hour, the blast is maintained at a high temperature in spite of the huge volume dealt with. By heating the blast, considerable economy of fuel results. The ore, fuel and limestone are raised by elevators to the top of the furnace and shot in at regular intervals. The temperature near the top is higher than one expects, and reduction of the iron to the metallic state commences almost immediately. As the burden sinks, the spongy iron absorbs carbon, becomes liquid, and travels quickly past the tuyères (blast orifices) into the lowest part of the furnace where it is protected from oxidation by a layer of slag.

### The Slag

Passing mention has been made of the addition of limestone to the charge. Since the ore always contains

sandy and clayey matters, some provision for liquefying them must be made. It is also necessary to eliminate, in liquid form, the ash of the coke which contains silica. By adding limestone in the correct proportion a very fusible and free-flowing slag of calcium silicate is formed, and this is capable of taking into solution all the alumina present. The slag falls rapidly through the furnace and floats on the surface of the liquid iron and protects it from oxidation.

The lime serves another useful purpose. In the hottest part of the furnace some is reduced to the metallic state when it is capable of combining with sulphur to form calcium sulphide which enters the slag. A small portion is converted into calcium carbide, as demonstrated by the smell of acetylene one notices on a damp still evening in the neighbourhood of a heap of slag on the roadside. The slag has a composition closely resembling Portland cement, but as a rule contains too much sulphur to be converted into cement. It is used in some districts for road foundations or lower surfaces, but the supply is greatly in excess of the demand.

### Cast Iron

So far we have only considered iron and carbon as the ingredients of cast iron, but a third element is of equal importance, viz., silicon. Cast irons devoid of silicon would be practically useless to the ironfounder, and the makers of wrought iron and steel would have had to make radical alterations in their processes. In general, it may be said that the hotter the furnace the more silicon will appear in the iron, so that the smelter can regulate the composition of his product by varying the fuel supply and temperature of the blast. Very hot working corresponds to high fuel consumption, so that the high silicon irons are relatively expensive. The importance of silicon in cast iron will be dealt with later.

Manganese in larger or smaller quantities according to the composition of the ore finds its way into the metal. Phosphorus is set free in the blast furnace by the presence of silica and carbon at a high temperature, and at once forms a liquid phosphide of iron which finds its way into the pig iron.

The coke used is hard, dense, and strong enough to support the burden of the furnace without crushing. It is made at the collieries in coke ovens where coal gas, tar and ammonia are recovered on the spot. The tar, when distilled, evolves benzene, toluene, and other valuable volatile products, light oils such as creosote, and finally road-tar and pitch.

The gases which leave the blast furnace have the following approximate percentage composition :—

$\text{CO}_2$ , 9.5 ;  $\text{CO}$ , 29.5 ;  $\text{H}_2$ , 1.0 ;  $\text{N}_2$ , 60 ;

from which it will be seen they possess a considerable, but not high, calorific value. About 30 per cent. are used for firing boilers for light and power purposes, about 30 per cent. are used for heating the hot blast stoves, 10 per cent. are lost, and 30 per cent. valued at £6,000 per year per furnace can be usefully used in neighbouring industries such as steel works. Large gas engines are sometimes installed, but they are not always free from trouble on account of the dust which is carried by the gases from the furnace. It has been found that by adding sodium chloride to the furnace charge, the blast furnace dust contains an appreciable quantity of potassium chloride (a relatively volatile salt), while sodium carbonate enters the slag. The potassium chloride, though valuable, is difficult to separate from the dust without considerable capital expenditure and high working expenses. About 200,000 tons of potash enter our British furnaces per year, and the economical recovery of a large portion of it deserves further research.

## Grading of Pig Iron

We have already noted that the composition of pig iron varies considerably, and even a single tapping may show considerable variation between the first and the last portions to leave the base of the furnace. For trade purposes, the various grades, which are readily recognised by fracturing pigs, are named, but different districts have different classifications. In general, it may be said that foundry pig contains at least 2 per cent. silicon, and the varieties of lower silicon content are used for making wrought iron and steel.

The following table gives one a rough idea of such a system and the composition one might expect. Too much reliance must not be put on such a table, since even single pigs exhibit considerable variation, depending on the rate of cooling of various parts.

TABLE III.—*Cleveland Pig*

	No. 1	No. 2	No. 3	Forge	Mottled	White
Carbon graphite .	3.3	3.1	3.0	2.7	1.8	—
Carbon combined	Trace	0.2	0.4	0.6	1.2	3.1
Silicon . . .	3.5	2.9	2.6	1.9	1.0	0.7
Sulphur . . .	0.05	0.06	0.08	0.10	0.32	0.40
Phosphorus .	1.6	1.6	1.6	1.6	1.6	1.6
Manganese . .	0.68	0.62	0.60	0.75	0.62	0.42

From the above table we can draw certain conclusions.

(1) That when the silicon is relatively high the carbon is almost entirely in the free graphitic state and the metal is very soft and fracture almost black.

(2) Conversely, when the silicon is low the whole of the carbon is in the combined state,  $\text{Fe}_3\text{C}$ , and the metal is almost glass hard and fracture white.

Between these extremes we have a series of intermediate varieties.

(3) Conditions of smelting which give a high silicon content give a low sulphur content, and *vice versa*.

(4) The phosphorus content depends solely on the ore used, and in a hæmatite series would be about 0.04 per cent.

(5) The manganese content, while depending on the ore used, rises somewhat as the silicon rises.

With regard to the total carbon, *i.e.*, combined plus graphite, we may assume it as constant. The sum total is of little or no commercial importance as a rule. A relatively high carbon iron will probably lose some of its carbon when remelted, and a relatively low carbon iron may absorb carbon as it passes down through the coke of the foundry cupola during remelting. What really concerns us is the relative proportions of combined carbon and graphite in the finished casting, and the founder regulates this by varying the silicon content of his metal to suit the work in hand. In fact, a founder may produce as many as four different mixtures in one afternoon, each one being adjusted for a particular type of work. There appears to be a certain ratio of combined to graphitic carbon which gives the maximum strength, and this ratio can be controlled by the silicon content. We have, however, another important factor to consider, and that is the rate of cooling. Thus, if the cooling of the casting is rapid, so much carbon may remain in the combined state that the metal is excessively hard and somewhat weak. On the other hand, if the cooling is very slow, every particle of carbon will appear as graphite, and the casting will be soft, weak, and possibly porous.

In the case of ordinary sand moulds the rate of cooling depends partly on the mass of metal, but in some cases even more on the ratio of cooling surface to mass of metal. Thus a compact 5-ton block of cast iron would take several days to cool in a sand mould, whereas a length of rain-water gutter about  $\frac{1}{2}$  in. thick would freeze and cool down in a few minutes. The ironfounder counteracts the

effect of rapid cooling by increasing the silicon content of his iron, and counteracts the effect of very slow cooling by reducing the silicon.

**Sulphur.**—This element is always present in cast iron, and is most objectionable. It should not exceed 0·06 per cent. in high-grade work. It makes the metal less fluid and segregates badly. The segregations are very apparent in the machine shop, as they cause local hard white patches. As white iron contracts more than grey iron, these white patches may tear on cooling and be a source of leakage.

**Phosphorus**, on the other hand, increases the fluidity of cast iron, and, in consequence, for ornamental work, is frequently used in excess, say 2 per cent., but for maximum strength the content should not exceed 0·55 per cent. This is rather less than usual, and to attain it a founder will frequently use some hæmatite-pig in his mixture. For general work, 1 to 1·5 per cent. is not excessive.

**Manganese.**—Staffordshire irons are frequently fairly high in manganese, and therefore can improve most mixtures. The action of manganese is threefold. (a) It causes the iron to crystallise in smaller particles when it freezes, and hence is said to produce a “close grain.” (b) It “takes charge of” some of the sulphur present and lessens the harm it might otherwise do in the form of ferrous sulphide. (c) It assists and probably delays the formation of graphite.

**Chill Castings.**—For certain purposes, very hard wearing surfaces which can only be trued up by grinding are produced on otherwise soft grey castings by chilling the fluid metal rapidly. To effect this a portion of the sand mould is replaced by a massive block of cast iron which has the effect of preventing the break-up of the carbide into graphite by accelerating the rate of cooling of the metal in contact with it.

To obtain a good depth of chill a relatively high manganese is desirable, and the silicon should be kept



rather low to give the process a fair chance. It is found that by chilling the top surfaces of locomotive fire-bars their life is doubled.

**Scrap Iron.**—Every founder wishes to use as much scrap as possible on account of its cheapness, but there are limits to its use. Briefly, they may be summed up by saying that much of the scrap available is low in silicon and high in sulphur. During ordinary foundry operations the metal invariably loses some silicon and manganese through oxidation and picks up more sulphur from the fuel. For this reason scrap is graded for trade purposes. The most valuable is “best machinery scrap,” *i.e.*, old lathe beds, etc., and the least valuable is old fire-bars, drain covers, etc.—articles which were probably made of very low-grade material in the first instance.

By using high-grade scrap, castings of very good quality can be made if a comparatively small quantity of No. 1 pig (high in silicon and low in sulphur) is added.

**Aluminium.**—The addition of aluminium to the molten cast iron in the ladle has a most powerful if not startling effect. A metal which would otherwise produce hard almost unmachinable castings can be made grey and easily workable even when only a few ounces per ton are added.

Aluminium tends to make the metal less fluid and the quantity added should be small, otherwise the castings will be too soft and weak.

It is doubtful whether the aluminium process is of much importance in the country where pig is cheap, but in colonial foundries situated perhaps 500 or 1,000 miles from the nearest seaport or blast furnace, aluminium as a means of using up huge accumulations of low-grade scrap has proved exceedingly useful.

### The Cupola

For many years the principal furnace used for re-melting cast iron has been the cupola. In a few cases, such as

the making of large rough castings for lining tube railways, etc., "direct casting" is adopted, *i.e.*, hot metal from the blast furnace is used for filling moulds near at hand.

In construction the cupola somewhat resembles a miniature blast furnace with open top and a side door

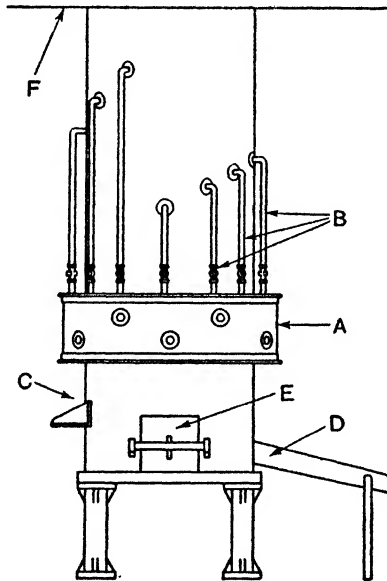

FIG. 7.—Poumay Cupola.  
(Lower Half.)

- A. Wind-belt supplying main tuyères, etc.
- B. Subsidiary tuyères with adjusting cocks.
- C. Slag notch and spout.
- D. Tapping hole and spout.
- E. Lighting-up door.
- F. Floor of charging room.

further down for charging. A drop bottom is provided (for dumping the contents at the end of the blow) and a side door near the bottom for access to repair the lining and for kindling. The fuel is hard dense coke and this is charged in at intervals together with pig iron and scrap. The size of the cupola depends upon the work on hand,

but is usually about 12 ft. high from the base to the charging door and about 3 ft. internal diameter. The blast is generally supplied through several orifices connected with the blower by a distributing belt about 3 ft. above the base. Even when really dense coke is used, much unburnt carbon monoxide passes through the charge and consequently the thermal efficiency seldom exceeds 30 per cent. Some forty years ago Greiner and Erpfs provided a series of subsidiary tuyères delivering air at various higher levels, with a view to burning the rising carbon monoxide and increasing the efficiency. The system was soon discarded as useless and some founders declared that it merely raised the fusion zone and increased the oxidation losses of silicon, manganese and iron, without showing any saving in fuel. Within recent years, however, Poumay has modified the system by greatly reducing the area of the main tuyères with the result that the fuel consumption has been reduced by about 25 or 30 per cent; and since the actual melting takes place in a reducing or neutral atmosphere the oxidation losses become negligible or nearly so. It is also claimed that less sulphur is found in metal melted in this cupola. Another comparatively recent type is known as the "balanced blast" cupola. In this, as in the Poumay, additional air is supplied through a number of openings leading from a relatively wide wind-belt above the main tuyères, and the delivery through the latter is carefully controlled by a valve on each. In some foundries a small addition of limestone is made to the charge to flux off the silica adhering to the pig and contained in the ash. If this is done and a slag-notch provided, the working hours per day of the cupola can be extended.

---

### **Toughened Cast Iron or Semi-Steel**

For nearly a century attempts have been made to improve the strength of cast iron by melting in the

cupola a mixture of cast iron and wrought iron or mild steel. At first sight the process appears very attractive, since equal parts of cast iron containing 3.5 per cent. of carbon and wrought iron containing 0.1 per cent. carbon might result in a fluid metal containing 1.8 per cent. carbon. As a matter of fact, this is far from true. The temperature of the cupola is insufficient to melt wrought iron until it has absorbed a considerable quantity of carbon from the coke, and even supposing this did not occur, a metal containing only 1.8 per cent. carbon would be difficult to cast.

The process certainly is attractive, judging by results which have been obtained, but it appears probable that the improvement in the cast iron is really due to a reduction in sulphur and phosphorus, rather than a reduction of carbon. It would even appear that equally good results could be obtained from ordinary pig iron mixtures if foundry operations were carried out under accurate metallurgical control.

Very good results have been obtained by some users of the "semi-steel" process and it has proved economical in works where large quantities of steel turnings are produced but which are situated several hundred miles from the nearest steel works. One difficulty connected with the process is that the temperature of the cupola is frequently insufficient to produce a homogeneous liquid metal and the results are in consequence somewhat erratic. Comparatively recently, however, great improvements have been effected by using a revolving (cylindrical) furnace, heated by means of a blowpipe using coal dust and pre-heated air (see Fig. 17). Such a furnace will develop a temperature exceeding  $2,000^{\circ}\text{C}$ ., so that mild steel and cast iron charges in all proportions can be melted and rendered homogeneous without difficulty. In the cupola "semi-steel" mixtures pick up carbon from the fuel, but in this type of furnace there is a loss of carbon in the metal due to oxidation. Consequently, anthracite

or coke must be added to the charge to carburise the metal to the required degree. Ferro-silicon is also added to adjust the silicon content to the necessary percentage. The process has proved exceedingly economical and specimens examined by the author exhibited about double the strength of ordinary cast iron. This is largely due to the fineness of the graphite particles found in them. The metal is easy to machine but it is necessary that the temperature at the time of casting should not be excessive.

### Constitution of Cast Iron

At this stage some description of the constitution of cast iron may enable the reader to form a mental picture of the structure of cast iron, and see more clearly how its mechanical properties are influenced by chemical composition and rate of cooling.

In dealing with iron castings we are not greatly concerned with "equilibrium diagrams" for the iron-carbon system, because, in foundry practice, we have the powerful influence of silicon and much more rapid cooling than would be necessary to attain complete equilibrium from a theoretical point of view.

It is convenient to regard molten cast iron as a solution of silicon and carbon in iron. Even while the metal is fluid in the ladle we occasionally notice some action on the part of silicon, because some of the carbon in the metal separates out as graphite and this floats up to the surface of the liquid. Immediately after the solidification of the metal in the mould, instability asserts itself, and, what was at the time of freezing a comparatively simple substance, breaks up, forming a conglomerate which continues to change in character during further cooling unless these changes, which take time, are checked by rapid cooling, or the presence of some element such as nickel, which acts as a powerful brake.

Now, if the cooling metal contains little or no silicon,

(white cast iron), the resultant solid is a somewhat complex conglomerate consisting of a groundwork of pearlite holding together relatively massive patches of iron carbide. This latter compound is known as cementite ( $\text{Fe}_3\text{C}$ ), is tin-white in colour, glass hard, strong under compressive loads, but brittle and weak in tension. Since white cast iron contains about 50 per cent. of this substance, it is not surprising that it should be glass hard. Fig. 8A shows the structure of such metal under low power magnification.

The next case we will consider is that in which silicon is present in larger quantities and is therefore capable of exercising considerable influence. In this case the cementite proves unstable and the large masses almost immediately break up, forming two substances, viz., an iron-carbon-silicon solid solution (silico-austenite) and graphite.\* The graphite cannot escape from the solid metal and is trapped in the form of more or less large plates among the metallic crystals. In fact, the whole metallic mass is parted in all directions by graphite plates. For this reason it is fairly evident that cast iron is not flexible like many pure metals, especially as the graphite is in itself so weak. The presence of graphite in cast iron accounts for the graphite which stains the turner's hands when cutting it in the lathe.

As the temperature falls, the solid solution iron-carbon-silicon (silico-austenite) undergoes further changes depending on circumstances, but if there is nickel present, these changes are slight. A casting containing 2 per cent. of nickel will have the spaces inside the network of graphite filled with a substance resembling tempered steel in what is termed the sorbitic state, but differing from steel in containing more silicon. In fact, it might be termed silico-sorbite. An iron casting exhibiting this

\* For simplicity the writer has purposely omitted a complete description of all the intermediate stages and constituents of freezing and cooling of cast iron and the eutectics it contains.

structure has a high mechanical strength unless phosphorus or some other pernicious element is in excess.

In the absence of nickel the sorbitic structure is unstable, and further changes take place. Firstly, the silico-sorbite changes into silico-pearlite. When this change has occurred the microscope presents a picture identical to that of a slowly cooled steel containing 0.89 per cent. carbon, but broken up in all directions by graphite plates. It is this structure which one expects in high-class castings made in the ordinary way without special ingredients.

Just as pearlitic steel is weaker than sorbitic steel, so pearlitic cast iron is weaker than sorbitic cast iron.

Yet another change may occur if the silicon content of the casting is too high and the rate of cooling rather prolonged. The silico-pearlite, which consists of microscopic laminae of silico-ferrite and silico-cementite, will part with some or all its carbon, forming massive silico-ferrite and additional graphite. Reference to Table III. shows that No. 1 pig, high in silicon, contains no combined carbon, and this substance corresponds exactly to what we have just described. No. 1 pig is very graphitic and very weak.

We will next consider what happens with cast irons of intermediate compositions and abnormal rates of cooling. We have discussed certain typical structures which may be regarded as stepping-stones. By varying the silicon and rate of cooling, we can at will make castings which exhibit the following structures and mechanical properties.

- |   |  |
|---|--|
| (a) Fifty per cent. massive cementite.                      | White, glass-hard, weak.                           |
| (b) Pearlite and graphite in excess over massive cementite. | Machines with difficulty, somewhat grey, stronger. |
| (c) Pearlite and graphite.                                  | Easily machined, stronger still, grey fracture.    |

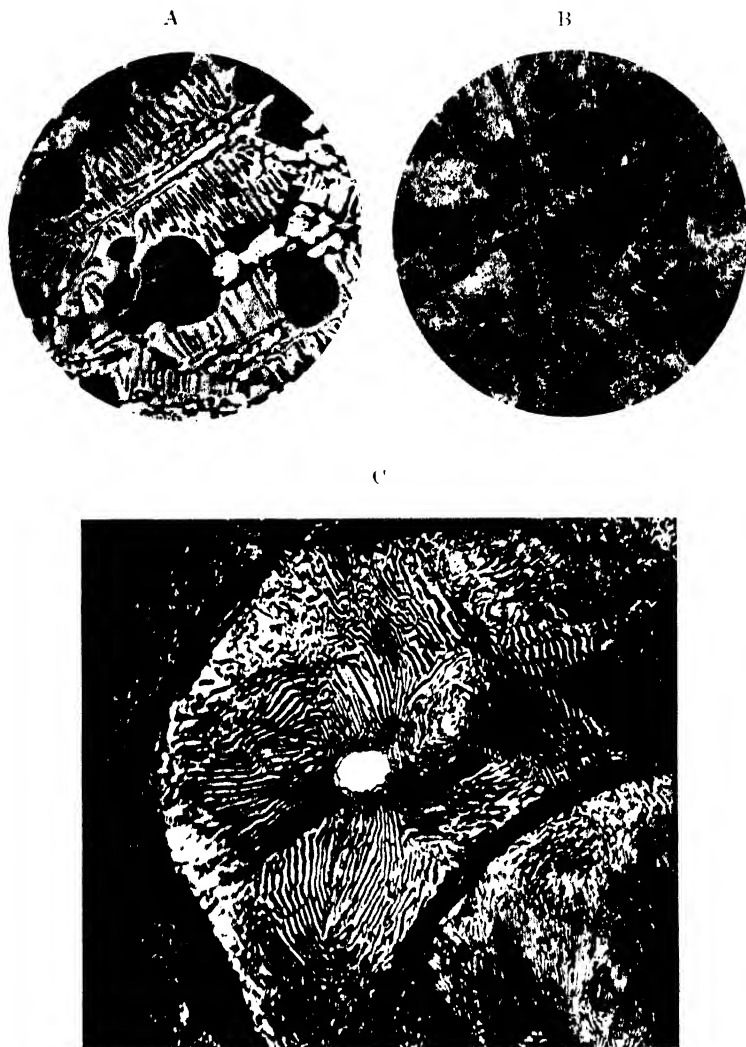

FIG. 8.—Structures of Cast Irons.

A. White cast iron. White = glass-hard cementite  $\text{Fe}_3\text{C}$ . Black = silico pearlite.

B. Grey cast iron (low magnification). White = silico-ferrite. Black = silico-pearlite. Grooving = graphite.

Z. Grey cast iron (high magnification). White = silico-ferrite. Black and white striation = silico-pearlite. Grooving = graphite.



eutectic freezes at a temperature about  $200^{\circ}$  C. below the initial freezing-point of cast iron, these local accumulations among the growing crystals of metal are to be expected. In view of the fact that the metallic mass is already considerably embrittled by the presence of the massive brittle cementite or graphite or both, it is not surprising to find that the presence of so much as 1.5 per cent. does not make very much difference in this respect, especially as its effects are very local.

### Special or Alloy Cast Irons

Reference has already been made to the influence of manganese upon cast iron. For many years it has been customary to use foundry mixtures relatively high in manganese for gas engine cylinders and chill castings. The action of manganese is one of restraint, so that not only is graphitisation of the cementite delayed and partly increased, but the graphite, when formed, does not coalesce so readily into large plates. In consequence the casting is closer grained and exhibits better wearing properties. It is of course less easy to machine. During recent years it has been discovered that for many purposes the introduction of from 1 to 5 per cent. of nickel has an even more striking influence upon cast iron. The nickel is added to the stream of cast iron as it flows from the cupola into the ladle by means of a nickel-silicon alloy of relatively low melting-point ( $1,250^{\circ}$  C.) compared with pure nickel ( $1,450^{\circ}$  C.). Nickel very conveniently performs the double function of brake and accelerator, or rather brake and continuer. As a brake it prevents the graphite coalescing into large plates and so produces a fine and strong structure. It also suppresses the pearlitic change, rendering the groundwork sorbitic and tougher. Like manganese, it delays graphitisation but does not harden the casting. Just as the accelerator of a motor vehicle enables us to maintain a constant speed as we pass onto a rising gradient, so nickel prolongs the process

of graphitisation which would otherwise be checked by the rapid cooling of thin parts of the casting, thus preventing local chilling and excessive hardness. At the same time the thicker portions exhibit sufficient stability to withstand any tendency for the sorbite to break up into ferrite and secondary graphite. Uniform graphitisation means equal contraction and equal ease of machining. Nickel cast irons show an increase of strength of about 30 per cent. Though nickel is relatively expensive, the addition appears to be a sound commercial proposition for certain purposes. Where extra good wearing properties are desirable, additional hardness in nickel cast irons may be obtained by the further addition of about 0.5 per cent. of chromium. For cylinder liners, etc., a cast iron containing 1 per cent. of nickel and 0.5 per cent. of chromium is frequently used. A feature of this material is that it can be heat-treated, after machining, to give a glass-hard surface. The usual treatment consists of oil hardening at 840° C. and tempering at 350° C. The liners are subsequently finished by grinding. Other cast irons containing about 14 per cent. nickel and 7 per cent. copper have recently come into use. They consist of graphite embedded in an austenitic matrix, and are non-magnetic, very resistant to corrosion and reheating effects. They are cast and machined without difficulty.

•

### Shrinkage of Cast Iron

It is common knowledge that almost all metals shrink to a considerable extent during cooling, a notable exception being a lead-tin-antimony alloy known as printers' type-metal. Pure metals, when cast, contract steadily during cooling, and the contraction curve does not exhibit any discontinuities. In the case of cast iron we have a complex mixture undergoing considerable change of internal structure during cooling, and it is therefore not surprising that the shrinkage curves of various

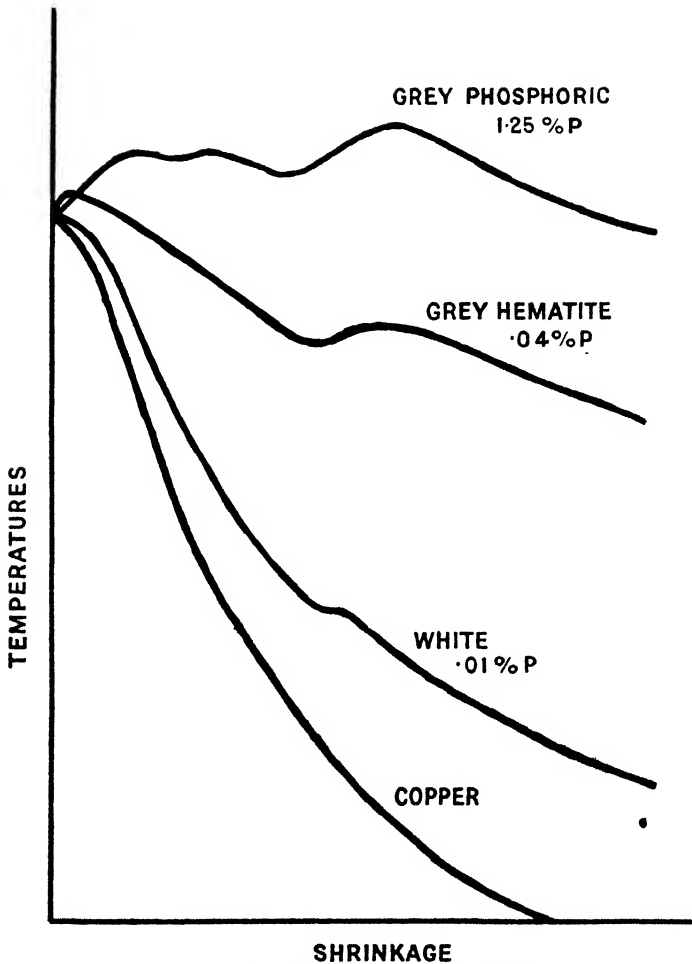

FIG. 9.—Temperature-Shrinkage Curves.

foundry mixtures vary very greatly in form. Work done by Keep in America and Turner in this country demonstrate these facts very clearly. Fig. 9 (copied from Turner's "Metallurgy of Iron") represents the shrinkage curves of copper, low silicon white iron, silicious hæmatite

(low in phosphorus), and silicious and highly phosphoric foundry irons.

It will be observed that the white iron shows one slight expansion. This takes place at about  $665^{\circ}\text{C}$ . The grey hæmatite shows a marked expansion just after solidification followed by another at about  $700^{\circ}\text{C}$ . In the case of the phosphoric grey iron three distinct expansions are clearly visible. The first expansion is attributed to the deposition of primary graphite immediately after solidification, the second to the freezing of the iron-iron phosphide eutectic, and the third one to the breaking up of the pearlite into ferrite and secondary graphite. The corresponding cooling curves show arrest points coinciding with these expansions indicating a dissipation of energy.

From the above we would naturally expect that the final shrinkage of grey irons would be much less than that of white cast iron. This is actually the case, and the pattern-maker makes an allowance of  $\frac{3}{16}$  in. per foot for the shrinkage of white castings, whereas for grey castings he allows only  $\frac{1}{8}$  in. per foot.

It has already been pointed out that the rate of cooling (which depends, in general, upon the ratio of cooling surface to mass of metal) has a marked influence upon the final composition of the casting. An iron suitable for a casting of medium weight and cooling surface would produce a very white and hard rainwater gutter, and a very grey and spongy massive casting weighing several tons. The more graphitic the casting the less it will contract, and *vice versa*. As a rule this difference of contraction of heavy and light castings made from the same metal is of no consequence, since the founder uses different mixtures for different jobs. But if for any reason a casting is so badly designed that it exhibits great variations of cross-section, the difference in the graphite contents of the various parts, and hence difference in shrinkage, may add to other troubles.

It is probable that every engineer's casting is to a certain extent in a state of internal stress, however well it is designed, but some are so highly stressed that they break in the mould or shortly afterwards in service.

Fig. 10 may be used to illustrate this point. The rim of the wheel was so light and presented such a large cooling surface that it solidified immediately and cooled down considerably while the centre was still liquid. When solidification and contraction of the centre and thick portions of the spokes took place, the rim was comparatively cool and rigid, with the result that the spokes were in a state of tension. After a short period of use one spoke broke and the gap was wide enough to accommodate the blade of a knife. It will be observed that the fact that the spokes were tangential to the boss has not saved the castings. Had the spokes been curved like the letters "C" or "S," rupture would not have taken place. By casting such a wheel in two halves it will not break even with radial spokes. Founders of experience can frequently prevent fracture of badly designed castings by adopting some means of accelerating the cooling of the more massive parts.

Abrupt change of section frequently produces almost insuperable difficulties. As an extreme case consider the example illustrated in Fig. 11. In this case the thin portion will cool very rapidly and become rigid and contract. Later on the thick portion will solidify and contract. Immediately after solidification, cast iron, like other metals, is very fragile, and rupture during further cooling is certain to occur along the junction between the thick and thin portions. Many castings are provided with local facings for machining, and these are frequently far too massive, with the result that they tend to become the centres of sulphur and phosphorus segregations, excessive hardness and shrinkage. Such troubles can be avoided if the height of the facing does not exceed one-quarter of the thickness of the metal below.



FIG. 10. - Cracked Belt Pulley.

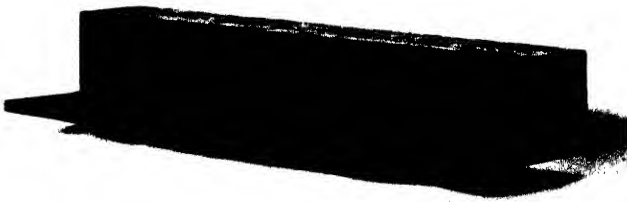

FIG. 11.—Abrupt Change of Section.



Another important consideration from the designer's point of view is the direction in which solidification takes place. Thus, if we consider the solidification of a casting, we see that the latent heat of fusion escapes in a direction normal to the surface, and that solidification takes place from the outside inwards.

In the case of the cube we have simultaneous growth of solid metal inwards from each of the six faces. The growth from any particular face is strong material, but where the growth from one face meets the growth from another, the interlacing of the crystals is by no means

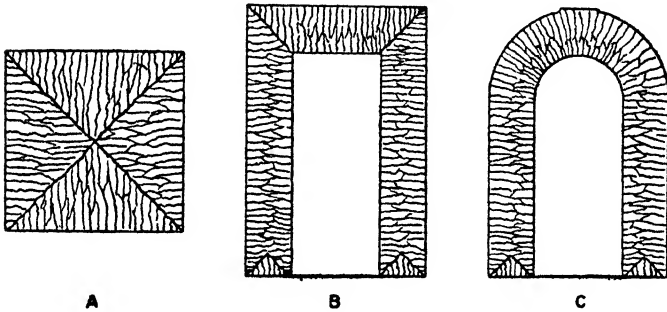

FIG. 12.—Solidification of Castings.

perfect, with the result that a plane of weakness is produced. This weakness may be increased by the presence of impurities of low freezing-point. In extreme cases we may regard a cube of cast metal as consisting of six pyramids loosely held together. Similarly a rectangular ingot of tool steel *may* consist, in the main, of four triangular prisms. Such ingots occasionally crack in a diagonal-direction when reheated, or as a result of a blow with the steam hammer.

- Now if we were to cast an hydraulic cylinder with perfectly flat top we should find that the "mitreing effect" at the corners would cause so much weakness that a cone would blow out under comparatively low pressure.



By making the top of the cylinder spherical the plane of weakness is avoided.

Though these "mitred" corners are weak in tension, they may exhibit extra strength in compression. This is shown by examining the end sections of brass test-bars which have been turned down from 1 in. square to 0.564 in. diameter and "pulled." The circular cross-section once more becomes nearly square, since lateral contraction in the direction of the original "mitreing" has been largely checked.

### Annealing and Growth of Cast Iron

One occasionally meets with a specification which requires that grey castings for some particular purpose must be annealed, presumably with a view to relieving internal stresses. Whether this is justifiable or not in the case of well-designed castings is a matter of opinion. Annealing may do good, and it may do infinite harm. Hatfield has shown that in many cases the tensile strength of a grey casting drops from 12 tons per square inch to about 4 tons when annealed at a temperature of 900° C. It would therefore appear that annealing may prove very detrimental and should be avoided whenever possible.

It has long been known that castings "grow" as a result of prolonged heating. Thus parts of kitchen stoves will in the course of a few years "grow" as much as  $\frac{1}{2}$  in. per foot. For this reason it is most important that due allowance should be made in connection with furnace parts, for otherwise buckled fire-bars or ruptured casings will result. Hatfield is of the opinion that growth is due to the slow oxidation of the silicon in the iron at high temperatures. Another cause of growth is the oxidation of the ferrite surrounding the graphite cavities.

**Malleable Cast Iron.**—We have seen that cast iron, a convenient substance from the point of view of its low

melting-point (about  $1,150^{\circ}$  C.) is a non-flexible material on account of the large quantity of massive graphite, or massive cementite, or both, which it contains. These are due to the high carbon content. If we reduce the carbon, the melting-point rises rapidly and becomes in the limit so high (pure iron melts at  $1,532^{\circ}$  C.) that the melting and casting operations become troublesome and costly. In fact, the casting of low carbon iron is simply the art of the steel-founder, whose products command a high price.

For many purposes something intermediate in cost, strength and flexibility proves extremely useful, such as "pocket wheels" for chain blocks, sheaves for wire rope blocks, bicycle joints, levers and fastenings for windows, bits, stirrups, harness buckles and door keys. Malleable sockets, tees, elbows and bends are extensively used for joining steel *gas and water* pipes. They are dipped in molten rosin to fill up the blow-holes.

There are two methods of producing malleable castings. In both of them the metal used is white (low silicon) pig iron low in phosphorus. The castings produced are, of course, white, glass-hard, and very brittle. They are then subjected to one of the following processes to render them malleable.

(a) In the Whiteheart or Reaumur process the castings are packed in ferric oxide and heated for several days to a temperature of about  $850^{\circ}$  to  $900^{\circ}$  C. As a result of such treatment the castings become almost completely decarburised, though a few odd residual flakes of graphite are found in them. A micro-section of a good sample may easily be mistaken for the cross-section of a high-class wrought iron bar (see Fig. 15A). The ferrite (pure iron) crystals appear to be identical, while a particle of graphite may be mistaken for a ribbon of slag (see Fig. 13A).

(b) In the "Blackheart" process the packing material is not of an oxidising nature, but sand, powdered fire-brick or almost any cheap refractory substance which is a reasonably good conductor of heat. This process is

quicker, but the carbon is not eliminated. The glass-hard cementite breaks up, not to form massive graphite plates, as in relatively high silicon irons, but minute particles of amorphous carbon, fairly widely separated, are formed among the ferrite crystals.

Fig. 13B represents a micro-section of such material from which it is observed that the ferrite background is sufficiently continuous to permit the metal being bent through a considerable angle without breaking. Though the casting as a whole is not decarburised, the portion near the surface loses its carbon by oxidation, and this is evident on a fractured specimen which exhibits a bright metallic appearance on the outside, but internally the structure resembles black velvet. For this reason the process is known as the "Blackheart process."

The temperature used in the process is in the neighbourhood of  $730^{\circ}\text{C}$ ., and it is very important that this should not be greatly exceeded, otherwise coalescence of the carbon particles occurs, massive graphite is formed, and an ordinary grey casting devoid of flexibility is the result. Precisely the same action occurs when such a casting is heated with a view to performing some forging operation upon it.

The physical properties of malleable castings made by the two processes are about the same. The Blackheart process takes less time, especially when the castings are of fairly large bulk. It is the principal process used in America, but in this country the Reaumur process is generally preferred. For some unknown reason the Reaumur process is usually considered better for our iron which is relatively high in sulphur. At one time it was thought that some of the sulphur was eliminated with the carbon by oxidation, but more recent research has proved that this is not the case. Just as phosphorus and sulphur must be kept low in wrought iron and mild steel, so the same applies to malleable castings. Hæmatite pig is used to keep down the phosphorus content, and it is customary

A

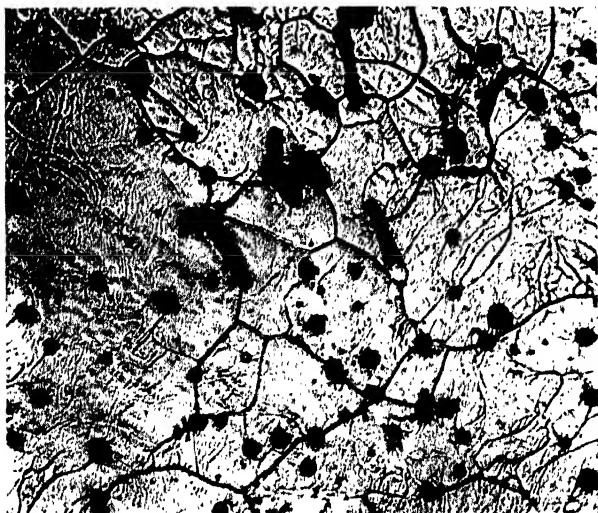

B

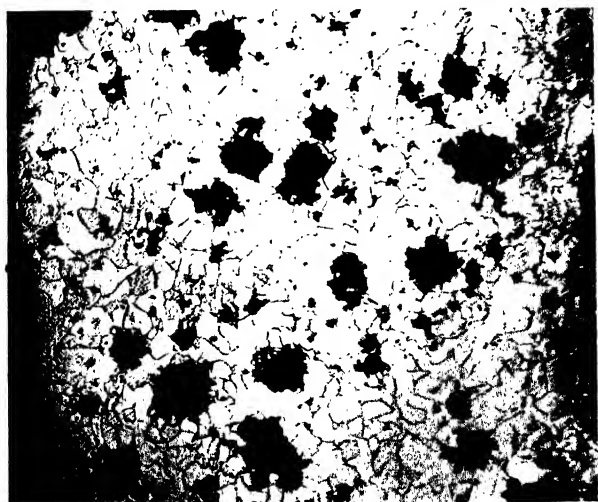

FIG. 13.

A. Whiteheart or Reaumur malleable cast iron.  
B. Blackheart malleable cast iron.



to avoid cupola melting which adds sulphur to cast iron and use the crucible, reverberatory or Siemens furnace instead. A representative sample of malleable cast iron has the following tensile properties: Yield, 12 tons; breaking stress, 20; elongation, 5 per cent. for a Reaumur, and 10 per cent. for a Blackheart casting.

After inspection of Figs. 13A and 15A the reader may reasonably inquire why malleable castings should exhibit ductility which is inferior to wrought iron or mild steel. There are three contributory reasons for this: (1) The ferrite of malleable castings contains about ten times as much silicon in solution, (2) the individual crystal grains are normally larger, (3) in almost all cast metals the crystalline cohesion is less than in metals which have been rolled or forged.

The reader must not confuse malleable cast iron with wrought iron, which is frequently referred to in Scotland as malleable iron.

## CHAPTER IV

### WROUGHT IRON

WE have already seen that wrought iron can be produced directly from the ore by reduction by means of charcoal. Direct reduction by the primitive method is, however, commercially impossible owing to the high cost of fuel and labour and the small quantity of iron produced. During the last 150 years the principal process in use has been an indirect one. The ore is first smelted in a blast furnace, the products of which are liquid and gaseous. The process is economical and continuous, but the resultant metal is simply a cast iron high in carbon, silicon, manganese, sulphur and phosphorus. To reduce the quantities of these constituents and to produce wrought iron, the puddling process is used. As a rule pig iron is charged direct into the puddling furnace, but in the Yorkshire process a rather costly preliminary treatment is carried out with a view to producing a superior article capable of commanding a higher price.

In the production of "Best Yorkshire Iron" the pig iron is heaped among coke in what looks like a glorified smith's fire erected on relatively high ground. The blast from a blower points downwards at a considerable angle into the fire and not only causes sufficient rise in temperature, but to a great extent oxidises some of the constituents. It will be noted from Table III. that very grey irons (high in silicon) have a relatively low sulphur content, and hence grey irons are used in Yorkshire. When sufficient metal has become melted and the oxidising effect of the blast has continued far enough (but not too far) the metal is tapped out and allowed to form a pool about 2 in. deep. Immediately the metal has

frozen, it is broken by means of a hammer into pieces of convenient size for handling.

TABLE IV.—*Stages in Production of Best Yorkshire Iron*

	Pig	Refined	Puddled	Finished
Combined carbon . . . . .	0.55	3.1	0.420	0.081
Graphite . . . . .	3.06	0.40	—	—
Silicon . . . . .	1.33	0.253	0.039	0.104
Sulphur . . . . .	0.049	0.038	0.008	Trace
Phosphorus . . . . .	0.367	0.244	0.240	0.041
Manganese . . . . .	0.806	0.720	Trace	Trace
Iron . . . . .	93.83	95.2	99.01	99.766

*Note.*—Some of the silicon is dissolved in the finished iron and has a hardening effect, but a relatively large proportion occurs as ferrous silicate in the entrapped slag, so has no hardening effect. Similarly a portion only of the phosphorus is in the metal, and the remainder is in the entrapped slag.

The puddling furnace is one of the reverberatory type with a basin-like hearth. The working door is provided with a notch to enable the puddler to rabble and stir the metal without opening the door. In the Yorkshire furnaces a preheating chamber is provided at the base of the chimney by which means the cold metal is brought up to a good temperature before being introduced into the main portion of the furnace, illustrated in Fig. 14.

The puddling operation is as follows: About 5 cwt. of metal is charged into the furnace, and in the course of about twenty-five minutes melts down into a quiet fluid. Oxide of iron is then shovelled in, and a reaction between the oxygen of the oxide and the carbon in the iron at once commences and carbon monoxide bubbles up through the molten metal. At this stage the metal appears to be boiling, owing to the escape of gas. As the process continues, a reduction of the carbon causes a raising of the



melting-point, the metal thickens and loses its fluidity. As a result of much energy expended by the puddler, who keeps rolling the metal over and over in a liquid slag of ferrous silicate, the metal assumes the form of a large porous ghost-like ball through which the furnace flame passes with comparative ease. When the puddler deems the process has gone on long enough he divides the spongy ball into smaller ones, which can be drawn through the furnace door. These are taken quickly to the hammer, squeezed at first and then consolidated into slabs of

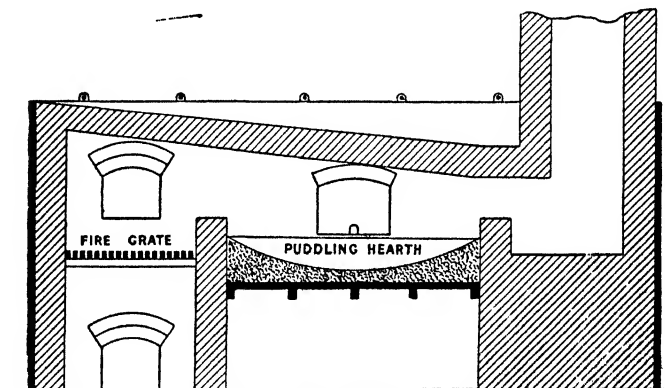

FIG. 14.—Puddling Furnace, Longitudinal Section.

“puddled iron.” During the hammering much slag is ejected in all directions, but still puddled iron is far from pure. It is still high in carbon, phosphorus, etc.

The slabs are broken when cold and the fracture is an indication as to whether the puddlers have completed their work. The broken slabs are then piled in a re-heating furnace, raised to a welding heat, forged under the hammer and passed to the rolling mill. The rolled material is sheared into short lengths, piled, welded and again rolled out. This process is known as “shingling,” and in general it may be said that the more frequently shingling is carried out, the better. Shingling is expensive and only

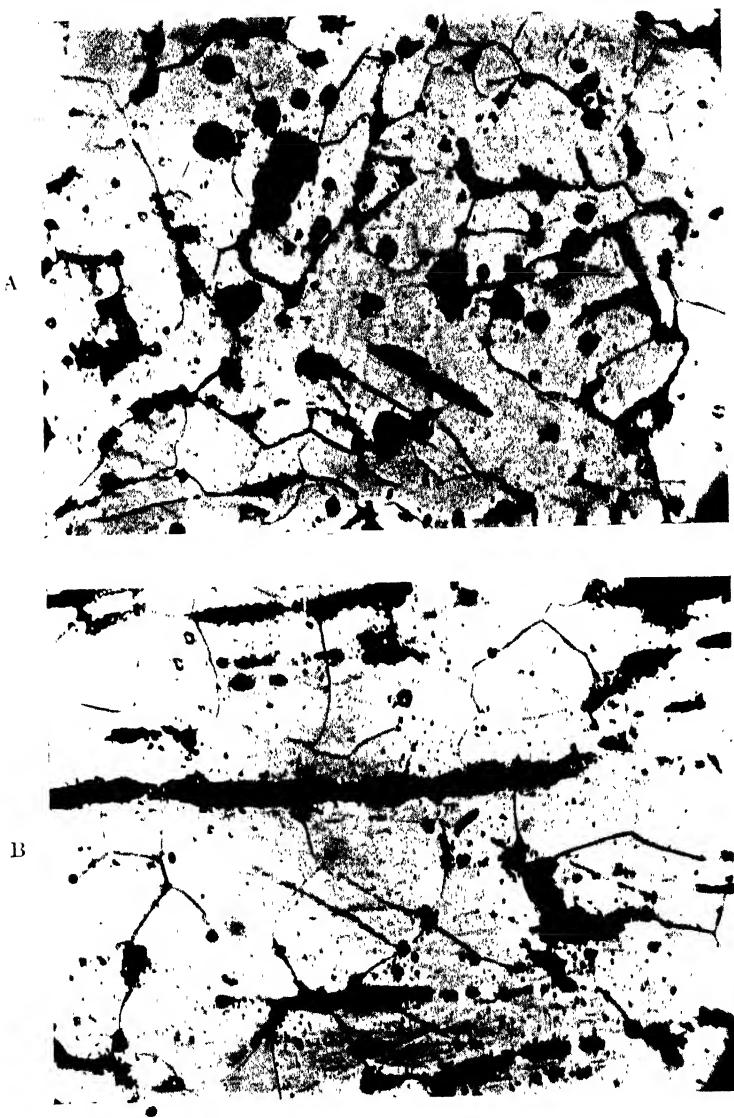

FIG. 15.—Structures of Wrought Iron.  
A. Transverse section.  
B. Longitudinal section.  
White = Ferrite.  
Black = Slag.



the best irons demand a sufficiently high price to justify repetitions of the process. Reference to the last two vertical columns of Table IV. shows the result of shingling. During the reheating process the surface of the metal becomes oxidised, and this coating of oxide attacks and removes much of the remaining carbon. There is also a very marked reduction in the phosphorus content. It is certain that most of the phosphorus remaining after puddling is in the slag entrapped in the metal, and hence is reduced in quantity when much of the slag is expelled by mechanical working.

The whole of the slag is never eliminated, and therefore some always remains in finished bars (see Figs. 15A and 15B). Being liquid at the rolling temperature, the particles are elongated and hence good wrought iron always contains "wires" or "ribbons" of slag lying in the direction of the rolling. These ribbons cause lamination, and if we notch and bend an iron bar we get a fracture resembling a piece of wood. This lamination which occurs in all wrought iron is frequently still referred to as "fibre"—a misleading word when used in this sense.

The process of notching and bending an iron bar is a cheap and rapid method of distinguishing between wrought iron and mild steel. As one would expect, the transverse strength of wrought iron is, owing to the presence of slag, distinctly less than that of samples tested in the direction of rolling.

Until the introduction of the mild-steel industry the wrought-iron trade of this country was very prosperous, but the quantity produced each year is falling rapidly. This is not surprising when we note that mild steel can be produced in large or small masses at a cheaper rate. The fuel consumption in the production of wrought iron is very great, and puddling is such an arduous and hot job that it is difficult to get men to take on the work as apprentices and stick to it later on. Attempts have been made to perform puddling by mechanical means, but no

process yet devised has been able to compete with the manual process, especially where quality is of supreme importance. For almost all structural purposes mild steel is cheaper, stronger, and more easy to procure. The question then arises : Why is wrought iron made at all ?

For certain purposes wrought iron, though more expensive and weaker, is preferable. Compared with ordinary mild steel, wrought iron is much easier to weld, and it is much less likely to be harmed by being raised to a scintillating heat as in hand rivets. There are several points in favour of wrought iron for such work. In wrought iron we have very low carbon, silicon and manganese compared with ordinary mild steel. The low carbon gives us a higher melting-point and greater plasticity, and in consequence the welding range of temperature is greater.

Silicon and manganese are both very easily oxidisable elements and are therefore highly objectionable at high temperatures. Like carbon, they reduce the plastic nature of the metal. At high temperatures the cohesion of the crystals is not great, and the escape of occluded hydrogen (producing scintillation at a welding heat) tends to open up the metal and cause intercrystalline oxidation, but there is less tendency for this to occur in the case of wrought iron, since the slag it contains appears to seal up any intercrystalline crevices which may form. There is little doubt that a reliable wrought-iron chain is easier to produce than one made of mild steel.

The slag in wrought iron obstructs crystal growth at a welding temperature, and this is an advantage from the point of view of the toughness of the finished article.

It is generally accepted that wrought iron is less corrodible than mild steel, but it is doubtful whether the advantage in this respect is commensurate with the extra cost, save in exceptional circumstances. So far our comparisons have been between wrought iron and the general run of mild steel. When we consider special cases, the

superior weldability of wrought iron is not so apparent. Thus, by making specially soft mild steels low in carbon, silicon and manganese, the resultant metal is quite suitable for " fire welds " even in boiler work and railway draw-gear.

Where electric welding is practicable, as in the case of bicycle-wheel rims, the composition of the metal does not matter very much from the welding point of view, but is a factor to be considered in connection with other subsequent processes. Formerly very large forgings were produced by welding together small pieces of wrought iron. Such a practice has, of course, been entirely superseded by use of suitable steel ingots.

Locomotive wheels were formerly wrought-iron forgings, but now they are simply steel castings which can be produced at a fraction of the cost. In fact, it appears probable that in the course of a few years the manufacture of wrought iron will cease entirely.

The demand for wrought iron for chain-making is likely to decrease since the advent of electrically welded and weldless steel chains. The latter are produced in a special form of rolling mill and are apparently superior to the older form.

## CHAPTER V

### TOOL-STEEL

DURING the manufacture of wrought iron by the puddling process, the carbon gradually falls from about  $3\frac{1}{2}$  per cent. in the cast iron to about  $\frac{1}{10}$  of 1 per cent. We naturally inquire whether we cannot stop the process at some intermediate stage and obtain a 1 per cent. carbon tool-steel. This is impracticable for the following reasons : Owing to the rapid decarburisation of the metal during the shingling operation it would be necessary to cease puddling when the carbon content was well over  $1\frac{1}{2}$  per cent., and the melting-point of such a metal is so low and the metal so devoid of good plasticity that shingling would prove exceedingly difficult. An even more serious difficulty arises through the fact that the metal at this comparatively early stage still contains excessive quantities of silicon, sulphur, phosphorus and manganese. The sulphur and phosphorus must be eliminated from the point of view of quality, and the silicon and manganese will intensify the difficulty of shingling. Hence we see that " Puddled Steel " cannot be regarded as a first-class product, and we must select a better process.

#### Blister Steel

In the production of this material about 10 tons of flat bar iron of the very best quality are packed in wood charcoal and heated in a suitable furnace for about ten days, during which time the wrought iron absorbs carbon, and the surface presents a series of blisters due to the action of the carbon upon the slag in the metal. Slagless metal, such as mild steel, does not blister in the same way.

The process is known as cementation. The product is far from uniform, the carbon being higher near the surface.

### Shear Steel

By welding together one or more pieces of blister steel a very much more uniform product is obtained. During re-heating to the welding heat some of the excess carbon near the surface is lost by oxidation, and at the high welding temperature the carbon has a much better chance of diffusing uniformly through the mass. In the case of double shear steel the welding process is repeated a second time.

Shear steel is an excellent product in many ways, but its uses are limited. Thus fine-edge tools prepared from it will be far from perfect because local interruptions of the cutting edge will occur where the threads or ribbons of slag (of the original wrought iron) occur.

The chief point in its favour is its capacity to withstand a high forging and a welding heat. Hence it is largely used for pointing colliers' picks and other tools. It possesses many of the qualities of wrought iron which assist welding, viz., low silicon and manganese content, both of which elements impair plasticity and are easily oxidisable, and it contains slag. The relatively high carbon content, however, lowers the melting-point and shortens the plastic range, so welding must be carried out with care. The writer was informed by a very expert colliery smith that the secret of success lay in heating the steel point for welding to a rather low temperature and making up the deficiency by heating the iron head of the pick to a higher temperature than usual when welding iron to iron.

•

### Crucible Cast Steel

We have noted that the slag in shear steel restricts its use for certain purposes, such as fine-edge tools, and it can



readily be seen that if we make a clock- or watch-pinion from it, one of the teeth may be separated from the hub by a ribbon of slag and snap off quite easily. The solution of this difficulty was found by Huntsman, a clock-maker in Doncaster in 1740, who devised the process of eliminating the slag, and producing a uniform metal by fusing blister steel in a crucible. Huntsman was so successful that he started work in Sheffield and revolutionised the tool-steel industry of the world.

Huntsman and other workers were faced with two serious difficulties: their ingots were frequently badly honeycombed with blow-holes and of such sulphur content that the metal was red-short. These difficulties are now got over by adding sufficient manganese to deoxidise the metal and take charge of the sulphur. Small quantities of ferrous sulphide are very detrimental to steel, but larger quantities of manganese sulphide are comparatively harmless.

Though the best tool-steel is made by melting blister steel in the crucible, less than half is made to-day in this way, since it is far cheaper to melt down mixtures of cast and wrought iron in suitable proportions. Cheaper brands of tool-steel for quarry work, etc., are produced in large quantities in the Siemens furnace. The electric furnace has proved so successful that it may, before long, supersede the crucible process.

It has been suggested that Huntsman was simply the re-inventor of a crucible cast-steel process, carried on for centuries by Indian natives and others, but this is apparently not so. The Indians performed the cementation in pots or crucibles and actually fused their metal, but did not cast it into ingots.

Tool-steel is usually cast in small ingots about 3 in. square, and these are subsequently topped and forged down into suitable bars. The process, though carried out by the steam hammer, is still spoken of as "tilting," since it was originally carried out by tilt hammers.

To-day the necessity for economy has resulted in much of the tool-steel being finished in the rolling mill, but the result is said to be inferior to tilting.

Many grades of tool-steel, depending on the carbon content, are made. For razors and hacksaws a high carbon, say  $1\frac{1}{2}$  per cent., is preferred, and for smiths, fullers and cresses, about 0.5 per cent. is ample. For general workshop purposes a steel containing about 0.9 per cent. carbon (the eutectoid composition) is generally preferred.

Steels much above the eutectoid ratio, such as those containing 1.5 per cent. carbon, are, even in the tempered state, somewhat fragile owing to the presence of the cementite ( $\text{Fe}_3\text{C}$ ) which has fallen out of solution. On the other hand, the low carbon steels used for smiths' tools and stamping dies, while capable of withstanding a good deal of battering, owing to the free ferrite which they contain, are unsuitable for turning tools, drills and cold chisels.

### Production of Tools

There are certain phenomena concerning steel which must be realised and pandered to if we wish to turn out serviceable tools. In the first place the heating of the steel must not be too rapid, or it will crack. The temperature must be high enough to make the steel plastic, but not high enough to induce so much crystal growth that the forging does not refine it again. Infinite and irreparable damage is done to the steel if it is subjected to hammer blows after the red disappears, since this produces microscopic hair cracks which never join up again, but spread rapidly later on. Any drawing down of round bars, which may be necessary should be performed in the square, and the final rounding up should be left till the last possible moment, and then done gently at a reasonably high temperature.

When the forging is being re-heated for hardening, we

must exceed the  $A_{c_3}$  point somewhat, but not by too much, otherwise crystal growth will develop and the tendency to crack is increased.

Since quenched steel occupies a greater volume than unquenched, this phenomenon is a source of trouble in dealing with cylindrical masses. The outside of such a mass cools, increases in volume and becomes rigid long before the centre is affected. When the centre subsequently increases in volume, the outside rigid portion is so severely stressed that it may crack. This accounts for many failures, and in general it may be stated that the higher the quenching temperature, the more likely will cracking develop. From this we see that a hollow forging dipped vertically is less liable to crack than a solid one. The quenching is also much more efficient.

The rate at which quenching in a liquid takes place depends on (1) its boiling-point, (2) its latent heat of evaporation, (3) its specific heat, (4) its chemical stability, (5) its conductivity, (6) its temperature.

Water is the most rapid quenching medium in everyday use, and its boiling-point, conductivity and specific heat may be slightly increased if we add stable soluble salts. Oil with its high boiling-point is chemically unstable and a bad conductor of heat. It is sometimes used for quenching tools of such a shape that water would almost certainly cause them to crack, but tools so treated are too soft for many purposes. Mercury on account of its low specific heat is only suitable for quenching watchmakers' drills and of no special merit for other tools of larger size.

For rapid quenching the temperature of the liquid must be kept low, though practical men find that tepid water is far less likely to cause cracking than that which is stone cold.

### Tempering

With few exceptions, such as files, all tools are more or less "tempered." Quenched carbon steel is chiefly

martensitic in character and too brittle. In fact, it requires "letting down"—a workshop term equivalent to tempering which implies that the metal is re-heated sufficiently to *partially* soften it and remove some of the brittleness. Since, in the case of tools, the amount of softening is a function of the temperature of re-heating, and since at each temperature the steel assumes a film of oxide of different colour, these "temper colours" are used as a means of estimating whether the softening has proceeded far enough. The softening which results is mainly a function of temperature, and time effects are, for the most part, negligible, unless the tempering period is unduly prolonged. If time were a serious factor, the process of tempering would present much difficulty.

When carbon steel is quenched in such media as oil or molten lead, the rate of cooling is so much slower that the process must be regarded as simultaneous quenching and tempering, so that great hardness is not to be expected. The same applies to other cases, such as the hardening of an axe by plunging the cutting edge, while hot, into plastic clay.

When a cutting operation is accompanied by a considerable evolution of heat as in the removal of metal in the lathe under heavy cuts at high speed, the cutting portion of the tool becomes excessively hot, and further tempering proceeds so rapidly that the tool becomes far too soft. Hence there is a limit to the rate of cutting which is possible with a carbon-steel tool.

### High-Speed Tools

When discussing the changes which occur in cooling cast irons, we saw that certain elements have a "braking effect" which makes them far less disposed to undergo structural change under thermal influences. Anything we can do to check tempering will enable us to run the tools for a longer period under heavy cuts.

In 1868, Mushet of Sheffield discovered, quite accident-

ally, that if a small proportion of tungsten is added to steel, it becomes self-hardening, *i.e.*, in good cutting condition without quenching and tempering. Later, he discovered that slight quenching by cooling the steel in a draught of air produced a distinct improvement. Further investigation showed that with improved mixtures these steels held their cutting edges far longer than those of simple carbon steel. The Mushet steel made no real headway for about twenty years. Tungsten was at that time expensive, and, save in the most up-to-date shops, managers could not be convinced as to the economy resulting from its use.

The next advance was again the result of an accident. A demonstration in America to show the advantage of performing all hardening of tools by scientific methods was a failure, since some hardened in a haphazard way gave better results. Taylor and White then tried experiments on a series of hardening temperatures up to the point of incipient fusion, and discovered that the best results were obtained with tools containing tungsten if heated to a temperature far in excess of anything previously used.

During the last thirty years the tungsten content has been increased very considerably, and the present-day high-speed steel contains on the average about 18 per cent. of that metal, though some brands contain even more. Such tools possess a property known as red-hardness—a capacity to keep their cutting edges for a time at red heat. Now if, when hardening high-speed tools we use moderate temperatures as in the case of carbon-steel tools, we find that they lose their hardness very soon, but if we cool rapidly in a blast of air or in oil from a temperature nearing incipient fusion, this red-hardness develops. The accepted view appears to be that this high temperature results in the formation of a hard tungsten carbide which is very stable.

The following is a typical analysis of high-speed steel

C, 0.65 per cent. ; Si, 0.20 per cent. ; Mn, 0.5 per cent. ; Cr, 4.5 per cent. ; W, 18.00 per cent. ; S and P, 0.02 per cent. max. For hardening such a steel it must be gradually and thoroughly heated to about 850° C. This will take from 20 to 30 minutes according to the size of the tool. It is then heated rapidly up to 1,300° C. and cooled in a blast of air or in oil. It is essential that the heating to the higher temperature should be short in duration, say, 1 to 2½ minutes, otherwise crystal growth will take place in spite of the presence of the chromium and tungsten. After this treatment the tool will be hard, but increased hardness is brought about by re-heating again to between 580° and 600° C. to induce what is termed "secondary hardness." It is then cooled rapidly in air or oil.

High-speed tools possess considerable advantage in certain classes of low-speed work. For instance, screwing dies and taps made from it maintain their original sizes and sharpness for much longer periods if made of high-speed steel.

The great success of tungsten steels has led investigators to try all sorts of other alloying elements such as molybdenum. Molybdenum steels have given good results, but apparently no better than those based on tungsten. Cobalt-chrome steel at first appeared attractive since it was capable of being cast into such articles as milling cutter blanks, ready gashed out and requiring little finishing. Its specific gravity was lower (about 10 per cent.), enabling more tools to be made per ton. The hardening temperature was considerably lower, which saved risk in spoiling taps, reamers, etc., during heating for hardening. The early cobalt-chrome steel was, however, disappointing, though more recent mixtures show considerable promise.

### Chisel Steel

Intensive research at Derby has demonstrated the enormous advantages to be gained by the use of nickel

and nickel-chrome steel for cold chisels. The L.M.S. Railway Specification requires : carbon, 0·38 to 0·42 per cent. ; manganese (max.), 0·6 per cent. ; and nickel, 3·0 to 3·5 per cent. After being forged and ground, the chisels are quenched in oil from 900° to 950° C. Microphotos of such tools show that before use they are chiefly in the soft unstable austenitic state, but immediately they are used, the harder martensitic structure develops at the cutting edge. The cutting edge, though well maintained for a considerable period against hard material, is very tough and sufficiently soft to permit resharping with a file. The use of this material instead of plain carbon steel has reduced the number of chisels reformed at Derby to *one-fifteenth* the former number. Other users of chisels pin their faith on nickel-chrome steels which are in many respects similar in properties.

### Stainless Alloys

Stainless cutlery contains about 12 per cent. of chromium. In order to harden these steels and produce the maximum resistance to corrosion it is necessary that the temperature should be high enough to permit the chromium being taken into solution in the iron. This is only attained at about 150° C. higher than the temperature used for hardening plain carbon steel. In the early days hardeners did appreciate this fact, and many knives, etc., were marketed in an unhardened condition. Apart from its use in cutlery, it is now extensively used in the manufacture of hydraulic machinery, since it saves much cost in replacing corroded rams and torn leathers, and ensures a more continuous output from the plant. It is used extensively for turbine blading, fruit-slicing machines, mirrors, and a host of other purposes.

Certain nickel-chrome steels exhibit considerable resistance to corrosion, *e.g.*, "Staybright," which contains 8 per cent. of nickel and 18·5 per cent. of chromium

This material is relatively soft and ductile, and therefore suitable for producing a number of articles which are pressed in dies.

Another stainless alloy of considerable interest is "Stellite." In view of the fact that iron in some samples is under 1 per cent. (and probably an impurity), it is a true non-ferrous alloy. It is so insoluble in acids that analysis is very difficult.

The analysis of two samples published showed :—

(1) Si, 0.29 ; W, 9.08 ; Cr, 32.95 ; Fe, 0.98 ; Co, 54.95.

(2) Si, 0.62 ; W, 17.59 ; Cr, 23.85 ; Fe, 5.23 ; Co, 52.94.

Hence we can regard the substance as a cobalt-chrome-tungsten alloy.

The alloy cannot be forged, and early samples were so brittle that they could not be used for work like turning the webs of large cranks. Newer samples are very much more satisfactory in this respect. They usually consist of : W, 15 to 20 per cent. ; Cr, 25 to 30 per cent. ; Co, 45 to 50 per cent. ; C, 2.5 to 2.75 per cent.

During the last forty years the price of aluminium has fallen from about 30s. per pound to about 1s. 3d. The price of vanadium (which is still costly) has similarly fallen. If and when pure chromium or a low carbon ferrochrome can be produced at a fraction of the present cost, we shall witness an enormous extension in the use of stainless steels.

### Case-Hardening

For many purposes the engineer requires a material possessing a glass-hard wearing surface, but internally soft and tough and capable of withstanding shocks and alternating bending or torsional stresses without risk of failure due to "creeping crack." Costs of material and machining are other factors of considerable commercial importance. Suppose we were to make, say, a motor car camshaft of crucible cast steel: the metal would cost



eight or ten times as much as mild steel, the machining operations would be slow and costly, and after quenching, the shaft would be practically glass-hard throughout. The sudden changes in contour and volume would almost certainly produce incipient cracks when quenched, and these would spread rapidly under working conditions. If we start with mild steel and subject it to cementation for a short period, we can harden the surface and maintain a low carbon content in the interior.

Every year witnesses extended use of the process which formerly was confined to such things as the link motions of steam engines.

In the cementation process for the manufacture of blister steel, charcoal alone is used, and very deep penetration is required, but in the case-hardening process the period is confined to a few hours, and something more rapid than pure wood charcoal is desirable. In the manufacture of blister steel, carbon monoxide is the carrier of carbon, but other gases are more energetic. It has long been known that freshly charred leather formed a very active carburising substance, and at one time old belting and boots were used. The activity of such charcoal is possibly due to occluded cyanogen gas, but it is by no means ideal, since the sulphur and phosphorus content is high and the presence of copper rivets and brass nails which may fuse on to the surface of the steel is highly objectionable.

Many of the proprietary articles sold for case-hardening are a mixture of charcoal and barium carbonate. Charcoal alone is slow in action when new, and after a time becomes less and less active, possible due to loss of nitrogen compounds. On the other hand, charcoal with barium carbonate is not only twice as active as charcoal alone, but does not lose its efficiency with repeated use.

It has been suggested that barium nitride is formed, and this in turn forms cyanogen. In addition to cyanogen gas, several compounds of carbon and hydrogen possess

good carburising properties, so that oil gas and acetylene can be used. Steel will even absorb carbon from fused cyanides.

In practice, the articles (except screws) are machined to within a few thousandths of an inch of their finished size and then carburised. Screws should be slightly undersize, since they swell slightly when quenched (see p. 62). They are then packed in charcoal and barium carbonate in iron boxes or muffles (resembling gas retorts) and heated for a few hours.

It is found that below the  $A_{c_3}$  point (say about  $870^\circ\text{C}$ .) the steel absorbs carbon very slowly, so a temperature of about  $900^\circ\text{C}$ . is necessary in order to get fairly brisk absorption of carbon. To ensure that the articles in the centre of the box or muffle reach  $900^\circ\text{C}$ . within a reasonable time, those near the outside are probably heated to over  $1,000^\circ\text{C}$ ., though possibly for a short period only. Care must be exercised that the temperature does not rise too high, otherwise we have a very sharp line of demarcation between the carburised and uncarburised portion. If this line of demarcation is very pronounced, the case (*i.e.*, the carburised portion) may shell off either when the metal is quenched or subsequently in service. Gradual transition from the case to the core is therefore to be aimed at.

But however carefully the process is carried out on the large scale, we cannot avoid crystal growth taking place during the carburising period, unless an alloy steel is used. The temperature factor may be well controlled, but the time factor is considerable. Hence, at the end of the carburising process the articles are coarsely crystalline and relatively weak. We shall see that it is possible to refine the grain of a steel by re-heating it to just over the  $A_{c_3}$  point. In case-hardened materials we have two steels and two  $A_{c_3}$  points to consider, viz., the mild steel core with  $A_{c_3}$  at about  $880^\circ\text{C}$ . and the 1 per cent. carbon case with an  $A_{c_3}$  at about  $720^\circ\text{C}$ . The procedure is as

follows : The pieces are re-heated to  $900^{\circ}$  to  $930^{\circ}$  C., *i.e.*, just above the  $Ac_3$  of the core. During the rise, the case will refine at  $720^{\circ}$  C., but coarsens again by the time the core refines. The pieces are quenched and again re-heated to approximately  $750^{\circ}$  C. to refine the case. They are then quenched to harden the case. Work which must be accurate to size is then ground up to the required dimensions. For some work it is immaterial whether we start with wrought iron or mild steel (though the latter is cheaper and easier to machine), but for most purposes steel is preferable. Thus if we make a cam of case-hardened wrought iron, pits will develop on the surface at points where the roller passes over ribbons of slag. The action is similar to the wear which occurs at the rail-joints in tramways.

Small articles can be lightly case-hardened by heating them to a good red heat and rolling them in powdered potassium ferrocyanide, re-heating and quenching. This makeshift process is frequently used in repair work, and is not entirely to be despised if its limits are recognised.

It has long been appreciated that even slight surface scratches on quite mild steel may develop into creeping cracks if the conditions are favourable. It is therefore not surprising that quenching cracks in the case not infrequently develop into creeping cracks in the core. For this reason some engineers confine the carburising to the actual wearing surfaces and avoid it at places where the bending moment reaches a maximum. The simplest method of doing this is to prevent the absorption of carbon in certain localities by a coating of copper applied by electrolytic means. In some articles it is practicable to machine off certain carburised portions before the hardening is done.

### Nickel Steels

We have already seen that when nickel is added to steel it acts as a stabiliser and retards the effect of slow

cooling. In this way we can make certain objects self-hardening.

Thus if we start with a 7 per cent. Ni and 0.12 per cent. C steel we have a pearlitic structure and a metal easily machined. If, however, we carburise the surface up to 0.9 per cent. or 1 per cent. carbon, the case will be martensitic even without quenching. The metal has good tensile properties as well as great hardness and many troubles due to water cracking and distortion are avoided. Many case-hardened articles to-day are made of steels containing about 5 per cent. of nickel. Such steels are so free from crystal growth during the carburising period that good results are obtained by one re-heat only prior to quenching.

### Nitriding

During recent years another very important process has been developed on the commercial scale. The articles to be hardened are heated to a low temperature—about 525° C. in an atmosphere of ammonia for about ninety hours. The penetration of the nitrogen is regulated by using a special steel containing a small percentage of aluminium. The advantages claimed for the process are : (1) No quenching is necessary ; (2) no coarsening of grain takes place, and hence no refining treatment is necessary ; (3) distortion and change of volume are negligible ; (4) the case is even harder than glass, so exhibits exceptional resistance to wear ; (5) less time and labour are required for final grinding to size. On the other hand the maintenance of the articles at 525° C.  $\pm$  10° C. for ninety hours requires the use of a special electrically heated receptacle provided with sensitive thermostatic control. The process is of special use in connection with gears.

## CHAPTER VI

### PRODUCTION OF STRUCTURAL STEELS

FROM time to time attempts have been made to accelerate the puddling process by performing the rabbling with tubes delivering compressed air into the metal, but without success.

#### Bessemer Steel

In the year 1856 Sir Henry Bessemer read a paper on the production of steel without fuel. We shall see that the last word but one requires some qualification. Bessemer's first converter was a fixed structure and its inconvenience led, almost immediately, to the vessel being mounted on trunnions like a cannon, one trunnion being hollow and used for the supply of air.

The vessel is built of steel plate, lined with refractory material, and provided with a detachable air-box at the base which permits the removal of the base plug and its air nozzles with comparative ease. The converter, which has a capacity from 1 to 25 tons, is turned over on its back and partially filled with molten cast iron, the air blast is turned on and the vessel raised into the vertical position so that the air bubbles up through the molten metal. The oxidation of the silicon and manganese commences immediately and for the first few minutes the action is mild in character and dense brown smoke (oxide of manganese) escapes from the mouth. During this period a marked rise in temperature takes place and then the oxidation of the carbon commences in real earnest and the action becomes fast and furious as the temperature rises still further. The temperature is so

high that carbon is burnt to carbon monoxide in the metal, and this gas produces a long roaring flame at the mouth. The flame is intensely white owing to minute particles of silica. After about twenty minutes the whole action is complete and the converter must be turned down and the blast shut off immediately the flame drops (the carbon has gone), otherwise the metal is badly oxidised. It is usual to eliminate the carbon completely and then re-carburise by means of anthracite coal or more frequently ferro-alloys: cast irons rich in manganese. Manganese additions are absolutely necessary, as in the production of crucible cast steel, to deoxidise the metal and remove red-shortness by taking charge of the sulphur (see p. 60). An oxidised steel will not produce a sound ingot because the oxide reacts with the carbon present, producing carbon monoxide, and blow-holes.

The composition and quantity of ferro-manganese depends on the desired carbon content of the steel. Thus for high carbon steels a relatively large quantity of ferro-manganese is used, somewhat low in manganese, whereas in making milder steels small quantities of rich ferro-manganese are used. The manganese is thrown into the converter and the metal is stirred by applying the blast again for a few seconds. Aluminium has proved to be one of the most efficient deoxidisers of steel known and is frequently added to the metal in the ladle, with a view to eliminating blow-holes, but manganese must be used in most steel processes to take charge of the sulphur.

The first converters were all lined with silica, an acid oxide, and hence the name "Acid Steel." The acid process does not eliminate phosphorus; in fact, the percentage of phosphorus in the steel is actually greater than in the cast iron. Hence the process is only applicable to high-grade hæmatite, low in phosphorus. We have seen that hæmatite is scarce and expensive compared with most of the phosphoric pig produced in this country.

Phosphoric pig can only be used if we form a very

basic slag by introducing lime into the converter to form calcium phosphate, but lime and silica readily combine and the lining would melt. A lining of lime is too friable, but Thomas and Gilchrist found that by using a lining composed of calcined dolomite  $x$  CaO,  $y$  MgO, satisfactory results could be obtained.

By using the basic process, steel of very low phosphorus content is easily made, and the phosphoric slag produced is a valuable fertiliser when finely ground. Since phosphorus is set free from calcium phosphate by carbon in the presence of silica at high temperatures, it is necessary to remove the slag before the metal is recarburised.

The basic Bessemer process never made any headway in this country. At the commencement it was found that the steel was of low quality and very dirty owing to the presence of non-metallic inclusions. Consequently the product got a bad name and large consumers would not accept it, so makers confined their activities to other processes. On the Continent, however, makers persevered with the process and not only mastered many technical difficulties, but were able to flood this country with cheap steel. Basic Bessemer steel possesses certain peculiarities which make it particularly suitable for the manufacture of tubes and tinplate. The undoubted advantage of it for certain trades combined with its cheapness has recently led to the installation of a large new plant near Kettering, where enormous deposits of suitable ore are located.

Pure iron melts at  $1,532^{\circ}$  C., and as the cast iron enters the converter at about  $1,300^{\circ}$  C., a rise of temperature of about  $500^{\circ}$  C. is necessary to maintain the fluidity of the metal until it is "teemed" into the ingot moulds. The combustion of the carbon in the cast iron (and carbon monoxide is chiefly formed) is quite insufficient to do this. The combustion of manganese accounts for a few heat units, but the steel-maker is mainly dependent on the heat of combustion of silicon in the acid process and

phosphorus in the basic process to produce the requisite heat. If the temperature rises too high, scrap steel may be added, and if it is too low, the addition of ferro-silicon or ferro-phosphorus during the blow is necessary.

The Bessemer process is by no means ideal. It is so rapid that very great skill in working the plant is required to produce uniform results, and there must be no hitch in the supply of molten metal and ingot moulds. The yield of steel per ton of pig iron used (about 80 per cent.) is distinctly low compared with Siemens working. Probably the worst feature of the process is its difficulty in consuming even its own scrap: rolling mill discard, crop-ends and shearings from plates, quite apart from scrap from other sources such as the ship-breakers.

The scrap question is so important that works have had to build Siemens furnaces to deal with it and sometimes the latter have entirely superseded the Bessemer.

The tendency to-day is for more and more firms to replace the Bessemer entirely for the production of steel ingots. A modification known as the Tropenas plant, in which the air impinges on the surface of the metal instead of passing through it from below, is still fairly popular for the production of small steel castings requiring a very hot and fluid metal.

We have seen that in the manufacture of wrought iron the puddling furnace produces small masses of metal, and for the production of large forgings welding was resorted to. The wrought-iron mills were for the most part small and incapable of dealing with even comparatively small Bessemer ingots. In consequence it was necessary to "cog" the early ingots down under the steam hammer till small enough in section for rolling. Now, of course, the cogging is performed more rapidly and cheaply in more powerful rolling mills. To-day a 50-ton ingot can be reduced to comparatively small billets in a few minutes in the cogging mill.

It appears likely that except for steel castings and



the duplex and triplex processes of steel-making, the acid Bessemer process will be extinct in a few years.

### Siemens Steel

The maximum temperature that it is possible to attain in a coal-fired puddling furnace is below  $1,500^{\circ}$  C., and hence at the end of the process the decarburised metal is no longer fluid, but a spongy mass. If we preheat the fuel and air to about  $800^{\circ}$  C. we might expect a furnace temperature of about  $2,200^{\circ}$  C., and although this is not actually the case, we are able to reach about  $2,000^{\circ}$  C., a temperature more than sufficient for our purpose, and which, if reached, would result in rapid destruction of the furnace by softening and fusing of the silica bricks of which it is composed.

It is not practicable to preheat solid fuel, so producer gas is used. This consists chiefly of carbon monoxide, hydrogen and methane diluted with nitrogen and some carbon dioxide. Continuous supplies of this gas are obtainable from suitable plants at a low cost compared with illuminating gas.

The temperature and economy of the Siemens furnace are dependent upon its regenerative principle. The hot products of combustion after leaving the furnace pass through two chambers packed with a chequer-work of silica bricks. These chequers attain a very high temperature in the course of about twenty minutes, after which the incoming gas and air are passed through them on their way to the furnace, where they meet. Meanwhile another pair of chequers are being heated by the products of combustion. Reversal takes place at frequent intervals. The chequers are for convenience frequently constructed below the furnace, but firms who have occasionally had one filled with liquid steel, through a leaky furnace bottom, prefer to place them elsewhere.

Fig. 16 shows a diagrammatic representation of the

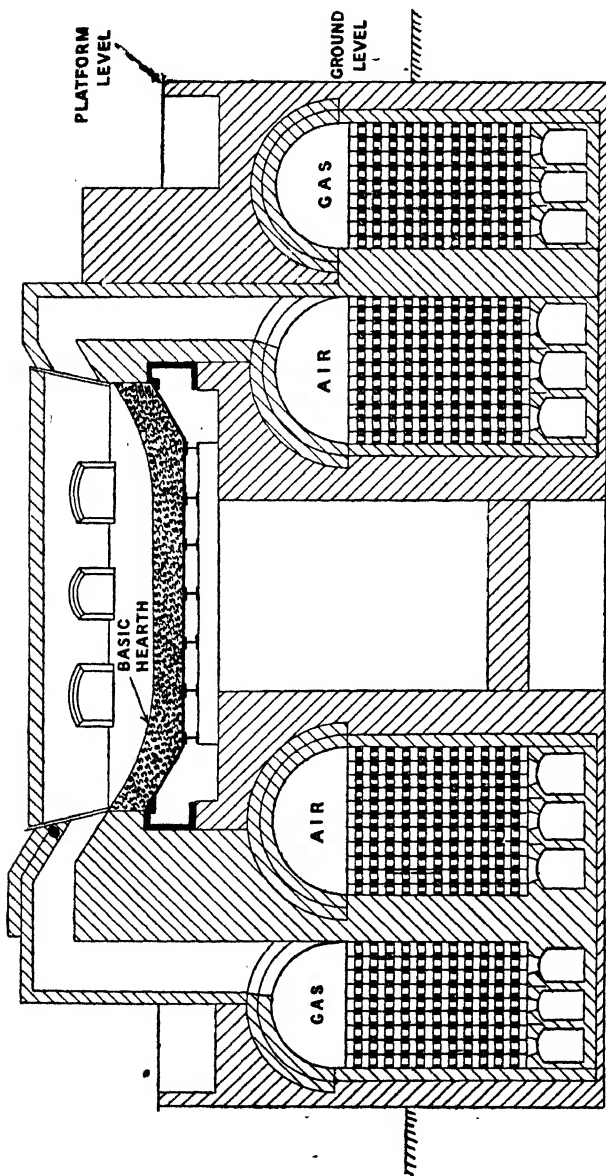

FIG. 16.—Siemens Basic Furnace: Longitudinal Section.

This furnace is provided with two gas ports and three air ports at each end. One of the former is shown at the left-hand end and one of the latter at the right-hand end. The reversing valves are in another plane and not shown.

furnace. The capacity as a rule varies from 25 to 200 tons, though the 100-ton furnace is the largest in general use in this country where qualities is preferred to quantity. Even with 100-ton furnaces various devices for casting several ingots at one time have to be used, otherwise many are cast far too hot and many far too cold.

In Siemens working it is usual to employ charges consisting of about equal quantities of pig iron and scrap steel. The scrap is charged in first and the pig above it. In some works liquid cast iron from a "mixer" fed by several blast furnaces is used instead of pig. The whole melts down into a quiet fluid, after which ferric oxide is added and the evolution of carbon monoxide causes the metal to boil gently.

From start to finish the process takes about six to seventeen hours, depending on the proportions of scrap and pig, during which time the furnaceman takes out samples, forges them on the anvil, breaks them and examines the fracture and sends them to the chemical laboratory for analysis. By prolonged experience a furnaceman can estimate the carbon and phosphorus content within exceedingly fine limits. The process can be stopped at any desired point, and a steel of any desired analysis can be obtained. The manganese is usually added to the stream of molten metal as it flows from the furnace to the ladle.

When making alloy steels the nickel pellets or cubes are added to the metal in the furnace, and the smaller the furnace, the less difficult it is to obtain uniform distribution. As in the Bessemer process, phosphorus is not eliminated except by basic working, *i.e.*, by adding lime to the charge in the furnace.

In the basic Siemens furnace only the portion in contact with the metal and slag is composed of calcined dolomite, as this material is too weak to use for the walls and roof. A neutral substance must be inserted in the junction between the acid and basic materials.

Owing to the higher price of hæmatite-pig, steel can be made more cheaply by the basic than by the acid process. Unfortunately, in this country, there has been such a prejudice against basic steel that very few large consumers would accept it, with the result that manufacturers were forced to devote most of their plant to acid working. In Germany and other countries such prejudice did not exist, and basic steel made enormous strides. The undoubted fine quality of basic steel combined with the gradual breaking down of prejudices has led to considerable increase in its use during recent years, and it will in all probability become the principal source of steel in the future.

During recent years the amount of steel scrap available for re-melting has grown considerably and the ratio of pig to scrap has been greatly reduced. This has cheapened the production of ingots but caused a good deal of unemployment in the blast furnace industry.

### Pure Ingot Iron

For certain purposes where metal of insignificant carbon and manganese content is required, a modification of the basic process is used. The phosphorus, silicon and sulphur are first worked down to a dead minimum and the temperature is raised for an hour or so. This causes some oxidation of the metal, with the result that the carbon and manganese are reduced to an exceedingly low figure. Deoxidisation after tapping is done by adding about  $1\frac{1}{2}$  lb. of aluminium per ton. Harbord quotes the following analysis for metal thus produced : C, 0.02 ; Mn, 0.02 ; S, 0.04 ; P, 0.04 ; O, 0.05 ; Fe, 99.80. In spite of the fact that the manganese was very low, the metal showed no signs of red-shortness.

### Double Processes

Several double processes have been used to a certain extent for a number of years, such as the one devised by

Talbot, in which the metal is partially treated in a basic furnace and a portion removed to an acid furnace for finishing. By this means the Siemens process becomes more continuous and it is easier to regulate the supply of hot ingots to the mills.

### Coal-Dust Furnaces

Mention has already been made on p. 37 of the use of a cylindrical rotating furnace fired with a coal-dust blowpipe using preheated air. On the Continent similar furnaces are being used for making the cheaper brands of steel, and it appears probable that their use will in time be extended on account of the low capital cost and working expenses (see Fig. 17).

### Electric Steel

In countries like Italy where water power is plentiful and coal expensive, there is plenty of scope for electric processes. In spite, however, of the relatively high cost of electricity in Britain, considerable progress has been made. In 1919 Sheffield boasted that it contained more electric furnaces than any other town in the world, and since then more have been installed. Until comparatively recently most of the electric furnaces were of the three-phase arc-tilting type, one electrode sometimes being placed in the base, with the result that eddy currents maintain a constant stirring which is very beneficial so far as uniformity of the steel is concerned. Many users, however, prefer to dispense with the base electrode, which leads to certain difficulties, and have three carbons passing down through the furnace roof. In such furnaces it is extremely easy to maintain an oxidising, neutral or reducing atmosphere at will.

More recently induction furnaces have been installed in considerable numbers. The smaller furnaces used in research laboratories are supplied with current of very



Charging.

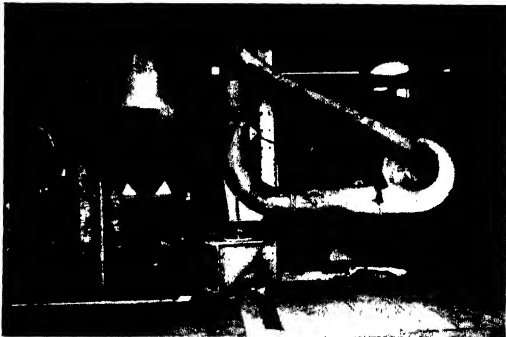

Melting.

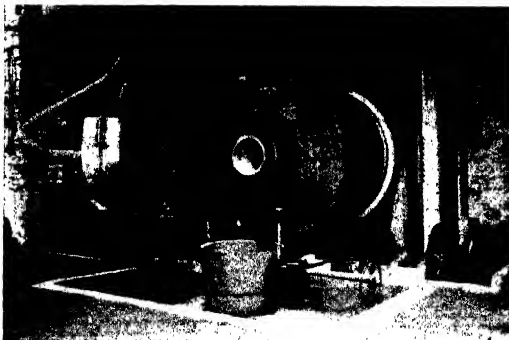

Tapping.

FIG. 17.—Brackelsberg Furnace.  
*Jas. Howden & Co. Ltd., Glasgow.*



high frequency such as 10,000 to 20,000 cycles per second, produced by spark-gap oscillators or thermionic valves. Valves for this purpose have been made to emit up to 500 kW. The larger furnaces used in steel-works employ many fewer cycles, two- and five-ton furnaces in Sheffield being supplied from motor generators at 1,000 cycles. The larger the furnace, the fewer are the cycles employed. In such furnaces there is a very rapid circulation of the metal up the centre and down the sides (or *vice versa*), so that fresh portions are continually passing under the slag which wipes away non-metallic inclusions. Another advantage of the electric furnace is that it is possible to superheat the metal at any stage to ensure the complete fusion of alloys of high melting-point and render non-metallic inclusions more fluid and more easily removed.

Not only does the electric furnace ensure clean and homogeneous steel but there is very little loss of valuable alloying elements such as chromium, molybdenum and vanadium through oxidation. The process is now used very extensively for the production of high-grade alloy steels which command a good selling price. For this purpose the electric power consumed is about 600 units per ton. If much refinement is necessary (*i.e.*, the removal of sulphur and phosphorus), the process takes longer and the current consumption is higher. A plant of moderate size, working continuously, produces a large tonnage per week owing to the short melting and refining time compared with the Siemens process. In fact there is so much in its favour that it may supersede the Siemens process in time, especially as there is a tendency to increase the ratio of scrap metal in the latter and hence use it more as a re-melting than a refining process.

### Slag and its Functions

In dealing with various processes, only casual reference has been made to the presence of slags in the furnaces



and the reader may think they are of minor importance. This is far from true, since chemical reactions in furnaces are largely dependent upon the slags. Fused metals are seldom actually in contact with the oxidising, neutral or reducing atmosphere of the furnace, but are separated by a layer of slag which is capable of carrying oxygen to or from the fused mass. Simple though the reactions in the puddling furnace appear at first sight, it is in reality a complex chemical process which has been evolved by years of practical experience. Not only must puddling slag contain sufficient silica to render it easily fusible, but the origin of the silica appears to be of some importance. Thus if the pig or refined iron which is being puddled contains less than about 0.2 per cent. of silicon, the metal is said to "work dry," and the workmen are faced with considerable difficulties.

In the Siemens process the composition of the slag controls the success or otherwise of the product. This statement should be specially emphasised in the case of the basic process, and producers of acid steel frequently, at first, experience a certain number of failures when a plant is changed over from acid to basic working.

### Clean Metals

Closely associated with the slag question is that of non-metallic inclusions in metals. Some are definitely injurious and a serious source of brittleness and weakness. Thus the presence of sulphide of iron in steel renders it "red-short," *i.e.*, unworkable at a red heat, whereas sulphide of manganese is much less injurious. In the former case many of the crystals are separated from their neighbours by their envelopes of readily fusible sulphide, which renders the mass rotten at a red heat. Manganese sulphide, on the other hand, segregates into certain localities and beyond reducing the continuity of the mass of metal, does little harm, if present in moderation. Phos-

phorus embrittles the crystals and forms local segregations, and renders the metal "cold-short." At first sight it would appear desirable that metals should be entirely free from oxides and silicates, as they reduce the continuity of the metallic mass and are consequently a source of weakness and poor flexibility and ductility. This is far from the truth. We have already seen that the presence of ribbons of slag (ferrous silicate) in wrought iron confer upon it valuable characteristics, one of which is that it checks crystal growth at a welding heat. In the manufacture of tungsten wire for the filaments of electric lamps it has been found necessary to introduce a non-metallic ingredient, thorium oxide, otherwise the tungsten crystals grow to an excessive size and rolling and wire drawing become impossible. In this case the oxide acts as a barrier and prevents one crystal absorbing its neighbour.

It has now been definitely established that there is a limit to which it is desirable to cleanse liquid steel and certain other metals for many purposes.

It is common knowledge that the frequent black fogs in certain cities are due to the condensation of moisture on particles of soot, and without particles of soot and grit in the atmosphere, fogs would be somewhat rare. When liquid steel cools in a mould, every particle of impurity forms a nucleus for the birth of a crystal. If the particles are few and far between, each crystal has plenty of room to grow before it meets another and under such conditions the whole mass would be composed of comparatively few very large crystals. This would prove extremely inconvenient in a steel casting which has to undergo thermal refinement of grain, since a very coarse structure is very difficult to break up and *tends* to remain permanent. Some steel-makers object to the use of aluminium as a deoxidiser because particles of aluminium oxide are found in the finished product. But while these particles do undoubtedly interfere with the con-

tinuity of the crystal aggregate to a certain extent, their presence increases the number of centres of crystallisation and the casting leaves the mould in a finer state.

One of the problems before the metallurgist is therefore to discover some means of increasing the number of centres of crystallisation without producing dirty steel.

Ironfounders who use the semi-steel process are aware that if the mixture is superheated in a coal-dust furnace and then cooled down to a suitable casting temperature, the resultant casting is not only fine grained but the graphite separates out in a very fine state of division. In fact, the result somewhat resembles that of adding nickel to the charge. At first sight one might attribute this to almost ultra-microscopic particles of grit entering the metal from the ash of the coal dust and forming nuclei for crystallisation, but this is questionable since superheating combined with rapid motion of the metal in an electric furnace has the same effect. Superheating in a cupola is impracticable on account of the high fuel consumption and the oxidation which take place, but semi-steel mixtures give a very fine grain and graphite, if calcium silicide is added to the metal as it flows from the cupola. This process is the basis of the Mehanite patents.

We have still much to learn before we can give a definite explanation of every case of what is known as heredity in metals, especially in cast irons, but it appears possible that it will be found that ultra-microscopic particles which are not removed during remelting are the cause. It is only within recent years that a satisfactory explanation has been found to account for the ageing effects in certain aluminium alloys.

### Steel Ingots

In both the Siemens and Bessemer processes the steel is covered by a layer of slag, and separation is a simple

matter. In the case of the acid Bessemer the slag is sometimes thickened by the addition of sand just before teeming, so that it remains in the converter until the more liquid steel has been run off. Any slag which through accident passes into the ladle usually floats to the surface.

Melted cast iron is invariably *poured* over the lip of the ladle, but steel is invariably "*teemed*" through nozzles in the base provided with valves and gear for manipulating them. Hence no slag should pass into the ingot moulds. As a rule ingot moulds are of rectangular cross-section with rounded corners and somewhat larger at the bottom than at the top. They rest on heavy cast-iron slabs, and if free from internal crevices can be removed from the ingots when the latter are partially solid. Any ingots which stick are removed by a hydraulic press. As soon as the ingots are sufficiently solid to bear handling, the moulds are lifted off and they are conveyed to soaking pits. These are brick-lined pits formed in the floor and provided with covers. Sometimes they are heated by gas flames, but frequently no external source of heat is employed. By their use gradual solidification right through to the centre is obtained without the exterior portion becoming unduly chilled. They *tend* to equalise the irregularities in composition of the various portions of ingots.

Every ingot is partly unsound. The metal, in cooling, shrinks, and a cavity is formed at the top, and this frequently extends some way down into the centre. Various devices are used to prevent deep "*piping*." Thus, by lining the top of the mould with silica bricks, the metal is not cooled so rapidly and the pipe is partially filled with liquid metal from above. In some works the rapid cooling of the surface of the ingot is checked by means of a gas blowpipe. Various other devices depending on the lateral compression of the hot ingot have been used, including the Talbot process which consists of

commencing the rolling-down operation while the centre is still more or less liquid.

If the steel were chemically pure, certain difficulties would not arise, but it always contains a percentage of material of low melting-point such as the iron-iron phosphide eutectic which solidifies at about 950° C. These easily fusible ingredients tend to collect in the centre whither they are pushed by the solidifying metal. Some subsequent redistribution by diffusion does, however, take place.

Experiments by Brearley have confirmed the opinion that more perfect ingots can be obtained by using ingot moulds which are comparatively small and massive near the base, and lighter and larger at the top. These accelerate cooling down below, and retard cooling and solidification near the top. They are less convenient than the older form. Large ingots of high and uniform quality are more difficult to make than small ones, and require more powerful mills. On the other hand, if the cast of steel is large and the moulds are small, it is impossible to fill them all with metal, some of which is not too hot or too cold. Even when the ingots are large it is customary to use "tun-dishes," *i.e.*, long troughs resting on several moulds with openings into each, by which means about six moulds can be filled at one time. Sometimes "bottom-poured" ingots are made by using a central runner connected to the bases of six or eight moulds. This system avoids splashing and is very expensive in material and labour, but is considered justifiable when making comparatively costly nickel-chrome steels. The process is by no means free from the objectionable passage of fire-brick particles into the ingots.

Apart from piping and segregation, other troubles occur in the production of ingots. Although the metal is very hot for a long period, large ingots are subject to considerable internal stress through the comparative rigidity of the outside.

It has been found in practice that an ingot with cross-section, shown in Fig. 18, B, is less likely to crack when forged in the press, than one shaped as at A.

When ingots are intended for forging without preliminary rolling they are frequently provided with necks like bottles which facilitate handling by means of the "porter

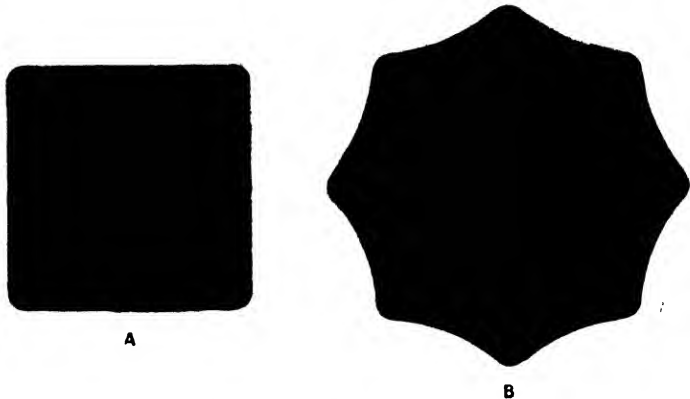

FIG. 18.—Shapes of Ingots.

bar," the equivalent of the smith's tongs. In view of the fact that from 10 to 20 per cent. of the upper portion of every steel ingot is composed of piped material and an excess of impurities, this results in what is termed "discard."

In the case of small tool-steel ingots they are topped before forging or rolling down, but this is not practicable in the case of large ingots of ductile steel without special plant. Hence large ingots are usually "broken down," *i.e.*, partially rolled in a powerful cogging mill and then sufficient discard is removed by shearing off billets of convenient size for remelting.

### Rolling Operations

The reader is referred to such works as "The Metallurgy of Steel" by Harbord and Hall for full details of rolling-

mill practice. The mills used may be divided into two main types, viz., cogging and finishing.

Cogging is the term used for the first rolling process applied to ingots. The mills are powerful and the reduction of thickness per pass is very considerable. Heavy reductions per pass are very desirable, since they result in the centre as well as the outside receiving sufficient mechanical work to break up the coarsely crystalline structure and produce fine-grained material. The rolls of cogging mills are frequently roughened by longitudinal grooves on their surfaces, so that they may obtain a good grip of the ingot when accepting it and during its passage between them. Without such roughening of the surfaces, the rolls may slip if a big reduction of cross-section of the ingot per pass is aimed at.

The cogged material is usually cut up into shorter lengths before passing it on to the finishing rolls which are either plain for plates or grooved for sections. If the steel is required for making small hammer forgings such as locomotive connecting rods, the cogged material is cut up into billets of convenient length and sold in billet form. In plate rolling, the mill will always accept the plate, as the reduction in thickness per pass is somewhat limited on account of the width dealt with. The question whether the mill can deal with the plate after accepting it is really a question of temperature. A relatively cold plate of course requires a very great expenditure of power.

The design of a set of grooved rolls calls for a good deal of care and experience, especially when certain sections are required, such as wide and shallow rolled-steel joists; in the production of such sections the transition from the rectangular cross-section to one of **I** form must be brought about in a series of intermediate stages determinable only by experience.

Material which has been rolled at the correct temperature possesses a fine-grained structure and is almost

entirely free from internal stresses. If cooled under average conditions, it answers the description of normal steel.

### Cold Rolling

For many purposes steels possessing a bright finish and considerable accuracy of dimensions prove extremely useful. They are prepared by removing the rolling-mill scale from "black" bars by means of dilute sulphuric acid, and then passing them through mills with highly polished and carefully adjusted rolls. For the most part the process may be regarded as one which converts the uneven, somewhat pitted surface of the metal into a very nearly flat one, but this results in a stiffening effect, accompanied by a rise in yield-point and falling off in ductility. In certain cases this stiffening effect may be of considerable utility, so the process is continued beyond the point necessary to produce the requisite surface. In other cases increase in hardness and loss of ductility are disadvantages and must be eliminated subsequently by heat treatment.

### Cold Drawing

This process, though chiefly used in the manufacture of wire, is largely used for other sections, such as squares up to 2 in. The only difference in the process as applied to long-wires and short rods is the method of applying the pull.

The black material from the rolling mill is pickled in acid to remove scale and the end is reduced in size by forging or a special machine.

The "draw-plate" is a die composed of hardened steel provided with a number of holes each varying in size by a few thousandths of an inch. The reduced end of the material to be drawn is passed through the largest hole in the draw-plate and attached to a rotating drum or gripped by a pair of tongs which travel along the bench. A copious supply of lubricant is applied to the wire or bar



behind the draw-plate. After one draught the material is drawn through the next smaller hole, and so on.

Just as in cold rolling, the material becomes stiffer, harder and more brittle, so there is a limit to the number of consecutive draughts which are possible without normalising. During their production, fine wires may require normalising several times before the required diameter is obtained. In the case of fine copper wires used for electric "flex," steel draw-plates, towards the end of the process, are replaced by diamonds. The normalising of copper wire is performed in an atmosphere of steam which prevents oxidation.

In the case of drawn rods it is found that the effect of cold drawing is chiefly confined to the surface.\*

Two aspects of wire drawing should be noticed. In the case of fine flex wire the copper leaves the rolling mill with a diameter of  $\frac{1}{8}$  in. and not quite circular, and the process is used to produce soft wires of small diameter. On the other hand, in the case of high tensile wire, we start with a fairly high tensile steel of about 50 tons breaking load and fair ductility, and by a process of wire-drawing produce a material with a tensile strength of about 200 tons per square inch, but very low ductility.

Not only is drawing applicable to soft materials, but is applied to tool-steels of various grades. The commercial "Silver Steel" is an example of this. Needless to say, the word "Silver" is only a trade term, and the steel does not contain any of that metal.

Though the smaller sizes of twist drills are usually carbon steel, high-speed steel is frequently drawn for the purpose. It is highly important that steel used for drawing should be free from segregation of impurities, otherwise there is a tendency for the centre of the bar or wire to break at frequent intervals with a cup and cone fracture. This phenomenon is spoken of as "cupping" in bars and wires.

\* See Taylor and Quinney : *Jour. Inst. Metals*, 1932.

### Reeling

All hot-rolled and cold-drawn bars are more or less bent at the end of the process and have to be straightened by one or other mechanical means. Round bars, especially of wrought iron, frequently leave the grooved rolls after the last pass in a distinctly oval condition.

For many purposes, such as material in long pieces to supply automatic lathes, it is very important that it should not only be straight but reasonably circular for chucking. The desired result is obtained by passing the cold bars through a mill of special form. One roll is slightly convex, and the other is slightly concave, and their axes are not parallel to one another. If the machine is simply used for straightening bent bars it produces little change in the physical character of the metal, but if it is used for rounding up very oval bars and giving them a smooth attractive finish, the result is similar to that produced by other cold-rolling or drawing processes. Obviously, reeling is only applicable to circular sections, and others have to be dealt with in a "mangle." This machine differs from the domestic form in having four or six pairs of rolls arranged in series in massive housings, and the cold distorted plate is acted upon by all the rolls at once.

•

### Steel Castings

A large volume might be devoted to the subject of steel castings, but a few outstanding points are of importance to the engineer. Compared with iron-founding, steel-founding is a very difficult and costly process. The melting-point of steel is so high that difficulties from this cause arise. The actual melting is costly, and special refractory and porous sands are required. As the best natural sands for this purpose do not appear to exist in Britain, some founders import foreign sands, while others prepare synthetic sands by mixing a small quantity of refractory clay with non-binding silica

sands. Whereas in iron-founding green-sand moulds are chiefly used, steel is almost invariably cast in moulds which are bone dry after being stoved. The freezing contraction of steel is so great, and the metal is so weak just below its freezing-point, that many castings are liable to be torn asunder in the moulds unless the latter are capable of "giving." If the sand is capable of giving, it is liable to be disturbed by the streams of molten metal or distorted by the ferrostatic pressure. Steel castings require large feeding heads and risers, and the removal and remelting of these involve considerable expense. The metal cut off and remelted averages about 25 per cent. of what is poured. Dressing the castings to remove fins, etc., after they leave the moulds, involves much time and labour. Since the castings are all in a coarsely crystalline condition they have to be normalised before use and this operation involves further expense in fuel, labour and furnace maintenance. During the normalising process it is essential that the heating should be rather rapid between the temperatures 600° and 700°C., otherwise further segregation will occur between these temperatures and the complete solution of the ferrite in the austenite at about 900°C. will not occur under works conditions. Great technical skill is required to prevent the formation of blow-holes, and non-metallic inclusions are a great source of trouble and weakness, unless every possible effort is made to produce a really clean liquid steel.

Owing to the great advances in technique in recent years, the products of the steel foundry have improved enormously and they are now being used for many purposes for which, a few years ago, forgings would have been specified. For certain intricate work like locomotive wheels they have for a long time superseded costly forgings, but for small articles required in very large numbers, such as spanners, they cannot compete with drop forgings.

## CHAPTER VII

### PRODUCTION OF FORGINGS

THE heating of comparatively large masses of steel preparatory to forging calls for a good deal of care and experience, for successful production depends not only on the temperature of the outside but on the rate at which heat can travel inwards and also upon the temperature at which forging ceases.

Some years ago the writer witnessed a really bad system of heating applied to billets which were being heated for drop forging. The furnace was small and the cold billets were placed directly in the flame of an oil blowpipe, with the result that their surfaces were up to a welding heat before the centres had become soft, like half-cooked potatoes. Further heating to soften the centres meant that the surfaces reached the point of incipient fusion and were burnt. Tests on the forgings produced showed that the metal left the dies in a very coarsely crystalline condition, the yield-point and elongation and contraction of area being all very much below normal.

To-day many firms are using long furnaces so arranged that the cold billets enter at the end where the temperature is low and are pushed along at regular intervals until they finally arrive at the hottest part, where they are withdrawn. Not only does this method produce a good condition of heating, but there is a decided economy in fuel, since the cold billets are capable of absorbing much heat from the products of combustion just before they pass up the chimney.

The final temperature it is necessary to attain depends partly on the material and partly on the forging process.

Thus some of the alloy steels are so stiff at a bright red heat that good reliable forgings can only be produced at a yellow heat. Again, in drop forging work a yellow heat is necessary, otherwise the metal is not sufficiently plastic to flow into all the angles of the dies. In general, it may be said that while it is necessary for the metal to become sufficiently plastic to undergo change of shape without the mass being left in a state of internal stress, the temperature should be no greater than necessary, otherwise the forging will be coarse-grained in structure, especially if the work put into it is comparatively small. With regard to the lower temperature at which work on the billet should cease, forging of carbon steels should be stopped some time before the red disappears, *i.e.*, before the metal ceases to be really plastic.

Welding unfortunately requires such a high temperature that crystal growth during the heating period is inevitable. It is therefore important that the scarves should be of such ample section as to allow for a considerable amount of mechanical work being done on the metal after the weld is closed to refine the grain as the temperature falls. Experienced smiths reheat their welds to about 900° C. in order to complete the refining process. In the case of chains made from round bar iron, it is usually impracticable to do much refining by hammering, so special attention should be paid to the question of heat treatment. When a tie-bar breaks outside the weld, it is an indication that the smith who handled the job allowed crystal growth to extend beyond the thickened-up portions through careless heating. There is little doubt that the presence of slag in wrought iron checks crystal growth to some extent.

The cheapest form of forging is that produced by the cogging mill, which is capable of reducing a coarsely crystalline ingot into billets of convenient size, and fine grain very rapidly. The use of the rolling mill is, however, restricted to the production of bars, sections, rails and



FIG. 19.—Defective Hammer Forgings (E. F. Lake).



plates. For many other purposes it is necessary to resort to the hammer or press. Where the work is small the steam hammer is quite satisfactory, especially if working upon a well-cogged billet, but for larger work, especially in connection with the production of forgings direct from the ingot as in the manufacture of locomotive cranks, the press produces not only a cheaper, but a very much superior article (see Frontispiece). To-day many metallurgists and engineers consider the 3-ton steam hammer is the largest which it is desirable to use, and above that limit the press possesses every advantage, not only in output, but in cost and quality. Large hammers up to 100 tons and over have been used in the past, but such giants have long since been scrapped.

From the metallurgical point of view the chief objection to the hammer is that, on large work, only the surface is properly forged and no deep internal refinement is accomplished, with the result that the forging is weak. Fig. 19,\* representing large shafts produced under the hammer in America and which broke after a comparatively short period of service, serves to illustrate this point very clearly. As a result of a large number of tests of gun forgings produced by both hammer and press, the writer is more than convinced regarding the superiority of press forgings. Large hammers apparently produce an objectionable shearing action in harder steels, and the detrimental effects of this appear in many cases to be extremely difficult if not impossible to eliminate, even by repeated heat treatments.

Steel is usually regarded as a homogeneous material, but this is far from the truth, as shown by sulphur prints and surface tests for phosphorus. There is no doubt that in steel we must recognise, as a result of the impurities it contains, a definite grain phenomenon (resembling the grain in wood) running in the direction of the

\* From "Composition and Heat Treatment of Steel," by E. F. Lake (McGraw-Hill).



flow of metal caused by action of the press or rolling mill.

Careful experiments have demonstrated that in order to produce a perfectly reliable crank for an aero engine it is necessary to conduct the operations of forging in such a way that the grain (segregations of impurities) exhibits a stream-like path from journal to web, from web to pin, and so forth, as shown in Fig. 20.

Occasionally in forging operations thicker portions are produced by setting up, as, for example, in the case of longitudinal stays for boilers and in the manufacture of black bolts and rivets. The action of setting up may or

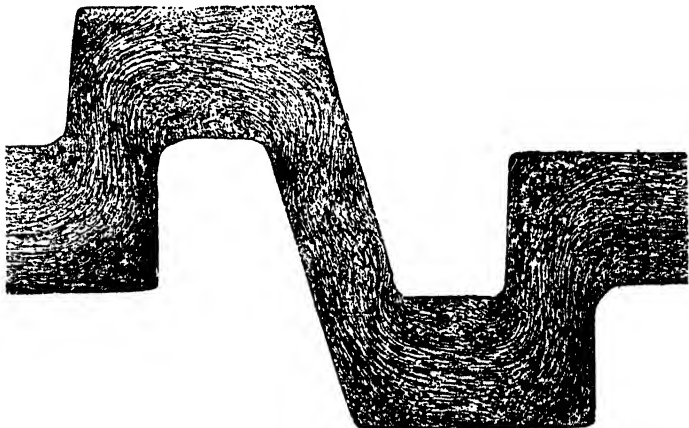

FIG. 20.—Aero Engine-Crank (Vickers Ltd.).

may not result in considerable turbulence of grain, and when turbulence does occur, weakness is the result. For this reason the valves of internal combustion engines are very much more reliable when produced by drawing down a thick bar instead of setting up a thin one, unless a very pure steel is used. It is quite possible that some of the good and bad features of forgings produced by different methods may be attributed to the actual movement of iron phosphide during the operation. The iron-iron

phosphide eutectic becomes fluid at about 950°C, and therefore, if forging is commenced at 1,150°C, it is easy to see that the liquid is squeezed about from place to place by the crystals as forging proceeds. That movement of this sort does occur is demonstrated by the fact that a shell forging made in a press was found to have a higher concentration of phosphorus near the outer surface. Stead, years ago, showed that the phenomenon of burning of steel was largely accounted for by the unaided movement of iron phosphide at very high temperatures.

In the production of certain important components such as tie-bars with enlarged ends, we have three alternatives. We can weld on pieces of steel of larger cross-section, but a particle of some sulphurous impurity in the fuel may cause a serious unseen defect in the joint. The rods may be set up at the ends while hot by hydraulic pressure, but this is accompanied by an element of risk of greatly reduced strength owing to turbulence. By far the most reliable tie-bar is the one produced by careful drawing down, but the operation is slightly more costly if the length of the bar is great.

It so happens that the process of drawing down in the production of most important forgings combines as a rule cheapness of production with what we may term ideal stream-line structure. Hooks should always be formed from bent material, and should not be stamped from rolled slabs (see p. 19 and Fig. 5).

From the point of view of the products of the rolling mill, the presence of piping in the ingot is highly objectionable, and even a comparatively shallow pipe results in a considerable amount of discard. Since conditions which produce deep piping also produce extensive segregation of sulphur and phosphorus in the same neighbourhood, it would appear that for the purposes of making certain hollow forgings such as guns, hollow shafts and railway tyres which are produced from trepanned ingots, there is much to be said in favour of piping and the concentration

of the impurities in the portion which is to be removed before forging is commenced.

Methods of mass production and the desire of some workmen to turn out their work with an attractive terra-cotta coloured surface frequently results in forgings being hammered at a temperature far below that at which they are plastic. The result is that the finished forging is in a state of internal stress, and possibly actually damaged. Most workmen know that steel is exceedingly brittle when at a blue heat, and yet they think nothing of giving, say, a finished connecting rod a tap or two of the steam hammer to straighten it, although it is at this dangerous temperature. Such an act may cause a deep incipient crack, which, passing unnoticed, may at some future time result in a serious accident.

The question as to whether finished forgings are subsequently to undergo heat treatment depends upon the purpose for which they are intended. Important drop forgings which leave the dies at a yellow heat should always be normalised before being put into service, so that the crystal grain may be refined. Certain other forgings, such as railway axles, are invariably re-heated, quenched and tempered.

## CHAPTER VIII

### ALLOY STEELS

WE have already noted that by adding suitable alloying elements to steels we can confer upon them special properties such as red-hardness in the case of high-speed steel, and resistance to corrosion in the case of stainless steel. There are, however, a number of properties in alloy steels of other compositions which prove exceedingly useful to the engineer. The following brief list, which is capable of great extension, shows some other advantages which alloy steels possess compared with simple carbon steels :—

Increased uniformity of physical properties in large masses.

Increased strength without loss of toughness.

Increased hardness combined with toughness.

Increased life under alternating stresses.

Less reduction in strength at elevated temperatures.

Increased or reduced electrical conductivity.

Increased or reduced magnetic permeability.

Reduced magnetic hysteresis losses.

Diminution of coefficient of expansion, etc., etc.

Within the scope of this volume it is not possible to do more than give the briefest outline of the subject.

Dead soft mild steel combines comparative weakness with considerable ductility. Increase of carbon enables us to increase the strength and hardness of steel, but at the expense of ductility and toughness. For most purposes a suitable carbon steel subjected to some particular heat treatment gives us a satisfactory material at the lowest possible cost, but modern engineering

practice demands a better material for some purposes, and the extra cost is entirely justified. For example, the reduction in tonnage of material more than justifies the use of nickel steels in the production of long span girder bridges. By making the gears of a high-powered vehicle from alloy steel, the reduction in weight under this heading may amount to 75 per cent., since smaller wheels with thinner and narrower teeth are capable of transmitting the same power.

For many purposes comparatively large masses of metal require quenching, and though moderate uniformity is obtainable with hollow forgings dipped vertically, the same does not apply to solid masses. From what has already been written, the reader will easily understand that when a large mass of carbon steel is plunged into a liquid, the outside only is appreciably affected and the internal portion cools very gradually by conduction to the exterior. Under such circumstances the outside only benefits from quenching, and the interior undergoes undesirable transformations, which are a source of weakness. On the other hand, if we introduce certain alloying elements such as nickel and manganese which act as brakes, we are able to prevent these internal transformations taking place, with the result that we obtain greater uniformity of structure and physical properties right through to the centre. For example, it is found that if massive ribbed slabs of steel containing 14 per cent. of manganese (used in rock-crushing machinery) are quenched, we obtain, in spite of the relatively slow cooling, an austenitic structure throughout, and the metal is soft, ductile and tough. When, however, the surface is disturbed by abrasion, it becomes so hard that no file or drill will touch it. This effect is only skin deep, but continues progressively with further disturbance of the surface. During recent years alloy steels containing nickel have been adopted by certain firms for cold chisels. The steel is so soft after heat treatment that

the cutting edges are simply filed up, but the first blow of the hammer is sufficient to induce the necessary hardness in it to maintain a perfect cutting edge.

If we compare two large forgings, one of carbon steel and the other of nickel steel, we find very little to choose between them as forged. After heat treatment it will be found that not only does the nickel steel show greater strength (as measured by its yield-point) and toughness, but almost every layer from the outside to the centre exhibits the same physical properties. We can therefore say definitely that not only are small pieces of nickel steel rendered very strong and tough by heat treatment, but the uniformity of large masses is incomparably better than simple carbon steels. Apart from the relative brittleness of high carbon steels, compared with nickel steels of the same yield-point, there is another factor in favour of the latter for long span bridges, viz., the comparative ease with which they are rolled, owing to their superior plasticity when hot.

Modern chemical plants, such as those used in the manufacture of synthetic ammonia, call for steels capable of maintaining considerable strength at elevated temperatures and without deterioration. Though this problem cannot be regarded as entirely solved, a good deal of success has been obtained by the use of a steel containing about 18 per cent. nickel and 8 per cent. chromium. Similar problems occur in other industries, such as the production of punches for piercing relatively long and hot billets preparatory to making seamless steel tubes. Obviously such punches, if made of tempered carbon steels, would soften rapidly and buckle, so an alloy steel containing nickel and chromium or some other stabilising material is necessary.

\* We have already discussed the properties of red-hardness under high-speed steel.

Modern ball bearings demand a material which combines intense hardness and toughness with the minimum risk of

cracking during treatment. For this purpose it is found that a relatively high chromium content is desirable.

It should be noted that apart from reduction of weight and increased strength, alloy steels possess another advantage. During the production of case-hardened material and drop forgings, etc., the crystal growth which occurs requires subsequent attention and treatment. Since, however, crystal growth in alloy steels is much less vigorous, the subsequent treatment becomes extremely simple and certain.

The reader must realise that whereas low carbon steels are used in the normalised condition, alloy steels are always used after some special heat treatment. Certain carbon-steel products such as straight railway axles are quenched in oil and tempered. The carbon content of such forgings is about 0.3 per cent.

It should be noted that the strength of steel is now, as a rule, based on the yield-point, and whereas in mild steels the yield stress is about 50 per cent. of the breaking stress, this ratio increases with the quantity of carbon and other alloying elements added. Further, that whereas the toughness of carbon steels falls with the rise in yield-point, this is not so noticeable in the case of alloy steels. Hence we see that alloy steels combine great strength owing to their high yield-point and at the same time great toughness as measured by their large contractions of area and high Izod figures. In order to emphasise this point, we may compare a 40-ton carbon steel with a 3 per cent. nickel steel and obtain figures such as the following :—

Steel	Yield	Ultimate	Elongation	Reduction in area
Carbon	23 tons	45 tons	20 per cent.	20 per cent.
3 per cent. Nickel.	33 „	50 „	22 „	50 „

From the above it will be noted that, so far as the breaking load and elongation are concerned (figures of secondary importance), there is not very much to choose between them, certainly not enough to justify the increased expense. On the other hand, the comparative figures for the yield-points and reductions of area show the enormous superiority of nickel steel as regards both strength and toughness. With small sections of carbon steel it is possible to improve their properties by heat treatment, but as we have already seen, the satisfactory heat treatment of large masses of carbon steel free from other alloying elements presents insuperable difficulties.

British steel-makers are always willing to advise their customers as to the most suitable material to use for a given purpose, and they are prepared to back their opinions by figures obtained in their own and other research laboratories. Unless, however, the purchaser is prepared to exercise the closest control over all heat treatments carried out in his own works, he will not only get inferior results, but will waste his money on the purchase of relatively expensive material. Some manufacturers purchase alloy steel bars already heat treated by the steel-maker for use in their machine shops. Some purchase billets for forging in their own works, and subsequently return the forgings to the steel-maker for heat treatment. This is practicable in a town like Sheffield, but not in other districts far away from the steel-maker, because of the cost and delay involved in transport. Though this procedure guarantees ideal final heat treatment, it does not prevent the forgers ruining the material by careless heating or doing the mechanical work at too high or too low temperatures. Hence the necessity for very strict thermal control from start to finish. Though startling figures are obtainable with certain steels, difficulty of handling them within very close limits of temperature or in the machine shop may detract from their usefulness under works conditions, and



it may be better to use a material of somewhat inferior mechanical properties with a view to obtaining greater uniformity of product, and hence reliability or lower machining costs.

It is impossible to give a comprehensive list of the alloy steels in everyday use, but a few typical examples will serve to indicate, in a general way, the sort of material one would use for certain machine components which call for mechanical properties outside the capacity of mild or medium carbon steel. Two carbon steels are given so that the reader may compare them with the alloy steels. The steels quoted are commercial steels, used in large quantities, and not freaks.

### 30-TON CARBON STEEL

Mild Steel for General Engineering purposes

#### *Analysis*

C.	Si. (Max.)	Mn.	S. (Max.)	P. (Max.)
0.28-0.40	0.30	0.45-0.80	0.05	0.05

*Mechanical Properties Normalised at 850° C.*

Yield stress, tons per sq. in., 15/20.

Ultimate tensile stress, tons per sq. in., 30/40.

Elongation, per cent., 25.

Reduction of area, per cent., 45.

### 40-TON CARBON STEEL

Medium Steel for General Engineering purposes where  
Higher Tensile stress is required

#### *Analysis*

C.	Si. (Max.)	Mn.	S. (Max.)	P. (Max.)
0.45-0.55	0.30	0.50-0.70	0.05	0.05

*Mechanical Properties Normalised at 850° C.*

Yield stress, tons per sq. in., 20/25.

Ultimate tensile stress, tons per sq. in., 40/50.

Elongation, per cent., 20.

Reduction of area, per cent., 40.

## 3 PER CENT. NICKEL STEEL

For parts subjected to torsion, shock and bending, for such parts as Valves, Propeller Shafts, Gear Shafts, Connecting Rods, etc. Hardened by oil quenching at 850° C. Tempered at 630° C., and cooled in air.

*Analysis*

C.	Si. (Max.)	Mn.	S (Max.)	P. (Max.)	Ni.
0.28-0.40	0.30	0.50-0.80	0.05	0.05	2.75-3.25

*Mechanical Properties*

Yield stress, tons per sq. in., 28/36.

Ultimate tensile stress, tons per sq. in., 45/55.

Elongation, per cent., 22.

Reduction of area, per cent., 50.

Izod impact, foot-pounds, 40.

## NICKEL-CHROME STEEL

For high duty work in Aeroplanes, Motor Cars and Lorries, for such parts as Crank Shafts, Propeller Shafts, Connecting Rods, Front Axles, etc. Hardened by oil quenching at 830° C. Tempered at 660° C., followed by quenching in oil or water.

*Analysis*

C.	Si. (Max.)	Mn.	S. (Max.)	P. (Max.)	Ni.	Cr.
0.28-0.34	0.30	0.45-0.70	0.05	0.05	3.0-3.75	0.50-1.0

*Mechanical Properties*

Yield stress, tons per sq. in., 41/49.

Ultimate tensile stress, tons per sq. in., 55/65.

Elongation, per cent., 20.

Reduction of area, per cent., 50.

Izod impact, foot-pounds, 40.

## NICKEL-CHROME STEEL

(with Alloys)

For the very highest duty work for Aero Engines and Racing Cars, for such parts as Crank Shafts, Propeller Shafts, Rear Axles, Gear-box Shafts, Connecting Rods, etc. Hardened by oil quenching at 850° C. Tempered at 610° to 620° C.

*Analysis*

C.	Si. (Max.)	Mn.	S. (Max.)	P. (Max.)	Ni.	Cr.	V. (Max.)	Mo. (Max.)
0.20-0.30	0.30	0.35-0.65	0.035	0.035	2.75-3.5	1.0-1.4	0.25	0.65

*Mechanical Properties*

Yield stress, tons per sq. in., 52/60.

Ultimate tensile stress, tons per sq. in., 65/75.

Elongation, per cent., 17.

Reduction of area, per cent., 40.

Izod impact, foot-pounds, 35.

## AIR-HARDENING GEAR STEEL

For Gears, Driving Pinions, Timing Wheels, Crown Wheels, owing to its great strength and its resistance to shock, also to its freedom from warping and distortion in hardening, it is much to be preferred to case-hardening steels. Hardened by heating to 810° C., followed by cooling in air. Tempered at 250° C., and cooled in air.

*Analysis*

C.	Si. (Max.)	Mn.	S. (Max.)	P. (Max.)	Ni.	Cr.
0.25-0.32	0.30	0.35-0.60	0.035	0.035	4.0-4.5	1.00-1.50

*Mechanical Properties*

Yield stress, tons per sq. in., 85/110.

Ultimate tensile stress, tons per sq. in., 100/130.

Elongation, per cent., 16/8.

Reduction of area, per cent., 20.

Izod impact, foot-pounds, 20/10.

Brinell hardness, minimum, 444 (2.90 mm.).

## CHAPTER IX

### THERMAL CHANGES IN METALS

SINCE the temperatures involved in metallurgical operations as a rule exceed the range of the mercury thermometer, other means of measuring them must be adopted.

**The Thermo-Couple.**—If we make a closed circuit of two dissimilar metals in series, keeping one junction at constant temperature and raise the temperature of the other, a weak electric current passes round the circuit, and this may be measured by means of a galvanometer. It is found that the current flowing, and hence the deflection of the instrument, is a function of the temperature. This enables us to determine relatively high temperatures if suitable dissimilar metals are used. Thus with a thermo-couple composed of wires of platinum and platinum-rhodium alloy respectively, temperatures up to  $1,600^{\circ}$  C. may be determined very accurately. For measuring the temperatures of large masses of metal in enclosed furnaces, the Féry radiation pyrometer is more suitable. In this instrument the radiation from a portion of the heated mass is reflected by means of a concave mirror on to a thermo-couple placed at the focus. At first sight it would appear that the distance of the mirror from the object would have a great influence on the readings, but within reasonable limits this is not so. The instrument is constructed so that the image of the hot body is considerably larger than the thermo-couple and that the radiation on to the couple is more concentrated when the distance is great. This instrument enables us to determine much higher temperatures.

In the Wanner pyrometer the temperature of a hot body

in a furnace is estimated by comparing its colour with that of an electric lamp. Certain rays from each source are selected by a form of polariscope, the dial of which is graduated in degrees Centigrade.

The platinum resistance pyrometer is based on the fact that the increase of resistance of a platinum wire is a function of the temperature. This instrument is limited to temperatures below  $1,600^{\circ}\text{C.}$ , and is only reliable at still lower temperatures if the surrounding atmosphere contains hydrogen or other gases which are absorbed by platinum and change its resistance.

The reader will find full particulars of pyrometric methods in such books as Woodward's "Metallography of Steel and Cast Iron."

In some industries an estimate of furnace temperatures is obtained by introducing small quantities of various materials of known fusing points. In forge practice the state of the scale on steel is a rough and ready means of judging the temperature. Thus if the scale shells off when the billet is worked, the temperature is below  $1,000^{\circ}\text{C.}$  If the scale is sticky, the temperature is in the neighbourhood of  $1,200^{\circ}\text{C.}$  On the other hand, if the scale is fluid and the billet looks "oily," the temperature exceeds  $1,300^{\circ}\text{C.}$ , and for many operations the metal has been made too hot.

Until means of measuring and recording temperatures were provided, metallurgists were confronted with insuperable difficulties. The use of the microscope for examining the structure of metallic masses has also resulted in enormous advances during the last forty years. There is no doubt that the reliability of the modern motor car and locomotive, to select two examples only, has been the result of untiring efforts, behind the scenes, in the metallurgical laboratory, where careful scientific investigation has determined compositions and heat treatments of metallic substances capable of withstanding the most exacting conditions of service.

The following brief outline of thermal metallurgy will serve to explain some of the phenomena which control the physical properties of certain of the engineer's materials. The significance of any particular phenomenon can only be appreciated when a good working knowledge of ferrous and non-ferrous metallurgy has been obtained, and the relationship between one phenomenon and another has been considered with the greatest care.

Before going further, it is desirable to define several terms, and the writer has no hesitation in quoting the words of Professor Edwards in his book, "The Physico-Chemical Properties of Steel."

**"Constituents in Metallic Alloys.**—The constituents known to be capable of existing in metallic alloys are :—

(1) An alloy may consist of an intimate mixture of its constituents distributed through the mass in a perfectly pure condition.

(2) The elements contained in an alloy may be capable of existing in different allotropic modifications.

(3) Two or more elements in an alloy may be mutually soluble in each other, even when they are in the solid state, in which case they give rise to what are known as crystalline solid solutions. A solid solution is a homogeneous mixture of two or more substances in the solid condition. Metallic solid solutions are solid isomorphous mixtures.

(4) Intermetallic compounds are often present in alloys, and may be formed by the combination of two metals or by the union of a metal with a non-metallic element, such as carbon and sulphur, etc.

(5) Eutectics, which are frequently described as constituents, are really intimate mixtures of two or more constituents which have crystallised from the liquid at the same time. During solidification the solid eutectic does not undergo any change in composition, and the composition of the liquid also remains the same during

freezing. They possess the lowest melting-point of any mixtures of their constituents.

(6) Eutectoids consist of two or more constituents which have been simultaneously deposited from a homogeneous solid solution of the same composition. They are similar to eutectics in structure, etc., but are formed whilst the mass is completely solid."

### Cooling of Lead-Tin Alloys

Pure lead melts at  $327^{\circ}$  C. and pure tin at  $232^{\circ}$  C., but if we make a solder composed of lead, 37 per cent. and tin, 63 per cent., we find that its melting-point is only  $183.5^{\circ}$  C. Experiment shows that no other mixture of the two becomes fluid when heated to such a low temperature. The microscope reveals the fact that each particle of the solid alloy is composite in character, consisting of alternate very thin layers of lead and tin. This mixture is said to be the one of eutectic composition (see Professor Edwards' definition, No. 5).

If we make a series of lead-tin alloys of different compositions and investigate the process of cooling of each, we find that alloys of other compositions do not become definitely solid or liquid at a given temperature, but pass through a pasty stage like the metal the plumber uses for wiping a joint. In fact, this is equivalent to saying that the freezing, instead of being abrupt at one temperature, as in the case of a piece of pure metal or eutectic, extends over a considerable range of temperature. Thus in the case of the wipe-joint, the plumber takes advantage of a fall of  $60^{\circ}$  C. between complete fluidity and complete solidity.

During the process of wiping, the metal has a peculiar "feel," resembling moist sand, and we shall see that in this case the grit is really small crystals of lead and the moisture is liquid alloy. Now it is found by experiment in the case of the lead-tin alloys that the initial freezing-point varies with the composition, but the final freezing-

point is independent of the original composition and coincides with the freezing-point of the metal of eutectic composition. We may therefore represent the initial and final freezing-points by the diagram (Fig. 21).

Let us consider the cooling of the solder a plumber uses for wiped joints and composed of lead, 66 per cent., and tin, 34 per cent. This occurs in the diagram at the line F G H.

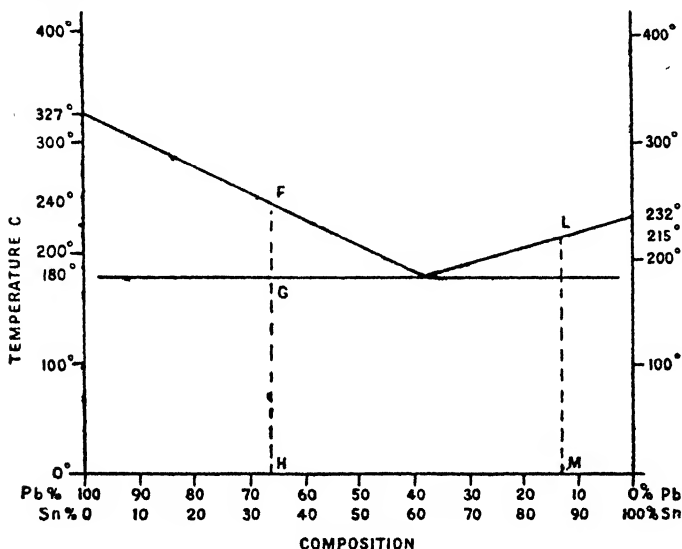

FIG. 21.—Lead-Tin Alloys.

From the diagram we see that initial freezing starts at 240° C. and the metal becomes finally solid at 180° C., giving a freezing range of 60° C. already mentioned. We know that when a strong saline solution is cooled, the salt commences to crystallise out, and that if the solution is very weak, ice will be formed before the salt starts to crystallise. Exactly the same occurs in the case of lead-tin alloys: the excess of one or other of the metals over the eutectic composition starts to crystallise out. Hence, immediately the plumber's solder cools to 240°C., we find



lead, the excess metal, crystallising out. But by the time a little of the lead has crystallised, we have a liquid alloy left of lower freezing-point, and so no further freezing can take place till the temperature is further lowered. If we do lower the temperature further, crystallisation of lead occurs, the freezing-point is lowered, and freezing ceases until the temperature again falls. By repeating the process in indefinitely small steps we finally have left lead crystals "moistened" with metal of the eutectic composition, and this eutectic freezes at  $180^{\circ}\text{C}$ . in the form of microscopic laminae of lead and tin. A wiped joint on a lead pipe will sometimes emit a few drops of metal when too cold and rigid to work, and these drops are the eutectic which is just on the point of solidification.

Now, if we consider an alloy very rich in tin, say, 85 per cent. tin and 15 per cent. lead, we see that this occurs on the right-hand side of the diagram at the line L M. Freezing of this alloy starts at  $215^{\circ}\text{C}$ ., but tin is the metal which crystallises out, otherwise the process is identical to the one just described. The pasty range is shorter, and the metal is very much more expensive than the one containing 66 per cent. of lead (£200 per ton compared with £80 per ton).

The principle of differential freezing accompanied by progressive lowering of the freezing-point of the residual metal is of supreme importance in metallurgical processes, *e.g.*, since silver and lead form an eutectic of low melting-point, the de-silverising of commercial lead is comparatively simple. A large pot of lead is allowed to cool and the crystals of lead are removed by a perforated ladle. More argentiferous lead is added, the temperature raised, and again lowered. More lead crystals are removed and the process is repeated until a large quantity of the lead-silver eutectic has accumulated. This eutectic is then removed and dealt with by another process.

Few alloys are as simple in their behaviour as those of lead and tin.

The Iron-Carbon Eutectoid

If we refer to Professor Edwards' definition of the term "Eutectoid" on p. 109, we notice that certain alloys in

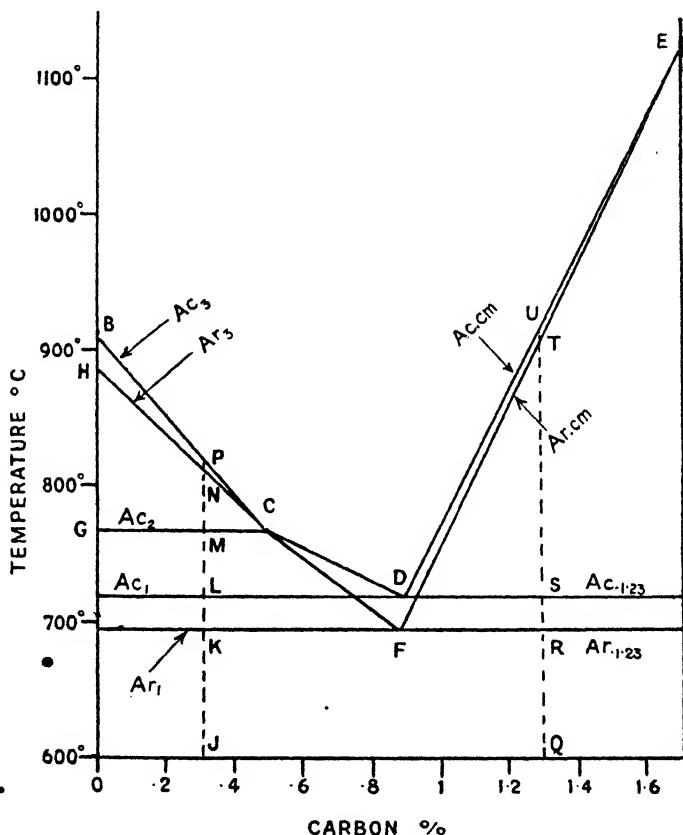

FIG. 22.—Iron-Carbon Diagram.

the solid state are capable of undergoing changes analogous to those in simple liquid alloys during their freezing range. These changes involve the separation of excess substances from solid instead of liquid solutions, the actual substance

ejected depending on the composition of the mother-substance in relation to the eutectoid composition.

Research has demonstrated that if we take a portion of the iron carbon series at certain temperatures we have phenomena occurring in the solid metal similar in character to those already described for lead and tin. The following diagram (Fig. 22), which represents the process, bears a marked similarity to Fig. 21, and should be compared with it.

In this case we have not two dissimilar metals, but iron for one and iron carbide,  $\text{Fe}_3\text{C}$ , for the other. The eutectoid of iron carbide and iron corresponding to the lead-tin eutectic occurs when the composition is carbon, 0.89 per cent. and iron, 99.11 per cent. If we increase the carbon by any amount up to 1.7 per cent., we have an excess substance in the form of iron carbide ejected from the solid crystals, but if the carbon content is less than 0.89 per cent. (the eutectoid composition), then metallic iron will be ejected from the crystals during the cooling process.

The following will demonstrate the fact that the thermal changes which occur in steels far below their melting-points are similar in many respects to the processes of freezing lead-tin alloys.

When the tin content is low, lead crystallises out until the eutectic composition is reached, after which the eutectic crystallises out as a laminated solid.

When the carbon content is low, pure iron (ferrite) separates from the solid solution until the eutectoid composition is reached, after which the solid solution breaks up into the laminated solid eutectoid pearlite.

When the tin content is high, tin crystallises out until the eutectic composition is reached, and then the eutectic freezes as a laminated solid.

When the carbon content is high, the excess of carbide  $\text{Fe}_3\text{C}$ , cementite, separates from the solid solution until the eutectoid composition is reached, when this splits up into a laminated solid.



A



B

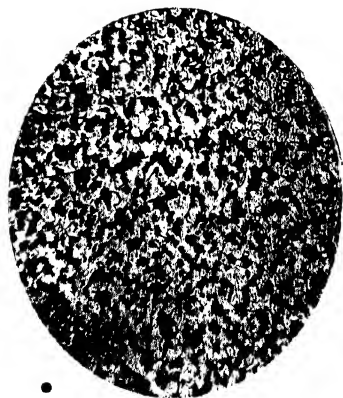

C



D

FIG. 23.—Structures of Steel.



When the lead-tin alloy is of eutectic composition, viz., 63 per cent. tin, the metal simply freezes at 180° C. and forms a laminated solid.

When the steel is of eutectoid composition, 0.89 per cent. carbon, the change-over to a laminated solid occurs at 690° C.

In both cases a progressively falling temperature is necessary, but thermally the processes differ. In the case of the lead-tin alloys considerable latent heat is evolved in the solidification of the lead, the tin, and the eutectic. In the case of steel very little heat is evolved during the separation of the excess substances ferrite and cementite, but the breaking up of the crystals of solid solution into pearlite is accompanied by considerable evolution of heat.

The four micro-photos on Fig. 23 show the phenomena.

(A) Represents the solid solution of carbide in iron.

(B) Shows the eutectoid and its striated structure after cooling. The iridescent mother-of-pearl-like structure of this material led Sorby, who first demonstrated it, to call it pearlite. The white patches are ferrite.

(C) Shows a steel containing 0.3 per cent. of carbon, in which case iron is the excess substance and appears white, while the eutectoid—the pearlite—appears black under this very low magnification.

(D) Shows a steel containing 1.1 per cent. carbon, after cooling. The areas shown black are the pearlite eutectoid under low magnification, while the white network is the carbide  $\text{Fe}_3\text{C}$ , known as cementite, the excess substance.

### Arrest Points

Let us take a simple case of an arrest point, and for the purpose suppose we place a crucible containing lead-tin alloy of the eutectic composition (lead, 37 per cent., tin, 63 per cent.) in a furnace. Let us insert a thermo-couple in the alloy and apply heat.

If we draw a time temperature curve of the metal while

we heat it and cool it in the furnace, it will take the form shown in Fig. 24 A.

During the heating process the temperature rises steadily until the melting-point  $180^{\circ}\text{C}$ . is reached. For a time the temperature of the alloy remains constant because all the heat it absorbs becomes latent heat of fusion. When the metal has become entirely fused, the temperature once more rises. Now if we remove the source of heat and allow everything to cool, we have a rapid fall in temperature for a time, but as soon as the

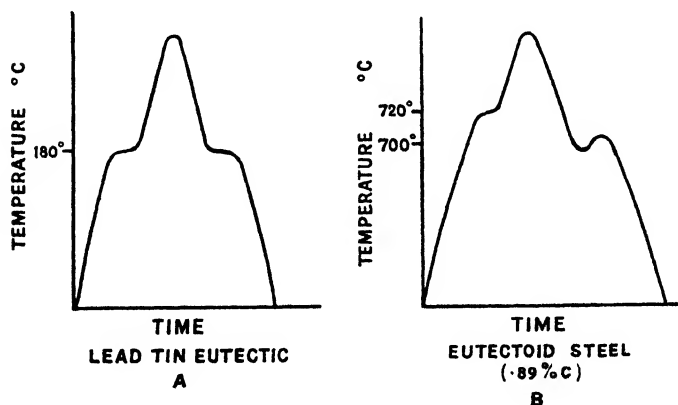

FIG. 24.—Arrest Points.

metal reaches  $180^{\circ}\text{C}$ . it commences to freeze, and no further fall in temperature occurs until the metal has solidified once more. When the latent heat has completely escaped, natural cooling commences once more. The change from a laminated solid into a liquid and *vice versa* is accompanied by the absorption or loss of latent heat, and this latent heat accounts for the arrest points. Now liquids, not subject to vibration, will sometimes pass below their freezing-point without freezing. Many of us have witnessed this phenomenon when walking in frosty weather. Pools of supercooled water suddenly become solid ice

due to the vibration of the road caused by our approaching footsteps. In metallurgy we usually talk of surfusion when a metal can be cooled below its freezing-point, without becoming solid. If our lead-tin eutectic is supercooled, *i.e.*, if the temperature falls much below  $180^{\circ}\text{C}$ ., it will freeze so suddenly that the latent heat evolved may raise a portion of it above  $180^{\circ}\text{C}$ . again.

We denote the arrest point on a rising temperature as Ac, and on a falling temperature as Ar.

The above heating and cooling curve is characteristic of the behaviour of most stable substances when changing from the solid to the liquid state and *vice versa*, and we shall see later that very similar curves can be drawn to show thermal changes in certain substances far below their freezing-points.

Let us perform the same experiment by substituting a piece of eutectoid steel (0.89 per cent. carbon) for the lead-tin eutectic, but in this case cease raising the temperature at some point well below the melting-point. The form of curve is precisely similar to the one just considered. It has the same arrest point Ac (though at a different temperature) on heating, but the kink Ar on the cooling curve is distinctly lower than the arrest point Ac on the heating curve (see Fig. 24B).

If the room is rather dark it is found that on cooling the metal loses heat steadily till it is nearly black, when it will glow out brightly for a short period. This is called "recalescence."

Now the phenomenon of surfusion in liquids is not an everyday occurrence where vibrations and other disturbing influences abound, but in the case of solids undergoing internal structural changes we usually find there is some delay, *i.e.*, increased rise or fall of temperature, before they respond to external thermal influences.

Hence it is not surprising to find that the arrest point on cooling is lower than that on heating. Probably the true change points are somewhere in the neighbourhood



of the mean of the two temperatures, though never, in solids, at the same temperature.

We can account for the arrest points in the lead-tin eutectic by saying that they represent absorptions or emissions of latent heat of fusion, but in the steel we are considering the changes which occur far below the melting-point. We know that a structural change has taken place—the solid solution has changed into pearlite; but is this sufficient to account for such an absorption or dissipation of heat? In the absence of any evidence of other changes we should have to think so, but other changes do occur. Thus if we draw a dilation curve of

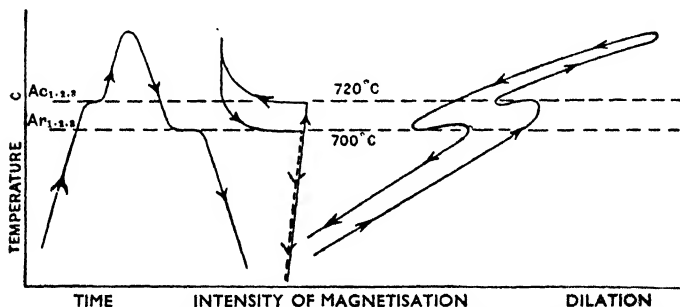

FIG. 25.—Thermal Curves for 0.89 per cent. Carbon Steel (Quinney).

the steel, we find a very marked discontinuity occurring at the same temperatures. The same applies to the electric conductivity curves, and on heating to a temperature above the change point the magnetic intensity of the steel falls to an almost negligible quantity (see Fig. 25). A 0.89 per cent. carbon steel must be heated to a temperature above the change point and quenched before recalescence takes place, otherwise it will not harden. A piece of coarsely crystalline steel becomes very much finer in the grain as it passes through the change point *on a rising temperature*. From the above it appears that the absorption or dissipation of heat at the change points is accompanied by some great internal

upheaval. Various scientists have speculated as to the nature of this upheaval, but the convenient view to accept is that some allotropic change has taken place. We know, for instance, that phosphorus may have two allotropic forms, yellow (very inflammable) and red (much less inflammable), and that allotropy is a very common phenomenon.

The iron of our tool-steel occurs in the  $\alpha$  allotropic form when below the arrest points, and in the  $\gamma$  form when at temperatures above the arrest points.

It does not appear necessary to attribute the discontinuities in the dilation and electric conductivity curves to an allotropic change in the metal, because it is quite reasonable to accept the view that these discontinuities are due to the transition of the simple structureless crystals of austenite into the composite crystals of pearlite and *vice versa*. In fact, it would be strange if such a profound change in crystal construction did not lead to such discontinuities.

So far we have been discussing the behaviour of steel containing 0.89 per cent. carbon ; but does the same apply to steel of all compositions from 0 per cent. carbon to 1.7 per cent. carbon ? By preparing a series of such alloys and determining the cooling curves of each, we find that between 0 and about 0.4 per cent. carbon,\* three arrest points are noticeable, and they are known respectively by the letters  $A_1$ ,  $A_2$  and  $A_3$ . The points  $A_2$  and  $A_3$ , though wide apart in the case of practically carbonless steel, approach nearer and nearer to one another till the carbon content is about 0.4 per cent. C, when they coincide. With the increase in carbon the  $A_3$  point is falling steadily and rather fast. After we pass 0.4 per cent. carbon the fall of the combined  $A_{2-3}$  point is less rapid, but by the time a 0.89 per cent. carbon steel is reached, it coincides with the  $A_1$  point, and hence we frequently talk of the

\* The  $A_1$  point will not be found unless there is at least a trace of carbon in the iron.

change point on heating a piece of eutectoid steel as the  $A_{1-2-3}$  point. Further increase of carbon causes the  $A_3$  point to remain stationary, but the  $Ac_{cm}$  line rises steeply.

The significance of the  $Ac_{cm}$  line will be explained later on p. 123.

The position of these points is represented by the lines BC, CD, DS and DE, shown in Fig. 22, when the temperature is rising, and the lines HC, CF, FR and FE, when the temperature is falling.

We have now to consider in more detail the changes which occur in steels while passing through the change points.

Above the lines HC, CF, and FE, the carbon is in a state of solid solution in iron. This solid solution of iron carbide in  $\gamma$  iron is termed austenite and is non-magnetic. When slow cooling takes place, the austenite, which is unstable at lower temperatures, commences to break up by ejecting from the crystals of solid solution either pure iron (ferrite) or iron carbide (cementite,  $Fe_3C$ ). This change is by no means abrupt, and the extent of the instability depends on the amount of temperature falls. For a small fall of temperature a small ejection of ferrite or cementite occurs, and when this has occurred, equilibrium is again established and the process stops. Further lowering of temperature causes further instability and ejection of material until equilibrium is again established. The more material ejected, the more stable the system becomes, and greater falls of temperature are necessary to make the action start again. If we reverse the process and heat the metal, the uniform solid solution is once more formed by the gradual absorption of ferrite or cementite, but the more ferrite or cementite which is absorbed, the greater the rise in temperature necessary to make the action continuous.

Let us consider a mechanical simile. Suppose we have a train of gear wheels driven by a clock spring and that all the bearings are clogged with a very viscous lubricant.

If the clock spring is fully wound up, the wheels will not turn, but if we warm the mechanism, say,  $3^{\circ}\text{C}$ ., we reduce the viscosity somewhat and the wheels will start rotating, but as the spring uncoils and becomes weaker, the train will come to rest. If we again apply heat, motion will start again and again cease, owing to the reduction of the driving force. Finally, when the spring is very nearly run down, a considerable change of temperature is necessary before further motion of the wheels can take place. In fact, the nearer we approach the equilibrium (unwound) state of the spring, the more heat we must apply to reduce the viscosity and permit motion.

This phenomenon in steel is of supreme importance in engineering practice. When tempering quenched tools we re-heat them so that changes can occur. We do not wish to pass directly from the pure solid solution to pure pearlite and cementite, but stop at some intermediate point determined by experience. The fact that any particular change in the steel is far more dependent on the temperature than the time is extremely convenient, because it enables us to temper large and small masses at our leisure, by simply watching the temperature (or, in certain cases, the equivalent temper colour), and, generally speaking, we may ignore the length of time the process lasts.

The same state of affairs exists in some of the heat treatments applied to large forgings. The forge-master lays great stress on the accurate determination of the temperature attained throughout when re-heating quenched forgings, but takes little or no notice of the time occupied during the process.

We have seen that as the temperature of a piece of heated steel falls, definite changes in its structure occur at various temperatures, and with slow normal cooling, temperature and not time is the controlling factor. This is in the main true for comparatively small masses of metal, but when we are dealing with very large steel

castings and forgings, the same does not hold good. For some reason very large masses of metal exhibit a distinct disinclination to undergo the thermal changes which occur in smaller masses at a given temperature quite readily. In consequence more time must be allowed for these changes to occur. In fact, large masses appear to exhibit some sort of internal "viscosity" or "inertia" by no means so apparent in smaller ones.

To assist the reader to appreciate the meaning of the diagram, Fig. 22, three examples of steels of varying carbon content will be considered. In the first place we will consider one containing 0.3 per cent. carbon as seen at the point J on the dotted line JP. At atmospheric temperature this consists of an intimate mixture of ferrite and pearlite, if it has been slowly cooled previously. The micro-structure is shown in Fig. 23c. As the temperature rises no structural change occurs till the point L on the  $Ac_1$  line is reached. At this point the iron of the pearlite changes into the  $\gamma$  variety, absorbs the carbide in contact with it and forms the solid solution austenite. The structurally free ferrite, however, remains in the  $\alpha$  condition. We have then a mixture of ferrite and austenite. As the temperature rises progressively, more and more ferrite is digested by the austenite. At the point M on the  $Ac_2$  line the  $\alpha$  ferrite still remaining loses its magnetic properties, becomes somewhat hard and brittle, and was formerly termed  $\beta$  iron. Further rises of temperature up to the point P on the  $Ac_3$  line result in the absorption of the ferrite into the austenite. The structure of the metal just above this temperature is seen in Fig. 23A. If the temperature be further raised, crystal growth will take place. If we allow the sample to cool slowly the reverse changes take place, but not all at the same temperatures at which they occurred on heating: At the point N on the  $Ar_3$  line the austenite commences to eject ferrite in the hard, brittle, non-magnetic condition and this continues down to the point M on

the  $A_2$  line when it becomes magnetic and less hard and brittle. Further fall of temperature to the point K on the  $Ar_1$  line is accompanied by a further ejection of  $\alpha$  ferrite from the austenite. At the temperature corresponding to the point K the austenite (solid solution of iron carbide in  $\gamma$  iron) changes into pearlite, an intimate mixture of iron carbide (cementite) and  $\alpha$  iron. The mass then consists of a mixture of structurally free  $\alpha$  ferrite and pearlite.

The next example we will consider is a steel containing 0.89 per cent. carbon, and therefore of the eutectoid composition. The structure of this material, if it has been slowly cooled, consists entirely of pearlite, as seen in Fig. 23 B, but without any white ferrite patches. As the temperature rises we have wholesale changes occurring at the point D on the  $Ac_{1-2-3}$  line. The pearlite changes into austenite, the iron changes from the  $\alpha$  state to the  $\gamma$  state. The magnetic properties disappear and the steel is capable of being hardened if quenched. If we cool the metal slowly no change occurs until the point F on the  $Ar_{1-2-3}$  line is reached. At this point the hardening power disappears, the  $\gamma$  iron reverts to the  $\alpha$  state, the magnetic properties reappear, and the austenite is once more converted into pearlite. Finally, we will consider a steel containing 1.3 per cent. carbon which occurs at the point Q. If the metal has been slowly cooled, the structure consists of pearlite grains surrounded by a network of free cementite more pronounced than seen in Fig. 23 D. As the temperature rises very marked changes occur at the point S on the  $Ac_{1-2-3}$  line. The pearlite is converted into austenite, the iron changes from the  $\alpha$  state into the  $\gamma$  state, the magnetic properties disappear and the steel can be hardened by quenching. Each austenitic grain, however, is surrounded by a network of cementite. The austenite will not digest *all* the cementite unless the temperature is raised considerably, viz., to the point U on the  $Ac_{cm}$  line. Tool-makers seldom heat high carbon steel to this temperature before quenching, because (a) a

coarsening of the crystals occurs during the whole of the rise of temperature from S to U ; and (b) such a high quenching temperature is a prolific cause of cracking and distortion. The fact that the cementite network has not been absorbed by the austenite is of minor importance in practice. Assuming we have raised the steel to the temperature U and cooled it slowly, no change occurs until the point T on the  $Ar_{cm}$  line is reached. At this point the network of cementite starts to reappear and develops progressively until the point R on the  $Ar_{1-2-3}$  line is reached. At this point sufficient cementite has been ejected from the austenitic grains to leave them with the eutectoid composition. On passing the point R the  $\gamma$  iron reverts to the  $\alpha$  state, the magnetism reappears, the steel loses its power of hardening if quenched and the austenite once more is converted into pearlite. Since crystal growth occurred during the rise of temperature from S to U and no refinement occurs on a *falling* temperature, we have, at atmospheric temperature, a coarser-grained steel than that with which we started ; assuming, of course, that the material was fine-grained in the first instance.

In the above examples we have ignored the martensitic, troostitic and sorbitic structures which the solid solution assumed prior to the formation of pearlite. Such structures can be " caught " by suitable quenching.

The lines FE and DE, unlike the others in the diagram, do *not* represent the loci of temperatures at which allotropic changes take place with a somewhat abrupt evolution or absorption of heat. They simply indicate what are believed to be the limits of ranges of temperature at which exothermic and endothermic changes *commence* on a falling temperature and *cease* on a rising temperature.

### Rectification of Annealed Tool-Steels

For the production of many tools such as taps and reamers, machining is necessary, and as a preliminary

operation the steel is annealed to render it as soft as possible and also to reduce the ill-effects caused by tilting or rolling at too low a temperature. With the exception of stamping dies and smiths' tools, which contain about 0.6 per cent. carbon, tools are frequently made from steel of approximately the eutectoid composition, viz., about 0.9 per cent. carbon. With such material annealing, by lessening the effects of cold working, does some good, and no harm. On the other hand, if the steel contains more carbon, say, 1.3 per cent., annealing, while doing good, may do much harm, unless the treatment is carried out with intelligence. The effect of annealing hyper-eutectoid steel, if done with great care, is to cause the network of free cementite to "spheroidise," i.e., break up into a multitude of exceedingly minute globules. Steel in this condition makes excellent tools when reheated to just over the  $Ac_{1-2-3}$  point, quenched and tempered. The free cementite remains in the spheroidised state and the tendency to crack is less than if it is in the network form. It is claimed by some authorities that the free cementite is easier to spheroidise in tilted bars than in similar ones which have been rolled, since hammering is said to break up the continuity of the network more effectively, prior to annealing. If, on the other hand, the annealing is unduly prolonged or the temperature is excessive, the minute spheroids of cementite will "ball up," i.e., coalesce and segregate into relatively large masses which are only reabsorbed by the austenite with difficulty. The segregation assists *rough* machining since the glass-hard lumps of cementite embedded in a soft matrix of pearlite are easily pushed out of the way by the cutting tool during the process. The action might be compared to that of a steam navvy working a clay bank containing a fair proportion of hard quartzite boulders. Obviously the same hard lumps render fine finishing cuts difficult to accomplish. If such metal is just quenched from above the  $Ac_{1-2-3}$  point and then



tempered, we have a badly segregated tool in a very second-rate condition. In order to rectify matters the steel must not only be re-heated to above the  $Ac_{cm}$  point, but must be held at such a temperature until the whole of the massive cementite has been absorbed by the austenite and diffused uniformly through it. By the time this has occurred the combination of high temperature and time has resulted in the appearance of another undesirable feature, viz., a marked coarsening of the grain, but this is easily remedied. The steel is allowed to cool rapidly (to avoid renewed segregation) to below the  $Ar_{1-2-3}$  point and then re-heated to just above the  $Ac_{1-2-3}$  point to refine the grain *on a rising temperature*. Thus, by the time it has been quenched and tempered it has been completely restored to a good structural and physical condition.

To return to our diagram (Fig. 24 B). The reader should note that we have an endothermic (heat absorbed) change occurring on a rising temperature, and an exothermic (heat evolved) change on a falling temperature. Hence we may regard austenite as an endothermic substance and pearlite as an exothermic one. It is common experience that endothermic substances, such as nitroglycerin and acetylene, are in a state of unstable equilibrium and therefore liable to undergo spontaneous decomposition with an evolution of heat if their equilibrium is disturbed by some outside agency such as sudden compression. In general, it may be said that the more endothermic a body is, the more instability it exhibits. Other influences, however, must be considered. Thus wet gun-cotton is entirely safe to handle, but dry gun-cotton is somewhat dangerous.

Acetylene cannot be compressed dry without risk of spontaneous decomposition (explosion), but in contact with acetone (forming dissolved acetylene) it is far more stable and quite safe. In the same way, if austenite contains nickel or certain other substances, it is far more

stable, though its internal energy may not be appreciably changed by the presence of such ingredients. If the products of decomposition of an endothermic substance are gaseous, the process, when once started, will continue rapidly, as in the case of gun-cotton, but if the products are solids, the process of decomposition is somewhat vigorously resisted and may require further temperature differences to overcome the resistance.

Let us form a mental picture of the dissipation of energy during the breaking up of the austenite. If our steel contains 0.89 per cent. carbon, almost the whole of the evolution of heat takes place at one change point, and is so great that recalescence is strongly marked. We attribute this dissipation to the change from the austenitic to the pearlitic state and the change from the  $\gamma$  to the  $\alpha$  allotropic form of iron. On the other hand, if we take the case of a 0.3 per cent. carbon steel, we have three discontinuities in our cooling curve which we account for by:—

(1) The partial breaking-up of the homogeneous solid solution of iron carbide in  $\gamma$  iron (austenite) with the formation of some  $\beta$  ferrite.

(2) The change of the  $\beta$  ferrite into  $\alpha$  ferrite with the formation of additional  $\alpha$  ferrite from the austenite.

(3) The change of the remaining austenite into pearlite.

Now since the quantity of pearlite in a 0.3 per cent. carbon steel is comparatively small, we should naturally expect that the dissipation of energy due to its formation would also be somewhat small, and this is in accordance with our experience. Hence, although a piece of tool-steel shows marked recalescence when cooling, a piece of low carbon material, such as the kitchen poker, will not exhibit it to the human eye.

Let us form another mental picture. Pearlite is composed of microscopic laminæ of ferrite and cementite, and therefore there appears to be no reason why the change from pearlite to austenite should not take place

very easily and rapidly when once a certain critical temperature is reached. On the other hand, the absorption is a very much more difficult process, as will be gathered from Fig. 23 c. The crystals of austenite have got to swallow up and digest all the free ferrite (or cementite) against their natural inclination, and the more they swallow, the more distasteful the process becomes. The instability of the system becomes greater and greater, demanding successive rises in temperature to enable the process to proceed. The process might almost be compared to the case of a man being compelled by threats to consume successive doses of strong mustard and water.

The reader may inquire whether the relatively slow absorption of free ferrite is connected with two other well-known phenomena, viz. : (a) that low carbon steels are less liable to suffer from excessive crystal growth at high temperatures ; and (b) that it is easier to refine the grain of steel castings which are relatively high in carbon. There would appear to be some connection, though the precise connection is not quite apparent.

### Quenching

Although metals undergo internal changes during slow cooling, the same does not apply if the metal is cooled instantly. For instance, cast iron containing 3 per cent. silicon and 3 per cent. carbon will, if slowly cooled from its freezing-point, consist almost entirely of silico-ferrite and graphite. On the other hand, if the metal is cooled almost instantly from its freezing-point, the internal changes are checked, and we have a glass-hard substance almost free from graphite. If we re-heat the quickly cooled iron and let it cool slowly, it turns into silico-ferrite and graphite.

We regard very rapid cooling, *i.e.*, quenching in a cold medium, as a process which checks further transformation

and retains the metal, *structurally*, in the condition in which it existed while hot. Upon this hypothesis, which we have no reason to dispute, is based the majority of the science of metallurgy.

The efficiency of quenching in preventing change depends on the nature of the metal or alloy. In many cases we find the instability so marked that quenching in liquid air cannot prevent the normal changes taking place. It is now well known that the efficiency of the quenching operation may be improved or impaired by the introduction of some other ingredient into our metal. For instance, by introducing increasing quantities of nickel or manganese we can depress the change points which occur on cooling to such an extent that they either occur below atmospheric temperature or are almost entirely suppressed. In fact, some steels containing nickel and manganese are so resistant to change that even unquenched samples are non-magnetic.

By preparing a series of cast irons of varying silicon content up to about 5 per cent. and quenching them, we see that silicon has the effect of accelerating the changes instead of checking them. Chromium, tungsten, and many other metals and non-metals have a profound influence upon the temperatures at which changes take place, and also on the rate of change.

Other ingredients of commercial alloys have no effect upon their physico-thermal constitution. Thus the addition of lead to brass results, not in one or more new solid solutions, but a solid mixture of brass and free lead.

So far we have only considered the simple solid solution above the upper critical point  $A_2$  and the structure which develops when this cools slowly below the  $A_1$  line, but we have seen that during the fall of temperature, changes are taking place, and such changes can be studied under the microscope.

The structure of the unaltered solid solution of carbon

in iron we call austenitic, and the metal in that condition is for convenience called austenite, though the termination "ite" (because Sorby, a pioneer of the microscopic method of examination, was a keen mineralogist) suggests a mineral such as granite or calcite rather than a metallic mass.

The final stages of cooling steel are called pearlitic, and the laminated portion is the pearlite in Fig. 23 B.

Austenite in high carbon steels is in itself not particularly hard, and we see no particular reason why it should be when it is just iron carbide dissolved in iron. When, however, the austenite *starts* to decompose, its whole structure changes, and we obtain the curious acicular appearance which is termed "martensitic" (see Fig. 26). Steel with this structure is extremely hard, and its hardness is probably due to the fact that some of the dissolved carbide has just been liberated in an ultra-microscopic state of division. In quenched samples of commercial mild steels we, as a rule, only find occasional needles of martensite, whereas tool-steel at this stage is almost entirely martensitic.

In the process of cooling, the next structure to develop is troostitic, a dark constituent. The acicular structure disappears and the picture becomes a confused but somewhat typical mass, which cannot be described in words. Further change gives us the sorbitic structure which may be described as an intermediate stage between the confused troostitic structure and the really fully developed pearlitic structure. Commercially, the sorbitic structure is of supreme importance where steel structures, require a comparatively soft and ductile metal of maximum strength capable of withstanding unceasing alternating stresses and shocks, as, for instance, crank axles.

From what has just been said, it is evident that the metallurgist can watch the stages in which hard steel becomes soft by tempering, and by inspecting a micro-

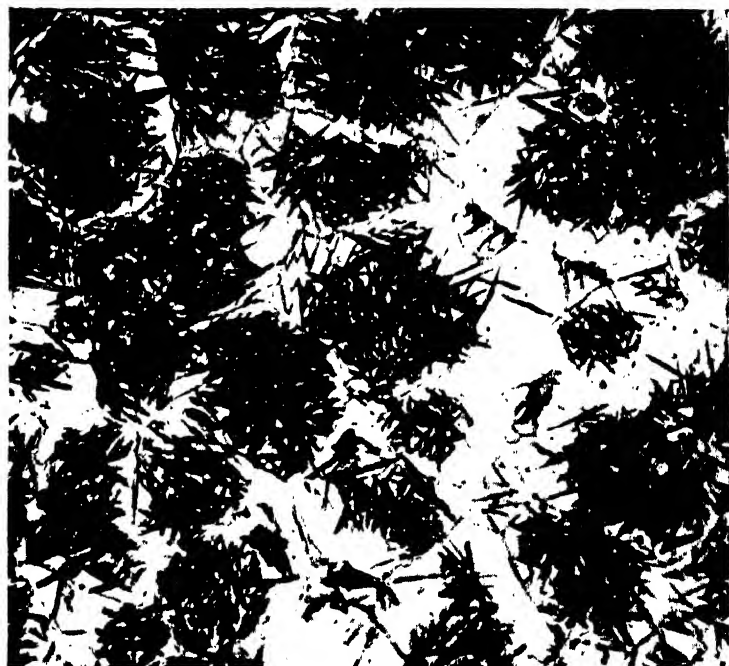

FIG. 26.—Martensitic Structure.



photo he can tell much of the thermal history of the specimen, assuming that he is examining a simple carbon steel.

We have now to consider the significance of the line GC in our diagram (Fig. 22). This line represents the locus of the  $A_2$  point for low carbon steels. The intensity of the thermal change at this point is very slight, and the arrest point is hardly noticeable unless very delicate instruments are used. The view formerly accepted was that it signified a change in the allotropic state of the metal from the  $\alpha$  to the  $\beta$  condition on heating, but now it is realised that a *true allotropic change* does *not* take place. That the  $\beta$  modification does exist is supported by the fact that iron which is magnetic below the  $A_2$  point is non-magnetic and somewhat harder and more brittle above it. It is more convenient to use the term  $\beta$  iron than the more cumbersome expression "non-magnetic somewhat brittle  $\alpha$  iron existing between the  $A_1$  and  $A_2$  temperatures." Practical men know to their cost that low carbon steel just below a red heat, *i.e.*, at a "blue heat," is extremely brittle and easily fractured by a blow. Any work (such as hammering or bending) must be suspended during the passage of steels through the  $\beta$  condition, *i.e.*, between the  $A_3$  and  $A_2$  points (see p. 98).

•

### Size of Crystal Grain

It is common experience that if a solid metal is maintained at a high temperature for a considerable period it becomes very coarsely crystalline. Thus if we fill a badly conducting mould with molten brass which is too hot, the mould becomes exceedingly hot and the metal remains very hot for a long time after it solidifies. By such means we may prepare very large crystals of brass.

If we heat the end of a normal steel bar to a high temperature, the minute crystals which compose it



coalesce to form large ones, and a coarsely crystalline bar is weak and unreliable.

The extent of this crystal growth depends on several factors, viz., the temperature, the time of exposure, the carbon content, and the mass of metal heated. High carbon steels become coarsened at lower temperatures and in shorter time.

A coarsely crystalline structure exists in many metals as a result of their being subjected to high temperatures for some time. This is specially the case in ferrous metal articles such as steel castings, steel ingots, bars heated to a welding heat, drop forgings finished at a yellow heat, etc. In this condition all such articles are weak, and before passing into use the grain must be refined again either by mechanical work or heat treatment. The normal fine grain found in structural steel is due to the breaking up of the coarsely crystalline structure of the ingot during rolling. The coarse structure of a welded bar is broken up subsequently by hammering if the operation is carried out properly. With steel castings, chains and drop forgings, we have to rely on heat treatment alone. In the production of large forgings direct from steel ingots, it is frequently necessary to complete the refinement of the grain by heat treatment. In all probability such forgings have to be reheated in any case, as they are usually put into service in the sorbitic condition.

If we place a piece of coarsely crystalline steel in a furnace and heat it to just above the  $A_c_3$  point, the coarse structure breaks up, and when we cool off again we have a very much finer one. If it is not fine enough, we repeat the process. This refining of the grain only takes place on a *rising* heat passing through the  $A_c_3$  point and no refinement takes place on a falling heat, viz., when passing through the  $A_r_3$  point. Care must be exercised that the temperature does not rise very much above the  $A_3$  point, otherwise crystal growth will start afresh.

This rebirth of crystals is accompanied by another

phenomenon, viz., the elimination of internal stresses and hardening due to cold working. Thus a piece of wire in the hard drawn state or a strip of cold rolled steel returns to its normal condition with this last treatment. But it must be clearly understood that this treatment is not going to remove all abnormalities.

Experience with comparatively heavy steam-hammer forgings shows that the displacements of metal under the blows frequently results in an embrittling effect, and that the elimination of these effects by heat treatment proves extremely difficult, if not impossible. The researches of Quinney, of Cambridge, on small test-pieces definitely point to the same conclusion. Quinney has found that with even repeated furnace heat treatments it is practically impossible to repair all the damage done to the structure of steel bars which have been over-strained while cold. On the other hand, researches by Hopkinson, Quinney and Woodward appear to show that if the normalising process is carried out by heating the specimen for less than a minute by passing an electric current through it, the repair of the damage is far more complete. Unfortunately such a process is not applicable to heavy forgings. The electric heating process for small sections appears to be not only exceedingly effective, but by no means expensive.

It is interesting to note that in cases where bars or strips are electrically welded by striking an arc across the gap and pressing the ends together, the material exhibits such remarkably good physical properties that we are led to the conclusion that, during the few seconds required for the process, the time is too short for crystal growth to take place. On the other hand, oxy-acetylene welds are so coarsely crystalline that the use of the process for repairing high pressure steam boilers appears extremely undesirable, especially as the local heating results in the plates being left in a state of internal stress. Electric arc welding in any form appears to be preferable.

The reader will have gathered from the above that fineness of grain is a criterion of quality, but some reservation on this point is necessary. Some experimenters have found that if the grain is *excessively* fine, the quality of the metal is impaired. Unfortunately the process of preparing the samples was not disclosed, but if the extreme fineness was produced by rolling between the  $A_3$  and  $A_2$  points, *i.e.*, when the iron was in the brittle so-called  $\beta$  condition, one would expect not only very fine grain, but internal damage to the metal resulting in poor physical properties.

**Normalising.**—If by re-heating to just above the  $A_c$  point, followed by comparatively rapid cooling, steel, which is coarsely crystalline, or which has undergone cold working, or which has been quenched from a high temperature, turns to its normal soft, fine-grained condition, free from internal stresses and distorted crystals, we say it has been normalised. (Quenched steel is abnormal.)

The term “comparatively rapid cooling” requires definition, and Stead defined the rate as that required for an inch bar to cool in air. Obviously fine steel wires of high carbon steel will practically quench in air when removed from the source of heat, and large forgings will have to be sprayed with water to accelerate the rate of cooling.

Normalising is the process adopted to-day in the case of steel castings. The time during which the castings are just above the  $A_3$  point is very short in the case of small castings, but rather longer in the case of large ones which, on account of their mass, refine somewhat sluggishly. As soon as refinement is deemed to have taken place, the gas is shut off from the furnace, the doors are opened, and the castings are removed as rapidly as possible and cooled in air.

Large important forgings such as cranks are dealt with rather differently. They are quenched in oil (which is

less likely than water to crack them). When cooled they are tempered to a sorbitic condition. This may be termed sorbitising.

**Annealing.**—Practical men and others frequently use this term when they are referring to normalising, but discrimination is very desirable, especially as the results are so different. As in normalising, we heat the steel to just over the  $Ac_3$  point, but in annealing the temperature is maintained for a considerable period. Then instead of cooling rapidly, the process is prolonged for a considerable period.

At one time this process was applied to steel castings and crane chains, but normalising is preferable.

Prolonged heating, save in exceptional circumstances, serves no useful purpose, while prolonged cooling undoubtedly reduces the strength and reliability of the material. The reason for this is quite evident from microscopic examination, which reveals the fact that the pearlite and ferrite became badly segregated. Thus instead of getting a fine and uniform distribution of pearlite and ferrite, we have them collected into large patches. This structure is physically weak and far below normal in every way (see p. 125).

The comparatively recent report on the heat treatment of oxygen cylinders, etc., emphatically discouraged an annealing process. Normalising is frequently carried out in the case of gas cylinders, not because there is any evidence that prolonged use alters the metal, for there is none, but because traces of oil from the compressors may find their way into them and detonate in the presence of compressed oxygen.

Two examples of the justifiable use of annealing may be cited. If in the absence of material of the right composition we make a medium steel forging which is rather too high in carbon and manganese, we find that the yield-point is considerably higher than necessary, but the elongation is below the specified limit. By annealing

such a forging the yield-point will be depressed by a few tons per square inch and the elongation may be brought up to the specified figure. Such a forging would not stand up to severe working conditions nearly as well as one made from steel of the right composition and normalised or sorbitised.

Another example is the preparation of high carbon steel forgings for machining. If they are annealed the segregation of its constituents facilitates rough turning with comparative heavy cuts, but it is far easier to produce a really fine finish if the metal has been carefully normalised and not annealed (see p. 125).

### Low Temperature Annealing

We have discussed some of the changes which occur in steels when heated to just above the  $A_3$  point and higher, but it is very important that the engineer should realise that other marked changes may occur, which may have disastrous results, if heat treatment is not carried out properly. Accidents have frequently occurred as a result of bad treatment.

If we take a bar of wrought iron, which has been pulled in the testing machine, and heat it for only ten minutes to about  $870^\circ\text{C}$ ., *i.e.*, a temperature not very much below the  $Ac_3$  point, we find a remarkable phenomenon occurring. Near the ends where the strain was maximum or minimum, no change in the size of crystal occurs, but in the middle of each piece where moderate straining has occurred, crystal growth has been extremely vigorous and the coarsening of the grain is very marked. Cathcart has shown the same phenomenon in another way. He welded a mild steel bar to form a circular ring, and when cold, pressed it to an elliptical shape and re-heated it for some time to a temperature below the  $Ac_3$  point. In this case Cathcart found that very pronounced crystal growth took place at four points where moderate straining had occurred, but the intermediate portions subjected to very

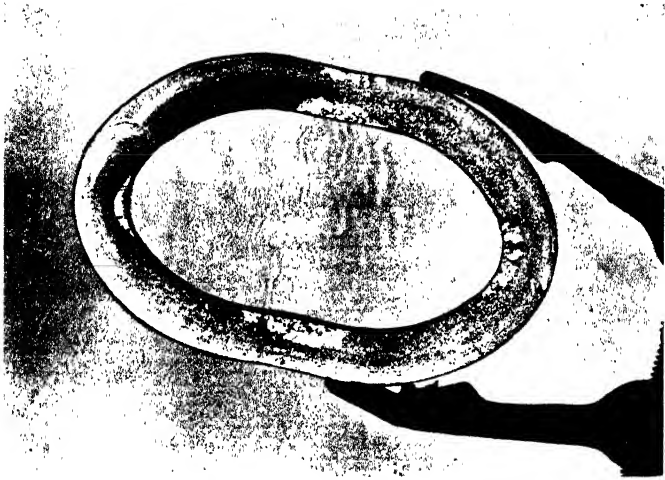

A



B

FIG. 27.—Crystal Growths in  
A. Ring subjected to slight strain.  
B. Portion of ring more severely strained.  
Annealed below the  $Ac_3$  point.



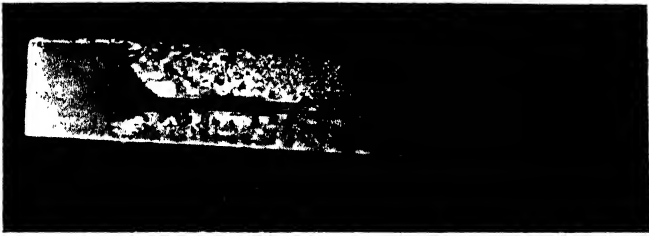

A

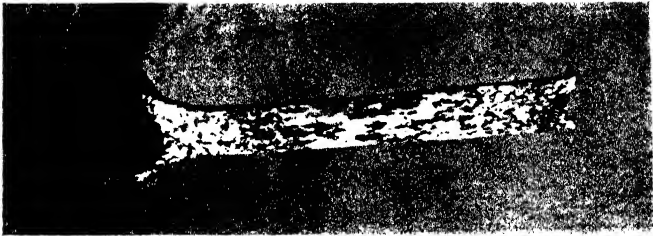

B



C

FIG. 28.—Crystal Growths in  
A. Laterally compressed bar.  
B. Extended bar.  
C. Bent bar.  
Annealed below the  $A_{c_3}$  point.





great or very little straining exhibited no change. Owing to the coarseness of the crystals such a link would prove exceedingly brittle and weak, as will be gathered by studying Figs. 27 and 28.

In some works it is the practice to collect crane chains and slings on Saturday morning and place them in a forge furnace for the week-end to anneal. No more pernicious practice could be contrived. If the furnace is very hot, every link will become coarsely crystalline and weak. The prolonged cooling is a further source of weakness. If all of the chain does not attain the  $A_c$  temperature, many of the overstrained links will become so coarsely crystalline that they will break at possibly one-fifth of their normal working load after such treatment. It is therefore obvious that if chains cannot be properly treated they should be left alone.

Another phenomenon connected with heat treatment following cold working is exhibited in high carbon cold rolled steel used for razor blades. When this is normalised during manufacture a portion of the carbon is sometimes deposited in the metal in the form of graphite. This, of course, interrupts the cutting edge of the blade and is highly detrimental. Possibly the silicon, which most tool steels absorb from the crucible, is partially responsible for this. A similar result is also obtained when nickel containing carbon is subjected to cold working and normalising.

In view of the fact that the change points in steel are profoundly influenced, not only by the carbon content, but by the presence of other ingredients, it is very important that they should be determined with accuracy in the laboratory before instructions are issued to the works. Since mass is also an important factor, this may entail some variation of the process according to the size and form of the article, as very large masses of steel behave very differently from small ones. It is essential that there should be the closest co-operation between the

works and the laboratory if first-class work is to be carried out.

### Changes at Atmospheric Temperature

Fifty years ago Ewing showed that if bars of wrought iron and steel were strained beyond their elastic limits, unloaded and then retested immediately, they had lost their true elastic properties. If, however, the overstrained bars were retested after a lapse of several hours, they had not only regained perfect elasticity, but possessed higher elastic limits and breaking strengths, though the elongations were less. About twenty years later, Muir, working under Ewing at Cambridge, discovered that similar results could be obtained by boiling the overstrained bars for about five minutes in water, instead of waiting for several hours. Muir further demonstrated that he could obtain, with each bar, successive rises of the elastic limit and breaking load accompanied by a marked reduction of ductility by repeating the operations a number of times. It has therefore been recognised for a long time that strained ferrous metals undergo gradual molecular changes at atmospheric temperature, and that these are enormously accelerated by a rise of only  $85^{\circ}\text{C}$ . These experiments therefore established the fact that ferrous metals exhibit "ageing" effects somewhat similar to those shown by certain quenched aluminium alloys. Recent research has shown that these early laboratory experiments, which have been overlooked or forgotten by some metallurgists, may prove of considerable industrial importance in chemical engineering and the production of ordnance. It has lately been realised that the best physical properties of certain steel articles, such as railway tyres, only develop (at atmospheric temperature) several months after manufacture.

Another example of molecular change in metals at atmospheric temperature is the spontaneous cracking

which frequently occurs in hard-drawn  $\alpha$  brass, six months or a year after manufacture. At one time this was known as "season cracking," but it is now realised that internal stress in the metal is responsible for the phenomenon and the time of year has nothing to do with it. The application of slight heat to the hard-drawn brass removes all tendency to future cracking.

## CHAPTER X

### NON-FERROUS METALS

#### Copper

OF the non-ferrous metals used in engineering, probably the most widely used is copper. Pure electrolytic copper is much in demand for electric cables and switch gear, and slightly less pure copper is used for such work as locomotive fire-boxes, injector pipes, etc. For the latter purposes small quantities of impurities such as cuprous oxide and arsenic improve the strength of the metal to a certain extent. It has recently been discovered that the addition of even  $\frac{1}{2}\%$  of 1 per cent. of silver to copper raises the elastic limit very considerably and overcomes the difficulty of maintaining the stays of locomotive fire-boxes free from leakage. Although enormous quantities of commercially pure copper are used every year, an even greater quantity is alloyed with other metals to form brasses, bronzes, white bearing alloys, and it is used in aluminium castings.

#### Copper Alloys

Copper is capable of dissolving many other metals, such as zinc, tin, nickel, iron, aluminium and manganese, and all these elements are used in the production of engineers' alloys.

Providing that the added metal constitutes a comparatively small proportion of the whole, the alloys are very similar in several respects. Under the microscope they have all the characteristics of a simple solid solution, and exhibit a simple crystalline structure similar to copper itself. The alloys are, like copper, soft and ductile, and

are known as  $\alpha$  alloys. The amount of the added metal which can be added to form such alloys varies considerably. Thus an  $\alpha$  brass may contain as much as 33 per cent. of zinc, but in the case of  $\alpha$  bronzes the limit is reached at about 10 per cent. of tin. If two metals are added to copper one partially takes the place of the other.

Now if we add more of the second metal, the structure and properties of the alloy change completely. Small further additions cause the formation of a number of crystals composed of a second solid solution known as  $\beta$  scattered throughout the mass. These  $\beta$  crystals stiffen the alloy considerably, and hence all the  $\alpha + \beta$  alloys are stronger and less ductile.

Further additions of the second metal give rise to hard and brittle alloys due to the presence of what are known as  $\gamma$ ,  $\delta$  and  $\eta$  constituents. These are for the most part hard brittle intermetallic compounds, such as  $\text{Cu}_2\text{Zn}_3$  (?), the  $\gamma$  of brass, and  $\text{Cu}_4\text{Sn}$ , the  $\delta$  of bronze. Such intermetallic compounds impair the toughness of the metal to such an extent that the engineer allows comparatively small quantities of them to exist in his alloys.

Heat treatment has considerable effect on the relative proportions of the micro-constituents of the copper alloys, and hence the mechanical properties.

### Brasses

Brasses are primarily alloys of copper and zinc. The two metals are mutually soluble in each other in all proportions, but the range of proportions producing a useful metal is fairly small, *i.e.*, between about 60 and 70 per cent. of copper. If we take the last-mentioned first, we have an alloy consisting of 70 per cent. copper and 30 per cent. zinc, usually known as 70/30, or  $\alpha$  brass.

This material has a characteristic pale lemon-yellow colour. It is extremely soft and ductile, and in the cold state may be rolled, drawn, stamped or spun with the greatest ease if the hardening which such a process

produces is removed at intervals by the application of a dull-red heat for a short time (otherwise cracking occurs). Thus a naval cartridge case 16 in. long and 7 in. diameter can be formed from a circular disc 0.75 in. thick and 12.65 in. diameter by pressing and drawing operations applied to the cold metal, but eight intermediate heat treatments are necessary, since the metal becomes harder and less ductile as a result of each pressing or drawing operation.

If we examine a piece of 70/30 brass under the microscope, we see a conglomeration of crystals all of pale lemon-yellow, consisting of a single solid solution of zinc in copper. Another brass much used in engineering is one containing approximately 60 per cent. of copper and 40 per cent. of zinc. It is known as 60/40, or  $\alpha/\beta$  brass. This metal, although it contains less copper than  $\alpha$  brass, is darker in colour—a pale orange, compared with a lemon colour. It possesses a higher yield-point and ultimate strength, but has a much smaller elongation. It is unsuitable for cold working, but can be forged or rolled with ease at a low red heat, whereas  $\alpha$  brass becomes friable at such a temperature. Microscopic examination shows a variation in its structure. We have a groundwork of soft ductile pale-yellow  $\alpha$  crystals, and this is reinforced by a skeleton of a darker, stronger and more brittle constituent known as  $\beta$ . It is the presence of this skeleton of  $\beta$  which raises the strength, reduces the ductility and renders the metal workable at a red heat. Another alloy formerly known as British standard brass has a composition about midway between the 70/30 and 60/40 and is much used for common brass castings.

When making or remelting such alloys some allowance must be made for a loss of zinc by volatilisation which results from its comparatively low boiling-point. Thus, when melting down scrap castings of 60/40 metal, the new castings made may have approximately the 70/30 com-

position unless the necessary zinc to make up for evaporation is added.

Brasses are seldom made from copper and zinc alone, the majority of castings containing other elements. Thus to ensure good deoxidisation of the metal, phosphorus is frequently added either in the elementary form or as phosphor copper, which is made by dissolving phosphorus in molten copper.

Lead to the extent of about 1 per cent. is usually added to brasses which have to be machined in order to cause the chip to break and to produce smoother cutting. Lead does not alloy with copper and will exude from a brass ingot when the latter is heated. The metal in the crucible is well stirred just before pouring, and the microscope shows that in the finished casting the lead occurs as minute globules fairly evenly distributed among the crystals composing the brass. Tin is occasionally added to reduce the corrodibility of the metal, especially in naval brass, which contains about 2 per cent. of tin.

Manganese is introduced by using an alloy known as manganese copper (say, Cu, 80 per cent., Mn, 20 per cent.) as part of the source of copper. It is added for a dual purpose: (a) as a powerful deoxidiser; (b) as a strengthener. When used as a deoxidiser alone, all of it collects as oxide in the scum on the surface of the molten metal and does not occur in the finished casting. In other cases sufficient is added to ensure that the finished casting contains about half of 1 per cent. Such manganese brasses are frequently sold as manganese bronze; in fact, 90 per cent. of the "manganese bronze" on the market is simply brass made with some manganese copper. It may or may not contain manganese when cast or possibly only minute traces. A good example of the use of manganese brass is the marine propeller which has the same tensile properties as mild steel, and, owing to the very thorough deoxidisation the metal has received, is very resistant to corrosion by sea water. Some designers



prefer an  $\alpha/\beta$  manganese brass for propellers while others prefer a  $\beta$  structure, with a view to producing blades which are less liable to be bent, but more brittle. According to W. Lambert the following figures represent typical chemical compositions and the mechanical characteristics of each class of alloy :—

Composition	Alpha/Beta Micro-structure	Beta Micro-structure
Copper . . .	56/58 per cent.	48/50 per cent.
Tin . . .	Approx. 1 per cent.	Not more than 1 per cent.
Iron . . .	Not more than 1 per cent.	Not more than 1 per cent.
Aluminium } Manganese } Nickel } Lead . . . }	Small proportions	Small proportions
Zinc . . .	40/41 per cent.	45/47 per cent.
TESTS		
Yield . . .	16/18 tons per sq. in.	18/20 tons per sq. in.
Breaking load . . .	33/36 " " " "	40/43 " " " "
Elongation on 2 in. . . .	25/30 per cent.	20/25 per cent.
Brinell Hardness No. . . .	125/130	145/150

The composition, micro-structure and the grain size have a distinct influence upon the strength and resistance of a metal to shock and fatigue stresses.

Nickel is frequently added to brass for the purpose of bleaching it. It forms solid solutions with copper and zinc producing both  $\alpha$  and  $\alpha + \beta$  alloys. Nickel brasses vary widely in composition, and are frequently known as German silvers or nickel silvers in the spoon and fork trade. They are much used as a base for electro-plated goods. Two nickel brasses of engineering importance may be cited, viz. :—

Ni, 25 per cent., Cu, 58 per cent., Zn, 17 per cent.  
and Ni, 10 per cent., Cu, 45 per cent., Zn, 45 per cent.

The first-named is a simple solid solution corresponding to  $\alpha$  brass, and is used for stamping and other cold working operations, such as the manufacture of motor car radiators. The second has a microscopic structure and physical properties corresponding to the 60/40 brass, and is rolled or forged hot. Many of the nickel brasses are whiter than chemically pure nickel.

Recent research has shown that the addition of about 2 per cent. of aluminium to brass renders it extremely resistant to the corrosive influences which attack condenser tubes.

Iron, when added to brass, raises the tensile strength without seriously reducing the ductility. It must be introduced by making a preliminary alloy of iron and zinc. A typical example consisting of

Cu, 55 per cent., Zn, 40 per cent., Fe + Mn, 4 per cent.,  
Sn or Al, 1 per cent.

has a tensile strength of 20 tons as cast, 30 tons when forged hot, and 40 tons when cold rolled. The metal possesses considerable resistance to corrosion, and is used for submerged pump connecting rods, etc. It is an  $\alpha + \beta$  alloy. The name "delta metal," usually applied to it, must not be confused with  $\delta$  constituents in copper alloys.

### Brazing Solders or Hard Solders\*

For brazing iron and steel articles soft brass wire (70/30) can be used, but since it has a relatively high melting-point (about 950° C.), this is rather a disadvantage. Brasses containing more zinc have a lower melting-point, and in consequence are used for brazing seams of brass tubes made from strip and attaching flanges to copper pipes. Such a solder would have about a 50/50 composition with a melting-point of about 870° C. Such a brass consists of the  $\beta$  solid solution, so rich in zinc that it

\* In some districts workmen call them spelters. This leads to confusion, since spelter is really commercial ingot zinc.

approximates nearly to the  $\gamma$  composition, and since the  $\gamma$  constituent is a hard brittle intermetallic compound, we should expect a rather brittle joint. In point of fact, this is not the case, since some of the zinc is lost through volatilisation and some diffuses into the metals which are being united, thus rendering the joint more ductile. Even the 50/50 solder has an inconveniently high melting-point for some purposes, so this is frequently further lowered by the addition of a small quantity of silver. This addition does not materially add to the cost of the solder for many purposes.

#### ✓ **Bronzes—Copper-Tin Alloys**

We have seen that in the case of brasses (copper-zinc alloys) the addition of 30 per cent. of zinc to copper results in a very soft ductile  $\alpha$  alloy. In the case of bronzes it is only possible to add relatively small quantities of tin to copper without producing excessive hardness and brittleness. Consequently the metal used for British bronze coinage is sufficiently hardened by the presence of 4 per cent. tin, and yet capable of being rolled and struck in dies. It is a true  $\alpha$  bronze. For general engineering purposes such as engine bearings, slide valves and boiler mountings, harder and less ductile bronzes are preferable, and these usually contain about 10 per cent. of tin. Under workshop conditions such alloys pass the  $\alpha$  limit, as we shall see presently. Bell metals are harder still, since they contain about 23 per cent. of tin and therefore contain a good proportion of the hard  $\delta$  constituent, which is regarded as an intermetallic compound having the formula  $\text{Cu}_4\text{Sn}$ . Hence bell metals are distinctly brittle. An alloy consisting of 66.6 per cent. copper and 33.4 per cent. tin, and known as speculum metal, is glass-hard, and has been used for the mirrors of large reflecting telescopes. It may be regarded as composed almost entirely of the hard  $\delta$  constituent  $\text{Cu}_4\text{Sn}$ .

To return to engineers' alloys which are usually referred

to as gun-metal (since ancient cannon usually had the same composition), it should be noticed that their properties vary considerably with the rate of cooling; quick cooling causing the alloy to be relatively soft and ductile, whereas slow cooling produces a harder metal, owing to changes which take place if the cooling is not too rapid. Assuming that the bronze contains 10 per cent. of tin, crystallisation will commence at about  $1,020^{\circ}\text{C.}$  and the (bronze)  $\alpha$  constituent solidifies. Then by the time the temperature has fallen to  $790^{\circ}\text{C.}$ , we have complete solidification and the resultant mass consists of two solid solutions of soft ductile material known respectively as the  $\alpha$  and  $\beta$  constituents. If the casting is now quenched it will be soft and ductile. With further slow cooling to below  $500^{\circ}\text{C.}$ , however, the  $\beta$  constituent will break up, producing more  $\alpha$  and some  $\delta$ . The  $\delta$  constituent is the glass-hard  $\text{Cu}_4\text{Sn}$ , so a slowly cooled casting consists of hard particles of  $\text{Cu}_4\text{Sn}$  ( $\delta$ ) embedded in soft ductile matrix of  $\alpha$ . This is why a slowly cooled bronze is harder than one which has been cooled by quenching from above  $500^{\circ}\text{C.}$  A bearing or slide valve which has been quenched from above  $500^{\circ}\text{C.}$  is less liable to crack, but will not wear well.

Soft bronzes for rolling consist entirely of the  $\alpha$  solid solution since their tin content is purposely kept low, below 8 or 9 per cent. Harder bronzes to withstand wear all contain more tin, viz., 9 or 10 per cent., so that a limited quantity of  $\delta$  may be present, but not in sufficient quantity to make them too brittle. Bronze flanges which are to be brazed on to copper pipes are usually of somewhat low tin content, so that they may have a relatively high melting-point, and not soften and distort on the brazing hearth.

As in the case of the brasses, so with the bronzes it is customary to add other elements. Thus phosphorus is used as a deoxidiser and also for the purpose of strengthening and toughening the metal. The excess phosphorus

over that required to deoxidise forms a compound,  $\text{Cu}_3\text{P}$ , which is extremely hard and improves the wearing properties of the castings. Some typical phosphor bronzes may be cited as follows :—

Cu.	Sn.	P.	
94.65	5	0.35	For rolling and wire-drawing.
89.3	10	0.7	„ engine bearings, etc.
88.5	10	1.5	„ worm wheels, etc.

The first-named has a tensile strength of 14 tons per square inch as cast, and 30 after cold working. It is very suitable for spring making, etc. Zinc to the extent of about 2 per cent. is generally added to bronze to deoxidise the metal, increase its fluidity, and reduce its tendency to corrosion, in which case it is often referred to as 88/10/2 gun-metal.

Lead is added as in the case of brass to facilitate machining. Manganese is sometimes used as a deoxidiser and strengthener, but such true manganese bronzes are not used to the same extent as manganese brass.

Nickel is added to bronze for two purposes: (a) to reduce corrosion, and (b) to give the metal strength at high temperatures. Thus Hopkinson's "Platnam" used for valve seatings consists of Ni, 54 per cent., Cu, 33 per cent., Sn, 13 per cent.

### Corronil

Another alloy of great importance for high temperature work is corronil, consisting of Ni, 70 per cent., Cu, 26 per cent., Sn, 4 per cent. At 620° C. this metal has a tensile strength of 40 tons per square inch compared with about 4 tons per square inch for ordinary brasses and bronzes at the same temperature. The falling off in strength of almost all alloys with a rise of temperature is a serious matter when they are used with superheated steam or under similar conditions, and serious accidents have occurred owing to this point not being appreciated.

### Imitation Gun-metal or Cock-metal

It is generally accepted that gun-metal (bronze) is superior to brass for many purposes on account of its greater resistance to wear and corrosion, and since it is a more expensive alloy it commands a higher price. Unfortunately, architects appear to be unaware that brass founders are flooding the market with domestic water taps, etc., which in colour are so like bronze, that they might almost deceive an expert. The metal used varies in composition, but a typical example of the following composition may be cited: copper, 72 per cent.; zinc, 12 per cent.; lead, 14 per cent.; tin, 4 per cent. Obviously this is a cheap alloy to produce, and from the brass finisher's point of view possesses two valuable properties: it machines like cheese, and a roughly filed-up casting assumes an attractively burnished finish after a few minutes' work with the calico "dolly" charged with tripoli. The extreme softness, however, results in stripped spindle threads within a short period. The metal is greatly inferior to the cheapest brass.

### Cupro-Nickel

Apart from the manufacture of nickel bronzes, nickel is much used for other purposes, such as the manufacture of nickel and nickel-chrome steel and the production of sorbitic cast iron. Several nickel-copper alloys are of interest. Thus one containing 20 per cent. of nickel and 80 per cent. of copper known as 80/20 cupro-nickel is remarkable for its white colour and great malleability, without any appreciable hardening due to cold working. It is used for the envelopes of service rifle bullets. The 70/30 cupro-nickel has been used extensively in place of simple brass or copper for condenser tubes. Another cupro-nickel extensively used is one known under the registered trade name "Monel Metal," which is obtained from an ore containing copper and nickel in the required

proportions and which is reduced without the separation of these metals. The alloy contains small but carefully controlled quantities of other elements to develop its optimum properties. The percentage composition is approximately copper, 30, nickel, 67, iron, 1.25, manganese, 1.25, plus carbon, silicon, etc. It is extensively used for turbine blades and parts of chemical plant, since it combines good mechanical properties with considerable resistance to corrosion.

Monel metal is also used in the preparation of austenitic cast iron.

### Heating Elements

The 80/20 and 70/30 nickel-chrome alloys are extensively used for the heating elements of domestic electric fires and industrial furnaces. They are extremely resistant to more than quite superficial oxidation and are not seriously embrittled by repeated or prolonged heating to 1,100° C. For certain industrial furnaces the somewhat cheaper 65/15/20 nickel-chrome-iron alloy has been used, but about 700° C. is the upper limit of temperature for which it is suitable. It gradually oxidises and may not prove more economical than the 80/20 alloy.

Comparatively recently an alloy has been placed on the market under the trade name "Kanthal." In addition to iron it contains about 5 per cent. aluminium, 20 per cent. chromium and 3 per cent. cobalt. It is capable of being run for a considerable period at 1,350° C. and in consequence will find extensive use for furnaces of the resistor type.

### Aluminium

Aluminium must be regarded as a comparatively new engineering metal since its economical production depends upon the use of large quantities of cheap electric power. The raw material, bauxite, an impure oxide, is first

refined with caustic soda, and a pure oxide of aluminium is formed. This in turn is electrolysed at a high temperature in a bath of fused cryolite, which is a double fluoride of sodium and aluminium. The fact that a single cell requiring 350 h.p. produces less than a cubic foot of metal per day shows that cheap electric power is essential if the metal is to be produced at its present price of about 1s. per pound.

Pure aluminium is chiefly used for electrical conductors, linings for brewers' vats, household utensils, etc. Compared with copper, its conductivity for a given capital expenditure is higher, but it cannot be soldered. Hence it is more suitable for bus-bar and overhead transmission lines than for other purposes. For the latter purpose the jointing may be effected by tying a reef knot, which gives great mechanical strength without lowering the yield-point of the cold-drawn wire, and then fusing the projecting ends in a blowpipe. For long spans it is now usual to use steel-cored aluminium transmission lines.

The extensive use of aluminium and its alloys for general engineering purposes is due to its low specific gravity. Thus whereas a cubic foot of steel weighs 490 lb., a similar quantity of aluminium weighs only 170 lb., *i.e.*, the same weight as a similar block of granite.

For casting such articles as motor-car crank-cases the alloy usually employed has the following approximate composition—aluminium, 92 per cent., copper, 8 per cent.—though others containing as much as 13 per cent. of zinc and less copper are used. Owing to the high contraction and weakness of these alloys at high temperature, it is advisable to strip the castings from the moulds as soon as they have frozen.

Within recent years research has shown the possibilities of an alloy of aluminium with 14 per cent. of silicon. It has, in the cast state, a yield-point of 14 tons per square inch with an elongation of  $7\frac{1}{2}$  per cent., and is 10 per cent. lighter than the alloys just mentioned. Having a much



lower coefficient of contraction, castings are easier to make without risk of fracture than with the usual alloys. It is largely used for the wheels of motor buses, etc.

### Duralumin

For aircraft work an alloy called duralumin has been much used. Weight for weight rolled sections have three times the tensile strength of mild steel. In addition to aluminium it contains about 4 per cent. Cu, 0.5 per cent. Mn, 0.5 per cent. Mg, and 1.25 per cent. Si. A peculiarity of this alloy is what is known as the ageing effect. To produce good tensile properties the rolled sections are re-heated to about 460° to 480° C., and quenched in water. After this operation the metal is comparatively soft and weak, but after about twenty-five hours have elapsed it develops its high tensile properties.

The following table serves to illustrate some of the properties of duralumin :—

State.	Yield-Point. Tons per sq. in.	Tensile Strength. Tons per sq. in.	Elongation. Per cent.	Brinell Hardness.
As annealed to dead soft state . . . .	3.5/5.0	11.5/15.5	12-20	42-55
As quenched from "solution" tem- perature, not aged	13.5/18.0	24.5/28.0	18-25	90-105
Fully heat-treated .	22.5/24.5	28.0/31.5	8-14	95-125

Further cold work upon quenched and aged duralumin increases the maximum stress up to 33 tons per square inch, but the elongation falls off rapidly and the process is not recommended.

The ageing effect is not confined to duralumin, since it is found in several other alloys. The best known of these is "Y" alloy consisting of the following in addition to

aluminium : copper, 4 per cent. ; nickel, 2 per cent. ; magnesium, 1.5 per cent. It is heavier than duralumin (S.G. 2.8), but its tensile properties are almost identical. It has proved one of the best aluminium alloys for pistons.

Aluminium forms intermetallic compounds with various metals of which  $\text{Cu Al}_2$  and  $\text{Ni Al}_3$  are examples. It is capable of holding these and certain others such as  $\text{Mg}_2\text{Si}$  and  $\text{Mg Zn}_2$  in solid solution at temperatures above  $500^\circ\text{C}$ ., the "solution temperature." If the alloy is allowed to cool down slowly these intermetallic compounds are no longer held in solution, but separate out. If, however, the alloy is quenched from above  $500^\circ\text{C}$ . the compounds remain dissolved for a short period in a state of such unstable equilibrium that they will separate out again of their own accord in the course of a few hours at atmospheric temperature. This accounts for the "ageing effect" so pronounced in many aluminium alloys. The material ejected from the solid solution is sub-microscopic, so the course of the process cannot be recorded photographically.

### Aluminium Paints

During recent years aluminium paints have come very much to the fore on account of their resistance to weathering. Ordinary paints usually consist of an oxidised film of linseed oil called linoxyn, which is reinforced, rendered opaque, and tinted by means of some base ground to an impalpable powder. Such bases vary in opacity, *e.g.*, white lead is more opaque than barium sulphate, and the greater the opacity, the longer the linoxyn vehicle withstands decomposition. In the case of aluminium paint the metal is in the form of flakes and not powder, and the vehicle is usually a cellulose derivative. Its durability is largely dependent upon the fact that, under the influence of surface tension, the metallic flakes arrange themselves like the scales of a fish or slates on a roof. Under such conditions the vehicle is very well protected against the influence of light, air and moisture.

### White Metals for Bearings

For many purposes brass or bronze bearings are used, and under light loads cool running is obtained even at relatively high speeds. In textile machinery we frequently find shafts covered by cast iron sleeves which run in cast iron bearings. Provided that the lubrication is good and the alignment perfect, such bearings are cheap and very satisfactory.

The use of white metal for bearings designed for heavy loads has become nearly universal except where Michell bearings are used. A white-metal bearing possesses the following advantages: (a) it is readily fitted to the journal in the first instance; (b) since the metal is always slightly plastic it readily accommodates itself to local wear of the journal, and hence a definite oil film of minimum thickness is maintained over the whole surface for long periods; (c) should the oil film be momentarily broken the white metal possesses good wearing properties and a low coefficient of friction; (d) should the supply of oil cease and heating take place, the white metal will fuse before the journal is damaged. Under similar conditions a bronze bearing would tear and the surface of the journal may be seriously damaged. Of the softer metals, lead and tin are used as the bases. Both are too plastic and too soft. Antimony has for long been used as a hardener in white metals. A small proportion goes into solution in the tin, but when about 6 or 7 per cent. are added we have formed hard cubes of an intermetallic compound  $\text{SnSb}$ . After formation these tend to float to the surface owing to their comparatively low density. Regularity of distribution is obtained by adding about 4 per cent. of copper. As the alloy cools a mass of fine lace-like needles of  $\text{Cu}_3\text{Sn}$  solidify first and these form an entanglement throughout the liquid. Later when the temperature has further fallen, the tin-antimony cubes come into existence, and as these are entrapped in the entangle-

ment, a very uniform distribution is obtained. The alloy is rendered harder and less plastic by the presence of these constituents embedded in the soft matrix. Since tin costs about £200 per ton, attempts have been made to replace practically all of it by lead, which is about one-tenth the cost. A certain amount of success has been achieved in this direction, but, speaking generally, it may be said that white metals of high tin content are superior to the cheaper alloys containing lead.

The exact quantity of copper and antimony which can be used depends on several factors. Large bearings which cool very slowly exhibit a different structure compared with small ones which cool rapidly. A metal suitable for a lightly loaded journal might prove too plastic for a heavily loaded one, especially under a reciprocating load. The selection of the best white metal for a given job must therefore be based on experiment.

### Coated Metals

In this country both the tin-plate and galvanised-steel industries are of very great importance.

In the tin-plate industry the sheets of steel are pickled in common sulphuric acid to remove the rolling mill scale. The cleaned surfaces are not very flat after the removal of the scale, so the sheets are subjected to cold rolling between finely finished rolls. They are then annealed and repickled in arsenic-free sulphuric acid, and then passed through molten tin, fluxes of zinc chloride, ammonium chloride and palm oil being used. The excess of tin is removed by passing the sheets between rolls as they leave the metal pot. As is well known, a thin coating of tin is a very poor protection against rust.

A similar process, but using a mixture of lead and tin, is also practised, and produces what are called "Tern" plates. These are used for certain purposes, such as oil drums, but cannot be used for canning food-stuffs, since lead salts are poisonous.

### Galvanising

In the galvanising industry corrugated sheets, fencing posts, tanks, pails, etc., are first made from black sheets, plates or sections of steel. These are then pickled in dilute sulphuric acid and scoured with sand and dipped in molten zinc. Makers of corrugated sheets frequently take off again as much of the zinc as they can, so it is usual to specify that such material must carry at least 1 oz. per square foot of surface. In the case of tank and pail work, the galvanising process renders watertight a structure which would otherwise leak like a sieve.

For some purposes curved corrugated sheets are required for roofs, etc. These must be curved before galvanising, otherwise the zinc would crack and the sheet rust away rapidly. In fact, the chief advantage in using heavy gauge steel is that it is less likely to be bent during transit or subsequent handling.

For many purposes the electro-deposition of lead and zinc are used in preference to dipping, especially where the pieces are large, *e.g.*, the side of a ship's life-boat. Another process of zinc coating sometimes applied to spring work is known as sherardizing. The articles are placed in zinc dust and heated to about 300° C., a temperature well below the melting-point of zinc and one which does not soften the steel appreciably. The coating so produced is said to withstand corrosion to a remarkable degree even if the metal is subsequently sharply bent.

### Metallisation

Metallisation is effected by bombarding the surface to be coated with a spray consisting of minute particles of fused metal. The spray is formed and carried by a stream of compressed air which atomises a globule of molten metal forming continuously at the end of a heated wire. The process is applicable to the deposition of zinc, copper, nickel, and a variety of other metals, and has been

applied with considerable success to steel window-frames and other articles. Even wood can be coated by this method.

### **Enamelling**

In the enamelling industry the process closely resembles the glazing of pottery. The articles to be treated, such as baths, sheet-metal signs, parts of stoves, etc., are thoroughly cleaned and sprayed or painted with a mixture consisting of white lead, borax, felspar, oxide of tin and turpentine. Various colours are produced by adding oxides of manganese, chromium, etc. The articles are then placed in a muffle and brought up to a red heat which evaporates the turpentine and produces the characteristic vitreous enamel coating.

## CHAPTER XI

### SELECTION OF MATERIALS

WHEN very large consumers of material are placing orders, they are in the fortunate position of being able to obtain almost anything for which they ask, as regards composition, physical properties and shape and form. Even the largest consumers must be reasonable in their demands and must not expect the maker to modify the routine of his works unless they are prepared to pay for such facilities. For example, in the manufacture of rolled steel joists, the normal demand for the larger sections, such as the  $18 \times 7$  in., does not justify the cost of a mill for this size only. So each maker rolls a certain quantity periodically, changes his rolls for another section and is not prepared to face the expense of changing back for a comparatively small quantity. Hence the consumer, if he is wise, sends out inquiries to various mills to ascertain their stock in hand, and probable dates of a further rolling. The same principle applies to special steels. Makers of special steels are not always prepared to produce a given quality at short notice unless the quantity ordered justifies the change in the works routine.

To-day cheapness and mass production go hand in hand. When orders run into large figures the manufacturer is always prepared to meet the consumer in every way. Even small departures from routine practice may add very considerably to costs. Specifications should be drawn up with the utmost care so that unavoidable irregularities in product will not lead to wholesale rejections. In other words, a good working margin is required. When a specification is badly drawn up without

full understanding of the factors which lead to irregularities occurring during manufacture, trouble is sure to ensue. One great point in favour of all the British standard specifications is that they are drawn up by committees representative of both manufacturers and consumers, and hence their figures should, and for the most part do, satisfy both, and lead to economy in production. It might be argued that standardisation of specification tends to obstruct progress, but experience shows that this is not the case. For instance, modern cements are being produced which in many properties greatly excel those complying with the standard specification. Again, although rolled steel sections have been standardised, one or two firms regularly produce additional sections of much use and convenience to the consumer. Certain classes of material are always available, and before anything different is demanded, the questions of cost and delay must be considered very carefully. A departure from standard practice may result in considerable economy when the question is considered from every angle. Thus, in the construction of long-span bridges, the great saving of weight effected by the use of a nickel steel may entirely justify its use, though such a change would involve a greatly enhanced price per ton. On the other hand, the specification of a steel of unusual composition for a large marine crank may add considerably to the cost, as the steel-maker would have a certain number of ingots left on his hands.

It must also be realised that certain steels can only be obtained in certain sections. Thus, though very large quantities of high silicon steels are used for railway rails, the same material is not rolled down into bars or other sections. On the other hand, though most of the alloy steels are purchased in bar form, frequently heat treated by the steel-maker, the purchaser can always obtain billets for forging and heat treatment in his own works. Whereas large consumers as a rule deal direct with the



steel works for most of their supplies, smaller consumers as a rule deal with a merchant. The merchant is a great convenience, as he is usually in a position to get the material very quickly if he knows his job. On the other hand, he requires a middleman's profit and the user sometimes has no guarantee that the right goods have been delivered.

Among the factors which may have to be considered when selecting materials are: strength, toughness, resistance to fatigue, wearing qualities, behaviour at elevated temperatures, first cost, cost of machining, and freedom from defects due to errors in treatment during fabrication. Unfortunately many desirable qualities are incompatible; and the student must realise that all design and selection of material is based on compromise. For general structural work the engineer adopts, for most purposes, a good quality mild steel which combines cheapness, ease of working and reliability. If a component of an engine or machine is highly stressed or subject to abrasion, the engineer at once thinks of "more carbon," and the steel-maker will offer a somewhat less ductile material of much higher yield-point. To get the best results from such material oil quenching followed by tempering is resorted to, but such treatments increase working costs. The gains in strength and wearing properties are reached, however, at the expense of ductility and enhanced works costs. Exactly how far it is legitimate to "push up" the carbon is, in many cases, a matter of opinion, and no one can say so with certainty. For years past railway engineers, with a view to cutting down maintenance charges, have been using harder and less ductile rails and tyres. Fractures are now far more common than formerly, and companies are wondering whether they have not overstepped the mark and whether the saving on maintenance has not been exceeded by the costs of serious accidents caused by broken rails and tyres. For components which have to withstand very

severe working conditions such as cranks, it is now recognised that, in spite of its enhanced cost, nickel steel must be used. Here again the best possible composition and heat treatment are still open to question. It was only by prolonged research, covering many years, that the Midland Railway Company succeeded in reducing their crank failures by 50 per cent and arriving at the best possible composition and heat treatments for their purpose. Possibly the next steps will be in the directions of improved design and method of forging, and not in the actual material or its physical state. Though the use of expensive nickel-chrome-molybdenum side rods may be entirely justified on the latest fast express engines, the same material is unnecessary and far too costly for slow-moving ones hauling coal trains. Reference to the chapter dealing with alloy steels will show their superiority in many properties which may amply justify their enhanced cost. In some cases the engineer will deliberately adopt a low-grade material or a bad process for the sake of economy. Thus we find on the market steels which are very high in phosphorus and therefore very easily machined and screwed ; in fact, a  $\frac{3}{8}$  in. Whitworth tap will produce a perfect thread in a hole 2 in. deep in such material without excessive torque being applied. In such material reliability under shock and fatigue are deliberately sacrificed for ease of machining. In many forges we still find work being produced by large steam-hammers, whereas presses would undoubtedly produce a better job, if the owners would only change their methods. The hemispherical heads of many wood-screws sold to-day are produced by setting up the end of a piece of cold steel wire in a special machine. This process is quite legitimate in the manufacture of copper rivets, but users of wood-screws made in this way frequently find that the heads twist off while they are being driven home.

No less an authority than Mr. J. H. Dickenson of the English Steel Corporation has openly confessed to the

writer that he has found it impossible to show in concise tabular form the best materials for particular purposes. From time to time, papers dealing with materials suitable for components used in some particular industry have been published, but the conclusions arrived at require constant revision in the light of further knowledge and experience. The requirements of the engineer become more exacting every year. Prime movers increase in size, power and speed; steam pressures and superheat temperatures are rising; castings and forgings of greater size, strength and reliability are required; and in order to cope with dead weight and inertia forces, sections of metal must be cut down by the adoption of superior material. Corrosion phenomena are being better understood, and, for such articles as condenser tubes, copper and simple brass no longer hold the field. Improvements in white metals and roller bearings have shaken our faith in engine "brasses." Machine tools increase in size and power and demand better cutters. For such purpose, even the apparently impregnable position of high-speed steel is being threatened by the advent of non-ferrous cutting materials such as "Stellite," tungsten carbide ("Widia") and molybdenum-titanium-carbide ("Cutanit").

The development of new steels and non-ferrous alloys continues apace, and the designing engineer cannot be expected to be fully conversant with all the most suitable materials for his purposes. Ferrous and non-ferrous metallurgists in Britain are honest men and are always willing to give the best of advice, untainted by commercialism. When failure occurs, the engineer usually blames the material, and not the design or execution, so the metallurgist hears all about it. He thus becomes an authority on both the uses and abuses of materials in the hands of others.

## INDEX

- ACETYLENE welding, 133  
Ageing, 138, 152  
Allotropy, 119, 131  
Alloy Cast Irons, 32  
  Steels, 99  
Alpha  
  brass, 141  
  bronze, 141, 146  
  iron, 119, 131  
Aluminium, 22, 150  
  alloys, 151  
  brass, 145  
  castings, 151  
  in cast iron, 34  
  in steel, 71, 73, 79, 83  
Annealing  
  cast iron, 48  
  chains, 135, 137  
  steel, 125, 135, 136  
Arrest points, 45, 115  
Austenite, 122, 130  
Austenitic  
  cast iron, 43  
  chisel steel, 66  
  manganese steel, 100  
  state, 122, 130
- BASIC  
  process, 74, 78, 81  
  slag, 74  
  steel, 74  
Bauxite, 150  
Bearing metals, 154  
"Bell metal, 146  
Bessemer steel, 72  
"Best Yorkshire," 52  
Beta iron, 122, 131  
Billets, 88, 103, 159  
• Blackheart castings, 49  
Blast furnace, 26  
Blister steel, 58  
✓ Brasses, 141  
Brearley, 86  
Brittleness, 6, 10, 18, 98  
✓ Bronzes, 146
- CALCINING, 21, 26  
Carburising, 58, 68  
Case-hardening, 67  
Cast iron, 31, 38  
Cementation, 60, 68  
Chains, 56, 94, 135, 137  
Chill castings, 33, 41  
Chisels, 65, 100  
Chromium cast iron, 43  
  steel. *See* Steel—chromium.  
Coal dust furnaces, 37  
Cogging, 75, 88, 94  
Cold rolling, 89  
  working, 6, 89, 133, 149  
Colours (temper), 63, 121  
Conchoidal fractures, 17  
Condenser tubes, 145, 149  
Contraction of area, 6, 103  
Converter, 72  
Cooling curves, 111, 116  
Copper, 140  
  alloys, 140  
  in cast iron, 43  
Corronil, 148  
Cracking, 17, 62, 67, 70, 98  
Cranks, 18, 19, 96, 161  
Creep tests, 7  
Creeping cracks, 17, 67, 70  
Critical points, 45, 115  
Crucible steel, 59  
Cryolite, 151  
Crystal growth, 18, 56, 61, 69,  
  102, 134, 137  
Cupola, 34  
Cupro-nickel, 149  
Cutanit, 162  
Cyanogen, 68
- DELTA constituent, 141, 146  
  metal, 145  
Design based on compromise, 160  
  of castings, 46  
Dickenson, 161  
Dilation, 118  
Discard, 75, 87

- Dolomite, 74  
 Drawing, 89  
 Drop forgings, 5, 93, 94, 98, 132  
 Duralumin, 16, 152
- ELECTRIC**  
   furnace, 80  
   normalising, 133  
   welding, 57, 133  
 Enamelling, 157  
 Endurance, 13  
 Equilibrium diagram, 113  
 Eutectic, 109  
 Eutectoid, 109, 113  
 Ewing, 138
- FATIGUE**, 11  
 Forging,  
   drop, 5, 93, 94, 98, 132  
   hammer, 95, 161  
   press, 95  
   temperature, 5, 93  
   tool-steel, 61, 94  
 Freezing of metals, 47, 92  
 Furnace,  
   blast, 26  
   electric, 80  
   forge, 93  
   puddling, 53  
   Siemens, 76
- GALVANISING**, 156  
 Gamma brass, 141, 146  
   iron, 122  
 Grading pig iron, 31  
 Grain growth, 18, 131, 136  
   refinement, 118, 124, 126, 132
- HAMMER** forgings, 95  
**Hardening**,  
   case, 67  
   hammer, 10, 18  
   high-speed steel, 65  
   work, 89, 90, 91, 142  
**Hardness tests**, 8  
**Hatfield**, 48  
**Heating elements**, 150  
**Hooks**, 19, 97  
**Hopkinson**, 7, 15, 133  
**Huntsman**, 60
- IMPACT tests**, 10  
**Ingots**, 47, 60, 84  
**Intermetallic compounds**, 109,  
   136, 141, 153  
**Iron phosphide**, 41, 86  
**Izod test**, 10
- KANTHAL**, 150
- LEAD**  
   in brass, 143  
   in bronze, 148  
   in white metals, 154  
 Lead-tin diagram, 111  
 Low temperature annealing, 136
- MACROGRAPHY**, 19  
**McWilliam**, 23  
**Magnesium**, 152  
**Magnetism**, 43, 118, 124  
**Malleable castings**, 48  
**Manganese**  
   copper, 143  
   deoxidiser, 60, 143  
   easily oxidised, 56, 59  
   in Armco, 79  
   in Bessemer steel, 73  
   in brass, 143  
   in bronze, 148  
   in cast iron, 30, 33  
   in crucible steel, 60  
   in pig iron, 30, 31, 33  
   reduces plasticity, 56  
   steel, 100  
   takes charge of sulphur, 33, 60, 73  
**Mangling**, 91  
**Martensite**, 130  
**Mehanite**, 84  
**Mercury quenching**, 62  
**Metallising**, 156  
**Micrography**, 19  
**Molybdenum**, 65, 106  
**Molybdenum-titanium-carbide**,  
   162  
**Monel metal**, 149  
**Muir**, 138  
**Mushet steel**, 63
- NICKEL-ALUMINIUM alloys**, 152  
**Nickel**  
   brasses, 144

- Nickel**  
 bronzes, 148  
 case-hardening steels, 70  
 cast iron, 39, 42  
 chrome steels, 65, 101, 105, 106  
 structural steels, 102, 105  
 tool steel, 65, 100  
 Nitrogen case hardening, 71  
 Normalising, 134  
 Nuclear theory, 83
- OIL-BLOW pipe, 93**  
**Oil-hardening, 43, 62, 65**  
**Oil-quenching, 43, 63, 65**  
**Ores, aluminium, 150**  
 iron, 25  
**Overstrain, 133, 138**  
**Oxygen cylinders, 135**  
**Oxy-acetylene, 133**
- PEARLITE, 115**  
**Phosphorus**  
 in brass, 143  
 in bronze, 147  
 in cast iron, 31, 33, 41  
 forgings, 96  
 malleable castings, 49  
 steel, 54  
 wrought iron, 53, 55  
**Pick axes, 59**  
**Piping, 85, 97**  
**Platnam, 148**  
**Potash recovery, 30**  
**Puddled steel, 58**  
**Puddling, 52, 75**  
**Pyrometry, 107**
- QUENCHING, 43, 63, 65, 100, 128**  
**Quinney, 90, 133**
- RAM'S-HORN test, 1**  
**Recalescence, 117, 127**  
**Red-hardness, 64**  
**Red-shortness, 60, 82**  
**Reeling, 91**  
**Rolling, cold, 89**  
**Rolling-mill, 88**
- SALT baths, 62**  
**Scale on billets, 108**
- Scrap cast iron, 34**  
 steel, 79  
**Selection of material, 158**  
**Semi-steel, 36**  
**Setting up, 96**  
**Shear steel, 59**  
**Sherardizing, 156**  
**Shingling, 54, 58**  
**Shrinkage, 43**  
**Siemens process, 76**  
**Silicon,**  
 affects plasticity, 56  
 easily oxidised, 34, 56  
 in foundry work, 29, 33, 34, 49  
 in rail steel, 159  
 in tool steel, 59  
 in scrap iron, 34  
 in wrought iron, 53, 56  
**Slag,**  
 basic, 74  
 blast furnace, 28  
 functions of, 81  
 in blister steel, 58  
 in wrought iron, 55, 56  
**Soaking pits, 85**  
**Solders, brass, 145**  
 silver, 146  
 soft, 110  
**Solid solutions, 109**  
**Sorbite, 115, 130**  
**Sorbitising, 16, 135**  
**Sorby, 115, 130**  
**Speculum metal, 146**  
**Spelter, 145**  
**Stainless steel, 66**  
**Standard test piece, 4**  
**Staving up, 96**  
**Stay-bright, 66**  
**Stead, 97, 134**  
**Steam hammer, 95**  
**Steel**  
 allotropy in, 119, 131  
 alloy, 94  
 Austenitic, 100  
 Bessemer, 72  
 blister, 58  
 castings, 75, 91, 121, 126, 132  
 chrome, 66, 101, 105, 106  
 cobalt-chrome, 65  
 crucible, 59  
 eutectoid, 61  
 forging, 61, 93  
 hardening, 62, 65  
 high speed, 65  
 hyper-eutectoid, 61, 123  
 hypo-eutectoid, 61, 122

**Steel**

ingots, 47, 60, 73, 84  
 ladle, 85  
 manganese, 100  
 molybdenum, 65, 106  
 mushet, 63  
 nickel, 65, 70, 100, 105  
 normalising, 134  
 puddled, 58  
 quenching, 62, 64, 128  
 shear, 59  
 stainless, 66  
 stay-bright, 66  
 tempering, 62, 121  
 tungsten, 64  
 welding, 57, 59

Stellite, 67, 162

Stoves, 28

**Sulphur**

in cast iron, 31, 33, 34  
 in ores, 21, 26  
 in pig iron, 31, 33  
 in tool steel, 60  
 in structural steel, 73, 82  
 in wrought iron, 53  
 prints, 20, 95

Supercooling, 117

Superheating, 81, 84

**TEMPERATURE** measurement,  
 107

Tempering, 62, 121

Tensile test, 2

Tern plates, 155

Thermit process, 22

Tilting, 60

Tin plate, 155

Titanium, 162

Tool steel, 58

Toughness, 6, 10, 102

Troostite, 130

Tropenas converter, 75

Tungsten, 64, 129

carbide, 64, 162

Turbulence, 96, 97

Turner, 9, 44

**VANADIUM**, 67

**WELDING**,

acetylene, 133

electric, 57, 133

fire, 56, 94

tool steel, 59

White cast iron, 25, 31, 39, 49

metals, 154

Widia, 162

Wire drawing, 89

Wrought iron, 23, 52, 94

**"Y" ALLOY**, 152

Yield point, 5, 102





## DATE OF ISSUE

This book must be returned within 3/7/14 days of its issue. A fine of ONE ANNA per day will be charged if the book is overdue.

---

--	--	--	--	--

