

# Birla Central Library

PILANI (Jaipur State)

Engg. College Branch

Class No :- 624

Book No :- S 94657

Accession No :- 55055





# STRUCTURAL THEORY



HALE SUTHERLAND AND HARRY LAKE BOWMAN  
STRUCTURAL THEORY, *Fourth Edition*  
STRUCTURAL DESIGN

HALE SUTHERLAND AND RAYMOND C. REESE  
INTRODUCTION TO REINFORCED CONCRETE DESIGN, *Second Edition*

# STRUCTURAL THEORY

---

*Fourth Edition*

HALE SUTHERLAND

*Member American Society of Civil Engineers  
Professor of Civil Engineering  
Lehigh University*

HARRY LAKE BOWMAN

*Member American Society of Civil Engineers  
Professor of Civil Engineering  
Drexel Institute of Technology*

JOHN WILEY & SONS, INC. · NEW YORK  
CHAPMAN & HALL, LIMITED · LONDON

COPYRIGHT, 1930, 1935, 1942, 1950

BY  
HALE SUTHERLAND  
and  
HARRY LAKE BOWMAN

---

*All Rights Reserved*

*This book or any part thereof must not  
be reproduced in any form without the  
written permission of the publisher.*

FOURTH EDITION

*Fifth Printing, May, 1956*

PRINTED IN THE UNITED STATES OF AMERICA

*Dedicated to*

CHARLES MILTON SPOFFORD

*in grateful appreciation of the debt  
owed him by the authors*



## PREFACE

As its name implies, this volume introduces the reader to the basic conceptions and principles of structural theory relating to trusses; rigid frames, and space frameworks. Its scope is somewhat more than that of the usual two- or three-semester undergraduate course in stress analysis offered in the engineering schools of this country. A fourth edition having become advisable, not only have certain additions been made in the material covered in the text but also advantage has been taken of the opportunity to rewrite much of the material with the object of simplification and clarification. Revision has been very extensive in the chapters dealing with slope and deflection, rigid frames, and indeterminate trusses. The problems have been left with small change since we have assumed that ours is the usual reaction when a new edition brings forth a new crop of problems, i.e., some unhappiness over extra work forced upon the instructor. There are more effective ways of dealing with the "fraternity file" than a fresh set of problems.<sup>1</sup>

Notable in present-day engineering instruction is the increasing emphasis being laid upon system and neatness in engineering computations. In the introductory chapter, in considerable part a review of basic mechanics, rules for computation work have been added, together with a sample problem solution. Another addition to this chapter is a brief consideration of the use of the virtual work theorem for reaction and bar stress determination, an addition made necessary by current technical discussions.

The chapter on graphic statics is complete in itself and will be found to contain sufficient material for the usual course in that subject, especially when linked to the succeeding chapter on roof trusses. The diagrams in this chapter have undergone considerable revision, chiefly with the view to making each serve a single function instead of two, as was formerly the case with several.

The importance of influence lines in stress analysis and also in facilitating the understanding of truss action in detail has justified their extensive use in the chapters dealing with truss and girder bridges and with long-span bridges. To the latter chapter has been added a brief treatment of the Wichert truss.

<sup>1</sup> For example, it is common practice to consider problem work as part of the instruction, required of the student but not made the basis of any grading unless done under supervision.

Beside extensive rewriting, the only notable change in the chapter on slope and deflection is the addition of solutions of compound trusses (e.g., the Fink truss) by means of the Williot-Mohr diagram.

Most extensively changed of all is the chapter on rigid frames. Besides a brief explanation of the fixed point in continuous beams, an addition required for providing an understanding of current technical discussion, and a considerable extension of the space given to the Morris method, the treatment of moment distribution has been supplemented by a fairly extensive consideration of members of varying moment of inertia. Criticism of our previous use of signs for the slope deflection equation has led to a return to the convention used in the first edition, modified as required by the modern practice of considering clockwise moments on a joint as positive.

The purpose of this book is made evident by certain significant omissions. The two-hinged arch and the suspension bridge are usually considered in graduate school; the hingeless arch is commonly studied in the course in reinforced concrete: therefore these subjects are outside the scope of a textbook planned for undergraduate use and only as an adjunct or reference in any graduate course. In many cases, however, the treatment of a subject will reach over into the graduate level, which suggests the desirability of occasional omissions for an undergraduate class.

In addition to the expression of appreciation made in previous editions, at this time we wish especially to acknowledge with thanks our debt to Professor John Charles Rathbun and other friends at the College of the City of New York, and to Dean Francis L. Castleman of the University of Connecticut.

HALE SUTHERLAND  
HARRY LAKE BOWMAN

*July 1960*

## TO THE STUDENT

There are no new principles for you to master as you study this book. Your study of physics (mechanics) put into your hands all the basic principles involved in structural design, and work in applied mechanics (statics, strength of materials) and the physical properties of materials enlarged your knowledge of these principles and their application. These facts and principles which you have already mastered are here considered in their application to the stresses in structures. In this volume we shall be concerned almost entirely with the subject of statics as involved in force systems. It is essential that the few simple principles governing such force systems be clearly and thoroughly in hand as you study the subject of structural stress analysis. It is advisable to carry on the reading of this text hand in hand with a review of statics. Too much emphasis cannot be placed upon the necessity of a clear and exact knowledge of basic principles.

Remember that this volume is introductory to the subject. There are depths of fact and theory probably not suggested by your previous work and only hinted at here. These will appear more clearly in a second volume on design, in preparation for which you will find it necessary to review strength of materials.

Perhaps the most characteristic mental faculty of structural designers is vision, the power of building up in the mind's eye a picture of the desired structure and its relations, which may be transferred to paper. The student should strive persistently to gain this faculty. Study always with pencil and paper at hand. Almost every element in this field can be represented graphically. Practice this constantly. The margins of your books should be full of neat explanatory sketches with clarifying notes, computations, and examples. In particular make notes to explain the units in which formulas and computations are expressed.

Above all avoid mere memorizing. Know the reasons for every step. Shun formulas (except the irreducible minimum) as the plague and instead think in terms of process and principle. Where a principle is written in algebraic language as a formula, indicate plainly on the page where it is printed, its exact function and limitations. If you memorize the formula, learn also these limitations.

One of the most troublesome habits that commonly handicap the beginner is that of trying to verify every point, every equation, as it is



reached. This is usually a hopeless task when the subject is complicated. The first endeavor should always be to gain an overall view of the topic, reading through the whole section rapidly. After an outline is in mind the details will usually be apprehended readily. In every textbook many a sentence which seems obscure is explained by what follows.

The most common ailment of students is paralysis, that attitude of mind and body which sits inertly before a problem or difficult point and wearily wonders what it all means. The cure is *action*. When a problem is to be solved, either one set as such or one that arises by failure to comprehend some statement, get into action rapidly: first, state the problem definitely, which in this field usually means drawing a free body diagram (see page 20) with its force system; second, rehearse the principles which apply to the problem; third, apply the principles.

Search for the simple proofs and the direct solutions. The literature of this subject is replete with elaborate and involved ways of doing what is best done by simpler and easier methods.

No one book is a complete text in any subject. The student, accordingly, will do well to own at least two textbooks on structural engineering and to form the habit of carrying on his intensive study in one with frequent cross-reference to the other.

*Note:* In this text, for purposes of illustration, free use has been made of structures which differ, often radically, from any in actual use. However, the unusual in practice will often present bar arrangements and other peculiarities every bit as difficult of analysis as any here given. Two motives have led to this use of the apparently impractical: first, the desire to simplify arithmetical labor and so facilitate focusing attention on the principle under discussion; and, second, the wish to compel the thoughtful application of a principle in place of a possible memory solution based on a previous example.

# CONTENTS

	PAGES
<b>Chapter 1. REACTIONS AND STRESSES</b> . . . . .	<b>1-40</b>
Introduction . . . . .	1
Framed Structures, definitions . . . . .	2
Stress Analysis: Reactions . . . . .	5
Computation Methods . . . . .	8
Virtual Work . . . . .	11
Shear and Bending Moment . . . . .	12
Method of Shears . . . . .	21
Method of Moments . . . . .	23
Method of Joints . . . . .	25
Rigid Trusses: Determinate and Indeterminate . . . . .	29
Distortion of Loaded Frames . . . . .	31
 <b>Chapter 2. GRAPHIC STATICS</b> . . . . .	 <b>41-72</b>
Force Systems in Equilibrium . . . . .	41
Composition of Forces . . . . .	42
Resolution of Forces . . . . .	43
Equilibrium Polygon . . . . .	44
Reactions . . . . .	46
Maxwell Diagram: Graphic Method of Joints . . . . .	47
Culmann's Method . . . . .	50
Shear and Moment . . . . .	52
Equilibrium Polygon as Curve of Bending Moment . . . . .	53
Equilibrium Polygon through Two and Three Points . . . . .	57
Three-Hinged Arch . . . . .	59
Lines of Resistance: Walls and Dams . . . . .	61
Arches . . . . .	64
 <b>Chapter 3. ROOF TRUSSES</b> . . . . .	 <b>73-85</b>
Definitions and Data . . . . .	73
Roof Loads . . . . .	76
Stresses in Roof Trusses . . . . .	79
 <b>Chapter 4. TRUSS AND GIRDER BRIDGES</b> . . . . .	 <b>86-150</b>
Definitions . . . . .	86
Weights of Bridges . . . . .	91
Dead Load Stresses . . . . .	92
Influence Lines . . . . .	94
Live Loads on Bridges . . . . .	100
Impact . . . . .	104
Maximum Stresses from Uniform and Excess Live Loads . . . . .	107
Reversal of Stress: Counters . . . . .	111
Concentrated Load Systems . . . . .	114

	PAGES
The Moment Diagram . . . . .	118
Absolute Maximum Moment . . . . .	122
Equivalent Loadings . . . . .	124
Long-Span Simple Bridges . . . . .	125
Trusses with Subdivided Panels . . . . .	126
..	
<b>Chapter 5. LONG-SPAN BRIDGES . . . . .</b>	<b>151-167</b>
The Three-Hinged Arch . . . . .	151
Cantilever Bridges . . . . .	157
The Wichert Truss . . . . .	161
Determinate and Indeterminate Structures . . . . .	162
..	
<b>Chapter 6. LATERAL BRACING AND PORTALS . . . . .</b>	<b>168-182</b>
Trusses with Multiple Web Systems . . . . .	168
Lateral Trusses . . . . .	169
Lateral Stresses in Curved Chord Bridges . . . . .	171
Portals and Bents . . . . .	174
Mill Building Bent . . . . .	177
Effect of Bridge Portal on Chords . . . . .	180
..	
<b>Chapter 7. SLOPE AND DEFLECTION . . . . .</b>	<b>183-229</b>
Introduction . . . . .	183
Method of Work . . . . .	184
Historical Note . . . . .	186
Beams: Method of Elastic Weights . . . . .	191
Deflection of Trusses . . . . .	197
Method of Elastic Weights . . . . .	197
Method of Elastic Weights: Bar Chain Method . . . . .	202
Williot-Mohr Diagram . . . . .	211
Maxwell's Law of Reciprocal Deflections . . . . .	219
Camber . . . . .	221
..	
<b>Chapter 8. RIGID FRAMES . . . . .</b>	<b>230-290</b>
Introduction . . . . .	230
Theorem of Three Moments . . . . .	230
Fixed Points in Continuous Beams . . . . .	235
Method of Least Work . . . . .	236
Method of Slope Deflection . . . . .	239
Method of Moment Distribution . . . . .	249
Morris' Method . . . . .	261
Members with Varying Moment of Inertia . . . . .	265
Method of the Column Analogy . . . . .	272
..	
<b>Chapter 9. WIND STRESSES IN TALL BUILDING FRAMES . . . . .</b>	<b>291-304</b>
Approximate Methods . . . . .	291
Method A: Cantilever Method . . . . .	291
Method B: Portal Method . . . . .	294
Results by Slope Deflection Method . . . . .	296
Method C . . . . .	296

# CONTENTS

xiii

	PAGES
Inaccuracies of All Methods . . . . .	301
Wind-Bracing Report . . . . .	302
Wind Loads and Allowable Unit Stresses . . . . .	302
Earthquake Stresses . . . . .	302
<b>Chapter 10. INDETERMINATE TRUSSES . . . . .</b>	<b>305-342</b>
Method of Least Work . . . . .	305
Method of Deflections . . . . .	311
Formulas . . . . .	313
Influence Lines . . . . .	317
Composite Structures . . . . .	332
Mechanical Analysis . . . . .	337
<b>Chapter 11. SECONDARY STRESSES . . . . .</b>	<b>343-363</b>
Introduction . . . . .	343
Mohr's Method . . . . .	344
Cross's Method . . . . .	355
Pin Joints . . . . .	357
Effect of Eccentricity . . . . .	357
Other Causes of Secondary Stress . . . . .	359
<b>Chapter 12. SPACE FRAMEWORKS . . . . .</b>	<b>364-389</b>
Force Systems in Space . . . . .	364
Reactions . . . . .	366
Statically Determinate and Statically Indeterminate Space Frameworks . . . . .	368
Bar Stresses . . . . .	370
Structures with More than Three Points of Support . . . . .	382
Towers . . . . .	383
<b>Index . . . . .</b>	<b>391-394</b>

## NOTATION

In general the meaning of all notation is explained as it appears in the text. The following symbols in common use appear at times without explanation.

- $M$  = moment, or bending moment
- $I$  = moment of inertia
- $E$  = modulus of elasticity
- $V$  = shear
- $s$  = normal stress intensity
- $L$  = span length
- $r$  = radius of gyration
- $w$  = load per unit of length

## The Parabola

The solution of problems involving the area between a parabola and its diameter or that between the curve and a tangent at the vertex is facilitated by the data in the figures herewith. When coordinate distances are desired in structural work, instead of using the ordinary

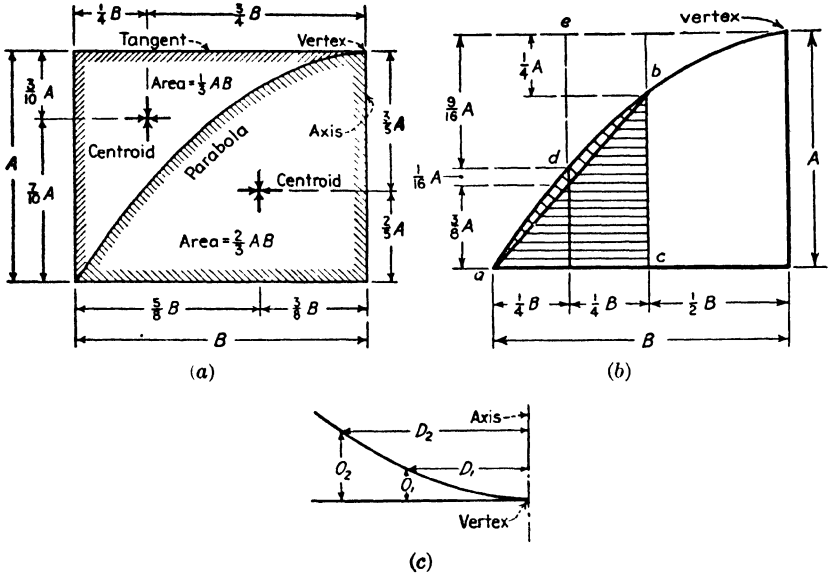

mathematical equation of the second-power parabola, it is better to express the relationship in words made familiar in surveying: offsets vary as the squares of the distances from the vertex, or, in terms of the dimensions shown in figure *c*,

$$O_1:O_2 = D_1^2:D_2^2$$

For sketching the curve and for other uses it is helpful to recall that for a parabola symmetrical about the *Y* axis, and with the origin at the vertex, the slope at any point is  $2y/x$ , or, in terms of the dimensions shown in figure *c*,  $2O_1/D_1$ .

Problems involving the area between a parabola and its diameter, or between a parabola and the tangent at its vertex, are common and are easily handled by aid of the data given in figures *a* and *b*. The shaded area under the curve in figure *b* equals the sum of the area of the triangle *abc* and the area between the curve and the segment *abd*, which equals that of a symmetrical parabola with base *ac* and central rise of  $A/16$ , using the dimensions chosen here for simple illustration, a total of  $3AB/16 + AB/48 = 10AB/48$ .

## Chapter 1

---

# REACTIONS and STRESSES

**1:1.** Buildings, bridges, towers, walls, and dams are the principal structures with which the structural engineer is concerned. Their design involves, first of all, the fitting of the structure, as a whole and in part, to the purpose it is intended to serve. A building to house a manufacturing plant must have the shape and size required by the processes of the industry, as limited by the lot and other factors. A bridge must be proportioned so that its roadway is at the proper elevation and so that there is sufficient clearance for the waterway or traffic underneath. Buildings, monumental bridges, and dams often have good appearance as a major element in their makeup and require the services of both the architect and the engineer. This planning of the broad features of a structure is possible only after long experience, rigorous training in the fundamental principles of design, and detailed economic study of all types of structures.

In this textbook we are concerned only with the load-carrying function of structures. Bridges, buildings, dams, and towers all have this element in common: each sustains the weight or pressure of certain loads, the carrying of which is a first and major purpose.

The determination of the loads which a given bridge or building should be proportioned to carry is often one of the most difficult and important tasks of the designer, one calling for mature judgment and experience. City building codes and bridge specifications define exactly the loads for ordinary structures, but the unusual in purpose or size always presents a subject for careful study. The data for such study are not given in the usual textbook but are to be gathered only from professional papers and records, from direct observation, and from experiment. A load which comes and goes upon a bridge or building is called a **live load** in contradistinction to the fixed or **dead load**, which is the weight of the structure itself.

The second preliminary task of the designer is the choice of the type of structure best suited to carry the given loads. Shall the building have a frame of steel or of reinforced concrete? Will a cantilever or a sus-

pension bridge be most economical across this wide river? How many spans and of what length will be most economical for use in this long viaduct? Such questions can be answered only by the detailed comparison of alternative designs and by the judgment gained by many such studies in the past. It is not the province of an introductory textbook to do more than hint at the chief reasons which determine the use of this or that type of framework.

With live loads known and a certain type of structure chosen, with its dimensions fixed as required by the situation, the next step is to estimate the dead weight, which of course constitutes a part of the total load to be carried. Formulas, curves, and tables (for example, see Art. 4:2) make it possible to estimate the final weight of many structures very closely, but it is always essential to check the actual weight of the structure as designed with the weight assumed. If the difference is great enough to warrant it, a second (or even third) design must be made, using a corrected dead weight based on the more exact determination resulting from the first trial. Failure to do this may result in a structure that is unsafe under its chosen maximum live load or, more usually, in one with too small a margin of excess strength to care for the increase of live load that generally comes with the development of railway and highway traffic on a bridge or that may come with expanding use of a building.

The actual process of design of a given frame to carry definite loads consists of three steps: first, an analysis which gives the stress in each and every part; second, dimensioning, or the determination of the cross-sectional dimensions of each part; third, preparation of general plans giving all the needed information for detail drawings and construction. The first step, stress analysis, is the subject of this volume. The other two topics are treated in books on structural design.

**1:2. Framed structures.** There are three basic types of structural members: **ties**, pieces subjected to axial tension only; **columns** or struts, pieces subjected to axial compression only; **beams**, members with transverse loading, subjected to shear and bending moment only. The **shaft**, a piece carrying torsion only, is rarely met with in ordinary structures. Any piece, by the nature of its loading, may be a combination of two or more of these basic types; for example, a horizontal timber supported at the ends and carrying an inclined load is a combination of a beam and a column or tie, depending upon the position of the horizontal reaction component.

In this textbook these terms (ties, columns, and beams), when used without qualification, will apply strictly to members as above defined. In common practice a beam is any piece the major part of whose load is

normal to the beam axis, a column or tie one with longitudinal loading either axially or eccentrically applied.

All four basic types of stress-carrying members are used in machines, which may be defined as assemblages of parts designed to produce certain desired motions. A machine in service under its loads, then, is wholly or in part in motion; most framed structures are at rest under their loads. However, certain structures, such as movable bridges and automobile, car, and airplane frames, are often in motion. But in contrast with machines, when in service carrying loads all parts of structural frames are at rest relative to each other. Many engineering constructions combine machine and structural elements. It must be remembered that the design of machines involves dynamic stress effects of great importance which are not indicated by the usual static stress analysis. This fact was brought forcibly to the attention of bridge engineers by the failure in 1928 of a movable bridge over the Hackensack River in New Jersey.<sup>1</sup>

A **framed structure** is an assemblage of structural members arranged to carry the given loads. There are two basic types of frames, the **truss** and the **rigid frame**.

A **truss** (Fig. 1:1) is a frame made up of pieces lying in a single plane joined only at their ends. Under theoretically ideal conditions the junction of the pieces is by means of frictionless pins through pin holes on the axes of the several bars, and the loads, which lie in the plane of the truss, are applied to the pins. By this arrangement only direct compression or tension<sup>2</sup> exists in any member, except the small amount of bending stress due to the dead weight of horizontal and inclined pieces.

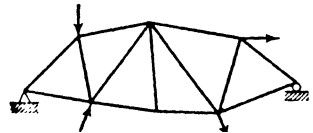

FIG. 1:1

Actually the ends of steel truss members are joined by pins which are far from frictionless, or by riveting to a common gusset plate, or by welding. In any case a certain amount of bending is inevitably introduced into all truss members by their end connections, but this is ignored in ordinary calculations and designs. The direct stresses of tension and compression computed under the assumption of frictionless joints are called **primary stresses**; those due to bending, incidental either to the rigidity of the end connection or to beam action under

<sup>1</sup> *Engineering News-Record*, June 6, 1929.

<sup>2</sup> If this is not obvious, sketch a single truss member lying in a horizontal plane. Show that it is not in equilibrium unless the two end forces are equal and opposite and have the same line of action.



the dead weight of the piece, are called **secondary stresses** (Art. 11:1).

Practically all structural trusses are self-contained, rigid affairs, not dependent upon the supporting reactions for maintaining their shape. This rigidity is ensured by their being either an assemblage of triangles (Fig. 1:1) or two or more triangle assemblages rigidly connected (truss H of Prob. 1:16).<sup>3</sup>

A **rigid frame** differs from a truss in that the members are fastened rigidly together at the joints in such a manner that no change is possible in the angles between the several pieces there meeting. It is obvious that the frame shown in Fig. 1:2 would not be stable unless it were rigid at the joints.

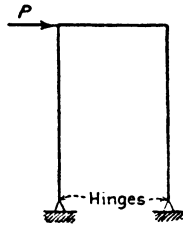

FIG. 1:2

Most structures with which the engineer has to do are composed of two or more planar frames connected by bracing. For example, the bridge shown in Fig. 1:3 is composed of a floor system (a series of beams supporting the railroad track) supported by two vertical trusses which are the essential parts of the structure. These trusses are planar frames and are joined not only by the floor system but also by an upper and a lower horizontal truss whose several parts and functions will be described later. Similarly the viaduct tower shown in Fig. 1:4 con-

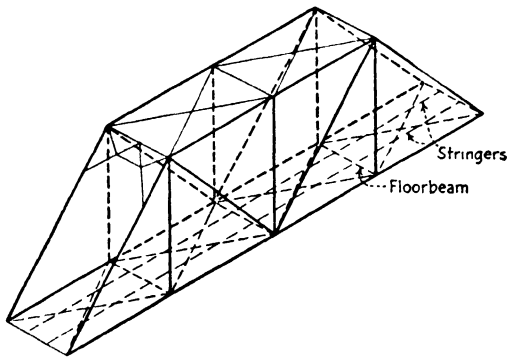

FIG. 1:3

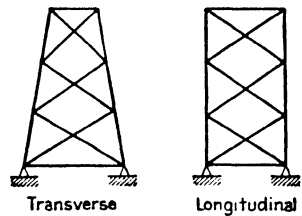

FIG. 1:4

sists of four planar trusses acting as cantilever beams, each tower leg being a common member of two trusses. In Chapter 12 consideration will be given to frames which are composed of a series of triangles not

<sup>3</sup> An interesting general theory of plane trusses is given in the second chapter of *Theory of Structures* by Timoshenko and Young (McGraw-Hill). By their classification the two types of trusses above described are named the *simple* and the *compound truss* respectively.

in the same plane, which cannot be resolved into a series of planar trusses. These are called **space frameworks**.

**1:3. Reactions.** In structural design a **force** (that which tends to change the direction or rate of motion of a body) is always a push or pull; it is either the gravitational pull upon a body, or the push or pull of one body upon another at a point of contact (often due to the weight of the first body), or the push or pull of one part of a member upon the rest at any imaginary section separating the two parts. This last is called an **internal force** or **stress**.

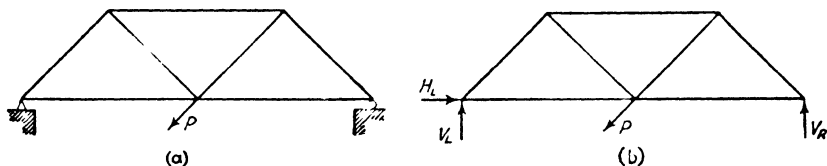



FIG. 1:5

In order to be determined completely three things must be known about a push or a pull, i.e., about a force: (1) a point on its line of action, usually the point where the force is applied to some given body; (2) the slope of its line of action; (3) the magnitude of the force, together with its sense, toward or away from the body on which it acts.

On first thought it would seem that these give a total of four essential attributes of a force. Consider, however, a concurrent coplanar force system with every element known except the magnitude and sense (toward or away from the point along a given line of action) of one force. The solution of a single equation will give both this magnitude and sense, just as in mathematics the solution of a single equation tells the number of units in an unknown and also whether these units are positive or negative. Evidently sense is not a separate and independent element.

It is generally more convenient to deal with the components of an inclined force than with the force itself. If we wish we may think of the three necessary elements of a force as the point of application and the magnitude (and sense) of each of two components (three components if dealing with non-planar systems).

The problem of reaction determination may most easily be explained by consideration of the loaded truss shown in Fig. 1:5. At both ends are supports, and the symbols of Fig. 1:5a need explanation. This symbol  indicates a pin (assumed frictionless) support. The point of application of the supporting force is taken as definitely fixed, but not its direction, which may be inclined at any angle *either upward*

or downward. The second symbol  $\overline{\overline{\overline{\text{O}}}}$  indicates that the physical construction (using rollers or links, etc.) at this point is such that the resulting reaction is normal to the supporting surface, acting *either away from the surface or toward it*.

The inclined force,  $P$ , brings into action the supporting forces (reactions) shown in Fig. 1:5*b*, and the truss is at rest under the action of these external forces ( $P, V_R, H_L, V_L$ ) which form a balanced coplanar non-concurrent system. In this case it is at once realized that the three conditions of equilibrium<sup>4</sup> of such a force system, usually expressed as  $\Sigma H = 0, \Sigma V = 0, \Sigma M = 0$ , furnish the three equations needed for the determination of the three unknown elements of reactions ( $H_L, V_L$ , and  $V_R$ ) due to the load  $P$ . Since the reactions may be found by the aid of the principles of statics, the truss is said to be *statically determinate* as regards outer forces.

In Fig. 1:6 is shown a familiar structure (a beam) which is *statically indeterminate* as regards the outer forces. There are four unknown reaction elements (one horizontal component and three verticals) and only three equations of statics. The student will recall how, in his study of strength of materials, he derived the needed fourth equation by making use of the elastic deformations of the beam.

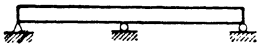

FIG. 1:6

The outer force system acting upon a body is made up of loads and reactions or supporting forces. The first step toward stress analysis usually is the computation of the reactions brought into play by the given loading. The general procedure for reaction calculations is illustrated by Ex. 1:2 following. It will be seen that the truss of this example has been treated as a free body, i.e., all contact with other structures has been eliminated, and the loads and reactions at surfaces of contact have been represented by arrows.

In order to determine whether a structure is statically determinate as regards the outer forces it is necessary to note whether the number

<sup>4</sup> It will be recalled that every non-concurrent coplanar force system in equilibrium satisfies three conditions:

$\Sigma X = 0$ , that is, the algebraic sum of the force components acting parallel to any axis in the plane of the forces equals zero;

$\Sigma Y = 0$ , that is, the algebraic sum of the force components acting parallel to a second axis in the plane and perpendicular to the first axis equals zero; and

$\Sigma M = 0$ , that is, the algebraic sum of the moments of *all* the forces in the system about *every* axis at right angles to the plane of the forces equals zero.

Since three independent conditions must be satisfied, three independent equations may be written, and the unknowns in the system may be found provided these number three.

of unknown reaction elements equals that of the independent equations of equilibrium of the appropriate force system. This is illustrated in the following example.

**Example 1:1.** Are the structures shown in Fig. 1:7 statically determinate as regards the outer forces?

*Note.* When such a question is propounded, do not answer "yes" or "no." Instead proceed as below.

*Ans.* (Fig. 1:7a.) At A the point of application of the reaction is known, at B the point of application and the line of action. Accordingly there are two unknown elements of reaction at A for any system of loading and one unknown at B, or total of three unknowns. There are three conditions of equilibrium:  $\Sigma M = 0$ ,  $\Sigma V = 0$ ,  $\Sigma H = 0$ . Accordingly the three unknowns may be found, and the truss is statically determinate as regards the outer forces.

Or briefly, unknowns: 1 magnitude at B, 1 magnitude at A, 1 line of action at A; total 3. 3 equations of statics.  $\therefore$  Determinate.

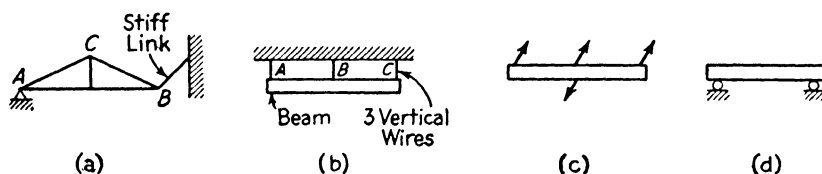

FIG. 1:7

A link is a piece acted on only by forces applied at two pin holes, one at each end.

*Ans.* (Fig. 1:7b.) There is no resistance available here to an upward force, and for such a system the structure is unstable.

A downward inclined load would cause a change of position to enable the wires to carry the horizontal force component as shown in Fig. 1:7c.

Accordingly, knowns: 3 points of application, 3 lines of action; unknowns: 3 magnitudes; equations: 3 of statics. At first thought the reply would be as before, determinate, but if the 3 equations are set up it will be discovered that that for  $\Sigma H = 0$  reduces to the same as that for  $\Sigma V = 0$ . There is actually one less equation than unknown, and the structure is statically indeterminate to the first degree.

This may be seen in another way. It will be recalled from statics that for a system of coplanar parallel forces to be in equilibrium only two conditions need be satisfied: the algebraic sum of the forces must be zero, and the sum of the moments about any moment center must be zero. Since only two conditions need be satisfied, only two independent equations may be written and the system is therefore statically indeterminate.

*This result emphasizes the fact that it is necessary not only to compare the number of unknowns and of equations but also to be sure that the equations are independent and that their use leads to a solution.*

*Ans.* (Fig. 1:7d.) For a system of vertical forces this is statically determinate: two unknowns and two equations,  $\Sigma V = 0$  and  $\Sigma M = 0$ . For non-vertical forces we have three conditions of equilibrium, the third condition being  $\Sigma H = 0$ , and only two unknown reaction elements. The structure is not stable, being unable to resist horizontal forces.

The problem of truss reaction determination which follows (Ex. 1:2) serves not only for a review of the application of the principles of statics involved but also to emphasize the necessity of determining the load acting upon the structure whose reactions are sought. The example also illustrates a matter of the first importance in structural engineering, the neat and systematic carrying through of computation work. In actual practice a checker reviews the figures of a computer, and the calculations must be put down with a view of making every step clear to him. In important work it is necessary to file computations for future reference and for legal scrutiny. The structural designer must be able to turn out clear, correct computations with the utmost speed consistent with accuracy. This training cannot begin too early. After the computation sheet of Ex. 1:2 are given rules to which students should conform in their work.

**Example 1:2.** Determine the reactions for the loaded truss shown in Fig. 1:8. Note that the cylinder is supported in part by the cable and in part by the truss.

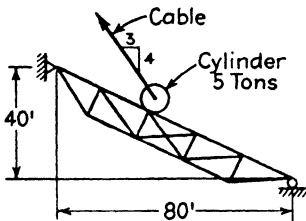

FIG. 1:8

*Comments.* See computation sheet. The cylinder is a free body acted on by the balanced force system consisting of its own weight, the pull of the cable, and the push of the truss. An algebraic solution of the force triangle for these three forces gave the desired push of the truss on the cylinder which is the opposite of the load acting on the truss, which must be known before the reactions can be found. Always find the load on the structure to be analyzed.

Next the truss was taken, a free body acted on by a balanced force system consisting of the load just found and the unknown reactions. These unknowns were found by application of the conditions of equilibrium.

Note that the unit of force used was the **kip** (kilopound or thousand pound unit).

**Computation rules.** 1. Work on quadrille ruled paper, four or five divisions to the inch. Rule top and side margins. In top margin enter course number (in school work), date, computer's name, number and page of problem, sheet number, and total number of sheets used for the problem. A firm black pencil, 2H to HB, is suggested. Do not use

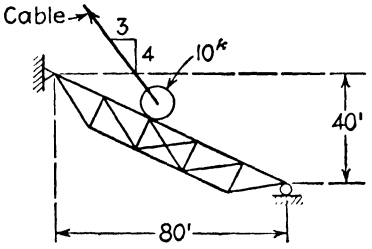
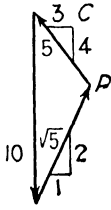
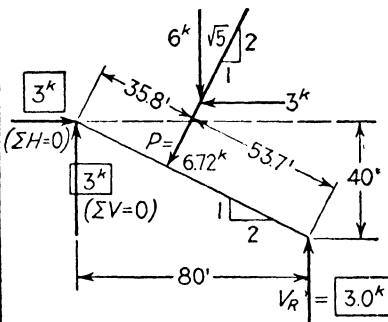
	Date	Name	Ex. 1:2	1 of 1
	 <p>Reactions = ?</p>			Data
	 $\sum H = 0 \quad \frac{1}{5}P - \frac{3}{5}C = 0$ $\sum V = 0 \quad \frac{2}{5}P + \frac{4}{5}C - 10 = 0$ $P \left( \frac{2}{5} + \frac{4}{5} \cdot \frac{5}{3} \right) = 10$ $P = 10 \cdot \frac{3\sqrt{5}}{10} = 6.72^k$			Load on Truss
	 $\sum M_L = 0$ $35.8 \times 6.72 - 80 V_R = 0$ $V_R = 3^k \uparrow$			Reactions
	$\sum M_R = 0$ $53.7 \times 6.72 = -361$ $80 \times 3 = +240$ $40 \times 3 = +120$ $\frac{-361 \quad +360}{\quad \quad}$ <p style="text-align: right;">OK.</p>			Check

EXAMPLE 1:2. Computation Sheet

ink, except, if desired, for the statement of data with sketch. All work is to be lettered: no script.

2. Set off the logical divisions of the solution in separate boxes in so far as that contributes to clarity. Avoid undue stretching out of a computation. Make answers prominent and show on sketch.

3. In the top box give a terse abbreviated statement of the problem with sketch and all necessary data.

4. Show each step clearly, but it is not necessary to overemphasize the obvious in the matter of oft-repeated, familiar operations. For example, in this simple case, after applying the equation  $\Sigma M = 0$  to find the right-hand reaction, the left-hand reaction components were found mentally by applying the other two equations of equilibrium, the operation being indicated simply by giving the equation used underneath the result.

5. Note the following procedural items:

a. The use of slopes without reference to trigonometric functions.

b. The use of the load components.

c. The evident use of a scratch pad in determining the length of truss chord along the slope (or a slide rule may have sufficed). A scratch pad is a great help if its use is not abused, whereupon it becomes a hindrance to progress. Do not work out problems on scratch paper and then copy. A computation sheet should represent first-hand work and no copying.

d. The manner of arranging the equation  $\Sigma M = 0$  in the check computation. This vertical tabulation is always advisable whenever the equation to be solved contains three or more terms.

e. The careful noting of force units and directions in the giving of results and elsewhere as required for clarity.

f. The use of a label (or the algebraic form) preceding each numerical equation as indication of the operation being performed.

**Example 1:3.** Determine the reactions of the beam shown in Fig. 1:9a. (Two beams, side by side, would probably be used for this structure; for the purpose of this example, the two may be treated as one.)

*Solution.* Two solutions are shown. The first, and simpler, would be followed if the reactions alone were desired. The second takes as loads on the beam the forces which act at the sheave axles. These forces are needed in the following article when it is desired to draw shear and moment curves.

*First Solution.* The entire structure, taken as a free body (Fig. 1:9b), is in equilibrium under the action of two loads (one horizontal, one vertical) of 5000 lb each and the three reaction components. Taking moments about the left point of support, assuming  $V_R$  to act upward,

$$\begin{aligned} -5000 \times 2 + 5000 \times 6 + 18V_R &= 0 \\ V_R &= -1110 \text{ lb} \quad \downarrow \end{aligned}$$

The negative result indicates action in a direction opposite to that assumed.

By use of the equation  $\Sigma V = 0$ ,  $V_L = 6110 \text{ lb } \uparrow$ .

By use of the equation  $\Sigma H = 0$ ,  $H_R = 5000 \text{ lb } \leftarrow$ .

*Second Solution.* If a single sheave be taken as a free body (Fig. 1:9c), it is evident from the geometry of the figure that the two equal forces acting on the rim may be replaced by a resultant which will pass through the axle. At this point the resultant may be resolved into components parallel to and equal to

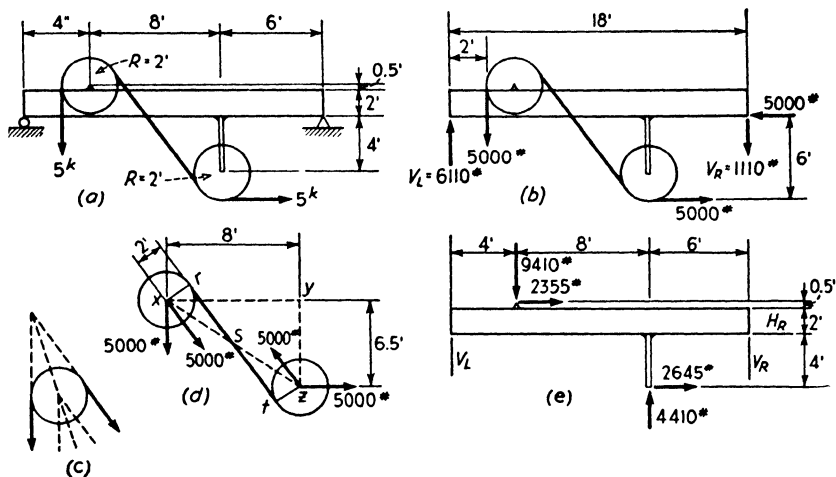

FIG. 1:9

the original forces. Hence it may be assumed (Fig. 1:9d) that at axle  $x$  there act a vertical force and an inclined force parallel to  $rt$ , and at  $z$  a horizontal force and an inclined force parallel to  $rt$ . Solving triangle  $xyz$ ,  $xz = 10.32 \text{ ft}$ ,  $yz = \tan^{-1} 6.5/8 = 39^\circ 5'$ ; angle  $xyz = 50^\circ 55'$ . From right triangle  $tsz$ , in which  $sz = 5.16 \text{ ft}$  (= one-half of  $xz$ ), angle  $tsz = \sin^{-1} 2/5.16 = 22^\circ 48'$ . (These slide-rule solutions should come without difficulty.) Therefore, the inclined forces of 5000 lb make angles of  $50^\circ 55' - 22^\circ 48' = 28^\circ 07'$  with the vertical and have the following components: horizontal 2355 lb, vertical 4410 lb. The loads on the beam may now be taken as shown on Fig. 1:9e. Using these, determine the reactions. Make sure that they are the same as those of the first solution.

**Virtual work.** Until recently the theorem of virtual work (or virtual displacements or virtual velocities) has had a place in American structural literature practically only as related to the computation of deflections. It is now coming into some consideration for use in reaction and truss stress computations.

The theorem may be thus stated: *if a small virtual displacement is given to a free body in equilibrium under the action of a balanced force*



system, the total work done by this force system in moving equals zero. Proof is hardly necessary beyond pointing out that the movement is very small, so that negligible change is made in the several balancing forces and the movement is entirely independent of, and unrelated to, the force system. It is intended that this be indicated by the labelling word *virtual*.

**Example 1:3a.** Determine the left vertical reaction on the beam of Fig. 1:9a by the method of virtual work.

*Solution.* Assume a vertical force  $V_L$  acting upward at the left end and let this point of application move a small distance  $d$  downward. Each of the two cable tensions shown moves, thereupon, a distance proportional to the distance of its line of action from the center of rotation of the whole beam, the right supporting point. The equation expressing the resulting work is as follows:

$$- V_L \times d + 5 \times \frac{1}{8}d + 5 \times \frac{1}{8}d = 0$$

$$V_L = +\frac{1}{18} = +6.11 \text{ kips}$$

i.e., upward as assumed.

**1:4. Beams: Shear and bending moment curves.**

In the preceding article the basic conceptions of statics have been reviewed briefly and informally. It is also necessary to get clearly in mind certain conceptions developed in the study of strength of materials.

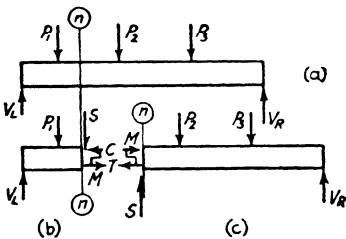

FIG. 1:10

In Fig. 1:10a is shown a horizontal beam carrying concentrated loads. At any section normal to the beam axis, as  $n$ , the shear is the algebraic sum, or resultant, of the transverse (normal to the longitudinal axis of the beam) forces on either side of the section.

The bending moment at any normal section, as  $n$ , is the moment about the centroidal axis of the section of all the forces on either side of the section. This definition includes those cases where inclined and eccentric longitudinal forces act on the beam as well as the case where all forces act normal to the beam axis. The utility of these conceptions is evident by consideration of the two free bodies shown in Fig. 1:10b-c. The free body on the left of section  $n$  is in equilibrium under the action of the force system consisting of the external forces  $V_L$  and  $P_1$  and the fiber stresses acting on the section  $n$ . The resultant of the shearing components of internal fiber stress is indicated as  $S$  and the resultants of the normal fiber stresses as  $C$ , resultant compression, and  $T$ ,

resultant tension. Since this free body is in equilibrium, these forces form a balanced coplanar non-concurrent system and the conditions of equilibrium of such a system enable us to evaluate the unknowns, in this case the internal stresses. (It is, of course, immaterial whether the left- or right-hand free body is taken.) Applying the condition  $\Sigma V = 0$  gives  $S = V_L - P_1$ , which is the shear. In other words, **the internal shear equals the shear computed from the external forces.** Applying the condition  $\Sigma M = 0$  similarly shows the moment of the couple ( $\Sigma H = 0$  and so  $C = T$ ) formed by the internal normal fiber stresses equal to the (bending) moment of the external forces to the left of section  $n$  about the section: **the resisting moment equals the bending moment.** In order to determine the unit fiber stresses in a beam and so judge its adequacy it is necessary to know the magnitude of the shear and moment at the section where the stress is being computed. The relations between internal stress and external load for beams of homogeneous material, with sections symmetrical about the plane of forces, are given by

$$s_s = \frac{VQ}{bI} \quad 1:1$$

and 
$$s = \frac{My}{I} \quad 1:2$$

where

$s_s$  = intensity of horizontal and vertical shearing stress in any given beam fiber (pounds per square inch).

$V$  = external shear at the section (pounds).

$Q$  = statical moment about an axis through the center of gravity, or centroid, of the portion of the cross section on either side of the fiber where the shear is being computed (inches<sup>3</sup>).

$b$  = breadth of the cross section at the level of the given fiber (inches).

$I$  = moment of inertia of the cross section about the centroidal axis (inches<sup>4</sup>).

$s$  = intensity of normal fiber stress in a fiber distant  $y$  inches from the centroidal axis (pounds per square inch).

$M$  = bending moment at the section (pounds-inches).

$y$  = distance from centroidal axis to the fiber where the normal stress intensity is being computed (inches).

Note that these equations are homogeneous, i.e., of equal dimensions on either side of the equality sign; for example, considering equation 1:1:

$$\frac{\text{lb}}{\text{in.}^2} = \frac{(\text{lb}) (\text{in.}^3)}{(\text{in.}) (\text{in.}^4)}$$

It is important to form the habit of rigorous inspection of equations for homogeneity of units, thus preventing error.

By definition shear is considered positive when the part to the left of the section tends to move upward under the action of the external forces; moment is considered positive when it tends to bend the member concave upward. (See Fig. 1:11.) As shown in Fig. 1:10*b-c*, the shear and moment at  $n$  are both positive, the resultant transverse force to the left of  $n$  acting upward and the moment causing compression in the top fibers.

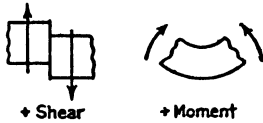

FIG. 1:11

The sign conventions for shear and moment hold as given for both horizontal and sloping beams. For a vertical beam it is common to consider the left side the top, as would be given by the usual drafting-room

convention. In continuous construction, with members placed horizontally, vertically, and at other angles, an excellent rule for plotting bending moment is to place the ordinates on that side of the member where compression exists, making no use of sign designations. Some, however, prefer to plot values on the tension side.

The authors have observed that much difficulty comes with failure to remember what "shear" and "bending moment" mean: they are simply labor-saving terms used to avoid saying "the resultant of all the transverse forces to the left of the section," "the moment of all the forces to the left of the section about the section." In time of confusion drop the short-cut and use the long statement.

A quick review of shear and moment may be had by checking the curves of Fig. 1:12. One method of constructing these curves would be to write the equations of shear and moment in each of the four sections into which the beam is naturally divided. Working from the left, we have, for a section  $x$  ft from  $A$ ,

$$V_{EB} = -x + 20 - 15 + 25$$

$$M_{EB} = \frac{-x^2}{2} + 20(x - 5) - 15(x - 10) + 25(x - 20)$$

As a check on the work, one comes to the end of the beam with the proper value known to obtain there. This method is, however, rather cumbersome. In particular it is poor practice to work always from one end of the beam: one should always work from both ends toward the middle.

From our training in the mechanics of materials we know these im-

portant relations (Fig. 1:13):

a. the ordinate of the (load / shear) curve equals the slope of the (shear / moment) curve;

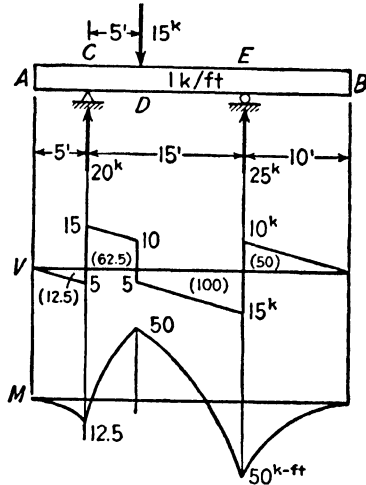

FIG. 1:12

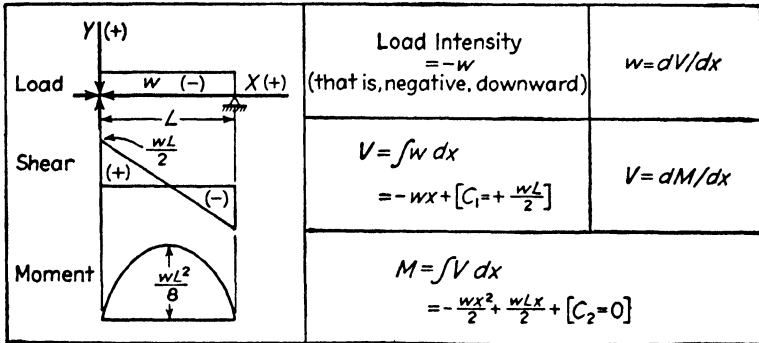

FIG. 1:13

b. the area of the (load / shear) curve between any two points equals the difference in ordinates of the (shear / moment) curve between the same two points.

The drawing of these curves is greatly facilitated by the use of these relationships. For example, in Fig. 1:12 the constant negative ordinate

of the load curve indicates constant negative slope of the shear curve. The shear curve areas, noted in parentheses in the figure, used in conjunction with the shear curve ordinates, which indicate moment curve slopes, make it easy to draw the moment curves directly without use of the equations for bending moment. In this case the moment curve must start at A with zero ordinate and zero slope (shear being zero), and must have increasing negative slope to the right with an ordinate at C equal to 12.5 kip-ft (the area of the shear curve between A and C). Note that the algebraic sum of the shear curve areas equals the known difference (zero) of the bending moments at A and B.

**Example 1:4.** Draw the curves of shear and moment for member AB, Fig. 1:14.

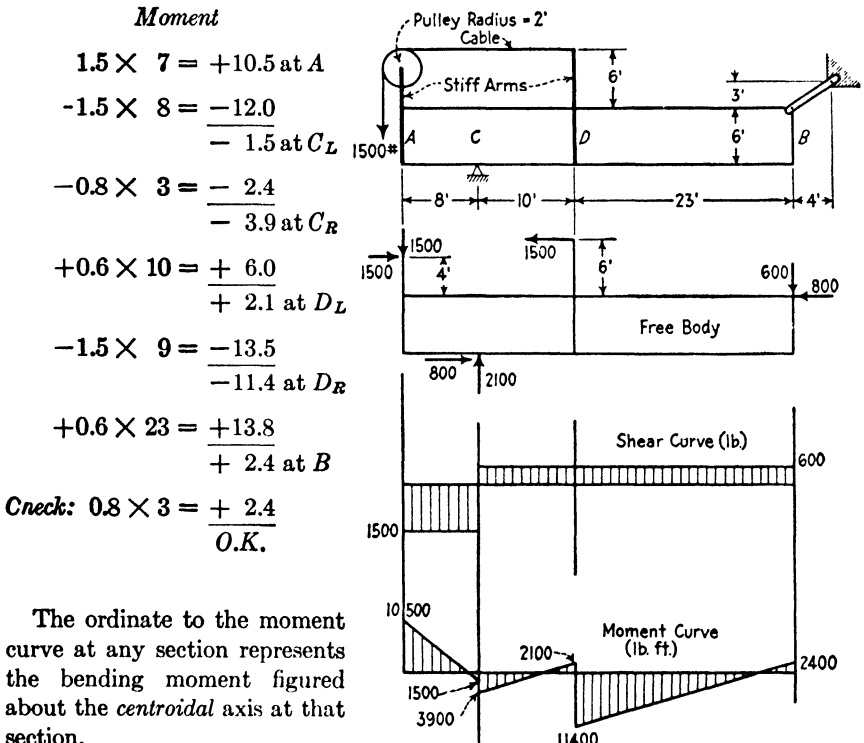

FIG. 1:14

*Comments.* The only computations of interest here are those relating to the moment curve, the reactions and the shear curve being easily verifiable.

The calculation of ordinates for the moment curve started from the left end, A, where a bending moment of 10,500 ft-lb is applied, causing compression in the top fiber. The situation at this end of the member is similar to that of a

short piece with a longitudinal load,  $P$ , eccentrically applied at a distance  $e$  from the axis (Fig. 1:15a). No change in deformation results from adding at the section opposed longitudinal forces, each equal to  $P$ , acting along the axis. The effect of the original loading, then, may be considered as equal to an axial load at  $P$  and a couple,  $P \times e$ . In our example we are considering only the transverse loading and moments; the longitudinal axial force does not affect either the shear or the moment curve.

The moment computation proceeds, always obtaining the total moment of all the forces on the left of the section. At the right end,  $B$ , the result was checked by taking the moment of the forces on the right of the section.

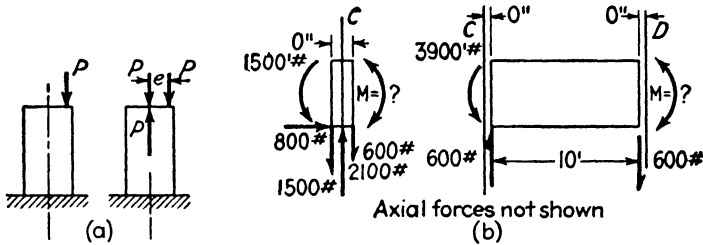

FIG. 1:15

The calculation of the moment on the right of  $C$  from that on the left, and of the moment at  $D$  from that to the right of  $C$ , is explained by the two free bodies shown in Fig. 1:15b.

In the first case the known transverse forces (obtained from the shear curve) and the moment acting on the left were shown acting in the proper directions and the unknown moment at the right face of the free body indicated. This unknown moment was computed by following the definition of bending moment as the moment of all the forces to the left of the section about (in this case) the intersection of the section with the long axis of the piece.

It is common to express this process as a theorem: *the moment at any section of a beam equals that at any other section plus (or minus) the shear at the other section times the distance between sections, plus (algebraically) the moment of all loads between the sections.* It will be seen that as soon as moment and shear are visualized as definite forces the usual definitions may be followed very simply with no thought of special theorems.

**Important.** Check these curves by use of the relationships preceding this example (Fig. 1:13). To illustrate, the load intensity from  $A$  to  $C$  is zero; hence, the shear curve has zero slope. The negative shear curve area from  $A$  to  $C$  is  $-12,000$  kip-ft; accordingly, the difference in moment from  $A$  to  $C$  is also  $-12,000$  kip-ft; etc.

If it were desired to compute fiber stress at a section of the beam, it would be necessary to use the familiar formula

$$s = \pm \frac{P}{A} \pm \frac{My}{I}$$

where  $P$  is the direct load (for example,  $-2300$  lb between  $C$  and  $D$ ), and  $A$  is the area of the cross section of the beam.

**Example 1:5.** Draw the shear and moment curves for the beam shown in Fig. 1:16.

*Discussion.* The purpose of this example is to illustrate an important relationship, and the values given are, accordingly, of greater precision than is usually desirable, since thus they facilitate checking. Before proceeding to Fig. 1:17 check the values of Fig. 1:16, using the load-shear-moment relationships to verify the slopes of shear and moment curves and the moment ordinates, starting with  $M_a = +1581 \times 1.5 = +2371$  lb-ft.

In Fig. 1:17a is shown the  $CB$  portion of the loaded beam of the previous figure, together with the internal shears and moments thereon acting. Note that this  $CB$  length is in equilibrium under the action of the load system shown.

This 18-ft length of beam may be considered as carrying two independent sets of loads, one of 160 lb per ft over its length, the other the two end moments shown. In Fig. 1:17b-c these two load systems are shown together with the resulting end reactions (shears): e.g.,  $(54,828 + 26,550)/18 = 4521$  lb. Then the shear and moment curves have been drawn for each load system, just as though we were dealing with a simple end-supported beam.

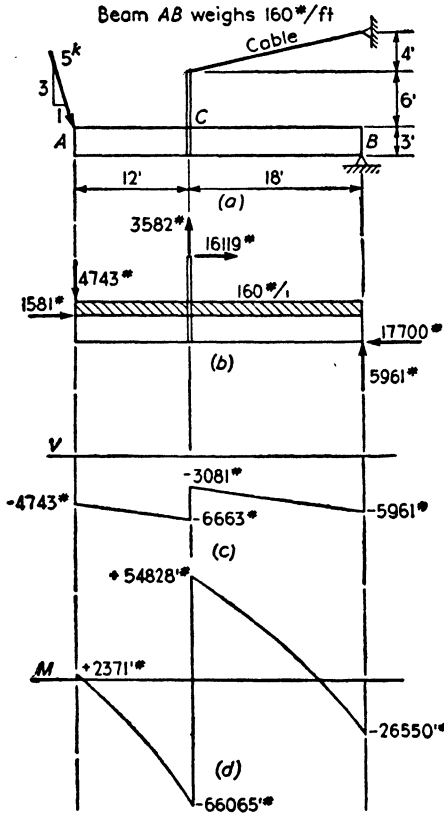

FIG. 1:16

If we add the ordinates of these two shear curves, we get those of Fig. 1:17d; adding the ordinates of the two moment curves gives those of Fig. 1:17e. This combining, we note, has brought us back to the shear and moment curves of Fig. 1:16. This combining process is called "superposition." It all follows from the fact that the whole equals the sum of all its parts.

The thing which we wish to note here is that the solid-line moment curve of Fig. 1:17e is lifted above the straight dotted line at all points an amount equal to the ordinates of Fig. 1:17b'': which leads to the following theorem.

**If any two points on the moment curve of a beam are joined by a straight line, the vertical intercepts between this line and the moment**

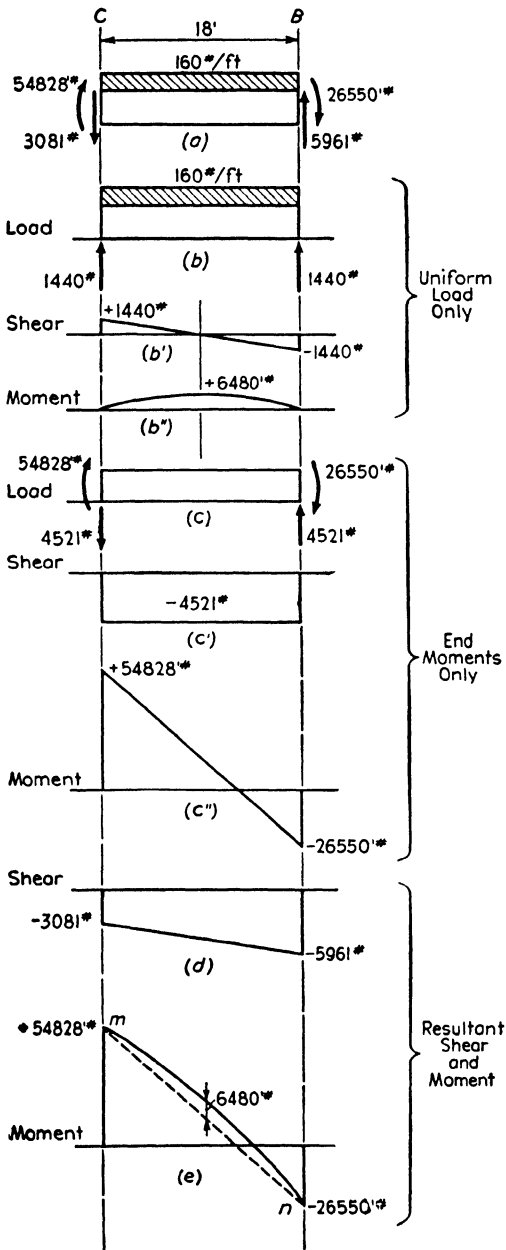

FIG. 1:17



curve will be the same as the ordinates of the moment curve of that part of the beam considered as a simple beam carrying the superimposed loads which come upon it in that length.

**1:5. The free body.** A loaded truss deflects under the action of the external forces, and each bar shortens or lengthens slightly. The first step in determining the stress which causes the change of length of any bar is to isolate a convenient portion of the truss from the rest by means of a section cutting the given bar, as is shown in Fig. 1:18a. This isolated portion is at rest under the action of a balanced force system consisting of the stresses in the bars cut by the section and the external forces, including the reaction, if any. Any part of a truss (or the whole, as in Fig. 1:5b) may be taken as a **free body**, i.e., a body which has all contact with other structures eliminated and has the forces (external and internal) acting upon it and the reactions (which act, or may act, at surfaces of contact) shown by arrows. All stress analysis is based upon the assumption that any part of a structure may be cut by a section and isolated from the remainder provided that, at the section where a member is cut, the effects of the removed portion—the shears, moments, and direct stresses — are represented by forces on the remaining portion which is to be considered. Usually these effects of the removed portions are unknowns which may be determined by the equations of statics.

The free body shown in Fig. 1:18a is in equilibrium under the action of the balanced non-concurrent coplanar force system consisting of the external force  $V_R$  and the bar stresses  $F_1$ ,  $F_2$ , and  $F_3$ . Just as the three conditions of equilibrium of such a system may be applied to the force system acting upon a free body consisting of the whole truss in order to find the reactions, so they may be applied to the free body shown in Fig. 1:18a in order to compute the three unknown bar stresses. By the use

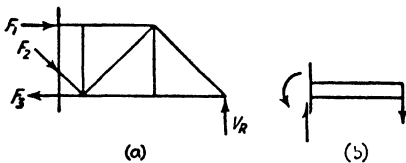

FIG. 1:18

of a series of properly chosen free bodies all the bar stresses of this truss may be determined. Similarly, as shown in Fig. 1:18b, a section may be taken as desired through a beam and the moment, shear, and internal fiber stresses computed.

The operation of stress analysis, once the external force system has been completely determined, consists simply in this repetition of the determination of the unknown forces (bar stresses in a truss; moments, thrusts, and shears in a rigid frame) acting upon a series of properly chosen free bodies, by application of the conditions of equilibrium of the force systems involved. This is the fundamental picture to grasp firmly in mind.

**In determining bar stresses:**

- (1) isolate a portion of the structure under consideration from the rest by an appropriate section;
- (2) picture carefully the complete force system acting on this free body, consisting of external forces and the stresses in the bars cut by the section; and
- (3) apply the conditions of static equilibrium of the force system to find the unknown stresses.

There are certain exceptions of detail in this procedure when the truss contains more bars than will permit solution by statics. These will be treated later.

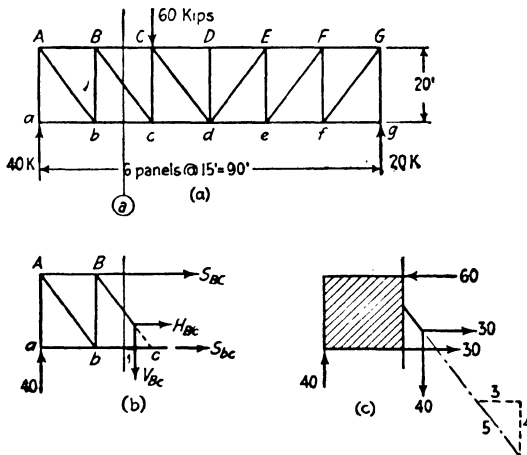

FIG. 1:19

**1:6. Trusses. Stress analysis by the methods of shears and moments.** The utility of shear and bending moment in connection with truss analysis is shown by study of the Pratt truss in Fig. 1:19. As a preliminary, certain definitions will be given.

The horizontal members in the truss are called **chords**, *AB*, *BC*, etc., being **top chord** or **upper chord** members; *ab*, *bc*, etc., being **bottom chord** or **lower chord** members. The other bars are the **web members**, designated as **verticals** and **diagonals**.

**Method of shears.** The simplest way of determining the stress in any diagonal, as *Bc*, is to take a vertical section through it and isolate the portion of the truss on either side (Fig. 1:19*b*). This free body is in equilibrium under the action of the left reaction, 40 kips, and the unknown axial stresses in the three bars cut by the section. There are three unknowns and three equations for their solution, given by the conditions of equilibrium of the force system. As the nature of these

stresses is unknown, each is assumed to be tension and is shown as pulling *away* from the free body.

It is noted at once that of the three bars cut by this section only one, the diagonal, has a component normal to the truss axis, a vertical component in this case. Writing the equation,  $\Sigma V = 0$ , calling an upward force positive,

$$\begin{aligned} 40 - V_{Bc} &= 0 \\ V_{Bc} &= +40 \end{aligned}$$

The plus sign of the result indicates that the assumed direction is correct and the bar stress is tension. The usual convention will be followed hereafter, that the plus (+) sign before a stress magnitude indicates tension, the minus (-) sign, compression. Then if tension is always assumed in advance, the sign of the result will agree with the actual state of stress. It will be seen that the convention of + for tension and - for compression agrees with the change of length of the bars under stress.

**The ratio of the actual stress in bar *Bc* to the vertical component is equal to the ratio of bar length to vertical projection.** That this is so may be seen by considering that the length of the bar (*Bc*) may be taken to represent the stress to some scale. The triangle *BCc* may be taken as the force triangle, *BC* and *Cc* representing the components into which the stress *Bc* may be resolved. Instead of dealing with the large triangle *BCc* it is often more convenient to use a small slope triangle such as the one shown on the diagonal in Fig. 1:19c. The actual stress in the diagonal is given by

$$\text{Stress } Bc = \frac{5}{4} \times 40 = +50 \text{ kips}$$

Note that in simple parallel chord trusses the diagonals "carry the shear," as we say; that is, the vertical component of any diagonal bar stress equals the shear in the panel.

The method of shears may also be used to advantage for finding the stress in the verticals of the truss shown in Fig. 1:19. For example, the stress in *Cc* is found by taking an inclined section sloping downward to the right through *BC* and *cd*. Applying the equation  $\Sigma V = 0$  to the force system acting on the free body on the left shows that the stress in *Cc* equals the shear on the inclined section, equals 40 kips compression.

The distribution of panel loads between upper and lower chord points does not affect the diagonals, but it does materially affect the vertical bar stresses. For example, in this case, were the 60 kips applied at *c*, the stress in *Cc* would be 20 kips tension, instead of the compression previously found, and all other stresses would be unchanged.

**Method of moments.** In the truss shown in Fig. 1:19 the same section and free body may be used to find the stresses in chords  $BC$  and  $bc$ . Taking  $BC$  first, note that the section cuts three bars. It is desired to avoid simultaneous equations and obtain the stress in  $BC$  by a single solution. The condition  $\Sigma M = 0$  may be applied, taking the center of moments at *any* point in the plane of the truss. If the moment center is taken at the intersection of the other two bars, the following equation, which contains  $S_{BC}$  as its only unknown (Fig. 1:19*b*), may be written:

$$\begin{aligned} 30 \times 40 + 20S_{BC} &= 0 \\ S_{BC} &= -60 \text{ kips} \end{aligned}$$

the negative sign indicating that the force acts in the sense opposite to that assumed, i.e., the bar is in compression. Note that clockwise moment is taken as positive. (This sign convention is entirely independent of that for bending moment.)

Similarly for  $bc$ :

$$\begin{aligned} 15 \times 40 - 20S_{bc} &= 0 \\ S_{bc} &= +30 \text{ kips} \end{aligned}$$

The results of our analysis are shown in Fig. 1:19*c*. A check is obtained by use of the one condition of equilibrium not hitherto employed,  $\Sigma H = 0$ , or by an independent application of  $\Sigma M = 0$ . Note that in drawing diagrams of free bodies it is not necessary to sketch in all the bars: show the free body outline and the bars cut by the section.

This method of finding a bar stress by taking a section cutting other bars besides that one whose stress is desired and applying the condition  $\Sigma M = 0$  with center of moments at the common intersection of these other bars is sometimes called **Ritter's method**, from the German engineer who devised it (Aug. Ritter, Hanover, 1863).

In both of the above cases it will be observed that the first term in the equation as written is the bending moment at the section through the center of moments. Accordingly note that, for a Pratt truss, the stress in any chord member equals the bending moment at the panel point which is the moment center for that bar, divided by the depth of the truss. The same is true for most simple trusses (Parker, Howe, Warren; see Fig. 4:2) with parallel or non-parallel chords and without subdivided panels, truss depth meaning the normal distance to the center of the chord from the moment center.

**Example 1:6.** What is the stress in diagonal  $Cd$  of the Parker truss of Fig. 1:20 for the load shown?

*Solution.* Section  $n$  was drawn as shown and a free body taken to the left, since this involves one less force than that to the right and is therefore simpler

to calculate. The section cuts three bars, and the intersection of the two chord bars, 100 ft to the left of the support, was taken as the moment center.  $\Sigma M = 0$  gives  $175 \times V_{Cd} - 100 \times 35 = 0$  and  $V_{Cd} = +20$  kips. The stress equals  $20 \times 7.8/6 = +26$  kips.

Note that resolving the stress into components horizontally opposite the moment center, thus eliminating the horizontal component from the equation,<sup>5</sup> is easier than methods which work in terms of trigonometric functions of angles or which find the normal distance from the moment center to the line of action of the diagonal stress.

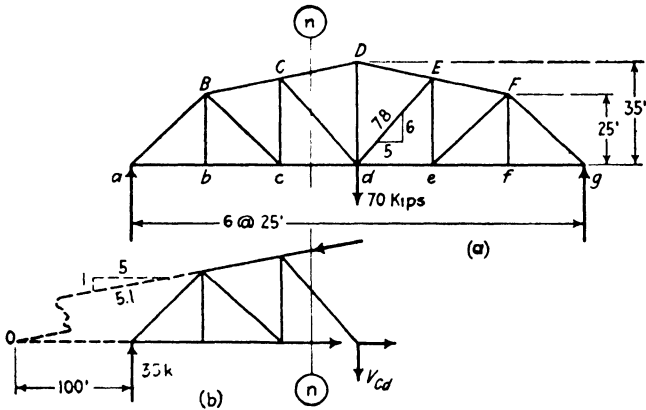

FIG. 1:20

The example which follows shows the use of the method of virtual work in determining bar stress, a very simple case. An attempt to apply this method with more complicated bar arrangements will soon make it plain that a considerable knowledge of kinematics is often needed to obtain the necessary displacement relationships.

The method of virtual displacements or virtual work (see Art. 7:2) was applied to the determination of bar stresses in trusses by Otto Mohr about 1874 but, in general, is not considered a practicable method in this country. A clear and interesting exposition of the method is given by Professors Timoshenko and Young in their *Theory of Structures* (McGraw-Hill).

<sup>5</sup> By Varignon's theorem (see textbooks on mechanics) the moment of a number of forces about any moment center is equal to the moment of their resultant about the same moment center. Conversely, at any point on its line of action a force may be replaced by its components and the moment of its components will equal the moment of the force about every moment center. The point selected for resolving the force in the example here has two advantages: the arm of one component is zero, that of the other is known.

**Example 1:7.** Determine the stress in bar  $Bc$  of the loaded truss in Fig. 1:19 (shown again in Fig. 1:21), using the method of virtual work.

*Solution.* Replace the bar  $Bc$  by two equal and opposite forces,  $X$ , and allow a small elongation,  $d$ , in the length of the diagonal. The displacement relationships are shown in Fig. 1:21. The unstressed truss  $AagG$  takes the shape  $A'a'gG$ , when  $Bc$  is elongated an amount  $d$ :  $B''c = Bc$ . The movement  $d$  is so

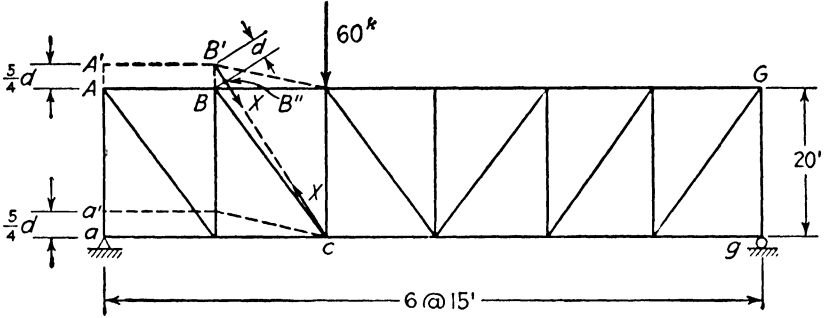

FIG. 1:21

small that  $BB'B''$  may be taken as a 3-4-5 triangle, giving  $AA' = aa' = \frac{5}{4}d$ . Actually the deformed truss is supported at  $a$ , not at  $a'$ , which means that the elongation of  $Bc$  causes the point of support of the 60-kip load to move downward an amount equal to the movement of point  $c$ , equal to  $\frac{1}{6}$  the distance  $aa'$ . The resulting work equation is

$$-Xd + 60 \times \frac{2}{3} \times \frac{5}{4}d = 0$$

$$X = +50 \text{ kips}$$

**1:7. Trusses. Stress analysis by the method of joints.** The first adequate stress analysis of a truss was made by Squire (first name, not a title) Whipple of Albany, N.Y., who in 1847 published a pamphlet describing a method based on the equilibrium of each joint.

The method of joints consists in passing a section around each joint of the truss in turn. Since the stresses in the members are axial and since the loads are applied at the joints, the forces acting at each joint form a concurrent coplanar force system in equilibrium. The conditions of equilibrium of such a system are two ( $\Sigma X = 0$  and  $\Sigma Y = 0$ ), and accordingly no joint can be solved where there are more than two unknowns.

In general no truss is analyzed by one method alone. Instead it is divided into free bodies by sections chosen to make the solution the simplest possible.

The efficient notation system employed in the example which follows was introduced by Robert H. Bow, London, 1873.

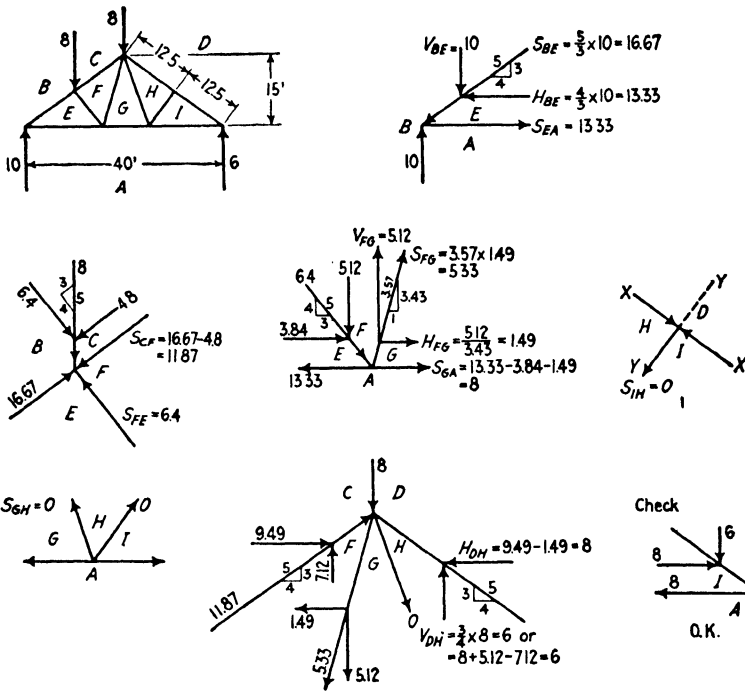

FIG. 1:22

**Example 1:8.** Determine the stresses in all bars of the truss of Fig. 1:22 by the method of joints.

*Discussion.* In order to designate each bar and force easily the sketch has been lettered in accordance with **Bow's notation**, placing the capitals so that each bar and force lies between two letters and only two. The left-hand reaction, then, is either **AB** or **BA**; the adjacent top chord, **BE** or **EB**.

Joint **ABE**, with two unknowns, **BE** and **EA**, was selected as the first free body for solution, and a separate sketch was made showing the three forces comprising the system at this joint, the value of the known force being noted directly and the components of the other two being indicated by letters,  $V_{BE}$ , etc. Applying the condition  $\Sigma V = 0$  showed that  $V_{BE} = 10$  acting downward; bar **BE** is in compression.  $H_{BE}$  was found from the known slope of the bar and the stress in the lower chord, **EA**, was found from  $\Sigma H = 0$ .

At the next joint **BCFE** it was found convenient to take the axes of reference along and perpendicular to the top chord, as otherwise simultaneous equations would have been required.

At joint **EFGA** there were two unknown horizontals and one unknown vertical; the vertical accordingly was found first, the slope of the bar then giving one of the horizontals.

It would have been possible to turn at once to joint **CDHGF** next, but it was

observed that labor would be saved by a partial solution of joint  $DIH$ , taking the axes, as before, along and perpendicular to the chord. The condition  $\Sigma Y = 0$  gives the stress in  $HI$  as zero, and similarly, from joint  $GHIA$ , there is no stress in bar  $GH$ . The stress analyst should always be on the watch for cases like these, which may be phrased for memory thus:

*At any unloaded truss joint where three bars meet, with two of these three lying on the same straight line, the third bar is without stress. If such a joint carries a load making an angle with the two continuous bars, the component of the load normal to these two bars is equal and opposite to the normal component of the stress in the third bar.*

After joint  $CDIIGF$  was solved, giving the last of the bar stresses, a check on the work was obtained by setting up the last remaining joint  $IDA$  as a free body and noting that the stresses previously found satisfied the conditions of equilibrium.

Although it is desirable and even necessary for the student at the outset to apply this method by drawing a free body for each joint in the manner illustrated in the previous example, it soon becomes possible with practice to dispense with these sketches and write directly on a single sketch of the truss the horizontal and vertical components of bar stresses. This has been done for the truss in Fig. 1:23, the components of bar stress being written on the sides of the slope triangle for all sloping bars with a sign inside the triangle,  $+$  or  $-$ , to indicate the kind of stress, tension or compression. Beginners like to supplement this procedure by showing the arrows representing components at each joint, thus combining the procedure of Fig. 1:22 with that of Fig. 1:23. Others are content with showing arrow heads, close to the joint, on the bars meeting there, thus indicating graphically the kind of stress. These supplementary procedures are not recommended, largely because of the difficulty of keeping the sketch neat and workmanlike, and should be followed only if there is genuine difficulty with the more professional method.

In Fig. 1:23 the reactions are readily computed from the loads as shown. Then, starting at joint  $L_0$  (a joint where there are two unknowns), it is at once apparent that the stress in  $L_0U_1$  must be compression, and its  $V$  component (from  $\Sigma V = 0$ ) must be 300 kips. The  $H$  component of this stress must be greater than the  $V$  component in the ratio of 25 to 20; therefore the  $H$  component equals  $300 \times \frac{5}{4} = 375$  kips. By  $\Sigma H = 0$  at the joint the stress in bar  $L_0L_1$  is seen to be tension, and its value must be 375 kips.

The next joint with two unknowns is  $L_1$ ; then  $U_1$ ; then  $U_2$ ; then  $L_2$ ; then  $L_3$ . At each of these joints it is possible to use at once either  $\Sigma H = 0$  or  $\Sigma V = 0$  and get a value without the use of simultaneous equations. When joint  $U_3$  is reached simultaneous equations may be



used;<sup>6</sup> or a vertical section may be passed cutting  $U_3U_4$  and the  $H$  component of stress in that member may be obtained by the method of moments; or, perhaps best of all, using joint  $U_3$  with its five forces as a free body, moments may be written at  $U_4$ , eliminating one unknown, and the other may be resolved into components at  $L_4$ . This method thus yields an easy solution for the horizontal component of stress in bar  $U_3L_4$ . Or a new start may be made at  $L_5$ , and the final check of  $\Sigma H = 0$  and  $\Sigma V = 0$  may be applied at joint  $U_3$  when that joint is

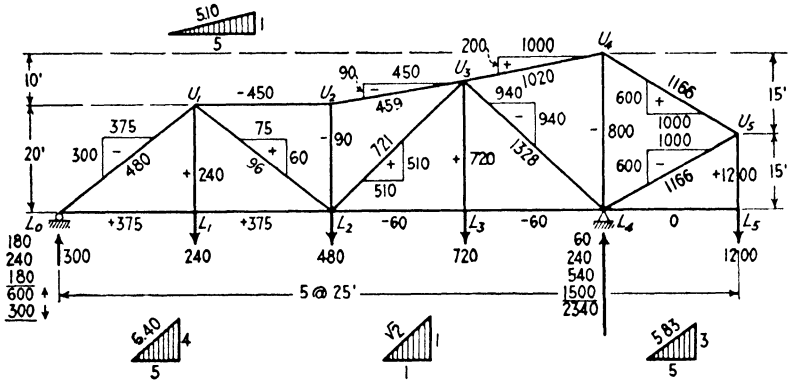

FIG. 1:23

reached, working from the right. After this check has been made, the true stresses in the diagonal bars may be computed and added, as has been done, to the sketch.

As has been said, each of the methods shown—moments, shears, and joints—may be used to advantage in certain cases. If it is desired to find the stress in one or, at most, a few members, the methods of moments and shears will usually yield the quickest results. When it is desired, however, to find the stress in every member of a structure, the method of joints is usually best. It will be observed that the method has the advantage of being self-checking in that if  $\Sigma H = 0$  and  $\Sigma V = 0$  at the last joint reached it may be assumed that all foregoing work is correct.

The conditions at joints  $U_4$  and  $U_5$  are typical of situations which occur very frequently, and they should be observed attentively. At  $U_4$  the horizontal components of the two chords must be equal and opposite ( $\Sigma H = 0$ ), and accordingly both these bars are bound to be

<sup>6</sup> Call  $V_{U_3L_4} x$ ,  $H_{U_3L_4} = x$ ; call  $V_{U_3U_4} y$ ,  $H_{U_3U_4} = 5y$ . Two equations may now be written,  $\Sigma H = 0$  and  $\Sigma V = 0$ , in which the unknowns  $x$  and  $y$  occur, and from which their values may be obtained.

stressed in tension or in compression, according to the loading. The stress in the vertical is of the opposite kind to that in the chords and equals the sum of their vertical components. At  $U_5$ , similarly, the horizontal components of the two sloping bars are equal and opposite. Therefore the vertical load brought to  $U_5$  by the vertical is divided between the other two bars in proportion to their slopes<sup>7</sup> (ratio of vertical to horizontal projections), in this case equally. Were the vertical projection of  $U_5L_4$  10 ft and that of  $U_4U_5$  20 ft, the vertical component of the first bar would be 400 lb and that of the second 800 lb. This may be proved by the triangle of forces as well as algebraically.

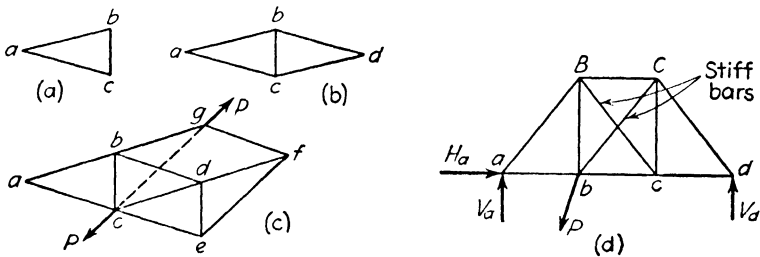

FIG. 1:24

**1:8. Rigid trusses; statically determinate trusses.** Many trusses are built containing too many members to permit stress analysis by the methods of statics. On the other hand there is the possibility of attempting to construct a truss with too few members for stability. It is important that the student learn to recognize these cases. As may be readily seen (Fig. 1:24a), three bars when joined together give a stable figure. If (Fig. 1:24b) at each of two joints an additional bar is connected lying in the plane of the figure, and these are joined at their outer ends, and if (Fig. 1:24c) this is continued indefinitely, there still results a **rigid figure** (or triangular net), which may be defined as a figure that will maintain its shape under the action of equal and opposite forces in the same line applied at any two joints. Every rigid figure constructed as above indicated will have three bars for the first three joints and two bars for each additional joint; i.e., where  $b$  is the number of bars, and  $n$  is the number of joints,  $b = 3 + 2(n - 3)$ , or  $b = 2n - 3$ . Experience teaches that, in such a figure, the methods already presented

<sup>7</sup> A mistake which is extremely common with beginners has its roots in a misconception of this situation. It consists, for example, in asserting that a vertical load at  $U_1$ , Fig. 1:23, causes an equal vertical component in the two diagonals which come to that point, since they have the same slope. This argument overlooks the fact that there is a third member coming to the joint which is capable of carrying a horizontal stress component.

in this chapter will serve for the computation of bar stresses for any system of known outer forces. Hence, the rule just given will be satisfied by every rigid trussed figure which is statically determinate as regards *inner* forces. A figure with fewer bars will be unstable, that is, will not maintain its shape under load unless proper external supports are provided. One with more bars, such as might be formed by adding a bar between two previously unconnected joints in an already rigid figure, will be statically indeterminate. The bars in excess of the number required for stiffness are termed redundant members.

Structures are frequently built which are statically determinate as regards *outer* forces but are indeterminate as regards *inner* forces. Of this type Fig. 1:24d is an illustration. There are six joints and ten bars; therefore the truss is indeterminate as regards inner forces.

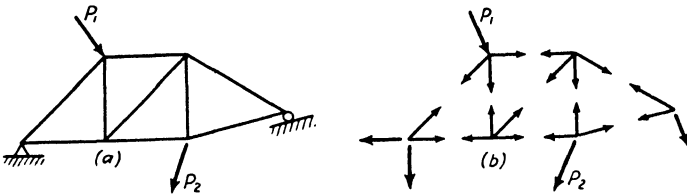

FIG. 1:25

If the diagonals  $Bc^8$  and  $Cb$  are capable of carrying tensions only, by reason of lack of rigidity (being made up each of a wire cable, let us say), a different result is reached. For example, with negative shear in the panel, diagonal  $Cb$  tends to lengthen and  $Bc$  to shorten. Lacking stiffness,  $Bc$  will fall slack and carry no stress. Accordingly only one of these two diagonals can be in action at a time, and the two count as one bar. Under this condition the truss is statically determinate. In practice an eyebar<sup>9</sup> member is so lacking in lateral stiffness that it can carry very small compressive stress. Therefore the two count as one bar if this pair of diagonals is made of eyebars.

The matter of statical determination will be investigated further with the aid of Fig. 1:25. Let the rigid truss of Fig. 1:25a carry any system of known loads (here  $P_1$  and  $P_2$ ) which will cause three unknown reaction components and nine unknown bar stresses (Fig. 1:25b); and, also, let it be assumed that only the two equations  $\Sigma X = 0$  and  $\Sigma Y = 0$

<sup>8</sup> Bar  $Bc$  is a single bar; likewise  $Cb$ . Where bars in line sketches cross, as do these two, usually their crossing is not a joint except in lateral trusses where diagonals are generally rigidly connected at their intersection. However, except in regard to simplicity, it is immaterial whether or not such a crossing is called a joint.

<sup>9</sup> For a description of an eyebar see Art. 4:8.

are available for the determination of the unknowns. At each joint two independent equations may be written, but, since every joint contains more than two unknowns, a direct joint-after-joint solution is impossible. However, the total number of bar stresses ( $b = 9$ ) and reaction components ( $r = 3$ ) is 12; for the determination of these unknowns  $2n = 2 \times 6 = 12$  independent equations may be written; and the equations may be solved by the usual methods for the solution of simultaneous equations. (Obviously, this is not advocated as a method to follow!) It is seen, therefore, that a planar structure will be statically determined as regards both outer and inner forces only when  $b + r = 2n$ , or

$$b = 2n - r$$

The methods of statics showed that a rigid figure is statically determined as regards outer forces when  $r = 3$ . Making this substitution gives the form  $b = 2n - 3$  which was previously arrived at as a measure of statical determination as regards inner forces in a rigid figure. Chapter 5 will deal with types of structures which are not rigid, as rigid is above defined. There it will be seen that, for such a structure to be stable, reaction components must be added as bars are omitted.

The structure of Prob. 1:16*G* illustrates the fact that caution must be exercised in reaching a conclusion. This truss—obviously unstable—satisfies the foregoing equation. Hence, perhaps the strongest statement that should be made is that a statically determinate structure will satisfy the equation. In other words, the structure is statically determinate if the  $2n$  equations that may be written are capable of solution, that is, are independent and consistent. This point is discussed in Art. 5:5, where the entire matter is further considered.<sup>10</sup>

**1:9. Distortion of loaded frames.** All the materials used in the making of structures are more or less perfectly elastic, i.e., they change form under stress and (if the stress is not too high) return to their original form upon its removal. Accordingly a truss or a rigid frame changes shape under load. However, these changes are relatively slight in amount and do not alter the dimensions of any ordinary structure sufficiently to make any sensible difference in the load and stress distribution. Accordingly these changes of bar lengths, the deflections, and the changes of slope and angle of various parts of a statically determinate structure do not enter into the stress calculations. The frame is treated as though it were absolutely rigid. In fact the term

<sup>10</sup> Some textbooks include non-rigid frames in their discussions of trusses and thus deal with the matter more generally than here: for example, Art. 17, etc., Chapter II, of *Theory of Structures* by Timoshenko and Young (McGraw-Hill).

“rigid body” is much used (often to replace the term “free body” here employed) to indicate that the analysis neglects the change of shape of the structure. The analysis of statically indeterminate frames, on the contrary, is based upon a consideration of these elastic deformations.

A very useful habit to form is that of visualizing to enlarged and distorted scale the shape taken by a loaded frame. The nature of stress induced by the loads is often easily detected thus and a qualitative check given to the results of calculation. Beginners, however, often fall into confusion through the difficulties of accurate picturization and through forgetting the simpler conception of the free rigid body in equilibrium with a force system which must conform to the conditions of equilibrium. The only way to clearness of vision is through the liberal use of pencil and paper to make sketches showing complete force systems! Do not try to picture change of shape when a picture of a balanced force system acting on a supposedly rigid body will suffice.

PROBLEMS

Art. 1:3 Reactions

**Problem 1:1.** Are these structures statically determinate as regards outer forces? It is assumed that these structures are loaded by external force systems known in direction, point of application, and magnitude, but not here shown.

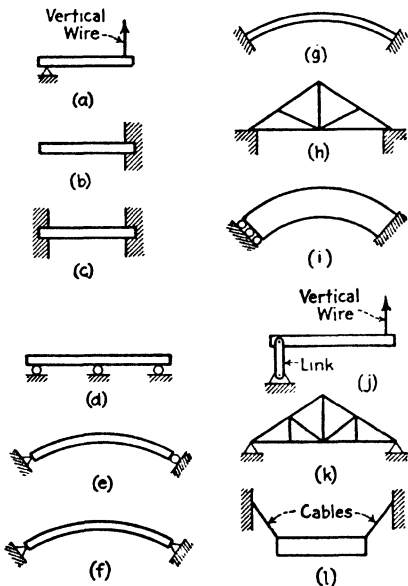

PROB. 1:1

forces? It is assumed that these structures are loaded by external force systems known in direction, point of application, and magnitude, but not here shown.

Ans.

a. Determinate. Unstable for loading, putting wire in compression.

b. Determinate.

Note under *b* that this applies only to the portion of the beam beyond the wall. The state of stress in the embedded part is highly uncertain, since the reaction on any surface of contact between the wall and the beam is not to be determined in any way. The same remark may be made regarding the next case.

The determinate free body to study consists of the portion of the beam to the left of a vertical section at the face of the wall. The unknown is the reaction brought into play by any assumed loading.

- c. Indeterminate, third degree, i.e., 6 unknowns, 3 equations.
- d. Unstable under any but vertical forces. Indeterminate, first degree, for vertical forces.

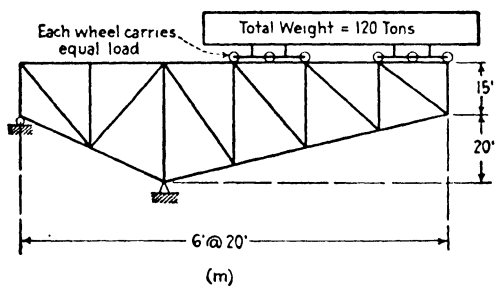
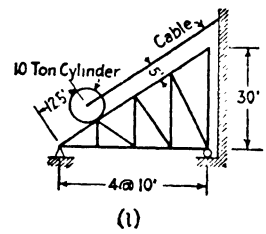
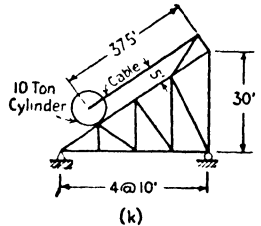
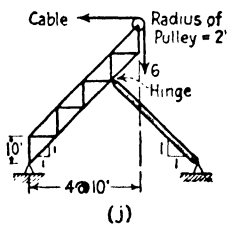
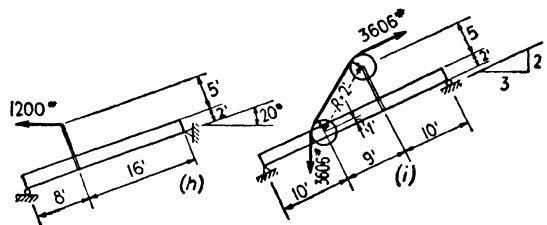
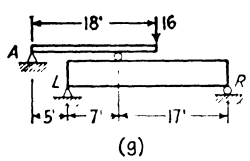
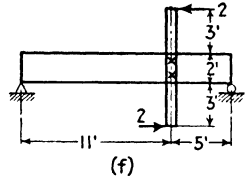
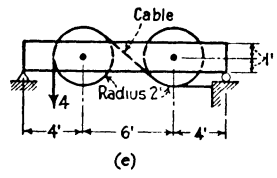
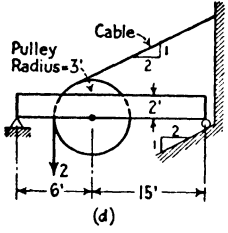
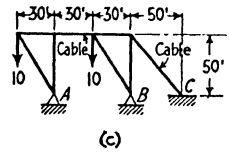
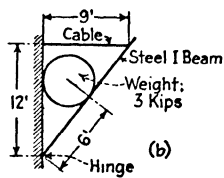
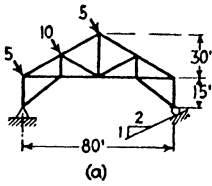

PROB. 1:2

e. Determinate.

f. Indeterminate, first degree.

g. Indeterminate, third degree.

h. Indeterminate, third degree.

i. Indeterminate, second degree.

j. Unstable; moving into a definite position consistent with equilibrium under any loading so long as cable is kept in tension. Determinate for new position.

k. Indeterminate, first degree.

l. Same as j.

**Problem 1:2.** Determine the horizontal and vertical components of reactions on these structures. The loads are in kips except as noted.

*Suggestions.*

a. Use resultant of the three loads.

b. Neglect friction between the weight and its supports.

d. Remove the pulley from its support and replace it by the force there exerted on the beam. This amounts to transferring the cable pulls (2 kips downward, 2 kips inclined upward) to the pulley bearing on the beam.

e. In this case it is simpler to consider the cable cut at the right end and take the beam and pulleys as the free body.

f. Students often forget that horizontal forces may induce vertical reactions; also that a couple can be balanced only by another couple.

k. The cylinder is entirely supported by the truss. Find the line of action of the vertical force of 20 kips.

l. The cylinder is only partly supported by the truss. Find the load on the truss.

m. Use the resultant weight, not the series of wheel loads.

*Ans.* (kips) a.  $H_L = 7.75 \leftarrow$   $V_L = 7.5 \uparrow$   $H_R = 4.25 \leftarrow$   $V_R = 8.5 \uparrow$

b. Tension in cable = 2.5

At hinge  $H = 1.5 \leftarrow$   $V = 3 \uparrow$

c.  $H_A = 6 \leftarrow$   $V_A = 10 \uparrow$   $H_B = 6 \leftarrow$   $V_B = 22 \uparrow$   $H_C = 12 \rightarrow$   
 $V_C = 12 \downarrow$

d.  $H_L = 1.63 \leftarrow$   $V_L = 0.79 \uparrow$   $H_R = 0.16 \leftarrow$   $V_R = 0.32 \uparrow$

e.  $H_L = 4 \leftarrow$   $V_L = 3.71 \uparrow$   $V_R = 0.29 \uparrow$

f.  $H_L = 0$   $V_L = 1 \uparrow$   $V_R = 1 \downarrow$

g.  $V_A = 8 \downarrow$   $V_L = 17 \uparrow$   $V_R = 7 \uparrow$

h. For an  $X$  axis parallel to the beam,  $X_L = +20$ ,  $Y_L = +56$ ,  
 $X_R = +1110$ ,  $Y_R = -466$

i. For an  $X$  axis parallel to the beam,  $X_L = -1606$ ,  $Y_L = +1164$ ,  
 $Y_R = +1836$

j.  $H_L = 5 \rightarrow$   $V_L = 7 \uparrow$   $H_R = 1 \rightarrow$   $V_R = 1 \downarrow$

k.  $H_L = 0$   $V_L = 16.5 \uparrow$   $V_R = 3.5 \uparrow$

l.  $H_L = 9.6 \leftarrow$   $V_L = 7.8 \uparrow$   $V_R = 5 \uparrow$

m.  $V_L = 300 \downarrow$   $V_R = 540 \uparrow$

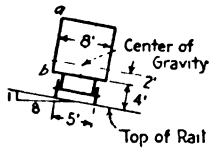

PROB. 1:3

**Problem 1:3.** What is the intensity of normal pressure of the uniformly distributed force (wind pressure) acting on the side  $ab$  of this car when the car is on the point of overturning? Car weighs 50,000 lb and has a side 40 ft long and 10 ft high.

*Ans.* 24.1 lb per sq ft.

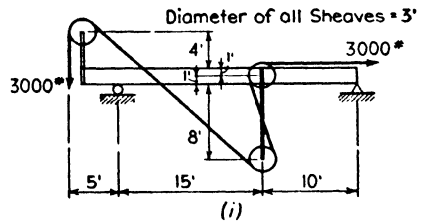
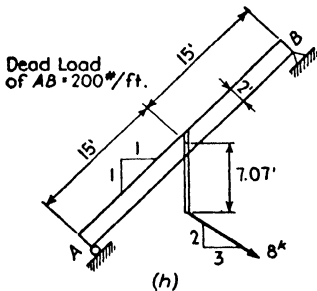
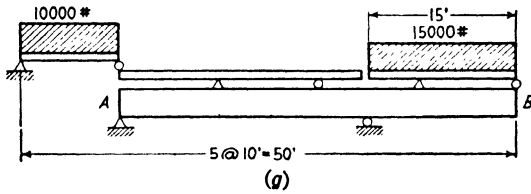
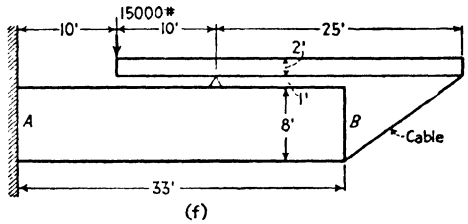
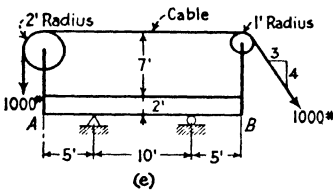
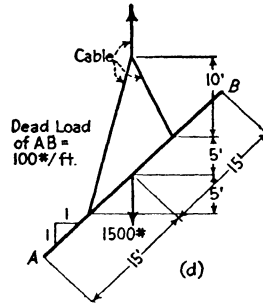
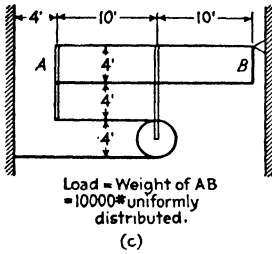
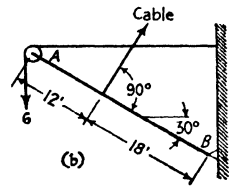
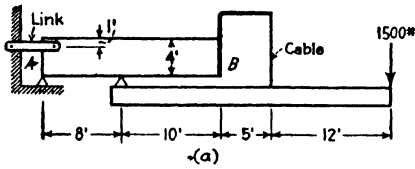



### Art. 1:4 Shear and Moment Curves

**Problem 1:4.** Draw the curves of shear and moments for the structures marked  $AB$  in the sketches here shown. Loads are given in kips except as noted.

*Comments and suggestions.* No results are given as the work is self-checking if properly done. If either shear or moment ordinates are computed successively from left to right, using always the forces on the left of the section, and if the result for the right end agrees with the value computed from the forces at that end, it is reasonably certain that the curve is correct.

When figuring shear or moment for an inclined piece remember that these functions concern a section normal to the longitudinal axis. The load components normal to the axis must be used, and the curves plotted on an axis parallel to the member.

Note that the distributed loads on the upper beams in Prob. 1:4g bring concentrated loads on  $AB$ .

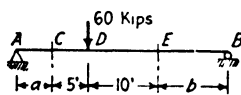

PROB. 1:6

**Problem 1:5.** Draw the moment and shear curves for the beams of Prob. 1:2d, e, f, h, i.

**Problem 1:6.** The bending moment at both  $C$  and  $E$  in this beam is  $+200$  kip-ft. How long is the beam  $AB$ ?

*Ans.*  $a = 5$  ft,  $b = 10$  ft,  $AB = 30$  ft.

### Arts. 1:5-7 Truss Analysis

**Problem 1:7.** Find the stress in each vertical and the vertical component of stress in each diagonal of the truss shown in Fig. 1:19 for this loading: loads of 6 kips each at  $A$  and  $G$  and 12 kips at each intermediate panel point on the top chord; 6 kips at each lower chord panel point. This is the truss loading resulting from a uniform load of 800 lb per ft extending the length of the bridge on the level of the top chord and 400 lb per ft on the lower chord. The stress in the center vertical is found by taking the joint at  $D$  as a free body.

<i>Ans.</i>	<i>Bar</i>	<i>Stress</i>	<i>Bar</i>	<i>Vertical component</i>
	$Aa$	-51 kips	$Ab$	+45 kips
	$Bb$	-39 kips	$Bc$	+27 kips
	$Cc$	-21 kips	$Cd$	+ 9 kips
	$Dd$	-12 kips		

**Problem 1:8.** What is the vertical component of stress in diagonal  $Cd$  of the truss of Fig. 1:20a, due to one load of 70 kips at  $b$  and another at  $c$ ?

*Suggestion.* Take the same section,  $n$ , as before and the free body to the right. Compare your sketch with Fig. 1:20b. *Ans.* -50 kips.

**Problem 1:9.** What is the stress in vertical  $Cc$  of the truss of Fig. 1:20a due to:

a. A load of 70 kips at each bottom chord panel point?

b. A load of 50 kips at each bottom chord panel point and 20 kips at each top chord panel point?

*Note.* Observe the difference in the stress of a vertical made by the distribution of load between lower and upper chord. *Ans.* a. +11.7 kips. b. -8.3 kips.

**Problem 1:10.** Compute the stress in chord bars  $CD$  and  $cd$  for the truss and loading of Fig. 1:20a.

*Note.* Use section  $n$  and the free body of Fig. 1:20b. The bending moment at  $d$ , the center of moments for  $CD$ , divided by 35 ft gives the horizontal component of  $CD$ ; the bending moment at  $C$  divided by 30 ft gives the stress in  $cd$ .

*Ans.*  $CD = -76.5$  kips,  $cd = +58.3$  kips.

**Problem 1:11.** Show on a sketch of each structure the  $H$  and  $V$  component of stress in each bar.

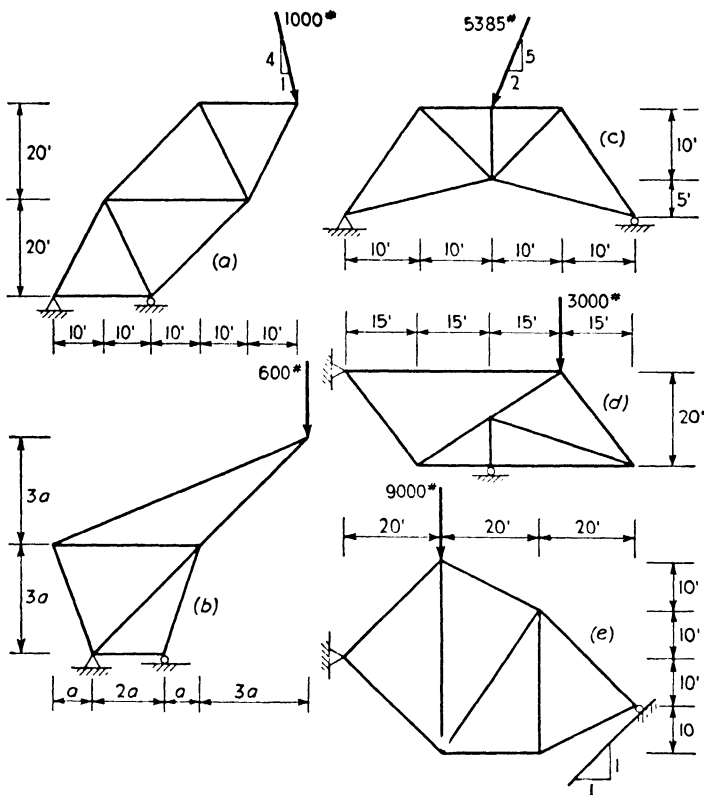

PROB. 1:11

**Problem 1:12.** Determine the stress, or a component of stress, in each of the lettered bars of these trusses by the method indicated in each case. Loads are in kips.

*Discussion and suggestions.* Make a neat sketch of the free body used for each bar, with all the forces in the system. Write out the equations carefully in full. Later, with proficiency, short-cuts and mental solutions will be in order. If possible work these problems without use of the suggestions.

A. Bar  $a$ : After finding the reactions take first the joint at the left support, then the one at the right support, and then the one between supports. Bar  $c$ : the section to use is shown dotted.

B. It is not necessary to obtain the reactions in finding these stresses.

C. Use the joint at the right end of  $a$ . Note that the horizontal components of bars  $a$  and  $c$  are equal numerically and opposite in kind. How is the vertical shear in this panel divided between  $a$  and  $c$ ? This arrangement of diagonals is called the  $K$  system.

D. Take a vertical section through  $a$ , and the intersection of the lines of the

REACTIONS AND STRESSES

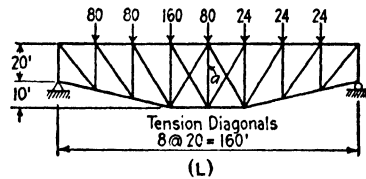
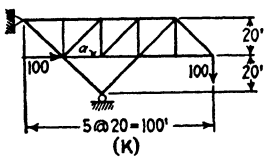
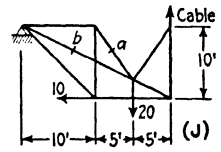
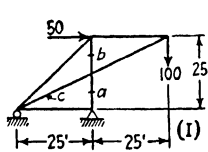
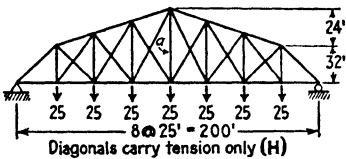
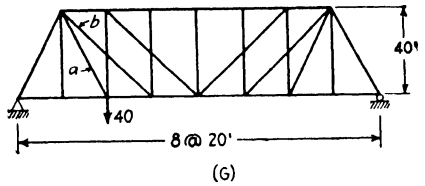
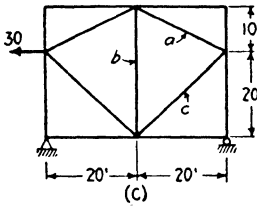
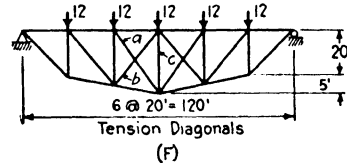
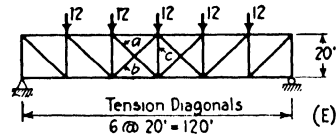
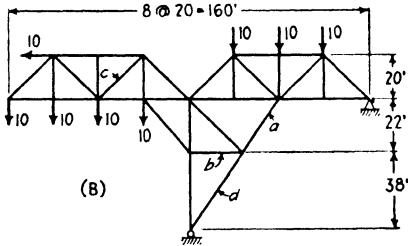
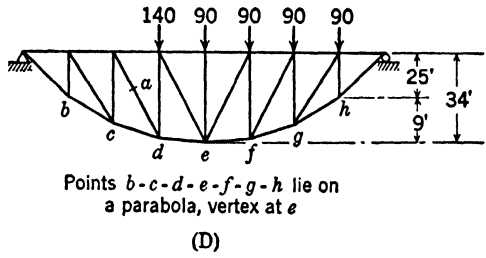
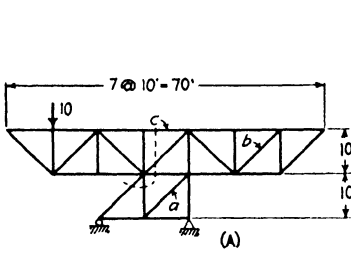

chords cut by it as the center of moments. In computing the reactions do not write an equation,  $\Sigma M = 0$ , but note that  $\frac{3}{8}$  of the 140,  $\frac{1}{2}$  of the adjoining 90, etc., are carried to the left reaction, the calculation of which becomes

$$\begin{array}{r} 140 \times \frac{3}{8} = \quad \quad \quad 87.5 \\ 90 (1 + 2 + 3 + 4)/8 = \quad \quad \quad \frac{112.5}{200.0} = V_L \end{array}$$

The use of the law of the lever should be almost automatic at this stage of progress.

*E.* Take a vertical section through *a* and *b*. The kind of shear determines which diagonal acts.

*F.* Take a vertical section through *a* and *b*. The diagonal in action (tension) supplies the moment needed to make the moment of the system about the chord intersection equal to zero.

*G.* Find first the stress in the bar *b*.

*H.* First determine which set of diagonals acts in an adjacent panel by the method of moments.

*L.* Take a sloping section through *a* parallel to the two diagonals in action and solve by method of shear.

<i>Bar</i>	<i>By method of</i>	<i>Ans. (kips)</i>	<i>Bar</i>	<i>By method of</i>	<i>Ans. (kips)</i>		
<i>A.</i>	<i>a</i>	joints	$H_a = + 15$	<i>F.</i>	<i>a</i>	moments	$V_a = + \frac{2}{3}$
	<i>b</i>	shear	$S_b = 0$		<i>b</i>	moments	$S_b = 0$
	<i>c</i>	moments	$S_c = + 20$		<i>c</i>	joints	$S_c = - 12$
<i>B.</i>	<i>a</i>	moments	$V_a = - 55$	<i>G.</i>	<i>a</i>	shear	$V_a = + 30$
	<i>b</i>	moments	$S_b = -100$		<i>b</i>	joints	$S_b = 0$
	<i>c</i>	shear	$V_c = + 30$	<i>H.</i>	<i>a</i>	joints	$S_a = + 25$
	<i>d</i>	joints	$S_d = 0$		<i>I.</i>	<i>a</i>	joints
<i>C.</i>	<i>a</i>	joints	$H_a = + 10$	<i>J.</i>	<i>b</i>	joints	$S_b = -250$
	<i>b</i>	joints	$S_b = - 10$		<i>c</i>		$V_c = -100$
	<i>c</i>	joints	$H_c = - 10$		<i>a</i>		$V_a = + 30$
<i>D.</i>	<i>a</i>	moments	$V_a = +160$	<i>b</i>		$V_b = - 30$	
	<i>E.</i>	<i>a</i>	shear	$V_a = + 6$	<i>K.</i>	<i>a</i>	
<i>b</i>	shear	$V_b = 0$	<i>L.</i>	<i>a</i>			$S_a = -112$
<i>c</i>	joints	$S_c = - 12$					

**Problem 1:13.** Determine which bars of the several trusses of Prob. 1:12 are unstressed by the loads given.

**Problem 1:14.** Solve Prob. 1:12*E, F, H, L*, assuming that the diagonals in the panels with two diagonals carry compression only.

### Art. 1:8 Statically Determinate Trusses

**Problem 1:15.** Show that the trusses of Prob. 1:12 are statically determinate as regards inner stresses.

**Problem 1:16.** Determine whether or not these trusses<sup>11</sup> are statically determinate as regards the inner forces.

<sup>11</sup> For information regarding the development of truss types see Johnson-Bryan-Turneaure's *Modern Framed Structures* (John Wiley), Part I, Chapter I. Modern bridge truss forms are shown in Fig. 4:2.

REACTIONS AND STRESSES



Tension members of Wrought Iron  
Compression members of Cast Iron.  
(A) Fink Truss (1852-76)

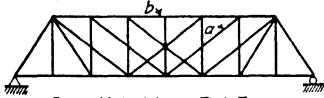

Same Materials as Fink Truss  
Tension Diagonals  
(C) Whipple Truss (1852-1890)

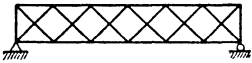

(E) Double System Warren Truss

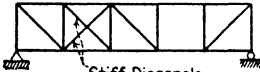

Stiff Diagonals  
(G)

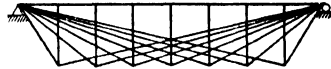

Same Materials as Fink Truss  
(B) Bollman Truss (1840-50)  
(Without sub-diagonals)

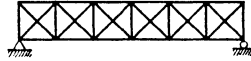

Diagonals carry compression only.  
Verticals of iron, rest of wood.  
(D) Howe Truss (1840 to date)

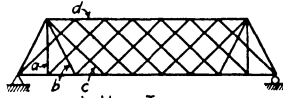

Lattice Truss  
(F)

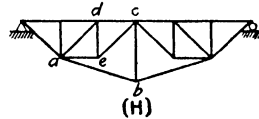

(H)

PROB. 1:16

Ans.

- A. (18 joints), Indeterminate, sixth degree.
- B. (16 joints), Determinate.
- C. Indeterminate, first degree.
- D. Determinate.
- E. Indeterminate, first degree.
- F. Indeterminate, third degree.
- G. Unstable, incapable of remaining in position shown (24 equations, 24 unknowns).
- H. Determinate.

# GRAPHIC STATICS

**2:1.** Most, if not all, problems in structural analysis may be solved by graphic as well as by algebraic methods. There is considerable difference of opinion as to which is the better way. To the student it may be said that it is absolutely essential that he understand the basic principles of both methods since both are widely used. Thereafter he may follow his own inclination.

The science of graphic statics begins, practically, with the publication in 1864–1866 of the book *Graphische Statik* by Professor Carl Culmann of Zurich.

The elementary concepts of graphic statics are treated in the study both of physics (mechanics) and of applied mechanics and are already known to all readers of this book. Accordingly this introduction to the subject is very brief.

A force may be represented by a line of a length proportional to force intensity, acting along the given line of action and cutting the body on which the force acts at a definite point. Actually a force is the push or pull (usually by reason of earth attraction) of one body on another acting at a surface of contact, or it is gravitational pull on the body itself. There are no such severe concentrations of load in nature as we represent by arrows in our diagrams.

All force systems in static analysis are assumed to act upon rigid (non-deforming) bodies. Actually there is always some small deformation with some consequent small change of dimension and shifting of the lines of action of the forces. It is always assumed that these changes of dimension may be neglected as being too small to cause any different stress distribution from that determined by using the dimensions of the unstrained body.

We are dealing here with rigid bodies at rest, in equilibrium under the action of balanced force systems. Every force system must satisfy the condition of equilibrium pertinent to it. For a system composed of forces lying in a single plane and meeting at a point (a concurrent coplanar system)  $\Sigma X = 0$ ,  $\Sigma Y = 0$ ; for a system composed of forces lying in one plane which do not meet at a point (a non-concurrent co-

planar system)  $\Sigma X = 0$ ,  $\Sigma Y = 0$ ,  $\Sigma M = 0$ . The discussion of this chapter is limited to coplanar systems. It is evident that in applying these tests of equilibrium to any force system the points of application of the forces do not enter in. Consequently, so far as equilibrium is concerned, a force may be considered as applied at any point on its line of action. However, the actual points of application must be used when dealing with the internal stresses set up in a structure by forces applied to it, because these stresses will differ for different points of application.

**Composition of forces.** Two forces whose lines of action intersect may be replaced by a single force, their **resultant**, which will have the same effect as the original forces. It has been demonstrated by experiment that the resultant is given in line of action, direction, and magnitude by the diagonal, drawn through the force intersection, of the parallelogram of which the two intersecting forces form two sides, as shown in Fig. 2:1a, b. Note, in applying the law of the parallelogram

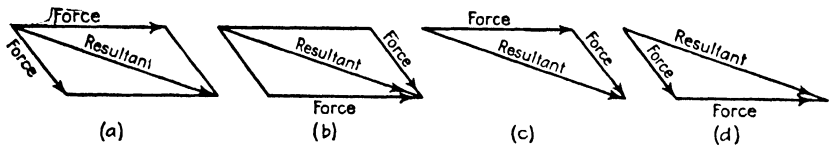

FIG. 2:1

of forces, that forces and resultant must either extend beyond (Fig. 2:1a) or approach (Fig. 2:1b) the intersection. It is evident that the magnitude and direction of the resultant may be obtained by the triangle of forces (Fig. 2:1c, d). The line of action is a line through the force intersection parallel to the direction thus found.

This resultant may be combined similarly with any other intersecting force and the process repeated indefinitely to give the resultant of a series of forces. The forces  $F_1$  and  $F_2$  in Fig. 2:2a are replaced by their resultant  $R_{1-2}$  at their intersection, the magnitude and direction of  $R_{1-2}$  being given by 0-2 of the force triangle 0-1-2, Fig. 2:2b; similarly  $R_{1-2-3}$  replaces  $R_{1-2}$  (i.e.,  $F_1$  and  $F_2$ ) and  $F_3$ .

The combination of the two force triangles, 0-1-2 and 0-2-3, becomes a force polygon, Fig. 2:2c, by omission of the line 0-2. Although the resultant of a series of forces may thus be found directly, the force triangles must be drawn, or visualized, if the position of the resultant is to be determined by this method. The method of Art. 2:2 is more general, however, as it may be used with parallel forces.

Notice should be taken of the notation employed: force  $F_1$  is indicated by 0-1 in the force polygon,  $F_2$  by 1-2, the sense of the force being that

indicated by reading in sequence its numerical designation in the force polygon. In consequence arrow heads will not be employed further.

The polygon in Fig. 2:2*d* was drawn designating  $F_2$  as  $F_1$ ,  $F_1$  as  $F_2$ . It should be evident that the magnitude, direction, and location of the resultant will be the same regardless of the order in which the forces are combined in drawing the force polygon.

**Resolution of forces.** Just as two or more forces may be combined into, or replaced by, a single force, so any single force, at any point on its line of action, may be resolved into, or replaced by, two or more

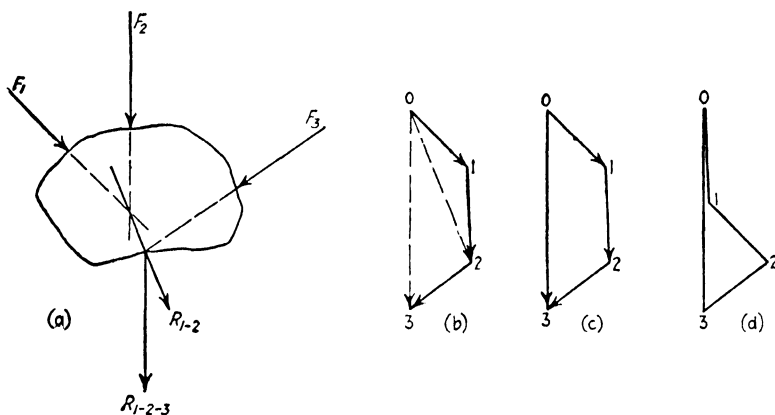

FIG. 2:2

forces, called **components** of the first. The process is the reverse of that just described. For example, in Fig. 2:1 the resultant may be considered the original force, and the two arrows labelled "Forces," two components replacing it.

Note that in both these situations the force triangle or polygon does not close: the arrows which represent the several forces (or components) lead continuously to the same point where terminates the single arrow representing the resultant of the several forces (or the force resolved into components).

**Equilibrant.** The rigid body of Fig. 2:2*a* is not in equilibrium. It will be at rest if a fourth force,  $F_4$ , called the **equilibrant**, is applied equal and opposite to  $R_{1-2-3}$ , acting along the line of action of that resultant. The force polygon for this system will close, 3-0 in the force polygon representing the force  $F_4$ , equal and opposite to  $R_{1-2-3}$ . However, it should be noted that were this force,  $F_4$ , applied at any point on the rigid body not on the line of action shown for  $R_{1-2-3}$ , the force polygon would still close. Although the closing of the force



polygon is one necessary condition for equilibrium, proving as it does  $\Sigma X = 0$ ,  $\Sigma Y = 0$ , it alone does not prove the equilibrium of the non-concurrent coplanar force system for which it is drawn, since it does not show whether or not  $\Sigma M = 0$ .

On the contrary, the conditions of equilibrium of a concurrent coplanar force system are two only,  $\Sigma X = 0$  and  $\Sigma Y = 0$ . Therefore, the several forces must be in equilibrium if the force polygon for such a system closes.

The closure of the force polygon makes it possible to determine two unknown elements of a balanced force system; for example, in Fig. 2:2 it was found that if the given rigid body is in equilibrium under the action of  $F_1$ ,  $F_2$ ,  $F_3$ , and a fourth force  $F_4$ , not known (and not shown), the magnitude and direction of  $F_4$  must be given by 3-0 in the force polygon. Similarly, if  $F_1$  and  $F_2$  only were given, together with the lines of action of  $F_3$  and  $F_4$ , these last two forces could be found by completing the polygon. This could be done by drawing through 2 a line parallel to  $F_3$ , through 0 a line parallel to  $F_4$ , giving the intersection 3. Then  $F_3$  is given by 2-3, acting downward to the left, and  $F_4$  by 3-0 acting upward, these being the directions necessary to make the polygon close, i.e., continuous in direction (or sense) throughout. It will be understood, however, that with a non-concurrent force system the additional construction of Fig. 2:2a is needed to ensure that the equation  $\Sigma M = 0$  is satisfied.

**2:2. Equilibrium polygon.** The method of composition of forces used in the preceding article fails when any point of intersection falls outside the drawing, and it does not apply to parallel forces. Therefore attention is directed to the general method of the **equilibrium** (or **funicular**) **polygon**, a method that serves for any non-concurrent coplanar system.

It is desired to find the resultant of the three forces ( $F_1$ ,  $F_2$ , and  $F_3$ ) shown in Fig. 2:3a. The magnitude, direction, and sense of the resultant are given by 0-3 of the force polygon in Fig. 2:3b, leaving the line of action unknown in relation to the original forces.

From any convenient point,  $P$  (called the **pole**), lines (called **rays**) are drawn to the several vertices of the force polygon. The triangle 0- $P$ -1 is a force triangle giving 0- $P$  and  $P$ -1, components of 0-1 =  $F_1$ ; 1- $P$ -2 a force triangle giving components 1- $P$  and  $P$ -2 of 1-2 =  $F_2$ ; and similarly 2- $P$ -3 for  $F_3$ . In Fig. 2:3a, at any convenient point on its line of action,  $F_1$  is shown resolved into (that is replaced by) its two components 0- $P$  and  $P$ -1. The line  $P$ -1 is extended to an intersection with  $F_2$ , at which point  $F_2$  is also replaced by its components 1- $P$  and  $P$ -2; the line  $P$ -2 is extended to cut  $F_3$ , where  $F_3$  is also replaced by

its components  $2-P$  and  $P-3$ . The original force system has now been replaced by another consisting of the six components named. Of these six forces  $P-1$  equals  $1-P$  in magnitude and is opposite to it in direction;  $P-2$  is equal and opposite to  $2-P$ . Since  $P-1$  and  $1-P$  act along a common line, they balance each other; similarly  $P-2$  is neutralized by  $2-P$ . This leaves  $0-P$  and  $P-3$  replacing the original three,  $F_1$ ,  $F_2$ , and  $F_3$ . The resultant of  $0-P$  and  $P-3$ , then, is  $0-3$  in the force polygon (i.e., the resultant of  $F_1$ ,  $F_2$ , and  $F_3$ ), and it must act through the point of intersection of  $0-P$  and  $P-3$ , as shown. The construction of Fig. 2:3a is called an **equilibrium** (or **funicular**) **polygon**. The lines composing it, extending from force to force, are named **strings**.

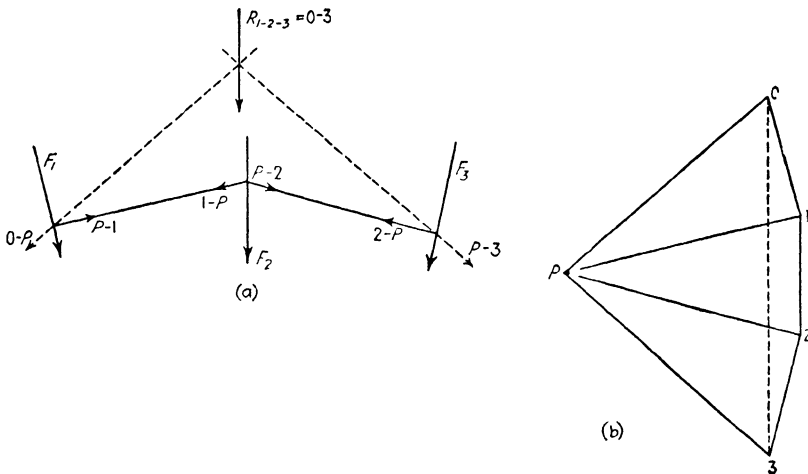

FIG. 2:3

The name “equilibrium polygon” comes from the obvious fact that its strings may be considered replaced by rigid links (bars carrying direct stress only) and the resulting frame will be in equilibrium under the loads of the balanced force system formed by the original forces and their equilibrant or reactions.

Consider the balanced non-concurrent coplanar force system formed by adding to the three forces shown in Fig. 2:3 a fourth force equal and opposite to  $R_{1-2-3}$  acting along the same line of action. For this system the force polygon is a closed figure,  $0-1-2-3-0$ . Study soon reveals that the equilibrium polygon shown is also a closed figure. The fourth force,  $3-0$  in the force polygon, is resolved into the components  $3-P$  and  $P-0$ , which are placed on the equilibrium polygon at the point of intersection of the fourth force (that is, the opposite of  $R_{1-2-3}$ ) and the dotted strings. Accordingly they balance the two hitherto unbalanced com-

ponents 0-P and P-3, thus closing the figure. The truth of this important theorem is thus evident: **for a balanced non-concurrent coplanar force system both the force and equilibrium polygons are closed figures.**

**2:3. Reactions.** Since the equilibrium polygon, as well as the force polygon, for a balanced force system is a closed figure, it is possible to find three unknown elements in such a system. The procedure is illustrated by the following examples.

**Example 2:1.** Determine graphically the reactions for the member shown in Fig. 2:4, carrying the loads  $F_1$  and  $F_2$ .

*Solution.* One point on the line of action of  $R_L$ , the left reaction, is known and the line of action of  $R_R$  is fixed in location and direction (vertical) by the

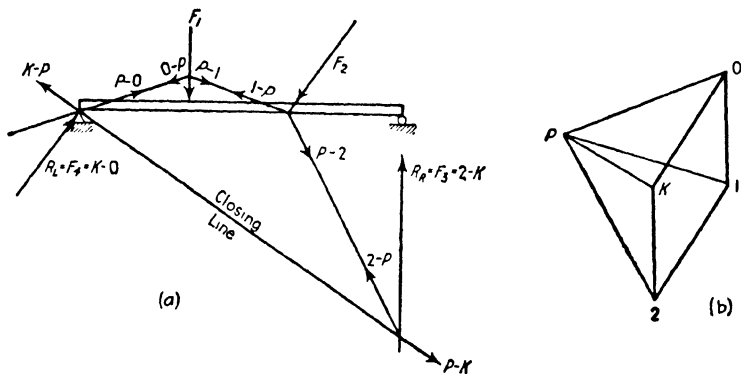

FIG. 2:4

roller bearing indicated. This leaves two unknown magnitudes and one unknown direction to find.

It was possible to construct at once a portion of the force polygon, 0-1-2, Fig. 2:4b. The pole  $P$  was located conveniently, and the rays  $P-0$ ,  $P-1$ , and  $P-2$  were drawn.

The funicular polygon was next constructed. The string  $P-0$  was drawn through the one known point on the line of action of  $R_L$  to meet  $F_1$ , then  $P-1$  to cut  $F_2$ , and  $P-2$  to cut the known line of action of  $F_3 = R_R$ . Since this funicular polygon must be a closed figure, the **closing line** must pass through this last intersection and the known point on  $R_L$ . The next step, the completion of the force polygon, is best explained by pausing to indicate on the funicular polygon the components which have replaced each of the forces. For  $R_R$ , a vertical force, there have been substituted  $2-P$  and  $P-K$ . Accordingly a ray was drawn through the pole  $P$ , parallel to the closing line, and also a vertical line through  $2$ , the two lines intersecting at  $K$ . This gave  $2-K$  as the right reaction,  $R_R$ ; the line  $K-0$  closed the force polygon and gave the left reaction.

**Example 2:2.** What are the reactions acting on the loaded truss shown in Fig. 2:5?

*Note.* The notation—Bow's—*s*—is that used in problems in stress analysis, and is explained in detail in Art. 1:7, Ex. 1:8. Since the force diagram has been plotted in the order in which the forces are met in passing clockwise around the figure, the force at the left end of the truss is *a-b*, the next *b-c*, etc., the reaction at upper right *e-f*, at lower right *f-a*.

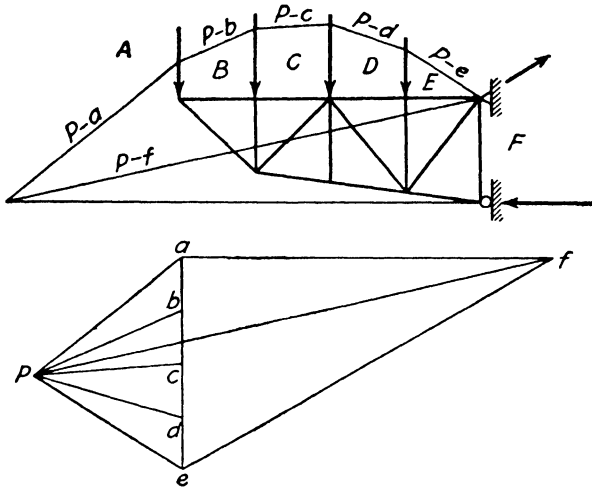

FIG. 2:5

*Solution.* After the force polygon *a-b-c-d-e-P* had been constructed, the equilibrium polygon was started by drawing *P-e* through the one known point on the line of action of *E-F* to an intersection with *D-E*, then *P-d* to meet *C-D*, etc. The intersection of *P-a* with the line of reaction *F-A* gave the point needed for drawing the closing line *P-f*, which was then added to the force diagram. Point *f*, needed for determining the reactions *E-F* and *F-A*, was at the intersection of *P-f* and a horizontal line (i.e., parallel to the known direction of *F-A*) through *a*. Investigate this problem carefully and check the components with which each force is replaced.

**2:4. Maxwell diagram: Graphic method of joints.** It is possible to find all the stresses in a loaded truss by drawing a series of force polygons, one for each joint, as shown in Fig. 2:6*a, b*. This presupposes the determination of the reactions by any convenient method. The loads and bar stresses acting at any joint constitute a balanced coplanar concurrent force system, and the fact that the force polygon must close enables us to determine completely the system when not more than two of the stresses are unknown, using graphic or algebraic methods.

In the series of force polygons shown in Fig. 2:6b either that for joint  $A-E-D$  or joint  $A-B-C-F$  could be constructed first, there being only two unknowns at each. The polygon for joint  $C-D-E-F$  involves three unknowns and cannot be drawn until one of these has been found from another polygon. It will be noted that these polygons have been drawn by taking the bars consecutively as reached by going around each

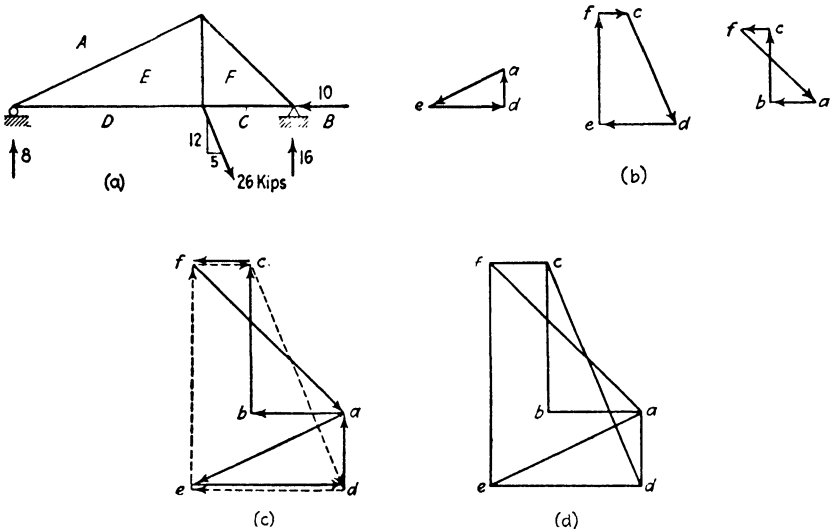

FIG. 2:6

joint in a clockwise direction. This was not necessary, as the order of the bars in the polygon is immaterial. However, *by carefully observing this clockwise order* the several force polygons may be combined into a single one, a **Maxwell diagram**, as has been done in Fig. 2:6c, d, the first rendering serving to identify the polygons and the second showing the appearance as usually drawn. The arrow heads are not needed, since the lettering indicates the direction of any force; **the two letters which designate a force, in the order given by going about the joint in a clockwise direction, are placed on the force polygon so that this order of the letters is along the direction of the force.** Thus, in the Maxwell diagram of Fig. 2:6d the letters  $da$  represent an upward force; the letters  $ed$  indicate that bar as a member of the force system at joint  $A-E-D$ , acting to the right, i.e., away from the joint, and in tension. The reading of the letters in the order  $de$  indicates that bar as a member of the force system at joint  $C-D-E-F$ , acting to the left, away from the joint, i.e., in tension.

The actual construction of the Maxwell diagram of Fig. 2:6*d* proceeded as follows. First the force polygon  $a-b-c-d-a$  was drawn for the external forces, taking them in sequence as reached going around the truss in a clockwise direction. Then joint  $A-E-D$  was selected as one with only two unknowns, and point  $e$  was located on the force polygon by the intersection of a line through  $a$  parallel to  $A-E$  with one drawn through  $d$  parallel to  $D-E$ . Next, in order to locate  $f$ , a line was drawn through  $e$  parallel to  $E-F$  and one through  $c$  parallel to  $C-F$ , the intersection giving  $f$ . To complete the diagram, and also to check its accuracy, a line was drawn through  $f$  parallel to  $A-F$ , the one bar not yet represented on the force polygon. This line should terminate at  $a$  exactly.

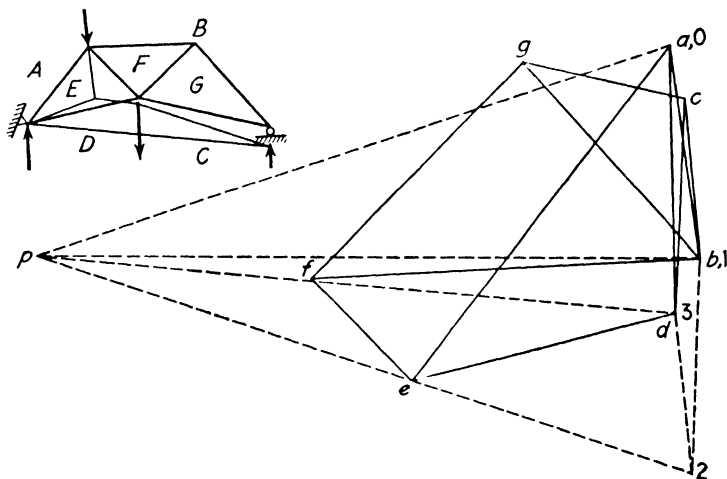

FIG. 2:7

It will be noted that in the description just given no attempt was made to trace out the force system at any point. Instead, the process consisted of locating points missing on the force polygon by drawing lines, parallel to the intervening bars, through each of the two known points between which the missing letter is located on the truss diagram. The result is a combination of force polygons as shown in Fig. 2:6*d* (cf. Fig. 2:6*c*). It is essential that a clockwise (or a counterclockwise) order be followed rigorously in laying out the polygon of external forces!

This diagram received its name from its inventor, James Clerk Maxwell, who published it in 1864.

**Example 2:3.** Determine reactions and bar stresses in the truss of Fig. 2:7.

*Solution.* Since the loads are on both chords, it was necessary first to determine reactions, and then to draw a new force polygon in which the forces

are arranged in the order in which they are met in going around the figure in a clockwise direction.

The determination of reactions was made in the usual manner, force  $A-B$  being 0-1,  $C-D$  being 1-2. Location of point 3 determined the reactions.

Next the closed force polygon  $a-b-c-d-a$  was drawn and the bar stresses were found.

Had the reactions been known, only the solid-line construction of Fig. 2:7 would have been required for the Maxwell diagram.

This example makes clear the use of the Maxwell diagram for a vast number of truss shapes, but when there are several joints where four or more members meet, difficulties may be encountered which require special procedures. One such instance is discussed in Prob. 2:11f, which should be studied carefully.

**2:5. Culmann's method.** The stress in several interior members of a truss may be found by the method of Professor Carl Culmann of Zurich. This method is the graphic equivalent of the algebraic method of moments. A section is passed cutting three members, one of them the member in which it is desired to find the stress. The part of the structure on one side of the section is taken as a free body in equilibrium under the action of the external loads acting on the free body and the stresses in the three bars which have been cut. There is then utilized the obvious principle that these forces may be considered in two groups and that the resultant of one of the groups must be colinear, equal, and opposite to the resultant of the other. The following examples illustrate the use of the method.

**Example 2:4.** Determine by Culmann's method the stress in bar  $H-A$  of the truss of Fig. 2:8.

*Solution.* To find the stress in  $H-A$ , section  $N$  was drawn and the free body to the left was taken for study. This is acted upon by external forces  $A-B$  and  $B-C$  and by the stresses in bars  $C-G$ ,  $G-H$ , and  $H-A$ . Consider these in two groups:  $C-G$ ,  $G-H$ ; and  $A-B$ ,  $B-C$ ,  $H-A$ . The resultant of each group must pass through 1 (the intersection of  $C-G$  and  $G-H$ , and therefore a point on their resultant) and 2 [the intersection of stress  $H-A$  with the resultant of  $A-B$  and  $B-C$ , which is located by the intersection of strings  $P-a$  and  $P-c$  at 3 (Why?)]. Adhering to the clockwise order followed in laying out the diagram of external forces, it is seen that the body is in equilibrium under force  $A-B$ , force  $B-C$ , a force in line 1-2, and force  $H-A$ . Therefore, through  $c$  in the force diagram a line is drawn parallel to 1-2, and through  $a$ , a line parallel to  $H-A$ . These intersect at  $h$  and give the stress desired in  $H-A$  as  $h-a$ , compression.

Also,  $c-h$  is the resultant of stresses  $C-G$  and  $G-H$ . By the method of the Maxwell diagram,  $g$  is located and the stresses in these bars are seen to be  $c-g$ , tension, and  $g-h$ , tension.

**Example 2:5.** Find the stresses in the three bars cut by section  $X$  in Fig. 2:9.

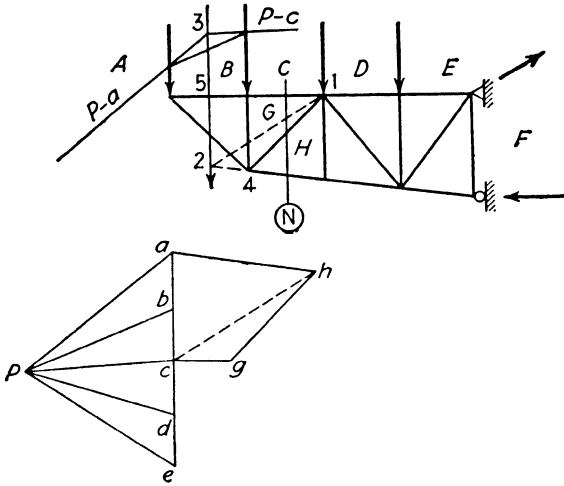

FIG. 2:8

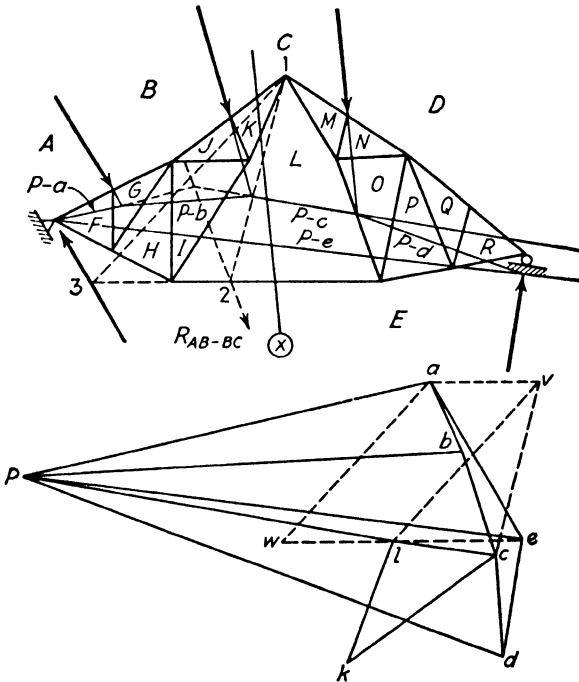

FIG. 2:9



*Discussion.* It will be seen that this truss is of the same general variety as that of Prob. 2:11f, to which attention has already been called, whose bar arrangement made impossible the direct application of the Maxwell diagram solution. The device used in solving that problem is not available in this case, since a substitute bar in the manner of Prob. 2:11f would leave bars  $K-L$  and  $I-L$  unsupported at their junction. Since these two bars are not in a straight line, this would result in a change of shape of the truss and a change in most of the bar stresses. Accordingly, recourse was had to Culmann's method.

Consider the free body to the left of section  $X$ . As in the previous example, two groups of forces act: the two bar stresses  $C-K$  and  $K-L$ , whose resultant must pass through point 1, and the four forces, three of them external,  $A-B$ ,  $B-C$ ,  $E-A$ , and  $L-E$ . We cannot find a point on the line of action of these four, since the resultant of the three external forces alone acts through the intersection of strings  $P-c$  and  $P-e$ , outside the limits of the drawing. The expedient has been adopted, accordingly, of determining the stress in bar  $L-E$  due, first, to force  $E-A$ , and, second, to the resultant of  $A-B$  and  $B-C$ . Combining the two results will give the actual stress in bar  $L-E$  and so locate point  $l$  in the force polygon. With this point located, the rest of the polygon may be constructed without further complication.

For the first case we have the free body acted upon by the two bar stresses intersecting at the peak, point 1, and the two forces  $L-E$  and  $E-A$ , with intersection at point 3. The line 1-3, then, is the line of action of the resultant of the two upper bar stresses and of the forces  $L-E$  and  $E-A$ . Turning to the force polygon, on which basis we may build a Maxwell diagram, we draw a line (dotted) through point  $a$  parallel to 1-3, and through  $e$  a line (dotted) parallel to  $L-E$ , with intersection at  $w$ . The stress in bar  $L-E$  due to force  $E-A$  alone is, then,  $w-e$ , tension.

In similar fashion we consider the free body acted upon by the two upper bars with intersection at point 1 and the three forces  $A-B$ ,  $B-C$ , and  $L-E$ , with intersection at point 2. In the force polygon a dotted line through  $c$  parallel to 1-2 and another through  $a$  parallel to  $L-E$  gives  $v-a$ , compression in bar  $L-E$ .

To find the actual stress in bar  $L-E$ , that due to the two sets of loads, we combine the two results by drawing through point  $v$  a dotted line parallel to  $a-w$ , intersecting line  $e-w$  at point  $l$ , giving, thus, distance  $e-l$  as the difference of the two stresses, tension. This point  $l$  may be taken as a point in a Maxwell diagram. Having thus points  $c$  and  $l$ , we may, in usual fashion, locate the point  $k$ , thus giving the stresses in the upper two bars as desired by the problem:  $k-l$ , tension, and  $c-k$ , compression.

The remainder of the Maxwell diagram may be constructed in the usual fashion and with no complications.

**2:6. Shear and moment.** The equilibrium polygon furnishes a simple means of determining shear and moment in beams and trusses. The following examples illustrate these methods.

**Example 2:6.** Determine graphically the shear at section  $a$  of the beam shown in Fig. 2:10.

*Solution.* This figure illustrates also the finding of moment at *a* and therefore shows many lines not essential to this problem.

The funicular polygon was constructed as usual and the closing line used to determine the reactions. The shear at *a* equals  $R_L - F_1 = K-1$  on the force polygon, acting upward, giving positive shear. This method is extended to live loads in Ex. 2:8.

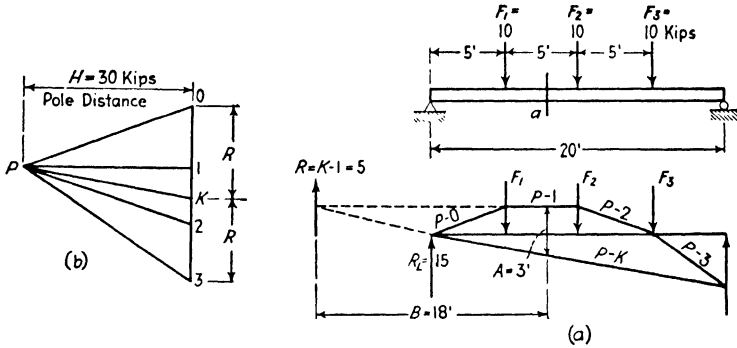

FIG. 2:10

**Example 2:7.** Determine graphically the bending moment at section *a*, 8 ft from the left end of the loaded beam shown in Fig. 2:10.

*Solution.* The resultant, *R*, of the forces acting on this beam to the left of the section equals the resultant of the components represented by the strings *P-1* and *K-P*, i.e., *K-1*, which acts through the intersections of these strings produced at a distance *B* from section *a*. The moment at *a* then equals  $B \times R = 5 \times 18 = 90$  kip-ft. It is not necessary to locate this intersection on the drawing owing to a simple geometrical relation first observed by Professor Culmann.

A line drawn through *a* parallel to *R*, i.e., vertical, forms with *P-1* and *P-K* a triangle with altitude *B* and base *A*, which is similar to triangle *P-1-K* in the force polygon, the altitude of that triangle being *H*, which was taken as 30 kips. On account of this similarity we may write  $A : B = K-1 : H$  or  $A \times H = 3 \times 30 = B(K-1 = R) = \text{moment at } a$ . Until the method is thoroughly mastered, it will be best for the student to sketch out each problem as in Fig. 2:10*a*, locate definitely the two similar triangles, and write Culmann's relation from this similarity.

**Note that lines *P-K*, *P-O*, *P-1*, *P-2*, and *P-3* form the moment curve for the beam. Ordinates in this curve are to be measured vertically from *P-K*, i.e., parallel to the resultant of the forces on either side of the section where the moment is desired.**

In Fig. 2:11 is shown a beam with cantilever end, part of whose loading is uniformly distributed. This portion of the load was divided up into a convenient number of equivalent concentrated loads, and an

equilibrium curve was drawn in the usual manner. The previous discussion demonstrates that **the bending moment at any section equals the vertical intercept between the extreme strings (to the scale of distances) multiplied by the pole distance  $H$  (to the scale of forces)**. The equilibrium polygon then is, to some scale, the moment curve for this loaded beam. It differs in appearance from the usual moment curve since there is no horizontal base line. However, if the closing line is extended to  $F_7$  and this intersection connected with the

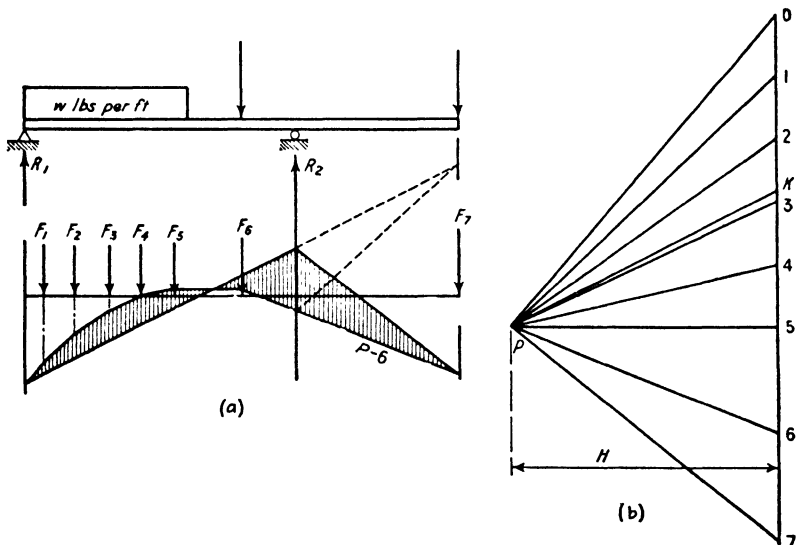

FIG. 2:11

intersection of string  $P-6$  with the line of action of  $R_2$ , the resulting figure will be identical with the usual moment curve except that the base line (the closing line and its extension) is sloping.

For live loads a funicular polygon is constructed as shown in Fig. 2:12, ready to use for any span. The most convenient method is to draw these strings on tracing cloth, thereby making it possible to lay the whole down over a sketch of the span drawn to the same scale and complete the construction by lightly penciling the closing line and scaling the necessary distances. For correct orientation of the polygon numerous horizontal reference lines are needed on the tracing cloth. Quadrille ruled cloth might well be used.

With accurate layout of the equilibrium polygon to a generous scale it becomes possible to determine graphically the maximum possible bending moment which any group of loads can produce on a given span,

and the section where this moment occurs, by noting carefully the maximum possible intercept.

**Example 2:8.** What is the shear at the center of a 22-ft beam when the system of concentrated live loads shown in Fig. 2:12 comes on the span from the right until the first load is 5 ft from the left end?

*Solution.* The force polygon shown was constructed with a convenient pole,  $P$ , and strings  $P-0$  to  $P-6$  of a funicular polygon were laid down without reference to this particular problem. Then the span  $A-B$ , 22 ft long, was drawn with  $A$  located on  $P-0$ , 5 ft from  $F_1$ . The intersection of  $P-4$  with a

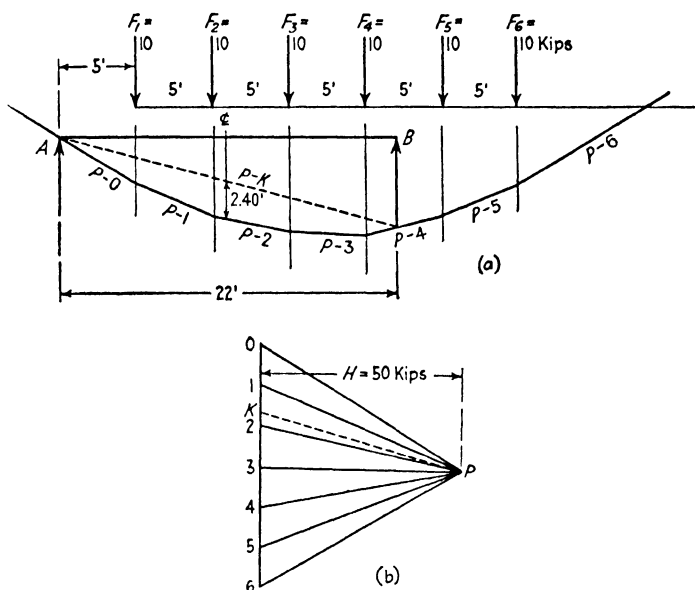

FIG. 2:12

vertical through  $B$  fixed the closing line  $P-K$ . On the force polygon the reaction at  $A$  equals  $K-0$  (17.3 kips) upward; that at  $B$  equals  $4-K$  upward. The shear at the center of the beam then is  $K-2$  downward, negative shear (2.7 kips).

The bending moment curve formed by the strings of this funicular would have been “right side up” had the pole of the force polygon been placed on the left instead of the right.

**Example 2:9.** What is the live-load moment at the center of a 22-ft beam due to the loads shown in Fig. 2:12a with  $F_1$  placed 5 ft from the left end?

*Solution.* The center line moment equals  $2.40 \text{ ft} \times 50 \text{ kips} = 120,000 \text{ ft-lb}$ .

The method is not limited to pure beam action (forces normal to the beam axis). The following example shows its application to a curved section.

**Example 2:10.** What is the bending moment at section *a* of the structure in Fig. 2:13 which carries the single load  $F_1$ ?

*Solution.* The reactions were determined by means of the force and funicular polygons shown. Check this completely before proceeding, placing arrow heads on the strings of the equilibrium polygon. Note the check on the accuracy furnished in this problem by the fact that three non-parallel forces in equilibrium must intersect at a point.

The moment at *a* here equals the left-hand reaction,  $R_1$ , multiplied by  $B$ , the normal distance from the centroid of section *a* to the force  $R_1$ . A line

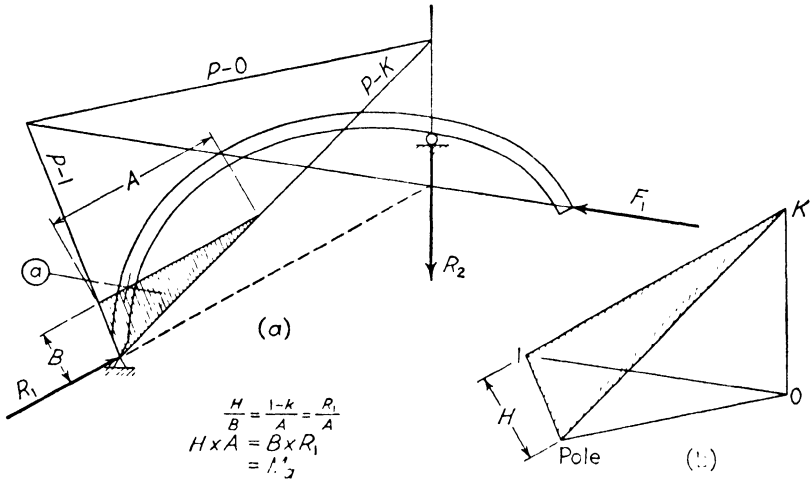

FIG. 2:13

drawn through the centroid of section *a* and parallel to  $R_1$  intercepts the distance  $A$  between the strings representing the components of  $R_1$  (or the strings extended, as required by some positions of the pole). By Culmann's relation the moment equals this intercept multiplied by the pole distance of the force polygon,  $H$ , i.e., the perpendicular distance from  $P$  to the force  $R_1$ , which here represents the resultant of all the forces on one side of the section.

The method to be followed in determining moment, therefore, is to draw, through the point about which the moments are to be figured, a line parallel to the resultant of all the forces on one side of the point, the moment of which about the point is the function desired. Measure on this line the intercept between the strings which represent the components of the resultant. Multiply this intercept (measured to the scale of the space diagram) by the pole distance, i.e., the perpendicular distance from the pole to the resultant (measured to the scale of the force polygon).

**2:7. Equilibrium polygon through two and three points.** In certain problems, notably in connection with arch analysis, it becomes necessary to draw a funicular polygon through definite points. This is very easily accomplished by making use of the fact that the equilibrium polygon for a balanced force system is a closed figure.

**Example 2:11.** Through points  $a$  and  $b$  draw an equilibrium polygon for forces  $F_1$ ,  $F_2$ , and  $F_3$  shown in Fig. 2:14.

*Solution.* Regardless of the actual manner of support for these forces, assume that they are carried by a frame with a hinged support at either  $a$  or  $b$  and a reaction of known direction acting through the other point. In this case a hinge was assumed at  $a$  and a vertical reaction through  $b$ . Next,

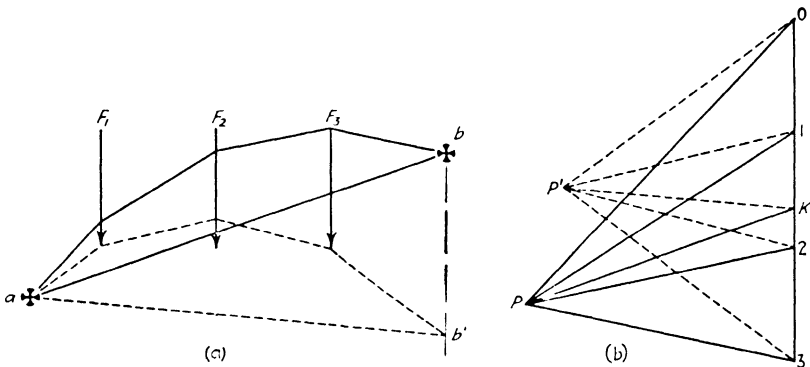

FIG. 2:14

the *dotted-line construction* was made exactly as would be done to obtain the magnitude of the reaction acting on the imaginary supporting structure. This gave  $ab'$ , the closing line of the dotted funicular polygon, and located  $K$  in the force polygon, 3- $K$  being the reaction through  $b$ , and  $K$ -0 that at  $a$ .

For an equilibrium polygon through  $a$  and  $b$  the closing line will be the line  $ab$ . Through  $K$  in the force polygon a line was drawn parallel to  $ab$ . An equilibrium polygon drawn from a force polygon with its pole,  $P$ , anywhere on this line ( $PK$ ), if started through one of the two given points, will pass through the other. It is evident that an infinite number of equilibrium polygons can be drawn through any two points.

**Example 2:12.** Through points  $a$ ,  $b$ , and  $c$ , draw an equilibrium polygon for the force system shown in Fig. 2:15.

*Solution.* The first step was exactly as in the previous example. The point  $K'$  was located (dotted lines) on the force polygon consistent with the reaction necessary for a structure supporting these forces with a hinged support at  $a$  and a vertical reaction acting through  $b$ . The line  $K'm$  was drawn through  $K'$  parallel to  $ab$ ; a pole anywhere on this line will give a force polygon resulting in an equilibrium polygon through  $a$  and  $b$ .

The position of point  $c$  is such that it will lie on the string connecting  $F_2$  and  $F_3$  in the final diagram. Consider only the forces  $F_1$  and  $F_2$ , lying between  $a$  and  $c$ , and assume they are supported by a structure with a hinged support at  $a$  and a vertical reaction through  $c$ . The closing line for the equilibrium

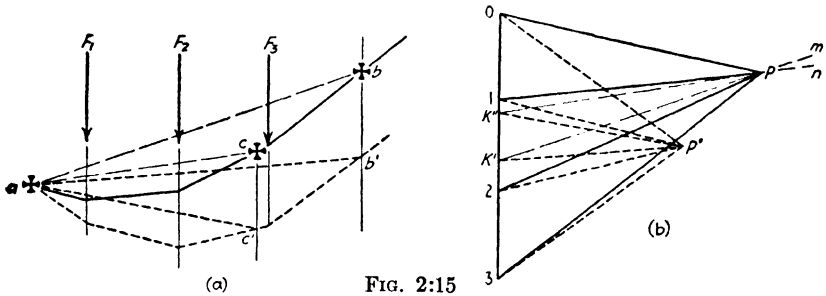

FIG. 2:15

polygon (dotted lines) drawn for this force system ( $F_1$ ,  $F_2$ , and the reactions at  $a$  and  $c$ ) is  $ac'$ , and it serves to locate  $K''$  on the force polygon, indicating  $2-K''$  as the reaction at  $c$  and  $K''-0$  that at  $a$ . It is desired to have  $ac$  as the closing line for the final equilibrium polygon for this force system, i.e., for this polygon to pass through  $a$  and  $c$ . An equilibrium polygon drawn for a force polygon with a pole anywhere on the line  $K''n$  drawn through  $K''$  parallel

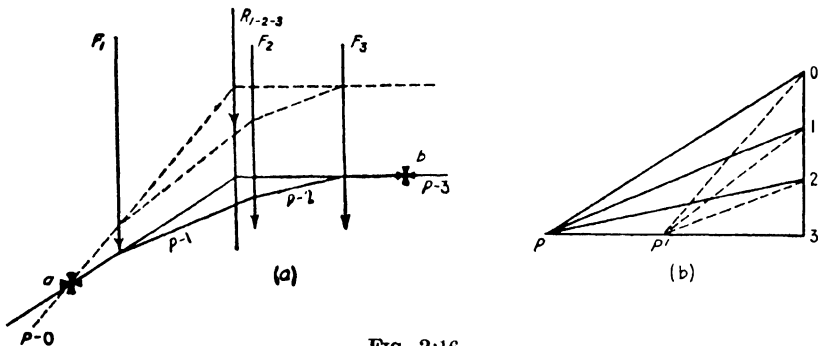

FIG. 2:16

to  $ac$  can be made to pass through these two points,  $a$  and  $c$ . Accordingly an equilibrium polygon drawn for a force polygon with a pole at the intersection of  $K'm$  and  $K''n$  will pass through all three points,  $a$ ,  $b$ , and  $c$ . Plainly only one equilibrium polygon can be drawn through three given points.

A common problem is illustrated in the following example. Note that the closure of the equilibrium polygon does not enter in here.

**Example 2:13.** Through points  $a$  and  $b$  draw an equilibrium polygon for the force system shown in Fig. 2:16, with the final string through  $b$  horizontal.

**Solution.** Any force polygon with its resulting equilibrium polygon serves to locate the resultant  $R_{1-2-3}$  of  $F_1$ ,  $F_2$ , and  $F_3$ , as shown by the dotted-line construction. Since the final strings through  $a$  and  $b$ ,  $P-0$  and  $P-3$ , must intersect on the line of action of this resultant and since  $P-3$  is horizontal, the

directions of the rays  $P-0$  and  $P-3$  in the force polygon are determined, their intersection locating the pole,  $P$ . The completion of the equilibrium polygon followed the drawing in of the two remaining rays.

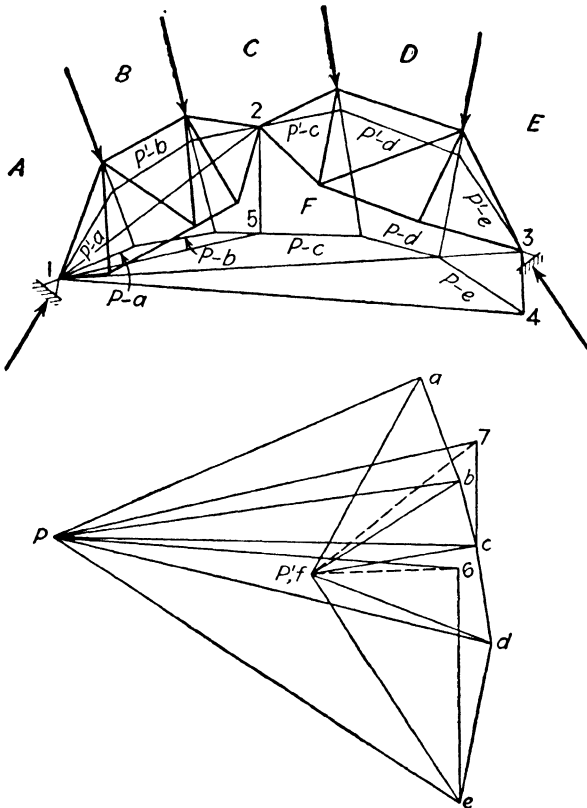

FIG. 2:17

**2:8. Three-hinged arch.** Several graphical methods are available for determining the reactions in a three-hinged arch. Such a structure has four unknown reaction components but is statically determinate because in addition to the usual three equations of statics a fourth equation is available from the condition that the center hinge cannot transmit moment. Hence, the moment about the center hinge of the external forces on each side thereof must equal zero. This means, graphically, that the resultant of the forces on each half of the arch must pass through the center hinge, permitting the reactions to be determined by the method of the preceding article.

**Example 2:14.** Determine the reactions of the structure of Fig. 2:17.

*First Solution.* Following the method of Ex. 2:12, it is desired to pass



an equilibrium polygon through points 1, 2, and 3. Corresponding to any pole,  $P$ , a trial equilibrium polygon commencing at 1 is drawn, which is intersected at points 4 and 5 by verticals drawn from 3 and 2. The intersections of verticals through  $e$  and  $c$  with rays through  $P$  parallel to 1-4 and 1-5 locate

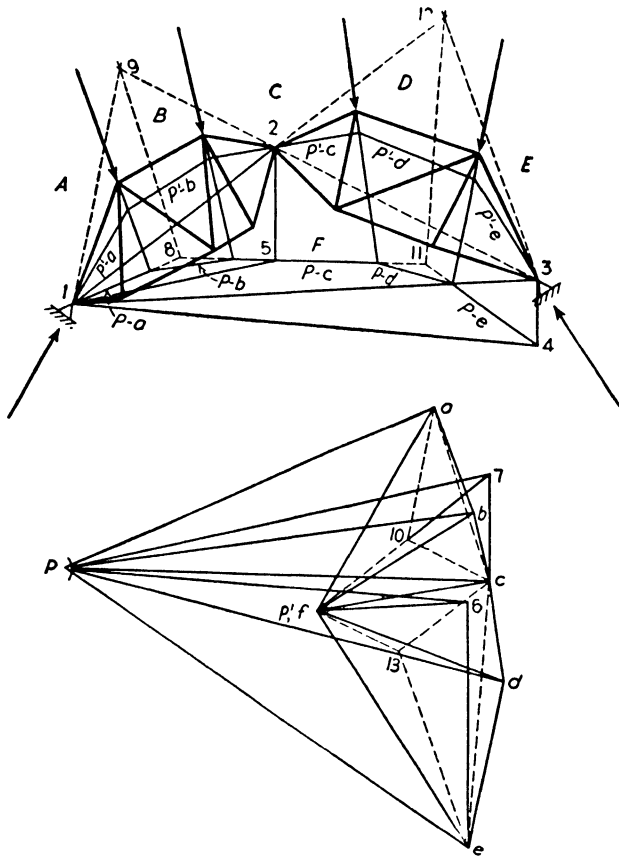

FIG. 2:18

points 6 and 7. Through these, lines are drawn parallel to 1-3 and 1-2 and intersecting at  $P'$ . A new equilibrium polygon corresponding to this pole,  $P'$ , is seen to pass through all three hinges. Relettering  $P'$  as  $f$ , the structure reactions are  $e-f$  and  $f-a$ . These reactions pass through the end hinges. Also,  $f-c$ , the resultant of the forces to the left of 2 (or  $c-f$ , resultant of the forces to the right) passes through 2. If desired, the triangles of the structure may be lettered and the Maxwell diagram completed.

*Second Solution.* (Fig. 2:18.) Draw the force polygon with pole,  $P$ , and the resulting equilibrium polygon. If this structure supported only the forces  $A-B$ ,  $B-C$ , and the resulting reactions, the right half would be a two-force

member, loaded at 2 and 3. For equilibrium the right reaction, therefore, would pass through both 2 and 3. The resultant of the loads  $A-B$  and  $B-C$  is parallel to  $a-c$  and passes through 8. Its intersection with the right reaction at 9 determines an additional point on the left reaction. (If a structure is in equilibrium under the action of three non-parallel forces, the three must intersect in a common point.) Therefore, a line through  $a$  parallel to 9-1 and another through  $c$  parallel to 3-2 intersect at 10 and give  $c-10$ ,  $10-a$ , as the reactions. In similar manner, if the only loads on the structure were  $C-D$  and  $D-E$ , the reactions would be at the right  $e-13$ , at the left  $13-c$ . The actual structure supports both sets of loads. Therefore, the true reactions are the sums of the above, i.e., by drawing through 13 parallel to  $c-10$  and through 10 parallel to  $13-c$  to obtain point  $f$ , the true reactions  $e-f$  and  $f-a$  are obtained.

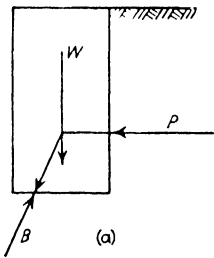

FIG. 2:19

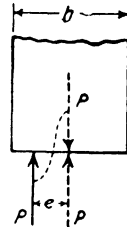
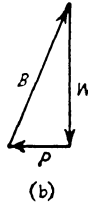

FIG. 2:20

**2:9. Lines of resistance: Masonry walls and dams.** The masonry wall shown in Fig. 2:19 is in equilibrium under the action of three forces: its own weight ( $W$ ); the horizontal push ( $P$ ) of the material resting against the side of the wall, usually assumed to act two-thirds of the way down from the ground level; and the pressure of the foundation on the base ( $B$ ). After  $W$  and  $P$  have been computed and located, the triangle of forces serves to give the magnitude and direction of the base pressure,  $B$ . The resultant of  $W$  and  $P$  cuts the base at the point given by drawing through the intersection of  $W$  and  $P$  a line parallel to this resultant. For positive pressure over the entire base the resultant must fall within the middle third.<sup>1</sup> The discussion of the design of walls, dams, and arches is not within the scope of this book.

Dams are often subjected to upward pressure from water percolating through the foundation bed. The magnitude of the resultant foundation pressure for this case and the location of the point where it cuts the base are shown in Fig. 2:21. Note that here the dam is subjected to two base pressures, that of water and that of the foundation material.

<sup>1</sup> The inclined base pressure may be resolved into a normal and a shearing component. The effect of the normal component, cutting the base a distance  $e$  from the center, is equivalent to that of an equal concentric force  $P$  and a couple as shown

High dams are studied for stability by dividing them horizontally into a series of sections and computing the fiber stress on each of the assumed joints. (Actually of course all dams are either monolithic concrete structures or masonry with irregular jointing.) With the

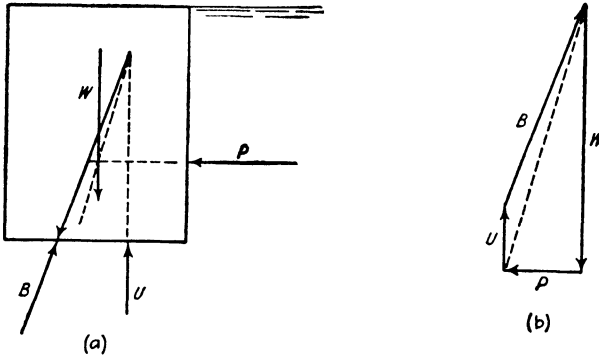

FIG. 2:21

reservoir full the pressure on each joint must act back of the forward middle-third point; with the reservoir empty the resultant joint pressure should preferably act forward of the rear middle-third point. The usual procedure is shown in Fig. 2:23. The weight of each section was first determined,  $W_1$ ,  $W_2$ , and  $W_3$ , together with its line of action.<sup>2</sup> By means

in Fig. 2:20. Let the fiber stress be  $s$ . Then

$$s = \pm \frac{P}{A} \pm \frac{Mc}{I} = \pm \frac{P}{A} \pm \frac{Pe(b/2)}{I \times b^3/12} = \left(\frac{P}{A}\right) \left(1 \pm \frac{6e}{b}\right)$$

where  $b$  is the base width of the section, which has a dimension of 1 ft normal to the drawing, and the other letters have their usual significance. If  $e$  exceeds  $b/6$ , i.e., if the pressure cuts the base outside the middle third, there will be tension at one edge if the material is capable of resisting tension. If incapable of resisting tension, there will be a triangular distribution of pressure with the center of gravity of the triangle under the point where the resultant cuts the base.

<sup>2</sup> The weight of each section is that of a trapezoidal mass of masonry, and the line of action of the weight acts through the center of gravity. There are several methods of locating the center of gravity of a trapezoid. Perhaps the easiest and most clearly logical graphic method is the one which follows.

Bisect the parallel sides, and draw the median  $ef$  (Fig. 2:22); the center of gravity must lie somewhere on this line. Draw either diagonal, as  $AC$ , and locate the centers of gravity of the two triangles into which the trapezoid is thus divided, points  $g$  and  $h$  on their respective medians; the center of gravity of the trapezoid must lie on the connecting line  $gh$ . (Why?) Therefore the intersection,  $k$ , of  $gh$  and  $ef$  must be the center of gravity (or centroid) of the trapezoid.

of the force polygon  $P-0-1-2-3$  the resultant of  $W_1$  and  $W_2 = R_{1-2}$ , and that of all three weights,  $R_{1-2-3}$ , were located. The line of action of  $W_1$  cuts joint 1 at  $d$ ; that of  $R_{1-2}$  cuts joint 2 at  $e$ ; that of  $R_{1-2-3}$  cuts joint 3 at  $f$ . The line joining  $d-e-f$  is called the *line of resistance* or *line of pressure*, *reservoir empty*. It cuts any horizontal plane very closely on the line of action of the resultant dead weight above that plane.

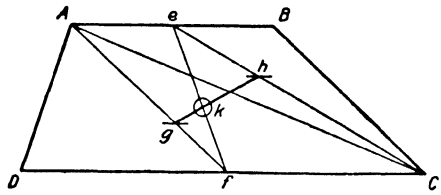
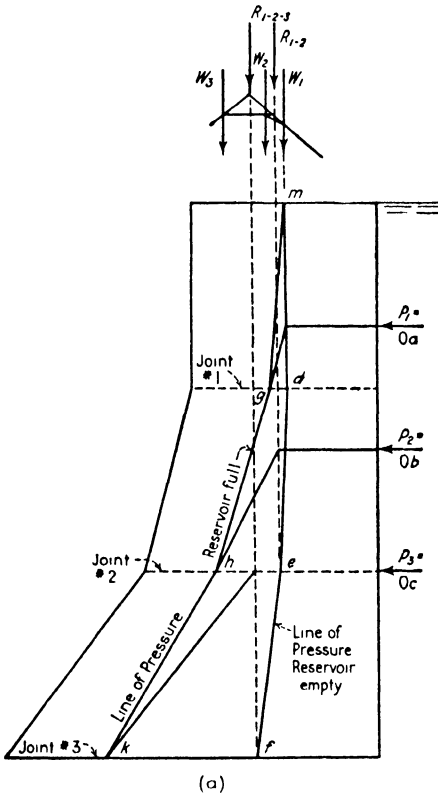
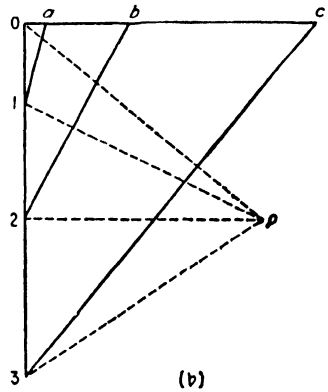

FIG. 2:22



(a)



(b)

This is a gravity dam, resisting water pressure by its weight alone.

FIG. 2:23

The total horizontal pressure above joint 1 is represented by  $P_1$  acting two-thirds of the way down from the surface; the total horizontal

pressure acting above joint 2 is  $P_2$  acting two-thirds of the way from the water surface down to that joint; similarly  $P_3$ . The triangle of forces  $a-0-1$  gives the resultant ( $a-1$ ) of  $P_1$  and  $W_1$  acting through their intersections and cutting joint 1 at  $g$ . The force triangle  $b-0-2$  gives the resultant ( $b-2$ ) of  $P_2$  and  $R_{1-2}$  acting through their intersection and cutting joint 2 at  $h$ . Similarly  $k$  is the point where the foundation pressure cuts the base, joint 3. The line  $m-g-h-k$  is the *line of resistance* or *pressure line, reservoir full*.

**2:10. Lines of resistance: Arches.** Hingeless voussoir arches are analyzed by graphic methods whereas monolithic arches of concrete are usually designed by some method based upon the elastic properties of the arch. However, an approximate result for a reinforced-concrete arch is often obtained by graphic means. The most commonly used assumption states that there is no tension at any section under a given loading if there may be drawn for that loading an equilibrium polygon which lies inside the middle third of the arch ring throughout. The method of analysis, then, is to draw a series of trial equilibrium polygons for the dead load plus the live load placed over the critical portions of the span. If for each critical loading a polygon can be drawn inside the middle third, it is assumed that the arch is satisfactory, provided the unit compressive stresses are within the limits.

This is illustrated in Fig. 2:24, which shows one-half of a fixed-ended arch under a uniform load over the whole span. On account of the symmetry of arch and loading the central string must be horizontal, and, therefore, the method of Fig. 2:16 may be followed. The first polygon—that corresponding to pole  $P'$ —might be drawn with ray  $P'-6$  not horizontal, since its sole purpose is to locate the resultant of the loads on the half arch. With the resultant located, a trial polygon was drawn through the axis at crown and springing. This polygon is plainly outside the middle third. The next attempt would be made by drawing the polygon through the upper middle-third points at both crown and springing.

At any section, as  $m$ , the probable stress may be found from the critical equilibrium polygon. Assuming for example that the polygon shown in Fig. 2:24 is the critical one for section  $m$ , the thrust at this section and its direction are given by  $P-3$  of the force polygon; its line of action is given by the string cutting the section. From this the normal component and the fiber stress are found directly.

The line of resistance for the loaded three-hinged arch shown in Fig. 2:17 is the final equilibrium polygon through the three hinges: any string gives the line of action of the resultant force on either side,

magnitude and direction being given by the corresponding ray of the force polygon. This construction makes possible quick determination

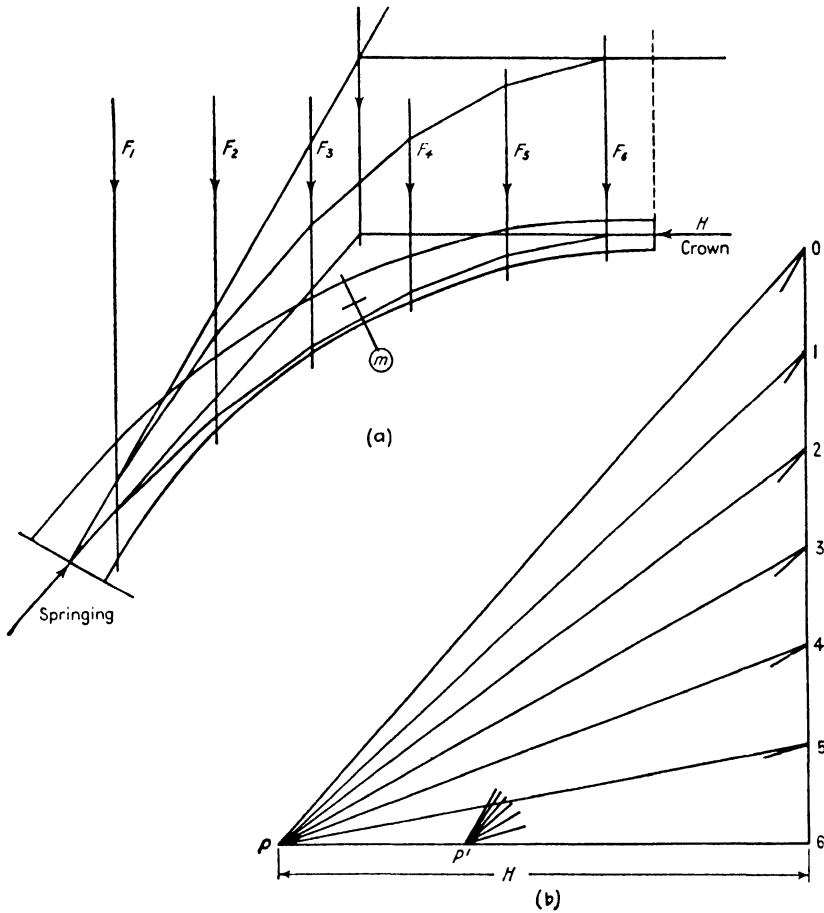

FIG. 2:24

of any bar stress by use of an appropriate section, the resultant force on the free body, other than the stresses in the cut bars, being given by the line of resistance.

PROBLEMS

Art. 2:1

**Problem 2:1.** Find the resultant of the concurrent coplanar force system shown, giving both horizontal and vertical components. Use scale of 1" = 40 kips.

**Problem 2.2.** Determine the force or forces which will hold  $F_1, F_2, F_3$  in equilibrium in the following cases:

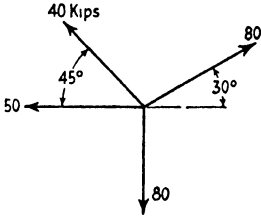

PROB. 2:1

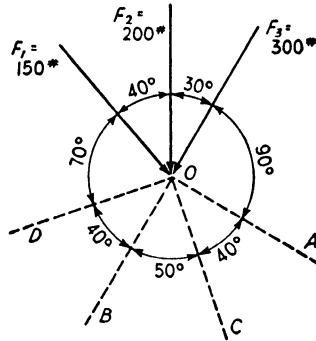

PROB. 2:2

- a. A single force.
- b. A force in line  $OA$  and another in line  $OB$ .
- c. A force in line  $OC$  and a force of 300 lb (two solutions).
- d. One force of 250 lb and another of 400 lb (two solutions).
- e. One force in line  $OA$ , a second in line  $OB$ , and a third in line  $OC$  (?).
- f. A single force in line  $OD$  (?).
- g. A single force of 500 lb (?).

**Problem 2.3.** Find the force which must act upon the rigid body shown to hold it in equilibrium and locate its line of action.

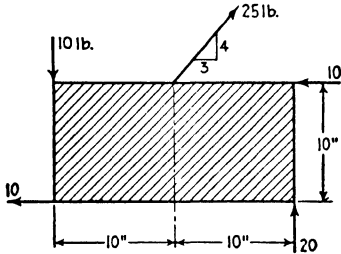

PROB. 2:3

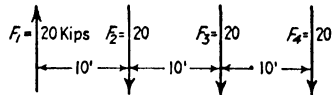

PROB. 2:5

### Art. 2:2 Equilibrium Polygon

**Problem 2:4.** Make a tracing of the force system  $F_1, F_2$ , and  $F_3$  in Fig. 2:3 and determine the resultant and its line of action, placing the pole to the right, instead of to the left, of the force polygon.

**Problem 2:5.** Determine the resultant of this force system by use of the funicular polygon. Scales:  $1'' = 10'$ ;  $1'' = 20$  kips.

**Problem 2:6.** Find and locate the resultants of the force systems shown.

**Problem 2:7.** Locate by the graphical method the centroid (center of gravity) of the 12-in. 40-lb channel section shown on p. 67.

*Suggestion.* This is equivalent to locating the resultant of a series of parallel forces whose magnitudes are represented by the areas of the rectangles and triangles

into which the cross section may be divided and which act through the centers of gravity of those small areas.

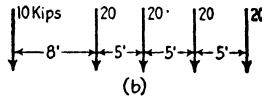
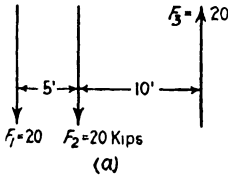

PROB. 2:6

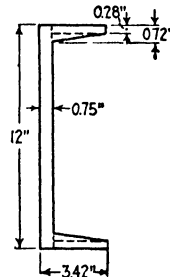

PROB. 2:7

Art. 2:3 Reactions

**Problem 2:8.** Determine both graphically and algebraically the reactions acting on the structures shown. Make the solution for each on an 8½ by 11 in. sheet and use as large a scale as is practicable for both distance and force.

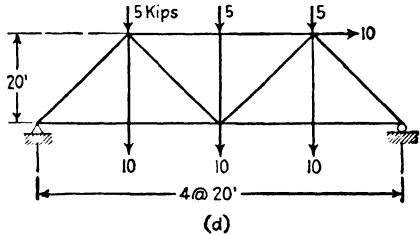
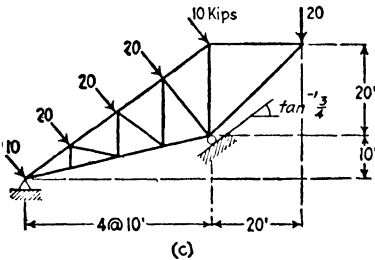
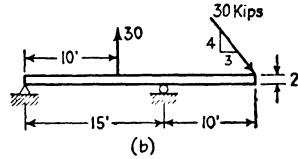
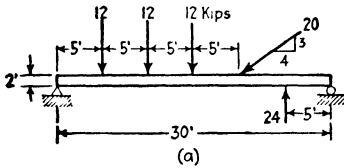

PROB. 2:8

**Problem 2:9.** Determine graphically the reactions for the loaded truss of Prob. 2:11e.

*Suggestion.* A similar problem is solved in Ex. 2:2.

Art. 2:4 Maxwell Diagram

**Problem 2:10.** By means of a Maxwell diagram determine the stresses in all the bars of the trusses of Prob. 2:8c, d. Record the stresses as found on a diagram of the truss.

**Problem 2:11.** Determine graphically the bar stresses for these trusses. Record the stresses as found on a diagram of the truss.



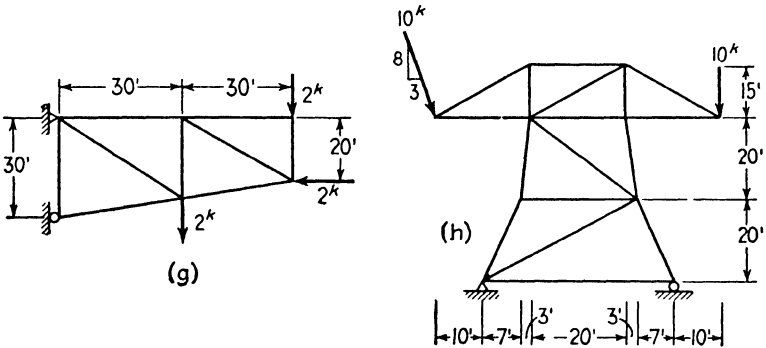
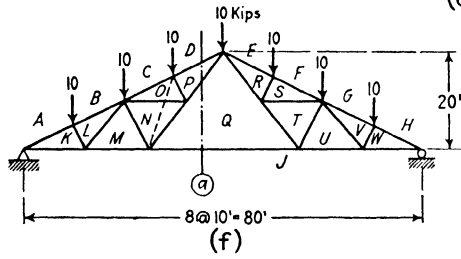
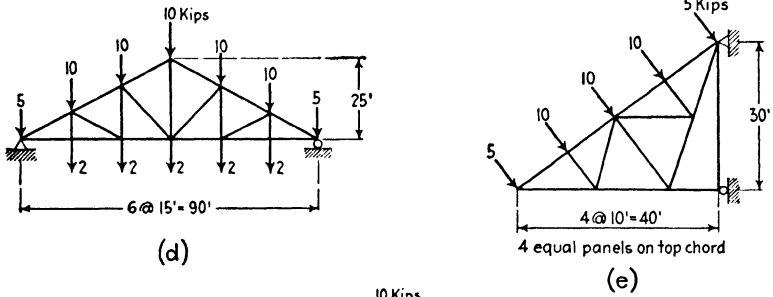
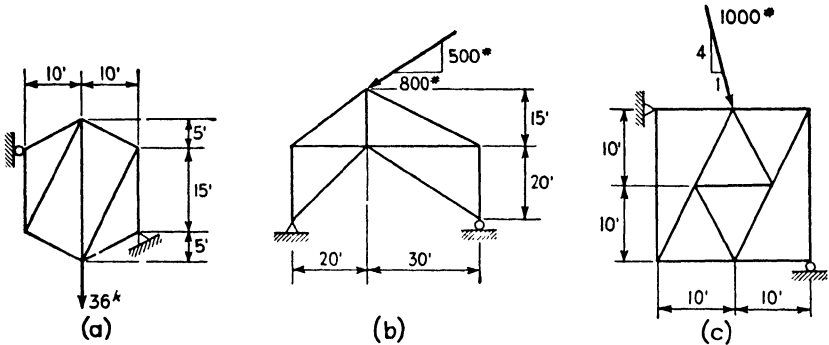

PROB. 2:11

*Discussion.* Since trusses (d) and (f) are symmetrical in every way, the Maxwell diagram need include only the bars of one-half of each truss. No difficulty will be found for truss (e) although it is not possible to locate the several points by taking the joints in strict sequence. Truss (f), however, offers difficulty as soon as points *k*, *l*, and *m* are located. Each of the joints next met has more than two unknowns. The difficulty is not overcome by going to the other side of the truss, the procedure which brings a solution of truss (e) immediately, since with points *w*, *v*, and *u* located we meet the same difficulty on that side. If one is making an algebraic solution by the method of joints, the same trouble occurs, of course, and is overcome by taking section *a* and computing the stress in bar *P-D* by the method of moments. This makes it possible to complete the analysis by the method of joints. The same result can be accomplished graphically as follows. The finding of the stress in *P-D* as just described shows that if bars *O-P* and *O-N* are replaced by the single dotted bar shown, there will be no change of stress in bar *P-D* and the magnitude of that stress can be found by the Maxwell diagram, there being only two unknowns at joint *B-C-O-N-M-L* under the new bar arrangement. With point *p* located on the Maxwell diagram, the temporary bar may be discarded and the regular construction resumed. Maxwell diagrams for a truss of this type are shown in the next chapter, Figs. 3:4 and 3:5.

If bars *P-Q* and *N-Q* did not lie in the same straight line, this substitution would not be possible. This problem is illustrated and discussed in Ex. 2:5.

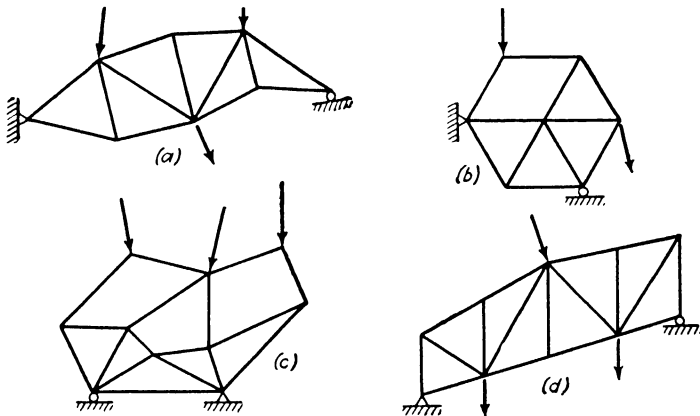

PROB. 2:12

**Problem 2:12.** Draw a figure similar in shape to that shown. Choose loads and determine reactions and bar stresses. A closed force polygon, funicular polygon, and stress diagram will indicate a correct solution.

**Problem 2:13.** Determine graphically the bar stresses in trusses (d) and (f) of Prob. 2:11 with the loads shown replaced by a wind load acting normal to the left-hand slope, with an intensity of 400 lb per ft of top chord. Record the stresses as found on a diagram of the truss.

**Problem 2:14.** Draw the Maxwell diagram for the truss and loads of Fig. 1:23. (See Ex. 2:3.) Record the stresses on the diagram of the truss.

**Problem 2:15A to L.** Determine graphically all stresses in the structures of Prob. 1:12A to L. Mark the stresses on the diagrams of the structures.

**Problem 2:16A, B, D.** Determine graphically all stresses in the structures of Prob. 7:10a, b, d. Mark the stresses on the diagrams of the structures.

**Problem 2:17B, C, D, E.** Determine graphically all stresses in the structures of Prob. 7:34b, c, d, e. Mark the stresses on the diagrams of the structures.

**Art. 2:5 Culmann's Method**

**Problem 2:18A.** Determine the stresses in bars *C-G*, *G-H*, and *H-A* of the truss of Ex. 2:4, Fig. 2:8, by Culmann's method, considering one group of forces to comprise 4-B, B-C, and C-G; the other *G-H* and *H-A*.

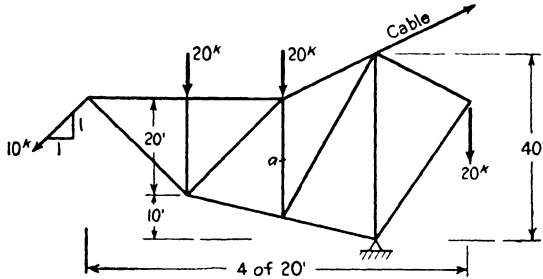

PROB. 2:18B

**Problem 2:18B.** Determine graphically the reactions of this structure. Find the stress in bar *a* by Culmann's method.

**Problem 2:19.** Solve Prob. 1:12D by Culmann's method.

**Problem 2:20.** Determine graphically the stresses in all bars of Prob. 1:10. Check the stresses in bars *CD* and *cd* by Culmann's method.

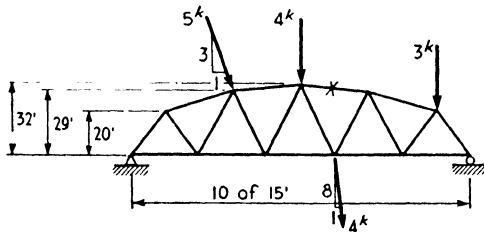

PROB. 2:21

**Problem 2:21.** Determine the reactions graphically (see Ex. 2:3). Draw the Maxwell diagram and mark all stresses on the diagram of the structure. Check the stress in bar *x* by Culmann's method.

**Problem 2:22.** Determine graphically the reactions and all stresses. Use Culmann's

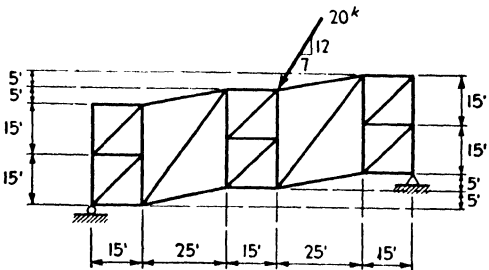

PROB. 2:22

method where you encounter difficulty in drawing the Maxwell diagram. Mark the stresses on the diagram of the structure.

**Art. 2:6 Shear and Moment**

**Problem 2:23.** Draw the curves of shear and bending moment for these beams by the graphic method.

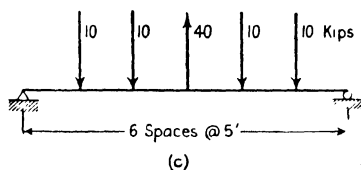
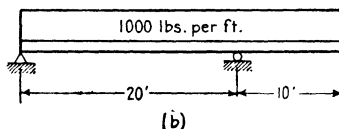
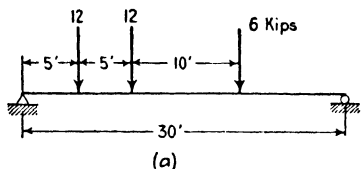

PROB. 2:23

*Suggestion.* First solve Prob. 2:23b by dividing up the load into 5-ft lengths. Then take 2-ft lengths. Compare these results with an algebraic solution.

**Problem 2:24.** Draw shear and moment curves for the beams of Figs. 2:10 and 2:12 with the loads in the positions shown. Compute and give ordinates at all points where the curves change direction.

**Art. 2:7 Equilibrium Polygon through Two and Three Points**

**Problem 2:25.** Draw the equilibrium curve for the loaded beam shown, to pass through the two supporting points and through a point 20 ft above the center of the beam.

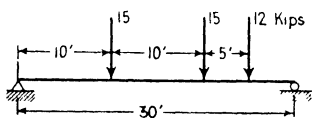

PROB. 2:25

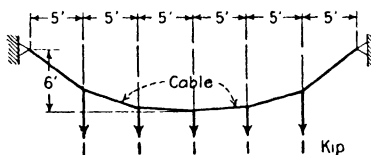

PROB. 2:26

**Problem 2:26.** Determine the elevation of each load point for the cable shown, neglecting the weight of the cable itself. Also determine the stress in each section of the cable.

*Note.* This problem makes very plain the meaning of the term “equilibrium polygon.” The loaded cable here corresponds exactly to the equilibrium polygon, and the stress in any section equals that given by the corresponding ray of the force polygon.

**Art. 2:9 Lines of Resistance**

**Problem 2:27.** Determine graphically the magnitude of the foundation pressure and the point where it cuts the base of this wall, with the water standing to the top:

- a. When there is no upward water pressure on the base.
- b. When there is upward water pressure assumed to act over two-thirds of the base area with an intensity of zero at the toe and full hydrostatic head at the heel.

Take the weight of masonry at 150 lb per cu ft and compute values for a 1-ft length.

- Ans.* a. 67.3 kips, 2.2 ft from center;  
 b. 58.6 kips, 3.1 ft from center.

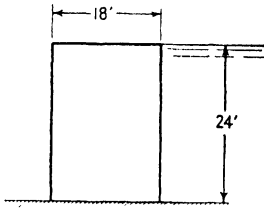

PROB. 2:27

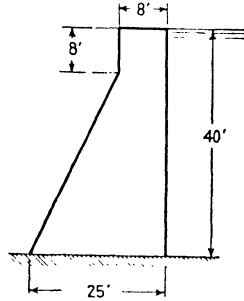

PROB. 2:28

**Problem 2:28.** Draw the lines of resistance for this dam, reservoir full and reservoir empty. Tabulate unit pressures (pounds per square inch) at both edges of all joints for both conditions of loading. Use sections 8 ft apart. Masonry weighs 150 lb per cu ft.

**Art. 2:10 Arches**

**Problems 2:29 and 2:30.** Determine graphically the reactions for the three-hinged arches shown. Draw the lines of resistance and find the stresses in bars *a*.

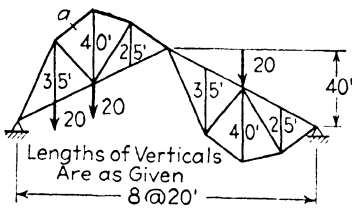

PROB. 2:29

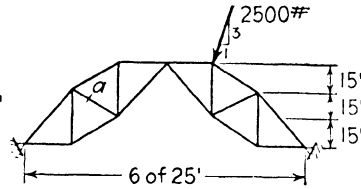

PROB. 2:30

## Chapter 3

# ROOF TRUSSES

**3:1.** The trusses used to support roofs over large rooms, such as shops and auditoriums, are of many different varieties on account of the

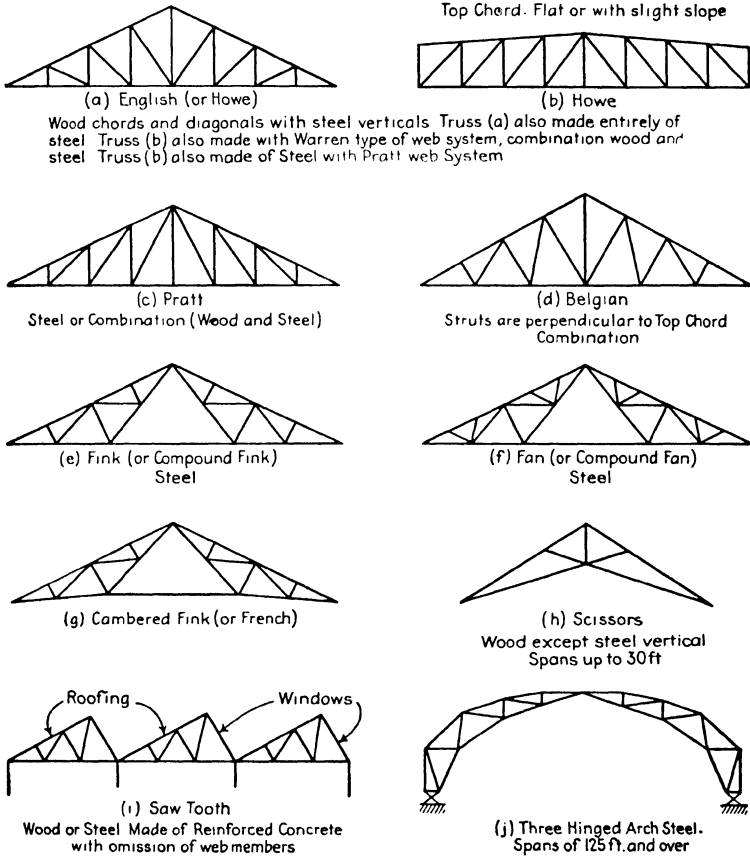

FIG. 3:1

many different conditions of span, slope, and kind of roof covering to be provided for. The principal types are illustrated in Fig. 3:1, and

brief notes are given concerning the material usually employed in their construction. In the form shown, the trusses *a* to *g* in the series are mostly limited to a span of about 60 ft. By increasing the number of panels, the Pratt and Howe truss can be used for longer spans, up to 80 or 90 ft. The scissors truss is the simplest of the many types used for architectural effect. The sawtooth roof is employed for mills and shops where thorough illumination is important. The trussed arch with two or three hinges is the economical form for long spans. The supporting hinges are usually connected by a tie-rod to take the horizontal reaction component.

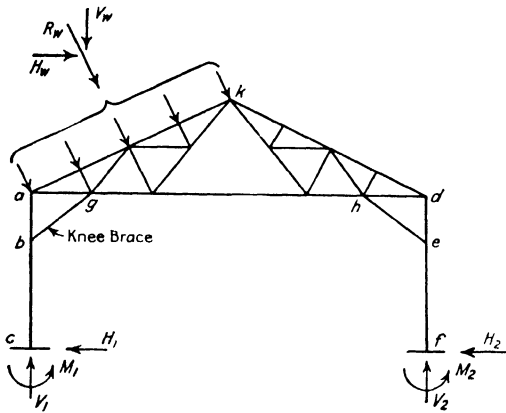

FIG. 3:2

The economical spacing for roof trusses is about 12 to 18 ft for spans up to 60 ft and 18 to 22 ft for spans from 60 to 100 ft. A roof truss with its supporting columns is termed a **bent**. (See Fig. 3:2.) The space between adjacent bents is called a **bay**.

**Purlins** are horizontal beams extending from truss to truss and supporting the roof. In some forms of constructions the roof covering is laid directly on the purlins; in others the roofing is laid on wood sheathing which in turn rests either upon the purlins or upon **rafters**, which are sloping beams extending from ridge to eaves and supported by the purlins. For bay lengths of 12 ft and less purlins may be omitted and the roofing placed over heavy planking resting directly upon the trusses.

It is becoming more and more the practice to support the purlins on the top chord between panel points. This requires chord sections strong enough to carry the bending due to the transverse load and results in a somewhat heavier but cheaper truss with fewer members than when

the purlins are supported at panel points. The purlins must be spaced at such distance as to provide a proper span for the roofing, sheathing, or rafters which they directly support. If it is desired to avoid bending in the loaded chord, purlins must be supported at panel points, and then the form of truss enters in as an element governing the purlin spacing.

Roof trusses are supported either by columns of wood, steel, or reinforced concrete, to which they are rigidly attached, or by masonry walls. For a truss with considerable depth at the ends, for example Fig. 3:1b, the supporting columns become the end verticals with connections to both chords. For a triangular truss, knee braces are required to provide stiffness (Fig. 3:2). Both these arrangements make the bent rigid

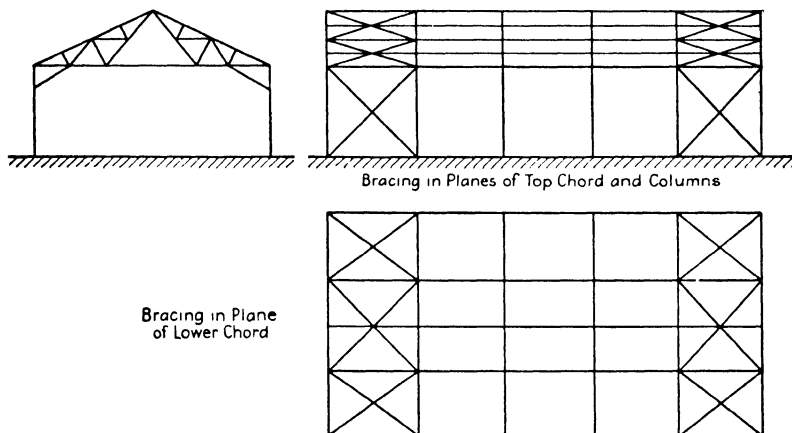

FIG. 3:3

and capable of resisting horizontal forces. Wall-bearing trusses of moderate length are often made fast to both supporting walls by means of bearing plates and anchor bolts, without provision for expansion with temperature change. Since horizontal reactions may be developed at both ends, this mode of support makes the truss indeterminate. This objection is overcome in some measure by providing a sliding support at one end with slotted holes for the anchor bolts. Large trusses are supported on a pin at one end and a roller bearing at the other.

**The pitch of the usual symmetrical roof truss is the ratio of its center height to its span.** The slope of the roof, and consequently that of the chord, must be that which gives proper weather-tightness with the roofing used. A pitch of  $\frac{1}{4}$  to  $\frac{1}{3}$  is economical and satisfactory for those roofing materials requiring steep slopes.



The longitudinal stability of a series of mill-building bents or of roof trusses is secured by the use of bracing between adjacent bents. This is illustrated in Fig. 3:3. If it is impossible to make each bent laterally stable by means of knee braces, owing to the presence of a crane-way, it becomes necessary to transmit the lateral load to the end bents by means of a horizontal truss in the plane of the lower chords of the roof trusses.

This brief description suffices to give a general picture of the essential features. The loads on roofs and the weights of roofing and trusses are treated in the next article, and *Structural Design*, by the authors, illustrates the complete design of a bent. Detailed descriptions of materials and other matters such as are required for practical design are to be found in the following books:

*Steel and Timber Structures*, Hool and Kinne, 2nd Edition (McGraw-Hill).

*Architects' and Builders' Handbook*, Kidder-Parker, 18th Edition, 1931 (John Wiley).

**3:2. Roof loads.** The external forces which may act upon a roof include: (a) a uniform live load of 20 to 30 lb per sq ft on flat roofs, to cover the effect of workmen and other human occupancy of the area; (b) the weight of snow and ice, in amount varying with climate and the steepness of the roof surface; and (c) wind, usually assumed a uniform normal pressure over the whole exposed surface.

The weight of *snow* to be assumed in the design of any roof depends upon the local climate and the slope of the roof. In the following table is given the allowance for snow recommended in Kidder-Parker's *Architects' and Builders' Handbook*, page 1396. Most of the data in this article are taken from the same source by permission.

SNOW LOADS FOR ROOF-TRUSS DESIGN IN POUNDS PER  
SQUARE FOOT OF ROOF SURFACE

Locality	Slope of Roof				
	45°	30°	25°	20°	Flat
Northwestern and New England States	10-15	15-20	25-30	35	40
Western and Central States	5-10	10-15	20-25	25-30	35
Southern and Pacific States	0-5	5-10	5-10	5-10	10

Presumably the range of choice in this table relates to type of roof covering, the smaller loading for a roof surfaced with slate, tile, or metal, the larger for a shingled roof.

Since high winds may come with the roof covered with ice or sleet,

it is necessary to set a minimum value to the snow load of 10 lb per sq ft of roof surface for all localities in this country, except perhaps in the Southern and Pacific coast states, where the allowance may be one-half of the maximum snow load.

The pressure of *wind* on a vertical surface is specified by building codes quite commonly at values of 30 lb per sq ft or less. This first is equivalent to assuming a wind velocity of around 80 or 90 mph. The relation between pressure,  $p$  lb per sq ft, on a vertical normal surface and wind velocity,  $V$  mph, is often taken as  $p = 0.004V^2$ . This is rather crude, since the unit pressure upon a small, square plate is less than upon the same area in long, narrow form.

The pressure of wind upon a sloping roof surface is taken as a force normal to the roof surface, and for the flatter roof slopes the unit pressure is less than upon a vertical surface. This reduced normal pressure intensity is still often computed by the ancient Duchemin formula (1829, verified by S. P. Langley, 1888):

$$P_n = P \frac{2 \sin \alpha}{1 + \sin^2 \alpha}$$

where  $P$  = the intensity on a vertical surface normal to the wind,  $P_n$  = the intensity of normal pressure on a sloping surface with horizontal trace perpendicular to the wind, and  $\alpha$  = the angle of the surface with the horizontal. A simpler formula, much used, is  $P_n = P \alpha / 45^\circ$ .

Continuing research has shown that the actual wind pressure on structures is quite different from what is commonly assumed. For many years it has been appreciated that the pressure on the leeward side of a building or roof is less than atmospheric.<sup>1</sup> An indication of this fact is that when a barn roof fails in a storm it is usually found that the covering on the leeward side has been lifted off. Windows are as often "sucked out" (that is, blown out from within) on the leeward side as blown in on the windward. This has meant little change in the design of the members of a roof truss but has necessitated the anchoring down of the truss and, in particular, of its covering. In 1934 and 1935 there appeared in the *Engineering News-Record* a major contribution to general knowledge in this field, a series of eight articles, "Aerodynamics and the Civil Engineer," by W. Watters Pagon. Especially to be noticed is the concluding article, "Using Aerodynamic Research Results in Civil Engineering Practice" (October 31, 1935, page 601). Also, this search for knowledge was given a great stimulus by the failure

<sup>1</sup> See the article "Wind Pressure on Structures" in *Handbook of Engineering Fundamentals*, by O. W. Eshbach (John Wiley), pages 9-64.

of the Tacoma Narrows Bridge in 1940, and technical literature is being enriched by the publication of the findings of the resulting tests.

In addition to the dead load these combinations of live load may be considered for long-span roofs: snow over all, wind on one side and ice (sleet or minimum snow) over the whole roof, snow on one side and wind on the other, wind on one side. The first two of these four combinations are usually considered the most reasonable for investigation. For moderate-span roofs it is customary to replace these load combinations with a single uniformly distributed load of sufficient intensity to give stresses equal to the maximum found by using the more precise loading. Recommended values of this equivalent uniform vertical load to replace snow and wind loads are given in the following table. These values are in pounds per square foot of roof surface and are adjusted for an allowable increase of one-third in working unit stresses for the wind stresses.

EQUIVALENT VERTICAL LOAD TO REPLACE SNOW AND WIND

Locality	Slope of Roof				
	60°	45°	30°	20°	Flat
Northwestern and New England States	28	26	24	35	40
Western and Central States	28	26	24	30	35
Southern and Pacific States	28	26	24	20	30

The values given in this table must be considered average and should not be chosen without careful consideration of their fitness for the type of truss and the local conditions. To obtain the total design load for a truss the dead load must be added to the tabulated values.

The dead load carried by a roof truss consists of the weight of the roof covering and sheathing, of purlins, rafters, bracing between trusses, ceiling, and other suspended loads, plus the weight of the truss itself. The actual weight of roof covering should be taken from the manufacturer's data; average values sufficient for a trial design are as follows:

Shingles: Common wood	2.5 to 3.0 lb per sq ft
Asphalt	2.0 to 3.0
Asbestos	4.5 to 6.5
Slate ( $\frac{3}{8}$ to $\frac{1}{2}$ in. thick)	7.0 to 16.0
Clay tile	10.0 to 16.0
Cement tile	15.0 to 20.0
Gypsum	4.0 to 6.0
Nailing concrete	7.5 to 8.0
Tin	1.0 to 1.5
Corrugated steel	1.0 to 3.0
Felt and gravel: 3-ply	1.5 to 2.0
5-ply	5.0 to 7.0
Sheathing	3.0 to 4.0

The weights of purlins and rafters can be determined with considerable exactness, if not finally, before the design of the truss is started. Approximate figures will be from 1.5 to 4 lb per sq ft of roof surface for purlins, 1 to 5 lb for rafters.

The weights of roof trusses may be estimated from the following formulas, where  $W$  = the total weight of truss in pounds,  $L$  = the span in feet,  $S$  = the spacing of trusses in feet, and  $P$  = the total vertical or equivalent vertical load supported by the truss. For timber trusses designed for an allowable tensile stress of 1500 psi

$$W = \frac{P}{65} \left( 1 + \frac{L}{30} + \frac{L}{5\sqrt{S}} \right)$$

For steel trusses designed for an allowable tensile working stress of 18,000 psi

$$W = \frac{P}{110} \left( 1 + \frac{L}{30} + \frac{L}{5\sqrt{S}} \right)$$

In general the weight of a roof truss is from 10 to 15 per cent of the total load supported by the truss.

Other formulas are available: for example, reference may be made to the rather comprehensive formula and data in Art. 9:4, *Structural Design* (John Wiley) by Sutherland and Bowman.

**3.3. Stresses in roof trusses.** Since the load combinations to be considered are very few, the simplest way of obtaining the stresses in a roof truss is the graphical method of joints described in the preceding chapter. The following example illustrates the general procedure.

**Example 3:1.** For what stresses should the bars of the truss shown in Figs. 3:4 and 3:5 be designed?

*Discussion.* The design loads are indicated clearly in the computation and are sufficiently explained in Art. 3:2 above. The only comment required by the stress diagrams relates to Fig. 3:5*b*, which is modified by the dot and by the dot and dash lines to show the stresses resulting when the horizontal reaction is applied at the left end, or at the right end, as well as equally at the two ends as shown. It will be noted that the only bars changing stress with these changes are those of the lower chord. If the lower chord were cambered (Fig. 3:1*g*), other bars would be affected. A small truss, such as this shown, would probably develop horizontal reactions at both ends, and conservative practice would require provision for the stresses developed by the full horizontal reaction acting at either end alone.

The stress table should be noted with some care. The final column gives

ROOF TRUSSES

the stresses resulting from using a single vertical loading of 45 lb per sq ft of roof over the whole span to replace the various combinations of dead, snow, ice, and wind. The magnitude of this load was obtained by adding to the dead load intensity the tabulated value suggested in Art. 3:2 for a load to replace wind and snow for a roof in New England, the district which deter-

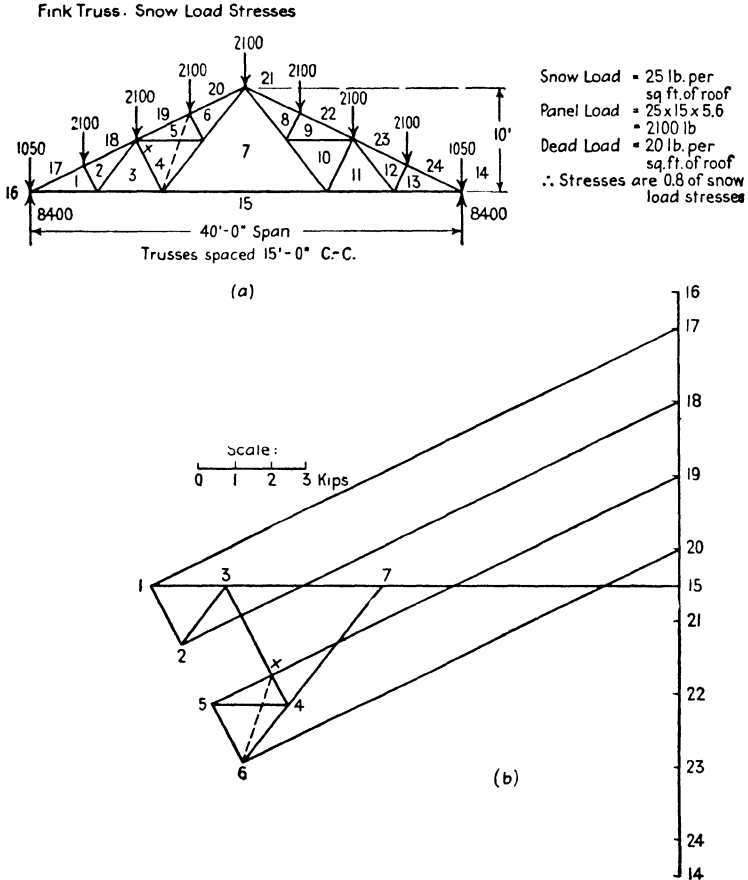

FIG. 3:4

mined the snow load previously chosen. The stresses thus obtained do not differ sufficiently from those given by the several combinations considered to justify the use of the more elaborate methods. In present-day practice this simplified loading is the one chosen. In justification of this, note that no provision was made for uplift on the leeward side, a force which is customarily neglected in the design of a closed building but which is carefully accounted for

in the design of an open shed. Undoubtedly this uplift will come into play in a severe storm, and it is good practice to make those tension members whose stress would be reversed by this action sufficiently stiff to carry considerable compression even if these stresses are not computed. *Attention must also be given to anchoring the roofing to the truss and the truss to its supports.*

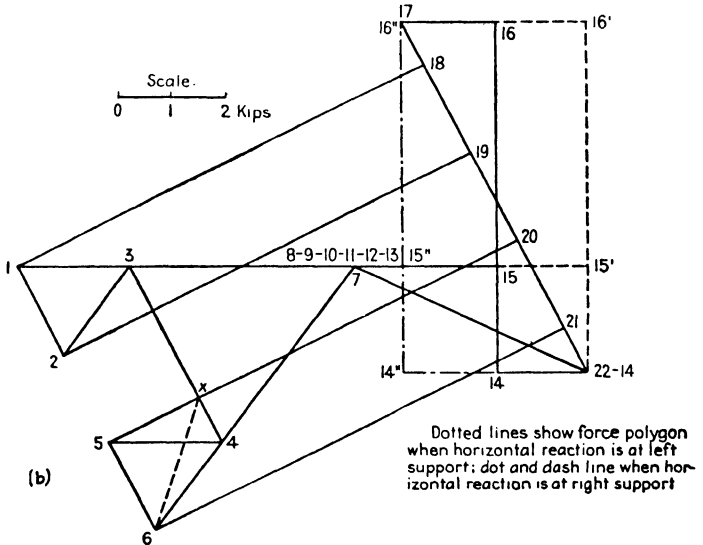
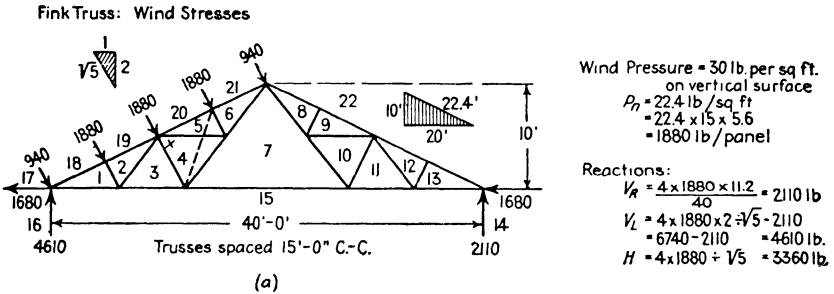
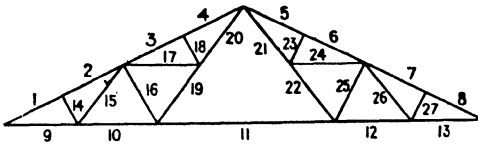

FIG. 3:5

On the next page is given a summary of the stresses found in Figs. 3:4 and 3:5 and their combination for maximum stress effect.

*Fink Truss: Maximum Stresses.*



Dead load; 20 lb per sq ft of roof.  
 Snow " 25 " " "  
 Ice " 10 " " "  
 Wind " 22.4 " " "  
 i.e., 30 lb per sq ft on a vertical surface.

Combinations: (a) Dead + Snow  
 (b) Dead + Ice + Wind right or left  
 Alternate load of 45 lb per sq ft of roof to cover all combinations.

Bar	Dead	Snow	Ice	Wind		Maximum	Alternate Loading
				Left	Right		
1	-13,200	-16,400	-6,600	- 8,500	- 4,700	-29,600	-29,600
2	-12,400	-15,500	-6,200	- 8,500	- 4,700	-27,900	-27,900
3	-11,600	-14,500	-5,800	- 8,500	- 4,700	-26,100	-26,100
4	-10,900	-13,600	-5,400	- 8,500	- 4,700	-24,500	-24,500
9	+11,800	+14,700	+5,900	+ 7,100	+ 4,200	+26,500	+26,500
10	+10,100	+12,600	+5,000	+ 5,000	+ 4,200	+22,700	+22,700
11	+ 6,700	+ 8,400	+3,400	+ 840	+ 4,200	+15,100	+15,100
12	+10,100	+12,600	+5,000	+ 840	+ 8,400	+23,500	+22,700
13	+11,800	+14,700	+5,900	+ 840	+10,500	+28,200	+26,500
14	- 1,500	- 1,900	- 750	- 1,900	0	- 4,150	- 3,400
15	+ 1,700	+ 2,100	+ 840	+ 2,100	0	+ 4,640	+ 3,800
16	- 3,000	- 3,800	-1,500	- 3,800	0	- 6,800	- 6,800
17	+ 1,700	+ 2,100	+ 840	+ 2,100	0	+ 4,640	+ 3,800
18	- 1,500	- 1,900	- 750	- 1,900	0	- 4,150	- 3,400
19	+ 3,400	+ 4,200	+1,700	+ 4,200	0	+ 9,300	+ 7,600
20	+ 5,000	+ 6,300	+2,500	+ 6,300	0	+13,800	+11,300
9	+11,800	+14,700	+5,900	+10,500	+ 840	+28,200	+26,500
10	+10,100	+12,600	+5,000	+ 8,400	+ 840	+23,500	+22,700
11	+ 6,700	+ 8,400	+3,400	+ 4,200	+ 840	+15,100	+15,100
12	+10,100	+12,600	+5,000	+ 4,200	+ 5,000	+22,700	+22,700
13	+11,800	+14,700	+5,900	+ 4,200	+ 7,100	+26,500	+26,500
9	+11,800	+14,700	+5,900	+ 8,800	+ 2,500	+26,500	+26,500
10	+10,100	+12,600	+5,000	+ 6,700	+ 2,500	+22,700	+22,700
11	+ 6,700	+ 8,400	+3,400	+ 2,500	+ 2,500	+15,100	+15,100

Horizontal reaction at right support

Horizontal reaction at left support

Equal horizontal reactions at the two supports

In this table no bar undergoes a reversal in the character of its stress. In Ex. 6:6, however, certain bars whose maximum stress is tension are stressed in compression by the wind and so must be made sufficiently stiff to carry this reversed stress. Evidently a design based on a single composite loading is not adequate in this case.

**Example 3:2.** Find the stresses in the loaded half of the three-hinged-arch roof truss shown in Fig. 3:6.

*Discussion.* The three-hinged arch is statically determinate; there are four unknown reaction elements, two at each hinge, and a fourth equation from the condition that there is no bending at the intermediate hinge. Stated mathematically, this condition is  $M = 0$ , i.e., the moment of all the forces acting on either side of the hinge equals zero, or the line of action of the re-

sultant of all the forces on either side of the intermediate hinge passes through that hinge.

*Solution.* It is possible to proceed with this problem exactly as in the previous example, determining the reactions in any convenient manner and drawing the Maxwell diagram for the bar stresses. Such a procedure is extremely difficult on account of the intricacy of the diagram. Algebraic methods are rather tedious

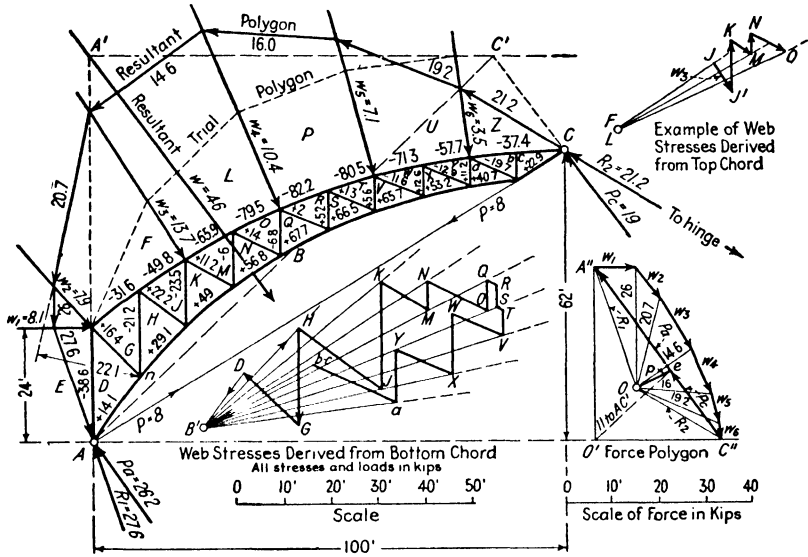

FIG. 3:6

and cumbersome. A method which promises perhaps the most expeditious solution is that suggested by David A. Molitor,<sup>2</sup> which is here shown.

Since it was desired to use the funicular polygon in a later step, the first operation was to construct the true polygon passing through the hinges A and C. A trial polygon was drawn, using the pole O'. It was assumed that the reactions acting on the left half of the arch were parallel to the resultant of the six loads (A''C'' in the force polygon), giving a closing line AC'. The usual construction located e on C''A'' in the force polygon, thus giving the magnitudes of the assumed reactions. (See Art. 2:7, Ex. 2:11.) The closing line of any polygon through the two hinges shown must be the line AC. Hence any polygon drawn with a pole on line p of the force polygon parallel to AC will pass through these two points. The actual direction of the reaction at C is as shown, through the hinge at the right reaction and that at C, the right half of the arch (not shown) being unloaded. Therefore if the extreme ray through C'' is taken parallel to this line of action and the pole located at its intersection with line p, not only will the resulting funicular polygon pass through points A and C but also it will be of the type shown in Fig. 2:24, any

<sup>2</sup> *Engineering News-Record*, April 25, 1929.



string of which is the line of action of the resultant of all the forces, including reaction, on either side of it, the magnitude of the resultant being given by the corresponding ray of the force polygon. This is why the funicular polygon in this problem is labelled "Resultant Polygon."

This *resultant polygon* was used in computing the chord stresses, the next step in the solution. For example, the stress in bar  $FG$  was found by taking a vertical section through that bar and applying the equation  $\Sigma M = 0$  to the free body to the right, with center of moments at  $n$ . The moment of all the forces to the right of the section equals the resultant of all those forces multiplied by the normal distance of its line of action from  $n$  ( $20.7 \text{ kips} \times 22.1 \text{ ft}$ ) and is equal and opposite to that of the bar stress ( $31.6 \times 14.5 \text{ ft}$ , the scaling of the arm not being indicated in the drawing). This procedure is plainly easy and quick of execution, and the results are written directly on the truss diagram.

The web stresses were found as follows. From any convenient center,  $B'$ , lines were drawn parallel to the lower chord bars, with the magnitude of each chord bar stress laid off on the appropriate line to convenient scale. At any joint, as  $n$ , where there were two unknowns, there remained only to complete the force polygon by drawing lines parallel to the unknowns; for example, through  $D$  a line parallel to  $DG$  and through  $H$  a line parallel to  $HG$ , intersecting at  $G$ . When a load acts at a joint it must be drawn in as indicated for an upper chord joint.

The results for both web and chord bars may be checked by carrying through a similar independent construction, using the panel point of the other chord. When a disparity in the values for any web member is found, the error lies in the chord stresses previously computed.

### PROBLEMS

**Problems 3:1 and 3:2.** Compute the maximum stresses in the members of these roof trusses. Assume a location in the — states and take values for snow and

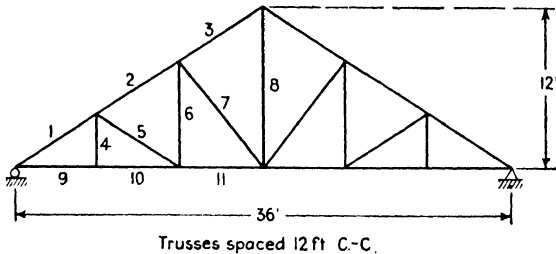

PROB. 3:1

alternate loads from Art. 3:2. Assume dead weight (including truss) at 18 lb per sq ft of roof surface. Compute by use of the — formula the normal pressure corresponding to a wind pressure on a vertical surface of 25 lb per sq ft. Consider the same combinations of load as are taken in Ex. 3:1.

*Note to Problem 3:2.* Assume one-half the horizontal reaction at each point of support. Note that the dotted members as shown may be used in making a graphic solution.

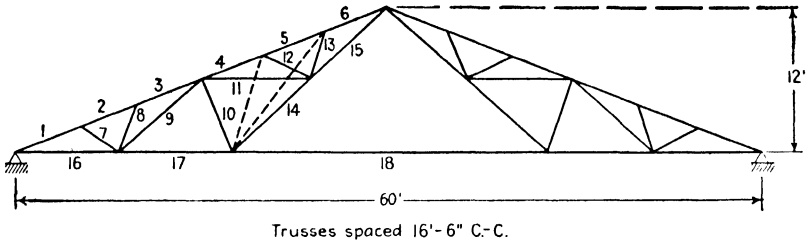

PROB. 3:2

**Problem 3:3.** Determine the stresses in this truss due to a pressure of  $12\frac{1}{2}$  lb per sq ft of exposed surface on one side of the roof acting together with a suction of like amount on the other side. Assume that the horizontal components of reactions are equal.

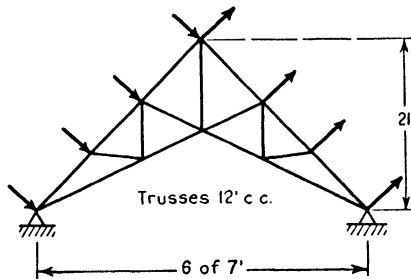

PROB. 3:3

*Comment.* It is a recognized fact that there is an appreciable suction behind buildings and on the lee side of roofs. Some engineers take this into account in design, usually by applying a pressure on one side of the roof and a suction on the other side, of about one-half of that used where pressure on one side only is assumed.

# TRUSS and GIRDER BRIDGES

**4:1.** The new element that enters the problem as we turn from roof to bridge trusses is *partial* live loading, which, in producing maximum stress, varies in extent of span coverage with the different bars. The live loads on a roof truss are definite in extent and combination, and the simplest method of solution is probably the graphic. For a bridge truss there are too many different positions of the live load to be considered to make graphic methods in general profitable, and we make our computations numerically instead.

It is impossible to understand the analysis of the stresses in bridge trusses without a clear mental picture of the floor system upon which the live load moves. The essential elements of the usual floor for both railway and highway bridges are made clear by Fig. 4:1, which shows, in somewhat diagrammatic fashion, a single-track **through** railway span, the "through" indicating that the trains pass actually through the structure. A **deck** bridge is one carrying its live load upon a deck or floor *at* or *above* the level of the upper chord. When the live load passes between the main carrying members—trusses or girders—but the depth is insufficient to allow the use of a top chord bracing system, the bridge is called a **half-through**. A truss of such a half-through bridge is called a **pony** truss.

In Fig. 4:1 the ties which carry the rails are shown resting directly upon short longitudinal beams called **stringers**, supported by the transverse **floor beams**, which in turn are supported by the main trusses. In highway bridges more than two stringers are used in each panel.

In steel structures these stringers are considered to be simply supported, and the negative moments developed by their continuous arrangement and rigid connection to the floor beams are neglected in design. As welded connections are developed, this continuity and the consequent reductions of bending moment will probably be counted upon in buildings and possibly to some extent in bridges.

The main trusses are connected in the planes of the upper and lower chords by horizontal trusses which serve to resist the lateral forces

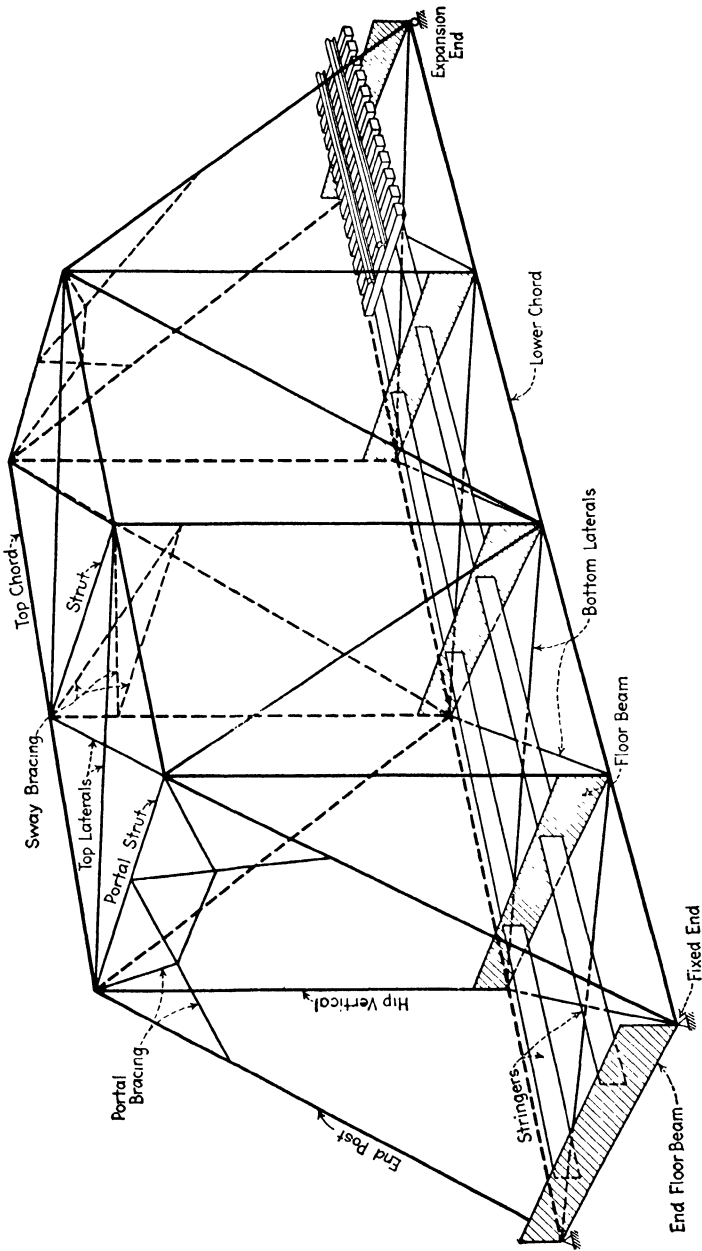

FIG. 4:1

set up by the wind, by the side sway of moving trains, and by centrifugal force if the bridge is on a curve. The reactions of the upper truss are transmitted to the abutments by the **end posts**, made into a rigid frame by their connecting **portal bracing**. Additional stability is given the structure by the **sway bracing**, connecting opposite verticals of the main trusses.

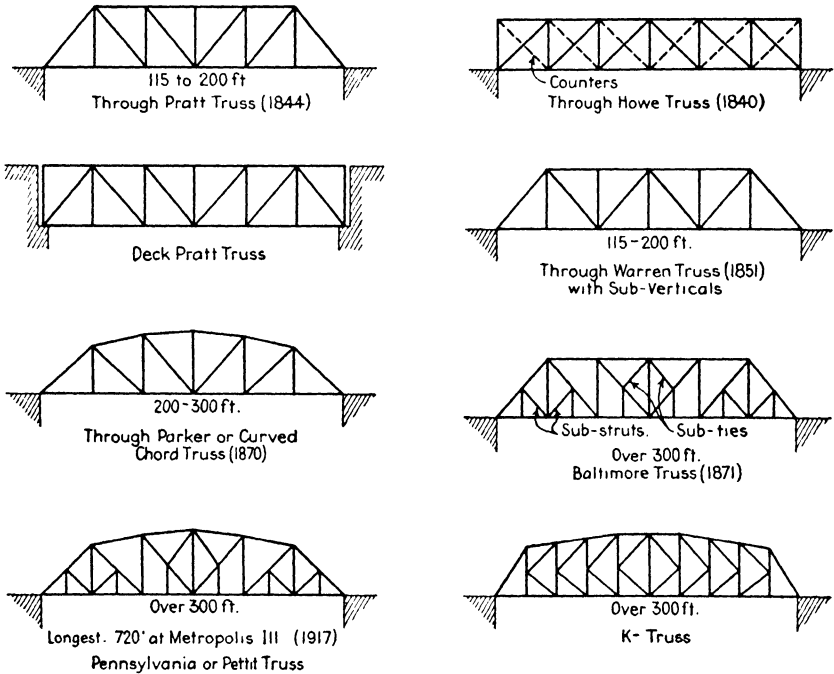

FIG. 4:2

In deck structures the track or highway floor may be carried by a floor system similar to that described or may rest directly upon the trusses.

The arrangement of floor beams and stringers already described (called an **open floor**) is also used when plate girders instead of trusses are the main members. Railway bridges are also often made with solid floors which carry the track on ballast.

Typical forms of present-day bridge trusses for simple spans are shown in Fig. 4:2, with notations indicating the usual (but not the maximum) range of span length.<sup>1</sup> All these trusses are built of steel

<sup>1</sup> For the types of some long-span simple truss bridges see the table on page 1222 of the Merriman-Wiggin *American Civil Engineers' Handbook* (John Wiley), 5th Edition.

except the Howe truss, which is of wood with iron or steel verticals. A steel truss with compression diagonals has the Howe type of bracing but is not a true Howe truss. All these forms are statically determinate. Plate girders have been used for simply supported spans as long as 188 ft: the usual limit is about 110 ft on account of shipment difficulties with increased depth. The main river crossing of the Charter Oak Bridge over the Connecticut River at Hartford, Conn., however, consists of an 840-ft girder continuous over three spans of 270-300-270 ft.<sup>2</sup>

In the Pratt truss, under dead load, the main diagonals, except the end diagonal, called the end post, are stressed in tension, and the verticals, except the hip vertical, in compression. The live load in certain cases may reverse the stress in some of the main diagonals and make necessary the use of a **counter** (that is, an adjustable tension bar placed in the opposite diagonal of the panel), or, better, a single stiff diagonal capable of carrying compression as well as tension. The Howe truss is made with counters in every panel. The diagonals of Warren trusses are always made single and capable of carrying reversed stress if necessary.

As the span length increases, economical truss proportions (depth =  $\frac{1}{8}$  to  $\frac{1}{6}$  of span) require greater depth and longer panel length. On the other hand long panels greatly increase the weight of the floor system. In order to obtain relatively short panels in a deep truss, the panel is subdivided as shown for the Baltimore and Pettit trusses, or the radically different bar arrangement of the K truss is adopted. The Baltimore truss is a subdivided Pratt and may use secondary struts throughout instead of a combination of struts and ties as shown in Fig. 4:2. The Warren truss with subverticals is often further subdivided, with intermediate verticals and secondary struts similar to the Baltimore truss.

All these types are used for both through and deck bridges, the curved chord being the lower one in a deck structure.

**Example 4:1.** Draw the curves of live load shear and moment for the stringers *CD* and *DE*, for floor beam at *D*, and for a girder of the single-track bridge shown in Fig. 4:3. Loads are given in kips per rail: each stringer is assumed to carry only the load on one rail.

*Note.* A common diagrammatic representation of bridges with floors is here shown, with stringers resting upon the floor beams and floor beams resting upon the girders. Actually, in half-through plate girder structures, the stringers are framed into the floor beams with the floor-beam top flanges slightly above the top flanges of the stringers. The floor beams, in turn, are placed between the girders with the bottom flanges of the girders slightly below the bottom

<sup>2</sup> *Engineering News-Record*, September 10, 1942, page 338.

flanges of the floor beams. In through or half-through truss railroad bridges, the general arrangement is like that just described except that the floor beams may be joined to the verticals at any point. The only truss members whose stresses are affected by the elevation of the floor system are the verticals directly supporting the floor beams. The stresses in the stringers, floor beams, and girders are the same whether the arrangement is actual or is that adopted for clarity in the conventional diagram.

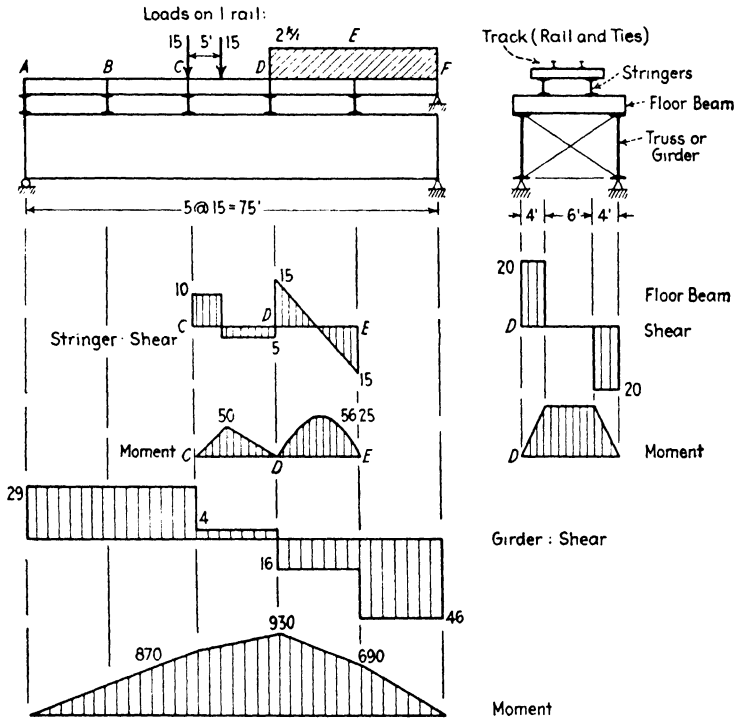

FIG. 4:3

*Discussion.* In the diagram in this example the left end stringers are shown resting on an end floor beam and those at the right end resting on independent pedestals. The shears and moments in the floor system and girders (but not the girder reactions) are the same for both modes of end stringer support. The shear in the left end panel equals the **net reaction**, i.e., **gross reaction** on the girder less the end floor beam reaction, which is zero for the loading of the present example.

The moment curve is a series of straight lines, and *the values at the panel points are the same as those that would occur in a simple beam of the same length with the same load.*

That the foregoing statement in *italics* is a general rule may be seen from

Fig. 4:4. Let a load be placed anywhere on the structure, for example, on stringer *bc*. The girder reactions in Fig. 4:4a will be equal to those in Fig. 4:4b. The moment at *b* in Fig. 4:4a will equal the left reaction times its arm, those at *c* and *d* the right reaction times an arm, and these are clearly equal to the moments at the corresponding points in Fig. 4:4b. Since the moment due to a number of loads is equal to the sum of the moments due to the individual loads, what has been proved here for one load will be true if the structure carries a series of loads. Therefore, the rule is seen to be general. Furthermore, it holds for the panel points of a truss as well as for those of a girder.

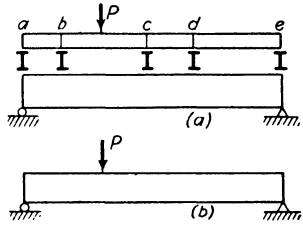

FIG. 4:4

**4:2. Weights of bridges.** Various formulas have been proposed for estimating in advance of design the weight of a given span complete: floor system, bracing, and trusses. Although these are all based on the actual weights of existing structures, they are necessarily approximate and the actual weight should always be computed and the design revised if need be.

It should be noted that the following formulas date from the period when the basic stress allowed in specifications was 16,000 lb per sq in. At the present time this figure has been raised to 18,000 lb per sq in. The resulting bridge weights would change approximately inversely as the change in stresses. Hence, a factor of 8/9 should be included in the following formulas if the design is to be made for a basic stress of 18,000 lb per sq in.

Professor Constant<sup>3</sup> gives the following for *w*, the weight of steel per foot of span for open-floor single-track railway bridges designed in accordance with the American Railway Engineering Association's Specifications of 1925, for Cooper loadings:<sup>4</sup>

Deck plate girders	$w = k(13l + 100)$
Through plate girders	$w = k(15l + 500)$
Through pin-connected or riveted trusses	$w = k(9l + 700)$

where *l* = length of span (feet), *k* = 0.88 for E-40, *k* = 1.00 for E-50, *k* = 1.12 for E-60 loadings. To arrive at the total weight of the bridge, the weight of the track must be added, 400 to 600 lb per ft of track, including rails, ties, guard timbers, and all fastenings. For a double-

<sup>3</sup> In Merriman-Wiggin, *American Civil Engineers' Handbook* (John Wiley), 5th Edition, page 1162.

<sup>4</sup> See Art. 4:5.



track structure multiply the results of these formulas by 2 for girder bridges, and by 1.8 or 1.9 for truss bridges.

**4:3. Dead load stresses.** For spans of moderate length the dead load of the bridge is assumed to be uniformly distributed, giving equal panel loads for the usual truss. For small bridges this load is assumed to act only on the loaded chord, that is, at the panel points of the chord placed at the level (approximately) of the floor. In longer structures the dead panel load is divided between top and bottom chords, two-thirds on the loaded chord being common. A better way is to calculate the weight of the floor system separately from the trusses and their bracing and place this load on the proper chord, and then to divide the truss weight equally between the chords. Actually the load at any joint is one-half of the weight of all the members meeting there, plus the floor-beam reactions for the loaded chord, and the actual dead weight is not uniform over the length of the span as assumed. However, it is not necessary to figure this variation except for large and important bridges.

The usual method for finding dead-load stresses is that of joints. It is a simple matter to write the dead stresses directly on a stress diagram as shown in the following examples.

**Example 4:2.** Find the dead stresses in the bars of one truss of the single-track through railway bridge shown in Fig. 4:5. Use Constant's formula for the dead weight; E-60 loading.

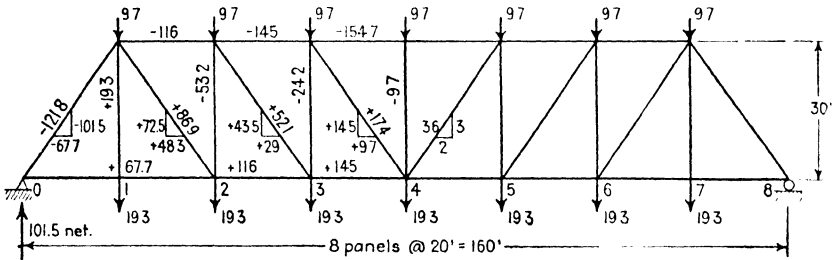

FIG. 4:5

*E-60 loading:* Use Constant's formula.

*Dead weight:*  $w = 1.12 (9 \times 160 + 700) = 2400$  lb per ft

Track:  $\frac{500}{2900}$  lb per ft of bridge

*Top chord:* Panel load =  $\frac{1}{2} \times \frac{1}{2} \times 2900 \times 20 = 9.7$  kips

*Bottom chord:* " " =  $\frac{1}{2} \times \frac{2}{3} \times 2900 \times 20 = 19.3$  kips

*Check:* Stress  $U_3U_4 = \frac{1}{30} \times \frac{wL^2}{8} = \frac{1}{30} \times \frac{1.45 \times 160^2}{8} = -154.7$

*Discussion.* Since the formula used does not give the weight of the floor system separately, it was not possible to use the more satisfactory method of

division of the dead load between the chords described above. Full panel loads were placed at  $U_1$  and  $U_7$  on account of the weight of the portal bracing and the heavy end posts at these points.

With the panel loads written on the diagram, the slope of the diagonals was indicated, and then the stresses were written by inspection as follows. Starting with joint  $U_4$ , the stress in the center vertical is  $-9.7$ . At joint  $L_4$  the tensile vertical component in each diagonal equals one-half the sum of vertical stress and panel load, this joint being at the center of the span and the stresses in these diagonals being equal by symmetry for symmetrical loading. At joint  $U_3$  there is a downward load of  $9.7$  and a downward vertical component in the diagonal of  $14.5$  to be balanced by the compression in the vertical. Thus the work proceeded to joints  $L_3, U_2$ , etc., in turn, a check being afforded at  $L_0$  by an independent computation of the reactions. Next the horizontal components of the diagonals were written and then the chord stresses, proceeding joint by joint toward the center, first on one chord, then on the other.

The first check for the chord stresses was the requirement of equal stress in bars diagonally opposite, as  $U_1-U_2$  and  $L_2-L_3$  (take section through these bars:  $\Sigma H = 0$ ); the second and positive verification was the independent

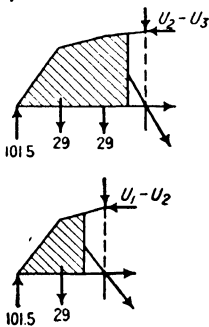
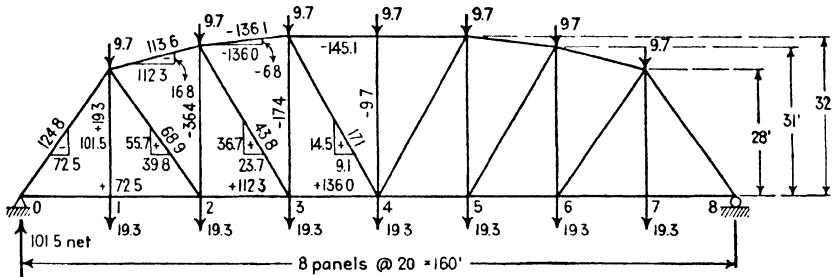

Fig. 4:6

computation of the stress in the top chord at the center, which equals the bending moment at the center of the span (moment center for the bar) divided by the truss depth. After this check, the actual stresses in the diagonals were added to the diagram.

**Example 4:3.** Same as Ex. 4:2 with a Parker truss, Fig. 4:6, replacing the Pratt truss there used.

*Discussion.* The same order of work was followed as in the previous example, except that the first step consisted in finding the horizontal and vertical components of stress in the two inclined chord bars, using the free bodies shown.<sup>5</sup>

<sup>5</sup> No slope triangles are shown in Fig. 4:6, since it was judged easier to find the actual stress in each diagonal and sloping chord directly from its horizontal and vertical components, there being six members and five different slopes. Agreement with this judgment will depend upon the computer's facility with the slide rule. The instruction books give directions for this operation, the method varying with the type of rule.

**4:4. Influence lines.** In the study of large and complicated trusses, curves called **influence lines** are drawn to show the variations of functions, such as shear, moment or deflection at a given section, or the stress in a given bar, due to the passage of a single unit load across the span. Such curves are important in the study of the effect of concentrated loads and also in the development of certain theorems of structural action, and a thorough understanding of them is essential. They were first used by Professor E. Winkler of Berlin in 1867.

**Any ordinate of an influence line gives the value of the function (shear, moment, bar stress, etc.) for which the curve is drawn when a load of unity is at the ordinate.**

For example, it is desired to draw the influence line for the shear at the center of the simple beam shown in Fig. 4:7. A load of unity placed

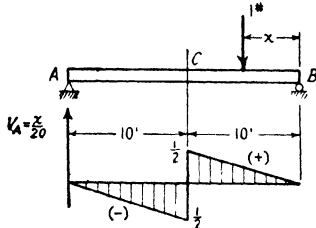

FIG. 4:7

between C and B at a point distant  $x$  from B causes a left-hand reaction of  $x/20$ , which equals the positive shear of C caused by the load when to the right of C. An ordinate equal to  $x/20$ , therefore, is erected at each point distant  $x$  from B, between C and B, and the locus of these ordinates—a straight line running from zero at B to a value of  $+1/2$  at C—is the influence line for this portion of the beam. Similarly, when the load is between A and

C, the shear is negative at C and equal to the right reaction  $-x/20$ , when the load is distant  $x$  from A.

When computing ordinates for influence lines for shear and moment, always compute the functions in terms of the forces on the side of the section away from the unit load, because thus the result is given usually by a single operation involving only one force, a reaction.

Contrast carefully shear and moment curves with influence lines for shear and moment. A shear or moment curve records graphically the value of the function at *all* sections of a beam under a *fixed* loading; an influence line for shear or moment records graphically the value of the function at a *single* section for a load at *all* sections.

Typical influence lines are shown in Fig. 4:8, the verification of which will ensure a sound foundation for problem solution. The curves in Fig. 4:8b relate to one girder (or truss) of a single-track four-panel bridge with the stringers symmetrically placed, distributing the track load equally to the two girders. The values of the ordinates presuppose two loads of unity opposite each other, one on each rail. It is to be noted that the influence line for shear in panel 1-2 gives the value of the shear

on any section through the girder between the floor beams at panel points 1 and 2, for a load on the stringers. Also note that these several influence lines for a girder loaded at panel points by means of a floor system are, in all cases, straight between panel points. The necessary proof of this fact can be generalized from the particular case of the

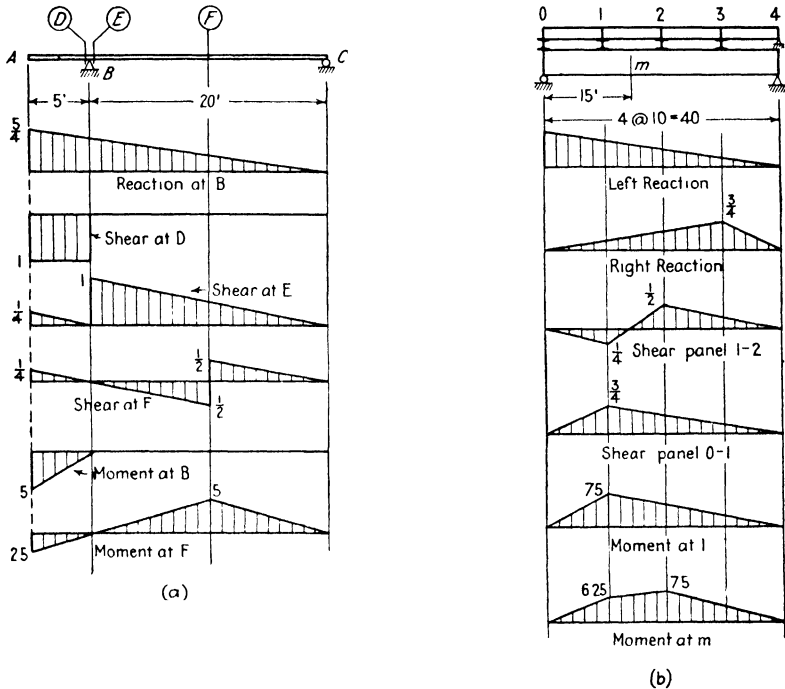

FIG. 4-8

line for shear in panel 1-2 with the load on the stringer 1-2. Call the distance of the unit load from 2,  $x$ , making the load brought to the girder at 1 equal to  $\frac{x}{10}$ , and that at 2,  $\frac{10-x}{10}$ . The shear in 1-2 due to the load in this position equals the left-hand reaction less the floor-beam reaction at 1, equals  $\frac{1}{2} \cdot \frac{(10-x)}{10} + \frac{3}{4} \cdot \frac{x}{10} - \frac{x}{10} = \frac{20-3x}{40}$ . This being a linear expression, the influence line must be a straight line between the two panel points.<sup>6</sup> Also note that in this structure, in which each stringer has a length of one panel, the influence line for

<sup>6</sup> A more general statement which will include structures of the type shown in Prob. 4:7 is this: *an influence line is a straight line for the length of any stringer.*

moment at any panel point is the same as the influence line for moment at the corresponding point in a simple beam.

From its manner of construction it follows that any influence line gives the effect of a concentrated load, or of a series of concentrated loads, of any magnitude, by the multiplication of each load intensity by the value of the influence line ordinate at the load. Any uniformly distributed load of intensity  $w$  may be considered to be a series of concentrated loads  $w dx$ , the effect of any one of which is  $wy dx$ , where  $y$  is the ordinate. Therefore, the effect of such distributed load  $\left(w \int y dx\right)$  is obtained by multiplying the intensity of the load by the area under the influence line within the limits of the load.

**Example 4:4.** See Fig. 4:8b. The live load for this bridge consists of a uniformly distributed load of 4000 lb per ft of track and a single axle load of 40,000 lb. What is the maximum live shear in the second panel of one girder?

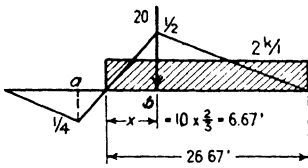

FIG. 4:9

*Solution.* Any influence line shows by its positive and negative areas where any load must be placed to produce a desired positive or negative effect. Inspection shows that the positive area of the given influence line for shear in the second panel is much larger than the negative. Therefore, the maximum shear

will be obtained by placing the loads as shown herewith, the uniform load extending from the right up to the **neutral point**, where the curve crosses the axis. The computations are (see Fig. 4:9)

$$\begin{aligned} 2 \times \frac{1}{2} \times \frac{1}{2} \times 26.67 &= 13.33 \\ 20 \times \frac{1}{2} &= 10 \\ \text{Maximum live shear} &= \underline{23.33 \text{ kips in panel 1-2}} \end{aligned}$$

Note the simple relation used in locating the neutral point, i.e.,  $x : 10 = \frac{1}{2} : (\frac{1}{2} + \frac{1}{4})$ . Note also that the ratio of the parts into which the neutral point divides the panel is the same as the ratio of the parts into which it divides the whole span. Consequently a load placed at the neutral point will cause a floor-beam reaction at the left end of the panel which equals the reaction at the left end of the girder, and the resulting panel shear will equal zero.

The truth of the following statements may be demonstrated by the construction of the proper influence lines.

*In a simple beam:*

Maximum shear at a fixed (given) point due to a single concentrated load occurs when the load is just to the right or left of the point and is on the longer of the two segments into which the point divides the beam.

Maximum shear at a fixed point due to a uniform load occurs when the load extends from the point to the more distant support.

Maximum shear due to a single concentrated load occurs at the support and equals the load.

Maximum shear due to a uniform load occurs at a support when the beam is fully loaded and equals one-half the load on the beam.

Maximum moment at a fixed point due to a single concentrated load occurs when the load is at the point.

Maximum moment at a fixed point due to a uniform load occurs when the load extends over the entire beam.

Maximum moment due to a single concentrated load occurs at the mid-point and equals  $\frac{1}{4}PL$ .

Maximum moment due to a uniform load occurs at the mid-point when the beam is fully loaded and equals  $\frac{1}{8}wL^2$ .

*In the girders of a bridge with floor beams (equally spaced) and stringers:*

Maximum shear in a given panel due to a single concentrated load occurs when the load is at the end of the panel nearer to the center of the span.

Maximum shear in a given panel due to a uniform load occurs when the load extends from the neutral point in the panel to the farther support. (Where is the neutral point in an end panel?)

Maximum shear due to a single concentrated load occurs in the end panel and equals  $P \frac{n-1}{n}$ , where  $n$  is the number of panels.

Maximum shear due to a uniform load occurs in the end panel when the load extends over the entire structure and equals  $w \frac{n-1}{2n} L$ .

Maximum moment at a given panel point due to a single concentrated load occurs when the load is at the panel point.

Maximum moment at a given panel point due to a uniform load occurs when the load extends over the entire structure.

When the number of panels is even, maximum moment due to a uniform load occurs at the center panel point under full load and equals  $\frac{1}{8}wL^2$ .

When the number of panels is odd, maximum moment due to a uniform load occurs at the panel points nearest the center under full load and equals  $\frac{1}{8}wL^2 \left( \frac{n^2-1}{n^2} \right)$ .

Any influence line problem resolves itself into an indefinite series of single computations of shear, moment, or stress, and the plotting of the result of each computation as the influence line ordinate at the location of the unit load. In solving these problems make generous use of sketches. For example, in Prob. 4:7B, in computing the ordinate for shear at  $S$  with load just to the left of the center of the span, the sketch of Fig. 4:10 at once leads to the answer. Note that the sketch is needlessly complete in detail.

Many students experience difficulty with influence lines, because of, first, failure to grasp their basic definition and function and, second, a confusion that seems to be rooted in the impossibility of easily visualizing complicated lines such as those in this problem. This last difficulty vanishes with the willingness to make patiently the necessary number of careful free body sketches. Since every student at this stage can solve any ordinary problem of shear, moment, or stress for a fixed load, every student can build up any influence line, ordinate by ordinate.

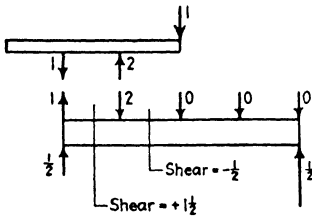

FIG. 4:10

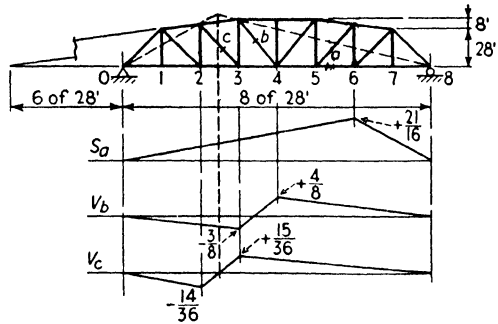

FIG. 4:11

**Example 4:5.** Draw the influence line for stress (or a component of stress) in bars *a*, *b*, and *c* of Fig. 4:11.

*Solution.* Bar *a*. Pass a vertical section which cuts bar *a*, and take moments about  $U_6$ , the moment center for bar *a*. As the unit load goes from  $L_0$  to  $L_6$ , it is evident, by use of the part of the structure to the right of the section, that the stress in *a* varies directly as the right reaction, equalling  $R_R \times \frac{5}{3} = \frac{x}{8 \times 28} \times \frac{5}{3}$ . With the load at  $L_6$  the stress in *a* is  $\frac{3}{4} \times \frac{5}{3} = +\frac{5}{4}$ .

Similarly, by use of the part to the left of the section, it is seen that the stress varies from  $+21/16$  to zero as the load goes from  $L_6$  to  $L_8$ . Since the stress is tension, the ordinate is plotted above the axis.

*This expressing of bar stress, or stress component, in terms of a reaction or a shear or a moment at some panel point, the variation of which is easily observed, is of material aid in giving the shape or local slope of the influence line.*

The triangular influence line with maximum ordinate at the moment center is typical for a chord member of a simple truss; the loaded chord of a Warren truss without verticals (see Ex. 4:6) furnishes the one exception to this rule.

Bar *b*. The shear in panel 3-4 equals the vertical component of stress in bar *b*. Note that the rule of Ex. 4:4 for the location of the neutral point holds in this panel where the chords are parallel.

Bar *c*. A vertical section through bar *c* cuts bar  $U_2U_3$ . Since this bar has a vertical component of stress, that in *c* does not equal the shear in the panel. Bar  $U_2U_3$  has a slope of 4 ft per panel, and its extension will intersect the line of

the lower chord  $28/4 = 7$  panel lengths to the left of  $L_1$ , i.e., 6 panels to the left of  $L_0$ . This intersection serves as the moment center for  $c$ . With the load at  $L_3$  (or to the right thereof) the stress in  $c$  depends on  $R_L$ , and we may write, using the part of the structure to the left of the section,

$$+9 \times 28 \times V_c - 6 \times 28 \times R_L = 0$$

$$V_c = +\frac{2}{3}R_L$$

Similarly, when the load is at  $L_2$  (or to the left thereof), using the part to the right of the section,

$$-9 \times 28 \times V_c - 14 \times 28 \times R_R = 0$$

$$V_c = -\frac{1}{9}R_R$$

Note that the influence lines for  $b$  and  $c$  lie partly above and partly below the axis. This is typical for the web members of a truss.

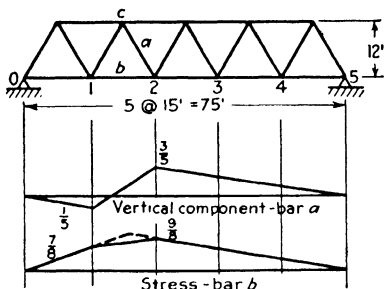

FIG. 4:12

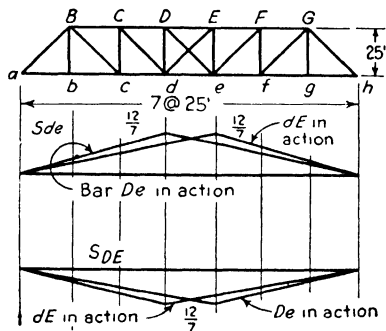

FIG. 4:13

**Example 4:6.** Draw influence lines for stress (or stress component) of bars  $a$  and  $b$  of this Warren truss with loads applied at lower chord panel points (Fig. 4:12). The diagonals of panel  $de$  carry tension only.

*Solution.* Bar  $a$ ; method of shears; each ordinate shows the magnitude of the shear on a vertical section through bar  $a$  which equals the vertical component of bar stress.

Bar  $b$ ; vertical section through  $b$  and method of moments. For a load at panel point 2 or to the right, using the free body to the left, center of moment at top chord point  $c$ , we may write for stress in  $b$ ,  $S_b = 22.5R_L/12$ , which indicates a straight line for the influence line from point 2 to the right. Inserting the value of  $R_L$  for a unit load at 2 gives  $9/8$  for the stress in bar  $b$ . Using the free body to the right in similar fashion, the ordinate at 1 is found.

In studying the effect of counters (see Art. 4:8) it is sometimes desired to draw an influence line for a given bar stress with a certain bar in action to compare with another drawn when that bar is not in action.

**Example 4:7.** Draw influence lines for stress in top and bottom chord members in the center panel of the Pratt truss of Fig. 4:13 with loads on the



bottom chord, when first one and then the other of the diagonals in the center panel is working.

*Discussion.* To verify these lines draw the truss with only one diagonal in the center panel and find the bar stress desired. Note carefully what each line tells us. For example, the influence line for stress in bar *de* with bar *De* in action gives the stress in *de* for a unit load on the span when the total live load on the bridge is such, and is so placed, that diagonal *De* acts and not *dE*. *The diagonal in action is determined by the total load effect and not by the unit load of the influence line study.*

**4:5. Live loads on bridges.** In this article is given a brief summary of the live loads on modern highway and railway bridges, sufficient only for understanding the problems in stress analysis under consideration in this volume.

**Highway bridges.** A modern highway bridge is designed throughout for the maximum stresses produced by loaded motor trucks, using either the actual concentrations produced by the trucks or an equivalent uniform load combined with a single concentrated load. This equivalent loading produces closely the same stress effect as the actual truck concentrations and is used to save labor, which increases considerably when the length to be loaded is relatively long. Considerable uncertainty also attaches to stress computation for the longer loaded lengths on account of the unlikelihood that trucks will travel at exactly that spacing which will produce maximum effects.

The specification most used in this country is that of the American Association of State Highway Officials. The 1949 edition of this specification provides for five classes of loading, known as the H20, H15, H10, H20-S16, H15-S12, the first three designating motor trucks weighing respectively 20, 15, and 10 tons, or an equivalent lane loading (uniform load with excess or concentrated load) which represents a train of loaded trucks. The H-S loadings consist of a tractor truck with semi-trailer, the truck being identical with the corresponding H loading and the trailer load being either 16 or 12 tons on a pair of wheels running at a variable distance, from 14 ft to 30 ft, behind the rear axle of the truck, the distance chosen being that leading to the greatest magnitude of the stress under consideration. Here also an equivalent lane loading is used with the longer loaded lengths. The H-S loading is optional by this specification.

The trucks for these loadings have these dimensions: wheels 6 ft center to center; axles 14 ft center to center; width of each rear tire (or pair of tires) 1 in. per ton of total weight of truck; clearance and lane width 10 ft; weight on rear axle 80 per cent of total weight.

The H20 and H20-S16 lane loading consists of a uniform load of 640 lb per linear ft of traffic lane combined with a single concentrated load

of 18,000 lb used in computing moment, 26,000 lb used in computing shear, distributed across the width of the lane: for H15 and for H15-S12 the lane loading is three-fourths, and for H10 one-half as much. For continuous spans a second concentrated load is added. These concentrated loads are so placed on the bridge as to produce maximum stress effect.

In computing stresses each standard truck per lane or each traffic lane loading is considered a unit, the number and position of loaded lanes and the type of loading (truck or uniform load with excess) being taken as necessary to produce maximum stress effect. Fractional lane widths are not used. If more than two lanes are used, a reduction

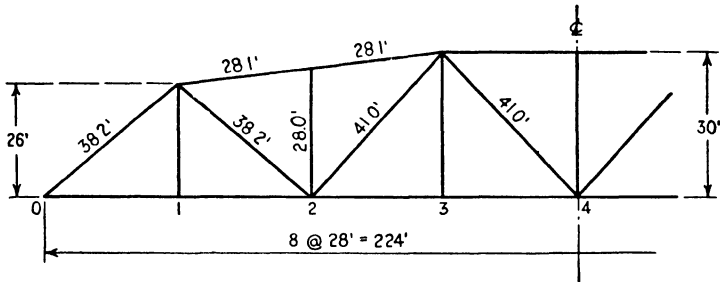

FIG. 4:14

is made in the computed live-load stress on account of the improbability of several lanes being loaded at the same time in such manner as to produce the maximum effect.

**Example 4:3.** Compute the live panel loads to be used in the design of the highway bridge shown in Fig. 4:14. Width of roadway, 20 ft. Live load, H20.

*Solution.* The only members receiving their loads from a relatively short loaded length are the floor-beam hangers,  $U_1L_1$  and  $U_3L_3$ , and for these the truck loads should be considered as well as the lane loads. The stresses in all other members are determined from the equivalent lane loading, since it is clear that with a long loaded length a series of trucks (the lane load represents a truck train) gives a greater load than a single truck.

$U_1L_1$ ,  $U_3L_3$ . *Truck load.* The maximum stress will occur when the rear truck axles are over the floor beam. Assume two trucks passing, which makes a symmetrical load on the floor beam. The floor-beam reaction, which is the panel load, equals

$$0.8 \times 40,000 + 0.2 \times 40,000 \times \frac{1}{2} = 36,000 \text{ lb}$$

*Lane loading.* Considering two loaded lanes, with the excess loads over the floor beam, gives

$$640 \times 28 + 26,000 = 43,900 \text{ lb}$$

which is the required panel load.

*Diagonals and end posts.* From the previous computation it is evident that at the critical panel point the panel load is 43,900 lb and at the other loaded points  $640 \times 28 = 17,900$  lb. Only one excess load is used (or pair of loads opposite each other in parallel lanes) regardless of the loaded length.

*Chords.* Since the maximum stresses in the chords occur with moment a maximum rather than shear, the excess is 18,000 lb. Accordingly, at the critical point the panel load is  $17,900 + 18,000 = 35,900$  lb; for other points 17,900 lb.

**Live loads on railway bridges.** Both floor systems and trusses of railway bridges are usually designed for the stresses produced by the wheel load concentrations of one or two locomotives followed by a uniform load to represent the weight of the train. The axial loads and spacings of actual locomotives, which are of many types and weights, are generally replaced by simplified standard loadings essentially equivalent to present and future expected concentrations. The Specifications for Steel Railway Bridges of the American Railway Engineering Association (1948) require the use of two 256-ton locomotives, with a load of 72,000 lb on a driving axle, followed by a uniform load of 7200 lb per ft of track (Cooper E-72 loading), or two axle loads of 90,000 lb each, placed 7 ft apart, whichever gives the larger stress. In 1894 Theodore Cooper proposed a series of locomotive and train loadings of uniform axle spacing but of varying weight, the heaviest of which equaled  $\frac{9}{2}$  of that given above, and this standard is known by his name, the numerical part of the designations indicating the weight on a driving axle, the letter E meaning engine. Loads have so increased that a Cooper E-90 loading is sometimes used. In Table 1 is given a moment diagram to facilitate computations of stresses for the Cooper E-10. The stresses due to any other Cooper loading may be found by multiplying the E-10 stress by the ratio of the axle loads, the effect of an E-70 being  $\frac{7}{10}$  that of an E-10.

Today the arrangement of driving wheels on heavy locomotives, and, in particular, the spacing, because of the large diameter of the wheels in

**Note: Table 1.**

The moments in the left-hand column in Table 1 correspond to those recorded in the diagram of Fig. 4:15; each value is the moment about the wheel numbered at the same level at the left of all the loads to the left. Any value in the column between wheels 2 and 3 is the moment about the designated wheel of all the loads to the left up to wheel 2, that is, excluding the first wheel. In general any moment recorded above the stepped line is that about the designated load of the wheels lying to the left of the designated wheel up to and including that one lying on the vertical forming the left division of the column in which the value appears.

The moments recorded below the stepped line are those of the wheels lying to the right of the designated wheel. Uniform load may be used on both sides of the locomotives if desired, as this condition often occurs in railway operation.

TABLE 1  
CLASS E-10 ENGINE LOADING

Wheel Numbers	Axle loads										Moments of Loads										1.0 k. per in. sq. uniform load
	1	2	3	4	5	6	7	8	9	10	11	12	13	14	15	16	17	18	19	20	
Spacing in feet	8	8	5	5	5	5	5	5	8	8	5	5	5	5	5	5	5	5	5	5	
Kips	15.0	25.0	35.0	45.0	51.5	55.0	64.5	71.0	79.0	86.0	96.0	106.0	115.0	122.5	128.0	138.9	142.0	142.0	142.0	142.0	
Feet	0	6	15	25	35	42	51	61	71.0	81.0	91.5	102.0	112.0	122.0	132.0	142.0	152.0	162.0	172.0	182.0	
Kips	142.0	137.0	127.0	117.0	107.0	97.0	90.5	84.0	77.5	71.0	65.0	59.0	53.0	47.0	41.0	35.0	29.0	23.0	17.0	11.0	
Feet	109	101	96	91	86	77	72	66	61	53	45	40	35	30	24	18	12	6	0	0	
Σ	8182.0	7657.0	6627.0	5667.0	4757.0	3937.0	3306.5	2928.5	2499.5	2103.0	1838.0	1588.0	1388.0	1188.0	988.0	838.0	701.5	571.5	421.5	221.5	
End of Train	18	17	16	15	14	13	12	11	10	9	8	7	6	5	4	3	2	1	0	0	
Σ	7472.0	6962.0	5922.0	5081.1	4222.0	3412.0	2944.0	2508.5	2112.0	1748.0	1508.0	1308.0	1108.0	988.0	838.0	701.5	571.5	421.5	221.5	22.5	
Σ	6794.5	6299.5	5389.2	4329.5	3719.5	2959.5	2524.0	2121.0	1757.0	1426.5	1210.5	1060.5	960.5	860.5	760.5	660.5	560.5	460.5	360.5	260.5	
Σ	6020.5	5555.6	4706.5	3905.5	3155.6	2455.6	2053.0	1735.0	1370.0	1077.5	892.5	762.5	682.5	602.5	522.5	442.5	362.5	282.5	202.5	122.5	
Σ	5408.0	4968.0	4168.0	3415.0	2718.0	2068.0	1704.0	1372.5	1080.0	832.0	660.0	520.0	430.0	360.0	290.0	230.0	170.0	110.0	60.0	10.0	
Σ	4894.0	3969.0	3259.0	2599.0	1969.0	1429.0	1123.5	850.5	616.5	415.0	300.0	150.0	50.0	55.5	149.5	279.5	442.0	622.0	822.0	1022.0	
Σ	3684.0	3464.0	2904.0	2194.0	1634.0	1124.0	851.0	610.5	408.0	240.0	150.0	50.0	50.0	141.0	264.5	427.0	622.0	822.0	1022.0	1222.0	
Σ	3354.0	3009.0	2399.0	1839.0	1329.0	869.0	628.5	420.5	251.5	115.0	50.0	50.0	150.0	273.5	429.5	624.5	822.0	1022.0	1222.0	1422.0	
Σ	2924.0	2604.0	2044.0	1534.0	1074.0	654.0	455.0	280.5	144.0	-40.0	50.0	150.0	300.0	456.0	641.5	872.0	1132.0	1332.0	1532.0	1732.0	
Σ	2316.0	2036.0	1556.0	1126.0	746.0	416.0	260.0	136.5	62.0	30.0	210.0	390.0	620.0	825.0	1085.5	1348.0	1650.0	1950.0	2250.0	2550.0	
Σ	1748.0	1608.0	1108.0	758.0	458.0	208.0	104.0	32.5	40.0	200.0	410.0	670.0	980.0	1240.0	1622.5	1864.0	2228.0	2528.0	2828.0	3128.0	
Σ	1425.5	1210.5	860.5	660.5	310.5	110.5	39.0	32.5	97.5	307.5	675.5	877.5	1227.5	1530.0	1865.0	2219.0	2615.5	2915.5	3215.5	3515.5	
Σ	1077.5	892.5	622.5	562.5	172.5	32.5	39.0	110.5	206.5	476.5	796.5	1165.5	1585.5	1917.0	2231.0	2684.0	3119.5	3519.5	3919.5	4319.5	
Σ	890.0	620.0	620.0	420.0	230.0	30.0	104.0	208.0	323.0	648.0	1018.0	1438.0	1908.0	2272.0	2638.5	3104.0	3672.0	4146.0	4620.0	5094.0	
Σ	415.0	300.0	150.0	50.0	63.5	149.5	279.5	442.0	607.0	1017.0	1477.0	1987.0	2547.0	2969.5	3424.5	3919.5	4446.0	4986.0	5526.0	6066.0	
Σ	240.0	150.0	50.0	50.0	141.0	264.5	427.0	622.0	812.0	1272.0	1782.0	2342.0	2952.0	3407.0	3894.5	4414.4	4973.5	5565.0	6176.0	6786.0	
Σ	115.0	50.0	50.0	150.0	273.5	429.5	624.5	822.0	1067.0	1372.0	1822.0	2342.0	2952.0	3407.0	3894.5	4414.4	4973.5	5565.0	6176.0	6786.0	
Σ	40.0	50.0	150.0	300.0	466.0	644.5	872.0	1132.0	1372.0	1682.0	2042.0	2402.0	2812.0	3192.0	3584.5	4004.5	4454.0	4934.0	5434.0	5954.0	
Σ	80.0	210.0	380.0	620.0	828.0	1058.5	1348.0	1690.0	1940.0	2280.0	2710.0	3110.0	3500.0	3872.0	4234.5	4624.5	5044.5	5494.5	5964.5	6454.5	

See Note, page 102

use, differ much from those of the Consolidation type locomotive—the heavy freight locomotive of 1894—which Mr. Cooper used. Many attempts have been made to obtain approval for axle weights and spacings which more nearly equal those of present-day locomotives. One such notable effort was made by Dr. D. B. Steinman.<sup>7</sup> For a time after 1923 the loading recommended in the Steinman paper was shown as an alternate in specifications.

The Cooper loading gives a convenient means of rating bridge capacities. The actual stress effects of the modern locomotives must be known, however, when bridges are designed or rated, and so in every railroad-bridge engineering office will be found moment diagrams similar to Table 1 for all the heavy engines in use on the road.

**4:6. Impact.** A train or a truck moving across a bridge causes larger stresses for any given position on the structure than when standing still in the same place. This is due in part to the rapid application of the load but more to such factors as movement over a somewhat uneven track, rough joints, imperfectly balanced driving wheels, flat or eccentric wheels, and lateral sway, throwing increased load on one set of wheels. Many formulas for computing this effect make the extra allowance to be added to the live-load stresses depend on the length of bridge occupied by the load.<sup>8</sup>

The A.R.E.A. formula in the 1931 specification is

$$I = S \frac{300}{300 + \frac{L^2}{100}} \quad (A)$$

where  $I$  = dynamic increment to be added to the live-load stress.

$S$  = computed live-load stress.

$L$  = length in feet of the portion of the span which is loaded to produce the given live-load stress.

<sup>7</sup> "Locomotive Loadings for Railroad Bridges," *Transactions of the American Society of Civil Engineers*, Vol. 86, page 606 (1923).

<sup>8</sup> For many years the A.R.E.A. has made its impact allowances depend upon the dimensions of the structure and not upon the length of track covered by the live load. The current (1949) specification is as follows:

*Art. 206.* To the (Cooper) axle loads specified . . . there shall be added impact forces applied at the top of rail and distributed thence to the supporting members, comprising:

(a) The rolling effect: Vertical forces due to the rolling of the train from side to side, acting downward on one rail and upward on the other, the forces on each rail being equal to 10 per cent of the axle loads.

(b) The direct vertical effect: Downward forces, distributed equally to the two rails and acting normal to the top-of-rail plane, due, in the case of steam locomotives,





The determination of the loaded length,  $L$ , to use in the impact formula is simplified, when the allowance to add to the maximum or minimum live stress is sought, by considering the stress to be caused by a uniform load and taking the length,  $L$ , as given by the influence line. Often this gives a length shorter than the distance between the end of the bridge from which the train is coming and the leading pilot wheel. Of course, if the stress is produced by a position in which one or more wheels have passed off the bridge, the length,  $L$ , to use is the span length.

The A.A.S.H.O. specifications of 1949 give the following formula for impact in highway bridges:

$$I = \frac{50}{L + 125}, \text{ but not more than 30 per cent} \quad (B)$$

where  $L$  = length of portion of span loaded to produce maximum.

**4:7. Maximum stresses from uniform and excess live loads.**

The main girders and trusses of some railway bridges and of practically all highway bridges are proportioned either for a uniform live load on the floor or a uniform live load in combination with one, two, or even three

hammer blow, track irregularities, speed effect, and car impact, and equalling the following percentages of the axle loads:

(1) For beam spans, stringers, girders, floorbeams, posts of deck truss spans carrying load from floorbeam only, and floorbeam hangers:

For  $L$  less than 100 ft  $60 - \frac{L^2}{500}$

For  $L$  100 ft or more  $\frac{1800}{L - 40} + 10$

(2) For truss spans  $\frac{4000}{L + 25} + 15$

or due, in the case of rolling equipment without hammer blows (diesels, electric locomotives, tenders alone, etc.) to track irregularities, speed effect and car impact, and equalling the following percentage of axle loads:

For  $L$  less than 80 ft  $40 - \frac{3L^2}{1600}$

For  $L$  80 ft or more  $\frac{600}{L - 30} + 16$

$L$  = length, in feet, center to center of supports for stringers, longitudinal girders, and trusses (main members), or  $L$  = length, in feet, of the longer adjacent longitudinal beam, girder, or truss for impact in floorbeams, floorbeam hangers, sub-diagonals of trusses, transverse girders, supports for longitudinal and transverse girders, and viaduct columns.



concentrated loads placed where their effect is a maximum. These loads are chosen of such magnitude as to give effects closely equal to those produced by the actual vehicles on the structure. A concentrated load thus used in combination with a uniform live load is usually called an **excess**, and its magnitude generally represents the load that can be brought to a panel point by a locomotive, or an extra-heavy truck, above that brought by the uniform load representing the train or ordinary traffic.

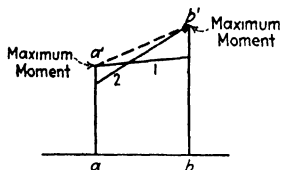

FIG. 4:16

It is customary not to use influence lines in stress computations with a loading of this sort but instead to use full live panel loads as a series of concentrated loads applied at panel points on the structure where required for maximum effect. This is illustrated in the examples which follow.

The maximum moment in a girder or truss loaded by means of stringers and floor beams is bound to be at a panel point. This is clear from Fig. 4:16, which shows partial moment curves for any two consecutive panel points of any bridge with panels, curve 1 being that when the loading makes the moment at panel point  $a$  a maximum, curve 2 that for maximum moment at  $b$ . Since the moment curve is always straight between panel points and  $a'$  and  $b'$  are the highest possible ordinates at  $a$  and  $b$ , not only is an intermediate moment ordinate larger than  $bb'$  not possible but it is clearly impossible to have one lying above the line  $a'b'$ .

It is commonly assumed that the line  $a'b'$ , Fig. 4:16, is the curve of maximum bending moment for intermediate points in the panel. This assumption is plainly on the safe side, since with the live loads in position for maximum moment at some intermediate point, the bending moments produced at  $a$  and at  $b$  are less than their maximum values,  $aa'$  and  $bb'$ , and the moment curve must lie below  $a'b'$ .

**Example 4:9.** (Same as Ex. 4:4 except method.) The live load for the bridge of Fig. 4:8b consists of a uniformly distributed load of 4000 lb per ft of track and an excess axle load of 40,000 lb. Compute the maximum live shear in the second panel of one girder in the usual (approximate) fashion. (Note that the influence line solution was exact.)

**Solution.** The maximum live panel load on one girder is  $\frac{1}{2} \times 4 \times 10 = 20$  kips resulting from live load over the whole length of the two adjacent panels. By inspection, the positive shear will be larger than the negative, the panel being in the left half of the span. For maximum positive shear in panel 1-2, panel points 2 and 3 are loaded, each with a full panel load, and the excess

is placed at 2. The left reaction equals the shear in the panel required, equals  $20 \left( \frac{1+2}{4} \right) + \frac{1}{2} \times 20 = 25$  kips. The 20 kips at panel point 3 causes a left reaction of  $\frac{1}{4}$  of itself; the load at 2,  $\frac{1}{2}$  of itself. The second term is the left reaction caused by the excess. This equation is the same as that resulting from the direct use of the influence line with these concentrated panel loads.

This value is larger than the exact result previously found, owing to the following fact. A full panel load can exist at 2 only when both stringers 1-2 and 2-3 are fully loaded, thus bringing a half panel load of 10 kips to point 1 on the girder. This half panel load at 1 is neglected always in the approximate method. Its effect is to make the live shear in this case 22.5 instead of 25. Check this result by use of the influence line.

The usual panel load method, when applied to shear computation, is thus seen to be approximate and on the safe side. For moment calculations it gives the same results as when the influence line is used.

The example which follows demonstrates a fact which should never be lost sight of: **the maximum moment at the first panel point of a bridge equals the maximum shear in the end panel multiplied by the panel length.**

**Example 4:10.** Compute the maximum live shear in the end panel and the maximum live moment at the first panel point of a 60-ft girder bridge of four equal panels, using a live load of 2000 lb per ft per rail.

*Solution.* Place a live load at each panel point; this gives a net end reaction of  $\frac{1}{2} \times 3 \times 30 = 45$  kips, which equals the maximum shear in the end panel. The maximum moment at the first panel point equals the maximum net reaction multiplied by the panel length, equals 675 kip-ft.

**Example 4:11.** Find the maximum live stresses in the lettered bars of the truss of Problem 4:10A due to a live load of 4000 lb per ft of track and a single axle load of 40,000 lb. Usual panel load method.

*Solution.* See Fig. 4:17.

*Comments.* Bar *a*. This bar is best studied by a curved section around joint  $L_1$  which shows that the bar is stressed only by a load at that panel point.

Bar *b*. Take a vertical section through bar *b* and use the free body shown. The bar carries the shear in panel 1-2, and since the panel is in the left half of the structure it is plain that the positive shear will attain a greater value than the negative. Accordingly load for maximum positive shear as shown.

Bar *c*. Take an inclined section with the free body shown. The bar carries the shear on that section, the positive value of which evidently will attain greater magnitude than the negative. Accordingly load for maximum positive shear on the inclined section as shown. Some may prefer to consider the joint  $U_2$  where it appears that the live stress in bar *c* is always equal and opposite to the vertical component of live stress in diagonal  $U_2L_3$ , the maximum value of which occurs with a loading giving maximum positive shear in panel 2-3.

Bar *d*. Take a vertical section through the bar and the free body shown.

A load anywhere on the structure will cause compression in a top chord bar, and so the entire bridge must be loaded for maximum stress. The position of the single concentrated excess load for maximum effect may be determined thus. Wherever that load is placed, the stress in bar  $d$  is found by taking moments about panel point  $L_3$ , using the free body shown. The moment of the stress in  $d$ ,  $S_d$ , about that point must be equal and opposite to the moment

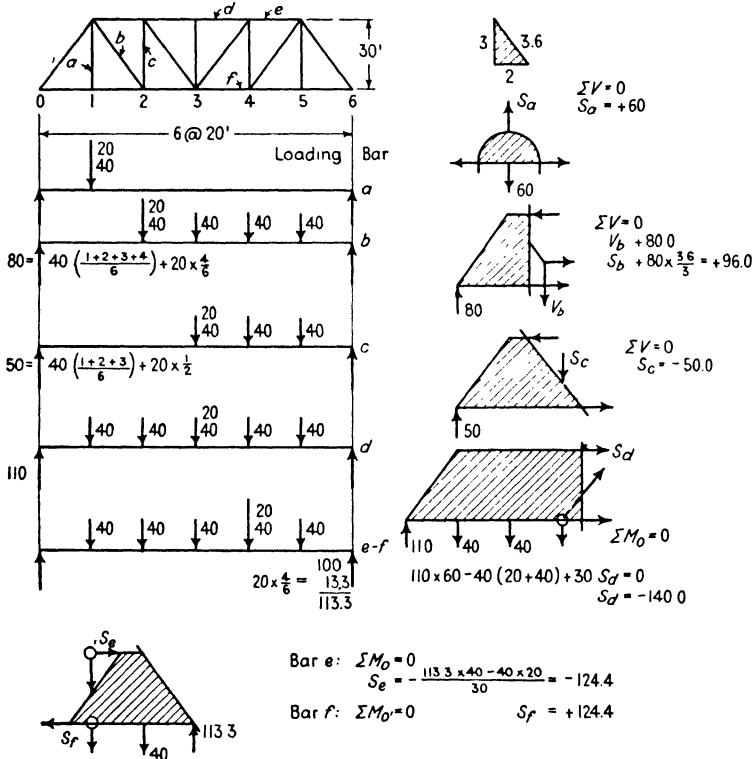

FIG. 4:17

of the reaction (and the load, if on the free body) about the same point. This moment of the external forces (in contradistinction to bar stresses) is plainly the bending moment at  $L_3$ . Therefore for maximum stress in bar  $d$  the bending moment at  $L_3$  must be a maximum. For maximum moment at any point in a simple span the load must be placed at the point. Accordingly the excess must be placed at  $L_3$ . (Compare bar  $b$ , Fig. 4:12.)

Note that in this example the following mental operation was performed for each bar. These questions were asked in this definite sequence: What section gives the simple solution for this bar and with what free body? What force system acts on this free body? What conditions of equilibrium apply? The first sentence in each comment and the sketch solution give the answers

to these questions. The student should form the habit of approaching each bar stress problem in this manner.

**4:8. Reversal of stress; counters.** Consideration of the influence lines makes it plain that certain truss web members may be subject to reversal of stress, i.e., that certain positions of the live load will induce a stress of opposite character to the dead-load stress and, perhaps, of greater magnitude. It is, of course, necessary to ascertain the maximum value of both kinds of stress, or, as it is generally phrased, determine the maximum and minimum stresses to which any piece is exposed.

Pratt trusses of long span and Parker trusses were formerly made with pin joints, and the tension diagonals were eyebars, long slender pieces (1 to 2 inches thick and not more than eight times as wide) with enlarged heads bored to receive the pins. Such a member buckles under a small load and is quite incapable of resisting compression. It was therefore necessary to provide a second tension diagonal (called a **counter**) in any panel where the live load might cause a reversal or near approach to a reversal of the usual dead-load stress. Counters were generally made with a turnbuckle for adjustment.

Similarly a Howe truss has diagonals of wood held in place by a dowel pin at each end, an arrangement obviously incapable of transmitting tension. Here counters are used in every panel, providing for all possible shear reversals and also permitting the proper adjustment of the whole truss by the tightening of the iron verticals which are threaded with nuts at both ends.

Unless every counter in a steel truss is adjusted so that it has no initial stress and carries no stress when the main diagonal is in action, a degree of indeterminateness is introduced. On this account the use of counters is generally considered objectionable. It is modern practice to make the main diagonal a stiff member capable of carrying both tension and compression, which is, of course, more economical. In the structures here considered, proper adjustment is assumed, so that only one diagonal is in action in any one panel at a time.

The two examples which follow make clear how the computations for maximum and minimum stress may be handled for the diagonals of a Pratt truss.

**Example 4:12.** Compute the maximum and minimum stress for diagonal  $a$  of the single-track through truss in Fig. 4:18. This is a stiff member capable of carrying both tension and compression. Dead load: 29 kips per panel per truss; live load: 3000 lb per ft of rail; locomotive excess: a wheel load of 40,000 lb. Impact by formula  $A$ , Art. 4:6.

*Solution.* (This is the truss of Ex. 4:2.) See Fig. 4:5.

*Discussion.* In the first place, note that all necessary figures were shown in this calculation. The method used for the maximum stress is simply a repetition of what has gone before. It was not necessary to record the details of calculating the left reaction with the load shown plainly as here. The checker knows instantly on glancing at the sketch that the four live panel

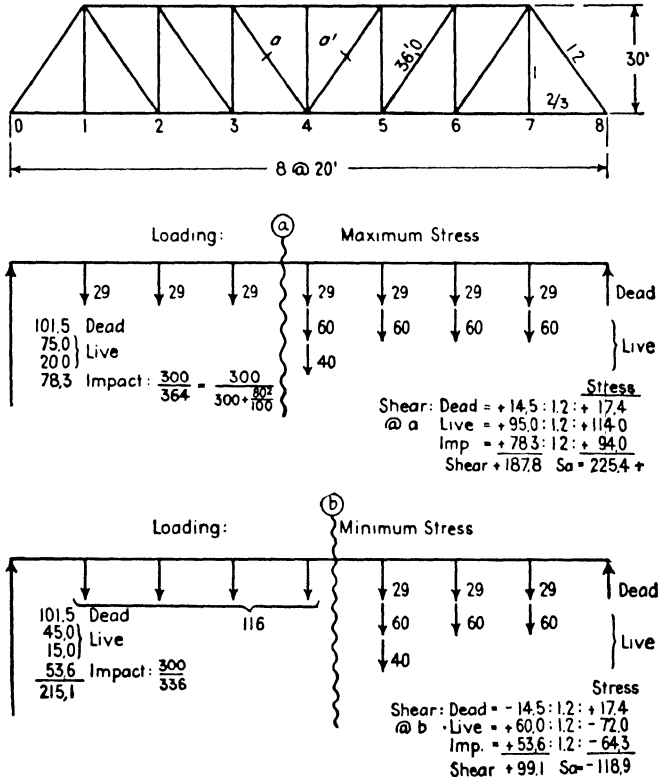

FIG. 4:18

loads produce a reaction at the left of  $(1 + 2 + 3 + 4 = 10)$  eighths of 60 and that the excess at  $L_4$  produces a reaction of  $\frac{1}{2}$  of itself. Similarly, having before him the formula for impact, a complete record of its solution would add needless figures. Both computer and checker can work more quickly if a certain amount of obvious detail is abbreviated or omitted.

The minimum stress in bar  $a$  (compression) occurs with negative shear in panel 3-4, and its maximum value comes from loading panel points  $L_1, L_2,$  and  $L_3$  with live load, placing the excess at  $L_3$ . Instead of carrying through the work as thus outlined, most computers prefer to take the corresponding bar in the other half of the truss, bar  $a'$ , and compute the stress brought to it when the

shear in panel 4-5 has its maximum positive value. This is plainly exactly the same in every way as considering bar *a*. (Consider the sketch you would make were you to load the truss at  $L_1, L_2, L_3$  as just described and draw what you saw by standing on the other side, i.e., the view gained by looking through the page.) This way of dealing with reversal of stress is advisable because it facilitates the tabulation of the work as shown in the next example. It is also easier to deal always with positive shear, and fewer mistakes will be made, probably. Furthermore, it is easier to load from the right if the computation is being made for the wheel loads of either a Cooper diagram or an actual locomotive, instead of in the approximate method of this example, since the diagrams—for no reason other than custom—are invariably drawn with the head end of the locomotive at the left.

Note the difference in sign between the dead and live stress in bar  $a'$ .

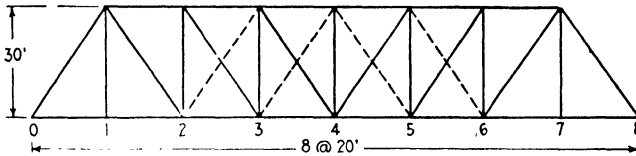

FIG. 4:19

**Example 4:13.** Compute the stresses for which the bars of the single-track through truss of Fig. 4:19 should be designed. Dead load: top chord panel points, 9.7 kips; bottom chord panel points, 19.3 kips; live load: on bottom chord, 3000 lb per ft of rail and an excess wheel load of 40,000 lb. Impact by formula A, Art. 4:6.

These are the same truss and loading as in the previous example, with counters placed in the center panels instead of stiff diagonals.

*Solution.*

CHORD STRESSES

Bar	Dead Stress	Live Stress			Impact 54%	Total $D+L+I$	
		Uniform	⊙	Excess			Total
$L_0L_1$	+ 67.7	+140.0	$L_1$	$35 \times 20 \div 30 = +23.3$	+163.3	+ 88.2	+319.2
$L_1L_2$	+ 67.7	+140.0	$L_1$	do +23.3	+163.3	+ 88.2	+319.2
$L_2L_3$	+116.0	+240.0	$L_2$	$30 \times 40 \div 30 = +40.0$	+280.0	+151.1	+547.1
$L_3L_4$	+145.0	+300.0	$L_3$	$25 \times 60 \div 30 = +50.0$	+350.0	+188.9	+683.9
$U_1U_2$	-116.0	-240.0	$L_2$	-40.0	-280.0	-151.1	-547.1
$U_2U_3$	-145.0	-300.0	$L_3$	-50.0	-350.0	-188.9	-683.9
$U_3U_4$	-154.7	-320.0	$L_4$	$20 \times 80 \div 30 = -53.3$	-373.3	-201.5	-729.5

Ratio: Live (uniform load) to Dead = 60/29

## WEB STRESSES

Bar	Dead Stress	Live Load				Impact		Total $D + L + I$
		Max. + Shear = Vert. Comp't.	Excess	Total V. C.	Stress	%	Stress	
$U_1L_0$	-121.8	$60(1+2+3+4+5+6+7)/8=210.0$	$40 \times \frac{1}{4} = -35.0$	-245.0	-294.0	54.0	-158.8	-574.6
$U_1L_2$	+ 86.9	$60(1+2+3+4+5+6)/8 = 157.5$	$10 \times \frac{1}{4} = +30.0$	+187.5	+225.0	67.6	+152.1	+464.0
$U_2L_3$	+ 52.1	$60(1+2+3+4+5)/8 = 112.5$	$40 \times \frac{1}{4} = +25.0$	+137.5	+165.0	75.0	+123.8	+340.9
$U_2L_4$	+ 17.4	$60(1+2+3+4)/8 = 75.0$	$40 \times \frac{1}{4} = +20.0$	+ 95.0	+114.0	82.5	+ 94.0	+225.4
$U_3L_4$	- 17.4	$60(1+2+3)/8 = 45.0$	$40 \times \frac{1}{4} = +15.0$	+ 60.0	+ 72.0	89.2	+ 64.3	+118.9
$U_4L_4$	- 52.1	$60(1+2)/8 = 22.5$	$40 \times \frac{1}{4} = +10.0$	+ 32.5	+ 39.0	95.0	+ 37.0	+ 23.9
$U_1L_1$	+ 19.3	60.0	+40.0		+100.0	95.0	+ 95.0	+214.3
$U_2L_2$	- 53.2	$60(1+2+3+4+5)/8 = 112.5$	$40 \times \frac{1}{4} = -25.0$		-137.5	75.0	-103.0	-293.7
$U_3L_3$	- 24.2	$60(1+2+3+4)/8 = 75.0$	$40 \times \frac{1}{4} = -20.0$		- 95.0	82.5	- 78.4	-197.6
$U_4L_4$	- 9.7			0	0		0	- 9.7
$(U_1L_4)$	+ 4.8	$60(1+2+3)/8 = 45.0$	$40 \times \frac{1}{4} = -15.0$		- 60.0	89.2	- 53.5	-108.7

*Discussion.* The dead-load stresses were found on Fig. 4:5, except that the truss there shown has stiff diagonals. The complete computations are shown in the two tables. The loaded length in the impact formula was taken as the length of the bridge for chord members and end posts, as 40 ft for the vertical  $U_1L_1$ , and as the distance from the right end of the bridge to the left load for other members.

The only point likely to cause difficulty is the calculation for counters. The first counter is  $U_4L_5$ . Assuming it to be in action (and, accordingly, the main diagonal out of action), the counter carries the dead shear in the panel and the stress is compression so far as that element is concerned. If this causes difficulty, study the figures for bar  $a'$  in the previous example, the only change being the reversal of the three signs for bar stress. Remember that when a counter (or a main diagonal) is in action it is exactly the same as though the other diagonal member in the panel did not exist. The live-load computation is the same as for the other diagonals, an advantage gained by taking the bars in sequence from left to right.

Bar  $U_4L_4$  will carry its maximum live stress under the loading which produces maximum live stress in the counter  $U_4L_5$ . Which diagonal in panel 3-4 is in action under this loading?

**4:9. Concentrated load systems.** There are various ways of determining the position of a series of concentrated live loads to produce maximum value to any given function. The simplest and most general method utilizes the influence line.

A glance at any given influence line will usually show where the heavy loads of the system in use must be grouped for maximum effect. The determination of the exact position consists of a series of trials, starting with some one load at the peak of the influence line and computing the change produced by moving the whole system up until the next load is

at the peak. The following will make clear the principle which underlies the method employed. Assume that it is desired to find the change in value of a function due to the movement of a load where the influence line for the function has ordinates of  $y_1$  and  $y_2$  at the two positions of the load, as in Fig. 4:20. When the load is in the first position, the function has the value  $P y_1$ , and in the second position,  $P y_2$ . The change in value is  $P(y_1 - y_2)$ . But  $y_1 - y_2$  is the change in ordinate, and since  $\frac{y_1 - y_2}{x_1 - x_2} = \frac{dy}{dx}$ , it follows that the change equals  $P(x_1 - x_2) \frac{dy}{dx}$ .

That is, **the change in the value of the function equals the product of three factors: the amount of the load, the distance moved, and the slope of the influence line.** Inspection will show whether the change is positive or negative.

Where the influence line is a triangle, like that for moment at panel point 1, Fig. 4:8*b*, a load must be placed at the peak ordinate of the influence line for maximum value of the function.

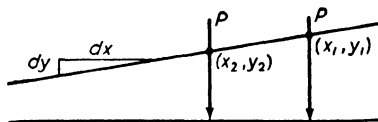

FIG. 4:20

As soon as movement of the load group starts, the loads under (or over) the rising part of the influence line cause an increase, those under the falling part a decrease, in the function, both changes being at a uniform rate. Assuming the difference to be an increase, this increase will continue until a load is brought to the peak. If loads come on or go off the span during the movement, the rate of increase becomes different but the character of the change will remain the same. In some cases each of two adjacent loads at the peak, and also any intermediate position, gives the same maximum value of the function.

For the common case presented by the usual influence line for shear in a panel bridge similar considerations to those just discussed indicate again that for maximum value of the function some load must lie at the peak ordinate. Influence lines, like that for moment at  $m$ , Fig. 4:8*b*, with exterior angles each greater than  $180^\circ$ , present an exception: maximum value of the function may occur with a critical load at either 1 or 2.

**Example 4:14.** What is the magnitude of the maximum live shear in the second panel of the 40-ft bridge with four equal panels, shown in Fig. 4:8*b*, due to a series of six axle loads of 40,000 lb each, 5 ft apart?

*Solution.* (Fig. 4:21.) Although it is evident that the maximum is not with the first load at panel point 2, yet for illustration this is the first position taken and for the same reason more positions are studied than are necessary.



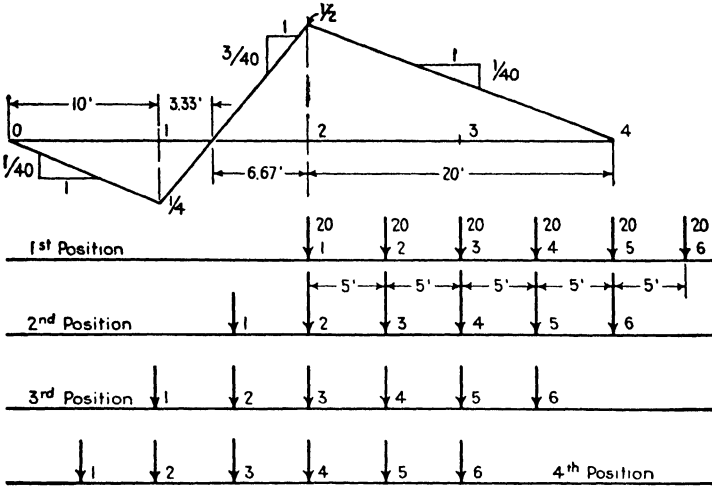

FIG. 4:21

Change of Shear in Panel 1-2

	Decrease	Increase
∴ Place	20 × 5 × $\frac{3}{40}$	< (4 × 20) × 5 × $\frac{1}{40}$
#2	(2 × 20) × 5 × $\frac{3}{40}$	> (4 × 20) × 5 × $\frac{1}{40}$
at 2	(2 × 20) × 5 × $\frac{3}{40}$	> (1 + 3) (20) × 5 × $\frac{1}{40}$
Shear: $V_L = 20$	$\left( \frac{5 + 10 + 15 + 20 + 25}{40} \right) = 37.5$	
Floor-beam reaction at 1	$\frac{-10}{27,500\#}$	
Max. shear 1-2	$= \frac{-10}{27,500\#}$	

The figures 1-2, etc., before each inequality indicate the positions studied, the first position with wheel 1, the next with wheel 2, at panel point 2. The first inequality states that these loads with wheel 2 at the second panel point give a greater shear than with wheel 1 at the panel point; or, put differently, moving the system so that wheel 1 is replaced at the peak by wheel 2 results in a greater increase than decrease of shear. Continuing, when wheels 3 and 4 are successively tried, the shear decreases, and, accordingly, the second wheel is the one to place at panel point 2 for maximum shear in the second panel.

To verify the result consider the following: Shear in second panel with load 1 at 2 = 25,000 lb; load 3 at 2 = 22,500 lb; load 4 at 2 = 17,500 lb. These values agree with the difference in shear given by the inequalities. It is not necessary usually to evaluate these inequalities, because it is possible to indicate the larger side by inspection.

This method of locating a load system for maximum effect is perfectly general and may always be employed. In some cases it may be

somewhat easier to use special methods or to apply certain criteria or rules. However, the authors are of the opinion that these complications had best be left for the study and use of the engineer who is much engaged in stress analysis. The student will find it a simple matter to learn or to devise short-cuts as the need arises if he has thoroughly mastered the basic principles here given. It is the purpose to present in this textbook enough to enable one to obtain live-load stresses with all requisite accuracy and speed and to understand readily any current discussion on the subject in technical papers.

As an illustration of these special methods the most important one is here described.

It is desired to ascertain the effect of moving a series of concentrated loads on a span,  $l$ , where the influence line for the given function (moment, chord stress, etc.) consists of a triangle with  $O =$  the maximum ordinate (Fig. 4:22).

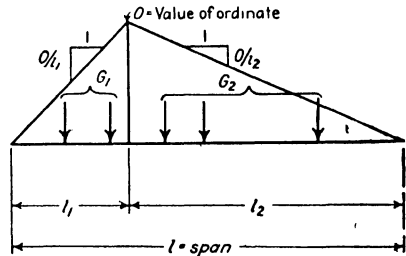

FIG. 4:22

The loads on the span are divided into two groups,  $G_1$  moving over the left segment, length  $l_1$ , and  $G_2$  over  $l_2$ . A movement of  $b$  feet to the left causes the change of function expressed by the following inequality, no load coming onto or leaving the span:

$$\begin{array}{ccc} \text{Decrease} & & \text{Increase} \\ G_1 \times b \times \frac{O}{l_1} & \geq & G_2 \times b \times \frac{O}{l_2} \end{array}$$

or

$$\frac{G_1}{l_1} \geq \frac{G_2}{l_2}$$

If this movement results in an increase in the function, the inequality becomes

$$\frac{G_1}{l_1} < \frac{G_2}{l_2}$$

This may be expressed in words: a movement of the loads to the left results in an *increase* if the average load per foot to the right of the peak ordinate exceeds the average load per foot to the left. Similarly a movement to the right results in an *increase* if  $\frac{G_1}{l_1} > \frac{G_2}{l_2}$ , that is, if the average to the left is the greater.

In both these cases the magnitude of the effect of the load system

on the function increases as the movement to the left, or right, is continued until one of the loads arrives at the peak ordinate. Loads coming on or going off the span increase the growth of the function with this movement. There results then this **critierion for the position of a concentrated load system which gives maximum value to a function with a triangular influence line: some load must be at the peak ordinate, such that when this load is just to the right of the ordinate the average load per foot to the right is greater than the average load to the left, and when this load is just to the left of the peak ordinate the average load per foot to the left exceeds that to the right.**

Under this condition, when the proper load is to the right of the peak, a movement to the left increases the function; when the same load is to the left, a movement to the right again increases the value. This position must, then, mark a maximum for this particular group of loads.

Except when the average load is the same on both sides of the peak a change in the function results from moving an adjoining load to the maximum point. So usually for maximum effect some load will be placed at the high point of the influence line.

**4:10. The moment diagram.** With the position of a concentrated load system determined, it is next required to compute the stress produced by the system so placed. This operation is much facilitated by the use of a moment diagram such as is shown in Table 1, Art. 4:5, and in Fig. 4:15. The diagram of Art. 4:5 is the more complicated and serves for office use. Also, in practice, stress computation is much aided by tables of moments and shears such as are given in the Final Report of the Special Committee on Specifications for Bridge Design and Construction, *Transactions of the American Society of Civil Engineers*, 1923.

This diagram in Fig. 4:15 gives the axle loads and their spacing, the sum of the loads, the sum of the distances from the head of the train to each load, and the moment about each load of all the loads that precede it. The student should check these tabulated moments and note that each value is greater than that next to the left by the sum of all the loads preceding multiplied by the distance to the next load; for example, the moment of wheels 1 and 2 about wheel 3 equals  $30(8 + 5) + 60 \times 5 = 240 + 90 \times 5 = 690$  kip-ft.

In using a moment diagram the computer lays off, on a strip of paper or at the top of his work sheet, a length to represent the span of his bridge, with sections and panel points indicated, drawn to the same scale as the diagram, and lays it on the moment diagram in the several re-

quired positions. The procedure arithmetically is illustrated by the following examples. In order to carry out the verification of these examples easily, lay off at the top of each page containing computations the span of the bridge to the same scale as Fig. 4:15.

**Example 4:15.** What is the gross reaction at the left end of one girder of a 75-ft single-track bridge of five equal panels, with load 13 of the Cooper E-60 loading over the right abutment? (Fig. 4:3.)

*Solution.* It is desired to find the moment of all the loads on the span about the right reaction, for this, divided by 75 ft, gives the reaction desired. The moment diagram (Fig. 4:15) gives this value directly. Therefore the reaction equals  $23,004/75 = 306.7$  kips for the bridge and  $\frac{1}{2} \times 306.7 = 153.3$  kips for one girder.

**Example 4:16.** What is the shear in the left panel in the previous example?

*Solution.* The shear equals the gross reaction minus the load brought to the girder by the end floor beam. In this position of the loads the end stringers carry the first three axles with load 3 one foot from the right end. Here again the moment diagram aids in finding the left-hand reaction, for the moment of these three loads about the right end of the panel equals  $690 + 150 \times 1 = 840$  and one floor-beam reaction is  $\frac{1}{2} \times \frac{3 \cdot 4^0}{1^5} = 28$  kips, making the net girder reaction  $153.3 - 28 = 125.3$  kips. This equals the shear in the end panel.

**Example 4:17.** What is the moment at panel point 2 for one girder of a 75-ft single-track bridge of five equal panels (bridge of Exs. 4:15, 4:16) with load 6 at the panel point? E-60 loading.

*Solution.* This position brings load 13 three feet from the right end and places load 1 off the span.

Moment of loads 1 to 12 about 13	23,004 kip-ft
Moment of load 1 about 13 = $30 \times 74$	- 2,220
Moment of all loads on span about 13	<u>= 20,784</u>
Add <span style="margin-left: 100px;">3(636-30)</span>	<u>+ 1,818</u>
Moment of loads on span about right support	22,602
Moment of left reaction about panel point 2	
equals $\frac{22,602}{75} \times 30 =$	9,040.8
Moment of loads 2 to 5 about panel point 2	
equals $4920 - (30 \times 32) =$	<u>- 3,960</u>
	2 <span style="border-left: 1px solid black; border-bottom: 1px solid black; padding-left: 5px;">5,080.8</span>
Bending moment at 2, one girder =	<u>2,540.4 kip-ft</u>

**Example 4:18.** What is the maximum live shear from an E-60 loading in the second panel of one girder of a single-track girder bridge 40 ft long with four equal panels? (Bridge of Fig. 4:8b, Exs. 4:4 and 4:9.)

*Solution.* In order to determine the position of the loads we can write the following from the influence line shown in the solution of Ex. 4:4:

Wheels at Panel Point 2	Shear 1-2	
	Decrease	Increase
1-2	$30 \times 8 \times \frac{3}{40}$	$< 180 \times 8 \times \frac{1}{40} + \delta$
2-3	$30 \times 2 \times \frac{3}{40} + 60 \times 5 \times \frac{3}{40}$	$> 180 \times 5 \times \frac{1}{40} + 30 \times 3 \times \frac{1}{40} + (\delta = 39 \times 1 \times \frac{1}{40})$

Place wheel 2 at panel point 2.

The term  $\delta$  covers the effect of a load coming onto the span during the movement, as already noted. It is not necessary to evaluate it unless, as in the second case above, its relatively small value seems likely to exercise a decisive effect on the result.

The shear with wheel 2 at point 2 is thus found:

$$\begin{aligned}
 M_5 &= && 2490 \text{ kip-ft} \\
 270 \times 5 &= && 1350 \\
 M\text{-right support} &= && 3840 \\
 \text{Left reaction} &= \frac{3840}{40} = && 96 \text{ kips}
 \end{aligned}$$

Floor beam loads at 0 and 1:

$$\begin{aligned}
 30 \times \frac{8}{40} &= && 24 \\
 \text{Shear in panel 1-2} & & 2 \left[ \begin{array}{c} 72 \\ 36.0 \text{ kips} \end{array} \right. && \\
 \text{for one girder} &= && 
 \end{aligned}$$

**Example 4:19.** Find the maximum live shear and moment together with impact, in an intermediate floor beam of a single-track through girder span due to Cooper E-50 loading. Impact by Pencoyd formula,  $I = S \frac{300}{300 + L}$ , where  $L$  is the loaded length. The stringers are spaced 6 ft 6 in. center to center, the girders are 14 ft 6 in. center to center, and the panel length (that is, the distance center to center of floor beams) is 12 ft 6 in.

*Solution.* (Fig. 4:23.) The influence lines for the loads brought to the points at which stringers are attached to the floor beam are as shown. By the average load criterion (Art. 4:9), or by inspection, it is evident that maximum load will come to floor beam  $C$  when wheels 2 and 3 are on stringer  $BC$ , and 4 and 5 are on  $CD$  (or when 3 is at  $C$ , or when 4 is at  $C$ , since each of these positions gives a constant load on  $C$ ). With 3 at  $C$ , the load at *each* load point on the floor beam is

$$25 \left( \frac{7.5 + 12.5 + 7.5 + 2.5}{12.5} \right) = 60 \text{ kips}$$

*Impact.*

$$I = S \frac{300}{300 + L} = S \frac{300}{300 + 25} = \frac{12}{13} S$$

$$\text{Impact shear} = \frac{12}{13} \times 60 = 55.4 \text{ kips}$$

$$\text{Impact moment} = \frac{12}{13} \times 240 = 221.6 \text{ kip-ft}$$

**Example 4:20.** What is the maximum live shear at a section 10 ft from the end of one girder of a single-track deck girder (a bridge without floor beams and stringers in which the ties are supported directly on the girders) of 50-ft span due to an E-50 loading?

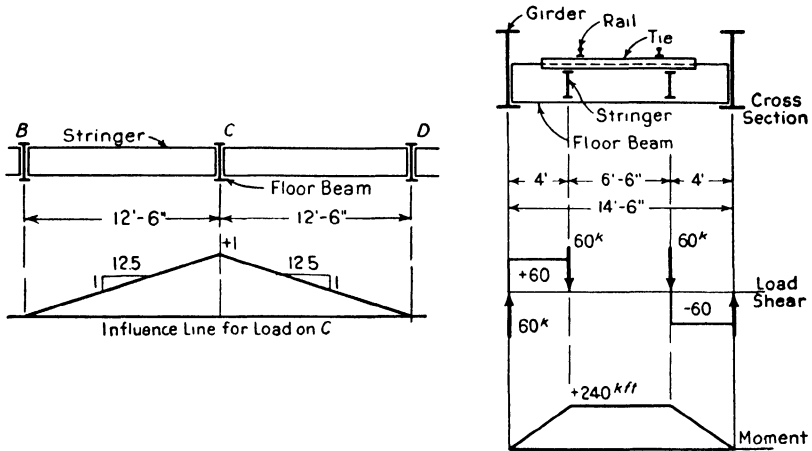

FIG. 4:23

*Solution.* (The influence lines are not here reproduced.)

	Loads	Decrease		Increase
Position:	1-2	30	<	$348 \times 8 \times \frac{1}{30} + \delta$
	2-3	60	>	$(426 - 30) \times 5 \times \frac{1}{30} + 30 \times 2 \times \frac{1}{30}$

Place wheel 2 at section.

$$\text{Shear: } V = \frac{1}{2} \left( \frac{10,488}{50} - 30 \right) \frac{50}{60} = 74.9 \text{ kips}$$

*Discussion.* Note that in the second comparison load 1 leaves the span from a position 2 ft from the end, thus decreasing the negative shear, or increasing the positive shear, by the amount given. In computing the shear the term in parentheses is that in two girders due to an E-60 loading. The heading "Loads" is an abbreviation for the statement that the two positions compared are those, first with one numbered wheel, and then with the other, at the section.

**Example 4:21.** What is the maximum live moment in one girder at a point 20 ft from the end of a single-track deck girder span of 50 ft due to an E-60 loading?

*Solution.* Instead of the influence line method hitherto used, this problem is solved by the criterion already established. The student should compare with this a solution using the more general method.

Position:	Average Load (kip per foot)	
	At Left	At Right
Wheel 3 at right of section	90/20	< (348 - 90)/30
at left of section	150/20	< (387 - 150)/30
Wheel 4 at left of section	210/20	> (426 - 210)/30
Place wheel 4 at section.		
Moment:	$10,488 \times 20/50$	= 4195.2
	Moment at wheel 4	1440
	Maximum moment in two girders at section	<hr style="width: 50%; margin: 0 auto;"/> 2755.2 kip-ft
	Maximum moment in one girder	1377.6 kip-ft

*Note.* Since the inequality written for wheel 3 at the left of the section showed the average load per foot to be greater on the right than on the left, there was no need for an inequality for wheel 4 at the right of the section, as it is impossible for the movement of the loads to the left which brought load 4 to the section to change the previous average load relation.

The average-load method holds wherever the influence line is a triangle. It can also be used where the influence line consists of two triangles, as in the case of shear in an intermediate panel of a bridge with floor beams, provided that the length covered by the loads lies entirely under one of the triangles, no load passing the neutral point.

**4:11. Absolute maximum moment.** In general the maximum moment in a simple beam under a set of concentrated loads does not occur at the center. In short spans the largest moment which a given load system causes may differ appreciably from the maximum at the center and it becomes necessary to develop a means of locating a group of concentrated loads on a span so that it causes the maximum possible moment, i.e., the so-called **absolute maximum moment**.

If a series of concentrated loads, as, for example, that of Fig. 4:24, is moved across a span, the maximum moment will occur under the load,  $P$ , where the shear is zero and will equal  $\frac{Rx}{L} (L - a - x) - R_L b$ , where  $R_L$  is the resultant of the loads to the left of  $P$ . This moment will reach its maximum value when the first derivative with respect to  $x$  equals zero, i.e., when

$$L - a - 2x = 0$$

or

$$x = L - a - x$$

Therefore the moment under load  $P$  will have its greatest value when that load is as far from one support as the resultant of all loads on the span is from the other support, or when the center of the span is half way between  $P$  and  $R$ .

In general, absolute maximum moment will occur under the load which causes maximum center moment when the loads are so placed that the center of the beam lies midway between that load and the resultant of all the loads on the span.

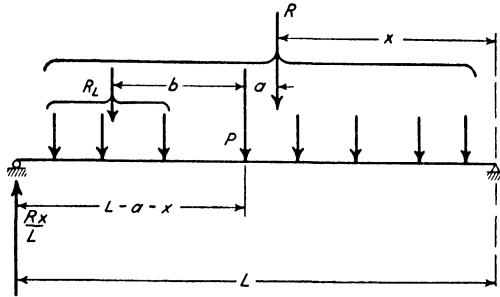

FIG. 4:24

If in Fig 4:24 wheel \$P\$ is the wheel which causes maximum center moment, the value of this moment with \$P\$ at the center will be

$$\begin{aligned}
 M &= \frac{R}{L} \left( \frac{L}{2} - a \right) \frac{L}{2} - R_L b \\
 &= \frac{R}{L} \left[ \left( \frac{L}{2} \right)^2 - \frac{La}{2} \right] - R_L b
 \end{aligned}$$

For absolute maximum moment, wheel \$P\$ must be moved a distance \$a/2\$ to the left. With the loads so placed, the moment at \$P\$ will be

$$\begin{aligned}
 M &= \frac{R \left( \frac{L}{2} - \frac{a}{2} \right)}{L} \left( \frac{L}{2} - \frac{a}{2} \right) - R_L b \\
 &= \frac{R}{L} \left[ \left( \frac{L}{2} \right)^2 - \frac{La}{2} + \left( \frac{a}{2} \right)^2 \right] - R_L b
 \end{aligned}$$

Therefore, absolute maximum moment exceeds maximum center moment by the amount

$$\frac{R}{L} \left( \frac{a}{2} \right)^2$$

**Example 4:22.** Compute the maximum moment which will occur in one girder of a single-track electric railway deck girder bridge of 40-ft span under the two 40-ton cars shown in Fig. 4:25.

*Discussion.* The solution is by a method of trial instead of by first locating the wheel which causes greatest center moment. Complete details of the



computation are given in the figure. In a simple case like this it is not necessary to try the three loadings shown because the results are obvious by inspection; they serve to illustrate the method, however.

The combination of two wheels at the end of one car and the nearest wheel on the next car was tried, but these three cannot be placed on the span in the critical position without bringing on a fourth wheel.

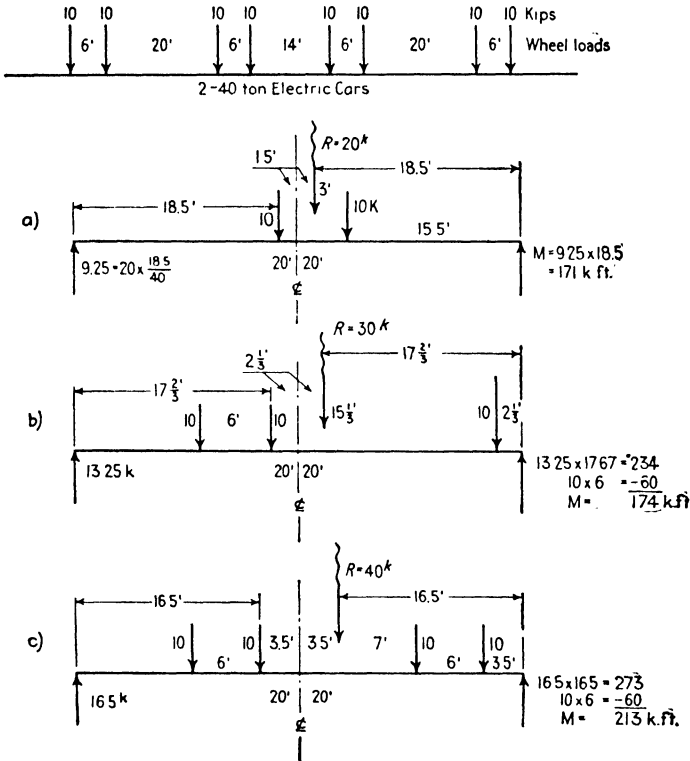

FIG. 4:25

**4:12. Equivalent loadings.** Although not sanctioned by the leading specifications, the use of simpler loadings, equivalent to the conventional systems of concentrated loads already studied, is continually being advocated and may some day come into general favor. When the variation of actual locomotives from the conventional systems is considered, together with the uncertainties as to the actual amount of impact increment, it is plain that the somewhat extreme precision of some of the computations in this and other textbooks denotes merely extra labor and not closer approach to the truth. However, wheel system stresses form our only possible criteria, and our simplified load-

ings must be chosen so as to give stresses closely equal to these. The difficulties in the way at once become clear from the following computation.

**Example 4:23.** Compute equivalent uniform live loads per foot of track to be used to replace the E-60 loading used for the girder of Prob. 4:31.

*Solution.* (The simple influence lines used here can be easily supplied by the student.) The loading desired is a uniform load of  $q$  lb per ft of span which will cover the whole bridge in every case except for maximum shear in the second panel, when it extends 40 ft from the support. The area under the influence line multiplied by  $q$  equals the stress found in Prob. 4:31.

$$\begin{array}{ll}
 \text{Shear: end panel} & q \times \frac{1}{2} \times \frac{3}{4} \times 60 = 100,500 \times 2 & q = 8930 \text{ lb per ft} \\
 \text{second panel} & q \times \frac{1}{2} \times \frac{1}{2} \times 40 = 48,800 \times 2 & q = 9760 \\
 \text{Moment: } \frac{1}{4} \text{ point} & q \times \frac{1}{2} \times 11.25 \times 60 = 1,508,000 \times 2 & q = 8930 \\
 \text{center} & q \times \frac{1}{2} \times 15 \times 60 = 1,941,000 \times 2 & q = 8630
 \end{array}$$

Since maximum  $\frac{1}{4}$ -point moment equals maximum end-panel shear multiplied by the panel length, the equivalent load for these two functions is plainly the same.

The preceding example has made it plain not only that no single uniform load intensity may be used to replace the E loading but also that a separate intensity must be used for each separate panel shear and panel point moment of each individual bridge, if the equivalence is to be at all exact. These equivalent loads can be obtained only by first calculating the stress due to the system to be replaced or by using some of the published data, for example, those prepared with immense labor and care by Dr. Steinman in the paper "Locomotive Loadings for Railway Bridges," *Transactions of the American Society of Civil Engineers*, 1923. Most engineers refuse to use the results of another's work without verification on their own part. The difficulties in the way of general acceptance of equivalent loadings are therefore obvious.

**4:13. Long-span simple bridges.** For spans of more than 250 or 300 ft the simple triangular trusses considered in the previous articles (Pratt, Howe, Parker, Warren) are not economical, and other forms have been developed. Truss depths must be increased as span increases in order to provide proper stiffness as well as to minimize the weight of metal in the chords. Since web members increase unduly in weight if the diagonals depart too largely from a 45-degree slope, this increase in depth means a longer panel length for these trusses and consequently heavier stringers and floor beams. In the usual highway bridge, stringers are properly made 15 to 25 ft in length, in railway bridges, 25 to 45 ft. The ratio of truss depth to span length for minimum weight of bridge varies from  $1/5$  to  $1/8$ , depending upon the panel

length, the type of truss, and the stresses used in design. For a span of 250 ft the ratio is commonly about  $1/6$ , and less for longer spans. The 720-ft truss of the Ohio River bridge at Metropolis, Ill., has a depth of 110 ft, a ratio of  $1/6.5$ . The early method of satisfying these conflicting requirements was by the use of multiple web systems as in the Whipple truss (1852), Prob. 1:16C. These trusses, which are not used at the present time because they are expensive and indeterminate, will be considered briefly later (Art. 6:1). The modern method is to subdivide the panels, as indicated by the dotted lines in the left half of Fig. 4:26. This type of subdivision was used by Albert Fink in 1868–1870. The widely used Baltimore truss (Fig. 4:2) is a Pratt truss with subdivisions. The subdivided Parker truss, known as the Pennsylvania

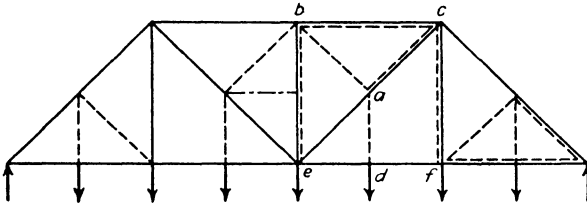

FIG. 4:26

or Pettit (Fig. 4:2), was first built on the Pennsylvania Railroad in 1871. In these deep trusses the length of the compression verticals is so great that it is necessary to brace them against buckling by deep sway bracing between trusses and by horizontal struts extended from adjacent intermediate joints, as indicated by the dot and dash line in Fig. 4:26. Such a strut carries no stress. The K truss is a much more recent solution of this problem, which gains in economy by eliminating the need of these struts by using in each panel two short diagonals (Fig. 4:2), extending from the top and bottom of one vertical to their junction at mid-height of the adjoining vertical. This type of truss was used in the Quebec bridge, Fig. 5:5. See also Ex. 4:27.

The longest simple bridge (end-supported) is that at Metropolis, Ill., already referred to, with a span of 720 ft (1917). For longer spans the arch, the cantilever, and the suspension bridge are employed. The essential features of the statically determinate forms of the arch and the cantilever are considered in the next chapter.

**4:14. Trusses with subdivided panels.** The simplest example of panel subdivision is that made by adding verticals to a Warren truss, Fig. 4:2, the original form of this truss (1851) being without them, the angles between members being 60 degrees throughout. Study of

this type shows that alternate verticals are simply bracing members carrying no load, whereas those verticals which effect the subdivision of panel lengths along the loaded chord are only stressed by live load when the adjacent stringers are loaded. Analysis of this truss is too simple to require further comment.

The subdivision which marks the Baltimore and Pennsylvania trusses consists essentially in placing in every panel of a Pratt or Parker truss a small secondary truss to carry the load of the intermediate panel point, distributing it to the adjacent panel points. This is shown in Fig. 4:26 by the dotted trusses in the right portion of the sketch. The dotted truss  $abc$  receives its load from the hanger  $ad$  and is supported by reactions at  $e$  and  $f$ . Accordingly member  $bc$  in the actual truss serves a dual function, that of top chord member for the main truss shown in full line and also that of chord member for the small dotted truss; similarly the diagonal  $ac$  serves two functions. Bars  $ab$  and  $ad$  are purely members of the secondary truss and are called **secondary<sup>9</sup> bars**. It is possible to carry through a complete analysis of these trusses by making use of this simple division into primary and secondary elements. However, it is more convenient to use the methods which follow.

**Baltimore truss.** Here the secondary members are best studied by taking a section either partly or completely about the intermediate joint, as shown for joints  $b'$  and  $d'$  in Fig. 4:27 and applying the equations of equilibrium to the force system acting on the free body within the section. The horseshoe section about  $b$  and  $b'$  cuts six bars; the lines of action of four of these intersect at  $c$ . The stress in the vertical  $b'B$  ( $S_{b'B}$ ) may be determined independently by applying the method of joints at its upper end. Applying the equation  $\Sigma M = 0$  to this free body, taking the moment center at  $c$ , and resolving the stress in  $ab'$  into components at  $a$ , give  $V_{ab'} = \frac{1}{2} (P_b + S_{b'B})$  compression. Similarly, for the circular free body about  $d'$ , with center of moments at  $C$ ,  $V_{a'E} = \frac{1}{2} (P_d + S_{d'D})$  tension. Or, if desired, the horizontal component may be found, taking moments about  $e$ ,  $H_{a'E} = (P_d + S_{d'D})p/h$ . A similar treatment of the force system acting on the joint  $b'$  is, of course, possible.

In general, for both parallel and non-parallel chord trusses, where the secondary has the same slope as the main diagonal, the vertical component of the stress in the secondary diagonal will equal one-half of the vertical load applied at the joint.

<sup>9</sup> In contrast with primary members, which are stressed with all positions of the loads, secondary members are sometimes defined as those which are stressed only by the loads in certain limited positions. Consideration of the influence lines shown in Figs. 4:28 and 4:32 will make clear this distinction.

The only primary stress in a secondary vertical such as  $d'D$  is that due to the dead-load weight at the upper joint (secondary stresses, stresses incidental to truss erection, and those caused by transverse forces are not here under study). However, if the chord changes direction at the end of a vertical, as is illustrated in Prob. 4:46, a load anywhere on the bridge stresses the vertical, and in consequence the diagonal ceases to be a secondary member.

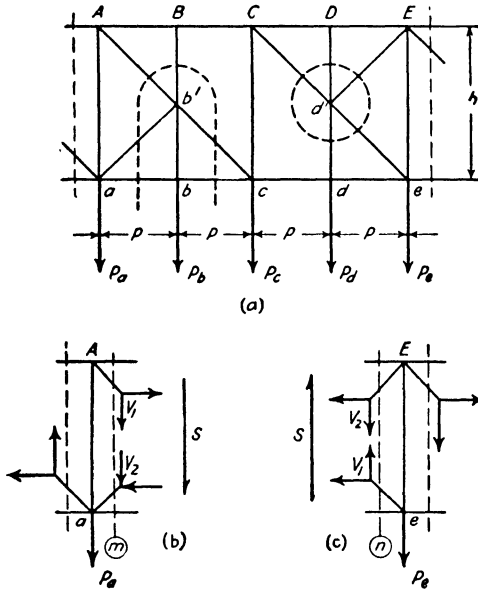

FIG. 4:27

Study of Fig. 4:27a shows that vertical  $Cc$  and diagonals  $b'c$  and  $Cd'$  are analyzed by the method of shear as simply as the corresponding bars in a Pratt truss. Likewise the chords offer no difficulty; for example, the stress in  $CD$  and  $DE$  is found by taking the moment center at  $e$  with a vertical section through panel  $cd$ , the stress in  $CD$  and  $DE$  always being the same. However, for maximum stress a single load is not placed at the moment center, as will be explained later. The stress in a vertical like  $Aa$  or  $Ee$  is found by taking an inclined section sloping downward to the right which will cut a secondary diagonal as well as the vertical. Since the vertical component of stress in the diagonal is easily found, here equal to the half of the intermediate panel load, the fact that the section cuts four bars offers no difficulty. Likewise a main diagonal lying above or below a secondary diagonal is handled by the

method of shear, as is shown in Fig. 4:27*b-c*. In the first sketch the arrow  $S$  represents shear on section  $m$ , here taken as positive. That is, the resultant of all the forces acting on the free body to the left of section  $m$  equals  $S$  acting upward, and the vertical components of the two diagonals cut by the section must supply a downward-acting force here represented as  $S$ . Then  $V_1 + V_2 = S$ ; or, since the vertical component of the secondary equals the half panel load,  $V_1 + \frac{1}{2}P_b = S$ . Similarly for section  $n$ , where  $S$  again is taken as positive shear and equal to the upward-acting force which must be supplied by the two vertical components of bar stress,  $V_1 - \frac{1}{2}P_d = S$ . Accordingly the criterion for maximum stress in these two main diagonals is not that of maximum shear in the panel as it is for those diagonals in panels without secondaries.

**Example 4:24.** Draw influence lines for stress or stress component for typical bars in the Baltimore truss shown in Fig. 4:28.

*Discussion.* The first bar offering difficulty is diagonal  $M_5L_6$ , which is studied by aid of a vertical section. Since there is no stress in the secondary diagonal  $M_5U_6$  except when a load is at  $L_5$ , the main diagonal,  $M_5L_6$ , carries the shear in the panel at all times except for this one position of the load. For this single position the vertical component of the main diagonal has the value  $-R_{12} + V(M_5U_6) = -\frac{5}{12} + \frac{6}{12} = +\frac{1}{12}$ , which brings the ordinate on the straight line connecting the ordinates on both sides. Its value is recorded in parentheses to aid in checking, the only values necessary for completeness being those at breaks in the curve.

The stress in vertical  $U_6L_6$  is found by taking the joint at  $U_6$  as the free body.

Chord  $U_4U_5$ ,  $U_5U_6$ ; take vertical section in panel 4-5, free body to the left, moment center at  $L_6$ . So long as the load is not on the free body, the chord stress equals the left reaction times  $180/60$ , with a maximum value for the load at  $L_5$ . Considering the free body to the right, load on the left segment, same moment center as before, the chord stress equals the right reaction multiplied by  $180/60$ , with a maximum value when the load is at  $L_4$ . The effect of the secondary members is to move the maximum ordinate away from the moment center, shown by the lines below the dotted line.

**Counters.** The effect of shear reversal in Baltimore trusses is met by making the necessary diagonals stiff members or by adding diagonals if it is desired that all these bars shall be tension members. In Fig. 4:29*a* this is shown, the position of the panels in the bridge determining which of bars 3 or 4 is the main member and which is the counter. If the effect of dead loads is to lengthen the diagonal distance along bars 1 and 4 and shorten that along 2 and 3, diagonals 1 and 4 are main diagonals, diagonal 3 is a counter, and diagonal 2 is a secondary with a vertical component of stress equal to one-half of the panel load  $P_m$ . If the distortion of the frame under dead load is the reverse of this, bar

4 is the counter and 1 is a secondary. From these considerations it is plain that bars 1 and 2 are always in action and that their vertical component can never under any circumstances be less than  $\frac{1}{2}P_m$ . Keep

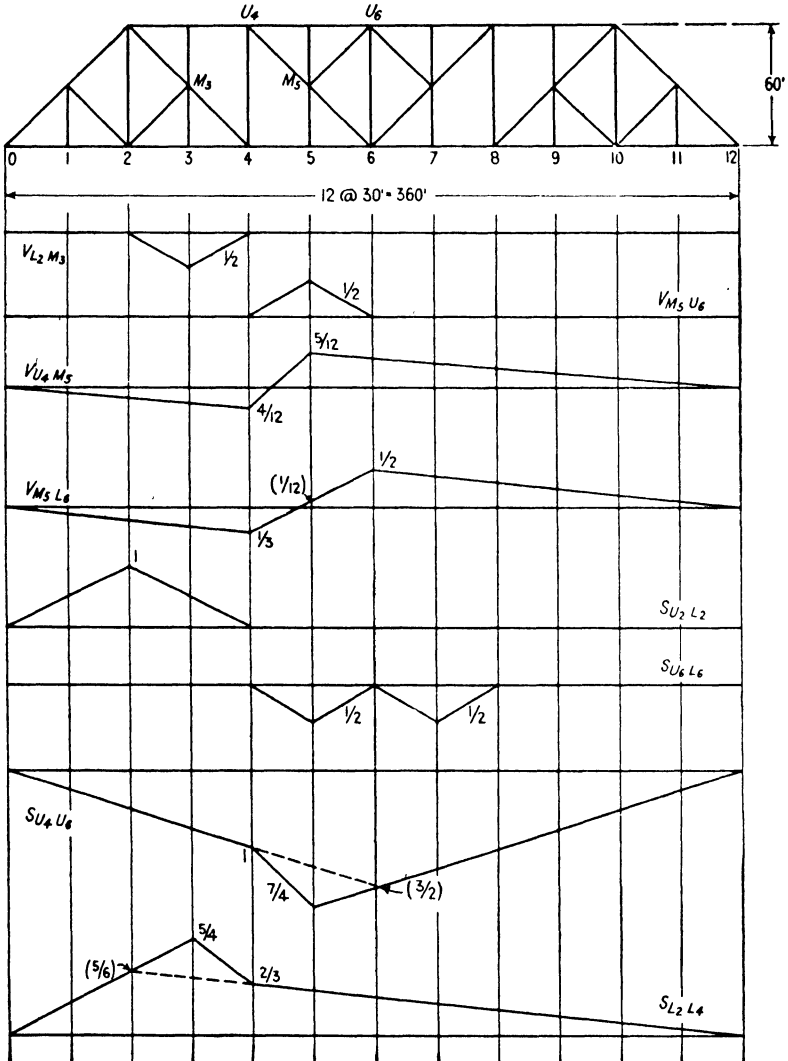

FIG. 4:28

this fact in mind, as it simplifies the visualizing of the operation of the counter.

Under any given loading either bar 3 or 4 is out of action. Either

section *a* or *b* serves equally well for the determination of the active diagonal. Taking section *a*, the vertical components must act in the directions shown in Fig. 4:29*b*, both being tension members; and  $V_1$  cannot have a value less than  $\frac{1}{2}P_m$ . The arrow  $S_a$  represents the shear on section *a*, that is, the vertical force which must be supplied by the combination of  $V_1$  and  $V_3$ , shown as negative shear in this case. It is plain that *not only is bar 3 bound to act if there is negative shear, with  $V_3 = S_a + \frac{1}{2}P_m$ , but also this bar acts if the shear is positive with a value less than  $\frac{1}{2}P_m$ .*

If the shear is positive and larger than  $\frac{1}{2}P_m$ , bar 3 is out of action. Similarly, considering section *b*, if  $S_b$  is negative and equal to or greater than  $\frac{1}{2}P_m$ , bar 4 does not act; for negative shear less than  $\frac{1}{2}P_m$  and for positive shear bar 4 acts.

Assume that the two panels shown in Fig. 4:29 are panels 6-7, 7-8 in the truss of Fig. 4:28. Under dead load the shear in both panels is negative and bar 4 is the counter and out of action. In order to bring it into action it is necessary either to reverse the shear in panel 7-8 or to bring the negative shear in that panel down to a value less than  $\frac{1}{2}P_m$ . In that case the shear in panel 6-7 is positive and greater than  $\frac{1}{2}P_m$ , ensuring the non-action of bar 3.

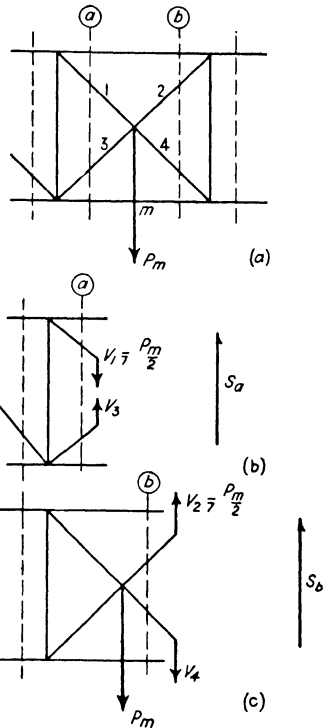

FIG. 4:29

**Example 4:25.** Compute the maximum stress, dead, live, and impact, in diagonals  $U_6M_7$  and  $M_7L_8$  of the truss of Fig. 4:30. Loads for one truss: dead, on top chord 1000 lb per ft, on bottom chord 2000 lb per ft; live, 3000 lb per ft on bottom chord and an excess concentration of 24,000 lb; impact  $I =$

$$300 + \frac{L^2}{100}$$

*Solution.* (Fig. 4:30.) Bar  $U_6M_7$  acts either as a main diagonal with the counter in action and  $L_6M_7$  out of action or as a secondary member with  $L_8M_7$  out of action. The first situation is shown in Fig. 4:30 on the upper line: the second, for which no sketch is given, follows; the maximum panel load is  $D +$



$L + I = 90 + (90 + 24) + (114 \times 0.89) = 306$  and the maximum stress in  $U_6M_7 = \frac{1}{2} \times 306\sqrt{2} = +216$  kips.

$M_7L_8$ —Inspection shows that a load at  $L_7$  tends to put compression in the counter,  $M_7L_8$ , and that for maximum stress the live load must be placed as

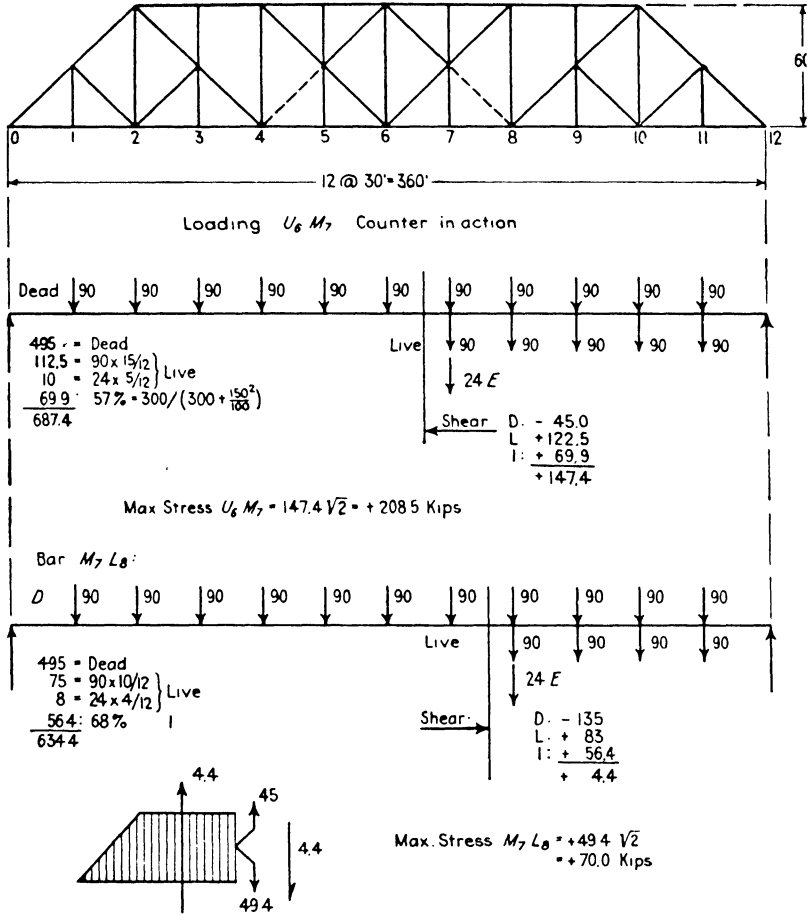

FIG. 4:30

shown on the lower line. In order that the resultant of the two vertical components of the counter,  $M_7L_8$ , and the secondary above,  $M_7U_8$ , equal the positive shear, 4.4, the vertical component of the counter must equal the shear plus one-half of the panel load at  $L_7$ .

Were it possible to reverse the shear in panel 8-9 a common arrangement to meet the condition would be the addition of a tension diagonal  $U_8M_9$ , maintaining the secondary  $M_9L_{10}$  as a stiff member. This results in making the

stress analysis of the diagonals indeterminate even though the member added is adjusted so that it carries no dead stress. By this arrangement there are two bars,  $M_9L_{10}$  and  $U_8M_9$ , capable of resisting the downward movement of  $L_9$  relative to  $L_8$  and  $L_{10}$  caused by the load at  $L_9$ , and the distribution of stress between them is uncertain.

Influence lines for the vertical components of diagonal  $U_6M_7$ , counter  $M_7L_8$ , and for stress in vertical  $U_6L_6$  are shown in Fig. 4:31.

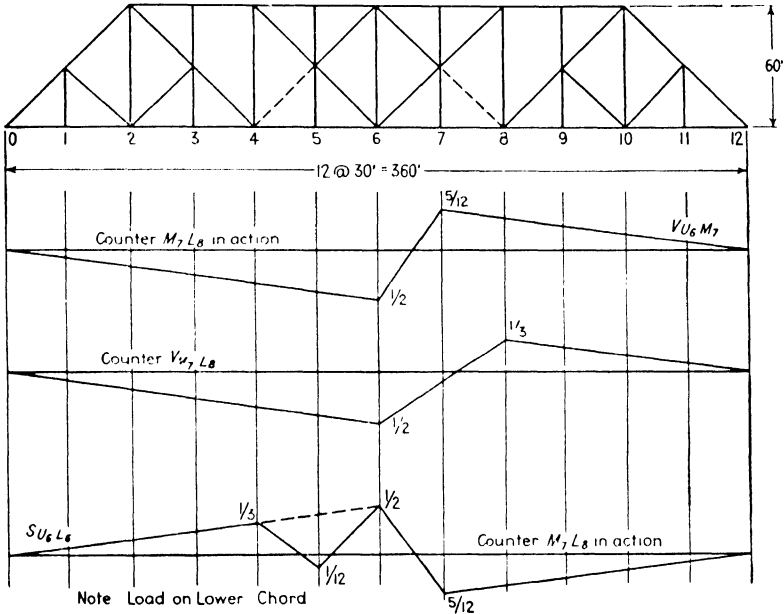

FIG. 4:31

**Pennsylvania truss.** In the example and problem which follow, the Baltimore truss of Fig. 4:28 has been modified by sloping the top chord, giving a simple type of Pennsylvania truss for study. Trusses of this sort are often made with the hip joint at the first instead of the second panel point and with the bars in the end panels arranged in the fashion of a Parker truss.

**Example 4:26.** Prove that diagonal  $f$  is the counter and  $b'$  the main diagonal in the truss of Fig. 4:32. All the diagonals in these panels carry tension only.

**Solution.** It is required to determine whether bar  $b'$  or  $f$  is in action under dead load. As in the Baltimore truss we are assisted by knowing the stress in bars  $c'$  and  $a'$  when each in its turn acts as the secondary diagonal. For  $c'$  take a circular section about the intermediate joint and the free body enclosed,

TRUSS AND GIRDER BRIDGES

$f$  being assumed out of action. Taking moments about  $L_6$  gives  $H_c' = +\frac{1}{2}$  and  $V_c' = 0.54$ . For  $a'$ , with the same section and free body,  $b'$  being assumed out of action, take moments about  $L_8$ , resolving the stress in  $a'$  into components at  $U_8$  and that in  $c'$  at the intersection of its line of action with the lower chord,

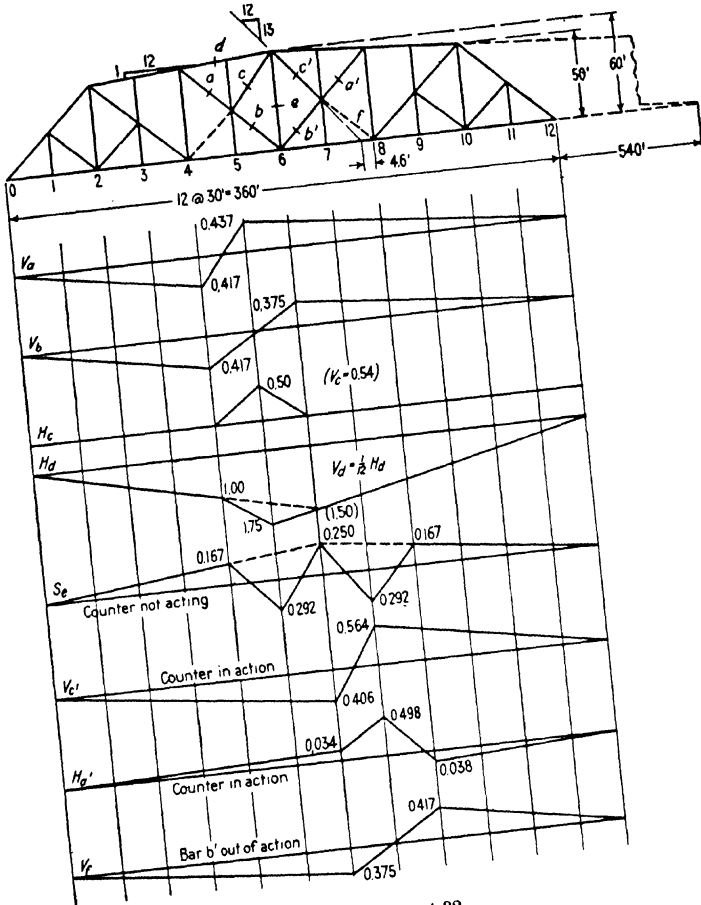

FIG. 4:32

4.6 ft to the left of  $L_8$ . This gives  $H_a' = \frac{1}{5}(30P_7 - 4.6V_c')$ . This last expression reveals that when  $a'$  is in action in combination with  $f$  it is not a true secondary, because under this condition its stress is a function of that in  $c'$  and this last is affected by a load anywhere on the structure. This is evident from inspection of the bars in question:  $c'$  and  $f$  are not on the same straight line and so when they are stressed in tension,  $a'$  has a double function, that of preventing

the downward movement of the intermediate joint under the load at  $L_7$  and that of carrying the compression incident to the tendency of this joint to rise under the straightening effect of the tension on the bent line of the two diagonals.

Represent the dead load by a unit force at each panel point. Take a vertical section through panel 6-7 and consider the free body to the left, applying the equation  $\Sigma M = 0$  with center of moments at the intersection of the chords prolonged:

$$\begin{array}{rcl}
 \text{Moment of left reaction:} & 5.5 \times 900 & = +4950 \\
 \text{Moment of panel loads 1-6:} & 6 \times 795 & = -4770 \\
 \text{Bar } c' \text{ supplies a moment at least equal to} & 0.54 \times 664.6 & = -359 \\
 \text{Total} & & \underline{\quad -179}
 \end{array}$$

This must be balanced by an equal and opposite clockwise moment which can be supplied only by a stress in  $b'$ .

It is even simpler to solve this problem by taking a section through panel 7-8. The student should carry this through. Since the clockwise moment which must be supplied in this case (using the free body to the left) exceeds that which the secondary element alone of  $a'$  provides (and the other element decreases it), diagonal  $a'$  must act and  $f$  be out of action.

*Another method of solution is this.* Assume that the stress in bar  $f$  is zero and that  $b'$  acts. If the stress in bar  $b'$  computed on this assumption proves to be tension, the bars act as assumed. If the stress comes out compression, the assumption is incorrect and bar  $f$  acts and not  $b'$ . The procedure involves an important method of attack not hitherto employed. It is suggested that several of the problems already considered be solved again, making use of this method, which, briefly, is as follows. Find the stress in  $L_6L_7-L_7L_8$  by taking a vertical section in panel 7-8 and applying the equation  $\Sigma M = 0$  to the free body to the right, center of moments at  $U_8$ ; then find the combined stress in  $L_6L_7$  and horizontal component of stress in  $b'$  by making similar use of a free body to the right of a vertical section through panel 6-7, center of moments at  $U_6$ ; the difference between the two results gives the horizontal stress component of  $b'$ . Thus

$$\begin{aligned}
 S_{L_6L_8} &= \frac{5.5 \times 120 - 4 \times 45}{55} = +8.73 \\
 S_{L_6L_8} + H_{b'} &= \frac{5.5 \times 180 - 5 \times 90}{60} = +9.00 \\
 \therefore H_{b'} &= \underline{\quad +0.27}
 \end{aligned}$$

showing that  $b'$  acts as assumed.

**Example 4:27.** Draw influence lines for the marked bars of Fig. 4:33.

*Solution.* Truss heights are: at panel 2, 34 ft; 3, 41 ft; 4, 46 ft; 5, 49 ft.

Bar  $a$ . Draw section  $A$  and take moments about  $U_2$ . The two verticals which are cut have no moment about  $U_2$ .

Bar  $b$ . Section  $B$ . Moments about  $U_3$ .

Bar *c*. Section *A*. By use of the equation  $\Sigma H = 0$  it is seen that  $H_c = -S_a$ . The influence line (not shown) is therefore the negative of that for *a*.

Bar *d*. Use the equation  $\Sigma H = 0$  at joint  $L_3$ .

Bar *e*. Use the equation  $\Sigma H = 0$  at joint  $M_2$ . Influence line for  $H_e$  (not shown) is the negative of that for  $H_d$ .

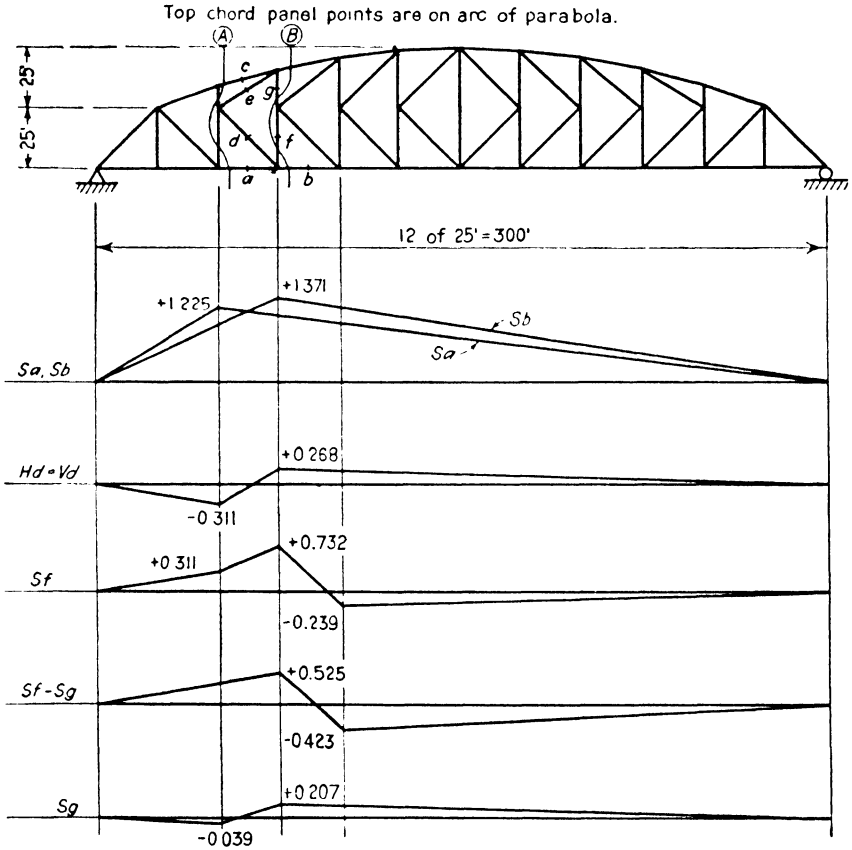

FIG. 4:33

Bar *f*. Use the equation  $\Sigma V = 0$  at joint  $L_3$ . Influence line is negative of that for  $V_d$  except when load is at  $L_3$ , at which time  $V_d + V_f = 1$ .

Bar *g*. Perhaps the best way to get values is by use of the equation  $\Sigma V = 0$  at joint  $U_3$ . However, an alternate method is to use section *B*, and take moments about the intersection of the chord bars which are cut. In this way an influence line may be constructed for the combined stress  $(S_f - S_g)$  in the verticals which are cut. This line, which is shown, may be subtracted from the influence line for  $S_f$ .

PROBLEMS

Art. 4:1

**Problem 4:1.** Draw the curves of shear and moment for the stringers *BC* and *CD*, floor beam at *C*, and the far girder of the bridge here shown. Note that one-half of each load rests on each rail: assume that each stringer carries the load of one rail or one-half the track load.

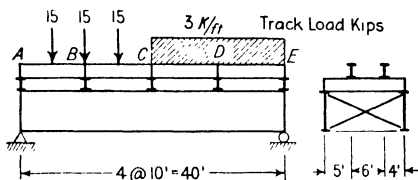

PROBS. 4:1, 4:2

**Problem 4:2.** Bridge of Prob. 4:1. Draw the curves of dead-load shear and moment for the same members. Data: Track (ties, rails, and fastenings) weighs 400 lb per ft; stringers 100 lb per ft; floor beams 200 lb per ft; girders 300 lb per ft.

*Ans.* Maximum values:

	Shear (pounds)	Moment (pound-feet)
Stringer	1,500	3,750
Floor beam	4,700	19,225
Girder	13,050	154,000

**Problem 4:3.** A train of weight *W* lb per lin ft goes around a 2-degree curve at 65 miles an hour. What is the centrifugal force exerted? Make the usual approximation that the radius of a curve of *d* degrees equals 5730/*d*. *Ans.* 0.10 *W*.

Arts. 4:2 and 4:3 Dead Load Stresses

**Problem 4:4.** Find the dead stresses for one truss of the single-track, open-floor through Warren truss bridge shown in Fig. 4:2. Panel length 25 ft; depth of truss, 30 ft. Assume an E-60 loading and a track weighing 580 lb per ft.

*Ans.* Panel loads: top chord 12 kips, bottom chord 24 kips. The results are self-checking.

**Problem 4:5.** Find the dead stresses for one truss of the single-track, open-floor deck truss bridge *F* shown in Prob. 4:10 designed for an E-50 loading. Assume that the track weighs 420 lb per ft. Use formula for through bridge weight.

*Ans.* Panel loads: top chord 14.7 kips, bottom chord 7.3 kips. The results are self-checking.

Art. 4:4 Influence Lines

**Problem 4:6.** Draw the influence line for floor-beam reaction at panel point *C* of the girder shown in Fig. 4:3.

*Discussion.* Assume an axle load of 2 unit wheel loads passing across the span. No load is brought to floor beam *C* except when the load is between *B* and *D*. The reaction at the end of the floor beam, the load brought by it to the girder, equals the load brought to the floor beam by each pair of stringers under one rail.

**Problem 4:7.** Draw these influence lines for the girders of the structures shown: for shear at  $S$ , for reaction at  $R$ , for moment at  $M$ . Give values of ordinates at all breaks in the curves.

*Note.* In certain of these problems the letter  $S$  (or  $R$  or  $M$ ) appears more than once.

In all these bridges there appear stringers with cantilever overhangs. In all these cases take the small distance between the end of such a stringer and that ad-

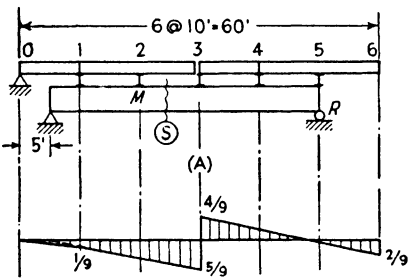

Answer for Shear at  $S$

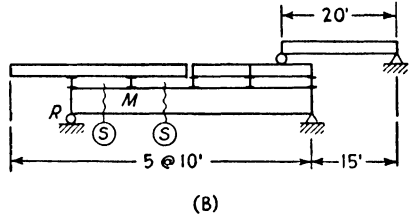

(B)

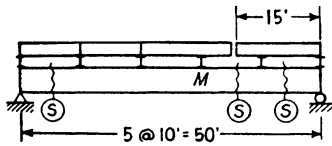

(C)

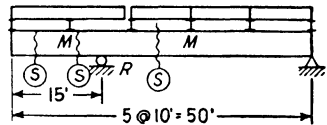

(D)

PROB. 4:7

joining as zero. It is perhaps needless to remark that these stringers do not represent actual construction but rather arrangements very good for instruction purposes. Also note that where this break comes between floor beams, as in the girder  $C$ , the influence line may not be continuous across that panel.

**Problem 4:8.** In the truss of Ex. 4:5 draw a line through  $L_1$  and  $U_3$  and another through  $L_0$  and  $U_2$ . Prove that these lines intersect vertically above the neutral point of the panel. Why? (Is there a clue in the fact that the two lines which were drawn form the moment curve for a load at the neutral point?)

**Problem 4:9.** Show that the influence line for stress in bar  $b$  of the truss of Ex. 4:6 is a straight line between the ordinates at points 1 and 2; also that if there were a vertical bar at  $c$ , cutting bar  $b$  into two parts with a load point on the lower chord midway between 1 and 2, the influence line for stress in bar  $b$  would be a triangle with apex on the vertical through  $c$ .

**Problem 4:10.** Draw influence lines for the stress (or for a component of stress) in each of the lettered bars of these trusses. In every case the floor system is on the level of the chord with the numbered panel points. These are single-track bridges with each truss carrying one-half the track load. Check results by means of the next problem with its answers.

The lower chord panel points are usually designated as  $L_0, L_1, L_2$ , etc., as here

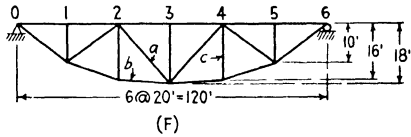
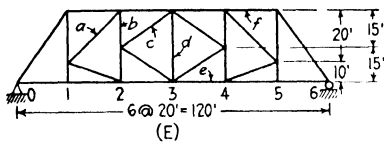
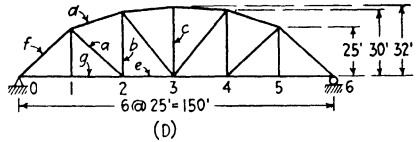
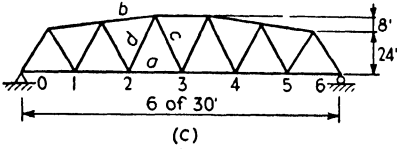
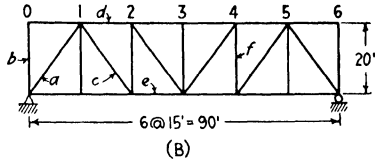
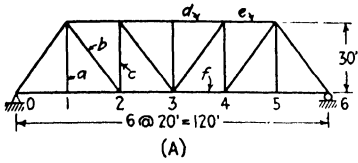

PROB. 4:10

numbered; the upper chord points  $U_1, U_2$ , etc.; intermediate joints, when present, as in truss  $E, M_1, M_2$ , etc. In truss  $A$ , bar  $a$  is called  $U_1L_1$ , bar  $b$   $U_1L_2$ , bar  $d$   $U_3U_4$ , etc.

*Suggestions.* (See also Ex. 4:11 and Prob. 4:15.)

- A: a. Method of joints, using lower end.
- b. Method of shear.

With vertical section through  $b$ , free body to the left and load to the right, we may write  $V_b = V_L$  (vertical component of stress in bar  $b$  equals the vertical reaction at the left). The influence line for  $V_L$  is a straight line from 6 to 2, which is determined by the computation of one ordinate only, that at 2,  $V_b = +\frac{2}{3}$ . This sort of analysis makes it possible to determine the critical ordinates whose values are sufficient to give the whole curve.

- c. Method of shear, inclined section.
- d. Method of moments, vertical section.

Using the free body to the left of the section, with the load at panel point 3 or to the right, we may write this expression for the stress in bar  $d$  in terms of the left reaction,  $V_L, S_d = -60V_L/30$ . Accordingly so long as the load is placed as noted the ordinates to the influence line for  $S_d$  equal twice those of the influence line for the left reaction. Similarly when the load is at panel point 3 or to the left the ordinates for  $S_d$  equal twice the corresponding ones of the influence line for the right reaction. This gives a simple means of obtaining the required line from those easily constructed for the reactions, the computation of a single ordinate being all that is required. This general procedure is advisable for all influence lines and makes easy the determination of the critical ordinates.

One more way of looking at this influence line will be given. It is clear that, for any random position of a load or loads,  $S_d = M_{L3}/30$ . Therefore the same influence line which gives moment at  $L_3$  will, to some different scale, give stress in  $d$ . By trial the student can readily convince himself that the influence line for moment at a panel point of the loaded chord of a



truss is the same as the influence line for moment at the corresponding point in a simple beam and is a triangle with its apex at the point. Consequently, the influence line for  $S_d$  must be a triangle with its apex at  $L_3$ .

*D: a.* Method of moments, vertical section.

When finding the ordinate at 2 use the free body to the left of the section, center of moments at the intersection of bars  $d$  and  $g$  prolonged; when finding the ordinate at 1 use the free body to the right of the same section, with the same center of moments.

*b, d, e.* Method of moments, inclined section.

*c.* Method of joints, using upper end.

The student will encounter many bars like this where no section cutting only three bars is possible and the only recourse is the method of joints. The stress in this bar depends on that in the two upper chord bars meeting at the center. It would be well to draw the influence line for one of these as a preliminary to the line here desired.

*f, g.* Method of joints, using that at the reaction.

*E: a.* Method of shear, finding the proportion carried by bar  $a$  by means of the equilibrium of the joint at the lower end of  $a$ .

*b, d.* Method of joints, upper end.

*e.* Method of moments, with a curved section cutting  $f$ , and the vertical and diagonal intervening, with center of moments at  $U_4$ .

**Problem 4:11.** Using the influence lines of Prob. 4:10 find the maximum live-load stresses in the lettered bars of the trusses of that problem due to a live load of 4000 lb per ft of track and a single axle load of 40,000 lb.

*Note.* This problem of maximum bar stress is approached from a different point of view in Art. 4:7 and in Prob. 4:15.

The student will be saved from many errors if he will note that for the usual loading the top chord of an end-supported truss is in compression and the lower chord in tension; also that for maximum stress in any chord bar in an end-supported truss the entire truss should be loaded.

<i>Ans.</i>	<i>A:</i>	$S_a = + 60$	$V_b = + 77.3$	$S_e = - 46.0$
		$S_d = - 140$	$S_e = - 124.4$	$S_f = + 124.4$
	<i>B:</i>	$V_a = - 91.7$	$S_b = - 35.0$	$V_c = + 61.3$
		$S_d = - 110.0$	$S_e = + 110.0$	$S_f = - 61.3$
	<i>C:</i>	$S_a = + 262.5$	$H_b = - 266.7$	$V_c = + 64.0$
		$V_d = - 44.9$		
	<i>D:</i>	$V_a = + 60.2$	$S_b = + 47.5$	$S_e = + 31.9$
		$H_d = - 188.9$	$S_e = + 188.9$	$V_f = - 141.7$
		$S_g = + 141.7$		
	<i>E:</i>	$V_a = - 51.6$	$S_b = + 51.6$	$V_c = - 23.0$
		$S_d = + 30.0$	$S_e = + 124.4$	$S_f = - 77.8$
	<i>F:</i>	$V_a = - 35.7$	$H_b = + 233.3$	$S_c = - 46.7$

**Problem 4:12.** Using the influence line, determine the stress in bar  $a$  of the truss shown in Prob. 4:10*F* when a uniform live load of 2000 lb per ft per rail covers the entire span.

*Query.* The lower chord panel points lie on a parabola. Does this explain your answer? It is suggested you compare the variation of bending moment with that of the length of truss verticals.

In Prob. 1:12*D* a somewhat similar truss is shown. Does the same result hold for bar  $a$  of that truss?

**Problem 4:13.** Same as Ex. 4:7 except that the tension diagonals are replaced by compression members.

**Problem 4:14.** Truss of Ex. 4:7 with the addition of tension counters in panels *cd* and *ef*. Draw influence lines (a) for stress in chord *ef* with each diagonal in that panel acting; (b) for stress in vertical *Ee* with each diagonal in adjacent panels acting.

*Note.* a. When studying maximum stress in this chord bar the loading will plainly be that to give maximum moment at *e* or to the right. Therefore the shear in panel *de* will be positive and bar *De* will act. It was not necessary, accordingly, to specify which bar to take in that panel.

b. There are four combinations of diagonals and, therefore, four possible influence lines. Are all four combinations actually possible under the action of live and dead loads?

**Art. 4:7 Maximum Stresses from Uniform and Excess Live Loads**

**Problem 4:15.** Using the loading of Prob. 4:11, find the maximum stresses in the lettered bars of trusses *B* to *F* of Prob. 4:10 by the usual method of full-panel loads.

*Suggestions.* Truss *D*; bar *a*. Vertical section through the bar and free body to the left; a load to the right of the section causes tension in the bar. Consider the free body to the right of the section; a load to the left of the section causes compression in the bar. Plainly the tension can attain a greater magnitude than the compression. Study these two free body sketches with care. The secret of expertness in stress analysis is clear visualization of force systems and their relations. Therefore be precise in sketches such as these.

The answers to Prob. 4:11 are sufficient check also for this, since only certain of the web members will differ.

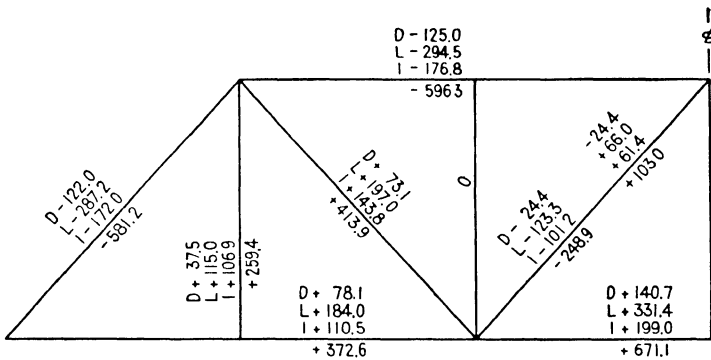

PROB. 4:16

**Problem 4:16.** Compute the design stresses for the bars of a single-track through Warren truss (see Fig. 4:2) of six equal panels of 25 ft; with a depth of 30 ft center to center of chords. Dead load: 3000 lb per ft of bridge on the lower chord; live load: 6000 lb per ft of track with a single axle load of 80,000 lb. Impact formula,

$$I = S \frac{2000 - L}{1600 + 10L} \quad (\text{A.S.C.E., 1923}). \quad \text{Arrange the work in tabular form.}$$

The results are given on the stress diagram. This is the method of giving stresses in practice.

**Problem 4:17.** Compute, in tabular form, the design stresses for the single-track through Parker truss marked *D* in the figure of Prob. 4:10. Where reversal of stress occurs, the diagonal is made a stiff member. Use the loading of the previous problem.

*Suggestions.* For the dead-load stresses follow the procedure of Ex. 4:3 with this variation: instead of finding the horizontal components of the top chord as the first operation, find the vertical components of diagonals  $U_1L_2$  and  $U_2L_3$  by taking a verti-

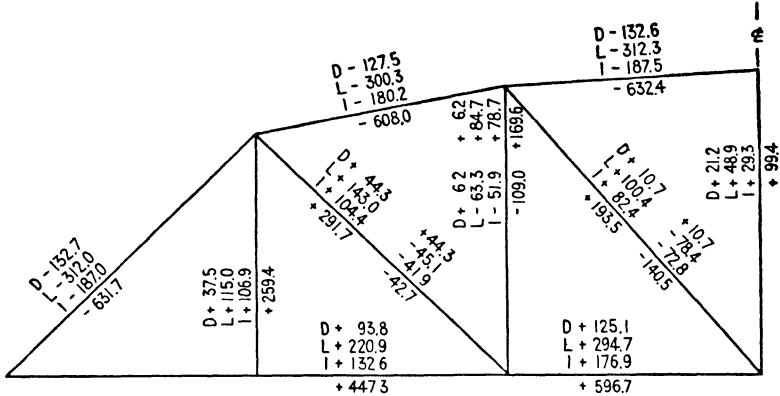

PROB. 4:17

cal section and using the intersection of the chords produced as center of moments. This will give lever arms which are used again when obtaining the live-load stresses in these diagonals. For example, the table for web stresses will contain the heading "Uniform Load—Vertical Component" and under this for  $U_1L_2$  will appear 75 (10/6) (100/150), where 100 is the distance in feet from the moment center to the support and 150 the distance from the same center to the point where the bar stress is resolved into components. The expression gives the vertical component in the diagonal due to live panel loads at the four right-hand panel points.

The stress diagram gives the results.

### Art. 4:8 Counters

**Problem 4:18.** What is the design stress for counter  $U_3L_4$  of the single-track through Parker truss shown? The loads are given in the figure on page 143. This is the truss and loading of the previous problem except for the use of intermediate tension diagonals instead of stiff members. Impact formula,  $I = S \frac{2000 - L}{1600 + 10L}$

*Suggestions.* Only the diagonals which are in action are shown. The loading is that which will produce maximum stress in the given counter if that member is required, i.e., if it can be brought into action. Verify this by drawing an influence line for the vertical component of counter stress for a truss composed of the bars shown. In a problem such as this, the question as to which of the two diagonals in a panel is in action is settled by considering a free body as given in the smaller sketch. In this case since the moment about *O* of the forces to the left of the section is plainly clockwise, the moment of the forces acting on the section, the bar stresses, about the same center must be counterclockwise. The two diagonals, *a* and *b*, are tension members, and, accordingly, bar *a* must be the one acting since the other bar would



**Problem 4:22.** Prepare a tabular computation of the design stresses in the web members of the truss of Prob. 4:18. This is in part a repetition of Prob. 4:17 and in part a summarizing of the several problems which intervene, with the addition of consideration of vertical  $U_4L_4$  (the possible reversal of stress in  $U_2L_2$ ).

*Ans.* For  $U_4L_4$  when bar  $U_3L_4$  acts. For maximum stress see Prob. 4:17.

Dead stress	+15.0
Live stress	+20.3
Impact stress	<u>+18.9</u>
Stress	+54.2

**Problem 4:23.** When truss  $F$  of Prob. 4:10 is made with tension diagonals (instead of stiff members as shown), in what panels are counters required?

*Discussion.* Under dead load there is no stress in any intermediate diagonal, and the horizontal component of lower chord stress is a constant. See Prob. 4:12; also check this as suggested in Prob. 4:18. Consequently the action of the tension diagonals in any panel depends entirely upon whether the live load comes on from the right or left. Consequently the answer is plain—counters are required in each of the four intermediate panels.

**Problem 4:24.** Truss  $F$  of Prob. 4:10 except that there are tension diagonals in the four intermediate panels. Determine the position of a concentrated load in panel 2-3 such that neither of the diagonals in that panel is stressed.

*Ans.*  $8\frac{1}{7}$  ft from  $U_3$ .

**Problem 4:25.** Truss  $F$  of Prob. 4:10 except that there are tension diagonals in the four intermediate panels. Draw the influence line for stress in bar  $U_2U_3$ .

*Discussion.* Draw a line assuming  $U_2L_3$  to act, which will be true for a load to the right of the critical point found in the previous problem. This gives a triangular line with peak ordinate of  $-5/3$  at panel point 3. Similarly, a line drawn assuming  $U_3L_2$  to be in action gives a peak ordinate at 2 of the same value. Theoretically the conditions are such that the unit load in its passage determines the action of the diagonals. On this basis the influence line is the composite formed by the bounding lines of the figure produced by drawing the two influence lines just described on the same base line. This results in a break in the line between panel point 2 and 3, which is contrary to what we have hitherto stated to be true. It is not an actual contradiction, however, for this composite line is actually drawn, in part, for one truss and, in part, for another. In such a case both lines should be drawn on the same base line and that one used which corresponds to the diagonal brought into action by the live loads.

**Problem 4:26.** This is the same in every way as Prob. 4:25 except that the intermediate diagonals carry compression only.

*Discussion.* The intersection of the two influence lines comes above the critical point with a common ordinate of  $-10/7$ .

**Problem 4:27.** Compute the design stresses for the highway truss of Ex. 4:8. Dead load, 3800 lb per ft of bridge; live load, H-20; impact, formula  $B$ , Art. 4:6.

**Problem 4:28.** Compute the design stresses for the bars of a single-track through Pratt truss of seven equal panels of 25 ft each and a depth of 30 ft center to center of chords. (A six-panel Pratt truss is shown in Fig. 4:2; in this case the center panel will have two sets of tension diagonals, as will all panels where counters are needed.) Use the same loading as for Prob. 4:16; dead load, 3000 lb per ft of bridge on lower chord; live load, 6000 lb per ft of track with a single axle load of 80,000 lb. Impact formula,  $I = S \frac{2000 - L}{1600 + 10L}$ . Arrange the work in tabular form and construct a stress sheet.

*Discussion.* The only difficulty in this problem arises in finding the live stress in the lower chord of the center panel, which has already been touched on in Ex. 4:7. This maximum will occur with the excess at mid-span and zero shear in the center panel, and will have a value a little less than the maximum for the top chord in the same panel, a stress that is obtained without complications. It is common to take the larger stress for the lower chord as well as the upper. The answer to the problem for these two bars is as follows:

Center Panel Chord	Upper	Lower
Dead stress	-187.5 kips	+187.5 kips
Live stress, uniform	-375.0	+375.0
excess	- 57.2	+ 50.0
Impact stress, 54.5 per cent	<u>-235.0</u>	<u>+231.5</u>
	-854.7 kips	+844.0 kips

### Art. 4:9 Concentrated Load Systems

**Problem 4:29.** Find the maximum shear in each panel of a 60-ft bridge with five equal panels due to a series of ten concentrated loads of 12,000 lb each, spaced 5 ft apart.

*Suggestion.* After you have drawn the three influence lines required, note their similarities. The whole series for a bridge of this sort may be obtained easily by drawing the influence lines for gross end reactions, that for the left reaction above the axis and that for the right, below, each end ordinate equaling unity. The influence line for any panel is obtained by connecting the ordinate for the upper line at the right end of the panel with that for the lower line at the left end. This line has the same slope in all the influence lines.

Note that if decrease equals increase in any comparison the two positions give the same shear. Check this in the case occurring for the end panel. Also, if a load goes off the span, the change equals load times slope times the distance moved on the span; the distance moved after leaving the span is obviously a matter of indifference.

It is not necessary usually to record the exact increase in shear caused by a load coming on the span during the shift from one wheel to the next at the peak of the influence line. Write the letter  $\delta$  in the inequality to indicate its presence, and if the decrease slightly exceeds the increase compute the exact value of the  $\delta$  term, as in this case its effect may be decisive; for example, in locating the loads for the center panel here

In computing the left reaction in this problem, with the loads placed, use the resultant of the loads on the bridge instead of the individual loads.

*Ans.* End panel 56.0 kips  
 Second panel 32.8 kips  
 Center panel 14.8 kips

**Problem 4:30.** Using a series of ten concentrated loads of 12 kips each, spaced 5 ft apart, find the maximum shear at the end and center and at sections situated respectively 10 ft and 20 ft from the end of a 60-ft deck girder. In a deck girder bridge the ties rest on the top flanges of the girders. Any distribution caused by the rails is neglected, and the wheel loads are considered concentrated loads applied directly to the girders.

*Discussion.* It is customary to take the left end and sections in the left half of the span in problems such as these, and thus deal with positive shear.

The series of influence lines here needed is constructed in the same manner as for the bridge with floor beams and stringers. The only difference is that the influence

line for any section is obtained by drawing through the section a vertical line connecting the two reaction lines referred to in the preceding problem. Note that the total height of this line is unity; the difference in shear at a section with the load first just to one side and then on the other equals the load itself.

As a load on the left of any section of a simple beam moves farther to the left, the negative shear which it causes at the section is decreased. If at the same time there are other loads on the right of the section which cause the total shear at the section to be positive, the movement of the load on the left farther to the left increases this positive shear. The student should verify this by an example.

Consider the problem presented by the locating of the load system for maximum shear at a section away from the end. Determine first the difference in shear at this section between that caused with the first load at the section and that occurring with the second load at the section. The first 12-kip load causes a decrease equal to itself as soon as it crosses the section, and as it moves 5 ft farther to the left it decreases that decrease by  $5 \times \frac{1}{80}$  of itself, the slope of the influence line being  $\frac{1}{80}$  per ft. Plainly this second term is an increase in the positive shear at the section. All the loads which are at the right of the section and move under the ascending line to the left cause an increase equal to their sum multiplied also by  $5 \times \frac{1}{80}$ . The decrease then is the magnitude of the load crossing the section; the increase is the total of the loads moving on the span multiplied by distance moved and by influence line slope. In each of these cases, and for these particular loads, the maximum occurs with the first wheel at the section. The decreases caused by moving up the second load in each of the above cases are, respectively, 3, 2, 3, and 5 kips. Check these values against the inequalities set up in solving this problem.

<i>Ans.</i>	End shear	75 kips
	Shear 10 ft from end	55 kips
	Shear 20 ft from end	36 kips
	Shear at center	21 kips

**Problem 4:31.** Compute the maximum live shear in each panel and the maximum live moment at each panel point for one girder of a 60-ft single-track half-through girder bridge of four equal panels with an E-60 loading or with its substitute, two axle loads of 75,000 lb each, spaced 7 ft apart.

*Discussion.* As soon as it is found that the maximum shear in the end panel with the first locomotive on the bridge occurs with wheel 3 at panel point 1, the diagram is shifted to bring the corresponding wheel of the second locomotive (12) to the same point. A brief calculation shows that slightly greater shear results from this position. **The maximum moment at the first panel point equals the maximum end shear (maximum net reaction) multiplied by the panel length.**

Similarly, although wheel 5 at panel point 2 is a position for maximum moment, still larger moment results when wheel 13 is at the point. Note that this is not the wheel corresponding to wheel 5.

<i>Ans.</i>	Shear end panel	100.5 kips
	second panel	48.8 kips
	Moment at 1	1508 kip-ft
	at 2	1941 kip-ft

**Problem 4:32.** Compute the maximum live shear at sections 10 ft apart, beginning at the support, in one girder of a single-track deck girder bridge of 60-ft span with an E-60 loading or two 75-kip axle loads, 7 ft apart.

<i>Ans.</i>	Shear: End	147.1 kips
	10 ft from end	108.5
	20 ft from end	72.4
	center	41.8

**Problem 4:33.** Compute the magnitude of the locomotive excess for the E-60 loading with panel lengths of 25 ft.

*Discussion.* This involves the calculation, first of all, of the maximum load brought to a floor beam by this loading. Draw the influence line and solve by the appropriate method. The difference between this floor-beam load and that caused by the uniform load of 6000 lb per ft of track is the excess. Compare with the excess used in Probs. 4:16 and 4:17.

*Ans.* 76.9 kips.

### Art. 4:10 The Moment Diagram

**Problem 4:34.** Substituting the E-60 loading (without the alternative axle loads) for uniform load and excess, carry through a solution of

- |                |                |
|----------------|----------------|
| a. Prob. 4:16. | d. Prob. 4:19. |
| b. Prob. 4:17. | e. Prob. 4:20. |
| c. Prob. 4:18. | f. Prob. 4:21. |

### Art. 4:11 Absolute Maximum Moment

**Problem 4:35.** Compute the maximum moment which occurs in a highway bridge stringer during the passage of a 20-ton motor truck, assuming that the stringer carries one-half the total weight. The truck axles are spaced 14 ft apart and the rear axle carries 0.8 of the weight. Span of stringer: (a) 26 ft; (b) 28 ft.

*Ans.* a. 104.0 kip-ft, with rear wheel at center of stringer.  
 b. 113.4 kip-ft, with both wheels on stringer.

**Problem 4:36.** Compute (a) the maximum moment at the center and (b) the absolute maximum moment due to an E-60 loading in one girder of a 40-ft single-track deck girder bridge.

*Note.* In order to show a two-figure difference, five-figure precision is necessary in the computation. Experience shows that the difference between maximum center moment and absolute maximum moment is negligible when using locomotive loads on spans of more than 30 ft.

*Ans.* a. 983.25 kip-ft.  
 b. 983.44 kip-ft.

### Art. 4:14 Trusses with Subdivided Panels

**Problem 4:37.** Draw influence lines for stress, or a stress component, of bars  $L_{10}M_{11}$ ,  $M_6L_9$ ,  $L_6M_7$ ,  $L_6L_7$  in the truss of Fig. 4:28.

**Problem 4:38.** Compute the maximum live stress in bars  $M_5L_6$ ,  $M_5U_6$ , and  $U_4U_6$  of the truss of Fig. 4:28 due to a live load of 3000 lb per ft per rail and a locomotive excess wheel load of 24,000 lb. This is a single-track bridge.

- a. By means of the influence lines.  
 b. By the method of panel loads.

*Ans.* a. Bar  $M_5L_6$ : 246 kips tension.  
 113 kips compression.  
 Bar  $M_5U_6$ : 80.6 kips tension.  
 Bar  $U_4U_6$ : 897 kips compression.  
 b. Bar  $M_5L_6$ : 250 kips tension.  
 117 kips compression.  
 Bar  $M_5U_6$ : 80.6 kips tension.  
 Bar  $U_4U_6$ : 897 kips compression.

**Problem 4:39.** Is a counter required in panel 7-8 of the bridge of Ex. 4-25 if there is no locomotive excess?

*Suggestion.* Make a sketch similar to the small free body at the bottom of Fig. 4:30. For this case the negative shear in the panel cannot be reversed, and its



minimum value is 9 kips. Consequently a vertical component of 36 kips downward must be supplied by a counter.

**Problem 4:40.** Verify the influence lines of Fig. 4:31.

**Problem 4:41.** What is the maximum total stress in vertical  $U_6L_6$ , bridge and loading of Ex. 4:25?

*Suggestion.* There are two cases to consider, with and without counter in action. The maximum stress without the counter acting comes with live loads at  $L_6$  and  $L_7$ , the excess at either. A reasonable value for  $L$  in the impact formula is 120 ft,  $L_4$  to  $L_8$ . When the counter acts, the first loading of Fig. 4:30 gives maximum positive shear on an inclined section, downward to the right, through the vertical. Remember the distribution of dead load.

<i>Ans.</i>		Counter Out	Counter Acting
	Dead	-120.0 kips	- 30 kips
	Live	-102.0 kips	-122.5 kips
	Impact	- 69.0 kips	- 69.9 kips
	Total	<u>-291.0 kips</u>	<u>-222.4 kips</u>

**Problem 4:42.** Verify the influence lines of Fig. 4:32.

**Problem 4:43.** Draw influence lines for stress (or component of stress) in the lettered bars of this truss.

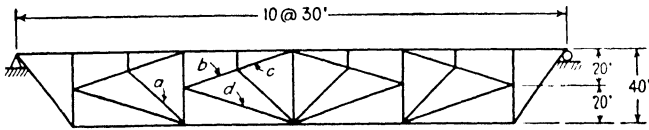

PROB. 4:43

**Problem 4:44.** Draw influence line for the stress (or a component of stress) in bar  $a$  of this truss.

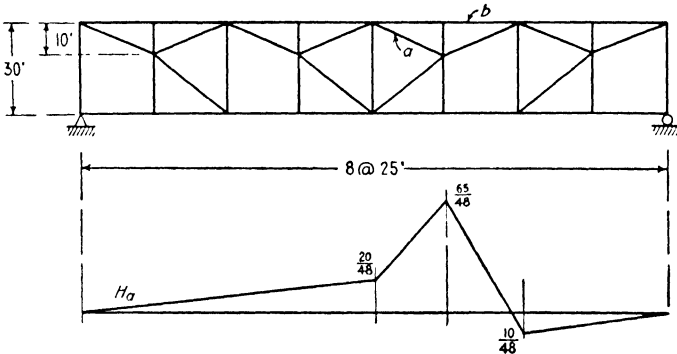

PROB. 4:44

*Suggestion.* Draw first the influence line for the stress in bar  $b$ , using a vertical section through that bar. This is also the influence line for the stress in the chord bar to the left of  $b$ , lying above  $a$ . Next draw an influence line for the combination of stress in chord  $b$  and horizontal component in bar  $a$ , using a vertical section through  $a$ . The desired line for  $a$  is the difference of these two lines. Shade in the area lying

between these two and compare with the result given. This is often an exceedingly useful method of attack.

**Problem 4:45.** What is the vertical component of stress in bar *a* of this truss due to the loads shown? *Ans.* +5.5 kips.

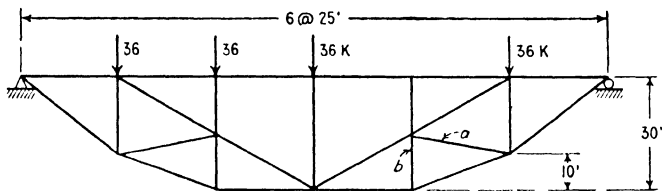

PROBS. 4:45, 4:46

**Problem 4:46.** Draw the influence line for the horizontal component of stress in bar *a*.

*Suggestion.* First draw the influence line for stress in bar *b*, or use equation  $\Sigma H = 0$  at joint  $L_5$ .

**Problem 4:47.** *a.* Find the stress in all bars of this truss due to a load of 18 kips at  $L_2$ , using the method of joints.

*b.* Draw influence lines for stress or stress component for the lettered bars.

*Suggestion.* Use the circular section shown and determine the distribution of shear between the two diagonals.

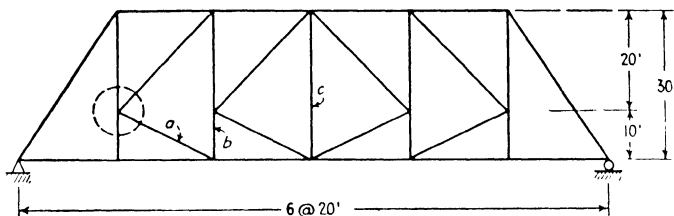

PROB. 4:47

**Problem 4:48.** Construct an influence line for the stress in bar *a* of this truss and by its use determine the maximum stress due to a live load of 2000 lb per ft on the top chord. *Ans.* +50 kips.

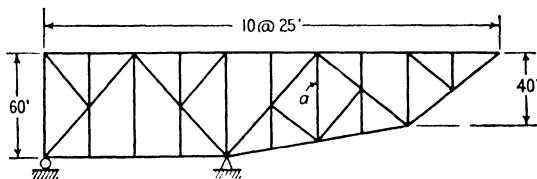

PROB. 4:48

**Problem 4:49.** Verify the influence lines shown for bar *a*.

**Problem 4:50.** Compute the stress for which bar *b* should be designed. Loads

on bottom chord: dead, 1000 lb per ft; live, 2000 lb per ft and 30,000 lb excess; impact 75 per cent. Ans. +155 kips.

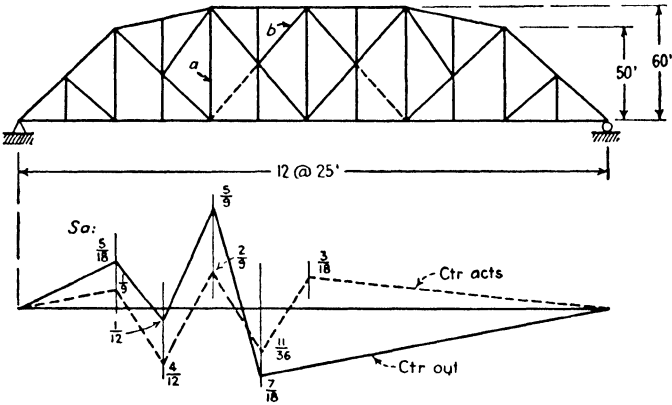

PROBS. 4:49, 4:50

Note. Take corresponding bar in other half of truss. Place live load  $L_7$  to  $L_{11}$ , excess at  $L_7$ . Counter is in action. Total panel load ( $D + L + I$ ) at  $L_7 = 165$  kips.

**Problem 4:51.** What is the maximum live stress in bar  $d$  of the truss of Fig. 4:32 due to Cooper E-60 loading? This is a double-track bridge.

Ans. -1815 kips with wheel 15 at  $L_4$ .

### LONG-SPAN BRIDGES

**5:1.** It is not economical to build simple truss bridges of greater span than about 700 ft. For longer spans the arch, the cantilever, and the suspension bridge are used. The suspension bridge is always a statically indeterminate structure and so does not fall within the scope of an introductory textbook. The essential features of the statically determinate arch and cantilever are treated in this chapter.

**5:2. The three-hinged arch.** The bridge trusses so far considered have parallel vertical reactions under vertical loading.<sup>1</sup> An arch under vertical loads develops converging reactions.

Steel arches are of two main types: the two-hinged arch supported on a pin at each abutment and the three-hinged arch which adds at the crown a third pin connecting the two parts of the frame. The two-hinged arch is statically indeterminate; the three-hinged arch is determinate, the intermediate hinge supplying the fourth equation, moment at hinge = 0 or  $M_H = 0$ , necessary for its solution. Note that no  $\Sigma$  appears in this equation.  $\Sigma M = 0$  (for the entire force system acting on the whole arch) holds for this hinge point and also for *every other point* in the plane of the arch. The hinge as constructed cannot resist any bending. Accordingly the moment of all the forces on *each* side of the hinge, about the hinge, must be zero so long as there is no motion.

Three-hinged steel arches are used for roofs of large buildings where floor space unobstructed by columns is desired and for both long- and short-span bridges.

An arch bridge is chosen in preference to a simply supported span when conditions at the site favor a structure of the arch shape and proportions and the foundation conditions are such that a heavy horizontal reaction component may be resisted.

<sup>1</sup> A more general statement which would include the structure of Fig. 1:25 would be: The rigid trusses (as rigid is defined in Art. 1:8) so far considered have reactions which are parallel to the applied loads when those loads act parallel to the reaction which is fixed in direction.

The longest three-hinged steel arch<sup>2</sup> in the United States is the highway bridge of 618-ft span built over the Colorado River in Arizona in 1928. Until 1932 the longest two-hinged arch was the railroad bridge over Hell Gate, New York, 977 ft 6 in. long (1917). Upon its completion in 1932 the two-hinged arch highway bridge over the Kill van Kull at Staten Island, New York, took first place with a span of 1675 ft.

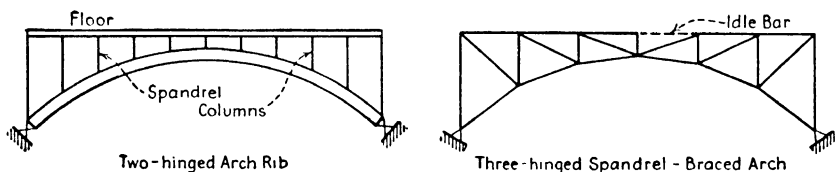

FIG. 5:1

The graphical analysis of a three-hinged arch for a roof has been dealt with in Chapter 3. By the aid of influence lines the maximum stresses in a bridge arch are found by the methods already made familiar.

Steel bridge arches, both two- and three-hinged, are of three sorts (Fig. 5:1): the ribbed arch of plate girder section, the spandrel braced arch consisting of two trusses with horizontal top chord, and the trussed arch with both chords curved.

**Reactions.** The first important principle to keep in mind in dealing with three-hinged arches is this: for any single load the line of action of the reaction on the unloaded segment passes through the intermediate hinge, since otherwise there would be a moment at the hinge, which is not possible. The line of action of the reaction on the loaded side passes through the intersection of the lines of action of the load and the other reaction, since the lines of action of three non-parallel forces acting on a rigid body in equilibrium meet at a point. The locus of all such load-reaction-line intersections is called the **position line** and is often used in arch analysis.

A single computation serves to give all the values needed to construct the influence lines for reaction components of an arch with three hinges. To illustrate this the general case of an arch with supports at different levels is taken (Fig. 5:2). A vertical load of unity is placed over the intermediate hinge where the lines of action of load and reac-

<sup>2</sup> A table of important American arch bridges appears in the Merriman-Wiggin *American Civil Engineers' Handbook* (John Wiley), 5th Edition, page 1269. See also an article "The World's Most Notable Bridges" by D. B. Steinman in the *Engineering News-Record*, December 9, 1948.

tions converge. The horizontal components ( $H$ ) of the two reactions are necessarily equal, and the left-hand vertical component equals  $\frac{2}{3}H$ , the right-hand vertical component,  $\frac{1}{3}H$ . The sum of these two verticals must equal unity, whence  $H = \frac{1}{1\frac{1}{3}}$ ,  $V_L = \frac{2}{3}$ , and  $V_R = \frac{1}{3}$ , for a unit load at  $U_2$  over the hinge. With the load at either end there is no hori-

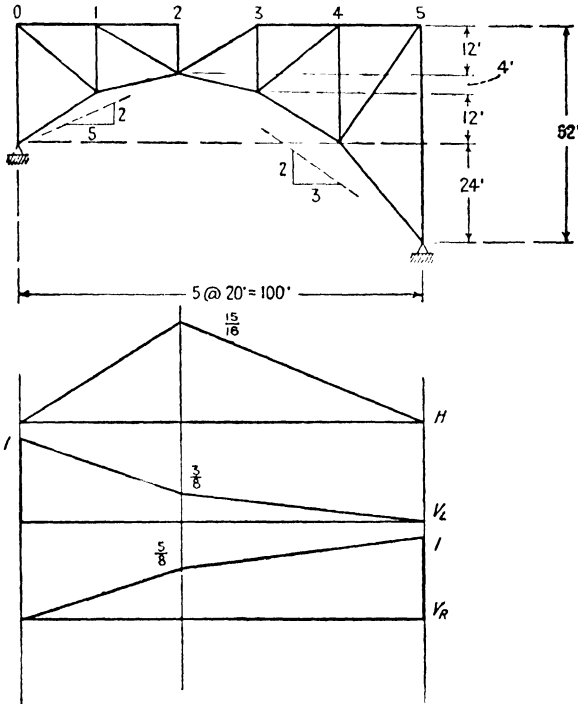

FIG. 5:2

zontal reaction component, and the vertical component under the load is unity. These several ordinates are connected by straight lines as shown, giving the complete influence lines. To prove that these connecting lines are straight, consider a load between 0 and 2: the right-hand reaction goes through the hinge. The equation for  $\Sigma M = 0$  about the left hinge is

$$\text{Load} \times \text{arm} + 24H - 100 \times \frac{2}{3}H = 0$$

This indicates straight-line variation for the left part of the influence line for  $H$ .  $V_R$  is a constant fraction of  $H$  while the load is on the left part of the arch, and so this portion of its line is straight. Proceeding thus, the correctness of the construction is proved.

When the two supports of a three-hinged arch are on the same level, the vertical components of reaction are the same as though the structure were a simple end-supported truss.

The computation of stresses in a three-hinged arch involves simply the application of the principles already made familiar. For example, consider bars  $a$ ,  $b$ , and  $c$  of the arch of Fig. 5:3 with a vertical load of unity at  $U_3$ . The reactions are read from influence lines previously constructed or are computed if the entire problem is limited to the single load and position. For bar  $a$  take a vertical section through the bar, free body to the left, and apply the condition  $\Sigma M = 0$  about the point of intersection of the two chord bars,  $100 \times \frac{5}{8} - 42 \times \frac{15}{8} - 60V_a = 0$ ; for bar  $b$ , vertical section, free body to the left,  $\Sigma M = 0$  about  $L_2$ ; bar  $c$ , vertical section, free body to the right, center of moments of  $U_7$ .

The arch of Fig. 5:3 has a parabolic lower chord which results in interesting stress conditions. For a uniform load over the whole structure the diagonals and the top chord carry no stress, and the horizontal component of lower chord stress is constant and equal to the horizontal component of reaction thrust.

**Example 5:1.** Draw influence lines for stress in bars  $a$ ,  $b$ , and  $c$  of the arch shown in Fig. 5:3.

*Note.* The values of the ordinates are here shown in common fractions to facilitate certain exact comparisons which follow. Also it is often convenient to work in common fractions where precision errors tend to be additive, expressing the results finally in the usual decimals.

*Discussion.* The general procedure has been indicated in the second paragraph preceding Ex. 5:1. For bar  $a$  draw a vertical section through the bar. So long as the load is to the right of  $U_3$  we may write, for the free body to the left,  $V_a = (100V_L - 42H)/60$ . Consideration of the three influence lines for reaction components at the bottom of Fig. 5:3 shows that this expression gives a straight line from 4 to 8, which is determined by the computation of the ordinate at 4. Similarly the ordinate at 2 gives the line from 0 to 2, leaving that at 3 for independent determination.

A much used method of computing influence lines is applied to bar  $a$  in Fig. 5:3b. The stress in any bar of this arch may be considered as consisting of two elements, that due to the vertical forces only and that due to the horizontal reaction thrust. Here the line  $afeb$  is the influence line for vertical component of bar  $a$ , considering that the arch acts as a simply supported beam, i.e., taking account only of the vertical forces. All the ordinates of this line represent tension in the bar. This line may be drawn in the way already outlined or by the construction indicated in the figure. Here the line  $acb$  is the influence line, considering only the left-hand vertical component of reaction, and it is valid for the bar from  $b$  to  $e$ , so long as the load is to the right of  $U_3$ ; similarly  $adb$  is the influence line, considering only the right-hand vertical component of

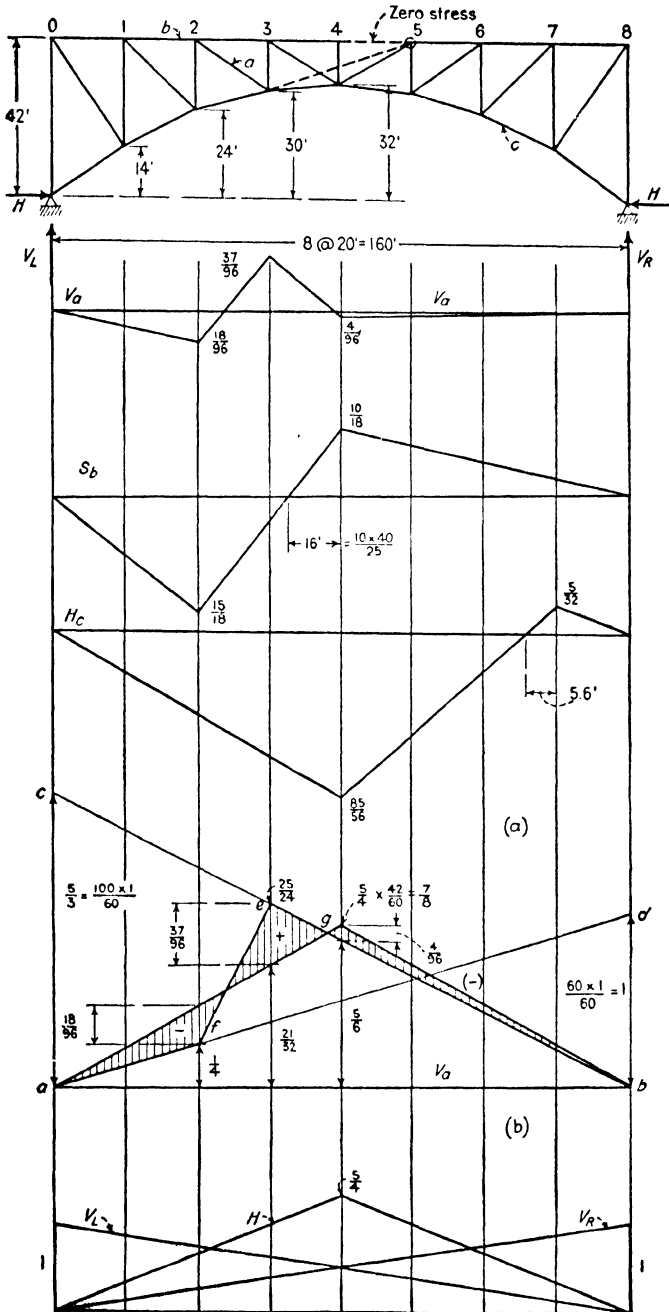

FIG. 5:3



reaction, which is valid so long as the load is to the left of  $U_2$ . The triangle  $agb$  is the influence line for bar  $a$ , considering only the horizontal component of reaction,  $H$ , and all the ordinates of this line represent compression in bar  $a$ . The actual influence line for the bar must be the combination of the two curves,  $afeb$  and  $agb$ , represented by the shaded area between them, the sign being determined by the greater ordinate of the two.

**Example 5:2.** What are the stress conditions at a transverse section through  $a$  of the parabolic plate girder three-hinged arch in Fig 5:4 due to the loads shown? The structure and loads are symmetrical about the center line.

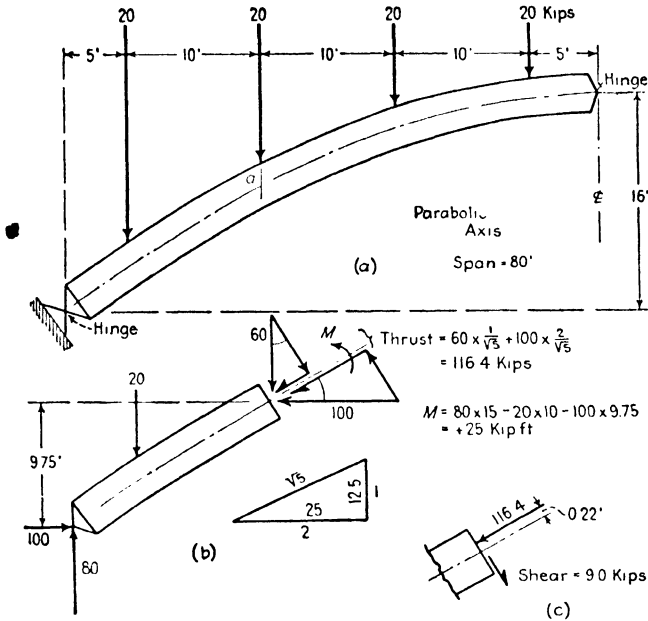

FIG. 5:4

*Discussion.* The free body used and the determination of the complete force system acting upon it require no explanation. It is not satisfactory, however, to leave the section through  $a$  with information simply as to the magnitude of the moment and of the horizontal and vertical components of inclined thrust acting upon it, since the unit stress conditions cannot be found from the total stresses in this form. The sketch of Fig. 5:4b shows how the normal thrust and transverse shear were found from the horizontal and vertical components of the actual thrust, which is inclined to the section. Figure 5:4c shows one of several possible ways of representing graphically the answer to the problem stated.

In dealing with parabolas it is convenient to remember that the tangent at any point when produced will cut the axis at a distance beyond the vertex equal to that from the vertex to the normal projection of the point of tangency on the axis. A small triangle in Fig. 5:4b shows how this fact was utilized.

A different arrangement of concentrated loads would have resulted in zero moment at the axis under each load, i.e., with equal loads, equally spaced, one of the loads acting at the center hinge. In the case considered in Fig. 5:4 note that the moment at load points due to vertical component of reaction combined with the vertical loads does not vary as a parabola.

**5:3. Cantilever bridges.** For long spans of 1000 ft and more two types of bridges are in competition, the suspension bridge (always an indeterminate structure) and the cantilever, i.e., a bridge with projecting arms. A typical arrangement, in the main features, is that of the Quebec bridge (completed 1917), the longest cantilever yet built (Fig. 5:5), with an open span of 1800 ft.<sup>3</sup> The main structure consists of two shore spans, each with an anchor arm and a projecting cantilever arm, and a suspended span which is essentially a simple bridge supported by the two cantilevers. A radically different arrangement is shown in Fig. 5:6, the Queensboro bridge, New York, where the suspended spans are omitted and the cantilever arms are joined directly by hangers (or rockers). Another well-known cantilever is that at Beaver, Pa., over the Ohio River (Fig. 5:7), with a maximum opening of 769 ft, a length only 49 ft greater than the longest simple span in the United States, the Pennsylvania truss over the same river at Metropolis, Ill. The range of span of these two types of bridges, and also that of the arch, overlap in the shorter lengths, the local situation, especially the practicality of using falsework, governing choice. Only the anchor spans of cantilever bridges require falsework for erection, the suspended span usually being built as ex-

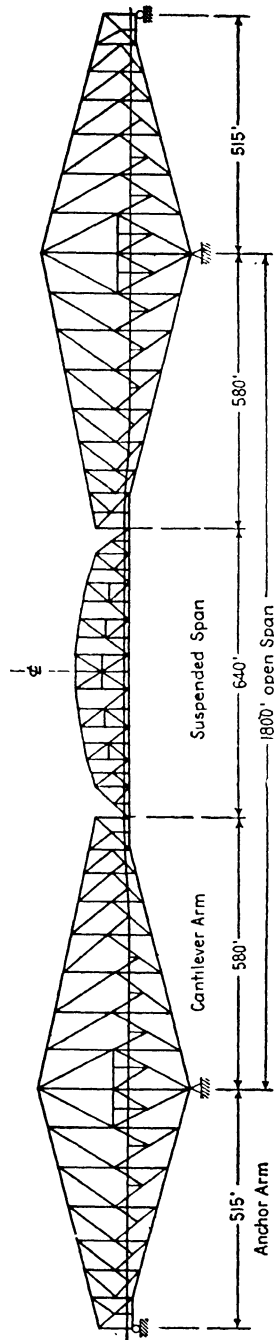

FIG. 5:5

<sup>3</sup> A list of the longest American cantilever bridges is given on page 1256 of Merriman-Wiggin, *American Civil Engineers' Handbook*, 5th Edition.

tensions to the cantilever arms by the use of temporary chord connections. In some of the longer bridges, notably the Quebec bridge and that at Carquinez Straits near San Francisco, the suspended span has been built on pontoons, floated to the site, and lifted into place.

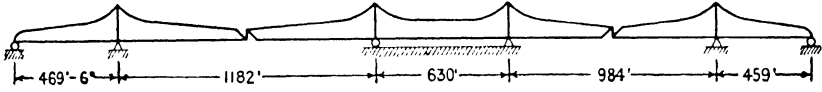

FIG. 5:6

The negative vertical reactions at the ends of the anchor arms are usually provided by long eyebars which engage pins on the trusses and are attached by pins to beams anchored deeply in the masonry of the pier or abutment.

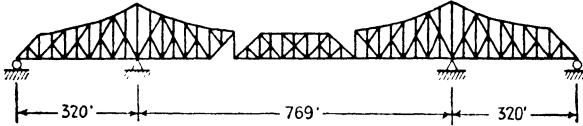

FIG. 5:7

**Reactions.** The reason for the development of the cantilever is made clear by the simple illustrations in Fig. 5:8, where first are shown three

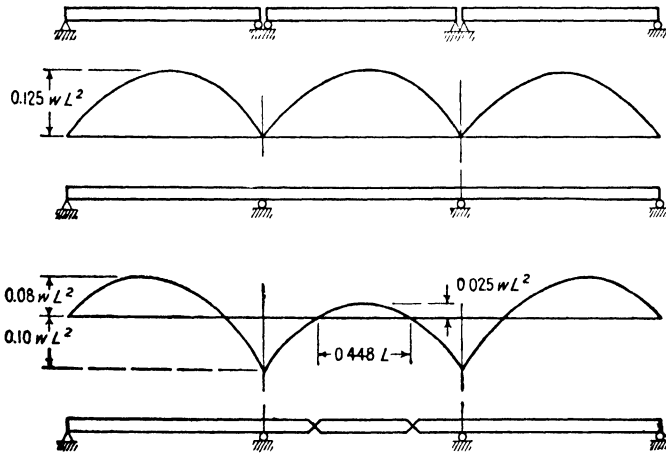

FIG. 5:8

simple spans with a bending moment of  $w l^2/8$  in each under a uniform load from end to end. Replacing these three beams with a single

continuous beam reduces the maximum moment for this loading by 20 per cent and also reduces the necessary width (parallel to the span length) of the supporting piers. Continuous construction is statically indeterminate and is open to objection, since small settlements of supports make relatively large changes in the stresses.<sup>4</sup> The advantages of continuity are retained, without this disadvantage, by inserting hinges at the inner points of inflection, the resulting cantilever having the same moment curve for this loading as the continuous beam. There is also the added advantage that the insertion of the two hinges makes the structure shown statically determinate as regards reactions, each hinge supplying an equation,  $M = 0$ .

However, it is not economical to carry the horizontal forces from braking and traction to a single support, and the arrangement shown in Fig. 5:7 is adopted, the hanger (or rocker) at the left end of the suspended span supplying besides  $M = 0$  the condition  $H = 0$ , meaning the sum of the horizontal forces on either side of the hanger must be zero. Contrast this equation with  $\Sigma H = 0$ , applied to the entire force system on the structure. Another manner of stating the condition is that the hanger does not transmit horizontal forces.

Another method of obtaining static determination with a truss is by the omission of diagonals as shown in Fig. 5:9. Here there can be no shear in panels 6-7, 19-20 without movement of the frame. Consequently the absence of diagonals in these panels gives the two equations  $S_{6-7} = 0$ ,  $S_{19-20} = 0$  (or  $M_6 = M_7$  and  $M_{19} = M_{20}$ ).

This same device is much used in draw spans. Often instead of no diagonals at all, very light bars are used which offer so little resistance to distortions that they are assumed to be non-existent.

Both the Queensboro bridge (Fig. 5:6) and the Quebec bridge (Fig. 5:5) are indeterminate. The latter would be identical in arrangement with the Beaver bridge (Fig. 5:7) were it not that a horizontal force acting on the suspended span develops horizontal reactions on both main piers.

The computation of reactions is illustrated in the following example.

**Example 5:3.** Draw influence lines for the vertical reactions at 6 and 7 of the bridge in Fig. 5:9.

<sup>4</sup> Continuous bridge construction is increasing in favor, since the gains in economy often more than offset any disadvantages. It is somewhat laborious to calculate indeterminate stresses but the results are just as certain and exact as though the structure were determinate. It is the practice to provide means of adjusting the level of supports where there is possibility of unequal settlement. See the discussion by Dr. D. B. Steinman in *Movable and Long-Span Steel Bridges*, Hool and Kinne (McGraw-Hill), Section 4.

*Solution.* Load at panel point 10. The solution is much simplified by first taking the suspended span as a free body. It is obvious that no reactions are developed acting on this free body except when it carries a load, and, consequently, only then does it bring load to either suspended span. It follows at once that each shore structure with its anchor and cantilever arms is entirely independent, carrying any load upon it without help from the other: a load on one does not affect the other.

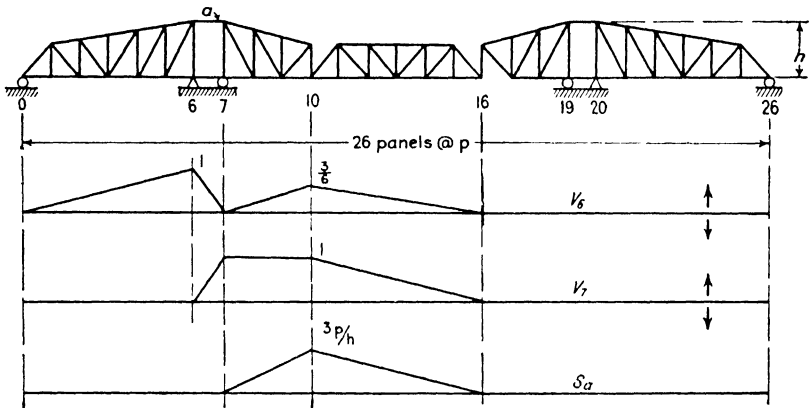

FIG. 5:9

For a load at point 10 there is no stress in the hanger at 16, and the shear in panel 19-20 being zero,  $V_{19}$  must be zero. Considering as a free body the right-hand shore structure, application of the conditions of equilibrium makes it plain that the reactions at points 20 and 26 are also zero. Considering the left shore structure,  $V_7 = 1 \uparrow$  ( $S_{6-7} = 0$ ); to balance the clockwise couple  $1 \times 3p$  there must be developed  $V_0 = \frac{1}{2} \downarrow$ ,  $V_6 = \frac{1}{2} \uparrow$ . The rest of the influence line may now be drawn very simply with no computations. The same applies to the second influence line, that for  $V_7$ .

**Example 5:4.** Draw influence line for the stress in bar  $a$  of the structure shown in Fig. 5:9.

*Solution.* The free body chosen was the cantilever arm supported by the reaction at 7 and the two horizontal bar stresses. In problems of this type remember that the load travels on a floor system and brings loads to the truss only at panel points.

**Example 5:5.** What are the reactions on the structure shown in Fig. 5:10 due to the load shown?

*Solution.* The equations available for use are (1)  $\Sigma M = 0$ , (2)  $\Sigma H = 0$ , (3)  $\Sigma V = 0$ , (4)  $M_6 = 0$ , (5)  $S_{3-4} = 0$ ; there are five unknowns and the structure is statically determinate. Probably the simplest procedure is to make use of these equations one by one and either evaluate any reaction element directly or express it in terms of another unknown, so that there results a free body with all the unknowns expressed in terms of one of them.

The 60-kip load is resolved into  $H$  and  $V$  components: since  $S_{3-4} = 0$ ,  $V_3 = 36 \uparrow$ . Calling the unknown horizontal component at  $L_8$ ,  $H$ ,  $V_8 = 2H$  since  $M_8 = 0$ ; also  $H_4 = 48 - H$  acting to the left, since  $\Sigma H = 0$ , and  $V_4 = 2H$  down since  $S_{3-4} = 0$ . This second use of this condition is equivalent to using  $\Sigma V = 0$ , and there remains only  $\Sigma M = 0$  for determining  $H$ . The most

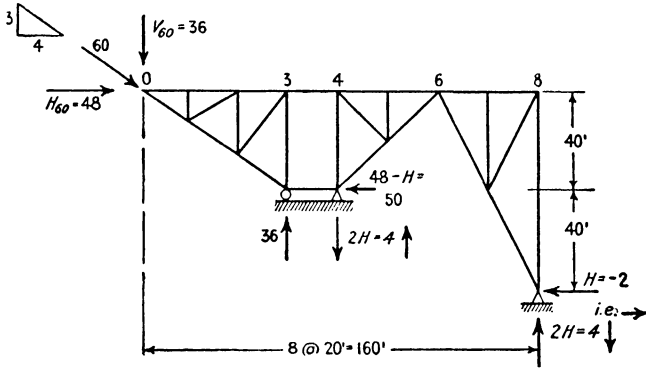

FIG. 5:10

convenient center of moments is at  $U_6$ , since it eliminates three terms of the moment equation, giving

$$-36 \times 60 - 2H \times 40 + (48 - H)40 = 0$$

whence  $H = -2$ , that is, acting in direction opposite to that assumed.

**5:4. The Wichert truss.** Although continuous structures are economical, they present one definite disadvantage: a relatively small settlement of a support may cause important redistribution of stresses. When erecting a continuous bridge it is often considered necessary to adjust the reactions to their design values by placing a support on test rings and jacks, which permit the reaction to be weighed as the height is adjusted. When the right value is gained, the shoe is set at the proper elevation and the load transferred to it. These disadvantages are not present with a statically determinate form of continuous structure known as the Wichert truss. Müller-Breslau discussed this bridge form as far back as 1887, but it remained unknown in this country until it was developed and patented by Mr. E. M. Wichert of Pittsburgh, Pa., in 1932.

A simple two-span Wichert truss is shown in Fig. 5:11. The distinguishing feature of the structure is the quadrilateral formed by the bars at the center support. There are eighteen joints in this structure, thirty-two bars and four unknown reaction elements, which makes the truss statically determinate. Since the left-hand support point is constrained to remain at constant level, there is no opportunity for the quadrilateral to flatten, for the proportions here shown. If the proportions of the center quadrilateral are changed, however, so that the supporting point  $f$  is placed at such a level that  $fe$  projected intersects

the horizontal through  $F$  at, or to the left of, the vertical through  $a$ , the reactions become infinite, indicating instability.

For the construction of the influence lines a unit load was placed on the lower chord level a distance  $x$  to the left of point  $F$ . Applying the equation  $\Sigma M = 0$  to the free body composed of the structure lying to the left of a vertical section just to the right of  $Ff$ , center of moments at  $F$ , gave this equation:  $90R_a + 30(R_f/2) - x = 0$ . A second equation involving the same reactions was obtained by taking moments about the right reaction point, considering the whole structure. The resulting expressions were:  $R_a = x/72 - \frac{1}{4}$ ,  $R_f = -x/60 + 1.5$ .

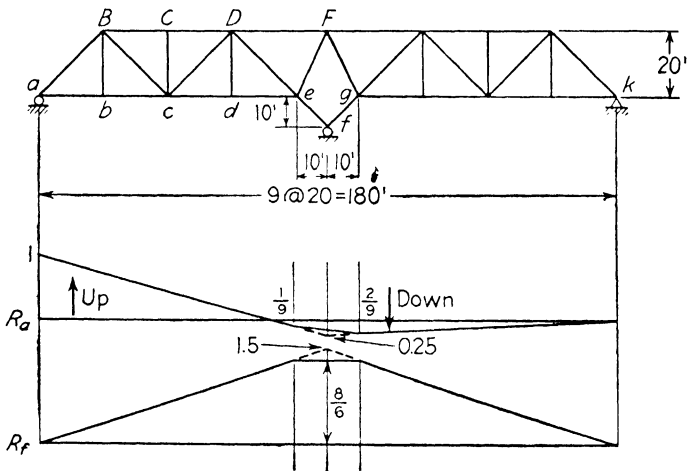

FIG. 5:11

This method of attack is cumbersome when a Wichert truss is of more than two spans, and special methods have been devised for its study. These methods are discussed fully, together with such matters as the proportioning of the structure for maximum economy, by Dr. D. B. Steinman, the New York bridge consultant, in his book, *The Wichert Truss* (D. Van Nostrand), 1932.

**5:5. Determinate and indeterminate structures.** The preceding articles of this chapter give methods for determining whether or not the structures here treated are determinate as regards outer forces. Since, however, these structures are not rigid, as that term is defined in Art. 1:8, they will not be composed of  $2n - 3$  bars,  $n$  being the number of joints. Since each joint represents a concurrent coplanar force system in equilibrium, as before,  $2n$  independent equations may be written. For a structure to be statically determinate as regards both outer and inner forces the combined number of reaction components,  $r$ , and bar stresses,  $b$ , must equal the number of equations. That is,  $b + r = 2n$ , or

$$b = 2n - r$$

and a structure that is both stable and statically determinate as regards *inner* forces will follow this rule.

The matter of statical determination as regards *outer* forces may be attacked more generally and in more elegant fashion mathematically with the aid of determinants. Being more general, this method is more powerful than the one

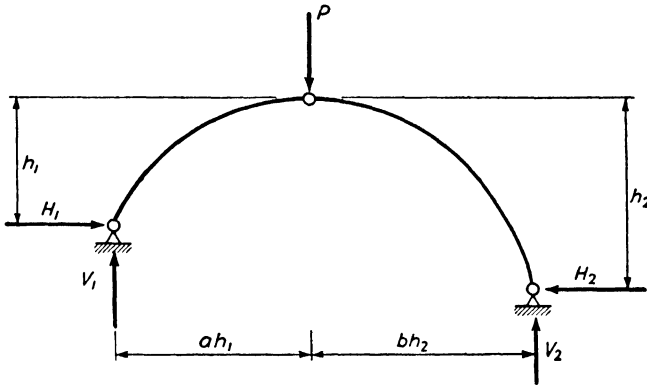

FIG. 5:12

previously presented. A simple illustration must suffice. Let it be desired to find the reactions in the structure of Fig. 5:12. The equations which will yield these are

$$\begin{aligned} V_1 + V_2 - P &= 0 \\ H_1 - H_2 &= 0 \\ V_1(ah_1 + bh_2) + H_1(h_2 - h_1) - P(bh_2) &= 0 \\ V_1(ah_1) - H_1(h_1) &= 0 \end{aligned}$$

If the solution of these is attempted with the aid of determinants, the determinant of the system,  $D$ , is found to equal  $-h_1h_2(a + b)$ , and the reactions may be computed if this determinant does not reduce to zero. However, the determinant will equal zero if  $h_1$  or  $h_2$  or  $a + b$  equals zero. In case  $h_2 = 0$ , it will be seen in the figure that both  $h_2$  and  $bh_2$  will equal zero. In other words, the right hinge and the center hinge will fall at the same point, and the structure is no longer a three-hinged arch. In case  $a + b = 0$ ,  $a = -b$ . But  $a$  and  $b$  are slopes, and the relation  $a = -b$  can obtain only if one of them is reversed in sense. But reversing one in sense and having them numerically equal will place all three hinges on a common straight line. In such a structure the reactions are infinite, or, expressed differently, the conditions are impossible.<sup>5</sup>

<sup>5</sup> This discussion of the use of determinants is based on Art. 5-9, pages 6-16, of *Theory of Statically Indeterminate Structures*, by W. M. Fife and J. W. Wilbur. In connection with the subject of statical determinateness see also a letter by A. T. Waidelich, *Civil Engineering*, September 1932, page 588.



The same manner of approach may be followed in attempting a solution of Prob. 1:16 or of the structures of Figs. 12:2 and 12:3. In the discussion accompanying the figures (as in the discussion of the three-hinged arch) it may be seen that not only must it be possible to write as many equations as there are unknowns but in addition the equations must be capable of solution, i.e., must be independent and consistent. Whether this is true may be learned, as in Art. 12:2, by attempting a solution, or, as in the preceding paragraph, by the aid of determinants. It is evident that the latter method may yield information which is not supplied by the former

PROBLEMS

Art. 5:2 The Three-Hinged Arch

**Problem 5:1.** Determine the stress in bar *a* of this structure due to the two loads shown.

**Problem 5:2.** Demonstrate that the influence lines of Fig. 5:3 verify the statement that for a uniform load over the whole structure the diagonals and top chord carry no stress; i.e., show for the influence line for *b*—also for *a*—that the positive and negative areas under the curve are equal.

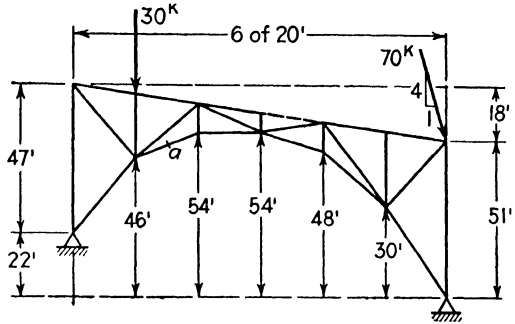

PROB. 5:1

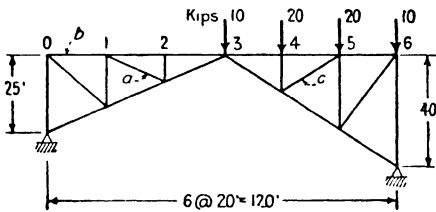

PROB. 5:4

**Problem 5:3.** Compute the stresses in bars *a*, *b*, and *c* of the arch of Fig. 5:3 due to a uniform load of 2000 lb per ft per truss on the floor system, extending from panel point 4 to panel point 8. Check results by the influence lines.

**Problem 5:4.** Compute the stresses in bars *a*, *b*, and *c* of the

three-hinged arch here shown due to the given loads. Draw influence lines for the three bars and use them to verify the stresses found.

*Suggestion.* For bar *a* take for a free body that lying between two vertical sections, one drawn through panel 1-2 and the other through 3-4. This will serve to call attention to the fact that in arches of this type and in cantilevers it is often possible to find a bar stress without computing the reactions. Also, this same statement may be made concerning any secondary member.

**Problem 5:5.** What are the stress conditions at a transverse section through *a* of the arch of Fig. 5:4 when the only loads on the span are the two to the left?

Ans. Normal thrust 17.9 kips  
 Moment +203.1 kip-ft  
 Shear, downward 7.8 kips

**Problem 5:6.** Find the stress in bar *a* of this structure due to a uniform load of 2 kips per ft acting down applied from *m* to *n*. Check result by means of an influence line.

Ans. Zero.

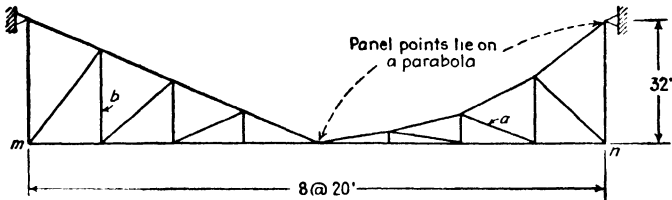

PROBS. 5:6, 5:7

**Problem 5:7.** Draw influence line for the stress in bar *b*.

Art. 5:3 Cantilever Bridges

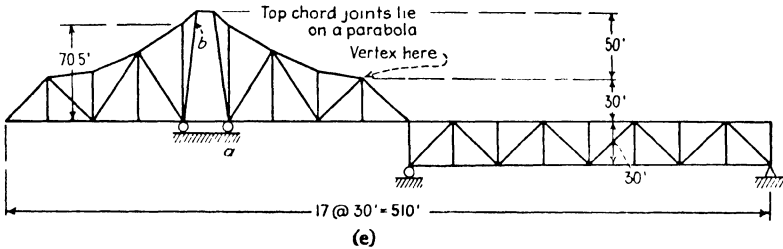
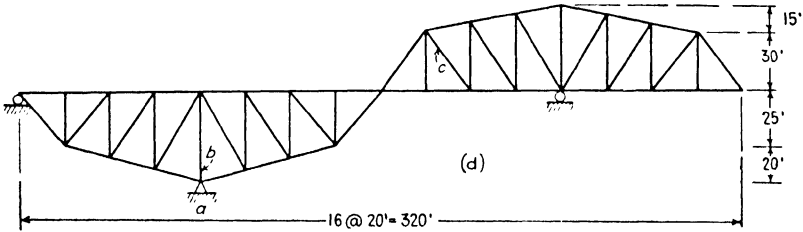
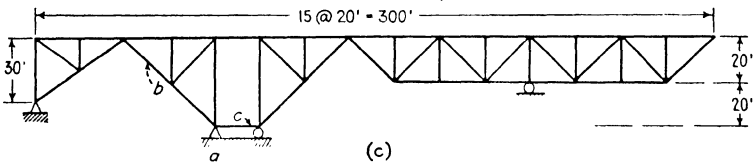
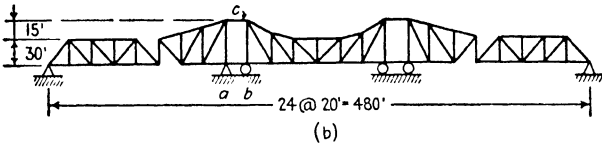
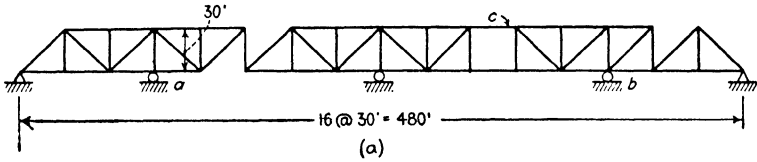

PROBS. 5:8, 5:9

**Problem 5:8.** Show that these structures are statically determinate as regards outer forces.

**Problem 5:9.** Draw influence lines for the lettered reaction components and for stress (or component of stress) in the lettered bars of these structures.

**Problem 5:10.** (Structure of Prob. 5:8c.) Determine the reactions and the stresses in bars *b* and *c* for a uniform load of 2000 lb per ft on the top chord extending from the right reaction to the right end of the bridge, a distance of 80 ft.

*Ans.* Bar *b* + 48.5 kips.  
*c* + 80.0 kips.

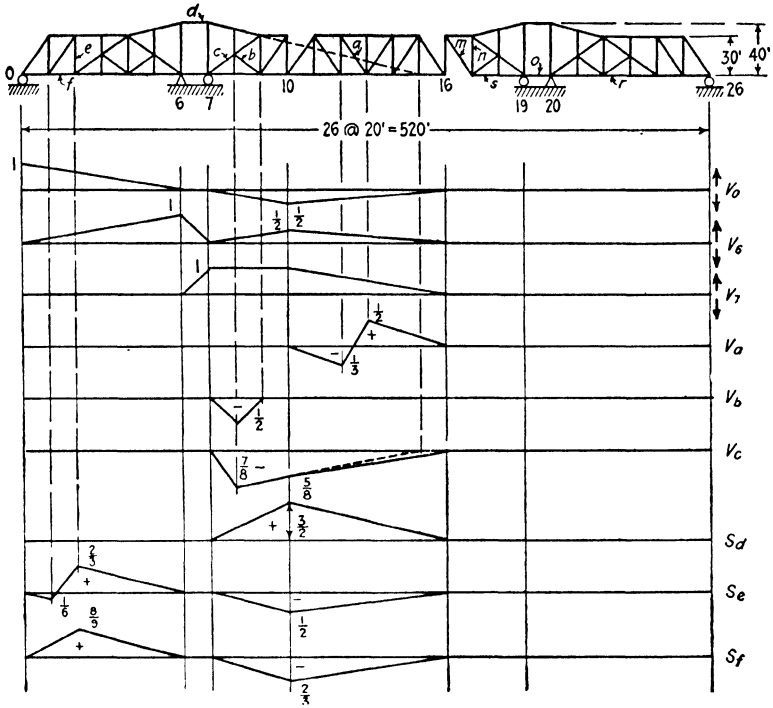

PROB. 5:11

**Problem 5:11.** *a.* Show that this cantilever bridge is statically determinate as regards outer forces.

*b.* Verify the influence lines shown.

*c.* Draw influence lines for stress (or stress component) of bars  $m$ ,  $n$ ,  $o$ ,  $r$ , and  $s$  of this structure.

LATERAL BRACING and PORTALS

6:1. Lateral trusses for bridges are indeterminate as usually built, and therefore in introduction to the study of them consideration will be given to certain forms of trusses, mostly obsolete, which will make clearer the problems involved in the structures of today.

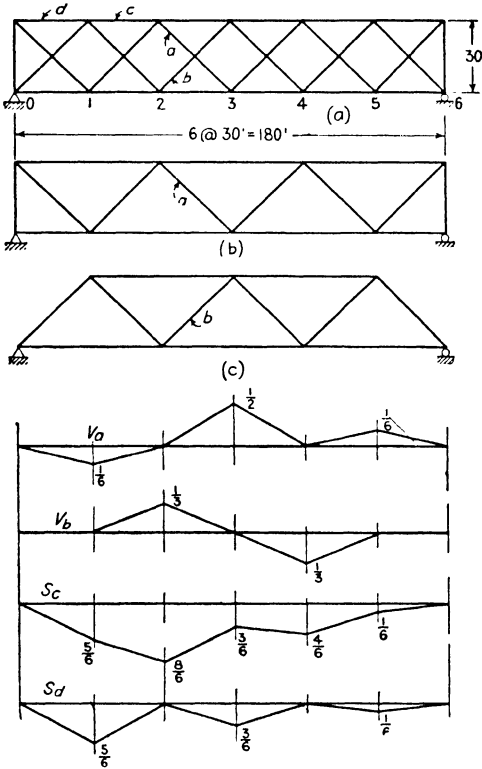

FIG. 6:1

The double system Warren truss shown in Fig. 6:1 is indeterminate, having one redundant bar. There are two sets of diagonals, each, with the chords, capable of forming a stable determinate truss (Fig. 6:1b, c), with no connection between the two systems which can carry shear except at the ends. An approximate stress analysis may be made by assuming that the stresses in the actual truss are those that would exist if it were made up of these two trusses, considered as entirely independent, each carrying alternate floor beams.

Many bridges have been designed on this assumption with satisfactory results, although the actual stresses

may vary considerably from those computed on this basis. The influence lines given explain this method of analysis, showing that a load at any panel point stresses only the diagonals in one system and that

the chord members for the most part belong to both systems. The computation for bar  $c$  is as follows:

Load at	Stress in $c$
$L_1$ (truss $b$ )	$\frac{5}{8} \times 30 \div 30 = -\frac{5}{8}$
$L_2$ (truss $c$ )	$\frac{4}{8} \times 60 \div 30 = -\frac{8}{8}$
$L_3$ (truss $b$ )	$\frac{3}{8} \times 30 \div 30 = -\frac{3}{8}$
$L_4$ (truss $c$ )	$\frac{2}{8} \times 60 \div 30 = -\frac{4}{8}$
$L_5$ (truss $b$ )	$\frac{1}{8} \times 30 \div 30 = -\frac{1}{8}$

The same method of analysis by division into independent web systems has been followed for the Whipple and the lattice truss (see figure for Prob. 1:16) but with far less accuracy, since here the webs are connected at the hip joints. Consequently a load at any panel point stresses not only the system directly supporting it but also the other system, through the reaction brought to the hip joint. It is customary to neglect this effect except for a load at the hip vertical, which is assumed to be divided equally among the systems there meeting. In the lattice truss shown in Prob. 1:16 this would mean a three-fold division of the load at the first panel point.

**6:2. Lateral trusses.** The top and bottom lateral systems of modern through and deck railway bridges are made as double system Warren trusses with connecting struts at every panel point. The diagonals are made of structural angles and are proportioned to carry both tension and compression. The struts serve to equalize the loads at opposite panel points, and a reasonable assumption, therefore, is that the shear in any panel is divided equally between the two diagonals. Where the slenderness ratio of the lateral diagonals exceeds the limit usually specified for modern bridges ( $l/r = 120$ ), it is necessary to assume that only one diagonal acts at a time, carrying the shear in tension. Modern highway bridges use the same type of lateral bracing but with slenderer diagonals ( $l/r = 140$ ), assumed to carry tension only. In older bridges, especially those carrying highways, steel rods, usually adjustable, have been used for the diagonals.

In deck bridges with parallel chords the lower lateral system carries its load directly to the shoes at the abutments; the upper lateral truss is supported by cross-frames between the main trusses in the plane of the end verticals. These cross-frames carry the upper lateral loads to the abutments. The upper lateral system of a through bridge is supported by the rigid frame formed by the end posts and the portal bracing, a cross-frame with diagonals being obviously out of the question.

The web members of a lateral truss of the type here discussed are stressed by the vertical load through the deformation of the chords,

a phenomenon which does not occur (except as purely one of secondary stress) when only one diagonal is used in a panel or when the transverse connecting struts are omitted.

**Example 6:1.** Compute the maximum stresses in the top and bottom lateral systems of the Pratt truss shown in Fig. 6:2. The wind load equals a moving load of 30 lb per sq ft on  $1\frac{1}{2}$  times the vertical projection of the structure, but not less than 200 lb per ft on the loaded and 150 lb per ft on the unloaded

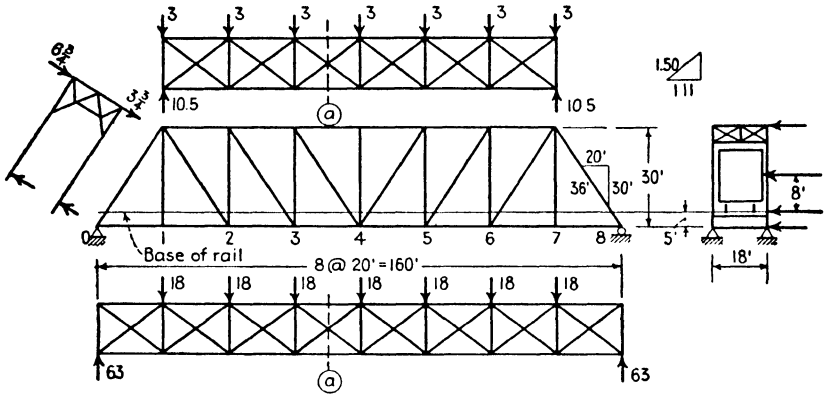

FIG. 6:2

chord, plus a moving load of 300 lb per ft applied 8 ft above the base of rail. The sway of the train is provided for by a load of 400 lb per ft applied at the base of rail. The top chord and end post sections are 18 in. deep; all other members 12 in. wide; stringers 33 in. deep.

*Loads:*

$$\begin{aligned} \text{Top chord: Tributary area: } & 1.5(120 + 2 \times \frac{1}{2} \times 36) = 234 \text{ sq ft} \\ & 1 \times \frac{1}{2}(7 \times 30 + 6 \times 36) = \underline{213} \end{aligned}$$

$$\begin{aligned} \text{Total wind load on upper chord} & = 447 \times 1\frac{1}{2} \times 30 \\ & = 20,100 \text{ lb} \end{aligned}$$

$$\text{Panel load} = 20,100 \div 7 = 2900 \quad \text{or} \quad 20 \times 150 = \underline{3,000} \text{ lb}$$

$$\begin{aligned} \text{Bottom chord: Area: } & 1.5 \times 2 \times \frac{1}{2} \times 36 = 54 \text{ sq ft} \\ \text{Web members as above} & 213 \\ & 2.75 \times 160 \quad \underline{440} \end{aligned}$$

$$\text{Total wind load on lower chord} \quad 707 \times 1\frac{1}{2} \times 30 = 31,800 \text{ lb}$$

$$\begin{aligned} \text{Panel load} & = 31,800 \div 8 = 4000 \quad \text{or} \quad 20 \times 200 = 4,000 \\ \text{Wind on train + Sway effect: } & 20(300 + 400) = 14,000 \end{aligned} \quad \left. \begin{array}{l} \\ \\ \end{array} \right\} \text{lb}$$

$$\text{Total panel load} \quad = \underline{18,000} \text{ lb}$$

*Stresses in diagonals: Top laterals: Moving loads*

kip

$$\text{Panel 1-2 Max. shear} = \frac{1+2+3+4+5}{6} \times 3 = 7.5 \quad \text{Stress} = \frac{1}{2} \times 7.5 \times \frac{1.5}{1} = \pm 5.6$$

$$2-3 \quad \text{“} \quad \text{“} = \frac{1+2+3+4}{6} \times 3 = 5 \quad \text{“} = \frac{1}{2} \times 5 \times \frac{1.5}{1} = \pm 3.8$$

$$3-4 \quad \text{“} \quad \text{“} = \frac{1+2+3}{6} \times 3 = 3 \quad \text{“} = \frac{1}{2} \times 3 \times \frac{1.5}{1} = \pm 2.3$$

*Bottom laterals:*

$$\text{Panel 0-1 Max. shear} = 18 \times \frac{2.8}{8} = 63.0 \quad \text{Stress} = 63 \times 0.75 = \pm 47.3 \text{ kips}$$

$$1-2 \quad \text{“} \quad \text{“} = 18 \times \frac{2.1}{8} = 47.3 \quad \text{“} = 47.3 \times 0.75 = \pm 35.5 \text{ kips}$$

$$2-3 \quad \text{“} \quad \text{“} = 18 \times \frac{1.5}{8} = 33.8 \quad \text{“} = 33.8 \times 0.75 = \pm 25.4 \text{ kips}$$

$$3-4 \quad \text{“} \quad \text{“} = 18 \times \frac{1.0}{8} = 22.5 \quad \text{“} = 22.5 \times 0.75 = \pm 16.9 \text{ kips}$$

*Stresses in struts:*

$$\text{Top lateral truss: Max. stress} = \frac{1}{2} \times 3 = -1.5 \text{ kips}$$

$$\text{Bottom lateral truss: Max. stress} = \frac{1}{2} \times 18 = -9.0 \text{ kips (taken by floor beam)}$$

*Stresses in chords at center: (Sections a)*

$$\text{Top lateral truss: } S = \frac{7.5 \times 50 - 3(10 + 30)}{18} = \pm 14.2 \text{ kips}$$

$$\text{Bottom lateral truss: } S = \frac{63 \times 70 - 18(10 + 30 + 50)}{18} = \pm 155 \text{ kips}$$

*Discussion.* As these computations relate to the lateral bracing, no attention is paid to the overturning effect of the several loads.

The loads shown on the sketch are those giving maximum shear in the end panels of the two lateral trusses. Because of the gusty wind pressure on the truss, the entire load is considered as moving, which explains why the maximum shear was computed in each case when determining the stress in the diagonals. Note that the ratio of length of diagonal to truss spacing is 1.5 : 1 and that each diagonal carries one-half the shear in the panel.

Study of any joint on the leeward truss will prove the truth of the statement that the strut serves to transmit half the panel load to that truss.

The computations are incomplete in that only the chord stresses at the center were found. This stress equals the moment at section *a* divided by the truss depth. These chord stresses are combined with those produced by the vertical loads. In estimating the adequacy of the sectional area of the chord under the total load an increased working stress is allowed.

**6.3. Lateral stresses in curved chord bridges.** In curved chord bridges adjacent panels of lateral systems do not lie in the same plane, and, therefore, vertical forces are produced by lateral loads at their connections with the trusses. In some large bridges, particularly long-span arches, these vertical forces are of considerable magnitude. The method of analysis used in the above example is also followed for the lateral truss connecting curved chords, the panel loads being equal and



the panel lengths (the lengths of the several chord bars) unequal. This amounts to straightening the curved lateral truss out and placing it in a plane. The results are correct for the diagonals of the lateral truss

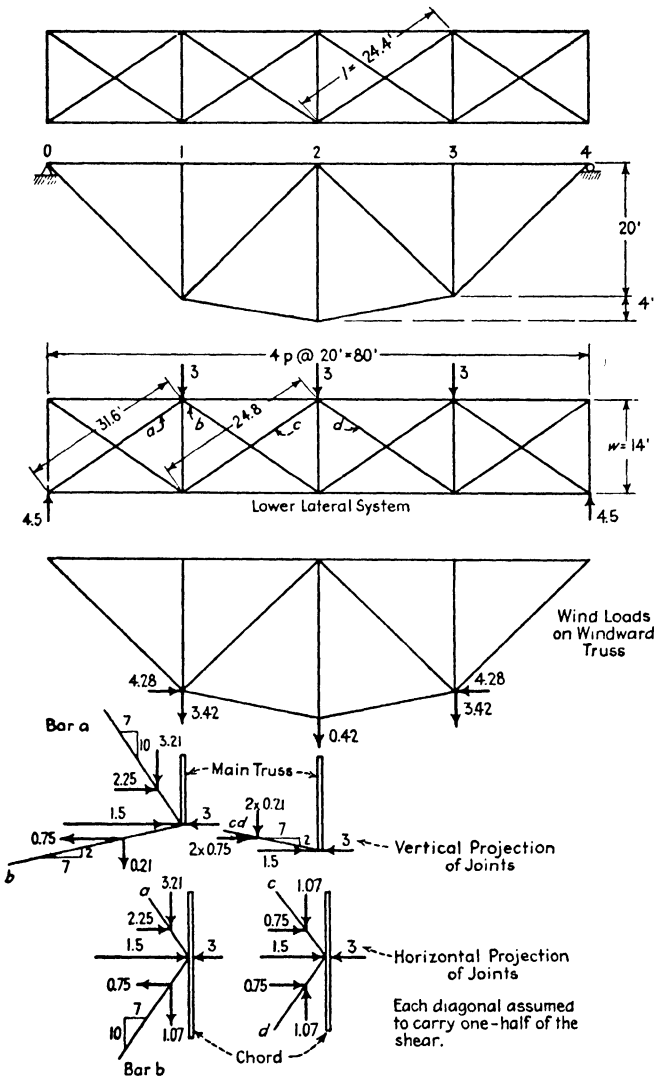

FIG. 6:3

but not for the chords. There are also other stresses that are not taken account of, but the approximation is sufficiently close for all practical purposes.

**Example 6:2.** What loads are brought upon the main windward truss by the wind load of 150 lb per ft extending over the whole span on the unloaded chord of the bridge of Fig. 6:3?

*Discussion.* Each diagonal was assumed to take half of the shear; with the slopes of all the bars known the solution follows directly by the method of joints. The bar stresses caused by these loads are found in the usual manner.

The proportions of this structure are not those of practice but were chosen for simplicity and clarity.

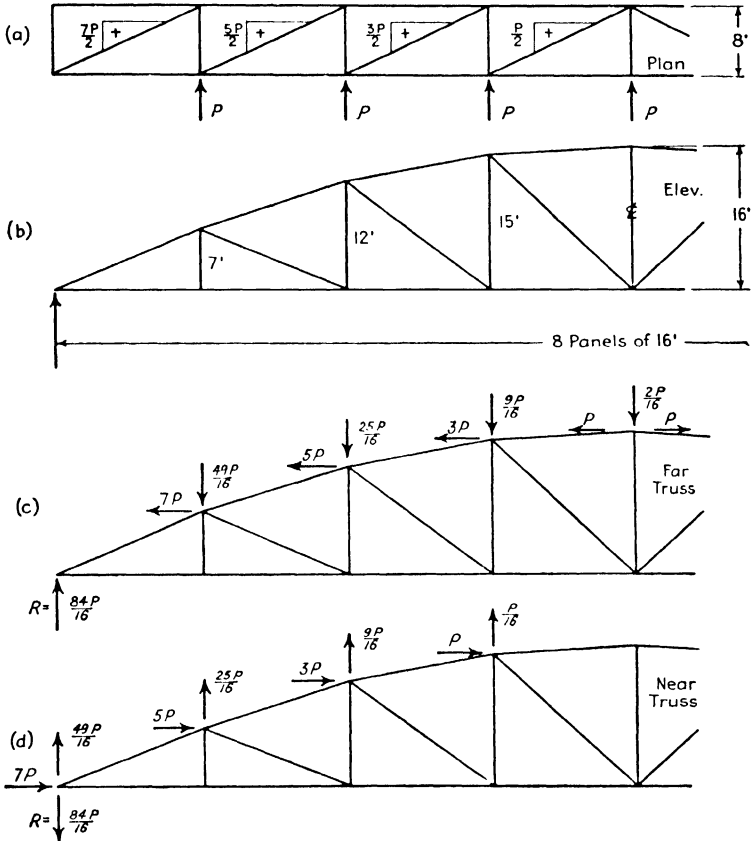

FIG. 6:4

**Example 6:3.** Determine the loads in the planes of the main trusses due to a lateral load of  $P$  at each top chord panel point of one truss of the structure of Fig. 6:4.

*Solution.* It is assumed that the top lateral system is a tension system and that, therefore, the other system of diagonals is not stressed by these loads. The loads will cause in the top lateral diagonals transverse components of the magnitude shown in Fig. 6:4a. For example, in the diagonal of the second

panel the transverse component is  $5P/2$ . The transverse projection of this diagonal is 8 ft. Its projection along the truss is 16 ft, and in a vertical direction 5 ft. Consequently, it has a component along the truss of  $\frac{16}{8} \times \frac{5P}{2} = 5P$ , and vertically of  $\frac{5}{8} \times \frac{5P}{2} = \frac{25P}{16}$ . In like manner the components of the other

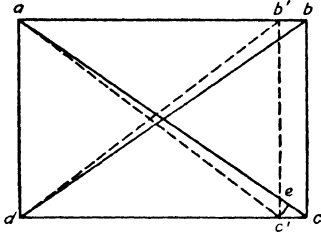

FIG. 6:5

lateral stresses may be found. These bring to the main truss panel points the loads shown in Figs. 6:4c, d.

**Example 6:1.** Compute approximately the stress in the diagonals of the top lateral truss of the structure shown in Fig. 6:3 caused by the shortening of the top chord under vertical load equivalent to a unit stress of 12,000 lb per sq in. Assume that the distance between trusses remains unchanged.

*Solution.* Under stress a panel takes the shape shown by the dotted lines in Fig. 6:5, assuming that the verticals (floor beams) prevent any sidewise expansion. We may write

$$30,000,000 = \frac{12,000}{cc'/20} \quad \text{and} \quad cc' = 0.0080 \text{ ft}$$

Triangles  $adc$  and  $c'ec$  are similar. Therefore

$$ce = 0.0080 \times \frac{20}{24.4} = 0.0066 \text{ ft}$$

Accordingly the stress in the diagonal is

$$30,000,000 \times \frac{0.0066}{24.4} = 8100 \text{ lb per sq in.}$$

The factor of safety is usually relied upon for covering this effect. Chord stresses are computed, as in the previous chapters, on the assumption that the main trusses only are stressed by the vertical loads. Actually, as illustrated by this example, the whole structure acts as a unit in space, and the arbitrary division into a series of planar trusses is not exact. Actually the chord stresses are less than computed owing to the distortions of the lateral systems and of the floor system caused by those loads and their consequent assistance in carrying stress. It must be remembered that the figures given are unit stresses. Because of the large differences in areas between chord members and laterals the change in the total stress in the chords will be small.

**6:4. Portals and bents.** The portal of a through bridge consists of the two end posts connected by bracing at the top and serves to support the horizontal load of the top lateral system, carrying the reactions to the abutments. Such a frame is statically indeterminate to the third degree, and magnitude, direction, and point of application of both sup-

porting forces are unknown. This is the same as saying that the unknowns acting at the foot of each post are  $V$ ,  $H$ , and  $M$  as shown in Fig. 6:6*a*, *b*. The actual situation is somewhat more complicated, since a steel end post consists of two side plates, connected by cover plates, resting on a pin. The distribution of the vertical component between the two plates is unequal (*c*), which is equivalent to the situation shown in *a*.

A solution of sufficient accuracy can be made by these assumptions: that each leg carries half the shear ( $H_L = H_R$ ) and that the positions of the points of contraflexure in the posts are known ( $M_1 = 0$ ,  $M_2 = 0$ ). The first assumption is closely in accord with the truth, as shown by more exact analysis, using methods described in a later chapter. The dead weight is relatively so large that the lower ends of the posts are more or less completely fixed, i.e., the tangents to their axes remain entirely or nearly vertical under the lateral loading. It is usual to guess that this results in the point of contraflexure being located from one-third to one-half of the distance from the shoe to the bracing. These three assumptions together with the three equations from statics make it possible to find the six unknowns.

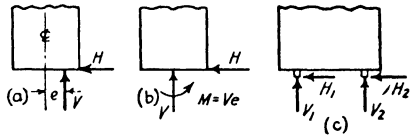

FIG. 6:6

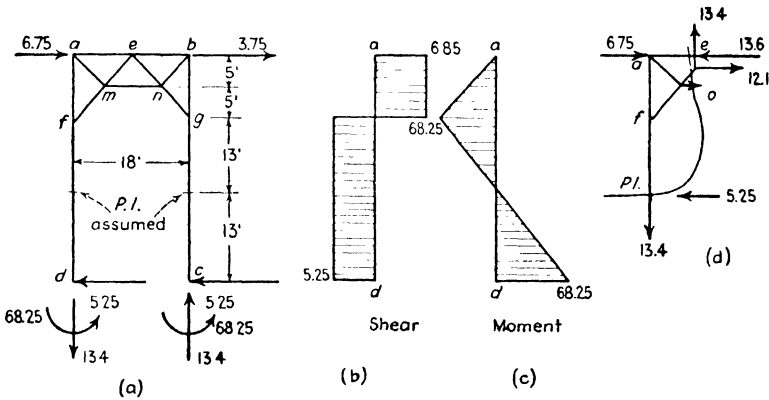

FIG. 6:7

**Example 6:5.** Draw the curves of shear and moment for the windward end posts and find the stresses in the bracing of the portal of Fig. 6:2.

*Solution.* Reactions: The points of contraflexure were assumed halfway between shoe and bracing, and the shear was divided equally between the two posts, 5.25 kips to each, as shown in Fig. 6:7. Since the moment at a point of contraflexure of all the forces below is zero, the moment acting at a column

base must equal  $5.25 \times 13 = 68.25$  kip-ft in a counterclockwise direction. Taking the frame above the points of contraflexure as a free body gives  $(10.5 \times 23)/18 = 13.4$  for the direct stress in each post. This is simpler than applying the equation  $\Sigma M = 0$  to the whole portal.

*Bar stresses.* To find the stress in  $mn$  take the section and free body shown, Fig. 6:7d, applying the equation  $\Sigma M_e = 0$ ;

$$-5S_{mn} - 9 \times 13.4 + 23 \times 5.25 = 0$$

$$S_{mn} = 0$$

Therefore the bars  $am$  and  $nb$  are also unstressed. The vertical components of bars  $fme$  and  $eng$  equal 13.4 kips ( $\Sigma V = 0$ ), the first in tension, the second in compression. The horizontal components equal  $13.4 \times \frac{9}{10} = 12.1$  kips. The stress in  $ae$  equals 13.6 kips, compression ( $\Sigma H = 0$ ); in  $eb$ , 10.6 kips, tension.

If the attempt is made to check the stresses in the top horizontal bars by use of the equations  $\Sigma H = 0$  at the ends, it must be remembered that the shears in the columns will enter into the equations.

The curves of shear and moment can be easily verified by making a free body sketch of the post.

Note that all the bars of the portal bracing between the end posts are treated as truss members, pin connected at the ends, although the connections in reality are by rivets. These members, with comparatively large slenderness ratios, are so much lighter than the end posts that this is a reasonable approximation. The heavy end posts are continuous from end to end and carry shear and moment as well as direct stress. The stability of the frame depends entirely upon this continuity.

The analysis of a mill building bent is similar to that of a bridge portal. This is illustrated in Ex. 6:6 for the vertical and lateral loadings due to dead weight, to snow and ice, and to wind.

**Example 6:6.** Determine the design stresses for the bars of the roof truss shown in Fig. 6:8. This is the same problem as that presented by the truss of Ex. 3:1, except that this truss is supported on steel columns, the combination of truss, knee braces, and columns forming a typical mill building bent.

*Solution.*

Mill Building Bent:

Maximum stresses in Fink truss and knee braces

Dead load: 20 lb per sq ft of roof  
 Snow " 25 " " "  
 Ice " 10 " " "  
 Wind " 22.4 " " "  
 " " 30 " " on vertical surface

Combinations:

- a. Dead + Snow
  - b. Dead + Ice + Wind right or left
  - c. Dead + Wind right or left
- Alternate loading: 45 lb per sq ft to cover all combinations

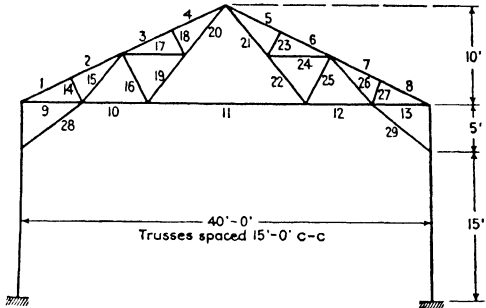

Bar	Dead	Snow	Ice	Wind		Maximum	Minimum	Alternate Loading
				Left	Right			
1	-13,200	-16,400	- 6,600	- 8,800	+19,800	-29,600	+ 6,600	-29,600
2	-12,400	-15,500	- 6,200	- 8,800	+19,800	-27,900	+ 7,400	-27,900
3	-11,600	-14,500	- 5,800	- 5,900	+ 4,800	-26,100	- 6,800	-26,100
4	-10,900	-13,600	- 5,400	- 5,900	+ 4,800	-24,500	- 6,100	-24,500
9	+11,800	+14,700	+ 5,900	+ 1,900	- 6,500	+26,500	+ 5,300	+26,500
10	+10,100	+12,600	+ 5,000	+ 1,100	-13,300	+22,700	- 3,200	+22,700
11	+ 6,700	+ 8,400	+ 3,400	- 4,800	- 4,800	+15,100	+ 1,900	+15,100
14	- 1,500	- 1,900	- 750	- 1,900	0	- 4,150	- 1,500	- 3,400
15	+ 1,700	+ 2,100	+ 840	+ 5,500	-16,800	+ 8,000	-15,100	+ 3,800
16	- 3,000	- 3,800	- 1,500	- 5,300	+ 7,500	- 9,800	+ 4,500	- 6,800
17	+ 1,700	+ 2,100	+ 840	+ 2,100	0	+ 4,640	+ 1,700	+ 3,800
18	- 1,500	- 1,900	- 750	- 1,900	0	- 4,150	- 1,500	- 3,400
19	+ 3,400	+ 4,200	+ 1,700	+ 5,900	- 8,400	+11,000	- 5,000	+ 7,600
20	+ 5,000	+ 6,300	+ 2,500	+ 8,000	- 8,400	+15,500	- 3,100	+11,300
28	0	0	0	+ 4,300	-21,600	-21,600	+ 4,300	0

*Note.* The wind pressure here used is greater than is usual for ordinary exposure: 15 lb per sq ft on vertical surfaces and 20 lb per sq ft on sloping surfaces, reduced for slope, are customary.

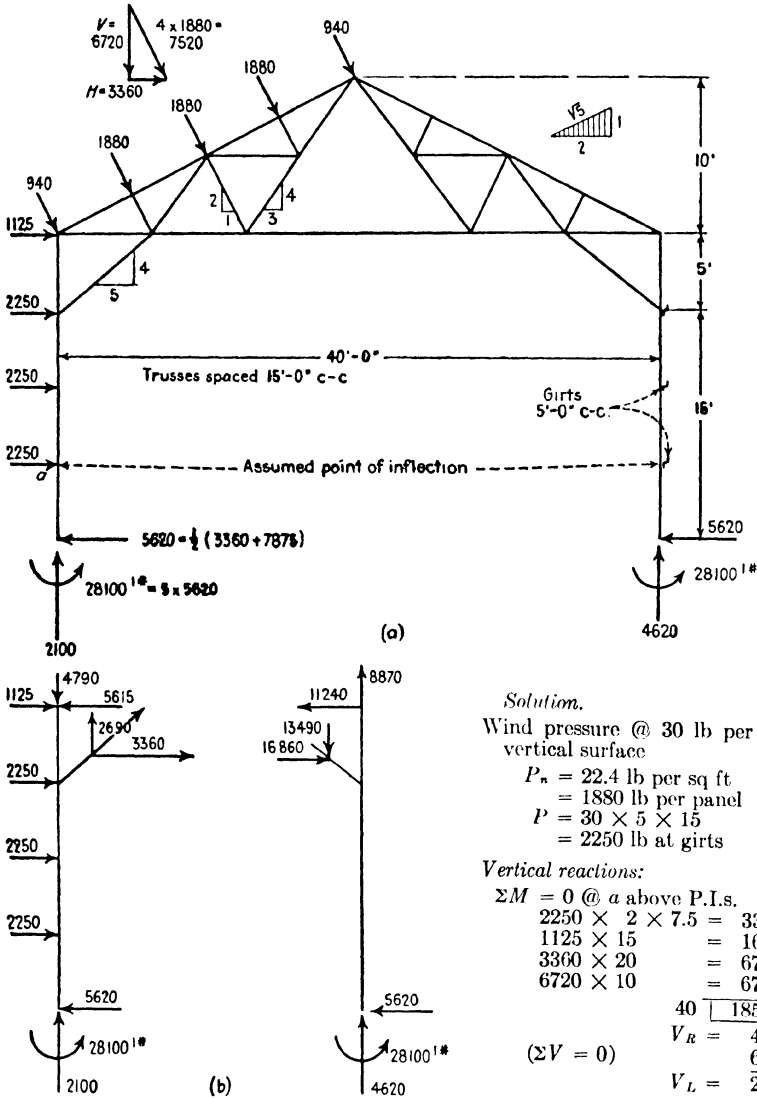

*Left post:*  
 $\Sigma M = 0 \text{ @ top}$   
 $-3 \times 2250 \times 10 = -67,500$   
 $-28,100$   
 $-95,600$   
 $5620 \times 20 = +112,400$   
 $5 \overline{+16,800}$   
 Knee brace  $H = 3,360 +$

*Right post:*  
 $\Sigma M = 0 \text{ @ top}$   
 Knee brace  $H = \frac{20 \times 5620 - 28,100}{5}$   
 $= 16,800 -$

FIG. 6:8

*Discussion.* Under vertical load the knee braces are assumed to be unstressed and all stresses are the same as in Ex. 3:1. The reactions applied to the truss through columns and knee braces under wind load were computed algebraically, and a graphic solution of stresses was made for the resulting force system<sup>1</sup> in Fig. 6:9.

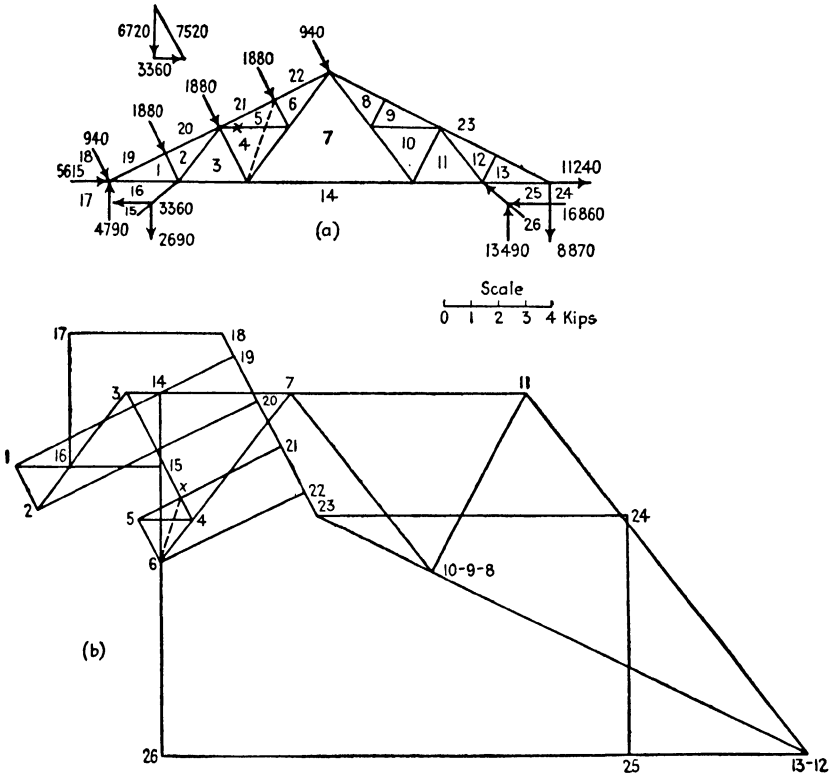

FIG. 6:9

**6:5. Sway bracing.** A bridge is a stable and, on the basis of our analysis hitherto, a statically determinate structure when it consists of the two principal trusses, two lateral trusses and the portal or cross-frame bracing at both ends. The addition of sway bracing (Fig. 4:1) provides additional paths for the stress to pass from truss to truss and so, while stiffening the structure, renders it indeterminate. Requisite accuracy of stress analysis, however, is obtained by using approximate methods. It is possible to omit the horizontal lateral truss at either

<sup>1</sup>The whole analysis may be made graphically if desired. See Wolfe's *Graphical Analysis*, page 137.



top or bottom chord by proportioning the sway bracing at each panel point to transfer the lateral load at that joint to the corresponding joint in the other chord. On this basis, in a through bridge, each pair of verticals with connecting bracing constitutes a rigid frame like a portal. When two lateral systems are used and both trusses deflect alike horizontally, the vertical frames will not be distorted and no transfer will then take place: the only member of the sway bracing under stress is the horizontal strut connecting the two chords. But when the bridge is without live load, the lateral system at the level of the floor is lightly stressed by the wind and the other lateral truss may be highly stressed. At such a time the two lateral systems deflect unequally, and a transfer of stress takes place.

Another cause of stress in the sway bracing is inequality of stringer

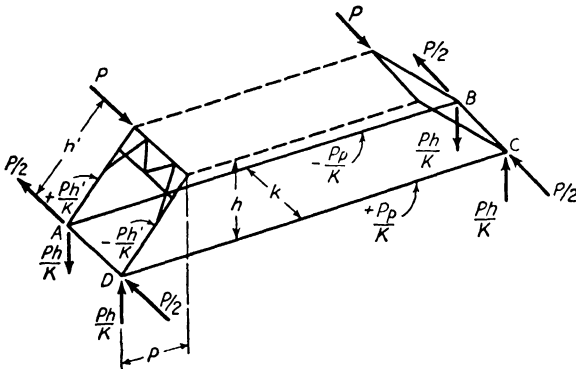

FIG. 6:10

loads because of wind on the train, or side sway, or, in a double-track bridge, load on one track only. Specifications sometimes require the sway bracing to be proportioned to transfer one-half of the excess load on one truss. This requires the cooperation of the lateral trusses, and usually the amount transferred is much less than given by this assumption.<sup>2</sup>

**6.6. Effect of bridge portal on chords.** An inclined portal causes stresses in bottom chord members as may be seen in Fig. 6:10. These stresses are greatest when the portal points of contraflexure are at the bases of the columns, and it is on this basis that Fig. 6:10 is drawn. In this case there will be a direct stress in the columns of the portal equal to  $Ph'/k$ . This stress has a vertical component of  $Ph/k$ , which goes to the

<sup>2</sup> See *Modern Framed Structures*, Part II, Johnson, Bryan, and Turneaure (John Wiley), Arts. 190-191.

support as a vertical reaction, and a horizontal component of  $Pp/k$ , which goes into the bottom chord. These values may be independently checked as follows. Using the free body of Fig. 6:10 and taking moments about  $AB$  as an axis, it is seen that there must be upward vertical forces equal to  $Ph/k$  acting at  $C$  and  $D$ . Also, if a transverse section is passed through the free body and moments are taken about a vertical axis through the intersection of  $AB$  with this section, it is seen that the stress in chord  $CD$  must be  $+Pp/k$ .

PROBLEMS

Art. 6:1

**Problem 6:1.** Draw influence lines for stress (or stress component) in the lettered bars of the Whipple and lattice trusses shown in Prob. 1:16. Panel length, 20 ft; truss depth, 40 ft.

Art. 6:3 Curved Chord Bridges

**Problem 6:2.** Compute the stresses in all bars of the leeward truss of the bridge of Fig. 6:3 due to the lateral loads there shown.

**Problem 6:3.** Find the change of length of the diagonal in Ex. 6:4 by differential calculus.

*Suggestion.*  $l = (p^2 + w^2)^{1/2}$ ; find the value of  $dl$  corresponding to  $dp = 0.0080$ . Is this an exact use of differentials?

Art. 6:4 Portals and Bents

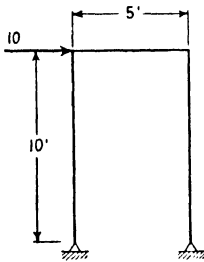

(a)

PROB. 6:4

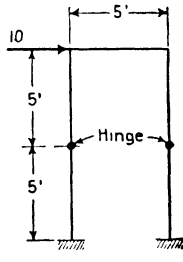

(b)

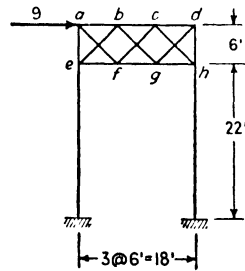

PROB. 6:5

**Problem 6:4.** To what degree are these rigid frames indeterminate? What is the direct stress and also the moment at the top of the right-hand posts, assuming each leg to carry equal shear?

*Note.* The symbol at the lower ends of the posts in  $b$  indicates a fixed end.

*Ans.* Both are indeterminate to the first degree.

a. 20 kips, compression.

b. 10 kips, compression.

a. 50 kip-ft.

b. 25 kip-ft.

**Problem 6:5.** Compute the stresses in the portal bracing here shown. Use the

same assumptions as in Ex. 6:5. Also, assume that the shear on a vertical section is resisted equally by the diagonals cut by the section.

$$\begin{aligned} \text{Ans. (kips)} \quad ab &- 13 & ef &+ 8.5. \\ bc &- 4.5 & fg &0. \\ cd &+ 4 & gh &- 8.5. \end{aligned}$$

Diagonals, vertical and horizontal components all equal  $\pm 4.25$ .

**Problem 6:6.** What is the stress in bar *a*? Bars *mno* and *prs* are continuous members capable of resisting bending.

*Question.* If these bars were non-continuous (i.e., each two pieces instead of one), would the upper structure be stable? Ans.  $V_a = +20$ .

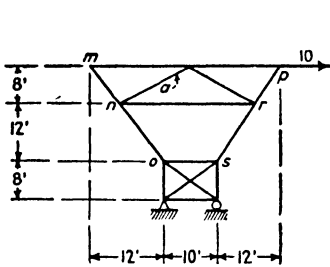

PROB. 6:6

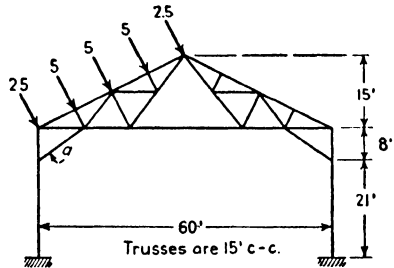

PROB 6:7

**Problem 6:7.** Compute (approximately) the stress in bar *a* of this mill building bent due to the roof wind loads shown. Assume the points of contraflexure 7 ft above the base.

*Note.* This ratio of height of point of contraflexure to knee brace height ( $\frac{1}{3}$ ) is a common assumption. The ratio of vertical to transverse force here is less than in a modern railway bridge portal, and the whole structure is also less rigid. It does not seem reasonable to assume complete fixity at the supports. On the other hand there must be some restraint, since the base of the column is a rigidly attached plate. The ratio  $\frac{1}{3}$  is often assumed in locating the points of inflection in the portals of light highway bridges.

$$\text{Ans. } H_a = +12.3 \text{ kips.}$$

*Suggestion.* Determine as regards this truss which is the most severe assumption for the location of the points of contraflexure, one-half or one-third the height to the knee brace or at the support. To do this compare the force systems acting on the truss under the three assumptions.

### SLOPE and DEFLECTION

**7:1.** There are two chief reasons why the calculations of slope and deflection are important: first, in the erection of large structures by the cantilever method, it is essential to know accurately the exact position of some or all joints at each stage of the work; and second, the most important methods of stress analysis for statically indeterminate structures are based upon study of their elastic distortion under load.

In the past the approach to the determination of slope and deflection for beams and girders has been by way of the differential equation of the elastic curve taken by the axis of the loaded beam, using the methods of the calculus:

$$\frac{d^2y}{dx^2} = \frac{d\left(\frac{dy}{dx}\right)}{dx} = \frac{M}{EI} \qquad 7:1$$

where  $x$  and  $y$  (inches) are abscissa and ordinate respectively of any point on the axis;

$M$  = bending moment at that point (pounds-inches);

$E$  = modulus of elasticity (pounds per square inch);

$I$  = moment of inertia (inches<sup>4</sup>).

The practical approach of today, however, employs theorems—moment area and elastic weights—given by the calculus relationships. A general review of these is given in Art. 7:3.

The student of the literature of higher structures must have a thorough understanding of this equation and of the many corollaries and theorems proceeding from it. However, mastery of all the essential tools of structural analysis may be much more easily obtained by other lines of reasoning, chief of which is the method of work (often named virtual work, virtual velocity, or dummy unit loading), the basic method for finding one component of deflection, or the rotation, at *one* point only of any loaded structure. If it is desired to find given components of movements of *all* the joints on either one or both chords of a truss,

this may be done algebraically by the method of elastic weights, or, often in practice, by the method of work; if the absolute movement of all joints is desired, we have recourse to the graphic method of the Williot-Mohr diagram. These few are the essential methods.

**7:2. Method of work.** When it is desired to find the movement of some point on a beam or truss under the action of a definite loading, the first step is to place a unit load (1) at the given point, before the action of the load causing the movement, acting in the direction of the movement it is desired to ascertain. When the external loads are applied, this unit load (usually called a **dummy load**) is carried by the beam or truss through the distance being measured ( $\delta$ ) and, in so doing, performs work ( $1 \times \delta$ ).

At once upon its application the dummy load causes stresses ( $u$ ) in all or some of the bars of the truss. The later application of the movement-causing loading brings changes in the lengths of these bars ( $\Delta L$ ). The internal forces caused by the dummy load move through these changes in bar lengths and so perform work,  $u\Delta L$  for one bar,  $\Sigma u\Delta L$  for the truss.

The law of the conservation of energy informs us that the external work of the dummy load ( $1 \times \delta$ ) must equal the internal energy change due to the same load ( $\Sigma u \cdot \Delta L$ ), energy stored in the structure by virtue of the movement:

$$1 \times \delta = \Sigma(u \cdot \Delta L) \quad (\text{lb-ft}) = (\text{lb-ft}) \quad 7:2$$

This equation indicates definitely that deflections depend upon the amounts of bar-length change regardless of their causes. In the derivation above only length changes due to loads were mentioned, but other causes are of importance. In truss erection it is sometimes necessary to heat or ice a bar to cause some desired movement. Unequal temperature changes sometimes occur in a truss. Many trusses have been built with bars adjustable in length by means of a turnbuckle. A bar may be too long or too short through an error in fabrication. In all these cases the deflection effect must be determined by use of the fundamental equation, equation 7:2. For computing the deflections due to loads it is desirable to put the equation into more workable form.

The change in length,  $\Delta L$  (inches or feet), of any bar of length  $L$  (inches or feet), cross-sectional area  $A$  (square inches), of material with modulus of elasticity  $E$  (pounds per square inch), carrying total stress  $S$  (pounds), is  $\Delta L = SL/AE$ . Using this expression, we can rewrite equation 7:2 thus:

$$\delta = \Sigma(u \cdot \Delta L) = \Sigma \frac{SuL}{AE} \quad 7:2a$$

redefining  $u$  as the ratio of the stress caused by the dummy load to the dummy load itself. The same redefinition of  $u$  may be made in equation 7:2 as desired.

If, instead of deflection, the rotation of any joint of a truss is desired, this rotation may be measured by using a dummy moment (unit couple 1 in.-lb or ft.-lb) instead of a unit force; the external work equals the couple times the angle of rotation ( $\alpha$ ); the internal work equals the summation of the stresses caused by the dummy couple multiplied by changes of bar length due to the loads whose rotation effect is desired; i.e., for a truss, notation and units as heretofore,

$$1 \times \alpha = \sum u \Delta L \quad 7:3$$

$$\alpha = \sum \frac{SuL}{AE} \quad 7:3a$$

The equality of external and internal work due to the dummy load must hold for a beam as well as for a truss. The evaluation of the internal work is best made by turning to the moment area theorem,<sup>1</sup> which states that the angle between any two tangents to the elastic curve of a deflected beam equals the area of the  $M/EI$  diagram between the two points. This angle between the tangents equals the angle between the beam sections at these two points, sections which are parallel in the unloaded beam: Fig. 7:1.

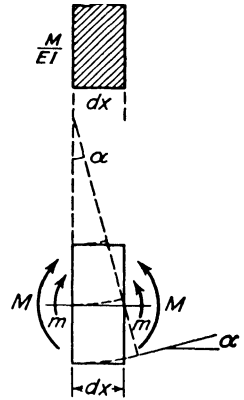

FIG. 7:1

Remembering that the work done by a couple equals the couple times the angle through which it turns, we may evaluate the internal work done by the dummy load in a differential distance as  $m \cdot M dx/EI$ , where  $m$  is the bending moment at the section due to the dummy load (or, the ratio of the moment due to the dummy load to the dummy load itself) and  $M dx/EI$  is the angle of rotation caused by the loading whose deflection effect is being determined. This gives for the beam

$$\delta = \int \frac{Mm dx}{EI} \quad 7:2b$$

<sup>1</sup> The moment area method is usually credited to Professor Charles E. Greene of the University of Michigan, who, about 1873, gave the following two theorems:

The angle between the tangents through any two points on the axis of any beam, i.e., the change in slope, is equal numerically to the area of the  $M/EI$  diagram between the two points.

The deflection of any point on the axis of any beam from the tangent through any other point equals the moment about the first point of the  $M/EI$  diagram between the two points.

If rotation instead of deflection is being computed, we have

$$\alpha = \int \frac{Mm \, dx}{EI} \quad 7:3b$$

In equations 7:2b and 7:3b,  $\delta$  will be in either inches or feet, and  $\alpha$  will be a ratio (radians) if the terms on the right-hand side of the equality sign are expressed consistently in pound and inch or in pound and foot units. These equations do not include the effect of shear, which in general is so small that it may properly be neglected.

The matter of direction of deflection or rotation needs attention. Consider the deflection of a point in a beam with simple supports. Let the load, or loads, by which the deflection is caused act downward. At the point of desired deflection apply the dummy load, also downward. Adopting the usual convention of plus for tension and minus for compression, it will be evident for all fibers of the beam that  $u$ , the stress due to the unit load, and  $\Delta L$ , the change of length due to the applied loads, will have the same sign, and, therefore, the product  $\sum(u \cdot \Delta L)$ , or

$\int \frac{Mm \, dx}{EI}$ , will be positive. In this case, experience tells us that the

deflection is in the direction of the unit load. A like examination may be made in the case of a truss. Sketch a truss and assume that, due to any cause, there is a change (+ or -) in the length of some one bar. Place a unit load at one joint where the deflection is to be determined. Investigation will show that if the unit load causes, in the bar of changed length, stress of the same sign as that change, the deflection is in the direction of the unit load; if stress of the opposite sign, deflection in the opposite direction. There follows the rule that **if the sign of the product**  $\sum(u \cdot \Delta L)$  **(or**  $\sum \frac{SuL}{AE}$ , **or**  $\int \frac{Mm \, dx}{EI}$  **) is positive the deflection,**

**or rotation, is in the direction of the dummy load, or dummy couple.**

The equality of the internal work of the stresses to the external work of the loads producing the stresses was set forth by Clapeyron in 1833 and is a basic principle of the modern theory of indeterminate structures. In 1846 James Clerk Maxwell published a brief paper (*Philosophical Magazine*) containing implicitly the method of determining deflections described in this article and describing a method of stress analysis for statically indeterminate trusses. Other writers developed the argument, notably Professor Otto Mohr, for whom this is often called the Maxwell-Mohr method. The credit for using a finite unit load as here presented is generally given to Professor Frankel of Dresden. The first publica-

tion of the method of work in this country was by Professor George F. Swain in 1883 (*Journal of the Franklin Institute*) in a paper entitled "On the Application of the Principle of Virtual Velocities to the Determination of the Deflection and Stresses of Frames." The method is often referred to as the principle of virtual work, as for example by Professor Hardy Cross in "Virtual Work: a Restatement" [*Transactions of the American Society of Civil Engineers*, Vol. 90 (1927)], a more general treatment than here presented. The reader of current professional discussions and of other textbooks will discover that the derivation of the method of work is sometimes stated in quite different terms from those here used and consequently with different definitions given to the significant elements of the equations.

Although others had suggested the possibility of so doing, probably the first actually to extend the method of work to the determination of rotation was Professor Swain in 1920 in a paper with the title "A New Principle of Structures" (*Transactions of the American Society of Civil Engineers*, Vol. 83).

**Example 7:1.** Find the slope and deflection of the end of the loaded cantilever beam of Fig. 7:2.

*Solution.* Place a unit clockwise couple at the right end of the beam. Then

$$\begin{aligned} \alpha &= \int \frac{Mm \, dx}{EI} = \int_0^L \frac{\left(-\frac{wx^2}{2}\right)(-1) \, dx}{EI} \\ &= \frac{wL^3}{6EI} \end{aligned}$$

Place a unit vertical downward load at the right end,

$$\begin{aligned} \delta &= \int \frac{Mm \, dx}{EI} = \int_0^L \frac{\left(-\frac{wx^2}{2}\right)(-x) \, dx}{EI} \\ &= \frac{wL^4}{8EI} \end{aligned}$$

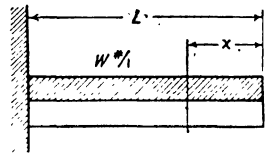

FIG. 7:2

The positive results indicate that the resulting slope and deflection are in the directions assumed, that is, downward to the right, and down.

**Example 7:2.** Find the slope and deflection of the end of the loaded cantilever beam of Fig. 7:2 when  $L = 10$  ft and the total load is 6000 lb;  $I = 100$  in.<sup>4</sup>



*Solution.* Using pound and foot units,

$$\begin{aligned}\alpha &= \frac{1}{EI} \int_0^{10} \left( \frac{-600x^2}{2} \right) (-1) dx \\ &= \frac{600 \times 10^3}{6 \times 30,000,000 \times 144 \times 100/12^4} = \frac{48}{10,000} \text{ radians}\end{aligned}$$

$$\begin{aligned}\delta &= \frac{1}{EI} \int_0^{10} \left( \frac{-600x^2}{2} \right) (-x) dx \\ &= \frac{36}{1000} \text{ ft}\end{aligned}$$

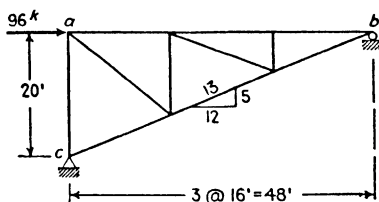

FIG. 7:3

**Example 7:3.** Find the horizontal movement of point  $a$  of the truss shown in Fig. 7:3 due to a rise of temperature of 50 degrees in top chord  $ab$  only. Coefficient of expansion, 0.0000065.

*Solution.* Place a horizontal unit load at  $a$  acting to the right, which causes unit compression in  $ab$ . Then

$$1 \times \delta_a = (-1) (+50 \times 0.0000065 \times 48)$$

$$\delta_a = -0.0156 \text{ ft, to left}$$

in direction opposite to assumed dummy load.

**Example 7:4.** What is the horizontal movement of point  $b$ , truss of Fig. 7:3, due to the 96,000-lb load shown? The area of each bar in square inches equals one-half its length in feet.  $E = 30,000,000$ .

*Solution.* Place a horizontal load of 1 lb at  $b$  acting to the right, causing a stress in  $bc$  of  $\frac{1}{1\frac{1}{2}}$  lb and not stressing any other bar. The applied load causes a change of length in  $bc$  of

$$\frac{104,000 \times 52}{8.67 \times 30,000,000} = \frac{(\text{lb})(\text{ft})}{(\text{in.}^2)(\text{lb}/\text{in.}^2)} = 0.0208 \text{ ft}$$

The horizontal movement of  $b$  equals

$$\delta_b = \left( \frac{13}{12} \right) (0.0208) = 0.0225 \text{ ft to right}$$

The positive result shows that the movement is to the right in the direction of the dummy load.

Note that where a bar is unstressed by either the dummy or the other load it does not enter into the calculations.

**Example 7:5.** What is the horizontal deflection of point  $U_3$  of the truss shown in Fig. 7:4 under the load shown? The area of each bar in square inches equals one-half its length in feet.  $E = 30,000,000$ .

*Solution.* Two stress diagrams were prepared, one for the load of 32 kips and one for a load of 1 lb at  $U_3$  acting horizontally to the right. Only those bars stressed by both loads appear in the following table.

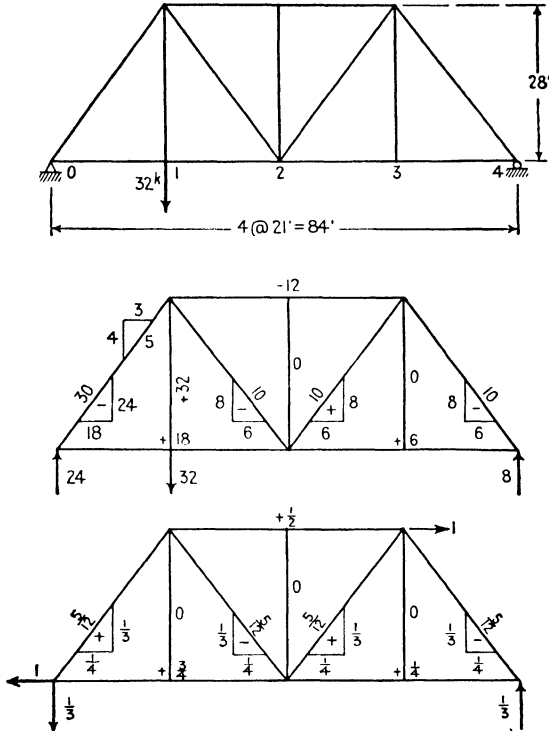

FIG. 7:4

Bar	$\frac{L}{A}$	$S$	$u$	$\frac{SuL}{A}$
$U_1L_0$	2	-30	$+\frac{5}{1\frac{1}{2}}$	-25
$U_1L_2$	2	-10	$-\frac{5}{1\frac{1}{2}}$	+ 8.33
$U_3L_2$	2	+10	$+\frac{5}{1\frac{1}{2}}$	+ 8.33
$U_3L_4$	2	-10	$-\frac{5}{1\frac{1}{2}}$	+ 8.33
$U_1U_3$	4	-12	$+\frac{1}{2}$	-24
$L_0L_2$	4	+18	$+\frac{3}{4}$	+54
$L_2L_4$	4	+ 6	$+\frac{1}{4}$	+ 6
				+85.0 -49.0

$$\delta = \sum \frac{SuL}{AE} = + \frac{36,000}{30,000,000}$$

$$= 0.0012 \text{ ft, to right}$$

It is necessary occasionally to find the relative movements of two truss panel points as, for example,  $U_1$  and  $L_3$  in Fig. 7:5, the determination of which is carried through in Ex. 7:6. As indicated in Fig. 7:5, place opposing loads of unity at the two points and proceed in the usual manner. Only the bars shown as heavy lines are stressed by this loading. One of the unit forces may be considered the active load and the other the fixed reaction, thus reducing the problem to the form of those previously considered.

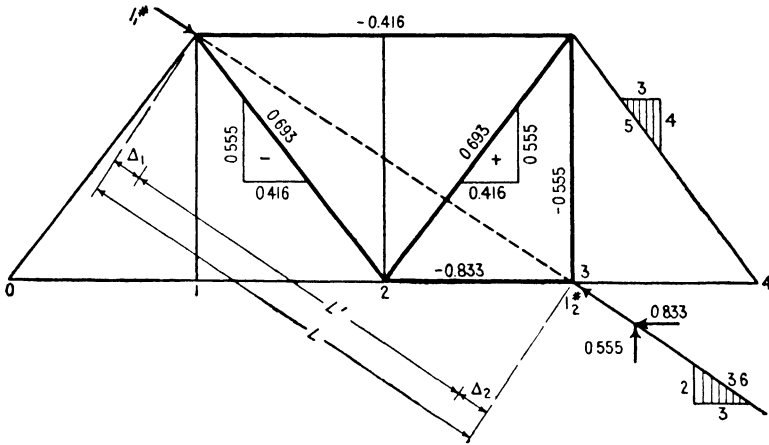

FIG. 7:5

A like argument serves in the situation pictured in Prob. 7:10f, where no reactions at the points of support are involved. Here the corner which the shortened diagonal fails to reach ( $a$ ) may be considered the point of support for the dummy load which is a pull on the end of the diagonal a half inch in from point  $a$ .

**Example 7:6.** Truss and loading of Ex. 7:5. Determine the relative movements of panel points  $U_1$  and  $L_3$  along the line connecting them.

*Solution.* Fig. 7:5.

Bar	$\frac{L}{A}$	$S$	$u$	$\frac{SuL}{A}$
$U_1U_3$	4	-12	-0.416	+20
$L_2L_3$	2	+6	-0.833	-10
$U_1L_2$	2	-10	-0.693	+13.9
$L_2U_3$	2	+10	+0.693	+13.9
$U_3L_3$	2	0	-0.555	
				+47.8
				-10

$$\delta(U_1 - L_3) = +37.8 \div 30,000 = +0.00126 \text{ ft, i.e., toward each other.}$$

**7:3. Slope and deflection of beams: Method of elastic weights (or conjugate beam method).** Another great contribution to structural theory was made by Otto Mohr in 1868 when he showed that, in a beam, properly chosen fictitious loads—often called **elastic loads** or **weights**—cause bending moments which are the numerical equivalents of the deflections. The method of elastic weights states that **in any**

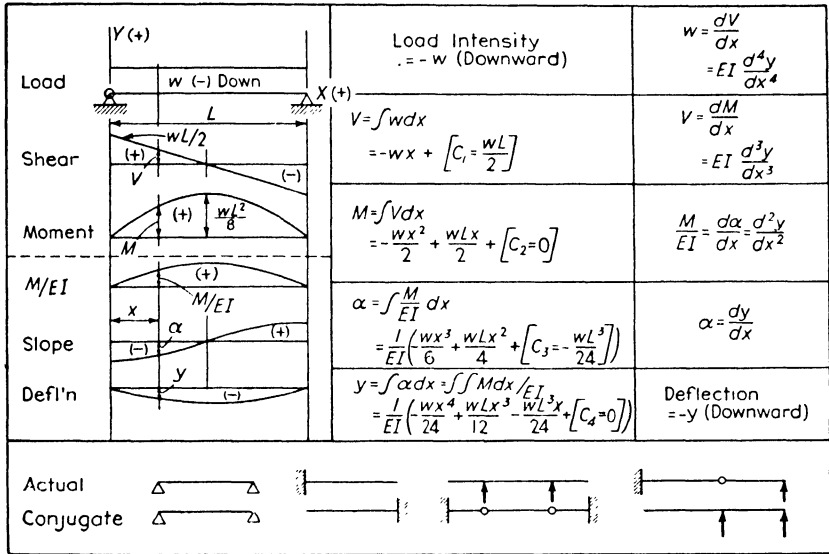

FIG. 7:6

**beam or girder the slope at any point equals the shear caused at the same point in a properly chosen fictitious (or conjugate) beam of the same length whose load curve is the  $M/EI$  diagram of the original beam; the deflection at any point equals the bending moment at the same point of the conjugate beam.** As applied to an end-supported beam for which the conjugate beam is also an end-supported beam, the proof of these theorems follows.

In Fig. 7:6 is shown the relationship among load, shear, bending moment,  $M/EI$ , slope and deflection curves, a relationship developed in textbooks on strength of materials. In this figure the general relationship is illustrated by reference to the special case of a uniformly loaded simple beam. The six curves divide logically into parallel groups: the expression for shear is obtained from that for load intensity by integration; the expression for bending moment is obtained from that for shear by a second integration; similarly the expressions for slope and deflection

are obtained from that for  $M/EI$  by integration. *It is usually simpler, however, to obtain the shear from the load by direct application of the definition for shear: the algebraic sum of the transverse loads on one side of the section; and to obtain the bending moment, likewise, by direct application of the definition for bending moment: the resultant moment about the section of the transverse loads on one side of the section.* Since the same mathematical relationship obtains among  $M/EI$ , slope, and deflection as among load, shear, and bending moment, it follows in logic that the same methods of successive derivation may be followed in the two cases, i.e., that the  $M/EI$  curve may be taken as load with the result that *the corresponding shear and bending moment for the  $M/EI$  loading will be the actual slope and deflection for the actual beam and actual loading.*

Since the shear and moment of the conjugate beam with its load, the  $M/EI$  curve of the actual beam, correspond to the slope and deflection of the actual beam, the manner of support and articulation of the conjugate beam must be such as to induce shear and moment in the conjugate in conformity to the slope and deflection induced by construction in the actual beam. The necessary principles are assembled in the lower portion of Fig. 7:6. *The length of the conjugate equals that of the actual beam.* At a simple support the actual beam changes slope but does not deflect; therefore at the corresponding point of the conjugate there must exist shear but no moment, a condition ensured by a simple support for the conjugate. At the fixed end of a cantilever there is neither change of slope nor deflection; at the corresponding end of the conjugate there can be neither shear nor moment, a condition ensured by complete lack of support, that is, by a free end. At the free end of a cantilever there is change of slope and deflection, which demands shear and moment at the corresponding conjugate support, a condition ensured by a fixed end. *The conjugate beam for a cantilever is a reversed cantilever of the same length.* From a like argument it follows that an interior support demands a hinge in the conjugate, a hinge in the actual beam demands an interior support in the conjugate.

Unlike actual beams, conjugate beams are often unstable in themselves. For example, the conjugate beam for a fixed ended beam is a floating beam, totally unsupported, of the same length. All conjugate beams are, however, in equilibrium under the action of their  $M/EI$  loading.

Probably the simplest sign convention for this method is that shown in Fig. 7:6, where the origin is taken at the left end of the beam with  $Y$  positive upward and  $X$  positive to the right. A downward load is thus negative, and the usual signs for shear and moment obtain automatically

upon integrating, exactly the same as when shear and moment are obtained by application of their definitions. Accordingly a positive  $M/EI$  curve corresponds with an upward load and causes negative moment, downward deflection.

At this point it is well that the student should recall other relationships learned in his course in strength of materials. In each of the two parallel series of curves any ordinate of one curve equals in magnitude and sign the corresponding slope of the next succeeding curve; the difference between two ordinates of a curve is given by the area between the corresponding ordinates of the previous curve. These relationships are of great practical value in the construction of these curves in engineering work.

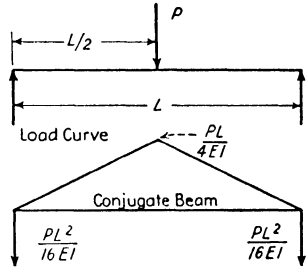

FIG. 7:7

**Example 7:7.** Find the end slope and center deflection of the beam shown in Fig. 7:7.

*Solution.* The end slope is the reaction of the conjugate beam,  $PL^2/16EI$ . The center deflection is the center moment,

$$\left(\frac{PL^2}{16EI}\right) (L/2 - L/6) = \frac{PL^3}{48EI}$$

**Example 7:8.** Using the results of Ex. 7:7, determine the end slope and center deflection of a beam 20 ft long which supports at its mid-point a load of 25,000 lb.  $I = 532 \text{ in.}^4$   $E = 30,000,000 \text{ lb per sq in.}$

*Solution.*

*Using foot units.*

$$\text{End slope} = \frac{PL^2}{16EI} = \frac{25,000 \times 20^2}{16 \times 30,000,000 \times 12^2 \times \frac{532}{12^4}} = 0.0056 \text{ radian}$$

$$\text{Center deflection} = \frac{PL^3}{48EI} = \frac{25,000 \times 20^3}{48 \times 30,000,000 \times 12^2 \times \frac{532}{12^4}} = 0.038 \text{ ft}$$

*Using inch units.*

$$\text{End slope} = \frac{PL^2}{16EI} = \frac{25,000 \times 20^2 \times 12^2}{16 \times 30,000,000 \times 532} = 0.0056 \text{ radian}$$

$$\text{Center deflection} = \frac{PL^3}{48EI} = \frac{25,000 \times 20^3 \times 12^3}{48 \times 30,000,000 \times 532} = 0.45 \text{ in.}$$

**Example 7.9.** Determine the deflection and slope at point *A* of Fig. 7:8a.  $E = 30,000,000$  lb per sq in.

*Solution.* The 10-kip load gives the moment curve of line *b*. The conjugate beam and its loading diagram are given in line *c*. Note that, because the

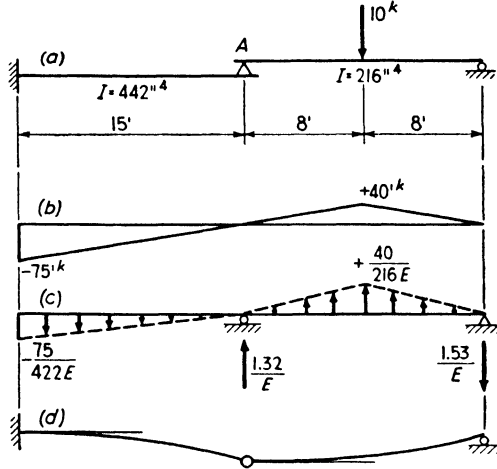

FIG. 7:8

moment is negative, the load on the conjugate beam to the left of *A* acts downward. The resultant of the loading to the left of *A* is  $\frac{1}{2} \times 15 \times \frac{75}{442E} = \frac{1.27}{E}$  and of the loading to the right of *A* is  $\frac{1}{2} \times 16 \times \frac{40}{216E} = \frac{1.48}{E}$ . These in turn cause the reactions shown on line *c*. Therefore,

$$\begin{aligned} \delta_A &= \text{conjugate beam bending moment at } A = -\frac{1.27}{E} \times 10 = -\frac{12.7}{E} \\ &= -\frac{12.7 \times 1728 \times 1000}{30,000,000} = -0.73 \text{ in.} \end{aligned}$$

the negative sign indicating downward movement.

$$\alpha_{A \text{ left}} = -\frac{1.27}{E} = -\frac{1.27 \times 144 \times 1000}{30,000,000} = -0.0061 \text{ radian (i.e., down to right)}$$

$$\alpha_{A \text{ right}} = \frac{-1.27 + 1.32}{E} = +0.0002 \text{ radian (i.e., up to right)}$$

Line *d* shows a greatly exaggerated deflection diagram.

Neither moment area nor elastic weights can be considered really practical methods unless the computer is familiar with the drawing of  $M/EI$  diagrams *by parts*. This consists of drawing a series of moment curves, one for each element of load and reaction, working from one

end of the beam; or of dividing the superimposed load into two or more parts and drawing the moment curve for each part. The superposition (combination) of any one set of such curves gives the actual resultant curve. This is illustrated in the next example.

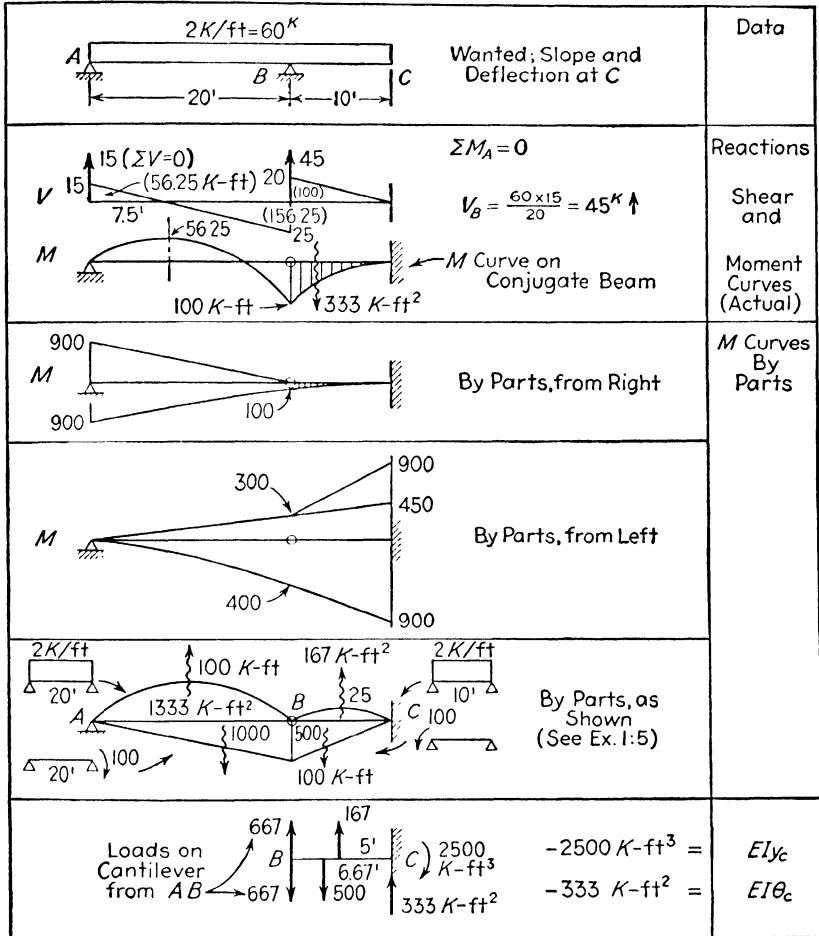

FIG. 7:9

**Example 7:10.** Compute the slope and deflection at the overhanging end of the beam shown in Fig. 7:9 by the method of elastic weights.

*Note.* A regular problem sheet solution is given here in the interest of promoting simplicity and conciseness. Note how few figures are required when the work is done directly on the sketches.



**Solution.** This problem requires the computation of the shear and moment at the right end of the conjugate beam, which, in turn, as a preliminary, requires the determination of the load brought to the hinged end of the 10-ft cantilever span by the 20-ft simple span.

As soon as the actual moment curve was drawn, it was evident that its use would be somewhat complex and difficult; hence, three alternative curves were drawn. A first trial moment curve, drawn from the right by parts, gave two curves, one for the uniform load alone and the other for the reaction at *B*. This combination would be convenient for use on the cantilever but awkward on the simple span. A second curve, working from the left (in three parts) gave a combination which would be easy to use on the simple span but difficult on the cantilever. (The curve drawn from the right might be used on the cantilever, that from the left on the simple span.) A third trial utilized the principle stated in boldface type at the end of Ex.

1:5. In this particular problem the third curve is the simplest to use.

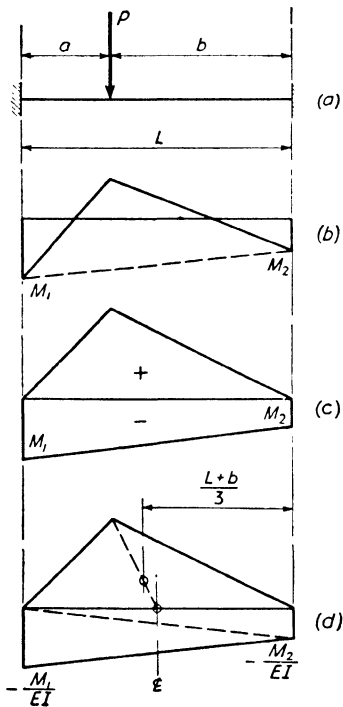

FIG. 7:10

beam of Fig. 7:10a will cause the moment curve shown in b. This, in turn, is equivalent to the curve of c where the part above the axis is the moment curve for a simple beam (see Ex. 1:5). By the rules given, it will be seen that the conjugate beam for this case is a beam without

Since the moment curve was used in place of the  $M/EI$  curve in the computation of Fig. 7:9, the resulting values are for slope and deflection multiplied by  $EI$ , in units of kip-feet<sup>2</sup> and kip-feet<sup>3</sup> respectively. Since  $E$  will be given in units of kips per square inch and  $I$  in inches<sup>4</sup>, the 333 found for  $EI\theta$  must be multiplied by  $12^2$  and divided by  $EI$  in order to obtain the answer in radians; the 2500 value of  $EI\delta$  must be multiplied by  $12^3/EI$  to give the deflection in inches. The negative signs indicate downward deflection and negative slope.

In this particular problem the ratio of the lengths  $AB$  and  $BC$  is such that for the given loading the shear and the moment equal zero in the conjugate beam at  $B$ . What does this mean as regards slope and deflection at  $B$  in the actual (given) beam?

The conjugate beam method is also applicable to beams which are statically indeterminate and may, in fact, be used to find end moments in such. For example, the load  $P$  on the fixed-end

support at either end and therefore in equilibrium under the action of the positive and negative  $M/EI$  loadings of  $d$ . There are two unknowns,  $M_1$  and  $M_2$ , and for their determination, two equations:  $\Sigma M = 0$  and  $\Sigma V = 0$ . Treating the negative areas as the sum of two triangles, it may be shown by writing and solving the above equations that

$$M_1 = -\frac{Pab^2}{L^2}, \quad M_2 = -\frac{Pa^2b}{L^2}$$

**7:4. Deflection of trusses: Method of elastic weights.** Professor Müller-Breslau extended the method of elastic weights to trusses in 1885 and provided two very different ways for computing these weights. The first method involves determining for each bar a weight, or weights, together with its position, such that its moment curve is identical with the curve of deflections caused by the change of length of the bar when the truss is carrying the given loading.

By the method of work (equation 7:2) the deflection at any point of a truss due to the change in length ( $\Delta L$ ) of a given bar equals  $\Delta L \cdot u$ , where  $u$  is the stress in the bar caused by a load of unity at the point where the deflection is being measured. Since each ordinate of the influence line for bar stress gives a value of  $u$ , it follows that **the deflection curve for the truss due to a change in length of a given bar is the influence line for this bar stress multiplied by  $\Delta L$ . The required elastic weight is the load, or loads, whose moment curve is this influence line multiplied by  $\Delta L$ .**

The determination of elastic weights by means of influence lines is illustrated in Fig. 7:11. The first determination is that of the weight required to give a bending moment curve whose ordinates will equal the vertical deflections of all bottom chord panel points due to a shortening ( $\Delta L$ ) of bar  $BC$ . The familiar triangular influence line has become the deflection curve with peak ordinate  $4p/3h$  multiplied by  $\Delta L$ . This deflection curve is the moment curve for an end-supported conjugate beam, each reaction of which equals the peak ordinate divided by the distance from peak to reaction: the single load, consistent with a triangular moment curve, equals the sum of the reactions and is applied at the peak point,  $\Delta L/h$  upward at point  $c$ .

Signs have been taken as previously for elastic weights with beams, the conjugate beam method. In this example a shortening of bar  $BC$  causes a downward movement of all points on the truss. The influence line, by usual conventions, also lies below the base line, a load anywhere on the bottom chord causing compression in the bar. It is drawn below the axis here, however, for another reason, that is, to agree with

the downward movements caused by the bar shortening. Had the change in length been a lengthening, all bottom chord points would have moved upward and the influence line would have been drawn above the base line in agreement: the elastic weight at  $c$  would have acted down as required by a positive moment curve. This may be put more generally: **where the break in the moment curve (deflection**

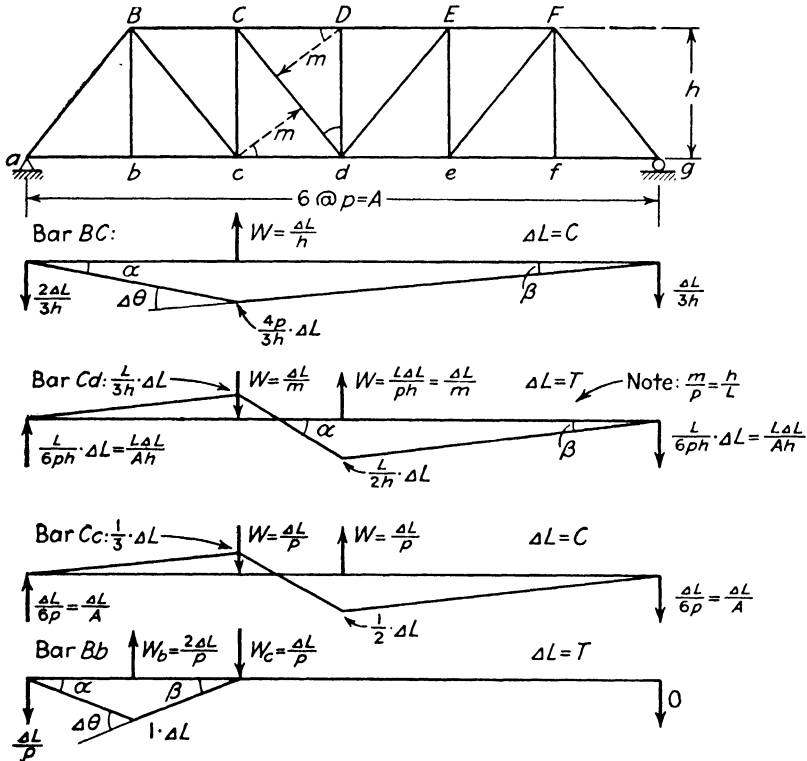

FIG. 7:11

curve) makes that curve concave downward, the elastic weight at that point also acts downward; where the curve is concave upward, the weight acts upward.

On the basis of this demonstration we may conclude that the elastic weight for a chord bar in a simple triangular truss with either horizontal or sloping chords equals the change in chord-bar length divided by the normal distance to the bar from the center of moments used in computing the bar stress.

The procedure for determining the elastic weights for diagonal  $Cd$ , Fig. 7:11, is slightly more complicated in detail. The familiar influence

line has positive and negative areas. The change in length is assumed to be that due to tension, a lengthening, with resulting downward movement of panel points to the right, upward to the left. The influence line has been drawn to agree with these movements rather than the usual plotting of tension above the axis. Note that  $L$  equals the length of the diagonal. The conjugate beam reactions, found as before from the moment curve (deflection curve, i.e., influence line multiplied by  $\Delta L$ ) peak ordinates, are here equal and constitute a couple equal to  $L\Delta L/h$ , a couple which must be balanced by an equal and opposite couple provided by the elastic weights. The resulting elastic weight expression is put in the simple form  $\Delta L/m$  upon noting the similar triangle relationship involved.

The finding of the elastic weights for a shortening of the vertical  $Cc$  requires no comment: Fig. 7:11. Had hanger  $Bb$  been out in mid-span, as in the case of a subdivided Warren truss, the two elastic weights and one reaction shown would have appeared as three elastic weights with no conjugate beam reactions.

The identity of the two applications of elastic weights to beams and to trusses is further established by consideration of the relationship existing between elastic weight and the slope of the deflection curve. In the case of the beam its conjugate carries as load the  $M/EI$  curve of the actual beam, and at any point the load equals  $M dx/EI$ , which equals the change of slope of the elastic curve at that point (in the distance  $dx$ ). It may be shown that each of the elastic weights found for change of length in a truss bar equals the change in slope of the resulting deflection curve at the point of application of the load. This is most easily seen for the bar  $Bb$ , Fig. 7:11, for the load at  $c$ . Here the original  $180^\circ$  angle below the base line at  $c$  has been decreased in amount  $\beta$ , an angle which may be taken as equal to its tangent,  $\Delta L/p$ , the value of the elastic weight at  $c$ . At  $b$  the increase in the original angle,  $\Delta\theta$ , equals  $\alpha + \beta$ , and the elastic weight correspondingly equals twice that at  $c$ . By noting that the change in slope at any deflection-curve break equals the sum of the two opposite interior angles, the proof of this relationship for the other elastic weights in Fig. 7:11 is simply made.

Two sets of deflection curves, with the corresponding elastic weights, are shown in Fig. 7:12, for the lengthening of a lower chord bar and the shortening of a diagonal of a Warren truss without verticals. One set considers the deflections of the lower chord panel points and the other the vertical movements of the panel points of both chords measured from a common base line. It is to be noted that in every case the elastic weight equals the change in base line slope at the point: e.g., for bar  $cD$ , considering all panel points, the change in slope of the deflection curve at the point of projection of  $D$  on the base line equals

$$\left(\frac{5}{9}\Delta L + \frac{4}{3} \times \frac{5}{6}\Delta L\right) \div 8 = \frac{\Delta L}{4.8}$$

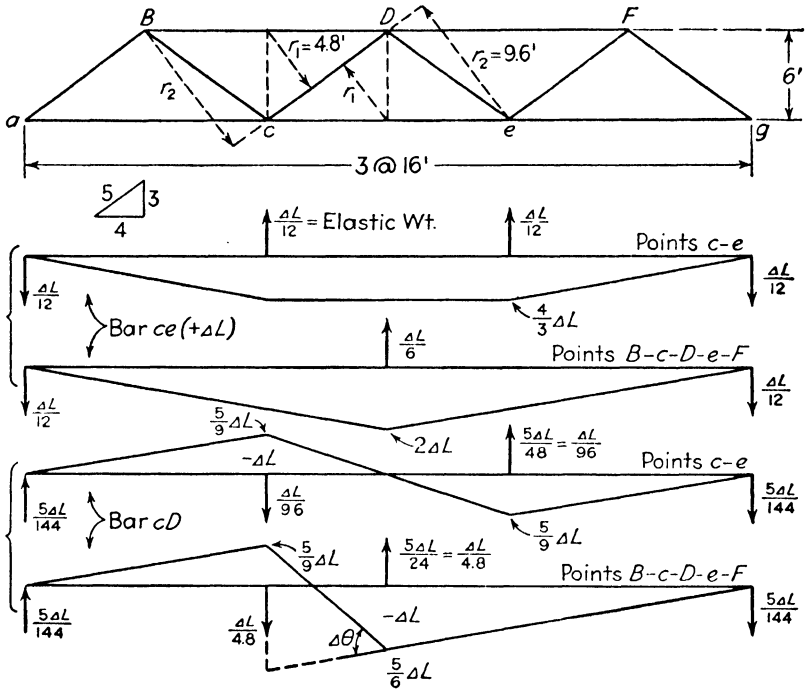

FIG. 7:12

The preceding demonstrations have provided rules for evaluating the elastic weights for the majority of typical bars in simple triangular trusses. Where these demonstrations do not suffice, it is necessary to resort to the influence line, a procedure illustrated in Ex. 7:11.

**Example 7:11.** Find the vertical deflection of all joints on the bottom chord of the truss shown in Fig. 7:13 due to load and stresses shown. For simplicity take the area of each bar in square inches as equal to its length in feet.

*Discussion.* All the necessary work except a few scratch computations and free body sketches appear in the figure and table. The elastic weights for bars not covered by the previous discussion were found by drawing the deflection curve (influence line multiplied by  $\Delta L$ ) due to its change of length and determining the weights giving an identical moment curve. The deflection curve for the truss (Fig. 7:13) is the bending moment curve for the total elastic loads. After the deflections of the lower chord panel points have been obtained, the deflections of the middle or upper points may be found by modifying the proper lower chord deflection by the change in length of the vertical bar, or bars, connecting the points.

An interesting variation in this problem is made by considering the truss to be a cantilever supported at points  $d$  and  $i$  and carrying an upward load of 60

**DEFLECTION OF TRUSSES: METHOD OF ELASTIC WEIGHTS 201**

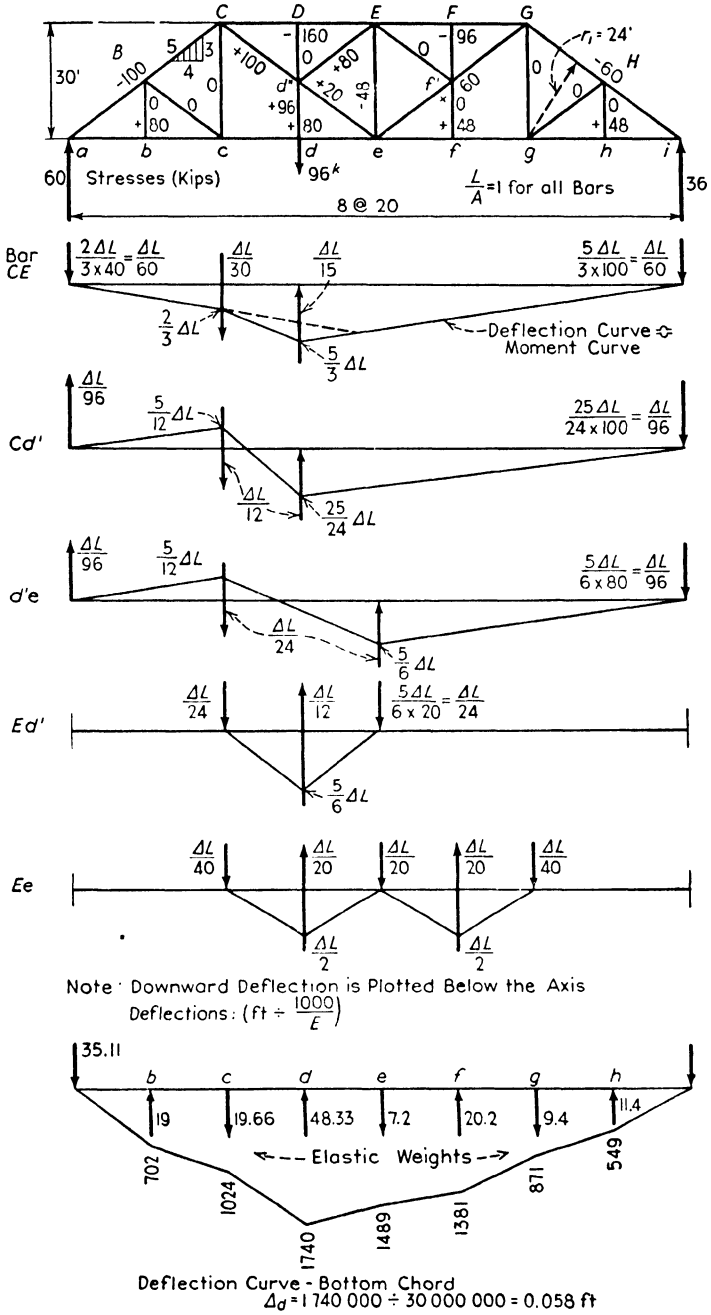

Fig. 7:13

ELASTIC WEIGHTS (See Fig. 7:13)

Bar	$\frac{SL}{A}$	$r$	$E\Delta L/r = \text{Elastic weight} \div 1000/E \text{ placed at}$						
			$b$	$c$	$d$	$e$	$f$	$g$	$h$
$aB$	-100	12	8.33 ↑						
$BC$	-100	24		4.17 ↑					
$CE$	-320	30-15*		10.67 ↓	21.33 ↑				
$EG$	-192	15-30					12.8 ↑	6.4 ↓	
$GH$	-60	24						2.5 ↑	
$Hi$	-60	12							5.0 ↑
$ac$	+160	15	10.67 ↑						
$ce$	+160	30		5.33 ↑					
$eg$	+96	30						3.2 ↑	
$gi$	+96	15							6.4 ↑
$Cd'$	+100	12*		8.33 ↓	8.33 ↑				
$d'e$	+20	24*		0.83 ↓		0.83 ↑			
$ef'$	+60	24				2.50 ↑		2.5 ↓	
$f'G$	+60	12					5.0 ↑	5.0 ↓	
$Ed'$	+80	*		3.33 ↓	6.67 ↑	3.33 ↓			
$d'd$	+96	10-20		4.80 ↓	9.60 ↑	4.80 ↓			
$Ee$	-48	*		1.20 ↓	2.40 ↑	2.40 ↓	2.4 ↑	1.2 ↓	
Loads =			19.0 ↑	19.66 ↓	48.33 ↑	7.20 ↓	20.2 ↑	9.4 ↓	11.4 ↑

\* See loads as determined on sketch.

kips at the left end. All stresses and elastic weights would remain as before, but the supports for the conjugate beam carrying these weights would be one fixed at the left end ( $a$ ), simply supported at the right end ( $i$ ), with a hinge at point  $d$ . The upward deflection of point  $a$  is then found to be 0.0928 ft.

**Elastic weights: Bar chain method.** Elastic weights, identical with those just described, may also be found by consideration of the changes in angle of the *bar chain*, the angles between the bars connecting the points whose deflections are sought: angles  $aBc$ ,  $BcD$ ,  $cDe$ , etc., Fig. 7:12, of bar chain  $aBcDeFg$ . Instead of finding the increment of elastic weight due to the change in length of each individual bar, the total weight at each angle vertex is found at once, considering all the bars contributing to that angle change. A vertical bar would not figure in the procedure, since the difference in deflection of its ends equals simply the change in length of the bar. The necessary general equation for computing elastic weights may be derived as follows.

Let it be desired to determine the vertical deflections of the joints of a chain of bars, such as the diagonals in Fig. 7:12, when two of these joints—e.g., joints  $a$  and  $g$ —have zero deflections. It will be shown that the chain may have any form provided that no bar is vertical.

Let  $A, B, C$  (Fig. 7:14) be three successive joints of a chain. In the unstrained position  $D_L$  and  $D_R$  are the lengths of the bars,  $L_L$  and  $L_R$  their horizontal projections, and  $\beta_L$  and  $\beta_R$  their angles with the horizontal (considered positive when measured counterclockwise from horizontal axes through their left ends).

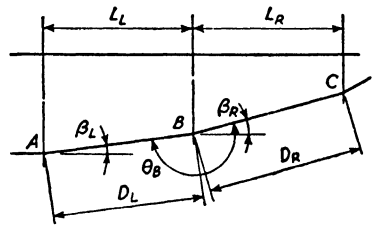

FIG. 7:14

Under load, the lengths of  $D_L$  and  $D_R$  will change, as will also the angles  $\beta_L$  and  $\beta_R$ . Assume that all changes are positive. Since the original deflection of  $A$  relative to  $B$  is  $D_L \sin \beta_L$ , it is evident (by the method of the differential calculus) that the added deflection of  $A$  relative to  $B$  will be<sup>2</sup>

$$\begin{aligned} \Delta_{AB} &= D_L \cdot \cos \beta_L \cdot \Delta\beta_L + \Delta D_L \cdot \sin \beta_L \\ &= L_L \cdot \Delta\beta_L + \frac{s_L D_L}{E} \sin \beta_L \\ &= L_L \left( \Delta\beta_L + \frac{s_L}{E} \tan \beta_L \right) \end{aligned}$$

Similarly,

$$\Delta_{BC} = L_R \left( \Delta\beta_R + \frac{s_R}{E} \tan \beta_R \right)$$

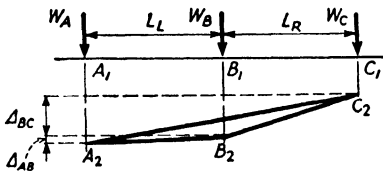

FIG. 7:15

Let  $A_1A_2, B_1B_2,$  and  $C_1C_2,$  the deflections of  $A, B,$  and  $C,$  be plotted from a horizontal base line,  $A_1C_1$  (Fig. 7:15). Our problem is to find the elastic weights ( $W_A, W_B, W_C,$  etc.) which will produce a moment curve that will have the same form as the truss deflection

curve. From the principle stated in Ex. 1:5, that if any two points on the moment curve of a beam are joined by a straight line the vertical intercepts between this line and the moment curve will be the same as those in the moment curve of that portion of the beam considered as a simple beam, it may be seen that the portion of Fig. 7:15 shown by three heavy lines is the moment curve produced in a span of length  $L_L + L_R$  by the load  $W_B$ . At  $B$  this moment

<sup>2</sup> Since these changes are very small, the relationships of the differential calculus hold:  $d(uv) = u dv + v du,$  and  $d \sin x = \cos x dx.$



will have the value  $\frac{W_B \times L_L \times L_R}{L_L + L_R}$ . But, from the geometry of the figure, it is evident that it also has the value  $\Delta_{BC} - \frac{L_R}{L_L + L_R} (\Delta_{BC} + \Delta_{AB})$ .

That is,

$$\begin{aligned} \frac{W_B \cdot L_L \cdot L_R}{L_L + L_R} &= \Delta_{BC} - \frac{L_R}{L_L + L_R} (\Delta_{BC} + \Delta_{AB}) \\ W_B \cdot L_L \cdot L_R &= \Delta_{BC}(L_L + L_R) - (\Delta_{BC} + \Delta_{AB})L_R \\ &= \Delta_{BC} \cdot L_L - \Delta_{AB} \cdot L_R \\ W_B &= \frac{\Delta_{BC}}{L_R} - \frac{\Delta_{AB}}{L_L} \end{aligned}$$

Substituting the values already determined for  $\Delta_{AB}$  and  $\Delta_{BC}$ ,

$$\begin{aligned} W_B &= \Delta\beta_R + \frac{s_R}{E} \tan \beta_R - \Delta\beta_L - \frac{s_L}{E} \tan \beta_L \\ W_B &= \Delta\theta_B - \frac{s_L}{E} \tan \beta_L + \frac{s_R}{E} \tan \beta_R \end{aligned} \quad 7:4$$

Similar weights at other points will cause a moment curve that will be the numerical equivalent of the deflection curve. The beam to which these loads are applied must be so supported that the deflections at the supports will have the correct value, i.e., will equal zero. Hence, it may be seen that the rules established in Art. 7:3 for the method of support of the conjugate beam, for the direction of the application of the elastic weights, and for the determination of the direction of the deflection will also hold for the beam to which the elastic weights are to be applied in determining truss deflections.

For a bar chain with bars horizontal  $\beta = 0$ , giving

$$W_B = \Delta\theta_B \quad 7:4a$$

Equation 7:4 for  $W_B$  cannot be solved when  $\beta = 90^\circ$ , that is, when a member of the bar chain is parallel to the deflection. This situation need not arise, since knowledge of the deflection of only one end of such a member need be given. The deflection of one end differs from that of the other merely by the change in bar length. If desirable, any element of a bar chain may be an imaginary bar.

In order to determine the elastic weights for trusses it is necessary to express the change in the angle between any two bars of a truss triangle in terms of the original angles of the unstressed triangle and the fiber stresses in the bars. Any such triangle is shown in Fig. 7:16,

and the successive operations necessary to express the change in  $\alpha$  are as follows.

$$\begin{aligned}
 L_1 &= L_2 \cos \alpha_3 + L_3 \cos \alpha_2 \\
 \Delta L_1 &= \Delta L_2 \cos \alpha_3 - L_2 \sin \alpha_3 \Delta \alpha_3 + \\
 &\quad \Delta L_3 \cos \alpha_2 - L_3 \sin \alpha_2 \Delta \alpha_2 \\
 &= \Delta L_2 \cos \alpha_3 + \Delta L_3 \cos \alpha_2 - h \Delta \alpha_3 \\
 &\quad - h \Delta \alpha_2 \\
 &= \Delta L_2 \cos \alpha_3 + \Delta L_3 \cos \alpha_2 + h \Delta \alpha_1
 \end{aligned}$$

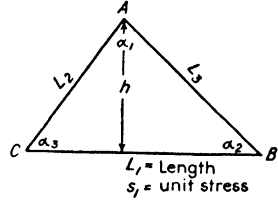

FIG. 7:16

Whence

$$h \Delta \alpha_1 = \Delta L_1 - \Delta L_2 \cos \alpha_3 - \Delta L_3 \cos \alpha_2$$

Substituting for  $\Delta L_1$  its value  $s_1 L_1 / E$ , etc., gives

$$\begin{aligned}
 E \Delta \alpha_1 &= \frac{s_1 L_1}{h} - \frac{s_2 L_2}{h} \cos \alpha_3 - \frac{s_3 L_3}{h} \cos \alpha_2 \\
 &= \frac{s_1}{h} (L_2 \cos \alpha_3 + L_3 \cos \alpha_2) - \frac{s_2 L_2}{h} \cos \alpha_3 - \frac{s_3 L_3}{h} \cos \alpha_2 \\
 &= (s_1 - s_2) \cot \alpha_3 + (s_1 - s_3) \cot \alpha_2
 \end{aligned} \tag{7:5}$$

Similarly

$$\begin{aligned}
 E \Delta \alpha_2 &= (s_2 - s_3) \cot \alpha_1 + (s_2 - s_1) \cot \alpha_3 \\
 E \Delta \alpha_3 &= (s_3 - s_1) \cot \alpha_2 + (s_3 - s_2) \cot \alpha_1
 \end{aligned}$$

A positive change indicates angle increase.

Figure 7:12 shows that  $\theta$ , as at  $B$ , may equal, in magnitude and sign, the change in certain truss angles (i.e.,  $\Delta \theta = \Sigma \cdot \Delta \alpha$ ), or, as at  $e$ , may equal the change in a certain angle in magnitude but may have the opposite sign (i.e.,  $\Delta \theta = -\Sigma \cdot \Delta \alpha$ ). The foregoing follows from the fact that, in every case, the angle  $\theta$  is *below* the bar chain. The elastic weight acts downward if the angle change,  $\Delta \theta$ , is a decrease, upward if an increase, these being the directions of action to give a positive bending moment curve in the first place, a negative curve in the second.

If one of the angles belongs to a quadrangular figure (for example, in a Baltimore truss), the procedure is to insert an imaginary bar dividing the polygon into triangles and calculate its change of length by the method of work. With this known it becomes possible to proceed as usual.

**Example 7:12.** Compute the elastic weights for panel points  $b$  and  $c$  for the truss and loading of Ex. 7:11, using the method just outlined.

*Solution.* The unit stresses in all bars of the truss were first determined,

as this is the form in which the information is usually directly given. All the angles between the several bars were named  $\alpha_1, \alpha_2$ , etc., and the values of the necessary cotangents computed. (Note.  $\alpha_1 = Bcb$ ;  $\alpha_2 = bBc$ ;  $\alpha_3 = cBC$ ; also  $\Delta\theta = -\Sigma\Delta\alpha$ .) It is to be noted that only three different angles appear in the computations for this truss. Then the relative movement of points  $c$  and  $d'$  was calculated (Prob. 7:9);  $uE\Delta L \div 1000 = 356.8$  corresponding to a unit stress of  $s_{ca'} = 356.8/25 = 14.3$  kips per sq in. compression. For angle  $Bba$  equation 7:5 gives  $(-4 - 4)(1.33) + (-4 - 0)(0.75) = -13.67$ .

Tabulating the work gives this:

Angle	Coefficient of			Values of $E\Sigma \cdot \Delta\alpha \div 1000$ (= $-E\Delta\theta \div 1000$ )		
	Cot $\alpha_1$ (1.33)	Cot $\alpha_2$ (0.75)	Cot $\alpha_3$ (0.293)			
$Bba$	-4-4	-4-0		-10.67	-3.00	-13.67
$Bbc$	0-4	0-0		-5.33		-5.33
	(Increase in $\theta$ )			Load at $b = -19.00$ acting up		
$bcB$		-4-0	-4-0	-3	-1.17	-4.2
$BcC$		+4-0	+4+14.3	+3	+5.4	+8.4
$Ccd'$		+6.4+14.3		+15.5		+15.5
$d'cd$						
	(Decrease in $\theta$ )			Load at $c = +19.7$ acting down		

**Example 7:13.** Draw the deflection curve for the lower chord points of the truss shown in Fig. 7:17, for the load shown. The area of each member in square inches equals the length in feet.  $\Delta\theta = -\Sigma \cdot \Delta\alpha$ . See Note on p. 208.

Angle	Factor of cot $\alpha$ cot $\alpha = 1.33$	Factor of cot $\beta$ cot $\beta = 0.75$	$(s_1 - s_2)$ cot $\alpha$	$(s_1 - s_3)$ cot $\beta$	$-E\Delta\theta =$ $E\Sigma \cdot \Delta\alpha$
$abB$	-38.1-38.1 = -76.2	-38.1- 0 = -38.1	-101.6	-28.6	
$Bbc$	+38.1-38.1 = 0	+38.1- 0 = +38.1	0	+28.6	-101.6
$bcB$		0-38.1 = -38.1		-28.6	
$BcC$	-76.1-38.1 = -114.2		-152.3		-174.5
$Ccd$	+38.1-76.1 = -38.0	+38.1+38.1 = +76.2	-50.7	+57.1	
$cdC$		-38.1-38.1 = -76.2		-57.1	
$CdD$	-114.2-38.1 = -152.3		-203.1		-493.5
$Dde$	-28.6-114.2 = -142.8	-28.6-28.6 = -57.2	-190.4	-42.9	
$deD$		+28.6+28.6 = +57.2		+42.9	
$DeE$	-85.8+28.6 = -57.2		-76.3		
$EeF$	-85.8-28.6 = -114.4		-152.5		-228.8
$Fef$		-28.6-28.6 = -57.2		-42.9	
$efF$	+28.6-57.2 = -28.6	+28.6+28.6 = +57.2	-38.1	+42.9	
$Ffg$	-57.2-28.6 = -85.8		-114.4		-131.0
$Gfg$		0-28.6 = -28.6		-21.4	
$fgG$	+28.6-28.6 = 0	+28.6- 0 = +28.6		+21.4	
$Ggh$	-28.6-28.6 = -57.2	-28.6- 0 = -28.6	-76.3	-21.4	-76.3



*Note.* The tabulation of the solution of equation 7:5 requires no explanation. The values of  $E\Delta\theta$  are all positive, indicating upward loads. The deflection at any point equals the bending moment due to the elastic loads; for example, that at  $b$  equals  $12,802 \div 30,000,000 = 0.00043$  ft downward. The deflection curve is shown in Fig. 7:18.

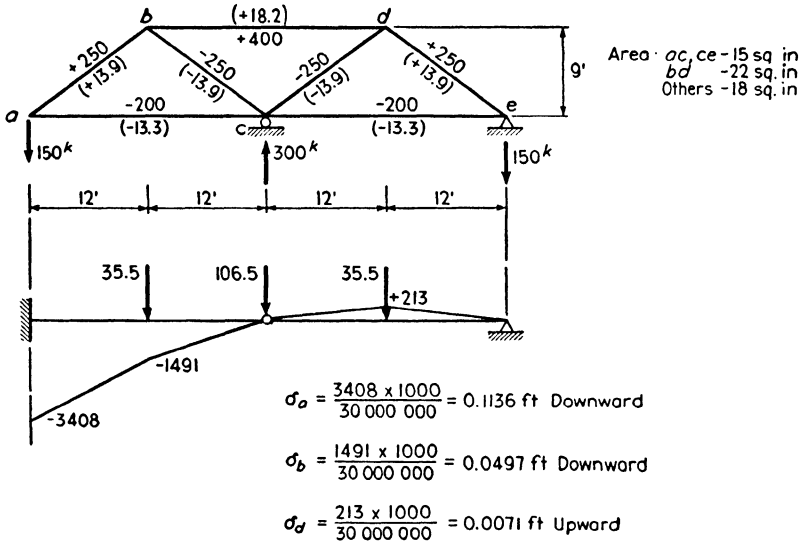

FIG. 7:19

**Example 7:14.** Determine by use of angle-change loading the vertical component of deflection at joints  $a$ ,  $b$ , and  $d$  of the truss of Fig. 7:19, when the structure is loaded with 150 kips at  $a$ .

*Solution.* The total stresses are shown on the bars, and also, in parentheses, the unit stresses (in kips per square inch). The chain  $abcde$  will be used, as it will give directly the desired deflections. In this truss  $abc$  and  $cde$  are  $\theta$  angles. On the contrary, angle  $bcd$  is equal to  $360^\circ - \theta$ . This will account for the plus signs before the values of  $\Sigma \cdot \Delta\alpha$  in the computations for  $E \cdot W_b$  and  $E \cdot W_d$ , and for the minus sign in the computation for  $E \cdot W_c$ . All the elastic weights act downward, since all are negative.

Compute  $E \cdot \Delta\alpha$  by equation 7:5:

$$\text{Angle } abc, [(-13.3) - (+13.9)]\frac{4}{3} + [(-13.3) - (-13.9)]\frac{4}{3} = -35.5$$

$$\text{Angle } bcd, [(+18.2) - (-13.9)]\frac{4}{3} + [(+18.2) - (-13.9)]\frac{4}{3} = +85.6$$

$$\text{Angle } cde = -35.5$$

$$\therefore E \cdot W_b = +(-35.5) - (+13.9) \left(+\frac{3}{4}\right) + (-13.9) \left(-\frac{3}{4}\right) = -35.5$$

$$E \cdot W_c = -(+85.6) - (-13.9) \left(-\frac{3}{4}\right) + (-13.9) \left(+\frac{3}{4}\right) = -106.5$$

$$E \cdot W_d = +(-35.3) - (-13.9) \left(+\frac{3}{4}\right) + (+13.9) \left(-\frac{3}{4}\right) = -35.5$$

Since the truss is supported at  $c$  and  $e$  and is free at  $a$ , the conjugate beam to which the elastic weights will be applied will be fixed at  $a$ , hinged at  $c$ , and supported at  $e$ . The elastic weights, moment curve, and deflections are shown in the figure.

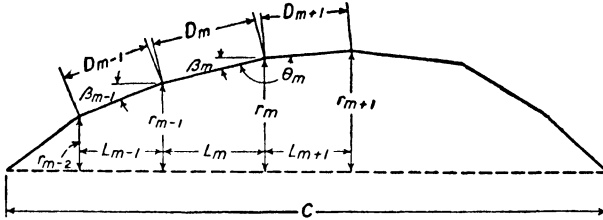

FIG. 7:20

**Example 7:15.** Determine the deflection of all joints on the bottom chord of the three-hinged arch shown in Fig. 7:21. (See Prob. 7:39 for the case of a three-hinged arch with end hinges at different levels.)

*Discussion.* The change in  $\theta$  (angle  $bCd$ ) at the hinge is a function of the rotation of each half of the arch about its supporting hinge as well as of angle changes in truss triangles. An expression may be found which will give the sum of the changes in all the  $\theta$ 's of the bar chain, all of which may be directly computed as hitherto (by use of equation 7:5) except  $\theta_c$ , the value of which follows by subtraction. This expression is derived as follows.

Consider any bar chain with span  $C$  as shown in Fig. 7:20. We may write

$$C = \sum D \cos \beta$$

$$\Delta C = \sum \Delta D_m \cos \beta_m - \sum D_m \sin \beta_m \Delta \beta_m \text{ (by the calculus. Compare the derivation of the expression for } \Delta_{AB}, \text{ page 203.)}$$

$$= \sum \frac{s_m}{E} D_m \cos \beta_m - \sum (r_m - r_{m-1}) \Delta \beta_m$$

$$= \sum \frac{s_m}{E} L_m + r_0 \Delta \beta_1 - r_1 \Delta \beta_1 + r_1 \Delta \beta_2 - r_2 \Delta \beta_2 + \text{etc.}$$

$$+ r_{m-2} \Delta \beta_{m-1} - r_{m-1} \Delta \beta_{m-1} + r_{m-1} \Delta \beta_m - r_m \Delta \beta_m + \text{etc.}$$

But  $r_0 = 0$

$$\therefore \Delta C = \sum \frac{s_m}{E} L_m + r_1 (\Delta \beta_2 - \Delta \beta_1) + r_2 (\Delta \beta_3 - \Delta \beta_2) + \text{etc.}$$

$$+ r_{m-1} (\Delta \beta_m - \Delta \beta_{m-1}) + r_m (\Delta \beta_{m+1} - \Delta \beta_m) + \text{etc.}$$

Clearly, as drawn,  $\Delta \theta_m = \Delta \beta_{m+1} - \Delta \beta_m$

$$\Delta \theta_{m-1} = \Delta \beta_m - \Delta \beta_{m-1}, \text{ etc.}$$

$$\therefore \Delta C = \sum \frac{s_m}{E} L_m + \sum r_m \Delta \theta_m$$

For the usual three-hinged arch  $\Delta C = 0$  and  $L$  is constant, giving

$$\sum r_m \Delta \theta_m = -L \sum \frac{s_m}{E} \tag{7:6}$$

The use of this equation gives the value of  $\theta_c$ , that at the hinge, which is supplied in equation 7:4 for  $W_c$  in the usual way.

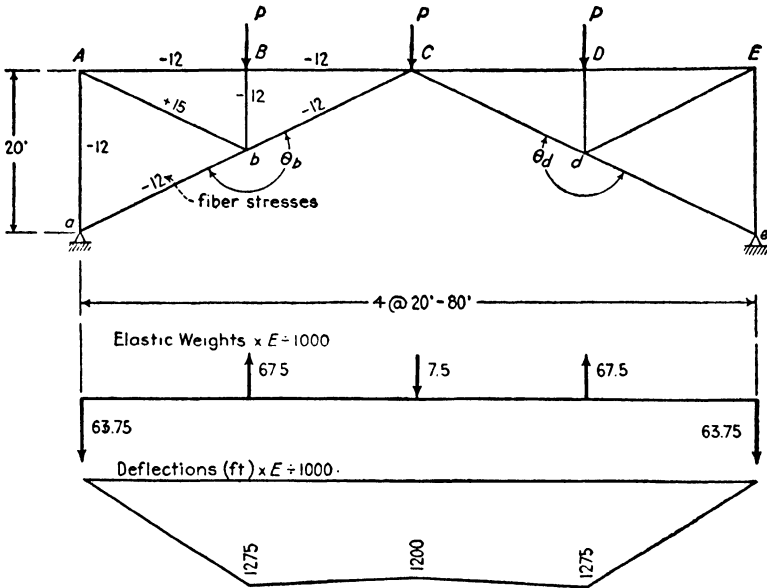

FIG. 7:21

Usually the deflection at the hinge greatly exceeds that elsewhere.

*Solution.*

$EW_m = E\Delta\theta_m - s_m \tan \beta_m + s_{m+1} \tan \beta_{m+1}$	
Angle	$E \times \text{Change of angle (Eq. 7:5)}$
$abA$	$(-12+12)\frac{1}{2} + (-12-15)\frac{1}{2} = -13.50$
$AbB$	$(-12-15)2 + (-12+12)0 = -54.0$
$BbC$	$(-12+12)2 + (-12+12)0 = 0$
Kip units:	$E\Delta\theta_b = E\Delta\theta_a = +67.50$

*Solving equation 7:4:*

$$EW_b = +67.50 + 12 \times \frac{1}{2} - 12 \times \frac{1}{2} = +67.50 \text{ up (kip units)}$$

$E\Sigma r_m \Delta \theta_m = -L\Sigma s_m$ (Eq. 7:6)					
Joint	Bar	$s_m$	$r_m$	$E\Delta\theta_m$	$r_m E\Delta\theta_m$
b	ab	-12	10	+67.50	+675.0
C	bC	-12	20		
$\Sigma s_m = 4 \times -12$ = -48			$\Sigma = +675 \times 2$ = 1350		

Solving equation 7:6:  
 $1350 + 20E\Delta\theta_C = -20(-48)$   
 $E\Delta\theta_C = -19.5$   
 By equation 7:4:  
 $EW_C = -19.5 - (-12)(\frac{1}{2}) + (-12)(-\frac{1}{2}) = -7.5$  down

Deflections:

Point b Deflection =  $1,275,000 \times 12 \div 30,000,000 = 0.51$  in.  
 Point C Deflection =  $1,200,000 \times 12 \div 30,000,000 = 0.48$  in.

**7.5. Williot-Mohr diagram.** The only direct method of determining the absolute displacement of truss joints is the graphical one devised by the French engineer Williot in 1877 and extended later, in the same year, by the German Otto Mohr. This was first brought to the attention of American engineers by David A. Molitor in the *Journal of the Association of Engineering Societies*, June 1894.

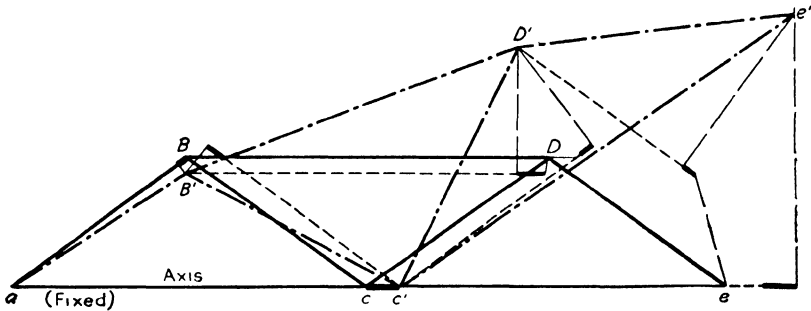

FIG. 7:22

In Fig. 7:22 is shown a Warren truss (solid lines) so loaded that the top chord and end posts are in compression, lower chord and diagonals in tension, as indicated in detail by the table attached to Fig. 7:23. The construction of the Williot diagram of Fig. 7:23b is explained by observation of the steps taken in passing from the undeformed truss in Fig. 7:22 to the shape taken by the deformed truss, represented with gross distortion by the dot-and-dash lines.

Let  $aBcDe$ , the solid-line truss of Fig. 7:22, represent the actual unloaded truss outline, laid out, let us say, on a loft floor. In order to have the necessary references as to place and direction we take a



convenient joint  $a$  as a fixed point and the bar  $ac$  as fixed reference line. Under load the bar  $ac$  increases in length by amount  $cc'$ , shown in heavy black line. In order to make visible what is happening it is necessary to exaggerate this change of length greatly. The actual lengthening, for example, if  $s = 15,000$  psi, is  $L/2000$  instead of the approximately  $L/10$  shown,  $L$  being the bar length.

To start the laying out of the deformed truss consider that the deformed bar  $aB$ , the end post, is laid down along line  $aB$  with one end at  $a$  and the other a small distance short of point  $B$ , as indicated by the heavy black line representing the shortening of the bar. Next, the diagonal  $cB$  is laid down parallel to its original position, along the dotted line with lower end at  $c'$ . Since this bar is lengthened by the stress, its upper end will lie a short distance above the top chord, as shown by the heavy black addition. The truss triangle is reunited by swinging two arcs, one from  $a$  with radius equal to the shortened length of the end post, and the other from  $c'$  with radius equal to the lengthened diagonal, with intersection of radii at  $B'$ . The triangle  $aB'c'$  represents, then, the distorted shape taken by  $aBc$  under load.

The first step in the construction of the Williot diagram, Fig. 7:23b, is to draw from a convenient point, which represents the origin  $a$ , a short, heavy line representing in direction and magnitude the movement of point  $c$  to  $c'$  with the lengthening of the bar: then from point  $c'$  a second heavy line upward to the left, representing the movement of the  $B$  end of bar  $cB$  with the lengthening of the bar, upward and away from  $c'$ : then a short, heavy line from origin  $a$  downward to the left, representing the movement of end  $B$  of the end post  $aB$ . Light-weight normal lines, intersecting at  $B'$ , represent the movements of the  $B$  ends of end post and diagonal upon the rotation of these bars into their final position. Since the deformations of the truss bars are very small in proportion to their lengths, it is permissible, without appreciable error, to substitute here tangents for the theoretically correct arcs.

Examination of the region  $B-B'$  of Fig. 7:22 will reveal at once the presence there of the figure which has just been described as the Williot diagram for this change in  $aBc$ . We can picture the  $B$  ends of the end post and diagonal tracing this diagram by thinking of the undeformed truss triangle being laid in position  $aBc$  with pin at  $B$  removed. As bar  $aB$  shortens, the  $B$  end moves downward to the left, and then on rotation follows the short arc (tangent) downward to the right to  $B'$ . When bar  $ac$  lengthens and  $c$  moves to  $c'$ , we may imagine bar  $cB$  being carried along by this movement without rotation. The  $B$  end of this diagonal then moves to the right horizontally the distance  $cc'$ , then upward to the left the amount of the bar change in length, then downward to the

left along the tangent upon rotation, to the intersection  $B'$ . The distance from origin  $a$  to point  $B'$  in the Williot diagram represents the movement of joint  $B$  in the loaded frame on the assumption that point

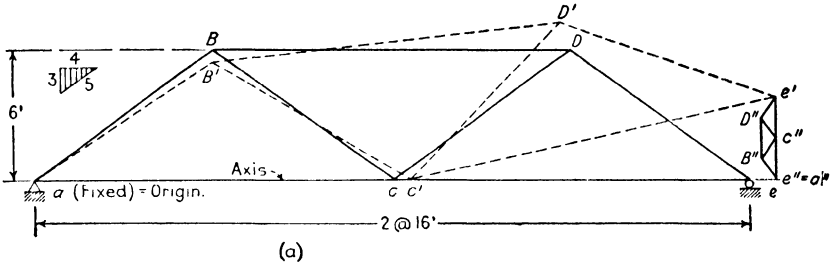

Bars	Unit Stress	Deformation (ft)
$ac, ce$	+16,000 psi	+256,000 $\div E$
$BD$	-12,000	-192,000 $\div E$
$aB, De$	-12,000	-120,000 $\div E$
$Bc, Dc$	+16,000	+160,000 $\div E$

$a$  is fixed in position, which is true, and bar  $ac$  fixed in direction, which is not true. The function of the Mohr diagram, which will be introduced shortly, is to correct for the effect of this untrue assumption.

We now have the displaced positions of two points,  $B'$  and  $c'$ , of truss triangle  $BcD$ , Fig. 7:22. Again, the  $D$  ends of the two bars, top chord  $BD$  and diagonal  $cD$ , trace out the Williot diagram elements. From  $B'$  and  $c'$  lay down these two bars in original length, parallel to original position, as shown in dotted lines. Inspection shows that the  $D$  ends of these bars have moved and separated as shown by the positions of points  $B'$  and  $c'$  relative to origin  $a$  of the Williot diagram, Fig. 7:23b. Returning to Fig. 7:22, shortening one bar, lengthening the other, and rotating both rejoin these two ends at  $D'$ . On the Williot diagram the movement of the  $D$  end of the top chord horizontally to the left is put down to scale from  $B'$ , the movement of the  $D$  end of the diagonal  $cD$  on its lengthening, upward to the right from  $c'$ . The normals representing the arcs unite at  $D'$ . The distance from origin  $a$

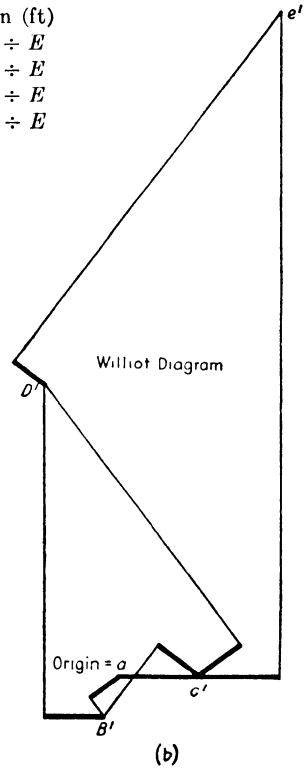

FIG. 7:23

to point  $D'$  represents the movement of joint  $D$  of the loaded truss on the assumptions already noted.

In the actual construction of a Williot diagram, point by point, we may "talk the thing to ourself" in some such fashion as this. The displaced positions  $D'$  and  $c'$  are known: the third point of triangle  $cDe$  is  $e$ . From  $D'$  we draw upward to the left, to scale, the movement of the  $e$  end of the end post,  $De$ , on shortening; from  $c'$  horizontally to the right the movement of the  $e$  end of the chord bar  $ce$  on lengthening: the normals from the ends of these indicated movements, representing movement on rotation, locate the point  $e$  at the intersection,  $e'$  in the Williot diagram. Then  $ac'$  is the displacement of joint  $e$  and, allowing for the difference in scales used, equals the distance  $ce'$  of Fig. 7:22.

Examine Fig. 7:22 and note that the additional construction for each new point involves all that has gone before: the starting points for point  $e$  really contain between them the whole preceding Williot diagram. Accordingly, all movements are measured from the origin.

**Mohr diagram.** The position of the deformed truss under the assumption that the axis  $ac$  remains unchanged in direction is shown by dotted lines in Fig. 7:23a. Actually the bar  $ac$  rotates about the fixed point  $a$ , and point  $e$  remains at the same level. To put the truss in its actual deflected position it is necessary to rotate it as a whole about point  $a$  till point  $e'$ , traveling through the arc (tangent)  $e'e''$ , arrives at its true level. Every other joint on the truss swings perpendicular to the line leading from it to point  $a$ , moving a distance proportionate to its distance from  $a$ . For example, point  $D$  moves the distance  $e'e''(aD \div ae)$ . The distortions are so small that the directions and magnitudes of movement are properly taken with reference to the original truss diagram.

On the line  $e'e''$  (Fig. 7:23a) as a lower chord a small truss, similar to the one whose deflections are being found, has been erected. These geometrical facts are to be noted about this small truss: every bar is perpendicular to the corresponding bar of the larger truss; the line from the farther end of any bar to  $e''$  is parallel to the rotation of that far end in the large truss on swinging  $e'$  to its proper level; for example,  $D''e''$  is parallel to the movement of  $D$  on rotation, also the distance  $D''e''$  in the small truss equals  $e'e''(aD \div ae)$ , which is the expression written above for the distance moved by  $D$  in the rotation. Accordingly  $D''e''$  is in direction and scale the distance moved by  $D$  on rotation,  $B''e''$  is the rotation movement of  $B$ ,  $c''e''$  that of  $c$ , etc. These distances are therefore the necessary corrections to be added to the movements given by the Williot diagram in order to obtain the absolute deflections, and the small truss constitutes a correction diagram to be combined with the Williot diagram. This is done in Fig. 7:24, which combines the

Williot diagram of Fig. 7:23b with the correction diagram in Fig. 7:23a. It is obvious that the fixed end of the truss of the correction diagram, to which Mohr's name is attached, must coincide with the corresponding point on the Williot diagram and that the lower chord must equal in length the vertical movement of point  $e$ . **The distance from any joint on the truss correction diagram to the corresponding point on the Williot diagram gives the actual movement of that point in direction and magnitude.** This follows from these two facts: that the distance from any joint on the correction diagram to  $a$  gives the amount and direction of the rotation that must be given to that joint to bring it to its true position from that where it was located by the Williot diagram; that the distance from  $a$  to the corresponding joint on the Williot diagram gives the movement of the joint with the axis remaining as assumed. The actual order of these movements is the reverse of that just given; for example, joint  $B$  moves the distance  $aB'$  (Fig. 7:24) and then rotates through  $B'B'''$ , a line parallel and equal to  $B''a$  in the correction diagram, giving the true movement  $aB'''$ . But  $aB'''$  is equal and parallel to  $B''B'$  in the combination Williot-Mohr diagram.

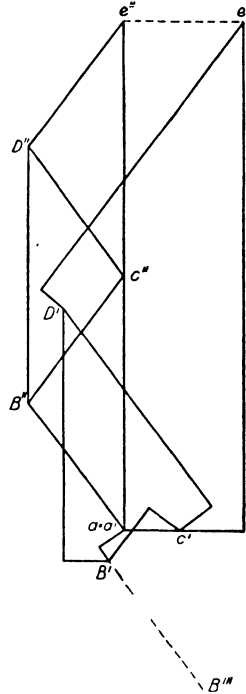

Fig. 7:24

The use of the fixed end of a truss as the origin of the Williot diagram usually results in a large and cumbersome figure. It is generally much better to use a bar in the central portion of the truss, the center vertical, if there is one, being the most convenient in general. A much more compact figure results, making possible the use of a larger scale with increased accuracy. The use of the center vertical as fixed bar is illustrated in Fig. 7:25.

The Williot diagram of Fig. 7:25b requires no comment beyond noting the fixed point and bar chosen: the Mohr diagram is given by the previous argument. The supporting point actually fixed by construction,  $d$ , must lie at  $d'$  of the Williot diagram, since absolute displacements are given by the distance from a point on the correction diagram to the corresponding point of the Williot. Point  $a$  is constrained by construction to move along a 1-to-4 slope: consequently this point of the Mohr diagram must lie somewhere on a line of that slope drawn through  $a'$

of the Williot. All rotational corrections converge at the fixed support point,  $d'$ , of the Williot diagram, and each is perpendicular to the line connecting the truss point with the fixed support. Accordingly,  $a''$ , the movable support point in the Mohr diagram, must lie on a line through  $d'$  which is normal to a line connecting the two support points of the truss. These two lines are dotted in the figure, converging at  $a''$ .

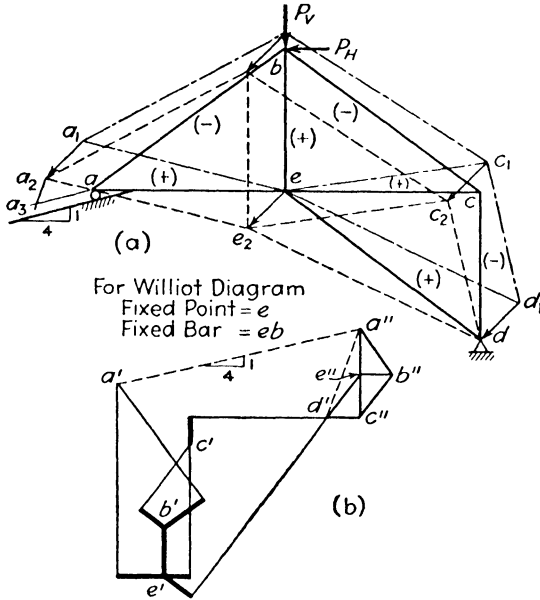

FIG. 7:25

The whole matter of the Mohr diagram may be put more generally. In every truss we have one point which is fixed (this is the starting point for the correction diagram, since it is a common point in both the Williot and the Mohr diagrams) and one point whose direction of motion is known. These two points on the correction diagram will be on a line perpendicular to the line connecting them on the actual truss, since this first line represents the rotational movement of the point of known direction of deflection. The point of known movement is located by observing that it must also lie on a line parallel to its known motion and through its position in the Williot diagram.

Further consideration of the joint movements involved when an intermediate bar is taken as reference is desirable. In Fig. 7:25a there is plotted, to about one-fourth the scale of the Williot diagram, the deformed truss with point  $e$  fixed and bar  $eb$  fixed in direction, shown in dot-and-dash lines. The distance  $dd_1$ , by which the fixed support point is moved from position by

these assumptions, equals the distance represented by  $e'd'$  in the Williot diagram. As a first step move the truss to the dotted-line position without any rotation, each point moving the distance  $d_1d$  (that is,  $d'e'$  in the Williot). This dotted truss is consistent with drawing the Williot diagram with point  $d'$  as the origin and bar  $eb$  remaining vertical. The movement of any point at this stage equals its distance from  $d'$ :  $d'$  to  $e'$  on translation of the truss;  $e'$  to the point in the Williot diagram on the original assumptions by which that diagram was drawn. For example, point  $a$  moves to  $a_1$  ( $e'a'$  by the Williot) and then by translation to  $a_2$  ( $d'e'$  by the Williot): resultant movement  $aa_2$ ,  $d'a'$  in the Williot diagram. There remains  $a_2a_3$ , the necessary rotation par-

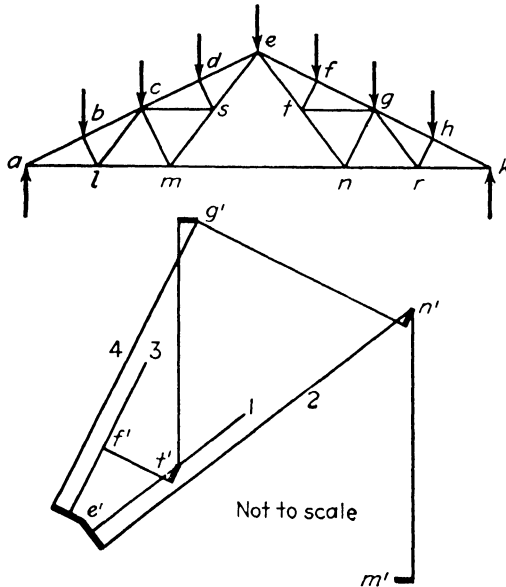

FIG. 7:26

allel to  $a''d'$  in the Williot by construction, with center  $d$ , to place point  $a$  on the line of its constrained slope. But the Williot distance  $d'a'$  is equal and parallel to  $aa_2$ , with due regard to scales:  $a'a''$  is parallel to  $a_3a$ . It follows geometrically that  $a''d'$  must represent by scale and direction the rotational movement  $a_2a_3$ , and  $a''a'$  must represent the resultant actual movement of joint  $a$  of the loaded truss. This last is the resultant of the three movements:  $a''d'$ ,  $d'e'$ ,  $e'a'$ . In similar manner it can be seen that the actual final movement of any joint is the distance from the point in the Mohr correction diagram to the point in the Williot diagram.

**Subdivided trusses.** A slight variation of the method must be used in dealing with subdivided trusses, that is, the Fink and fan trusses of Fig. 3:1 and the Baltimore and Pennsylvania trusses of Fig. 4:2. This is shown for a Fink roof truss in Fig. 7:26. Starting with bar  $al$  as the fixed bar, points  $a'$ ,

$b', c', d', e', l', m'$  and  $s'$  are located without any complications. In the portion of the Williot diagram shown in the figure points  $e'$  and  $m'$  are shown in approximately correct position: the diagram is not to scale. From  $e'$  the change in length of bar  $et$  is laid off downward to the right, and a normal, line 1, erected. Point  $t'$  will lie somewhere on this line. From  $e'$  the change of length of bar  $tn$  is laid off in addition, locating line 2. Point  $n'$  must lie on this line. From  $m'$  is laid off the change in length of bar  $mn$  and the normal thereto drawn. The intersection of this normal and line 2 locates  $n'$ . From  $e'$  the changes of bars  $ef$  and  $fg$  are laid off in series, thus locating the normals 3 and 4;  $f'$  must lie somewhere on line 3 and  $g'$  on line 4. From  $n'$  the change in length of bar  $ng$  is laid off and the normal drawn whose intersection with line 4 locates  $g'$ . The location of  $t'$  and  $f'$  follows similarly. The remainder of the diagram follows in usual fashion.

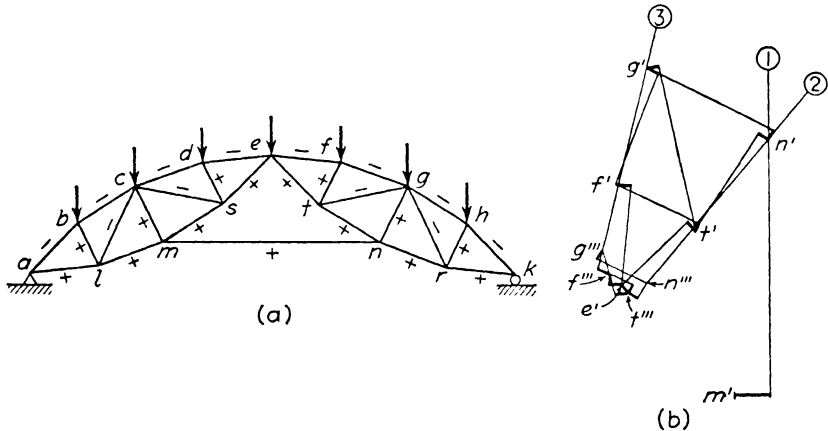

Fig. 7:27

The method just described serves also for a Baltimore truss. Suppose, for example, a diagram is to be constructed for the truss of Fig. 4:28 and the start is made at the center vertical. Working to the left, points  $U_4'$  and  $L_4'$  are obtained in usual fashion. Then, by using the combined changes of length of  $U_4U_2$  and  $L_4L_2$ , point  $U_2'$  is located. Similarly, knowing the combined length changes for  $L_4L_2$  and the change in length of  $U_2L_2$ , point  $L_2'$  is found. Intermediate points  $M_3'$  and  $L_3'$  are then located in a fashion similar to that described above.

The truss of Fig. 7:26 and the Baltimore truss of Fig. 4:28 are both special cases in that the two bars whose length changes are combined here lie in the same straight line. This is not the case with the truss of Fig. 7:27, whose similarity to the Fink truss will be noted. Taking bar  $al$  as the fixed reference bar, all the points on the left segment of the truss are found without complication. A portion of the Williot diagram is shown in the figure with  $e'$  and  $m'$  the only two points of this left-hand truss element. From  $m'$  the change in length of

$mn$  is plotted and a perpendicular erected, marked 1, on which  $n'$  will lie. The combined changes in length of bars  $et$  and  $tn$  cannot be plotted, since the bars do not lie in a single straight line. A new assumption is made, accordingly, that bar  $et$  retains its direction unchanged, and points  $t'''$ ,  $f'''$ ,  $g'''$ , and  $n'''$  are found. It is now necessary to rotate the portion of the truss  $etfgn$  about  $e$ , which rotation will cause point  $n'''$  in the Williot diagram to move along the line 2 drawn perpendicular to a line joining point  $n$  to the center of rotation  $e$ . The intersection of lines 2 and 1 locates  $n'$  in correct place. The same rotation causes  $g'''$  to move along the line 3, which is perpendicular to a line joining  $g$  to the center of rotation,  $e$ . From  $n'$  the change in length of bar  $ng$  is plotted, and a normal erected whose intersection with line 3 locates  $g'$ . In this example  $n$  and  $g$  rotate the same distance, being equal distances from  $e$ , which provides a check on this part of the work:  $n''n'$  must equal  $g''g'$ . (The check exists even if the points are not equidistant from the center, since the rotational movements will then be in proportion to the radii.) It is now possible to work back and locate  $t'$ ,  $f'$ , and  $e'$ , the last as a test of accurate workmanship, as it must fall at the original position. The triple-prime points have served their temporary purpose and are discarded. The rest of the construction is done in the usual fashion.

**Example 7:16.** Draw the Williot-Mohr diagram for the three-hinged arch of Fig. 7:28.

*Solution.* For the symmetrical loading but unsymmetrical arch of the example, the stresses are of the character indicated on the upper figure. Commencing at a common point  $a'$ ,  $f'$ , two Williot diagrams are drawn for the two halves of the arch, one for the left half on the assumption that  $aA$  remains vertical, the other for the right half on the assumption  $fF$  remains vertical. Based on these assumptions, the deflection of  $c$  is found to be  $a'c'$ , of  $d$ ,  $f'd'$ . But  $c$  and  $d$  are a common point and must have the same deflection. By use of the rotation method previously employed it is clear that  $c$  must lie somewhere on a line through  $c'$  and perpendicular to  $ac$ ,  $d$  on a line through  $d'$  and perpendicular to  $fd$ . These lines intersect at  $c'''$ ,  $d'''$ . Therefore,  $a'c'''$  and  $f'd'''$  give the true (and common) deflection of point  $c$ ,  $d$ . But it is known that the true deflection of a point is given by the distance from the point in the correction diagram to the point in the Williot diagram. Therefore, a line  $c''c'''$  is drawn, equal and parallel to  $a'c'''$  (in this case almost vertical),  $c''$  locating a point in the correction diagram. (Or, from the previously established rule,  $c''$  must lie on a line through  $a'$  perpendicular to  $ac$  and on a line through  $c'$  parallel to the now known direction of motion of  $c'''$ .) With  $a'' (=a')$  known, the correction diagram for the left half of the arch is readily constructed. In like fashion, the correction diagram for the right half is also drawn.

**7:6. Maxwell's law of reciprocal deflections.** Consider any structure, for example the truss of Fig. 7:29. The deflection at  $b$  in the direction indicated due to the load  $P$  at  $a$  equals  $\Delta_{ba}$  = deflection at  $b$  for load at  $a = \Sigma Su_b L / AE$ , where  $S$  is the stress in any bar due to load  $P$  and  $u_b$  that due to a unit load as shown at  $b$ . This stress  $S$  equals



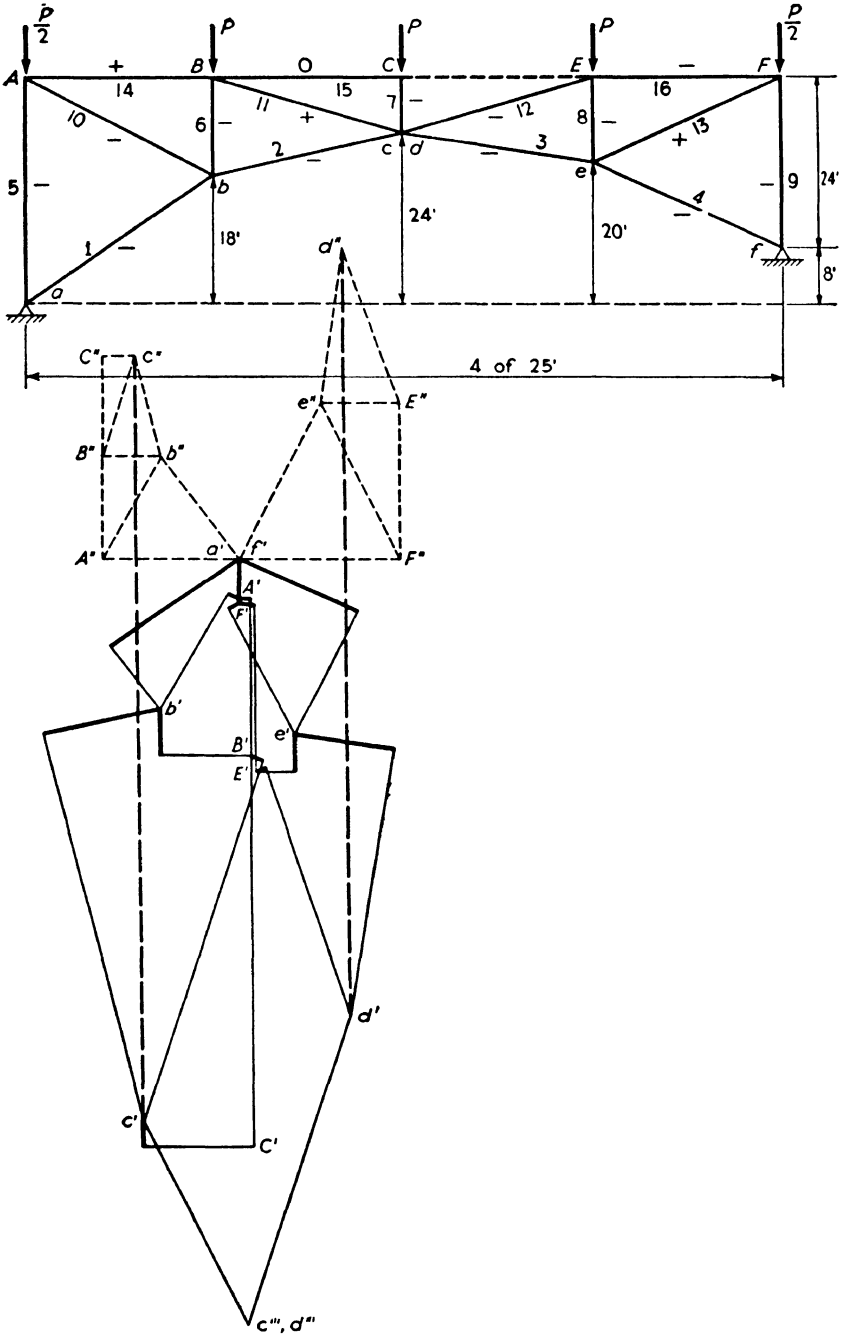

FIG. 7:28

$Pu_a$ , where  $u_a$  is the stress in any bar due to a unit force at  $a$  acting in the same direction as  $P$ . This gives  $\Delta_{ba} = \Sigma Pu_a u_b L/AE$ . But  $Pu_b$  equals the stress in any bar due to load  $P$  acting horizontally at  $b$  along the line of action of the unit force first employed there to find the deflection. Therefore the same expression gives the deflection at  $a$  along the line shown when  $P$  acts at  $b$  instead of  $a$ . That is,  $\Delta_{ab} = \Sigma (Pu_b) u_a L/AE = \Delta_{ba}$ . Perhaps the best way to remember this law is thus

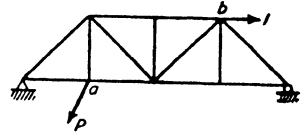

FIG. 7:29

$$\Delta_{ba} = \Delta_{ab} \quad 7:7$$

Expressed in words, it is rather awkward; any deflection component at a given point  $b$  on a structure due to a load at some other point  $a$  equals the deflection component at  $a$  along the original line of action of the load when the load acts at  $b$  in the direction of the first deflection component. The law is even more general than here stated, as the relation extends also to rotations.<sup>3</sup> This law was discovered and put forward by Maxwell in 1864 in a famous paper which will be referred to in the study of indeterminate trusses.

One important result from this principle is that *any deflection curve for a load of unity at some point on a structure is also the influence line for deflection at that point*, since any ordinate of the deflection curve under a unit load at some given point equals not only the deflection at the ordinate due to the unit load thus placed but also, by this theorem, equals the deflection which a unit load at the ordinate would cause at the given point.

Maxwell's law is a special case of Betti's law, a much more general principle which was discovered years later. This may be stated briefly as  $W_{AB} = W_{BA}$ : the work done by loads  $A$  already on the structure when loads  $B$  are applied, causing further distortion, equals that done by loads  $B$  when loads  $A$  are the second in order of application. This depends on the principle of independence of effect of forces, which is true so long as the distortions are small and also independent.

**7:7. Camber.** For the sake of appearance it is not considered desirable that the panel points of the usual straight lower chord deflect below the horizontal line through the supports at any stage of loading. To ensure this, trusses are cambered, that is, constructed so that under dead load these lower chord joints lie above the level of the supports and approach the horizontal only under full live load. This effect may be accomplished by making each compression member longer than its normal length an

<sup>3</sup> Parcel and Maney, *Statically Indeterminate Stresses* (John Wiley), Art. 9.

amount equal to its maximum shortening under full load, and shortening each tension member similarly. For short-span trusses a rule of thumb is often followed: making each top chord panel longer than the bottom chord by  $\frac{1}{8}$  in. for every 10 ft, and altering the diagonals to fit. This has about the same effect on the rise of the truss above the normal horizontal as if one-half as much change were made in both top and bottom chords. It corresponds, then, to assuming an average stress in the chords of approximately  $30,000,000 \times \frac{1}{18} \div 120 = 15,600$  lb per sq in. This approximate rule has the advantage of changing the lengths of all diagonals in the top chord lateral system by the same amount.

The exact method, i.e., altering the shop lengths of members by the amounts they will change under stress, is used for trusses longer than 200 ft, for all subdivided trusses, and for the trusses of all swing bridges. In any pin-connected truss allowance must be made for the equivalent change in member length which is caused by the clearance in the pin holes.

Plate girders shorter than about 75 ft are not cambered. Longer girders are assembled on blocking which has been given the required camber. In long, deep girders each piece of the web is usually given the shape of a rhomboid to fit the cambered shape of the girder.

PROBLEMS

Art. 7:2 Method of Work

**Problem 7:1.** By the method of work, verify the slopes and deflections given in the table.

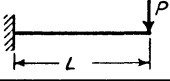
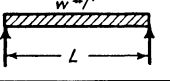
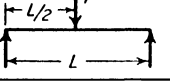
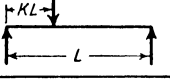
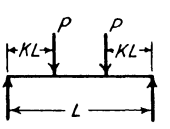
	Deflection	Slope
	At right end $\frac{PL^3}{3EI}$	At right end $\frac{PL^2}{2EI}$
	At center $\frac{5}{384} \frac{wL^4}{EI} = \frac{5}{384} \frac{WL^3}{EI}$	At left end $\frac{wL^3}{24EI} = \frac{WL^2}{24EI}$
	At load $\frac{PL^3}{48EI}$	At left end $\frac{PL^2}{16EI}$
	At load $\frac{PL^3}{3EI} (1-K)^2 K^2$	At load $\frac{PL^2}{3EI} K(1-K)(1-2K)$
	At load $\frac{PKL^3}{EI} (\frac{1}{2} - \frac{2}{3}K)$	At left end $\frac{PL^2}{2EI} K(1-K)$
	At center $\frac{PKL^3}{6EI} (\frac{3}{4} - K^2)$	

PROB. 7:1

**Problem 7:2.** By the method of work, determine the slope and deflection at point c due to the load shown.

Ans.  $\alpha = \frac{PL^2}{6EI}$ ,  $\delta = \frac{17PL^3}{162EI}$

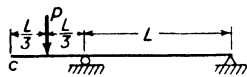

PROB. 7:2

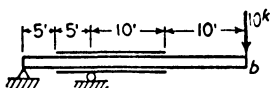

PROB. 7:3

15160  
 $2 - \pi \cdot 9 \times \frac{\pi}{8} \times 15'$   
 I of Beam = 609"⁴  
 I of Reinforced Section = 1295"⁴

**Problem 7:3.** By the method of work, determine the deflection of b due to the 10-kip load. Ans. 2.03 in.

**Problem 7:4.** Find the horizontal and vertical movement of point a of this truss due to the change in length of ab caused by a 40-degree fall in temperature. Coefficient of expansion = e = 0.0000065.

Ans. 0.0108 ft to right; none vertically.

**Problem 7:5.** What is the horizontal movement of point a of the same truss due to the load shown at d? E = 30,000,000, L/A = 1 for all bars.

Ans. 0.00096 ft to left.

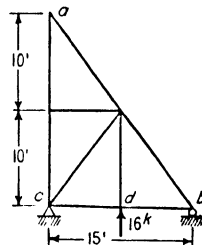

PROBS. 7:4, 7:5

**Problem 7:6.** What change must be made in the length of bar  $b$  of this truss to raise point  $a$   $\frac{1}{2}$  in.?

*Ans.* Shortened 0.47 in.

**Problem 7:7.** Find the vertical deflection of  $U_3$  and the horizontal movement of  $U_6$  of the truss of Prob. 4:10 $F$  due to a load of 24 kips at each top chord panel point. Take  $L/A = 1$  for all bars.  $E = 30,000,000$ .

*Ans.* 0.0616 ft down; 0.024 ft to left.

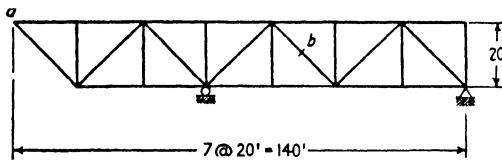

PROB. 7:6

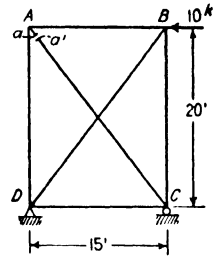

PROB. 7:8

**Problem 7:8.** Bar  $AC$  of the truss here shown is cut close to the upper end at  $a-a'$  and carries no stress. How much will point  $a$  move away from point  $a'$  under the action of the load of 10 kips at  $B$ ? Assume  $L/A = 1$  for all bars.

*Ans.* 0.011 in.

**Problem 7:9.** Find the relative movements of points  $c$  and  $d'$  of the loaded truss of Ex. 7:11, Fig. 7:13.

*Ans.* These points approach each other along the line joining them by an amount  $\Sigma u\Delta L = 356,800 \div E = 0.0119$  ft.

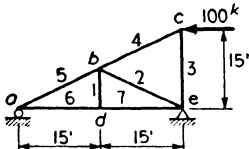

Areas: 1, 2, 3 - 4 sq. in.  
4, 5 - 10 sq. in.  
6, 7 - 7 sq. in.

(a)

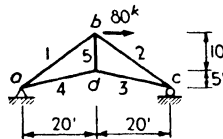

Areas: 1, 2 - 7.5 sq. in.  
3, 4 - 4 sq. in.  
5 - 3 sq. in.

(b)

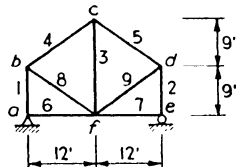

(c)

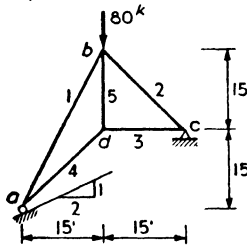

Areas: Bar 1 - 8 sq. in.  
Others - 5 sq. in.

(d)

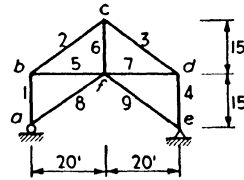

Areas: 1, 4 - 15 sq. in.  
2, 3 - 25 sq. in.  
5, 7 - 10 sq. in.  
6, 8, 9 - 3 sq. in.

(e)

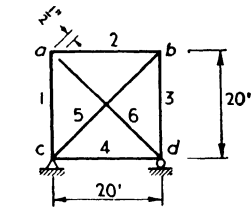

Areas of all Bars the same

(f)

PROB. 7:10

**Problem 7:10.** By the method of work ( $E = 30,000,000$  lb per sq in.):

- a. Determine the vertical deflection of *d*. Ans. 0.0213 ft down.  
 b. Find the deflection of *c*. Ans. 0.0388 ft to the right.  
 c. Find the horizontal movement of *d* when bar 3 is shortened 1 in.  
Ans.  $\frac{3}{8}$  in. to the right.  
 d. Determine the deflection of *a*. Ans. 0.0625 ft down to the left.  
 e. Find the horizontal load which, when applied at *a*, will cause that point to move 0.055 ft to the left. Ans. 36.3 kips.  
 f. Find the unit stress in bar 6 if that bar is made  $\frac{1}{2}$  in. short and then forced into position as a member of the frame. Ans. 12,900 lb per sq in.

**Problem 7:11.** By the method of work, determine the *H* and *V* components of movement of:

- |                                   |                                   |
|-----------------------------------|-----------------------------------|
| a. Joint <i>h</i> of Prob. 7:34a. | d. Joint <i>a</i> of Prob. 7:34d. |
| b. Joint <i>e</i> of Prob. 7:34b. | e. Joint <i>e</i> of Prob. 7:34e. |
| c. Joint <i>l</i> of Prob. 7:34c. | f. Joint <i>g</i> of Prob. 7:34f. |

### Art. 7:3 Elastic Weights: Beams

**Problem 7:12.** A horizontal timber beam, 6 in. by 12 in. by 16 ft, is supported at one end and at a point 12 ft away, leaving an overhang of 4 ft. A load of 8000 lb is at the center of the 12-ft span and one of 3000 lb at the end of the overhang, 10 ft from the other load. Compute the deflection of the beam at the 3000-lb load.  $E = 1,500,000$  lb per sq in.

*Suggestion.* A simple solution results if there are applied to the beam simultaneously the separate moment curves due to the two loads.

Ans. 0.0036 ft upward.

**Problem 7:13.** Solve Prob. 7:2 by the conjugate beam method.

**Problem 7:14.** Solve Prob. 7:3 by the conjugate beam method.

**Problem 7:15.** Determine by the conjugate beam method the end moments and the center deflection in a beam with fixed ends and span  $L$  due to a center concentrated load  $P$ .

$$\text{Ans. } M = -\frac{PL}{8}, \quad \delta = \frac{PL^3}{192EI}.$$

**Problem 7:16.** Determine by the conjugate beam method the end moments and the center deflection in a beam with fixed ends and span  $L$  due to a continuous uniform load of  $w$  lb per ft.

$$\text{Ans. } M = -\frac{wL^2}{12}, \quad \delta = \frac{wL^4}{384EI}.$$

**Problem 7:17.** A simple beam 24 ft long ( $I = 508.7$  in.<sup>4</sup>,  $E = 30,000,000$  lb per sq in.) carries a 12-kip load 15 ft from the left end. Determine the amount and position of the maximum deflection. Ans. 0.36 in., 12.85 ft from the left end.

**Problem 7:18.** Solve Ex. 7:1 by the conjugate beam method.

**Problem 7:19.** Solve Prob. 7:1 by the conjugate beam method.

**Problem 7:20.** Utilizing the calculus and the results obtained in connection with Fig. 7:10, determine for a single moving load the position which will cause maximum negative moment in a span with fixed ends. Find the value of this moment.

$$\text{Ans. } a = \frac{L}{3}, \quad M = -\frac{4PL}{27}.$$

**Problem 7:21.** Utilizing the results obtained in connection with Fig. 7:10, derive an expression for the positive moment at a single moving load in a span with fixed ends. What position of the load will make this moment greatest? What is the value of the greatest moment?

$$\text{Ans. } M = +\frac{2Pa^2b^2}{L^3}, \quad a = \frac{L}{2}, \quad M = +\frac{PL}{8}.$$

## Art. 7:4 Elastic Weights: Trusses

**Problem 7:22.** Prove that the elastic weights for diagonal  $U_1L_2$  in the truss of Fig. 4:6 are equal to  $\Delta L/r$ ,  $r$  being in one case the normal distance to the diagonal from  $L_1$ , in the other the normal distance from  $U_2$ .

**Problem 7:23.** What are the elastic weights for the vertical  $U_2L_2$  in the truss of Fig. 4:6, the change in length being a shortening?

*Ans.* At  $L_2$ ,  $(\Delta L/20)34/31$  downward; at  $L_3$ ,  $\Delta L/20$  upward.

**Problem 7:24.** Determine the deflection of all lower chord joints of the truss of Ex. 7:11 with the loading there shown, with this change: assume that the truss is made up *only* of the bars stressed under this loading.

*Discussion.* The altered truss is of the Warren type, with the addition of the bars  $dd'$ ,  $d'E$ , and  $Ee$ , and contains only two intermediate panel points on the loaded chord,  $d$  and  $e$ . Do not follow the rules previously suggested without careful investigation! Keep the values of  $A$  as in Ex. 7:11.

The deflections for  $d$  and  $e$  are the same as found in Ex. 7:11; for the other joints the values are different.

*Ans.* Elastic weights: at  $d$ ,  $41.6 \times 1000/E$ ; at  $e$ ,  $6.1 \times 1000/E$ .

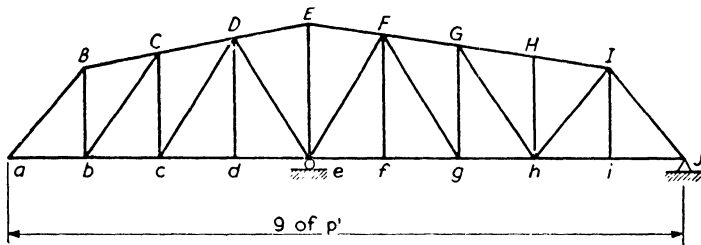

PROBS. 7:25, 7:26, 7:27

**Problem 7:25.** Compute the deflection of points  $a$  and  $g$  due to a lengthening  $\Delta L$  of bars  $efg$ . Call length  $Ff = h$ .

*Ans.*  $a$ :  $16 p\Delta L/5h$  upward.

$g$ :  $3 p\Delta L/5h$  downward.

**Problem 7:26.** Compute the deflection of points  $a$  and  $g$  for a lengthening  $\Delta L$  of bar  $gh$ . Call  $Gg = h$ .

*Ans.*  $a$ :  $12 p\Delta L/5h$  upward.

$g$ :  $6 p\Delta L/5h$  downward.

**Problem 7:27.** What would be the elastic loads for bar  $bC$  if the chords were parallel, the change of length being a lengthening?

*Ans.* Two loads of  $\Delta L/r$ , where  $r$  is the normal distance to the diagonal from either adjacent panel point, one acting down at  $c$  and the other up at  $b$ .

**Problem 7:28.** Complete the computation of elastic weights for the truss of Ex. 7:12, using the method of that example.

**Problem 7:29.** Determine the deflection of point  $a$  in the truss of Ex. 7:14, taking the lower chord as the bar chain.

**Problem 7:30.** By the elastic weight method ( $\Delta L/r$  method) determine the vertical deflections of the panel points of the horizontal chords of the trusses of Prob. 7:34.

**Problem 7:31.** For the trusses and loads of Prob. 7:34, determine by the bar chain method the vertical deflections:

- a. Of points *b, g, d*.
- b. Of all panel points.
- c. Of the lower chord panel points.
- d. Of the lower chord panel points.
- e. Of points *f, c, h, e*.
- f. Of the top chord panel points.

**Art. 7:5 Williot-Mohr Diagram**

**Problem 7:32.** Draw the Williot-Mohr diagram for the truss of Prob. 7:7.

**Problem 7:33.** Draw the Williot-Mohr diagrams for the structures of Prob. 7:10.

*Suggestions.* e. Assume a load of any magnitude at *a*. Compute the deflection. Within the elastic limit, loads and deflections are proportional.

f. Place two loads, *P*, one at *a* acting in, the other at the *a* end of the bar 6 acting out, of such magnitude that *S/A* in bar 6 has an assumed value of, say, 10,000 lb per sq in. Find the relative movement of the two points. Determine the required value of *S/A* to make the movement equal one-half inch.

**Problem 7:34.** Draw the Williot-Mohr diagrams for these structures.

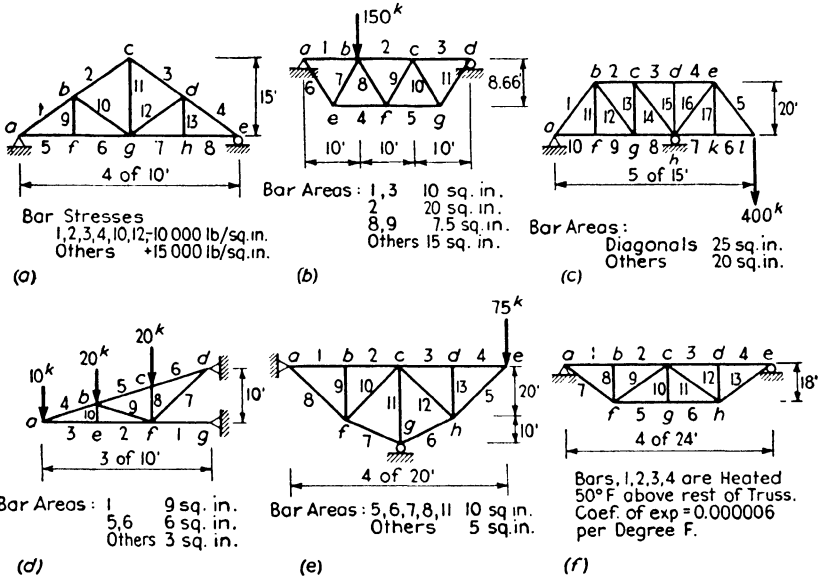

PROB. 7:34

**Problem 7:35.** In this truss the loaded bars are stressed to 15,000 lb per sq in. Determine the vertical deflection of points *b* and *c* by:

- a. The method of work.
- b. The method of elastic weights (i.e., by use of  $\Delta L/r$ ).
- c. The bar chain method.
- d. The Williot-Mohr method.

**Ans.** Deflection of *b*, 0.636 in.; *c*, 0.708 in.  
Note the effect of the unstressed bar *be* upon the shape of the deformed truss.

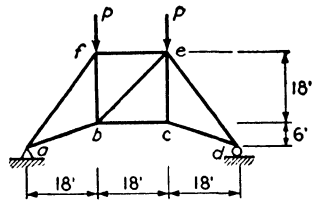

PROB. 7:35



**Problem 7:36.** Determine the vertical deflection of all lower chord panel points of the single-track railway bridge here shown, due to a live load causing the given stresses. Bar areas are also given. Also check the live-load stresses, which are those caused by a Cooper E-50 loading, placed so as to give maximum bending moment at the center panel point, occurring with wheel 12 at that point. Use these methods for computing deflections:

- a. Method of work.
  - b. Elastic weights, first method.
  - c. Elastic weights, bar chain method.
  - d. Williot-Mohr method.
- Ans. Deflection of b, 0.490 in.; c, 0.748 in.; d, 0.893 in.; e, 0.733 in.; f, 0.445 in.

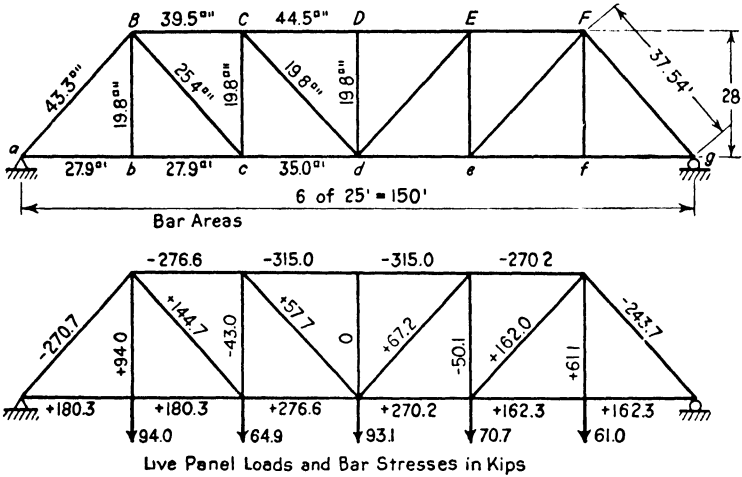

PROB. 7:36

**Problem 7:37.** Determine the deflection of the lower chord panel points of the truss of Prob. 11:2, using the loads of that problem by:

- a. The method of work.
- b. The method of elastic weights (by use of  $\Delta L/r$ ).
- c. The bar chain method.
- d. The Williot-Mohr method.

**Problem 7:38.** Determine the vertical deflection of points a, b, d of Fig. 7:19 by:

- a. The method of work.
- b. The method of elastic weights (by use of  $\Delta L/r$ ).
- c. The Williot-Mohr method.

**Problem 7:39.** For the truss of Ex. 7:16, the area of bars ab, bc, de, ef is 20 sq in., of the verticals is 10 sq in., of the other bars is 15 sq in. Determine for the loading of that example ( $P = 90$  kips) the vertical component of the deflection of joints b, c, and e by:

- a. The method of work.
- b. The method of elastic weights ( $\Delta L/r$  method).
- c. The bar chain method. *Note.* In applying the bar chain method, since the end hinges are not at the same level, equation 7:6 must be modified. Let the projections of the bar lengths on the line joining the hinges be  $G_m$ , etc., and the normal distances of the panel points from this line be  $t_m$ , etc. Working with the angles  $\gamma_m$ ,

etc., which are the angles the bars make with lines parallel to that through the hinges, the resulting equation will be

$$\Sigma t_m \cdot \Delta \theta_m = -\Sigma G_m \frac{\delta_m}{E} \qquad 7:6a$$

In general, the distances  $G_m$ , etc., will *not* be equal.

**Problem 7:40.** On the truss of Prob. 7:39 let a load of 4 kips per ft extend from  $A$  to  $C$ . Determine the vertical component of the deflection of joints  $b$ ,  $c$ , and  $e$  by:

- a. The method of work.
- b. The method of elastic weights ( $\Delta L/r$  method).
- c. The bar chain method. (See note with Prob. 7:39c.)
- d. The Williot-Mohr method.

**Problem 7:41.** For the truss of Ex. 7:15 determine the vertical component of deflection at  $b$ ,  $C$ , and  $d$  by:

- a. The method of work.
- b. The Williot-Mohr method.

RIGID FRAMES

**8:1.** A rigid frame consists of a series of structural members, lying in a single plane, with stiff joints capable of resisting bending. Such frames are usually highly indeterminate, and the exact computation of stress is a complicated and difficult matter. Even the simple portal shown in Fig. 8:1 has six unknown reaction elements and is statically indeterminate to the third degree. All the stresses in the three-column

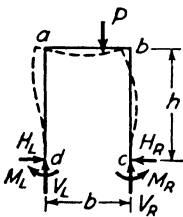

FIG. 8:1

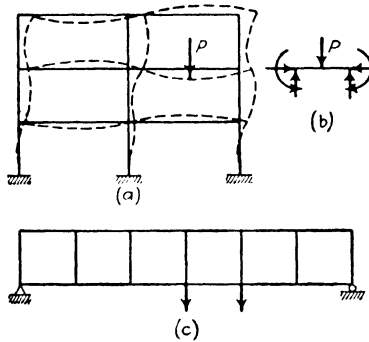

FIG. 8:2

three-story bent shown in Fig. 8:2a may be computed as soon as the moment, shear, and thrust at any point in each of the six horizontal members have been determined. The solution of the Vierendeel girder in Fig. 8:2c requires the determination of the moment, thrust, and shear in six of the seven verticals. Those stresses which cannot be found by statics are derived by consideration of the elastic deformation of the structure. The methods most used are those of least work, slope deflection, moment distribution, and column analogy. Another theorem which should be considered in this connection is that of three moments, since it is applicable for the approximate solution of continuous members under transverse loading in rigid frames.

**8:2. Theorem of three moments.** The theorem of three moments followed from the labors of three French investigators: Bertot, who,

in *Mémoires et comptes rendus de la société des ingénieurs civil de France*, 1855, investigated the beam with unequal spans and uniform load; Clapeyron, who, in *Comptes rendus de l'académie des sciences*, 1857, investigated loads that were uniform in any span but unequal in the spans; and Bresse, who, in *Comptes rendus de l'académie des sciences*, 1862, extended the method to include concentrated loads.

This theorem is an equation connecting the bending moments at any three consecutive supports of a continuous beam and is always derived by equating two expressions for the slope at the intermediate support, one being in terms of the loads, moments, etc., of the span to the left and the other in terms of the same functions to the right. Probably the simplest of the several methods of derivation<sup>1</sup> possible is that which

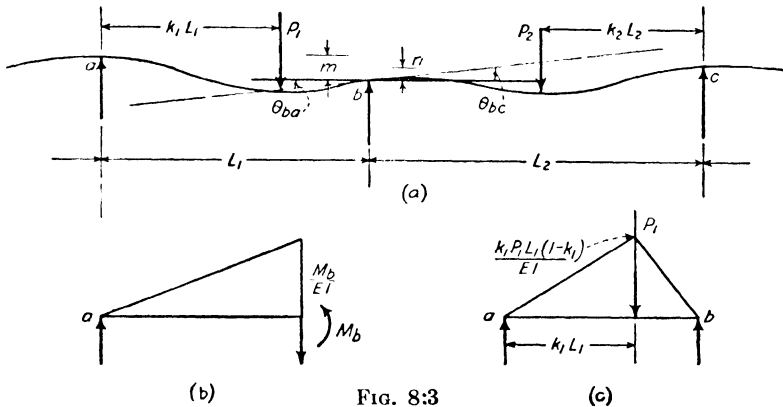

FIG. 8.3

makes use of elastic weights for obtaining the slope expression and also uses the principle of superimposition, the fact that a total effect equals the sum of all its parts. This principle applies generally in structural analysis, since most force effects (deformations) are independent of the deformations of the other applied loads. Where this is not the case, as in slender members under loads which are near the buckling limit, the law does not hold.

In Fig. 8.3 are shown any two consecutive spans of a continuous beam of indefinite length, cross section constant in any one span and homogeneous material ( $E$  constant), the supports of which were originally at the same level. The slope  $\theta_{ba}$  of the tangent to the elastic curve at the right end of beam  $ab$  depends upon four elements:

1. The bending moment,  $M_b$ , in the beam at  $b$ , which gives to  $\theta_{ba}$  a value equal numerically to the reaction at  $b$  caused by loading a simple

<sup>1</sup> This proof is given somewhat more thoroughly in *Statically Indeterminate Stresses*, by Parcel and Maney (John Wiley), page 133.

span  $L_1$  with the triangular  $M/EI$  diagram shown in Fig. 8:3b, giving

$$\theta_{ba} = \frac{M_b L_1}{3EI_1}$$

2. The bending moment at  $a$ , giving

$$\theta_{ba} = \frac{M_a L_1}{6EI_1}$$

3. The loads on the span, any one of which is shown as  $P_1$ , a distance  $k_1 L_1$  from  $a$ , giving the  $M/EI$  diagram of Fig. 8:3c, from which

$$\theta_{ba} = \frac{P_1 L_1^2 (k_1 - k_1^3)}{6EI_1}$$

4. The difference in elevation between  $a$  and  $b$ , whence

$$\theta_{ba} = -\frac{m}{L_1}$$

The total of these gives the slope at  $b$  in terms of the elements to the left as

$$\theta_{ba} = \frac{1}{6EI_1} \left( 2M_b L_1 + M_a L_1 + \Sigma P_1 L_1^2 (k_1 - k_1^3) - \frac{6EI_1 m}{L_1} \right)$$

This assumes that  $M_a$  and  $M_b$  are positive (causing compression in the top fiber) and that positive slope is that shown in the figure,  $m$  and  $n$  being taken as positive upward from  $b$ .

Similarly the value of  $\theta_{bc}$  in terms of the four elements to the right is

$$\theta_{bc} = \frac{1}{6EI_2} \left( -2M_b L_2 - M_c L_2 - \Sigma P_2 L_2^2 (k_2 - k_2^3) + \frac{6EI_2 n}{L_2} \right)$$

Since the slope at the  $b$  end of span  $ab$  equals that at the  $b$  end of span  $bc$ , these two expressions are equal, giving

$$\begin{aligned} \frac{M_a L_1}{I_1} + 2M_b \left( \frac{L_1}{I_1} + \frac{L_2}{I_2} \right) + \frac{M_c L_2}{I_2} &= -\frac{1}{I_1} \Sigma P_1 L_1^2 (k_1 - k_1^3) \\ &\quad - \frac{1}{I_2} \Sigma P_2 L_2^2 (k_2 - k_2^3) + 6E \left( \frac{m}{L_1} + \frac{n}{L_2} \right) \end{aligned} \quad \text{8:1}$$

For constant cross section in all spans this becomes

$$\begin{aligned} M_a L_1 + 2M_b (L_1 + L_2) + M_c L_2 &= -\Sigma P_1 L_1^2 (k_1 - k_1^3) \\ &\quad - \Sigma P_2 L_2^2 (k_2 - k_2^3) + 6EI \left( \frac{m}{L_1} + \frac{n}{L_2} \right) \end{aligned} \quad \text{8:1a}$$

In using these equations note that the signs for  $M_a$ ,  $M_b$ , and  $M_c$  are those for bending moment (Art. 1:4), that the loads  $P$  are downward,

that  $m$  is positive if support  $b$  has become depressed below  $a$ ,  $n$  is positive if support  $b$  has dropped below  $c$ .

For a uniform load over all of span  $ab$ , replacing  $P_1$  by  $w_1 dx$  and  $k_1$  by  $x/L_1$ ,  $-\Sigma P_1 L_1^2 (k_1 - k_1^3)$  becomes

$$-\int_0^{L_1} (w_1 dx) (L_1^2) \left[ \frac{x}{L_1} - \left( \frac{x}{L_1} \right)^3 \right] = \frac{-w_1 L_1^3}{4}$$

In a similar manner the right-hand side of the general equation can be modified for a uniform load over a part of the span or for a variable load, because, in general, for each load applied on either span there will be a term on the right side of the equation. For an external moment applied at any point it is necessary to return to the derivation of the theorem, replacing the term for  $\theta_{ba}$  given by the loading on the span by another appropriate to the load of the applied moment. Variation of cross section may also be taken care of by the use of elastic weights.

The method of least work, the three-moment theorem, the slope deflection method, and the moment distribution method have in common the fact that they give the bending moments at certain selected points in structures. After these moments are found, construction of the entire bending moment curve is simplified, first, by dealing separately with the beam loads and the bending moments at supports when computing reactions, and, second, by using the areas under the shear curve in computing moments, instead of writing the standard equations for these moments. This is illustrated in Ex. 8:2, which follows immediately. The theorem set forth in Ex. 1:5 (q.v.) will often be found useful here also.

Warning should be given that dependence upon the shear curve for obtaining bending moments is of most questionable value if the practice is allowed to obscure exactly what bending moment is.

**Example 8:1.** What is the center reaction of a continuous beam of two equal spans with a uniform load of  $w$  lb per ft over the whole length? The beam has supported (i.e., neither fixed nor restrained) ends.

*Solution.* From equation 8:1a we can write at once

$$0 + 2M_2(2L) + 0 = -\frac{wL^3}{4} - \frac{wL^3}{4}$$

$$M_2 = -\frac{wL^2}{8}$$

Also 
$$M_2 = -\frac{wL^2}{2} + RL$$

This gives  $R = \frac{3}{8}wL$  at each end

whence  $R = \frac{5}{4}wL$  at the center support

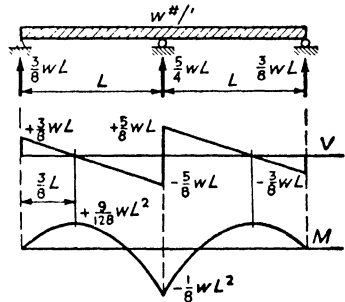

FIG. 8:4

**Example 8:2.** With the aid of the three-moment equation find the moments at the points of support of this beam, which is supported at *A* and *B* and is fixed at *C*. Find the reactions, and draw the shear and moment curves.

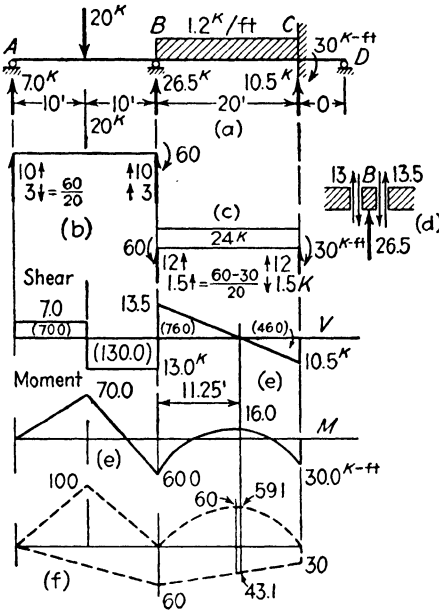

Fig. 8:5

*Solution.* When the beam considered has a fixed end, the device used in employing the three-moment equation is to add at the fixed end a span of zero length. (By drawing a curve of deflections, it may be seen that the effect of moving the supports at *C* and *D* close together until the distance between them becomes zero is to cause the tangent at *C* to become horizontal, and that is the actual condition when the end is fixed.) In this case the moments at *A* and *D* are zero. Writing the three-moment equation for spans *AB* and *BC*, and then for *BC* and *CD*, will give two equations which will permit the unknown moments at *B* and *C* to be found. These equations are:

$$0 + 2M_B(20 + 20) + 20M_C = -20 \times 20^2[\frac{1}{2} - (\frac{1}{2})^3] - \frac{1}{4} \times 1.2 \times 20^3$$

$$20M_B + 2M_C(20 + 0) + 0 = -\frac{1}{4} \times 1.2 \times 20^3$$

Solving these yields the following results:  $M_B = -60$  kip-ft,  $M_C = -30$  kip-ft.

With the bending moments at *B* and *C* determined, the first step in computing reactions was to take the free body *A-B* (Fig. 8:5*b*), the end sections of the free body being taken at infinitesimal distances inside the supports. This free body is acted upon by the 20-kip load which causes end reactions (shears) of 10 kips (see Art. 1:5), and the 60 kip-ft end moment, which causes end reactions of 3 kips, down at *A* and up at *B*. The free body *B-C* was similarly treated, Fig. 8:5*c*. Then the reactions were recorded on the original sketch of the *A-B-C* structure. The supporting force at *B* equals the sum of the shears required to support the *B* ends of the two free bodies. Figure 8:5*d* may be helpful in visualizing in detail what happens.

The shear and moment curves require no comment beyond pointing to the recording and subsequent use of the shear curve areas. Study here also the application of the theorem of Ex. 1:5 by the aid of Fig. 8:5*f*.

The problem of the solution of simultaneous equations arises with the analysis of continuous beams of several spans. At the end of Art. 8:5

will be found a summary of the methods employed. Regardless of the method adopted, one expedient should be used in solving equations derived from the three-moment equation. Consider a case in which there are *five* unknowns. The first equation will contain only the first two unknowns. This equation may be combined with the second to produce a new one in which the first unknown does not appear. Similarly, the next-to-last and last equations may be combined to produce another in which the last unknown does not appear. There will now remain three equations with three unknowns and these may be solved much more easily than five equations with five unknowns. The original first and last equations will then yield the values of the remaining two unknowns.

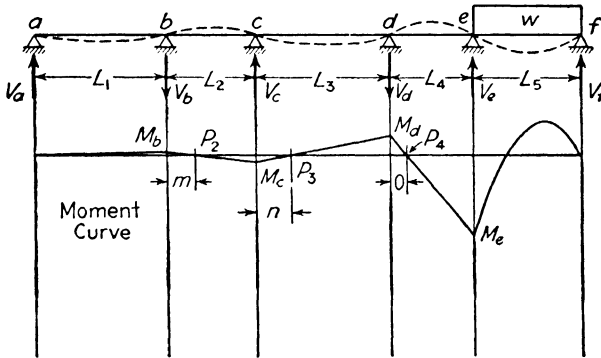

FIG. 8:6

**8:3. Fixed points in continuous beams.** The literature of the continuous beam is voluminous, many methods of attack having been proposed. Study of many of these methods will be facilitated by knowledge of a relationship which is useful in both algebraic and graphical approaches, the *fixed point*.

In Fig. 8:6 is shown a continuous beam with load on the extreme right-hand span only. In any unloaded span the bending moment curve is a straight line crossing the axis at point *p*. The positions of these points are constant regardless of the cause or magnitude of the moment at point *e*, and hence their name, *fixed points*. For a load on the left-hand span, other spans unloaded, there are corresponding fixed points in the right-hand halves of the unloaded spans.

The three-moment equation serves to give the relationships involved. Writing the equation for supports *a*, *b*, and *c* we have

$$2M_b(L_1 + L_2) + M_cL_2 = 0$$



whence 
$$M_b = -M_c \frac{L_2}{2(L_1 + L_2)} = -f_2 M_c$$

Proceeding for supports  $b$ ,  $c$ , and  $d$ , substituting for  $M_b$  the value just derived, gives

$$M_c = -M_d \frac{L_3}{2(L_2 + L_3) - f_2 L_2} = -f_3 M_d$$

Similarly  $M_d = -f_4 M_e$ , where  $f_4 = L_4/[2(L_3 + L_4) - f_3 L_3]$ . To locate any fixed point, for example, that in the second span, we may write (Fig. 8:6)

$$\frac{m}{L_2} = \frac{M_b}{M_b + M_c} = \frac{f_2 M_c}{f_2 M_c + M_c}$$

whence 
$$m = \frac{L_2}{1 + 1/f_2}$$

Similarly, 
$$n = \frac{L_3}{1 + 1/f_3}$$

These relationships enable us to determine the moments at the supports of a continuous beam with relative directness, in this case without the use of simultaneous equations. With the values of  $f$  computed for all spans to the left, the writing of the three-moment equation for the last three supports gives an equation with a single unknown,  $M_e$ . For load on an intermediate span,  $L_4$  for example, this method gives a pair of equations with two unknowns instead of the conventional four equations for the five-span beam under discussion, because the equation for supports  $c$ ,  $d$ , and  $e$  will involve only two unknowns,  $M_d$  and  $M_e$ : that for supports  $d$ ,  $e$ , and  $f$  will involve the same unknowns. Were there other spans to the right this would still be true, using the  $f$  values for loads to the left.

It is sometimes desired to draw a series of bending moment curves for a continuous beam, each for the condition of one span only under load. This is not a tedious task with the aid of the fixed points.

**8:4. Method of least work.** In 1879 the Italian Castiglione published an elaborate research in indeterminate structures, using the method of least work. Euler in the eighteenth century and Menabrea in a paper printed in 1858 had made use of this principle, but only since Castiglione's epoch-making treatise has the method taken its present high place in the estimate of the structural engineer, an esteem based on the simplicity of its conceptions, its wide scope, and the directness of its results. It is commonly known as Castiglione's second theorem.

**The theorem of least work states that in any statically indeterminate structure the total internal work accomplished during its deformation under load is the minimum consistent with equilibrium.** It is often considered sufficient proof of the theorem to urge that it is inevitable that the natural expenditure of energy for the establishment of equilibrium in a disturbed body is the least possible.

Castigliano's first theorem states that for any structure loaded with gradually applied loads the deflection under any load equals the first partial derivative of the total internal work in the structure with respect to the stated load.<sup>2</sup> If this deflection is zero, as for a point of support, this derivative with respect to that supporting force (considered as a load) equals zero, which is the condition for a minimum value of the work function. This is sufficient to establish the second theorem, that of least work, for a structure with redundant reactions. The situation is similar for a truss with a redundant bar. We consider the stress,  $X$ , in the chosen redundant as one of the loads acting on the structure, applying it as action and reaction on the two sides of a section through the bar.<sup>3</sup> The relative displacement of the two faces of the bar formed by this section is zero.

The operation of the theorem consists in expressing the total work done in the structure in terms of the loads and the one or more redundant elements (reaction, bar stress, etc., in excess of those necessary for equilibrium), placing the derivative of this expression with respect to the unknown (or the series of partial derivatives with respect to each of the unknowns) equal to zero and solving for the redundant element sought.

The expressions for work in a truss or beam are derived in a manner similar to that by which the work equations were obtained in Art. 7:2. Since loads on structures are gradually applied, the work ( $W$ ) done by a stress ( $S$ ) in deforming a bar an amount  $SL/AE$  is equal to the average stress multiplied by the total deformation,  $W = S^2L/2AE$ . This is known as Clapeyron's law (1833). For a beam  $W = \int \frac{M^2 dx}{2EI}$ .

This expression can be written directly upon noting that in any differential length of beam,  $dx$ , the work done is the average moment,  $M/2$ , multiplied by the rotation, the angle between the two end tangents,  $M dx/EI$ . The evaluation of the integral is often facilitated by noting

<sup>2</sup> See *Statically Indeterminate Stresses* by Parcel and Maney (John Wiley), page 36. A more detailed statement of the least work derivation is given on page 121.

<sup>3</sup> This assumes that the bar exactly fits into the unloaded structure. If the bar length differs from the theoretically true one and has been forced into position, the effect of this under-run or over-run in length upon the truss stresses is a separate problem in itself. See Prob. 7:10f.

that it equals the moment about the base line of the total area under the moment curve, divided by  $EI$ .

**Example 8:3.** Solve Ex. 8:1 by the method of least work.

*Solution.* This beam is indeterminate in the first degree, having one redundant reaction. Taking either of the end reactions ( $V$ ) as the unknown, the total work in the beam equals

$$W = \frac{2}{2EI} \int_0^L \left( Vx - \frac{wx^2}{2} \right)^2 dx$$

$$\frac{dW}{dV} = 0 = \int_0^L 2 \left( Vx - \frac{wx^2}{2} \right) (x) dx = \frac{VL^3}{3} - \frac{wL^4}{8}$$

Therefore,  $V = \frac{3}{8}wL$  at each end and it follows that the reaction at the center support  $= \frac{5}{4}wL$ . The labor of solution is materially reduced by differentiating before integrating, noting that  $du^n/dx = nu^{n-1} du/dx$ .

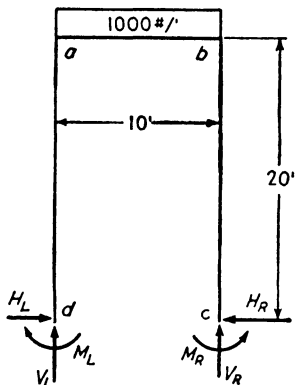

FIG. 8:7

**Example 8:4.** Compute the reactions of the portal frame shown in Fig. 8:7 for a load of 1000 lb per ft over the span  $ab$ . The frame is of uniform material and section throughout.

$$I = 400 \text{ in.}^4 \quad A = 20 \text{ sq in.} \quad h = 20 \text{ ft}$$

$$b = 10 \text{ ft}$$

*Solution.* Since the structure has six reaction components, it would, under unsymmetrical loading, be statically indeterminate to the third degree (i.e., there are three components in excess of the number which may be found by statics). In the present symmetrical example it is seen that the two verticals must be equal, and the equation  $\Sigma V = 0$  gives their value.

Likewise  $M_L = M_R = M$  and  $H_L = H_R = H$ . The total work in the frame in terms of these two unknowns is

$$W = 2 \int_0^{20} \frac{(M - Hx)^2 dx}{2EI} + \frac{1}{2EI} \int_0^{10} \left( M - 20H + 5x - \frac{x^2}{2} \right)^2 dx$$

$$+ \frac{2 \times 5^2 \times 20}{2AE} + \frac{10H^2}{2AE}$$

$$\frac{\partial W}{\partial M} = 0 = 2 \int_0^{20} 2(M - Hx) dx + \int_0^{10} 2 \left( M - 20H + 5x - \frac{x^2}{2} \right) dx$$

$$= 40M - 400H + 10M - 200H + 250 - 167$$

$$M = 12H - 1.7$$

$$\begin{aligned} \frac{\partial W}{\partial H} = 0 &= \frac{1}{I} \int_0^{20} 2(M - Hx)(-x) dx + \frac{1}{I} \int_0^{10} \left( M - 20H + 5x - \frac{x^2}{2} \right) (-20) dx \\ &\quad + \frac{10H}{A} \\ &= \frac{1}{I} (-400M + 5333H - 200M + 4000H - 5000 + 3333) + \frac{10H}{A} \end{aligned}$$

Substituting the numerical values of  $I$  and  $A$ , putting both into foot units since the lengths were taken in feet,  $400/12^4$  and  $20/12^2$ , gives

$$0 = -31,000M + 483,800H - 86,400 + 72H$$

$$M = 15.6H - 2.8$$

Solving,  $M = 2080$  ft-lb, and  $H = 314$  lb

The work of solving is simplified usually by taking the unknowns as the center shear, thrust, and moment in the horizontal members. The method is cumbersome, however, to such a degree that the stock joke of the structural engineer refers to it as the method of most work. In many situations, however, it is easier of application than its rivals, and for certain composite structures (Art. 10.5) it is the only available method.

The error introduced in the results by neglecting the work due to direct stress (i.e., neglecting the  $72H$  in the second simultaneous equation) is imperceptible in the previous example and in general is very small. Accordingly, this approximation is used a great deal. Moreover, both the slope deflection method and the method of moment distribution make a similar assumption, i.e., that the members retain their original lengths, and the corresponding assumption must be made with the method of least work if it is desired to check precisely results obtained by the other methods.

**8:5. Method of slope deflection.** In 1915 Professor George A. Maney<sup>4</sup> presented the method of slope deflection as a general method for the solution of rigid-joint problems, making use of expressions for the end moments in restrained pieces originally proposed in closely similar form by Manderla in 1878 and in modern form by Otto Mohr in 1892, both writing on the problem of secondary stresses. The method consists in writing a series of simultaneous equations, each expressing the relation between the moments acting at the ends of certain of the members of the given frame, in terms of slope and deflection. The solution of these equations gives either the end moments directly or, more commonly, the slope and deflection of the various joints from which values the moments may be computed.

The general method of stress analysis of indeterminate structures

<sup>4</sup> *Engineering Studies No. 1*, University of Minnesota.

which uses deformations in place of stress as the unknown quantities was given general formulation by A. Ostenfeld of Copenhagen (1925).

A picture of the physical relations involved is gained by inspection of Fig. 8:2a where, under the load  $P$ , the whole frame is deformed, there being a small rotation of each joint and a slight deflection of the upper end of each vertical with respect to the lower. As would be expected, the deformations, and accordingly the stresses, caused by such a load are large only in the piece directly under it and in those members directly joined to the loaded piece.

The several members of this frame are described as restrained at the ends, i.e., subject to a bending moment which, for two or more members loaded, may be larger or smaller than that required to fix the end (prevent rotation of the end tangent) under the transverse loading.

The relation usually used in setting up the necessary simultaneous equations is that of the equilibrium of a joint. Every joint being in equilibrium under the action of the moments applied to it by the members there meeting, the sum of the moments acting on the ends of the members meeting at any joint must equal zero. When necessary, other relations are found by considering the equilibrium of selected portions of the frame.

The moment at the end of a restrained member consists of three elements: (1) that moment which, acting with the moment at the other end, gives the end tangents of the unloaded beam the actual slope held in the deformed frame; (2) that added moment required to prevent further rotation of the tangent when one end of the bar is deflected with respect to the other; and (3) that added moment required to prevent further rotation of the end tangent when the loads are placed on the member.

*Element 3.* No new derivation is required to obtain an expression for the increment of moment required to prevent further rotation of the end tangent when the loads are placed on the member, because it is recognized as the moment existing at the end of a fixed beam of the same span and loading as the given member in the rigid frame. This element will be designated as  $M_F$  (for fixed beam moment), with further subscript to denote its location.

The three-moment equation can be used to evaluate this fixed-end beam moment, or the value may be taken from the tables in various handbooks, which cover a wide range of loading. A general expression which may be expanded for all loadings for constant  $EI^6$  is given in

<sup>6</sup> For members of variable section see "The Modified Slope-Deflection Equations" for frames composed of members of variable moment of inertia, by L. T. Evans, *Journal of the American Concrete Institute*, October 1931, page 109.

the discussion accompanying Fig. 7:10, and its use is illustrated in Probs. 8:14 to 8:17.

The fixed-end beam moments always act in such a direction on the ends of the beam as to cause tension on the side where the load is applied, and by the convention usual in connection with bending moment in beams they are classed as negative moment. **A different convention is usual, however, for the slope deflection method, a clockwise moment acting on the end of the piece being taken as negative, counterclockwise as positive.**<sup>6</sup> In any specific problem the direction of the transverse loading serves to indicate the direction of each fixed-end moment, and, therefore, shows whether  $M_F$  is plus or minus.

*Element 1.* In Fig. 8:8 is shown a beam acted upon by two end moments,  $M_{ab}$ , moment at the  $a$  end of member  $ab$ , and  $M_{ba}$ , moment at the  $b$  end of  $ab$ , both positive (counterclockwise). It is required to express these moments in terms of the end slopes,  $\theta_a$  and  $\theta_b$ , which they cause, both counterclockwise and, as usual, considered as positive in sign. The bending moment curve is here drawn in the accustomed manner, with signs as previously used in the conjugate beam problems. To simplify the finding of the elastic reactions the elastic loading has been taken in two parts, a triangular load from the moment curve due to  $M_{ab}$  alone, and another triangular load due to  $M_{ba}$  alone, their summation giving the actual curve. From Fig. 8:8 we have directly

$$\theta_a = \frac{L}{6EI} (2M_{ab} - M_{ba}), \quad \theta_b = \frac{L}{6EI} (-M_{ab} + 2M_{ba})$$

Solving these equations gives, with  $K = I/L$ ,

$$M_{ab} = 2EK(2\theta_a + \theta_b), \quad M_{ba} = 2EK(2\theta_b + \theta_a) \quad 8:2$$

It is helpful thus to consider the significance of sign relationship. A positive (counterclockwise)  $M_{ab}$  causes a positive  $\theta_a$ . Let the  $b$  end now be rotated counterclockwise, giving a positive  $\theta_b$ . This tends to produce a clockwise rotation at  $a$ , and an increase in positive (counterclockwise) moment  $M_{ab}$  is required to prevent this change in  $\theta_a$ .

*Element 2.* The moments required to fix the ends when one end deflects a distance  $d$  normal to the original axis may be evaluated by aid of the theorem which states that this deflection equals the moment about one end of the area under the whole  $M/EI$  diagram (footnote, page 185).

<sup>6</sup> The opposite convention was used in the first and second editions of this book. The change is occasioned by the fact that it is becoming increasingly common in technical literature—particularly when using the method of moment distribution—to regard as positive a moment which tends to rotate clockwise the joint to which the member connects. By this convention the moment in a beam with fixed ends and with downward vertical loads is positive at the left end, negative at the right.

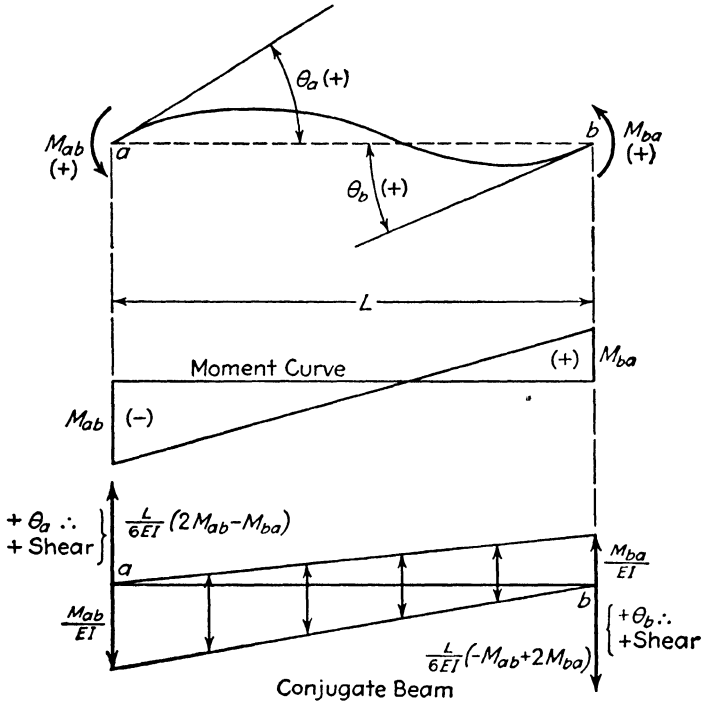

FIG. 8:8

Negative deflection is taken as that occurring when the line connecting the two ends of the piece rotates in a clockwise direction.

These end moments are both positive for negative deflection, as shown in Fig. 8:9, which shows that

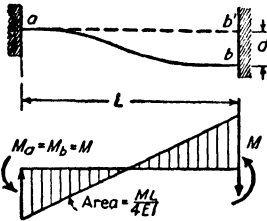

FIG. 8:9

$$-d = \frac{ML}{4EI} \times \frac{2L}{3} = \frac{ML^2}{6EI}$$

and

$$M = \frac{-6EId}{L^2} = -6EKR$$

where  $\frac{d}{L} = R$

Combining these three elements gives

$$M_{ab} = 2EK(2\theta_a + \theta_b - 3R) \pm M_{Fab} \tag{8:2a}$$

$$M_{ba} = 2EK(2\theta_b + \theta_a - 3R) \pm M_{Fba} \tag{8:2b}$$

the general slope deflection equations for the moments at the ends of a restrained prismatic piece under transverse loading.

**Example 8:5.** Solve Ex. 8:4 by the slope deflection method.

*Solution.* By symmetry it is noted that  $\theta_a = -\theta_b$  and that there is no deflection horizontally of either point  $a$  or  $b$ . There is only one unknown, therefore,  $\theta_a$ .

For the columns,  $K_c = I/20$ ; for the connecting beam,  $K_b = I/10 = 2K_c$ ;  $M_{Fab} = wL^2/12 = (1 \times 10^2)/12 = 8.33$  kip-ft. The sign is plus, since this moment is counterclockwise, acting on  $ab$ .

From the general slope deflection equation (equation 8:2a)

$$M_{ab} = 2E(2K_c)(\theta_a) + 8.33$$

$$M_{ad} = 2EK_c(2\theta_a)$$

$$M_{da} = 2EK_c(\theta_a)$$

For joint  $a$   $M_{ab} + M_{ad} = 0$

whence  $\theta_a = \frac{-8.33}{8EK_c}$ , indicating clockwise rotation.

Solving,  $M_{ad} = -4EK_c \left( \frac{8.33}{8EK_c} \right)$

$$= -4167 \text{ ft-lb}$$

$$M_{da} = -2083 \text{ ft-lb}$$

This indicates a clockwise moment at both top and bottom of vertical  $ad$ . The shear in the vertical equals  $H = (4167 + 2083) \div 20 = 313$  lb.

These results check the least work solution. Note that the slope deflection equation does not take account of the change of length of a member under stress. Also note how the substitution of slope as the unknown element in place of stress elements simplified the work, avoiding simultaneous equations. It often happens that there are fewer unknown elastic than stress elements, which is one reason for the advantage of this method of analysis.

**Example 8:6.** Determine the bending moment at the intermediate support of a beam continuous over two equal spans ( $L$ ) carrying a uniform load of  $w$  lb per ft over the whole length, using the slope deflection method. This is the structure of Ex. 8:1.

*Solution.* Designate the left end of this two-span beam as  $a$  and the center support as  $b$ . Note that symmetry informs us that  $\theta_b = 0$ . From the general equation (with  $M_F = \pm wL^2/12$ ),

$$M_{ba} = 2EK(\theta_a) - \frac{wL^2}{12}$$

$$M_{ab} = 0 = 2EK(2\theta_a) + \frac{wL^2}{12}$$



whence

$$\theta_a = -\frac{1}{2} \left( \frac{1}{2EK} \right) \left( \frac{wL^2}{12} \right)$$

Substituting this value of  $\theta_a$  in the equation for  $M_{ba}$  gives

$$M_{ba} = -\frac{wL^2}{8}$$

the negative sign indicating clockwise direction on the right end of beam  $ab$ , or negative moment by the usual beam convention. The reactions are found as before in Ex. 8:1.

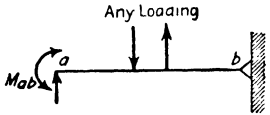

FIG. 8:10

The solution of the above example would have been simpler had the general equation been put in a different form for use when one end of a member is hinged and therefore without any restraining moment. This special form may be obtained by writing the values of the moments at the ends of  $ab$  in Fig. 8:10, end  $b$  being hinged:

$$M_{ab} = 2EK(2\theta_a + \theta_b - 3R) \pm M_{Fab}$$

$$M_{ba} = 2EK(2\theta_b + \theta_a - 3R) \mp M_{Fba} = 0$$

whence

$$\theta_b = \left[ \left( \pm \frac{M_{Fba}}{2} \right) \left( \frac{1}{2EK} \right) \right] - \frac{\theta_a}{2} + 1.5R$$

Substituting the value of  $\theta_b$  in the expression for  $M_{ab}$  gives

$$\begin{aligned} M_{ab} &= 2EK(1.5\theta_a - 1.5R) \pm M_{Fab} \pm 0.5M_{Fba} \\ &= 2EK(1.5\theta_a - 1.5R) \pm H_{ab} \end{aligned} \quad 8:2c$$

where  $H_{ab}$  equals the arithmetical sum of  $M_{Fab}$  and  $0.5M_{Fba}$  and takes its sign as for the fixed-end moment at the restrained end by the usual rule. ( $M_{Fab}$  and  $0.5M_{Fba}$  are usually of opposite sign, and their difference algebraically therefore gives their arithmetical sum with same sign as for  $M_{Fab}$ .)

Applying equation 8:2c to the solution of Ex. 8:6 gives

$$\begin{aligned} M_{ba} &= 2EK(0 - 0) - \left( \frac{wL^2}{12} + \frac{1}{2} \frac{wL^2}{12} \right) \\ &= -\frac{wL^2}{8} \end{aligned}$$

The accompanying table will facilitate the solution of slope deflection problems.

VALUES OF CONSTANTS  $M_F$

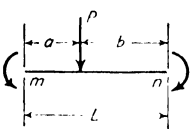
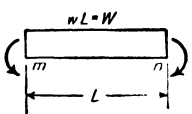
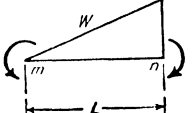
Loading	$M_{F_{mn}}$	$M_{F_{nm}}$
	$\frac{Pab^2}{L^2}$	$\frac{Pa^2b}{L^2}$
	$\frac{WL}{12}$	$\frac{WL}{12}$
	$\frac{WL}{15}$	$\frac{WL}{10}$

Note that  $Pab^2/L^2$  is the maximum simple beam moment multiplied by  $b/L$ : that  $WL/12$  is two-thirds of the maximum simple beam moment.

**Example 8:7.** Determine the reactions on the portal frame of Fig. 8:11 for the load shown.

*Solution.* Under this loading the frame deflects to the right, both points  $a$  and  $b$  moving the same distance, and the  $R$  term for one vertical equals that for the other. Besides this unknown deflection there are two other unknowns, the rotations of joints  $a$  and  $b$ . The moments at the ends of the several members can be expressed as follows, noting that  $K_{ad} = K$  and  $K_{ab} = 2K$  as in Ex. 8:5, all members having the same cross section:

$$\begin{cases} M_{ab} = 2E(2K)(2\theta_a + \theta_b) \\ M_{ad} = 2EK(2\theta_a - 3R) \\ M_{ba} = 2E(2K)(2\theta_b + \theta_a) \\ M_{bc} = 2EK(2\theta_b - 3R) \\ M_{da} = 2EK(\theta_a - 3R) \\ M_{cb} = 2EK(\theta_b - 3R) \end{cases}$$

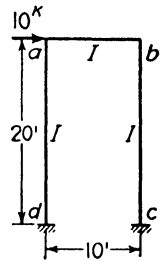

Fig. 8:11

For the determination of these three unknowns ( $\theta_a$ ,  $\theta_b$ , and  $R$ ) we have the two joint equations:

$$\begin{aligned} M_{ab} + M_{ad} &= 0 && 1 \\ M_{ba} + M_{bc} &= 0 && 2 \end{aligned}$$

A third equation may be secured by considering the free body cut out by two horizontal sections, one just below  $ab$  and one just above  $cd$ , and therefore consisting of the two verticals as shown in Fig. 8:12, with the forces acting. Applying the condition  $\Sigma M = 0$  at any point in the plane of the free body, it becomes apparent that the sum of the four end moments must equal the total

shear in the bent multiplied by the height ( $Hh$ ). Assuming all these end moments to be positive, that is counterclockwise, we obtain from the equation  $\Sigma M = 0$

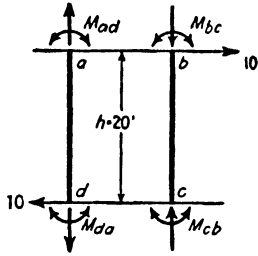

FIG. 8:12

$$-M_{ad} - M_{da} - M_{bc} - M_{cb} + 200 = 0 \quad 3$$

Substituting the values of the end moments previously written in these three equations gives the three needed for determination of the three unknowns:

$$6\theta_a + 2\theta_b - 3R = 0 \quad 1$$

$$2\theta_a + 6\theta_b - 3R = 0 \quad 2$$

$$3\theta_a + 3\theta_b - 12R = \frac{Hh}{2EK} \quad 3$$

The arithmetical work of solving these equations and that of checking are made easier by working with coefficients as shown in their reformulation in the table which follows. The making of mistakes is easy in work of this sort, and it is highly advantageous to carry on a running check as indicated here in the last column of the table. Any figure in the check column must equal the algebraic sum of the coefficients in the four columns to the left and also equal the value obtained from the check figures above by carrying through the operation indicated. For example, the sum of the coefficients in equation 1' equals 1.500, which also equals the check figure of equation 1 divided by 6, the coefficient of  $\theta_a$ , this division being the operation which gave equation 1' from equation 1.

No.	Operation	Coefficients of $\theta_a$ , etc.			Right Side of Equation	Check
		$+\theta_a$	$+\theta_b$	$-3R$	$Hh/2EK$	
1		6	2	1	0	9
2		2	6	1	0	9
3		3	3	4	1	11
1'		1	0.333	0.167	0	1.500
2'		1	3.000	0.500	0	4.500
3'		1	1.000	1.333	0.333	3.666
a	2'-1'		2.667	0.333	0	3.000
b	3'-1'		0.667	1.166	0.333	2.166
a'			1.000	0.125	0	1.125
b'			1.000	1.750	0.500	3.250
c	b'-a'			1.625	0.500	2.125
c'				1	0.3080	
			1		-0.0385	
		1			-0.0385	

Substituting these values for  $\theta_a$ ,  $\theta_b$ , and  $3R$  in the moment expressions gives all the end moments.

$$-M_{ab} = -M_{ba} = +M_{ad} = +M_{bc} = 46,000 \text{ lb-ft}$$

$$M_{da} = M_{cb} = +53,670 \text{ lb-ft}$$

The complete computations for the reactions and the moment curves are shown on the sketch herewith, Fig. 8:13.

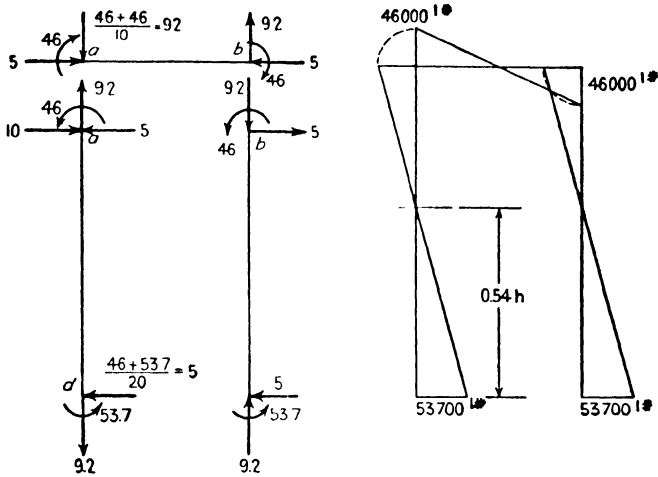

FIG. 8:13

*Note.* All ordinates of this moment curve are plotted on the compression side of the member.

The solution of this problem would have been materially shortened by observing in the beginning that the symmetry of the structure indicates equality of resistance to rotation at joints  $a$  and  $b$ , and the constant equality of  $\theta_a$  and  $\theta_b$ . Had this not been at first observed, inspection of equations 1 and 2 leads to the same conclusion. This solution for two unknowns would not have served, however, to demonstrate this practical method of solving simultaneous equations. In connection with this solution attention is called to the notes following the tabulated solution of equations in Ex. 11:2, where are discussed details which should be observed in solving simultaneous equations.

The method of equation solution here used is a variation, due to Dean Turneaure [in *Modern Framed Structures*, part 2, by Johnson, Bryan, and Turneaure (John Wiley)], of that originated by the celebrated astronomer Gauss.<sup>7</sup>

<sup>7</sup> **Solution of Equations.** This subject has a voluminous literature, and many methods, each of which has its advocates, have been proposed. Of these methods, mention may be made of the following:

a. *Determinants*, described in every advanced algebra textbook. This method is valuable in an investigation such as that discussed on page 163, herewith, but it is not well fitted for use in numerical problems.

b. *Gauss's method*, originated by the celebrated astronomer, Gauss. A brief description of the method will be found in the article "The Determination of Stresses, in Mitered Lock Gates . . .," by Henry Goldmark, *Transactions of the American Society of Civil Engineers*, Vol. 81 (1917), pp. 1652-1655.

c. *Doolittle's method*, in a measure similar to Gauss's. While it is slightly more abbreviated than the latter, it is much harder to follow. It is described in "Application of Theory of Least Squares to the Adjustment of Triangulation," by Oscar S. Adams, *Special Publication No. 28*, U. S. Coast and Geodetic Survey.

d. *Successive approximations or iteration*. See, e.g., "Simultaneous Equations in Mechanics Solved by Iteration," by W. L. Schwalbe, *Transactions of the American Society of Civil Engineers*, Vol. 102 (1937), pp. 939-969. (This paper says the method had its beginning in the year 1674.)

Applied to the above example, the three equations may be rewritten as below on the lines marked (1). Next it is assumed that  $\theta_a$  and  $\theta_b$  have zero values, giving the value of  $-0.250$  for  $3R$  [top line (2)]. In the second line (2) this value of  $3R$  is used together with the assumption that  $\theta_b = 0$ , thereby obtaining the value  $\theta_a = -0.042$ . Using the values found for  $3R$  and  $\theta_a$ , a first approximation for  $\theta_b$  is  $-0.028$  [third line (2)]. Next the (3) lines are computed in the same fashion, followed by the (4) and (5).

$$\begin{aligned}
 (1) \quad 3R &= -0.250 + 0.75\theta_a + 0.75\theta_b \\
 (2) &= -0.250 + 0 \quad + 0 \quad = -0.250 \\
 (3) &= -0.250 - 0.032 - 0.021 = -0.303 \\
 (4) &= -0.250 - 0.030 - 0.028 = -0.308 \\
 (5) &= -0.250 - 0.029 - 0.029 = -0.308
 \end{aligned}$$

$$\begin{aligned}
 (1) \quad \theta_a &= 0 - 0.333\theta_b + 0.167(3R) \\
 (2) &= 0 - 0 \quad - 0.042 \quad = -0.042 \\
 (3) &= 0 + 0.010 - 0.050 \quad = -0.040 \\
 (4) &= 0 + 0.012 - 0.051 \quad = -0.039 \\
 (5) &= 0 + 0.013 - 0.051 \quad = -0.038
 \end{aligned}$$

$$\begin{aligned}
 (1) \quad \theta_b &= 0 - 0.333\theta_a + 0.167(3R) \\
 (2) &= 0 + 0.014 - 0.042 \quad = -0.028 \\
 (3) &= 0 + 0.013 - 0.050 \quad = -0.037 \\
 (4) &= 0 + 0.013 - 0.051 \quad = -0.038 \\
 (5) &= 0 + 0.013 - 0.051 \quad = -0.038
 \end{aligned}$$

The variation of this method given in *Statically Indeterminate Stresses*, by Parcel and Maney, 1936, pp. 276-277, is of interest as it uses differences. However, it will be found that the above illustration, which uses for the second approximation of  $\theta_b$  the already obtained second approximations of  $\theta_a$  and  $3R$ , yields more rapid convergence.

e. *Successive elimination*. See "Successive Elimination of Unknowns in the Slope-Deflection Method," by John B. Wilbur, *Transactions of the American Society of Civil Engineers*, Vol. 102 (1937), pp. 346-371.

f. *Converging increments*. See "Solution of Equations in Structural Analysis by Converging Increments," by George H. Dell, *Transactions of the American Society of Civil Engineers*, Vol. 104 (1939), p. 1543.

**8:6. Method of moment distribution.** In much rigid frame analysis, particularly in reinforced concrete construction, the laboriously achieved precision of the methods already described is either needless or without real meaning. Professor Hardy Cross, then of the University of Illinois, now of Yale University, made public in 1929 his method of moment distribution, which may be applied very quickly and simply for an approximate solution or, with a little more labor, extended to any degree of exactness desired.<sup>8</sup>

The application of the method of moment distribution requires knowledge of the following moment relations: (A) **the moments developed at the ends of loaded beams with fixed ends**, the determination of which is considered in Probs. 8:14, 15, 16, and in the table preceding Ex. 8:7; (B) **the resisting moment developed at a joint on the end sections of the several members whose junctions form the joint, by reason of a moment applied to the joint**; and (C) **the resisting moment developed at the fixed end of a beam by action of a moment applied at the other end which is not fixed**. The slope deflection method easily develops the last two relations.

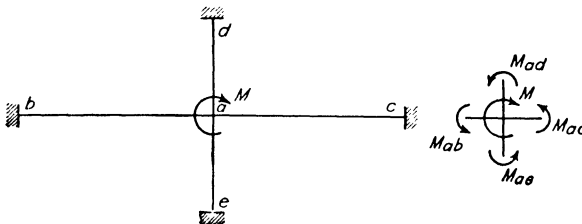

FIG. 8:14

**B.** The distribution of resistance to a moment acting on a joint among the members meeting at the joint is illustrated by Fig. 8:14, where a moment,  $M$ , is applied to joint  $a$ , the farther ends of all the members there meeting being fixed. By the slope deflection equation (equation 8:2) we may write

$$M_{ab} = 2EK_{ab}(2\theta_a), \quad M_{ac} = 2EK_{ac}(2\theta_a)$$

$$M_{ad} = 2EK_{ad}(2\theta_a), \quad M_{ae} = 2EK_{ae}(2\theta_a)$$

The external moment applied to the joint rotates it in a clockwise

<sup>8</sup> "Continuity as a Factor in Reinforced Concrete Design," *Proceedings of the American Concrete Institute*, 1929; "Simplified Rigid Frame Design," *Journal of the American Concrete Institute*, December 1929; see also *Transactions of the American Society of Civil Engineers*, Vol. 96 (1932), and *Continuous Frames of Reinforced Concrete*, Hardy Cross and Newlin Doble Morgan (John Wiley), 1932.

direction and impresses a clockwise moment, accordingly, upon the *a* ends of the members there meeting, a negative moment by the convention adopted. The joint, taken as a free body, is in equilibrium, that is,

$$M_{ab} + M_{ac} + M_{ad} + M_{ae} + M = 0$$

$$2EK_{ab}(2\theta_a) + 2EK_{ac}(2\theta_a) + 2EK_{ad}(2\theta_a) + 2EK_{ae}(2\theta_a) + M = 0$$

$$2\theta_a = \frac{-M}{2E\Sigma K}$$

Therefore  $M_{ab} = -M \frac{K_{ab}}{\Sigma K}$ ,  $M_{ac} = -M \frac{K_{ac}}{\Sigma K}$ , etc.

when *E* is constant for all members.

The foregoing relation takes care of the common case where all members entering a joint are fixed—or may be so considered—at their far

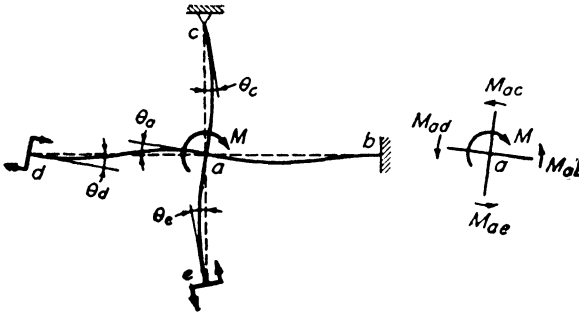

FIG. 8:15

ends. However, there are three other cases of frequent occurrence, and a relation will be established now which will care for them as they are encountered. The cases, including the one already discussed, are:

1.  $\theta_b = 0$ , i.e. (Fig. 8:15), the member is fixed at its far end;
2.  $M_c = 0$ , i.e., the member is simply supported at its far end;
3.  $\theta_d = \theta_a$ , i.e., the member rotates through the same angle at the far end as at the near end and in the same direction; and
4.  $\theta_e = -\theta_a$ , i.e., the member rotates through the same angle at the far end as at the near end but in the opposite direction.

Then

$$M_{ab} = 2EK_{ab}(2\theta_a) \dots \dots \dots = 4E\theta_a \times K_{ab}$$

$$M_{ac} = 2EK_{ac}(2\theta_a + \theta_c): \text{ but } M_{ca} = 0 = 2EK_{ac}(2\theta_c + \theta_a)$$

$$\theta_c = -\frac{\theta_a}{2}, \text{ and}$$

$$M_{ac} = 2EK_{ac}(\frac{3}{2}\theta_a) \dots \dots \dots = 4E\theta_a \times \frac{3}{4}K_{ac}$$

$$M_{ad} = 2EK_{ad}(2\theta_a + \theta_d) = 2EK_{ad}(3\theta_a) = 4E\theta_a \times \frac{3}{2}K_{ad}$$

$$M_{ae} = 2EK_{ae}(2\theta_a + \theta_e) = 2EK_{ae}(\theta_a) = 4E\theta_a \times \frac{1}{2}K_{ae}$$

But  $M_{ab} + M_{ac} + M_{ad} + M_{ae} + M = 0$ , or

$$4E\theta_a(K_{ab} + \frac{3}{4}K_{ac} + \frac{3}{2}K_{ad} + \frac{1}{2}K_{ae}) = -M$$

so that 
$$\theta_a = \frac{-M}{4E\Sigma K_{\text{modified}}}$$

when the term in parentheses in the second preceding line is designated  $\Sigma K_{\text{modified}}$ . Substituting,

$$M_{ab} = -M \frac{K_{ab}}{\Sigma K_{\text{mod.}}}$$

$$M_{ac} = -M \frac{\frac{3}{4}K_{ac}}{\Sigma K_{\text{mod.}}}$$

$$M_{ad} = -M \frac{\frac{3}{2}K_{ad}}{\Sigma K_{\text{mod.}}}$$

$$M_{ae} = -M \frac{\frac{1}{2}K_{ae}}{\Sigma K_{\text{mod.}}}$$

These equations say that in distributing the moment at a joint the value of  $K$  in the numerator is to be modified depending on the condition at the far end and that a like modification is to be made in summing up the  $K$ 's in the denominator. The examples of this and the next article will make plain the use to which these factors are put.

Discussion of moment distribution is facilitated by introducing the concept of **stiffness**, which is usually defined as **that moment which, when applied at the simply supported end of a beam, will cause there unit rotation ( $\theta = 1$ ) when the far end is fixed against rotation**. Signifying stiffness by  $S$ , we have, from the previous discussion,  $S = 4EK$ . If the far end of the beam is also simply supported, a smaller moment will cause unit rotation at the near end; that is, the stiffness is modified,  $S = 3EK$ . Similarly  $S = 6EK$  and  $S = 2EK$  for the third and fourth cases listed in the preceding paragraph, members  $ad$  and  $ae$  of Fig. 8:15.

Using this concept of stiffness, we find that **the distribution of resistance at a joint to a moment tending to rotate the joint is in proportion to the stiffness (or modified stiffness) of the members there meeting.**



C. Returning to Fig. 8:14, it will be seen that, when  $a$  rotates in a clockwise direction and  $b$  is fixed,

$$M_{ab} = 4EK_{ab}\theta_a, \quad M_{ba} = 2EK_{ab}\theta_a$$

Both these moments are in the same direction and so, by the sign convention adopted, are of the same sign. Therefore,

$$M_{ba} = \frac{1}{2}M_{ab}$$

This moment  $M_{ba}$  may be termed that “carried over” from  $a$  to  $b$ , and the fraction  $\frac{1}{2}$  the **carry-over factor**, a term that will have other values for beams of variable cross section.

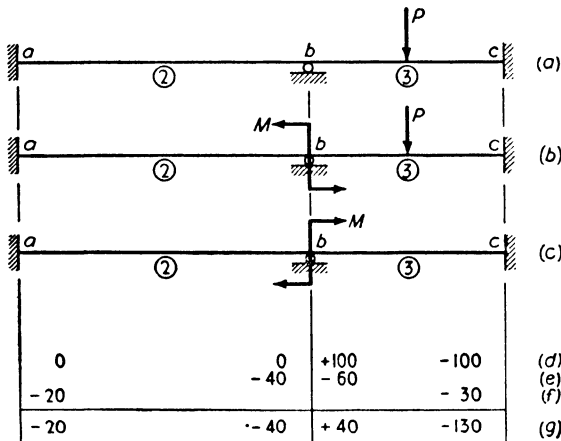

FIG. 8:16

The method of moment distribution will first be described with regard to structures composed of members of constant cross section in any one span or story, so loaded that all joints may reasonably be considered to be without motion of translation. In Fig. 8:16a we have a two-span continuous beam with fixed ends: the procedure for determining the moments at the supports of this beam due to the load shown is as follows.

**Step 1. Fixed-end moments.** The joint at  $b$  is considered to be locked against rotation, and the given load,  $P$ , is applied (line  $b$ ). In this situation beam  $bc$  is a fixed-ended beam and the end moments are computed and recorded, 100 kip-ft at each end (line  $d$ ).  $M_{bc}$  is positive, since the loaded beam tends to rotate joint  $b$  in a clockwise direction ( $M_{bc}$  acts clockwise on the joint  $b$ , counterclockwise on the end of the beam  $bc$ );  $M_{cb}$ , similarly, is negative.

**Step 2. Distribution.** The locking of joint  $b$  involved applying there a counterclockwise moment equal to the fixed-end moment caused by the load. Line  $d$  records the effect of the load combination,  $M$  and  $P$  (line  $b$ ). If we combine this effect with that caused by the application of the opposite of the locking moment at  $b$  (line  $c$ ), the effect of the locking moment will be neutralized and the sum of the effects will be that of load  $P$  alone. A clockwise moment  $M = 100$  kip-ft applied to joint  $b$  sets up the resisting moments at that point which are recorded in line  $e$ . These moments are in proportion to the  $K$ ,  $(I/L)$ , values of the two members there meeting, which are recorded in circles on the figure. Since the unlocking moment tends to rotate the joint clockwise, both the resisting moments act in a counterclockwise direction upon the joint, and so are negative.

In these operations it is not necessary to picture the locking and unlocking moments, which are brought into the description simply to make clear the force systems actually involved. It is possible, instead, to consider that the joint is locked by some mechanical means and that the  $+100$  kip-ft, the fixed-end moment, is tugging away at the joint in consequence. Upon the unlocking of the joint this fixed-end moment starts rotating the joint clockwise, a process which stops only when the resisting moment built up in the  $b$  end of  $ab$ ,  $-40$  kip-ft, equals the diminished fixed-end moment which started the rotation,  $100 - 60 = 40$  kip-ft; in other words, when the joint comes to balance. This is why this step is called *distributing the fixed-end moment* or *balancing the joint*.

**Step 3. Carry-over.** Unlocking the intermediate joint sets up moments at  $a$  and  $c$ , the carry-over moments already described. They are recorded in line  $f$ .

Adding the results of these three steps gives the effect of load  $P$  alone and leaves all joints in a state of balance, indicating the completion of the analysis.

If span  $ab$  in Fig. 8:16 is also loaded, there will be initial fixed-end moments at  $a$  and  $b$ , which would be recorded in line  $d$ . The unbalanced moment tending to rotate the locked joint  $b$  would be the algebraic sum of these two fixed-end moments,  $M_{ba}$  and  $M_{bc}$ .

The process which has been outlined is the method of moment distribution as applied to this particular problem. The application to more complicated structures without lateral translation of joints is essentially the same, since as a preliminary all joints are assumed to be fixed and only one is unlocked at a time.

The special terminology of the method facilitates its application. The fixed-end moments first written are called the *unbalanced mo-*

ments, since they are not balanced, or developed, by the actual construction. Unlocking a joint consists in finding the distributed moments of resistance due to application of the unbalanced moment to the joint. It is simple and logical, therefore, to think of the process as one of *distributing the unbalanced moment*. As has already been noted, the determination of the moment at a far end brought into action by the distributed moment at the near end is referred to as *carrying over* the distributed moment.

The application of the method in general to structures without lateral translation of joints may be detailed thus:

1. Assuming all joints locked and all members, accordingly, fixed-ended, write down the fixed-end moments at ends of all loaded members.

2. Distribute the unbalanced moment (algebraic sum of fixed-end moments) at each joint. This assumes that only one joint, that where the distributing is being done, is unlocked at a time.

Were the carry-over moments of zero magnitude, this would constitute a complete solution, with each joint in equilibrium (balanced). These two steps may be thought of as a complete round giving results which are in approximation according to the magnitudes of the carry-overs.

3. Write down all carry-over moments. This assumes that the joints where each carry-over is written are locked. The result constitutes a new set of unbalanced moments.

4. Distribute the moments just carried over. These two steps constitute a new complete moment determination in error only in the degree that the new and as yet unwritten carry-over moments are large. The result of these two steps leaves the joints again balanced. Moments should be checked to be sure that balance exists.

5-6, etc. Another set of carry-over moments are written and distributed, and check made for balance. The carry-over moments progressively decrease as these steps are repeated. The process is halted when the desired precision is attained.

**Example 8:8.** Determine the bending moments at the supports of the continuous beam of constant cross section shown in Fig. 8:17 for the loading given.

*Solution.* Since the beam is of constant cross section and since, therefore,  $K$  varies inversely as  $L$ , the  $K$  values are, reading from left to right, in the ratio 8 : 5 : 6, as recorded in circles on the figure. For the loads given, the fixed-end moments (which may be computed with the aid of the table on page 245) are as recorded on line  $a$ . It will be seen that there is an unbalanced  $-12$  at  $n$ ,  $+42$  at  $o$ . Considering  $o$  locked, the unbalanced  $-12$  at  $n$  is distributed  $\frac{8}{13}$  to  $nm$  and  $\frac{5}{13}$  to  $no$ , as shown on line  $b$ . Similarly, considering  $n$  locked,

the unbalanced moment at *o* is distributed. Neglecting carry-over, the joints are now balanced and the sum of lines *a* and *b* would give a first approximate solution, as indicated by drawing a line under *b*. However, the carry-over values are too large to neglect. These are computed and shown on *c*, the new

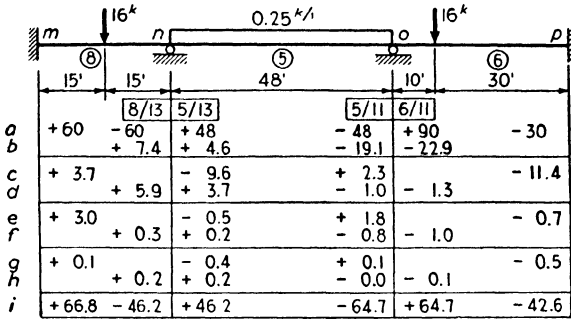

FIG. 8:17

unbalanced values at *n* and *o* being distributed on *d*. After two more cycles the carry-over values become negligible. Hence, the moments on lines *a* to *h* are summed up in *i*, these later values constituting the solution of the example.

**Example 8:9.** Determine the bending moments at the supports of the continuous beam of constant cross section shown in Fig. 8:18 for the loading given.

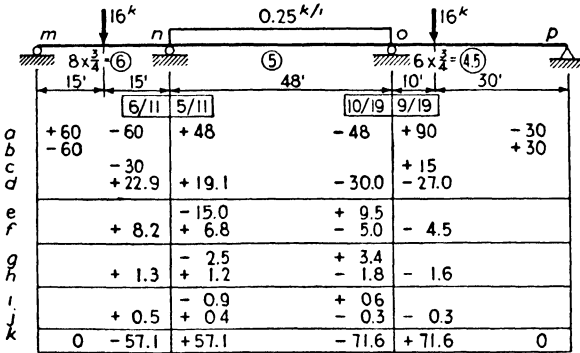

FIG. 8:18

**Solution.** This is the beam of Fig. 8:17 except for the fact that simple supports have been substituted at *m* and *p*. As has been demonstrated, when a member is simply supported at its far end, the *K* value is modified by multiplying by the factor  $\frac{3}{4}$ . Hence, after modification, the *K* values are in the ratio 6 : 5 : 4.5. The fixed-end moments are shown on line *a*. Keeping *n* locked, the unbalanced +60 at *m* is distributed, all, of course, going to *mn* and a carry-over moment of -30 (line *c*) going to *n*. At the same time a similar

distribution is made at  $p$ . The carried-over values to  $n$  and  $o$  are now combined with the fixed-end values to give unbalanced moments of  $-42$  at  $n$ ,  $+57$  at  $o$ . The unbalanced  $-42$  at  $n$  is distributed  $\frac{8}{11}$  to  $nm$  and  $\frac{5}{11}$  to  $no$  (line  $d$ ). Since allowance has been made for the fact that  $m$  is hinged, there will be no carry-over to  $m$ , but the usual carry-over (with factor  $\frac{1}{2}$ ) to  $o$ . As in Ex. 8:8, the carry-over moments were considered negligible after four cycles. The summed-up values of line  $k$  constitute the solution of the example.

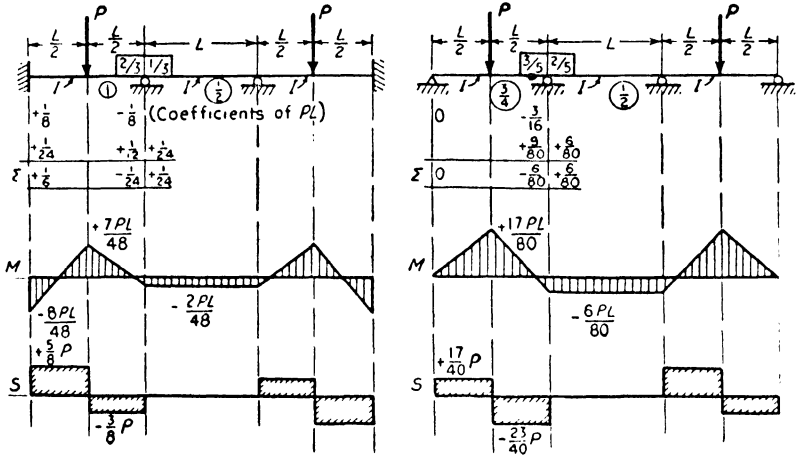

FIG. 8:19

**Example 8:10.** Determine the bending moments at the supports and draw the moment curves for the beams of Fig. 8:19.

*Solution.* These are symmetrical structures and, in addition, are symmetrically loaded. Therefore the unbalanced moments of  $\frac{1}{8}PL$  at the interior supports of the left structure ( $\frac{3}{8}PL$  in the right: equation 8:2c with  $\theta = 0$ ) may be released simultaneously, causing those points to rotate equal amounts

but in opposite directions. As already shown, under this condition the  $K$  value of the center member is to be multiplied by the factor  $\frac{1}{2}$ . (The distributed moments in this member are the true moments, i.e., there is no carry-over under this condition.) The usual sign convention for beams has been followed in drawing the moment and shear curves.

	$B_L$	$C_A$	$C_B$	$B_R$
	$K/2K$	$K/2K$	$K/2K$	$K/2K$
	$\Sigma$	$\Sigma$	$\Sigma$	$\Sigma$

FIG. 8:20

In dealing with structures which include both girders and columns, the method of recording results (due to the Portland Cement Association) which is illustrated in Fig. 8:20 will be found convenient. The figure shows how the results would

be given for the four members at each interior joint ( $B_L$  = beam left,  $C_A$  = column above,  $C_B$  = column below,  $B_R$  = beam right).

**Example 8:11.** Determine the moments at the supports of the structure of Fig. 8:21.

*Solution.* The ratio of  $I$ 's is shown in the upper figure. As in previous examples the  $K$  values are shown encircled. Note that the lower part of the

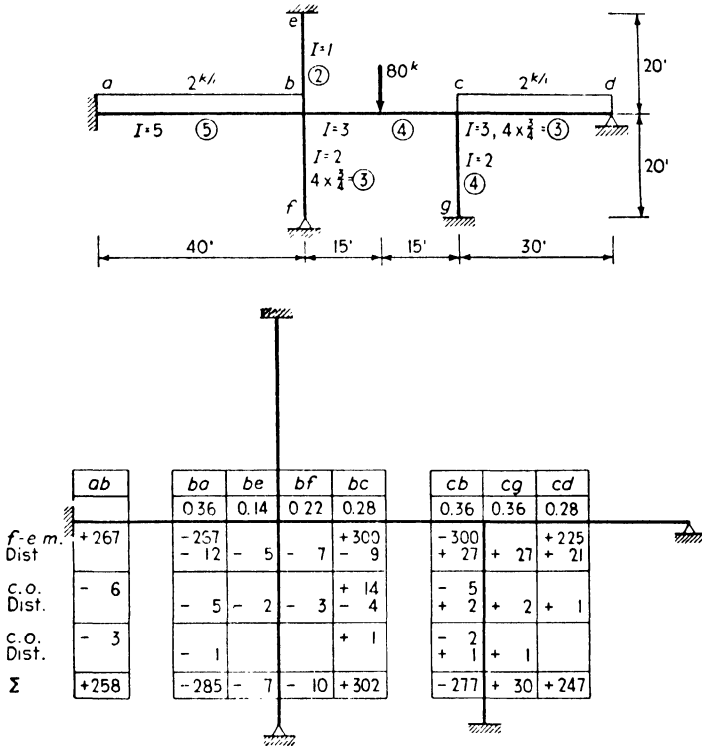

FIG. 8:21

figure is not drawn to scale. Also, note that the intermediate values of the moments at  $e$  and  $g$  have not been computed, since members  $eb$  and  $cg$  are not loaded. Instead, we may say  $M_{eb} = \frac{1}{2}M_{be} = -3$ ;  $M_{gc} = \frac{1}{2}M_{cg} = +15$ .

**8:7. Moment distribution: Side sway.** A rigid frame deflects sidewise under the action of transverse loads and of unsymmetrical vertical loads. Where the girders are much stiffer than the columns, as in most bents, a simple approximate solution for lateral loading may be made on the assumption that the girders are infinitely rigid. The lateral

deflection of any column will cause it to take the shape shown for a horizontal member, Fig. 8:9, and end moments will be set up equal to  $-6EKR$ . Since the points of inflection are at mid-height, the end moment is also equal to the column shear multiplied by the half length. Accordingly the shear in a column in a rigid frame with girders of infinite stiffness, with fixed-end columns at the foundation level, is given by

$$S_c = \frac{12EI_d}{L^3}$$

$d$  being the lateral deflection of one end of the column relative to the other. Where  $d$  has the same value for a series of columns in a single story, this relation makes it possible to determine the apportionment of shear among the columns, on the basis of the assumptions noted. This division is in proportion to what may be called the **lateral stiffness**, both ends fixed, **measured by**

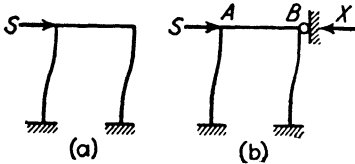

FIG. 8:22

$I/L^3$ , just as, in distributing the unbalanced moment at a joint, the division is in proportion to rotational stiffness, far ends fixed, measured by  $I/L$ .

A moment distribution determination of the end moments in a rigid

frame one story in height, loaded by lateral forces applied at the floor levels, consists of the following steps:

a. The girders are assumed infinitely rigid and the structure is allowed to deflect freely, as shown in Fig. 8:22a. In this position the shear is divided between the columns in proportion to their  $I/L^3$  values, as above explained, and the points of inflection are at mid-height. The fixed-end moments equal the shears multiplied by the half-column lengths.

b. Distributing the unbalanced moments at joints  $A$  and  $B$  would be accompanied by rotation of those joints, and this in turn would cause additional movement to the right. Assume that at the end of step  $a$  the structure just touches a support at  $B$ , Fig. 8:22b, i.e., that  $X = 0$ . This support will prevent horizontal movement as the joints are balanced, and a force  $X$  will build up. After moment distribution is completed, the moments will correspond to a top force equal to  $S - X$ .

The deflection of the actual structure due to  $S - X$  is equal to the deflection of the structure with *rigid* girder due to  $S$ . To justify this statement, show by the moment area method that the deflections of  $a$ , Fig. 8:23, are equal: (1) when the end moments,  $M_{ad}$  and  $M_{da}$ , each

equal +50 kip-ft, and (2) when they equal, respectively, +37.5 and +43.75 kip-ft, following the unlocking and balancing of the joints.

c. The actual bending moments  $M$  in the frame must be to the moments  $M'$  found in step  $b$  as their respective shears, or

$$M = M' \left( \frac{S}{S - X} \right)$$

The value of the shear ( $S - X$ ) is easily computed from the moments found in step  $b$ , using the fact that the shear in a member equals the change in moment between its ends divided by its length.

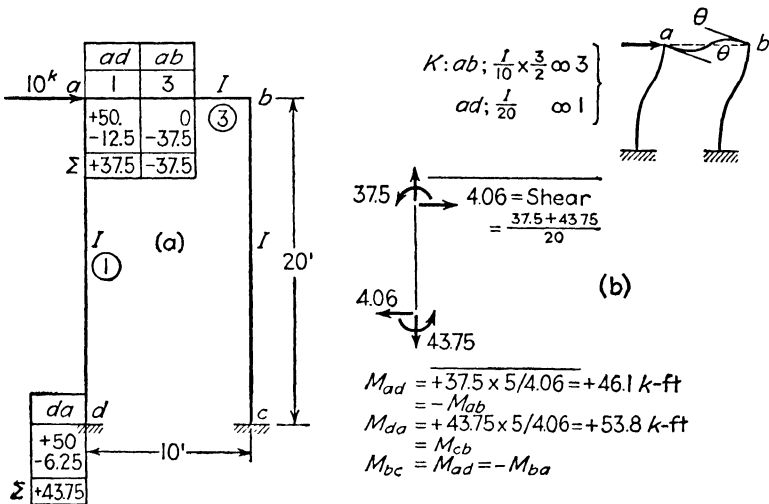

FIG. 8:23

**Example 8:12.** Determine the end moments in the members composing the frame shown in Fig. 8:23, using the method of moment distribution. This is the same problem as that set in Ex. 8:7, using the method of slope deflection.

*Solution.* In this solution advantage is taken immediately of symmetry, and, accordingly, it is not fair to compare the two examples directly when weighing the merits of the two methods.

Recognizing the fact that the rotation at  $a$  must be equal to that at  $b$  in magnitude and direction (since the rotating effect upon each top joint, because of the tendency of the columns to straighten, equals the resistance to rotation offered by the girder connecting the two joints), the  $K$  value for  $ab$  was modified by multiplying by  $\frac{3}{2}$ . The shear is equally distributed between the two columns, making the fixed-end moments equal to  $5 \times 10 = 50$  kip-ft. The solution proceeds as above described, a single unlocking sufficing to complete the first two steps of the work.



Taking one of the columns as a free body in equilibrium, it was noted that the end moments just found were consistent with a shear of 4.06 kips instead of the 5 kips actually present. (In Fig. 8:22b, accordingly, the force  $X$  equals  $10 - 8.12 = 1.88$  kips.) The actual end moments were found by multiplying the values just found by the ratio of the true shear, 5 kips in each column, to 4.06 kips.

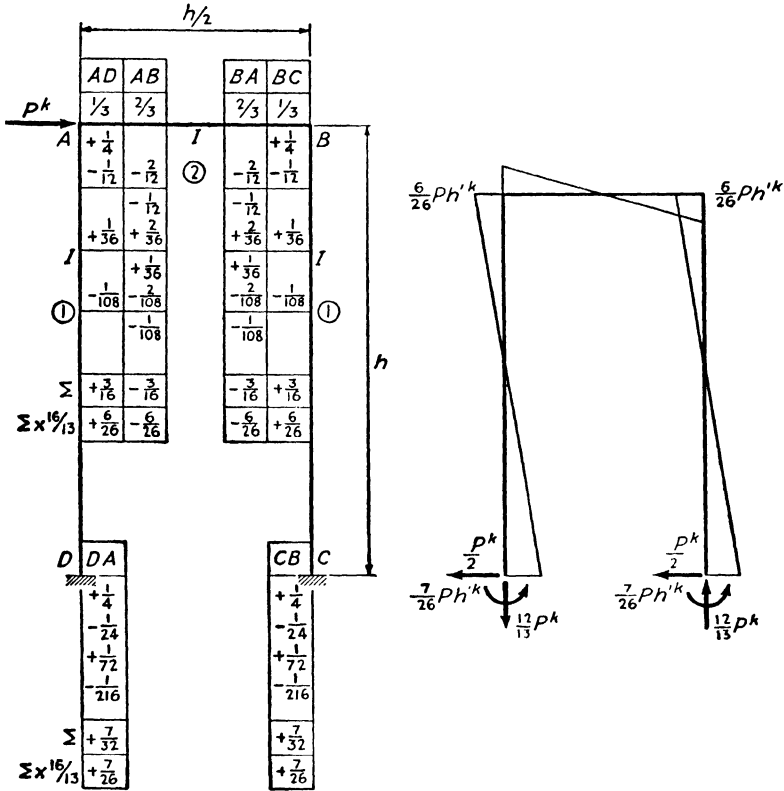

FIG. 8:24

**Example 8:12a.** Same as Ex. 8:12 but carried through without regard to symmetry. (Fig. 8:24.)

**Solution.** Proceeding as in Ex. 8:12, the fixed-end moments equal  $+Ph/4$ . The work proceeds, using common fractions in order to bring out a mathematical relationship which is sometimes of practical service in giving a precise answer. The operations of distribution and carry-over proceed until, after several cycles, it becomes evident that the terms under AD, for example, constitute a geometric series, each term equaling the preceding one multiplied by minus one-third. Also, it is known that the sum of the infinite series  $a, ar, ar^2, \dots$ , where  $r$  is a

proper fraction, is  $\frac{a}{1-r}$ . In the present case, therefore,  $M_{AD} = \frac{\frac{1}{4}Ph}{1 - (-\frac{1}{3})} = +\frac{3}{16}Ph$ . Similarly,  $M_{DA} = +\frac{1}{4}Ph + \frac{-\frac{1}{2}\frac{1}{4}Ph}{1 - (-\frac{1}{3})} = +\frac{7}{32}Ph$ .

Under vertical (gravity) loading a frame of the sort we are here considering will deflect sideways if there is dissymmetry either of loading or of frame itself. A solution parallel to that for transverse loading would proceed in four steps: (1a) the determination of all fixed-end moments, assuming that there is neither rotation nor translation of any joint, followed by (1b) the unlocking of all joints and the balancing of the moments thereon acting, without further translation; (2) the determination of the transverse restraining force brought into play by this balancing; (3) the determination of the end moments induced by the opposite of this restraining force; (4) the combination algebraically of the joint moments first found, step 1, with those induced by the opposite of the transverse restraining force, step 3, thus giving the moments due to the vertical loading alone.

**Example 8:13.** Determine the joint moments caused in the structure of Fig. 8:25 (same as that in Fig. 8:23 and Fig. 8:24) by the 10-kip vertical load shown.

*Solution.* (References to Fig. 8:25.) The values recorded in *a* are those based on rotation of the joints without translation. In *b* the shear in each column is computed consistent with rotation without translation, a resultant for the two columns of 0.19 kip. The moments found in *a* are those consistent with the application of the given vertical load and a transverse force at the level of the girder, 0.19 kip acting to the left, as shown in *c*. To obtain the true moments those in *a* must be combined with those due to a transverse force of 0.19 kip acting to the right, as shown in *d*. These last moments were found by proportion from Fig. 8:23: had this solution not been available, it would have been necessary to make one. Combining the moments in *a* and *d*, that is, combining the effects of the loads shown in *c* with those for the load in *d*, the transverse load effect is made zero, and there result the moments due to the vertical load alone, as shown in *e*. The bending moment curve shown is drawn with all ordinates recorded on the side of the member which is in compression.

**Morris' method.** When side sway enters into the analysis of frames of two or more stories, the method hitherto employed runs into difficulties. At each level a restraining force (*X*, Fig. 8:22*b*) is set up, and the elimination of the several restraints involves simultaneous equations. A direct and easier method has been suggested by Professor C. T. Morris<sup>9</sup> of Ohio State University. The first step is that already used, which, in the case of transverse loading, is the setting up of the fixed-end

<sup>9</sup> *Transactions of the American Society of Civil Engineers*, Vol. 96 (1932), page 66.

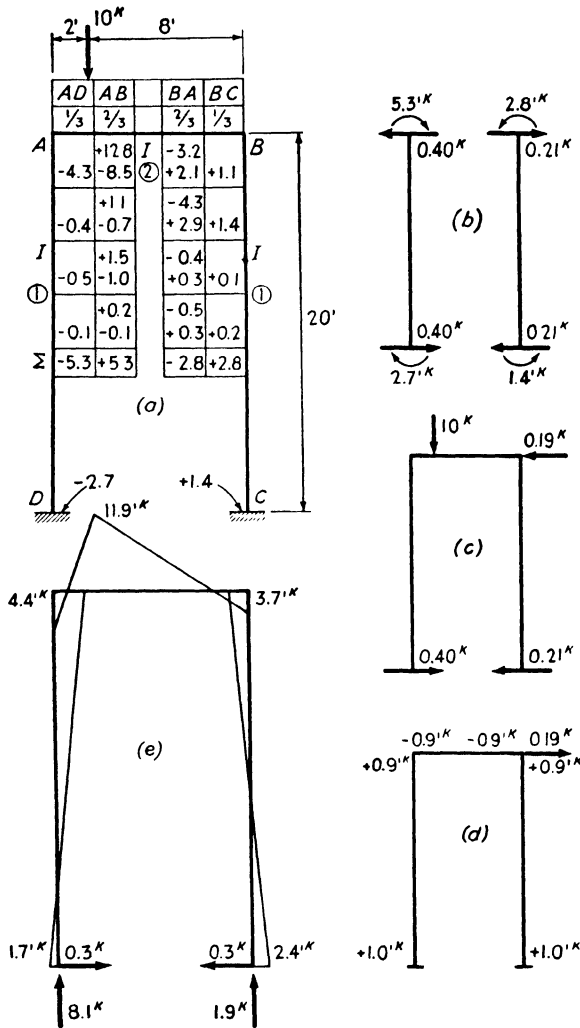

FIG. 8:25

moments for the columns on the assumption of rigid girders. These moments may be computed as column shear multiplied by half-column length, the shear being proportional to the  $I/L^3$  value of the column. Noting that these moments must vary with  $I/L^2$ , and that the sum of the column end moments in a story must equal the shear multiplied by the story height, it is possible to write the several moments directly by proportion.

With the fixed-end moments recorded, the first unlocking of joints and distribution of moments follow, and then the writing down of the first set of carry-overs. If the moments—fixed-end plus distributed plus carry-over—at the ends of the columns in a story are now added, the sum, having been diminished by the distribution and carry-over values, will not equal the product of shear times story height. At this stage in the process the computed shear in the story differs from the actual shear. It is logical, therefore, to introduce a correction at this time to bring the moment sum back to its final inevitable value, actual shear times story height. This is done by taking the total change made, that is, the sum of the distributed moments and the carry-overs in the story, and distributing this sum, with signs reversed, in proportion to the  $I/L^2$  values, half at each end of a column. This correction, plus the carry-over written above it, constitutes a new unbalanced moment ready for the next distribution and carry-over operation. This again throws the sum of moments in the story out of proper value, and another correction is then made, the total being the sum of the second distributed and carry-over moments, apportioned as before. And so the solution proceeds until the desired degree of precision has been obtained.

**Example 8:14.** Determine by Morris' method the moments in the two-story frame shown in Fig. 8:26 under the two 6-kip loads shown.

*Solution.* The total end column moment in the upper story is  $6 \times 20 = 120$  kip-ft,  $12 \times 30 = 360$  kip-ft in the lower. Since the two columns are of the same length, these moments are distributed in each story in proportion to the  $I$  values, one-third to  $AC$  and two-thirds to  $BD$ , divided equally top and bottom (lines  $a$  in Fig. 8:26). After the first distribution and carry-over (lines  $b-c$ ) the correction total to be added in the upper story is  $(10 + 15 + 30 + 5 + 26.7 + 36.8 + 73.6 + 13.3) = +210.4$ . One-sixth of this goes to the top and to the bottom of  $AC$ , 35.1 each; one-third to top and to bottom of  $BD$ , 70.1 each. For the lower story the corresponding corrections are  $+17.4$  and  $+34.8$ . These several corrections appear on lines  $d$ . Then follow a second distribution (lines  $e$ ), a second carry-over, and then a second correction.

Final values which will more nearly check a slope deflection solution may be obtained as follows. Using  $M_{AB}$  for illustration, it will be evident that each time an approximate solution was made the values added to the moment were roughly half of those added in the preceding solution. Continuing, we would expect a seventh solution to add  $-0.5$ , an eighth,  $-0.25$ , etc. But the sum of such a series is  $-1.00$ . Therefore, we would expect the final value for this moment to be  $-40.7$ . Actually, a slope deflection solution gave  $-40.5$ .

**Example 8:15.** Using Morris' variation of the moment distribution procedure, compute the joint moments of the loaded frame of Fig. 8:27. This is the problem of Ex. 8:13, Fig. 8:25.

*Solution.* Lines  $a$ ,  $b$ , and  $c$  of this solution are identical with those of Ex.

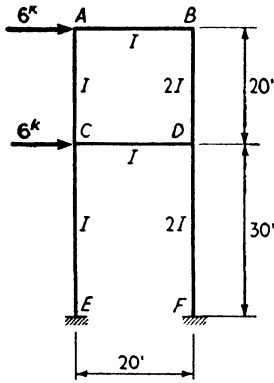

		$M_{AC}$		$M_{AB}$				$M_{BA}$		$M_{BD}$											
		$\frac{1}{2}$		$\frac{1}{2}$				$\frac{1}{3}$		$\frac{2}{3}$											
(a)		+20.0								+40.0											
(b)		-10.0		-10.0					-13.3		-26.7										
(c)		-15.0		-6.7					-5.0		-36.8										
(d)		+35.1		-6.7					+70.1		-18.9										
(e)		-6.7		-6.7					-9.4		-18.9										
		-5.5		-4.7					-3.4		-17.7										
		+18.0		-3.9					-5.0		+36.0										
		-3.9		-2.5					-2.0		-9.9										
		-2.5		-2.5					-2.0		+8.4										
		+8.9		-1.9					-2.4		+17.8										
		-1.9		-1.2					-1.0		-5.0										
		-1.2		-1.2					-1.0		+4.1										
		+4.4		-1.0					-1.2		+8.7										
		-1.0		-0.6					-0.5		-2.4										
		-0.6		+2.1					-0.5		+2.0										
		+2.1		-0.5					-0.6		+4.3										
		-0.5		+39.7					-43.8		-1.2										
		-0.5		-39.7							+43.8										
		$M_{CA}$			$M_{CE}$			$M_{CD}$			$M_{DC}$			$M_{DB}$			$M_{DF}$				
		$\frac{3}{8}$			$\frac{2}{8}$			$\frac{3}{8}$			$\frac{3}{13}$			$\frac{6}{13}$			$\frac{4}{13}$				
(a)		+20.0		+60.0											+40.0		+120.0				
(b)		-30.0		-20.0											-73.6		-49.6				
(c)		-5.0		+17.4											-13.3		+34.8				
(d)		+35.1		-7.3											+70.1		-23.5				
(e)		-10.9		-10.9											-35.4						
		-3.4		+7.7											-9.5		+15.4				
		+18.0		-3.4											+36.0		-11.2				
		-5.0		+3.6											-16.8						
		-2.0		+1.6											-5.0		+7.3				
		+9.0		-2.4											+17.8		-5.4				
		-2.4		+1.7											-8.1						
		-1.0		+0.7											+2.5		+3.5				
		+4.4		-1.2											+8.7		-2.6				
		-1.2		-0.5											-3.9						
		-0.5		+0.9											-1.2		+1.6				
		+2.1		-0.5											+4.3		-1.3				
		-0.5													-1.9		+1.6				
		-0.5															-1.3				
		+26.7		+57.8											-94.7		+89.0				
															+5.7						
		$M_{EC}$			$M_{FD}$																
(a)		+60.0		+120.0																	
(c)		-10.0		-24.8																	
(d)		+17.4		+34.8																	
		-3.7		-11.8																	
		+7.8		+15.4																	
		-1.7		-5.6																	
		+3.7		+7.3																	
		-0.8		-2.7																	
		+1.8		+3.5																	
		-0.4		-1.3																	
		+0.9		+1.6																	
		+75.0		+136.4																	

FIG. 8:26

8:13, except that record has been added for the moments at the bases of the columns. The end moments of the columns now add to  $(-4.3 - 2.2 + 1.1 + 0.6) = -4.8$  kip-ft, whereas they should total zero, as there is no shear in the bent. The correction, accordingly, is  $+4.8$ , one-fourth at each end of each column,  $+1.2$ . This gives  $+2.3$  to distribute on unlocking joint A,  $-3.1$  on unlocking joint B.

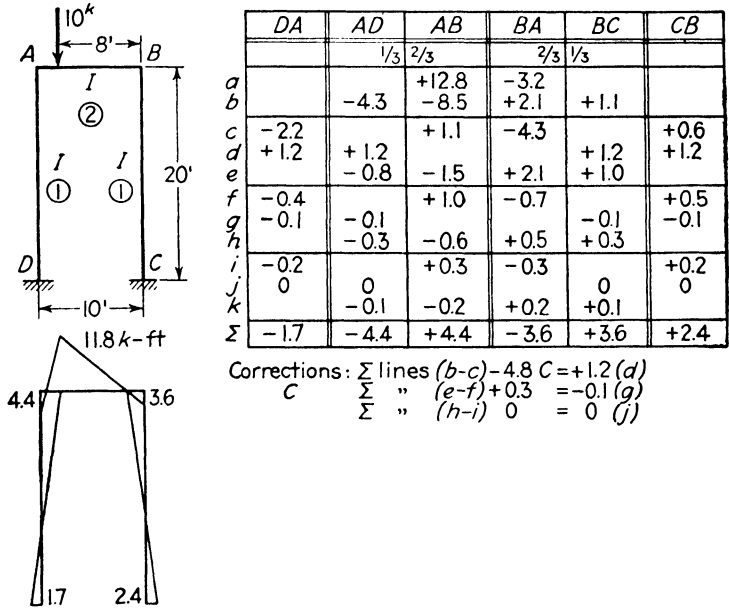

FIG. 8:27

**8:3. Members with varying moment of inertia.** The moment distribution procedure is usually exactly the same for a structure with members of varying cross section as for prismatic members. The task of determining stiffness, carry-over factors, and fixed-end moments is, however, very laborious. Fortunately a considerable amount of information—reference to which is made at the end of this article—has been published in the form of curves and tables giving these factors for the more common types of varying section. Data of this sort are indispensable to the engineer in practice. The determination of beam and load factors by the conjugate beam method is illustrated in the example which follows.

**Example 8:16.** Determine the stiffness and carry-over factors for the wedge-shaped beam shown in Fig. 8:28. The moment of inertia varies as the cube of the depth.

*Solution.* The first part of this problem, as set in the figure, is to determine

the carry-over factor from end *a* to end *b*, that is, the ratio,  $r_a$ , of the moment induced at fixed end *b* by the application of a moment,  $M$ , at simply supported end *a*. Next, the stiffness at *a* is determined, the value of the moment,  $S_a$ , which will induce unit rotation at *a* when end *b* is fixed. Finally, the carry-over

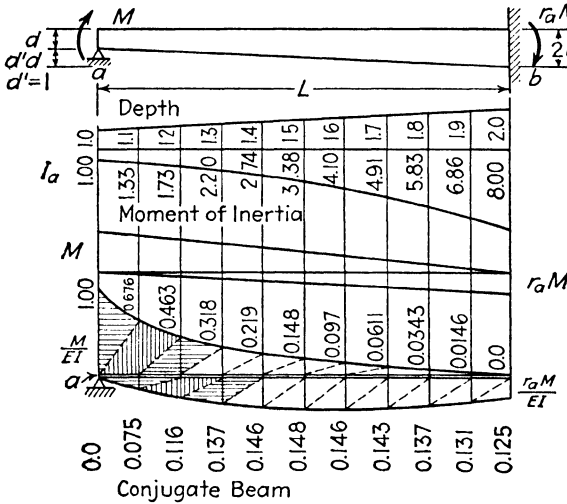

Sect.	Arm from <i>a</i>	$\frac{M}{EI_a}$		$\frac{r_a M}{EI_a}$	
		Area	Area x Arm	Area	Area x Arm
1	0.033 <i>L</i>	0.0500 <i>L</i>	0.00167 <i>L</i> <sup>2</sup>	—	—
2	0.10 <i>L</i>	0.0676 <i>L</i>	676	0.0075 <i>L</i>	0.00075 <i>L</i> <sup>2</sup>
3	2	463	926	116	232
4	3	318	954	137	411
5	4	219	876	146	584
6	5	148	740	148	740
7	6	097	582	146	876
8	7	061	427	143	1001
9	8	034	272	137	1096
	0.90 <i>L</i>	015	135	131	1179
	0.967 <i>L</i>	—	—	063	609
	Sums	$\frac{0.2531 ML}{EI_a}$	$\frac{0.0576 ML^2}{EI_a}$	$\frac{0.1242 r_a ML}{EI_a}$	$\frac{0.0680 r_a ML^2}{EI_a}$

Carry-Over :  $r_a$   
 $\sum M_a = 0$

$$-\frac{0.0576 ML^2}{EI_a} + \frac{0.0680 r_a ML^2}{EI_a} = 0$$

$$r_a = \frac{0.0576}{0.0680} = [0.847]$$

Stiffness:  
 $S_a \theta_a = 1 \quad \sum V = 0$

$$I = \frac{0.2531 ML}{EI_a}$$

$$- \frac{0.1242 \times 0.847 ML}{EI_a}$$

$$M = 6.75 EI_a / L$$

$$= S_a [6.86]$$

FIG. 8:28

from *b* to *a* is found, and the stiffness at *b*, end *a* being considered fixed and *b* simply supported.

Since only relative values of  $I$  are required here, that at *a*, the small end, is taken as unity, and then record is made of the relative value at each tenth point along the span. The bending moment curve is drawn in two parts, the values at the tenth points being already sufficiently indicated by the depth ratios just below the beam sketch. The conjugate beam, simply supported at *a*, free at

$b$ , is loaded by the  $M/EI$  curve, the ordinates being as shown. The divisions made of these areas for computation are indicated by the cross-hatching at the left end of the beam. Since the loaded conjugate beam is in equilibrium, the value of  $r_a$  must be that which will make the rotation tendency about  $a$  zero. With  $r_a$  known, the relative magnitudes of the two areas of the  $M/EI$  load curve are known, their difference, for equilibrium, equaling the left-hand reaction. For stiffness this reaction has the hypothetical value of unity, which establishes the corresponding value of the moment at  $a$ .

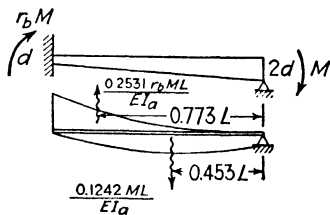

FIG. 8:29

The second part of the problem is set forth in Fig. 8:29, the areas under the two-part  $M/EI$  curve coming from the solution just traced out. It is necessary to locate the centroids of these areas:

For  $\frac{M}{EI}$ ,  $x = \frac{0.0576L^2}{0.2531L} = 0.227L$  from  $a$ ,  $0.773L$  from  $b$

For  $\frac{r_a M}{EI}$ ,  $x = \frac{0.0680L^2}{0.1242L} = 0.547L$  from  $a$ ,  $0.453L$  from  $b$

Proceeding as before,  $r_b$  is found to equal 0.287 and  $S_b = 19.40EI_a/L$ . More precise values from published data are 0.294 and 19.46; corresponding values for  $r_a$  and  $S_a$  are given in brackets in Fig. 8:28, following the values given by the computation.

To be complete this example should call also for the determination of fixed-end moments, but since no new principle is involved this has been set for a problem at the end of this chapter.

When the far end of a varying section member is simply supported, or is given the same or opposite rotation to that of the near end, the stiffness of the near end is modified just as with members of uniform cross section. The work of many problems is much simplified by using these modified stiffness factors. A general derivation of these modifications proceeds as follows.

In Fig. 8:30a is shown a beam of either uniform or varying section. Simultaneously there are applied to the beam ends two moments,  $S_a$  at end  $a$ , causing there unit rotation, and  $r_a S_a$  at end  $b$ , the moment required to fix  $b$  against rotation.  $S_a$  is thus the stiffness at  $a$  with  $b$  fixed, and  $r_a$  is the carry-over ratio from  $a$  to  $b$ . To release end  $b$  from fixation and make it simply supported, a counter moment of  $r_a S_a$  is applied at  $b$ , neutralizing the first or fixation moment, and at the same time a moment of  $r_a S_a$  is applied at  $a$  in order to prevent change in





Areas Under Curves for Uniform Loads			
$d'$	$M_a$	$d'$	$M_a$
0.0	$0.0833 wL^2$	1.0	$0.1024 wL^2$
0.5	$0.0956 wL^2$	2.0	$0.1099 wL^2$

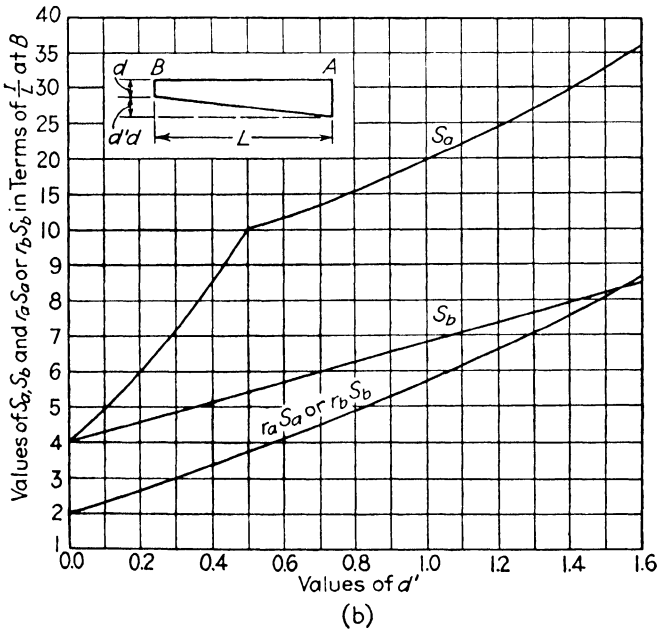
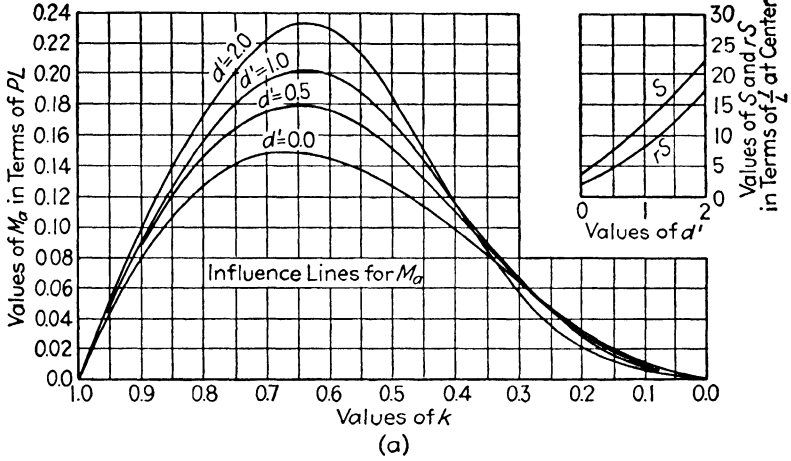
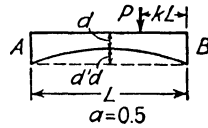

FIG. 8:32



*Concrete Bridges*, to which the reader should refer for a complete study of the design stresses. Further study of the same structure is made in another P.C.A. publication, No. ST 42 of the *Concrete Information* series of leaflets.

The beam and load factors given below are those computed in the P.C.A. pamphlet and are described as "given with greater accuracy than that generally required." Presumably they could be found with the aid of the two sets of curves in Fig. 8:32 with sufficient accuracy, but a more precise set of data actually was employed.

Two assumptions are made on the basis of construction conditions. The footings rest on earth and will offer small resistance to rotation: accordingly, hinged supports are assumed, with effect of a slightly smaller corner moment than for fixed supports. Both the backfill and the approach slab tend to resist side sway under unsymmetrical loading. This tendency to horizontal movement is reduced by the fact that the unsymmetrical load will usually cover only one lane of a bridge which is twice that width or more: the unloaded portion will have no side-sway tendency and will resist movement. Accordingly, side sway is assumed absent, an assumption which results in increased corner moment.

*Solution.*

*Stiffness and carry-over. Deck:*  $d' = 1.43$ ;  $S = 16.25$  (Fig. 8:32);  $rS = 12.0$ :  $r = 0.74$

*Walls:*  $d' = 0.70$ :  $S_a = 6.0$ :  $S_b = 13.3$ :  $r_a S_a = r_b S_b = 4.4$  (Fig. 8:32):  
 $r_a = 0.73$ :  $r_b = 0.331$

Modified  $S_b = S_b' = S_b(1 - r_a r_b) = 13.3(1 - 0.73 \times 0.33) = 10.1$

*Relative CK values:*  $I$ -deck  $\propto 1.75^3 \propto 1.0$ :  $I$ -wall  $\propto 2.50^3 \propto 2.91$

$CK$ -deck:  $16.25 \times 1/60 = 0.271 \propto 0.141$

$CK$ -wall:  $10.1 \times 2.91/17.88 = 1.643 \propto \frac{0.859}{1.000}$

*F.E.M. Uniform L.L.:*  $M = 0.106wL^2$  (Fig. 8:32a, by interpolation)  
 $= 0.106 \times 90 \times 60^2 = 34,300$  lb-ft

*Concentrated L.L.:*  $M_b = 2.5 \times 60 \times 0.216 = 32,400$  lb-ft

$M_c = 2.5 \times 60 \times 0.099 = 14,900$  lb-ft

*Moment distribution:*

Dist. and C.O.	ba 0.859	bc 0.141	$\leftarrow 0.74 \rightarrow$	cb 0.141	cd 0.859
F.E.M.		+66.7		-49.2	
Dist.	-57.3	-9.4		+6.9	+42.3
C.O.		+5.1		-6.9	
	-4.4	-0.7		+1.0	+5.9
		+0.7		-0.5	
	-0.6	-0.1		+0.1	+0.4
Sum	-62.3	+62.3		-48.6	+48.6

*Correction for curvature:*

$$\begin{aligned}\text{Max. corner moment} = M_b &= 62.3 \left( \frac{H + R/2}{H + R} \right) \\ &= 62.3 \left( \frac{17.88 + 1.5/2}{17.88 + 1.5} \right) = 59,900 \text{ lb-ft}\end{aligned}$$

**Design data.** The basic textbook for study of the rigid frame problem is *Continuous Frames of Reinforced Concrete* by Cross and Morgan (John Wiley). Here is found a set of diagrams giving stiffness, carry-over, and fixed-end moment factors for a considerable range of varying section members. Beside his contribution to slope deflection already referred to (footnote, Art. 8:5) Mr. L. T. Evans has given us a valuable volume, *Rigid Frames* (Edwards Bros.), with a wealth of design data. The Portland Cement Association has been very active in these studies, and practicing engineers find invaluable its *Concrete Information Sheets* ST 40, 42, and 43. The P.C.A. *Handbook of Frame Constants* (which replaces ST 41) gives many tables of factors and also a complete derivation of the general expressions for these constants, using the calculus, for members with parabolic haunches of various length and depth ratios, as well as for members with straight haunches and for members tapered in two directions (piers).

**8:9. Method of the column analogy.** The second major method of rigid frame analysis introduced by Professor Cross is the column analogy<sup>10</sup> for single-span structures with not more than three redundant elements. In the words of its discoverer, "The column analogy is a mathematical identity between the moments produced by continuity in a beam, bent, or arch and the fiber stresses in a short column eccentrically loaded." Though sometimes involved in detail, the operation of obtaining column stresses is essentially a simple one which is familiar to every student of structures. The analogy reduces a complex problem of elastic analysis to a simple, familiar process and accordingly is an important weapon in the armory of the structural engineer. It excels in ease and directness when the structure under study is composed of members with non-uniform sections.

In Fig. 8:34*d* is shown a closed ring in equilibrium under the action of a set of forces  $P_1 \cdots P_4$ . For convenience the center line of a circular

<sup>10</sup> After appearing for several years in class notes used at the University of Illinois the new method was first presented to the general public in 1930 in "The Column Analogy," *Bulletin* 215, University of Illinois Engineering Experiment Station. Also, it received complete treatment in *Continuous Frames of Reinforced Concrete*, Cross and Morgan (John Wiley), 1932.

structure such as would be obtained by cutting a length of pipe has been selected, but the following derivation will apply to a closed figure of any shape, with  $E$  and  $I$  either constant or variable. Also, the structure need not be actually closed, for the drawing represents typical indeterminate structures, such as the fixed-end beam, the bent, and the arch, in which the end fixation, i.e., the earth support, is a portion of the ring with  $EI$  of infinite magnitude. Figures 8:34a, b, c are suggestive of the many structures to which the method is applicable.

Under the action of the forces shown in Fig. 8:34d, there will be shear, thrust (or tension), and moment at section  $A$ . The resultant of these on each side of section  $A$  may be represented by  $F$ . Were the ring cut at  $A$ , the combined effect of the external loads,  $P$ , and these forces,  $F$ , would be to make the ring continuous at the section.

Assume that the ring is cut at  $A$  and that the two sets of forces act separately. The loads,  $P_1, P_2$ , etc., cause bending throughout the ring and the (now) statically determinate moment at any section due to these loads may be designated  $m_a$ . Owing to this moment the tangents at the ends of a length  $ds$  at a section such as  $B$  will have a relative rotation  $\Delta\theta_1 = m_a ds/EI$ , as indicated by the moment area theorem. This rotation in the length  $ds$ , shown greatly exaggerated in Fig. 8:34d, causes the cut ends at  $A$  to assume the positions  $A', A''$ .

Using for convenience an origin located at  $A'$ , the coordinates of  $B$  are  $(x_1, y_1)$ , and the components of movement of  $A''$  relative to  $A'$  are  $\Delta x_1, \Delta y_1$ . Since the angle  $\Delta\theta_1$  is small,  $A'A'' = \Delta\theta_1 \cdot AB$ , and  $A'A''$  may be assumed normal to  $BA'$ . From similar triangles ( $A'BC$  and  $A''A'D$ ),  $x_1 : A'B = \Delta y_1 : A'A''$ , or,  $\Delta y_1 = (A'A''/A'B)x_1 = \Delta\theta_1 \cdot x_1$ . Similarly,  $\Delta x_1 = \Delta\theta_1 \cdot y_1$ .

But  $\Delta\theta_1$  is also the angle through which one part of the severed tangent at  $A$  rotates relative to the other. If then the total rotation due to the

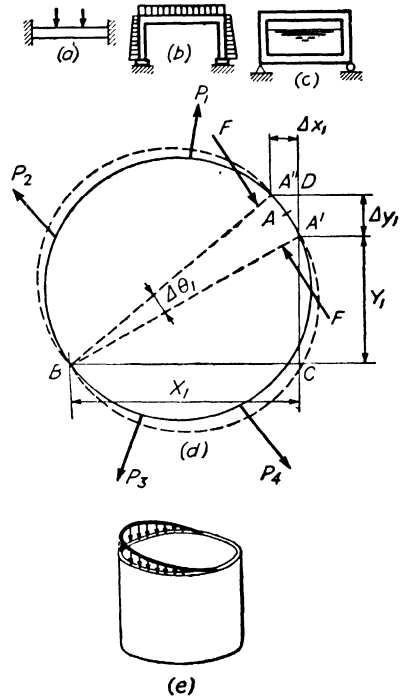

FIG. 8:34

moments  $m_a$  throughout the ring is denoted  $\theta'$  and the components of the total separation at  $A$  are called  $x'$ ,  $y'$ , we may write

$$\theta' = \int m_a \frac{ds}{EI}$$

$$x' = \int m_a \cdot y \frac{ds}{EI}$$

$$y' = \int m_a \cdot x \frac{ds}{EI}$$

Consider next the effect of the indeterminate forces,  $F$ . Owing to these forces there will be indeterminate moments,  $m_i$ , throughout the ring. Since these moments change as their distances from  $A$ , they will have *straight-line variation*. Furthermore, since the actual ring is continuous at  $A$ , the total effect of the indeterminate moments,  $m_i$ , is to produce rotation and components of translation which are equal but opposite to those caused by the determinate moments,  $m_a$ . That is,

$$\int m_i \frac{ds}{EI} = - \int m_a \frac{ds}{EI}$$

$$\int m_i \cdot y \frac{ds}{EI} = - \int m_a \cdot y \frac{ds}{EI}$$

$$\int m_i \cdot x \frac{ds}{EI} = - \int m_a \cdot x \frac{ds}{EI}$$

As the final step, conceive of a column with a cross section having, in general, the shape of the ring but with its thickness varying inversely as  $EI$ . Suppose this column is loaded at one end with loads of unit intensity equal to  $m_a$ , i.e., the determinate moments of Fig. 8:34d would cause the loading shown in Fig. 8:34e. These loads on the end of the column will cause, on a cross section some distance away, unit fiber stresses,  $f$ , with *straight-line variation*. For convenience, assume that the column, the loads, and the resulting stresses are each parallel to a vertical axis. Taken together, the loads,  $m_a$ , and the resulting stresses,  $f$ , constitute a system of parallel forces in space. The system is in equilibrium, and such a system in equilibrium satisfies three conditions: the algebraic sum of the forces equals zero ( $\Sigma V = 0$ ), and the sum of the moments about any two perpendicular axes in any horizontal plane each equal zero ( $\Sigma M_X = 0$ ,  $\Sigma M_Y = 0$ ). Let such equa-

tions be written, using a vertical axis, and  $X$  and  $Y$  axes through point  $A'$  (Fig. 8:34d).

$$\begin{aligned}\Sigma V = 0: & \quad \int f \frac{ds}{EI} = - \int m_a \frac{ds}{EI} \\ \Sigma M_x = 0: & \quad \int f \cdot y \frac{ds}{EI} = - \int m_a \cdot y \frac{ds}{EI} \\ \Sigma M_y = 0: & \quad \int f \cdot x \frac{ds}{EI} = - \int m_a \cdot x \frac{ds}{EI}\end{aligned}$$

Since both  $m_i$  and  $f$  have straight-line variation, comparison of this group of equations and the similar-appearing set previously written reveals the analogy discovered by Professor Cross; that is,  $m_i = f$ . Since the actual moment,  $m$ , at any point of the ring of Fig. 8:34d equals  $m_a$  minus  $m_i$ , it follows that

$$m = m_a - f$$

Hence the method of determining moments by the column analogy in a statically indeterminate structure which may be represented by a closed ring is as follows. *By means of a cut section, hinge, or similar device produce a statically determinate structure and compute the moments,  $m_a$ , due to the given set of loads. Use these moments as a system of loads on an analogous column and compute the resulting stresses,  $f$ . Combine  $m_a$  and  $f$  to find the actual moments.*

The problem of determining  $f$  is that of computing fiber stress in a column either centrally or (more commonly) eccentrically loaded. This is rather simple in a section which has an axis of symmetry. That is, if the total load due to  $\Sigma m_a(ds/EI)$  is represented by  $P$ , and the area of the analogous column  $\Sigma(ds/EI)$  by  $A$ ,

$$f = \frac{P}{A} + \frac{M_x \cdot y}{I_x} + \frac{M_y \cdot x}{I_y}$$

where  $M_x$  and  $M_y$  are moments about the principal axes  $X$  and  $Y$  due to  $P$ ,  $x$  and  $y$  are distances measured from those same axes, and  $I_x$  and  $I_y$  are moments of inertia about those axes.

**Signs.** Use the beam convention, i.e., consider compression on the top of a beam or on the outside of a ring as positive moment. Then

$$\text{Actual moment} = \text{Determinate moment} - \left( \frac{P}{A} + \frac{M_x \cdot y}{I_x} + \frac{M_y \cdot x}{I_y} \right)$$

In applying this rule, the load, both in the  $P$  and in the  $M$  terms, is to



be given its determinate moment sign. Also, for the moment arm (in  $(M_x \cdot y)/I_x$ , etc.) and for  $x$  and  $y$ , the usual convention is to be followed, i.e.,  $x$  values to the right of the  $Y$  axis are positive, those to the left negative, etc.

**Example 8:19.** Using column analogy, draw the bending moment curve for the fixed-end beam of Fig. 8:35.

*First solution.* Consider the beam as a portion of a ring. In order to fix  $A$  and  $B$ , the remainder of the ring (not shown) is assumed to be of infinite

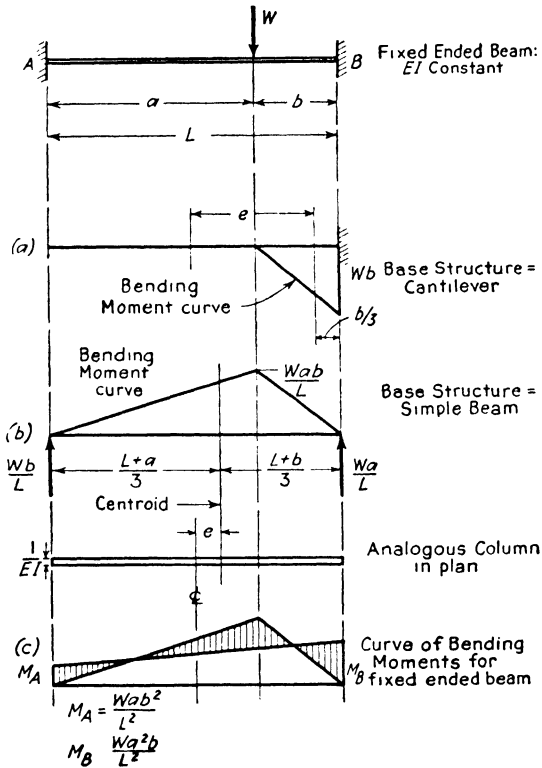

FIG. 8:35

stiffness and will not appear as part of the analogous column, since for it  $1/EI$  will equal zero. Consequently the analogous column has width  $L$  and uniform thickness  $1/EI$ . (Note that the form of the analogous column is independent of the method selected for producing a determinate structure.)

In this solution the structure has been made determinate by cutting at  $A$ , the resulting moment curve being shown on line  $a$ . Since the moment is

negative, the loading on the column will also be negative, and we may write

$$\begin{aligned}
 M_A &= 0 - \left[ \frac{-\frac{1}{2}b \frac{Wb}{EI}}{\frac{L}{EI}} + \frac{\left(-\frac{Wb^2}{2EI}\right)\left(\frac{L}{2} - \frac{b}{3}\right)\left(-\frac{L}{2}\right)}{\frac{1}{12}L^3 \frac{1}{EI}} \right] \\
 &= 0 - \left[ -\frac{Wb^2}{2L} + \frac{3Wb^2}{2L} - \frac{Wb^3}{L^2} \right] = -\frac{Wb^2}{L} \left[ -\frac{1}{2} + \frac{3}{2} - \frac{b}{L} \right] \\
 &= 0 - \frac{Wb^2}{L} \left[ \frac{L-b}{L} \right] = -\frac{Wab^2}{L^2}
 \end{aligned}$$

Similarly, reversing the signs of the last two terms because, for  $B$ ,  $x$  is positive (i.e.,  $= +L/2$ )

$$\begin{aligned}
 M_B &= -Wb - \left[ -\frac{Wb^2}{2L} - \frac{3Wb^2}{2L} + \frac{Wb^3}{L^2} \right] \\
 &= -\frac{WbL^2}{L^2} + \frac{2Wb^2L}{L^2} - \frac{Wb^3}{L^2} \\
 &= -\frac{Wb}{L^2} [L^2 - 2bL + b^2] = -\frac{Wa^2b}{L^2}
 \end{aligned}$$

*Second solution.* Here the beam has been considered simply supported, giving the positive moment curve of line  $b$ . For a member of uniform  $E$  and  $I$  the solution is somewhat simplified by taking the thickness of the analogous column as 1. Making this change, we obtain (see Fig. 8:35)

$$\begin{aligned}
 M_A &= 0 - \left[ \frac{\frac{1}{2}L \frac{Wab}{L}}{L} + \frac{\left(\frac{Wab}{2}\right)\left(\frac{a}{3} - \frac{L}{6}\right)\left(-\frac{L}{2}\right)}{L^3/12} \right] \\
 &= -\left[ \frac{Wab}{2L} - \frac{Wa^2b}{L^2} + \frac{Wab}{2L} \right] \\
 &= -\frac{Wab}{L^2} \left[ \frac{L}{2} - a + \frac{L}{2} \right] = -\frac{Wab^2}{L^2} \\
 M_B &= 0 - \frac{Wab}{L^2} \left[ \frac{L}{2} + a - \frac{L}{2} \right] = -\frac{Wa^2b}{L^2}
 \end{aligned}$$

The desired moment curve is obtained in the usual manner from these values. Note in the first solution that the determinate moment at  $B$  does not equal zero. (It *does* equal zero at  $A$  in that solution and at both  $A$  and  $B$  in the second solution.)

**Example 8:20.** Draw the bending moment curve for the beam of Fig. 8:36, using the column analogy to determine the moment at  $A$ .

*First solution.* This structure has been selected because it contains a hinge. There, for an infinitesimal length, the beam has zero stiffness (and  $I$ ), and the analogous column, for an infinitesimal length, has infinite width. This is indicated by the heavy line at the right end of the analogous column. In consequence the column has infinite area (therefore the  $P/A$  term will equal zero), the center of gravity is at the right end, and the moment of inertia of the column about the gravity axis equals  $L^3/3EI$  (or  $L^3/3$  if the thickness is taken as 1). (Note that the fin of zero thickness has no moment of inertia about the  $Y$  axis, since all of it is at zero distance from that axis.)

The beam has been made determinate by removing the support at  $B$ , giving the negative moment curve of line  $a$ .

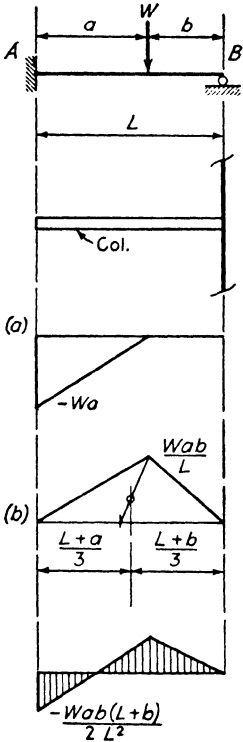

FIG. 8:36

Hence  $M_A = -Wa -$

$$\begin{aligned}
 & \left[ 0 + \frac{\left(-\frac{1}{2} Wa \cdot a\right)\left(-L + \frac{a}{3}\right)\left(-L\right)}{L^3/3} \right] \\
 &= -Wa + 0 + \frac{3Wa^2}{2L} - \frac{Wa^3}{2L^2} \\
 &= -\frac{Wa(2L^2 - 3aL + a^2)}{2L^2} \\
 &= -\frac{Wa(2L - a)(L - a)}{2L^2} \\
 &= -\frac{Wab(L + b)}{2L^2}
 \end{aligned}$$

*Second solution.* Assume the beam to be simply supported, giving the positive moment of curve of line  $b$ . Now

$$\begin{aligned}
 M_A &= 0 - \left[ 0 + \frac{\left(\frac{1}{2} L \frac{Wab}{L}\right)\left(\frac{-L - b}{3}\right)\left(-L\right)}{L^3/3} \right] \\
 &= -\frac{Wab(L + b)}{2L^2}
 \end{aligned}$$

Note, in each solution, that the determinate moment at  $B$  equals zero,  $P/A$  also equals zero, and the stress due to bending equals zero because  $B$  is on the neutral axis of the analogous column. Combined, these give a value of zero for  $M_B$ , and this accords with the known condition of a simple support at  $B$  in the actual structure.

**Example 8:21.** Solve Ex. 8:7, by the column analogy.

*Solution.* Cut the frame anywhere to the right of  $a$ , giving the moment curve of Fig. 8:37*b*. Since the section is constant, the width of the analogous column is taken as 1.

$$P = \frac{1}{2} \times (-200) \times 1 \times 20 = -2000$$

$$A = 1(20 + 20 + 10) = 50$$

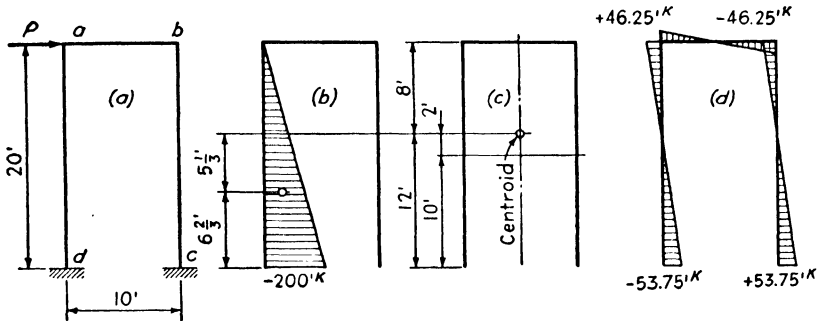

FIG. 8:37

Location of centroid, moments about an axis 10' below  $a$ ,

$$\bar{y} = \frac{(10 \times 1) (+10)}{50} = +2$$

Moments of inertia:

$$\begin{array}{rcl} I_X = 2 \times \frac{1}{12} \times 1 \times 20^3 & = & 1333 \\ 2 \times 20 \times 1 \times 2^2 & = & 160 \\ 10 \times 1 \times 8^2 & = & 640 \\ \hline & & 2133 \end{array} \qquad \begin{array}{rcl} I_Y = \frac{1}{12} \times 1 \times 10^3 & = & 83 \\ 2 \times 20 \times 1 \times 5^2 & = & 1000 \\ \hline & & 1083 \end{array}$$

Whereas the column thickness at each point has been taken as 1, the actual width is  $1/EI$  and is therefore negligibly small when it comes to computing  $I$  about the gravity axis which is parallel to the length of a member. Furthermore, if the moment of inertia of the girder had been twice the moment of inertia of the columns, the width of the columns in the analogous column would have been twice that of the girder, since width varies inversely as  $I$ .

$$\frac{P}{A} = \frac{-2000}{50} = -40$$

$$\frac{M_X \cdot y}{I_X} = \frac{(-2000) (-5\frac{1}{3})y}{2133} = +5y$$

$$\frac{M_Y \cdot x}{I_Y} = \frac{(-2000) (-5)x}{1083} = +9.25x$$

$$\begin{aligned} m &= m_d - (-40 + 5y + 9.25x) \\ &= m_d + 40 - 5y - 9.25x \end{aligned}$$

Hence,

$$\begin{aligned}
 m_a &= 0 + 40 - 5(+8) - 9.25(-5) \\
 &= 0 + 40 - 40 + 46.25 = +46.25 \\
 m_b &= 0 + 40 - 5(+8) - 9.25(+5) \\
 &= 0 + 40 - 40 - 46.25 = -46.25 \\
 m_c &= 0 + 40 - 5(-12) - 9.25(+5) \\
 &= 0 + 40 + 60 - 46.25 = +53.75 \\
 m_d &= -200 + 40 - 5(-12) - 9.25(-5) \\
 &= -200 + 40 + 60 + 46.25 = -53.75
 \end{aligned}$$

*Suggestion.* Rework this problem, assuming that the structure is made determinate by inserting hinges at *a* and *b*. Note that one of the resulting moment areas will be positive, the other negative. Hence *P/A* will be zero and so will the moment about the *X* axis.

In a sense, each of the examples considered to this point in this article has been a special case, since each of the analogous columns has had at least one axis of symmetry. For such a structure the ordinary

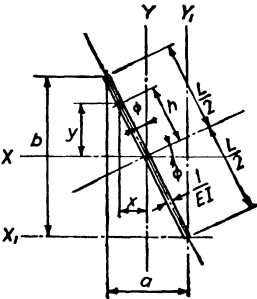

**STRAIGHT MEMBER**

$$\begin{aligned}
 I_x &= \Sigma (y^2 \cdot \frac{dh}{EI}) = 2 \int_0^{\frac{L}{2}} (h \cos \phi)^2 \frac{dh}{EI} \\
 &= \frac{2 \cos^2 \phi}{EI} \int_0^{\frac{L}{2}} h^2 dh = \frac{\cos^2 \phi}{EI} \frac{L^3}{12} \text{ (or } = \frac{L b^2}{12 EI} \text{)}
 \end{aligned}$$

Similarly

$$I_y = \frac{\sin^2 \phi}{EI} \frac{L^3}{12} \text{ (or } = \frac{L a^2}{12 EI} \text{)}$$

$$I_{x_1} = \frac{\cos^2 \phi}{EI} \frac{L^3}{3}$$

$$I_{y_1} = \frac{\sin^2 \phi}{EI} \frac{L^3}{3}$$

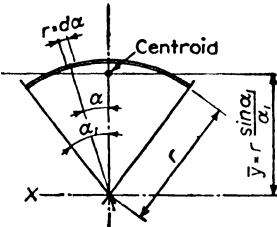

**SEGMENTAL MEMBER (Treated as a Line)**

$$2r \alpha_1 \bar{y} = 2 \int_0^{\alpha_1} r \cdot d\alpha (r \cos \alpha)$$

$$\bar{y} \alpha_1 = r \int_0^{\alpha_1} \cos \alpha \, d\alpha = r \cdot \sin \alpha \Big|_0^{\alpha_1}$$

$$\bar{y} = r \frac{\sin \alpha_1}{\alpha_1}$$

$$\begin{aligned}
 I_x^* &= 2 \int_0^{\alpha_1} r \cdot d\alpha (r \cos \alpha)^2 = 2r^3 \int_0^{\alpha_1} \cos^2 \alpha \, d\alpha \\
 &= r^3 [\alpha_1 + \sin \alpha_1 \cos \alpha_1]
 \end{aligned}$$

Similarly

$$I_y = r^3 [\alpha_1 - \sin \alpha_1 \cos \alpha_1]$$

\* Note that this Axis is not through the Centroid

FIG. 8:38

bending formulas are applicable without modification. When this is not true, as for example in Prob. 8:23h, the solution involves the use of principal moments of inertia, products of inertia, etc. Space limitations

prohibit the inclusion of the general case in this book. However, the student will be able to solve this with the aid of textbooks on strength of materials which discuss bending in sections that do not have an axis of symmetry.<sup>11</sup>

There is, though, one further special structure to which it is desired to call attention, i.e., one which has two hinges. As in any structure with hinges, the  $P/A$  term equals zero, the determinate moment at the hinges equals zero, and since the final moment must be zero, it is clear that the stress due to bending in the analogous column must equal zero at the hinges. In other words the neutral axis passes through these points. For such a case it is known that stress may be figured from the familiar relation  $s = Mz/I$ , where  $M$  is moment about neutral axis,  $z$  is distance from neutral axis, and  $I$  is moment of inertia about the neutral axis. To facilitate the use of this relation, Fig. 8:38 is given. This figure also gives properties of segmental members which it is desired to use in Ex. 8:23.

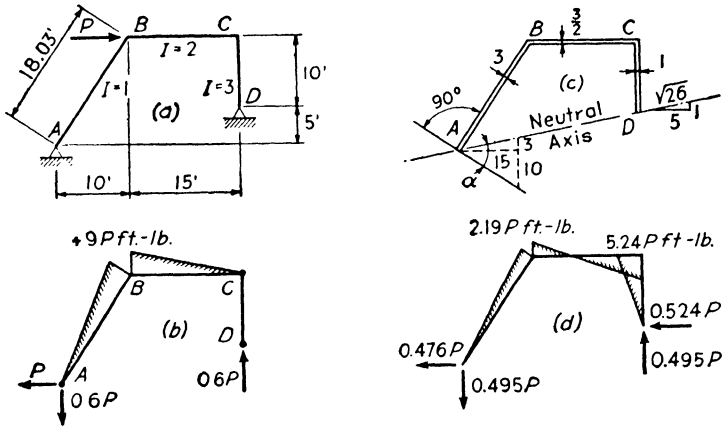

FIG. 8:39

**Example 8:22.** Determine the moments and reactions caused by the load  $P$  acting on the structure of Fig. 8:39a.

*Solution.* If the structure is made determinate by inserting a hinge at  $C$ , there will result the moment curve of Fig. 8:39b. The analogous column has the form shown in Fig. 8:39c, the relative dimensions being as shown. Since the neutral axis passes through  $A$  and  $D$ , it is necessary to compute the moment of inertia about this axis, the moment of the load about the same axis and the dis-

<sup>11</sup> If this material is unfamiliar, the authors recommend a reading of Appendix A and Art. 1-5 of *Structural Design*, by Hale Sutherland and H. L. Bowman (John Wiley). Note equation 1-4A or 1-4B, pages 13-14.

tances of points  $B$  and  $C$  therefrom. Member  $AB$  makes with the neutral axis an angle  $90^\circ - \alpha$ , where

$$\tan \alpha = \frac{\frac{3}{15} + \frac{10}{15}}{1 - \left(\frac{3}{15}\right)\left(\frac{10}{15}\right)} = \frac{3 \times 15 + 10 \times 15}{225 - 30} = \frac{195}{195} = 1$$

Hence,  $I_{NA}$ , for

$$AB = \frac{3(18.03)^3}{3} \left(\frac{1}{\sqrt{2}}\right)^2 = 2926$$

$$BC = \frac{3(15)^3}{2 \times 12} \left(\frac{1}{\sqrt{26}}\right)^2 + \frac{3(15)}{2} \left[10 \left(\frac{5}{\sqrt{26}}\right) + \frac{15}{2} \left(\frac{1}{\sqrt{26}}\right)\right]^2 = 2878$$

$$CD = \frac{10^3}{3} \left(\frac{5}{\sqrt{26}}\right)^2 = \frac{321}{6125}$$

$$\text{Also, } M_{NA} = \frac{(+9P)18.03 \times 3}{2} \left(\frac{2}{3} \times \frac{18.03}{\sqrt{2}}\right) = 2075P$$

$$\frac{(+9P)15 \times 3}{2 \times 2} \left[10 \left(\frac{5}{\sqrt{26}}\right) + \frac{2 \times 15}{3} \left(\frac{1}{\sqrt{25}}\right)\right] = \frac{1190P}{3265P}$$

$$\text{And, } z_B = \frac{18.03}{\sqrt{2}} = 12.76$$

$$z_C = 10 \left(\frac{5}{\sqrt{26}}\right) = 9.81$$

Therefore,

$$M_B = +9P - \left[0 + \frac{3265P \times 12.76}{6125}\right] = +2.19P \text{ ft-lb}$$

$$M_C = 0 - \left[0 + \frac{3265P \times 9.81}{6125}\right] = -5.24P \text{ ft-lb}$$

Using these moment values, the reactions follow without difficulty.

**Example 8:23.** Determine the moments and reactions caused by the uniform load acting on member  $DE$  of the structure of uniform moment of inertia of Fig. 8:40a.

*Solution.* Use will be made of the information tabulated in the lower part of Fig. 8:38. In the present example

$$\alpha_1 = 90^\circ - \tan^{-1} \frac{1}{2} = 90^\circ - 26^\circ 34'$$

$$= 63^\circ 26' = 63.46^\circ$$

$$= \frac{63.46}{90} \times \frac{\pi}{2} = 1.107 \text{ radians}$$

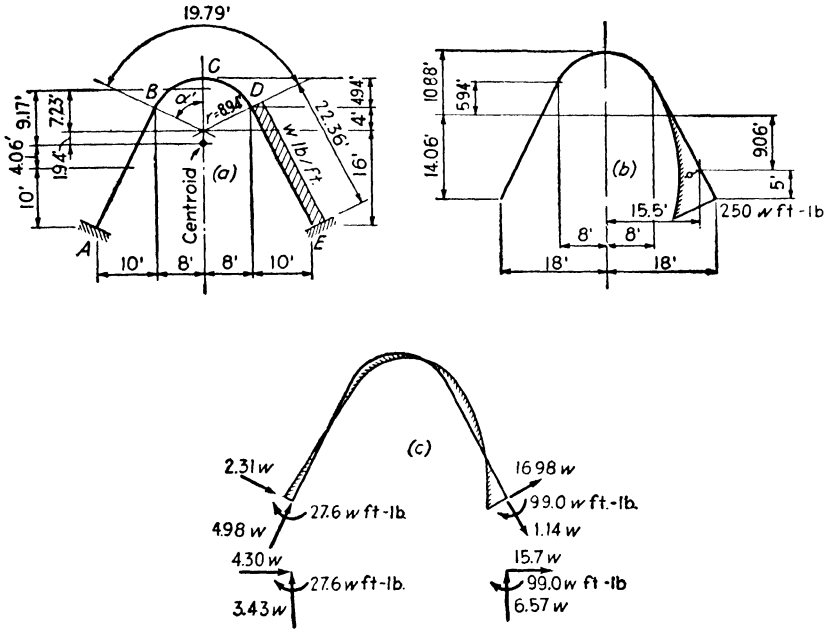

FIG. 8:40

For the circular arc,  $\bar{y} = \frac{r \sin \alpha_1}{\alpha_1} = \frac{8.94 \times 8/8.94}{1.107} = 7.23 \text{ ft}$

$$I_{X_{\text{center}}} = r^3[\alpha_1 + \sin \alpha_1 \cos \alpha_1] = 8.94^3 \left[ 1.107 + \frac{8 \times 4}{8.94^2} \right] = 1078$$

$$I_{X_{\text{centroid}}} = 1078 - 19.79 (7.23)^2 = 45$$

$$I_Y = r^3[\alpha_1 - \sin \alpha_1 \cos \alpha_1] = 8.94^3[1.107 - 0.4] = 505.6$$

Location of centroid of bent (moments about center of curvature)

$$\frac{-2 \times 22.36 \times 6 + 19.79 \times 7.23}{2 \times 22.36 + 19.79} = -\frac{125.2}{64.51} = -1.94$$

The structure has been made determinate by cutting at A. This will produce the moment curve of Fig. 8:40b. The resulting load,  $P$ , on the analogous column will be

$$P = \frac{-250 \times 22.36}{3} = -1863$$



For the entire analogous column,

$$\begin{array}{rcl}
 I_x & = & 45 \\
 19.79(9.17)^2 & = & 1663 \\
 2\left(\frac{22.36 \times 20^2}{12}\right) & = & 1491 \\
 2 \times 22.36 \times 4.06^2 & = & \frac{737}{3936}
 \end{array}
 \qquad
 \begin{array}{rcl}
 I_y & = & 506 \\
 2\left(\frac{22.36 \times 10^2}{12}\right) & = & 373 \\
 2 \times 22.36 \times 13^2 & = & \frac{7560}{8439}
 \end{array}$$

Hence,

$$\begin{aligned}
 M_A &= 0 - \left[ \frac{-1863}{64.51} + \frac{-1863(-9.06)(-14.06)}{3936} + \frac{-1863(+15.5)(-18)}{8439} \right] \\
 &= 0 + 28.9 + 60.4 - 61.7 = +27.6 \\
 M_B &= 0 + 28.9 - 25.5 - 27.4 = -24.0 \\
 M_C &= 0 + 28.9 - 46.7 \pm 0 = -17.8 \\
 M_D &= 0 + 28.9 - 25.5 + 27.4 = +30.8 \\
 M_E &= -250 + 28.9 + 60.4 + 61.7 = -99.0
 \end{aligned}$$

These moments will permit the computation of the leg shears and the vertical components of reactions. Proper combination of these will give the alternate sets of reactions shown in Fig. 8:40c.

**Beam stiffness and carry-over.** The load placed at any point upon the analogous column,  $Mds/EI$ , is recognized as the change of slope in a differential length of the actual structure. Rotational stiffness has been defined as the moment which, applied at the simply supported end of a beam, will produce there unit rotation, the far end being fixed. Another way of stating it would be that stiffness is the moment induced at one end of a fixed ended beam when the support at that end is rotated through a unit angle. The method of the column analogy enables us to compute the effect of such an induced unit rotation by determining the stresses set up by application of a unit load applied at the end of the analogous column, these stresses being the induced moments.

As an example consider the computation of the stiffness of a fixed ended beam of length  $L$  and uniform section. The analogous column has a cross section of length  $L$  and width  $1/EI$ , and is loaded by a single unit load at one end. The eccentricity of this load is  $e = L/2$ . The stresses at the ends, that is, the moments at the supports, equal

$$\begin{aligned}
 \frac{P}{A} \pm \frac{M_c}{I} &= \frac{1}{L/EI} \pm \frac{(1 \cdot L/2)L/2}{\frac{1}{12} \frac{1}{EI} L^3} \\
 &= \frac{EI}{L} \pm \frac{3EI}{L} \\
 &= 4EK \text{ at the rotated end} \\
 &= -2EK \text{ at the far end}
 \end{aligned}$$

Both end moments act in the same direction. The stiffness is given by  $4EK$ , a value already made familiar. The computation has also given the carry-over factor, the ratio of the moment induced at the far end to that at the end with the impressed rotation, that is, one-half.

PROBLEMS

Art. 8:2 Theorem of Three Moments

**Problem 8:1.** A clockwise couple,  $M$ , is applied at the center of each span of a continuous beam of two equal spans,  $L$ , and with simple supports at its ends. What are the reactions?

*Note.* In deriving the three-moment equation for beams loaded at the center by a couple, the value of  $\theta_a$  due to a moment,  $M$ , applied at the center of the beam, is  $ML/24EI$ . The right side of equation 8:1 then takes this form,  $-M_1L_1/4I_1 + M_2L_2/4I_2$ , there being no loads,  $P$ , and  $m = n = 0$ . Note that both  $M_a$  and  $M_c$  equal zero.

*Ans.*  $V_a = M/L$  down;  $V_b = 0$ ,  $V_c = M/L$  up.

**Problem 8:2.** What is the reaction at point  $c$  of this beam? Note that the moment at  $c$  equals  $-32$  kip-ft.

*Ans.* 19,000 lb.

**Problem 8:3.** Draw the curves of shear and moment for a continuous beam of four equal spans with a uniform load of  $w$  over the whole length. The beam ends are supported.

*Suggestion.* There are three unknown bending moments at the three interior supports, requiring three independent simultaneous equations for solution. Write the three-moment equations successively for supports 1-2-3, 2-3-4, 3-4-5, giving the three equations. (As an alternative method, what use might be made of symmetry?)

*Ans.*  $M_1 = M_5 = 0$ ,  $M_2 = M_4 = -\frac{3}{8}wL^2$ ,

$M_3 = -\frac{1}{4}wL^2$ . The complete curves are given in many textbooks.

**Problem 8:4.** A simple beam 27 ft 6 in. long was designed for a dead load of 1500 lb per ft and a live load of 1550 lb per ft. Later when it became necessary to increase the live load to 2400 lb per ft, it was found possible to insert a post under the beam, 11 ft 9 in. from one end. If this was done while the beam carried only the dead load, did the beam require reinforcement? What was the maximum load on the new post?

*Ans.* No. 41,900 lb.

**Problem 8:5.** A simple beam of span  $2L$  carries a uniform load of  $w$  lb per ft. A jack is placed under the mid-point of the beam, and that point is then raised. Determine the center reaction and draw the moment curve for the beam when the amount the center is raised is: zero,  $\frac{1}{5}\Delta$ ,  $\frac{2}{5}\Delta$ ,  $\frac{3}{5}\Delta$ ,  $\frac{4}{5}\Delta$ ,  $\frac{5}{5}\Delta$ ,  $\frac{6}{5}\Delta$ ,  $\frac{7}{5}\Delta$ , and  $\frac{8}{5}\Delta$ , where  $\Delta$  is the distance the center is below the ends when the beam is without center support.

**Problem 8:6.** Find the moments in these beams by use of the three-moment equation. Find reactions and draw shear and moment curves. (Note that the answer of part  $a$  is given as  $M_{BA} = -60.6$  kip-ft. This is the moment at the  $B$  end of member  $AB$  and is given this way in accordance with the convention of the methods of slope deflection and moment distribution.)

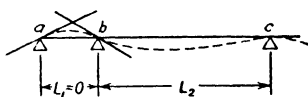
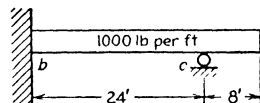

PROB. 8:2

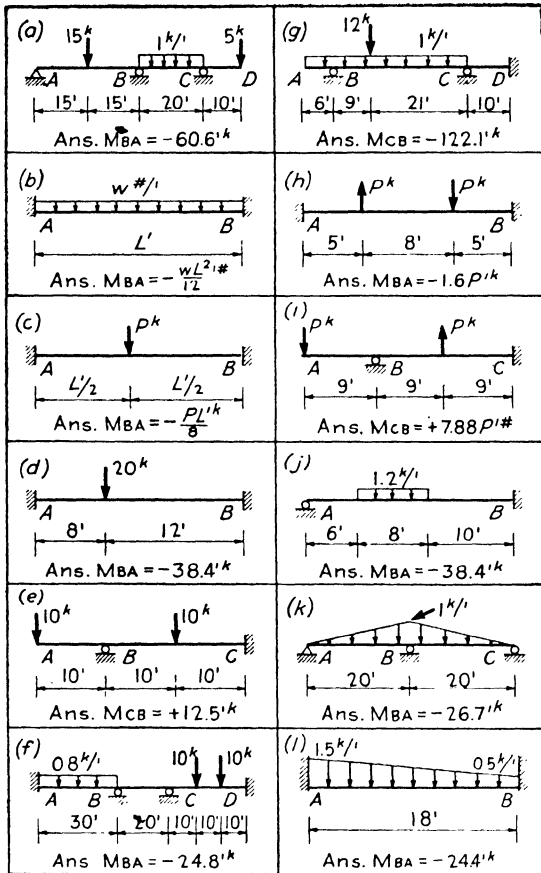

PROB. 8:6 (Probs. 8:11, 19, 22, 27)

Art. 8:3 Fixed Points

**Problem 8:64.** Construct three sets of moment curves for a continuous beam of five equal spans of 20 ft each for a uniform load of 2000 lb per ft placed, first, over the right-hand or fifth span, then over the fourth, and finally over the whole length of the middle span.

Load on	Answer (Kip-feet):			
Span	$M_b$	$M_c$	$M_d$	$M_e$
3	+10.5	-42.1	-42.1	+10.5
4	- 2.88	+11.5	-43.1	-39.2
5	+ 0.96	- 3.84	+14.4	-53.6

$f_2 = 0.250 \quad f_3 = 0.267 \quad f_4 = 0.268$

**Art. 8:4 Method of Least Work**

- Problem 8:7.** Solve Prob. 8:1 by the method of least work.
- Problem 8:8.** Solve Prob. 8:2 by the method of least work.
- Problem 8:9.** Solve Ex. 8:2 by the method of least work.
- Problem 8:10.** Solve Ex. 8:4 by the method of least work, taking the moment and thrust at the center of  $ab$  as the unknowns.
- Problem 8:11.** Solve Prob. 8:6 by the method of least work. Find reactions and draw shear and moment curves.
- Problem 8:12.** Solve these structures by the method of least work. Determine reactions and draw moment curves. See figure on page 288.
- Problem 8:13.** Solve these structures by the method of least work. Determine reactions and draw moment curves. See figure on page 289.

**Art. 8:5 Method of Slope Deflection**

- Problem 8:14.** What are the end moments for a beam of constant cross section, with fixed ends, span  $L$ , carrying a uniform load of  $w$  lb per ft over the whole length? Use the expression accompanying the discussion of Fig. 7:10.  
*Suggestion.* Set up an integral, replacing  $P$  by  $w dx$ , making  $a = x$ .  
*Ans.*  $-wL^2/12$ .

- Problem 8:15.** What are the end moments for a beam of constant cross section, with fixed ends, span  $L$ , carrying a uniform load of  $w$  lb per ft over the left half of its length?  
*Note.* This problem differs from that preceding only in the limits of the definite integral.  
*Ans.*  $M_L = -\frac{1}{192}wL^2$ ;  $M_R = -\frac{5}{92}wL^2$ .

- Problem 8:16.** What are the end moments for a beam of constant cross section, with fixed ends, span  $L$ , carrying a uniformly varying load of zero intensity at its left end and intensity  $w$  at its right end? Use the expressions accompanying the discussion of Fig. 7:10.  
*Suggestion.* Replace  $P$  by  $(wx/L) dx$ . Note that  $W = wL/2$ .  
*Ans.*  $M_L = -WL/15$ ;  $M_R = -WL/10$ .

- Problem 8:17.** Solve the three preceding problems using:
  - a. The three-moment equation.
  - b. The conjugate-beam method.

- Problem 8:18.** Draw the moment curve for the frame and loading here shown. Assume uniform section and material throughout. Use the slope deflection method.

*Note.* Although the deflection for column  $ad$  equals that for column  $bc$ , the  $R$  terms are unlike. The third equation necessary may be obtained by applying the condition  $\Sigma H = 0$  to the free body consisting of the entire structure, the second and third terms in the following equation being the shears at the bases of the left and right columns:

$$10 - \frac{M_{da} + M_{ad}}{10} - \frac{M_{bc} + M_{cb}}{20} = 0$$

*Ans.*  $M_{da} = +50.0$  kip-ft,  $M_{ad} = +33.3$  kip-ft,  
 $M_{cb} = +16.7$  kip-ft,  $M_{bc} = +16.7$  kip-ft.

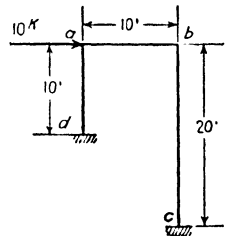

PROB. 8:18

- Problem 8:19.** Solve parts  $a, e, f, g, i$  of Prob. 8:6 by the slope deflection method.
- Problem 8:20.** Solve Prob. 8:12 by the slope deflection method.
- Problem 8:21.** Solve Prob. 8:13 by the slope deflection method.

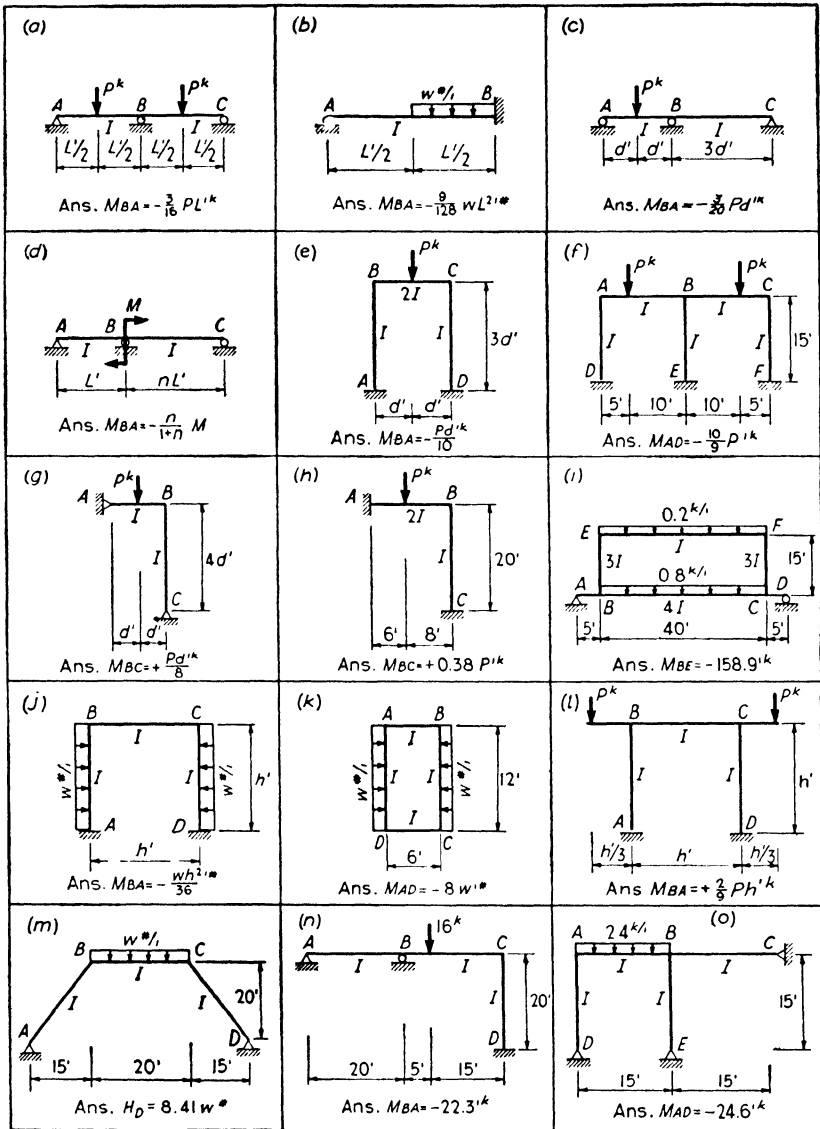

PROB. 8:12 (Probs. 8:20, 23, 28)

**Art. 8:6 Method of Moment Distribution**

**Problem 8:22.** Solve parts a, e, f, g, i of Prob. 8:6 by the method of moment distribution.

**Problem 8:23.** Solve Prob. 8:12 by the method of moment distribution.

<p>(a)</p> <p>Ans. <math>M_{BA} = +\frac{3}{14}Ph^k</math></p>	<p>(b)</p> <p>Ans. <math>M_{AD} = +\frac{1}{8}Ph^k</math></p>	<p>(c)</p> <p>Ans. <math>M_{AB} = +7.06^k</math></p>
<p>(d)</p> <p>Ans. <math>M_{CB} = +41.6^k</math></p>	<p>(e)</p> <p>Ans. <math>M_{DC} = +119.4^k</math></p>	<p>(f)</p> <p>Ans. <math>M_{DC} = -6.67^k</math></p>
<p>(g)</p> <p>Ans. <math>M_{DC} = +1474^k</math></p>	<p>(h)</p> <p>Ans. <math>M_{DC} = +58.6^k</math></p>	<p>(i)</p> <p>Ans. <math>M_{CB} = +41.0^k</math></p>
<p>(j)</p> <p>Ans. <math>M_{BC} = +145.5^k</math></p>	<p>(k)</p> <p>Ans. <math>M_{AD} = +4.32P^k</math></p>	<p>(l)</p> <p>Ans. <math>M_{AB} = -791^k</math></p>
<p>(m)</p> <p>Ans. <math>M_{AD} = -\frac{15}{148}Ph^k</math></p>	<p>(n)</p> <p>Ans. <math>M_{AD} = -\frac{Ph^k}{4\sqrt{2}}</math></p>	<p>(o)</p> <p>Ans. <math>M_{AD} = -0.38Pd^k</math></p>

PROB. 8:13 (Probs. 8:21, 24, 29)

**Art. 8:7 Moment Distribution: Side Sway**

**Problem 8:24.** Solve Prob. 8:13 by the method of moment distribution.

**Problem 8:25.** Solve Prob. 8:18 by the method of moment distribution.

**Art. 8:8 Members with Varying Moment of Inertia**

**Problem 8:25A.** Compute the end moments for a fixed-end beam of span  $L$  carrying a uniform load of  $w$  lb per ft over its whole length, the depth of beam varying uniformly from  $d$  at one end to  $2d$  at the other. The moment of inertia is proportional to the cube of the depth. *Ans.*  $0.0529wL^2$ ,  $0.1216wL^2$ .

**Art. 8:9 Method of the Column Analogy**

**Problem 8:26.** Solve Prob. 8:2 by the method of the column analogy.

**Problem 8:27.** Solve by the method of the column analogy those parts of Prob. 8:6 to which the method is applicable.

**Problem 8:28.** Solve by the method of the column analogy those parts of Prob. 8:12 to which the method is applicable.

**Problem 8:29.** Solve by the method of the column analogy those parts of Prob. 8:13 to which the method is applicable.

**Problem 8:30.** Solve Prob. 8:18 by the method of the column analogy.

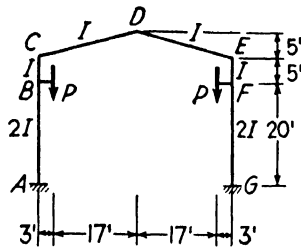

PROB. 8:31

**Problem 8:31.** Draw the moment curve for this structure, using the method of the column analogy in your computations.  $P = 10$  kips. *Ans.*  $M_{GF} = +10.4$  kip-ft.

# WIND STRESSES in TALL BUILDING FRAMES

**9:1.** In addition to supporting the usual live and dead loads, which act vertically, the frame of a tall building must also resist the horizontal loads caused by the wind. The horizontal forces are assumed to stress the bents formed by the columns and girders (or beams) in the vertical planes parallel to the direction of the wind. In rare cases it is possible to introduce diagonal members into these frames, but ordinarily their use is undesirable, and it is then necessary for the columns and girders to act as a frame with rigid joints. The stresses in such a frame may be obtained with the aid of the methods of the previous chapter. A solution by these, however, is so laborious that it is seldom, or never, attempted. An additional disadvantage of these relatively exact methods is that each may be used only to investigate stresses in a frame that has already been designed. In all cases a design must first be made by an approximate method, and generally no attempt is made at greater precision. In this field, the principal use of the exact methods is to test the accuracy of the approximate when both exact and approximate are applied to simple cases.

**9:2. Approximate methods.** A large number of approximate methods have been proposed, but only two find much favor at the present time. These are designated Methods *A* and *B* and are given below.

**Method A:**<sup>1</sup> Cantilever Method. It is assumed:

1. that points of contraflexure are located at the mid-points of girders;
2. that points of contraflexure are located at the mid-points of columns; and
3. that the unit direct stresses in the columns vary as the distances of the columns from the center of gravity of the bent. (It is usually further assumed that all columns in a story are of equal area. In this case the total column direct loads will vary as the distances from the center of gravity of the bent.)

<sup>1</sup> "Wind Bracing with Knee Braces or Gusset Plates," by A. C. Wilson, *Engineering Record*, September 5, 1908.



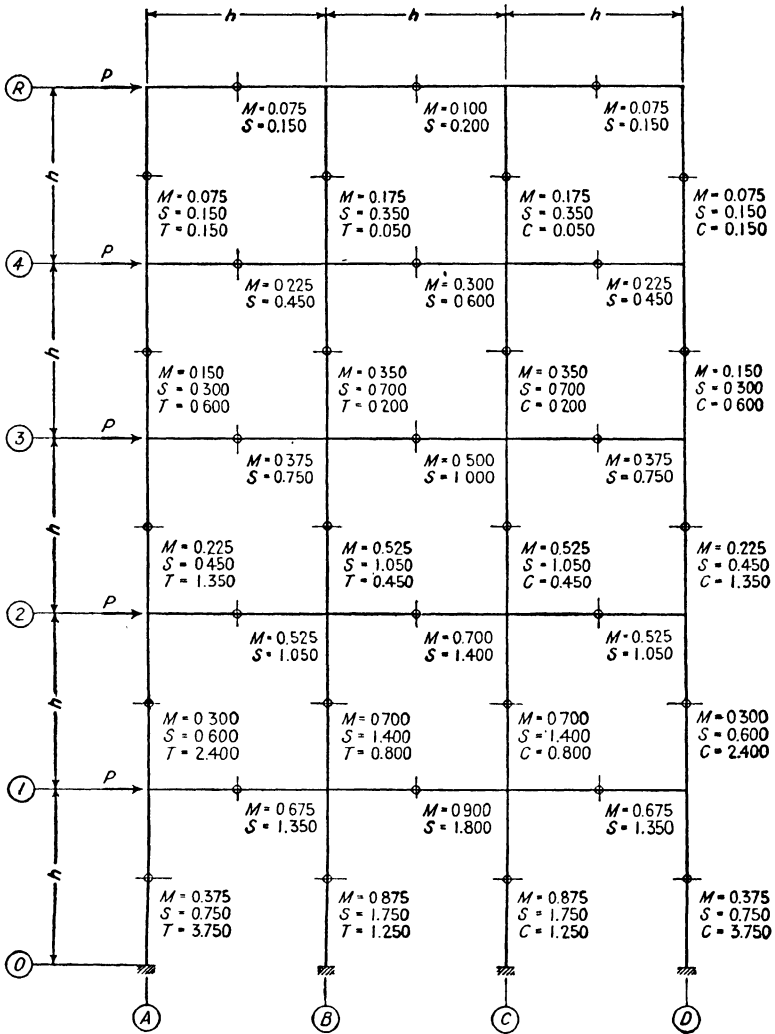

Note: Values given for S (Shear), T (Tension) and C (Compression) are in terms of P, those for M (Moment) are in terms of Ph.

SOLUTION BY METHOD A

FIG. 9:1

**Method B:**<sup>2</sup> Portal Method. It is assumed:

1. that points of contraflexure are located at the mid-points of girders;

<sup>2</sup> "Wind Stresses in the Frames of Office Buildings," by Albert Smith, *Journal of the Western Society of Engineers*, April 1915, page 341.

2. that points of contraflexure are located at the mid-points of columns; and

3. that the shear in each exterior column is the same and equals one-half the shear in an interior column.

**9:3. Solution by Method A.** The application of Method A to a four-story and basement, three-bay building, with equal story heights and with bay widths equal to the story heights, is shown in Fig. 9:1. The first two assumptions of the method located the points of contra-

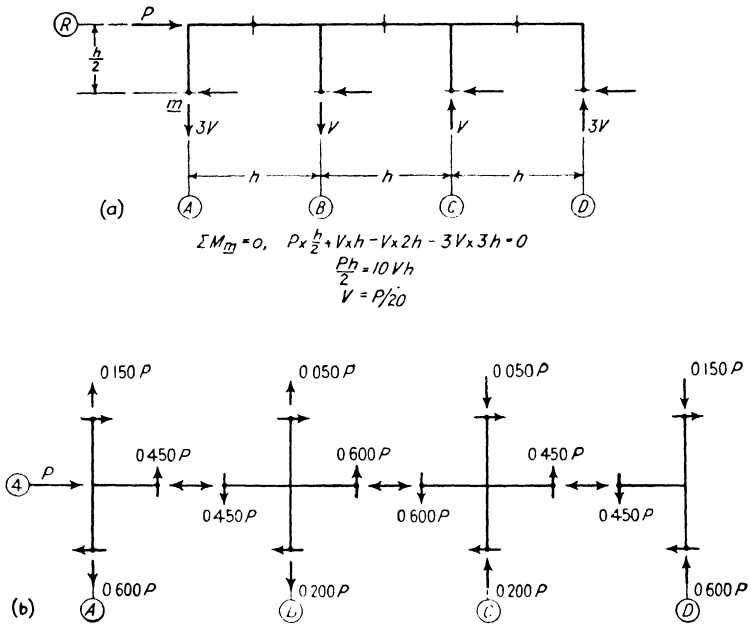

FIG. 9:2

flexure. A section passed through the points of contraflexure in the top-story columns, with the part above the section removed, gave that part of the frame shown in Fig. 9:2a. By assumption, there is tension in the two columns to the left and compression in the columns to the right, and the stresses in the interior columns are equal to each other and to one-third the stresses in the exterior columns. It was therefore possible to write an equation as was done in Fig. 9:2a and solve for the values of the column direct stresses. These values, when obtained, were entered at once on Fig. 9:1, i.e., tension (*T*) in left column equals 0.150*P*, etc. In a similar manner the direct stresses in the columns of the other stories were computed by passing a section through the points of con-

traflexure of the columns of each story and dealing with the part of the building above the section.

After the column direct stresses were found, the girder shears followed at once. For example, the tension in column *A* in the fourth story is  $0.150P$ . The tension in the same column in the third story is  $0.600P$ . Therefore, by  $\Sigma V = 0$  at the joint where the fourth-story girder joins column *A*, the girder shear is  $0.450P$ . Figure 9:2*b* shows the method of obtaining this and the remaining shears of the fourth-story girders. These shears may, of course, be written directly on Fig. 9:1 without the aid of a sketch such as Fig. 9:2*b*, and this was done with the shears in the other girders.

With the girder shears known the girder moments followed directly. These equal the shear in a girder times one-half the span length and have been added in Fig. 9:1. In Fig. 9:2*b*, the directions of the column and girder shears have been indicated, and study of the various joints will show that, from  $\Sigma M = 0$  at any joint, the sum of the girder moments must equal the sum of the column moments. Using this principle, the moments in the columns at the roof were obtained from the roof girder moments. Since the points of contraflexure in the columns are at mid-height, this same value equals the moment at the junction with the fourth floor. Then the moment at the top of the third-story column was obtained from the principle stated above, and in a similar way the other column moments were found.

The column shears were obtained from the column moments. As a check it will be observed that the shear in the columns of any story equals the sum of the horizontal external loads above that story.

**9:4. Solution by Method B.** The solution of the same bent and loads by Method *B* was made on a figure (not shown) similar to Fig. 9:1 and the results were transferred to the table "Comparison of Stresses." The work was done directly on the sketch, the relations being so simple that no scratch figures or further records of details were required. The procedure was as follows. The column shears were written first, one-sixth of the shear in any story being carried by each exterior column and one-third by each interior column. The moments at top and bottom of each column followed, equalling the product of column shear by one-half the story height. It is to be noted that the moment at the top of a column causes compression in the left-hand fibers and that at the bottom, tension. Next the girder moments were recorded, starting at the upper left corner of the frame, where girder and column moment are equal. Since the points of contraflexure are at the center, the moment at the right end of each girder has the same value as that at the left but is of opposite sign. Next came the girder shears, from the relation that shear

multiplied by half of span length equals girder end moment. (See Fig. 9:2b.) Lastly, column direct stress came directly from girder shears. It will be seen that by this method for equal column spacing the moments at the ends of all girders of a floor are equal, and the direct stresses in interior columns are zero.

**9:5. Results by slope deflection method.** In order that an opinion may be formed as to the accuracy of the foregoing approximate methods, a bent of uniform moment of inertia throughout and of the same dimensions and loads as Fig. 9:1 has been solved by the slope deflection method, and the results of the solution are shown in the table "Comparison of Stresses."

The moments and shears are symmetrical about the center vertical axis of the bent, and the column direct stresses are of opposite character about the same axis.

The following points should be observed in the study of these results:

1. The points of contraflexure in exterior girders are not at the mid-points but are fairly uniform and do not vary much from the mid-points. As would be expected from symmetry, the point of contraflexure is at the mid-point in interior girders.

2. The points of contraflexure in the columns vary greatly from mid-point. Furthermore, the points of contraflexure in interior and exterior columns of any story are not at the same height.

3. The shears are greater in the exterior girders of any floor than in the interior girder of that floor. As a consequence the direct stresses in the columns are, passing from left to right, tension, compression, tension, compression. This variation has been verified by model analysis.

**9:6. Method C.** It should be understood that it is possible so to proportion a bent that the actual stresses will be closely, if not exactly, those given by Method A. The same is true for Method B. In practice, however, the problem is not to select a bent which will fit some method of figuring but instead to select a method for the analysis of a given bent. As a result of a study of a large number of examples worked by the exact method, the following approximate method is proposed.

It is assumed, in Method C:

1. that points of contraflexure in exterior girders are located at 0.55 of their length from their outer ends and in other girders at their mid-points except (a) in the center bay, where the total number of bays is odd,<sup>3</sup> and (b) in the two bays nearest the center, where the total number of bays is even. In these excepted cases the points of contra-

<sup>3</sup> A point of contraflexure will be at the mid-point of the center girder if the bent is symmetrical.

flexure in girders will be located as required by the conditions of symmetry and equilibrium;

2. that in bents of one or more stories, the points of contraflexure in bottom-story columns are at 0.60 height from the base; in bents of two or more stories, the points of contraflexure in top-story columns are at 0.65 height from the top; in bents of three or more stories, the points of contraflexure in the columns of the story next to the top are at 0.60 height from the upper end; in bents of four or more stories, the points of contraflexure in the columns of the second story from the top are at 0.55 height from the upper end; and in bents of five or more stories the points of contraflexure in the columns of stories not provided for above are at mid-height; and

3. that there is divided equally<sup>4</sup> among the columns of the bottom story an amount of shear equal to  $\left(\frac{\text{Number of bays} - \frac{1}{2}}{\text{Number of columns}}\right)$  times the total shear in the story, that the remaining shear in the bottom story is divided among the bays *inversely* as their widths,<sup>5</sup> and that the shear in a bay is divided equally between the two columns adjacent to the bay; that there is divided equally<sup>4</sup> among the columns of the other stories an amount of shear equal to  $\left(\frac{\text{Number of bays} - 2}{\text{Number of columns}}\right)$  times the total shear in the story, that the remaining shear in the story is divided among the bays *inversely* as their widths,<sup>5</sup> and that the shear in a bay is divided equally between the two columns adjacent to the bay.

On trial it will be found that this method may be applied about as rapidly as either *A* or *B*. In using the method, after locating the points of contraflexure, the values will be found in the following order: column shears, column moments, girder moments, girder shears, column direct stresses.

<sup>4</sup> Where the column moments of inertia of a story are not equal, as when investigating an existing building, this part of the shear should be divided among the columns in proportion to their moments of inertia.

<sup>5</sup> Where the moments of inertia of the girders above any story are not equal, as when investigating an existing building, this part of the shear should be divided among the bays *directly* as (Moment of inertia/Length) of the girders above the bays.

COMPARISON OF STRESSES AS COMPUTED BY DIFFERENT METHODS

Story	COLUMN A					COLUMN B				
	Moment		Per Cent of Story Shear	Point of Zero Moment from Top	Direct Stress	Moment		Per Cent of Story Shear	Point of Zero Moment from Top	Direct Stress
	Top	Bottom				Top	Bottom			
4-R	0.075	0.075	15.0	0.50	+0.150	0.175	0.175	35.0	0.50	+0.050
	0.083	0.083	16.7	0.50	+0.167	0.167	0.167	33.3	0.50	0.000
	0.119	0.060	17.9	0.66	+0.219	0.184	0.137	32.1	0.57	-0.051
	0.122	0.066	18.8	0.65	+0.222	0.203	0.109	31.2	0.65	-0.016
3-4	0.150	0.150	15.0	0.50	+0.600	0.350	0.350	35.0	0.50	+0.200
	0.167	0.167	16.7	0.50	+0.667	0.333	0.333	33.3	0.50	0.000
	0.223	0.153	18.8	0.59	+0.753	0.336	0.288	32.2	0.54	-0.141
	0.226	0.150	18.8	0.60	+0.753	0.374	0.250	31.2	0.60	-0.059
2-3	0.225	0.225	15.0	0.50	+1.350	0.525	0.525	35.0	0.50	+0.450
	0.250	0.250	16.7	0.50	+1.500	0.500	0.500	33.3	0.50	0.000
	0.315	0.250	18.8	0.56	+1.638	0.492	0.443	31.2	0.53	-0.300
	0.310	0.254	18.8	0.55	+1.589	0.515	0.421	31.2	0.55	-0.117
1-2	0.300	0.300	15.0	0.50	+2.400	0.700	0.700	35.0	0.50	+0.800
	0.333	0.333	16.7	0.50	+2.667	0.667	0.667	33.3	0.50	0.000
	0.396	0.349	18.6	0.53	+2.859	0.636	0.619	31.4	0.51	-0.513
	0.376	0.376	18.8	0.50	+2.734	0.624	0.624	31.2	0.50	-0.202
0-1	0.375	0.375	15.0	0.50	+3.750	0.875	0.875	35.0	0.50	+1.250
	0.417	0.417	16.7	0.50	+4.167	0.833	0.833	33.3	0.50	0.000
	0.408	0.694	22.0	0.37	+4.278	0.604	0.794	28.0	0.43	-0.810
	0.438	0.657	21.9	0.40	+4.213	0.562	0.843	28.1	0.40	-0.639

Floor	GIRDER A-B				GIRDER B-C		
	Moment		Shear	Point of Zero Moment from Left End	Moment	Shear	Point of Zero Moment from Left End
	Left	Right					
R	0.075	0.075	0.150	0.50	0.100	0.200	0.50
	0.083	0.083	0.167	0.50	0.083	0.167	0.50
	0.119	0.100	0.219	0.54	0.084	0.168	0.50
	0.122	0.100	0.222	0.55	0.103	0.206	0.50
4	0.225	0.225	0.450	0.50	0.300	0.600	0.50
	0.250	0.250	0.500	0.50	0.250	0.500	0.50
	0.283	0.251	0.534	0.53	0.222	0.444	0.50
	0.292	0.239	0.531	0.55	0.244	0.488	0.50
3	0.375	0.375	0.750	0.50	0.500	1.000	0.50
	0.417	0.417	0.833	0.50	0.417	0.833	0.50
	0.468	0.417	0.885	0.53	0.363	0.726	0.50
	0.460	0.376	0.836	0.55	0.389	0.778	0.50
2	0.525	0.525	1.050	0.50	0.700	1.400	0.50
	0.583	0.583	1.167	0.50	0.583	1.167	0.50
	0.646	0.575	1.221	0.53	0.504	1.008	0.50
	0.630	0.515	1.145	0.55	0.530	1.060	0.50
1	0.675	0.675	1.350	0.50	0.900	1.800	0.50
	0.750	0.750	1.500	0.50	0.750	1.500	0.50
	0.757	0.662	1.419	0.53	0.561	1.122	0.50
	0.814	0.665	1.479	0.55	0.521	1.042	0.50

Notes. Results are recorded in the order:

- Method A
- Method B
- Slope Deflection Method
- Method C

Values for Shear and Direct Stress are in terms of P, those for Moment in Ph.  
Points of Zero Moment are located in decimal parts of member lengths.

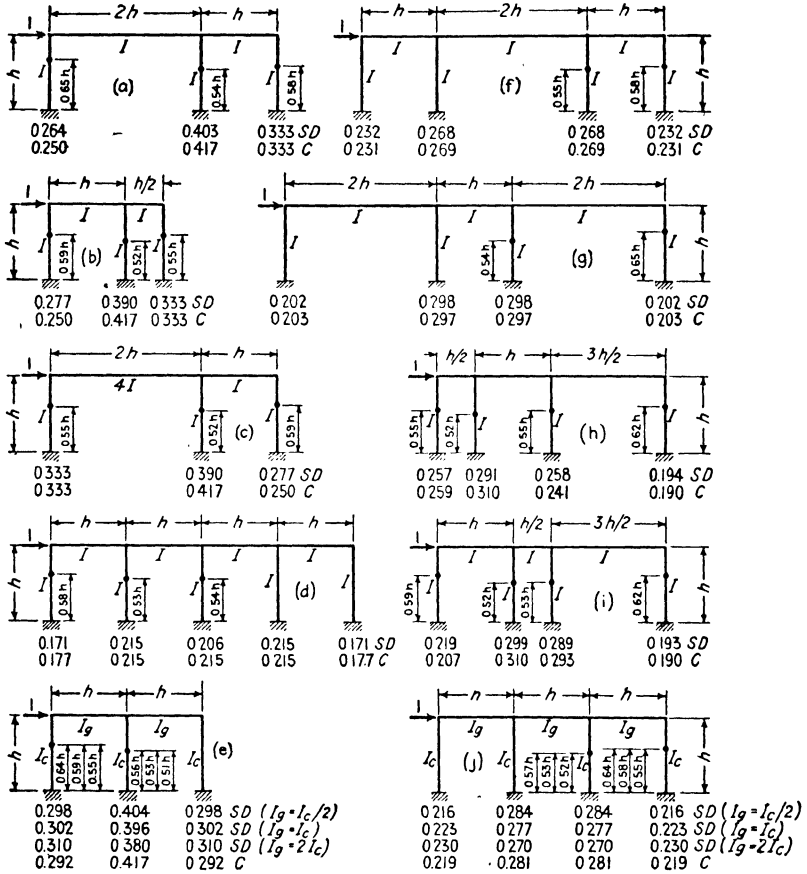

COLUMN SHEARS & POINTS OF CONTRAFLEXURE  
 SD = Exact shear by Slope Deflection Method  
 C = Approximate shear by Method C  
 Points of Contraflexure by Slope Deflection Method

FIG. 9-3

Figure 9:3 has been added to show the comparison between the shear<sup>6</sup> as computed by the slope deflection method and by Method C in a number of one-story bents. The actual points of contraflexure are also shown.

The bent already studied both approximately and exactly has been analyzed by Method C, the complete computation<sup>7</sup> being shown in the table "Comparison of Stresses."

<sup>6</sup> The computation of shears for the bent of Fig. 9.3h is as follows:

Ratio of shear per bay $\Sigma = 5.5$	1 →	3	3/2	1	←
		←	←	←	←
$1 \left( \frac{3 - \frac{1}{2}}{4} \right) = 0.625$		$\frac{0.625}{4} = 0.1563$	0.1563	0.1563	0.1563
0.375		$\frac{0.375}{5.5 \times 2} =$		0.0341	0.0341
1.000					
$0.0341 \times 1.5 =$			0.0511	0.0511	
$0.0341 \times 3 = 0.1023$			0.1023		
Shear		0.259	0.310	0.241	0.190
			$\Sigma = 1.000$		

<sup>7</sup> Solution by Method C. Shears.

---

<i>Bottom story:</i>	$\frac{3 - \frac{1}{2}}{4} = 0.625$	$\frac{0.625}{4} = 0.1563$
	$\frac{0.375 \div (3 \times 2)}{1.000}$	$= 0.0625$
<i>Check:</i>	0.219	Proportion of shear: Wall column = 0.2188
	0.281	<u>0.0625</u>
	0.281	Proportion of shear: Interior column = 0.2813
	0.219	
	<u>1.000</u>	

---

<i>Upper stories:</i>	$\frac{3 - 2}{4} = 0.25$	$\frac{0.25}{4} = 0.0625$
	$\frac{0.75 \div (3 \times 2)}{1.00}$	$= 0.1250$
<i>Check:</i>	0.188	Proportion of shear: Wall column = 0.1875
	0.312	<u>0.1250</u>
	0.312	Proportion of shear: Interior column = 0.3125
	<u>0.188</u>	
	<u>1.000</u>	



**Example 9:1.** Solve by Method *C* the bent of Fig. 9:4, in which all moments of inertia are equal.

*Solution.* The column shears may be taken from Fig. 9:3e. The column moments follow directly from the column shears. Then  $M_{AB} = M_{AD} = 2336$ . Also, by symmetry,  $M_{BA} = M_{BC} = \frac{1}{2}M_{BE} = 1664$ . The girder

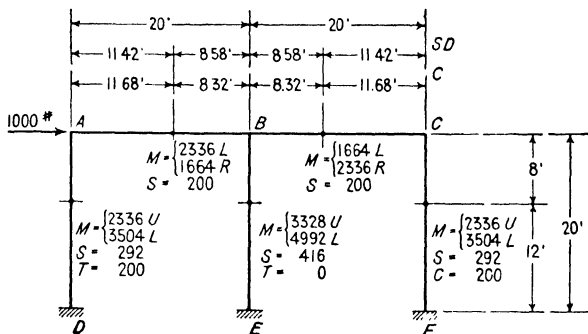

FIG. 9:4

shear is, therefore,  $(2336 + 1664)/20 = 200$ , and the point of contraflexure in girder *AB* is  $(2336/4000)20 = 11.68$  ft from *A*. For comparison, the location of the point of contraflexure as determined by the slope deflection method is shown in the sketch.

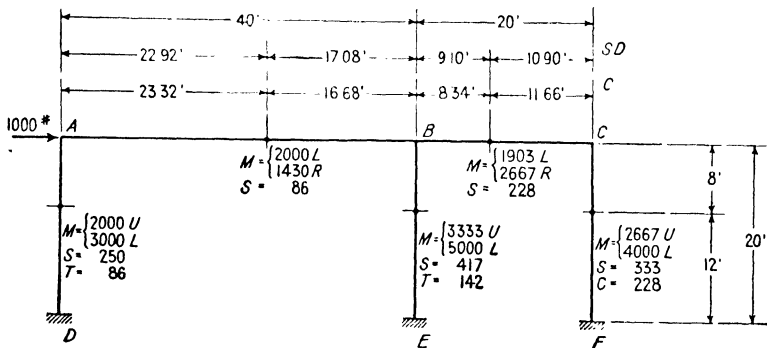

FIG. 9:5

**Example 9:2.** Solve the bent of Fig. 9:5 by Method *C*; all moments of inertia equal.

*Solution.* The column shears are taken from Fig. 9:3a. The column moments and moments at outer ends of girders follow at once. Some assumption must now be made regarding the distribution of  $M_{BE}$  between members *BA* and *BC*. It will be assumed that the part to each girder will vary as the moment

at its outer end. Therefore

$$M_{BA} = 3333 \times \frac{2000}{2000 + 2667} = 1430 \text{ lb-ft}$$

$$M_{BC} = 3333 - 1430 = 1903$$

(A similar method would be followed for the two interior girders of any bent with an even number of bays.)

$$\text{Shear}_{AB} = \frac{3430}{40} = 86 \text{ lb}$$

$$\text{Shear}_{BC} = \frac{4570}{20} = 228$$

The sketch shows the location of the girder point of contraflexure as determined from these moments and, for comparison, as located by the slope deflection method.

**9:7. Inaccuracies of all methods.** Because exact methods are cumbersome, the designer of wind bracing is forced to use an approximate method. It is believed that the errors involved in the use of the method here proposed are less than errors which arise from the failure of any method to consider the following facts.

*a.* A considerable part of wind shear is carried by the building walls and partitions.

*b.* The rigid floor construction employed in modern buildings causes all bents at a floor to deflect equally and, therefore, may cause a bent to carry loads which are different from those it would carry if the loads on bents were proportional to the wall areas adjacent to the bents, as commonly assumed.

*c.* The floor members of a wind bent are commonly encased in concrete and, consequently, are much stiffer than assumed in computations.

*d.* Unsymmetrical wind pressure on symmetrical frames and pressure on unsymmetrical frames cause torsional effects with resultant stresses which are generally neglected.<sup>8</sup>

*e.* In spite of the fact that heavy connections are provided to make the girders carry their end moments from wind, these same girders, in steel construction, are almost invariably considered as simply supported, i.e., without end moment under live and dead loads. Large end moments from vertical loads must exist, and the end connections must be greatly overstressed if subjected to simultaneous maximum live load and wind.

The girders of any story serve to distribute the load applied at that

<sup>8</sup> For discussion of torsion see *Proceedings of the American Society of Civil Engineers*, June 1933, pages 988-996.

story to the various columns which carry it in shear. These girders, therefore, are carrying a certain amount of direct stress from wind, but the amount is so small that it is properly neglected.

**9:8. Wind-bracing report.** For some years before the appearance of the third edition of this textbook, a sub-committee of the Committee on Steel of the Structural Division of the American Society of Civil Engineers had been studying wind pressures and wind bracing in steel buildings. Six progress reports were published, and, in *Transactions*, Vol. 105 (1940), pages 1713–1739, a final report. The references accompanying the final report will direct the interested reader to the worthwhile articles which have been published on these subjects. Taken together, the progress and final reports constitute the most valuable material available on the subjects considered.

For investigation of the stresses due to wind load in a bent the Committee recommends a method much more complicated than those here considered, the Witmer method of  $K$ -percentages (*Proceedings of the American Society of Civil Engineers*, June 1939, pages 975–976, and June 1941, pages 961–974).

**Wind loads.** “As a standard wind load for the United States and Canada the sub-committee recommends a uniformly distributed force of 20 lb per sq ft for the first 300 ft above ground level, increased above this level by 2.5 lb per sq ft for each additional 100 ft of height, no omission of wind force being permitted for the lower parts of the building by reason of alleged shelter. Special wind-force specifications shall be formulated locally for areas that are definitely known to be subject to hurricanes or tornadoes.”

Recommendations are also made regarding the effect of wall opening and regarding pressure and suction effects on flat, sloping, and rounded roofs.

**Permissible stresses.** “The sub-committee recommends that for members or details subject to wind stress only, except rivets and bolts, the permissible stress should be the same as that allowed for dead load or for dead load and live load.

“For members subject to stresses arising from the combined similar action of wind and other loads, and for rivets and bolts subject to wind stress, the wind stress up to  $33\frac{1}{3}$  per cent of the other stresses may be neglected, the excess wind stress being considered as equivalent to added live-load stress, provision being made for it at the basic working stress for dead load and live load only. Higher combined stresses may be acceptable in the columns of very tall buildings.”

**9:9. Earthquake stresses.** In an earthquake the ground carrying the foundations of a structure is set in violent oscillation, the principal

movement affecting the structure being in a horizontal plane. There is considerable uncertainty as to the nature and magnitude of the vibrations set up by earthquakes in centers of destruction, and as yet there is no standard method of analysis of earthquake stresses in frame structures. Safe and economical design to resist these stresses is too complicated a matter for an elementary textbook, and the reader is referred to the current periodical discussion of this still-debated question. Five methods of determining earthquake forces applied to building frames may be noted:

- a. Wind-load basis.
- b. Gravity inertia loading.
- c. Dynamic vibration method:
  1. Creskoff.
  2. Westergaard's approximation.
- d. Kinetic energy method.

After the San Francisco earthquake and fire of 1906 a committee of the American Society of Civil Engineers reported that a building designed to resist a wind load of 30 lb per sq ft would resist safely the forces incident to a quake of the intensity there experienced. It is plain that the stresses set up by horizontal oscillations are a function, among other elements, of the weight above the plane of stress, something which may have no direct relation to wind load on exposed area. This method is seldom used at the present time.

Considering a building to be a (nearly) rigid body, it has seemed logical to assume that the horizontal force applied is in proportion to the acceleration of earth motion. Some reports would indicate that in magnitude these accelerations may be expected to equal about one-tenth that of gravity in rock and two or three times as much in soft ground. This ratio is known as the *seismic factor*, and a value of  $\frac{1}{10}$  is usually specified for design. In applying this method a horizontal force is assumed at each floor, acting exactly like wind load, equal in magnitude to one-tenth the weight of the building and contents at that level.

Instead of being rigid, actually a building acted upon by an earthquake is a vibrating elastic system, and the relation between the natural period of this system and that of the earthquake vibrations is a very important matter. If these periods are closely coincident, resonance may largely increase the stresses set up by the vibrations. Mr. Jacob Creskoff indicates<sup>9</sup> methods of determining these dynamic effects and providing for them. Professor Westergaard<sup>10</sup> has presented an approxi-

<sup>9</sup> *Dynamics of Earthquake Resistant Structures*, J. J. Creskoff (McGraw-Hill), 1934.

<sup>10</sup> "Earthquake Shock Transmission in Tall Buildings," H. M. Westergaard, *Engineering News-Record*, November 30, 1933.

mate analysis based on consideration of the wave of deformation through a building frame, impelled by ground tremor.

PROBLEMS

**Problem 9:1.** Find stresses in this bent by Methods *A* and *B*.

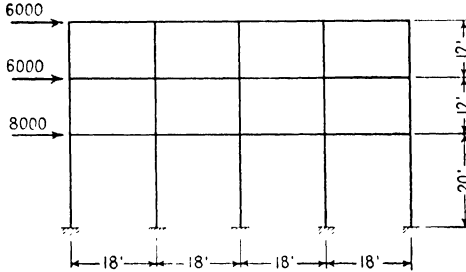

PROBS. 9:1, 9:2

**Problem 9:2.** Assuming that all moments of inertia are equal, find the stresses in the bent of Prob. 9:1 by Method *C*.

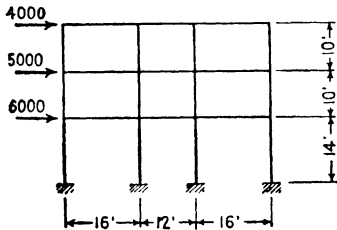

PROBS. 9:3, 9:4

**Problem 9:3.** Determine by Method *C* the stresses in the bent here shown, assuming that all members have the same moment of inertia.

**Problem 9:4.** Determine by Method *C* the stresses in the bent of Prob. 9:3, assuming that the girder moments of inertia are constant in any story and that the moments of inertia of interior columns are to the moments of inertia of exterior columns in the ratio of 4 to 3.

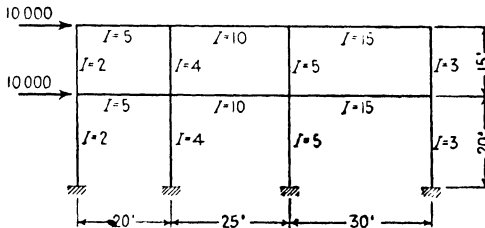

PROB. 9:5

**Problem 9:5.** Assuming the moments of inertia to vary in the manner shown, determine by Method *C* the stresses in this bent. Draw shear and moment curves for the roof girder and for the right column.

**Problem 9:6.** Solve Prob. 9:5 by the method of moment distribution, *Morris* variation.

# INDETERMINATE TRUSSES

**10:1.** The early forms of bridge trusses were often complicated with many redundant bars. For all spans, development has led to simpler forms. In America the preference has been given to statically determinate structures, whereas in Europe the economy of material possible with continuity over intermediate supports has led to the large use of continuous structures, often indeterminate on account of redundancy of bars as well as of supports. The advantages of economy and also of stiffness are leading to increased use of indeterminate structures in this country as well.

The theory of statically indeterminate structures has also evolved from the complicated to the relatively simple. The early arguments leading up to the theorems employed in this chapter and elsewhere were often abstruse and complicated mathematically. As the reader will see on proceeding, today the logic of analysis is very simple, although the labor of applying it to an actual structure is usually extremely arduous.

**10:2. Method of least work.** The discussion of the method of least work in Art. 8:4 may be summarized briefly thus. The total internal work performed by the fiber stresses in a statically indeterminate structure under load is the minimum consistent with equilibrium. This fact makes a stress solution possible in the following manner. The one or more redundant elements are considered to be removed or put out of action and each replaced by an appropriate unknown stress (force or moment) acting upon the statically determinate base structure (or independent system) which results from the removal of the redundants. The actual stress in any remaining member is a function of the loads and reactions acting upon the independent system, among which loads are the one or more forces representing the unknown redundant elements. The necessary mathematical operations consist in writing an expression for the total internal work, including that in all redundant bars, differentiating this expression in respect to each unknown in turn, placing the derivatives each equal to zero, and solving the resulting equation, or equations, for the values of the unknowns.

The independent system, carrying in addition to the loads upon the

original structure the unknowns representing the redundants (represented by  $X$ ,  $Y$ , etc.), is the exact equivalent of the actual structure, and the process of evaluation outlined gives the actual values of the redundant elements. There is no more uncertainty about the stresses in a statically indeterminate structure than in one which is statically determinate. The only difference is the amount of labor required for stress determination.

In any truss member the work,  $W$ , performed by the stress,  $S$ , causing its deformation equals the maximum deformation multiplied by the average magnitude of the stress;  $W = (SL/AE) (\frac{1}{2}S) = S^2L/2AE$ . In an indeterminate truss under load the total internal work equals  $W = \Sigma S^2L/2AE$ , where  $S$  is the total stress in any member. For any bar of the independent system (a statically determinate structure carrying the given loads and also those representing the redundants,  $X_a$ ,  $X_b$ , etc.),  $S$  is a function both of the given loads and of  $X_a$ ,  $X_b$ , etc.; for any redundant bar  $S$  is  $X_a$  or  $X_b$  or whatever letter is used to designate that unknown. Differentiating this expression for work with respect to the unknowns gives (when  $E$  is constant)

$$\left. \begin{aligned} \frac{\partial W}{\partial X_a} &= \Sigma(S) \left( \frac{L}{A} \right) \left( \frac{\partial S}{\partial X_a} \right) = 0 \\ \frac{\partial W}{\partial X_b} &= \Sigma(S) \left( \frac{L}{A} \right) \left( \frac{\partial S}{\partial X_b} \right) = 0, \text{ etc.} \end{aligned} \right\} 10:1$$

Thus as many independent equations are obtained as there are unknowns in excess of the number which may be found by the aid of statics. The direct application of equation 10:1 gives a simple solution for indeterminate trusses. The only disadvantage to its use is the process of differentiation involved, which makes it impossible to turn the work of analysis over to a computer who is unfamiliar with the calculus. This difficulty is easily met by turning the equation into a formula.

The stress in any bar of an indeterminate truss may be expressed as  $S = S' + X_a u_a + X_b u_b + \dots$ , where  $S'$  is the stress due to the given external loads acting on the independent system, and  $u_a$ ,  $u_b$ , etc., are the stresses produced by a unit force acting along the line of action of  $X_a$ ,  $X_b$ , etc., i.e., along the line of action of the given redundant. Using this expression for  $S$ , we may rewrite equation 10:1 in another form with interesting results. For simplicity the equation is rewritten here only for a structure indeterminate in the first degree ( $E$  constant),

$$\begin{aligned} \frac{dW}{dX} &= \Sigma(S' + Xu) \left( \frac{L}{A} \right) (u) = 0 \\ &= \Sigma(S') \left( \frac{L}{A} \right) (u) + X \Sigma \left( \frac{L}{A} \right) u^2 = 0 \end{aligned}$$

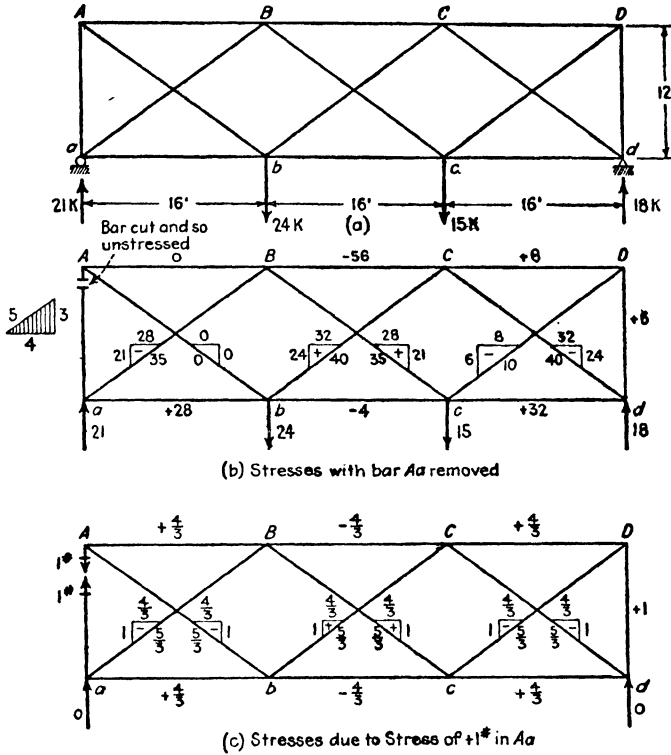

FIG. 10:1

EXAMPLE 10:1. METHOD OF LEAST WORK

Bar	$\frac{L}{A}$	$S = S' + Xu$	$\frac{dS}{dX} = u$	$\frac{SL}{A} \cdot \frac{dS}{dX}$	Actual Bar Stress
AB	1	$+ (4/3) X$	$+4/3$	$(16/9) X$	-20.1
BC	1	$-56 - (4/3) X$	$-4/3$	$(16/9) X$	-35.9
CD	1	$+ 8 + (4/3) X$	$+4/3$	$(16/9) X$	-12.1
ab	1	$+28 + (4/3) X$	$+4/3$	$(16/9) X$	+ 7.9
bc	1	$- 4 - (4/3) X$	$-4/3$	$(16/9) X$	+16.1
cd	1	$+32 + (4/3) X$	$+4/3$	$(16/9) X$	+11.9
Aa	1	$+ X$	$+1$	$(9/9) X$	-15.1
Dd	1	$+ 6 + X$	$+1$	$(9/9) X$	- 9.1
Ab	1	$- (5/3) X$	$-5/3$	$(25/9) X$	+25.2
aB	1	$-35 - (5/3) X$	$-5/3$	$(25/9) X$	- 9.8
Bc	1	$+35 + (5/3) X$	$+5/3$	$(25/9) X$	+ 9.8
bC	1	$+40 + (5/3) X$	$+5/3$	$(25/9) X$	+14.8
Cd	1	$-40 - (5/3) X$	$-5/3$	$(25/9) X$	-14.8
cD	1	$-10 - (5/3) X$	$-5/3$	$(25/9) X$	+15.2

$$\frac{dW}{dX} = \sum S \left( \frac{L}{A} \right) \frac{dS}{dX} = 0 \quad 443.33 + (264/9) X = 0 \quad X = -15.1 \text{ kips}$$



which gives

$$X = - \frac{\Sigma(S')(L/A) u}{\Sigma u^2(L/A)} \quad 10:1a$$

This expression is the same as equation 10:2*b* in the next article, which was obtained by the method of deflections. It is thus clear that the two methods are essentially identical.

If the unknown,  $X$ , is a bar stress, there is, of course, no  $S'$  for that bar and in this case the summation of the numerator will contain one less term than the denominator, which will contain as many terms as there are bars whose stress cannot be computed by statics alone (in Ex. 10:1, e.g., all the bars in the structure; in Prob. 10:3*d*, four less than the number of bars in the structure, since there are four bars in which the stresses may be computed by statics).

Equations 10:1 and 10:1*a* can be applied to the analysis only of a structure whose bar areas are known, and, accordingly, they cannot be used directly in design. In practice a trial design is made by approximation and later checked by least work or another exact method. A useful device for obtaining an approximate design is given in "The Design of Statically Indeterminate Trusses," by Albert Haertlein, *Journal of the Boston Society of Civil Engineers*, April 1936.

**Example 10:1.** Determine the stresses in all bars of the double system Warren truss shown in Fig. 10:1 for the loads there given. For simplicity the area of each member in square inches is taken as equal to its length in feet.<sup>1</sup>  $E = 30,000,000$  lb per sq in.

*Discussion.* This truss is statically determinate as regards outer forces and indeterminate in the first degree as regards inner forces. Bar  $Aa$  was taken as the redundant, and the stresses found in all the other bars with  $Aa$  cut and therefore out of action (Fig. 10:1*b*); also the stresses in all bars caused by a unit tension in  $Aa$  were computed (Fig. 10:1*c*). All the necessary computations appear in the table which consists of columns headed by the several factors of equation 10:1. The results appear in the final column.

**Example 10:2.** Compute the bar stresses in the truss shown in Fig. 10:2 for the loads shown.  $L/A = 1$ ;  $E$  is a constant.

*Discussion.* The two intermediate reactions are taken as the two redundants, and the solution follows the line of the previous one except for the simultaneous equations necessary for results. The necessary computations are found in and under the table. The significance of the signs is readily apparent. Since the value which is found for  $X$  has a positive sign, the reaction acts up at  $d$  as assumed in Fig. 10:2*c*, while that at  $e$  acts in the opposite direction from that assumed in Fig. 10:2*d* in consequence of the negative sign in the value for  $Y$ .

<sup>1</sup> The authors have seen so many go astray at this point that they are ready to question the wisdom of this simplifying expedient. That is, it is remembered that in obtaining column 5 of the solution of this example the terms in columns 3 and 4 were multiplied, neglecting column 2 because its terms were each equal to unity. Hence, the danger of still neglecting column 2 when its terms have a different value.

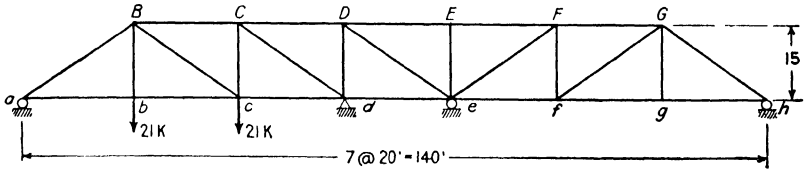

(a)

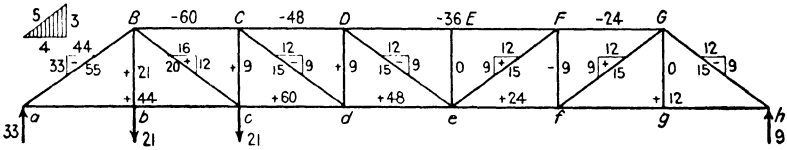

(b) Stresses with no supports at *d* and *e*

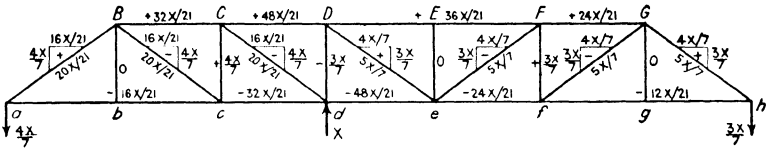

(c) Stresses due to force *X* at *d*

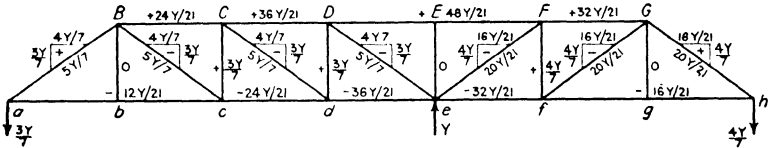

(d) Stresses due to force *Y* at *e*

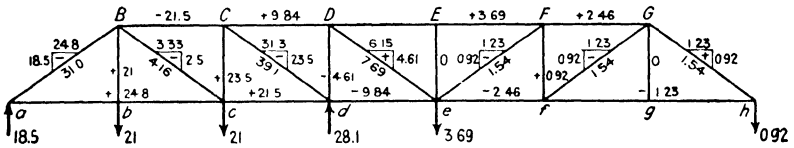

(e) Actual Reactions and Stresses

FIG. 10:2

EXAMPLE 10.2. Method of Least Work

EXAMPLE 10.2. METHOD OF LEAST WORK (See Fig. 10.2)

Bar	$\frac{L}{A}$	$S$	$\frac{\partial S}{\partial X}$	$\frac{\partial S}{\partial Y}$	$\frac{SL}{A} \cdot \frac{\partial S}{\partial X}$	$\frac{SL}{A} \cdot \frac{\partial S}{\partial Y}$
BC	1	-60+1.52 X+1.14 Y	+1.52	+1.14	+91.2	+2.31 X+1.73 Y
CD	1	-48+2.29 X+1.72 Y	+2.29	+1.72	-110.0	+5.25 X+3.94 Y
DF	2	-36+1.72 X+2.29 Y	+1.72	+2.29	-123.8	+5.92 X+7.88 Y
FG	1	-24+1.14 X+1.52 Y	+1.14	+1.52	-27.4	+1.30 X+1.73 Y
ac	2	+44-0.763 X-0.572 Y	-0.763	-0.572	-67.1	+1.16 X+0.872 Y
cd	1	+60-1.52 X-1.14 Y	-1.52	-1.14	-91.2	+2.31 X+1.73 Y
de	1	+48-2.29 X-1.72 Y	-2.29	-1.72	-110.0	+5.25 X+3.94 Y
ef	2	+24-1.14 X-1.52 Y	-1.14	-1.52	-27.4	+1.30 X+1.73 Y
fh	1	+12-0.572 X-0.763 Y	-0.572	-0.763	-13.7	+0.654 X+0.872 Y
aB	1	+55+0.952 X+0.715 Y	+0.952	+0.715	-52.4	+0.906 X+0.680 Y
Bc	1	+20-0.952 X-0.715 Y	-0.952	-0.715	-19.0	+0.906 X+0.680 Y
Cd	1	-15-0.952 X-0.715 Y	-0.952	-0.715	+14.3	+0.906 X+0.680 Y
De	1	+15+0.715 X-0.952 Y	+0.715	-0.952	-10.7	+0.511 X-0.511 Y
eF	1	+15-0.715 X-0.952 Y	-0.715	-0.952	-10.7	+0.511 X+0.680 Y
fG	1	+15+0.715 X+0.952 Y	+0.715	+0.952	-10.7	+0.511 X+0.680 Y
Gh	1	+21	+0.715	+0.952	-10.7	+0.511 X+0.680 Y
Bb	1	+9+0.572 X+0.428 Y	+0.572	+0.428	+5.15	+0.327 X+0.245 Y
Cc	1	+9-0.428 X+0.428 Y	-0.428	+0.428	-3.85	+0.183 X-0.183 Y
Dd	1	-9+0.428 X+0.572 Y	+0.428	+0.572	-3.85	+0.183 X-0.183 Y
Ff	1	-9-0.428 X+0.572 Y	-0.428	+0.572	+3.85	+0.245 X+0.327 Y
					-764.25+30.909 X+28.300 Y	-681.25+28.300 X+30.909 Y

$$\begin{cases} 30.9 X + 28.3 Y = 764.3 \\ 28.3 X + 30.9 Y = 681.3 \end{cases}$$

---

$$30.9 X + 33.8 Y = 744$$

$$1-2' = 3 \quad \begin{cases} -5.5 Y = 20.3 \\ 30.9 X - 104.4 = 764.3 \end{cases}$$

$$1'' \quad \begin{cases} Y = -3.69 \text{ kips} \\ X = +28.1 \text{ kips} \end{cases}$$

$$1. \quad \frac{\partial W}{\partial X} = 2S \left( \frac{L}{A} \right) \frac{\partial S}{\partial X} = 0$$

$$2. \quad \frac{\partial W}{\partial Y} = 2S \left( \frac{L}{A} \right) \frac{\partial S}{\partial Y} = 0$$

**10:3. Method of deflections. (Maxwell-Mohr method.)** In 1864 James Clerk Maxwell, the English physicist, published a method of analysis of redundant frameworks based on the work theorem of Clapeyron. Ten years later Professor Otto Mohr of Dresden arrived independently at the same method, basing his reasoning on the theorem of virtual work. Many engineers have worked to extend the scope of this theory and to simplify its application, notably Professor H. Müller-Breslau of Berlin, whose books are probably the most comprehensive treatises on structural analysis in any language.

In his study of strength of materials the student made use of what is essentially this method when he determined the center support of a two-span continuous beam by finding, first, the downward center deflection of the loaded beam with the intermediate support removed and then the magnitude of the upward force, applied at the center, which would cause an equal upward deflection. The whole theory is summed up in this simple example. The problem reduces to (first) finding the deflection (or rotation) of each point on the loaded base structure where redundant elements (forces or moments) act when the redundants are not in action (i.e., extra supports removed or superfluous bars cut so as not to carry stress), and (second) finding the forces (or moments) acting on the otherwise unloaded base structure along the lines of action of the redundants at their points of application, with magnitudes such that the deflections (or rotations) at their points of application are equal and opposite to those first found. Under the combined action of the original loads and the redundant elements thus determined, these rotations and deflections are reduced to zero, which is the condition of the actual structure.

When the superfluous element is a bar, it is considered to be cut by a section which puts it out of action as a stress-carrying member of the original frame. In the first operation the distance of separation or overlapping of the two sections at the cut is found. In the second, the unknown  $X$  is the actual stress in the bar and therefore is represented by two equal and opposite forces acting, one on each section of the bar, at the cut section. These equal forces are of such magnitude that they will bring together again the cut surfaces of the bar.

Plainly no formulas are necessary, and on the basis of the seventh chapter the student is prepared with all the tools actually required. One advantage in solving problems by this method without formulas is that there is little opportunity for confusion over signs and directions of forces. However, for influence line computations and other problems it is advantageous to have the method put into systematic equation form. This is done later in this article.

**Example 10:3.** What are the reactions for the beam shown in Fig. 10:3?

*Solution.* Here there is one redundant, or superfluous, element. Either the moment at *a* or the reaction at *b* may be removed, leaving a determinate independent beam. For this illustration the moment at *a* was removed, leaving a simply supported beam. Under the load shown the rotation at *a* for the independent beam equals the left reaction for the elastic loading shown, Fig. 10:3b, which equals  $wL^3/24EI$ . A clockwise moment, *M*, applied at *a* on the otherwise unloaded independent beam produces a rotation of  $ML/3EI$ , as shown in the figure.

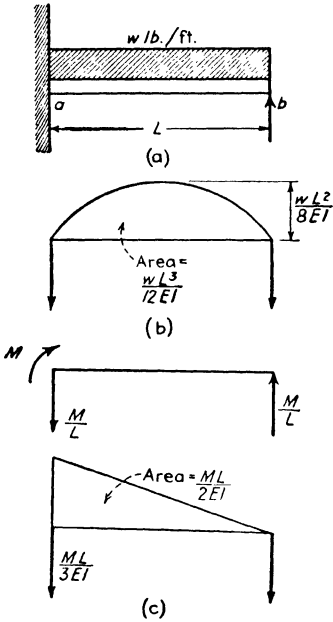

FIG. 10:3

$$\frac{ML}{3EI} + \frac{wL^3}{24EI} = 0$$

$$M = \frac{-wL^2}{8}$$

That is, this moment is counterclockwise. The moment is also negative by the convention for sign of moments in beams.

From this value  $V_b$  was found to be  $3wL/8$  upward, and  $V_a$  was  $5wL/8$  upward.

**Example 10:4.** What are the reactions of the loaded truss shown in Fig. 10:2a (Ex. 10:2)? The length of each bar in feet equals its area in square inches. *E* is constant for all bars.

*Discussion.* In Fig. 10:4bb is shown the independent system chosen, the end-supported truss left by the removal of the supports at *d* and *e*. The first problem was to find the deflection of these two points of the base structure as shown in the first section of the tabulated computations. The stress diagrams for the unit loads at *d* and *e* are shown in Fig. 10:4cc-dd. Next the unknown load *X* was placed acting downward at *d* and *Y*, downward at *e*. The deflection of point *d* or *e* in the independent structure under the two 21-kip loads is equal and opposite to that of the same point in the base structure carrying the unknowns, *X* and *Y*. The stress diagram for the two loads, *X* and *Y*, is shown in Fig. 10:4ee. The deflection of point *d* was found in the usual manner by placing a unit load acting downward at *d*: the next to the final column of the table totals the internal work of this force, which equals the deflection. Similarly the last column gives the internal work when a unit load is at *e* and so gives the deflection at *e*. Equating these two expressions for deflection to the values found for the loaded base structure, reversing the signs, gave the resulting values of *X* and *Y*. Note the interpretation placed upon the sign of the result.

*Query.* Would it be clearer to say that under the combined action of four loads (the two 21-kip loads, and the unknowns,  $X$  and  $Y$ ) the deflections at points  $d$  and  $e$  each equal zero? Carry such a solution far enough to convince

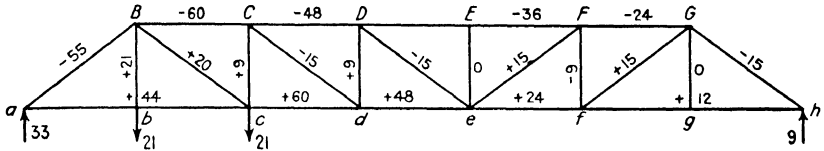

(bb) Stresses ( $S'$ ) with supports at  $d$  and  $e$  removed

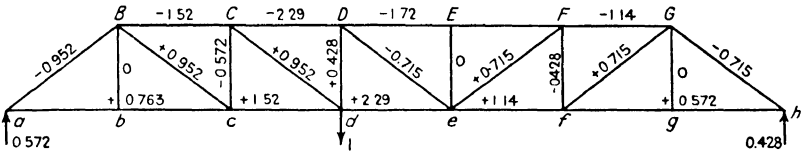

(cc) Stresses ( $u_d$ ) due to unit load at  $d$

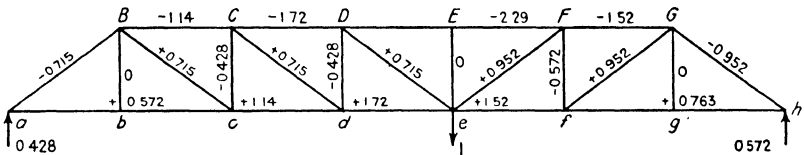

(dd) Stresses ( $u_e$ ) due to unit load at  $e$

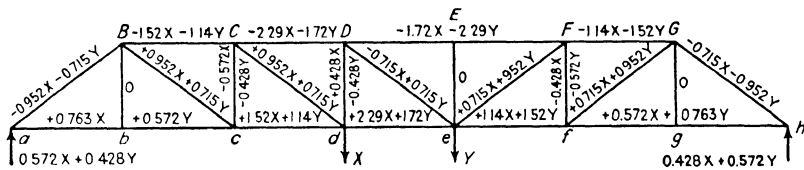

(ee) Loading producing same deflection at  $d$  and  $e$  as caused by loads shown in (bb) above

FIG. 10:4

yourself that the entries in the table would be the same (but the order different) and that the final equations and results are identical with those given here. Note also the similarity between the table here and that of the least work solution, Ex. 10:2.

*Formulas.* Consider a truss with  $r$  redundant bars, carrying any given system of loads. The base structure, composed of the  $n$  bars necessary to form a stable frame, is the statically determinate frame resulting from cutting each redundant at some section and applying equal and opposite axial forces at the section to hold the cut surfaces in contact under load.

EXAMPLE 10.4. METHOD OF DEFLECTIONS

Deflection at  $d$  and  $e$  due to redundants  $X$  and  $Y$ .

Deflection at  $d$  and  $e$  due to two 21-kip loads.

Bar	$L/A$	$S'$	$u_d$	$S'u_dL/A$	$u_e$	$S'u_eL/A$	$S$	$S'u_dL/A = E\delta_d$	$S'u_eL/A = E\delta_e$
BC	1	-60	-1.52	+91.2	-1.14	+68.4	-1.52 X - 1.14 Y	+2.31 X + 1.73 Y	+1.73 X + 1.30 Y
CD	1	-48	-2.29	110.0	-1.72	82.6	-2.29 X - 1.72 Y	+5.25 X + 3.94 Y	+3.94 X + 2.96 Y
DF	2	-36	-1.72	123.8	-2.29	165	-1.72 X - 2.29 Y	+5.92 X + 7.88 Y	+7.88 X + 10.5 Y
FG	1	-24	-1.14	27.4	-1.52	36.5	-1.14 X - 1.52 Y	+1.30 X + 1.73 Y	+3.94 X + 2.31 Y
ac	2	+44	+0.763	67.1	+0.572	50.4	+0.763X + 0.572Y	+1.16 X + 0.872Y	+0.872X + 0.654Y
cd	1	+60	+1.52	91.2	+1.14	68.4	+1.52 X + 1.14 Y	+2.31 X + 1.73 Y	+1.73 X + 1.30 Y
de	1	+48	+2.29	110.0	+1.72	82.6	+2.29 X + 1.72 Y	+5.25 X + 3.94 Y	+3.94 X + 2.96 Y
ef	1	+24	+1.14	27.4	+1.52	36.5	+1.14 X + 1.52 Y	+1.30 X + 1.73 Y	+1.73 X + 2.31 Y
fh	2	+12	+0.572	13.7	+0.763	18.3	+0.572X + 0.763Y	+0.654X + 0.872Y	+0.872X + 1.16 Y
aB	1	-55	-0.952	52.4	-0.715	39.3	-0.952X - 0.715Y	+0.906X + 0.680Y	+0.680X + 0.511Y
Bc	1	+20	+0.952	19.0	+0.715	14.3	+0.952X + 0.715Y	+0.906X + 0.680Y	+0.680X + 0.511Y
Cd	1	-15	+0.952	-14.3	+0.715	-10.7	+0.952X + 0.715Y	+0.906X + 0.680Y	+0.680X + 0.511Y
De	1	-15	-0.715	+10.7	+0.715	-10.7	-0.715X + 0.715Y	+0.511X - 0.511Y	-0.511X + 0.511Y
eF	1	+15	+0.715	10.7	+0.952	+14.3	+0.715X + 0.952Y	+0.511X + 0.680Y	+0.680X + 0.906Y
fG	1	+15	+0.715	10.7	+0.952	14.3	+0.715X + 0.952Y	+0.511X + 0.680Y	+0.680X + 0.906Y
Gh	1	-15	-0.715	10.7	-0.952	14.3	-0.715X - 0.952Y	+0.511X + 0.680Y	+0.680X + 0.906Y
Bb	1	+21	0	0	0	0			
Cc	1	+9	-0.428	-5.15	-0.428	-3.85	-0.428X - 0.428Y	+0.327X + 0.245Y	+0.245X + 0.183Y
Dd	1	+9	+0.428	+3.85	-0.428	-3.85	+0.428X - 0.428Y	+0.183X - 0.183Y	-0.183X + 0.183Y
Ff	1	-9	-0.428	-3.85	-0.572	+5.15	-0.428X - 0.572Y	+0.183X + 0.245Y	+0.245X + 0.327Y
$E\delta_d' = +764.25$								30.909X + 28.300Y	+28.300X + 30.909Y

$$\delta_d' = 764.3 \div E \quad \delta_e' = 681.3 \div E \quad \delta_d = (30.9 X + 28.3 Y) \div E \quad \delta_e = (28.3 X + 30.9 Y) \div E$$

$$\begin{aligned} \delta_d &= -\delta_d' \\ \delta_e &= -\delta_e' \end{aligned}$$

$$\begin{aligned} 30.9 X + 28.3 Y &= -764.3 \\ 28.3 X + 30.9 Y &= -681.3 \end{aligned}$$

$Y = +3.69$  i.e.  $\downarrow$  as shown: kips  
 $X = -28.1$  i.e.  $\uparrow$





leads to the following:

$$\left. \begin{aligned} X_a \sum_0^{n+a} \frac{u_a^2 L}{AE} + X_b \sum_0^n \frac{u_b u_a L}{AE} + X_c \sum_0^n \frac{u_c u_a L}{AE} + \dots &= -\sum_0^n \frac{S' u_a L}{AE} \\ X_a \sum_0^n \frac{u_a u_b L}{AE} + X_b \sum_0^{n+b} \frac{u_b^2 L}{AE} + X_c \sum_0^n \frac{u_c u_b L}{AE} + \dots &= -\sum_0^n \frac{S' u_b L}{AE} \\ X_a \sum_0^n \frac{u_a u_c L}{AE} + X_b \sum_0^n \frac{u_b u_c L}{AE} + X_c \sum_0^{n+c} \frac{u_c^2 L}{AE} + \dots &= -\sum_0^n \frac{S' u_c L}{AE} \end{aligned} \right\} 10:2a$$

Equation 10:2a is simply the working form of equation 2.

The same equation would have resulted for a redundant support, except that the summation for each term would have been limited to the necessary bars, there being no  $X_a L_a / A_a E$  term.

The solution of these equations is facilitated by noting that  $\delta_{mn} = \delta_{nm}$ , by Maxwell's theorem of reciprocal deflections.

Solving for the unknown in a structure indeterminate in the first degree, equation 10:2a takes this form,

$$X_a = -\frac{\sum_0^n S'(L/A) u}{\sum_0^{n+a} u^2(L/A)} \quad 10:2b$$

This is the same as equation 10:1a, which was derived by the method of least work in the preceding article, and, as has been noted, shows the essential identity of the two methods of stress analysis.<sup>2</sup> Similarly, from equation 10:2 we have

$$X_a = -\delta_a' / \delta_{aa} \quad 10:2c$$

Equation 10:2a is expressed in terms of the method of work; equation 10:2 is stated more generally in terms of deflections, leaving their evaluation to be made by any method desired.

The first report of this method of analysis of indeterminate structures in American literature was in the paper already referred to by Professor Swain, *Journal of the Franklin Institute*, 1883. His results were left closely in the form of equation 10:2a without pointing out the physical significances which led to equation 10:2, which is identical with the form given by Messrs. Parcel and Maney.<sup>3</sup> Equation 10:2a is closely

<sup>2</sup> The reason for the identity, very briefly, is that the deflection of any point equals the partial derivative of the internal work of deformation with respect to a load at the point. This is Castigliano's first theorem. If the point is a redundant support with a reaction,  $X$ ,  $\delta = 0 = \partial W / \partial X$ . See Parcel and Maney, *op. cit.*, Art. 41, etc.

<sup>3</sup> *Op. cit.*, page 112.

that of Professor Kinne in *Stresses in Framed Structures*, Hool and Kinne, page 394.

**Example 10:5.** Solve Ex. 8:1 by the deflection formula.

*Solution.* Let the center reaction be called  $X$ . See Prob. 10:9.

$$X = -\frac{\int \frac{M' m dx}{EI}}{\int \frac{m^2 dx}{EI}} = -\frac{\frac{2}{EI} \int_0^L \left( wLx - \frac{wx^2}{2} \right) \left( \frac{x}{2} \right) dx}{\frac{2}{EI} \int_0^L \left( \frac{x}{2} \right)^2 dx} = -\frac{5}{4} wL \text{ i.e., upward}$$

**Example 10:6.** Solve Ex. 10:1 by the method of deflections, equation 10:2b.

*Solution.*

Bar	$L/A$	$S'$	$u$	$E\delta_a' = S'uL/A$	$E\delta_{aa} = u^2L/A$	Actual Bar Stress
$AB$	1		+4/3		16/9	-20.1
$BC$	1	-56	-4/3	+74.67	16/9	-35.9
$CD$	1	+8	+4/3	+10.67	16/9	-12.1
$ab$	1	+28	+4/3	+37.33	16/9	+7.9
$bc$	1	-4	-4/3	+5.33	16/9	+16.1
$cd$	1	+32	+4/3	+42.67	16/9	+11.9
$Aa$	1		+1		1	-15.1
$Dd$	1	+6	+1	+6	1	-9.1
$Ab$	1		-5/3		25/9	+25.2
$aB$	1	-35	-5/3	+58.33	25/9	-9.8
$Bc$	1	+35	+5/3	+58.33	25/9	+9.8
$bC$	1	+40	+5/3	+66.67	25/9	+14.8
$Cd$	1	-40	-5/3	+66.67	25/9	-14.8
$cD$	1	-10	-5/3	+16.67	25/9	+15.2
				+443.33	264/9	

$$X_a = -\frac{\delta_a'}{\delta_{aa}} = -\frac{\sum \frac{S'uL}{A}}{\sum \frac{u^2L}{A}} = -\frac{443.33}{264/9} = -15.1 \text{ kips}$$

$$\text{Actual bar stresses} = S' + Xu$$

Bar  $Aa$  was taken as the redundant and cut as shown. The necessary values had already been obtained on the stress diagrams for the least work solution. This assembly in the table herewith differs in order and title only from that of the other method.

**10:4. Influence lines.** The large amount of labor required to find the stresses in even a simple indeterminate structure makes it impractical to use these methods for a variety of different loadings. Instead an

influence line is constructed for each of the redundant elements, after which the stress analysis can proceed much as for a statically determinate structure.

The construction of influence lines by use of equation 10:2 is illustrated in the two examples which follow.

**Example 10:7.** Draw the influence line for the stress in bar *Aa* of the truss in Fig. 10:1. This is the same truss as that of Exs. 10:1 and 10:6.

*Solution.*

Bar	<i>L/A</i>	1 lb @ <i>a</i> <i>u</i>	1 lb @ <i>b</i> <i>S<sub>b</sub>'</i>	1 lb @ <i>c</i> <i>S<sub>c</sub>'</i>	<i>Eδ'<sub>ab</sub></i> = <i>S<sub>b</sub>'uL/A</i>	<i>Eδ'<sub>ac</sub></i> = <i>S<sub>c</sub>'uL/A</i>	<i>Eδ'<sub>aa</sub></i> = <i>u<sup>2</sup>L/A</i>
<i>AB</i>	1	+4/3					16/9
<i>BC</i>	1	-4/3	-16/9	- 8/9	64/27	+32/27	16/9
<i>CD</i>	1	+4/3	+ 8/9	- 8/9	32/27	-32/27	16/9
<i>ab</i>	1	+4/3	+ 8/9	+ 4/9	32/27	+16/27	16/9
<i>bc</i>	1	-4/3	- 4/9	+ 4/9	16/27	-16/27	16/9
<i>cd</i>	1	+4/3	+ 4/3		48/27		16/9
<i>Aa</i>	1	+1					9/9
<i>Dd</i>	1	+1	+ 2/3	- 2/3	18/27	-18/27	9/9
<i>Ab</i>	1	-5/3					25/9
<i>aB</i>	1	-5/3	-10/9	- 5/9	50/27	+25/27	25/9
<i>Bc</i>	1	+5/3	+10/9	+ 5/9	50/27	+25/27	25/9
<i>bC</i>	1	+5/3	+ 5/3		75/27		25/9
<i>Cd</i>	1	-5/3	- 5/3		75/27		25/9
<i>cD</i>	1	-5/3	-10/9	+10/9	50/27	-50/27	25/9
					+510/27	-18/27	+792/27

$$X_a \delta_{aa} = - \delta_a'$$

$$1 \text{ lb @ } b; X_a = -510 \div 792 = -0.644 = \text{Stress } Aa$$

$$1 \text{ lb @ } c; X_a = +18 \div 792 = +0.0227 = \text{Stress } Aa$$

*Discussion.* This problem involved the solution of equation 10:2*b* twice, once for a unit force at *b* and again for a unit load at *c*. Note that the denominator was the same for both cases. The computations for *S<sub>b</sub>'* and *S<sub>c</sub>'* (stress in bars of base system due to unit load at *b* and *c* respectively) are not shown. The influence line is the solid-line curve plotted in Fig. 10:8.

**Example 10:8.** Draw the influence lines for the reactions at *d* and *e* of the truss shown in Fig. 10:5. (Same as that of Exs. 7:13, 10:2, and 10:4.) Assume *L/A* = 1 for all members.

*Solution.* In Ex. 7:13 (page 206) the deflection curve was drawn for the independent system formed by removing the supports at *d* and *e* under a unit load at *d*. The deflection curve for the same independent system under a unit load at *e* is here shown. These curves give the four pairs of simultaneous equations (Eq. 10:2) needed, one set for each load point:

$$\left. \begin{aligned} X_d \delta_{da} + X_e \delta_{de} &= - \delta_d' \\ X_d \delta_{ed} + X_e \delta_{ee} &= - \delta_e' \end{aligned} \right\} \text{Equations for 1 lb load at any load point.}$$

$EX_d$	$EX_e$	$E\delta'$ for Unit Load at			
		$b$	$c$	$f$	$g$
30.850	28.262	12.802	23.572	21.096	11.310
28.262	30.850	11.310	21.096	23.572	12.802
28.262	25.891	11.728	21.594	19.326	10.361
	+4.959	-0.418	-0.498	+4.246	+2.441
	$X_e$	-0.084	-0.100	+0.856	+0.492
$X_d$		+0.492	+0.856	-0.100	-0.084

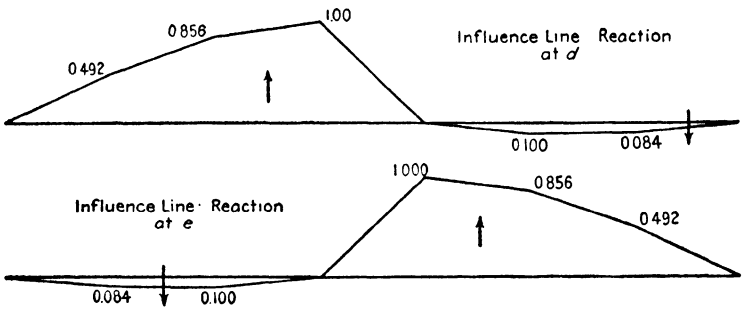
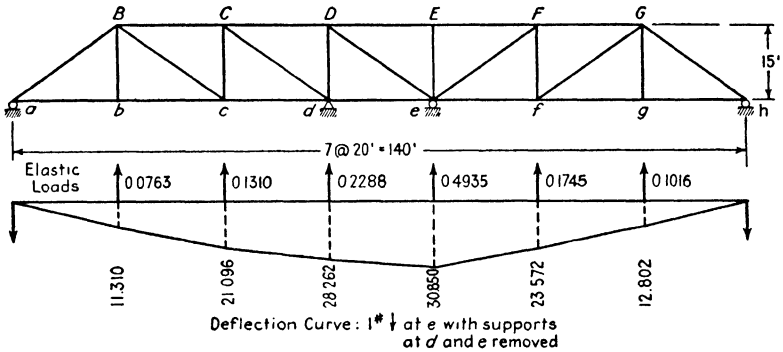

FIG. 10:5

Note that in Ex. 7:13 the work proceeded in pound units, and that the units for  $E\delta$  are pound-feet/pounds per square inch: in Fig. 10:5 kip units were used, or, what here amounts to the same, a load equal to 1/1000 of that in Ex. 7:13.

*Suggestion.* Check the results of Exs. 10:2 and 10:4 by means of the influence line here constructed.

**The deflection curve as an influence line.** The construction of influence lines is often facilitated by use of the following relation between deflection curves and influence lines noted by Professor Müller-Breslau.

Consider the truss of Fig. 10:2, studied in Exs. 10:2, 10:4, and 10:8,

which is shown in Fig. 10:6, carrying a unit load at  $d$ , the support of which has been removed. Any ordinate of the deflection curve for this condition gives the deflection at that point due to 1 lb at  $d$ , support  $d$  removed ( $\delta_{bd}$  = deflection at  $b$  due to 1 lb acting at  $d$ ). By Maxwell's theorem of reciprocal deflections  $\delta_{bd} = \delta_{db}$ ; any ordinate gives also the magnitude of the deflection at  $d$  (support removed) caused by a unit load at the ordinate. Therefore the deflection curve for 1 lb at  $d$  is also the influence line for deflection at  $d$ . If in addition to the unit load shown another equal and opposite is applied upward at  $d$ , it also will cause a deflection

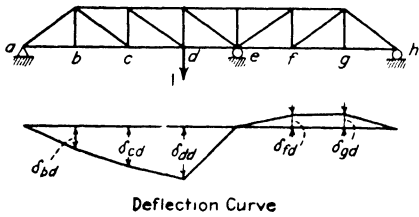

Fig. 10:6

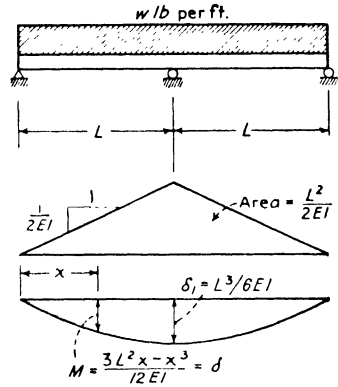

Fig. 10:7

of  $\delta_{dd}$  and point  $d$  will return to its original position. That is, a unit load at  $d$  on the actual structure causes a unit reaction at  $d$ . A unit load at  $b$ , support at  $d$  removed, causes a deflection at  $d$  of  $\delta_{db} = \delta_{bd}$ . The upward force at  $d$  required to return that point to its original place under the unit load at  $b$  will equal  $\delta_{bd}/\delta_{dd}$ , force being proportional to deflection. That is, a unit load at  $b$  on the original structure causes a reaction of  $\delta_{bd}/\delta_{dd}$  at  $d$ ; a load at  $f$  causes a downward reaction at  $d$  of  $\delta_{fd}/\delta_{dd}$ . Thus by dividing each ordinate by  $\delta_{dd}$  the deflection curve shown, which is the influence line for deflection at  $d$ , becomes the influence line for reaction at  $d$ . This then is the Müller-Breslau relation: **the ordinates of the influence line for any redundant element of an indeterminate structure equal those of the deflection curve drawn for the structure carrying a unit load in place of the redundant, divided by the deflection at the point of application of the unit load.**

This relation could have been set forth somewhat more simply, first, by recalling (page 221, Art. 7:6) that any deflection curve for unit load

is also the influence line for deflection at the load point, and, second, by observing equation 10:2c,

$$X_a = \frac{-\delta_a'}{\delta_{aa}}$$

**Example 10:9.** Find the reactions of the beam shown in Fig. 10:7 (same as Ex. 10:5) by the use of an influence line.

*Solution.* Below the beam in the figure was constructed the elastic loading diagram for a downward center load of unity with the support at that point removed. The moment curve for that loading, drawn below the load curve, is the deflection curve for this unit center load. Also it is the influence line for deflection at the center with the center support removed (by Maxwell's law,  $\delta_{ab} = \delta_{ba}$ ). Its ordinates divided by  $\delta_1$  (the center deflection under the load) equal those of the influence line for reaction at the center when the support is in place. The ordinate at point  $x$  for the influence line for center reaction then equals  $R = [(3L^2x - x^3)/12EI] \div (L^3/6EI) = (3L^2x - x^3)/2L^3$ .

For a uniform load over the whole span the support equals the area under this influence line multiplied by load intensity, equals

$$2w \int_0^L \frac{(3L^2x - x^3)dx}{2L^3}$$

or 
$$\frac{5wL}{4}$$

as before.

This example has served for review and assurance on two important theorems but obviously is not advanced as a practical method of solution for this type of problem.

**Example 10:10.** Draw the influence line for stress in bar  $Aa$  due to loads on the lower chord level for the truss shown in Fig. 10:8. Use the Müller-Breslau relation. This is the same truss and problem given in Ex. 10:7.

*Solution.* Assume bar  $Aa$  cut by a section just above its lower end at  $a$ . A downward force of unity applied to the hanging bar at this section causes deflections at panel points  $b$  and  $c$  and also causes the upper section to overlap the lower by an amount equal to the downward deflection of point  $A$  plus the elongation of the bar  $Aa$ . These several movements are found by the method of work, as indicated in the accompanying table. This table is the same as that in Ex. 10:7 except for slight differences in column headings, and so the body of the table is not here given.

Bar	$L/A$	$S = u_a$	$u_b$	$u_c$	$\frac{E\delta_{aa} = Su_a L/A}{Su_a L/A}$	$\frac{E\delta_{ba} = Su_b L/A}{Su_b L/A}$	$\frac{E\delta_{ca} = Su_c L/A}{Su_c L/A}$
				Totals	+792/27	+510/27	-18/27

$$\delta = \sum \frac{SuL}{AE} \quad \text{Influence line ordinates:}$$

$$@ b \quad S_{aA} = + \frac{510}{792} = + 0.644$$

$$@ c \quad = - \frac{18}{792} = - 0.0227$$

By Maxwell's law the relative movement of the cut surfaces of the bar *Aa* with a unit load at *b* equals the deflection at *b* with unit forces at the cut, that is,

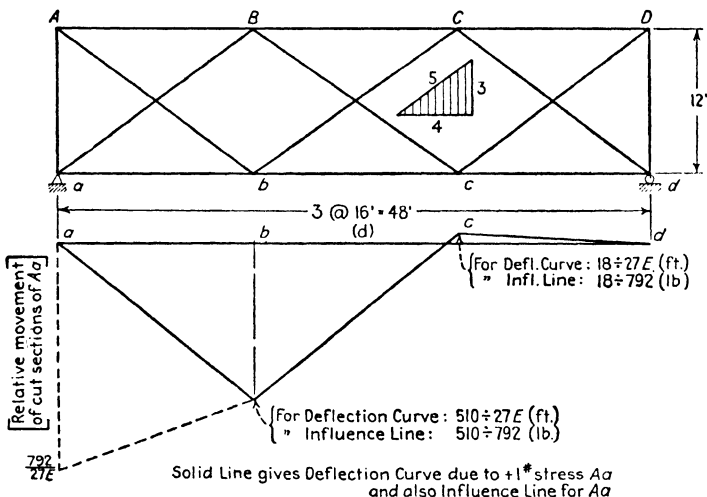

FIG. 10:8

$510 \div 27E$ . If unit forces at the cut ends cause a relative movement of  $792 \div 27E$ , a movement of  $510 \div 27E$  would be caused by a force of  $510 \div 792$ .

As an indication of the variety possible in problems of this sort there is shown in Fig. 10:9 a Williot-Mohr diagram from which the necessary deflections were found for constructing Fig. 10:8. Bar stresses are those given in Fig. 10:1c. The diagram was made with bar *Aa* omitted. The vertical distance *AA'* ( $= 6 \times 41/9E + 9/9E = 255/9E = 765/27E$ ) shows, accordingly, the downward movement of point *A*. Consider that bar *Aa* is in position, cut at a point just above the lower end *a*. This cut section *a* moves downward with point *A* the distance just noted, plus the extension of the bar under its unit load,  $1/E$ . Adding this movement to that of *A* gives a total movement at the cut section of  $792/27E$ . In like manner the vertical deflection of point *b* is *bb'*, which equals  $2 \times 41/9E + \frac{2}{3}(3 \times 41/9E + 1/E) = 510/27E$ : and the

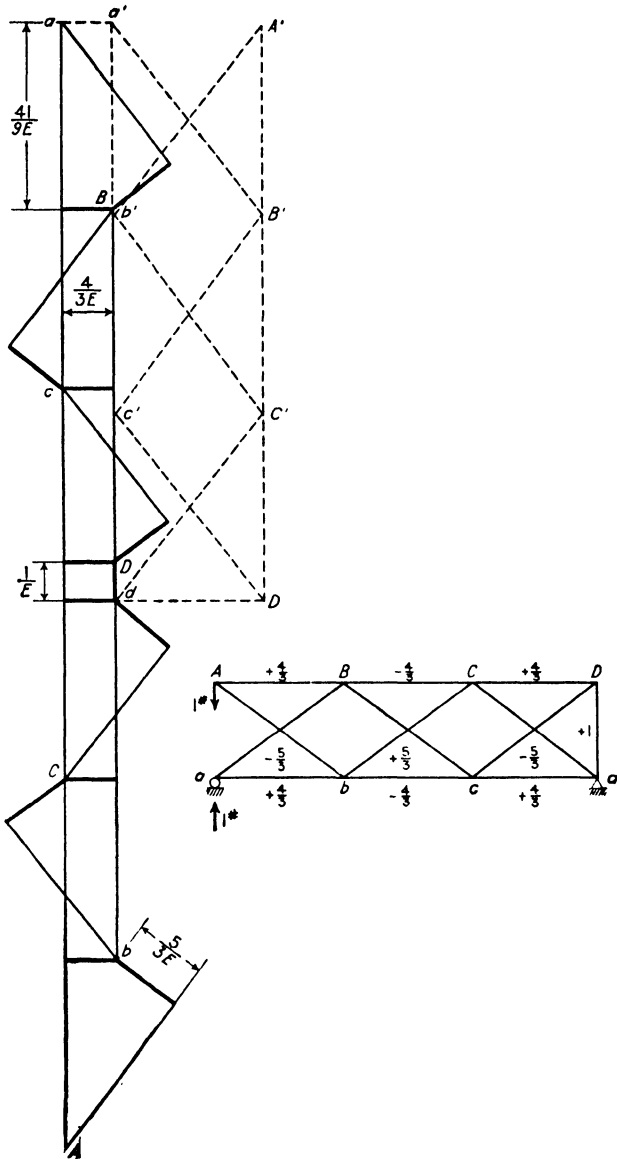

FIG. 10:9



vertical deflection of  $c, c'$ , equals  $\frac{1}{3}(3 \times 41/9E + 1/E) - (41/9E + 1/E) = -18/27E$ .

As suggested in the preceding paragraph, the necessary values for constructing the influence line for a redundant—reaction or bar stress—may be obtained from a Williot-Mohr diagram. Moreover, as the

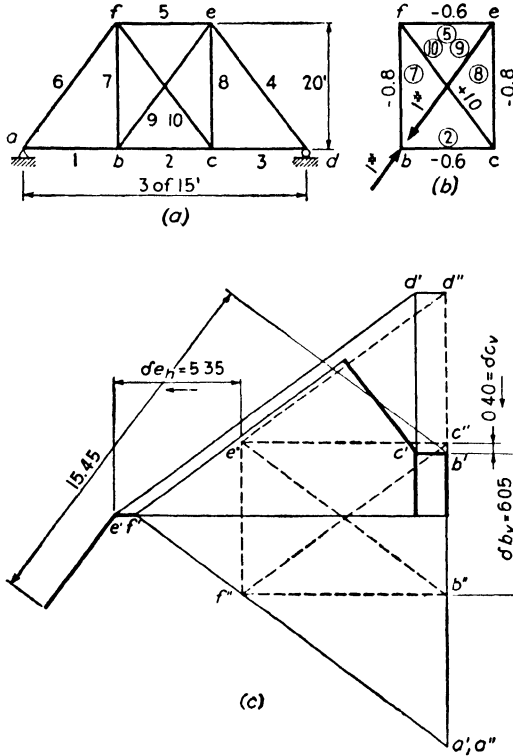

FIG. 10:10

following examples will show, for a structure which is statically indeterminate to the first degree, a single Williot-Mohr diagram will give values which will yield by simple proportion the stress in the redundant due to any load, acting at any joint, and in any direction. Similarly, for a structure which is statically indeterminate to the  $n$ th degree, the construction of  $n$  Williot-Mohr diagrams will give values which will produce the  $n$  simultaneous equations needed in finding the redundant stresses due to any load acting at any joint in any direction. Note that the Williot-Mohr diagram is independent of the actual loads which may later be placed on the structure.

*Signs.* A downward vertical load at  $b$ , Fig. 10:10a, causes the cut

section in bar 9, Fig. 10:10*b*, to open. The unit forces in bar 9 will then have to act as shown in that figure to close the gap in the bar (i.e., to bring the cut ends together as in the actual structure). Therefore, under a downward load at *b*, the stress in bar 9 will be tension. Although it was easy in the foregoing figure to determine the character of the stress in the redundant bar, there will come cases where the answer will be less obvious. Keeping in mind the fact that the point of application of the external load will move in the direction of the load, the following rule will be found helpful: **if the applied load causes its point of application to move in the same direction as the point moved in the Williot-Mohr diagram under the action of unit forces that cause tension in the redundant bar, the stress in the redundant bar is compression, if in the opposite direction, tension.** For example, point *b* moved upward, Fig. 10:10*c*, owing to the unit loads in bar 9; therefore, a downward load at *b* will cause tension in bar 9. Point *c* moved downward owing to the unit loads in bar 9; therefore a downward load at *c* will cause compression in bar 9. Point *e* moved to the left under the action of the unit loads in 9; therefore an external horizontal load acting to the right at *e* will cause tension in 9.

**Example 10:11.** With the aid of a Williot-Mohr diagram determine the stress in bar 9 of Fig. 10:10 due to vertical loads of 5 kips each acting downward at *b* and *c* and a horizontal load of like amount acting to the right at *e*. Bar areas: bars 1, 2, and 3 are 7 sq in.; bars 4 and 6 are 14 sq in.; bar 5 is 11 sq in.; bars 7 and 8 are 6 sq in.; bars 9 and 10 are 5 sq in.

Bar	$\frac{L}{A}$	<i>u</i>	$\frac{uL}{A}$
2	2.14	-0.6	-1.28
5	1.37	-0.6	-0.82
7	3.33	-0.8	-2.67
8	3.33	-0.8	-2.67
9	5.00	+1.0	+5.00
10	5.00	+1.0	+5.00

*Solution.* Having first made the adjacent table, next draw the Williot-Mohr diagram for the unit loads shown acting in Fig. 10:10*b*. Since relative values are to be scaled from the diagram, *E* has been neglected, and a convenient scale selected to use with the entries of the last column of the table. From the diagram the following may be scaled: overlap of the cut ends of bar 9 = 15.45;

vertical movement of *b* = 6.05 upward; vertical movement of *c* = 0.40 downward; horizontal movement of *e* = 5.35 to the left. (See the rule concerning signs immediately preceding this example.) Hence, owing to the 5-kip load acting downward at *b*,

$$S_9 = +5000 \left( \frac{6.05}{15.45} \right) = +1960 \text{ lb}$$

Owing to the 5-kip load acting downward at *c*,

$$S_9 = -5000 \left( \frac{0.40}{15.45} \right) = -130 \text{ lb}$$

Owing to the 5-kip load acting horizontally to the right at  $e$ ,

$$S_9 = +5000 \left( \frac{5.35}{15.45} \right) = +1730 \text{ lb}$$

The movement of the cut section at the lower end of bar  $be$  can be found in two ways. The Williot diagram shown was constructed with origin  $c$  and axis bar  $bc$ . Point  $e$  moves, accordingly, from  $c'$  in the Williot to  $e'$ , and the section at the lower end of bar  $be$  moves with  $e$ . The elongation of the bar carries the section downward to the left the distance laid off by the heavy line from  $e'$ . Meanwhile the lower side of the cut section of bar  $be$ , point  $b$ , moves from  $c'$  to  $b'$ . Since both movements are laid off from a common point, the overlap of the section is given as shown, measured parallel to bar  $be$ . The second method involves use of the correction (Mohr) diagram. Point  $e$  moves from  $e''$  to  $e'$ , and the lower end of the bar likewise: bar elongation carries the section on downward to the left. Point  $b$  moves upward vertically the distance  $b''b'$ . Lay this distance off vertically from  $e''$ : it will be found that this line will terminate on the extension line leading upward to the left from  $b'$ , thus requiring the same 15.45 dimension as is shown. Another way of regarding this is simpler. The two sides of the cut section have two positions in the Williot diagram: (1)  $b'$ , and (2) the unlettered point which is most distant to the left in the diagram. The motion of each point may be measured from point  $b''$  of the correction diagram, and the motion of one with respect to the other by the distance from  $b'$  to the unlettered point. But the desired value is the projection of this distance in the direction of bar  $be$ , that is, the 15.45 units marked.

**Example 10:12.** With the aid of a Williot-Mohr diagram and for the structure of Fig. 10:11a draw the influence line for the horizontal component of reaction at  $f$  due to the passage of the load over the top chord. Bar areas: 1, 4, and 14 are 5 sq in.; 5, 10, 11, and 17 are 10 sq in.; others are 7.5 sq in.

Bar	$L$	$A$	$\frac{L}{A}$	$u$	$u \frac{L}{A}$
2	18.00	7.5	2.40	+1.00	+2.40
8	12.00	7.5	1.60	-2.00	-3.20
9	15.00	7.5	2.00	-1.67	-3.33
11	18.97	10.0	1.90	+1.06	+2.01
12	10.82	7.5	1.44	-1.20	-1.72
13	15.00	7.5	2.00	0	0

*Solution.* Taking the horizontal component of reaction as the redundant,  $f$  was placed on a roller, the unit loads of Fig. 10:11b were added, the resulting stresses computed, and the adjacent table filled in. Making use of the last column of the table, the Williot-Mohr diagram was constructed on

the assumption that  $ch$  remained vertical. From the diagram the values were scaled, which permitted the influence line of Fig. 10:11c to be drawn.

In applying the rule of signs which precedes Ex. 10:11,  $m$  and  $f$  may be assumed to be connected by a member of infinite area, so the rule is applied to determine the stress in this member.

Also, from the diagram the value of  $H_f$  due to a load acting down to the right at a 45° angle at  $d$  (angle and point selected arbitrarily) is found to be

$$\frac{18.1}{37.2} P = 0.49 P \text{ to the left}$$

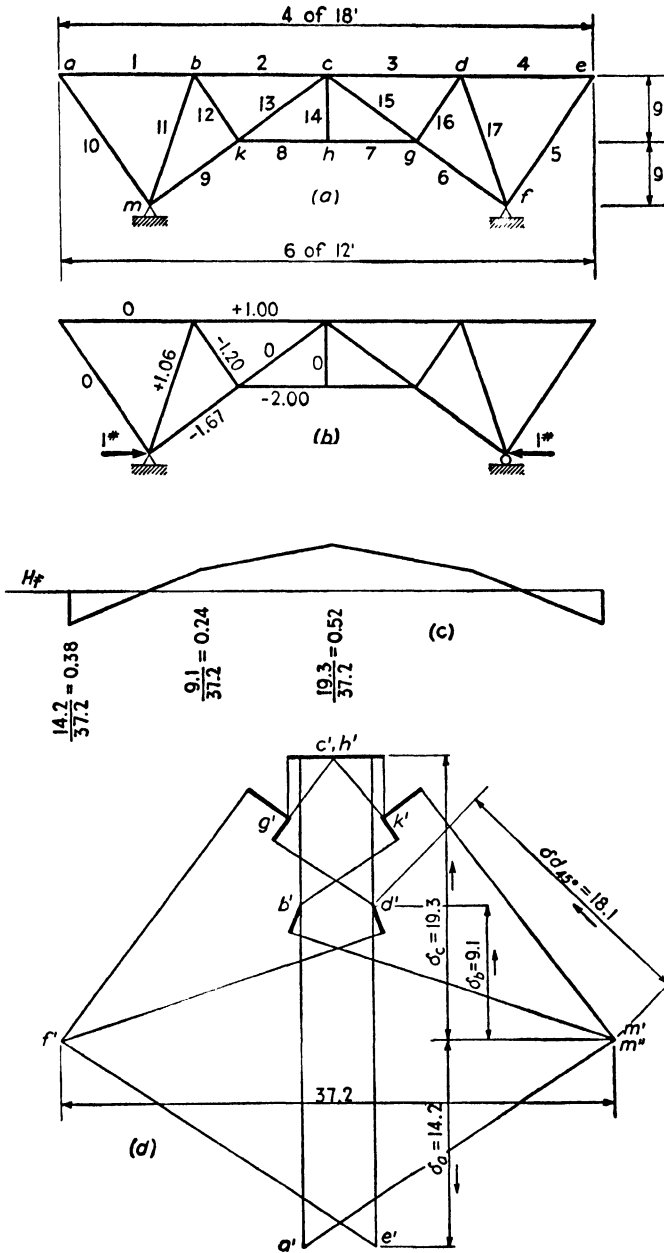

FIG. 10:11

**Example 10:13.** With the aid of Williot diagrams, determine the reactions caused by the vertical load at *c* in the structure of Fig. 10:12a. Assume that, for each member of the structure,  $L/A$  equals unity. Check the reactions by the method of least work.

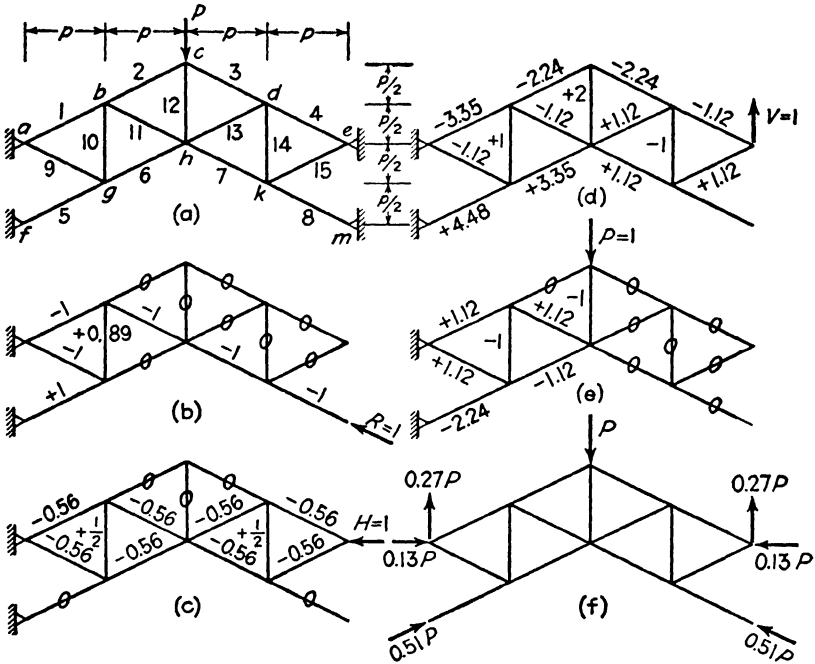

FIG. 10:12

*Williot diagram solution.* This rigid truss structure has six reaction components and is, therefore, statically indeterminate to the third degree. Three reaction components ( $R_m$ ,  $H_e$ , and  $V_e$ ) were selected as the redundants, and unit loads, applied in their stead, produce the stresses shown in Figs. *b*, *c*, and *d*. Corresponding to these stresses, the Williot diagrams of Fig. 10:13, in which it was found expedient to use three different scales, were drawn. Each diagram selects *af* as a starting member, and since this (imaginary) member retains its original direction, no correction diagrams are required.

Consider the diagram of Fig. 10:13*b*, for example. By Maxwell's law, equation 7:7,

$$\Delta_{cm} = \Delta_{mc}$$

Expressed otherwise, this law says that the reaction,  $R$ , at *m* caused by the vertical load,  $P$ , at *c* will equal  $(6.49/6.80) P$ .

In like manner, the horizontal load,  $H$ , acting to the left at *e* will cause a

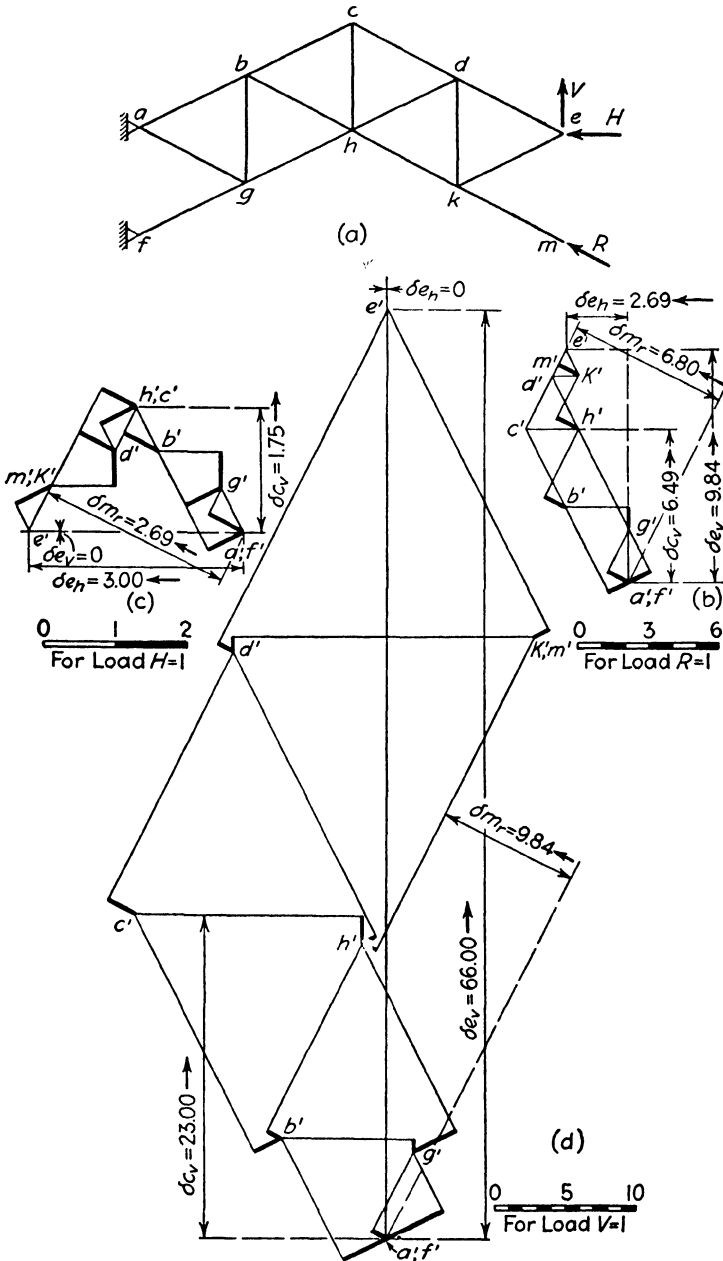

FIG. 10:13

reaction,  $R$ , at  $m$  equal to  $(-2.69/6.80)H$ ; and the vertical load,  $V$ , acting upward at  $e$  will cause a reaction,  $R$ , at  $m$  equal to  $(-9.84/6.80)V$ . If all three (that is,  $P$ ,  $H$ , and  $V$ ) act at the same time, the reaction  $R$  will equal the sum of the three values. That is,

$$R = \frac{6.49}{6.80}P - \frac{9.84}{6.80}V - \frac{2.69}{6.80}H$$

or

$$6.80R + 2.69H + 9.84V = 6.49P$$

Similarly, the two other Williot diagrams yield the following two additional equations:

$$2.69R + 2.98H = 1.75P$$

$$9.84R + 66.00V = 23.00P$$

Solution of the three equations, Table A, provides the values of Fig. 10:12f. As a rough check it will be found that the vertical reaction at  $e$  plus the vertical component of the reaction at  $m$  equals  $P/2$ .

EXAMPLE 10:13. TABLE A

Equation		$R$	$H$	$V$	$=$	$P$	Check
	1	+6.80	+2.69	+ 9.84		+ 6.49	+25.82
	2	+2.69	+2.98	0		+ 1.75	+ 7.42
	3	+9.84	0	+66.00		+23.00	+98.84
	1'	+1	+0.396	+ 1.446		+ 0.955	+ 3.797
	2'	+1	+1.106			+ 0.650	+ 2.756
	3'	+1		+ 6.708		+ 2.337	+10.045
2'-1'	$a$		+0.710	- 1.446		- 0.305	- 1.041
3'-1'	$b$		-0.396	+ 5.262		+ 1.382	+ 6.248
	$a'$		+1	- 2.040		- 0.430	- 1.470
	$b'$		-1	+13.320		+ 3.495	+15.815
$a'+b'$	$c$			+11.280		+ 3.065	+14.345
				$V$		+ 0.272	
	$a'$		$H$	- 0.555		- 0.430	
			$H$			+ 0.125	
	1'	$R$	+0.049	+ 0.393		+ 0.955	
		$R$				+ 0.513	

Part check:  $V + R_e = \frac{1}{2}P$

$$0.272 + \frac{0.513}{\sqrt{5}} = 0.272 + 0.230 = 0.502$$

INFLUENCE LINES

EXAMPLE 10-13. TABLE B

Bar	$\frac{L}{A}$	S				$\frac{\partial S}{\partial R}$	$S \cdot \frac{\partial S}{\partial R} \frac{L}{A}$				$\frac{\partial S}{\partial H}$	$S \cdot \frac{\partial S}{\partial H} \frac{L}{A}$				$\frac{\partial S}{\partial V}$	$S \cdot \frac{\partial S}{\partial V} \frac{L}{A}$			
		R	H	V	P		R	H	V	P		R	H	V	P		R	H	V	P
1	1	-1	-0.56	-3.35	+1.12	-1	+0.56	+3.35	-1.12	-0.56	+0.56	+0.31	+1.87	-0.63	+3.35	+1.87	+11.25	-3.75		
2	1			-2.24													+5.00			
3	1			-2.24													+5.00			
4	1			+4.48	-2.24	+1				-0.56		+0.31	+0.63				+1.25			
5	1	+1	-0.56	+3.35	-1.12	+1	+0.56	+3.35	-1.12	-0.56	+0.56	+0.31	+1.87	+0.63	+4.48	+4.48	+20.00	-10.00		
6	1	-1	-0.56	+1.12		+1	+0.56	+1.12		-0.56	+0.56	+0.31	-0.63		+1.12	-1.12	+11.25	-3.75		
7	1	-1	-0.56	+1.12		+1	+0.56	+1.12		-0.56	+0.56	+0.31	-0.63		+1.12	-1.12	+11.25	-3.75		
8	1	-1	-0.56	+1.12		+1	+0.56	+1.12		-0.56	+0.56	+0.31	+0.63	-0.63	+1.12	+1.12	+0.63	+1.25		
9	1	-1	-0.56	+1.12		+1	+0.56	+1.12		-0.56	+0.56	+0.31	+0.63	-0.63	+1.12	+1.12	+0.63	+1.25		
10	1	+0.89	+ $\frac{1}{2}$	+1	-1	+0.89	+0.80	+0.89	-0.89	+ $\frac{1}{2}$	+0.45	+0.25	+0.50	-0.50	+0.89	+0.25	+1.00	-1.00		
11	1	-1	-0.56	-1.12	+1.12	-1	+0.56	+1.12	-1.12	-0.56	+0.56	+0.31	+0.63	-0.63	+1.12	+1.12	+0.63	+1.25		
12	1			+2	-1					-0.56		+0.31	-0.63		+2	+2	+4.00	-2.00		
13	1			-0.56	+1.12					+ $\frac{1}{2}$		+0.25	-0.50		+1.12	+1.12	+1.25			
14	1			+ $\frac{1}{2}$	-1					+ $\frac{1}{2}$		+0.25	-0.50		+1.12	+1.12	+1.25			
15	1			-0.56	+1.12					-0.56		+0.31	-0.63		+1.12	+1.12	+1.25			
							+6.80	+2.69	+9.84	-6.49		+2.69	+2.98	0	+9.84	0	+66.00	-23.00		



*Least work solution.* In addition to the stresses which were formerly computed, it is necessary to find those caused by the load  $P$  in the (now) statically determinate structure (Fig. 10:12e). The values of Figs. 10:12b, c, d, e were entered in the  $S$  column in Table B. Next the three partial derivatives were taken, the remaining tabular values computed, and the summations obtained, each to be set equal to zero, since there is no movement at joints  $m$  and  $e$ .

The solution was stopped when it was observed that the equations are *identical* with those obtained by the first solution. (Actually a first trial showed a near equality which led to a careful redrawing of the Williot diagrams and produced diagrams in which the values *are* the same, as closely as they can be scaled.)

In comparing the two methods of solution it may be said that the graphical method requires quite accurate drafting but has a decided advantage if reactions from more than a single load are to be computed, since, for each additional load, it is necessary only to scale three values in order to obtain the necessary three additional equations.

**10:5. Composite structures.** The name "composite structures" is suggested, for want of a better, for structures in which some members carry direct stress and bending while others carry direct stress only.

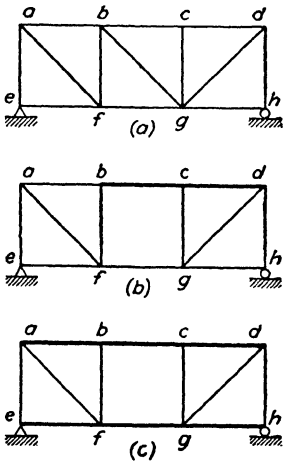

FIG. 10:14

In some of the types of structures considered in Chapter 8 and in this chapter, it has been found that many methods are available in making a solution. In the type now to be considered, on the contrary, the method of least work appears to be the only method available. Since the structures are of importance (suspension bridge towers, some types of portals, railroad car sides, etc.), brief consideration seems desirable.

Figure 10:14a, if pin connected throughout, will be recognized as a statically determinate structure. Let us assume that for some reason it is necessary to omit the diagonal in the center panel. Experience shows that this may be done, Fig. 10:14b, provided  $bd$  (or  $ac$  or  $eg$  or  $fh$ )

is made a stiff member,  $cg$  being still pin connected at each end. In fact, each time a member is stiffened at a joint (as  $bd$  at joint  $c$ ) the number of unknowns in the structure is increased by one. If  $ad$  and  $eh$  of Fig. 10:14a were made stiff throughout, that structure would be indeterminate to the fourth degree. Dropping out a diagonal, as in Fig. 10:14c, with the chords stiff throughout but with the six web members pin connected at their ends gives a structure which is statically indeterminate to the third degree.

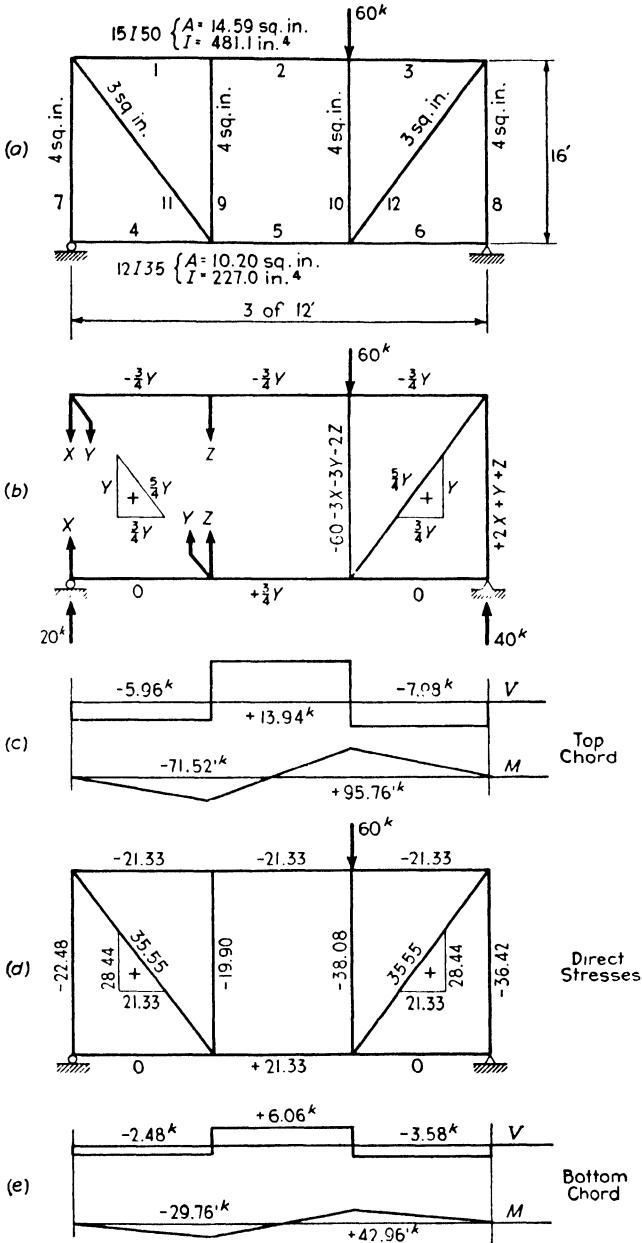

FIG. 10:15

**Example 10:14.** Determine the stresses in the structure of Fig. 10:15 in which the top and bottom members are each a continuous member, whereas the web members may be assumed pin connected.

*Solution.* The discussion preceding this example has established the fact that this structure is statically indeterminate to the third degree. Let the following be selected as redundants:

$$S_7 = X, \quad V_{11} = Y, \quad S_9 = Z$$

The tabular work for this example is given in Tables *A* and *B* which follow.

As shown in Fig. 10:15*b*, the direct stresses (and, as will be apparent, the moments) throughout the structure are readily found in terms of the external load and the redundants. Considering first the work due to direct stress, the partial derivatives with respect to  $X$ ,  $Y$ , and  $Z$  are found in Table *A*.

Next must be considered the work due to bending. In member 1 this is

$$W_1 = \int_0^{144} [(X + Y)x]^2 \frac{dx}{2 \cdot E \cdot 481}$$

and the partial derivatives are as shown for bar 1 in Table *B*, i.e.,

$$\frac{\partial W_1}{\partial X} = 2070X + 2070Y, \text{ etc.}$$

For the other members the work due to bending is

$$W_2 = \int_0^{144} [(X + Y)(144 + x) + Zx]^2 \frac{dx}{2 \cdot E \cdot 481}$$

$$W_3 = \int_0^{144} [(2X + 2Y + Z)x]^2 \frac{dx}{2 \cdot E \cdot 481}$$

$$W_4 = \int_0^{144} [(X + 20)x]^2 \frac{dx}{2 \cdot E \cdot 227}$$

$$W_5 = \int_0^{144} [(X + 20)(144 + x) + (Y + Z)x]^2 \frac{dx}{2 \cdot E \cdot 227}$$

$$W_6 = \int_0^{144} [(2X + Y + Z + 40)x]^2 \frac{dx}{2 \cdot E \cdot 227}$$

and the partial derivatives of these with respect to  $X$ ,  $Y$ , and  $Z$  are given in Table *B*. To these, on the last line of Table *B*, are added the partial derivatives of the direct stresses to give the desired three equations. The solution of these equations gives the following results:

$$X = -22.48 \text{ kips}$$

$$Y = +28.44 \text{ kips}$$

$$Z = -19.90 \text{ kips}$$

Next it is a simple matter to determine the top and bottom chord shears and moments, and the direct stresses in the bars, all as shown in Figs. 10:15*c*, *d*, *e*.

TABLE A  
EXAMPLE 10.14. METHOD OF LEAST WORK

Bar	$L$	$A$	$\frac{L}{A}$	$P$	$\frac{\partial P}{\partial X_i}$	$P \frac{\partial L}{\partial X} \frac{L}{A}$	$\frac{\partial P}{\partial Y}$	$P \frac{\partial L}{\partial Y} \frac{L}{A}$	$\frac{\partial P}{\partial Z}$	$P \frac{\partial L}{\partial Z} \frac{L}{A}$
1	144	14.59	9.87		0	0	$-\frac{8}{3} Y$	+ 6 Y	0	0
2	144	14.59	9.87		0	0	$-\frac{8}{3} Y$	+ 6 Y	0	0
3	144	14.59	9.87		0	0	$-\frac{8}{3} Y$	+ 6 Y	0	0
4	144	10.20	14.11		0	0	$+\frac{8}{3} Y$	0	0	0
5	144	10.20	14.11		0	0	$+\frac{8}{3} Y$	0	0	0
6	144	10.20	14.11		0	0	0	0	0	0
7	192	4	48	$+ X$	+1	+ 48 X	0	0	0	0
8	192	4	48	$+ 2 X + Y + Z$	+2	+ 192 X + 96 Y + 96 Z	+1	+ 96 X + 48 Y + 48 Z	+1	+ 96 X + 48 Y + 48 Z
9	192	4	48	$+ Z$	0	0	0	0	+1	+ 48 Z
10	192	4	48	$- 60 - 3 X - 3 Y - 2 Z$	-3	+ 8640 + 432 X + 432 Y + 288 Z	-3	+ 8640 + 432 X + 432 Y + 288 Z	-2	+ 5760 + 288 X + 288 Y + 192 Z
11	240	3	80	$+\frac{3}{4} Y$	0	0	$+\frac{3}{4} Y$	+ 125 Y	0	0
12	240	3	80	$+\frac{3}{4} Y$	0	0	$+\frac{3}{4} Y$	+ 125 Y	0	0
						+ 8640 + 672 X + 528 Y + 384 Z		+ 8640 + 528 X + 756 Y + 336 Z		+ 5760 + 384 X + 336 Y + 288 Z

See Fig. 10:15a, b.  $X = S_1, Y = V_{11}, Z = S_5$

TABLE B  
EXAMPLE 10:14. METHOD OF LEAST WORK

Bar	$\frac{\partial W}{\partial X} = 0$						$\frac{\partial W}{\partial Y} = 0$						$\frac{\partial W}{\partial Z} = 0$											
	X		Y		Z		Abs.		X		Y		Z		Abs.		X		Y		Z		Abs.	
1	2,070	2,070	2,070	2,070	2,070	2,070		2,070	2,070	2,070	2,070	2,070	2,070	2,070	2,070		2,070	2,070	2,070	2,070	2,070	2,070	2,070	
2	14,490	14,490	14,490	14,490	14,490	14,490		14,490	14,490	14,490	14,490	14,490	14,490	14,490	14,490		14,490	14,490	14,490	14,490	14,490	14,490	14,490	
3	8,280	8,280	8,280	8,280	8,280	8,280		8,280	8,280	8,280	8,280	8,280	8,280	8,280	8,280		8,280	8,280	8,280	8,280	8,280	8,280	8,280	
4	4,385	4,385	4,385	4,385	4,385	4,385	87,700	4,385	4,385	4,385	4,385	4,385	4,385	4,385	4,385	219,200	4,385	4,385	4,385	4,385	4,385	4,385	4,385	219,200
5	30,685	10,960	10,960	10,960	10,960	10,960	613,900	10,960	4,385	4,385	4,385	4,385	4,385	4,385	175,400	175,400	8,770	8,770	8,770	8,770	8,770	8,770	8,770	175,400
6	17,540	8,770	8,770	8,770	8,770	8,770	350,800	8,770	4,385	4,385	4,385	4,385	4,385	4,385	8,640	8,640	528	528	528	528	528	528	528	8,640
Direct	672	672	672	672	672	672	8,640	672	756	756	756	756	756	756	384	384	384	384	384	384	384	384	384	5,760
	78,132	45,098	29,429	1,061,040	45,098	34,366	18,421	403,240	45,098	18,421	403,240	45,098	18,421	403,240	29,429	18,421	403,240	45,098	18,421	403,240	45,098	18,421	403,240	29,429

$$\frac{\partial W}{\partial X} = 78,132 X + 45,098 Y + 29,429 Z + 1,061,040 = 0$$

$$\frac{\partial W}{\partial Y} = 45,098 X + 34,366 Y + 18,421 Z + 403,240 = 0$$

$$\frac{\partial W}{\partial Z} = 29,429 X + 18,421 Y + 13,198 Z + 400,360 = 0$$

**10:6. Mechanical analysis.** Since a deflection curve for a unit load acting in place of a redundant element is also, to some scale, the influence line for that redundant, it becomes evident that direct observation of the distortions of indeterminate structures could be made to obtain data for preparing influence lines and determining stress under load. However, models made of suitable homogeneous elastic material will give true results, since the absolute value of the modulus of elasticity does not enter into the determination of stress magnitude. For a continuous beam a spline furnishes the means of constructing the deflection curve, and results of considerable precision may be obtained, using relatively large distortions.<sup>4</sup>

Model analysis is particularly useful in connection with continuous beams of non-prismatic cross section, with arches, and with rigid frames of the kinds considered in Chapter 8.

In 1922 Professor George E. Beggs published (*Proceedings of the American Concrete Institute*, 1922, 1923; *Journal of the Franklin Institute*, March 1927) an account of a method of stress analysis using cardboard or celluloid models with deformations so small that a microscope is required for their measurement. A deformation (thrust, shear, or rotation) of definitely known magnitude is given to the point of application of a redundant by means of an accurate deformeter gage, and the corresponding movement is measured at the point where the load is applied. The ratio of redundant element to load is, by Maxwell's law, equal to the ratio of observed to gage deformation. This method is generally acknowledged as accurate and dependable, and its use is increasing steadily.

In 1922 Otto Gottschalk of Buenos Aires made public (*Journal of the Franklin Institute*, July 1926) an account of his Continostat, essentially a steel bar with arms designed to hold models made from steel splines in a distorted position while observations are made of the deformations. No microscopes are required as the deformations are large. This device has also been successfully used for a considerable range of structures.

The use of models made of brass wire with soldered joints was described by Anders Bull in *Engineering News-Record*, December 8, 1927. Here also large distortions are used. He extended this method to trusses later ("A New Method of Mechanical Analysis for Trusses," *Civil Engineering*, December 1930). Professor W. J. Eney of Lehigh University has developed mechanical types of connections which make this method easily available for office practice.

Professor Eney has also applied the method of Professor Beggs directly,

<sup>4</sup> If the deformations are large, the difference in shape from the original structure may be so great as to result in materially different stress distribution.

using relatively large distortions, developing special deformeters, gages, and clamps for this ("New Deformeter Apparatus," *Engineering News-Record*, February 11, 1939; "Model Analysis of Continuous Girders," *Civil Engineering*, September 1941).

The utility of models is by no means confined to stress analysis of indeterminate structures. As an example of the range of usefulness of models attention may be directed to these articles among many others:

"Settlement Stresses Found with a Model," Anders Bull, *Civil Engineering*, August 1937.

"Earthquake Resistance of Elevated Water Tanks," A. C. Ruge, *Transactions of the American Society of Civil Engineers*, Vol. 103 (1938).

"Determining the Deflections of Structures with Elastic Models," W. J. Eney, *Civil Engineering*, March 1942.

Models also come to effective use for the determination of the constants used in application of the method of moment distribution, i.e., the stiffness and carry-over factors and the fixed-end moments ("Fixed Ended Moments by Cardboard Models," W. J. Eney, *Engineering News-Record*, December 12, 1935).

Since 1943 many important papers on model analysis have appeared in the *Proceedings of the Society for Experimental Stress Analysis*.

PROBLEMS

Art. 10:2 Least Work

**Problem 10:1.** Solve Ex. 10:1, using equation 10:1a.

**Problem 10:2.** Had Ex. 10:1 given 15 kips tension as the true stress in *Aa*, would the final stress diagram have revealed the error? Construct the stress sheet for this case.

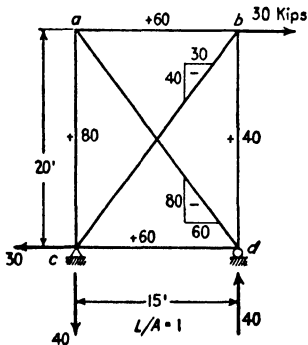

PROB. 10:2

*Ans.* One is able to construct a perfectly consistent stress diagram but with rather startling magnitudes which at once lead to questioning the result. But since the results are statically consistent, evidently statics gives no proof at all of correctness. An infinitude of results will all satisfy static requirements, but only one will satisfy both elastic and static requirements. The only check possible on the stresses in a redundant truss is an independent solution or an investigation of the consistency of the distortions. For an extreme example consider the adjacent frame, assuming that an analysis has given the stresses there shown. These results, which are consistent

statically, are obviously inconsistent elastically. The changes of bar lengths of triangle *bcd* move *b* upward to the left; those of triangle *acd* move *a* upward to the right, thus bringing *a* and *b* toward each other. The stress in bar *ab* indicates a separation of these points.

**Problem 10.3.** Compute the reactions for the loaded trusses *a*, *b*, and *c* and the bar stresses for trusses *d*, *e*, and *f* by the method of least work. Unless otherwise indicated,  $L/A = 1$  for all members. Where bar areas are given in brackets along side the bar, the figures are in square inches.  $E$  is constant.

- Ans. *a.*  $V_A = V_C = 20.9$  kips;  $V_B = 58.2$  kips.  
*b.*  $V_A = 71.5$  kips and  $V_B = 17$  kips down;  $V_C = 88.5$  kips up;  
 $H_C = 120$  kips to the left.  
*c.*  $V_A = 83$  kips up,  $H_A = 44$  kips to the left,  
 $H_B = 44$  kips to the right;  $V_C = 17$  kips up.  
*d.* Stress in  $bC = 19,000$  lb tension.  
*e.* Stress in  $bC = 25,500$  lb tension.  
 Stress in  $Cd = 12,600$  lb compression.  
*f.* Stress in  $ab = 12,300$  lb tension.

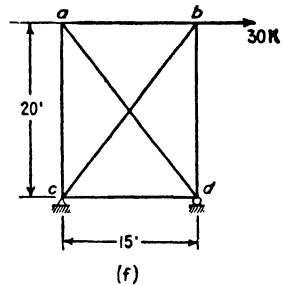
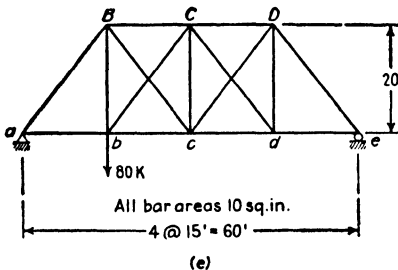
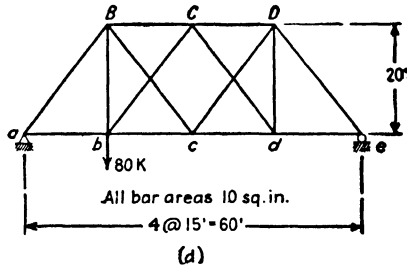
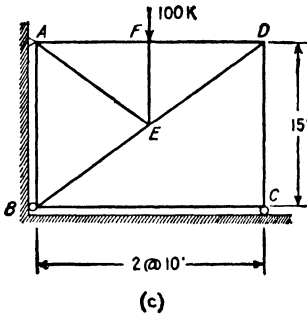
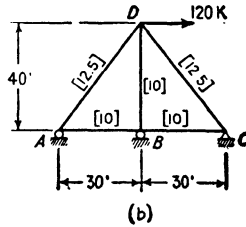
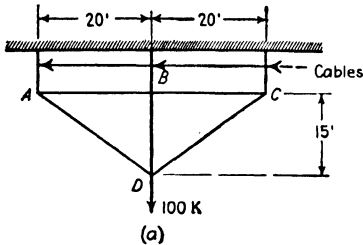

PROB. 10:3



INDETERMINATE TRUSSES

(a) All bars in common plane. Find stresses.

(b) Areas 1,2,3,4,12,13 - 11.2 in<sup>2</sup>  
Others - 10.0 in<sup>2</sup>  
Find reactions

(c) Each area, 5 in<sup>2</sup>  
S<sub>5</sub> = ?

(d) Bars in common plane  
Find stresses

(e) S<sub>1</sub> = ?

(f) All bars have same area  
S<sub>1</sub> = ?

Areas  
1, 2, 3, 4 - A  
5, 6 - 2A  
7, 8 - 4A  
S<sub>2</sub> = ? (g)

(h) Figure is regular hexagon All bars have same area Find stress in all bars

(i) Determine the horizontal component of the right reaction in this TWO-HINGED ARCH.  
Areas 1, 2, 9 - 15 in<sup>2</sup>  
3, 4, 5, 6 - 16.8 in<sup>2</sup>  
7, 8 - 11.2 in<sup>2</sup>

(j) To what degree is this structure statically indeterminate? Find the stress in each bar  
Areas, bars 1 to 7, 4 in<sup>2</sup>, others 6 in<sup>2</sup>

(k) S<sub>10</sub> = ?  
Areas, 1, 2, 3, 4, 7, 8 - 10 in<sup>2</sup>  
5, 6, 9, 10 - 15 in<sup>2</sup>

(l)

Areas  
1, 2, 3 - 10 in<sup>2</sup>  
4, 5, 6 - 5 in<sup>2</sup>  
S<sub>5</sub> = ?

(m) S<sub>9</sub> = ?  
Areas 1, 2, 3, 4, 7, 11 - 2A  
Others - A

**Problem 10:4. a.** Show that the distortions of the truss in Prob. 10:3f are consistent.

b. After solving Prob. 10:3f, remove bar *ab* but place loads equal to its stress at *a* and *b*. Compute, by any appropriate method of Chapter 7, the relative displacement of these points. Is this consistent with the change in length of *ab*?

**Problem 10:5.** By the method of least work, determine the bar stresses or reactions in these indeterminate structures as directed on the figure on p. 340.

*Ans.*

- |                             |   |
|-----------------------------|---|
| a. $S_1 = +25.5$ kips.      | h. $S_8 = -7.9$ kips.                     |
| b. $R_R = 16.25$ kips down. | i. $H_R = 28.7$ kips, to left.            |
| c. $S_5 = -29.4$ kips.      | j. $S_3 = +0.335W$ , $S_{11} = -0.335W$ . |
| d. $S_1 = +614$ lb.         | k. $S_{10} = +1.08W$ .                    |
| e. $S_1 = +7.7$ kips.       | l. $S_6 = +3.78$ kips.                    |
| f. $S_1 = +3.76$ .          | m. $S_9 = +0.321$ .                       |
| g. $S_2 = +0.62P$ .         |   |

**Problem 10:6.** Carry through a solution for the beam of Ex. 10:3, taking the reaction at *b* as the superfluous element.

**Problem 10:7.** Using the influence line of Fig. 10:8, check the stress in bar *Aa* of the Warren truss of Fig. 10:1.

### Art. 10:3 Method of Deflections

**Problem 10:8.** Solve Prob. 10:3 by the method of deflections.

**Problem 10:9.** Using (a) the method of least work, (b) the method of deflections, prove that the magnitude of the superfluous reaction for a beam with three supports is

$$X = - \frac{\int \frac{M'm dx}{EI}}{\int \frac{m^2 dx}{EI}}$$

*Suggestion.* See Arts. 7:2, 8:3. The expression for work in a beam due to the applied loads is  $\int M^2 dx/2EI$ ; that for work due to a unit load caused to deflect by other loads is  $\int Mm dx/EI$ . *M'* is to be interpreted similarly to *S'* in equation 10:2b.

**Problem 10:10.** Solve Ex. 10:5, taking an end reaction as the unknown and using the equation of Prob. 10:9.

**Problem 10:11.** Solve Ex. 10:4 by use of equation 10:2a.

### Art. 10:4 Influence Lines

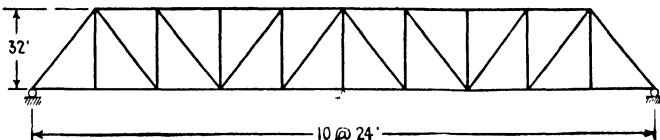

PROB. 10:12

**Problem 10:12.** Draw influence line for the center reaction of this truss. The

length of each bar in feet equals its area in square inches.  $E$  is constant for all bars. Check your results by an independent solution.

**Problem 10:13.** Solve Prob. 10:3, using the Müller-Breslau relation and a Williot-Mohr diagram.

**Problem 10:14.** Solve Prob. 10:5, using the Müller-Breslau relation and a Williot-Mohr diagram.

**Problem 10:15.** Determine the stresses in all bars of this two-hinged spandrel-braced arch, using successively the several methods and variations of method which have been made available in this textbook. Assume that the length of each bar in feet equals three times its cross-sectional area in square inches.  $E = 30,000,000$  lb per sq in.

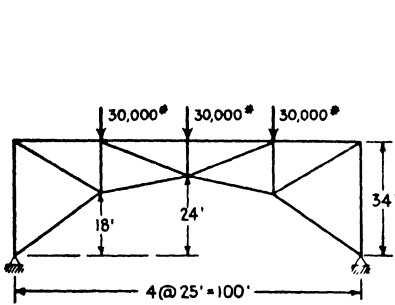

PROB. 10:15

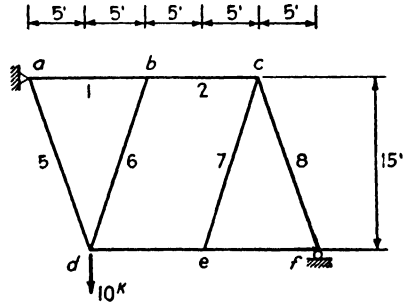

PROB. 10:16

### Art. 10:5 Composite Structures

**Problem 10:16.** Members  $ac$  and  $df$  are continuous throughout their lengths ( $A = 16$  sq in.,  $I = 800$  in.<sup>4</sup>). The other members are pin connected at their ends ( $A = 5$  sq in.).

- Determine the stresses in the structure if bar  $ad$  is omitted.
- Determine the stresses in the structure as drawn.
- Determine the stresses if a member  $be$  ( $A = 5$  sq in.) is added to the structure as drawn.

SECONDARY STRESSES

11:1. A clear idea of the nature of primary and secondary stress may be obtained by consideration of Fig. 11:1. Here is shown a simple triangular truss with a load at the apex. If the bars are connected by frictionless pins there is freedom of motion and under load the truss will take the full line position in Fig. 11:1a, bars 1 and 2 shorten, bar 3 lengthens, the angles between 1 and 3 and 2 and 3 decrease, and that

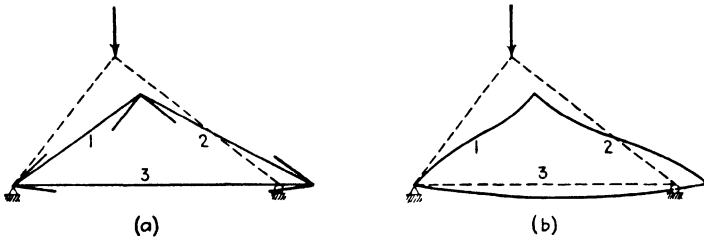

FIG. 11:1

between 1 and 2 increases. If the members are perfectly straight and the pins are placed on the center of gravity line of each, loads applied at the joints will cause only direct tension or compression in any bar. It is customary to assume that the conditions above enumerated actually obtain, and the stresses thus computed are called *primary stresses*. In computing primary stresses the original dimensions of the unloaded frame are used, since the changes under load are very small and entirely negligible.

As a matter of fact the conditions which occur in actual structures vary considerably from these assumptions. Even in a pin-connected truss considerable frictional resistance to turning is developed at each pin, and the changes in the truss angles noted above are prevented in some degree. In a riveted connection with gusset plates or in a welded structure the change in angle, if any, is extremely small. The angles will, therefore, take the positions and directions indicated by the short solid lines in Fig. 11:1a, and in meeting this position at their ends it will

be necessary for the bars to bend as indicated in Fig. 11:1b. Note that, except for the left joint, which has a motion of rotation only, the joints have a motion both of translation and of rotation. Since the members are actually bent, bending stresses are set up, and these are called *secondary stresses*.

Besides the bending set up by the more or less complete rigidity of the truss joints there are two other less important causes of bending and secondary stress: (a) horizontal and inclined members are always deflected by their own weight; and (b) in some cases the gravity axes of the members meeting at a joint do not intersect in a point, and, consequently, the direct stress—tension or compression—is eccentrically applied.

The problem of determining the stresses caused by the bending of truss bars was studied as early as 1877 or earlier. In 1879, H. Manderla, an assistant in the Technische Hochschule of Munich, offered an exact solution of the problem. This original method is so involved that it is not used in practical computations, and in its place certain less exact but more useful solutions have found favor. The problem has been vigorously attacked, particularly in Germany, and a number of ways of solving it have appeared. Since about 1908 references to secondary stresses have become increasingly common in English and American books, technical society proceedings, and periodicals. Three such articles which because of their usefulness merit special mention are: (a) a committee report which appeared in Vol. 15, *Proceedings of the American Railway Engineering Association*; (b) Chapter VII of Part II, *Modern Framed Structures*, Johnson, Bryan, and Turneure; and (c) "Secondary Stresses in Bridges," Cecil Vivian von Abo, Vol. 89, *Transactions of the American Society of Civil Engineers*. This last paper with its discussion occupies 224 pages and includes an extended bibliography on the subject.

It is of interest to note that shortly after the work of Manderla, and apparently inspired by that work, an article by Charles B. Bender, "Secondary Stresses in Statical Structures," appeared in *Railway Gazette* of April 4, 1884. This article contained all the information that one would need in attacking the problem but it appears not to have been noticed, and its effect can be judged from the facts that it is not mentioned in any of the modern bibliographies and that the next article published in English did not appear until about twenty years later.

**11:2. Mohr's method.** In 1892, Professor Otto Mohr, of Dresden, presented his semi-graphic method for computing secondary stresses. The slope deflection method, which has come into common use for computing stresses in rigid frames, developed from this method of

Professor Mohr's.<sup>1</sup> Since the slope deflection method has already been presented in this book, and since Mohr's method presents a solution for the secondary stress problem which compares favorably with any other of the older methods for brevity and accuracy, it will be presented in this chapter as an illustration of the classic methods.

In Art. 11:1 it was pointed out that under stress the joints of a frame have two movements—a movement of translation and a movement of rotation. It will be recognized that these are the elements which enter into the slope deflection equation, and that knowing these, the moments at the ends of a member may be obtained. In Mohr's semi-graphic method the movement of the end of any member perpendicular to the axis of the member is obtained from a Williot diagram. This movement when divided by the length of the member gives the  $R$  of the slope deflection equation.<sup>2</sup> This is illustrated in Fig. 11:6, which differs from Fig. 11:1*b* in that no rotation of the several joints has been permitted. The values of  $R$  may also be computed from the changes which take place in the angles of the triangles which make up the frame, a fact also evident upon inspection of Fig. 11:6*a*. These  $R$  terms will enter the slope deflection equation as known numerical values and will leave as the unknowns the  $\theta$ 's, that is, the angles through which the various joints rotate. The number of unknown  $\theta$ 's will equal the number of joints, and to obtain this number of unknowns it will be necessary to set up the same number of equations. These equations will be obtained from the relation, already used in dealing with frames, that the sum of the moments under which any joint is in equilibrium must equal zero. This relation yields one equation at each joint.

**11:3. Procedure.** The relation of angle change to the value of  $R$  may be shown thus. Consider the simple symmetrical frame shown in Fig. 11:2 with frictionless pins assumed at all joints. Under the load shown, the joints, i.e., the ends of the members, will move, but, by symmetry, it is evident that bar 5 will remain vertical. It is also evident that each of the other bars must rotate through an angle equal to the change in the angle where the bar in question joins bar 5 and that this change is the slope deflection  $R$ . Were the conditions such that bar 5 rotated through some angle,  $\Delta\alpha$ , instead of remaining vertical, each connecting bar would rotate through an angle  $\Delta\alpha$  plus (algebraically) the change in the angle where the bar in question joins bar 5.

<sup>1</sup> Professor Mohr also suggested a solution of the secondary stress problem by the elastic weight method.

<sup>2</sup> The subject matter of Arts. 11:2 and 11:3 depends so closely upon Art. 8:5, method of slope deflection, that they may be regarded as a part of that article. The assumption is made here that the reader is familiar with the method and that any remarks as to the meaning of terms, convention of signs, etc., are unnecessary.

Later it will be shown that relative and not absolute values of  $R$  may be used, and the method is not handicapped where the true value of  $R$  is unknown for all bars.

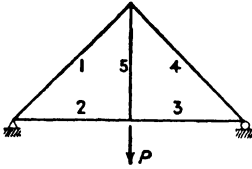

FIG. 11:2

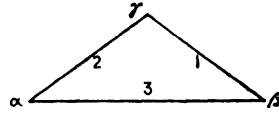

FIG. 11:3

In another connection (equation 7:5, Art. 7:4) it has already been shown that under unit stresses  $s_1, s_2, s_3$  in the members of a triangle, Fig. 11:3, the accompanying changes of angles are given by the expressions:

$$E \cdot \delta\alpha = (s_1 - s_3) \cot \beta + (s_1 - s_2) \cot \gamma \quad 11:1a$$

$$E \cdot \delta\beta = (s_2 - s_3) \cot \alpha + (s_2 - s_1) \cot \gamma \quad 11:1b$$

$$E \cdot \delta\gamma = (s_3 - s_1) \cot \beta + (s_3 - s_2) \cot \alpha \quad 11:1c$$

Expressed in words, this relation states that  $E$  times the change in any angle equals the unit stress in the side opposite minus (algebraically) the unit stress in one adjacent side, multiplied by the cotangent of the included angle, plus the unit stress in the side opposite minus the unit stress in the other adjacent side, multiplied by the cotangent of that included angle. These changes in angle are assumed to be those which exist between the original angles and the angles



FIG. 11:4

formed by the straight lines connecting the displaced apices of the triangle. This is obviously justified, since the curved length of any bar is closely that of the straight line connecting its ends.

If several members, four for example, meet at joint 1 (Fig. 11:4) and no external moment is applied at the joint, we may write (see equations 8:2a and 8:2b):

$$\Sigma M_1 = M_{12} + M_{13} + M_{14} + M_{15} = 0$$

$$\text{i.e., } 2EK_{12} (+2\theta_1 + \theta_2 - 3R_{12}) + 2EK_{13} (+2\theta_1 + \theta_3 - 3R_{13}) + 2EK_{14} (+2\theta_1 + \theta_4 - 3R_{14}) + 2EK_{15} (+2\theta_1 + \theta_5 - 3R_{15}) = 0$$

$$\text{or } 2\theta_1 (K_{12} + K_{13} + K_{14} + K_{15}) + K_{12}\theta_2 + K_{13}\theta_3 + K_{14}\theta_4 + K_{15}\theta_5 - 3R_{12}K_{12} - 3R_{13}K_{13} - 3R_{14}K_{14} - 3R_{15}K_{15} = 0$$

$$\text{or, in general, } 2\theta_{near} \Sigma K + \Sigma K\theta_{far} = \Sigma 3RK \quad 11:2$$

If an external moment were applied at the joint, the  $2E$  term which has been dropped above would not disappear from the equation. Instead we would divide through by this  $2E$  term, and the numerical term on the right side of the equation would be modified by the value of the external moment divided by  $2E$ . Equation 11:2 furnishes a convenient abbreviation to aid in writing the condition  $\Sigma M = 0$  at each joint and aids in tabulation of the work.

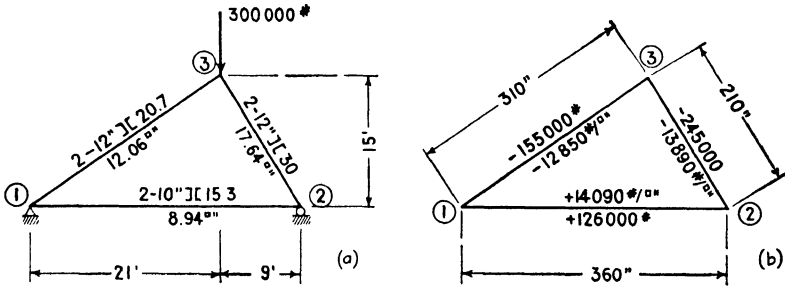

FIG. 11:5

**Example 11:1.** A frame with the section shown in Fig. 11:5 is used to carry a vertical load of 300,000 lb at joint 3. Determine the amount of secondary stress at each end of each member and also the percentage of secondary stress to primary stress.

*Solution.* *R by angle change.*

$$\cot \textcircled{1} = \frac{21}{15} = 1.400 = \cot 35^\circ 30'$$

$$\cot \textcircled{2} = \frac{9}{15} = 0.600 = \cot 59^\circ 00'$$

$$\cot \textcircled{3} = \cot 85^\circ 30' = 0.0787^3$$

$$\begin{aligned} E\delta_1 &= (-13,890 - 14,090)0.600 + (-13,890 + 12,850)0.0787 \\ &= -16,850 \end{aligned}$$

$$\begin{aligned} E\delta_2 &= (-12,850 - 14,090)1.400 + (-12,850 + 13,890)0.0787 \\ &= -37,634 \end{aligned}$$

$$\begin{aligned} E\delta_3 &= (+14,090 + 13,890)0.600 + (+14,090 + 12,850)1.400 \\ &= +54,484 \end{aligned}$$

$$\Sigma E\delta = 0, \text{ check.}$$

<sup>3</sup> Better, perhaps, would be:

$$\cot(\alpha \pm \beta) = \frac{\cot \beta \cot \alpha \mp 1}{\cot \beta \pm \cot \alpha} = \frac{\frac{15}{21} \cdot \frac{15}{9} - 1}{\frac{15}{21} + \frac{15}{9}} = \frac{\frac{225}{189} - 1}{\frac{135 + 315}{189}} = \frac{36}{450} = \frac{2}{25} = 0.08$$



CASE I

CASE II

NOTE: Positive  $R$  is for counterclockwise rotation (Fig. 8:9).

By construction,  $R_{12} = 0$

$$ER_{12} = 0$$

$$E\delta_1 = -16,850$$

$$ER_{13} = -16,850$$

$$E\delta_3 = +54,484$$

$$ER_{32} = +37,634$$

$$E\delta_2 = -37,634$$

$$ER_{21} = 0$$

Assume  $R_{13} = 0$

$$ER_{31} = 0$$

$$E\delta_3 = +54,484$$

$$ER_{32} = +54,484$$

$$E\delta_2 = -37,634$$

$$ER_{21} = +16,850$$

$$E\delta_1 = -16,850$$

$$ER_{13} = 0$$

$$K = I/l$$

$$K_{12} = 133.8/360 = 0.372$$

$$K_{23} = 322.4/210 = 1.535$$

$$K_{31} = 256.2/310 = 0.826$$

$R$  by Williot diagram. The Williot diagram, Fig. 11:6b, gives the  $Ed$  distances which are divided by bar lengths to give  $R$ .

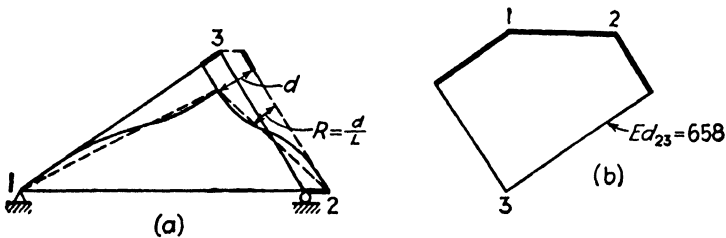

FIG. 11:6

Bar	$P/A$ (ksi)	$L$ (ft)	$PL/A =$ $E\Delta L$	$Ed$ (k-ft/in. <sup>2</sup> )	$ER$ (ksi)
1-2	14.09	30.00	422.7	0	0
1-3	12.85	25.83	332.0	436	-16.85
2-3	13.89	17.50	243.0	658	+37.63

FORMATION OF EQUATIONS, ETC.

Joint	Bar	K	Case I					Case II				
			ER	3ERK	3ER	Eθ	E × (+2θ <sub>n</sub> + θ <sub>f</sub> - 3R)	ER	3ERK	3ER	Eθ	E × (+2θ <sub>n</sub> + θ <sub>f</sub> - 3R)
1	13	0.826	-16,850	-41,754	-50,550	-30,621	+9,411	0	0	0	-13,771	+9,411
	12	0.372	0	0	0	-20,907	-20,907	+16,850	+18,805	+50,550	-20,907	-20,907
	Σ	1.198		-41,754					+18,805			
2	21	0.372	0	0	0	+40,335	+50,049	+16,850	+18,805	+50,550	+57,185	+50,049
	23	1.535	+37,634	+173,305	+112,902	-12,129	-12,129	+54,484	+250,899	+163,452	-12,129	-12,129
	Σ	1.907		+173,305					+269,704			
3	32	1.535	+37,634	+173,305	+112,902	+20,103	-32,361	+54,484	+250,899	+163,452	+36,953	-32,361
	31	0.826	-16,850	-41,754	-50,550		+60,135	0	0	0	+60,135	+60,135
	Σ	2.361		+131,551					+250,899			

SOLUTION OF EQUATIONS

$2\theta_n \Sigma K + \Sigma K \theta_f = \Sigma 3RK$						Case I	Case II
Equation 11.2	$\Sigma M = 0$	No.	$\theta_1$	$\theta_2$	$\theta_3$	E·Absolute	E·Absolute
	Jt. 1	1	+2 396	+ 0.372	+0.826	- 41,754	+ 18,805
	Jt. 2	2	+0.372	+ 3.814	+1.535	+173,305	+269,704
	Jt. 3	3	+0.826	+ 1.535	+4.722	+131,551	+250,899
	1'		+1.000	+ 0.1553	+0.3447	- 17,427	+ 7,848
	2'		+1 000	+10.2527	+4.1263	+465,873	+725,011
	3'		+1.000	+ 1.8584	+5.7167	+159,262	+303,752
	2'-1'	a		+10.0974	+3.7816	+483,300	+717,163
	3'-1'	b		+ 1.7031	+5.3720	+176,689	+295,904
	a'			+ 1.000	+0.3745	+ 47,864	+ 71,024
	b'			+ 1.000	+3 1542	+103,746	+173,745
	b'-a'	c			+2.7797	+ 55,882	+102,721
	a'			$\theta_3$	+ 20,103	+ 36,953	
	a'			$\theta_2$	- 7,529	+ 47,864	
	a'			$\theta_2$	+ 40,335		
	1'			$\theta_2$	- 13,839		+ 71,024
	1'			$\theta_2$	- 6265	- 6,929	+ 57,185
	1'			$\theta_1$	- 8879	- 12,740	
	1'			$\theta_1$		- 30,621	+ 7,848
	1'			$\theta_1$			- 13,771

Note A

Note A. — In these lines entries in columns  $\theta_1$ ,  $\theta_2$  and  $\theta_3$  are coefficients of column headings. All other tabular entries are values of column headings. For example, equation 1 of Case I would be  $+2.396 \theta_1 + 0.372 \theta_2 + 0.826 \theta_3 = -41,754/E$ .

## MOMENTS AND STRESSES

Joint	Bar	$\frac{l}{c}$	Moments = $2EK(+2\theta_n + \theta_f - 3R)$ (in- lb)	$s$ sec.	$s$ primary	%
1	13	42.8	+15,550	363	-12,850	2.82
	12	26.8	-15,550	580	+14,090	4.10
2	21	26.8	+37,235	1389	+14,090	9.85
	23	53.8	-37,235	692	-13,890	4.98
3	32	53.8	-99,345	1847	-13,890	13.30
	31	42.8	+99,345	2321	-12,850	18.06

*Notes.* The stress in the tension member 1-2 used in computing the changes of angles is the gross stress. This is the usual method and is substantially correct because the changes of angles depend upon the changes of bar lengths. In a tension member this change of length is dependent more upon the gross area, which extends for the greater part of the length of the member, than upon the net area, which occurs at infrequent sections distributed along the length of the member. It will be recognized that both primary and secondary stress as here obtained are to be increased by the ratio of gross to net area when used for purposes of design.

It will be seen that two solutions have been carried in parallel. In Case I, advantage has been taken of the fact that joints 1 and 2 remain on the same horizontal plane and that  $R_{12}$  must be zero. Knowing  $R_{12}$ , it is possible to compute the true value of the  $R$  of each other member. In many problems the true value of  $R$  for no one member is known, and to obtain such a true value would call for a long computation. Case II is intended to illustrate the fact that it is unnecessary to have the true values of  $R$ . In this instance it has been assumed that  $R_{13}$  is zero, although *any* other value might have been assigned to *any* other  $R$ .

With the values of  $R$  known (or assumed) the first table giving the values needed for writing equation 11:2 was started by filling in the values of  $K$  and the first two columns under each case. With the information then in hand it was possible to tabulate the equations at the joints (see equation 11:2), and these equations, together with their solution, are shown in the second table. In this table the right-hand side of each joint equation appears multiplied by  $E$ , resulting in a solution with values of  $\theta$  multiplied also by  $E$ . After the values of the  $\theta$ 's were obtained, the first table was completed. It will be seen that the last column under the two cases is the same, proving that any value may be assigned to  $R$  for one member. That this is true should occasion no surprise. To assign an erroneous value to any  $R$  is equivalent to rotating the entire frame through the same angle. This will introduce the same error into every value of  $R$  and every value of  $\theta$ . Then in using the equation

$$M = 2EK(+2\theta_n + \theta_f - 3R)$$

the error will be introduced three times into the  $\theta$  terms with one sign and three times into the  $R$  term with the opposite sign, thereby eliminating the effect of the error.

When the first table was completed, it became a simple matter to fill in the last. The fourth column of this final table is significant because it serves to check the equations,  $\Sigma M = 0$ , set up at the joints. The signs of the moments are as would be anticipated from an inspection of the similar frame shown in Fig. 11:1b.

It will be noted that in computing  $ER$  in both cases progress has been in a clockwise direction around the truss. When this is done, an increase in angle, positive angle change, is a positive  $R$ ; and a decrease, negative angle change, is a negative  $R$ ; accordingly signs are automatically correct for the slope deflection solution when algebraic combination is made.

It will be realized that at the end of any member the secondary stress given is tension at the extreme fibers on one side of the axis and compression on the other. Therefore, at one side the secondary stress opposes the direct stress, and at the other side the two stresses are to be added.

In Ex. 11:1 the computation was carried much farther as regards significant figures than ordinarily would be either necessary or desirable. This was done to show beyond any possibility of doubt that the two ways of treating  $R$  gave identical results. In most examples the 10-in. slide rule is all that need be used, although in dealing with trusses with a large number of joints a 20-in. slide rule will be found a help in attaining the desired accuracy. In this example the two solutions provided the necessary check on the accuracy of the work. Otherwise the check column shown in the table giving the solution of equations in Ex. 11:2 should be carried, and the values of the  $\theta$ 's obtained should be substituted back into the original equations to provide an intermediate check before it is possible to apply the  $\Sigma M = 0$  check.

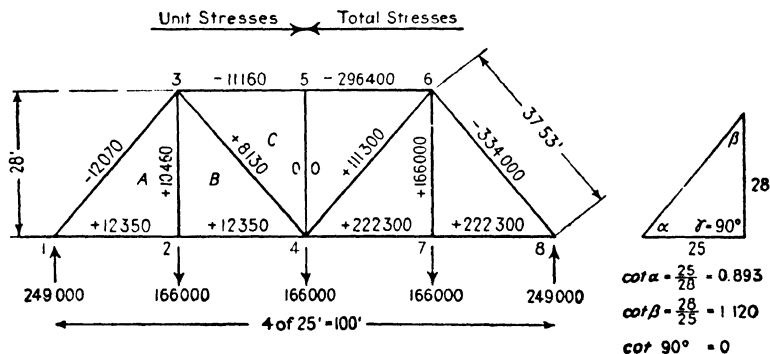
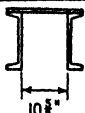
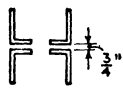

FIG. 11:7

**Example 11:2.** Determine the secondary stresses at the joints of the truss shown in Fig. 11:7 due to loads of 166,000 lb at all lower chord joints. The makeup of the members is given in the following table.

MAKEUP OF MEMBERS

Bar	Section	Area	$I$	$I''$	$K$	$\frac{I}{c}$	$e$	Sketch
1-3	2- $\square 15 \times 33.9$ 1-Pl. $18 \times \frac{7}{16}$	27.68	961.0	450.44	2.133	167.5 90.1	2.20	
3-5	2- $\square 15 \times 33.9$ 1-Pl. $18 \times \frac{7}{16}$	26.55	922.8	300.00	3.076	156.0 97.6	1.96	
1-2 2-4	4-L <sub>s</sub> 6 $\times 3\frac{1}{2} \times \frac{1}{2}$	18.00	175.3	300.00	0.584	27.5		
2-3	4-L <sub>s</sub> 6 $\times 3\frac{1}{2} \times \frac{7}{16}$	15.88	153.8	336.00	0.458	24.1		
3-4	4-L <sub>s</sub> 6 $\times 3\frac{1}{2} \times \frac{3}{8}$	13.68	131.8	450.44	0.293	20.7		
4-5	4-L <sub>s</sub> 5 $\times 3 \times \frac{3}{8}$	11.44	79.1	336.00	0.235	14.7		

Solution.

CHANGES OF ANGLES

Triangle	Angle	Factor of $\cot \alpha$ $\cot \alpha = 0.893$	$(s_1 - s_2)$ $\cot \alpha$	Factor of $\cot \beta$ $\cot \beta = 1.120$	$(s_1 - s_2)$ $\cot \beta$	$E \cdot \delta \perp$
A	312					
	123	-12,070 - 12,350 = -24,420	-21,810	+10,460 + 12,070 = +22,530	+25,220	+25,220
	231	+12,350 + 12,070 = +24,420	+21,810	-12,070 - 10,460 = -22,530	-25,220	-47,030
B	423	+8,130 - 12,350 = -4,220	- 3,770	+8,130 - 10,460 = -2,330	- 2,610	- 6,380
	234	+12,350 - 8,130 = +4,220	+ 3,770	+10,460 - 8,130 = +2,330	+ 2,610	+ 3,770
	342					+ 2,610
C	534			0 - 8,130 = -8,130	- 9,100	- 9,100
	345	-11,160 - 8,130 = -19,290	-17,220			-17,220
	453	+8,130 + 11,160 = +19,290	+17,220	+8,130 - 0 = +8,130	+ 9,100	+26,320

VALUES OF R

$ER_{41} = 0$	$ER_{42} = -14,610$	$ER_{21} = -68,020$	$ER_{22} = -20,990$	$ER_{23} = -26,320$
$E\delta_{41} = -17,220$	$E\delta_{42} = - 6,380$	$E\delta_{21} = +25,220$	$E\delta_{22} = + 3,770$	$E\delta_{23} = +26,320$
$ER_{31} = -17,220$	$ER_{32} = -20,990$	$ER_{12} = -42,800$	$ER_{34} = -17,220$	$ER_{44} = 0$
$E\delta_{31} = + 2,610$	$E\delta_{32} = -47,030$	$E\delta_{12} = +21,810$	$E\delta_{33} = - 9,100$	
$ER_{11} = -14,610$	$ER_{21} = -68,020$	$ER_{22} = -20,990$	$ER_{23} = -26,320$	

FORMATION OF EQUATIONS, VALUES OF  $s$ , ETC.

Joint	Bar	K	$E \cdot R$	$E \cdot 3 KR$	$E \cdot 3 R$	$E \cdot \theta$	$E(+2 \theta_n + \theta_f - 3 R)$	$M = 2EK(+2\theta_n + \theta_f - 3 R)$	$\frac{I}{c}$	$s$	%	
1	13	2.133	-42,800	-274,000	-128,400	+54,200	-15,900	-67,800	167.5	T-405	3.36	
	12	0.584	-68,020	-119,200	-204,060		+57,160	+66,750	27.5	B+685	19.90	
	$\Sigma$	2.717		-393,200					-1050 $\neq$ 0			
2	21	0.584	-68,020	-119,200	-204,060	+38,500	+72,860	+85,150	27.5	3100	25.10	
	23	0.458	-20,990	-28,800	-62,970		-49,930	-45,730	24.1	1900	18.20	
	24	0.584	-14,610	-25,600	-43,830		-33,170	-38,750	27.5	1410	11.40	
	$\Sigma$	1.626		-173,600					+670 $\neq$ 0			
3	35	3.076	-26,320	-243,000	-78,960	+35,900	+7,160	+44,050	156.0	T+283	4.05	
	34	0.293	-17,220	-15,100	-51,660		-20,140	-11,800	20.7	B-452		7.02
	32	0.458	-20,990	-28,800	-62,970		-47,330	-43,370	24.1	1800		17.20
	31	2.133	-42,800	-274,000	-128,400		+2,400	+10,250	167.5	T-61		0.51
	$\Sigma$	5.960		-560,900					-870 $\neq$ 0			
4	42	0.584	-14,610		-43,830	0	+5,330	+6,230	27.5	227	1.84	
	43	0.293	-17,220		-51,660		+15,760	+9,240	20.7	447	5.50	
	45	—	0		0		0	0	14.7	0	0	
5	54	—	0		0	0	0	0	14.7	T-1700	0	
	53	3.076	-26,320		-78,960		+43,060	+265,000	156.0	B+2720	15.20	

SOLUTION OF EQUATIONS

Source	No.	$\theta_1$	$\theta_2$	$\theta_3$	$E \times \text{Absolute}$	Check	Check eqs. 1, 2, and 3
					100,000		
Jt. 1	1	+5.434	+0.584	+ 2.133	- 3.932	+ 4.219	-2.945-0.225-0.766=-3.936 -0.317-1.253-0.161=-1.732 -1.157-0.176-4.280=-5.613
Jt. 2	2	+0.584	+3.252	+ 0.458	- 1.736	+ 2.558	
Jt. 3	3	+2.133	+0.458	+11.920	- 5.609	+ 8.902	
	1'	+1.000	+0.107	+ 0.393	- 0.724	+ 0.776	$E \cdot \theta_1 = -54,200$ $E \cdot \theta_2 = -38,500$ $E \cdot \theta_3 = -35,900$
	2'	+1.000	+5.570	+ 0.784	- 2.972	+ 4.382	
	3'	+1.000	+0.215	+ 5.585	- 2.630	+ 4.170	
2'-1'	a		+5.463	+ 0.391	- 2.248	+ 3.606	
3'-1'	b		+0.108	+ 5.192	- 1.906	+ 3.394	
	a'		+1.000	+ 0.072	- 0.411	+ 0.661	
	b'		+1.000	+48.050	-17.650	+31.400	
	b'-a'	c		+47.978	-17.239	+30.739	
				$\theta_3$	- 0.359	←	
			$\theta_2$	+ 0.026	- 0.411		
			$\theta_2$		- 0.385	←	
		$\theta_1$	+0.041	+ 0.141	- 0.724		
		$\theta_1$			- 0.542	←	

Notes. It will be observed that the value of  $R_{45}$  has been taken as zero, which is obviously its correct value in this center member under symmetrical loading.<sup>4</sup> Since the value of  $R_{45}$  is the true value, the values of the other  $R$ 's will also be true values. Furthermore, joints 4 and 5 have no tendency to rotate either clockwise or counterclockwise. That is, it may be seen by inspection that  $\theta_4$  and  $\theta_5$  both equal zero. The unknowns, therefore, are  $\theta_1$ ,  $\theta_2$ , and  $\theta_3$ , and in this particular problem it is necessary to set up only three equations to obtain the values of the unknowns.

In making a solution of this character advantage should be taken of every opportunity to apply a check. For example, after computing the changes of angles the computer should be sure that for each triangle  $\Sigma E\delta \perp = 0$ . Next, the values entering into the three original equations should be carefully inspected to be sure no error has entered at this point. In solving the equations use should be made of a check column. After the value of the first unknown is obtained, the check column must be discarded, and to guard against error beyond this point the values obtained for the unknowns should be substituted back into the original equations. As a last check use the relation that  $\Sigma M = 0$  (that is,  $\Sigma 2EK (+2\theta_n + \theta_f - 3R) = 0$ ) at each joint. In the present instance, where unusual care was not taken, this final check was rather unsatisfactory. It will be seen, however, that even if the error were all in one member at any joint the additional resulting fiber stress would be small.

<sup>4</sup> If this fact were missed, it would be necessary to solve for eight unknowns as in Prob. 11:1.

Attention will be directed to several points in the solution of the equations which will be of assistance in similar problems. First, in setting up the "Solution of Equations" table it will be seen that the numerical terms were divided by 100,000. This was done to make all values of the same order, thereby facilitating the use of the check column. Second, in each instance the value in the check column was obtained by the addition, algebraically, of the terms of the equation. That is, for illustration, the value of +0.661 in the check column for equation  $a'$  was obtained by addition and checked by division. This will be found of assistance in keeping small differences out of the check column which will creep in if the values are obtained by division and checked by addition. Third, inspection will show that the equation which arose at joint 1 has a large coefficient for  $\theta_1$ , the equation at joint 2 a large coefficient for  $\theta_2$ , etc. In eliminating  $\theta_1$  from the equations, equation 1' which came from equation 1 should be combined with both 2' and 3'. This method, if continued, will furnish a group of equations in each of which one coefficient is large. Fourth, in substituting back to obtain the value of one unknown after some of the others have been found, the equation with the large coefficient of the unknown should be selected. For example, after values have been found for  $\theta_2$  and  $\theta_3$ , the value of  $\theta_1$  may be obtained from equation 1', 2', or 3'. Substitution in each of these will probably yield three different values for  $\theta_1$ . The value from 1' which came from 1 will be least in error and, therefore, should be used. The reason for this is as follows. The value of  $\theta_2$  previously found may be in error 0.5 of the last figure. In using 1' there would be introduced 0.1 times this error, while in using 2', 5.5 times the error would enter. Following this suggestion will be found of real assistance when it comes to checking the solution of the equations.

**11:4. Cross's method.** The solution of secondary stresses by moment distribution is a very simple application of the method; the fixed-end moments are computed as the truss is allowed to deflect without rotation of the joints, and then the process of unlocking and carry-over proceeds until the joints are balanced with the desired accuracy. This accuracy may be as great as desired within the same limits as those of the Mohr method.

**Example 11:3.** Compute the secondary stress end moments for the truss and loading of Ex. 11:2, by Cross's method.

*Solution.* The procedure of the Cross solution is exactly that previously followed, through the computation of the  $ER$  values. After that the end moments are computed, and the process of distribution started. Were this solution proceeding from the beginning, the first three tables used in working Ex. 11:2 would be constructed without change. For ease of reference the values of  $K$  and  $ER$  have been reproduced here on a line diagram of the truss, Fig. 11:8. Next a table shows the computation of the distribution factors for each joint,  $K/\Sigma K$ , and the values of the fixed-end moments,  $-6EKR$ . In a problem of this sort it is easier to keep track of the several steps of distribution and carry-over if the work is tabulated, although, if desired, the



part of the table relating to each joint may be placed adjacent to the joint on a truss diagram. For convenience the distribution factors are placed in the columns between the bar designations and the fixed-end moments. The first distribution is explained by these figures for joint 1:  $-(+238 + 546) \times 0.785 = -616$  goes to bar 1-3,  $-(+238 + 546) \times 0.215 = -168$  to bar

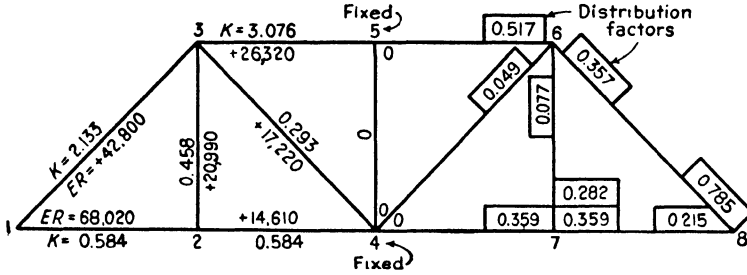

FIG. 11:8

NOTE: All ER values are negative

1-2. Note that the joint is balanced after this operation, i.e., the moment in bar 1-2 is  $+238 - 168 = +70$ , that in 1-3 is  $+546 - 616 = -70$ , and  $\Sigma M = 0$ . The table from which these values are taken is on page 357.

Comparison will show that the results of this method are closely the same as those of the Mohr solution. Had decimals been carried, a closer check would have resulted. Obviously the precision here is more than ample.

Joint	Bar	K	K/ΣK	Fixed-End Moment = $-6EKR$ (kip-in.)
1	1-2	0.584	0.215	$-6 \times (-68,020) \times 0.584 = +238$
	1-3	2.133	0.785	$-6 \times (-42,800) \times 2.133 = +546$
	Σ	2.717		
2	2-1	0.584	0.359	+238
	2-3	0.458	0.282	$-6 \times (-20,990) \times 0.458 = +58$
	2-4	0.584	0.359	$-6 \times (-14,610) \times 0.584 = +51$
	Σ	1.626		
3	3-1	2.133	0.357	+546
	3-2	0.458	0.077	+58
	3-4	0.293	0.049	$-6 \times (-17,220) \times 0.293 = +30$
	3-5	3.076	0.517	$-6 \times (-26,320) \times 3.076 = +485$
	Σ	5.960		

Joint	1		2			3				4		5
Bar	1-2	1-3	2-1	2-3	2-4	3-1	3-2	3-4	3-5	4-2	4-3	5-3
$K/\Sigma K$	0.215	0.785	0.359	0.282	0.359	0.357	0.077	0.049	0.517	Joints Balanced		
F.E.M. Dist	+238 -168	+546 -616	+238 -125	+ 58 - 97	+ 51 -125	+546 -400	+ 58 - 86	+ 30 - 55	+485 -578	+51	+30	+485
<i>CO</i> <i>D</i>	- 63 + 57	-200 +206	- 84 + 46	- 43 + 35	- 46 + 46	-308 +128	- 49 + 27	- 18 + 18	+184	-63	-28	-289
<i>CO</i> <i>D</i>	+ 23 - 19	+ 64 - 68	+ 29 - 15	+ 14 - 13	- 15	+103 - 43	+ 18 - 9	- 6	- 63	+23	+ 9	+ 92
<i>CO</i> <i>D</i>	- 8 + 6	- 22 + 24	- 10 + 5	- 5 + 5	+ 5	- 34 + 15	- 7 + 3	+ 2	+ 21	- 8	- 3	- 32
<i>CO</i> <i>D</i>	+ 3 - 2	+ 8 - 9	+ 3 - 2	+ 2 - 1	- 2	+ 12 - 5	+ 3 - 1	- 1	- 8	+ 3	+ 1	+ 11
<i>CO</i> <i>D</i>	- 1 + 1	- 3 + 3	- 1 + 1			- 5 + 2			+ 3	- 1		- 4
$\Sigma$	+ 67	- 67	+ 85	- 45	- 40	+ 11	- 43	- 12	+ 44	+ 5	+ 9	+263

**11:5. Pin joints.** The effect of pin-connected joints is of interest. As in any other problem involving friction, the largest moment which a member can resist without rotating at the pin may be computed. If a computation for secondary stress, made as in the previous articles, shows a moment at the end of that member greater than the moment required to produce rotation, a second computation must be made in which the moment that would cause rotation is introduced, for the bar in question, as a known numerical value into the  $\Sigma M = 0$  equation at the joint. That this procedure is correct may be seen from the following. As loads come on a truss, the moment at the end of a member will build up until it equals the moment that will cause rotation. Further increase will cause the bar to rotate, but only enough to reduce the moment to the rotation value.

**11:6. Effect of eccentricity.** It will be recalled that in truss analysis one of the assumptions commonly made is that the center of gravity lines of the members meeting at a joint intersect in a point, i.e., that the members are not eccentric. Many times in arranging details it is found impractical fully to realize this condition. For example, it will be seen by referring to Ex. 11:2 that the member 3-5 has an eccentricity of 1.96 in. and member 3-1 an eccentricity of 2.20 in. Let it be assumed that these members are beveled to meet on a line making the same

angle with the center line of each member and that the center lines of the channels meet at a common point on this line, Fig. 11:9. Further assume that the center lines of members 3-2 and 3-4 intersect at the point where the center of gravity line of member 3-5 meets the beveled end of that member. Owing to the difference in eccentricity between members 3-1 and 3-5 the center of gravity line of member 3-1 will miss the common intersection point of the other three members by 0.24 in.,

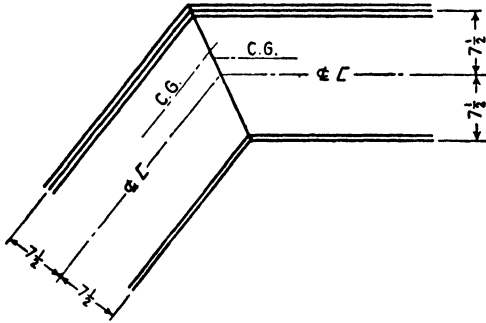

FIG. 11:9

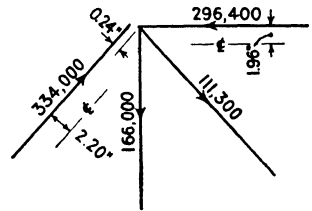

FIG. 11:10

Fig. 11:10. It will be evident that the resultant of the stresses in the three members meeting at the common intersection is 334,000 lb and that this resultant and the stress in bar 3-1 form a couple which tends to rotate joint 3 in a clockwise direction. Likewise, positive moment at the end of any of the members coming into the joint will also tend to rotate the joint in a clockwise direction. The equation set up at joint 3 will then read,

$$+M_{35} + M_{34} + M_{32} + M_{31} + 0.24(334,000) = 0$$

$$M_{35} + M_{34} + M_{32} + M_{31} = -80,160$$

$$2(+E \cdot 2\theta_3 \Sigma K + \Sigma E \cdot K\theta_f - \Sigma E \cdot 3KR) = -80,160$$

i.e., 
$$E \cdot 2\theta_3 \Sigma K + E \cdot \Sigma K\theta_f = E \cdot \Sigma 3KR - \frac{80,160}{2}$$

If none of the other joints was eccentric, the other joint equations would be as before. The only point of difference would be that in setting up and checking  $\Sigma M = 0$  at joint 3 the moment of 80,160/2 in.-lb would have to be taken into the equation.

Occasionally, for some reason or by some construction, a large moment is applied at a joint of a truss. An exact solution for resulting stresses may be made by the method just outlined, but it is sometimes desired to

find an approximate measure for the stresses. A rule commonly used is that the moment divides among the members entering the joint in direct proportion to their  $K$ 's. It may be readily shown<sup>5</sup> that this rule is equivalent to saying that the ends of the members away from the joint in question are either all hinged or all fixed and also that the  $R$ 's for the various members are zero. These assumptions are likely to be far in error, but the rule serves the useful purpose of indicating to all who apply it the serious nature of an eccentric moment and serves as a warning either to change the construction or else add area.

Many times the heel joints of roof trusses are made eccentric in cases where a little ingenuity in detailing would eliminate the eccentricity. The rule of this article would serve to give warning of the stresses involved in the use of this faulty detail, and in many cases, if applied, this approximate investigation would lead to a change of construction.

**11:7. Other causes of secondary stress. Remarks.** The secondary stresses which so far have been discussed in this chapter are the largest that are present in an ordinary truss. However, mention might well be made of two additional causes of secondary stress. First, a floor beam, the verticals into which it connects, and the strut of the top lateral system form a rigid rectangular frame. As the floor beam deflects under load, its ends are no longer vertical and the members to which it connects will be bent enough to cause rather high stresses. The problem may be solved in the same manner as any other problem involving a rigid frame. Second, as the bottom chord of a through truss increases its length under load and the stringers keep their original length, the floor beams must bend in a horizontal direction. Bending stresses thus produced may double the floor-beam stresses in cases where an excessive flange width is used.

Before closing this chapter it may be well to make several disconnected remarks:

*a.* Since the problem of secondary stresses is one involving the elastic properties of the members and is not a problem of statics, the secondary stresses can be computed only in a design which has already been made.

$$\begin{aligned}
 & M_{ab} + M_{ac} + M_{ad} + M_{\text{external}} = 0 \\
 \text{Let } & M_{ba} = M_{ca} = M_{da} = R_{ab} = R_{ac} = R_{ad} = 0 \\
 & +2EK_{ab}(1.5\theta_a) + 2EK_{ac}(1.5\theta_a) + 2EK_{ad}(1.5\theta_a) = -M_{\text{ext.}} \\
 & \theta_a = \frac{-M_{\text{ext.}}}{2 \times 1.5E\Sigma K} \\
 & M_{ab} = +2EK_{ab}(1.5\theta_a) = -\frac{K_{ab}}{\Sigma K} M_{\text{ext.}}
 \end{aligned}$$

Similarly for fixed ends away from joint *a*.

b. Ordinarily it is enough to compute secondary stresses for one position of the live load such as, for example, the position of loads giving maximum center moment. Where it is desired to make a complete investigation, use may be made of influence lines. Chapter VII, Part II, *Modern Framed Structures*, by Johnson, Bryan, and Turneure (John Wiley), shows an ingenious way of using an increasing load which greatly reduces the amount of labor involved in making the computation for influence lines.

c. Since the problem of secondary stresses has been solved by the methods of slope deflection and moment distribution, account may be taken readily of any loads, concentrated or uniform, which are applied between joints.

d. In fairness to the reader it may be pointed out that the entire subject of secondary stresses is a matter of controversy. Engineers are far from being united in their ideas as to the significance and seriousness of these stresses. The discussion of the Von Abo paper to which attention has already been directed is a fair sample of this difference of opinion. There opinion ranges all the way from that which insists that the stresses as computed are too high, owing to the fact that gusset plates cannot be absolutely rigid, to that which holds that the stresses are too low because the bending which takes place in a member does not take place over its entire length but is concentrated in that part of the member which is free between gusset plates. Obviously, careful tests are needed to show which of these views is correct and to shed light on the effect of a change in size of gussets.

e. In 1929 committees from the American Society of Civil Engineers<sup>6</sup> and the American Railway Engineering Association prepared a General Specification for Steel Railway Bridges. This specification says:

Secondary stresses shall be avoided as far as practicable. In trusses without sub-paneling, secondary stresses due to distortion need not be considered in any member the width of which, measured parallel to the plane of flexure, is less than one-tenth of its length. Other secondary stresses shall be considered.

The examples of the present chapter seem to indicate that secondary stresses may be of large magnitude in a member whose width is less than one-tenth of its length.

### PROBLEMS

**Problem 11:1.** Determine the secondary stresses at the joints of the truss of Ex. 11:2 due to the unsymmetrical loads shown. (See diagram on next page.)

*Note.* Part c of the figure shows a Williot diagram for the truss of this problem.

<sup>6</sup> *Proceedings*, December 1929, page 2653.

PROBLEMS

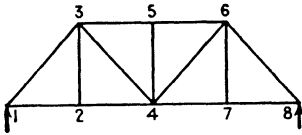
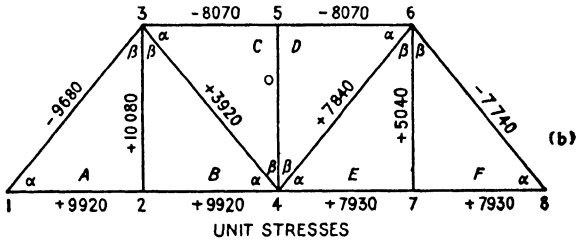
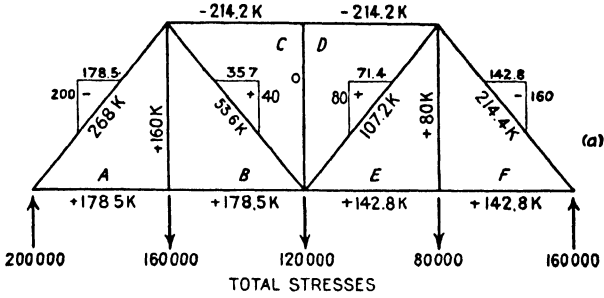

Bar	$\frac{PL}{A}$
1-2	248,000
1-3	363,000
2-3	282,000
2-4	248,000
3-4	147,000
3-5	202,000
4-5	0
4-6	294,000
5-6	202,000
4-7	198,000
6-7	141,000
6-8	290,000
7-8	198,000

↑  
change of length in feet

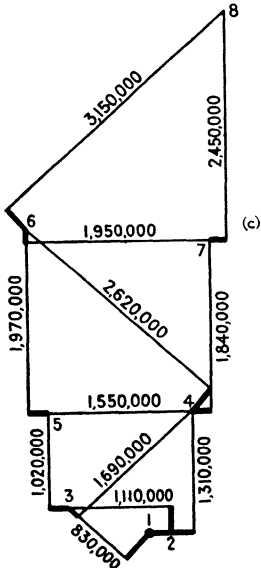

Scale: 1" = 2,000,000

PROB. 11:1

Certain values have been scaled from the diagram and are marked on the figure. As will be made clear by reference to Fig. 11:6, each marked value is the distance (arc) through which one end of a member swings with reference to the other end.

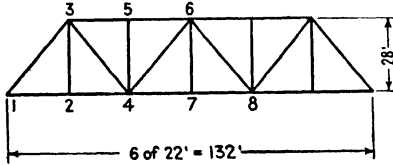

PROB. 11:2

This value when divided by the length of the member gives  $R$ . For example, point 6 is located by swinging together the ends of members 5-6 and 4-6. From the diagram, 5-6 swings through an arc of 1,970,000 ft/ $E$  and 4-6 through 2,620,000 ft/ $E$ . These values when divided by the lengths of the members will be found to check the  $R$  values as determined by the change of angle method previously used,

provided the same assumption is made, namely that  $R_{12} = 0$ . The  $R$  values for all members may be checked in like manner.

**Problem 11:2.** Determine the secondary stresses in the members of this truss due to top-chord panel loads of 8000 lb and bottom-chord panel loads of 158,000 lb. Use Mohr's method.

Member	Section	Area (sq in.)	$I_{1-1}$	Sketch
1-2 2-4	2-Webs $16 \times \frac{1}{2}$ 4-Ls $3\frac{1}{2} \times 3\frac{1}{2} \times \frac{1}{8}$	25.92	873	
4-7 7-8	2-Webs $16 \times \frac{1}{4}$ 4-Ls $4 \times 4 \times \frac{1}{2}$	43.00	1369	
1-3	2-Webs $16 \times \frac{3}{8}$ 4-Ls $6 \times 6 \times \frac{3}{8}$	48.44	1733	
3-5 5-6	2-Webs $16 \times \frac{1}{2}$ 4-Ls $6 \times 6 \times \frac{1}{2}$	43.00	1499	
3-4 4-6	2-□s $15 \times 40$	23.52	695	
2-3 6-7	4-Ls $6 \times 3\frac{1}{2} \times \frac{7}{16}$	15.88	144	
4-5	4-Ls $6 \times 3\frac{1}{2} \times \frac{1}{4}$	13.68	123	

**Problem 11:3.** Determine the secondary stresses in the members of this roof truss due to the loads shown. Assume that the connections are on the center of gravity lines of the members. Use Mohr's method.

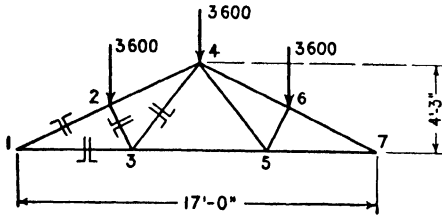

All Members, 2-*L* 2½ × 2 × ½  
Gussets, ½" Plate  
Rivets, ½" Diam.

PROBS. 11:3, 11:4

**Problem 11:4.** Same truss and loads as Prob. 11:3. Assume that the connections are on the gage lines (1⅜ in. from back of short leg) and include effect of eccentricity. Use Mohr's method.

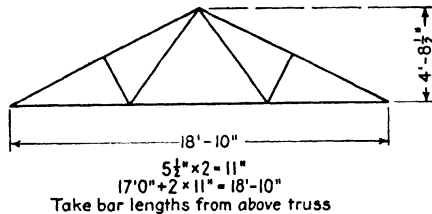
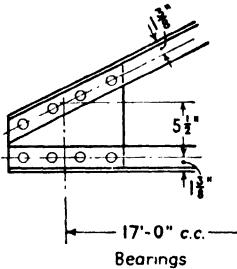

PROB. 11:5

**Problem 11:5.** Same truss and loads as Prob. 11:4 except for heel detail as shown. Assume that total and unit direct stresses, and changes of angles, are as in Prob. 11:3. Use Mohr's method.

**Problem 11:6.** Solve Ex. 11:1 by Cross's method.

**Problem 11:7.** Solve Prob. 11:1 by Cross's method.

*Discussion.* Although probably no time will be saved, a somewhat simpler solution arithmetically will be obtained if the true values of  $R$  are used. These are equal to the relative values of Prob. 11:1 plus the angle through which the truss must be rotated to bring point 8 back to the horizontal (compare Fig. 7:23a), which equals the vertical movement of the point divided by the span. This vertical movement equals the sum of the differences in elevation of the right and left ends of the three chord bars, 2-4, 4-7, 7-8. Each such difference of elevation equals the relative  $R$  of the bar, already found, multiplied by the panel length. This correction for  $ER$  equals +56,000. The advantage of using the *relative* values of  $R$ , with bar 1-2 fixed, is that the fixed-end moments are all positive, which results in the signs for any one set of carry-overs or distributions being alike.

**Problem 11:8.** Solve Prob. 11:2 by Cross's method.

**Problem 11:9.** Solve Prob. 11:3 by Cross's method.

**Problem 11:10.** Solve Prob. 11:4 by Cross's method.

**Problem 11:11.** Solve Prob. 11:5 by Cross's method.



### SPACE FRAMEWORKS

**12:1.** The determination of reactions and bar stresses in space frameworks—i.e., structures such as transmission towers, radio towers, and framed domes, the members of which do not all lie in one plane and which cannot be divided into simple planar structures—is a common structural problem which may be solved with the aid of certain principles of statics relating to the equilibrium of forces in space. These principles will be briefly reviewed.

Consider any force in space. This force may be resolved, at any point in its line of action, into a vertical component and a component in a horizontal plane. The component in the horizontal plane may further be resolved into two components parallel to two axes at right angles to each other in the horizontal plane. The force in space will have been resolved into three components, and each component will be parallel to one of three axes which are at right angles to each other. Any force, therefore, is fully defined if we know a point on its line of action and the direction and amount of its components parallel to three axes at right angles to each other. For convenience, these axes may be called  $X$ ,  $Y$ , and  $Z$  axes. The force itself will be equal to the square root of the sum of the squares of the three components.

At a point in space acted upon by a system of forces not in a plane, each force may be resolved, as above, into three components. It is evident that for the point to be in equilibrium under the action of the system of concurrent, non-coplanar forces the algebraic sum of the components of all the forces along each of three reference axes must be zero. That is, *a system of concurrent, non-coplanar forces is in equilibrium if  $\Sigma X = 0$ ,  $\Sigma Y = 0$ , and  $\Sigma Z = 0$ .*

Consider next a force  $F$  acting parallel to the  $X$  axis and at a point whose coordinates are  $x, y, z$ , Fig. 12:1a. At the point  $a$ , Fig. 12:1b (coordinates  $0, y, 0$ ), a pair of opposing forces was inserted, each force equal to and parallel to the force  $F$ . Thus the original force was replaced by a parallel force  $F$ , acting at  $a$ , and a couple  $Fz$  acting in the  $XZ$  plane. (The  $XZ$  plane is any plane at right angles to the  $Y$  axis.) Similarly, another pair of forces equal to  $F$  was inserted acting along

the  $X$  axis and at the origin of coordinates (Fig. 12:1c). Although all these forces were equal, they were, for convenience, numbered  $F_1$ ,  $F_2$ , and  $F_3$ . For the original force  $F$  there were substituted a couple  $F_1z = Fz$ , in the  $XZ$  plane; a couple  $F_2y = Fy$ , in the  $XY$  plane; and a force  $F_3 = F$ , parallel to and in the direction of the original force and acting at the origin. We see, therefore, that a force acting parallel to the  $X$  axis causes moment about both the  $Y$  and  $Z$  axes (unless it happens to pass through one of these axes) but causes no moment about the  $X$  axis, i.e., *a force causes no moment about an axis to which it is parallel.*

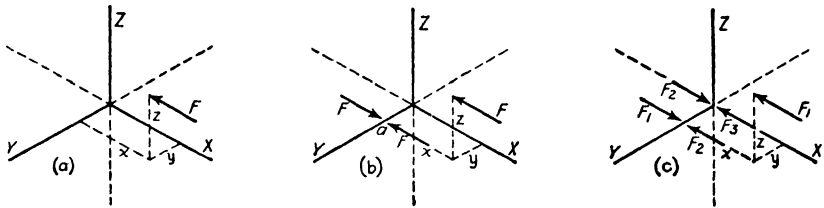

FIG. 12:1

Furthermore, *a force in a plane causes no moment about an axis in that same plane*, for the force is either parallel to the axis, in which event it falls under the case of the preceding paragraph, or, if not parallel to the axis, it may be prolonged to intersect the axis. In either case the moment is zero.

It will be evident that any *inclined* force acting through the point  $x, y, z$  (Fig. 12:1a) may be split into components parallel to the  $X, Y$ , and  $Z$  axes. Just as the force  $F$  causes moment about the  $Y$  and  $Z$  axes but no moment about the  $X$  axis, the  $Y$  component causes moment about the  $X$  and  $Z$  axes but none about the  $Y$  axis, and the  $Z$  component causes moment about the  $X$  and  $Y$  axes but none about the  $Z$  axis.

The procedure used above may be followed in inquiring into the conditions necessary for equilibrium in a body in space acted upon by a system of non-concurrent, non-coplanar forces. Each force may, at some convenient point in its line of action, be replaced by  $X, Y$ , and  $Z$  components. These components may, in turn, be treated as was the force  $F$  of Fig. 12:1. For the body to be in equilibrium the algebraic sum of the components acting along each of the three axes, at the origin, must be zero, and, in addition, the algebraic sum of the couples acting about each of the three axes must be zero. That is, *a body acted upon by a system of non-concurrent, non-coplanar forces is in equilibrium if*  $\Sigma X = 0$ ,  $\Sigma Y = 0$ ,  $\Sigma Z = 0$ ,  $\Sigma M_x = 0$ ,  $\Sigma M_y = 0$ , and  $\Sigma M_z = 0$ .

**12:2. Reactions.** The foregoing principles may be used in one certain case to determine the reactions of solid bodies acted upon by any system of forces. The one case referred to is a solid body with six reaction components, since for a system of non-concurrent, non-coplanar forces in equilibrium six independent equations may be written. If the body has less than six reaction components it will be unstable, and if it has more than six it will be statically indeterminate.

Consider (Fig. 12:2a) a solid cube, 10 ft on a side, supported at *a*, *b*, and *c* by six forces<sup>1</sup>— $V_a$ ,  $Y_a$ ,  $V_b$ ,  $X_b$ ,  $V_c$ , and  $Y_c$ <sup>2</sup>—and loaded at *e* by a force with components as shown.

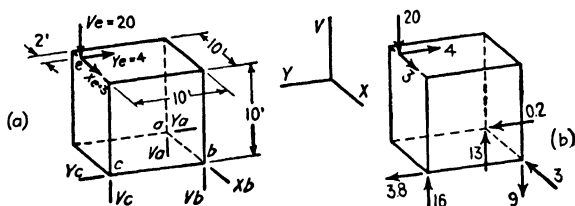

FIG. 12:2

The body is in equilibrium; therefore, the equation  $\Sigma X = 0$  was applied. From the fact that the algebraic sum of the forces acting parallel to the *X* axis equals zero, it was seen at once that  $X_b$  equals 3 and acts to the left. Moments were taken next about an axis through *c*, parallel to the *V* axis (hereafter referred to as a *V* axis through *c*).  $V_a$ ,  $V_b$ ,  $V_c$ , and  $V_e$  are parallel to this axis and have no moment about it. Also,  $Y_c$  and  $X_e$  have no moment about the axis, since their lines of action intersect it. The only forces remaining to be considered in a moment equation are  $Y_e$  and  $X_b$ , known forces, and  $Y_a$ , an unknown force. Therefore, assuming  $Y_a$  to act to the right,

$$-10X_b + 8Y_e + 10Y_a = 0$$

$$-10 \times 3 + 8 \times 4 = -10Y_a$$

$$Y_a = -0.2$$

<sup>1</sup> The six forces may be applied from short rigid bodies connected at their ends by universal joints so that they are capable of taking direct stress but are unable to take moment or shear. In practice, the direction of reactions may be fixed by a number of devices—rollers, sliding sole plates with slotted anchor-bolt holes, tie rods, etc.—which are familiar to structural engineers.

<sup>2</sup> The *X*, *Y*, and *Z* axes previously considered were any three axes at right angles to each other. For convenience in most cases encountered in practice one of these axes is taken as a vertical axis and called the *V* axis. Where one axis is vertical, the other two lie in a horizontal plane.

Since the result had a negative sign,  $Y_a$  acts to the left. From the equation  $\Sigma Y = 0$ ,  $Y_c$  equals 3.8 and acts to the left.

Next moments were taken about a  $Y$  axis through  $c$  and  $b$ . It was evident that the only forces tending to cause rotation about this axis are  $V_a$ ,  $V_c$ , and  $X_c$ . Therefore, assuming  $V_a$  to act upward,

$$+10V_a - 8 \times 20 + 10 \times 3 = 0$$

$$V_a = +13$$

The positive sign shows that the force was correctly assumed to be acting upward.

An  $X$  axis through  $b$  was next used. The forces to be considered in writing a moment equation about this axis were  $V_c$ ,  $Y_c$ , and  $V_c$ . Therefore

$$-10 \times 20 + 10 \times 4 + 10V_c = 0$$

$$V_c = 16 \text{ acting upward}$$

By using the equation  $\Sigma V = 0$ , it was found that  $V_b$  equals 9 and acts downward. This result was checked by taking moments about a  $Y$  axis through  $a$ . The results obtained were assembled in Fig. 12:2b.

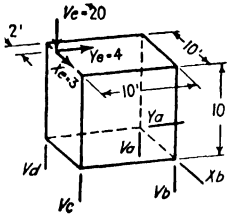

FIG. 12:3

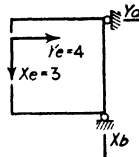

FIG. 12:4

For the case just considered it was found that the solid with six reaction components was statically determinate. The conclusion must not be drawn that every six supporting forces will give a statically determinate system. As a matter of fact, the six supporting forces must be selected with care. This is illustrated in Fig. 12:3. Suppose the cube is again considered. Let it carry the same loads as before, but this time let the six supporting forces be  $V_a$ ,  $V_b$ ,  $V_c$ ,  $V_d$ ,  $Y_a$ , and  $X_b$ . From  $\Sigma X = 0$  it was found that  $X_b$  equaled 3. Taking moments about a  $V$  axis through  $c$ , it was found that  $Y_a$  equaled 3.2 acting to the left. But  $Y_a$  and  $Y_c$  are the only forces acting parallel to the  $Y$  axis, and they must be equal and opposite for equilibrium. Since the two ways of computing the value of  $Y_a$  give different results, it is evident that the figure is unstable.

In general, it may be said that in order for a system to be in equilibrium the figure obtained by projection on any plane must be in equilibrium. If we project Fig. 12:3 on an  $XY$  plane, we obtain Fig. 12:4. This figure is obviously not in equilibrium, as it is a well-known principle of statics that a body acted on by a system of non-concurrent, coplanar forces must have, for equilibrium, three reaction components, since three independent equations may be written ( $\Sigma X = 0$ ,  $\Sigma Y = 0$ , and  $\Sigma M = 0$ ).

**12:3. Statically determinate and statically indeterminate space frameworks.** A space framework was defined as a structure composed of a number of members which do not all lie in one plane. As in the case of planar trusses, the following conditions are assumed: the members are straight between joints, the center of gravity lines of the members meeting at a joint intersect in a point, the members are free to rotate at the joints, and the loads are applied at the joints. If these conditions are fulfilled, the members will be subjected to direct stresses only.



FIG. 12:5

Earlier a rigid pin-connected structure was defined as one that could be supported at any one joint with a load applied at any other joint without the structure changing shape. Further, it was seen that a triangle is the simplest rigid pin-connected planar structure. The simplest rigid pin-connected space figure is one formed by placing three bars one at each apex of a triangle and joining them at their outer ends, Fig. 12:5a. The figure may be extended by adding three more bars, one at each of three joints, and joining the outer ends at a new joint, Fig. 12:5b. Such a rigid figure will have 6 bars for the first 4 joints and 3 additional bars for each joint after the first four. That is, the number of bars in a rigid pin-connected space figure will be

$$b = 6 + 3(n - 4)$$

or

$$b = 3n - 6$$

where  $b$  is the number of bars and  $n$  is the number of joints. As has been seen, structures with fewer bars than the number required for rigidity may be used provided that additional reaction components are substituted (Chapter 5), or provided that the joints are made stiff (Chapter 8).

Such non-planar structures often have some joints where the intersecting members all lie in a common plane as well as joints where the intersecting members do not all lie in one plane. If the structure is in equilibrium under the action of applied forces and the resulting reactions, two equations are fulfilled at each joint where the members all lie in a single plane ( $\Sigma S = 0$  and  $\Sigma T = 0$ , where  $S$  and  $T$  are two axes at right angles to each other and in the plane of the bars) and three equations are fulfilled at those joints where the members do not all lie in one plane ( $\Sigma X = 0$ ,  $\Sigma Y = 0$ , and  $\Sigma Z = 0$ ). Therefore, each structure which is statically determinate as regards its inner forces and reactions will satisfy the following equation

$$b + r = 2m + 3n$$

where  $b$  is the number of bars in the structure.

$r$  is the number of reaction components.

$m$  is the number of joints where all intersecting members lie in a common plane.

$n$  is the number of joints where all intersecting members do not lie in a common plane.

If  $b + r < 2m + 3n$  the structure is unstable. If  $b + r > 2m + 3n$  the structure is statically indeterminate.

Figure 12:6 serves to illustrate the application of the foregoing equation.

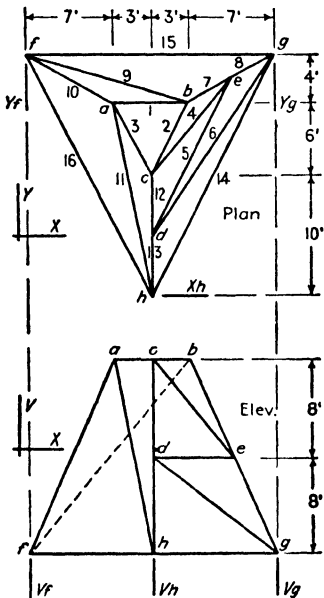

FIG. 12:6

In this figure all bars at joints  $d$  and  $e$  lie in the plane  $cbgh$ . At joints  $a$ ,  $b$ ,  $c$ ,  $f$ ,  $g$ , and  $h$  all bars are not in one plane.

$$\begin{array}{rcl}
 m = 2, & 2 \times 2 = & 4 \\
 n = 6, & 6 \times 3 = & 18 \\
 & & \hline
 & & 22
 \end{array}
 \qquad
 \begin{array}{rcl}
 b = 16 \\
 r = 6 \\
 & & \hline
 & & 22
 \end{array}$$

and the figure is statically determinate. The structure of Fig. 12:7a has no  $m$

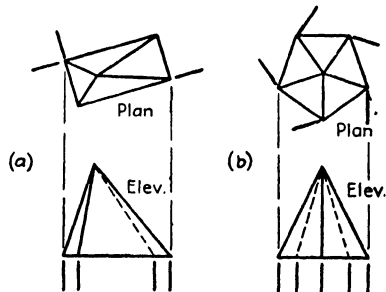

FIG. 12:7

joints, five  $n$  joints, eight bars, and seven reaction components and is statically determinate. In Fig. 12:7b there is shown a structure which has no  $m$  joints, six  $n$  joints, ten bars, and ten reaction components. This structure is statically indeterminate to the second degree.

In connection with the reactions of solids it was shown that a structure which is statically determinate as regards outer forces had six reaction components. By the method used with solids, the reactions of Fig. 12:6 may be determined without regard for the bar stresses. On the other hand, the reactions of Fig. 12:7a cannot be figured directly but must be computed indirectly, together with the bar stresses, since the number of reaction components exceeds six. The same might be said concerning Fig. 12:7b, but in this case, since the structure is statically indeterminate, the solution must be made by the method of least work.

A word of caution may be needed concerning the effect on bar stresses of supporting points fixed in position. In the structure of Fig. 12:8 it would appear that

$$\begin{aligned}
 m &= 0, & 0 & b = 12 \\
 n &= 6, & 6 \times 3 &= \frac{18}{18} & r &= \frac{9}{21}
 \end{aligned}$$

and the structure is statically indeterminate to the third degree. As a matter of fact, this structure is statically determinate. Since the points  $d$ ,  $e$ , and  $f$  are fixed in position, bars 10, 11, and 12 cannot change in length and are bars of zero stress. The number of unknowns is eighteen, and these eighteen bar stresses

and reaction components may be found as in any statically determinate structure.

**12:4. Bar stresses.** In a planar structure the following relations were found to hold: **the stress in any bar of a structure is to the length of the bar as the component of stress in any direction is to the projection of length in that same direction; and the component of stress in one direction is to the component of stress in a second direction as the projection of the length of the bar in the first direction is to the projection of the length of the bar in the**

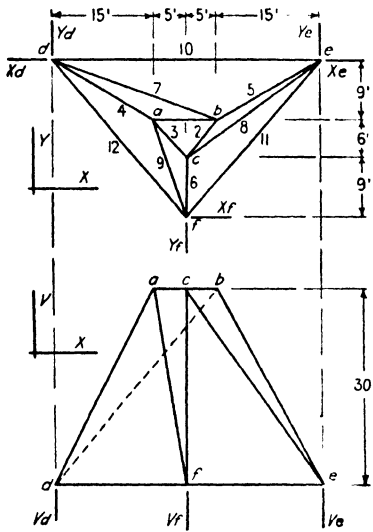

FIG. 12:8

**second direction.** It will now be shown that these same relations hold for the non-planar structure.

Figure 12:9 shows a member in space whose length is  $ad$  and whose projections are: vertical,  $cd$ ; parallel to the  $X$  axis,  $ab$ ; and parallel to the  $Y$  axis,  $bc$ . In the vertical plane which contains the member  $ad$ ,

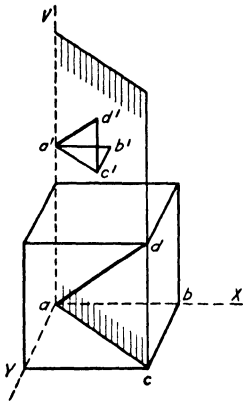

FIG. 12:9

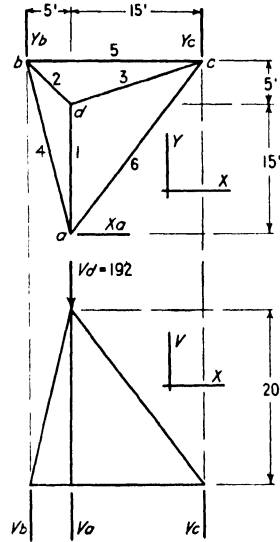

FIG. 12:10

plot, to any convenient scale, a line  $a'd'$  whose length represents the stress in the bar. Then, by the usual graphic method, resolve the force  $a'd'$  into a vertical component,  $c'd'$ , and a horizontal component,  $a'c'$  (parallel to  $ac$ ). In a horizontal plane (not shown) which contains the horizontal component  $a'c'$ , further resolve this component into a component  $a'b'$  parallel to the  $X$  axis and a component  $b'c'$  parallel to the  $Y$  axis.

It is evident that the diagrams shown in Fig. 12:9 are similar and the following relations hold:

$$\frac{\text{Stress}}{\text{Length}} = \frac{V \text{ component}}{V \text{ projection}}$$

$$\frac{\text{Stress}}{\text{Length}} = \frac{X \text{ component}}{X \text{ projection}}$$

$$\frac{\text{Stress}}{\text{Length}} = \frac{Y \text{ component}}{Y \text{ projection}}$$

$$\frac{X \text{ component}}{Y \text{ component}} = \frac{X \text{ projection}}{Y \text{ projection}}$$

$$\frac{X \text{ component}}{V \text{ component}} = \frac{X \text{ projection}}{V \text{ projection}}$$

$$\frac{Y \text{ component}}{V \text{ component}} = \frac{Y \text{ projection}}{V \text{ projection}}$$



**Example 12:1.** Determine the bar stresses and reaction components of the simple statically determinate structure of Fig. 12:10.

*Solution.* Since the structure has six reaction components, these were found at once. The equation  $\Sigma X = 0$  showed that  $X_a = 0$ . A  $V$  axis through  $b$  was next used. All  $V$  forces are parallel to the axis and have no moment about it,  $Y_b$  intersects the axis, and  $Y_c$  is the only force left which might have a moment about the axis. In this instance, it was obvious that  $Y_c = 0$ . From this it followed that, since  $\Sigma Y = 0$ ,  $Y_b = 0$  also.

Next bar 5 was taken as an axis and  $V_a$  was assumed to act upward.

$$192 \times 5 - 20V_a = 0$$

$$V_a = +48 \text{ acting up}$$

Moments about a  $Y$  axis through  $b$  gave

$$192 \times 5 - 48 \times 5 - 20V_c = 0$$

$$V_c = +36 \text{ acting up}$$

From the equation  $\Sigma V = 0$ , it was seen that  $V_b = 108$  acting up. This value was checked by taking moments about a  $Y$  axis through  $a$ .

By using the equation  $\Sigma V = 0$  at joints  $a$ ,  $b$ , and  $c$  it was found that

$$V_1 = -48$$

$$V_2 = -108$$

$$V_3 = -36$$

Bar	+ or -	Components			Stresses
		$V$	$X$	$Y$	
1	-	48	-	36	60
2	-	108	27	27	115
3	-	36	27	9	46
4	+	0	$6\frac{1}{2}$	27	28
5	+	0	$20\frac{1}{2}$	0	20
6	+	0	$6\frac{1}{2}$	9	11

and from the relation previously given between stress components and bar projections it followed that

$$Y_1 = V_1 \times 15/20 = -48 \times 15/20 = -36$$

$$Y_2 = V_2 \times 5/20 = -108 \times 5/20 = -27$$

$$X_2 = V_2 \times 5/20 = -108 \times 5/20 = -27$$

$$Y_3 = V_3 \times 5/20 = -36 \times 5/20 = -9$$

$$X_3 = V_3 \times 15/20 = -36 \times 15/20 = -27$$

These values were checked by applying the equations of equilibrium at joint *d*.

$$\begin{aligned} \Sigma V = 0, \quad \text{Load} + V_1 + V_2 + V_3 &= 0 \\ 192 - 48 - 108 - 36 &= 0 \\ \Sigma X = 0, \quad X_2 - X_3 &= 0 \\ -27 - (-27) &= 0 \\ \Sigma Y = 0, \quad Y_2 + Y_3 - Y_1 &= 0 \\ -27 - 9 - (-36) &= 0 \end{aligned}$$

In like manner, the remaining values were found. At joint *b*

$$\begin{aligned} \Sigma Y = 0, \quad Y_2 + Y_4 + Y_b &= 0 \\ -27 + Y_4 + 0 &= 0 \\ Y_4 &= +27 \\ X_4 = Y_4 \times 5/20 &= +27 \times 5/20 = +6\frac{3}{4} \\ \Sigma X = 0, \quad X_2 + X_4 + X_5 &= 0 \\ -27 + 6\frac{3}{4} + X_5 &= 0 \\ X_5 &= +20\frac{1}{4} \end{aligned}$$

At joint *c*

$$\begin{aligned} \Sigma Y = 0, \quad Y_3 + Y_6 + Y_c &= 0 \\ -9 + Y_6 + 0 &= 0, \text{ assuming bar 6 in tension} \\ Y_6 &= +9 \\ X_6 = Y_6 \times 15/20 &= +9 \times 15/20 = +6\frac{3}{4} \end{aligned}$$

This completed the computation of components, but the student should not consider the problem complete until he has applied, as a check, the remaining unused equations:  $\Sigma X = 0$  at joint *c* and  $\Sigma X = 0$  and  $\Sigma Y = 0$  at joint *a*.

The components of bar stresses were assembled in the table adjoining the figure. After a computer becomes accustomed to a problem of this sort, it is often possible to fill in the missing values in the table directly, after the reactions have been found, without writing the equations as was done here for illustration.

Where only three bars with unknown stresses intersect at a joint, a somewhat different method of solution may be followed, as may be illustrated at joint *d* of the preceding example. The lengths of the bars intersecting at the joint were computed. For bars 1, 2, and 3 these were found to be 25.0, 21.2, and 25.5 ft respectively. Next the funda-

mental equations of equilibrium at the joint were applied.

$$\Sigma X = 0, \quad -(5/21.2)S_2 + (15/25.5)S_3 = 0$$

$$\Sigma Y = 0, \quad (5/21.2)S_2 + (5/25.5)S_3 - (15/25)S_1 = 0$$

$$\Sigma V = 0, \quad (20/21.2)S_2 + (20/25.5)S_3 + (20/25)S_1 + 192 = 0$$

In this manner three equations with three unknowns were obtained, and the solution of the equations would yield the values of  $S_1$ ,  $S_2$ , and  $S_3$ . The solution of Ex. 12:3 is based on this method.

The use of the **tension coefficient**—defined as the stress in a member divided by its length—presents an alternate method of solution.<sup>3</sup>

As applied to the illustration of the preceding paragraph, the stress in bar 2 is  $21.2t_2$ , its  $X$  component is  $5t_2$ , and the three equations for solution are:

$$\Sigma X = 0, \quad -5t_2 + 15t_3 = 0$$

$$\Sigma Y = 0, \quad 5t_2 + 5t_3 - 15t_1 = 0$$

$$\Sigma V = 0, \quad 20t_2 + 20t_3 + 20t_1 + 192 = 0$$

If this method were used for solving Ex. 12:2, a column of  $t$ 's would be added to the table—preferably a new third column—and as joints were solved, the  $t$  values would be recorded. The values for the  $V$ ,  $X$ ,  $Y$ , and Stress columns would be obtained by multiplying the  $t$ 's by the respective projections and lengths.

In writing the equations of equilibrium at a joint where all intersecting bars except one lie in a common plane, two of the reference axes may be taken in this plane and the third axis will be perpendicular to the plane. Summing up the force components parallel to the third axis leads to two useful principles: (a) *at a joint where all intersecting bars except one lie in a common plane, the stress component, normal to the plane, of this one bar equals the component, normal to the plane, of the external loads applied at the joint;* and (b) *at a joint where all intersecting bars except one lie in a common plane and no external load is applied at the joint there is zero stress in the bar not in the plane.*<sup>4</sup>

**Example 12:2.** What are the reaction and stress components in the structure of Fig. 12:11 due to the horizontal load shown acting at  $b$ ?

<sup>3</sup> "Primary Stress Determination in Space Frames," R. V. Southwell, *Engineering*, Vol. 109 (1920), pages 165–168.

<sup>4</sup> Formulated by Prof. C. M. Spofford in *Theory of Structures* (McGraw-Hill).

*Solution.* The components of the load are  $V_b = 0$ ,  $X_b = 20$  to the left, and  $Y_b = 40$  down (i.e., down the page).

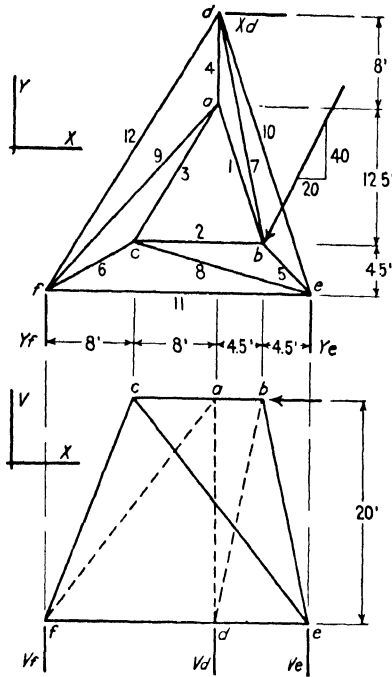

FIG. 12:11

Since  $\Sigma X = 0$ ,  $X_d = 20$  to the right.

By taking moments about a vertical axis through  $f$  the following equation was written:

$$\Sigma M_{V_f} = 0, \quad +25 \times 20 - 4.5 \times 20 + 20.5 \times 40 - 25Y_e = 0$$

$$Y_e = 49.2 \text{ up}$$

$$\Sigma Y = 0, \quad Y_f = 9.2 \text{ down}$$

$$\Sigma M_{11} = 0, \quad 20 \times 40 + 25V_d = 0$$

$$V_d = -32 \text{ down}$$

$$\Sigma M_{Y_f} = 0, \quad +16 \times 32 - 20 \times 20 - 25V_e = 0$$

$$V_e = +4.48 \text{ up}$$

$$\Sigma V = 0, \quad V_f = +27.52 \text{ up}$$

Bar	+ or -	Components			Stresses and Reactions
		V	X	Y	
1		0	0	0	0
2	-	0	34.400	0	34.400
3		0	0	0	0
4		0	0	0	0
5	-	32.000	7.200	7.200	33.581
6	-	27.520	11.008	6.192	30.280
7	+	32.000	7.200	32.800	46.386
8	+	27.520	23.392	6.192	36.645
9		0	0	0	0
10	-	0	17.349	48.192	51.220
11	+	0	1.157	0	1.157
12	+	0	9.851	15.392	18.275
$R_d$		32.00 ↓	20.00 →	0	37.74
$R_e$		4.48 ↑	0	49.20 ↑	49.40
$R_f$		27.52 ↑	0	9.20 ↓	29.01

At joint  $a$ , bars 3, 4, and 9 lie in a common plane. The only remaining bar at the joint is bar 1, and since no load is applied at the joint the stress in bar 1 is zero. Similarly, at joint  $c$ , bars 2, 6, and 8 are in a common plane. Therefore, since no load is applied at that joint, the stress in bar 3, which is not in the plane, is zero. It now had been shown that the stress in two of the four bars intersecting at  $a$  is zero. This left only bars 4 and 9 to consider, and the stress in these bars also is zero. This followed from the fact that joint  $a$  may be considered as a point in equilibrium under the action of two possible forces. It is known that a point can be in equilibrium under the action of two forces only when these forces are equal, and opposite, and have the same line of action. Since, in this case, bars 4 and 9 do not have the same line of action, they must be bars of zero stress.

Using equation  $\Sigma V = 0$  at joint  $d$  showed that since the stress in bar 4 is zero, the  $V$  component of stress in bar 7 is 32.0 and the stress in the bar is tension. Another application of the same equation at joint  $b$  showed that the  $V$  component of stress in bar 5 is 32.0 and the stress in the bar is compression. Similarly, by considering joint  $f$  it was seen that the  $V$  component of stress in bar 6 is  $-27.52$ , and, for equilibrium at joint  $c$ , the  $V$  component of stress in bar 8 has to be  $+27.52$ . Using the properties of the figure, the  $X$  and  $Y$  components of stress in bars 5, 6, 7, and 8 were obtained by proportion and are as given in the table.

Next, the stress in bar 2 was found by the use of equation  $\Sigma X = 0$  at joint  $c$ .

$$+11.008 + 23.392 + X_2 = 0$$

$$X_2 = -34.4$$

This value was checked by taking a section around joint  $b$  and using the equation  $\Sigma M_{V_e} = 0$ . In applying this equation the stress in bar 7 may be split

into its components at any convenient point. The most convenient point, in this instance, was point *d* because for this point the line of action of the *X* component passes through the moment axis and the arm of the *V* component is known. (The *Y* component is parallel to the axis and produces no moment regardless of where the force is split into components.) The force in bar 5 produces no moment about the axis, since its line of action intersects it, and the *Y* component of the external load is parallel to the axis.

$$\Sigma M_{Y_e} = 0, \quad -9 \times 32 - 20 \times 20 - 20X_2 = 0$$

$$X_2 = -34.4$$

This value was checked by applying the equation  $\Sigma X = 0$  at joint *b*.

$$X_2 + X_7 - X_5 + 20 = 0$$

$$X_2 + (+7.2) - (-7.2) + 20 = 0$$

$$X_2 = -34.4$$

It was also seen by inspection that  $\Sigma Y = 0$  at joints *b* and *c*.

It was still necessary to find the stresses in the bars of the bottom ring. This was done as follows:

$$\text{Joint } f, \Sigma Y = 0, \quad -9.2 + Y_{12} + Y_6 = 0$$

$$-9.2 + Y_{12} + (-6.192) = 0$$

$$Y_{12} = +15.392$$

$$X_{12} = +15.392 \times 16/25 = +9.851$$

$$\text{Joint } f, \Sigma X = 0, \quad X_{11} + X_6 + X_{12} = 0$$

$$X_{11} + (-11.008) + (+9.851) = 0$$

$$X_{11} = +1.157$$

$$\text{Joint } d, \Sigma Y = 0, \quad Y_{10} + Y_7 + Y_{12} = 0$$

$$Y_{10} + (+32.8) + (+15.392) = 0$$

$$Y_{10} = -48.192$$

$$X_{10} = -48.192 \times 9/25 = -17.349$$

This completed the computation of the stresses, but four equations had not been used (at joint *d*,  $\Sigma X = 0$ ; at joint *e*,  $\Sigma X = 0$ ,  $\Sigma Y = 0$ , and  $\Sigma V = 0$ ). The student should apply these equations as a check to be sure no mistake was made in the work.

Sometimes a structure is encountered where four bars are intersecting at each joint and where no three of these four bars lie in a common plane. Figure 12:12 illustrates a statically determinate structure of this type, and the example which follows shows how the stresses may be found.

**Example 12.3.** Find the bar stresses and reaction components in the structure of Fig. 12:12 due to the load shown.

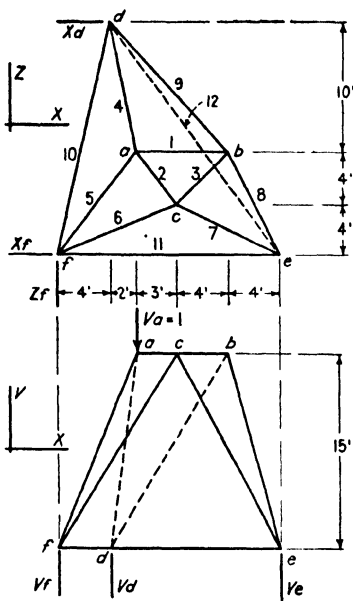

FIG. 12:12

Bar	$L^3$	$L$	$V/L$	$X/L$	$Z/L$
1	...	7.00	.....	1.000	.....
2	25	5.00	.....	0.600	0.800
3	32	5.66	.....	0.707	0.707
4	329	18.14	0.828	0.110	0.552
5	325	18.03	0.833	0.333	0.443
6	322	17.94	0.837	0.502	0.223
7	305	17.46	0.860	0.458	0.229
8	305	17.46	0.860	0.229	0.458
9	406	20.15	0.744	0.447	0.497
10	340	18.44	.....	0.217	0.977
11	...	17.00	.....	1.000	.....
12	493	22.20	.....	0.586	0.812

*Solution.* The computation of reactions due to the unit vertical load shown acting at  $a$  presented no difficulties. The values of reaction components were:

$$\begin{aligned}
 X_d &= X_f = Z_f = 0 \\
 V_d &= 0.444 \text{ up} \\
 V_o &= 0.249 \text{ up} \\
 V_f &= 0.307 \text{ up}
 \end{aligned}$$

Joint b

Equation		$S_3$	$S_8$	$S_9$	=	A
Source	No.					
$\Sigma X = 0$	1	+0.707	-0.229	+0.447		-1
$\Sigma Z = 0$	2	+0.707	+0.458	-0.497		0
1-2	3		-0.687	+0.944		-1
$\Sigma V = 0$	4		+0.860	+0.744		0
3	3'		-1.000	+1.375		-1.457
4	4'		+1.000	+0.865		0
3'+4'	5			+2.240		-1.457
5	5'			+1.000		-0.650
		-0.823A	+0.562A	-0.650A		

Joint c

Equation		$S_2$	$S_6$	$S_7$	=	A
Source	No.					
$\Sigma X = 0$	6	+0.600	+0.502	-0.458		-0.581
$\Sigma Z = 0$	7	-0.800	+0.223	+0.229		-0.581
6	6'	+1.000	+0.837	-0.763		-0.968
7	7'	-1.000	+0.279	+0.286		-0.726
6'+7'	8		+1.116	-0.477		-1.694
$\Sigma V = 0$	9		+0.837	+0.860		0
8	8'		-1.000	+0.427		+1.517
9	9'		+1.000	+1.027		0
8'+9'	10			+1.454		+1.517
10	10'			+1.000		+1.042
		+0.726A	-1.072A	+1.042A		

Joint a

Equation		$S_4$	$S_5$	=	A
Source	No.				
$\Sigma X = 0$	11	+0.110	+0.333		+ 1.435
$\Sigma Z = 0$	12	-0.552	+0.443		- 0.580
11	11'	+1.000	+3.030		+13.060
12	12'	-1.000	+0.800		- 1.050
11'+12'	13		+3.830		+12.010
13	13'		+1.000		+ 3.140
		+3.560A	+3.140A		

Bar	Stress	V Comp.	X Comp.	Z Comp.
1	-0.180	.....	0.180	.....
2	-0.131	.....	0.079	0.105
3	+0.148	.....	0.105	0.105
4	-0.641	0.531	0.071	0.354
5	-0.565	0.471	0.188	0.250
6	+0.193	0.162	0.097	0.043
7	-0.188	0.162	0.086	0.043
8	-0.101	0.087	0.023	0.046
9	+0.117	0.087	0.052	0.058
10	+0.212	.....	0.046	0.207
11	+0.045	.....	0.045	.....
12	+0.109	.....	0.064	0.089



Consider joints  $a$ ,  $b$ , and  $c$ . At these joints nine independent equations may be written, and these will suffice to give the values of the stresses in the nine bars intersecting at the joints. These values may be obtained by writing and solving the nine equations referred to above. Much less work is involved, however, if three sets of three equations each are solved; and this method was followed in the present case. The stress in bar 1 was called  $A$ . At joint  $b$ , the stress was found in bars 3, 8, and 9 in terms of  $A$ . Similarly, at joint  $c$ , the stress in bar 3 being known in terms of  $A$ , the stress in bars 2, 6, and 7 was found in terms of  $A$ . Next, at joint  $a$ , the stress in bars 4 and 5 was found in terms of  $A$  by use of the equations  $\Sigma X = 0$  and  $\Sigma Z = 0$ .

Then, also at joint  $a$ , the value of  $A$  was found from the equation  $\Sigma V = 0$ .

$$\begin{aligned} &+0.828S_4 + 0.833S_5 + 1 = 0 \\ &+0.828(+3.56A) + 0.833(+3.14A) + 1 = 0 \\ &+2.95A + 2.62A = -1 \\ &A = -0.180 \\ &S_1 = -0.180 \end{aligned}$$

The value of  $A$  was substituted back where the bar stresses had been determined in terms of  $A$ . This gave the values of the stresses as recorded for bars 1 to 9 in the last table. After this was done, the stresses in bars 10, 11, and 12 were readily computed.

The structure of the foregoing example may be solved by using a different and, in many respects, simpler method. Again one joint is taken as a free body, and use is made of the fact that since the system of forces at the joint is in equilibrium, its resultant equals zero, and, consequently, the moment of the force system about any axis must equal zero. Example 12:4 which follows illustrates the use of this method.<sup>5</sup>

**Example 12:4.** Find bar stresses and reaction components in the structure of Fig. 12:12 due to the load shown.

*Solution.* The structure is statically determinate as regards outer forces, and the values of the reactions may be taken from Ex. 12:3:

$$\begin{aligned} X_d &= X_f = Z_f = 0 \\ V_d &= 0.444 \text{ up} \\ V_e &= 0.249 \text{ up} \\ V_f &= 0.307 \text{ up} \end{aligned}$$

<sup>5</sup> A still different method for stress determination, based upon "conjugate stresses," is presented by Prof. F. H. Constant in "Stresses in Space Structures," *Transactions of the American Society of Civil Engineers*, Vol. 100, page 928. In addition, in the author's closure, Professor Constant uses a method of substitution which might be applied in finding stresses in the structure of Ex. 12:3.

At each joint of the structure there are four unknown bar stresses; hence a direct solution at any joint is impossible. As in Ex. 12.3, the stress in bar 1 may be called  $+A$ . Consider the four forces entering joint  $b$ . These constitute a force system in equilibrium. Therefore, their moment about bar 12 as an axis (as about any other axis) equals zero. Bars 8 and 9 have no moment

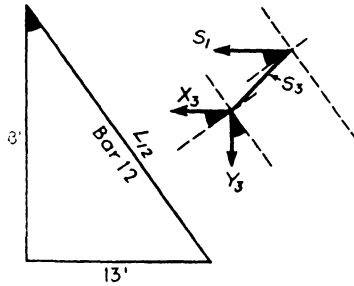

FIG. 12:13

about this axis which they intersect. There will remain in the moment equation the forces  $S_1$ ,  $X_3$ , and  $Y_3$ . Each of these may be split, in their common plane, into a component parallel to bar 12 and another component normal to this first component. The moment equation will then be (see Fig. 12:13)

$$\begin{aligned}
 S_1 \times \frac{18}{L_{12}} \times 15 + X_3 \times \frac{18}{L_{12}} \times 15 + Y_3 \times \frac{13}{L_{12}} \times 15 &= 0 \\
 +18A + 18 \times 0.707S_3 + 13 \times 0.707S_3 &= 0 \\
 S_3 &= \frac{-18}{31} \times \frac{A}{0.707} = -0.822A
 \end{aligned}$$

If joint  $c$  is taken as a free body and a moment equation is written about bar 11 as an axis, it will be apparent at once that

$$Y_2 = -Y_3 = -(0.707)(-0.822A) = +0.581A$$

Furthermore,  $X_2 = \frac{3}{4}Y_2 = +0.436A$ .

Next take joint  $a$  as a free body and write a moment equation about a vertical axis through  $d$ . (The unit load at  $a$  has no moment about this axis.) Split  $S_6$  into components at  $a$ .

$$\begin{aligned}
 -10S_1 - 10X_2 + 2Y_2 + 10X_5 + 2Y_5 &= 0 \\
 -10A - 10(+0.436A) + 2(+0.581A) + 10X_5 + 2 \times \frac{8}{3} \times X_5 &= 0 \\
 -10A - 4.36A + 1.162A &= -\frac{3.8}{3}X_5 \\
 X_5 &= +1.042A \\
 V_5 &= +2.605A
 \end{aligned}$$

$$\begin{aligned} \Sigma X = 0, \quad X_1 + X_2 - X_5 - X_4 &= 0 \\ +A + 0.436A - 1.042A &= X_4 \\ X_4 &= +0.394A \\ V_4 &= +2.955A \\ \Sigma V = 0, \quad V_4 + V_6 + 1 &= 0 \\ +2.955A + 2.605A &= -1 \\ A &= -0.180 (= S_1) \end{aligned}$$

With the value of  $S_1$  known, all remaining stresses may be found without difficulty. For example, again use joint  $b$  as a free body. With the stresses known in bars 1 and 3, split  $S_8$  into components at  $e$ , and use  $X_d$  as a moment axis. Bar 9 and  $Y_8$  intersect the axis;  $S_1, X_3$ , and  $X_8$  are parallel to the axis. Only  $Y_3$  and  $V_8$  appear in the moment equation. That is

$$15Y_3 + 18V_8 = 0$$

Hence, 
$$V_8 = -\frac{5}{6}Y_3$$

In similar fashion, when the stresses have been found in bars 2 and 3,  $Z_f$  as an axis will give the value of  $V_7$ . The other stresses of the structure will offer no difficulty.

**12:5. Structure with more than three points of support.** A structure with four or more points of support ordinarily will have more than six reaction components, and for that reason it will be impossible to figure its reaction components directly. Instead, these components must be figured in conjunction with the bar stresses. In addition, in most cases there will be no joint with only three unknowns.

**Example 12:5.** Determine the bar stresses and reaction components in the structure of Fig. 12:14, loaded as shown.

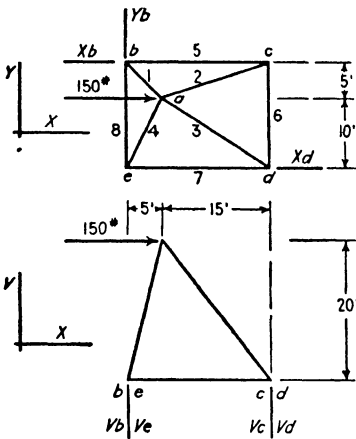

FIG. 12:14

Bar	+ or -	Components			Stresses and Reactions
		V	X	Y	
1	+	100	25	25	106
2	-	100	75	25	127
3	-	50	37.5	25	67
4	+	50	12.5	25	57
5	+	0	75	0	75
6	+	0	0	25	25
7	-	0	12.5	0	13
8	-	0	0	25	25
$R_b$		100 ↓	100 ←	0	141
$R_c$		100 ↑	0	0	100
$R_d$		50 ↑	50 ←	0	71
$R_e$		50 ↓	0	0	50

*Solution.* The structure has seven unknown reaction components. The three components which lie in the horizontal plane were readily determined ( $Y_b = 0$ ,  $X_b = 100$  to the left,  $X_d = 50$  to the left), but the four vertical components were found indirectly.  $V_c$  was given a value  $S$  and assumed to act up. By using bar 7 as an axis it was evident that  $V_b = S$ , down. Next, moments about bar 8 as an axis gave

$$\Sigma M_8 = 0, \quad +20 \times 150 - 20S - 20V_d = 0$$

$$V_d = (150 - S) \text{ up}$$

$$\Sigma V = 0, \quad V_e = (150 - S) \text{ down}$$

From the foregoing it was evident that

$$V_2 = -S, \quad Y_2 = -S/4$$

$$V_3 = -150 + S, \quad Y_3 = -75 + S/2$$

$$\text{Joint } c, \Sigma Y = 0, \quad Y_6 + Y_2 = 0$$

$$Y_6 = +S/4$$

$$\text{Joint } d, \Sigma Y = 0, \quad Y_6 + Y_3 = 0$$

$$S/4 - 75 + S/2 = 0$$

$$S = +100$$

With the value of  $S$  known it was a simple matter to fill in the values in the table.

**12.6. Towers.** The principles illustrated in the preceding articles may be used to determine the stresses in transmission and other towers—structures commonly built in such a manner as to make them statically indeterminate. One of the cases which must be analyzed in trans-

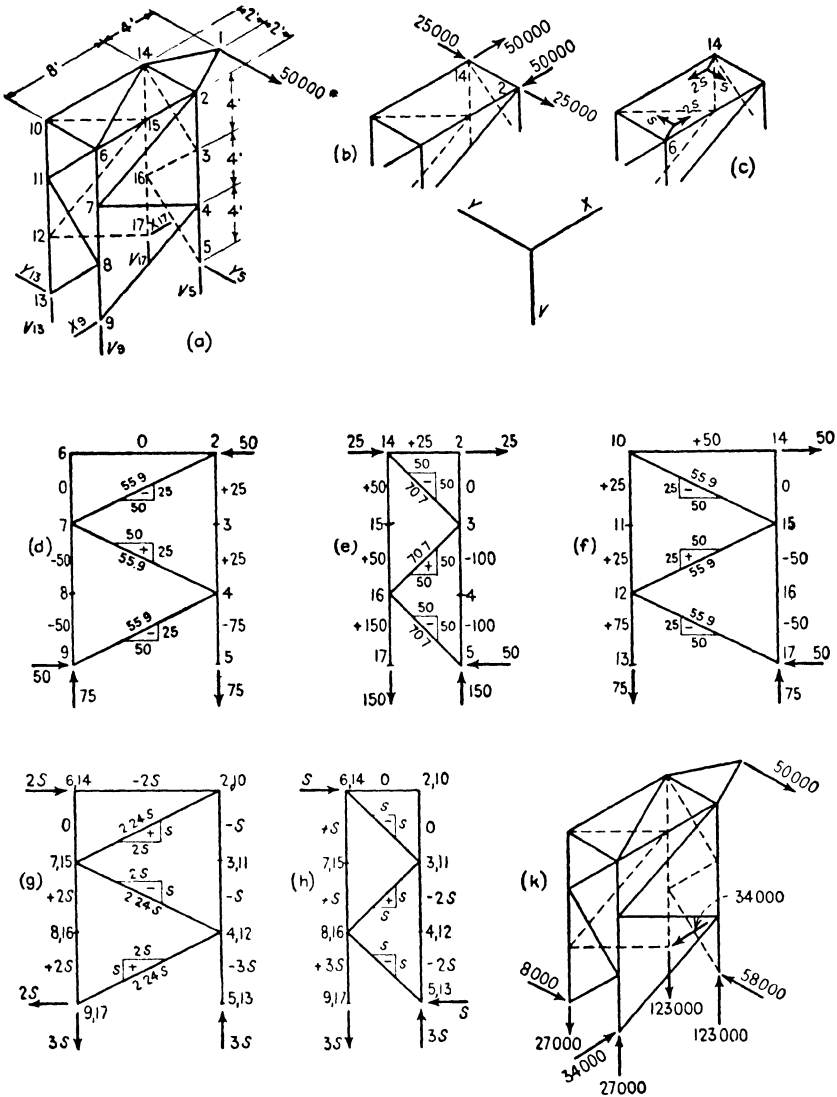

FIG. 12:15

mission tower design is that arising from an unbalanced pull at the end of a cross arm, a condition of loading which subjects the tower to torsion. Partly to illustrate the effects of torsion (which effects are quite different from certain empirical assumptions that have been published) and partly to illustrate the manner of dealing with an indeterminate space framework the following simple example is given.

**Example 12:6.** Determine the bar stresses and reaction components in the structure of Fig. 12:15a. Each of the legs has an area of 14 sq in., and each of the other members an area of 7 sq in.

Bar	$L$	$A$	$L/A$	Stress = $F$	$dF/dS$	$F \times dF/dS \times L/A$	Stress (kips)
6-14	8.95	7	1.28	+ 2.24 $S$	+2.24	+ 6.40 $S$	+ 17.9
2-3	4	14	0.29	+ 25.0 - 1.00 $S$	-1.00	- 7.25 + 0.29 $S$	+ 17.0
3-4	4	14	0.29	- 75.0 - 3.00 $S$	-3.00	+ 65.25 + 2.61 $S$	-109.0
4-5	4	14	0.29	- 25.0 - 5.00 $S$	-5.00	+ 36.25 + 7.25 $S$	- 65.0
6-7	4	14	0.29	+ 1.00 $S$	+1.00	+ 0.29 $S$	+ 8.0
7-8	4	14	0.29	- 50.0 + 3.00 $S$	+3.00	- 43.50 + 2.61 $S$	- 26.0
8-9	4	14	0.29	- 50.0 + 5.00 $S$	+5.00	- 72.50 + 7.25 $S$	- 10.0
10-11	4	14	0.29	+ 25.0 - 1.00 $S$	-1.00	- 7.25 + 0.29 $S$	+ 17.0
11-12	4	14	0.29	+ 25.0 - 3.00 $S$	-3.00	- 21.75 + 2.61 $S$	+ 1.0
12-13	4	14	0.29	+ 75.0 - 5.00 $S$	-5.00	-108.75 + 7.25 $S$	+ 35.0
14-15	4	14	0.29	+ 50.0 + 1.00 $S$	+1.00	+ 14.50 + 0.29 $S$	+ 58.0
15-16	4	14	0.29	+ 3.00 $S$	+3.00	+ 2.61 $S$	+ 24.0
16-17	4	14	0.29	+100.0 + 5.00 $S$	+5.00	+145.00 + 7.25 $S$	+140.0
6-2	8	7	1.14	- 2.00 $S$	-2.00	+ 4.56 $S$	- 16.0
2-7	8.95	7	1.28	- 55.9 + 2.24 $S$	+2.24	-160.30 + 6.40 $S$	- 38.0
7-4	8.95	7	1.28	+ 55.9 - 2.24 $S$	-2.24	-160.30 + 6.40 $S$	+ 38.0
4-9	8.95	7	1.28	- 55.9 + 2.24 $S$	+2.24	-160.30 + 6.40 $S$	- 38.0
10-6	4	7	0.57				0.
6-11	5.66	7	0.81	- 1.41 $S$	-1.41	+ 1.62 $S$	- 11.3
11-8	5.66	7	0.81	+ 1.41 $S$	+1.41	+ 1.62 $S$	+ 11.3
8-13	5.66	7	0.81	- 1.41 $S$	-1.41	+ 1.62 $S$	- 11.3
14-10	8	7	1.14	+ 50.0 - 2.00 $S$	-2.00	-114.00 + 4.56 $S$	+ 34.0
10-15	8.95	7	1.28	- 55.9 + 2.24 $S$	+2.24	-160.30 + 6.40 $S$	- 38.0
15-12	8.95	7	1.28	+ 55.9 - 2.24 $S$	-2.24	-160.30 + 6.40 $S$	+ 38.0
12-17	8.95	7	1.28	- 55.9 + 2.24 $S$	+2.24	-160.30 + 6.40 $S$	- 38.0
2-14	4	7	0.57	+ 25.0			+ 25.0
14-3	5.66	7	0.81	- 70.7 - 1.41 $S$	-1.41	+ 81.00 + 1.62 $S$	- 82.0
3-16	5.66	7	0.81	+ 70.7 + 1.41 $S$	+1.41	+ 81.00 + 1.62 $S$	+ 82.0
16-5	5.66	7	0.81	- 70.7 - 1.41 $S$	-1.41	+ 81.00 + 1.62 $S$	- 82.0
						-832.80 + 104.24 $S$	

$$S = \frac{832.80}{104.24} = 7.99 \text{ kips, say } 8.0 \text{ kips}$$

**Solution.** At joints 2, 6, 10, and 14 three equations may be written. At the other thirteen joints only two equations may be written. The total number of equations is, therefore,  $4 \times 3 + 13 \times 2 = 38$ . The structure has 31 bars and 8 reaction components and is, therefore, statically indeterminate to the first degree. Because of the symmetry of the structure, the solution is simplified by taking bar 6-14 as the redundant member. The stresses in the structure with this bar removed were obtained from Figs. 12:15b,  $d$ ,  $e$ , and  $f$ . The stresses due

to the unknown stress, the  $Y$  component of which is  $S$  in bar 6-14, were obtained from Figs. 12:15c, g, and h. After the true bar stresses were obtained from the table, Fig. 12:15k was added to show the reaction components.

PROBLEMS

**Problem 12:1.** The figure represents a solid loaded and supported as shown. Find the value of the reaction components.

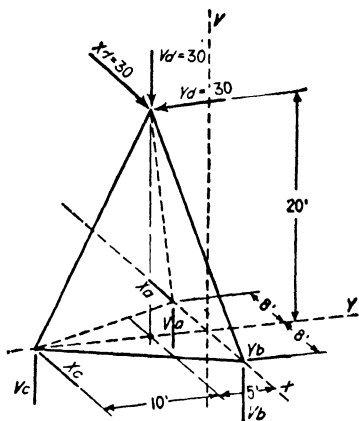

PROB. 12:1

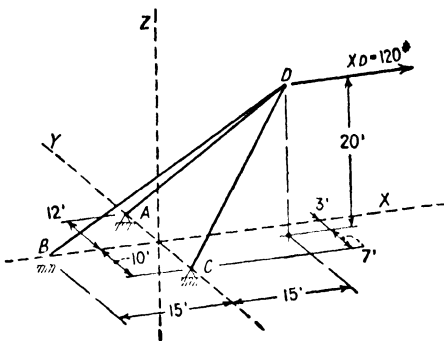

PROB. 12:2

**Problem 12:2.** Show the projection of bars  $AD$ ,  $BD$ , and  $CD$  on the  $XY$  and  $YZ$  planes. Compute the stresses in the bars due to the load shown acting at  $D$ .

**Problem 12:3.** Same as Prob. 12:2, except figure.

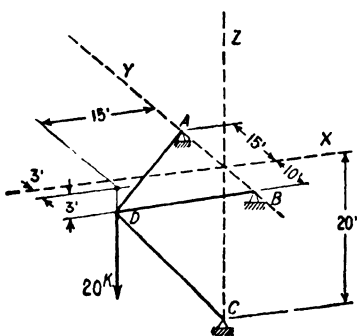

PROB. 12:3

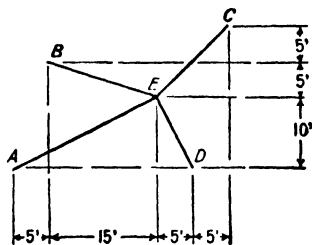

PROB. 12:4

**Problem 12:4.** Four bars  $AE$ ,  $BE$ ,  $CE$ , and  $DE$ , each of the same material and area, have their lower points ( $A$ ,  $B$ ,  $C$ , and  $D$ ) in a common horizontal plane. The supports are of the type shown in Prob. 12:2. Projected on this plane, the bars give the figure shown. In space, point  $E$  is 25 ft above plane  $ABCD$ . A vertical load

of 1000 lb acts at  $E$ . Determine by the method of least work the stresses in the bars.

Determine the reactions and stresses in the following cases for the loads indicated:

**Problem 12:5.** Fig. 12:10.  $X_a = 1$ , acting to the right.

**Problem 12:6.** Fig. 12:10.  $X_a = 20$ , acting to the right;  $Y_a = 20$ , acting down.

**Problem 12:7.** Fig. 12:8.  $V_a = 30$ , acting down;  $X_a = 10$ , acting to the right;  $Y_a = 20$ , acting down.

**Problem 12:8.** Fig. 12:6.  $X_b = 100$ , acting to the right;  $X_c = 100$ , acting to the left.

**Problem 12:9.** Fig. 12:11.  $X_a = 1$ , acting to the right.

**Problem 12:10.** Fig. 12:11.  $V_a = 1$ ,  $V_b = 1$ ,  $V_c = 1$ , each acting down.

**Problem 12:11.** Fig. 12:14.  $V_a = 1$ , acting down.

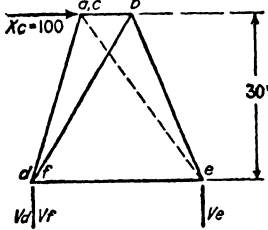
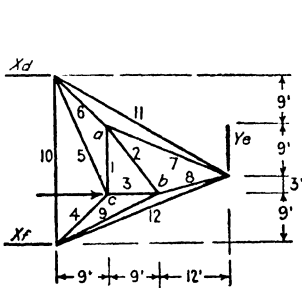

PROB. 12:12

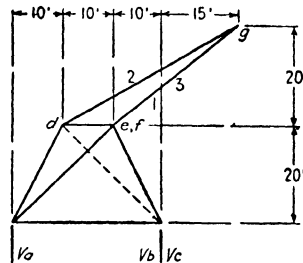
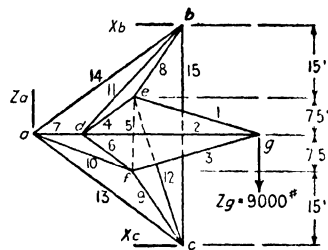

PROB. 12:13

**Problems 12:12 to 12:16.** (a) May the reaction components be found directly without computing bar stresses? (b) Is the figure statically determined as regards outer and inner forces combined? (c) Find bar stresses and reaction components.



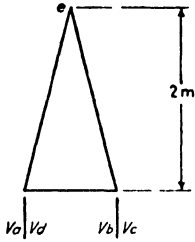
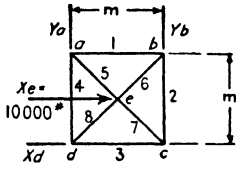

PROB. 12:14

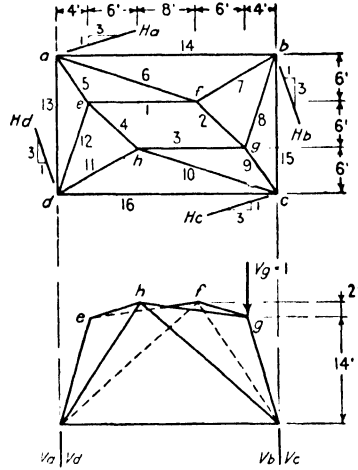

PROB. 12:15

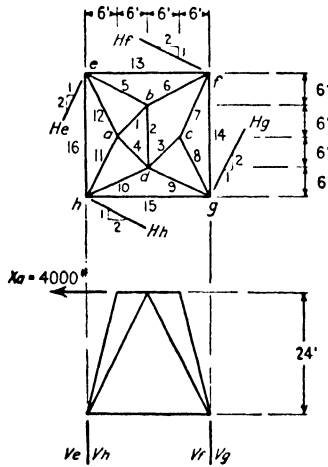

PROB. 12:16

**Problem 12:17.** Bars 4, 5, and 6 form an equilateral triangle. The area of each bar in square inches is equal to its length in feet. (a) May the reaction components be found directly without computing bar stresses? (b) Is the structure statically determined as regards outer and inner forces combined? (c) Find bar stresses and reaction components. (d) Find the deflection of point *d* in the direction of the applied load.

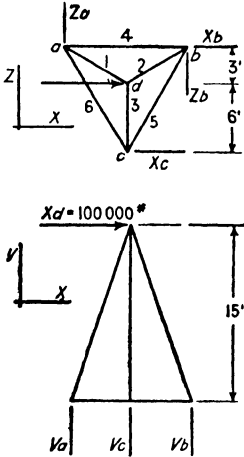

PROB. 12:17

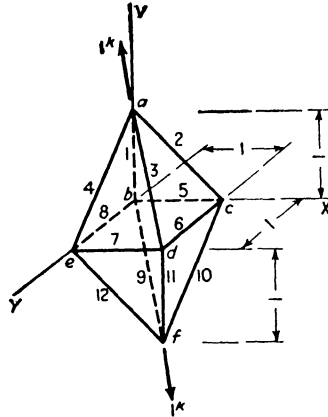

PROB. 12:18

**Problem 12:18.** This figure is in equilibrium under the action of two loads of 1 kip each, one acting at *a*, the other at *f*. Joints *b, c, d, e* form a square; *a* is vertically over *b*; *f* is vertically under *d*. Determine bar stresses.

*Suggestion.* First resolve the loads into components parallel to the axes.



## INDEX

### A

- Aerodynamics, 77
- Arch, Colorado River, 152
  - Hell Gate, 152
  - Kill van Kull, 152
- Arches, hingeless, 64
  - line of resistance, 64
  - position line, 152
  - ribbed, 152
  - spandrel braced, 152
  - three-hinged, 59, 82, 151-157
    - deflection of, 209-210, 219-220
  - two-hinged, 151-152
  - trussed, 152
- Average load criterion, 117

### B

- Bar chain method, 202
- Bay, 74
- Beam, 2
  - deflection and slope, 184, 191-197
  - floor beam, 86
  - stress, 13, 17
- Beggs, George E., 337
- Bender, Charles B., 344
- Bending moment, curves, 14
  - defined, 12
  - and shear, relationship, 15
  - signs, 14
- Bent, mill building, 74, 176
- Bertot, 230
- Betti's law, 221
- Bow's notation, 26
- Bracing, lateral, 87, 168
  - portal, 87, 174
  - roof trusses, 75
  - sway, 87, 179
- Bresse, 231
- Bridge, arch, 151-157
  - cantilever, 157-164
  - curved chord, 171
  - deck, 86
  - floors, 86

- Bridge, half-through, 86
  - long-span, 125, 151-164
  - through, 86
  - trusses, 86-150, 305-338
  - weights, 91
- Bull, Anders, 337

### C

- Camber, 221
- Cantilever bridges, 157-164
  - Beaver, 157
  - Carquinez Straits, 158
  - Quebec, 157
  - Queensboro, 157
- Carry-over, 253
- Castigliano, 236
- Centroid, parabolic area, xiv
  - trapezoid, 62
- Clapeyron, 186, 231, 237
- Column, 2
- Column analogy, method of, 272
- Composite structures, 332
- Computation rules, 8
- Conjugate beam method, 191
- Constant, F. H., 91
- Continostat, 337
- Cooper loading, 102
- Counters, 89, 111
  - for Baltimore truss, 129
  - for Pratt and Howe trusses, 111
- Creskoff, J. J., 303
- Cross, Hardy, 187, 249, 272
- Culmann, Carl, 41, 50, 53

### D

- Dams, 61
- Deflection and slope, 183-222
- Deflections, method of, 311
- Design, steps in, 1
- Determinateness, 6
  - criteria, 29, 162, 368
- Duchemin formula, 77

## E

- Earthquake stress, 302
- Elastic curve, equation of, 183
- Elastic weights, bar chain method, 202
  - beams, 191
  - trusses, 197
- Eney, W. J., 337
- Equations, solution of, 247
- Equilibrant, 43
- Equilibrium, conditions of:
  - for concurrent coplanar system, 41
  - for concurrent non-coplanar system, 364
  - for non-concurrent coplanar system, 6, 41, 46
  - for non-concurrent non-coplanar system, 365
- Equilibrium polygon, 44, 57
- Equivalent live loads, 124
- Euler, 236
- Evans, L. T., 272
- Excess, 108

## F

- Fink, Albert, 126
- Fixed points, 235
- Floor beams, 86
- Force, 5, 41
  - attributes of a, 5, 364
  - internal, 5
  - polygon, 42
- Force systems:
  - concurrent coplanar, 41
  - concurrent non-coplanar, 364
  - non-concurrent coplanar, 6, 41, 46
  - non-concurrent non-coplanar, 365
- Forces, composition of, 42
  - resolution of, 43
- Frankel, 186
- Free body, 20, 32
- Funicular polygon, 44

## G

- Gottschalk, Otto, 337
- Graphic statics, 41-72
  - equilibrium polygon, 44, 57
  - line of resistance, 61, 64
  - method of joints, 47
  - method of moments, 50
  - shear and moment, 52
- Greene, Charles E., 185

## I

- Impact, 104
- Indeterminate trusses, 305-338
- Influence lines, 94
  - indeterminate structures, 317
  - deflection curve, 319
  - maximum stress, 96, 107, 114
  - with concentrated loads, 114

## J

- Joints:
  - method of, 25, 47
  - pin, 3, 357
  - riveted, 3

## K

- Kinne, W. S., 317
- Kip, defined, 8

## L

- Langley, S. P., 77
- Lateral trusses, 168-171
- Least work, 236, 305
- Line of resistance, 61, 64
- Link, 7
- Loads, dead, 1
  - bridges, 91
  - roofs, 78
- Loads, live, 1
  - Cooper loading, 102
  - equivalent, 124
  - highway bridges, 100
  - railway bridges, 102
  - roofs, 76
  - snow, 76
  - Steinman loading, 102
  - wind, 77

## M

- Machines, 3
- Manderla, 239, 344
- Maney, George A., 239
- Maxwell, James Clerk, 49, 186, 221, 311
- Maxwell-Mohr method, 186, 311
- Maxwell's law, 219
- Maxwell (stress) diagram, 47
- Mechanical analysis, 337
- Menabrea, 236
- Mill building bents, 74, 176
- Mohr, Otto, 186, 191, 211, 239, 311, 344

- Molitor, David A., 83, 211
- Moment, 12  
 absolute maximum, 122  
 bending, 12  
 curve, 14, 53, 90  
 method of, 23, 50  
 resisting, 13  
 and shear, relations, 15  
 signs, 14
- Moment area, 185
- Moment diagram, 103, 105, 118
- Moment distribution, method of, 249  
 and secondary stress, 355  
 with variable I, 265
- Morris, C. T., 261
- Müller-Breslau, 161, 197, 311, 320
- N
- Neutral point, 96
- O
- Ostenfeld, A., 240
- P
- Pagon, W. W., 77
- Panel loads, 92
- Parabola, xiv
- Pitch of roof trusses, 75
- Portals, 87, 174
- Portland Cement Association, 272
- Purlins, 74
- R
- Rafters, 74
- Reactions, 5, 46, 366  
 graphic determination of, 46  
 net and gross, 90  
 static determination of, 5, 8  
 symbols for, 5
- Reciprocal deflections, law of, 219
- Resultant, 42
- Rigid bodies, 32
- Rigid frames, 3, 4, 230-285
- Ritter's method, 23
- Ruge, A. C., 338
- S
- Secondary members, 127
- Secondary stresses, 343-360
- Shaft, 2
- Shear, 12  
 curve, 14, 90  
 intensity, beams, 13  
 maximum live, approximate, 109  
 exact, 96  
 method of, 21  
 and moment, relation, 15  
 signs, 14
- Side sway, 257
- Slope and deflections, 183-222  
 elastic weights, 191, 197  
 method of work, 184  
 moment area, 185  
 Williot-Mohr diagram, 211-219
- Slope deflection, method of, 239
- Society for Experimental Stress Analysis, 338
- Space frameworks, 5, 364-386
- Steinman, D. B., 102, 125, 162  
 loading for railway bridges, 102, 125
- Stiffness, lateral, 258  
 rotational, 251, 284
- Stress:  
 earthquake, 302  
 intensity, beams, 13  
 internal and external, 13  
 method of joints, 25, 47  
 method of moments, 23, 50  
 method of shear, 21  
 primary, 3  
 reversal, 111  
 secondary, 4, 343  
 wind, tall buildings, 291
- Stringer, 86
- Structural member (beam, column, shaft, tie) defined, 2
- Structures, framed, 3
- Strut, 2
- Subdivided panels, 126
- Swain, George F., 187, 316
- Sway bracing, 179
- Symbols, reaction, 5
- T
- Tension coefficient, 374
- Three moment theorem, 230
- Tie, 2
- Towers, 383
- Truss, 3  
 Baltimore, 88, 127

- Truss, Belgian, 73**  
   Bollman, 40  
   bridge, 86  
   deflection, 183-219  
   distortion, 31  
   English, 73  
   fan, 73  
   Fink, 40, 73, 80  
   French, 73  
   Howe, 40, 73, 88, 111  
   K, 88, 126, 136  
   lateral, 168-171  
   lattice, 40  
   members (chord, web, verticals, diagonal), 21  
   Parker, 88, 111, 142  
   Pennsylvania, 88, 126, 133  
   Pettit, 88, 126  
   Pony, 86  
   Pratt, 21, 73, 88  
   rigid, 29  
   roof, 73-85  
   scissors, 73  
   stable form for, 29  
   statically determinate, 29  
   statically indeterminate, 30, 305-338  
   stresses by virtual work, 24
- Truss, subdivided, 126  
   through, 86  
   Warren, 40, 88, 168  
   Whipple, 40, 126, 169  
   Wichert, 161
- V
- Varignon's theorem, 24  
 Virtual work (or velocities), 11, 24  
   slope and deflection, 187  
   truss stresses, 24  
 von Abo, C. V., 344
- W
- Weights, bridges, 91  
   roof trusses, 79  
 Westergaard, H. M., 303  
 Whipple, S., 25  
 Wichert, E. M., 161  
 Williot, 211  
 Williot-Mohr diagram, 211-219, 322, 341  
   subdivided trusses, 217  
 Wind, load, 77  
   stress, tall buildings, 291-304  
 Winkler, 94  
 Witmer, F. P., 302  
 Work, method of, 184





## DATE OF ISSUE

This book must be returned within 3, 7, 14 days of its issue. A fine of ONE ANNA per day will be charged if the book is overdue.

---

--	--	--	--	--

