

BIRLA CENTRAL LIBRARY
PILANI [RAJASTHAN]

Class No. 66S-7

Book No. N56C

Accession No. 59599

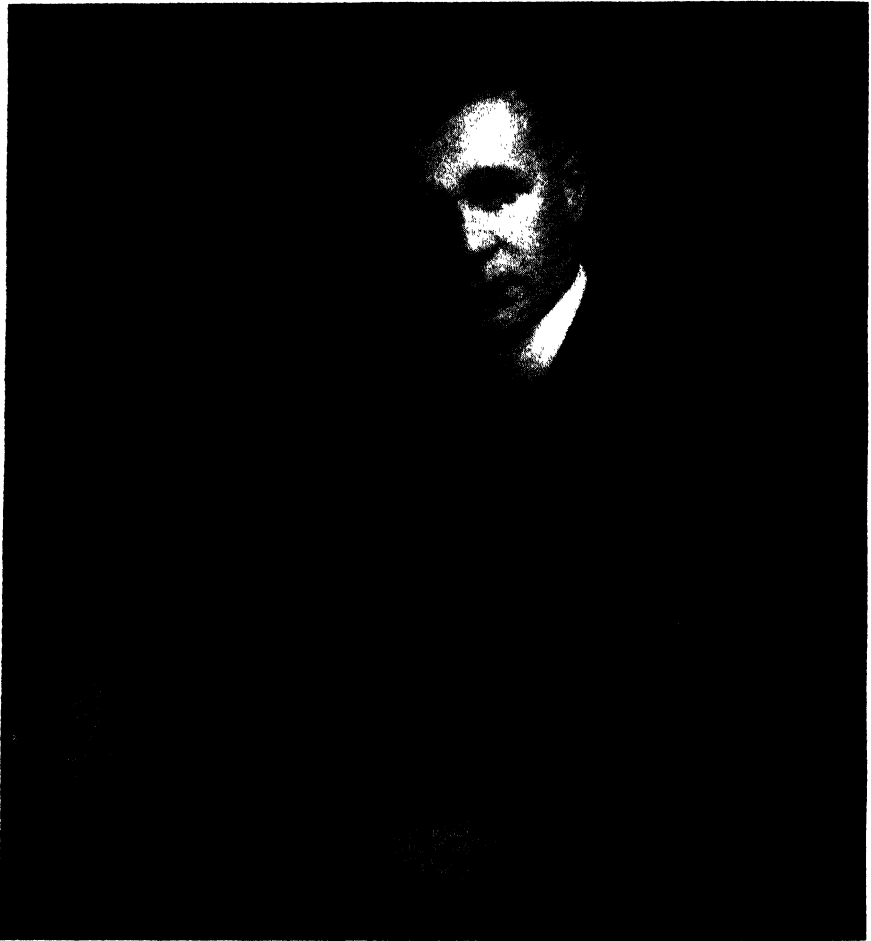

Julius Arthur Nieuwland, 1878-1936

Professor of organic chemistry, University of Notre Dame, 1918-1936; Dean of the College of Science, University of Notre Dame, 1918-1920; recipient of the Morehead medal of the International Acetylene Association, 1932, the American Institute medal, 1934, the Nichols medal, 1935, and the Mendel medal of Villanova College, 1936; botanist, and founder and editor of the *American Midland Naturalist*.

THE CHEMISTRY OF ACETYLENE

By

JULIUS A. NIEUWLAND, C.S.C.

*Late Professor of Organic Chemistry
University of Notre Dame*

and

RICHARD R. VOGT

*Professor of Chemistry
University of Notre Dame*



American Chemical Society
Monograph Series

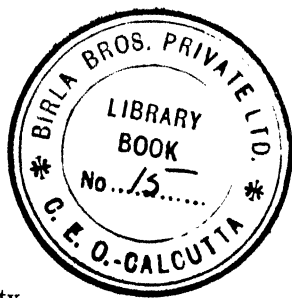

REINHOLD PUBLISHING CORPORATION
330 WEST FORTY-SECOND ST., NEW YORK, U.S.A.

1945

Copyright 1945 by
REINHOLD PUBLISHING CORPORATION

All rights reserved

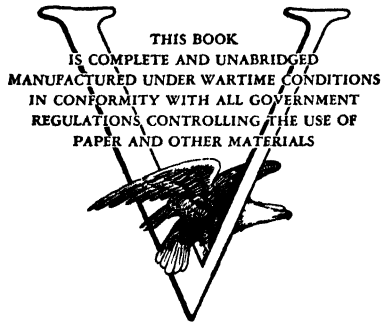

Printed in U.S.A. by
WAVERLY PRESS, BALTIMORE, MD.

Acknowledgment

Grateful acknowledgment is due to Dr. A. S. Carter and Dr. H. W. Starkweather of Jackson Laboratory, E. I. du Pont de Nemours and Company, who prepared Sections 7-10 Chapter V, and to Dr. G. F. Hennion of the University of Notre Dame who contributed parts of Chapter IV, and whose advice and criticism has been most helpful.

GENERAL INTRODUCTION

American Chemical Society Series of Scientific and Technologic Monographs

By arrangement with the Interallied Conference of Pure and Applied Chemistry, which met in London and Brussels in July, 1919, the American Chemical Society was to undertake the production and publication of Scientific and Technologic monographs on chemical subjects. At the same time it was agreed that the National Research Council, in coöperation with the American Chemical Society and the American Physical Society, should undertake the production and publication of Critical Tables of Chemical and Physical Constants. The American Chemical Society and the National Research Council mutually agreed to care for these two fields of chemical development. The American Chemical Society named as Trustees, to make the necessary arrangements for the publication of the monographs, Charles L. Parsons, secretary of the society, Washington, D. C.; the late John E. Teeple, then treasurer of the society, New York; and Professor Gellert Alleman of Swarthmore College. The Trustees arranged for the publication of the A. C. S. series of (a) Scientific and (b) Technologic Monographs by the Chemical Catalog Company, Inc. (Reinhold Publishing Corporation, successors) of New York.

The Council, acting through the Committee on National Policy of the American Chemical Society, appointed editors (the present list of whom appears at the close of this introduction) to have charge of securing authors, and of considering critically the manuscripts submitted. The editors endeavor to select topics of current interest, and authors recognized as authorities in their respective fields.

The development of knowledge in all branches of science, especially in chemistry, has been so rapid during the last fifty years, and the fields covered by this development so varied that it is difficult for any individual to keep in touch with progress in branches of science outside his own speciality. In spite of the facilities for the examination of the literature given by Chemical Abstracts and by such compendia as Beilstein's *Handbuch der Organischen Chemie*, Richter's *Lexikon*, Ostwald's *Lehrbuch der Allgemeinen Chemie*, Abegg's and Gmelin-Kraut's *Handbuch der Anorganischen Chemie*, Moissan's *Traité de Chimie Minérale Générale*, Friend's and Mellor's *Textbooks of Inorganic Chemistry* and Heilbron's *Dictionary of Organic Compounds*, it often takes a great deal of time to coördinate the knowledge on a given topic. Consequently when men who have spent years in the study of important subjects are willing to coördinate their knowledge and present it in concise, readable form, they perform a service

of the highest value. It was with a clear recognition of the usefulness of such work that the American Chemical Society undertook to sponsor the publication of the two series of monographs.

Two distinct purposes are served by these monographs: the first, whose fulfillment probably renders to chemists in general the most important service, is to present the knowledge available upon the chosen topic in a form intelligible to those whose activities may be along a wholly different line. Many chemists fail to realize how closely their investigations may be connected with other work which on the surface appears far afield from their own. These monographs enable such men to form closer contact with work in other lines of research. The second purpose is to promote research in the branch of science covered by the monographs, by furnishing a well-digested survey of the progress already made, and by pointing out directions in which investigation needs to be extended. To facilitate the attainment of this purpose, extended references to the literature enable anyone interested to follow up the subject in more detail. If the literature is so voluminous that a complete bibliography is impracticable, a critical selection is made of those papers which are most important.

AMERICAN CHEMICAL SOCIETY

BOARD OF EDITORS

F. W. WILLARD, *Editor of Monographs*

Scientific Series:—

S. C. LIND,
W. MANSFIELD CLARK,
LINUS C. PAULING,
L. F. FIESER.

Technologic Series:—

WALTER A. SCHMIDT,
E. R. WEIDLEIN,
W. G. WHITMAN,
C. H. MATHEWSON,
THOMAS H. CHILTON,
BRUCE K. BROWN,
W. T. READ,
CHARLES ALLEN THOMAS.

Introduction

In this work an attempt is made to present a brief but fairly complete account of the preparation, properties and reactions of acetylene along with an extensive classified bibliography. A restricted section of this subject, namely the manufacture of calcium carbide and the derived acetylene, is covered quite thoroughly in a number of earlier books (1) and in several special periodicals (2). Accordingly, only an abridged discussion of this topic appears here. The use of acetylene as a raw material for industrial syntheses also has been the subject of a few books (3) and numerous short review articles (4).

The arrangement of this work is based entirely on a classification of the methods of preparation and type reactions of acetylene, rather than on considerations of historical sequence or industrial status.

In any treatise on acetylene numerous references to other acetylenic compounds are inevitable. In the first place many of these are best prepared by substitution in acetylene. The substitution products in turn serve as intermediates in many useful laboratory preparations; accordingly, a short section has been included which points out the principal stepwise syntheses from acetylene through substituted acetylenes. Secondly, many reactions of acetylene are best understood by comparison with parallel reactions of other acetylenic compounds. Historically, a number of reactions were first applied to other acetylenic hydrocarbons and were later adapted to acetylene, and this order of development is still common, because reactions of acetylene are often more complicated and difficult than those of other compounds of the series. For these reasons numerous reactions of other acetylenic compounds are cited, but it should be remembered that a complete survey of the reactions of the series is not intended.

Because of unavoidable delays in the completion and publication of this work, it has not been possible to cover the literature on most topics later than 1938.

References

- (1) Lefvre, "Acetylene," Paris, 1897. Dommer, "Calcium Carbid und Acetylen," Munich, 1898. Panaotovic, "Calcium Carbid und Acetylen," Leipzig, 1897. Gibbs, "Acetylene and its Production and Use," London, 1898. Lewes, "Acetylene," London, 1900. Kuhn, "Ein Beitrag zur Geschichte der Acetylenindustrie," Munich, 1901. Morel, "L'Acetylene, Theorie, Application," Paris, 1903. Castellani, "l'Acetilene," Milan, 1903. Leeds and Butterfield, "Acetylene, Principles of its Generation and Use," London, 1903. Vogel, "Handbuch für Acetylen," Braunschweig, 1904. Liebetanz, "Calcium Carbid und Acetylen, Wesen, Darstellung und Anwendung," Leipzig, 1909. Liebetanz, "Calcium

- Carbid Fabrikation," 3d ed., Leipzig, 1910. Bingham, "The Manufacture of Calcium Carbide," W. Wesley & Son, London, 1920. Caro, Ludwig and Vogel, "Handbuch für Acetylen," Leipzig, 1923. Taussig, "Die Industrie des Calcium-carbids," Halle, W. Knapp, 1930. Pond, "Calcium Carbide and Acetylene," 4th ed., *Bull. Pennsylvania State College* (1931). Thorpe, "Dictionary of Applied Chemistry," 4th ed., **2**, 215-9, Longmans, Green & Co., London, 1938. Ullmann, "Enzyklopädie der technischen Chemie," 2nd ed., **1**, 144-54 (1928); **2**, 749-85 (1928), Urban und Schwarzenberg, Berlin.
- (2) *The Acetylene Journal*, 1899-1930 (Chicago). *Acetylene* (London). *Z. Calcium-carbid Fabrikation* (Berlin). "Acetylen in Wissenschaft und Industrie," 1898. (Halle). *Journal de l'acetylene* (Paris).
- (3) Vogel and Schulze, "Carbid und Acetylen als Ausgangs Material für Producte der Chemischen Industrie," O. Spamer, Leipzig, 1924. Naunton, "Synthetic Rubber," Macmillan & Co., London, 1937. Thorpe, "Dictionary of Applied Chemistry," 4th ed., **1**, 79-95 (1937). Ullmann, "Enzyklopädie der technischen Chemie," **1**, 154-63 (1938).
- (4) Anon., *Oil, Paint and Drug Reporter*, **91**, No. 20, 72 (1917). Duisberg, *Kunststoffe*, **8**, 121-2 (1918). Dubose, *Caoutchouc and Guttapercha*, **14**, 9316-8 (1917). Witherspoon, *Can. Chem. J.*, **3**, 250-3 (1919). Marshall, *ibid.*, **3**, 254-7 (1919). Mathewson, *ibid.*, **3**, 258-61 (1919). Ochi, *J. Chem. Ind. (Japan)*, **23**, 733-47 (1920). Anon., *Schweiz. Chem. Ztg.*, **1921**, 291-6. Dilys, *Industrie Chimique*, **8**, 422-5 (1921). Anon., *J. Soc. Chem. Ind.*, **41**, 189-92 R (1922). Hess, *Elektrotechn. Z.*, **43**, 957-60, 982-5 (1922). Guyot, *Chimie et industrie*, **10**, 13-22 (1923). Muhlert, *Apparatebau*, **36**, 191-5 (1924). Deschiens, *Chimie et industrie*, **5**, 239-56, 398-408, 518-28 (1921); *Rev. prod. chim.*, **29**, 397-404 (1926). Thorin, *Tek. Tid. Kemi*, **59**, 83-93 (1929). Cadenhead, *Chem. Met. Eng.*, **40**, 184-8 (1933); *Can. Chem. Met.*, **19**, No. 12, 235 (1935). Lowy, *Ind. Eng. Chem. (News Ed.)*, **11**, 156 (chart) (1933). Witherspoon and Cadenhead, *Trans. Electrochem. Soc.*, **70**, 49-55 (1936). Lichtenberger, *Tech. moderne*, **29**, 601-8 (1937).

Contents

GENERAL INTRODUCTION	v
INTRODUCTION	vii
CHAPTER I. THE PHYSICAL PROPERTIES, PREPARATION AND PURIFICATION OF ACETYLENE	
1. The physical and thermodynamic properties and the molecular structure of acetylene	1
2. A brief survey of the structure and synthesis of acetylenic carbides	4
3. The manufacture of calcium carbide	7
4. The generation and purification of acetylene from carbides	11
5. The equilibrium of acetylene with carbon and hydrogen and its bearing on the direct synthesis, decomposition and storage of acetylene	14
6. The preparation of acetylene by desaturation processes employing chemical reagents	18
7. The production of acetylene by the pyrolysis of organic compounds	20
8. The production of acetylene by the incomplete combustion of organic compounds and related methods	27
9. The solubility of acetylene in liquids and its adsorption on solids as applied to storage of the gas and separation from gas mixtures	29
10. The laboratory purification and analysis of acetylene	36
CHAPTER II. METALLO-DERIVATIVES OF ACETYLENE	
1. Types of metallo-derivatives of acetylene	40
2. The preparation of acetylides by direct reaction of acetylene with alkali or alkaline-earth metals	41
3. The preparation of acetylides by metathetic reactions of acetylene with metal compounds having weakly negative anions	44
4. The preparation of acetylides by metathetic reactions of acetylides with other metal salts	48
5. The preparation of acetylides by metathetic reactions of acetylene with certain metal salts in aqueous or alcoholic solutions	49
6. The addition of cuprous salts to acetylene	58
7. The addition of mercury salts to acetylene	61
8. The addition of aluminum halides to acetylene	65
9. The addition of arsenic trichloride and tribromide to acetylene	66
10. The addition of compounds of other metals to acetylene	68

CHAPTER III. THE SUBSTITUTION OF NON-METAL ATOMS OR RADICALS FOR THE HYDROGEN OF ACETYLENE

1. Types of substitution of non-metal atoms or radicals in acetylene 71
2. The preparation of acetylenic hydrocarbons by the reaction of acetylides with halides, sulfates or sulfonate esters. Rearrangement of acetylenic hydrocarbons. 74
3. The preparation of acetylenic carbinols and glycols and their ethers by the reactions of acetylides on aldehydes, ketones olefin oxides, acetals, ketals and alpha-halo ethers. 81
4. The preparation of acetylene mono- and dicarboxylic acids by the action of acetylides on carbon dioxide. 88
5. The preparation of diacetylenes from certain acetylides. 89
6. The preparation of halo-acetylenes by the reaction of acetylides or of acetylene in alkaline media with halogens or halogen compounds. 90
7. Some further substitution reactions of the monosubstituted derivatives of acetylene. 92

CHAPTER IV. THE ADDITION OF NON-METALLIC ELEMENTS AND COMPOUNDS TO ACETYLENE

1. Types of addition reactions. 95
2. The hydrogenation of acetylene. 95
3. The addition of hydrogen halides to acetylenes. 98
4. The addition of halogens and hypo-halites to acetylene. 101
5. The oxidation of acetylene. 109
6. The preparation of acetaldehyde by the catalytic addition of water to acetylene. 115
7. The preparation of alkali metal acetates and of acetone directly from acetylene. 123
8. The preparation of vinyl ethers and acetals by the addition of alcohols to acetylene. 126
9. The preparation of vinyl and ethylidene esters from acetylene. 129
10. The addition of sulfur and its compounds to acetylenes. 135
11. The addition of nitrogen and its compounds to acetylene. 135

CHAPTER V. THE POLYMERIZATION OF ACETYLENE AND CONDENSATION WITH CARBON COMPOUNDS

1. Types of polymerization and condensation reactions. 138
2. The condensation of acetylene to hydrocarbons which exhibit little unsaturation and are chiefly aromatic. 138
3. The condensation of acetylene to cuprene by copper and other metallic compounds. 147

CONTENTS

4. Polymerization of acetylene by physical means other than heat . .	150
5. The condensation of acetylene with other compounds of carbon .	153
6. The preparation of heterocyclic compounds from acetylene	156
7. The polymerization of acetylene by cuprous salt catalysts	160
8. Chloroprene	171
9. Polymerization of chloroprene	175
10. Properties and uses of neoprene	179
 AUTHOR INDEX	 185
 SUBJECT INDEX	 200

Chapter I

The Physical Properties, Preparation, and Purification of Acetylene

1. The physical and thermodynamic properties and the molecular structure of acetylene. Acetylene is a colorless gas, and when pure is said to have a slight, pleasant odor. The rather disagreeable odor of acetylene prepared from calcium carbide appears to be due to traces of impurities. Physiologically, acetylene acts as an anesthetic and the purified gas has been used for this purpose (1).

The reported critical temperature of acetylene is 36.5° (1*b*, 2-5), the critical pressure 61.6 atm (1*b*, 3), and the critical volume 83 cc (3). Liquid acetylene has been found to have a density of 0.451 at 0° and 0.613 at -80° (1*b*, 3, 5, 6). Under a pressure somewhat above one atmosphere solid acetylene is reported to melt at $-81-2^{\circ}\text{C}$. (1*b*, 3, 5, 7-10) and to sublime at $-83-4^{\circ}$ at atmospheric pressure (1*b*, 5, 7, 11). The vapor-pressure curve of acetylene has been plotted (3, 5, 10, 12-14). The properties indicate that acetylene like other simple hydrocarbons is not an associated substance. In this respect acetylene is totally unlike other simple labile hydrogen compounds, such as ammonia, hydrogen cyanide and water, which are associated because of hydrogen bonding to atoms of oxygen or nitrogen.

Villard (8) has reported the formation of a crystalline hydrate of acetylene, $\text{C}_2\text{H}_2 \cdot 6\text{H}_2\text{O}$, at low temperatures and increased pressure. This substance is frequently responsible for clogging acetylene pipe lines. Forcrand and Thomas (8*a*) also investigated several mixed hydrates of acetylene with halogenated hydrocarbons.

The absorption spectrum of acetylene and deuterioacetylene in both the infrared (15-36) and ultraviolet regions (37-43) has been extensively studied. The Raman effect in acetylene also has been the subject of numerous investigations (44-58). Herzberg, Patat and Spinks (26, 52) have deduced the bond lengths in acetylene from Raman spectrum data and report the C-H distance to be 1.058 Å and the C-C distance 1.199 Å. On the basis of electron diffraction measurements Pauling, Springall and Palmer (59) assign the values 1.058 Å for the C-H distance and 1.205 Å for the C-C distance. The optical data also point to a linear structure of the acetylene molecule (19, 58) as indicated in the ordinary structural formula. The zero dipole moment of some symmetrical disubstituted acetylenes may be cited in further confirmation of a linear structure in acetylenic compounds (60-62). Physical data of this type tend to dis-

prove the existence of acetylidene isomers of the acetylenes, which had been proposed by Nef and other investigators (63-66) and which had later been discredited on purely chemical grounds (67, 68). However, the existence of a small proportion of an acetylidene isomer in tautomeric equilibrium is a possibility (66).

The heat of formation of acetylene from graphite and hydrogen has been calculated by several methods (69-71) and an average value of $-54,900$ cal. per mol has been reported recently (72). The highly endothermic character of acetylene is the driving force behind many of its addition reactions, and gives it outstanding value as a gaseous fuel, but also is attended by the danger of explosive decomposition to the elements (see Chapter I, Sect. 5) which may be initiated by heat, electric sparks, or by the detonation of the metal acetylides formed under certain conditions (see Chapter II). The hazard of acetylene explosions has led to numerous recommendations and legal restrictions on its storage, shipping, and use (1a, 73). Numerous books, articles and reviews describe explosions of acetylene (see Ref. 1, Introduction, and Refs. 35, 41-53, Chapter I, Section 5). As a result of the hazardous nature of gaseous acetylene, especially under pressure, it is always stored in a solvent in cylinders filled with a porous solid (see Chapter I, Sect. 9).

References

- (1) Wieland and Gauss, *Klin. Wochenschrift*, **2**, 113 (1923). Horwitz, *Lancet*, **1**, 619 (1923). Boehringer and Wieland, *Brit. P.* 20, 241 (1923). Rimarski, *Z. angew. Chem.*, **38**, 409-12 (1925).
- (1a) *idem* "Acetylen in sicherheitstechnische Hinsicht," Halle (1925).
- (1b) Manson, "Tables de constantes de l'acetylene et de l'oxygene," Paris (1937) 48 pp.
- (2) Ansdell, *Proc. Roy. Soc. London*, **29**, 209 (1879).
- (3) McIntosh, *J. Phys. Chem.*, **11**, 306-17 (1907).
- (4) Cardoso and Baume, *Compt. rend.*, **151**, 141-3 (1910).
- (5) Maas and Wright, *J. Am. Chem. Soc.*, **43**, 1089-1111 (1921).
- (6) Cailletet, *Compt. rend.*, **85**, 851-2 (1877).
- (7) Ladenburg and Krugel, *Ber.*, **32**, 1818-32 (1899).
- (8) Villard, *Compt. rend.*, **120**, 1262-5 (1895); *Bull. soc. chim.*, (3) **13**, 997-8 (1895).
- (8a) Forcrand and Thomas, *Compt. rend.*, **125**, 109-11 (1897).
- (9) Willson and Suckert, *J. Franklin Inst.*, **139**, 327 (1896).
- (10) Hunter, *J. Phys. Chem.*, **10**, 330-60 (1906).
- (11) Burrell and Robertson, *J. Am. Chem. Soc.*, **37**, 2482-6 (1915).
- (12) *Idem*, Bur. Mines Tech. Paper 142 (1916).
- (13) Pollitzer, *Z. angew. Chem.*, **36**, 262-6 (1923).
- (14) Aries, *Compt. rend.*, **166**, 802-5 (1918).
- (15) Deslandres, *ibid.*, **181**, 387-92 (1925).
- (16) C. F. Meyer and Levin, *Proc. Nat. Acad. Sci.*, **13**, 298-302 (1927).
- (17) C. F. Meyer, Bronk and Levin, *J. Opt. Soc. Am.*, **15**, 257-65 (1927).
- (18) Levin and C. F. Meyer, *ibid.*, **16**, 137-64 (1928).
- (19) Hedfeld and Mecke, *Z. Physik*, **64**, 151-61 (1930); **66**, 241-5 (1930).
- (20) Childs and Mecke, *ibid.*, **64**, 162-72 (1930). Mecke, *ibid.*, **64**, 173-90 (1930).
- (21) Badger, *Phys. Rev.*, **35**, II, 1433 (1930).

- (22) Deslandres, *Compt. rend.*, **192**, 1417-21 (1931).
- (23) Hedfeld and Lueg, *Z. Physik*, **77**, 446-58 (1932).
- (24) Lochte-Holtgreven and Eastwood, *ibid.*, **79**, 450-4 (1932); *Nature*, **130**, 403 (1932).
- (25) Strong and Woo, *Phys. Rev.*, **42**, 267-78 (1932).
- (26) Herzberg, Patat and Spinks, *Nature*, **133**, 951 (1934).
- (27) Mecke, Ganswein and Vierling, *Z. Elektrochem.*, **40**, 474-5 (1934).
- (28) Herzberg and Spinks, *Z. Physik*, **91**, 386-99 (1934).
- (29) Sutherland, *Nature*, **134**, 775-6 (1934); *Phys. Rev.*, **43**, **II**, 883-6 (1933).
- (30) Bradley and McKellar, *Phys. Rev.*, **46**, 664-6 (1934), **47**, 914-17 (1935).
- (31) Funke and Herzberg, *ibid.*, **49**, 100 (1936).
- (32) Funke, *Z. Physik*, **99**, 341-52 (1936).
- (33) Ganswein and Mecke, *ibid.*, **99**, 189-203 (1936).
- (34) Mecke and Ziegler, *ibid.*, **101**, 405-17 (1936).
- (35) Funke, *ibid.*, **104**, 169-87 (1937).
- (36) Funke and Lindholm, *ibid.*, **106**, 518-31 (1937).
- (37) Hopfield, *Phys. Rev.*, **29**, 356 (1927).
- (38) Kistiakowsky, *ibid.*, **37**, 276-8 (1931).
- (39) Herzberg, *Trans. Faraday Soc.*, **27**, 378-84 (1931).
- (40) Rose, *Z. Physik*, **81**, 751-63 (1933).
- (41) Price, *Phys. Rev.*, **45**, 483-4 (1934); **47**, 444-52 (1935).
- (42) Jonesco, *Compt. rend.*, **199**, 710-13 (1934); **200**, 817-19 (1935).
- (43) Gopfert, *Z. wiss. Phot.*, **34**, 156-73 (1935).
- (44) Daure, *Trans. Faraday Soc.*, **25**, 825-8 (1929).
- (45) Venkateschar and Sibaiva, *Indian J. Physics*, **5**, 747-54 (1930).
- (46) Mecke and Hedfeld, *Z. Elektrochem.*, **36**, 803 (1930).
- (47) Segré, *Atti accad. Lincei*, **12**, 226-8 (1931); *C. A.*, **25**, 2641 (1931).
- (48) Bhagavantam, *Nature*, **127**, 817-8 (1931); **128**, 188 (1931); *Indian J. Physics*, **6**, 319-30 (1931); *C. A.*, **26**, 1190 (1932).
- (49) Daure and Kastler, *Compt. rend.*, **192**, 1721-3 (1931).
- (50) Mecke, *Z. physik. Chem.*, **B17**, 1-20 (1932).
- (51) Glockler and Davis, *J. Chem. Phys.*, **2**, 881-9 (1934); *Phys. Rev.*, **46**, 535 (1934).
- (52) Herzberg, Patat and Spinks, *Z. Physik*, **92**, 87-99 (1934).
- (53) Morino, *Sci. Papers Inst. Phys. Chem. Res. (Tokyo)*, **25**, No. 537, 232-4 (1934); *C. A.*, **29**, 2084 (1935).
- (54) Glockler and Morrell, *Phys. Rev.*, **47**, 569 (1935).
- (55) Herzberg, Patat and Verleger, *Z. Physik*, **102**, 1-22 (1936).
- (56) Glockler and Morrell, *J. Chem. Phys.*, **4**, 15-22 (1936).
- (57) Bhagavantam and Rao, *ibid.*, **4**, 293 (1936); *Proc. Indian Acad. Sci.*, **3A**, 135-9 (1936); *C. A.*, **30**, 4401 (1936).
- (58) Placzek, "Handbuch der Radiologie," Vol. 6, Part 2, Akademische Verlagsges Leipzig, 1934.
- (59) Pauling, Springall and Palmer, *J. Am. Chem. Soc.*, **61**, 927-37 (1939).
- (60) Smith and Zahn, *ibid.*, **47**, 2501-6 (1925).
- (61) Watson, Rao and Ramaswamy, *Proc. Roy. Soc. London*, **A143**, 558-88 (1934).
- (62) Wenzke and Allard, *J. Am. Chem. Soc.*, **56**, 858-60 (1934).
- (63) Carstanjen, *J. prakt. Chem.* (2), **4**, 419-26 (1871).
- (64) Nef, *Ann.*, **298**, 332-74 (1897); **308**, 264-328 (1899).
- (65) Lawrie, *Am. Chem. J.*, **36**, 487-510 (1906).
- (66) Ingold, E. H., *J. Chem. Soc.*, **125**, 1528-37 (1924).
- (67) Biltz, *Ber.*, **46**, 143-9 (1913); **60**, 2413 (1927).
- (68) Peratoner and Spallino, *Ber.*, **34**, 2718-22 (1901).
- (69) Berthelot, *Compt. rend.*, **82**, 24-30 (1876).
- (70) Thomsen, *Pogg. Ann.*, **148**, 384-404 (1873).
- (71) Mixer, *Am. J. Sci.* (4), **12**, 347-57 (1901); (4), **19**, 434-44 (1905); (4), **22**, 13-18 (1906).

- (72) Parks and Huffman, "The Free Energies of Some Organic Compounds," pp. 84-86, New York, Chemical Catalog Co., Inc. (Reinhold Publishing Corp.), 1932.
- (73) Rosemberg, "Recueil des règlements, prescriptions, recommandations concernant les industries du carbure de calcium, de l'oxygène, de l'acetylene et de la soudre autogène," Paris (1930) 141 pp.; *Chim. et ind.*, **23**, 1589 (1930). "Safety in the Manufacture and Use of Acetylene," International Labour Office Studies and Reports, Series F, Second Section, No. 5, King and Sons, Ltd., London. Bloch-See and Rosemberg, *J. acetylene*, No. **95**, 986-93 (1935). Bucar, *Rév. gén. mat. plastiques*, **14**, 3-5 (1938); *C. A.*, **32**, 4688 (1938).

2. A brief survey of the structure and synthesis of the acetylenic carbides.* The carbides of the alkali metals, M_2C_2 , and of the alkaline-earth metals, MC_2 , yield acetylene upon hydrolysis with water or treatment with various acidic substances. Under similar conditions the rare-earth carbides, MC_2 , yield mixtures of hydrogen and acetylene with ethylene, ethane (formerly reported as methane), and small proportions of higher aliphatic hydrocarbons. There is evidence that these carbides are all electrovalent compounds of the metals with the bivalent anion C_2 . All of them are solids of comparatively high melting point and very slight solubility in non-polar solvents. On the basis of x-ray studies of their crystal structure, the carbides of calcium, strontium, barium, lithium, cerium, praseodymium and neodymium are considered by Stackelberg (3) to have ionic lattices of a modified sodium chloride type in which the anion is the C_2 group. Investigations of the electrical conductivity of fused calcium carbide (4) and the electrolysis of lithium carbide and calcium carbide dissolved in the fused hydrides (5) show that these substances are ionized to the metal cation and the C_2 anion at high temperatures. The conductivity of sodium acetylide in liquid ammonia solution (6) and of compressed solid sodium carbide and lithium carbide (7) also tends to prove the electrovalent nature of these carbides. From the research of Damiens (8) it appears that the rare-earth carbides also may be principally simple compounds of the metals with the C_2 anion, and that the metals change from the bivalent state to a higher valence during hydrolysis, yielding acetylene and nascent hydrogen with subsequent hydrogenation and polymerization of a part of the acetylene to give complex and variable gas mixtures.

The acetylenic carbides of the alkali metals and of magnesium begin to decompose to their elements at relatively low temperatures. Probably for this reason these carbides may be made most readily through replacement of the hydrogen of acetylene at low temperatures by the metals (see Chapter II, Section 2). These carbides have not been made by the

* The literature has been briefly reviewed by Moissan (1) and Putnam and Kobe (2).

action of the metal oxides on carbon, and have been prepared with difficulty and in an impure state by the action of carbon or carbon compounds on the metals. A mixture of potassium carbide with much excess carbon was probably obtained by E. Davy (9) on heating acid potassium tartrate with carbon; and the hydrolysis of this material yielded a gas having a composition and properties which indicate that it was acetylene. This is the earliest recorded preparation of acetylene (1837). Parsons (18a) claimed that sodium carbide was produced in mixture with boron carbide upon heating sodium tetraborate with carbon at about 1200°. The action of sodium, potassium, rubidium and cesium on carbon at 400–800° has been studied (10, 11, 12) without obtaining evidence of the formation of acetylenic carbides in appreciable quantities. Moissan (13) states that sodium carbide begins to decompose at about 400° and considers its synthesis from sodium and carbon impracticable; but later workers (14) claim that small quantities can be prepared at higher temperatures, presumably as an equilibrium mixture with the metal and carbon. Baimakov (18) has investigated the formation of sodium carbide on a carbon cathode during the electrolysis of fused sodium halides. Lithium carbide was isolated by Moissan (15) upon heating lithium carbonate with carbon in an electric tube furnace until the vapor of metallic lithium just began to be evolved. Guntz (16) was unable to prepare it by a similar method, but obtained it from lithium and carbon at a dull red heat, at which temperature some decomposition took place. Antropoff and Müller (7) state that the decomposition of lithium carbide begins at 300°. Moissan (13) proved that the carbide MgC_2 was decomposed in the electric furnace and the work of later investigators (17) on the reaction of carbon with magnesium oxide at high temperatures shows that little or no carbide is formed. However it has also been claimed (18, 19) that a small proportion of magnesium combines with carbon at lower temperatures.

Another method of preparing somewhat impure samples of these thermally unstable carbides consists in heating the metals in a stream of a gaseous carbon compound, such as an oxide of carbon, a hydrocarbon, or an organic oxy-derivative. Thus lithium carbide was made by Guntz (16) from lithium and ethylene, carbon monoxide, or carbon dioxide. Earlier work (20) on the reactions of gaseous carbon compounds with heated magnesium has been reviewed and explained by Novak (19), who treated magnesium with various hydrocarbon gases at 400–800°. He obtained mixtures of two carbides, MgC_2 predominating in the lower temperature range and yielding acetylene on hydrolysis, and Mg_2C_3 reaching a maximum of 74 per cent in the product from pentane and magnesium at 700° and yielding methylacetylene on hydrolysis. Above 800° little carbide of magnesium appears to be formed (19, 21). From their mode of formation

it is evident that the carbides of the alkali metals and of magnesium are of little possible value as primary sources of acetylene, although the carbide Mg_2C_3 might serve as a source of methylacetylene.

The carbides of the rare-earth metals, on the other hand, are quite stable at high temperatures and have been made by heating the metal oxides with carbon, usually in an electric tube furnace (22). Damiens (23) has reviewed the methods of preparation of these carbides and the earlier explanations of the origin of the mixed gaseous products derived from them. However, the rare-earth carbides are entirely unsuitable for the practical production of acetylene, because of the mixed gases produced by their hydrolysis and because of the scarcity of these elements.

Barium carbide was first prepared by Maquenne (24) on heating barium carbonate with magnesium powder and carbon, although he did not succeed in making the carbides of strontium or calcium in this way. Moissan (25) prepared small quantities of barium and strontium carbides from the metal oxides and carbon in the electric tube furnace. Thompson (27) has studied the equilibrium of barium oxide and carbon with barium carbide and carbon monoxide at 1145° and 1295°, and the easy reduction of barium oxide as compared to the other alkaline-earths has been demonstrated by F. Fischer (28) at 850–1150°. A few patents on the production of barium carbide exist (29, 30, 31), including a method of firing a mixture of coal with barium oxide in a suitable furnace. After hydrolyzing the barium carbide to produce acetylene, it was proposed to recover the barium hydrate and return it to the carbide furnace.

Calcium carbide possesses so many advantages, both from the manufacturing viewpoint and in the abundance and low equivalent weight of calcium, that it has become almost the sole commercial source of acetylene and is accorded a more extensive treatment in the following section.

References

- (1) Moissan, "The Electric Furnace," The Chemical Publishing Co., Easton, Pa. 2nd ed., 1920.
- (2) Putnam and Kobe, *Chem. Rev.*, **20**, 131–43 (1937).
- (3) Stackelberg, *Naturwiss.*, **18**, 305–6 (1930); *Z. physik. Chem.*, **9**, B 437–75 (1930); *Z. Elektrochem.*, **37**, 542–5 (1931).
- (4) Hanekop, *Z. angew. Chem.*, **12**, 592–5 (1899).
- (5) Guntz and Benoit, *Compt. rend.*, **176**, 970–1 (1923).
- (6) Skossarevsky, *Compt. rend.*, **159**, 769–71 (1914); *J. chim. phys.*, **13**, 3–17 (1915).
- (7) Antropoff and Müller, *Z. anorg. Chem.*, **204**, 305–14 (1932). Müller, Thesis, "Ueber die elektrische Leithaftigkeit und den Verbindungs Typus der Alkali Carbide," Bonn (1931).
- (8) Damiens, *Compt. rend.*, **157**, 214–6 (1913); *Bull. soc. chim. (4)*, **15**, 370–2 (1914); *Ann. chim. (9)*, **10**, 137–83 (1918).
- (9) E. Davy, *Ann.*, **23**, 144–6 (1837); *B. A. Rep.* 62 (1836); *ibid.*, 60 (1837); *Proc. Irish Acad.*, **1**, 88 (1837); *Trans. Irish Acad.*, **18**, 80 (1838); *Thomson's Records*, **4**, 321 (1836).

- (10) Fredenhagen and Cadenbach, *Z. anorg. Chem.*, **158**, 249-63 (1926).
 (11) Fredenhagen and Suck, *ibid.*, **178**, 353-65 (1929).
 (12) Tammann and Sworykin, *ibid.*, **168**, 218-20 (1927).
 (13) Moissan, *Bull. soc. chim. (3)*, **19**, 865-70 (1898); *Compt. rend.*, **126**, 302-8 (1898).
 (14) Guernsey and Sherman, *J. Am. Chem. Soc.*, **47**, 1932-40 (1925); *ibid.*, **48**, 140-6 (1926). Hackspill and Schwarz, *Ann. chim. (10)*, **13**, 5-39 (1930). Ylla Conte, German P. 526, 627 (1930); *C. A.*, **25**, 4808 (1931).
 (15) Moissan, *Compt. rend.*, **122**, 362-3 (1896); *Bull. soc. chim. (3)*, **17**, 260-1 (1897).
 (16) Guntz, *Compt. rend.*, **123**, 1273-5 (1896); *ibid.*, **126**, 1866-8 (1898); *Bull. soc. chim. (3)*, **15**, 756 (1896).
 (17) Lebeau, *Compt. rend.*, **144**, 799-801 (1907). Watts, *Trans. Am. Electrochem. Soc.*, **11**, 279-89 (1907). Slade, *J. Chem. Soc.*, **93**, 327-33 (1908).
 (18) Baimakov, *Tsvetnye Metal.*, **14**, No. 7, 84-8; *C. A.*, **34**, 3180 (1940).
 (18a) Parsons, U.S.P. 1,473,510 (1923); *C. A.*, **18**, 447 (1924).
 (19) Novak, *Ber.*, **42**, 4209-13 (1909); *Z. phys. Chem.*, **73**, 513-46 (1910).
 (20) Keiser, *J. Franklin Inst.*, (1895); *Am. Chem. J.*, **18**, 328-32 (1896).
 (21) Treadwell and Hartnagel, *Helv. Chim. Acta*, **17**, 1372-84 (1934).
 (22) Pettersson, *Ber.*, **28**, 2419-27 (1895). Moissan, *Compt. rend.*, **122**, 357-62 (1896); **123**, 148-51 (1896); **131**, 591-600, 924-6 (1900); *Bull. soc. chim. (3)*, **15**, 1293-6 (1896); **(3)**, **17**, 261-6 (1897). Moissan and Etard, *Bull. soc. chim. (3)*, **15**, 1271-5 (1896); *Compt. rend.*, **122**, 573-7 (1896). Damiens, *Compt. rend.*, **157**, 214-6 (1913); *Bull. soc. chim. (4)*, **15**, 370-2 (1914); *Ann. chim. (9)*, **10**, 330-52 (1918). Lebeau and Damiens, *Compt. rend.*, **156**, 1987-9 (1913). Fichter and Scholly, *Helv. Chim. Acta*, **3**, 164-72 (1920). Schmahl, *Z. Elektrochem.*, **40**, 68-70 (1934).
 (23) Damiens, *Ann. chim. (9)*, **10**, 137-83 (1918).
 (24) Maquenne, *Compt. rend.*, **114**, 361-2 (1892); *ibid.*, **115**, 558-61 (1892); *Bull. soc. chim. (3)*, **7**, 370-1, 773-7 (1892).
 (25) Moissan, *Bull. soc. chim. (3)*, **11**, 1007-10 (1894); *Ann. chim. phys. (7)*, **9**, 247-64 (1896).
 (27) Thompson, *Trans. Am. Electrochem. Soc.*, **54**, 91-106 (1928).
 (28) F. Fischer, *Brennstoff-Chem.*, **9**, 328-33 (1928).
 (29) Limb, *Brit. 7282* (1899); *J. Soc. Chem. Ind.*, **20**, 463 (1901). German P. 130,664 (1902); *Chem. Zentr.*, **1902**, I, 1082. German P. 176,615 (1906); *Chem. Zentr.*, **1906**, II, 1669.
 (30) Ylla Conte, French P. 654,966 (1928); *C. A.*, **23**, 3780 (1929).
 (31) Internat. Ind. and Chem. Co., French P. 682,479 (1928); *C. A.*, **24**, 4362 (1930).

3. The manufacture of calcium carbide.* Hare (1) and Deville and Debraye (2) at an early date probably obtained mixtures containing calcium carbide by heating lime with carbon. Wöhler (3) prepared the carbide from carbon and a zinc-calcium alloy, and was the first to recognize the nature of the compound and to identify acetylene as the gaseous product of its hydrolysis. For almost thirty years after this synthesis no further important work on calcium carbide was reported. In 1893 Willson (4) was granted a United States patent for the production of calcium carbide from lime and coke in the electric furnace according to the equation, $\text{CaO} + 3\text{C} \rightarrow \text{CaC}_2 + \text{CO}$. At about the same time Boehm (5), Moissan (6) and Bullier (7) made the carbide by somewhat similar methods. The

* For reviews see Introduction (1, 2).

priority claims of Willson were sustained, and it is generally conceded that he initiated the commercial development of calcium carbide in America. The conflicting claims of these workers and the early history of the development have been discussed by Eimer (8) and in several publications on calcium carbide.*

Calcium oxide and some form of carbon are the usual raw materials which enter into the synthesis of calcium carbide in the electric furnace. The calcium oxide is prepared by calcining limestone or hydrated lime, which sometimes is recovered from acetylene generators. Special treatises* on carbide manufacture have described numerous variations in the composition and pretreatment of the furnace charge. As sources of carbon, besides coke or anthracite, a number of much less suitable carbonaceous materials, including charcoal, bituminous coal, lignite, bitumen, pitch, tar, peat and wood waste have been suggested. However in modern industrial practice coke is employed almost exclusively. Domenico (19) has shown that a coke of high electrical resistivity gives best results in modern furnaces.

To a very limited extent other compounds of calcium have been employed in the manufacture of calcium carbide. When calcium phosphate is heated with sufficient carbon in the electric furnace, phosphorus is obtained by volatilization, while calcium carbide remains in the furnace as a by-product. This process has been investigated and developed by a number of workers (9). Similarly sulfur and calcium carbide have been obtained from calcium sulfate and carbon (10), and calcium carbide and carbon disulfide from calcium sulfide and carbon (11). The quantity of calcium carbide originating as a by-product in these processes is of course small as compared to the total production.

For the manufacture of calcium carbide as a source of high-grade acetylene, coke and lime containing only minimum quantities of phosphorus, nitrogen, sulfur and arsenic are desired, since these lead to impurities in the gas (see Section 4). Silicon and iron as impurities influence the course of the reaction (12) and often yield ferrosilicon. Magnesium oxide has a deleterious effect in increasing the temperature of the furnace charge and the energy consumption (13).

In the ordinary type of carbide furnace heat is generated by the passage of an electric current between electrodes of carbonaceous matter and directly through the highly resistant charge of raw materials. Furnaces in which the heat is supplied wholly or in part by an arc or by a separate resistance unit have been used occasionally. Descriptions of the earlier

* See Introduction (1, 2).

forms of carbide furnaces may be found in special works on carbide manufacture.* The larger modern furnaces have been described in a number of journal articles (14), and more recent minor improvements and modifications are the subject of patents too numerous for inclusion in the present work.

The energy consumption in the manufacture of calcium carbide varies with a number of factors, such as size and construction of the furnace and percentage of carbide in the final product; but yields of approximately one ton per 4000 kilowatt hours usually have been reported. Power consumption and yields have been discussed by several writers (15).

The reaction in the electric furnace begins near the melting point of the eutectic between calcium oxide and calcium carbide and takes place chiefly between this molten material and the suspended solid particles of carbon. In the absence of impurities the eutectic is said to contain about 32 per cent of calcium oxide, but in the presence of ordinary impurities the eutectic holds about 30 per cent of calcium oxide and melts at about 1630°. When the reaction has progressed to the point that calcium carbide forms over 70 per cent of the total fused material the melting point rises towards that of pure calcium carbide, about 2300°. As a result, when the reaction nears completion, increased temperature is needed to maintain the reactive fused condition. However, as the melting point approaches that of pure carbide (about 2300°), decomposition of the carbide to calcium and carbon begins, and the energy consumed in maintaining the higher temperature increases costs. For these reasons a product containing more than 90 per cent calcium carbide is seldom made commercially (16) and in some cases it is cheaper to make acetylene from 70- to 80-per cent carbide. It has been shown that the reaction, $\text{CaO} + 3\text{C} \rightarrow \text{CaC}_2 + \text{CO}$, is to some extent reversible and is influenced by the partial pressure of carbon monoxide. These factors influencing reactions in the furnace have been discussed in several technical articles (17).

Since in this process the volume of carbon monoxide produced approximately equals that of the acetylene, the recovery and use of gases from the electric furnace are economically important and have received much study (18).

It has been proposed (20) to prepare calcium carbide and other alkaline earth carbides by heating the corresponding hydrides to 1750–2000° in the presence of carbon. Somewhat similar methods consist of heating an alkaline earth metal chloride (20) or carbonate (21) with hydrogen or ammonia in the presence of carbon.

* See Introduction (1, 2).

References

- (1) Hare, *L'Institut*, **1840**, 312; *Am. J. Sci. (1)*, **37**, 269 (1839).
- (2) Deville and Debraye, *Ann. mines (5)*, **16**, 1 (1859); *Jahresber. über die Fortschritte der Chemie*, **1859**, 254-6.
- (3) Wöhler, *Ann.*, **124**, 220 (1862).
- (4) Willson, U. S. P. 492,377 (1893); *Progress Age*, **1898**, 51; *Am. Manufactures*, **1898**, Dec., 16; *Brit. P.* 16,342 (1894), 16,705 (1894); *J. Soc. Chem. Ind.*, **15**, 103 (1896); *Brit. P.* 15,360 (1895); *ibid.*, **15**, 582 (1896). Willson and Suckert, *J. Franklin Inst.*, **139**, 221 (1895).
- (5) Boehm, U. S. P. 552,026 (1895); *Mineral Industry*, **9**, 64 (1901); *Technologist*, **6**, 9, 265 (1901).
- (6) Moissan, *Compt. rend.*, **115**, 1031-3 (1892); *ibid.*, **118**, 501-6 (1894); *Bull. soc. chim. (3)*, **11**, 1002-7 (1894).
- (7) Bullier, German P. 77,168 (1894); *Chem. Zentr.*, **1895**, **I**, 191.
- (8) Eimer, *Trans. Am. Electrochem. Soc.*, **51**, 73-8 (1927).
- (9) Hilbert and Frank, German P., 92,838 (1895); *Chem. Zentr.*, **1897**, **II**, 878. Morehead, U. S. P. 862,092 (1907); *C. A.*, **1**, 3066 (1907). Yasuda, *Jap. P.* 35,560 (1919); *C. A.*, **14**, 3023 (1920). Soc. d'études chimiques pour l'industrie, French P. 675,411 (1929); *C. A.*, **24**, 2842. Swiss P. 134,612 (1928); *C. A.*, **24**, 1709 (1928). Seyfried, U. S. P. 1,777,582 (1930); *Brit. Chem. Abs.*, **1931B**, 537.
- (10) Jacobsen, German 89,959 (1895); *Chem. Zentr.*, **1897**, **I**, 528. Limb, German P. 117,920 (1899); *Chem. Zentr.*, **1901**, **I**, 427. Voiret, French P. 712,603 (1931); *C. A.*, **26**, 2021 (1931).
- (11) Harrison, *Brit. P.* 477,100 (1937); *C. A.*, **32**, 4290 (1938).
- (12) Krylov, *Metallurg*, **12**, No. 7, 15-24 (1927); *C. A.*, **32**, 6157 (1938).
- (13) Aall, *Compt. rend.*, **204**, 1340-1 (1937).
- (14) Allmand and Williams, *J. Soc. Chem. Ind.*, **38**, 303-4R (1919). Anon., *Engineering*, **87**, 405, 443, 477, 522, 546, 729 (1909). Anon., *J. four electr.*, **36**, 165-7 (1927). Bergeron, *Bull. soc. Franc. elec.*, **6**, 75-80 (1925); *Rev. gen. elec.* **22**, 797-802 (1927). Mantel, "Industrial Electrochemistry," pp. 405-24 (1931). Meneghini, *Atti ist. Veneto sci.*, **94**, 587-96 (1935).
- (15) Flusin, *Eng. Mining J.*, **107**, 479 (1918). Brunet, *Rev. gen. elec.*, **5**, 913-23 (1920). Furasuki, *J. Chem. Ind. Japan*, **25**, 24-36 (1922). Baumann, *Chem. Ztg.*, **50**, 629-31 (1926). Schlumberger, *ibid.*, **50**, 676 (1926); *Z. angew. Chem.*, **40**, 141-6 (1927). Gal, *Chem. Ztg.*, **51**, 251-2 (1927). Danneel, *Z. Elektrochem.*, **36**, 474-82 (1930).
- (16) Aktiengesellschaft für Stickstoffdünger, French P. 809,308 (1937); *C. A.*, **31**, 6566 (1937).
- (17) Ruff and Foerster, *Z. anorg. allgem. Chem.*, **131**, 321-47 (1923). Ruff, *Z. Elektrochem.*, **30**, 356-64 (1924). Ruff and Josephy, *Z. anorg. allgem. Chem.*, **153**, 17-32 (1926). Schlumberger, *Chem. Ztg.*, **50**, 976 (1926); *Z. angew. Chem.*, **39**, 213-20 (1926); *ibid.*, **40**, 141-6 (1927). Danneel, *Z. Elektrochem.*, **36**, 474-82 (1930). Dutoit and Rossier, *J. chim. phys.*, **29**, 238-41 (1932).
- (18) Morehead, U. S. P. 825,234 (1907); *C. A.*, **1**, 115 (1907). Schläpfer, *Z. Elektrochem.*, **25**, 409-14 (1919). Soc. anon. l'exploitation brevets Jullien, French P. 699,459 (1929); *Fr. P.* 668,579 (1929); *C. A.*, **24**, 1586 (1930); *C. A.*, **25**, 3256 (1931). Hilger, German P. 522,573 (1925); *C. A.*, **25**, 3578 (1931); *Ger.* 541,395 (1929); *C. A.*, **26**, 1866 (1932); *Ger.* 580,262 (1933); *C. A.*, **27**, 4744; *Ger. P.* 596,170 (1934); *C. A.*, **28**, 4321 (1934). Hibi, *Jap. P.* 90,215 (1931); *C. A.*, **25**, 2928 (1931). Cartoux, *Chaleur et ind.*, **19**, 419-21 (1938); *C. A.*, **32**, 6951 (1938).
- (19) Domenico, *Boll. cent. Volpi elletrologia*, No. 2, 11-12 (1938).
- (20) Gardener, *Brit. P.* 496,294 (1938); 496,295 (1938); *C. A.*, **33**, 3541-2 (1939).
- (21) Pincas, *Chem. Age*, **37**, 169-70; *C. A.*, **31**, 8839 (1937).

4. **The generation and purification of acetylene from carbides.*** The acetylenic carbides described in the preceding sections were found by the earliest investigators to react rapidly with water, giving acetylene and the corresponding metallic hydroxides. The heat of hydrolysis (1) may produce localized temperatures high enough to polymerize a part of the acetylene, unless overheating is prevented by the use of excess water or by some other means. The hydrolysis of calcium carbide has of course been studied most thoroughly, and the heat of this reaction has been reported by Lewes (2) to be about 475 cal. per gram of pure carbide, and by Mason, Anderson, and Jane (5) as 166 Btu per cubic foot of acetylene generated. Lewes (2) claimed that when a minimum of water reacts with a mass of carbide a part of the acetylene may react with steam to give carbon monoxide and hydrogen; and in a few cases localized decomposition of acetylene to hydrogen and carbon has been reported.

Besides moisture, air, finely divided solids, and condensation products resulting from overheating, the crude acetylene also may be contaminated with a small percentage of other gases arising from impurities in commercial carbide* (3). Nitrogen, sulfur, phosphorus, silicon and arsenic may be present in carbide in combination with calcium or other metals. On treatment with water the hydrides, ammonia, phosphine, silicomethane and arsine, may be evolved to some extent, while most of the hydrogen sulfide is held in the alkaline solution. Modern methods of carbide manufacture minimize these impurities by careful control of the composition of the charging materials. Analysis of acetylene generated from a typical modern carbide is said to show the presence of .015-.025 per cent of phosphine, less than .015 per cent of ammonia, less than .01 per cent of hydrogen sulfide, and less than .0003 per cent of arsine. At the high temperatures occurring when little water is present during the hydrolysis of calcium carbide, the simple hydrides above noted if present may be condensed with acetylene to give volatile organic derivatives which are difficult to remove. Kennedy and Holm (16) have identified divinyl sulfide as an important impurity, and state that more is present if the temperature of hydrolysis of the carbide is high. They have suggested removal of this impurity by scrubbing with Chloramine T or sulfuric acid. Hydrogen is sometimes present in very small quantities. Methods for the estimation of impurities in crude acetylene have been reviewed by Brown (4) and others.†

A high reaction temperature during the hydrolysis of carbides results in a decomposition and condensation of the acetylene which both con-

* The generation of acetylene from carbide, and the impurities and purification of the gas have been extensively discussed in special treatises; see Introduction (1, 2).

† See Introduction (1, 2).

taminates the product and reduces the yield. Accordingly, it has been the commonest practice to prepare acetylene by the total immersion of calcium carbide in a comparatively large volume of water which acts as a cooling medium. Methods and devices for the hydrolysis of calcium carbide by this method have been studied extensively, but most of the technical literature* covers small automatic generators for local or domestic acetylene supply.

Recently Mason, Anderson and Jane (5) have described a large-scale method of hydrolyzing calcium carbide using little more than an equivalent quantity of water, which is based to some extent on earlier methods (6). This procedure consists in spraying the crushed carbide either in a ball mill or in a rotating screen drum with a minimum of water, and continuously separating the powdered calcium hydrate. By this method localized overheating is prevented and no temperature above 240°F was observed. A few other recent patents and articles (7) describe the hydrolysis of calcium carbide with a minimum of water. The Prestolite Company controls United States patents (7a) on a process and apparatus by which water is brought into reaction with calcium carbide near the bottom of a cylindrical reaction chamber, provided with an agitator rotated about a vertical axis. The acetylene and powdered calcium hydroxide rise to the top of the cylinder, and in one modification the powdered hydroxide, which overflows the top of the cylinder fills an annular seal similar to a liquid seal. If the recovered dry hydrate could be converted to a briquet or lump form (8), it could be used profitably for calcium carbide manufacture. Since in some localities the accessible supply of limestone suitable for carbide manufacture is somewhat limited, recovery of the calcium hydroxide is of interest.

Even when prepared in the best type of generator from a good grade of carbide, commercial acetylene usually contains traces of impurities. These are said not to be deleterious in the gas used for welding or cutting (11, 12) but may act as poisons for the catalysts employed in the chemical utilization of acetylene. For some purposes it has been common practice to oxidize these impurities, particularly phosphine, by reagents which scarcely attack acetylene and to remove the acidic oxidized products by contact with alkalis or by precipitation. Solutions or porous masses containing calcium hypochlorite or potassium permanganate were at one time used or proposed, and masses containing chromic acid appear to have been extensively used in Europe. A purifying material, which was originally patented by Granjon (15) and which is at present used in the U. S., consists of a mixture of ferric chloride, ferric oxide, manganese dioxide, mercuric chloride, and cupric sulfate. The mercuric chloride appears to bind the

* See Introduction (1, 2).

phosphine in a complex which is then oxidized by the ferric salts, and the cupric sulfate catalyzes the reoxidation of the ferrous salts by air and thus regenerates the purifying material. This method is said to remove 95 per cent of the phosphine. At the present time nitre cake is said to be used also in the commercial purification of acetylene. Oxidation of phosphine by sulfuric acid of about 85 per cent concentration at about 70° is reported to be an industrial method of purification. Methods of evaluating commercial preparations for the purification of acetylene and some comparative tests on such materials have been published (9, 13, 14). An older proposed method of purification consisted in the complete precipitation of these impurities by cuprous chloride or mercuric chloride with other chloride salts. However, these solutions are not perfectly inert toward acetylene, and a small percentage of volatile addition products usually was formed. The drying of acetylene by refrigeration, or by the use of aluminum oxide with proper precautions, or by countercurrent washing with saturated calcium chloride solution are said to be accepted industrial practices.

There is reason to believe that a trace of oxygen is a very important impurity in acetylene to be used in certain syntheses, but this possibility has received little attention. A small quantity of oxygen is known to be very deleterious in the preparation of vinylacetylene, and probably has effects in the polymerization, halogenation and hydration of acetylene. The acetylene mixtures prepared by pyrolytic processes are probably more nearly free from oxygen than acetylene derived from carbide. Both commercially and in the laboratory, oxygen can best be removed from acetylene by washing with an aqueous alkaline solution of sodium hydro-sulfite containing a small percentage of anthraquinone β -sulfonic acid (10).

Gaseous hydrocarbons, carbon monoxide and hydrogen are much more difficult to remove from acetylene; the total elimination of these impurities is not attempted commercially, since they are not particularly detrimental in the use of acetylene either as a fuel or for chemical synthesis.

References

- (1) Fal'kevich, *Khimstroï*, **6**, 442-5 (1934).
- (2) Lewes, *J. Soc. Chem. Ind.*, **17**, 532-42 (1898).
- (3) Willgerodt, *Ber.*, **28**, 2107-8 (1895). Lunge and Cedercreutz, *Z. angew. Chem.*, **10**, 651-5 (1897). Moissan, *Compt. rend.*, **127**, 457-63 (1898); *Ann. chim. phys.* (7), **18**, 343-51 (1899). Wolff, *Z. angew. Chem.*, **11**, 931-41 (1898). Caro, *J. Gasbeleuchtung*, **42**, 616-7 (1899); *Chem. Zentr.*, (1899) II, 642. Keppeler, *J. Gasbeleuchtung*, **45**, 777-82, 802-5, 820-25 (1902); *Chem. Zentr.*, **1902**, II, 1484-5. Bullier and Maquenne, *Rev. gen. de chimie pure et appl.*, **6**, 348-50 (1903); *Chem. Zentr.*, **1903**, II, 643.
- (4) Brown, Carnegie-Illinois Steel Company, Pamphlet (1927); *C. A.*, **21**, 3327 (1927).
- (5) Mason, Anderson and Jane, *Can. Chem. Met.*, **19**, 183-6, 192 (1935).

- (6) Dolan, U. S. P. 638,448 (1899). Dickinson, U. S. P. 604,139 (1898); U. S. P. 671,693 (1901). Davies, U. S. P. 701,852 (1902). Gibbs, "Lighting by Acetylene," p. 89, (1899).
- (7) Weibezahn and Walter, U. S. P. 1,947,120 (1934); *C. A.*, **28**, 2371 (1934). U. S. P. reissue 20, 527 (1937); *C. A.*, **31**, 8549 (1937). Mues (to I. G. Farbenind. A.-G.), U. S. P. 2,122,889 (1938); *C. A.*, **32**, 6842 (1938). I. G. Farbenind A. G., Ger. P. 648,687 (1937); *C. A.*, **31**, 8549 (1939). Mues, *Z. Kompr. fluss. Gase*, **33**, 57-60 (1937); *C. A.*, **33**, 6093 (1939). Bayerische Stickstoff-Werke A. G. (Wilm, Volkmann and Kaess, inventors) Ger. P. 67,303 (1939); *C. A.*, **33**, 6349 (1939). Auto-genwerk Sirius G.m.b.H. (Becker, inventor) Ger. P. 673,779 (1939); *C. A.*, **33**, 6099 (1939).
- (7a) Kojolo and O'Brian, Brit. P. 483,601 (1938); *C. A.*, **32**, 7249 (1938); U. S. P. 2,204,184 (1940); *C. A.*, **34**, 6948 (1940). O'Brian, U. S. P. 2,189,762 (1940); *C. A.*, **34**, 3956 (1940). Ness and Kojolo (to Prestolite Co.) U. S. P. 2,233,108 (1941), 2,233,109 (1941); *C. A.*, **35**, 4942 (1941).
- (8) Winter and Hartmann, U. S. P. 2,017,558 (1935); *C. A.*, **29**, 7834 (1935).
- (9) Sumiya and Yamada, *J. Chem. Soc. Japan*, **33**, 527-9 (1930); *C. A.*, **25**, 1360 (1931).
- (10) Fieser, *J. Am. Chem. Soc.*, **46**, 2639-47 (1924).
- (11) Rimarski, Kantor and Streb, *Forsch. Gebiete Ingenieurw.*, No. 317 (1929).
- (12) Holzhaüser, *Autogene Metallbearb.*, **23**, 286-96 (1931); **24**, 192 (1931); *C. A.*, **25**, 3302 (1931).
- (13) News Bulletin of the Compressed Gas Manuf. Assoc., July 21 (1931), New York.
- (14) Sherun, Chem. Fabrik (1938), 207-10.
- (15) Granjon, Fr. P. 434,137; U. S. P. 1,074,501 (1913); *J. l'Acetylene*, (1934), 457-61.
- (16) Kennedy and Holm, *Can. Chem. Process Inds.*, **23**, 490-5 (1939).

5. The equilibrium of acetylene with carbon and hydrogen and its bearing on the direct synthesis, decomposition and storage of acetylene. Berthelot (1) prepared small quantities of acetylene by means of an arc between carbon electrodes in an atmosphere of hydrogen. Dewar (2) concluded that this reaction resulted solely from the high temperature attained. The equilibrium of carbon and hydrogen with acetylene has been investigated by a number of workers (3-7, 9-11). In the equilibrium mixtures produced, either from acetylene or from the elements, little acetylene appears to exist between 1000° and 1700°, and above 1700° the concentration increases with rising temperature up to a point at which the equilibrium changes because of the formation of atomic hydrogen. Frost (12) states that considerable yields can be obtained only in the region of 3100° to 3200°. The continuous formation of acetylene in this high temperature range may be due in part to a tendency of complex carbon structures to break down under these conditions into C₂ groups rather than into any other simple units. The proportion of acetylene recoverable from the carbon arc in hydrogen has been reported as about seven to eight per cent. Since a higher concentration of acetylene can be made by the pyrolysis of hydrocarbons, the synthesis of acetylene from the elements has not usually been considered suitable for commercial application, although Brading (13) has patented an arc apparatus for this purpose. A somewhat related method consists in cracking hydrocarbons in the electric arc in the presence of finely divided carbon (22).

Of greater practical significance is the fact that acetylene, being an endothermic compound, can decompose to its elements with the evolution of heat. The decomposition at pressures not much above one atmosphere will first be considered. Berthelot (14) noted that at atmospheric pressure and a dull red heat in vessels of inert material, polymerization was the principal reaction of acetylene (see Chapter V, Section 2), while at somewhat higher temperatures the polymerization was associated with decomposition to carbon and hydrogen. He considered that this decomposition took place through a mechanism involving the formation and total dehydrogenation of polymers. Haber (15) observed that heat was evolved during these reactions. It was later found that the decomposition of acetylene was practically complete in the range 1150° – 1325° (7, 16), and that noticeable decomposition began in porcelain tubes at about 480° and became the chief reaction at 800° (9).

Several metals have been found to increase the rates of polymerization or decomposition and to influence somewhat the nature of the products. Some of these metals, when finely divided, have also been reported to initiate the reactions at comparatively low temperatures. Thus Moissan and Moureau (17) found that pyrophoric iron, nickel and cobalt, and finely divided platinum became incandescent when placed in a rapid stream of acetylene at room temperature, and noted the formation of hydrogen, carbon and oily products. Since these reactions are promoted by increased heat and pressure, it appears probable that the catalytic effect of metals is at least partly due to the localized heat of adsorption of the acetylene and also to the high concentration of acetylene in the adsorbed layer. Berthelot (8) first discovered the catalytic decomposition of acetylene by iron. A similar effect of iron, nickel and cobalt has been observed by several workers at temperatures between 200° and 400° (18–23). Extensive decomposition of acetylene in contact with iron has been noted at higher temperatures (24–28), and a few iron compounds have been found to produce a similar effect (29, 30). Finely divided platinum (18, 31) and palladium (32) have been reported to induce the decomposition of acetylene at moderate temperatures. Copper and to a lesser extent a few other metals cause the condensation of acetylene to cuprene at about 250° (see Chapter V, Section 3), but the catalytic decomposition of acetylene over copper at somewhat higher temperatures has been observed also (21, 25, 27, 33, 34). Manganese (21) was found to promote acetylene decomposition above 480° . Most of these reactions were accompanied by hydrogenation and the appearance of traces of oily condensation products of acetylene. In many cases particles of the metals became distributed throughout the carbon deposits, so that coating of the metal with carbon did not completely stop the catalytic effect. Metals other than those mentioned above appear to have little effect on the rate of decomposition of acetylene (8). The effect

of the various forms of carbon on acetylene decomposition is naturally difficult to determine, and has been the subject of seemingly conflicting reports. Schlapfer and Brunner (35) considered that carbon accelerates the decomposition of acetylene. The catalytic effect of various substances on acetylene decomposition has been reviewed by Egloff, Lowry and Schaad (36).

As a result of these studies it is obvious that only substances which do not catalyze the decomposition of acetylene should be used in apparatus for the pyrolytic processes of manufacturing acetylene, to be discussed in Section 7. To prevent catalytic deposition of carbon in apparatus of this type, several materials of construction or special coatings have been patented, including an alloy of iron and chromium (37), a coating of tungsten, molybdenum, osmium or tantalum, or their alloys or carbides (38), a coating of molybdenum, tantalum or chromium (39, 40), and a process for treating the surface of apparatus at high temperatures with boron, silicon, phosphorus, arsenic, antimony, bismuth or selenium, or their compounds (40).

At pressures somewhat above one atmosphere a decomposition which is initiated in any part of a mass of acetylene may spread through the whole body of the gas with explosive violence. Propagation of the explosion may be prevented if the heat of localized decomposition is rapidly dissipated, as for example by the cooling effect of a narrow tube or of packing material. Berthelot and Vielle (41) showed that at above two atmospheres' pressure explosions of acetylene were initiated by a spark, an incandescent wire, or a detonator. At pressures below two atmospheres it was more difficult to cause explosions. These findings were confirmed and extended by numerous other investigators (35, 42-46). The dilution of acetylene by inert gases was found to hinder explosive decomposition. The explosiveness of liquefied acetylene (41, 47, 49) and of solid acetylene (50) has been demonstrated by a number of workers. Experiments on acetylene explosions have been summarized in several reviews (36, 51-53). These properties make pure acetylene at high pressures an exceedingly dangerous material; accordingly, it cannot be stored by simple liquefaction or compression in cylinders, as is the practice with most other gases, but must be dissolved in a solvent under suitable conditions (see Section 9). However it has been claimed in a patent that solid acetylene is safe for transportation and storage (54).

References

- (1) Berthelot, *Ann. chim. phys.* (5), **67**, 52-76 (1863); *Ann.*, **123**, 207-16 (1862); *Compt. rend.*, **54**, 640-4 (1862).
- (2) Dewar, *Chem. News*, **39**, 282-3 (1879); *Proc. Roy. Soc. London*, **30**, 85-93 (1881).
- (3) Bone and Jerdan, *Proc. Chem. Soc.*, **1896**, 60, 175; *J. Chem. Soc.*, **71**, 41-81 (1897).
- (4) *Idem*, *Proc. Chem. Soc.*, **1901**, 162; *J. Chem. Soc.*, **79**, 1042-3 (1901).

PHYSICAL PROPERTIES, PREPARATION, PURIFICATION 17

- (5) Pring and Hutton, *Proc. Chem. Soc.*, **22**, 260-1 (1906); *J. Chem. Soc.*, **89**, 1591-1601 (1906).
- (6) Pring, *ibid.*, **97**, 498-511 (1910).
- (7) von Wartenburg, *Z. anorg. Chem.*, **52**, 310-15 (1907).
- (8) Lichtenberg, *Aluminum*, **20**, 465-6 (1938); *C. A.*, **32**, 7388 (1938).
- (9) Bone and Coward, *J. Chem. Soc.*, **93**, 1975-93 (1908); *ibid.*, **97**, 1219-25 (1910).
- (10) Pring and Fairlie, *J. Chem. Soc.*, **99**, 1796-1811 (1911); *ibid.*, **101**, 91-103 (1912).
- (11) Contardi, *Atti congresso. naz. chim. ind.*, **1924**, 358-70; *C. A.*, **19**, 1941 (1925).
- (12) Frost, *Materials on Cracking and Chemical Treatment of Products Obtained, Khimtoret (Leningrad)*, **2**, 98-106 (1935); *C. A.*, **29**, 5626 (1935).
- (13) Brading, U. S. P. 1,797,400 (1931); *C. A.*, **25**, 2739 (1931).
- (14) Berthelot, *Compt. rend.*, **62**, 905-9 (1866); *ibid.*, **63**, 479-84, 515-8 (1866); *Bull. Bull. soc. chim. (2)*, **6**, 268-72 (1866); *Ann. chim. phys. (4)*, **9**, 445-69 (1866); *ibid.*, (4), **12**, 52-81 (1867).
- (15) Haber, "Experimental Untersuchungen über Zersetzung und Verbrennung von Kohlenwasserstoffen," p. 71-2, Munich, 1896.
- (16) Berthelot, *Ann. chim. phys. (8)*, **6**, 184 (1905).
- (17) Moissan and Moureu, *Compt. rend.*, **122**, 1240-3 (1896); *Bull. soc. chim. (3)*, **15**, 1296-9 (1896).
- (18) Sabatier and Senderens, *Compt. rend.*, **130**, 1628-30 (1900); *ibid.*, **131**, 187-90, 267-70 (1900); *ibid.*, **134**, 1185-8 (1902); *Bull. soc. chim. (3)*, **25**, 678-84 (1901); *Ann. chim. phys. (8)*, **4**, 439-52 (1905).
- (19) Hilpert, *Ges. Abhandl. Kenntnis Kohle*, **1**, 271-5 (1917); *Chem. Zentr.*, **1919**, I, 709-16.
- (20) Hodgkinson, *J. Soc. Chem. Ind.*, **37**, 86-7T (1918).
- (21) Tiede and Jenisch, *Brennstoff-Chem.*, **2**, 5-8 (1921).
- (22) Standard Oil Development Co., Fr. P. 797,626 (1936); *C. A.*, **30**, 6998 (1936); Brit. P. 45,567 (1936); *C. A.*, **31**, 1826 (1937).
- (23) F. Fischer, Peters and Koch, *Brennstoff-Chem.*, **10**, 383-5 (1929).
- (24) Pictet, German P. 255,733 (1913); Brit. P. 24,256 (1910); *C. A.*, **6**, 145 (1910); French P. 421,838 (1910); *J. Soc. Chem. Ind.*, **30**, 542 (1911).
- (25) Rimarski and Kanschack, *Acetylen in Wiss. und Ind.*, **31**, 24-9 (1928); *ibid.*, **33**, 97 (1930).
- (26) Bradley and Parr, *Chem. Met. Eng.*, **27**, 737-44 (1922).
- (27) Berl and Hoffmann, *Z. angew. Chem.*, **44**, 259-61 (1931).
- (28) Gross, *Compt. rend.*, **206**, 1654-6 (1938).
- (29) Gooch and Baldwin, *Am. J. Sci. (4)*, **8**, 354-8 (1899); *Z. anorg. allgem. Chem.*, **22**, 235-40 (1900).
- (30) Bahr, *Ges. Abhandl. Kenntnis Kohle*, **8**, 283-5 (1929); *C. A.*, **24**, 5717 (1930).
- (31) Schutzenberger, "Traite de Chimie Generale," I, 723 (1880).
- (32) Zelinsky and Kasansky, *Ber.*, **57**, 264-76 (1924).
- (33) Erdmann and Koethner, *Z. anorg. allgem. Chem.*, **18**, 48-58 (1898).
- (34) Alexander, *Ber.*, **32**, 2381-4 (1899).
- (35) Schläpfer and Brunner, *Helv. Chim. Acta*, **13**, 1125-51 (1930).
- (36) Egloff, Lowry and Schaad, *J. Phys. Chem.*, **36**, 1457-1520 (1932).
- (37) Curme, Can. P. 268,569 (1927); *C. A.*, **21**, 2382 (1927); U. S. P. 1,646,349 (1928); *C. A.*, **22**, 92 (1928).
- (38) Hull and Imperial Chemical Industries Ltd., Brit. P. 304,914 (1928); *C. A.*, **23**, 4628 (1929).
- (39) I. G. Farbenind. A.-G., Brit. P. 296,753 (1927); *C. A.*, **23**, 2566 (1929).
- (40) *Idem*, Brit. P. 26,752 (1927); *C. A.*, **23**, 2566 (1929); Fr. 717,494 (1931); *C. A.*, **26**, 2747 (1932).
- (41) Berthelot and Vielle, *Compt. rend.*, **123**, 523-30 (1896); *ibid.*, **124**, 1000-4 (1897).
- (42) Berthelot and Le Chatelier, *Compt. rend.*, **129**, 427-34 (1899); *Ann. chim. phys. (7)*, **20**, 15-26 (1900).

- (43) Mixer, *Am. J. Sci.* (4), **9**, 1-9 (1900); *ibid.* (4), **10**, 299-309 (1900).
 (44) Frank, *Z. angew. Chem.*, **18**, 1733-5 (1905).
 (45) Burrell and Oberfell, Bureau of Mines, Tech. Paper 112 (1915).
 (46) Alexejev, *Isvestia d. Pedagog. Schelaputin-Inst. Moscow*, **4**, 1-167 (1915); *Chem. Zentr.*, **1925**, **II**, 1588.
 (47) Rasch, *Acetylen in Wiss. und Ind.*, **4**, 180 (1900).
 (48) Buccar, *l'Industrie chimique*, **24**, 452 (1937).
 (49) Kraus, *Autogene Metallbearbeitg.*, **28**, 72-4 (1935); *C. A.*, **31**, 4123 (1937).
 (50) Rimarski and Metz, *Autogene Metallbearbeitg.*, **26**, 341-7 (1935); *C. A.*, **29**, 4942 (1935).
 (51) Caro, *Verh. Ver. geförderung Gewerbebeisses*, **85**, 205-36, 245-92 (1906).
 (52) Rimarski, *Z. angew. Chem.*, **42**, 933-6 (1929).
 (53) de Liefde, *Chem. Weekblad*, **31**, 711-13 (1934); *C. A.*, **29**, 3161 (1935).
 (54) I. G. Farbenind. A.-G., French P. 694,001 (1930); *C. A.*, **25**, 1973 (1931); *Brit. P.* 351,634 (1930); *C. A.*, **26**, 4447 (1932); *Ger. P.* 515,916.

6. The preparation of acetylene by desaturation processes employing chemical reagents. Acetylene has been prepared by several reactions which result in splitting off pairs of atoms or groups from more completely saturated carbon compounds. The term "desaturation reactions" is applied as a general designation for processes of this kind. For the preparation of acetylene the removal of one or more pairs of halogen atoms by metals or of one or two molecules of hydrogen halide by alkalies has been employed most frequently. As applied to the production of acetylene, reactions of these types have chiefly a historical interest, some of them having served as an early source of the pure gas. The type reactions may be represented by the following equations in which X represents a halogen and M a metal.

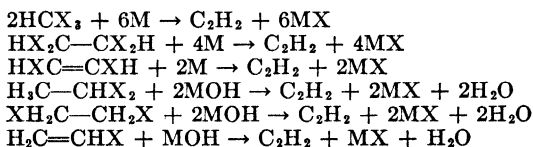

Acetylene has been prepared from several organic halogen compounds by the dehalogenating action of sodium, zinc and a few other metals. In this way acetylene was made from chloroform (1), iodoform (2), bromoform (3), tetrabromoethane (4, 11), the diiodoethylenes (5) and the symmetrical dibromoethylenes (5a). This method has served for the preparation of acetylene homologs in a few cases, but its use for this purpose is limited by the lack of easy means of obtaining suitable halogen compounds.

The action of alkalies in splitting out hydrogen halides from vinyl halides or from dihaloethanes was utilized for the production of acetylene from vinyl chloride, vinyl bromide (6, 12), symmetrical dibromoethane (7), ethylidene dibromide (12) and symmetrical dichloroethane (8). Hot alcoholic solutions of caustic alkalies have customarily been employed in these reactions because of their solvent power for organic halides. The authors (unpublished) have also found that ethylene dichloride and vinyl

chloride are readily converted to acetylene by a solution of sodamide or of sodium in liquid ammonia.

Acetylene mixed with haloacetylenes usually results from the action of alkalis on more highly halogenated derivatives of ethylene or ethane. In these cases the removal of hydrogen halide is either accompanied or followed by replacement of the remaining halogen by hydrogen. Thus acetylene has been obtained from tribromoethane (9), dibromoethylene (10), tetrabromoethane (11), dichloroethylene (12), dibromoethylene (13) and diiodoethylene (14). The haloacetylenes are also known to be converted to acetylenes by caustic alkalis (see Chapter III, Section 1). A similar replacement of halogen by hydrogen may sometimes occur during the removal of halogen atoms by metals. Thus some acetylene has been obtained from the reaction of tribromoethylene (15) and tetrabromoethylene (16) with zinc dust in alcohol. These procedures are somewhat dangerous because the chloro- or bromoacetylenes, when present in the gaseous product, are explosive and spontaneously inflammable in air.

Processes of dehydrohalogenation provide the most general method for the preparation of other acetylenic compounds. However, many of these procedures require prolonged heating of the halogen compounds with alkalis, and this sometimes results in dehydrohalogenation in an unexpected direction or in rearrangement of the acetylenic product (see Chapter III, Section 2). For this reason, when pure acetylenic compounds are desired, it is often advisable to employ the alternative synthetic methods of substitution in acetylene described in Chapter III.

References

- (1) Berthelot, *Ann.*, **116**, 116-22 (1860). Fittig, *Z. Chemie*, **1866**, 127. Kletzinsky, *ibid.*, **1866**, 127. Haller, Dissertation, p. 42, Nancy (1879).
- (2) Cazeneuve, *Bull. soc. chim.* (2), **41**, 106-10 (1884).
- (3) *Idem*, *ibid.*, (3) **7**, 69-2 (1892).
- (4) Sabanejev, *Ann.*, **216**, 241-79 (1883).
- (5) Keiser, *Am. Chem. J.*, **21**, 261-5 (1899).
Kaufmann, *Ber.*, **55**, 249-60 (1922).
- (5a) Kraus and White, *J. Am. Chem. Soc.*, **45**, 773 (1923).
- (6) Miasnikov, *Ann.*, **118**, 330-3 (1861). Sawitsch, *Jahresber. Fortschritte Chemie*, **1861**, 646; *Ann.*, **119**, 182-5 (1861).
- (7) Sawitsch, *Jahresber. Fortschritte Chemie*, **1861**, 646. De Forcrand, *Ann. chim. phys.* (6), **11**, 477 (1887). Mackenzie, *J. Chem. Soc.*, **79**, 1221 (1901). Meunier and Desparmet, *Compt. rend.*, **144**, 273-5 (1907); *Bull. soc. chim.* (4), **1**, 342-6 (1907).
- (8) De Wilde, *Ber.*, **7**, 352-3 (1874).
- (9) Reboul, *Ann.*, **124**, 267-72 (1862).
- (10) Fontaine, *ibid.*, **156**, 260-2 (1870).
- (11) Sabanejev, *ibid.*, **178**, 109-28 (1857).
- (12) Loevenich, Losen, and Dierichs, *Ber.*, **60**, 950-7 (1927).
- (13) Nef, *Ann.*, **298**, 332-41 (1897).
- (14) Nef, *Ann.*, **298**, 341-3 (1897).
- (15) Sabanejev and Dworkwitsch, *Ann.*, **216**, 279-85 (1882).
- (16) Nef, *ibid.*, **308**, 323-8 (1899).

7. The production of acetylene by the pyrolysis of organic compounds.

Berthelot (1) isolated acetylene by regenerating it from cuprous acetylides, which had been observed previously (2, 3) as a precipitate formed by the action of pyrolytic hydrocarbon gases on an ammoniacal cuprous salt solution. Following this discovery, a variety of organic compounds were found to yield acetylene when pyrolyzed in a hot tube or exposed to induction sparks (4-10). Although in a few cases (4, 7) the gaseous product was fairly rich in acetylene, the yield on the basis of organic material broken down was usually very low. The other products were liquids, hydrogen, amorphous carbon, lower olefins and paraffins.

After the successful commercial production of acetylene from calcium carbide beginning about 1894, interest in the pyrolytic preparation of acetylene declined for a time, only to be revived much later by the increasing supply of very cheap organic raw materials such as natural gas, mixtures of gaseous paraffins and olefins from cracking processes, crude petroleum and its various fractions, and heavy tars and asphalts. Methane, which is the principal constituent of natural gas, cannot be transported profitably from many producing regions, and use as a fuel or as a source of carbon black is limited. Accordingly, processes for converting it to other hydrocarbons have been much sought. However, the high temperature required for the rapid pyrolysis of methane obviates good yields of olefins or higher paraffins, and although aromatic hydrocarbons may be formed at about 1200°, the conversion of methane to acetylene and hydrogen promises to become one of the most important methods for its utilization. For these reasons the high-temperature cracking of methane has received more attention than any other proposed process for the pyrolytic manufacture of acetylene. In parts of Europe where natural gas is not abundant, a study also has been made of the pyrolysis of coke-oven gas, or of water gas or methane mixtures derived from carbon monoxide and by-product hydrogen. The cracking of low-value petroleum residues, asphalts and tars as potential sources of acetylene has aroused some interest. Since the other gaseous paraffins, the gaseous olefins, and the low-boiling distillates are valuable for other purposes, they have been given less attention as raw materials.

The failure of the earlier investigators to obtain high yields of acetylene and prevent carbon deposition in the pyrolysis of gaseous hydrocarbons may be ascribed to the unduly prolonged heating periods employed. More recent work has shown that there is a very short optimum heating interval for maximum acetylene production, which varies in length with the temperature, pressure and the composition of the gas to be treated. A temperature in the range 1400-1500° often has been employed. The advantage of a short heating period is apparently that the decomposition and poly-

merization of acetylene, when diluted with other gases, is slower than the reactions which lead to its formation. Accordingly, by carefully limiting the duration of heating, good yields of acetylene may be obtained; more prolonged heating produces the usual equilibrium mixture, containing much less acetylene and increased proportions of carbon and hydrogen and small percentages of methane and other hydrocarbons. A short heating period implies a quick and effective method of cooling the off-gases, and this is usually accomplished by an extremely rapid flow of gas through the pyrolyzing chamber and into the cooling mechanism.

The pyrolysis of methane or mixtures, such as natural gas or coke-oven gas, has been the subject of numerous investigations during the past decade (11-48). A variety of heat sources have been used for this purpose, including externally heated tubes, electric resistance heating elements, and spark or arc electric discharges. Of these methods cracking by means of an electric arc at rather low pressure appears to be most effective. In general at a temperature of 800-1100° benzene and other aromatic hydrocarbons are formed in considerable quantities from methane (11-14) unless the heating period is very short. A group of German chemists studied the pyrolysis of methane by a flow method at low pressures and at various temperatures above 900° and with heating intervals of 0.0001 to 1.0 second (15-22). By plotting the yield of acetylene against the time of heating at a constant pressure and a number of different temperatures, it was shown that the optimum heating period decreased with rising temperature. Diminished pressure was found to favor acetylene formation; under the best conditions the yields were high on the basis of the methane reacting, and few by-products were obtained. A number of other investigators have observed the advantages of low pressure on the production of acetylene from methane (23-28). Studies of the pyrolysis of methane by several chemists also have shown (28, 29, 36) similar effects of pressure, temperature and heating time.

A number of diluents have been shown to increase the yields of acetylene based on the quantity of methane pyrolyzed, although the concentration of acetylene in the gaseous product may be lowered by the dilution (18, 26, 28, 29-40). Another purpose of dilution is to decrease or prevent the deposition of carbon in the apparatus. Although hydrogen may constitute 75 per cent or more by volume of the gases formed in the pyrolysis of methane a number of investigators have observed that addition of hydrogen to the methane before pyrolysis increases the yield of acetylene (18, 26, 28, 29-35). It has been claimed (36, 37) that addition of hydrogen chloride or equivalents of hydrogen and chlorine to methane increases the yield of acetylene. The use of carbon dioxide or steam as diluents also has been found to give favorable results (38-40). Carbon dioxide, steam

and hydrogen chloride have the great advantage of being easily removed by washing.

The catalytic effect of the wall materials in the reaction chamber and of several solid packing materials on the pyrolysis of methane has been the subject of a few investigations (11, 12, 33, 41-44). In general the yield of acetylene was sometimes decreased and never markedly raised by contact with the solids.

Concerning the reactions occurring during the pyrolysis of methane, somewhat divergent views have been expressed (14, 41, 42, 45-48). Fischer (14) considered that the radicals $-\text{CH}_3$, $=\text{CH}_2$ and $\equiv\text{CH}$ were formed as intermediates, and Peters and Wagner (21, 45) interpreted the spectrum analysis of the arc pyrolysis of methane as indicating the presence of these radicals. A mechanism based on thermodynamic considerations has been proposed by Kassel (46) in which methene, CH_2 , formed by direct dehydrogenation of methane, combines with a second molecule of methane to give ethane. The ethane is then dehydrogenated to ethylene and the ethylene to acetylene. This mechanism has been in part confirmed by Storch (47), who was able to isolate large proportions of ethylene and ethane when methane was heated at low pressures by a carbon filament in a quartz bulb immersed in liquid nitrogen. Later Belchetz (48) claimed to have detected methene as the primary product of the decomposition of methane.

The similar preparation of acetylene from other lower paraffins or olefins has received less study (6, 29, 49-57). Fischer and Pichler (54) have investigated the effects of pressure, temperature, heating time and dilution in the pyrolysis of ethylene and ethane, and in general their results were similar to those observed with methane.

A number of writers (15, 18, 20, 29, 30, 32, 34, 55, 58-66) have reviewed the production of acetylene from methane and other organic materials and have compared the cost and the power consumption in arc pyrolysis with those of the calcium-carbide industry. For example Peters (20) states that if the reaction, $2\text{CH}_4 \rightarrow \text{C}_2\text{H}_2 + 3\text{H}_2 - 91 \text{ cal.}$, could be realized, the cost of acetylene should be only about 36 per cent of the cost of acetylene from carbide. Although a close approach to this efficiency is not likely to be attained, it appears that acetylene as a mixture with other gases probably can be produced much more cheaply by pyrolytic methods than from calcium carbide. However, the cost of separating or concentrating the acetylene from the gas mixtures largely offsets this decreased cost of production (see Section 9).

The patent literature on the pyrolytic manufacture of acetylene has grown enormously in the past few years. A large number of patents have been issued for the arc treatment of gaseous, vaporized or sprayed liquid

hydrocarbons and other carbonaceous materials, which specify modified types of the arc apparatus, special characteristics of the arc, or which limit the rate of passage, partial pressure, dilution or intake temperature of the hydrocarbons used (67-80).

The pyrolysis of similar materials by contact with the heating elements of electric resistance or induction furnaces has also been the subject of a few reviews and patents (81-84).

The preparation of acetylene by the passage of an arc through liquid hydrocarbons is a promising method and has the advantage of quickly cooling the gaseous product by contact with the liquid. Since the hot gases do not come into contact with the walls of the reaction chamber, catalytic decomposition of acetylene at the walls and the breakdown of the wall materials present no problems. The carbon formed may be filtered from the liquid and is accordingly less troublesome than accumulations of carbon during the pyrolysis of hydrocarbon gases. The gas mixtures produced by this method usually contain a considerable proportion of lower olefins along with acetylene and hydrogen. Special apparatus and procedures for the manufacture of acetylene by means of a submerged arc have been claimed in a number of patents (85-88) and have been the subject of a few review articles (89, 89a, 90). The use of electrical resistance heating units immersed in liquid hydrocarbons also has been patented (91).

The lack of cheap electric power near some important sources of natural gas and petroleum has drawn attention to other possible methods of heating (92-98). As stated by Storch (40, 55), temperatures of 1500-1600°, suitable even for the pyrolysis of methane, may be obtained by the combustion of preheated natural gas with preheated compressed air. The heat may be applied either to the outside of refractory tubes (92, 92a) or, more efficiently, to a checker-work heat exchanger in which combustion and pyrolysis take place alternately (96-98). Procedures of the latter type have been patented. This method is related to the preparation of acetylene by the incomplete combustion of hydrocarbons described in the following section.

Processes of these types are of special interest in America where cheap hydrocarbon gases are available; but European investigators have given more attention to electrical methods of pyrolysis in order to conserve their scanty resources of gaseous hydrocarbons.

A variation of the pyrolytic preparation of acetylene has been proposed (99), which consists in passing hydrocarbon gases at high temperature over an alkali or alkaline-earth oxide to form an acetylenic carbide, from which the acetylene is regenerated in the usual way.

References

- (1) Berthelot, *Compt. rend.*, **54**, 1044-6 (1862); *Ann. chim. phys. (3)*, **67**, 52-77 (1863); (4), **9**, 418-21 (1866); (7), **23**, 444 (1901).
- (2) Quet, *Compt. rend.*, **46**, 903-5 (1858); *Ann.* **108**, 116-7 (1858).
- (3) Boettger, *Ann.*, **109**, 351-62 (1859).
- (4) Vohl, *Jahresber. Fortschritte Chemie*, **1865**, 841.
- (5) Bradley and Parr, *Chem. Met. Eng.*, **27**, 737-44 (1902).
- (6) Bone and Coward, *J. Chem. Soc.*, **93**, 1197-1225 (1908).
- (7) Destrem, *Jahresber. Fortschritte Chemie*, **1884**, 272.
- (8) Truchot, *Compt. rend.*, **84**, 714-6 (1877).
- (9) Pizarello, *Gazz. chim. ital.*, **15**, 233-8 (1885).
- (10) Bredig, *Z. Elektrochem.*, **4**, 514-5 (1898).
- (11) Wheeler and Wood, *Fuel in Science and Practice*, **7**, 535-9 (1928); *C. A.*, **23**, 3212 (1929).
- (12) Chamberlain and Bloom, *Ind. Eng. Chem.*, **21**, 945-9 (1929).
- (12a) Stanley and Nash, *J. Soc. Chem. Ind.*, **48**, 1-8T, 238-42T (1929).
- (13) Wheeler and Wood, *Fuel in Science and Practice*, **9**, 567-74 (1930); *C. A.*, **25**, 1654 (1931).
- (14) F. Fischer, *Brennstoff-Chem.*, **9**, 309-15 (1928); *C. A.*, **23**, 2694 (1929).
- (15) F. Fischer and Pichler, *ibid.*, **13**, 381-3 (1932); *C. A.*, **27**, 2016 (1933).
- (16) F. Fischer and Peters, *ibid.*, **10**, 108-13 (1929); *C. A.*, **23**, 4326 (1929).
- (17) Peters and K. Meyer, *ibid.*, **10**, 324-9 (1929); *C. A.*, **24**, 484 (1930).
- (18) F. Fischer and Peters, *Z. physik. Chem., Abt. A*, **141**, 180-94 (1929); *C. A.*, **23**, 3861 (1929).
- (19) Peters and Pranschke, *Brennstoff-Chem.*, **11**, 239-47 (1930); *C. A.*, **25**, 399 (1931).
- (20) Peters, *Z. angew. Chem.*, **43**, 855-60 (1930); *C. A.*, **24**, 5715 (1930).
- (21) Peters and Wagner, *Z. physik. Chem., Abt. A*, **153**, 161-86 (1931); *C. A.*, **25**, 2682 (1931).
- (22) F. Fischer and Pichler, *Brennstoff-Chem.*, **13**, 406-11, 435, 441-5 (1932); *C. A.*, **27**, 2016 (1933).
- (23) Jones, *J. Chem. Soc.*, **1929**, 419-22.
- (24) Frolich, White and Dayton, *Ind. Eng. Chem.*, **22**, 20-3 (1930).
- (25) Montagne, *Compt. rend.*, **194**, 1490-2 (1932).
- (26) Frost, *Materials on Cracking and Chemical Treatment of Products Obtained, Khimteoret (Leningrad)*, **2**, p. 98-106 (1935); *C. A.*, **29**, 5626 (1935).
- (27) Bozhko and Kosyakova, *J. Applied Chem. (U. S. S. R.)*, **11**, 43-55 (1938); *C. A.*, **32**, 4442 (1938).
- (28) Koller, *Khim. Tverdogo Topliva*, **7**, 808-19 (1936); **8**, 65-75 (1937); **8**, 820-4 (1937); *C. A.*, **31**, 2525 (1937); **31**, 6978 (1937); **32**, 2438 (1938). Vasil'ev, Kobozev and Eremin, *Khim. Tverdogo Topliva*, **8**, 75-8 (1937); *C. A.*, **31**, 6978 (1937).
- (29) Egloff and Wilson, *Ind. Eng. Chem.*, **27**, 917-33 (1935). Tropsch and Egloff, *ibid.*, **27**, 1063-7 (1935). Tropsch, Parrish and Egloff, *ibid.*, **28**, 581-6 (1936).
- (30) Frolich, White, Uhrmacher and Tufts, *ibid.*, **22**, 20-5 (1930).
- (31) Padovani and Magaldi, *Atti III congresso naz. chim. pura applicata*, **1930**, 730-9; *C. A.*, **25**, 3309 (1931).
- (32) Moor and Strigaleva, *Materials on Cracking and Chemical Treatment of Cracking Products (U. S. S. R.)*, **3**, 474-83 (1936); *C. A.*, **31**, 6185 (1937).
- (33) Klyukvin and Voronova, *Natural Gases (U. S. S. R.)*, **4/5**, 5-28 (1932); *C. A.*, **31**, 3663 (1937).
- (34) Kobayashi, Yamamoto, Hinonishi and Yamamoto, *J. Soc. Chem. Ind. Japan*, **40**, Suppl. binding 182-4 (1937); *C. A.*, **31**, 6979 (1937).
- (35) British Celanese Ltd., Dreyfus and Groombridge, *Brit. P.* 458,160 (1936); *C. A.*, **31**, 3070 (1937); *Brit. P.* 471,837 (1937); *C. A.*, **32**, 1282 (1938).
- (36) Rudder and Biedermann, *Compt. rend.*, **190**, 1194-6 (1930); *Bull. soc. chim. (4)*, **47**, 704-30 (1930); *French P.* 748,861 (1933); *C. A.*, **27**, 5340 (1933).

PHYSICAL PROPERTIES, PREPARATION, PURIFICATION 25

- (37) Imperial Chem. Industries, Ltd., and Binnie, Brit. P. 343,881 (1929); *C. A.*, **26**, 155 (1932); U. S. P. 2,000,118 (1935); *C. A.*, **29**, 4028 (1935).
- (38) Peters, *Brennstoff-Chem.*, **10**, 441-4 (1929); *C. A.*, **24**, 2955 (1930). Peters and Pranschke, *Brennstoff-Chem.*, **11**, 473-6 (1930); *C. A.*, **25**, 645 (1931).
- (39) Ferguson and Imperial Chemical Industries, Ltd. Brit. P. 342,771 (1929); *C. A.*, **25**, 5436 (1931).
- (40) Storch and Golden, *Ind. Eng. Chem.*, **25**, 768-71 (1933).
- (41) Holliday and Exell, *J. Chem. Soc.*, **1929**, 1066-74.
- (42) Holliday and Gooderham, *ibid.*, **1931**, 1594-1604.
- (43) Klyukvin and Klyukvina, *Khim. Tverdogo Topliva*, **6**, 130-46 (1935); *C. A.*, **29**, 7617 (1935).
- (44) Kobozev, Kashtanov and Kobrin, *J. Gen. Chem. (U. S. S. R.)*, **5**, 143-8 (1935); *C. A.*, **29**, 4920 (1935).
- (45) Peters and Wagner, *Brennstoff-Chem.*, **12**, 67-8 (1931); *C. A.*, **25**, 1737 (1931).
- (46) Kassel, *J. Am. Chem. Soc.*, **54**, 3949-61 (1932).
- (47) Storch, *ibid.*, **54**, 4188-98 (1932).
- (48) Belchetz, *Trans. Faraday Soc.*, **30**, 170-9 (1934). Rice and Dooley, *J. Am. Chem. Soc.*, **56**, 2747-49 (1934). Belchetz and Rideal, *ibid.*, **57**, 1168-74 (1935).
- (49) Walker, *J. Phys. Chem.*, **31**, 961-96 (1927).
- (50) Hague and Wheeler, *J. Chem. Soc.*, **1929**, 378-93.
- (51) Fujio, *Bull. Chem. Soc. Japan*, **5**, 249-60 (1930); *C. A.*, **24**, 5644 (1930).
- (52) Piotrowski and Winkler, *Przemysl Chem.*, **14**, 49-64, 83-92 (1930); *C. A.*, **24**, 4924.
- (53) Vernazza and Stratta, *Industria chimica*, **6**, 761-8 (1931); *C. A.*, **26**, 1198 (1932).
- (54) F. Fischer and Pichler, *Brennstoff-Chem.*, **13**, 406-11 (1932); *C. A.*, **27**, 2016 (1933).
- (55) Storch, *Ind. Eng. Chem.*, **26**, 56-60 (1934).
- (56) Balandin, Eidus and Zalagin, *Compt. rend. Acad. Sci. U. S. S. R.*, **4**, 132-5 (1934); *C. A.*, **29**, 6153 (1935).
- (57) Koller, Russ. P. 45,927 (1936); *C. A.*, **32**, 5313 (1938).
- (58) Contardi, *Atti congresso naz. chim. ind.*, **1924**, 358-70; *C. A.*, **19**, 1941 (1925); *Giorn. chim. ind. applicata*, **7**, 195-201 (1925); *C. A.*, **20**, 3230 (1926).
- (59) Storch, Bur. Mines Circ. 6549 (1932).
- (60) Simon, *J. Acetylene*, **94**, 973-7 (1935); *C. A.*, **30**, 839 (1936).
- (61) Kobayashi, Yamamoto, Ishikawa and Hinonishi, *J. Soc. Chem. Ind. Japan*, **38**, Suppl. binding 550-5 (1935); *C. A.*, **30**, 1210 (1936).
- (62) Logvinovich, *Org. Chem. Ind. (U. S. S. R.)*, **3**, 203-9 (1937); *C. A.*, **31**, 6978 (1937).
- (63) F. Fischer, *Ber.*, **71 A**, 56-67 (1938).
- (64) Thorpe, "Chemical Dictionary," Longmans, Green & Co., London, 4th ed., I, 75-8 (1937).
- (65) Carleton Ellis, "Chemistry of Petroleum Hydrocarbons," Reinhold Publishing Corp., New York, **1**, 38-49, 147-53, 255-64 (1934); **2**, 52-57, 165-71, 253-6 (1937).
- (66) Hurd, "The Pyrolysis of Carbon Compounds," Chemical Catalog Co., Inc. (Reinhold Publishing Corp.), New York, 1929.
- (67) F. Fischer and Peters, German P. 580,261 (1923); *C. A.*, **27**, 4745 (1933); German P. 591,756 (1934); *C. A.*, **28**, 2731 (1934); German P. 641,091 (1937); *C. A.*, **31**, 2944 (1937).
- (68) Soc. anon. le petrole synthetique, Brit. P. 223,453 (1923); *C. A.*, **19**, 1101 (1925); Brit. P. 261,267 (1926); *C. A.*, **21**, 3368 (1927); Brit. P. 271,767 (1927); *C. A.*, **22**, 1596 (1928).
- (69) I. G. Farbenind. A.-G. (*et al.*): *German Patents*: 507,920 (1926); *C. A.*, **25**, 648 (1931). 514,592 (1925); *C. A.*, **25**, 2060 (1931). 523,627 (1929); *C. A.*, **25**, 3577 (1931). 535,256 (1926); *C. A.*, **28**, 926 (1932). 540,897 (1926); *C. A.*, **26**, 2127 (1932). 575,752 (1933); *C. A.*, **27**, 4812 (1933). 587,129 (1933); *C. A.*, **28**, 717 (1934). 595,463 (1934); *C. A.*, **28**, 3990 (1934). 603,742 (1934); *C. A.*, **29**, 691 (1935). 606,011 (1934); *C. A.*, **29**, 1332 (1935). 611,113 (1935); *C. A.*, **29**, 3923

(1935). 630,825 (1936); *C. A.*, **31**, 46 (1937). 637,187 (1936); *C. A.*, **31**, 3799 (1937). 652,348 (1937); *C. A.*, **32**, 1590 (1938).

British Patents: 263,859 (1925); *C. A.*, **22**, 32 (1928). 264,827 (1926); *C. A.*, **22**, 242 (1928). 264,845 (1926); *C. A.*, **22**, 242 (1928). 269,547 (1926); *C. A.*, **22**, 1364 (1928). 286,825 (1927); *C. A.*, **23**, 504 (1929). 294,494 (1927); *C. A.*, **23**, 1828 (1929). 296,752 (1927); *C. A.*, **23**, 2566 (1929); 296,753 (1927); *C. A.*, **23**, 2566 (1929). 306,008 (1927); *C. A.*, **23**, 4899 (1929). 332,057 (1929); *C. A.*, **25**, 39 (1931). 332,917 (1929); *C. A.*, **25**, 462 (1931). 336,261 (1929); *C. A.*, **25**, 1745 (1931). 337,088 (1929); *C. A.*, **25**, 1744 (1931). 363,375 (1930); *C. A.*, **27**, 1580 (1933). 365,045 (1930); *C. A.*, **27**, 1832 (1933). 366,102 (1930); *C. A.*, **27**, 2028 (1933). 370,414 (1930); *C. A.*, **27**, 2888 (1933). 371,916 (1931); *C. A.*, **27**, 3044 (1933). 371,917 (1931); *J. Soc. Chem. Ind.*, **1932**, 633. 382,690 (1931); *J. Soc. Chem. Ind.*, **1933**, 51. 389,165 (1931); *J. Soc. Chem. Ind.*, **1933**, 377. 397,987 (1933); *C. A.*, **28**, 1936 (1934). 470,258 (1937); *C. A.*, **32**, 587 (1938). 480,781 (1938); *C. A.*, **32**, 6163 (1938).

French Patents: 626,794 (1927); *Chem. Zentr.*, **99**, **I**, 562 (1928). 626,795 (1927); *Chem. Zentr.*, **99**, **I**, 751 (1928). 634,210 (1927); *C. A.*, **22**, 3667 (1928). 653,505 (1928); *C. A.*, **23**, 3635 (1929). 674,459 (1929); *C. A.*, **24**, 2385 (1930). 687,884 (1930); *C. A.*, **25**, 648 (1931). 687,973 (1930); *C. A.*, **25**, 648 (1931). 690,869 (1930); *C. A.*, **25**, 1169 (1931). 717,056 (1931); *C. A.*, **26**, 2747 (1932). 717,494 (1931); *C. A.*, **26**, 2747 (1932). 717,608 (1931); *C. A.*, **26**, 2930 (1932). 719,068 (1931); *C. A.*, **26**, 3364 (1932). 721,826 (1931); *C. A.*, **26**, 4142 (1932). 721,877 (1931); *C. A.*, **26**, 4142 (1932). 739,952 (1933); *C. A.*, **27**, 2101 (1933). 750,521 (1933); *C. A.*, **28**, 717 (1934). 799,757 (1936); *C. A.*, **30**, 8580 (1936). 823,303 (1938); *C. A.*, **32**, 5313 (1938).

U. S. Patents: 1,746,934 (1930); *C. A.*, **24**, 1586 (1930). 1,757,454 (1930); *C. A.*, **24**, 3346 (1930). 1,766,718 (1930); *C. A.*, **24**, 4305 (1930). 1,794,004 (1931); *C. A.*, **25**, 2060 (1931). 1,847,095 (1932); *C. A.*, **26**, 2585 (1932). 1,880,924 (1933); *C. A.*, **27**, 468 (1933). 1,892,973 (1933); *C. A.*, **27**, 2101 (1933). 1,902,351 (1933); *C. A.*, **27**, 3147 (1933). 1,904,426 (1933); *C. A.*, **27**, 3409 (1933). 1,923,140 (1933); *C. A.*, **27**, 5085 (1933). 1,941,077 (1934); *C. A.*, **28**, 1283 (1934). 1,942,131 (1934); *C. A.*, **28**, 1611 (1934). 1,984,957 (1935); *C. A.*, **29**, 1021 (1935). 1,992,598 (1935); *C. A.*, **29**, 2461 (1935). 2,002,003 (1935); *C. A.*, **29**, 4274 (1935). 2,013,996 (1935); *C. A.*, **29**, 6849 (1935). 2,074,530 (1937); *C. A.*, **31**, 2944 (1937).

- (70) Soc. anon. pour l'industrie chim. a Bâle, Brit. P. 296,355 (1927); *C. A.*, **23**, 2537 (1929). Brit. P. 368,164 (1930); *C. A.*, **27**, 1580 (1933). French P. 718,088 (1931); *C. A.*, **26**, 2662 (1932). U. S. P. 1,951,961 (1934); *C. A.*, **28**, 3315 (1934).
- (71) Hull and Imperial Chemical Industries, Ltd., Brit. P. 311,352 (1928); *C. A.*, **24**, 793 (1930). Brit. P. 317,558 (1928); *C. A.*, **24**, 2067 (1930). Brit. P. 317,920 (1928); *C. A.*, **24**, 2139 (1930).
- (72) Consortium für Elektrochem. Ind., German P. 543,109 (1929); *C. A.*, **26**, 2383 (1932). French P. 694,109 (1930); *C. A.*, **25**, 1744 (1931).
- (73) Herrmann and Baum, U. S. P. 1,898,301 (1933); *C. A.*, **27**, 2691 (1933).
- (74) Kipper (to Baylor Knox), U. S. P. 1,883,799 (1933); *C. A.*, **27**, 1154 (1933).
- (75) Nutting and Rowley (to Dow Chemical Company), U. S. P. 1,887,658 (1933); *C. A.*, **27**, 1285 (1933).
- (76) Soc. Ind. des Hydrocarbures de Derives, Brit. P. 352,688; *J. Soc. Chem. Ind.*, **1931**, 959.
- (77) Gros, German P. 434,831 (1926); *Frdl.*, **15**, 79-80. French P. 573,487 (1923); Brit. P. 211,125 (1924); *C. A.*, **18**, 1617 (1924).
- (78) Institut für physikalische Grundlagen der Medizin, Brit. P. 357,534 (1929); *C. A.*, **26**, 4687 (1932). Brit. P. 362,869 (1930); *C. A.*, **27**, 1421 (1933). French P. 693,641 (1930); *C. A.*, **25**, 1643 (1931). French P. 740,062 (1932); *C. A.*, **27**, 2101 (1933).
- (79) Standard Oil Development Co., French P. 797,626 (1936); *C. A.*, **30**, 6998 (1936). Brit. P. 455,567 (1936); *C. A.*, **31**, 1826 (1937).

PHYSICAL PROPERTIES, PREPARATION, PURIFICATION 27

- (80) Rose, U. S. P. 2,080,931 (1937); *C. A.*, **31**, 4909 (1937).
(81) Banck, German P. 501,179 (1922); *C. A.*, **24**, 4470 (1930); U. S. P. 1,773,611 (1930); *C. A.*, **24**, 4994 (1930). U. S. reissue 19,794 (1936); *C. A.*, **30**, 1071 (1936).
(82) Ruhrchemie A.-G., German P. 594,124, 594,125 (1934); *C. A.*, **28**, 3315 (1934).
(83) Eymann, U. S. P. 1,957,254 (1934); *C. A.*, **28**, 4071 (1934).
(84) Dubois, *Gaz i Woda*, **11**, 236-9, 270-5 (1931); *C. A.*, **26**, 2577 (1932).
(85) Soc. l'air liquid (and Mercier), Brit. P. 316,336 (1928); *C. A.*, **24**, 1736 (1930). Brit. P. 316,352 (1928); *C. A.*, **24**, 1736 (1930). French P. 672,912 (1929); *C. A.*, **24**, 2067 (1930). German P. 537,522 (1929); *C. A.*, **26**, 1201 (1932). U. S. P. 1,830,615 (1932); *C. A.*, **26**, 659 (1932).
(86) Longhi, U. S. P. 1,744,173 (1930); *C. A.*, **24**, 1306 (1930).
(87) Tatarinov, Russ. P. 40,352 (1934); *C. A.*, **30**, 3731 (1936).
(88) Petran and Malyshev, Russ. P. 50,392 (1937); *C. A.*, **31**, 8399 (1937).
(89) Miloslavski and Glizmaneko, *Avtogetno Delo (U.S.S.R.)*, **6**, No. 8, 29-30 (1935); *C. A.*, **30**, 3976 (1936).
(89a) Gobert, *J. Acetylene*, **92**, 948 (1934); *Chimie et industrie*, **33**, 103 (1935); *C. A.*, **29**, 2855 (1935).
(90) Beilin, *Avtogetno Delo*, **6**, 18-20 (1936); *C. A.*, **31**, 3796 (1937).
(91) Bethenod, Brit. P. 316,905 (1928); *C. A.*, **24**, 1806 (1930).
(92) Dreyfus, Brit. P. 440,432 (1935); *C. A.*, **30**, 3836 (1936). Brit. P. 478,668 (1938); *C. A.*, **32**, 5190 (1938). Brit. P. 479,438 (1938); *C. A.*, **32**, 5004 (1938). French P. 824,425 (1938); *C. A.*, **32**, 6035 (1938).
(92a) Ruhrchemie A.-G., Brit. P. 391,206 (1933); *C. A.*, **27**, 4812 (1933).
(93) Morrell, U. S. P. 2,030,070 (1936); *C. A.*, **30**, 2362 (1936).
(94) International Industrial & Chemical Co., French P. 692 451 (1929); *C. A.*, **25**, 1264 (1931). French P. 692,452 (1929); *C. A.*, **25**, 1265 (1931).
(95) F. Fischer and Pichler, German P. 649,102 (1937); *C. A.*, **31**, 8542 (1937).
(96) Wulff, Brit. P. 334,178 (1929); *C. A.*, **25**, 962 (1931). Can. P. 306,263 (1930); *C. A.*, **25**, 715 (1931). U. S. P. 1,843,965 (1932); *C. A.*, **26**, 2040 (1932). U. S. P. 1,880,306 (1933); *C. A.*, **27**, 544 (1933). U. S. P. 1,880,307 (1933); *C. A.*, **27**, 515 (1933). U. S. P. 1,880,308 (1933); *C. A.*, **27**, 515 (1933). U. S. P. 1,880,309 (1933); *C. A.*, **27**, 515 (1933). U. S. P. 1,880,310 (1933); *C. A.*, **27**, 515 (1933). U. S. P. 1,917,627 (1933); *C. A.*, **27**, 4656 (1933).
(97) N. V. de Baatfische Petroleum Maatschappij (and Pyzel and Lacomble), French P. 725,114 (1931); *C. A.*, **26**, 4823 (1932). Brit. P. 369,351 (1930); *C. A.*, **27**, 2163 (1933). Brit. P. 392,643 (1933); *C. A.*, **27**, 5529 (1933). Brit. P. 392,644 (1933); *C. A.*, **27**, 5530 (1933). German P. 646,327 (1937); *C. A.*, **31**, 6252 (1937).
(98) Pyzel (to Shell Development Co.), U. S. P. 1,983,992 (1935); *C. A.*, **29**, 914 (1935).
(99) Wulff, U. S. P. 1,996,185 (1935); *C. A.*, **29**, 3353 (1935).

8. The production of acetylene by the incomplete combustion of organic compounds and related methods. Berthelot (1) first showed that acetylene resulted from the incomplete combustion of organic compounds, and procedures of this type for the laboratory preparation of acetylene were devised (2-3). Hofmann and Will (5) made an early investigation of the formation of acetylene by the incomplete combustion of several organic compounds. Since this method avoids both the high cost of electric discharge heating and many of the heat-exchange difficulties of other pyrolytic methods, attempts have recently been made to apply it on a manufacturing scale. However, the optimum temperature for the formation of acetylene is not readily reached in this way, and the product usually contains a lower concentration of acetylene than that from other pyrolytic processes.

Fischer and Pichler (6) have reported the preparation of acetylene from mixtures of coal gas or methane with air or oxygen at various pressures when passed through heated porcelain tubes at different rates of flow. Apparatus and methods for the manufacture of acetylene by incomplete combustion of gaseous hydrocarbons have been the subject of numerous patents (7-17). Patents of the I. G. Farbenindustrie (7) claim an improved yield of acetylene by the incomplete combustion of gaseous hydrocarbons in the presence of elemental silicon, and the Soc. d'Études et d'Exploitations des Matières Organiques (10) has employed a number of metals and their compounds as catalysts. Methods and apparatus for the preparation of acetylene by the incomplete combustion of liquid hydrocarbons by a submerged flame also have been patented (18, 19). This method is said to be promising because clogging of the apparatus with carbon can be avoided and because the off gases are quickly cooled by the surrounding liquid.

Wheeler, Binnie and Imperial Chemical Industries (20) and Rudder and Bierdermann (21) have patented methods consisting in the addition of hydrogen and chlorine to a gaseous hydrocarbon so that the heat of the resulting reaction decomposes the hydrocarbon. The advantages of dilution are thus secured and the hydrogen chloride may be removed by washing more readily than other diluents.

References

- (1) Berthelot, *Ann. chim. phys.* (4), **9**, 413-8 (1866); (5), **10**, 365-9 (1877).
- (2) McLeod, *J. Chem. Soc.*, **19**, 151-4 (1866).
- (3) Rieth, *Z. Chem.*, **1867**, 598-9.
- (4) Roemer, *Ann.*, **233**, 182-5 (1886).
- (5) Hofmann and Will, *Ber.*, **55**, 3228-33 (1922).
- (6) F. Fischer and Pichler, *Brennstoff-Chem.*, **11**, 501-7 (1930).
- (7) I. G. Farbenind. A.-G., Brit. P. 265,234 (1926); *C. A.*, **22**, 243 (1928). Brit. P. 290,322 (1927); *C. A.*, **23**, 846 (1929). Brit. P. 347,493 (1930); *C. A.*, **26**, 2752 (1932). Brit. P. 408,691 (1932); *Brit. Chem. Abs.*, **1934B**, 615. Brit. P. 408,934 (1934); *Brit. Chem. Abs.*, **1934B**, 615; *C. A.*, **28**, 5467 (1934). Brit. P. 408,691 (1934); *C. A.*, **28**, 5467 (1934). Brit. P. 470,360 (1937); *C. A.*, **32**, 596 (1938). French P. 705,854 (1930); *C. A.*, **26**, 155 (1932). French P. 818,183 (1937); *C. A.*, **32**, 2148 (1938). German P. 536,361 (1929); *C. A.*, **26**, 999 (1932).
- (8) Haeuber and Linkh, U. S. P. 1,894,765 (1933), *C. A.*, **27**, 2458 (1933).
- (9) Mittasch Frankenburger and Wietzel, U. S. P. 1,823,503 (1932); *C. A.*, **26**, 150 (1932).
- (10) Soc. d'Études et d'Exploitations des Matières Organiques, Brit. P. 282,690 (1926); *C. A.*, **22**, 3667 (1928).
- (11) Burgin (to Shell Development Co.), U. S. P. 1,965,770 (1934); *C. A.*, **28**, 5474 (1934). Groll and Burgin, U. S. P. 1,965,771 (1934); *C. A.*, **28**, 5474 (1934). Can. P. 353,604 (1936); *C. A.*, **30**, 1543 (1936).
- (12) Voituren, Brit. P. 349,067 (1929); *C. A.*, **26**, 5314 (1932). Brit. P. 352,280 (1929); *C. A.*, **26**, 5315 (1932).
- (13) Soc. d'Études Scientifiques et d'Enterprises Industrielles, Brit. P. 349,067 (1930); *Brit. Chem. Abs.*, **1931B**, 832. Brit. P. 352,280 (1929); *Brit. Chem. Abs.*, **1931B**, 960. French P. 692,395 (1929); *C. A.*, **25**, 1259 (1931).

- (14) Winter, Hull, Ferguson and Imperial Chemical Industries, Ltd., Brit. P. 332,731 (1929); *C. A.*, **25**, 304 (1931).
- (15) Millar (to Shell Development Co.), Can. P. 309, 544 (1931); *C. A.*, **25**, 2441 (1931); U. S. P. 1,896,552 (1933); *C. A.*, **27**, 2696 (1933).
- (16) F. Fischer and Pichler, French P. 719,035 (1931); *C. A.*, **26**, 3261 (1932).
- (17) Chaffette, French P. 733,248 (1932); *C. A.*, **27**, 813 (1933).
- (18) N.-V. de Bataafsche Petroleum Maatschappij, French P. 713,012 (1930); *C. A.*, **26**, 1624 (1932). Brit. P. 364,418 (1930); *C. A.*, **27**, 1365 (1933).
- (19) Consortium für Elektrochem. Industrie, German P. 568,673 (1927); *C. A.*, **27**, 2741 (1933). Hermann and Baum, U. S. P. 1,864,196 (1932); *C. A.*, **26**, 4347 (1932).
- (20) Wheeler, Binnie and Imperial Chemical Industries, Ltd., Brit. P. 353,913 (1930); *C. A.*, **26**, 5314 (1932); U. S. P. 1,942,889 (1934); *C. A.*, **28**, 1720 (1934).
- (21) Rudder and Biedermann, French P. 748,861 (1933); *C. A.*, **27**, 5340 (1933).

9. The solubility of acetylene in liquids and its adsorption on solids, as applied to storage of the gas and separation from gas mixtures. Acetylene is characterized by a high solubility in certain selective solvents as compared to the lower solubility of gaseous olefins and paraffins in the same media. This property finds application in the storage of dissolved acetylene in cylinders and in the solvent separation of acetylene from gas mixtures. The abnormal solubility of acetylene appears to be the result of an attraction or association between either a labile hydrogen atom or to a lesser extent an unsaturated carbon atom of acetylene and an electronegative atom in the solvent such as oxygen, nitrogen or halogen, which has an unshared electron pair in its outer shell. Copely and Holley (1) have postulated hydrogen bonding between the hydrogen of acetylene and oxygen or nitrogen atoms in several solvents. Other chemists, however, regard this affinity of an acidic hydrogen for an electronegative atom as a simple electrostatic attraction. Similar associations involving the hydrogen atoms of hydroxyl and amino groups are well known. However, certain acetylenic compounds which do not contain a labile hydrogen atom also appear to have a rather high solubility in certain solvents containing oxygen or nitrogen, and this behavior may perhaps be due to the presence of unsaturated carbon atoms. In this connection it is significant that the presence of unsaturated carbon atoms in keto and nitrile groups also appears to produce molecular association of compounds containing these groups.

The solubility of acetylene in selective solvents is greatly increased by a high pressure of the gas above the solvent. This condition may be represented by an equilibrium which is forced to the right by an increased partial pressure of acetylene:

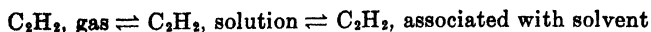

According to these concepts, several features of the composition and structure of the molecules of a liquid may influence the effectiveness of the

liquid as an acetylene solvent. If solubility is the result of the presence of an uncoordinated electronegative atom in the solvent molecule, then solvents containing oxygen or nitrogen and no acidic hydrogen should be more effective than similar solvents containing acidic hydrogen and consequently having association between solvent molecules. It is significant that water, alcohols (1), phenols, carboxylic acids (1), amides and aryl amines are not particularly good solvents for acetylene. On replacing the labile hydrogen in any of these substances by a small alkyl group their solvent power for acetylene appears to be markedly increased.

In general, atoms having the greatest electronegativity would be expected to have the greatest effect in increasing acetylene solubility. However, a steric factor also may be important in establishing the equilibrium

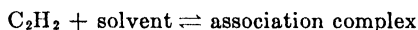

The speed of dissociation of this complex may depend chiefly on the strength of the attraction or bonding between the acetylene molecule and the electronegative atom of the solvent, while the speed of association may depend in large part upon the accessibility of the electronegative atom, and be in inverse proportion to the steric hindrance of the remainder of the solvent molecule. The attractive force between acetylene and a solvent is probably weak at best; and according to this concept the maintenance of a high concentration of such a weakly associated complex depends chiefly on a very high rate of association, made possible by a very accessible electronegative atom in the solvent. This may be the reason why oxygen in carbonyl groups and nitrogen in nitrile groups appear to be more effective in promoting the solubility of acetylene than oxygen in ethers or nitrogen in tertiary amines. Similarly, primary alkyl chlorides having an exposed chlorine atom seem to act to some extent as selective solvents for acetylene.

The weak association complexes formed by acetylene with solvents are naturally much more stable at lower temperatures, and the solubility of acetylene in these selective solvents usually increases rapidly with diminishing temperature.

Table 1 gives the reported solubility of acetylene in a number of liquids.

In order to show the effect of electron donor atoms in the solvent Copley and Holley (1) have computed the mol fraction solubility of acetylene in a number of solvents under one atmosphere partial pressure of acetylene, as compared with the theoretical mol fractions calculated from Raoult's law. Their results are given in Table 2.

The earliest application of the solubility of acetylene consisted in the development of the practice of storing acetylene in solution. Claude and Hess (4) found that the danger of explosion was obviated by storing acetylene as a solution in acetone under pressure, and noted the enormous

PHYSICAL PROPERTIES, PREPARATION, PURIFICATION 31

Table 1. Solubility of Acetylene.

Solvent	Temp. (°C.)	Total press.	Cc C ₂ H ₂ per cc solvent	Grams C ₂ H ₂ per 100 g solvent	Ratio of conc. ^a of C ₂ H ₂ in gas to C ₂ H ₂ in liq.	Ref.
Acetone ^b	-80	1 atm ^a	2000			2
"	0				38.6	3
"	5				34.4	3
"	10				30.68	3
"	15				27.33	3
"	20				22.0	3
"	30				19.8	3
"	35				17.88	3
"	40				16.19	3
"	15	1 atm	25			4
"	18	1 atm	18.1			5
"	25	1 atm	13.1			5
"	15	12 atm	300			4
Methyl propyl ketone	-10	1 atm	14.8			6
Acetoacetone	-10	1 atm	10.2			6
Acetaldehyde ^c	-10	745 mm	59.9 ^b			6
Acrolein ^d	-10	1 atm	22.6			6
Propionaldehyde	-10	1 atm	24.2			6
Methylal ^e	-10	735 mm	54.3 ^b			6
Acetal	-10	742 mm	28.8 ^b			6
Methyl formate ^e	-10	740 mm	48.4 ^b			6
Ethyl formate	-10	738 mm	42.2 ^b			6
Methyl acetate	-10	736.5	52.3 ^b			6
" "	0				38.04	3
" "	10				30.13	3
" "	25				21.25	3
Ethyl acetate	-10	742 mm	44.5 ^b			6
Isoamyl formate	-10	739 mm	17.5 ^b			6
Isoamyl acetate	-10	738.5	29.3 ^b			6
Dimethyl formamide	20	1 atm	33-37			5
" "	25	1 atm	28-32			5
Diethyl formamide	20	1 atm	20.6			5
Dimethyl acetamide	20	1 atm	27.8			5
Tetramethyl urea	20	1 atm	29.2			5
Dimethyl acetylamine	23	1 atm	14.3			5
Trimethyl carbamate	23	1 atm	18.5			5
Trimethyl glycine	23	1 atm	15.5			5
N, N, N', N'-tetramethyl amino amino acetamide	23	1 atm	16.4			5
Dimethyl oxamethane	24	1 atm	14			5
Ethanol ^g	18	1 atm	6			7
Cyclohexanol	26				0.963	8
Amyl alcohol	18	1 atm	3.5			7
Acetic acid	18	1 atm	6			7
Paraffin oil ^g	0	755 mm	1.03			9
Chloroform	18	1 atm	4			7
Carbon bisulfide	18	1 atm	1			7
Carbon tetrachloride	0		0.25			10

Solvent	Temp. (°C.)	Total press.	Cc C ₂ H ₂ per cc solvent	Grams C ₂ H ₂ per 100 g solvent	Ratio of conc. ^a of C ₂ H ₂ in gas to C ₂ H ₂ in liq.	Ref.
Aniline	4.2	1 atm		0.8		11
Benzene	4	755 mm		0.744		11
Dimethylaniline	0.3	751 mm		0.737		11
Nitrobenzene	3.8	735 mm		0.553		11
Ethyl mustard oil	-10	1 atm	3.2			6
Ethylidene cyanhydrin	-10	1 atm	2.8			6
Water ^f	19.5	755 mm	0.97			9
"	12	755 mm	1.06			9

^a These values are little influenced by pressure.

^b See (14, 15, 17, 17a) for additional data. See also (13) for acetone-water mixture.

^c Acetaldehyde in mixtures (6).

^d Acrolein formed a solid complex with acetylene.

^e Average values are given.

^f See (9, 13, 16).

^g See also (12).

^h Gas volume reduced to standard conditions.

Table 2. Solubility of Acetylene in Donor Solvents.

Solvent	Temp. (°C.)	Mol fraction	
		Observed	Calculated
Diethyl acetal	-10	0.200	0.04
Methylal	-10	0.192	0.04
Acetaldehyde	-10	0.177	0.04
Ethyl acetate	-10	0.168	0.04
Ethyl formate	-10	0.144	0.04
Methyl acetate	-10	0.163	0.04
Methyl formate	-10	0.142	0.04
Isoamyl acetate	-10	0.166	0.04
Isoamyl formate	-10	0.095	0.04
Acetic acid	18	0.0150	0.0245
Ethyl alcohol	18	0.0151	0.0245
Benzene	4	0.0252	0.0342
Aniline	4.2	0.0223	0.034
Dimethyl aniline	0.3	0.037	0.0382
Nitrobenzene	3.8	0.0223	0.0345
Cyclohexane	3	0.0175	0.0352
Acetone	0.0	0.092	0.038
Acetone	15	0.074	0.026
Acetone	15	0.490	0.312 ^e
Acetone	25	0.0402	0.0206

^e Pressure of acetylene was 12 atmospheres.

increase in the solubility of acetylene in acetone produced by high pressures of acetylene (2, 4, 18). Janet (19) observed that the margin of safety is greatly increased by allowing the acetone to impregnate a porous ma-

terial, and a number of such materials have been patented for this purpose. Cylinders filled with a porous solid saturated with a solvent liquid are almost universally used at the present time for the transportation and storage of acetylene (17). Sauerbrei (27) has reviewed the subject of solid fillers for acetylene cylinders. Acetone is almost always employed but the similar use of several other solvents (6) has been proposed. However, for this purpose a solvent either must be cheap or must have low volatility to reduce losses as the gas is withdrawn. If the acetylene is to be used as a fuel for cutting or welding, the solvent must be such as to have no adverse effects on the properties of the flame.

As was stated in the preceding sections, the gases produced by the pyrolysis of organic compounds at high temperatures contain acetylene mixed with much hydrogen, some methane, and lesser quantities of other saturated, olefinic and aromatic hydrocarbons. Traces of more highly unsaturated substances such as butadiene, allene, methylacetylene and diacetylene, or their homologs, also may be present. Carbon monoxide is an important component of the mixed gases when the pyrolysis is carried on in the presence of steam, carbon dioxide or oxygen as in the incomplete combustion methods. When nitrogen is present, ammonia and a trace of hydrogen cyanide may also be formed. Often the concentration of acetylene in the mixtures is less than 20 per cent by volume. Since this diluted gas cannot be stored in cylinders with solvent acetone in the usual way, and since it is unsatisfactory for some fuel and chemical uses, a number of attempts have been made either to remove the most objectionable impurities, to concentrate the acetylene, or to separate it from mixtures of this type. The separation and purification of acetylene from pyrolytic gas mixtures is the most expensive step in this mode of preparation. The most promising methods of separation involve the use of selective solvents. These have sometimes been applied in combination with other procedures such as selective adsorption on solids, removal of impurities by chemical reagents, and partial condensation at low temperatures and high pressures.

As a preliminary step in the solvent separation of acetylene, some of the more reactive impurities and those having the highest boiling points usually are removed. The acidic components of the gas mixture, such as hydrogen cyanide, hydrogen sulfide and carbon dioxide, may be eliminated by washing with aqueous alkalis. The removal of hydrogen sulfide by oxidation also is possible. The small proportion of products having more than two carbon atoms in the molecule may be extracted by fractional condensation (20) or by washing at temperatures near their boiling points with solvents of low volatility such as nitrobenzene, gas oil (21, 22) or halogenated hydrocarbons (21). The dienes and higher acetylenic hydrocarbons are even more soluble in acetone than is acetylene and may be stripped out by

acetone at temperatures above that suitable for dissolving acetylene (23). These highly reactive unsaturated hydrocarbons also may be removed by polymerization by sulfuric or phosphoric acid (24), or on contact with silica gel (24, 25) or aluminum chloride (24).

After these preliminary steps the gas mixture is treated with selective solvents which extract the acetylene from the residual gas, consisting chiefly of hydrogen, methane, ethylene and ethane. Separations by selective solution of the acetylene have been described, employing acetone at low temperatures (26), acetaldehyde (6), acetonitrile at -10° (28, 29), water under pressure (30), liquid sulfur dioxide, carbon dioxide, ammonia, methyl chloride or ethyl chloride (31), glycol diacetate (32) and various other ethers and esters of glycol and glycerol, ethyl lactate (33), poly glycols and their esters and ethers (34), "Cellosolves" (35), lactones (36), diethyl oxalate (37), diethyl carbonate (38), cyclohexanone (39), ketones having more than three carbon atoms (40), several completely alkylated amides of carboxylic acids (5) and a variety of other organic solvents (41).

The boiling points of the principal gaseous components of these mixtures are so low that the methods of total fractional condensation and distillation have not been applied commercially to their separation. However the condensation of all components except methane and hydrogen, followed by fractionation of the liquefied portion, is said to be feasible on an industrial scale (42), but involves the hazards of handling liquid acetylene. Methods consisting of combinations of solvent extraction with partial condensation and fractionation also have been patented (43-45).

Another type of process for the separation of these gas mixtures is the selective adsorption of the gases on porous solids. Acetylene and the highly unsaturated components appear to be more firmly held on most adsorbent solids than the simple olefins, and these in turn are more firmly held than the lower paraffins or hydrogen. Silica gel, kieselguhr (46) and charcoal (47-49) have been patented as adsorbents for the separation of acetylene. In practice, some provision must be made for dissipating the heat of adsorption of acetylene in processes of this kind and this presents a difficult problem. It is claimed that the acetylene may be recovered from the solid by lowering the pressure and increasing the temperature or by treating with steam. These adsorption methods may be used in combination with solvent extraction.

It should be noted that the hydrogen and most of the other hydrocarbon gases in the mixtures are recovered in these processes, and the value of these by-products must be considered in evaluating the separation methods.

As an alternative procedure, it has been proposed to use gas mixtures containing acetylene for the direct synthesis of acetaldehyde (50-52) and in other chemical processes.

References

- (1) Copely and Holley, *J. Am. Chem. Soc.*, **61**, 1599-60 (1939).
- (2) Claude, *Compt. rend.*, **128**, 303-4 (1899).
- (3) Horiuti, *Bull. Inst. Phys. Chem. Res. (Tokyo)*, **9**, 697-730 (1930); *Sci. Papers Inst. Phys. Chem. Res. (Tokyo)*, **14**, No. 267-70; *C. A.*, **25**, 3543 (1931); *Sci. Papers Inst. Phys. Chem. Research (Tokyo)*, **17**, 125-256 (1931); *C. A.*, **26**, 2104 (1932).
- (4) Claude and Hess, *Compt. rend.*, **124**, 626-8 (1899).
- (5) Scott and Harris (to E. F. DuPont de Nemours & Co.), U. S. P. 2,146,448 (1939); *C. A.*, **33**, 3398 (1939).
- (6) James, *J. Am. Inst. Chem. Eng.*, **5**, 133-49 (1912); *Ind. Eng. Chem.*, **5**, 115-20 (1913). James and Watson, U. S. P. 928,867 (1909); *C. A.*, **3**, 2374 (1909).
- (7) Berthelot, *Ann. chim. phys. (4)*, **9**, 425 (1866).
- (8) Cauquill, *J. chim. phys.*, **24**, 53-5 (1927).
- (9) Müller, *J. prakt. Chem.*, **58**, 21-3 (1898).
- (10) Nieuwland, "Some Reactions of Acetylene," Thesis, Catholic University of America, 1904.
- (11) Garelli, *Atti accad. Lincei (6)*, **2**, 120-4 (1925); *C. A.*, **20**, 853 (1926).
- (12) Kireev and Romanchuk, *J. Gen. Chem. (U. S. S. R.)*, **6**, 78-80 (1936); *C. A.*, **30**, 7421 (1936).
- (13) Kremann and Honel, *Monatsh.*, **34**, 1089-94 (1913).
- (14) Butler, *J. Soc. Chem. Ind.*, **40**, 25-61 (1921).
- (15) Müller and Kumpfmiller, *Z. Elektrochem.*, **34**, 70 (1928).
- (16) Winkler, Landolt-Bornstein, *Physikalische-thermische Tabellen*, 5th ed., **1**, 767 (1923); see "International Critical Tables," Vol. III, p. 260, McGraw-Hill Book Co., New York.
- (17) Mies, *Autogene Metallbearb.*, **30**, 17-20 (1937); **32**, 2-6 (1939); *C. A.*, **32**, 2715 (1938); **33**, 2395 (1939).
- (18) Claude, *Proc. XII Internat. Congr. Acetylene, Oxy-Acetylene Welding and Allied Ind.*, 878-81, London (1936); *C. A.*, **32**, 471 (1938).
- (19) Janet, *Z. Calcium Carbide und Acetylen*, **5**, 237 (1901).
- (20) I. G. Farbenind. A.-G., Brit. P. 371,142 (1931); *Brit. Chem. Abs.*, **1932B**, 762. Bueckert, Stadler and Tanneberger, U. S. P. 1,945,592 (1934); *C. A.*, **28**, 2371; German P. 615,834 (1935); *C. A.*, **29**, 7834 (1935); German P. 639,662 (1936); *C. A.*, **31**, 3944 (1937). Baumann, Bueckert, Sandhaas and Schilling, U. S. P. 1,988,032 (1935); *C. A.*, **29**, 1438 (1935).
- (21) I. G. Farbenind. A.-G., Brit. P. 386,052 (1931); *Brit. Chem. Abs.*, **1933B**, 216; French P. 739,289 (1932); *C. A.*, **27**, 1896 (1933); German P. 578,072 (1933); *C. A.*, **27**, 4252 (1933).
- (22) Standard Oil Development Co., French P. 744,772 (1933); *C. A.*, **27**, 4252 (1933). Murphree (to Standard Oil Development Co.) Can. P. 369,341 (1937); *C. A.*, **32**, 2148 (1938).
- (23) Ruhrchemie, A.-G., French P. 748,193 (1933); *C. A.*, **27**, 5175 (1933); Brit. P. 415,377 (1934); *C. A.*, **29**, 913 (1935). Grimme and Tramm, U. S. P. 1,989,273 (1935); *C. A.*, **29**, 1970 (1935).
- (24) I. G. Farbenind. A.-G., Brit. P. 340,787 (1929); *C. A.*, **25**, 4012 (1931); German P. 568,630 (1930); *C. A.*, **27**, 2638 (1933); Brit. P. 368,782 (1930); *C. A.*, **27**, 2163 (1933); German P. 630,249 (1936); *C. A.*, **30**, 5597 (1936); Albert Auerhahn, U. S. P. 1,960,326 (1934); *C. A.*, **28**, 4436 (1934).
- (25) I. G. Farbenind. A.-G., French P. 716,882 (1931); *C. A.*, **26**, 2202 (1932). Zobel and Reich, U. S. P. 1,973,840 (1934); *C. A.*, **28**, 6726 (1934).
- (26) Curme, U. S. P. 1,422,182 (1922); *C. A.*, **16**, 3195 (1922).
- (27) Sauerbrei, *Autogene Metallbearb.*, **21**, 90 (1928).
- (28) Nicodemus (to I. G. Farbenind. A.-G.), U. S. P. 1,813,946 (1931); *C. A.*, **25**, 5277 (1931).
- (29) I. G. Farbenind. A.-G., Brit. P. 303,068 (1928); *Brit. Chem. Abs.*, **1929B**, 547; French P. 666,387 (1928); *C. A.*, **24**, 1393 (1930); German P. 535,727 (1931); *Frdl.*, **17**, 126-7.

- (30) I. G. Farbenind. A.-G., Brit. P. 280,885 (1927); *C. A.*, **22**, 3499 (1928); French P. 643,387 (1927); *C. A.*, **23**, 1419 (1929).
- (31) I. G. Farbenind. A.-G., Brit. P. 377,193 (1931); *Brit. Chem. Abs.*, **1932B**, 926; French P. 724,476 (1931); *C. A.*, **26**, 4823 (1932). Schilling and Stadler (to I. G. Farbenind. A.-G.), U. S. P. 2,029,120 (1936); *C. A.*, **30**, 1616 (1936).
- (32) Hull and Imperial Chemical Industries, Ltd., Brit. P. 331,610 (1929); *C. A.*, **25**, 116 (1931).
- (33) Horsley and Roffey, to Imperial Chemical Industries, Ltd., Brit. P. 331,654 (1929); *C. A.*, **25**, 116 (1931); U. S. P. 1,854,141 (1932); *C. A.*, **26**, 3364 (1932).
- (34) Groll and Burgin, Brit. P. 400,054 (1933); *C. A.*, **28**, 2166 (1934); U. S. P. 1,965,100 (1934); *C. A.*, **28**, 5474 (1934). N. V. de Bataafsche Petroleum Maatschappij, German P. 606,343 (1934); *C. A.*, **29**, 1614 (1935); French P. 751,284 (1933); *C. A.*, **28**, 1058 (1934).
- (35) Koller, *Khim. Tverdogo Topliva*, **8**, 1149-55 (1937); *C. A.*, **32**, 4016 (1938).
- (36) Isham, U. S. P. 2,063,680 (1937); *C. A.*, **31**, 710 (1937).
- (37) Taylor, U. S. P. 1,996,088 (1935); *C. A.*, **29**, 3353 (1935).
- (38) Metzger (to Air Reduction Co.), U. S. P. 1,900,655 (1933); *C. A.*, **27**, 2966 (1933); Brit. P. 401,531 (1933); *C. A.*, **28**, 2371 (1934); French P. 749,625 (1933); *C. A.*, **28**, 492 (1934).
- (39) Müller-Conradi, Eisenhut and Schilling (to I. G. Farbenind. A.-G.), U. S. P. 1,938,083 (1933); *C. A.*, **28**, 1046 (1934).
- (40) Johnson (from I. G. Farbenind. A.-G.), Brit. P. 325,817 (1928); *Brit. Chem. Abs.*, **1930B**, 449.
- (41) Minister of Navy (Hujio, inventor), Jap. P. 109,413 (1935); *C. A.*, **29**, 4218 (1935).
- (42) Bronn, *Z. angew. Chem.*, **42**, 760-8 (1929).
- (43) Wulff, U. S. P., 1,938,991 (1934); *C. A.*, **28**, 1364 (1934).
- (44) Gesellschaft für Linde's Eismaschinen A.-G., Brit. P. 468,614 (1937); *C. A.*, **32**, 6 (1938); French P. 815,294 (1937); *C. A.*, **32**, 957 (1938).
- (45) Pyzel (to Shell Development Co.), U. S. P. 1,985,548 (1935); *C. A.*, **29**, 1235 (1935).
- (46) I. G. Farbenind. A.-G., French P. 667,091 (1929); *C. A.*, **24**, 1119 (1930); Brit. P. 368,782 (1930); *Brit. Chem. Abs.*, **1932B**, 491; German P. 594,161 (1934); *C. A.*, **28**, 3315 (1934).
- (47) Askenasy (to Soc. anon. pour l'industrie chim. a Bâle), German P. 556,776 (1928); *C. A.*, **27**, 312 (1933); French P. 678,830 (1929); *C. A.*, **24**, 3519 (1930); U. S. P. 1,865,422 (1932); *C. A.*, **26**, 4347 (1932).
- (48) I. G. Farbenind. A.-G., Brit. P. 325,309 (1930); *Brit. Chem. Abs.*, **1930B**, 406; French P. 688,186 (1930); *C. A.*, **25**, 752 (1931); German P. 556,776 (1932); *Frdl.*, **17**, 127-9.
- (49) Deutsche Gold- und Silber-Scheideanstalt vorm. Roessler, German P. 643,219 (1937); *C. A.*, **31**, 4170 (1937).
- (50) I. G. Farbenind. A.-G., Brit. P. 278,324 (1926); *C. A.*, **22**, 2573 (1928); French P. 641,406 (1928); *Chem. Zentr.*, **1928**, II, 1938; French P. 657,027 (1928); *C. A.*, **23**, 4231 (1929).
- (51) Ferguson and Imperial Chemical Industries, Ltd., Brit. P. 342,771 (1929); *C. A.*, **25**, 5436 (1931).
- (52) Hirst and Imperial Chemical Industries, Ltd., Brit. P. 302,515 (1928); *C. A.*, **23**, 4231 (1929).

10. The laboratory purification and analysis of acetylene. For laboratory use acetylene usually is either generated from calcium carbide or drawn from a commercial storage cylinder. If carbide is employed it is preferable to use a carbide to water type generator, observing precautions against localized overheating. It is also advisable to use a precipitant or an oxidative purifying agent to remove traces of phosphine and other

PHYSICAL PROPERTIES, PREPARATION, PURIFICATION 37

impurities. (See Chapter 1, Section 4.) However, it is usually more convenient to use the gas from a storage cylinder. In this case most of the impurities arising from carbide have been reduced to a proportion which is negligible if the gas is to be used as a raw material for laboratory syntheses. The gas from a cylinder does contain acetone in quantities which increase with decreasing pressure in the cylinder. Sodium bisulfite solution has been employed to remove acetone. Passing the gas through strong sulfuric acid in an efficient wash bottle also removes acetone and part of the other trace impurities but may introduce sulfur dioxide and acid spray. These may be eliminated by a soda-lime tower or by a dilute sodium hydroxide wash followed by a drying agent. If it is essential to remove oxygen from the gas an alkaline solution of sodium hydrosulfite containing a little anthroquinone sulfonic acid (1) may be placed in the train. Horiuti (2) and Conn, Kistiakowsky and Smith (3) have described somewhat more elaborate purification methods. However, acetylene may contain traces of impurities such as hydrogen, nitrogen, methane, or ethane which can not be removed by chemical reagents. Accordingly if the gas must be exhaustively purified it appears essential to liquify and distil it. This procedure requires special technique and precautions which do not seem to have been adequately described in the literature.

For the qualitative detection of acetylene a variation of the cuprous acetylide precipitation is always used, since the characteristic red color of the acetylide can be seen even when present in minute quantities. (See Chapter II, Section 5.) However, the acetylide is readily oxidized with darkening by air in an alkaline medium, and a reducing agent such as hydroxylamine is necessary to preserve the pure red color. Test papers based on this reaction have been described (4). For a much more sensitive test, modifications of Flosvay's solution have been recommended (5). This consists of an ammoniacal cuprous chloride solution containing gelatin which acts as a protective colloid to keep the acetylide in a fine state of division so that its color is more readily observable at great dilution. Czaco (5) states that this reagent is sensitive to acetylene in concentrations of 2-4⁻¹⁰ per cent if proper precautions are taken.

Flosvay's solution, also has been used for the colorimetric estimation of acetylene (5,6). However, the color depends upon both the size of the colloidal particles and the absence of impurities such as traces of hydrogen sulfide or larger quantities of oxygen or carbon dioxide. Accordingly, most investigators have preferred to estimate the quantity of acetylide formed either by careful drying and weighing as the explosive carbide C_2Cu_2 (7) or better, by dissolving the acetylide in acid and determining the copper by any standard method (8). Since the red cuprous acetylide in an ammoniacal solution is readily attacked by oxygen which darkens the color and may alter the

ratio of copper to carbon, it is recommended that a reducing agent such as hydroxylamine or hydrazine be added to the ammoniacal cuprous chloride solution (5).

Chevastelon (9) and Ross and Trumbull (10) have described the estimation of acetylene, especially in the presence of ethylene, by titration of the nitric acid liberated by the gas from a neutral silver nitrate solution according to the equation, $C_2H_2 + 3AgNO_3 \rightarrow C_2Ag_2AgNO_3 + 2HNO_3$. Hoepfner and Willstätter and Marchmann (11) report that the method is not very reliable. Novotny (12) proposed that the silver in the precipitate be determined. Lebeau and Damiens and Wellers (13) used a slightly alkaline solution of mercuric iodide and potassium iodide to precipitate acetylene in the presence of olefins.

In gas volumetric analysis methods, reagents, containing copper, silver or mercury which are capable of absorbing acetylene are nearly always capable of taking up lesser quantities of olefins, diolefins, carbon monoxide or higher acetylenic hydrocarbons, so that methods depending upon loss of gas volume in such reagents are of questionable accuracy.

A microchemical method for the estimation of acetylene by reaction with a bead of cuprous chloride made alkaline with ammonium hydroxide has been proposed (14).

The analysis of carbide acetylene for common impurities has been described in several treatises on calcium carbide and acetylene (see Ref. 1, Introduction) and a few reviews (15). A number of methods which describe special adaptation of these procedures to particular gas mixtures cannot be discussed in this work.

References

- (1) Feiser, *J. Am. Chem. Soc.*, **46**, 2639-47 (1924).
- (2) Horiuti, *Sci. Papers Inst. Phys. Chem. Research (Tokyo)*, **17**, 130 (1931); *C. A.*, **26**, 2104 (1932).
- (3) Conn, Kistiakowsky and Smith, *J. Am. Chem. Soc.*, **61**, 1868-76 (1939).
- (4) Llorens, *Anal. Fis. Quim.*, **10**, 139 (1912); **11**, 320 (1913). Deniges, *Bull. soc. pharm. Bordeaux*, **1921**, No. 2; *Report. pharm.*, **33**, 232 (1921); *C. A.*, **16**, 395 (1922).
- (5) Ilosvay, *Ber.*, **32**, 2697-9 (1899); *Z. anal. Chem.*, **40**, 123-4 (1901). Czaco, *Z. angew. Chem.*, **44**, 388 (1931). Riese, *ibid.*, **44**, 701-3 (1931). Schulze, *ibid.*, **44**, 703 (1931). Pietsch and Kotkowski, *ibid.*, **44**, 309-12, 388, 703 (1931). Novotny, *Coll. Czechoslov. Chem. Communications*, **6**, 514-27 (1934); *C. A.*, **29**, 2878 (1935).
- (6) Weaver, *J. Am. Chem. Soc.*, **38**, 352 (1916). Schulze, *Z. angew. Chem.*, **29**, 341 (1916).
- (7) Scheiber, *Z. anal. Chem.*, **48**, 537 (1909).
- (8) Scheiber, *Ber.*, **41**, 3816 (1908); Muller, *Bull. soc. chim.*, **27**, 69 (1920); Arnold, Möllnay and Zimmermann, *Ber.*, **53**, 1034 (1920); Willstätter and Maschmann, *ibid.*, **53**, 939 (1920).
- (9) Chevastelon, *Compt. rend.*, **125**, 245 (1897); Tucker and Moody, *J. Am. Chem. Soc.*, **23**, 671-4 (1901).
- (10) Ross and Trumbull, *J. Am. Chem. Soc.*, **41**, 1180 (1919).

PHYSICAL PROPERTIES, PREPARATION, PURIFICATION 39

- (11) Hoepfner, *Z. Nahr. Genussm.*, **34**, 453 (1917); Willstätter and Maschmann, *Ber.*, **53**, 939 (1920).
- (12) Novotny, *Collection Czechoslov. Chem. Communications*, **7**, 84-9 (1935).
- (13) Lebeau and Damiens, *Compt. rend.*, **156**, 557 (1913); Wellers, *Stahl u. Eisen*, **42**, 1449 (1922).
- (14) Blacet, MacDonald and Leighton, *Ind. Eng. Chem. Anal. Ed.*, **5**, 272-4 (1933).
- (15) Herites, *Chem. Listy*, **24**, 493-9 (1930); *C. A.*, **25**, 2664 (1931). Korschak, *Acetylen Wiss. Ind.*, **35**, 118-22 (1932); *C. A.*, **23**, 3029 (1934). Assman, *ibid.*, **35**, 184-6 (1932); *C. A.*, **28**, 3029 (1934). Strizhevskii and Checkhovitch, *Zavodskaya Lab.*, **8**, 220-2 (1939); *C. A.*, **33**, 9198 (1939).

Chapter II

Metallo-Derivatives of Acetylene

1. Types of metallo-derivatives of acetylene. The metallo-derivatives of acetylene are of two distinct types.

First, acetylides, in which the triple bond persists, are formed by the replacement of one or both of the hydrogen atoms of acetylene by a metal or a metallo- radical. They may result from the action of acetylene on a metal with the evolution of hydrogen, from the action of acetylene on a metal compound with the elimination of the corresponding hydrogen compound, or from a metathetic reaction between an acetylide and a metal salt.

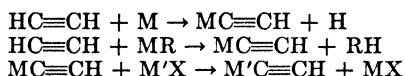

Second, metallo- addition compounds of acetylene usually contain all of the components of acetylene and an added metal compound.

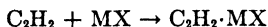

In several cases the components of the metal salt become directly linked to the carbon atoms with partial or complete saturation of the triple bond. The structures of several other metallo- addition compounds of acetylene remain unknown.

Metals of the first two groups of the periodic table and a few other metals and metallo- radicals of low valence are known to form acetylides. No attempt has been made to prepare and study all the possible metal acetylides, and only those have been investigated thoroughly which are useful either for the qualitative or quantitative estimation of acetylene or as intermediates in the preparation of substituted acetylenes (see Chapter III). Side reactions appear to prevent the formation of acetylides of certain metals. Thus reactions which might be expected to yield cupric acetylide yield diacetylene and a cuprous salt, and several other metals probably behave in the same way. The hydrogenation of acetylene by chromous salts and its oxidation by osmium salts appear to obviate the preparation of acetylides of these metals.

The metal compounds which add to acetylene include mercuric and cuprous salts; halides of aluminum, phosphorus, arsenic and antimony; a few palladous, aurous, chromous and silver salts; and possibly others. The greatest importance of some of these metal compounds lies in their use to promote the addition of non-metallic substances to acetylene. Metal

salts employed in this way are commonly referred to as catalysts; however, additive compounds of the metal salt with acetylene can usually be shown to exist in the catalytic mixtures, and these should probably be looked upon as intermediates which are continually regenerated in a cycle of reactions. As will be shown later, metal compounds are used for the promotion or control of most of the commercially important addition reactions of acetylene.

The formation of metal acetylides is reviewed in Sections 2-5, and the metallo- addition compounds in Sections 6-10 of this chapter.

2. The preparation of acetylides by direct reaction of acetylene with alkali or alkaline-earth metals. With the alkali and alkaline-earth metals acetylene behaves as a very weak acid (see Section 3), forming the metal acetylides with evolution of hydrogen. Berthelot (1) early suggested that the acetylides of the alkali metals formed at ordinary temperatures have the simple formula, $MC\equiv CH$, and this view is usually accepted. Moissan (2) later advanced the theory that these compounds, as well as the alkaline-earth acetylides, consist of one molecule of acetylenic carbide associated with one molecule of acetylene, $MC\equiv CM \cdot C_2H_2$. In confirmation, he cited the fact that these compounds lose acetylene and are converted to the carbides on heating. However, the same reasoning would assign complex formulas to many metal hydroxides and amides which are generally considered to have simple ones. Moissan also claimed to have obtained sodium carbide from the acetylide by treatment with iodine, but this reaction has not been confirmed. In opposition to this theory, Skossarevsky (3) pointed out that all the reactions of these acetylides may best be explained on the basis of the simple formulas. The question can be settled conclusively only by the development of a technique for determination of the molecular weights of the compounds, but all other evidence points to the simple formulas, $M-C\equiv CH$ and $M(C\equiv CH)_2$.

On this basis the replacement of one hydrogen atom of acetylene by an alkali or alkaline-earth cation appears to retard greatly the replacement of the second hydrogen atom. At low temperatures these metals thus tend to form the monometallic acetylides rather than the carbides, just as under similar conditions they form the hydroxides rather than the oxides and the amides rather than the imides or nitrides. Different and more drastic treatment is needed for the replacement of both hydrogen atoms of acetylene by these metals.

The simple acetylides are formed with some evolution of heat by the direct action of acetylene on the more electropositive metals, either in the solid or fused state, or better in liquid ammonia solution.

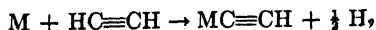

Acetylene acts upon the solid alkali or alkaline-earth metals to give at most a superficial coating of acetylide which delays further reaction, as was early observed by Berthelot (1) and later by Moissan (2). The same authors and also Matignon (4) prepared the acetylides of sodium and potassium by the reaction of acetylene with the metal heated slightly above its melting point. Further elevation of the temperature results in the formation of acetylenic carbides, $MC\equiv CM$, and the method is, accordingly, not applicable to the preparation of acetylides of metals having a higher melting point, such as lithium and the alkaline-earth metals. It appears very difficult to secure complete reaction between acetylene and molten sodium or potassium because of enclosure of particles of unreacted metal by the acetylide.

The production of the alkali-metal acetylides from the fused metals suspended in xylene has been patented (5); however even in this type of procedure incrustation of the metal globules hinders the reaction. A method also has been patented in which the molten metals mixed with an inert solid material are treated with acetylene in a revolving drum (6).

The alkali and alkaline-earth metals are soluble in liquid ammonia, and crystalline acetylides of these metals are obtained readily by the action of acetylene on the solutions. In this way Moissan (2) made the acetylides of lithium, sodium, potassium, calcium, rubidium and cesium. Hess and Munderloh (7) employed the method for making a quantity of sodium acetylide. Cottrell (8) reported a similar preparation of the acetylide of magnesium, although this metal is very slightly soluble in liquid ammonia. Some of the acetylides made in this way appear to hold ammonia of crystallization. The acetylide of lithium was found to retain two molecules of ammonia for each atom of metal, calcium acetylide four molecules of ammonia per atom of metal, and magnesium acetylide a maximum of five molecules of ammonia per atom of metal; the other alkali-metal acetylides held no ammonia at ordinary temperatures. These proportions conform to the general rule that the number of molecules of ammonia of crystallization in a salt increases as the radius of the cation decreases or as its valence increases. In further confirmation of this view all reactions of the ammoniated acetylides in liquid ammonia solution appear to be similar to those of the non-ammoniated acetylides. The authors in unpublished work have found that the ammonia can be removed completely from calcium acetylide by placing it over phosphorus pentoxide in an atmosphere of acetylene.

Vaughn, Hennion, Vogt and Nieuwland (9) have called attention to a modified technique for the more rapid preparation of sodium acetylide in liquid ammonia, which is of interest because of the extensive use of this material in making substituted acetylenes. This method is equally ap-

plicable to the acetylides of the other metals which dissolve in this medium. At atmospheric pressure acetylene appears to be quite soluble in both liquid ammonia and also in the liquid ammonia-acetylide solutions at a temperature below their boiling points, but it is completely expelled from the solutions on boiling. The presence of metallic sodium in the ammonia greatly diminishes the solubility of acetylene, and if the concentration of the metal is high, the solubility of acetylene seems to be practically nil. Accordingly, the most rapid reaction takes place with a minimum concentration of sodium metal and a high concentration of acetylene attained by cooling the liquid ammonia solvent several degrees below the boiling point. If no other means of cooling is at hand, a solution of acetylene may be maintained by blowing a stream of excess acetylene through the liquid ammonia, thus cooling it by evaporation. It should be remembered that in this reaction a volume of hydrogen and ethylene is evolved equal to one-half the volume of acetylene reacting, and some cooling results from evaporation of ammonia in this gas stream. Sodium may be added to the reaction mixture in a concentrated solution or better by regulating the depth of immersion of a solid stick of the metal suspended on a wire (10). To avoid loss of time, the reacting solution is never allowed to become blue throughout. At approximately -33° solid sodium does not dissolve readily in the saturated acetylide solution, and concentrated solutions of sodium appear not to be miscible with it. At this temperature the accumulation of dissolved sodium acetylide retards the reaction and a rapid rate can be attained only in solutions which are somewhat less than saturated. In a bath cooled by solid carbon dioxide the solubility of sodium acetylide in liquid ammonia is decreased and sodium is soluble in the saturated solution. Accordingly, at the lower temperature solid sodium acetylide accumulates in the reaction mixture. The saturated solutions of the less soluble acetylides of the other metals also give much less retardation. The liquid ammonia used as a solvent should be anhydrous and the solutions should be protected from contact with moist air, because the sodium hydroxide formed is a very undesirable impurity. By observing these precautions large quantities of sodium acetylide can be prepared in a fraction of the time otherwise required.

Moissan (2) found that the nascent hydrogen produced in liquid ammonia solution hydrogenated a portion of the acetylene, and hydrogenation of the mono-substituted acetylenes in reactions of this type also has been reported (9, 11). Accordingly a metathetic reaction with sodamide (see Section 3) is advisable with the more costly monosubstituted acetylenes; but sodium acetylide is more easily made from the liquid ammonia solution of the metal, and any loss through conversion of acetylene to ethylene is neglected.

The replacement of both hydrogen atoms of acetylene by the alkali or alkaline-earth metals has been accomplished only at somewhat higher temperatures, either by the action of acetylene on the metals or their hydrides, or by the loss of a molecule of acetylene from two molecules of the alkali acetylides, $MC\equiv CH$. The formation of sodium carbide by these methods between 190° and 220° has been reported by several investigators (1, 2, 4, 12). The authors (13) have noted that loss of acetylene from sodium acetylide begins at about 160° under partial vacuum. Moissan (2) prepared the carbides K_2C_2 , Rb_2C_2 and Cs_2C_2 by heating quickly the corresponding acetylides, but some decomposition of these substances occurred at the same time. Moissan also reported the preparation of Li_2C_2 from the ammoniated acetylide, to which he assigned the formula $Li_2C_2 \cdot C_2H_2 \cdot 2NH_3$, and of CaC_2 from the compound $CaC_2 \cdot C_2H_2 \cdot 4NH_3$ on heating. Botolfsen (14) showed that mixtures of calcium carbide with the nitride and other impurities resulted from heating the ammoniated calcium acetylide. We have recently been informed in a private communication (15) that pure calcium carbide may be prepared from the ammoniated acetylide by the removal of the ammonia under vacuum at room temperature and subsequent heating to eliminate acetylene.

References

- (1) Berthelot, *Ann. chim. phys.* (4), **9**, 402-7 (1866).
- (2) Moissan, *Compt. rend.*, **126**, 302-6 (1898); **127**, 911-17 (1898); **136**, 1217-22, 1522-5 (1903).
- (3) Skossarevsky, *J. Russ. Phys.-Chem. Soc.*, **36**, 863-72 (1904); *Chem. Zentr.*, **1904**, II, 1024; *Compt. rend.*, **159**, 769-71 (1914); *J. Chim. phys.*, **13**, 3-17 (1915); *C. A.*, **9**, 2342 (1915).
- (4) Matignon, *Compt. rend.*, **124**, 775-7 (1897).
- (5) I. G. Farbenind. A.-G., German P. 494,575 (1926); *C. A.*, **24**, 3517 (1930).
- (6) Deutsche Gold und Silber Scheideanstalt vorm Roessler, French P. 689,466 (1930); *C. A.*, **25**, 909 (1931); German P. 535,071 (1929); *C. A.*, **26**, 1297 (1932); German P. 539,573 (1930); *C. A.*, **26**, 1944 (1932).
- (7) Hess and Munderloh, *Ber.*, **51**, 379-80 (1918).
- (8) Cottrell, *J. Phys. Chem.*, **18**, 85-100 (1914).
- (9) Vaughn, Hennion, Vogt and Nieuwland, *J. Org. Chem.*, **2**, 1-22 (1937).
- (10) Hennion, *Proc. Ind. Acad. Sci.*, **47**, 116-21 (1938); *C. A.*, **32**, 9039 (1938).
- (11) Lagermark and Eltekov, *J. Russ. Phys.-Chem. Soc.*, **11**, 125 (1879); *Ber.*, **12**, 854-5 (1879). Favorsky, *ibid.*, **19**, 561 (1887). Moureu and Delange, *Bull. soc. chim.* (3), **25**, 304 (1901). Lebeau and Picon, *Compt. rend.*, **157**, 137-9, 223-4 (1913).
- (12) Forcrand, *Compt. rend.*, **120**, 1215-8 (1895); *Bull. soc. chim.* (3), **13**, 996-7 (1895).
- (13) Unpublished.
- (14) Botolfsen, *Ann. chim.* (9), **18**, 5-48 (1922).
- (15) Vaughn, T. H., private communication.

3. The preparation of acetylides by metathetic reactions of acetylene with metal compounds having weakly negative anions. Since a hydrogen atom when directly linked to an acetylenic carbon atom is more labile than

the hydrogen of most other hydrocarbons, some investigators have looked upon acetylene and the mono-substituted acetylenes as weak acids. However, the researches of several chemists have shown that acetylene is only very slightly ionized as measured by its conductivity in water or liquid ammonia solutions (1). A fairly accurate concept of the lability of the hydrogen atoms in acetylene may be attained by a comparison of the metathetic reactions of acetylene and other substances having labile hydrogen with salts having weakly negative anions. The following reactions illustrate the position of acetylene in a series of slightly acidic hydrogen compounds.

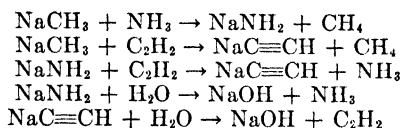

In general these reactions appear to lead to the formation of the hydride having the least labile hydrogen, and accordingly the order is methane, ammonia, acetylene and water. In these reactions the equilibrium is far to the right and the displacements are practically complete. Strictly consistent results are obtained with similar compounds of all the more electro-positive metals, but the covalent compounds of some of the less positive metals do not react in this way. The series of weakly negative anions and of the corresponding hydrides might easily be interpolated and extended: for instance, many aryl groups occupy a position between the alkyl groups and the amino group, while the oxyradicals of alcohols and phenols appear to be capable of displacing the ethynyl group, and amino and imino groups probably fall either above or below the ethynyl group, depending upon their organic components. A series of this kind is of value in predicting substitution reactions of acetylene. In this connection research to determine the relative acidity of a number of very weak acids is of interest (2).

Metathetic reactions of weakly acidic hydrogen compounds and their salts frequently do not go entirely to completion, but the tendency to reaction is often strong enough to overcome unfavorable factors of solubility or volatility. Thus slightly soluble sodamide suspended in liquid ammonia is easily converted to the soluble acetylide by the action of acetylene. However some evidence may be cited for the existence of traces of these acetylides in equilibria with aqueous or alcoholic alkalis. For example, Billitzer (1) concluded that the greater solubility of acetylene as compared to ethylene in aqueous alkalis was due to the formation of minute proportions of alkali acetylides. Better evidence of equilibrium conditions may be found in the experiments of Reyerson and Yuster (3), which proved that a rather rapid exchange of deuterium for the hydrogen of acetylene took

place in solutions of alkali in heavy water, while no exchange could be detected in neutral or acidified heavy water. Bell (4), using a lower concentration of heavy water at 76° in most of his experiments, failed to observe the isotopic exchange; but further work by Reyerson (5) and Reyerson and Gillespie (6) confirmed the previous findings. These results can best be ascribed to the formation of acetylides ions in alkaline solution, and the same conclusion can be derived from the necessity for alkaline conditions in a number of substitution reactions of acetylene to be discussed in Chapter III.

When one hydrogen atom of acetylene has been replaced by a substituent, the lability of the remaining hydrogen atom is influenced. The introduction of the same substituent into water, acetylene and ammonia appears to produce the same qualitative effect on the lability of the remaining hydrogen atoms; for example, phenol, phenyl acetylene and aniline appear to have more labile hydrogen atoms than the corresponding water, acetylene and ammonia. However the comparative lability of hydrogen atoms in mono-substituted acetylenic compounds has received little study.

The only procedure of the metathetic type which has been applied extensively to acetylene is the reaction with alkyl or aryl Grignard derivatives in ether.

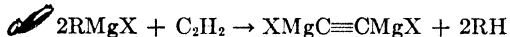

The halomagnesium group, unlike the alkali metals, upon replacing one hydrogen atom of acetylene does not appear to retard greatly the replacement of the second hydrogen atom at ordinary temperature. Jozitsch (7) reported the preparation of compounds of the type $\text{XMgC}\equiv\text{CMgX}$ by the action of acetylene on ether solutions of the Grignard reagents prepared from methyl, ethyl, isobutyl and isoamyl iodides, from propyl, butyl, isobutyl, isoamyl and benzyl bromides, and from tertiary-butyl and benzyl chlorides. Similar results were obtained later by others (8). These dihalomagnesium derivatives of acetylene are useful for the direct synthesis of certain other di-substituted derivatives of acetylene (see Chapter III). Lespieau (9) claimed that the dihalomagnesium acetylides could also serve for the preparation of mono-substituted acetylenes by the preferential reaction of one of the MgX groups, *e.g.*,

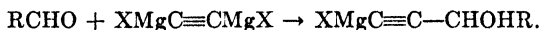

However, the synthesis of mono-substituted acetylenes from these reagents usually has been accounted for by assuming that the Grignard derivative from acetylene contains a greater or less proportion of a monohalomagnesium acetylide, $\text{HC}\equiv\text{CMgX}$.

Oddo (10) appears first to have called attention to the possibility of obtaining a considerable proportion of a monohalomagnesium derivative of

acetylene in a reaction of this kind. He made the compound $\text{HC}\equiv\text{CMgBr}$ from acetylene and phenylmagnesium bromide. Jozitsch and later Zal'kind and Rosenfeld (11) also made this compound as almost the sole product when acetylene was passed into the boiling ether solution during the preparation of phenylmagnesium bromide. Evidence that varying quantities of a similar product may result from other Grignard reagents with acetylene was noted by Dupont and later workers (8). Grignard, Lepayre and Tcheou Faki (12) investigated conditions of temperature and acetylene pressure governing the relative formation and the equilibrium of the di- and monohalomagnesium derivatives of acetylene in ether and benzene solutions. The equilibrium, $\text{XMgC}\equiv\text{CMgX} + \text{C}_2\text{H}_2 \rightleftharpoons 2\text{HC}\equiv\text{CmgX}$, was forced to the right by an added pressure of one-half atmosphere of acetylene, and yields of 80 to 90 per cent of $\text{HC}\equiv\text{CMgX}$ were obtained at various temperatures. Thus the proportions of the two types of acetylene compounds appear to be reached either by direct formation or by equilibrium changes, and to be influenced by the identity of the original Grignard reagent and by acetylene pressure, temperature and solvent.

By a similar reaction Jozitsch (7) made $\text{IZnC}\equiv\text{CZnI}$ from ethylzinc iodide and acetylene in ether, and Durand (13) claimed to have obtained the compound ZnC_2 from zinc diethyl and acetylene in ligroin.

The organic groups of organo-metallic compounds of the less electro-positive metals are not replaced by reaction with acetylene (14) and in this respect are quite unlike the organo-compounds of the alkali metals, of zinc and of magnesium. Thus Durand (13) failed to replace the organic radicals by reactions between acetylene and the ethyl and phenyl compounds of mercury and lead, which of course are practically non-ionized. On the other hand the authors, in unpublished work, reported that they were able to dissolve insoluble amide or imide compounds of silver, lead, tin and mercury by the action of acetylene on the solids suspended in liquid ammonia made alkaline by the presence of sodium or potassium acetylide. The soluble silver and mercuric compounds were obviously quite different from the acetylides of these metals made in aqueous solutions (see Section 5). Similarly, it is known that the amides and imides of several of the less electropositive metals are converted to oxides or hydroxides by water, whereas the organo-compounds of the same metals are inert toward water. It is quite probable that most metallic amides and imides, which are decomposable by water, will also react with acetylene in liquid ammonia under the proper conditions, but this procedure has received little attention.

Moissan (15) made the acetylides of sodium, potassium, rubidium, cesium and calcium by the action of acetylene on the hydrides of the metals at 100° , according to the reaction, $\text{MH} + \text{C}_2\text{H}_2 \rightarrow \text{MC}\equiv\text{CH} + \text{H}_2$. He later reported that in the presence of traces of water a violent reaction

between acetylene and the hydrides began at ordinary temperature, whereas in the absence of water the reaction began at about 42°.

Picon (16) found that sodamide suspended in liquid ammonia was converted to sodium acetylide by acetylene, and the experience of several investigators (16, 17) shows that sodium compounds of the mono-substituted acetylenes are best prepared by the parallel action of the hydrocarbons on sodamide.

References

- (1) Jones and Allen, *Am. Chem. J.*, **18**, 375-7 (1896). Jones, *ibid.*, **18**, 623-4 (1896). Bredig and Usoff, *Z. Elektrochem.*, **3**, 116-7 (1896). Billitzer, *Monatsh.*, **23**, 489-511 (1902); *Z. physik. Chem.*, **40**, 535-44 (1902). Cottrell, *J. Phys. Chem.*, **18**, 85-100 (1914). Gatterer, *J. Chem. Soc.*, **1926**, 299-316.
- (2) Wooster and Mitchell, *J. Am. Chem. Soc.*, **52**, 688-94 (1930). Conant and Wheland, *ibid.*, **54**, 1212-21 (1932). McFwen, *ibid.*, **58**, 1124-9 (1936).
- (3) Reyerson and Yuster, *ibid.*, **56**, 1426-7 (1934).
- (4) Bell, *ibid.*, **57**, 778-9 (1935).
- (5) Reyerson, *ibid.*, **57**, 779-80 (1935).
- (6) Reyerson and Gillespie, *ibid.*, **57**, 2250-1 (1935); **58**, 282-4 (1936); **59**, 900-2 (1937).
- (7) Jozitsch, *J. Russ. Phys.-Chem. Soc.*, **34**, 242-4 (1902); *Bull. soc. chim. (3)*, **30**, 210-11 (1903); *J. Chem. Soc.*, **106** (I), 393, 405 (1914); *J. Russ. Phys.-Chem. Soc.*, **35**, 1269-75 (1903); *J. Chem. Soc.*, **106** (I), 403-4 (1914); *J. Russ. Phys.-Chem. Soc.*, **38**, 252-3 (1906); *J. Chem. Soc.*, **106** (I), 394 (1914).
- (8) P. Gautier, *Ann. chim. phys. (8)*, **16**, 334-43 (1909). Dupont, *Compt. rend.*, **149**, 1381-3 (1909); **150**, 1121-3 (1910). Pieroni and Coli, *Gazz. chim. ital.*, **44** (II), 349-53 (1914).
- (9) Lespieau, *Compt. rend.*, **179**, 1606-7 (1924).
- (10) Oddo, *Atti. accad. Lincei (5)*, **13** (II), 187-93 (1904); *Chem. Zentr.*, **1904**, II, 943; *Gazz. chim. ital.*, **34** (II), 429-36 (1904); **38** (I), 625-35 (1908).
- (11) Zal'kind and Rosenfeld, *Ber.*, **57B**, 1690-2 (1924). Jozitsch, *J. Russ. Phys.-Chem. Soc.*, **38**, 252-3 (1906); *Bull. soc. chim. (4)*, **4**, 981-2 (1908).
- (12) Grignard, Lepayre and Tcheou Faki, *Compt. rend.*, **187**, 517-20 (1928); *Contrib. Inst. Natl. Acad. Peiping*, **1**, 127-49 (1934); *C. A.*, **29**, 2513 (1935).
- (13) Durand, *Compt. rend.*, **176**, 992-3 (1923); *Bull. soc. chim. (4)*, **35**, 161-71 (1924).
- (14) Nelson, *Iowa State Col. J. Sci.*, **12**, 145-7 (1937); *C. A.*, **32**, 3756 (1938).
- (15) Moissan, *Compt. rend.*, **136**, 1522-5 (1903); *Bull. soc. chim. (3)*, **31**, 720-3 (1904); *Ann. chim. phys. (8)*, **6**, 323-33 (1905).
- (16) Picon, *Compt. rend.*, **173**, 155-8 (1921); *Bull. soc. chim. (4)*, **29**, 709-13 (1921).
- (17) Bourgeul, *Compt. rend.*, **178**, 777-9 (1924); *ibid.*, **179**, 686-8 (1924); *Ann. chim. (10)*, **3**, 191-235 (1925). Jacobson and Carothers, *J. Am. Chem. Soc.*, **55**, 1622-4 (1933). Heisig, *ibid.*, **53**, 3256 (1931). Vaughn, Vogt and Nieuwland, *ibid.*, **56**, 2120-2 (1934). Vaughn, Hennion, Vogt and Nieuwland, *J. Org. Chem.*, **2**, 1-22 (1937).

4. The preparation of acetylides by metathetic reactions of acetylides with other metal salts. A promising but meagerly developed general method for the preparation of acetylides consists in the metathetic reactions of anhydrous salts of the metals or metalloids with sodium acetylide in liquid ammonia or with acetylenic Grignard reagents in ether or other organic solvents. Thus Mahler (1) has reported the formation of amor-

phous compounds of the empirical composition P_2C_6 and As_2C_6 from $XMgC\equiv CMgX$ on reaction with the phosphorus and arsenous halides in ether. These compounds were inert toward acids and alkalis and insoluble in ordinary solvents. The yellow phosphorus compound ignited on warming in air, and the brown arsenous compound exploded by warming or friction. Wieland and Wesche (2) prepared the compound $(CH_3)_2AsC\equiv CAs(CH_3)_2$ by the action of cacodyl chloride, $(CH_3)_2AsCl$, on the compound $BrMgC\equiv CMgBr$. Acetylene was regenerated from the bis-cacodyl acetylide by the action of alkalis.

The authors (3) have carried out some investigations on the action of a large excess of sodium acetylide in liquid ammonia solution on cuprous, silver and mercuric salts. The products first formed were soluble, and by rapid evaporation of the solutions were obtained in mixture with a sodium salt and sodium acetylide as non-explosive, colorless solids. However, when the same solutions were allowed to stand for some time, or when less than one equivalent of sodium acetylide was used, precipitates resulted which resembled the ordinary explosive, insoluble "carbides" of these metals. Weibel (4) also obtained acetylide precipitates of variable composition by the action of anhydrous nickel and lead thiocyanates on a solution of potassium acetylide in liquid ammonia. It was found that the nickel compound decomposed on standing to give a cuprene-like solid.

References

- (1) Mahler, *Bull. soc. chim.* (4), **29**, 1071-3 (1921).
- (2) Wieland and Wesche, *Ann.*, **431**, 39-40 (1923).
- (3) Unpublished (1934).
- (4) Weibel and Vogt, unpublished.

5. The preparation of acetylides by metathetic reactions of acetylene with certain metal salts in aqueous or alcoholic solutions. On treatment with acetylene in aqueous or alcoholic media, acetylide compounds are precipitated from alkaline or even neutral or slightly acid solutions of certain salts of copper, silver, mercury, gold and perhaps a few other metals. In order to react in this way it appears that the metal must exist as a cation in solution, since slightly ionized compounds such as the cyanides and the thioglycolates of these metals are inert. It is quite probable that both the slight ionization of the resulting acetylides and the insolubility of most of them are factors favoring their formation. However, these reactions cannot be attributed entirely to the insolubility of the products; for instance, the acetylide compounds from silver thiosulfate and from alkyl mercuronium salts are quite soluble in aqueous alkalis. A number of these compounds have a complex structure due to the introduction into the acetylide molecule of groups or anions which were linked to the metal in the original salt.

The preparation of acetylides in this way seems to depend upon a specific property of the metals named, and acetylide formation does not occur with salts of most other metals in aqueous or alcoholic solution. Thus Durand (1) failed to obtain acetylide precipitates from the hydroxides of nickel, cobalt or lead in aqueous alkaline solutions. Alkaline media are most favorable for this reaction, and of course metals such as lead and tin, which ordinarily form a part of the anion in alkaline solutions, cannot be expected to react in this manner; but the authors have also failed to obtain an acetylide from the cation of triethyllead chloride in alcoholic potash, although the alkylmercuronium salts reacted readily under the same conditions. It is probably significant that most of the metal salts which yield acetylides in water or alcohol are also known to form more or less definite addition or association compounds with unsaturated hydrocarbons in the same solvents, indicating that similar addition compounds may be intermediates in this type of acetylide formation. The best example of this mechanism has been provided by Manchot and co-workers (2), who have proved that certain liquid mono-substituted acetylenes form compounds of the type $RC\equiv CH \cdot CuCl$ when treated with dry cuprous chloride; these compounds, on contact with aqueous ammonia or even with water, lose hydrogen chloride and are converted to acetylides of the composition $RC\equiv C-Cu$.

In fact metal-salt addition compounds of acetylene may be present in some acetylide precipitates of this type, and it is difficult to distinguish between addition compounds and complex acetylides of these metals by analyses alone. Although the substances thrown down by acetylene from alkaline solutions of salts of the metals are thought to be acetylides in all cases, the precipitates formed in neutral and acid solutions of mercuric salts appear to be almost entirely addition products, while the structure of some similarly formed silver and copper compounds is rather doubtful.

Acidic substances, especially the halogen acids and hydrogen sulfide, evolve acetylene from the acetylides of these metals. Baeyer (3) first used a potassium cyanide solution to liberate diacetylene from its cuprous salt, and this method has also been found applicable to acetylides. However the alkali cyanides cease to act in the presence of much caustic alkali and the acetylides can even be made from the cyanides of copper, silver and mercury in strongly alkaline solutions. The results are probably due to the non-ionized condition of these metal cyanides in neutral solutions. Another test for acetylide structure in compounds of this type consists in the formation of diiodoacetylene on treatment with iodine in solution. In the present work it has been assumed that a compound of these metals is an acetylide rather than an addition compound if it conforms to one or more of these tests.

Some, but not all, of the acetylide compounds of the metals named are explosive. Accordingly, non-explosiveness is not sufficient to prove that a precipitate formed in this way is an addition compound, as sometimes has been assumed. The explosive properties of the silver acetylide derivatives have been studied most and appear to be due primarily to the large quantity of energy released upon their decomposition with liberation of elemental silver and carbon. Thus Berthelot and Delepine (4) calculated that the heat of formation of the compound C_2Ag_2 from the elements is -87.15 kcal/mole, as compared to -8.8 kcal for C_2Na_2 , -6.25 kcal for CaC_2 and -58.1 kcal for acetylene. The presence in complex acetylides of oxidizing groups such as nitrate, bromate or perchlorate, and also of the halogens, appears to increase the explosiveness, while the presence of non-oxidizing anions, such as sulfate, phosphate or organic acid residues, appears to decrease the explosiveness. Although the explosion of these substances is very rapid on friction or excessive heating, their quiet decomposition can be accomplished by careful heating at a lower temperature.

Copper, silver, mercury and gold, in contrast to the alkali and alkaline-earth metals, tend to replace both hydrogen atoms of acetylene at ordinary temperature. The preparation of the acetylide compounds of these metals will now be taken up in detail.

The red, explosive acetylide precipitate obtained by passing pyrolytic gases through an ammoniacal cuprous chloride solution was described (5) a few years before its exact nature was known. By treating this precipitate with hydrochloric acid Boettger (5) regenerated a gas which Berthelot (6) prepared in the same way, purified and named acetylene. Early workers assumed that recovery of the acetylene from the cuprous acetylide precipitate was quantitative, but it was soon found that the regenerated acetylene was not perfectly pure because of an addition reaction of hydrochloric acid to form vinyl chloride, and also because of alteration of the precipitate in air to yield a cuprous compound of diacetylene (see Chapter III, Section 5).

A number of attempts have been made to deduce the structure of the red cuprous acetylide from analytical data (7-13). Blochmann (8) and Scheiber and Reckleben (11) showed that the apparently water-free precipitate had the approximate composition $Cu_2C_2 \cdot H_2O$ and suggested the structural formula $HC \equiv C - Cu \cdot CuOH$. Acids, hydrogen sulfide and potassium cyanide solutions were found to regenerate acetylene from this substance, while iodine in sodium hydroxide solution gave diiodoacetylene (13). It was also found that on prolonged drying over sulfuric acid (9) or calcium chloride (11) the precipitate approached the composition Cu_2C_2 . A similar red precipitate has been obtained from ammoniacal solutions of other cuprous salts in the presence of salts of other metals (11). Kuespert (14)

called attention to the colloidal condition of the acetylide made in dilute solutions of cuprous salts, and found that the colloid could be stabilized by the addition of gelatin. This acetylide is best prepared in a pure state in the presence of a reducing agent such as hydroxylamine (15), sulfur dioxide (16) or hydrazine sulfate (17).

The distinctive red color of these copper acetylide precipitates from alkaline solutions is the basis for a number of qualitative tests for acetylene. Berthelot early called attention to the reaction as a specific test, and Deniges (18) developed a test paper for acetylene based on this reaction; Pietsch and Kotowski (19) have devised an especially sensitive method using a cuprous salt in a hydroxylamine solution.

For quantitative determinations of either acetylene or copper Scheiber (11) advises the preparation of the red acetylide precipitate, followed by either dehydration and direct weighing or conversion of the copper to sulfide or thiocyanate. This reaction also has been employed in many gas-analysis methods for estimation of acetylene by the loss in volume on contact with an alkaline cuprous solution (20). A modification of the cuprous salt-hydroxylamine reagent containing gelatin has been employed for the colorimetric estimation of acetylene (21).

There is some evidence of the formation of more complex cuprous acetylide compounds in neutral or slightly acid solutions of certain cuprous salts. Thus Bhaduri (22) obtained an acetylide precipitate containing the thio-sulfate group from a solution containing cuprous thiosulfate, and Scheiber and Reckleben (11) found that iodine entered into the composition of what appeared to be a cuprous acetylide compound precipitated in the presence of potassium iodide.

From a dilute ammoniacal cupric salt solution an explosive acetylide precipitate was prepared by Soederbaum (23), who assigned to it the formula $12\text{CuC}_2 \cdot \text{H}_2\text{O}$. Only a "humic" material was liberated from this substance by acids or a potassium cyanide solution. Durand (1) obtained a red-brown precipitate by passing acetylene into a solution of cupric oxide in aqueous potassium hydroxide. The fresh material gave acetylene on treatment with hydrochloric acid, but the older, blackened material gave only a colloidal substance. These substances may have been impure cuprous acetylide precipitates resulting from partial reduction of the cupric salts. The probable decomposition of cupric acetylides is discussed in the following chapter in connection with the preparation of diacetylene.

An explosive precipitate of silver acetylide was obtained by Quet and by Boettger (5) on passing pyrolytic gases through an ammoniacal silver nitrate solution, Berthelot (6, 7) in his early studies on acetylene also investigated this precipitate, and noted that the material varied in color from

yellow to pure white due to conditions of formation. Plimpton, Arth and Stettbacher (24) later established that the yellow precipitate was formed first, especially in dilute ammoniacal solutions of silver salts. Blochmann (8) assigned the formula $\text{HC}\equiv\text{C}-\text{Ag}_2\text{OH}$ to a yellow specimen when dried at a low temperature; his analysis showed a percentage of silver only a fraction of one per cent above the theoretical value of 83.7 per cent. Lossen (25) also obtained a yellow substance closely approximating this composition by the elimination of carbon dioxide from the silver salt of acetylene dicarboxylic acid upon treatment with hot water. Berthelot and Delepine (4) later obtained a similar yellow substance by the action of acetylene on moist silver oxide. However, the yellow precipitate appears to pass into a white substance containing a higher proportion of silver on more prolonged reaction; white precipitates also are obtained directly from more concentrated solutions of silver salts in aqueous ammonia. Conditions suitable for formation of these different types of precipitates have never been defined exactly, and in view of these facts some of the investigations of silver acetylide precipitates may have been made upon mixtures of more than one compound.

Early analyses of air-dried precipitates having little yellow coloration (26) gave varying proportions of silver up to 89 per cent, and formulas with more or less oxygen and hydrogen were proposed. Keiser (9) proved that his white precipitate, when washed with alcohol and ether and dried over sulfuric acid at reduced pressure, closely approached a silver content of 89.99 per cent, the composition of Ag_2C_2 , and that the weight of the dried material remained practically unchanged on explosion in vacuum, with no evolution of hydrogen, oxygen or steam. This constitution of the thoroughly dried white acetylide precipitate from ammoniacal silver nitrate solutions was later confirmed by other workers (4, 27). Pollitzer (28) has suggested the quantitative determination of acetylene from the weight of this compound.

More complex acetylide precipitates are also formed by the action of acetylene on neutral or slightly acid solutions of a number of silver salts and even on alkaline solutions of the silver halides. In these reactions a portion of the anionic material of the silver salt is liberated as acid, while the remainder is held in the precipitate. Berthelot (7) reported a compound, $\text{HC}_2\text{Ag}_2\text{Cl}$, from ammoniacal silver chloride, and precipitates of undetermined composition from the sulfate, phosphate and benzoate. Berthelot and Delepine (4) studied precipitates obtained from ammoniacal silver chloride, silver iodide in aqueous potassium iodide, and aqueous silver nitrate and sulfate, and proposed formulas based on the composition $\text{C}_2\text{Ag}_3\text{X}$, in some cases with an added molecule of C_2Ag_2 or of the original silver salt. By the action of acetylene on neutral aqueous solutions of

silver salts Plimpton (24) reported precipitates of the compositions $C_2Ag_2 \cdot \frac{1}{2}H_2O$ and $C_2Ag_2 \cdot \frac{1}{3}H_2O$ from the acetate, and $3C_2Ag_2 \cdot 2AgNO_3 \cdot H_2O$ and $C_2Ag_2 \cdot 2AgNO_3 \cdot H_4O$ from the nitrate. Similarly, Edwards and Hodgkinson (29) obtained a precipitate of the composition $C_2H_2 \cdot Ag_2O \cdot Ag_2CrO_4$ from silver bichromate, and also precipitates of undetermined composition from the acetate, benzoate, butyrate, selenate, tungstate, phosphate, vanadate, and thiocyanate. They also reported that acetylene produced no silver acetylene compounds in aqueous potassium cyanide or potassium thiosulfate solutions. Nieuwland and Maguire (30) analyzed a peculiar non-explosive substance having an exceptionally low percentage of silver, of the approximate composition $3C_2H_2 \cdot 2H_3PO_4 \cdot Ag_3PO_4 \cdot H_2O$, which resulted from the reaction of acetylene with an acid solution of silver phosphate; and they also prepared explosive precipitates of undetermined constitution from acid solutions of silver fluoride, bromate and perchlorate. Bhaduri (22) reported an acetylide precipitate $4Ag_2S_2O_3 \cdot 7Na_2S_2O_3 \cdot 86Ag_2C_2 \cdot 13C_2H_2$ from an aqueous solution of silver nitrate with sodium thiosulfate, but since this precipitate is rather soluble in water it can scarcely be as complex as this formula indicates. Chevastelon (31) calculated the formula of an acetylide precipitate from neutral silver nitrate solution to be $C_2Ag_2 \cdot AgNO_3$. Willgerodt (32) proposed the formula HC_2Ag_2Cl for a precipitate from ammoniacal silver chloride and the formula $HC_2Ag_2NO_3$ for a precipitate from neutral silver nitrate solution.

These analytical results are rather confusing, but some conclusions concerning the true structure of these substances may be inferred from the following facts. It has been established by a number of workers that practically all the silver compounds of acetylene yield considerable quantities of acetylene on treatment with reagents such as hydrochloric acid, alkali cyanide solutions or hydrogen sulfide. Compounds giving these reactions must contain the structures $HC \equiv CAg$ or $AgC \equiv CAg$, to which one or more molecules of a silver salt are in some way linked, rather than any more saturated addition products of acetylene or an acetylide with a silver salt. This view is further confirmed by the fact that Chevastelon (31), Berthelot and Delepine (4) and other investigators have found that some of these precipitates approach more and more closely the composition Ag_2C_2 on continued reaction, and also on treatment with ammonia. It is probable that those silver salts which give the most soluble primary reaction products with acetylene yield a final precipitate approaching most closely to the composition Ag_2C_2 . Concerning the attachment of a silver salt to an acetylide residue, it has been shown that the precipitates from monosubstituted acetylenes and silver nitrate in alcohol all appear to have a constitution $RC \equiv C \cdot Ag \cdot AgNO_3$, and a similar composition has been established by Krause and Schmitz (33) even for the non-acetylenic com-

pound, $C_6H_5-Ag \cdot AgNO_3$. These facts point to the conclusion that the silver acetylide precipitates probably may be represented by formulas of the type $XAg(\cdot AgC \equiv CAg \cdot)_n AgX$, although sometimes the groups $HC \equiv CAg \cdot$ and $\cdot AgOH$ may be present; nearly all the analytical results may be explained satisfactorily on this assumption. Similarly the compound C_2Ag_2 quite possibly may be a polymer of the structure $(\cdot AgC \equiv CAg \cdot)_n$.

Due to the uncertain availability of mercury for the manufacture of fulminate in time of war, the possibility of using silver acetylide compounds as detonating agents has been studied. It has been found (34) that material approaching the composition Ag_2C_2 releases practically no gas on explosion in vacuum, whereas the acetylide precipitate from an acid solution of silver nitrate evolves a considerable volume of gas, and accordingly has more explosive force.

Tucker and Moody (35) have suggested the use of dilute aqueous silver nitrate solution for the semiquantitative separation of ethylene and acetylene. Terry (36) has patented the separation of copper and silver, as acetylides from ore solutions.

An explosive mercuric acetylide compound was obtained by Berthelot (7) from an ammoniacal solution of mercuric iodide and potassium iodide, and Basset (37) reported an explosive precipitate from the action of pyrolytic gases on Nessler's solution. Keiser (38) studied the explosive compound formed by the action of acetylene on an aqueous solution of mercuric iodide, potassium iodide and potassium hydroxide. The air-dried material appeared to contain some water, and upon prolonged heating at 100° the composition approximated C_2Hg . Plimpton and Travers (39) made a similar substance by the action of acetylene on mercuric oxide suspended in an ammoniacal solution of ammonium carbonate. Estimation of both mercury and carbon indicated the formula to be $2C_2Hg \cdot H_2O$, and the proportion of mercury was not further increased by drying at 100° . These authors reported that ammoniacal solutions of mercuric salts were not completely precipitated by acetylene unless other salts such as $CuSO_4$ or $ZnCl_2$ were added. Keiser (38) and Plimpton and Travers (39) reported that the acetylide compounds yielded some acetylene with hydrochloric acid and diiodoacetylene with iodine solutions. Ferber and Roemer obtained an explosive compound, $2HgC_2 \cdot C_2H_2 \cdot H_2O$, possibly having an acetylide structure, by the reaction of acetylene with a saturated mercuric acetate solution in acetic acid (40). Acid and neutral solutions of mercuric salts are known to give addition compounds with acetylene in many cases (see Section 7), and accordingly a small proportion of addition products has been found to result from the reaction of mercuric salts or acids on the mercuric acetylide compounds. The acetylide precipitate from an alkaline solution of mercuric iodide and potassium iodide has been employed for the

quantitative determination of acetylene (41), and an alkaline mercuric cyanide solution also has been used for this purpose (41a).

Investigations by Spahr, Vogt and Nieuwland (42) concerning the acetylide compounds of organo-mercuric radicals are helpful in understanding the properties of the acetylides of the less electropositive metals. The most stable compounds of this class have the type formula $R-Hg-C\equiv C-Hg-R$, in which R may be any one of a number of alkyl or aryl groups; however, there is good reason to believe that more soluble compounds of the type $HC\equiv CHgR$ are first formed. The compounds $RHgC\equiv CHgR$, which were partially precipitated by the action of acetylene on concentrated solutions of organo-mercuric salt in alcoholic sodium hydroxide, were more or less soluble in organic solvents, depending upon the specific organic radical present. The most soluble of the compounds was the isopropyl-mercuric derivative, and this substance when suspended in alcoholic sodium hydroxide was completely dissolved by passing in excess acetylene, probably by conversion to the simpler monometallic acetylide: $RHg-C\equiv C-HgR + C_2H_2 \rightarrow 2HC\equiv C-HgR$. On heating or on reducing the pressure above this solution, acetylene was given off and the original compound was reprecipitated. The conversion of the less soluble compounds of the type $RHgC\equiv CHgR$ by means of excess acetylene was much slower. In no case were compounds of type $HC\equiv CHgR$ completely isolated, because of the ease with which they lost acetylene. The reactions of these simple and soluble acetylide compounds are probably similar to the slower and more obscure reactions of the much less soluble acetylides of this group of metals. Apparently either one or both of the hydrogen atoms of acetylene may be replaced by them at ordinary temperatures. When the product resulting from the replacement of one hydrogen atom of acetylene is quite insoluble, this may predominate in the precipitate, as possibly in the case of the reported compounds $HC\equiv C-Cu \cdot CuOH$, $HC\equiv C-Ag \cdot AgOH$ and $HC\equiv C-Ag \cdot AgCl$, etc. If this first product is somewhat soluble, the reaction may proceed to the formation of less soluble disubstituted or chain products. However, if all the possible products are somewhat soluble, an equilibrium probably results which is dependent on the solubilities and the quantity of acetylene in solution.

A good example of an acetylide of a bivalent metallo-radical is presented by Hilpert and Gruettner (43), who made a highly insoluble precipitate by the reaction of acetylene with an alkaline solution of a salt of the radical $-Hg(CH_2)_6Hg-$. They considered their product to be polymeric, and it quite probably consisted of one or more compounds containing a structure $[-C\equiv C \cdot Hg(CH_2)_6Hg-]_n$.

The unstable acetylides prepared from mercurous salts have received little study. Burkhardt and Travers (44) found that mercurous acetate

suspended in water was converted by acetylene into a gray, easily decomposable substance from which acetylene was regenerated on treatment with hydrochloric acid.

Salts of a few other metals have been found to yield acetylides in aqueous or alcoholic solutions. Berthelot (7) reported that acetylene produced a yellow explosive precipitate in an ammoniacal solution of aurous thiosulfate, but he did not analyze this material. Matthews and Watters (45) found that a similar precipitate from an ammoniacal solution of sodium aurous thiosulfate had the composition Au_2C_2 after drying over sulfuric acid and yielded acetylene on treatment with hydrochloric acid; it decomposed slowly to gold and carbon in boiling water or upon slow heating. They found that acetylene had no effect upon an alkaline solution of auric chloride or upon an aqueous or ammoniacal solution of potassium auricyanide, while it reduced a neutral solution of auric chloride to metallic gold.

Berthelot (7) also reported that a transient rose-violet precipitate appeared on passing acetylene through an ammoniacal solution of chromous sulfate. He considered this to be an acetylide, but it decomposed almost immediately to ethylene and chromic oxide.

Gebauer (46) found that a thin yellow film was formed by the action of acetylene at the surface of solid sodium hydroxide immersed in alcoholic solutions of the iodides of either zinc or cadmium, and he attributed this coloration to a trace of the acetylides of these metals. He also made an orange acetylide precipitate having a percentage of cadmium corresponding to $CdC_2 \cdot C_2H_2 \cdot Cd_2I_2$ by passing acetylene through an acetone solution of $CdI_2 \cdot C_6H_5NH_2$. On long washing with cold water or alcohol the cadmium percentage approximated the formula $Cd_2 \cdot C_2H_2$, but hot water liberated acetylene from both compounds.

References

- (1) Durand, *Bull. soc. chim.* (4), **35**, 161-171 (1924).
- (2) Manchot, Withers and Oltrogge, *Ann.*, **387**, 257-93 (1912).
- (3) Baeyer, *Ber.*, **18**, 2269-81 (1885).
- (4) Berthelot and Delepine, *Compt. rend.*, **129**, 361-78 (1899); *Ann. chim. phys.* (7), **19**, 5-56 (1900).
- (5) Quet, *Compt. rend.*, **46**, 903-5 (1858); *Ann.*, **108**, 116-7 (1858). Boettger, *ibid.*, **109**, 351-62 (1859).
- (6) Berthelot, *Compt. rend.*, **50**, 805-8 (1860); *Ann. chim. phys.* (3), **67**, 52-77 (1863).
- (7) Berthelot, *Ann.*, **123**, 216 (1862); **138**, 245-53 (1866); **139**, 150-64 (1866); **140**, 314-17 (1866); *Compt. rend.*, **54**, 1044-6 (1862); *Bull. soc. chim.* (2), **5**, 176-93 (1866); *Ann. chim. phys.* (4), **9**, 385-413 (1866).
- (8) Blochmann, *Ann.*, **173**, 167-91 (1874).
- (9) Keiser, *Am. Chem. J.*, **14**, 285-90 (1892).
- (10) Makowka, *Ber.*, **41**, 824-9 (1908).
- (11) Scheiber, *Z. anal. Chem.*, **48**, 529-38 (1909). Scheiber and Reckleben, *Ber.*, **44**, 210-23 (1911).

- (12) Biltz and Reinkober, *Ann.*, **404**, 219-36 (1914).
 (13) Le Compte, *J. pharm. chim.* (6), **16**, 297-300 (1902); *Chem. Zentr.*, **1902**, **II**, 1499. Scheiber, *Z. anal. Chem.*, **48**, 529-38 (1909).
 (14) Kuespert, *Z. anorg. Chem.*, **34**, 453-4 (1903).
 (15) Ilosvay, *Ber.*, **32**, 2697-9 (1899); *Z. anal. Chem.*, **40**, 123-4 (1901). Czaco, *Z. angew. Chem.*, **44**, 388 (1931).
 (16) Rupe, *J. prakt. Chem.* (2), **88**, 79-82 (1913).
 (17) Cattelain, *J. pharm. chim.* (8), **3**, 321-2 (1926); *C. A.*, **20**, 2626 (1926).
 (18) Deniges, *Bull. soc. pharm. Bordeaux*, **1921**, No. 2; *Repert. pharm.*, **33**, 232 (1921); *C. A.*, **16**, 395 (1922).
 (19) Pietsch and Kotowski, *Z. angew. Chem.*, **44**, 309-12 (1931).
 (20) Novotny, *Coll. Czechoslov. Chem. Communications*, **6**, 514-27 (1934); *C. A.*, **29**, 2878 (1935).
 (21) Schulze, *Z. angew. Chem.*, **29**, 341-2 (1916). Riese, *ibid.*, **44**, 701-3 (1931).
 (22) Bhaduri, *Z. anorg. Chem.*, **76**, 419-21 (1912); **79**, 355-6 (1913).
 (23) Soederbaum, *Ber.*, **30**, 760-5, 814-5 (1897).
 (24) Plimpton, *Proc. Chem. Soc.*, **1892**, 109-11. Arth, *Compt. rend.*, **124**, 1534-6 (1897). Stettbacher, *Z. ges. Schiess.-u. Sprengstoffw.*, **11**, 1-4 (1916); *Chem. Zentr.*, **1919**, **II**, 126-7.
 (25) Lossen, *Ann.*, **272**, 139-41 (1893).
 (26) Berthelot, *Bull. soc. chim.* (2), **5**, 176-93 (1866). Miasnikov, *Ann.*, **118**, 330-3 (1861).
 (27) Knorr and Mathes, *Ber.*, **32**, 736-42 (1899). Eggert, *Z. Elektrochem.*, **24**, 150-4 (1918); *Chem. Ztg.*, **42**, 199-200 (1918). Eggert and Shimank, *Ber.*, **51**, 454-6 (1918).
 (28) Pollitzer, *Z. angew. Chem.*, **36**, 262-6 (1923).
 (29) Edwards and Hodgkinson, *Chem. News*, **90**, 140 (1904).
 (30) Nieuwland and Maguire, *J. Am. Chem. Soc.*, **28**, 1025-31 (1906).
 (31) Chevastelon, *Compt. rend.*, **124**, 1364-6 (1897).
 (32) Willgerodt, *Ber.*, **28**, 2107-15 (1895).
 (33) Krause and Schmidt, *ibid.*, **52**, 2150-65 (1919).
 (34) Ramondt, *Chem. Weekblad*, **14**, 544-7 (1917); *C. A.*, **11**, 2733 (1917). Eggert, *Chem. Ztg.*, **42**, 199-200 (1918); *Z. Elektrochem.*, **24**, 150 (1918). Stettbacher, *Z. ges. Schiess.-u. Sprengstoffw.*, **11**, 1-4 (1916); *Chem. Zentr.*, **1919**, **II**, 126-7.
 (35) Tucker and Moody, *J. Am. Chem. Soc.*, **23**, 671-4 (1901).
 (36) Terry, U. S. P. 1,544,197 (1925); *C. A.*, **19**, 2631 (1925).
 (37) Basset, *Chem. News*, **19**, 28 (1869).
 (38) Keiser, *Am. Chem. J.*, **15**, 535-9 (1893).
 (39) Plimpton and Travers, *J. Chem. Soc.*, **65**, 264-9 (1894).
 (40) Ferber and Roemer, *J. prakt. Chem.*, **139**, 277-83 (1934). Lebeau and Damiens, *Ann. chim.*, (9), **8**, 239-45 (1917).
 (41) Wellers, *Stahl u. Eisen*, **42**, 1449 (1922); *C. A.*, **17**, 946 (1923). Wilmet, *Compt. rend.*, **185**, 1136-8 (1927). Van Dam, *Ing. chim.*, **17**, 75-7 (1929); *C. A.*, **23**, 5439 (1929).
 (41a) Treadwell and Tauber, *Helv. Chim. Acta*, **2**, 601-7 (1919).
 (42) Spahr, Vogt and Nieuwland, *J. Am. Chem. Soc.*, **55**, 2465-8, 3728-31 (1933).
 (43) Hilpert and Gruettner, *Ber.*, **47**, 177-85 (1914).
 (44) Burkhardt and Travers, *J. Chem. Soc.*, **81**, 1270-2 (1902).
 (45) Matthews and Watters, *J. Am. Chem. Soc.*, **22**, 108-11 (1900).
 (46) Gebauer, *Z. anorg. Chem.*, **176**, 283-4 (1928).

6. The addition of cuprous salts to acetylene. Berthelot (1) first reported the formation of precipitates by the action of acetylene on neutral aqueous solutions containing a cuprous halide and the corresponding potassium halide, but he erroneously regarded these as complex substitution

products of acetylene. It has been shown that secondary reactions occur in neutral aqueous solutions or in the presence of ammonium or alkali halides. Therefore, the simpler addition reactions in slightly acid solutions will be discussed first.

By passing acetylene into an acidified aqueous or alcoholic solution of cuprous chloride, Chevastelon (2) obtained colorless crystals of a substance with the approximate composition $C_2H_2 \cdot Cu_2Cl_2$. Berthelot (3) also obtained this substance and observed that the absorption of acetylene in similar solutions varied with the temperature and with the pressure of acetylene. Manchot (4) studied exhaustively the absorption of acetylene in acidified aqueous solutions of cuprous chloride and found that, over and above the dissolved acetylene, the absorption reached a maximum corresponding to the formation of the complex $C_2H_2 \cdot CuCl$ when the hydrogen chloride concentration ranged from about 0.6 to 1.0 mol per liter and the cuprous chloride concentration was less than 0.4 mol per liter. On treating an alcoholic cuprous chloride solution with acetylene, Manchot believed he obtained $C_2H_2 \cdot CuCl$ as a crystalline deposit which dissociated rapidly to give the original reactants on removal from the mother liquor. When a higher concentration of dissolved cuprous chloride and the same or a higher concentration of HCl was employed in the aqueous solutions, a white precipitate appeared, and only about half as much acetylene reacted, indicating the formation of the substance $C_2H_2 \cdot Cu_2Cl_2$ as previously reported by Chevastelon and Berthelot. It was also observed that the same white precipitate was in some cases produced by the evolution of acetylene from clear solutions of the postulated complex $C_2H_2 \cdot CuCl$. Manchot stated that the white precipitate lost acetylene too rapidly to permit accurate analysis. Hofmann and Kuespert (5) claimed to have obtained a different precipitate, having the composition $C_2H_2 \cdot 3Cu_2Cl_2$, in mixture with an oily liquid upon passing acetylene into a solution of cupric chloride in absolute alcohol, but this result has not been confirmed. The simple addition products of acetylene with other cuprous salts have not been investigated.

Manchot (4) studied similar reactions of a number of acetylenic compounds in an attempt to shed light on the structure and behavior of these addition products, and found that the ability of an acetylenic compound to react with cuprous chloride was influenced by the presence of certain atoms or groups directly linked to an acetylenic carbon atom. Thus while acetylene, having two hydrogen atoms in this position, added either one or two equivalents of cuprous chloride, a number of monosubstituted acetylenes combined with one equivalent of cuprous chloride to give crystalline solids of the composition $RC \equiv CH \cdot CuCl$. Moreover the compounds $C_6H_5-C \equiv C-I$, $C_6H_5-C \equiv C-Br$, $C_6H_5-C \equiv C-CONH_2$ and $C_6H_5-C \equiv C-CN$ also readily combined with cuprous chloride, while a number

of other disubstituted acetylenes and diacetylenes failed to react. These addition compounds all dissociated to cuprous chloride and the original acetylenic compound on standing or heating. The molecular structure of these substances derived from acetylene and substituted acetylenes remains uncertain.

A number of more complex reaction products with cuprous salts also have been reported. Berthelot (1) observed that acetylene produced yellow precipitates by reaction with aqueous solutions of cuprous chloride containing potassium chloride or ammonium chloride, and also precipitates of a transient orange yellow color with aqueous solutions of cuprous bromide and potassium bromide, cuprous iodide and potassium iodide, and cuprous sulfite and ammonium sulfite. These precipitates were found to contain acetylene in combination with both salts of the original mixture. Chevastelon (6) reported that a white substance, $C_2H_2 \cdot 2Cu_2Cl_2 \cdot KCl$, was formed by the reaction of acetylene with an aqueous solution of cuprous chloride and potassium chloride and that this could be converted to the yellow substance, $C_2H_2 \cdot 4Cu_2Cl_2 \cdot 2KCl$, either by further addition of the salts or by loss of acetylene as in washing the white substance with ether. Tzyurikh and Ginzberg (7) found that during the preparation of vinylacetylene the precipitate formed by acetylene in a solution of ammonium chloride and cuprous chloride had the composition $6CuCl \cdot 3NH_4Cl \cdot C_2H_2$. The authors have observed that when solutions of this kind have been standing for some time in contact with acetylene, the yellow precipitate consists at least in part of a compound of the cuprous salt with vinylacetylene which dissociates on heating. This polymerization probably occurs while the acetylene is in combination with cuprous chloride, but the mechanism of the change and the structure of the compounds involved is not known. The authors have also found that similar yellow precipitates are formed in aqueous cuprous chloride solutions containing ammonium chloride or amine hydrochlorides and in a solution of cuprous chloride with pyridine and acetic acid. The conversion of acetylene to vinylacetylene by a cuprous chloride catalyst is the first step in the industrial process for making neoprene synthetic rubber (see Chapter V, Section 7).

Chevastelon (8) noted that aqueous cuprous chloride solutions acidified with 5 per cent of concentrated hydrochloric acid reacted with acetylene to give first a yellow precipitate, which was then converted to a white precipitate as more acetylene was taken up. The passage of a current of carbon dioxide through the suspension of the white precipitate regenerated the yellow substance, presumably by the removal of acetylene. Manchot (4) observed that a yellow coloration was produced by acetylene in strongly acid cuprous chloride solutions. It will be noted that the color changes in the solution containing a high concentration of hydrochloric acid appear

to be strictly analogous to those in solutions containing alkali chlorides or ammonium chloride, and may indicate the existence of a complex containing hydrogen chloride.

Berthelot (1) and several later workers have observed the appearance of a violet or purple precipitate when acetylene reacted with a dilute neutral aqueous solution of cuprous chloride. Chevastelon (9) found that a precipitate of the same color was produced when the substance $\text{Cu}_2\text{Cl}_2 \cdot \text{C}_2\text{H}_2$ was treated with water and derived the following equation from analytical data:

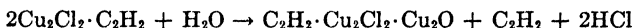

Manchot (4) stated that when 1.0 gram of cuprous chloride in 100 cc of 0.2 *N* hydrochloric acid was treated with acetylene, a clear solution of an addition product first resulted which then gave off a part of the acetylene and deposited a violet precipitate having the composition $\text{C}_2\text{Cu}_2 \cdot \text{CuCl} \cdot \text{H}_2\text{O}$. In this substance he considered that at least a part of the hydrogen of the acetylene had been replaced by copper. In like manner the cuprous chloride addition compounds of a few monosubstituted acetylenes were found to lose hydrogen chloride and to be converted into the cuprous acetylides on treatment with water or dilute ammonia. Berthelot and Delepine (10) obtained a red precipitate of the composition $\text{C}_2\text{Cu}_2 \cdot \text{Cu}_2\text{I}$ by the action of acetylene on a slightly alkaline aqueous solution of cuprous iodide and potassium iodide, and in similar solutions of higher alkalinity a precipitate richer in copper was produced. These results all appear to indicate that in neutral, slightly alkaline or very slightly acid aqueous solutions the cuprous salts give precipitates with acetylene which are intermediate in composition between cuprous acetylides formed in distinctly alkaline solutions and the addition products formed in more strongly acid or saline solutions.

References

- (1) Berthelot, *Ann. chim. phys.* (4), **9**, 385-92 (1866).
- (2) Chevastelon, *Compt. rend.*, **126**, 1810-12 (1898).
- (3) Berthelot, *Ann. chim. phys.* (7), **23**, 34-5 (1901).
- (4) Manchot, *Oesterr. Chem. Ztg.*, **14**, 264-5 (1911); *C. A.*, **6**, 800 (1912). Manchot, Withers and Oltrogge, *Ann.*, **387**, 257-93 (1912).
- (5) Hofmann and Kuespert, *Z. anorg. Chem.*, **15**, 204-7 (1897).
- (6) Chevastelon, *Compt. rend.*, **130**, 1764-6 (1900); **131**, 48-50 (1900); **132**, 1489-92 (1901).
- (7) Tzyurikh and Ginzberg, *J. Gen. Chem. (U.S.S.R.)*, **5**, 1468-78 (1935); *C. A.*, **30**, 2169 (1936).
- (8) Chevastelon, *Compt. rend.*, **130**, 1634-6 (1900).
- (9) *Idem, ibid.*, **127**, 68-9 (1898).
- (10) Berthelot and Delepine, *Ann. chim. phys.* (7), **19**, 54-6 (1900).

7. The addition of mercury salts to acetylene. Kutscherov (1) first observed that mercuric chloride, bromide or sulfate in neutral solutions

catalyzed the addition of water to acetylene to form acetaldehyde and to a few substituted acetylenes to form ketones. He recognized that addition compounds of the acetylenes with the mercuric salts were intermediates in this process, and postulated rather complex structural formulas for these substances. It is now known that certain mercuric salts in acid media promote the rapid addition of water and likewise the analogous addition of many alcohols, phenols and carboxylic acids to acetylene. Many attempts have been made to isolate the addition compounds which are present in these reactions and to clarify their structure, but because of the alterability of these substances the results are somewhat confusing.

Perhaps the simplest reported addition product of acetylene with a mercuric salt is that formed in a dilute hydrochloric acid solution of mercuric chloride. Biginelli (2) assigned the formula $\text{CHCl}=\text{CHHgCl}$ to a white precipitate prepared from acetylene and an acid aqueous solution of mercuric chloride. This substance melted at $129-30^\circ$ and was soluble in a mixture of alcohol and water. Employing a similar method, Brame (3) prepared this substance as a white, crystalline, vesicant powder. The vesicant property is also shown by the simple addition product of mercuric chloride with ethylene, but is absent in the more complex addition products of acetylene with mercuric salts. Brame's material lost acetylene on heating, and with water yielded some hydrochloric acid, a little acetaldehyde, and a more complex organic compound of mercury; it was converted by aqueous alkalies into an explosive substance which was probably mercuric acetylide. Chapman and Jenkins (4) obtained a white, crystalline substance by circulating acetylene for several hours through an acidified alcoholic solution of mercuric chloride. This material melted at about 113° , was soluble in organic solvents and also had a composition approximating $\text{C}_2\text{H}_2 \cdot \text{HgCl}_2$. Hydrochloric acid in higher concentrations retards or almost entirely prevents the reaction of acetylene with mercuric chloride solutions.

Keiser (5) analyzed a white substance which was precipitated by acetylene from a neutral aqueous mercuric chloride solution, having the approximate composition $\text{C}_2\text{Hg}_2\text{Cl}_2 \cdot \frac{1}{2}\text{H}_2\text{O}$. Hofmann (6) suggested the formula $(\text{ClHg})_2\text{C}-\text{CCl}_2$ for the amorphous precipitate formed by acetylene in an



aqueous solution of mercuric chloride and sodium chloride, but his analyses showed a deficit of chlorine and he assumed some replacement of chlorine by the hydroxyl group. On the basis of analyses, Biltz and Mumm (7) assigned the formula $(\text{ClHg})_3\text{C}-\text{CHO}$ to the precipitate formed by acetylene in a neutral aqueous solution of mercuric chloride, and showed that approximately one mol of hydrogen chloride was liberated for each mol of

mercuric chloride reacting. In opposition to the work of Hofmann, they stated that the only effect of sodium chloride was to retard, and when concentrated to prevent the reaction, and they postulated the formation of an intermediate, $(\text{ClHg})_3\text{C}-\text{CHCl}_2$, which was then hydrolyzed to the final precipitate. The substituted acetaldehyde structure of this substance was confirmed by the fact that it yielded iodoform rather than diiodoacetylene with an alkaline iodine solution. Hofmann (8) in reply stated that, although almost pure $(\text{ClHg})_3\text{C}-\text{CHO}$ was probably formed by acetylene in neutral aqueous mercuric chloride solutions, the compound $\text{C}_2\text{Hg}_3\text{Cl}_4$ was the principal product when an equimolecular quantity of sodium chloride was present. Biltz (9) further discussed the structure of these substances. Ferber and Roemer (10) claim to have obtained a compound having the empirical formula $\text{C}_2\text{Hg}_3\text{Cl}_3$ by the action of acetylene on an alcoholic mercuric chloride solution. Manchot and Hass (19) assigned the formula $\text{C}_2\text{Hg} \cdot \text{HgCl}_2 \cdot \text{HgCl} \cdot \text{H}_2\text{O}$ to a precipitate produced by acetylene in an aqueous mercuric chloride solution, and claimed that both mercurous and mercuric ions were obtained from this substance. Mercuric bromide gave a similar precipitate.

Koethner and Erdmann and Koethner (11) reported "a double compound of mercuric carbide and mercuric nitrate" prepared as a white precipitate by passing acetylene into a slightly acidified aqueous solution of mercuric nitrate, and assigned the formula $\text{C}_2\text{Hg}_3\text{NO}_3 \cdot \text{H}_2\text{O}$ to this substance, which they found to yield acetaldehyde on treatment with acids. Hofmann (12) made a white, crystalline compound by reaction of acetylene with a dilute nitric acid solution of mercuric nitrate, which he stated to be identical with a product prepared by the mercuration of acetaldehyde. From analyses

he suggested the formula
$$\begin{array}{c} \text{NO}_3\text{Hg} \qquad \qquad \text{H} \\ \diagdown \qquad \qquad \diagup \\ \text{Hg}=\text{C}-\text{C}=\text{O} \end{array}$$
 for this substance, and noted

that it yielded acetaldehyde with hydrochloric acid and aldehyde resin with sodium hydroxide or potassium cyanide solutions. Hofmann also investigated the compound of Erdmann and Koethner, which appeared to result from a more prolonged action of mercuric nitrate, and proposed the

formula
$$\begin{array}{c} \text{NO}_3\text{Hg} \qquad \qquad \text{H} \\ \diagdown \qquad \qquad \diagup \\ \text{OHg}_2=\text{C}-\text{C}=\text{O} \end{array}$$
. Kearns, Hizer and Nieuwland (13) later

found that nitric acid solutions were reduced by acetylene in the presence of mercuric nitrate and that most of the acetylene was oxidized to oxalic acid and a little carbon dioxide.

Hofmann (14) prepared a white explosive precipitate of the composition $\text{C}_2\text{Hg}_3\text{ClO}_5\text{H}$ from acetylene and an aqueous solution of mercuric chlorate, and found that it was converted by hydrochloric acid to the previously reported derivative, $(\text{ClHg})_3\text{C}-\text{CHO}$. At the same time he reported a

nitrite derivative $C_2Hg_2NO_3H$ made by reaction of acetylene on an aqueous solution of mercuric nitrate and potassium nitrite. Nieuwland and Maguire (15) also prepared a nitrite compound which had an odor of acetaldehyde and gave the iodoform reaction, and they further reported a mercuric chromate derivative which deflagrated by friction.

No consistent results have been reported on the analyses of precipitates produced by acetylene in dilute sulfuric acid solutions of mercuric sulfate, but Erdmann and Koethner (11) anticipated modern commercial practice by recommending this solution as the best available catalyst for the continuous preparation of acetaldehyde from acetylene and water, and modifications of this solution and procedure are the subject of very numerous patents (see Chapter IV, Section 6). Likewise Nieuwland and Maguire (15) noted very erratic analytical data for precipitates formed by acetylene in acidified solutions of mercuric fluosilicate, fluoborate and perchlorate, although the iodoform reaction indicated the presence of an acetaldehyde structure. The authors have since found that acid solutions of these salts are very useful catalysts for addition reactions of acetylene. It is probably significant that the precipitates which give the most variable analyses are formed in those solutions which are most active catalytically. These variable results have tended to discourage further efforts to determine the mechanism of the catalytic action of mercuric salts in acetylene addition reactions by strictly analytical methods.

Frieman, Kennedy and Lucas (16) have determined the effect of concentration of acetylene, acetaldehyde and mercuric sulfate on the rate of hydration of acetylene in homogeneous solution. They report that the reaction is second order with respect to mercuric sulfate concentration, and suggest that this may indicate an intermediate compound of one molecule of acetylene with two molecules of mercuric sulfate or acid sulfate. In an investigation of the addition of mercuric acetate to a number of mono- and disubstituted acetylenic compounds Myddleton, Barret and co-workers (17) have shown that hydrogen bound to acetylenic carbon is first replaced by mercury and that both these substitution products and disubstituted acetylenes then react to form compounds with the central

group,
$$\begin{array}{c} | & & | \\ -C & - & C- \\ | & & | \\ CH_3COOHgO & & HgOOCCH_3 \end{array}$$
. It is possible that acetylene may

follow a somewhat similar course of reaction. Hennion, Vogt and Nieuwland (18) have discussed the possible courses of the addition and replacement of mercuric compounds as catalysts in the addition of water and organic hydroxy compounds to acetylenes.

During the catalytic addition of hydroxy compounds to acetylene by means of a mercuric salt, secondary reactions of unknown nature occur

which result in the gradual precipitation of insoluble and inactive organo-mercury compounds or of metallic mercury in amounts which bear no constant relation to the quantity of addition products formed. Many modifications of the acetaldehyde process have been proposed to overcome this catalyst loss (see Chapter IV, Section 6). It is probable that these side reactions are connected with the presence of variable quantities of oxygen or other impurities in the acetylene.

No definite addition compounds of mercurous salts with acetylene have been reported, but the authors (unpublished, 1931) have found that mercurous sulfate in concentrated sulfuric acid is an even more active catalyst than mercuric sulfate for the condensation of acetylene with olefinic or aromatic hydrocarbons (see Chapter V, Section 5), and it is quite probable that an addition compound of the mercurous salt is an intermediate in this reaction. When acetylene reacts with some mercuric salts in acid solutions, mercurous compounds are known to be formed, and may play a part in the catalytic reaction.

References

- (1) Kutscherov, *Ber.*, **14**, 1532-9, 1540-2 (1881); **17**, 13-29 (1884).
- (2) Biginelli, *Ann. de Pharmatoterap. chim.*, 16-20 (1898); *Chem. Zentr.*, **1898**, **I**, 926.
- (3) Brame, *J. Chem. Soc.*, **87**, 427-32 (1905).
- (4) Chapman and Jenkins, *ibid.*, **115**, 847-9 (1919).
- (5) Keiser, *Am. Chem. J.*, **15**, 535-9 (1893).
- (6) Hofmann, *Ber.*, **32**, 870-80 (1899).
- (7) Biltz and Mumm, *ibid.*, **37**, 4417-27 (1904).
- (8) Hofmann, *ibid.*, **37**, 4459-60 (1904); **38**, 663 (1905).
- (9) Biltz, *ibid.*, **38**, 133-6 (1905).
- (10) Ferber and Roemer, *J. prakt. Chem.*, **139**, 277-83 (1934).
- (11) Koethner, Dissertation (1896); *Ber.*, **31**, 2475 (1898); Erdmann and Koethner, *Z. anorg. Chem.*, **18**, 48-58 (1898).
- (12) Hofmann, *Ber.*, **31**, 1904-9, 2212-8, 2783-7 (1898).
- (13) Kearns, Hizer and Nieuwland, *J. Am. Chem. Soc.*, **45**, 795-9 (1923).
- (14) Hofmann, *Ber.*, **38**, 1999-2005 (1905).
- (15) Nieuwland and Maguire, *J. Am. Chem. Soc.*, **28**, 1025-31 (1906).
- (16) Frieman, Kennedy and Lucas, *ibid.*, **59**, 722-6 (1937).
- (17) Myddleton, Barrett and Seager, *ibid.*, **52**, 4405-11 (1930); Myddleton and Barret, *ibid.*, **49**, 2258-64 (1927); Myddleton, Berchem and Barrett, *ibid.*, **49**, 2264-9 (1927).
- (18) Hennion, Vogt and Nieuwland, *J. Org. Chem.*, **1**, 159-62 (1936).
- (19) Manchot and Hass, *Ann.*, **399**, 123-54 (1913).

8. The addition of aluminum halides to acetylene. Baud (*1*) demonstrated the absorption of acetylene by anhydrous aluminum chloride* at temperatures close to the boiling point of acetylene, but the gas was almost completely regenerated as the temperature was raised. At room temperature he found that a limited quantity of acetylene was completely absorbed

* See C. A. Thomas, "Anhydrous Aluminum Chloride in Organic Chemistry," A. C. S. Monograph #87, Reinhold Publishing Corp., 1941.

by the anhydrous chloride in the course of several days to give a light brown solid which appeared to be a derivative of an acetylene polymer. At 70° the reaction was very rapid, with evolution of fumes and blackening of the solid product, and when the temperature was raised to 120–140°, about 40 mols of acetylene were taken up by one mol of Al_2Cl_6 before the reaction ceased. Under the conditions no hydrogen chloride but some hydrogen and hydrogenation products of acetylene were given off, and the product on analysis was found to have a higher ratio of carbon to hydrogen than occurs in acetylene. Some aromatic material and tar was obtained from the solid product on further heating. Gangloff and Henderson (2) were unable to detect reaction of acetylene with aluminum chloride at room temperature, but confirmed the results of Baud at 60° and higher. By passing acetylene into solutions of AlCl_3 in absolute ethyl or methyl alcohols they obtained crystalline compounds of the approximate compositions: $\text{AlCl}_3 \cdot \text{C}_2\text{H}_2 \cdot \text{CH}_3\text{OH} \cdot \text{H}_2\text{O}$, $\text{AlCl}_3 \cdot \text{C}_2\text{H}_2 \cdot 2\text{C}_2\text{H}_5\text{OH}$ and $\text{AlCl}_3 \cdot 2\text{C}_2\text{H}_2 \cdot 2\text{H}_2\text{O}$. They stated that the analyses were unsatisfactory because of the evolution of acetylene and alcohol from these compounds on standing.

The initial addition of an aluminum halide to acetylene is probably much simpler than these reports indicate. For instance, in the addition of the arsenic trihalides to acetylene discussed in the next section it has been suggested that intermediates of the type $\text{Al}(\text{HC}=\text{CHX})_3$ are formed by the successive reaction of three molecules of acetylene with one molecule of aluminum halide.

References

- (1) Baud, *Compt. rend.*, **130**, 1319–22 (1900); *Ann. chim. phys.* (8), **1**, 36–44 (1904).
- (2) Gangloff and Henderson, *J. Am. Chem. Soc.*, **38**, 1382–4 (1916); **39**, 1420–7 (1917).

9. The addition of arsenic trichloride and arsenic tribromide to acetylene.

Nieuwland (1) first reported the formation of poisonous, evil-smelling products from the reaction of acetylene with arsenic trichloride in the presence of anhydrous aluminum chloride, but did not identify the compounds formed. During the World War I this reaction was further investigated by chemists of the United States Chemical Warfare Service, and the addition products of arsenic trichloride were isolated. Their military use under the name "Lewisite" was proposed, but the data on this synthesis were not made available immediately. Dafert (2) also obtained a compound to which he ascribed the formula $\text{AsCl}_3 \cdot 2\text{C}_2\text{H}_2$ by the action of arsenic trichloride on acetylene in the presence of aluminum chloride. The present extensive knowledge of the synthesis is mostly due to the publications of Green and Price (3), Mann and Pope (4), Lewis and Perkins (5) (in part a resume of the work of the U. S. Chemical Warfare Service), and Lewis and Steigler (6), who employed an aluminum halide or in a few

cases mercuric chloride as an essential catalyst. An addition compound having the composition $\text{AlCl}_3 \cdot \text{AsCl}_3 \cdot 3\text{C}_2\text{H}_2$ was shown to occur as an intermediate in the reaction of acetylene with aluminum chloride and arsenic trichloride. When the freshly prepared crude product was treated with dilute hydrochloric acid to remove aluminum chloride, the compound β , β' , β'' -trichlorovinylarsine, $(\text{ClCH}=\text{CH})_3\text{As}$, was found to predominate over the two other possible derivatives, $(\text{ClCH}=\text{CH})_2\text{AsCl}$ and $(\text{ClCH}=\text{CH})\text{AsCl}_2$, even when an excess of arsenic trichloride was present during the reaction. However, on warming with arsenic trichloride, the compound $(\text{ClCH}=\text{CH})_3\text{As}$ or the intermediate containing aluminum chloride yielded an equilibrium mixture containing the other two derivatives. Lewis and Steigler (6) also found that pure chlorovinylarsines could be prepared from arsenic trichloride and acetylene with aluminum bromide as a promoter and that the corresponding pure bromovinyl arsines could be prepared from arsenic tribromide and acetylene with aluminum chloride as a promoter, proving that only halogen from the arsenic halide entered into the composition of the halovinyl groups in the final product. The following equations illustrate the structure and mechanisms proposed by Lewis and his co-workers on the basis of this evidence.

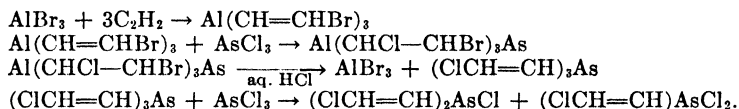

The halogen of the halovinyl groups in these compounds is quite inert, but when halogen atoms remain directly linked to arsenic they may be replaced readily, and the arsenic of all the compounds may be oxidized to the quinquivalent state. The reactions and other characteristics of the compounds have been described by numerous investigators (7, 8). According to Nekrasov and Nekrasov (8) the halovinyl arsines, like bis-cacodyl acetylide, yield acetylene on treatment with aqueous alkali. Jackson and Jackson (9) have reviewed the history, preparation, reactions and properties of these compounds.

The condensation of methyl dichloroarsine with acetylene by a similar method has also been investigated (10).

Before the development of the halovinyl arsines Heinemann (11) and Fischer (12) had reported the addition of arsenic trichloride to behenic and to stearic acids at the triple bonds. In these cases it is of interest to note that the reactions occurred on heating without the aid of catalysts.

References

- (1) Nieuwland, "Some Reactions of Acetylene", Thesis, Catholic University of America, Washington, D. C., 1904.

- (2) Dafert, *Monatsh.*, **40**, 313-23 (1919).
- (3) Green and Price, *J. Chem. Soc.*, **119**, 448-53 (1921).
- (4) Mann and Pope, *ibid.*, **121**, 1754-9 (1922).
- (5) Lewis and Perkins, *Ind. Eng. Chem.*, **15**, 290-5 (1923).
- (6) Lewis and Steigler, *Science*, **56**, 55 (1922); *J. Am. Chem. Soc.*, **47**, 2546-56 (1925).
- (7) Wieland, *Ann.*, **431**, 30-40 (1923). Vedder, "Medical Aspects of Chemical Warfare", Williams & Wilkins Co., Baltimore, 1925. Burton and Gibson, *J. Chem. Soc.*, **1926**, 464-70. Herbst, *Kolloidchem. Beihefte*, **23**, 313-44 (1926). Roviada, *Sperimentale*, **80**, 5-24 (1926); **83**, 101-13, 114-20 (1929). Scherlin and Epstein, *ibid.*, **61**, 1821-5 (1928). Fegler, *Compt. rend. soc. biol.*, **100**, 218-21 (1929). Nametkin and Nekrasov, *Z. anal. Chem.*, **77**, 285-9 (1929). Shiver, *J. Chem. Ed.*, **7**, 95-108 (1930). Gibson and Johnson, *J. Chem. Soc.*, **1930**, 2785-6; **1931**, 753-6. Kretov and Berlin, *J. Gen. Chem. (U.S.S.R.)*, **1**, 411-18 (1931). Anon., *Gassechutz Luftschtutz*, **2**, 264 (1932). Johnson, *Ber.*, **65**, 294-302 (1932). Gorski, Shpanski and Mulyar, *ibid.*, **67**, 730-5 (1934).
- (8) Nekrasov and Nekrasov, *Ber.*, **61**, 1816-21 (1928).
- (9) K. Jackson and M. Jackson, *Chem. Rev.*, **16**, 439-52 (1935).
- (10) Hirenda Nath Das-Gupta, *J. Ind. Chem. Soc.*, **13**, 305-8 (1936); *C. A.*, **30**, 7098 (1936).
- (11) Heinemann, German P. 257,641 (1913); U. S. P. 1,082,510 (1913); *Frdl.*, **11**, 1079-80.
- (12) E. Fischer, *Ann.*, **403**, 106-17 (1914); U. S. P. 1,178,708 (1916); *C. A.*, **10**, 1578 (1916); U. S. P. 1,191,580 (1916); *C. A.*, **10**, 2278 (1916).

10. Evidence for the addition of compounds of other metals to acetylene.

Erdmann and co-workers (1, 2) reported that a cold aqueous solution of palladous chloride, when treated with acetylene, gave a light-brown precipitate which was soluble in aqueous solutions of ammonium hydroxide, potassium cyanide and alkali bisulfites and which gave an odor resembling acetaldehyde. Makowka (3) suggested the formula

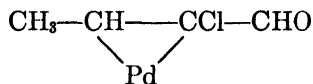

for this substance on the basis of analysis and because it gave butyric acid after fusion with caustic potash, decomposition with sulfuric acid and steam distillation; but the evidence for this structure is far from conclusive.

Berthelot (4) reported the reduction of an auric chloride solution by acetylene, and Erdmann and Koethner (1) stated that a gold chloride solution first became dark violet red on contact with acetylene, and that a black precipitate then appeared which was possibly an addition compound and which on heating gave off a gas with a sharp odor and left a residue of metallic gold. Kindler (5) further investigated the reaction of gold chloride and gold bromide solutions with acetylene and identified glyoxal as the principal organic product of the decomposition of the black precipitate. Erdmann and Koethner (1) found that osmium salts were reduced by acetylene, and Kinder (5) stated that the halides of osmium, molybdenum and tungsten were reduced by acetylene with production of glyoxal. Erd-

mann and Makowka (2) have devised methods based on acetylene reactions for the qualitative and quantitative separation of salts of some of these metals from salts of metals such as rhodium, iridium and platinum which do not appear to react with acetylene.

Although there is some evidence for the existence of unstable addition compounds of silver salts with olefins, the products of the reaction of silver salts with acetylene and monosubstituted acetylenes usually appear to be acetylides. However it is quite possible that addition compounds occur as intermediates in these cases of acetylide formation. In this connection it is of interest to note that no reactions of silver salts with disubstituted acetylenes have been reported.

Kutscherov (6) described the catalytic addition of water to acetylene and a few homologs induced by zinc and cadmium salts as well as by mercuric salts, but analogous addition compounds of the zinc and cadmium salts have never been detected. If they occur the quantity present in the catalytic solutions must be comparatively small, and the catalytic action is certainly much slower than that of the mercuric compounds.

Berthelot and Jungfleisch (7) found that acetylene was absorbed by antimony pentachloride, forming crystals having the composition $\text{SbCl}_5 \cdot \text{C}_2\text{H}_2\text{Cl}_2$. On heating this compound with excess antimony pentachloride, symmetrical tetrachlorethane was evolved. Sabanejev (8) was unable to repeat this work and reported explosions, but Nieuwland (9) found that the reaction and the formation of the crystalline precipitate sometimes took place readily, but did not determine the factor responsible for this effect. Nieuwland and some later workers have used the addition compound as a cyclic intermediate for the chlorination of acetylene (see Chapter IV, Section 5). Nieuwland obtained traces of tarry products having very disagreeable odors on passing acetylene over a mixture of aluminum chloride and antimony trichloride.

Nieuwland (9) observed that traces of a compound having a disagreeable odor resulted from passing acetylene into a solution of aluminum chloride and phosphorus pentachloride in phosphorus trichloride, but this reaction has not been further investigated. A possible parallel exists in the addition of phosphorus pentachloride to a few other acetylenic compounds described by Bergman and Bondi (10).

It is possible that an addition of an alkali hydroxide to acetylene occurs as an intermediate step in the preparation of alkali-metal acetates from acetylene (see Chapter IV, Section 7). Such an addition would be analogous to the additions of alkali hydroxides, alkoxides or amides, which are sometimes postulated as intermediates in rearrangements of acetylenic hydrocarbons (see Chapter III, Section 2).

References

- (1) Erdmann and Koethner, *Z. anorg. Chem.*, **18**, 48-58 (1898).
- (2) Erdmann and Makowka, *Ber.*, **37**, 2694-7 (1904); *Z. anal. Chem.*, **46**, 141-5 (1907); Makowka, *ibid.*, **46**, 145-50 (1907).
- (3) Makowka, *Ber.*, **41**, 824-9 (1908).
- (4) Berthelot, *Ann. chim. phys.* (4), **9**, 385-413 (1866).
- (5) Kindler, *Ber.*, **54**, 647-9 (1921).
- (6) Kutscherov, *ibid.*, **42**, 2759-62 (1909).
- (7) Berthelot and Jungfleisch, *Compt. rend.*, **69**, 542-5 (1869).
- (8) Sabanejev, *Ann.*, **216**, 251-79 (1883).
- (9) Nieuwland, "Some Reactions of Acetylene", Thesis, Catholic University of America, Washington, D. C., 1904.
- (10) Bergman and Bondi, *Ber.*, **66**, 278-86 (1933).

Chapter III

The Substitution of Non-Metal Atoms or Radicals for the Hydrogen of Acetylene

1. Types of substitution of non-metal atoms or radicals in acetylene.

Most of the procedures which are in regular use for the introduction of substituents into hydrocarbons of other series are not readily applicable to acetylene, and a number of special substitution methods have been devised for this purpose. Several inorganic radicals, such as the nitro, amino or sulfonic groups, which are commonly occurring substituents in other fields of organic chemistry, have not been attached to a carbon atom of acetylene. Processes of sulfonation and nitration as ordinarily employed lead to mixtures of oxidation, polymerization and addition products with acetylene. As applied to a monosubstituted acetylene, Krafft and Heizmann (1) claimed to have accomplished the direct nitration and sulfonation of 1-hexadecyne in the cold to give the 1-nitro and the 1-sulfonic acid derivatives, but this is an isolated instance and the work has not been extended or repeated.

The direct methods of substitution by halogens which are applicable to saturated and aromatic hydrocarbons lead to halogen addition reactions with acetylene. However, halogen substitution on an acetylenic carbon atom may be attained readily by the action of halogens on metal acetylides or on acetylene in certain solutions which combine with the liberated halogen acid (see Section 6). The haloacetylenes in turn fail to give many of the characteristic substitution reactions common to the alkyl and aryl halides, and in consequence are of little use in further synthesis. The haloacetylenes react with alkaline hydroxides to give acetylene and the hypohalite salt. However, in the case of a few arylacetylenes this reaction yields instead the corresponding saturated carboxylic acid or its derivatives (2), and it is possible that this result indicates the formation and rearrangement of a hydroxy acetylenic compound: $\text{RC}\equiv\text{C}-\text{OH} \rightarrow \text{RCH}=\text{CO} \xrightarrow{+\text{H}_2\text{O}} \text{RCH}_2\text{COOH}$. Replacement of the halogen of haloacetylenes by reaction with alkali sulfides, cyanides or thiocyanides, or with the alkali salts of alcohols, phenols, oxyacids or mercaptans have not been reported. The few known compounds of the class of ethynyl ethers and thio-ethers have all been prepared by dehydrohalogenation methods rather than by replacement of the halogen in a haloacetylene (3). Cyanoacetylene and dicyanoacetylene have been made by the dehydration of the corresponding carboxylic acid amides (4). A few compounds of the type $\text{RC}\equiv\text{C}-\text{CN}$ have

Table 3. Type Substitution Products of Acetylene.

Products of one stage of substitution	Section*	Products of two stages of substitution	Section*	Products of alteration of the substituents	Section*
$\text{HC}\equiv\text{CR}\dagger$	2	$\text{RC}\equiv\text{CR}$ $\text{RC}\equiv\text{C}-\text{CH}_2\text{OH}$ $\text{RC}\equiv\text{C}-\text{CH}_2\text{CH}_2\text{OH}$ $\text{RC}\equiv\text{C}-\text{CRHOH}$ $\text{RC}\equiv\text{C}-\text{CR}_2\text{OH}$	2 3 3 3 3	Rearr'd hydrocarbons	2
		$\text{RC}\equiv\text{C}-\text{CH}_2\text{OR}$ $\text{RC}\equiv\text{C}-\text{CHO}$ $\text{RC}\equiv\text{C}-\text{CO}-\text{R}'$ $\text{RC}\equiv\text{C}-\text{CH}(\text{OR})_2$ $\text{RC}\equiv\text{C}-\text{CR}'\text{OH}$ $\text{RC}\equiv\text{C}-\text{COOH}$ $\text{RC}\equiv\text{C}-\text{COOR}$ $(\text{RC}\equiv\text{C})_2\text{CO}$ $(\text{RC}\equiv\text{C})_2\text{COH}$ $\text{RC}\equiv\text{C}-\text{CX}$	3 7 7 7 7 4 7 7 7 6 5	Enynes $\text{R}-\text{C}\equiv\text{C}-\text{CO}-\text{R}'$ Carbonyl halides $\text{RC}\equiv\text{C}-\text{CR}_3$ $\text{RC}\equiv\text{C}-\text{CR}_2-\text{CR}_2-\text{C}\equiv\text{CR}$ Enynes	3 3 3 3 3 3
$\text{HC}\equiv\text{C}-\text{CH}_2\text{OH}$ $\text{HC}\equiv\text{C}-\text{CH}_2\text{CH}_2\text{OH}$ $\text{HC}\equiv\text{C}-\text{CHROH}$ $\text{HC}\equiv\text{C}-\text{CR}_2\text{OH}$ $\text{HC}\equiv\text{C}-\text{CH}_2\text{OR}$ $\text{HC}\equiv\text{C}-\text{COOH}$	3 3 3 3 4	$\text{HOCH}_2-\text{C}\equiv\text{C}-\text{CR}$ $\text{HOCH}_2-\text{C}\equiv\text{C}-\text{CH}_2\text{OH}$ $\text{HOCH}_2-\text{CH}_2-\text{C}\equiv\text{C}-\text{CH}_2\text{CH}_2\text{OH}$ $\text{HOCHR}-\text{C}\equiv\text{C}-\text{CHROH}$ $\text{HOCR}-\text{C}\equiv\text{C}-\text{CR}_2\text{OH}$ $\text{ROCH}_2-\text{C}\equiv\text{C}-\text{CH}_2\text{OR}$ $\text{ROCHR}-\text{C}\equiv\text{C}-\text{CHROH}$ $\text{HOOC}-\text{C}\equiv\text{C}-\text{COOH}$ $\text{XC}\equiv\text{C}-\text{COOH}$ $\text{HOOC}-\text{C}\equiv\text{C}-\text{C}\equiv\text{C}-\text{COOH}$	3 3 3 3 3 3 3 4 7 7	Dialkynyl carbinols Trialkynyl carbinols	7 7
$\text{HC}\equiv\text{C}-\text{C}\equiv\text{CH}$ $\text{HC}\equiv\text{Cl}$	5 6	$\text{XC}\equiv\text{CX}$	6	Dienynes Dienynes	3 3

* The numbers indicate the section of this chapter in which the preparation is cited.

† R is a primary alkyl group. It is worthy of note that R as an acetylene substituent may also indicate the vinyl group, since vinylacetylene undergoes substitution like an alkylacetylene. R' may be either an alkyl or aryl group. X is chlorine, bromine or iodine.

been made by the action of cyanogen chloride on the halomagnesium derivatives of mono-substituted acetylenes (5).

The most valuable of the substitution methods applicable to acetylene comprise the reactions of sodium acetylide or of the acetylenic Grignard reagents with organic halides or with organic carbonyl compounds. Each of these acetylide intermediates has definite limitations, as is shown in the following sections, but their use in nuclear synthetic reactions has made possible the preparation of a large number of compounds in the acetylene series, including hydrocarbons, carbinols, aldehydes, ketones, carboxylic acids and derivatives of these several classes. Another reaction of some importance is the synthesis of conjugated diacetylenic compounds from copper acetylides or from acetylenic halomagnesium compounds. Most of these methods may be used to replace either one or both of the hydrogen atoms of acetylene and in many cases two unlike substituents have been introduced by separate steps. Table 3 presents the type formulas of compounds which can be prepared from acetylene by these methods.

These substitution reactions provide the only important method of carbon skeleton synthesis by which an organic radical may be attached directly to an unsaturated aliphatic carbon atom, and although costly and imperfectly developed at present, they promise to be of the greatest value in the study of unsaturated chain compounds.

An enormous number of other organic compounds can be made indirectly from acetylene by passing through the substitution products as intermediates. This field has been very incompletely developed, and cannot be discussed or documented in the present work. For example, by addition at the triple bond most of these acetylenic compounds can be converted into *cis* or *trans* olefinic compounds, saturated compounds, ketones or ketals, dihalides or tetrahalides, hydrohalides or dihydrohalides, substituted vinyl or ethylidene esters, and numerous other types. The functional groups as substituents are also capable of many transformations. It will be noted that an acetylene with a functional substituent can be converted by certain addition reactions into a bifunctional compound which may in turn serve for the synthesis of elongated chains or heterocyclics. Accordingly, it is of considerable interest to perfect the methods of substitution in acetylene in order to make the substitution products more readily available as intermediates for laboratory syntheses.

References

- (1) Krafft and Heizmann, *Ber.*, **33**, 3586-90 (1901).
- (2) Grignard and Perrichon, *Ann. chim. (10)*, **5**, 5-36 (1926).
- (3) Slimmer, *Ber.*, **36**, 294-5 (1903). Fromm, Benziger and Schaefer, *Ann.*, **394**, 325-37 (1912).

- (4) Moureu and Bongrand, *Compt. rend.*, **150**, 225-7 (1910); **151**, 946-8 (1910); **158**, 1092-6 (1914); **170**, 1025-8 (1920); *Bull. soc. chim.* (4), **5**, 846 (1909); *Ann. chim.* (9), **14**, 5-58 (1920).
- (5) Grignard, Bellet, and Courtot, *Ann. chim.* (9), **4**, 54-5 (1915). Grignard and Courtot, *Bull. soc. chim.* (4), **17**, 228-31 (1915).

2. The preparation of acetylenic hydrocarbons by the reaction of acetylides with halides, sulfates or sulfonate esters. Rearrangement of acetylenic hydrocarbons. Sodium acetylide, and to a lesser extent the acetylides of other strongly electropositive metals and the acetylenic halomagnesium compounds, have been used as intermediates in the synthesis of acetylenic hydrocarbons according to the type reactions:

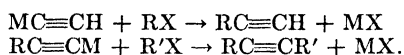

Sodium acetylide is employed either as a suspension in ether or as a solution in liquid ammonia, which is the only medium in which it is appreciably soluble. The halomagnesium compounds of acetylene are ordinarily used in ether solution. In a few instances there is evidence of the direct synthesis of disubstituted acetylenic hydrocarbons, conforming to the equation:

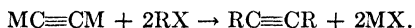

In these reactions RX is usually an alkyl or aliphyl halide, but recently alkyl sulfates and sulfonates have been used for this purpose.

The general method has a number of limitations and is not suitable for the preparation of all classes of acetylenic hydrocarbons. Reactions of this type have served only for the introduction of straight chain alkyl groups, alkyl chains branched beyond the 2-position, and arylated methyl groups. The few aryl halides which have been investigated are inert under the ordinary conditions of these reactions, and accordingly compounds having an aromatic ring directly linked to an acetylenic carbon atom have usually been made by desaturation processes. Organic halides containing also free hydroxyl, carboxyl or other acidic groups act on the acetylides to form salts and liberate acetylene. The possibilities of reactions between these salts and acetylides have not been investigated. The alkali acetylides remove hydrogen halides from many organic halides in preference to forming the substituted acetylenes. Among the compounds usually dehydrohalogenated by the acetylides are the secondary and tertiary alkyl halides, primary halides having a carbon chain branched at the 2-position, vinyl halides and their homologs, and compounds having two or more halogen atoms linked to the same or to adjacent carbon atoms. As a side reaction sodium acetylide removes hydrogen halide even from most straight-chain alkyl halides, forming olefins as a by-product of the acetylene synthesis. In this respect alkali acetylides behave much like the alkali hydroxides,

alkoxides, and amides in reactions with organic halides, and a comparison with these better known processes may lead to some extensions of the method for the production of substituted acetylenes.

The synthesis of monoalkylacetylenes by the reaction of alkyl iodides on sodium acetylide in liquid ammonia was first reported and developed by Lebeau and Picon (1). The ethyl, *n*-propyl, *n*-butyl, *n*-amyl, *n*-octyl, hexadecyl and isoamyl derivatives were prepared by this method at temperatures ranging from -33° at atmospheric pressure to room temperature in an autoclave or sealed tube. On the other hand Picon (1) found that isopropyl chloride and iodide, isobutyl iodide, *sec.*-butyl iodide, *tert.*-butyl iodide, active amyl iodide, *tert.*-amyl iodide and *sec.*-hexyl iodide required a somewhat higher temperature for reaction with sodium acetylide in liquid ammonia, and yielded olefins as almost the sole product according to the equations:

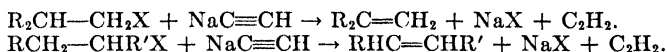

Maas and Wright (2) and Hurd, Meinert and Spence (3) made methylacetylene from methyl iodide in liquid ammonia. The latter authors pointed out that pure methylacetylene was obtained in this way, while that made by a dehydrohalogenation method was contaminated by the isomeric allene. Tehao Yin Lai (4) reported a 78 per cent yield of ethylacetylene from ethyl iodide and sodium acetylide in liquid ammonia. Morehouse and Maas (5) made methyl, ethyl, propyl, dimethyl and diethyl acetylenes by similar methods.

Vaughn, Vogt, Hennion and Nieuwland (6) have carried out a great number of large runs employing straight-chain primary alkyl chlorides, bromides and iodides with sodium acetylide dissolved or in part suspended in liquid ammonia. These reactions proceeded readily even at atmospheric pressure and a temperature of about -33° . Reaction in an autoclave or a sealed tube at a higher temperature occurred more rapidly but was less convenient and usually yielded a higher percentage of by-products, which included alkylamines, alcohols, ethers and dialkylacetylenes. The alcohols and ethers arose from traces of water or alcohols in the reagents. The synthesis of these by-products was accounted for by the following equations:

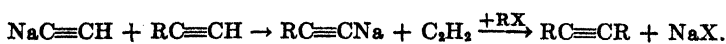
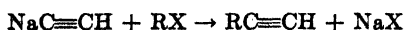
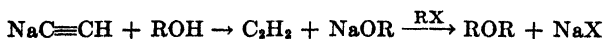
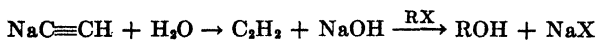

Increased temperature of the reacting solution accelerated the direct reaction of alkyl halides with ammonia and by increasing the solubility of sodamide, sodium hydroxide, sodium alcoholates and the sodium salts of the alkylacetylenes, it also augmented the yields of the other by-products. When the reaction was performed in liquid ammonia boiling under atmospheric pressure, only traces of these by-products were formed. On the other hand no consistent relation was noted between the reaction temperature and the formation of an olefin which usually occurred to a slight extent according to the equation:

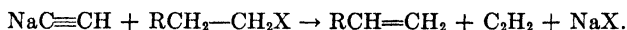

When employing batches of from two to fifteen moles, the operation was conducted most conveniently with vigorous stirring in large flasks, in which contact of the materials with moist air was minimized by proper precautions but could not be prevented entirely.

At atmospheric pressure most of the alkyl halide used in these reactions was either converted to the alkylacetylene or recovered unchanged, and the slight loss probably was due to olefin formation. When the process was carried out for several hours at room temperature in an autoclave, little alkyl bromide and no alkyl iodide were recovered, and amines formed a predominant by-product.

In order to reduce costs it would be desirable to use the alkyl chlorides in this process. Since the boiling point of an alkyl chloride lies close to that of the corresponding acetylene, the two cannot be separated readily by fractional distillation. Accordingly it is necessary either to insure total reaction of the alkyl chloride or to devise some other method of separation, and neither of these objectives has as yet been reached. A mixture of an alkyl bromide with the corresponding alkylacetylene usually can be fractionally distilled to yield the hydrocarbon containing only a small proportion of the bromide, and mixtures of an alkyl iodide with an alkylacetylene are still more readily fractionated. However, if alkylacetylenes completely free from halides are desired, it is probably best to treat a liquid ammonia solution of sodium acetylide with an alkyl iodide in the autoclave and to allow sufficient time for the conversion of unreacted alkyl iodide to alkylammonium iodide.

In preparing methyl- or ethylacetylene by this method the effluent gases liberated during the entire course of the reaction were conducted over water or dilute sulfuric acid, through a calcium chloride tower and into a refrigerated condenser for collection of the acetylenic product. After the reaction was practically complete, water was added cautiously to the liquid ammonia solution. In preparing the higher acetylene homologs, most of the product collected as an oil layer after dilution with water

and was separated, dried and distilled. A slight loss occurred by volatilization or entrainment with ammonia during dilution and by solution in the strong aqueous ammonia. It was found inadvisable to evaporate the liquid ammonia completely before treatment with water, since the hydrolysis of any excess sodium acetylide may cause local overheating with the possibility of isomerizing or polymerizing the alkylacetylene.

Dialkylacetylenes have been prepared from acetylene by first synthesizing a monoalkylacetylene as previously described, converting this to an acetylide by the action of sodamide, and treating the acetylide of the monoalkylacetylene with an alkyl halide:

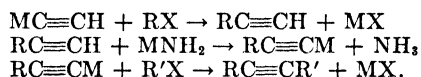

The dialkylacetylenes, when prepared from alkyl chlorides, do not appear to present difficulties of fractionation, but nevertheless alkyl bromides and iodides have usually been employed for their preparation. Heisig (7) and Heisig and Davis (8) made dimethylacetylene by the action of methyl iodide on the sodium salt of methylacetylene in liquid ammonia. In the later work the dimethylacetylene was crystallized from the reaction mixture at the temperature of solid carbon dioxide. The authors have made diethylacetylene from ethyl chloride and sodium ethyl acetylide in a similar manner and have employed sodium alkyl acetylides and alkyl bromides for the synthesis of several of the higher homologs (9). Since the solubility of the sodium salt in liquid ammonia appears to diminish with increasing molecular weight of the alkylacetylene, the use of an autoclave at room temperature or above should prove advantageous for increasing the solubility and reactivity of the sodium salts of the higher homologs. Bried and Hennion (10) have recently prepared several symmetrical dialkylacetylenes by the action of the lower alkyl halides on a mixture of sodium acetylide and sodamide in liquid ammonia.

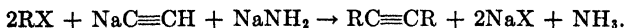

They have also made several unsymmetrical dialkylacetylenes by conducting this reaction in stages, but without isolation of the intermediate monoalkylacetylene. This is probably the most rapid and convenient technique for preparing the dialkylacetylenes.

McCusker and Kroeger (11) prepared several acetylenic ethers by treating the ethers of ethylene bromohydrin with sodium acetylide in liquid ammonia.

Lespieau and Journaud (12) investigated the reactions of the allyl halides with sodium acetylide in liquid ammonia. Presumably allylacetylene was first formed, but subsequently the labile hydrogen atoms

of the central methylene group appear to have been replaced first by sodium and then by the allyl group. With allyl chloride and bromide, 25 per cent of a hydrocarbon was obtained which was thought to have the structure $\text{HC}\equiv\text{C}-\text{CH}(\text{CH}=\text{CH}_2)\text{CH}_2\text{CH}=\text{CH}_2$, and with allyl iodide the hydrocarbon $\text{HC}\equiv\text{C}-\text{C}(\text{CH}=\text{CH}_2)(\text{CH}_2-\text{CH}=\text{CH}_2)_2$ was probably formed. The remaining products were unsaturated hydrocarbons which failed to give a precipitate with alcoholic silver nitrate. A similar series of reactions was observed by Tchao Yin Lai (4) between homologs of propargyl bromide, $\text{RC}\equiv\text{C}-\text{CH}_2\text{Br}$, and the sodium salts of monosubstituted acetylenes, $\text{R}'\text{C}\equiv\text{CNa}$. Products of the types $\text{R}'\text{C}\equiv\text{C}-\text{CH}_2-\text{C}\equiv\text{CR}$, $\text{R}'\text{C}\equiv\text{C}-\text{CH}(\text{C}\equiv\text{CR})-\text{CH}_2\text{C}\equiv\text{CR}$, and $\text{R}'\text{C}\equiv\text{C}(\text{RC}\equiv\text{C})\text{C}(\text{CH}_2\text{C}\equiv\text{CR})_2$ along with resins of unknown composition were obtained. It is apparent that the hydrogen atoms of the methylene group are activated by the adjacency of two unsaturated residues.

Bourguel (13) first employed an alkyl sulfate in an alkylation of this type, causing dimethyl sulfate to react with the sodium salts of alkylacetylenes in ether. Only one of the methyl groups of dimethyl sulfate is effective in this reaction, and the sodium salt of methylsulfuric acid is formed as a by-product. Truchet (14) employed the ethyl and butyl esters of *p*-toluenesulfonic acid and the allyl ester of benzenesulfonic acid in a similar way. The authors and their co-workers have found that it is possible to prepare methylacetylene and ethylacetylene in fair yields by reaction of the sulfate esters on sodium acetylide or calcium acetylide in liquid ammonia, alkylamines being formed as a by-product (6). Johnson, Schwartz and Jacobs (15) have made several alkyl- and chloralkylacetylenes by the action of the *p*-toluenesulfonates on the sodium or halomagnesium derivatives of acetylene and alkylacetylenes. The preparation of alkylacetylenes from alkali acetylides and alkyl sulfates or sulfonates in a diluent such as diphenyl oxide at 190° has been patented (16). The action of dialkyl sulfates or alkyl esters of aromatic sulfonic acids on alkali or alkaline-earth acetylides appears to be a satisfactory general method for the attachment of an alkyl radical to an acetylenic carbon atom. The principal disadvantage of the method is that the higher alkyl esters are less readily available than the corresponding alkyl halides.

From a somewhat limited experience (17) it does not appear that the less soluble acetylides of the other alkali and alkaline-earth metals possess any advantage over the cheaper sodium acetylide in reactions of this type.

The acetylenic carbides of the alkali and alkaline-earth metals are much less soluble in liquid ammonia and in consequence are probably less reactive than the corresponding acetylides towards organic halides; these reactions have received little attention. Methods of obtaining methyl-

acetylene and ethylacetylene from methyl alcohol and calcium carbide (18, 19) and reactions of organic hydroxyl and halogen compounds with calcium carbide for the production of acetylenic hydrocarbons (20) have been patented. High temperatures were used to promote these reactions.

The acetylenic halomagnesium compounds are quite inert toward primary alkyl halides, although they give substituted acetylenes with more reactive halogen compounds such as the allyl or phenylated methyl halides and also with alkyl sulfates or sulfonates. Grignard, Lepayre and Tcheou Faki (21) reported that they obtained butylacetylene, allylacetylene and benzylacetylene by the action of the corresponding bromides on the monobromomagnesium derivatives of acetylene in ether. Danehy, Killian and Nieuwland (22) were able to prepare allylacetylene by a similar method only after the addition of cuprous bromide as a catalyst to the Grignard solution, and were unable to prepare alkylacetylenes even with the aid of this catalyst. Wieland and Kloss (23) introduced the diphenyl methyl and triphenyl methyl groups by the action of the corresponding chlorides on the dihalomagnesium derivative of acetylene or on a halomagnesium derivative of phenyl acetylene.

It is also possible to prepare dialkylacetylenes by first synthesizing an alkylacetylene as previously described, converting this to a halomagnesium derivative, and treating this acetylide with an alkyl sulfate or sulfonate. Thorn, Hennion and Nieuwland (24) have investigated a few of these reactions.

A number of alkyl- and dialkylacetylenes prepared by means of the substitution reactions have been rearranged to give isomeric acetylenic hydrocarbons, and these processes may be described briefly at this point. Favorsky (25) first noted that in the presence of sodium above 100° the dialkylacetylenes and some allene derivatives were converted to the sodium salts of isomeric monoalkylacetylenes, *e.g.*,

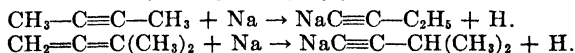

The rearrangement of allenic hydrocarbons by heating with sodium has been studied by several other workers (26). Bourguel (27) employed sodamide at about 160° to produce a similar rearrangement of the dialkylacetylenes, and by treating the resulting sodium compound with methyl sulfate lengthened the chain of the acetylenic hydrocarbons in a series of successive steps, *e.g.*,

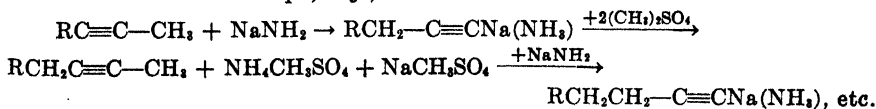

The ammonia was not evolved, but retained in a "double compound" with the sodium salt of the alkylacetylene. Bourguel also reported re-

arrangements in which the triple bond was shifted more than one place in the chain, *e.g.*,

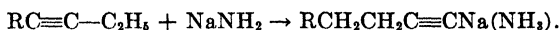

However, these reactions did not give a quantitative yield of the rearranged product, some of the original dialkylacetylene remaining even after prolonged treatment.

By heating the monoalkylacetylenes with alcoholic potash Favorsky (28) also effected a shift of the triple bond towards the center of the chain to produce the isomeric dialkylacetylenes or in a few cases allenic hydrocarbons, *e.g.*,

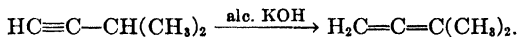
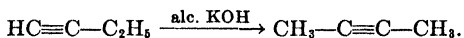

He reported that dry alkalis do not promote this rearrangement, and proposed a mechanism consisting essentially in the addition of a hydrogen atom and an ethoxy group, followed by removal of the ethoxy group with a different hydrogen atom, *e.g.*,

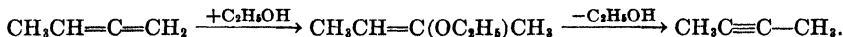
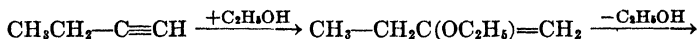

Favorsky isolated the addition product, $\text{CH}_3\text{C}(\text{OC}_2\text{H}_5)=\text{CH}_2$, from methyl acetylene and alcoholic potash. Wislicenus and Schmidt (29) reported that ethylacetylene was not completely rearranged in this way Guest (30) found that the monoalkylacetylenes were also in part isomerized by heating over dry soda lime, and considered that the isomers were in equilibrium at higher temperatures and that the rearrangements were usually not complete.

Slobodin (31) has noted a rearrangement of methylallene to ethylacetylene and of unsymmetrical dimethylallene to isopropylacetylene over Floridin at 215–334° and later (32) observed a partial reverse rearrangement of ethylacetylene under similar conditions. Hurd and Christ (33) noted that traces of allenic hydrocarbons were formed during the pyrolysis of alkynes.

Acetylenic hydrocarbons prepared by these isomerization reactions are frequently impure and for the same reason acetylenes made by dehydrohalogenation with either alkali hydroxides or amides may be contaminated with isomeric hydrocarbons, especially at temperatures above about 150°.

References

- (1) Lebeau and Picon, *Compt. rend.*, **156**, 1077–9 (1913); Picon, *ibid.*, **158**, 1184–7, 1346–9 (1914); **168**, 825–8, 894–6 (1919); **169**, 32–4 (1919).

- (2) Maas and Wright, *J. Am. Chem. Soc.*, **43**, 1098-1111 (1921).
- (3) Hurd, Meinert and Spence, *ibid.*, **52**, 1138-46 (1930).
- (4) Tchao Yin Lai, *Bull. soc. chim. (4)*, **53**, 687-92, 1537-43 (1933).
- (5) Morehouse and Maas, *Can. J. Research*, **11**, 637-43 (1934); *C. A.*, **29**, 1059 (1935).
- (6) Vaughn, Vogt, Hennion and Nieuwland, *J. Org. Chem.*, **2**, 1-22 (1937).
- (7) Heisig, *J. Am. Chem. Soc.*, **53**, 3254-8 (1931).
- (8) Heisig and H. M. Davis, *ibid.*, **57**, 339-40 (1935).
- (9) Unpublished.
- (10) Bried and Hennion, *ibid.*, **59**, 1310-11 (1937); **60**, 1717-19 (1938). Hennion, *Proc. Indiana Acad. Sci.*, **47**, 116-21 (1938); *C. A.*, **32**, 9039 (1938).
- (11) McCusker and Kroeger, *J. Am. Chem. Soc.*, **59**, 213-14 (1937).
- (12) Lespieau and Journaud, *Bull. soc. chim. (4)*, **49**, 423-5 (1930).
- (13) Bourguel, *Compt. rend.*, **179**, 686-8 (1924); *Ann. chim. (10)*, **3**, 325-89 (1925).
- (14) Truchet, *Compt. rend.*, **191**, 854-6 (1930).
- (15) Johnson, Schwartz and Jacobs, *J. Am. Chem. Soc.*, **60**, 1882-4 (1938).
- (16) I. G. Farbenind. A.-G., German P. 562,010 (1931); *C. A.*, **27**, 736 (1933).
- (17) Vaughn and Danehy, *Proc. Indiana Acad. Sci.*, **44**, 144-8 (1934); *C. A.*, **30**, 429 (1936).
- (18) Soc. anon. l'ind. chim. à Bâle, British P. 298,090 (1927); *C. A.*, **23**, 2722 (1929).
- (19) Dutt, French P. 677,338 (1928); *C. A.*, **24**, 2956 (1930).
- (20) Corson, British P. 279,095 (1926); *C. A.*, **22**, 2755 (1928); French P. 642,170 (1927); *C. A.*, **23**, 1135 (1929).
- (21) Grignard, Lepayre and Techeou Faki, *Contrib. Inst. Chem. Natl. Acad. Peiping*, **1**, 127-49 (1934); *C. A.*, **29**, 2513 (1935).
- (22) Danehy, Killian and Nieuwland, *J. Am. Chem. Soc.*, **58**, 611-2 (1936).
- (23) Wieland and Kloss, *Ann.*, **470**, 201-23 (1929).
- (24) Thorn, Hennion and Nieuwland, *J. Am. Chem. Soc.*, **58**, 796-7 (1936).
- (25) Favorsky, *J. Russ. Phys.-Chem. Soc.*, **19**, 553-65 (1887); *J. Chem. Soc.*, **54**, 1168-9 (1888); *J. prakt. Chem. (2)*, **37**, 417-31 (1888).
- (26) Gustavson and Demyanov, *J. prakt. Chem. (2)*, **38**, 201-7 (1888); Jozitsch, *J. Russ. Phys.-Chem. Soc.*, **29**, 90-97 (1897); *Chem. Zentr.*, **1897**, **1**, 1011-2.
- (27) Bourguel, *Compt. rend.*, **178**, 1984-6 (1924); **179**, 686-8 (1924); *Ann. chim. (10)*, **3**, 191-235 (1925).
- (28) Favorsky, *J. Russ. Phys.-Chem. Soc.*, **19**, 414-27 (1887); *J. Chem. Soc.*, **54**, 798-9 (1888); *Chem. Zentr.*, **1887**, 1539-40; *J. prakt. Chem. (2)*, **37**, 382-95, 531-6 (1888); *ibid.*, (2), **44**, 208-38 (1891).
- (29) Wislicenus and Schmidt, *Ann.*, **313**, 220-2 (1900).
- (30) Guest, *J. Am. Chem. Soc.*, **50**, 1744-6 (1928).
- (31) Slobodin, *J. Gen. Chem. (U.S.S.R.)*, **4**, 778-82 (1934); *C. A.*, **29**, 2145 (1935); *J. Gen. Chem. (U.S.S.R.)*, **5**, 48-52 (1935); *C. A.*, **29**, 4732 (1935).
- (32) Slobodin, *J. Gen. Chem. (U.S.S.R.)*, **7**, 2378-80 (1937); *C. A.*, **32**, 2081 (1938).
- (33) Hurd and Christ, *J. Am. Chem. Soc.*, **59**, 2161-5 (1937).

3. The preparation of acetylenic carbinols and glycols and their ethers by the reactions of acetylides on aldehydes, ketones, olefin oxides, acetals, ketals and alpha-halo ethers. A large number of syntheses have been reported in which sodium or halomagnesium acetylides react with aldehydes or ketones to yield the metal salts of acetylenic carbinols:



In like manner, acetylenic glycols have been formed either as by-products in the preparation of carbinols from acetylene or directly from the di-metallic derivatives of acetylene:



The reactions of the halomagnesium acetylides usually have been carried out in ether solution, and both ether and liquid ammonia have been employed as media for the reactions of the sodium compounds. Similar products also have been obtained in many instances by reactions in which the starting materials were acetylene and aldehydes or ketones in the presence of alkali amides, alcoholates or hydroxides, or acetylene and the metal enolates of aldehydes or ketones. In most of these reaction mixtures an equilibrium probably is set up involving the metal acetylide, the metal enolate, the acetylene and the carbonyl compound:



The reaction leading to the formation of an acetylenic carbinol is probably an addition of the acetylide anion to the carbon atom of a carbonyl group:

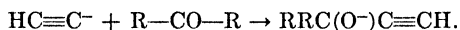

The formation of molecular acetylene and metal enolates in equilibrium accordingly may retard the reaction and it is perhaps significant that non-enolizable benzaldehyde and benzophenone give superior results. The acetylenic carbinols or glycols are recovered from these reaction mixtures by cautious hydrolysis of the alcoholates. These reactions are analogous to the synthesis of cyanohydrines by the addition of alkali cyanides to aldehydes or ketones, and to the synthesis of alcohols by the reactions of alkyl or aryl Grignard reagents with aldehydes or ketones.

By these methods formaldehyde yields primary alcohols, and the higher aldehydes yield secondary alcohols, while ketones give tertiary alcohols. It is also obvious that the higher aldehydes and the unsymmetrical ketones must produce carbinols with an asymmetric carbon atom as mixtures of dextro and levo forms. Similarly acetylene glycols derived from the higher aldehydes or unsymmetrical ketones have two asymmetric carbon atoms and consist of mixtures of the meso with dextro and levo or racemic forms.

The first highly successful reaction of this type was reported by Nef (1) who employed the sodium derivative of phenylacetylene with a few ketones, and similar procedures were then applied to other monosubstituted acetylenic hydrocarbons (2-4).

The earlier attempts (4, 5) to prepare carbinols from sodium acetylide or carbide acting directly on aldehydes or ketones without a diluent gave very poor yields. The researches of Merling, as represented by the patents of the Farbenfabrik von F. Bayer & Co. (6) appear to have been the first successful attempts to prepare acetylenic carbinols from acetylene and aldehydes or ketones by means of alkali-metal compounds. Acetaldehyde, acetone, methyl ethyl ketone, diethyl ketone and cyclohexanone

yielded carbinols with acetylene in this way. Alternative methods patented included the action of sodium acetylide on aldehydes or ketones the action of acetylene on the sodium enolates, or the action of acetylene on the aldehydes or ketones in the presence of alkaline reagents such as sodamide or sodium alcoholates. The reactions were all performed in ether, usually at about 0°. Similar methods have been employed to prepare acetylenic carbinols from acetylene with methyl heptenone (7), acetone (8), isohexyl methyl ketone, nonyl methyl ketone, diisopropyl ketone, ditertiary-butyl ketone (9), methyl isopropyl ketone, methyl butyl ketone, methyl amyl ketone (10), methyl isobutyl ketone (10, 11), methyl butenyl ketone (12), acetophenone (11, 13), methyl isohexyl ketone (11), cyclohexanone (11, 14), acetaldehyde, propionaldehyde, butyraldehyde, phenylacetaldehyde, methyl ethyl ketone (13) and isobutyraldehyde (15). Favorsky (16) has patented the reaction of acetone with acetylene in the presence of various alkalies. In general, aldehydes were found to give poorer yields of acetylenic carbinols than did ketones. In many of these preparations it was reported that by-products were formed by condensation of the enolizable aldehydes or ketones in the alkaline media.

Under some conditions acetylenic glycols are formed as by-products of the action of ketones on sodium acetylide. The production of glycols from sodium acetylide and ketones in an inert diluent at about 130° has been patented (17). It has also been noted by Hennion (private communication) that glycols may be formed from ketones and sodium acetylide on prolonged contact in liquid ammonia at about -33°. McCallum (18) has patented the production of the acetylenic glycols by heating the sodium compounds of the acetylenic carbinols, causing the elimination of acetylene:

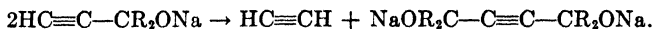

These methods have proved valuable as a tool for the synthesis of some complex unsaturated organic compounds. Thus Fischer and Lowenberg (19) reacted acetylene with sodamide and a ketone at two successive stages in the synthesis of phytol, and Ruzicka and Fischer (20) employed the method in the preparation of complex diterpene compounds. Ruzicka and Hofmann (21) obtained carbinols from potassium acetylide and *trans*-androsterone and 5-*trans*-anhydro androsterone. The Soc. pour l'ind. chim. à Bâle (22) has patented a process for manufacturing an alcohol related to vitamin A in which the reaction of acetylene with sodamide and a ketone is used at two successive stages.

Perkin (23) employed the sodium salts of ethylene glycol monoalkyl ethers as alkalis in the reaction of acetylene with ketones. Dialkyl

ethers of glycol were used as solvents. Improved yields of acetylenic carbinols by the use of potassium tertiary butylate or amylate as an alkali with acetylene and ether solutions of beta-ionone or cyclohexanone have been reported (24, 25).

One of the Merling patents mentions the use of liquid ammonia as a solvent for sodium acetylide in this reaction (6). Kreimeier (26) and McCallum (27) patented the reaction of sodium acetylide with aldehydes and ketones in liquid ammonia. It is claimed that the reactions are much more rapid than in ether, probably because the alkali compounds are more soluble in liquid ammonia than in ether or other organic media. It is further claimed that the alkali has a "catalytic" effect and that based on sodium, yields of 175 per cent of dimethylethynylcarbinol have been obtained. Similar effects of alkali had been reported previously in reactions of phenylacetylene. This probably indicates that the reactions continue as long as acetylide anions exist in equilibrium. Liquid ammonia has been employed as a medium for the extensive preparation of acetylenic carbinols in this laboratory (28).

Another approach to the problem is indicated by Kazarian (29), who found that powdered calcium carbide with potassium hydroxide in ether acted on acetone to form first the acetylenic carbinol and later the acetylenic glycol, and this technique has been adopted by a few other workers (30).

Jozitsch (31) first appears to have made acetylenic halomagnesium compounds and to have used them in ether solution for syntheses of this type. His earliest research employed the halomagnesium compounds of monosubstituted acetylenic hydrocarbons and later work (32-39) has shown that these reactions are perfectly general. As might be expected, the treatment of the halomagnesium compounds from acetylene (see Chapter II, Section 3) with aldehydes or ketones is complicated by the fact that either one or two carbinol groups may be introduced, depending upon the conditions of the reaction. In mixed products from acetylene the relative proportions of acetylenic carbinol, $\text{HC}\equiv\text{C}-\text{C}(\text{OH})\text{RR}'$, and acetylenic glycol, $\text{R}'\text{R}(\text{OH})\text{C}-\text{C}\equiv\text{C}(\text{OH})\text{RR}'$, are thought to depend chiefly upon the proportions of the compounds $\text{HC}\equiv\text{CMgX}$ and $\text{XMgC}\equiv\text{CMgX}$ present in the acetylenic Grignard reagent, and these proportions are in part governed by regulation of the pressure of excess acetylene in solution (see Chapter II, Section 3). Control of the reaction for the exclusive introduction of a single carbinol group into acetylene has not been attained, and sodium acetylide appears to be a more suitable intermediate for this purpose. On the other hand acetylenic glycols have been obtained as almost the sole products of the reactions of aldehydes and ketones with the Grignard reagent prepared under conditions which favor the formation of a high proportion of the bis-halomagnesium compound of acetylene.

This procedure is accordingly well adapted to the production of symmetrical acetylenic glycols according to the equation

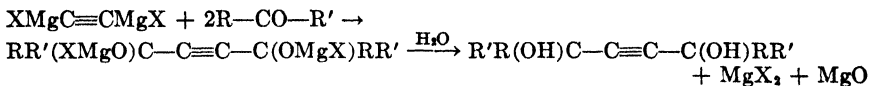

Jozitsch (32) carried out the first syntheses of this type, employing the bis-bromomagnesium compound of acetylene with acetone, pinacolone methylcyclohexanone, menthone, carvone, chloral, isobutyraldehyde and cinnamic aldehyde and obtained the glycols, but apparently he was unable to isolate the stereoisomeric forms. Later he employed acetaldehyde and methylethylketone, pinacolone, methylcyclohexanone and benzaldehyde. He also obtained mixtures of the carbinol with the glycol by passing acetylene into the ether solution of a bromomagnesium compound of acetylene during reactions with trioxymethylene, methylcyclohexanone, menthone and oenanthylic aldehyde. Jozitsch also prepared acetylenic glycols from the bis-iodomagnesium compound of acetylene by reaction with bromal, anisic aldehyde, diethyl ketone, methyl butyl ketone, diisopropyl ketone, methyl hexyl ketone, isobutyl *tert.*-butyl ketone, acetophenone, suberone, cyclohexanone, camphor and chloral. Zal'kind and Teterin (40) have reported the preparation of unsymmetrical acetylenic glycols by the action of a mixture of an aldehyde and a ketone on the dibromomagnesium compound of acetylene. Lespieau and Lombard (41) obtained principally the carbinols on reaction of the bromomagnesium compound from acetylene with acrolein and crotonaldehyde. Teterin and Ivanov (42) suggest that carbinols prepared from acetylene may be identified by converting their halomagnesium compounds to glycols by reaction with benzophenone and determining the melting point of the glycol.

Some interesting types of acetylenic hydrocarbons have been prepared from the acetylenic carbinols and glycols derived from aldehydes or ketones. By several methods of dehydration these acetylenic carbinols have been found to yield enynes (43-45) while acetylenic gamma-glycols yielded dienyne (46-48).

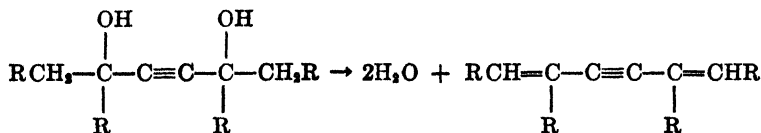
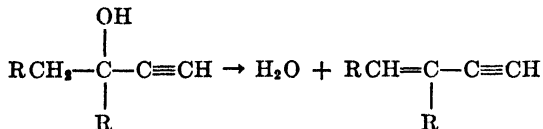

Tchao Yin Lai (49) has converted a few acetylenic carbinols into carbinyl bromides by the action of phosphorus tribromide, and from these has prepared gamma-diacetylenes by reaction with sodium or magnesium metal, as well as beta-diacetylenes by reaction with sodium compounds of alkyacetylenes. Campbell and co-workers (50) have converted acetylenic tertiary carbinols to the carbinyl chlorides by the action of hydrogen chloride. The carbinyl chlorides on treatment with alkyl Grignard reagents were found to yield tertiary alkyl acetylenes.

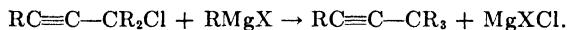

Dupont (51) oxidized to ketones a few acetylenic glycols of the type $\text{HORHC}-\text{C}\equiv\text{C}-\text{CHROH}$ in which R was aryl.

The reaction of alpha-halo ethers with acetylides leads to the preparation of ethers of acetylenic carbinols and glycols. Gautier (52) first reported the synthesis of ethers of acetylenic glycols by the reaction of acetylene dimagnesium bromide with alpha-halo ethers according to the equation:

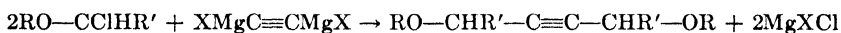

Methyl chloromethyl ether, ethyl chloromethyl ether, propyl chloromethyl ether, isoamyl chloromethyl ether and methyl alpha-chloroethyl ether were used. This reaction also has been applied to the halomagnesium compounds of several monosubstituted acetylenes (53-55).

Acetylenic halomagnesium compounds were found to react with a few acetals to yield similar ethers (56).

The preparation of acetylenic carbinols from acetylenic Grignard reagents and alkylene oxides was first reported by Jozitsch (57), who prepared 3-pentyn-1-ol from methylacetylene and ethylene oxide. The reaction was extended by Faucounau (58), Danehy, Vogt and Nieuwland (59) and Bachman (60). The carbinols so prepared are all of the type $\text{R}-\text{C}\equiv\text{C}-\text{CH}_2\text{CH}_2\text{OH}$ and were prepared in each case from ethylene oxide in anhydrous ether.

Kreimeier (61) has reported the preparation of alkynyl carbinols and glycols by reacting sodium acetylide with ethylene and propylene oxides in liquid ammonia.

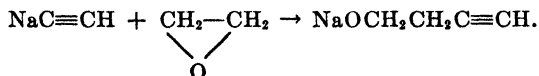

It is claimed that the method applies equally well with various alkylene oxides and acetylides of monosubstituted acetylenes.

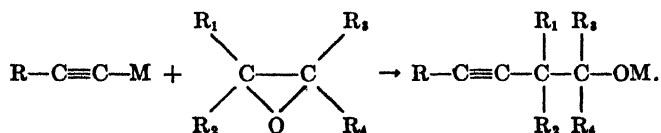

A similar reaction had been applied previously to the halomagnesium compounds of several alkylacetylenes (57-60).

References

- (1) Nef, *Ann.*, **308**, 264-328 (1899).
- (2) Favorsky, *J. Russ. Phys.-Chem. Soc.*, **37**, 643-5 (1905); *Chem. Zentr.*, **1905**, **II**, 1018. Skossarevsky, *J. Russ. Phys.-Chem. Soc.*, **37**, 645-7 (1905); *Chem. Zentr.*, **1905**, **II**, 1018. Favorsky and Skossarevsky, *J. Russ. Phys.-Chem. Soc.*, **32**, 652 (1900); *Bull. soc. chim.* (3), **26**, 284 (1901).
- (3) Moureu and Desmots, *Compt. rend.*, **132**, 1223-6 (1901); **134**, 355-7 (1902); *Bull. soc. chim.* (3), **27**, 360-73 (1902).
- (4) Matignon, *Compt. rend.*, **125**, 1033-5 (1897).
- (5) Hess and Munderloh, *Ber.*, **51**, 377-84 (1918).
- (6) Farbenfabrik von F. Bayer & Co., German P. 280,226 (1914); 284,764 (1915); 286,920 (1915); 289,800 (1915); 291,185 (1916); 285,770 (1915); 288,271 (1915); *Frdl.*, **12**, 51-61.
- (7) Ruzicka and Fornasir, *Helv. Chem. Acta*, **2**, 182-8 (1919).
- (8) Scheibler and Fischer, *Ber.*, **55**, 2903-23 (1922).
- (9) Locquin and Sung Wouseng, *Bull. soc. chim.* (4), **35**, 597-604, 604-6 (1924). Sung Wouseng, *Ann. chim.* (10), **1**, 346-416 (1924).
- (10) Leers, *Bull. soc. chim.* (4), **39**, 421-3 (1926).
- (11) Rupe and Kambli, *Helv. Chim. Acta*, **9**, 672 (1926). Rupe, Messner and Kambli, *ibid.*, **11**, 449-62 (1928). Rupe and Giesler, *ibid.*, **11**, 656-70 (1928). Rupe, Wira and Lotter, *ibid.*, **11**, 965-71 (1928). Rupe, Swiss P. 121,563; *Chem. Zentr.*, **1927**, **II**, 3105; Swiss P. 123,448, 123,449 (1927); *Chem. Zentr.*, **1928**, **I**, 1328; British P. 267,954 (1927); *Chem. Zentr.*, **1927**, **II**, 1085.
- (12) Colonge, *Bull. soc. chim.* (4), **49**, 441-51 (1931).
- (13) Carothers and Coffman, *J. Am. Chem. Soc.*, **54**, 4071-6 (1932).
- (14) Levina and Vinogradova, *J. Applied Chem. (U.S.S.R.)*, **9**, 1299-1302 (1936); *C. A.*, **31**, 2587 (1937).
- (15) Krestinsky and Solodsky, *Ber.*, **60**, 1869-73 (1927).
- (16) Favorsky, Russian P. 31,017 (1933); *C. A.*, **28**, 3425 (1934).
- (17) I. G. Farbenind, A.-G., German P. 636,456 (1936); *C. A.*, **31**, 703 (1937).
- (18) McCallum (to E. I. du Pont de Nemours & Co.), U. S. P. 2,162,676 (1936). *C. A.*, **33**, 7816 (1939).
- (19) F. G. Fischer and Lowenberg, *Ann.*, **475**, 183-204 (1929).
- (20) Ruzicka and W. H. Fischer, *Helv. Chim. Acta*, **17**, 633-41 (1934).
- (21) Ruzicka and Hofmann, *ibid.*, **20**, 1280-2 (1937).
- (22) Soc. pour l'ind. chim. à Bâle, German P. 601,070 (1934); *C. A.*, **28**, 7261 (1934).
- (23) Perkins (to Carbide and Carbon Chemicals Corp.), U. S. P. 2,161,191 (1937). *C. A.*, **33**, 7313 (1939).
- (24) Gould and Thompson, *J. Am. Chem. Soc.*, **57**, 340-5 (1935).
- (25) Pickney, Nesty, Wiley and Marvel, *ibid.*, **58**, 972-6 (1936).
- (26) Kreimeier, U. S. P. 2,106,180, 2,106,181 (1938); *C. A.*, **32**, 2547 (1938).
- (27) McCallum (to du Pont Co.), U. S. P. 2,125,384 (1938); *C. A.*, **32**, 7480 (1938).
- (28) K. Campbell, B. Campbell and Eby, *J. Am. Chem. Soc.*, **60**, 2882-4 (1938).
- (29) Kazarian, *J. Gen. Chem. (U.S.S.R.)*, **4**, 1347-52 (1934); *C. A.*, **29**, 3978 (1935). Gambarian and Kazarian, Russian P. 41,516 (1935); *Chem. Zentr.*, **1935**, **II**, 3702.
- (30) Zakharova, *Sci. Repts. Leningrad State Univ.*, **2**, No. 2, 162-95 (1936); *C. A.*, **32**, 2506 (1938).
- (31) Jozitsch, *J. Russ. Phys.-Chem. Soc.*, **34**, 100-2 (1902); *Bull. soc. chim.* (3), **28**, 922-3 (1902).
- (32) Jozitsch, *J. Russ. Phys.-Chem. Soc.*, **34**, 239-44 (1902); *Bull. soc. chim.* (3), **30**, 208-11 (1903). *Idem.*, *ibid.*, **35**, 430-2, 1269-75 (1903); *Bull. soc. chim.* (3), **32**, 5251-3 (1904); **34**, 181-4 (1905). *Idem. ibid.*, **36**, 1545-51 (1904); *Bull. soc. chim.* (3), **36**, 177-9 (1906). *Idem. ibid.*, **38**, 252-3, 656-9 (1906); *Bull. soc. chim.* (4), **4**,

- 981-2, 1203-5 (1908). Jozitsch, Breitfous, Rudolf, Stassevitch, Elmanovitch, Kondyrev and Fomine, *ibid.*, **39**, 652-7 (1907); *Bull. soc. chim.* (4), **6**, 98-100 (1908). Jozitsch, Cholokhov, Andereg and Levinson, *ibid.*, **41**, 529-30, 540-2 (1909); *Bull. soc. chim.* (4), **8**, 889, 890 (1910). Jozitsch and Afanassiev, *ibid.*, **42**, 373-4 (1910); *Bull. soc. chim.* (4), **10**, 172 (1911). Jozitsch, *ibid.*, **42**, 1490-1 (1910); *Bull. soc. chim.* (4), **10**, 1294 (1911). Jozitsch, Tokarsky and Chibaev, *ibid.*, **42**, 1493-4 (1910); *Bull. soc. chim.* (4), **10**, 1324 (1910).
- (33) Moureu, *Bull. soc. chim.* (3), **33**, 151-7 (1905).
- (34) Carothers and Berchet, *J. Am. Chem. Soc.*, **55**, 1094-6 (1933); U. S. P. 1,963,935 (1933); *C. A.*, **28**, 5082 (1934). Carothers and Jacobson, U. S. P. 1,963,934 (1934); *C. A.*, **28**, 5081 (1934).
- (35) Zal'kind and Pletz, *Trans. Leningrad Chem. Tech. Inst.*, **1**, 57-60 (1934); *J. Gen. Chem. (U.S.S.R.)*, **4**, 1088-90 (1934); *C. A.*, **29**, 2908 (1935).
- (36) Wilson and Hyslop, *J. Chem. Soc.*, **123**, 2612-8 (1923); **125**, 1556-8 (1924).
- (37) Guest, *J. Am. Chem. Soc.*, **47**, 860-3 (1925).
- (38) Yvon, *Compt. rend.*, **180**, 748-9 (1925).
- (39) Tchao Yin Lai, *Bull. soc. chim.* (4), **53**, 682-7 (1933).
- (40) Zal'kind and Teterin, *Ber.*, **66**, 321-5 (1933); *J. Gen. Chem. (U.S.S.R.)*, **3**, 369-72 (1933); *C. A.*, **28**, 2321 (1934). Zal'kind and Zakharova, *J. Gen. Chem. (U.S.S.R.)*, **3**, 432-3 (1933); *C. A.*, **28**, 4035 (1934).
- (41) Lespieau and Lombard, *Bull. soc. chim.* (5), **2**, 369-73 (1935); *C. A.*, **29**, 3977 (1935).
- (42) Teterin and Ivanov, *J. Gen. Chem. (U.S.S.R.)*, **7**, 1629-31 (1937); *C. A.*, **31**, 8503 (1937).
- (43) Bayer & Co., German P. 290,588 (1916); *Frdl.*, **12**, 61. Carothers and Coffman, *J. Am. Chem. Soc.*, **54**, 4071 (1932).
- (44) Scheibler and A. Fischer, *Ber.*, **55**, 2903-23 (1922).
- (45) Favorsky, Russian P. 31,015 (1933); *C. A.*, **28**, 3425 (1934).
- (46) Dupont, *Compt. rend.*, **152**, 197-199 (1911); *Ann. chim. phys.* (8), **30**, 510-9 (1913).
- (47) Bayer & Co., German P. 241,424 (1911); *Frdl.*, **10**, 1043.
- (48) Zakharova, *Sci. Repts. Leningrad State Univ.*, **2**, No. 2, 162-95 (1936); *C. A.*, **32**, 2506 (1938).
- (49) Tchao Yin Lai, *Bull. soc. chim.* (4), **53**, 1537-48 (1933).
- (50) Campbell and Eby, *J. Am. Chem. Soc.*, **62**, 1798-1800 (1940).
- (51) Dupont, *Bull. soc. chim.* (4), **15**, 604-8 (1914).
- (52) Gautier, *Ann. chim. phys.* (8), **16**, 334-58 (1909).
- (53) Jozitsch and Orelkin, *J. Russ. Phys.-Chem. Soc.*, **42**, 373 (1910); *Bull. soc. chim.* (4), **10**, 172 (1911).
- (54) Gredy, *Ann. chim.* (11), **4**, 42-51 (1935).
- (55) Lespieau, *Compt. rend.*, **157**, 1439 (1913); *Ann. chim.* (9), **2**, 280-92 (1914); *Compt. rend.*, **173**, 1367-8 (1921); **184**, 1329-32 (1927); *Bull. soc. chim.* (4), **43**, 199-210 (1928).
- (56) Kranzfelder and Vogt, *J. Am. Chem. Soc.*, **60**, 1714 (1938).
- (57) Jozitsch, *et al.*, *J. Russ. Phys.-Chem. Soc.*, **39**, 652-7 (1907); *Bull. soc. chim.* (4), **6**, 98-100 (1909).
- (58) Faucounau, *Compt. rend.*, **199**, 605-7 (1934).
- (59) Danehy, Vogt and Nieuwland, *J. Am. Chem. Soc.*, **56**, 2790 (1934); **57**, 2327 (1935).
- (60) Bachman; *ibid.*, **57**, 382 (1935).
- (61) Kreimeier, U. S. P. 2,106,182 (1938); *C. A.*, **32**, 2547 (1938).

4. The preparation of acetylene mono- and dicarboxylic acids by the reaction of acetylides with carbon dioxide. The sodium salts-derived from monosubstituted acetylenic hydrocarbons long have been known to yield salts of acetylenic carboxylic acids on treatment with carbon dioxide (1-6):

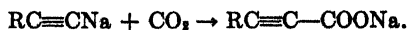

This reaction was later applied to sodium acetylide by Skossarevsky (7), who treated this substance with carbon dioxide under 50–60 atm pressure and obtained propiolic acid in 75 per cent yield: $\text{HC}\equiv\text{CNa} + \text{CO}_2 \rightarrow \text{HC}\equiv\text{C}-\text{COONa}$.

Jozitsch (8) carbonated acetylene dimagnesium bromide in ether and prepared acetylene dicarboxylic acid, $\text{XMgC}\equiv\text{CMgX} + 2\text{CO}_2 \rightarrow \text{XMgOOC}-\text{C}\equiv\text{C}-\text{COOMgX}$. Oddo (9) and Tcheou Faki (10) made propiolic acid by the action of carbon dioxide on acetylene monomagnesium bromide. Halomagnesium derivatives of monosubstituted acetylenes also have been used for the preparation of homologs of propiolic acid (11–13).

References

- (1) Glaser, *Ann.*, **154**, 137–71 (1870); *Ber.*, **2**, 442–4 (1869).
- (2) Pinner, *Ber.*, **14**, 1081–2 (1881).
- (3) Lagermark, *Ber.*, **12**, 853–4 (1879). Lagermark and Eltekov, *J. Russ. Phys.-Chem. Soc.*, **12**, 287–98 (1880); *Bull. soc. chim. (2)*, **33**, 159 (1880).
- (4) Favorsky, *J. Russ. Phys.-Chem. Soc.*, **19**, 553–65 (1887); *J. Chem. Soc. Abs.*, **54**, 1168 (1888); *J. prakt. Chem. (2)*, **37**, 417–30 (1888).
- (5) Moureu and Delange, *Compt. rend.*, **132**, 988–90 (1901); **136**, 552–4 (1903); *Bull. soc. chim. (3)*, **29**, 648–62 (1903). Moureu, *Ger. P.* 132,802 (1902); *Chem. Zentr.*, **1902**, II, 169.
- (6) Krafft and Heizmann, *Ber.*, **33**, 3586–90 (1900).
- (7) Skossarevsky, *J. Russ. Phys.-Chem. Soc.*, **36**, 863–72 (1904); *Chem. Zentr.*, **1904**, II, 1025.
- (8) Jozitsch, *J. Russ. Phys.-Chem. Soc.*, **34**, 242–44 (1902); *Bull. soc. chim. (3)*, **30**, 210 (1903).
- (9) Oddo, *Gazz. chim. ital.*, **38**, (I), 625–35 (1908).
- (10) Tcheou Faki, *Contrib. Inst. Chem. Natl. Acad. Sci. Peiping*, **1**, 127–49 (1934); *C. A.*, **29**, 2513 (1935).
- (11) Jozitsch, *J. Russ. Phys.-Chem. Soc.*, **35**, 431–2 (1903); *Bull. soc. chim. (3)*, **32**, 552 (1904).
- (12) Dupont, *Compt. rend.*, **148**, 1522–4 (1909).
- (13) Carothers and Berchet, *J. Am. Chem. Soc.*, **55**, 1094–6 (1933).

5. The preparation of diacetylenes from certain acetylides. It long has been known that cuprous acetylides derived from monosubstituted acetylenic hydrocarbons could be converted to diacetylenic compounds by the action of specific oxidizing agents such as oxygen, potassium ferricyanide and a number of *-ic* salts, notably cupric chloride and bromide (1–9):



In general it appears that any reaction which might be expected to give a cupric acetylide invariably produces a diacetylene, and in this respect the cupric acetylides resemble cupric cyanide, which readily yields dicyanogen. It is probable that reactions directed toward the preparation of acetylides of some other metals result in similar decompositions. Halomagnesium acetylides of several monosubstituted acetylenes also have been found to yield diacetylenes by reaction with oxygen, *-ic* salts, nitrobenzene or a limited quantity of iodine (10–14).

Attempts to apply these reactions to acetylene have not been very successful. A part of the difficulty probably lies in the tendency of copper and the halomagnesium group to replace both hydrogen atoms of acetylene and as a consequence the diacetylene appears to be produced in mixture with polyacetylenes and carbonaceous material. Noyes and Tucker (15) obtained small quantities of diacetylene, $\text{HC}\equiv\text{C}-\text{C}\equiv\text{CH}$, isolated as the hexabromide, on treatment of cuprous acetylde with cupric chloride. Straus and Kollek (16) also made diacetylene in a similar manner.

References

- (1) Glaser, *Ber.*, **2**, 422-4 (1869); *Ann.*, **154**, 159-60 (1870).
- (2) Baeyer, *Ber.*, **15**, 51-52 (1882); German P. 19,266 (1881); *Frdl.*, **1**, 136-7.
- (3) Baeyer and Landsberg, *Ber.*, **15**, 57-61 (1882); Straus, *Ann.*, **342**, 190-265 (1905).
- (4) Griner, *Ann. chim. phys.* (6), **26**, 354-67 (1892).
- (5) Dupont, *Compt. rend.*, **148**, 1522-4 (1909).
- (6) Favorsky and Morev, *J. Russ. Phys.-Chem. Soc.*, **50**, 571-81 (1920); *C. A.*, **18**, 2496 (1924).
- (7) Kunkell, *Ber. pharm. Ges.*, **23**, 188-227 (1913); *C. A.*, **7**, 2388-9 (1913).
- (8) Reich, *Arch. Sci. Phys. Nat.*, **45**, 191-216, 259-76 (1918); *C. A.*, **12**, 1877 (1918).
- (9) Manchot, Withers and Oltrogge, *Ann.*, **387**, 257-93 (1912).
- (10) Danehy and Nieuwland, *J. Am. Chem. Soc.*, **58**, 1609-10 (1936).
- (11) Moureu, *Ann. chim. phys.* (8), **7**, 545 (1906).
- (12) Jozitsch and Orelkin, *J. Russ. Phys.-Chem. Soc.*, **42**, 728 (1910); *Bull. soc. chim.* (4), **10**, 647 (1911).
- (13) Grignard and Perrichon, *Ann. chim.* (10), **5**, 13-15 (1926).
- (14) Grignard and Tcheou Faki, *Compt. rend.*, **188**, 357-61 (1929).
- (15) Noyes and Tucker, *Am. Chem. J.*, **19**, 123-28 (1897).
- (16) Straus and Kollek, *Ber.*, **59**, 1664-81 (1926).

6. The preparation of haloacetylenes by the reaction of acetylides or of acetylene in alkaline media with halogens or halogen compounds. The halogens and various compounds of a halogen with an electronegative group react with acetylides to yield haloacetylenes. Iodine has commonly been employed with the metallo substitution products of acetylene, because the corresponding chloro and bromo derivatives are poisonous, explosive and spontaneously inflammable gases. Regardless of whether one or both hydrogen atoms of the acetylene molecule are replaced by a metal, halogen atoms occupy both positions in the product:

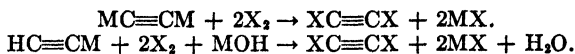

These reactions are so characteristic of all acetylides that the best test for acetylde structure in a metallo derivative of acetylene appears to be treatment with iodine and recognition of the disagreeable odor of diiodoacetylene. As early as 1864 Berend (1, 2) showed that diiodoacetylene could be obtained by shaking silver acetylde with an ether solution of iodine. Biltz (3) reported that diiodoacetylene mixed with the tetraiodoethylene resulted from the action of iodine potassium iodide solution on

calcium carbide. Jozitsch (4) used iodine directly with acetylene dimagnesium bromide and obtained diiodoacetylene. Sodium acetylide in liquid ammonia also reacts with iodine to give diiodoacetylene (5).

Acetylene has been found to react with halogens and certain halogen compounds in alkaline media to yield dihaloacetylenes. It appears possible that this is a reaction of the small proportion of acetylide ion which seems to exist in equilibrium in aqueous alkaline solutions. In these cases also both hydrogen atoms of acetylene are replaced, and it thus appears that replacement of one hydrogen atom of acetylene by halogen makes the other hydrogen atom more easily replaceable. Biltz and Kuppers (6) observed the formation of diiodoacetylene on passing acetylene into cold aqueous potassium hydroxide solution to which iodine potassium iodide solution was added slowly. Dehn (7) prepared diiodoacetylene by passing acetylene into potassium iodide solution to which sodium hypochlorite or hypobromite was added. Dussol (8) prepared the same compound by the electrolysis of sodium or potassium iodide into which acetylene was passed. The hypohalite synthesis of dihaloacetylenes was studied recently by Straus and Kollek (9). The general reaction may be written as $\text{HC}\equiv\text{CH} + 2\text{NaOX} \rightarrow \text{XC}\equiv\text{CX} + 2\text{NaOH}$, and X may be chlorine, bromine or iodine. These investigators stress the necessity for an alkaline solution; using 0.5–0.7*N* hypohalite solution it was found well to employ four or more mols of free alkali. There is marked variation in the velocity of reaction of the three hypohalites. For half transformation hypochlorites require about ten times as long as hypobromites. Hypoiodites react almost instantly. Diiodoacetylene also results from the slow action of iodine on acetylene in liquid ammonia (5).

Monoiodoacetylene may be prepared from acetylene by an indirect procedure. Propiolic acid, produced from an acetylide and carbon dioxide, is treated with iodine in alkaline solution to yield iodopropiolic acid, $\text{I}-\text{C}\equiv\text{C}-\text{COOH}$, and this substance is then decarboxylated to monoiodoacetylene (10).

Knowledge of the principles governing halogen substitution reactions of this type has been greatly extended by the general applications of these reactions to monosubstituted acetylenes. Early investigators (2, 11, 12) employed iodine with silver acetylides to make the iodoacetylenes. Grignard and co-workers (13–15) made the bromo and iodo compounds by the action of cyanogen bromide or cyanogen iodide on the halomagnesium acetylides.

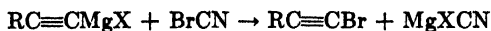

Under the same conditions cyanogen chloride yielded cyanoacetylenes rather than chloroacetylenes. Bourguel and Truchet (16) made chloro-

acetylenes of this type by the action of benzene sulfonyl chloride on the sodium salts of the monosubstituted acetylenes.



Iodine in liquid ammonia yields iodoacetylenes readily by reaction with phenylacetylene and vinylacetylene, but reacts very slowly with alkylacetylenes. The sodium salts of alkylacetylenes react rapidly with iodine in liquid ammonia to yield the alkyliodoacetylenes (17). McCusker and Vogt (18) recommended the action of bromine on alkynyl magnesium bromides in ether at -32° to produce alkylbromoacetylenes, and the action of chlorine on potassium alkyl acetylides in ether at -70° to produce alkylchloroacetylenes. Strauss, Kollek, and Hauptmann (19) have studied the preparation of dihalo diacetylenes by the action of hypohalites on the hydrocarbons.

References

- (1) Berend, *Ann.*, **131**, 122-3 (1864).
- (2) *Idem, ibid.*, **135**, 257-66 (1865).
- (3) Biltz, *Ber.*, **30**, 1200-10 (1897). De Chalmot, *Am. Chem. J.*, **19**, 877-8 (1897).
- (4) Jozitsch, *J. Russ. Phys.-Chem. Soc.*, **35**, 1269-75 (1903); *Bull. soc. chim.* (9), **34**, 181-4 (1905).
- (5) Vaughn and Nieuwland, *J. Am. Chem. Soc.*, **54**, 787-91 (1932).
- (6) Biltz and Kuppers, *Ber.*, **37**, 4412-6 (1904).
- (7) Dehn, *J. Am. Chem. Soc.*, **33**, 1598-1601 (1911).
- (8) Dussol, *Bull. soc. chim.* (4), **35**, 1618-29 (1924).
- (9) Straus, Kollek and Heyn, *Ber.*, **63**, 1868-85 (1930); Straus and Kollek, German P. 495,787 (1930) (to I. G. Farbenindustrie); *Frdl.*, **16**, 123-4.
- (10) Baeyer, *Ber.*, **18**, 2269-81 (1885).
- (11) Lieberman, *Ann.*, **131**, 123 (1864); **135**, 266-90 (1865).
- (12) Holleman, *Ber.*, **20**, 3080-2 (1887).
- (13) Grignard and Courtot, *Bull. soc. chim.* (4), **17**, 228-31 (1915); Grignard, Bellet and Courtot, *Ann. chim.* (9), **4**, 28-57 (1915).
- (14) Grignard and Perrichon, *Ann. chim.* (10), **5**, 5-36 (1926).
- (15) Grignard and Tcheou Faki, *Compt. rend.*, **188**, 357-61 (1929).
- (16) Bourguel and Truchet, *ibid.*, **190**, 753-5 (1930).
- (17) Vaughn and Nieuwland, *J. Am. Chem. Soc.*, **55**, 2150-3 (1933); **56**, 1207-9 (1934); *idem, J. Chem. Soc.*, **1933**, 741-3.
- (18) McCusker and Vogt, *J. Am. Chem. Soc.*, **59**, 1307-10 (1937).
- (19) Straus, Kollek and Hauptmann, *Ber.*, **63**, 1886-99 (1930).

7. Some further substitution reactions of the monosubstituted derivatives of acetylene. A number of reactions leading to symmetrical disubstitution products of acetylene have been noted in the preceding sections. Numerous substitution reactions of the alkylacetylenes have also been cited to supply analogy and historical background for similar reactions of acetylene. In addition to these, several other types of substances have been or may be prepared by the introduction of a second substituent into the monosubstituted derivatives previously described, and it is the purpose of this section to note the more important processes of this kind.

Moureau and Delange (1) and Andre (2) obtained acetylenic ketones by the action of acyl halides on the sodium salts of alkylacetylenes.

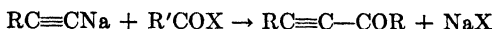

Acetic anhydride also was found to react in a similar manner with the halomagnesium compounds of alkylacetylenes (3). The action of sodium alkyl acetylides on ethyl formate yielded acetylenic aldehydes (4), and with orthoformic ester gave acetylenic acetals (5).

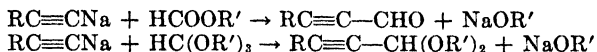

When an acetylenic ketone is formed in the presence of an excess of an acetylenic halomagnesium compound, a diacetylenic carbinol is formed in a second stage of reaction (6-13):



Acetylides derived from alkylacetylenes also react with carbonic esters or haloformic esters to yield esters of alkylacetylene carboxylic acids as primary products (14-16). Successive stages of the reaction employing an excess of the acetylide may produce diacetylenic ketones or triacetylenic carbinols (14, 17, 18).

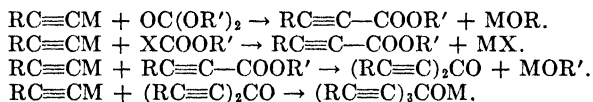

Diacetylene dicarboxylic acid was obtained by Baeyer upon oxidizing the cuprous compound of sodium propiolate with potassium ferricyanide (19). By similar oxidations Lespieau obtained the compounds $(\text{HOCH}_2-\text{C}\equiv\text{C}-)_2$ and its dimethyl ether (20). He also prepared the compound $\text{IC}\equiv\text{C}-\text{CH}_2\text{OH}$ by the action of iodine on the corresponding cuprous acetylide compound. Few other substances of these types appear to have been made. Examples involving a number of other possible combinations of two substituents linked to acetylenic carbon atoms have not been reported; these include carbinol carboxylic acids, carbinol keto compounds, keto halogen compounds, and their derivatives.

References

- (1) Moureu and Delange, *Compt. rend.*, **131**, 710-12 (1900); *Bull. soc. chim.* (5), **25**, 302-13 (1901); *Ann. chim. phys.* (7), **25**, 239-68 (1902).
- (2) Andre, *Compt. rend.*, **151**, 75-8 (1910); *Ann. chim. phys.* (8), **29**, 557-68 (1913).
- (3) Kroeger and Nieuwland, *J. Am. Chem. Soc.*, **58**, 1861-3 (1936).
- (4) Moureu and Delange, *Compt. rend.*, **133**, 105-7 (1901).
- (5) *Idem*, *ibid.*, **138**, 1339-41 (1904).
- (6) Viguier, *ibid.*, **153**, 955-7 (1911); *Ann. chim. phys.* (8), **28**, 433-536 (1913).

- (7) Jozitsch and Lebedev, *J. Russ. Phys.-Chem. Soc.*, **42**, 1494-5 (1910); *Bull. soc. chim. (4)*, **10**, 1294 (1911).
- (8) Jozitsch, Tokarski and Schibajev, *J. Russ. Phys.-Chem. Soc.*, **42**, 1493-4 (1910); *Bull. soc. chim. (4)*, **10**, 1324 (1911).
- (9) Jozitsch and Kochelev, *J. Russ. Phys.-Chem. Soc.*, **42**, 1082 (1910); *Bull. soc. chim. (4)*, **10**, 1148 (1911).
- (10) Jozitsch and Orelkin, *J. Russ. Phys.-Chem. Soc.*, **42**, 1082 (1910); *Bull. soc. chim. (4)*, **10**, 1148 (1911).
- (11) Gillespie and Marvel, *J. Am. Chem. Soc.*, **52**, 3368-76 (1930).
- (12) Liang, *Bull. soc. chim. (4)*, **53**, 33-47 (1933).
- (13) Rossander and Marvel, *J. Am. Chem. Soc.*, **51**, 932-6 (1929).
- (14) Jozitsch and Lebedev, *J. Russ. Phys.-Chem. Soc.*, **42**, 1490-1, 1494-5 (1910); *Bull. soc. chim. (4)*, **10**, 1294 (1911).
- (15) Moureu and Delange, *Compt. rend.*, **132**, 988-90 (1901); **136**, 552-4 (1903); *Bull. soc. chim. (3)*, **29**, 648-62 (1903).
- (16) Moureu, German P. 132,802 (1902); *Chem. Zentr.*, **1902**, **II**, 169; German P. 133,631 (1902); *Chem. Zentr.*, **1902**, **II**, 553; German P. 158,252 (1905); *Chem. Zentr.*, **1905**, **I**, 783.
- (17) Salzberg and Marvel, *J. Am. Chem. Soc.*, **50**, 1737-44 (1928).
- (18) Coffmann, Chen Yu Tsao, Schniepp and Marvel, *ibid.*, **55**, 3792-6 (1933).
- (19) Baeyer, *Ber.*, **18**, 2269-81 (1885).
- (20) Lespieau, *Ann. chim. phys. (7)*, **11**, 281-7 (1897).

Chapter IV

The Addition of Non-Metallic Elements and Compounds to Acetylene

1. Types of addition reactions. This chapter deals with those reactions of acetylene in which the triple bond is destroyed by the addition of non-metallic elements other than carbon, or of compounds of those elements. The addition of metals and their compounds has been discussed in Chapter II, and the reactions in which the triple bond is destroyed with formation of new carbon-to-carbon linkages are described as condensation and polymerization reactions in Chapter V. The substances capable of addition to acetylene include hydrogen, the halogens, oxygen, sulfur, nitrogen and many compounds in which these elements are linked. Water and hydroxyl compounds comprise a particularly important group of addenda. An addition reaction may convert acetylene to either an olefinic or a saturated compound or may result in the cleavage of the acetylene molecule as in the high-temperature addition of nitrogen, oxygen or sulfur.

2. The hydrogenation of acetylene. Acetylene may be hydrogenated, either by hydrogenating reagents or by molecular hydrogen in the presence of catalysts, to yield ethylene and ethane. This reaction is often associated with condensation reactions, which produce mixtures of higher saturated, olefinic or cyclic hydrocarbons. Increased quantities of these substances are formed at higher temperatures, or when the heat of the exothermic reaction is not dissipated. Since acetylene is usually more valuable than any of the products, the hydrogenation of concentrated acetylene is of no commercial importance under normal economic conditions. However, the catalytic treatment of pyrolytic hydrogen-acetylene mixtures has been investigated as an emergency source of ethylene and fuel oils.

The non-catalytic hydrogenation of acetylene has not been studied extensively. Berthelot (1) reported the reduction of acetylene to ethylene by the action of an ammoniacal solution of chromous chloride, and Traube (2) patented methods for carrying out a similar reaction in acid solutions. Traube and Passarge (3) observed that acetylene was converted to ethylene by zinc and hydrochloric acid in the presence of chromium salts. The reaction of acetylene with sodium in liquid ammonia solution has been found to be attended by more or less hydrogenation. Billitzer (4) stated that electrolytic reduction of acetylene in water solution at a platinum electrode gave ethylene and, at higher current densities, ethane. Feuchter

(5) observed that acetylene was absorbed by a fused mixture of metallic sodium with sodium and potassium hydroxides, and that ethane was evolved during hydrolysis of the product. Pring and Fairlie (6) investigated the reaction of acetylene with hydrogen in an electrically heated porcelain tube above 700°. Taylor and Van Hook (7) have investigated the kinetics of direct combination of acetylene with hydrogen at 495–535°.

As catalysts for the hydrogenation of acetylene platinum, palladium, nickel, cobalt, iron, copper and their alloys have been employed. The effectiveness of a catalyst has been found to depend partly upon the specific metal present and partly upon its physical condition. The less effective catalysts usually necessitate a higher temperature, which tends to increase the formation of condensation products. The ratio of ethylene to ethane formed is also influenced to some extent by the catalyst, as well as by the ratio of hydrogen to acetylene.

Platinum black at ordinary temperature was observed by de Wilde (8) to catalyze the hydrogenation of acetylene to ethane, which contained some ethylene unless an excess of hydrogen was used. Sabatier and Senderens (9) found that the hydrogenation of acetylene at 180° over platinum sponge yielded ethane and liquid hydrocarbons. Paal and co-workers (10) observed that acetylene and hydrogen reacted in the presence of palladium hydrosol to give good yields of ethylene; but when platinum hydrosol was used, some ethane was formed. Fischer and Knorr (11) investigated the hydrogenation of acetylene at the surface of a palladium wire. Morris and Reyerson (12) made a study of the catalytic action of various metals deposited on silica gel. They found that both ethylene and ethane were formed in proportions which varied with the catalyst and the ratio of hydrogen to acetylene. Palladium on silica gel was reported to be an effective catalyst at 50°, platinum at 100° and copper at 200°. Similar catalysts have been investigated by Yoshikawa (13).

Finely divided nickel has been extensively used as a catalyst for the hydrogenation of acetylene both in the gas phase and in a liquid medium. Sabatier and Senderens (14) employed freshly reduced nickel and obtained both ethylene and ethane, depending upon the ratio of the entering gases. Heat was evolved and some higher hydrocarbons were formed. The reaction may be controlled to give good yields of ethylene. Thus Ross, Culbertson and Parsons (15) found that an 80 per cent yield of ethylene was obtained when a mixture of 47 volume-per cent acetylene and 51 volume-per cent of hydrogen was passed over freshly reduced nickel, from which all hydrogen had been removed. Larger proportions of hydrogen led to the formation of more ethane. According to patents of Sauerwein (16), steam inhibits the formation of oily polymerization products when

nickel or other catalytic metals are used. Yoshikawa (13) has studied the effects of temperature and dispersion of a nickel catalyst on kieselguhr on the rate of hydrogenation of acetylene. Pichler (17) found that at 55° with a nickel-molybdenum catalyst ethylene was obtained almost exclusively from a pyrolytic mixture of acetylene with a large excess of hydrogen, but at 70° equal parts of ethylene and ethane were formed. Ackermann (18) studied the production of ethylene from acetylene and a large excess of hydrogen over nickel and cobalt catalysts and also in liquid media. Dupont (19) has shown that acetylene can be hydrogenated over Raney nickel in the cold to give ethylene and ethane. There was no sharp break in the velocity of the reaction after the first two hydrogen atoms had been added. Raney nickel was also found to have a polymerizing effect on acetylene. Fischer and Peters (20) reported that hydrogenation of acetylene by reduced nickel in liquid media permitted better control of temperature.

Reduced copper and copper deposited on silica gel were found by Sabatier and Senderens (21) and Morris and Reyerson (12) to be less active catalysts than nickel, and to require higher temperatures (130 to 200°) to be effective. The hydrogenation of acetylene with a copper catalyst has been reported also by Wilde (8).

Other catalysts have been proposed for the hydrogenation of acetylene. According to Sabatier and Senderens (22) iron is less effective than copper. The use of aluminum, cerium, cerium oxide and tellurium as catalysts has been patented (23). Caro (24) patented palladium-nickel and other mixed catalysts for the hydrogenation of acetylene. Pichler (17) investigated the use of nickel-molybdenum and nickel-iron alloys and also of cobalt, iron and molybdenum as catalysts. Jaeger (25) proposed a contact mass containing nickel, copper or manganese.

Similar catalysts have been used for the condensation and hydrogenation of acetylene to liquid products, usually at higher temperatures or pressures. Sabatier and Senderens (14, 21, 22) reported the formation of various proportions of liquid products during the hydrogenation of acetylene. Oda (26) observed a liquid product from acetylene and hydrogen at 25-35° with a mercury-nickel catalyst. An apparatus suitable for the hydrogenation and condensation of acetylene to liquid hydrocarbons has been patented (27). In Germany an extensive series of experiments has been carried out covering the conversion to liquid hydrocarbons of acetylene-hydrogen mixtures and dilute acetylene from the pyrolysis of methane or coke-oven gas (28). A wide variety of metal catalysts was investigated. Kwal (29) claimed the production of a good grade of motor fuel from acetylene and hydrogen with a catalyst composed of active charcoal and

copper oxide. Petrov and Antzus (30) obtained a liquid product with a boiling range of 20–180° by the hydrogenation of acetylene under pressure with a reduced nickel catalyst.

Bonhoeffer and Hartek observed that acetylene remained practically unchanged by monatomic hydrogen (31).

The work on hydrogenation of the substitution products of acetylene is of considerable interest as a means of preparing *cis* and *trans* olefinic and saturated compounds, but is far too extensive to be cited in this work.

References

- (1) Berthelot, *Ann. chim. phys.* (4), **9**, 401–2 (1866).
- (2) Traube, *Ger. P.* 287,565 (1915); *Frdl.*, **12**, 18–19; *Ger. P.* 295,976 (1917); *Frdl.*, **13**, 29.
- (3) Traube and Passarge, *Ber.*, **49**, 1692–6 (1916).
- (4) Billitzer, *Monatsh.*, **23**, 199–216 (1902).
- (5) Feuchter, *Chem. Ztg.*, **38**, 273–4 (1914).
- (6) Pring and Fairlie, *J. Chem. Soc.*, **99**, 1807–11 (1911).
- (7) Taylor and Van Hook, *J. Phys. Chem.*, **39**, 811–19 (1935).
- (8) Wilde, *Ber.*, **7**, 353–5 (1874).
- (9) Sabatier and Senderens, *Compt. rend.*, **131**, 40–2 (1900).
- (10) Paal and Hohenegger, *Ber.*, **48**, 275–87 (1915). Paal and Schwarz, *ibid.*, **48**, 1202–7 (1915).
- (11) M. Fischer and Knorr, *Z. Elektrochem.*, **43**, 608 (1937).
- (12) Morris and Reyerson, *J. Phys. Chem.*, **31**, 1332–7 (1927).
- (13) Yoshikawa, *Bull. Chem. Soc. (Japan)*, **7**, 201–10 (1932); *C. A.*, **26**, 4747 (1932).
- (14) Sabatier and Senderens, *Compt. rend.*, **128**, 1173–6 (1899); **134**, 1185–8 (1902).
- (15) Ross, Culbertson and Parsons, *Ind. Eng. Chem.*, **13**, 775–8 (1921).
- (16) I. G. Farbenind. A.-G., *Brit. P.* 325,152 (1929); *C. A.*, **24**, 3802 (1930). Sauerwein, *U. S. P.* 1,860,624 (1932); *C. A.*, **26**, 3807 (1932).
- (17) Pichler, *Ges. Abhandl. Kenntnis Kohle*, **11**, 395–401, 401–3 (1934); *C. A.*, **29**, 6567, 6568 (1935).
- (18) Ackermann, *Brennstoff-Chem.*, **18**, 357–61 (1937); *C. A.*, **31**, 8501 (1937).
- (19) Dupont, *Bull. soc. chim.* (5), **3**, 1030–5 (1936).
- (20) F. Fischer and Peters, *Brennstoff-Chem.*, **12**, 286–93 (1931).
- (21) Sabatier and Senderens, *Compt. rend.*, **130**, 1559–61 (1900).
- (22) *Idem*, *ibid.*, **130**, 1628–30 (1900).
- (23) I. G. Farbenind. A.-G., *Brit. P.* 325,695 (1929); *C. A.*, **24**, 4051 (1930); *Fr. P.* 683,301 (1929); *C. A.*, **24**, 4523 (1930); *Brit. P.* 336,999 (1929); *C. A.*, **25**, 1843 (1931).
- (24) Caro, *Ger. P.* 253,160 (1912); *Frdl.*, **11**, 15.
- (25) Jaeger (to Selden Co.) *U.S.P.* 1,910,837 (1933); *C. A.*, **27**, 3944 (1933); *U.S.P.* 1,931,846 (1934); *C. A.*, **28**, 481 (1934).
- (26) Oda, *J. Chem. Ind. (Japan)*, **24**, 1161–6 (1921); *C. A.*, **16**, 2399 (1922).
- (27) Soc. anon. le pétrole synthétique, *Brit. P.* 223,543 (1923); *C. A.*, **19**, 1101 (1925).
- (28) F. Fischer and Pichler, *Brennstoff-Chem.*, **10**, 279–82 (1929). F. Fischer, Peters and Koch, *ibid.*, **10**, 383–5 (1929). Peters and Neumann, *ibid.*, **14**, 165–8 (1933); *Ges. Abhandl. Kenntniss Kohle*, **11**, 423–33 (1934).
- (29) Kwal, *Chim. et ind.*, **34**, 773–6 (1935).
- (30) Petrov and Antzus, *Compt. rend. acad. sci. (U.R.S.S.)*, (4), 295–9; *C. A.*, **29**, 2906 (1935). *Refiner Natural Gas. Mfr.*, **13**, 79–80 (1934); *C. A.*, **28**, 2170 (1934).
- (31) Bonhoeffer and Hartek, *Z. physik. Chem.*, **139**, 64–74 (1928).

3. The addition of hydrogen halides to acetylenes. A catalyst or conditions of increased temperature or pressure have usually been found ad-

vantageous for promoting the addition of gaseous hydrogen halides to acetylene. A vinyl halide is formed by the first stage of the reaction, and the addition of the second equivalent of hydrogen halide results in the formation of an ethylidene dihalide, except when hydrogen bromide reacts in the presence of certain catalysts or oxidizing substances to produce the isomeric ethylene dibromide. As a practical application the manufacture of vinyl chloride from acetylene and hydrogen chloride has been proposed, but this product can at present be prepared more cheaply from ethylene derived from cracking processes.

The reactions of aqueous halogen acids with acetylene were studied by a few of the earlier workers, and more recently the catalyzed addition of aqueous acids has been accomplished. Berthelot (1) reported the slow addition of concentrated hydriodic acid to acetylene at ordinary temperatures, and stated (2) that vinyl iodide was first formed, and that ethylidene diiodide resulted after prolonged contact with concentrated acid. Berthelot (1, 2) and Reboul (3) also found that aqueous hydrobromic acid reacted with acetylene at 100° to form vinyl bromide. The addition of hydrogen chloride to acetylene was found to be more difficult. Sabanejev (4) noted the formation of ethylidene dichloride when concentrated hydrochloric acid acted on cuprous acetylide. The use of mercuric salts as catalysts for the addition of hydrogen halides to acetylene in aqueous or other media or in vapor phase has been patented (5). Plauson and Vielle (6, 7) claimed the preparation of vinyl chloride by the action of hydrochloric acid on calcium carbide in the presence of compounds of mercury, copper, zinc, aluminum or tin. Ostromislensky (8) reported that mercuric chloride catalyzed the addition of hydrogen chloride to acetylene in aqueous solution. Nieuwland and Foohey (9) and Perkins (10) employed cuprous chloride to promote the formation of vinyl chloride from aqueous hydrochloric acid and acetylene. Kozlov (11) has reported a similar method of preparing both vinyl chloride and vinyl bromide. The effects of concentration of the components of the cuprous chloride solution, temperature of reaction, and other factors in the addition of hydrogen chloride have been studied (12).

Toussaint (13) patented the preparation of vinyl chloride from a mixture of acetylene and dry hydrogen chloride passed through a solution or suspension of mercuric chloride in stannic chloride at about 55°.

The preparation of vinyl halides by the addition of hydrogen halides to acetylene in the gas phase has been the subject of a number of patents. Plauson and Vielle (6, 7) patented the preparation of vinyl halides from acetylene and hydrogen halides heated at 100–120° under a pressure of one to two atmospheres for several hours. Bauer (14) promoted the reaction by the use of actinic rays at a temperature near 0°. Active

charcoal alone or mixed with metal halides (15) has been employed as a catalyst at about 180°. Other patents (16) claim the catalytic production of vinyl halides from acetylene and hydrogen halides in contact with mixtures of several metal halides deposited on active carbon or silica gel at temperatures from 120–350°. A carbon catalyst which had been pre-treated with the hydrogen halide at 200–600° has also been used (17). Wibaut and von Dalfsen (18, 19) stated that mercuric chloride on silica gel was the best catalyst for the addition of gaseous hydrogen chloride to acetylene, and that bismuth, zinc and ferric chlorides were effective in decreasing order.

The addition of two equivalents of hydrogen chloride or hydrogen iodide to one of acetylene usually appears to yield almost exclusively the ethylidene dihalide. The addition of two equivalents of hydrogen bromide to one equivalent of acetylene yields mixtures of ethylene dibromide and ethylidene dibromide, in proportions which depend on the nature of the catalyst. One group of patents (5) claims that only ethylidene dibromide was produced in the presence of mercuric bromide on porous packing material at 200° but this claim was not confirmed by Wibaut (20). Bauer (14) claimed the preparation of ethylene dibromide from acetylene and hydrogen bromide when exposed to actinic rays at 0°, and later (21) patented the formation of ethylene dihalides, employing air, oxygen, ozonized oxygen, nitrogen dioxide or formic acid vapor as catalysts. Wibaut (20) reported that the addition of two equivalents of hydrogen bromide to acetylene with mercuric bromide on asbestos as a catalyst yielded a mixture containing 80–90 per cent of ethylidene dibromide, and that bismuth bromide, antimony tribromide, aluminum bromide and ferric bromide as catalysts gave a larger proportion of ethylene dibromide. Wibaut and von Dalfsen (18, 19) found that ethylidene dichloride was the principal product when two equivalents of hydrogen chloride were added to acetylene in the presence of mercuric chloride on silica gel, and that zinc chloride, bismuth chloride and ferric chloride were less effective catalysts.

The preparation of 1,1,2-trichloroethane by the addition of hydrogen chloride and chlorine to acetylene in the gas phase has been patented (22). Various packing materials were used such as coke or silica, and these were usually impregnated with metal halides, mercuric chloride being particularly effective.

A patent has been issued for the addition of dry hydrogen fluoride to acetylene in the presence of mercuric oxide on active carbon as a catalyst (23).

References

- (1) Berthelot, *Compt. rend.*, **58**, 977–8 (1864).
- (2) *Idem*, *Ann.*, **132**, 122–4 (1864).

- (3) Rebol, *Jahresber. über die Fortschritte der Chemie*, **1872**, 304.
- (4) Sabanejev, *Ann.*, **178**, 111 (1875).
- (5) Chem. Fabrik Griesheim-Elektron, Ger. P. 278,249 (1912); *Frdl.*, **11**, 1187; Fr. P. 462,711 (1913); *C. A.*, **8**, 3221 (1914); Ger. P. 288,584 (1913); *C. A.*, **10**, 2502 (1916).
- (6) Plauson and Vielle, Brit. P. 156,120 (1920); Brit. P. 156,117 (1920); *C. A.*, **15**, 1728 (1921).
- (7) Plauson, U.S.P. 1,445,168 (1923); *C. A.*, **17**, 148 (1923). Can. P. 227,883 (1923); *C. A.*, **17**, 1241 (1923).
- (8) Ostromislensky, U.S.P. 1,541,174 (1925); *C. A.*, **19**, 2210 (1925).
- (9) Nieuwland and Foohey, *Proc. Indiana Acad. Sci.*, **38**, 196 (1929); *C. A.*, **25**, 2683 (1931). Nieuwland, U.S.P. 1,812,542 (1931); *C. A.*, **25**, 4894 (1931).
- (10) Perkins, Can. P. 329,042 (1933); *C. A.*, **27**, 1365 (1933); U.S.P. 1,934,324 (1934); *C. A.*, **28**, 488 (1934).
- (11) Kozlov, *J. Applied Chem. (U.S.S.R.)*, **10**, 116-8 (1937); *C. A.*, **31**, 4263 (1937).
- (12) Arutyunyan and Marutyan, *Caouchouc and Rubber (U.S.S.R.)*, **1937**, No. 2, 36-44; *C. A.*, **31**, 6188 (1937).
- (13) Toussaint, Can. P. 348,472 (1935); *C. A.*, **29**, 3353 (1935).
- (14) Bauer, U.S.P. 1,414,582 (1922); *C. A.*, **16**, 2150 (1927).
Röhm and Haas A.-G., Ger. P. 368,467 (1922); *Frdl.*, **14**, 104.
- (15) I. G. Farbenind. A.-G., Brit. P. 339,727 (1928); *C. A.*, **25**, 2735 (1931); Brit. P. 349,097 (1929); *C. A.*, **26**, 5314 (1932).
- (16) Consortium für Elektrochem. Ind., Fr. P. 684,836 (1929); *C. A.*, **24**, 5307 (1930); Brit. P. 339,093 (1928); *C. A.*, **25**, 2438 (1931). Hermann and Baum, U.S.P. 1,919,886 (1933); *C. A.*, **27**, 4815 (1933).
- (17) Baxter and Imperial Chem. Industries, Brit. P. 349,017 (1930); *C. A.*, **26**, 1945 (1932); U.S.P. 1,944,161 (1934); *C. A.*, **28**, 2012 (1934).
- (18) Wibaut and van Dalfsen, *Rec. trav. chim.*, **51**, 636-40 (1932).
- (19) Van Dalfsen and Wibaut, *ibid.*, **53**, 489-96 (1934).
- (20) Wibaut, *Z. Elektrochem.*, **35**, 602-5 (1929). *Idem*, *Rec. trav. chim.*, **50**, 313-37 (1931).
- (21) Bauer, U.S.P. 1,540,748 (1925); *C. A.*, **19**, 2210 (1925).
Röhm and Haas A.-G., Ger. P. 394,194 (1924); *Frdl.*, **14**, 106.
- (22) I. G. Farbenind. A.-G., Ger. P. 547,005 (1932); *Frdl.*, **17**, 118-20; Brit. P. 344,592 (1929); *C. A.*, **26**, 155 (1932); Fr. P. 687,307 (1929); *C. A.*, **25**, 715 (1931); Brit. P. 349,097 (1929); *C. A.*, **26**, 5314 (1932). Soll, U.S.P. 1,944,306 (1934); *C. A.*, **28**, 2019 (1934).
- (23) I. G. Farbenind. A.-G., Ger. P. 641,878 (1937); *C. A.*, **31**, 5809 (1937); Brit. P. 469,421 (1937); *C. A.*, **32**, 587 (1938).

4. The addition of halogens and hypohalites to acetylene. The chlorination of acetylene may be controlled by regulation of the conditions of reaction and the proportions of the reactants to yield either a mixture of the *cis* and *trans* dichloro- addition compounds, the tetrachloro- addition compound, or a mixture of these with their chloro-substituted derivatives. At moderate temperatures the reaction appears to be the simple addition of successive pairs of chlorine atoms to the unsaturated carbon atoms:

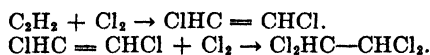

Tetrachloroethane is manufactured in this way on a large scale, and much of it is converted to trichloroethylene by the removal of hydrogen chloride. At higher temperatures substitution by chlorine as well as desaturation reactions may take place.

In the absence of catalytic substances gaseous chlorine does not appear to react appreciably with acetylene in darkness and at ordinary temperature and pressure. However, the reaction is both highly exothermic and is accelerated by heat and pressure, so that explosion may occur when reaction is suddenly initiated in a mixture of the gases. These facts were noted by early investigators (1, 2, 3). The commercial methods accordingly comprise means of initiating and smoothly maintaining the reaction by use of light, heat or catalysts, and means of controlling the reaction and preventing explosion by the use of solvents, gaseous diluents or solid packing material. Methods for promoting the chlorination will be discussed first.

The effect of light in initiating the reaction of chlorine with acetylene in the gaseous phase was noted by the earliest workers in this field. Berthelot (1) and Schlegel (4) observed that little or no reaction occurred between the gases in the dark and at room temperature, but that the mixture usually exploded when illuminated. Nieuwland (5) reported that gaseous chlorine united quietly with acetylene at a temperature near 0° in diffuse daylight without the aid of catalysts. Lidholm (6) found that acetylene tetrachloride could be formed smoothly and in good yield when the reaction was promoted by light of the proper wave length and constant intensity in the absence of catalysts. Peters and Neumann (7) investigated the photochemical chlorination of acetylene at low pressure and in the presence of gaseous diluents. For the manufacture of the chlorination products from acetylene, however, it has usually been considered most convenient to employ catalysts rather than illumination.

Increased temperature and pressure are known to promote the reaction of chlorine with acetylene, although they also increase the danger of explosion unless the partial pressure of acetylene is reduced. A number of patents in this field specify temperatures suitable to a particular catalyst and means of control. High temperatures under some conditions seem to favor the formation of chloro-substitution products by the replacement of hydrogen or the elimination of hydrogen chloride. For example, Nieuwland (5) detected hexachloroethane among the products when acetylene and chlorine were passed into a tube above 100° in the absence of catalysts; Suknevitch and Khomutin (8) reported the formation of hexachloroethane above 100° in contact with an iron catalyst; and Roka (9) claimed the preparation of a mixture of trichloroethylene with the normal chloro-addition products of acetylene when steam was used as a diluent at 500° in contact with refractory clay. At the temperature of explosive reaction, free carbon and hydrogen chloride and sometimes hexachloroethane are formed, as reported by Nieuwland (5).

Among the substances which have been thought to catalyze the reaction

of chlorine with acetylene are certain impurities which are sometimes found in acetylene. Mouneyrat (10) stated that chlorine added smoothly to oxygen-free acetylene in diffuse daylight in the presence of a chlorinated solvent, but upon the admission of a small amount of air the reaction in the gas phase was accelerated to the point of explosion. Tako (11) stated that oxygen-free acetylene united quietly with gaseous chlorine even at 100° in direct sunlight, whereas the presence of a trace of air caused explosion. Under other conditions Nieuwland (6) reported that a stream of about equal volumes of chlorine and acetylene reacted quietly in diffuse daylight at 0.1–0.2°, even when the reaction tube was open to the air. Römer (12) attributed the explosive reaction of chlorine with certain samples of acetylene to the presence of diacetylene, which may have been present in the gas as formerly prepared from copper acetylide. Berthelot (13) also suggested that a trace of chloroacetylene might initiate explosive chlorinations, and this substance may have been present when acetylene was prepared by certain dehydrohalogenation reactions. Of these substances only oxygen probably occurs in acetylene as at present prepared, and no modern studies of the effect of oxygen in chlorination appear to have been published.

Antimony pentachloride was the first chlorinating agent to be employed in this reaction. Berthelot and Jungfleisch (14) reported that the addition compound $C_2H_2 \cdot SbCl_5$ decomposed to give antimony trichloride and acetylene dichloride when heated alone, or to give acetylene tetrachloride when heated with excess antimony pentachloride. A number of methods have been devised for using this addition compound as a catalytic intermediate in the production of symmetrical tetrachloroethane (5, 15, 17). The methods consisted in the alternate introduction of acetylene and chlorine into a solution of antimony pentachloride in tetrachloroethane, operating in a way to avoid gas-phase reaction and consequent explosion hazards. According to Chavanne (18), antimony pentachloride has also been employed in the addition of two atoms of chlorine per molecule of acetylene, yielding approximately equal quantities of *cis*- and *trans*-dichloroethylene. The use of antimony chlorides in the commercial chlorination of acetylene has been discussed in several reviews (19, 20).

Iron and various iron compounds have been employed extensively as promoters in commercial processes for the chlorination of acetylene. In all these cases it is probable that ferric chloride is the active agent. Numerous patents (11, 21–26) have described methods for the chlorination of acetylene, at moderate temperatures in the presence of iron salts or a packing composed of metallic iron or an iron alloy. Processes of this type have also been described frequently in review articles (8, 20, 27). The catalyst may be suspended in a chlorinated liquid, such as tetrachloro-

ethane, or may be packed in a reaction tower through which the gases pass upward while the liquid products flow downward. In all processes employing a temperature below the boiling point of the product, it is probable that the reaction occurs chiefly in the liquid surrounding the catalyst. Both 1,2-dichloroethylene and tetrachloroethane have been made in this way depending chiefly upon the ratio of chlorine to acetylene. The optimum temperature for the preparation of tetrachloroethane without substitution reaction is said to be 60–75°, and yields of 90 per cent or higher have been claimed.

The chlorination of acetylene at higher temperatures (350–500°) in contact with chlorides or iron, copper or calcium has been patented (9). Superheated steam was used as a diluent to prevent the polymerization and explosive chlorination of the acetylene, and the mixed product contained a large proportion of trichloroethylene.

In contact with activated charcoal at about 40° the addition of chlorine is said to take place smoothly, giving the di- or tetrachloride, depending upon the ratio of the reactants (28). Other methods employing active charcoal as a catalyst have been patented (29). Silica gel also has been suggested for this purpose (30).

Several other catalysts have been suggested for the chlorination of acetylene. Cupric chloride was used for this purpose (31) and catalysts containing aluminum have been described (27, 32, 33). With sulfur monochloride and iron as a catalyst, tetrachloroethane was formed at a low temperature, and when the mixture was heated to boiling, hexachloroethane was obtained (34). Maze (35) patented the reaction of chlorine with acetylene in a solution of alkali hydroxides or carbonates.

Promotion and control of the chlorination of acetylene by the use of chlorinated solvents appears first to have been applied by Mouneyrat (10), who employed 1,2-dichloroethane and carbon tetrachloride for this purpose. Nieuwland (5) used the end product, tetrachloroethane. Tetrachloroethane has been adopted most frequently as a solvent in the commercial chlorination of acetylene; it serves to facilitate external cooling of the apparatus and in some cases to hold catalytic material in solution or suspension. Patents describe the addition of tetrachloroethane at the top of a reaction tower packed with an iron catalyst (26, 30) and passage of acetylene and chlorine through tetrachloroethane containing a catalyst such as ferric chloride (36). A similar method has been described by Favorsky and by Suknevitch and Khomutin (8). In other cases the tetrachloroethane formed in the reaction apparently serves the same purpose.

In the gas phase chlorination of acetylene, the rise in temperature is decreased and explosions are prevented by the use of gaseous diluents. Peters and Neumann (7) found that hydrogen used as a diluent did not

react with chlorine during the photochemical chlorination of acetylene. The chlorination of acetylene diluted with hydrogen or of pyrolytic gas mixtures containing acetylene and hydrogen has been patented (37, 38). Nieuwland (6) employed steam as a diluent, and Roka (9) has patented the addition of steam in catalytic methods for the chlorination of acetylene. An excess of acetylene has been used as a diluent in the preparation of 1,2-dichloroethylene (24). The introduction of vapors of the end products as diluents in the reaction also has been patented (39), and the same condition is doubtless realized in the later stages of all vapor-phase chlorinations of acetylene. Since both acetylene and the products may act as diluents, it is evident that the process may be controlled to some extent by the manner in which the acetylene is introduced. Peters and Neumann (7) reported that explosions could not occur during the chlorination of acetylene at 70 mm pressure, and a process of this type might be applicable to the gaseous products of low-pressure cracking of hydrocarbons (See Chapter I, Section 7).

Finely divided inert packing material has been found to reduce explosion hazards in the gas-phase reaction of chlorine with acetylene, and it is probable that solid catalysts act in the same way. Processes in which mixing and reaction of the gases occur in capillaries or in the interstices of a solid have been described (8) and specified in several patents (21, 24, 30, 40).

An interesting modification of the process consists in heating acetylene with one of the highly chlorinated products, such as tetrachloroethane, to form dichloroethylene by a simultaneous dechlorination chlorination reaction (41, 42). Nickel deposited on active carbon has been suggested as a suitable catalyst for this process.

Bromine, in the liquid phase or in solution, usually adds quietly to acetylene, presumably with the formation of a dibromo- addition compound in the first stage of reaction; however, in many cases the tetrabromo- addition compound is the principal end product.

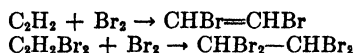

Since both stages of reaction are fairly rapid, it is probable that the relative concentration of bromine and acetylene at the point of reaction is an important factor in determining the composition of the end material. These bromo- derivatives of acetylene are too costly for most commercial uses, and the reaction has been applied principally for the estimation of acetylene in mixed gases.

The reaction of acetylene with liquid bromine covered with a layer of water was first studied by Berthelot (43), who reported that the chief product was a dibromide; but a number of investigators (44) have shown that under similar conditions the tetrabromide is almost the sole product.

O'Meara and Clemmer (45) obtained yields of 90–95 per cent of the tetrabromide by this method. Reboul and Sabanejev (44) also isolated small quantities of a solid bromo-derivative in this reaction from acetylene prepared from cuprous acetylde, but Noyes and Tucker (46) showed that this substance was probably a hexabromide of the diacetylene produced by the oxidation of cuprous acetylde.

Sabanejev (44) found that acetylene was rapidly absorbed by a well cooled solution of bromine in chloroform with the formation of much tetrabromide and a small yield of dibromide. With excess acetylene and a dilute alcoholic solution of bromine the chief product was dibromide. Gray (47) obtained the *trans* dibromide by treating an aqueous solution of acetylene with a saturated solution of bromine in the dark.

By vapor-phase photobromination of acetylene at 150°, Booher and Rollefson (48) found that dibromide was the first product, and that a slower bromination to tetrabromide then occurred in the presence of excess bromine. Franke and Schumacher (49) also have proposed a mechanism for the photobromination of acetylene, and Müller and Schumacher (50) have studied the effect of varying temperature and partial pressure of the reactants on this process.

A method and apparatus for introducing acetylene into an aqueous solution of bromine has been patented (51), and the reaction may be accelerated by the presence of the products of bromination. Pavlov and Ryazantzev (52) treated natural lyes containing bromides, with chlorine water, and then passed acetylene into the solution to form tetrabromoethane.

The addition of iodine to acetylene does not occur as readily as that of bromine or chlorine, and the reaction stops when one molecule of iodine has been added. Berthelot (53) found that no reaction took place at ordinary temperatures even in direct sunlight, but that the solid diiodide was formed in a sealed flask kept at 100° for several hours. Ellis (54) has shown that acetylene does react in the course of a few days with iodine sublimed onto the walls of a flask, but that when the walls of the flask had been first coated with paraffin, the reaction is retarded.

Sabanejev (44) found that iodine moistened with alcohol reacted slowly with acetylene at room temperature to give mainly the solid *trans* diiodide. This result has been confirmed by Plimpton (55), Blitz (56), Ellis (54) and Paterno and Peratoner (57). A little of the liquid *cis* isomer was obtained in some cases.

At a temperature of 140–160° Keiser (58) found that a mixture of the *cis* and *trans* diiodides was formed from acetylene and iodine. The *cis* compound was also obtained when the reaction occurred in the presence of hydrogen iodide.

The halogen halides add to acetylene, usually yielding a mixture of

products. Plimpton (55) obtained a mixture of halogenated substances from the reaction of acetylene with an aqueous solution of bromine chloride, and Sabanejev (59) reported that acetylene reacted very vigorously with bromine chloride to form a dichloro-dibromoethane. Plimpton (55) found that chloriodoethylene was formed by the action of acetylene on iodine chloride in hydrochloric acid solution. Sabanejev (59) showed that dichloroethylene and more highly halogenated substances were also formed in this reaction. Thiele and Haakh (60) developed this method for the preparation of chloriodoethylene. Plimpton (53) and Sabanejev (59) reported that acetylene was readily absorbed by a solution of iodine bromide to form a mixture of products, including dibromoethylene and bromiodoethylene. Van der Valle and Landsberg (61) investigated some of the factors which determine the proportions of the components in this mixture.

Wittorf (62) found that acetylene, on treatment with hypochlorous acid or hypobromous acid, yielded the dihaloacetaldehyde with some dihaloacetic acid. A number of other acetylenic compounds are known to give dihaloketones on treatment with these reagents.

References

- (1) Davy, *Ann.*, **23**, 144-6 (1837).
- (2) Berthelot, *Ann. Chim. phys.* (3), **67**, 70-7 (1863); *ibid.*, (4), **9**, 426-8 (1866).
- (3) Wohler, *Ann.*, **124**, 220 (1862).
- (4) Schlegel, *Ann.*, **226**, 153-7 (1884).
- (5) Nieuwland, "Some Reactions of Acetylene," Thesis, Catholic University of America, Washington, D. C., 1904; *Chem. Zentr.*, **1905** I, 1585-6.
- (6) Lidholm, Ger. P. 201,705 (1908); *Frdl.*, **9**, 19; Ger. P. 204,516 (1908); *Frdl.*, **9**, 19-20; Fr. P. 358,146 (1905); Brit. P. 22,094 (1905); U.S.P. 831,725 (1905); *C. A.*, **1**, 255 (1906).
- (7) Peters and Neumann, *Z. angew. Chem.*, **45**, 261-6 (1932).
- (8) Suknevitch and Khomutin, *Trans. State Inst. Applied Chem. (U.S.S.R.)*, **24**, 54-66 (1935); Favorsky, Margules, and Davuidova, *ibid.*, **24**, 47-54 (1935); *C. A.*, **29**, 7271 (1935).
- (9) Holzverkohlungs Ind. A.-G., Ger. P. 387,452 (1923); *Frdl.*, **14**, 107; Brit. P. 174,635 (1922); *C. A.*, **16**, 1779 (1922); Roka, U.S.P. 1,418,822 (1922); *C. A.*, **16**, 2695 (1922); U.S.P. 1,516,350 (1925); *C. A.*, **19**, 300 (1925).
- (10) Mouneyrat, *Bull. soc. chim.* (3), **19**, 448-55 (1898).
- (11) Tako, Japan P. 90,708 (1931); *C. A.*, **25**, 4894 (1931).
- (12) Römer, *Ann.*, **233**, 182-5, 214-5 (1886).
- (13) Berthelot, "Les carbures d'hydrogen VI," P. 309, Paris, 1901.
- (14) Berthelot and Jungfleisch, *Compt. rend.*, **69**, 542-5 (1869).
- (15) Consortium für Elektrochem. Ind., Ger. P. 154,657 (1903); Fr. P. 346,562 (1904); *Frdl.*, **7**, 769-70.
- (16) Askenasy and Mugdan, Brit. P. 18,602 (1904); *J. Soc. Chem. Ind.*, **24**, 150 (1905).
- (17) Tompkins, Ger. P. 196,324 (1908); *Frdl.*, **8**, 1348-50. Brit. P. 19,568 (1904); *Chem. Zentr.*, **1908** I, 1504; *J. Soc. Chem. Ind.*, **24**, 902 (1905).
- (18) Chavanne, *Compt. rend.*, **154**, 776-7 (1912).
- (19) Fabre, *J. pharm. chim.*, **21**, 268-78 (1920); *C. A.*, **14**, 2334 (1920). Igi, *J. Chem. Ind. (Japan)*, **23**, 1217-37 (1920); *C. A.*, **15**, 2273 (1921); *Bull. soc. chim.* (4), **30**, 1495 (1921). Anon., *Schweitz. Chem. Ztg.*, **1921**, 291-6; *C. A.*, **15**, 3271 (1921). Guyot, *Chem. et ind.*, **10**, 13-22 (1923); *C. A.*, **17**, 3478 (1923).

- (20) Vincens, *Rev. chim. ind.*, **37**, 224-7, 258-60, 291-3 (1928); *C. A.*, **23**, 384 (1929). Kraft and Alekseev, *J. Chem. Ind. (Moscow)*, **8**, 861-3 (1931); *C. A.*, **26**, 79 (1932). Miloslavskii and Postovskii, *J. Ind. Chem. (Moscow)*, **7**, 1414-9 (1930); *C. A.*, **25**, 5391 (1931). Langguth, *Chim. et ind.*, **25**, 22-5 (1931); *C. A.*, **25**, 2112 (1931). Valyashko and Kosenko, *Ukrain Khem. Zhur.*, **7**, No. 1, Sci. pt., 12-35 (1932); *C. A.*, **27**, 1611 (1933). Frydender, *Rev. prod. chim.*, **37**, 737-42 (1934); **38**, 33-6, 65-7, 385-90, 417-22, 449-52 (1935); *C. A.*, **29**, 7935 (1935). Durand, *Bull. soc. ind. Rouen*, **65**, 211-14 (1937); *C. A.*, **32**, 7015 (1938).
- (21) Consortium fur Elektrochem. Ind., Brit. P. 25,967 (1910); Fr. P. 425,327 (1910); *J. Soc. Chem. Ind.*, **30**, 923 (1911).
- (22) Ornstein, Brit. P. 2375 (1911); *J. Soc. Chem. Ind.*, **30**, 982 (1911); Fr. P. 420,489 (1910); *J. Soc. Chem. Ind.*, **30**, 307 (1911).
- (23) Hoeffler and Mugdan, U.S.P. 985,528 (1911); *J. Soc. Chem. Ind.*, **30**, 446 (1911).
- (24) Chem. Fabrick Griesheim-Elektron, Ger. P. 254,069 (1911), 264,006 (1912); Brit. P. 16,620 (1912); Fr. P. 446,263 (1912); *Frdl.*, **11**, 20-2.
- (25) Hilpert, Ger. P. 368,892 (1919); Ger. P. 372,193 (1920); *Frdl.*, **14**, 105-6; Comp. Prod. chim. d'alais et de la Camargue. Brit. P. 132,757 (1919); *C. A.*, **14**, 285 (1920); Ger. P. 410,529 (1925); *Frdl.*, **15**, 78.
- (26) Guyot, Can. P. 213,787 (1921); *C. A.*, **16**, 1099 (1922).
- (27) Fukagawa, *Proc. World Eng. Cong. Tokyo (1929)*, **31**, 387-98; *C. A.*, **25**, 5660 (1931).
- (28) I. G. Farbenind A. G., Brit. P. 310,964 (1928); *C. A.*, **24**, 630 (1930); Ruppert, W. Fischer, Voigt and Hennig (to I. G. Farbenind A. G. (U.S.P. 1,868,077 (1932); *C. A.*, **26**, 5106 (1932).
- (29) Dow, U.S.P. 1,437,636 (1922); *C. A.*, **17**, 770 (1923).
- (30) Compagnie de produits chim. et electro-metallurgiques Alais, Froges et Camargue, Fr. P. 744,359 (1933); *C. A.*, **27**, 3951 (1933).
- (31) Consortium für Elektrochem. Ind., Fr. P. 714,995 (1931); *C. A.*, **26**, 1624 (1932); Brit. P. 366,348 (1930); *C. A.*, **27**, 1896 (1933).
- (32) Ornstein, Ger. P. 241,559 (1909); *Frdl.*, **10**, 18.
- (33) Salzbergwerk Neu Strassfurt, Ger. P. 174,068 (1904); *Frdl.*, **8**, 18; U.S.P. 817,188 (1905); Fr. P. 355,776.
- (34) Maze, U.S.P. 1,425,669 (1922); *C. A.*, **16**, 3314 (1922).
- (35) Consortium fur Elektrochem. Ind., Ger. P. 659,434 (1938); *C. A.*, **32**, 5857 (1938).
- (36) Rhur chemie A. G., Ger. P. 613,607 (1935); *C. A.*, **29**, 8007 (1935); Fr. P. 743,778 (1933); *C. A.*, **27**, 3941 (1933); Tramm, U.S.P. 2,016,658 (1935); *C. A.*, **29**, 8005 (1935).
- (37) I. G. Farbenind. A. G., Fr. P. 739,183 (1932); *C. A.*, **27**, 1894 (1933); Brit. P. 397, 961 (1933); *C. A.*, **28**, 1052 (1934); Ger. P. 606,694 (1934); *C. A.*, **29**, 3691 (1935); Baumann, Stadler and Willig (to I. G. Farbenind A. G.) U.S.P. 2,016,572 (1935); *C. A.*, **29**, 8005 (1935).
- (38) Norsk Alkali A. S., Norwegian P. 31,377 (1920); *C. A.*, **15**, 2101 (1921).
- (39) Chem. Fabrick Griesheim-Elektron, Ger. P. 204,883 (1905); *Frdl.*, **9**, 20; Fr. P. 278,713 (1907); Brit. P. 13,411 (1907); U.S.P. 908,051 (1908).
- (40) Chem. Fab. von Heyden A. G., Ger. P. 566,034 (1931); *C. A.*, **27**, 1011 (1933); Ger. P. 567,272 (1932); *C. A.*, **27**, 1365 (1933).
- (41) Alexander Wacker Gesellschaft fur elektrochemische Industrie G.m.b.H., Brit. P. 480,568 (1938); *C. A.*, **32**, 5857 (1938).
- (42) Berthelot, *Ann.*, **124**, 272-5 (1862); *Ann. chim. phys. (3)*, **67**, 72-5 (1863); (4), **9**, 426-7 (1866).
- (43) Reboul, *Ann.*, **124**, 267-72 (1862). Sabanejev, *Ann.*, **176**, 109-28 (1875). Elbs and Newmann, *J. prakt. Chem. (2)*, **58**, 245 (1898). Muthmann, *Z. Krystall.*, **30**, 73-4 (1898); *Chem. Zentr.*, **1898 II**, 449.
- (44) O'Meara and Clemmer, Bur. Mines Repts. of Investigations, No. 2897 (1928); *C. A.*, **23**, 1598 (1929).

- (46) Noyes and Tucker, *Am. Chem. J.*, **19**, 123-8 (1897).
(47) Gray, *J. Chem. Soc.*, **71**, 1023-30 (1897).
(48) Booher and Rollefson, *J. Am. Chem. Soc.*, **56**, 2288-94 (1934). Rollefson, *Z. physik. chem.*, **B37**, 472-3 (1937); *C. A.*, **32**, 423 (1938).
(49) Franke and Schumacher, *Z. physik. chem.*, **B34**, 181-6 (1936); *C. A.*, **31**, 1298 (1937).
(50) Muller and Schumacher, *Z. physik. chem.*, **B39**, 352-70 (1938); *C. A.*, **32**, 6551 (1938); *ibid.*, **B40**, 318 (1938); *C. A.*, **32**, 6950 (1938).
(51) Kali-Forschungs-Anstalt G. m. b. H., Fr. P. 731,190 (1932); *C. A.*, **27**, 816 (1933).
(52) Pavlov and Ryazantzev, Russ. P. 33,535 (1933); *C. A.*, **28**, 3424 (1934).
(53) Berthelot, *Ann. chim. phys.* (4), **9**, 428-30 (1866).
(54) C. P. Ellis, *J. Chem. Soc.*, **1934**, 726-7.
(55) Plimpton, *J. Chem. Soc.*, **41**, 391-7 (1882).
(56) Biltz, *Ber.*, **30**, 1200-10 (1897).
(57) Paterno and Peratoner, *Gazz. chim. ital.*, **19**, 580-601 (1889).
(58) Keiser, *Am. Chem. J.*, **21**, 261-5 (1899).
(59) Sabanejev, *Ann.*, **216**, 251-79 (1883).
(60) Thiele and Haakh, *ibid.*, **369**, 135 (1909).
(61) Van der Walle and Landsberg, *Bull. sci. acad. roy. Belg.*, **16**, 369-93 (1930); *Bull. soc. chim. Belg.*, **39**, 309-30 (1930); *C. A.*, **24**, 5017 (1930).
(62) Wittorf, *J. Russ. Phys.-Chem. Soc.*, **32**, 87-117 (1900); *Chem. Zentr.*, **1900 II**, 29.

5. Oxidation of acetylene. The most significant technical applications of acetylene oxidation concern its uses as fuel for welding and cutting. These processes are, of course, combustions rather than oxidations in the common chemical meaning. Incomplete combustion of acetylene deposits carbon (acetylene black). The complete combustion to carbon dioxide and water is a highly exothermic process, liberating some 312,000 calories per mole and making possible flame temperatures above 3000°C when used with a correctly designed and operated torch.

The oxy-acetylene flame is widely used for welding and cutting operations (1); indeed, this is a major outlet for commercial acetylene and the basis of a large industry. The chemistry of the oxy-acetylene flame is of some interest because it yields the highest flame temperatures available for technical purposes. The oxy-acetylene flame consists of two distinct combustion zones. The inner cone is blue-white and is surrounded by a less sharply defined bushy envelope. In the inner cone acetylene dissociates into its elements, $C_2H_2 \rightarrow 2C + 2H$, and carbon is oxidized to carbon monoxide. The extent of dissociation of the acetylene and the products of combustion at the flame temperatures have been calculated (2, 3). The oxidation is completed in the outer zone, yielding carbon dioxide and water. The complete combustion equation is therefore

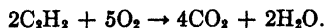

However, in welding practice a reducing flame is maintained by using less than the theoretical quantity of oxygen. The most efficient flames are obtained when the acetylene and oxygen are mixed in approximately equal

volumes, the remaining oxygen being taken from the surrounding atmosphere. In the cutting flame excess oxygen is employed.

Acetylene-oxygen mixtures are highly explosive, as has been long known (4). This is at least partly due to the high thermodynamic instability of acetylene. Parks and Huffman (5) call attention to the reaction,

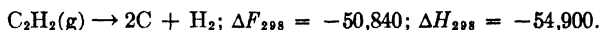

and state that the large evolution of heat is here sufficient to raise the temperature of the products to about 3000°K if the explosion is adiabatic. A small amount of oxygen present in acetylene may cause oxidation of the latter and thereby initiate an acetylene explosion, particularly if the gases are under considerable pressure. The explosiveness of acetylene-oxygen mixtures is reduced by admixture with inert gases. Thus an investigation (6) of the explosive limits of acetylene-oxygen-nitrogen mixtures has shown that there is no risk of explosion when the oxygen content is less than 8 per cent or the acetylene content less than 2.5 per cent.

The slow combustion of acetylene has been studied by many investigators, usually to establish the mechanism of the reaction or to develop syntheses for useful products. The early investigations of Bone and Andrew (7) are notable in this regard. It was shown by these workers that interaction between acetylene and oxygen, sealed in a glass tube at atmospheric pressure, begins at about 250° and proceeds rapidly at 300°. With $2\text{C}_2\text{H}_2 + \text{O}_2$ and $\text{C}_2\text{H}_2 + \text{O}_2$, explosive decomposition sets in at 350°, and with $2\text{C}_2\text{H}_2 + 3\text{O}_2$ at about 375°. Carbon monoxide and formaldehyde simultaneously arise at an early stage. Bone and Carruthers (8) have recently observed the occurrence of carbon monoxide, carbon dioxide, water, formaldehyde and formic acid among the products of the slow combustion of acetylene.

The concentration zones of mixtures of acetylene and air, at atmospheric pressure, which will undergo combustion at a mean temperature of 310°, depend on the rate of heating (9). Heating at 40° per minute caused combustion in mixtures containing 17–85 per cent acetylene by volume, while at a rate of 25° per minute the same result was obtained only with mixtures having 35–70 per cent acetylene. Outside these zones, a faint green luminescence and lowering of pressure was observed. The effect of electric fields on the combustion of acetylene with oxygen at low pressures also has been investigated (10, 11).

It is now quite definitely established that thermal oxidation or slow combustion of acetylene is a chain reaction. Kistiakowsky and Lenher (12) studied the reaction, in "Pyrex" vessels, at 250–315°, and claimed that the reaction is homogeneous and of the chain type, the process going through glyoxal, formaldehyde and formic acid and yielding also carbon monoxide,

carbon dioxide and hydrogen. In fact, a process was patented (12) as suitable for the preparation of glyoxal.

The velocity of the reaction is said to be proportional to the square of the acetylene concentration and independent of the oxygen concentration (8, 11). In packed vessels the homogeneous oxidation is almost entirely suppressed and a heterogeneous reaction takes place, on the glass surface, directly to carbon dioxide and water.

Slow oxidation by the circulation method (13) permits the isolation of the more stable oxidation products, glyoxal, formaldehyde and formic acid. In this manner the reaction rate is accelerated by oxygen when acetylene is in excess, but is slightly retarded when oxygen is in excess. At the optimum oxygen concentration the rate is proportional to the square of acetylene concentration, whereas when less oxygen is present, a lower power of acetylene concentration maintains.

In the slow combustion mechanism, it has been postulated that chains originate upon the surface, undergo considerable branching in the gas phase, where some deactivation by oxygen occurs, and finally are broken at the walls of the vessel (14). At 320° wall activation is predominant, whereas at this temperature and 400 mm total pressure, the reaction is almost completely inhibited by the walls in vessels less than 4 mm in diameter. In vessels greater than 6 mm in diameter, inhibition by the wall is small compared with inhibition by oxygen (15).

Steacie and McDonald investigated the kinetics of oxidation of acetylene by the static method. Their results (16) confirm the chain mechanism. They claim that the apparent heat of activation of the reaction is about 35,000 calories.

Mardles (17) is of the opinion that oxidation of acetylene by air involves the formation of peroxides. This conclusion was reached on the basis of experiments below the self-ignition temperature with and without inhibitors. Thus formaldehyde, formic acid, etc. are said to be formed by decomposition of the peroxides. Inhibitors and metal surfaces reduce the accumulation of peroxides and so affect the rate of gaseous reaction and reduce its temperature coefficient. In this connection it is of interest to note that the liquid-substituted acetylenes are known to form peroxides with air or oxygen at room temperature (18). Peroxide formation is not due to olefinic impurities or polymers. Experiments with 1-hexyne and oxygen showed that the peroxide concentration became constant after several weeks, excess peroxide oxidizing the 1-hexyne to valeric acid. Passage of oxygen through 1-hexyne for about three months at 35-40° gave a product which was 2.12 normal in acid content.

Attempts have been made to catalyze the slow acetylene combustion in

various ways. For example, oxidation of acetylene over boric or phosphoric acids, impregnated in burnt clay or diatomaceous earth, gives formaldehyde (19). Lenher found that nitric oxides or nitric acid promoted the vapor-phase oxidation of acetylene with oxygen. The main product was trimeric glyoxal (20).

A number of studies are reported concerning the reaction of acetylene with ozone. Mailfert (21) reacted acetylene with ozone and obtained carbon dioxide and formic acid. Otto (22) reported that this reaction was violent, frequently causing explosions. More recent studies (23) of the acetylene-ozone reaction have confirmed Otto's observation (22) regarding explosions. It is certainly well to dilute the reactants with an indifferent gas or to employ a solvent. With these techniques glyoxal may be obtained. Thus mixtures of 1-2 per cent ozone, 3-4 per cent acetylene and 94-96 per cent air give glyoxal (24, 25) particularly if water vapor or spray is introduced, permitting the withdrawal of a concentrated glyoxal solution. Briner and Wunenburger (23) used liquid methyl chloride as a solvent and obtained glyoxal and formic acid.

Atomic oxygen at low temperatures has been reported to give an addition product with acetylene which decomposes at higher temperatures, yielding glyoxal, formic acid, and oxides of carbon (26).

The oxidation of acetylene by aqueous oxidizing agents has been rather extensively studied. Berthelot (27) reported that acid permanganate acted on acetylene to yield carbon dioxide and formic acid, whereas alkaline solutions gave oxalic acid; dilute chromic acid yielded acetic acid (28). Dilute nitric acid reacts with acetylene in the presence of a mercury salt and gives excellent yields of oxalic acid. Thus when acetylene and air are passed into a solution composed of 900 cc of nitric acid (d. 1.42), 300 cc of water and 25 g of mercuric nitrate, oxalic acid forms readily (29). Mercuric salts act catalytically, as was also reported by Orton and McKie and others (30). The action of fuming nitric acid on acetylene yields complex heterocyclic condensation products as reported in Chapter V, Section 6. Gautier (31) used iodine pentoxide as an oxidizing agent in attempts to detect acetylene. Carbon monoxide, carbon dioxide and iodine were formed. Aqueous hydrogen peroxide, in the presence of ferrous sulfate, is reported (32) to give acetic acid from acetylene, small amounts of aldehyde and alcohol also being formed. Coehn states (33) that the discharge potential of oxygen from a solution of potassium hydroxide is depressed from about 1.7 to 1.2 volts, when acetylene is passed through the solution. The acetylene oxidizes quantitatively to formic acid when the emf lies between the above limits. In solutions of sulfuric acid the presence of acetylene diminishes the anodic polarization by about 0.19 volt. Acetaldehyde is formed which, in turn, oxidizes to acetic acid. The current effi-

ciency is 100 per cent when the emf used is less than that required to liberate oxygen. When acetylene is passed into solutions of sodium chlorate and osmium tetroxide, acetic acid is formed together with another compound, likely glyoxalic acid (34). Auric chloride, in dilute aqueous solution, is quantitatively reduced to free gold (35). The acetylene is converted to carbon dioxide (12 per cent) and glyoxal (about 86 per cent). A solution of uranium acetate, saturated with acetylene and exposed to light, causes oxidation of the acetylene (36).

The action of oxidizing agents on other acetylenic compounds has received much study. In most instances oxidation results in the formation of a diketo compound, or of two molecules of a carboxylic acid, and the identification of these products serves to locate the position of the triple bond in the original chain.

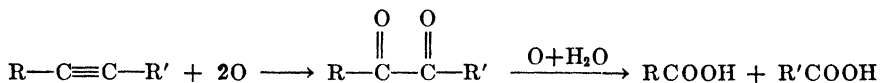

However, a molecule of carbon dioxide may be lost in some cases, resulting in the formation of a carboxylic acid with a shorter carbon chain (37). The oxidizing agents employed include ozone (38-43), dilute permanganate solutions (27, 28, 37, 44, 47, 48, 51, 52, 53), chromic acid solutions (27, 28, 44, 45, 46), nitric acid (49, 50), and peracetic acid (54). The oxidation of acetylenic hydrocarbons (27, 28, 41-47, 49), long-chain acetylenic acids (37, 39, 50-54), and acetylenic glycols (48) has been investigated. In the oxidation of alkyl acetylenes with selenium dioxide, Trachet (55-57) reports that a CH₂ group adjacent to an acetylenic carbon atom is attacked, yielding an acetylenic carbinol.

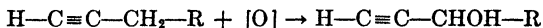

References

- (1) These non-chemical processes are outside the scope of the present work. For a brief discussion of acetylene welding and cutting see Thorpe's "Dictionary of Applied Chemistry," Vol. 1, pp. 112-6, Longmans Green and Co., 4th ed., 1937; also, Kemper, *Chem. Ztg.*, **59**, 533-6 (1935).
- (2) Ribaud and Seferian, *Chaleur et ind.*, **15**, No. 167, 130-45 (1934); *C. A.*, **28**, 6039 (1934). Seferian, *Rev. soudure autogene*, **26**, 6-7 (1934); *C. A.*, **29**, 3159 (1935).
- (3) Montagne, *Chaleur et ind.*, **19**, 54-62 (1938); *C. A.*, **32**, 5271 (1938).
- (4) L. Meyer, *Ber.*, **27**, 2764 (1894). Le Chatelier, *Compt. rend.*, **121**, 1144-7 (1895). Grehant, *ibid.*, **122**, 832-3 (1896). Berthelot and Vielle, *ibid.*, **123**, 523-30 (1896); **128**, 777-87 (1899). Clowes, *J. Soc. Chem. Ind.*, **15**, 418, 701 (1896). Bunte, *Ber.*, **31**, 5-25 (1898). Howard and Sast'y, *J. Chem. Soc.*, **111**, 841-3 (1917). Mason and Wheeler, *ibid.*, **115**, 578-87 (1919).
- (5) Parks and Huffman, "Free Energies of Some Organic Compounds," p. 228, New York, The Chemical Catalog Co., Inc., (Reinhold Publishing Corp.) 1932.
- (6) Yagi and Takioka, *J. Soc. Chem. Ind. Japan*, **34**, 205-7 (1931); *C. A.*, **25**, 5291 (1931).

- (7) Bone and Andrew, *J. Chem. Soc.*, **87**, 1232-48 (1905).
- (8) Bone and Carruthers, *Proc. Roy. Soc. London*, **A162**, 502-11 (1937); *C. A.*, **32**, 1170 (1938).
- (9) Mondain-Monval and Wellard, *Compt. rend.*, **196**, 1226-8 (1933).
- (10) Malinovskii and Egorov, *Physik Z. Sowjetunion*, **5**, 453-63 (1934); *C. A.*, **28**, 4295 (1934). Malinovskii, Rossikhin and Timkovskii, *ibid.*, **5**, 212-20, *C. A.* **28**, 4569 (1934); 902-5 (1934); *C. A.*, **29**, 985 (1935).
- (11) Skalov and Sokolik, *J. Phys. Chem. (U.S.S.R.)*, **5**, 617-24 (1934); *C. A.*, **29**, 7764 (1935).
- (12) Kistiakowsky and Lenher, *J. Am. Chem. Soc.*, **52**, 3785-96 (1930). U. S. P. 1,955,885 (1934); *C. A.*, **28**, 4072 (1934).
- (13) Spence and Kistiakowsky, *J. Am. Chem. Soc.*, **52**, 4837-47 (1930). Bodenstein, *Z. phys. Chem.*, **B12**, 151-64 (1931).
- (14) Spence, *Nature*, **128**, 153 (1931).
- (15) *Idem*, *J. Chem. Soc.*, **1932** (I), 686-96.
- (16) Steacie and McDonald, *J. Chem. Phys.*, **4**, 75-81 (1936).
- (17) Mardles, *Trans. Faraday Soc.*, **27**, 718-21 (1931).
- (18) Young, Vogt and Nieuwland, *J. Am. Chem. Soc.*, **56**, 1822 (1934); **58**, 55-6 (1936). *J. Chem. Soc.*, **1935**, 115.
- (19) Mittasch, Willfroth and Balz, U. S. P. 1,487,020 (1924); *C. A.*, **18**, 1672 (1924).
- (20) Lenher, *J. Am. Chem. Soc.*, **53**, 2962-7 (1931); U. S. P. 1,988,455 (1935); *C. A.*, **29**, 1439 (1935).
- (21) Mailfert, *Compt. rend.*, **94**, 1186-7 (1882).
- (22) Otto, *Ann. chim. phys. (?)*, **13**, 116-7 (1898).
- (23) Briner and Wunenburger, *Helv. Chim. Acta*, **12**, 786-90 (1929).
- (24) Marks, *Brit. P.* 140,478 (1917); *C. A.*, **14**, 2203 (1920). (An abstract in *J. Chem. Soc.*, **118** (I), 420 (1920) ascribes this patent to Alexander Bosshard.)
- (25) Wohl and Braunig, *Chem. Ztg.*, **44**, 157 (1920); *Brit. P.* 157,329 (1921); *C. A.*, **15**, 1905 (1921).
- (26) Geib and Harteck, *Ber.*, **66**, 1815-25 (1933).
- (27) Berthelot, *Ann. chim. phys. (4)*, **15**, 343-53 (1868).
- (28) *Idem*, *Ann. (Suppl.)*, **8**, 44-50 (1872).
- (29) Kearns, Heiser and Nieuwland, *J. Am. Chem. Soc.*, **45**, 795-9 (1923).
- (30) Orton and McKie, *J. Chem. Soc.*, **117**, 283-96 (1920). Deutsche Gold und Silber Scheideanstalt vorm. Roessler, *Ger. P.* 377,119 (1923); *Frdl.*, **14**, 286-7. Kazarovskii, *Org. Chem. Ind. (U.S.S.R.)*, **2**, 3-9 (1936); *C. A.*, **31**, 661 (1937).
- (31) Gautier, *Compt. rend.*, **126**, 936-7, 1303 (1898). Jaubert, *ibid.*, **141**, 1233-4 (1905). Gautier, *ibid.*, **142**, 15 (1906).
- (32) Cross, Bevan and Heiberg, *Ber.*, **33**, 2015-18 (1900).
- (33) Coehn, *Z. Elektrochem.*, **7**, 681-5 (1901).
- (34) Hofmann, Ehrhart and Schneider, *Ber.*, **46**, 1668 (1913).
- (35) Kindler, *Ber.*, **54**, 647-9 (1921). *Ger. P.* 362,745 (1922); *Chem. Zentr.*, **94** (II), 478 (1923).
- (36) Aloy and Valdiguie, *Bull. soc. chim. (4)*, **37**, 1135-40 (1925).
- (37) Arnaud and Hasenfratz, *Compt. rend.*, **152**, 1603-6 (1911).
- (38) Molinari, *Ber.*, **40**, 4154-61 (1907); **41**, 585-9, 2782-5 (1908).
- (39) Harries, *Ber.*, **40**, 4905-8 (1907); **41**, 1227-32 (1908).
- (40) Brus and Peyresblanques, *Compt. rend.*, **190**, 685-6 (1930).
- (41) Tchao Yin Lai, *Bull. soc. chim. (4)*, **53**, 1542, 1547 (1933).
- (42) Jacobs, *J. Am. Chem. Soc.*, **58**, : 272-3 (1936).
- (43) Hurd and Christ, *J. Org. Chem.*, **1**, 141-5 (1936).
- (44) Berthelot, *Ann. (Suppl.)*, **5**, 97-100 (1867).
- (45) Flavitzky and Kriloff, *Ber.*, **10**, 2240 (1877).
- (46) Hecht, *Ber.*, **11**, 1050-5 (1878).
- (47) Krestinskii and Kelbovskaia, *Ber.*, **68B**, 512-19 (1935).
- (48) Dupont, *Compt. rend.*, **149**, 1381-3 (1909); **150**, 1523-5 (1910); *Ann. chim. phys. (8)*, **30**, 529-35 (1913).

- (49) Mostly unpublished work. Cf. Bried and Hennion, *J. Am. Chem. Soc.*, **60**, 1717-19 (1938).
- (50) Overbeck, *Ann.*, **140**, 62-3 (1866).
- (51) Hazura and Grüssner, *Monatsh.*, **9**, 947-55 (1888).
- (52) Grossmann, *Ber.*, **26**, 639-49 (1893).
- (53) Arnaud, *Compt. rend.*, **134**, 547-9 (1902).
- (54) Boeseken and Slooff, *Rec. trav. chim.*, **49**, 95-9 (1930).
- (55) Truchet, *Compt. rend.*, **196**, 706-9 (1933).
- (56) *Idem, ibid.*, **196**, 1613-4 (1933).
- (57) Melnikov, *Uspekhi Khim.*, **5**, 443-50 (1936); *C. A.*, **30**, 5180 (1936).

6. The preparation of acetaldehyde by the catalytic addition of water to acetylene. Kutscherov (1) first observed the formation of acetaldehyde from acetylene, and of ketones from acetylene homologs, by the addition of water in aqueous solutions of mercuric salts. He also noted that during the reaction organo-mercuric compounds were precipitated, which he considered to be additive intermediates. A number of later workers (2) obtained similar results. Frieman, Kennedy and Lucas (3) recently studied the mechanism of this reaction and reported that the initial rate is first order with respect to acetylene and second order with respect to mercuric sulfate. Erdmann and Kothner (4) reported a laboratory method for the preparation of acetaldehyde by passing acetylene with agitation into a hot solution of mercuric sulfate in dilute sulfuric acid. Their method was essentially similar to the processes in present use for the commercial production of acetaldehyde. Wunderlich (5) applied for a patent (not granted) covering catalysis by mercury salts in solutions of organic acids or of sulfuric and other inorganic acids.

Thus the principal features of this synthesis of acetaldehyde long have been known, but large-scale manufacture was delayed for many years in part by the lack of demand for acetaldehyde, which first found extensive use during the World War. The earlier attempts to develop the process encountered two important technical difficulties. First, the acetaldehyde was not readily removed from the acid catalytic solutions, and tended to accumulate in them, with consequent formation of undesired condensation products. Secondly, the mercury catalysts were more or less rapidly inactivated either by reduction to metallic mercury or by conversion to highly insoluble organo-mercury derivatives, or by coating with tarry condensation products. Nearly all of the numerous patented modifications of the process consist of proposed methods for overcoming these two difficulties.

The earliest attempts for rapid and complete recovery of the acetaldehyde from the catalytic solutions were reported in patents by Grünstein with the Chemische Fabrik Griesheim Elektron and by chemists of the Consortium für Elektrochemische Industrie, these concerns having been the first to apply the reaction on an industrial scale. These patentees later engaged in a polemical discussion concerning the priority and value of the

early modifications (6). Grünstein stated that it was impracticable to distill the acetaldehyde from sulfuric acid at atmospheric pressure, because of the greater formation of crotonaldehyde and other more complex condensation products at higher temperatures. He proposed a number of methods of removal (7, 8) including vacuum distillation (see also 9, 10), the addition of an indifferent salt to force the acetaldehyde out of solution, extraction with solvents, and finally the use of a stream of excess acetylene to sweep out the dissolved acetaldehyde (8, 11, 12). Extraction with solvents also has been proposed in a few other patents (61). The Consortium für Elektrochemische Industrie (13, 14) patented a process for distilling acetaldehyde from a very dilute sulfuric acid catalyst solution, and the same concern appears to have been the first to patent and employ industrially a method of sweeping out the acetaldehyde with a stream of excess acetylene, which has proved to be the most successful method of removal, and is now the common practice.

Most of the later patents on the subject specify the removal of acetaldehyde by a stream of excess acetylene, and differ in various other features such as temperature, pressure, or acid strength, or in the kind of acid, mercury salt or auxiliary substances used, or in the design and operation of the apparatus (15-24). In processes of this type the gases leaving the reaction vessel are usually first dried by condensation or absorption of the water vapor; the acetaldehyde is then condensed at a lower temperature, and the excess acetylene is returned to the reaction vessel.

It was early proposed to substitute for mercuric sulfate and sulfuric acid other acids, such as phosphoric or various sulfonic acids with the corresponding mercuric salts (5, 7, 8, 25). The authors have also used dilute perchloric acid and aqueous solutions of boron fluoride for this purpose. These acids and mercuric salts probably do not possess any advantages over mercuric sulfate and sulfuric acid which are sufficient to offset their higher costs. The halogen acids are unsuitable both because of their volatility and the catalytic inactivity of the mercury halides. Later patent claims often apply to all mercuric salts or mention a considerable number of them, but apparently none of these has displaced the sulfate solution in the practice of any manufacturer. In general, the concentration of an acid, such as sulfuric, is decreased when a higher operating temperature is employed and the concentration is kept constant by the admission of steam (26) or water.

Several patents describe the use of acid sulfates or phosphates of the alkali metals or ammonia in the catalytic solutions (27-29). These salts tend to force the acetaldehyde out of solution, but also decrease the solubility of acetylene and thus retard the reaction. The authors were able to achieve a satisfactory catalytic action in a saturated aqueous solution of

sodium acid sulfate only when the solution was distributed in films on an inert packing material, and in this case paraldehyde was the principal product (30).

By the addition of water-soluble organic liquids to the catalytic solution, the solubility of acetylene and usually the speed of reaction are increased. A number of patents describe catalytic solutions containing water, a strong acid and the corresponding mercuric salt, and a water-soluble organic liquid such as acetic acid or an alcohol (31-36). Acetic acid forms vinyl and ethylidene acetates, and the alcohols form acetals under such conditions; but these compounds hydrolyze to acetaldehyde in the presence of aqueous acids. The net effect is to increase the solubility of acetylene and the retention of the product in the solutions, often with an increased tendency toward formation of condensation products. It is questionable whether the advantages claimed from the addition of organic liquids to the catalytic medium are sufficient to compensate for the increased difficulty of separating and purifying the acetaldehyde.

If pyrolytic gas mixtures containing acetylene are employed in this process, the acetaldehyde may be swept out of the catalytic solutions by the unreactive portion of the gas mixture (20, 21, 37, 43, 51). Under these conditions several patents claim advantages in treating the mixed gases at 2-3 atmospheres' pressure (20, 21, 40). Pyrolytic gases containing acetylene and diacetylene yield acetaldehyde and biacetyl (39).

Numerous modifications of the process have also been proposed with a view to diminishing the loss of mercury catalyst, or to increasing its effectiveness. Side reactions, which have not been completely explained, result in the precipitation of an inactive gray sludge consisting chiefly of finely divided metallic mercury mixed with insoluble mercury organic compounds and sometimes with tarry condensation products. The amount of this material formed bears no stoichiometric relation to the quantity of acetaldehyde produced, but varies widely under different conditions. A number of attempts have been made to prevent this reduction or to regenerate the original mercuric salt by the addition of oxidizing agents to the catalytic solutions. Among those suggested are ferric, chromic, vanadic, manganic, ceric, and cupric salts (37, 44-53) and hydrogen peroxide (44, 54), oxygen (55) or ozonized oxygen (56). Oxygen or air in the presence of an iron salt has also been specified as an oxidizing agent (57, 58). However, another series of patents claims that formation of undesirable condensation products is diminished by the presence of ferrous salts (47, 59). The electrolytic oxidation of mercury directly in the catalytic solution is the subject of several patents (60, 62-70). The mercury sludge also may be removed from the reaction vessel and recovered by a number of methods including carbonization (71, 72), reduction by metals in acid media (73, 74),

electrolysis in alkaline solution (71, 74), catalytic oxidation in the presence of nitric acid or oxides of nitrogen (75, 76) or ferric salts (76, 78), and chlorination (79).

Several of the patents previously cited describe as an advantageous procedure the preparation of catalysts by treating mercuric oxide with acids in the catalytic solution. Dreyfus (80) claims that the conditions under which the mercuric compounds first come in contact with acetylene influences their lasting qualities. The addition to the solution of salts of weak acids such as borates (81) and of salts of strong acids with weak bases (82) have also been patented.

A number of patents (83) claim the catalytic preparation of acetaldehyde in solutions containing the chloride or other salts of zinc, chromium, iron, or cadmium along with salts of mercury, uranium, gold or platinum.

Because of the corrosive action of these catalytic solutions on most metals, the apparatus for use in this process is constructed of special materials, such as iron-silicon alloys (84), or is lined with lead (85, 86) or nickel-chromium-molybdenum steel (87).

Several brief reviews of the commercial processes with some patent citations have been published (88-96) (See also Chapter I, Section 1). Benson and Cadenhead (94) have listed a number of by-products isolated in small quantities from the commercial product. Deuterioacetaldehyde has been prepared from dideuterioacetylene and heavy water by the action of an acid solution of a mercuric salt (97).

The technical difficulties encountered in the production of acetaldehyde from acetylene and water in acid solutions of mercuric salts and also in other liquid-phase methods resulted in a number of attempts to effect this synthesis of acetaldehyde in the vapor phase by the aid of suitable promoters. With most catalysts it was found that a temperature of 200-500° was required to cause sufficiently rapid reaction, and that at this temperature a large excess of steam or other diluent was needed to prevent the extensive formation of condensation products. The resulting dilution of the acetaldehyde with water and contamination with condensed by-products are serious disadvantages of several proposed processes of this type.

A great variety of catalysts have been used or proposed for the vapor-phase addition of water to acetylene. These include iron, nickel and cobalt (98-100); molybdic acid (101-102); molybdates, chromates and vandates (102); tungsten compounds (103-104); aluminum oxide mixed with borates, phosphates, oxides, sulfides or selenides of mercury, cadmium, zinc, copper, iron, cobalt or nickel (103-106); aluminum oxide (107); borates or phosphates of copper, nickel and zinc (108); charcoal or silica coated with oxides of mercury, zinc, copper, molybdenum, iron, nickel, tin, aluminum, or lead (109); bismuth molybdate (110); zinc molybdate, boron phosphate, and

cadmium metaphosphate (111); alkaline-earth phosphates, and iron or magnesium silicates (112); cadmium phosphate (113-115); phosphates of zinc and silver (115); activated carbon impregnated with dilute phosphoric acid (116); fused zinc chloride or aluminum chloride, or mixtures of the oxides of cerium, zinc, chromium, manganese, barium, and titanium (117).

A number of patents describe the reaction of acetylene with steam to which air or oxygen has been added to produce partial or complete oxidation of the acetaldehyde to acetic acid (118-122). In general the catalysts employed are similar to those used for the vapor-phase hydration of acetylene, but oxides of nitrogen (122) and a mercury, molybdenum, or vanadium catalyst (123) also have been suggested. It is claimed that oxygen diminishes the formation of condensation products, and prolongs the life of the catalysts, as well as oxidizing acetaldehyde to acetic acid.

It is doubtful whether these high-temperature vapor-phase processes can compete with the liquid-phase mercury catalyst method for the conversion of concentrated acetylene to acetaldehyde, but the vapor-phase process may be of value, for the utilization of acetylene in mixture with steam or inert diluent gases.

References

- (1) Kutscherov, *Ber.*, **14**, 1532-9, 1540-2 (1881); **17**, 13-29 (1884).
- (2) Hoffmann, *Ber.*, **32**, 870-80 (1899); **37**, 4459-60 (1904). Biltz and Mumm, *Ber.*, **37**, 4417-27 (1904). Biltz, *Ber.*, **38**, 133-6 (1905). Nieuwland and Maguire, *J. Am. Chem. Soc.*, **28**, 1025-31 (1906).
- (3) Frieman, Kennedy, and Lucas, *J. Am. Chem. Soc.*, **59**, 722-6 (1937).
- (4) Köthner, Dissertation (1896); *Ber.*, **31**, 2475 (1898). Erdmann and Köthner, *Z. anorg. Chem.*, **18**, 48-58 (1898).
- (5) Wunderlich, Ger. Pat. Applications 27,177; 29,233 (1908); *Frdl.*, **9**, 55 (1911).
- (6) Consortium für Elektrochemische Industrie, *Z. angew. Chem.* **31** (I), 148,220 (1918); **32** (I), 32, 224, 336, 396 (1919); Grünstein, *ibid.*, **31** (I), 180 (1918); **32** (I), 31-2, 104, 335-6, 396 (1919).
- (7) Grünstein, Ger. P. 250,356 (1910); *C. A.*, **7**, 217 (1910); Ger. P. 253,707 (1910), 253,708 (1910); *C. A.*, **7**, 868 (1913); Ger. P. 267,260 (1910); *C. A.*, **8**, 790 (1914); Ger. P. 270,049 (1910); *C. A.*, **8**, 2222 (1914); U.S.P. 1,044,169 (1913); *C. A.*, **7**, 216 (1913); *Can. P.* 134,792 (1911); *C. A.*, **5**, 3611 (1911).
- (8) Chem. Fabrik Griesheim Elektron, Fr. P. 425,057 (1911); *J. Soc. Chem. Ind.*, **30**, 923 (1911). Fr. P. 474,246 (1914); *J. Soc. Chem. Ind.*, **34**, 735 (1915); *Brit. P.* 29,073 (1910); *J. Soc. Chem. Ind.*, **30**, 1088 (1911); *Brit. P.* 15,669 (1914); *J. Soc. Chem. Ind.*, **34**, 1168 (1915).
- (9) Compagnie des produits chimiques d'Alais et de la Camargue, Ger. P. 369,353 (1922); *Frdl.*, **14**, 210 (1926). *Brit. P.* 130,650 (1918); *C. A.*, **14**, 72 (1920).
- (10) Guyot, U.S.P. 1,343,715 (1920); *C. A.*, **14**, 2344 (1920).
- (11) Grünstein, U.S.P. 1,184,177 (1916); *C. A.*, **10**, 1774 (1916); U.S.P. 1,477,951 (1923); *C. A.*, **18**, 693 (1924); Ger. P. 425,665 (1926); *Frdl.*, **15**, 104-6 (1928).
- (12) Chem. Fabrik Griesheim Elektron, Swiss P. 71,806 (1916); *C. A.*, **10**, 1910 (1916).
- (13) Consortium für Elektrochemische Industrie, *Brit. P.* 6000 (1913); *J. Soc. Chem. Ind.*, **33**, 278 (1914); *Brit. P.* 16,957 (1914); *J. Soc. Chem. Ind.*, **34**, 888 (1915); *Brit. P.* 16,848 (1913); *J. Soc. Chem. Ind.*, **33**, 440 (1914); *Brit. P.* 17,017 (1913); *J. Soc. Chem. Ind.*, **34**, 818 (1915); *Fr. P.* 460,553 (1913); *C. A.*, **8**, 2220 (1914);

- Fr. P. 455,370 (1913); *C. A.*, **8**, 402 (1914); *J. Soc. Chem. Ind.*, **32**, 959 (1913); Fr. P. 460,553 (1913); *J. Soc. Chem. Ind.*, **33**, 42 (1914); Ger. P. 518,290 (1913); *C. A.*, **25**, 2441 (1931); Ger. P. 517,893 (1914); *C. A.*, **25**, 2739 (1931); Ger. P. 383,528 (1923); *Frld.*, **14**, 211-3; Swed. P. 43,001 (1917); *C. A.*, **12**, 484 (1918).
- (14) Baum and Mugdan, U.S.P. 1,107,019 (1914); *C. A.*, **8**, 3348 (1914); U.S.P. 1,096,667 (1914); *C. A.*, **8**, 2220 (1914); U.S.P. 1,489,915 (1924); *C. A.*, **18**, 1836 (1924).
- (15) Hibbert, Can. P. 181,657 (1918); *C. A.*, **12**, 588 (1918); U.S.P. 1,247,270 (1918); *C. A.*, **12**, 280 (1918).
- (16) Matheson, Can. P. 218,373 (1922); *C. A.*, **16**, 2518 (1922); Brit. P. 132,557 (1918); *C. A.*, **14**, 288 (1920); U.S.P. 1,384,842 (1921); *C. A.*, **15**, 3850 (1921).
- (17) Canadian Electro Products Co., Brit. P. 208,689 (1923); *C. A.*, **18**, 1672 (1924).
- (18) Reid and Hovey, Can. P. 270,333 (1927); U.S.P. 1,687,228 (1928); *C. A.*, **21**, 3368 (1927).
- (19) Holzverkohlungs Industrie A. G., Fr. P. 678,745 (1929); *C. A.*, **24**, 3519 (1930).
- (20) I. G. Farbenind. A. G., Brit. P. 349,022 (1929); *C. A.*, **26**, 5106 (1932); Fr. P. 671,285 (1929); *C. A.*, **24**, 2145 (1930).
- (21) Roth, Elbert and Steinberger (to I. G. Farbenind. A. G.), U.S.P. 1,975,480 (1934); *C. A.*, **28**, 7267 (1934).
- (22) Hand, Bartram and Maude, U.S.P. 1,738,649 (1930); *C. A.*, **24**, 866 (1930).
- (23) Deutsche Gold und Silber Scheideanstalt vorm Roessler, Ger. P. 562,739 (1930); *C. A.*, **27**, 1012 (1933).
- (24) Boehringer and Soehne, G.m.b.H., Ger. P. 575,533 (1933); *C. A.*, **27**, 4819 (1933).
- (25) Farbenfabrik von F. Bayer and Co., Ger. P. 291,794 (1913); *C. A.*, **11**, 1519 (1917).
- (26) Verein für Chemische Industrie, Brit. P. 288,707 (1927); *C. A.*, **23**, 607 (1929). Walter, U.S.P. 1,669,384 (1928); *C. A.*, **22**, 2170 (1928).
- (27) Hibbert, Can. P. 181,656 (1918); *C. A.*, **12**, 588 (1918). Hibbert and Morton, U.S.P. 1,213,486; 1,213,487 (1917); *C. A.*, **11**, 1016 (1917).
- (28) I. G. Farbenind. A. G., Ger. P. 489,285 (1927); *C. A.*, **24**, 2145 (1930); Ger. P. 507,795 (1928); *C. A.*, **25**, 524 (1931); Brit. P. 312,716 (1928); *C. A.*, **24**, 866 (1930); Brit. P. 319,542 (1928); *C. A.*, **24**, 2474 (1930); Fr. P. 757,027 (1928); *C. A.*, **23**, 4231 (1929); Fr. P. 678,450 (1929); *C. A.*, **24**, 3519 (1930).
- (29) Millar and Steck (to Shell Development Co.), Can. P. 337,706 (1933); *C. A.*, **28**, 1720 (1934); U.S.P. 2,005,946 (1935); *C. A.*, **29**, 5461 (1935).
- (30) Vogt and Nieuwland, *J. Am. Chem. Soc.*, **43**, 2071-81 (1921).
- (31) Consortium für Elektrochemische Industrie, Brit. P. 5132 (1915); *J. Soc. Chem. Ind.*, **35**, 556 (1916); Brit. P. 260,305 (1925); *C. A.*, **21**, 3368 (1927); Brit. P. 264,791 (1926); *C. A.*, **22**, 243 (1928); Ger. P. 499,507 (1925); *C. A.*, **24**, 4523 (1930).
- (32) Herrmann and Deutsch, Can. P. 274,219 (1927); *C. A.*, **21**, 3907 (1927); U.S.P. 1,816,326 (1931); *C. A.*, **25**, 5436 (1931).
- (33) Dreyfus, Fr. P. 479,656 (1916); *C. A.*, **11**, 870 (1917); additions: Fr. P. 20,201 and 20,202 (1917).
- (34) Consortium, M. Mugdan, Swed. P. 42,331 (1917); *C. A.*, **11**, 2138 (1917).
- (35) Karpati and Hubsch, Brit. P. 294,227 (1927), void; *C. A.*, **23**, 1910 (1929).
- (36) Deutsche Gold und Silber Scheideanstalt vorm Roessler, Ger. P. 571,318 (1928); *C. A.*, **27**, 2696 (1933).
- (37) I. G. Farbenind. A. G., Brit. P. 460,145 (1937); Fr. P. 806,401 (1936); *C. A.*, **31**, 4680 (1937). Taack-Trakanen and Wietzel (to I. G. Farbenind. A. G.) U.S.P. 2,079,976 (1937); *C. A.*, **31**, 4680 (1937). I. G. Farbenind. A. G. and Johnson, Brit. P. 466,569 (1937); *C. A.*, **31**, 7892 (1937); Fr. P. 47,812 (1937); *C. A.*, **32**, 4611 (1938); Brit. P. 484,500 (1938); *C. A.*, **32**, 7480 (1938).
- (38) I. G. Farbenind. A. G., Brit. P. 448,871 (1936); *C. A.*, **30**, 7587 (1936).
- (39) *Idem.*, Brit. P. 460,862 (1936); *C. A.*, **31**, 4680 (1937).
- (40) *Idem.*, Brit. P. 278,324 (1926); *C. A.*, **22**, 2573 (1928); Fr. P. 641,406 (1927); *C. A.*, **23**, 1142 (1929).

- (41) Contardi, *Atti congresso naz. chim. ind.* (1924) 358-70; *C. A.*, **19**, 1941 (1925).
- (42) Plauson and Vielle, *Brit. P.* 156,152 (1920); *C. A.*, **15**, 1725 (1921).
- (43) Standard Oil Development Co., *Fr. P.* 744,772 (1933); *C. A.*, **27**, 4252 (1933).
- (44) Farbwerk vorm Meister Lucius and Breuning, *Ger. P.* 292,818 (1914); *C. A.*, **11**, 1518 (1917); *Ger. P.* 293,070 (1914); *C. A.*, **11**, 1519 (1917); *Ger. P.* 299,466 (1917); 299,467 (1917); *Frdl.*, **13**, 95-96 (1928); *Brit. P.* 24,153 (1914); *C. A.*, **10**, 1579 (1916); *Swiss P.*, 71,651 (1916); *C. A.*, **10**, 1775 (1916).
- (45) Duden and Peters, *U.S.P.* 1,151,928 (1915); 1,151,929 (1915); *C. A.*, **9**, 2796 (1915). *Reissues: U.S.P.* 14,063 (1916); *U.S.P.* 14,064 (1916); *C. A.*, **10**, 1078 (1916).
- (46) Crossfield and Sons and Hillditch, *Brit. P.* 124,702 (1918); *C. A.*, **13**, 1715 (1919); *Brit. P.* 131,084 (1918); *C. A.*, **14**, 72 (1920).
- (47) Utheim, *Dan. P.* 23,175 (1918); *C. A.*, **12**, 2326 (1918).
- (48) Soc. anon. de produits chimiques, *Brit. P.* 140,784 (1920); *C. A.*, **14**, 2203 (1920).
- (49) Ochi, Onozawa, and Tokio Industrial Laboratory, *Jap. P.* 38,752 (1921); *C. A.*, **16**, 2150 (1922).
- (50) Trevoux, *U.S.P.* 1,436,550 (1923); *C. A.*, **17**, 563 (1923).
- (51) Hirst and Imperial Chemical Industries, Ltd., *Brit. P.* 302,515 (1928); *C. A.*, **23**, 4231 (1929).
- (52) Riley and Imperial Chemical Industries, Ltd., *Brit. P.* 346,883 (1930); *C. A.*, **26**, 1617 (1932).
- (53) Roth, Elvert, and Steinberger (to I. G. Farbenind. A. G.) *U.S.P.* 2,074,619 (1937); *C. A.*, **31**, 3070 (1937); *Fr. P.* 815,717 (1937); *C. A.*, **32**, 1718 (1938).
- (54) Crossfield and Sons and Hillditch, *Brit. P.* 125,926 (1918); *C. A.*, **13**, 2218 (1919).
- (55) Farbfabrik vorm F. Bayer & Co., *Ger. P.* 305,182 (1921); *Frdl.*, **13**, 96-8 (1928).
- (56) Poutermann, *Ger. P.* 566,517 (1930); *C. A.*, **27**, 2459 (1931).
- (57) Soc. chimique des usines du Rhone, *Brit. P.* 238,520 (1924); *C. A.*, **20**, 1995 (1926); *Ger. P.* 428,930 (1926); *Frdl.*, **15**, 106-7 (1928).
- (58) Ledru and Bachmann, *U.S.P.* 1,532,190 (1925); *C. A.*, **19**, 1575 (1925).
- (59) Consortium für Elektrochemische Industrie, *Swiss* 79,339 (1918); *C. A.*, **13**, 2374 (1919); *Norw. P.* 30,948 (1920); *C. A.*, **15**, 1029 (1921); *Ger. P.* 309,103, 309,-104 (1919); *Frdl.*, **13**, 99-101 (1928).
- (60) Baum and Mugdan, *U.S.P.* 1,096,667 (1913); *C. A.*, **8**, 2220 (1914).
- (61) Dreyfus, *Brit. P.* 105,064 (1917); *C. A.*, **11**, 2138 (1917); *Brit. P.* 106,483 (1917); *C. A.*, **11**, 2138 (1917).
- (62) Grünstein, *U.S.P.* 1,477,951 (1924); *C. A.*, **18**, 693 (1924). Grünstein and Berge, *Can. P.* 262,271 (1926); *C. A.*, **20**, 3397 (1926).
- (63) Chemische Fabrik Griesheim Elektron, *Brit. P.* 143,891 (1920); *C. A.*, **14**, 2935 (1920); *Ger. P.* 360,417 (1916), 360,418 (1917); *Frdl.*, **14**, 205-7 (1928); *Ger. P.* 408,181 (1924); *Frdl.*, **14**, 207-8 (1928).
- (64) Soc. anon. pour l'industrie chimique a Bâle, *Brit. P.* 130,138 (1918); *C. A.*, **14**, 72 (1920).
- (65) Soc. des aciéries et forges de Firminy, *Brit. P.* 124,194 (1919); *C. A.*, **13**, 1595 (1919); *Brit. P.* 132,529 (1919); *C. A.*, **14**, 284 (1920).
- (66) Plauson and Vielle, *Brit. P.* 156,147 (1920); *C. A.*, **15**, 1661 (1921); Plauson, *U.S.P.* 1,471,058 (1924); *C. A.*, **18**, 25 (1924).
- (67) Stockholms Superfosfat Fabriks A. G., *Swed. P.* 54,703 (1923); *C. A.*, **18**, 1672 (1924); *Brit. P.* 155,775 (1920); *C. A.*, **15**, 1534 (1921).
- (68) Trevoux, *U.S.P.* 1,428,668 (1922); *C. A.*, **16**, 3665 (1922).
- (69) Thorin, *U.S.P.* 1,501,502 (1924); *C. A.*, **18**, 2716 (1924); *Can. P.* 220,175 (1922); *C. A.*, **16**, 2868 (1922).
- (70) Consortium für Elektrochemische Industrie, *Brit.* 260,305 (1925); *C. A.*, **21**, 3368 (1927).
- (71) Chemische Fabrik Griesheim Elektron, *Brit. P.* 10,140 (1915); *C. A.*, **11**, 86 (1917).

- (72) Matheson, *Brit. P.* 132,559 (1918); *C. A.*, **14**, 288 (1920).
- (73) Soc. anon. de produits chimiques Malettra, *Brit. P.* 165,085 (1921); *C. A.*, **16**, 566 (1922).
- (74) Consortium für Elektrochemische Industrie, *Ger. P.* 332,202 (1920), 319,476 (1920); *Frdl.*, **13**, 107 (1928).
- (75) Elektrizitätswerk Lonza, *Ger. P.* 310,994 (1920); *Ullman's Dictionary*, I, 96.
- (76) Hirst, Rowell and Imperial Chemical Industries, Ltd., *Brit. P.* 309,888 (1928); *C. A.*, **24**, 698 (1930).
- (77) Riley, and Imperial Chemical Industries, Ltd., *Brit. P.* 346,883 (1930); *Brit. Chem. Abs.*, **1931B**, 710.
- (78) Riley, Rowel, and Imperial Chemical Industries, Ltd., *Brit. P.* 332,106 (1929); *C. A.*, **25**, 176 (1931).
- (79) Dreyfus, *Brit. P.* 105,064 (1917); *C. A.*, **11**, 2138 (1917); *Brit. P.* 106,483 (1917); *C. A.*, **11**, 2580 (1917); *U.S.P.* 1,310,743 (1919); *Swiss P.* 78,947 (1918); *C. A.*, **13**, 2374 (1919).
- (80) Hibbert and Morton, *U.S.P.* 1,213,486 (1917); *C. A.*, **11**, 1016 (1917); Electric Furnace Products Co., *Norw. P.* 28,537 (1918); *C. A.*, **12**, 1558 (1918).
- (81) Firma Gustav Weinmann, *Ger. P.* 362,983 (1922); *Swiss P.* 91,865 (1919); *Frdl.*, **14**, 208-9 (1928).
- (82) I. G. Farbenind. A. G., *Brit. P.* 313,864 (1928); *C. A.*, **24**, 1125 (1930); *Ger. P.* 620,402 (1935); *C. A.*, **30**, 737 (1936); *Brit. P.* 393,690 (1933); *C. A.*, **27**, 5751 (1933); *Ger. P.* 621,292 (1935); *C. A.*, **30**, 1071 (1936); *Fr. P.* 776,518 (1935); *C. A.*, **29**, 3354 (1935); *Brit. P.* 425,069 (1935); *C. A.*, **29**, 5128 (1935); *Ger. P.* 623,877 (1936); *C. A.*, **30**, 3444 (1936); *Brit. P.* 443,928 (1936); *C. A.*, **30**, 5240 (1936); Rosinsky and Baumann (to I. G. Farbenind. A. G.) *U.S.P.* 2,077,586 (1937); *C. A.*, **31**, 3944 (1937). Rosinsky (to I. G. Farbenind. A. G.) *U.S.P.* 2,081,770 (1937); *C. A.*, **31**, 4994 (1937). I. G. Farbenind. A. G., *Fr. P.* 46616 (1936); *C. A.*, **31**, 7892 (1937).
- (83) Dreyfus, *Brit. P.* 115,899 (1917); *C. A.*, **12**, 1885 (1918).
- (84) *Idem*, *U.S.P.* 1,310,984 (1919); *C. A.*, **13**, 2374 (1919). *U.S.P.* 1,361,974 (1921); *C. A.*, **15**, 537 (1921).
- (85) Soller, Hotz, and British Cellulose and Chemical Mfg. Co., *Brit. P.* 151,086 (1919); *C. A.*, **15**, 537 (1921).
- (86) I. G. Farbenind. A. G., *Brit. P.* 299,234 (1928); *C. A.*, **23**, 3235 (1929) (grant of patent refused).
- (87) Garcon, *Bull. soc. encour. ind. nat.*, **127**, 568-81 (1917); *J. four elec. et electrolyse*, **26**, 233-4 (1917).
- (88) Matheson, *Can. Chem. J.*, **3**, 258-61 (1929).
- (89) Ullrich, *Metallbörse*, **21**, 315-6, 363-4, 413 (1931); *C. A.*, **25**, 1810 (1931).
- (90) Deschiens, *Chimie et Industrie*, **5**, 239-56, 398-408, 518-28 (1921).
- (91) Rooney, *Chem. Met. Eng.*, **22**, 847-50 (1920); Thommen, *Chem. Ztg.*, **58**, 797-800 (1934).
- (92) Benson and Cadenheat, *J. Soc. Chem. Ind.*, **53**, 40-3T (1934).
- (93) Genin, *J. four elec.*, **46**, 192-3 (1937); *C. A.*, **31**, 7396 (1937).
- (94) Kakuya, *Chem. Rev. (Japan)*, **4**, 117-29 (1938); *C. A.*, **32**, 9040 (1938).
- (95) Zanetti and Sickman, *J. Am. Chem. Soc.*, **57**, 2735 (1935).
- (96) I. G. Farbenind. A. G., *Ger. P.* 504,862 (1914); *C. A.*, **25**, 524 (1931); *Ger. P.* 511,634 (1915); *C. A.*, **25**, 1264 (1931); *Ger. P.* 514,591 (1916); *C. A.*, **25**, 2156 (1931).
- (97) Stuer and Grob, *U.S.P.* 1,421,743 (1922); *C. A.*, **16**, 3093 (1922). *Brit. P.* 109,983 (1916); *J. Soc. Chem. Ind.*, **36**, 1194 (1917).
- (98) Chem. Fabrik Rhenania, *Brit. P.* 107,585, *Ger. P.* 365,285 (1922), *Ger. P.* 369,515 (1922), *Ger. P.* 379,596 (1923), *Austrian P.* 89,922 (1915), *Swiss P.* 92,120 (1920); *Frdl.*, **14**, 196-202 (1928).
- (99) Deutsche Gold und Silber Schiedeanstalt vorm Roessler, *Brit. P.* 107,584 (1917); *Brit. P.* 107,585 (1917); *J. Soc. Chem. Ind.*, **38**, 845 (1919); *Ger. P.* 334,357 (1921); *Fr. P.* 518,086 (1917); *Frdl.*, **13**, 98-9 (1928).

- (102) Scheller, U.S.P. 1,244,901 (1918); *C. A.*, **12**, 155 (1918). Wohl, Ger. P. 526,853 (1919); *C. A.*, **25**, 4894 (1931); Brit. P. 154,579 (1920); *C. A.*, **15**, 1139 (1921); Fr. P. 526,875 (1921); *Chem. Zentr.*, **94**, **II**, 1247 (1923); *Z. angew. Chem.*, **35**, 593 (1922).
- (103) I. G. Farbenind. A. G., Brit. P. 329,867 (1929); *C. A.*, **24**, 5768 (1930); Brit. P. 425,069 (1935); *C. A.*, **29**, 5128 (1935); Ger. P. 544,286 (1929); *C. A.*, **26**, 2471 (1932); Fr. P. 717,184 (1931); *C. A.*, **26**, 2752 (1932); Fr. P. 776,518 (1935); *C. A.*, **29**, 3354 (1935).
- (104) Horst-Dietrich and Wietzel, (to I. G. Farbenind. A. G.), U.S.P. 1,856,639 (1932); *C. A.*, **26**, 3521 (1932).
- (105) I. G. Farbenind, Ger. P. 568,547 (1929); *C. A.*, **27**, 2696 (1933); Brit. P. 332,635 (1929); *C. A.*, **25**, 304 (1931); Brit. P. 425,069 (1935); *C. A.*, **29**, 5128 (1935); Fr. P. 688,047 (1930); *C. A.*, **25**, 715 (1931).
- (106) Zobel and Luther, U. S. P. 1,926,691 (1933); *C. A.*, **27**, 5756 (1933).
- (107) Boswell and Dilworth, *J. Phys. Chem.*, **29**, 1487-1506 (1925).
- (108) I. G. Farbenind. A. G., Ger. P. 489,360 (1926); *C. A.*, **24**, 2145 (1930); Ger. P. 550,993 (1930); *C. A.*, **26**, 4924 (1932). Andrussov and Durr, U.S.P. 1,882,712 (1932); *C. A.*, **27**, 736 (1933).
- (109) Bender, U.S.P. 1,355,299 (1921); *C. A.*, **15**, 96 (1921).
- (110) Tanner and Imperial Chemical Industries, Ltd., Brit. P. 344,638 (1930); *C. A.*, **25**, 4559 (1931).
- (111) Horsley and Imperial Chemical Industries, Ltd., Brit. P. 334,427 (1929); *C. A.*, **25**, 972 (1931); Brit. P. 351,016 (1930); *C. A.*, **26**, 2990 (1932); Brit. P. 346,288 (1930); *C. A.*, **26**, 479 (1932).
- (112) Dreyfus, U.S.P. 2,045,841 (1936); *C. A.*, **30**, 5597 (1936).
- (113) I. G. Farbenind. A. G. (Schuermann, Brill, and Wietzel, inventors) Ger. P. 637,186 (1936); *C. A.*, **31**, 711 (1937); Fr. P. 802,945 (1936); *C. A.*, **31**, 1826 (1937); Fr. P. 803,248 (1936); *C. A.*, **31**, 2619 (1937); U.S.P. 2,102,751 (1937); *C. A.*, **32**, 1283 (1938).
- (114) British Celanese Ltd., Groombridge, and Dee, Brit. P. 465,199 (1937); *C. A.*, **31**, 7070 (1937).
- (115) Walter (to Deutsche Gold und Silber Scheideanstalt vorm Roessler), U.S.P. 2,098,842 (1938); *C. A.*, **32**, 195 (1938).
- (116) Eberhardt (to I. G. Farbenind. A. G.), U.S.P. 2,093,146 (1937); *C. A.*, **31**, 7892 (1937).
- (117) Consortium für Elektrochemische Industrie, Fr. P. 722,190 (1931); *C. A.*, **26**, 4067 (1932); Brit. P. 373,893 (1931); *Brit. Chem. Abs.*, **1932 B**, 832; Ger. P. 583,975 (1933); *C. A.*, **28**, 1058 (1934).
- (118) I. G. Farbenind. A. G., Ger. P. 509,020 (1936); *C. A.*, **25**, 714 (1931); Ger. P. 533,466 (1927); *C. A.*, **26**, 480 (1932); Fr. P. 645,967 (1927); *C. A.*, **23**, 1910 (1929); Fr. P. 36,583 (1929); *C. A.*, **24**, 5768 (1930); Brit. P. 321,241 (1928); *C. A.*, **24**, 2474 (1930); Jochheim (to I. G. Farbenind. A. G.) U.S.P. 1,828,372 (1932); *C. A.*, **26**, 737 (1932).
- (119) Wohl, Brit. P. 154,579 (1920); *C. A.*, **15**, 1139 (1921).
- (120) I. G. Farbenind. A. G., Ger. P. 554,784 (1930); *C. A.*, **26**, 5971 (1932); Ger. P. 544,691 (1930); *C. A.*, **26**, 3521 (1932); Brit. P. 364,255 (1930); *Brit. Chem. Abs.*, **1932 B**, 459. Eberhardt, U.S.P. 1,972,476 (1934); *C. A.*, **28**, 6446 (1934).
- (121) Heckel and Nashan, U.S.P. 1,943,385 (1934); *C. A.*, **28**, 2018 (1934).
- (122) Gutehoffnungshütte Oberhausen A. G., Ger. P. 641,347 (1937); *C. A.*, **31**, 3070 (1937).
- (123) Lozovskii and Mendeleva, *Natural Gases (U.S.S.R.)*, No. 8, 59-71 (1934); *C. A.*, **31**, 3869 (1937).

7. Preparation of alkali-metal acetates and of acetone directly from acetylene. Feuchter (*I*) first observed that acetylene reacts directly with fused alkalis to form acetates. He conducted acetylene into a fused,

anhydrous caustic soda-potash mixture at about 220° and recovered acetic acid upon dissolving the melt in water and acidifying. A careful study of this reaction was made by the Consortium für Electrochem. Ind. (2, 3) and in the United States by the Dow Chemical Company (4, 5, 6). It was observed that the presence of water materially improved the yield and purity of the product. Since the water is consumed in the reaction, the following equation illustrates the process.

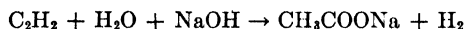

The sole products are sodium acetate and hydrogen, the latter being quite pure. Hydrogenation reactions are not encountered. Below 220° the reaction proceeds slowly and above 325° decomposition of the sodium acetate occurs. Pressure is not required, though it is desirable to increase the available acetylene. It is convenient to employ pressures of about 50–60 lbs. Higher pressures are avoided, to prevent explosive decomposition of the acetylene.

The yields are excellent. In one report (4) it is claimed that conversion of caustic to acetate was 96 per cent complete; the acetylene absorption was quantitative except for a 2–5 per cent loss with the hydrogen vented.

Caustic potash may be used also as well as mixtures of caustic soda and potash. Potash alone, or in mixtures, permits lower temperatures and a more rapid reaction (5, 6). Oxides and hydroxides of other alkali-forming metals, such as calcium and barium, may be employed, but the reaction rate is decreased. It has been found desirable to start the reaction with a mixture of fused hydroxide and acetate (3, 5). The optimum reaction rate is thus maintained until approximately two-thirds of the original alkali has reacted.

Water may be admitted to the reactants in various ways, such as steam or as caustic solution. A desirable method is to saturate the acetylene with water vapor at about 80°. In this way the gaseous charge contains about equal volumes (or moles) of water and acetylene.

It has been found in subsequent studies that other substances may be substituted for acetylene. Thus alkali-metal acetates are formed by reacting ethyl alcohol with a fused mixture of sodium and potassium hydroxides at 250–300° (7). Ethylene-propylene mixtures also yield sodium acetate under similar conditions if an inorganic basic aluminum compound (e.g., Al_2O_3) is present (8).

Under proper conditions of temperature, pressure and catalyst, acetylene reacts directly with steam to yield acetone. The catalysts employed include various basic metallic oxides, hydroxides, carbonates or acetates, and the reaction is usually conducted in the temperature range 250–450° and at pressures varying from about three to ten atmospheres. Although

the mechanism of the reaction has not been definitely established, it probably consists of the formation and decomposition of a metal acetate:

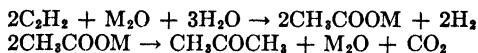

The metal oxide regenerated can then react further with steam and acetylene. It is significant that a number of other substances, including ethyl alcohol, acetaldehyde and acetic acid, yield acetone under similar conditions.

The earliest patent (9) claims as suitable catalysts the hydroxide, oxide or carbonate of thorium, or double salts of thorium, such as potassium thorium carbonate. Later patents (10) claim the use of oxides, carbonate or acetates of alkaline-earth metals or of zinc, tin, aluminum and magnesium, and in particular those metals whose acetates yield acetone on heating. Numerous more recent patents advocate the use of catalytic mixtures containing oxides of manganese, chromium, iron, and nickel, along with compounds of the more basic metals (11-21).

While a considerable number of patents have been issued covering processes for producing acetone from acetylene, it does not appear that any of these have attained great industrial importance. A few review articles have discussed this process (22-24).

References

- (1) Feuchter, *Chem.-Ztg.*, **38**, 273-4 (1914).
- (2) Consortium für Electrochem. Ind. (Mugdan and Wimmer), Ger. P. 540,207 (1930); *C. A.*, **26**, 1621 (1932).
- (3) *Idem*, Ger. P. 544,888 (1930); *C. A.*, **26**, 3517 (1932).
- (4) Strosacker, Kennedy and Pelton, U.S.P. 1,866,430 (1932); *C. A.*, **26**, 4345 (1932).
- (5) Strosacker and Stephenson, U.S.P. 1,866,328 (1932); *C. A.*, **26**, 4345 (1932).
- (6) Strosacker, Kennedy and Pelton, U.S.P. 1,866,329 (1932); *C. A.*, **26**, 4345 (1932).
- (7) *Idem*, U.S.P. 1,961,625 (1934); *C. A.*, **28**, 4844 (1934).
- (8) Britton, Nutting and Huscher, U.S.P. 2,000,878 (1935); *C. A.*, **29**, 4026 (1935).
- (9) Elektrizitätswerk Lonza, Brit. P. 192,392 (1923); *C. A.*, **17**, 3190 (1923).
- (10) I. G. Farbenind. A. G., Brit. P. 299,048 (1927); *C. A.*, **23**, 2989 (1929).
- (11) *Idem*, Brit. P. 330,350 (1929); *C. A.*, **24**, 5769 (1930). Schlicht U.S.P. 1,907,882 (1933); *C. A.*, **27**, 3724 (1933).
- (12) Holzverkohlungs-Industrie A. G., Brit. P. 280,184 (1926); *C. A.*, **22**, 2952 (1928).
- (13) Martin and Krehma (Commercial Solvents Corp.), U.S.P. 1,779,676 (1931); *C. A.*, **25**, 116 (1931).
- (14) Deutsche Gold und Silber Scheideanstalt vorm Roessler (Roka and Wiesler, inventors) Ger. P. 565,944 (1926); *C. A.*, **27**, 2459 (1933). Roka and Wiesler, U.S.P. 2,014,294 (1935); *C. A.*, **29**, 7346 (1935).
- (15) *Idem* (Roka, inventor) Ger. P. 566,833 (1929); *C. A.*, **27**, 2459 (1933).
- (16) *Idem* (Pohl, inventor) Ger. P. 567,118 (1930); *C. A.*, **27**, 1365 (1933). Pohl, U.S.P. 1,953,499 (1934); *C. A.*, **28**, 3744 (1934).
- (17) *Idem* (Walter, inventor) Ger. P. 584,517 (1933); *C. A.*, **28**, 1058 (1934); (Walter and Schultz, inventors) Ger. P. 577,705 (1933); *C. A.*, **28**, 493 (1934).
- (18) Querforth, U.S.P. 1,929,331 (1934); *C. A.*, **28**, 173 (1934).
- (19) Deutsche Gold und Silber Scheideanstalt vorm Roessler, Ger. P. 619,295 (1936); *C. A.*, **30**, 333 (1936).

- (20) *Idem*, Ger. P. 655,969 (1938); *C. A.*, **32**, 3773 (1938).
 (21) Shawinigan Chemicals Ltd., Brit. P. 472,093 (1937); *C. A.*, **32**, 1283 (1938).
 (22) Ushakov and Rozengart, *J. Chem. Ind. (Moscow)*, **1934**, No. 4, 66-9; *C. A.*, **28**, 4698 (1934).
 (23) Zelinskii, Ushakov, Mikhailov and Arbuzov, *J. Chem. Ind. (Moscow)*, **1933**, No. 7, 63-5; *C. A.*, **28**, 1015 (1934). *J. Applied Chem. (U.S.S.R.)*, **7**, 83-90 (1934); *C. A.*, **28**, 7245 (1934).
 (24) Platonov, Plakidina and Veltistov, *J. Gen. Chem. (U.S.S.R.)*, **4**, 421-33 (1934); *C. A.*, **29**, 1774 (1935).

8. The preparation of vinyl ethers and acetals by the addition of alcohols to acetylene. A number of alcohols combine with acetylene in the presence of catalysts. The first stage of this addition presumably results in the formation of a vinyl ether, but Hill and Pidgeon (1) and others (2) have shown that in the presence of acid catalysts and excess alcohols these vinyl compounds react very rapidly with a second alcoholic-hydroxyl group to form an acetal.

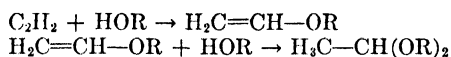

When polyhydric alcohols are employed under these conditions the chief products are cyclic acetals. By a similar catalytic reaction ketals have been formed from homologs of acetylene. The most effective catalysts for these additions are mercuric salts of strong acids, particularly sulfuric or a sulfonic acid or the strongly acid solution of boron trifluoride in the reacting alcohol. It has been postulated by Hennion and Vogt (29) that one or two equivalents of a mercuric alcoholate form an intermediate addition compound with acetylene, and that the mercury is then replaced in this substance by hydrogen in acid solutions.

The first patents for the production of vinyl and ethylidene ethers and esters by the action of acetylene on organic hydroxy compounds employed a mercuric salt such as the sulfate as a catalyst (3). Boiteau (4) also patented a similar process specifically for making acetals. Reichert, Bailey and Nieuwland (5) investigated the preparation of acetals from a series of monohydric alcohols and acetylene employing mercuric sulfate with sulfuric acid as the catalyst. Alcohols higher than ethyl gave poor yields, probably because of the dehydrating action of the sulfuric acid. Hill and Hibbert (6) successfully applied this method to the production of cyclic acetals from acetylene and ethylene glycol, trimethylene glycol, 1,2-propylene glycol, 1,4-tetramethylene glycol, glycerol α -bromhydrin, glycerol, pinacol, 2-methyl-2,4-pentanediol, and α -methylglucoside. Tamaru and Tanaka (7) and Contardi and Ciocca (8) have described the preparation of dimethyl acetal.

Nieuwland, Vogt and Foohey (9) reported an improved method for the

synthesis of acetals from acetylene in which the sulfuric acid and mercuric sulfate were replaced as catalysts by a mercuric salt and an acid derived from the reaction of an alcohol with boron trifluoride. With this catalyst acetals, chiefly cyclic, were prepared by the reaction of acetylene with a number of polyhydric alcohols, their ethers, and chlorhydrins, and similar compounds were also obtained from a few hydroxy carboxylic acids and their esters. This method was applied by Hinton and Nieuwland (10) to the synthesis of numerous acetals of monohydric alcohols. Bowlus and

H

Nieuwland (11) proposed the formula $RO \rightarrow BF_3$ for the acid compounds which are present in this reaction, and O'Leary and Wenzke (12) made conductivity measurements of the solutions which supported this view. Vaughn (13) called attention to the fact that the presence of a small quantity of water caused the formation of tarry by-products during the preparation of ethylene glycol acetal by this method, and it is probable that water is detrimental in all cases. The alkoxy-fluoboric acids have advantages over sulfuric acid for the synthesis of acetals in that they are more lasting and effective at low concentration and have no oxidizing properties and less tendency to split off water or hydrogen halides from the alcoholic substances. This appears to be the best method available for the preparation of many acetals. In like manner Hennion, Killian, and Nieuwland (14-16) have used the alkoxy-fluoboric acids with their mercuric salts as catalysts for the addition of alcohols to other acetylenic hydrocarbons to form ketals.

A few attempts have been made to isolate vinyl ethers from the first stage of addition of alcohols to acetylene, employing mercuric salts and an acid as catalysts. Plauson (17) patented the preparation of vinyl ethers by the reaction of alcohols with vinyl sulfate which was formed by the addition of concentrated sulfuric acid to acetylene at 2-5 atmospheres' pressure and 0° to -15° in the presence of mercuric sulfate. The vinyl ether was removed at diminished pressure. Patents have also been issued for the preparation of vinyl ethers from alcohols and acetylene in ligroin solution with a mercuric phosphate catalyst (18), and for the formation of vinyl ethers from acetylene and alcohols or phenols with freshly precipitated mercuric sulfate as a catalyst in the absence of mineral acids (19). The preparation of vinyl ethers by the cleavage of acetals in contact with metals such as silver, gold, platinum or palladium also has been patented (20). The production of vinyl ethers from phenolic compounds by reaction with acetylene in the presence of zinc or cadmium salts of organic acids at about 270° is another related reaction (21). It is probable that

the condensation of acetylene with the ring of phenolic compounds passes through a vinyl ether intermediate stage, which is then rearranged (see Chapter V, Section 5).

Favorsky (22) first postulated the existence of addition products of alkali alcoholates with acetylenic hydrocarbons as intermediates in the rearrangements of the hydrocarbons, and isolated 2-ethoxypropylene from the reaction of propyne with a solution of sodium ethylate in alcohol in a sealed tube. Chemists of the I. G. Farbenindustrie have obtained several patents for the preparation of vinyl ethers from acetylene and alcoholic substances employing strongly alkaline catalysts such as oxides, hydroxides or alcoholates of the alkali or alkaline-earth metals (23-28). In one modification the acetylene is passed into an alcoholic solution of an alkali-metal oxide, hydroxide, or alcoholate at 80-250° and approximately atmospheric pressure. The reaction of alcohols with acetylene at higher temperatures in vapor phase over soda lime or a similar alkaline catalyst (24) or over zinc or cadmium salts (21) has also been employed. It is claimed that vinyl ethers have been prepared by slight modifications of these methods from a variety of hydroxylic compounds, including hydroxy-alkyl amines (23, 25), terpene alcohols (26) and carbohydrate derivatives (27), as well as simple alcohols having comparatively low boiling points (28). The alkalies appear to be much more satisfactory than the acid mercuric salt catalysts for the production of vinyl ethers from acetylene.

References

- (1) Hill and Pidgeon, *J. Am. Chem. Soc.*, **50**, 2718-25 (1928).
- (2) Reppe and Baur (to I. G. Farbenind. A. G.) U.S.P. 2,000,252 (1935); *C. A.*, **29**, 4029 (1935).
- (3) Chemische Fabrik Griesheim Elektron, Brit. P. 14,246 (1913); *C. A.*, **9**, 149 (1915). Ger. P. 271,381 (1912); *C. A.*, **9**, 356 (1915). Fr. P. 461,223 (1913); *C. A.*, **8**, 3220 (1914). Klatte, U.S.P. 1,084,581 (1914); *C. A.*, **8**, 991 (1914).
- (4) Boiteau, Brit. P. 15,806 (1914); *C. A.*, **10**, 93 (1916). Brit. P. 15,919 (1914); *C. A.*, **10**, 93 (1916).
- (5) Reichert, Bailey and Nieuwland, *J. Am. Chem. Soc.*, **45**, 1552-7 (1923).
- (6) Hill and Hibbert, *J. Am. Chem. Soc.*, **45**, 3108-16 (1923).
- (7) Tamaru and Tanaka. *J. Chem. Soc. Japan*, **56**, 486-504 (1935); *C. A.*, **29**, 4733 (1935).
- (8) Contardi and Ciocca, *Ricerca sci.* (2), **7**, II, 610-21 (1936); *C. A.*, **32**, 9039 (1938).
- (9) Nieuwland, Vogt and Foohey, *J. Am. Chem. Soc.*, **52**, 1018-24 (1930).
- (10) Hinton and Nieuwland, *J. Am. Chem. Soc.*, **52**, 2892-6 (1930).
- (11) Bowlus and Nieuwland, *ibid.*, **53**, 3835-40 (1931). Vaughn, Bowlus and Nieuwland, *Proc. Ind. Acad. Sci.*, **40**, 203-6 (1930).
- (12) O'Leary and Wenzke, *J. Am. Chem. Soc.*, **55**, 2117-21 (1933).
- (13) Vaughn, *Proc. Ind. Acad. Sci.*, **42**, 127-30 (1933).
- (14) Hennion, Killian, Vaughn and Nieuwland, *J. Am. Chem. Soc.*, **56**, 1130-2 (1934).
- (15) Killian, Hennion and Nieuwland, *ibid.*, **56**, 1384-5, 1786-7 (1934); **58**, 80-1, 892-4, 1658-9 (1936).
- (16) Hennion and Nieuwland, *ibid.*, **57**, 2006-7 (1935).

- (17) Plauson and Vielle, *Brit. P.* 156,121 (1920); *C. A.*, **15**, 1728 (1921). Plauson, U.S.P. 1,436,388 (1923); *C. A.*, **17**, 564 (1923).
- (18) Consortium für Elektrochemische Industrie, *Brit. P.* 231,841 (1924); *C. A.*, **19**, 3491 (1925).
- (19) Mitchell and Imperial Chemical Industries, *Brit. P.* 428,080 (1933); *Brit. Chem. Abs. B.*, (1935) 618.
- (20) I. G. Farbenindustrie A. G., *Brit. P.* 345,253 (1929); *C. A.*, **26**, 156 (1932). Ger. P. 525,836 (1931); *Fr. P.* 703,509 (1931); *Chem. Zentr.*, **102** II, 1191 (1932). Baur, U.S.P. 1,931,858 (1934); *C. A.*, **28**, 485 (1934).
- (21) I. G. Farbenind. A. G., *Brit. P.* 430,590 (1935); *C. A.*, **29**, 8001 (1935). Ger. P. 643,220 (1937); *C. A.*, **31**, 4341 (1937). Reppe and Wolff, U.S.P. 2,017,355 (1935); *C. A.*, **29**, 8001 (1935).
- (22) Favorsky, *J. Russ. Phys.-Chem. Soc.*, **19**, 414-27 (1887); *J. Chem. Soc.*, **54**, 798-0 (1888); *Chem. Zentr.* (1887) 1539-40. *J. prakt. Chem. (2)*, **37**, 382-95 (1888); *ibid.* (2), **44**, 208-38 (1891).
- (23) I. G. Farbenind. A. G., *Brit. P.* 369, 297 (1930); *C. A.*, **27**, 2159 (1933). *Fr. P.* 724, 955 (1931); *C. A.*, **26**, 4825 (1932). Ger. P. 584,840 (1933); *C. A.*, **28**, 1058 (1934). Reppe (to I. G. Farbenind. A. G.) U.S.P. 1,959,927 (1934); *C. A.*, **28**, 4431 (1934).
- (24) I. G. Farbenind. A. G., *Fr. P.* 45,333 (1935); *C. A.*, **30**, 2578 (1936); Ger. P. 639,843 (1936); *C. A.*, **31**, 3939 (1937); *Brit. P.* 427,036 (1935); *C. A.*, **29**, 6247 (1935). Reppe and Wolff (to I. G. Farbenind. A. G.) U.S.P. 2,066,076 (1937); *C. A.*, **31**, 1037 (1937).
- (25) I. G. Farbenind. A. G., *Fr. P.* 44,892 (1935); *C. A.*, **29**, 6247 (1935).
- (26) *Idem.*, *Fr. P.* 46,543 (1936); *C. A.*, **30**, 8241 (1936).
- (27) *Idem.*, *Brit. P.* 462,903 (1937); *C. A.*, **31**, 3811 (1937).
- (28) *Idem.*, *Brit. P.* 430,764 (1935); *C. A.*, **29**, 8001 (1935); *Fr. P.* 45,742 (1935); *C. A.*, **30**, 3838 (1936); Ger. P. 640,510 (1937); *C. A.*, **31**, 4341 (1937). Reppe and Wolff (to I. G. Farbenind. A. G.) U.S.P. 2,021,869 (1936); *C. A.*, **30**, 486 (1936).
- (29) Hennion and Vogt, *J. Org. Chem.*, **1**, 159-62 (1936).

9. The preparation of vinyl and ethylidene esters from acetylene. Several aliphatic carboxylic acids have been added to acetylene in the presence of catalysts to yield vinyl esters as a first product or ethylidene diesters as the product of a second stage of addition.



The catalysts most commonly employed are combinations of a mercuric salt with a strong acid. The addition of acetic acid to acetylene has received the major share of attention, and the vinyl acetate produced is an important raw material for synthetic resins; ethylidene diacetate is a source of acetic anhydride and acetaldehyde.

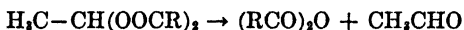

In a liquid medium a variety of mercuric salts with their corresponding acids have been employed as catalysts for these additions. Mercuric sulfate with a small quantity of sulfuric acid appears to have been used first for this purpose (1-3). However, it was found that sulfuric acid caused undesirable side reactions of oxidation, dehydration, and poly-

merization in this process and a more suitable acid was sought. Mercuric phosphate was used in a few cases (3-5).

The reaction of fuming sulfuric acid or sulfur trioxide on acetic acid, or of concentrated sulfuric acid on acetic anhydride produces acetyl sulfuric acid, which rearranges on warming to sulfoacetic acid, $\text{HO}_3\text{SCH}_2\text{COOH}$. These substances with their mercuric salts have been found to be a satisfactory catalyst for the addition of acetic acid to acetylene. For example, a catalyst for the preparation of ethylidene diacetate consists of mercuric oxide and sulfur trioxide or fuming sulfuric acid added to acetic acid (6), and a similar mixture, which is said to contain acetyl sulfuric acid, has been used at 20-60° for the preparation of vinyl esters (7). Acetic anhydride appears to promote the addition of acetic acid to acetylene and has been used for this purpose in conjunction with a mercuric salt and sulfonic acids (8) in the preparation of ethylidene diacetate, and with sulfoacetic acid for preparing vinyl esters (8-12). Several other sulfonic acids also have been patented as components of similar catalysts (8, 12, 13); these include benzene sulfonic (8, 12), naphthalene sulfonic (8-12, 14), camphor sulfonic (12), methionic (12, 13), and aldehyde disulfonic (12), and benzene disulfonic acids (13). Methylene sulfate (14) also has been suggested for this purpose.

Chemists of the I. G. Farbenindustrie A. G. have obtained several patents covering the use of mercuric compounds with acids containing boron and fluorine as catalysts in these reactions. The compounds used include boron fluoride (15-17), boron oxide (18), and mixtures of hydrogen fluoride with boric acid, boron oxide, or boron fluoride (19). Dihydroxyfluoboric acid also has been used in this way (20). The mercuric salts of silico-, phospho-, and borotungstic acids, silico- or phosphomolybdic acids, and tungstomolybdophosphoric acid have been patented as catalysts (21). The addition of silica (22, 23) and Japanese acid clay (24) as supports for mercury catalysts has been proposed. The addition of oxidizing substances to the catalytic mercury salt solutions is said to prevent reduction of the mercury compounds and to diminish tar formation (25-27). Inert diluents for the reaction mixture have been suggested (28).

At somewhat higher temperatures and pressures of acetylene other metallic salts may replace mercuric salts as catalysts in the liquid-phase addition of carboxylic acids to acetylene. Patents cover zinc and cadmium salts of these acids (29-30) and compounds of magnesium, iron, zinc, aluminum, and boron (31).

Several patents describe methods of producing vinyl acetate with a minimum of ethylidene diacetate from the liquid-phase addition of acetic acid to acetylene. Since the vinyl ester is the low-boiling component of the mixture it can be swept out with excess acetylene (32-35) or distilled off

after neutralization of the mineral acid present (36). The formation of the vinyl ester is favored if the bulk of the liquid medium is not excess acetic acid, but an inert diluent such as kerosene or paraffin oil (37), having a boiling point higher than vinyl acetate.

If ethylidene diacetate is desired, more prolonged contact with excess acetic acid is essential. In distilling the crude product to obtain ethylidene diacetate, neutralization of the mineral acid of the catalyst by the addition of sodium acetate has been proposed (38-39). A few patents also describe the conversion of vinyl esters to ethylidene esters by the further addition of acetic or other carboxylic acids with catalysts consisting of oxides of sulfur (41) or sulfuric, phosphoric, or sulfonic acids and a mercuric salt (3, 42).

Many of the patents on catalysts and methods for making vinyl acetate and ethylidene diacetate are sufficiently broad to cover homologous esters of other carboxylic acids, however, these other esters do not appear to have found any important practical application. Among the acids which have been specifically cited for these processes may be mentioned propionic, lactic, the chlorinated acetic acids (1), crotonic (16), butyric (32), and polycarboxylic acids which may have been partially esterified (30).

The use of dilute acetylene from pyrolytic processes for conversion to ethylidene diacetate by similar processes also has been proposed (43).

Similar addition reactions of carboxylic acids with acetylene have been performed in vapor phase. A series of patents claims that zinc or cadmium acetate, which may be supported by carbon or silica gel, are effective catalysts for this purpose (44). Dreyfus (45) claims that an ethylidene ester may be made the sole product of a vapor-phase process, if from three to six mols of an acid are used with each mol of acetylene. Walter (46) suggested that the vapor of an acid mixed with acetylene be passed through a catalytic solution. An apparatus consisting of a tube at 200° containing a water-cooled central tube has been patented for use in this reaction (47). Ushakov and Feinstein (48) have discussed the effect of various factors on the vapor-phase synthesis of vinyl acetate.

Vinyl formate has been prepared by an acid exchange reaction (58).

A few review articles have appeared which cover the addition of acetic acid to acetylene (49-52). See also Introduction (3, 4).

Vinyl acetate is an important constituent of several commercial resinous materials such as "Mowilith", "Gelva", "Alvar", and "Vinylite" (53-55). The preparation, properties, and structure of vinyl acetate polymers has been discussed by Hermann and Haehnal (56) and Staudinger, Frey, and Starck (57). The polymer can be saponified to a polyalcohol.

Ethylidene diacetate and its homologs have been cleaved by a number of methods to yield acetaldehyde and acetic anhydride. Catalysts employed

in cleavage in the liquid state include strong mineral acids such as hydrogen chloride, sulfuric acid, or better, phosphoric acid (59-64), oxides of sulfur (65), mercuric salts, which remain from the synthesis of the ethylidene diacetate (66), and zinc chloride (67). Ethylidene diacetate may be simultaneously formed and cleaved in a mixture of acetic acid with vinyl acetate (64). Diluents may be used in this process. Cleavage also may be performed in the vapor phase by heat (68, 69) or with the aid of metallic catalysts (70, 71) which may be supported on alumina, silica or charcoal. Coffin and co-workers (72) have investigated the vapor-phase decomposition of ethylidene diacetate and have reported that the reaction is homogeneous and of the first order. The homologs produced from alkyl acetylenes and carboxylic acids yield ketones and acid anhydrides upon cleavage (72, 73). A few reviews have discussed the production of acetic anhydride from ethylidene diacetate (74-77).

References

- (1) Chem. Fabrik Griesheim Elektron., Fr. P. 461,223 (1913); *C. A.*, **8**, 3220 (1914); Brit. P. 14,246 (1913); *C. A.*, **9**, 149 (1915); Ger. P. 271,381 (1914); *Frdl.*, **11**, 54 (1915). *Chem. Zentr.*, **1914 I**, 1316.
- (2) Klatte, U.S.P. 1,084,581 (1914); *C. A.*, **8**, 991 (1914).
- (3) Chemische Fabrik Griesheim Elektron., Ger. P. 313,696 (1919); *Frdl.*, **13**, 104 (1928).
- (4) Morrison (to Canadian Electro Products Co.) Can. P. 287,495 (1929); *C. A.*, **23**, 1909 (1929); U.S.P. 1,710,181 (1929); *C. A.*, **23**, 2724 (1929).
- (5) Skirrow and Morrison (to Canadian Electro Products Co.) Can. P. 287,494 (1929); *C. A.*, **23**, 1908 (1929); U.S.P. 1,710,197 (1929); *C. A.*, **23**, 2724 (1929).
- (6) Matheson and Skirrow (to Canadian Electro Products Co.) Can. P. 237,664 (1924); *C. A.*, **18**, 988 (1924); U.S.P. 1,720,184 (1929); *C. A.*, **23**, 4231 (1929).
- (7) Skirrow and Morrison, Brit. P. 308,169 (1928), 308,170 (1928); *C. A.*, **24**, 129 (1930); Ger. P. 559,436 (1929); *C. A.*, **27**, 736 (1933); Can. P. 318,838 (1932); *C. A.*, **26**, 1944 (1932). U.S.P. 1,855,366 (1932); 1,855,367 (1932); *C. A.*, **26**, 3265 (1932).
- (8) Soc. chimique des usines du Rhone, Fr. P. 611,878 (1925); Ger. P. 453,021 (1927); *Frdl.*, **15**, 133 (1928). Brit. P. 252,632 (1925); *C. A.*, **21**, 2274 (1927). Bouvier and Hugoniot (to Soc. chimique des usines du Rhone), U.S.P. 1,680,760 (1928); *C. A.*, **22**, 3669 (1928); Can. P. 262,826 (1926); *C. A.*, **20**, 3460 (1926).
- (9) Imperial Chemical Industries Ltd., Brit. P. 351,318 (1929); *C. A.*, **26**, 5309 (1932).
- (10) Dykstra (to E. I. duPont de Nemours & Co.), U.S.P. 1,849,616 (1932); *C. A.*, **26**, 2752 (1932).
- (11) Strain (to E. I. duPont de Nemours & Co.), U.S.P. 1,849,647 (1932); *C. A.*, **26**, 2749 (1932); Brit. P. 379,705 (1932); *C. A.*, **27**, 3944 (1933).
- (12) Soc. chimique des usines du Rhone, Ger. P. 334,554 (1923); *C. A.*, **17**, 1801 (1923); Brit. P. 112,765 (1917); *C. A.*, **12**, 1050 (1918); Koetschet and Beudet, U.S.P. 1,306,964 (1919); *C. A.*, **13**, 2219 (1919).
- (13) Boehringer and Soehne, Fr. P. 770,154 (1934); *C. A.*, **29**, 481 (1935); Brit. P. 427,448 (1935); *C. A.*, **29**, 5864 (1935); Ger. p. 643,800 (1937); *C. A.*, **31**, 5817 (1937); Rabald, U.S.P. 2,011,011 (1935); *C. A.*, **29**, 6609 (1935).
- (14) Soc. chimique des usines du Rhone, Brit. P. 112,766 (1917); *C. A.*, **12**, 1050 (1918); Koetschet and Beudet, U.S.P. 1,304,989 (1919); *C. A.*, **13**, 2040 (1919).
- (15) I. G. Farbenind. A. G., Ger. P. 582,544 (1933); *C. A.*, **28**, 778 (1934). Weibezahn, U.S.P. 1,912,608 (1933); *C. A.*, **27**, 4243 (1933).
- (16) I. G. Farbenind. A. G., Ger. P. 637,257 (1936); *C. A.*, **31**, 3938 (1937).

- (17) *Idem.*, Ger. P. 638,003 (1936); *C. A.*, **31**, 3939 (1937).
- (18) *Idem.*, Ger. P. 636,212 (1936); *C. A.*, **31**, 3938 (1937).
- (19) *Idem.*, Brit. P. 438,728 (1935); *C. A.*, **30**, 2986 (1936). Fr. P. 773,476 (1934); *C. A.*, **29**, 1432 (1935); Ger. P. 604,640 (1934); *C. A.*, **29**, 813 (1935); Brit. P. 459,882 (1937); *C. A.*, **31**, 4341 (1937); Fr. P. 46,452 (1936); *C. A.*, **30**, 8241 (1936).
- (20) E. I. duPont de Nemours & Co. (Nieuwland and Sowa, inventors) Brit. P. 463,545 (1937); *C. A.*, **31**, 6677 (1937).
- (21) Carbide and Carbon Chemicals Corp., Fr. P. 827,757 (1938); *C. A.*, **32**, 8438 (1938).
- (22) Deutsche Gold und Silber Scheideanstalt vorm Roessler, Ger. P. 599,631 (1934); *C. A.*, **28**, 7267 (1934).
- (23) Verein für Chemische Ind. A. G., Fr. P. 666,042 (1928); *C. A.*, **24**, 1390 (1930).
- (24) Kuwata and Kato, *J. Soc. Chem. Ind. Japan*, **39**, 127-8 (1936); *C. A.*, **30**, 5109 (1936).
- (25) Soc. chimique des usines du Rhone, Brit. P. 252,640 (1925); *C. A.*, **21**, 2274 (1927); Ger. P. 455,583 (1928); *Frdl.*, **16**, 713 (1931). Ledru and Bachmann, Can. P. 269,818 (1927); *C. A.*, **21**, 2274 (1927); U.S.P. 1,672,646 (1928); *C. A.*, **22**, 2573 (1928).
- (26) Deutsche Gold und Silber Scheideanstalt vorm Roessler, Ger. P. 556,775 (1927); *C. A.*, **27**, 312 (1933).
- (27) Dreyfus, Fr. P. 808,712 (1937); *C. A.*, **31**, 6252 (1936).
- (28) Deutsche Gold und Silber Scheideanstalt vorm Roessler, Ger. P. 571,318 (1938); *C. A.*, **27**, 2696 (1933).
- (29) Consortium für Elektrochemische Ind. G.m.b.H., Ger. P. 553,071 (1930); *C. A.*, **26**, 4611 (1932).
- (30) I. G. Farbenind. A. G., Brit. P. 395,478 (1933); *C. A.*, **28**, 484 (1934); Ger. P. 588,352 (1933); *C. A.*, **28**, 1357 (1934); Fr. P. 763,424 (1934); *C. A.*, **28**, 5469 (1934). Reppe, U.S.P. 2,066,075 (1937); *C. A.*, **31**, 1037 (1937).
- (31) Plausons Forschungsinstitut Ges., Ger. P. 373,369 (1923); *Frdl.*, **14**, 268.
- (32) Consortium für Elektrochemische Ind., Brit. P. 231,841 (1924); *C. A.*, **19**, 3491 (1925); Fr. P. 594,219 (1925); Ger. P. 483,780 (1929); *Frdl.*, **16**, 683-4 (1931).
- (33) Herrmann and Baum, Can. P. 264,158 (1926); *C. A.*, **20**, 3696 (1926).
- (34) Herrmann, Deutsch and Baum, U.S.P. 1,790,920 (1931); *C. A.*, **25**, 1537 (1931).
- (35) Skirrow and Herzberg, U.S.P. 1,638,713 (1927); *C. A.*, **21**, 3204 (1927).
- (36) *Idem.*, Can. P. 237,841 (1924); *C. A.*, **18**, 988 (1924).
- (37) Dykstra and Sly (to E. I. duPont de Nemours & Co.), Brit. P. 319,589 (1928); *C. A.*, **24**, 2470 (1930); U.S.P. 1,786,647 (1931); *C. A.*, **25**, 710 (1931); Fr. P. 682,129 (1929); *C. A.*, **24**, 4306 (1930).
- (38) Marshall and Shaw, U.S.P. 1,450,982 (1923); *C. A.*, **17**, 1969 (1923). Marshall, Can. P. 237,663 (1924); *C. A.*, **18**, 988 (1924).
- (39) Courtaulds Ltd. and Brown, Brit. P. 353,318 (1930); *C. A.*, **26**, 5314 (1932).
- (41) Skirrow and Dick, Can. P. 228,127 (1923); *C. A.*, **17**, 1241 (1923); U.S.P. 1,449,918 (1923); *C. A.*, **17**, 2290 (1923).
- (42) Consortium für Elektrochemische Ind. Ges., Brit. P. 288,549 (1927); *C. A.*, **23**, 608 (1929).
- (43) I. G. Farbenind. A. G., Fr. P. 819,395 (1937); *C. A.*, **32**, 2148 (1938).
- (44) Consortium für Elektrochemische Ind. Ges., Ger. P. 485,271 (1927); *C. A.*, **24**, 862 (1930); Brit. P. 285,095 (1928); *C. A.*, **22**, 4537 (1928); Fr. P. 649,455 (1928); *C. A.*, **23**, 2986 (1929). Baum, Deutsch, Hermann, and Mugdan, U.S.P. 1,666,482 (1928); *C. A.*, **22**, 1983 (1928); Hermann, Deutsch, and Baum, U.S.P. 1,822,525 (1931); *C. A.*, **25**, 5900 (1931).
- (45) Dreyfus, Brit. P. 450,684 (1936); *C. A.*, **31**, 110 (1937); U.S.P. 2,121,342 (1938); *C. A.*, **32**, 6260 (1938).
- (46) Verein für Chem. Industrie A. G. and H. Walter, Brit. P. 288,707 (1927); *C. A.*, **23**, 607 (1929). Walter, U.S.P. 1,669,384 (1928); *C. A.*, **22**, 2170 (1928).
- (47) Ruhrchemie A. G., Brit. P. 378,873 (1931); 378,979 (1931); *Brit. Chem. Abs.-B* (1932) 1071.

- (48) Ushakov and Feinstein, *Ind. Eng. Chem.*, **26**, 5614 (1934).
- (49) Morrison and Shaw, *Trans. Electrochem. Soc.*, **63**, 425-47 (1933); *C. A.*, **27**, 2625 (1938).
- (50) Carleton Ellis, "Chemistry of Petroleum Derivatives", vol. **1**, 681-2 (1934), vol. **2**, 717-18 (1937); New York, Reinhold Publishing Corp.
- (51) Ullmann, "Enzyklopadie der technischen Chemie", vol. **10**, 283-5 Berlin, Urban and Schwarzenberg, 1932.
- (52) Thorpe, "Dictionary of Applied Chemistry", 4th ed., vol. **1**, 91-92. Longmans, Green and Co., New York, 1937.
- (53) Carleton Ellis, "The Chemistry of Synthetic Resins," Chapter 51-2; New York, Reinhold Publishing Corp. 1935.
- (54) Thorpe, "Dictionary of Applied Chemistry", 4th ed., vol. **1**, 93-5 New York, Longmans Green and Co., 1937.
- (55) Elliot, *Can. Chem. Met.*, **18**, 173-6 (1934).
- (56) Herrmann and Haehnel, *Ber.*, **60 B**, 1658-63 (1927).
- (57) Staudinger, Frey, and Starck, *Ber.*, **60 B**, 1782-92 (1927).
- (58) Consortium fur Elektrochemische Ind., Fr. P. 777,556 (1935); *C. A.*, **29**, 4029 (1935). Brit. P. 425,673 (1935); *C. A.*, **29**, 5462 (1935).
- (59) Bosnische Elektricitats A. G., Ger. P. 284,996 (1914); Brit. P. 23,190 (1914); Kaufler, U.S.P. 1,152,098 (1915); *Frdl.*, **12**, 76.
- (60) Consortium für Elektrochem. Ind., Ger. P. 391,674 (1924); *Frdl.*, **14**, 222-3 (1926).
- (61) Marshall and Shaw, Can. P. 217,576 (1922); *C. A.*, **16**, 1781 (1922); U.S.P. 1,578,454 (1926); *C. A.*, **20**, 1630 (1926).
- (62) Soc. chem. des usines du Rhone, Ger. P. 346,236 (1921); *C. A.*, **17**, 1247 (1923); Fr. P. 486,591 (1918); *C. A.*, **14**, 72 (1920); Brit. P. 110,906 (1917); *J. Soc. Chem. Ind.*, **37**, 282A (1918); Koetschet and Beudet, U.S.P. 1,306,963 (1919); *C. A.*, **13**, 2219 (1919).
- (63) Verein fur Chemische Industrie A. G., Ger. P. 495,334 (1928); *C. A.*, **24**, 3251 (1930).
- (64) Consortium für Elektrochem. Ind., Ger. P. 526,795 (1928); 526,797 (1928); *C. A.*, **25**, 4559 (1931); Ger. P. 503,131 (1927); *C. A.*, **24**, 5045 (1930); Brit. P. 288,549 (1927); *C. A.*, **23**, 608 (1929).
- (65) Skirrow, U.S.P. 1,429,650 (1922); *C. A.*, **16**, 3903 (1922).
- (66) Matheson and Grattan, Can. P. 217,575 (1922); *C. A.*, **16**, 1781 (1922); U.S.P. 1,425,500 (1922); *C. A.*, **16**, 3314 (1922).
- (67) Soc. chim. des usines du Rhone, Brit. P. 238,825 (1924); *C. A.*, **19**, 1995 (1926); Roy, U.S.P. 1,579,248 (1926); *C. A.*, **20**, 1630 (1926).
- (68) Matheson (to Canadian Electro Products Co.) U.S.P. 1,872,479 (1932); *C. A.*, **26**, 5971 (1932).
- (69) Dreyfus, U.S.P. 2,106,798 (1938); *C. A.*, **32**, 2546 (1938).
- (70) Farbenfabriken vorm F. Bayer & Co., Ger. P. 360,325 (1922); *Frdl.*, **14**, 250.
- (71) Boehringer and Soehne, Fr. P. 746,684 (1933); *C. A.*, **27**, 4545 (1933); Ger. P. 580,930 (1933); *C. A.*, **28**, 180 (1934); Brit. P. 396,276 (1933); *C. A.*, **28**, 492 (1934); Fr. P. 779,212, (1935); *C. A.*, **29**, 4776 (1935).
- (72) Coffin, *Can. J. Research*, **5**, 636-47 (1931); *C. A.*, **26**, 1502 (1932); *Can. J. Research*, **6**, 417-27 (1932); *C. A.*, **26**, 3429 (1932). Coffin, Dacey and Parlee, *Can. J. Research*, **15 B**, 247-63 (1937); *C. A.*, **31**, 6538 (1937). Coffin and Beasley, *Can. J. Research*, **15 B**, 229-36 (1937); *C. A.*, **31**, 4879 (1937).
- (73) I. G. Farbenind. A. G., Ger. P. 590,237 (1934); *C. A.*, **28**, 2014 (1934).
- (74) Ullmann, "Enzyklopadie der technischen Chemie", vol. **4**, 694-5 Berlin, Urban and Schwarzenberg, 1929.
- (75) Mayor, *Rev. chim. ind. (Paris)*, **45**, 302-11 (1936); *C. A.*, **31**, 1763 (1937).
- (76) Lichtenberger, *Tech. moderne*, **29**, 601-8 (1937); *C. A.*, **32**, 5527 (1938).
- (77) Kazarnovskii and Pisarev, *Org. Chem. Ind. (U.S.S.R.)*, **1**, 195-202 (1936); *C. A.*, **30**, 7539 (1936).

10. The addition of sulfur and its compounds to acetylenes. Reference is made in Chapter V, Section 6, to the formation of carbon disulfide and hydrogen sulfide as the principal products when acetylene is passed into heated sulfur in attempts to prepare thiophene. No intermediates appear to have been isolated (1). In form this reaction corresponds to the complete oxidation of acetylene to carbon dioxide and water.

Little is known concerning the addition to acetylenes of compounds containing the —SH group. Tomkinson (4) reported the production of colored condensates of unknown composition from acetylene and hydrogen sulfide at 300–400° in contact with oxides or sulfides of molybdenum, zinc, cadmium, or thorium. Guest (2) reports that acetylene reacts with liquid hydrogen sulfide to give a little thioacetaldehyde. Patents claim the addition of hydrogen sulfide to acetylene under pressure in solution and in the presence of potassium hydrosulfide as a method for the preparation of trithioaldehyde, ethyl mercaptan, vinyl ethyl sulfide, or the diethyl ether of ethanedithiol (3). The somewhat analogous addition of thiophenols, hydrogen disulfide, hydrogen sulfide and sulfur to divinyl acetylene has been reported (Chapter V, Section 7). It is of interest to note that mercury salts of thio-compounds appear to be but very slightly ionized and to be incapable of playing a role in the addition of sulfur compounds similar to the mercury catalyzed additions of the oxygen analogs.

References

- (1) Meyer and Sandmeyer, *Ber.*, **16**, 2176 (1883). Capelle, *Bull. soc. chim. (4)*, **3**, 150–4 (1908). Coninck, *Bull. sci. acad. roy. Belg.* (1908) 303.
- (2) Guest, *Iowa State Col. J. Sci.*, **8**, 197–8 (1933); *C. A.*, **28**, 2631 (1934).
- (3) I. G. Farbenind. A. G., *Fr. P.* 793,151 (1936); *C. A.*, **30**, 4240 (1936); *Brit. P.* 444,689 (1936); *C. A.*, **30**, 5594 (1936); *Ger. P.* 625,660 (1936); *C. A.*, **30**, 5595 (1936).
- (4) Tomkinson, *J. Chem. Soc.*, **125**, 2264–6 (1924).

11. The addition of nitrogen and its compounds to acetylene. Under mild conditions of temperature and pressure and in the absence of catalysts, acetylene and its homologs are remarkably inert to most nitrogen compounds. In fact diazomethane is the only C—H—N compound known to react readily with acetylene in the cold and without catalysts. Under more drastic conditions a variety of complex condensation products are produced, as has been shown in Chapter V, Section 6. Fuming nitric acid leads to a number of heterocyclics containing nitrogen (see Chapter V, Section 6). For the present purpose only those reactions which involve one molecule of acetylene are discussed.

When acetylene and nitrogen are sparked at atmospheric pressure, carbon and hydrocyanic acid are formed, as was first shown by Berthelot (1). Further studies of this reaction were made by other chemists, notably Mixter (2), Montemartini (5), Garner (6), and Francesconi and Ciurlo (7). The

conversion of acetylene to hydrocyanic acid can be made quantitative, in the presence of excess hydrogen, if the acid is removed by alkalis as soon as formed. The most notable byproduct is ammonia. It is likely that the primary reaction is the decomposition of acetylene into carbon and hydrogen; these products then react with the nitrogen. Oxygen, if present, reacts (4) and may increase the HCN yield (6). If acetylene and nitrogen are passed through an electric furnace at 200°, HCN is produced, but at 350° the HCN disappears, giving place to a small amount of benzene (7). The conversion to HCN is said to be promoted by the corona effect (5).

Thermal processes involving acetylene and ammonia usually give complex mixtures of pyridine bases (see Chapter V, Section 6). However, if the speed of the gases through the reactor is made very slow, pyridine bases are obtained only in small amounts and acetonitrile and other nitriles are formed (8). The reaction must proceed, of course, with the loss of hydrogen:

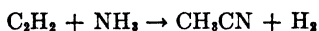

It is possible that the reaction mechanism involves pyrolysis of nitrogen-containing heterocyclics. Aliphatic amines may be used also, and compounds of zinc are suitable catalysts. At higher temperatures (700°) ammonia reacts with acetylene, ethylene or methane to yield hydrogen cyanide (9).

Patents (10) have been issued claiming the preparation of ethylidene aniline from aniline and acetylene in the presence of boron fluoride and a mercuric salt, or of cuprous salts. The addition of diaryl amines to acetylene in the presence of alkalis to produce diaryl vinyl amines also has been patented (11).

Certain catalytic processes involving acetylene and liquid aniline probably yield ethylidene aniline and homologs which when heated give products of the quinaldine type (see Chapter V, Section 6). When acetylene is passed into a solution of sulfur in aniline a dithio-oxalanilide, $(\text{CSNH}-\text{C}_6\text{H}_5)_2$, is said to be formed (12).

When purified acetylene is passed into an ethereal solution of diazomethane, surrounded by ice, a 50 per cent yield of pyrazole is obtained after two days (13).

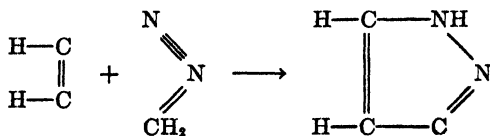

Azoimide reacts with acetylene, when heated 70 hours at 100° in a sealed tube, to yield 1,2,3-triazole (14).

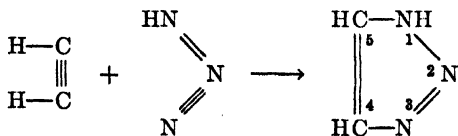

Phenylazoimide behaves similarly and gives 1-phenyl-1,2,3-triazole. The reactions are carried out in acetone solution.

There are numerous reactions of acetylenic compounds with nitrogen-containing compounds which do not take place with acetylene or the alkyl acetylenes. All these necessitate that the triple linkage be conjugate with a double or triple bond as in the systems, $-\text{C}\equiv\text{C}-\text{C}=\text{O}$ or $-\text{C}\equiv\text{C}-\text{C}\equiv\text{N}$. Although some of these reactions apply to a few of the substitution products of acetylene cited in Chapter III, they cannot be included in this work.

References

- (1) Berthelot, *Compt. rend.*, **67**, 1141-5 (1868); *Bull. soc. chim. (2)*, **11**, 446-50 (1869); *Ann.*, **150**, 60-6 (1869).
- (2) Mixer, *Am. J. Sci.* (iv) **9**, 1-8 (1900); (iv) **10**, 299-309 (1900).
- (5) Montemartini, *Gazz. chim. ital.*, **52**, (II) 96-7 (1922).
- (6) Garner and Matsumo, *J. Chem. Soc.*, **119**, 1903-14 (1921); **121**, 1729-36 (1922). Garner and Saunders, *ibid.*, **125**, 1634-41 (1924).
- (7) Francesconi and Ciurlo, *Gazz. chim. ital.*, **54**, 687-97 (1924).
- (8) I. G. Farbenind. A. G., Fr. P. 38,072 (1930); *C. A.*, **25**, 5434 (1931).
- (9) Bredig, Elöd and Demme, *Z. Elektrochem.*, **36**, 991-1003 (1930).
- (10) E. I. duPont de Nemours & Co. Brit. P. 384,332 (1932); *C. A.*, **27**, 4252 (1933); Fr. P. 733,663 (1931); *C. A.*, **27**, 1011 (1933).
- (11) I. G. Farbenind. A. G., Ger. P. 618,120 (1935); *C. A.*, **30**, 110 (1936); Fr. P. 801,519 (1936); *C. A.*, **31**, 418 (1937). Keyssner and Wolff (to I. G. Farbening. A. G.), U.S.P. 2,123,733, 2,123,734 (1938); *C. A.*, **32**, 7055 (1938).
- (12) Consonno and Cruto, *Gazz. chim. ital.*, **51** (I), 177-83 (1921).
- (13) Pechmann, *Ber.*, **31**, 2950-1 (1898).
- (14) Dimroth and Fester, *Ber.*, **43**, 2219-23 (1910).

Chapter V

The Polymerization of Acetylene and Condensation → with Carbon Compounds

1. Types of Polymerization and condensation reactions. In this chapter it is proposed to discuss all the reactions of acetylene in which the triple bond is broken and new carbon-to-carbon linkages are formed. These reactions may be subdivided into condensations or polymerizations involving acetylene alone as a starting material and condensations of acetylene with other carbon compounds. Addition reactions in which organic compounds become attached to acetylene without forming new carbon-to-carbon linkages are, of course, not included in this group.

The self-condensation of acetylene has been brought about by a variety of means, including heat, other forms of radiant energy, and catalysts. A striking difference in the degree of unsaturation of the end products is notable. In thermal condensation the products show little unsaturation and are principally aromatic. Heterocyclic compounds may be formed when suitable forms of sulfur, selenium or nitrogen are available. The inert solid cuprene if produced from acetylene in contact with certain metallic catalysts also appears to be saturated in character and is probably a three-dimensional polymer. On the other hand, some of the liquids and solids produced by other physical means and the polymers formed in catalytic cuprous salt solutions are highly unsaturated.

Egloff, Lowry and Schaad (1) have compiled an extensive review of the condensation and polymerization reactions of acetylene, and a few bibliographies on this subject have appeared (2, 3).

References

- (1) Egloff, Lowry and Schaad, *J. Phys. Chem.*, **36**, 1457-1520 (1932).
- (2) Neumann, *Ges. Abhandl. Kenntnis Kohle*, **11**, 404-14 (1934); *Chem. Zentr.*, **1934 II**, 878.
- (3) Anon., *Industrie chimique*, **25**, 2-5, 75-8, 146-50, 291-3 (1938); *J. Acetylene*, No. 107, 71-83 (1938).

2. The condensation of acetylene to hydrocarbons which exhibit little unsaturation and are chiefly aromatic. The polymerization and condensations of acetylene which occur above 400°, or at even lower temperatures in the presence of certain metals or other contact catalysts, is associated with a number of complicated side reactions, which include processes of hydrogenation and dehydrogenation, further condensations of the simpler

derivatives and probably the formation and reaction of free hydrocarbon radicals. The final products ordinarily isolated are complex mixtures of aromatic hydrocarbons, together with hydrogen, carbon, methane, ethylene, ethane, lesser quantities of higher paraffins and olefins, and perhaps traces of acetylene homologs. The aromatic products which have been isolated include benzene, styrene, naphthalene, anthracene (1-3); toluene, diphenyl, fluorene, pyrene, chrysene (4); acenaphthene, phenanthrene (5); m- and p-xylene, methylnaphthalene, 1,4-dimethylnaphthalene, tetrahydronaphthalene (6); o-xylene, pseudocumene, mesitylene, hydrindene, fluoranthene (7); and higher hydrocarbons of undetermined structure (8).

These mixtures do not have sufficient commercial value to justify their manufacture from pure acetylene under present conditions. Recent interest in this process from an industrial viewpoint centers chiefly in the possibility of converting methane into liquid hydrocarbons by first pyrolyzing it to a mixture of acetylene and hydrogen (see Chapter I, Section 7) and then polymerizing the acetylene in the mixed gas. The so called direct methods of converting methane to aromatics may pass through these stages in a single operation. For this purpose modifications of the process are desired which will yield a low-boiling liquid suitable for fuel or solvent uses.

The most characteristic product of the thermal polymerization of acetylene is benzene, which often forms a major part (20-90 per cent) of the liquid product. The mechanism of this polymerization has been studied by several workers. In investigating the condensation of acetylene in a "Pyrex" tube at 400-650°, Pease (9) found that the rate was approximately halved by dilution with an equal volume of nitrogen and was decreased by packing, and he concluded that the rate-determining process was a homogeneous reaction involving two molecules of acetylene. Schläpfer and Brunner (10) independently arrived at the same conclusion. It is obvious that two bimolecular reactions accompanied by ring closure constitute a more probable mechanism for benzene formation, especially in the vapor phase, than the simultaneous union of three acetylene molecules. Vinylacetylene and divinylacetylene, or radicals derived from them, appear to be the most probable intermediates in a bimolecular polymerization process, and small proportions of these substances have been detected in thermal polymerizations of acetylene (11-13). In this connection the extended structure of vinylacetylene and of divinylacetylene may be somewhat significant, because they must apparently undergo an addition reaction before the end carbon atoms can approach each other for ring closure (see Chapter I, Section 1). From this viewpoint it appears that an essential condition for the formation of benzene from acetylene may be the presence of a substance which is capable of adding to the chain polymers

and again splitting off after ring closure. Accordingly, reactions of hydrogenation and dehydrogenation which have heretofore been regarded as merely incidental in this process may be in fact an essential part of the mechanism for the synthesis of aromatic hydrocarbons from acetylene. Still more significant may be the remarkable increase in the proportion of light aromatic hydrocarbons when acetylene is condensed in the presence of reactive diluents such as steam or added hydrogen. This view is consistent with current theories of the synthesis of benzene by the pyrolysis of lower olefins or paraffins in which the intermediates are thought to be chain or cyclic olefinic compounds and naphthenes (14, 15).

Concerning the origin of the other constituents of the mixtures which result from the thermal treatment of acetylene, a number of theories have been or may be advanced. The formation of higher aromatic hydrocarbons may be accounted for by assuming either substitution in the benzene ring or the cyclization of aliphatic chains containing more than six carbon atoms. Free hydrogen and carbon may arise from the decomposition of acetylene or from the total dehydrogenation of higher aromatic compounds as intimated by Berthelot (1), and it may be added that some of the chain trimers of acetylene and their higher homologs are known to carbonize with great readiness. Bone and Coward (16) found that a higher percentage of methane is often formed in this process than can exist in equilibrium with carbon and hydrogen at the same temperature; accordingly they rejected the direct synthesis of methane from the elements and postulated the scission of acetylene to $\equiv\text{CH}$ residues, some of which decomposed to carbon and hydrogen, and others were hydrogenated to methane. Hurd (17) objected to this mechanism because of the high energy required for complete rupture of the triple bond, and suggested as a possible source of methane the demethylation of some of the higher condensation products in the presence of hydrogen. Processes of methylation and demethylation or other free radical reactions must also be assumed to account for the formation of hydrocarbons containing an odd number of carbon atoms, such as toluene, which are often found among the products. The higher olefins and paraffins which have been isolated from these mixtures provide good evidence of a mechanism of polymerization to chain compounds with attendant hydrogenation. Hexenes and octenes have been identified and it is also possible that cyclo-olefins may be present.

Experimental data concerning the thermal polymerization and condensation of acetylene, which have been accumulated by a great number of workers, show that the composition of the end product varies widely with changes in the conditions of reaction. Unfortunately, few of the experiments have been planned to determine the effects of variations in a single

experimental factor. It is evident, however, that the course and extent of these reactions are much influenced by the temperature, the duration of heating, the dilution of the acetylene, the catalytic effect of the deposited carbon or of added metals or other contact catalysts, and probably by pressure and other variable conditions, and it is possible to indicate at least a few suggestive general trends of the process which are induced by variations in these factors.

The earlier workers stressed the importance of the reaction temperature; but, since the heat was usually applied for an interval of from one to several minutes, their results are not valid for comparatively short heating periods. Berthelot (1) first observed that a complex mixture of aromatic hydrocarbons was formed on heating acetylene for about one-half hour at the softening point of glass, whereas decomposition to hydrogen and carbon predominated at bright red heat or above. Walker (18) reported slow condensation of acetylene to a liquid hydrocarbon mixture at 400–450° and somewhat more rapid condensation at 550°. Hague and Wheeler (19) obtained maximum yields of liquid products at 650–700° in a quartz tube. Bone and Jerdan (20) and Berthelot (21) showed that decomposition was rapid and nearly complete above 1000°. Bone and Coward (16) reported that polymerization reached a maximum at 600–700° and that decomposition and methane formation increased with rising temperature and became the principal reaction above 800°. They also found that when acetylene was quickly heated in unpacked tubes to about 800°, the decomposition was attended by a flash of light and a further rise in temperature, and the same phenomenon has been observed by other workers at an initial temperature below 650°. The usual way of avoiding this difficulty consists in diluting the acetylene, packing the reaction vessel or raising the temperature gradually. Thus Meyer and co-workers (4, 5, 7) diluted the acetylene with hydrogen and raised the temperature of the mixture by stages in passing it through a series of tubes heated at various temperatures from 550° to 900°. In contradiction to some of the older work, Kovache and Tricot (22) found that the optimum temperature for acetylene condensation was 950° when the gas was passed into a heated porcelain tube enclosing a concentric, water-cooled copper tube, which no doubt served to shorten the effective heating period. In this apparatus it was found that the velocity of the reaction and the proportion of higher-boiling hydrocarbons increased with rising temperature. Fischer and Pichler (23) have patented the production of aromatic hydrocarbons from methane or methane in coke-oven gas by heating at 1000–1100° for an interval of 0.05 to 0.2 second, and under these conditions it is highly probable that acetylene is formed as an intermediate. It appears that no reliable conclusions can be drawn concerning the effect of temperature on acetylene

condensations unless the length of the heating period is also specified. In any commercial application of this process it is probable that the use of a rather high temperature for a short time interval would prove most convenient.

In the thermal condensation of acetylene the results of dilution with other gases depend on the nature of the diluent. Inert diluents would be expected to retard the bimolecular reactions of polymerization, and while diminishing the danger of flashing and explosion, they appear to make necessary either a higher temperature or a more prolonged heating period than is required to reach the same stage of reaction in undiluted acetylene. Pease (9) has reported a decrease in the rate of polymerization of acetylene diluted by nitrogen in the temperature range 400–650°, and Fischer, Bangert and Pichler (24) noted that a higher temperature was needed to produce oil from acetylene which had been diluted with nine times its volume of methane or hydrogen. Hydrogen, which has been most frequently used as a diluent, undoubtedly combines with acetylene and its polymers as well as producing the effects ascribed to unreactive added gases. Thus Binnie (25) reported the conversion of acetylene to methane and ethylene when heated at 600° in a silica tube with 24 times its volume of hydrogen. A number of other workers, including Meyer and co-workers (4, 5, 7) and Fischer, Bangert and Pichler (24), have noted that admixture of hydrogen in lower concentrations decreased the tendency of acetylene to flash when quickly heated, caused condensation to proceed more smoothly, lessened the deposition of carbon and increased the proportion of low-boiling liquid products. Dilution with hydrogen is essential when acetylene is condensed in contact with iron, nickel, cobalt, or platinum (see Chapter I, Section 5). For these reasons the mixtures of acetylene and hydrogen obtained by the pyrolysis of methane or other hydrocarbons appear to be especially well adapted for conversion to liquid products. Berl and Hoffman (26) obtained the highest recorded yield, 98.8 per cent of liquid products, by passing acetylene mixed with 15 per cent of steam at 740° through a glass tube packed with porcelain beads. Fischer, Bangert and Pichler (24) found that the dilution of acetylene with carbon dioxide before heating resulted in raising the proportion of light oils in the product. However, Sandonini (28) found that water was formed in considerable quantities when mixtures of acetylene and carbon dioxide were heated at 200–300°, particularly when in contact with iron, nickel and cobalt; accordingly the results attributed to carbon dioxide may have been due to water. It should be remembered that traces of moisture and also hydrogen from decomposition reactions were probably present in nearly all the reported experiments on acetylene condensation. Kato and Aikawa (29) describe a

method for condensing acetylene in which the preheated gas is mixed with a diluent gas at a still higher temperature.

Changes in the course of acetylene polymerization and condensation induced by variations in the pressure of the gas have been little studied, but theoretically increased pressures would be expected to promote the process. Fischer, Bangert and Pichler (24) found that practically no advantage was attained by reducing the pressure from 750 to 200 mm. Dangerous explosions result on increasing the pressure of gaseous acetylene much above one atmosphere at a temperature suitable for this reaction. However, a patent (30) claims that acetylene may be condensed to give a very high yield of liquid hydrocarbons while dissolved in an inert oil under a pressure of 10 to 200 atmospheres and in the presence of finely divided iron or magnesium bromide as a catalyst.

The role of contact catalysts in this process is somewhat difficult to determine and often of short duration, because a coating of carbon is practically always deposited during the thermal condensation of acetylene at a temperature of about 650° or above and in the absence of reactive diluents such as hydrogen and steam. This carbon is thought to influence the course of the reaction, and in some cases it may accumulate in a quantity sufficient to choke the reaction vessel. Zelinsky (31) claimed that activated carbon as a packing material reduced flashing and carbon deposition and increased the proportion of benzene in the product at 600–650°. Iki and Ogura (32) stated that there was little difference in the catalytic effects of activated carbon, coke and coalite at 600° and upward. Kovache and Tricot (22) could detect no specific influence of activated carbon, and found that aluminum oxide, quartz, porcelain, pumice and brick fragments were equally effective at an optimum temperature of 650° after becoming coated with carbon from acetylene decomposition. Fischer, Bangert and Pichler (24) believed that deposited carbon acted as a catalyst for acetylene polymerization at 600–650° and Fujio (27) noted a similar effect. Berl and Hofmann (26) thought that the more porous forms of carbon favored the decomposition of acetylene, and that the denser forms promoted conversion to liquids.

Several metals which are known to promote reactions of hydrogenation and dehydrogenation, particularly iron, nickel, cobalt and platinum, act chiefly as catalysts for the decomposition of acetylene in the absence of hydrogen (see Chapter I, Section 5), whereas in mixtures of acetylene with hydrogen the same metals cause rapid hydrogenation and polymerization. In the presence of the metals, these reactions are initiated at a much lower temperature of the entering gas and this phenomenon may be in part due to the localized heating and compressing effect of the ad-

sorption of acetylene and hydrogen at the metallic surface. Moissan and Moureu (33) reported that finely divided platinum or pyrophoric iron, nickel and cobalt, which had been reduced in hydrogen, were brought to incandescence by the adsorption and reaction of acetylene. Sabatier and Senderens (34) have also noted a rise in temperature of these metals in contact with acetylene or mixtures of acetylene and hydrogen, and suggested that this might be due to the heat of reaction of adsorbed hydrogen with acetylene. The carbon formed by the decomposition of acetylene in contact with these metals has been found to contain the metals in a finely divided state, as has been reported for cobalt and iron by Sabatier and Senderens (34), for iron and nickel by Hodgkinson (35) and for platinum by Schutzengerger (36). For this reason coating of the metals by carbon retards the catalytic action only after a very heavy carbon deposit has accumulated. When mixtures of acetylene and hydrogen are condensed in contact with these metals or their alloys at a suitable temperature, the decomposition of acetylene is minimized or prevented and good yields of oil are obtained. At room temperature and with a large admixture of hydrogen, Sabatier and Senderens (34) found that nickel caused the hydrogenation of acetylene to ethylene and ethane and that only small quantities of higher paraffins and olefins and a trace of benzene were formed; raising the temperature augmented the conversion to liquids, and lowering the proportion of hydrogen increased the yield of aromatic hydrocarbons. The same authors reported similar results with a platinum catalyst. Charitschkov (37) obtained liquid products which were in part olefinic by the condensation of a mixture of acetylene and hydrogen over nickel at 300°. Fischer, Peters and Koch (38) found that in contact with iron at 300–350° some decomposition occurred along with oil formation even when a dilution of 91 per cent hydrogen and 9 per cent acetylene was employed. In reactions of this type Sabatier and Senderens (34) considered the effectiveness of cobalt to be intermediate between that of iron and nickel. Fischer, Peters and Koch (38) condensed mixtures of 10 per cent acetylene and 90 per cent hydrogen at 250° over various alloys of iron-nickel-copper, iron-copper and iron-nickel, and converted 30–70 per cent of the acetylene to oils in which benzene was the principal constituent. When an alloy of ten parts of chromium and one part of nickel was used under the same conditions, unsaturated hydrocarbons were found to predominate in the light-oil fraction of the product. Fischer and Peters (39) reported that better temperature control was made possible in these reactions by suspending the metal catalysts in paraffin oil or in hydrogenated methylnaphthalene. Under these conditions nickel caused more extensive hydrogenation and less polymerization than when used in the dry state at the same temperature, only 28 per cent of oils being formed at 250° while the re-

maining acetylene was converted to ethylene and ethane. A catalyst of nickel and iron in the ratio of 1:9 acting at 200° on a mixture of one part acetylene and two parts hydrogen yielded nearly 75 per cent of liquid hydrocarbons. Peters and Neumann (40) studied the effect of iron with several different promoters in converting acetylene to liquid hydrocarbons. The decomposition of heated undiluted acetylene over palladium has been reported by Zalinsky (31), and Campbell (42), but the effect of palladium on mixtures of acetylene and hydrogen does not appear to have been investigated. Copper also promotes the hydrogenation of acetylene to some extent, but its principal effect is to cause a special type of condensation to cuprene with only a small yield of oils (see Section 3).

A number of attempts to use other substances as catalysts for the condensation of acetylene have been recorded. Binnie (25) found that nickel carbonyl caused the conversion of as much as 65 per cent of acetylene to oil containing a large proportion of olefins when the gas in admixture with nitrogen and hydrogen was heated at 190°. Ceric sulfate has been patented (43) as a catalyst for the condensation of producer gas containing acetylene and methane occurring at 80°. The alkali and alkaline-earth metals do not appear to promote acetylene polymerization but yield acetylides mixed with more or less carbon. Bahr (44) reported that tin-plating of an iron reaction tube aided oil formation until the temperature reached 475°, when the tin coating was removed. Fischer, Schraeder and Ehrhardt (45) and Fujio (27), on the contrary, noted increased decomposition of acetylene in contact with tinned iron. Tiede and Jenische (46) reported that manganese favored the decomposition and that a number of other metals had no significant effect. Lozovoi (47) employed anhydrous zinc chloride at 370–450° as a catalyst for the polymerization of acetylene.

Apparatus for large-scale condensation of acetylene to liquid hydrocarbon has been devised by Gros (48), Ylla Conte (49) and Ipatiev (50).

The polymerization of deuterioacetylene to hexadeuterobenzene has been studied by Clemo and McQuillen (51).

The polymerization of acetylene induced by free methyl radicals has been noted by Sickman and Rice (52), Taylor and Jungers (53) and Joris and Jungers (2).

At still lower temperatures acetylene combines with certain chemical condensing agents and is then converted to mixtures of substances which appear to be chiefly aromatic. The primary reaction of anhydrous aluminum chloride is probably a simple addition, but according to Baud (43) and Gangloff and Henderson (55) the final product is a solid organic material containing aluminum chloride and having a smaller proportion of hydrogen than acetylene, but exhibiting no properties of unsaturation. Liquid aromatic hydrocarbons in small quantity are evolved on heating this

substance. Acetylene is absorbed by concentrated sulfuric acid, and especially in the presence of traces of oxygen the final product is a tarry material which is thought to be aromatic in nature. The reaction is greatly accelerated by the addition of mercury salts; this occurs even in dilute sulfuric acid to a certain extent, so that a little tar is frequently formed in the production of acetaldehyde from acetylene (see Chapter IV, Section 6).

References

- (1) Berthelot, *Compt. rend.*, **62**, 905-9 (1866); **63**, 479-84, 515-8 (1866). *Bull. soc. chim.* (2), **6**, 268-82 (1866). *Ann. chim. phys.* (4), **9**, 445-69 (1866); (4) **12**, 52-81 (1867).
- (2) Joris and Jungers, *Bull. soc. chim. Belg.*, **47**, 135-47 (1938); *C. A.*, **32**, 4426 (1938).
- (3) Haber and Oechelhauser, *J. Gasbeleucht.*, **39**, 830-4 (1896). *Chem. Zentr.* **1897** **1**, 225-6.
- (4) R. Meyer, *Ber.*, **45**, 1609-33 (1912).
- (5) R. Meyer and Tanzen, *ibid.*, **46**, 3183-99 (1913).
- (6) R. Meyer and Fricke, *ibid.*, **47**, 2765-74 (1914).
- (7) R. Meyer and W. Meyer, *ibid.*, **51**, 1571-87 (1918).
- (8) R. Meyer and Taeger, *ibid.*, **53**, 1261-5 (1920).
- (9) Pease, *J. Am. Chem. Soc.*, **51**, 3470-5 (1929).
- (10) Schläpfer and Brunner, *Helv. Chim. Acta*, **13**, 1125-51 (1930).
- (11) Mignonac and Ditz, *Compt. rend.*, **199**, 367-9 (1934).
- (12) Tzyurikh, Efremova, Bartashev and Yanitz, *J. Gen. Chem. (U.S.S.R.)*, **6**, 197-202 (1936); *C. A.*, **30**, 4807 (1936).
- (13) Ammonia Casale S.A., *Fr. P.* 797,935 (1936); *C. A.*, **30**, 7121 (1936). *Swiss P.* 188,617 (1937); *C. A.*, **31**, 6674 (1937). *Brit. P.* 473,219 (1937); *C. A.*, **32**, 1815 (1938).
- (14) Schneider and Frohlich, *Ind. Eng. Chem.*, **23**, 1405-10 (1931).
- (15) Ipatiev and Pines, *ibid.*, **27**, 1364-9 (1935).
- (16) Bone and Coward, *J. Chem. Soc.*, **93**, 1197-1225 (1908); *Proc. Chem. Soc.*, **24**, 167 (1908).
- (17) Hurd, Communication quoted by Egloff, *J. Phys. Chem.*, **36**, 1460-1 (1932).
- (18) Walker, *ibid.*, **31**, 970-4 (1927).
- (19) Hague and Wheeler, *J. Chem. Soc.*, **1929**, 391. Dunstan, Hague and Wheeler, *Chaleur et industrie*, **15**, No. 167, 402-13 (1934); *C. A.*, **28**, 6557 (1934).
- (20) Bone and Jerdan, *J. Chem. Soc.*, **71**, 41, 59-61 (1897); *Proc. Chem. Soc.*, **17**, 164 (1901).
- (21) Berthelot, *Ann. chim. phys.* (8), **6**, 184 (1905).
- (22) Kovach and Tricot, *Chimie et industrie*, **13**, 361-72, 537-47 (1925).
- (23) F. Fischer and Pichler, *Brit. P.* 316,126 (1928); *C. A.*, **24**, 1649 (1930).
- (24) F. Fischer, Bangert and Pichler, *Brennstoff-Chem.*, **10**, 279-82 (1929).
- (25) Binnie, *J. Soc. Chem. Ind.*, **50**, 297-9T (1931).
- (26) Berl and Hofmann, *Z. angew. Chem.*, **44**, 259-61 (1931).
- (27) Fujio, *J. Soc. Chem. Ind. (Japan)*, **31**, 77-86 (1928); *C. A.*, **22**, 2363 (1928).
- (28) Sandonini, *Gazz. chim. ital.*, **57**, 781-92 (1927).
- (29) Kato and Aikawa, *J. Electrochem. Assn. Japan*, **3**, 261-4 (1935); *C. A.*, **30**, 2555 (1936).
- (30) N.V. de Bataafsche Petroleum Maatschappij, *Dutch P.* 29,103 (1933); *Brit. P.* 334,470 (1928). *C. A.*, **26**, 150 (1932).
- (31) Zelinsky, *Compt. rend.*, **177**, 882-5 (1923); *Ber.*, **57**, 264-76 (1924).
- (32) Iki and Ogura, *J. Soc. Chem. Ind. (Japan)*, **30**, 461-9 (1927); *C. A.*, **21**, 3046-7 (1927).

- (33) Moissan and Moureu, *Compt. rend.*, **122**, 1240-3 (1896). *Bull. soc. chim.* (3), **15**, 1296-9 (1896). Moissan, *J. Franklin Inst.*, **143**, 147 (1897).
- (34) Sabatier and Senderens, *Compt. rend.*, **128**, 1173-6 (1899); **130**, 250-2, 1559-61, 1628-30 (1900); **131**, 187-90, 267-70 (1900); **134**, 1185-8 (1902); *Ann. chim. phys.* (3), **4**, 439-52 (1905); *Bull. soc. chim.* (3), **25**, 678-84 (1901).
- (35) Hodgkinson, *J. Soc. Chem. Ind.*, **37**, 86-7T (1918).
- (36) Schutzenberger, "Traité de Chimie Generale," Vol. I, P. 723 (1880).
- (37) Charitschkov, *J. Russ. Phys.-Chem. Soc.*, **38**, 878-81 (1906); *Chem. Zentr.*, **1907** I, 294.
- (38) F. Fischer, Peters and Koch, *Brennstoff-Chem.*, **10**, 383-5 (1929).
- (39) F. Fischer and Peters, *ibid.*, **12**, 286-93 (1931).
- (40) Peters and Neumann, *Brennstoff-Chem.*, **14**, 165-8 (1933); *Ges. Abhandl. Kenntnis Kohle*, **11**, 423-33 (1934); *C. A.*, **29**, 6567 (1935).
- (42) E. D. Campbell, *Am. Chem. J.*, **17**, 691 (1895).
- (43) Compagnie Générale de Produits de Synthèse, Fr. P. 658,643 (1928); *C. A.*, **23**, 5305 (1929).
- (44) Bahr, *Ges. Abhandl. Kenntnis Kohle*, **8**, 283-5 (1928); *C. A.*, **24**, 5717 (1930).
- (45) F. Fischer, Schraeder and Ehrhardt, *Ges. Abhandl. Kenntnis Kohle*, **4**, 389, 393 (1919).
- (46) Tiede and Jenisch, *Brennstoff-Chem.*, **2**, 5-8 (1921).
- (47) Lozovoi, *J. Gen. Chem. (U.S.S.R.)*, **1**, 717-28 (1931); *C. A.*, **26**, 3229 (1932).
- (48) Gros, Brit. P. 211,461 (1924); Fr. P. 562,141 (1923); *Chem. Zentr.*, **1925** II, 766; Ger. P. 475,883 (1929); *Frdl.*, **16**, 87-8.
- (49) Ylla Conte, Brit. P. 299,425 (1927); *C. A.*, **23**, 3232 (1929); Swiss P. 143,697 (1928); *C. A.*, **25**, 4010 (1931); Fr. P. 662,896 (1928); *J. Inst. Petroleum Tech.*, **15**, 744 (1929). Swiss P. 136,910 (1928); *C. A.*, **24**, 4304 (1930); Brit. P. 301,325 (1927); *C. A.*, **23**, 3934 (1929); Ger. P. 567,070 (1928); *C. A.*, **27**, 1359 (1933); Fr. P. 664,180 (1928); *C. A.*, **24**, 954 (1930).
- (50) Ipatiev, *Natl. Petroleum News*, **23**, No. 25, 61 (1931).
- (51) Clemo and McQuillen, *J. Chem. Soc.*, **1935**, 851-5.
- (52) Sickman and Rice, *J. Chem. Phys.*, **4**, 613 (1936).
- (53) Taylor and Jungers, *Trans. Faraday Soc.*, **33**, 1353-60 (1937).
- (54) Baud, *Compt. rend.*, **130**, 1319-22 (1900).
- (55) Gangloff and Henderson, *J. Am. Chem. Soc.*, **38**, 1382-4 (1916).

3. The condensation of acetylene to cuprene by copper and other metallic compounds. Erdmann and Koethner (1) first reported a special type of condensation occurring when acetylene was heated to about 230° in contact with copper or its oxides. The principal product was a chemically inert, very light, microscopically fibrous or cork-like solid, having a color ranging from buff to dark brown, which was later named cuprene by Sabatier and Senderens (2). Erdmann and Koethner (1) suggested the formula $C_{44}H_{66}Cu_3$ for this substance; but Gooch and Baldwin (3) found that the copper content varied from 1.5 to 24.2 per cent, and Alexander (4) extracted nearly all the copper with a solution of hydrochloric acid and ferric chloride, indicating the material to be a mixture of copper or a copper compound with one or more hydrocarbons. Sabatier and Senderens (2) proposed the formula $(C_7H_6)_n$ for the cuprene hydrocarbon; analyses by Kaufmann and Schneider (5) showed compositions varying from $(C_{11}H_{10})_x$ to $(C_{16}H_{10})_x$, depending upon conditions of formation. Calhoun (6) found that the proportion of hydrogen retained in the cuprene

decreases while the quantity of hydrogen and hydrogenated by-products increases with rising reaction temperature. On heating cuprene with zinc dust Erdmann and Koethner obtained aromatic hydrocarbons and also claimed to have extracted cresol from it by treatment with caustic soda solution. It was found by Kaufmann and Monhaupt (?) that cuprene did not absorb oxygen in the cold, was halogenated with difficulty, and yielded mellitic acid on oxidation with nitric acid. They concluded that the one or more hydrocarbons present were probably polycyclic aromatic substances with practically no alkyl or unsaturated side chains. Calhoun (6) considers cuprene to be a three-dimensional polymer. In such a structure numerous cross linkages must be present to produce the observed degree of saturation.

Sabatier and Senderens (2) found hydrogen and hydrogenated derivatives, such as ethylene, ethane and higher paraffins, as well as simple aromatic hydrocarbons, including benzene and styrene, among the by-products of cuprene formation at 180–250°. The formation of liquid by-products also has been reported by a number of other workers. Schläpfer and Stadler (8), in describing a process for the manufacture of cuprene at 250–300°, stated that the total yield comprised 75–80 per cent of cuprene, 5.5–7 per cent of tar and 13–17 per cent of gases. The tar was mainly aromatic with smaller proportions of olefins and paraffins and contained hexene, octene, benzene, styrene, naphthalene, anthracene and some methyl, ethyl and propyl derivatives of these aromatic hydrocarbons. Calhoun (6), on circulating acetylene over a cupric oxide catalyst at 250–350°, obtained yields averaging about 85 per cent of cuprene and 10 per cent of tar, and recovered the remaining material as ethylene, ethane and hydrogen.

It has been claimed that either metallic copper or certain of its compounds may act as catalysts for the formation of cuprene from acetylene. However, Erdmann and Koethner (1) reported that copper caused a slower reaction than oxides of copper, or a material made by heating anhydrous copper ferrocyanide in air. Gooch and Baldwin (3) stated that cuprene was formed only over the oxidized portion of a piece of copper gauze. Kaufmann and Monhaupt (?) found that cuprene was not formed from very pure acetylene over reduced copper at 230–300°. Horwitz has patented the addition of oxygen or oxygen supplying substances to the acetylene used in the process. Alexander (4), Sabatier and Senderens (2), and Hilpert (9) employed the metal as a catalyst, and Schläpfer and Stadler (8) have described a commercial process using the metal; however, it should be remembered that acetylene prepared from carbide nearly always contains a small proportion of oxygen (see Chapter I, Section 4). A copper compound of acetylene appears to be formed as an intermediate

in the reaction and some copper is distributed throughout the mass of cuprene. For this reason loss of catalyst activity through coating is long delayed, and cuprene, because of its copper content, also serves to catalyze the process. Calhoun (6) noted that an induction period occurred when copper oxide was used as a catalyst, and proposed a chain polymerization mechanism for the process.

A patent of the Elektrizitätswerk Lonza (10) specifies carrying out the reaction in an inert, high-boiling oil, with a copper bronze catalyst and diluting the acetylene with nitrogen, and Fischer and Peters (11) described a somewhat similar method. A few other modifications of the process have also been patented. Lichtenhahn (12) has patented the use of nitrogen as a diluent for acetylene in the manufacture of cuprene.

A few other metals and combinations of metals also convert acetylene into cuprene at temperatures of 200–300° (13). Sabatier and Senderens (2) reported that nickel became coated with cuprene on heating at 180–300° for a long time in a slow current of acetylene, and in like manner cobalt caused the formation of a little cuprene along with much carbon and some gaseous and liquid hydrocarbons. Fischer, Peters and Koch (14) noted condensation to cuprene over a copper-iron alloy containing over 10 per cent of copper. Patents claim the preparation of cuprene with catalysts consisting of copper, nickel, iron or their oxides treated with a small quantity of magnesium (15), as well as the addition of a small proportion of stannic oxide to the copper catalyst as a promoter (16). The formation of liquid and solid products from acetylene in the presence of aluminum chloride has been noted in Section 2.

Solids resembling cuprene in physical properties also have been produced by the action of various types of radiation on acetylene (see Sect. 4).

The light weight, chemical inertness and absorbent properties of cuprene make it suitable for many industrial uses, and patents covering these applications have been reviewed (17, 18).

References

- (1) Erdmann and Koethner, *Z. anorg. Chem.*, **18**, 48–58 (1898).
- (2) Sabatier and Senderens, *Bull. soc. chim.* (3), **21**, 530–1 (1899). *Compt. rend.*, **130**, 250–2 (1900). *Ann. chim. phys.* (8), **4**, 439–52 (1905). See also Sabatier-Reed, "Catalysis in Organic Chemistry," pp. 329–32 (1923).
- (3) Gooch and Baldwin, *Am. J. Sci.* (4), **8**, 354–8 (1899); *Z. anorg. Chem.*, **22**, 235–40 (1900).
- (4) Alexander, *Ber.*, **32**, 2381–4 (1899).
- (5) Kaufmann and Schneider, *ibid.*, **55B**, 267–82 (1922).
- (6) Calhoun, *Can. J. Res.*, **B15**, 208–23 (1937).
- (7) Kaufmann and Monhaupt, *Ber.*, **56B**, 2533–6 (1923).
- (8) Schläpfer and Stadler, *Helv. Chim. Acta*, **9**, 185–99 (1926).
- (9) Hilpert, *Ges. Abhandl. Kenntnis Kohle*, **1**, 271–5 (1917).
- (10) Elektrizitätswerk Lonza, *Brit. P.* 200,087 (1923); *C. A.*, **18**, 276 (1924); *Ger. P.* 407,485 (1922).

- (11) F. Fischer and Peters, *Brennstoff-Chem.*, **12**, 286-93 (1931).
- (12) Lichtenhahn, Can. P. 238,888 (1924); Brit. P. 200,087; *C. A.*, **18**, 1300 (1924).
- (13) See Green, "Industrial Catalysts," (1928) Ernest Benn, Ltd., London; also Sabatier, "Catalysts in Organic Chemistry" (1922).
- (14) F. Fischer, Peters and Koch, *Brennstoff-Chem.*, **10**, 388-5 (1929).
- (15) N. V. Electro-Zuurstof en Waterstoffabriek, Brit. P. 303,797 (1928); *C. A.*, **23**, 4485 (1929); Dutch P. 20,851 (1929); *C. A.*, **24**, 931 (1930).
- (16) R. H. Davis and Levy, Brit. P. 418,005 (1934); *C. A.*, **29**, 1440 (1935).
- (17) Herzog, *Chem. Ztg.*, **55**, 461-2, 478-9 (1931). *Kunststoffe*, **21**, 49-53 (1931); *C. A.*, **25**, 2683 (1931).
- (18) Genin, *J. acetylene*, **105**, 50-2 (1937).

4. Polymerization of acetylene by physical means other than heat.

The polymerization of acetylene has been promoted by a number of physical methods, and in several cases the product is a solid with physical properties somewhat resembling those of cuprene. However, several of these polymers differ from cuprene by reacting with oxygen in the cold; and accordingly must have much less cyclic or cross linked structure than cuprene prepared in contact with metal catalysts.

Mund and Koch (1) and Lind, Bardwell and Perry (2) studied the effect of alpha particles on both pure acetylene and acetylene diluted with inert gases. They reported the reaction of about twenty molecules of acetylene for each ion pair produced, and suggested that a cluster of acetylene molecules surrounding a positive gas ion is neutralized by an electron resulting in polymerization of the cluster to a compound of high molecular weight without the formation of any simple intermediates. It was found later (3) that the solid product combined with oxygen at room temperature.

Roemer (4) and Bone and Wilson (5) reported the decomposition and polymerization of acetylene by sunlight, but it appears from later investigations that the acetylene probably contained some reactive impurity. Reinicke (6) and Toul (7) could detect no change in acetylene exposed to sunlight. Several investigators (6-11) have reported the polymerization of acetylene to a yellow or brown, inert and insoluble solid by the light from a mercury-vapor arc. Livingston and Schifflett (12) found that benzene, a yellow, viscous liquid, and two solid products were formed from acetylene exposed to light from a quartz mercury-vapor arc at 270-376°. Kemula and Mrazek (13) confirmed this result and studied the simpler compounds formed by means of absorption spectra. Lind and Livingston (9) reported that light of wave lengths longer than 2537 Å was not effective in this reaction, that the quantum yield was 9.2 ± 1.5 , and that the reaction appeared to occur in a single step without the formation of simpler products. Bates and Taylor (14) and Melville (15) reported the mercury-photo-sensitized polymerization of acetylene. Kato (31) reported the formation of both benzene and a cuprene-like solid by the action of light of various

wave lengths at 0°. Moens and Juliard (16) reported the polymerization of acetylene to a yellow powder when subjected to high-frequency electromagnetic fields.

Kinoshita (17) noted the decomposition of acetylene by canal rays, and also a drop in pressure of the gas, indicating polymerization. Glockler and Martin (18) observed the polymerization of acetylene to a solid by slow electrons.

By employing a high-frequency electric discharge through acetylene with the electrodes at -60° , Mignonac and Saint Aunay (19) obtained the trimers dipropargyl, $\text{HC}\equiv\text{C}-\text{CH}_2-\text{CH}_2-\text{C}\equiv\text{CH}$, 3-methyl-1:4-pentadiyne, $\text{HC}\equiv\text{C}-\text{CH}(\text{CH}_3)\text{C}\equiv\text{CH}$, and divinylacetylene, $\text{H}_2\text{C}=\text{CH}-\text{C}\equiv\text{C}-\text{CH}=\text{CH}_2$. They considered that these resulted from combination of acetylene with vinylacetylene. A number of earlier investigations (20) had shown that acetylene was polymerized by the more extended action of the silent discharge to either a very insoluble solid or to a liquid which usually solidified on standing. Both the solid and the liquid material had approximately the same composition as acetylene and combined readily with oxygen, showing that they were highly unsaturated. By maintaining a comparatively low temperature during the reaction Kaufmann (21) obtained only a liquid mixture of rather high boiling point which became solid on standing or heating, and which absorbed bromine readily and gave a precipitate with alcoholic silver nitrate, showing the presence of mono-substituted acetylenes. It is evident that the silent discharge in acetylene produces a much greater variety of aliphatic polymers than polymerization in cuprous chloride solutions (see Chapter V, Sect. 7). Volmar and Hirtz (22), Lind and Schultze (23) and Montagne (24) found that when mixtures of acetylene with hydrogen were exposed to the silent discharge both polymerization and hydrogenation of acetylene and its polymers occurred.

Coolidge (25), McLennan, Perrin and Treton (26), and Marshall (27) reported that acetylene was polymerized to a yellow solid without the elimination of hydrogen by the action of cathode rays, and Marshall noted that this material took up about 30 per cent of its weight of oxygen on standing in air. In this it resembled the higher polymers prepared from acetylene by means of the silent discharge or by the further polymerization of vinylacetylene and divinylacetylene.

Lind, Jungers and Schifflett (28) compared the polymerization of acetylene and deuterioacetylene to solid products by the alpha radiation from radon. Mund and Rosenblum (29) studied the absorption spectrum of the products during the polymerization of acetylene by radon radiations and observed benzene formation. Rosenblum (30) discussed the mechanism of the polymerization.

References

- (1) Mund and Koch, *Bull. soc. chim. Belg.*, **34**, 125-26, 241-55 (1925). *J. Phys. Chem.*, **30**, 289-93 (1926).
- (2) Lind and Bardwell, *Science*, **62**, 422-4, 593-4 (1925); **63**, 310-1 (1926); *J. Am. Chem. Soc.*, **48**, 1575-84 (1926). Lind, Bardwell and Perry, *ibid.*, **48**, 1556-75 (1926).
- (3) Lind and Schiflett, *ibid.*, **59**, 411-3 (1937).
- (4) Roemer, *Ann.*, **233**, 182-5 (1886).
- (5) Bone and Wilson, *Proc. Chem. Soc.*, **197**, 155-6 (1898); *Chem. Zent.*, **1899** (1), 19.
- (6) Reinicke, *Z. angew. Chem.*, **41**, 1144-6 (1928).
- (7) Toul, *Collection Czechoslov. Chem. Communications*, **6**, 163-89 (1934); **7**, 491-2 (1935); *C. A.*, **28**, 5745 (1934).
- (8) Berthelot and Gaudechon, *Compt. rend.*, **150**, 1169-72 (1910); **155**, 207-10 (1912); *Rev. gen. sci.*, **22**, 330 (1911).
- (9) Lind and Livingston, *J. Am. Chem. Soc.*, **52**, 4613-4 (1930); **54**, 94-106 (1932); **56**, 1550 (1934).
- (10) Rideal, *Proc. Roy. Soc. London*, **146A**, 266-70 (1934).
- (11) Jungers and Taylor, *J. Chem. Phys.*, **3**, 338-40 (1935).
- (12) Livingston and Schiflett, *J. Phys. Chem.*, **38**, 377-81 (1934).
- (13) Kemula and Mrazeck, *Z. physik. Chem.*, **23B**, 358-69 (1933). Kemula, *Collection Czechoslov. Chem. Communications*, **7**, 319-20, 493-4 (1935); *C. A.*, **29**, 7775 (1935); **30**, 1645 (1936).
- (14) Bates and Taylor, *J. Am. Chem. Soc.*, **49**, 2438-55 (1927).
- (15) Melville, *Trans. Faraday Soc.*, **32**, 258 (1936).
- (16) Moens and Juliard, *Bull. sci. acad. roy. Belg.*, **13**, 201-5 (1927).
- (17) Kinoshita, *Physik. Z.*, **8**, 35-8 (1906).
- (18) Glockler and Martin, *Trans. Am. Electrochem. Soc.*, **74**, 67-82 (1938).
- (19) Mignonac and Saint Aunay, *Compt. rend.*, **188**, 959-61 (1929). Saint Aunay, *Chimie et industrie*, **29**, 1011-25 (1933); *C. A.*, **27**, 3911 (1933).
- (20) Wilde, *Ber.*, **7**, 357 (1874). Thenard, *Compt. rend.*, **78**, 219 (1874). Berthelot, *ibid.*, **111**, 471-2 (1890); **126**, 570-1 (1898); *Ann. chim. phys.* (5), **10**, 66-9 (1877); (6), **24**, 135-7 (1891). Schutzenberger, *Compt. rend.*, **110**, 889-92 (1890). H. Jackson and Northall-Laurie, *Proc. Chem. Soc.*, **22**, 155 (1906). Losanich, *Ber.*, **40**, 4656-66 (1907); *Sitz. Akad. Wiss. Wien*, **117**, IIB, 467-76 (1908); *Bull. Soc. stiin. Bucharest*, **23**, 3-33 (1914); *C. A.*, **11**, 254 (1917); *Bull. sci. acad. roy. Belg.* (5), **11**, 325 (1925). Jovichich, *Monatsh.*, **29**, 1-14 (1908); *Sitz. Akad. Wiss. Wien*, **116**, IIB, 1241-54 (1907); *Bull. sci. acad. roy. Belg.* (5), **10**, 465 (1924); (5), **13**, 365-70 (1927). Stratta and Vernazza, *Industria chimica*, **8**, 698-702 (1933); *C. A.*, **27**, 5254 (1933).
- (21) Kaufmann, *Ann.*, **417**, 34-59 (1918).
- (22) Volmar and Hirtz, *Bull. soc. chim.* (4), **49**, 684-702 (1931).
- (23) Lind and Schultze, *J. Am. Chem. Soc.*, **53**, 3355-66 (1931). *Trans. Am. Electrochem. Soc.*, **59**, 165-80 (1931).
- (24) Montagne, *J. école polytech.*, **33**, 1-159 (1935); *C. A.*, **29**, 7200 (1935).
- (25) Coolidge, *Science*, **62**, 441-2 (1925); *J. Franklin Inst.*, **202**, 693 (1926).
- (26) McLennan, Perrin and Treton, *Proc. Roy. Soc. London*, **125A**, 246-62 (1929).
- (27) Marshall, Private communication quoted by Egloff, *et al.*, *J. Phys. Chem.*, **36**, 1502-3 (1932).
- (28) Lind, Jungers and Schiflett, *J. Am. Chem. Soc.*, **57**, 1032-4 (1935).
- (29) Mund and Rosenblum, *J. Phys. Chem.*, **41**, 469-75 (1937). Rosenblum, *ibid.*, **41**, 651 (1937).
- (30) Rosenblum, *Bull. soc. chem. Belg.*, **46**, 503-18 (1937); *C. A.*, **32**, 2840 (1938).
- (31) Kato, *Bull. Phys.-Chem. Research (Tokyo)*, **10**, 343-50 (1930); *C. A.*, **25**, 5845-6 (1931).

5. The condensation of acetylene with other compounds of carbon.

A few condensations have been observed in which one molecule of acetylene reacts with one or more molecules of another carbon compound, the carbon skeletons becoming directly linked together. The substances which have been found to add to acetylene in this way include hydrogen cyanide, the simple olefins and paraffins, a number of aromatic hydrocarbons and their derivatives, and a few acyl halides.

Francesconi and Ciurlo (1) found that succinic dinitrile was produced along with the corresponding isonitrile by the condensation of acetylene with hydrogen cyanide in the silent electric discharge. A process has been patented (2) for the preparation of acrylonitrile by heating a mixture of acetylene and hydrogen cyanide over various catalysts including barium cyanide and active carbon.

Heinemann (3) has patented the production of propylene by the condensation of acetylene and methane at 100–200° over a catalytic alloy of one of the metals iron, nickel, copper, silver or aluminum with one of the metals of the platinum, palladium, iridium group. Patents (4) cover the manufacture of propylene or higher olefins by the condensation of acetylene with methane or higher paraffins at 200–350° over catalysts including oxides or compounds of silicon, titanium, molybdenum, tungsten, thorium or zirconium. It was proposed to employ these olefins for further synthesis, for example to produce isopropyl alcohol and acetone from propylene. Under ordinary conditions olefins can be manufactured much more cheaply by petroleum cracking processes than by synthesis from acetylene, and this method was probably intended chiefly as an emergency measure to insure supplies of olefins.

The production of aromatic hydrocarbons by heating a mixture of acetylene with olefins on contact with catalysts consisting of carbon, silicon, lead, tin, zinc, aluminum or their alloys has been patented (5). In a modification of this process acetylene and ethylene heated in a tin-lined manganese-copper tube yielded 13 per cent of butadiene. The products of these condensations appear to be chiefly aromatic at temperatures above about 500° and chiefly olefinic in the lower part of the temperature range. Kozlov and Fedoseev (6) and Klyukvin (7) have also reported experiments on the preparation of butadiene from mixtures of ethylene and acetylene over aluminum oxide and other catalysts at 200–600°. Ylla Conte (8) patented the condensation of acetylene in the absence of catalysts with other hydrocarbons which were preheated to 300–700°. The authors (9) have condensed acetylene with ethylene or propylene in a sulfuric acid solution containing mercurous or mercuric sulfate. A liquid of wide boiling range resulted which appeared to consist mainly of hydroaromatic

hydrocarbons of terpene-like odor. Klatt (10) described the formation of an oily product from a mixture of acetylene and ethylene over coke or graphite at 500–900°.

Schutzenberger (11) investigated the condensation of acetylene with benzene promoted by an electric discharge and obtained a solid which absorbed oxygen and somewhat resembled the products from acetylene alone.

Varet and Vienne (12) first reported the condensation of acetylene and benzene in the liquid phase with aluminum chloride as a catalyst and claimed a high yield of styrene with a smaller yield of unsymmetrical diphenylethane, but this synthesis of styrene has not been duplicated by later workers. Cook and Chambers (13) identified dimethylantracene dihydride among the products of this reaction. Boeseken and Adler (14) noted that the principal product appeared to be a substance of high molecular weight produced from approximately equimolecular proportions of benzene and acetylene. Most of this material could not be depolymerized to styrene by heating and accordingly was considered to differ from ordinary polystyrene. Judging from the structure of the simple products, it is reasonable to suppose that the higher hydrocarbons are formed chiefly by the linkage of several benzene nuclei through ethylidene groups:

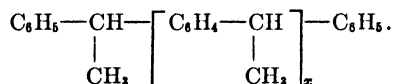

Waterman (15) has patented the addition of acetylene to the aromatic hydrocarbons of petroleum fractions in the presence of aluminum chloride to produce lubricating oil and resins.

A similar condensation of acetylene with aromatic hydrocarbons in the liquid phase at room temperature or lower was investigated by Reichert and Nieuwland (16), who employed a small quantity of concentrated sulfuric acid with mercuric sulfate as a catalyst. The hydrocarbons used were benzene, toluene, xylene, mesitylene and ethylbenzene. Yields of from 20–50 per cent of the corresponding unsymmetrical diphenylethane derivatives and lesser quantities of the corresponding dimethyldihydroanthracenes were reported. The diphenylethane compounds were found to be high-boiling oils stable up to approximately 350°. Reilly and Nieuwland (17) extended the method to the condensation of acetylene with tetrahydronaphthalene and with a number of monoalkylbenzenes. They stated that diphenyl, diphenylmethane, triphenylmethane, sym-diphenylethane and naphthalene failed to react with acetylene under the same conditions. Wenzke and Nieuwland (18) studied the condensation of acetylene with phenols in alcoholic sulfuric acid containing mercuric sulfate. Phenol,

the cresols, hydroquinone, pyrogallol and phloroglucinol reacted readily with acetylene in this way, but no simple products were isolated. Acetylene became linked to two molecules of resorcinol in a position ortho and para to the hydroxyl groups forming ethylidene dioresorcinol. By the spontaneous loss of a molecule of water this compound was converted to the internal ether, dihydroxymethylxanthene, which was changed to hydroxymethylfluorene by oxidation. Acetylene united with two molecules of alpha-naphthol in the position para to the hydroxyl groups, giving ethylidene-di-alpha-naphthol. Beta-naphthol reacted mainly like the aliphatic alcohols to give the acetal with only a minor proportion of ethylidene-di-beta-naphthol. Ortho- and para-nitrophenols, phenolsulfonic acid, methyl salicylate and phenetole did not react with acetylene by this method, and it was concluded that meta-directing substituents prevented linkage of the acetylene residue to the ring and that orthopara substitution ordinarily occurred. Flood and Nieuwland (19), using methyl alcohol as a solvent, showed that resorcinol and resorcinol dimethyl ether reacted with acetylene to form the corresponding vinyl derivative as a primary product.

Syntheses of this type leading to the preparation of styrene, unsymmetrical diphenylethane and its derivatives, and anthracene derivatives might be of value if the yields were good and the formation of more highly condensed products could be eliminated. In the liquid phase it appears very difficult to stop the reactions at the simpler products.

Reppe and Keyssner (20) have patented the condensation of acetylene with phenols at 100-300° in the presence of an amine, such as piperidine or cyclohexylamine, or of zinc and cadmium salts. Kozlov and Mazo (21) have also patented the condensation of acetylene with phenols. Cornillot and Alquier (22) have reported the condensation of acetylene and acetyl chloride in the presence of aluminum chloride to form methyl-beta-chlorovinylketone. Kroeger, Sowa and Nieuwland (23) added acetyl chloride to a number of alkyl- and dialkylacetylenes. The main reaction proceeded as follows (R, R' = hydrogen or alkyl groups):

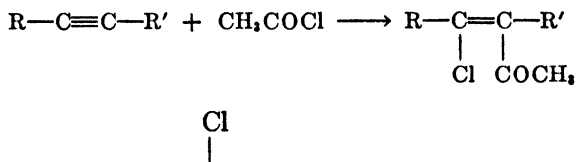

Considerable chloroolefin, $\text{RC}=\text{CHR}'$, was obtained in each instance. Stannic chloride in small amounts proved to be an effective catalyst.

Gustafson (24) and Ciocca and Scattola (25) reported the condensation of ethyl acetoacetate with acetylene in the presence of mercuric salts.

References

- (1) Francesconi and Ciurlo, *Gazz. chim. ital.*, **53**, 327-30 (1923).
- (2) Consortium für Elektrochem. Ind., A.-G., Ger. P. 559,734 (1930); *C. A.*, **27**, 735 (1933).
- (3) Heinemann, Ger. P. 315,747 (1919); *Frdl.*, **13**, 32-3; U.S. P. 1,134,677 (1915).
- (4) Chemische Fabrik Buckau, Ger. P. 294,794 (1916); *Frdl.*, **13**, 30-32.
- (5) Winkler and Häuber, U.S. P. 1,868,127 (1932); *C. A.*, **26**, 5101 (1932). I. G. Farbenind. A.-G., Brit. P. 316,422 (1928); *C. A.*, **24**, 1649 (1930); Ger. P. 630,952 (1936); *C. A.*, **31**, 109 (1937); Ger. P. 653,413 (1937); *C. A.*, **32**, 6664 (1938).
- (6) Kozlov and Fedoseev, *Sintet Kauchuk*, **3**, No. 5, 36-8 (1934); *C. A.*, **32**, 5774 (1938).
- (7) Klyukvin, *Sintet Kauchuk*, **3**, No. 6, 37-41 (1934); *C. A.*, **32**, 5774 (1938).
- (8) Ylla Conte, Ger. P. 653,143 (1937); *C. A.*, **32**, 1712 (1938).
- (9) Unpublished.
- (10) Klatt, *Erdol u. Teer*, **10**, 241-4, 253-5, 265-7 (1934); *C. A.*, **28**, 7243 (1934).
- (11) Schutzenberger, *Compt. rend.*, **110**, 889-92 (1890).
- (12) Varet and Vienne, *ibid.*, **104**, 1375-7 (1887).
- (13) Cook and Chambers, *J. Am. Chem. Soc.*, **43**, 334-40 (1921).
- (14) Boeseke and Adler, *Rec. trav. chim.*, **48**, 474-85 (1929).
- (15) Waterman (to Shell Development Co.), Can. P. 359,746 (1936); *C. A.*, **30**, 6937 (1936); U.S.P. 2,088,500 (1937); *C. A.*, **31**, 6864 (1937).
- (16) Reichert and Nieuwland, *J. Am. Chem. Soc.*, **45**, 3090-1 (1923).
- (17) Reilly and Nieuwland, *ibid.*, **50**, 2564-6 (1928).
- (18) Wenzke and Nieuwland, *ibid.*, **46**, 177-81 (1924).
- (19) Flood and Nieuwland, *ibid.*, **50**, 2566-73 (1928).
- (20) Reppe and Keyssner (to I. G. Farbenind. A.-G.), U.S. P. 2,027,199 (1936); *C. A.*, **30**, 1468 (1936). U.S. P. 2,072,825 (1937); *C. A.*, **31**, 3598 (1937). Ger. P. 642,886 (1937); *C. A.*, **31**, 5900 (1937). Ger. P. 645,112 (1937); *C. A.*, **31**, 6378 (1937). Ger. P. 647,036 (1937); *C. A.*, **31**, 8752 (1937).
- (21) Kozlov and Mazo, Russ. P. 50,467 (1937); *C. A.*, **31**, 8751 (1937).
- (22) Cornillot and Alquier, *Compt. rend.*, **201**, 837-8 (1935).
- (23) Kroeger, Sowa and Nieuwland, *J. Org. Chem.*, **1**, 163-9 (1936).
- (24) Gustafson, *Finska Kemistsamfundets Medd.*, **44**, 85-7 (1935); *C. A.*, **30**, 5561 (1936).
- (25) Ciocca and Scattola, *Gazz. chim. ital.*, **66**, 394-8 (1936); *C. A.*, **31**, 2585 (1937).

6. The preparation of heterocyclic compounds from acetylene. A few heterocyclic substances have been made by the condensation of two or more molecules of acetylene with a compound of nitrogen, or with sulfur or selenium or their compounds. It has been suggested (1) that dimerization of acetylene to a conjugated compound is probably the first step in these syntheses. The reactions are closely related to the condensation of acetylene to aromatic hydrocarbons and take place under similar conditions. For this reason the reaction product is usually a mixture of heterocyclic substances along with aromatic hydrocarbons formed from acetylene alone. The heterocyclic derivatives are potentially valuable, but the reported yields from acetylene condensations are scarcely high enough to make these processes practicable.

Dewar (2) noted the formation of pyrrole along with ammonium cyanide when acetylene mixed with hydrogen cyanide was passed through a hot tube. From a mixture of acetylene, or acetylene and illuminating gas, with hydrogen cyanide heated at 800° Meyer and Tanzen (3) obtained

pyridine and homologs of pyridine. Among the products from acetylene and hydrogen cyanide Meyer and Wesche (4) identified pyrrole, pyridine, quinoline, aniline and benzonitrile. Since ammonia is formed from hydrogen cyanide in this reaction, the pyrrole may originate in a condensation of acetylene with ammonia.

Chichibabin (5) and Chichibabin and Moschkin (6) heated acetylene with ammonia in contact with alumina and produced a condensate containing pyrrole, alpha- and gamma-picoline, beta-collidine, other collidines of unknown structure, 1,4-dimethylpyridine and other substances. Meyer and Wesche (4) isolated pyrrole, pyridine, aniline, benzonitrile, quinoline, indole and a few aromatic hydrocarbons among the products of the thermal treatment of an acetylene-ammonia mixture. Patents have been issued (7) covering the reaction of acetylene with ammonia over bauxite and similar metal oxide catalysts in the presence of water vapor to produce acetonitrile and other nitriles and nitrogen bases such as pyrrole and picoline and their homologs. Brutzkus (8) claimed the formation of like products in a compression apparatus. Patents (9, 10) also describe the condensation of acetylene and ammonia over oxides of zinc, zirconium or thorium to produce denaturants for alcohol, and the use of chlorides of zinc, cadmium, iron or copper as catalysts for the formation, among other products, of methylated homologs of pyridine, which could be hydrogenated to piperidine bases.

In a few cases condensations of acetylene with amines have been observed. Chichibabin (5) identified indole and gamma-methylquinoline formed in the reaction of acetylene with aniline at 360–420° over aluminum oxide. Majima, Unno and Ono (11) reported the formation of indole and carbazole from acetylene and aniline heated to 700° with a nickel catalyst in an iron tube. The condensation of alkyl or aryl amines with acetylene in contact with a catalyst such as zinc chloride has been patented (10). Homologous quinoline bases were obtained from acetylene with aniline, ortho-toluidine, meta-xylidine, n-ethylaniline, orthochloroaniline, etc. Claims were also made covering the production of hydroquinoline derivatives from acetylene, aniline and hydrogen over oxides of chromium, zinc or aluminum supported on silica gel. The production of resinous materials from acetylene and aniline in the presence of a mercury salt has also been patented (12). The authors (13) made quinaldine and homologs of unknown structure from acetylene and aniline in an aqueous sulfuric acid solution containing mercuric sulfate, but in this case acetaldehyde was probably an intermediate. Willihnganz and Nieuwland (14) observed the condensation of acetylene with liquid aniline in the presence of mercuric chloride. Kozlov and coworkers (15–24) obtained condensation products such as quinaldine from acetylene and aniline or its homologs or derivatives

carbon disulfide and hydrogen sulfide on heating acetylene with sulfur, and de Coninck (31) made a little thiophene in this way. This reaction has been investigated by other workers with similar results (32). Steinkopf and Kirchhoff (33) prepared thiophene mixed with other products by passing acetylene over pyrites or other sulfur-containing compounds at 300°. Chichibabin (5) and Chichibabin and Bagdassarjanz (34) investigated the reaction of acetylene with hydrogen sulfide when heated in contact with alumina and other metal oxides. Meyer and Wesche (4) obtained thiophene from heated acetylene mixed with hydrogen sulfide and hydrogen, and when coal gas was added to the mixture they isolated thiophene, thioxene and thionaphthene from the final product. Patents (7) have been issued claiming the condensation of acetylene with hydrogen sulfide at 300–500° over bauxite to give thiophene and its homologs. Briscoe, Peel and Robinson (35) claimed that a condensate formed from acetylene and carbon disulfide at 700° contained 10 per cent of thiophene.

Briscoe, Peel and Robinson (36) prepared the analogous selenophene from acetylene and selenium vapor at 400°.

References

- (1) Schneider, Bock and Häusser, *Ber.*, **70**, 425–9 (1937).
- (2) Dewar, *Jahresber. Fortschritte Chemie*, **1877**, 445.
- (3) R. Meyer and Tanzen, *Ber.*, **46**, 3195–8 (1913).
- (4) R. Meyer and Wesche, *ibid.*, **50**, 422–41 (1917).
- (5) Chichibabin, *J. Russ. Phys.-Chem. Soc.*, **47**, 703–13 (1915); *C. A.*, **9**, 2512 (1915).
- (6) Chichibabin and Moschkin, *J. Russ. Phys.-Chem. Soc.*, **54**, 611–24 (1924); *J. Chem. Soc.*, **126 I**, 313 (1924); *J. prakt. Chem.*, **107**, 109–21 (1924).
- (7) Stuer and Grob, U.S. P. 1,421,743 (1922); *C. A.*, **16**, 3093 (1922). Chem. Fabrik Rhenania, Stuer and Grob, Brit. P. 109,983 (1916); *J. Soc. Chem. Ind.*, **36**, 1194 (1917). Ger. P. 382,091 (1923); *Frdl.*, **14**, 360–2. Austrian P. 88,454, 88,669, 88,626, 89,922 (1922); *Chem. Zentr.*, **1923 II**, 191, 685.
- (8) Brutzkus, Brit. P. 155,776 (1920); *C. A.*, **15**, 1585 (1921). Brit. P. 217,747 (1923); *C. A.*, **19**, 382 (1925).
- (9) I. G. Farbenind. A.-G., Brit. P. 283,163 (1927); *C. A.*, **22**, 3892 (1928). Brit. P. 295,276 (1927); Ger. P. 477,049 (1927); *C. A.*, **23**, 3933 (1929); *C. A.*, **23**, 2188 (1929). Brit. P. 316,282 (1928); *C. A.*, **24**, 1711 (1930); Fr. P. 658,614 (1928); *C. A.*, **23**, 5283; Fr. P. 38,072 (1930); *C. A.*, **25**, 5434 (1931).
- (10) I. G. Farbenind. A.-G., Fr. P. 646,711 (1928); *C. A.*, **23**, 2185 (1929). Brit. P. 334,193 (1929); *C. A.*, **25**, 969 (1931). Ger. P. 558,656 (1929); *C. A.*, **27**, 817 (1933). Schlecht and Roetger (to I. G. Farbenind. A.-G.), U.S.P. 1,936,995 (1934); *C. A.*, **28**, 1052 (1934); Brit. P. 451,794 (1936); *C. A.*, **31**, 418 (1937).
- (11) Majima, Unno and Ono, *Ber.*, **55**, 3854–9 (1922).
- (12) Soc. pour l'ind. chim. à Bâle, Brit. P. 292,168 (1927); *C. A.*, **23**, 1518 (1929).
- (13) Vogt and Nieuwland, *J. Am. Chem. Soc.*, **43**, 2071–81 (1921).
- (14) Willihnganz, Thesis, University of Notre Dame, 1924.
- (15) Kozlov and Fedoseev, *J. Gen. Chem. (U.S.S.R.)*, **6**, 250–8 (1936); *C. A.*, **30**, 4864 (1936).
- (16) Kozlov and Golod, *ibid.*, **6**, 1089–91 (1936); *C. A.*, **31**, 1028 (1937).
- (17) Kozlov *et al.*, *ibid.*, **6**, 1341–54 (1936); *C. A.*, **31**, 1374 (1937).
- (18) Kozlov and Mogilyansky, *ibid.*, **6**, 1897–1901 (1936); *C. A.*, **31**, 4286 (1937).
- (19) Kozlov, Serko and Rodman, *ibid.*, **7**, 832–8 (1937); *C. A.*, **31**, 5775 (1937).

- (20) Kozlov and Mitskevich, *ibid.*, **7**, 1082-5 (1937); *C. A.*, **31**, 6209 (1937).
 (21) Kozlov, *ibid.*, **7**, 1860-5 (1937); *C. A.*, **32**, 565 (1938).
 (22) Kozlov and Olifson, *ibid.*, **7**, 2301-5 (1937); *C. A.*, **32**, 565 (1938).
 (23) Kozlov, *ibid.*, **8**, 366-9, 413-7, 419-23, 475-6 (1938); *C. A.*, **32**, 5386, 7916 (1938).
 (24) Kozlov and Fedoseev, *ibid.*, **7**, 51-5 (1937); *C. A.*, **31**, 4320 (1937).
 (25) Baschieri, *Atti. Real. Accad. Lincei*, (5), **9 I**, 391-3 (1900); *Chem. Zentr.*, **1900**, II, 528.
 (26) Testoni and Mascarelli, *ibid.*, **10**, 442 (1901).
 (27) Mascarelli, *Gazz. chim. ital.*, **33 II**, 319-24 (1903); *Chem. Zentr.*, **1901 II**, 127-8.
 (28) Quilico and Freri, *ibid.*, **59**, 930-41 (1929); **60**, 172-84 (1930); **60**, 721-44 (1930); **61**, 265-76 (1931); **61**, 484-500 (1931); **61**, 759-72 (1931). *C. A.*, **24**, 3484, 3788 (1930); **25**, 1247, 4548 (1931); **26**, 454, 1606 (1932).
 (29) V. Meyer and Sandmeyer, *Ber.*, **16**, 2176-80 (1883).
 (30) Capelle, *Bull. soc. chim.* (4), **3**, 150-4 (1908).
 (31) Coninck, *Bull. sci. acad. roy. Belg.*, **1908**, 30-31; *C. A.*, **3**, 643 (1909).
 (32) Bhatt, Nargund, Kanga and Shah, *J. Univ. Bombay*, **3**, 159-60 (1934); *C. A.*, **29**, 4762 (1935).
 (33) Steinkopf and Kirchhoff, *Austrian P.* 72,291 (1916); *Ger. P.* 252,375; *Frld.*, **11**, 140.
 (34) Chichibabin and Bagdassarjan, *J. prakt. Chem.*, **II 108**, 200-8 (124).
 (35) Briscoe, Peel and Robinson, *J. Chem. Soc.*, **1928**, 2857-8.
 (36) Briscoe and Peel, *ibid.*, **1928**, 1741-7; Briscoe, Peel and Robinson, *ibid.*, **1928**, 2628-9.

7. The polymerization of acetylene by cuprous salt catalysts.* Early work of Nieuwland relating to the reactions of acetylene (1) led to the observation that when acetylene was passed into a solution of cuprous chloride in sodium or ammonium chloride, there was developed a peculiar odor, quite unlike that of acetylene. Further investigation revealed that a saturated solution of cuprous and ammonium chlorides would absorb a substantial volume of acetylene and, upon subsequent distillation, would yield a portion of the acetylene converted to a highly refractive liquid which corresponded to the molecular formula C_6H_8 and which later proved to be the new compound divinylacetylene (1,5-hexadiene-3-yne) (2, 3). The E. I. Du Pont de Nemours & Company had been interested in the utilization of acetylene as a raw material for the synthesis of a substitute rubber, and upon learning of the novel Nieuwland reaction, arrangements were made to continue the study with the general purpose of broadening the knowledge of acetylene polymerization. Although a satisfactory synthetic rubber was not obtained from divinylacetylene, it proved to be a suitable raw material for the preparation of drying oils of unusual properties, and the investigation of its polymerization led to a commercial process for the manufacture of vinylacetylene (1-butene-3-yne) which subsequently proved to be the basic raw material for the first commercially successful synthetic rubber, neoprene, formerly called by the trade name "Du-prene" (4).

* Sections 7, 8, 9, and 10 of this chapter were written in 1938 by Dr. A. S. Carter and Dr. H. W. Starkweather of the Jackson Laboratory, E. I. du Pont de Nemours & Company.

The neoprene process involves three basic steps:

(1) Acetylene polymerization to vinylacetylene,

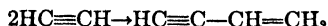

(2) Vinylacetylene hydrohalogenation to chloroprene, 2-chloro-1,3-butadiene,



(3) Polymerization of chloroprene to a rubber-like material, neoprene.

These reactions as carried out commercially by the du Pont Company to produce neoprene, and as duplicated by the Russians to produce "Sovprene" (5) are the subject of many reviews (5-27).

A substantially saturated aqueous solution of ammonium or alkali chloride and cuprous chloride will absorb acetylene with the formation of a heterogeneous crystalline mass of dissolved and precipitated addition products (4, 28). Upon subsequent distillation, acetylene and higher polymers are recovered, the proportion of the latter increasing to approximately 100 per cent as the interval between charging and distillation approaches 120 hours. The polymer product resulting from this ageing is essentially a trimer, divinylacetylene, and a tetramer, 1,5,7-octatriene-3-yne. However, a continuous process (3, 29) in which acetylene is introduced and removed continuously, isolating intermediate products formed in small amounts, reveals the fact that vinylacetylene (30) is the primary polymerization product, and this subsequently combines with acetylene or with itself to form the trimer and tetramer. It is probable that a cuprous chloride addition product of vinylacetylene exists (4, 30, 31) in a form analogous to that formed with acetylene, and this constitutes the reactive constituent in the formation of the higher polymers. The first step of the reaction appears to be monomolecular; the ratio of products under various conditions of operation would indicate that one molecule of acetylene or vinylacetylene is activated by the catalyst, and thereafter adds to a second acetylenic molecule, thus providing the following possibilities:

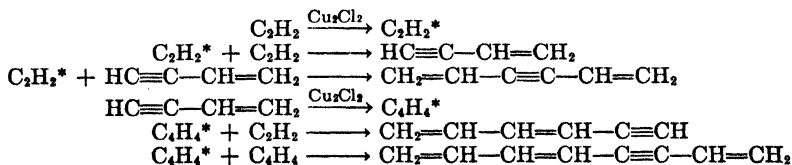

Several theories of the mechanism of the polymerization have been advanced (32-34). All of the products indicated above have been identified in the mixture obtained by the polymerization of acetylene in the presence of cuprous chloride (4, 35). Further, 1,3-hexadiene-5-yne, which still

* Indicates the active molecule, that is the molecule associated with Cu_2Cl_2 .

possesses acetylenic hydrogen, might react with (a) acetylene, (b) vinylacetylene or (c) itself to produce respectively (a) 1,3,5-octatriene-7-yne or 1,3,7-octatriene-5-yne, (b) two decatetraeneynes, and (c) one dodecapentaene. These have not been isolated, but traces of higher molecular weight hydrocarbons indicate their probable existence in the polymer product.

Numerous variations in the catalyst have improved its physical properties and durability. Traces of acetaldehyde and chlorinated hydrocarbons are produced simultaneously with the polymerization. In part, this may be controlled by the state of reduction of the mixture through the addition of metallic copper, and in part through control of the pH of the catalyst by returning chlorine as hydrogen chloride, equivalent to that lost as chloro-derivatives (36, 37). Amines (3, 4, 30, 38) and alkali and alkaline-earth salts (4, 39) have been used in the capacity of ammonium chloride to solubilize the cuprous chloride addition salts, and the catalyst has been used in a relatively dehydrated state for vapor phase polymerization of acetylene (40, 41). The catalyst has been compounded in non-aqueous solvents such as glycerol and glycols (42) and in organic acid media (36, 43) such as mixtures of acetic acid and pyridine. Dispersing agents have been added to improve the physical properties of the mixture (44).

Two forms of catalyst contact have proved satisfactory, (a) a horizontally agitated catalyst vessel (29, 30) and (b) a tower-type (45-48) in which the catalyst is circulated, generally counter current to the stream of gas. The latter type has been described particularly for use in the reaction of dilute pyrolysis acetylene without isolation (45, 46). Batch manufacture is successful for divinylacetylene, but a continuous process (30) in which a conversion of 10 to 30 per cent is obtained is essential to obtain good yields of the intermediate vinylacetylene. In the continuous process a relatively fluid catalyst such as a saturated solution corresponding to the molecular formula $\text{Cu}_2\text{Cl}_2 \cdot 2\text{NH}_4\text{Cl}$ operated at 50-75° is convenient. The pH of the catalyst must be adjusted in the absence of acetylene; thus the pH may be brought to 1.5 as determined by the glass electrode prior to the addition of acetylene; but when saturated with acetylene, it will drop to an unmeasurable value as though acetylene were acting as an acid of phenomenal strength. The pH during operation can be readjusted when necessary by boiling out acetylene and polymers to obtain the original uncharged condition.

A typical vinylacetylene plant is illustrated in Figure 1 (30). Unit 7 constitutes a catalyst tube, having a volume approximately twice that of the catalyst, cylindrical, mounted horizontally and carrying a horizontal agitator shaft with blade-type paddles. The material of construction may be copper; and the tube may be conveniently mounted on railroad trucks

to facilitate removal and replacement during catalyst changes. Gases leaving the catalyst tube pass through an entrainment catcher and thence to unit 9, a preliminary condenser in which water and occasionally small amounts of divinylacetylene (DVA) are removed, the condensate being separated continuously into a water layer, which is returned to the catalyst at 19, and an oil layer which is removed at 10 and treated as divinylacetylene in the subsequent process. Gases from the separator are compressed and dried by contact with calcium carbide (49). Dry compressed gas is introduced into the low-temperature condenser at 12, operated slightly above the boiling point of acetylene, to which refrigeration is supplied from an external source such as multi-stage centrifugal compressors. Uncondensed acetylene in 12 returns to the catalyst via 18, pump 3 and a pre-heater 5, as shown. The low-temperature condenser system may be built in duplicate, as indicated, to facilitate thawing in the event that ice accumulates in condenser 12. The liquid condensate is warmed to the boiling point of vinylacetylene in 13; the off-gas is returned to 7 via 15 and the liquid is delivered to storage 14 for subsequent purification. In view of the fact that the residue of divinylacetylene is thermally unstable, heat may be applied to the purification still by means of a flat plate film-evaporator with a low-temperature differential between the heating medium and the distilling liquid. Volatilized vinylacetylene (MVA) may be condensed and stored in tanks, or directly delivered to the chloroprene unit after scrubbing with bisulfite to remove acetaldehyde (50). Numerous heat exchangers may be placed in the system at advantageous points to recover refrigeration. In the figure shown, for example, heat exchange might be established between the gases in the following locations: 8 with 6, and 11 with 18. Under certain circumstances the apparatus may be rearranged to advantage; for example, the gas from 13 may be returned through 15 to line 11 if its content of vinylacetylene is high.

Divinylacetylene discharged from the purification still may be combined with that obtained in the process at 10; this may contain a small amount of vinylacetylene, justifying further working, or it may be piped directly to the polymerization unit for the manufacture of synthetic drying oil, or other disposition. In the system outlined, fresh acetylene is fed in through an automatic valve at 2 to maintain a constant pressure on the reactor, therefore replacing that which is polymerized. The pressure on the condensing system may be higher than the reaction pressure, and in this case, the higher level is reduced to the reactor pressure at an automatic valve in line 16, maintaining a constant pressure on the condensation system, and pump 3 may be located in line 11.

Early in the work on divinylacetylene, it was found that contact with air resulted in the formation of explosive products. In view of the fact that

divinylacetylene readily oxidizes to form peroxides which detonate with a violence comparable to mercury fulminate, special precautions are required to guard against leaks in valves and process lines, and a special technique has been necessary in handling it (51, 52).

Other processes for the manufacture of vinylacetylene have not become commercially important. Vapor-phase processes have been described (40, 41, 53).

Poor yields have been obtained by thermal polymerization of acetylene (54) over certain metals (55) and salts (53); by photopolymerization of acetylene (56) and by silent discharge (57-59), for example in amylene. It has been found that butadiene obtained from petroleum cracking contains vinylacetylene to the extent of 0.7 per cent (5).

Vinylacetylene and divinylacetylene have been prepared by the action of zinc in butanol on 3-ethoxy-4-bromo-1-butyne and 2,5-diethoxy-1,6-dibromo-3-hexyne, respectively (60, 61), and from diacetylene hexabromide (62).

The first preparation of vinylacetylene was by exhaustive methylation of tetramethyl-1,4-diamino-2-butene (63), which has been developed as a laboratory method (64). Homologs of vinylacetylene have been prepared by dehydration of carbinols (65-67) such as 3-methyl-1-butyne-3-ol (68, 69). The literature relating to the preparation of suitable carbinols is extensive, particularly the preparation from alkylene oxides (70), aldehydes (65, 71, 72) or ketones (65, 73, 74) with sodium acetylide or calcium carbide (75, 76). Homologs have also been prepared from dihaloalkenes by removal of two molecules of HX (77).

Vinylacetylene, C_4H_4 , is a colorless liquid having a sharp, sweet odor associated with synthetic butadiene; between -3° and -80° , its density is given by the equation $D_0^t = 0.7095 - 0.00114t$; the following vapor pressures illustrate the behavior in the normal range.

Temperature ($^\circ C$)	Vapor Pressure (mm)
-36	100
-19	250
-9.5	400
+5.5	760
+30	1750

The flame temperature, heat of combustion and heat of dissociation have been calculated (78), and the use of vinylacetylene as a welding fuel has been proposed (79-81). Infrared (82-84) and Raman spectra (85, 86) have been investigated. The structure of vinylacetylene has been proved by hydrogenation, bromination and hydration, the latter yielding 1-butene-3-one. The presence of an acetylenic hydrogen is established by the formation of characteristic acetylides with mercury (white) (87-91), silver (white) and copper (brilliant yellow). It forms a crystalline hydrate of uncertain

composition, probably $C_4H_4 \cdot 2H_2O$, at temperatures below -10° in the presence of moisture. The chemical reactions of vinylacetylene have been extensively studied, particularly the polymerization (92-96) which, when conducted thermally, may yield styrene or cyclobutane-linked polymers (97) or products of different character from radon treatment (98, 99). Hydrogenation may yield butane, butylene and butadiene (100-105), particularly the latter, by chemical reduction with chromous salts (106, 107), as well as hydrogenated polymers which are interesting as drying oils (108). Acid solutions of mercury salts hydrate vinylacetylene (104, 109-113) to methyl vinyl ketone, 1-butene-3-one, and also result in oxidation to diacetyl (114, 115). Alcohols may be added to the triple bond with alkaline catalysts to give alkoxybutadienes (104, 116-118), or with catalysts such as BF_3 to give trialkoxybutanes (119); similarly, glycols form dioxoles (120), and thiophenols give the thioethers (117, 121). Butadienyl esters are formed by addition of carboxylic acids (104, 122-124). The formation and a variety of reactions of the vinylacetylenyl Grignards which have been particularly useful have been described (125-130), together with the sodium acetylide, in the preparation of vinyl ethynyl carbinols (128, 129, 131, 132). Vinylacetylene reacts with chloromethyl methyl ether to give 3-chloro-1-methoxy-2,4-pentadiene (133, 134); with acyl chlorides to form 1-acyl-2-chlorobutadienes (135); simultaneously with formaldehyde and a dialkylamine to give dialkylaminomethyl vinylacetylenes (136, 137) which can be converted to the corresponding amino-chloroprenes. Vinylacetylene reacts as the equivalent of methyl vinyl ketone in the formation of azabenzanthrones from aminoanthraquinones (138). The acetylenic hydrogen may be replaced by alkyls through the alkali acetylide (139-141), or by halogen through the agency of hypohalites (90, 142-144), which may further react with hydrohalogen acids to form 1,2-dihalo-1,3-butadienes (145, 146).

Divinylacetylene, C_6H_6 , is a colorless liquid, rapidly becoming straw-colored upon exposure to sunlight, and possessing an unusual alliaceous odor. The following physical properties are sensitive to polymerization and oxidation: d_4^{20} 0.7759; n_D^{20} 1.5047; b_{760} 85.0° , b_{250} 52.5° , and b_{100} 31° ; m . -87.8° ; latent heat of evaporation 7923 cal.

Divinylacetylene may be hydrogenated to n-hexane by the addition of exactly eight atoms of hydrogen; intermediate hydrogenation products may be isolated (147-150), particularly 3-hexene (151) which may be obtained in high yields. Polymers of divinylacetylene may be hydrogenated, or it may be hydrogenated and simultaneously or subsequently polymerized giving interesting drying oils (101, 148). Addition of six atoms of bromine forms a mixture of isomeric 1,2,3,4,5,6-hexabromo-3-hexenes melting at 81° and 114° . Further direct bromination results in substitution. Divinylacetylene rapidly absorbs oxygen from the air, forming highly explosive

peroxides; when pure, divinylacetylene thermally decomposes in the liquid state at 105° , but may be heated to substantially higher temperatures as a dilute vapor or dilute liquid.

Polymerization (51, 52, 152-61) of divinylacetylene results in products linked through cyclobutane rings (162) which find extensive commercial use as synthetic drying oils in the formulation of coating compositions (14, 52, 115, 151, 155-158, 163-170), resins (171, 172), molding compositions (52, 173, 174), impregnating agents (175, 176), and adhesives for rubber, metal and the like (177, 178). Modifications of the polymer with special properties have been made by treatment with sulfur chloride (149, 179, 180) and by hydrogenation (101, 147, 148, 150). The polymer has found special use in filter coatings (181), modifying lubricating oils (182, 183), in diesel fuels (184) and as a rubber plasticizer (185).

The high degree of unsaturation in divinylacetylene results in numerous chemical reactions peculiar to its structure. The use of antioxidants such as the polyhydroxyphenols, amines, aminophenols and, as a general class, rubber antioxidants (51, 52) avoids peroxidation and affords a safe handling technique. The investigation of reactions has included formation of thioethers by addition of thiophenols (117, 121), halogenation (180, 186, 187), reaction with sulfur monochloride (179, 180, 188, 189), chlorination with sulfuryl chloride (180, 190), the simultaneous addition of sulfur and hydrogen sulfide (191), addition of hydrogen polysulfide (192), the addition of HCl to form mono- and dihydrochlorides (193) and hydrogenation (*loc. cit.*). It is claimed that the hydration of divinylacetylene to yield 1,5-hexadiene-3-one has been accomplished (194).

1,3-Hexadiene-5-yne, isomeric with divinylacetylene, b_{100} 32° , b_{250} 51° , b_{760} 83.4° , d_4^{20} 0.7734, m. -81.0° , n_D^{20} 1.5095, latent heat of evaporation 7895 cal., primarily differs from divinylacetylene in possessing a typical acetylenic hydrogen, which displays the usual properties, forming acetylides (10, 88), Grignards, and hydrating to a carbonyl derivative, 1,3-hexadiene-5-one, b_{760} 145° , n_D^{20} 1.5265, d_4^{20} 0.8762. The chlorohexatriene, C_6H_7Cl , formed by addition of HCl to the triple bond, is known (10).

1,3,7-Octatriene-5-yne, C_8H_8 , the tetramer of acetylene, b_{20} 40° , b_{100} 82° , d_{20} 0.830, n_D^{20} 1.576, resembles divinylacetylene except in physical properties. A polymeric chloro-octatetraene has been prepared by the addition of HCl to this tetramer in exactly the manner used for the addition of vinyl- or divinylacetylene (195).

References

- (1) Nieuwland and Foohey, *Proc. Ind. Acad. Sci.*, **38**, 196 (1929).
- (2) E. I. du Pont de Nemours & Co., *Brit. P.* 384,654 (1932); *Ger. P.* 588,283; *Fr. P.* 733,633 (1931); *Ital. P.* 307,647; *Jap. P.* 103,472.
- (3) Nieuwland, to E. I. du Pont de Nemours & Co., *U.S. P.* 1,811,959 (1931); *Can. P.* 368,210 (1937).

- (4) Nieuwland, Calcott, Downing and Carter, *J. Am. Chem. Soc.*, **53**, 4197 (1931).
- (5) Afanassjew, Lurje, Maruschkin and Pimenow, *Sint. Kauch. (U.S.S.R.)*, **3**, (6), 19 (1934); *Chem. Zentr.*, **1935 II**, 1977. Buizov, *J. App. Chem. (U.S.S.R.)*, **6**, 1074; *Foreign Pat. Tech.*, **2**, 185, 213 (1934); *C. A.*, **28**, 5712.
- (6) Akobshanov, *Rev. gén. mat. plastiques*, **10**, 370 (1934); *Rubber Age (London)*, **16**, 14 (1935); *C. A.*, **29**, 3872 (1935).
- (7) Anon., *Chem. Ind.*, **37**, 273 (1935).
- (8) Anon., *J. Acetylene*, **97**, 1018 (1935).
- (9) Anon., *Ind. chimique*, **25**, 2 (1938).
- (10) Egloff, "Reactions of Pure Hydrocarbons," Reinhold Pub. Corp., New York, 1937.
- (11) Geay, *Rev. chim. ind.*, **42**, 94 (1933); *Chem. Zentr.*, **1935 II**, 456.
- (12) Guerin, *Ind. chimique*, **23**, 171, 250, 326 (1936).
- (13) Henglein, *Chem. Ztg.*, **61**, 684 (1937).
- (14) Klebanski, *Kauch. i Rezina*, **I** (4), 16 (1937).
- (15) Kubelnek, *J. Rubber Ind. (U.S.S.R.)*, **10**, 72 (1933); *C. A.*, **27**, 6016 (1933).
- (16) Lichtenberger, *La Technique Moderne*, **29**, 601 (1937).
- (17) Lowy, *Ind. Eng. Chem. News Ed.*, **11**, 156 (chart) (1933).
- (18) Motovilova, *Sintet. Kauchuk*, **4** (5), 27 (1935).
- (19) Nicodemus, *Z. angew. Chem.*, **49**, 787 (1936).
- (20) *Idem*, *Umschau*, **41**, 5 (1937).
- (21) Nieuwland, *Proc. Ind. Acad. Sci.*, **44**, 17 (1934).
- (22) *Idem*, *Tech. Eng. News*, **16**, 71, 82 (1935).
- (23) Pesin, Kozlov, Shter and Zelinskii, *Sintet. Kauchuk*, **1932** (3), 4; *C. A.*, **27**, 6016 (1933).
- (24) Vogl, *Oesterr. Chem. Ztg.*, **40**, 373 (1937); *C. A.*, **31**, 8065 (1937).
- (25) Zelinskii, *Uspekhi Khim.*, **2**, 352 (1933); *C. A.*, **27**, 6016 (1933).
- (26) Zelinskii, Kozlov and Shter, *Bull. Acad. Sci. (U.S.S.R.)*, **7**, 141 (1934); *Brit. chem. Abs.*, **1934**, 639.
- (27) Stine, *J. Soc. Chem. Ind.*, **52**, 416 (1933).
- (28) Tzyurikh and Ginzburg, *J. Gen. Chem. (U.S.S.R.)*, **5**, 1468 (1935); *C. A.*, **30**, 2169 (1936).
- (29) Calcott and Downing, to E. I. du Pont de Nemours & Co., U.S. P. 1,876,857 (1932); Can. P. 368,209 (1937).
- (30) Carter and Downing, to E. I. du Pont de Nemours & Co., U.S. P. 2,048,838 (1936); Fr. P. 43,351/733,663 (1934); Ital. P. 316,747; Can. P. 356,449 (1936); Brit. P. 401,678 (1933).
- (31) Lurge, Maruschkin, Schlossberg and Tschistow, *Sintet. Kauchuk*, **3** (6), 13 (1935); *Chem. Zentr.*, **1935 II**, 1976.
- (32) Favorsky, *Org. Chem. Ind. (U.S.S.R.)*, **3**, 131 (1937); *C. A.*, **31**, 4952 (1937).
- (33) Favorsky and Favorskaya, *Compt. rend.*, **200**, 839 (1935).
- (34) Hurd, Private communication (1935) to Egloff (q.v.).
- (35) Klebanski, Dranilzina and Dobromil'skaya, *Compt. rend. Acad. Sci. (U.S.S.R.)*, **2**, 229 (1935); *Rev. Petrolifère*, **642**, 992 (1935); *C. A.*, **29**, 6205 (1935).
- (36) E. I. du Pont de Nemours & Co., Brit. P. 390,179 (1933); Ger. P. 589,561 (1933); Ital. P. 311,333; Jap. P. 106,173; Norw. P. 53,416; Swiss P. 191,727 (1931); Fr. P. 41,454/733,663 (1931).
- (37) Nieuwland, to E. I. du Pont de Nemours & Co., U.S. P. 1,926,056 (1933); Can. P. 356,446 (1933).
- (38) E. I. du Pont de Nemours & Co., Brit. P. 384,654 (1932); Ger. P. 588,283; Fr. P. 733,663 (1931); Ital. P. 307,647; Jap. P. 103,472.
- (39) I. G. Farbenind., Brit. P. 438,548 (1935); Fr. P. 792,642 (1936).
- (40) *Idem*, Brit. P. 451,442 (1936); Fr. P. 798,309 (1936).
- (41) A. Wacker, *Ges. Elektrochem. Ind.*, Fr. P. 824,453 (1938).
- (42) Carter, Downing and Hutton, to E. I. du Pont de Nemours & Co., U.S. P. 1,926,039 (1933).

- (43) Nieuwland and Vogt, to E. I. du Pont de Nemours & Co., U.S. P. 1,926,055 (1933); Can. P. 356,447 (1936).
- (44) I. G. Farbenind., Brit. P. 450,761 (1936); Fr. P. 797,642 (1936); Ger. P. 639,242 (1936).
- (45) *Idem*, Brit. P. 445,358 (1936); Fr. P. 792,917 (1936).
- (46) *Idem*, Brit. P. 479,477 (1938); Fr. P. 823,333 (1938).
- (47) Perkins and Toussaint, to Carbide and Carbon Chem. Corp., U. S. P. 1,971,656 (1934); Can. P. 370,627 (1937).
- (48) Tzyurikh, *Kauch. i Rezina*, **1937** (3), 3; *Chem. Zentr.*, **1937 II**, 2755-6.
- (49) Chilton, to E. I. du Pont de Nemours & Co., U.S. P. 1,999,397 (1935).
- (50) Carter, to E. I. du Pont de Nemours & Co., U.S. P. 2,110,371 (1938).
- (51) Calcott and Downing, to E. I. du Pont de Nemours & Co., U.S. P. 1,924,979 (1933); Can. P. 366,155 (1937).
- (52) E. I. du Pont de Nemours & Co., Brit. P. 384,655 (1932); Ger. P. 601,504 (1934).
- (53) Tzyurikh, Efremova, Bartashev and Yanitz, *J. Gen. Chem. (U.S.S.R.)*, **6**, 197 (1936); *C. A.*, **30**, 4807 (1936).
- (54) Mignonac, Fr. P. 805,621 (1936).
- (55) Soc. anon. ammonia casale, Fr. P. 797,935 (1936); Brit. P. 473,219 (1937); Swiss P. 188,617 (1937).
- (56) Kemula and St. Mrazek, *Z. physik. Chem.*, **B23**, 358 (1933).
- (57) Meneghini and Sorgato, *Gazz. chim. ital.*, **62**, 621 (1932).
- (58) Mignonac and Saint-Aunay, *Compt. rend.*, **188**, 959 (1929).
- (59) Saint-Aunay, *Chimie et industrie*, **29**, 1011 (1933).
- (60) Lespieau and Guillemonat, *Compt. rend.*, **195**, 245 (1932).
- (61) Lespieau, Guillemonat and Urion, *Kolloid-Z.*, **63**, 84 (1933).
- (62) Straus, Kollek and Hauptmann, *Ber.*, **63**, 1886 (1930).
- (63) Willstätter and Wirth, *Ber.*, **46**, 535 (1913).
- (64) Makashina, Shilov, Smirnova and Yakimov, *Sintet. Kauchuk*, **1933** (1), 4; *C. A.*, **27**, 5052 (1933).
- (65) Carothers and Coffman, to E. I. du Pont de Nemours & Co., U.S. P. 1,950,441 (1934).
- (66) G. Dupont, *Ann. chim.*, **30**, 512 (1913).
- (67) Favorsky, *J. Russ. Phys.-Chem. Soc.*, **37**, 643 (1905).
- (68) *Idem*, Russ. P. 31,015 (1933); *Chem. Zentr.*, **1934 I**, 2488.
- (69) *Idem*, Russ. P. 31,017 (1933); *Chem. Zentr.*, **1934 I**, 2488.
- (70) Kreimeier, to E. I. du Pont de Nemours & Co., U.S. P. 2,106,182 (1938).
- (71) Hess and Munderloh, *Ber.*, **51**, 377 (1918).
- (72) Kreimeier, to E. I. du Pont de Nemours & Co., U.S. P. 2,106,181 (1938).
- (73) Bayer Farbenind., Ger. P. 280,226; 284,764; 295,770; 286,920; 287,933; 288,271; 289,497; 289,800; 290,558; 290,858; 291,185; 293,059.
- (74) Kreimeier, to E. I. du Pont de Nemours & Co., U.S. P. 2,106,180 (1938).
- (75) Kazarian, *J. Gen. Chem. (U.S.S.R.)*, **4**, 1347 (1934); **7**, 956 (1937).
- (76) Kazarian and Gambarian, Russ. P. 41,516 (1935); *Chem. Zentr.*, **1935 II**, 3702; *C. A.*, **30**, 8241 (1936).
- (77) Grignard, *Bull. soc. chim.*, **21**, 574 (1899).
- (78) Kraus, Proc. XIIth International Congress of Acetylene, **6**, 1422, 1459 (1936).
- (79) I. G. Farbenind., Fr. P. 789,174 (1935).
- (80) Kraus, to I. G. Farbenind., U.S. P. 2,043,212 (1936); Can. P. 349,941 (1935); Ger. P. 613,781; Brit. P. 439,689 (1935).
- (81) Kraus, to I. G. Farbenind., Ger. P. 632,755 (1936); Brit. P. 460,641 (void).
- (82) Bartholome and Karweil, *Z. physik. Chem.*, **B35**, 442 (1937).
- (83) Mecke, Ganswein and Vierling, *Z. Elektrochem.*, **40**, 474 (1934).
- (84) *Idem*, *Z. Physik.*, **99**, 189 (1936).
- (85) Glockler and H. M. Davis, *J. Chem. Phys.*, **2**, 881 (1934).
- (86) Mecke and Timm, *Z. Physik.*, **94**, 1 (1935).
- (87) Carothers, Berchet and Jacobson, *J. Am. Chem. Soc.*, **55**, 4665 (1933).

- (88) Klebanski and Dobromil'skaya, *Sintet. Kauchuk*, **1936** (9), 12; *C. A.*, **31**, 6502 (1937).
- (89) Peregud, *Kauch. i Rezina*, **1937** (7-8), 63; *C. A.*, **32**, 3197 (1938).
- (90) Vaughn, *J. Am. Chem. Soc.*, **55**, 3453 (1933).
- (91) Zakharov, *Sintet. Kauchuk*, **1936** (5), 9; *C. A.*, **30**, 6672 (1936).
- (92) Carter and Downing, to E. I. du Pont de Nemours & Co., U.S. P. 1,896,162 (1933); *Brit. P.* 385,963 (1932); *Ger. P.* 624,992 (1936); *Can. P.* 356,445 (1936).
- (93) Egloff, Wilson, Hulla and Van Arsdell, *Chem. Rev.*, **20**, 345 (1937).
- (94) Harkness, Kistiakowsky and Mears, *J. Chem. Phys.*, **5**, 682 (1937).
- (95) I. G. Farbenind. *Fr. P.* 798,036 (1936).
- (96) Lawson and Arvin, to E. I. du Pont de Nemours & Co., U.S. P. 2,077,485 (1937).
- (97) Dykstra, *J. Am. Chem. Soc.*, **56**, 1625 (1934).
- (98) Heisig, *ibid.*, **53**, 4460 (1931).
- (99) *Idem, ibid.*, **55**, 2304 (1933).
- (100) Calcott, Carter and Downing, to E. I. du Pont de Nemours & Co., U.S. P. 1,920,242 (1933).
- (101) I. G. Farbenind., *Brit. P.* 474,234 (1937); *Fr. P.* 820,286 (1937).
- (102) *Idem, Fr. P.* 828,194 (1938).
- (103) *Idem, Fr. P.* 828,195 (1938).
- (104) Klebanski, Tzyurikh and Dolgopolski, *Bull. Acad. Sci. (U.S.S.R.)*, **1935** (2), 189-226; *Rub. Chem. Tech.*, **9**, 406 (1936); *Research Assoc. Brit. Rub. Mfg.*, **13**, 505 (1935); *Chem. Zentr.*, **1935 II**, 3843; *C. A.*, **30**, 1259 (1936).
- (105) Lebedev, Gulyaeva and Vasil'ev, *J. Gen. Chem. (U.S.S.R.)*, **5**, 1421 (1935); *C. A.*, **30**, 2169 (1936).
- (106) Baumann and Tanneberger, to I. G. Farbenind., *Ger. P.* 540,003 (1930); U.S. P. 1,955,046 (1934).
- (107) I. G. Farbenind., *Brit. P.* 486,094 (1938); *Fr. P.* 828,859 (1938).
- (108) Anon., *Paint Tech.*, **3**, 61 (1938).
- (109) Carter, to E. I. du Pont de Nemours & Co., U.S. P. 1,896,161 (1933); *Brit. P.* 388,402 (1933); *Ger. P.* 594,083 (1934); *Fr. P.* 719,309 (1932); *Can. P.* 356,444 (1936).
- (110) Conaway, to E. I. du Pont de Nemours & Co., U.S. P. 1,967,225 (1934).
- (111) I. G. Farbenind., *Fr. P.* 824,777 (1938).
- (112) Kozlov and Krechkov, *Russ. P.* 42,073 (1935); *C. A.*, **30**, 8248 (1936).
- (113) Nicodemus and Weibezahn, to I. G. Farbenind., *Ger. P.* 590,237 (1934).
- (114) Eberhardt, to I. G. Farbenind., U.S. P. 2,062,263 (1936); *Brit. P.* 421,676 (1934); *Ger. P.* 615,637 (1935); *Fr. P.* 776,584 (1935).
- (115) Eberhardt and Lieseberg, to I. G. Farbenind., U.S. P. 2,110,699 (1938); *Fr. P.* 810,239 (1937); *Brit. P.* 460,862 (1937).
- (116) Carothers, Dykstra and Jacobson, *J. Am. Chem. Soc.*, **56**, 1169 (1934).
- (117) Carothers and Jacobson, to E. I. du Pont de Nemours & Co., U.S. P. 2,013,725 (1935).
- (118) Rotenberg and Favorskaya, *J. Gen. Chem. (U.S.S.R.)*, **6**, 185 (1936); *C. A.*, **30**, 4808 (1936).
- (119) Nieuwland, Killian and Hennion, *J. Am. Chem. Soc.*, **56**, 1786 (1934); **58**, 892 (1936). Norris, Verbanc and Hennion, *ibid.*, **61**, 887 (1939).
- (120) Nieuwland, Killian and Hennion, *ibid.*, **58**, 1658 (1936).
- (121) Carothers, *ibid.*, **55**, 2008 (1933).
- (122) Klebanski and Chevuaichiova, *Sintet. Kauchuk*, **4** (4), 5 (1935); *C. A.*, **29**, 6799 (1935).
- (123) Werntz, to E. I. du Pont de Nemours & Co., U.S. P. 1,963,108 (1934).
- (124) Werntz, *J. Am. Chem. Soc.*, **57**, 204 (1935).
- (125) Carothers and Berchet, *ibid.*, **55**, 1094 (1933).
- (126) *Idem*, to E. I. du Pont de Nemours & Co., U.S. P. 1,963,935 (1934).
- (127) *Idem*, to E. I. du Pont de Nemours & Co., U.S. P. 2,082,568 (1937).
- (128) Carothers and Jacobson, *J. Am. Chem. Soc.*, **55**, 1097 (1933).

- (129) E. I. du Pont de Nemours & Co., Fr. P. 753,465 (1934).
(130) Zal'kind and Pletz, *Trans. Leningrad Chem. Tech. Inst.*, **1**, 57 (1934); *J. Gen. Chem. (U.S.S.R.)*, **4**, 1088 (1934); *C. A.*, **29**, 2908 (1935).
(131) Carothers, Berchet and Jacobson, to E. I. du Pont de Nemours & Co., U.S. P. 1,963,074 (1934).
(132) Carothers and Jacobson, to E. I. du Pont de Nemours & Co., U.S. P. 1,963,934 (1934).
(133) Dykstra, *J. Am. Chem. Soc.*, **58**, 1747 (1936).
(134) *Idem*, to E. I. du Pont de Nemours & Co., U.S. P. 2,119,531 (1938).
(135) Nelles and Bayer, to I. G. Farbenind., Brit. P. 461,080 (1937); Ger. P. 642,147 (1937).
(136) Carothers, to E. I. du Pont de Nemours & Co., U.S. P. 2,110,199 (1938).
(137) Coffman, *J. Am. Chem. Soc.*, **57**, 1978 (1935).
(138) I. G. Farbenind., Brit. P. 485,175 (1938); Fr. P. 828, 581 (1938).
(139) Bergstrom and Fernelius, *Chem. Rev.*, **20**, 413 (1937).
(140) Carothers and Jacobson, *J. Am. Chem. Soc.*, **55**, 1622 (1933).
(141) *Idem*, to E. I. du Pont de Nemours & Co., U.S. P. 2,082,569 (1937).
(142) Jacobson, to E. I. du Pont de Nemours & Co., U.S. P. 1,967,864 (1934).
(143) Nieuwland and Vaughn, *J. Chem. Soc.*, **1933**, 741.
(144) *Idem*, *J. Am. Chem. Soc.*, **55**, 2150 (1933).
(145) Carothers and Jacobson, *ibid.*, **55**, 4667 (1933).
(146) Klebanski, Wolkenstein and Orlowa, *J. prakt. Chem.*, **145**, 1 (1936); *J. Gen. Chem. (U.S.S.R.)*, **5**, 1255 (1935).
(147) Calcott, Carter and Downing, to E. I. du Pont de Nemours & Co., U.S. P. 1,959,343 (1934); Can. P. 366,156 (1937).
(148) *Idem*, U.S. P. 1,959,408 (1934).
(149) *Idem*, U.S. P. 1,903,501 (1933).
(150) E. I. du Pont de Nemours & Co., Brit. P. 389,108 (1933); Ger. P. 649,000 (1937).
(151) *Idem*, Ger. P. 659,084 (1938).
(152) Calcott and Downing, to E. I. du Pont de Nemours & Co., U.S. P. 1,950,429 (1934); Can. P. 366,161 (1937).
(153) Calcott, Downing and Powers, to E. I. du Pont de Nemours & Co., U.S. P. 1,829,502 (1931).
(154) *Idem*, U.S. P. 1,903,500 (1933).
(155) Collins, to E. I. du Pont de Nemours & Co., U.S. P. 1,812,849 (1931); Can. P. 366,160 (1937).
(156) *Idem*, U.S. P. 1,869,668 (1932).
(157) *Idem*, U.S. P. 2,078,194 (1937).
(158) E. I. du Pont de Nemours & Co., Fr. P. 733,681 (1931).
(159) *Idem*, Brit. P. 389,109 (1933).
(160) Nieuwland, to E. I. du Pont de Nemours & Co., U.S. P. 1,812,541 (1931); Can. P. 356,448 (1936).
(161) Werntz, to E. I. du Pont de Nemours & Co., U.S. P. 2,055,597 (1936).
(162) Carothers and Cupery, *J. Am. Chem. Soc.*, **56**, 1167 (1934).
(163) Calcott and Downing, to E. I. du Pont de Nemours & Co., U.S. P. 1,958,418 (1934).
(164) Collins, to E. I. du Pont de Nemours & Co., U.S. P. 1,812,544 (1931); Can. P. 366,163 (1937).
(165) *Idem*, U.S. P. 2,008,746 (1935).
(166) Hayden, *Ind. Eng. Chem.*, **24**, 563 (1932).
(167) *Idem*, *ibid.*, **25**, 1219 (1933).
(168) Light, *Synthetic and Applied Finishes*, **4**, 71 (1933).
(169) Rodman, to E. I. du Pont de Nemours & Co., U.S. P. 2,036,300 (1936); Brit. P. 443,235 (1935).
(170) Zhavoronkov, *Org. Chem. Ind. (U.S.S.R.)*, **2**, 219 (1936); *C. A.*, **31**, 1003 (1937).
(171) Bakelite Ltd., Brit. P. 478,703 (1938).

- (172) Haskins, to Gen. Electric Co., U.S. P. 2,031,481 (1936); Brit. P. 440,924 (1936).
 (173) Calcott and Reynolds, to E. I. du Pont de Nemours & Co., U.S. P. 2,034,895 (1936).
 (174) Rohm and Haas, Brit. P. 475,552 (1937).
 (175) Calcott, Carter and Downing, to E. I. du Pont de Nemours & Co., U.S. P. 1,950,430 (1934).
 (176) Volin and Morosov, Russ. P. 42,049 (1934); *Chem. Zentr.*, **106 II**, 3959.
 (177) Firestone Tire and Rubber Co., Brit. P. 471,613 (1937); Can. P. 366,034 (1937).
 (178) Humphrey, to Firestone Tire and Rubber Co., Can. P. 371,143 (1938).
 (179) Calcott, Carter and Downing, to E. I. du Pont de Nemours & Co., Can. P. 352,499 (1935).
 (180) E. I. du Pont de Nemours & Co., Brit. P. 389,122 (1933).
 (181) Badollet, to Johns Manville Corp., U.S. P. 2,040,818 (1936).
 (182) Wizevich, to Standard Oil Development Co., Can. P. 365,654 (1937).
 (183) *Idem*, to Standard Oil Development Co., U.S. P. 2,104,409 (1938); Ger. P. 634,511 (1936); Brit. P. 442,979 (1936).
 (184) Stadler, Lappe and Wilke, to I. G. Farbenind., U. S. P. 2,028,308 (1936).
 (185) Standard Oil Development Co., Fr. P. 812,490 (1937).
 (186) Calcott and Carter, to E. I. du Pont de Nemours & Co., U.S. P. 1,896,159 (1933).
 (187) Carothers and Coffman, *J. Am. Chem. Soc.*, **55**, 2040 (1933).
 (188) Calcott and Carter, to E. I. du Pont de Nemours & Co., U.S. P. 1,896,157 (1933).
 (189) Calcott, Carter and Downing, to E. I. du Pont de Nemours & Co., U.S. P. 1,896,158 (1933).
 (190) Calcott and Carter, to E. I. du Pont de Nemours & Co., U.S. P. 1,896,160 (1933); Can. P. 356,443 (1936).
 (191) Carter and Downing, to E. I. du Pont de Nemours & Co., U.S. P. 2,061,019 (1936); Can. P. 373,502 (1938).
 (192) Carothers, to E. I. du Pont de Nemours & Co., U.S. P. 2,061,018 (1936); Can. P. 373,501 (1938).
 (193) Nieuwland, Carothers and Coffman, *J. Am. Chem. Soc.*, **55**, 2048 (1933).
 (194) Zhavoronkov, Alekhina and Shter, *Sintet, Kauchuk*, **1934**, (2) 12; *C. A.*, **29**, 3976 (1935).
 (195) v. Zutphen, to I. G. Farbenind., U.S. P. 2,119,629 (1938); Ger. P. 657,945 (1938).

8. Chloroprene. The greatest commercial interest in these acetylene polymers relates to the formation of butadiene derivatives from vinylacetylene. In the presence of many metallic halides, vinylacetylene adds an equivalent weight of hydrogen halide with the formation of 1-halo-2,3-butadienes (1-5). In the presence of cuprous salts, these rearrange to isomeric 2-halo-1,3-butadienes (1, 6, 7, 8), which subsequently may add a second molecule of hydrogen halide with the formation of the 1,3-dihalo-2-butenes (4, 5, 7, 9). The following hydrogen halide addition products are described: 1-chloro-2,3-butadiene, b.p. 87.7-88.1°; 2-chloro-1,3-butadiene, b_{100} 6.4°, b_{400} 40.5°, b_{760} 59.4°, $\log_{10} P = -\frac{1545.3}{T} + 7.527$; 1,3-dichloro-2-butene, b_{50} 53-54°, b_{70} 61-63°, b_{756} 127-29°, d_4^{20} 1.1591; 1-bromo-2,3-butadiene, b_{181} 64-66°, b_{760} 108-12°, d_4^{20} 1.4255; 2-bromo-1,3-butadiene, b_{166} 42-43°, d_4^{20} 1.397; 1,3-dibromo-2-butene, b_{23} 73°, b_{760} 168° (decompn.), d_4^{20} 1.877; 1-iodo-2,3-butadiene, b_{38} 43-45°, d_4^{20} 1.7130; 2-iodo-1,3-butadiene, b_{760} 111-13°, d_4^{20} 1.7278.

Although all the haloprenes (halobutadienes) polymerize to rubber-like materials, the most valuable combination of physical properties is obtained in chloroprene (2-chloro-1,2-butadiene) from which the commercial polymer, neoprene, is prepared. The commercial production of chloroprene may be accomplished by batch (5, 7, 10-13) or continuous methods (14), the latter being designed to obtain high yields of chloroprene without substantial loss to by-product dichlorobutene. Chloroprene may be made by a cyclic process similar to the MVA process in Figure 1; gaseous HCl and

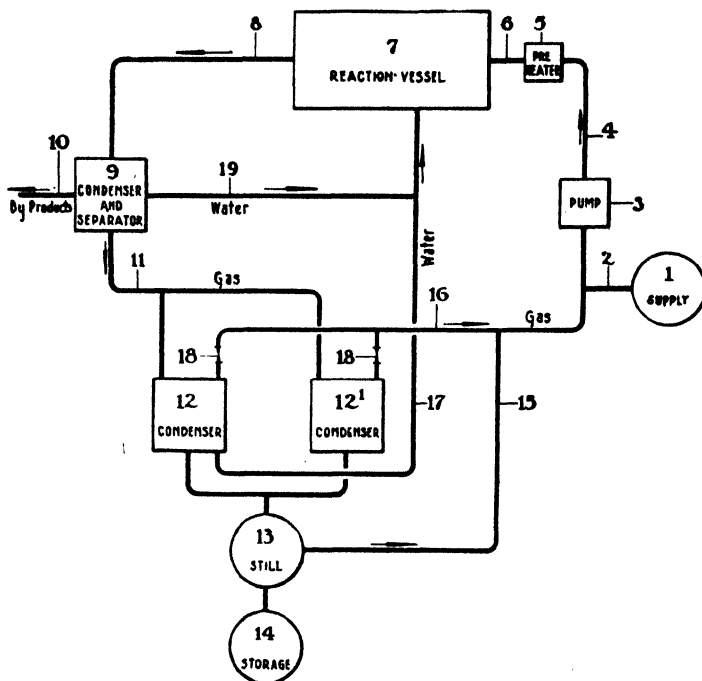

FIGURE 1

vinylacetylene are introduced into a reactor vessel which may be constructed in a manner similar to the acetylene polymerization reactor 7, but of suitable materials, such as enamel or Hastelloy. A typical catalyst solution may consist of a 5 to 25 per cent aqueous solution of Cu_2Cl_2 containing 18 to 38 per cent hydrogen chloride. Addition of NH_4Cl (7) or alkali metal halides (13) has been made without particular advantage (10). Hydrogen chloride is added to maintain a constant composition in the solution (15); vinylacetylene is added as consumed by automatically maintaining a constant vinylacetylene pressure in the reaction system. The reaction vessel is generally maintained at a temperature of 30° to 60° by

means of a water jacket. Effluent gases may pass through an entrainment catcher to a tubular cooler designed to recover refrigeration, thence to a brine-cooled exchanger in which water, reaction products and unreacted vinylacetylene are condensed. Permanent gases may be purged off through a condenser at this point; water may be separated and returned to the catalyst, and the non-aqueous condensate passed into a stripping still in which most of the unreacted vinylacetylene is removed by warming to room temperature under reflux. The return gas is combined with the fresh vinylacetylene after warming. Crude chloroprene may be freed of vinylacetylene in a column from which the gas, containing some chloroprene, is returned to the initial condenser. Chloroprene may be purified by steam or vacuum fractionation for storage or immediate polymerization. The residue is essentially polymerized chloroprene and dichlorobutene (DC), from which the latter can be recovered by further distillation.

Modifications of the chloroprene process have been described, particularly reaction in the vapor phase (16), utilization of dilute vinylacetylene without isolation (17), direct synthesis from acetylene in a single step combining the polymerization and hydrohalogenation reactions (18), and the use of immiscible solvents for the separation of chloroprene (13). It is claimed (19) that chloroprene can be prepared by the addition of vinyl chloride and acetylene in the presence of cupric chloride; divinylacetylene is stated to be an intermediate. Chloroprene has been reported in the product from the chlorination of 2-chloro-2-butene at 500° (20); it has been obtained by the dehydrohalogenation of 1,3-dichloro-2-butene (21, 22, 23) of 1,2-dichloro-3-butene (24) and by cracking chlorocyclohexene (25).

Homologs of chloroprene have been prepared by the addition of HCl to alkyl vinylacetylenes (22, 26-29) and their polymers have been compared with neoprene. Numerous analogs, particularly the oxyprenes (2-alkoxy-1,3-butadienes), have been synthesized from vinylacetylenes (30) or 1-chloro-2,3-butadiene (31, 32, 33) for comparison with chloroprene.

Chloroprene, as a typical butadiene, undergoes the Diels-Alder addition to maleic acid, naphthaquinone and similar reactants to form the typical hydrocyclic products (34); chlorination of chloroprene results in the formation of trichlorobutenes, tetra- and pentachlorobutanes (35). Chlorination of 1-chloro-2,3-butadiene, and 1,3-dichloro-2-butene have also been described (35, 36, 37), the products from the latter proving to be valuable intermediates for the synthesis of 2,3-dichloro-1,3-butadiene (36), which has also been prepared by dehydrohalogenation of a tetrachlorobutane (38). The isomer of chloroprene, 1-chloro-2,3-butadiene, has proved to be a valuable intermediate for the formation of chloroprene analogs, in view of the fact that the chlorine, unlike that of chloroprene, is very reactive and that at the same time, the products may be rearranged to 2-substituted

1,3-butadienes by contact with copper salts. Thus the chlorine of the isomer has been replaced by alkyl- or aryl- (31, 39), by hydroxyl, alkoxy, amino, cyano (33) and acyloxy (32) groups; tri (4-butadienyl) amine has been prepared by treatment with ammonia (40). Similar replacements occur at one of the two chlorines in 1,3-dichloro-2-butene (9, 41).

References

- (1) Carothers and Berchet, *J. Am. Chem. Soc.*, **55**, 2807 (1933).
- (2) Carothers, Berchet and Collins, *ibid.*, **54**, 4066 (1932).
- (3) Carothers and Collins, to E. I. du Pont de Nemours & Co., U.S. P. 1,950,433 (1934).
- (4) Carothers, Kirby and Collins, *J. Am. Chem. Soc.*, **55**, 786 (1933).
- (5) Carothers, Williams, Collins and Kirby, *ibid.*, **53**, 4203 (1931).
- (6) Carothers, to E. I. du Pont de Nemours & Co., U.S. P. 2,104,789 (1938).
- (7) Carothers and Collins, to E. I. du Pont de Nemours & Co., U.S. P. 1,950,431 (1934); *Brit. P.* 387,325 (1933); *Ger. P.* 588,708 (1933); *Australia P.* 3619/31; *Czech. P.* 51,643; *Dutch P.* 31,084; *Ital. P.* 301,326; *Jap. P.* 96,820; *Norw. P.* 52,-261; *Spanish P.* 123,629; *Swed. P.* 79,586; *Swiss P.* 164,539.
- (8) E. I. du Pont de Nemours & Co., *Swiss P.* 166,215.
- (9) Carothers and Collins, to E. I. du Pont de Nemours & Co., U.S. P. 2,102,611 (1937).
- (10) Klebanski, Dolgopolski and Chevychalova, *Kauch. i Rezina*, **I** (1) 31; (2) 19 (1937); *C. A.*, **32**, 4006 (1938).
- (11) Klebanski, Tzyurikh and Dolgopolski, *Bull. Acad. Sci. (U.S.S.R.)*, **1935** (2) 189-226; *Rub. Chem. Tech.*, **9**, 406 (1936); *Research Assoc. Brit. Rub. Mfg.*, **13**, 505 (1935); *Chem. Zentr.*, **1935 II**, 3843; *C. A.*, **30**, 1259 (1936).
- (12) Kozlov and Gimpelvitch, *Sintet. Kauchuk*, **4** (4) 31 (1935); *C. A.*, **29**, 6798 (1935).
- (13) Perkins, to Carbide and Carbon Chem. Corp., U.S. P. 3,027,550 (1936); *Can. P.* 371,092 (1938).
- (14) Carter, Downing and Hutton, to E. I. du Pont de Nemours & Co., U.S. P. 1,950,-434 (1934); *Fr. P.* 41,933/721,532 (1933); *Ital. P.* 319,110; *Ger. P.* 636,309 (1936).
- (15) Khaltykyan, *Sintet. Kauchuk*, **5**, (11-12) 15 (1936); *Chimie & industrie*, **38**, 1149 (1937); *C. A.*, **31**, 6051 (1937).
- (16) Eberhardt and Stadler, to I. G. Farbenind. A.-G., U.S. P. 2,098,089 (1937); *Brit. P.* 458,100 (1936); *Fr. P.* 805,238 (1936).
- (17) I. G. Farbenind. A.-G., *Brit. P.* 471,744 (1937).
- (18) Collins, to E. I. du Pont de Nemours & Co., U.S. P. 1,950,435 (1934).
- (19) Eringer, to Pharm. Ges. Pharmazeutik U. Chem., *Belg. P.* 417,026 (1936); *Brit. P.* 480,320 (1938); *Ital. P.* 345,887 (1937); *Fr. P.* 811,433 (1937).
- (20) N. V. de Bataaf. Pet. Maat., *Brit. P.* 468,016 (1937).
- (21) Carothers, to E. I. du Pont de Nemours & Co., U.S. P. 2,038,538 (1936).
- (22) Carothers and Coffman, to E. I. du Pont de Nemours & Co., U.S. P. 1,950,441 (1934).
- (23) Klebanski, Chevychalova and Belen'kaya, *J. Applied Chem. (U.S.S.R.)*, **9**, 1985 (1936); *C. A.*, **31**, 2580 (1937).
- (24) I. G. Farbenind. A.-G., *Fr. P.* 819,963 (1937).
- (25) Konrad and Bachle, to I. G. Farbenind. A.-G., *Fr. P.* 819,963 (1937).
- (26) Carothers and Jacobson, *J. Am. Chem. Soc.*, **54**, 4071 (1932).
- (27) *Idem, ibid.*, **55**, 1624 (1933).
- (28) Favorsky, *Russ. P.* 31,016 (1933); *C. A.*, **28**, 3425 (1934); *Chem. Zentr.*, **1934 I**, 2488.
- (29) Jacobson, to E. I. du Pont de Nemours & Co., U.S. P. 1,950,440 (1934).
- (30) Dykstra, *J. Am. Chem. Soc.*, **57**, 2255 (1935). Norris, Verbanc and Hennion *ibid.*, **60**, 1159 (1938).

- (31) Carothers, to E. I. du Pont de Nemours & Co., U.S. P. 2,072,867 (1937).
- (32) Carothers and Berchet, to E. I. du Pont de Nemours & Co., U.S. P. 2,073,363 (1937).
- (33) Coffman, *J. Am. Chem. Soc.*, **57**, 1981 (1935).
- (34) Carothers and Collins, to E. I. du Pont de Nemours & Co., U.S. P. 1,967,862 (1934).
- (35) Carothers and Berchet, *J. Am. Chem. Soc.*, **55**, 1628 (1933).
- (36) Carothers and Berchet, to E. I. du Pont de Nemours Co., U.S. P. 1,965,369 (1934); *J. Am. Chem. Soc.*, **55**, 2004 (1933).
- (37) Coffman, to E. I. du Pont de Nemours & Co., U.S. P. 1,964,720 (1934).
- (38) I. G. Farbenind. A.-G., Brit. P. 418,469 (1934).
- (39) Carothers and Berchet, *J. Am. Chem. Soc.*, **55**, 2813 (1933).
- (40) I. G. Farbenind. A.-G., Fr. P. 815,312 (1937).
- (41) Berchet, to E. I. du Pont de Nemours & Co., U.S. P. 2,079,758 (1937).

9. Polymerization of Chloroprene. The polymerization of chloroprene is capable of being controlled to give a wide variety of products (1, 2, 3), ranging from oily dimers or trimers to plastic, rubber-like materials which after compounding and vulcanizing are elastic but essentially non-plastic, to hard, horny polymers which are neither plastic nor elastic and are insoluble in any known solvent. The fact that the course of this polymerization can be controlled to yield products superior to natural rubber in many respects makes chloroprene especially practical as a source of synthetic, rubber-like materials (4, 5).

The rate of polymerization of chloroprene, like that of many other polymerizable compounds, is greatly influenced by oxygen and other catalysts (2, 6-9). Samples of chloroprene, freed from peroxides by treatment with triphenylmethyl, distilled in high vacuum and sealed off in glass tubes without exposure to air, show an appreciable increase in viscosity only after a period of one or two months, and polymerization is incomplete after twelve months. Even this slow polymerization may be due to incomplete removal of peroxides. Exposed to air, chloroprene spontaneously polymerizes to rubber-like materials; the liquid gradually becomes more viscous and eventually is converted into a non-plastic material. This polymerization is accompanied by approximately 23 per cent decrease in volume.

If the chloroprene is allowed to polymerize spontaneously in the presence of air until it will flow only with difficulty, it will be found to contain 20 to 30 per cent of high molecular weight polymers. The polymer isolated from this mass either by pouring it into alcohol or by removing the monomer by distillation is a plastic, benzene-soluble material resembling plasticized natural rubber (10). If the polymerization is allowed to go appreciably beyond 25 or 30 per cent, the isolated polymer is much less soluble in solvents such as benzene, less plastic, and is more difficult to process. The yield of plastic polymer can be appreciably increased by diluting the chloroprene with an inert solvent such as carbon tetrachloride (11).

Organic peroxides, such as benzoyl peroxides and various other oxidizing compounds, function as catalysts (2, 12). Water and ethylene oxide appreciably increase the rate of polymerization (6, 13). The polymerization is inhibited by antioxidants. Compounds such as phenols, quinones, amines, mercaptans, thiophenols, aromatic nitro compounds and halogens either stop or appreciably retard the polymerization in a homogeneous system.

Polymerization at elevated temperatures tends to give lower molecular weight material. If chloroprene is polymerized at 50–60° in the presence of an inhibitor such as catechol, it largely will be converted into cyclic dimers or trimers. After prolonged storage at room temperature, chloroprene containing inhibitors will be found to contain appreciable percentages of these low molecular weight polymers. While light, such as that of 3130 Å wave length, accelerates normal polymerization, it also causes the formation of hard, slightly elastic granules which are non-plastic and insoluble. The formation of this granular polymer is autocatalytic. It occasionally appears in chloroprene which is polymerizing slowly. It is formed by polymerization of chloroprene from the gaseous phase, especially when illuminated by ultraviolet light or in contact with certain metals. When its formation is once started, it tends to consume all the available chloroprene.

The polymerization of chloroprene takes place more rapidly at elevated pressures (14) than at atmospheric pressure. At approximately 6000 atmospheres' pressure a difference of 1000 atmospheres has essentially the same influence in the polymerization rate as a difference of 10° (15). The rate of reaction is pseudo-unimolecular. Under extremely high pressure and high shearing stress chloroprene polymers can be converted into a horn-like substance (16).

The presence of many other compounds appreciably influences the character of the products. Inhibitors such as iodine or tetra-alkyl thiuram disulfides have been found to cause the formation of polymers which are hard at low temperatures but become soft and plastic at 60° and sticky at higher temperatures (17–20). Polymerization in the presence of many materials which are soluble in the chloroprene tends to give more plastic polymers (21, 22). If these materials are polymerizable, their effect on the properties of the isolated polymers may be even more marked (23–35). This probably is due to the formation of interpolymers as well as copolymers.

Chloroprene dispersed in a liquid, in which it is not appreciably soluble, containing an emulsifying agent polymerizes to give a product closely resembling natural rubber latex. The liquid for this purpose may be either water (12, 35a, 36–42) or such a material as formamide or a polyhydric alcohol (43, 44). The latices formed by polymerizing chloroprene dis-

persed in water may be either negatively or positively charged (45) depending upon the emulsifying agent and conditions of the polymerization. Polymerization in emulsion is more rapid than in the massive condition and is usually complete within a few hours. The rate of polymerization is influenced by the concentration of the emulsifying agent as well as by the temperature and presence of other catalysts. The size of the particles formed by emulsion polymerization is appreciably smaller than those present in natural rubber latex. The average size may vary somewhat, depending upon the emulsifying agent and condition of polymerization. In a sodium oleate latex the mean radius was found to be 0.063μ (2). These particles can be readily deposited from the latices by the passage of an electric current (46).

The products formed by polymerizing chloroprene dispersed in an aqueous solution of an emulsifying agent such as sodium oleate, when isolated by the addition of salts, acids or alcohols, resemble vulcanized rubber somewhat more closely than raw rubber. They have a very low plasticity and are difficult to process on conventional rubber machinery. However, it is claimed that, by carrying out this emulsion polymerization in the presence of small proportions of neutral alkali or ammonium salts which exert no oxidizing action under conditions of working and have no emulsifying action, it is possible to isolate plastic polymer (22, 47). It is also claimed that the presence during emulsion polymerization of H_2S , SO_2 (48) or organic compounds which under suitable conditions are capable of forming monomolecular addition compounds with chloroprene (49) results in the formation of a plastic product. By this means (48, 49) it is possible to isolate polymerized chloroprene of practically any desired plasticity.

All these products are mixtures of polymers of a wide range of molecular weights. The lower polymers are more soluble and more odiferous. They can be removed by washing with a solvent such as alcohol in which the higher molecular weight polymers are insoluble (2, 3, 10, 50, 51).

It is possible to impregnate porous material such as leather, wood and tile with liquid chloroprene and to polymerize the chloroprene in place (2, 52).

Bromoprene also can be polymerized to yield rubber-like materials (53, 54), but its use has not been developed commercially.

References

- (1) Carothers and Collins, to E. I. du Pont de Nemours & Co., U.S. P. 1,950,432 (1934); Can. P. 366,157 (1937).
- (2) Carothers, Williams, Collins and Kirby, *J. Am. Chem. Soc.*, **53**, 4203 (1931).
- (3) E. I. du Pont de Nemours & Co., Australian P. 3620; Brit. P. 387,363 (1933); Ger. P. 641,468 (1937); Fr. P. 787,151; Dutch P. 35,092; Ital. P. 299,937; Jap. P. 103,999; Norw. P. 53,427; Spanish P. 123,759; Swedish P. 84,288.
- (4) Bridgwater, *Ind. Eng. Chem.*, **28**, 394 (1936).
- (5) Carothers, *ibid.*, **26**, 30 (1934).

- (6) Starkweather, to E. I. du Pont de Nemours & Co., U.S. P. 1,950,437 (1934).
- (7) N. V. de Bataaf. Pet. Maat., Fr. P. 819,619 (1937).
- (8) R. E. Vogel, *Kunststoffe*, **26**, 103 (1936).
- (9) Yarovonkov and Alckhima, *Chimica e Ind.*, **20**, 30 (1938); *Research Assoc. Brit. Rub. Mfg.*, **16**, 206 (1936).
- (10) Williams, to E. I. du Pont de Nemours & Co., U.S. P. 1,950,436 (1934).
- (11) Williams and Walker, to E. I. du Pont de Nemours & Co., U.S. P. 1,950,442 (1934).
- (12) Collins, to E. I. du Pont de Nemours & Co., U.S. P. 1,967,865 (1934).
- (13) Williams and Walker, *Ind. Eng. Chem.*, **25**, 199 (1933).
- (14) Bridgman and Conant, to E. I. du Pont de Nemours & Co., U.S. P. 1,952,116 (1934); Can. P. 319,486.
- (15) Starkweather, *J. Am. Chem. Soc.*, **56**, 1870 (1934).
- (16) Bridgman, *Phys. Rev.*, **48**, 825 (1935).
- (17) Carothers, Collins and Kirby, to E. I. du Pont de Nemours Co., U.S. P. 1,950,438 (1934); Can. P. 366,158 (1937).
- (18) Carothers and Kirby, to E. I. du Pont de Nemours & Co., U.S. P. 1,950,439 (1934).
- (19) Klebanski, Dolgopolski, Margules and Khomutin, Russ. P. 49,192 (1936).
- (20) Kolesov and Zowadovski, Russ. P. 48,283 (1936).
- (21) Carothers, Collins and Kirby, to E. I. du Pont de Nemours & Co., U.S. P. 1,967,860 (1934); Can. P. 366,162 (1937).
- (22) I. G. Farbenindustrie A.-G., Brit. P. 469,820 (1937).
- (23) Carothers, Collins and Kirby, to E. I. du Pont de Nemours & Co., U.S. P. 2,029,410 (1936); Can. P. 369,362 (1937).
- (24) *Idem*, U.S. P. 2,066,329 (1937); Brit. P. 468,693 (1937).
- (25) *Idem*, U.S. P. 2,066,330 (1937).
- (26) *Idem*, U.S. P. 2,066,331 (1937); Fr. P. 820,476 (1937).
- (27) Chemische Forschungsgesellschaft, Fr. P. 806,324 (1936); Brit. P. 475,162 (1937).
- (28) *Idem*, Fr. P. 806,325 (1936); Brit. P. 469,976 (1937); Swiss P. 190,731 (1937).
- (29) *Idem*, Brit. P. 469,319 (1937).
- (30) E. I. du Pont de Nemours & Co., Fr. P. 815,987 (1937).
- (31) I. G. Farbenind. A.-G., Fr. P. 802,707 (1936).
- (32) *Idem*, Fr. P. 803,563 (1936).
- (33) *Idem*, Fr. P. 806,713 (1936).
- (34) Pummerer, *Angew. Chem.*, **47**, 209 (1934).
- (35) Ryumina-Alekhina and Zhavoronkov, *J. Rub. Ind. (U.S.S.R.)*, **1936** (8-9), 912.
- (35a) Barrett and Dorough, to E. I. du Pont de Nemours & Co., U.S. P. 1,967,220 (1935).
- (36) Chemische Forschungsgesellschaft, Fr. P. 801,034 (1936).
- (37) Collins, to E. I. du Pont de Nemours & Co., U.S. P. 1,967,861 (1934).
- (38) *Idem*, U.S. P. 2,010,012 (1935).
- (39) Dales and Downing, to E. I. du Pont de Nemours & Co., U.S. P. 2,080,561 (1937).
- (40) *Idem*, U.S. 2,088,407 (1937).
- (41) E. I. du Pont de Nemours & Co., Brit. P. 393,172 (1933); Ital. P. 316,767.
- (42) Twiss and Carpenter, to International Latex Process, Ltd., Brit. P. 443,987 (1936).
- (43) Carothers, to E. I. du Pont de Nemours & Co., U.S. P. 2,080,558 (1937).
- (44) Dales and Downing, to E. I. du Pont de Nemours & Co., Brit. P. 460,916 (1937).
- (45) *Idem*, Brit. P. 461,279 (1937).
- (46) Collins, to E. I. du Pont de Nemours & Co., U.S. P. 2,109,968 (1938).
- (47) I. G. Farbenind. A.-G., Brit. P. 464,053 (1937); Ger. P. 645,201 (1937).
- (48) E. I. du Pont de Nemours & Co., Fr. P. 819,379 (1937).
- (49) *Idem*, Fr. P. 821,580 (1937).
- (50) MacDonald, to B. B. Chemical Co., U.S. P. 2,067,854 (1937); Can. P. 369,205; Brit. P. 468,435; Fr. P. 797,084; Australian P. 25,514.

- (51) *Idem*, U.S. P. 2,107,796 (1938).
 (52) Williams, to E. I. du Pont de Nemours & Co., U.S. P. 1,967,275 (1934).
 (53) Carothers and Collins, to E. I. du Pont de Nemours & Co., U.S. P. 1,950,433 (1934).
 (54) Carothers, Kirby and Collins, *J. Am. Chem. Soc.*, **55**, 789 (1933).

10. Properties and Uses of Neoprene. Plastic polymer, whether obtained by polymerization of chloroprene alone, diluted with a solvent, or emulsified, tends to become less plastic and less benzene-soluble upon storage. Secondary aromatic amines such as phenylbetanaphthylamine greatly retard this spontaneous curing of plastic polymers at room temperature (1, 2). Certain other inhibitors of normal polymerization, such as mercaptans, have been found to improve further the stability of plastic polymers made in emulsion (3). These stabilizers do not prevent the vulcanizing of these polymers at elevated temperatures. Derivatives of ethylene oxide also have been used as stabilizers of chloroprene polymers (4).

The exact structure of neoprene has not been definitely established. However, the most likely structure is

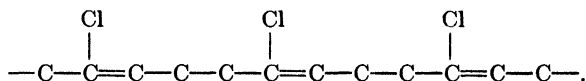

The fact that upon oxidation it yields succinic acid does not serve to distinguish between . . . 1,4-1,4 1,4-4,1 . . . or 4,1-1,4 . . . order for the joining of chloroprene units (1, 5, 6, 7). The fact that it gives a sharp x-ray pattern would indicate that the structure of its molecules is freer from irregularities than those of other synthetic rubbers (1, 8, 9). Electron diffraction measurements give the size of the crystallites as smaller than in natural rubber (10, 11). It has been suggested that of all types of synthetic, rubber-like materials, neoprene consists most nearly of simple long chains with the absence of side chains (12). Ultracentrifuge measurements by the sedimentation equilibrium method indicate that the molecular weight may be over 100,000 (13). Dielectric constant measurements show that neoprene is non-polar (14).

Iodine absorption data indicate that the polymers are highly unsaturated (15, 16). Neoprene can be chlorinated to give film-forming materials suitable for use in coating films and adhesives and materials of improved flame and freeze resistance (17-22). It has been claimed that neoprene reacts with HCl to form a transparent sheet (23). The catalytic hydrogenation of neoprene as well as of natural rubber has been reported (24).

While monomolecular chloroprene is toxic, it loses these dangerous properties during polymerization (25, 26, 27).

Neoprene, like natural rubber, is used commercially in three different

forms: as a latex; as a cement dissolved in solvents such as benzene, solvent naphtha or chlorinated hydrocarbons; and as a plastic polymer which can be compounded, shaped and vulcanized to an essentially non-plastic, elastic rubber-like material.

The latices and cements are used for forming dipped goods, coating and impregnating a wide variety of objects, and as adhesives (28-41). The gelling of cements is said to be retarded by the addition of 3-5 per cent of camphor (42).

Plastic neoprene can be processed in much the same manner and with the same equipment as natural rubber. The vulcanizing differs from that of natural rubber in that the addition of sulfur is not required to convert the plastic into the elastic, non-plastic form, although sulfur does have an activating effect on many stocks. Uncompounded neoprene can be cured by the action of heat alone, but the physical properties of the vulcanizate are greatly improved by the use of certain metallic oxides and other compounding ingredients (1, 2, 43-53). While zinc oxide and magnesia are used to activate most neoprene stocks, the magnesia must be omitted and litharge used to obtain maximum water resistance (45, 54). Wood rosin is used to improve the stability of carbon black-loaded stocks, and it functions also as a secondary vulcanizing agent (44, 47, 49, 54, 55).

The usual forms of carbon black and other loading materials used in natural rubber can be used in neoprene also (2, 46-49, 56). A considerable number of resins and synthetic materials have been suggested to improve certain properties (57-70). The plasticity, processing characteristics and stability of unvulcanized, compounded stocks can be improved by the use of many of the softening agents employed in compounding natural rubber and in plasticizing resins (2, 46, 47, 49, 55, 71-80).

Ordinary rubber accelerators have found comparatively little use in the compounding of neoprene, although certain amines and aromatic hydroxy compounds have a definite accelerating effect (47, 51, 54).

Cured neoprene closely resembles vulcanized natural rubber in both gum and loaded stocks (1, 2, 43, 47, 48, 49, 81-85). The tensile properties of neoprene gum stocks at elevated temperatures are inferior to those of similar rubber stocks (84, 86), but there is less difference in the case of carbon black-loaded stocks. The uses of neoprene depend upon its superiority to natural rubber in many respects, such as resistance to the action of light, heat, ozone, petroleum products, vegetable oils, animal fats and many chemicals, resistance to combustion and to the diffusion of many gases and liquids (43, 56, 81, 82, 83, 87-121).

Neoprene can be bonded to natural rubber or to metals and also is used as an adhesive or bonding material (22, 31, 37-41, 122-129). While alone it is not suitable as a hard rubber, neoprene can be compounded with natural rubber and sulfur to yield a flexible hard rubber (130, 131, 132).

References

- (1) Carothers, Williams, Collins and Kirby, *J. Am. Chem. Soc.*, **53**, 4203 (1931).
- (2) Williams, to E. I. du Pont de Nemours & Co., U.S. P. 1,950,436 (1934).
- (3) E. I. du Pont de Nemours & Co., Fr. P. 822,418 (1937); Ital. P. 350,047.
- (4) I. G. Farbenind. A.-G., Brit. P. 440,957 (1936); Ger. P. 642,562 (1937).
- (5) Collins, to E. I. du Pont de Nemours & Co., U.S. P. 2,010,012 (1935).
- (6) Klebanski and Vasil'eva, *J. prakt. Chem.*, **144**, 251 (1936).
- (7) Wibaut, *India-Rubber J.*, **92**, 609 (1936); *Kautschuk*, **14**, 54 (1938).
- (8) Clews, *Nature*, **141**, 513 (1938).
- (9) Garbsch and Susich, *Kautschuk*, **8**, 122 (1932).
- (10) Kruilov, *J. Exptl. Theoret. Phys. (U.S.S.R.)*, **5**, 524 (1935); *C. A.*, **30**, 64 (1936).
- (11) *Idem*, *Kauch. i Rezina*, **1938** (2), 26.
- (12) Guth, *Kautschuk*, **13**, 201 (1937).
- (13) Kraemer and Nichols, Paper presented at Chapel Hill meeting of American Chemical Society, 1937.
- (14) Li, *J. Chinese Chem. Soc.*, **5**, 117 (1937); *C. A.*, **31**, 8990 (1937).
- (15) Kemp and Mueller, *Ind. Eng. Chem., Anal. Ed.*, **6**, 52 (1934).
- (16) Klebanski and Rakhlina, *J. Gen. Chem. (U.S.S.R.)*, **7**, 1299 (1937); *C. A.*, **31**, 6921 (1937).
- (17) Carothers, to E. I. du Pont de Nemours & Co., U.S. P. 2,067,172 (1937).
- (18) I. G. Farbenind. A.-G., Brit. P. 444,697 (1936).
- (19) *Idem*, Brit. P. 470,778 (1937).
- (20) *Idem*, Ger. P. 641,801 (1937).
- (21) Klebanski and Rakhlina, *Org. Chem. Ind. (U.S.S.R.)*, **2**, 392 (1936); *Rubber Chem. Tech.*, **10**, 467 (1937).
- (22) Metallgesellschaft A.-G., Brit. P. 481,396 (1938); Fr. P. 821,714 (1937).
- (23) Marsene Corp. of America, Brit. P. 447,110 (1936).
- (24) Flint, to E. I. du Pont de Nemours & Co., U.S. P. 2,046,257 (1936).
- (25) Von Oettingen, *J. Ind. Hyg. Toxicol.*, **19**, 349 (1937).
- (26) Von Oettingen, Hueper, Deichmann-Gruebler and Wiley, *ibid.*, **18**, 240 (1936).
- (27) Von Oettingen and Deichmann-Gruebler, *ibid.*, **18**, 271 (1936).
- (28) Blinkov, *J. Rubber Ind. (U.S.S.R.)*, **12**, 365 (1935); *C. A.*, **29**, 6441 (1935).
- (29) Collins and Larson, to E. I. du Pont de Nemours & Co., U.S. P. 1,967,863 (1934); Brit. P. 413,666 (1934).
- (30) *Idem*, U. S. P. 2,077,399 (1937).
- (31) Farberov, Gorina, Grigoreva, Myagkova and Zueva, *J. Rubber Ind. (U.S.S.R.)*, No. 8-9, 900 (1936); *C. A.*, **31**, 3332 (1937).
- (32) Gribova, Komarov and Khuka, *Colloid J. (U.S.S.R.)*, **2**, 113 (1936).
- (33) Kirby, to E. I. du Pont de Nemours & Co., U.S. P. 2,076,949 (1937).
- (34) Mongaritov, *Caoutchouc and Rubber (U.S.S.R.)*, No. 5, 3 (1937); *C. A.*, **31**, 8246 (1937).
- (35) Twiss and Jones, to Dunlop Rubber Co., Brit. P. 445,940 (1936); Fr. P. 794,672 (1936).
- (36) Twiss, Wilson and Neale, to Dunlop Rubber Co., Brit. P. 426,757 (1935).
- (37) United Shoe Machinery Co., Brit. P. 468,361 (1937).
- (38) *Idem*, Brit. P. 472,685 (1937).
- (39) Wedger, to Boston Blacking & Chem. Co., U.S. P. 2,061,296 (1936).
- (40) *Idem*, U.S. P. 2,061,297 (1936).
- (41) *Idem*, U.S. P. 2,087,878 (1937).
- (42) Hanslick and Ridge, to Dominion Rubber Ltd. Co., Can. P. 366,317 (1937).
- (43) Bridgwater, *Ind. Eng. Chem.*, **26**, 33 (1934).
- (44) Bridgwater and Krismann, *ibid.*, **25**, 280 (1933).
- (45) Clapson, *ibid.*, **29**, 789 (1937).
- (46) E. I. du Pont de Nemours & Co., Australian P. 3620; Brit. P. 387,363 (1933); Ger. P. 641,468 (1937); Fr. P. 787,151; Dutch P. 35,092; Ital. P. 299,937; Jap. P. 103,999; Norw. P. 53,427; Spanish P. 123,759; Swedish P. 84,288.
- (47) E. I. du Pont de Nemours & Co., The "DuPrene" Manual (1934).

- (48) E. I. du Pont de Nemours & Co., "The Limitations of Rubber" series (1938).
- (49) E. I. du Pont de Nemours & Co., "Neoprene Compounding Principles" (1937).
- (50) Evstratov, *Sintet. Kauchuk*, No. 3, 20 (1934); *C. A.*, **29**, 6798 (1935).
- (51) Jones, *Ind. Chemist*, **14**, 248 (1938).
- (52) Starkweather and Walker, *Ind. Eng. Chem.*, **29**, 872 (1937).
- (53) Vanderbilt News, **8**, 4 (1938).
- (54) Starkweather and Walker, *Ind. Eng. Chem.*, **29**, 1380 (1937).
- (55) *Idem*, *India Rubber World*, **97**, 43 (1937).
- (56) Driscoll, to Johns-Manville Corp., U.S. P. 2,052,610 (1936).
- (57) British Thomson-Houston Co., Brit. P. 479,625 (1938); Fr. P. 812,479 (1937).
- (58) Carrington, *Rubber Age*, **41**, 237 (1937).
- (59) Compagnie Française pour l'Exploitation des Procèdes Thomson-Houston, Fr. P. 812,479 (1937); Brit. P. 479,625.
- (60) Corchera Internacional S.A., Brit. P. 479,353 (1938).
- (61) De Holczer, to New York Belting and Packing Co., U.S. 1,967,292 (1934); Brit. P. 421,435; Fr. P. 771,438; Can. P. 360,800.
- (62) Deutsche Dunlop Gummi-Compagnie, Ger. P. 643,565 (1937).
- (63) Patrick, U.S. P. 1,962,460 (1934).
- (64) Standard Oil Development Co., Brit. P. 479,478 (1938).
- (65) Winkelmann, to Marbon Corp., U.S. P. 2,046,986 (1936).
- (66) *Idem*, U.S. P. 2,075,252 (1937).
- (67) *Idem*, U.S. P. 2,075,253 (1937).
- (68) *Idem*, U.S. P. 2,075,254 (1937).
- (69) *Idem*, U.S. P. 2,087,078 (1937).
- (70) Winkelmann and Moffet, to Marbon Corp., U.S. P. 2,075,253 (1937).
- (71) Hanslick and Ridge, to Dominion Rubber Ltd. Co., Can. P. 366,318 (1937).
- (72) *Idem*, Can. P. 366,811 (1937).
- (73) *Idem*, Can. P. 366,812 (1937).
- (74) I. G. Farbenind. A.-G., Brit. P. 472,653 (1937); Fr. P. 818,777 (1937).
- (75) Ott, to Hercules Powder Co., Brit. P. 470,168 (1937).
- (76) Shinkle, Brooks and Cady, *Ind. Eng. Chem.*, **28**, 275 (1936).
- (77) Shinkle, to U.S. Rubber Co., U.S. P. 2,016,027 (1936).
- (78) U.S. Rubber Co., Brit. P. 452,078 (1936); Can. P. 366,317 (1937); Fr. P. 799,345 (1936).
- (79) *Idem*, Brit. P. 457, 310 (1936); Can. 366,318 (1937).
- (80) *Idem*, Brit. P. 457,311 (1936); Can. 366,811 (1937).
- (81) Brazier, Chem. Eng. Congr. World Power Conf., 1936.
- (82) Bridgwater, *Ind. Eng. Chem.*, **28**, 394 (1936).
- (83) Garner, *Aircraft Eng.*, **9**, 209 (1937).
- (84) Whitby and Katz, *Ind. Eng. Chem.*, **25**, 1204, 1388 (1933).
- (85) Yerzley, *ibid.*, *Anal. Ed.*, **9**, 392 (1937); *British Plastics*, **9**, 644 (1938).
- (86) Braun, *J. Elisha Mitchell Sci. Soc.*, **53**, 236 (1937).
- (87) Bogomolov, Fainberg and Trankovskaya, *J. Rubber Ind. (U.S.S.R.)*, **12**, 223 (1935); *C. A.*, **29**, 6469 (1935).
- (88) British Celanese Ltd., Brit. P. 476,639 (1937).
- (89) Browne, U.S. P. 2,041,743 (1936).
- (90) Buichkev and Koryushenko, *J. Rubber Ind. (U.S.S.R.)*, **12**, 1035 (1935); *C. A.*, **30**, 6981 (1936).
- (91) Christenson, to Johns-Manville, U.S. P. 2,052,603 (1936).
- (92) Clarke, *Caoutchouc and Guttapercha*, **34**, 226 (1937); *India-Rubber J.*, **95**, 381 (1938).
- (93) Cosler, *Can. Mining Met. Bull. No. 296*, 437 (1936).
- (94) Cutler, Fr. P. 791,905 (1935); Brit. P. 457,937 (1936).
- (95) Dawson, *Trans. Inst. Rubber Ind.*, **11**, 391 (1935).
- (96) Dumonthier, Dumonthier and Ottenhoff, *Rubber Age*, **41**, 237 (1937).
- (97) E. I. du Pont de Nemours & Co., "Neoprene Notebook" (1938).

- (98) Freedlander, to Dayton Rubber Co., U.S. P. 2,054,620 (1936).
- (99) *Idem*, U.S. P. 2,088,470 (1937).
- (100) *Idem*, U.S. P. 2,088,471 (1937).
- (101) *Idem*, U.S. P. 2,088,472 (1937).
- (102) Garner, *India-Rubber J.*, **94**, No. 18A, 23 (1937).
- (103) Hansel, to Felters Co., U.S. P. 2,003,934 (1935).
- (104) Hayden and Krismann, *Ind. Eng. Chem.*, **25**, 1219 (1933).
- (105) Henley's Telegraph Works Co.; Brit. P. 452,361 (1936).
- (106) Hirakawa, Kambara and Tanaka, *J. Soc. Chem. Ind. Japan*, **40**, suppl. 266 (1937).
- (107) Jones, Naunton and Smith, *Trans. Inst. Rubber Ind.*, **9**, 169 (1933); *Rubber Chem. Tech.*, **7**, 234 (1934).
- (108) Kambara, *J. Soc. Chem. Ind. Japan*, **39**, 319 (1936).
- (109) Kirchhoff, *Chem. Ztg.*, **58**, 542 (1934).
- (110) Konquest and Robison, to Continental Can Co., U.S. P. 2,119,280 (1938).
- (111) Osipov-Schmidt, *Rev. gen. caoutchouc* (suppl.) p. VII, (1937).
- (112) Pavlovich and Shchekin, *J. Rubber Ind. (U.S.S.R.)*, **1936** (8-9), 893; *C. A.*, **31**, 3329 (1937).
- (113) Saeger, *India Rubber World*, **94**, 31 (1936).
- (114) Shohei Saito, *J. Soc. Rubber Ind. Japan*, **10**, 15 (1937).
- (115) Steward, to Garlock Packing Co., U.S. P. 2,099,241 (1937).
- (116) *Idem*, U.S. P. 2,099,242 (1937).
- (117) Surety Rubber Co., *Rubber Age*, **41**, 329 (1937).
- (118) Turman, to Gates Rubber Co., U.S. P. 2,108,759 (1938).
- (119) Tyler, *Chem. Industries*, **34**, 303 (1934).
- (120) West, to Crown Cork and Seal Co., U.S. P. 2,087,942 (1937); Brit. P. 466,375 (1937).
- (121) Williams, to E. I. du Pont de Nemours & Co., U.S. P. 2,093,501 (1937).
- (122) Beldam, Brit. P. 472,118 (1937).
- (123) Carothers, *J. Am. Chem. Soc.*, **55**, 2008 (1933).
- (124) Habgood, *Trans. Inst. Rubber Ind.*, **13**, 136 (1937).
- (125) *Idem*, to I.C.I., Brit. P. 467,202 (1937).
- (126) *Idem*, Brit. P. 469,801 (1937).
- (127) Habgood and Morgan, to I.C.I., Brit. P. 476,319 (1937).
- (128) International Latex Process Ltd., Brit. P. 462,101 (1937); Fr. P. 811,214 (1937).
- (129) Kuzmick and Hilton, to Raybestos-Manhattan, Inc. U.S. P. 2,122,691 (1938).
- (130) Garner, *British Plastics*, **9**, 488 (1938).
- (131) Jones and Smith, Brit. P. 428,052 (1935).
- (132) Morgan Ebonite Co., Brit. P. 484,932 (1938).

Author Index

- Aall, 10
Ackermann, 97, 98
Adler, 154, 156
Afanassiev, 88
Afanassjew, 167
Aikawa, 142, 146
Air Reduction Co., 36
Akobshanov, 167
Aktiengesellschaft für Stickstoffdünger, 10
Alckhima, 178
Alekhina, 171
Alekseev, 108
Alexander, 17, 147, 148, 149
Alexander Wacker Gesellschaft, 108
Alexejev, 18
Allard, 3
Allen, 48
Allmand, 10
Aloy, 114
Alquier, 155, 156
Ammonia Casale S.A., 146
Andereg, 88
Anderson, 11, 12, 13
Andre, 93, 93
Andrew, 110, 114
Andrussov, 123
Ansdell, 2
Antropoff, 5, 6
Antzus, 98, 98
Arbuzov, 126
Aries, 2
Arnaud, 114, 115
Arnold, 38
Arth, 52, 58
Arutyunyan, 101
Arvin, 169
Askenazy, 107
Assman, 39
Autogenwerk Sirius, G.m.b. H. 14
- Bachle, 174
Bachman, 88
Bachmann, 121, 133
Badger, 2
Badollet, 171
Baeyer, 50, 57, 90, 92, 93, 94
Bagdassarjanz, 159, 160
Bahr, 17, 145, 147
Bailey, 126, 128
Baimakov, 5, 7
Bakelite Ltd., 170
Balandin, 25
Baldwin, 17, 147, 148, 149
Balz, 114
Banck, 26
Bangert, 142, 143, 146
Bardwell, 150, 152
Barret, A. W., 64, 65
Barret, H. J., 178
Bartram, 120
Bartashev, 146, 168
Bartholome, 168
Baschieri, 158, 160
Basset, 55, 58
Bates, 150, 152
Baud, 65, 66, 145, 147
Bauer, 99, 100, 101
Baum, 26, 101, 120, 121, 133
Baumann, J., 10
Baumann, P., 35, 108, 122, 169
Baume, 2
Baur, 128, 129
Baxter, 101
Bayer, 170
Bayer and Company, 88
Bayer Farbenind., 168
Bayerische Stickstoff-Werke A.G., 14
Baylor Knox, 26
B. B. Chemical Co., 178
Beasley, 134
Becker, 14
Behm, 7, 10
Beilin, 27
Belchetz, 22, 25
Beldam, 183
Belen'kaya, 174
Bell, 46, 48
Bellet, 74, 92
Bender, 123
Benoit, 6
Benson, 118, 122
Benziger, 73
Berchet, 88, 89, 168, 169, 170, 174, 175
Berend, 90, 92
Berge, 121
Bergeron, 10
Bergman, 69, 70
Bergstrom, 170
Berl, 17, 142, 146
Berlin, 68
Berthelot, 3, 14, 15, 16, 16, 17, 19, 20, 24, 27, 28, 35, 41, 42, 44, 51, 52, 53, 54, 55, 57, 57, 58, 58, 59, 60, 61, 61, 68, 69, 70, 95, 98, 99, 100, 102, 103, 105, 106, 107, 108, 109, 112, 113, 114, 135, 137, 140, 141, 146

- Bethenod, **27**
 Beudet, **132, 134**
 Bevan, **114**
 Bhaduri, **52, 54, 58**
 Bhagavantam, **3**
 Bhatt, **160**
 Biedermann, **24, 28, 29**
 Biginelli, **62, 65**
 Billitzer, **45, 48, 98**
 Biltz, **3, 58, 62, 63, 65, 90, 91, 92, 106, 109**
 Bingham, **viii**
 Binnie, **28, 29, 142, 145, 146**
 Blacet, **39**
 Blinkov, **181**
 Blochmann, **51, 53, 57**
 Bloch-See, **3**
 Bloom, **24**
 Bock, **159**
 Boehringer, **2**
 Boehringer und Soehne, **120, 132, 134**
 Boeseken, **115, 154, 156**
 Boetger, **24, 51, 52, 57**
 Bogomolov, **182**
 Boiteau, **126, 128**
 Bondi, **69, 70**
 Bone, **16, 17, 24, 110, 114, 140, 141, 146, 150, 152**
 Bongrand, **74**
 Bonhoeffer, **98, 98**
 Booher, **106, 109**
 Bosniche Elektricitats A.G., **134**
 Boston Blacking and Chemical Co., **181**
 Bosshard, **114**
 Boswell, **123**
 Botolfsen, **44, 44**
 Bourguel, **48, 78, 79, 81, 91, 92**
 Bowlus, **127, 128**
 Bozhko, **24**
 Brading, **14, 17**
 Bradley, **3, 17, 24**
 Brame, **62, 65**
 Braun, **182**
 Barunig, **114**
 Brazier, **182**
 Bredig, **24, 48, 137**
 Breitfous, **88**
 Bridgman, **178**
 Bridgwater, **177, 181, 182**
 Bried, **77, 81, 115**
 Brill, **123**
 Briner, **112, 114**
 Briscoe, **159, 160**
 British Celanese Ltd., **24, 123, 182**
 British Cellulose and Chemical Mfg. Co., **122**
 British Thompson-Houston Co., **182**
 Britton, **125**
 Bronk, **2**
 Bronn, **36**
 Brook, **182**
 Brown, **11, 13**
 Browne, **182**
 Brunet, **10**
 Brunner, **16, 17, 139, 146**
 Brus, **114**
 Brutzkus, **157, 159**
 Buccar, **3, 18**
 Bueckert, **35**
 Buichkev, **182**
 Buizov, **167**
 Bullier, **7, 10, 13**
 Burgin, **28, 36**
 Burkhardt, **56, 58**
 Burrell, **2, 18**
 Burton, **68**
 Butler, **35**
 Butterfield, **viii**
 Cadenbach, **7**
 Cadenhead, **viii, 118, 122**
 Cady, **182**
 Cailletet, **2**
 Calcott, **167, 168, 170, 171**
 Calhoun, **147, 148, 149, 149**
 Campbell, B., **87**
 Campbell, K., **86, 87, 88**
 Campbell, E. D., **145, 147**
 Canadian Electro Products Co., **120, 132, 134**
 Capelle, **158, 160**
 Carbide and Carbon Chemicals Corp., **87, 133, 168, 174**
 Cardoso, **2**
 Caro, **viii, 13, 97, 98**
 Carothers, **48, 87, 88, 89, 168, 169, 170, 171, 174, 175, 177, 178, 179, 181, 183**
 Carpenter, **178**
 Carrington, **182**
 Carruthers, **110, 114**
 Carstanjen, **3**
 Carter, **167, 168, 169, 170, 171, 174**
 Cartoux, **10**
 Castellani, **viii**
 Cattelain, **58**
 Cauquil, **35**
 Cazeneuve, **19**
 Cedercreutz, **13**
 Chaffette, **29**
 Chalmot, *see de Chalmot*
 Chamberlain, **24**
 Chambers, **154, 156**
 Chapman, **62, 65**

- Charitschkov, 144, **147**
 Chavanne, 103, **107**
 Checkovish, **39**
 Chemische Fabrik Buckan, **156**
 Chemische Fabrik Griesheim-Elektron,
101, 108, 115, 119, 121, 128, 132
 Chemische Fabrik Rhenania, **122, 159**
 Chemische Fabrik von Heyden, **108**
 Chemische Forschungsgesellschaft, **178**
 Chen, **94**
 Chevastelon, **38, 38, 54, 58, 59, 60, 61, 61**
 Chevuichaiova, **169**
 Chevychalova, **174**
 Chibaev, **88**
 Chichibabin, 157, 159, **159, 160**
 Childs, **2**
 Chilton, **168**
 Cholokov, **88**
 Christ, 80, **81, 114**
 Christenson, **182**
 Chiocca, 126, **128, 155, 156**
 Ciurlo, 135, **137, 153, 156**
 Clapson, **181**
 Clarke, **182**
 Claude, 30, **35**
 Clemmer, 106, **108**
 Clemo, 145, **147**
 Clews, **181**
 Clows, **113**
 Coehn, 112, **114**
 Coffin, **134**
 Coffman, **87, 88, 94, 168, 170, 171, 174, 175**
 Collins, **170, 174, 175, 177, 179, 181**
 Commercial Solvents Corp., **125**
 Compagnie Française pour l'Exploitation des Procédés Thompson-Houston, **182**
 Compagnie Générale de Produits de Synthèse, **147**
 Compagnie des Produits Chimiques d'Alais et de la Camarque, **108, 119**
 Conant, **48, 178**
 Coli, **48**
 Colonge, **87**
 Coninck, see de Coninck
 Conn, **37, 38**
 Consonno, **137**
 Consortium für Elektrochem Ind., pyrolytic acetylene, **26, 29**; vinyl halides, 101, acetylene chlorination, **107, 108**; acetaldehyde, 115, **119, 120, 121, 122, 123**; sodium acetate, 124, **125**; vinyl ethers and esters, **129, 133, 134**; acetic anhydride, **134**, acrylonitrile, **156**
 Consortium M. Mugdan, **120**
 Contardi, **17, 25, 121, 126, 128**
 Conway, **169**
 Cook, 154, **156**
 Coolidge, 151, **152**
 Copley, 29, 30, **35**
 Corchera Internacional S.A., **182**
 Cornillot, 155, **156**
 Corson, **81**
 Cosler, **182**
 Cottrell, 42, **44, 48**
 Courtalds Ltd. and Brown, **133**
 Courtot, **74, 92**
 Coward, **17, 24, 140, 141, 146**
 Cross, **114**
 Crossfield Sons and Hilditch, **121**
 Cruto, **137**
 Culbertson, 96, **98**
 Cupery, **170**
 Curme, **17, 35**
 Cutler, **182**
 Czaco, 37, **38, 58**
 Dacy, **134**
 Dafert, 66, **68**
 Dales, **178**
 Dalfsen, see van Dalfsen
 Damiens, 4, 6, **6, 38, 39, 58**
 Danehy, 79, **81, 86, 88, 90**
 Danneel, **10**
 Das-Gupta, **68**
 Daure, **3**
 Davies, **14**
 Davis, H. M., **3, 77, 81, 168**
 Davis, R. H., **150**
 Daviduova, **107**
 Davy, 5, **6, 107**
 Dawson, **182**
 Dayton, **24**
 Debraye, 7, **10**
 De Chalmont, **92**
 De Coninck, 159, **160**
 De Forcrand, 1, **2, 19, 44**
 Dehn, 91, **92**
 De Holczer, **82**
 Deichmann-Gruebler, **181**
 Delange, **44, 89, 93, 93, 94**
 Delepine, 51, 53, 54, 57, 61, **61**
 De Liefde, **18**
 Demme, **137**
 Demyanov, **81**
 Deniges, **38, 52, 58**
 De Rudder, **24, 28, 29**
 Deschiens, **122**
 Deslandres, **2, 3**
 Desmots, **87**
 Desparmet, **19**

- Destrem, **24**
 Deutsch, **120, 133**
 Deutsche Dunlop Gummi Compagnie, **182**
 Deutsche Gold und Silber Scheideanstalt vorm Roessler, **36, 44, 114, 120, 122, 123, 125, 133**
 Deville, **7, 10**
 Dewar, **14, 16, 156, 159**
 DeWilde, **19, 96, 97, 98, 152**
 Dick, **133**
 Dierichs, **19**
 Dilworth, **123**
 Dilys, **viii**
 Dimroth, **137**
 Ditz, **146**
 Dobromil'skaya, **167, 169**
 Dolan, **14**
 Dolgopolski, **169, 174, 178**
 Domenico, **8, 10**
 Dominion Rubber Co. Ltd., **181, 182**
 Dommer, **vii**
 Dooley, **25**
 Dorough, **178**
 Dow, **108**
 Dow Chemical Co., **26, 124**
 Downing, **167, 168, 169, 170, 171, 174, 178**
 Dranilzina, **167**
 Dreyfus, **24, 27, 118, 120, 121, 122, 123, 131, 133, 134**
 Driscoll, **182**
 Dubois, **27**
 Dubosc, **viii**
 Duden, **121**
 Duisberg, **viii**
 Durand, J. F., **47, 48, 50, 52, 57**
 Durand, M., **108**
 Dumonthier, **182**
 Dunlop Rubber Co., **181**
 DuPont de Nemours, E. I. and Co., acetylenic carbinols, **87, 168**; chloroprene preparation, **174**; chloroprene reactions, **175**; divinylacetylene preparation, **160, 166**; divinylacetylene reactions, **170, 171**; ethyldene aniline, **137**, homologs and analogs of chloroprene, **174, 175**; homologues of vinylacetylene, **168**; neoprene, **181, 182, 183**; vinylacetylene, preparation, **167, 168**; vinylacetylene reactions, **169, 170**
 Dupont, G., **47, 48, 88, 89, 90, 97, 98, 114, 168**
 Durr, **123**
 Dussol, **91, 92**
 Dutoit, **10**
 Dutt, **81**
 Dworkitsch, **19**
 Dykstra, **132, 133, 169, 170, 174**
 Eastwood, **3**
 Eberhardt, **123, 169, 174**
 Eby, **87, 88**
 Edwards, **54, 58**
 Efremova, **148, 168**
 Eggert, **58**
 Egloff, **16, 17, 24, 138, 138, 152, 167, 169**
 Egorov, **114**
 Ehrhardt, **145, 147**
 Ehrhart, **114**
 Eidus, **25**
 Eimer, **8, 10**
 Eisenhut, **36**
 Elbert, **120**
 Elbs, **108**
 Electric Furnace Products Co., **122**
 Elektrizitätswerk Lonza, **122, 125, 149, 149**
 Elliot, **134**
 Ellis, Carleton, **25, 134**
 Ellis, C. P., **106, 109**
 Elmanovitch, **88**
 Elöd, **137**
 Eltekov, **44, 89**
 Elvert, **121**
 Epstein, **68**
 Erdmann, **17, 63, 64, 65, 68, 70, 115, 119, 147, 148, 149**
 Eremin, **24**
 Eringer, **174**
 Etard, **7**
 Evstratov, **182**
 Exell, **25**
 Eymann, **27**
 Fabre, **107**
 Fainberg, **182**
 Fairlie, **17, 96, 98**
 Falkevich, **13**
 Farbenfabrik vorm F. Bayer & Co., (see Bayer & Co.) **82, 87, 88, 120, 121, 134**
 Farberov, **181**
 Farbwerk, vorm Meister Lucius und Breuning, **121**
 Favorskaya, **169**
 Favorsky, **44, 79, 80, 81, 83, 87, 88, 89, 90, 104, 107, 128, 129, 167, 168, 174**
 Fedoseev, **159, 160, 153, 156**
 Fegler, **68**
 Feinstein, **131, 134**
 Felters Co., **183**
 Ferber, **55, 58, 62, 65**
 Ferguson, **25, 29, 36**

- Fernelius, 170
 Fester, 137
 Feuchter, 98, 123, 125
 Fichter, 7
 Fieser, 14, 38
 Firestone Tire and Rubber Co., 171
 Firma Gustav Weinmann, 122
 Fischer, A., 87, 88
 Fischer, E., 67, 68
 Fischer, F., 6, 7, 17, 22, 24, 25, 27, 28, 28,
 29, 97, 98, 141, 142, 143, 144, 145,
 146, 147, 149, 150
 Fischer, F. G., 83, 87
 Fischer, M., 96, 98
 Fischer, W., 108
 Fischer, W. H., 83, 87
 Fittig, 19
 Flavitzky, 114
 Flint, 181
 Flood, 155, 156
 Flusin, 10
 Foerster, 10
 Fomine, 88
 Foohey, 99, 101, 126, 128, 166
 Forcrand, see de Forcrand
 Fornasir, 87
 Foucounau, 86, 88
 Francesconi, 135, 137, 153, 156
 Frank, 10, 18
 Franke, 106, 109
 Frankenburger, 28
 Fredenhagen, 7
 Freedlander, 183
 Freri, 158, 160
 Frey, 131, 134
 Fricke, 146
 Frieman, 64, 65, 115, 119
 Frolich, 24, 146
 Fromm, 73
 Frost, 17, 24
 Frydlander, 108
 Fujio, 25, 143, 145, 146
 Fukagawa, 108
 Funke, 3
 Furasaki, 10

 Gal, 10
 Gambarian, 87, 168
 Gangloff, 66, 66, 145, 147
 Ganswein, 3, 168
 Garbsch, 181
 Garcon, 122
 Gardner, 10
 Garelli, 35
 Garlock Packing Co., 183
 Garner, T. L., 182, 183

 Garner, W. E., 135, 137
 Gatterer, 48
 Gaudechon, 152
 Gautier, 48, 86, 88, 112, 114
 Gauss, 2
 Geay, 167
 Gebauer, 57, 58
 Geib, 114
 General Electric Co., 171
 Genin, 122, 150
 Gesellschaft für Linde's Eismaschinen,
 36
 Gibbs, vii, 14
 Gibson, 68
 Gillespie, G., 46, 48
 Gillespie, H. B., 94
 Gimpelvitich, 174
 Ginzberg, 60, 61, 167
 Glaser, 89, 90
 Glizmaneko, 27
 Glockler, 3, 151, 152
 Gobert, 27
 Golden, 25
 Golod, 159
 Gooch, 17, 147, 148, 149
 Gooderham, 25
 Gopfert, 3
 Gorina, 181
 Gorski, 68
 Gould, 87
 Granjon, 12, 14
 Grattan, 134
 Gray, 106, 109
 Gredy, 88
 Green, S. J., 66, 68, 150
 Gribova, 181
 Grignard, 47, 48, 73, 74, 79, 81, 90, 91,
 92, 168
 Grigoreva, 181
 Griner, 90
 Grob, 122, 159
 Groll, 36
 Groombridge, 24, 123
 Gros, 26, 145, 147
 Gross, 17
 Grossmann, 115
 Grünstein, 115, 116, 119, 121
 Grüssner, 115
 Gruettner, 56, 58
 Guerin, 167
 Guernsey, 7
 Guest, H. H., 80, 81, 88
 Guest, H. P., 135, 135
 Guillemonat, 168
 Gulyaeva, 169
 Guntz, 5, 6, 7

- Gustafson, 155, 156
 Gustavson, 81
 Gutehoffnung hütte Oberhausen A.G.,
 123
 Guth, 181
 Guyot viii, 107, 108, 119

 Haakh, 107, 109
 Haber, 15, 17
 Habgood, 183
 Hackspill, 7
 Haehnal, 131, 134
 Haeuber, 28
 Hague, 25, 141, 146
 Haller, 19
 Hand, 120
 Hanekop, 6
 Hansel, 183
 Hanslick, 181, 182
 Hare, 7, 10
 Harkness, 169
 Harries, 114
 Harris, 35
 Harrison, 10
 Harteck, 98, 98, 114
 Hartmann, 14
 Hartnagel, 7
 Hasenfratz, 114
 Haskins, 171
 Hass, 63, 65
 Häuber, 156
 Hauptmann, 92, 92, 168
 Häusser, 159
 Hayden, 170, 183
 Hazura, 114
 Hecht, 114
 Heckel, 123
 Hedfeld, 2, 3
 Heiberg, 114
 Heinemann, A., 153, 156
 Heinemann, F., 67, 68
 Heiser, 114
 Heisig, 77, 81, 169
 Heizmann, 71, 73, 89
 Henderson, 66, 66, 145, 147
 Henglein, 167
 Henley's Telegraph Works Co., 183
 Hennig, 108
 Hennion, 42, 44, 48, 64, 65, 75, 77, 79,
 81, 83, 115, 126, 127, 128, 129, 169
 Herbst, 68
 Hercules Powder Co., 182
 Herites, 39
 Herrmann, 26, 101, 120, 131, 133, 134
 Herzberg, G., 1, 3
 Herzberg, O. W., 133

 Herzog, 150
 Hess, A., 30, 35
 Hess, J., viii
 Hess, K., 42, 44, 87, 168
 Heyn, 92
 Hibbert, 120, 122, 126, 128
 Hibi, 10
 Hilbert, 10
 Hill, 126, 128
 Hilpert, 17, 56, 58, 108, 148, 149
 Hilton, 183
 Hinonishi, 24, 25
 Hinton, 127, 128
 Hirakawa, 183
 Hirst, 36, 121, 122
 Hirtz, 151, 152
 Hizer, 63, 65
 Hodgkinson, 17, 54, 58, 144, 147
 Hoefler, 108
 Hönel, 35
 Hoepfner, 38, 39
 Hofmann, K., 83, 87
 Hofmann, K. A., 27, 28, 59, 61, 62, 63,
 65, 114
 Hofmann, K. W., 17, 143, 146
 Hohenegger, 98
 Holleman, 92
 Holley, 29, 30, 35
 Holliday, 25
 Holm, 11, 14
 Holzhäuser, 14
 Holzverkohlungs Industrie A.G., 107,
 120, 125
 Hopfield, 3
 Horiuti, 35, 38
 Horsley, 36, 123
 Horst-Dietrich, 123
 Horwitz, 2
 Horwitz, 148
 Hotz, 122
 Hovey, 120
 Howard, 113
 Hubsch, 120
 Hueber, 28 (see Haeuber)
 Hueper, 181
 Huffman, 4, 110, 113
 Hujio, 36
 Hull, 17, 26, 29, 36
 Hulla, 169
 Humphry, 171
 Hunter, 2
 Hurd, 25, 75, 80, 81, 114, 140, 146, 167
 Huscher, 125
 Hutton, D., 167, 174
 Hutton, R. S., 17
 Hyslop, 88

- I. G. Farbenind, A.G.; acetaldehyde, **120, 121, 122, 123**; acetone, **125**; acetonitrile, **137**; acetylene, adsorption of, **36**; acetylene condensation, **156**, with phenols, **156**, with ammonia, **157**, with hydrogen sulfide, **135**; acetylene from pyrolysis, **17, 25, 26, 28, 28, 35**; acetylene mixtures, use, **36**; acetylene solid, **18**; acetylene solvents, **35, 36**; acetylides, **44**; acetylenic glycols, **87**; alkylacetylenes, **81**; chloroethylenes and ethanes, **101, 108**; chlorooctotetraene **171**; chloroprene, **174, 175, 178**; divinylacetylene reactions, **171**; hydrogenation of acetylene, **98**; vinylacetylene preparation, **167, 168**; vinylacetylene reactions, **169, 170**; vinyl diaryl amines, **137**, vinyl and ethylidene esters, **130, 132, 133, 134**; vinyl and ethylidene ethers, **128, 129**, neoprene, **181**
- Igi, **107**
 Iki, **143, 146**
 Ilosvay, **37, 38, 58**
 Imperial Chemical Industries Ltd., acetaldehyde, **121, 122, 123**; acetylene addition of hydrogen halides, **101**; acetylene, from pyrolysis, **17, 25, 26, 28, 29**, acetylene mixtures, **36**, acetylene solvents, **36**; vinyl ethers, **129**; vinyl and ethylidene esters, **132**
- Ingold, **3**
 Institut für physikalische Grundlagen der Medizin, **26**
 International Industrial and Chemical Co., **7, 27**
 International Latex Process Ltd., **178, 183**
 Ipatiev, **145, 146, 147**
 Isham, **36**
 Ishikawa, **25**
 Ivanov, **85, 88**
- Jackson, H., **152**
 Jackson, K., **67, 68**
 Jackson, M., **67, 68**
 Jacobs, **78, 81, 114**
 Jacobsen, **10**
 Jacobson, **48, 88, 168, 169, 170, 174**
 Jaeger, **97, 98**
 James, **35**
 Jane, **11, 12, 13**
 Janet, **32, 35**
 Jaubert, **114**
 Jenisch, **17, 145, 147**
- Jenkins, **62, 65**
 Jerdan, **16, 146**
 Jochheim, **123**
 Johns Manville Corp., **182**
 Johnson, G. W., **120**
 Johnson, J. D. A., **68**
 Johnson, J. R., **78, 81**
 Johnson, J. Y., **36**
 Jones, F. A., **181**
 Jones, Maldwin, **183**
 Jones, C. W., **24**
 Jones, —, **182**
 Jones, H. C., **48**
 Jonesco, **3**
 Joris, **145, 146**
 Josephy, **10**
 Journaud, **77, 81**
 Jovichich, **152**
 Jozitsch, **47, 48, 84, 85, 87, 88, 89, 89, 90, 91, 92, 94**
 Juliard, **151, 152**
 Jungers, **145, 146, 147, 151, 152**
 Jungfleisch, **69, 70, 103, 107**
- Kaess, **14**
 Kakuya, **122**
 Kali Forschungs-Anstalt G.m.b.H., **109**
 Kambara, **183**
 Kambli, **87**
 Kanga, **160**
 Karpati, **120**
 Karweil, **168**
 Kasansky, **17**
 Kashtanov, **25**
 Kassel, **22, 25**
 Kastler, **3**
 Kato, Osamu, **133**
 Kato, Sechi, **150, 152**
 Kato, Yogoro, **142, 146**
 Katz, **182**
 Kaufer, **134**
 Kaufmann, **19, 147, 148, 149, 151, 152**
 Kazarian, **84, 87, 168**
 Kazarnovskii, **114, 134**
 Kearns, **63, 65, 114**
 Keiser, **7, 19, 53, 55, 57, 58, 62, 65, 106, 109**
 Kelbovskaia, **114**
 Kemp, **181**
 Kemula, **150, 152, 168**
 Kennedy, C. C., **125**
 Kennedy, D. J., **11, 14**
 Kennedy, E. R., **64, 65, 115, 119**
 Keppeler, **13**
 Keyssner, **137, 155, 156**
 Khaltykyan, **174**
 Khuomotin, **102, 104, 107, 178**

- Khuka, 181
 Killian, 79, 81, 127, 128, 169
 Kindler, 68, 70, 114
 Kinoshita, 151, 152
 Kipper, 26
 Kirby, 174, 177, 178, 179, 181
 Kirchhoff, F., 183
 Kirchhoff, G., 159, 160
 Kireev, 35
 Kistiakowsky, 3, 37, 38, 110, 114, 169
 Klatt, 154, 156
 Klatte, 128, 132
 Klebanski, 174, 167, 169, 170, 178, 181
 Kletzinski, 19
 Kloss, 79, 81
 Klyukvin, 24, 25, 153, 156
 Knorr, C.A., 96, 98
 Knorr, L., 58
 Kobayashi, 24, 25
 Kobe, 6
 Kogozev, 24, 25
 Kobrin, 25
 Koch, H., 17, 98, 144, 147, 149, 150
 Koch, W., 150, 152
 Kochelev, 94
 Koethner, 17, 63, 64, 65, 68, 70, 115, 119,
 147, 148, 149
 Koetschet, 132, 134
 Kojolo, 14
 Kolesov, 178
 Kollek, 90, 90, 91, 92, 92, 168
 Koller, 24, 25, 36
 Komarov, 181
 Kondyrev, 88
 Konquest, 183
 Konrad, 174
 Konschak, 17, 39
 Koryushenko, 182
 Kosenko, 108
 Kosyakova, 24
 Kotkowski, 38, 52, 58
 Kovache, 141, 146
 Kozlov, 99, 101, 153, 156, 157, 159, 167,
 169, 174
 Kraemer, 181
 Kraft, 71, 73, 89
 Kraft, 108
 Kranzfelder, 88
 Kraus, A., 18
 Kraus, C. A., 19
 Krause, E., 54, 68
 Krauss, A., 168
 Krehma, 125
 Krehov, 169
 Kreimier, 84, 86, 87, 88, 168
 Kremann, 35
 Krestinsky, 87, 114
 Kretoev, 68
 Kriloff, 114
 Krismann, 181, 183
 Kroeger, 77, 81, 93, 155, 156
 Krugel, 2
 Kruilov, 181
 Krylov, 10
 Kubelnek, 167
 Kuespert, 51, 58, 59, 61
 Kuhn, vii
 Kumpfmiller, 35
 Kunckel, 90
 Kuppers, 91, 92
 Kutscherov, 61, 65, 69, 70, 115, 119
 Kuwata, 133
 Kuzmick, 183
 Kwal, 97, 98

 Lacomble, 27
 Ladenburg, 2
 Lagermark, 44, 89
 Landsberg, L., 90
 Landsberg, V. de, 107, 109
 Langguth, 108
 Lappe, 171
 Larson, 181
 Lawrie, 3
 Lawson, 169
 Lebeau, 7, 38, 39, 44, 58, 75, 80
 Lebedev, V. I., 94
 Lebedev, S. V., 169
 LeChatelier, 17, 113
 Le Compte, 58
 Ledru, 121, 133
 Leeds, viii
 Leers, 87
 Lefevre, vii
 Leighton, 39
 Lenher, 110, 114
 Lepayre, 47, 48, 79, 81
 Lespieau, 46, 48, 77, 81, 85, 88, 94, 168
 Levin, 2
 Levina, 87
 Levinson, 88
 Lewes, vii, 11, 13
 Lewis, 66, 67, 68
 Li, 181
 Liang, 94
 Lichtenberg, 17
 Lichtenberger, viii, 134, 167
 Lichtenhahn, 149, 150
 Lidholm, 102, 107
 Lieberman, 92
 Liebetanz, viii
 Liefde (see de Liefde)

- Lieseberg, **169**
 Light, **170**
 Limb, **7, 10**
 Lind, **150, 151, 152**
 Lindholm, **3**
 Linkh, **28**
 Livingston, **150, 152**
 Llorens, **38**
 Lochte-Holtgreven, **3**
 Locquin, **87**
 Loevenich, **19**
 Logvinovich, **25**
 Lombard, **85, 88**
 Longi, **27**
 Losanich, **152**
 Losen, **19**
 Lossen, **58**
 Lotter, **87**
 Lowenberg, **83, 87**
 Lowry, **16, 17, 138, 138**
 Lowy, **viii, 167**
 Lozovoi, **145, 147**
 Lozovski, **123**
 Lucas, **64, 65, 115, 119**
 Ludwig, **viii**
 Lueg, **3**
 Lunge, **13**
 Lurje, **167**
 Luther, **123**

 Maas, **2, 75, 81**
 McCallum, **83, 84, 87**
 McCusker, **77, 81, 92, 92**
 MacDonald, A. D., **178**
 MacDonald, G. D., **39**
 McDonald, R. D., **111, 114**
 McEwen, **48**
 McIntosh, **2**
 Mackenzie, **19**
 McKellar, **3**
 McKie, **112, 114**
 McLennan, **151, 152**
 McLoed, **28**
 McQuillen, **145, 147**
 Magaldi, **24**
 Maguire, **54, 58, 64, 65**
 Mahler, **48, 49**
 Mailfert, **112, 114**
 Makashina, **168**
 Makowka, **57, 68, 69, 70**
 Majima, **157, 159**
 Malinowskii, **114**
 Malyshev, **27**
 Manchot, **50, 57, 59, 60, 61, 61, 63, 65,**
 90
 Mann, **66, 68**
 Manson, **2**

 Mantell, **10**
 Maquenne, **6, 7, 13**
 Marbon Corp., **182**
 Mardles, **111, 114**
 Margules, **107, 178**
 Marks, **114**
 Marsene Corp. of America, **181**
 Marshall, M. J., **viii, 133**
 Marshall, —, **151, 152**
 Martin, F. W., **151, 152**
 Martin, J., **125**
 Maruschkin, **167**
 Marutyan, **101**
 Marvel, **87, 94**
 Mascarelli, **158, 160**
 Maschman, **38, 39**
 Mason, G. M., **11, 12, 13**
 Mason, W., **113**
 Mathes, **58**
 Matheson, **120, 122, 132, 134**
 Mathewson, **viii**
 Matignon, **42, 44, 87**
 Matsumo, **137**
 Matthews, **57, 58**
 Maude, **120**
 Mayor, **134**
 Maze, **104, 107**
 Mazo, **155, 156**
 Mears, **169**
 Mecke, **2, 3, 168**
 Meinert, **75, 81**
 Melnikov, **115**
 Melville, **150, 152**
 Mendeleva, **123**
 Meneghini, **10, 168**
 Mercier, **27**
 Merling, **82, 84**
 Messner, **87**
 Metallgesellschaft, A.G., **181**
 Metz, **18**
 Metzger, **36**
 Meunier, **19**
 Meyer, C. F., **2**
 Meyer, K., **24**
 Meyer, L., **113**
 Meyer, R., **141, 146, 156, 157, 159, 159**
 Meyer, V., **135, 158, 160**
 Meyer, W., **146**
 Miasnikov, **19, 58**
 Mies, **35**
 Mignonac, **146, 151, 152, 168**
 Mikhailov, **126**
 Millar, **29**
 Miller, **120**
 Miloslavskii, **27, 108**
 Minister of Navy (Japan), **36**
 Mitchell, W., **129**

- Mitchell, N. W., **48**
 Mitskevich, **160**
 Mittasch, **28, 114**
 Mixter, **3, 18, 135, 137**
 Möllnay, **38**
 Moens, **151, 152**
 Moffet, **182**
 Mogilyansky, **159**
 Moissan, **5, 6, 6, 7, 7, 10, 13, 15, 17, 41, 42, 43, 44, 44, 47, 48, 144, 147**
 Molinari, **114**
 Mondain-Monval, **114**
 Mongaritov, **181**
 Monhaupt, **148, 149**
 Montagne, **24, 113, 151, 152**
 Montemartini, **135, 137**
 Moody, **38, 55, 58**
 Moor, **24**
 Morgan, **183**
 Morgan Ebonite Co., **183**
 Morehead, **10**
 Morehouse, **75, 81**
 Morel, vii
 Morev, **90**
 Morino, **3**
 Morosov, **171**
 Morrell, C. E., **3**
 Morrell, J. C., **27**
 Morris, **96, 97, 98**
 Morrison, **132, 134**
 Morton, **120, 122**
 Moschkin, **157, 159**
 Motovilova, **167**
 Mouneyrat, **103, 104, 107**
 Moureu, **15, 17, 44, 74, 87, 88, 89, 90, 93, 93, 94, 143, 147**
 Mrizeck, (See St. Mrizeck)
 Mueller, **181**
 Mühlert, viii
 Müller, E., **35**
 Müller, J. F., **5, 6**
 Müller, K. L., **106, 109**
 Müller-Conradi, **36**
 Mues, **14**
 Mugdan, **107, 108, 120, 121, 125, 133**
 Mulyar, **68**
 Mumm, **62, 65**
 Mund, **150, 151, 152**
 Munderloh, **42, 44, 87, 168**
 Muthmann, **108**
 Myagkova, **181**
 Myddleton, **64, 65**

 Nametkin, **68**
 Nargund, **160**
 Nash, **24**

 Nashan, **123**
 Naunton, viii, **183**
 Neale, **181**
 Nef, **2, 3, 19, 82, 87**
 Nekrasov, P. A., **67, 68**
 Nekrasov, A. S., **67, 68**
 Nelles, **170**
 Nelson, **48**
 Ness, **14**
 Nesty, **87**
 Neumann, L., **98, 102, 104, 105, 107, 138, 145, 147**
 Newmann, **108**
 New York Belting and Packing Co., **182**
 Nichols, **181**
 Nicodemus, **35, 167, 169**
 Nieuwland, **35, 42, 44, 48, 54, 56, 58, 63, 64, 65, 66, 67, 69, 70, 75, 79, 81, 86, 88, 90, 92, 93, 99, 100, 102, 103, 104, 105, 107, 114, 120, 126, 127, 128, 133, 154, 155, 156, 157, 159, 166, 167, 168, 169, 170, 171**
 Norsk Alkali A.S., **108**
 Northall-Laurie, **152**
 Novak, **5, 7**
 Novotny, **38, 39, 58**
 Noyes, **90, 90, 106, 109**
 Nutting, **26, 125**
 N. V. Electro Zuurstof en Waterstof-fabriek, **150**
 N. V. de Bataafsche Petroleum Maatschappij, **27, 29, 36, 146, 174, 178**

 Oberfell, **18**
 O'Brian, **14**
 Ochi, **121**
 Oda, **97, 98**
 Oddo, **46, 48, 89, 89**
 Ogura, **143, 146**
 O'Leary, **127, 128**
 Olifson, **160**
 Oltrogge, **57, 61, 90**
 O'Meara, **106, 108**
 Ono, **157, 159**
 Onozawa, **121**
 Orelkin, **88, 90, 94**
 Orlowa, **170**
 Ornstein, **108**
 Orton, **112, 114**
 Osipov-Schmidt, **183**
 Ostromislensky, **99, 101**
 Ott, **182**
 Ottenhoff, **182**
 Otto, **112, 114**
 Overbeck, **115**

- Paal, 96, **98**
Palmer, 1, **3**
Parks, 3, 110, 113
Parlee, **134**
Parr, **17, 24**
Parrish, 24
Parsons, C. E., 5, 7
Parsons, W. H., 96, **98**
Passarge, 95, **98**
Patat, 1, **3**
Paterno, 106, **109**
Patrick, **182**
Panaotovic, vii
Pauling, 1, **3**
Pavlov, 106, **109**
Pavlovich, **183**
Pease, 139, 142, **146**
Pechmann, **137**
Peel, 159, **160**
Pelton, **125**
Peratoner, **3, 106, 109**
Peregud, **169**
Perkins, G. A., 83, **87, 99, 101, 168, 174**
Perkins, W. L., 66, **68**
Perrichon, **73, 90, 92**
Perrin, 151, **152**
Perry, 150, **152**
Peters, G., **121**
Peters, K., 17, 22, 24, **25, 97, 98, 102, 104, 105, 107, 144, 145, 147, 149, 150**
Pessin, **167**
Petran, **27**
Petrov, 98, **98**
Petterson, 7
Peyresblanques, **114**
Pharm. Ges. Pharmazeutic U. Chem., **174**
Pichler, 22, 24, **25, 27, 28, 29, 97, 98, 141, 142, 143, 146**
Pickney, **87**
Picon, 44, 47, **48, 75, 80**
Pictet, 17
Pidgeon, 126, **128**
Pieroni, **48**
Pietsch, **38, 52, 58**
Pincas, 10
Pines, **146**
Pinner, **89**
Piotrowski, **25**
Pisarev, **134**
Pizareello, **24**
Placzek, **3**
Plakidina, **126**
Platonov, 126
Plauson, 99, 101, **121, 127, 129**
Plauson's Forschungsinstitut Ges., **133**
Pletz, **88, 170**
Plimpton, 53, 54, 55, **58, 106, 107, 109**
Podovani, **24**
Pohl, **125**
Pollitzer, **2, 53, 58**
Pond, viii
Pope, 66, **68**
Postovskü, **108**
Poutermann, **121**
Powers, **170**
Pranschke, **24, 25**
Prestolite Co., 12, **14**
Price, T. S., 66, **68**
Price, W. C., **3**
Pring, **17, 96, 98**
Pummerer, **178**
Putnam, **6**
Pyzel, **27, 36**

Querforth, **125**
Quet, **24, 52, 57**
Quillico, 158, **160**

Rabald, **132**
Rakhlina, **181**
Ramaswamy, **3**
Ramondt, **58**
Rao, **3**
Rasch, **18**
Raybestos-Manhattan Inc., **183**
Reboul, **19, 99, 101, 106, 108**
Reckleben, 51, 52, 57
Reed, **149**
Reich, **90**
Reichert, 126, **128, 154, 156**
Reinicke, 150, 152
Reinkober, **58**
Reilly, 154, **156**
Reppe, **128, 129, 155, 156**
Reyerson, 45, 46, **48, 96, 97, 98**
Reynolds, **171**
Ribaud, 113
Rice, F. O., **25**
Rice, O. K., 145, **147**
Rideal, **25, 152**
Ridge, **181, 182**
Ried, **120**
Riese, **38**
Rieth, **28**
Riley, **121, 122**
Rimarski, **2, 14, 17, 18**
Robertson, **2**
Robinson, 159, **160**
Robison, **183**
Rodman, E., **170**
Rodman, G., **159**
Röhm, and Hass, **101, 103, 107, 171**

- Roemer, A., **28, 150, 152**
 Roemer, E., **55, 58, 62, 65**
 Roetger, **159**
 Roffey, **36**
 Roka, **102, 105, 107, 125**
 Rollefson, **106, 109**
 Romanchuk, **35**
 Rooney, **122**
 Rosander, **94**
 Rose, A., **3**
 Rose, J. R., **27**
 Rosemberg, **3**
 Rosenblum, **151, 152**
 Rosenfeld, **47, 48**
 Rosinsky, **122**
 Ross, **38, 38, 96, 98**
 Rossier, **10**
 Rossikhin, **114**
 Rotenberg, **169**
 Roth, **120, 121**
 Rovida, **68**
 Rowell, **122**
 Rowley, **26**
 Rozengart, **126**
 Rudder, (de Rudder) **24, 28, 29**
 Rudolf, **88**
 Ruff, **10**
 Ruhrchemie, A.G., **27, 35, 108, 133**
 Rupe, **58, 87**
 Ruppert, **108**
 Ruzicka, **83, 87**
 Ryazantzev, **106, 109**
 Ryumina, **178**
- Sabanejev, **19, 69, 70, 99, 101, 106, 107, 108, 109**
 Sabatier, **17, 96, 97, 98, 144, 147, 147, 148, 149, 149**
 Saeger, **183**
 Saint Aunay, **151, 152, 168**
 St. Mrazek, **168**
 Salzberg, **94**
 Salzbergwerk Neu Strassfurt, **108**
 Sandhaas, **35**
 Sandmeyer, **135, 158, 160**
 Sandonini, **142, 146**
 Sastry, **113**
 Sauerbrei, **33, 35**
 Sauerwein, **96, 98**
 Saunders, **137**
 Sawitsch, **19**
 Scattola, **155, 156**
 Schaad, **16, 17**
 Schaefer, **73**
 Scheiber, **38, 51, 52, 57, 58**
 Scheibler, **87, 88**
- Scheller, **123**
 Scherlin, **68**
 Scheuermann, **123**
 Schibajev, **94**
 Schiepp, **94**
 Schiflett, **150, 151, 152**
 Schilling, **35, 36**
 Schläpfer, **16, 17, 139, 146, 148, 149**
 Schlecht, **159**
 Schlegel, **102, 107**
 Schlicht, **125**
 Schlossberg, **167**
 Schlumberger, **10**
 Schmal, **7**
 Schmidt, **80, 81**
 Schmitz, **54, 58**
 Schneider, G. G., **159**
 Schneider, —, **114**
 Schneider, H. P., **147, 149**
 Schneider, V., **146**
 Scholly, **7**
 Schraeder, **145, 147**
 Schultz, **125**
 Schultze, G. R., **151, 152**
 Schulze, A., **viii, 38, 58**
 Schumacher, **106, 109**
 Schutzemberger, **17, 144, 147, 152, 154, 156**
 Schwartz, **81**
 Schwarz, E., **7**
 Schwarz, —, **98**
 Schwarzenberg, **134**
 Scott, **35**
 Seacie, **111, 114**
 Seferian, **113**
 Segre, **3**
 Selden Co., **98**
 Senderens, **17, 96, 97, 98, 144, 147, 147, 148, 149, 149**
 Serko, **159**
 Seyfried, **10**
 Shah, **160**
 Shaw, **133**
 Shawinigan Chemicals Ltd., **126**
 Shell Development Co., **27, 28, 29, 36, 120, 156**
 Shermann, **7**
 Sherun, **14**
 Shilov, **168**
 Shimank, **58**
 Shinkle, **182**
 Shiver, **68**
 Shchekin, **183**
 Shohei, Sato, **183**
 Shpanski, **68**
 Shter, **167, 171**

- Sibaiva, **3**
 Sickmann, **122, 145, 147**
 Simon, **25**
 Skalov, **114**
 Skirrow, **132, 133, 134**
 Skossarevsky, **6, 41, 44, 87, 89, 89**
 Slade, **7**
 Slimmer, **73**
 Slobodin, **80, 81**
 Sloof, **115**
 Sly, **133**
 Smirnova, **168**
 Smith, C. P., **3**
 Smith, E. A., **37, 38**
 Smith, W. F., **183**
 Soc. anon. ammonia casale, **168**
 Soc. anon. de produits chimiques Maletra, **121, 122**
 Soc. anon. l'exploitation brevets Julien, **10**
 Soc. anon. l'ind. chimique à Bale, **18, 26, 83, 87, 121, 159**
 Soc. anon. le pétrole synthétique, **25, 98**
 Soc. l'air liquid, **27**
 Soc. chimique des usines du Rhone, **121, 132, 133, 134**
 Soc. des acieries et forges de Firminy, **121**
 Soc. d'études scientifique et d'entreprises industrielles, **28**
 Soc. d'études et d'exploitation des matières organiques, **28, 28**
 Soc. Ind. des hydrocarbures de dérives, **26**
 Soederbaum, **52, 58**
 Sokolik, **114**
 Soller, **122**
 Solodsky, **87**
 Sorgato, **168**
 Sowa, **133, 155, 156**
 Spahr, **56, 58**
 Spallino, **3**
 Spence, L. V., **75, 81**
 Spence, R., **114**
 Spinks, **1, 3**
 Springall, **1, 3**
 Stackelberg, **4, 6**
 Stadler, O., **148, 149**
 Stadler, R., **35, 108, 171, 174**
 Standard Oil Development Co., **17, 26, 35, 121, 171, 182**
 Stanley, **24**
 Starck, **131, 134**
 Starkweather, **178, 182**
 Stassevitch, **88**
 Staudinger, **131, 134**
 Steck, **120**
 Steigler, **66, 67, 68**
 Steinberger, **120, 121**
 Steinkopf, **159, 160**
 Stephenson, **125**
 Stettbacher, **53, 58**
 Steward, **183**
 Stine, **167**
 Stockholm's Superfosfat Fabriks A.G., **121**
 Storch, **22, 23, 25**
 Strain, **132**
 Stratta, **25, 152**
 Straus, **90, 90, 91, 92, 92, 168**
 Strigaleva, **24**
 Strizhevskii, **39**
 Strong, **3**
 Strosacker, **125**
 Stuer, **122, 159**
 Suck, **7**
 Suckert, **2, 10**
 Suknevitch, **102, 104, 107**
 Sumiya, **14**
 Sung, **87**
 Surety Rubber Co., **183**
 Susich, **181**
 Sutherland, **3**
 Sworykin, **7**
 Taack-Trakanen, **120**
 Taeger, **146**
 Takioka, **113**
 Tako, **103, 107**
 Tamaru, **128**
 Tamann, **7**
 Tanaka, **128, 183**
 Tanneberger, **35, 169**
 Tanner, **123**
 Tanzen, **146, 156, 159**
 Tatarinov, **27**
 Tauber, **58**
 Taussig, **viii**
 Taylor, G. B., **36**
 Taylor, H. A., **96, 98**
 Taylor, H. S., **145, 147, 150, 162**
 Tchao, **75, 81, 86, 88, 114**
 Tcheou, **47, 48, 79, 81, 89, 89, 90**
 Terry, **55, 58**
 Testoni, **158, 160**
 Teterin, **85, 88**
 Thenard, **152**
 Thiele, **107, 109**
 Thomas, **1, 2**
 Thommen, **122**
 Thompson, A. F., **87**
 Thompson, M. D., **7**
 Thomsen, **3**

- Thorin, viii, **121**
 Thorn, 79, **81**
 Thorpe, viii, **25, 134**
 Tiede, 17, **145, 147**
 Timkovskii, **114**
 Timm, **168**
 Tokarski, **88, 94**
 Tokio Industrial Laboratory, **121**
 Tompkins, **107**
 Tompkinson, **135, 135**
 Toul, **150, 152**
 Toussaint, 99, **101, 168**
 Trankovskaya, **182**
 Traube, 95, **98**
 Travers, 55, **56, 58**
 Treadwell, 7, **58**
 Treton, 151, **152**
 Trevoux, **121**
 Tricot, 141, **143, 146**
 Tropsch, **24**
 Truchet, 78, **81, 91, 92, 115**
 Truchot, **24**
 Trumbull, 38, **38**
 Tschistow, **167**
 Tucker, C. W., 90, **90, 106, 109**
 Tucker, S. A., **38, 55, 58**
 Tufts, **24**
 Turman, **183**
 Twiss, **178, 181**
 Tyler, **183**
 Tzyurikh, 60, **61, 146, 167, 168, 169, 174**
- Uhrmacher, **24**
 Ullrich, **122**
 Ullmann, viii, **134**
 United Shoe Machinery Co., **181**
 United States Rubber Co., **182**
 Unno, 157, **159**
 Urban, **134**
 Urion, **168**
 Ushakov, **126, 131, 134**
 Usoff, **48**
 Utheim, **121**
- Valdiguie, **114**
 Valyashko, **108**
 Van Arsdell, **169**
 Van Dalfsen, 100, **101**
 Van Dam, **68**
 Vanderbilt News, **182**
 Van der Valle, 107, **109**
 Van Hook, 96, **98**
 Van Oettingen, **181**
 Varet, 154, **156**
 Vasil'ev, A. A., **169**
 Vasil'ev, S. S., **24**
- Vasil'eva, **181**
 Vaughn, 42, **44, 48, 68, 75, 81, 92, 127, 128, 169, 170**
 Veltistov, **126**
 Venkateschar, **3**
 Verein für Chemische Industrie A.G., **120, 133, 134**
 Verleger, **3**
 Vernazza, **25, 152**
 Vielle, J. A., 99, **101, 121**
 Vielle, P., 16, **17, 113**
 Vienne, 154, **156**
 Vierling, **3, 168**
 Viguier, **93**
 Villard, 1, **2**
 Vincens, **108**
 Vinogradova, **87**
 Vogel, J. H., **178**
 Vogel, R. E., viii
 Vogl, **167**
 Vogt, 42, **44, 48, 49, 56, 58, 64, 65, 75, 81, 86, 88, 92, 92, 114, 120, 126, 128, 129, 159, 168**
 Vohl, **24**
 Voigt, **108**
 Voiret, **10**
 Voituron, **28**
 Volin, **171**
 Volkmann, **14**
 Volmar, 151, **152**
 Von Wartenburg, **17**
 Voronova, **24**
- Wacker, A., **167**
 Wagner, 22, **24, 25**
 Walker, **25, 141, 146, 178, 182**
 Walter, F., **14**
 Walter, H., **120, 123, 125, 131, 133**
 Wartenburg, **17**
 Waterman, 154, **156**
 Watson, **3**
 Watters, 57, **58**
 Watts, **7**
 Weaver, **38**
 Wedger, **181**
 Weibel, 49, **49**
 Weibezahn, K., **14**
 Weibezahn, W., **132, 169**
 Wellard, **114**
 Wellers, 38, **39, 58**
 Wenzke, 3, **127, 128, 154, 156**
 Wernitz, **169, 170**
 Wesche, 49, **49, 157, 159, 159**
 Wheland, **48**
 Wheeler, R. V., **24, 25, 113, 141, 146**
 Wheeler, T. S., **28, 29**

- West, 183
Witby, 182
Witherspoon, viii
White, A., 24
White, G. F., 19
Wibaut, 100, 101, 181
Wieland, Heinrich, 49, 49, 68, 79, 81
Wieland, Hermann, 2
Wiesler, 125
Wietzel, G., 28, 120
Wietzel, R., 123
Wizevich, 171
Wilde (see de Wilde)
Wiley, 87
Wilke, 171
Will, 27, 28
Willfroth, 114
Willgerodt, 13, 54, 58
Williams, E. R., 10
Williams, I., 174, 178, 179, 181, 183
Willig, 108
Willihnganz, 157, 159
Willson, 2, 7, 8, 10
Willstätter, 38, 38, 39, 168
Wilm, 14
Wilmet, 58
Wilson, E., 24, 169
Wilson, F. J., 88
Wilson, J. A., 181
Wilson, J., 150, 152
Winkelmann, 182
Winkler, F., 156
Winkler, J., 25
Winkler, L. W., 35
Wimmer, 125
Winter, E., 14
Winter, R. M., 29
Wirth, 168
Wislicenus, 80, 81
Withers, 57, 61, 90
Wittorf, 107, 109
Wöhler, 7, 10, 107
Wohl, 114, 123
Wolff, P., 13
Wolff, W., 129, 137
Wolkenstein, 170
Woo, 3
Wood, 24
Wooster, 48
Wright, 2, 75, 81
Wulff, 27, 36
Wunderlich, 115, 119
Wunenberger, 112, 114
Yamada, 14
Yakimov, 168
Yamamoto, 24, 25
Yanitz, 146, 168
Yarovonkov, 178
Yasuda, 10
Yerzley, 182
Yella Conte, 7, 145, 147, 153, 156
Yogi, 113
Yoshkawa, 96, 97, 98
Young, 114
Yuster, 45, 48
Yvon, 88
Zahn, 3
Zakharov, 169
Zakharova, 87, 88
Zal'kind, (Salkind), 47, 48, 85, 88, 170
Zalogin, 25
Zanetti, 122
Zelinskii (Zelinsky), 17, 126, 143, 145,
146, 167
Zhavoronkov, 170, 171, 178
Ziegler, 3
Zimmermann, 38
Zobel, 123
Zowadovski, 178
Zueva, 181
Zutphen, 171

Subject Index

- Accelerators, for neoprene, 180
- Acetaldehyde, acetylenic carbinols from, 82, 83
as acetylene solvent, 34
by product of vinylacetylene, 162, 163
from acetylene, 115-119
from gas mixtures, 34, 117
from ethylidene diacetate, 131, 132
solubility of acetylene in, 31, 32
- Acetaldehyde, dihalo-, from acetylene, 107
- Acetal, diethyl-, solubility of acetylene in, 31, 32
- Acetals, ethers of acetylenic carbinols from, 81, 86
from acetylene, 117, 126, 127
- Acetals, acetylenic, 72
- Acetamide, dimethyl- as acetylene solvent, 31, 34
N,N,N',N' tetramethylamino- solubility of acetylene in, 31
- Acetates, from acetylene, 124
- Acetic acid, addition to acetylene, 117, 129-132
from acetylene, 119
solubility of acetylene in, 31, 32
- Acetic anhydride in addition of acetic acid, 130
from ethylidene diacetate, 131, 132
reaction with acetylenic Grignards, 93
- Acetoacetic ester condensation with acetylene, 155
- Acetoacetone, solubility of acetylene in, 31
- Acetone, acetylenic carbinols and glycols from, 82-85
from acetylene, 124-125
removal from acetylene, 37
for separation of alkynes and alka-dienes, 34
solubility of acetylene in, 31, 32
as acetylene solvent, 30, 33, 34
- Atonitrile, from acetylene, 136, 157
as acetylene solvent, 34
- Acetyl chloride, condensation with acetylene, 155
- Acetylene dihalo-, see dichloroacetylene, etc.
- Acetylene black, 109
- Acetylene dicarboxylic acid, 89
- Acetylene dihalides, see dichloroethylene, etc.
- Acetylene tetrahalides, see tetrachloroethane, etc.
- Acetylene halo-, see chloroacetylene, etc.
- Acetylenic compounds, preparation by desaturation reactions, 19
- Acetylidine isomers, of acetylenes, 2
- Adetylide structure, tests for, 50
- Acetylides, acetylenic carbinols, glycols, and ethers from, 81-86
acetylenic carboxylic acids from, 88-89, 93
acetylenic hydrocarbons from, 74-80
ammonated, 42, 44
diacetylenes from, 89-90
dihaloacetylenes from, 90-92
from acetylene, 40-58
from other acetylides, 48, 49
haloacetylenes from, 90-92
reaction with acetals, 86
with acyl halides, 93
with aldehydes, 81-85
with alkali cyanides, 50
with alkyl halides, 74-78, 79
with alkyl sulfates, 78
with alkyl sulfonates, 78
with allyl halides, 77-78
with alphahalo ethers, 86
with alphyll halides, 79
with carbon dioxide, 88-89
with carbonic esters, 93
with haloformic esters, 93
with halogens and hypohalites, 90-92
with ketones, 81-85
with metal salts, 48, 49
with olefin oxides, 86
with orthoformic esters, 93
with oxidizing agents, 89-90, 93
structure and formulae of, 41
- Acetyl chloride, addition to acetylenes, 155
- Acenaphthene, from acetylene condensation, 139
- Acid anhydrides, from alkylidene esters, 132
- Acidity, of acetylene, 41, 44, 45
- Acid salts in acetaldehyde synthesis, 116, 117
- Acids, in addition to acetylene, of alcohols, 126, 127
of aromatic hydrocarbons, 154
of carboxylic acids, 129-131
of olefins, 153
of phenols, 154-155
of water, 115-117
in cleavage of ethylidene diacetate, 132

- Acids, acetylenic, carboxylic, synthesis, 72, 88, 89
oxidative cleavage of, 113
- Acids, carboxylic, from oxidation of acetylenes, 113
addition to acetylene, 129-132
- Acrolein, solubility of acetylene in, 31
- Acrylonitrile, from acetylene, 153
- Acyl chlorides, condensation with acetylenes, 155, 165
- Acyl halides, reaction with acetylides, 93
- Addition compounds of acetylene, with salts, 40-41, 58-70
- Addition reactions of acetylene, see names of addenda
- Adhesives, from divinylacetylene, 166
- Adsorbents, for acetylene, 34
- Adsorption, of acetylene by solids, 33-34
- Alcoholates, as alkalis in synthesis of carbinols, 82-84
- Alcohols, addition to acetylenes, 126-128
addition to vinylacetylene, 117, 165
by product in synthesis of alkylacetylenes, 75
reaction with acetylides, 45
solubility of acetylene in, 30-32
- Alcohols, amino-, addition to acetylene, 128
- Alcohols, acetylenic, see carbinols
- Aldehydes, acetylenic carbinols and glycols from, 82-86, 164
solubility of acetylene in, 31
acetylenic, synthesis of, 72, 93
- Alkadiynes, 40, 86, 89, 90
- Alkali acetylides, see acetylides
- Alkali cyanide solutions, reaction with acetylides, 50
- Alkalis, addition compounds with acetylenes, 69, 80
catalysts for addition of alcohol, 128
in dehydrohalogenations, 18, 19
in synthesis of acetates from acetylene, 124
in synthesis of acetylenic carbinols, 82, 85
- Alkaline earth acetylides, see acetylides
- Alkenyl esters, from acetylene, 73
- Alkenynes, 165, 173
- Alkylacetylenes, addition reactions of, see names of addenda
isomerization of, 79, 80
substitution reactions of, see names of substituents, dialkylacetylenes.
synthesis of, 72, 74-80
- Alkylamines, by product of acetylene alkylation, 75-78
- Alkylation, of acetylene, 74-80
of alkylacetylenes, 75, 77-80
of vinylacetylene, 165
- Alkylbenzenes, condensation with acetylene, 154
- Alkyl halides reaction with acetylides, 74-77, 79
- Alkylidene esters, from acetylenes, 132
- Alkylmercuronium salts, reaction with acetylene, 50, 56
- Alkyne oxides, acetylenic carbinols from, 81, 86-87, 164
- Alkyl sulfates, reaction with acetylides, 74, 78, 79
- Alkyl sulfonates, reaction with acetylides, 74, 78, 79
- Alkylvinylacetylenes, 165, 173
- Alkynes, see alkyl- and dialkylacetylenes
- Alkynes, chloro-, 78
- Alkynediols, see glycols, acetylenic
- Alkynoic acids, see acids, acetylenic
- Alkynols, see carbinols acetylenic haloesters of, see carbinyl halides, acetylenic
- Alkynones, see Aldehydes and ketones, acetylenic
- Allene, as impurity in acetylene, 33
- Allenic hydrocarbons, from acetylenes, 79, 80
isomerization to acetylenes, 79, 80
- Allylacetylene, 77, 78
- Allyl halides, reaction with acetylides, 77-79
- Alpha particles, effect on acetylene, 150
- Alpha radiation, polymerization of acetylene, 157
- Aluminum chloride, action on acetylene, 145
in condensation of acetyl chloride with acetylene, 155
in condensation of benzene with acetylene, 154
to remove unsaturated hydrocarbons from acetylene, 34
- Aluminum halides, addition to acetylene, 40, 65, 66, 67
- Amides, alkali, in the synthesis of acetylenic carbinols, 82, 83
reaction with acetylene, 47, 48
see also sodamide
- Amides of carboxylic acids, solubility of acetylene in, 30
- Amides, alkylated, as acetylene solvents, 31, 34
- Amine, dimethylacetyl-, as acetylene solvent, 31
tributadienyl-, 174

- Amines, aliphatic, condensation with acetylene, 136, 157
as byproducts in alkylation of acetylene, 75, 78
aryl-, in curing plastic polymer, 179
condensation of acetylene with, 157
solubility of acetylene in, 30, 32
dialkyl-, reaction with vinyl acetylene, 165
hydroxy alkyl-, addition to acetylenes, 128
- Ammonia, condensation with acetylene, 136, 157
as impurity in acetylene, 11, 33
from acetylene and nitrogen, 136
of crystallization in acetylides, 42
- Ammonia, liquid, as solvent for acetylene, 34
solvent for preparing acetylides, 42, 43, 48
solvent for reaction of acetylides with salts, 49
- Ammonium chloride, in catalyst for acetylene polymerization, 160-162
- Amylacetylene, 75
- Apparatus, for acetylene hydration, 118
for carbide hydrolysis, 12
for vinylacetylene production, 162, 163
- Analysis, of acetylene, 37, 38
- Anesthetic, acetylene as, 1
- Aniline, condensation with acetylene, 136, 157
from condensation of hydrogen cyanide with acetylene, 157
solubility of acetylene in, 32
- Aniline, n-ethyl-, condensation with acetylene, 157
ortho-chloro-, condensation with acetylene, 157
- Anthracene, from acetylene condensation, 139, 148
- Anthracene, dihydro- and homologs, from condensation of acetylene with aromatic hydrocarbons, 154
- Anthraquinones, amino-, reaction with vinylacetylene, 165
- Antimony halides, addition to acetylene, 40, 69
- Antimony pentachloride, in chlorination of acetylene, 103
- Antioxidants, inhibitors of chloroprene polymerization, 175
for divinyl acetylene, 166
- Arc pyrolysis of hydrocarbons, 21-23
- Arsenic carbide, 49
- Arsenic trichloride, addition to acetylenic acids, 67
- Arsenic trihalides, addition to acetylene, 40, 66, 67
- Arsine as impurity in acetylene, 11
- Arsines, halovinyl-, from acetylene, 67
- Auric salts, addition to acetylene, 40, 68
oxidation of acetylene by, 68, 113
- Aurous thiosulfate, acetylides from, 57
- Azabenzanthrones, from vinylacetylene, 165
- Azoimide, reaction with acetylene, 136, 137
- Azoimide, phenyl-, reaction with acetylene, 137
- Barium carbide, 46
- Barium cyanide, catalyst in condensation of acetylene with hydrogen cyanide, 153
- Benzene, condensation with acetylene, 154
from acetylene, 136, 139-144, 148
solubility of acetylene in, 32
- Benzene, ethyl-, condensation with acetylene, 154
- Benzenesulfonyl chloride, chloroacetylides from, 92
- Benzonitrile, from condensation of acetylene with hydrogen cyanide, 157
- Benzylacetylene, 79
- Benzyl bromide, reaction with acetylenic Grignard, 79
- Bond lengths in acetylene, 1
- Borates in catalyst for hydration of acetylene, 118, 119
- Boron trifluoride, in addition to acetylene,
of alcohol, 165
of carboxylic acids, 130
of water, 116
in addition of alcohol to vinylacetylene, 165
- Bromine, addition to acetylene, 105, 106
addition to vinylacetylene, 164
addition to divinylacetylene, 165
- Bromine chloride, addition to acetylene, 107
- Bromoacetylene, 19
- Bromidoethylene from acetylene, 107
- Bromoprene, 177
- Bromovinylarsines, from acetylene, 67
- 1,2-Butadiene, 3-methyl, isomerization of, 80

- 1,3-Butadiene, as impurity in acetylene, 164
from ethylene condensation with acetylene, 153
from vinylacetylene, 165
vinylacetylene as impurity in, 164
- 1,3-Butadiene, 2-chloro-, see chloroprene
- 1,3-Butadienes, 1-acyl-2-Chloro-, 165
- 2-alkoxy-, 165, 173
- 1-2-dihalo-, 165
- 2-halo-, 171
- 2-substituted, 173-174
- 2,3-Butadienes, from vinylacetylene
- 1-acyloxy-, 174
- 1-alkyl-, 174
- 1-alkoxy-, 174
- 1-aryl-, 174
- 1-amino-, 174
- 1-chloro-, 171, reactions of 173-174
- 1-cyano-, 174
- 1-bromo-, 171
- 1-hydroxy-, 174
- 1-iodo-, 171
- Butadienyl esters, from vinylacetylene, 165
- 1,3-Butadiyne, see diacetylene
- 1,3-Butadiyne, dihalo-, 92
- Butane, from vinylacetylene, 165
- Butane dichloro-, byproduct of chloroprene, 172
- hexabromo-, 106
- pentachloro-, 173
- tetrachloro-, 173
- Butanes, trialkoxy-, from vinylacetylene, 165
- 1-Butene-3-one, 164, 166
- 1-Butene-3-yne, see vinylacetylene
- 2-Butene, from vinylacetylene, 165
- 2-Butene, 2-chloro-, chloroprene from, 173
- 1,2-dichloro-, chloroprene from, 173
- 1,3-dichloro-, 171, chloroprene from, 173
- substitution in, 174
- 1,3-dibromo-, 171
- tetra methyl-1,4-diamino-, vinylacetylene from, 164
- Butenes, trichloro-, 173
- Butenyne, see vinylacetylene
- n-Butylacetylene, 75, 76, 78, 79, 80
- 1-Butyne, see butylacetylene
- 1-Butyne, 3-ethoxy-4-bromo-, vinylacetylene from, 164
- 3-methyl-, 80
- 3-ol, 3 methyl-, dehydration of, 164
- 2-Butyne, 75, 77, see dimethylacetylene
- 2-Butyndioic acid, 89
- 2-Butyndioic dinitrile, 71
- Butyric acid, addition to acetylene, 131
- Cacodyl carbide, 49
- Cacodyl chloride, reaction with acetylenic Grignard, 49
- Cadmium acetylide, 51
- Cadmium salts, in hydration of acetylene, 69
- Calcium acetylide, 42
- alkylacetylens from, 78
- Calcium carbide, comparison with other carbides, 6
- from calcium acetylide, 44
- history of synthesis, 8
- hydrolysis of 11, 12
- impurities in, 8, 11
- in synthesis of acetylenic carbinols, 84, 164
- manufacture, 7-10
- energy consumption in, 9
- reactions during, 9
- reaction with methanol, 79
- with organic halides, 79
- reviews on, see Introduction
- structure of, 4
- Calcium oxide, in carbide manufacture, 8
- Calcium phosphate, carbide from, 8
- Calcium sulfate, carbide from, 8
- Calcium sulfide, carbide from, 8
- Canal rays, polymerization of acetylene by, 151
- Carbazole, from condensation of acetylene with aniline, 157
- Carbide furnaces, 8
- Carbides, generation of acetylene from, 11, 12
- Carbides, acetylenic, 4-10, 42, 44
- of alkali metals, 4, 5
- of alkaline earth metals, 4-6, 9
- of calcium, see calcium carbide
- of rare earth metals, 4, 6
- Carbinols, acetylenic, from acetylens, 72, 81-87, 113
- dehydration of, 85, 86, 164
- diacetylenic, 93
- triacetylenic, 93
- vinylethynyl, 165
- Carbinyl halides, acetylenic, 72, 86
- Carbon, as condensation catalyst, 15
- effect on acetylene decomposition, 143
- Carbon black, in neoprene compounding, 180

- Carbon dioxide, from acetylene oxidations, 109-113
diluent in condensation of acetylene, 142
liquid as acetylene solvent, 34
removal from acetylene, 20, 33
- Carbon disulfide, condensation with acetylene, 159
from sulfur and acetylene, 135
solubility of acetylene in, 31
- Carbonic esters, reaction with acetylides, 93
- Carbon monoxide, impurity in acetylene, 13, 33
byproduct of carbide manufacture, 9
from oxidation of acetylene, 109, 110
- Carbon tetrachloride, solubility of acetylene in, 31
- Carbohydrates, addition to acetylenes, 128
- Carboxylic acids, addition to acetylene, 129-132
addition to vinylacetylene, 165
from oxidation of acetylenes, 113
solubility of acetylene in, 30
- Carboxylic acids, acetylenic, 72, 88, 89
hydroxy-, addition to acetylenes, 127
- Catalysts, for acetone production, 124, 125
for addition to acetylene, 40, 41
of alcohols, 126, 128
of aniline, 136
of carboxylic acids, 129-131
of chlorine, 102-105
of hydrogen, 96-98
of hydrogen halides, 99-100
of oxygen, 112, 113
of water, 115-119
for addition of alcohols to vinylacetylene, 165
for cleavage of ethylidene diacetate, 132
for condensation of acetylene with acetyl chloride, 155
with acetoacetic ester, 155
with ammonia, 157
with aniline, 157
with aromatic hydrocarbons, 154
with hydrogen cyanide, 153
with itself, 142-149
with paraffins, 153
with phenols, 155
with sulfur, 159
for cuprene formation, 147-149
for decomposition of acetylene, 15
for oxidation of mercury, 117, 118
of phosphine in acetylene, 12, 13
for preparation of acetylene by incomplete combustion, 28
for polymerization of acetylene, 160-162
of chloroprene, 175-177
for pyrolysis of hydrocarbons, 22
for isomerization of 1-halo-2,3-butadienes, 171
- Cathode rays, polymerization of acetylene by, 151
- Cellosolves, as acetylene solvents, 34
- Ceric sulfate, as condensation catalyst, 145
- Cerium carbide, 4
- Cesium acetylide, 42
- Cesium carbide, 44
- Charcoal, as adsorbent for acetylene, 34
- Chlorine addition to acetylene, 101-105
addition to 1-chloro-2,3-butadiene, 173
addition to chloroprene, 174
addition to 2,3-dichloro-2-butene, 173
addition to neoprene, 179
- Chloroacetic acid, addition to acetylene, 131
- Chloroacetylene, 19
- Chloroalkylacetylenes, 78
- Chloroform, acetylene from, 18
solubility of acetylene in, 31
- Chloriodoethylene, from acetylene, 107
- Chloromethyl ether, reaction with vinylacetylene, 165
- Chloroolefins, 155
- Chloroprene, manufacture of, 161, 171-174
polymerization of, 175-177
reactions of, 173-174
toxicity of, 179
- Chloroprene, amino-, 165
- Chloroprene homologs, 173
- Chlorovinylarsines, 67
- Chromic acid, oxidation of acetylenes by, 112, 113
- Chromous acetylide, 57
- Chromous chloride, reaction with acetylene, 95
- Chromous salts, hydrogenation of acetylene by, 40, 57
hydrogenation of vinylacetylene by, 165
- Chrysene, from acetylene condensation, 139
- Coating compositions, from divinylacetylene, 166

- Cobalt, as catalyst for acetylene condensation, 142-144
for acetylene decomposition, 15
for acetylene hydrogenation, 96, 97
- Coke, for carbide manufacture, 8
- Collidines, from condensation of acetylene with ammonia, 157
- Combustion, of acetylene, 109, 110
incomplete as source of acetylene, 27-28
heat of for vinylacetylene, 164
- Compounding, of neoprene, 180
- Condensation reactions, of acetylene, 138-159
accompanying hydration, 115-119
accompanying hydrogenation, 95-98
- Copolymers, of chloroprene, 176
- Copper, catalyst for cuprene formation, 148
catalyst for condensation of acetylene, 144, 145
catalyst for decomposition of acetylene, 15
catalyst for hydrogenation of acetylene, 96, 97
in catalyst for synthesis of vinylacetylene, 162
- Copper acetylides, 51, 52
- Cresols, condensation with acetylene, 155
- Critical constants, of acetylene, 1
- Crotonaldehyde, as byproduct of acetaldehyde, 116
- Crotic acid, addition to acetylene, 131
- Cuprene, from acetylene, 145, 147-149
- Cuprene like products, of acetylene condensation, 150
- Cupric acetylide, 52
diacetylene from, 89
- Cupric chloride, catalyst for chlorination, 104
- Cupric salts, in preparation of diacetylene, 89, 90
- Cuprous acetylide compounds, 51-52
in detection and estimation of acetylene, 37-38
- Cuprous chloride, addition to acetylenes, 50, 59-61, 161
acetylide from, 37, 38
ammoniacal, as reagent for acetylene, 37, 38
catalyst for addition of hydrogen chloride, 99, 172
catalyst for polymerization of acetylene, 160-162
- Cuprous cyanide, acetylide from, 50
- Cuprous bromide, catalyst for Grignard reaction, 79
- Cuprous iodide, acetylide compound from, 52
- Cuprous salts, addition to acetylene, 40, 58-61
catalysts for addition of hydrogen halides to acetylene, 99
catalysts for isomerization of 1-halo-2-3-butadienes, 171
reaction with sodium acetylide, 49
- Cuprous thiosulfate, acetylide compound from, 52
- Cuprous vinylacetylide, 164
- Cutting flame, oxyacetylene, 109, 110
- Cyanoacetylenes, 71, 73, 91
- Cyanogen halides, reaction with acetylenic Grignards, 73, 91
- Cyclohexane, as solvent for acetylene, 32
- Cyclohexane, chloro-, chloroprene from, 173
- Cyclohexanol, solubility of acetylene in, 31
- Cyclohexaneone, as solvent for acetylene, 34
- Cylinders, for acetylene storage, 33
- Decatetreneynes, 162
- Decomposition, of acetylene, 15, 16
explosive, 2, 16
during thermal condensation, 141
of divinylacetylene, 166
- 1-Decyne, 75
- Dehalogenation, for the preparation of acetylenes, 18
- Dehydrogenation, in acetylene condensation, 139, 140, 148
- Dehydrohalogenation, for the preparation of acetylenes, 18, 19
of 1,3-dichloro-2-butene, 173
- Demethylation, in thermal condensation of acetylene, 140
- Detection, of acetylene, 37
- Deuterium exchange, with acetylene, 45, 46
- Deuterioacetaldehyde, 118
- Deuterioacetylene, 45, 46
hydration of, 118
polymerization of, 157
spectrum of, 1
- Diacetyl, from vinylacetylene, 165
- Diacetylene, from acetylene, 90
as impurity in acetylene, 33
copper compound of, 51
- Diacetylene dicarboxylic acid, 72, 93

- Diacetylene hexabromide, 106
Diacetylenes, alpha, from copper acetylides, 40, 89, 90
 beta and gamma, 86
Diazomethane, addition to acetylene, 135, 136
Dibromoacetaldehyde, from acetylene, 107
Dialkylacetylenes, from acetylides, 75, 77
 from acetylenic Grignards, 79
 isomerization of, 79, 80
Dibromoethylenes, acetylene from, 18, 19
 from acetylene, 105-107
Dibromoethanes, acetylene from, 18
 from acetylene, 100
Dichlorodibromoethane, from acetylene, 107
Dichloroacetaldehyde, from acetylene, 107
Dichloroethanes, acetylene from, 18, 19
 from acetylene, 99-100
Dichloroethylenes, acetylene from, 19
 from acetylene, 101, 103, 104, 105, 107
Dicyanoacetylene, 71
Diels-Alder reactions, of chloroprene, 173
Dieneynes, from acetylenic glycols, 72, 85, 86
Diethylacetylene, 75, 77
Diethyl carbonate, as acetylene solvent, 34
Diethyl formamide, as acetylene solvent, 31, 34
Diethyl oxalate, as acetylene solvent, 34
Dihaloacetaldehydes, from acetylene, 107
Dihaloacetic acids, from acetylene, 107
Dihaloacetylenes, from acetylene, 90-92
Dihaloalkenes, vinylacetylene homologues from, 164
Dihalodiacetylenes, 92
Dihaloethenes, acetylene from, 18, 19
 from acetylene, 99-100
Dihaloketones from acetylenes, 107
Dihalomagnesium acetylides, see Grignards, acetylenic
Dihaloolefins, from acetylenes, 73, 105-107
Diiodoacetylene, from acetylides, 50, 51, 55, 90-91
Diiodoethylenes, acetylene from, 18, 19
 from acetylene, 106
Diluent gases, in pyrolytic preparation of acetylene, 21, 22
Dilution, of acetylene during thermal condensation, 142
Dimerization, of acetylene, 139, 160-164
 of chloroprene, 175, 176
Dimethylacetonylamine, as acetylene solvent, 31
Dimethylacetylene, 75, 77
Dimethylallene, unsymmetrical isomerization of, 80
Dimethylaniline, solubility of acetylene in, 32
Dimethylformamide, as acetylene solvent, 31, 34
Dimethyloxamethane, as acetylene solvent, 31, 32
Dioxoles, from vinylacetylene, 165
Diphenyl, from acetylene condensation, 139
Diphenyl ethane, and homologs, from acetylene condensation with aromatic hydrocarbons, 154, 155
Diphenylmethyl chloride, reaction with acetylenic Grignards, 79
Diphenyl oxide, medium for acetylides reaction, 78
Dipropargyl, from acetylene polymerization, 151
Dipole moment, of symmetrical acetylenes, 1
Dispersing agent, in catalyst for vinylacetylene preparation, 162
Dissociation, of acetylene in flame, 109, 110
 heat of, for vinylacetylene, 164
Distillation, of acetylene, 37
 of gas mixtures containing acetylene, 34
 of chloroprene, 173
 of vinylacetylene, 163
Dithiooxanamide, 136
Divinylacetylene, from acetylene by electric discharge polymerization, 151
 by catalytic polymerization, 160-166
 by thermal polymerization, 139
 physical properties of, 165
 reactions of, 165, 166
Divinyl sulfide, as impurity in acetylene, 11
Dodecapentenyne, 162
Drying, of acetylene, 13
Drying oils, from vinylacetylene, 165
 from divinylacetylene, 165, 166
Duprene, see neoprene

- Electric discharge, polymerization of acetylene by, 151
- Electromagnetic field, polymerization of acetylene by, 151
- Electron diffraction, in acetylene, 1
- Electrons, polymerization of acetylene by, 151
- Emulsion polymerization, of chloroprene, 176-177
- Enolates, alkali, in synthesis of acetylenic carbinols, 82
- Eneynes, 72, 85, 86
- Esters, as acetylene solvents, 31, 32, 34
- Esters, butadienyl, from vinylacetylene, 165
- ethylidene, from acetylene, 129-32
- vinyl, from acetylene, 129-32
- Ethane, acetylene from pyrolysis of, 22
- byproduct of acetylene condensation, 139, 148
- hydrogenation of acetylene to, 95-97
- impurity in acetylene, 34
- separation from acetylene, 34, 37
- Ethane, dihalo-, see dichloroethane, etc.
- Ethane, diphenyl-, see diphenylethane
- Ethanes, halogenated, acetylene from, 18-19
- from acetylene, 101-105
- Ethanedithiol diethyl ether, 135
- Ethanol, solubility of acetylene in, 31, 32
- Ethers, of acetylenic carbinols, 77, 86
- of acetylenic glycols, 86
- Ethers, alpha halo, reaction with acetylides, 81, 86
- dialkyl, as byproduct in synthesis of acetylenes, 75
- ethynyl, 71
- ethyl propenyl, 80
- Ethyl acetate, solubility of acetylene in, 31, 32
- Ethyl acetoacetate, condensation with acetylene, 155
- Ethylacetylene, from sodium acetylide, 75, 76, 78
- from calcium carbide, 79
- from isomerization of methyl allene, 80
- Ethylbenzene, condensation with acetylene, 154
- Ethyl chloride, as acetylene solvent, 34
- Ethylene, acetylene from pyrolysis of, 22
- byproduct of acetylene condensation, 139, 148
- byproduct of acetylide preparation, 43
- condensation with acetylene, 153, 154
- from hydrogenation of acetylene, 95-97
- impurity in acetylene, 34
- separation in acetylene, 34
- Ethylenes, halogenated, acetylene from, 18, 19
- from acetylene, 101-105
- Ethylene bromohydrin ethers, reaction with sodium acetylide, 77
- Ethyl formate, acetylenic aldehydes from, 93
- solubility of acetylene in, 31, 32
- Ethylidene aniline, from acetylene and aniline, 136
- Ethylidene cyanhydrin, as solvent for acetylene, 32
- Ethylidene dihalides, acetylene from, 18
- from acetylene, 99, 100
- Ethylidene diacetate, cleavage of, 131, 132
- from acetylene, 117, 129-132
- Ethylidene diresorcinol, 155
- Ethylidene esters, cleavage of, 131, 132
- from acetylene, 129-132
- Ethyl lactate, as acetylene, solvent, 34
- Ethyl mercaptan, from acetylene, 135
- Ethyl mustard oil, as solvent for acetylene, 32
- Ethynyl ethers, and thio ethers, 71
- Explosions, of acetylene, 2, 16
- of acetylene oxygen mixtures, 110
- of acetylene with ozone, 112
- of acetylene with chlorine, 102-105
- Explosive acetylides, 51
- Explosive products, from divinylacetylene, 163, 164
- Ferric chloride, as catalyst for chlorination of acetylene, 103, 104
- Flame temperature, of acetylene, 109
- of vinylacetylene, 164
- Fluoranthene, from condensation of acetylene, 139
- Fluorene, from condensation of acetylene, 139
- Fluorene, hydroxymethyl-, 155
- Formaldehyde, from combustion of acetylene, 110, 111
- acetylenic carbinols from, 82
- reaction with vinylacetylene and dialkyl amine, 165
- Formic acid, from combustion of acetylene, 110, 111, 112
- Fractional condensation, of gas mixtures, 33, 34
- Free radicals, in acetylene condensation, 140

- Fuels, liquid, from acetylene, 139, 142, 144, 145
divinylacetylene polymer in, 166
- Furan derivatives, from condensation of acetylene, 158
- Generation, of acetylene from carbide, 11, 12
- Generators, acetylene, 12
- Glycerol, in catalyst for vinylacetylene, 162
- Glycerol esters, as acetylene solvents, 34
- Glycine, trimethyl-, as acetylene solvent, 31
- Glycol, diacetate, as acetylene solvent, 34
esters, as acetylene solvents, 34
ethers as acetylene solvents, 34
- Glycols, addition to acetylene, 126, 127
addition to vinylacetylene, 165
in catalyst for vinylacetylene, 162
- Glycols, acetylenic, from acetylides, 72, 81-87
dehydration to eneynes, 85, 86
oxidation of, 113
- Glyoxal, from acetylene, 68, 110-113
- Glyoxalic acid, from acetylene, 113
- Gold acetylide, 57
- Gold salts, addition to acetylene, 40, 68
oxidation of acetylene by, 68
- Grignard reagents, acetylenic, (see also acetylides) preparation of, 46, 47
reaction with acetic anhydride, 93
with aldehydes, 81, 86
with alkyl halides, sulfates and sulfonates, 74, 79
with arsenic trihalides, 49
with cacodyl chloride, 49
with carbon dioxide, 89
with cyanogen halides, 91
with benzyl bromide, 79
with ketones, 81-86, 93
with oxidizing agents, 89
with phenylmethyl chlorides, 79
with phosphorus trihalides, 49
- Grignard reagents, alkyl or aryl, reaction with acetylene, 46, 47
- Grignard reagents, from 1,3 hexadiene-5-yne, 166
from vinylacetylene, 165
- Haloacetylenes, acetylene from, 19
from acetylene or acetylides, 90-92
from polyhalo ethylenes or ethanes, 19
reactions of, 71, 72
- Haloformic esters, reaction with acetylides, 93
- Halogen acids, see hydrogen halides
- Halogenation, see individual halogens
addition of
- Halogen halides, addition to acetylene, 106-107
- Halogens, addition to acetylene, 101-107
substitution in acetylene, 71, 90-92
- Halomagnesium compounds, see Grignards
- Haloprenes, 172
- Halovinylarsines, from acetylene, 67
- Heat of formation, of acetylene, 2
- Heavy water, reaction with acetylene, 45, 46
- 1-Heptyne, 75
- Hexachloroethane, from acetylene, 102, 104
- Hexadecylacetylene, 75
- Hexadiene, 71
- Hexadiene, 1-nitro-, 71
1-sulfonic acid, 71
- 1,3-Hexadiene-5-yne, 161, 162, 166
metal salts of, 166
- 1,5-Hexadiene-3-yne, see divinylacetylene
- 1,3-Hexadiene-5-one, 166
- 1,5-Hexadiene-3-one, 166
- 1,5-Hexadiyne, 151
- Hexadienedioic acid, 72, 93
- n-Hexane, from divinylacetylene, 165
- Hexatriene, chloro-, 166
- Hexene, byproduct of cuprene, 148
- 3-Hexene, from divinylacetylene, 165
- 3-Hexene, 1,2,3,4,5,6-hexabromo-, 165
- 1-Hexyne, 75
- 1-Hexyne, 5-methyl-, 75
- 3-Hexyne, 75, 77
- 3-Hexyne, 2,5-diethoxy-1,6-dibromo-, vinylacetylene from, 164
- Hydrate, of acetylene, 1
of vinylacetylene, 164, 165
- Hydration, of acetylene, 115-119, (see water addition of)
of acetylene, apparatus for, 118
of divinylacetylene, 166
of 1,3-Hexadiene-5-yne, 166
of vinylacetylene, 164, 165
- Hydrazine, in preparation of cuprous acetylide, 38
- Hydrides, of alkaline earth metals, carbides from, 9
- Hydrindene, from condensation of acetylene, 139

- Hydrocarbons, acetylene from incomplete combustion of, 28**
acetylene from submerged flame in liquid, 28
acetylene from submerged arc in liquid, 23
acetylene from pyrolysis of, 20-23
formed during hydrogenation of acetylene, 95-98
as impurities in acetylene, 33, 34
- Hydrocarbons, acetylenic, byproducts of acetylene condensation, 139**
isomerization of, 79-80
oxidation of, 113
allenic, isomerization of, 79-80
aromatic, acetylene condensation with, 154
byproduct of cuprene, 148
from acetylene, 138-146, 156
from olefins and acetylene, 153
chlorinated, byproducts of vinylacetylene, 162
- Hydrogen, addition to acetylene, etc., see hydrogenation of acetylene, byproduct of cuprene, 148**
diluent in thermal condensation of acetylene, 142
impurity in acetylene, 11, 13, 21, 33
loss of during thermal condensation of acetylene, 139, 140, 148
recovery from mixtures with acetylene, 34
replaceability of, in acetylene, 41, 44-46, 51
separation from acetylene, 34, 37
- Hydrogenation, of acetylene, 40, 95-98**
during preparation of acetylides, 43
during condensation of acetylene, 139, 140
of divinylacetylene, 165, 166
of neoprene, 179
of polymers of divinylacetylene, 165
of vinylacetylene, 165
- Hydrogen bonding, of acetylene to solvents, 29, 30**
- Hydrogen bromide, addition to acetylene, 99-100**
addition to vinylacetylene, 171
- Hydrogen chloride, addition to acetylene, 99-100**
addition to alkylvinylacetylenes, 173
addition to divinylacetylene, 166
addition to 1,3-Hexadiene-5-yne, 166
addition to vinylacetylene, 161, 171-172
in catalyst for vinylacetylene, 162
reaction with neoprene, 179
- Hydrogen cyanide, from acetylene, 135, 136**
condensation with acetylene, 153, 156, 157
impurity in acetylene, 33, 34
- Hydrogen fluoride, addition to acetylene, 100**
- Hydrogen halides, addition to acetylenes, 73, see also individual hydrogen halides.**
addition to vinylacetylene, 171, 172
addition to 2-halo-1,3-butadienes, 171
addition to halovinylacetylenes, 165
removal of, see dehydrohalogenation
- Hydrogen iodide, addition to acetylene, 99, 100**
addition to vinylacetylene, 171
- Hydrogen peroxide, oxidation of acetylene, 112**
- Hydrogen polysulfide, addition to divinylacetylene, 166**
- Hydrogen sulfide, addition and condensation with acetylene, 135, 159**
addition to divinylacetylene, 166
as impurity in acetylene, 11
reaction with acetylides, 50, 51
removal from acetylene, 34
- Hydrohalogenation, see hydrogen halides addition**
- Hydrolysis, of carbides, 11, 12**
- Hydroquinoline bases, from acetylene and aniline, 159**
- Hydroquinone, condensation with acetylene, 155**
- Hydroxides, alkali, in synthesis of acetylenic carbinols, 82, 84**
in synthesis of acetates, 123-124
in removal of hydrogen halides, 18, 19
- Hydroxylamine, in preparation of cuprous acetylide, 37, 38**
- Hypobromous acid, addition to acetylene, 107**
- Hypochlorous acid, addition to acetylene, 107**
- Hypohalites, reaction with acetylene and acetylides, 91**
reaction with vinylacetylene, 165
- Ilosvay's solution, 37**
- Imides. metal, reaction with acetylene, 47**
- Impregnating agents, from divinylacetylene, 166**
from chloroprene, 177

- Impurities, in acetylene from carbide, 11-13
in acetylene from incomplete combustion, 33, 34
in calcium carbide, 11
- Interpolymers, of chloroprene, 176
- Indole, from condensation of acetylene with ammonia or aniline, 157
- Iodine, addition to acetylene, 107
adsorption by neoprene, 179
reaction with acetylides and acetylenes, 50, 90-92
- Iodine chloride, addition to acetylene, 107
- Iodine pentoxide, oxidation of acetylene by, 112
- Iodoacetylene, 72, 91
- Iodoform, acetylene from, 18
from mercury addition compounds of acetylene, 63
- Iron as catalyst for acetylene condensation, 142-145, 149
catalyst for decomposition of acetylene, 15
catalyst for hydrogenation of acetylene, 96, 97
catalyst for chlorination of acetylene, 103, 104
- Isomylacetylene, 75
- Isomyl acetate, solubility of acetylene in, 31, 32
- Isomyl formate, solubility of acetylene in, 31, 32
- Isoimerization, of acetylenes and allenes, 79, 80
of 1-halo-2,3-butadienes, 17
- Isonitrile, from acetylene and hydrogen cyanide, 153
- Isopropylacetylene, 80
- Isoxazole derivatives, from acetylene and nitric acid, 158
- Ketals, from acetylenes, 73, 126, 127
- Ketones, acetylenic, 72, 93
diacetylenic, 93
dihalo- from acetylenes, 107
from acetylenes, 73, 115
from alkylidene esters, 132
solvents for acetylene, 30-34
reaction with acetylenic Grignards, 93
- Ketone, vinyl methyl-, 164, 165
- Kieselguhr, as adsorbent for acetylene, 34
- Lactic acid, addition to acetylene, 131
- Lactones, as acetylene solvents, 34
- Latex, from emulsion polymerization of chloroprene, 177, 179
- Lead imide, reaction with acetylene, 47
- Lead thiocyanate, reaction with acetylide, 49
- Lead tetraethyl, and triethyl chloride, failure to react with acetylene, 47, 50
- Lewisite, 66
- Light, polymerization of acetylene by, 150, 164
polymerization of chloroprene by, 176
in chlorination of acetylene, 102, 103, 105
- Lime, impurities in, effect on carbide manufacture, 8
- Liquid acetylene, physical properties, 1
explosiveness of, 16, 34
- Litharge, in neoprene compounding, 180
- Lithium acetylide, 42, 44
- Lithium carbide, 4, 5, 44
- Lubricating oils, divinylacetylene polymer in, 166
- Magnesia, in neoprene compounding, 180
- Magnesium, in cuprene catalyst, 149
- Magnesium acetylide, 42
- Magnesium carbides, 5, 6
- Magnesium oxide, effect in carbide manufacture, 8
- Maleic acid, reaction with chloroprene, 173
- Metallo derivatives, of acetylene, 40-70
- Metal alkyls, acetylides from, 45
- Metal amides, acetylides from, 45
- Metal hydroxides, acetylide equilibrium with, 44, 46
- Metals, acetylides from, 41-44
acetylene decomposition effect on, 15
as condensation catalysts for acetylene, 142, 145
- Melting point, of acetylene, 1
- Mercaptans, stabilizers of plastic neoprene, 179
- Mercuric acetylide, 47, 50, 55
- Mercuric cyanide, acetylide from, 50
- Mercuric halides, catalysts for hydrogen halide addition to acetylene, 99-100
- Mercuric imide, acetylide from, 47
- Mercuric iodide, in determination of acetylene, 38
- Mercuric salts, acetylides from, 55
addition to acetylene, 40, 61-65

- catalysts for addition of alcohols to acetylene, 126-127
- catalysts for addition of carboxylic acids to acetylene, 129-130
- catalysts for addition of water to acetylene, 115-118
- catalysts for addition of water to vinylacetylene, 165
- catalysts for condensation of acetylene with acetoacetic ester, 155
- catalysts for condensation of acetylene with aniline, 157
- catalysts for condensation of acetylene with phenols, 155
- catalysts for condensation of acetylene in sulfuric acid, 154
- catalysts for nitric acid oxidation of acetylene, 112
- catalysts in activation of, 115, 117
- recovery from spent catalysts, 117-118
- reaction with sodium acetylides, 49
- Mercuric vinylacetylides, 164
- Mercurous acetylides, 56, 57
- Mercurous salts, acetylides from, 56, 57
- addition to acetylene, 65
- catalysts for condensation of olefins with acetylene, 153
- Mercury diethyl, failure to react with acetylene, 47
- Mercury diphenyl, failure to react with acetylene, 47
- Mesitylene, from acetylene condensation, 139
- condensation with acetylene, 154
- Methane, acetylene from incomplete combustion of, 28
- from pyrolysis of, 20-23
- byproduct of acetylene condensation, 139, 141
- impurity in acetylene, 34
- separation from acetylene, 34, 37
- Methylacetylene from sodium acetylides, 75, 76, 78
- addition of alcohol to, 80
- from calcium carbide, 5, 6
- impurity in acetylene, 33
- Methyl acetate solubility of acetylene in, 31, 32
- Methylal, solubility of acetylene in, 31, 32
- Methylallene, isomerization of, 80
- Methylation, in thermal condensation of acetylene, 140
- Methyl-*betachlorovinyl* ketone, 155
- Methyl chloride, as acetylene solvent, 34
- Methyldichloroarsine addition to acetylene, 67
- Methyl formate, solubility of acetylene in, 31
- Methyl radicals, induced polymerization by, 145
- Methyl sulfate, reaction with acetylides, 79
- Microchemical estimation, of acetylene, 38
- Molding compositions, from divinylacetylene, 166
- Molecular structure, of acetylene, 1, 2
- Molybdenum halides, reduction by acetylene, 68
- Naphthalene, from condensation of acetylene, 139, 148
- Naphthalene, 1,4-dimethyl- from condensation of acetylene, 139
- methyl-, from condensation of acetylene, 139
- tetrahydro-, from condensation of acetylene, 139
- condensation with acetylene, 154
- Naphthols, condensation with acetylene, 155
- Naphthoquinone, reaction with chloroprene, 173
- Neodymium carbide, 4
- Neoprene, preparation, 160, 175-177
- properties and uses, 179-180
- reactions, 179, 180
- Nickel, catalyst for condensation of acetylene, 142-144, 149
- catalyst for decomposition of acetylene, 15
- catalyst for hydrogenation of acetylene, 96-98
- Nickel carbonyl, catalyst for condensation of acetylene, 145
- Nickel thiocyanate, reaction with acetylides, 49
- Nitration, of acetylenes, 71
- Nitric acid, oxidation of acetylenes, 112, 113
- fuming, reactions with acetylene, 158
- Nitriles from acetylene and ammonia, 136, 157
- Nitriles, acetylenic, 71, 73
- Nitrobenzene, oxidation of acetylenic Grignards, 89
- solubility of acetylene in, 32
- solvent for impurities in acetylene, 33

- Nitroform, from acetylene, 158
 Nitrogen, diluent in cuprene manufacture, 149
 separation from acetylene, 37
 reaction with acetylene, 135, 136
 Nitrogen compounds, addition to acetylene, 135-137
- 1-Octadecyne, 75
 Octatetraene, chloro-, polymer of, 166
 1,3,7-Octatriene-5-yne, 162, 166
 1,3,5-Octatriene-7-yne, 162
 1,5,7-Octatriene-3-yne, 161
 Octene, byproduct of cuprene, 148
 n-Octylacetylene, 75
 Odor, of acetylene, 1
 of divinylacetylene, 165
 of vinylacetylene, 164
 Oils, drying, from divinylacetylene, 160, 166
 from vinylacetylene, 165
 Olefins, byproducts in synthesis of alkylacetylenes, 74
 byproducts of acetylene condensation, 139, 148
 from condensation of paraffins with acetylene, 153
 from hydrogenation of acetylenes, 73, 98
 pyrolysis of in preparation of acetylene, 22
 Olefins, dihalo-, from acetylene, 73, 101-107
 Olefin oxides, reaction with acetylenic Grignard, 81, 86, 87
 Organo mercuric acetylides, 56
 Organo mercuric intermediates, in hydration of acetylene, 115, 117
 Organo metallic compounds, reaction with acetylene, 46, 47
 Orthoformic ester, acetylenic acetals from, 93
 Osmium salts, oxidation of acetylene by, 40, 68
 Osmium tetroxide, oxidation of acetylene by, 113
 Oxalic acid, from acetylene, 112
 Oxidation, electrolytic of acetylene, 112, 113
 Oxidation, of acetylene, 109-113
 of mercury in catalyst for acetaldehyde, 117, 118
 Oxygen, catalyst for polymerization of chloroprene, 175
 impurity in acetylene, 13
 reaction with acetylene, 109-112
 reaction with divinylacetylene, 165, 166
 in reaction of nitrogen with acetylene, 136
 removal from acetylene, 37
 Oxygen, atomic, reaction with acetylene, 112
 Oxyrenes, 173
 Ozone, reaction with acetylenes, 112, 113
- Palladium, catalyst for decomposition of acetylene, 15, 145
 catalyst for hydrogenation of acetylene, 96, 97
 Palladous chloride, addition to acetylene, 40, 68
 Paraffin oil, solubility of acetylene in, 31
 Paraffins, byproducts of acetylene condensation, 139, 148
 acetylene from, 20, 22
 2,4-Pentadiene, 3-chloro-1-methoxy-, 165
 1-Pentene-4-yne, 77, 78
 1-Pentyne, 75
 Peracetic acid, oxidation of acetylenes, by, 113
 Perchloric acid, in catalyst for hydration of acetylene, 116
 Permanganate, oxidation of acetylenes by, 112, 113
 Peroxides, catalysts for polymerization of chloroprene, 175, 176
 Peroxides of acetylenes, 111
 of divinylacetylene, 164, 165, 166
 Phenanthrene, from acetylene condensation, 139
 Phenols, condensation with acetylene, 154, 155
 solubility of acetylene in, 30
 reaction with acetylenes, 127, 128
 reaction with acetylides, 45
 Phenylacetylene, reaction with iodine, 92
 sodium compound, reaction with ketones, 82, 84
 Phenyl magnesium bromide, acetylenic Grignard from, 47
 Phosphine, impurity in acetylene, 11, 12, 13
 removal from acetylene, 37
 Phosphoric acid, in catalyst for hydration of acetylene, 116
 Phosphorus, as byproduct of calcium carbide, 8
 Phosphorus carbide, 49
 Phosphorus halides, addition to acetylene, 40, 69
 Phloroglucinol, condensation with acetylene, 155

- Photochlorination, of acetylene, 102, 103, 105
- Photobromination, of acetylene, 106
- Photopolymerization, of acetylene, 150, 164
- of chloroprene, 176
- Picolines, from condensation of acetylene with ammonia, 157
- Platinum, catalyst for condensation of acetylene, 142, 143, 144
- catalyst for decomposition of acetylene, 15
 - catalyst for hydrogenation of acetylene, 96
- Polyglycol esters and ethers, as acetylene solvents, 34
- Polymerization, of acetylene, by cuprous salts, 160-166
- thermal, 138-146, 147-149
 - by radiations, 150-151
 - mechanism of, 139, 140
 - of chloroprene, 175, 176
 - of divinylacetylene, 166
 - of vinylacetylene, 165
- Polymers, of acetylene, 151, 164-166
- of chloroprene, 175, 177, 179
 - of divinylacetylene, 165, 166
 - of vinylacetylene, 165
- Potassium acetylide, 42
- reaction with lead and nickel thiocyanates, 49
- Potassium alkylacetylides, reaction with bromine, 92
- Potassium carbide, 4, 5, 44
- Potassium cyanide solutions, reaction with acetylides, 50, 51
- Potassium ferricyanide, oxidation of cuprous acetylides, 89
- Potash, alcoholic, for dehydrohalogenations, 18
- isomerization of alkylacetylenes and allenes by, 80
- Praseodymium carbide, 4
- Pressure, effect on decomposition and explosions of acetylene, 16
- Propiolic acid, 72, 89
- iodo-, 72
 - iodoacetylene from, 91
- Propionaldehyde, solubility of acetylene in, 31
- Propionic acid, addition to acetylene, 131
- n-Propylacetylene, 75
- Propylene, condensation with acetylene, 153
- from methane and acetylene, 153
- 1-Propyne, 3 phenyl-, 79
- Pseudocumene, from condensation of acetylene, 139
- Purification, of acetylene, from carbide, 12, 13
- of acetylene from pyrolysis by selective solvents, 33-34
 - of acetylene in laboratory, 36, 37
- Purifying materials, for acetylene from carbide, 12, 13
- Pyrazol, from acetylene and diazomethane, 136
- Pyridine, in catalyst for acetylene polymerization, 162
- Pyridine bases, from acetylene condensations, 136, 157
- Pyrene, from condensation of acetylene, 139
- Pyrogallol, condensation with acetylene, 155
- Pyrolysis, of organic compounds, production of acetylene by, 20-23.
- (see also combustion.)
 - metals in apparatus for, 16
- Pyrrole, from condensation of hydrogen cyanide and acetylene, 156, 157
- Qualitative tests, for acetylene, 37, 38
- Quantitative determination, of acetylene, 38
- Quinoline bases, from condensation reactions of acetylene, 157
- Quinaldine, from acetylene and aniline, 157
- Radon, polymerization of acetylene by, 151
- polymerization of vinylacetylene by, 165
- Raman spectrum, of acetylene, 1
- Raney nickel, catalyst for hydrogenation of acetylene, 97
- Rearrangement, molecular, see isomerization
- Reducing agents, in preparation of cuprous acetylide, 37, 38
- Reducing flame, of acetylene, 109
- Resins, from vinylacetate, 131
- Resorcinol, condensation with acetylene, 155
- Resorcinol dimethyl ether, condensation with acetylene, 155
- Rosin, in neoprene compounding, 180
- Rubber, xynthetic, see neoprene, oxyne
- Rubidium acetylide, 42
- Rubidium carbide, from acetylide, 44

- Selective solvents, for acetylene, 30, 33, 34
- Selenium, condensation with acetylene, 159
- Selenium dioxide, oxidation of acetylenes by, 113
- Selenophene, from acetylene, 159
- Separation, of acetylene from gas mixtures, 29, 33-34
- Shipping, of acetylene, legal restrictions on, 2
- Silent electric discharge, polymerization of acetylene, 151, 164
- Silicomethane, as impurity in acetylene, 11
- Silica gel, as adsorbent for acetylene, 34 for polymerizing impurities in acetylene, 34
- Silver acetylides, preparation of, 50, 52-55
as detonating agents, 55
- Silver carbide, 51, 53
- Silver cyanide, acetylides from, 50
- Silver imide, reaction with acetylene, 47
- Silver nitrate, reagent for determination of acetylene, 38
- Silver salt of acetylene dicarboxylic acid, 53
- Silver salts, addition to acetylene, 40, 69
reaction with sodium acetylides, 49
- Silver vinylacetylides, 164
- Sodamide, acetylides from, 43, 45, 48
isomerization of acetylenes and allenes by, 79, 80
- Sodium, isomerization of acetylenes and allenes by, 79
- Sodium acetylides, conductivity in liquid ammonia, 4
preparation of, 42, 43, 45, 47, 48
reaction with aldehydes and ketones, 81-84
with alkyl sulfates and sulfonates, 74, 78
with allyl halides, 77, 78
with carbon dioxide, 89
with halogens, 91, 92
with olefin oxides, 86
with organic halides, 74, 77
with salts, 49
- Sodium acetate, from acetylene, 124
- Sodium alkylacetylides, preparation, 48, 77, 79
reaction with acetylenic carbonyl bromides, 78
reaction with alkyl halides, 77
reaction with methyl sulfate, 79
reaction with iodine, 92
- Sodium vinylacetylides, 165
- Sodium carbide, 4, 5, 44
- Sodium chloride, in cuprous chloride catalyst for polymerization of acetylene, 160
- Sodium chlorate, oxidation of acetylene by, 113
- Sodium methyl, reaction with acetylene, 45
- Sodium propionate, oxidation of cuprous compound, 93
- Softening agents, for neoprene, 180
- Solid acetylene, 1, 16
- Solubility, of acetylene, 29-32, 45
- Solvents, for acetylene, 29-43
for separation and purification of acetylene, 33-34
- Spectrum, of acetylene, 1
of vinylacetylene, 164
- Stabilizers, for plastic polymer, 179
- Stannic chloride, catalyst for condensation of acetylenes with acetyl chloride, 155
- Steam, as diluent in thermal condensation of acetylene, 142
- Storage, of acetylene in solvents, 30, 33
legal restrictions on, 2
- Strontium carbide, 4, 6
- Styrenene, from acetylene condensation, 139, 148
from condensation of benzene with acetylene, 154, 155
from vinylacetylene, 165
- Substitution reactions, of acetylene, 71-94
- Succinic dinitrile, from condensation of acetylene with hydrogen cyanide, 153
- Succinic acid, from oxidation of neoprene, 179
- Sulfonation, of acetylenes, 71
- Sulfonic acids, in catalyst for hydration of acetylene, 116
in catalyst for addition of carboxylic acids to acetylene, 130, 131
- Sulfur, condensation with acetylene, 158, 159
- Sulfur dioxide, as reducing agent in preparation of cuprous acetylides, 52
liquid, as acetylene solvent, 34
removal from acetylene, 37
- Sulfur monochloride, reaction with divinylacetylene, 166

- Sulfuric acid, condensation of acetylene by, 146
reagent for purifying acetylene, 34, 37
Sulfuryl chloride, reaction with divinyl acetylene, 166
Synthesis from acetylene, reviews, Introduction
- Tensile properties, of neoprene, 180
Terpene alcohols, addition to acetylene, 128
Test papers, for detection of acetylene, 37, 52
Tetrabromoethane, from acetylene, 105, 106
acetylene from, 18, 19
Tetrabromoethylene, acetylene from, 19
Tetrachloroethane, from acetylene, 101-105
Tetrahydronaphthalene, condensation with acetylene, 154
from acetylene condensation, 139
Tetraiodoethylene, from calcium carbide, 91
Tetramers, of acetylene, 161, 162, 166
N, N, N', N' Tetramethylaminoacetamide, solubility of acetylene in, 31
Tetramethylurea, as acetylene solvent, 31, 34
Thioacetaldehyde, from acetylene, 135
Thioethers, from divinylacetylene, 166
from vinylacetylene, 165
Thioethers, ethynyl, 71
Thionaphthene, from condensation of acetylene with sulfur, 159
Thioxene, from condensation of acetylene with sulfur, 159
Thiophene, from condensation of acetylene with sulfur, 159
Thiophenols, addition to divinylacetylene, 166
addition to vinylacetylene, 165
Tin, effect in condensation of acetylene, 145
Tin imide, reaction with acetylene, 47
Toluene, from condensation of acetylene, 139
condensation of acetylene with, 154
Toluidine, ortho-, condensation with acetylene, 157
Trialkynyl carbinols, 72
1,2,3-Triazole, from acetylene, 136, 137
1,2,3 Triazole, 1-phenyl-, from acetylene, 137
Tribromoethane, acetylene from, 19
Tribromoethylene, acetylene from, 19
Trichloroethane, from acetylene, 100
Trichloroethylene, from acetylene, 104
Trichlorovinylarsine, from acetylene, 67
Trimers, of acetylene, 151, 155-156
of chloroprene, 175, 176
Trimethyl carbonate, as acetylene solvent, 31
Triple bond, locating position of, 113
Triphenylmethyl chloride, reaction with acetylenic Grignards, 79
Trithioacetaldehyde, from acetylene, 135
Tungsten halides, reduction by acetylene
- Uranium acetate, oxidation of acetylene by, 113
Urea, tetramethyl-, as acetylene solvent, 31, 34
- Vapor pressure, of acetylene, 1
of vinylacetylene, 164
Vinyl acetate, from acetylene, 117, 129-131
polymers of, 131
Vinylacetylene, acetylides from, 164-165
addition reactions of, 92, 165, 171-173
from desaturation reactions, 164
from electric discharge in acetylene, 151, 164
from thermal polymerization of acetylene, 139, 164
from catalytic polymerization of acetylene, 160-164
from photopolymerization of acetylene, 164
impurity in butadiene, 164
physical properties of, 164
polymerization of, 165
substitution reactions of, 165
Vinylacetylene, dialkylaminomethyl-, 165
Vinyl bromide, acetylene from, 18
from acetylene, 99-100
Vinyl chloride, acetylene from, 18, 19
from acetylene, 99-100
Vinyl esters, from acetylene, 129-131
Vinyl ethers, from acetylene, 126-128
Vinyl ethyl sulfide, from acetylene, 135
Vinyl formate, 131
Vinyl halides, acetylene from, 18-19
from acetylene, 99-100
Vinyl iodide, from acetylene, 99-100
Volumetric determination, of acetylene, 38

- Water, addition to acetylene, 115-119
addition to divinylacetylene, 166
addition to vinylacetylene, 165
solubility of acetylene in, 30, 32, 34
- Welding, with acetylene, 109, 110
with vinylacetylene, 164
- Xanthene, dihydroxymethyl-, from
acetylene condensation with re-
sorcinol, 155
- Xylenes, condensation with acetylene,
154
from acetylene, 139
- Xylidene, meta, condensation with
acetylene, 157
- Zinc acetylide, 47, 57
- Zinc carbide, 47
- Zinc chloride, catalyst for polymeriza-
tion of acetylene, 145
- Zinc ethyl iodide, acetylide from, 47
- Zinc diethyl, carbide from, 47
- Zinc oxide, in neoprene compounding,
180
- Zinc salts, in catalytic addition of water
to acetylene, 69

American Chemical Society
MONOGRAPH SERIES

PUBLISHED

No.

1. The Chemistry of Enzyme Action (Revised Edition). By K. George Falk.
2. The Chemical Effects of Alpha Particles and Electrons (Revised Edition). By Samuel C. Lind.
3. Organic Compounds of Mercury. By Frank C. Whitmore. (Out of Print)
4. Industrial Hydrogen. By Hugh S. Taylor. (Out of Print)
5. Zirconium and Its Compounds. By Francis P. Venable.
6. The Vitamins (Revised Edition). By H. C. Sherman and S. L. Smith.
7. The Properties of Electrically Conducting Systems. By Charles A. Kraus.
8. The Origin of Spectra. By Paul D. Foote and F. L. Mohler. (Out of Print)
9. Carotinoids and Related Pigments. By Leroy S. Palmer.
10. The Analysis of Rubber. By John B. Tuttle. (Out of Print)
11. Glue and Gelatin. By Jerome Alexander. (Out of Print)
12. The Chemistry of Leather Manufacture (Revised Edition). By John A. Wilson. Vol. I and Vol. II.
13. Wood Distillation. By L. F. Hawley. (Out of Print)
14. Valence and the Structure of Atoms and Molecules. By Gilbert N. Lewis. (Out of Print)
15. Organic Arsenical Compounds. By George W. Raiziss and Jos. L. Gavron.
16. Colloid Chemistry (Revised Edition). By The Svedberg.
17. Solubility (Revised Edition). By Joel H. Hildebrand.
18. Coal Carbonization. By Horace C. Porter. (Revision in preparation)
19. The Structure of Crystals (Second Edition) and Supplement to Second Edition. By Ralph W. G. Wyckoff.
20. The Recovery of Gasoline from Natural Gas. By George A. Burrell. (Out of Print)
21. The Chemical Aspects of Immunity (Revised Edition). By H. Gideon Wells.
22. Molybdenum, Cerium and Related Alloy Steels. By H. W. Gillett and E. L. Mack.
23. The Animal as a Converter of Matter and Energy. By H. P. Armsby and C. Robert Moulton.
24. Organic Derivatives of Antimony. By Walter G. Christiansen.
25. Shale Oil. By Ralph H. McKee.
26. The Chemistry of Wheat Flour. By C. H. Bailey.
27. Surface Equilibria of Biological and Organic Colloids. By P. Lecomte du Noüy.
28. The Chemistry of Wood. By L. F. Hawley and Louis E. Wise. (Out of Print)
29. Photosynthesis. By H. A. Spoehr. (Out of Print)
30. Casein and Its Industrial Applications (Revised Edition). By Edwin Sutermeister and F. L. Browne.
31. Equilibria in Saturated Salt Solutions. By Walter C. Blasdale.
32. Statistical Mechanics as Applied to Physics and Chemistry. By Richard C. Tolman. (Out of Print)
33. Titanium. By William M. Thornton, Jr.
34. Phosphoric Acid, Phosphates and Phosphatic Fertilizers. By W. H. Waggaman.

No.

35. Noxious Gases. By Yandell Henderson and H. W. Haggard. (Revised edition)
36. Hydrochloric Acid and Sodium Sulfate. By N. A. Laury.
37. The Properties of Silica. By Robert B. Sosman.
38. The Chemistry of Water and Sewage Treatment. By Arthur M. Buswell. (Revision in preparation)
39. The Mechanism of Homogeneous Organic Reactions. By Francis O. Rice.
40. Protective Metallic Coatings. By Henry S. Rawdon. Replaced by Protective Coatings for Metals.
41. Fundamentals of Dairy Science (Revised Edition). By Associates of Rogers.
42. The Modern Calorimeter. By Walter P. White.
43. Photochemical Processes. By George Kistiakowsky.
44. Glycerol and the Glycols. By James W. Lawrie.
45. Molecular Rearrangements. By C. W. Porter.
46. Soluble Silicates in Industry. By James G. Vail.
47. Thyroxine. By E. C. Kendall.
48. The Biochemistry of the Amino Acids. By H. H. Mitchell and T. S. Hamilton. (Revision in preparation)
49. The Industrial Development of Searles Lake Brines. By John E. Tceple.
50. The Pyrolysis of Carbon Compounds. By Charles D. Hurd.
51. Tin. By Charles L. Mantell.
52. Diatomaceous Earth. By Robert Calvert.
53. Bearing Metals and Bearings. By William M. Corse.
54. Development of Physiological Chemistry in the United States. By Russell H. Chittenden.
55. Dielectric Constants and Molecular Structure. By Charles P. Smyth. (Out of Print)
56. Nucleic Acids. By P. A. Levene and L. W. Bass.
57. The Kinetics of Homogeneous Gas Reactions. By Louis S. Kassel.
58. Vegetable Fats and Oils (Second Edition). By George S. Jamieson.
59. Fixed Nitrogen. By Harry A. Curtis.
60. The Free Energies of Some Organic Compounds (Second Edition in preparation). By G. S. Parks and H. M. Huffman.
61. The Catalytic Oxidation of Organic Compounds in the Vapor Phase. By L. F. Marek and Dorothy A. Hahn.
62. Physiological Effects of Radiant Energy. By H. Laurens.
63. Chemical Refining of Petroleum. By Kalichevsky and B. A. Stagner. (Second Edition.)
64. Therapeutic Agents of the Quinoline Group. By W. F. Von Oettingen.
65. Manufacture of Soda. By T. P. Hou. (Revised Edition)
66. Electrokinetic Phenomena and Their Application to Biology and Medicine. By H. A. Abramson.
67. Arsenical and Argentiferous Copper. By J. L. Gregg.
68. Nitrogen System of Compounds. By E. C. Franklin.
69. Sulfuric Acid Manufacture (Second Edition in preparation). By Andrew M. Fairlie.
70. The Chemistry of Natural Products Related to Phenanthrene (Second Edition with Appendix). By L. F. Fieser.
71. The Corrosion Resistance of Metals and Alloys. By Robert J. McKay and Robert Worthington.
72. Carbon Dioxide (Second Edition in preparation). By Elton L. Quinn and Charles L. Jones.
73. The Reactions of Pure Hydrocarbons. By Gustav Egloff.
74. Chemistry and Technology of Rubber. By C. C. Davis and J. T. Blake.
75. Polymerization. By R. E. Burk, A. J. Weith, H. E. Thompson and I. Williams.

76. Modern Methods of Refining Lubricating Oils. By V. A. Kalichevsky.
77. Properties of Glass. By George W. Morey.
78. Physical Constants of Hydrocarbons. By Gustav Egloff. Vols. I and II.
79. Protective Coatings for Metals. By R. M. Burns and A. E. Schuh.
80. Raman Effect and its Chemical Applications. By James H. Hibben.
81. Properties of Water. By Dr. N. E. Dorsey.
82. Mineral Metabolism. By A. T. Shohl.
83. Phenomena at the Temperature of Liquid Helium. By E. F. Burton, H. Grayson Smith and J. O. Wilhelm.
84. The Ring Index. By A. M. Patterson and L. T. Capell.
85. Photodynamic Action and Diseases Caused by Light. By Harold Francis Blum.
86. Photochemistry of Gases. By W. A. Noyes, Jr., and P. A. Leighton.
87. Anhydrous Aluminum Chloride in Organic Chemistry. By Charles A. Thomas.
88. Isomerization of Pure Hydrocarbons. By G. Egloff, G. Hulla, and V. I. Komarewsky.
89. Chemistry of Natural Coloring Matters. By F. Mayer.
90. Proteins, Amino Acids and Peptides. By E. J. Cohn and I. T. Edsall.
91. Potash in North America. By J. W. Turrentine.
92. Chemistry of Aliphatic Orthoesters. By H. W. Post.
93. Biochemistry of Fatty Acids. By W. R. Bloor.
94. Tungsten. By K. C. Li and C. Y. Wang.
95. Physical Chemistry of Electrolytic Solutions. By H. E. Harned and B. B. Owen.
96. Constituents of Wheat Flour. By Clyde H. Bailey.
97. Wood Chemistry. By Louis E. Wise.

IN PREPARATION

- Piezo-Chemistry. By L. H. Adams.
- The Chemistry of Coordinate Compounds. By J. C. Bailar.
- Water Softening. By A. S. Behrman.
- Writing Inks. By Robert I. Casey.
- Proteins in Metabolism and Nutrition. By George E. Cowgill.
- The Refining of Motor Fuels. By G. Egloff.
- The Alkaline Earth and Heavy Metal Soaps. By S. B. Elliott.
- Organometallic Compounds. By Henry Gilman.
- Animal and Vegetable Waxes. By L. W. Greene.
- Surface Energy and Colloidal Systems. By W. D. Harkins and T. F. Young.
- Raw Materials of Lacquer Manufacture. By J. S. Long.
- The Chemistry of Leather Manufacture (Supplement). By G. D. McLaughlin and E. R. Theis.
- Peroxides. By Nicholas A. Milas.
- Acetylene. By the late J. A. Nieuwland and R. R. Vogt.
- Sulfonamides. By E. H. Northey.
- Furfural and other Furan Compounds. By F. N. Peters, Jr., and H. J. Brownlee.
- Aliphatic Sulfur Compounds. By E. Emmet Reid.
- Hydrocarbons in Petroleum. By F. D. Rossini and B. J. Mair.
- Aluminum Thermic Reduction. By B. D. Saklatwalla.
- Electrical Precipitation of Suspended Particles from Gases. By W. A. Schmidt and Ewald Anderson.
- Dipole Moments. By C. P. Smyth.
- Precise Electric Thermometry. By W. P. White and E. F. Mueller.
- Colloidal Carbon. By W. B. Wiegand.
- Ketenes. By Jonathan W. Williams.
- Measurement of Particle Size and Its Application. By L. T. Work.

