

Birla Central Library

PILANI (Rajasthan) R

Class No. 581.4.

Book No. S.166.F... VI.

Accession No. 31951

FLORAL MORPHOLOGY
A NEW OUTLOOK

FLORAL MORPHOLOGY

A NEW OUTLOOK

with special reference
to the
Interpretation of the Gynæceum

by E. R. SAUNDERS, F.L.S.

*Sometime Fellow and Lecturer in Botany,
Newnham College, Cambridge*

VOLUME ONE

Cambridge
W. HEFFER & SONS LTD

FIRST PUBLISHED IN 1937

PRINTED AND BOUND IN GREAT BRITAIN AT THE WORKS OF
W. HEFFER AND SONS LTD.,
CAMBRIDGE, ENGLAND

PREFACE

A short statement as to how the present volume came to be written will perhaps best serve to explain the form which it has taken.

Some fifteen years ago a very exceptional summer was followed by the appearance in a culture of the Garden Stock (grown for the purpose of genetical analysis) of many flowers with an exceptional form of gynæceum. An examination of these exceptional flowers made it clear that the construction of their gynæcea could not be reconciled with the traditional view of the morphology of the ovary of the Cruciferæ. This chance circumstance led me to re-investigate the whole subject of carpel morphology, and, as the necessity became apparent, the wider field of floral morphology in general. The new interpretations to which this study gave rise, and the evidence upon which they rest, have been fully set forth in the series of papers cited on pp. 23–25 which have appeared in the intervening period. These papers are, as was inevitable, both detailed and lengthy. It was recently suggested to me that a summarised statement of the substance of these papers, designed especially to serve as a guide to the study of types in the laboratory, was greatly needed. This suggestion has borne fruit in the present volume.

It appeared to me that the end in view would be most satisfactorily attained if I confined myself to such data as were directly or indirectly relevant to the new viewpoint, leaving the reader to acquire other information from existing works on systematic botany. This mode of treatment would allow fuller consideration of the types selected for description as best illustrating the principles underlying floral arrangement than would otherwise be possible without greatly increasing the size of the whole

book. This procedure would have the further advantage that publication need not necessarily be postponed until the book was complete. Thus, it would be possible if the contents were divided for the earlier part to be issued without delay as a first volume. This would be followed as soon as practicable by a second volume.

The present volume contains an exposition of the general principles which are regarded as underlying floral arrangement. Thirty-nine Families are then considered from this new standpoint. In each Family the general characters of the flower are described, and one or more 'Illustrative Types' are examined in detail. It is proposed to deal similarly with other Families in the second volume.

E. R. SAUNDERS.

Cambridge, April, 1937.

CONTENTS

	PAGE
PREFACE - - - - -	V

PART I

INTRODUCTION AND GENERAL CONSIDERATIONS -	I
---	---

PART 2

(A) DICOTYLEDONS - - - - -	29
Family I. Nymphaeaceæ - - - - -	29
" 2. Magnoliaceæ - - - - -	32
" 3. Myristicaceæ - - - - -	33
" 4. Ranunculaceæ - - - - -	35
" 5. Lardizabalaceæ - - - - -	38
" 6. Berberidaceæ - - - - -	40
" 7. ✓Cruciferae - - - - -	41
" 8. ✓Papaveraceæ - - - - -	45
" 9. ✓Capparidaceæ - - - - -	58
" 10. ✓Moringaceæ - - - - -	59
" 11. ✓Resedaceæ - - - - -	60
(B) MONOCOTYLEDONS - - - - -	62
Family 12. Liliaceæ - - - - -	62
" 13. Juncaceæ - - - - -	66

PART 3

(A) DICOTYLEDONS - - - - -	69
Family 14. Geraniaceæ - - - - -	69
" 15. Oxalidaceæ - - - - -	73
" 16. Linaceæ - - - - -	76
" 17. Tropæolaceæ - - - - -	78
" 18. Erythroxylaceæ - - - - -	79
" 19. Cneoraceæ - - - - -	80

Family 20.	Balsaminaceæ	-	-	-	-	81
” 21.	Rutaceæ	-	-	-	-	83
” 22.	Zygophyllaceæ	-	-	-	-	86
” 23.	Meliaceæ	-	-	-	-	89
(B)	MONOCOTYLEDONS	-	-	-	-	90
Family 24.	Amaryllidaceæ	-	-	-	-	90
” 25.	Iridaceæ	-	-	-	-	91
” 26.	Orchidaceæ	-	-	-	-	92
PART 4						
(A)	DICOTYLEDONS	-	-	-	-	99
Family 27.	Limnanthaceæ	-	-	-	-	99
” 28.	Violaceæ	-	-	-	-	100
” 29.	Caryophyllaceæ	-	-	-	-	101
” 30.	Portulacaceæ	-	-	-	-	104
” 31.	Malvaceæ	-	-	-	-	106
” 32.	Bombacaceæ	-	-	-	-	111
” 33.	Sterculiaceæ	-	-	-	-	114
” 34.	Tiliaceæ	-	-	-	-	120
” 35.	Sarraceniaceæ	-	-	-	-	124
” 36.	Droseraceæ	-	-	-	-	126
” 37.	Nepenthaceæ	-	-	-	-	128
(B)	MONOCOTYLEDONS	-	-	-	-	129
Family 38.	Gramineæ	-	-	-	-	129
” 39.	Cyperaceæ	-	-	-	-	131

Part I

INTRODUCTION

The subject-matter of the present volume has been treated (as explained in the Preface and further indicated in the Table of Contents) along lines different from those adopted in works on systematic botany, which deal almost exclusively with the external characters of the plant. The end in view has been to direct attention particularly to those features and inter-relations of the floral members, consideration of which is vital to a correct interpretation of the floral ground-plan, rather than to give a complete description of each type. A satisfactory solution of the problems of floral morphology is not to be expected unless the evidence of external appearance is supplemented by that of internal structure. The importance of the latter class of evidence cannot, indeed, be overrated, especially when there is union between the floral members, whether of the same or of different whorls, such as very generally occurs in the gynæceum.

The plan adopted has been to select particular Families for consideration and to examine these Families primarily from the standpoint of the problems presented by particular types of construction, apart from systematic relationship, though, so far as this could conveniently be done, groups of related Families have been treated together. For the same reason the 'Illustrative Types' cited have been chosen, not as being the most representative of the Family, but as affording the clearest evidence supporting the interpretation given in the general account, and as being at the same time likely to be more

or less readily available. Where a type cited is of a species occurring in the British Isles, or that of a genus represented in the British Flora, an asterisk is prefixed to the name.

THE GYNÆCEUM

The gynæceum is interpreted in accordance with the view that in true apocarpous the individual ovary is formed of a single carpel, which arises as a separate structure, but that in syncarpous and pseudo-apocarpous forms it is composed of two kinds of carpels, sterile and fertile. This view is known as the theory of carpel polymorphism.

In general, the two kinds of carpels differ markedly in form as well as in function, and constitute two alternating whorls. In the syncarpous gynæceum the members of the whorls arise, and remain, laterally conjoined. In pseudo-apocarpous the syncarpous gynæceum becomes cleft sooner or later into more or less separate and uniform portions, through the radial longitudinal splitting of the fertile carpels. Each portion thus consists of a whole sterile carpel with which is conjoined half the neighbouring fertile carpel on each side. It follows from the above that the typical complete cyclic flower with a syncarpous or pseudo-apocarpous gynæceum must be regarded as consisting of six whorls (two of perianth, two of andræcium, two of gynæceum).

Less often, carpels of different form and function alternate in the same whorl. The complete cyclic flower with this type of syncarpous gynæceum, or with an apocarpous gynæceum, has no more than five whorls, since it lacks a second carpel whorl.

In various dioecious types in which the male flower has a rudimentary infertile gynæceum, the infertility results from the absence of the second carpel whorl.

Another feature of such male flowers in some syngonous

(= epigynous of traditional terminology, see 4*) species is a condition of more or less complete apocarpy as in some Hydrocharitaceæ, whereas in the female flower the gynæceum is syncarpous at the level at which it becomes free from the outer whorls. Similarly, in hypogynous species with a syncarpous gynæceum in the female or hermaphrodite flower, the functionless gynæceum of the male flower (or of the exceptional hermaphrodite flower in which for some reason the inner carpel whorl fails to develop) becomes more or less apocarpous, as in some Rutaceæ. In the absence of the connection which the inner carpels supply, the outer carpels are unable to remain united.

The substitution of the term syngonous for epigynous leaves the classification of flowers into three categories (hypogynous, perigynous, syngonous) unaltered. The old term 'epigynous' rests upon two contingent assumptions, both untenable. In the first place it has been presumed that in flowers so described the outer wall of the loculi is constructed of the concave floral axis conjoined and fused with the carpels; and secondly, that the outer whorls originate on the rim of this concave axis and hence above, or upon, the gynæceum. Whereas the term syngonous indicates the true position, *viz.* that this wall is the common base of all the whorls which are as yet undefined from one another and only become distinct as they become exerted.

GENERAL CONSIDERATIONS

The radial position of the floral members is the outcome of an inherent rhythm.

This rhythm is of two kinds:—

(a) Single and continuous, underlying the acyclic

* For the list of published papers to which all numbers in brackets refer, see pp. 23–25.

arrangement. In the acyclic type a line drawn through the exertion points of successive floral members forms a continuous even spiral. The exertion points occur at approximately equal distances (measured horizontally), except when, as sometimes happens, a change of rhythm occurs at the level of a sharp transition from one form of morphological member to another. The floral axis is generally elongated, and as a rule, each floral member is exerted separately.

- (b) Interrupted or twofold, underlying the cyclic arrangement. In the cyclic type the floral members are exerted in a succession of whorls (as the result of a regular but intermittent flattening of the turns of the inherent spiral). The members of each whorl develop on approximately equidistant radii. The floral axis is generally very short. The individual members of a whorl may be exerted either separately or conjoined.

The effect of this twofold rhythm is to bring about the regular alternation of successive whorls where they are isomerous. But although complete isomery and strict alternation may be looked upon as the basic scheme of the cyclic form, many types show oligomery (decrease in number) in the inner whorls, or the superposition of two successive whorls, or both conditions. Both are probably to be attributed to restriction of space resulting from a shortened floral axis.

Oligomery may be brought about by fusion, by simple suppression, or as the result of a change of ground-plan following a process of reconstruction of the vascular scheme comparable with that occurring at the nodes in the vegetative axis.

Reduction by fusion is well seen in certain species of

Veronica. The *Veronica* calyx is constructed upon a five-sepalled ground-plan, but the median posterior sepal is gradually disappearing. Some species with five sepals have a pentamerous corolla, others apparently, a four-petalled corolla. In this latter class a median posterior corolla segment is superposed upon a median posterior sepal. Such superposition at once suggests that the posterior corolla segment does not represent an individual petal. That it is, in fact, constructed of two petals fused together is indicated in some species by the great width of this segment as compared with the other three. In species in which there is no such marked difference in size, proof of fusion is, nevertheless, very generally afforded by the vascular scheme; for in most such types the posterior segment is found to possess two midrib bundles each with its own system of laterals. A similar condition occurs in the calyx of species of the orchid *Cypripedium* (Lady's Slipper), which consists of two members, one large, alternating with the paired petals, one smaller, on the same radius as the unpaired petal. The double vascular system in this latter member gives proof that it is a compound structure, and that despite its unbroken outline it is not the equivalent of a single sepal, but results from the fusion of two. Hence the alignment of this member on the intervening (petal) radius naturally follows. Another instance of simple fusion is to be found in those forms of *Hypericum* (St. John's Worts), among which are the British species *H. Elodes* and *H. humifusum*, which have only three bundles of stamens following upon a pentamerous calyx and corolla, whereas the bulk of *Hypericum* species have five bundles of stamens. The positions occupied by the three groups, the proportionate number of stamens in each group and the vascular scheme, all afford clear proof that only one of the three bundles is in reality a

single bundle, each of the others being a double bundle formed as the result of the fusion of two.

Reduction by simple suppression can be seen in process of taking place, as mentioned above, in the calyx of *Veronica*, where every grade between normal development of the median posterior sepal and its complete disappearance can be observed. Another example of this form of reduction is afforded by species of *Acer* (Sycamore, Maple), in which only eight of the ten stamens present in the male flower are usually developed in the hermaphrodite flower, the median stamen in each whorl being suppressed. Again, some grasses have only two stamens. These members occupy the same positions as the two lateral stamens in the more usual trimerous androecium. In such cases of simple suppression it is possible to say which members of the full ground-plan remain and which have disappeared.

Reduction may also take place following upon a process of reconstruction in the vascular system similar to that which occurs at the nodes in many vegetative axes. In this way a new ground-plan may come into being with fewer members to the whorl. The members of the new oligomerous whorls, as in the fuller whorls, are equally spaced; consequently they will not in every case stand on the same radii as the members of the earlier whorls. Hence the relation of the reduced to the full whorls is not simply one of disappearance and persistence.

Similarly, when pleiomery (increase in number) occurs, not associated with branching in the vascular system or of duplication through division, but following upon reconstitution of the residual vascular cylinder, the radii occupied by the more numerous members of the new whorl may not correspond with more than one or two of the radii occupied by members of the preceding whorls.

In certain exceptions to the outward expression of the inherent rhythm among isomerous forms, two floral whorls occur in succession on the same set of radii instead of on the alternate radii. In order to understand how this condition arises it is essential to take into account the origin and arrangement of the vascular system, for the vascular ground-plan is directly related to the floral ground-plan. The one is just as much fixed and inherited as the other.

Sepals, petals, stamens and carpels, like foliage leaves, ordinarily have a main vascular strand—the midrib.

Typically, the midrib bundles for the members of a whorl turn out from the central vascular cylinder of the axis in a corresponding whorl, but in some types in which the central cylinder enlarges considerably at the flower base the bundles for the second and later whorls are detached from the inner face of the cylinder, and afterwards bend outwards. When the vascular development takes place in this way the regularity of the pattern is, at first, often less well marked.

In some types, presumably where the conditions of time and space allow, the midrib bundles for each whorl of members turn out from the central cylinder independently. In such types a process of reorganisation of the vascular cylinder, of greater or lesser extent, comparable with that occurring at the nodes in the vegetative axis, takes place between the successive emergence of the several whorls of midrib bundles.

In other types, presumably where time and space conditions are more stringent, the midrib bundles for two superposed whorls (*e.g.* petals and antepetalous stamens) are organised from the same delimited portion of the central cylinder without any intervening process of reorganisation. These delimited units may divide into their two components at the moment that they turn out

from the central cylinder, or they may remain unresolved for a longer or shorter distance during their course from the boundary of the vascular cylinder to the exertion level of the corresponding floral members. Such compound bundles are termed trunk cords. This method of compressing the development of the vascular system into less time and space is conveniently termed 'condensation.'

Where the midrib bundles for two superposed whorls originate as a single whorl of trunk cords, or from the same delimited units of the vascular cylinder, the two whorls are treated as a single whorl in the scheme of alternation. Hence, when such 'condensation' occurs, the law of alternation, though contravened in the floral ground-plan, is obeyed in the vascular ground-plan.

'Condensation' in the vascular ground-plan accounts for the fact that if one (generally the inner) of the two whorls supplied by the same whorl of trunk cords fails to develop, the radial position of the members of the succeeding whorl is not affected.

In certain circumstances the rule of alternating whorls is broken in both the floral ground-plan and the vascular ground-plan. This condition occurs commonly, and probably always, in those six-whorled types in which all the whorls of midribs originate independently, except where some special structural feature is present, which has the effect of providing extra time or space for the development of the innermost whorls, *i.e.* the carpel whorls. In the absence of such features the outer carpels and the loculi are antepetalous, whereas unbroken alternation would bring them on to the sepal radii. Features which have a counteracting effect, permitting continuous alternation of the whorls, are the presence of a gynophore or stipe (= unexpanded basal region of the gynæceum), or other structural development of such a nature that the enlarging gynæceum is no longer invested

by, and conjoined with, the ring of outer whorls at the level at which the outer carpel bundles are organised.

The above form of disturbance of the normal rhythm does not occur among isomerous Monocotyledons nor among isomerous Dicotyledons possessing an apocarpous gynæceum or showing the type of 'condensation' of the vascular system described above. These facts regarding the incidence of this type of departure from the general rule of alternation suggest that it stands in some close relation to the time-space conditions. As to the precise manner in which the spatial stringency affects development we have no direct evidence. But if we may suppose that the rapid and successive organisation of the vascular systems of four successive whorls (sepals, petals, outer and inner stamens) has produced a temporary state of 'block' or 'congestion,' then it is conceivable that by the time this condition has been overcome the rhythmic growth impulse has passed from the sepal to the petal radii. All that can be said at the moment is that this supposition meets the known facts. If it should prove in the future not to be well-founded, the true explanation will be still to seek.

In the isomerous syngonous (see above, p. 3) flower the midrib bundles for the sepals, antesealous stamens, and one set of carpels generally arise conjoined into one set of trunk cords on one set of radii. Similarly, those for the petals, antepetalous stamens, and other set of carpels, usually originate from one set of cords on the other set of radii. Resolution of these cords into their components then takes place at different levels.

Certain trunk cords sometimes include other components besides midrib bundles. This form of construction occurs when the marginal veins of the sepals do not take their rise from the sepal midrib bundles, but originate directly from the central vascular cylinder and turn

outwards on the alternate set of radii conjoined with the petal midrib bundles, from which they become disjoined in their course through the cortex of the axis. The calyx component of each such trunk cord forms two strands which diverge and furnish a marginal vein to the neighbouring sepal to right and left, respectively. This commissural mode of origin of the sepal marginal veins is characteristic of many Families, and is well seen, for example, in Cruciferæ, Caryophyllaceæ, Geraniaceæ, and most Primulaceæ. Like the other instances of trunk cord formation described above it may have resulted from the time-space conditions. Apart from this possibility as to its general significance, this feature is associated in types having only a single perianth whorl with a definite distribution of colour. In such types, tepals (members of a single perianth) with commissural marginals have a non-green (coloured or white) marginal strip, or are coloured over the inner surface. Where the tepals have true lateral marginals they are green (19a, 19b).

THE CARPELS

The following types of carpel are distinguished :—

- (a) Valve, usually showing pinnate venation with a pair of well-marked marginal lateral veins, from which, if the carpels are fertile, the bundles of the ovules are derived. The ovules are usually borne singly on one or both margins (placentæ). Only in a few genera is the valve type of carpel fertile in a syncarpous gynæceum. When this type of carpel alone is present the gynæceum is generally, if not always, apocarpous.
- (b) Consolidated, with or without a median bundle, but with a pair of strongly-developed bundles close to the mid-line which, when the carpel is fertile, furnish the strands to the ovules. The

ovules are usually borne on either side of the mid-line of the carpel in one to many rows, or only a pair may be formed, or one alone. The

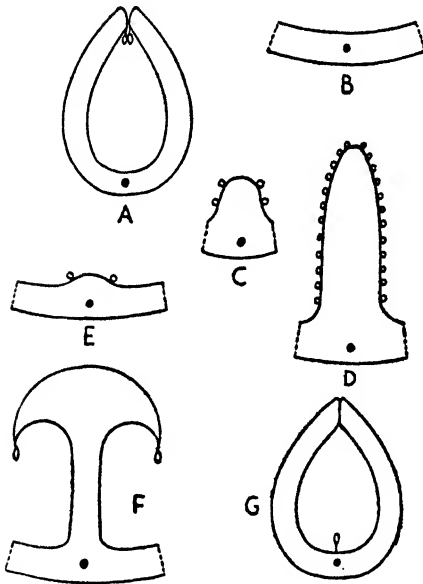

- A—Valve, fertile, from an apocarpous gynæceum.
 B—Valve, sterile, from a syncarpous gynæceum.
 C—Solid, fertile, columnar.
 D—Solid, fertile, forming a radial plate.
 E—Semi-solid, fertile, from a syncarpous unilocular gynæceum.
 F—Semi-solid, fertile, from a syncarpous multilocular gynæceum.
 G—Semi-solid, fertile, from an apocarpous gynæceum.

FIGURE 1.

Types of carpel as seen when cut transversely.

consolidated carpel very rarely occurs in the apocarpous condition. In genera with a syncarpous gynæceum, composed of both valve and consolidated carpels, it is the consolidated form which in almost all cases is fertile.

The consolidated type of carpel appears in two forms which, however, intergrade. When contracted to a column or radial sheet of tissue it is conveniently distinguished as a solid carpel. When expanded so that in outward shape it resembles the valve type it is said to be of semi-solid or pseudo-valve form. The solid carpel is thus distinguished from the typical valve carpel by its shape as well as by the position of the ovules; the semi-solid carpel sometimes by the position of the ovules alone, sometimes by its internal outline as well.

If the carpels of one whorl are of the valve type, and those of the other are consolidated, it is always those of the outer (earlier) whorl which are of valve form, whether this whorl is antesealous or antepetalous.

As a rule both sterile and fertile carpels share in the formation of the wall of the syncarpous ovary, both in the more usual case where the two kinds occur in different whorls, and in the rarer instances where they alternate in the same whorl (the only one present). Exceptionally, only the sterile outer whorl forms the wall, while the inner fertile whorl forms a central column free from the wall. This latter arrangement gives the 'free-central' placentation of the old terminology.

Although typical examples of the above three kinds of carpels are readily recognisable, intermediate forms occur which bridge the gap between them. It is obvious that no hard and fast line can be drawn between a solid carpel, slightly extended laterally, and a rather contracted semi-solid carpel, whether they are sterile or fertile. Again, it may in some cases be difficult to determine whether sterile carpels, if much extended laterally, are of the valve or of the semi-solid class. Or, if they are less broad, whether they represent the valve type somewhat contracted, or the solid type somewhat extended. A

carpel ordinarily typical of one class may occasionally, or in certain circumstances regularly, assume the form of another class, and may also then change its function. Examples of such exceptional transformation have been observed in Cruciferae. Thus, one of the two lateral carpels may remain unexpanded so that the gynæceum is formed of three solid carpels and only one of the valve type, and is then, consequently, unilocular, in contrast with the normal ovary which is composed of two consolidated and two valve carpels, and becomes bilocular (8, p. 49†). Again, among papaveraceous types with the cruciferous form of gynæceum (*e.g.* *Chelidonium majus*, Greater Celandine), one of the two valve carpels has been observed exceptionally to develop in part of its length a placental cushion over the midrib, with a placental vascular bundle and typical placental hairs, and so comes to exhibit the characters of the semi-solid carpel (unpublished). Regular transformation of one type of carpel to another occurs in the four-valved ovaries which occur from time to time in most cruciferous genera; for here the two median carpels which are ordinarily of the consolidated class assume the valve form. Furthermore, in these cases one or both of the median valve carpels may remain unexpanded (*i.e.* consolidated) for some distance from the base, and then take on the valve character. When such transformation occurs in the course of the length of the carpel, the result is an illusory appearance that the carpel in question has arisen at a higher level than the other members of the same whorl (1, p. 461†).

A comparison of various ranalean acyclic, hemicyclic and cyclic types suggests the possibility that polymorphism of the carpels, as well as the arrangement of the floral members in whorls, resulted from restricted time and space conditions set up by the shortening of the floral axis.

The monocarpellary ovary of the apocarpous gynæceum is unilocular, and the carpel is almost always of the valve type ; only very rarely is it of the pseudo-valve or semi-solid form. Midrib and placental strand(s) originate from the same vascular bundle or from the same delimited group of vascular elements in the central cylinder, and hence stand on the same radii.

The syncarpous gynæceum may be either unilocular or multilocular, according as all the carpels fail to form complete septa, or as some or all extend inwards sufficiently far to meet in the centre or to fuse with the tissue of the axis. Only the carpels of one whorl are, as a rule, thus extended, and the number of loculi will then be equal to the number of carpels composing one whorl. Less frequently both sets of carpels may extend to the centre. The loculi will then be equal in number to the whole number of carpels in that region of the ovary where this condition obtains.

In the syncarpous gynæceum in which the carpels of one whorl are of valve form and are sterile the midribs of these carpels and the placental strands (formed by the carpels of the other whorl) will lie on alternate radii.

It follows from the relations detailed above that the terms 'parietal,' 'axile' and 'free central,' as applied to the mode of placentation, signify a different structural condition from that which they have been used hitherto to connote.

The same remark applies to the term 'gynobasic,' employed to describe the style when it does not spring from the summit of the ovary, but takes its rise at, or near, the base. The ovary, if syncarpous, is then lobed above, and the style deeply sunk between the lobes. This conformation results when the style is a direct prolongation of the carpels of the inner whorl, and when those of

the outer whorl, owing to their shape and rate of elongation, must become curved inwards and downwards in the region between the summit of the ovary and the style base. Hitherto, on the traditional view that the carpels are all of one kind and arranged in a single whorl, it has been necessary to suppose that the growth of the dorsal side was more vigorous than that of the ventral. (Examples of the 'gynobasic' condition among the Families treated in the present volume occur in Limnanthaceæ and Rutaceæ.)

In the syncarpous gynæceum stigmas may be formed by the sterile carpels, or by the fertile carpels, or by both. Stigmas centred over the fertile carpels are the 'commissural' stigmas of the old terminology.

It may be well to emphasise here that the sessile stigma with a median groove of some monocarpellary ovaries must be distinguished from the genuinely bilobed stigma of some syncarpous gynæcea. The grooved stigma terminating a single valve carpel is only symmetrical about the median plane. The bilobed form is symmetrical about the lateral as well as the median plane, as in *Matthiola incana* (Garden Stock) and (among short-styled types) *Chelidonium majus* (Greater Celandine).

In certain isomerous six-whorled types, *viz.* those in which the midribs for each floral whorl are organised separately and at successively higher levels, the carpels which stand in line with the petals, as stated above (p. 8), develop before those on the sepal radii. Hence the loculi in such types are antepetalous, whereas, if in six-whorled types the whorls alternate throughout, the loculi arise on the sepal radii. If in such six-whorled types having antepetalous loculi the two whorls of carpels are of equal radial dimension, so that the ovary appears circular in cross-section, the flower remains diplostemonous as *e.g.* in Caryophyllaceæ. If, on the other hand, as

occurs more frequently, the antepetalous carpels have a greater radial dimension than those of the antesepalous whorl, the flower shows obdiplostemony.

The term obdiplostemony is used throughout in the strict sense to denote that in the isomerous six-whorled type the vascular bundles for the antepetalous stamens arise from the central vascular cylinder before those for the antesepalous whorl, and stand further from the centre. This condition of true obdiplostemony is associated with antepetalous loculi in the ovary, and is to be distinguished from false obdiplostemony, in which the filaments of the antepetalous stamens at the level of origin stand nearer the centre than the antesepalous stamens, but later bend outwards so as to appear outside these members. This latter condition is well seen in the isomerous six-whorled type *Limnanthes Douglasii*, in which, owing to the particular structural relations of the two carpel whorls, the loculi are antesepalous, but the stamens simulate obdiplostemony.

The general principles outlined above, with their implications, serve to bring the known facts into line so that they constitute a co-ordinated whole. They dispose of many morphological fictions, including hypothetical splittings and unions, hypothetical suppressed whorls, 'commissural' stigmas, 'false' partitions, 'free-central' placentation and epigyny as traditionally interpreted, while 'parietal' and 'axile' placentation and 'septicidal' dehiscence now have an altered significance. They provide an explanation of obdiplostemony, various forms of fruit dehiscence, and many other hitherto unexplained features.

In conclusion, it may not be out of place to stress the point that, although in those Families which exhibit great uniformity it is no doubt desirable in the first instance to select for study the most 'typical' forms available, it should

not be overlooked that it is often among the minority of exceptional or outlying genera that evidence is to be found indicating the original ground-plan from which the type form has been derived, the manner in which this position of stability has been reached, or the true nature of a structure of uncertain morphological equivalence. Examples of such 'milestone' or 'key' genera are *Bunias* and *Biscutella* (Cruciferæ), *Samolus* and *Soldanella* (Primulaceæ), *Arachis* and *Scorpiurus* (Leguminosæ-Papilionatæ), *Pavonia* and its allies (Malvaceæ), *Aphyllanthes* and *Fritillaria imperialis* (Liliaceæ), *Bambusa* and *Nardus* (Gramineæ), *Eschscholzia* (Papaveraceæ).

As the preceding pages are intended to supply a general introduction to certain principles underlying the relations of the floral whorls, details are given below of two simple models by which these relations can be illustrated.

MODEL I.

Materials.—A bill file with an 11-inch tongue, cotton reels, and cardboard figures (see Fig. 2).

The cardboard figures B, C, D, E are pierced, as shown, so that they, as well as the reels, can be threaded on the metal tongue in such order as desired to represent whorls and internodes (see A). B, duplicated and suitably coloured, serves for a pentamerous calyx and corolla. C and D are used for the andrœcium. The individual stamens (C) are for convenience of handling cut separately, the required number for one whorl being threaded at the same level. They can be bent upwards within the loose ring (D), which is nicked in order to hold them on their proper radii, while the ring at the same time rests on the cross-bar left on the filaments. E (coloured green) and F (uncoloured) are used for the gynœceum, E for an outer sterile, F for an inner fertile carpel whorl. Like the stamens, the carpels are for convenience cut separately,

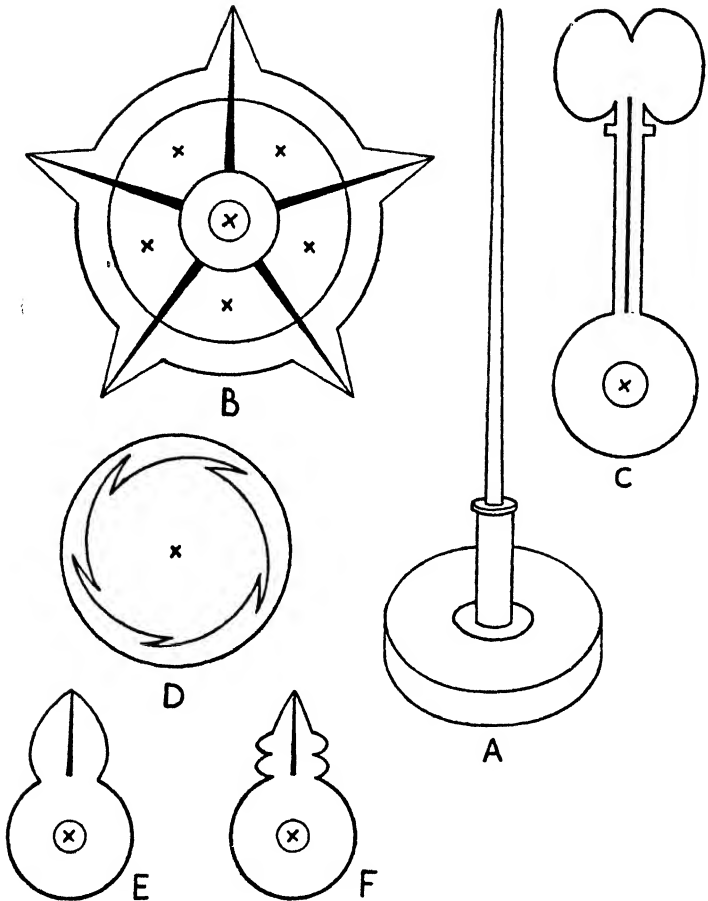

FIGURE 2.

The separate parts of Model 1.

those for one whorl being threaded at the same level and adjusted to their proper radii by hand. (All portions in the drawings marked thus \times to be cut out.)

Figures similar in scheme to B and D, but cut in accord with a trimerous ground-plan, can be used for monocotyledon types.

Examples of method of use to illustrate the relations between the floral and the vascular ground-plan:—

Case 1.

An isomerous, trimerous six-whorled Monocotyledon, a type which is always diplostemonous, in which the antesealous stamen bundles arise conjoined with the sepal midrib bundles, and the antepetalous stamen bundles are similarly conjoined at first with the petal midrib bundles (see earlier, pp. 7 and 8).

Order of threading on the file tongue:—

- (1) Reel (merely for convenience).
- (2) Calyx whorl, followed by three superposed stamens.
- (3) Reel.
- (4) Corolla whorl, followed by three superposed stamens, both arranged on the alternate radii.
- (5) Reel.
- (6) Three outer carpels arranged on the sepal radii.
- (7) Reel.
- (8) Three inner carpels arranged on the petal radii.
- (9) Reel (to keep the inner carpels in position).

Bend the stamens upwards and drop two rings over them, fixing each whorl in position by means of corresponding nicks.

Case 2.

An isomerous, pentamerous six-whorled Dicotyledon, in which the vascular bundles for all the whorls arise independently, a type which is almost always obdiplostemonous (see earlier, p. 8).

Order of threading on the file tongue:—

- (1) Reel (merely for convenience).
- (2) Calyx whorl.
- (3) Reel.
- (4) Corolla whorl alternating with the calyx whorl.
- (5) Reel.
- (6) Outer stamen whorl arranged on the radii of the petals.
- (7) Reel.
- (8) Inner stamen whorl arranged on the radii of the sepals.
- (9) Reel.
- (10) Outer carpels arranged on petal radii.
- (11) Reel.
- (12) Inner carpels arranged on sepal radii.
- (13) Reel (to keep inner carpels in position).

Bend the stamens upwards and fix in position as in Case 1.

MODEL 2.

Materials.—Iced drink straws. A dark coloured cardboard cylinder (preferably with a loose cover top and bottom), such as is used as a container for various commodities. A cylinder of the same height, but considerably wider, of gelatine or similar transparent material. This is easily made by fastening rectangular sheets of gelatine together with strips of kartrofix. (The use of five sheets where the model is to be used to illustrate a pentamerous ground-plan will obviate the necessity for certain measurements in the horizontal direction.) A narrow strip of

cardboard clipped on to the inner face of the gelatine cylinder top and bottom will prevent it from buckling. The gelatine cylinder is pierced with holes at successive levels (nodes) on the alternate sets of radii. If found

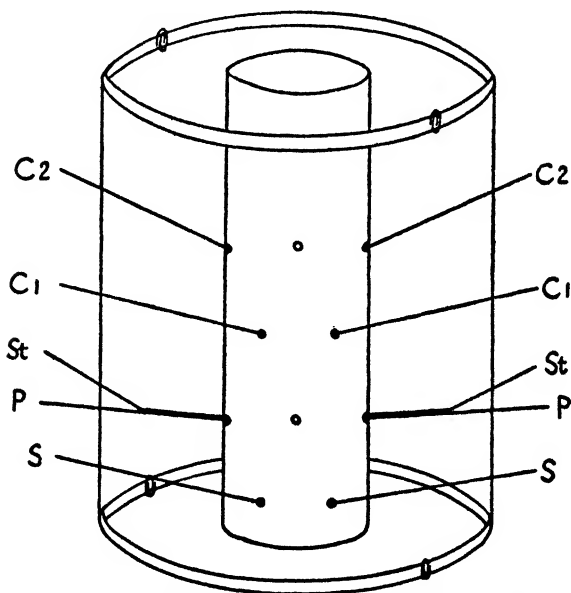

S—Sepal. P—Petal. St—Stamen. C1—Outer carpel.
C2—Inner carpel.

FIGURE 3.

Model 2 partly put together.

necessary, the inner cylinder should be similarly pierced on the same radii, but at somewhat lower levels. The straws representing the midrib bundles of the several floral whorls are then pushed from the outside in a slightly downward direction through the holes in the gelatine cylinder (representing the surface of the floral axis) as far as (or through) the inner cylinder (representing the central vascular cylinder). It may be found convenient

to remove the bottom cover of the inner cylinder during the process of handling. It can then be replaced when the model is completed.

This model can be used to illustrate either the *alternation* of whorls which occurs where the midrib bundles for the members of the successive whorls turn out from the central cylinder independently, or the *superposition* of whorls where the midrib bundles for two whorls leave the central cylinder conjoined into one set of trunk cords, which become resolved into their two components during their course through the cortex of the axis to the exertion level of the members to which they belong.

In the above illustration a type is represented with only one staminal whorl. The bundles for this whorl leave the central cylinder conjoined with the petal midrib bundles, hence the single staminal whorl is superposed upon the petals and the outer carpels are antesealous, whereas strict alternation would bring about antesealous stamens and antepetalous outer carpels. For simplicity in the drawing the vascular bundles have been represented on only two of the sepal and two of the petal radii. When the model is put together for use the full number of straws for each whorl should be placed in position.

Where microscopic examination of the flower is desirable unstained, hand-cut, transverse sections of decolorised (alcohol) material, cleared if necessary in chloral hydrate and mounted in glycerine (a more satisfactory medium than canada balsam on account of its refractive index), will, in general, suffice to exhibit the relevant main features of the vascular ground-plan. (Such preparations can readily be rendered permanent by ringing with brunswick black.) In particular cases, where it is necessary to trace the whole course of the bundles, uncut material can often be rendered sufficiently transparent if placed in chloral hydrate for some hours.

To facilitate reference to the more detailed evidence contained in the series of papers referred to in the Preface, a list of these papers arranged in chronological order is given below. In the succeeding Parts it will therefore suffice to cite the numbers corresponding with those in this list.

The sign † following a number indicates that the paper is illustrated with figures, and ‡ that it contains floral diagrams.

1. 1923. *Ann. Bot.*, 37 : "A Reversionary Character in the Stock (*Matthiola incana*), and its Significance in regard to the Structure and Evolution of the Gynœcium in the Rhœadales, the Orchidaceæ, and other Families."
2. " *New Phytol.*, 22 : "The Bractless Inflorescence of the Cruciferæ."
3. 1925. *Ann. Bot.*, 39 : "On Carpel Polymorphism. I."
4. " *New Phytol.*, 24 : "The Inferior Ovary."
5. " *New Phytol.*, 24 : "Perigyny and Carpel Polymorphism in some Rosaceæ."
6. 1926. *New Phytol.*, 25 : "A Reply to Comments on the Theory of the Solid Carpel and Carpel Polymorphism."
7. 1927. *Ann. Bot.*, 41 : "On Carpel Polymorphism. II."
8. 1928. *New Phytol.*, 27 : "Illustrations of Carpel Polymorphism. I."
9. " *New Phytol.*, 27 : "Illustrations of Carpel Polymorphism. II."
10. " *New Phytol.*, 27 : "Illustrations of Carpel Polymorphism. III."
11. 1929. *New Phytol.*, 28 : "Illustrations of Carpel Polymorphism. IV."

12. 1929. *Ann. Bot.*, 43: "On Carpel Polymorphism. III."
13. 1930. *New Phytol.*, 29: "Illustrations of Carpel Polymorphism. V."
14. " *New Phytol.*, 29: "Illustrations of Carpel Polymorphism. VI."
15. 1931. *Ann. Bot.*, 45: "On Carpel Polymorphism. IV."
16. " *New Phytol.*, 30: "Illustrations of Carpel Polymorphism. VII."
17. 1932. *Ann. Bot.*, 46: "On Carpel Polymorphism. V."
18. " *New Phytol.*, 31: "On some recent Contributions and Criticisms dealing with Morphology in Angiosperms."
- 19a. " *Proc. Linn. Soc.*, 144: "The Cause of Petaloid Colouring in 'Apetalous' Flowers." (Abs.)
- 19b. 1933. *Journ. Linn. Soc.*, 49: "The Cause of Petaloid Colouring in 'Apetalous' Flowers."
20. 1934. *Journ. Linn. Soc.*, 49: "A Study of *Veronica* from the Viewpoint of Certain Floral Characters."
21. " *New Phytol.*, 33: "A Note on the Floral Anatomy of *Rivina humilis* L."
22. " *New Phytol.*, 33: "Comments on 'Floral Anatomy and its Morphological Interpretation'."
23. " *Ann. Bot.*, 48: "On Carpel Polymorphism. VI."
24. 1935. *Proc. Linn. Soc.*, 147: "On Rhythmic Development and Radial Organisation in the Flower." (Abs.)
25. " *Ann. Bot.*, 49: "On the Gynæceum of *Filipendula Ulmaria* Maxim. and *Filipendula hexapetala* Gilib.: a Correction."

26. 1936. *New Phytol.*, 35, No. 1: "The Vascular Ground-plan as a Guide to the Floral Ground-plan: illustrated from Cistaceæ."
27. " *Ann. Bot.*, 50: "On Certain Features of Floral Construction and Arrangement in the Malvaceæ."
28. " *Journ. Linn. Soc.*, 50: "On Rhythmic Development and Radial Organisation in the Flower."
29. " *Journ. of Bot.*, 74: "Some Morphological Problems presented by the Flower in Nymphæaceæ."
30. " *New Phytol.*, 35, No. 5: "On Certain Unique Features of the Gynœcium in Nolanaceæ."

Part 2

Dicotyledons

Family	1.	Nymphæaceæ
”	2.	Magnoliaceæ
”	3.	Myristicaceæ
”	4.	Ranunculaceæ
”	5.	Lardizabalaceæ
”	6.	Berberidaceæ
”	7.	Cruciferæ
”	8.	Papaveraceæ
”	9.	Capparidaceæ
”	10.	Moringaceæ
”	11.	Resedaceæ

Monocotyledons

Family	12.	Liliaceæ
”	13.	Juncaceæ

Dicotyledons

1. NYMPHÆACEÆ

Flower generally acyclic without a sharp distinction between petals and stamens, sometimes hemicyclic with distinct corolla and andrœcium ; generally hypogynous, rarely perigynous. Gynœceum syncarpous or apocarpous ; when apocarpous ovaries few and definite, or several and variable in number, monocarpellary (29, pp. 217-221).

The few genera in the Family are grouped into three sub-Families, each of which is characterised by exceptional features in the gynœceum.

(i) NELUMBOIDÆ

Flower acyclic. Gynœceum apocarpous. The several ovaries are sunk in the greatly enlarged top-shaped summit of the floral axis. The venation of each ovary (*i.e.* carpel) is exceptional in being of the palmate type of the foliage leaves. Stigma rotate. The actinomorphic symmetry of the stigma results from the radiate pattern of the venation system ; for although a midrib bundle is recognisable it comes to an end in a gland situated below the top of the ovary, and hence produces no unilateral effect on the stigma outline. This type of symmetry is not found in the stigma of the single pinnately-veined carpel. The solitary ovule is suspended between two veins lying on either side of, and at a little distance from, the ventral mid-line.

(ii) CABOMBOIDÆ

Flower hemicyclic. Calyx and corolla in alternating, trimerous whorls. Gynœceum apocarpous. Ovules borne at two levels. The lower ovules, usually two, are slung from points situated about midway between the midrib

and the two ventral veins at which converging branches from midrib and ventrals effect a junction. If a pair of ovules is also developed at a higher level they are similarly suspended in the same position, but if only one is formed it is borne, as in the normal monocarpellary type, exactly in the ventral mid-line. For the two ventral veins eventually converge to a point in this line, and it is from this point that the ovule bundle originates.

(iii) NYMPHÆOIDEÆ

Flower hemicyclic. Gynæceum syncarpous, of numerous consolidated carpels in two alternating whorls, the outer columnar and sterile, the inner forming radial plates; covered over the whole inner surface except the ventral mid-line with ∞ ovules. This configuration may be compared with that of *Papaver* (see under Papaveraceæ) except that here the fertile carpels extend to the centre so that the ovary is multilocular.

ILLUSTRATIVE TYPES

For the significance of the asterisk preceding the names of genera and species, see Part I, p. 2.

With regard to all floral formulæ throughout the text it must be understood that they represent the structural ground-plan of the flower irrespective of whether individual members attain separate morphological form or not.

(i) NELUMBOIDEÆ

Nelumbium speciosum (Sacred Lotus of Egypt). Tepals (perianth members not sharply differentiated into sepals and petals) and stamens ∞ . Ovaries in successively smaller concentric rings.

(ii) CABOMBOIDEÆ

Cabomba caroliniana K 3 C 3 A 6 alternating with the perianth which is thus treated as a single whorl. Ovaries generally three, on the radii of the petals.

(iii) NYMPHÆOIDEÆ

***Nuphar luteum** (Yellow Water Lily). The superior ovary is surmounted by a large stigmatic disc. Stigmatic rays as many as the loculi and superposed upon them. Each ray is double and has a double vascular supply. This comes about in the following way. The sterile carpel midribs, as frequently happens in carpels of the consolidated type, divide in two. Towards the summit of the ovary the two halves of each midrib turn inwards to the centre. Each half bundle in its course picks up half the vascular system of the neighbouring fertile carpel so that the double system of each ray may be represented in terms of carpels thus:—

double stigma ray = $\frac{1}{2}$ | $\frac{1}{2}$ carpels = $\frac{1}{2}$ $\overbrace{\frac{1}{2} \frac{1}{2}}^{\text{}} \frac{1}{2}$ vascular bundles.
 The bracketed half bundles = the vascular system of one sterile carpel; the unbracketed half bundles = half the system of two different fertile carpels.

***Nymphæa alba** (White Water Lily). Flower perigynous. The more or less erect stigmas stand over the loculi. They are defined laterally through partial median radial splitting of the fertile carpels. Each, as in *Nuphar*, corresponds to $\frac{1}{2}$ | $\frac{1}{2}$ carpels.

2. MAGNOLIACEÆ

Flower hermaphrodite or unisexual, acyclic, hemicyclic or cyclic, hypogynous. Gynæceum apocarpous, but in some genera the monocarpellary ovaries become slightly or almost completely concrescent by their lateral faces. Each ovary is formed of one carpel. The individual fruit may be dry, one-seeded and indehiscent, or one- to several-seeded and dehiscent, or a berry.

ILLUSTRATIVE TYPES

Magnolia spp. Individual fruit with one or more seeds, dehiscent down the dorsal mid-line. The unusual mode of dehiscence is attributable to the fact that the ovary tissue remains attached throughout the length of the ventral face to the tissue of the axis.

Liriodendron tulipiferum (Tulip tree). Individual fruit one-seeded and indehiscent.

In both genera the spiral arrangement of the carpels is especially clearly seen on the elongated axis.

The vascular system of the ovaries shows an unusual feature in that lateral veins of commissural origin are present in addition to the placental strand and sterile laterals derived from the carpel midrib. This development is associated with an exceptional arrangement of the vascular tissue in the floral axis in which, owing to the large number of ovaries, the vascular bundles are arranged in concentric rings.

Illicium anisatum. Floral axis short with the ovaries in a single whorl. Individual fruit one-seeded, dehiscent along the free upper edge.

A ring of undifferentiated vascular elements is present in the floral axis within the ring of bundles which supply the ovaries. As all the ovaries stand at the same level these elements are not required. Survivals, presumably, of another tier of carpels now lost, they are no longer utilised, and shortly come to an end. In consequence the carpels have no lateral veins of commissural origin.

Drimys Winteri. Floral axis short. Ovaries few, indehiscent. Fruit a berry.

3. MYRISTICACEÆ

Flowers dicecious, cyclic. Perianth single, coloured (19*a* and 19*b*, p. 209). Tepals (members of such a perianth) 3. ♂ Flower with three to eighteen stamens in a single ring. ♀ Flower with a single unilocular ovary of two similar carpels, of which one bears a single marginal ovule near the base. The junctions of the carpels are indicated externally in the ovary by two opposite longitudinal furrows. Stigmas two, sessile, centred over the two carpels. The fruit is a berry which splits down the two sutures into two valves. The solitary seed is partly enclosed by a fleshy aril (here a post-fertilisation structure forming an additional incomplete integument). It has a ruminant (wrinkled) surface and abundant endosperm.

ILLUSTRATIVE TYPES

Myristica fragrans (Nutmeg tree). The lace-like aril furnishes the mace, and the seed the nutmeg of commerce.

The vascular scheme of the ♀ flower is unusual. The vascular elements remaining after the emergence of the bundles for the tepals form a complete ring of bundles, which are continued directly into the gynæceum. No individual bundles can be distinguished as the carpel midribs, but the junctions of the carpels are clearly defined by a radial sheet of regularly arranged cells extending from the epidermis to the central cylinder. They have the appearance characteristic of layers bordering a free or potential surface. Each of the two marginal vascular bundles on one side of the ovary (*i.e.* one marginal bundle of each carpel) gives off a strand towards the loculus. One of these two strands supplies the ovule.

Although each Nutmeg tree usually produces flowers of only one sex, it is not uncommon for some male trees to produce a larger or smaller number of female flowers. These female flowers are frequently two-seeded, and then may show in the ovary three or four, or even six or eight furrows, indicating a corresponding increase in the number of carpels. It may be inferred that the usual G 2 represents a reduction from a

fuller ground-plan. When only two carpels develop, half the vascular cylinder continues directly into each carpel. When three, four, or more are present, a third, a quarter, or a smaller fraction of the cylinder is continued into each carpel. The fact that none of the bundles of the central ring assume the prominence of midribs may be connected with the circumstance that the whole cylinder may become marked off into a varying number of sectors, in accordance with the number of carpels which make up the ovary in a particular flower.

4. RANUNCULACEÆ

Flower hypogynous, generally acyclic or hemicyclic and actinomorphic, rarely cyclic or zygomorphic. Perianth single and petaloid in most acyclic types, in other members differentiated into calyx and corolla. Stamens variable in number, generally indefinite in the acyclic and hemicyclic types, definite in the two cyclic genera (*Xanthorrhiza*, *Aquilegia*). Gynæceum generally apocarpous, sometimes pseudo-apocarpous (see Part I, p. 2), rarely syncarpous. Individual fruit in apocarpous types generally dry, one-seeded and indehiscent (achene) ; those of pseudo-apocarpous types several-seeded and dehiscent down the ventral mid-line (follicle) or, exceptionally, down the dorsal line. Single fruit of the syncarpous gynæceum a capsule, or baccate, or folliculate.

In some normally apocarpous species (e.g. *Isopyrum thalictroides*) the gynæceum is reduced occasionally to a single monocarpellary ovary. This ovary may then appear to occupy a central position but, in fact, the solitary carpel does not arise as a terminal structure. After the organisation of the staminal bundles the residual vascular tissue no longer constitutes a complete cylinder. A larger or smaller arc of the cylinder in such flowers is destitute of differentiated vascular elements, those originally present in this sector having come to an end with the formation of the staminal bundles. Those elements still remaining are concentrated at one point, and shortly become organised into a single strand from which midrib and placental bundle(s) are derived.

On the other hand, in types where a supposedly monocarpellary ovary is truly terminal, as in *Actæa* and in species of *Delphinium* (*Ajacis*, *consolida*, *Gayanium*), the ovary proves to be bicarpellary. In such forms the residual differentiated vascular elements for the one

gynæceum are concentrated at two opposite points in the vascular cylinder. Those on the one side give rise to the midrib bundle of a sterile carpel, those on the opposite side to the characteristic twin bundles of a fertile carpel.

ILLUSTRATIVE TYPES

***Anemone, *Clematis.** Flower acyclic, actinomorphic. Perianth single, coloured. Gynæceum apocarpous. Ovaries numerous, monocarpellary. Placental bundle arising as a branch from the midrib and standing in line with it. Individual fruit an achene.

***Ranunculus spp.** (*e.g. acris, repens*). Flower hemicyclic, actinomorphic, with distinct calyx and corolla. Gynæceum apocarpous. Ovaries numerous, monocarpellary; midrib and placental strand, and fruit as in the preceding types.

***Delphinium** (Larkspur), ***Aconitum** (Monkshood). Flower acyclic, zygomorphic. Gynæceum pseudo-apocarpous. Ovaries generally two to five and then formed of $\frac{1}{2}$ \times $\frac{1}{2}$ carpels, rarely solitary (see below). Individual fruit a follicle.

It is convenient to retain the term follicle for fruits which have hitherto been so described, but it follows from the above account that it cannot henceforth be defined as invariably monocarpellary.

Nigella (Love in the Mist). Flower hemicyclic, actinomorphic. Gynæceum syncarpous; carpels typically five, sterile, of valve form + five, solid, fertile. Fruit a capsule.

***Myosurus** (Mousetail). Floral axis greatly elongated, showing clearly the spiral arrangement of the indefinite monocarpellary ovaries.

Xanthorrhiza. Flower when cyclic throughout actinomorphic, five-whorled or sometimes six-whorled, generally pentamerous, diplostemonous (K 5 C 5 A 5 + 5 G 5 or 5 + 5). Gynæceum apocarpous. Ovaries monocarpellary. But it is to be noted that even in K 5 C 5 A 5 + 5 flowers the number

of carpels (ovaries) may range from five to seventeen or more. Such serial variation indicates that the cyclic rhythm has not yet become firmly established throughout, and that the genus is still in process of transition from the hemicyclic to the cyclic condition.

***Thalictrum, Coptis.** Gynæceum apocarpous, ovaries stipitate, monocarpellary.

***Actæa spicata** (Baneberry). Ovary single, of two carpels, one sterile, one fertile. The residual vascular tissue for the gynæceum consists of two bundles on opposite sides of the central ground tissue. One bundle becomes the midrib of the sterile carpel; the other gives rise to the system of a semi-solid fertile carpel. This system consists of a weak median strand (midrib) which shortly comes to an end, and strong twin laterals which furnish the strands to the ovules and the secondary laterals in the ovary wall. Shortly after the disappearance of the median strand the fertile carpel becomes cleft between the twin placental bundles. This mid-ventral cleavage which brings the loculus into communication with the exterior extends upwards to the stigma. At the top of the ovary the persistent placental bundles turn horizontally, each becoming fused on the corresponding side with the sterile carpel midrib. The resulting single cord thus represents the vascular system of the sterile carpel, flanked on each side by half that of the fertile carpel. The large sessile stigma crowns the whole summit of the ovary, and similarly represents $\frac{1}{2}$ $\bar{1}$ $\frac{1}{2}$ carpels. Like the stigmas of most monocarpellary types in the Family it shows a median groove, for the symmetry of a structure consisting of $\frac{1}{2}$ $\bar{1}$ $\frac{1}{2}$ carpels, like that of one composed of a single carpel, is zygomorphic (see Part I, p. 15). Ovules in two rows. Fruit a berry.

Delphinium consolida. Ovary as in *Actæa*, but at first the residual vascular elements for the gynæceum extend all round the central parenchyma. A single strand on one side of the cylinder becomes the sterile carpel midrib. Two on the opposite side become organised into the two placental bundles of the fertile carpel, the secondary veins of which are furnished by the remainder of the elements. In the absence of a median strand the fertile carpel becomes cleft as soon as the loculus makes its appearance. The cleavage extends to the top of the short style, where the lining cells become stigmatic. Only the sterile carpel midrib is prolonged up the style, the fertile carpel veins having come to an end at its base. Ovules in two rows. Fruit a follicle.

***Helleborus.** Flower acyclic, actinomorphic. Gynæceum pseudo-apocarpous, ovaries three to five, each of $\frac{1}{2}$ $\bar{1}$ $\frac{1}{2}$ carpels.

5. LARDIZABALACEÆ

Flowers polygamous or unisexual, with reduced structures representing the non-functional sex, monœcious or dioœcious, generally cyclic throughout, rarely acyclic in the gynœceum, hypogynous, trimerous. Sepals generally in two whorls. Petals present in both sexes, or only in the male and then reduced to small glandular structures, or absent in both sexes; when present, in two whorls. Stamens in two whorls, free or sometimes united in the male into a tube. Anthers often with the connective prolonged. Gynœceum in male flowers apocarpous. Each ovary of a single carpel cleft ventrally to the loculus throughout its length, without stigma or ovules. In polygamous forms some flowers may have ovaries of the male type, but with rudimentary ovules. Gynœceum in female flowers pseudo-apocarpous (see Part I, p. 2). Each ovary of $\frac{1}{2}$ or $\frac{1}{2}$ carpels, closed throughout its length or cleft ventrally at the base, at the level of appearance of the loculus. Ovules in two rows near the ventral mid-line when borne only by the half carpels, or in several rows covering the side walls of the loculus when borne also by the whole carpel. Stigma sessile, broad, with a median groove as in some Ranunculaceæ (see under *Actæa spicata*), or elongated and trowel-shaped. Fruit baccate, opening along the ventral mid-line. Full ground-plan: ♂ K 3 + 3 C 3 + 3 A 3 + 3 G 3. ♀ K 3 + 3 C 3 + 3 A 3 + 3 G 3 + 3.

The bundles for the petals and superposed stamens are organised from the same delimited group of vascular elements in the central cylinder; hence the suppression of the petals in some types does not affect the radial position of the succeeding whorls.

In the male flower the residual vascular tissue for the gynœceum consists of three bundles on the radii of the outer sepals. Each of these bundles becomes the midrib bundle

of a carpel, and usually forms a pair of marginal laterals which generally remain undifferentiated. In the female flower vascular elements for the gynæceum are differentiated on both sets of radii, and form a complete cylinder. Those on the radii of the outer sepals give rise to the vascular system of the whole carpel in each ovary; those centred on each alternate radius become divided in half. As the halving of the tissue of each of the inner carpels becomes complete, one half comes to form part of the ovary on the one side, the other half, similarly, forms part of the ovary on the other side. The halved bundles may give rise to strong laterals, as may also the midrib bundle of the whole carpels. If only the main bundles of the two half carpels give off strands to the ovules, the ovules are borne in two rows. If the strong laterals of both the whole carpel and of the half carpels supply strands to the ovules, the ovules are borne in several rows.

ILLUSTRATIVE TYPES

Akebia. Monœcious. $K\ 3\ C\ 0$. Stamens free in both ♂ and ♀ flowers. Ovaries three to nine. Ovules in numerous rows.

Lardizabala. Polygamous or diœcious. $K\ 3 + 3\ C\ 3 + 3$. Stamens united in a tube in the ♂, free in the ♀ flower. Ovaries three. Ovules in several rows.

Decaisnea. Polygamous or unisexual and monœcious. $K\ 3 + 3\ C\ 0$. Stamens as in *Lardizabala*. Ovaries three. Ovules in two rows.

Stauntonia. Monœcious. $K\ 3 + 3$. C lacking in the ♀, present in the ♂ flower in the form of glandular structures adnate to the stamens and hence easily overlooked. Stamens free in both ♂ and ♀ flowers. Ovaries three. Ovules in several rows.

Holboëllia as *Stauntonia*, but anthers in the ♀ flower effete.

6. BERBERIDACEÆ

Flower cyclic, hypogynous. Perianth (calyx and corolla) of two or more, andrœcium of two, alternating di- or trimerous whorls. Gynœceum syncarpous. Carpels two, one of valve form, sterile, one consolidated, fertile (3, p. 128). Ovules in two or several rows, or two only, or solitary.

ILLUSTRATIVE TYPES

Epimedium. Carpels two; the sterile valve carpel small, without style and stigma, the fertile semi-solid carpel large, with style and small capitate stigma ('commissural') (3, pp. 131-133†; 16, p. 110‡). Ovules in two rows in the mid-line of the fertile carpel. Fruit dry, dehiscing by separation of the two carpels from above downwards, each having its own vascular system. This mode of dehiscence, which occurs also in the closely related genus *Vancouveria*, in *Achlys* with its small one-seeded fruit and large semi-circular stigma, and in the capsule of *Jeffersonia*, furnishes outward evidence of the bicarpellary construction of the gynœceum not afforded by the other genera in the Family which have indehiscent dry or succulent fruits.

***Berberis** (Barberry). Carpels two; one sterile and one fertile as in *Epimedium* (9, pp. 175-183†). Style with enlarged, completely symmetrical, rotate stigma. (This shape of stigma is not found in individual pinnately-veined carpels of the valve class, as commonly assumed and required on the traditional monocarpellary formula. See also under Nymphæaceæ.) Ovules one to several in the mid-line of the fertile carpel. Fruit a berry, indehiscent.

7. CRUCIFERÆ

Inflorescence generally bractless, *i.e.* without any exerted (free) foliar structure subtending the flowers (2†). Flower cyclic, hypogynous. K 4, orthogonal, in two pairs, the two lateral often larger, pouched and exerted slightly below the median pair in order to accommodate the nectaries which are situated in line with, or beside, the lateral stamens.

Exsertion of the four sepals of tetramerous types as two pairs at different levels occurs in many Families when the æstivation is imbricate (*i.e.* when the sepal margins overlap), even where there is no isobilateral nectary development. Furthermore, if a bract is present immediately beneath the calyx in a tetramerous flower, the vascular bundles for the four sepals may originate at as many as three levels, the posterior member first, then the lateral pair, and lastly the anterior member (18, pp. 179, 180†). These slight variations in level do not involve a disturbance of the primary rhythm which causes the corolla to alternate with the calyx as a whole.

C 4, diagonal. A 2, lateral, short + 4, diagonal, long (tetradynamous). The two median members of the outer whorl are lacking.

The occurrence in some genera (*Matthiola*, *Cheiranthus*) of occasional flowers with seven or even eight stamens, four short and four long, supports the view that the present-day condition A 2 + 4 has arisen by suppression from A 4 + 4. The vascular ground-plan precludes the supposition that the four inner members result from the division of a median pair. A trend towards still further reduction in the andrœcium is manifest in species of *Cardamine*, *Senebiera* and *Lepidium*, in which the number of stamens may range from six to two.

Nectaries, here outgrowths from the floral axis, are present in all genera, but vary in size, position and number.

In some genera (*e.g.* *Conringia*, *Crambe*) two large nectaries are formed in the lateral plane, one lying between the base of each lateral staminal filament and the ovary, and two smaller ones in the median plane and below the diagonal filaments. The large nectaries cause the outer lateral filaments to

be pushed still further outwards. Hence the pouching of the lateral sepals. In other types (*e.g. Berteroa incana*) four equal-sized nectaries are present, one on each side of each lateral filament. Here the result is again to force these filaments considerably further outwards (18, pp. 179, 180†).

Carpels four, orthogonal, in two pairs; two median, consolidated, fertile, two lateral, of valve form, sterile. Ovary with four vascular systems, separate at first, anastomosing later (18, pp. 191–193†); bilocular through the extension to the centre and subsequent fusion of the two fertile carpels which together form a median partition (replum). Ovules borne beside the midrib in two rows on each median carpel, or two only, or solitary. Stigmas, when borne on a longer or shorter style and distinct, centred over the fertile carpels ('commisural'); when sessile mainly over the valve carpels owing to the greater width of these carpels as compared with the solid pair. Fruit elongated (siliqua) or short (silicula). Siliqua with median carpels solid and lateral carpels of typical valve form (1, p. 453†); dehiscent by separation of the valve members from the conjoined solid pair. Silicula with median carpels semi-solid and lateral carpels of the valve type; dehiscent by rupture of the tissues in the same region as in the siliqua, consequently the fruit valves do not correspond exactly with individual whole carpels (3, p. 136†).

Two forms of silicula may be distinguished:

- (a) Compressed from side to side (latiseptal). Median carpels narrow, boat-shaped, lateral carpels broad, flat.
- (b) Compressed from back to front (angustiseptal). Median carpels broad, flat, lateral carpels narrow, boat-shaped.

ILLUSTRATIVE TYPES

Bunias orientalis. In a transverse section of the ovary the four carpels are seen to be similar in size, shape and venation, except for the formation of placental strands in the median pair (18, p. 195†).

Bunias Erucago. Fruit four-sided and four-winged, with four chambers arising through the undulations of the replum which fuses with the lateral walls of the ovary as it bends out of the vertical from one side to the other (8, pp. 47, 48 and 18, p. 195†). A 'key' genus (see p. 17).

***Cheiranthus Cheiri** (Wallflower). Stigmas 'commissural.' Fruit a siliqua.

***Matthiola incana** (Garden Stock). Stigmas sessile, stigmatic papillæ forming a continuous crest, but appearing centred over the valve carpels owing to their greater width. Fruit a siliqua. The lateral boundaries of the four carpels are well defined in the internal tissues by a narrow tract of thick-walled cells which bound the area supplied by each vascular system (1, p. 453†). In the glabrous (wallflower-leaved) strains these boundaries are particularly easily seen also on the surface owing to the absence of the tomentum.

Lunaria biennis (Honesty). Fruit a latiseptal silicula (3, p. 136†).

***Capsella Bursa-pastoris** (Shepherd's Purse). Fruit an angustiseptal silicula (3, p. 136†).

The variety **Heegeri** has a top-shaped silicula (3, p. 136†). This change of shape is due to increased breadth of the valve carpels and a corresponding decrease in that of the fertile members. The chromosome number is the same as in the type.

Biscutella (1, p. 467†). An exceptional genus in which the solid median carpels are sterile and the lateral valve carpels fertile.

The sporadic occurrence of three- and four-valved fruits in many genera in this Family (1, p. 464) and the existence of a few forms in which this condition is more or less stable and inherited (3, pp. 136-140†), point to the probability that the ground-plan of two valve and two consolidated carpels may have originated by reduction from a two-whorled gynæceum of four orthogonal, sterile, valve carpels + four diagonal,

consolidated, fertile carpels. Among such more or less stable exceptional forms are a three-valved strain of **Lepidium sativum**, and the following four-valved strains:—

Capsella Bursa-pastoris var. Viguleri (3, *loc. cit.*, and 9, p. 189†). Stem fasciated, chromosome number half that of the type.

Brassica campestris var. Sarson.

Tropidocarpum gracile var. capparideum.

Tetrapoma, probably merely a form of **Nasturtium palustre**.

Holargidium, probably merely a form of **Draba daurica**.

8. PAPAVERACEÆ

Flower almost always hypogynous. Generally K 2, median, caducous (falling before full expansion). C 2, lateral + 2, median. A ∞ or definite. G 2 — 10 — 12 + 2 — 10 — 12. Ovary unilocular, the fertile carpels not extending to the centre. Ovules generally in several rows, sometimes only in two rows, or two only, or solitary. Styles present and connate or absent, very rarely distinct, and then two, or four, or more. Stigmas generally distinct and borne by the fertile carpels ('commissural'), sometimes centred over the sterile carpels, sometimes borne by both kinds of carpels. If borne by both kinds and distinct, those of the one kind sometimes differing in form and function from those of the other; in types having several styles all similar. When sessile usually distinct, but sometimes confluent.

(i) PAPAVEROIDEÆ

Flower actinomorphic. A ∞ . G as above. Stigmas sessile, or borne on a single, or on separate styles. When sessile generally distinct, standing over the fertile carpels; sometimes confluent forming a continuous crest over all the carpels. When borne on a single style, sometimes centred over the valve carpels, each then representing $\frac{1}{2}$ \times $\frac{1}{2}$ carpels through median radial splitting of the fertile members; sometimes standing over the fertile carpels, each then representing one fertile member. (For the exceptional case of *Eschscholzia*, see under Illustrative Types.)

Discrepancies in the accounts of different writers regarding the position of the stigmas (through the attaching of significance to different features) make it desirable to amend in more precise form the statements made in 1, p. 469, and 8, p. 52. In *Chelidonium*, *Sanguinaria*, *Glaucium* and *Macleaya* the stigmatic papillæ form a continuous crest, depressed over the

slightly, or distinctly, shorter fertile carpels, standing higher over the valve members. In *Bocconia*, with a well-developed style and two stigmatic arms, the arms stand over the fertile carpels.

(ii) HYPECOIDEÆ

Corolla isobilateral (*i.e.* symmetrical about both median and lateral planes, but the median halves and lateral halves are dissimilar), or almost actinomorphic. A 2, lateral + 2, median, or a single whorl of four situated in the diagonal planes. G 2, lateral, of valve form, sterile + 2, median, solid, fertile. Style single, dividing above into two stigmatic arms, with the arms sometimes in line with the sterile carpels, sometimes with the fertile. Fruit generally pod-like, breaking across into numerous one-seeded segments; exceptionally dehiscent by two lateral valves.

(iii) FUMARIOIDEÆ

Corolla isobilateral, or zygomorphic and then exhibiting the exceptional condition of *lateral* symmetry. A 2, lateral + 2, median split into half stamens which stand beside the lateral members and arise, or become, conjoined with them for all or part of the length of the filament, thus giving rise to two groups of three. G 2, lateral, of valve form, sterile + 2, median, solid, fertile (3, p. 132†). Style single, formed of all four carpels, with four vascular bundles, expanding at the stigma level, with two pairs of receptive areas corresponding with the two pairs of carpels. Fruit siliquoid or siliculoid, dehiscent by two valves, generally many-seeded, rarely few-seeded; or indehiscent and one-seeded.

The characteristic difference in the conformation of the andrœcium in Hypecoideæ and in Fumarioideæ is associated with a corresponding difference in the vascular scheme.

In *Hypocoum*, with otherwise the same ground-plan as the Fumarioideæ, the sequence of events is as follows. The four vascular bundles in the floral axis break up into an outer

ring of four trunk cords in the orthogonal planes, and an inner set of four residual bundles on the intervening radii. These latter residual bundles, after a process of reconstruction, give rise to the main bundles of the four carpels; they become delimited and take up their position in the orthogonal planes before those of the outer whorls. The above-mentioned four outer trunk cords supply the bundles for the calyx, corolla and androecium, the two in the median plane furnishing successively those for the sepals, inner petals and inner stamens; the two in the lateral plane those for the outer petals and outer stamens. In every case the bundles for the members of a new whorl are detached whole from the inner face of the corresponding trunk cord.

A characteristic but trivial feature of the androecium has assumed some importance since, owing probably to the incompleteness of the original account, a cardinal point has come to be incorrectly represented in textbook diagrams (18, p. 209, Diagram A), and this error has led to a false inference. The connective in all four stamens is slightly prolonged above the pollen sacs. In the lateral pair, in which the connective is very narrow, this prolongation takes the form of a finger-like process, but in the rather broader median stamens, where the connective is much wider, it becomes a flattened expansion with a slightly emarginate outline. The vascular bundle, as well as the ground-tissue, is continued beyond the top of the pollen sacs. In the finger-like process of the lateral stamens the bundle remains unbranched, but in the median stamens it may break up into two, generally unequal, strands just beneath the prolongation. Now these strands are not, as is usually depicted, in alignment with the mid-line of each anther lobe. They continue upwards for a short distance in the central region of the expanded prolongation, and are aligned *between* the two lobes (*loc. cit.*, Diagram B). Branching of the vascular bundle, it may be noted, is very usual in the stamens of any type in which the connective terminates in a lamina-like expansion. The vascular development in the median stamens of *Hypocotum* has no more significance than in other such cases. It in no wise suggests, or supports, an origin of the median members from the fusion of two half stamens derived from primordia proper to the lateral pair. The statement of some writers that all four stamens in *Hypocotum* do, in fact, arise from two lateral primordia, must be due to error in observation. For four primordia are distinct from the outset, occupying the four sides of a rectangle. The erroneous interpretation of this appearance is probably due to the fact that the connective

of the median stamens is so broad that the two sacs of one median anther stand farther apart than the neighbouring sacs of a median and a lateral anther; hence the ready though mistaken supposition that, as in the *Fumarioideæ*, so also in *Hypocoum*, there are only two large lateral three-lobed primordia.

In the *Fumarioideæ* only the bundles for the lateral stamens are carried outwards conjoined with petal midrib bundles, and become detached later. Those for the median pair arise independently directly from the central cylinder. But this different mode of development will necessarily have its effect on the time relations. As the moment arrives for the development of the median staminal bundles, the conditions which have to be met in this new situation are as follows. The median petal bundles, which were carried out in the same trunk cords which supplied the sepal bundles (also median), have now become detached and occupy a position which blocks the emergence, both anteriorly and posteriorly, of a staminal bundle in the median plane. Furthermore, the interposition among the elements of the central cylinder destined to supply each median stamen of the elements which will become, but are not yet consolidated into, a median carpel bundle, precludes the consolidation of these staminal elements into a single compact group. They remain separated into two groups which must, of necessity, turn out from the central cylinder at two separate points to right and left of the median plane. Hence two bundles instead of one are formed for each median member of the andrœcium. Since this halving of the vascular complement has already occurred before the vascular elements involved turn out from the central cylinder, *i.e.* before the determinate phase has been reached, this condition is accompanied, not by multiplication, but by fractionisation of the corresponding member. Hence two half stamens develop in the anterior and posterior positions instead of one whole stamen.

ILLUSTRATIVE TYPES

(i) PAPAVEROIDEÆ

***Papaver** (Poppy) (8, p. 54†). Carpels 10 (or more or fewer), of valve form, sterile + 10 (or more or fewer), solid, fertile, forming incomplete partitions. (Direct evidence as to the outer-inner relation of the two carpel whorls is generally lacking since the basal portion of the valve carpel bundles has disappeared; it is not, therefore,

possible to tell the exact level at which they might be supposed to turn outwards. Analogy with other types leaves no doubt, however, that the valve members form the outer whorl.) Stigmas sessile over the fertile carpels. Fruit a capsule, dehiscing by apical pores through separation of the valve carpels at their apex from the solid members.

***Chelidonium majus** (Greater Celandine). Carpels two, lateral, of valve form, sterile + two, median, solid, fertile. Stigma lobes two on a short style, centred over the sterile carpels; each representing $\frac{1}{2}$ + $\frac{1}{2}$ carpels (see under account of Papaveroideæ). Fruit siliquoid, dehiscing by valves.

The occurrence has been observed in an exceptional flower of the formation of a placental cushion with a placental vascular bundle and placental hairs on one of the valve carpels (unpublished). This case, and similar examples elsewhere, show the relations between the different carpel types to be such that although the character of the carpels in any species is ordinarily constant, a change of conditions may bring about the transformation of one type into another.

***Glaucium flavum** (Yellow horned Poppy). Carpels and fruit as in *Chelidonium*. The considerable width of the fertile carpels renders the superficial carpel boundaries particularly conspicuous. Stigmas sessile. The receptive papillæ form a continuous crest standing higher over the longer valve carpels than over the fertile carpels.

Eschscholzia, a 'key' genus (see Part I, p. 17). Flower slightly perigynous. K 2, united into a hood, falling in one piece. C 2 + 2. A ∞ , originating in twelve groups and supplied by twelve main vascular bundles which undergo branching. These bundles lie in the median and lateral planes and in two additional intervening planes in each diagonal quadrant. This arrangement is most easily observed in a flower from which perianth and stamens have fallen, since the scars of the staminal

bundles are then plainly visible on the persistent 'collar' surrounding the ten-ribbed ovary. Gynæceum probably derived from a ground-plan of 12 + 12 carpels (1, p. 469-471). Of this total all in one whorl but, as a rule, only eight in the other develop. The outer-inner relation of the two whorls, as in *Papaver*, is not at once obvious, since the basal portion of the midrib bundles of the members of the incomplete whorl has been lost. Hence the vascular system of these members does not connect with the central cylinder. But since the carpels of the complete whorl (two fertile + ten sterile forming the ribs) lie on the same radii as the twelve groups of stamens, it is legitimate to conclude that the incomplete whorl of the valve carpels is the outer one. (The order in which these numbers are given in an earlier account (G 12 + 8, see (8, p. 53)) represents merely a natural order of descending magnitude, not the sequence in order of the whorls which had not then been definitely determined.) The four missing valve members are those on either side of the two median members of the complete whorl. Their disappearance may be attributed to restricted space conditions. All the eight persisting carpels are sterile, as normally are also all but the two median members of the inner whorl. Styles in the earlier flowers of the season generally four, two borne by the median fertile carpels and two centred over the two lateral groups of carpels. In species with a comparatively short-flowering season (*caespitosa*, *tenuifolia*) this number may remain constant, but in *californica* with a longer flowering season, only the two styles in the lateral plane are developed in the later flowers. Not infrequently in *californica*, less often in the smaller species, flowers occur with a higher number than four, especially in vigorous over-wintered plants in which six, eight, twelve, sixteen, or even twenty may be present (3, pp. 132-135†, and 7, pp. 616-617†).

These higher numbers occur when certain of the sterile carpels develop styles independently. These additional styles are sometimes formed by individual carpels. They are then slender and furnished with a single vascular bundle. Sometimes a common style may be formed by

Plan of the inner whorl of twelve carpels from a normal and from three exceptional flowers of *Eschscholzia*. The sterile carpels are represented by the small dots, the fertile carpels by the larger ones.

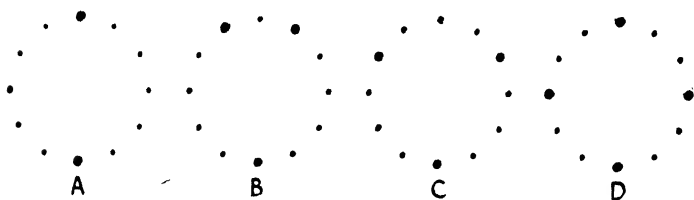

- A—Type. Two median carpels alone fertile.
 B—Exceptional. Three carpels fertile, separating unequal numbers of sterile carpels.
 C—Exceptional. Three carpels fertile, separating the sterile carpels into equal groups.
 D—Exceptional. Four carpels fertile, separating the sterile carpels into equal groups.

FIGURE 4.

two or three neighbouring carpels. They are then stouter and receive a corresponding number of vascular bundles. When the total number does not exceed twelve they are generally all borne by the carpels of the inner whorl. When more than twelve are present some are formed also by members of the outer whorl.

An increase in number is not, however, always entirely due to the formation of whole filaments, whether separate or connate, by carpels which are normally style-less. In some flowers it may happen that the twin placental vascular strands of a median carpel do not, as normally, converge and ultimately fuse, but remain distinct. When

this condition occurs two filaments, each representing half a carpel, may develop in place of the normal single filament representing a whole member.

Another unusual feature may occasionally be observed in early flowers. In these exceptional specimens, which are otherwise normal, one or two ribs in addition to the median pair of carpels bear a full quota of ovules. From the following illustrations of the cases investigated (unpublished) it is evident that any one of the ten normally sterile ribs can, in some circumstances, become fertile and so furnish further proof of its carpellary nature.

The above facts suggest that the normal *Eschscholzia* gynæceum is the outcome of a cruciferous trend superimposed upon a basically papaveraceous constitution.

Ovules ∞ , densely packed in several rows on the two median carpels.

Owing to crowding, many of the ovules must, of necessity, form exceptionally long funicles. They thus serve excellently to illustrate all stages in the development of the anatropous condition.

Fruit siliquoid, dehiscing into two lateral, ten-ribbed, compound (= many-carpelled) valves from which the thread-like, median, fertile members are easily detached. Exceptionally, the fertile carpels may remain behind as a U-shaped frame (replum) (I, p. 467, Fig. 46).

Sanguinaria canadensis. Carpels 2, lateral, of valve form, sterile + 2, median, solid, fertile. Carpel boundaries clearly outlined, not only on the glabrous surface of the ovary as in *Glaucium*, but also internally through the differentiation of a well-defined radial tract of parenchyma extending from the small-celled epidermis of the boundary lines to the loculus. In these features *Sanguinaria* resembles *Matthiola* (see under Cruciferae). Such anatomical delimitation of the carpels is rare. It occurs also, as stated earlier, in *Myristica* (see under Myristicaceae).

Hesperomecon (Platystigma) linearis. Carpels 3, solid, sterile + 3, semi-solid, fertile. The ovary is three-angled and three-sided. The narrow sterile carpels occupy the angles, the broad fertile carpels the flat sides. Ovules ∞ , borne in numerous rows as in *Papaver*. But as the fertile carpels in *Hesperomecon* do not, as in *Papaver*, form radial plates but are extended laterally, the ovules are spread over almost the whole of the ovary wall, the three angles alone being left bare (13, pp. 46-49†).

Platystemon. K 3 C 3 + 3 A ∞ G (typically) 12, of valve form, sterile + 12, solid, fertile. Ovary appearing almost apocarpous in the fruit through the presence of a deep furrow in the mid-line of each fertile carpel; unilocular, the main chamber being thrown out into twelve bays in line with the twelve valve carpels (13, p. 50†). Ovules in two rows on each fertile carpel. The bays are so narrow that there is only room in each at any one level for a single ovule to enlarge. Hence about half of the ovules mature in these side chambers and half in the central cavity (8, pp. 54-57†). Styles distinct, centred over the sterile carpels, stigmatic throughout their length on the inner face; each formed of $\frac{1}{2}$ \times $\frac{1}{2}$ carpels; with one vascular strand representing the vascular system of one sterile carpel conjoined with half that of the fertile carpel on each side.

(ii) HYPECOIDEÆ

Hypocoum. Corolla isobilateral. Petals 2, lateral + 2, median. Stamens 2, lateral + 2, median. Vascular bundles of the stamens derived from the same groups of elements as the petal midribs. Filaments separate. Anthers becoming coherent as they mature. G 2 + 2 (7, p. 617). Style single, formed of all four carpels with the four corresponding midrib bundles, ending in two stigmatic arms standing over the sterile carpels.

Each arm represents the termination of $\frac{1}{2} \times \frac{1}{2}$ carpels and receives three vascular bundles, *viz.* the midrib of a sterile carpel which shortly comes to an end, and persisting to the apex half the main bundle of the fertile carpel on each side. Fruit pod-like, breaking across into numerous one-seeded segments or, exceptionally, dehiscent by two lateral valves.

Pteridophyllum. Corolla almost actinomorphic. Petals four, orthogonal as in *Hypecoum*. Stamens four, diagonal. Filaments and anthers free. Style single, with two vascular bundles. These bundles are the main bundles of the two fertile carpels; those of the two sterile carpels come to an end at the top of the ovary. The style terminates in two short arms standing over the fertile carpels. Fruit siliculoid, dehiscent by lateral valves; the fertile carpels remain behind on the pedicel in the form of a U-shaped frame similar to that occurring in exceptional flowers of *Eschscholzia* (see above).

The diagonal position of the single staminal whorl is unique among Papaveraceæ. This interposition of a tetramerous diagonal whorl after the two dimerous orthogonal whorls of the corolla and before those of the gynæceum is probably to be attributed to the four-sided shape of the axis at this level, coupled with the fact that the vascular bundles for the perianth and stamen whorls, unlike those of *Hypecoum*, turn out from the central cylinder separately and independently. The contour of the axis at the level of origin of the stamen bundles is four-sided. This means more room for development on the longer diagonal radii, which correspond with the angles, than on the shorter orthogonal radii. After the emergence of the staminal bundles on the diagonal radii, development of the carpels on the orthogonal radii naturally follows.

A similar difference in the space conditions on the two sets of radii in all probability accounts for the antepetalous position of the outer carpels and loculi in some tetramerous Lythraceæ. In these types, in which the axis at the carpel level is also four-sided, the outer carpels stand on the diagonal radii and are antepetalous, whereas strict alternation should bring them on to the orthogonal radii in line with the sepals.

In regard to the form and position of the stigmas, *Pteridophyllum* affords a precise parallel with *Cheiranthus* (Wallflower) in Cruciferæ (see under that Family); *Hypocoum*, on the other hand, represents the counterpart in the present sub-Family of *Chelidonium* in the Papaveroideæ (see p. 45).

(iii) FUMARIOIDEÆ

***Corydalis.** Corolla zygomorphic, one lateral petal being spurred to accommodate the nectary. Filaments of the lateral stamens fused throughout their length with that of the half stamen on either flank. Stigmas in two pairs, of various forms. Ovules generally in two rows. Fruit siliquoid or siliculoid, dehiscing by two valves from below upwards, many-seeded.

***C. lutea.** Stigmas of the sterile carpels forming a basin in which the pollen collects (18, p. 209†), covered with a sticky secretion, receptive; those of the fertile carpels in the form of finger-like processes, capable of becoming receptive if smeared with the secretion of the sterile carpel stigmas. At the stigma level the fertile carpel bundles divide in half; the two halves diverge and anastomose with the sterile carpel midrib on each side.

***Fumaria** (Fumitory). Corolla and staminal filaments as in *Corydalis*; stigmas as in *C. lutea*. Fertile carpel vascular bundles remaining undivided in the stigma. Fruit one-seeded and indehiscent.

Dicentra. Corolla isobilateral, both lateral petals being spurred. Filaments of the lateral stamens free below from those of the half stamens, united with them above. Vascular bundles of the half stamens excentric

at the base of the filament. Their position on the side of the filament towards the median plane is consonant with their origin by the halving of the vascular complement proper to each of two whole median stamens. Ovules in more than two rows.

D. formosa, D. canadensis. The styler canal extends to the surface in the median plane in consequence of the splitting in half of the fertile carpel stigmas. Each half stigma of one fertile carpel fuses more or less completely with the half stigma of the other fertile carpel. Thus, an upper pair of stigmatic processes comes to be superposed upon the lower pair formed in line with the lateral sterile carpels. Such superposition naturally follows when each of the stigmas of the lower pair is that of one whole carpel, while each of those forming the other pair represents the conjoined halves of two different carpels. In *canadensis* it is possible to observe in transverse section a slight difference between the levels at which the vascular bundles for the lateral and median carpels become organised, an indication that the two pairs of carpels represent two whorls. In general this difference is not easily made out.

D. spectabilis, D. eximia. The styler canal extends to the surface in the lateral plane at the level of the sterile carpel stigmas. Hence the fertile carpel stigmatic areas alternate with those of the sterile carpels.

The zygomorphic genera *Corydalis* and *Fumaria* afford examples where members of the *same* whorl arise at different levels, owing to unequal development of either the members of a later whorl or of axial structures on the same set of radii (9, p. 184†, and 18, p. 209†). In the two above-mentioned genera the trunk cord supplying the bundle for the spurred member of the outer petal whorl leaves the central cylinder before the corresponding cord supplying the other unspurred member of the whorl. Thus time and space are afforded for providing accommodation for the nectary developed on that side. A similar disturbance of level occurs in those Cruciferæ having large lateral nectaries. In such types the bundles for the two lateral sepals leave the central cylinder at a lower level than those for the median sepals (see under Cruciferæ).

9. CAPPARIDACEÆ

Floral ground-plan based on the same tetramerous scheme as that of the Cruciferæ (*viz.* K 4, orthogonal. C 4, diagonal. A 2, lateral + 4, diagonal, tetradynamous. G 4, orthogonal, 2 being median, solid, fertile, 2 lateral, of valve form and sterile), but generally modified in various ways. Sepals, when imbricate, as in general in tetramerous types, in two pairs; when valvate, all four uniform. Disc often present, differing from the separate isobilaterally symmetrical nectaries of Cruciferæ in being either ring-shaped, or posterior and then associated with zygomorphy, as in Resedaceæ. Stamens exerted directly from the torus or, when a gynophore is present, sometimes conjoined for some distance with that structure (= androphore); generally 2 + 4, or numerous (12-100 or more) through subdivision of the primordia and corresponding vascular units of the outer whorl, or of both whorls. Rarely in two complete simple whorls (4 + 4), or in one complete whorl, the inner whorl being suppressed (4 + 0). Carpels either four in one whorl, with ovules in two rows on the two fertile carpels, as in Cruciferæ; or in two four-eight-membered whorls, the outer members of valve form and sterile, the inner solid and fertile, with ovules in several rows. Ovary uni-, bi- or multilocular according as the fertile carpels are columnar, only forming part of the outer wall; or are radially extended to meet in the centre forming a single 'replum,' or more than one septum. Fruit dry, siliquoid or siliculoid, dehiscent by two valves from the replum frame; or baccate and indehiscent.

ILLUSTRATIVE TYPES

Cleome. Very near to the crucifer type, but differing in various features as illustrated in the species cited below.

spinosa. C regular; no distinct disc, the gland tissue forming an unbroken layer on the surface of the axis;

A 2 + 4; fruit siliquoid. But K scarcely imbricate, A subequal and gynophore present. (Subequal stamens occur in the crucifer *Cardamine africana*.) In the glabrous ovary the surface boundaries of the two pairs of carpels are sharply defined as in similar Cruciferae, but there is no demarcation of these boundaries in the internal tissues, such as occurs in some cruciferous types, e.g. *Matthiola*.

trinervia. C regular, A 2 + 4 tetradynamous, ovary sessile, fruit siliquoid. But with posterior disc.

monophylla. C regular, A 2 + 4 tetradynamous, ovary sessile, fruit siliquoid. But with a shortly stipitate ovary. (A short stipe is present in some Cruciferae, e.g. *Cardamine subumbellata*, probably a form of *hirsuta*.)

scaposa, tenella. C regular, A 2 + 4, ovary sessile, fruit siliquoid. But A subequal (see above under *spinosa*).

brachycarpa. C regular, A 2 + 4, ovary sessile, fruit siliculoid. But A subequal (see above under *spinosa*).

violacea. A 2 + 4 tetradynamous, ovary sessile, fruit siliquoid. But C zygomorphic and large posterior disc present.

carnosa. Ovary sessile, fruit siliquoid. But C zygomorphic, A 4₂, short + 4, long.

trandra, quinquenervia, droserifolia, brachystyla, pruinosa, polytricha, macradenia, ovalifolia. Ovary sessile, fruit siliquoid. But A 4 + 0. (A 4 + 0 occurs in occasional flowers of species of *Lepidium* among Cruciferae).

Polanisia spp. Fruit siliquoid. But with ring-shaped disc and A > 6 owing to subdivision (A 10-16 occur in the crucifer *Megacarpaea polyandra*).

Gynandropsis spp. A 6. Fruit siliquoid. But androphore and gynophore present.

Mærua spp. Fruit siliquoid. But with ring-shaped disc, K valvate, A ∞ (4_x + 4_y), androphore and gynophore present.

Boscia spp. K 4 C 0 A 4 + 4 G 4 + 4 with gynophore. (The full complement of eight stamens is found occasionally in Cruciferae (individual flowers of *Matthiola*), and G 4 + 4 occurs as an occasional or more or less constant feature in many crucifer genera. Suppression of the corolla is common in species of *Cardamine*, *Lepidium* and *Cochlearia*.)

Capparis spinosa (Caper plant). K 4 C 4 A ∞ G 8 + 8 with gynophore. Ovules in numerous rows. Fruit baccate.

10. MORINGACEÆ

A small Family, including only the genus *Moringa*. Flower six-whorled, slightly zygomorphic, pentamerous with an oligomerous gynæceum (K 5 C 5 A 5 + 5 G (generally) 3 + 3). Andrœcium perigynous, the members of the antesepalous whorl often more or less staminodal. Staminal bundles carried out conjoined with the perianth midribs. Ovary borne on a gynophore, unilocular. Outer sterile carpels solid, inner fertile carpels semi-solid. The boundaries of the carpels are defined on the outer surface as in the siliqua of many Cruciferæ, but here the sterile carpels form the smaller arcs as seen in cross-section, and the fertile carpels the larger ones. Style single. Fruit a capsule, dehiscing by median longitudinal splitting of the sterile carpels into three valves, each of $\frac{1}{2}$ + $\frac{1}{2}$ carpels, bearing seeds down the middle line. It thus differs from the siliqua in which dehiscence occurs through the separation of whole carpels.

ILLUSTRATIVE TYPES

Moringa spp. See the characters of the Family.

II. RESEDACEÆ

Flower cyclic, hypogynous, rarely perigynous. Ovary syncarpous and unilocular, rarely apocarpous. When apocarpous, carpels generally 6 in one whorl, all similar and all fertile, with one or occasionally two ovules in each ovary, borne on, or beside the midrib. When syncarpous, carpels 3 or 4 or 6 sterile + 3 or 4 or 6 fertile, rarely 4 only, of which two are sterile and two fertile. Ovules two, or in two to several rows on each fertile carpel. Stigmas generally centred over the sterile carpels, sometimes over the fertile carpels ('commissural'), rarely over both.

ILLUSTRATIVE TYPES

***Reseda.** G syncarpous, unilocular, open above. Ovules in several rows on each fertile carpel. Stigmas sessile, borne by the sterile carpels or, exceptionally, by the fertile carpels as well.

R. odorata (Mignonette). G 3, solid, sterile (posterior and antero-lateral) + 3, semi-solid, fertile (anterior and postero-lateral) (6, p. 303† and 16, p. 110†).

***R. luteola** (Weld, Dyer's Weed). G 3 + 3 in the same positions as in *odorata* but with form and functions reversed, the anterior and postero-lateral being solid and sterile, the posterior and antero-lateral semi-solid and fertile (3, p. 129; 6, p. 303† and 16, p. 110†).

Astrocarpus sesamoides. A 'key' genus. The apocarpous gynæceum is unique, not among Resedaceæ alone, but among Dicotyledons, in that the single carpel forming each of the five or six ovaries is of the semi-solid class, bearing one or, occasionally, two ovules on, or beside,

the midrib. Each ovary when ripe dehisces down the ventral suture.

Randonia. Flower perigynous. Gynæceum syncarpous, of four orthogonal carpels, two median, solid, sterile, two lateral, semi-solid, fertile. Ovules in two rows. Stigmas sessile over the fertile carpels ('commissural'). The gynæceum ground-plan is similar to that of the Cruciferæ, but the functions of the two pairs of carpels are reversed.

Monocotyledons

12. LILIACEÆ

Flower hypogynous, isomerous and six-whorled, with diplostemonous androecium and antesepalous loculi. Exceptionally, five-whorled through absence of the second carpel whorl (*Tofieldia*, *Narthecium*). Generally K 3 C 3 A 3 + 3 G 3, sterile + 3, fertile (28, p. 309 and 7, p. 619†), rarely dimerous (*Maianthemum*) or tetramerous (*Paris quadrifolia*, *Aspidistra elatior*) (8, pp. 56–58†).

(Unlike the majority of corresponding Dicotyledons all six-whorled isomerous Monocotyledons are diplostemonous with antesepalous loculi. It is this fact which suggests the probable cause of that disturbance in the normal rhythm of alternation which results in antepetalous loculi and an obdiplostemonous androecium (see Part 1, p. 8).)

(a) Six-whorled types. G syncarpous. Ovary generally trilocular, rarely bi- or quadrilocular. Outer sterile carpels generally solid, rarely semi-solid; inner fertile carpels semi-solid forming the 'septa'; sometimes disjoined along their inner face above, rendering the ovary unilocular at the top. Ovules borne at the central end of the 'septa' ('axile' placentation). Each fertile carpel bears one row of ovules, or sometimes one ovule only, on each side. Thus, as always with this mode of placentation, the two rows (or the pair) of ovules in each loculus belong to different carpels, the one row (or the one ovule of a pair) being borne by the inner carpel bounding the loculus on one side, the other by the corresponding carpel on the other side. Styles generally united, sometimes separating above, or distinct throughout their length, or absent. When present, standing over the loculi. Stigmas in the styled forms more or less distinct, centred over the sterile carpels; when sessile, confluent,

forming a continuous crest surmounting both fertile and sterile carpels, but owing to the almost negligible width of the latter members appearing centred over the former. Fruit a capsule or a berry. When a capsule generally dehiscing loculicidally (through median radial splitting of the sterile carpels), sometimes septicidally (through similar splitting of the fertile carpels). Nectaries generally present; often as septal glands (interstitial median radial channels in the fertile carpels ('septa') lined by secretory cells and opening on to the surface of the ovary at varying heights); or in the form of a superficial, median furrow or notch, at the base of the fertile carpels; or they may be simply a localised region of the perianth members. When present as septal glands they involve the break-up of the vascular system of each fertile carpel into twin systems running up in the 'septa'.

(b) Five-whorled types. G apocarpous. Each ovary of one valve carpel.

ILLUSTRATIVE TYPES

(a i) Six-whorled types without septal glands. Fertile carpels as well as sterile carpels with a well-marked midrib bundle. Stamen bundles organised independently of those for the perianth.

Both *Tulipa* and *Fritillaria* occur in Britain but are represented by other species than those here cited.

Tulipa Gesneriana (Garden Tulip). G 3, solid, sterile + 3, semi-solid, fertile. Ovary bluntly three-angled with the sterile carpels at the angles and the fertile carpels forming the flat sides. Stigmas sessile, appearing centred over the fertile carpels. Nectaries absent. Fruit a capsule, dehiscing loculicidally (3, pp. 126, 158†, 163, 164† and 16, p. 106†).

The boundaries of the fertile carpels are delimited throughout the ovary on their inner face and on that

portion of the lateral face extending from the loculus to the sterile carpel midrib. On the inner face the surfaces though in contact are disjoined. On the lateral face the two limiting cell layers are continuous. They mark a potential but not an actual surface. (These features are easily observed in transverse sections of the ovary.)

***Lilium Martagon** (Turk's-Cap Lily). Carpels as in *Tulipa*, but the fertile members are undelimited throughout on their lateral faces, and only delimited on their inner face in the upper region of the ovary. Styles united. Stigmas three, centred over the sterile carpels. Nectaries in a median groove of both outer and inner perianth members. Fruit a capsule, dehiscent loculicidally (3, pp. 163, 164†).

Fritillaria Imperialis (Crown Imperial). Carpels of both whorls of the semi-solid type (well seen in the fruit), but the sterile members narrower than the fertile. Fruit a six-sided, six-winged capsule dehiscent loculicidally (3, pp. 126-128, 158†, 163, 164†). The wings represent the conjoined edges of two neighbouring carpels, as in *Bunias* (see under Cruciferae). Nectaries at the base of both outer and inner perianth members.

The three preceding types are exceptional in that the bundles for the stamens are not carried outwards conjoined with those for the perianth members, but are organised separately and independently. The flower, nevertheless, is diplostemonous with antesealous loculi, since the gynæceum becomes disjoined from the outer whorls below the level at which the carpels expand to accommodate the loculi.

(a ii) Six-whorled types with septal glands. The fertile carpels lack a definite midrib bundle, its place being taken by small veins on each side of the loculus. Stamen bundles not organised independently.

***Ornithogalum** (Star of Bethlehem), ***Allium** (Onion

and its allies), **Kniphofia** (Red-Hot Poker) and most other genera.

(a iii) Six-whorled types showing exceptional features in the gynæceum.

Aphyllanthes monspeliensis. A monotypic genus unique among Liliaceæ in that the style bears two separate sets of stigmas, both functional. The three terminating the sterile carpels spreading, broad and grooved; those of the fertile carpels erect and narrow. Nectaries in a median notch of the fertile carpels at the base of the ovary (8, p. 56†).

Aspidistra elatior. A common pot plant in rooms. Flowers borne at, or slightly below, soil level. Style ending in a large stigmatic plate on which the receptive papillæ form a continuous belt. The sinuosities in the pattern indicate that portions of this belt are derived from the sterile carpels and alternate portions from the fertile carpels (8, p. 56†).

(b) Five-whorled types.

***Tofieldia palustris.** The apocarpous gynæceum consists of three ovaries each formed of a single carpel of the valve type, in which midrib and placental strand(s) lie on the same radius (8, pp. 56-58†, 28, p. 311).

13. JUNCACEÆ

Flower hypogynous, isomerous and six-whorled with diplostemonous androecium and antesealous loculi (K 3 C 3 A 3 + 3 G 3, sterile + 3, fertile). The stamen bundles arise combined with the midrib bundles of the perianth members. Hence the conditions which give rise to obdiplostemony do not obtain here (see Part I, p. 8; also under Liliaceæ (Illustrative Types). Ovary syncarpous, trilocular or unilocular according as the fertile carpels merely constitute alternate portions of the ovary wall or, as well, extend as radial plates of tissue ('septa') to the centre. Fruit a capsule, dehiscing loculicidally.

ILLUSTRATIVE TYPES

***Juncus spp.** (Rush). Ovary trilocular.

***Luzula spp.** (Woodrush). Ovary unilocular.

Part 3

Dicotyledons

- Family 14. Geraniaceæ
- ” 15. Oxalidaceæ
- ” 16. Linaceæ
- ” 17. Tropæolaceæ
- ” 18. Erythroxylaceæ
- ” 19. Cneoraceæ
- ” 20. Balsaminaceæ
- ” 21. Rutaceæ
- ” 22. Zygophyllaceæ
- ” 23. Meliaceæ

Monocotyledons

- Family 24. Amaryllidaceæ
- ” 25. Iridaceæ
- ” 26. Orchidaceæ

Dicotyledons

14. GERANIACEÆ

Flower hypogynous, six-whorled, generally isomerous throughout and pentamerous, rarely oligomerous in the gynæceum, usually actinomorphic (3, pp. 213, 214). Nectaries generally present, most frequently in the form of five protuberances between the sepals and antesealous stamens. These glandular structures are usually supplied with undifferentiated, rarely with well-developed, vascular strands, detached from the sepal midrib bundles after the latter have left the central cylinder. Since these strands do not arise independently the nectaries do not 'count' in the scheme of alternating whorls. The radial position of the next whorl is therefore not affected. Andrœcium two-seriate, filaments cohering at the base, typically ten and obdiplostemonous, exceptionally fifteen, owing to duplication through splitting of the antepetalous members. Since the division into two portions of the vascular complement for each antepetalous member takes place outside the central vascular cylinder, such halving results in the formation of whole stamens. (This result is in contrast with that produced in the Fumarioideæ, where the division of the vascular complement for each member of the median pair of stamens takes place before the strands in question have turned out from the central cylinder, and where, therefore, only half stamens are developed (see Part 2, under Papaveraceæ).) Ovary generally beaked, star-shaped in cross-section, multi-locular, and when isomerous with antepetalous loculi. Fruit in isomerous types a schizocarp, dehiscing by tearing of the free portion of the outer valve carpels from the solid carpels; when oligomerous, a capsule dehiscing loculicidally.

The Family is divided into four tribes, of which Geraniæ is the largest.

GERANIÆ

Flower pentamerous. $G\ 5 + 5$, the outer antepetalous valve carpels fertile, the inner antesepalous solid ones sterile, a very exceptional condition (compare with *Biscutella* in Cruciferæ (see under that Family in Part 2) where, however, the two kinds of carpels alternate in the same whorl). Ovary generally prolonged into a beak, star-shaped in cross-section owing to the greater radial dimension of the valve, as compared with the solid carpels. This difference is sufficient to account for the obdiplostemonous condition, but exceptionally, it may be due to another cause (see under Illustrative Types). The beak passes above into a style which ends in five stigmatic arms standing over the valve carpels. Ovules two in each loculus of which only one matures. Fruit a schizocarp, the portion of the valve carpels forming the outer wall of the ovary splitting away from below upwards from the solid carpels which remain behind together with the placentæ of the valve carpels as a central column.

ILLUSTRATIVE TYPES

***Geranium** (Crane's Bill). Flower actinomorphic. Nectaries present between the sepals and antesepalous stamens with undifferentiated vascular strands. Both stamen whorls functional with well-developed vascular bundles. Bundles of the antepetalous stamens not carried out with the petal midrib bundles, and not apparently delimited simultaneously with them or from the same vascular units. Ovary beaked, showing in cross-section above the ovule level five tracts of conducting tissue which connect with the loculi. As the central parenchyma of the axis comes to an end the five tracts

fuse forming the core of beak and style, but again become distinct as the style gives rise to the stigmatic arms, one tract being continued into each arm. The placental strands of the fertile valve carpels are used up in supplying the ovules, but the midrib bundles are continued up the length of the beak and style into the stigmatic arms. As the ovary contracts above the ovule level to pass into the beak the midribs of the solid carpels give off a strand which, by analogy, may be considered to be a placental strand though it serves no ovules. The midrib bundles of these carpels are also continued up the beak to the top of the style where, however, they fork and then come to an end. It follows from the above that a transverse section of the style taken below the summit shows ten vascular bundles, and a section of each stigmatic arm only one bundle. Seeds solitary. When ripe the fruit splits through the tearing of the valve carpels from below upwards along their line of junction with the outer face of the solid carpels which, together with the placentæ, are left behind as a column. The edges of the basal portion of the valves, as they fall, are sufficiently wide apart to allow the seeds to remain behind on the placentæ. But the rupture of the fruit wall often causes the funicles also to break away. The loose seeds are then flung free. The awn (beak portion) of the detached valve remains straight and untwisted.

***Erodium** (Stork's Bill). Antepetalous stamens lacking anthers and vascular bundles. Edges of the basal portion of the detached valves of the fruit so near together that when shed they retain the seed. Awn becoming twisted and bent on drying. With antesealous stamen glands and in other respects similar to *Geranium* (16, p. 112, 113†).

Pelargonium. Flower zygomorphic. Nectary single, formed by a spur of the posterior sepal, adherent to the axis. The three front antepetalous stamens generally

sterile. Often also all five in the posterior sector, only the two antero-lateral antesepalous members then remaining functional. Vascular bundles of all the antepetalous members feebly developed. Filaments of these members flatter and thinner than those of the antesepalous whorl, causing the obdiplostemonous condition to be less pronounced than in *Geranium*. Solid carpels, though sterile, with placental strand in the upper part of the ovary as in *Geranium* and *Erodium*.

Monsonia. Nectaries as in *Geranium*, but with vascular bundles showing some differentiation. Stamens fifteen owing to duplication of the antepetalous members, separating into five groups of three with an antesepalous stamen as the middle member of each triplet. Vascular bundles of the antepetalous stamens carried out from the central cylinder conjoined with the petal midrib bundles. Hence in this genus it is unnecessary to presume a state of congestion as the cause of the antepetalous position of the loculi (see Part I, General Considerations, p. 9). Solid carpels without placental strand. Style with fifteen bundles owing to splitting in half of the solid carpel bundles. All fifteen bundles continue up into the stigma arms, three passing into each arm where they shortly fuse into one. Each arm therefore represents $\frac{1}{2} \times 1 \frac{1}{2}$ carpels. Awn as in *Erodium*.

Sarcocaulon (16, pp. 102, 103† and 117). Nectaries as in *Geranium*, but with well-developed vascular bundles. Stamens fifteen derived as in *Monsonia*, but all becoming free. Bundles of the antepetalous stamens delimited from the same vascular unit of the central cylinder as the petal midrib bundles, and carried outwards conjoined with them. Hence antepetalous loculi naturally follow as in *Monsonia*. Sterile solid carpels with placental strand in the upper part of the ovary. Style and stigma bundles as in *Monsonia*, but the three in each stigmatic arm remain distinct, showing still more plainly in this type that each arm represents $\frac{1}{2} \times 1 \frac{1}{2}$ carpels. Awn as in *Erodium*.

15. OXALIDACEÆ

Flower actinomorphic, hypogynous, six-whorled, typically pentamerous throughout (K 5 C 5 A 5 + 5 G 5 + 5) and obdiplostemonous with antepetalous loculi (10, pp. 197-214† and Pl. iv). Many species trimorphic, some (including the British forms) monomorphic. Stamens monadelphous below. Staminal tube glandular at the base.

In trimorphic forms the filaments of the antepetalous stamens are short, those of the antesepalous whorl either long or of mid-length. Exceptionally, the gland tissue may at first form a continuous ring (*Oxalis cernua*). As a rule it is localised at the base of the antepetalous stamens, arising beneath, and sometimes extending through almost the whole thickness of the filament at the level of origin (*Biophytum*). In the great majority of species, although it may produce a swelling (*Oxalis Origiesii*), it passes evenly without a break in the contour line into the non-glandular tissue of the filament, but in *Oxalis Acetosella* the five protuberances take separate shape. In some species the antesepalous filaments develop a dorsal concavo-convex non-vascular process, or the filaments may be merely broadened at the base to form a 'shoulder' on each side. Intermediate grades between the two conditions occur, even sometimes in the same flower. Very frequently the antepetalous filaments are glabrous and the antesepalous filaments hairy. When dorsal processes are present on the antesepalous filaments they behave as integral portions of these filaments. If hair-formation begins on the filament below the level of separation of the process, it, too, develops hairs. If the filament remains glabrous at this level, though becoming hairy higher up, the process remains glabrous. All the above facts indicate that both glands and processes are mere excrescences and are opposed to the conception that the latter structures represent surviving remnants of a lost external antesepalous stamen whorl. Fifteen stamens are present in the small genus *Hypseocharis*, but they do not constitute three alternating whorls. They arise in the same manner as the fifteen members of the androecium in the two geraniaceous genera *Monsonia* and *Sarcocaulon* (see under Geraniaceæ), and correspond to one antesepalous whorl and one antepetalous whorl which undergoes duplication (24, pp. 138, 139). *Averrhoa Carambo* with sterile antepetalous stamens similarly represents the counterpart in this Family of *Erodium* in the Geraniaceæ.

Ovary syncarpous, more or less star-shaped in cross-section, quinquelocular, becoming unilocular above as the central parenchyma of the axis comes to an end. Antepetalous carpels of the valve class and the antesepalous carpels then solid; or the antepetalous carpels contracted to the solid form and the antesepalous carpels then expanded assuming the semi-solid shape. In either case the antepetalous carpels are sterile and the antesepalous fertile. The functional relations of the two whorls are thus the opposite of those characterising the Geraniaceæ. Although, as a rule, only the fertile carpels form placental strands, a few species of *Oxalis* agree with the bulk of the Geraniaceæ in that vascular strands corresponding with placental strands are also formed by the sterile carpels. These exceptional species occupy an intermediate position between the typical representatives of the two Families. In them the functional change-over from the one set of carpels to the other has taken place, but the sequel to this change, the suppression of the non-functional placental strands, has not yet followed. Styles generally free and centred over the sterile carpels, rarely connate. Stigmas terminal, appearing more or less bilobed as the result of the revolute curvature of the dorsal portion of the stigmatic crest, and of the opening of the stylar canal to the surface below the apex on the ventral side. Fruit a capsule, dehiscent loculicidally through splitting in the mid-line of the sterile carpels; or baccate and indehiscent.

The vascular system of the sterile carpels shows various stages of degeneration. In some species a midrib persists throughout. In others it ceases to be differentiated from the level of origin of the first pair of laterals which are formed just beneath the loculus. Or the basal region may be lost so that each sterile carpel system no longer connects with the central cylinder of the axis. Species in which this latter condition obtains may be compared with certain members of

the Papaveroideæ (see Part 2, under Papaveraceæ). Or it may be untraceable throughout the whole carpel.

The fertile carpels become cleft radially in the region of the ovary from without inwards in the median plane. This halving is accompanied by a corresponding halving of the vascular system, so that as the ovary passes into the separate styles, each style shows two vascular bundles representing half the vascular system of the neighbouring fertile carpel on each side. If the sterile carpel midribs persist a third bundle occurs between the other two. Or this third bundle may be traceable only at intervals, the intervening portions being undifferentiated or obliterated. Each separate style filament, therefore, corresponds to $\frac{1}{2}$ \times $1\frac{1}{2}$ carpels.

When the capsule dehisces the five segments remain connected together if the central parenchyma of the axis persists in the ovule-bearing region as in *Oxalis*. If it ceases below this level as in *Biophytum* the segments separate in the form of a star.

ILLUSTRATIVE TYPES

***Oxalis**. See characters of the Family (10, *loc. cit.* and 16, pp. 112, 113†).

***O. corniculata**. With glandular areas at the base of the antepetalous stamens, but without distinct protuberances.

***O. Acetosella** (Wood Sorrel). With distinct glands at the base of the antepetalous stamens.

O. cernua. With a complete glandular ring.

O. valdiviensis, **O. incarnata**, **O. Ortgiesii**. Antepetalous stamens with a well-developed process. Sterile carpels of **Ortgiesii** without a traceable midrib, but with a central non-functional (placental) strand.

O. rubra, **O. articulata**, **O. latifolia**, **O. violacea**. Antepetalous stamens with a dorsal swelling extending laterally into a shoulder-like expansion (see Payer, *Organogénie* II, Pl. 11, Fig. 22).

***O. stricta**, **O. corniculata** var. **atropurpurea**. Sterile carpels with a vascular system (midrib and laterals) differentiated at the base, and continuous with the central vascular system of the axis.

O. articulata, **O. latifolia**. Basal region of the sterile carpel midrib undifferentiated or lacking.

Biophytum spp. (10, pp. 208–210†). Vascular scheme exceptionally simple and regular.

Averrhoa spp. (10, pp. 199 and 210, 211†). Sterile carpel midrib differentiated throughout.

16. LINACEÆ

Flower actinomorphic, hypogynous, six-whorled, typically pentamerous throughout (K 5 C 5 A 5 + 5 G 5 + 5) (3, pp. 148-150†), sometimes through duplication with more than ten stamens (*Ixonanthes*), sometimes with an oligomerous gynæceum (e.g. *Reinwardtia trigyna*), rarely tetramerous throughout (*Radiola millegrana*). Stamens monadelphous below, diplostemonous, generally dimorphic, antepetalous filaments then the shorter. Both whorls fertile or the antepetalous filaments non-vascular and without anthers (*Linum*), as in *Erodium* in Geraniaceæ and *Averrhoa Carambola* in Oxalidaceæ. Glands often present on the outer face of the staminal tube at the base of the antesepalous filaments. Ovary syncarpous, circular in transverse section when the carpels of the two whorls are of similar form, hence the diplostemonous andrœcium. Loculi in such types when pentamerous at first ten, later five, antepetalous, as the sterile carpels cease to extend to the centre and become more or less withdrawn into the ovary wall (*Linum*). Diplostemony also obtains even though the carpels of the two whorls differ in form so that the ovary is bluntly five-angled if the petal bundles at their origin block the way to the turning outwards of the antepetalous stamen bundles (*Hugonia Mystax*). This blocking has the further effect that the five outer sterile carpels and the loculi are then antesepalous. (It is natural that in the above circumstances the resistance to radial expansion on the petal radii should be greater than that normally to be overcome where the petal bundles lie further outwards. For another example of 'blocking' by the petal bundles, see Part 2, Papaveraceæ-Fumarioideæ, p. 48.) Styles generally distinct, rarely completely connate (*Ixonanthes*) or partially so (*Linum hologynum*). Stigmas terminal and

dorsally revolute as in Oxalidaceæ, or linear extending down the ventral surface. Fruit a capsule, dehiscing through median splitting of the carpels; or stone-like and indehiscent.

ILLUSTRATIVE TYPES

***Linum** (Flax). K 5 C 5 A 5 + 5 G (generally) 5 + 5 (16, pp. 112, 113†). Antesepalous stamens with glands, antepetalous filaments antherless, reduced to non-vascular teeth. Ovary circular in cross-section. Carpels of the two whorls similar, consolidated, fertile as well as sterile members with midrib bundle, sterile members antepetalous. Loculi at the base of the ovary where the sterile as well as the fertile carpels extend to the centre forming complete partitions, ten; at a higher level as the sterile carpels become withdrawn from the centre, five, in line with these carpels (3, *loc. cit.*). Styles distinct and centred over the sterile carpels, exceptionally partially connate (*e.g. L. hologynum*). Each with a single vascular bundle—the sterile carpel midrib. Fruit a capsule, dehiscing in the mid-line of each carpel into ten segments, each consisting of half a sterile and half a fertile carpel ($\frac{1}{2} \frac{1}{2}$).

The rupture of the sterile carpels occurs beside the midrib bundle, and does not immediately extend to the loculi. That of the fertile carpels takes place between the two strands into which the midrib bundle divides at the summit of the ovary. Rendered easier by this bifurcation of the midrib, splitting begins first in these latter members. As the splitting proceeds, the fruit as it dries gapes widely at the top and so permits the shedding of the seeds.

***L. usitatissimum**. Homostyled, stigmas linear, extending down the ventral face of the style.

***L. perenne**. Heterostyled, stigmas oval, capitate.

17. TROPÆOLACEÆ

Flower hypogynous, zygomorphic but with the plane of symmetry of the gynæceum diverging slightly from the median plane, reduced from a six-whorled pentamerous basic ground-plan (K 5 C 5 A 5 + 5 G 5 + 5) to K 5 C 5 A 8 (4 + 4) G 3 reaching full development + 3 traceable only by their vascular strands which soon cease, or 3 + 0 (3, pp. 148-150†; 10, pp. 211, 214 and 16, pp. 112, 113†). Derivation from a full pentamerous ground-plan is supported by the fact that in some exceptional flowers nine stamens are developed and that the additional member is then always situated in the median plane, being sometimes anterior, sometimes posterior. And by the further fact that in other exceptional flowers a whorl of five carpels attains full development with one carpel strictly median so that the plane of symmetry then coincides with the median plane. The carpels of the outer whorl, which alone take shape, are of the valve type and fertile. In this respect Tropæolaceæ differs from Oxalidaceæ and Linaceæ and agrees with Geraniaceæ. But in Tropæolaceæ the degeneration of the inner carpel whorl leads to the formation of separate monocarpellary ovaries held in position by a prolonged floral axis. Style single ending in three arms stigmatic at the tips in line with the three carpels.

ILLUSTRATIVE TYPES

Tropæolum majus (Nasturtium). See the characters of the Family.

18. ERYTHROXYLACEÆ

Flower hypogynous, six-whorled, pentamerous with an oligomerous gynæceum (K 5 C 5 A 5 + 5 G (generally) 3, sterile + 3, potentially fertile, but only one, as a rule, develops so far as to form ovules) (23, pp. 687, 688†). Stamens monadelphous at the base. Ovary with three loculi of which two become obliterated. The bundles for the antepetalous stamens are blocked at first in their course outwards from the central cylinder to the periphery by the petal midrib bundles so that they remain nearer the centre than the bundles of the antesepalous members. Hence the whorls of bundles regularly alternate at the level of origin. Similar 'blocking' by the petal bundles occurs in *Hugonia Mystax* (see under Linaceæ). Styles generally free, sometimes connate, centred over the sterile carpels.

ILLUSTRATIVE TYPES

Erythroxylum Coca. See the characters of the Family.

19. CNEORACEÆ

Flower hypogynous, generally trimerous, rarely tetramerous, five-whorled (K 3 C 3 A 3 G 3, solid, sterile + 3, semi-solid, fertile (23, p. 687†). Sepals without commissural marginal veins. Ovary borne on a stipe, three-lobed. Style single. Stigmatic arms three, centred over the loculi. Fertile carpels with an interstitial, median, radial, longitudinal split, as in some Rutaceæ. These slits are continued up the style. Alternating with the slits are three tracts of conducting tissue which succeed the closed loculi and three groups of three vascular bundles, each group representing the midrib of a sterile carpel and half the vascular system of the fertile carpel on each side ($\frac{1}{2}$ I $\frac{1}{2}$). Fruit splitting in the mid-line of each fertile carpel by the extension of the interstitial cleavage to the surface.

ILLUSTRATIVE TYPES

Cneorum tricoccum. See the characters of the Family.

20. BALSAMINACEÆ

Flower zygomorphic, hypogynous, six-whorled, having one staminal and three carpellary whorls in place of the usual two whorls of andrœcium and gynœceum, a unique construction, but paralleled in the case of the gynœceum by *Capsella Bursa-pastoris* var. *Viguieri* (see Part 2 under Cruciferæ), in which, however, all three whorls are vascular; pentamerous throughout (K 5 C 5 A 5 G 5 + 5 + 5) (10, pp. 209-214† and Pl. iv; 16, pp. 112, 113‡). Stamens with a continuous membranous, curtain-like outgrowth on the inner face of the filaments causing the whole andrœcium to be shed in one piece, sometimes extending so far over the stigmas as to hinder fertilisation. Carpels of the outer whorl antepetalous, of the valve type, with a midrib and pair of primary laterals, composing nearly but not quite the whole circumference of the ovary, sterile; those of the second whorl antesepalous, completing the circumference of the ovary, consisting of radial sheets of tissue (the partitions) extending from the surface to the central core and thus bounding the loculi, non-vascular, sterile; those of the third whorl constituting a central core with midrib bundles, from which arise the strands for the ovules, standing in line with the petals. In species in which this core forms a very slender column, the arrangement of the vascular elements in five distinct bundles is not always obvious, but where this tissue is more bulky the formation of five antepetalous bundles is clearly evident. The fertile carpels come to an end after bearing the uppermost ovules. The gynœceum then becomes unilocular with the partitions formed of the second carpel whorl projecting freely into the chamber. As the ovary passes into the short style the midribs of the outer carpels divide in half, the adjacent halves of neighbouring midribs fuse giving rise to five reconstructed bundles on the alternate

(sepal) radii. Shortly above this level the style ends in five stigmatic teeth standing in line with these bundles. The 'commissural' position of the stigmas reflects the presence of a middle (second) carpel whorl which must lie on the sepal radii. Fruit a capsule, dehiscing explosively through rupture of the delicate tissue of the partitions (second carpel whorl) in such a way that the outer carpels, together with torn portions of the second whorl, spring elastically away from the remaining central column formed of the third (fertile) whorl and the remnants of the second.

In the proportion of the ovary wall which they constitute, and in the demarcation of their surface boundaries, the second whorl of carpels in *Impatiens* may be compared with the solid carpels in the siliqua of the Cruciferæ. And in the extreme tenuity of the partitions which they form they resemble the fertile carpels of Caryophyllaceæ (see later under that Family).

ILLUSTRATIVE TYPES

****Impatiens*** (Balsam) is the only genus in the Family.

***I. noli-me-tangere** (Touch me not). The boundaries of the two outer carpel whorls are traceable on the surface of the ovary. As the ripe fruit explodes and the carpels of the second whorl are torn into shreds, the outer valve carpels become spirally coiled from below upwards; those of the fertile, third whorl thus become exposed as a central core from which the seeds are torn by the violence of the rupture.

I. tricornis. The vascular elements of the third carpel whorl appear in transverse section as five distinct bundles on the petal radii.

21. RUTACEÆ

Plant with numerous oil glands. Flower generally ♀ sometimes unisexual by abortion, hypogynous, typically six-whorled and pentamerous or tetramerous throughout, rarely trimerous (23). Exceptionally, zygomorphic; or five- or four-whorled through suppression of the antepetalous stamen whorl or of both this whorl and the corolla; or with ∞ stamens through splitting; or with an oligomerous gynæceum. Sepals generally with commissural marginal veins (23, p. 654, Figs. 24, 25). Both staminal whorls vascular; both fertile, or one whorl (sometimes the antesepalous, sometimes the antepetalous) sterile. When isomerous and six-whorled generally obdiplostemonous, since the antepetalous stamen bundles are usually carried out from the central cylinder conjoined with the sepal commissural marginal veins and petal midribs into one set of trunk cords. Exceptionally, the bundles for both staminal whorls turn out independently. In general this latter condition is likewise associated with obdiplostemony (see Part I, p. 8), but in one genus in which it obtains in this Family (*Calodendrum*) the development of a gynophore results in diplostemony (23, p. 654, Figs. 26-28) and antesepalous loculi. In some other types (e.g. *Ruta*) in which the bundles for both staminal whorls turn out independently and the loculi, as is to be expected where there is no gynophore, are antepetalous, the difference in level between the two staminal whorls is masked by the sinuous outline of the disc. Filaments cylindrical, free, or dilated and flattened at the base and then often monadelphous. Between the andrœcium and gynæceum a conspicuous, glandular, generally ring-shaped disc. Ovary of two carpel whorls, the outer sterile, the inner fertile; often more or less pseudo-apocarpous through median radial splitting from

without inwards of the fertile carpels (23, p. 646, Figs. 4-6). Styles completely connate or only united at the apex (23, p. 672, Figs. 85 C and D), often arising below the summit of the ovary, sometimes terminal. Stigmas completely united, or lappeted, or distinct, centred over the sterile carpels, but sometimes so divided and recombined as to form rays or arms over the fertile carpels (23, p. 650, Figs. 15, 16), each arm representing $\frac{1}{2}$ \times $\frac{1}{2}$ carpels. Midrib bundles of the sterile carpels rarely well-developed, a characteristic common among types with an abundant secretion of oil; those of the fertile carpels often untraceable, a condition frequently associated with premature radial splitting. Fruit sometimes dry, sometimes a leathery berry. When dry separating more or less completely into segments of $\frac{1}{2}$ \times $\frac{1}{2}$ carpels according as the splitting of the fertile carpels is partial or complete. The individual segments may remain stone-like and closed, or may split slightly or completely in the mid-line of the sterile carpels, giving rise in the latter case to two valves, each composed of half a sterile and half a fertile carpel ($\frac{1}{2}$ \times $\frac{1}{2}$).

ILLUSTRATIVE TYPES

Ruta graveolens (Rue). Flower isomerous, terminal pentamerous, lateral tetramerous, obdiplostemonous with antepetalous loculi. Sepals with true lateral veins. Ovary deeply lobed but remaining syncarpous. Sterile carpels with a differentiated midrib bundle. Style single arising below the summit of the ovary. Fruit dry, dehiscing at the apex in the mid-line of the sterile carpels.

Citrus spp. (Citron, Orange, Lemon, Lime, Shaddock) (23, p. 668, Figs. 65-68). A 5 + 5 or ∞ owing to splitting. Ovary completely syncarpous. Style terminal. Fruit a berry.

In the navel orange the axis, which normally in *Citrus* is prolonged up the centre of the ovary, bears a second series of

two carpel whorls, more or less completely enclosed by those of the first series and similar to them. In other strains with otherwise normal flowers the inner, fertile, carpel whorl is suppressed. The outer sterile carpels, unable under these conditions to become or remain united at their edges, form a ring of finger-like structures devoid of loculi and ovules (see Engler, "Die natürlichen Pflanzenfamilien," III, 4, p. 199, Fig. 116).

Zanthoxylum spp. (23, pp. 660, 661, Figs. 37-49). Flower unisexual by abortion. Gynæceum in the ♀ flower of two carpel whorls ($G n + n$), spuriously apocarpous through early radial splitting of the tissues proper to the inner carpels. The resulting ovaries of $\frac{1}{2} \times 1 \frac{1}{2}$ carpels split in the fruit into two valves, each consisting of half a sterile and half a fertile carpel ($\frac{1}{2} \frac{1}{2}$). Gynæceum in the ♂ flower lacking the inner carpel whorl ($G n + 0$) and hence with separate sterile carpels, with a loculus open above, and without ovules. The same features are to be seen in ♂ flower of *Phellodendrum* (23, p. 672, Fig. 88). In these two genera the male condition arises, as is often the case, from failure to develop the last (second carpel) whorl. Here this arrest in development is of regular occurrence. In the exceptional *Citrus* form cited above it occurs as a rare sport.

22. ZYGOPHYLLACEÆ

Plant without oil glands. Flower hypogynous, generally six-whorled, isomerous and pentamerous (K 5 C 5 A 5 + 5 G 5, sterile + 5 fertile), sometimes oligomerous in the gynæceum, obdiplostemonous with antepetalous loculi (23, pp. 673-683†). Sepals with commissural marginal veins. The antepetalous stamen bundles arise conjoined with these marginals and the petal midribs and in this way are carried out some distance from the central cylinder before they become independent. In some species the antesepalous stamen bundles are similarly carried out united with the sepal midrib bundles, but for a shorter distance, so that when detached they stand nearer the centre than the detached bundles of the antepetalous stamens. In these species obdiplostemony results, though from causes quite apart from a difference in radial dimension between the two carpel whorls (the usual cause of obdiplostemony in types in which the vascular bundles for the several whorls originate independently (see Part 3, p. 70)). Gynæceum syncarpous. Style single. Sterile carpel vascular system well-developed. Fruit generally a capsule, often deeply lobed, dehiscing through splitting in the mid-line either of the sterile carpels (loculicidally), or of the fertile carpels (septicidally).

ILLUSTRATIVE TYPES

Zygophyllum Fabago. (For illustrations of another species with a similar ground-plan see 23, Figs. 97-106.) Flower pentamerous throughout. Vascular ground-plan diagrammatically clear. The antesepalous and antepetalous stamen bundles are carried out from the central cylinder conjoined with the midrib bundles of the sepals and petals, respectively. The andrœcium is, nevertheless, obdiplostemonous, and the loculi antepetalous. (For the

explanation of these relations see the account of the Family.) Ovary tapering gradually into the style. Style without vascular bundles, the carpel midribs coming to an end as the loculi close ; with five tracts of conducting tissue standing over the closed loculi. As the central parenchyma comes to an end the stylar canal appears into which these tracts lead. Stigmas small.

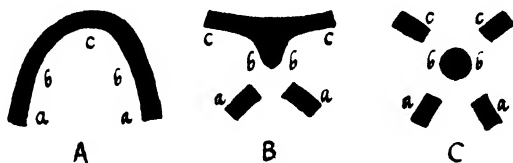

FIGURE 5.

Tribulus terrestris (23, Figs. 107-109). Flower, in the main, as in *Zygophyllum*. But the style is thick and solid ; with five stout vascular cords, each formed of a sterile carpel midrib together with half the system of the fertile carpel on each side ; dome-shaped at the apex with five longitudinal stigmatic furrows in line with the fertile carpels. Furrows confluent at the summit dividing the crown into five vertical stigmatic lobes in line with the sterile (antepetalous) carpels, each lobe consisting of one sterile carpel flanked by half the fertile carpel on each side ($\frac{1}{2}$ I $\frac{1}{2}$).

Peganum Harmala (23, Figs. 110-118). Perianth as in the preceding genera, but A $5 + 5_2$ and G generally oligomerous. Each of the five portions of the central vascular cylinder giving rise to sepal commissural marginal veins, petal midrib and the antepetalous stamen complement appears in cross-section in the form of an arc (as in A) which breaks up in the following way. The middle portion (c) yields two sepal commissural marginal veins.

The adjoining portions on each side (*b, b*) coalesce and become a petal midrib (see B and C). The residual separate portions (*a, a*) do not approach one another but remain distinct, hence the antepetalous stamen whorl is duplicated. *Peganum* thus corresponds in this Family, in respect of the androecium, to *Monsonia* and *Sarcocaulon* in Geraniaceæ and to *Hypseocharis* in Oxalidaceæ. Ovary becoming unilocular at the summit as the central parenchyma comes to an end. Style more or less 'gynobasic,' with as many pairs of vascular bundles as there are fertile carpels. The two bundles of each pair represent, respectively, half the vascular complement of the adjacent fertile carpel on each side of the intervening sterile carpel, the midrib of which came to an end below the style. Consequently there is no intervening bundle with which the bundles of each pair can coalesce, and they remain distinct.

Guaiacum officinale (23, Figs. 119-125). Perianth and androecium pentamerous (K 5 C 5 A 5 + 5). Gynæceum generally oligomerous (G 2, sterile + 2, fertile), rarely isomerous ; with distinct stipe. Upper region of the stipe and ovary in the dimerous gynæceum with two longitudinal furrows due to bilobing of the fertile carpels. In preparation for this change of shape the residual vascular cylinder in the basal region of the stipe becomes elliptical and then halved transversely. Each half portion represents the vascular complement of one sterile carpel flanked on each side by half that of a fertile carpel. *Guaiacum* affords an example of the utilisation for a reduced number of carpels of the entire residual vascular cylinder which in the isomerous gynæceum serves for the full number. In this respect this genus affords a parallel with *Myristica* (see under Myristicaceæ).

23. MELIACEÆ

Flower hypogynous, generally isomerous and six-whorled ($K n C n A n + n G n$, sterile $+ n$, fertile, n varying mostly from four to six) (23, pp. 685-687†). Stamens more or less monadelphous, filaments often with appendages. Disc in the form of a ring, or stipe-like, or absent. Ovary with n loculi. Loculi sometimes antesealous, sometimes antepetalous, according to the particular conditions obtaining in different genera (23, pp. 685-687†).

ILLUSTRATIVE TYPES

Melia Azedarach (23, Figs. 142-145). Flower six-whorled and isomerous throughout ($K n C n A n + n G n$, sterile $+ n$, fertile). Sepals with commissural marginal veins. Staminal filaments completely monadelphous. Those of both whorls with two non-vascular lateral appendages at the level of the anthers; sometimes with a smaller non-vascular dorsal appendage at a lower level as well. The vascular bundles of both whorls arise independently from the central cylinder. Between the andrœcium and the ovary which is circular in cross-section is a ring-shaped disc, which has the same effect as a gynophore in so far that although the stamen bundles of both whorls arise independently the loculi are antesealous. Sterile carpels lacking differentiated midrib bundles. Ovary multilocular, becoming unilocular above as the central parenchyma of the axis comes to an end. Style single, with a ring of n narrow cavities representing the n loculi not completely closed. Alternating with these slits n vascular bundles corresponding with n fertile carpels. In the centre a small canal filled at this level with conducting tissue with which the slit-like cavities connect at a higher level. Stigmas in the form of n teeth standing over the fertile carpels ('commissural').

Monocotyledons

24. AMARYLLIDACEÆ

Flower syngonous (see Part 1, p. 3), usually actinomorphic, sometimes zygomorphic, six-whorled, usually trimerous throughout ($K\ 3\ C\ 3\ A\ 3\ +\ 3\ G\ 3$, sterile, solid + 3, fertile, semi-solid). Exceptionally, A may be as many as eighteen through multiplication. The fertile carpels extend to the centre rendering the ovary trilocular. Outer carpels and loculi antesealous. Placentation 'axile.' Style single, tapering to a stigmatic point, or stigmas three, distinct, centred over the sterile carpels. Fruit generally a capsule, dehiscent loculicidally; sometimes a berry.

It is convenient to retain the term capsule for the dry, dehiscent, multi-carpellary fruit of syngonous types although the 'wall' of the ovary in such types is not composed strictly of the two carpel whorls but consists of the common undifferentiated base of all the whorls.

The floral vascular scheme is typical of the syngonous Monocotyledon. At the base of the flower six trunk cords turn out from the centre and pass up in the 'wall' of the ovary. Below the top they become resolved into their components. Those on the one set of radii yield the sepal midribs, antesealous stamen bundles, and the sterile carpel midribs which are prolonged into the style. Those on the other set of radii give rise to the petal midribs and antepetalous stamen bundles. The residual vascular elements left in the centre at the flower base become organised into the placental bundles of the fertile carpels which usually lack a midrib bundle.

ILLUSTRATIVE TYPES

Galanthus (Snowdrop). Corolla without a corona. Petals free, nectar-secreting. Ovary without septal glands.

***Narcissus** (Narcissus, Daffodil, Jonquil). Corolla with a corona, gamopetalous, without nectaries. Ovary with septal glands.

25. IRIDACEÆ

Flower syngonous, generally actinomorphic, seldom zygomorphic, five-whorled owing to suppression of the antepetalous stamen whorl, trimerous throughout (K 3 C 3 A 3 + 0 G 3, sterile, solid + 3, fertile, semi-solid). Ovary generally trilocular with 'axile' placentation, as in Amaryllidaceæ (see under that Family), rarely unilocular with 'parietal' placentation. Outer carpels and loculi antesealous. Style single, generally dividing above into three stigmatic branches centred over the sterile carpels. Stylar branches often bifurcate or notched, sometimes expanded and petaloid. Stigmas of various forms. Fruit a capsule, dehiscing loculicidally.

The vascular scheme of the flower is similar to that of the Amaryllidaceæ (see under that Family), except that no staminal bundle is detached from the cords on the petal radii. Since the bundles for an inner staminal whorl, if present, would not arise independently but would be combined with the petal midribs, suppression of this whorl does not affect the radial position of the outer carpels.

ILLUSTRATIVE TYPES

***Iris** (Flag). Base of the perianth tube nectar-secreting. Stylar branches broad, petaloid, notched, stigmatic on the under surface. Ovary without septal glands.

***Crocus**. Base of the perianth tube without nectaries. Stylar branches of various forms, stigmatic at the apex. Ovary with septal glands.

26. ORCHIDACEÆ

Flower syngonous, zygomorphic, six-whorled, based on the typical monocotyledon ground-plan (K 3 C 3 A 3 + 3 G 3, sterile + 3, fertile) but lacking some members of the andrœcium. Resupinate (inverted) owing to twisting either of the ovary or of the pedicel. The median stamen of the outer whorl invariably attains distinct morphological form whether sterile or fertile. The two adjacent members of the inner whorl also reach morphological expression when fertile and occasionally when sterile. The two other members of the outer whorl are represented in some genera by auricles on the labellum (unpaired petal), in others merely by vascular strands running in the margins of the labellum. The third member of the inner whorl, often wholly absent, is sometimes represented by a vascular strand running in the short, central stamen-style column. (The relations of the orchidaceous andrœcium were first established by Darwin (1862), who investigated the course of the vascular bundles. His observations and deductions stand to-day (see Illustrative Types), and afford the classic example of the use of the vascular ground-plan for the elucidation of the floral ground-plan.) Outer carpels antesepalous, solid, sterile; inner carpels antepetalous, semi-solid, fertile (3, pp. 126, 127 and 16, p. 106†). Ovary trilocular with antesepalous loculi or unilocular according to whether the fertile carpels extend to the centre or not. Styles generally wanting; when present, three, distinct, borne by the sterile carpels. Stigmas, where sessile, confluent, centred over the sterile carpels. Fruit generally a capsule, in some types dehiscent by three slits in line with the sterile carpels, in others by six slits at the carpel junctions.

The Family is divided into two sections.

(i) MONANDRÆ

The unpaired outer stamen with anther, the two lateral members of the inner whorl staminodal. The unpaired median stigma in the form of a non-receptive cushion (rostellum), the two others functional. Ovary twisted.

(ii) DIANDRÆ

The unpaired outer member of the androecium staminodal, the two lateral members of the inner whorl with anthers. All three stigmas receptive. Pedicel twisted.

For a reversal of function between two whorls of the same kind of member, such as that occurring between the two staminal whorls in the Monandræ and Diandræ, comparison may be made with that occurring between the two carpel whorls in *Reseda odorata* and *R. luteola* (see under Resedaceæ and 16, p. 110, Diagrams 15, 16).

ILLUSTRATIVE TYPES

(i) MONANDRÆ

***Epipactis palustris.** The vascular ground-plan below the exertion level of the perianth consists of six trunk cords standing on the radii of the sepals and petals. Each of the cords on the three sepal radii breaks up into three bundles. The outermost of the three becomes a sepal midrib, the innermost the midrib of a sterile carpel. The middle bundle on the radius of the unpaired sepal enters the fertile stamen. The corresponding bundle on the radii of the paired sepals runs in the marginal portion of the unpaired petal (labellum), as described by Darwin. The fact that these two bundles originate in the same manner as the bundle for the fertile stamen indicates that they also represent staminal bundles, the members to which they belong having been converted into petaloid structures fused completely with

the intervening petal. As commonly happens when any member undergoes petaloid modification the bundles give rise to a branch system. (Petalody of members of the

Diagram of the vascular ground-plan of *Epipactis* showing the significant difference in origin of the marginal veins in the paired and unpaired petals, respectively, those of the paired petals originating from the same trunk cords as the petal midribs, those of the unpaired petal originating from trunk cords on the alternate (sepal) radii.

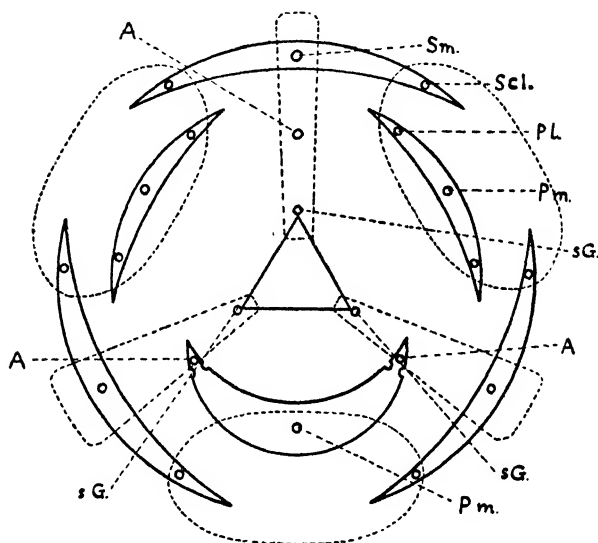

S m.—Sepal midrib. *Scl.*—Sepal commissural lateral. *P m.*—Petal midrib. *PL.*—Petal lateral. *A, A, A*—Bundles of the outer staminal whorl. *sG, sG, sG*—Bundles of the outer (sterile) carpel whorl.

FIGURE 5.

androecium of this character occurs as a normal feature also among Primulaceæ, Theophrastaceæ, Labiatæ, and as an exceptional modification in some Veronicas.) Each of the trunk cords on the petal radii gives rise to a commissural marginal vein for the sepal on either side and a

petal midrib. Each of the two paired petals has, in addition to the midrib, a pair of primary laterals, derived from the corresponding trunk cord though fused at first with the sepal commissural lateral on the same side. Thus a triplet of bundles enters each petal at the exertion level. But it follows from the above facts that the marginals of the paired petals and of the unpaired petal not only originate in a different way but represent structures of a different morphological order. The former are merely lateral branches of the petal system, the latter are the midribs of staminal members. No further break-up of the petal cords takes place for (1) the unpaired member of the inner stamen whorl is suppressed without trace, (2) the two persisting staminodes are non-vascular and (3) the fertile carpel system ends at this level, only the sterile carpel midribs being prolonged to the stigma level. Ovary unilocular.

The vascular relations set out above are illustrated in the accompanying diagram, in which the several bundles derived from the break-up of each original trunk cord are enclosed in a ring.

***Orchis spp.** Outer median stamen pollen-bearing, lateral members (if present) staminodal. Two stigmas functional, one (rostellum) non-receptive. Ovary conspicuously twisted.

(ii) DIANDRÆ

***Cypripedium Calceolus** (Lady's Slipper). Outer median stamen staminodal, lateral members pollen-bearing. All three stigmas receptive. Vascular ground-plan similar to that of *Epipactis* except that each of the trunk cords on the radii of the paired petals gives rise to a staminal bundle as well as to the petal system and to the sepal commissural laterals. For the fertile stamens which replace in this section the non-vascular staminodes of the Monandræ are always vascular.

Part 4

Dicotyledons

- Family 27. Limnanthaceæ
- ” 28. Violaceæ
- ” 29. Caryophyllaceæ
- ” 30. Portulacaceæ
- ” 31. Malvaceæ
- ” 32. Bombacaceæ
- ” 33. Sterculiaceæ
- ” 34. Tiliaceæ
- ” 35. Sarraceniaceæ
- ” 36. Droseraceæ
- ” 37. Nepenthaceæ

Monocotyledons

- Family 38. Gramineæ
- ” 39. Juncaceæ

Dicotyledons

27. LIMNANTHACEÆ

Flower hypogynous, six-whorled, isomerous ($K\ n\ C\ n\ A\ n + n\ G\ n$, sterile + n , fertile), diplostemonous notwithstanding that the vascular bundles for both staminal whorls turn out from the central cylinder independently (10, pp. 197, 198†). Gynæceum pseudo-apocarpous through separation of the outer carpels at first from each other as the intervening disc tissue comes to an end, and then from the central column formed by the inner whorl. Outer carpels antesealous, of valve form, fertile; inner carpels antepetalous, solid, sterile, prolonged upwards into the single style which is completely 'gynobasic.' Stigmatic arms standing over the fertile carpels ('commissural').

This Family agrees with Geraniaceæ in the exceptional feature that it is the outer carpel whorl which is fertile; but differs in that these carpels and the loculi stand on the sepal radii.

ILLUSTRATIVE TYPES

Limnanthes Douglasii. Flower pentamerous ($K\ 5\ C\ 5\ A\ 5 + 5\ G\ 5$, fertile + 5, sterile) (10†). Sepals without commissural marginal veins. Antesealous stamens with a dorsal gland, as in some Geraniaceæ (e.g. *Erodium* see p. 71). The disposition of the outer carpels (and hence of the loculi) on the sepal radii (with consequent diplostemony) is attributable to the following features: (1) the almost complete separation of the outer carpels from each other and from the inner carpels, and (2) the early disappearance of the central parenchyma which gives place to a large cavity (stylar canal) into which the fertile carpels protrude. Both these features serve to lessen the state of compression or congestion which, presumably, accompanies expansion of the carpels in a completely syncarpous gynæceum in which the centre is occupied by tissue.

28. VIOLACEÆ

Flower ♂, rarely polygamous or diœcious, zygomorphic or almost actinomorphic, five-whorled, generally pentamerous with an oligomerous gynœceum (K 5 C 5 A 5 G 3, sterile + 3, fertile, or 2, sterile + 2, fertile). Ovary unilocular, placentation 'parietal' (7, pp. 618-620†). Style single. Stigma terminal, generally single, rarely with lobes corresponding in number with the sterile carpels. Fruit generally a capsule, dehiscing through median longitudinal splitting of the sterile carpels; rarely a berry.

ILLUSTRATIVE TYPES

***Viola** (Violet, Pansy). Generally herbs. Flower zygomorphic. Sepals five, equal, prolonged below the level of exsertion. Petals five, unequal, the unpaired anterior member spurred to contain the nectar secreted by appendages on the two antero-lateral stamens. G 3 + 3, outer carpels of valve form and sterile, inner semi-solid and fertile. Ovules borne in two to several rows. Style single, receiving only the vascular bundle of the anterior sterile carpel (16, p. 110, Diagram 17). Fruit a capsule, dehiscing loculicidally.

Hymenantha. Generally shrubs. Flower almost actinomorphic. K 5 C 5 A 5 G 2 + 2. Style receiving the vascular bundles of the two sterile carpels. Stigma bilobed, lobes standing over the sterile carpels. Fruit a berry.

29. CARYOPHYLLACEÆ

Flower hypogynous, actinomorphic, generally ♂ and six-whorled, pentamerous or tetramerous throughout, or with an oligomerous gynæceum (17, pp. 239-261†‡ and 283-285); sometimes lacking the antepetalous stamen whorl, or both this whorl and the corolla; exceptionally, unisexual. Sepals generally with conspicuous commissural marginal veins. Andrœcium diplostemonous. Staminal bundles arising independently from the central cylinder (commonly in Silenoideæ), or derived from the same vascular unit as the perianth bundles (commonly in Alsinoideæ). Gynophore often present. Both outer, sterile, and inner, fertile carpels with midrib bundles; these extend equally far outwards so that the ovary is circular in cross section. Hence isomerous six-whorled types exhibiting these features, even though the bundles for the andrœcium arise independently, are nevertheless diplostemonous (see Part I, p. 8). Ovary multilocular at first, becoming unilocular above as the fertile carpels ('septa') cease to reach the centre and become free on their inner face. In the fruiting stage the unilocular condition obtains throughout owing to the drying up of the thin sheets of parenchyma forming the 'septa.' The result is to leave the placental column in the centre detached from the ovary wall, and to bring about the appearance of 'free-central' placentation. Loculi in isomerous types possessing a gynophore and in those without a gynophore in which the staminal bundles are derived from the same vascular units as the perianth bundles, antesealous; in those without a gynophore in which the staminal bundles arise independently, antepetalous. Styles and stigmas distinct, standing over the sterile carpels. Fruit generally a capsule opening by apical teeth through splitting in the mid-line of the

fertile carpels (*Lychnis*), or of the sterile carpels (*Agrostemma*), or of both (*Melandryum* and *Cerastium*). In *Lychnis* and *Agrostemma* each tooth represents $\frac{1}{2}$ $1\frac{1}{2}$ carpels, and stands in the former case in line with the sepals, in the latter in line with the petals. In *Melandryum* and *Cerastium* each tooth represents the conjoined adjacent halves of two neighbouring carpels ($\frac{1}{2}$ $\frac{1}{2}$) and stands neither in line with the sepals nor with the petals, but on the intervening radii. Rarely a berry.

ILLUSTRATIVE TYPES

(i) SILENOIDEÆ

Calyx gamosepalus.

**Lychnis* spp. (e.g. *L. cœli-rosa* (17, Figs. 1-14 and p. 261, Diagrams A and B), **L. flos-cuculi*, Ragged Robin). Flower six-whorled, pentamerous throughout. Staminal bundles arising from the central cylinder independently. Gynophore present. Sterile carpels and loculi antesepalous. Fruit opening by five teeth in line with the sepals.

**Agrostemma Githago* (Corn Cockle) (17, Figs. 16-18 and p. 261, Diagrams C and D). Flower six-whorled, pentamerous throughout. Staminal bundles arising from the central cylinder independently. Gynophore absent. Sterile carpels and loculi antepetalous. Fruit opening by five teeth in line with the petals.

**Melandryum album* (17, Figs. 19-27). ♀ Flower four-whorled, pentamerous. Base of the corolla tube with ten staminal bundles, five standing in line with the sepals and five with the petals. But the staminal members do not attain morphological form and the bundles shortly come to an end. Hence despite the absence of a gynophore the sterile carpels and loculi are antesepalous. Fruit opening by ten teeth alternating with the ten radii of the perianth whorls.

***Cucubalus baccifer** (probably introduced) (17, Figs. 41-46). Flower pentamerous, but with an oligomerous gynæceum (G 3 + 3). The separate vascular systems of the fertile carpels are particularly clearly defined, in contrast with those of the preceding types which often remain in contact and undefined until the carpels are about to separate along their inner face. Fruit a berry.

(ii) ALSINOIDEÆ

Sepals free.

***Cerastium spp.** (*e.g.* **C. arvense**, Field Chickweed) (17, Figs. 47, 48). Flower six-whorled, pentamerous throughout. Gynophore absent. Staminal bundles derived from the same vascular units as the perianth bundles; hence the sterile carpels (and therefore the loculi) are antesealous despite the lack of a gynophore. Fruit opening by ten teeth alternating with the ten radii of the perianth whorls.

30. PORTULACACEÆ

Plant more or less succulent. Flower generally ♀, hypogynous, actinomorphic, rarely partially syngonous (*Portulaca*) or slightly zygomorphic (*Montia*). Sepals generally two, free or united at the base. Petals five. Stamens sometimes five superposed on the petals or fewer through suppression; sometimes numerous through multiplication associated with branching of the corresponding vascular units; sometimes originating also on the sepal radii. Carpels in two whorls, generally 3 + 3, sometimes 2 + 2, rarely 4-8 + 4-8, the outer of valve form and sterile, the inner solid and fertile, both with midrib bundles. Ovary tri-, di- or multilocular below, becoming unilocular above, with placentation as in Caryophyllaceæ (see under that Family). Style single. Stigmas distinct, as many as the sterile carpels, and standing over them. Fruit a capsule, dehiscing in the mid-line of the sterile or of the fertile carpels, or transversely, or remaining closed.

The vascular bundles for the stamens are derived from the same vascular units as the perianth bundles. When only one whorl of stamens is represented, whether by five or fewer stamens, or by a larger number due to multiplication, the corresponding bundles are detached only from those units which furnish the petal midribs. Hence in such forms petals and stamens are superposed.

ILLUSTRATIVE TYPES

**Claytonia perfoliata*. K 2, united. C 5, petals separate and equal. A 5, superposed on the petals. G 3, sterile + 3, fertile. Fruit a capsule, dehiscing loculicidally into three valves.

***Montia fontana** (Blinks, Water Chickweed). K 2, united. C 5, petals unequal, conjoined except anteriorly. A 3 owing to the suppression of the two postero-lateral members. G 3, alternating with the stamens, sterile + 3, fertile, opposite the stamens. Fruit a capsule, dehiscing loculicidally into three valves.

31. MALVACEÆ

Plant generally with abundant mucilage and with reduced vascular development in the gynæceum. An epicalyx often present. Flower generally hypogynous, rarely slightly perigynous, five-whorled owing to the suppression of the antesealous stamens, generally pentamerous (27, pp. 247-282†), sometimes with a pleiomerous (27, Figs. 76, 79), rarely with an oligomerous gynæceum (27, Figs. 25-28). Calyx valvate. Sepals generally with commissural marginal veins. Corolla contorted. Stamens conjoined into a tube, sooner or later becoming free above. Those of the antesealous whorl suppressed without trace. Those of the antepetalous whorl generally numerous, disposed in two linear series in front of each petal; rarely as few as ten. Filaments with reniform, half (monothecal) anthers. The halving and arrangement are explained by the fact that the vascular bundle for each petal and those for the superposed double group of stamens are derived from the same delimited tract of vascular elements. Hence the superposition upon the petals of the one staminal whorl present. This vascular tract is extended tangentially so that in transverse section it appears as an arc. The petal component is located in the central region of the arc, hence the staminal component is divided in two (27, Figs. 4, 6, 7, 36, 38-41, 81). This division takes place before the determinate phase in development has been reached, hence the halving of the staminal members. (A similar halving of members of the androecium occurs in *Fumarioideæ*, see under *Papaveraceæ*, Part 2, p. 48). The initial halving is followed by numerous further divisions, but since the determinate phase has by that time supervened, these later divisions do not cause further fractionisation but merely lead to a corresponding increase in the total number of half stamens.

As the filaments become free each receives a single vascular bundle. Only in *Sidalcea* and *Kydia* do the filaments become detached in groups (phalanges) constituting in the latter genus a single series, in the former two series, one within the other. The tube ends above in most genera in a truncate rim ; in others in five simple or lobed teeth in line with the petals. These teeth represent sterile prolongations of the members of the antepetalous stamen whorl (27, Figs. 18, 20, 21, 23). Styles connate, ending in free stigmatic branches. The number of carpels and loculi and their position, and the number of stigmatic branches vary, but are more or less uniform in the four sections of the Family.

(i) MALVEÆ

G 10 (or more or fewer), sterile + 10 (or more or fewer), fertile. Styles more or less 'gynobasic.' Stigmatic branches equal in number to, and centred over, the sterile carpels, each formed of $\frac{1}{2}$ x $\frac{1}{2}$ carpels. Fruit consisting of numerous cocci formed by median radial splitting of the fertile members ; or of several-seeded partial fruits, separating from the prolonged floral axis or remaining attached, opening or remaining closed (27, Figs. 24 and 66-81).

(ii) URENEÆ

G 5, sterile + 5, fertile ; loculi 5, generally antepetalous sometimes antesepalous, the position varying in accord with variations in the manner of origin of the vascular bundles for the carpels. Loculi originally antepetalous, may later, owing to torsion of the corolla, come to occupy intermediate radii between those of the sepals and petals (27, Fig. 30). Style column 'gynobasic' (27, Fig. 31). Stigmas distinct, borne by the fertile as well as by the sterile carpels. The formation of separate styles or stigmas by both sterile and fertile carpels is an exceptional

feature of rare occurrence. It is a distinguishing characteristic of *Aphyl'anthes* among Liliaceæ (see under that Family) and of some Eriocaulaceæ, and is met with as an exceptional feature, varying in the extent to which it is expressed, in *Eschscholzia* (see under Papaveraceæ). All the genera included in Ureneæ, like those in other Families cited above, have therefore a special interest as 'key' types. Fruit of five cocci formed by median radial splitting of the fertile carpels (27, Figs. 19-23, 29-34 and 36-57).

(iii) MALOPEÆ

$G \infty + \infty$, the carpels in each whorl developing in a continuous succession from five fixed points. Premature median radial splitting of the fertile carpels gives rise to separate ovaries at an early stage, each ovary being composed of $\frac{1}{2} \text{ I } \frac{1}{2}$ carpels. The ovaries appear in five 'fields,' antesepalous or antepetalous according to the position of the points at which carpel development begins, which in turn depends upon the position of the original points of disjunction of the corolla-andrœcium tube from the gynœceum. Later, owing to the piling up of the ovaries in five double vertical rows, the original 'fields' become divided in half and new 'fields' are built up on the alternate radii. Styles 'gynobasic,' conjoined below, separating above into five phalanges. Individual style filaments as many as the carpels in one whorl, centred over the sterile members. Each filament composed of $\frac{1}{2} \text{ I } \frac{1}{2}$ carpels. Fruit of ∞ one-seeded cocci remaining *in situ* or becoming detached from the axis (27, Figs. 35 and 58-65).

(iv) HIBISCEÆ

G generally $5 + 5$; loculi 5, antesepalous. Styles terminal. Stigmatic branches 5, centred over the sterile carpels. Each branch formed of $\frac{1}{2} \text{ I } \frac{1}{2}$ carpels (27, Figs.

13-16). Exceptionally, $G\ 10 + 10$; or through reduction $3 + 3$ or $2 + 2$; or through suppression of the entire outer sterile whorl 5-3 in one whorl, all semi-solid and fertile. Fruit a capsule, dehiscing loculicidally (27, Figs. 1-18 and 25-28).

ILLUSTRATIVE TYPES

(i) MALVEÆ

***Malva spp.** (Mallow). Plant with abundant mucilage. Epicalyx present. Sterile carpel vascular system feebly developed. Fruit of numerous cocci arranged in a ring round a prolongation of the axis.

Abutilon spp. Plant without mucilage reservoirs. Epicalyx absent. Carpel vascular scheme diagrammatically clear (27, Fig. 67); the system of the sterile carpels well differentiated. Partial fruits with several seeds.

Sidalcea spp. The twin vascular cords of each antepetalous stamen complement undergo tangential as well as radial division. At its summit the staminal tube splits into phalanges which in accord with the above divisions of the pairs of vascular cords form two concentric rings. The splitting into phalanges occurs on the sepal radii in the outer ring and on the petal radii in the inner ring. Consequently the whole number of phalanges, which together represent the five members of the antepetalous whorl, come to present the illusory appearance of two alternating whorls (27, Fig. 24). This appearance has been mistakenly interpreted as evidence that in *Sidalcea* both staminal whorls reach development.

(ii) URENEÆ

Staminal tube often terminating in antepetalous sterile teeth.

Urena lobata. The entire floral vascular scheme diagrammatically regular (27, Fig. 48). The vascular system of the outer sterile carpels originates on the petal radii; hence the loculi are antepetalous (27, Fig. 50). Stigmas $5 + 5$ (27, Fig. 56).

Gœthea strictiflora. The vascular system of the outer sterile carpels is organised on the sepal radii; hence the loculi are antesepalous (27, Fig. 57). Stigmas $5 + 5$.

Pavonia multiflora, **Malvaviscus mollis**. The stigmatic arms at the level at which they have become defined but are not yet disjoined are seen in section in two alternating whorls, five outer over the sterile carpels and five inner over the fertile carpels (27, Figs. 34, 45).

(iii) MALOPEÆ

Kitaibelia vitifolia. 'Fields' of ovaries originally centred on the sepal radii, later becoming antepetalous as new 'fields' arise through the piling of the ovaries upon one another. This order of succession of the ovaries follows naturally from the way in which the corolla-stamen tissue separates from the gynæceum since this process begins in the sepal sectors. (27, Figs. 58-64).

Malope trifida. 'Fields' of ovaries originally antepetalous, the process of disjunction of the petal-stamen tissue from the gynæceum taking place first in the petal sectors (27, Fig. 35).

(iv) HIBISCEÆ

Staminal tube often terminating in antepetalous sterile teeth.

Hibiscus spp. G 5 + 5. (27, Figs. 2-5 and 8-16).

Gossypium spp. (Cotton). G generally 0 + 3, rarely 0 + 5, reduced from 5 + 5. Carpels all semi-solid and fertile (27, Figs. 25-27). The suppression of the outer sterile carpels has the result that the radial boundaries of the fertile members are defined in the manner in which potential surfaces are similarly indicated in the ovary of *Tulipa* (see under Liliaceæ); and that the styler canal opens to the surface on the radii of the lost carpels so that the three stigmatic lobes stand over the placentæ.

32. BOMBACACEÆ

Plant with abundant mucilage. Epicalyx sometimes present. Flower hypogynous or sometimes perigynous, actinomorphic, in general five-whorled through suppression of the antesepalous stamen whorl, pentamerous, rarely with an oligomerous or pleiomerous gynæceum. Calyx valvate; sepals generally with commissural marginal veins. Corolla contorted. Stamens five, separate, antepetalous, or ∞ in a ring. Filaments conjoined for a longer or shorter distance into a tube, separating above individually, or into compound filaments, or into phalanges. Anthers, as in Malvaceæ (see under that Family), always monothechal, borne singly, or in pairs or triplets, or in larger groups, more or less grown together. Outer carpels sterile, solid, when isomerous superposed upon the antepetalous stamens, hence the loculi are also antepetalous; inner carpels fertile, semi-solid. Style single. Stigmatic lobes or arms as many as the sterile carpels and loculi, and standing in line with them, each of $\frac{1}{2}$ or $\frac{1}{2}$ carpels. Fruit a capsule dehiscing loculicidally, or indehiscent, or a berry.

ILLUSTRATIVE TYPES

(i) ADANSONIÆ

Adansonia digitata (Baobab). A ∞ , arising in five antepetalous groups, united about half-way into a tube, becoming free individually above. The vascular complement for each antepetalous staminal group is organised from the same vascular complex as the systems for one of the petals and sterile carpels; hence the three successive whorls are at the outset superposed, though owing to torsion of the corolla the loculi are not truly aligned with the petals. Each staminal vascular complement, as in Malvaceæ (see under that Family), is organised in two

portions, and each portion breaks up again into numerous bundles. Hence when the staminal tube gives place to the individual filaments, each represents a half filament; each has a single vascular strand and bears a monothechal (half) anther. G 5-10-12, sterile + 5-10-12, fertile. Ovary multilocular, becoming unilocular above as the fertile carpels fail to meet in the centre. Style terminating in as many stigmatic rays as there are sterile carpels and loculi. Each ray receives the whole vascular system of a sterile carpel and half the system of the neighbouring fertile carpel on each side, and hence represents $\frac{1}{2} \text{ I } \frac{1}{2}$ carpels. Fruit indehiscent.

Eriodendron anfractuosum. A 5, distinct, antepetalous, with coiled, trithechal, or occasionally dithechal anthers. G 5 + 5; outer sterile carpels antepetalous. Superposition of petals, stamens and sterile carpels is due to the same cause as in *Adansonia* (see above). Similarly, torsion of the corolla and the asymmetry of the petals cause the exertion points of these members to become shifted from the radii of origin towards the intervening radii, hence the loculi appear not to be truly aligned with the petals. Separation of each staminal vascular component into two portions occurs in the same way as in Malvaceæ (see under that Family). The further break-up of one of these portions leads to the formation of three staminal bundles on each petal radius. Lateral shifting of the bundles produces the illusory appearance that one out of each triplet is the bundle of an antesepalous member. One antepetalous triplet of bundles passes into each antepetalous staminal filament which represents three half filaments united throughout their length and bearing three conjoined half anthers. Exceptionally, neither of the two original portions of the vascular complement of an individual stamen undergoes further division. The staminal filament then receives

only two vascular bundles and bears an anther consisting of two half anthers, thus simulating a normal dithecous anther. Ovary quinquelocular, becoming unilocular above. Style ending directly in a slightly enlarged obscurely five-lobed stigma. Fruit a capsule, dehiscing loculicidally through radial median splitting of the sterile carpels.

(ii) DURIONEÆ

Durio zibethinus (Durian). Epicalyx present. $A \infty$, arising in five antepetalous groups as in *Adansonia*, united into a tube below, separating above into five phalanges. Each phalange with several vascular bundles representing a corresponding number of conjoined half filaments ; later becoming resolved, partially or completely into its components. If resolution is complete the filament bears a single monothecal anther ; if, as more often happens, resolution is incomplete, the anther is polythecal, in this respect presenting a parallel with *Kydia* among Malvaceæ (see under that Family). Ovary and stigma as in *Eriodendron*. Fruit indehiscent.

33. STERCULIACEÆ

Plant with abundant mucilage or gum. Flower without epicalyx. Usually hypogynous, ♂, actinomorphic, six-whorled. Exceptionally, unisexual functionally but with reduced organs of the non-functional sex (Sterculiæ); or zygomorphic; or five-whorled through absence of a distinct corolla or of the antesealous stamen whorl. Generally pentamerous throughout (15, pp. 91-110), sometimes with an oligomerous, rarely with a pleiomerous gynæceum. An androgynophore sometimes present. Sepals (and, where they occur, usually also tepals) valvate, generally with commissural marginal veins. (Where there is no distinct corolla, but where the individual perianth members have commissural marginal veins and are in consequence coloured wholly or along the margins, or are white, they are conveniently termed tepals (15, p. 97, foot-note 1).) Corolla contorted. Andrœcium obdiplostemonous. The filaments united, as in Malvaceæ, into a longer or shorter tube seated on the corolla; the antesealous members generally staminodal and single, sometimes suppressed; the antepetalous members single, or in pairs or triplets, or multiplied still further. The vascular bundles for the antesealous members turn out directly from the central cylinder and remain undivided. Those for the antepetalous members (whether represented by single stamens or by groups), as in Malvaceæ, are components of trunk cords which also provide in addition the sepal commissural marginals and petal midrib bundles. They are thus carried out from the central cylinder before those for the antesealous staminodes turn outwards, hence obdiplostemony results. As the elements of the trunk cords allocated to the stamens are not, as a rule, separated into two portions by those forming the petal midrib, but are detached as a single strand from the

inner face of each petal-stamen cord, the products resulting from the bipartitions leading to multiplication are therefore whole stamens, not as in Malvaceæ, half stamens (see under Malvaceæ).

One genus, *Fremontia*, shows a departure from the general rule in the formation of the andrœcium. In this character it stands apart, not only from other Sterculiaceæ, but also from Malvaceæ and Bombacaceæ. It possesses five alternitepalous stamens with irregularly shaped, elongated, adnate anthers and no separate staminodes. Each staminal filament has three vascular bundles, the middle one turning out directly from the central cylinder on the radii alternating with the tepals, the outer ones becoming detached from strands serving the adjacent half of the neighbouring tepal on each side. Each single staminal filament thus represents a whole staminal member lying on what may for convenience be termed a petal radius flanked on each side by half an antetepalous staminal member. The single anther borne by each compound filament is not therefore in reality one whole anther, but two half anthers joined by a whole non-anther-bearing member. It is to this construction, accompanied possibly by different rates of growth of the sterile and the fertile components, that the irregular sinuous contour of the anthers is probably due. *Fremontia* is thus exceptional in that it is the antetepalous staminal members (corresponding with the antesepalous members of forms with both calyx and corolla) which are fertile and become split into half members, and the alternitepalous members which are sterile and undivided. This construction further explains how it is that when in exceptional specimens additional fertile filaments alternating with the normal filaments are present, they bear the reniform shape of anther typical of half anthers (unpublished). For these additional filaments have

single vascular bundles which result from secondary divisions of the already halved bundles of the antetepalous members (see 15, pp. 106, 107 with Fig. 45). Gynæceum usually syncarpous, rarely at once becoming pseudo-apocarpous. Outer carpels solid, sterile; inner carpels semi-solid, fertile. Style single. Stigmas, when distinct, as many as the sterile carpels and centred over them. Ovary generally quinquelocular, becoming unilocular above as the fertile carpels fail to reach the centre. Fruit generally a capsule, dehiscing loculicidally through radial longitudinal splitting of the sterile carpels; sometimes separating into cocci through radial longitudinal splitting of the fertile carpels; rarely baccate.

ILLUSTRATIVE TYPES

(i) FREMONTIÆ

Fremontia californica (*loc. cit.*). T 5 A 5 G 5 + 5. Flower partially syngonous. Tepals coloured, imbricate, with midrib and, in addition, half the vascular system in the alternate sectors on each side exclusive of the portions serving the andrœcium and gynæceum. Thus each tepal corresponds to $\frac{1}{2}$ 1 $\frac{1}{2}$ floral members, *i.e.* to a sepal bordered on each side by half a petal, and is consequently coloured. For the andrœcium see description of the Family. Since the vascular bundles for the fertile antetepalous components of the compound stamens do not originate directly from the central cylinder, the bundles for the sterile carpels naturally turn outwards in alternation with the sterile components of the stamens; hence the loculi are antetepalous. Fruit a capsule, dehiscing loculicidally. The radii of dehiscence are foreshadowed in the ovary as soon as it becomes disjoined from the andrœceum. At this level the sterile carpel midribs break up into twin systems (15, p. 94, Figs. 17, 18) and a radial demarcation

line appears between them, similar to that which occurs in the same position in *Gossypium* (see under Malvaceæ), though in the latter genus the indication of a potential surface marks the disappearance, and in *Fremontia* the halving, of the sterile carpels.

(ii) DOMBEYÆ

Dombeya spp. K 5 C 5 A 5 (staminodes) + 5₂₋₅ G 5 + 5 (15, pp. 97-99† and 109‡). Obdiplostemony results from the following vascular relations. The antepetalous stamen bundles are carried out from the central cylinder conjoined with the petal midrib bundles, while those for the antesepalous members turn out independently, and so later, from the central cylinder. The outer, sterile carpels (and therefore the loculi) naturally follow on the petal radii, but owing to torsion of the corolla and asymmetry of the petals they appear later to stand almost on the sepal radii. (A similar though slighter discrepancy in alignment occurs in some Ureneæ (see under Malvaceæ; also 27, Fig. 30).) Fruit a capsule, dehiscent loculicidally.

(iii) HERMANNIÆ

Hermannia spp. K 5 C 5 A 0 + 5 G 5 + 5 (15, pp. 93-96† and 109‡). Antepetalous stamen bundles carried out conjoined with the petal midrib bundles. Sterile carpels and loculi, owing to the suppression of the antesepalous staminal whorl, in line with the sepals. Style slightly 'gynobasic.' Fruit a capsule, dehiscent loculicidally.

(iv) BUTTNERIÆ

Theobroma Cacao (Cocoa tree). K 5 C 5 A 5 (staminodes) + 5 G 5 + 5 (15, pp. 93-95† and 109‡). Antepetalous stamen bundles carried out conjoined with the petal midrib bundles. Sterile carpels and loculi

antepetalous. Style springing from the summit of the ovary. Stigmas distinct, standing over the sterile carpels. Fruit baccate.

(v) LASIOPETALÆ

Thomasia solanacea (15, pp. 104-106†). T 5 (white) C 5 (reduced to minute non-vascular scales) A 5 (very small non-vascular staminodes) + 5 G (generally) 3 + 3. Fruit a capsule, dehiscent loculicidally.

(vi) HELICTERES

Pterospermum acerifolium (15, pp. 103-105†). K 5 C 5 A 5 (staminodes) + 5₃ G 5 + 5. An androgynophore is present. The vascular bundles for the staminal whorls originate in the same way as in *Dombeya* (see above), hence obdiplostemony and antepetalous outer carpels and loculi result. Fruit a capsule, dehiscent loculicidally.

The manner of origin of the bundles for the antepetalous stamen whorl nullifies the effect on radial arrangement produced by a gynophore in a six-whorled flower in which the bundles for all the whorls arise independently (see Part I, p. 8).

(vii) STERCULIÆ

Flower unisexual. Perianth of one whorl. Tepals coloured. Androgynophore present. (15, pp. 97-103† and 109†)

Cola acuminata. T 5 (coloured) A 5 (alternating with the tepals) G (generally) 5 + 5. Sterile carpels and loculi antepetalous. (15, p. 98, Fig. 31).

Sterculia spp. T 5 (coloured) A 5 + 5 or 5 + 5₂ or 5 + 5₃, obdiplostemonous G 5 + 5, becoming pseudo-apocarpous very early through premature radial splitting of the fertile carpels. It follows that the traditional view that the individual segments of the ovary of *Sterculia (Firmiana) platanifolia* offer a striking illustration of a carpellary leaf bearing marginal ovules is illusory, since

each separate segment represents not one carpel but $\frac{1}{2}$ or $1\frac{1}{2}$ carpels. The usual effect of the formation of a gynophore on the position of the carpel whorls (see above, also under Caryophyllaceæ) is not produced, since the delimitation of the vascular strands for the staminal members takes place at the base of the androgynophore while it is still encircled by, and is continuous with, the perianth tissue. Hence antetepalous loculi result with consequent obdiplostemony. (15, p. 98, Fig. 31 and p. 106, Fig. 44).

34. TILIACEÆ

Flower generally ♂, actinomorphic, six-whorled and pentamerous, sometimes tetramerous. Calyx valvate. Sepals with, or without, commissural marginal veins. Stamens generally ∞ through multiplication, free, or in five, rarely in ten, phalanges. Phalanges when five sometimes antesepalous, sometimes antepetalous. Gynæceum usually isomerous, but sometimes oligomerous or pleio-merous. Ovary multilocular, often becoming unilocular above as the fertile carpels fail to extend to the centre. Loculi when isomerous sometimes antesepalous, sometimes antepetalous. Style single, with a pointed or capitate stigma, or ending in branches as many as the sterile carpels and loculi, and standing over them. Fruit generally either a capsule dehiscing loculicidally, or splitting septucidally into separate nutlets.

The Family is divided into four sections, to one of which, *Tilieæ*, belong the more widely known genera.

ILLUSTRATIVE TYPES

TILIEÆ

Tilia* (Lime), *e.g.* **T. platyphyllos. Flower pentamerous. Sepals without commissural marginal veins. A ∞ , free or in five antepetalous phalanges. G 5, antesepalous, sterile + 5, antepetalous, fertile. Style with five stigmatic teeth standing over the sterile carpels. Each tooth with the midrib bundle of a sterile carpel and half the vascular system of the fertile carpel on each side, corresponds to $\frac{1}{2}$ r $\frac{1}{2}$ carpels. Fruit separating by septicial splitting into nutlets.

The phalanges of stamens, when five in number, do not correspond with the similarly situated phalanges in *Bombacaceæ* nor with the antepetalous groups in *Malvaceæ*,

both of which are products by multiplication of the antepetalous staminal members (see under these Families). In *Tilia* the phalanges are neither unit groups nor exclusively antepetalous in origin, although centred in line with the petals. Their true equivalence is made clear by the vascular ground-plan which shows some unusual features and is as follows. The midrib bundles for the sepals and the bundles for the antesepalous stamen members are derived from the same delimited group of elements. As the sepal midribs become detached the residual portion of these vascular units is divided radially in half. These half portions break up further so that a double group of strands, serving a corresponding number of stamens, stands in line with each sepal. These stamens are whole stamens, since the successive divisions of the vascular units take place outside the central vascular cylinder and hence after the determinate phase has been reached. The petal midribs do not arise, as ordinarily, directly from the central cylinder, but are detached laterally from the complex which serves the antesepalous group of stamens, an exceptional fusion due probably to the torsion of the corolla. It follows that the bundles to turn out from the central cylinder on the petal radii after the sepal-stamen cords on the sepal radii are those for the antepetalous stamen members. These bundles often (? always) remain undivided, in which case a single stamen stands in front of each petal. These stamens are conjoined for a short distance with the adjacent halved antesepalous group on each side. As development proceeds the double group of stamens in front of each sepal separates into two half groups, with the result that in the fully developed flower the whole androecium consists of five antepetalous phalanges, each phalange being composed of a single antepetalous member in the centre flanked by half the antesepalous group on

each side. This unusual scheme of recombination is paralleled in *Fremontia* (see under Sterculiaceæ) where, however, each phalange simulates an individual stamen, though actually it is made up of one whole alternitepalous staminode flanked on each side by half an antetepalous stamen, the three components remaining united throughout their length. The above vascular scheme in *Tilia* explains the diplostemonous arrangement which among isomerous six-whorled Dicotyledons is quite exceptional (see Part I, p. 8).

Sparmannia africana. Flower tetramerous, but often with a pleiomerous gynæceum. Sepals with commissural marginal veins. The four trunk cords which turn out from the central vascular cylinder on the petal radii give rise, in addition to these marginal veins, to the petal midrib bundles and, through a further break-up of the residual portion, to numerous bundles serving a group of antepetalous stamens. Later, a bundle turns out from the central cylinder on each sepal radius and breaking up into several strands similarly serves an antesepalous group of stamens. Each antepetalous staminal group divides in two, the filaments of the two resulting half groups being conjoined with the adjacent antesepalous group on either side. The andrœcium is therefore obdiplostemonous in origin, but when fully developed comes to consist of four antesepalous phalanges which shortly become resolved into their constituent filaments. These relations of the two whorls are thus the opposite of those in *Tilia* in accord with the differences in the two vascular schemes. The midrib bundles for the outer sterile carpels do not, as ordinarily, arise from the central cylinder but are detached from the complex system of the andrœcium on each petal radius; hence in the isomerous gynæceum the loculi are antepetalous. When pleiomery occurs additional bundles are

similarly detached on some of the sepal radii. The elements remaining in the central cylinder are organised into the fertile carpel bundles on the alternate radii. Ovary, style and stigmas as in *Tilia*. Fruit a capsule, dehiscing loculicidally.

Corchorus olitorius (Jute). Flower small, pentamerous. The early stages in vascular development are condensed as follows. The whole vascular supply for calyx, corolla and andrœcium leaves the vascular cylinder as five cords consisting, respectively, of 3, 2, 2, 2, 1 bundles which shortly diverge singly and take up their position on their proper (sepal and petal) radii. Those on the sepal radii become the sepal midribs. Those on the petal radii give rise to commissural marginal veins of the sepals, petal midribs and a residual portion which breaks up into several strands serving a corresponding number of free stamens. No antesealous stamens are present. As a result the antepetalous stamens spread out laterally forming a ring occupying both sets of radii and so present an appearance simulating that of two whorls. Ovary, style and stigma as in the preceding types. Fruit a pod-shaped capsule, dehiscing loculicidally.

35. SARRACENIACEÆ

Plant insectivorous. Flower actinomorphic, hypogynous. Perianth double or single, generally pentamerous. Stamens definite (15) or indefinite. Carpels generally 5 + 5 or 3 + 3 (16, pp. 81-85† and 104†). Ovary multilocular at the base, sooner or later becoming unilocular as the central parenchyma comes to an end, the inner surfaces of the fertile carpels, nevertheless, generally remaining in contact after they have become free. Placentation 'parietal' from the base up, or becoming so as the central parenchyma disappears. Style single. Stigmas sometimes in line with the sterile carpels, sometimes centred over the fertile carpels ('commissural'). Fruit a capsule, dehiscing by median longitudinal splitting of the sterile carpels.

ILLUSTRATIVE TYPES

Sarracenia (Saddle Flower) (16, Figs. 1-6 and Diagram 1). $K\ 5\ C\ 5\ A\ \infty\ G\ 5$, sterile, solid + 5 fertile, semi-solid. Ovary quinquelocular. Style ending in a large umbrella-shaped expansion. Stigmas in the form of five finger-like processes at emarginate points on the rim of the expanded style top, each process terminating a sterile carpel. Centred on the alternate radii and occupying the whole area between the processes the non-stigmatic broadened ends of the fertile carpels.

Heliamphora nutans (16, Figs. 7-10). Perianth single, coloured. Stamens numerous. Carpels 3 + 3. Ovary trilocular. Stylar canal opening to the surface dorsally in the mid-line of the sterile carpels after division in two of the midrib bundles. Stigma lobes three, centred over the fertile carpels ('commissural'), each consisting of $\frac{1}{2}$ + $\frac{1}{2}$ carpels.

Darlingtonia californica (16, Figs. 11-14). K 5 C 5 A 15 G 5 + 5. Style terminating in five arms in line with the sterile carpels. The styler canal opens to the surface along the mid-line of each arm, thus defining the five V-shaped segments composing the stigma, each segment being centred, like the lobes in *Heliamphora*, over the fertile carpels and corresponding to $\frac{1}{2}$ 1 $\frac{1}{2}$ carpels. This type of stigma in which the structural units do not correspond with the stigmatic units is paralleled in *Boronia megastigma* (see under Rutaceæ), though in this latter genus the carpel relations are the opposite of those in *Heliamphora*. For in *Boronia* it is the sterile carpels which remain unsplit and the fertile carpels which are divided in half.

36. DROSERACEÆ

Flower actinomorphic, generally hypogynous, rarely perigynous (*Roridula*), pentamerous or tetramerous, but often with an oligomerous gynæceum (7, pp. 618-620† and 16, pp. 85-87† and 104†). Stamens 5, antesepalous, or 10 in two whorls (5 + 5), or 15 or 20 through multiplication of the antepetalous whorl. Ovary unilocular throughout, or with as many loculi at the base as there are sterile carpels, becoming unilocular as the central parenchyma comes to an end and the fertile carpels forming the 'septa' fail to coalesce in the centre. Styles connate, the single filament ending in a toothed stigmatic rim; or distinct, as many as the sterile carpels and standing over them. The basal shanks remaining entire or becoming once, twice, or thrice bifurcate. Each branch with an entire or bifid stigma. Placentation 'parietal.' Ovules numerous extending for some distance up the inner face of the fertile carpels; or confined to the extreme base of these carpels, the appearance then simulating that of 'free-central' placentation. Fruit a capsule, dehiscing by splitting down the mid-line of the sterile carpels.

ILLUSTRATIVE TYPES

***Drosera** (Sundew). Generally $K\ 5\ C\ 5\ A\ 5\ G\ 3 + 3$ (7, Fig. 218; 16, Diagram 2). Placentation plainly 'parietal.' Styles distinct, remaining entire as far as the stigma level, or bifurcating one or more times.

Roridula spp. (16, Figs. 15, 16 and Diagram 3). Floral formula and placentation as in *Drosera*, but style single. Styler canal opening to the surface dorsally in line with the sterile carpels after division in two of the midribs. Stigma lobes three, centred over the fertile

carpels ('commissural') each representing $\frac{1}{2} \text{ I } \frac{1}{2}$ carpels as in *Heliamphora* among Sarraceniaceæ (see under that Family).

Dionæa muscipula (Venus' Flytrap). K 5 C 5 A 5 + 5, or through multiplication of the antepetalous whorl 5 + 5₂₋₃, G 5 + 5. Ovules confined to the extreme base of the fertile carpels, so that the placentation though actually 'parietal' appears to be 'free-central.' Style single, terminating in a many-toothed stigmatic rim.

37. NEPENTHACEÆ

Flower unisexual without trace of the other sex, dioecious, actinomorphic, hypogynous. Perianth single, tetramerous. Tepals in two pairs, the two median overlapping the two lateral members as frequently in tetramerous types. ♂ P 4 A 4-16 arranged in a ring; when 4, standing in line with the perianth segments. ♀ G 4, sterile, standing in line with the perianth segments + 4, fertile on the alternate radii. Ovary with four loculi at the base immediately becoming unilocular. Stigmas four, sessile, standing over the fertile carpels ('commissural'). Fruit a capsule, dehiscing loculicidally through median longitudinal splitting of the sterile carpels.

The superposition of the stamens, when, four and of the sterile carpels on the perianth segments is due in part to the asymmetry and torsion of these segments, and in part to the curved course taken by the corresponding vascular bundles in their horizontal course through the axis tissue to the points of exsertion. In both ♂ and ♀ flowers the residual vascular tissue for androecium and gynæceum, respectively, consists of four cords alternating with the perianth segments and it is from each of these cords that a stamen or a carpel bundle, as the case may be, is derived. The later superposition of these members on the tepals is thus of secondary origin.

The 'commissural' position of the stigmas follows from the opening of the loculus to the dorsal surface in line with the sterile carpels at the summit of the ovary. The stigmatic region thus becomes divided into quadrants standing over the fertile carpels.

ILLUSTRATIVE TYPES

Nepenthes spp. (Pitcher Plant). See characters of the Family.

Monocotyledons

38. GRAMINEÆ

Whole inflorescence in the form of a spike, raceme or panicle of spikelets. Spikelets one-, two- or several-flowered. Axis of the spikelet generally with one, two, or more barren bracts (glumes), followed by one or more fertile bracts. In the axil of each fertile bract (lemma) a single flower, generally accompanied by a bracteole (palea). Flower generally ♂ or ♀ and ♂ in the same inflorescence; seldom ♂ and ♀ in separate inflorescences or in separate parts of the same inflorescence.

Basic floral ground-plan conforming to the typical monocotyledon ground-plan of alternating trimerous whorls. But always with one or two whorls wanting and others incomplete, the perianth being represented by a single whorl of small scales (lodicules), the inner whorl of stamens being generally suppressed and the inner carpel whorl being represented by a single member (3, pp. 155-157). Ovary unilocular with a single ovule borne at, or near, the base of the fertile carpel which is always posterior. Style single or wanting. Stigmas standing over the sterile carpels, generally two, less often three, rarely one. When three sterile members are present one is anterior and two postero-lateral; if only two develop the anterior one is missing. In well-developed types a corresponding number of vascular bundles pass up in the ovary wall and are continued for a longer or shorter distance into the style and stigmas. In less well-developed types these bundles may only be traceable for a short distance or may be absent altogether. The fertile posterior carpel, with its strong vascular bundle, comes to an end at the level of origin of the excentrically attached ovule.

The following variations occur among ♀ types :—

- (i) P 3 A 3 + 3 G 3, anterior and postero-lateral, sterile + 1, posterior, fertile (some Bamboos).
- (ii) P 2 A 3 + 3 G generally 2, occasionally 3, sterile + 1, posterior, fertile (in a few genera) (8, p. 60).
- (iii) P 2 A 3 + 0 G always 2, sterile + 1, posterior, fertile (most frequent type).
- (iv) P 2 A 3 + 0 G 1, anterior, sterile + 1, posterior, fertile (rare).
- (v) P 2 A 2 + 0 G 2, sterile + 1, posterior, fertile (in a few genera).

Fruit indehiscent, one-seeded, with the seed-coat adnate to the thin pericarp (caryopsis).

ILLUSTRATIVE TYPES

Triticum spp. P 2 (well-developed) A 3 + 0 G 2 + 1.

Oryza sativa (Rice). P 2 A 3 + 3 G 2 + 1 (8, p. 59†).

***Spartina stricta.** Typically P 2 A 3 + 0 G 2 + 1, but occasionally P 2 A 3 + 0 G 3 + 1. Style with two or three vascular bundles and ending in two or three stigmatic branches.

Zea Mals (Maize), **Coix Lachryma** (Job's Tears). Flowers unisexual. ♀ with gynæceum as in **Spartina**.

Stipa pennata. P 2 A 3 + 0 G 3 + 1. Ovary with three vascular bundles in the wall, but lacking the third (anterior) stigma. Lemma awned.

***Anthoxanthum odoratum** (Vernal Grass). P 2 A 2 + 0 G 2 + 1.

***Nardus stricta** (Mat Grass). P 2 A 3 + 0 G 1 (anterior) + 1 (posterior).

39. CYPERACEÆ

Inflorescence, as in the Gramineæ, of spikelets arranged in spikes, heads or panicles. Flower ♂ or unisexual, also like that of the Gramineæ based on a trimerous ground-plan, but still more rarely with the full number of members in the perianth and andrœcium, only one whorl of each being usually present and that of the andrœcium being often incomplete. Gynæceum of an outer whorl of three or two sterile carpels, which form the wall of a unilocular ovary, continue upwards as a single style, ultimately separating into a corresponding number of stigmatic arms. Ovule solitary, basal and central. It thus differs in position from the solitary ovule of Gramineæ which is excentric in origin (see under that Family). That the ovule in Cyperaceæ, although appearing to be terminal does not in reality terminate, the floral axis is indicated by certain features of the vascular system. In those types in which the vascular system of the gynæceum is particularly well-developed, as *e.g.* in *Cladium Mariscus*, the vascular elements immediately beneath the ovary constitute a compact core from which the sterile carpel bundles turn outwards. The residual elements then form a loose anastomosing complex without definite arrangement, as at a node. Only a single fine strand is continued on into the funicle. These facts support the interpretation that the residual vascular complex represents the surviving vascular tissue of an inner carpel whorl of which only one member is fertile. A similar construction occurs among Dicotyledons in Plumbaginaceæ and is to be interpreted in the same way. Fruit one-seeded and indehiscent.

ILLUSTRATIVE TYPES

**Scirpus* spp. Spikelet generally many-flowered. Flower ♂. Perianth in the form of bristles. A 3.

Sterile carpels three or fewer. (For the position of the fertile carpels see the account of the Family.)

***Cladium Mariscus.** Spikelet one to three-flowered. Flower ♀ (offering particularly favourable material for microscopic examination). Perianth wanting. Generally A 2 G 3, sterile, sometimes A 3 G 3, sterile or A 2 G 2, sterile, rarely A 2 G 4, sterile; for the fertile whorl see under *Scirpus*. When only two stamens develop they lie on two of the radii occupied by a trimerous androecium, thus showing that reduction has occurred through suppression of the third member. When the sterile carpels are reduced to two, one, as in the trimerous gynæceum, is anterior. The other is posterior, a new position. Here reduction occurs through the mode of reconstruction associated with a change of ground-plan which makes possible a new orientation (see Part I, p. 4).

***Carex spp.** Spikelet one-flowered. Flower unisexual. ♂ A 3. ♂ Sterile carpels three; for the fertile whorl see under *Scirpus*. The ovary is enclosed in a loose structure formed by the folding of the accompanying bracteole.

DATE OF ISSUE

This book must be returned within 3/7/14 days of its issue. A fine of ONE ANNA per day will be charged if the book is overdue

--	--	--	--	--

