

**BIRLA CENTRAL LIBRARY**

**PILANI (Rajasthan)**

Class No:- 621.38

Book No:- M742H

Accession No:- 48038





**HOUSE TELEPHONES, BELLS AND  
SIGNALLING SYSTEMS**

# NEWNES' "ELECTRICAL ENGINEER" SERIES

General Editor : E. MOLLOY

UNIFORM WITH THIS VOLUME

- No. 1. *Electric Wiring : (Domestic)*
- „ 2. *Practical Design of Small Motors and Transformers*
- „ 3. *Installation and Maintenance of Electric Motors*
- „ 4. *House Telephones, Bells and Signalling Systems*
- „ 5. *Wiring Circuits for Lighting, Power and Industrial Control*
- „ 6. *Testing Electrical Installations and Machines*
- „ 7. *Factory Installation Work*
- „ 8. *A.C. Motors and Control Gear*
- „ 9. *Switchboard Instruments*
- „ 10. *Cables and Wires : Selection, Jointing and Testing*
- „ 11. *Power Transformers*
- „ 12. *Electro-Plating and Anodising*
- „ 13. *Power Rectifiers*
- „ 14. *Electric Lifts*
- „ 15. *Private Generating Plant*
- „ 16. *Electric Relays*
- „ 17. *Physics for Engineers*
- „ 18. *101 Electrical Examination Questions : With Model Answers*
- „ 19. *Mathematics for Engineers*
- „ 20. *Introduction to Electricity and Radio*
- „ 22. *Mechanics for Engineers*
- „ 23. *Diesel Electric Shunting Locomotives*
- „ 24. *Electronic Developments*

# HOUSE TELEPHONES, BELLS AND SIGNALLING SYSTEMS

A Practical Handbook for Installation  
Engineers, Contractors and  
Electric Wiremen

EDITED BY  
E. MOLLOY

WITH 127 DIAGRAMS AND PHOTOGRAPHS

LONDON  
GEORGE NEWNES LIMITED  
TOWER HOUSE, SOUTHAMPTON STREET  
STRAND, W.C.2

*Copyright*  
*All rights reserved*

<i>First Edition</i>	.	.	1940
<i>Second Edition</i>	.	.	1942
<i>Third Edition</i>	.	.	1943
<i>Fourth Edition</i>	.	.	1948

PRINTED IN GREAT BRITAIN

## PREFACE

**T**HIS book has been specially prepared for installation engineers, contractors, and all engaged on the utilisation side of the electrical industry, who have experienced a need for a book dealing in a practical way with modern types of bell and indicator systems and house telephones used for offices, works, hotels, and similar services.

Bells and telephones are, of course, the most widely used, and, for this reason, more than half the available space has been devoted to these subjects.

For convenience, the subject of House Telephones has been sub-divided under three distinct headings, namely:

TELEPHONES FOR PRIVATE HOUSES, HOTELS AND BOARDING HOUSES.

TELEPHONES FOR BLOCKS OF FLATS.

TELEPHONES FOR FACTORIES AND OFFICES.

It will be observed that the phrase "House Telephones" is used in its widest sense, to comprise practically all types of telephones apart from those installed by the Post Office.

The subject of Post Office Telephones has already been exhaustively covered in such standard works as Herbert's *Telephony*, and Poole's *Telephone Handbook*. Moreover, only employees of the G.P.O. Engineering Department have occasion to install or service such equipment.

It is for these reasons that no attempt has been made to deal with the telephone system of the G.P.O. in the present work.

Bells and indicator systems, alarm circuits, staff location systems, manual exchange telephone systems, and loud-speaking and special telephone facilities, each form the subject of special chapters.



Although in every case the work involved is of a somewhat specialised nature, there is no reason why any electrical contractor or installation engineer should not undertake the installation and maintenance of these. In actual fact, the makers of equipment of this type frequently prefer to have the installation work carried out by qualified installation engineers. Careful study of the information contained in the present book is, therefore, likely to prove not only interesting but also of very real commercial value to anyone engaged on this side of the electrical industry.

The guiding principle which has been followed in compiling this book has been to bring together useful technical data and circuit diagrams relating to the various types of commercial telephone equipment and signalling systems which are in present day use. It is obvious that such an undertaking could only have been rendered possible by the willing co-operation of the principal makers of telephone equipment in this country.

We have pleasure here in expressing our indebtedness to the manufacturers concerned, and in particular we would mention the following:—

ERICSSON TELEPHONES, LTD.  
GENERAL ELECTRIC CO., LTD.  
GENT & CO., LTD.  
JULIUS SAX & CO., LTD.  
PHŒNIX TELEPHONE & ELECTRIC WORKS, LTD.  
RADIOVISOR PARENT, LTD.  
RELIANCE TELEPHONE CO., LTD.  
SIEMENS BROTHERS & CO., LTD.  
STANDARD TELEPHONES & CABLES, LTD.  
TELEPHONE RENTALS LTD.

In conclusion, we offer this work to telephone engineers contractors and installation engineers, as a compact and reliable reference book on the more widely used types of telephones and signalling equipment.

E. M.

## CONTENTS

	PAGE
PREFACE . . . . .	V
CHAPTER I. TELEPHONES FOR PRIVATE HOUSES, HOTELS AND BOARDING HOUSES	I
Transmitters — Receivers — Batteries — Bells and Buzzers—Using Existing Bell Wiring—Battery Call Telephones—Reduction of Side Tone—Using a Generator for Calling—Intercommunication Tele- phones—Circuit Arrangement—Wiring and Joint- ing—Doctors' Night Telephones.	
CHAPTER II. TELEPHONES FOR BLOCKS OF FLATS	24
Connection to a Reply Panel—Calling Procedure— Connection of Tenant to Service Line—Circuit Conditions when Calling—Power Supply—Tele- phones for Service Flats—Non-automatic Tele- phones—Tradesmen's Telephones.	
CHAPTER III. TELEPHONES FOR FACTORIES AND OFFICES . . . . .	42
Choice of System—Types of Automatic Exchanges —Installing a 10-Line Switchboard—Power Supply —Line Circuits—Establishment of Speech Channel —Loud-Speaking Telephones—Maintenance and Locating Faults.	
CHAPTER IV. BELLS, INDICATORS AND RELAYS	54
Bells and Pushes—Size of Wire—Power Supply— Indicators—Tandem Indicators—Supervision or Control Indicators—Bell Relay Indicators—Relays —Testing Bell Installations.	
CHAPTER V. ALARM AND INDICATOR CIRCUITS .	78
Power Supply—Use of Relays—Alarm Circuits— Silent or Luminous Call System—Portable Buzzers —Indicators for Hospitals and Hotels—Alarm and Relay Circuits—Smoke Indicators.	

	PAGE
CHAPTER VI. MAINTENANCE OF TELEPHONE SYSTEMS . . . . .	98
Instrument Construction—Magneto Ringing Systems—Reception Faults—Transmission Faults—Bell Faults—Battery Testing—Automatic Systems—Fault Locating Methods—Relay Adjustment.	
CHAPTER VII. MANUAL EXCHANGE TELEPHONE SYSTEMS . . . . .	115
Magneto Telephone Switchboards—Testing—Single Cord, Double-ended cord and Double-cord Switchboards—Cordless Switchboard—Central Battery System—C.B. and Line Circuit—C.B. Cord Circuit—Lamp Signalling—Testing of C.B. Systems.	
CHAPTER VIII. LOUD SPEAKING AND SPECIAL TELEPHONE FACILITIES . . . . .	131
Intercommunication Loud-speaking Master Station Sub-Station Instruments — Circuit Details — —Special Facilities on Private Automatic Systems—Automatic Dialling—Loud-to-loud-speaking—Telematic P.A.X. Master Instrument—Priority Facilities—Tie Line Service.	
CHAPTER IX. STAFF LOCATING SYSTEMS . . . . .	146
The "Tangent" System—Use of Lamp Signals—Standard Telephones & Cables, Ltd.—Use of Microphones and Loud Speakers—Reliance Telephone Co., Ltd.—Code Sending Apparatus—Siemens Brothers & Co., Ltd.—Automatic Staff Call System—Staff Location by Voice Paging—Voice Paging with P.A.X. Instruments—Further Uses of Sound Installation.	
INDEX . . . . .	177

# HOUSE TELEPHONES, BELLS, AND SIGNALLING SYSTEMS.

## CHAPTER I

### TELEPHONES FOR PRIVATE HOUSES, HOTELS AND BOARDING HOUSES

A SIMPLE private telephone installation consists essentially of a pair of transmitters and receivers connected together with suitable wiring, and either a common battery or a separate battery at each end. For signalling or ringing between the two stations a buzzer or bell is also required. The battery used for speaking may also be used for ringing, although a separate battery is more usual. Ringing may be done without a battery by using a hand generator or magneto ringer (referred to later), this method being suitable for distances exceeding about 250 yards.

#### **The Transmitter.**

The majority of transmitters contain a number of carbon granules held between a pair of polished carbon electrodes. One electrode is fixed to the transmitter case and the other is attached to a thin metal diaphragm so that when spoken into it is free to vibrate. The carbon microphone or transmitter is not sensitive until a current is passing between the electrodes by way of

## 2 HOUSE TELEPHONES, BELLS, SIGNALLING SYSTEMS

the carbon granules. When, however, a battery is connected across the transmitter the vibrations imparted to the diaphragm due to the speech action cause the resistance of the carbon granules to vary accordingly.

Consequently the current flowing in the microphone circuit varies and faithfully reproduces the original speech or sounds in a receiver suitably connected in the circuit.

### **The Receiver.**

The telephone receiver which is connected to the distant transmitter contains an electro magnet, the poles of which almost touch a thin metal diaphragm. This vibrates when speech currents are passing through the windings. Actually the receiver is rendered more sensitive by means of a permanent magnet which maintains a strong field between the poles and the diaphragm, a steady flow of current being passed through the receiver in addition to the speech currents.

Although correct polarity is not essential for the operation of the receiver it is usual to connect it so that the direct current flowing through the receiver windings assists the permanent magnet. If the receiver is connected in the opposite way it is rendered less sensitive owing to the partial neutralisation of the field of the permanent magnet. In the better class of telephone instruments the receiver and transmitter are combined, the arrangement being variously known as a hand set, a micro telephone or hand micro set. The hand sets are available to hang on the switch hook of a wall type telephone, or to rest in the cradle of a desk type instrument.

**Batteries.**

The usual source of power for house telephones is a dry battery, and as the current consumption is very low one set of cells should last several months, unless the telephone is used considerably. In the case of large installations, accumulators are a better proposition used in conjunction with a trickle charger. With these larger installations several speaking circuits may be in operation at the same time, so that the current is more easily maintained than would be the case with dry cells.

It is usual to install one common battery which should be placed as centrally as possible in a cool spot. On the other hand the local battery system makes use of a separate battery at each station, no direct current passing over the lines when two stations are in communication, except the speech current. There is another type of local battery system in which the batteries of the two stations in communication are connected in series, in which case the direct current must pass over the lines.

The number of cells for the voltage of the battery depends on the nature of the system and the distance between the persons communicating. Generally six volts may be regarded as the minimum for the speaking circuit and twenty-four a maximum. When a separate ringing battery is used it may be of lower or higher voltage than the speaking battery, depending on the design of the buzzer and the extent of the installation.

**Bells and Buzzers.**

The type of bell used for battery ringing is essentially of the same construction as the ordinary domestic

#### 4 HOUSE TELEPHONES, BELLS, SIGNALLING SYSTEMS

house bell, while a buzzer is simply a bell without a hammer and gong. Usually a buzzer is preferred on account of it being less noisy than a bell. In the case where a magneto ringer is used (referred to later) a different type of bell is used. This is a polarised or A.C. bell and it has no contacts. The vibration of the polarised armature is caused by the alternating current passing through the magnet coils when the magneto handle is turned.

#### Using Existing Bell Wiring.

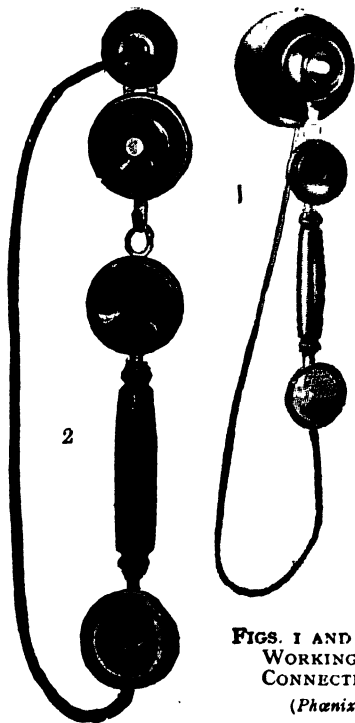

The simplest type of house telephone is one which provides for ringing only from a master station, and speaking to and from one or more sub-stations. In many cases these can be connected to the existing bell circuits without difficulty. Typical instruments are shown in Figs. 1 and 2, while wiring diagrams are shown in Figs. 3 to 6.

Such a telephone system is, of course,

**FIGS. 1 AND 2.**—TWO EXAMPLES OF DIRECT WORKING TELEPHONES SUITABLE FOR CONNECTING TO EXISTING BELL CIRCUITS.  
(Phanix Telephone & Electric Works Ltd.)

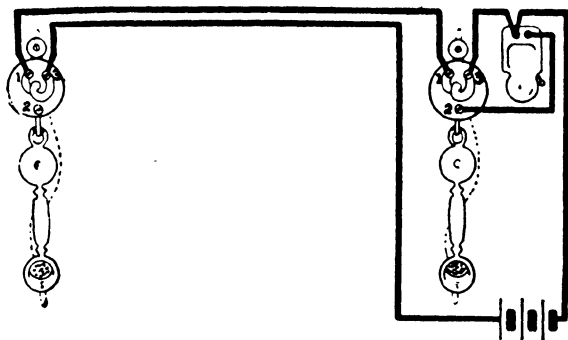

FIG. 3.—WIRING DIAGRAM SHOWING METHOD OF CONNECTING INSTRUMENTS SHOWN IN FIGS. 1 AND 2, TO AN EXISTING BELL CIRCUIT.

(Phoenix Telephone & Electric Works Ltd.)

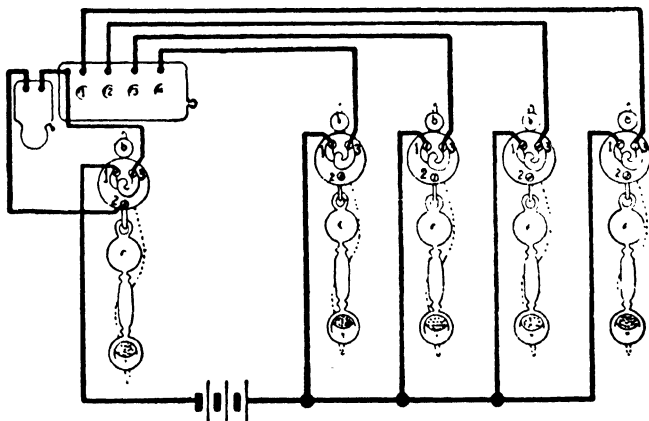

FIG. 4.—SHOWING METHOD OF CONNECTING A NUMBER OF DIRECT WORKING TELEPHONES TO AN EXISTING BELL AND INDICATOR CIRCUIT.

(Phoenix Telephone & Electric Works Ltd.)



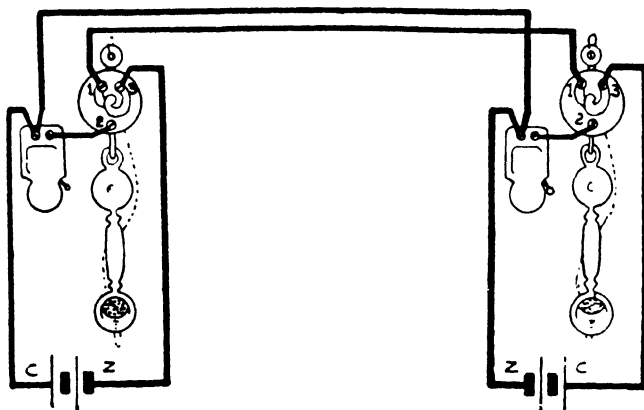

FIG. 5.—SHOWING A PAIR OF INSTRUMENTS SIMILAR TO FIGS. 3 AND 4, CONNECTED FOR CALLING BOTH WAYS WITH A BATTERY AT EACH STATION.

Note polarity of battery at each end.  
 (Phoenix Telephone & Electric Works Ltd.)

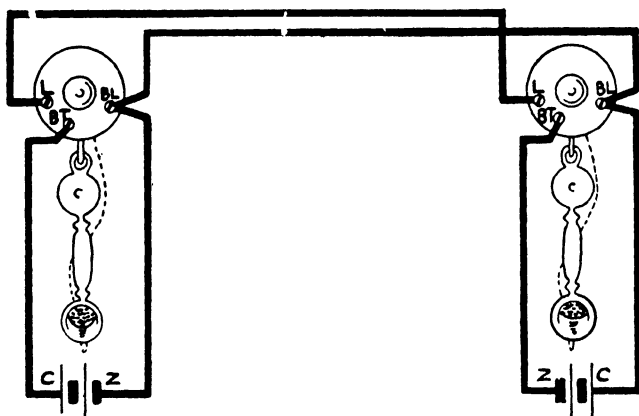

FIG. 6.—SHOWING TWO INSTRUMENTS CONNECTED FOR CALLING BOTH WAYS, WITH A BATTERY AT EACH STATION.

Bell or buzzer in each case is self-contained.  
 (Phoenix Telephone & Electric Works Ltd.)

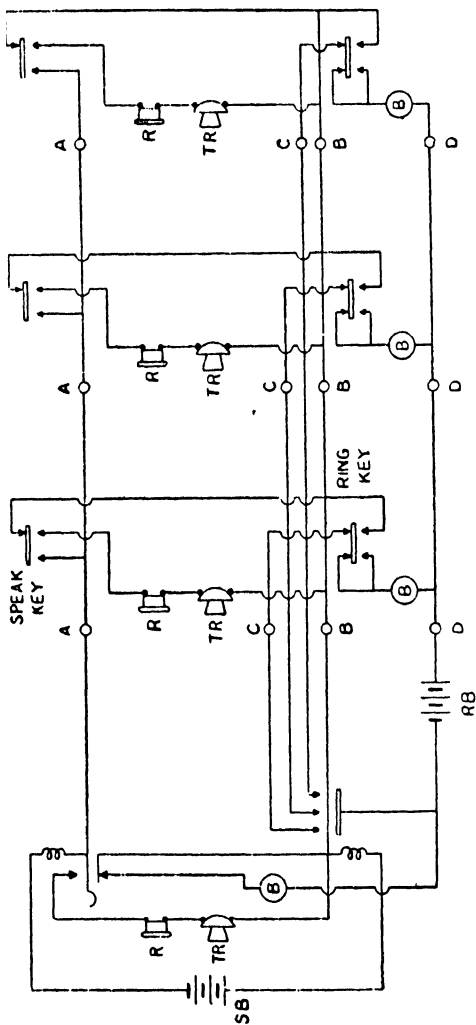

FIG. 7.—CIRCUIT SHOWING MASTER STATION AND THREE SUB-STATIONS WITH TWO COMMON TALKING LINES A AND B.

The master station can ring the sub-stations, and the sub-stations can ring the master station, but they cannot ring one another. R is the receiver, TR the transmitter, B buzzer, SB speaking battery, and RB ringing battery.

(Standard Telephones & Cables Ltd.)

only suitable for domestic use where it is required to communicate with the servants' quarters and for similar situations. The natural development of this system is to provide for ringing the master station from the sub-stations, the sub-stations being unable to call one another. Fig. 7 shows the circuit of a typical system of this type. A and B are the common talking lines which reduces the wiring to a minimum although it does not prevent a second sub-station from overhearing another conversation.

The master station is shown on the left of the diagram, the energising current from the transmitters being obtained from the common battery SB. Two retard coils are connected in series with the battery leads to prevent the speech currents passing round the battery circuit instead of through the microphone of the call station. A development of this system provides for ringing and speaking both ways between two or more points. This is the simplest application of the intercommunication telephone which is referred to later.

### **Battery Call Telephones.**

The battery call telephone is really a "local battery" instrument designed for use with a few cells at each instrument, but when the two instruments are close together one may desire to fit only a single battery and there is no disadvantage in doing so.

The calling device consists of a push button which feeds current over the line to the buzzer of the called telephone and at the same time disconnects the caller's buzzer. This buzzer is of the simple trembler type and usually has a resistance of about 20 ohms. Other

types of signal can always be provided, however, such as the lamp sometimes desirous in hospitals.

The handset rest of the telephone operates what is known as a "gravity switch" but perhaps more commonly called a "switch hook." Apart from its convenience in automatically stopping the bell from ringing, and connecting the battery to the transmitter, upon the handset being lifted to answer a call the gravity switch serves a very essential purpose, namely, that of ensuring that the battery is disconnected when the handset is replaced at the end of a conversation.

The "solid back" transmitter fitted to pedestal type telephones on the public exchanges and the inset or capsule transmitter of earlier days had many faults. Packing of the carbon granules was quite common with both forms of transmitter, whilst the inset transmitter, particularly when used in a handset, would sometimes open circuit altogether. It also frequently made unpleasant noises, aptly called "frying."

The frequency response was very poor, there usually being a complete dropping off at a little more than 1,500 cycles a second, with one pronounced, and several smaller resonances. The modern inset transmitter is suitable for use in a much greater range of circuits, the same inset being used on the better types of battery call telephones as is used for the Post Office telephones. The response curve is not a perfectly straight line, but has not the strong resonances of the early inset transmitter. Moreover, response is maintained fairly well up to some 3,500 cycles a second.

### **Use of an Induction Coil.**

With an efficient transmitter and receiver,

## IO HOUSE TELEPHONES, BELLS, SIGNALLING SYSTEMS

conversations are possible by the simple arrangement of connecting them in series with one another and with the other telephone, and inserting a battery in the circuit. The efficiency is, however, poor, as the power available from the transmitter is not necessarily in the most suitable form for acceptance by the receiver.

An "induction coil" which is really a simple form of transformer becomes desirable to ensure efficiency, but we must digress before dealing with this as it is involved with another important matter, namely, "sidetone."

### **Energy Absorption by the Local Receiver.**

When two telephones are connected together and in use, the local receiver absorbs more energy than is conveyed to the receiver at the listener's end, unless some special arrangement be made. This absorption of energy by the local receiver is known as "sidetone," and serves only one useful purpose, namely, that of showing that his transmitter is working.

With inefficient transmitters no harm is done, but the modern inset transmitter is so powerful that the effect in a simple circuit would be like a loud-speaker close to the speaker's ear. The result being unpleasant the speaker naturally lowers his voice to the point when it no longer annoys him, regardless of the listener's requirements.

At the far telephone, moreover, the listener may be in a noisy room and his transmitter picking up all sorts of sounds which are transferred to his receiver to mingle with the all too faint speech.

### **Reduction of "Sidetone."**

In practice it is usually desirable to arrange for the amount of "sidetone" to be approximately equal to

## FOR PRIVATE HOUSES, HOTELS AND BOARDING HOUSES II

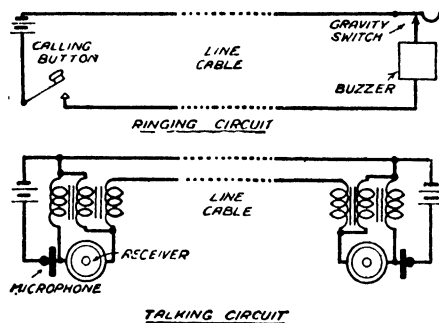

FIG. 8.—SCHEMATIC DIAGRAM OF A BATTERY CALL TELEPHONE CIRCUIT.

Details of switches are omitted for clarity. The three-winding transformer is the A.S.T.I.C. unit referred to in the text.

the volume of sound which the speaker would hear were he speaking naturally without a telephone. For a noisy position, however, it is preferable to reduce the sidetone still further, with the result that the speaker, only hearing himself faintly, tends to speak louder.

In consequence, the ratio of speech to noise conveyed from a noisy room is improved, and when listening the man in the noisy room can hear well, because of the lack of extraneous noises in his receiver.

The first anti-sidetone transformers in practical use were used in conjunction with an ordinary induction coil, but later types of instrument employ a single transformer fulfilling the dual purpose of ordinary voltage regulation and anti-sidetone adjustment.

The combined transformers are known as anti-sidetone induction coils and the circuits in which they are employed are termed A.S.T.I.C., which is derived from the initials of the transformer's full name (see Fig. 8).

Whilst the telephones described above are really designed for working in pairs it is a fairly simple matter to provide a two-way switch at each station, together

with an additional buzzer or bell. A group of three stations is then possible. A manufacturer will always provide a diagram of connections, but the idea is essentially simple, namely, there is a buzzer or bell fitted for each of the other stations to signal, and a switch for connecting the telephone circuit to whichever station is required.

### **Use of a Generator for Calling.**

The battery call telephones serve a very useful purpose, but whilst the current for the microphone is derived from local cells, the current for signalling has to be fed over the line and a limit is imposed thereby upon their practical use. It is the signalling device that must be changed and the most convenient way is to fit a small magneto electric machine.

The "hand generator" as used on telephones employs a number of horseshoe magnets clamped to suitably shaped pole-pieces between which a small H armature is revolved. A fair speed is obtained by simple gearing. As no commutator is fitted the output is alternating current, and a bell of suitable design becomes necessary to respond thereto.

The "ringer" or polarised bell is found to be most satisfactory, and in its usual form consists of a horseshoe type electro-magnet, similar to that used in the trembler bell, but seldom of less than 1,000 ohms resistance. The armature, however, is pivoted centrally so that it can swing to either pole-piece instead of as in the trembler bell.

The permanent magnet is fitted centrally, and therefore the pull at the two ends of the armature is more or less balanced. Upon alternating current being fed

through the coil windings the pull at one pole is increased whilst at the other pole it is reduced, and the armature swings in phase with the generated current. A hammer attached to the armature strikes gongs as it vibrates.

As high impedance bells are used and they are not battery operated it is possible to leave them bridged across the line during conversation. There is little advantage in this when the telephones are used in pairs as the bell circuit can be, and usually is, passed through the "gravity switch" springs.

The real advantage is that a number of telephones can be bridged across the same line, and those bells left in circuit due to any of the telephones being unattended do not affect speech appreciably. At one time magneto telephones were often provided with low resistance bells and wired-in series, but this method is practically obsolete nowadays.

### **Intercommunication Telephones.**

In a small building the expense of an operator or elaborate automatic switchboard may not be warranted, and the selection of the wanted line by the calling party affords a solution.

The term "intercommunication telephones" is meant here to denote any system giving internal communication in a building, as distinct from telephones connecting to the public telephone system. In the telephone industry, however, a certain class of instruments has been given the name intercommunication telephones, colloquially abbreviated to "intercoms." The telephones in question are those having radial switches, plugs and sockets, or rows of push buttons for selection



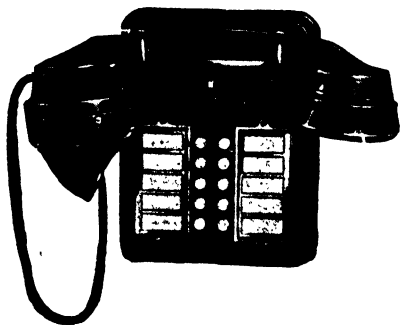

FIG. 9.—A TYPICAL INTERCOMMUNICATION TELEPHONE INSTRUMENT IN WHICH THE CALLING IS SELECTIVE BUT THE SPEAKING CIRCUIT IS COMMON.

(*Phoenix Telephone & Electric Works Ltd.*)

purposes. Figs. 9 and 10 show typical examples of intercommunication telephones, while a circuit diagram is shown in Fig. 11.

For a small number of stations, the ease of operation and the general simplicity of the system is a great advantage. As the number of stations and their distance apart increases, however, we gradually lose ground to the small automatic system (which is described in a later chapter) on account of the cost of cable. The modern automatic telephone system needs only two conductors from each telephone back to the

FIG. 10. — ANOTHER EXAMPLE OF AN INTERCOMMUNICATION TELEPHONE INSTRUMENT, WHICH IS INTENDED FOR THE DESK OR TABLE.

(*Phoenix Telephone & Electric Works Ltd.*)



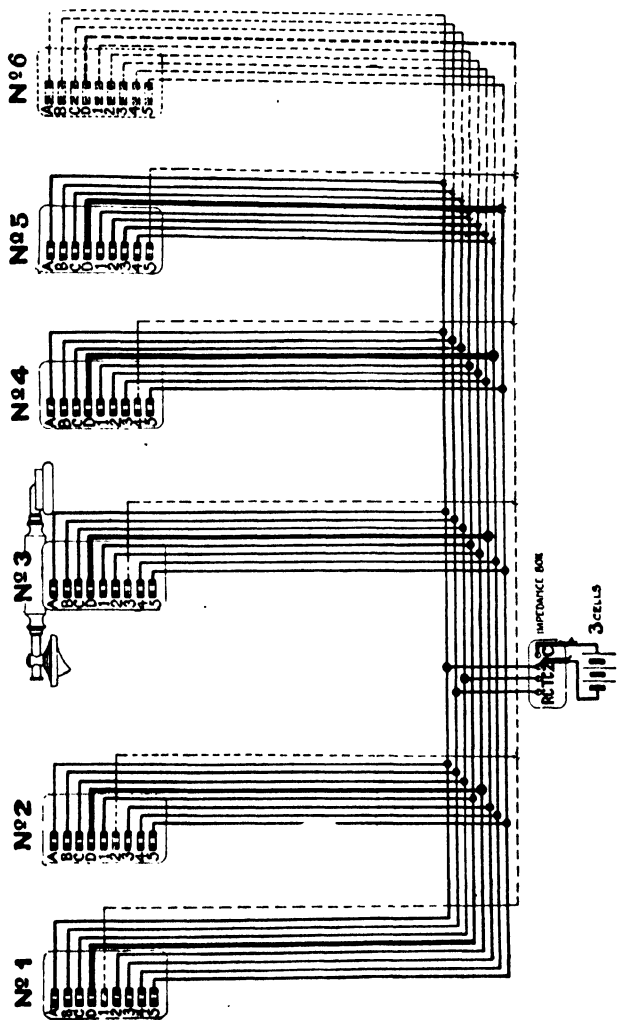

FIG. 11.—SHOWING TELEPHONE INSTRUMENTS AS FIGS. 9 AND 10, CONNECTED FOR INTERCOMMUNICATION WITH A CENTRAL BATTERY AND AN IMPEDANCE COIL.

If not more than five stations are used, the broken line should be disregarded.  
 (Phenix Telephone & Electric Works Ltd.)

## 16 HOUSE TELEPHONES, BELLS, SIGNALLING SYSTEMS

central point where the apparatus is fitted, but the intercommunication system must have a separate calling wire for each station, plus at least one and usually two or three commons for battery feeds and the return path.

No hard and fast rule can be laid down, but unless the stations are very scattered the "intercom" will probably be a better proposition up to ten lines, and definitely less suitable above twenty lines than an automatic system.

### **Circuit Arrangement.**

The early forms of "intercom," employing a radial switch arm passing over studs, were usually prone to faulty contacts, and are now practically obsolete. The push button telephone is free from these objections and time has proved its satisfactory design. Circuits vary considerably with regard to the arrangement of the talking circuit, but otherwise are very similar.

A buzzer is connected to the home line of each telephone and this line is connected to every other telephone it is required to call, going to the line terminal corresponding to the correct number. The buzzer is connected to one side of a battery, and is called by the calling button being fully depressed when current returns to the other pole of the battery, which is commoned throughout the system. The buzzer circuit passes through a gravity switch contact, so that it is broken upon the handset being raised to answer the call.

The calling button, however, does not return fully upon the caller raising his finger, but is locked in an intermediate position by a bar, which acts as a pawl;

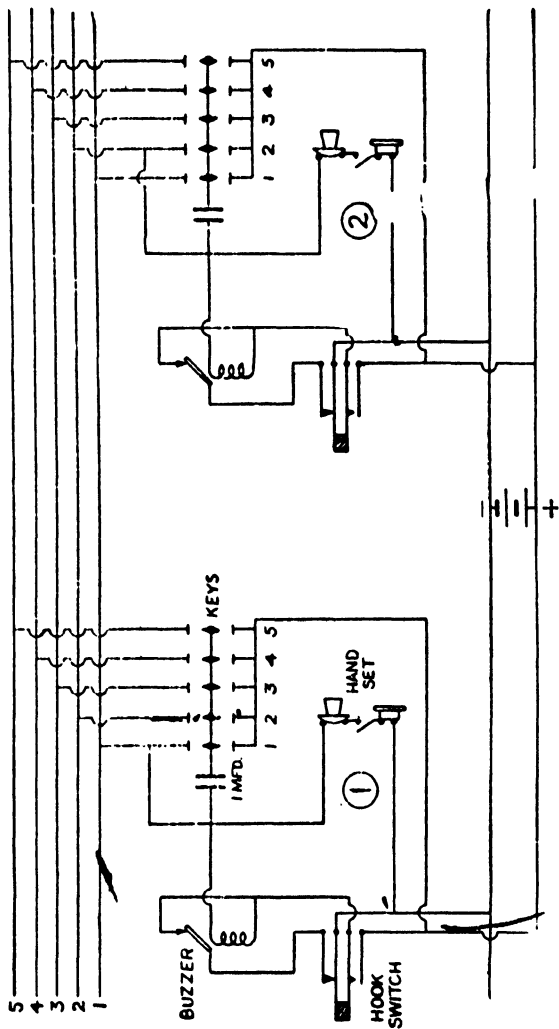

Fig. 12.—Wiring Details Showing Two Stations of a Five-Line Intercommunication System. All contacts are shown normal. When station 1 rings station 2, the plunger or key number 2 makes on both top and bottom contact. When the key is released, it is locked down so that it, makes on the upper contact only. There is only one wire to each line, a common return being used.

(Siemens Brothers & Co., Ltd.)

# 18 HOUSE TELEPHONES, BELLS, SIGNALLING SYSTEMS

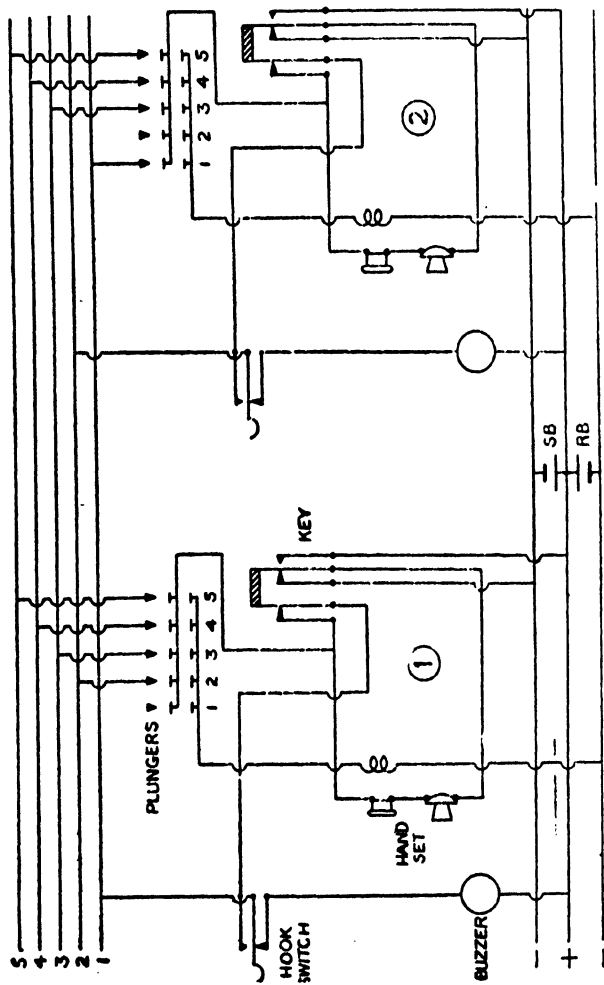

FIG. 13.—ANOTHER EXAMPLE SHOWING TWO STATIONS OF A FIVE-LINE EQUIPMENT. All contacts are shown normal. When one of the selecting buttons is depressed the ringing circuit is established, and when it is released it is locked on the upper contact so that speaking may take place.

(Erickson Telephones Ltd)

and in this position the calling line becomes the talking wire. Many different talking circuits have been devised, some giving rather poor speech, others causing rather a lot of cross talk. The well-known induction coil circuit would be fairly satisfactory, but complicates the instrument unduly.

The gravity switch of a telephone allows current to flow to the microphone upon the handset being removed from its rest and the caller has linked the two handsets with his condenser upon depressing a calling button, so there is no need for the called party to press any button, as in some circuits. Figs. 12 and 13 show circuits of telephone instruments of this type.

The pawl which holds the push button of the calling telephone in the operated position is pushed aside by the gravity switch lever when the handset is replaced and, therefore, leaves the line ready for further calls.

Some "intercoms" employ what is probably the most simple arrangement possible: the two handsets are connected straight across the ends of the go and

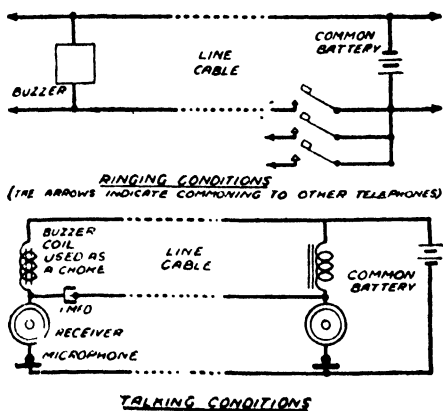

FIG. 14.—SCHEMATIC DETAILS OF AN INTERCOMMUNICATION INSTRUMENT.

This incorporates the "Stone" feeding bridge referred to in the text.

return wires, and the battery in series with a choke coil is bridged across the same two wires in shunt to the handsets. Current is fed out to both transmitters, but the choke coil having high impedance to speech currents prevents the battery from shunting the handsets.

Unfortunately, there is unequal distribution of current, as one telephone may be close to the battery whilst the other has considerable line resistance in series.

### **The "Stone" Feeding Bridge.**

On large manual and certain automatic systems the "Stone" feeding bridge is made use of. In this the current from the battery is fed out through choke coils to the telephone, one being inserted in each line of the talking pair. The arrangement is exactly similar for both caller and called telephone. (See Fig. 14.)

To link the two telephones together for speech purposes, condensers are fitted between the called and calling lines. The telephones are not now in metallic circuit and have individual battery feed, but the condensers conduct the speech currents satisfactorily. Whilst it is not possible to use this exact arrangement without undue complications in "intercoms" it is possible to compromise between it and the simple parallel choke feed circuits described above.

The result is what proves to be a most satisfactory circuit. The handsets become individually fed through choke coils from the battery connecting wires. The battery wires act as a return path for the speech currents and being in parallel, as far as this purpose is concerned, do not allow a potential to build up and cause cross talk. The other path for speech currents

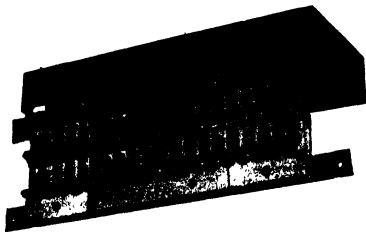

FIG. 15.—JUNCTION BOX FOR USE WHEN MAKING TEE JOINTS ON MULTIPLE CABLES FOR INTERCOMMUNICATION TELEPHONES.

This is referred to in the text.

(*Phoenix Telephones & Electric Works Ltd.*)

is from the calling line terminal of one telephone to the home line of the other, there being a condenser in series with the line to prevent metallic circuit.

### Wiring and Jointing.

Owing to the general simplicity of "intercom" systems maintenance is fairly easy. The dry cells used as a battery will have to be replaced occasionally, and some of the cords may need attention as they wear. Otherwise faults are confined more or less to dirty switch or buzzer contacts which can be localised fairly simply.

It must be remembered that every microphone is fed by means of a local choke coil directly from the battery leads which are commoned to all telephones and it is essential that these leads be of good size, say .029 inch diameter conductors. If ordinary telephone cable be used and the conductors are of the usual size, .036 inch diameter, at least three wires should be twisted together to form a battery lead. The resistance of the lines is not otherwise of great importance provided that the buzzers will operate over them, as good speech will be obtained long after the line limit for the buzzers is reached. In general, .036 inch diameter conductors should be provided for lines and are quite satisfactory.



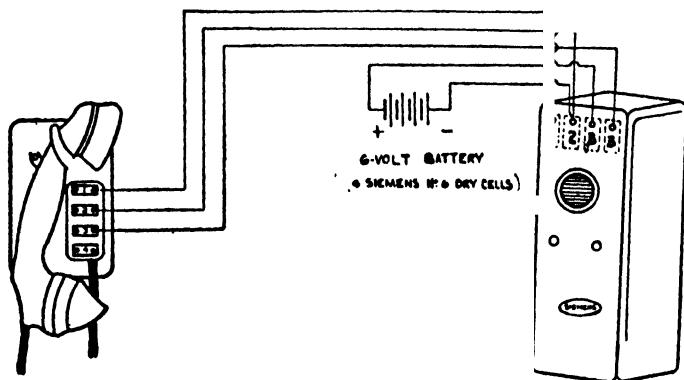

FIG. 16.—WIRING DETAILS OF THE "NEOPHONE" DOCTORS' FRONT DOOR TO BEDSIDE TELEPHONE.

(Siemens Brothers & Co., Ltd.)

As cables have to be joined in to many telephones, looping in, namely, removing the insulation and clamping the intact wire under a telephone instrument terminal, is sometimes practised, whilst others cut the cable but still join through on the telephone block either by twisting wires together or using china connectors. These methods are a source of trouble and all jointing should be made on a suitable junction box. (See Fig. 15.)

If a further telephone is required on a system and it is desired to avoid the use of a junction box, extra washers should be used on the telephone terminal block and used in between the two wires on each terminal.

### Doctors' Night Telephones.

A simple loud speaking telephone for ringing one way only and specially intended for the homes of medical men is made by Messrs. Siemens Brothers &

Co., Ltd., and known as the "Neophone." The doctor replies to a call from his night door bell by speaking into a small handset installed near his bed. The telephone at his front door is of the loud speaking type and all the caller has to do is to reply to the doctor's questions without touching the instrument in any way. The speech transmission with equipment of this type is particularly clear and distinct, and the diagram of connections (Fig. 16) shows that the arrangement is essentially simple.

## CHAPTER II

### TELEPHONES FOR BLOCKS OF FLATS

**I**N a number of ways the modern blocks of flats which are now so prominent a feature of large cities afford examples of specialised application of electrical equipment in that problems not found elsewhere are encountered when the needs of large groups of tenants are to be met.

Amongst the most notable of these examples are the measures taken to enable tenants to obtain the rapid service of the common staff. Bells, lamps and indicators (referred to in a later chapter) are employed with a reasonable degree of success, but even by the use of codes the instructions that can be given and the amount of information which can be imparted are extremely limited. Only predetermined messages can be given—generally a simple request for attendance—and, of course, can usually pass only one way—from tenant to personnel. With these limitations in mind, resort is now made to the natural method of imparting instruction and information by the spoken word, a telephone system being employed for the purpose.

#### **Connection to a Reply Panel.**

In a telephone system serving flats, each apartment will have to be equipped with a telephone instrument connected to a reply panel. As a rule, this panel

should be fitted in or near the porter's office, the porter fulfilling the duties of attendant. Also connected to the reply panel will be lines to such service points as the manager's office, kitchen and garage, the equipment of the reply panel being designed to enable the attendant to establish connection between any flat and a service line.

Provision will not have to be made for connecting one flat to another, since tenants, although resident in the one building, are individual members of the public, and thus a telephone system which allowed inter-

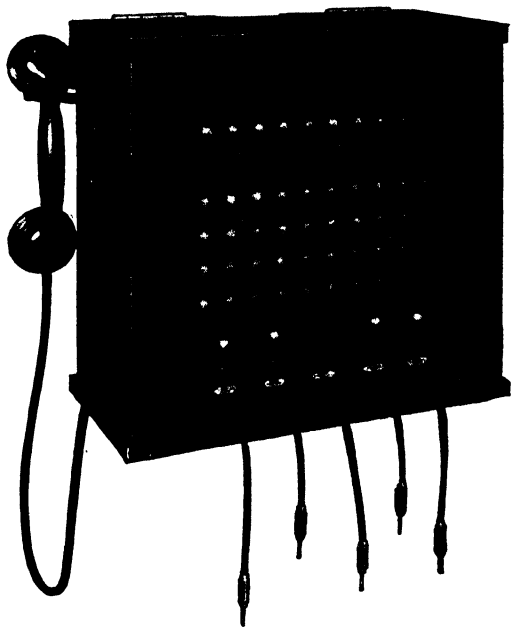

FIG. 17.—REPLY PANEL, EQUIPPED FOR 40 LINES TO FLATS, AND FOUR SERVICE LINES.

(General Electric Co., Ltd.)



FIG. 18.—EXAMPLE OF THE TYPE OF INSTRUMENT INSTALLED IN A TENANT'S FLAT.

(General Electric Co., Ltd.)

communication between them would infringe the rights of the Postmaster General. A properly designed reply panel prevents unwitting or deliberate infringement.

A typical reply panel, equipped for forty lines to flats, is illustrated. The forty jacks, with associated calling lamps, are seen in four rows of ten, beneath which are plug-ended cords

terminating the service lines, together with a similar cord connected to the attendant's handset. (See Fig. 17.)

A typical telephone is shown in Fig. 18. It consists of a coloured moulded handset and case, the latter designed for wall-mounting and incorporating a calling buzzer. Each telephone is connected to the reply panel by two line wires, which terminate on a jack.

### Procedure When Calling Attendant.

When a tenant lifts his handset to make a call, his

calling lamp lights and a buzzer sounds to attract the attention of the attendant. The attendant inserts his reply plug—the centre one of the five shown—in the jack beneath the lamp which he sees to be glowing, thus cutting off the visual and audible calling signals, and answers the call on his handset. The tenant may request the attendant to perform any of the usual porter's duties, in which case, after instructions are acknowledged, both handsets are replaced and the plug withdrawn to clear the connection.

### **Connection of a Tenant to a Service Line.**

Should, however, the tenant request that he be connected to a service line, say the kitchen, the attendant withdraws the reply plug and inserts the plug of the kitchen line in the flat-line jack.

The kitchen is then called by depression of the key above the kitchen jack, the buzzer in the kitchen telephone set attracting attention. When the handset there is removed conversation may follow. At the end of the call both handsets are replaced, the circuit conditions then being such that the kitchen-line lamp glows and the buzzer sounds to denote to the attendant that conversation is finished.

The attendant then withdraws the plug, whereupon the lamp is extinguished, the buzzer ceases and circuit conditions are restored to normal.

Reply panels are made in various sizes, typical capacities being for 20, 50, 100, 160 and 240 lines to flats. Since the lamps and jacks are mounted in strips of ten, the capacity of any particular panel may be arranged to be any multiple of ten within the maximum of the panel.

**Telephone System for Grouped Blocks of Flats.**

A facility usually offered, which assists towards securing the best and most economic service, is that by which a number of reply panels may be incorporated in a system.

When a large number of flats are contained in one building of considerable size, or in two or more neighbouring buildings under the same management, there will almost certainly be more than one member of the staff whose duties permit of attention to the requirements of a reply panel. By taking advantage of this fact a number of reply panels may be installed at selected points and linked to each other by tie lines, the capacities of the panels being chosen to serve the flats in their respective buildings or section.

By thus avoiding the necessity for running flat lines to one central board, the shortest total length of wiring is secured, an important item in economic considerations, particularly if lines pass into the open and require to be of cable suitable for running in the open.

The panel illustrated is equipped for ten tie lines to other panels, the lamps and jacks associated with these lines being seen at the top of the front equipment. At the sub-panel these lines terminate in plug-ended cords, simple co-operation between attendants enabling any flat on any panel to be connected to service lines whether these appear on the same panel or not.

Operation, it will be seen, is quite simple, involving only the insertion of plugs and depression of ringing keys, and the attendant need understand no more than the correct procedure in these respects.

The engineer, on the other hand, will require to

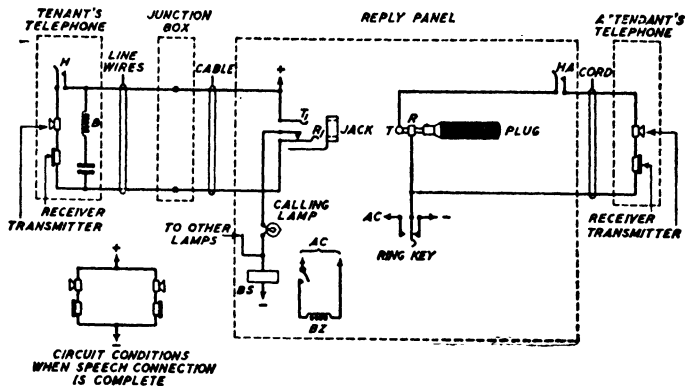

FIG. 19.—SIMPLIFIED DIAGRAM OF SERVICE TELEPHONE INSTALLATION FOR A BLOCK OF FLATS.

know more of the system, if only for his own satisfaction, apart from the help such knowledge would provide in installation and maintenance duties.

### Circuit Conditions when Calling.

The simplified diagram, Fig. 19, will convey an understanding of the circuit conditions established when a flat calls the porter, which are typical of those obtaining in the case of other calls.

The plug shown is the attendant's reply plug, incorporating two points of contact, tip (T) and ring (R), insulated from each other and to which connections are made by means of a flexible cord passing through the body of the plug.

The jack is that of any flat line and incorporates a spring (T<sub>1</sub>), which makes contact with the tip of the plug when the latter is inserted, a second spring (R<sub>1</sub>), which makes contact with the ring of the plug, and a third spring normally making, with R<sub>1</sub>, a contact that



### 30 HOUSE TELEPHONES, BELLS, SIGNALLING SYSTEMS

is broken by insertion of the plug. When the tenant lifts his handset, hookswitch H establishes a circuit from + through transmitter and receiver, spring R<sub>1</sub>, calling lamp and relay BS.

The lamp lights and relay BS operates. Contacts on the relay close the circuit for the calling buzzer and thus the attendant receives visual and audible signals. He responds by inserting the plug, which, by breaking the contact at spring R<sub>1</sub>, extinguishes the calling lamp and cuts off the buzzer. When the attendant lifts his handset, hookswitch HA connects the two telephones together in a manner which is the equivalent of the circuit given in the small diagram shown in Fig. 19.

#### **Power Supply.**

The positive and negative connections shown in Fig. 19 are made to the source of power supply, which is almost invariably a small A.C. mains unit. This incorporates transformers and rectifiers for providing direct current for speech circuits and for lighting lamps, whilst supplying also an A.C. feed at mains frequency and suitable voltage for operating the buzzers. The use of 40/60 cycle alternating current for this purpose has the advantage that buzzers do not require any vibrating contacts.

#### **System for Service Flats.**

The telephone system described below has been specially designed to meet conditions where a number of persons require communication with a central point, such as a group of service flats. (See Fig. 20.)

The apparatus consists of a telephone set, which may be either a wall or table type, connected by only.

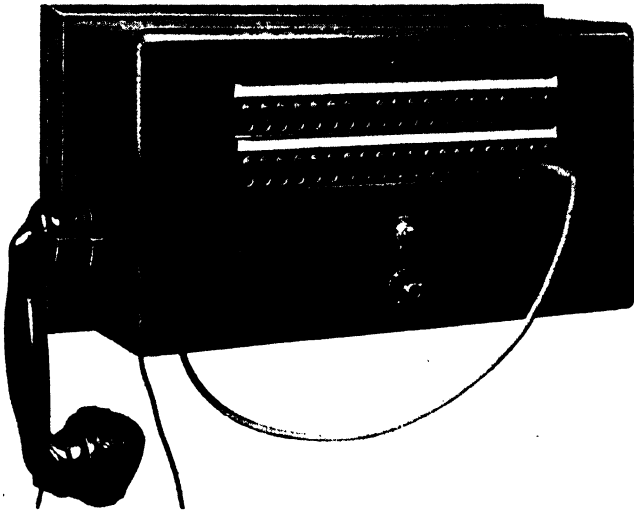

FIG. 20.—A 40-LINE SWITCHBOARD FOR INSTALLATION IN A BLOCK OF FLATS.

*(Standard Telephones & Cables Ltd.)*

two wires to a central switchboard; the operating current is obtained from a power unit which is connected directly across the A.C. Mains. The lifting of the handset automatically lights a lamp connected to that particular line on the switchboard and, if the switchboard attendant is not present, simultaneously rings an alarm bell, which can be switched in and out of service as required. To answer a call it is only necessary for the attendant to plug into the jack immediately below the lamp before speaking.

The facilities provided by these house telephones give intercommunication between any specified positions; for example, it may be found convenient for patrons to have direct communication with such

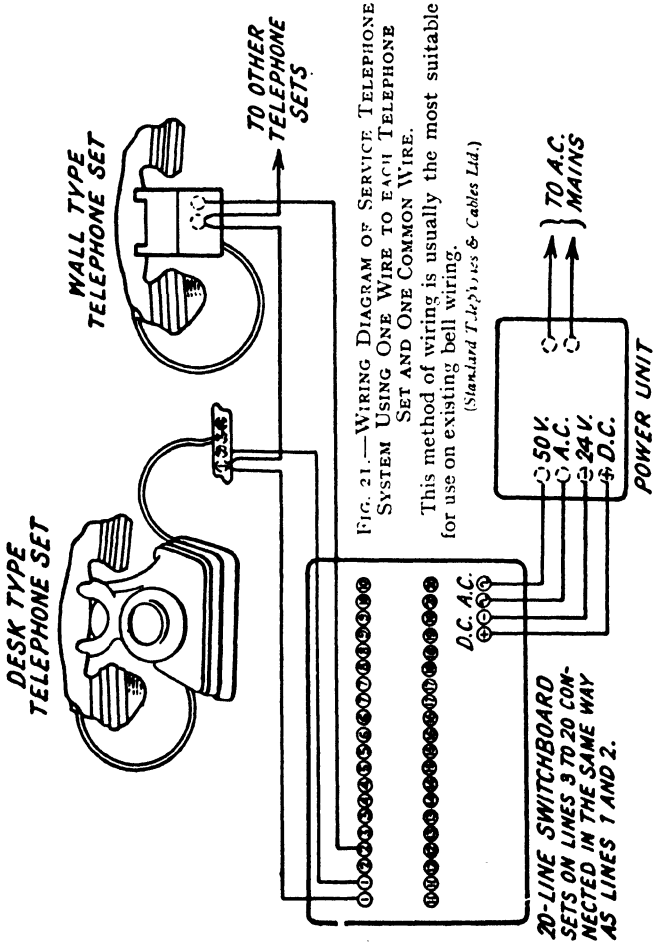

FIG. 21.—WIRING DIAGRAM OF SERVICE TELEPHONE SYSTEM USING ONE WIRE TO EACH TELEPHONE SET AND ONE COMMON WIRE.

This method of wiring is usually the most suitable for use on existing bell wiring.

(Standard Telephone & Cables Ltd.)

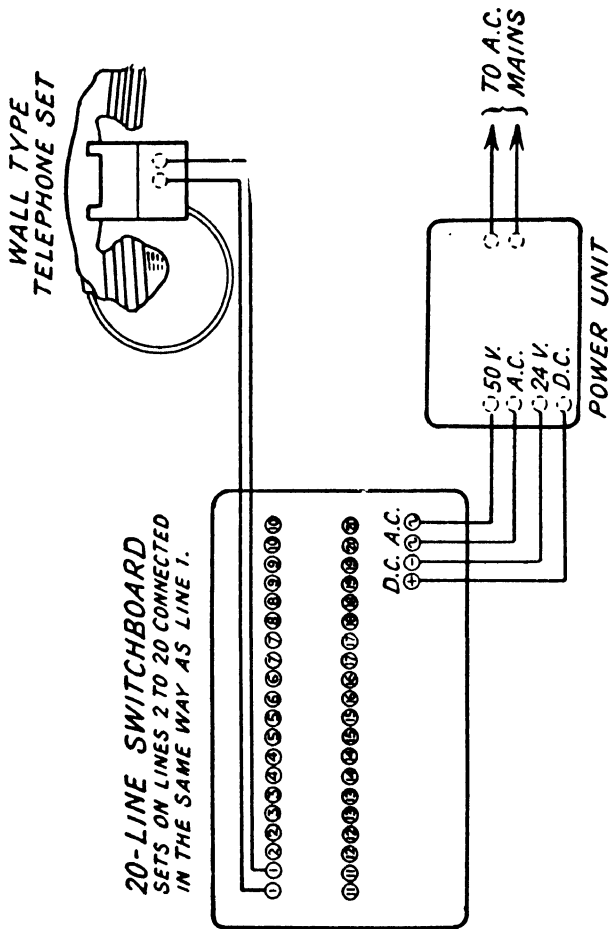

FIG. 22.—WIRING DIAGRAM OF SERVICE TELEPHONE SYSTEM USING TWO WIRES TO EACH TELEPHONE SET.  
 (Standard Telephones & Cables Ltd.)

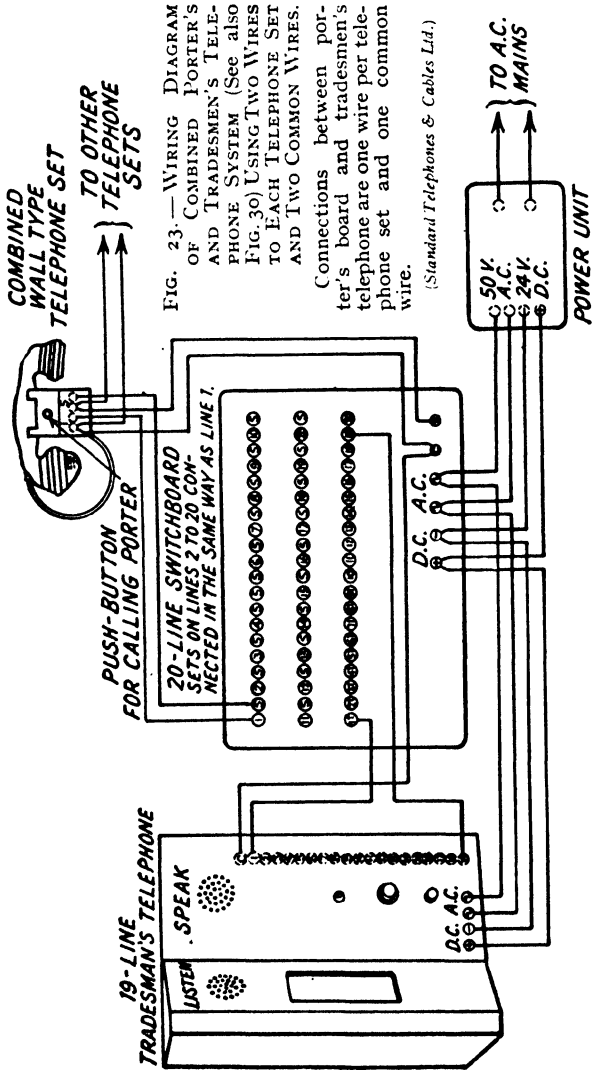

FIG. 23.—WIRING DIAGRAM OF COMBINED PORTER'S AND TRADESMEN'S TELEPHONE SYSTEM (See also FIG. 30) USING TWO WIRES TO EACH TELEPHONE SET AND TWO COMMON WIRES.

Connections between porter's board and tradesmen's telephone are one wire per telephone set and one common wire.

(Standard Telephones & Cables Ltd.)

positions as the Reception Clerk's Office, Restaurant, Management, Garage, etc. In this case, after ascertaining for whom the incoming call is intended, the attendant immediately plugs into the jack of the wanted line and when the receiver at the called end is lifted, conversation between the two calling parties is at once established.

If it is found necessary for more than one switchboard to be fitted into a building, these should be linked together and terminated on a main central position for night service. Tie lines for specific requirements can also be provided. An advantage of this system is that it is possible to utilise the existing bell wiring, except where a combined service and tradesmen's telephone is installed, provided that 50 volts A.C. can be carried. In the majority of cases it will be found that modern bell wiring is suitable for this system. (See Figs. 21, 22, and 23.)

### **Non-Automatic Telephones.**

Push button instruments also are extremely convenient for installing in blocks of flats and in small factories and offices (see next chapter) and in this case the desired station is rung by taking up the micro-telephone and pressing the selector button, of the line wanted, to its full extent. The called station has only to take up the micro-telephone to reply.

A selector button having been pressed is retained in an intermediate position to give the correct circuit arrangement, and is automatically restored to normal by replacing the micro-telephone or by pressing the button of any other station with which communication is desired. It is therefore unnecessary to replace the

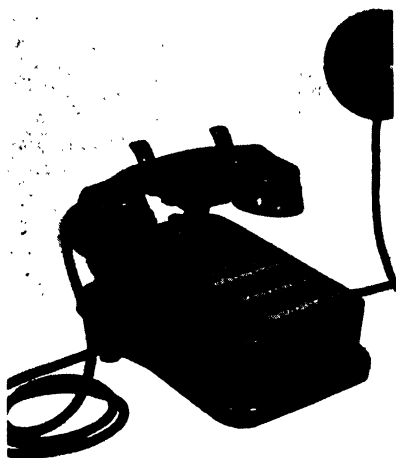

FIG. 24.—AUTO-RESET PUSH BUTTON  
SELECTOR TYPE INSTRUMENT.  
(Ericsson Telephones Ltd.)

micro-telephone before calling another station. When ringing a station: if a buzzing noise is heard in the receiver it indicates line "disengaged" while silence indicates line "engaged." A wall pattern instrument of this type is shown in Fig. 24.

The instruments are installed in accordance with the diagram Fig. 25, which refers to in-

struments made by Messrs. Ericsson Telephones Ltd. Junction boxes, battery boxes, cells, cables, saddles and staples are required to complete an installation.

An instrument, of moulded Bakelite, specially arranged for use in factories, shops, and small offices, where a simple two-way telephone system is required, is also made by Messrs. Ericsson. (See Fig. 26.)

The push-button for calling is fitted in front of the micro-telephone, and the interior apparatus comprises a trembler bell, induction coil and connecting terminals.

The diagrams show the connections for central battery and for separate battery working. When more than two stations are required a code ringing system must be adopted. (See Figs. 27 and 28.)

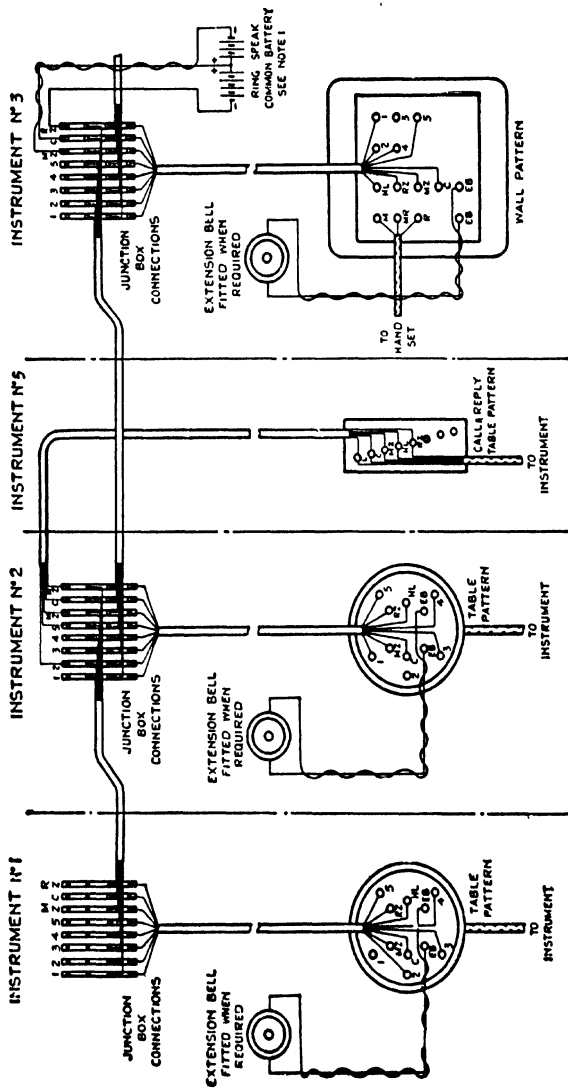

FIG. 25.—DIAGRAM OF CONNECTIONS OF PUSH-BUTTON SELECTOR TYPE INSTRUMENTS—CENTRAL BATTERY SINGLE LINE WORKING.

Terminal C—Carbon  
 MZ—Microphone zinc  
 RZ—Ringing zinc  
 (Connect with the line wire corresponding to the station's number).

The batteries must be connected as shown and fitted near the centre of the system.

(Falcon Telephone Ltd.)





FIG. 26.—BATTERY RINGING TELEPHONE FOR USE WHERE A SIMPLE TWO-WAY TELEPHONE SYSTEM IS REQUIRED.

(Ericsson Telephones Ltd.)

### Tradesmen's Telephones.

In this case calling is from one way only, and a Tradesmen's Instrument is shown in one of the illustrations. To make a call it is only necessary to turn the pointer to the number of the flat required and press the ringing button. The buzzer is then operated at the distant end and the reply is heard at the instrument *via* a loud-speaker. As the tradesman talks

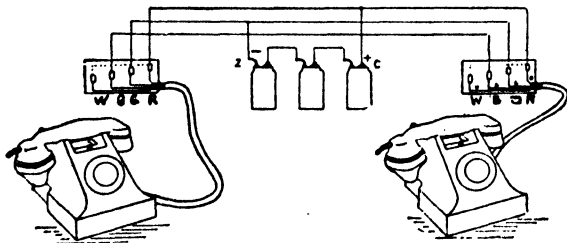

FIG. 27.—CONNECTIONS FOR TWO INSTRUMENTS AS FIG. 26, USING A CENTRAL BATTERY.

(Ericsson Telephones Ltd.)

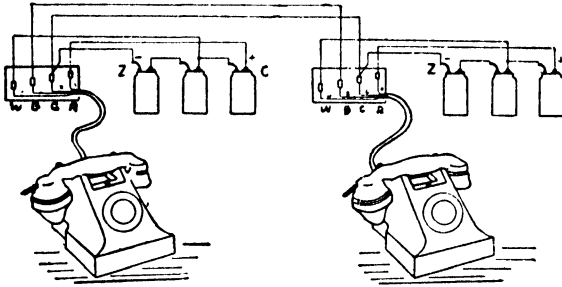
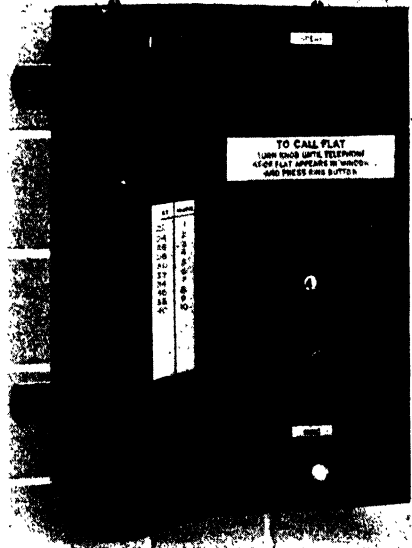

FIG. 28.—CONNECTIONS FOR TWO INSTRUMENTS AS FIG. 26, USING SEPARATE BATTERIES.  
(Ericsson Telephones Ltd.)

through a microphone located in the front of the instrument, his hands are free for taking down orders if necessary. These instruments are particularly

FIG. 29.—TRADESMEN'S TELEPHONE FOR A BLOCK OF FLATS.  
(Standard Telephones & Cables Ltd.)



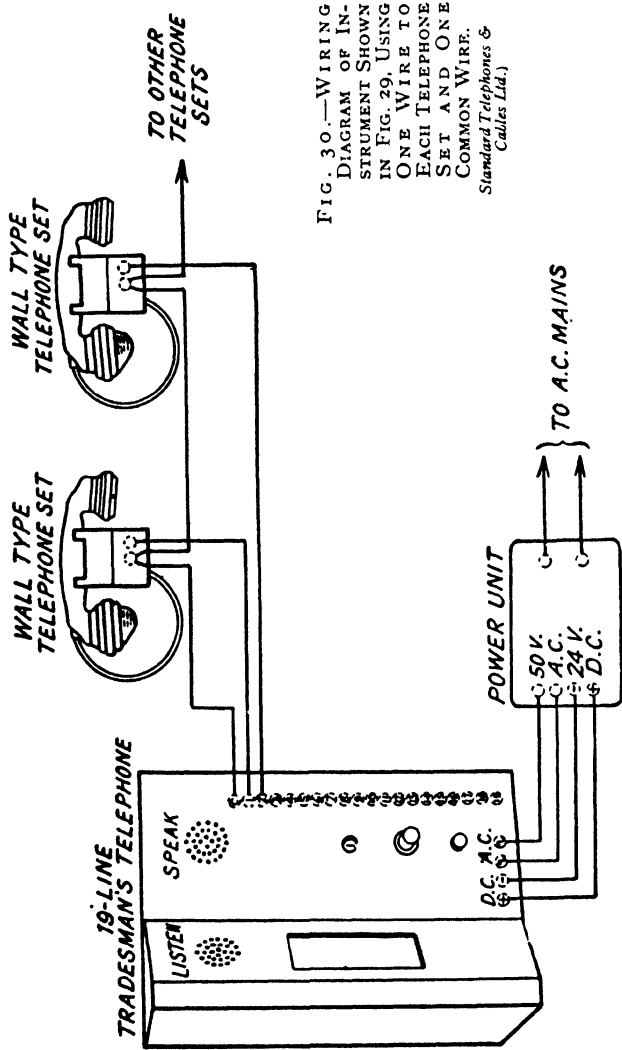

FIG. 30.—WIRING DIAGRAM OF INSTRUMENT SHOWN IN FIG. 29, USING ONE WIRE TO EACH TELEPHONE SET AND ONE COMMON WIRE.  
Standard Telephones & Cables Ltd.)

suitable for blocks of flats, for not only is the tradesman saved from using the passenger lifts, but the system provides a safeguard against unauthorised persons roaming along the corridors. The diagram shows clearly how the instrument is connected to its power unit. (See Figs. 29 and 30.) Fig. 31 shows another instrument of this type, which is made by the General Electric Co., Ltd.

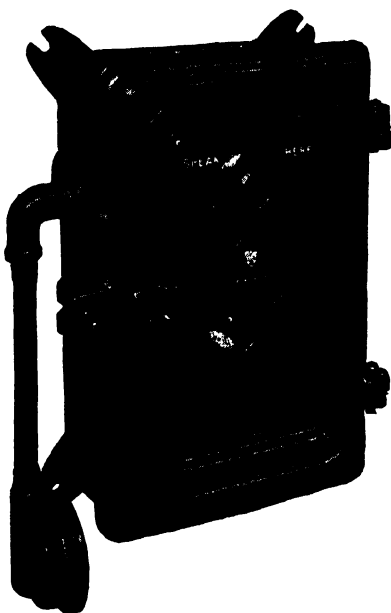

FIG. 31.—ANOTHER EXAMPLE OF A TRADESMEN'S TELEPHONE FOR A BLOCK OF FLATS.  
(General Electric Co., Ltd.)

## CHAPTER III

### TELEPHONES FOR FACTORIES AND OFFICES

**T**HE first thing to be decided is whether a push-button inter-communication system or its alternative—an exchange system—is to be employed. The objective of each is the establishing of speech channels between members of the personnel but the methods employed differ. In an inter-communication system each telephone is fitted with a set of push-buttons

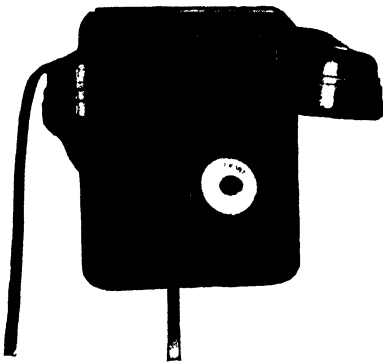

FIG. 32.—A BATTERY CALL INSTRUMENT.  
(Siemens Brothers & Co., Ltd.)

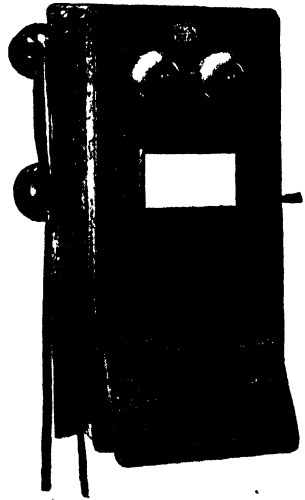

FIG. 33.—A MAGNETO TELEPHONE INSTRUMENT.  
(Siemens Brothers & Co., Ltd.)

(as described in the previous chapter), one button for each line, any required party being called by depression of the appropriate button. Selection of the wanted line is thus made actually at the calling instrument. This requires, however, that all telephones be linked together by a multiple cable



FIG. 34.—A TELEPHONE INSTRUMENT OF THE INTER-COMMUNICATION TYPE.  
(Siemens Brothers & Co., Ltd.)

containing wires to a number in excess of the number of lines. This cable and the necessity for push-buttons impose economic and other limits governing the number of telephones.

The inter-communication telephones described in the previous chapter are equally suitable for installation in factories and offices, and Figs. 32-34 show further examples of the range of instruments of this type which are available.

### Choosing System to use.

In an exchange system, on the other hand, the telephones are not linked to each other but are individually connected to a central switching equipment at which selection of the wanted line is made. Only the usual two wires are required to each telephone and the system is of unlimited capacity. The switching

equipment may be manually-operated, in which case an attendant selects the wanted line and completes the connection when a call is made, or may be automatic in operation in which case the telephones are fitted with dials. In modern exchange practice automatic operation is almost always preferred on the grounds of accuracy, rapidity, secrecy, hours of service and the facility with which certain special features may be incorporated.

The choice, then, is between a push-button system and an automatic exchange and the decision will largely be governed by the number of lines. For more than, say, 20 lines, an exchange should always be chosen, whilst even for a lesser number, although a push-button system may be considered, one of the smaller automatic exchanges may well be favoured as providing the best service and dispensing with the multiple cable.

### **Sizes of Automatic Exchanges.**

An automatic installation as a whole consists of an automatic switchboard, telephone instruments and a suitable power plant to operate the switching equipment and provide current for the speech circuits. Switchboards are made in sizes having line capacities of ten, twenty-five, fifty and upwards, each equipped for any number of lines up to their respective maximums. The smaller sizes consist of single units, whilst above fifty lines a board comprises a number of fifty-line units installed as and when required in order to serve any number up to approximately 400 lines. When the number of lines is in excess of this figure switching equipment will have to be mounted on open racks,

as in the case of large public exchanges.

With a knowledge of the number of persons to whom telephones are to be allotted, and bearing in mind the possibility of future developments of a nature such as would necessitate further telephones, a switchboard of suitable capacity can be selected. It should be noted, however, that the number of lines is not necessarily equal to the number of telephones, since, when the duties of the users permit, economy can be secured by serving two telephones in close proximity by one line.

In modern practice the telephones are of the Bakelite pattern, preferably self-contained, i.e., with the bell inside the case. When this type is employed the convenience

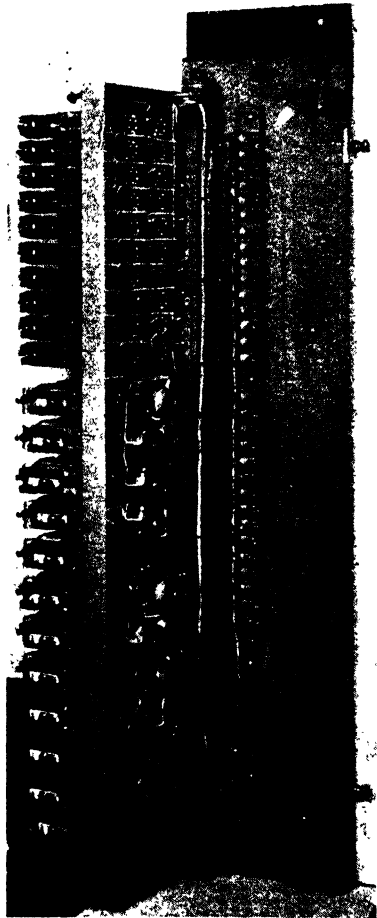

FIG. 35.—LINE AND POWER TERMINALS OF A 10-LINE PRIVATE AUTOMATIC EXCHANGE.

(General Electric Co., Ltd.)



of the handset is gained and the necessity for a separate bell-box and its wiring is avoided.

An extremely useful accessory is a loudspeaking telephone, as described at the end of this chapter.

### A ten-line Switchboard.

Space will not permit descriptions to be given of the installation and maintenance of all the various sizes of private automatic exchange (P.A.X.) systems. It is the intention, therefore, to select one—the smallest—for particular reference.

The ten-line switchboard illustrated, employs relays for all switching operations, thus ensuring accuracy in operation and securing the advantages of compactness, minimum current consumption and low operating voltage. A further advantage of this switchboard is that operation can be effected from A.C. mains through a small rectifier unit, whereas in the case of the larger switchboards, such a practice would necessitate a

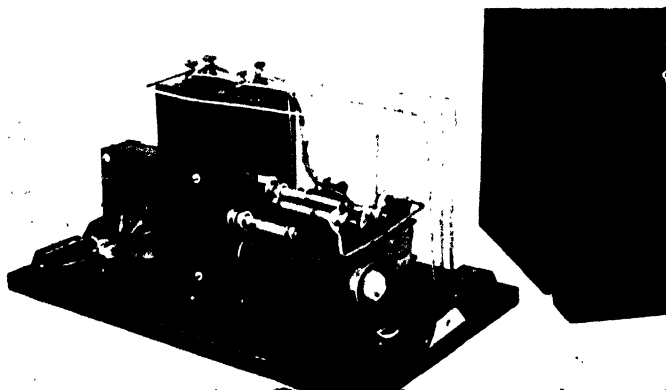

FIG. 36.—TELEPHONE MAINS UNIT, COVER REMOVED.  
(General Electric Co., Ltd.)

mains unit of unduly large proportions. (See Figs. 35 and 36.)

### **Installation.**

The relay mounting plate is hinged to a wood backboard which may be secured in any convenient position on a wall. By swinging the mounting plate forward, the line and power terminals are disclosed, these being of the screw type to simplify connection. A telephone system employing this switchboard is an exception to the general rule in exchange systems, in that three line wires are required instead of the usual two. The backboard thus carries three terminals for each line and also three terminals for the power leads, the reason for which will be apparent later. With the connection of the line and power leads to the appropriate terminals, attention may be directed to installation of the telephone instruments.

Externally the self-contained telephone specially designed for use with the ten-line board is very similar to other Bakelite telephones, being provided with a flexible cord connected to a rosette for the termination of the line wires. The rosette is fixed in a suitable position on desk or wall, and the three line wires are connected to the appropriately designated terminals.

### **Power Supply.**

If batteries are employed as a source of power for the automatic unit it is preferable that they be of the secondary type. Since the voltage required is the low one of eight volts, the batteries may be portable, being removed when charging is necessary. In the majority of instances, however, a mains unit will be preferred.

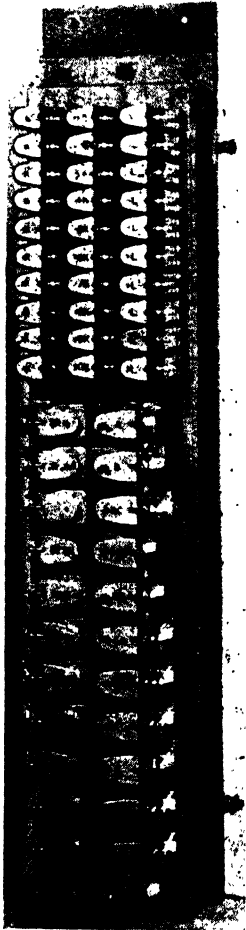

FIG. 37.—RELAYS OF A  
10-LINE PRIVATE  
AUTOMATIC TELE-  
PHONE EXCHANGE.

(General Electric Co., Ltd.)

Such a unit comprises a straightforward arrangement of mains transformer and metal-rectifier, together with smoothing condensers and chokes. It should be installed as near as possible to the switchboard in order to minimise the resistance of the power leads. On the output side three terminals are provided, corresponding to the three terminals on the switch-board. Three leads (say, 7/.044) should be run between these terminals, thus providing, since one terminal is common, two separate power feeds. The local wiring of the switchboard provides for the allocation of one feed to the speech circuits and of the other to the operating circuits, thus preventing varying potentials set up during operation of the apparatus from causing disturbance in an already established connection. Whilst the duties of maintenance are hardly likely to call for an intimate knowledge of circuit details, it is necessary to possess a clear conception of principal functions. These are outlined in the following notes on another page.

The relays employed are of two types, both of which are illustrated. Of the two, the larger is of the more robust construction and possesses the better operating characteristics, being, therefore, used in the heavy-duty circuits—those taken into use on every call. (See Fig. 37.)

### **The Line Circuits.**

Associated with each line is a line circuit, which, since it is brought into action only when a call is made or received on its line, does not require relays of the performance characteristics possessed by the large type. In these circuits, therefore, the smaller pattern relay is incorporated.

It will be seen in the illustration of the 10-line switchboard that the top half of the mounting plate accommodates the line relays, of which there are three per line, whilst the lower half carries the common circuits. These latter comprise two connecting links, a register and a trio of relays for interrupting ringing current to give an effective calling signal. Relays in the line circuits are designated L, K and K<sub>1</sub>, the K and K<sub>1</sub> relays being associated also with the first and second links respectively.

### **How a Speech Channel is Established.**

A speech channel is established when a calling and the called lines are joined to each other by one of the connecting links, the provision of two links thus permitting of two simultaneous conversations. The relays in the first link are designated HR, H, F, BF and RH respectively, those in the second being HR<sub>1</sub>, etc. These relays occupy ten positions on the left of

the mounting plate, whilst on the right are eleven relays in the register circuit, the function of which is to react to manipulation of the dial on a telephone in a manner depending upon the number dialled.

### **How a Call is Made.**

In preparing a small directory for the system each line is allotted a single digit from 1 to 0. To make a call, the number of the wanted line is dialled, relays in the register circuit responding and "marking" a lead to the K and K<sub>1</sub> relays of the called line. With the first movement of the dial the L relay in the calling line circuit is operated and prepares a circuit for its associated K and K<sub>1</sub> relays. If it be assumed that the first link is not already engaged on a call, relay H operates over a circuit established by the register and completes the circuits for the K relays of the two lines. The operation of these relays connects the lines to the link, current being applied to the line by relay F in order to ring the bell of the wanted party. When the call is answered, current is fed through the coils of relay BF for speech over the through connection, relay BF establishing circuit conditions by which a succeeding call will find the first link busy and pass to the second. When this link is taken into use the K<sub>1</sub> relays in the line circuits operate instead of the K relays.

### **Loud Speaking Telephones.**

Loud speaking telephones are frequently called for, and a number of systems all equally good are available. One of these designed by the Arden Acoustic Laboratories Ltd., is available in three types.

The "Duocall" provides communication with one

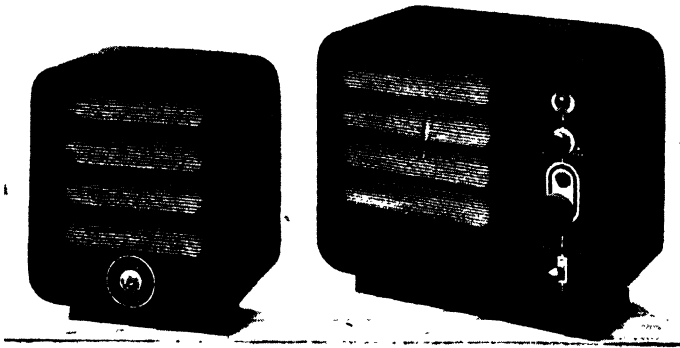

FIG. 38.—LOUD SPEAKING COMMUNICATION UNITS.  
(Ardente Acoustic Laboratories Ltd.)

remote station only. The "Selectacall" can be used for from two to ten remote stations, while the "Multi-call" can also be used for ten stations, but provides some rather special facilities. The master units used for loud speaking communication resemble somewhat small radio receivers, and have a "press to talk" switch, a number of selecting switches according to size, and an illuminated number to show which station is being called. (See Fig. 38.)

The master unit has to be connected to the mains (either A.C. or D.C. 100 to 135 or 200 to 250 volts) and to the sub-stations by a special cable system, when the communication system is ready for use. In each case the user at the master station closes the "speak" switch and the switch relating to the required sub-station. He is then able to communicate with persons who may be within about 20 ft. of their transmitter-receiver in a remote part of the building. When no calls are being made by the master station the selector

switch registers "R" and is not illuminated. In this position calls from any sub-station can be received. Such a system is ideal for large hotels, for passing orders from a restaurant to the kitchen.

The "Multicall" system provides selective loud speaking inter-communication, enabling private two-way conversation to be carried on between any two stations. With this system it is possible for five separate and distinct conversations to take place simultaneously without break-through or interference. This is, of course, intended principally for high speed inter-communication between executives in business houses who may be too busy to rely upon the ordinary house telephone and who wish to have their hands free to refer to documents. Chapter VIII gives further details of loud speaking and other special telephones.

### **Maintenance and Locating Faults.**

In the case of a battery-operated switchboard the source of unsatisfactory operation of any kind should first be sought at the battery, particular attention being paid to voltage on load.

A mains unit is not likely to give much trouble, perhaps the least unlikely fault being the breakdown of a smoothing condenser, denoted by mains hum and other noises in the telephones.

Tests on the automatic unit can be made by means of a portable test telephone of a type similar to those in service. If a telephone definitely reserved as a test instrument be not available, then one of the service instruments may be temporarily removed for the purpose. When a fault is reported, the nature of the fault should be considered. If, for example, an

unsatisfactory signal is given by the bell of a telephone, the bell itself should first be examined for incorrect adjustment. Removal of the four screws in the telephone base will permit the Bakelite case to be removed, thus disclosing the bell. If the fault persists, contacts on the relays should be cleaned by the careful application of a little pure carbon tetrachloride, a camel-hair brush being employed.

In the event of a report that a connection cannot be established when a dial is operated, the line wires of the affected line should be removed from the terminals on the switchboard and the test telephone connected in their stead. If operation of the dial on this telephone does not cause a response on the part of relays in the register circuit, contacts on the relays should be cleaned. Should the register circuit seem in order, then operation of the connecting links should be observed. If a call cannot be made via the first link, relay BF in this link should be held operated by hand and another attempt made, this automatically taking into use the second link. Success in this second attempt will indicate a fault in the first link, relay contacts on which should then be cleaned and wiring examined.

From the foregoing, it is seen that after battery voltage, the most likely source of faults is dust on relay contacts. If the precaution of replacing the cover be always observed, the number of faults will be minimised and routine inspection will be unnecessary.



## CHAPTER IV

### BELLS, INDICATORS AND RELAYS

**T**HERE is a wide range of types and sizes of electric bells available, ranging from those having gongs about two inches in diameter, to those for installation in noisy situations, having gongs about twelve inches in diameter. The smallest

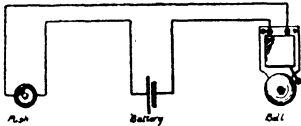

FIG. 39.—A SIMPLE BELL CIRCUIT.

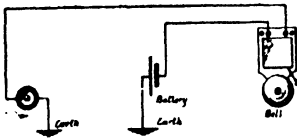

FIG. 40.—A SIMPLE BELL CIRCUIT USING AN EARTH RETURN.

bells require about two volts from a primary battery for their operation or they can be operated from the mains via a suitable transformer, while the largest bells are usually of the high resistance type intended for direct connection to the mains.

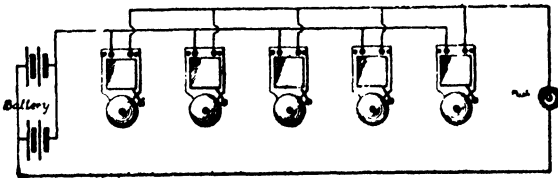

FIG. 41.—CIRCUIT SHOWING A NUMBER OF BELLS IN PARALLEL.

It is essential that each bell shall be of the same resistance.

### Bells and Pushes.

When choosing a bell reference should be made to the catalogue of the leading makers as some of the cheaper forms of bell are liable to give trouble in service. There are two types of contact makers used on bells, the rubbing type which cleans itself in use, and the pillar type, and in the better class of

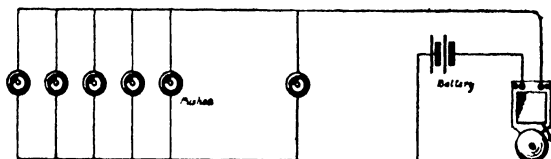

FIG. 42.—HOUSE BELL CIRCUIT SHOWING ONE BELL RUNG FROM A NUMBER OF POINTS.

bell the contact points are of silver and the springs of uncorrodible metal, the design being such that there is nothing to get out of adjustment and cause trouble in service.

Bell pushes are made in a variety of types and sizes, from those of the surface type and others which can be recessed into a door frame, to single or multiple pushes for placing on office tables. Most

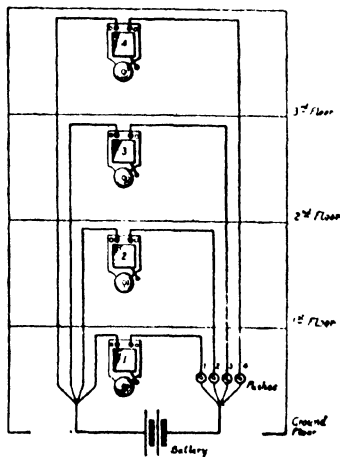

FIG. 43.—A BELL SYSTEM FOR RINGING FROM THE ENTRANCE HALL TO A NUMBER OF FLATS.

bell pushes are intended for use with battery circuits, but high grade pushes are available for mains use. The principal point is that the contact springs should be of good quality and preferably made of some non-ferrous metal, such as phosphor-bronze or nickel silver.

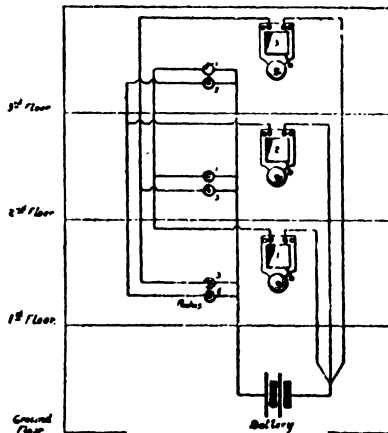

FIG. 44.—A USEFUL CIRCUIT PROVIDING TWO-WAY COMMUNICATION BY MEANS OF BELLS.

### Wire.

In view of the low potential generally used on bell installations, small wires of high resistance should never be used for wiring the circuits, the most suitable being either .029 or .036 of an inch in diameter. The wire should be of high conductivity tinned copper with a minimum covering of pure india-rubber, double cotton covered and paraffin waxed.

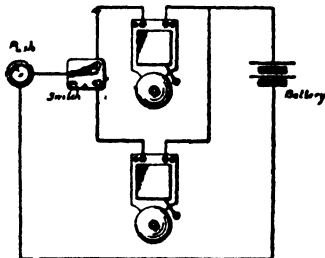

FIG. 45.—BELL CIRCUIT SUITABLE FOR A DOCTOR, PROVIDING DAY OR NIGHT CALLS.

Either bell may be rung from one push, by means of a two-way switch.

FIG. 46. — USING THIS CIRCUIT, ONCE THE BELL IS SET RINGING, IT WILL NOT STOP UNTIL THE CORD IS PULLED.

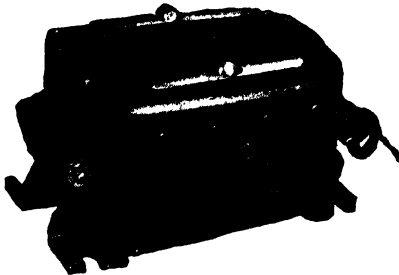
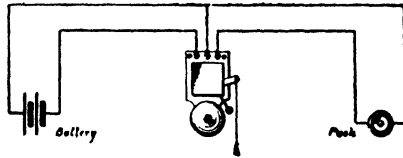

FIG. 47.—AN IRON-CASED BELL TRANSFORMER.

(General Electric Co., Ltd.)

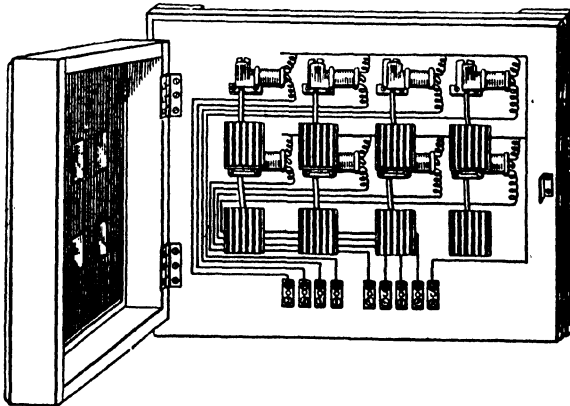

FIG. 48.—THE PENDULUM TYPE OF INDICATOR.

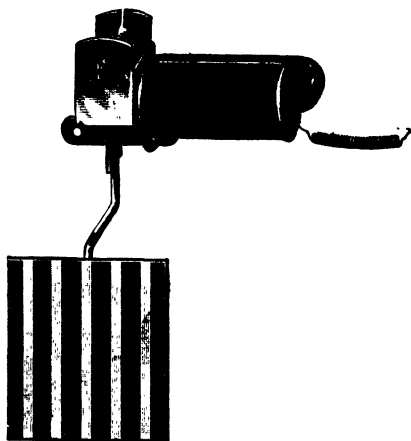

FIG. 48A.—MOVEMENT OF A PENDULUM INDICATOR.

In the past very little trouble was taken with bell installations, but it should be stressed that these should be treated in exactly the same way as any

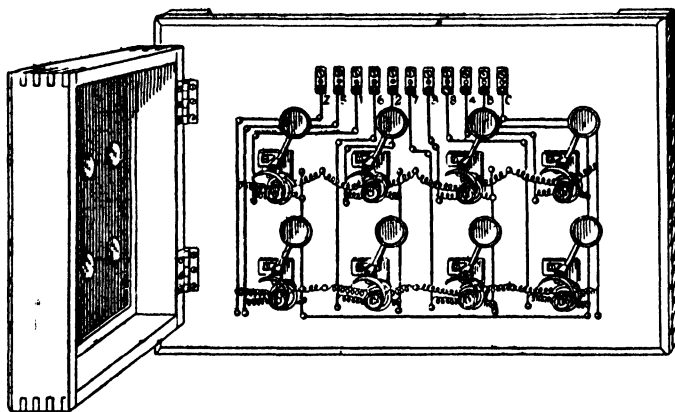

FIG. 49.—ELECTRICAL REPLACEMENT TYPE OF INDICATOR.

house wiring installation, adequate protection being given to the wires and all joints being carefully made. Figs. 39-46 show a number of useful bell circuits.

### Power Supply.

Either dry or wet primary batteries can be used as the power supply for bell and indicator circuits. The wet Leclanché cell is extremely reliable provided it receives reasonable attention, but the modern dry battery is very efficient and, depending upon how much the bells are used, a set of cells would last six months or more without attention.

A number of firms now supply transformers specially

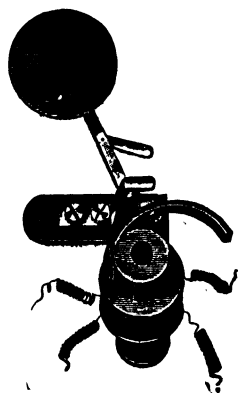

FIG. 49A.—MOVEMENT OF AN ELECTRICAL REPLACEMENT INDICATOR.

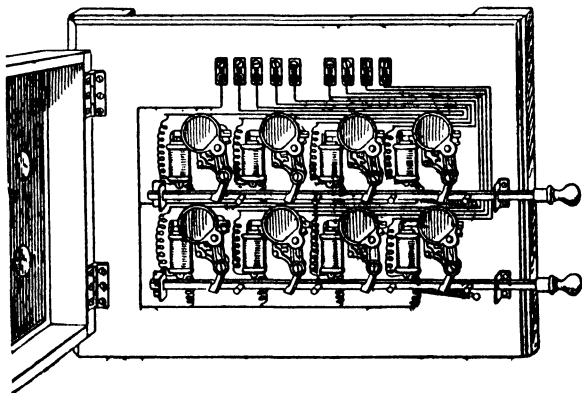

FIG. 50.—MECHANICAL REPLACEMENT TYPE OF INDICATOR.

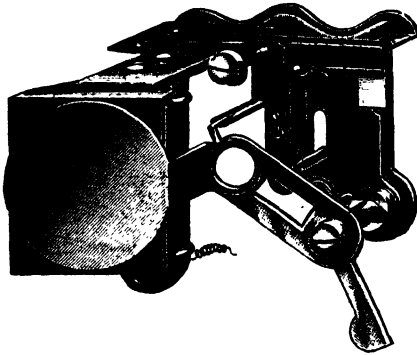

FIG. 50A.—  
MOVEMENT OF  
MECHANICAL  
INDICATOR.

intended for use on bell installations, and these usually have a choice of about three outputs, giving about four, six and eight volts respectively. The bell circuits are run in the usual way, and the output terminals of the transformer are connected to where the battery would normally be joined, but it should be borne in mind that the wiring to the input side of the transformer is at mains potential, so that well-insulated wire should be used preferably run in conduit, and the metal case of the transformer itself should be efficiently earthed. Fig. 47 shows a typical bell transformer.

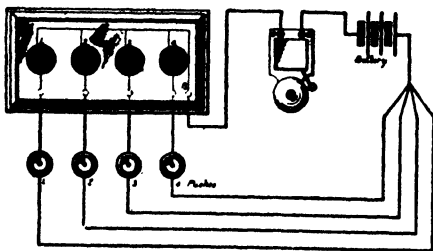

FIG. 51.—A SIMPLE BELL AND INDICATOR CIRCUIT.

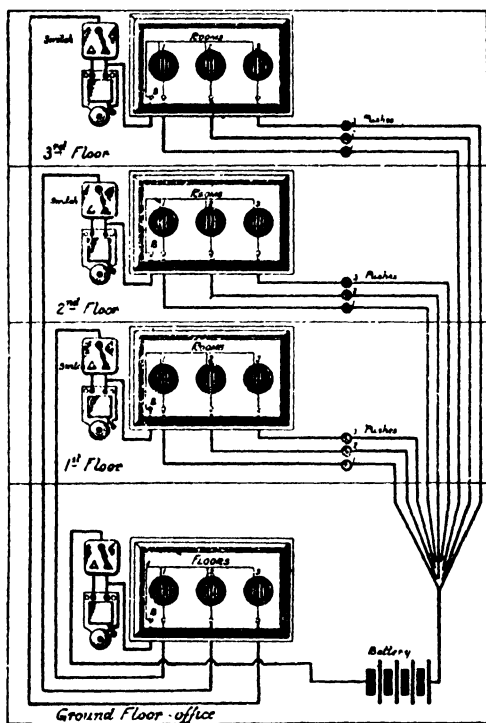

FIG. 52.—INDICATOR CIRCUIT FOR A SMALL HOTEL.

This is intended for use by staff on each floor by day, and by one attendant on the ground floor at night.

### Indicators.

The three most popular types of indicators in use have movements either of the pendulum, mechanical replacement or electrical replacement type (see Figs. 48, 49 and 50), and in each case consist basically of a small electro magnet through which the current operating the bell passes. Indicators are available



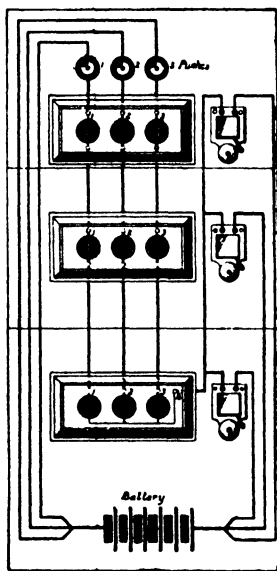

FIG. 53.—CIRCUIT SHOWING A GROUP OF INDICATORS AND BELLS TO WORK SIMULTANEOUSLY.

either as single units, or several indicators may be grouped together in a cabinet having a glass front. Figs. 51-56 show a number of useful circuits incorporating indicators.

Usually the windings of the electro magnets have a resistance of about three and half ohms, and an important point to note is that the resistance of indicators should be comparable with that of the bells in conjunction with which they are used, taking into consideration, of course, the resistance of the run of wire. Otherwise there is the risk of the indicator functioning without passing

sufficient current to ring the bell.

Another type of indicator system which is frequently required is the luminous system for hotels, ships and hospitals. Briefly the method utilises a door lamp fitting and a relay reset push to each room, a section lamp indicator, buzzer, relay and battery or transformer in each servery, and a double change-over switch for transferring calls from that particular servery to a master indicator board. This system is referred to in detail in the next chapter, but Fig. 57 shows the circuit details of a typical system.

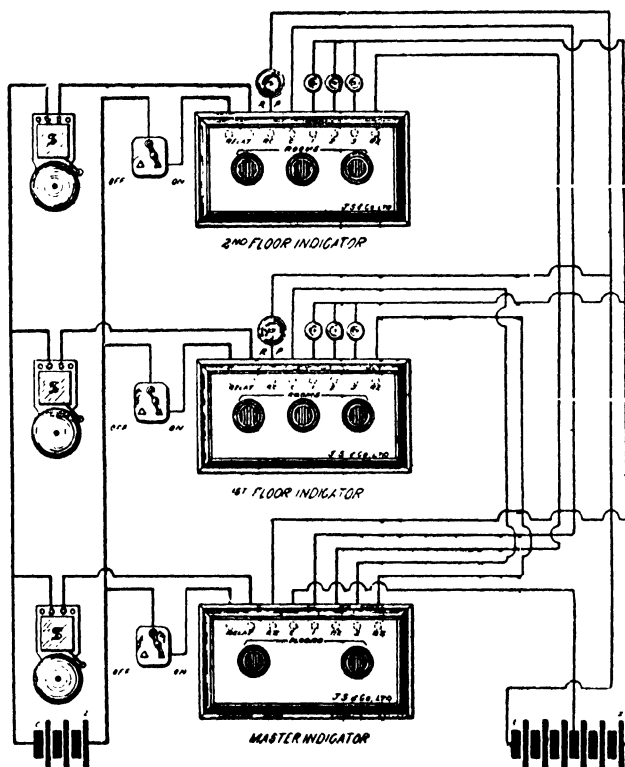

FIG. 54.—AN HOTEL BELL SYSTEM USING ELECTRICAL REPLACEMENT INDICATORS.

When a push is pressed, the corresponding movement on the landing indicator, together with the correlated movement on the master indicator is operated. When the replacement push is pressed it replaces both movements.

(Julius Sax & Co., Ltd.)

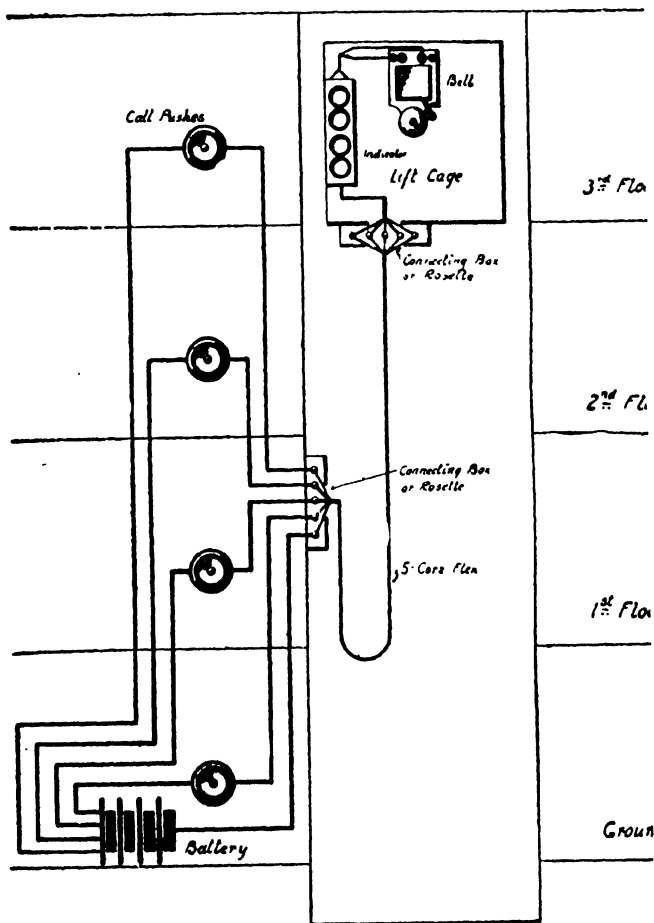

FIG. 55.—A LIFT-CALL BELL CIRCUIT USING MECHANICAL REPLACEMENT INDICATORS.

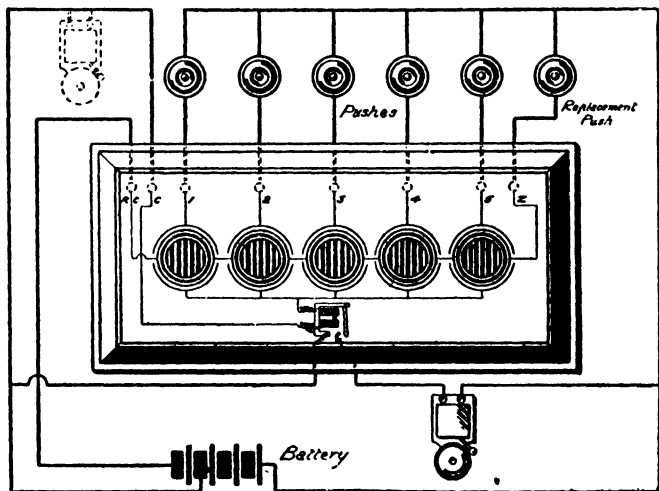

FIG 56.—A SMALL ELECTRICAL REPLACEMENT INDICATOR SYSTEM

For larger circuits it is advisable to employ a separate ringing battery. The bell shown dotted is used when no relay is employed.

### Duplicate or Tandem Indicators.

In large establishments where the attendant is not always near the indicator, it is sometimes advisable to have a duplicate indicator fixed in another part of the building so that a call may not be unattended, and to avoid the need of a journey to ascertain from which room the call originated.

For this purpose two or more of the indicators may be wired in series, as shown in the diagram. They should be of the pendulum type, or, if replacement type, then the "Topples-over" replacement type should be employed, as it permits of replacement from a distance.

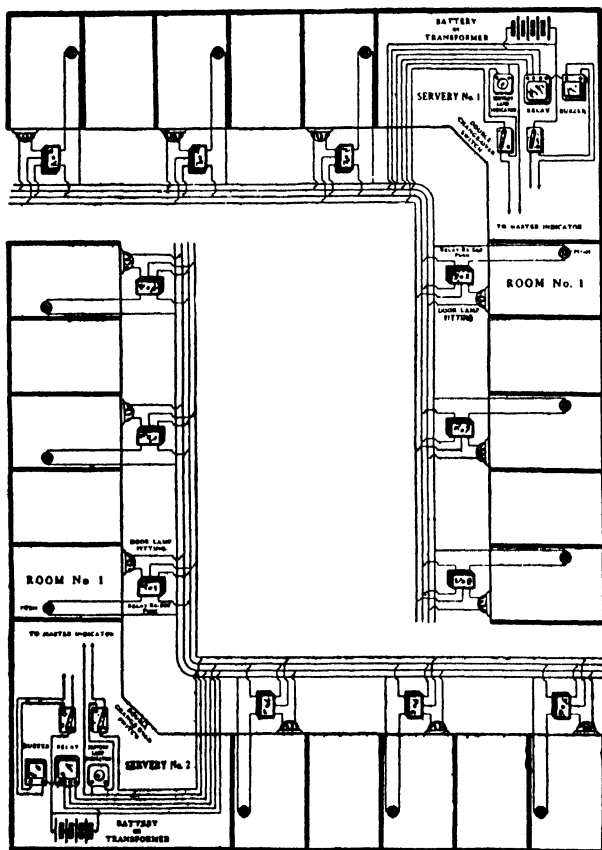

FIG. 57.—A SIMPLE LUMINOUS CALL SYSTEM.

Assuming that the push in Room 1 is pressed, the lamp outside the room and the lamp in the servery glow, while the audible signal sounds. When pressure is released the signal stops but the lamps remain alight. The maid arriving at Room 1 presses the relay reset push, which extinguishes the lamp.

(Julius Sax & Co., Ltd.).

To ensure satisfactory results, all the indicators but the last one are fitted with a second row of terminals at the bottom of the case from which the wires are led direct to the next indicator. The last indicator has the common return wire of all signals led (with or without a relay) to all the bells of the various indicators. The use of relays is recommended where more bells are required than shown in Fig. 58.

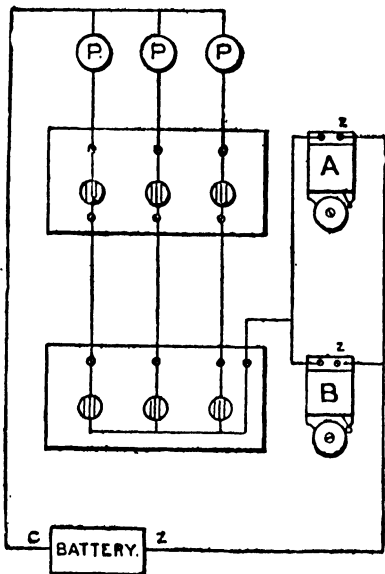

FIG. 58.—A SYSTEM USING DUPLICATE OR TANDEM INDICATORS.  
(Gent & Co., Ltd.)

The diagram shows the method of connecting indicators in series together with arrangement of bells for each indicator connected in the common return.

In hotels it is usual, in order to ensure the attention of servants, to have an indicator in the office, working in conjunction with the indicators on the different floors, or in different wings of the building. They may be arranged as above, or according to the methods described below.

Several bell schemes or systems are available for hotels, large houses, ships, etc. Something, however,

depends upon the method of management of the establishment, as to which is best for any particular instance.

The following paragraphs give some useful suggestions for indicator circuits:—

A pendulum indicator on each landing showing each room thereon, and a ground floor indicator showing all rooms on each landing, and all rooms on ground floor, so that the attendant on the ground floor knows of every call that is rung, and from which room the signal emanated.

A drop indicator on each landing or floor, and also a "tell-tale" indicator showing the attendant (perhaps in the bureau) from which floor a bell is rung, and also that the signal has, or has not, had attention and been replaced.

A drop indicator on each floor, and a "tell-tale" indicator in the bureau, calling attention of the management only in case a bell has rung and no attention has been given within a certain interval.

An indicator with a signal for each room, fixed, say, on a landing, coupled with a lamp signal and a reset key, fixed outside each room; the indicator and the lamp signal both to "show" until the servant attends the room, and presses the reset key outside the room, when both lamp signal and indicator signal are cleared, unless a pendulum indicator is used for the landing indicator.

### **Supervision or Control Indicators.**

Where an inexpensive but efficient control system of indicators is desired permitting supervision by the management of the attendants or servants, the

use of a drop type system with electrical replacement, master, or control indicator is recommended. (See Fig. 59.)

On the floors or landings of the hotel may be fixed drop-pattern indicators. To these indicators special contacts are added to effect the electrical replacement of the signal registered on the master indicator fixed in the office.

On a call being made on any of the landing indicators a duplicate call is shown on the master indicator in the office. When the call is attended a replacement knob is pressed by the attendant, replacing the signal on

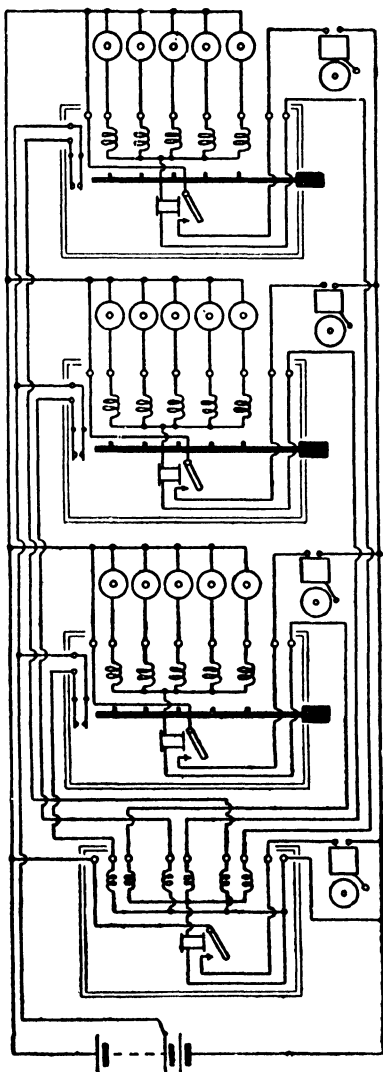

FIG. 59.—SHOWING USE OF SUPERVISION OR CONTROL INDICATORS.  
(Gent & Co., Ltd.)



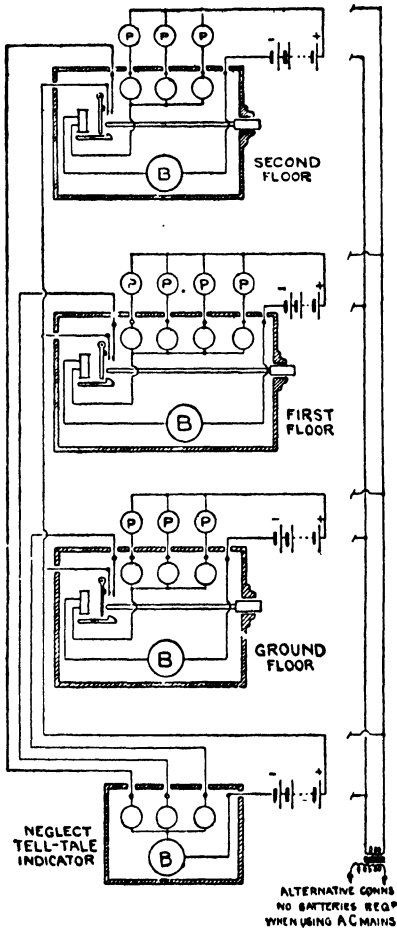

FIG. 60.—CIRCUIT INCORPORATING  
DELAY RELAY INDICATORS.  
(Gent & Co., Ltd.)

the landing indicator, also electrically cancelling the same signal on the master indicator.

This system requires a relay and replacement contacts on each landing indicator, which indicator may be of the drop pattern.

#### Delay Relay Indicators.

An attractive system of electric bell indicators suitable for the management of hotels is "The Delay Relay," or "The Lag Relay" systems of Messrs. Gent & Co., Ltd., which tells in the bureau only of neglect on the landing.

By this arrangement landing indicators are provided on each landing, or in each section of

the hotel. If these are attended promptly, the guest is assured of service. If, however, for any reason the indicator is not replaced within a pre-arranged time, say two minutes, from the first signal given on the indicator, then, and only then, does the "Lag Relay," or Relays, in each "Landing Indicator" make a contact, and a "Signal of Neglect" is shown in the bureau or office of the management on the "Tell-Tale Indicator" fixed there. (See Fig. 60.)

The smaller indicators should be in one row, larger indicators in two or three rows, as demanded by the situation. The "Tell-Tale Indicator" contains one self-replacing signal for each "Landing Indicator," or if desired, one self-replacing signal for each horizontal row of the "Landing Indicator," and a bell, buzzer, or lamp calls the attention of the management to the neglected signal on such "Tell-Tale."

### Relays.

There are many types of relays, but those used in bell and indicator work are comparatively simple in construction. Roughly speaking, they resemble an electric bell with the exception that the armature has not a trembling action, but is positive in breaking or

FIG. 61.  
ORDINARY BELL  
AND INDICATOR  
CIRCUIT INCOR-  
PORATING A RE-  
LAY.

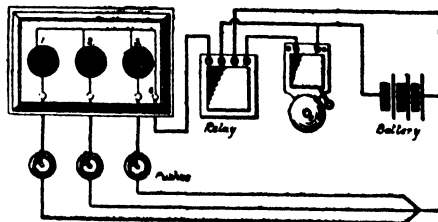

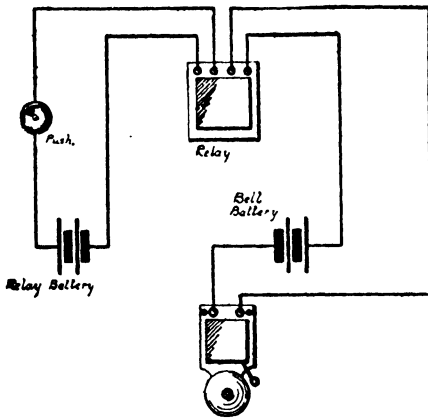

FIG. 62.—A SIMPLE RELAY CIRCUIT.

The relay is connected as near the bell as possible, thus cutting out the resistance of the run from the bell circuit.

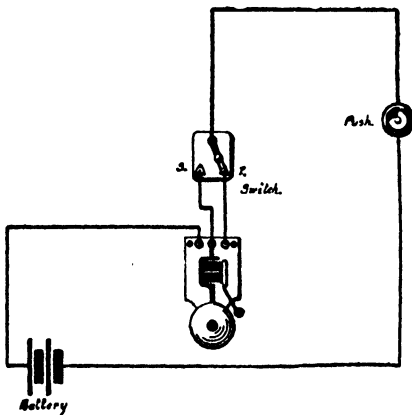

FIG. 63.—A USEFUL BELL CIRCUIT.

By fitting a third terminal connected to the iron frame of an ordinary bell, and by means of a switch, the bell can be used either as a single stroke or an ordinary trembler bell.

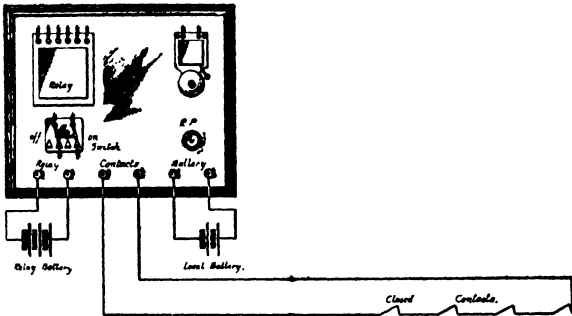

FIG. 64.—WIRING OF RELAY INSTALLATION IN CONNECTION WITH ALARM CONTACTS.

making a contact; in other words relays are really electrically operated switches.

Usually four terminals are provided, two of which are connected to the relay winding, the other two

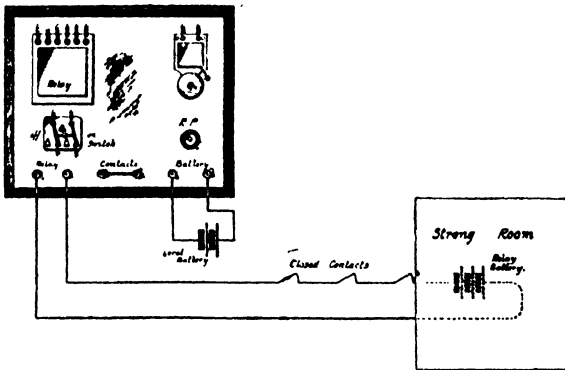

FIG. 65.—ALTERNATIVE ARRANGEMENT OF A RELAY INSTALLATION.

To make the system shown in Fig. 64 quite foolproof, it is necessary to short-circuit the contact terminals and install a relay battery in the room to be protected.

being connected to the circuit to be controlled. The intermittent open circuit relay operates only while a bell push is being pressed, while the continuous action relay releases a contact arm upon the push being pressed, the circuit remaining closed until the relay is reset. The usual resistance of relays of this type is about five ohms. (See Figs. 61-65.)

The closed circuit system is ideal for use in connection with burglar alarms, and here the current flows continuously, but immediately the circuit is broken the relay operates causing the bell or other alarm to sound. The resistance of such relays must be high in order that the current consumption shall be low, and the coils are usually wound to have a resistance of about 200 ohms.

Another type of relay frequently called for is one in which a low voltage circuit causes a high voltage circuit to be closed. Such an example is where a bell push battery and relay will cause a mains operated bell or syren to sound. Here the relay is usually of

FIG. 66.—TYPICAL  
EXAMPLE OF A  
MERCURY TUBE  
RELAY.

(Londex Ltd.)

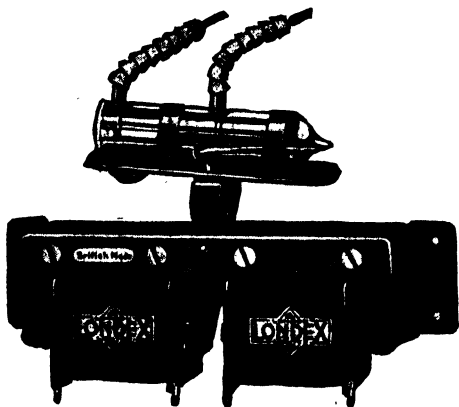

the mercury tube type, the tube tilting when the relay operates causing a circuit to be completed through the mercury. (See Fig. 66.)

Relays are an essential feature of fire alarm systems. A common type consists of a circular case painted red, with the instructions "In case of fire break glass." The breaking of the glass is all that is required as this causes relay contacts to close, leaving the alarm sounding continually. The required number of alarm points is installed round the building, and these are wired in parallel so that any one will actuate the alarm. Additional pushes under lock and key will usually be required at various points for testing the circuit without actually breaking the glass. (See Fig. 67.)

Further details of alarm and relay circuits are given in the next chapter.

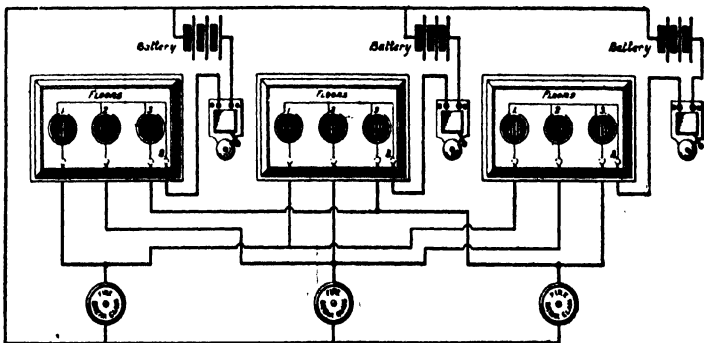

FIG. 67.—A SIMPLE FIRE ALARM SYSTEM.

On whichever floor the fire occurs the alarm is given. This action rings all bells and drops all flags relating to that particular floor. A separate battery should be used for each floor.

### Testing Bell Installations.

The first point is, of course, to test the batteries or examine the transformer if one is installed. If Leclanché cells are used the electrolyte may have almost all evaporated, while in the case of dry batteries these may be exhausted. If a simple test with a voltmeter shows the batteries to be in order a loose connection should be looked for.

Indicators used with bell circuits rarely give trouble, but if these are suspected the first thing to do is to disconnect the batteries and join the two ends of the line wires together, taking one or two cells to test the bell and then the indicators both separately and together. If the bell is at fault there are several points which may require attention. The contacts may be dirty or may require adjustment while the

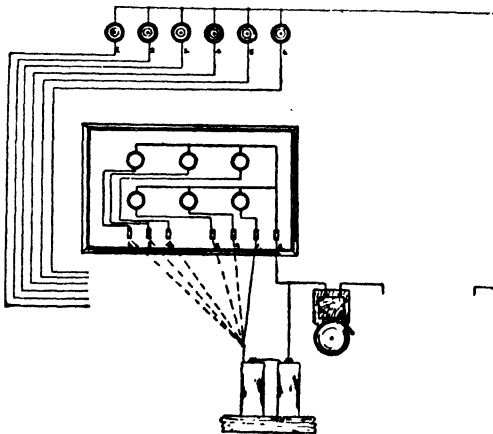

FIG. 68.—TESTING AN INDICATOR CIRCUIT.

Each movement should be tested in turn from its respective terminals.

tension of the armature spring is usually rather critical—over tension or under tension both preventing a bell from working correctly. Indicators can be adjusted by connecting one wire from a cell or cells to the common wire, and with the other testing each indicator movement from its respective terminals.

The wiring throughout the bell system can be tested for continuity by using one or two cells and a low reading voltmeter, or in the absence of the latter a portable bell which is known to be working correctly can be used. On the other hand wiring, if carried out on the lines of any high grade electric light installation is not likely to cause trouble. Figs. 68-70 illustrate the usual methods adopted in carrying out tests.

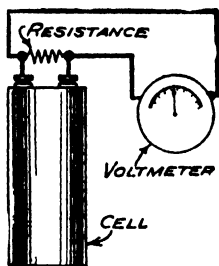
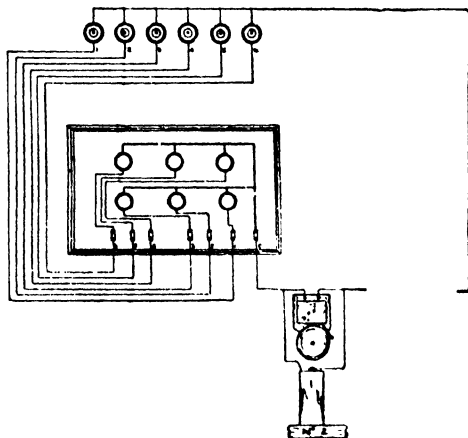

FIG. 69.—ARRANGEMENT FOR TESTING CONDITION OF BATTERY. A 5-ohm resistance should be used.

FIG. 70.  
METHOD OF TESTING BELL ON SITE.

The battery is connected directly across the two terminals of the bell.





## CHAPTER V

### ALARM AND INDICATOR SYSTEMS

**A**S there is such a wide range of alarms and indicators, it would be as well to define some of the components of their circuits which are common to all types.

All of them, for example, will contain a switch, contactor, or other operating device. The ordinary electric push-button at the door of a house or on an office desk is a switch which operates the electric bell. The switch button is held in the "off" position by a coil spring, and the bell in such a circuit will ring only so long as the button is depressed. The contactor in other circuits may be a wipe contact actuated by the opening of a door such as that of a shop, and the current flows only while the two contacts are sliding past each other. As will be seen later, circuits are frequently used in which the bell rings when the switch is opened instead of when it is closed; this is called closed-circuit operation.

#### **Power Supply.**

Whatever form the operating switch takes it is dependent upon a source of electrical energy. Bell circuits used to be supplied from Leclanché cells, frequently housed in some out-of-the-way corner where the solution evaporated to the point at which the bell

ceased to work. Accumulators can be installed and provide much better service. To-day most alarm and indicator circuits can be supplied from a transformer, and some of the alarms to be dealt with would be capable of direct operation from the mains.

### Use of Relays.

It does not follow that the circuit which is closed by the operating device will necessarily be supplied from the same source of current as is used to actuate the bell or other alarm. For example, there might be bells which were so large as to require an independent supply. Similarly the very small currents which flow on the depression of a little switch such as a bell push might not be sufficient to actuate some alarm device in which the moving parts were much heavier than those of the domestic bell, and therefore it might be necessary for a bell or other device to remain in

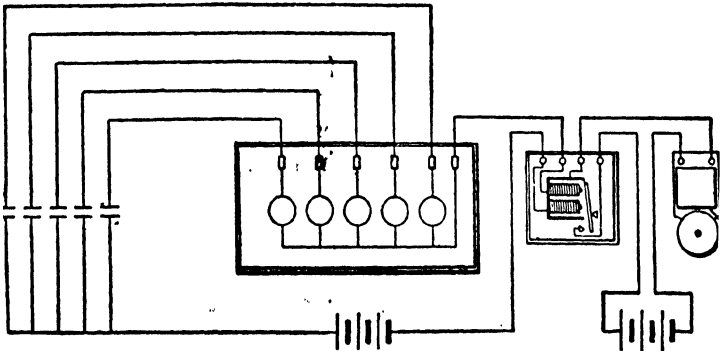

FIG. 71.—INDICATOR WITH RELAY AND LOCAL BATTERY FOR RINGING A BELL.

The relay is used in this case where there are either long runs of wire, or where a large bell might be required to work in conjunction with an indicator.

operation after the actuating switch had closed and opened. For example, in a burglar-alarm system, unless special provision were made to the contrary, the alarm would ring while the burglar was getting through the window and would cease ringing as soon as he closed the window after him. (See Fig. 85.)

In these cases a relay must be interposed between the push circuit and the circuit operating the alarm. It accepts the impulse of the operating circuit and may transmit it in such a way that the alarm is continuously operated until the relay is reset, or alternatively may pass the impulse on exactly as received but in a magnified form.

The next item in the circuit is the alarm itself, usually a bell; although in certain domestic situations bells are being displaced by a special form of lamp signal. The alarm or bell may in industry be replaced by some form of mechanical operation which carries out a process which would otherwise have to be performed by hand; for example, a machine can be stopped or started following upon the operation of the relay, and at least one form of industrial control when applied to power presses will prevent the press from acting if the operator's hands are in a dangerous position.

### **Types of Alarm Circuits.**

A wide range of domestic and industrial uses is covered by electrical alarm circuits of one type or another. Those most familiar are the domestic bell circuits. In hotels or hospitals they may be of a special type, although the circuit diagrams will be much the same in principle as those used for smaller

installations. Alarm circuits as distinct from call circuits may be used for burglar alarms, fire alarms, or to give warning of alterations showing some undesirable variation in an industrial process. For example, it is undesirable that the smoke emerging from a factory chimney should exceed a certain thickness or density; thick smoke may indicate incorrect and uneconomic consumption of fuel, or on the other hand may transgress local or other by-laws. There is an alarm circuit, dealt with later, operated by an increase in the density of the smoke issuing from a chimney. (See Fig. 86.)

Call circuits where the calling signal is by bell or lamp are not limited to use in houses or hotels; they are found in varying types in steamships, railway trains, and large aircraft or flying-boats; while there is a wide range of signalling devices used below ground in coal mines in this country. A calling signal may do more than light a lamp; it may actuate a relay which in turn will start the motors of a lift or hoist.

It is not necessary to describe or illustrate the working of the ordinary type of flag or pendulum indicator as used in the small domestic installation, as this has been dealt with in Chapter IV.

Even in many large hotels, old-type indicators with as many as fifty ways are still employed, but new hotels, steamships, and hospitals require a call system in which the ringing of a bell at the end of some corridor will not disturb the occupants of about ten bedrooms in the vicinity.

### **The Silent or Luminous Call System.**

The modern system has been styled the silent

call system; the components of the circuit are exactly the same in principle as those previously described, but differ slightly in the method of operation.

The essence of the system is a combined lamp and relay switch, shown in Fig. 72. The coil shown, when energised, attracts the armature and allows the little tube and lamp above to push forward and automatically lock the armature in position; an arm pushes the bank of four contact springs together and thereby closes various lamp circuits to be described later.

This switch and relay is reset by pressing the lamp cap down, when the armature is released and the contact spring is broken, thus replacing the movement to normal. Fig. 72A shows a side view of the one-way

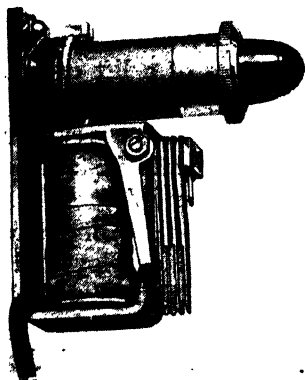

FIG. 72.—COMBINED LAMP  
AND RELAY SWITCH.  
(General Electric Co., Ltd.)

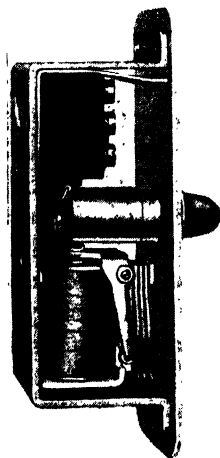

FIG. 72A.—THE UNIT  
SHOWN IN FIG. 72  
WITH FRONT PLATE  
AND TERMINAL  
BLOCK.  
(General Electric Co., Ltd.)

unit complete with its wallplate and terminal plug above. Fig. 74 shows a two-way unit with its cover removed.

### Luminous System for Hotels.

Each visitor's room in an hotel is provided with a one-, two-, or three-way bell push of the usual type; almost any high-grade bell push, as Fig. 73, may be used; and with it the visitor may summon the servant required, maid, waiter, or valet. Outside each door in the corridor the relay switch illustrated in Figs. 72 and 74 is fitted and is provided with one to three lamps of different colours.

The building will, of course, be divided into sections, each section consisting of a certain number of rooms, which in small hotels or hospitals may be all the rooms upon a single floor. For each such floor or such section a group indicator is provided and fitted in such a position as to be readily seen by the responsible servant. A small indicator for use in such a position is illustrated in Fig. 75, in order to show the difference between the pendulum type and the latest pattern. It is possible to provide a master indicator in the reception office on the ground floor so as to duplicate the calls from other sections or floors; while at any

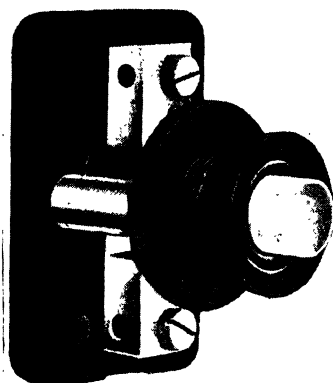

FIG. 73.—DETAILS OF PUSH DESIGNED FOR USE WITH SILENT CALL SYSTEM.

(General Electric Co., Ltd.)

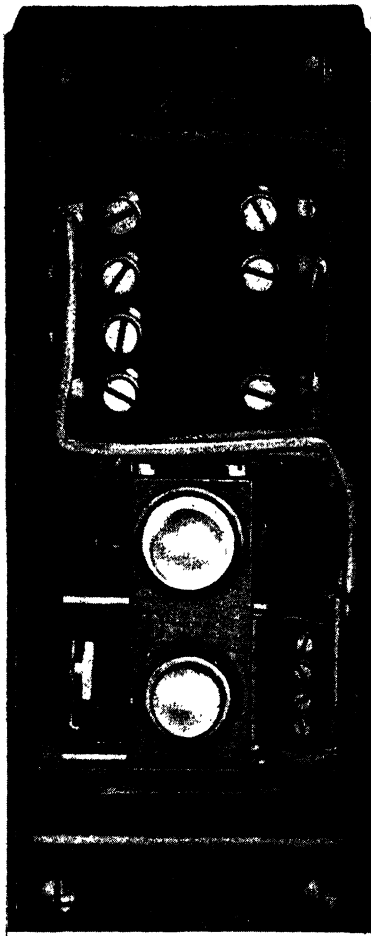

FIG. 74.—INTERIOR OF RELAY SWITCH  
HAVING TWO COLOURED LAMPS.

(General Electric Co., Ltd.)

point, if required, audible signals can be arranged by means of a small bell or buzzer.

Such a buzzer has two main uses. If the maid is in the same room as the indicator, the buzzer will call her attention to the indicator and she will know at once from which group or floor the call has originated. If she were in a corridor, and could hear the buzzer, she need not return to the indicator; instead, a glance at the relay switches with their lamps above each door will show from which room the call emanates. Before entering the room she presses the colour-

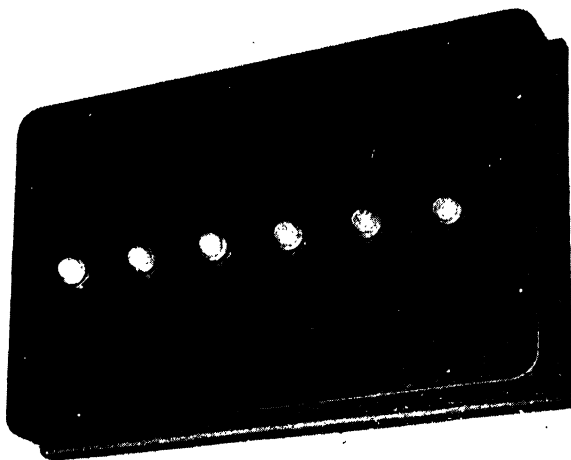

FIG. 75.—SIX-WAY CALL POSITION CARRYING SIX LAMPS  
IN A HARDWOOD BOX.

*(General Electric Co., Ltd.)*

reset button of the relay switch and thereby extinguishes the signal lamps relaying this particular call. In the event of there being more than one call simultaneously from the same section, all signal lamps remain alight until the last call in that particular section has received attention.

#### **Use of Portable Buzzer.**

The buzzer has yet another use; to meet such a case as maids employed in making a bed in a visitor's room at a time when a call emanates from some other part of the floor, it is advisable to wire a circuit which provides a wall socket in every bedroom connected into the indicator-board circuit. When engaged in any room the maid is able to plug into such a wall



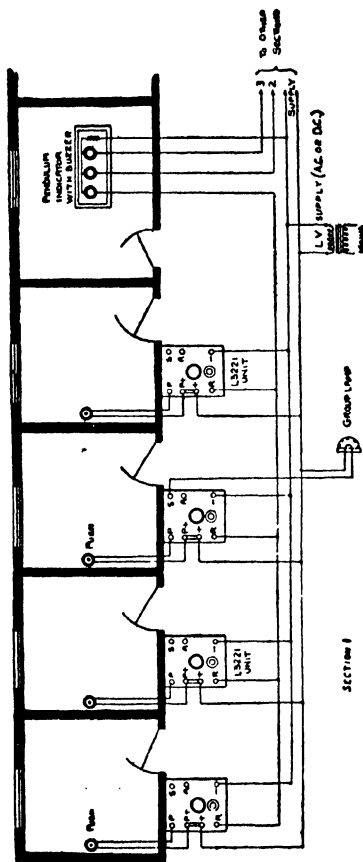

FIG. 76.—GENERAL LAY-OUT OF LUMINOUS CALL SYSTEM.

Combined lamp and reset units are fitted outside each room, but use of a pendulum indicator renders only three conductors necessary.

(General Electric Co., Ltd.)

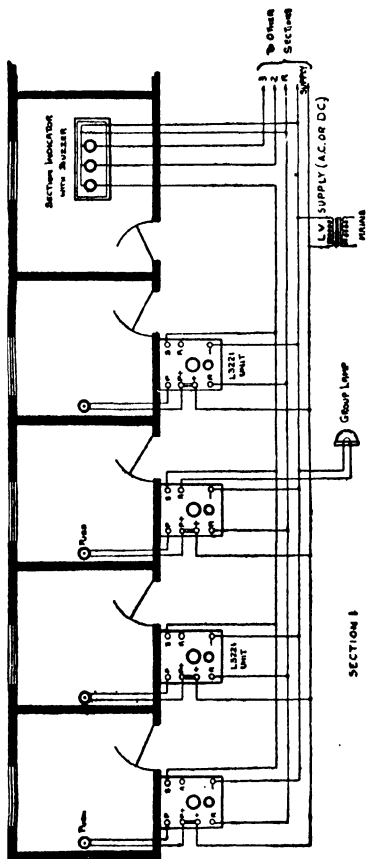

FIG. 77.—LUMINOUS CALL SYSTEM FOR SINGLE CALLS, FOUR CONDUCTORS  
BEING NECESSARY.  
(General Electric Co., Ltd.)

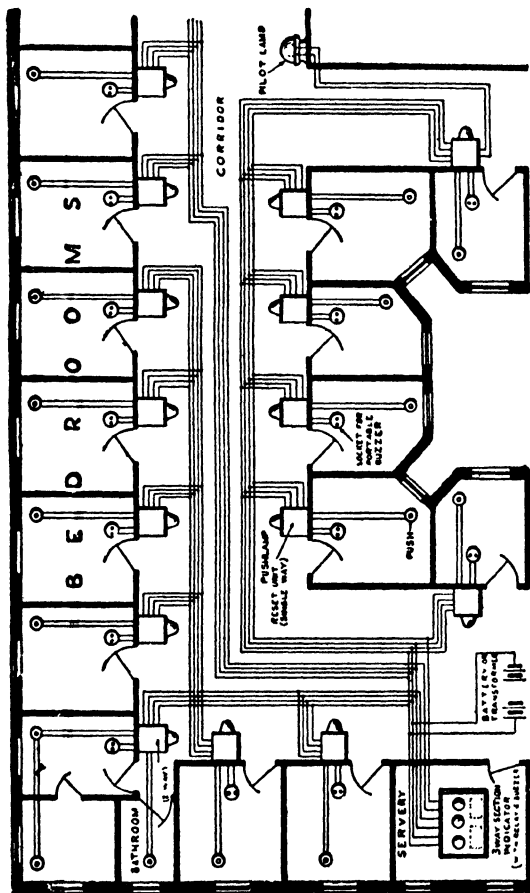

FIG. 78.—LAY-OUT OF SINGLE CALL SYSTEM FOR AN HOTEL.

Each floor is divided into sections, each section having one indicator on the section indicator. On a call being made, both the lamp outside the door and the section lamp will glow until reset by hand.

(General Electric Co., Ltd.)

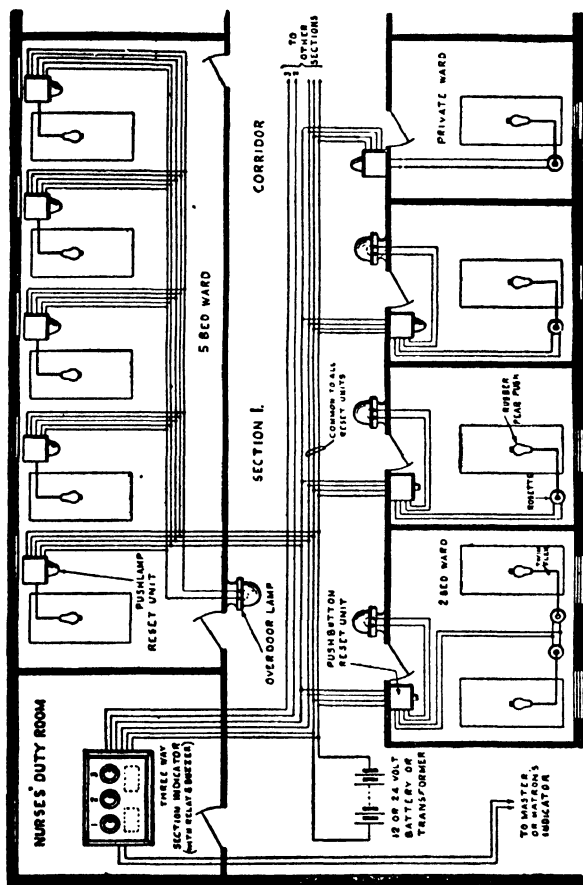

FIG. 79.—SINGLE CALL SYSTEM FOR HOSPITALS.

Pilot lamps are fitted in the corridor outside each ward door, with the resetting units inside. Left at bottom, note connection to matron's indicator, so that check can be kept on the service.

(General Electric Co., Ltd.)

socket a portable buzzer, and any call is then sounded on the portable buzzer as well as on that on the indicator board in the servery.

### **Indicator System for Series of Rooms.**

The system can be simplified and also rendered less expensive by the omission of some of the refinements detailed in this description. The simplest circuit for a series of rooms is illustrated in Fig. 76, which shows combined lamp and resetting units fitted outside each room, but a pendulum indicator replaces the lamp type, which would require a fourth wire. Only three conductors are therefore necessary for connecting lamp and reset units throughout the building; in this system the buzzer sounds only when a call button is pressed, but the lamp outside the door remains alight until the reset button is operated.

Fig. 77 shows a more orthodox luminous call system for single calls; four conductors are necessary throughout the circuit. It is possible to arrange audible signals to operate until the call is cancelled. It should be noted that this system operates only where a single push-button is fitted in each room, that is, the single-call system; for dual call or triple call, one or two additional conductors respectively will be required.

Fig. 78 shows a more complete installation still, with a single-call system for the sake of simplicity, for an hotel. In each bedroom will be seen the portable buzzer socket referred to previously. Where rooms are situated off the main corridor, pilot lamps as shown in the illustration are connected in parallel with the lamps in the reset units.

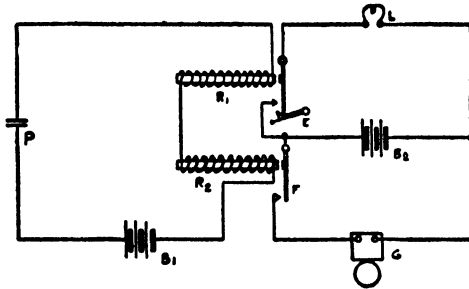

FIG. 80.—COMBINED AUDIBLE AND LUMINOUS CALL CIRCUIT.

This enables the bell *L* to be rung only while the push *P* is depressed, but the lamp *L* remains lit until reset. This is achieved by a locking relay *R* and catch *E* which holds the armature in the contacting position until reset.

Fig. 79 shows the circuits necessary for a single-call system in a hospital. Each ward will register a separate indication on the duty-room indicator, or, alternatively, as shown in Fig. 79, the wards can be grouped together to form several sections. The illustration also shows pilot lamps in the corridor outside each ward door with the resetting unit inside. Two wires are shown leading from the left side of the

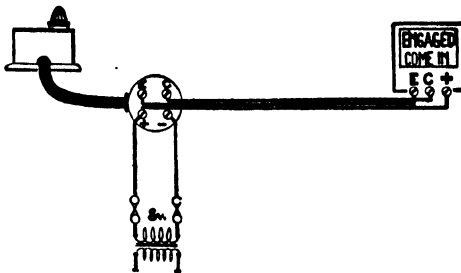

FIG. 81.—WIRING FOR "ENGAGED" AND "COME IN" INDICATORS.

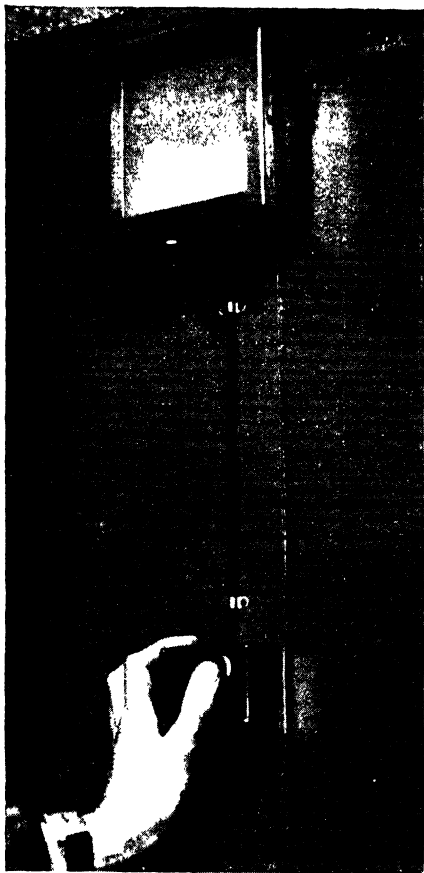

FIG. 82. — SHOWING OPERATION OF "COME IN" AND "ENGAGED" INDICATOR FOR PRIVATE OFFICE USE.

The indicator is fitted outside office door and push-lamp is placed on private office desk. When anyone raps on door for admittance, the "come in" signal is given by depressing the table push-lamp as shown. On release of push-lamp the word "Engaged" appears and the push-lamp also glows as a reminder that "Engaged" signal is showing. To extinguish, push-lamp is rotated slightly in clockwise direction.

three-way section indicator in the nurses' duty-room for connection to the matron's indicator in order that a check may be kept on the service.

Figs. 80-82 show details of a "come in" and "engaged" indicator for private office use.

### Alarm and Relay Circuits.

For reasons stated previously, burglar- or fire-alarm circuits are generally made of the closed-circuit type, operating by the opening of a switch instead of by the closing of a switch. Supposing, for example, that entry should be effected to a house without actually ringing the alarm, and the burglar decides to cut the alarm wires, the effect either of his breaking the alarm circuit or of connections being broken by the heat of an accidental fire will be in each case to set the alarm in motion, when it will continue ringing

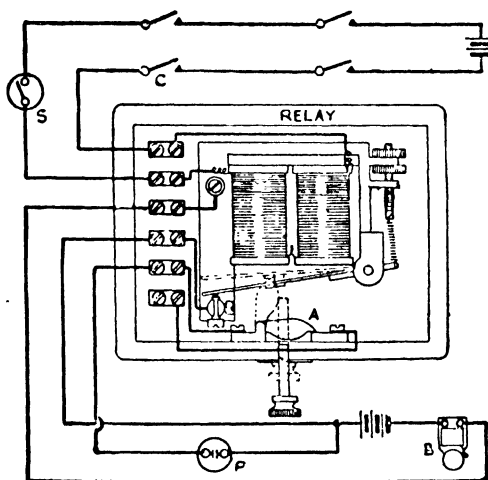

FIG. 83.—CLOSED-CIRCUIT, SELF-SETTING BURGLAR-ALARM CONNECTIONS.

On the main alarm circuit being broken at switch *S* at any door or window, bell *B* rings and will continue to do so until it is cut out of circuit by pushing up the strut *A*. This bell must be operated from a battery, as it would be ineffective if connected to a mains supply which might be cut off.

(General Electric Co., Ltd.)



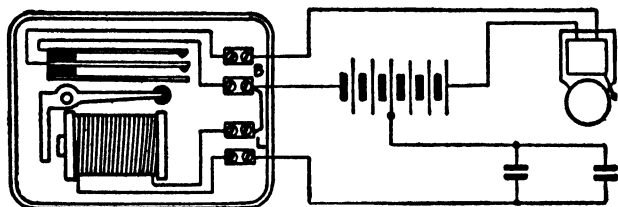

FIG. 84.—A SIMPLIFIED CLOSED-CIRCUIT DIAGRAM.

not only until the circuit is again closed but until the alarm relay is reset by hand. (See Fig. 85.)

In a closed-circuit system the alarm contacts at all points must be connected in series; current flows continuously round the energising circuit of the relay, but it is usual for the windings to have a considerable resistance in order to reduce the consumption of current. If, however, current is taken from bell transformers instead of from batteries this is not so important.

A closed-circuit, self-setting burglar-alarm system is illustrated in Fig. 83; in shops or other places, where the door or window is open all day, the switch at *S* can be eliminated, as the contact *C* at that point would automatically take its place. On the main alarm circuit being broken by the opening of the master switch *S* at any door or window the bell *B* rings and will continue to ring until it is cut out of circuit by pushing up the strut *A*; on leaving the premises the alarm is automatically reset when the last contact is closed. It is recommended that this bell circuit should always be operated by a battery; if the current were switched off from the house, or there were an electrical breakdown, the burglar-alarm would otherwise cease to be serviceable. (See also Fig. 84.)

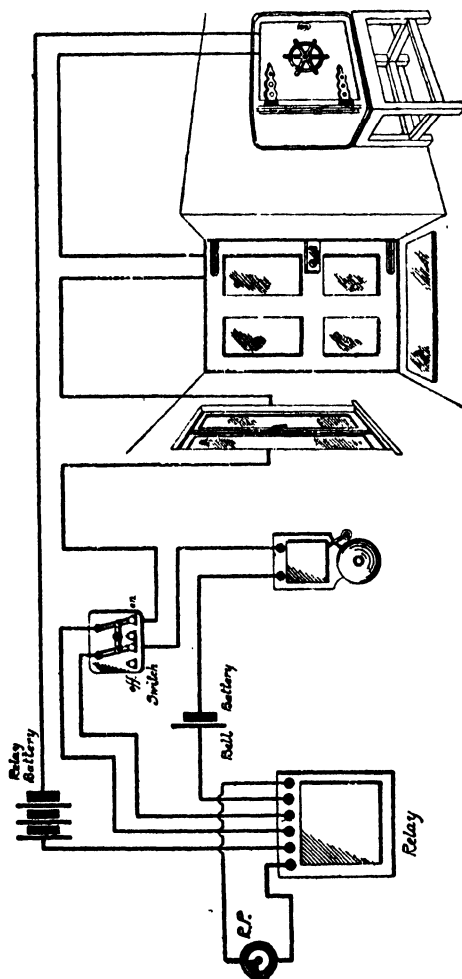

FIG. 85.—A BURGLAR-ALARM SYSTEM INCORPORATING A CLOSED-CIRCUIT CONTINUOUS ACTION RELAY WITH AN ELECTRICAL REPLACEMENT.

When all doors are shut and the switch closed, the alarm rings until replacement push is used. Being a closed-circuit, the wires cannot be tampered with. When a door is opened the bell cannot be stopped even by closing the door, but only by using the replacement push.

(Julius Sax & Co., Ltd.)

The type of relay used for domestic purposes is both simple and inexpensive, but in industry a relay may be required to control processes, the failure of which may involve a financial loss of hundreds of pounds, and industrial relays are therefore much more complex, much more reliable and certain in their operation, despite this complexity, and considerably more expensive.

They have for long been an important factor in the solution of many laboratory and industrial control problems, such as the control of temperatures, chemical processes, speeds, voltages, and currents; they can be used as poisonous- and explosive-gas detectors; to check and signal overloads or excessive earth leakage; to open circuits, operate quantity counters, switch on lights, act as height gauges, limit gauges, or turbidity indicators.

### **Smoke Indicators.**

A valve relay circuit can be used to indicate density of smoke in a flue uptake before it reaches the top of the stack; and Fig. 86 illustrates the diagram of connections. It will be seen that a beam of light from a projector is thrown across the base of the uptake flue and directed upon a receiver containing a light-sensitive cell. Connected to this receiver is the control box shown in Fig. 86; leads from this control box are taken to the distant local indicators. The usual type of indicator is a 7-in. dial switchboard-mounted indicator illustrated at the top of Fig. 86; the scale is calibrated in smoke units varying from white, labelled "0," to very black, labelled "5".

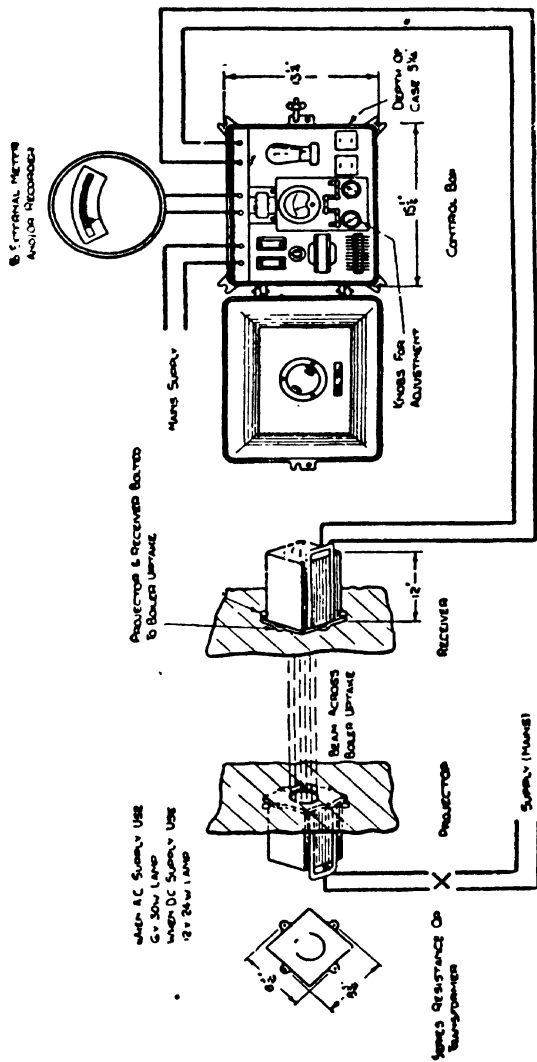

FIG. 86.—DIAGRAM OF CONNECTIONS OF SMOKE INDICATOR ALARM.  
 (Radiovisor Patent Ltd.)

## CHAPTER VI

### MAINTENANCE OF TELEPHONE SYSTEMS

**D**ESPITE their comparatively simple design telephone systems may develop faults which can be puzzling to those not experienced in telephone maintenance. Such faults may occur immediately before or during a period when a system is in operation and consequently the person responsible for its operation should be able to locate and remove the trouble without any delay.

There will probably be different patterns of instruments to service, including wooden case wall type, weather-proof wall type and light desk type instruments.

All types will, however, be found to have the following essential components: transmitter, receiver, calling device, press button or hand-generator, change-over spring assembly and induction coil, whilst there will be little or no difference in the circuit arrangements.

#### **Telephone Instruments.**

All transmitters function on the same principle and employ a small amount of carbon granules enclosed in a cell. The back portion of the cell is usually a carbon block whilst the front is formed by a carbon diaphragm. The movement of the diaphragm, caused by sound waves striking it, presses the granules more or less

closely together, thereby varying the electrical resistance between the block and the diaphragm. The variations thus caused in the current are transmitted along the line to the distant telephone and cause the diaphragm of the receiver to vibrate in a similar manner to the transmitter diaphragm.

The vibrations of the receiver diaphragm therefore reproduce similar sound waves to those originated at the transmitter, and by this means words spoken at one end of the line are reproduced at the other end. The three types of transmitters found in general use are inset, solid-back, and loose granule types.

#### **Inset and Solid-Back Transmitters.**

Many of the modern telephones employ the "inset" type of transmitter. This is a self-contained unit which fits into the handset receptacle, and is held in position by the mouthpiece. It is easily removed for inspection, and when found to be faulty should be replaced by a new one.

The solid-back type is frequently found on pedestal, or standard type instruments, and also on wall fitting telephones having fixed transmitters instead of handsets. It is very reliable in operation but as special tools are required for dismantling and assembling, it is advisable to replace a faulty one by a spare transmitter and return it to the makers for inspection and adjustment.

#### **Loose Granule Transmitters.**

This type of transmitter, although first brought into use many years ago, is very efficient and consequently still to be found on several makes of telephones. When



FIG. 87.  
ILLUSTRATING  
REMOVAL OF  
CARBON  
GRANULES.

the cover and the carbon diaphragm are removed the granules will be found on a carbon block within a soft felt ring, as shown on Fig. 87.

Small tufts of wool are sometimes placed within the ring to keep the granules evenly distributed and so prevent them from packing. Moisture in the breath will make the granules damp and cause them to pack, and in such cases they should be removed from the transmitter and dried. The felt ring, cotton tufts and other parts should also be quite dry before the instrument is reassembled.

### Receivers.

The two most common type of receivers in general use are the Bell and Watch types, the latter being

shown in Fig. 87. The constructional details of these instruments vary with different makes, but the principles of operation remain the same. The Bell receiver employs a horseshoe magnet whilst a circular magnet is fitted in the Watch type. Both types have soft iron pole-pieces wound with fine copper wire to suitable resistances. The variations in the current flowing through these coils (caused by the varying of the distant transmitter resistance) strengthen and weaken the magnetic field of the receiver magnet, thus setting up vibrations of the diaphragm and so converting the electrical energy into sound waves.

Both types of receivers are extremely robust and give little trouble in operation, and from the summary of common faults given later it will be seen that most of them are easily rectified.

### **Magneto Ringing Systems.**

Alternating currents are used for signalling purposes in magneto systems, and therefore a polarised bell is fitted on each telephone. The usual pattern has a double pole electromagnet formed by two coils secured to a yoke, and an armature which carries a hammer is pivoted over the coils. A permanent magnet is fitted so that one end of it is over the centre of the armature, which therefore becomes polarised by induction. Assuming this pole of the permanent magnet is south, the middle of the armature becomes north and each of its ends south. The opposite pole of the permanent magnet causes the free ends of the coil cores to become north.

When current flows through the coils in one direction it strengthens the northern polarity of one coil and



tends to neutralise the northern polarity of the other. As a result one end of the armature is attracted to the strengthened coil causing the hammer to strike one of the gongs. The reversal of current which immediately follows causes the opposite effect to take place, and the armature is attracted to the other coil. By this means the gongs are struck alternately at a rate corresponding with the frequency of the current.

The hand generator is really a simple A.C. generator having three or four horseshoe magnets fitted to cast iron pole-pieces. The armature is revolved between the pole-pieces by a cranked handle geared to the armature spindle. An automatic cut-out is provided and this is usually of the spring contact type operated by a partial withdrawal of the spindle when pressure is applied to the handle. The cut-out either short-circuits or disconnects the armature coil, according to the telephone circuit arrangement, in order to remove its resistance from the circuit. It also short-circuits or disconnects the bell so that it will not ring when the generator is being operated.

The remaining components are the induction coil and the change-over springs. From the circuit explanatory given below it will be seen that the former has two windings and acts as a step up transformer, whilst the latter are operated by the receiver rest and change the circuit from the calling to talking conditions.

### **Magneto Telephone Circuit.**

Fig. 88 shows the circuit arrangement of two magneto telephones connected directly together. Whilst the generator is being operated, the cut-out springs remove

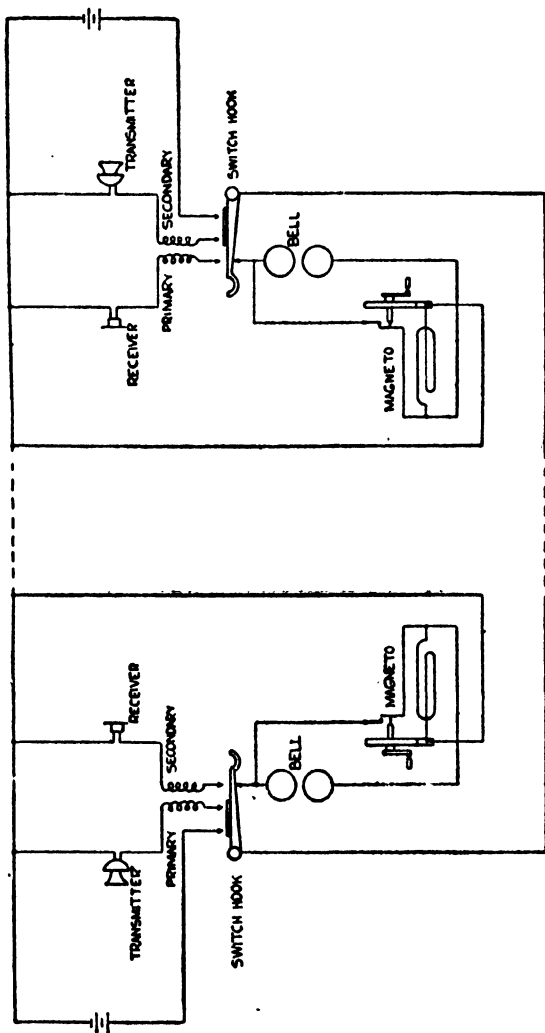

FIG. 88.—CIRCUIT ARRANGEMENT OF TWO MAGNETO TELEPHONES CONNECTED DIRECTLY TOGETHER.

the shunt from the armature and place it across the bell. The current generated flows from the frame side of the armature to line, through the shunt of the called telephone's generator, bell coils and switch springs to line, the circuit being completed at the calling telephone via the switch springs to the generator.

In the talking conditions both receivers are, of course, removed and the upper switch springs make contact, thereby completing the primary and secondary circuits. The primary is purely a local circuit consisting of transmitter, primary winding of induction coil and battery. The secondary circuit is the receiver joined in series with the line. The variations set up in the primary circuit are induced into the line circuit through the induction coil.

### **Reception Faults.**

Faulty reception may be due to any of the following conditions:—

- (1) Receiver diaphragm being buckled causing it to touch pole-pieces.
- (2) Distance pieces removed from under diaphragm causing it to touch pole-pieces.
- (3) Iron filings or other foreign matter between pole-pieces and diaphragm.
- (4) Receiver cord loose on terminals.
- (5) Receiver cord intermittently faulty when shaken.
- (6) Change-over springs not making good contact.
- (7) Receiver coils disconnected or short-circuited.
- (8) Induction coil disconnected or short-circuited.

### Transmission Faults.

Faulty transmission may be due to:—

- (1) Local batteries weak.
- (2) Handset cord loose on terminals.
- (3) Handset cord intermittently faulty when shaken.
- (4) Induction coils disconnected or short-circuited.
- (5) Change-over springs not making good contact.
- (6) Foreign matter between diaphragm and mouth-piece.
- (7) Faulty transmitter—if inset or solid back type replace with good one. If loose granule type dismantle and inspect. If carbon diaphragm is damaged replace with new one; if granules are packing take out and replace, taking care to see that they, and other parts of transmitter, are quite dry before reassembling.

### Bell Faults.

Common bell faults are as follows:—

- (1) Bell ringing faintly. Gongs out of adjustment, armature out of adjustment or polarising magnet weak.
- (2) Bell fails to ring. Hammer jammed between gongs, cradle springs out of adjustment, or bell coils disconnected.

### Line Faults.

A galvanometer and a battery are sufficient for testing lines on a simple system. There are, however, other means by which faults can be quickly localised if testing apparatus is not available.

A line short-circuit can be proved by disconnecting

the lines from the instrument and blowing into the transmitter whilst listening in the receiver. Should a short-circuit exist, the blowing will be heard in the receiver. If on disconnecting the lines the blowing cannot be heard it proves of course that the fault exists beyond that point, and by disconnecting at lightening protectors, junction boxes and other suitable places the fault can be localised. Should the fault be a disconnection, it can be localised by placing a short-circuit at different points and testing as already explained.

The above faulty conditions can also be tested by means of the hand generator. If, when the handle is turned, the movement is found to be heavy and jerky, it denotes a short-circuit, but should it revolve more easily and smoothly than under normal conditions a disconnection is indicated.

### **Testing Local Battery.**

The E.M.F. of a primary cell falls during discharge to a degree depending upon the condition of the depolarising agent and rises again during a period of rest. Consequently when the E.M.F. is measured consideration should be given to the conditions under which the cell works. The local battery of a magneto telephone feeds the primary circuit for comparatively long periods, and therefore measurements should be made immediately after use or after imitating the working condition.

One method commonly employed when testing after a period of rest is to shunt the cell by a two ohm resistance for one minute. The E.M.F. shown when the shunt is removed is noted and, in the case of a

Leclanché cell, if it is below one volt the cell is considered unsatisfactory.

Many troubles can be avoided by periodic testing of batteries and functioning of all circuits. Care on the part of the maintenance operator, during inspections and repairs, will also prevent faults from occurring. Loose connections due to bad soldering, or screws not properly tightened, will lead to intermittent faults, which are sometimes difficult to localise. Intermittent contacts or short-circuits due to small pieces of wire or solder being dropped between springs and tags are among other faults which can be avoided by careful maintenance.

### **Automatic Systems.**

Automatic systems are the most likely to give trouble because there is much more apparatus to go wrong and more skill is required in servicing the apparatus. It should not, however, be assumed that automatic telephones are unreliable, as they work efficiently for many years if well maintained. There are many house telephone equipments installed over twenty years ago which still work well and cost but little to maintain.

Large telephone systems as used for public exchanges are arranged for the use of routine testers which make regular test calls over all circuits, imposing conditions more severe than are met in ordinary use. Many of these testers are automatic and rapidly find their way over all circuits on a switchboard with but little human aid; but as a system gets smaller and less elaborate in design, the maintenance engineer has more and more to rely upon his own knowledge in

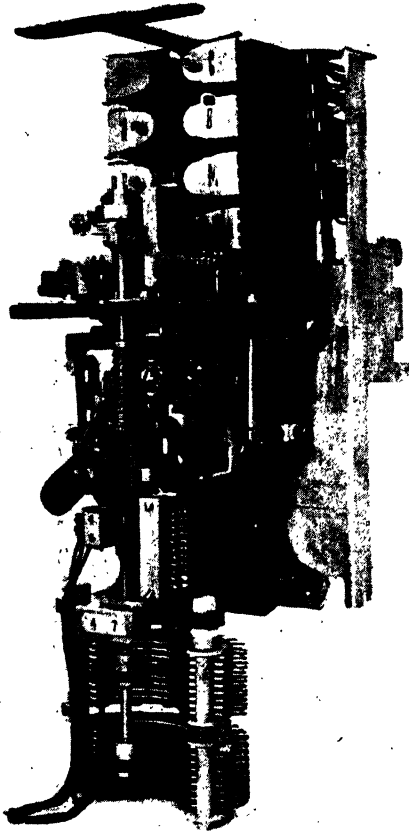

FIG. 89.  
FRONT VIEW OF  
SELECTOR MOUNT-  
ING, SHOWING THE  
POSITION OF RE-  
LAYS, CONDENSERS,  
AND RESISTANCES.

making thorough routine tests, and in tracing and rectifying faults.

The maintenance engineer should be able to assume that every part of a system has at one time worked correctly—this reduces the fault locator's search to a small fraction of the number of possible causes that

might be found in the factory, or by an installer upon first testing out a system.

Whenever "trial-and-error" methods are used it is always wise to make only one adjustment at a time, and to record the original state of the apparatus before altering. If the proposed alteration is likely to give an adjustment outside the limits set by the designing engineer, he should be consulted before such a change is contemplated, and it may be assumed that such a procedure is very seldom necessary except in the case of a new and untried system.

### **Methods of Fault Location.**

The usual method of fault location in a chain of apparatus is to start at the centre if the chain can be broken; this method is quicker than working link by link from one end. In the case of telephone systems there is a sort of natural centre which is the junction of a line to the switchboard. On the more expensive systems a testing frame is usually located where the lines enter the switchboard, but even if only screw or solder terminals are provided, it is normally still the most convenient position for testing when a telephone is stated to be out of order.

Many faults from their nature seem to have no connection with lines or telephone instruments, and search for these will, of course, begin elsewhere, for example in the bell, buzzer, or power supply. At one time it was usual for most faults to be traced to telephones, but with modern dial-switches and transmitters the balance of faults became more evenly divided between instruments and switchboard.

Long cords are conducive to faults, and the use of a



table telephone located between two desks and used by several people reaching from different angles is to be discouraged.

### Intermittent Faults.

The pet aversion of the telephone man is the fault which comes and goes, is always there when the manager wants to use the telephone, but gone before the maintenance man arrives. When a genuine intermittent fault occurs it can be very troublesome, as such a fault follows no definite law. Most so-called intermittent faults, though, are fortunately what

might be termed dependent faults, becoming apparent only when the operating battery reaches a certain voltage or when the switchboard is busy.

They may not be very obvious faults to trace, but the best procedure is to reproduce the fault-causing conditions and so locate and rectify the trouble. Perhaps the most common defect

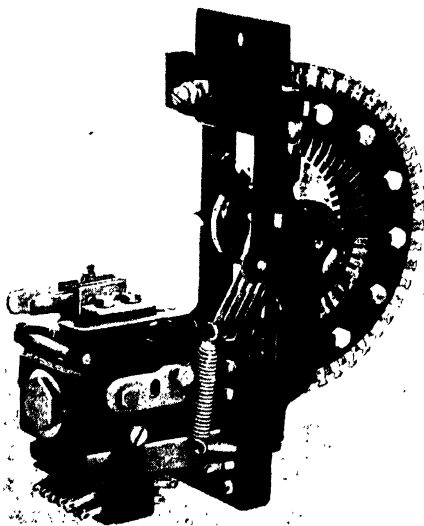

FIG. 90.—A TYPICAL UNISELECTOR SWITCH.

Oiling should include the passage of a piece of oiled wire between the tips of the contact wipers.

with small systems is low voltage at maximum load. When dealing with 12-volt or even 24-volt systems the combined losses of bad, or badly fitted, fuses and loose intercell connections of a battery can easily reduce the E.M.F. available at the switchboard to below the minimum required. Whenever any erratic behaviour of a telephone system occurs it is always worth while checking the voltages on the switchboard itself under different conditions of load.

### **Adjustment.**

Various limits of adjustment have to be maintained; whilst some parts are not readily adjustable, others are easily so, also whilst some parts are largely used and need fairly frequent adjustment, others almost identical seldom do so. As an example a relay common to a busy circuit may be in almost continuous use many hours a day repeating dial impulses, whilst another nearly similar relay may only operate once each time a quiet line is taken into use.

There are certain relays and switch parts which should be examined visually and have their various spring tensions, gaps and travels checked regularly, but alteration should not be made unless the manufacturer's stated limits are exceeded. Oiling and graphiting should also be carried out regularly but sparingly. Unselector switches work much better when their oiling includes the passage of a piece of oiled wire between the tips of the contact wipers, but unfortunately many seem to be averse to oiling such contacts, even though they cannot substantiate their attitude.

### Relays.

Relays cause little trouble, but those which operate very frequently, such as the impulse relays of selector circuits, should have their reluctance gaps, contact movements and pressures checked periodically. Other adjustments on a relay should not vary appreciably, but sometimes through a fault or faulty material residual magnetism may become troublesome—if not by itself then combined with a reduction in the size of

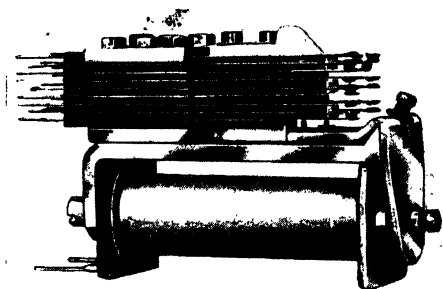

FIG. 91.—A MODERN TELEPHONE RELAY.

Relays which operate frequently, such as the impulse relays of selector circuits, should have their resistance gaps, contact movements, and pressures checked periodically.

the residual gap, due to constant hammering of the stop pin.

When dealing with spring sets, attention should be paid to the ease with which tension can be increased to the correct value; if any great difficulty is experienced the spring set should be replaced, as the metal is probably fatigued. The contacts of any spring set should on no account be touched by file or abrasive paper, nor should ordinary paper be set between them

to hold open a circuit for testing purposes. The correct treatment for dirty contacts is a burnishing rather than a cleaning process, with a special contact cleaner of the sand-blasted steel or other recognised type. With the old-fashioned pair of contacts, i.e., one pointed and the other flat, a slight re-alignment of the springs to bring new surfaces in contact is permissible when roughness or pitting is visible. One last, but most important, point about contact adjustments—never start adjustment before verifying that no special adjustments are called for either as regards stroke and tension, or as to the relative succession of operation compared with other springs on the same relay.

### **Power Troubles.**

Unfortunately we can ill afford to lose potential across fuses, etc., and therefore poor fuses should always be carefully examined. When batteries are not used, but operating current is obtained from A.C. supply mains via some form of transformer-cum-rectifier circuit, various regulation losses are inevitable. Such apparatus is only supplied with switchboards which will work between fairly wide voltage limits, but further losses should be avoided even so. The supply voltage may be low at certain times of the day and the percentage drop in the output voltage will assuredly be greater than that of the mains, assuming that no compensating circuit is fitted.

Transformers and chokes are not likely to cause many faults. Electrolytic condensers may break down through being subjected to excess either of ripple current or applied voltage, and having partially

#### **114 HOUSE TELEPHONES, BELLS, SIGNALLING SYSTEMS**

broken down, may cause heavy loading and low voltage of the switchboard supply.

Rectifiers should not cause trouble if correctly treated, but valve rectifiers will gradually age and give smaller outputs, whilst those of the cold plate type may develop high internal resistance at low temperatures or break down through overheating; properly ventilated and not overloaded, they should not give trouble.

#### **Maintenance of Manual Exchange Systems.**

The reader is referred to the next chapter for special notes on maintenance and testing for faults in manual exchange telephone systems.

## CHAPTER VII

### MANUAL EXCHANGE TELEPHONE SYSTEMS

**T**HERE are many private manual exchange systems in operation and in some cases, manual switchboards are still preferred to private automatic systems. A switchboard operator is often required as a source of information, and, if a wanted party is engaged, the operator can be asked to connect, which she can of course do directly the indicator shows the wanted line to be free.

Manual switchboards can take many forms as each of the different pieces of apparatus may vary, but the functions to be performed vary very little. Links to connect two lines together may take the form of key switches or jacks and plug-ended cords. Indication of a party wanting or finishing a call may be by mechanical indicator or by lamp. Talking and ringing current may be from (1) local batteries and generators at each telephone, (2) from a central battery, or (3) possibly by a combination, namely, local talking batteries and a common signalling battery.

#### **Magneto Telephone Switchboards.**

A magneto system will continue to give service when the wiring has deteriorated far beyond the condition necessary for operating successfully common battery, manual or automatic, systems.

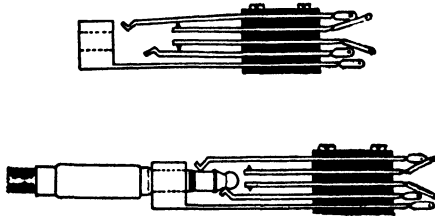

(A)

Five point break jack, and jack with plug inserted.

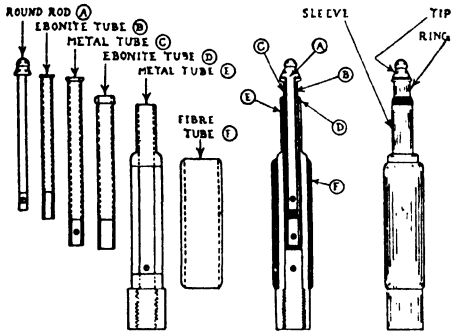

(B)

Construction of a 3-way plug.

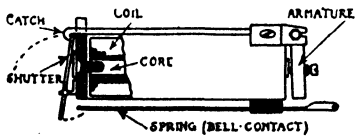

(C)

Drop indicator for signalling the switchboard.  
 FIG. 92.—MAGNETO SWITCHBOARD APPARATUS.

When testing for correct functioning and location of faults, the same considerations apply as are given on pp. 104-107. If a faulty line is fairly long, it may be more convenient to employ a galvanometer to test for disconnection than to use the "blowing" test previously described.

On magneto switchboards, the conductors from the telephones usually terminate on jacks, comprising a number of German-silver springs into which can be inserted a cylindrical plug (Fig. 92A). The jacks are usually in strips of ten or twenty. The plugs are two- or three-way as required, a three-way plug being shown in Fig. 92B.

The cord which connects the plug to the switchboard consists of two flexible conductors twisted together with cotton wormings, over which are lappings of soft cotton and finally a braided glazed cotton cover.

For the purpose of drawing the switchboard operator's attention to the fact that her assistance is required to set up or clear down a connection, indicators of an electro-mechanical type are provided, usually of the drop-shutter type, as illustrated in Fig. 92C. This consists of a soft-iron core over which is wound insulated copper wire. A soft-iron armature is pivoted at one end of the core and to this is fastened a lever which has a catch to hold the shutter in the vertical position. When the core is energised, the armature is attracted, thus lifting the latch and permitting the shutter to fall. When the shutter is in the horizontal position, it closes a bell contact to which can be connected some form of audible alarm. Such a device in the form of a trembler bell is useful if the switchboard is attended by a



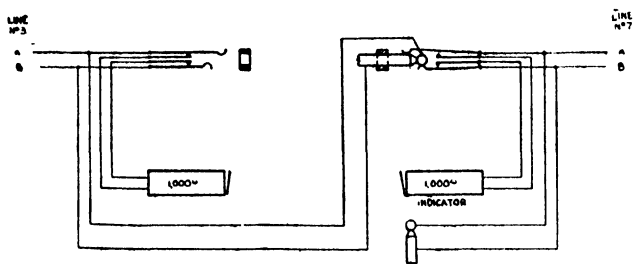

FIG. 93.—THROUGH CONNECTION OF SINGLE-CORD MAGNETO SWITCHBOARD.

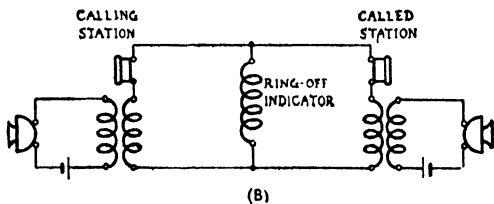
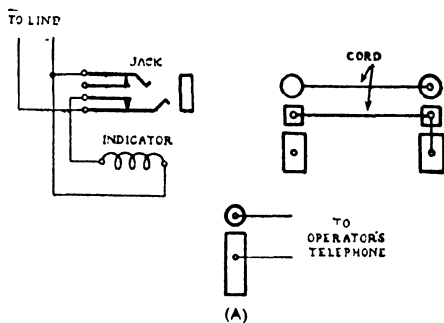

FIG. 94.—DOUBLE-ENDED CORD SWITCHBOARD.

(A) Circuit. (B) Two stations connected for speaking.

part-time operator whose other duties necessitate her leaving the board.

### **Single-cord Magneto Switchboard.**

The through-circuit condition of this board is shown in Fig. 93. When an indicator falls, the operator inserts her plug into the associated jack, thereby connecting her telephone to the calling line. On ascertaining the number required, the operator transfers her plug into the jack of the required line and turns her generator to ring the wanted telephone's bell. The operator then inserts the plug associated with the called line into the jack of the calling line; each plug, except the operator's, is permanently connected to a line in the same manner as the jacks, and therefore the two lines are now connected together. The operator may withdraw from the circuit or remain in for supervisory purposes until conversation commences.

On withdrawing from the circuit, the operator leaves the jack of the called line in a normal condition. Therefore, as can be seen from the diagram, the indicator of the called line is connected across the line. This indicator is of a high resistance, so as to offer little impedence to the talking currents. At the termination of the conversation, the subscribers turn their generators. This action causes the indicator to drop and signals the operator to take down the connection.

### **Double-ended Cord Switchboard.**

In the double-ended cord switchboard, instead of a plug and cord fitted to each extension, as in the single-cord switchboard, the calling and answering jacks are connected together by means of a cord having a plug at each end (see Fig. 94). By virtue of the connection

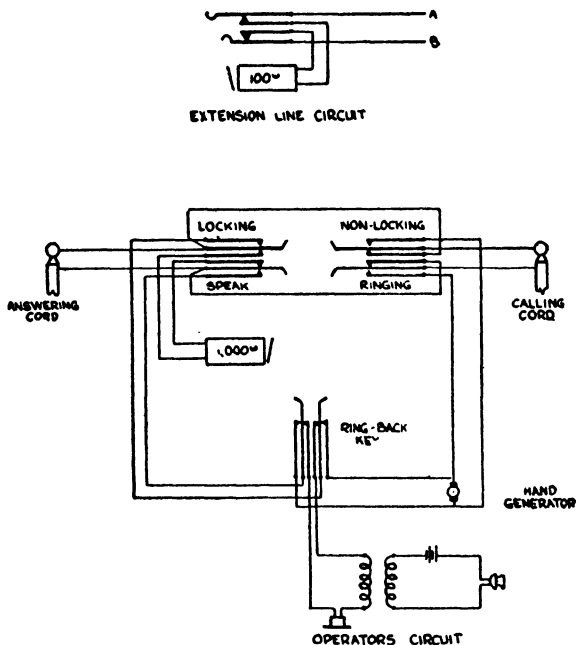

FIG. 95.—LINE AND CORD CIRCUITS OF TYPICAL DOUBLE-CORD MAGNETO SWITCHBOARD.

between ring and sleeve on one of the plugs, only one indicator is left bridged across the circuit to give the clearing signal when either station rings off. A disadvantage is that supervision cannot be exercised without breaking down the connection, and operation is slower than with the single-cord switchboards.

### Double-cord Magneto Switchboard.

The methods of operation described above would not be practicable on large switchboards and, therefore,

double-cord circuits are employed which are independent of the extension lines. Fig. 95 shows the line and cord circuit of a double-cord switchboard. The line circuit merely consists of a jack and an indicator, the latter being disconnected when a plug is inserted. The cord circuit comprises a lever-type key similar to that shown in Fig. 96. It has three positions: the normal position connects the answering and calling plugs together; the speaking position connects the operator's circuit to the cords; whilst the remaining position, which is non-locking, applies ringing current to the calling cord.

An indicator of 1000 ohms resistance is normally across the circuit to act as ring-off signal. The method of operation is as follows:

When an indicator shutter falls, the operator inserts the answering cord of any disengaged cord circuit into the associated line jack, which disconnects the line indicator. She then places the key in the speaking position and requests the required number. The calling plug is placed in the appropriate jack and the key is

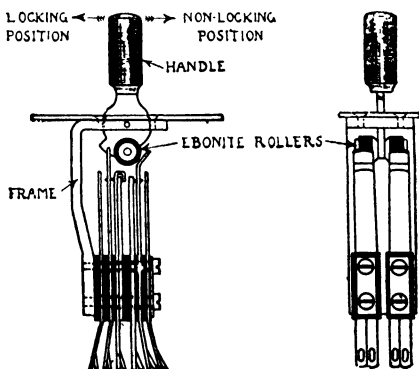

FIG. 96.—DETAILS OF SPEAKING AND RINGING KEY.

held in the ringing position whilst the generator is turned. When the key is released it returns to the normal position, thus leaving the two lines connected together, with the ring-off indicator in parallel. The operator can re-enter the circuit at any time by merely placing the key in the speaking position.

### Cordless Switchboard.

Fig. 97B shows a magneto switchboard of the cordless type, utilising key switches for setting up the connections, and mechanical indicators. To connect two lines together, keys associated with each line are

FIG. 97A.—MAGNETO TELEPHONE CIRCUIT.

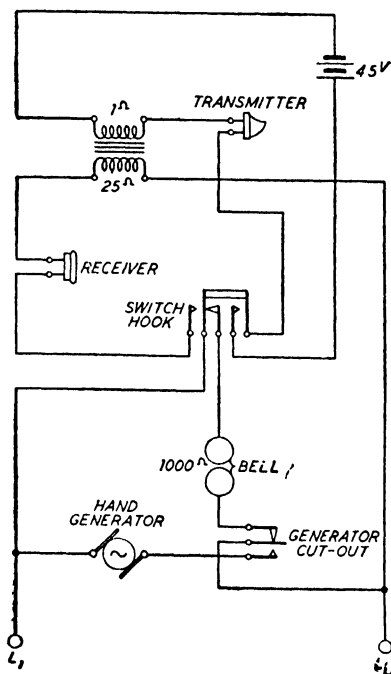

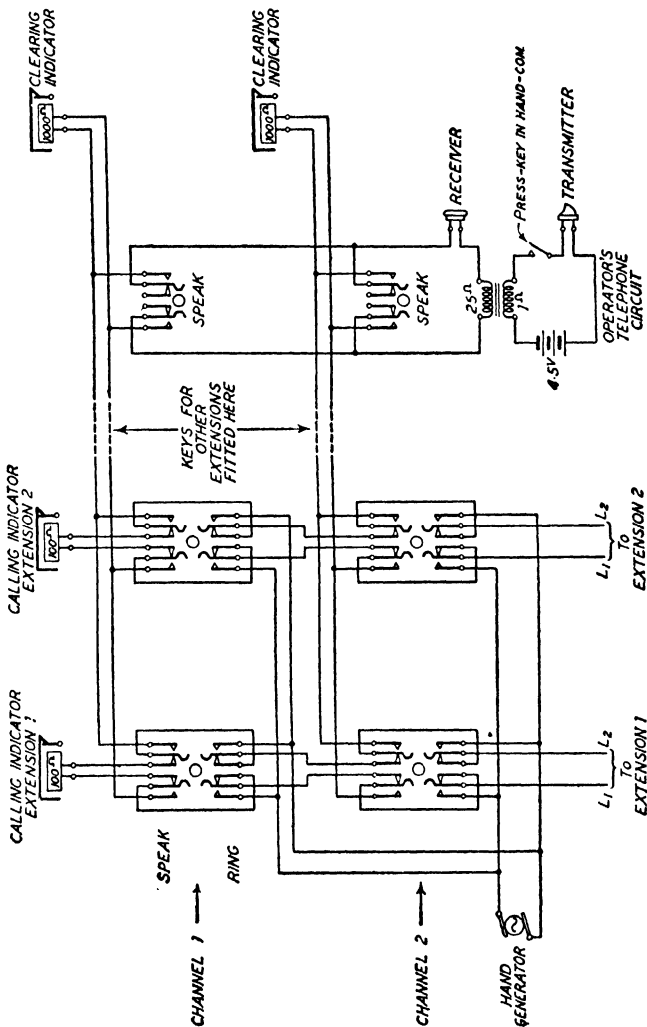

FIG. 100 — COBBYSS MAGNETO TELEPHONE SWITCHBOARD UTILIZING KEYS FOR SETTING UP CONNECTIONS.

thrown so as to connect to a common point of connection circuit. Another pair of lines needing connection simultaneously must be connected to a common point. It is for this reason that the system is only commended for use on small switchboards, or where calls are, in the main, confined to extension to operator and very few through (i.e. extension to extension) calls are necessary. In the circuit illustrated, it will be noted that two speech channels are shown, permitting two simultaneous through conversations. Any number of such channels, or circuits, may be incorporated in a switchboard to satisfy the demands of a particular installation, but in normal practice, the ratio of speech channels to the number of lines is one channel to ten lines. Thus, on a fifty line switchboard each line would want five keys to connect it to whichever connector circuit appears to be free. When jacks are used, no such duplication is necessary: we simply have to increase the number of plug-ended cords, each of which is a connecting link, and the space occupied by the cords is not particularly troublesome as they are normally fitted in a horizontal shelf and dragged out of the way when not in use by suitable pulley weights.

The circuit operation, referring to Figs. 97A and 97B is as follows: The caller turns the hand generator of his instrument several times, thus generating an alternating current which flows through the calling indicator associated with his line at the switchboard, via the speak and ring keys; it should be noted that the operation of the generator handle causes the cut-out attached, to automatically disconnect the bell from the line, and connect the generator thereto. The calling indicator operates, dropping a flap to reveal the extension number, and the operator at the switch-

board throws the speak-key of a disengaged channel and the corresponding speak-key in his telephone circuit. This connects his instrument across the calling line, and when the switch in the handcom. is depressed the local transmitter circuit is completed for the operator to speak. Meanwhile the caller has removed his handcom. from the switch hook thus completing a similar circuit for his transmitter, at the same time as his receiver is connected, via the secondary of the induction coil, across the line. Conversation between the caller and operator ensues, and if the call is to the latter, the circuit is cleared by both caller and operator restoring their handcoms. and the latter releasing the speak-keys.

If the calling extension requires a through call to another extension the operator proceeds to ring the required instrument by throwing the corresponding key to the ringing position and operating the generator. When the called extension answers, the operator restores his speak-key and throws the speak-key of the called extension; the caller and called are now able to converse. At the conclusion of conversation, the caller operates his generator thereby causing the clearing indicator to drop, when the operator restores both speak-keys to normal.

It should be noted that the clearing indicator is bridged across the speech channel during conversation, and on this account the coil is designed to offer a high impedance to the speech currents, so avoiding attenuation of the conversation.

### **Central-battery System.**

This system, as its name implies, employs a battery situated at a central position, namely the exchange,



which feeds current for the operation of the whole system.

The main advantages of this system as compared with the magneto system are as follows:

(1) Automatic calling and clearing signals are transmitted to the exchange by the removal and replacement of the handset.

(2) No batteries are required at the telephone instruments, thus effecting considerable economy in maintenance cost.

(3) No generator is required in the telephone.

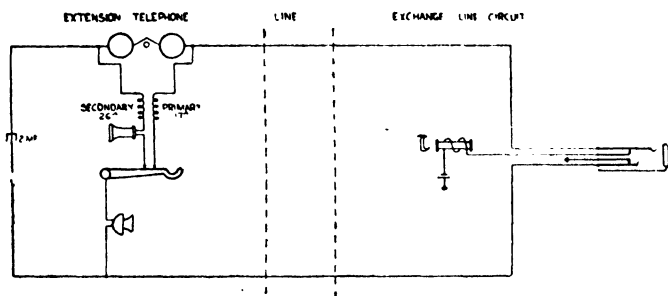

FIG. 98.—SIMPLIFIED CENTRAL BATTERY TELEPHONE AND LINE CIRCUIT.

### C.B. Battery Telephone and Line Circuit.

A simplified C.B. telephone and line circuit is shown in Fig. 98. The exchange is called by a loop being placed across the line when the caller removes his receiver. When the receiver is on the cradle, the telephone circuit consists of the bell in series with a 2-mfd. condenser across the line. The condenser prevents the direct current of the calling circuit from flowing through the bell circuit, but permits the alternating

ringing current to pass and ring the bell. It will be noted from the diagram that the condenser in series with the secondary winding of the induction coil and the receiver is connected across the transmitter. When the resistance of the transmitter is varied, surges to and from the condenser are produced in the secondary winding which increase the variations in the primary circuit.

The transmission is seriously impaired if the condenser is omitted or the coils are incorrectly connected. Speech current is received through the primary winding and transmitter and induced into the secondary circuit: it does not flow through the bell coils owing to their high impedance.

When the receiver is removed, the cradle contacts are closed and battery flows through the line indicator, inner spring of line jack, along line, through telephone loop, and back to battery on the other inner spring of the line jack. The indicator shown is of the self-restoring type. The armature when attracted displays a white disc carrying the number of the line. When the armature is released it returns to normal by gravity.

### **C.B. Cord Circuit.**

The cord circuit shown in Fig. 99 provides separate supervision for the answering and calling cords.

When the operator plugs into a jack to answer a call the inner jack springs are disconnected, and thus the indicator and line current are removed from the line, as already explained. Current is, however, supplied to the line through impedance coil  $C_1$ , answering supervisory indicator, ring-back key contacts and

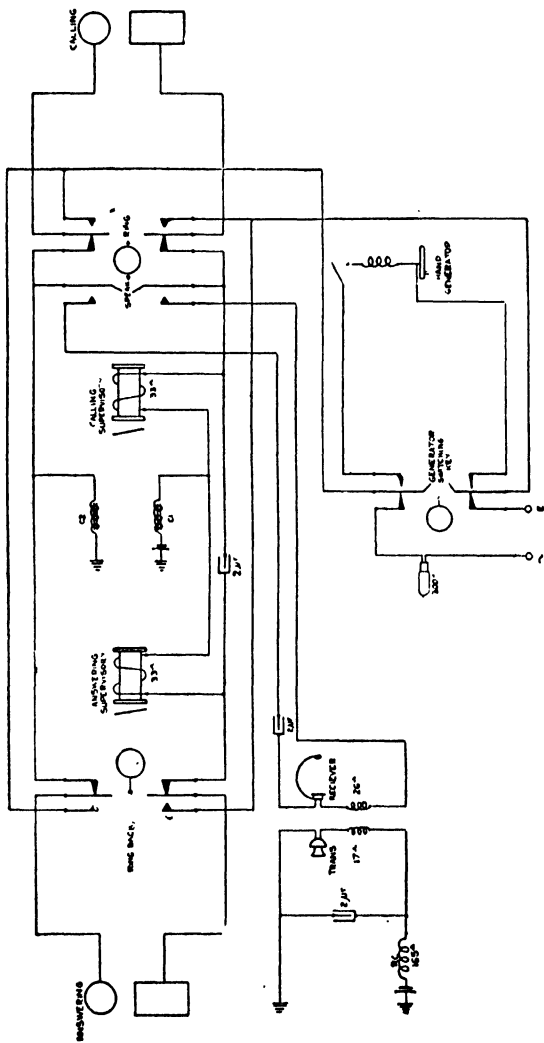

FIG. 99.—CORD CIRCUIT C.B. SWITCHBOARD.

impedance coil C2. The answering supervisory indicator is thus operated to indicate that the caller is on the line. The operator places the key in the speaking position, which connects her telephone to the line, and then ascertains the number required.

The calling plug is inserted into the required number and the key is placed in the ringing position whilst the hand generator is turned to ring the required telephone. When the called person answers, current also flows around his loop via the calling supervisory indicator, which operates and enables the operator to supervise without having to re-enter the circuit. When the conversation is finished the receivers are replaced and the supervisory signals are thus automatically restored. The operator, on noticing this, withdraws the plugs from the jacks, thereby restoring the line circuits to normal. A ring-back key is provided, to allow the operator to ring the calling line without changing plugs should the caller have hung up before the conversation is completed.

### **Lamp Signalling.**

When a large number of indicators have to be fitted within the reach of an operator, lamps are usually employed in place of mechanical indicators. When the extension lines have very low resistance, the lamps may be connected directly in the line circuit in the same manner as indicators. On general-purpose switchboards, a relay is used in conjunction with each lamp, so that their operation will not be affected by the different resistances and leakages of the various lines.

The lamps occupy much less space than indicators, as each one is only about  $\frac{1}{4}$ -in. diameter. They are

held in position by springs assembled in strips, similar in form to ordinary jack strips.

### **Testing of C.B. Systems.**

Faults which may affect apparatus common to magneto and C.B. systems have already been described in connection with the former system, and therefore will not be reiterated here.

The blowing and generator tests for short circuits and disconnections referred to under magneto systems will not, of course, apply to C.B. systems, and therefore a galvanometer should always be brought into use.

The following faults are peculiar to C.B. systems:

Bell out of order. Condenser disconnected or induction coils in contact.

Permanent call at exchange. Loop on line, probably due to short-circuit of line conductors, cradle springs out of adjustment, or receiver left off.

## CHAPTER VIII

### LOUD-SPEAKING AND SPECIAL TELEPHONE FACILITIES

THE types of telephone systems particularly suitable for business use are broadly two; in one, an exchange, either manually operated or automatic, selects the wanted line, whilst in the other the wanted line is actually selected by the calling party at his own telephone by depression of the appropriate push-button. In general, for capacities above 15 or 20 lines, an exchange system is more suitable, and for the smaller installations the push-button intercommunication system referred to in a previous chapter is preferred, especially when the stations are situated close to each other. Whichever system be adopted in any given instance, its utility can be increased by the use of loud-speaking telephones.

With a loud-speaking telephone it is not necessary to hold a receiver. The user therefore has both hands free. He need not remain seated at a desk, because the telephone reproduces received speech at sufficient volume for it to be heard anywhere in an office of usual size, and will pick up and transmit replies. Telephone conversation thus becomes as facile as normal conversation, and just how much that differs from the use of a handset, with the restrictions on movement and position that a handset imposes, is never realised until a loud-speaking telephone has been tried.

An installation generally consists of one, two or three

loud-speaking master stations and one to twenty substations.

### **Intercommunication Loud-speaking Master Station.**

A typical loud-speaking telephone itself consists of a walnut cabinet (Fig. 100) in which are fitted a loud-speaker and microphone behind a decorative and protective grille.

A row of keys projects from the cabinet and each is designated with the name of an individual or department. A flick of any key and a buzzer sounds on a corresponding distant telephone. The reply comes from the loud-speaker, and the microphone transmits query, instruction or request.

Should a called telephone be already engaged, a

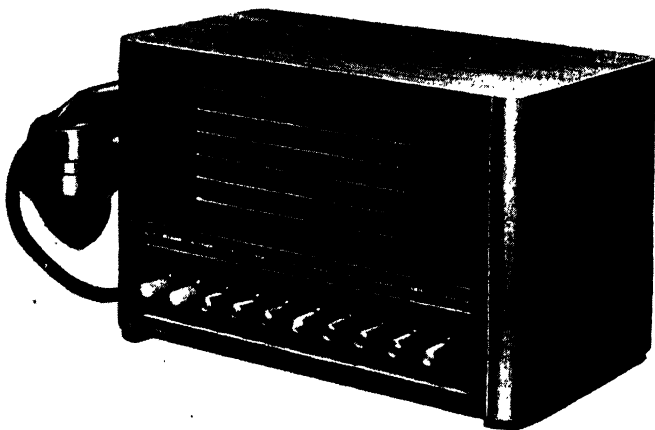

**FIG. 100.—LOUD-SPEAKING MASTER STATION FITTED WITH KEYS FOR CALLING TWO OTHER MASTER STATIONS AND EIGHT SUBSTATIONS.**

*(Reliance Telephone Co., Ltd.)*

lamp glows to warn the speaker that he is being called from a master station and should terminate his conversation to take the call.

All departments and important individuals are therefore literally at the executive's finger tip, and in discussions with them he has complete freedom of movement to consult papers, files or wall charts, without interruption of conversation.

Incoming calls are signalled on the loud-speaking telephone by a buzzer, whilst a lamp glows to indicate to the executive the source of the call. The lamps are associated with the keys, and depression of a key beneath a glowing lamp enables a call to be answered. Thus the flicking of a key is the only action required in making or answering a call, and conversation may then be carried on in normal tones.

Telephone calls may be of a confidential nature and at times it may be desired to prevent received speech from being overheard by others who may be present in the executive's office. A handset is therefore fitted to the master station telephone, the hook switch on which it rests automatically cutting off the loud-speaker when the handset is lifted. Incoming speech is then heard only by the executive and not by any other person who may be present.

In a different respect, calls on an executive's line are always private in that no other user of the telephone system can interrupt or overhear.

This secrecy, however, does not prevent the incorporation of conference facilities. Joint discussion on any subject can be extremely valuable in the conduct of business, and the interested parties can be "brought together" without their leaving their desks by means



of the conference facility. The executive merely depresses the appropriate keys to call the individuals and all are then party to the conversation.

Provision can be made for additional features to aid the busy executive still further. One of the keys on the loud-speaking telephone can be arranged for its depression to provide a "busy" indication so that a caller will hear a tone when attempting to call the executive. Not only is the caller thus advised that the executive is busy and he cannot expect a reply but, since depression of the key also cuts off the buzzer, the executive is not troubled by audible signals. The key may be arranged also to light a warning lamp outside the office to secure personal as well as telephone privacy for the executive.

The loud-speaking telephone is normally fitted with ten or twenty keys for calling the corresponding number of telephones, of which two may themselves be of



FIG. 101.—INTER-COMMUNICATION SUBSTATION TELEPHONE FITTED WITH BUTTONS FOR CALLING THREE MASTER STATIONS AND SEVENTEEN SUBSTATIONS.

Note the three translucent apertures, the appropriate one of which glows whenever a call is coming through from a master station.

(*Reliance Telephone Co., Ltd.*)

the loud-speaking type, making a possible total of three loud-speaking telephones in a system.

### Substation Telephone.

The other telephones are of the familiar type illustrated in Fig. 101, and are fitted with ten or twenty push-buttons as desired. In addition, the case has three translucent apertures, the appropriate one of which glows should a received call, as signalled by an internal buzzer, be from a master station. It is this visual signal that warns the user to terminate a call on which he may be engaged, in order to answer the calling executive.

The push-buttons are designated with the names of individuals and departments on the system, and the depression of the appropriate button establishes

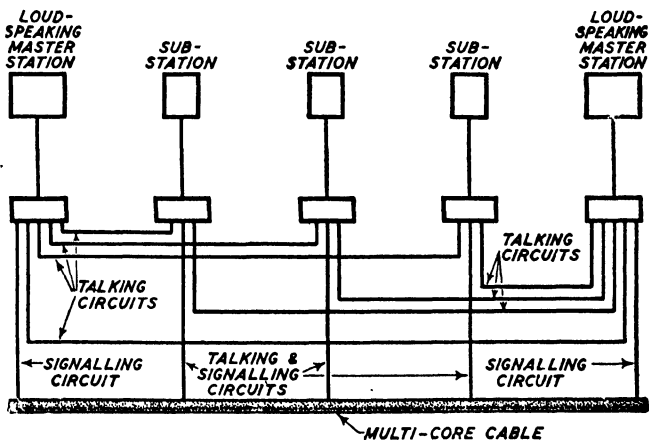

FIG. 102.—SCHEMATIC DIAGRAM SHOWING WIRING BETWEEN STATIONS ON INTERCOMMUNICATION SYSTEM.

(Reliance Telephone Co., Ltd.)

contact with any other telephone, except that, as already explained, a master station cannot be called should the executive wish to remain undisturbed.

### **Circuit-Details.**

Fig. 102 is a schematic diagram in which two master stations and three substations are shown. The connections are representative of those for any number of stations up to the maximum capacity of the system. Each instrument is connected by a flexible cord to a junction box, which terminates the line wires. The usual multi-core cable of an inter-communication system links all the stations together and provides circuits for signalling and talking between substations as well as for signalling on all calls to or from master stations. Talking circuits for master stations, however, are provided by additional wiring to each substation and to other master stations, as shown. These individual talking circuits give the master stations complete secrecy and freedom from overhearing.

Since the multi-core cable is looped to all junction boxes, the changing of a station from one type to the other involves, as far as wiring is concerned, only the addition or removal, as the case may be, of the master station talking-circuit wiring.

The circuit conditions to be established on a call to or from a master station require a number of switch contacts at a substation. The most practicable method of obtaining the necessary number of contacts is to relieve the push-buttons of them by using relays. In consequence, each of the push-buttons corresponding with a line to a master station is associated with a relay. There is therefore a maximum of three relays per

substation telephone and they are conveniently fitted in the junction box.

Shorn of key contacts and signalling lamps, a talking circuit is as shown in Fig. 103. A substation calling a master station will of necessity use a handset, with transmitter and receiver, as shown in the diagram, and

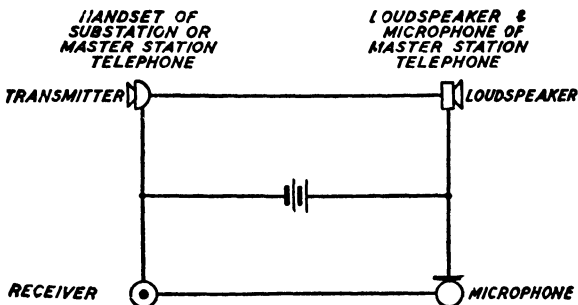

FIG. 103.—ELEMENTS OF TALKING CIRCUIT.  
(Reliance Telephone Co., Ltd.)

a master station calling a second master will use the handset in order that there shall be adequate volume at the receiving end, where the call may be taken on the loud-speaker. To assist in gaining the necessary level of received speech, circuit conditions are established for the current through the transmitter to be of high value. If, however, the handset be taken into use at the called master station also, it is required that the current through the calling transmitter be immediately reduced because the high volume of received speech is no longer necessary. Relays are incorporated in the master station telephones to give this reduction of current by means of circuits that are the subject of a patent.

Since the loud-speaking effect is obtained as a result of the high sensitivity and power output of the microphone, coupled with the sensitivity of the loud-speaker, amplifiers are unnecessary. With the exception of the dry batteries that are used to feed the talking and signalling circuits, there is nothing to replace, and maintenance attention consists principally of careful cleaning of contacts and replacement of parts that may be damaged by unduly rough usage.

Loud-speaking telephones of the above and similar types, can also be used in hotels for communicating with kitchen staff, in power stations, and in large theatres for issuing instructions to stage hands above and on the stage.

### **Special Facilities on Private Automatic Systems.**

The details of a P.A.X. installation have been given in Chapter III, from whence it will be gathered that the wanted number is dialled in just the same manner as in the Post Office automatic system. The P.A.X. switchboard selects the dialled number provided there is a free connector available in the switchboard; and then makes the connection if the called line is disengaged.

The caller must therefore be aware of three warning tones, just as with a P.O. instrument.

1. *Dial Tone.* When he lifts his handset, he must firstly wait for dial tone. When he gets this he knows the switchboard is ready to deal with his call.

2. *Ringing Tone.* This indicates that the connector is ringing the called number.

3. *Engaged or Busy Tonè.* This means that the called number is not being rung because it is already engaged.

**Automatic Dialling and "Loud-to-Loud" speaking.**

Normally, two digits only have to be dialled where the installation includes less than a hundred stations and three digits will suffice beyond this, which will cover the requirements of all but the very largest private installations. Even so, some chief executives find it irksome to do this dialling as well as memorise the numbers on, or alternatively make reference to, the private telephone list.

Again, where the managing director and his chief executives desired the special facilities afforded by a loud-speaking telephone, a special loud-speaker was, until recently, fitted alongside each such executive's dial instrument. This was not an ideal arrangement, added to which was the fact that when one loud-speaking station spoke to another similar station, one or other, according to a pre-arranged courtesy, had to use the handset.

This was due to the difficulties which arose and marred the call because of "feed-back" if conversation was carried out on what is known as a "loud-to-loud" basis. Speech issuing from one loud-speaker would pass to the transmitter in the same room, thence to the loud-speaker in the other room and back again to the original loud-speaker. This process builds up into a continuous "howl."

After years of patient and persistent research the problem of "loud-to-loud" has been solved, and with it comes the creation of the P.A.X. master instrument which gives chief executives the utmost refinements in private internal communication.

### The Telematic P.A.X. Master Instrument.

The illustration in Fig. 104 shows an instrument developed by Telephone Rentals, Ltd. There is combined in one wooden cabinet: the microphone transmitter, the loud-speaker receiver, a handset for privacy of conversation if required, a dial, and also a bank of key switches, all of which provide special facilities for principal executives.

When this P.A.X. Master is installed, say for the managing director's use, those executives with whom he knows he has to make most frequent internal telephone calls are allotted respectively to his bank of key switches

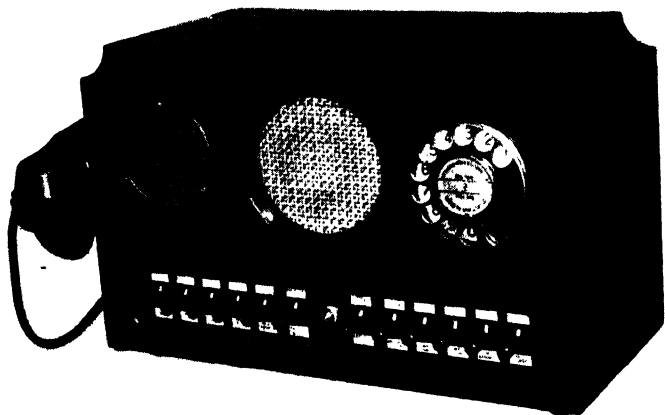

FIG. 104.—TELEMATIC P.A.X. LOUDSPEAKER MASTER INSTRUMENT WITH KEY SENDER CONTROLS.

Automatic loudspeaking telephone instrument with loud-to-loud features, and including keys which relieve the caller of the necessity of dialling specially-selected numbers. Fig. 105 shows the key sender mechanism.

*(Telephone Rentals Ltd.)*

on which 20 names can be accommodated. It is clear that in the run of the day's work the managing director may make over 90 per cent of his internal calls upon that bank of keys. Consequently he is saved the trouble of remembering the numbers and making the dialling movements. All he has to do is to operate the desired key switch, and a suitable mechanism automatically carries out, in effect, the dialling of the called number corresponding to the key operated.

It should be noted that another principal executive having a Telematic P.A.X. Master may have a somewhat different set of names allocated to his keys. All such executives consider their own respective needs and the facilities are provided accordingly.

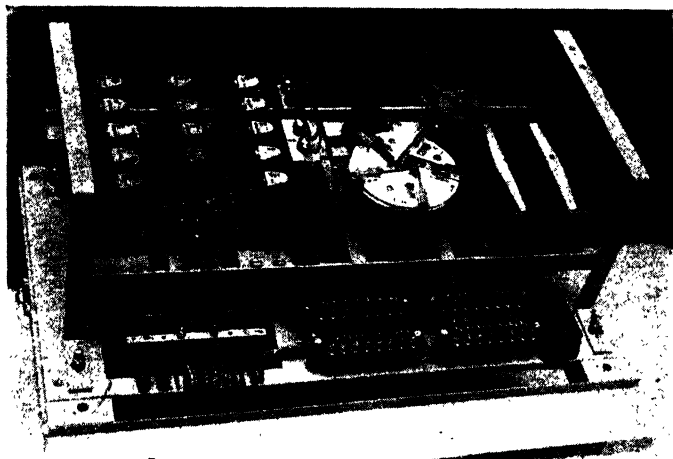

FIG. 105.—KEY SENDER MECHANISM.

This automatically dials the telephone numbers of the people to whom the keys on the Master Instrument (Fig. 104) are allocated.

*(Telephone Rentals Ltd.)*



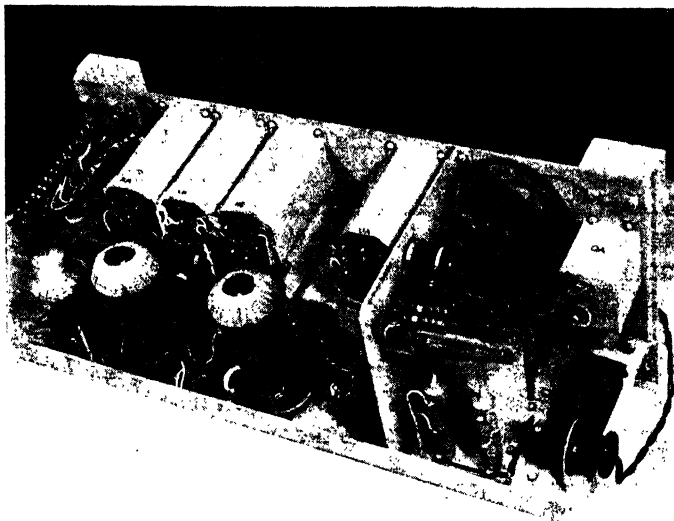

FIG. 106.—AMPLIFIER SERVING P.A.X. MASTER FOR LOUD SPEECH.  
The amplifier is specially designed to give loud-to-loud features.  
(*Telephone Rentals Ltd.*)

For instance, the managing director would certainly include the company secretary and the chief accountant on his keys, but the works' director may prefer say the head of the planning and progress department and the chief transport officer in their stead.

If and when a P.A.X. Master station executive needs to call a number other than those allocated to his bank of keys, he does so on the dial in the normal way.

Then, in addition, each P.A.X. Master has its loud-speaking facility and if talking to another P.A.X. Master both can use their loud-speaker facilities since the problem of "loud-to-loud" has been solved. But if necessity demands, the handset can be used, where

it is desired that the incoming conversation should be heard in private.

Telematic P.A.X. Master facilities can be installed for any number of executives and the balance of the instruments in the installation would be of the normal type.

### Priority Facilities on P.A.X.

On a P.A.X. installation there must be times when the person called is engaged in conversation on the internal system with another number. In such cases the caller normally gets the engaged signal, and having put back his handset or key switch he can ring again a little later.

A few principal executives may wish to have the facility of breaking in on the called person's conversation if engaged. Where this is so they are given what is called "Priority," in other words the right to break in.

Obviously such priority facilities should be kept down to the very minimum number of executives' instruments, otherwise, if carried too far, the automatic system would cease, in an increasing degree, to be a "secret system."

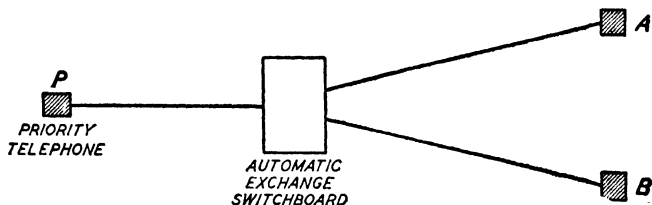

FIG. 107.—PRIORITY FACILITY.

When a call is made from a priority instrument, and the called instrument is already engaged, the priority facility automatically comes into action. This means that the caller breaks into the existing conversation and becomes in actual fact a member of a 3-party conference.

The two parties originally engaged in conversation will be aware of the entry of the priority line, because it is accompanied by a short distinctive tone signal.

We can represent this priority facility thus (Fig. 107): where "A" and "B" are in conversation and "P" breaks in when calling "A".

If privacy is not important "P" says what he has to say to "A" and can then withdraw from the conference by restoring his key or handset.

If he desires a private conversation with "A" he may say to "A" "*Please ring me back,*" or it can be arranged upon the simple request by "P" to "A"—"*Priority please, Mr. 'A',*" upon which both "A" and "B" restore their handsets. Upon so doing, Mr. "A" is automatically rung again, lifts his handset and is in private conversation with Mr. "P".

### **Tie Line Service.**

Private automatic exchange communication need not be limited to one building. Where an organisation is housed in separate premises, even miles apart, P.A.X. telephones fitted in each can be treated as one installation for private internal communication among the members of the organization.

The two or more premises are linked together by what is known as a tie line service, which usually

shows a positive economy in the cost of inter-premises calls in addition to the advantages of internal communication as if all departments operated under one roof.

A private automatic exchange switchboard is fitted within each of the premises to be connected by tie lines. Then a special "Tie Line Unit" is fitted to each switchboard for each tie line between the switchboards. The tie line itself, which is practically always a line hired from the Post Office is then connected to the tie line units at its two ends.

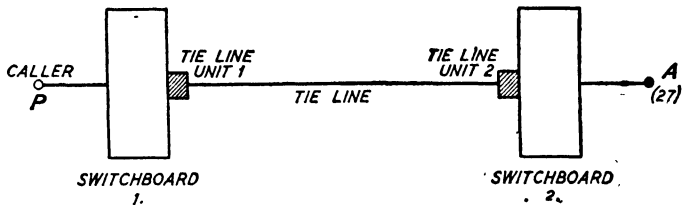

FIG. 108.—OPERATION OF TIE LINE SERVICE.

The operation can be simply explained from Fig. 108. which shows two switchboards connected by a tie line. At each end, i.e. on each switchboard, a special digit, usually 9, is allotted for tie line calls. If "P" wishes to call "A" whose number is 27, he dials 9 and waits for dial tone from Switchboard 2. "P" then goes on to dial 27 to obtain "A's" number.

The whole operation is exactly similar for calls made in the opposite direction over the tie line.

Priority facilities allotted to certain executives through one switchboard can be extended through the other switchboard if required.

## CHAPTER IX

### STAFF LOCATING SYSTEMS

**A**N important system of signalling not yet dealt with in this book, is Staff Location, which is becoming increasingly used in factories, warehouses, hospitals, offices and departmental stores. These systems provide means whereby officials and executives can be given a signal, audible or visual, that they are wanted, the signal reaching them no matter in what part of the building they happen to be. The visual signal is particularly necessary in hospitals where silence is essential, and in stores where it is undesirable to inform customers also which members of the staff are wanted, which would be the case, for example, if some system incorporating loud-speakers were used.

#### **The "Tangent" System.**

The first system to be described is known as the "Tangent" system. In this case the telephone attendant or any other qualified person merely rotates a control dial to the appropriate position (Fig. 109), or selects a switch (Fig. 110), presses a button, and in all departments coloured lamps light providing a signal to the wanted person. To each member of the staff likely to be called is allocated a colour or combination of colours. In addition audible signals, if necessary, call attention to the signal lamps and the wanted person



FIG. 109.—TELEPHONE OPERATOR ORIGINATING A SIGNAL ON A DIAL TYPE STAFF  
LOCATING TRANSMITTER.  
(Gent & Co., Ltd.)

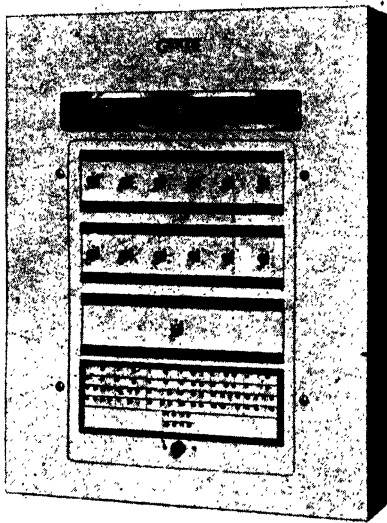

FIG. 110 (*left*)—STAFF LOCATOR TRANSMITTER FOR CALLING 26 PERSONS ON THREE LAMP SYSTEM.

Selection by means of key switches. This type of transmitter has a greater capacity than the dial type.

(*Gent & Co., Ltd.*)

goes to the nearest house telephone, or to his office.

An installation consists of the following equipment:

- i. A Transmitter or staff signal-board.



FIG. 111.—LAMP SIGNAL UNIT FOR SUSPENSION MOUNTING IN CORRIDORS.

(*Gent & Co., Ltd.*)

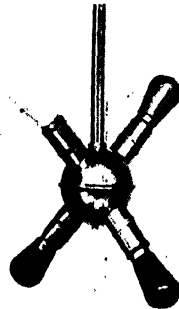

FIG. 112.—LAMP SIGNAL UNIT FOR SUSPENSION MOUNTING.

(*Gent & Co., Ltd.*)

2. A number of lamp signal units (visual), Figs. III-II3.
3. A number of sounders—bells, buzzers or horns (acoustic)—to draw attention to the visual units if desired.

The transmitter or staff signal-board is fixed near and is in the charge of the telephone operator, commissioner, or general clerk, who originates the signal calls.

Each lamp signal unit and each sounder is fixed in a prominent position in the various rooms, workshops, wards or yards. These are called "Stations." One sounder will often suffice for two stations and vice versa. Assuming that "Mr. Drummond" is wanted, the operator rotates the "Control" to the appropriate position on the dial of the staff signal-board, and lamps of a certain colour, or combination of colours, light up and give the visual signal at all "stations," while simultaneously electric sounders give an audible warning. The attention of the staff, engaged in various matters of business at different places, is attracted by the

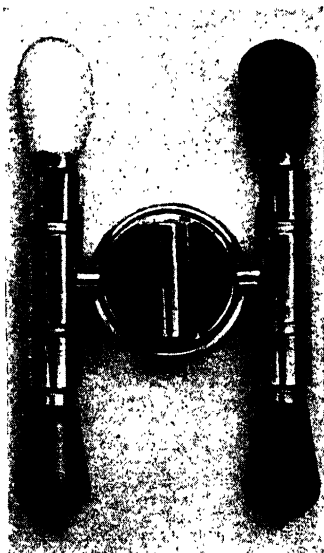

FIG. 113.—LAMP SIGNAL UNIT  
DESIGNED FOR WALL FIXING.

(Gent & Co., Ltd.)



## 150 HOUSE TELEPHONES, BELLS, SIGNALLING SYSTEMS

sounders, but on glancing at the nearest lamp signal none but "Mr. Drummond" is interested, and *he* immediately proceeds to the nearest departmental telephone or to his office.

A conference of all, or some of the members of the staff may also be summoned by a pre-arranged combination of lamps.

Standard colours of lamps are employed, viz., red, green, orange and white, as these in practice will be found to be the most satisfactory tints.

When once a call has been originated all lamps remain illuminated until the call is cancelled by the operator.

On the other hand, the sounders may be operated intermittently by over-pressing the "Control."

This intermittency conveys an urgency and is less annoying to those not interested in the call. This intermittent ringing is also available in an automatic form.

When planning an installation of this type the main considerations are:

1. The number of staff "on call." This number determines the size of the staff signal-board and also how many lamps are required to form the signal at each "Station."

2. The number of "stations" to be fitted with lamp units or sounders, or both.

With a 2-lamp system 3 different calls may be given, namely:

- |          |    |                |
|----------|----|----------------|
| Call No. | 1. | Red and white. |
|          | „  | 2. Red only.   |
|          | „  | 3. White only. |

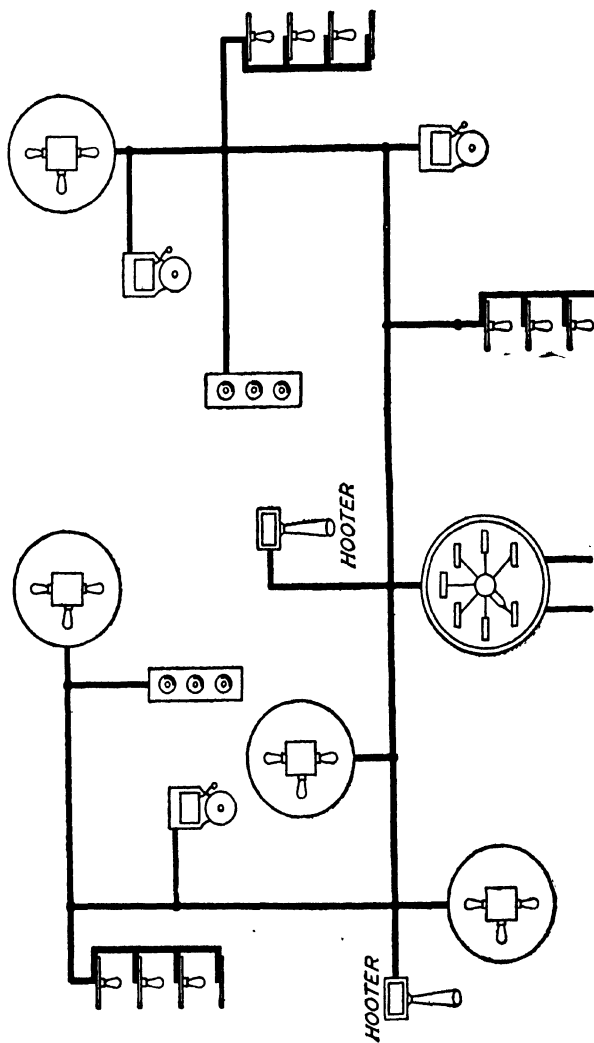

**A.C. OR D.C. MAINS:**

FIG. 114.—DIAGRAMMATIC OUTLINE OF A 7-SIGNAL STAFF LOCATOR, THE "TANGENT."  
 The system shown would enable seven persons to be called, or fourteen persons if the flicker device referred to in the text is used. The cable has five conductors, and is "teed" off as desired.  
 (Gent & Co., Ltd.)

## 152 HOUSE TELEPHONES, BELLS, SIGNALLING SYSTEMS

For connecting up in this combination, a band of 4 wires (or a 4-wire cable) for serving lamps and sounders is required to be run between all stations. (If sounders are not required then 3 wires suffice.) See Fig. 114.

With a 3-lamp system 7 different calls may be given. This necessitates a band of 5 conductors (or a 5-wire cable) serving lamps and sounders. (If sounders are not required then 4 wires suffice.)

Call No. 1.	Green.	Call No. 4.	Green and white.
„ 2.	Green and red.	„ 5.	Red.
„ 3.	Green, red and white.	„ 6.	Red and white.
		„ 7.	White.

With a 4-lamp system 15 different calls may be given. This necessitates a band of 6 conductors (or a 6-wire cable) serving lamps and sounders. (If sounders are not required then 5 wires suffice.)

Call No. 1.	Green.	Call No. 8.	Green, red and white.
„ 2.	Green and red.	„ 9.	Red and orange.
„ 3.	Green, red and orange.	„ 10.	Red, orange and white.
„ 4.	Green, red, orange and white.	„ 11.	Red and white.
„ 5.	Green and orange.	„ 12.	Red.
„ 6.	Green, orange and white.	„ 13.	Orange.
„ 7.	Green and white.	„ 14.	Orange and white.
		„ 15.	White.

To double the number of calls in any of the systems shown above, an arrangement is available in the "flicker system." This is accomplished by having a flicker signal on lamps for the additional calls, thus 1 to 15 calls are available on a 4-lamp system, as above,

with an additional 15, which latter are identical in colour with the first 15, but the lamps flicker during the duration of the lamp signal: again, with a 2-lamp system,  $3 \times 2 = 6$  signals may be obtained: with the 3-lamp system, 14 calls become available, and with a 4-lamp system 30 calls become available. Where this arrangement is fitted, each space on the staff signal-board is lettered with two names, and where the second name is to be signalled, the operator in addition to pressing the key, switches the "Flicker Motor" into the lamp circuit.

The staff signal-board contains the necessary contacts to operate both visible signals and audible warning signals, and is insulated for mains voltage up to 250 A.C. or D.C. To operate the "Control" is rotated to the name required, and pressed. The appropriate contacts are closed thereby lighting the appropriate lamps.

The sounders are then operated by merely overpressing the "Control". This is usually done intermittently, thereby adding a personal feeling to the call. For example, a series of quick calls indicates "Call important" or "Hurry up." This intermittent sounding may be accomplished automatically instead of manually if so desired, so that the operator be free for other duties until the call is answered. This is accomplished by the aid of an "intermittent contact maker." The usual period of operation is 3 seconds sound, 7 seconds silence. This interval signal is preferable to a continuous sound which would tend to cause annoyance to those not interested in the call.

To cancel all signals after use, it is only necessary

to withdraw the "Control" and the instrument is ready for the next call.

The number of signals can be still further extended by combining steady and flashing lights in one signal; thus, with a four-lamp system, the number of persons that can be called is 80. Fig. 110 shows the type of transmitter used.

### **Standard Telephones & Cables, Ltd.**

The staff locating and emergency system developed by this firm, is an audible system, and in its complete form comprises microphone, control panel, amplifier and loud-speakers. Two types of microphones are available, and the numbers required and points where installed will vary according to the requirements of the factory or premises concerned.

The microphone is incorporated on a control panel which also includes "on-off" switches for the amplifier with indicator lamps to show when the equipment is ready for use. Separate keys can be provided to enable any loud-speaker or groups of speakers, to be switched out of circuit by the operator at the central position if it is not desired to relay an announcement through these points. A useful feature is to include constant impedance volume controls, so that the volume on individual speakers or groups can be controlled according to requirements.

This firm has available many different types of loud-speakers for this type of service, including a 3-ft. 6-inch horn and their Sea Sled horn which is shown in an illustration. This is constructed from light metal, has a coiled air column, and the speaker unit is located

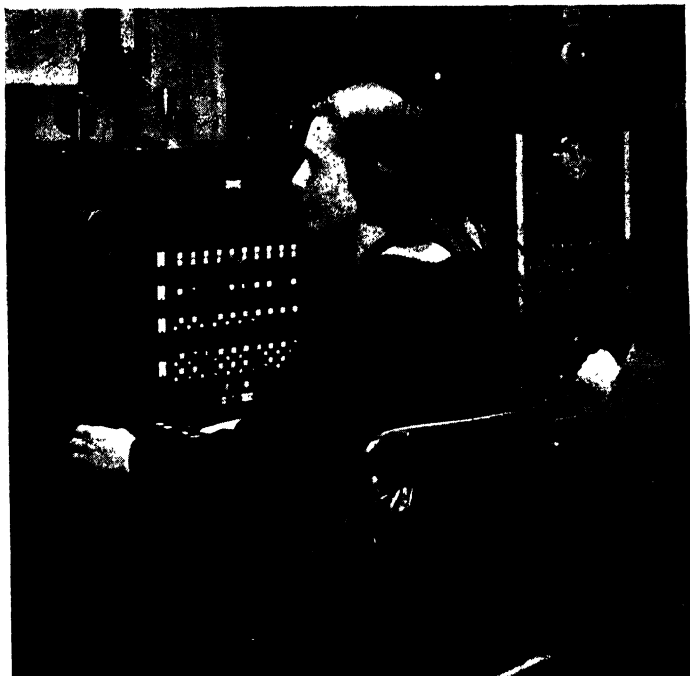

FIG. 115.—USING A MICROPHONE IN CONJUNCTION WITH A TELEPHONE SWITCHBOARD FOR STAFF LOCATION.

*(Standard Telephones & Cables, Ltd.)*

inside the horn itself. It is claimed that it is practically impossible for water to reach the unit, and that in fact the speaker will continue to function even if a fire hose is played on it.

As in the case of the equipment described earlier, the best position for the microphone and control panel is at the main telephone switchboard, where it is under the control of the chief operator. Additional microphone positions can of course be arranged if

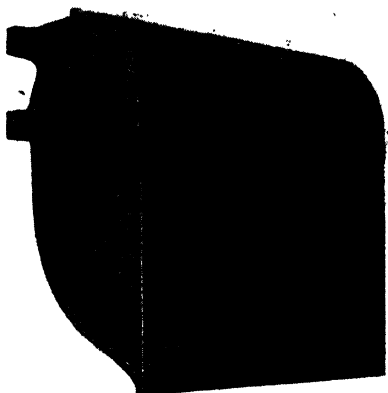

FIG. 116.—“SEA SLED”  
LOUD-SPEAKER FOR USE  
WITH STAFF LOCATION  
SYSTEM.

*(Standard Telephones & Cables,  
Ltd.)*

required. In the case of a large concern, for example, the works manager or governing director might require a microphone and control panel installed in his office. This will necessitate a simple visual indicator lamp mounted on each control panel, to show if the amplifier is in use from the other microphone position or positions.

### **Reliance Telephone Co., Ltd.**

There are a number of “Reliance” systems, the application of a particular scheme depending on the requirements of the actual site, but the one about to be described is most commonly used.

The system may be operated in two ways, manually, or automatically. In the first case, the setting up of a call is performed by a member of the staff allocated to the task, usually the telephone operator, for obvious reasons. In the second method, the call is originated via the private automatic telephone system where such exists.

In both cases, the method of calling is the same, i.e. a lamp signal, or a combination of lamp and sound signals, is used to locate the person. These signals are fitted in the most favourable positions throughout the site, being operated simultaneously. Where an office block is concerned, it is usual to instal a lamp signal in conjunction with a buzzer or small bell, since a loud-sounding device is unnecessary, and is very often a source of irritation to the staff. In the workshops, or manufacturing portion, particularly where noisy machinery is installed, a lamp in conjunction with a loud-sounding device is necessary; the latter taking the form of a hooter, or large-gong bell.

The "Reliance" system utilises either battery or mains energised signals, in the latter case, small contactors being fitted. The question of battery or mains operation is chiefly dependent on the number of signals to be fitted, and the area of the site. For

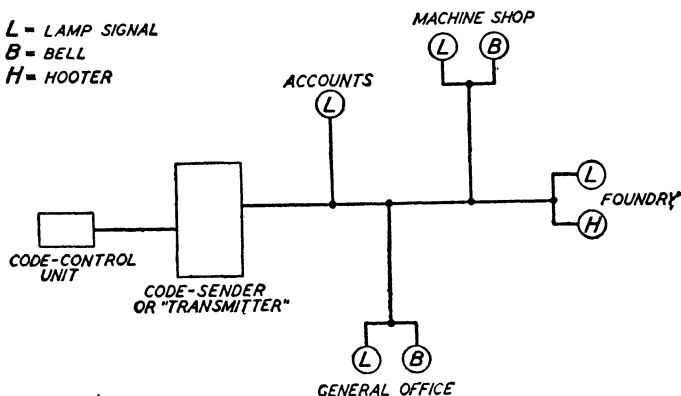

FIG. 117.—DIAGRAMMATIC LAYOUT OF MANUALLY CONTROLLED STAFF LOCATOR SYSTEM.

(Reliance Telephone Co., Ltd.)



example, where a moderate installation of, say, ten signal points is considered, and a suitable battery exists, (e.g. on a private telephone system) the battery operated type could advantageously be used. Where a large number of signals, covering a wide area are required, and the existing battery, if any, is of too small a capacity, a mains-operated system is indicated. The foregoing, however, are only examples and not to be taken too rigidly.

Considering, now, the manually operated system, this consists of the coder apparatus, which is responsible for transmitting the code signals to the lamps, etc., and a code control unit, as shown in Fig. 117. The control, or "setting up" of the codes, may be originated in two ways, (1) by operating a switch or "key," (2) by inserting a plug into a jack. In the first case, the switches are mounted in a small cabinet, suitably labelled, or where a private telephone system exists, they may be incorporated in one of the telephone instruments, the base being suitably modified. The second method utilises a strip of jacks, located in the coder cabinet, the insertion of the plug into the appropriate jack being sufficient to start the code-sending.

The operation of such a scheme is as follows: To each member of the organisation (usually a responsible official in each department) a code is allocated, consisting of a single, or combination of single short signals, repeated at intervals. Assuming "Mr. Brown" to be required, the telephone operator depresses the key on the control unit allocated to him, thus operating the code-sender of "transmitter." "Mr. Brown," on seeing his code repeated, proceeds to the nearest telephone, where the operator is immediately in com-

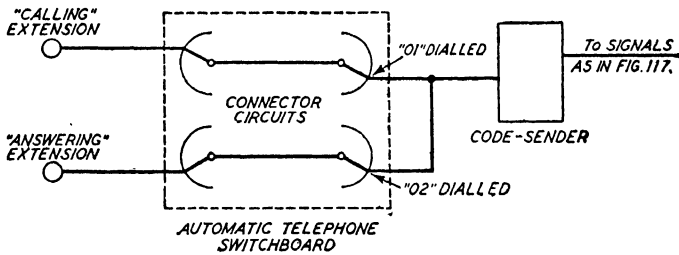

**NOTE**  
 "01" DIALLED TO ENGAGE  
 CODER.  
 "02" DIALLED TO STOP CODER  
 AND CONNECT WANTED  
 PERSON TO CALLER

FIG. 118.—DIAGRAMMATIC LAYOUT OF STAFF LOCATOR SYSTEM CONTROLLED VIA AUTOMATIC TELEPHONE SWITCHBOARD.

(Reliance Telephone Co., Ltd.)

munication with him, and consequently releases the key, thus stopping the code.

Referring now to the alternative method of code-calling, i.e. via the automatic telephone switchboard, it should be noted that with this method any extension on the switchboard may originate a code-call as compared with the centralised control of the manual system. Fig. 118 illustrates diagrammatically the layout, and the setting up of a call is as follows: The originator of the call engages the switchboard, in the usual way, and then dials a number allotted to the code-call apparatus; the connector on the switchboard automatically switches the caller through to the code-caller, and a further number is dialled into the latter. The number dialled will depend on the person whom it is desired to locate, the code-caller discriminating accordingly, and transmitting the corresponding code.

Assuming "Mr. Brown" to be called, he will on observing his code set up, proceed to the nearest telephone and dial a "common" number into the switchboard; this automatically switches him through to the person calling, at the same time disconnecting the code-caller.

The code-caller or "transmitter" is illustrated in Fig. 119 and consists of a cabinet in which are placed the relays controlling the code and those which govern the "timing" or intervals at which the signals are energised, in other words the discriminating and timing circuits respectively.

The strip of jacks and plug referred to under the description of the manually operated system will be observed on the left hand side of the cabinet.

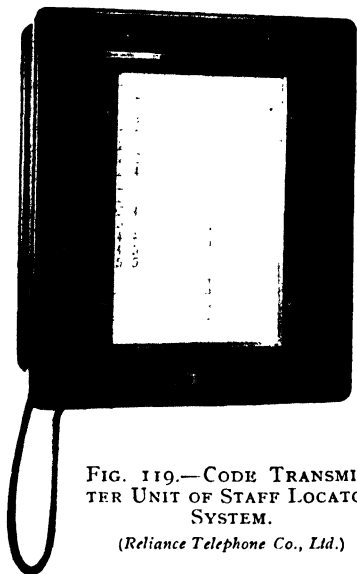

FIG. 119.—CODE TRANSMITTER UNIT OF STAFF LOCATOR SYSTEM.

(Reliance Telephone Co., Ltd.)

A test switch and lamp are provided at the top, and enable a local test of the various codes to be made without actually operating the signals. By throwing the key to the "test" position, and inserting the plug into the jacks, the coder is set in motion, the codes being reproduced on the test lamp. The exterior signals are disconnected by the operation of the "test" key. The "Reliance"

Staff-locator system may also be used as a fire-alarm, in the manner described, the most easily recognised signal being allocated for this purpose.

### **Siemens Brothers & Co., Ltd.**

The Siemens hand-controlled system enables an official to be found by giving audible or visible calling signals on bells, hooters, lamps, etc. These are placed in suitable positions to give out distinctive code calls which are heard or seen by the official concerned who then gets into touch with the operator controlling the signals. The signals are under the control of the telephone operator, attendant or other person, and remain in action until switched off at the controller.

The system comprises a central control cabinet, signal bells, buzzers, line wires, etc. and can be arranged for either battery or all mains working.

The system is usually arranged to give up to 15 different code calls but, if required, 25 codes can be provided. These codes consists of a definite series of signals on the call bells or lamps, typical codes begin:

Mr. A.	--	--	--	--	--	--	--
Mr. B.	---	---	---	---	---	---	---
Mr. C.	-	----	-	----	-	----	-

each hyphen representing the duration of the sound or signal given out to attract attention.

Each official who is on the staff call service is allotted one of these codes and, on hearing or seeing his signal, would go to the nearest telephone and call the operator controlling the signals to ascertain what is wanted. Relays are used for controlling the codes, these relays

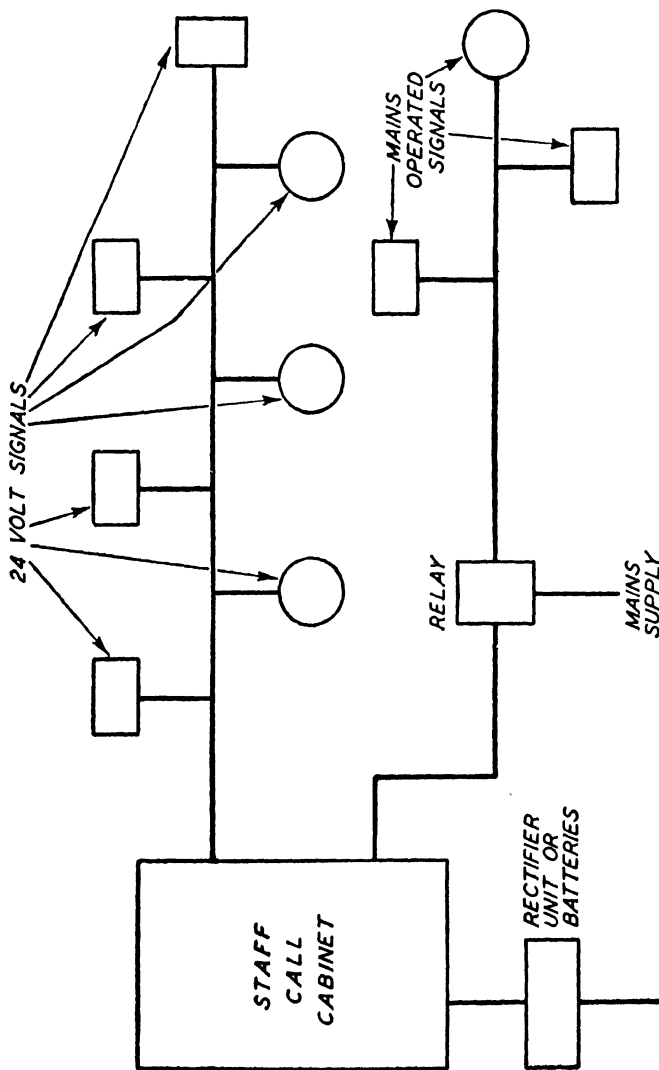

FIG. 120.—GENERAL LAYOUT OF HAND CONTROLLED STAFF CALL SYSTEM.  
(Siemens Bros. & Co., Ltd.)

being mounted in the central control cabinet which measures 16"  $\times$  18"  $\times$  10" and is intended for wall fixing.

In front of this control cabinet are a number of sockets marked with the name and code of each official on the system. By inserting a plug (which is attached to the cabinet) into any of the marked

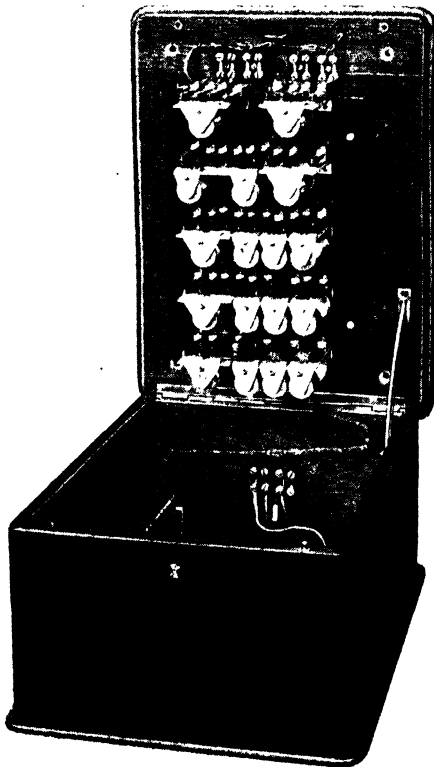

FIG. 121.—  
INTERIOR OF  
CENTRAL CON-  
TROL PANEL OF  
SIEMENS AUTO-  
MATIC STAFF CALL  
SERVICE.

(Siemens Bros. & Co.,  
Ltd.)

sockets the appropriate code is sent out repeatedly until the plug is withdrawn. A supervisory lamp signal on the controller enables the operator to check the signal which is being given. Additional sockets are provided for continuous non-interrupted and fast-interrupted signals, which are useful for special services such as "Fire," "Time," etc.

Provision is also made for testing the controller by means of a test switch and signal lamp which are fitted on the front of the cabinet. By moving the handle of the switch to the "Test" position and inserting the plug into a socket the corresponding code is flashed on the "Test" lamp, but the code bells and signals do not operate. The correct operation of the control apparatus can thus be checked without disturbing the normal routine.

The power required for the system is 24 volts D.C., or, if the mains supply is A.C. of normal voltage and frequency, the system can be operated from these mains by employing a Siemens "Transrecter." The cables from the power supply to the control cabinet should not have smaller than 31.036 conductors.

The external wiring for connecting the bells, etc., to the controller is of the simplest, consisting only of a pair of wires of suitable size, across which the bells, etc., are connected in parallel. Care should be observed regarding the size of cable used for wiring these external circuits so as to avoid voltage drop where the runs are of abnormal length.

The intensity of the audible and visible signals sent by the controller can be arranged to meet local conditions. This is very useful in places such as hospitals, as it enables very moderately toned audible signals

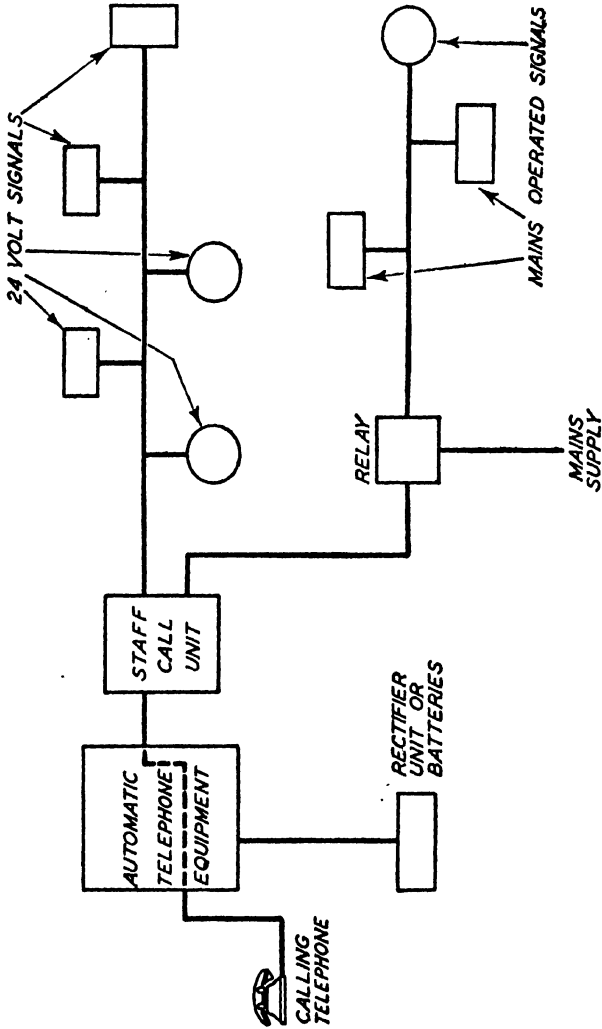

FIG. 122.—GENERAL LAYOUT OF AUTOMATIC STAFF CALL SYSTEM SHOWING CALLING TELEPHONE OPERATING SIGNALS.  
(Siemens Bros. & Co., Ltd.)



to be employed and thus avoids disturbing the patients.

For normal conditions, bells having gongs of from 4" to 6" diameter or a medium size buzzer are suitable. If the signals are required in noisy positions, a mains operated siren, bell or lamp would be necessary and would require a local relay for control purposes.

The various bells, etc., are controlled by the contacts of a master relay which is contained in the cabinet. There are four of these contacts (each capable of carrying a maximum current of 3 amps.) which enable the external bell circuits to be arranged in separate groups if required. Alternatively one contact can be used for bells, another for buzzers or relays and another for transmitting tone signals to places where the code call must be audible but not loud enough to cause disturbance to patients. In such places small telephone receivers, suitably mounted, are fitted and these receivers reproduce the tone signals in accordance with the code sent out.

### **Automatic Staff Call System.**

Another arrangement now largely used is the Automatic staff call system. This system which works in conjunction with an automatic telephone exchange is controlled entirely by the exchange and is not manually operated in any way.

When an official is required the caller dials from his telephone the code call number, followed by the particular number of the wanted official. Thus the caller has dialled an additional number to those normally used in making calls on the automatic telephone system.

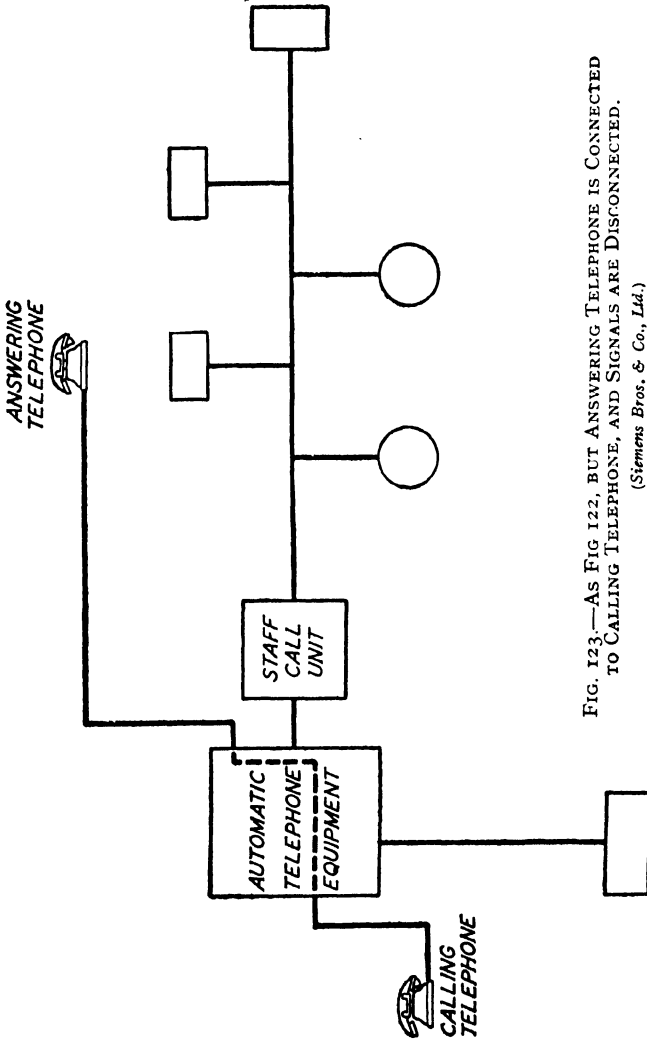

FIG. 123.—AS FIG 122, BUT ANSWERING TELEPHONE IS CONNECTED TO CALLING TELEPHONE, AND SIGNALS ARE DISCONNECTED.

(Siemens Bros. & Co., Ltd.)

This feature is a safeguard as it obviates false calls bringing the code call system into operation.

When the code number is dialled followed by the wanted executive's code the staff call unit proceeds to send out the code on the visual and audible signals. The wanted executive upon noting he is required, goes to the nearest automatic telephone connected to the system and dials the code answering number. This operation connects the answering to the calling telephone and at the same time disconnects the code call unit. See Figs. 122 and 123.

The circuit of the code call unit is so designed that it cannot be disconnected except at the end of a complete cycle of operation, which prevents the code signal being mutilated.

A special number can be allocated for "Fire" and this, in addition to setting up a special signal throughout the offices and factory, will operate a central fire alarm and ring the telephone in the firemen's quarters. Directly the fireman lifts his telephone to answer he is connected to the caller to receive instructions.

### **Staff Location by Voice Paging.**

In large organisations, usually where a P.A.X. system is installed, the installation of a broadcasting system with loud-speakers and microphone, for staff location by voice paging has distinct advantages over a coding system.

Fig. 124 illustrates in a simple way the operation of a sound system for broadcasting voice sound waves from a microphone.

(1) The voice sound waves impinge upon the diaphragm of the microphone, a device which produces

electric or voltage waves which vary in accordance with the sound waves impressed upon it. But the electric waves generated by the microphone are very minute and quite inadequate to drive a loudspeaker which is necessary for broadcasting sound over a considerable area within any premises.

(2) Therefore the electric waves are passed through an amplifier which electronically increases them to a point where they will operate the loud-speaker.

(3) The amplified voltage waves then reach the loud-speaker(s) where they are reconverted into sound waves.

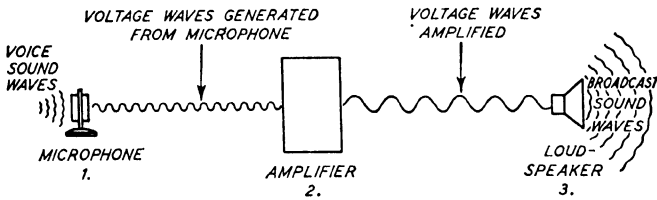

FIG. 124.—OPERATION OF SOUND SYSTEM FOR VOICE STAFF LOCATION

Between normal short distance internal telephones, amplification is not necessary because the minute electric waves will operate the speaker mechanism at an adequate volume for direct reception by the listener within his office. Here then is the essential difference between point to point telephoning and the broadcasting of amplified sound waves.

It should be noted that: (a) for comfortable reception of the broadcast message under commercial and industrial conditions, there must be properly located throughout the premises to be covered, a sufficient number of loud-speakers of suitable types and power to

deal with the acoustic and noise conditions prevailing; and (b) as the amplified electric waves have to drive all the speakers in the installed sound system, the amplifier must be of sufficient power to ensure this.

By microphone voice paging, any member of the organization may be paged by name without any confusion in interpretation. There is therefore perfect freedom of action when any desired person has to be located. All that is necessary is to speak into the microphone a request of which the following is typical: "*Calling Mr. Roberts. . . . Will Mr. Roberts please ring the works manager.*"

The verbal message from the microphone indicates to the called person the degree of urgency and therefore the speed with which he should take action. Here are two microphone messages to illustrate this:

*"Calling Mr. Simpson. . . . Will Mr. Simpson please telephone his office at his convenience."*

Mr. Simpson, busily engaged at some point within the premises, hears the message and carries on until it is convenient for him to break away to telephone.

*"Calling Mr. Jenkins. . . . Trunk call for Mr. Jenkins!"*

Obviously this is urgent and Mr. Jenkins takes speedy action at the nearest Post Office telephone, without preliminary recourse to the P.A.X. telephone.

A good illustration of the flexibility of microphone paging occurs when, as quite often happens, a visitor is on the premises and his office wishes to contact him by telephone with an urgent message. Obviously he cannot have a code, but the microphone message would soon locate him.

Some managing directors object to being paged by

RADIO UNIT  
AND  
CONTROLS

GRAMOPHONE  
UNIT

AMPLIFIER  
INCLUDING  
SIGNAL GENERATOR,  
COVER LOCK AND  
MAINS SWITCHES

POWER UNIT

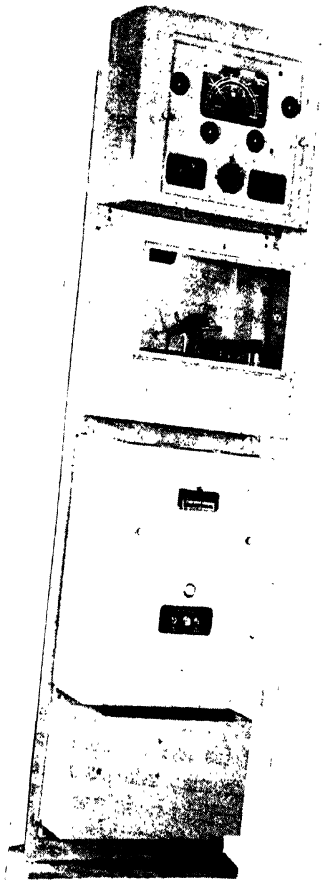

FIG. 125.—EQUIPMENT FOR STAFF LOCATION VOICE-PAGING  
AND BROADCASTING.  
(Telephone Rentals Ltd.)

name, and some do not like the idea of certain information being broadcast in the microphone messages. In these cases, a message can be broadcast like this:

*"Calling Mr. Robinson. . . . Will Mr. Robinson please ring the operator."*

Or merely,

*"Calling number 26. . . . Calling number 26."*

This being the number by which the managing director understands that he is being called by the operator. Upon telephoning her, she can then give him the message just as privately as by coding signal.

### **Operation of Voice Paging System.**

In cases where only one microphone is installed, it is usually located for operation by the P.O. switchboard operator. All staff location calls are then dealt with by her. This has the advantage that her skill in speaking over the telephone, enables her to broadcast messages from the microphone clearly and distinctly. Besides which, she very often needs the microphone when locating a "wanted" person in connection with an incoming Post Office call.

Additional microphones can be installed at other points for use by special executives, and if need be, one microphone may have priority over the remainder so that its use for emergency situations, as in the case of fire, may take precedence over any other microphone that might be in use at the time.

Each microphone is normally fitted with a pilot lamp and a switch. The latter is depressed before use. This turns on the pilot lamp in all microphones, to show that one microphone is in use.

After use, the pilot light warns the operator to switch

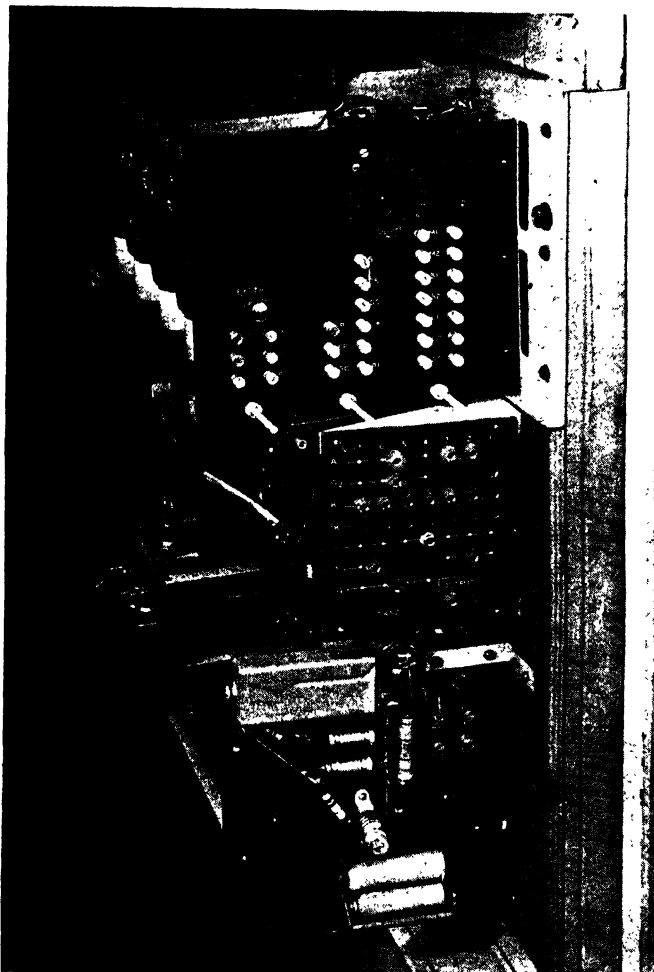

FIG. 126.—AMPLIFIER OF BROADCAST EQUIPMENT  
SHOWN IN FIG. 125.  
(*Telephone Rentals, Ltd.*)



off, otherwise conversation within the room will be broadcast through the loud-speakers.

### **Voice Paging with P.A.X. Instruments.**

Where only staff location by voice paging is required, the most recent development is to make use of the microphone transmitter on the P.A.X. Master, or the transmitter in the handsets of the ordinary P.A.X. instruments as the microphone.

The amplifier and loud-speakers are installed in the normal way, but instead of depressing a switch on a separate microphone, a given number—usually 7, is dialled on the P.A.X. instrument.

This done, the instrument transmitter is connected via the automatic switchboard to the amplifier. It is then only necessary to put the message through the telephone instrument for it to be broadcast through all the loud-speakers.

In practice, all that is necessary is to say, if the caller's number is 15:

*"Calling Mr. Davies. Will Mr. Davies please ring number 15."*

The caller can then replace his handset at once and so free the switchboard for any other staff calls.

This is simplicity itself for staff location voice paging with a P.A.X. installation. Every instrument is a potential microphone for this purpose, and since the majority of staff location calls will be originated by the callers themselves for the sake of speed, there is a corresponding reduction in the consumption of the telephone operator's time for this purpose.

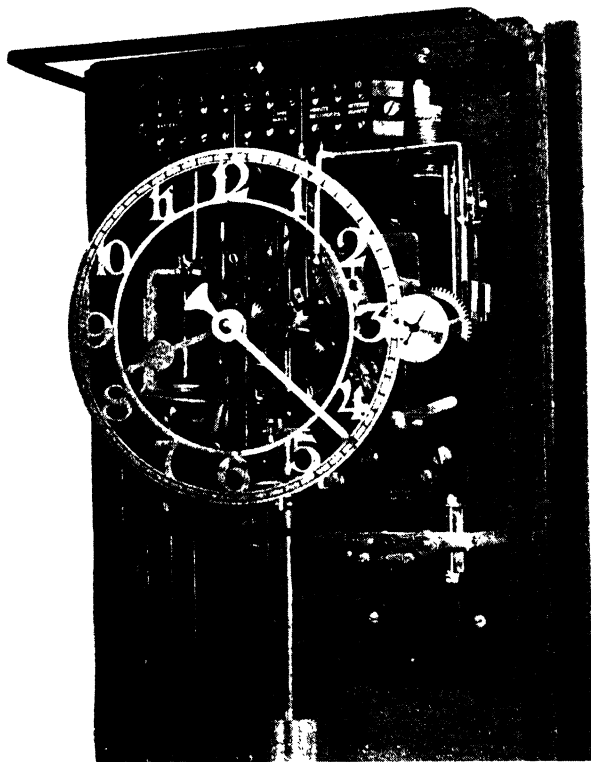

FIG. 127.—MASTER CLOCK MECHANISM WITH MAINS-CONTROLLED PENDULUM.

For automatic timing of warning signals sent out on loud speaker system.

*(Telephone Rentals, Ltd.)*

### **Further uses of a Sound Installation.**

Whilst it is found profitable to instal a sound system throughout a given premises solely for staff location voice paging, the same system can be used for broadcasting from:

(1) *An additional Microphone*, for making special announcements to employees; or maintaining voice contact with employees when a state of emergency arises, such as a fire, for

- (i) issuing instructions for speedy access to safety,
- (ii) relieving the apprehension of employees, and
- (iii) preventing disorganisation.

(2) *A Radio-gram*. Music programmes from the B.B.C., or specially selected gramophone records, will provide music for workers as a relief for fatigue and boredom. The recent war period accelerated the introduction of this broadcasting feature into thousands of factories with great advantage in the majority—particularly where careful consideration was given to the choice of the right types of tunes and the preparation of music programmes for a maximum of one hour's duration during any work session.

(3) *A Signal Generator*. Special warning signals for starting and stopping work time and possibly fire alarm can be put through the loud-speaker system. The former can be controlled automatically from a master clock mechanism thus ensuring accurate timing. (See Fig. 127.)

Such warning signals are generated as electric waves which are then amplified and reproduced by the loud-speakers as tones with such distinct variations as to be readily understood by employees.

## INDEX

- Adjustment of Telephone Relays, 111
- Alarm Circuits, 80
- Alarm and Indicator Systems, 89
- Amplifier for Loud-speaker, 142, 169, 171, 173
- Ardente Acoustic Laboratories, Ltd., 51
- Automatic Exchange, Private:
  - Adjustment of, 111
  - Automatic Dialling, 139, 142
  - Fault Location, 52, 109
  - Installation, 47
  - Line Circuits, 49
  - Loud Speaking Facilities, 138
  - “Loud-to-Loud” Speaking, 139, 142
  - Maintenance, 107
  - Operation of, 49
  - Power Supply, 47
  - Power Troubles, 113
  - Priority Facilities, 143
  - Relays, 112
  - Sizes of, 44
  - Telematic Paxmaster, 140
  - Ten-line, 46
  - Tie-line Service, 144
- Battery Call Telephones, 3, 8, 42
- Battery Ringing, 38
- Battery Testing, Telephone, 106
- Bell Circuits, 55, 63, 72
- Bell Faults, Telephone, 105
- Bell Installations, Testing, 76
- Bells, 3, 54
- Bells and Pushes, 55
- Bell Telephone Receiver, 101
- Bell Transformer, 57
- Blowing Test, 106, 117
- Burglar Alarms, 74, 93, 95
- Buzzers, 3
- Central Battery Telephone Exchange:
  - Advantages, 126
  - Cord Circuit, 127
  - Lamp Signalling for, 129
  - Line Circuit, 120
  - Telephone Circuit, 126
  - Testing of, 130
- Call and Reply Switchboard, 24, 30
- Circuit Diagrams, Bell, 55, 63, 72
- Circuit Diagrams, Indicators, 68, 69, 76
- Circuit Diagrams, Telephones, 5, 7, 15, 17, 33, 37, 135
- Closed Circuit System, 93
- Condenser:
  - Electrolytic, 113
  - in Telephone Line Circuit, 126
- Cord Circuit, Central Battery Switchboard, 127
- Cord, Telephone Switchboard, 117
- Cordless Switchboard, 123
- Delay Relay Indicators, 70
- Dialling, Automatic, 139
- Doctor's Night Telephones, 22
- Double-cord Switchboard, 120
- Double-ended Cord Switchboard, 119
- Drop Indicators, Telephone Switchboard, 116, 121, 122
- “Duocall,” 50
- Electrical Replacement Indicator, 58, 63, 65
- “Engaged” Indicator, 92
- Ericsson Telephones, Ltd., 18, 36, 37, 38, 39
- Exchange, Manual:
  - Magneto, 115
  - Central Battery, 125
- Exchange, Private Automatic:
  - Adjustment of, 111
  - Automatic Dialling, 139, 142
  - Fault Location, 52, 109
  - Installation, 47
  - Line Circuits, 49
  - Loud-Speaking Facilities, 138
  - “Loud-to-loud” Speaking, 139, 142
  - Maintenance, 107
  - Operation of, 49
  - Power Supply, 47
  - Power Troubles, 113
  - Priority Facilities, 143

- Exchange, Private, Automatic—  
*contd.*
- Relays, 112
  - Sizes of, 44
  - Telematic Paxmaster, 140
  - Ten-line, 46
  - Tie-line service, 144
- Factories and Offices, Tele-  
 phones for, 42
- Faults, Telephone, 104, 109, 117,  
 130
- Feeding Bridge, Telephone, 19, 20
- Fire Alarm System, 75
- Flats, Telephones for, 24, 30
- Galvanometer Test for Tele-  
 phones, 105, 117
- General Electric Co., Ltd., 25,  
 26, 41, 45, 46, 48, 57, 82, 83,  
 84, 85, 86, 87, 88, 89, 93
- Generator, Hand, 12, 101
- Gent & Co., Ltd., 67, 69, 70, 147,  
 148, 149, 151
- Hospital Call System, 89
- Hotel Call System, 88
- Indicator Circuits, 68, 69, 76
- Indicator, Electrical Replace-  
 ment, 58
- Indicator, Mechanical Replace-  
 ment, 59, 60
- Indicator, Pendulum, 57
- Indicators for Bells, 61
- Indicators, Telephone Switch-  
 board:
- Drop, 116, 121, 122
  - Lamp, 129
  - Self restoring, 127
- Induction Coil, Use of, 9
- Installation, Telephone, 47
- Intercommunication Loud  
 Speaking Telephone Systems,  
 56, 131
- Intercommunication Telephones,  
 13, 35, 43, 132
- Jack, Telephone, 27, 116
- Joining and Wiring, 21
- Key Switches, Telephone Switch-  
 board, 121, 122
- Lag Relay, 71
- Lamp Indicators, Switchboard,  
 129
- Lamp Signals, 148
- Leclanché Cell, 59, 107
- Line Circuit, C.B. Telephone, 126
- Line Faults, Telephone, 105
- Local Battery System, 3
- Locating Telephone Faults, 52
- Londex, Ltd., 74
- Loud-speaker, Amplifier for, 142,  
 169, 171, 173
- Loudspeaking Telephone Sys-  
 tems:
- Intercommunication, 50, 131
  - P.A.N., 138
- “Loud-to-Loud” Telephony, 139
- Luminous System for Hotel  
 Signals, 65, 81, 83, 86, 87
- Magneto Telephone, 12, 42, 102,  
 122
- Magneto Telephone Circuit, 102,  
 122
- Magneto Telephone Exchange:
- Single-cord Switchboard, 119
  - Double-ended Cord Switch-  
 board, 119
  - Double-cord Switchboard, 120
  - Cordless, 122
  - Testing, 117
- Maintenance, Telephone:
- Automatic, 52, 107
  - Central Battery Switchboard,  
 130
  - Magneto, 104
  - Magneto Switchboards, 117
  - Receiver, 100, 104
  - Transmitter, 99, 100, 105
- Manual Telephone Exchange:
- Central battery, 125
  - Magneto, 115-125
  - Maintenance of, 117, 130
- Mechanical Replacement Indi-  
 cator, 59, 60, 64
- Mercury Tube Relay, 74
- Neophone, 22, 23

- Office Indicators, 91, 92
- Pendulum Indicator, 57
- Phœnix Telephones and Electric Works, Ltd., 4, 5, 6, 14, 15, 21
- Plug Cords, Telephone, 28, 117
- Plug, Telephone Switchboard, 116.
- Power Supply for Bells, 59
- Power Supply for Indicator Systems, 78
- Power Supply for Telephones, 30, 47
- Power Troubles, Telephone, 113
- Priority facility, 143
- Private Automatic Exchange:
- Adjustment, 111
  - Automatic Dialling, 139, 142
  - Fault Location, 52, 109
  - Installation, 47
  - Line Circuits, 49
  - Loud Speaking Facilities, 138
  - "Loud-to-loud" Speaking, 139, 142
  - Maintenance, 107
  - Operation of, 49
  - Power Supply, 47
  - Power Troubles, 113
  - Priority Facilities, 143
  - Relays, 112
  - Sizes of, 44
  - Telematic Paxmaster, 140
  - Ten-line, 46
  - Tie-line Service, 144
- Private Manual Exchanges, 115
- Push-button Telephone, 44
- Radiovisor Parent Ltd., 97
- Receiver, Telephone:
- Connection, 2
  - Maintenance, 100, 104
  - Operation, 2, 100
- Rectifier, 48, 114
- Relay Circuit, 72, 93
- Relay Installation, 73
- Relays, 54, 79
- Relays for Bells, 71
- Relays, Telephone, 48, 112
- Reliance Telephone Co., Ltd., 132, 134, 135, 156, 157, 159, 160
- Reply Panel, Telephone, 25
- Sax, Julius, & Co., 63, 66, 95
- Sax Call System, 66
- Selectacall, 51
- Self-restoring Indicators, Telephone Switchboard, 127
- Short Circuit, Telephone Line, 105
- Sidetone, Reduction of, 10
- Siemens Bros. & Co., Ltd., 17, 22, 42, 43, 161, 162, 163, 105
- Signalling Circuits, 87
- Signalling Indicators, Telephone Switchboard:
- Drop, 116, 121, 122
  - Lamp, 129
  - Self-restoring, 127
- Silent Call System, 81
- Single Call System, 88, 89
- Single-cord Switchboard, 119
- Solid Back Transmitter, 9, 99
- Staff Locating Systems, 146
- Standard Telephones & Cables, Ltd., 7, 31, 32, 33, 34, 39, 40, 154, 155, 156
- Supervision or Control Indicators, 68, 69
- Switchboards, Telephone:
- Call and Reply, 24, 30
  - Central Battery, 126
  - Cordless, 123
  - Double-ended Cord, 119
  - Double-cord, 120
  - Magneto, 115
  - Single Cord, 118
- Switches, Key, Telephone Switchboard, 121, 122
- Tandem Indicators, 65, 67
- "Tangent" Staff Location, 146
- Telephone Bell Faults, 105
- Telephone Circuits:
- Battery Call, 11
  - Call and Reply Switchboard, 29
  - Central battery, 126
  - Central battery Switchboard, 128
  - Intercom., 15, 17, 19, 135
  - Loud-speaking, 137

- Telephone Circuits—*contd.*  
 —Magneto, 103, 122  
 —Magneto Exchange, 118, 120, 123  
 Telephone Faults:  
 —Automatic, 107  
 —Bell, 105  
 —Line, 105, 117  
 —Local Battery, 106  
 —Reception, 104  
 —Transmission, 105  
 Telephone, Feeding Bridge, 19, 20.  
 Telephone, Intercommunication, 13, 35, 43, 132  
 Telephone Line Faults, 105  
 Telephone Mains Unit, 46  
 Telephone Maintenance, 52, 98, 117, 130  
 Telephone Receivers, 2, 100  
 Telephone Relays, 111, 112  
 Telephone Rentals, Ltd., 140, 141, 142, 171, 173, 175  
 Telephone Speech Channel, 49  
 Telephone Switchboard (*see Switchboards*)  
 Telephone Transmission Faults, 105  
 Telephones for Flats, 30  
 Telephones over Bell Circuits, 4  
 Telephones, Loud-speaking, 50, 131-142  
 Telephones, Tradesmen's, 38  
 "Tell-Tale," Indicator, 71  
 Testing of:  
 —C.B. Systems, 130  
 —Local Battery, 106  
 —Magneto Systems, 117  
 —Primary Battery, 77, 106  
 Tie Line Service, 144  
 Tradesmen's Telephones, 38, 39, 41  
 Transformer, Bell, 60  
 Transmission Faults, Telephone, 105  
 Transmitters, Telephone:  
 —Construction, 1, 99  
 —Maintenance, 99, 100, 105  
 —Operation, 1, 98.  
 Wire for Bells, 56  
 Wiring and Jointing, 21



# CABLES & FLEXIBLES

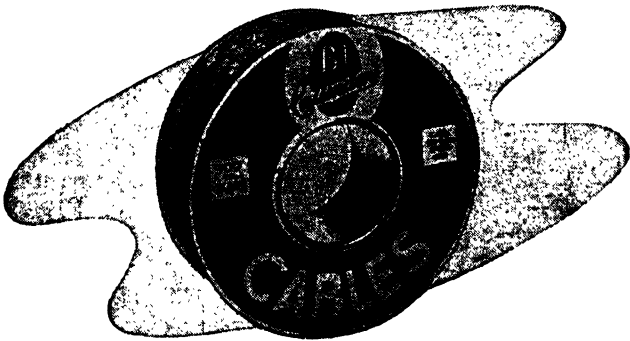

are manufactured to the highest possible standards in a very wide range for *every electrical purpose*, backed by years of practical experience and scientific research . . . the cables with a world-wide reputation for long life and satisfactory service.

**BRITISH INSULATED CALLENDER'S CABLES Ltd.**  
NORFOLK HOUSE, NORFOLK STREET, LONDON, W.C.2



# AMBITIOUS ENGINEERS

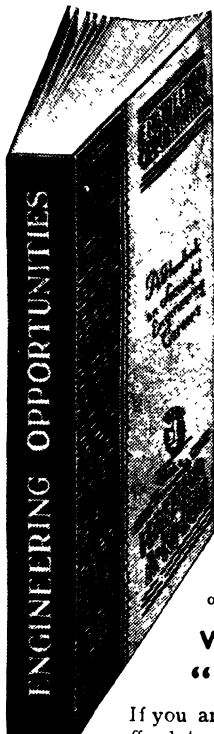

## HAVE YOU HAD YOUR COPY OF "ENGINEERING OPPORTUNITIES" ?

Whatever your age or experience—whether you are one of the "old school," or a newcomer to Electrical Engineering anxious to hold your position in the more difficult days of peace—you must read this highly informative guide to the best paid Electrical Engineering posts.

The book shows, among other intensely interesting matter, the easiest way of passing **A.M.I.E.E., B.Sc., A.M.Brit.I.R.E., CITY and GUILDS, G.P.O.**, and every other important technical Examination, whilst details are given of over 200 Courses in all branches of Engineering. The Electrical Group of Courses includes—

<b>Alternating Current.</b>	<b>Power House Design.</b>
<b>Mains Engineering.</b>	<b>Telephony.</b>
<b>Electrical Design.</b>	<b>Television.</b>
<b>General Electrical Engineering.</b>	<b>Electricity Supply.</b>
<b>Neon Lighting.</b>	<b>Electrical Installations.</b>
<b>Electric Traction.</b>	<b>Telegraphy.</b>
<b>Measuring Instruments.</b>	<b>Wireless.</b>
<b>Automobile Electricity.</b>	<b>Sound-film Projection</b>
<b>Electrical Technology.</b>	<b>Radio Servicing, etc., etc.</b>

The Handbook also explains the unique advantages of our Employment Department.

## WE DEFINITELY GUARANTEE "NO PASS—NO FEE"

If you are earning less than £10 a week you cannot afford to miss reading "**ENGINEERING OPPORTUNITIES**"; it tells you everything you want to know to *secure your future in Electrical Engineering*, and describes many chances you are now missing. In your own interest we advise you to write for your copy of this enlightening guide to well-paid posts NOW—**FREE** and without obligation.

## BRITISH INSTITUTE OF ENGINEERING TECHNOLOGY

135, SHAKESPEARE HOUSE, 17, 18 and 19 STRATFORD PLACE  
LONDON, W. 1

THE B.I.E.T. IS THE LEADING INSTITUTE OF ITS KIND IN THE WORLD

# NOTE-WORTHY!

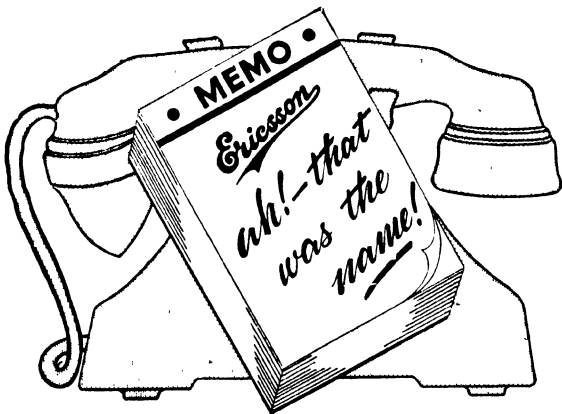

## ERICSSON TELEPHONES LTD.

22, LINCOLN'S INN FIELDS  
LONDON, W.C.2

TEL. HOL. 6936

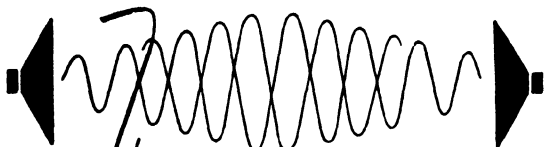

*There's no* **"COME BACK"**

With a TR Telematic Installation, there is no "come back"—either technical or figurative. Thanks to many years persistent research, loud-speaker to loudspeaker "howl" has been eliminated. Conversation between the users of PAX master loudspeaker instruments is crystal clear and free from microphonic interference.

All equipment conforms to the strictest engineering standards and all the latest facilities are available.

DIRECT CONTACT  
LOUD SPEECH  
STAFF LOCATION  
CODING OR VOICE PAGING  
CONFERENCE  
PRIORITY  
SECRETARIAL SERVICE  
TIE LINES, etc.



*Demonstrations of latest telephonic equipment will  
be arranged for any interested telephone or P. A.  
installation engineer on request.*

**TELEPHONE RENTALS LIMITED**

Dept. P.8, Kent House, Knightsbridge, London, S.W.7

*Kensington 9201-5*

Branches throughout the Country

**Also TR TIME CONTROL & FACTORY BROADCASTING**



## DATE OF ISSUE

This book must be returned within 3, 7, 14 days of its issue. A fine of ONE ANNA per day will be charged if the book is overdue.

--	--

