

# Birla Central Library

PILANI (Jaipur State)

( Engg College Branch )

Class No :- 690

Book No :- G 26 MA

Accession No :- 32876

Acc. No... ..

**ISSUE LABEL**

***Not later than the latest date stamped below.***

--	--	--

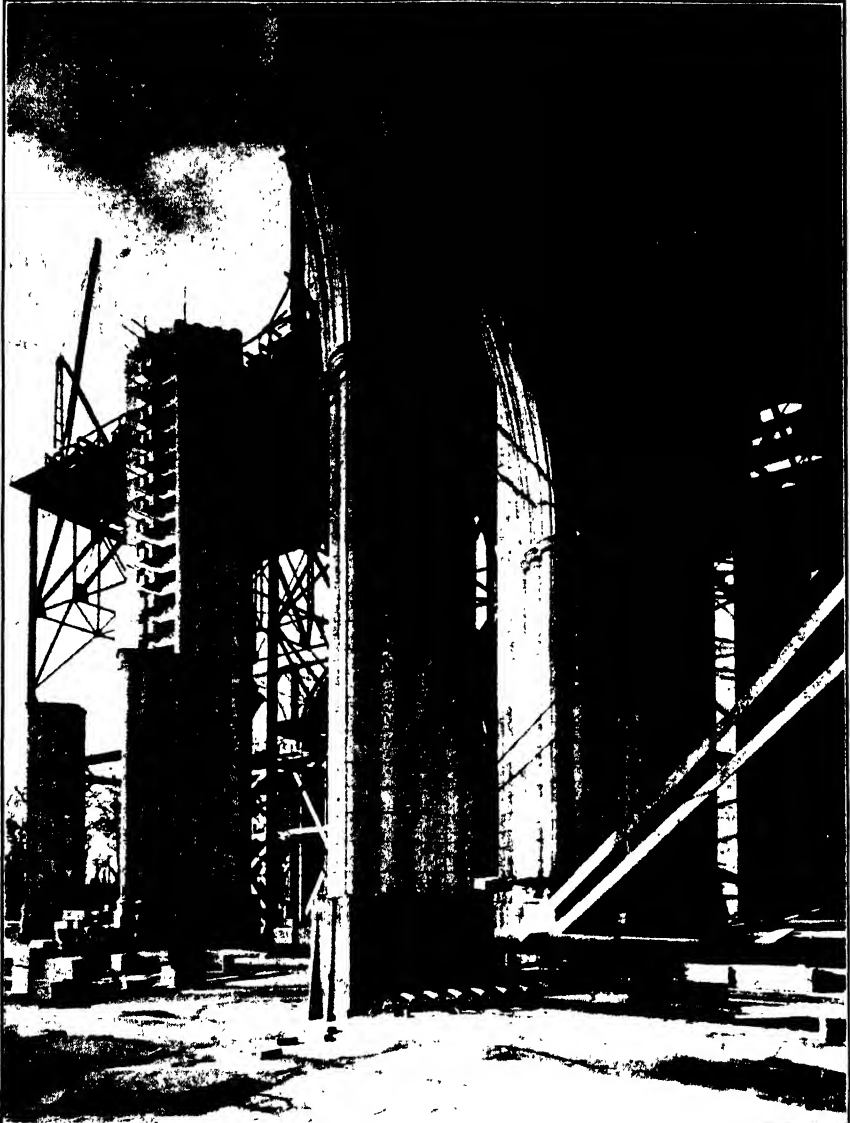

*Frohman, Robb and Little, Architects*

STONE VAULTING, WASHINGTON CATHEDRAL.

# Materials and Methods of Architectural Construction

BY

CHARLES MERRICK GAY, A.B., B.S.

*Associate Director, Franklin Institute*

*Formerly Professor of Architectural Construction  
University of Pennsylvania*

AND

HARRY PARKER, M.S.

*Professor of Architectural Construction  
University of Pennsylvania*

SECOND EDITION

*Sixth Printing*

NEW YORK  
JOHN WILEY & SONS, INC.  
LONDON: CHAPMAN & HALL, LIMITED

COPYRIGHT, 1932, 1943

CHARLES MERRICK GAY AND HARRY PARKER

*All Rights Reserved*

*This book or any part thereof must not  
be reproduced in any form without  
the written permission of the publisher.*

SECOND EDITION

*Sixth Printing, November, 1947*

Printed in the United States of America

## PREFACE

The intention in introducing this new edition is thoroughly to modernize the contents of the first edition published ten years ago so that the volume now offered may be of distinct present-day value.

To this end chapters on reinforced concrete and light and heavy wood framing are largely rewritten to correspond with the most recent recommendations and tables of the Joint Committee on Concrete and Reinforced Concrete and the National Lumber Manufacturers' Association. The tables of properties of structural steel shapes are revised in accordance with the dimensions and weights now produced by the rolling mills, and the allowable stresses in riveted connections agree with the latest practice. Discussions and data concerning other subjects modified to conform with present-day standards include cements, foundations, floor and roof construction, architectural terra cotta, welded joints, plastics, pressed wood, structural glass, metal timber connectors and building codes.

The original purpose of this book was to present in one volume condensed essential information on the materials and methods used in the construction of buildings. Excellent books are available for those who desire complete and detailed knowledge of a specific material. For students, however, such books are often too comprehensive and may, perhaps, be useless without a background of fundamentals. This book is not intended to take the place of the more complete treatises. It does, however, contain the necessary basic information concerning the commonly used materials and the methods of combining them and of computing their dimensions. Particular care has been devoted to the arrangement of the subject matter for textbook requirements. The needs in preparation for Civil Service and state board examinations have also been fully considered.

It is hoped that the book, in its new form, will continue to find favor as a textbook and as a source for ready reference.

CHARLES MERRICK GAY  
HARRY PARKER

PHILADELPHIA  
*June, 1943*



# CONTENTS

## PART I

### MATERIALS OF CONSTRUCTION

CHAPTER	PAGE
I. GENERAL CONSIDERATIONS	
INTRODUCTORY.....	3
II. LIME, GYPSUM AND CEMENT	
LIME.....	14
GYPSUM.....	17
CEMENT.....	20
III. CONCRETE	
COMPOSITION OF CONCRETE.....	27
PROPORTIONING CONCRETE.....	29
MIXING CONCRETE.....	33
TRANSPORTING CONCRETE.....	34
PLACING CONCRETE.....	35
FORMS.....	37
IV. WOOD	
CHARACTERISTICS OF WOOD.....	39
GRADING OF WOOD.....	42
CONVERSION OF WOOD.....	45
SELECTION AND STRENGTH OF WOOD.....	46
PRINCIPAL WOODS FOR BUILDING CONSTRUCTION.....	48
V. BRICK	
MANUFACTURE.....	51
BRICK MASONRY.....	56
VI. TERRA COTTA, GYPSUM AND CONCRETE BLOCKS AND CAST STONE	
STRUCTURAL TERRA COTTA.....	67
ARCHITECTURAL TERRA COTTA.....	74
GYPSUM TILE.....	75
CONCRETE BLOCKS.....	79
DOOR BUCKS.....	81
CAST STONE.....	82
VII. STONE	
COMPOSITION.....	84
CLASSIFICATION.....	86



CHAPTER	PAGE
QUARRYING AND DRESSING.....	90
STONE MASONRY.....	92
<b>VIII. IRON AND STEEL AND NON-FERROUS METALS</b>	
HISTORICAL.....	98
PIG IRON.....	98
CAST IRON.....	101
WROUGHT IRON.....	102
STEEL.....	104
OPEN-HEARTH PROCESS.....	105
BESSEMER PROCESS.....	107
STRUCTURAL STEEL.....	109
NON-FERROUS METALS.....	110
NON-FERROUS ALLOYS.....	111
<b>IX. FLOOR AND ROOF SYSTEMS AND FIREPROOFING OF STEEL</b>	
GENERAL CONSIDERATIONS.....	113
CONSTRUCTION ON THE GROUND.....	114
FLOOR CONSTRUCTION WITH WOOD BEAMS.....	117
FLOOR CONSTRUCTION WITH STEEL BEAMS.....	119
FLOOR CONSTRUCTION WITH CONCRETE BEAMS.....	128
ROOF SYSTEMS.....	130
FIREPROOFING STEEL.....	133
<b>X. FINISHED FLOORING</b>	
WOOD FLOORING.....	137
FLOOR AND WALL TILE AND PLASTICS.....	142
COMPOSITION FLOORING.....	147
CEMENT AND TERRAZZO FLOORS.....	147
CORK AND RUBBER FLOORING.....	150
<b>XI. ROOFING MATERIALS, ROOF DRAINAGE AND SKYLIGHTS</b>	
SHINGLES.....	152
SLATE.....	154
TILE.....	155
SHEET METAL AND GLASS.....	157
BUILT-UP ROOFING.....	160
SELECTION OF ROOFING MATERIAL.....	162
ROOF DRAINAGE.....	163
SKYLIGHTS.....	168
<b>XII. PLASTER, LATH, FURRING AND STUCCO</b>	
PLASTER.....	170
LATH.....	175
FURRING.....	179
STUCCO.....	182

# CONTENTS

ix

CHAPTER	PAGE
<b>XIII. DOORS AND WINDOWS</b>	
WOOD DOORS.....	185
WOOD WINDOWS.....	190
METAL DOORS AND WINDOWS.....	195
<b>XIV. EXTERIOR AND INTERIOR TRIM</b>	
EXTERIOR WOOD TRIM.....	205
EXTERIOR METAL TRIM.....	209
INTERIOR WOOD TRIM.....	211
INTERIOR METAL TRIM.....	221
<b>XV. PAINT, GLASS AND GLAZING</b>	
PAINT.....	223
GLASS.....	233
GLAZING.....	239

## PART II

### *METHODS OF CONSTRUCTION*

<b>XVI. MECHANICS OF MATERIALS</b>	
STATICS.....	245
UNIT STRESSES.....	251
MOMENTS AND REACTIONS.....	256
BENDING MOMENTS AND SHEAR.....	259
FLEXURE FORMULA, PROPERTIES OF SECTIONS.....	267
DESIGN, SAFE LOADS AND INVESTIGATION OF BEAMS.....	273
DEFLECTION OF BEAMS.....	275
OVERHANGING BEAM, INFLECTION POINT, NEGATIVE BENDING MOMENTS	276
COLUMNS.....	279
<b>XVII. BRICK AND STONE CONSTRUCTION</b>	
BRICK CONSTRUCTION.....	288
STONE CONSTRUCTION.....	296
<b>XVIII. HEAVY TIMBER CONSTRUCTION</b>	
FLOOR FRAMING.....	304
WOOD COLUMNS.....	322
SLOW-BURNING CONSTRUCTION.....	327
<b>XIX. LIGHT WOOD FRAMING</b>	
THE BRACED FRAME.....	333
THE BALLOON FRAME.....	357
ROOF CONSTRUCTION.....	360
<b>XX. STEEL CONSTRUCTION</b>	
STRUCTURAL SHAPES AND THEIR PROPERTIES.....	372
DESIGN OF SIMPLE AND CANTILEVER BEAMS.....	384

CHAPTER	PAGE
BEAM CONNECTIONS. RIVETING AND WELDING.....	397
PLATE AND BOX GIRDERS.....	407
COLUMNS.....	417
COLUMN CONNECTIONS.....	423
WIND BRACING.....	428
LIGHT STEEL FRAMING.....	434
<b>XXI. ROOF TRUSSES</b>	
DEFINITIONS.....	436
TYPES OF ROOF TRUSSES.....	437
ROOF LOADS.....	439
REACTIONS.....	441
STRESSES IN ROOF TRUSSES.....	449
DESIGN OF ROOF TRUSSES.....	456
<b>XXII. REINFORCED CONCRETE</b>	
GENERAL CONSIDERATIONS.....	466
REINFORCEMENT.....	468
BEAMS AND SLABS.....	473
CONCRETE FLOOR CONSTRUCTION.....	492
FLAT SLABS.....	504
COLUMNS.....	511
WALLS.....	516
ILLUSTRATIVE CASES.....	522
<b>XXIII. STAIRS</b>	
GENERAL DISCUSSION.....	537
WOOD STAIRS.....	544
STEEL STAIRS.....	546
REINFORCED CONCRETE STAIRS.....	548
ESCALATORS.....	552
<b>XXIV. FOUNDATIONS</b>	
GENERAL CONSIDERATIONS.....	554
CLASSES OF FOOTINGS.....	559
FOOTINGS FOR LIGHT BUILDINGS.....	560
FOOTINGS FOR HEAVY BUILDINGS.....	563
SPREAD FOOTINGS. ILLUSTRATIVE PROBLEMS.....	577
<b>XXV. PILING, SHORING AND UNDERPINNING</b>	
PILES AND PILING.....	591
SHORING, NEEDLING AND UNDERPINNING.....	601
<b>XXVI. EXCAVATION AND WATERPROOFING</b>	
EXCAVATION IN DRY GROUND.....	607
EXCAVATION IN WET GROUND.....	612
WATERPROOFING.....	616

PART I  
*MATERIALS OF CONSTRUCTION*



# MATERIALS AND METHODS OF ARCHITECTURAL CONSTRUCTION

## CHAPTER I

### GENERAL CONSIDERATIONS

**Introductory.** When our ancestors emerged from caves and natural refuge their first efforts at procuring man-made shelters were probably devoted to propping branches against trees and rocks and covering them with large leaves and palms. From these beginnings was developed the post and lintel system of construction, that is, the support by two uprights of a horizontal member which spans the distance between them, together with the employment of enclosing walls carrying the beams of the roof.

For unknown centuries the post and lintel constituted the only generally employed method of stone construction; according to this method were produced the marvelous monuments of Egypt and Persia, with final culmination of beauty, refinement and frank expression in Greece.

Since spans were covered by stone lintels the width of the span was necessarily limited by the procurable lengths of the stone. The great halls of Egyptian temples and palaces could be constructed only by the introduction of a multitude of columns to support the lintels and beams of the roof. With restraint and absolute logic the Greeks, however, proportioned their requirements to the rational limits of their materials and to human scale. They sought the perfection of their constructional system and its expression rather than the importation of more expansive devices.

In Mesopotamia the presence of excellent alluvial clay and the scarcity of stone and timber led in very early days to the initiation of brick construction and the development of the vault and dome as a means of covering spans and areas. In Persia, great vaulted buildings were erected at Susa, Ctesiphon and Sarvistan, the remains of which are now being uncovered.

Although the Greeks felt no need of arches and domes, the Romans with their imperialism, their materialism and their efficiency adopted with eagerness these means of roofing large areas without the necessity

of columns and lintels. During their empire round arches, vaults and domes were perfected as never before, in stone, brick and concrete. This development was made possible by the abundance in Italy of good limestone and of pozzuolana, a volcanic material, which when mixed with lime produced an excellent cement. The hidden structural masses were largely of the cheaper materials, brick and concrete, with exterior facings of marble or stone.

By the employment of the arch a new characteristic was introduced into the art of building which does not exist in the lintel, that is, the side thrust. There are two ways of meeting side thrusts: by the downward pressure of the wall against which they operate or by external abutments. The Romans resisted the thrusts by the sheer inertia of vast wall thickness, or else by so planning their buildings that dividing walls should act as stays for their vaults. As the Romanesque style developed in the tenth and eleventh centuries the buttress came into being to strengthen the walls at the points where the thrusts of the groined vaults were concentrated. Independent arches or ribs along the lines of the groins were likewise introduced acting as a support or centering for the vault.

But the Romanesque builders had always experienced difficulties in the vaulting of oblong compartments because the height of the crown of a semicircular arch is determined by its span. In an oblong compartment the crowns of the ribs spanning the long sides, the short sides and the diagonals would all be at different heights, and in order to construct the vaults the narrow arches must be stilted and the vault domed. Such procedure resulted in powerful thrusts and awkward surfaces.

The introduction of the pointed arch obviated these difficulties since the crowns of all arches could be readily brought to the same level whatever their differences of span. The pointed arch, then, made possible the Gothic style, but it was not the only element in that remarkable architecture. It was at its perfection "a system of construction in which vaulting on an independent system of ribs is sustained by piers and buttresses whose equilibrium is maintained by the opposing action of thrust and counterthrust."\* The lines of the ribs continue to the ground; the intervening walls, no longer needed for stability, are reduced until the window openings fill the entire space between the supports; the flying buttresses are applied at the exact points of resultant thrusts, and the entire exterior and interior fabric becomes a frank and perfect expression of the constructive framework of the edifice.

The awakening of classical culture in the fifteenth and sixteenth centuries brought with it the Renaissance of imperial Roman architecture. And, indeed, the spirit of those days made a fresh and living thing of the revived elements, developing and perfecting them far beyond their Roman values, though structurally contributing little

\* "Gothic Architecture," Charles Herbert Moore.

Great skill and dexterity were attained in the use of the wall, the column, the lintel, the vault, the dome and the truss; iron in the shape of restraining bands and tie rods was introduced and great areas were spanned. The constructive principles, however, were those of load-bearing walls and of thrusts resisted by weight and mass. These principles have endured until, in our own time, the introduction of steel and reinforced concrete inaugurated new possibilities in construction and new problems of frank expression. The structural scheme is again as in Gothic days, that of a skeleton framework, but the materials at hand have indefinitely expanded the possibilities.

Greek and Gothic are considered to be the two perfect examples of absolute sincerity in the expression of structure. The exterior declared and testified by material, form and element the manner and method of erection. To us in our day the steel skeleton and the reinforced concrete frame are offering new visions never before dreamed and demanding new expressions to proclaim their structural capabilities. Our ideal should be to develop the extraordinary possibilities of modern structural principles and of modern materials in the light of simplicity, economy and the demands of our time, and to give frank utterance to these principles and materials in all the members and aspects of our building.

It is of interest to note briefly the influence of materials upon the schools of architecture. Where alluvial clay abounded, as in Egypt and Mesopotamia, sun-dried brick were easily and cheaply made. In Egypt, however, stone was also obtainable and, because of its dignity and durability, became the material of the temples, tombs and palaces, while the less pretentious dwellings were built of brick. But in Mesopotamia vast piles of brick buildings were constructed, and, in the absence of stone and wood to span their areas, the arch and the dome came into being. Greece was endowed with most perfect marble for columns and lintels, and the arch and dome received little attention. A fortunate combination of lime, limestone, clay and pozzuolana gave Rome stone and cement, and the great mass of her structures is largely due to the union of stone, brick, strong mortar and concrete. In Lombardy and Holland, on the other hand, where stone was scarce but clay was plentiful, brick and terra cotta construction were highly developed. In Northern Europe, Switzerland and Russia, where forests abounded and other materials were difficult to procure, wooden architecture was characteristic for buildings of all types.

In America the early settlers found a readily accessible supply of wood and progressed from huts of logs to spacious mansions of sawed lumber. So prevalent was the supply and the water power to prepare it, that wood continued to be the most used building material until the last part of the nineteenth century. The increase in the cost of timber, the tremendous losses by fire and the demand of other types of materials



for our skyscrapers and monumental buildings have in this century increased to an enormous extent the employment of steel, concrete, stone, glass, metal, brick and terra cotta, and with it have altered and defined our architectural expression in all its elements.

Science, machinery and easy transportation are now bringing to the hands of architects resources of materials hitherto unknown or unobtainable. The precedents of past architectural methods may be ignored and expression given only by means of the structural frame and the materials, glass, terra cotta, brick and metal with which the walls are built. But the architect must be intimate with his materials, their color, texture, characteristics and capabilities, and with the efficient methods of combining and supporting them. Without such understanding his design will be inert and uneconomical, and his materials unfit for their purposes or unproductive of their possibilities.

The study of the materials and methods of construction as employed in the United States at the present time is the purpose of this book. But, as an introduction to the examination of these materials and methods, consideration should be given to the classifications of buildings and to the general rules governing their design and erection as set forth by the building codes.

**Building Codes.** All cities and towns of any size have now instituted building codes or laws whose object is to insure the construction of buildings according to methods of approved safety and to protect the public against injury to life and property and the encroachment of rights. The types of construction, quality of materials, floor loads, allowable stresses and many other requirements relating to building are covered by these codes. The codes are generally administered by a building department, which examines and passes upon the plans of the proposed buildings and which includes a force of inspectors who visit the buildings in course of construction to make sure that they are being erected according to the drawings which the building department has approved. These codes at the present time vary quite widely as to their demands, so that an architect having work to do in any city must of necessity become familiar with the code of that city, even though he may know very well the requirements of a nearby community. Several agencies, such as the Building Code Committee of the Department of Commerce, the National Board of Fire Underwriters and the American Society for Testing Materials, are at work to improve this situation, to standardize the codes and to make them more uniform. The communities, also, as they from time to time revise their codes, are constantly accepting more modern standards and placing their regulations upon more scientific and at the same time more reasonable bases. In any case, no buildings can be erected until the drawings have been examined and approved by the authorities of the particular community wherein the construction is to take place.

**Types of Buildings.** The majority of building codes, together with the national agencies, divide buildings into classes based upon the manner of their construction and also upon their use or occupancy.

The following division into classes is based upon the manner of construction:

- (a) Frame Construction.
- (b) Non-fireproof Construction.
  1. Ordinary Construction.
  2. Mill or Slow-burning Construction.
- (c) Fireproof Construction.

**FRAME CONSTRUCTION** embraces all buildings with exterior walls of wooden framework sheathed with wood shingles or siding; veneered with brick, stone or terra cotta; or covered with stucco or sheet metal. Such buildings naturally have floors and partitions of wood and are considered as comprising the most inflammable type of construction.

**NON-FIREPROOF CONSTRUCTION** includes all buildings with exterior walls of masonry but with wood floor construction and partitions. Ordinary construction implies the usual joist framing of floors and stud partitions. **MILL OR SLOW-BURNING CONSTRUCTION** designates heavy timber framing so designed as to be as far as possible fire retardant, the heavy beams and girders of large dimension proving far less inflammable than the slender joists and studs of **ORDINARY CONSTRUCTION**.

**FIREPROOF CONSTRUCTION** includes all buildings constructed of fireproof material throughout, with floors of iron, steel or reinforced concrete beams, filled in between with terra cotta or other masonry arches or with concrete slabs. Wood may be used only for under and upper floors, window and door frames, sash, doors and interior finish. In buildings of great height the flooring must be of incombustible material and the sash, doors, frames and interior finish of metal. Wire glass is used in the windows, and all structural and reinforcing steel must be surrounded with fireproof material, such as hollow terra cotta and gypsum tile or cinder concrete, to protect the steel from the weakening effect of great heat.

In the early codes only one type of fireproofing was recognized, and all buildings not of that type were considered as non-fireproof. The revised codes, however, permit varying degrees of fire-resistance depending upon the fire hazard involved by occupancy, height and location. A less degree of fire-resistance is therefore allowed for a building of moderate height and ordinarily hazardous occupancy in certain sections of a city, while a greater degree of fire-resistance is required for a more hazardous occupancy, for a higher building or for a congested zone. The principles of zoning and the restriction of specific areas in a city to particular occupancy and purposes greatly aid the application of these regulations.

The following division into classes is based upon the uses to which

buildings are put or upon the character of their occupants. Such considerations determine in many communities the type of fire-resistance required under their building codes, the height and the percentage of the building lot which may be covered by the construction.

(a) Human Occupancy.

1. Special Hazards.

Theatres and motion-picture houses.

2. Ordinary Hazards.

Dance halls, assembly rooms, restaurants, schools, churches, libraries, railroad stations and museums.

Hospitals, asylums, prisons, monasteries and convents.

Hotels, apartment houses, dormitories and clubs.

Dwellings.

Office buildings.

(b) Commercial Occupancy.

1. Highly hazardous.

Buildings for the manufacture of highly inflammable or explosive materials.

2. Hazardous.

Storage buildings for highly inflammable or explosive materials, paint and oil; dry-cleaning establishments, planing mills, filling stations.

3. Semi-Hazardous.

Private garages.

Public garages.

4. Ordinary Hazards.

Stores, factories, warehouses not included in (1) or (2).

5. Non-Hazardous.

Power plants, ice plants, shops for the manufacture of incombustible materials.

**Fire Limits.** The building codes of most communities require that the buildings erected in the more congested parts of the city shall be of more fire-resistant construction than in other less congested districts. The boundaries of such districts are called the FIRE LIMITS. Within these limits frame buildings are entirely prohibited, and non-fireproof buildings are not permitted above a certain height, varying from one to four stories, depending upon the use or occupancy of the building. Schools of one story and apartments, dwellings and business buildings of four stories are generally allowed, but the floor construction over the basement must be fireproof because the heating plant is usually in the basement. Above these heights the buildings must be fireproof throughout.

**Permitted Areas of Lots.** Buildings as a rule are not permitted to cover the entire lot, uncovered spaces such as courts, yards, areas, etc., being provided to supply light and air to the occupants and to the surrounding structures. These spaces must be open to the sky from the second floor level, the portion of the lot to be left open depending upon whether the building is on a corner lot or in the middle of a block, upon the use of

the building and upon its height. Hotels, apartments and tenements must have the largest open area, 15% or more, depending upon height and situation. Other types of buildings are generally required to leave only 10% of open space.

**Zoning.** In 1916 New York City passed zoning ordinances which were at once successful in their aim and have since served as a model for many other communities. These ordinances regulate the height, bulk and use of buildings, the density of population and the use of land. They recognize the need of zones and centers where business can be transacted with the least possible friction and loss of time, and they also have regard for the desire of people to live in districts without the interference or confusion of business. The types of districts are kept as few as possible but several of each type are scattered through the city. Four types are instituted: residential, business, industrial and unre-

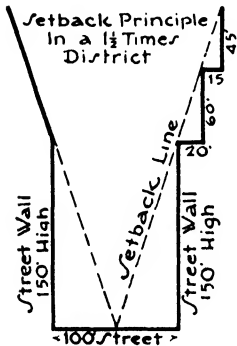

Typical Skyscraper Form showing the Results of Zoning Regulations.

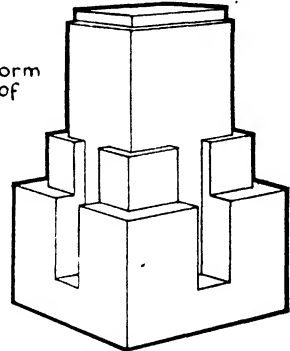

FIG. 1.—Effect of Zoning Regulations on Tall Buildings.

stricted. A business area is incorporated within a reasonable walking distance of each residential area for marketing and shopping. The industrial zones are generally near waterways, railroads and switch connections. The outlying districts are zoned in the same manner to preserve them for present and future use.

The zoning ordinances also regulate the heights of buildings to preserve light and air and reduce congestion in the streets. The height to which the wall fronting upon the street may rise is restricted, but if the wall be stepped back when the limit is reached the set-back portion may rise to a greater height. The blanketing and darkening of the streets and lower stories of adjoining buildings which had resulted from the erection of the earlier skyscrapers was thus to a great extent eliminated.

**Set-backs.** The permissible height of a building depends upon the zone in which it is located and upon the width of the street upon which it is erected, taller buildings being allowed generally upon wider avenues and parks than upon narrow streets. But if portions of the buildings are set back from the street wall, these portions may rise still further,

depending upon the amount of set-back. In certain zones the height of buildings is restricted to  $2\frac{1}{2}$  times the width of the street with a further allowance in height of 5' for every foot of set-back, while in other zones the height is limited to  $\frac{1}{4}$  of the width of the street with an allowance of only 1' in height for every 2' of set-back. The construction over  $\frac{1}{4}$  of the lot may rise to any height (Fig. 1).

Quite aside from the original purpose, that of giving more light and air to the buildings and streets, these set-backs have added a most interesting variety, vitality and picturesqueness to city architecture and have brought about a type of tall building, already adopted throughout the country, far superior to the forbiddingly straight fronts and heavy cornices of the structures erected before the adoption of the ordinances.

**Bearing Wall and Skeleton Frame.** From the point of view of method of construction all buildings may be divided into the following groups, comprising the two great principles upon which structural design is based:

- (a) Bearing Wall Construction.
- (b) Skeleton Frame Construction.

(a) **BEARING WALL CONSTRUCTION** has been the method of structural design employed from the earliest days. By this method the loaded floor and roof beams rest upon the exterior and interior walls, these walls in turn transmitting the loads to the foundations. It is evident that the walls must be of sufficient thickness to carry the imposed loads as well as their own weight; consequently, as the height of buildings increased, the required thickness of the walls and the weights brought upon the foundations became excessive and uneconomical.

(b) **SKELETON FRAME CONSTRUCTION** has been made possible by the development of structural steel and later of reinforced concrete. According to this method the loaded floor and roof beams rest upon girders running between the columns. The columns are placed along the building line and are known as exterior or wall columns, and at required intervals within the body of the building, in which case they are called interior columns. A rigid framework or cage is thereby formed, the walls being carried upon the wall girders at each story level. The walls are consequently mere enclosures bearing no weight and are of the same thickness on all stories. The columns transmit the loads to the foundations. By the employment of this method the modern skyscrapers are being built with beams, girders and columns of steel or reinforced concrete.

**Floor and Roof Loads.** Before calculating the required sizes of beams, girders or columns to support the weights upon them, it is necessary first to determine the weights or loads supported by the structure. These consist of the dead loads and the live loads. By **DEAD LOAD** is meant the weight of the construction itself, the walls, floors, ceilings, roofs and permanent partitions. By **LIVE LOAD** is meant the weight of the furniture, equipment, occupants, stored material, snow upon the

roof and movable partitions. The live loads should include all loads except the dead loads. Wind pressure, really a lateral load, is often classed as a live load, but may be considered as producing a separate stress.

The building codes of the various communities specify the weights per square or cubic foot of wood, stone, steel, concrete, plaster, terra cotta and other structural materials comprising the dead loads. They likewise regulate the live load per square foot, which depends upon the use or occupancy of the building and which must be employed in calculating the weights upon the structural members.

The various building codes differ as to the amount of live load to be safely used under the same conditions. The U. S. Department of Commerce, after careful investigations, has made recommendations which, it is hoped, will influence the standardization of the requirements by cities and towns throughout the country. The following table gives

Table I. Minimum Live Loads

Classes of Buildings	Minimum Live Loads per Square Foot of Floor						
	New York 1938	Phila- delphia 1941	Boston 1930	Chicago 1939	Denver 1927	San Francisco 1928	Depart- ment of Com- merce
Dwellings	40	40	50	40	60 & 40	40	40
Hotels, Tenements, Lodg- ing Houses, Apartments, Hospitals	40	40	50	40	90 & 70	40	40
Office Buildings: First floor	100	100	125	100	120	125	100
Other floors	50	60	65	50	70	40	50
Schools, Class Rooms	60	50	50	50	75	75	50
Buildings or Rooms for Public Assembly:							
With fixed seats	75	60	100	75	90	75	50
Without fixed seats	100	100	100	100	120	125	100
Aisles and corridors	100	100	100	100	120	125	100
Garages: Public	175	100	150	100	150	100	100
Private	75	100	75	100	150	100	80
Warehouses	120	150	125-250	100-250	200	125-250	100-250
Manufacturing: Heavy	120	200	250	100	250	250	100
Light	120	120	125	100	120	125	75
Stores: Wholesale	120	110	250	100	120	125	100
Retail	120	110	125	100	120	100	75
Sidewalks	300	120	250	150	150	150	250

the minimum live or superimposed loads required by several cities and as recommended by the Department of Commerce.

**Deductions.** In storage warehouses the entire live load may be acting on all the floors at the same time, but in other types of buildings allowance is made for the fact that it is not probable that every square foot of every floor will be fully loaded at the same time, although small areas may be at any time subjected to the specified load. A reduction of total loads is therefore permitted in designing the columns, piers, walls, trusses, girders and foundations. No reduction is allowed when these members carry only one story, nor is any reduction permitted for floor beams. It is considered that any one story might be fully loaded at some time but not two stories at the same time. The percentage of reductions permitted increases from the top of the building downward until 50 or 60% reduction is arrived at, all stories below this point being calculated at the maximum percent of reduction.

Table II, the schedule of reductions, quoted from the Boston Building Law, is good practice.

Table II

Carrying one floor . . . . .	No reduction
“ two floors . . . . .	10% “
“ three “ . . . . .	20% “
“ four “ . . . . .	30% “
“ five “ . . . . .	40% “
“ six “ . . . . .	50% “

**Roof Loads.** On flat roofs and those of slight pitch the snow load will be at the maximum and the wind pressure at the minimum. As the pitch of the roof increases, the snow load will decrease and the wind load increase. The Boston Building Law includes the following regulations:

Roofs shall be designed to support safely minimum live loads as follows:

Roofs with a pitch of 4" or less per foot, a vertical load of 40 lbs. ft.<sup>2</sup> of horizontal projection.

Roofs with pitch of more than 4" and not more than 8" per foot, a vertical load of 15 lbs./ft.<sup>2</sup> of horizontal projection and a wind load of 10 lbs./ft.<sup>2</sup> of surface acting at right angles to one slope, these two loads being assumed to act either together or separately.

Roofs with pitch of more than 8" and not more than 12" per foot, a vertical load of 10 lbs./ft.<sup>2</sup> of horizontal projection and wind load of 15 lbs./ft.<sup>2</sup> of surface acting at right angles to one slope, these two loads being assumed to act either together or separately.

Roofs with pitch of more than 12" per foot, a vertical load of 5

lbs./ft.<sup>2</sup> of horizontal projection and a wind load of 20 lbs./ft.<sup>2</sup> of surface acting at right angles to one slope, these two loads being assumed to act either together or separately.

The expected snow load naturally varies widely in different parts of the United States as exhibited by the requirements of the local building codes.

**Wind Loads.** Besides the wind loads on roofs as above outlined, the vertical sides of buildings must withstand a pressure from the wind. This pressure may cause high stresses in the framework and special calculations for wind bracing must be made, particularly in the case of tall or isolated buildings.

The Boston Building Law contains the following specifications:

All buildings and structures shall be calculated to resist a pressure per square foot on any vertical surface as follows:

For 40' in height. . . . .	10 lbs.
Portions from 40 to 80' above ground . . . . .	15 lbs.
Portions more than 80' above ground . . . . .	20 lbs.



## CHAPTER II

### LIME, GYPSUM AND CEMENT

Lime, gypsum and cement are the three materials most widely used in building construction for the purpose of binding together masonry units such as stone, brick and terra cotta and as constituents of wall plaster. Cement is, furthermore, the most important component of concrete. These materials are manufactured in enormous quantities and form a very important element in all masonry structures. As a class they are designated as CEMENTING MATERIALS.

#### Article 1. Lime

**Lime.** Calcined lime was used in ancient times in mortar, the burning of limestone being described by Pliny A.D. 23-79. Pure limestone or calcium carbonate ( $\text{CaCO}_3$ ) is composed of calcium oxide ( $\text{CaO}$ ) and carbon dioxide ( $\text{CO}_2$ ). Limestone is, however, rarely found in this pure form, being mixed with impurities such as magnesium carbonate ( $\text{MgCO}_3$ ), silica ( $\text{SiO}_2$ ), alumina ( $\text{Al}_2\text{O}_3$ ) or iron oxide ( $\text{Fe}_2\text{O}_3$ ). Limestone is found in almost all parts of the United States, so that the manufacture of building lime is very widespread. It varies in composition according to locality, from limestone containing 98% calcium carbonate to limestone containing about equal parts (54.35 and 45.65%) of calcium carbonate and magnesium carbonate. The stones containing 90% or more of calcium carbonate are known as HIGH CALCIUM LIMESTONES; those containing 10% or more of magnesium carbonate are classed as MAGNESIUM LIMESTONES and those containing more than 25% magnesium carbonate are called DOLOMITIC LIMESTONES. Commercially, lime is divided into CALCIUM LIME containing more than 70%  $\text{CaO}$  and MAGNESIUM LIME containing more than 30%  $\text{MgO}$ . When the limestones contain sufficient amounts of silica and alumina the resulting manufactured lime is endowed with the ability of setting under water and is classed as HYDRAULIC LIME. Such limes are not produced to a great extent in this country, their place being taken by the HYDRAULIC CEMENTS. It will be seen under the study of cement that its hydraulic qualities are likewise dependent upon the presence of silica and alumina in the manufactured product.

Magnesium limes are slower slaking and cooler than high calcium limes, and are less plastic, but develop a higher ultimate strength. The preference between the two limes arises from familiarity with one or the other, depending upon the locality where it is found.

**Quicklime.** The manufacture of commercial or building lime consists in heating or "burning" the limestone in shaft or rotary kilns to a temperature of about  $925^{\circ}\text{C}$ . or  $1700^{\circ}\text{F}$ . The carbon dioxide is driven off by the heat leaving  $\text{CaO}$ , calcium oxide, known as quick or caustic lime. Quicklime is highly caustic and possesses a great affinity for water, readily combining with about 30% of its own weight. It is shipped in lumps as it comes from shaft kilns or in the form of a coarse powder from rotary kilns.

**Slaked or Hydrated Lime.** Quicklime can never be used as such for structural purposes, but must first be mixed with water or slaked. During the slaking the water is absorbed, heat is very energetically evolved, driving off much of the excess water in form of steam, the lime bursts into pieces and is finally reduced to powder. The lime has now become calcium hydroxide ( $\text{CaO}_2\text{H}_2$ ), and is called slaked or hydrated lime. It is ready to be made into plaster or mortar by adding water and sand to form a plastic mass.

Lime is slaked at the building by putting quicklime in watertight boxes or rings of sand and adding water by pails or hose. The lime must be continually stirred by a shovel or hoe during the slaking process to reduce all unhydrated particles which may slake later in the building, causing popping, pitting and disintegration, especially objectionable in wall plaster. Different kinds of lime vary considerably as to the rapidity with which they react to the combining of water, the slaking process beginning and continuing more quickly with the so-called hot, fat or calcium limes than with the cool or lean magnesium limes. Intelligence must, therefore, be used in the manner of adding water to the lime.

Quick slaking tends to produce a colloidal condition whereas slow slaking tends toward coarser crystalline grains and reduced plasticity. Magnesian limes are consequently less plastic and should be mixed with less sand. They are, however, said to be smoother and more easily worked under the trowel.

After the slaking action has ceased, the lime destined for plastering, called lime putty, is run through a sieve and stored for a minimum of two weeks before using. The lime to be employed in mason's mortar is not screened and need not be stored over twenty-four hours.

**Mill Hydrated Lime.** Because of the many failures due to improper slaking by unskilled laborers, lime can now be obtained slaked at the mill or kiln and called mill hydrated lime. The proportion of lime and water and the stirring are scientifically carried out by mechanical means, and the product is very dependable. It is reduced to a fine powder and shipped in paper bags ready to mix with water and sand to form plaster or mortar. It sometimes tends to be coarse and gritty and cannot then be used for finishing plaster.

**Lime Mortar.** If it were attempted to use lime as a plaster or mortar unmixed with other materials, wide cracks would occur on account of the shrinkage of the lime while hardening. Therefore sand is commonly

used to mix with the lime to reduce the shrinkage and for economy of cost. The usual mixtures for mortar are 1 part lime to 2 to 5 parts sand by volume, the New York Building Code requiring a 1 to 3 mixture. Water is also added to form a plastic mass which is easily workable. With a large proportion of lime the mortar is called a rich mortar, and with a large proportion of sand a lean mortar. With too much sand the mortar will work with difficulty and is said to be stiff. If the mixture will slide readily from the trowel the quality is satisfactory. The difficulty of working a stiff mortar is a great safeguard against the use of too much sand by workmen.

Lime mortar will not harden under water, and in all cases exposure to air is necessary for prompt setting. The process of hardening is, therefore, slow, especially below the surface of the mortar, and in the case of high buildings rapidly erected the mass of the mortar of the lower stories does not harden with sufficient quickness to sustain the weight of the upper stories. Some building codes limit the use of lime mortar to the lower and lighter types of buildings only and prohibit it in fireproof construction. Lime mortar should never be used in foundations or where exposed to moisture. It is not as strong as cement mortar and, although widely used before the development of Portland cement, it has now almost entirely given place to the latter in this country. Ten per cent of the cement in cement mortar is often replaced by lime to improve the workability of the mortar. Brick is often set with a mixture of 1 part cement, 1 part lime and 6 parts sand. The greatest structural use for lime in the United States is for wall plaster.

**Sand.** Since sand is a large constituent of all mortars it is important that the quality of the sand should be satisfactory. Tests have shown that a mixture of sand up to a 1 to 2 proportion actually adds strength to the mortar but that over this proportion the mixture becomes weaker as the sand is increased.

Sand is obtained from deposits such as banks and pits, from river beds and from the sea-shore. Clean bank and pit sand is best for mortar and fine river sand for plaster. Sea sand must be thoroughly washed with fresh water to remove the alkalines, which attract moisture and cause dampness in walls. Sand should be coarse, of various sizes, absolutely free from dust, loam, clay, earthy or vegetable matter and large stones. It is now considered by architects that it is not necessary for sand to be sharp and angular, as was formerly specified, but that coarseness of grain governs the quality. Coarse grains take up more lime and thereby increase the strength of the mortar. Sand should never stain the hands when rubbed, as such staining shows the presence of loam or dirt.

**Alca Lime.** In order to increase the sand-carrying capacity, to improve workability and to advance the set, a lime known as alca lime is produced by incorporating about 15% of calcium aluminate with hydrated lime. It is used especially for wall plasters.

**Hydraulic Limes.** Certain limestones after burning produce limes containing sufficient free calcium to develop a slaking action and sufficient silica, iron oxide and alumina to cause them to set under water. Commercial hydraulic lime contains about 60% of lime and 25% of silica. It is burned to a sufficiently high temperature, about 1600° F., to cause reaction between the calcium and the silica and alumina, and to drive off the carbon dioxide but not to produce fusion. These limes are much used in Europe, but in this country Portland cement, since it is as low in cost and has greater strength and hydraulic properties, is preferred.

**Preserving Quicklime.** Fresh burned lime has so much affinity for water that it will quickly absorb moisture and carbon dioxide from the atmosphere, become air slaked and lose its cementing qualities. It must, therefore, be kept in dry storage and carefully protected from dampness until used. Lump lime is more difficult to preserve than finely ground lime.

**Setting of Lime.** Slaked lime hardens or sets by gradually losing its water through evaporation and absorbing carbon dioxide from the air, thus changing from calcium hydroxide ( $\text{CaO}_2\text{H}_2$ ) to calcium carbonate ( $\text{CaCO}_3$ ) or limestone.

An interesting cycle is completed in the chemical changes from the original limestone, through the burning, slaking and setting, as shown below.

- (a) By burning, the limestone loses its carbon dioxide and becomes oxide of lime or quicklime.  $\text{CaCO}_3 + \text{heat} = \text{CaO} + \text{CO}_2$
- (b) By slaking, the oxide of lime is combined with water and becomes calcium hydroxide, known as slaked or hydrated lime.  $\text{CaO} + \text{H}_2\text{O} \rightarrow \text{CaO}_2\text{H}_2$
- (c) By setting, the calcium hydroxide loses its water through evaporation and absorbs carbon dioxide from the air, becoming  $\text{CaCO}_3$  or limestone once more.  
 $\text{CaO}_2\text{H}_2 - \text{H}_2\text{O} \rightarrow \text{CaO} \quad \text{CaO} + \text{CO}_2 \rightarrow \text{CaCO}_3$

The calcium carbonate ( $\text{CaCO}_3$ ) hardens around the grains of sand in the mortar and binds them together. It is evident that as the outer surface becomes more impervious to the passage of the carbon dioxide ( $\text{CO}_2$ ) the rate of setting is greatly decreased, thus accounting for the long time required for lime mortar to harden completely throughout its mass.

The magnesia limes ( $\text{CaCO}_3 + \text{MgCO}_3$ ) pass through similar reactions during burning, slaking and setting.

## Article 2. Gypsum

**Gypsum.** Gypsum is a combination of sulphate of lime with water of crystallization ( $\text{CaSO}_4 + 2\text{H}_2\text{O}$ ). Large deposits of impure gypsum rock

are found in various parts of the United States, and of late years the manufacture and use of gypsum products such as plaster, hollow building tile and wall board have greatly increased. It is hard, fire-resistant, sets quickly and is quite light in weight, but is never used in situations exposed to the weather. In its calcined state it was used in early days as a wall plaster and is mentioned by Theophrastus (372 B.C.).

As found in nature the gypsum rock usually contains silica, alumina, lime carbonate, oxide of iron and other impurities. To be classed as gypsum rock at least 64.5% by weight must be  $\text{CaSO}_4 + 2\text{H}_2\text{O}$ . Pure gypsum is known as alabaster.

**Manufacture.** The gypsum rock is ground fine and is heated to a temperature above the boiling point of water,  $212^\circ \text{F.}$ , but not exceeding  $374^\circ \text{F.}$ , when about  $\frac{3}{4}$  of the combined water passes off in steam.  $(\text{CaSO}_4 + 2\text{H}_2\text{O}) + \text{heat} \rightarrow (\text{CaSO}_4 + \frac{1}{2}\text{H}_2\text{O}) + 1\frac{1}{2}\text{H}_2\text{O}$ . The remaining product is PLASTER OF PARIS if pure gypsum has been used and HARD WALL PLASTER if less than 39.5% of impurities are present or added to retard the set and improve the working qualities. Hard wall plaster is sometimes called cement plaster. The calcined material is ground to a fine powder before shipping to the consumer.

Plaster of Paris is used for cast ornamental plaster work, and it is admirable for this purpose, producing hard surfaces, sharp contours and arrises, and being sufficiently strong. It sets in 20 to 40 minutes, which is an advantage in cast work but which renders it unfit for wall plastering. Hard wall plaster, because of admixtures, has a slower set, from 2 to 32 hours, and has of late years been widely used for general plaster work. It is harder than lime plaster, sets more quickly and thoroughly and for these reasons often permits of greater speed in the construction of buildings.

If the gypsum rock be heated to  $400^\circ \text{F.}$  practically all the water is driven off in steam and the time of set is also much retarded.  $(\text{CaSO}_4 + 2\text{H}_2\text{O}) + \text{heat} \rightarrow (\text{CaSO}_4) + 2\text{H}_2\text{O}$ .

This material is finely ground and borax or alum is added to improve the workability and accelerate the set, the resulting product being known as HARD FINISH PLASTER. KEENE CEMENT is one variety of hard finish plaster which is much used as wainscoting for bathrooms, kitchens and laundrys, or wherever a very hard, waterproof coating is required on the walls. It is manufactured by burning pure gypsum first to a temperature over  $212^\circ \text{F.}$ , then dipping the lumps in an alum bath and finally drying and again heating to a temperature of  $400^\circ$  or  $500^\circ \text{F.}$ , after which the product is very finely ground and screened. The resultant material sets in 1 to 4 hours and has a tensile strength of 400 lbs./in.<sup>2</sup>

Gypsum plaster is rendered more plastic by the addition of clay or of hydrated lime. The cohesiveness is increased by adding hair or shredded wood fiber. The hair is generally manila or jute fiber and not cattle hair, which was formerly used.

Gypsum plaster is mixed with sand at the building before using. It

may also be obtained from the producers already mixed with sand in the exact proportions best adapted to scratch coat, brown coat or finishing coat work. This is called sanded plaster and is shipped in bags.

**Setting.** The setting of gypsum plaster is not a chemical change as in the case of carbonate of lime but is due to the recombination of the dehydrated lime sulphate,  $\text{CaSO}_4$  or  $\text{CaSO}_4 + \frac{1}{2}\text{H}_2\text{O}$ , with water to form the original hydrated sulphate,  $\text{CaSO}_4 + 2\text{H}_2\text{O}$ . This dihydrate precipitates from the solution to form a solid mass of fine interlocking crystals. The water of crystallization is obtained from the water with which the plaster is mixed before use.

The materials added to hard wall plaster to retard its set consist of colloids, such as flour and glue, which adhere around the particles of calcium sulphate. Hydration and the formation of crystals are consequently impeded and the plaster is rendered more practical for use.

**Structural Gypsum.** Plaster board, wall board, partition, floor and roof slabs and other formed products for structural use are also made from calcined gypsum mixed with asbestos or cocoa fiber, wood pulp, cinders, sand or other materials.

Plaster boards or lath consist of sheets of gypsum, either plain or perforated, with not more than 15%, by weight, of fiber, intimately mixed and pressed, or of alternate layers of gypsum and fiber. The sheets may or may not be covered on the outside with paper, but the surface must readily receive and retain gypsum plaster. They are 16" to 32" wide, 32" to 48" long and  $\frac{1}{4}$ " to  $\frac{1}{2}$ " thick and are used as a base for gypsum plaster in place of lath. An insulating lath is made by applying an aluminum foil to the outer surface which reflects radiant heat. Another type containing cane fiber also possesses insulating characteristics.

Wall boards consist of sheets of gypsum, with or without fiber, intimately mixed and pressed, and are covered with paper to form a smooth surface fit for decorating. The sheets are from  $\frac{1}{4}$ " to  $\frac{1}{2}$ " thick, 32" to 48" wide and from 4' to 12' long, and are used without plaster coating. The edges are either butted or a  $\frac{1}{2}$ " space may be left between the sheets and the joints filled with gypsum plaster. A recessed edge is sometimes provided on the board into which a continuous fiber is cemented to avoid cracks and the recess smoothed off with plaster. To produce the effect of panels, mouldings may be applied over the butted joints.

Waterproofed wall board 24" x 48" x  $\frac{1}{2}$ " with tongued and grooved long edges are used for outside sheathing under shingles, stucco or brick veneer. No building paper is necessary.

Gypsum tile will be treated in Chapter VI, Terra Cotta and Hollow Tile.

### Résumé of Gypsum Plasters

Sulphate of lime ( $\text{CaSO}_4 + 2\text{H}_2\text{O}$ ) heated over 212° F. but below 374° F. gives  $\text{CaSO}_4 + \frac{1}{2}\text{H}_2\text{O}$ .

Products: From pure gypsum.....Plaster of Paris  
 From gypsum with retarding mixture.....Hard wall plaster or  
 cement plaster

$\text{CaSO}_4 + \frac{1}{2}\text{H}_2\text{O}$  further heated to  $400^\circ\text{F}$ . loses remaining water and acquires  
 a slower rate of set.

Products: After mixing with alum or borax.....Hard finish plaster  
 After heating above  $212^\circ\text{F}$ ., receiving an  
 alum bath and again heating to  $400^\circ\text{F}$ .....Keene's cement

### Article 3. Cement

**Natural Cement.** Natural cement is made from natural rock as quarried rather than from a mechanical combination of several materials. The rock is usually a clayey limestone, which is burned to a sufficient temperature to drive off the carbonic acid gas, the clinker then being finely ground. Natural cement has hydraulic qualities but is quick setting and of relatively low strength, and is not adapted for reinforced concrete. It is consequently used only in large masses of concrete, such as dams and foundations, where weight rather than strength is a requisite. Mortar made from natural cement, sand and lime is often satisfactory in laying brick and setting stone.

The tensile strength recommended by the American Society for Testing Materials is as follows:

7 days (1 day in moist air, 6 days in water) 75 lbs./in.<sup>2</sup>  
 28 days (1 day in moist air, 27 days in water) 150 lbs./in.<sup>2</sup>

**Pozzuolan Cement.** The earliest cements, and especially those used by the Romans, were a mixture of slaked lime and pozzuolana or volcanic ash containing silica. This cement proved of great value in the making of mass concrete and mortar employed in the vast constructions of the Empire. Pozzuolan cement is still manufactured to some extent in Europe but not in this country. A cement consisting of hydrated lime and blast-furnace slag made in the United States is, however, sometimes called pozzuolan cement.

**Portland Cement.** Portland cement is a product obtained by mixing and then burning to incipient fusion two raw materials, the one composed largely of lime ( $\text{CaO}$ ) and the other being a clayey or argillaceous material containing silica ( $\text{SiO}_2$ ), alumina ( $\text{Al}$ ) and iron ( $\text{Fe}$ ). The two raw materials are ground to extreme fineness before mixing and are then mixed to give definite proportions of lime, silica, alumina and iron oxide. The mixture is then burned to incipient fusion or clinkering condition and the clinker is very finely pulverized. The finished product should contain, approximately, not less than 1.6 parts nor more than 2.3 parts by weight of lime to 1 part of silica, alumina and iron oxide combined. After the clinker is cooled, but before grinding, approximately 3% of gypsum is added to retard the set. The raw mix is analyzed several times each hour during manufacture to maintain the composition within

proper limits. The finished product should receive no additions other than gypsum, except that not more than 1% of proved harmless material may be present.

The properties and manufacture of Portland cement have been given much study by the American Society for Testing Materials, who have published standard specifications by which cement may be tested in a reliable manner by architects and engineers. Other than in types of cements for special purposes the specifications do not fix a particular composition except to limit the magnesia and sulphuric acid content, because different localities use varying local raw materials and change the composition to obtain the correct physical qualities.

The following different raw materials are used in various parts of the United States:

1. Argillaceous limestone (cement rock) and pure limestone.
2. Pure limestone and clay
3. Marl and clay.
4. Pure limestone and blast-furnace slag.

Cement rock is a term used in the Lehigh Valley of Pennsylvania, where great quantities of cement are produced, for a local limestone containing also silica and alumina. Pure limestone is mixed with the cement rock to raise the calcium content. Slag also contains all three ingredients but must be combined with pure limestone to increase the calcium in the mixture. It should be noted that most clays are composed chiefly of silica and alumina and consequently add these necessary elements to the calcium of the limestone.

The percentages of the principal components of Portland cement range as follows: lime 60 to 64; silica 19 to 25; alumina 5 to 9; iron oxide 2 to 4. More than 5% magnesia or 2% sulphur trioxide is not permitted. These proportions do not differ very materially from the composition of hydraulic lime, the chief difference lying in the fact that the cement is burnt to a higher temperature, which destroys the slaking qualities and greatly increases the strength and hydraulic power.

Portland cement was first manufactured in England in 1824 by Joseph Aspdin and received its name from a fancied resemblance in appearance to Portland stone, a natural limestone much used at that time in London. In the United States the earliest Portland cement was made by David O. Saylor in 1875 at Coplay, Pa.

**Specifications.** Five types of Portland Cement, for different uses, are included in the Specifications of the American Society for Testing Materials. The most important requirements for standard structural, or Type I, Portland cement are as follows:

**Fineness:** By turbidimeter. Average value 1600.

**Setting:** Shall not develop initial set in less than 60 minutes. Final set shall be attained within 10 hours.



**Tensile strength:** Briquets of 1 part cement and 3 parts sand by weight:

7 days  $\left\{ \begin{array}{l} 1 \text{ day in moist air} \\ 6 \text{ days in water} \end{array} \right\} 275 \text{ lbs./in.}^2$

28 days  $\left\{ \begin{array}{l} 1 \text{ day in moist air} \\ 27 \text{ days in water} \end{array} \right\} 350 \text{ lbs./in.}^2$

**Compressive strength:** Cubes of 1 part cement and 2.75 parts sand by weight:

7 days  $\left\{ \begin{array}{l} 1 \text{ day in moist air} \\ 6 \text{ days in water} \end{array} \right\} 2000 \text{ lbs./in.}^2$

28 days  $\left\{ \begin{array}{l} 1 \text{ day in moist air} \\ 27 \text{ days in water} \end{array} \right\} 3000 \text{ lbs./in.}^2$

**Packing and marking:** Cement shall be shipped in bags containing 94 lbs., in barrels containing 376 lbs. or in bulk. The name of the manufacturer shall be plainly marked upon the container or upon the shipping advices when sent in bulk.

Cement is now shipped almost entirely in bags or in special tight cars in bulk, and very seldom in barrels, although quantities are still designated and prices quoted by the standard barrel.

**Use.** The careful study applied to cement and the general acceptance of the standard specifications, together with its very general use in recent years throughout the country, have resulted in improving and standardizing the industry to a marked degree, so that now Portland cement of best quality can be obtained anywhere at moderate cost. It is constantly finding wider fields of application and has already worked a revolution in engineering and architectural construction, especially in its use in plain and reinforced concrete.

Cement is made all over the country wherever the raw materials are available, and its manufacture is now one of the very greatest industries in the United States. It is considered one of the two most important building materials we possess, the other being steel. In 1928 about 176,000,000 barrels were manufactured in this country.

**Manufacture.** The limestone and the clay material are separately stored and pulverized. They are first brought together in the mixing room where the components are exactly apportioned by weighing machines. The mixture is ground once more and enters the kiln to be burned. Kilns consist of rotating sheet steel, brick-lined cylinders, 5' to 15' in diameter and 60' to 250' long. They are inclined at 15° to the horizontal. The raw material enters at the higher end and powdered coal is blown by forced draft into the lower end. The powdered stone as it slowly progresses along the length of the kiln meets an ever-increasing heat until it is fused into clinkers at the lower end of the kiln. It is then removed to the cooling rooms and after cooling is mixed with a small proportion of gypsum (2 to 3%) to retard the initial set of the cement. The clinker is finally ground to an extremely fine powder and goes to the finished cement storage bins. Fine grinding greatly increases the strength of the cement by improving the conditions for complete hydration. (Fig. 1).

**Setting.** The three chief chemical constituents, formed during the making and using of cement, are tricalcium aluminate, tricalcium silicate and dicalcium silicate— $3\text{CaO}\cdot\text{Al}_2\text{O}_3$ ,  $3\text{CaO}\cdot\text{SiO}_2$ , and  $2\text{CaO}\cdot\text{SiO}_2$ —and the setting or hardening is caused by the hydration and crystallization of the constituents in the order named. When water is added these

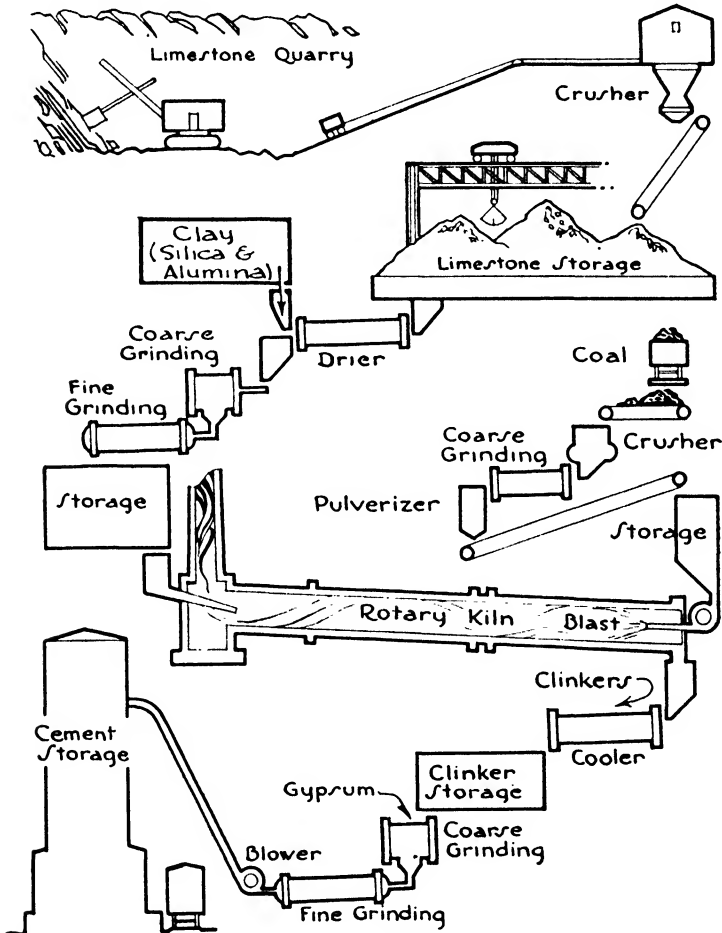

FIG. 1.—Cement Manufacturing.

substances first form a paste or jelly and then crystallize. The interlacing of the crystals binds the whole mass together into a rock-like material. By initial set is meant the early hardening due to the preliminary jelly-like formation. The final set and later increases in strength are caused by the gradual progress of the crystallization. A saturated solution is most favorable to crystallization, too much water retarding and tending to prevent the formation of crystals.

**Masonry Cement.** Cements have been developed for use in mortars for laying unit masonry such as brick, structural tile and building blocks. They are not as strong as standard Portland cements, but since their characteristics include easy workability, high water-retaining capacity, plasticity and accurate set, and because their cost is less, they are widely used when their compressive strength is sufficient. Waterproofing material is often added during manufacture to produce greater density and to prevent efflorescence.

Compressive strengths of 350 lbs./in.<sup>2</sup> at the age of 7 days and of 600 lbs./in.<sup>2</sup> at 28 days are required by the American Society for Testing Materials. Initial set should not be developed in less than 60 minutes, and final set should be attained within 24 hours.

**Non-staining Cement.** Ordinary Portland cement will stain limestones, marbles and other light-colored stones when used in the mortar with which the stone is set. Lime free from iron oxide makes the best non-staining mortar, but to gain greater strength non-staining cements have been developed. The first to be employed was a hydraulic lime called Lafarge cement made in France and imported to this country. The large cement manufacturing companies in the United States have now perfected non-staining white Portland cements, free from iron oxide and water-soluble alkali, which have almost the same tensile strength as ordinary Portland cement. White cement is now widely used for setting light-colored stone and for making stuccos and artificial or cast stone.

**High Early Strength Cement.** For some purposes it is a distinct advantage to use a cement with the ability to attain a higher early strength than is the case with the ordinary cement. This is particularly true in concrete road making, floor and machine base construction, and in concrete building carried on in freezing weather. Any shortening in the waiting time required while concrete attains its strength is always an economical saving for both the owner and the contractor. Such cements are now widely used but are as yet slightly more costly than standard Portland cement. They are of two general classes: first the high alumina cements made from a melted mixture of about equal quantities of limestone and an aluminum ore called bauxite; and secondly the accelerated Portland cements, frequently termed "superцемents," which have a high lime ratio, are very finely ground and are burned at higher temperatures than ordinary cement. The compressive strength attained by a quick-hardening cement concrete in 1 day is approximately equal to the 28-day compressive strength of a standard cement concrete of similar proportions. The standards of the American Society for Testing Materials require a tensile strength of 375 lbs./in.<sup>2</sup> and a compressive strength of 3000 lbs./in.<sup>2</sup> after 3 days. A considerable degree of heat accompanies the rapid hardening, which is an advantage in cold weather. The concrete should be kept wet during curing to prevent its drying out too quickly. The initial set takes place no earlier than in ordinary

cement; consequently mortar and concrete can be laid and poured in the usual manner.

**Testing Cement.** On large work, where great quantities of cement are used, samples are generally tested at the building site to make sure that the cement maintains the standards of the American Society for Testing Materials. Cement is tested for tensile strength as an assurance of its adhesive and paste-forming qualities and in compression for its practical working strength. The present-day standardization of manufacturing renders the testing of cement unnecessary in the general run of moderate-sized work when a well-known and approved brand of cement is used.

**Portland Cement Mortar.** Mortar is a mixture of cement, sand and water to form a plastic workable mass. It may be mixed by hand or by mechanical mixers, the mixers being preferable for large quantities. Mixing by hand is done on watertight platforms, the cement and sand being first thoroughly shoveled together in small quantities in the required proportions and rendered completely homogeneous before the water is added. After adding the water the whole mass is then remixed until the hoe or shovel appears clean and bright when drawn out of the mass. Mortar should be fairly stiff and not too thin or wet, and should not be used later than 4 hours after mixing. The usual proportions are 1 part cement to 3 parts sand for ordinary work, and 1 part cement to 1 or 2 parts sand for top surface of floors and sidewalks. Hydrated lime, not exceeding 10 or 15% of the cement by volume, may replace the cement to increase the plasticity and workability of the mortar. A very satisfactory mortar for brickwork consists of 1 part Portland cement, 1 part lime and 6 parts sand.

**Effect of Temperature.** Very hot or dry weather causes the water in the mortar to evaporate too quickly. Stones and brick should consequently be thoroughly soaked in such weather so that the mortar will not be reduced to a powder.

In cold weather the mixing and placing of all mortar are generally more difficult, and lime and natural cement mortars are materially injured by alternate freezing and thawing. Mortar composed of 1 part Portland cement and not more than 3 parts sand is, however, very little injured by the effects of freezing weather. Where heating facilities can be obtained it is possible to improve conditions by using high early strength Portland cement and by heating the water, sand, brick and stone. Under such conditions work is frequently carried on all winter in northern climates without delays.

#### Summary of Cementing Materials.

Gypsum	{	Sulphate of lime. $\text{CaSO}_4 + 2\text{H}_2\text{O}$ . Burned above $212^\circ$ or above $400^\circ$ F.
		Low heat. Does not slake. Hardens by reabsorption of water and crystallization.

Common lime { Pure limestone. Carbonate of lime.  $\text{CaCO}_3$  } Burned to  $1600^\circ$   
 { Magnesia limestone.  $\text{CaCO}_3 + \text{MgCO}_3$  } F. Low heat.  
 } Slakes.

Hardens by reabsorption of carbon dioxide.

Hydraulic lime { Stone composed of carbonate of lime, silica and alumina.  
 } Burned to  $1600^\circ$  F. Low heat. Sets under water. Slakes.

Portland cement { Artificial mixture of limestone and clayey materials con-  
 taining silica and alumina. Burned to fusion at  $2700^\circ$  to  
 }  $3000^\circ$  F. High heat. Sets under water. Does not slake.  
 } Hardens by formation of new chemical compounds and  
 } crystallization.

## CHAPTER III

### CONCRETE

#### Article 1. Composition of Concrete

Our two most important building materials may now be considered to be structural steel and concrete. For foundations, footings, basement walls, cellar bottoms and fireproof floor construction, the use of concrete is almost universal, while the number and importance of the buildings whose columns, girders, beams and walls are entirely of concrete are rapidly increasing with each succeeding year.

**Definition.** Concrete may be considered an artificial conglomerate stone made by uniting cement and water into a paste and mixing into this paste a fine material such as sand and a coarser material such as broken stone, gravel, slag or cinders. Upon the hardening of the paste the entire mass becomes like a solid stone. Mass concrete was employed by the Egyptians and the Romans, but the use of steel reinforcement did not begin until the nineteenth century of our era.

Because of its composition concrete has great compressive strength but little ability to withstand tension. Steel bars, rods or mesh fabric are consequently incorporated in those parts of the concrete members where it is required that tensile stresses be resisted. Concrete may, therefore, be divided into two classes: **MASS CONCRETE**, where weight or bulk is required and where to a large degree only compressive stresses are present; and **REINFORCED CONCRETE**, where it is necessary to introduce steel into the body of the material to counteract the tensile stresses caused by the nature of the existing loads.

**Matrix.** The chemically active element of concrete is the cement, sometimes called the matrix. It becomes hydrated, that is, united chemically and physically with the water, and produces what may be termed a glue, binding the sand, stone or other coarse material together.

**Aggregates.** The remaining ingredients of concrete besides the cement and water, that is the sand, broken stone, cinders, slag, etc., are chemically inert and are classed as the **AGGREGATES**. The material under  $\frac{1}{4}$ " in diameter is designated as **FINE AGGREGATE** and generally refers to the sand. All material over  $\frac{1}{4}$ " in diameter is called **COARSE AGGREGATE** and includes the broken stone, cinders, etc. Any crushed rock or slag of durable character, or any clean, hard, natural gravel, may properly be used as coarse aggregate. Granite, traprock or hard limestone are preferred and are prepared at the quarries in great quantities for such use. They are crushed and screened to adopted sizes, so that the aggregates

may be exactly graded by sieve analysis. Such grading is impossible with natural gravel, unless it be screened and then remixed in fixed proportions as to size. Rocks containing iron pyrites, forming sulphuric acid by oxidation, and mica, which easily disintegrates, should not be used. Soft fragments, clay lumps, coal and material finer than #200 sieve are also objectionable.

Most building codes limit coarse aggregate for reinforced concrete to  $1/5$  the narrowest dimensions between forms, not to exceed  $1\frac{1}{4}$ " size, and for mass concrete not reinforced to 2". Some codes, however, permit much larger stones in rubble concrete but specify 6" of mortar between any two stones or between any stone and the formwork. Rubble concrete is permitted only in masses without reinforcement. It should not be used for projecting footings.

Cinder concrete is much used in some localities for reinforced floor and roof slabs of short span and for fireproofing. It should not be used for walls, columns, beams or other structural purposes. The cinders should be hard, well-burned, vitreous clinker, reasonably free from sulphides, fine ashes, unburned coal and foreign matter. Sulphur in any form is likely to corrode and destroy the metal reinforcement. Cinders from anthracite coal are preferable to those from soft coal, which are likely to contain more of these harmful sulphides.

Blast-furnace slag when crushed to the proper size is a good aggregate for mass construction, though often containing too much sulphur for use in reinforced work. It is fairly hard, though very porous, has high compressive strength and offers a durable, pitted surface for the adhesion of the cement.

Aggregates for light-weight concrete consist of tufa, lava, pumice, burnt clay and similar products. The strength of such concrete should not be considered to be more than 70% that of concrete composed of denser materials. The sizes of the aggregates vary from dust to  $\frac{3}{4}$ ", and the weights should not exceed 70 lbs./ft.<sup>3</sup> for fine and 55 lbs./ft.<sup>3</sup> for coarse.

**Admixtures.** Frequently substances have been mixed with concrete to accelerate its set, improve its workability, increase its waterproof qualities, harden its surface or lend to it other advantages. Calcium chloride, hydrated lime and kaolin are the chemicals most commonly used. Calcium chloride accelerates the setting of the concrete and acts as a surface hardener; hydrated lime and kaolin render the concrete more workable and thereby reduce somewhat the required quantity of mixing water. Integral waterproofing compounds, put on the market by many manufacturers, are fairly effective for waterproofed cement mortar coats as used in the surface-coating method of waterproofing. In large masses of concrete, however, they are powerless to prevent the passage of water through settlement cracks, fill-lines, joints or pockets.

In general it should be understood that admixtures must not be relied

upon to counteract errors in following the fundamental principles governing the making of good concrete.

**Water.** By the earlier methods of proportioning too much water was almost invariably used, producing an inferior concrete. If water rises to the top when the concrete is spaded or tamped it is a sign of an excessive amount in the mixture. Under such conditions a thin milky layer containing cement and other fine particles, called LAITANCE, will appear upon the surface. These layers are always subject to failure upon exposure to the weather. Excess of water also renders concrete porous and greatly reduces its strength and durability.

## Article 2. Proportioning Concrete

In proportioning the ingredients to form concrete the aim should be to secure a workable and economical mixture with a maximum density and the desired strength. Many methods of proportioning concrete have been proposed, and continual study and research are constantly being applied to the subject.

**Arbitrary Proportions.** A method very generally used until recently is known as the method of ARBITRARY PROPORTIONS. It specifies a ratio of cement, sand and coarse aggregates without reference to their characteristics nor to the amount of water to be used in the mix. Thus a 1 : 2 : 4 mix designated 1 part of cement to 2 parts of sand to 4 parts of broken stone, and such a mixture was considered capable of producing a concrete with a strength of 2000 lbs./in.<sup>2</sup> in 28 days. Workability and flow were obtained by adding water without regard to its influence upon the strength of the concrete. Although it is true that much successful concrete has been produced by this method of proportioning, its adequate strength is in most cases due to over design and high factors of safety. The method is neither exact nor economical.

**Water-Cement Ratio.** The Concrete Institute and the revised building codes of several cities have of recent years adopted a far more exact and economical method, first developed by Professor D. A. Abrams. As has been said, the cement and the water are the two chemically active elements in the concrete, forming by their combination a paste or glue which coats and surrounds the particles of the inert aggregates and upon hardening binds them together. Too much water renders this paste thin and watery and reduces its holding strength. Many tests have shown that the strength of workable concrete remains the same for a given water-cement ratio irrespective of the amounts of the aggregates. A small amount of aggregate will produce a fluid consistency; more aggregate will cause a plastic condition, and still additional aggregate will render the concrete dry and stiff, but the strength will always remain the same. If the concrete is too dry, water must not be added but the combined aggregate must be reduced. The amount of aggregate to be mixed with the water-cement paste should be such that the con-



crete is workable and adapted to its purpose. The degree of workability or consistency of concrete may be measured by the slump test. This test consists in filling with the concrete a metal mould in the shape of the frustum of a cone 12" high and without top or bottom. The mould is immediately raised, leaving the specimen of concrete free. The consistency is recorded in terms of inches of subsidence or slump of the specimen, or slump = 12" minus inches of height after subsidence. A dry mixture will have less slump than a wet one.

As the result of many tests and much study and practical experience, the Joint Committee of the American Concrete Institute published in 1940 the following tables relative to water-cement ratios, strengths, aggregates and consistencies.

**Table I. Water Contents (Gallons per Sack of Cement) for Ordinarily Exposed Buildings and Structures**

Severe or Moderate Climate, Wide Range of Temperatures, Rain and Long Freezing Spells or Frequent Freezing and Thawing					Mild Climate, Rain or Semi-Arid, Rarely Snow or Frost				
Thin Sections		Moderate Sections		Heavy and Mass Sections	Thin Sections		Moderate Sections		Heavy and Mass Sections
Reinf.	Plain	Reinf.	Plain		Reinf.	Plain	Reinf.	Plain	
6	6½		7		6	7		7½	

Attention must be given to what is known as the BULKING OF AGGREGATES. Sand and crushed rock carry from ¼ gal. to 1 gal. of water/ft.<sup>3</sup> This water must be considered in determining the ratio of water to cement. The water carried by sand may also increase the bulk or volume of the sand from 15% to 30%.

Concretes designed with the amounts of water to one sack of cement shown in Table I should have at 28 days the compressive strength shown in Table II

**Table II. Compressive Strengths**

Compressive Strength lbs./in. <sup>2</sup>	Water-Cement Ratio U. S. Gal. of Water per Sack of Cement
2000	8½
2250	8
2500	7½
2750	7
3000	6½
3300	6
3700	5½
4250	5

The architect should indicate upon his plans or in his specifications the strength of concrete to be used and the water-cement ratio necessary to produce the strength. The contractor can, then, under the supervision of the architect, determine by trial batches, composed of different proportions of any satisfactory coarse and fine aggregates locally and cheaply obtainable, a workable mixture of the specified strength and at minimum cost.

**Table III. Grading of Fine Aggregates**

Sieve Size	Total Passing % by Weight
3/8 in.	100
No. 4	95-100
No. 16	45-80
No. 50	5-30
No. 100	0-8

Some building codes designate such tested concretes as CONTROLLED CONCRETES and require that only the desired strength be included in the specifications. Tests using the proposed materials are then made with four different water-cement ratios and at least four specimens from each ratio. That water-cement ratio is used in construction which corresponds to a strength 15% higher than the strength called for in the specifications.

The concrete should be of such consistency that it can be worked readily into corners and angles of the forms without segregation of materials or collection of free water on the surface.

**Table IV. Grading of Coarse Aggregates**

Designated Sizes	Percentage by Weight Passing Laboratory Sieves Having Square Openings							
	2 1/2"	2"	1 1/2"	1"	3/4"	1/2"	3/8"	No. 4
No. 4- 1/2"					100	90-100	40-75	0-15
No. 4- 3/4"				100	90-100		20-55	0-10
No. 4- 1"			100	90-100		25-60		0-10
No. 4- 1 1/2"		100	95-100		35-70		10-30	0-5
No. 4- 2"	100	95-100		35-70		10-30		0-5
3/4- 1 1/2"		100	90-100	20-55	0-15			
1- 2"	100	90-100	35-70	0-15				

**Grading and Size of Aggregates.** Durability, density, watertightness and compressive strength are controlled by the relative proportions of cement and water, by curing and by the grading and size of the aggregates. The last factors are important because they influence to a large degree the economical use of cement, workability, freedom from honeycomb, homogeneous structure and the methods of placing and compacting. The maximum size of the coarse aggregate is determined by the

type of concrete construction, the size of the member and the spacing of the reinforcement. The 1940 Report of the Joint Committee recommends the gradings shown in Tables III and IV.

Table V. Recommended Mixes (4" Slump)

Max. Size Coarse Agg., in.	Estimated 28-day Compression Strength, lbs./in. <sup>2</sup>	Cement Factor. Sacks of Cement per Cubic Yard Freshly Mixed Concrete	Maximum Water per Sack of Cement, gals.	Fine Aggregate, % Total Aggregate	Approximate Weights of Aggregates per Sack of Cement, lbs.		
					Total	Fine Aggregate	Coarse Aggregate
1	2250	4.9	8	40-46	660	280	380
2	2250	4.5	8	37-43	740	300	440
3	2250	4.1	8	34-40	840	310	530
1	2750	5.6	7	39-45	570	240	330
2	2750	5.1	7	36-42	640	250	390
3	2750	4.7	7	33-39	720	260	460
1	3000	6.0	6½	38-44	520	210	310
2	3000	5.5	6½	36-42	590	230	360
3	3000	5.1	6½	34-40	660	240	420
1	3300	6.5	6	37-43	470	190	280
2	3300	6.0	6	35-41	530	200	330
3	3300	5.5	6	33-39	600	220	380
1	3700	7.2	5½	36-42	420	160	260
2	3700	6.7	5½	34-40	470	170	300
3	3700	6.2	5½	32-38	530	180	350
1	4250	8.0	5	35-41	370	140	230
2	4250	7.4	5	33-39	420	150	270
3	4250	6.8	5	31-37	470	160	310

Table VI. Consistencies and Aggregate Sizes

Portion of Structure	Consistency-Slump		Maximum Size Coarse Aggregate, in.
	Max., in.	Min., in.	
Reinforced foundation walls and footings	5	2	1½
Plain footings, caissons and sub-structure walls	4	1	2
Slabs, beams and reinforced walls	6	3	1
Building columns	6	3	1
Pavements	3	2	2
Heavy mass construction	3	1	3 to 6

Tables V and VI present recommended mixes, grading, sizes of coarse aggregates and consistencies.

It will be seen from Table V that increasing the coarseness of the aggregate permits a reduction in the quantity of the cement without

affecting the strength of the concrete. The consistency will become stiffer, however, and the procedure is limited by the demands of workability.

### Article 3. Mixing Concrete

**Mechanical Mixers.** Concrete is most perfectly and economically mixed by mechanical mixers for either small or large constructions. The quantities of the cement, water and aggregate are exactly measured and the ingredients are thoroughly stirred for exact periods of time. For these reasons mechanical mixing is superior to hand mixing and is now employed in all types of concrete work. The mixers consist of drums or barrels rotated by gasoline engines and provided on the inside with paddles or scoops which thoroughly raise, cut and stir the materials as the container turns over. The drum types are discharged through spouts and the barrel types by tilting the barrel. Small, medium and large sizes of mixers are manufactured, containing from 2 ft.<sup>3</sup> to 4 yd.<sup>3</sup>, so that they are available for every class of job.

The materials may be measured by volume or weight, but in both methods allowances must be made for the amount of water carried by the aggregates, since water increases both the weight and the bulk. The most usual method is to measure by volume, a sack of cement weighing 94 lbs. being considered as a cubic foot of cement, and the United States gallon, containing 231 in.<sup>3</sup> and weighing 8.35 lbs., as the unit for water measurement. The specified amount of water must be carefully maintained, some mixers being equipped with water-measuring devices which can be set and locked to prevent the passage of water into the mixer except at proper times. The drums are revolved at a speed of about 200 peripheral feet per minute, greater speed producing a less thorough mix. One minute is generally allowed for mixing each batch of 1 yd.<sup>3</sup> or less with 15 seconds added for each extra  $\frac{1}{2}$  yd.<sup>3</sup> Every effort should be made to hold to the same amounts of the various constituents with equal proportions of water and periods of mixing throughout the batches, so that the same strength, homogeneity and workability of concrete will be maintained during the entire construction work.

When for any reason mechanical mixers are impracticable, the concrete is mixed by hand in tight wood or metal boxes. The dry cement and sand are first shoveled or hoed together until the mixture assumes a uniform color. The coarse aggregates and the water are then added and the whole mass repeatedly shoveled over until it becomes of the same color and homogeneous in composition.

**Ready-mixed Concrete.** In large cities central mixing plants have been established where ready-mixed concrete may be purchased. The concrete is transported to the building site in watertight dumping trucks or in trucks with large revolving drums which prevent separating of the aggregates during the journey. The concrete may be completely mixed including the water before leaving the mixing plant or may be mixed dry

before starting and the water added during transit. When the proportioning and mixing are done by approved methods this system offers great convenience to builders especially in cramped quarters and crowded districts. Not more than  $1\frac{1}{2}$  hours should intervene between adding the cement and discharging at the job.

#### Article 4. Transporting Concrete

**Position of Mixer.** It is important that, after mixing, concrete should be transported to its final resting place in the forms as quickly as possible and with a minimum of separation or segregation of its ingredients. The mixer should therefore occupy a central position and one convenient also for charging with the cement, aggregates and water. The basement of a new building is sometimes chosen for the mixing operations, the materials being dumped from trucks on the street level down into the storage bins and the concrete raised by hoists to the required levels. When the mixer is at the street level, the materials are raised from the trucks by bucket elevators to the bins above the mixer.

**Transporting.** The transporting of the concrete from the mixer to the forms is given careful study to insure efficiency, speed and economy. The usual methods are by buckets, barrows or carts, chutes or spouts, and belt conveyors. Buckets may be either self-dumping by overturning or bottom-dumping. Barrows are the ordinary steel body wheelbarrows containing about  $1\frac{1}{2}$  ft.<sup>3</sup>; carts have two wheels and carry  $4\frac{1}{2}$  ft.<sup>3</sup> The barrows, however, can be used on narrower and less rigid runways and scaffolding. Spouts and chutes are now generally used on projects of any size, because they are both efficient and speedy, and, although their first cost and maintenance are high, they are economical when large amounts of concrete are to be handled. The outfit consists of a tower or steel mast in a central location to the top of which the concrete is hoisted in self-dumping buckets and deposited into the mast hopper. From the mast hopper chutes are run at the proper incline to the various forms. The mast hopper can be readily shifted up and down the mast, and the chutes are capable of being turned at a wide angle to reach any part of the work.

To attain a minimum of vertical supports, counterweight chutes have been developed which have a projecting rear end with a counterweight attached, thus keeping the main portion of the chute in position without supports from below. On larger areas the concrete is sometimes hoisted to the top of a main tower, then sent through a chute to the foot of an auxiliary tower where it is again raised and then distributed throughout the work. If there are two or more towers or masts, the chutes may be hung from cables extending from one mast to the next.

Since it is essential that there should be no separation of the coarse aggregate from the mortar during transportation the slope of the chutes should conform to the wetness of the mix.

### Article 5. Placing Concrete

**Pouring.** Concrete should be placed or poured with care so that the ingredients are not separated, honeycomb is eliminated, reinforcement is well embedded and all parts of the forms are completely filled. A drop of more than 4' into the form should be avoided since a longer fall tends to separate the aggregates, and regular layers with horizontal surfaces should be maintained. Masses of concrete should not be allowed to accumulate at the mouth of the chute to be spread later by shoveling. Sufficient tapping is necessary to render the concrete firm and dense without air holes, and spading along the sides of the forms is often required to produce smooth outside surfaces free from pits and honeycomb and thoroughly to embed the reinforcement. Concrete should, however, be of such plasticity that excessive tamping and spading may be avoided.

**Pneumatic Placing and Pumping.** The placing of concrete by pneumatic gun and by pumping has been developed in recent years. By means of the pneumatic gun the concrete is placed in the forms under air pressure through a discharge hose. A very dense concrete is the result, which is claimed to have greater strength and watertight qualities than are attained by the usual placing. Concrete of medium consistency gives better results than a sloppy mixture. The volume of concrete at each discharge of the gun should not exceed 7 ft.<sup>3</sup>, and the distance from gun to nozzle should be less than 1000 ft. The placing of mortar and concrete on mesh reinforcement around steel members for fireproofing or on self-centering reinforcement to produce curved surfaces or decorative and openwork units is greatly facilitated by use of the air gun.

Concrete in large quantities may be transported by pumping through a pipe line to the forms. A working pressure of at least 300 lbs./in.<sup>2</sup> should be available at the pump, and the pipe should have as few and as easy bends as possible, preferably less than 45°. A charging hopper is used for loading the pump, and deflectors, spouts, hoses and swivel elbows for placing the concrete. Stiff concretes with a slump of 2" or less can be easily handled by pumping, with care in procuring fine sands and not too coarse stone or pebbles. Pipe sizes of 6, 7 and 8" are common.

**Vibration.** Concrete may be compacted by means of electrical or pneumatic vibrators upon the surface of the concrete or upon the outside of the forms. This treatment permits economies through the use of leaner and stiffer mixtures with lower water and cement contents than are possible with the usual method of placement. The concrete should not be so dry as to render pouring difficult, but the slump rarely exceeds 3". Vibration should never be used where decrease in volume of the concrete is no longer apparent or where the concrete has hardened and ceased to become plastic.

**Expansion Joints.** In relatively short buildings expansion and contraction in the mass of the concrete can generally be provided for by additional reinforcement, but in long buildings a freedom to expand and contract should exist in the form of vertical joints through the concrete. The position and number of such joints depend upon the exposure. In severe conditions, the spacing of joints should not exceed 200'; in milder climates 300' may be permitted. Roofs are more exposed to heat and cold than walls, and joints are there often spaced 100' apart. The joints should be located at junctions in L-, T- or U-shaped buildings and at light wells, stairs and elevators. They should extend with complete separation from the footings to the roof.

**Construction Joints.** It is preferable theoretically that each beam, girder, column, wall or floor slab should be poured in one operation to produce a homogeneous member without seams or joints, but in a work of any magnitude this is manifestly impossible. The planes separating the work done on different days, called construction joints, when unavoidable, are placed where they will contribute the minimum amount of weakness to the structure. They should generally be either horizontal or vertical. In walls the joints should be horizontal except in very long walls where vertical joints are also introduced as contraction joints. In beams, slabs and girders continuous pouring for the entire member is particularly desirable, but when necessary, the joints should be vertical and conform to planes of minimum shearing stress, at the center lines of slabs and at the mid-span of beams and girders. Each column should be poured in one operation to the under side of the beam or floor slab above. The vertical joints are formed by placing blocks in the forms to stop off cleanly the concrete on the desired plane. The face of the old work should always be wet and covered with thin cement grout before the new concrete is poured upon the succeeding day.

**Placing in Cold Weather.** Since the chemical processes entailed in the hardening of concrete are dependent upon warmth and moisture, it is evident that concrete deposited in cold or freezing weather will set very slowly and may never attain its normal strength. The most favorable temperatures for hardening are considered to be between 50° and 70° F. It is imperative, then, in very cold weather that the concrete be maintained at a temperature of at least 50° F. for not less than 72 hours after placing for normal cement and 24 hours for high early strength cement. Such a temperature is not difficult to procure with modern methods of construction, and many concrete buildings have progressed without serious interruption throughout our northern winters. The water, sand and stone are heated before mixing, the water to about 150° F. After depositing, the exposed surfaces of the concrete are protected with canvas, tarpaper and salt hay. Protection of the completed story is provided by canvas curtains hung over the exterior wall openings, sometimes entirely covering the finished portions of the building. Artificial heat is then supplied by small stoves called salamanders, distri-

buted over the floor slabs, at the centers of the exterior bays and near the exterior columns. In large construction, where steam is available, steam coils are run through the material piles and to the water barrels to heat them before mixing. Where steam is not available, the water pipes are run through wood fires, and fires are also built in large sewer pipes or under sheet metal forms over which the sand and stone are piled. The canvas curtains remain in place together with the artificial heat from 2 to 6 days, depending upon weather conditions.

**Curing.** If the water evaporates in the early days of setting, the chemical reactions are retarded and a weaker concrete is the result. Floors are, therefore, covered with wet burlap, sand or earth to prevent evaporation, and beams, columns and walls are sprinkled or sprayed. Proper moisture should be present for at least 7 days for normal cement and 3 days for high early strength cement. The water content of heavy massive construction such as footings, dams and reservoirs evaporates slowly, but in slender members like beams, girders and columns and the extensive areas of floors and walls, exposed to air on all sides, the evaporation is rapid, and particular care is required to maintain the moisture in the concrete.

### Article 6. Forms

**Construction.** By forms and formwork is meant the structure of wood or sheet metal which holds the concrete in place until it has sufficiently hardened to support its own weight and any loads from other members of the construction which may come upon it. Since the beams, columns, walls and floors of a building receive their dimensions, surfaces and contours absolutely and entirely from the forms, it is evident that this work must be put together with exactness, upon accurate measurements, true to line, plumb and level. The formwork is held in place with studs, wales, tie rods and posts, and it must be sufficiently strong to carry the entire weight of the concrete within it without deformation or deflection. Its cost is a large part of the expense of concrete; consequently it must be designed and constructed with economy and simplicity, and with especial attention to ease of erection and stripping and capability of re-use in the same building or other buildings. Spruce and S. L. yellow pine are largely used in the East and South for wooden forms. The boards should be planed on one side and two edges, and for floors and walls, tongue and grooved lumber is often used. To obtain very smooth surface on the concrete, plywood or pressed wood is satisfactory. Plaster moulds are necessary for ornamental work, but cornices are usually run from wood moulds. The forms for columns and capitals, now generally made of sheet steel, are manufactured in standard sizes and can be either rented or bought outright. Steel forms for walls and floors are also used, being made in sections capable of extension to suit a variety of conditions.

Forms are constructed as far as possible in units or panels in the shop,



each unit of as large dimensions as can be effectively handled. Besides the column forms, the beam and girder forms are made in large units, as are the floor and wall forms. These units are so designed that they can be taken down without difficulty and without harm to themselves or to the concrete and used again on succeeding stories of the building. Steel bolts and rods and wood battens and wedges are employed as far as possible to fasten the units in place, with a minimum of nailing. Wood form should be thoroughly wet and plywood and pressed-wood forms coated with oil before the concrete is poured. Plaster forms are given two coats of shellac.

For the smaller members and thin walls, self-centering reinforcement combined with concrete applied with an air-gun has been developed, in recent years, to reduce the amount of formwork. The reinforcement may be bent into a large number of shapes, and the concrete can be laid on in any thickness. The restrictions imposed by the expense and lack of pliability of formwork are thus, to a certain extent, removed.

**Stripping.** Forms must not be removed until the concrete is sufficiently strong to carry its own weight and any loads which may be placed upon it. The members in direct compression without bending, such as walls and columns, may be stripped earlier than the floor slabs, beams and girders where bending stresses will exist. Likewise the side forms of beams and girders may be stripped before the bottom forms. In most cases posts and shores are introduced to support the bottoms of beams, girders and floor slabs after the forms are removed. This practice is called re-posting. The posts should remain in place for 28 days; therefore, at the usual rate of pouring one story each week, 3 stories below the story last finished will always be re-posted. It is economical to strip the unit forms from one story and set them in place in the next higher story in one operation.

## CHAPTER IV

### WOOD

#### Article 1. Characteristics of Wood

**Importance of Wood.** The abundance and consequent cheapness of wood in almost all parts of the United States until recent years, the ease of procuring and working it, together with its lightness, strength and durability, have resulted in its wide and general use in every type of building for structural framing as well as for interior finish. At the present time, also, in spite of the fact that lumber is becoming more scarce and more expensive, an enormous amount is still employed throughout our country for a vast number of purposes in building construction. Therefore a thorough knowledge of its characteristics, varieties, selection and methods of use is of first importance to an architect

**Growth of Wood.** Exogenous trees, or those which increase in size by the growth of new wood each year on the outer surface under the bark, are the only trees used here for lumber. They may be classed as the softwoods, or the conifer or needle-leaved trees, known as evergreens, such as pines, spruces, hemlocks and redwoods, which retain their leaves in the winter; and the hardwoods, or deciduous or broad-leaved trees, such as oaks, ash and maples, which shed their leaves every autumn. The structure of both classes consists of longitudinal bundles of fibers or cells, crossed in a radial direction from pith to bark by other fibers called MEDULLARY or PITH RAYS binding the whole structure together. The fibers, ducts and cells vary in the different kinds of trees in shape and disposition and determine to a large extent the appearance, durability and strength of the lumber. Wood is composed chiefly of carbon, oxygen and hydrogen. When dry, about half its weight is carbon and half oxygen and hydrogen.

Wood growth takes place in the spring when the sap contains only soil juices and water, and again in the summer when it has absorbed carbon from the air and is much denser. The SPRING WOOD is therefore lighter in color and more porous than the SUMMER WOOD. These layers of wood are deposited all over the trunk and branches between the bark and the old wood and in cross-section can be recognized as concentric bands, called ANNUAL RINGS. As the tree increases in age the inner layers become choked with the secretory substances peculiar to the tree and fall out of use as sap carriers, serving only as support for the tree, the tubes and cells of the outer layers carrying the sap. There

are, therefore, two kinds of wood in a tree, the dense and strong **HEART WOOD** and the lighter and more porous **SAP WOOD**.

The width of the annual rings varies greatly in different trees, being narrow in slow-growing and wide in fast-growing trees. The width and distinctness of line between the spring and summer woods determine the grain of the wood, either wide and very marked called **COARSE GRAIN** or narrow and less distinct called **FINE GRAIN**. When the direction of the fibers is parallel to the axis the wood is **STRAIGHT GRAINED**; when spiral or twisted, it is **COARSE GRAINED**.

Branches or limbs affect the grain, since the fibers below the branch curve and run out into the branch and those above bend aside and are not continuous with the limb. The tensile and compressive strength of wood is affected by the direction of the grain, the resistance to tension along the fiber being much greater than the resistance between the fibers. Therefore a cross-grained piece of wood when bending will give way from tension between the fibers on its under side much more quickly than a piece in which the grain runs longitudinally. Likewise, knots on the under side reduce the tensile strength because they interrupt the continuity of the fibers (Fig. 1).

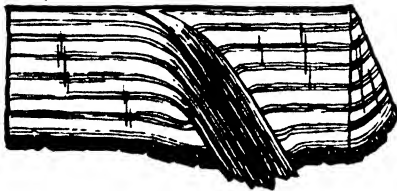

FIG. 1.—Branch Fibers.

The weight of the wood substance is 1.6 times the weight of water, being about the same for all species, but wood floats because the cells are filled with air. The greater weight of green wood arises from the amount of sap and water in the cells of all living trees. Before green wood can become suitable for building timber the moisture and sap which it contains must be expelled, otherwise it will putrefy and decay. During the drying process the wood will shrink and often check and crack. Therefore it is essential that this shrinking and cracking should take place before the wood is incorporated into a building.

**Seasoning.** The moisture content of green lumber is reduced by exposure to air or by heating in kilns. The former process is called **SEASONING** and reduces the moisture content from 30 to 35% down to 12 to 20%. The lumber is stacked in a yard under cover, and the layers are separated by 1" strips placed between them so that air can circulate through the stack. Framing timber is generally dried out in this way and rarely remains in the stack more than 3 or 4 months. Most cracks in the interior of wood frame building are caused by the continuation of the drying-out process with consequent shrinkage after the building is finished. Lumber used for interior finish and floors, where shrinkage is very objectionable and unsightly, is further dried in kilns or tight chambers, where the stacks are subjected to a constant current of air heated to 150° or 180° F., reducing the moisture content to from

3% to 8%. All lumber will absorb moisture quickly after it is dried; therefore all finishing lumber and flooring must be well protected after delivery and not set in place until the plastering is finished and the building thoroughly dry. Since moisture in the air of inhabited buildings is generally about 10%, this may be taken as the measure of dryness of thoroughly seasoned lumber. Framing timber and outside finish may be considered well seasoned with 19% moisture content. Tests show that seasoned wood is also stronger, stiffer and more durable than green woods. In large pieces, however, checking and cracking sometimes offset the strengthening influence of seasoning.

Drying out the moisture causes the walls of the fiber cells to shrink. Side fiber walls shrink more than end walls, thick walls more than thin, summer wood more than spring wood, sap wood more than heart wood. For all these causes internal stresses are set up which result in checking, cracking and warping. Woods vary in their amount of shrinkage, softwoods generally shrinking more than hardwoods.

**Decay.** Decay is the result of the action of certain forms of plant life called fungi, consisting of very fine, threadlike filaments which penetrate the wood in all directions, feeding upon the cells and breaking down their structure. There are four requirements for the growth of the fungi: air, moisture, food and a favorable temperature. If air be excluded, as when the wood is continually under water, the fungi cannot exist and the wood will be preserved intact for very long periods of time. If the wood cells, which form the food of the fungi, be impregnated with poisons, the fungi cease to operate. Such poisoning is accomplished very generally, especially when the wood is intended for locations alternately wet and dry, by the use of commercial preservatives such as coal-tar creosote and zinc chloride. Paint also when applied to dry wood will keep out the dampness and prevent the development of the fungi. The high temperatures of the drying kilns, likewise, kill the fungi as well as expel the moisture; consequently well-seasoned lumber is less likely to decay, if properly protected, than green lumber.

**Defects in Lumber.** Besides decay there are other defects which affect the acceptability of wood for commercial purposes from the standpoints of strength, appearance or durability. These defects are classed as shakes, checks, knots, wane and pitch pockets.

**CHECKS** are cracks arising from the effects of seasoning the wood (Fig. 2,a).

**SHAKES** are cracks formed in the living tree. They may be **HEART SHAKES**, or radial splits occurring in the center of the tree, or **CUP SHAKES** separating one layer or set of annual rings from another (Fig. 2,a).

**KNOTS** are classified as **SOUND**, **LOOSE**, **ENCASED** and **ROTTEN**. They are also divided as to size and diameter into **PIN**, **SMALL**, **MEDIUM** and **LARGE KNOTS**. **SPIKE KNOTS** are those sawn in a lengthwise direction.

**PITCH POCKETS** are well-defined openings between annual rings con-

taining solid or liquid pitch. They are classed as **VERY SMALL**, **SMALL**, **MEDIUM** and **LARGE** (Fig. 2,*b*).

**WANE** signifies bark or lack of wood on the edge or corner of a piece. If wane is not desired, square edge should be specified.

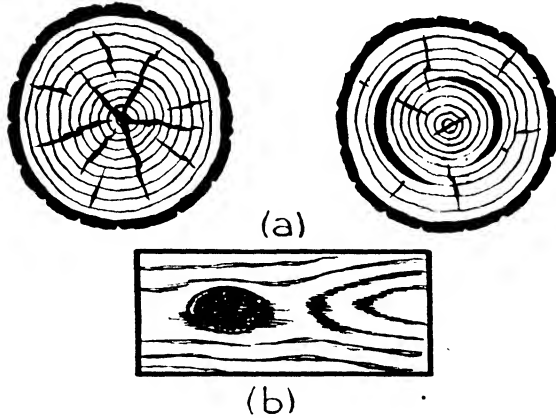

FIG. 2.—Defects in Timber.

Any one of these defects, when excessive, should condemn the lumber in which it occurs.

## Article 2. Grading of Wood

**Grading.** Much attention has been devoted in recent years to the systematic classifying of lumber into grades according to its appearance and its strength. Especially as regards strength, the lumber associations, such as the National Lumber Manufacturers Association, the Southern Pine Association and the West Coast Lumbermen's Association, together with the Department of Agriculture at Washington, having made exhaustive tests and careful studies, published specifications and rules with the result that the various grades of lumber as now sold throughout the United States can be depended upon to meet definite requirements in regard to strength and density. The importance of such grading is very evident when it is remembered that wood as a material is not of one quality or of one strength, as is structural steel, but varies through a wide range according to its species, its density and its freedom from defects. The ability to rely, then, upon exact working stresses in the grades of the various woods, without being forced to use an excessive factor of safety to cover unknown qualities of material, produces very real economies for the user of wood and is of great sales value to the lumberman. Higher allowable working stresses for good structural material are consequently also being permitted by the various municipal building codes.

These grades are based on the strength of clear, dense, green material in each species as shown by its resistance to bending, compression perpendicular and parallel to grain and shear. The various grades, called stress grades, are distinguished by their allowable stresses determined as percentages of the allowable stresses in the clear, dense, green material. These percentages depend upon variations in quality such as density in terms of annual rings per inch, slope of grain, knots, shakes and wane. No material of less than 50% grade should be used for structural purposes.

The grades are distinguished by their allowable working tensile stresses in pounds per square inch, as 1400# Beech or 1600# Oak, and sometimes by a name in addition, as 2000# Select Structural L.L. Yellow Pine and 1200# Framing and Joist Douglas Fir.

Softwood, as it comes from the sawmill, is divided into three main classes as follows:

- (a) Yard lumber.
- (b) Structural material.
- (c) Factory and shop lumber.

**YARD LUMBER** comprises the wood found most generally in retail lumber yards for general utility purposes. It includes boards and siding less than 2" thick, finishing material, flooring, ceiling, lath, pickets, shingles, planks less than 4" thick, scantlings less than 5" thick and heavy joists 4" thick. The much-used 2" x 4", 3" x 4", 4" x 4", 2" x 6" and 3" x 6" studs and the ordinary run of joists and rafters are included in this class. Where beams, girders or posts are required to meet definite working stresses they should be chosen from structural material.

**STRUCTURAL MATERIAL** is intended primarily for load bearing and is divided into grades according to density, strength and stiffness. Such items as beams, girders, posts and sills, over 5" in their least dimensions, together with heavy plank flooring, are included in this class, definite stress values being assigned to each grade.

**FACTORY AND SHOP LUMBER** is graded largely by appearance and upon the presence or absence of blemishes and defects. It is intended for further manufacture into doors, window sash, millwork, interior trim, patterns, toys and other industrial commodities.

**Yard lumber** is generally graded in six grades as follows: Grades A, B and C and Grades No. 1 Common, No. 2 Common and No. 3 Common, Grades A and B often being combined into a grade called Grade B or Better. The first three grades are for interior trim and fittings either painted or with natural finish. The last three grades are used where appearance is not so important. Unless subjected to special loads ordinary studding is taken from Nos. 1 or 2 Common Grade.

**Structural Timber.** Structural material is now generally graded according to density and freedom from defects in agreement with the recommendations of the National Lumber Manufacturers Association and the Department of Agriculture, as follows:

Species of Timber	Grades
Douglas Fir, Coast Region	{ Dense Select Structural { Select Structural { 1200# Framing and Joist { 900# Framing and Joist
Larch	{ Select Structural { Structural { Common Structural
Long-Leaf Southern Pine	{ Select Structural { Prime Structural { Merchantable Structural { Structural Square Edge and Sound { No. 1 Structural
Short Leaf Southern Pine	{ Dense Select Structural { Dense Structural { Dense Structural, Square Edge and Sound { Dense No. 1 Structural
Redwood	{ Close-grained { Dense Select All-heart { Select All-heart

The following woods are classified into grades according to strength and are designated by the allowable bending stress.

Cedar.	Fir, Balsam.	Pine, Calif., Idaho, Sugar,
Cypress.	Hemlock.	Norway, White,
Tamarack.	Oak.	Lodgepole, Ponderosa.
Douglas Fir, Rocky Mt. Region.	Spruce.	

**Factory and Shop Lumber.** Factory and shop lumber is classified in four grades, A, B, C and D, the first two being suitable for natural finishes and the last two for painted work. This lumber is further cut up into sizes adaptable to the manufacture of sash, doors and interior trim, and the cuttings are again graded according to the percentage of good material procurable from each piece.

**Qualities.** The lowest qualities that should be used for framing and structural purposes in the dry and protected locations usual in buildings are as follows:

- (a) For lumber less than 2" thick and for all studding, No. 1 Common, Yard lumber.
- (b) For joists and rafters, Common, Structural material.
- (c) For girders, posts and heavy beams, Structural, Select Structural or Structural Square Edge and Sound, depending upon the species of wood.

The dense and select grades of structural material should be chosen in building construction whenever the stresses are sufficiently high to require absolutely dependable quality of material. Otherwise these grades are used only for trestles, bridges and exposed positions under heavy loads.

### Article 3. Conversion of Wood

**Conversion.** Lumber is generally sawed in parallel slices longitudinally through the log with gang or circular saws, the edges of the slices being trimmed afterward by a circular saw. Such lumber is called **BASTARD SAWED OR FLAT SAWED**. It will be seen that about 25% of the lumber will come from the central part of the log; and, the cuts being almost at right angles to the annual rings, the grain on the face of the lumber will show in long parallel lines. Such grain is called **EDGE grain** or **COMB grain** and presents a very durable wearing surface, flooring boards often being chosen from this material. The remaining 75% of the lumber is cut more or less tangentially to the annual rings and the material is said to have **FLAT grain** (Fig. 3,*a*). The angle to the horizontal axis of a piece at which the grain runs, called **SLOPE OF GRAIN**, is an important factor in grading the piece.

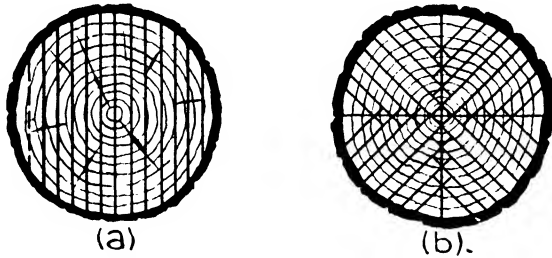

FIG. 3.—Methods of Sawing Logs.

Lumber is also quarter sawed to obtain all boards with edge, comb or rift grain for flooring or to show the beauties and figuring of the grain, as in quartered oak. By this method the log is first sawed into quarters and then each quarter is sawed again into slices with cuts at an angle of  $45^\circ$  to the quartering cuts, all the cuts being nearly at right angles to the annual rings. It is, however, a less economical method than flat or bastard sawing (Fig. 3,*b*).

Framing timber is usually sawed in even dimensions such as 2" x 4", 4" x 6", 2" x 8" and 2" x 12". Floor joists and studding are sawed 2", 3" and 4" thick. Timber and boards are cut in even lengths as 10', 12', 14' and 16'. The actual cross-sectional dimensions of commercial lumber are somewhat less than the nominal dimensions on account of the sawing, planing or surfacing and the shrinkages in the drying kilns. Lumber is not regarded as having short dimensions unless the actual dimensions fall below certain standards approved by the Department of Commerce. Structural lumber is generally  $\frac{1}{2}$ " less each way than the nominal sizes; dressed or surfaced boards are usually from  $7\frac{3}{8}$ " to  $\frac{3}{8}$ "



less in thickness and  $\frac{3}{8}$ " to  $\frac{1}{2}$ " less in width than the nominal sizes. Thus an 8" x 12" girder will be actually  $7\frac{1}{2}$ " x  $11\frac{1}{2}$ ", and a 1" x 10" dressed board will be  $2\frac{5}{32}$ " x  $9\frac{1}{2}$ ". Calculations for strength of timbers should always be made upon the actual rather than the nominal dimensions.

Framing timber, planks and boards are sold by the thousand board feet, that is the number of superficial feet the piece would contain if sawed into boards 1" thick. To compute the board measure of any timber or board, divide the sectional area in inches by 12 and multiply by the length of the board in feet. Thus the number of board feet in a 2" x 4" stud 8'0" long is  $\frac{2 \times 4}{12} \times 8$  or  $5\frac{1}{3}$ ' board measure. A 1" board 10" wide and 12'0" long contains  $\frac{10 \times 1}{12} \times 12$  or 10 board feet, and a 6" x 10" girder 16'0" long contains  $\frac{6 \times 10}{12} \times 16$  or 80 board feet. Veneers are sold by the square foot, lattice and mouldings by the lineal foot and shingles and laths in bunches or by the thousand.

#### Article 4. Selection and Strength of Wood

**Selection of Wood.** In selecting the kind of wood its adaptability to the intended purpose should be considered. For framing timbers, woods that are abundant, cheap and obtainable in large dimensions are selected. In some cases extra strength, stiffness and durability are the most important considerations. For outside finish, ease of working and freedom from warping and checking are desired. For floors, wearing qualities are required. For interior finish, ease of working and ability to take paint well are necessary for painted work, and color and grain control the choice for work in natural finish.

In general, the kind of wood to be economically used will vary in different sections of the country as determined by the species ordinarily found in the local lumber yards. The most abundant varieties of timber now cut are as follows:

##### WESTERN UNITED STATES:

Douglas fir.  
Redwood  
Western white and yellow pine.  
Larch.  
Western hemlock.  
Red cedar.  
Sitka spruce.

##### EASTERN UNITED STATES:

Yellow pine and white pine.  
Eastern hemlock.  
Eastern spruce.  
Oak.  
Poplar.  
Cypress.  
Chestnut.  
Maple.  
Birch.  
Gum.

As a rule, the woods grown in the vicinity of the market will be less costly than those requiring long railroad hauls. There are exceptions, however, in the case of redwood, Douglas fir and Western white pine, which are now found in many Eastern lumber yards. Almost all red cedar shingles come from the Pacific coast.

The woods most commonly used for various purposes in building are as follows:

POSTS, GIRDERS, TRUSSES and HEAVY FRAMING: dense yellow pine, Douglas fir, white oak, larch, spruce.

LIGHT FRAMING, STUDS, JOISTS and RAFTERS: spruce, hemlock, common yellow pine, larch.

OUTSIDE FINISH: white pine, cypress, redwood, Western white pine, poplar, spruce.

SHINGLES: cedar, cypress, redwood.

SIDING and CLAPBOARDS: cypress, redwood, larch, spruce.

SASH, DOORS and FRAMES: white pine, fir, Western white pine.

FLOORS: oak, maple, yellow pine, birch, beech.

LINEN and WOOLEN CLOSETS: red cedar.

INTERIOR FINISH, PAINTED: white pine, birch, gum, Western white pine, redwood, poplar.

NATURAL: oak, chestnut, walnut, mahogany and any hardwoods. Also white pine, birch, redwood, cedar.

It will be seen that several options in wood are available. Architects should take advantage of those kinds most easily procurable.

**Strength.** Lumber may be divided as to strength into the stout, dense and stiff varieties such as dense yellow pine, white oak and Douglas fir, which should be used wherever especial strength and stiffness in posts, girders, trusses or heavy framing is required, and the lighter varieties with more open grain such as common yellow pine, spruce and hemlock for studding, floor joists, rafters and light framing. Douglas fir is becoming very popular for all sorts of framing because it is light in weight as well as strong. In the South and Middle West, yellow pine of various kinds is used for many purposes; in the West, Douglas fir, Western hemlock and redwood, and in the East, spruce, Eastern hemlock and yellow pine.

Its cellular structure renders wood much stronger against tensile stresses with the grain than across the grain, since the fibers are harder to break in the direction of their length than to pull apart from each other. Also the tubes have more compressive strength parallel to their axes than across them and are more easily split apart longitudinally than sheared across transversely.

The working unit stresses per square inch recommended by the Forest Products Laboratory of the Department of Agriculture are given in Chapter XVIII.

## Article 5. Principal Woods for Building Construction

### A. CONIFERS, EVERGREENS OR NEEDLE-LEAFED TREES, KNOWN AS SOFTWOODS

**SOUTHERN YELLOW PINE.** Grown throughout most of the Southern states, it is divided botanically into long-leaf and short-leaf yellow pine. The long-leaf pine contains a large proportion of strong, heavy, dense, close-ringed material; the short-leaf pine has more soft-textured, open grain and light-weight wood. The same range of strength value may, however, be found in both species, and there are no fundamental differences which make all the wood of one species preferable to all the wood of the other for any given purposes. The former designations of Georgia Pine, North Carolina Pine, etc., are no longer recognized officially although they may still be used to some extent among lumber dealers.

Southern yellow pine is employed very generally for many purposes, especially for heavy and light framing and for boarding, and is the most extensively cut of any wood in the country.

**NORTHERN WHITE PINE.** Northern or Eastern white pine, also known as soft pine, was the first lumber used by the settlers of New England and the Northern Atlantic States. It is soft, of fine grain, easy to work and withstands exposure to weather. Its use continued in the Eastern part of the United States for all purposes until it has become almost extinct in lumbering sizes and is very high in price. White pine is particularly valuable for window sash and doors, window and door frames, interior and exterior trim and wherever a soft, workable wood is required with a minimum of shrinking and warping. Since it has become so scarce and expensive many species of Western white pine are used in its place, such as California and Idaho pine, Ponderosa pine and sugar pine. These all come from the Rocky Mountains or the Pacific coast districts, and none of them quite equals Eastern white pine in quality, freedom from pitch or durability. White wood or poplar, gum and birch are also used in place of white pine.

**DOUGLAS FIR.** Douglas fir, also known commercially as Oregon pine, is neither a fir nor a pine but is the sole merchantable representative of the species *Pseudotsuga taxifolia*, which was segregated in 1825 by David Douglas, a Scotch botanist. It grows in great abundance in Washington and Oregon, and reaches enormous size, commonly over 200' high with diameter of 5' to 6'. Douglas fir has unusual strength and density and ranks equally with Southern yellow pine as to the high working stresses allowed for these qualities. It is, however, softer, less pitchy and lighter in weight than Southern pine, and it consequently handles and works more easily.

Because of the great size of the logs and its close dense grain, Douglas fir is available for an endless variety of purposes. Its strength, stiffness and large dimensions render it very suitable for heavy framing, and

its lightness makes it convenient to handle for the studs and joists of light framing. It is also excellent for boarding and siding, window sash and frames, doors and interior finish.

**SPRUCE.** Spruce is divided commercially into two varieties, the Eastern spruce and the Western or Sitka spruce. The Eastern variety was used in very early days by the settlers of New England for ship-building, framing and general construction. Although the supply of Eastern spruce is decreasing it is still largely employed in certain localities for studding, light framing, siding, concrete formwork, scaffolding and wood lath.

Sitka spruce is stronger and grows in greater dimensions than Eastern spruce. Its best-known use is in airplane construction, for which it is suitable because of its texture, strength, lightness and shock-resisting qualities, but it is likewise favored in the West for interior and exterior finish, siding and general construction work and is sold also in the Eastern markets.

**HEMLOCK.** Hemlock is also divided commercially into an Eastern and a Western or West Coast variety. The Eastern hemlock has been used for many years for studding, joists, light framing and rough boarding. It is not so tough as spruce and is more brittle and liable to splinter, but yet has a wide use in certain localities. Both hemlock and spruce hold nails well and are easier to work than yellow pine.

West Coast hemlock is harder, stronger and stiffer than Eastern hemlock and is much used for flooring, paneling and interior trim, as well as general structural purposes, on the Pacific coast.

**REDWOOD.** Redwood, or *Sequoia sempervirens*, grows only on the Pacific slope of the Coast Range Mountains in California in a strip extending from the Oregon line south to Santa Barbara. Yet the trees are so immense and the growth so close that the stand of timber is the heaviest in the United States, with individual trees 20' in diameter and over 300' high. Another variety of redwood, *Sequoia gigantea*, comprises the famous "big trees" of California. These are even more gigantic than the *sempervirens* but are protected by the Government and are not cut for lumber.

Redwood has a cherry color, is soft, clear, fine-grained, durable, light in weight and non-resinous, but is not so strong as Southern yellow pine or Douglas fir. On the Pacific Coast, redwood has been used for years for all kinds of construction and finish. Of recent years it has been introduced in the Middle West and Eastern markets in the shape of sash, doors, frames, shingles and wide boarding. Its use is rapidly growing.

**SOUTHERN CYPRESS.** Southern cypress is grown in the swamp lands of the Southern states. It is soft, easily worked, clear and extremely resistant to decay in the presence of moisture. For these reasons it is largely used for exterior siding and finish, gutters, blinds, sash and doors, cornices, railing, steps, shingles and water tanks.

**CEDAR.** Western red cedar is the largest and most generally used of the cedars and is grown in the Pacific Northwest. Because it resists decay and holds its position well without warping or checking, it is largely manufactured into siding and shingles. It is reddish brown in color, soft, even-grained, clear and light in weight. Most of the cedar shingles in the United States are now made of Western red cedar, although some are sawed from Northern and Southern white cedar.

Eastern red cedar grown in Tennessee and other Southern states is very aromatic and supplies the material used in linings of moth-proof closets.

#### B. DECIDUOUS OR BROAD-LEAFED TREES, KNOWN AS HARDWOODS

**OAK.** Oak is the most abundant wood in the Mississippi Valley and the Appalachian region. It is hard, heavy and strong, and was formerly much used for posts, girders, beams and heavy framing. Yellow pine and Douglas fir have now largely taken its place for such purposes, but oak is still employed for furniture, interior trim and flooring. It is often quarter-sawed to show the grain and markings. White oak is considered to be the best variety for trim and flooring.

**BIRCH.** Birch is grown in New England, New York, Pennsylvania and the Lake district, yellow and sweet birch being the two varieties used commercially. It is fine and even-textured, hard and strong, and takes a beautiful natural or painted finish. Much birch is used for veneers, interior trim, doors, paneling and flooring. Because of its hardness, mouldings and sharp carvings are often made of birch in connection with white pine and other softwood paneling.

**MAPLE.** Commercial maple comes largely from the Lake district and has fine and dense texture with great strength and durability. It is used for doors and paneling and especially for finished flooring and stair treads.

**POPLAR.** Poplar, as grown for lumber, is most abundant in the Appalachians. It is soft, fine-textured, clear, easy to work and light in weight. In New England and New York it is often known as whitewood. Owing to the scarcity of white pine, a great deal of poplar is used as a substitute in the making of doors, sash, shelving, trim and general millwork.

**MAHOGANY.** True mahogany is grown only in Florida, the West Indies and Central America. So-called mahogany also comes from Africa. It is hard and heavy and is naturally a light reddish brown in color but takes darker stains very readily. The grain may be plain or figured. Furniture, paneling, interior trim and doors are largely made of mahogany for the better class of hotels, office buildings and residences.

**WALNUT.** American black walnut was formerly much used for interior trim and is now returning to popularity. It is hard, clear and dark brown in color. Circassian walnut originated in Asia and was transplanted to Europe. It has very finely figured grain much used for interior paneling and is known commercially as English, French and Italian walnut.

## CHAPTER V

### BRICK

#### Article 1. Manufacture

**Use of Brick.** Brick is the oldest of all artificial building materials, and even at the present day it is the most extensively used element in construction with the exception of concrete, steel and wood. Indeed, it is probable that, as the supply of lumber decreases, brick, concrete and terra cotta will largely take the place of wood for exterior walls.

Brick is more durable than stone against weather, acids and fire when above ground, but common brick is not suitable for work underground. It is less expensive than stonework but costs more than concrete. Brickwork is adapted to a great variety of uses, such as exterior and interior walls, fireproofing, backing of stone and terra cotta and for decorative purposes. A wide range of color is obtainable in the bricks themselves as well as a great variety of surfaces, consequently a multitude of effects may be presented by combinations and contrasts of shades, textures and jointing.

**Ingredients.** Bricks are made of hard-burned clay, the proper material for their manufacture being found in almost all inhabited parts of the country. Brick clay may be divided into two classes: (a) the non-calcareous clays composed of sandy clay (silicate of alumina) with feldspar grains and iron oxide which when burned becomes buff, red or salmon in color; and (b) the calcareous clays or marls, containing upward of 15% of calcium carbonate, which when fired have a yellowish color. Iron oxide varies from 2% to 10% and the red color depends largely on this content. When lime is present in the clay it should be finely divided because it is calcined in the burning and later slakes upon exposure to the weather. Consequently any sizable fragments will expand and chip or spall the brick.

**Manufacture.** The clay is first prepared by washing to free it from pebbles, soil or excessive sand, then ground and reduced to a plastic mass in a pug mill, consisting of a horizontal cylinder with revolving blades which cut up the clay and mix it thoroughly. The clay is then moulded into bricks by either the **SOFT MUD**, the **STIFF MUD** or the **DRY-PRESS** process.

**SOFT-MUD PROCESS.** The clay is mixed with water to a soft and plastic mass and is then pressed into moulds by hand or machine. The moulds are dipped in water or sand to prevent the clay from adhering to them, the brick being accordingly termed slop-moulded

or sand-struck. All hand-made brick are produced by the soft-mud process.

**STIFF-MUD PROCESS.** The clay is mixed with only sufficient water to render it plastic. It is then forced by machinery through a die, forming a long continuous ribbon with a cross-section of the size of a brick. The individual bricks are cut off automatically by means of wires, and may be either end cut or side cut, the cut surfaces having a rough texture while the other surfaces are smooth.

**DRY-PRESS PROCESS.** The clay has only its natural water content and is pressed into the moulds by hydraulic power. Very perfect face brick are formed by this process.

**DRYING.** After moulding, bricks are stacked in open sheds or in drying ovens where they are allowed to dry before burning. This process may consume from 7 days to 6 weeks, depending upon the water content of the clay.

**BURNING.** After the brick are sufficiently dry to hold their shape they are placed in the kilns for burning or firing. Kilns may be UP-DRAUGHT or DOWN-DRAUGHT. The original up-draught kilns were constructed by piling the bricks themselves to form a row of arched openings in which the fires were built. Bricks were piled loosely above these arches and, as the kilns were burnt, those nearest the fire were so intensely heated that they became partly vitrified and almost black while those at the tops of the kilns were but slightly burned and pink in shade, with a gradual gradation of color between. It is from these differences of burning that the terms ARCH BRICK, CHERRY BRICK and SALMON BRICK originated. The extent of firing in the kiln is measured by the amount of shrinkage in the top of the pile. This sort of kiln is still used, especially in small brick yards. Modern up-draught kilns have permanent enclosures and the heat is generated in ovens with iron grates outside the walls. The bricks are piled inside the enclosures with arches as before and the heat passes through the arches and up through the bricks, which are burned much more evenly by this method.

Down-draught kilns are usually circular in plan and in the shape of bee-hives. The heat comes from fire-boxes built outside the ovens and, passing through vertical flues, enters the kiln near the top. It is then drawn downward by the draft, passes through the bricks, under the floors and then up the chimneys. Terra cotta and pottery were in the past burned in down-draught beehive kilns, and it is generally considered that all kinds of clay wares including bricks can be more evenly burned by the down-draught method.

Continuous up-draught kilns are now widely used in large brick yards. They consist of several compartments connected by heat flues with the stoves. The fire is kept continually burning in the stoves, and the heat is turned off and on in the ovens at will. By this method, bricks may at the same time be in course of charging in one compartment, burning in the next, cooling in another and unloading in a fourth,

without interference with each other and without lowering the fire. In the old-fashioned kilns, it was necessary to put out the fire, allow the bricks to cool, dismantle the kilns, haul away the bricks and then build up new arches of green bricks before burning could be re-commenced.

The latest development in brick kilns is the tunnel kiln, consisting of a long tunnel divided into 3 compartments, the pre-heating chamber, the firing chamber and the cooling chamber. The brick are loaded on cars which are pushed into the pre-heating chamber where they remain under a low heat for about 36 hours. They then proceed to the firing chamber for burning under temperatures of about 1600° F. at the entrance to 2000° F. at the exit. The gas or oil burners are situated in this chamber. The brick then pass to the cooling chamber where they rest until they can be handled. The temperature in the pre-heating chamber is derived from hot air passing in from the firing chamber. The cars enter a door at the end of the tunnel and are pushed through the chambers, one car against the next, by a plunger outside the kiln. The temperature can be absolutely controlled by means of pyrometers regulating the gas or oil burners. Brick are generally dried at 212° F. and then water smoked at 800° F. in separate ovens before entering the tunnel kilns. This preliminary process expels the chemically combined water.

The burning or vitrification of brick takes place at 1600° to 2000° F., when the silicates melt and fill the spaces between the more refractory materials, so binding or cementing them together. By vitrification the bricks become harder, stronger, more dense and less absorptive.

**Sizes of Brick.** Brick were formerly made in a variety of sizes depending upon the locality. Of recent years the Common Brick Manufacturing Association together with the Department of Commerce have adopted as a standard size of common brick, the dimensions 2¼" thick, 3¾" wide and 8" long. Face brick, enamel brick and glazed brick sometimes differ from these dimensions, and in making detailed drawings the exact size of the brick chosen should always be ascertained. The end of a brick is called the **HEADER** and the side is called the **STRETCHER**.

Moulded brick is a general name for brick moulded in special shapes for ornamental purposes such as mouldings, belt courses, cornices and window trim or in wedge shapes to form arches and round chimneys. Architectural terra cotta has now largely taken the place of ornamental shapes in brick, but for arches and chimneys brick will be moulded upon order for any radius required.

**Kinds of Brick.** The kinds of brick most generally used in building are common brick, face brick, enamel brick, glazed brick and fire brick.

**COMMON BRICK** refers to the ordinary brick used for walls and piers, the backing of terra cotta and stone, for fireproofing and for all purposes where a special color, texture or shape is not required. It is also used



in the well-burned qualities for the face or exposed surfaces of walls where certain effects are desired, as in the combination of dark headers with deep red stretchers.

Common brick is divided into the following three grades by the American Society for Testing Materials; Grade SW for exposure to freezing in wet locations, compressive strength 2500 lbs./in.<sup>2</sup>; Grade MW for exposure to freezing in dry locations, compressive strength 2500 lbs./in.<sup>2</sup>; Grade NW for backing and for interior masonry or where no freezing occurs, compressive strength 1500 lbs./in.<sup>2</sup>

**FACE BRICK** is a trade name to denote a brick especially made or selected for its color, shape, evenness or irregularity of contour and surface texture or for other characteristics to give a desired effect. It is used upon the exposed surface of a wall and may be backed with common brick.

**GLAZED BRICK** is a trade name for face brick having a smooth outer face with a dull satin or high gloss finish. The bricks are made of fire clay very perfectly formed in standard sizes and are finished with ceramic glaze, salt glaze or clay coated glaze.

The ceramic glaze is a compound of chemicals sprayed upon the brick before burning. The sprayed unit is then subjected to a temperature of 2000° F. which fuses the glaze to the body. It produces a surface with matt or high gloss in a great variety of colors, approximately 45 of which have been standardized.

Salt glaze consists of sodium iron silicate applied to a fire-clay body as a vapor while the units are at a temperature of 2000° F. The glaze, being transparent, presents the color of the fire-clay body, gray, cream or buff, under a lustrous gloss.

Clay coated is a smooth unit made from fire clay with a dull, non-reflecting vitreously applied surface. The colors have a great variety, and the tones are generally softer than in the ceramic glazes.

Glazed brick are load-bearing, fire-resistant and impervious; their glazes are permanent and will withstand hard usage. They are usually formed with vertical hollow cores through the body and with scoring on the back.

**FIRE BRICK** are made from a mixture of clay, silica, flint and feldspar; as they have a very high fusing point they can be subjected to great heat, as in furnaces, ovens, fire-boxes and chimney stacks. They are softer than common brick, and white or light brown in color.

**Brickwork.** To be strong and durable all brickwork must be laid up with each brick set in a bed of mortar and with mortar filling all vertical joints, the strength and durability depending upon the strength of the bricks and the mortar and upon the workmanship, that is, the manner in which the bricks are laid and bonded together. Tests at the Bureau of Standards in Washington on brick walls show that when the mortar beds were smooth and the vertical joints well filled the walls

were from 24% to 109% stronger than those with furrowed mortar beds and carelessly filled vertical joints. Joints in common bricks are from  $\frac{3}{16}$ " to  $\frac{1}{2}$ " thick ordinarily, although they may often be a matter of design and, to give a desired effect, are sometimes 1" thick.

**Striking Joints.** On sides of walls which are to be covered up from view the mortar projecting from the joints is merely cut off with trowel flush with the face of the wall. Wherever the wall is exposed to view, however, the joints should be struck or finished in some manner. This may be done with the point of the trowel or by a special tool called a jointer (Fig. 1).

**Face Brick Joints.** The joints in face brick naturally vary with the kind of brick. Where rough brick is used and texture is desired in the wall a wide joint, either full, tooled, raked or struck, is appropriate. For smooth-face brick, such as light-colored brick in a shaft or court, a



FIG. 1.—Brick Joints.

narrow joint with white cement and fine sand mortar may be employed. Smooth red face brick is not used as much as formerly. A piece of brickwork showing a finished face is usually set up as a sample for the approval of the architect (Fig. 1).

**Freezing Weather.** Lime mortar should not be used in freezing weather, but cement mortar is not injured by frost, after the initial set. Precautions must be taken, however, by heating the materials and by protecting the wall to prevent freezing before the set takes place. A sudden thaw is liable to soften the mortar and cause settlement if not more serious trouble.

**Selection.** Great judgment is possible in the selection of brick to gain pleasing effects in color or shade, to give interest to the wall or to arrive at certain practical ends. An almost unlimited variety in color, tone and texture is available in the market, and a very wide range of choice is consequently at hand. In a locality free from smoke and soot, brick of varying shades or with rough textures can be employed effectively; in many cities where soft coal is burned or where there is much manufacturing, a smooth-faced brick of dark color which the rain will wash may seem more practical. This, however, is very much a matter of opinion. The same question arises as in the selection of building stones, whether a warm color and agreeable texture, even if somewhat stained and begrimed, is not after all more satisfying than a cold

and forbidding color and a hard, smooth, metallic, though perhaps cleaner, surface.

In courts, light shafts or alleys, a white enamel or light-colored pressed brick is desirable to reflect light into the building, and because it can be washed when dirty. Such brick should always be laid in a very narrow full joint of white cement mortar. Light-colored pressed brick have to a great extent taken the place of white glazed brick for these purposes.

## Article 2. Brick Masonry

**Thickness.** According to modern methods of construction the thickness of brick walls generally varies according to height, length and the requirements of local building laws from 8" to 24", pilasters or piers of an additional thickness of 4" or 8" being introduced to carry the concentrated loads. In skeleton frame construction wherein the walls are carried by the structural frame at each floor level the thickness is usually fixed at 12" by the building codes. See Chapter XVII, "Brick and Stone Construction."

**Equipment.** When more than twelve brick masons are employed in the construction of a building a machine mixer for the mortar is more economical than mixing by hand. In any event the mixing should be done at a central point so that the transporting distances to all parts of the building are nearly equal. The dry materials, the brick and the water should also be conveniently placed. Hoists are often installed to carry up the brick and mortar. These may run through temporary hatchways in the floors, in exterior towers or in one of the elevator wells.

Common brick is now generally laid from the inside and face brick from the outside of the wall, the first because ordinary horse scaffolds, consisting of masons' horses and planks, can be set up on the floor beams, and the second because the laying, bonding and pointing of the face brick can be more conveniently accomplished from the exterior of the wall

Outside scaffolding for masonry and concrete buildings are generally of the putlog type. These consist of a line of vertical wood poles or scantlings placed about 7'0" apart and 6'0" from the wall. To these poles are fastened cross pieces of wood called putlogs which are built into the wall at their inner ends and support the floor planking of the scaffold. Galvanized-iron pipes are now often used in place of the wood poles and putlogs because of superior strength and fire-resistance.

Swinging exterior scaffolds are most used for steel frame buildings, where the wall is carried at each story. Steel drums are fastened to outriggers from the highest parts of the steel frame. Upon these drums are wound wire cables supporting the swinging scaffolds on which the masons work and from which the drums are controlled. By this means it is possible to carry the brick walls up to within two stories of the

floor arches and to begin the work at the third or fourth story when material for the lower floors is not delivered. Two crews of masons can also be used at different levels upon the face of the building.

**Bonding.** Bricks must be so laid that they will tie in with each other in order that the wall will act as one mass and concentrated loads will be distributed over the whole area. The three most usual bonds are Common Bond, English Bond and Flemish bond (Fig. 2).

**COMMON BOND** consists of five stretcher courses and then a header course. It is generally begun with a row of headers or soldiers as the bottom course.

**ENGLISH BOND** consists of alternate courses of headers and stretchers.

**FLEMISH BOND** consists of alternate headers and stretchers in each course.

The English and Flemish bonds are more expensive to lay but form very strong and well-bonded walls. The Flemish bond is much used as

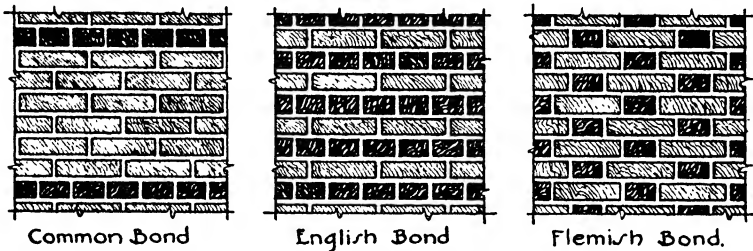

FIG. 2.—Brick Bonds.

a face bond with dark headers and red stretchers to give a texture and variety of color in the wall.

Face brick are usually tied to the backing with ties of galvanized steel built into the joints, especially when the face brick are of a different thickness from the common brick backing so that the horizontal joints are not always on the same level. When the brick are merely tied and not bonded, the facing is not included in determining the thickness of the wall. A better wall results when the face and backing brick are of the same thickness and the face brick is bonded into the backing by one of the bonds just described. Facing and backing should be built up at the same time.

In stone facing, unless every second course of stone extends back into the brick backing at least 8", the stonework is not considered part of the load-bearing wall and the brick backing must be thick enough in itself to carry all loads. The backing is carried up with stone facing, and the course next the stone should be laid in non-staining cement mortar if limestone, sandstone or marble is used. When architectural terra cotta is the facing, the brickwork should extend into all open voids in the back of the terra cotta to form a bond.

**Curtain Walls.** In buildings of skeleton steel frame construction the outer masonry walls are supported at each story by means of spandrel girders and therefore carry only their own weight. Such walls are called curtain or spandrel walls. On alley and lot line exposures the curtain walls are generally 12" thick, of brick, to act as adequate fire protection.

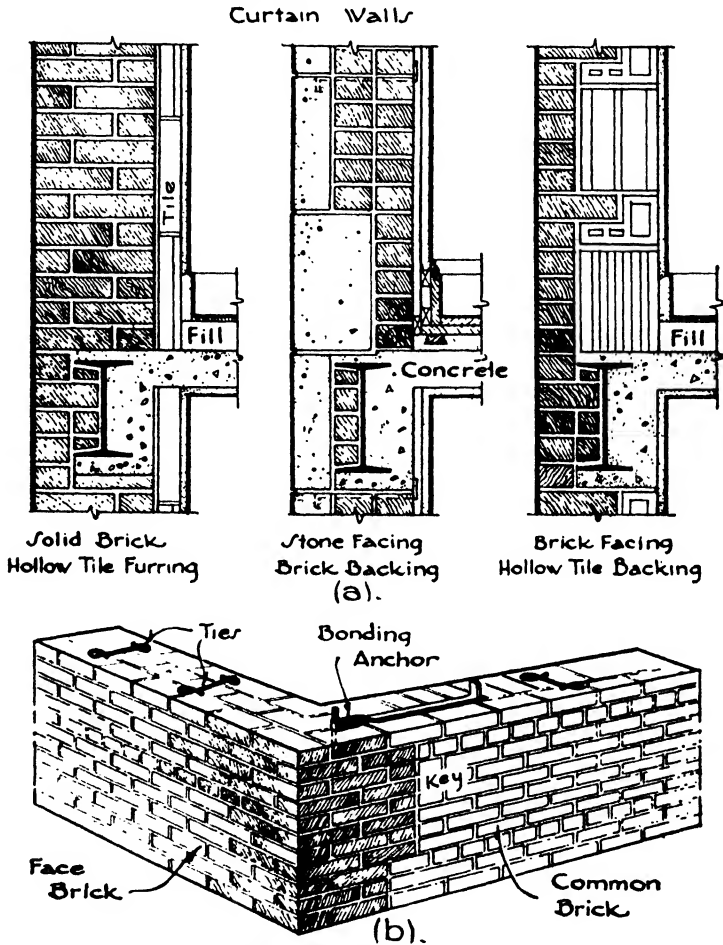

FIG. 3.—Curtain Walls and Corner Bonding.

In street walls, however, where large windows occur, the curtain walls may be composed of a variety of materials, provided that the wall is fireproof and has a dead air space for insulation against the penetration of moisture. It is these curtain walls and the brick around the columns which are generally built from swinging scaffolds. A few of the combinations of materials for the foregoing walls may be listed as follows (Fig. 3,a).

- (a) 12" brick and 2" tile or metal furring.
- (b) 4" and 8" stone and 8" and 4" brick with 2" furring.
- (c) 4" brick and 8" hollow terra cotta tile.
- (d) 4" architectural terra cotta and 8" brick or hollow tile.

The distinction between curtain walls which carry only their own weight and bearing walls which also sustain applied loads such as floors and roofs should be kept in mind.

**Anchoring.** Brick bearing walls should be braced by being tied to the floor beams at horizontal intervals of 6'0" at each tier of beams. This is done either by means of steel anchors built into the walls and spiked to the floor beams, by box anchors or by joist hangers. The anchors should be spiked near the bottom of the beam so that if the beam should fall during a fire it would not pull down the wall. Steel box anchors are shaped like open boxes. They are built into the wall, providing a bearing for each beam and also anchoring the beam to the wall. Joist hangers are of steel, shaped somewhat like a stirrup, and hang entirely free from the wall. They carry the joists, anchoring them in place, and yet do not weaken the brick wall. They are considered to provide the best means of carrying and anchoring the beams. (See Chapter XVIII, Fig. 4.)

Walls running parallel to joists are tied by building steel straps into the walls and running them over the tops of the two nearest joists, to which they are then spiked.

**Bonding Walls at Angles.** When possible, both walls forming an angle should be built up together so that all courses in both walls will be thoroughly bonded. When this is not convenient, as often happens when the party walls of a house are built before the street wall, toothings should be left in the wall first built, 8 or 9 courses high, into which the other wall may be bonded. Anchors should also be built into the first wall with a part extending out at least 8" to be incorporated in the other wall (Fig. 3,b).

**Hollow Brick Walls.** Solid brick or stone walls absorb moisture, and some sort of insulation must be provided either by air spaces or by damp-proofing. The air space is most often formed by furring brick walls on the inside with wood or metal furring strips, or 2" or 4" hollow tile furring blocks are laid up against the inside of the brickwork. Another method, formerly quite generally employed, is to build hollow brick walls usually consisting of a 4" wall on the outside, an 8" bearing wall on the inside and a 2" air space between them. The walls are tied together with steel wire or flat steel bars bent up to fit between the bricks, since bonding across with bricks allows the moisture to pass from one wall to the other. At window and door openings the walls are built solid. This method has now given place generally to hollow tile or metal furring to provide the air space, although it has lately been revived in the building of cheap dwellings. By this method one wall is 4" thick with brick on the flat and the other wall 2½" thick with

brick on edge, total thickness 8". The walls are bonded across at every seventh course of stretchers.

**Brick Veneer Construction.** In some parts of the country, wood frame buildings are put up with a brick veneer 4" thick on the outside. The only advantages over solid brick walls are the cheapness and the air spaces which stop the passage of moisture and heat, rendering the houses cooler in summer and warmer in winter. Insurance rates are also somewhat less than for wood frame buildings. The frame of wood should be very solidly constructed to carry all the floor and roof loads, and the foundations should project sufficiently beyond the frame to support the brick veneer. The studs are sheathed or boarded on the outside, and sometimes building paper is applied. The 4" brick veneer is then built up on the foundation, leaving 1" air space between the brick and the sheathing. The veneer is tied to the frame with wires or straps nailed to the sheathing and built in between the joints of the brick every fourth or fifth course. Brickwork over window or door openings should be supported by small steel lintel angles.

**Reinforced Brickwork.** Brick walls have little flexural strength and have sometimes failed from lateral wind pressure and earthquake shocks. Likewise, although it is true that open spaces have long been spanned by brickwork designed as arches, nevertheless bricks and mortar are not adapted to resist the tension stresses caused by the bending actions of simple beams. To counteract these tension stresses reinforced brickwork has of late years been developed, by which method steel rods or bands are introduced between the courses of brick very much as in reinforced concrete. These rods and bands are placed horizontally in beams and lintels and horizontally and vertically in walls; in general, the theory of reinforced concrete applies also to reinforced brickwork. The expense of formwork, however, is eliminated. Because of deficient flexural strength, brick walls do not withstand hurricanes and earthquakes nearly as well as concrete and steel. Reinforcement in brick walls might, therefore, greatly increase their resistance to such stresses.

**Brick Arches.** It is evident that the arc of the outer ring or extrados of a round arch is greater than the arc of the inner ring or intrados. In stonework this difference is adjusted by the wedge-shaped arch stones or voussoirs. In brickwork two methods are used, that of wedge-shaped bricks or of wedge-shaped mortar joints. In common brick masonry, where the joints are not seen or their appearance is unimportant, the mortar joints are made thicker and thin pieces of slate are introduced at the extrados, this being a rapid but not a good-looking method of laying the brick. Where appearance is more important, as in face brick, the bricks themselves are made in a wedge shape, the sides of each brick tapering so that the joints radiate from a common center when the arch is built. The taper may be formed by laying the arch ring out on a floor and rubbing down each brick to fit exactly in place so

that the radial joints are of the same thickness throughout. This method is called GAUGED WORK and entails more or less labor on the part of the masons. At the present time MOULDED WORK is more employed, by which the brick, when made in the yard, are especially moulded upon order to fit each particular arch. They may then be quickly set in place by the masons without further fitting or adjustment.

**Arch Bond.** In face brickwork the brick are bonded on the face of the arch to correspond with the face of the wall. Arches of common brick are generally built in concentric rings, either with no connection between rings, called a ROWLOCK ARCH, or with bonding courses built in at intervals, called BLOCK-IN-COURSE bond. The objection to concentric rings without bond lies in the fact that each ring acts independently, and any settlement in the outer rings throws additional weight on the inner rings which they may not be able to support. For wide spans or heavy loads, therefore, rowlock arches should have some form of block-in-course bond (Fig. 4).

**Segmental Arches** have the form of an arc of a circle less than a semi-circumference. They are stronger than semicircular arches but transmit more thrust to the supports. Strong abutments are necessary, and tie rods are often required to take the thrust (Fig. 4).

**Skewbacks.** Arches of large span should have solid bearings from which to spring, such as stone or cast-iron skewbacks. They are used particularly in segmental arches and should bond into the brickwork of the piers, the springing surface being a true plane radiating from the center from which the arch is struck.

**Flat Arches.** Flat arches are often built to span door and window openings. A slight camber or upward curve is sometimes given to the soffit or under side of the arch to offset any appearance of sag. The center of the radiating joints is a matter of design and should not give too sharp an angle to the end bricks. Flat arches are not as dependable as segmental or semicircular arches to carry a load without sagging or cracking. Angle iron lintels are therefore generally introduced to support the arch and the load of the wall above (Fig. 4).

**Relieving Arches.** Arches usually segmented in form may be built in a wall several brick courses above an opening to relieve a flat arch spanning the opening. The flat arch then carries only the load of the brickwork between it and the relieving arch above (Fig. 4).

**Brick Vaults.** Vaults may be described as very wide arches with the bricks bonded lengthwise of the vault. They may be entirely of brick or a combination of brick cross arches or ribs between which is poured a filling of reinforced concrete. Vaults and domes are now generally built, however, of several layers of overlapping 1" tiles similar to the Guastavino system of construction which will be studied in Chapter VI under "Vault Tile." The tile systems are far lighter in weight than brickwork and more adaptable to use with a skeleton steel frame.



**Centers or Forms.** All brick arches and vaults are built on wood centers and forms except where steel lintels are used. These forms are cut to the required curve of the arch and must be sufficiently heavy to hold the arch or vault in place and carry superimposed loads until the mortar is set.

**Chimneys.** The design of a chimney depends upon the number, arrangement and size of the flues and upon the height of the chimney.

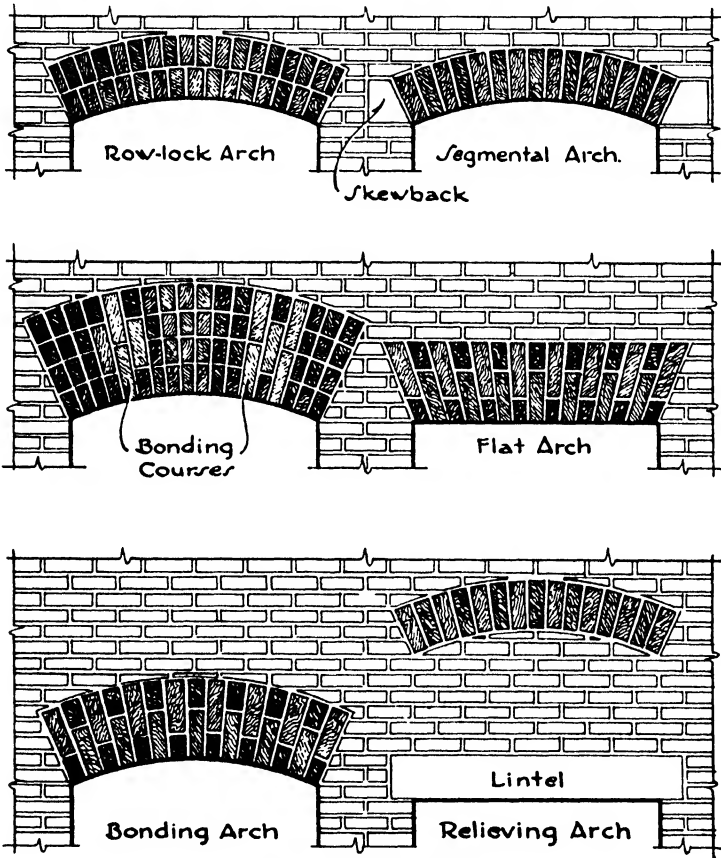
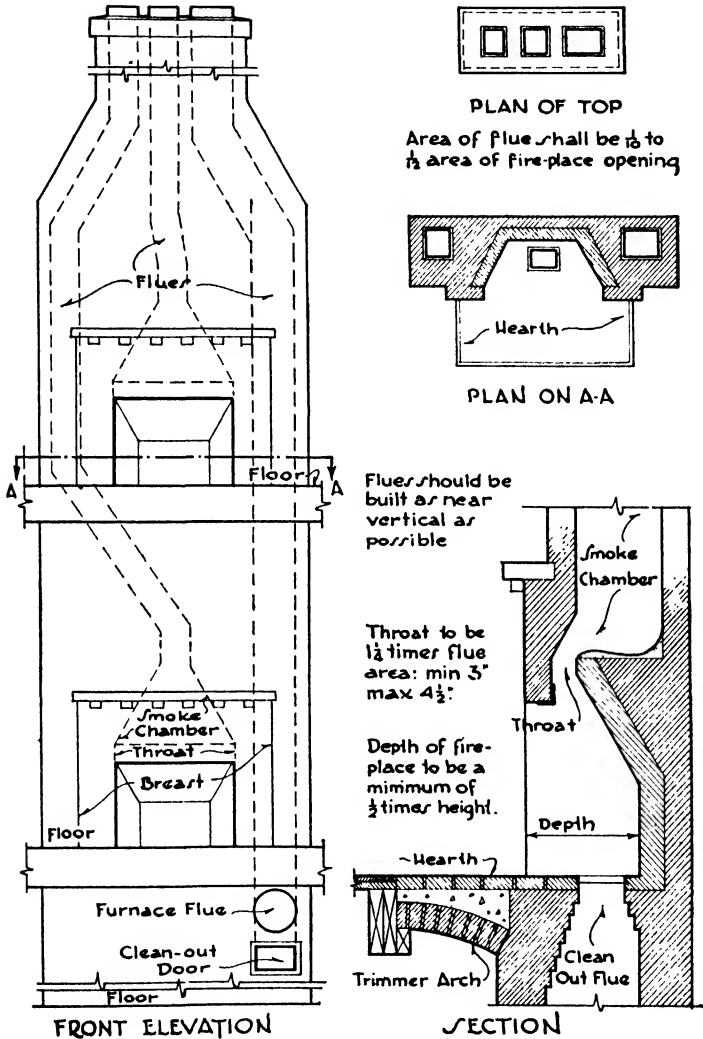

FIG. 4.—Brick Arches.

In a residence the flue from the heater, either boiler or furnace, should be at least 40'0" high, if possible, to give good draught. The chimney should extend not less than 3'0" above any neighboring roof which may cut off the draught or cause air currents tending to flow down the flues. The sizes of the flues are determined by their use. For ordinary furnaces or heating boilers the flue should be 9" x 13", and for ranges and stoves 9" x 9" or 9" x 13". The flue for a fireplace should be  $\frac{1}{8}$  to  $\frac{1}{10}$  the area of the fireplace opening. Thus a fireplace opening 4'0" wide

by 2'6" high would have an area of 1440 in.<sup>2</sup>, and the flue should have an area of 1440/10 = 144 in.<sup>2</sup> or 12" x 12". All flues should always be lined with terra cotta flue lining, which is manufactured to fit the laid-up brick dimensions. The nearest commercial size must therefore be chosen,



PLAN OF TOP  
 Area of flue shall be  $\frac{1}{10}$  to  $\frac{1}{12}$  area of fire-place opening

Flues should be built as near vertical as possible

Throat to be  $\frac{1}{2}$  times flue area: min 3' max 4 1/2'

Depth of fire-place to be a minimum of  $\frac{1}{2}$  times height.

FIG. 5.—Fireplace Construction.

selecting the next larger rather than the next smaller one. Thus for the above-mentioned 12" x 12" fireplace flue the nearest lining is 13" x 13", which is the one to be selected (Fig. 5).

Flues should have 8" of brick all around them for fire protection and

to form a solid chimney, although usually the divisions or withes between flues side by side may be 4" thick if flue lining is used and there are not too many flues. Brick walls of flues lined with flue lining are now sometimes built 4" thick, the flue lining being depended upon to stiffen the chimney. This is not an advisable method of building, especially in a wood frame house, in which the chimney is erected as an independent construction and cannot depend upon the house walls for support. When two or three outside walls of the chimney are thick and heavy the other one or two walls may be reduced to 4" if valuable space is saved thereby.

The flow of smoke may be considered somewhat like the flow of water; that is, the interior of flues should be as smooth as possible with no rough mortar projections, with easy changes of direction and with flue lining joints well filled so that no leakages will occur.

**Fireplaces.** The misfortune of a smoking fireplace may be avoided by applying the proper principles of design. The size of the flue should be adequate and depend upon the size of the fireplace opening, as already set forth. The sides of the fireplace should slope outward from rear to front, and the back should slope forward from rear to front in order to throw the heat into the room instead of up the chimney. The arch over the top of the fireplace opening should be only 4" thick, and the throat should be projected toward the front as much as possible, thus forming the smoke shelf behind it. The area of the throat should be  $1\frac{1}{4}$  times the area of the flue with minimum and maximum widths of 3" and  $4\frac{1}{2}$ " respectively, the narrow throat causing a quick suction into the flue. The sides of the fireplace above the throat are drawn together to form the flue, which should always start exactly over the center of the fireplace. The smoke shelf is very necessary to stop back draughts. The trimmer arch which supports the hearth may be either an arch of brick with a concrete fill over it or a flat reinforced concrete slab. The depth of the fireplace should be  $\frac{1}{2}$  the height of the opening with a maximum of 24". The back should rise  $\frac{1}{3}$  the height of the opening before sloping forward and should be  $\frac{2}{3}$  of the opening in width (Fig. 5).

**Cleaning Down.** When the exterior work is completed, brick walls are washed down with 10% muriatic acid and water and scrubbed with brushes until all stains are removed. At the same time all open joints under window sills and in the stone and terra cotta work are pointed, and holes left by scaffolding are filled. When the cleaning down is completed the entire walls should be in perfect condition.

**Efflorescence.** White stains often appear upon the faces of brick walls after they have been exposed to moisture. These stains are caused by the action of water in dissolving the salts, such as those of sodium, lime and magnesium, contained in the mortar and the brick and depositing them upon the surface of the wall. A natural preventive lies in the choice of materials possessing a minimum of these salts. Since most water enters the brickwork through the mortar joints the efflorescence

can also be reduced by mixing water-repellent material such as calcium and ammonium stearate with the mortar, by using damp-proof courses in parapet walls and walls near the ground and by effective drips upon projecting members, the effort being to keep the water out of the masonry. Efflorescence may be removed by cleaning the walls with brushes and dilute muriatic acid and water.

**Damp-Proofing.** All brick walls absorb moisture, especially under driving rains, with a resulting staining of interior plaster and paint. Therefore they should be provided with an air space upon the inside, separating the plaster from the brickwork, or else they should be coated with a liquid damp-proofing composition. The air space is formed by applying wood or metal furring strips or by setting hollow tile furring blocks, 2" thick, against the wall and plastering upon the face of the blocks. (See Chapter XII, Article 3).

Damp-proofing is of two general types, black tar or asphalt compositions applied to the inside of the wall and covered by plaster, and colorless liquids consisting of oils, wax or soapy materials brushed over the outside of the wall. The tar or asphalt compositions are usually preferred except where the surfaces are exposed to view, such as face brick parapet walls and copings and cornices of cut or cast stone. In these locations colorless damp-proofing compounds are often resorted to, since they are claimed not to alter the color or appearance of the masonry in any degree.

Black damp-proofing compositions are brushed upon the inside of masonry walls, and plaster may be applied directly upon them. When furring is employed in particularly exposed situations, the inside of the furring is often coated with damp-proofing to give a double protection against the penetration of moisture. An especially vulnerable point is at the juncture of floor slabs with spandrel beams. At this section the damp-proofing should be brought outside the spandrel beam before the face brick is laid.

All efforts to eliminate the penetration of moisture should begin with a thorough pointing of the brickwork, since porous mortar joints present a very easy passage for moisture through walls. The joints in the top surfaces of stonework, such as copings and cornices, should be raked out and pointed with elastic cement.

Lead, copper, aluminum or chromium sheets have been used as an outside sheathing over spandrel walls and window mullions to exclude moisture. Where backed up with masonry such sheathing has proved effective as well as speedy and inexpensive to erect. (See Chapter VIII, Article 8, and Chapter XIV, Article 2.)

A DAMP COURSE generally signifies a horizontal sheet of copper or of heavy waterproof felt extending completely through the wall to cut off the penetration of moisture upward or downward in the masonry, as in basement walls and parapets.

**Mortar.** The following mortars are most often used in laying brick masonry. The proportions are by volume.

1. Lime Mortar: 1 part hydrated lime to 3 parts sand.
2. Lime-Cement Mortar: 1 part hydrated lime, 1 part Portland cement, 6 parts sand.
3. Cement Mortar: 1 part Portland cement, 3 parts sand, with an addition of hydrated lime not exceeding 15% of the volume of the cement.
4. Mortars made of proprietary materials, generally natural cement, mixed according to manufacturer's direction.

Only Portland cement mortars should be used for construction below grade, where moisture is encountered or where heavy loads are to be carried. Other mortars may be used for backing brickwork or where only small stresses exist.

## CHAPTER VI

### TERRA COTTA, GYPSUM AND CONCRETE BLOCKS AND CAST STONE

#### Article 1. Structural Terra Cotta

**Uses.** Terra cotta may be divided into two classes as follows:

- (1) Structural terra cotta.
- (2) Architectural terra cotta.

Both classes are composed, like brick, of clay, moulded and burned in a kiln, but because of differences in manufacture a distinctive product is obtained with special physical characteristics quite unlike those of brick. Structural terra cotta is used for purely constructive purposes. Architectural terra cotta, on the other hand, is employed only for facing and decoration.

Structural terra cotta is variously known as hollow tile, terra cotta tile and terra cotta blocks, the name used generally by the manufacturers being STRUCTURAL CLAY TILE. It has become a widely used building material because of its strength, lightness of weight, insulation against heat, noise and dampness, resistance to weather and excellent fire-protection qualities. Floor arches, roof slabs, interior partitions, light exterior walls and the furring and backing of masonry walls are extensively constructed of structural clay tile, and for the fireproofing of structural steel it has proved one of the most effective and practical materials employed.

**Description.** As generally made, structural clay tile are in the form of hollow blocks open on two ends, with interior webs or partitions  $\frac{3}{4}$ " to 1" thick, dividing the block into longitudinal cells and adding to its strength. When the tile are built into a wall the interior cells or voids prevent the passage of moisture, heat and sound through the wall, thereby contributing insulating properties. The exterior surfaces of the tile, unless intended to be exposed to view, are channeled or grooved to form a key for plaster or stucco.

Hollow fire-clay tile with either one or two finished surfaces have also been developed to be used without plaster. These surfaces are either salt-glazed or enameled in one firing with the body of the tile and are suitable for exterior or interior use. Wainscot caps, cove base and bull-nose tile accompany both glazed and enamel tile. The finishes are both lustrous and matte, and the range of colors is sufficient to render the finished tile adaptable to a variety of design. The surface being resistant to acids and water, the necessity of additional plaster, paint or stucco

is avoided. The tile run from  $1\frac{3}{4}$ " to 8" thickness, and the face dimensions vary from  $2\frac{1}{4}$ " x 8" to 8" x  $16\frac{1}{4}$ ".

Structural clay tile may be classified as:

- (a) Load-bearing tile, for exterior walls of light buildings and capable of carrying moderate floor and roof loads.
- (b) Partition tile, for interior non-bearing partitions.
- (c) Backer tile, for backing exterior load-bearing or curtain brick walls.
- (d) Furring tile, for furring the inside of exterior masonry walls.
- (e) Floor tile, for flat or segmental floor arch construction.
- (f) Fireproofing tile, for protecting steel beams, girders and columns.
- (g) Book tile, for roof construction.

**Load-bearing tile** are used for the main bearing walls of light buildings such as residences, garages, shops and retail stores. The height of such walls is generally limited by building laws to 4 stories or 40'0". Although not as strong as brick, tile have the advantages of greater size, ease of handling and insulating properties. They are more economical therefore in labor and mortar and because additional furring is not required. Either the dense or the semi-porous types should be selected on account of their greater strength. Many special shapes have been patented and put on the market which are claimed to have various advantages over the plain hollow tile as to bonding, insulation, strength or facility of fitting and laying. The tile are manufactured according to the following standard sizes as specified by the American Society for Testing Materials.

Table I. Load-bearing Tile

Size of Units, inches	Number of Cells	Weight, pounds
$3\frac{3}{4}$ x 12 x 12	3	20
6 x 12 x 12	6	30
8 x 12 x 12	6	36
10 x 12 x 12	6	42
12 x 12 x 12	6	48
12 x 12 x 12	9	52
$3\frac{3}{4}$ x 5 x 12	1	9
8 x 5 x 12	2	16
8 x 5 x 12	3	16
8 x 5 x 12 (L-shaped)		16
8 x $6\frac{1}{4}$ x 12 (T-shaped)	4	16
8 x $7\frac{3}{4}$ x 12 (Square)	6	24
8 x $10\frac{1}{4}$ x 12 (H-shaped)	7	32
8 x 8 x 8 (Cube)	9	18

Setting the tile with the cells horizontal is called **SIDE CONSTRUCTION**; with the cells vertical, **END CONSTRUCTION**. End construction, with compressive strength of 1400 lbs./in.<sup>2</sup>, capable of bearing greater loads, but this advantage is offset in side construction, with compressive strength

of 700 lbs./in.<sup>2</sup>, by the better bed presented for the horizontal mortar joints and greater ease in handling. Most walls of plain tile are laid up in end construction, whereas patent bonding tile often require side construction. Specially formed tile are required for window jambs and sills and, in side construction, for corners also, so that the open cells will not be exposed. Tile are set in straight horizontal courses with broken vertical joints. Load-bearing tile are manufactured with corrugated surfaces to receive plastering and stucco, or with one or two faces glazed or enameled when plastering or stucco is not required.

Partition tile are not necessarily as strong as load-bearing tile and are often of semi-porous and porous terra cotta. The following are the standard sizes of the American Society for Testing Materials and their weights per square foot.

Table II. Partition Tile

Size of Units, inches	Number of Cells	Weight, pounds
3 x 12 x 12	3	15
4 x 12 x 12	3	16
6 x 12 x 12	3	22
6 x 12 x 12	4	25
8 x 12 x 12	4	30
10 x 12 x 12	4	35
12 x 12 x 12	4	40

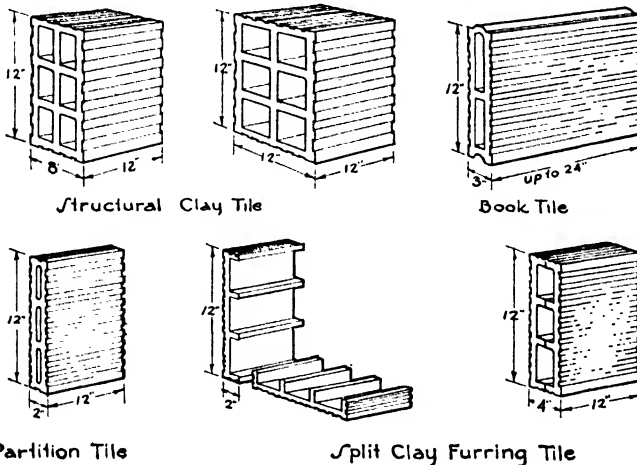

FIG. 1.—Structural Clay Tile.

Partition tile are generally scored to receive plaster. Glazed and enamel surfaces are supplied upon order, or finished load-bearing tile may be used. Partitions of 3" tile can be safely constructed up to 12'0" high, of 4" tile up to 16'0" and of 6" tile up to 20'0". It is good prac-



tice in most cases to build elevator enclosures of 6" tile, corridor and stairway enclosures of 4" tile and room partitions of 3" tile. Partition tile are considered as bearing no load; they should start upon the structural floor slab below and their heads be well wedged with slate under the slab above (Fig. 1).

**Backer tile** are especially made in angle or tee shapes to back up and bond into the brickwork of an exterior wall. By their excellent bond they may be counted as part of the structural wall in load-bearing brick walls, and by their lightness of weight they form an economical backing for brick curtain walls. They are usually arranged to form a bond at every sixth course of the brickwork. Backer tile may be obtained upon order with glazed and enamel faces, but the standard surface is scored for plaster.

**Furring tile** are used to provide air spaces upon the inside of exterior masonry walls to prevent the passage of heat and moisture through the wall. They do not carry any load. The type most generally used when attached to the wall is the **SPLIT TILE**, that is, a hollow tile which, during manufacture, has been cut parallel with its cells into two equal units  $1\frac{1}{2}$ " or 2" thick. It is set with the ribs in mortar vertical against the wall but without mortar in the cells, being fastened by driving 10d. nails into the joints of the brickwork and bending the heads of the nails down over the tile. When the wall must be furred out to a line, 3" partition tile should be tied to the wall at intervals with metal anchors, or 4" partition tile, known as free-standing furring, may be built up without anchors. Furring tile is grooved for plastering (Fig. 1).

**Floor Tile.** Terra cotta tile spanning between steel and concrete beams are used for both segmental and flat floor arch construction, the latter being the more usual except in warehouses, factories and sidewalk vaults where the great strength and lightness of the segmental arch often give it the preference.

Segmental arches are set in side construction, that is, with the cells parallel to the beams. The tile are slightly wedge-shaped, and the joints between them radiate from the center of the arch. A steel tie rod between the beams takes the thrust, the most effective location for the rod being near the bottom of the beams. Unless appearances are not important, a suspended ceiling should be added to cover the under side of the arches and the rods and beams. The tile are 6", 8" and 10" deep, the 6" tile being the most common. The average weights per square foot of floor are 26, 32 and 38 lbs., respectively.

Flat arches may be set with either side or end of tile parallel to the beams, the side construction giving better fire protection to the beams and better bed for mortar, whereas the end construction transmits the thrust directly through the webs and walls of the tile and is therefore stronger. A combination method, with end tiles or skews and a center tile or key in side construction and the intermediate tiles or inters in end construction, presents a satisfactory union of the two systems.

The skews are especially moulded to fit over the bottom flange of standard I-beams, or flat tile called soffit blocks are inserted under the flange. The sides of the tiles are cut with the same slant; all the joints on one side of the key are therefore parallel and the tile are interchangeable.

The following table gives the depths and weights of the tile in flat arch construction.

Table III. Floor Tile

Depth of Arch, inches	Average Weight per Square Foot of Floor, pounds
6	27
7	30
8	32
9	34
10	36
11	39
12	42

Ribbed slabs, also known as concrete joist construction and combination hollow tile and concrete construction, consist of reinforced concrete joists or ribs running in one direction or in two directions at right angles to each other, the space between the ribs being filled with a hollow tile. These tile are similar in shape to partition tile, being lighter in weight with fewer webs than the load-bearing tile. Tile for the two-way system have no exterior openings to prevent concrete from entering the cells. The following table presents the sizes and weights of the tiles.

Table IV. Floor Filler Tile

Size of Units, inches	Minimum Number of Cells	Weight, pounds
4	3	16
6	3	22
6	4	25
8	4	30
10	4	35
12	4	40

**Fireproofing Tile.** Structural tile is well adapted to the fireproofing of steel because of its strength, ease of handling and light weight. The tile is usually hollow whenever the total thickness permits. The units are manufactured in various shapes and sizes to fit over the webs and flanges of beams and girders and to surround square, rectangular and round columns.

When the lower flanges of beams and girders are not covered by the skew tile of the floor construction special shoe tile are provided for their protection. Angle soffit and filler tile are also made for the soffits and sides of box girders and doubled beams.

Columns are protected by tile set close against their webs and fitted in between their flanges. The entire column is then surrounded by hollow tile similar to partition tile 2" or 3" thick.

**Book tile** are flat hollow tile about 3" thick, 12" wide and 16" to 24" long, with one edge rounded and the opposite edge grooved somewhat similar to the shape of a book, which permits adjoining units to fit into each other. They are used to span between tee purlins on penthouses, bulkheads and roof trusses, and are covered by the roofing material. Book tile are very light in weight but cannot be used with heavy loads (Fig. 1).

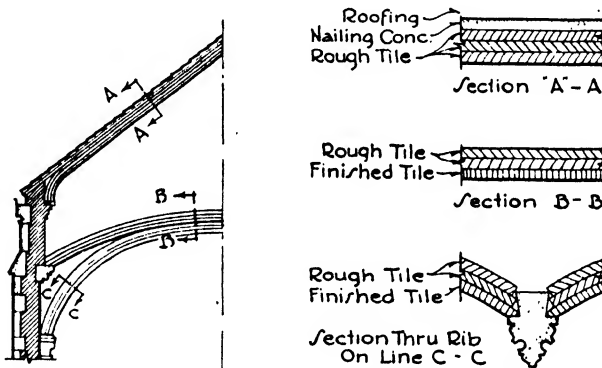

FIG. 2.—Guastavino Vault System.

**Dome and Vault Tile.** A patented method, known as the Guastavino System for constructing domes and vaulted ceilings is very successful and has been employed in many large churches and other monumental buildings. The vaults and domes are built of several superimposed layers of special clay tile 1" thick, 6" wide and from 12" to 24" long. The tile are laid flat in 1 to 2 cement mortar and are bonded together to make a solid and homogeneous mass very light in weight. For ordinary spans the crown of the arch is 3" or 4" thick, but the system can be designed to carry any load. Level floors or sloping roofs may be constructed upon the vaults by the use of dwarf walls 24" on centers which carry the floor and roof tile. The soffits of the vaults and domes may be left with the rough tile exposed, or glazed and unglazed tinted ceramic tile to form decorative patterns or colored fields may be employed. Tile with acoustical value have also been developed for use on walls and on vaulted or flat ceilings to absorb the sound. When the dome or roof construction also forms the outside shell of the building

layers of porous tile and hollow tile can be introduced in the construction for insulation against heat and dampness (Fig. 2).

**Manufacture.** The basic raw material in the making of structural tile is a fine clay, or a mixture of several clays, together with very fine sand. The clays are carefully proportioned, cleaned of pebbles, thoroughly pulverized, mixed with water, forced through a die and cut into the proper lengths. The tile are then dried and finally burned in kilns at a temperature from 1700° to 2400° F. The kilns are usually of the down-draught beehive type described in the chapter on brick.

Structural terra cotta is made in three types: dense, semi-porous and porous.

**Dense Terra Cotta.** Dense structural tile is burned to a temperature of 2000° to 2400° F., which renders it adaptable for exterior and bearing walls on account of its high crushing strength and its imperviousness to moisture. It is more brittle than the less dense varieties and, if highly heated and chilled by cold water, is likely to crack. For fire-proofing use, the more porous terra cotta is preferred. Its standard absorption is 5 to 12%; its strength on the flat 1000 lbs./in.<sup>2</sup> and on end 2000 lbs./in.<sup>2</sup>

**Semi-porous Terra Cotta.** Semi-porous tile are not burned at so high a heat as the dense tile. The clay has about 20% of ground coal, sawdust or chopped straw added to it, which aids in the burning and also serves to make the material lighter and more porous. This tile has considerable strength and is as fire-resistant as the porous. It is particularly used for floor arches and interior partitions. Its standard absorption is 5 to 16%; its strength on the flat 700 lbs./in.<sup>2</sup> and on end 1400 lbs./in.<sup>2</sup>

**Porous Terra Cotta.** For porous tile the clay is mixed with 25 to 35% of sawdust or chopped straw which is destroyed in the burning and leaves a light porous material. It can be cut with a saw, nails and screws can be driven into it and it is a very good non-conductor of heat, resisting well the action of extremely high temperatures followed by sudden chilling. It should not be used in positions exposed to the weather. Its standard absorption is 5 to 25%; its strength on the flat 500 lbs./in.<sup>2</sup> and on end 1000 lbs./in.<sup>2</sup>

**Erection.** All terra cotta should be set in Portland cement mortar, and the quality of mortar and manner of laying are in general similar to brick masonry, the joints not being over  $\frac{1}{4}$ " to  $\frac{3}{8}$ " thick. As described under load-bearing walls, the tile are often set with the cells perpendicular since the tile have greater compressive strength in this direction. But because of the difficulty and delay in bedding the tile with proper bearing on account of the open cells, it may at times be preferable to lay non-bearing partition tile with the cells running horizontally. Porous tile are sometimes introduced to act as nailing blocks for wood trim in walls otherwise built of dense or semi-porous tile.

Tile when used as floor arches are set in Portland cement mortar and must be laid on wood forms to support them until the mortar is set and

the arch can carry its load. The forms are hung by hooked rods from cross pieces of wood resting upon the tops of the beams. Methods of tile floor construction are treated in Chapter IX, Floor and Roof Systems.

## Article 2. Architectural Terra Cotta

**Characteristics.** Terra cotta was employed in Greece and Rome and during the Renaissance for such architectural purposes as roof tiles, ornamental facing, plaques, tracery, gutters and cornices. Its mouldability in a plastic state and its adaptability to colored glazing are distinctive characteristics which were well understood by the classic and Renaissance architects. Its composition and methods of manufacture lend it particularly to both plain textures and polychrome glazes and to broad surfaces on the one hand and to profuse modeling on the other. It is in color, perhaps, more than in any other way that the individuality of terra cotta can be expressed. It should, therefore, be used for its own sake in its own peculiar field and must never be considered as an imitation of, or substitute for, something better. It has high fire-resistant and insulating qualities, is light in weight and its surface is practically non-absorbent.

**Raw Materials.** The clays must be of high quality and must be carefully selected and proportioned to avoid warping, inaccuracies and other defects. Part of the mixture should be an infusible fire clay to reduce the rate of vitrification, and at least a third generally consists of a finely pulverized burnt clay known as grog.

**Manufacture.** Terra cotta was formerly produced by pressing the clay into plaster moulds by hand when a series of pieces of the same pattern was to be produced. If the piece is not repetitious the clay is worked upon directly and is then fired, showing the exact impress of the modeler's technique. The pieces are hollow, with cross webs, and have either open or closed backs.

In recent years the development of machine-made or extruded terra cotta has been perfected in a high degree. This method is used particularly for ashlar and partition blocks and wall facings with hollow cores but closed backs. Air entrapped in the clay body is removed by a so-called vacuum or de-airing process before the material is forced through the extruding die. A denser, truer product is thereby obtained. The faces of the units are planed before firing and are ground to accurate surfaces and setting joints after firing.

Both the hand- and machine-made blocks are next dried in special driers, are treated for surface color and texture and are baked in kilns. The surface may be unglazed or may be treated to produce a variety of glazes from dull to full lustrous. These finishes are obtained by spraying or brushing a thin layer of feldspar and silica, called a slip, on the surface before firing.

**Colors.** The colors are obtained by means of minerals and metal oxides producing colored silicates, the true effect not being apparent until after the piece is fired. Practically any color can be produced, the cost ranging from the unglazed, through the matte and the full glazed, which in scarlets and golds are the most expensive. Polychrome denotes two or more colors on the same piece, and its use in a wide range of beautiful tones has greatly developed in recent years.

**Firing.** After the slip or glaze has been applied to the dried clay block, it is burned in the kiln at a temperature gradually rising to 2000° or 2400° F., depending upon the glaze. Two firings are sometimes required for special colors. The kilns were formerly down-draught, beehive kilns, but of late years they consist of long heated tunnels through which the pieces travel loaded upon cars. See Chapter V, Brick.

**Fitting.** Hand-made terra cotta is usually formed in blocks from 12" to 30" wide, from 4" to 12" thick and of a height determined by the character of the work. The blocks are generally hollow, with outer shells and interior cross webs about  $1\frac{1}{4}$ " thick, and without backs. It is consequently necessary to build the backing wall into the terra cotta simultaneously as the pieces are set. Often anchors and clips are also required to secure the work to the masonry walls and steel frame of the building. Hand-made blocks are now produced by some companies with closed scored backs and small hollow cores which bed with better balance on the wall and weigh less than open-back terra cotta when filled with brickwork.

Extruded machine-made blocks, ranging in size from 12" x 24" to 24" x 48", are widely used as facing for both exterior and interior walls and as partitions. They may be solid slabs  $1\frac{7}{8}$ " thick or have small hollow cores with a thickness of  $3\frac{3}{4}$ ". When used as facing the exposed surface may be finished in any glaze and any color and the edges and back scored for bonding or for plaster. When used as partitions the two exposed surfaces may be glazed to provide a final finish. Base, cap mouldings, jams, sills, bull nose and external angles are available in all cases.

### Article 3. Gypsum Tile

**Description.** Gypsum partition, roof, fireproofing, floor and furring tile consist of hollow or solid gypsum blocks formed at the mill and shipped ready to be set in place. They are used for non-bearing partitions, light roofs and floors, wall furring, vent and pipe ducts and the fireproofing of steel construction. The value of gypsum tile is due to their excellent heat-insulating qualities, their little weight and the fact that they are strong enough for light or temporary partitions and for floor and roof slabs which are not heavily loaded. They should not be used for bearing partitions or for floors and roofs carrying heavy loads, nor will they withstand the action of moisture sufficiently well to make them adaptable for exterior walls.

**Manufacture.** As generally used, gypsum tile are composed of 97% finely ground calcined gypsum and 3% by weight of fibrous material, usually wood chips. These ingredients are mixed with water and shaped in moulds and upon drying set naturally into a fairly hard mass. The tile are either solid or hollow with circular cell spaces or cores running through them. The partition tile are rectangular, 1½" to 6" thick and 12" by 30" in face dimensions, the tile 1½" and 2" thick being most often used as furring tile. The pre-cast roof and floor tile are reinforced with wire mesh, steel bars or heavy wire.

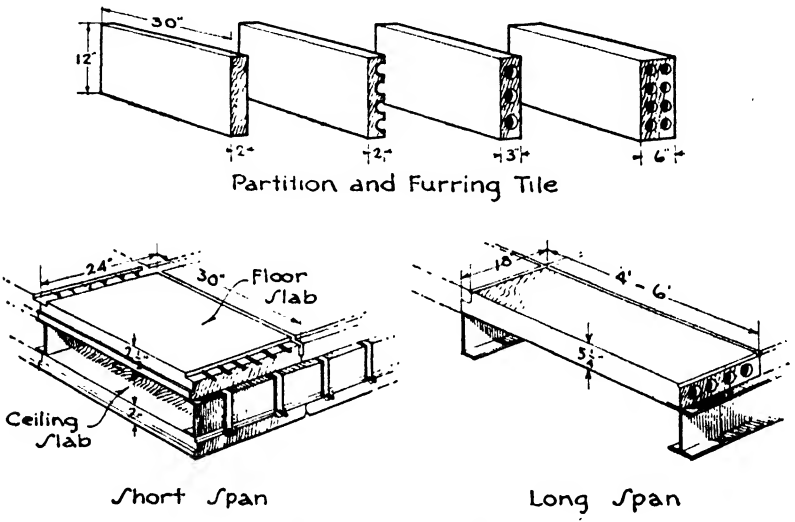

FIG. 3.—Gypsum Tile.

Gypsum tile may be classified as:

- (a) Partition tile, for interior non-bearing partitions.
- (b) Furring tile, for furring the inside of exterior masonry walls.
- (c) Floor tile, for light pre-cast floor construction.
- (d) Roof tile, for light pre-cast roof construction.
- (e) Fireproofing tile, for protecting steel beams, girders and columns.

**Partition tile** are generally manufactured of gypsum and wood chips in units 30" long and 12" wide. The American Society for Testing Materials requires a standard compressive strength of 75 lbs./in.<sup>2</sup> when tested dry and 25 lbs./in.<sup>2</sup> when tested wet. The following table presents the sizes and weights of partition tile both plastered and unplastered. A weight of 3 lbs./ft.<sup>2</sup> is allowed for plaster on one side and 6 lbs. for plaster on two sides, ½" grounds (Fig. 3).

Gypsum partition tile is easily sawed by hand to fit around pipes or into difficult positions. It is light and easy to handle and can therefore be

used in larger units than clay tile. Grounds and bucks may be readily attached by nailing.

**Furring tile** are furnished already split to 1½" and 2" thicknesses by some manufacturers, but owing to breakage in transit 3" and 4" complete hollow tile, which are scored to be split on the job, are sometimes preferred. Furring tile may be either split tile attached to the wall by rod. nails or be free-standing 2" solid or 3" or 4" hollow tile as described in Article 1 under clay tile furring. For furring around pipes, vent ducts and elsewhere, 2" solid or 3" or 4" hollow tile are also used, depending upon the height of ceiling (Fig. 3).

Table V. Partition Tile

Size in Inches	For Ceiling Heights up to	Weight of Tile, lbs./ft. <sup>2</sup>	Weight of Mortar, lbs./ft. <sup>2</sup>	Total Weight, lbs./ft. <sup>2</sup>	
				Plastered 1 Side	Plastered 2 Sides
1½" Split— 1½ x 12 x 30	Furring	4.9	1.4	9.3	
2" Split— 2 x 12 x 30	Furring	6.4	1.4	10.8	
2" Solid— 2 x 12 x 30	10'0"	10.0	1.5	14.5	17.5
3" Hollow—3 x 12 x 30	13'0"	10.5	2.0	15.5	18.5
3" Solid— 3 x 12 x 30	15'0"	13.5	2.0	18.5	21.5
4" Hollow—4 x 12 x 30	17'0"	14.0	2.5	19.5	22.5
5" Hollow—5 x 12 x 30	22'0"	16.5	2.7	22.2	25.2
6" Hollow—6 x 12 x 30	28'0"	19.0	3.0	25.0	28.0

**Floor Tile.** Gypsum pre-cast floor tile are made in several patented forms by different manufacturers at their mills but are of one general type. They consist of reinforced slabs of calcined gypsum with a small percentage (2½ or 3) of softwood fiber or shavings. A very generally employed tile is 30" long, 24" wide and 2½" thick, with rabbeted ends and reinforced with 6 longitudinal steel wires, 3/16" in diameter and spaced 4" on centers. Each wire projects 2½" from both ends of the slab. The slabs are placed close together on the top of steel I-beams or channels or open web trussed joists, the projecting wires are twisted together and the joints are filled with 1 to 2 gypsum grout. A ceiling tile is included with this system consisting of 2" gypsum slabs 30" long and 24" wide reinforced with two 3/8" x 1/4" steel bars projecting beyond each end of the slab. These ceiling slabs are set in place before the floor slabs by inserting the ends of the reinforcing bars into slotted steel hangers which are bent over the tops of the beams and joists.

Gypsum ceiling slabs 1½" and 2" thick and 18" x 36" face are also made which may be clipped on from below to the under sides of floor beams or trussed joists or to ceiling hangers and can consequently be applied after the floor arch or slab is in place (Fig. 3).



Gypsum partition tile are sometimes used as fillers in ribbed slab floor construction similar to hollow clay tile as described in Article 1. To offer a gypsum base for plaster throughout, soffit blocks 1" thick of gypsum are attached to the bottoms of the concrete joists.

Cast-in-place systems of gypsum floors will be described in Chapter IX, Floor and Roof Systems.

**Roof Tile.** Gypsum pre-cast roof tile are made for both short and long spans. The short-span slabs are generally 12" or 24" wide and 30" long. They are reinforced with wire mesh and may be either solid or hollow, the solid tile being from 2½" to 3½" thick and the hollow 3" and 4". Short-span tile require sub-purlins crossing the main purlins to support them. The weights per square foot are as follows (Fig. 3):

Table VI. Short-span Slabs

2½" solid.....	11 lbs.
3 " solid.....	14 to 17 lbs.
3½" solid.....	17 lbs.
3 " hollow.....	11 lbs.
4 " hollow.....	17 lbs.

Long-span slabs are 18" to 24" wide and may be any length up to 6'0" or 7'0" depending upon the spacing of the main purlins, thereby requiring no sub-purlins. Their thickness ranges from 3" to 6", and they may be solid or hollow tile. The reinforcement consists of two kinds, either welded wire 4" x 4" mesh or ⅜" wires of the suspension type. The suspension wires project 2½" from the ends of the slabs and are twisted together after the slabs are in place, the wires in the end panels being anchored to the outside beam or purlin. The weights per square foot are as follows:

Table VII. Long-span Slabs

3 " solid.....	14 lbs.
3½" solid.....	17 lbs.
5 " hollow.....	20 lbs.
6 " hollow.....	25 lbs.

The composition of the roof slabs is similar to that of the floor slabs and the joints are filled with gypsum grout in the same way, rabbets and bevels being moulded in the edge of the tile to permit efficient grouting.

**Fireproofing Tile.** Columns, beams and girders may be protected from fire and heat by gypsum partition tile which can easily be cut or sawed to fit difficult angles and slight curves. Solid shoe tile, moulded to fit over the lower flanges of I-beams, and soffit and angle tile are also made to protect the bottoms of built-up girders and trusses. The sides of columns and the webs of deep beams and trusses are covered with

2" solid or 3" hollow partition tile. At least 2" of protection to the steel should always be given.

**Erection.** Gypsum mortar, composed of 1 part gypsum plaster and 2 or 3 parts by weight of clean sand, should always be used in setting gypsum tile, since Portland cement is injured by the sulphate of the gypsum. Partition tile are usually laid with 1 to 3 mortar in side construction with the long edge horizontal. They may be set upon the structural arch or upon any finished flooring except wood. In basements or cellars the first course should consist of hollow clay tile because of possible dampness. The tile are laid in horizontal courses with vertical broken joints and well wedged with pieces of gypsum tile under the floor arch above.

The joints of roof and floor tile are grouted and pointed with 1 to 2 gypsum mortar. Fireproofing of columns is built up in the same way as partition tile. Fireproofing of beams is set in 1 to 2 gypsum mortar and bound with wires around the members where required.

#### Article 4. Concrete Blocks

**Description.** Concrete blocks may be divided into two general classes as follows:

- (1) Blocks and tile for structural use only.
- (2) Cast stone for architectural purposes.

Both classes are composed of a mixture of Portland cement, aggregates and water, but they are intended for quite different purposes. The first class includes concrete hollow blocks and tile to be used for light bearing walls, partitions, furring and backing much as structural clay tile is employed. The second class is made with great care in its mixture and aggregates to imitate building stones or to produce desired effects in color, the face of the blocks being treated to expose the aggregates or dressed with a tool as stone is dressed. These blocks are then used as wall facing, cornices, trim, etc., as limestone, granite or marble is used.

**Structural Concrete Blocks.** Hollow concrete blocks and tile are cast in moulds and allowed to set just as mass concrete sets or hardens. High-pressure steam is sometimes employed to hasten the set and produce a harder block with less shrinkage. The hollow spaces are punched out by cores with upward and downward movements while the concrete is in the mould but before it hardens. The walls and webs are generally about 2" thick. Stone and gravel were the original aggregates, but crushed and graded cinders are now more widely used because they are highly cellular, light in weight, fire-resisting, insulating, nailable and provide good mortar and stucco bond. The cinder concrete is not so strong as gravel or stone concrete but it will carry sufficient loads for many purposes and its other advantages have advanced hollow concrete

blocks to be a real rival of structural clay tile in the construction of light walls, in backing and in fireproofing (Fig. 4).

Concrete block are usually from 8" to 12" thick, 8" to 12" high and 16" to 32" long, the 8" x 8" x 16" block being the most common. Concrete tile are also made commonly 3" or 4" x 8" x 16" and 3" or

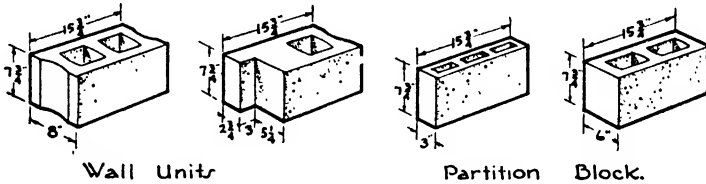

FIG. 4.—Concrete Blocks.

4" x 12" x 12" in dimension. Both the block and the tile are hollow and were first developed as a cheap, practical and easily handled unit with which to erect the exterior walls and interior partitions of dwellings and other buildings of few stories and light loads. To this end several special types have been put on the market to provide light handling, abundant air space and good bonding qualities. Their surfaces forming the exterior face of a building are usually finished with stucco coatings or cement paint (Fig. 4). Of recent years hollow concrete blocks have come into use also in steel frame buildings for partitions, backing and fireproofing. They are not used to any extent for floor arches. Although concrete blocks will harden in 24 to 48 hours, they should not be used until they have ripened for 28 days to avoid shrinking in the wall and resulting cracks.

The following table presents the sizes and weights of the more usual cinder concrete block and tile.

Table VIII. Cinder Concrete Block

Size of Units, inches	Number of Cells	Weight, lbs./ft. <sup>2</sup>
3 x 8 x 16. Tile.....	Solid Top 3	14
3 x 12 x 12. Tile.....	Solid Top 3	15
4 x 8 x 16. Tile.....	3	16
6 x 8 x 16. Tile.....	2	25
8 x 8 x 16. Block.....	2	33
12 x 8 x 16. Block.....	4	52
8 x 5 x 16. L-shaped Block Header.....	2	xxxx
8 x 8 x 16. Jamb or Joist Block.....	1	33
8 x 8 x 16. Steel Sash Block.....	2	33
12 x 8 x 16. Steel Sash Block.....	2	52
8 x 8 x 16. Block.....	Solid	43
12 x 8 x 16. Block.....	Solid	67
2 1/4 x 3 3/4 x 8. Brick.....	Solid	3
8 x 16 x 16. Chimney.....	4	xxxx
4 x 8 x variable. Lintel.....	Solid	xxxx

**Light-Weight Concrete** partition and wall blocks are also manufactured from patented materials described in Chapter IX, Article 4. The Haydite product consists of hollow blocks with high fire-resisting and sound-insulating qualities and satisfactory strength. Interior trim can be nailed directly to the units, which are 8" x 16" on the face and 4", 8" and 12" thick. Aerocrete blocks are 12" x 24" on the face and 3", 4" and 6" thick. The material weighs only 50 to 60 lbs./ft.<sup>3</sup> and absorbs sound to a marked degree.

Types of porous concrete pre-cast roof and floor slabs are manufactured which are very light in weight. They are composed of Portland cement and sand only, with no cinders, and are produced in such a manner as to be honeycombed with air cells. For this reason they are good insulators against heat and sound and hold nails well so that tile and slate can be applied directly to them. The slabs may be used for either short or long span construction and weigh from 12 to 17 lbs./ft.<sup>2</sup> They are generally reinforced with welded wire mesh and will carry loads up to 60 and 70 lbs./ft.<sup>2</sup> See Chapter IX, Article 4.

#### Article 5. Door Bucks

Some form of door buck or frame is necessary in all types of tile partitions to support the hinges and lock, to stiffen the sides and top of the opening and to furnish a stop against which the door may close. These bucks may be of wood, pressed steel or structural steel.

**Wood bucks** are planks usually 3" thick and as wide as the thickness of the partition. They are set before the partition, the tile being bonded to the buck as the partition is built. Wood bucks are not permitted in fireproof construction unless they are encased in sheet metal or completely surrounded by metal door trim and jamb.

**Pressed steel bucks** are formed by machine pressing heavy #8 to #18 sheet steel into long channels. These are set with the face to the opening and the flanges extending back into the partition and anchored to the tile which are built between them. When pressed from the heavier metal the bucks cannot be given sharp edges or delicate mouldings but can be used where high rigidity is essential and plain surfaces are permissible, as in industrial plants and freight elevator doors. Because they act in the three capacities they are called COMBINATION BUCK, JAMB AND TRIM. Such combinations are also pressed from medium-weight metal for lighter service, in which case simple mouldings may be obtained. Where delicacy and refinement of mouldings and sharp arrises are desired, as in the typical doors of a building, a combination buck, jamb and trim may be pressed from light-gauge metal and reinforced with heavy pieces to act as anchors and to carry the hinges and locks. Sometimes heavy metal is used as a simple buck to carry the loads, and an elaborate trim and jamb pressed from light metal is hooked and clipped around it. The corners are mitered and the mouldings perfectly fitted and welded (Fig. 5).

**Structural steel bucks** consist generally of channels set with the web toward the opening and the flanges extending back to receive the tile. They are used where great rigidity is required, as at lift and elevator

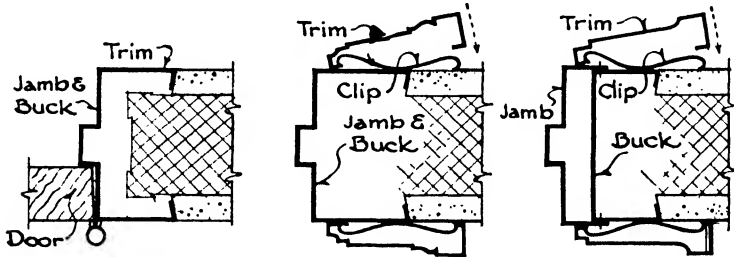

FIG. 5.—Steel Bucks and Trim.

doors, and often extend the entire distance between the steel floor beams. For better appearance they may be covered with a light steel trim and jamb, the flanges being turned outward toward the opening to receive the metal trim and the tile secured to the channel with metal anchors.

## Article 6. Cast Stone

**Description.** The improvement in strength, quality and appearance of architectural cast stone compared to natural stone has been due partly to its lower cost since the First World War and partly to the recognition by architects that any kind of texture and color scheme can be obtained through the great range of aggregates and through the absolute control of manufacture. Cast stone of the better quality was first perfected as an imitation of sandstone, limestone and granite, and, by the studied selection and combination of the cement and the aggregates and by hand or machine tooling of the face of the blocks, these imitations have become remarkably successful. The development of the material is now progressing still further, and cast stone with distinctly characteristic colors and textures is being produced, not intended to imitate any natural stone but to harmonize with color schemes and to produce effects determined by the imagination of the designer.

**Manufacture.** It is distinctly the aggregate which gives character to cast stone; consequently the aggregate must be exposed upon the face side of each piece. The white or gray cement, aggregates and water are mixed as for any concrete and then cast in moulds. The moulds may be of sand or wood, or of metal, plaster or gelatine, as the requirements of the piece indicate. The aggregates obtainable are of the greatest variety, and much skill is required in selecting and combining them to give the color, texture and character of surface desired. To imitate a fine and homogeneous limestone or sandstone is obviously simpler than to

reproduce the effect of a complex granite or marble where many minerals, tones and hues appear upon the surface.

The best cast stone made in sand moulds is of the same composition throughout the piece. Much stone is cast in moulds of metal or other materials; only the face is composed of the selected aggregates, and the backing is of a cheaper mixture. By this method the quantity of special aggregate is relatively small, and distinctive results may be obtained without great increase in cost.

After the pieces have set sufficiently they are removed from the moulds and are ready for the surface treatment. In some the finish is given by hand tooling and hammering by stone masons or by grinding upon silicon carbide beds as is done to natural stone. In others the cement must be eliminated from the surface and the color and texture of the aggregates definitely exposed. This may be accomplished by spraying a fine water mist at about 40 lbs. pressure upon the face of the piece when first removed from the mould. Another method is to brush the face when 6 to 24 hours old with bristle brushes or with fine wire mesh, and a third method is to clean the surface with 20% to 50% muriatic acid and water.

In order to produce a polish the aggregates must be so combined and graded that they cover almost the entire surface of the face since the cement will not take a polish. The block is then ground, sanded and rubbed in the same manner as natural marble and granite.

To obtain special color effects, not in imitation of any stone, crushed ceramics of desired colors and grading have been used. The surface is then treated to eliminate the gray cement, and the colors and texture of the aggregate become evident in their true values.

A metallizing process is likewise perfected for the surface of cast stone, and the field may be broadened to include the entire exterior faces of monolithic concrete buildings. By this method a skin of glistening protective metal such as chrome steel is coated upon the surface; since any metal can be used, a wide range of colors and combinations is available for the production of most striking results.

Cold mineral oxide glazes are also applied to concrete units before the cement has hardened, producing much the same effects as the baked glazes on terra cotta. Glazed concrete units are less costly than glazed terra cotta but the surface is not so hard. However, it is sufficiently tough to resist moderately severe usage.

Reinforced concrete units 2" thick and containing up to 100 ft.<sup>2</sup> of surface are now manufactured which weigh approximately 25 lbs./ft.<sup>2</sup> and very materially reduce erection costs. The units are reinforced with welded steel mesh; the cement, water and aggregate ratios are properly adhered to, and vibration is often used to compact the concrete. Any desired surface textures and color combinations may be obtained, and the material is enduring and economical. It is secured to the structural brick, concrete or hollow tile walls by stirrups and bolts.

## CHAPTER VII

### STONE

#### Article 1. Composition

**Use.** Stone has been recognized as a building material since the earliest days, and until the advent of steel it was considered as the most important material for permanent construction. Almost all famous monuments of classic times, of the mediaeval and Renaissance periods and of the eighteenth and early nineteenth centuries were erected in stone, since stone alone could contribute the qualities of strength, beauty, dignity and durability worthy of monumental architecture. Stone walls carried the loads, and stone foundations supported the entire building.

Since the development of steel and concrete and their employment in the foundations and structural members of buildings, the use of stone has been more confined to the facing or outer shell of the walls and to the embellishment of the interiors, and for these purposes it continues to be highly valued because of its never-failing beauty, dignity and durability. Owing to the great increases in the amount of building, more stone is now quarried than at any time in the past.

**Composition.** Rocks are aggregates of minerals, which in turn are compounds of chemical elements. The number of minerals occurring in the rocks suitable for building purposes is very small and may be classified as follows:

1. Silica Minerals composed of silica ( $\text{SiO}_2$ ) in different forms.
2. Silicate Minerals composed of silica combined with various metallic bases.
3. Calcareous Minerals composed of calcite or carbonate of lime ( $\text{CaCO}_3$ ) and its combinations.

**Silica Minerals.** QUARTZ is almost pure silica and is the most important silica mineral. It is more abundant than other minerals, is very hard and insoluble and resists abrasion and decomposition better than most minerals with which it is associated. Crystalline in structure, it has a clear, colorless appearance and an irregular glass-like fracture. Quartz is the principal constituent of sand since it endures in granular form after the other minerals in the disintegrated rocks from which sand is derived have been ground to powder and sifted or washed away. Quartz also occurs in most clays and is an essential constituent of granite, gneiss, mica schist and sandstone.

Silica is the cementing medium in many sandstones and limestones

**Silicate Minerals.** FELDSPAR is a silicate of alumina with either potash, soda or lime. The feldspar containing potash is known as orthoclase and occurs most frequently in building stones such as granites and some sandstones. It may be hard and compact with few cavities, in which case the granite will be hard and capable of withstanding the weather without disintegration; or it may be porous and filled with minute cavities and flaws, in which case the granite will be easier to cut but not so durable. The color of granite often depends upon the feldspar which may be pink, red or clear and glassy. The decomposition of feldspar results in the formation of clay which is largely alumina.

MICA is a silicate of alumina with other minerals. All varieties are soft and split into thin elastic leaves but do not easily decompose. Black mica or biotite has a large proportion of iron with the alumina; the white or colorless variety called muscovite is a mixture of alumina with potash. Mica being soft and easily split is a source of weakness in stones if it occur in abundance or in parallel layers. In a good rock it should be present only in small flakes evenly distributed. It is prevalent in granite, limestone, sandstone, schist and clay.

HORNBLLENDE is a silicate of alumina with lime and iron, and appears in dark green, brown and black crystals. It takes a good polish and being a strong and durable mineral its presence adds much to the value of a building stone. It occurs in granite and gneiss.

SERPENTINE is a silicate of magnesia and is a rather soft green or yellow mineral of soapy feel and no cleavage. It is with calcite or dolomite a predominating constituent of serpentine or verd-antique marbles and also is found in small particles in other marbles.

**Calcareous Minerals.** CALCITE is a carbonate of lime ( $\text{CaCO}_3$ ) which when pure is white in color and fairly soft. It is an essential constituent of limestones, marbles, dolomites and travertine, and also often appears as the cementing material of sandstone and shale. In the form of limestone, calcite is quarried not only for a building stone but also for making quicklime, Portland cement and to act as a flux in the manufacture of steel and iron. Calcite actively effervesces when treated with dilute hydrochloric acid and is also slightly soluble in water containing carbon dioxide. For this reason pits and voids are sometimes found in limestones and marbles.

DOLOMITE is a carbonate of lime and magnesia ( $\text{CaMgCO}_3$ ) and, like calcite, occurs in large masses, being quarried for building stone and for making lime. It is harder than calcite and is little affected by dilute acid. Many limestones contain magnesia in greater or less quantities and are definitely known as dolomites rather than magnesian limestones when the magnesia content amounts to 45%. Many of our so-called marbles also are really dolomites.

GYPNUM is a hydrous sulphate of lime ( $\text{CaSO}_4 + 2\text{H}_2\text{O}$ ) which occurs in large masses and is quarried for manufacture into plasters and hollow tile. It is soft but is not affected by acids, and in this way can be distinguished



from calcite which it somewhat resembles. In its fine translucent varieties, the alabasters, it is used for ornamental work but is not adapted to the requirements of a structural building stone.

**PYRITES** is an iron disulphide ( $\text{FeS}_2$ ) and is generally considered as an undesirable constituent in building stones owing to its liability to oxidize and at times to liberate free sulphuric acid, thus staining and even disintegrating the rock. It appears either in small brassy yellow cubes or in very fine granular condition.

## Article 2. Classification

Rocks may be divided into three groups:

1. Igneous Rocks.
2. Sedimentary Rocks.
3. Metamorphic Rocks.

**Igneous Rocks** are formed from molten matter erupted from the interior of the earth and gradually cooled and solidified near the earth's surface. They are usually crystalline and massive in structure, that is, without stratification planes. The igneous building stones are granite, gneiss and traprock. Such eruptive rocks are found in the older mountainous parts of the United States, in the Appalachian range in the East and the Rocky Mountain, Sierra Nevada, Cascade and Coast ranges in the West. They are not evident in the level prairie regions in the center of the continent where the rock is of later and sedimentary origin.

**GRANITE.** The essential constituents of granite are quartz and potash feldspar with usually some hornblende and mica. The rock varies in texture from very fine and evenly granular to coarse. Its color may be gray, yellow, pink or deep red, the various hues being due to the colors of the feldspar and hornblende and to the presence of either light or dark mica. Granite is very hard, strong and durable and takes a high polish, and for these reasons together with its variety of texture and color has a very important place among building stones. It is used particularly for basements, base courses, columns, steps and thresholds, although there are many examples of its use for entire façades. Its lines, edges and contours do not appreciably soften with time and weather.

**GNEISS.** The constituents of gneiss are the same as those of granite but the rock has been altered by pressure and heat during the upheavals of the earth's crust. It is therefore a metamorphic rock and will be considered under that head.

**TRAPROCK.** The chief constituent of traprock is soda or lime feldspar; its color is dark gray or black, and its texture is very fine and dense. Because of its great hardness, its total lack of rift or grain and its tendency to split irregularly it is difficult to cut and dress and is therefore little used as a building stone. It has in the past been employed as a paving stone, but its use as crushed rock aggregate in con-

crete has led to an enormously increased production. In localities where it is conveniently obtainable it is considered as the best material for concreting purposes on account of its toughness, strength and durability.

**Sedimentary Rocks.** Sedimentary or stratified rocks are largely formed from the sediment deposited by lakes and seas in beds or strata of widely varying thickness. The deposits are, however, sometimes laid down by the actions of wind or by chemical precipitation. The sediment deposited is either calcareous, as in the limestones, originating from chemical action or from the breaking up of shells, corals and the remains of other marine animals, or is largely siliceous, as in the sandstones, derived from the disintegration of older rocks resulting in sand and clay. The grains of lime, sand or clay were bound together under great pressure by cementing materials consisting of silica, lime carbonate, iron oxide or clay. The strength of the stone depends largely upon the character of this cement, the silica and iron oxide being the strongest and most durable, the lime and the clay being weaker and more soluble through exposure to weather. The sedimentary rocks are most abundant in the central part of the United States, which is supposed to consist of old sea bottoms, where there have been no geological changes since the rocks were laid down.

**LIMESTONE** is composed of fine particles of carbonate of lime either as round grains or as the remains of shells and skeletons of marine animals. These particles are usually cemented together by silica, iron oxide or lime carbonate. The silica is hard and insoluble, the iron oxide dissolves somewhat and may discolor the stone and the lime carbonate is readily soluble especially with water containing carbon dioxide ( $\text{CO}_2$ ). The strength and durability of the stone therefore depend largely upon the kind of cementing material. The color may be white, cream, yellowish brown or gray, depending upon the amount of iron oxide and the character of the impurities. The texture may be very fine, dense and homogeneous, or it may be varied by the presence of fossil shells and skeletons or by small pits and dents. Either the fine-grained, smooth-surfaced stones or the stones with marked and pitted faces, called variegated and rustic finishes, are used in building, depending upon the effect desired.

There are several varieties of limestone determined by their structure and by the presence of other constituents beside calcite. **CHALK** is soft, fine and white and is almost pure calcite. **COQUINA** consists of an aggregate of shells loosely cemented together. It is found near St. Augustine, Florida, and though used there as a building stone, is too fragile and too easily affected by frost to be practical elsewhere. **TRAVERTINE** is a porous limestone formed by the action of springs and running water and is much valued for interior wall facing. **HYDRAULIC LIMESTONE** is used for making hydraulic lime and contains sufficient silica and alumina to give to the lime the ability of setting under water. **OÖLITIC** limestone is the name given to the stone formed of small rounded grains which

furnishes the material of finest quality as that from Bedford, Indiana, or Caen, France. HIGH-CALCIUM limestones are those containing less than 10% and MAGNESIAN limestones those with more than 10% of magnesia. DOLOMITE limestone is a crystalline aggregate of the mineral dolomite, which, as we have learned, contains 45% of magnesia. It is heavier and harder than calcite limestone, is little affected by acid and can be polished.

Limestone is widely used throughout the country not only as a building stone of first importance but for many industrial purposes, large quantities being quarried for the making of quicklime and cement, for blast-furnace flux and in chemical industries. It has approximately the same strength in all directions, and though soft when first taken from the ground, weathers hard upon exposure. The denser varieties can be polished and for that reason are sometimes classed as marble in the trade, the dividing line between limestone and marble often being difficult to determine.

SANDSTONE is composed of rounded and angular grains of sand or quartz so cemented together as to form solid rock. If cemented with silica and hardened under pressure the stone becomes almost the same as pure quartz, is light in color and is very strong and durable. When the cement is largely iron oxide the stone is more easily cut and its color becomes red or brown. Lime and clay are less durable binding materials, the sandstone sometimes disintegrating through dissolving of the lime cement or through the action of frost in the absorptive clay cement. When first taken from the ground the rock contains much quarry water or quarry sap. This water renders the stone easy to cut, and upon its evaporation the material becomes considerably harder.

Brownstone and red sandstone were formerly much used, but the lighter-colored gray and buff Ohio stone is now preferred. Several constituents occur besides the quartz in the different varieties, such as mica, lime, clay and feldspar.

Conglomerates consist of a gray ground mass or paste in which are embedded rounded pebbles of various sizes. It is very prevalent in Massachusetts and has been considerably used there. Although the composition makes it impossible to dress, by taking advantage of the numerous joint or cleavage faces and by placing them outward, a comparatively smooth wall may be built.

The use of sandstone is very widespread throughout the country and, especially in the buff Ohio types, is a most satisfactory material, being fine-grained, easily worked and sufficiently strong and durable.

**FLAGSTONES.** Sandstone split into thin plates for flagging.

**SHALE.** A thin-layered rock formed by consolidation of clay. It is used as a source of clay in making tile and brick and is the basis from which slate may have been metamorphosed.

**Metamorphic Rocks** are those which have gone through certain changes or re-organizations caused by great heat and pressure. These influences usually result in producing a crystalline and banded structure

in the sedimentary rocks upon which they act but, since they undergo varying degrees of heat and pressure, the amount and perfection of the crystallization differ also. The heat and pressure are derived from the nearby presence of molten lava and from the movements and workings of the earth's crust in the process of mountain making; consequently, the chief metamorphic building stones, marble, gneiss and slate, are found, like the igneous rocks, only in the older and mountainous formations of the continent.

**MARBLE** is a crystalline stone derived by metamorphosis from non-crystalline limestone and dolomite. Its texture is usually fine and compact, and it will take a high polish. The great range of color found in marbles is due to the presence of oxides of iron, silica, mica, graphite, serpentine and carbonaceous matter, which are scattered through their masses in grains, streaks or blotches. Pure marbles are white. **BRECCIA** is a marble composed of rounded and angular fragments embedded in a colored paste or cementing material. Marble is very widely employed as a building stone where beauty and dignity are desired. Certain varieties are decomposed by weather and are suitable only for interior work and decoration. **ONYX** marble has high translucency and is ornamented by veins and cloudings of iron oxide. It is formed by the percolation of limewater into pits and caves and is used only for decoration and ornament. **SERPENTINE** marble is massive and composed largely of the mineral serpentine. It may be green, yellow, black, red or brown, and is sometimes known as verd-antique. Exposure to the weather is apt to cause deterioration and it is therefore used only in sheltered positions.

**SLATE** is formed by metamorphic action from clayey shales deposited as fine silt on ancient sea bottoms and may be classed as clay slates and mica slates, the latter being stronger and more elastic. The marked characteristic of slate is its very distinct cleavage, caused by long-continued pressure, which permits splitting masses of the stone into the thin flat sheets,  $\frac{1}{4}$ " or more thick, so widely used as roofing slates. The texture is fine and compact with very minute crystallization, and the usual colors, caused by the presence of iron and carbonaceous matter, are red, green, black, gray and purple. Ribbon slate, black with very faint brownish bands, is often used instead of pure black slate where the latter proves too costly. Thick roofing slates with diversified shading and irregular surfaces are now often preferred to the thin slates of even color in order to improve the interest and texture of the roof. Slates should not be so soft that nail holes will become enlarged nor so brittle as to break easily upon the roof or during squaring or punching.

Thick slabs of black or ribbon slate, known as structural slate, are made into stair treads, toilet and shower-bath partitions, switchboards, sinks, and blackboards. Flagstones also are split or sawed from the cheaper varieties of slate.

**GNEISS** is of the same composition as granite but has been changed to

a laminated structure by metamorphic influences. It is very hard and durable and can be split to form paving blocks and curb stones.

SCHIST is similar to gneiss but is more finely foliated. The mica schists contain an excess of mica and are easily disintegrated and decomposed. Hard schist is often split into flagstones.

### Article 3. Quarrying and Dressing

**Quarrying.** Stone is broken out from its natural ledge by drilling and splitting. For the stratified stones such as sandstones and limestones the process is facilitated by the natural bedding of the rock, the spacing of the beds, however, limiting the thickness of the stone. Holes are drilled close together along the face lines of the stone; plugs and wedges are then driven into the holes, exerting sufficiently pressure to split the rock between the holes. For stratified rocks the holes are drilled only on the faces perpendicular to the beds, but for unstratified rock, like granite, it is necessary to drill lines of both vertical and horizontal holes. The splitting is sometimes done by driving wooden plugs into the holes and then pouring water upon the plugs, the resulting expansion of the wood causing the rock to split. On account of its hardness, granite is more slow to drill than all but the densest of limestones, sandstones and marbles. Channeling machines which cut vertical channels are also used for the limestones, sandstones and marbles of ordinary hardness but cannot be used for granites or very hard stone. The horizontal holes, when necessary, are drilled and the stone split in the usual manner.

**Cutting and Dressing.** Rock comes from the quarries with the irregularities of face caused by the splitting. Sometimes building stones are used with this quarry face untouched, but more often they are dressed by hand hammers and chisels or by machines to a more even finish. The large quarry blocks are first cut or split to the desired rough size of the stone as required for its use and position in the building. Power saws are now largely employed, even for granite, to cut the block to the desired dimensions. For fairly thin stones like 4" and 8" ashlar facing, or 1" slabs for wainscoting, gang saws cut several slabs from a block at the same time. Sawing is slow work but leaves the surface so even that much time is saved in the subsequent dressing and polishing.

Stone veneers for both exterior and interior work are now much used. For this purpose slabs 1" thick are available in marble and 1¼" thick in granite. Marble may also be obtained as tile ½" thick with rubbed back and as thin translucent slabs.

Hand tools and pneumatic machine tools of special sorts for the different finishes, such as hammers, picks, axes or peen hammers, bush hammers, crandalls, patent hammers and various chisels are employed to give textures to the exposed face of a block or piece. This face may be rough, more or less as it comes from the quarry, or it may be a plane surface marked by a tool to a desired finish. Such finishes are known as

ROCK-FACE; POINTED; PEEN-HAMMERED; BUSH-HAMMERED; HAND-TOOLED; MACHINE-TOOLED; PATENT-HAMMERED; CRANDALLED. A very usual finish is that of the patent hammer, which has a head consisting of four, six or eight cutting blades or chisels bolted together side by side, the total thickness of the blades being always about 1". The finish is known as four-cut, six-cut or eight-cut, according to the number of blades in the hammer, and signifies four, six or eight cuts to the inch. The marks of the hammer should be vertical on wall facing, parallel to the length of the piece on mouldings and at right angles to the length on top surfaces of washes, steps, sills and copings.

Planing machines driven by power are also used to smooth the faces of stones preparatory for hammered finishes or for honed and polished surfaces. The honing is done by rubbing with silicon carbide or sand and water, the larger surfaces by machine, the smaller surfaces and mouldings by hand. A polish is obtained by further machine rubbing, using a fine polishing material. Only granites, marbles and some very dense limestones will acquire and keep a polish.

Power-driven lathes have likewise been developed for turning columns, balusters and other members which are round in section.

**Selection of Stone.** Building stones may be judged by four standards: appearance, economy, durability and strength. In selecting a stone an architect will probably first judge the appearance, that is, the suitability of the stone in color, texture, aging qualities and general characteristics to the type and style of the building he is designing. The general characteristics would perhaps be considered first, since stones vary greatly in their individualities from those proper for buildings of dignity and distinction to those adaptable only for the picturesque. Marble might be considered typical of the first class and field stones and boulders of the last, while limestones and sandstones occupy the broad field of general utility. In color and texture there is a wide range of choice from brilliant hues to dull, from warm tones to cold, as well as from coarseness and roughness of texture to extreme fineness and density. As to aging qualities certain stones, especially the granites, soften very slowly in tone and outline, retaining indefinitely a forbidding hue, a wire edge and a hard contour. Other stones, however, will mellow in tone and outline without losing their lasting qualities.

The question of cost must always be among the first considerations in an architect's choice of stone, this question depending upon proximity of the quarry, abundance of the stone and its workability. Other things being equal, a stone from a nearby quarry should be less expensive than one from a great distance, a stone produced on a large scale cheaper than one that is scarce and a stone quarried and dressed with ease more economical than one upon which excessive time and labor must be spent.

From the practical point of view, durability is the most important consideration in the selection of stone, suitability depending both upon the lasting qualities of the stone itself and upon the locality where

it is erected. Frost is the most active agent in the destruction of stone. In those parts of the country where the temperature is never below freezing or where the atmosphere is very dry almost any stones may be used with good results. But where frost and wet weather often occur, a porous stone containing much water will be seriously affected when the water freezes, especially if the pores are crooked so that the ice cannot expand. Rocks of the same general kind, as limestone, sandstone and marble, differ very much in durability, some being soft and porous and others dense and hard. For instance, certain limestones and marbles stand well for exterior work, while others are never used except for interior trim and decoration. Some old, red, porous sandstones have proved very defective, whereas the harder and finer light-colored sandstones are being used more every day. Where the rainfall is high and the variations in temperature are excessive, as over much of the United States, only stones of low porosity and high resistance to expansion and contraction should be considered for exterior work. Stones from a new quarry must be accepted with caution until their weathering qualities have been tested and proved.

The strength of stones has been the subject of much investigation, and their bearing qualities have been carefully determined. These facts were of great importance in the days when vast edifices and engineering works were erected with load-bearing walls and foundations of stone. Today, however, our use of stone is largely confined to the facing of steel frame buildings and to constructions with bearing walls not over four or five stories in height. The loads in such positions are comparatively small, and any stone worthy of the name should have sufficient compressive strength to support them.

#### Article 4. Stone Masonry

**Classes of Stone Masonry.** Stonework may be divided into three general classes; rubble work, ashlar and trimming.

**Rubble Work** is not truly cut stonework, since it is constructed usually from local stones such as conglomerates, schists and slates which may be quarry or field stones. Rock of these kinds are not easily cut but will generally split to give one satisfactory face and so may be used to good effect for walls either alone or with cut stone or brick trimmings. Rubble walls should have vertical joints roughly broken and bond stones at proper intervals running through the wall. All interstices should be filled with spalls or pieces of broken stone and mortar, leaving no hollows in the center of the masonry. After the stonework is completed the joints on the face should be filled flush with mortar and roughly smoothed off with the trowel. Rubble work may be coursed or uncoursed. It is used in building solid structural walls and not as a facing only.

**Ashlar.** The outside facing of a wall, when of cut stone, is called

ashlar, without regard to how the stone is finished or its coursing. The joints are carefully dressed to planes, and the stones are generally of the same height laid in continuous courses, known as **REGULAR COURSE ASHLAR**. The facing is sometimes, however, laid in alternate wide and narrow courses called **ALTERNATE REGULAR COURSE ASHLAR**, or the stones may be of various sizes and the courses not preserved at all, as in **BROKEN ASHLAR** and **RANDOM ASHLAR**.

The term **RUSTICATED** was formerly used to denote honeycombed and vermiculated facing, but, as such texture is now rarely used, the term applies rather to describe sunken or beveled joints in the ashlar intended to emphasize the jointing by lines of shadows.

**Quoins.** The stones at the salient intersection of two walls are called quoins and are often emphasized by projecting in front of the ashlar line and sometimes by rustication. They are arranged to appear alternately as long and short stones on each side of the corner (Fig. 1).

**Jambs.** The stones at the sides of door and window openings are called jambs. Some of the jamb stones should run through the wall to form a good bond, and the joints of the short stones should be placed at the inside angle or rebate of the jamb (Fig. 1).

**Trimming** denotes mouldings, caps, sills, cornices, quoins, door and window facings and all stonework other than ashlar. When stone trimming is used upon a building with brick walls the architect must ascertain the exact measurements of the bricks with their horizontal mortar joints as laid in the wall so that the stonework may be designed and dimensioned to fit exactly with the brickwork (Fig. 1).

**Drips.** Cornices, belt courses and sills should have a **DRIP** or groove cut near the outer edge of the projecting under side so that water, which may carry dust and cinders, will drop from this point rather than wash down over the face of the stonework below and discolor it.

**Washes.** The top surfaces of all cornices, copings and projecting members should be cut with a slope or pitch from the wall line to carry the water away and prevent it from penetrating nearby mortar joints or seeping into the wall below. Narrow washes such as those upon belt courses and window sills slope outward. It is now generally preferred, however, to give an inward slope to the wide upper surfaces of copings and cornices, so that the water may flow back upon roofs or into rain conductors, rather than an outward slope which projects the water down upon the sidewalks below.

**Lintels.** Stone lintels are usually supported upon steel members spanning the opening. When the span does not exceed 6'0" a steel angle may be used, but for more than 6'0" span an I-beam is indicated. For supporting a lintel and the superimposed wall as well, two I-beams or channels with a steel plate riveted to the lower flanges are generally employed. A lintel consists of a single stone acting as a beam. When an opening is spanned by several wedge-shaped stones acting as an arch, a different principle is involved.



**Sills.** Window and door sills are of two kinds: slip and lug. Slip sills are sufficiently long to fit exactly into the width of the door or window opening and are not built into the jambs. Lug sills have flat ends which

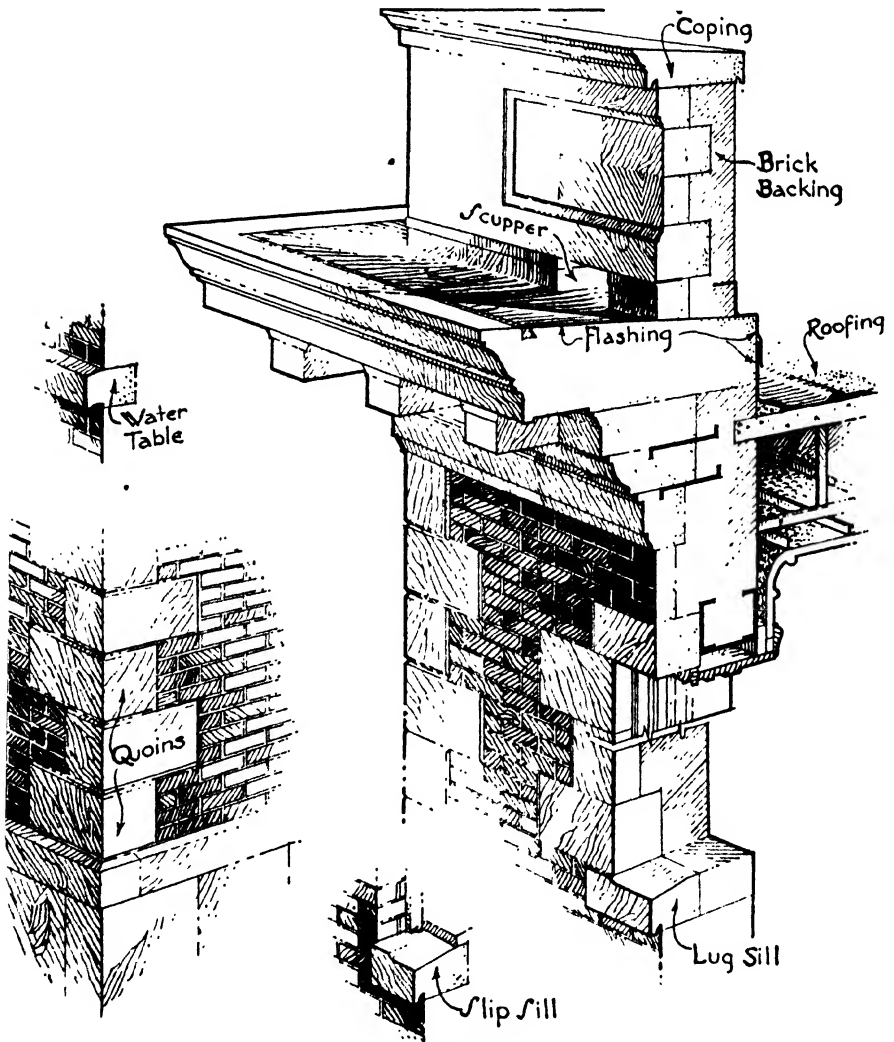

FIG. 1.—Stone Details.

are built not more than 4" into the wall on each side. Slip sills are less expensive than lug sills but the mortar may wash out of the vertical end joints and their appearance is not always pleasing. There is, however, less danger of their cracking from unequal settlement, and they are often preferred for this reason for the lower openings of heavy buildings.

All sills should be cut with a wash on the upper surface. They should be bedded in mortar at the ends only and should not be built into adjoining piers because of unequal settlement. (Fig. 1.)

**Arches.** Arches may be either circular, elliptical, pointed, segmental or flat; they are constructed of wedge-shaped stones called voussoirs. In circular or round arches the joints between the voussoirs radiate from the center of the arch, which is usually stilted or raised slightly above the actual spring line of the arch. Voussoirs may form a concentric

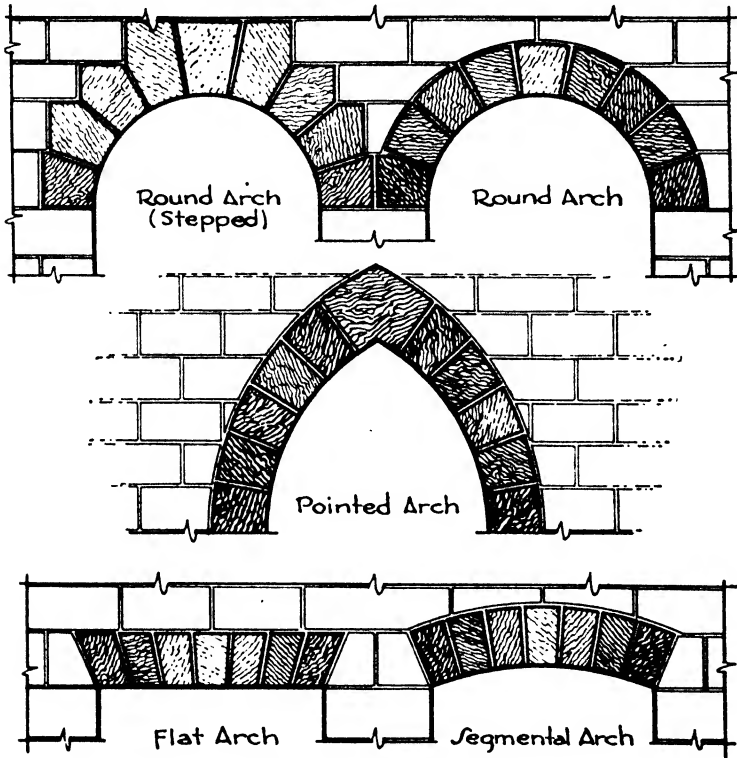

FIG. 2.—Stone Arches.

ring, or their tops may be horizontal and run through with courses of ashlar. The latter is generally preferable in appearance and permits the ashlar blocks to have square ends instead of tapering to sharp wedge shapes which are not practical nor agreeable in stone masonry. The voussoirs are uneven in number, the central one being called the keystone (Fig. 2).

**ELLIPTICAL ARCHES** have the form of a true ellipse, each joint being perpendicular to a tangent to the curve at the point where the joint is made. Sometimes the curve of the arch is not a true ellipse but is made up of consecutive arcs of circles struck from three separate centers.

Such a curve is called a three-centered ellipse, and the joints then radiate from the center from which the corresponding arc is struck. A Tudor arch is one that is pointed at the crown and roughly elliptical at the haunch. It is a combination of arcs of circles struck from four separate centers.

**POINTED OR GOTHIC ARCHES** are generally composed of two arcs of circles intersecting at the crown. They may be made of many different proportions by taking different centers and lengths of radii (Fig. 2).

**SEGMENTAL ARCHES** are used in place of full centered or semicircular arches because of limited space or for purposes of design, especially over doors and windows. The joints radiate from the center from which the arc of the segment is struck (Fig. 2).

**FLAT ARCHES** are much used over doors and windows. The span should not be over 5'0" unless the arch is supported upon a steel lintel, which is the usual modern method of construction (Fig. 2).

Flat or circular rubble stone arches are often employed to span moderate openings such as windows and doors in a dwelling. The stones should be long and narrow and roughly dressed to a wedge shape.

**Centers for Arches.** Arches are built on wooden centers cut to fit exactly the curve of the arch and rigidly set in place. They are made of planks, braced and spiked together and strong enough to bear the weight of the arch and of the wall above, for no weight should bear on the arch until the mortar is set.

**Columns.** When not exceeding 8'0" in height, columns usually have a shaft in one piece and cap and base in separate pieces. For columns of greater height the shaft is built of separate pieces, called drums, except in special cases where monolithic shafts are desired. The joints should be exactly normal to the axis and dressed to a true plane to distribute the pressure. Sheet lead pads are sometimes set between the drums of heavy columns and no mortar is used. Caps and bases of engaged columns should be built into the wall or anchored.

**Entablatures** may be of one piece or if of considerable size may be built up of several horizontal courses. The crown mouldings, corona and fascia are often of one horizontal piece, the dentils and bed mouldings of another, then the frieze of a vertical slab and the architrave in a fourth horizontal piece. The members of entablatures and cornices with wide projection should extend far enough back into the wall to balance the projection. All members must be well anchored to the backing.

**Copings.** All walls not covered by a roof should be capped with wide stones called copings. On horizontal walls, copings should have a wash sloping either outward or inward or in both directions. The coping stones are connected at the joints with bronze anchors or dovetails. Upon sloping gables the copings are bonded into the wall or anchored in place.

**Steps.** Each step should have a bearing of 1½" on the back edge of the step below, and the tread should pitch outward ⅛" to shed water.

**Thickness of Ashlar.** Ashlar when backed with brick or other material should be at least 4" thick throughout or should consist of alternate stones 4" and 8" thick. When all stones of the facing are only 4" thick each piece is tied to the backing with metal anchors. When the stones are alternately 4" and 8" thick they may be bonded into the backing and considered part of the structural thickness of the wall. If stones are 18" or more high they should be anchored as well as bonded (Fig. 1).

**Joints.** Bed joints should be full and square, not worked hollow in the center or slack in the back thus shifting the weight to fall on the front edge, causing it to spall and the middle of the stone to crack.

The width of ashlar joints varies from  $\frac{3}{16}$ " to  $\frac{1}{2}$ ". In heavy masonry  $\frac{1}{4}$ " is about the maximum width. Joints should not be made on miter lines or at the intersection of mouldings.

**Backing.** Ashlar may be backed with rough stone, brick, hollow terra cotta tile or hollow concrete blocks, brick and hollow tile and blocks being the most common. Backing may be set with standard Portland cement if the courses next to the stonework are set in white non-staining cement to avoid staining the stone. The backing should be carried up at the same time as the ashlar.

**Setting Cut Stonework.** All stones except sills should be set in a full bed of mortar. Sometimes the stones are laid upon thin slips of wood, the exact thickness of the joint, which bear the weight of the wall above until the mortar has set, when the slips are pulled out. Mortar is kept back 1" from the edge of the stone for pointing. Light-colored stones are set and their backs parged with non-staining cement mortar to prevent discoloration from the backing material and mortar. Laminated rocks such as limestone and sandstone should be set on their quarry or cleavage beds to prevent water from entering and freezing between the layers.

**Pointing** is done when the exterior is completed. The joints are raked out 1" and pointing mortar consisting of stainless white cement or lime and fine sand is applied with a small trowel, squeezed in and rubbed smooth with a jointer to a flat or slightly concave surface.

**Cleaning.** Marble, limestone and sandstone are cleaned down after the exterior is finished to remove all stains of weather and handling. Acids and wire brushes or sand blasting should never be used, soap and water and bristle brushes alone being permissible.

**Seasoning.** All stone is better for being exposed to the air after quarrying and before it is set, to evaporate the contained water known as quarry sap. Carving should be done when possible before seasoning. Exposure allows the water to evaporate and, in so doing, to deposit certain amounts of the natural cementing material held in solution. These deposits are left in the outer edges and faces of the stone, forming a crust of a harder and denser material than that in the center. Any carving done before the evaporation takes place is consequently hardened and toughened through the later deposits of cementing material.

## CHAPTER VIII

### IRON AND STEEL AND NON-FERROUS METALS

**Historical.** The utilization of iron and steel for human needs is one of the very greatest achievements in the world's history and most far-reaching in its influences. In Architecture the supremacy of steel as a building material is rivaled only by the ascendancy of concrete, each one occupying, however, a rather different field. To steel we owe the possibilities of the architecture of the present day, and especially in this country, with our buildings of extreme height and the constant shift of our growing cities. Steel has contributed the material to enable not only speed, strength, rigidity and lightness in erection but also ease and rapidity of demolition, apparently worthy of equal consideration.

Iron was used by the Assyrians, Phoenicians, Greeks, Romans and ancient Britons. It was produced, however, in small quantities in a shallow forge by heating to a pasty mass and hammering into shape, and was devoted almost entirely to the making of weapons, armor and small tools. In 1400 A.D. masonry furnaces were invented and iron could then be subjected to a melting heat and produced in sufficient quantities for casting. Between 1860 and 1870 Henry Bessemer developed the converter in England and William Siemens the open-hearth furnace in America. It then became possible to produce, by melting in large quantities, a material whose chemical properties could be accurately controlled and which could be cast and rolled into large shapes. This material is what we know as steel.

#### Article I. Pig Iron

**Iron Ores.** In this country the most important iron ores are the oxides of iron, hematite  $\text{Fe}_2\text{O}_3$  and magnetite  $\text{Fe}_3\text{O}_4$ , by far the larger percentage being hematite. Certain impurities in the form of silica, sulphur, manganese, phosphorus and earthy matter are also often present in the ore. The value of an iron ore depends largely upon the amount of iron contained in it, the ores with more than 50% of iron being known as high-grade ores, and those with less than 50%, low-grade. It is found to be more economical, first to reduce the ore to an impure metallic iron by roasting and deoxidizing by means of the blast furnace, and then by separate processes to manufacture the impure iron into cast iron, wrought iron and steel, removing such impurities in the process as may be required for each product. Some of the original impurities of the ore, however, are previously removed in the blast furnace.

**Manufacture or Smelting.** Iron ore is reduced by means of tall stacks known as blast furnaces, the resulting product being used in its molten state directly in the steel furnaces or else cast into rough shapes, called pigs, capable of being handled and transported (Fig. 1).

The blast furnace consists of a tall, vertical steel stack 40' to 100' high, lined with fire brick. The fuel is generally coke, which is light and porous and has high crushing strength. A FLUX is also required to unite with the impurities of the ore forming a fusible mixture which can be drawn off from the furnace separately from the molten iron. Since most of the undesirable ingredients in the ore, such as sulphur, alumina and silica, are acid, the flux must be basic, and limestone ( $\text{CaCO}_3$  or  $\text{MgCaCO}_3$ ) is found to be a very satisfactory material for this purpose. The combination of the flux and the impurities, called slag, is fusible and will float upon the top of the molten iron. Its removal is consequently easily accomplished. The reduction of the ore is greatly facilitated by the introduction near the bottom of the furnace of a blast of hot air at a temperature of  $1000^\circ \text{F}$ . under a pressure of 15 lbs./in.<sup>2</sup> The air is blown into a large circular pipe called the BUSTLE PIPE which surrounds the outside of the furnace like a horizontal ring and from which the air enters the furnace through smaller pipes called TUYÈRES (Fig. 1).

The coke, ore and limestone are dumped into the top of the stack in alternate layers through a double bell and hopper so arranged that the inside of the furnace is never open to the outside air. This charging is continuous during a combustion period of heat in the furnace. The combustion of the fuel largely takes place near the bottom of the stack under the action of the hot blasts of air, producing carbon monoxide,  $\text{CO}$ , which rises up through the layers of coke, ore and flux, as they in turn move downward, deoxidizing the iron and forming iron,  $\text{Fe}$ , and carbon monoxide and dioxide,  $\text{CO}$  and  $\text{CO}_2$ . The carbonic gases escape through the exhaust pipe at the top of the stack, and the iron gradually becomes melted and drips down to the hearth at the bottom of the furnace. The limestone,  $\text{CaCO}_3$ , changes to calcium oxide and carbon dioxide,  $\text{CaO}$  and  $\text{CO}_2$ , the lime uniting with other impurities and running down as slag to the hearth where it floats on top of the molten iron. Some of the silica and sulphur joins with the slag and some combines with the iron. The manganese, phosphorus and some carbon from the coke also remain in the iron. The pig iron, as it comes from the blast furnace, may therefore be high or low in phosphorus, depending upon the amount in the ore and what is retained from the fuel. The amount of phosphorus largely governs the adaptability of pig iron for various purposes such as the making of steel, malleable iron, cast iron, etc., some permitting more and some less phosphorus content in their manufacture.

The slag is drawn off every 2 hours and the molten iron every 5 hours. Much slag is now used in the making of Portland cement because of

its lime content. The iron may be cast into pigs and in sand moulds, or it may be poured into cast-iron moulds hung like buckets on an endless chain. By the time a mould has reached the end pulley of the chain the iron is sufficiently hard to be dumped into a freight car by the overturning bucket. The chain and buckets often pass through a tank of water to facilitate the cooling of the pigs. When the blast furnace is in the same plant as the furnaces for manufacturing finished iron and steel,

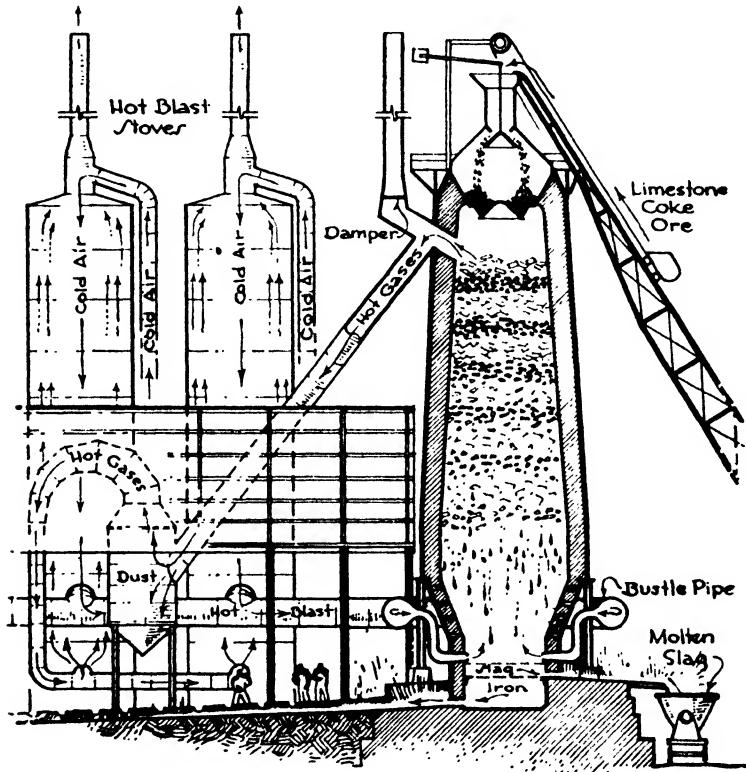

FIG. 1.—Blast Furnace.

the molten pig iron is conveyed by ladles directly to the latter furnaces and is re-used in its fluid state.

The hot, combustible gases discharged by the blast furnace are very economically utilized for heating the hot-air blast and for running the blowing engine. Four tall vertical steel cylinders, called stoves, are usually connected with each blast furnace. The stoves are filled with fire brick set in a checkerboard pattern so that air or gases can pass all around them. These bricks are heated by turning the hot discharge gases from the furnace into the stoves. When the bricks are heated, the gases are turned off and air is forced over the hot bricks, raised to

about 1000° F., and then blown through the bustle pipe and tuyères into the furnace. The stoves are alternately heated by the gases for an hour and then in turn heat the incoming air for 20 minutes. This method of using the hot exhaust gases to heat the forced air required in a furnace is used also in the steel plants and is called the **REGENERATIVE PROCESS**.

## Article 2. Cast Iron

**Uses.** Cast iron is high in compressive but low in tensile strength and is employed in building construction only where the stresses will be those of direct compression as in short columns, caps, bases and bearing plates. Even for these purposes, steel is rapidly taking the place of cast iron because as a product it is far more dependable. Cast iron is used, however, in the manufacture of many articles indirectly connected with building structures, such as pumps, motors and engines, because it is cheap, lends itself well to casting and can be machined. It is hard and brittle and should not be subjected to shock.

**Manufacture.** Cast iron is made by melting a mixture of pig iron and iron scrap in a furnace called a cupola which somewhat resembles a small blast furnace. The fuel is coke, the cupola being charged with alternate layers in close contact with the fuel and the iron. No flux is used to carry off impurities and consequently there is little change in the chemical composition of the iron after it is melted except for foreign ingredients, especially carbon, which may be picked up from the fuel. Phosphorus, as it usually occurs in pig iron, does not influence the casting except to prolong the fluid state. The percentages of sulphur, silicon and manganese, however, materially affect the physical qualities of the cast iron, rendering it harder, softer, or more or less brittle, consequently the remelting is necessary in order to combine pig iron and scrap iron of different compositions into a cast iron with exactly the required percentage of each ingredient. The molten iron is run off into the moulds which are of sand formed by the impressions of wood patterns. In general, small castings should be high in silicon and phosphorus and large castings high in manganese and sulphur.

**Gray Cast Iron.** The usual product of the cupola furnace is a cast iron with a gray crystalline fracture, containing carbon largely in the form of graphite in flakes mixed mechanically with the iron, together with some carbon chemically combined with the iron. **GRAY IRON** is hard or soft depending upon the amount of combined carbon and also upon the percentage of silicon, sulphur and manganese. The silicon tends to increase the amount of graphite and thereby soften the iron; the sulphur and manganese by increasing the combined carbon tend to counteract the effect of the silicon. Soft gray iron is much used for ordinary casting, is easily machined and is cheaply produced. It contains too much carbon to permit annealing into malleable iron.



**Air Furnace Iron.** The air furnace, similar to the puddling furnace for wrought iron, is designed so that the iron is isolated from the fire and therefore does not pick up impurities, especially sulphur and carbon, from the fuel. The different stages in the melting are under better control, and this sort of furnace is sometimes used for making cast iron of a higher quality but at greater cost than that produced by the cupola. White cast iron can be produced directly from the air furnace.

**Chilled Castings.** The slow cooling of cast iron is favorable to the precipitation of the carbon in the form of graphite whereas a sudden chilling leaves more carbon in the combined state. Consequently by the slow cooling of a casting a softer iron is produced, but a sudden chilling makes a harder casting. The iron suddenly cooled has a white metallic fracture with little carbon appearing in flakes and is called **WHITE CAST IRON**. It is used to resist abrasion but, though having a more durable surface than gray iron, is more brittle. It is sometimes desired, as in car wheels, that part of the casting be hard and durable and the remaining part soft, easily machined and more resistant to shock. This may be accomplished by lining parts of the mould with metal which quickly absorbs the heat from those parts of the casting while other portions cool more slowly.

**Malleable Iron.** White cast iron can be given greater ductility and tensile strength by an annealing process consisting of packing the casting in an oxidizing agent and heating for several days without melting. This process removes the carbon from the surface as carbon monoxide and changes the combined carbon in the interior to graphite but in fine amorphous particles rather than flakes. The softness, ductility and shock resistance of the iron are thereby increased and also the tensile strength since the graphite is well distributed in fine grains rather than concentrated in fairly large flakes. Malleable iron is used for hardware, concrete inserts and hangers, and can be depended upon to resist a slight amount of twisting and bending stresses and a fair amount of shock and vibration. It cannot be rolled or forged.

**Flaws.** Iron castings should be inspected for shrinkage cracks, checking and blow holes. In the case of hollow cast-iron columns the thickness of the shell should be tested as it may be irregular.

### Article 3. Wrought Iron

**Use.** Wrought iron, since it contains very little carbon or other impurities, is tough, ductile and easily wrought and welded. It carries some slag but otherwise is nearly pure iron and as such is highly resistant to the action of rust or corrosion. On this account its manufacture into roofing sheets, rods, metal lath, wire, gas and water pipes and boiler tubes is widespread. It is likewise used for wrought plain and ornamental ironwork in connection with buildings such as grilles, window guards and gratings. Wrought iron was formerly an important structural

material in the form of beams and girders, but since the advent of the Bessemer and open-hearth processes of manufacture it has been entirely replaced by steel for structural purposes.

**Manufacture.** Wrought iron is made by melting pig iron in a reverberatory or puddling furnace, consisting of a grate with a hearth placed beside it and divided from it by a low wall called the fire bridge. The fuel, usually soft coal or gas, burns upon the grate, and the flame and gases, passing over the fire bridge, are deflected by the roof of the furnace directly down upon the pig iron which lies upon the hearth. The pig selected for making wrought iron is high in silicon, which assists in forming a fluid slag over the molten iron, thus protecting it from oxidation by the air. The hearth is bedded with basic iron oxide, usually in the form of high-grade ore, which, during the heating and melting periods, oxidizes the carbon of the pig iron into carbon monoxide

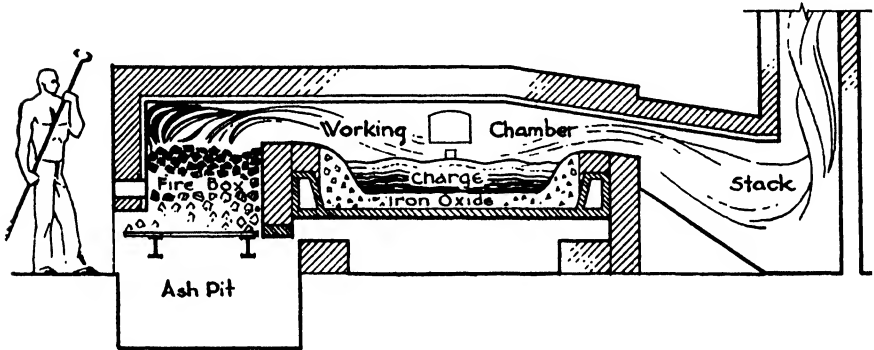

FIG. 2.—Puddling Furnace.

and carbon dioxide, and the silicon, manganese and phosphorus into oxidation products forming a slag on top of the iron. Sulphur is removed to the least extent. The mass is continually stirred or puddled during the melting. The temperature of the furnace is lowered when the melting is finished and the boiling begins. This boil is caused by the formation of carbon monoxide,  $\text{CO}$ . The molten iron boils and increases in volume as the carbon monoxide bubbles up through it. The melting point of the iron rises as the impurities are eliminated. The temperature is again raised to keep the iron in the proper fluid state for about half an hour. The temperature is then again reduced, and the man in attendance, called the **PUDDLER**, gathers together on long rods the slowly cooling pasty iron into balls weighing about 100 lbs. called **MUCK BALLS**. These balls are removed by the puddler and placed under the squeezer or hammer. The temperature is controlled by opening or closing a large damper in the chimney. During the boil a portion of the slag runs over through a door in the side of the furnace. The muck balls contain some slag, but much of it is squeezed out by the squeezer

and hammer. The balls are then rolled out into MUCK BARS, piled into layers, heated to welding heat and again rolled into MERCHANT BARS which may be plate, flats, rounds, squares or other shapes. The slag is never entirely removed by the squeezing process, but the particles of iron and slag are elongated by the rollers, and a fibrous structure streaked with minute shreds of slag is produced which is characteristic of wrought iron (Fig. 2).

Because of the hard labor required by the hand-puddling process many attempts have been made to produce wrought iron by mechanical means and in large tonnage quantities. The Aston process is the most promising of these methods and will undoubtedly increase the use of wrought iron in many fields.

The chief difference between wrought iron and low-carbon steel lies in the fact that wrought iron is puddled then rolled and forged into shape, never melted and cast in a mould, and is consequently less dense and homogeneous. It usually contains less than 0.12% carbon and has between 1% and 2% of slag scattered through its structure. The slag may contain some chemical impurities, but these impurities do not affect the qualities or characteristics of the iron itself because the slag is mixed with the iron mechanically and not chemically.

#### Article 4. Steel

**Description.** We have seen that cast iron retains most of the impurities of pig iron and is not forged or rolled. It is consequently brittle and has little resistance to tension or bending. The chemical impurities are removed from wrought iron, so that it is almost pure iron. It is drawn off from the furnace in pasty balls and is rolled into shape. It consequently will resist tension and bending stresses to a fair amount, but is fibrous and contains some slag. We now come to steel, which, like wrought iron, has few impurities, but which, because it is melted and cast into billets and then re-heated and rolled into shapes, attains a finer and denser structure without slag and a much greater strength, both in compression and tension, than wrought iron. The melting of steel in the furnace and subsequent casting in large ingots also permits the rolling of structural members with greater speed and in far larger quantities than are possible by the forging processes used in the making of wrought iron.

**Carbon Steels.** As in the manufacturing of wrought iron, the elements in the pig iron which must be eliminated or controlled are carbon, sulphur, phosphorus, silicon and manganese.

**PHOSPHORUS** causes the steel to be brittle at normal temperatures or **COLD SHORT**. It is difficult to control, and the amount of phosphorus in the original ore, most of which is retained in the pig iron, has an influence in determining the method of manufacture, whether by the open-hearth or the Bessemer process. Phosphorus should be largely eliminated from

the finished steel, not more than 0.06% being permitted for structural steel made in the open-hearth furnace.

SULPHUR renders steel RED SHORT or brittle when heated and therefore difficult to forge or weld. It is limited to 0.045% by the specifications of the American Society for Testing Materials.

SILICON is liable to cause brittleness and in structural steel should not exceed 0.2%. For special purposes, such as castings, a larger percentage is often an advantage.

CARBON is a very important ingredient in the composition of steel, rendering the product stronger, harder and stiffer as its percentage is increased. It causes the steel, however, to be less ductile and more brittle, and consequently its proportion must be carefully controlled. Steel is then classified according to carbon content as follows:

CARBON	
Soft, mild or low-carbon steel.....	Up to 0.25%
Medium or medium-carbon steel.....	0.25 to 0.50%
Hard or high-carbon steel.....	Over 0.50%

Wire is usually made from low-carbon steel because it has greater ductility. High-carbon steel is used for purposes requiring special hardness and strength such as springs and tools, whereas most structural members and reinforcing bars are rolled from medium-carbon steel, this being best adapted to withstand the stresses produced in building construction.

**Alloy Steels.** Besides carbon, other elements giving distinctive characteristics are combined with iron to produce steel. These are called ALLOY STEELS as distinguished from carbon steels. Nickel steel is stronger than carbon steel and already has had some use in building construction. It is rolled in the standard sections. Chromium steel is extremely hard and is used in bearing plates. It can be machined when annealed. Manganese steel is adapted for castings where great resistance to abrasion is required, as in steam shovel points and grab buckets. It cannot be machined.

The two methods by which structural steel is made are the OPEN-HEARTH and the BESSEMER processes.

### Article 5. Open-Hearth Process

**Description.** Most iron ores in this country are fairly high in phosphorus; for this reason, and because the process can be constantly inspected and controlled, the basic open-hearth method is in widest use. Calcined limestone is added to the charge, rendering the reactions basic; and the acid phosphorus, being removed from the steel, unites with the slag. A cheap high-phosphorus ore can therefore be utilized. There is also an acid open-hearth process in which no limestone is added to

the charge, the silicon, manganese and carbon are oxidized, the reactions are acid and the phosphorus remains in the steel. An ore very low in phosphorus must therefore be used, and such ores are scarce and expensive in the United States.

**Manufacture** (Fig. 3). The furnace consists of a shallow hearth roofed over with fire brick into which is fed the charge, consisting of pig iron, steel scrap, iron ore and calcined limestone. Gas, the fuel most generally used, is admitted through a port at one end of the furnace where it immediately mixes with pre-heated air admitted through another port at the same end and ignites. The hot gases pass over the surface of the metal, the heat being absorbed through the layer of molten slag on top of the steel. This layer of slag protects the iron itself from loss through oxidation. The oxygen in the iron ore combines with the phosphorus, manganese and silicon, forming oxides which unite with the limestone and form the slag. The carbon is also oxidized

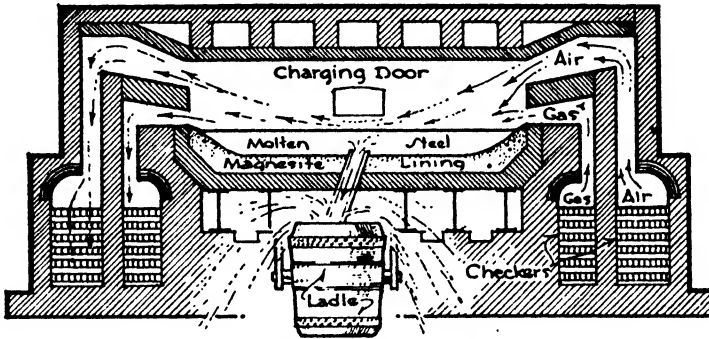

FIG. 3.—Open-Hearth Furnace.

to carbon dioxide,  $\text{CO}_2$ , and escapes with the exhaust gases. The oxidizing of the sulphur is rather uncertain.

About 5 hours is generally required to refine the charge. The entire operation may be watched through peep-holes, and small samples of the molten iron may be removed and tested. If it be found necessary to remove more impurities, additional iron ore can be put in the furnace to furnish an increased supply of oxygen.

**Regeneration.** The gas and air are pre-heated by the regenerative system, similar to that used with blast furnaces. At least four heating chambers, each filled with checkerboard brick, are connected with each furnace. They are placed under or beside the furnace, the hot air and gases being led from a hot chamber into one end of the furnace, and the hot gases exhausted from the other end passing back into another chamber and heating it to a high temperature. After about 20 minutes the currents are switched to other chambers so that hot gas and air are always supplied to the furnace and the exhaust gases from the

furnace are continually heating up the chambers. No forced draught is employed.

The usual fuel is producer gas made from coal. Powdered coal is also used to some extent, as are tar, natural gas and fine sprayed oil.

When the molten steel has become sufficiently refined it is removed from the hearth by opening the tap hole through which it flows into ladles. From the ladles the steel is poured into moulds, either to form a special casting or to be shaped into ingots, weighing 3 tons to 6 tons each, which are later re-heated and rolled into structural shapes.

**Recarburization.** In the furnace the carbon is usually reduced below the amount required in the steel. It is therefore necessary to add carbon after the steel is removed from the furnace to bring the product up to the percentage desired. This is accomplished by mixing carbon in the form of crushed anthracite or coke or in the form of ferromanganese with the molten steel in the ladle. Ferromanganese is a pig iron rich in manganese and carbon and is valuable because, besides adding carbon, it contributes manganese, which combines easily with sulphur and oxygen, preventing them, together with any remaining carbon monoxide, from combining with the iron.

### Article 6. Bessemer Process

**Description.** Molten pig iron is always used in the Bessemer process, and no fuel is added other than the oxides contained in the iron which burn out under the action of an air blast. In the acid Bessemer process the converter which holds the molten iron is lined with silica and no flux is added to the charge. Silicon is the chief fuel and burns out together with the carbon and manganese, the sulphur and phosphorus being retained in the steel. Pig iron high in silicon and very low in phosphorus and sulphur is therefore required for this process. Such ores are scarce in the United States.

A basic Bessemer process is also used, especially in England and Germany, wherein the lining is limestone. Lime is charged into the converter to produce a basic slag with which the phosphorus will unite, forming calcium phosphate, and be removed. The percentage of silicon must be low so that the slag will not turn acid by its influence, and phosphorus must be the chief source of heat. Ores low in silicon and very high in phosphorus are therefore required, few of which are found in our country.

**Manufacture** (Fig. 4). Molten pig iron is carried from the blast furnaces to a receiving vessel called a mixer where the molten iron from several furnaces is mixed to secure greater uniformity. Still in a molten state, the iron is then carried to a pear-shaped receptacle lined with silica and swung upon trunnions. Compressed air is furnished to the bottom of the converter by pipes passing through one of the trunnions. While being charged the converter lies in a horizontal position, the

charge being loaded at the open end. It is then tipped up to a vertical position with the open end at the top, the forced air or blast is turned on and the blow is said to be in progress. The heat is greatly increased and the impurities unite and burn out in the current of air. Silicon and manganese first burn with a yellow flame, then the carbon begins to burn with an intense white flame. After about 10 minutes of blow the flame drops and the contents of the converter have become nearly chemically pure iron. The converter is then tipped down into an inclined position and the contents are poured into a ladle. Small quantities of pig iron high in carbon and manganese are added as required to produce low, medium or high-carbon steel. The manganese removes any absorbed gases, iron oxide or carbon monoxide remaining in the steel. After

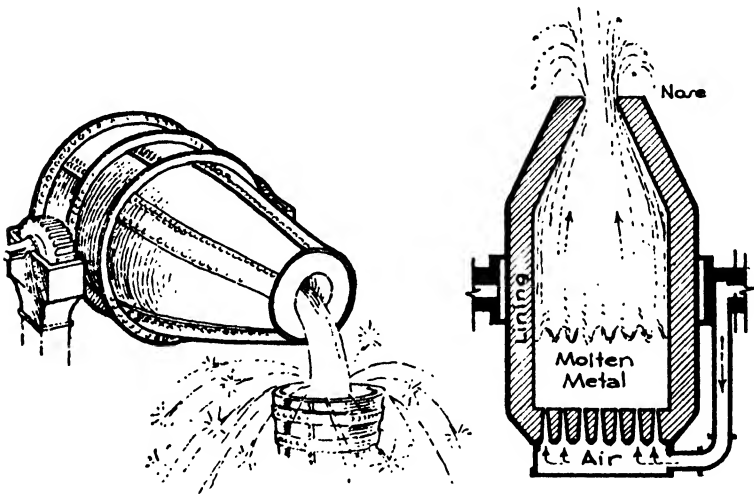

FIG. 4.—Bessemer Converter.

the recarburizing and deoxidizing process the ladle of molten steel is lifted by a hydraulic crane and poured into a row of ingot moulds. It should be noted that no fuel has been added.

The Bessemer process is quick and economical because no fuel is required. It demands, however, ores with definite proportions of impurities, and even then is variable in product, the success of the process depending largely upon the skill of the operator in judging the appearance of the flame issuing from the converter. Suitable iron ores are also scarce in this country, our ores being too high in phosphorus for the acid process and too low in phosphorus for the basic. Therefore, although Bessemer steel is made in the United States, the greatest amount of the product comes from the open-hearth process.

Because of the speed with which the Bessemer process is accomplished a combination of methods has been developed called the DUPLEX

PROCESS. By this method the molten pig iron is first subjected to the Bessemer acid process until the silicon, manganese and part of the carbon have been oxidized and then transferred to a basic open-hearth furnace where the phosphorus and the remainder of the carbon are removed. This combination increases the production in a given period and has become an important process in American plants.

### Article 7. Structural Steel

**Uses.** The various forms of steel employed in building construction such as structural shapes (I-beams, angles and channels), slabs, plates for stacks and tanks, wire, bolts, rivets, nails, screws, pipes and thin sheets for roofing are all made from rolled steel, and the importance of this process is very great.

**Rolling.** We have seen that the molten steel from the furnace was poured into ingot moulds forming what is called BILLET STEEL. In

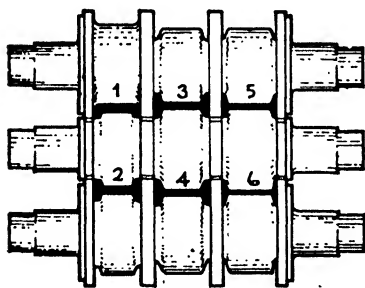

FIG. 5.—Steel Rolls.

cooling, the temperature of the surface of the ingots is too low for successful rolling, consequently they must be re-heated in a SOAKING PIT. These pits are heated by waste gas from the furnaces, and the ingot is raised from a red heat to a white heat about 200° F. below liquefaction. Stresses which take place when the metal solidifies in the mould are also relieved. The ingots or billets are then transported by cranes to the moving bed of the rolling mill. The bed carries

the billet between the immense revolving rolls, one above and one below, which flatten out and elongate the billet. The faces of the rolls differ to correspond with the kind of piece to be rolled, being flat for sheets and plates, and grooved or beveled for I-beams and channels. As soon as the billet has passed once through the rolls the movement of the bed is reversed, the rolls are brought nearer together and the billet is squeezed back between the rolls again. Many passages through the rolls are necessary before the piece receives its final shape, but the whole operation consumes only a few minutes. The piece, if a structural member, is then straightened and finally cut into the proper lengths to fill the steel order for the contemplated building (Fig. 5).

The rolling of steel betters its quality by closing up small cavities and packing the particles densely together. Structural steel is rolled at a red heat, and the strength and ductility are thereby improved. If steel be given its final shaping at temperature below red heat it is called cold-rolled steel and its strength is increased above that given by hot-rolling but its ductility is decreased. Cold-drawing steel through



hardened steel dies has the same effect as cold-rolling. Interior metal trim and mouldings, so much used in fireproof buildings, are often cold-drawn to give them increased stiffness and to render the profiles and contours sharper and more accurate.

### Article 8. Non-Ferrous Metals

**Importance.** Although it is true that our greatest and most widely used metals in building construction are iron and steel, yet the non-ferrous metals, copper, zinc, tin, lead, chromium and aluminum, have many uses of much importance to an architect. The methods of refining these metals from the ore will not be described here but their uses will be briefly discussed.

**Copper.** Copper is a malleable, ductile metal of a characteristic reddish color. The treatment and mechanical working of copper very greatly affect its physical characteristics. Soft-rolled or hot-rolled copper is soft and malleable and easily dented; hard-rolled or cold-rolled copper is harder and stronger and less ductile.

The two very characteristic qualities of copper which give it a wide use in construction are its high electric conductivity and its resistance to corrosion. As a conductor of electricity it has a great indirect importance in building, and as used for non-rusting cornices, spandrels, roofing, flashing, rainwater leaders and gutters it has its part in almost all buildings erected and contributes largely to their long life. Roofing and flashing sheets are made of hot-rolled copper because of its pliability; cornices, gutters, leaders and ornamental copper work are usually of the stiffer and stronger cold-rolled material. A thin green coating of carbonate forms upon the surface of copper exposed to air which protects the metal from further corrosion.

Copper is also used as an important constituent of the alloys bronze and brass, which enter largely into building requirements.

**Zinc.** Zinc is a malleable and ductile metal of bluish-white color which changes to a dull gray upon exposure to weather owing to the formation of a thin coating of zinc carbonate upon the surface which protects the body of the metal. It is resistant to atmospheric corrosion but is readily attacked by acids. ROLLED sheet zinc is somewhat used for roofing and flashing, but its widest use in building is found as a protective coating to iron and steel to prevent rusting. GALVANIZING consists in dipping the iron or steel in a molten zinc bath or in electroplating the metals with zinc, the former method now being the more common. SHERARDIZING consists in covering the iron and steel with a coating formed by the condensation of volatile zinc dust. Galvanized and sherardized iron and steel are used for a great variety of purposes where the metals are exposed to corrosion, such as pipes, wire screens, wire fencing and anchors for stone and brick.

Zinc is also widely used in electric batteries, in manufacturing paint and, with copper, as a constituent of the alloy brass.

**Lead.** Lead is a highly plastic and malleable metal of light bluish-gray color which changes upon the surface to a dull dark gray by oxidization when exposed to air. It has great resistance to corrosion and for centuries has been used in sheets for roofing but has now largely given place to copper for this purpose. Lead is stiffened and hardened by mixing with antimony and is then known as hard lead, which is used for rain leaders, gutters, flashing, leader heads and for casting in ornamental designs. White and red leads are the basis for all lead and oil paints, and terne roofing sheets are coated with a mixture of lead and tin.

Lead was once the only metal used for plumbing pipes, but its place is now largely taken by cast and wrought iron.

**Tin.** Tin is a silvery white lustrous metal with a bluish tinge. It is soft and malleable and has been employed by man from the earliest times. Tin is resistant to corrosion, and its chief use is as a coating to steel and iron sheets destined for roofing or for the making of receptacles such as cans and boxes. Roofing sheets are known as **TERNE PLATE** when coated with 25% tin and 75% lead or as **BRIGHT TIN PLATE** when coated with pure tin.

Tin has an important use as the chief constituent with copper in making the alloy bronze.

**Aluminum.** Aluminum is a silvery white metal of considerable ductility and malleability and of extreme lightness of weight. On account of its good conductivity, light weight and fair strength it is much used for long electric transmission lines. It is also a base in the manufacture of paints, and is employed for a variety of purposes, especially when alloyed with tin, copper and zinc, where its light weight and resistance to corrosion render it very valuable, as in spandrels, sheet roofing and the manufacture of automobiles and airplanes. It is produced in sheets, bars, wire, structural shapes and castings, and can be machined and forged. Certain aluminum alloys have a tensile strength almost equal to that of mild steel and weigh only  $\frac{1}{3}$  as much.

**Chromium.** Chromium is a silvery white lustrous metal, very hard and resistant to corrosion. It takes a high polish and does not become dull as will nickel. As a plating metal and as a steel alloy it is used in modern buildings upon window sash and frames, doors, decorative panels and balustrades.

### Article 9. Non-Ferrous Alloys

**Description.** A large variety of useful alloys are produced by melting together various combinations of non-ferrous metals. Theoretically the solution should be entirely homogeneous with no one metal appearing in an isolated state. Chemically an alloy is considered merely as a mixture of the constituent metals, which may be present in almost

any proportion, but in the case of some metals the alloying in certain prescribed proportions appears to produce definite chemical compounds. The properties of the alloy are often widely different from those of the constituent metals. The utility of alloys arises from the fact that the pure metals are often too soft, weak or costly for use alone.

**Bronze.** Bronze is an alloy of copper and tin and may contain these metals in proportions varying from 75% copper and 25% tin to 95% copper and 5% tin. Zinc, nickel, manganese, phosphorus, aluminum and silicon are also sometimes added to the copper and tin to obtain special qualities. The ductility decreases with increase in tin. The tin combines chemically with the copper, forming a crystalline structure which renders bronze very strong and resistant to wear. It is primarily a casting metal, whereas brass, though capable of being cast, is more ductile and malleable and better adapted to rolling and drawing. Bronze has excellent resistance to corrosion, and its natural color and the changes of hue which may take place after exposure to the weather depend upon the proportion of copper to the other constituents.

Bronze is largely used in building construction for doors, window sash, frames, grilles, balconies, balustrades, screens, hardware and a great variety of ornamental purposes.

**Brass.** Brass is an alloy of copper and zinc and may vary in composition from 60% copper and 40% zinc to 90% copper and 10% zinc. Most commercial wrought brass contains 65% copper and 35% zinc. Brasses are more ductile than bronze but are not so hard, and do not contain the durable crystals that make bronzes valuable for machine bearings. Brass is distinctly adapted to rolling into sheets or drawing into wire although it is often cast when required. It is very resistant to corrosion.

Brass is used in building for thresholds, stair treads, grilles, protective sheets and especially for finished hardware. Although bright yellow when fresh it quickly becomes dull and requires constant polishing.

## CHAPTER IX

# FLOOR AND ROOF SYSTEMS AND FIREPROOFING OF STEEL

### Article 1. General Considerations

The fundamental object of building construction is to provide walls and roofs for shelter and floors to carry the inmates and their possessions. If the building be of only one story it is possible to support the floor upon the ground, but if a cellar be dug under the building, or if the structure be more than one story high, some means must naturally

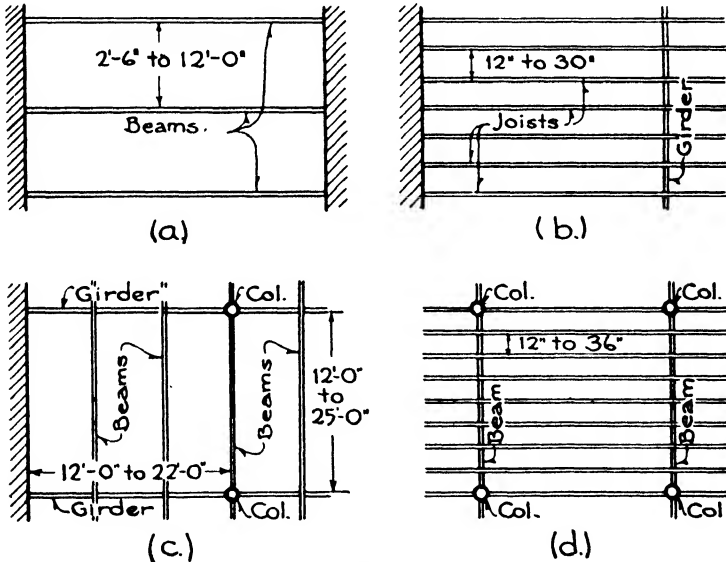

FIG. 1.—Floor Framing.

be found for supporting the floors. Save only in vaulted construction, this support, whether the building be of wood, steel or concrete, is always contrived, with one single exception, by introducing parallel horizontal members, called beams, at intervals to sustain the flooring. The beams are in turn supported at their ends by the walls of the building, by columns or by other heavier beams, called girders, which span from column to column or from wall to wall. The one exception is a reinforced concrete floor system, called girderless floor construction,

in which the floor slab carries from column to column without the use of beams and girders (Fig. 1).

The beams being in place, it is next a question of devising a system of construction which will span from beam to beam and so provide a firm and continuous floor throughout the entire story. There are several such floor systems to fulfil safely and economically the demands of various constructive conditions, such as wood, steel, concrete, fireproof and non-fireproof framework, widely spaced beams and beams close together, heavy loads and light loads.

These various systems of floor construction may be classified according to the type of beams, whether of wood, concrete or steel, to which they are best adapted. Accepted methods of constructing floors directly upon the ground as in cellars and basements are also included in this classification.

#### CLASSIFICATION OF FLOOR SYSTEMS

1. Construction on the Ground.
  - (a) Preparation.
  - (b) Hollow Tile Base.
  - (c) Cement Concrete Base.
2. With Wood Beams and Girders.
  - (a) Plank Floor System.
  - (b) Laminated Floor System.
  - (c) Wood Joists.
3. With Steel Beams.
  - (a) Brick Arches. Segmental.
  - (b) Hollow Tile Arches. Flat and Segmental.
  - (c) Stone Concrete Solid Slab. One and Two-Way.
  - (d) Cinder and Gypsum Concrete Slab. One-Way.
  - (e) Ribbed or Combination Slabs. One and Two-Way.
  - (f) Light I-beam Joists.
  - (g) Pressed Sheet Joists. Metal Lumber.
  - (h) Trussed Joists (Bar Joists).
  - (i) Steel Plate.
4. With Concrete Beams.
  - (a) Stone Concrete Solid Slab and T-beam. One and Two-Way.
  - (b) Ribbed or Combination Slabs. One and Two-Way.
  - (c) Reinforced Concrete Flat Slabs (Girderless Construction).

#### Article 2. Construction on the Ground

**Preparation.** In the case of cellar or basement floors or the floors of rooms laid directly on the ground the vital consideration is the elimination of dampness. If the ground be normally dry and naturally well drained 12" to 18" of broken stone or cinders should be sufficient as a foundation upon which to place the floor base itself. If, on the other hand, the floor must rest upon wet or only damp ground, very

definite arrangements must be made to carry off the water or to protect the floor from moisture (Fig. 2,*a,b*).

When there is no head of water, that is, when the soil is not saturated with standing water but is merely damp, the earth should be excavated for a depth of 18" or 24" below the bottom of the floor bed and lines of terra cotta drain pipe should be run across the floor area to carry away any water which may accumulate. These drains should have a slope of  $\frac{1}{4}$ " to 1' and should lead to a low point where a drain carries the water to the sewer, or, if the sewer be too high, lead the water outside the foundation walls to a dry well or cesspool. Broken stone and

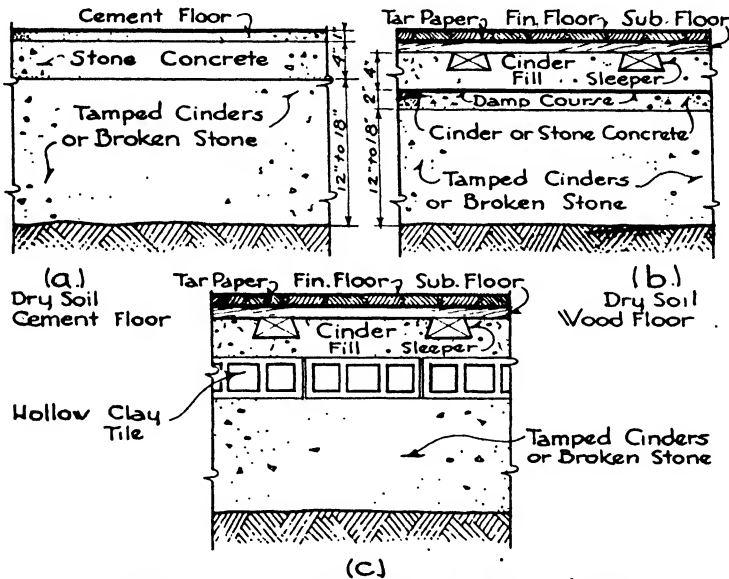

FIG. 2.—Floor Construction on Soil.

cinders are filled in around the drain pipe up to the proper level to receive the floor bed or base.

When there is a definite head of water, that is, when the ground is saturated so that the water has a distinct buoyancy and exerts an upward pressure, then the floor bed must be made sufficiently strong and heavy to resist the pressure, or else adequate under-floor drains must be introduced to carry away the water and relieve the pressure. In the first method, the floor bed consists of a heavy waterproofed concrete slab, reinforced to withstand upward bending and held down by its own weight and by the structural columns of the building (Fig. 3,*b*). In the second method; lines of pipe should be placed close together to drain all parts of the area and should be laid in a bed of broken stone.

The drains are then led to the street sewer if it be sufficiently low or to a receiver, called a sump-pit, from which the accumulated water is raised to the sewer by automatic electric pumps. According to this second method the drains are relied upon to carry away the water and reduce its upward pressure, consequently the floor bed, although waterproofed, is not required to be so stout or so heavy (Fig. 3,a).

**Hollow Tile Base.** When the earth bottom under the floor has been properly prepared by layers of broken stone or cinders either with or without sub-drainage, the type of floor bed or base itself must be determined. If dampness be present or may be expected, but without standing water or water pressure, a layer of hollow clay tile is sometimes placed all over the area to provide definite air spaces between the floor and the earth. This method is used particularly where the finished floor

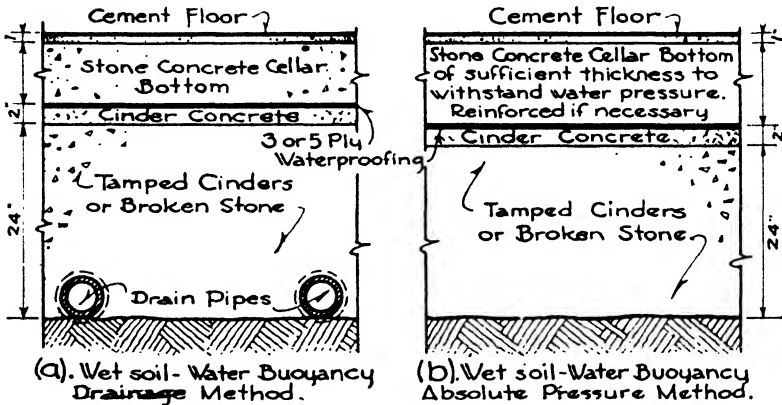

FIG. 3.—Floor Construction on Wet Soil.

is to be of wood, as in the living rooms of a residence with no cellar below them. The purpose is to prevent the dampness from penetrating to the wood floor or from rising into the rooms (Fig. 2, c).

A layer of cinders is then spread over the tile into which strips or sleepers are embedded to serve as nailing for the finished floor.

**Cement Concrete Bases.** In the case of normally dry ground with a stone or cinder fill, a bed of cement concrete is laid upon the fill to act as a firm base for the finished flooring. For ordinary conditions this concrete base is usually made about 4" thick and composed of 1 part cement to 2½ parts sand to 5 parts broken stone. It should be fairly well tamped to eliminate all voids and pockets.

Where water with definite buoyancy is present the floor base is made sufficiently strong to withstand the buoyancy, called the method of ABSOLUTE PRESSURE; or the water is drained away to eliminate the pressure, called the DRAINAGE METHOD. Both these methods are already described. The presence of water in such quantity is not unusual, espe-

cially in large buildings in cities, where basements and sub-basements, sometimes four or five in number, are sunk down below the sidewalk level. The natural level of the water in the ground, determined by a nearby sea, lake, river, spring or by other circumstances, may well be many feet above the lowest floor level, and consequently a very appreciable pressure is exerted against the cellar bottom.

If the method of absolute pressure be employed the floor base consists of a cement concrete slab thick enough to withstand the upward pressure of the water. Steel reinforcing bars may be introduced to strengthen the slab still further, and a system of girders from column to column may be devised to stiffen the floor construction, the uniform upward pressure of the water being considered in the same manner as the uniformly distributed downward load coming upon a typical story. The under side of the floor base is also heavily waterproofed with alternate layers of tarred felt and hot coal tar or asphalt to prevent any seepage of water through the concrete (Fig. 3,*b*). See Chapters XXIV, Foundations, and XXVI, Waterproofing.

When the drainage method is used the floor base is called upon to withstand little water pressure and is usually only 6" to 8" thick, depending upon the live loads coming on the floor. The base should be waterproofed according to some well-tested and approved system. With both the absolute pressure and the drainage methods the concrete base is laid upon a foundation of broken stone or hard cinders. The wearing surface or finished flooring is generally applied to the floor base at a later time as the building approaches completion (Fig. 3,*a*).

### Article 3. Floor Construction with Wood Beams

**Girders, Beams and Joists.** It will be noticed in the descriptions of floor systems that the words GIRDERS, BEAMS and JOISTS are constantly used, and the distinctions between their meanings should be understood. All three denote horizontal members of floor framework and may be of either wood, steel or concrete. A girder usually denotes a heavy member spanning between columns or walls and serving as the support for beams and joists. A beam is generally considered as lighter than a girder, carrying less load and supported at its ends by girders, walls or columns (Fig. 1,*a,c,d*). Joists are again lighter members than beams, being spaced more closely and consequently individually carrying less load. Their ends are supported by girders, beams, walls or columns (Fig. 1,*b*). Girders are usually set further apart than beams and carry heavier loads, beams are in turn more widely spaced than joists; the latter are seldom more than 30" on centers and consequently may be of much smaller cross-section. Joists are used instead of beams to support a floor when it is found to be more economical to use a larger number of relatively small members than a smaller number of larger ones. The floor slab itself also enters into the question, since a slab



must be thicker and heavier and therefore more costly to span widely spaced beams than to carry across joists set closely together.

Wood construction may be divided into two classes, **MILL CONSTRUCTION** and **LIGHT FRAME CONSTRUCTION**. The first class uses wood columns and girders, as heavy and as few in number as is practical, for the purpose of retarding fire. The second class employs light studs and joists spaced close together for economy and speed in erection.

**Plank Floor System.** Mill construction is based upon the use of masonry exterior walls and heavy wood columns, girders and floors. The girders span from wall to column and from column to column in one direction only, and the floor system consists of heavy planks carrying across from girder to girder. There are no beams in true mill construction. The method was developed for use in the erection of mills, factories and warehouses where the loads are heavy and the fire-risk high. The large dimensions of the posts and girders, the smooth under surface of the floor planks and the absence of pockets, flues and light projecting beams all help to render the building framework as little inflammable as possible in wood construction. Heavy timbers and smooth surfaces do not catch fire so readily as light projecting pieces, since they char rather than burst into flame and all parts are easily reached by water from the automatic sprinklers. Mill construction, then, retards the spread of fire and often resists its destructive force until the fire is extinguished. The girders are spaced from 8' to 11' on centers and the columns from 16' to 25' apart.

The plank floor system consists of heavy planks from 3" to 6" or more thick placed side by side on the flat. The edges may be tongued and grooved or the planks may be held together by wood splines driven into the edges (Fig. 4,a).

**Laminated Floor System.** This system is also used in mill-construction and consists of planks 6" or 8" wide spanning from girder to girder, but in this case the planks are set on edge and spiked together. On account of the greater strength of the planks on edge the girders are spaced from 12' to 18' apart (Fig. 4,b).

When plank floors are laid flat, the pieces should extend over two girders if possible and should break joints every 4' in width. In the case of laminated floors with their longer span it may be difficult to obtain planks two bays in length. The planks are then butted at their ends at the quarter points of the span between the girders, with joints breaking so that no continuous line of joints across the floor will occur.

A top floor in either one or two thicknesses is usually added in both the plank and laminated floor systems to serve as a smooth wearing surface. The methods of design of plank and laminated floors are described in Chapter XVIII, Article 1.

**Floor System with Wood Joists** (Fig. 4,c). Wood joists as used in light frame construction are usually 2" or 3" thick, from 6" to 14"

deep and are set on edge 12" or 16" apart on centers. With such short spans it is evident that the floor system may consist of fairly thin boards, usually  $\frac{7}{8}$ " thick. These boards may be in only one layer, in which case they form also the finished flooring. This is, however, a very poor method, because the floor is not stiff and, since it must be laid as soon as the joists are in place for the convenience of the workmen, it soon becomes marred by water, plaster and hard usage. It can be laid only in one direction, perpendicular to the run of the joists.

The accepted method is to lay first an under floor or sub-floor, consisting of tongued and grooved boards,  $\frac{7}{8}$ " thick by 6" wide, diagonally

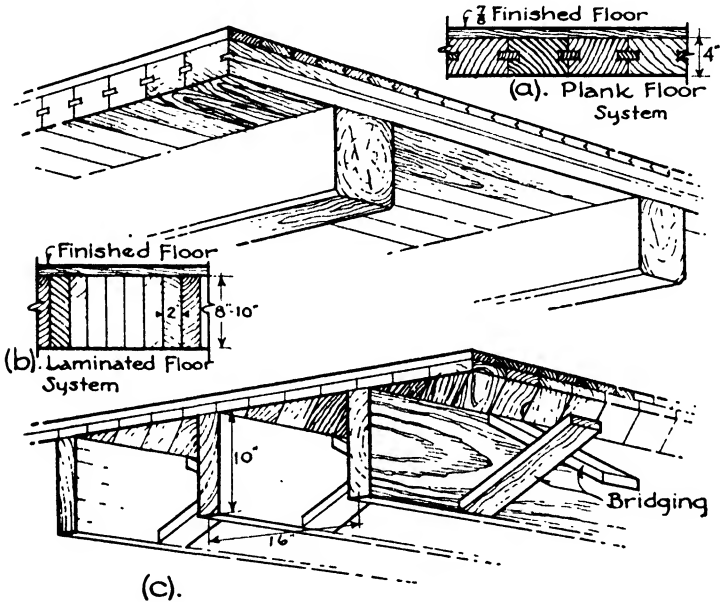

FIG. 4.—Wood Floor Construction.

across the joists. A sub-floor laid in this way greatly braces the building, provides a floor for the workmen and makes it possible to lay the upper or finished floor in any direction to suit the shape of the room or hallway. The finished floor is then laid over the sub-floor after the plastering is finished, the building dried out and the interior trim installed. The result is a stiff, stout floor system without squeaking or vibration.

#### Article 4. Floor Construction with Steel Beams

**General Considerations.** Steel beams have their greatest use in fireproof buildings, and therefore the floor systems adapted to steel beams should be of fireproof material also, or so surrounded by fireproof material as to be thoroughly protected from the effects of great heat.

These systems consist of brick or hollow tile in the form of arches, concrete slabs of several types and light steel joists supporting thin slabs.

**Brick Arches.** Brick, being very fire-resistant, was the first material used for fireproof floor construction. Brick arches will support heavy loads, but the material is of such great weight that unnecessarily high dead loads are brought upon the steel beams and columns, thereby increasing their required dimensions and adding to their cost. Much lighter fireproof materials have been introduced, which have now largely taken the place of brick for floor construction (Fig. 5,a).

The arch is segmental, spanning from one beam to the next, its haunches resting upon the lower flanges of the beams and its rise at

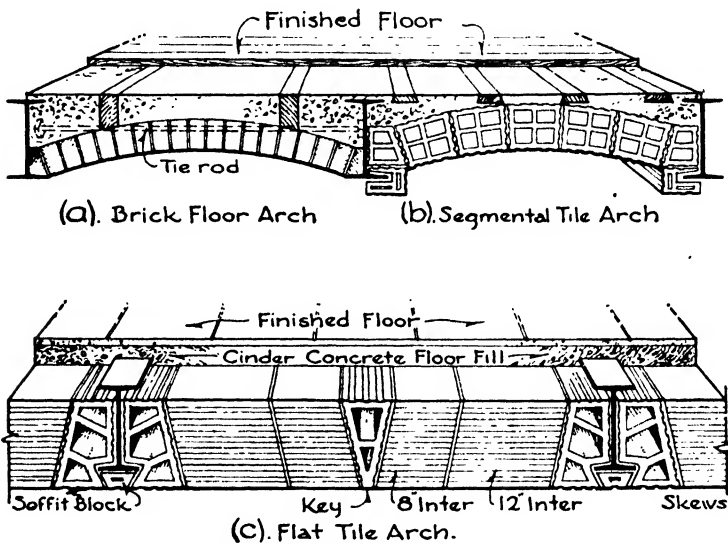

FIG. 5.—Early Forms of Brick and Tile Floor Arches.

the center amounting to  $1\frac{1}{2}$ " for each foot of span. The bricks are set dry on edge on a curved wooden form or center and the joints are then filled full with a wet mixture of cement and sand called grout. The bricks in adjoining lines should break joints, and steel tie rods, connecting the beams, are used to counteract the thrusts of the arches. The space between the haunches of the arch and the floor is filled with stone or cinder concrete leveled off on top to receive the floor. The design of brick arches is described in Chapter XVII, Article 1.

**Hollow Tile Arches.** Flat hollow tile arches are light in weight and are particularly adapted for square or rectangular floor panels. For irregular panels and spaces they are difficult to manage since the blocks are not well suited to cutting or patching. They are not practical with concrete beams and have now little general use (Fig. 5,c).

The depths of tile vary from 6" to 16", and the maximum spans of

the arches allowable for the given depths vary, at  $1\frac{1}{2}$ " for each foot of span, from 4'0" to 10'0" as follows:

Table I

Depth of Arch, inches	Maximum Safe Spans	
	feet	inches
6	4	0
7	4	6
8	5	0
9	6	0
10	6	6
12	8	0
14	9	0
15	9	6
16	10	0

The tile are usually placed in relation to the beams so that their under sides carry through with the under sides of the soffit blocks, thus giving a flat surface to receive the plaster ceiling. The blocks are scored to give a bond to the plaster ceiling applied directly to the tile. A cinder fill  $3\frac{1}{2}$ " thick over the beams is usually provided into which when required the beveled wood sleepers are embedded to receive the finished wood flooring. Flat wood platforms or forms must be provided to carry the tile arch until the mortar has hardened.

Segmental tile arches (Fig. 5, *b*) may be used when the loads are heavy, as in warehouses and factories. The curved wood forms or centering make the placing of the tile more difficult than for flat arches, and steel tie rods should be added to take up the thrust as is the case for all segmental arches. A plastered ceiling may be suspended by metal hangers from the arch if the appearance of the soffits of the arches is objectionable. The tile for flat and segmental arches are described in Chapter VI, Article 1, and the methods of designing the arches in Chapter XX.

**Reinforced Concrete Slabs.** Solid slabs of either cinder or stone reinforced concrete are used both with steel and with reinforced concrete beams. When used with steel, the beams must be surrounded for fire protection with the same type of concrete as that in the slabs. As a general rule, columns in ordinary construction are seldom placed over 22'0" apart on centers, and from 16'0" to 20'0" spacings are often used. The rectangular floor space enclosed will be square if the columns be spaced equally in both directions as 18'0" by 18'0", or rectangular if the spacing of the columns be greater on one axis than on the other as 16'0" by 20'0". It is usually more economical not to attempt to span this large floor area with one solid slab but rather to subdivide the space by introducing one or more cross beams, thereby

reducing the size of the slabs. A line of girders is therefore employed spanning each row of columns in one direction, and the beams cross from girder to girder in the other direction, with one line of beams always coinciding with column axes. It is, likewise, found to produce a more economical girder, because of the stresses, to apply the concentrated loads of the beams at the third points of the girder's span rather than at the half or the quarter points and to give girders the shorter spans in a rectangular panel.

If we suppose, then, a floor panel 18'0" by 20'0" with the girders running the shorter way, divided into three sub-panels by beams, the area of each panel will be 6'0" by 20'0". The load will be largely carried on the short span, and steel bars or rods, running the short way, are introduced in the concrete to withstand the tensile stresses produced by bending. The steel bars or rods are placed near the bottom of the slab at the center of the span, and one half the rods from the slab on each side of a supporting steel beam would be bent up at  $\frac{1}{4}$  span

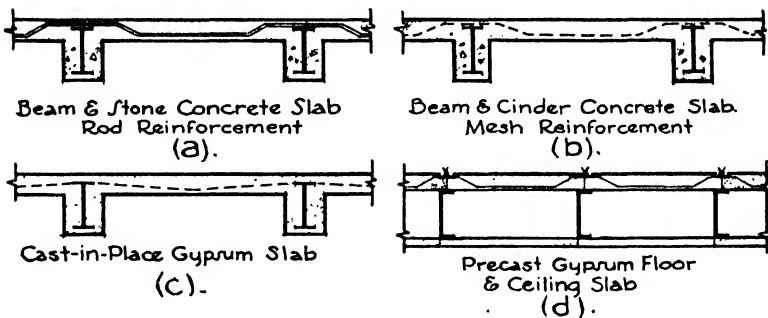

FIG. 6.—Concrete and Gypsum Floor Slabs.

and run over the top of the beam, the tensile stresses being in the bottom in the center of the slab and in the top over a beam. The amount of the stress is practically the same in both locations, and by bending up the rods as described equal amounts of steel reinforcement would be obtained in both places. This method is called **ONE-WAY** reinforcement, the steel rods running only in one direction (Fig. 6, a).

Rods or bars are used as reinforcement of slabs with heavy loads, but for light slabs woven wire mesh or expanded metal in wide sheets is often employed. Steel in this shape is much quicker and simpler to lay in position than steel in the form of rods. The expanded metal is also made with crimped ribs, called ribbed metal lath, which both provides reinforcement and acts as a form to hold the concrete. Ceilings plastered on the under side of the expanded metal act as a fireproofing, or protection may be obtained by plaster on metal lath clipped to the bottom flange of the steel beams.

When the design of the building lends itself to square floor panels instead of oblong, it is often economical to run the rods or bars in both

directions, crossing each other at right angles, since the load is equally distributed in both directions. This method is called **TWO-WAY** reinforcement and is not used if the length of the panel be more than 1.3 times the width, for in this case so large a proportion of the load is carried on the shorter span that one-way reinforcement is the more logical and more economical.

The methods of designing solid slabs are described in Chapter XXII.

**Cinder Arches.** Solid reinforced slabs of stone concrete as here described are best suited for heavy loads of 125 lbs. or more/ft.<sup>2</sup>, as in industrial buildings. For lighter loads, as those imposed by offices and school rooms and for short spans of 8'0" or less, flat solid slabs of cinder concrete, also called cinder arches, reinforced with wire mesh or metal lath, are far more economical than those of stone concrete. The cinders must be of good quality, free from sulphur, which are not always easily obtainable, and metal lath must be attached to the under sides of the beams if a plaster ceiling be desired. These two conditions sometimes interfere with the use of cinder concrete slabs on account of cost. Cinder concrete, although not as strong as stone concrete, is much lighter in weight and very fire-resistant. The steel beams are surrounded with the concrete poured integrally at the same time that the slabs are poured. The wire mesh sheets are unrolled across the beams and easily held in place. The forms consist of boards supported on cross pieces which are hung from the steel beams by heavy wires. Permanent crimped metal sheets resting upon the I-beams are also used as forms for concrete slabs and rod reinforcement. Stone concrete has an allowable working strength of 650 lbs./in.<sup>2</sup> and weighs 150 lbs./ft.<sup>3</sup>; cinder concrete has a working strength of 300 lbs./ft.<sup>2</sup> and a weight of 108 lbs./ft.<sup>3</sup> Cinder concrete floor slabs are not adaptable to stone concrete building frames and are used only with steel frame construction. The mixture should not be leaner than 1 part cement, 2 parts sand and 5 parts cinders (Fig. 6,b).

**Processed Concretes.** In addition to standard concretes composed of cement, stone and cinders as just described, several processed concretes have been developed for floor and roof construction which are lighter in weight and of high insulating quality, yet have sufficient strength to withstand moderate stresses. These concretes may be divided into two classes: (a) Those in which a chemical is added to Portland cement and sand or cinder concrete which, by generating gases, expands the mixture and forms minute air cells throughout the material. (b) Those in which an aggregate is first prepared by crushing special clays or shales and then burning them in a kiln until a porous clinker is produced. This clinker is then crushed, screened and graded to desired sizes, the cellular structure existing in the smallest particles. The concrete is made by mixing this aggregate with cement and water in the usual manner.

These concretes may be poured in place over welded wire reinforcement or may be manufactured into pre-cast filler tile and slabs for floors and roofs and into blocks for wall construction and the fireproofing of steel. Their size and characteristics are similar to those of the gypsum arches which follow.

Floor and roof slabs of shallow depth and consequent light weight per square foot of surface are also constructed by shooting cement and sand concrete upon the reinforcement under high pneumatic pressure with a patented machine called a CEMENT GUN. The constituents are mixed dry, and the water is added at the nozzle just before the concrete is forced from the gun. Tensile and compressive strength, adhesion and impermeability superior to those in hand-deposited concretes and mortars are thereby attained. Floor slab thickness may be reduced to  $1\frac{1}{2}$ " and curtain walls to 2" by this method.

**Gypsum Arches.** For small live loads, floor slabs are made of gypsum mixed with wood chips, the composition being light in weight and fire-proof. The slabs may be PRE-CAST at the factory and simply laid in place upon the tops of the beams at the building. The floor slabs are generally  $30'' \times 24'' \times 2\frac{1}{2}''$  and are reinforced with welded wire mesh. The steel cross beams are usually light channels, spaced  $2'6''$  on centers to receive the slabs. The steel is not embedded in fireproof material but is protected by gypsum ceiling slabs 2" thick clamped across the soffits of the channel flanges. A safe working load of 150 lbs./ft.<sup>2</sup> is recommended for the floor slabs (Fig. 6,d).

Pre-cast reinforced slabs are manufactured of both gypsum and light-weight concrete which are tongued and grooved on all four edges. This interlocking joint filled with grout permits the slabs to cantilever over the supports and the end joints to be staggered. The slabs are from 2" to 3" thick and 10" to 16" wide with lengths up to 10'0". The span of the slabs between steel supports varies from  $2'0''$  to  $8'0''$  depending upon the floor or roof load to be carried. Pre-cast slabs having the edges bound with steel tongue and groove shapes are likewise made. The steel binding supplements the reinforcement provided by the embedded wire mesh. The sizes are the same as the slabs without the steel binding.

Gypsum arches are also Poured in Place at the building. The mixture is the same as that for pre-cast slabs, and the reinforcement consists of welded wire mesh. The principle is that of the suspension bridge, and the strength of the slab depends upon the tensile strength of the wires. The steel beams are embedded in gypsum for fire protection at the same time that the slabs are poured (Fig. 6,c). Gypsum board with varying degrees of sound insulation may be used as permanent forms for the poured gypsum and as a finished under surface for the slabs.

**Ribbed Slabs or Concrete Joist Construction.** The tensile stresses in the lower part of a concrete slab are resisted by the steel reinforcement, and the concrete below the neutral axis has no function except to withstand a part of the shearing stresses, which are low in slab con-

struction. If the steel rods be considered as grouped in pairs at intervals of 12" to 20", it is evident that the concrete between these groups and below the neutral axis is unnecessary and can be eliminated, thus saving much material and reducing the weight of the whole construction. This type of floor then becomes a system of ribs or joists fairly close together, each one reinforced as a beam against tension and shear. The slab between any two ribs is greatly reduced in thickness and is reinforced, if at all, only with wire mesh or light rods,  $\frac{1}{4}$ " or  $\frac{3}{8}$ " in diameter, to take care of shrinkage and other unknown stresses. Reinforcement, however, is often entirely omitted from the slab (Fig. 7,a).

To construct rigid wood forms at each story for the above-described ribbed system would be complicated and expensive. Consequently hollow clay or gypsum tile called fillers, or else metal pans, all very light in weight, are widely used to act as permanent forms and create the voids between the ribs. The clay tile, though heavier than the gypsum and metal tile, add considerable strength and stiffness to the

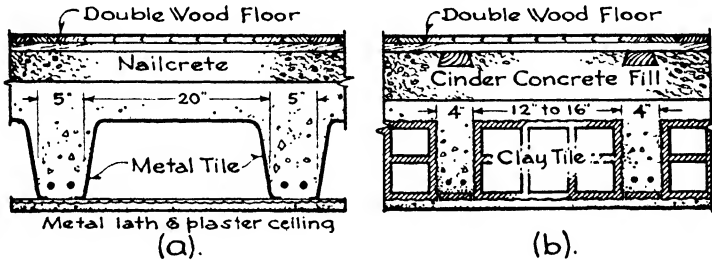

FIG. 7.—Ribbed Floor Construction.

floor panels. Removable metal tile and collapsible hinged wood forms are also obtainable which may be taken down after the concrete is hard and re-used for other construction (Fig. 7,b).

Ribbed slabs, especially with clay and metal tile, have largely replaced solid floor slabs of stone concrete where the loads are not excessive, as in hotels, office buildings and apartment houses for spans over 8'0", because they are much lighter and therefore produce economies not only in concrete but also in the steel frame, owing to the reduced weights brought upon it. They may be constructed in both one- and two-way systems, the one-way type being simpler and requiring cheaper centering but also necessitating a thicker slab than where the panel dimensions favor a two-way design. Metal lath for a ceiling must be added to the cost of metal tile and wood forms which is not required for clay and gypsum tile.

The centering required consists of a single plank under the bottom of each joist wide enough to catch the corners of the tile, and supported at intervals by posts. Terra cotta and gypsum hollow tile are now made with closed ends which prevent the concrete from entering the cells in the tile. They are especially used in the two-way system.



Hollow clay tile are 12" by 12" in plan with depths from 4" to 12". The ribs are usually 4" wide, giving a center to center distance of 16". Gypsum tile are 19" wide and 6" to 12" deep, which with a 4" rib gives a center to center distance of 23". Metal tile are 20" across the bottom, 30" to 48" long and 4" to 14" deep, and are generally used with a 5" rib, giving a dimension of 25" from center to center of ribs.

**Concrete Joists.** Concrete joists made of light-weight aggregates are now pre-cast at the factory for use with both pre-cast concrete slabs and with slabs poured in place. The joists are manufactured from 6" to 14" deep and are reinforced with longitudinal compression and tension bars at top and bottom respectively and with diagonal stirrups. The weight varies from 33 to 40 lbs./ft.<sup>2</sup> of floor area, and the joists may be used with either steel or concrete beams. Ribbed slab constructions are also called COMBINATION FLOOR SYSTEMS.

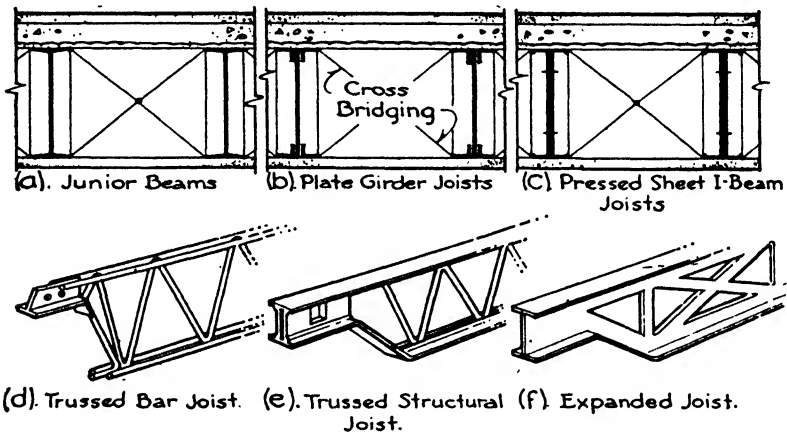

FIG. 8.—Steel Joist Construction.

**Steel Joists.** In addition to concrete joists or ribs, steel joists which are light, conveniently handled and rapidly erected have become widely used in recent years. They may be divided into three classes as follows:

- Light-rolled joists.
- Pressed-steel joists.
- Trussed joists.

Light hot rolled I-beam joists, also known as JUNIOR BEAMS, are rolled into shapes in the same manner as structural I-beams but with thinner flanges and webs, the thickness of section varying from  $\frac{1}{8}$ " to  $\frac{1}{4}$ ". They consequently weigh much less per linear foot of beam and yet are adequately strong and stiff when spaced fairly close, to carry the light live loads imposed upon the floors of office buildings, hotels, apartments and schools. They may rest on the upper flange of the structural beams, or their tops may be lowered by supporting them by angles or hangers. Bridging is provided at intervals of 6'0" by

crossed tension and compression wires or by horizontal tie rods. (Fig. 8, a.)

Light plate girder joists are also made up of structural steel angles, forming the flanges, electrically welded to a steel web plate. They are used in the same manner and for the same purpose as the Junior beams (Fig. 8, b).

The following table gives the properties of junior beams.\*

Table II

Depth in.	Weight, lbs./ft.	Flange Width in.	Web Thickness in.	Moment of Inertia		Section Modulus	
				Hor. Axis	Vert. Axis	Hor. Axis	Vert. Axis
12...	11.74	3.06	0.175	72.21	0.978	12.01	0.638
11...	10.23	2.84	.165	53.08	.746	9.63	.525
10...	8.96	2.69	.155	39.01	.608	7.78	.452
9...	7.48	2.38	.145	26.20	.394	5.81	.332
8...	6.54	2.28	.135	18.67	.343	4.65	.301
7...	5.48	2.08	.126	12.13	.248	3.45	.239
6...	4.41	1.84	.114	7.30	.165	2.42	.179

The following table gives the properties of plate girder joists. †

Table III

Depth	Weight lbs./ft.	Flange Width in.	Thickness of Metal in.		Moment of Inertia	Section Modulus
			Flange	Web		
14	12.0	4	0.125	0.134	104.52	14.93
12	9.3	3½	"	.120	61.08	10.18
11	8.5	3½	"	.109	48.64	8.84
11	8.1	3	"	.109	44.92	8.17
10	7.6	3½	"	.095	37.88	7.58
10	7.2	3	"	.095	34.81	6.96
10	6.8	2½	"	.095	31.78	6.36
9	6.5	3	"	.083	26.59	5.91
9	6.1	2½	"	.083	24.15	5.37
8	5.6	2½	"	.072	17.95	4.49
7	5.3	2½	"	.072	13.24	3.78
6	5.0	2½	"	.072	9.32	3.11

Pressed sheet I-beam joists consist of two channels, pressed from sheet steel, placed back to back and welded or riveted together. The web has therefore a double thickness, and the flanges are stiffened by bend-

\*Jones & Laughlin Steel Corp.

†Truscon Steel Co.

ing the edge of the flange parallel to the web. These beams are sometimes called metal lumber and have proved successful under light loads when near together. They are fastened to the standard steel beams of the structural frame with hangers and angles. The thickness of the sheets from which they are pressed varies from  $\frac{1}{4}$ " to  $\frac{1}{2}$ " (Fig. 8,c).

Trussed joists, also called bar joists, consist of Warren or Pratt trusses built up and welded together with bars or round rods for the web members and with round rods, flat bars, channels or T-sections for the top and bottom chords. The ends are strengthened with vertical and horizontal plates and T-sections to act as bearing and gusset plates. These joists are light and strong and permit the installation of plumbing and heating pipes and electric wires rather more easily than the solid web joists. An expanded type of trussed joist is also made all in one piece by slitting the webs of small I-beams and rolling them out to the required depth, the vertical and diagonal web members being formed in the process (Fig. 8,d,e,f).

In connection with all three types of steel joists a thin floor slab, either pre-cast or poured, generally of gypsum or cinder concrete reinforced with wire mesh, is most often used, resting upon their top flanges. The joists are spaced from 12" to 30" apart, and it is necessary to brace them laterally to prevent buckling or twisting. A metal lath and plaster ceiling is ordinarily attached to their bottom flanges which acts also as a fire protection for the joists.

**Corrugated and Cellular Steel Floors.** Floors and roof sections of copper alloy sheet steel are formed in a variety of types to take advantage of the increased stiffness and load-bearing qualities of corrugated, ribbed and cellular shapes. The gauges range from 10 to 24, and the formed sheets are therefore adapted to many loads and spans. The sheets are from 12" to 24" wide and up to 24'0" long. In general they are for roof decks and are clipped to the roof beams and joists. Some of the cellular types, however, are capable of carrying loads of 500 lbs./ft.<sup>2</sup> and can be safely used for floor construction. The top surfaces are sufficiently even to receive finishing roof and floor materials.

## Article 5. Floor Construction with Concrete Beams

**General Considerations.** Since the beams and girders in this case are themselves of reinforced stone concrete, the most adaptable floor systems are those which are also of stone concrete and can be poured to a large extent integrally with the beams and girders. For this reason the steel joists, hollow tile and brick arches and cinder concrete slabs, described above in connection with steel beams, are seldom used in buildings of concrete structural frame. The flat slab or girderless system, on the other hand, is used with concrete columns only and never with a steel frame.

The floor systems most logical in connection with concrete buildings and those most generally employed are the following:

- (a) Reinforced stone concrete solid slabs and T-beams.
- (b) Ribbed slabs (combination joist systems).
- (c) Flat slabs (girderless construction).

**Concrete Solid Slabs.** As described for steel beams, the slab is solid concrete with no fillers, but since, in this case, the beams are also of concrete and poured at the same time as the slab a different and more economical method is permitted for calculating the dimensions of the beam and the amount of reinforcement required. The beam and a portion of the slab on each side of the beam is considered as one unit, called a T-beam, having a wide upper flange. This upper flange is very effective in resisting the compression stresses existing above the neutral axis in most loaded beams, and consequently the total required effective depth of the T-beam will be less than for a beam of rectangular section with the same load. It is, however, essential that the slab and the beam be absolutely monolithic with no horizontal seams or joints between them (Fig. 9).

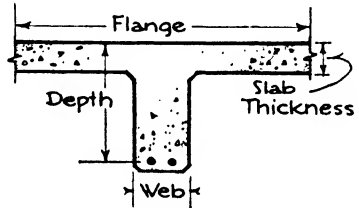

FIG. 9.—Concrete T-Beam.

The slab itself and its reinforcement are calculated in the same manner as for steel beams. See Chapter XXII.

**Ribbed Slabs** (Fig. 7*a,b*). Except with short spans or very heavy loads, ribbed slabs, that is, concrete joists combined with hollow clay tile, hollow gypsum tile or metal pans, are more economical both in concrete and in weight imposed upon the beams and column than solid concrete slabs. For long spans and moderate loads one of the ribbed slab combination systems is therefore usually chosen in connection with concrete beams as with steel beams, and their methods of construction are the same as those described in Article 4. Spans up to 40'0" are possible with this floor system although such an extreme is seldom encountered in practice. See Chapter XXII.

**Flat Slabs.** (See Chapter XXII, Figs. 13-14.) Flat slab or girderless floor construction is a system employed only in buildings with concrete columns. It consists of a concrete slab so designed that it transfers its load directly to the columns without the intervention of beams and girders. The columns may or may not have capitals, and the slabs may have entirely level under surfaces or they may be made thinner in their central portions to form sunken panels. Also they may be thickened around the capitals to form projecting drops. This floor system has many advantages where heavy loads are imposed, as in warehouses and factories, and is widely used. The thin floor slab without beams or girders is an economy in both space and material. By its use an entire

extra story has at times been gained in a given total building height. Better lighting and better accommodation for machinery shafting and sprinkler pipes are also obtained.

The most common type, and generally the most economical, combines a flaring column capital and a thickened portion of slab over the capital called the DROP. The remainder of the slab is of a uniform thickness. The object of the drop is to present more thickness of concrete to resist the shearing stresses, and the purpose of the flaring capital is to reduce the span and therewith the bending moments. The columns and capitals are usually round in plan and the drops square.

Flat slab construction is advisable only when the floor panels are square. The consequent equal spacing of columns in both directions is often possible and economical in warehouses and factories but can seldom be arranged in hotels, apartments and office buildings because of the architectural necessities of the plan. The system is, therefore, largely confined to buildings of an industrial type with heavy live loads and large open lofts where the thick columns and wide capitals do not interfere with partitions and are not objectionable in appearance.

The two generally used systems of reinforcement are:

1. The TWO-WAY TYPE consisting of two main bands of reinforcing rods extending directly from column to column in two directions, with secondary bands crossing the center of the slab parallel to the column bands.
2. The FOUR-WAY TYPE consisting of direct bands from column to column and diagonal bands across the center of the slab and also extending over the columns.

## Article 6. Roof Systems

**Wood Beams.** In light wood construction the roof beams play the same part in supporting level or flat roofs as do the floor joists in supporting the floors, and they are covered with roofing boards spanning from beam to beam just as the joists are covered by the sub-floor. These roofing boards or roofers in turn form a solid and rigid base for the roofing material. On flat roofs the roofers should be laid diagonally for bracing purposes in the same manner as the sub-floor. Pitched or sloping roofs are supported on rafters which correspond also to the floor joists in purpose but are sloping instead of level. The rafters support the roof system, which varies according to the type of roofing. For slate or tile roofs the rafters are covered with 1" by 6" tongued and grooved roofers which in turn carry the roofing. For shingle roofs tight roofers are sometimes used which give a good insulation against cold, wind and sifting snow but which cut off the proper ventilation of the shingles. On this account 1" by 2" shingle lath are often employed spanning across the rafters and spaced at proper distances apart to give nailing for the shingles. In this way the backs of the shingles are exposed

to the air. A combination of insulation and ventilation is sometimes procured by retaining the roofers and nailing the shingle lath to them. This is very good practice but somewhat more expensive. Building paper may also be stretched over the roofers to increase the insulating properties. (See Fig. 1, Chapter XI).

In mill construction the roof is usually level and constructed of flat planks or a laminated system in the same manner as the floors for reasons of fire-resistance. The roofing is then applied to the plank foundation. Skylights may be introduced, but their construction is not a part of the roof system and will be considered in Chapter XI.

The roof system upon wood roof trusses consists of wood cross beams or steel channels called purlins spanning from truss to truss. They are usually set at the panel points, that is, at the points of intersection of the upper chord with the struts and diagonals, to avoid bringing bending stresses upon the chord. Rafters again span from purlin to purlin and carry the roof boarding. If the purlins are spaced sufficiently close, thick wood planking may be applied directly to them. The roof boarding or planking carries the roofing material.

**Steel Beams.** With flat roofs the roof systems are generally the same as the floor systems, the dimensions and reinforcement being calculated from the roof loads. If the roofs are used for promenades, playgrounds or other purposes imposing live loads similar to those upon the floors, or if there is expectation of building additional stories at a future time, the roof would be constructed in the same manner as the floors below.

For flat roofs of penthouses and bulkheads where the loads are light, clay book tile are often used supported on small steel T-beams. The tile somewhat resemble a book in shape with one edge rounded and the opposite edge hollow. They are then placed so that the round edge of one tile fits into the hollow edge of the next. Book tile are made hollow from 16" to 24" long, 12" wide and 3" to 4" thick. The 24" length is most general, and the T-beams are then spaced 25" on centers. (See Chapter VI, Fig. 1.)

Gypsum slabs either poured in place or pre-cast are also used for light roofs. The poured-in-place gypsum can be used only for flat roofs, the method of reinforcing being the suspension type as described for floors in Article 4 of this chapter. Pre-cast gypsum slabs are adaptable for either sloping or flat roofs and may be of long-span or short-span types. The short-span slabs are 30" long and require sub-purlins crossing the main purlins to support them. The long-span type are 6'0" or 7'0" long and also require sub-purlins. Tongued and grooved slabs as described in Article 4 are also adaptable to light-weight roofs. The characteristics of gypsum slabs are described in Chapter VI, Article 3. (See Chapter VI, Fig. 4.)

Steel roof trusses are sometimes covered with heavy wood planking attached to the steel purlins which span across from truss to truss, the planking in turn carrying the finished roofing.

A porous cement slab has been developed which is honeycombed with air cells and is consequently very light in weight though strong. It is adapted for steep tower and mansard as well as flat roofs and is made in both long- and short-span lengths. The material is more fully described in Chapter VI, Article 4, and Chapter IX, Article 4.

When the surfaces of vaults or domes constructed according to the Guastavino system also form the exterior structure of a building, porous and hollow tile are introduced into the layers of structural tile to produce sufficient insulation and the roofing material is applied upon the exterior.

Table IV

Type of Building	Wood Frame	Steel Frame	Concrete
<p style="text-align: center;"><b>A</b></p> Industrial buildings Warehouses Heavy loads	1. Flat plank 2. Laminated	1. Solid stone concrete slab 2. Terra cotta segmental arch	1. Solid stone concrete slab and beam 2. Flat slab (girderless)
<p style="text-align: center;"><b>B</b></p> Office buildings Hotels Apartments Schools Institutions Light loads	1. Wood joists and under-flooring	1. Terra cotta flat arch 2. Pre-cast gypsum slab 3. Ribbed combination system 4. Steel joists 5. Trussed joists 6. Cinder concrete slab	1. Ribbed combination system

**Concrete Beams.** Buildings with concrete frames usually have flat roofs and the roof system is the same as that adopted for the floors. In the most modern use of concrete, however, roofs of any pitch or curve are possible, and the systems of roof construction promise to be extremely varied. The concrete is poured directly in the curved or sloping forms, pre-cast slabs are used with inserts of glass or the required shapes are attained by applying the concrete in successive layers to the reinforcement by means of the cement gun.

**Floor Fill.** All fireproof floor systems, except when trussed joists or hung ceilings are employed, must provide an accommodation for the passage of plumbing, water and gas pipes and electric conduits. These pipes are usually buried in the floor fill, a layer of lean cinder concrete spread over the structural slab. The wood floor sleepers are also em-

bedded in this fill, and the base for finished floors can be spread directly upon it.

**Selection.** The two most important considerations in selecting a floor or roof system are economy and intensity of loading. The system must produce sufficient strength to carry the imposed loads, but to install a floor of unnecessary strength or of excessive weight and thickness is uneconomical. Ease and speed of erection, non-interference with the general progress of construction, saving of space and weight, type of ceiling, character of occupancy and methods of fireproofing likewise should influence the selection. Very often the question of expense is the determining factor, and a decision can be made only after several types have been designed and the actual costs compared.

Table IV presents a general classification based upon character of occupancy and the probable resulting live loads.

### Article 7. Fireproofing Steel

**Temperatures in Burning Buildings.** Observations of actual fires and the tests made by the Bureau of Standards upon old buildings in Washington indicate average temperatures of 1500° F. with a maximum of 2500°. Much study is now being devoted to this subject, not only to determine the proper temperatures to which materials should be subjected in testing their fire-resistant and protective qualities but also the probable heat generated under the various conditions of occupancy and the amount and kind of fuel accumulated under these conditions. The degree of fireproofing required for each type of building may then be determined. At the present time, however, most building codes specify only the most thorough protection for all so-called fireproof buildings, although a few lately revised codes, such as those of Philadelphia and New Orleans and the West Coast Joint Code, recognize more than one class of fire-resisting buildings and several classes of protecting materials.

**Effect of Heat upon Steel.** In temperatures up to 500° F. the compressive and tensile strength of steel is increased by about 25% but the elastic limit and yield point are decreased. At 800° F. the strength again becomes normal, and at 1000° to 1300° F. the ultimate strength has decreased to the value of the allowable working stress so that a column or beam is likely to fail under its load. At yet higher temperatures the steel softens and yields under its own weight. It is evident that steel should be insulated even at relatively low temperatures to maintain the yield point.

**Protective Materials.** Materials whose function is to protect steel from the destructive influence of fire need not necessarily have load-bearing qualities but must be low conductors of heat and maintain their integrity as a protection to the enclosed structural member. The prime object is to insulate the steel against an increase of tempera-



ture above 800° F., and to attain this end the material must in itself withstand very high temperatures without disintegration.

The most satisfactory insulators are brick, structural clay tile, gypsum, cinder concrete, concrete blocks and metal lath and plaster. The last named is used only for secondary construction and not for main columns, beams and girders. Concrete made of aggregates containing minute air cells, such as Haydite, is also employed with success as a fire-resisting and heat-insulating material.

**BRICK.** Brick is most excellent fire protection, but because of its weight it is not used with interior columns except in basements. Exterior columns are, however, often enclosed with 8" on the outside and 4" on the inside faces. The steel should be parged with cement mortar or sprayed by the gunite method to give a  $\frac{1}{4}$ " protective coating against corrosion. The brick should be built close around the steel in all parts.

**STRUCTURAL CLAY TILE.** Hollow clay tile because of its light weight, strength and ease of handling is very generally employed and has proved well adapted for the insulation of columns, beams and girders. For the best protection a total of at least  $2\frac{1}{2}$ " of solid material should be provided outside the column face. A variety of shapes and sizes are manufactured to fit the flanges and webs of beams and girders and into the contours of built-up and H-columns. The tile should be set with the cells vertical for column protection, should start upon the structural slab and should extend to and be wedged tight against the under side of the floor construction of the story above. The fireproofing should be tied around with #10 gauge wire at intervals of 6", with U-shaped clips or with wire mesh. Pipes and conduits should be enclosed in separate compartments outside the fireproofing required for the column and entirely independent from it (Fig. 11, *a, b, c, d*).

The protection of beams, girders and trusses is accomplished in the same manner as that of columns, each member being encased completely by the use of the appropriate tile unit. The fireproofing is fastened in place by clamps, ties or wire wrapping.

**GYPSUM TILE.** Gypsum is light in weight and has high insulating value because of the water in its composition. The gradual changing of the water into steam retards a rise in temperature for very appreciable lengths of time. Protection may be derived by wrapping the steel member with wire fabric and pouring the gypsum in place or by attaching pre-cast tile to the member. Tile of a variety of shapes are made adapted to the different parts of the beam or column, and the regular solid or hollow partition tile may be easily cut or sawed to fit special cases. Gypsum tile are more brittle than terra cotta tile (Fig. 10, *e*).

**CONCRETE.** Stone concrete is too heavy for general use in fireproofing, but cinder concrete, being much lighter, is a close rival to terra cotta for heat insulation. It is usually poured in place and consequently is more used for the protection of beams, girders and trusses than for columns. Wire mesh, not exceeding 4" x 4" in size, is often used as

reinforcing for the concrete. Poured concrete is convenient in inaccessible places in connection with pre-cast tile. Blocks and tile of cinder concrete are also in the market for use in fireproofing. A total thickness of material of  $3\frac{3}{4}$ " is generally required by the codes. The blocks are installed in the same manner as terra cotta and gypsum tile (Fig. 11, a, b).

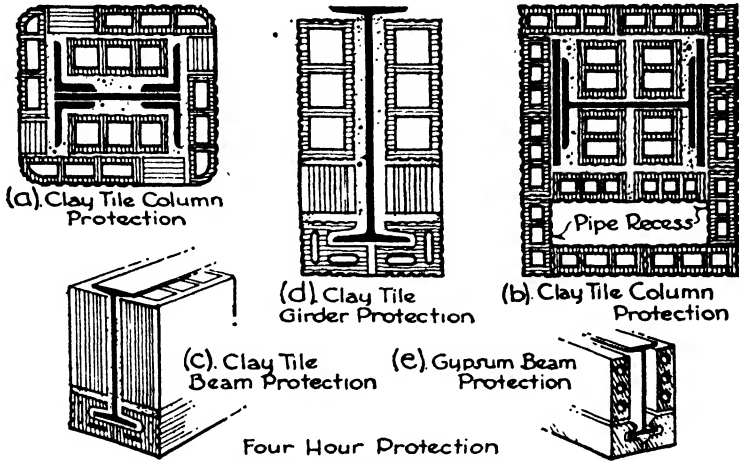

METAL LATH AND PLASTER. The resistant qualities of metal lath and plaster are not as great as those of clay, gypsum and concrete, and its power of withstanding hose streams is less. It is not, therefore, used for the fireproofing of main structural members such as columns, girders, beams and trusses. For secondary and sub-beams in some types of

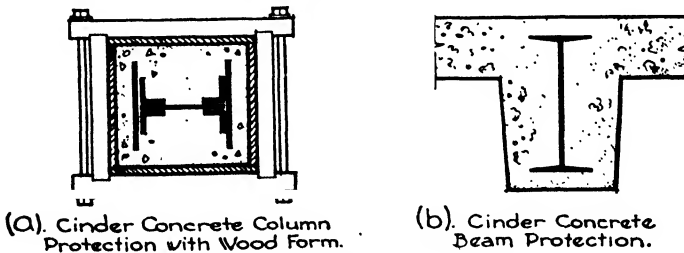

floor panels, metal lath and plaster ceilings suspended under the beams or clipped to their lower flanges are permissible if the main structural beams and girders surrounding the panels are protected in a more thorough manner. Double layers of lath and plaster separated by a  $\frac{3}{4}$ " air space are considered to be more effective than one layer and to give much better resistance to hose streams (Fig. 12, a, b).

When roof trusses are more than 20'0'' above the top floor they are suitably protected by a continuous metal lath and plaster ceiling suspended below the lower chord. When situated at this height the other members of the truss and the purlins are seldom fireproofed individually.

**Selection.** The choice of fireproofing material is often determined by the type of floor arch construction. If the arch is of terra cotta or gypsum tile the beams and girders can most economically be protected with skew-backs, soffit blocks and web tile of the same material. Likewise, if the floor system consists of poured cinder concrete arches the

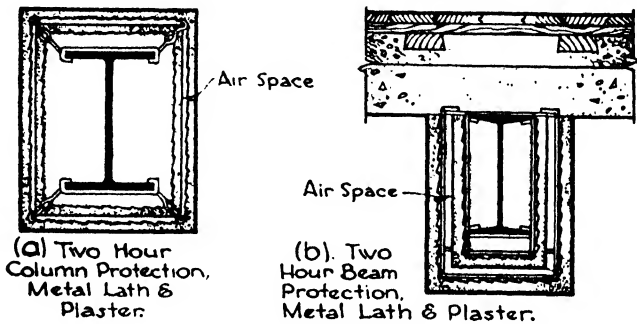

FIG. 12.—Metal Lath and Plaster Fire Protection.

forms and centering can easily be arranged to fit around the beams and girders so that the concrete will embed them also.

For columns, terra cotta protection would invariably follow terra cotta floor arches, and even with a poured cinder concrete floor system, terra cotta fireproofing might well be specified for the columns. This combination arises from the necessity of constructing forms around the columns to hold the concrete and the consequent expense and interference with other trades.

Since all fireproofing materials are now classified by the Bureau of Standards according to their rated hours of fire-resistance under test, the material and the method of application may be proportioned to the fire hazard of the building, depending upon its occupancy and zone. This latitude of choice, however, is possible only under the lately revised building laws, but it is most probable that all codes will ultimately be influenced by its logic.

## CHAPTER X

### FINISHED FLOORING

**General Considerations.** By finished flooring is meant the final wearing surface which is applied to the floor construction. There are many of these surfaces, each one adaptable to the set of conditions imposed by a particular usage. Durability and ease of cleaning being essential in each case, various conditions may also demand heavy wear and hard treatment as in storehouses and loading platforms, comfort to the users as in offices and shops, appearance as in residences and monumental buildings or resistance to dampness as in bathrooms. The types of flooring may be classified as follows:

Wood.

Tile.

Composition.

Cement and Terrazzo.

Cork and Rubber.

#### Article 1. Wood Flooring

**Materials.** Yellow pine, oak and maple are most generally used for wood flooring since these varieties show the highest resistance to wear among the woods which are readily obtainable. All wood flooring should be thoroughly kiln dried and taken from clear stock. Pieces tongued and grooved at sides are often called matched flooring.

YELLOW PINE flooring is manufactured from both flat-sawed and quarter-sawed lumber, but the flat-grain material should be selected for only the cheapest work because it is apt to splinter badly with use. The densest wood, that having the greatest number of annual rings per inch of diameter, should be chosen, since its

wearing qualities on edge grain are much superior to those of pine having wider rings. For ordinary use where the wear is not excessive, as in residences, offices and hotels, the thickness is  $25/32''$ , and the widths range from  $2\ 1/4''$  to  $5\ 1/4''$  on the face. The long edges are tongued and grooved, or matched, and the back is sometimes ploughed or slightly hollowed to prevent warping. Heavier flooring from  $1\ 11/32''$

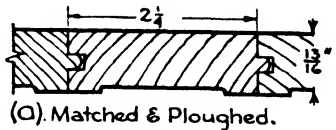

(a). Matched & Ploughed.

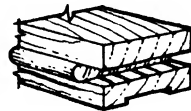

(b). Side & End Matched.

FIG. 1.—Matched Flooring.

to 2 5/8" thick, and from 2 1/4" to 5 1/8" face is also manufactured for heavier traffic (Fig. 1,a).

The flooring of heavy framed buildings constructed by the methods of standard mill construction spans from girder to girder for distances of from 8'0" to 11'0". Such flooring must consequently be heavier than that for light frame construction. For this purpose, planks 3" to 6" thick and 6" to 8" wide are provided, and are laid either flat or on edge. When laid flat these planks may have tongued and grooved edges or both edges may be grooved for splines. When laid on edge as for laminated floors the planks are usually not surfaced in order to provide minute air spaces between the faces of the planks to avoid dry rot. A finished floor 25/32" thick, generally of maple, is laid over the planks to act as a wearing surface.

**OAK.** White and red oak are both used for flooring, the white oak being preferred for its hardness, durability and beautiful grain. Both

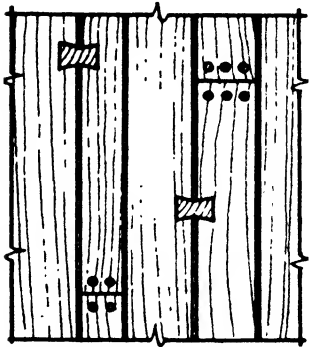

Plank flooring, showing crack lines, plugs, dovetail keys & random widths.

FIG. 2.—Plank Finished Flooring.

flat- and quarter-sawed oak is manufactured, but the quarter-sawed exposes the mottled and varied grain to much better advantage and therefore produces the best quality flooring where appearance is of importance. Quarter-sawed oak is sold in three grades, Clear, Sap Clear and Select; and the plain oak in four grades, Clear, Select, No. 1 and No. 2 Common. The edges and often the ends are tongued and grooved and the backs ploughed, thereby preventing warping and bending, and the standard widths are 1 1/2", 2" and 2 1/4" face. The thicknesses are 3/4", 1/2", 3/8" and 5/16" (Fig. 1,b).

Special flooring has also been developed by certain manufacturers to produce particular effects. Thus flooring can be obtained in random widths, varying from 2 1/4" to 8", to lend more interest and texture to the surface. Also still broader boards up to 12" wide are manufactured to imitate old plank floors. The disadvantage of the wider boards is their tendency to warp under the influence of temperature and atmospheric changes even when their thickness is correspondingly increased. The finest quality of flooring with wide boards consists of several layers of wood glued together on the flat with the grain crossed in successive layers to avoid warping. These boards may be put down with tight joints as in ordinary flooring, with beveled edge to show a V-shaped groove at the joint, or the joints may be emphasized by strips of a dark-colored wood. Round pins at the end joints and dovetails across the side joints are also introduced to add

interest and variety to the floor. Such special designs are naturally much more costly than standard flooring (Fig. 2).

Random widths as above described may also be obtained in yellow pine, and teak and walnut are sometimes used for broad plank floors.

**MAPLE.** Maple is very hard, dense, smooth and durable and withstands heavy wear as in stores, schools, warehouses and assembly halls. It also takes wax and polish well and makes an excellent dancing floor. The grain is fine but the surface is not so interesting in appearance as either yellow pine or oak nor is it improved by staining to bring out the grain. It is used, then, particularly where a resistance to wear or an especially smooth surface is desired. Maple is a satisfactory wood for a finished wearing surface over the plank floor systems of mill buildings.

The standard grades of maple flooring are White Clear, Red Clear, Second Grade and Third Grade. The usual sizes are face widths of 1½", 2" and 2¼" for the ¾" thickness, 1½", 2", 2¼" and ¾" for the 25/32" thickness and 2", 2¼" and ¾" for the 1⅛" to 1¼"

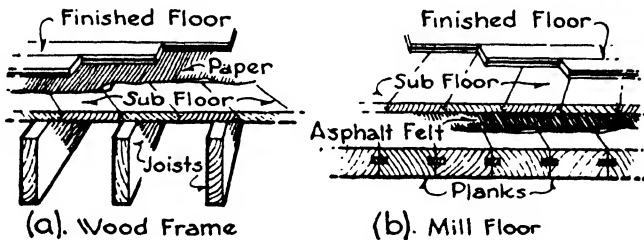

FIG. 3.—Laying Wood Floors.

thicknesses. The edges and ends are tongued and grooved and the backs often ploughed.

**BEECH and BIRCH** are somewhat darker with slightly coarser grain than maple but otherwise closely resemble it and are sold under the same grades.

**Laying Wood Floors.** In wood frame construction the finished wood floor should always be laid over a sub-floor of matched boards not over 6" wide running diagonally across the joists. Over the rough floor building paper or tar paper is stretched for insulation. The first strip along the wall should be straight and square, for it affects the direction of all the strips. Each strip is well driven up against the adjoining one to make a tight joint and nailed with 8d. flooring brads about 16" apart driven diagonally into the edge just above the tongue. Strips with great contrasts of color should not be laid next each other. With the sub-floor on the diagonal, the finished floor can run in either direction as is best suited to the proportions of the room. In corridors and passages the strips run parallel to the line of travel, that is longitudinally (Fig. 3,a).

The finished floor in mill construction is usually laid over an under-

floor running diagonally on the plank floor system, thereby bracing the floors, reducing vibration and distributing the loads. Between the planking and the flooring two layers of asphalt-saturated felt are stretched in such a manner as to make a thoroughly watertight floor to a height of at least 3" above floor level. Scuppers are often introduced in the walls at each story to carry off the water in the event of fire. A space  $\frac{1}{2}$ " wide should be left between floor and wall to allow for swelling when wet (Fig. 3, *b*).

When a smooth surface is desired, as in residences and ballrooms, the floor is scraped along the grain with hand scrapers or with machines. It is then sand-papered, swept and wiped clean. Flooring with slight bevels on the ends and sides is also manufactured which is sanded, stained and waxed at the factory thus avoiding finishing on the job. An even and level base is required. The finished floor is the last material installed in a building after all plastering is thoroughly dry and the trim is in place.

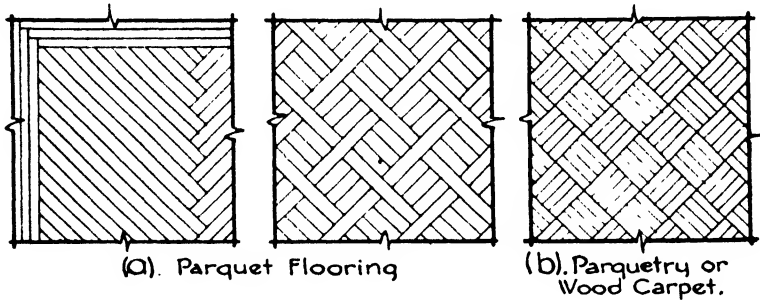

FIG. 4.—Parquet and Parquetry Flooring.

**Borders.** The borders are now generally confined to one or more strips, carried all around the room before the strips of the field are laid. The border strips are never mitered at the corners, but their ends are allowed to run alternately past each other.

**Parquet Flooring.** Parquet is a general name for floors laid in patterns. Such patterns are today usually limited to dividing the room area into panels and laying the strips diagonally in each panel to produce a herringbone pattern over the whole floor. The diagonal strips should be  $\frac{13}{16}$ " thick and sufficiently long to give good scale to the room. A level under-floor is required, and the finished floor should be well scraped and sand-papered. Oak is most often used in parquet flooring, but walnut, teak and white mahogany make beautiful floors of a more expensive type (Fig. 4, *a*).

**Veneered and Laminated Flooring.** Squares and planks of three-ply elm veneer,  $\frac{1}{2}$ " thick over all, are made which are factory finished and thoroughly sealed against expansion and contraction. The pieces are tongued and grooved and may be laid in mastic or with 4d. nails. Also

9" x 9" and 6" x 12" blocks of oak and beech are manufactured of wood strips glued together to finish  $25/32$ " and  $33/32$ " thick. When laid in mastic these blocks are provided with springs next the wall, concealed under the base trim, which force the outer rows of blocks to their original position when the pressure of expansion is reduced.

Laminated flooring consists of built-up pieces of edge and end grain wood glued together in strips  $2\frac{7}{8}$ " wide by 7' long and from  $1\frac{1}{16}$ " to  $1\frac{3}{4}$ " thick. The strips are tongued and grooved at the sides and provided with metal splines at the ends and are nailed together laterally. This flooring is particularly adapted to heavy traffic and has also been found satisfactory as a wall surface for squash and handball courts.

**Parquetry.** Short pieces  $\frac{5}{16}$ " thick forming small patterns are glued to a cloth back and called parquetry or wood carpet. It is nailed to the under-floor with 1" brads driven through the face of the wood and countersunk for puttying. Waterproof paper is laid under the parquetry, and the building should be heated for a few weeks before the floor is installed. Parquetry may be had in one kind of wood or in a combination of woods with contrasting colors such as walnut, cherry, white holly and mahogany (Fig. 4, b).

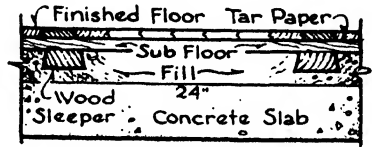

FIG. 5.—Wood Floor in Fireproof Construction.

Another type of unit flooring consists of pieces  $\frac{1}{2}$ " or  $25/32$ " thick joined into  $6\frac{3}{4}$ ", 9" and  $11\frac{1}{4}$ " squares by steel splines set into the backs of the flooring. These squares and rectangles are laid in a sound-deadening plastic cement over a wood sub-floor or concrete. No nails are used. The plastic cement, also called mastic, retains its resiliency indefinitely.

**Wood Floors in Fireproof Construction** (Fig. 5). Wood finished floors are generally permitted in fireproof construction if the building does not exceed a certain height. Over this height all flooring and interior trim must be of fireproof material.

Since the floor systems in fireproof buildings consist of terra cotta, gypsum or some form of concrete, it is necessary to provide an additional material to which the finished flooring may be nailed. This may be accomplished by embedding wood strips, called sleepers, in the floor fill or by spreading over the floor fill a plastic material which will receive and hold the nails. Parquetry squares and rectangles can be laid with nails directly upon the concrete floor slab in a layer of mastic composition.

Wood sleepers are long strips usually 2" square in section with the sides beveled inward toward the top to form a key for the cinder floor fill which holds them in place. They extend across the floor space in parallel lines spaced about 24" apart. Metal clips embedded in the floor fill are also used to prevent the sleepers from springing out of line.



The plastic nailing materials are concretes of special composition to receive the nails without cracking and to hold them firmly. They are spread in a layer about 2" thick over the floor fill or the top of the floor slab and are very carefully leveled and smoothed to receive the wood flooring.

**Wood Blocks.** Blocks of yellow pine or redwood with the grain vertical may be used where the traffic is very heavy, as in warehouses and factories. They are laid like brick on sub-floors of concrete, and their thickness ranges from 2" to 4" depending upon the service required. They are usually set in a tar pitch, asphalt or cement mortar bed, and their joints are filled with asphalt or pitch. Yellow pine blocks are generally impregnated with creosote (Fig. 6,*a*).

A type of wood block flooring has recently been devised which consists of yellow pine blocks 2" x 3½" x 2" thick set on end, dovetailed and glued at the bottom to a wood strip 1" thick. The strips are the width of the block and 8'0" long with their sides grooved for splines.

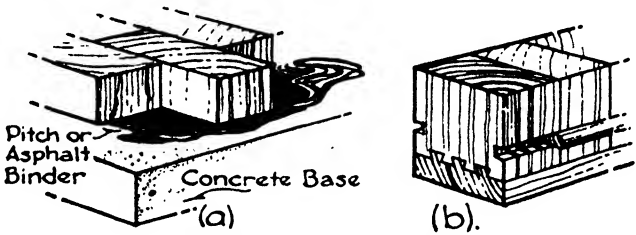

FIG. 6.—Wood Block Flooring.

Each strip is driven tight against the adjoining strip and blind nailed to joists, sleepers or under-flooring or set in asphalt mastic (Fig. 6,*b*).

The end grain of wood blocks makes an excellent wearing surface but collects dirt. The blocks are, therefore, generally used in industrial buildings only, although redwood blocks are sometimes seen in residences, clubs and hotels with the exposed surface sand-papered, waxed and polished to gain a desired effect.

Wherever flooring is set in mastic and not nailed, expansion joints should be provided at the walls. They are often concealed under the base trim.

## Article 2. Floor and Wall Tile and Plastics

**General Considerations.** Tile are manufactured from a mixture of clays, shales, feldspar and flint which may be obtained locally or from distant parts of the country or even from foreign lands. Differing compositions of the ingredients, methods of mixing and ways of firing account for the various types, colors and surfaces of tile. In 1927 the Department of Commerce at Washington in conjunction with manu-

facturers, architects and dealers established standards for the manufacture, sizes and grades of white glazed tile and unglazed ceramic mozaic, which have greatly simplified and improved the product and the industry.

Tile are made in many different colors and with both glazed and unglazed surfaces. They are used very widely as a covering for floors and walls, presenting hard and impervious surfaces which, on account of the great variety of possible hues and textures, are adaptable to a wide range of purposes and characteristics of design. In addition to the standard sizes and plain colors many tile are especially made to carry out architects' requirements with colors and designs inlaid, painted or incised, forming geometrical or nautralistic compositions in panels or upon entire wall surfaces. The possibilities of color effects and compositions are almost unlimited.

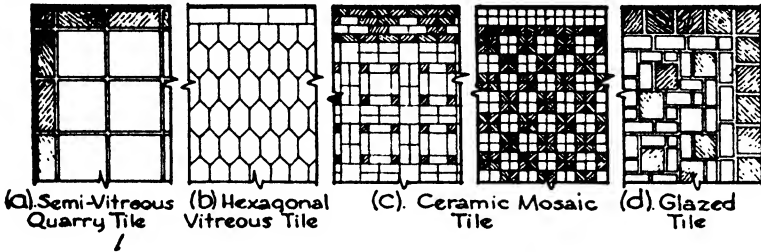

FIG. 7.—Floor Tiles.

**Manufacture.** The ingredients pass through grinding, mixing and refining processes and are then formed into the desired shapes by either the plastic or the dust pressed method.

By the **PLASTIC METHOD** the materials are fairly wet and are shaped in moulds by hand. By the **DUST PRESSED METHOD** the excess water is removed, and the materials, in an almost dry state, are pressed by machinery to a solid mass.

**Unglazed tile** are produced in one firing, and their colors depend upon the kind of clay or upon the addition of oxides. Some mixtures are more fusible than others and can be burned to more complete vitrification; consequently two classes of unglazed tile are produced, **VITREOUS** or completely fused, and **SEMI-VITREOUS** or partially fused. Practically, the vitreous and semi-vitreous tile differ only in color, the vitreous hues being white, cream, silver gray, green, blue green, light and dark blue and pink, and the semi-vitreous hues being buff, salmon, light and dark gray, red, chocolate and black. Mottled combinations of these colors, called **granites**, can also be produced (Fig. 7, *a* and *b*).

Unglazed tile are made in the following shapes and sizes:

Square: from  $1\frac{1}{8}''$  to  $9''$ .

Oblong: from  $1\frac{1}{8}'' \times 1\frac{17}{32}''$  to  $9'' \times 4\frac{1}{2}''$ .

Octagonal: from 3" x 3" to 6" x 6".

Hexagonal: from 4 $\frac{1}{8}$ " x 2 $\frac{1}{8}$ " to 6" x 5 $\frac{3}{8}$ ".

Triangular: 1 5/32" to 3".

**Ceramic mosaic** consists of the smaller sizes of unglazed tile arranged as they are to be laid and with paper pasted on their faces to hold the pieces together. The tile are then set in sheets and the paper is soaked off the face. Borders in color are also included in mosaic. The sizes of tile are 11/32" to 2 $\frac{3}{16}$ " square, 1/2" x 1 $\frac{1}{16}$ " to 1 $\frac{1}{16}$ " x 2 $\frac{3}{16}$ " oblong and 1" to 1 $\frac{1}{4}$ " hexagonal (Fig. 7,c).

The larger tile have a thickness of 1/2" to 1" and the ceramic mosaic 1/4".

**Glazed tile** are made of the same materials and by the same methods as unglazed tile but in two firings. The body, called also the bisque or biscuit, is first made and burned, then the glaze is applied and the tile is fired a second time. The glaze is a paste composed of feldspar, silica and coloring metallic oxides spread upon the bisque, which is somewhat porous. The second firing at a higher temperature melts the feldspar which fills the pores of the bisque, and a continuous, semi-transparent glaze results. Glazed tile are now also made to some extent by applying the glaze before burning and then baking the glaze and tile in one firing (Fig. 7,d).

By trade custom the term **GLAZED TILE** generally refers to white tile and the term **ENAMELS** is used to designate tile with a colored glaze.

Glazed tile and enamels are made in the following sizes and shapes: Square 1/2" to 6"; oblong 2 $\frac{1}{8}$ " x 1 $\frac{1}{16}$ " to 9" x 6"; hexagonal 2 $\frac{5}{16}$ " x 2 21/32" to 3" x 3 15/32"; octagonal 3".

Both glazed and enamel tile are produced in bright glaze with a high surface gloss, matte finish without gloss and semi-matte or dull finish with a gloss between the bright finish and the matte.

**Encaustic Tile.** The term encaustic tile applies only to decorative tile with an inlaid figure or ornament of one color upon a field of another color. The word encaustic is sometimes wrongly used as a general designation for tiles other than inlaid tile.

**Faience.** This term is applied to tile made by the plastic method and produced with a comparatively uneven surface to lend character and interest to the composition. They are glazed with bright or dull enamels in a great variety of color and texture and may be painted or inlaid to create highly decorative effects. The use of faience has proved very successful in carrying out modernistic designs.

**Trim Tile.** Tile are made of many shapes to act as caps, bases, mouldings, plinth blocks, finish for door and window openings, gutters and other trimming requirements. They are glazed and unglazed to match the field of the tile work and are widely used especially in bathrooms, toilet rooms, swimming pools, kitchens, operating rooms and wherever tile are employed for sanitary purposes. They are also procurable to match decorative tile where required.

**Grades of Tile.** Although the effort may be to produce tile of only the best quality, certain uncontrollable influences, especially in the firing, bring forth slight variations in color shades, size, appearance and evenness. White glazed tile are therefore separated according to their degree of perfection into Selected, Standard and Commercial grades; and enamels, vitreous tile and ceramic mosaic into two grades, Selected and Commercial.

The STANDARD grade is used for general classes of work, the SELECTED grade for the finest class and the COMMERCIAL grade where sanitation and service are more important than appearance.

**Uses.** The unglazed vitreous and semi-vitreous tile, the enamels and ceramic mosaic are most generally used for floor tile where sanitary or impervious qualities are the important considerations. When the question is largely one of design, color or artistic creation the decorative types, such as inlaid or faience tile, are available as floor tile. Quarry and esplanade tile are semi-vitreous, much used especially in clear shades of red, for floors of vestibules, hallways, restaurants, terraces, roof gardens and locations where heavy foot traffic is expected. They are especially effective in the large sizes, 12" x 12" or 9" x 9" by 1" thick.

White glazed tile and the enamels are used for the wall tile of bathrooms, toilet rooms, operating rooms, dairies, kitchens and the service portions of buildings demanding impervious and easily cleaned linings and wainscotings. For ornamental purposes, on the other hand, the broad field of enamels and faience offer unlimited possibilities in wall decoration. The variety of color and texture together with the possibilities of painted and inlaid design have developed modern tilework into a medium of the greatest flexibility and effectiveness.

**Concrete Tile.** Tile made of cement concrete with various types of aggregate are used for both wall and floor coverings. The tile are formed by forcing the concrete into moulds under hydraulic pressure, and allowing it to set and cure. Such tile are not baked and are very true with straight, sharp edges. They are generally less expensive than clay tile. Concrete tile may be finished with glazed surfaces and with patterns in different colors. The design is set into the face of the tile by filling brass moulds with colors varying in the different sections of the pattern as desired. The brass moulds are then removed, the back is added and the pressure is applied.

Non-slip tile for stair-treads, elevator landings, corridors, ramps and shop floors consist of an aggregate of corundum, a very hard abrasive material made by fusing aluminum oxide in an electric furnace. The corundum may extend throughout the body of the tile or may be incorporated only in the top surface.

**Imitation Wall Tile.** Sheets of cement and asbestos finished with a hard polished lacquered surface may be used for wall covering in imitation of tile. The sheets measure 32" x 48" x  $\frac{1}{4}$ " and are scored to

reproduce 4" x 4" tile. They are fastened to the wall by rabbeted bases and caps, and the joints are covered by metal strips.

**Acoustical Tile.** Many types of tile as well as plasters are now manufactured to absorb sound and reduce resonance and echo within a room. The tile usually consist of a sound-absorbing material, such as rock wool, covered with perforated sheets of asbestos fiber and cement. Ceilings are most often lined with these tile, although walls may also be faced with them when necessary to produce satisfactory results.

**Marble Tile.** Marble floors may be installed with slabs of any size to suit the design of the architect. Standard size of marble tile, 8" x 16", 10" x 20" and 12" square, are always obtainable without delay, the standard thicknesses being  $\frac{7}{8}$ ",  $1\frac{1}{4}$ ",  $1\frac{1}{2}$ " and 2". Marbles of proved resistance to abrasion should be chosen, and the surface should have a fine sanded or honed finish, not polished.

Certain kinds of marble, suitable for exterior use, are likewise often used for flagstones, especially in garden installations.

**Slate Tile.** Slate slabs make a very good floor for certain situations such as entrance halls, vestibules and terraces. The tile are 1" thick and may be irregular in shape or cut into squares and rectangles. The colors are black, red, green, purple and brown, and the finish may be quarry cleft, planed or sand-rubbed.

Slate also makes excellent flagstones used in large pieces and of the same colors as for interior tile. It is very strong and seldom cracks under ordinary use or through the action of frost.

**Glass Tile.** Opaque structural glass sheets are available in a great variety of colors and finishes for wainscoting, store fronts, counters and table tops. They can be obtained in several sizes up to 72" x 130" and range in thickness from  $11\frac{1}{32}$ " to  $1\frac{1}{4}$ " (Chapter XV, Article 2).

**Plastics.** In recent years phenol plastics have been greatly developed for wall coverings, wainscoting and table and counter tops. The finish may be in plain colors and textures, or thin wood veneers may be incorporated with the plastic bases under heat and pressure to provide a genuine wood finish. The material is smooth, hard, wear-resisting and stain-proof. Simple weave and inlay designs of the same material or of metal are possible, and photographic murals may be pressed into the sheets.

For wainscoting, the material in  $\frac{1}{8}$ " thickness is glued to a plywood or pressed wood backing which is nailed to grounds or it may be applied directly to plastered walls. The joints may be splined butt joints or covered with metal mouldings. The sheets have a maximum size of 4' x 12'.

**Pressed Wood.** Sheets of felted wood fiber with smooth surface formed under heat and great pressure are now used in a variety of ways for wall covering, exterior and interior finish, framework and backing. The oil and turpentine are removed from the wood in the process of manufacture, and the material is generally classed as slow burning.

Its moisture absorption is low, and it may be cut and nailed in the same way as wood. Its thickness varies from  $1/10''$  to  $1/2''$  and its surface is usually  $4'$  wide by  $12'$  long.

### Article 3. Composition Flooring

**General Considerations.** Several compositions for finished flooring have been developed which may be spread upon the rough floor in a plastic state and will then harden into durable wearing surfaces. The two principal materials used for this purpose are magnesite and asphalt. In general, these floors are designated as composition floors to distinguish them from cement floors which are also spread while in a plastic state.

**Magnesite Flooring.** This material is usually composed of calcined magnesium oxide and magnesium chloride. It is installed in a plastic state in two coats totaling  $1/2''$  in thickness, the first coat containing coarse fibrous fillers and the second being of fine grain to give a smooth finish. Magnesite flooring can be of any color or combination of colors; it furnishes a warm, quiet, resilient, non-slip, fireproof and waterproof flooring, very satisfactory for all types of buildings where there is much foot traffic. It can be applied directly to wood or concrete, metal lath sometimes being introduced as a base over wood floors. Bases and wainscots of the same composition may be installed as a continuous sheet with magnesite plastic flooring.

Marble chips are sometimes incorporated with magnesite to form a magnesite terrazzo plastic flooring. The chips appear upon the surface and form a pleasing, durable and resilient finish.

**Asphalt Flooring.** This composition flooring consists of asphalt mixed with mineral pigments and generally with asbestos fiber, thoroughly incorporated under heat and pressure. It may be laid as a continuous plastic sheet with sanitary base, or it may be manufactured into tile which are then laid individually. The colors are dark red, green, blue, marbled and black. Asphalt flooring is intended for situations where there is heavy foot traffic and trucking. For foot traffic the thicknesses range from  $1/8''$  to  $3/4''$ , and for trucking from  $1''$  for light service to  $2''$  for pavements and driveways. For heavy service the asphalt is sometimes mixed with crushed rock and formed into blocks. The material is resilient, durable, waterproof and fireproof, acid-resistant and non-slip.

Marble chips may be incorporated with hot asphalt, poured into shallow moulds and subjected to pressure. After cooling, the slabs are ground down to a smooth surface and cut to tile sizes. The result is an asphalt terrazzo tile about  $1/2''$  thick with dark colors predominating.

### Article 4. Cement and Terrazzo Floors

**Cement Floors.** A mixture of cement, sand and water produces a finished floor surface which, when spread over the under-flooring, is

most excellently adapted to fulfill many conditions. A cement floor may be worked into the top surface of the concrete floor slab before it has set, thus becoming an integral part of the slab, or it may be applied as a coating about 1" thick to the slab or floor fill after the latter has hardened. It may likewise be used with wood floors, in which case it is usually spread upon a wire mesh previously stretched over the wood under-floor. Cement floors are an economical and satisfactory finish and are widely used in a variety of buildings.

**Integral Cement Flooring.** After the floor slab forms have been filled with concrete and leveled even with the finished floor grade, the cement finishers go over the top thoroughly with long flat strips of wood with handles, called floats, and bring the surplus water in the concrete to the surface. This water carries with it a milky substance called LAITANCE consisting of very finely powdered hydrated lime and cement, having little strength and forming a thin dusty coat when dry. The excess water and the laitance are scraped off the slab with floats, and a 1 to 1½ dry mixture of cement and sand is added and worked into the surface of the slab, filling all depressions, enriching the top and producing a denser composition. This mixture is thoroughly floated and incorporated with the top of the slab and is then burnished with a steel trowel into a hard, unabrasive wearing surface. The finishing should be begun within half an hour after the slab is poured. After completion the finished floor should be covered with sawdust, earth or sand to preserve it from abuse and to prevent the moisture from drying out too quickly from the cement, thus greatly aiding the proper curing and setting of the concrete. It is evident that an integral or monolithic floor finish can be applied only to a cement concrete floor slab. If terra cotta floor arches or cinder concrete fills are employed a bonded cement flooring must be used.

**Bonded Cement Flooring.** A cement floor finish laid after the floor slab or the floor fill has hardened is often called a bonded cement flooring to distinguish it from an integral or monolithic flooring. The surface upon which the cement floor is to be laid should be thoroughly wet before hand, and sometimes a thin coating of cement and water of about the consistency of rich-cream is spread over the bed and well brushed in. The finished cement surface, about 1" thick, is then laid before the grout commences to dry, its top being smoothed to an even plane with wood floats or steel trowels. Two trowelings are sometimes preferred: one, as soon as the surface can bear the weight of the cement finishers who kneel on boards to do their work; and a second, just before the initial set takes place.

Bonded floors are more likely to crack during set and break away from the base if not properly laid. On the other hand, integral floors delay the progress of other work in the building since bonded floors are generally not put down until the construction is nearly finished.

**Cement Flooring with Wood Framing.** When cement floors are used with wood frame construction a concrete bed of adequate thickness must

first be installed to receive the finishing layer. To acquire sufficient space for the necessary thickness of bed the wood floor joists must be dropped so that their tops are at least 4" below the finished level of the floor. A tight platform or sub-floor is nailed across the tops of the joists, and upon this is stretched waterproof felt and a wire mesh similar to chicken wire to prevent cracking in the concrete. A bed composed of 1 to 6 cinder concrete 2" thick is then laid upon the platform, and on this bed the finished cement surface 1" thick is spread and floated (Fig. 8,a).

If, as sometimes happens, it is impracticable to drop the floor joists in new buildings, their tops are beveled to a blunt edge and wood flooring is cut in between the joists about 2" below their tops. On this flooring a cinder concrete bed is poured, its upper surface being leveled off 1" above the tops of the joists. Over this surface wire mesh is stretched, and the finished cement surface 1" thick is troweled on. Waterproof

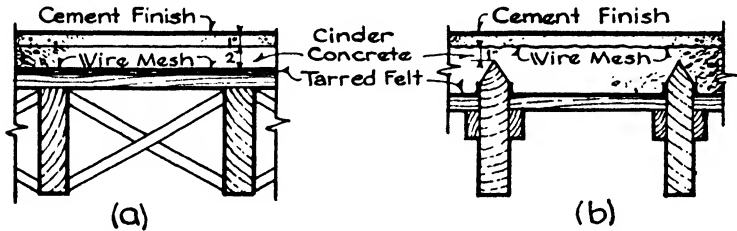

FIG. 8.—Cement Floor on Wood Joist.

felt is often stretched over the wood platforms before the beds are poured. The method just described must be used when it is desired to lay a cement floor in an old building; otherwise the finished cement level would be 2" above the floor levels of adjoining rooms (Fig. 8,b).

**Granolithic Floors.** A more enduring wearing surface where traffic is heavy may be obtained by using a concrete composed of 1 part cement, a part sand and 1 part fine crushed stone. This proportion produces a surface often termed granolithic floor finish because fine granite chips were originally used in the aggregate. Finely ground corundum may also be a part of the aggregate to produce an enduring and non-slip surface.

**Dusting.** When the cement finish is not properly put down and floated the top surface may wear off rapidly and produce a dust which is very unpleasant. To obviate this dusting, many patented solutions called **HARDENERS** are on the market intended for application after the floor is finished. Those most widely used are based upon the action of magnesium-fluosilicate, sodium silicate, aluminum sulphate and zinc sulphate. Most hardeners are fairly effective, and architects often specify that a hardener be used as a safeguard against faulty workmanship in the laying of the floor.

**Terrazzo Floors.** Terrazzo finish to cement floors is very widely used



and makes a durable wearing surface and one attractive in appearance. The bed must be a least  $2\frac{1}{2}$ " below the finished floor level, and upon this bed is poured 2" of stone concrete. A layer about 1" thick, consisting of cement, sand and marble chips or abrasives mixed almost dry, is spread over the concrete and worked into its top by rolling until the proper finished grade is reached. The surface is then honed and polished with machines. By the use of white cement, coloring matter and carefully chosen marble chips a great variety of effects may be produced.

To prevent shrinkage and settlement cracks, wire mesh is often spread over the bed before the concrete is poured. In addition, terrazzo floors are almost invariably divided into panels by the use of brass, zinc alloy or colored plastic strips about  $\frac{1}{8}$ " wide which are set upon the bed before the concrete is poured and extend up to the finished floor level. Arranged in geometrical designs, they add much to the interesting effect of the floor and also confine the shrinkage to limited areas.

### Article 5. Cork and Rubber Flooring

**In General.** Floor coverings of cork and rubber have been developed to provide impervious surfaces which are at the same time resilient to the tread and pleasing in appearance. Rubber flooring is manufactured in the shape of tile; cork flooring is made both as carpet called linoleum and as tile.

**Cork Flooring.** Cork flooring is classified as linoleum or cork carpet and cork tile. The first class is made of fine-ground cork and pressed into wide strips of great length; the second is composed of coarser cork shavings pressed into square and rectangular tiles.

LINOLEUM has linseed oil as one of its principal ingredients. The oil is oxidized by exposure to air until it hardens into a tough, rubber-like substance and is then thoroughly mixed with powdered cork, wood flour, various gums and color pigments. The resulting plastic mass is then pressed on burlap, dried and seasoned for 2 to 6 weeks. The surface is sometimes finished with lacquer. Linoleum is made in plain colors or may be inlaid or embossed. The inlaid type consists of several colors running through the linoleum to the burlap. It may be striated or marbled and may be manufactured in large sheets or in straight-line blocks or tile. Embossed linoleum is made in many patterns, the interliners between the blocks of the pattern and certain portions of the pattern itself being slightly depressed to give an embossed effect resembling hand-set ceramics. A very great variety of designs are produced by these different means, the most successful being those which develop the inherent possibilities of the linoleum rather than those attempting to imitate other materials. Linoleum is manufactured in thickness ranging from  $\frac{1}{8}$ " to  $\frac{1}{4}$ " and generally 6'0" wide and is shipped in large rolls. The heavy  $\frac{1}{4}$ " grade is known as Battleship Linoleum. CORK CARPET is composed of coarser particles of cork and is more

resilient and more noiseless than linoleum. It is made only in plain colors.

Linoleum may be laid directly upon wood or cement floors. A lining felt is often first pasted down on wood floors and sometimes on cement floors. The linoleum is then laid, pasted and thoroughly rolled to insure complete adhesion to the floor. In laying strips of plain linoleum the edges should be lapped  $\frac{1}{2}$ " and when trimmed both pieces are cut through simultaneously to insure a perfectly tight seam. After the body of the strips are rolled from the center outward and the edges trimmed, the seams are pasted with waterproof cement and rolled and weighted until firm adhesion takes place.

CORK TILE is manufactured from cork shavings, compressed in moulds and baked. The color is a warm light, medium or dark brown, and the surface has a more interesting texture than linoleum. The thickness of the tile is  $\frac{5}{16}$ " or  $\frac{1}{2}$ ", and the sizes range from 2" to 18" squares and from 2" x 6" to 18" x 36" rectangles. Borders and sanitary bases can be furnished for all shades of tile. This type of flooring is very resilient, warm and noiseless and is excellent for use in offices, banks and corridors. The tile are set in special paste and rolled similarly to linoleum.

**Rubber Flooring.** A very resilient, noiseless, waterproof and durable flooring is made by vulcanizing pure rubber under great pressure and delivering it in rolls and sheets or in strips, runners and square and rectangular tile. Very fine cotton fiber and mineral fillers are incorporated in the material by some manufacturers. The finish may be plain or marbled in various designs, the colors running throughout the body of the tile. Interlocking shapes were formerly produced, but square and rectangular tile are almost entirely used at the present time. Sizes range from 4" to 18" squares and from 9" x 18" x 36" rectangles, the thicknesses being from  $\frac{3}{16}$ " to  $\frac{1}{2}$ ". The tile are laid in waterproof rubber cement and thoroughly rolled. A lining of heavy cotton sheeting is often tacked down over wood floors before the tile are set in place.

Rubber in  $\frac{1}{16}$ " sheets may also be used as wainscoting up to 48" high in operating rooms, hospitals, baths, corridors and kitchens.

## CHAPTER XI

### ROOFING MATERIALS, ROOF DRAINAGE AND SKYLIGHTS

**General Considerations.** Just as the floor construction is covered with a finishing layer to furnish a smooth, durable and comfortable wearing surface, so the roof construction must be overlaid with a finishing layer to provide a lasting, waterproof and often fireproof sheathing which will protect the building, its contents and occupants from rain, snow, wind and to some extent from heat and cold. Several materials have withstood the tests of time and have proved most satisfactory, each one in its own field. Flat roofs require a different type of covering from pitched roofs, and fireproof structures are roofed with other materials than buildings of wood frame construction. The most generally approved types of roofing materials may be classified as follows:

- |               |                            |
|---------------|----------------------------|
| (a) Shingles. | (d) Sheet Metal and Glass. |
| Wood.         | Tin.                       |
| Asbestos.     | Copper.                    |
| (b) Slate.    | Lead.                      |
| (c) Tile.     | Zinc.                      |
| French.       | Aluminum.                  |
| English.      | Steel.                     |
| Spanish.      | Glass.                     |
| Mission.      | (e) Built-up Roofing.      |
| Quarry.       |                            |

#### Article 1. Shingles

**Wood Shingles.** Wood shingles are manufactured mainly from Western red cedar, redwood and cypress, although in certain localities Eastern white cedar and Southern pine are used to some extent. The lengths are 16", 18" and 24", with butts about  $\frac{1}{2}$ " thick and random widths from  $2\frac{1}{2}$ " to 16". They are packed in bunches of the equivalent of 250 shingles 4" wide to each bunch. Special shingles are also made to imitate the old hand-split shingles with butts  $\frac{5}{8}$ " to 1" thick, which lend much more texture to the roof. Shingles were originally split from blocks of wood and then shaved with a draw knife so that one end was thicker than the other. They are now cut by means of shingle saws which in the larger mills produce from 100,000 to 250,000 shingles a day. The best shingles are cut to have edge grain, which may be recognized by the vertical lines running across the butts.

Shingles should not be used on roofs with a less slope than 6" vertical

to 12" horizontal. They are laid in horizontal rows overlapping each other and showing 4½" to the weather for 16" shingles and somewhat greater exposures for 18" and 24" lengths. Zinc-coated and galvanized nails should always be used since uncoated wire nails rust through and release the shingles. The rows or courses are started at the eaves with doubled or tripled shingles to give more thickness at the edge of the roof (Fig. 1).

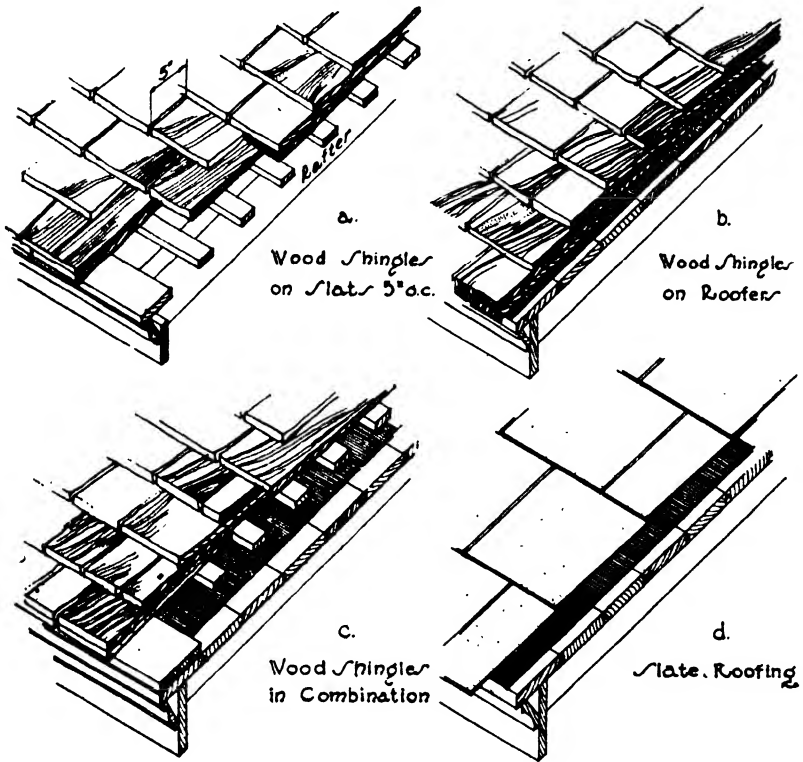

FIG. 1.—Shingle and Slate Roofing.

In wood frame construction the rafters are crossed by tight matched boards called roofers or by wood slats spaced 4" or 5" apart to support the shingles and provide nailing. The details of these methods are described in Chapter IX, Roof Systems. Wood shingles are never used in fireproof construction (Fig. 1, a, b, c).

**Asbestos Shingles.** Shingles are also made of asbestos to imitate wood shingles in shape and size and, to a slight degree, in appearance. They are very durable, suffer little from climatic conditions and are fireproof, being composed of about 15% asbestos fiber and 85% cement formed under great pressure. Some effort has been made to reproduce

in asbestos shingles the charm in color and texture of weathered wood shingles. They never change their tone, however, never ripen or mellow with age and are always hard, cold and uninteresting in appearance.

Asbestos shingles are laid with galvanized iron or copper nails on matched roofers previously covered with slaters' felt or waterproof paper.

The ridges and hips are finished in the same manner with both wood and asbestos shingles. The most usual methods of finishing the ridges are by **COMBING** or by a **BOSTON LAP**, and the hips by **BOSTON LAP** or **CLOSE HIP**. Combing consists merely of cutting the shingles on the leeward side flush with the top of the ridge and running the shingles on the windward side an inch or two over and past the ends of the cut-off shingles. The combing should project away from the direction of prevailing winds. Boston lap consists of a row of shingles on each side of the ridge or hip, placed over the regular courses of shingles. In a close

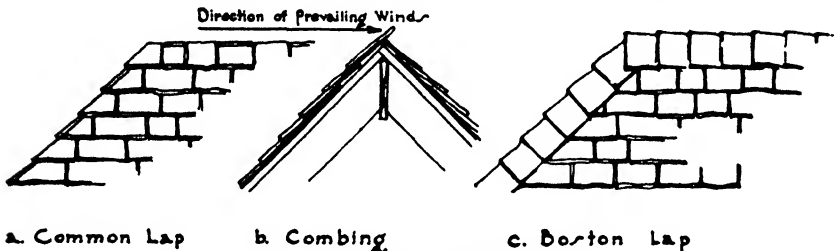

FIG. 2.—Shingling Ridges and Hips.

hip the shingles of the regular courses are cut off flush with the line of the hip, a shingle on each side alternately lying over a shingle on the other side. A piece of sheet copper called flashing bent over the hip should be placed under each shingle to avoid leaks. The valleys are finished as described later under **Flashing** (Fig. 2, a, b, c).

## Article 2. Slate

**Description.** Because of its very marked cleavage, slate rock is easily split into thin sheets which have from early days been used as roof covering. The common commercial sizes of the sheets are 12" x 16" and 14" x 20" on the surface and  $\frac{3}{16}$ " and  $\frac{1}{4}$ " thick. Slates up to 2" thick can also be obtained to give the effect of old English and French roofs, with random widths and varying exposure to the weather, thus giving a texture and picturesqueness to the roof. Slate never changes in color tone, and the texture of surface and interest of design must be achieved when the slate is laid, as they will not come with time (Fig. 1, d).

**Laying.** Matched roofing boards are nailed over the rafters in wood frame construction and covered with asphalt roofing felt. In fireproof construction, wood nailing strips are embedded in the slabs, or porous terra cotta or nailing concrete is introduced to receive the nails. The

slates are laid like shingles, with broken side joints and a lap at the top of 3'' under the second course above, and are fastened with two copper roofing nails. The nail holes in the slate are usually drilled in the factory. The top course along the ridge, the courses within 1' of hips and valley and those within 2' or 3' of gutters should be laid in elastic roofing cement. Copper flashing is used as for shingles and will be described under Flashing.

Slate is fireproof and durable, and if well selected and intelligently laid will make a very satisfactory roof both in service and appearance. Its weight is much greater than that of shingles, consequently the rafters and roof slabs must be designed for the increased load.

### Article 3. Tile

**Types.** Roofing tile are made of wet clay pressed in moulds and then burned in a kiln much as terra cotta is produced. They may be classified in five types as follows:

- French.
- Spanish.
- Mission.
- Shingle Tile.
- English.

**FRENCH TILE** are 9'' x 16'' flat tile with heavily corrugated surfaces and interlocking flush joints at the sides. They are laid in horizontal courses, each course lapped 3'' over the course below. The lower edge of each tile is finished with a rounded bull nose (Fig. 3).

**SPANISH TILE** are 9'' x 13'' and have a rounded surface and an interlocking side joint, being laid in horizontal courses with the bottom of each tile overlapping by 3'' the top of a tile in the course below (Fig. 3).

**MISSION TILE** were first made in Mexico by the Spanish missionaries and were later employed in the missions in California and the Southwest. Today they are used, together with the true Spanish tile, in connection with the Spanish, Mission and Mediterranean architecture so popular in many parts of the country. They consist of sheets 14'' to 18'' long, curved in cross-section to the arc of a circle and slightly tapered from top to bottom. They are laid in horizontal courses, the tiles in each course being set alternately with the concave and the convex side up, forming covers and pans. The side edges of a cover thus fit over the side edges of the adjoining pans, and the lower ends in one course lap over the upper ends in the course below (Fig. 3).

**PROMENADE or QUARRY TILE** are large, red, unglazed rectangular or square flat tile for use on flat roofs with built-up roofing. They are about 1'' thick and vary from 3'' to 12'' square and from 3'' x 6'' to 6'' x 12'' rectangular.

**SHINGLE TILE** are about  $\frac{1}{2}$ '' thick, 12'' to 15'' long and 7'' wide. They are flat and are laid like shingles with a 2'' head lap under the

third course above. A variety of colors and textures are produced to give the picturesqueness found in the clay tile of old French, English and Breton roofs.

ENGLISH TILE are flat tile which when laid have much the effect of shingle tile. They have, however, interlocking side joints and are lapped 3" over the tile of the course below (Fig. 3).

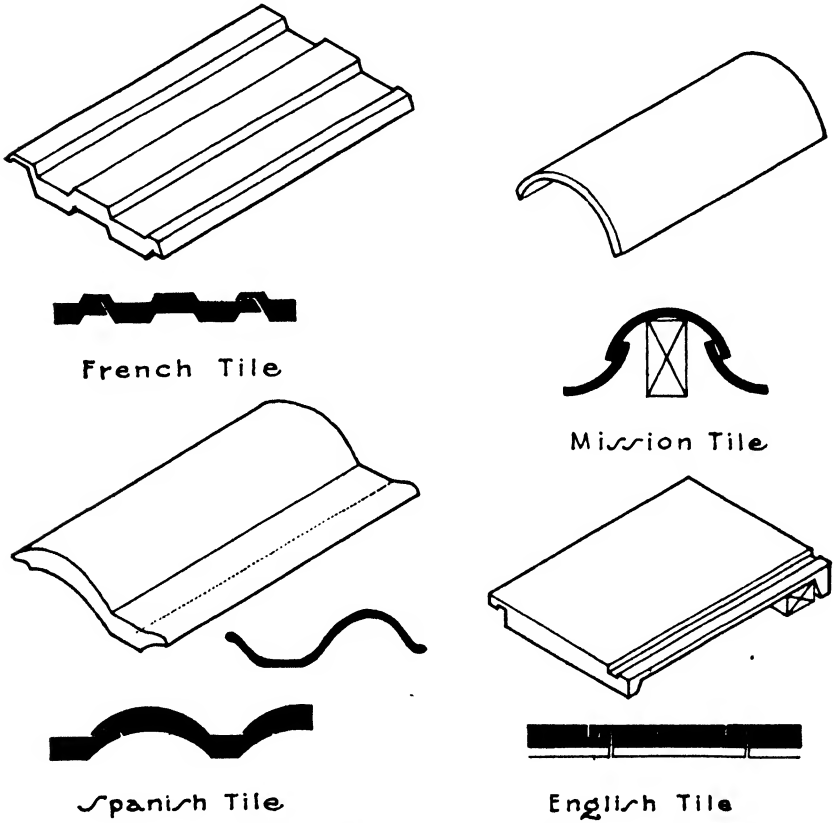

FIG. 3.—Terra Cotta Roofing Tile.

**Laying.** Clay tile are fastened with copper nails except over metal flashing where they are tied with copper wire and elastic cement. Special shapes are usually made to cover the ridges and hips. Valleys are often open flashed with copper, although closed valleys are sometimes used especially with shingle tile. Asphalt felt is laid over the roof surface before the tiling begins. Wood cant strips are provided at the eaves to give the first row of tiles the same inclination as the succeeding rows above. Strips are also set on the ridges and hips to stiffen the ridge tile and hip rolls, and in the case of Mission tile a wood strip is set under each cover tile to receive the nailing. Promenade or quarry tile

are set in a bed of cement mortar spread over the top layer of built-up roofing, the joints between the tile being filled with cement grout or elastic cement. Expansion joints 1" or 2" wide filled with elastic cement should be introduced all around the roof between the tile field and parapet walls, penthouses and other projections to allow for expansion and contraction due to heat and cold.

#### Article 4. Sheet Metal and Glass

**General Considerations.** Tin, copper, zinc and lead have been used for very many years as covering for roofs, especially on flat roofs with too little slope for shingles, slate or tile, and on curved roofs, such as domes, where stiff plates would not be practical.

Corrugated iron and corrugated glass sheets are also employed for the roofing of industrial buildings.

**Tin.** Roofing sheets of iron and steel coated with tin are widely used for covering flat and low-pitched roofs. Iron has proved less liable to corrosion than steel when coated with tin, and of late years the manufacture of pure iron for tin plate has greatly increased. Iron sheets, when coated on both sides with pure tin, are known as BRIGHT TIN PLATE, or as TERNE PLATE when coated with a mixture of 75% lead and 25% tin. Terne plate is less expensive than bright tin plate and is more generally used for roofing. If kept well painted with red lead and linseed oil a tin roof is fairly successful in its resistance to corrosion and will last from 30 to 50 years. The sheets are generally 14" by 20" or 20" by 28" packed 112 in a box.

Tin roofs are laid over felt on a tight board roof. The joints between the sheets may be either flat or standing seams. Flat seams are made by turning up the long edges of the sheets  $\frac{1}{2}$ ", locking the edges together, turning the locked joints down flat upon the roof and thoroughly soldering the seam. Standing seams are made by turning up the edge of one sheet  $1\frac{1}{2}$ " and of the adjoining sheet  $1\frac{1}{4}$ " and then bending and curling the edges together without soldering. The sheets are fastened down by nailing strips of tin about  $1\frac{1}{2}$ " wide, called cleats, to the wood roof sheathing and folding them into the seams when the latter are formed. By this method no nails are driven through sheets. The cleats should be 8" apart for flat seams and 12" for standing seams. Lengths of tin roofing are made up in the shop with flat, soldered cross seams. The lengths are then laid down on the roof, and the side seams between adjoining lengths are formed incorporating the cleats. Flat roofs generally have flat, soldered seams throughout; roofs with a pitch of over 4" to the foot may have unsoldered standing side seams (Fig. 4).

Ribbed or battened seams are formed on pitched roofs by nailing 2" x 2" or 4" x 4" wood strips in parallel lines running with the slope of the roof from ridge to eaves. The sheet metal is laid in between the battens and bent up against their sides where the sheets are held in



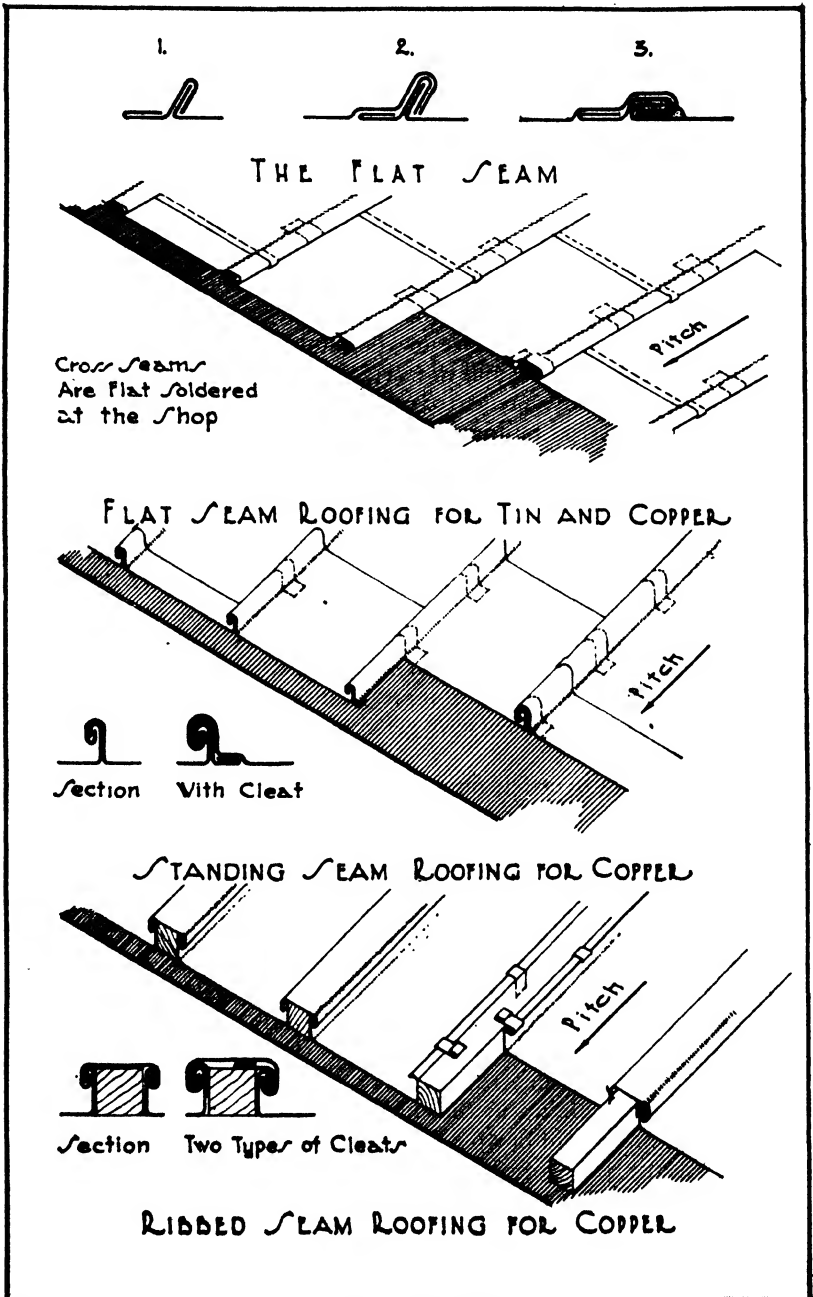

FIG. 4.—Sheet Metal Roofing.

place by metal cleats nailed to the batten and locked into the sheets. A sheet metal cap is then set on top of the cleat with its edges locked into the edges of the roofing sheet.

**Copper.** Copper is generally considered to be the most satisfactory and most enduring material for metal roofing. It is more expensive than tin to install, but it requires no paint and very little attention after installation and has been known to last for generations. Upon exposure to the air it acquires a coating of carbonate of copper and turns green, this action preventing further deterioration. Copper is ductile, tenacious and malleable, easy to work but expands with heat more than tin-coated steel sheets. It does not, however, creep so much on steep roofs as soft lead, and it expands less and is more durable than zinc.

Copper roofing is laid over asphalt felt in the same manner as tin roofing except that, since its expansion is greater, standing and battened seams are preferred on steep roofs and locked seams on flat roofs. Soldering should be avoided as much as possible. Roofing copper should be soft rolled and weigh at least 16 oz. to the square foot. The recommended sizes of sheet are for flat seam 10'' x 14'' and 14'' x 20'', and for standing and ribbed seams 20'' x 96'' and 30'' x 96'' (Fig. 4).

**Lead.** Lead has been very long in use as a sheet roofing material. It is extremely pliable, can be drawn and stretched to fit warped surfaces without cutting or soldering, weathers to a soft even gray tone and is little affected by acids. It is, however, very heavy and will creep on steep roofs because of expansion. Hard lead has been developed of late years which has more tenacity and less expansion, and the interest in lead as a roof covering has much increased. Variety of texture can be produced together with a softness of outline which is almost impossible in other metals. Many roofing accessories, such as rainwater leaders, leader heads, finials and gutters both plain and highly decorated, are now made of hard lead with great success. Lead-coated steel and copper sheets are likewise available which combine the lightness of the core metal with the soft even color of the lead. Batten or ribbed seams are best adapted for lead roofing, solder and nails should not be used and allowance must be made for expansion and contraction by the introduction of lock and rolled joints.

**Zinc.** In this country, zinc has grown in use in recent years as a roofing material, being slightly cheaper than copper. It is somewhat affected by acids and must not be placed near other metals on account of corroding galvanic action. Zinc is lighter and stiffer than lead and should be cut and soldered. It also has a high coefficient of expansion which must be allowed for by the use of joint rolls and roll caps. It weathers to a gray tone not so pleasing as that of lead.

**Aluminum.** Shingles and flat sheets are manufactured of aluminum for roofing purposes; they are very light in weight, non-corrosive, rigid and durable. The flat sheets are produced in natural light gray or in

polished or oxide finishes, and are laid in the same manner as tin roofing except that welding is employed instead of soldering. Aluminum shingles are obtainable with colored baked enamel finishes or in three shades of gray oxide. They are laid starting at the ridge or top of the roof and proceeding down to the eaves, just the reverse of wood shingles, slate and tile. Aluminum roofing is more expensive than other sheet metals but because of its lightness and durability and also, in modern types of design, because of its bright polish it finds employment to a moderate degree.

**Corrugated Steel and Iron.** On industrial buildings black or galvanized sheets of copper-bearing steel or pure iron are sometimes used as a cheap covering. The sheets are usually 26" wide with 2½" corrugations, and are given an end lap of 6" and side laps of 2 corrugations. They may be fastened by nailing to wood roof boarding or by clips and straps directly to the steel purlins. Sheets not galvanized should be well painted with red lead and linseed oil. Condensation of water on the under side of corrugated sheets may be prevented by stretching several layers of asbestos paper under the sheets supported on wire mesh stretched over purlins.

**Asbestos.** Corrugated steel sheets are produced encased in layers of asphalt, asbestos and waterproofing to be employed where there are acid fumes, gases, alkalis, heat or moisture. The sheets are of the same size as the unprotected steel sheets and are laid in the same way. Clips should be of aluminum or copper.

Corrugated asbestos sheets are also made of a mixture of asbestos fiber and Portland cement under great pressure. They make a light, lasting, fireproof roof unaffected by fumes, gases and moisture.

**Glass.** Flat glass is used for roofing greenhouses, and ribbed or prism glass may be used as inserts on domes or the roofs of public buildings and corrugated glass on industrial buildings. Where strength is required, wire glass is employed. Glass inserts are often cast in cement slabs, and corrugated glass sheets may be used in connection with corrugated steel and asbestos. The ends are lapped, but the side joints are butted and covered with asbestos cushions and metal caps.

### Article 5. Built-up Roofing

**General Considerations.** Built-up roofing is adapted to flat roofs of fairly large area too extensive for sheet metal roofing because of the tendencies to expansion and contraction and also because of the greater cost of sheet metal. When well laid with good materials and workmanship it is an enduring roof, and by the addition of a layer of promenade tile on the top it will last for many years under considerable foot traffic. Built-up roofing may be laid on a wood plank roof, upon concrete or gypsum slab or upon a cinder concrete roof fill. It is composed of 3 or 5 layers of rag felt or jute saturated with coal-tar pitch or with asphalt,

each layer set in a mopping of hot tar or asphalt. The top is finished with a covering of crushed slag or clean gravel if little traffic be expected upon the roof or with a layer of flat clay quarry tile set in cement mortar.

**Laying.** When laid on a wood roof deck, a layer of sheathing paper or unsaturated felt is first laid down on the boarding with 1" laps. Then 2 plies of tarred felt are laid down lapping each sheet 17", and nailed to hold in place until the remaining felt is laid. This entire surface is then coated with hot tar pitch, and 3 plies of tarred felt are laid in the pitch, lapping each sheet 22" and mopping the full lap with hot tar pitch. Finally a coating of tar pitch is poured over the entire surface into which, while hot, is embedded a layer of clean and dry crushed gravel or slag from 1/4" to 5/8" in size (Fig. 5).

On concrete roof slabs or roof fill a coating of pitch is first applied into which are laid 4 plies of tarred felt, lapping each sheet 24 1/2" and

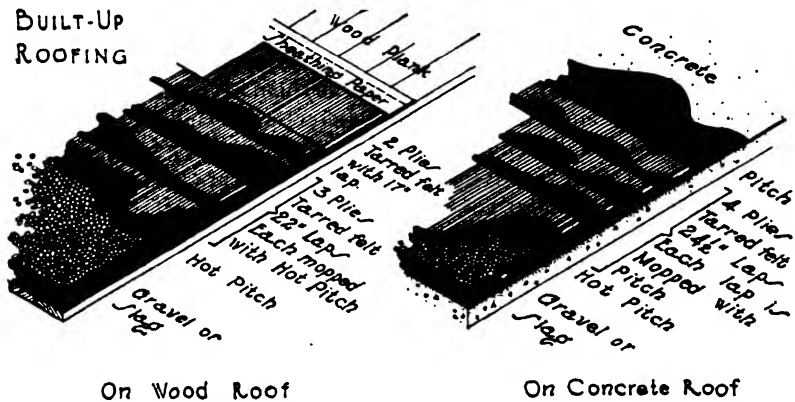

FIG. 5.—Built-up Roofing.

mopping the full lap with hot tar pitch. The final coating of tar and of gravel or slag is the same as for a wood roof deck. Somewhat lighter roofings of 4 plies on wood and 3 plies on concrete are also applied in cheaper work (Fig. 5).

Built-up roofing is also constructed in the same general manner as just described but using asphalt instead of coal-tar pitch and felt or jute impregnated with asphalt instead of tarred felt. Asbestos felts are also used impregnated with asphalt.

Tar may be defined as the deposit obtained from blast furnaces, by the distillation of coal or in the manufacture of coke and gas. It is usually first distilled to obtain the aromatic substance such as benzene, toluene and naphthalene, and the residue is known as pitch. It is a hydrocarbon and very impervious and repellent to water. Coal-tar pitch is better suited for roofing purposes than the other pitches.

Asphalt is a natural product found in large deposits called lakes in Trinidad and Venezuela. It is a mixture of hydrocarbons, clay and

water, and is refined before use. The oils of asphalt evaporate more slowly than those of coal tar, and asphalt roofs are therefore considered by some architects as having more life and flexibility than tar roofs. Very many coal-tar roofs are, however, laid every year with most satisfactory results, and there seems little to choose between the two materials.

When laid by approved roofing contractors the durability of built-up roofs is often insured to the owners by the manufacturers of the roofing materials for periods of 10 to 20 years depending upon the number of plies.

**Prepared Roofing.** Several brands of ready-prepared roofing are manufactured consisting of paper or felt saturated with tar, asphalt and other waterproofing compounds. They are delivered in rolls and are generally intended for sloping, wood-sheathed roofs. The roofing is laid parallel to the eaves, each course lapped 1" or 2" over the course next below it, the lap well covered with roofing cement and nailed down with galvanized nails. Such roofing is not very lasting but offers a quick and cheap method of covering unimportant structures.

**Roof Insulation.** No roofing materials in themselves are good insulators against heat and cold, nor are concrete roof slabs, consequently some means are usually employed to protect the upper story of a flat-roofed building from excessive variations in temperature. The insulation may be effected by cinder concrete fill or by a layer of 3" hollow tile on the outside over the roof slab upon which the roofing material is then placed. One or two layers of cork 1" thick is also a very excellent insulator but more expensive than cinder fill or hollow tile.

Insulation is also provided inside the building by suspending a plastered ceiling below the roof slab thus obtaining a dead air space. The ceiling consists of wire lath carried by metal hangers from the under side of the slab. It gives good results in all classes of buildings.

### Article 6. Selection of Roofing Material

It is seen that the various types of roofing differ widely in character, appearance, weight, cost, durability and fire-resistance, and it is by measuring the existing degree of each quality and its suitability to the building in question that a choice from among these types may be made.

For roofs with a slope of 4" in 12", shingles, slate, tile or sheet metal may be used, the first being non-fireproof and the others fireproof. Shingles, adapted particularly to wood frame construction, are less expensive than slate, tile, lead or copper, are lighter in weight and weather to attractive soft tones. In most cases they last from 16 to 20 years without renewal. Slate and tile are heavy and expensive but enduring and, if well chosen, contribute texture, color and charm to the building. By proper selection, also, either dignity or picturesqueness can be attained according to the demands of the design. Lead and copper are very lasting and are suitable rather for formal than for

informal structures. Slate, tile and sheet metal may be used on either wood or fireproof construction.

Upon flat roofs of moderate extent sheet metal may be used, tin being less expensive than lead and copper but much shorter lived. Lead is heavier than copper or tin. Of late years built-up roofing has come into frequent use even for small flat roofs, and for those of large area it may be considered as the most generally adopted type. When well and durably laid such roofing has a life of 25 or 30 years and, unless covered with quarry tile, its weight is not excessive. Built-up roofing is less expensive than sheet metal. The frequent painting required by tin roofs makes their up-keep much higher than that for the other types.

Because our roofing materials, with the possible exception of the built-up type, are of ancient origin they are individually connected by tradition with definite characteristics of architecture and consequently when properly chosen contribute largely to the production of a harmoniously designed building. The perfecting of built-up roofing in recent years has, likewise, produced, especially when finished with quarry tile, an ideal protection for the broad expanses of flat roof on our most modern buildings. Consequently a wise and sympathetic selection of roof covering is as important both practically and artistically as the choice of wall material or ashlar facing.

### Article 7. Roof Drainage

**In General.** A very important consideration in the case of all roofs, whether flat or pitched, is the disposal of the water falling upon the roof. This water must be gathered in some way either by the slope of the roof or by gutters to cause it to flow into the vertical rain conductors or leaders which carry it to the sewer or to rainwater cisterns. Rainwater and melted snow must not be permitted to drop from the edge of the roof to give annoyance to the occupants and to passers-by and, in the country, to damage sod and flower borders. Also the water must not be allowed to leak into the interior of the building through the joints between the roofing material and other surfaces such as chimneys, penthouses, parapet walls and dormer windows nor at the intersection of the roof planes themselves as at valleys, hips and ridges. Finally, care must be taken that the pitch of the roof is sufficient for the type of covering selected so that water cannot back up or be blown up between the lapped joints of the roofing material.

**Pitch.** In a flat roof only enough pitch or slope is required to enable the water to flow to the gutters or directly into the leaders. The latter method is employed on roofs of fairly large areas with leaders inside the walls, the roof surface being divided into several gently sloping planes, by grading the cinder fill, thus forming channels directing the water to the catch basins at the leader heads. Some architects prefer that a flat roof covered with built-up roofing be level throughout its area because

of the simplified construction, maintaining that the water collecting in inequalities in the surface protects the roof from heat and does no damage. A slope of  $\frac{1}{2}$ " to the foot is sufficient for flat roofs covered with built-up roofing or with sheet metal with flat soldered seams. Sheet metal roofs with standing seams should, however, have a slope of at least 4" to the foot.

Roofs covered with material laid in lapped courses, such as shingles, tile, slate, glass or corrugated steel, must have sufficient pitch to carry the water off promptly and not permit it to be forced up between the laps by the wind or other agents. The recommended minimum vertical rise of roof to 12" on the horizontal for various materials may be scheduled as follows:

Wood and Asbestos Shingles.....	6"
Corrugated Steel and Glass.....	4"
Tile.....	4" to 7"
Slate.....	6"

**Flashing.** The sealing of all joints between two planes of the same roof or between a roof and intersecting vertical surfaces is of the greatest importance. Such joints are best rendered watertight by the introduction of metal sheets, either copper, tin, zinc or lead. Galvanized steel and composition flashing cannot be depended upon. Copper weighing 16 oz./ft.<sup>2</sup> is by far the best material and should be used wherever possible. Tin and zinc may be used in cheaper work but the tin must always be kept well painted. Lead is used only in special conditions where its pliability is of value.

A valley is the re-entering intersection of two planes of a pitched roof and may be open or closed. Flashing for open valleys consists of long pieces of copper soldered together forming a strip 18" to 20" wide, which is laid down over the entire length of the valley and nailed near its edges to the roof boarding or to nailing strips. The pieces of roofing, either shingles, slate or tile, are lapped 4" to 6" over this copper strip on each side, leaving an open space 6" to 8" wide in the center covered only by the flashing (Fig. 6,d). Closed valleys are formed by laying the shingles, slate or tile close together and inserting under each course trapezoidal pieces of copper, 15" x 10" x 9", overlapping each other at least 3". Closed valleys have a better appearance than open valleys but are more difficult to make tight. Tin should not be used as flashing for closed valleys on account of the retained moisture which soon rusts it out. Hips and ridges are usually covered by additional courses of shingles and slate without using flashing, although the slate are often set in elastic roofing cement. Special shapes are manufactured in the case of tile to cover ridges and hips (Fig. 6,e).

Against dormer windows or any wood wall a piece of copper about 7" square is laid on the roof boarding under each course of shingles or slate,

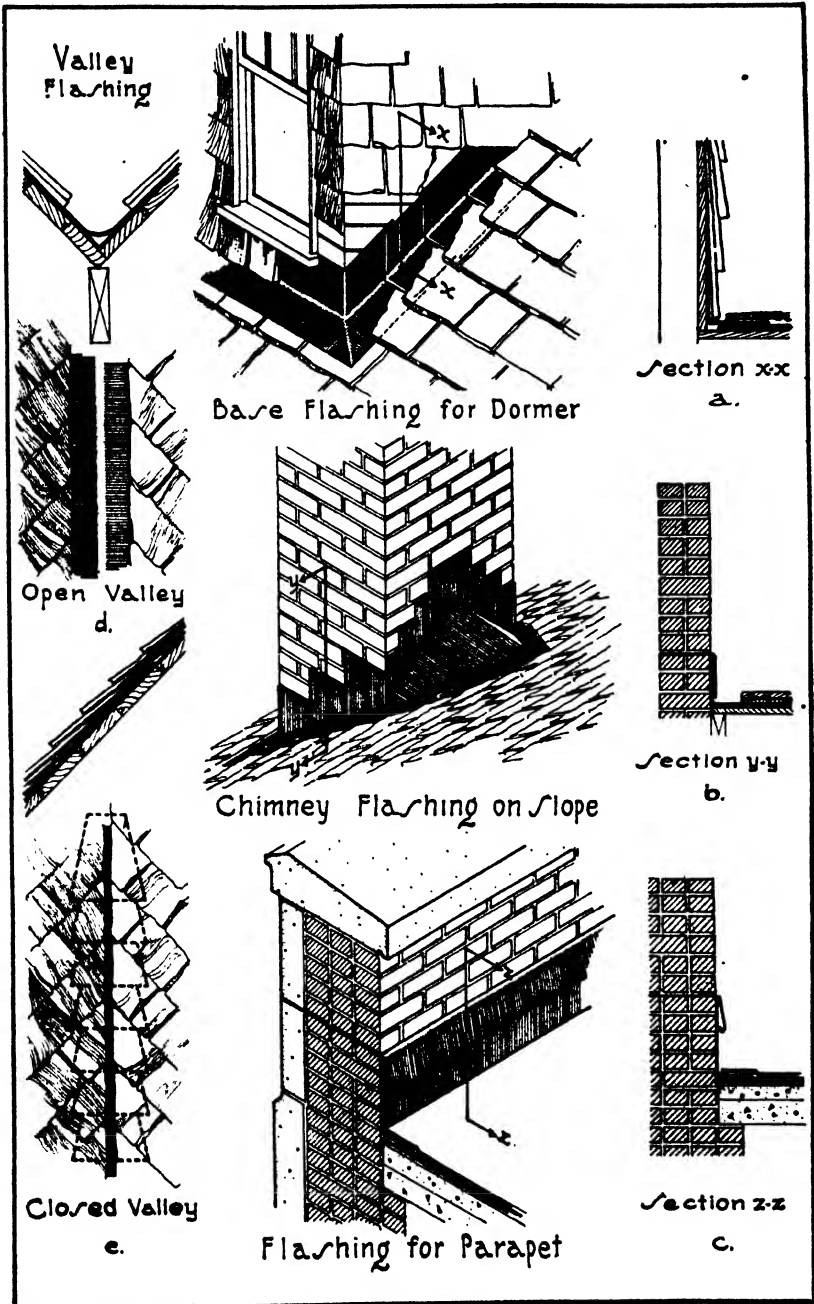

FIG. 6.—Metal Flashing.



bent to a right angle and extended up under the wood or slate siding on the dormer (Fig. 6,a).

Flashing against masonry such as chimneys or walls is done by laying pieces of copper, called base flashing, under the shingle, slate or tile, and bending them up against the masonry. The pieces should extend at least 6" under the roofing and 9" up the face of the masonry. Another strip of copper or lead, called counter-flashing or cap flashing, is built into the masonry and turned down over the base flashing. By this method expansion is allowed for without reducing the watertight qualities of the flashing. Behind chimneys on pitched roofs, crickets or saddles are built with sloping sides and covered with copper to prevent the lodging of snow (Fig. 6,b).

In the case of flat roofs covered with built-up roofing and surrounded with masonry parapet walls, the flashing of the parapets or of any inter-

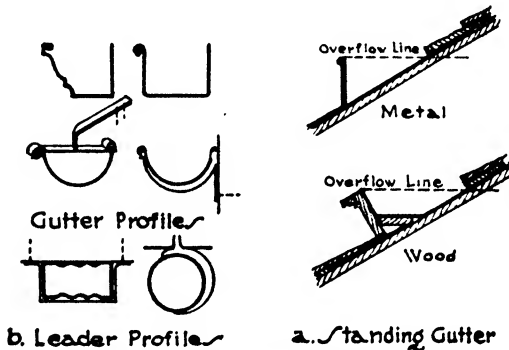

FIG. 7.—Gutters and Leaders.

secting penthouse walls is done by means of base flashing extending under the roofing material and bent up against the walls. Cap flashing is then built into the joints of the masonry walls and turned down over the base flashing (Fig. 6,c).

**Gutters.** Gutters are used to catch the water running down a roof and, by directing its course to the leaders, to prevent it from flowing off the eaves or cornice. They may be made of wood or sheet metal, preferably copper. Wood gutters are often selected for wood frame buildings, since they may be moulded to form the top member of the cornice. (See Chapter XIV, Fig. 1.) In cases where there is no cornice or where it is impractical to include the gutter in the cornice design, a standing gutter consisting of a plain board set on the roof back of the eaves will be found effective. The board may be set vertically or at right angles to the roof's slope and should be provided with a floor between it and the roof surface behind it. This floor slopes toward the end of the gutter where the leader is placed. A standing gutter is covered with sheet metal, generally copper or tin plate, which should extend well up under

the roofing to prevent water and snow collected in the gutter from backing up under the roof covering. Cypress is most used for wood gutters and has proved very lasting (Fig. 7,a).

A metal gutter may be shaped as a moulding on its outer face to act as a member of the cornice, but the most usual form is half-round in section, and is hung under the eaves in cases where there is no cornice. Metal gutters are best made of hard copper and are hung with bronze or galvanized-iron hangers in such a way that there is a slope of about  $\frac{1}{4}$ " to a foot toward the leaders (Fig. 7,b).

Stone or terra cotta cornices always have a slope or wash on their upper surfaces to shed water. Formerly this slope was outward and threw the water away from the face of the building into the street below. The drip from such cornices was unpleasant to pedestrians on the sidewalks, and auxiliary gutters and leaders were difficult to arrange. In recent years, projecting cornices on tall buildings are usually cut with the upper surface sloping backward to the flat roof behind the cornice. Scuppers or draining holes are cut in balustrades or parapet walls if such exist, and the water is taken care of by the leaders of the main roof.

When mansard or sloping roofs are used with a stone or terra cotta cornice the gutter may be formed in the top of the cornice to receive the water from the roof.

**Leaders.** There are two classes of leaders: OUTSIDE or those attached to the exterior of a building, and INSIDE or those installed inside the wall (Fig. 8).

Outside leaders are of sheet metal, either round or rectangular in section. Copper makes the best outside leader, although hard lead is sometimes used for architectural effect. Galvanized steel rusts out in a very few years and should be avoided. The leaders are attached to the gutters by curved or bent lengths of the leader material or by goose

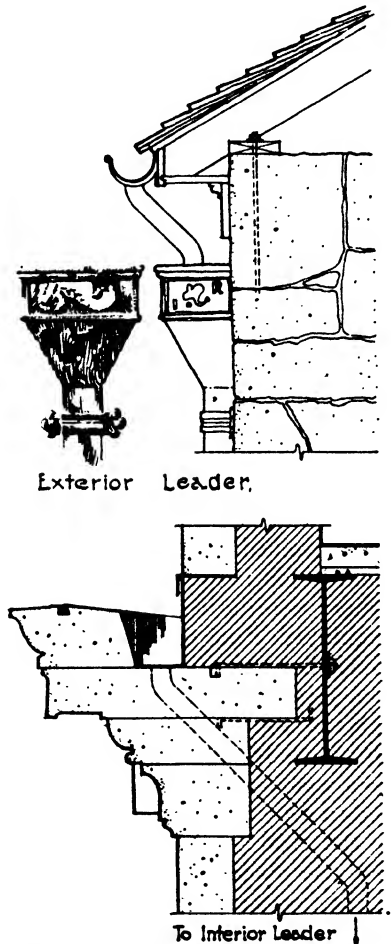

FIG. 8.—Interior and Exterior Leaders.

necks of lead pipe. The upper end of the leader is sometimes enlarged into an ornamental head with the connection from the gutter draining into it. Outside leaders are attached to the wall by bands of copper or by bronze or galvanized-iron fixtures, and their lower ends drain into cast-iron underground pipes which in turn are connected with the sewer or by lengths of terra cotta pipe to buried cisterns. If the rain-water is used for domestic or other purposes the cisterns are lined with brick or stone laid in mortar or with stone concrete. When the intention is to allow the water to seep into the surrounding soil the cisterns are simply holes in the ground filled with roughly graded stones, sometimes called dry wells. Outside leaders are largely confined to isolated buildings in the country or in suburbs and are usually prohibited in cities.

Inside leaders are of cast-iron pipe and are installed with caulked joints in the same way as plumbing pipes. They are usually placed in chases or recesses in the inner face of the outside walls, or they may be enclosed in furred spaces. They are the most practical means of carrying off the water from flat roofs or from tall buildings with any type of roof and are generally required in the closely built-up districts of cities. The cast-iron pipe, however, is more expensive than the sheet-metal outside leader.

### Article 8. Skylights

Both flat lights flush with the roof surface and steel or wood frames with pitched or sloping tops are included in the terms skylight. Where ventilation is not required the flat lights are more generally used, but where ventilation is necessary the pitched type of skylight must be employed. Roof lights are usually  $8\frac{1}{4}$ " square, wired diffusing glass  $\frac{1}{2}$ " thick being a standard. The lights are supported on either reinforced concrete or galvanized steel two-way ribs forming panels about 8'0" wide between beams. Each light is generally set in a cast-iron, aluminum or bronze frame with tar and sulphur or other elastic compound to serve as a watertight cushion around the glass. The size of the ribs has been reduced by good design until the effective glass area is now about 90% of the total area. Hollow glass blocks  $2\frac{1}{2}$ " thick with a partial vacuum are also made which add insulation to the equipment. Watertightness is the first necessity, of course.

Sloping skylights project above the roof and may be either lean-to, pitched, gable, gambrel, hip or sawtooth. They consist of an aluminum or galvanized copper-bearing steel frame with fixed and movable steel sash glazed with  $\frac{1}{4}$ " wired glass. The glass was formerly held in place with putty, but the sash are now generally designed to receive the glass without its use, forming what are known as **PUTTYLESS** skylights (Fig. 9). Gutters are provided under the bars and muntins to catch the condensation which forms on the under side of the glass. The movable sash are controlled by geared bars and wheels which may be operated by hand

or, for long skylights, by electric motors. Automatic thermostatic control with electric motor has likewise been perfected by which the sash are opened or closed according to the temperature within the building. For train sheds, industrial buildings, museums and wherever skylights of large area are required, corrugated wired glass may be used. The sheets are  $27\frac{3}{4}$ " wide and  $\frac{3}{8}$ " thick. Unsupported spans of 60" to 96" may be covered, depending upon the slope of the skylight.

The various forms of sloping skylights imitate the most common roof forms, the lean-to having only one sloping surface and the pitched a sloping surface on each side. The gable skylight is terminated squarely at the ends, the gambrel has a double slope on each side and the hipped skylight has a slope on all four sides. Sawtooth skylights are high and

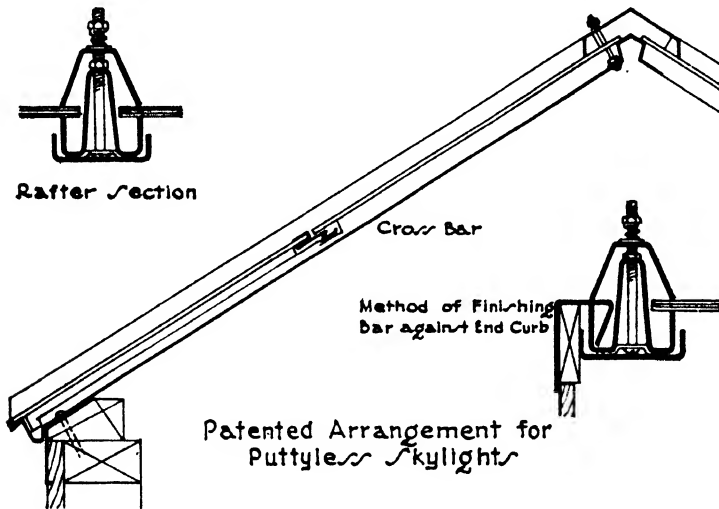

FIG. 9.—Metal Skylight.

steeply pitched, with one slope roofed and the other slope glazed, and are used in industrial buildings. They often occur in parallel rows or batteries with the glazed side facing the best light.

Small skylights are required over stair-wells and elevator shafts and are also employed to light the rooms and hallways of top stories. In non-fireproof buildings they may be built of wood, but steel and concrete are now most generally used in all situations.

## CHAPTER XII

### PLASTER, LATH, FURRING AND STUCCO

#### Article 1. Plaster

**In General.** Plaster is a material, capable of being moulded and troweled, applied as a finish to walls and ceilings in the interior of buildings. Upon setting it forms a hard surface which will satisfactorily receive whitewash, paint or wall paper and acts as a partial insulation against the passage of heat, air and sound. According to the character of its base or cementing material, plaster may be classed as **LIME PLASTERS**, derived from carbonate of lime, and **GYPSUM PLASTERS**, from sulphate of lime. These plasters will adhere to brick, concrete or other masonry surfaces through natural and chemical bond, but upon wood or metal lath a physical or mechanical bond is required which is provided by the design of the lath and by the addition of cattle hair or vegetable fiber to the plaster to increase its tensile strength.

**Lime Plaster.** The base of lime plaster is hydrated or slaked lime,  $\text{CaO}_2\text{H}_2$  or  $\text{CaMgO}_2\text{H}_2$ , depending upon the presence of magnesia in the limestone. (See Chapter II.) Both high-calcium limes and magnesia limes are satisfactory as bases for lime plaster, the preference for one or the other arising largely from the habits and traditions of localities. The magnesia limes found in Ohio are manufactured into plasters in large quantities and have a wide reputation for their reliability. Very good plaster, however, has been made for centuries from high-calcium limes, so there appears to be little difference in their qualities as a base. Appreciable amounts of foreign ingredients in limestone other than magnesia are, however, detrimental to the production of good plaster, and only lime made by reputable manufacturers should therefore be used. Proper burning is also an essential of satisfactory lime, over-burned particles requiring an undue length of time to slake. Such unhydrated particles continue their slaking after being incorporated in wall or ceiling, causing popping and pitting of the surface. For this reason it is recommended that lime be stored for a minimum of 14 days after slaking to eliminate the raw and caustic qualities and become thoroughly ripened and hydrated. It is also screened through a #8 or #10 sieve.

As has been shown in Chapter II, lime may be slaked at the building site or it may be obtained from the manufacturers already hydrated at the mill. Having been produced by mechanical means according to scientific methods, mill-hydrated lime is the more dependable and is

now more generally used for plastering purposes. Hydrated lime is delivered in 50-lb. paper bags. It is generally designated by the manufacturers as finishing lime and may be obtained either as plain lime or mixed with hair or fiber as required for base coats.

**PREPARATION.** If pure hydrated lime were mixed with water and applied to a wall it would shrink upon drying, causing checks and cracks throughout its surface. Sand is consequently mixed with the lime to reduce the shrinkage, and, since sand is cheaper than lime, it also reduces the cost. Lime is seldom shipped already mixed with sand, as is sometimes done in the case of gypsum plasters, and the mixing is therefore usually done at the building. Some manufacturers are, however, instituting the shipping of ready-sanded lime plaster from the mill.

The hydrated lime is usually first mixed with water by sifting it through a coarse screen into a box or tank containing clean water and allowing it to settle and thoroughly unite with the water to form a putty, which should be permitted to soak 24 hours without being disturbed. The lime putty is then mixed with sand and hair or fiber in the proper proportions for the base plaster coats. The last or finish plaster coat is not usually mixed with sand but consists of lime putty to which plaster of Paris and sometimes marble dust is added to form a hard, smooth and burnished surface. The sand should be clean and free from loam, dust and saline, alkaline, organic or other deleterious substances, and should be fairly fine but well graded.

The thorough mixing of all plasters and mortars is of the very greatest importance. Sand pockets and porous plaster are most apt to result if the blending of the sand and lime be not complete. The hair and fiber should be beaten into the plaster with a hoe, for upon its complete incorporation throughout the mass depends the tensile strength of the material.

**APPLICATION.** Three coats of plaster—the scratch coat, the brown coat and the finish or skim coat—are usually applied to wood and metal lath, and two coats—the scratch and finish coats—to concrete, brick, tile, gypsum block and concrete block. Two coats called double-up work are sometimes used on wood lath in cheap construction. The scratch coat is so called because its surface is scratched to give a bond for the brown coat, which in turn receives its name from its color due to the increased amount of sand in its composition.

**UPON WOOD AND METAL LATH.** In three-coat work on metal and wood lath the first or scratch coat consists of stiff lime putty 1 part by volume, sand 3 parts by volume and hair or fiber 6 lbs./yd.<sup>3</sup> of plaster. The brown coat consists of stiff lime putty 1 part by volume, sand 4 parts by volume and hair or fiber 3 lbs./yd.<sup>3</sup> of plaster. The finish coat consists of lime putty without sand to which is added plaster of Paris, called gauging plaster, in the proportion of 200 lbs. of hydrated finishing lime to 50 lbs. of plaster of Paris. The mixing is done by forming a ring of the lime putty on a platform, pouring water into the center of the ring

and then sifting the gauging plaster into the water. The whole is then thoroughly mixed with a trowel and reduced to a workable condition. Only enough for immediate use is mixed in each batch.

The scratch coat should be applied with a plasterer's trowel and with sufficient pressure to force the plaster well between the wood lath or into the openings of metal lath to insure a good clinch and key. The hair and fiber contribute tensile strength to enable the plaster to form a mechanical bond and hang firmly to the lath. As soon as this coat has become firm but not dry the entire surface is scratched with a broom or metal scratcher to provide bond for the brown coat. When the scratch coat has become thoroughly dry, in 3 or 4 days under good conditions, the brown coat is applied. This is a leveling coat and is evened out to the face of the grounds with long wood strips called **DARBIES** and straight edges known as **RODS**. When firm it is rubbed evenly with a wood float to eliminate shrinkage cracks. Keene's cement or Portland cement in the proportion of 15% to 20% by weight of lime may be mixed with the scratch coat to give a harder set if desired, although this is rarely done in ordinary plastering. The finish coat, sometimes called the white coat, is applied when the brown coat is dry. It is about  $\frac{1}{8}$ " thick and is troweled to a burnished finish with a steel trowel, the surface of the plaster being kept moist during the process by applying water with a brush. The total thickness of the three coats is  $\frac{3}{8}$ ". Marble dust is sometimes added to the gauged lime putty of the finish coat to give a harder and smoother surface. White sand finishes are also obtained by using equal parts of lime putty and fine sand with a small amount of plaster of Paris.

Roughened surfaces are made by employing a wood or cork float instead of a steel trowel. Textured finishes of limitless variety may also be obtained with lime putty gauged with either plaster of Paris or Keene's cement and including fine white sand if a sanded texture be desired. Such finishes are applied in two coats to the brown coat, the first very thin and the second heavier to receive the texture which is produced by the hands or by suitable tools. The white coat is sometimes entirely omitted and a sanded finish applied to the brown coat.

In very cheap work on wood lath two coats only are sometimes applied, known as **DOUBLE-UP WORK**, the total thickness being  $\frac{3}{4}$ ". This is done by applying the first coat as in three-coat work then, after adding one more part of sand to the plaster, by doubling back on the first coat and bringing out to the grounds, rodding and darbying as before. The finish coat is then applied as in three-coat work. This method is not as satisfactory nor as perfect as applying three distinct coats. It should not be used on metal lath.

**UPON MASONRY.** With masonry such as brick, stone, hollow clay and gypsum tile and hollow concrete blocks, lime plaster creates a chemical bond, and hair and fiber are not necessary. Two coats, the brown and the finish coat, are generally considered sufficient. The first coat is

mixed in the proportion of 1 part stiff lime putty to  $3\frac{1}{2}$  parts sand by volume, and the finish coat is composed as for plaster on lath. The surfaces of the masonry should be free from oil, dirt, dust or other foreign matter and should be wet down before starting the plaster. The first coat is applied with sufficient pressure to insure a good bond and is then doubled back with the same plaster bringing the coat up to the grounds, rodding and darbying to an even surface. When firm but not dry it is rubbed evenly with a wood float to eliminate and prevent shrinkage cracks. When dry the finish coat is applied as in three-coat work on lath. The total thickness is  $\frac{5}{8}$ ".

Upon concrete surfaces, the natural bond is weaker and the plaster is mixed somewhat richer in lime, the recommended proportions being 1 part lime putty to  $2\frac{1}{2}$  parts fine sand by volume for ceilings and 1 part lime putty to 3 parts fine sand by volume for walls. After the concrete ceiling has been cleaned a priming coat of neat Portland cement is slushed on to improve the bond. When this coat is dry the plaster coat is applied as thin as possible. If a white finishing coat be desired, a small amount of fine white sand should be added to the regular white coat. In the case of walls the concrete is cleaned and the neat cement priming coat is slushed on as for ceilings. When this is dry one coat of 1 to 3 plaster is applied, and then, after adding 1 more part of sand, a second coat is put on and brought out to the grounds. The rod and darby are used to even the surface, and after the plaster becomes firm but not dry it is rubbed with a wood float to remove and prevent shrinkage cracks. The finish coat is applied when the undercoat is thoroughly dry. Instead of slushing with neat cement the concrete may be hacked and roughened to improve the bond.

It should be remembered that stone, brick and concrete all absorb moisture which dampens plaster applied directly to their surfaces, and that they also chill the warm interior air thus causing condensation of moisture on the plaster. For these reasons it is considered to be far better practice to provide an air space by furring the inside of all stone, brick and concrete walls, and to plaster upon the furred surface rather than to coat directly upon the solid masonry.

**Gypsum Plaster.** As has been explained in Chapter II, gypsum plasters are not slaked but are made by driving off water of crystallization from gypsum rock ( $\text{CaSO}_4 + 2\text{H}_2\text{O}$ ) by heat, a process known as CALCI-NATION. The temperature to which the gypsum is heated and the resulting amount of water driven off affect very much the properties of the product. Thus under a temperature slightly over  $212^\circ\text{F}$ . about  $\frac{3}{4}$  of the water is driven off and the product is called PLASTER OF PARIS if the gypsum rock were without impurities, or HARD WALL PLASTER when adulterants are present or are added to retard the set. Plaster of Paris sets too quickly for ordinary plastering but is excellent for casting in moulds for ornamental plastering and decoration. It forms the basis for the so-called casting and moulding plasters which are especially pre-



pared for these purposes. Hard wall plaster is the standard gypsum plaster and is sometimes called in the trade **CEMENT PLASTER**, which may lead to confusion since it has quite different properties from Portland cement. Hard wall plaster is used for the scratch and brown coats in ordinary plastering.

If the gypsum rock be heated to  $400^{\circ}$  F. instead of  $212^{\circ}$  F. practically all the water of crystallization is driven off and the time of set is much retarded. The resulting product is known as **HARD FINISH PLASTER** and is used largely for finish plaster coats. An important variety of hard finish plaster is Keene's cement, which when set has a very hard, fine, durable and impervious surface. It is used for very high-grade plastering and particularly for wainscoting and mouldings of bathrooms, toilets, laundries and kitchens. It is manufactured by first heating the gypsum rock to  $212^{\circ}$  F., dipping the lumps in a borax or an alum bath and then drying and again heating to  $400^{\circ}$  or  $500^{\circ}$  F. The product is then very finely ground and screened.

Gypsum plaster is shipped in paper or jute bags which contain 80 lbs. and 100 lbs. It may be obtained either neat, called **Cement Plaster**; mixed with wood fiber, called **Wood Fiber Plaster**, or mixed with sand called **Prepared or Ready-Sanded Plaster**. Special plasters are also manufactured for bonding to concrete and for finishing. **WOOD-FIBER PLASTER** contains short fibers of wood which improve its insulating and sound-deadening properties and its flexibility. It is generally used without sand. **READY-SANDED PLASTERS** are mixed at the factory with the proper proportions of clean sand and therefore need only the addition of water at the building to be ready for use. They prevent the possibility of oversanding and are convenient in localities where it is difficult to obtain good plastering sand. **BONDING PLASTER** is composed of materials which improve its adhesion to concrete, and **FINISH PLASTERS** have a fine hard surface either white or colored. Lime putty is generally mixed with the gypsum to form the finish plasters. Both bonding and finish plasters are delivered ready to use when mixed with water.

Unsanded gypsum plaster is mixed in the proportion of 1 part plaster by weight to 2 parts sand for the scratch coat and 1 part plaster by weight to 3 parts sand for the brown coat. The finishing coat is applied without sanding if a specially prepared finishing plaster be used.

**APPLICATION.** The application of gypsum plaster is similar in method to that of lime plaster as already described except that, on account of the quick-setting properties of gypsum plaster, wood lath and masonry surfaces, except gypsum lath and gypsum tile, are often wet before the scratch coat is applied to reduce the absorption of the water from the plaster. Gypsum plasters should be used within an hour after mixing, and plaster which has begun to set should never be re-tempered, that is mixed again with water for re-use. Tools should never be cleaned in the mixing water. Small amounts of set plaster from the mixing box or from the water barrel accidentally incorporated in fresh plaster will

cause the whole batch to set too quickly. Gypsum plaster should not be used in damp locations or as outside stucco as it is easily affected by moisture.

For both lime and gypsum plaster three-coat work on wood and metal lath gives the best results and produces the strongest and most enduring finish. Since each coat is allowed to dry before the succeeding coat is applied, the three-coat method often necessitates removing the scaffolds and re-erecting them after several days. In doubled-up work the second coat is put on directly after the first coat and from the same scaffolding. This method is cheaper and quicker but does not result in such good plaster as three-coat work.

**Plaster Screeds.** When walls and especially ceilings are of wide extent plaster screeds are used as an assistance in producing perfectly plane and level surfaces. These screeds consist of strips of plaster 5'' or 6'' wide run across the ceiling or wall 5'0'' or 6'0'' apart, and carefully leveled with each other. The brown coat is then filled in between the screeds, the whole surface being continuously tested with a straight edge.

**Mouldings and Ornamental Plaster.** The base for low mouldings is formed of the brown coat approximating the contour of the moulding. For coves, cornices and projecting mouldings a frame must be built up of wood or light metal furring bars covered with metal lath. The white coat is then applied to the base or the framework, and the profiles of the mouldings and coves are cut by applying before the plaster dries a sheet metal template cut to the exact form of the contours and running it along horizontally on guides. Corners and miters are formed by hand or cast and applied before the mouldings are run. Dentils, brackets, modillions, rosettes and other ornaments are cast in gelatine moulds and are made of casting plaster, a preparation of plaster of Paris or of whiting, glue and fiber. Cornices, coves and mouldings are run before the wall and ceiling plaster is applied.

**Selection of Plaster.** Lime plaster has been in use for generations and when well burned from good limestone and properly slaked and applied it has stood the test of time. The inconvenience of slaking lime on the premises and the possibilities of slaking and popping in the wall have been largely avoided by using lime hydrated at the mill. It does not echo sound as does gypsum plaster but is not so fire-resistant. Gypsum, on the other hand, does not require slaking and produces a harder and quicker-setting plaster. It does not absorb sound to the extent of lime plaster and cannot slake in the wall. In large buildings assembly rooms are sometimes plastered with lime because of the more agreeable sound conditions and the other rooms with gypsum.

## Article 2. Lath

**General.** Except when plaster is applied to masonry some material must be provided to form a rigid backing or foundation for the plaster.

This material by open spaces or by corrugations in its surface must permit the entering of the soft plaster to form a key or grip to hold it in place. The original material used for this purpose consisted of slats of wood split by hand and nailed horizontally to the wood framework, the plaster obtaining a grip by penetrating into the rough joints between the slats. Wood lath are now sawed into strips and nailed to the wood studs with  $\frac{3}{8}$ " intervals between them, the plaster entering the spaces and locking over onto the back of the lath. Of late years metal lath has also been manufactured by weaving wire together or by puncturing iron sheets, the plaster keying into the mesh of the wire or into the holes in the sheets. Slabs called plaster board are also made of woven fiber or of fiber mixed with asphalt or with gypsum which are nailed to the studs and hold the plaster by corrugations or by chemical bond.

**Wood Lath.** Wood lath are generally of spruce, pine, cypress or fir and are about  $\frac{1}{4}$ " thick,  $1\frac{1}{2}$ " wide and either 32" or 48" long. They should be free from bark, sap or loose knots which discolor the plaster or cause a cracked and broken surface, and should have a straight grain to avoid buckling and warping when wet. By wetting the lath before application the pieces which become crooked can be discarded and the later plaster cracks avoided. Wood lath are graded No. 1 and No. 2. The No. 1 lath should usually be specified because the No. 2 lath will necessitate a large amount of culling. Lath should not be wider than  $1\frac{1}{2}$ " to reduce as far as possible expansion when wet which breaks the plaster keys.

Wood lath should be applied horizontally, never diagonally or vertically. Joints are broken on both walls and ceilings so that not more than 7 consecutive lath have the same bearing. Lath on ceilings run in one direction only. Lath are spaced at least  $\frac{3}{8}$ " apart for lime plaster and not less than  $\frac{1}{4}$ " apart for gypsum. The abutting ends should have an interval of  $\frac{1}{4}$ " between them. Because of the more generally accepted length of 48" for wood lath, wood studs and joists are spaced either 12" or 16" apart and rafters 12", 16" or 24" apart depending upon their loads, thereby obtaining good nailing and jointing without cutting the lath. Each lath should be nailed at every bearing with at least one 3d. wire nail.

**Metal Lath.** Metal lath may be woven from wire into a fabric with 2" or  $2\frac{1}{2}$ " square mesh called wire lath or it may be formed by cutting slits in metal sheets and by pulling the sheets transversely, opening out the slits and forming a perforated lath called expanded metal lath. Although woven wire was the first type of metal lath to be made, expanded metal is now become more generally used. Woven wire is largely employed, however, for reinforcing purposes. Wire lath is shipped in rolls containing 150' of lath 36" wide. Expanded metal lath is usually shipped in flat sheets 18" and 24" wide and 8'0" long (Fig. 1, a, b).

Ribbed metal lath is furnished with V-shaped ribs crimped into the sheet at intervals of about 4". These ribs have either  $\frac{3}{8}$ " or  $\frac{3}{4}$ " projection from the surface, thus acting as furring strips to provide an air space between the lath and any masonry surface and likewise serve to stiffen the lath when used for furred or suspended ceilings (Fig. 1,c).

**Suspended Ceilings.** It is often desired that a finished ceiling be hung at some distance below the under side of the floor beams either to provide an insulating air space as under flat roofs, to cover projecting floor beams and girders, to give better proportions to a room or for other purposes. In fireproof construction such ceilings are built by wiring metal lath to horizontal  $\frac{3}{4}$ " channels called **FURRING CHANNELS** spaced 12" apart for flat lath and 18" for ribbed lath. The furring channels are wired or clipped to  $1\frac{1}{2}$ " channels, called **RUNNER CHAN-**

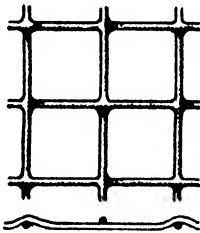

Woven Wire Lath  
a.

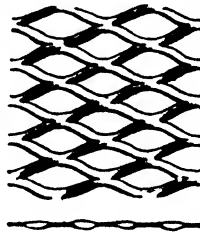

Expanded Metal Lath  
b.



Ribbed Metal Lath  
c.

FIG. 1.—Metal Lath.

NELS, which run horizontally at right angles to the furring channels and are spaced 4'0" apart. The runner channels are suspended from the floor arches by metal hangers consisting of  $\frac{1}{4}$ " round rods, 1" flat bars or heavy #8 wire, spaced 4'0" apart in each direction. A common method is to use for hangers 1" x  $\frac{3}{8}$ " flat bars bolted at the lower end to the runner channels and at the upper end to metal inserts incorporated in the floor slab when the concrete is poured or set between the joints of the tile in the case of structural tile floor arches (Fig. 2,a).

In wood frame construction suspended ceilings are built on the same principle as described for fireproof construction except that the runners and hangers are of wood and must be of sufficient size and stiffness to offer solid nailing for the lath. The hangers are nailed to the wood joists or rafters 16" apart, and the runners are nailed to the hangers and usually lie in a direction at right angles to that of the joists or rafters. Unlike the method for fireproof construction no additional set of cross furring strips is used unless for leveling purposes.

**Furred Ceilings** in fireproof construction generally signify a ribbed lath ceiling fastened by metal clips directly to the lower flanges of the

steel floor beams which run between the heavier girders. This method produces a flat ceiling under all the cross beams but permits the deeper girders to drop below the ceiling level, a system often used in office buildings, apartment houses and hotels for economy and to increase the ceiling height (Fig. 2,b).

In the case of concrete beams the metal lath may be wired to the reinforcing bars or it may be placed directly upon the forms before

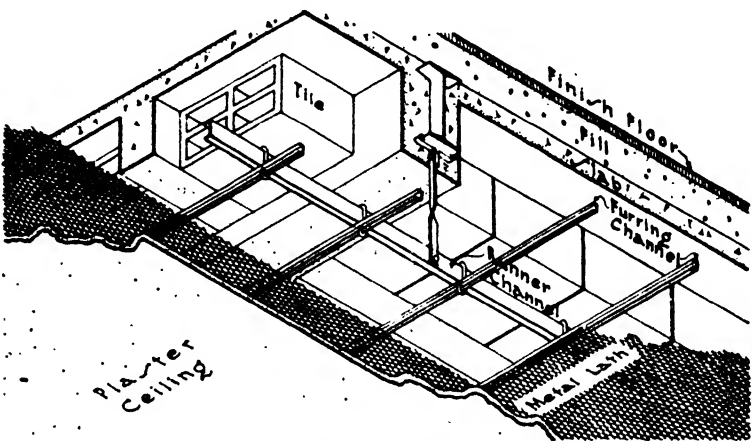

a. Suspended Ceiling in Fireproof Construction

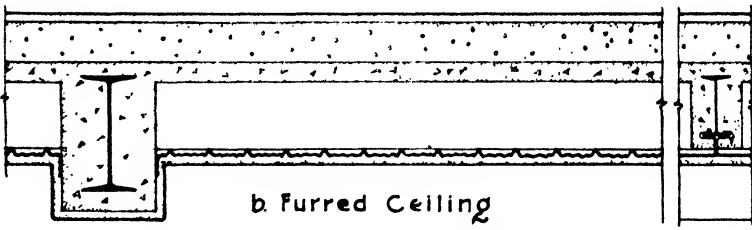

b Furred Ceiling

FIG. 2.—Furred and Suspended Ceilings.

pouring the concrete and so become embedded in the bottoms of the beams without the necessity of ties or clips.

In wood frame construction of the best class 1" x 2" strips of wood, 16" apart, called CROSS FURRING, are often run across the under side of the floor joists to level the ceiling. Any inequalities in the alignment and depth of the joists can be compensated during the application of the cross furring and perfectly true and level bearing supplied for the nailing of the lath.

**Corner Beads.** The projecting corners and angles of plaster work are naturally easily broken and must be provided with vertical wood or

metal strips let into the corners to reinforce them. These strips, called **CORNER BEADS**, were originally of wood but now metal beads have become universal. They are attached to the lath and by projecting the exact thickness of the plaster coats they form a ground for truing up the surface. The corner may be brought to an edge, in which case the bead is practically invisible, or where hard usage is expected the corner is rounded back to a blunt bull nose. The wings of the bead may be of sheet metal perforated to hold the plaster or they may consist of strips of metal lath (Fig. 3).

**Grounds.** In order that the plaster may be put on with an even thickness all over the wall and may be true, level and plumb, guides consisting of wood strips the exact thickness,  $\frac{7}{8}$ "',  $\frac{3}{4}$ "' or  $\frac{5}{8}$ "', intended for the plaster are nailed upon the wood studs, hollow tile or other material of which the structural frame is composed. The grounds also serve as bases for the application of wood or metal trim and are consequently placed around door and window openings and at the proper levels on the walls to receive baseboards, wainscoting, chair-rails or picture mouldings.

**Plaster Board.** Sheets composed chiefly of gypsum with surfaces adapted to hold gypsum plaster are manufactured to be applied upon wall and partition members in place of lath. They have been described in Chapter II.

**Selection of Lath.** It has been shown by test of the Forest Products Laboratories of the Department of Agriculture that plaster on wood lath increases the stiffness of horizontally sheathed wood walls over 200%. Metal lath does not increase the stiffness of wood framed buildings and requires more plaster to embed the lath, but from virtually every other standpoint metal lath is to be preferred. It is fire-resistant and quickly applied, it does not shrink and warp nor does it stain the plaster. In fireproof construction it is required by the building codes, and in non-fireproof construction it should be used over heating plants, on the sides of shafts, on the soffits of stairs and all positions where the fire hazard is conspicuous. Because it is more flexible than wood lath it should be used in all corners and angles and where materials of different kinds butt or join each other.



**Corner Beads in Metal**  
FIG. 3.—Metal Corner Beads.

### Article 3. Furring

**In General.** The term **FURRING** is used to include any framework of wood, hollow tile or metal, not a part of the structure of the building, which is employed to provide air spaces for insulation, to even or level surfaces, to cover unsightly structural work or mechanical equipment

or, by aligning surfaces and balancing elements, to achieve the requirements of the architectural design.

**Wall Furring.** It has already been said that solid masonry permits the passage of moisture and heat and also by its cold surface chills the warm air in the interior of buildings, causing the moisture in the air to condense upon the inner face of the wall. These actions may be classified as:

1. Passage of moisture from exterior to interior.
2. Passage of heat from interior to exterior.
3. Condensation of moisture from chilled interior air.

Because of these actions plaster should not be applied directly to a masonry wall unless an air space, as nearly continuous as possible, has been contrived between the plaster and the masonry. Such air spaces may be formed by hollow tile or concrete blocks set against the face

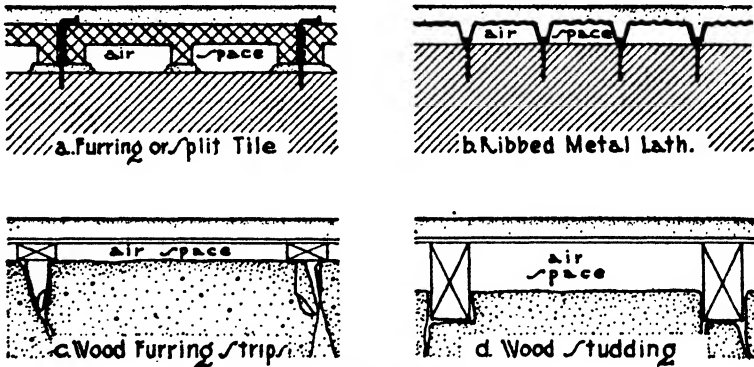

FIG. 4.—Methods of Furring.

of the wall or by wood or metal strips applied vertically against the inner face of the wall forming bases for the lath and offsetting it from the wall by the thickness of the strips.

Hollow clay tile from 4" to 8" thick may be used as the backing of stone, brick and concrete walls and thus provide the air space, or 1½" and 2" clay furring tile may be set against the inside of solid masonry walls. The 1½" and 2" tile are similar to a 3" or 4" tile split in two longitudinally, and are sometimes called split tile. They are fastened to the wall with nails through the joints with a minimum of mortar and provide an air space about 1⅜" wide. Cinder concrete hollow blocks are also used as backing and furring. The plaster is applied directly to the hollow tile (Fig. 4,a).

Metal furring strips are long narrow sheets bent into a V-shaped cross-section and fastened to the wall vertically from 16" to 2'0" apart. They are used in fireproof construction, the metal lath being wired in place across their edges. Ribbed metal lath is also used without

furring strips, the ribs being set with their projecting edges against the wall, thus holding the lath about 1" away from the wall (Fig. 4,b).

In non-fireproof construction vertical wood furring strips 16" to 24" apart may be used. These strips consist of 1" x 2" pieces fastened in place by nailing to wood plugs inserted in the stone and brick joints (Fig. 4,c). Because of the labor involved in plumbing and leveling these strips to give a true and even base for the wood lath, another method, consisting of 2" x 3" studs built up in place, is now more generally used. This studding forms a complete light framework throughout the exterior walls of the building. It is self-supporting, the studs being set 16" or 20" apart, and is provided with sills and plates. The stone or brick walls are then built up on the outside of this framework embedding it to a depth of 1" to 1½", thus leaving about 1½" projecting from the inner face of the masonry. The lath is then nailed to the studding, and a sufficient air space is maintained between the plaster and the stone, brick or concrete wall (Fig. 4,d).

**Built-up Furring.** Light wood construction consisting of 2" x 3" or 2" x 4" studs are built up wherever it is required in the interior of buildings that surfaces be aligned or elements balanced to carry out the architectural design. False beams, columns and pilasters may also be erected with light framing of studs and plaster, or pipes and ducts enclosed to screen them from view. It is only necessary in these cases that the furring studs and strips be sufficiently firm to hold the lath and plaster rigidly without producing cracks and settlements.

In fireproof construction the furring may be done with furring or partition tile upon which the plaster is directly applied, or with light rolled steel channels and angles which are bolted together and to which metal lath is wired.

**Coved Ceilings and Cornices.** Suspended, furred and cross-furred ceilings have already been explained in Article 2. Coved ceilings, false beams and cornices require additional built-up furring of more or less elaborate character depending upon the design. The chief elements consist of series of steel brackets accurately bent and shaped to conform to the general outline of the finished beam or cornice, built up of channels, angles, tees or flat bars of sufficient size to support the imposed weights rigidly and securely. These brackets are supported by longitudinal top and bottom rails of bar iron and by bar iron braces securely connected to the beams or walls. Metal lath is then bent into shape and wired to the brackets, following their external outline and forming a base for the plaster.

Falsework of this kind was originally made of wood but was of necessity cumbersome and awkward, and, since the advent of steel shapes, metal furring is almost exclusively employed.

**Solid Plaster Partitions.** For the sake of lightness of weight and economy of space low non-bearing partitions are built consisting of ¾" steel channel studs set vertically 12" on centers and bolted to metal



runners or tracks below and above. Ribbed metal lath or plaster board is then wired to one side of the channels and plaster is applied to both sides of the lath. Such solid partitions may not be more than  $1\frac{1}{2}$ " or 2" thick and should not be built more than 12'0" high because of their lightness. Double partitions  $3\frac{1}{2}$ " to  $7\frac{1}{2}$ " thick with an air space in the center are likewise constructed of two sections of metal lath with ribs spaced  $1\frac{1}{2}$ " apart, set with the ribs horizontal and supported on  $1\frac{1}{2}$ " or 2" channel studs. Plaster is then applied to the outside of each section of lath. In both cases it is best to gauge the scratch coat with

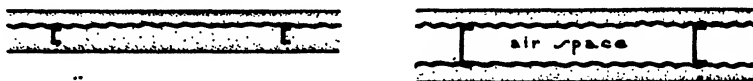

Solid Plaster Partition

Double Plaster Partition

Fig. 5.—Metal and Plaster Partitions.

plaster of Paris to insure a rapid set and rigid base for the brown coat (Fig. 5).

#### Article 4. Stucco

**Description.** Stucco is a plaster applied to the exterior of buildings to form a finishing coat. It is a very old method and was brought to a high development during ancient times in Greece, Rome and Egypt, where lime and volcanic ash were mixed to form the material of the stucco and pigments introduced to give it color. Before the introduction of Portland cement, lime was much used in America to make stucco, and because of the rigidity of the old masonry walls, the care in curing the lime and the number of thin coats applied, very enduring lime stucco was produced. Changed conditions in the present day and the apparent necessity for speed have now largely eliminated the use of lime for stucco, Portland cement having taken its place almost entirely. A great variety of colors and surface textures have been developed to lend warmth and interest, so that the possibilities of stucco as an exterior finish may be said to be constantly multiplying with the limit far from reached.

**Bases for Stucco.** Stucco is usually applied to walls of concrete, brick, hollow tile, concrete blocks or wood frame. In all cases the wall must be stout and rigid and free from shrinkages and settlements, for any movement in the wall will cause cracks in the stucco. The bond between the stucco and the wall must likewise be assured, otherwise the coatings will not adhere and cracks and loosened areas will result. Concrete walls often are brushed with wire before the surface is hard to produce a roughened face. Hollow tile, concrete blocks and brick should be clean and have a rough texture, and wood frame walls should be covered with wire fabric or expanded metal lath. In the last case the studs

should not be over 16" apart, they should be covered with wood sheathing boards not over 6" wide and the boards in turn should be protected with heavy roofing felt. Over the felt the wire lath or expanded metal should be stretched upon furring strips projecting at least ½" from the surface of the felt to give a proper key. The tops of stucco walls should be properly protected by projecting eaves or by flashing to prevent water from penetrating behind the stucco. Stucco should not be applied when the temperature is below 32° F. (Fig. 6).

**Application.** Stucco is applied in three coats, the first or scratch coat, the second or brown coat and the finish. The first coat should be well troweled with sufficient force to bond it into masonry walls or key it thoroughly into the metal lath. The surface is scratched or lightly scored to give a bond for the second coat. It should be sprinkled and kept wet for at least 48 hours. The second or brown coat should not be applied until 5 days after the scratch coat or until it is thoroughly dry.

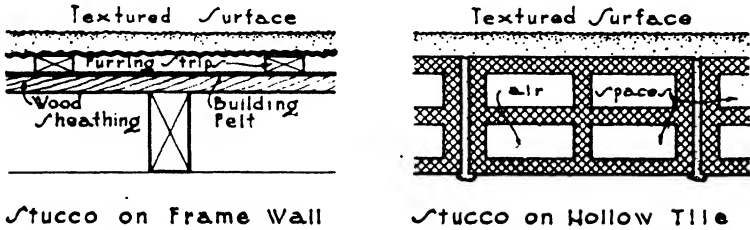

FIG. 6.—Stucco on Frame and Tile Walls.

The brown coat, like the scratch coat, should be at least ½" thick. It is applied similarly to the scratch coat and is sprinkled and allowed to dry slowly in the same manner. The finish coat should be applied not less than a week after the brown coat.

A variety of finishes have been devised for the last coat. They are produced by smoothing or floating the surface with metal trowels or by metal or wood floats, the surface being left perfectly smooth or showing the marks of the float as desired. Mixtures of cement and sand or coarse pebbles may be sprayed or thrown against the surface while it is still soft to produce sand dash or pebble dash finishes.

**Color.** Colored stucco has been used of late years to an increasing extent. The pigments are mineral and are mixed with the sand and cement before application. Prepared stuccos already colored can be obtained from the manufacturers, and when possible such prepared stuccos should be used, otherwise a mottled appearance may result from an attempt to mix the color on the job.

**Proportions.** All three coats should be mixed in the proportion of 1 part of cement to 3 parts of sand, to which may be added hydrated lime equaling 10% of the weight of the cement. The proportions in the last coat may vary slightly as to size of aggregate depending upon the

kind of finish desired. Sand is considered as graded from 0" to  $\frac{1}{4}$ ". For a finish of coarse texture this sand would be satisfactory, but for a smooth finish the sand should be sifted to remove the coarser particles. In this case the proportion of 1 part cement to  $2\frac{1}{2}$  parts fine sand will be more satisfactory.

**Magnesite Stucco.** Of late years a stucco composed of magnesium, sand and asbestos called magnesite stucco has been developed. Liquid magnesite chloride is added on the job to form a plastic material which is as strong as Portland cement stucco and may be used in a similar manner. It is sometimes produced with the magnesite chloride already mixed with it in a powdered form, in which case it is only necessary to add water on the job.

Magnesite stucco is more plastic and elastic than cement stucco, it cracks less and can be applied at temperatures below freezing. It is, however, a proprietary article and expensive, it does not withstand the action of dampness as well as cement and it has a tendency to corrode metal lath. Wood lath or galvanized metal lath should therefore be used in connection with it. Color and surface finishes may be employed as in the case of Portland cement stucco.

## CHAPTER XIII

### DOORS AND WINDOWS

#### Article 1. Wood Doors

**Types.** According to their manner of construction doors may be divided into three classes:

- (a) Battened.
- (b) Framed and Lileged.
- (c) Framed and Paneled.

(a) **BATTENED DOORS** are constructed of two thicknesses of  $\frac{3}{8}$ " matched boards nailed together and the nails clinched on the back. The boards are arranged to cross each other at right angles and generally run diagonally with the door. Battened doors are often used as the foundation for metal-covered fire-doors of rough and heavy type (Fig. 1,*a*).

(b) **FRAMED AND LEDGED DOORS** consist of a frame of uprights and cross pieces, called ledges, with their joints mortised or halved together. Sometimes diagonal braces are added. The frames are then covered on one side with matched boarding. When there are no braces the boarding may be let into grooves in the edges of the frame, the uprights and cross pieces then showing on both sides. Ledges are sometimes used with no uprights (Fig. 1,*b*).

(c) **FRAMED AND PANELED DOORS** consist of a frame filled in by wood or glass panels. The uprights are called stiles, and the cross pieces, rails. The rails are mortised into the outside stiles, wedged and glued. The center stile is mortised into the rails. The panels are held in place in grooves in the inner edges of the frame or by mouldings fastened to the frame. Because of the probable shrinking and swelling of their broad surfaces, panels should never be rigidly fixed but should be permitted to move freely in the grooves or between the mouldings. A variety of arrangements can be effected by changing the number of the stiles and rails and the proportions of the panels (Fig. 1,*c*).

Paneled doors are the most generally employed of the three types and may be solid or built up of small strips and veneered. Exterior doors where exposed to the weather are preferred to be solid by most architects, but for interior work the built-up veneered doors are far more dependable. Solid interior doors are used in much cheap and moderate-priced work but they invariably swell in damp weather during those portions of the year when buildings are unheated.

**Manufacture.** The stiles and rails of built-up doors are composed of  $\frac{3}{8}$ " strips of wood glued together face to face. These strips are generally of white pine or chestnut and are  $\frac{1}{2}$ " less in width than the thickness of the door. The outer edge of the stiles is covered with a  $\frac{3}{8}$ " piece of the finishing wood when natural finish is to be employed. A  $\frac{1}{2}$ " hardwood spline is glued into a groove in the edges of the stiles and rails, and on this spline the mouldings are glued which hold the panels in place but permit freedom to expand and contract. The panels may be solid, but it is better practice to build them up of 3 or 5 plies

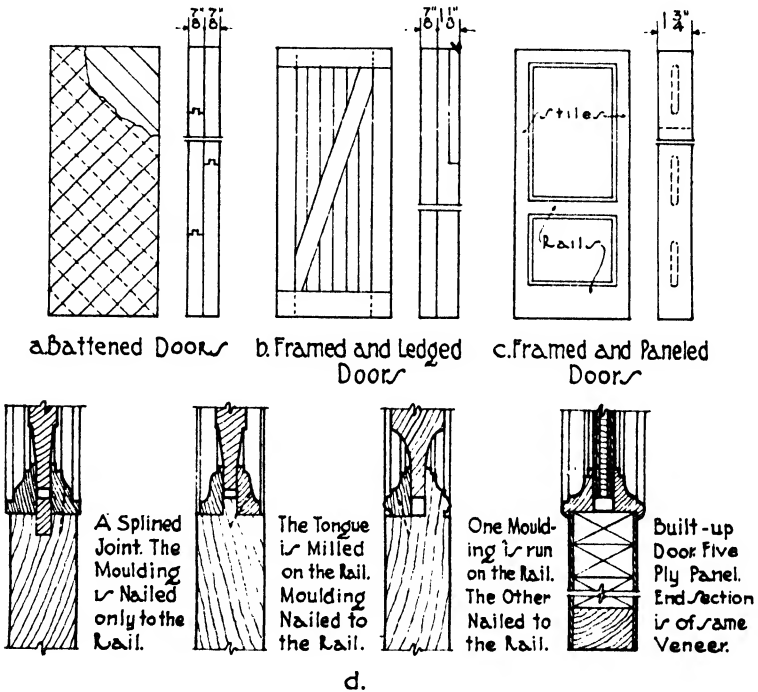

FIG. 1.—Types of Doors.

on pine or chestnut cores, as described in Chapter XIV, Article 3. All gluing should be done under great pressure (Fig. 1, d).

Flush doors without raised or sunk panels consist of stiles and rails glued up as just described. The panels are constructed of pieces of white pine, ash or chestnut 3" or 4" wide glued and doweled together. The annual rings should be reversed in direction in each piece to avoid warping. On this core, covering both stiles and rails in one piece, four veneers are glued under pressure, two on each side. They are  $\frac{1}{16}$ " to  $\frac{1}{20}$ " thick and arranged so that the grain of the inner veneer crosses that of the outer or finish veneer. The inner or cross veneer is generally of oak.

Proper seasoning is very important in all door and veneer work. The wood should be thoroughly kiln-dried before assembling, and the finished doors should again be placed in the kilns after gluing to reduce the moisture to about 6%.

• **Stock Doors.** Doors are made to fixed standard sizes in sash and door mills and are sold in large numbers. They are usually solid without veneering and are intended for the cheaper types of building. Of late years, however, great improvement has been made in the quality of

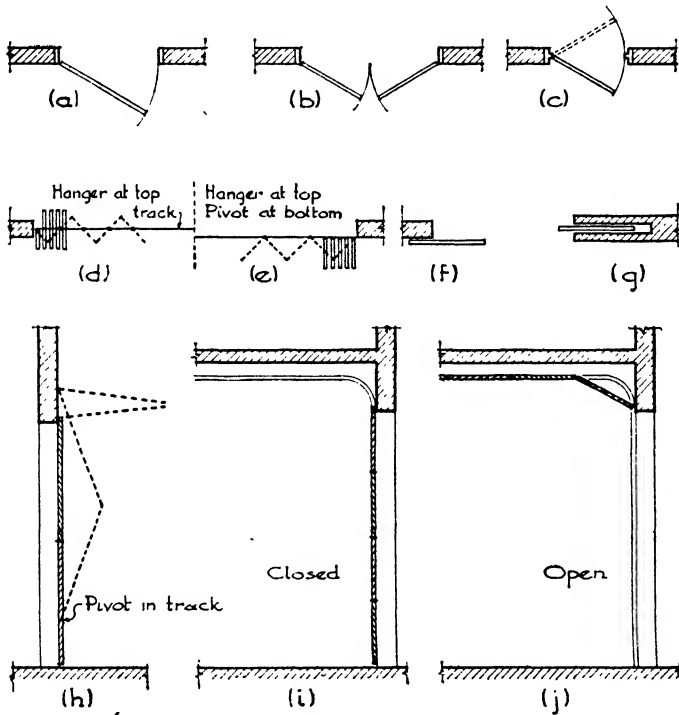

Fig. 2.—Operation of Doors.

stock built-up and veneered doors, and a very excellent product is turned out by the better manufacturers, some of their processes being patented.

**Thickness.** Outside entrance doors are finished from 2" to 2¼" thick and interior doors from 1⅜" to 1⅞" thick. Closet doors may be 1⅜" and cupboard and dresser doors from ⅞" to 1¼" thick. The thickness is partly a matter of harmony with the architectural style.

**Operation.** The most general method of operating doors is to hang them to the door frame on hinges or butts fixed to a side of the door so that they swing on a vertical axis. For special situations, however, doors

may be suspended by wheeled hangers to slide horizontally on a track or may be moved upward or downward between lateral guides.

Swinging doors may be single, double or double-acting. Single doors consist of one leaf hinged on one edge, the so-called hand of the door, right or left, being determined by the side upon which the hinges are placed. Doors are usually beveled upon the edge containing the lock so that they may fit closely without binding when opening and closing. It is necessary to specify the hand and the bevel when ordering locks and hinges (Fig. 2,*a*).

Double doors have two leaves each hinged on an opposite edge and meeting at the center (Fig. 2,*b*). Double-acting doors are hung on special spring hinges holding them closed when not in operation. They swing in either direction and are much used between kitchens, pantries and dining rooms (Fig. 2,*c*).

Horizontal sliding doors are either solid or accordion. Solid doors may be single and slide to one side or be composed of two or more leaves sliding in the same or opposite directions. In both cases they either pass along the outside of the wall or operate into pockets concealed in the thickness

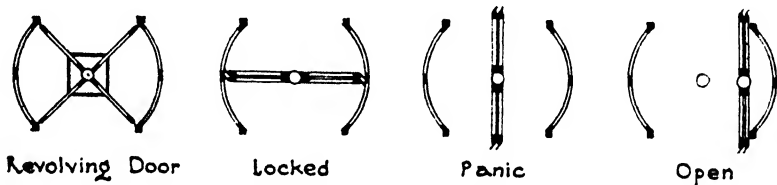

FIG. 3.—Revolving Doors.

of the wall (Fig. 2,*f,g*). Accordion doors are for very wide openings and may be used as folding partitions. They consist of a series of leaves or panels hinged together and moving laterally upon hangers and tracks at the top. The bottom edges may or may not be provided with pivots sliding in a guide in the floor (Fig. 2,*d,e*).

Vertical sliding doors are used in garages and industrial buildings and to loading platforms. They may be canopy doors as shown in Fig. 2,*h*, which are divided into two leaves opening upward and outward on two side pivots sliding in guides, or overhead doors consisting of four leaves hinged together and moving on wheels in a track upwardly and inwardly to a horizontal position below the ceiling (Fig. 2,*i,j*).

**Revolving Doors.** Revolving doors are very much used in the outside entrances to hotels, office buildings and the larger shops. The door consists of four upright cross wings which revolve about a vertical axis passing through their intersection. The wings are enclosed in a circular vestibule 7'0" in diameter and 7'6" high. The edges of the wings are provided with rubber weather stripping, fitting snugly against the inside of the vestibule. Two quarters of the vestibule opposite each other on the main axis are open to form a passageway, the other two

quarters being enclosed. In this manner, throughout every complete revolution of the door there are always two wings in contact with the sides of the vestibule, preventing draughts and cold from entering the building. In case of panic the wings may be folded together in the center to give free egress, and in summer they may be swung completely to one side (Fig. 3).

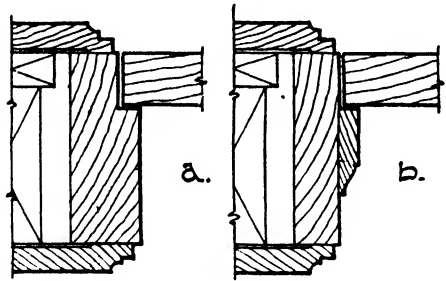

Interior Door Frames

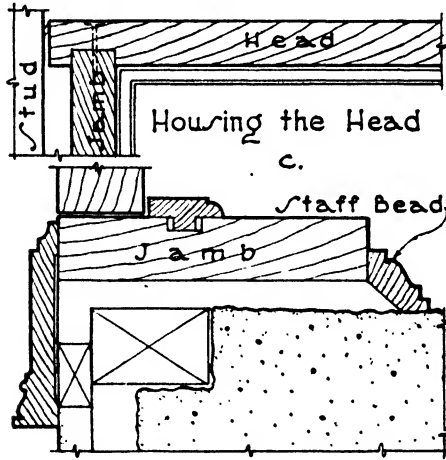

Exterior Door Frame

FIG. 4.—Wood Door Frames.

**Door Frames.** Interior wood door frames are made of  $1\frac{3}{4}$ " plank rabbeted out  $\frac{1}{2}$ " for the door stop, or of  $1\frac{1}{8}$ " plank with the door stop planted on. Stops may be made adjustable to suit any possible warping in the door. The sides or jambs of the frame are housed into the head and nailed from the top. There should be a space of  $\frac{3}{4}$ " to  $\frac{7}{8}$ " between the back of the frame and the studding for plumbing and wedging of the frame (Fig. 4, a, b).

Exterior wood door frames are much the same as the frames for interior doors except that they may be heavier, from  $1\frac{3}{4}$ " to  $2\frac{1}{8}$ ", to



carry the weight of the thicker doors, and in brick or stone walls they are built into the masonry or fastened to metal anchors, or to wood plugs or blocking in the wall. A staff bead covers the joint between the frame and the masonry. A screen door stop is often added on the outside of the frame (Fig. 4,c).

Metal bucks and frames are sometimes used with wood doors, but when these members are of steel and the doors are usually hollow metal or metal covered for fire-proofing purposes.

## Article 2. Wood Windows

**Types.** Windows may be divided into three classes according to the manner of hanging the sash:

- (a) Double-hung.
- (b) Hinged or casement.
- (c) Pivoted.

The double-hung windows are most used in this country; the hinged or casement sash are preferred in Europe. Large store and bank windows are sometimes pivoted, but the most frequent use is in transom sash.

**Double-hung Windows.** The sash of a double-hung window is divided horizontally into two parts, the upper and lower sash, which are set on separate planes so they may slide past each other. The sash are hung on a cord or chain passing over pulleys and provided with counterbalancing lead or iron weights so that the sash will readily slide up and down yet remain at rest at any point. The window frame in both wood and masonry walls consists of head and sill and the boxes at the sides in which the weights slide up and down. The back of the box in wood buildings is generally formed by the doubled studs of the rough opening, but in masonry buildings a complete box is made with a wood back, the entire frame being built into the masonry as the wall is erected. The front of the box is called the pulley or hanging stile, and the sides, the outside and inside casings. The top of the frame is known as the head or yoke, and the bottom as the sill (Fig. 5,a,b).

In the East, material for window frames should be white pine, cedar or cypress to withstand the weather and not shrink or warp. Fir, sugar pine and redwood are used in the West. The pulley or hanging stile which carries the pulleys at the top, and against which the sash slide, should be of yellow pine and should be oiled, not painted. All other parts of the frame should be well painted before being set. A piece about 18" high and  $2\frac{1}{4}$ " wide with beveled ends should be made removable in the lower part of the pulley stiles to give access to the weights. The tongues on the edges of the pulley stiles are important because they greatly stiffen the frame. The pulley stiles should also be housed into the head in the same manner as in door frames. The stop-bead for the inside sash should be fastened by round-headed screws,

sometimes set in metal cups, so that it can be easily removed or adjusted without being marred.

In frame walls with 2" x 4" studs and with sash 1 3/4" thick, the outside casing is sometimes set outside the outside sheathing to give more room for the weights and also to allow space for setting fly-screens

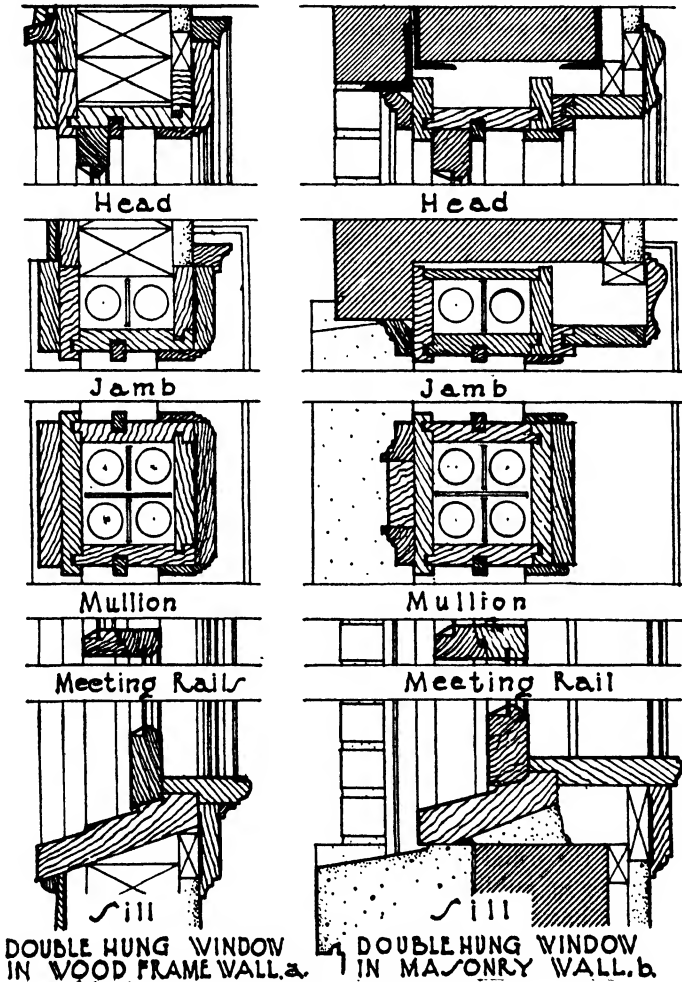

FIG. 5.—Double Hung Window Frames.

and blinds. The head or yoke should then be 1 1/8" thick on account of its extra width.

The inside trim, stool and apron and the stop bead should match the interior woodwork of the room, either painted or natural finish.

Building paper should be brought well over the outside casing and

the outside trim applied upon it. Where the outside casing is set outside the sheathing the paper should be put around the opening before the frame is installed and the outside casing nailed over it. Frames should be flashed at the head by bringing 16-oz. soft sheet copper over the top of the outside trim and up under the shingles or clapboarding before the latter are put on. It is safest also to set flashing under the clapboards or shingles and out against the back edge of the outside trim at the sides of the window.

For masonry walls the same frame is used with the addition of the back lining to box in the weights and the staff moulding to cover the joint between the outside casing and the masonry jamb of the opening. Masonry walls usually have sufficient thickness to allow plenty of room for the weights and sash. Any excess of space inside the frame may be covered by a jamb casing extending from the frame to the interior trim or architrave of the window. The space between the outside casing and the masonry jamb should be carefully caulked with oakum and caulking compound. The joint between the masonry sill and the wood sill should also be caulked from the inside and the space under the wood sill filled with mortar. A slot is cut in the under side of the sill to receive the siding.

**TRANSOMS AND MULLIONS.** Transom sash are placed over doors and casement windows or over the inner sash of a double-hung window, and are either hinged at the bottom or pivoted at the sides. They are supported on a horizontal sill called a transom bar, which is sometimes strengthened by a 2" x 4" spiked to the doubled 2" x 4" of the rough opening.

A mullion is a vertical bar dividing a window opening and separating two or more sash placed side by side. For double-hung windows the mullion consists of two weight boxes and pulley stiles.

**STORM WINDOWS.** In very exposed positions in the winter, especially on the north, east and west sides of buildings, extra protection from the cold may be obtained by an additional outside sash screwed in place and removable in the summer, by double glazed sash or by two sets of sliding sash.

**SASH.** Sash are made 1 $\frac{3}{8}$ " thick for small windows or for cheaper work, but for the usual windows in residences the sash are 1 $\frac{3}{4}$ " thick. Wide windows in public buildings and stores should have sash 2 $\frac{1}{8}$ " thick. For the heavier sash the head or yoke and the pulley stile should be 1 $\frac{1}{8}$ " thick. The horizontal members are the top rail, the bottom rail and the meeting rail, and the vertical members are the stiles. The intermediate dividing strips between the panes are called muntins. The widths of the stiles, rails and muntins are very expressive of the type of architecture of the house and should be carefully designed. The members of the sash are rabbeted on the outside to receive the glass and putty and are moulded on the inside. The rails are mortised into the stiles, and the muntins into the stiles and rails. The mouldings are coped against each other.

In order to permit window glass to be cleaned with safety to the cleaner, several methods have been devised and patented by which double-hung sash may be turned on one edge or pivoted so that both sides may be cleaned from the inside of the building. None of these methods has been widely adopted, however, and the standard sash is most generally used wherever double-hung windows are desired. In high buildings, steel double-hung or casement sash, however, are now required by most communities in place of wood for fireproofing reasons.

To protect the window-cleaner, bronze hooks are screwed or bolted into the window frames, to which the cleaner attaches a broad leather or web belt. He then cleans the window while standing on the outside stone sill, the belt supporting him should he slip or fall.

**PULLEYS.** Pulleys are made of iron for cheap work; they consist of a frame supporting a wheel over which passes the chain or cord by which the sash is hung. The pulleys of the best type are of the same design but are of bronze and equipped with ball-bearing wheels.

**CHAIN AND CORD.** Cord was first used for carrying double-hung windows and is still used for light-weight sash. The best cord is of smooth cotton; it may be obtained with wire reinforcing woven into the strands. Chain, now used on heavy sash, is more lasting than the cotton cord. The chain may be of galvanized steel, bronze-plated steel or bronze metal, the last being the most durable but the most expensive.

**Casement Windows.** Sash hinged at the side, arranged to open inward or outward, were the earliest form of movable windows and have never been equaled for appearance or comfort. Unless carefully made with special attention to the detail of the stiles and rails, however, they are likely to leak, especially at the sill. For this reason double-hung windows are popular in this country.

**CELLAR WINDOWS.** Although perhaps unworthy of the title of casement, cellar windows are hinged and will therefore be considered in this place. The frame of a cellar window consists of  $1\frac{3}{4}$ " plank rabbeted for the sash and for a fly-screen. The sash are usually hinged at the top to open in. The sill and head are made wider than the sides or jambs to form lugs to be built into the masonry and to permit the housing of the jambs.

**CASEMENTS OPENING IN.** The frames of casement windows are simpler to make than those of double-hung windows since they consist only of head, jambs and sill very similar to a door frame. Skill is required, however, so to shape the joints between the sash and the frame that no water will penetrate, especially with driving rains. The frames are usually of  $1\frac{3}{4}$ " plank with rabbets for the sash, and they are constructed at the head and sill in the same manner as door frames. In masonry walls the joints next to the stone or brick jambs should be carefully caulked and covered with a staff moulding. The frame is usually set up and temporarily braced in a plumb position, and the masonry wall is built around it, holding it securely in place.

The side stiles of the sash should be made with a projecting half-round on the edge seating into a groove in the frame when the sash is closed. The meeting stiles are formed in two ways, either with a half-round on one stile fitting into a groove in the other, or with rabbeted edges covered

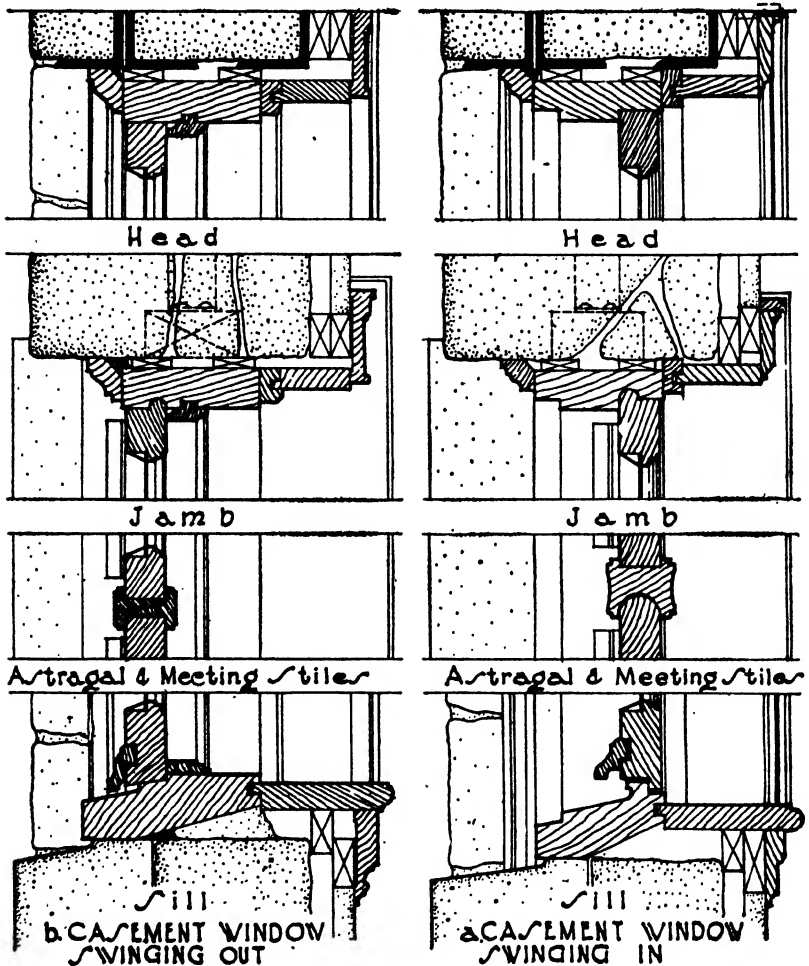

FIG. 6.—Casement Window Frames.

with an astragal moulding. The rail at the bottom should be provided with an undercut drip moulding on the outside and with grooves in the bottom edge to catch any entering film of water and drain it back in drops upon the sill. The sill should have a sharp slope and be furnished with grooves and a raised lip for the same purposes. Casement windows opening in are used throughout Europe and are perfectly weather-tight when properly made (Fig. 6,a).

**CASEMENTS OPENING OUT.** The frames are also of  $1\frac{3}{4}$ " plank rabbeted to receive the sash and are simpler than those for casements opening in. A drip should be provided, however, on the bottom edge of the lower rail to prevent water from driving through. It is difficult to arrange shutters with this type of casement, and the fly-screens must be put on the inside. Adjusters are necessary to prevent the sash from swinging the wind, when open (Fig. 6,*b*).

**Stock Sash.** Stock sash of standard sizes can be obtained ready-made all over the country. They are not so well or strongly fabricated as those here described, and their use is largely limited to speculative building. Lights of glass are produced by the manufacturers in fixed sizes, and it naturally causes less waste to confine the sash dimensions to those which will exactly receive the lights without cutting the glass. Stock sash are therefore manufactured in fixed thicknesses and sizes and will fit only in corresponding sizes of frames. The window openings must then be proportioned to take the sash sizes rather than to satisfy the demands of the design.

### Article 3. Metal Doors and Windows

In the effort to render the interiors of buildings fireproof and to retard the spread of flames, the manufacture of doors and sash entirely of metal or of wood covered with metal has been greatly developed, involving a high perfection of workmanship. The metal doors and windows now required in most building codes for use in structures of any height may be divided into three classes:

- (a) Metal-covered.
- (b) Hollow metal.
- (c) Solid metal.

**Metal-covered Work.** For many years wood doors have been covered with tin to render them fireproof, but no effort was made to produce a finished appearance, the use of the doors being confined to boiler rooms, fire-walls and basements. The need throughout tall buildings for fireproof doors and windows has led to great improvements in the methods of drawing sheet metal over the surfaces of wood doors, frames and sash and in forming mouldings with extreme sharpness and accuracy of profile.

**KALAMEIN IRON** is the trade name given to sheet steel with a thin covering of an alloy of tin and lead, and a kalamein door is strictly a door covered with sheet iron or steel. The use of the word has led to a certain confusion, it being sometimes understood to mean wood covered with copper or bronze as well as steel. **METAL-COVERED WORK** is a much better general term for doors, sash or mouldings clad with sheet metal.

**Metal-covered Doors.** The wood doors are first made with solid or built-up stiles and rails of kiln-dried white pine which are mortised

and tenoned together to form the frames as in the best type of standard wood doors. The panels are often of asbestos composition to avoid shrinking and warping and to resist heat. The metal covering may be ordinary galvanized sheet steel of #26 gauge, but in the best work #20 to #24 gauge furniture stock steel is used which has been smoothed and re-leveled to avoid all waves and pits in the surface. It is drawn or pressed on the frame and panels and fastened to the wood with waterproof glue to prevent buckling. The joinings in the metal are welded or soldered and smoothed so that no trace of seam remains. The panel mouldings are usually of drawn or extruded metal forming independent members attached by screws, although some manufacturers draw the moulding as an integral part of the stiles and rails. The wood core is sometimes covered with asbestos paper to resist the high heat conductivity of the sheet metal. Wood door trim, frames and bucks are covered with steel in the same way. Bronze and copper-covered doors are similarly fabricated, with #14 to #20 gauge bronze and 16 to 32-oz. copper on the doors and jambs and #23 gauge bronze and 14 to 16-oz. copper on the mouldings and trim. The joints are placed on the inside of the stiles and rails. Where butt joints occur they are brazed directly to a bronze plate under the joint and smoothed to render them invisible. Extruded mouldings are used with the best types of bronze-covered doors.

**Metal-covered Windows.** Wood window sash and frames may be covered with sheet steel or bronze in the same way as the doors, but for fireproof construction they have largely been replaced by hollow metal and solid steel sash. Very beautiful bronze-covered sash and frames are made, however, for monumental buildings.

**Hollow Metal Work.** Hollow metal construction threatened at one time to take the place of metal-covered work because of its superior workmanship and durability. The great improvements in material and fabrication of metal-covered doors of late years have, however, maintained them as a rival in fireproof construction. Hollow metal construction consists of heavy sheet steel drawn or joined by seams into hollow shells of the required shapes to form door stiles and rails and window sash. Drawn mouldings are also made to accompany this type, thus forming a distinct method of producing fireproof doors, sash and trim without wood cores or other backing.

**Hollow Metal Doors.** The stiles and rails are formed from single sheets of #18 gauge steel drawn through dies to the required shapes with all joints and miters made by continuous welds. The panel mouldings are generally electrically welded to the stiles and rails. Cork strips are inserted in the stiles and rails to deaden the metallic ring of hollow metal. The panels are of #20 gauge steel and are lined on the inside with  $\frac{1}{4}$ " asbestos. The joints are fitted, reinforced, welded and dressed down to produce invisible connections. Where hinges and locks are to be attached, the metal is reinforced on the inside with welded steel

plates. None but the best furniture stock patent leveled steel should be used, so that the surface will be free from waves or buckling. After the doors are thoroughly cleaned from rust, grease and other impurities they are given six or eight coats of enamel paint, all coats being baked on in ovens at 300° F. After baking, each coat is smoothed before the next is applied, and the final coat is rubbed to a dull gloss. The surfaces

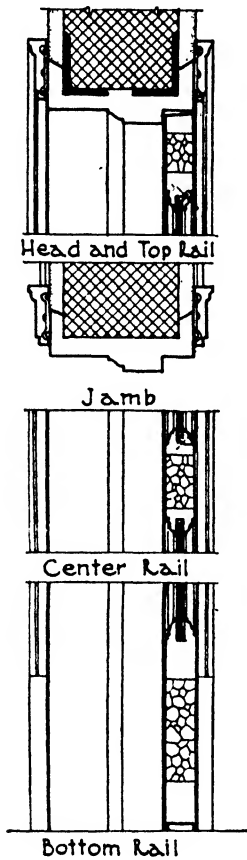

FIG. 7.—Hollow Metal Door.

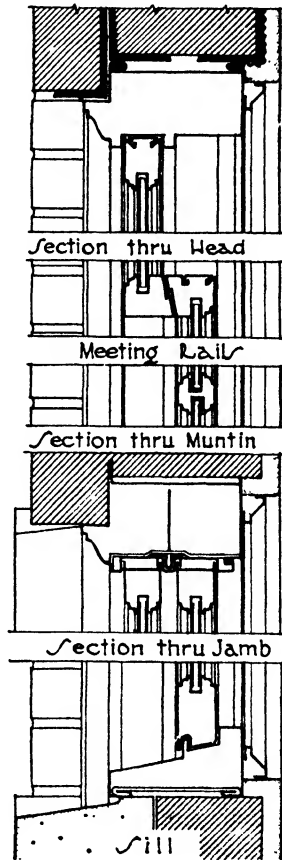

FIG. 8.—Hollow Metal Window.

can be finished with a solid color or may be grained to imitate natural woods (Fig. 7).

Bronze doors are constructed likewise of hollow members but in a somewhat different manner. The stiles and rails may be formed from bronze tubing or may be built up of plates. The tubing is either extruded or drawn. All joints are reinforced with a bronze plate against which



the seams are brazed and smoothed to an invisible finish. The mouldings are extruded and applied with screws. Ornaments may be either extruded or cast.

**Cold-drawn Mouldings.** It has been found that by drawing the metal cold through dies much sharper and more clean-cut outlines can be obtained than by pressing or hot rolling. The best type of architraves, cornices, mouldings and all other details necessary for interior trim doors and windows are now drawn in this way, which is called the cold-drawn or cold-rolled process.

**Hollow Metal Windows.** This type of double-hung window has now been standardized through the efforts of the Board of Fire Underwriters so that when the label of approval of the Board is placed upon a window its construction and protecting qualities may be trusted. All windows built according to the specifications of the Board are called **LABELED WINDOWS** and are designed to be as fire-resistant as practical considerations will permit. The stiles and rails are hollow and are formed integrally with the glass mouldings. The sash are glazed with wire glass in particularly hazardous locations such as elevator shafts, air shafts, courts and over the roofs of adjoining buildings. The materials used are galvanized iron and copper-bearing steel. Galvanized iron has been found to corrode; consequently the best windows are now made of copper-steel or pure iron, called toncan or ingot iron, and last much longer. Average windows are constructed of #24 gauge iron and a better type of #16 gauge. The sash are made tight by projecting fins engaging in grooves in the frame. The pulley stiles are made removable and are reinforced with heavy metal to carry the pulleys. The inside of all sash and frames should be painted before assembling. The joints are welded or soldered, and the sill should be filled with cement. Sherardized steel is used for the sash chain, and the pulleys are iron with bronze axles (Fig. 8).

**Solid Steel Industrial Windows.** A wide range of windows with sash, frames and sill constructed of solid steel is manufactured for large expanses of glass in industrial, commercial, educational and institutional buildings where movable sections are combined with fixed lights. They differ in type depending upon use and are classified by the Simplified Practice Recommendations of the Department of Commerce as follows:

1. **PIVOTED WINDOWS.** Both vertically or horizontally pivoted sash are very generally used as ventilating sections in industrial buildings and power houses. They are the cheapest in first cost and are combined with fixed sash to form complete windows. The sash pivoted at the center of the sides are most often employed (Fig. 9,a).

2. **PROJECTED WINDOWS.** This class includes sash hinged or pivoted at top or bottom to project entirely outward or inward. The sash are rated as Commercial and Architectural, and they are suitable according to type for factories, shops, schools and institutions. They act as ventilating units incorporated with fixed sash (Fig. 9,b).

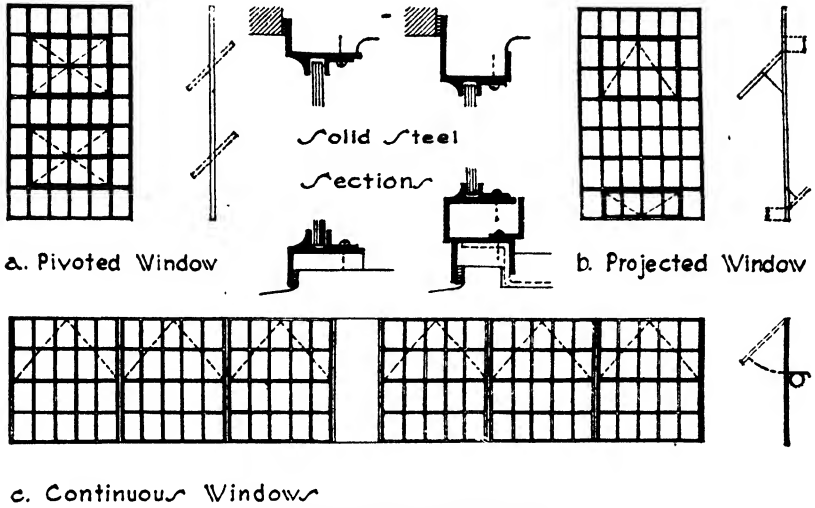

FIG. 9.—Steel Industrial Windows

3. CONTINUOUS WINDOWS. These windows consist of a series of adjoining sash arranged to be opened and closed in sections. They are intended for use in the monitors, long skylights and saw-tooth roof construction of power houses and industrial plants. The sash are hinged at the top and are built of heavy sections (Fig. 9,c).

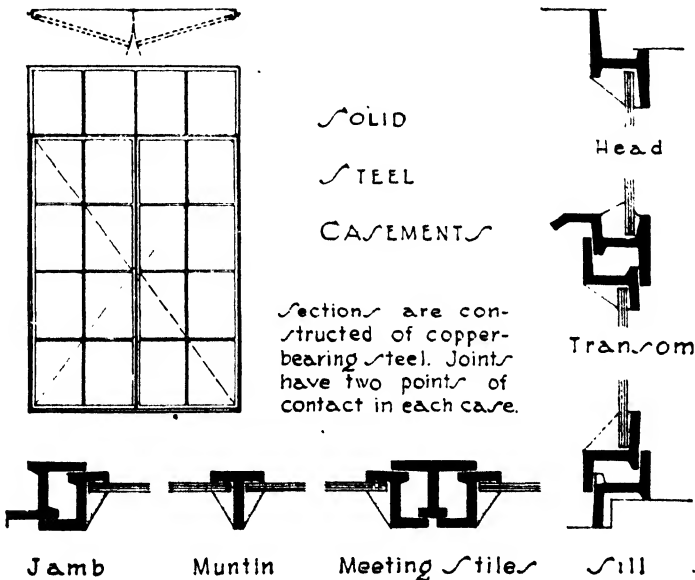

FIG. 10.—Steel Casements.

4. **BASEMENT WINDOWS.** Steel windows are much used in the basements of residences on account of their non-sticking and non-swelling properties.

The movable sash of the first three classes are furnished with mechanical operators of the rack-and-pinion, worm-and-gear or tension type, depending upon the method of hanging the window. The operators are generally worked by hand, but electric motor control is also used when the sections to be moved are heavy and cumbersome.

**Solid Steel Casements** (Fig. 10). Sash hinged at the sides to open out or in have been developed for use in hotels, churches, apartments and residences. Their design was originally based upon the old iron sash and leaded glass windows of Europe, but the designs of the present day include many thoroughly modern types. The sash and frames are constructed of copper-bearing steel of specially rolled sections which fit each other so as to form weatherproof joints, generally with two points of contact all around. The corners are electrically welded and smoothed. The window is cleaned free from rust and scale and given two shop coats before erection. The hardware is usually of solid bronze except the hinges which are sometimes sherardized steel. Mullions, transom bars and leaded glass are readily combined with steel casements, and steel sash fly-screens can be adapted to the frames. Non-corrosive and non-staining window sills are now made of cast and of extruded aluminum which does not require painting.

**Solid Steel Double-hung Windows.** The sash consist of flat steel bars which slide in slots in the frame. The material is #12 gauge blue annealed steel, and all joints are welded and smoothed. The sill, meeting rails and head are fitted with flexible metallic weather stops, and the vertical guides and sash members are provided with interlocking stops within the boxes. The steel is painted and not galvanized. Sash chains are galvanized steel, and the weights are single unit castings. This type of steel window has become very popular in modern skyscrapers because of its flat appearance and weather tightness.

**Solid Bronze Windows.** Double-hung and casement windows can be obtained at moderate expense for installation in the better type of buildings of every class. The improvements in the production of bronze, nickel and aluminum shapes, especially by the extruded method, have made possible the fabrication of windows of these materials. The extruding process consists of forcing semi-molten billets through steel dies and thereby forming profiled sections of great uniformity and precision. All parts of the window are made by special dies of extruded bronze producing accurately matched wedge-shaped tongues and grooves which effect positive multiple contacts throughout the perimeter of the sash. The sash of double-hung windows generally have an extruded section open at the back, but the casements often have tubular or closed sections of drawn metal. The pulleys of the double-hung windows are of bronze, and the sash chains are galvanized and bronze plated.

Interior trim of bronze is also fabricated for these windows, and the whole installation is very weather-tight and pleasing in appearance.

Aluminum and nickel double-hung and casement windows are manufactured according to the same details as the bronze windows.

**Store Front Construction.** In modern stores and shops it has become the custom to make the entire front of the store in one or more large windows with lights of plate glass from 6'0" to 10'0" in width and 7'0" or 8'0" in height and often with other lights or transoms 3'0" or 4'0" high above them. The window usually rests on a framed or masonry base called a bulkhead. As the desire of the merchant is often to have as much glass as possible, the columns which support the wall above are usually placed as far back from the face of the wall as possible and the glass is set flush with the wall line and in front of the columns, thus giving a wide expanse of glass unbroken except by the entrances. Such large sheets of plate glass are very heavy and were formerly held by wood frames sometimes reinforced with steel angles and tees. Present practice, however, is to use small cast-iron shapes often moulded or ornamented, or to employ steel reinforcement covered with hard copper mouldings which hold the glass in place. Bronze mouldings and transom bars are also used in the most expensive work in connection with the copper sections holding the glass. By these methods the width and depth of the frame are reduced to a minimum, and the appearance of the whole front is greatly improved. The copper mouldings which hold the glass can be adjusted by set screws. The bottom of the glass rests on cushions made of felt or other resilient material. The condensation of moisture on the inside of the glass is caught in gutters and drained by tubes to the outside. Sometimes the transom bar is of wood covered with copper, and the glass is set in hard copper mouldings screwed to wood backing. A space is often arranged back of the frieze of the transom bar for the roller of an awning to shade the show window. Electric lights of special design are also installed in metal frames at the floor and ceiling of the show window space to light the goods on exhibition (Fig. 11).

**Special Steel Doors.** Three types of special steel doors should be given consideration: rolling, sliding and counterbalanced doors.

**ROLLING STEEL DOORS** are used at loading platforms and show windows and in warehouses and freight stations. They are also employed as fire-doors within buildings. The construction consists of interlocking steel slats coiled upon a drum at the top of the opening and traveling in steel guides mounted at the sides. The door is counterbalanced by means of helical springs enclosed in the drum, and a hood of steel protects the drum from the weather. When the openings do not exceed 100 ft.<sup>2</sup> in area the door can be pushed up and down in the same manner as a window shade, since it is counterbalanced by the springs in the drum. For heavier doors a reduction gear and endless chain is used, or a

shafting, gear and crank. Electric motor operation is also installed where a series of doors are operated at the same time.

COUNTERBALANCED STEEL DOORS are widely used at the openings in freight elevator shafts. They are divided in two halves horizontally, the upper half sliding upward and the lower half downward along the inside face of the shaft. The door sections are hung by steel chains over ball-bearing sheaves and slide on guide rails at the sides, no counterweights being necessary. These doors may be operated by hand or by electric motor and are provided with safety controls and interlocks.

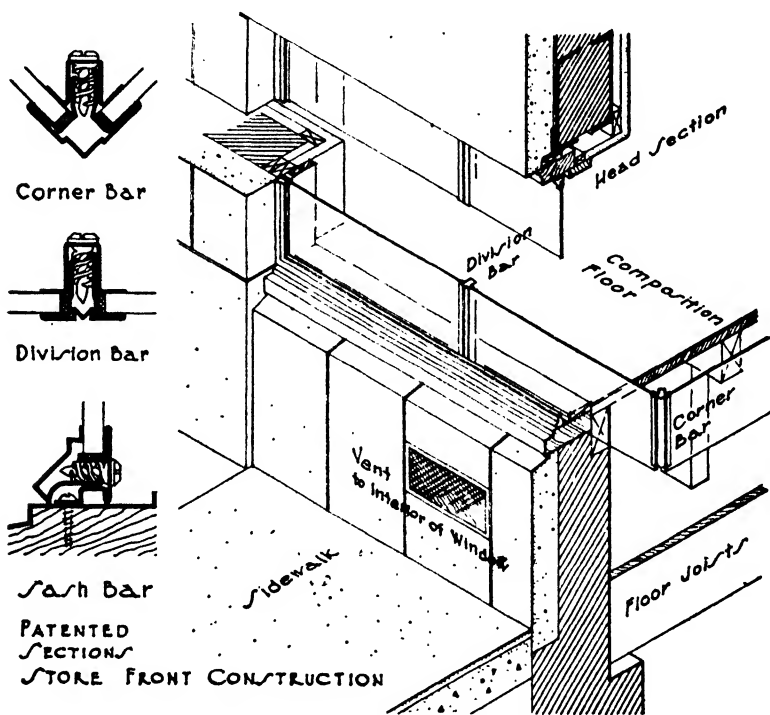
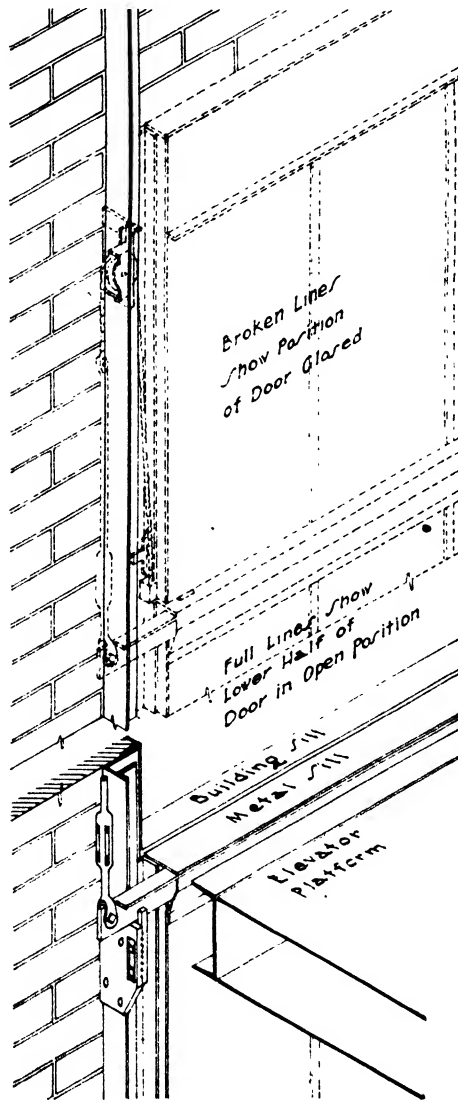

FIG. 11.—Store-Front Construction.

One type of counterbalanced door is furnished with a truckable sill. This sill consists of a heavy bar fastened to the top edge of the lower half of the door which always comes to rest just level with the floor. The bar is also supported upon heavy stops bolted to the guide rails, and it bridges the gap between the floor saddle and the elevator car, thus providing a smooth passage for trucks (Fig. 12).

SLIDING STEEL DOORS are much used for the openings in elevator shafts and to a less extent in other locations where swinging doors are impracticable. Elevator doors are usually of hollow metal; they are suspended from the top by hangers equipped with ball-bearing wheels

rolling upon a horizontal track. They may consist of one leaf or of two, three or four leaves, the one- and two-leaf being the most common.



Patented Counterbalanced Doors

FIG. 12.—Counterbalanced Door.

The two-leaf type consists of two units which may slide behind the wall of the elevator shaft on opposite sides or on the same side of the opening.

In the latter case the two leaves slide past each other, one moving at twice the speed of the other. In both types the leaves are arranged so that both will open when one is pulled back. The functioning of elevator doors has been highly perfected to prevent the opening of the doors when the car is not at the floor level and in other ways to insure the safety of the passengers.

Steel and metal-clad doors are also used at openings in fire-walls. They are hung on an inclined track and will automatically close when released by the melting of a fusible link due to the presence of fire.

## CHAPTER XIV

### EXTERIOR AND INTERIOR TRIM

#### Article 1. Exterior Wood Trim

The trim on the exterior of a building comprises the finishing pieces at the cornice, eaves, gables, doors, windows, corners, base or other location which are necessary to cover the rough construction or are applied for decoration or accent. Trim is used on both wood and masonry buildings, the material harmonizing with the material of the structure. Brick and stone finish are described in Chapter V, Brick, and Chapter VII, Stone.

Upon wood frame buildings the chief points where finish is applied are at the eaves or junction of roof and side wall, at the meeting of the side wall with the masonry foundation, at the gable ends and around the doors and windows.

**Eaves.** There is naturally a great variety in the design of the eaves, for here the character of the building is strongly expressed. The projection may be wide or narrow, the rafter ends may be exposed or concealed and the style may express formality or playfulness in harmony with the mood of the architect, but in all cases the practical purpose of the eaves is to close the junction of the roof rafters with the wall construction and to dispose of the water flowing down the roof slope. A wide projection casts a deep shadow, protects the wall below and suggests bright sun and torrential rains, while the slight overhangs and flat surfaces of the New England and Pennsylvania farmhouses lend austerity and preciseness. The projecting rafters may be exposed to view as in open eaves, the spaces between at the wall being stopped with a finishing board or with masonry. The rafter ends may be cut to a curved profile and carved as in the Gothic and Renaissance periods. On the other hand a horizontal surface is often formed under the rafter ends called a *planceer* or *soffit*, and a face piece is run across the front of the rafters, so boxing them in. Boxed eaves may be developed into a classical cornice with carved and ornamented mouldings and balustrades as seen in the Colonial mansions of the Atlantic coast. A change in slope, when desired, may be made by stopping the rafters at the plate and carrying the projecting eaves upon outlookers cut to a curve on their upper edges (Fig. 1).

In all cases the water must be cared for, and the incorporation of the gutter is a very important element in all eaves designs. Sheet copper or



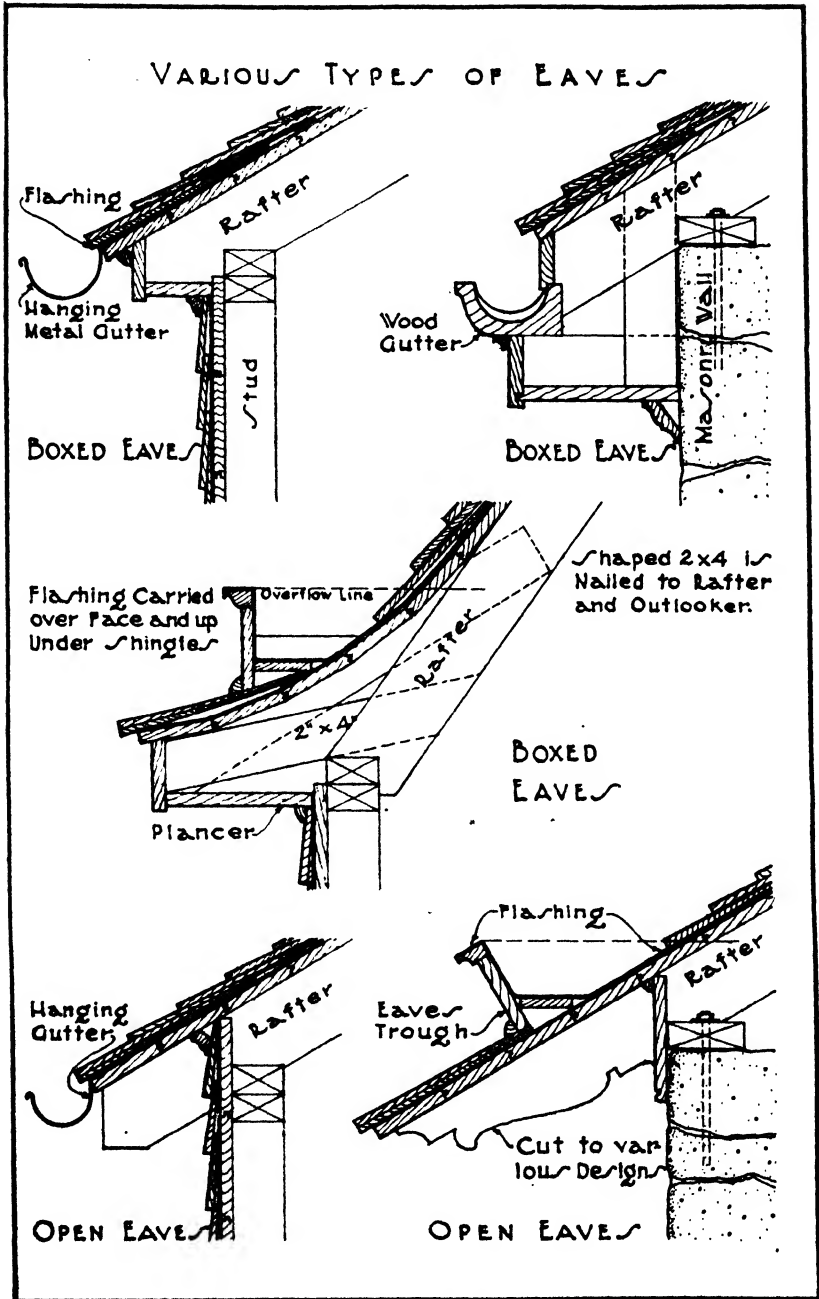

FIG. 1.—Eave Construction.

lead gutters may be hung under the edge of the eaves, or troughs of wood lined with metal may be erected on top. In formal cornices the crowning moulding may be hollowed out to form the gutter. The water is led away through vertical rain leaders or conductors of copper, lead or wood and so drained into the ground. The leaders in frame construction are usually fastened to the outside of the wall and, if properly placed, contribute acceptable vertical accents on the façades. Gutters and leaders are more fully described in Article 7, Chapter XI.

**Water Tables.** At the bottom of wood walls and just above the masonry foundations there should be an offset to act as a finishing piece for the wall and throw the water away from the masonry. The top of the water table should be flashed up under the wall siding. Water tables are not used on shingled walls, but the shingles are some-

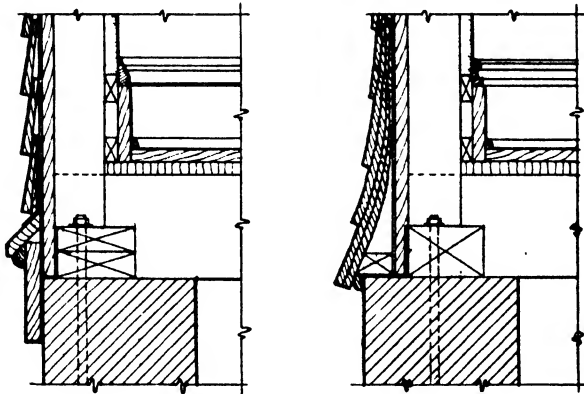

FIG. 2.—Water Tables.

times curved slightly outward at the base of the wall to throw off the water (Fig. 2).

**Gables.** The variety of methods for finishing the gable ends is nearly as great as that of designing the eaves. With a classic cornice the crowning mouldings may be carried up the rake of the gable in the same manner as a classic pediment. When the eaves are simple boxed or open eaves the gables are finished with pieces called **BARGE BOARDS** or **VERGE BOARDS** following the slope of the gable. In the Gothic these boards were often heavily carved and ornamented (Fig. 3).

**Corner Boards.** A wall covered with clapboards or siding must have vertical boards at the corners against which the clapboards are finished. The width is a matter of design, generally 3" to 6" wide at salient corners and 2" to 3" wide at re-entrant angles. The finish may be made in the shape of pilasters.

**Belt Courses.** Horizontal members across walls and gables are sometimes desired. The upper surface projects over the lower to give a line

of shadow and to shed water. The manner of arrangement depends upon the style of the building.

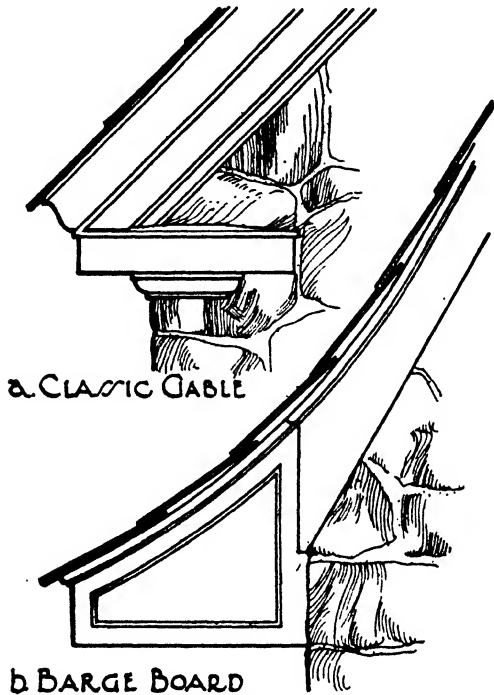

FIG. 3.—Wood Gables.

**Half-Timber.** During Gothic days in France and England the heavy framing timbers were left exposed upon the exterior and the spaces between them were filled in with brick or stucco. To gain this same effect at the present day and to insure against leaking joints,  $1\frac{1}{4}$ " boards are applied to the outside of the wall construction and have no functional purpose. They are used especially with stucco finish. In very cheap work the wood strips are nailed to the sheathing and the stucco brought against them with flashing between (Fig. 4, *a*). In better work the strips are thick enough to be rabbeted on the edges. The stucco is worked into the rabbets so that no crack appears if the wood should shrink.

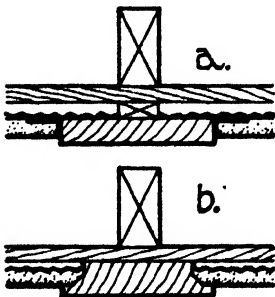
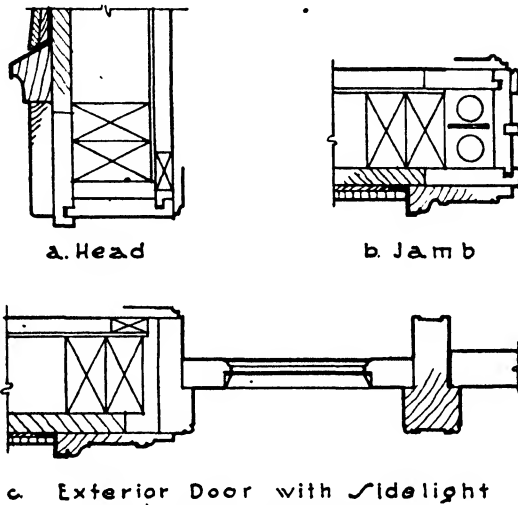

FIG. 4.—False Half-Timber.

The thickness of the half-timber strips is proportioned to their width to prevent warping and curling (Fig. 4, *b*).

**Door and Window Trim.** Exterior door and window trim for wood frame construction may have the same elaborateness of detail as interior trim but in general it may be said to be of more sturdy character. The trim or architraves are usually in one piece, since built-up members do not stand the weather and therefore cannot be used in exposed situations. They may have a perfectly plain outer face or may be moulded with much refinement to suit the type of architecture. The outside sheathing is nailed over the studs and is flush with the outside casing of double-hung window frames. The exterior trim is applied on top of the sheathing and covers its joint with the frame. The thickness



a. Head  
 b. Jamb  
 c. Exterior Door with Sidelight  
 FIG. 5.—Door and Window Trim.

of the trim should be sufficient to receive the shingles or siding which is nailed to the outside of the sheathing. The back moulding of the architrave is often flashed with sheet copper back under the siding or shingles (Fig. 5).

**Selection of Wood.** It is very important that the wood selected for exterior trim should be capable of standing dampness and hot sun without warping, shrinking, swelling or checking. For this purpose Eastern white pine was the most satisfactory wood, but since its virtual disappearance from the market, cypress and California white pine are considered the best substitutes in the East. Redwood and Douglas fir are likewise used on the Pacific coast.

**Article 2. Exterior Metal Trim**

Sheet metal has long been used for cornices, panels and the covering of walls and columns but always rather with a feeling that it was a cheap substitute for something better. In the employment of gal-

vanized steel durability was certainly sacrificed to cost, for the metal was corroded by rust in a few years and for color it depended upon paint which quickly disappeared. The use of the permanent metals, copper, lead, aluminum and chromium, has, however, been particularly developed in recent years for exterior facing, to attain lightness of weight and economy of space and to fulfill the requirements of design.

**Copper.** In the use of sheet copper a perfect sincerity can be claimed because it is a metal of great permanence and of characteristic quality and, consequently, is worthy of treatment as a distinct material. It has been so treated for generations in company with its alloys, bronze and brass, and until the present day has contributed more than any other metal to the creation of distinctive metallic profiles, contours and details. Copper is extremely flexible and ductile and can be bent to the sharpest angles and the most subtle curves. Its color upon exposure to the atmosphere changes from a bright reddish yellow to bright and dark greens and soft rich brown. For cornices, gutters, moulded belt courses, cresting and panels the hard type of copper is best adapted; soft copper is preferred for roofing sheets and flashing. Cornices and panels are attached to masonry and braced in position by wood or bronze brackets, and stiffening rods may be introduced in the more projecting portions, allowance always being made for expansion and contraction under change of temperature. Weights of 16 oz. to 20 oz./ft.<sup>2</sup> are most satisfactory for exterior trim. Copper is employed in modern treatments of tall buildings as spandrel panels and window trim. It may be treated by acids to assume a variety of shades of green.

**Lead.** This soft, heavy but very enduring metal shares with copper an early recognition of excellent natural adaptability to architectural requirements. It melts readily and casts extremely well and is therefore an excellent metal for the fabrication of ornamental finials, leader heads, spandrels, gutters, leaders and crestings. It weathers to a soft gray, non-staining patina which assists in bringing out the true value of adjacent materials. Lead is heavier than other sheet metals and its weight must be considered in designing the structural frame if considerable quantities are used. Metal weighing 2½ and 3 lbs./ft.<sup>2</sup> is recommended for sheets, and the weight of castings is naturally greater.

**Aluminum.** It was not until 1890 that aluminum became obtainable for commercial use through the discovery of the electrolytic process of reducing bauxite ore. Aluminum is produced in sheets, bars, rods, wire, structural shapes, mouldings, screws, castings and forgings. Therefore the same metal can be used for a variety of related purposes, thus eliminating the necessity of employing dissimilar metals in juxtaposition with possible electrolysis as a result. It is light and strong, easily worked and very resistant to corrosion. A variety of surface finishes is possible, either polished with great reflectivity, sand or "Carborundum" blasted with a gray etched surface or wire-brushed with a satin sheen. Certain aluminum alloys have a tensile strength of

60,000 lbs./in.<sup>2</sup> comparable to mild steel, and their weight is about  $\frac{1}{3}$  that of steel. In recently built tall buildings cast aluminum spandrel facings have been largely used because they are free from warping, easily ornamented, light in weight, convenient to handle and capable of receiving a variety of lasting finishes. These facings are supported by brackets to the steel frame, are turned in under the sill of the window above and set over the head of the window frame below, the joints being caulked all around. They thus protect the brick or terra cotta spandrel walls from the penetration of dampness, these walls being made as thin as the building laws allow. Insulating materials only 2" thick, such as rock wool and magnesia, have been developed for use in connection with sheet metal spandrels, which have as much insulating value as a 12" masonry wall and save very appreciable amounts of space and weight. On the exterior the spandrels may be finished to tone in shade with the windows or may be polished to reflect the light as determined by design. Aluminum may be joined by welding, riveting, screwing or bolting.

**Chromium.** Chromium has come into general use in the manufacture of alloy steels and for plating. It is an extremely hard metal, takes a high polish and does not corrode or tarnish in the atmosphere. For these reasons it has been much employed as a plating on steel, but like all platings it can be economically deposited only in very thin layers and has a tendency to peel. When combined with nickel to form chrome-nickel steel, sometimes called stainless steel, an alloy is formed which casts well, is malleable and ductile and may be rolled both hot and cold. It retains the properties of chromium in that it is hard, does not corrode or tarnish and is susceptible of a high polish. Since it is of the same composition throughout, there can be no peeling or wearing away of the brilliant surface. The stainless steels are taking the place of chrome plating for the bright work of motor cars, and in modern architecture are used for exterior window trim, panels and facing. For exterior finish the sheets are usually #8 gauge or about 1/20" thick. The window trim as used on the Empire State Building in New York by Shreve, Lamb and Harmon, the architects, was formed of chrome-nickel steel sheets sufficiently long to run a full story height. They were angle-braced and attached by straps to the structural frame. Where necessary to join the vertical sheets, the upper length was superimposed over the lower with a shingle lap. The trim is caulked at its junctions with window frames and spandrels as well as with the stonework. The finish is highly polished.\*

### Article 3. Interior Wood Trim

**Introductory.** Wood has been used for the interior finishing of rooms for very many generations. The Romans preferred colored plaster or

\* R. H. Shreve, *Architectural Forum*, July, 1930.

marble slabs, as may be seen in Pompeii and Herculaneum, but from the Middle Ages to the present day wood has been employed as a wall covering and as a trimming material in all centuries. Carved wainscoting was brought to great perfection during the Gothic period and the Renaissance, entire wall surfaces of masonry being faced with highly decorated wood panels ingeniously contrived to avoid splitting in case of shrinkage or expansion.

At the present time wood is used in built-in interior work as a trim around doors and windows, as a border at the junction of walls and floors and as wainscoting, bookcases, cupboards, shelving, cabinets and dressers.

**Selection of Wood.** To produce a satisfactory painted surface a wood must be clear, without knots, and have a fine grain. It must stand without shrinking or warping and be free from sap and pitch. Eastern white pine has for years been preferred for painted trim because it best combined the above requirements and because it was also soft and easy to work without splitting. It has now become very scarce and several woods with similar characteristics are used as a substitute, such as basswood, poplar, whitewood, sugar pine, gum, redwood and California, Idaho and Ponderosa pine. None of these woods works as easily as white pine, and the Idaho and Ponderosa pines are difficult to obtain in clear pieces. They give, however, the effects sometimes desired in pine paneling with natural waxed finish. As these woods are all rather soft, birch is often used in good construction for mouldings and carving to resist denting upon edges and arrises.

For wood with natural finish, that is unpainted but stained, oiled, varnished or waxed, the hard varieties with decorative grain are most often used, such as oak, walnut and mahogany. Redwood, although a soft wood, is very popular in the West for natural finish because of the facility with which it responds to the action of stains producing a large range of curious effects. White pine has always been liked for the soft warm tones which it acquires with age. In modern work it is usually slightly stained to imitate the mellowness of time and then waxed.

All wood for interior trim must be thoroughly kiln-dried to withstand our dry artificial heat. It should never be installed until all plastering is thoroughly dried out and the moisture content within the building generally is as low as the content in the woodwork. There are many instances of imported antique paneling and furniture which have stood in perfect condition for centuries in the very moderately heated buildings of Europe, warping, cracking, shrinking and falling to pieces in a few months when subjected to the extremely desiccating influences of steam, hot-water and warm air in this country.

**Workmanship.** Until the days of machines interior woodwork was fabricated by hand by highly skilled workmen called joiners, whose trade was entirely distinct from that of the carpenters. To be acceptable the paneling and trim must have perfect surfaces, contours and profiles.

and above all must be so put together that the joints are not apparent, the methods of erecting are unseen and the panels are free to shrink and swell without splitting or warping.

In our day and in this country interior trim is manufactured largely by power in planing mills and factories. The wood is surfaced and the mouldings cut by machines, but the assembling of the parts and the erection in the building are still handwork, and, although our joiners are seldom the experts they once were, they should certainly be given the credit of belonging to an especially skilled class of workmen.

When trim, paneling, mantels, bookcases and cabinets are put together in the shop ready for erection in the building, they are smoothed and sand-papered before delivery. In the less expensive work, however, when the trim consists solely of door and window architraves and baseboards, it usually arrives at the site in the condition it left the planer with machine and tool marks still evident upon its surfaces. The pieces under these circumstances are scraped and sand-papered, cut, fitted and erected by carpenters in the building. Although such work does not constitute a separate trade, most contractors have special men who are particularly skillful in the nicer and more exacting types of carpentry.

**Joints.** Joinery in this country is generally designated as cabinet work, and its basic elements are the construction of the joints and the panels. The joints should be tight, delicate and inconspicuous, the character of the joining marking the real difference between cabinet work and carpentry. End wood, that is wood showing grain on edge, should never be seen, and resistance to shrinkage must be maintained.

**BUTT JOINT.** This is the simplest joint but should not be used because it is not strong and opens with shrinkage. When made at an angle it shows end wood (Fig. 6,a):

**TONGUED AND GROOVED JOINT.** Also called matched lumber. A tongue is formed on the edge of one piece and a groove in the edge of the other, the tongue being driven into the groove. This joint holds the surfaces flush and prevents warping. It shows an open joint upon shrinking but is much used as matched flooring. When employed for sheathing or ceilings a bead is often worked alongside the tongue so that if the joint opens it presents an appearance of two grooves, one on each side of the bead (Fig. 6,b).

**SPLINED JOINT.** The two abutting edges are grooved and a separate strip of wood called a spline is forced into the grooves holding the two pieces together and preventing warping, the spline being sometimes glued in place. This joint is superior to the tongued and grooved joint for pieces of small dimensions (Fig. 6,c).

**DOWELS.** Two pieces may be held together by round wooden pegs driven into holes bored at intervals in the edges of both pieces. The dowels are usually glued in place and a strong joint results (Fig. 6,d).

**MITERED JOINTS.** At corners of door and window frames the pieces are cut at an angle of  $45^{\circ}$  which permits a perfect intersection of the



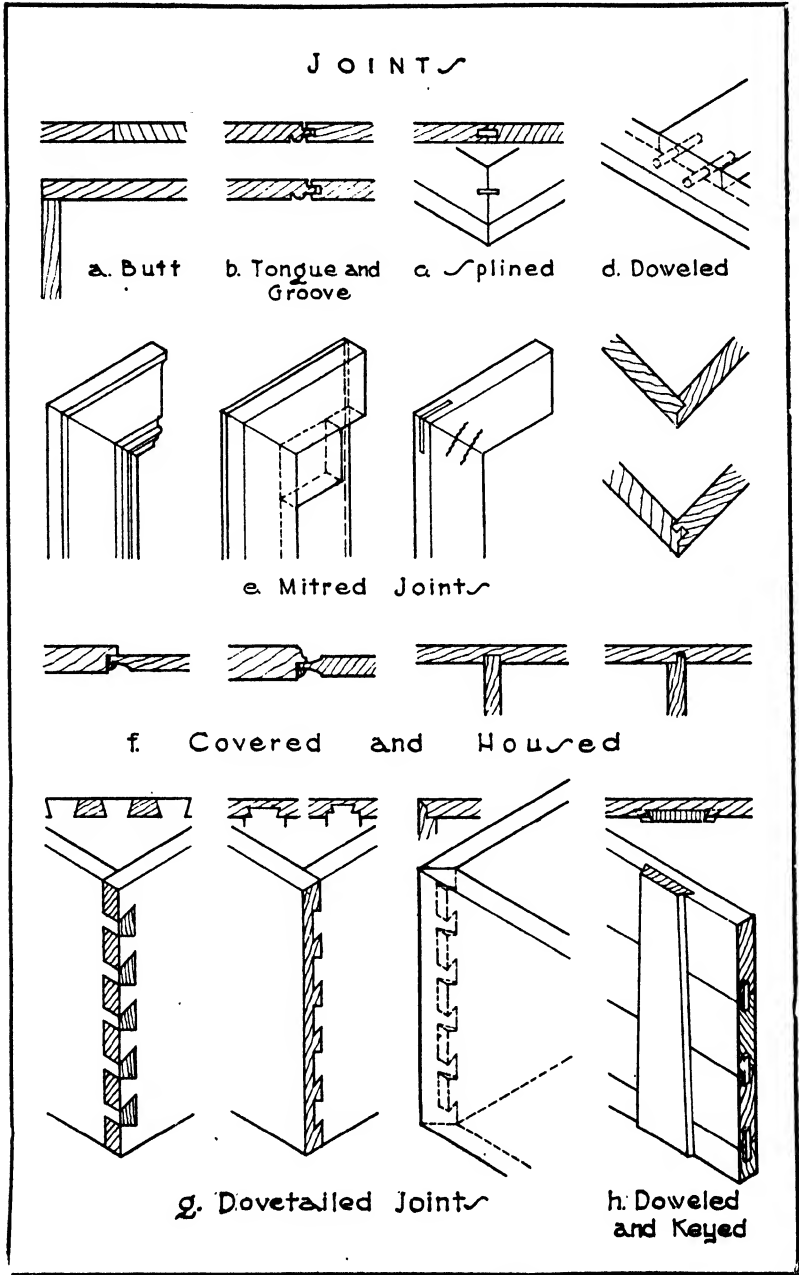

FIG. 6.—Joints for Cabinet Work.

face mouldings and a balanced joining of the frame. Mitered joints are liable to open through shrinkage, unless held together by special means, such as splines and dowels, glued blocks on the inside of the angle or miter brads. These last are corrugated strips of steel driven into the back of the frame across the miter joint. It is well to use splines together with the miter brads to keep the joint from warping. The mitered edges may also be cut with rabbets or tongues and grooves to hold the pieces in place (Fig. 6,e).

**COVERED AND HOUSED JOINTS.** In the fitting of panels into their frames it is necessary that the panel should be free to move in the frame without showing an open joint. This is accomplished by using covered and housed joints. The panel is set into a rabbet in the frame and held in place by a strip fastened to the frame forming a covered joint, or is set into a groove in the face of another piece when it is called a housed joint. The latter is always used in window frames and in letting stair-treads and risers into strings (Fig. 6,f).

**DOVETAILED JOINTS.** These joints connect two pieces at an angle and consist of wedge-shaped mortises and tenons. They are used particularly for connecting drawer fronts to the sides. The same dovetail in each piece shows end wood unless the front is covered by a moulding. A lapped dovetail is common which shows no end wood on the front of the drawer. A mitered or secret dovetail is a combination of a mitered joint and a dovetail and shows no end wood on either side (Fig. 6,g).

**GLUED AND BLOCK JOINTS.** Many pieces are merely glued together with blocks behind the joint to stiffen the connection. Much glue is used in cabinet making, but it is better not to depend entirely upon it when making joints, without the assistance of splines, dowels, mortises or dovetails. The layers of laminated wood and veneers are, however, held together entirely with glue.

**DOWELED AND KEYED.** When flush surfaces are required too wide for a single piece without warping, several widths are doweled together and a tapering length of kiln-dried hardwood with beveled edges, called a key, is driven tight into a dovetailed groove across their backs. The key is not glued and permits the boards to expand and contract although maintaining them in the same plane. When it is desired that a wide surface appear as one piece of wood, a backing of white pine is glued up, doweled and keyed as just described and one or two thicknesses of veneer are glued over the entire face (Fig. 6,h).

**SCRIBING.** Cutting a strip of wood to fit against the contour of a moulding or any uneven surface such as plaster or wood is called scribing. The contour may be obtained by holding the board against the uneven surface and passing one point of a carpenter's compass along the irregular contour. The other point of the compass will mark the exact profile upon the board.

**Mouldings.** The profiles of mouldings are generally designed in full size by the architect, and these profiles are followed exactly in the

planing mill by adjusting the knives in the machine to coincide with the outline desired. There are, however, a series of stock mouldings which are run in all mills and kept always on hand in varying dimensions. The profiles most generally found in the mills are given the following trade names irrespective of the exact contour: Half-round, quarter-

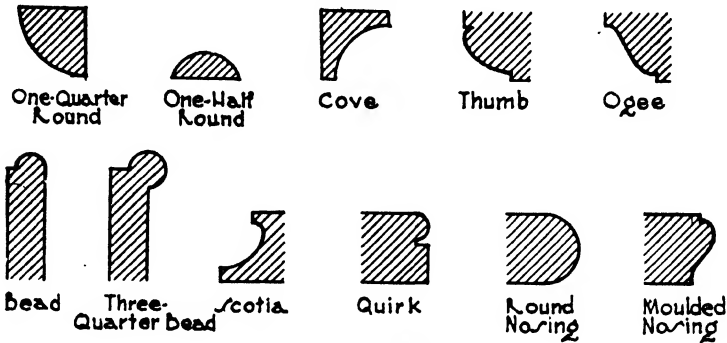

FIG. 7.—Wood Mouldings.

round, cove, thumb mould, ogee, bead, three-quarter bead, scotia, quirk, round nosing, moulded nosing (Fig. 7).

**Base Board.** (Fig. 8,*a*.) The two types of trim generally used even in the simplest construction are the baseboard and the door and window

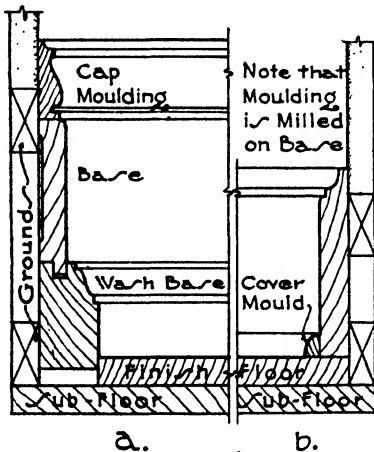

FIG. 8.—Base Board.

trim. The base or baseboard is the piece skirting the wall just above the floor. It covers the termination of the plaster and makes a transition between the floor and the wall. When 8" or less in height it is usually in one piece but if higher is often formed of several pieces to avoid warping. A sub-base or washbase of hardwood with natural finish is sometimes added in office buildings and public places to receive the rough usage incidental to washing floors. The base should be nailed to the grounds before the finished floor is laid. A wide base is often nailed to the upper ground only and allowed to have play at the lower ground. It is held in place at the bottom by the finished flooring or by the washbase. Quarter-round and cove mouldings called cover moulds or carpet strips are sometimes used to conceal the joint between the base and the flooring. They are ugly and only serve to hide bad workmanship. The back of the base is often ploughed out to prevent warping (Fig. 8,*a*).

**Door and Window Trim.** The door trim, also called door casing, covers the termination of the plaster and the rough door buck or frame. There are many varieties but that which is mitered at the corners is most satisfactory. A fairly narrow trim without much projection of moulding is usually in one piece. For a strong projection it is more economical and less likely to cause warping if the main moulding be rabbeted onto the casing. The back of the trim should be ploughed to resist warping, and ploughing is often done to the projecting edge to give a lighter appearance and avoid blockiness. The casing should have sufficient projection to receive the base and the cap of the wainscoting. Plinth blocks act as a base for the casings and avoid carrying their sharp mouldings to the floor. They are thicker and have simpler outline than the casings but follow the general contour (Fig. 9, *a, b*).

Window trim is the same as the door trim except that, when the window opening does not extend to the floor, the trim finishes upon a horizontal shelf called a stool. The termination of the plaster below the stool is covered by the apron. With masonry walls a board called a jamb casing connects the window frame with trim and covers the rough wall. This casing is paneled when too wide for one board (Fig. 9, *c, d*).

**Wainscoting.** Wainscoting is the wood sheathing of a room throughout its whole height or in part only. The sheathing may be of plain matched boards, but much more often wainscoting signifies a framework built up of stiles and rails carrying wood panels. It should be put together in the shop in lengths as long as conveniently possible, ready to be erected in the building. The third coat of plaster is usually omitted behind wainscoting for economy, and sometimes all plastering is left out in order to save room. The space between the studs may be plastered flush with the face of the studs. In modern steel buildings with brick or tile walls, the masonry of the walls is often damp-proofed on the inside and not plastered. It is thought that the paneling warps less under these conditions because the plaster is liable to carry moisture for a very long time. The plastering is stopped on a wood ground a little below the cap moulding, which is delivered loose and scribed to the plastering after the wainscoting is set (Fig. 10, *a*).

In good construction the panels and frames should both be built up on white pine or chestnut cores with one or two plies of veneer on each side. The frames are composed, like the stiles and rails of doors, of 3/8"

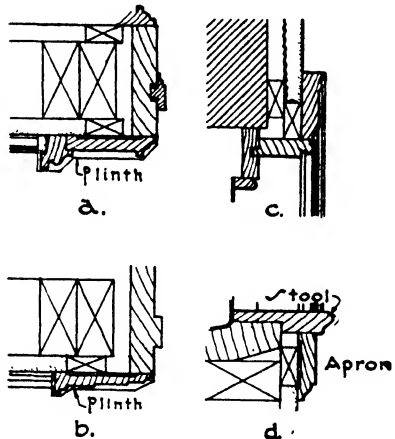

FIG. 9.—Interior Door and Window Trim.

wide strips glued together and two plies of veneer on each face. Whether the frames are solid or veneered, the panels, because of their width, should always be built up of three or five plies. The core should be of white pine or chestnut. The first ply of veneer runs across the grain of the core, the outer ply then running across the first ply and parallel to the core. The first ply on the face and both plies on the back are often of oak (Fig. 10,*b*).

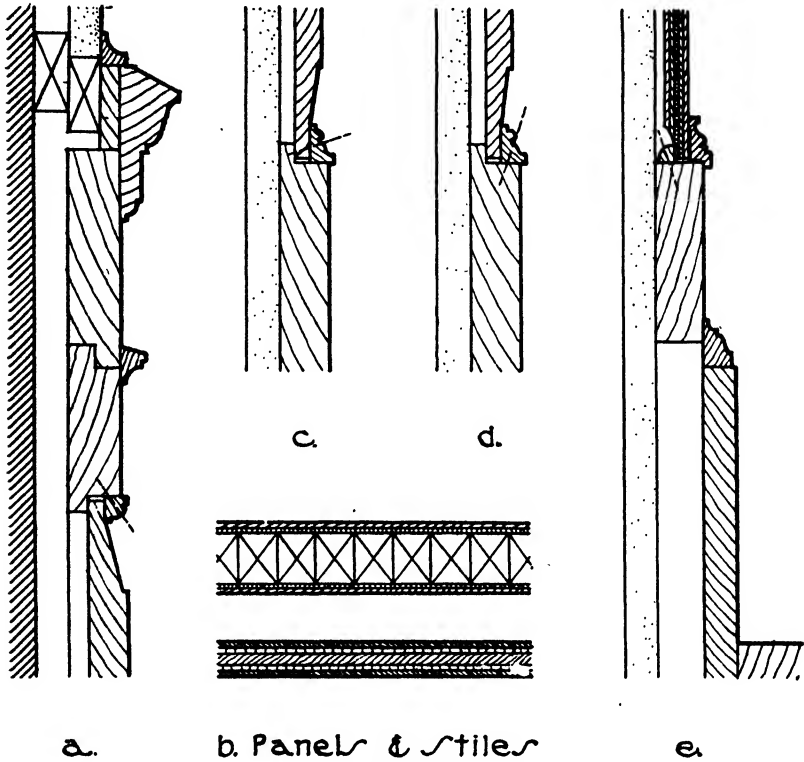

FIG. 10.—Wainscoting.

The panel is never rigidly fixed to the framework by nails or glue because, if it cannot move, any shrinkage in the wood will produce splits and cracks. The stiles and rails may be rabbeted and the panel held in place against the rabbet by a moulding nailed to the stile or rail only and not to the panel. The best method is to glue the face moulding to the framework and to secure the panel by means of a quarter-round nailed to the stile at the back. Panels are often completely stained and finished before being set, so that shrinkage will not show any unfinished surface (Fig. 10,*c,d,e*).

In recent years, plywood, pressed wood and plastics have been greatly

developed as large flat panels to cover wall surfaces. Mouldings are simple and inconspicuous and are often of metal, Chapter X, Article 2.

**Chair-Rail.** In order to protect plastering from the backs of chairs a moulding 3" or 4" wide similar to the cap moulding of wainscoting may be carried around a room about 3'2" above the floor.

**Picture Moulding.** The profile is shaped to receive standard picture hooks. Grounds should be provided behind the moulding for nailing (Fig. 11,*a*).

**Wire Mouldings.** The profile has a trough on the upper side to receive bell and telephone wires. The lower part is often combined with a picture moulding. Wire mouldings are used in the corridors of large buildings with many offices and other rooms requiring such wires (Fig. 11,*b*).

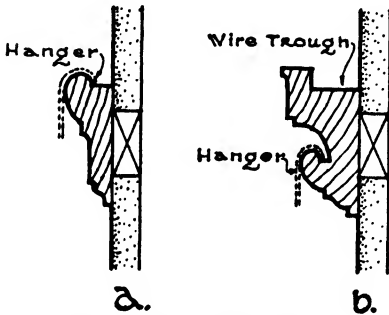

FIG. 11.—Picture Moulding.

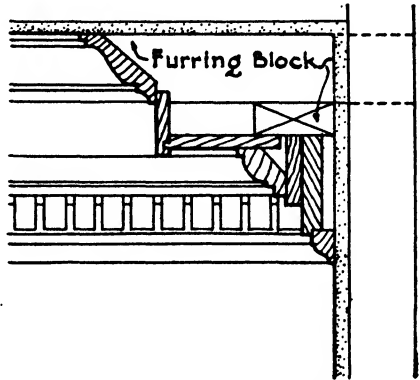

FIG. 12.—Interior Wood Cornice.

**Cornices and Beams.** Cornices and entablatures should be built up and glued together in long sections in the shop before setting in place. Blocks of white pine are fastened in the back where necessary for stiffening, and brackets or outlookers are provided on the wall to support the projecting members. All grounds and brackets are firmly fixed to the wall before plastering. Horizontal joints should be made wherever possible between members to prevent warping. The moulding next the ceiling is left loose to be scribed and fitted after the cornice is in place. The friezes of entablatures are usually veneered (Fig. 12).

**Ceiling Beams.** Unless a suggestion of rough-hewn wood is desired beams are generally built up of 1/8" material rather than cut from the solid. The building and fitting are done in the shop. Blocks and braces are provided on the inside to stiffen the beams. Strong grounds must be installed in the ceiling to receive them.

**Columns.** Columns are built up of many pieces to avoid checking and cracking. The octagonal shaft is first splined and glued together in one or two layers. When of two layers the backing is sometimes of greener wood than the face so that by shrinking it will close the joints

of the face tightly. The vertical joints are arranged to come near the middle of a flute and not on an arris. After the shell is glued and splined together it is turned on a lathe like a solid timber. The base is made of octagonal rings glued one on top of the other and then turned into shape. The capital is glued up of pieces of wood sufficiently thick to be carved. The shaft is rabbeted into the cap and base, and all three parts are left hollow in the center (Fig. 13, *a, b*).

Several special lock-joints have been patented by the manufacturers of wood columns (Fig. 13, *c*).

**Fixtures.** There are many built-in fixtures, especially in dwellings and apartments, which are a part of interior woodwork. Pantry dressers are composed of cupboards with wood doors and shelves resting on the floor, then a row of drawers covered with a counter shelf. Over the counter shelf is a cabinet for table china. The counter shelf is 28" deep and 2'8" from the floor. The shelves of the cabinet should be 14" deep and are closed with hinged or sliding glass doors.

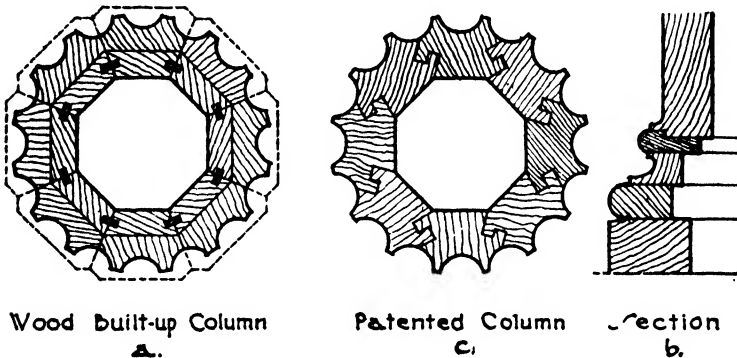

FIG. 13.—Built-up Columns.

Shallow medicine cabinets are often set in bathrooms within the thickness of the wall. The shelves should be of glass, and the door is flush with the face of the plaster and often carries a mirror. Very good medicine cabinets are made of pressed metal with enamel finish; they are now generally preferred to wood cabinets.

Bedroom closets are fitted with a high shelf for hats and a pole under the shelf for coat and dress hangers. Low shelves for shoes and compartments for gloves and umbrellas may be added.

Linen closets are sometimes furnished with drawers and shelves and sometimes with shelves only. The drawers often have open flush lattice bottoms for ventilation.

Cedar closets are lined on floor, walls, door and ceiling with red cedar  $\frac{1}{2}$ " to  $\frac{5}{8}$ " thick for the protection of furs and woollens from moths. The shelves and drawers are either lined with red cedar or built solid.

Bookcases are matters of design to conform with the type of room.

In bookcases without doors the books show to better advantage, are more convenient for use and lend their decorative quality to the room; bookcases furnished with glass doors protect the books from dust and atmospheric changes. The shelves may be fixed or adjustable and should be supported every 3'0" in their length to avoid sagging. Shelves are from 8" to 12" apart and need not be more than 9" deep; in fact an 8" shelf will accommodate ordinary books. Bookcases and shelves should be made as light in appearance as possible.

**Erection.** Ordinary trim, especially when it is to be painted, is cut from long lengths, fitted in the building and nailed in place to the grounds with brads. Nailing should be done in the quirks of mouldings where possible, the brads counter-sunk and the holes puttied. Hardwood finish of the better class is put together in the mill, the joints splined, glued and doweled and the surface sand-papered, filled, stained and given one or two coats of varnish. The sections are then erected by means of screws behind loose mouldings and below the finished floor, no nails being used. All trim should be painted on the back before erection to preserve the wood from dampness and consequent warping.

**Article 4. Interior Metal Trim**

The demands of fireproof construction have developed a large industry in the fabrication of metal door and window casings, cornices, picture and wire mouldings, panel mouldings, chair-rails and bases. Wood has also been treated in various ways to render it fire-retardant, but metal trim has so far proved more satisfactory where the wood texture is not required.

**Manufacture.** Metal trim is made of both steel and bronze sheets. The steel is generally #18 gauge furniture stock, cold-rolled and leveled to give perfectly true surfaces. The bronze is of best grade commercial stock and should be of suitable hardness and uniform color. Steel mouldings are either pressed or cold-drawn, accurately mitered, welded and dressed to give a perfect and invisible joint.

**METAL TRIM**



a. Window Trim



b. Picture Moulding

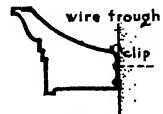

c. Wire Moulding

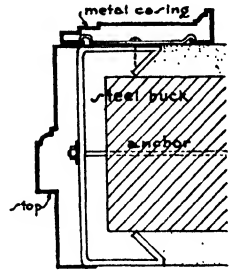

d. Door Trim

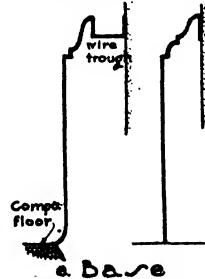

FIG. 14.—Metal Trim



Combination trim and jamb casings of #16 gauge steel are also produced with sharp profiles by cold-rolling.

Steel window and door casings are plain or moulded and are clipped to the window frames and door bucks with concealed fastenings. Door jambs for walls over  $7\frac{1}{2}$ " thick are usually of #16 gauge and are attached to the bucks with screws. Window stools should be at least #16 gauge (Fig. 14,*a,d*).

Picture and wire mouldings and cornices are snapped over meat brackets without visible fastenings. The brackets should be sufficiently close to support any weight coming upon the mouldings. Chair-rails are attached in the same manner (Fig. 14,*b,c*).

Bases may be plain or moulded and are usually supplied with a bronze sanitary cove moulding at the junction with the floor (Fig. 14,*e*).

Bronze trim is executed and attached in a similar manner except that the material is two gauges heavier and the joints are made either by welding or by riveting, screwing and brazing. The finish is natural bronze of various shades. Mouldings are sometimes extruded through a die instead of cold-drawn.

**Finish.** The most perfect finish upon steel trim is obtained by cleaning, priming and filling the metal and then applying a series of coats of paint. Each coat is baked on the steel in an oven under high temperature and then sand-papered. The final coat is rubbed to a dull gloss. Imitation of the natural graining of mahogany, oak and walnut has likewise been brought to a high degree of perfection. This method is known as a baked enamel finish. In cheaper work the steel is primed and then sprayed with a lacquer finish coat without baking.

## CHAPTER XV

### PAINT, GLASS AND GLAZING

#### Article 1. Paint

**In General.** Under the general heading of paint should be included the many fluid materials used as thin coatings on wood, metal, cement, plaster, brickwork and stucco for protective or decorative purposes. These materials may be divided into two classifications, TRUE PAINT and VARNISH, the distinction being that true paint is a mixture of a pigment with a vehicle whereas varnish contains no pigment.

Paint is necessary on iron, steel and sheet metal to protect them from corrosion and on wood to guard it from decay and warping; for decorative purposes it is used with success on wood, plaster, cement and stucco.

**Paint.** The fluid portion of paint is called the VEHICLE. It carries the particles of the pigment in suspension and either by oxidation and hardening binds them upon the painted surface or by evaporation deposits them thereon. The chief vehicles are oil and water, the first forming oil paints and the second water colors and cold-water paints.

The PIGMENT consists of finely divided solid particles added to the vehicle to contribute color and durability to the paint. It is not dissolved in the vehicle but carried in suspension.

**Oil Paint.** The term oil paint signifies a paint in which the vehicle is a drying oil. The oil most generally used is LINSEED OIL because of its great ability to absorb oxygen and change to a solid state. It is extracted from ground flaxseed, also known as linseed, by cold or hot pressing. In the cold-pressed process the seed is not previously heated; in the hot-pressed process it is pressed at a temperature of 160° to 180° F., the latter being the more general method. The oil is filtered and allowed to stand from 4 to 6 months in order that all cloudiness may disappear and the product become a clear, translucent amber color. It is then known as RAW LINSEED OIL. If heated to 350° F. and then cooled it is called BOILED LINSEED OIL, although boiling does not actually take place. The object of heating linseed oil is to increase its speed of oxidation and consequent hardening; to assist this process, certain materials called DRIERS are usually heated with the oil. Commercially, then, the term boiled linseed oil generally signifies an oil which has been heated and mixed with driers. Although several days are consumed in the drying of a film of raw oil, boiled oil will dry in less than one day but loses much in durability, elasticity and penetration. For these reasons boiled oil is most generally used only for the painting of interiors of buildings

where the conditions for oxidation are less favorable than out of doors and where the paint is protected from the elements. Oil is sometimes bleached to remove impurities which tend to produce a yellow tint in white interior paint.

The oil or vehicle may be modified by the use of **THINNERS** and **DRIERS**. The best thinner is turpentine, its purpose being to act as a solvent both for the materials of the paint and for the resin in the wood surface, thereby attaining greater penetration and anchorage in the pores. It improves the brushing and spreading qualities of the paint and also hastens its drying by absorbing oxygen from the air and transferring it to the linseed oil. Turpentine is added in larger quantities to the first or priming coats on woodwork to assist the penetration of the paint and in much less quantities to the outer coats especially for exterior work. Because it dries without a gloss it is mixed with the final coats for interior work when a dull or **FLAT** finish is desired. Turpentine is a spirit obtained by steam distillation of the resin or gum which exudes from pine trees. The residue of the distillation is known as **ROSIN**, used in the making of varnish. A certain amount of turpentine is also extracted by distillation from waste wood and sawdust. Its composition is nearly the same as that of the gum spirits or true turpentine, and when refined it is satisfactory for use in paint and varnish. Turpentine is colorless and volatile and soon evaporates.

**DRIERS** are used not only with boiled linseed oil as already described but also in less quantities with raw oil to hasten the hardening of paint. Their function is largely catalytic, that is, they accelerate the union of the oil with oxygen from the air. They continue to act after the oil has dried, and consequently if used in excessive quantities they will destroy the toughness of the film and cause the paint to crack and disintegrate.

The driers may be divided into two classes: **OIL DRIERS** which are used in a powdered or crystalline form, and **JAPAN DRIERS** or those used in a liquid state.

The most-used oil driers are the inorganic compounds monoxide of lead called litharge ( $\text{PbO}$ ), and manganese dioxide ( $\text{MnO}_2$ ) and borate ( $\text{MnB}_4\text{O}_7$ ). Manganese borate tends to darken the oil less than the oxides.

The liquid japan driers are organic compounds of lead, manganese and cobalt dissolved in benzine or turpentine and mixing readily with the oil at ordinary temperatures. Lead and manganese compounds when combined result in a very good drier, uniting the quick surface hardening caused by the manganese with the slower but more complete drying qualities of the lead. Cobalt is a very energetic drier, as is also vanadium, but the latter causes brownish films to form upon white paints.

The **PIGMENTS** most generally employed in the manufacture of oil paints are **LEAD** and **ZINC**. These are called body pigments because they form the bulk of the paint and contribute the characteristic properties to the coating. The leads may be carbonate or sulphate of lead, which

are white, and oxide of lead which is red. The zinc may be oxide or sulphate of zinc, both of which are white.

CARBONATE OF LEAD,  $(\text{PbCO}_3)_2 + \text{Pb}(\text{OH})_2$ , the most extensively used pigment for oil paint, is produced by the corrosion of metallic lead by the action of acetic acid and carbon dioxide gas. It is a white, amorphous, opaque powder, insoluble in water; when mixed with linseed oil it has good covering and protecting qualities and spreads well. Sulphate of lead, also known as sublimed lead,  $(\text{PbSO}_4)_2 + \text{Pb}(\text{OH})_2$ , is produced by collecting in bags the fumes from roasting galena ore or lead sulphide. The bags permit the air and gas to escape through their mesh and retain the sulphate of lead as a white powder. Sulphate of lead has properties similar to those of lead carbonate but is somewhat finer and denser and absorbs more oil. Both are employed with linseed oil in making what is commonly known as lead and oil paint. Lead paint fails in time by losing its bond with the dried oil film and brushes or washes from the painted surface in the form of powder. Zinc oxide is sometimes added to the lead to overcome this tendency to chalk, since zinc forms a harder surface. Too much zinc, however, will cause cracking and chipping, so that an excess must be avoided in proportioning. The minimum requirements of the U. S. Government for lead paint are 60% white lead, 30% zinc oxide and 10% other pigments, and a maximum of 100% of white lead is permitted.

RED LEAD or lead tetroxide,  $\text{Pb}_3\text{O}_4$ , is a bright red or orange-red powder which has, on account of its physical structure, high pigment concentration when mixed with linseed oil and which therefore gives maximum protection. It is the best preventive of rust available, being tough and durable, and consequently is widely used as a priming coat for structural steel. A black graphite paint makes an excellent finishing coat over the red lead because of its long life, and continued resistance to the atmosphere. Red lead is prepared by heating metallic lead in furnaces in the presence of air. Litharge ( $\text{PbO}$ ) is first formed, and a further heating to about 700° F. in a muffle furnace produces the red lead. No drier is needed with this pigment, and it is usually mixed with more inert materials to prevent scaling.

GRAPHITE paints are prepared by mixing linseed oil with the amorphous variety of plumbago or flake graphite, either found as a very pure natural form of carbon or produced artificially. Graphite causes a slow drying of the oil, and the long life and lasting elasticity of the paint are probably due to this fact. A certain amount of silica usually occurs with the graphite which adds hardness to the paint.

OXIDE OF ZINC, called zinc white, is a very fine white powder produced by heating metallic zinc and oxidizing the fumes in long chambers. It forms a very white paint when mixed with linseed oil with good spreading and covering qualities and a hard surface. It does not chalk but is liable to crack and chip. White lead is therefore mixed with the zinc as explained above.

When zinc sulphate solution is added to a solution of barium sulphide a powder is precipitated known as LITHOPONE ( $\text{BaSO}_4\text{ZnS}$ ) which is the whitest of all the pigments and has a good covering power. It is not durable for outside exposure but is extensively used as an inside paint when combined with linseed oil and for enamels. Some oxide of zinc pigment is usually mixed with the lithopone to prevent chalking. It must never be used with white lead or lead driers, for the combination forms a substance very dark in color.

In addition to lead and zinc, TITANIUM and ALUMINUM have recently been developed as base pigments and their use is constantly increasing. Titanium white ( $\text{BaSO}_4 + \text{TiO}_2$ ) is an oxide of titanium combined during manufacture with barium sulphate. The combination is a very fine white pigment with high oil absorption, great elasticity and twice the covering power of white lead. The barium sulphate is added to increase the opacity, and resistance to abrasion is improved by mixing zinc oxide in the paint. Titanium white is an excellent pigment for flat coats or enamels for inside use but is inferior to white lead for exterior work. It is usually mixed with proportions of zinc white and lithopone. Aluminum in fine flake form is incorporated in oil paint, varnishes and lacquers for both priming and finishing coats on wood, metal and concrete. The fine opaque flakes tend to seek the surface of the vehicle and to overlap like fish scales thus forming a bright continuous film with high moisture-excluding properties. The powder-like flakes are produced by stamping sheet aluminum in heavy power-driven machines. The leafing of the flakes obliterates brush marks and also protects the vehicle from the action of light, one of the chief causes of failure in paint films.

Beside the body or basic pigments, lead and zinc, there are two kinds of accessory pigments, the EXTENDERS and the COLOR PIGMENTS. The extenders have little covering or hiding power, their chief value being to assist in maintaining the other pigments in suspension and prevent too rapid settling, to give tooth or holding power and to improve the brushing quality. The materials most generally used are barium sulphate, magnesium silicate, silica, gypsum, calcium carbonate and China clay. These materials are less costly than lead and zinc and were formerly considered merely as adulterants to cheapen the paint. Study and experiment, however, have now proved them of real value in improving the quality of the paint when well selected and used in proper proportions. They form a part of most paints which come ready-mixed from the manufacturers. Gypsum, calcium carbonate and barium tend to stimulate corrosion and should not be used on iron or steel.

COLOR PIGMENTS are used to give the desired color to paint. In white, black and very dark paints the color is given by the body pigment itself, but in the case of the brighter shades and lighter tones the hue is produced by mixing color pigments with the white lead or zinc body. The black pigments LAMP BLACK and CARBON BLACK, made from soot formed by the burning of oil and gas, and BONE BLACK, produced from

burned animal bones, are mixed with extenders to form the body pigments of black paint. GRAPHITE, also called black lead and plumbago, is a natural carbon which produces a very impermeable film with high excluding and resisting power and is much used as a top coat for steel and ironwork over the red lead priming coat as already described. The color pigments such as the reds, blues, greens, yellows, browns and lakes are in some cases natural earths and in some cases made by chemical processes. The pigments known as lakes are formed by precipitating coal-tar dyes upon a mineral base such as barium sulphate, whiting or alumina, thereby coloring it. Color pigments are ground very fine and mixed with oil to the consistency of paste in which form they are stirred into white paint either singly or in combination to produce the required tint.

**Water Paint.** The term water paint signifies a paint in which the vehicle is water. Water paints include WHITEWASH and CALCIMINE, the latter sometimes called cold-water paint. Whitewash is made by slaking quicklime in water, then straining to remove the lumps and adding water for the proper brushing consistency. Hydrated lime may be used instead of quicklime. Rice, glue and skimmed milk are sometimes mixed in to increase its adhesion, and salt as a preservative. Whitewash will be more tenacious if applied hot.

Calcimine consists of whiting (powdered white chalk), water, coloring pigment and glue or casein as a binder. Gypsum is sometimes included for its covering power. It is generally obtained from the manufacturers in a powdered form ready to be mixed with water. When alum is added to render the glue insoluble the paint is known as a distemper. Casein paint consists of a mixture of finely ground casein and slaked lime with water and is fairly insoluble when dried. Distempers and casein paint may be washed to some extent, but they cannot be considered waterproof. Whitewash is used for exterior work because of its low cost, although its lasting qualities are not great. Calcimine and distemper are limited almost entirely to the painting of interior plaster surfaces.

The color pigments used with water paints are the same as for oil paints except that they are used in a powdered form to mix with water.

Transparent liquids called glazes are sometimes used over cold-water paints to produce a blending of colors and soft sheen to the surface.

**Varnish.** Varnish is a solution of resin in drying oil or in a volatile solvent such as alcohol or turpentine. It contains no pigment and hardens into a smooth, hard and glossy coat by the oxidation of the oil or the evaporation of the alcohol. OIL VARNISHES are solutions of resin in boiled linseed oil or china wood oil; SPIRIT VARNISHES signify a resin dissolved in alcohol or turpentine. CHINAWOOD OIL or TUNG OIL is pressed from the seeds of the tung tree which grows in China and to some extent in Florida. It is a much faster drying oil than linseed oil and more durable and resistant to wear but not so elastic. The use of chinawood oil is increasing very rapidly, especially in the making of varnishes and

enamels. Turpentine is also added in the manufacture of oil varnish as a thinner together with a certain amount of drier.

The chief resins employed in varnishes are COPAL, or African fossil gums; DAMMAR, or resins from Singapore and the East Indies; ROSIN, the residue left after the extraction of turpentine from pine resins, and ROSIN ESTERS, obtained by treating rosin with glycerol to make it waterproof when dry.

Many varnishes are manufactured with qualities adapted for special purposes connected with building, such as floor varnish, rubbing varnish, spar or exterior varnish, interior varnish and flat varnish. By varying the amounts and kinds of oil, spirits, driers and resins, and by greater or less degrees of heating, the properties of elasticity, hardness, luster and imperviousness to moisture can be controlled and varnishes produced to meet the various requirements. In general, oil varnishes are more durable but not so hard or quick drying as spirit varnishes.

Spirit varnishes are either DAMMAR VARNISH, made by treating dammar resins with turpentine, or SHELLAC VARNISH, made by dissolving white or orange shellac in grain alcohol. They dry by the evaporation of the solvent. Shellac is made by refining seed lac, and its natural color is orange, the white shellac being obtained by bleaching. Lac is a resin exuded by certain insects in India upon the twigs of trees. These twigs with the resin attached are called stick lac and are crushed and washed to produce seed lac. Shellac is used as an under or preparatory coat for varnish and wax finishes upon interior woodwork and floors, but is not generally satisfactory as an independent finish since it is not durable and turns white from contact with water. It is also employed to cover wood knots before a priming lead and oil coat is applied, because of its ability to kill the resin in the knot and prevent discoloration.

**Enamel.** Enamel is a true paint since it is composed of a pigment and a vehicle. The base pigment is usually white, such as titanium or zinc oxide, to which colored pigments are added to obtain the desired hue. The vehicle is generally varnish with which turpentine may be mixed if a flat, dull or eggshell gloss be required. The combination of pigment with varnish produces a paint which flows out to an even coat and dries to a hard, smooth and glossy surface without brush marks or ridges and is more resistant to wear than lead and oil paint. It requires an undercoat with a flat or dull surface to hide the raw material, either wood or metal, and to provide a surface free from gloss, so preventing the enamel from sliding or pulling. Lacquers containing coloring pigments are sometimes called enamels.

**Lacquer.** Lacquers have widely increased in use because of their durability, hardness, luster, smoothness and quick-drying property. They consists of a composition of nitrocellulose, resins, solvents and softeners. Toughness and resistance to abrasion are contributed by the nitrocellulose; adherence, hardness, luster and brittleness by the resins, and elasticity and plasticity by the softeners. The solvents are volatile

nitrocellulose solvents and gum solvents such as acetates and alcohols, and the softeners are non-volatile liquids such as castor-oil. Nitrocellulose, also known as pyroxylin, is a compound made by treating short-fiber cotton with nitric acid. Dammar or Kauri gums are used in the best lacquers. The quick-drying properties arise from the evaporation of the very volatile solvents and permit the application of several coats in a day. Varnish, on the other hand, being a solution of gums in linseed oil, dries more slowly as the oil oxidizes. Lacquers may be clear with a glossy or flat finish or they may be opaque with a variety of colors like enamel paint. They dry with a very smooth surface of high tensile strength which does not scratch and is easily cleaned. Owing to the inelastic quality of the lacquer, metal surfaces, such as metal interior trim, doors and furniture, are better adapted to its application than is wood, which by expanding and contracting under the influence of dampness causes the lacquer to crack, especially on exterior woodwork. Many lacquers are prepared with proper consistency for spraying.

When pigments are incorporated with the lacquer to establish an opaque color, which also assists in protecting the cellulose nitrate from decomposition by the sun, the material is now sometimes called enamel.

**Stains.** Stains are used to change or modify the color of wood and to bring out its grain and texture. They may be classed as oil, water, spirit and chemical stains.

**OIL STAINS** the vehicle is oil to which turpentine or benzene may be added as a solvent and to increase the penetration. Either pigments or aniline dyes may be used to color the stains, the latter being cheaper and easier to apply. Oil stains are often wiped off across the grain of the wood before they are hard to even the color and emphasize the grain. Varnish is sometimes used instead of oil as a vehicle.

**WATER STAINS** are solutions of aniline dyes in water. They do not obscure the grain and they bring out its beauties to more advantage than oil stains but are liable to fade and to raise the grain of the wood. The latter may be avoided by dampening the surface before application and then sandpapering.

**SPIRIT STAINS** are composed in the same manner as water stains except that the solvent is volatile, as alcohol or acetone. They are liable to fade as are water stains, and sometimes mild acids are added to render them more permanent.

**CHEMICAL STAINS** contain no coloring matter but change the color of the wood through the action of chemicals such as iron salts, potassium and sodium bichromate, copperas, zinc sulphate and potassium permanganate dissolved in water. These chemicals act upon the tannin in the wood and change its color to browns, reds, green, silvery gray and weathered effects. They are employed chiefly with coarse-grained woods such as oak, chestnut and ash, and varnish or wax produces a satisfactory finish over them.

Shingles are often stained with oil or spirit stains mixed with creosote



oil to color and preserve them. Such stains, however, rarely produce the soft and pleasing tones of naturally weathered shingles.

**Fillers.** Fillers are generally intended to fill the pores and grain of wood and not to color it, although pigments are sometimes added. They are applied after the stains. The best filler consists of sharp-grained silica or barytes mixed with a quick-drying boiled oil. It is generally in a paste form, being thinned with turpentine before use, and is applied with stiff brushes. After it has become partially dry it is rubbed off across the grain so that only the grain and pores of the wood remain filled. Paste fillers are used on coarse-grained wood. When thinned down for use on close-grained wood they are called liquid fillers.

**Mixing Paint.** White lead and zinc paint may be obtained in two forms: either as a rather thick pigment paste to be reduced to the proper consistency by the painter at the building, or in a prepared form ready for use. When obtained as a paste the oil and drier must be added slowly while stirring the paste with a wood paddle in order to break down the stiff consistency of the pigment and thoroughly incorporate it with the vehicle. It is customary to add from 4 to 6 gals. of linseed oil and 1 pt. of drier to each 100 lbs. of paste. If a colored paint be desired, the proper tints ground in oil are then added and well stirred to mix them completely with the pigment and prevent streaking. The breaking down of the paste and its thorough incorporation with the oil by hand is a slow and rather tedious process, but it must be conscientiously accomplished in order that a satisfactory paint may result.

Paints ready for use are produced by many manufacturers. At one time they were looked upon with some suspicion because of their unknown composition, and many of the older house painters preferred to mix their own lead and oil. Of recent years the manufacturers and the Federal Government have given much scientific study to the composition of paint for different purposes, and certain ingredients, such as extenders, formerly considered only as cheap adulterants are now recognized as contributing valuable properties when properly selected and proportioned. For these reasons, ready-mixed paints are now widely employed by contractors and amateurs alike, and those produced by reliable manufacturers give very satisfactory results for both inside and outside work. The ingredients are measured and mixed by machinery according to methods approved after much study and experiment, and the product is consequently more constant and for many purposes better composed than hand-mixed paint. The lead and zinc naturally sink to the bottom of the container and the paint must consequently be re-mixed before use. This is best done by pouring off the liquids from the container into a clean can or pot and then mixing the pigment and vehicle with a paddle while slowly pouring back the liquids. The entire contents should then be poured back and forth from one container to the other until the paint is of a homogeneous consistency with no lumps or thick masses. Ready-mixed paint is usually too thick for the

priming coats, and oil and turpentine should be added. The second and third coats are usually applied with little modification. Driers should never be added to ready-mixed paint.

Varnishes, enamels, shellacs and stains are generally obtained from the manufacturers ready for use. Turpentine and spirits are sometimes added to the varnishes and alcohol to the shellacs to thin them to the desired consistency.

**Application.** All surfaces must be thoroughly dry when paint is applied, and exterior painting should never be done in damp weather. Sap streaks and knots should be brushed with turpentine or shellac to soften the resin and allow the paint to soak into the wood. If the paint be prepared on the job a gallon of turpentine should be added to each 100 lbs. of the paste and oil for the first or priming coat to thin the paint and increase its penetration. For ready-mixed paint from 2 to 3 pts. of turpentine should be added to each gallon of paint. For the second coat on outside work only about 1 pt. of turpentine should be added to each gallon of paint and for the third coat no turpentine should be used. This coat will then dry to a film rich in oil, weather-resistant and with a high gloss.

For interior work, turpentine may be added to all the coats if a flat or dull finish be desired. Upon interior wood trim, several coats rubbed smooth between the coats with fine sandpaper or with pumice stone and water produce a very smooth, even surface with a dull, eggshell finish. A coat of thin, transparent varnish is sometimes applied to the last coat and rubbed in the same way. The enamel paints are, however, taking the place, to some extent, of rubbed finishes because of the saving of labor. Turpentine may be added to the enamel to give a flat finish with only a slight gloss. In all cases a number of thin coats of paint are preferable both in appearance and durability to a few thick coats. After the priming coat is applied, all nail-holes, dents and open joints should be filled with putty before beginning the second coat. The priming coat prevents the oil in the putty from being absorbed by the wood and thus causing the putty to crumble and break loose. Each coat of paint should be thoroughly dry before the succeeding coat is applied.

Putty should consist of whiting or powdered chalk mixed with raw linseed oil. A little white lead is sometimes added to harden the putty.

**Concrete, Stucco and Plaster.** These materials must be thoroughly dry before painting and should contain no lumps of free lime or calcium carbonate. In order to be sure that such alkaline spots, if present, will be neutralized and rendered harmless the wall should be first treated with a coat of zinc sulphate and warm water. The free lime is converted into calcium sulphate and the priming coats may then be applied. Alum and soap may also be used as a preparatory coat. Plaster walls are likewise often treated with size to reduce their absorption, espe-

cially when painted with calcimine. Size may consist of glue and water for calcimine, and of varnish or a mixture of oil paint and varnish for oil paint.

**Brickwork.** One or two coats of raw linseed oil and drier or of lead paint long in oil are necessary to reduce the absorption of unglazed brick, which have high suction properties. When the pores of the brick have been sealed in this way the ordinary lead and oil paints may then be used.

**Steel.** Exclusion of air and moisture and inhibition of rust formation by chemical action are necessary to prevent the rusting of structural steel, and red lead has proved the most satisfactory pigment for these purposes. When mixed with linseed oil it is very generally used as the priming coat on all kinds of steelwork. It is bright red in color. Sublimed blue lead sulphate is also used with success for steel protection. Black graphite or red lead made black by adding lampblack and Prussian blue are excellent paints for the finishing coats, which should also have high excluding power and resistance to the atmosphere. Galvanized metal is oily when new and should be washed with soapy water before painting.

**Function and Character of Paint on Wood.** Paint saturates wood surfaces to an appreciable depth with a water-repellent oil and covers the surface with a tough film which greatly lessens the penetration of water and oxygen, thereby preventing decay. Paint fails through the loss of elasticity and toughness and the increase in brittleness due to gradual oxidation. Either chalking or cracking results, depending upon the composition of the paint, chalking being preferred since it leaves the surface in a better condition for repainting. Paint of the proper composition will chalk mildly without washing off and will often maintain a good protective film free from cracking and scaling for a period of 5 years.

**Paint and Varnish Removers.** Dried paint and varnish may be dissolved by several different agents, the most generally used being alcohols and acetones, sodium carbonate and ammonium hydroxide. Alcohol and acetone evaporate before becoming effective and are therefore mixed with benzol and paraffin wax and applied in paste form. Carbonate of soda and ammonium hydroxide are liquid solutions and are used with an abrasive such as steel wool or a stiff-bristled brush.

**Spraying Paint.** Machines called spray guns have been developed for spraying paint, varnish and lacquers by compressed air instead of brushing on by hand. This process requires more paint, but the labor cost is less where conditions are suitable. Spraying is particularly adapted to large surfaces, both exterior and interior, as in mills, barns and factories where covering the areas for purposes of protection, cleanliness or light radiation is the important consideration. Lacquers are often sprayed on automobiles, and railroad and traction cars, but less often in building construction. The spraying machine consists of a tank for the paint and an air condenser operated by gaso-

line engines or electric motors. The paint is forced through a hose to the nozzle by air pressure, where it is formed into a spray, and controlled by the operator with valves and triggers.

**Selection of Paint.** In résumé it may be said that the vehicle, linseed oil, of a paint if used alone would be too soft to stand ordinary wear, would not exclude water and would easily be destroyed by the action of sun and air. The pigments are therefore added to fill up the pores, to harden the surface and to give body to the oil film. This body must be as dense as possible in order to protect the film from exposure, and consequently three sizes of pigments, coarse, medium and fine, are better than one size. Carbonate of lead is most generally used as a coarse pigment and because of its opacity and weather-resistance; calcium carbonate, magnesium silicate or China clay as a medium pigment and to give tooth and prevent settling; and zinc oxide as a fine pigment and to maintain whiteness and reduce chalking. It will be seen, then, that although paint consisting of carbonate of lead (white lead) and linseed oil only, has been used for generations, modern study and practice incline toward a combination of more ingredients to produce longer wear, less chalking and cracking and more permanent whiteness in outside use.

For inside use, oil paints consisting of zinc white, lithopone and titanium are taking the place of carbonate of lead since they are whiter, finer and smoother. Water paints have been greatly improved of late years for plaster surfaces, some of them being even washable to a moderate degree.

Varnishes should be chosen for the particular work in hand, whether for floors, wood trim, furniture or outdoor use.

The science of testing, analyzing and proportioning is always advancing, and the chemistry of paints is constantly evolving new pigments and vehicles.

## Article 2. Glass

**Materials.** Limestone ( $\text{CaCO}_3$ ) and sand ( $\text{SiO}_2$ ) at high temperatures interact to form calcium silicate ( $\text{CaSiO}_3$ ), which is insoluble but brittle and crystalline. By adding sodium carbonate (soda ash) a molten mass is obtained which, upon cooling, becomes transparent, non-crystalline, insoluble in water and not too brittle for general use. The raw materials employed in the manufacture of glass to contribute these characteristics are limestone, sand, soda ash, sodium sulphate (salt cake), cullet (broken glass) and a small amount of alumina. The materials are fused in large earthenware pots or in regenerative furnaces at a temperature of about  $3000^\circ$  F. Glass when fluid can be stirred, ladled, poured and cast, and when viscous can be rendered hollow by blowing, rolled like dough or extended into a long rod or tube.

· **Manufacture.** Window glass may be classified according to methods of manufacture as Cylinder or Blown Glass, Flat or Drawn Glass and Plate or Cast Glass.

**Cylinder Glass.** Cylinder glass, also known as sheet glass, is made by blowing a mass of the molten material into a hollow cylinder about 15" in diameter and 6'0" or 7'0" long. This cylinder while soft is cut lengthwise, laid out on a preheated iron table and placed in an annealing oven to flatten. On account of the method of manufacture the glass cannot be entirely perfect nor absolutely flat. Small bubbles, streaks, waves and other defects appear, and sheets may have a slight bow or regular curvature. It is not permitted, however, that the height of the arc of curvature shall be more than 0.5% of the length of the sheet. According to thickness, cylinder glass is classed as follows:

Single Thick—About 1/12" thick.

Double Thick—About 1/8" thick.

Crystal Sheet—In weight from 26 oz. to 39 oz./ft.<sup>2</sup>, from 1/8" to 1/5" thick.

According to defects the Federal Government Standards grade cylinder glass as AA, A and B quality. Only about 3% of the total glass produced is of AA grade and it is largely used in picture framing. Grade A comprises the quality of window glass most widely used in buildings of the better class; grade B is used in mills, factories, basements and the cheapest class of residences. Only one quality of glass is actually produced, the classifications being determined by selecting out for the better grades the sheets containing only small lines or bubbles when not too close together nor located in the center of the sheet. Sizes of double thick sheets should not exceed 40" x 48". For larger sheets, crystal sheet or plate glass should be used.

**Flat or Drawn Glass.** A process has been developed by means of which sheet glass, instead of being blown into a cylinder and then flattened out, is drawn up vertically in a continuous even sheet. This process consists in lowering a metallic bar, called the bait, into the tank of molten glass for a few seconds until the glass has adhered to it. The bait is then raised and the glass is drawn directly upward between asbestos rollers, the thickness of the sheet depending upon the speed of draw. Upon reaching the annealing chamber at the top, the glass is cut off the upward moving sheet into desired lengths the full width of the sheet. The result is a perfectly flat glass without bow and with less tendency to other defects than found in cylinder glass. This process is considered to be a great improvement upon the blown method. The glass is graded according to the accepted standards of the Federal Government as given in the preceding paragraph, but several of the defects listed in the standards are seldom present in the drawn sheet glass.

**Plate Glass.** Plate glass is made by pouring the molten material upon a heated, flat, iron table with a raised rim and rolling it to the required

thickness with a heavy iron roller. The glass is thus cast instead of being blown or drawn as is the method for cylinder or sheet glass. The plate is then annealed and forms what is known as **ROUGH PLATE GLASS**. It is unevenly fire-polished on the upper side and rough on the side next the table, and is used for vault lights and skylights. To procure **POLISHED PLATE GLASS** the rough plate is placed on a revolving table and the surface ground down with fine sand and rollers. It is then removed to another table, the surface is polished with felt blocks and rouge or peroxide of iron. The standard thicknesses for plate glass range from  $\frac{1}{8}$ " to  $1\frac{1}{2}$ ", the usual thickness for window glass being  $\frac{1}{4}$ ". The heavier plate glass is used for shelving, table tops and toilet partitions. According to defects, plate glass is divided into **SILVERING** and **GLAZING** quality. The silvering grade is as nearly perfect as can be manufactured and is used for the best type of mirrors. The glazing quality may contain a few small bubbles and fine scratches but not enough to impair its value for glazing the finest buildings.

**Obscured Glass.** Many types of glass are produced for use where light is to be transmitted but vision obscured, as in office doors and partitions and public toilets. One type of obscured glass is called **ROLLED** or **FIGURED GLASS** and has a pattern or figure impressed upon one side, the other side being smooth. It is made by casting the molten glass upon a table into which the pattern or figure has been cut and immediately rolling to the required thickness, generally about  $\frac{1}{8}$ ". There are a variety of patterns, none of them very pleasing, and they catch dust to an unpleasant degree.

A second type of obscured glass is called **PROCESSED GLASS** and may be classified as **GROUND GLASS** and **CHIPPED GLASS**.

Ground glass was originally made by subjecting a sheet of glass to a blast of fine sand. It is easily soiled or pencil marked and has now been superseded by acid ground glass which is treated with hydrofluoric acid and has a finer and more silvery cast, a smoother surface and is more easily cleaned. Chipped glass is made by coating a sheet of glass with hot oil or glue and gradually drying. The contracting oil or glue chips off small flakes of glass which leave a surface obscured to vision. If oil or glue is again applied on the same side the glass is called **DOUBLE PROCESS CHIPPED GLASS**, and the result is a more evenly chipped surface with finer flakes. Chipped glass is now often preferred to figured glass on account of its better appearance, greater cleanliness and freedom from dust. Glass polished on one side and with a fluted or reeded pattern on the other is a new type where obscurity is desired.

Many improved types of obscured glass are constantly being introduced in the effort to produce smooth surface, true obscurity, uniform diffusion, maximum transmission and a pleasing appearance.

**Wire Glass.** Wire glass is made with either a welded wire mesh or one resembling chicken wire embedded in its body for fire-retarding purposes and to hold the fragments of glass together, preventing them from

flying or dropping out of the sash if the glass is cracked. It is manufactured in three ways: by pouring molten glass over wire mesh stretched on the casting table; by pressing wire mesh down into the soft glass after it has been cast and then smoothing the top surface; or by casting a thin sheet of glass, placing the mesh on the sheet and then pouring and rolling a second sheet over the mesh, embedding the wire. It has a standard thickness of  $\frac{1}{4}$ " for fire-prevention purposes, and sheets are not acceptable to the Fire Underwriters if they exceed 720 in.<sup>2</sup> or have more than 48" of unsupported surface in any dimension. Wire glass may be rough as it comes from the rollers, ribbed, prism, figured or polished. More bubbles and blemishes are allowed in wire glass than in ribbed glass.

**Prism Glass.** Prism glass is intended to change the direction of the rays of light by refraction and so throw the light back into the far sides of rooms, into basements or wherever desired. It has horizontal lines of prisms on one side and is smooth on the other. By changing the angles of the prisms light may be refracted in almost any direction. Prism plate glass has the smooth side ground and polished. Prism wire glass is designed for use where deflection of light and fire protection are both required. Prism tile are made in 4" and 5" squares and are set in zinc or copper bars making plates of any size required. Each case requiring deflection of light should be studied individually so that prisms of the proper angle may be used. The standard thickness is about  $\frac{1}{4}$ " for clear glass and  $\frac{3}{8}$ " for wire glass.

**Vault Lights.** Basement and sidewalk vaults are often lighted by round or square lenses set in reinforced concrete or steel frames flush with the sidewalk. The glass may be either plain flat units or prismatic drop lenses according to the manner of distributing the light.

**Colored Glass.** Colored glass, generally known as stained glass, is made by adding oxides of metals to the molten glass which with the silica give colored silicates. Milky or opalescent glass contains calcium fluoride. The green color of bottle glass is due to iron (ferrous silicate) from impure sand or limestone. Almost any shade or combination of colors may be obtained by means of coloring matter in the body of the glass or by blowing a thin film of colored glass upon sheets of clear glass, a product known as flashed glass. The pure, untreated, self-colored glass is called pot metal.

The stained glass of the best Gothic period, the thirteenth century, was composed of various pieces of colored glass held in place by lead strips, each one shaped to form a definite piece of color in the entire design. Thus the head of a figure might be of brownish pink glass, the drapery of red glass and a scroll held in the hand of white glass, each surrounded by a lead strip. The features of the face, the folds of the drapery and the letters on the scroll were, however, too minute to be delineated by separate pieces of glass, and the only way of showing them was by painting. The paint was confined at first to an opaque

brown used as a means of stopping out the light, the lines appearing as black merging into the lead work when the glass was set in the window. Any modeling desired was achieved by series of lines and cross-hatching as in pen-drawing and not by tinting with solid color. The glass was not made in large sheets as today but in small pieces to imitate brilliant jewels; the whole design was a mosaic, and the art was primarily that of the glazier and not of the painter. Through the succeeding centuries, however, the painter appropriated the art, much to its detriment. Enamels consisting of finely powdered glass mixed with gum fused to the glass surface by heat were widely used, the design being considered as a painted picture with the leading arranged so as not to interfere with the composition instead of boldly surrounding it. Of late years a better understanding has developed of the methods of window design peculiar and proper to glass. It is again agreed that the art begins with glazing, that the all-needful thing is beautiful and brilliant self-colored glass and that painting should be reduced to a minimum.

Cathedral glass has a slightly hammered or dented surface and is made either tinted or without color. It is largely used in church windows when stained glass is not desired, and more recently has been employed as obscured glass in high-class offices, where it makes the best appearance of all the obscured glasses. Both sides of the glass are roughened, however, so that lettering is difficult.

**Actinic Glass.** The actinic and heat rays of the sun often damage cloth fabrics and other materials by fading their colors. Glass is consequently made to cut off these rays without intercepting the light, for use in the large windows and skylights of warehouses and shops. Actinic glass, by absorbing the infra-red rays of the sun, also reduces to a great extent the glare and heat transmitted through ordinary glass in factories and mills and avoids the use of curtains and shades.

**Quartz Glass.** Glass made of pure quartz permits the passage of the ultra-violet rays of the sun which are beneficial to health and are largely cut off by ordinary window glass. Quartz glass is used to some extent in hospitals and schools to gain all possible advantage of these rays.

**Bullet-proof Glass.** Glass is manufactured consisting of very thin sheets cemented together under heat and pressure with a colorless transparent material and having the appearance of solid plate glass. This glass, owing to the cushioning effect, will crack when struck but will not shatter or fly in pieces and will resist the penetration of an ordinary bullet. It is built up of five layers, three of glass and two of binding material, and is 1" thick. The enclosures around the working spaces and tellers' counters in banks are now glazed with bullet-proof glass, with very satisfactory results.

Shatter-proof glass is made on the same principles as bullet-proof glass but with fewer and thinner layers, the total thickness of a sheet being the same as for ordinary glass. It will not shatter under the force of a high wind or when struck by heavy blows. It is now generally used



for motor-cars, asylums, skylights, showcases and on the exposed sides of buildings.

**Structural Glass.** The use of glass as a structural material for walls, roofs and floors has grown rapidly of recent years both in Europe and this country. Its most striking development is seen in wall enclosures built of glass either in the form of hollow blocks or as the facing of concrete units. The possibilities of glass in these forms have had a most important influence in the evolution of modern architecture. The problems of loss of heat in winter and sun radiation in summer, together with the psychological effects upon the inmates, should, however, be carefully studied by the architect in each case.

Glass blocks are formed of two equal shells which, when hermetically fused together, enclose a central hollow cell. This cell may act as a dead-air space or, if evacuated of air to some degree, will form a partial vacuum. In either case, very good insulation against heat and sound and a high freedom from condensation are the result. The blocks are manufactured 4" thick and 6", 8" and 12" square and 5" by 8" oblong with shells approximately  $\frac{1}{4}$ " thick. In order to obscure the glass and to diffuse the light, ribs, flutes and prisms are cast upon either the inside or the outside face or upon both faces. In this manner not only translucence but also diffusion, decorative effects and freedom from glare are attained. The light may also be directed upward against the ceiling for further reflection downward. Spun and woven glass fibers are sometimes introduced in the hollow centers of the blocks to soften the light still further and to improve the insulation. Windows, large panels and entire walls may thus be constructed of glass. The blocks for exterior walls are set in cement mortar with joints from  $\frac{1}{4}$ " to  $\frac{3}{8}$ " wide containing expanded metal wall ties. For large areas vertical I-beam stiffeners of H mullions and horizontal shelf angles are required as reinforcement against wind pressure.

Although hollow glass blocks have fair compressive strength, they are not recommended for use as a load-bearing material. In fact, they should be set with  $\frac{1}{2}$ " cushioning strips at all junctions with masonry, metal or wood frames to protect the glass from direct contact with the structure and to act as expansion joints. Chases or recesses should be furnished in the head, jambs and sills of openings to receive the blocks and the expansion strips. The glass is finally caulked into the chases with oakum. Where ventilation or vision is required in outside walls, windows in metal sash and frames may be installed in the glass panels. Very effective interior partitions are also constructed securing illumination with privacy. Blocks of clear glass may be introduced in the panels wherever visibility is desired. These partitions consist of frames of bronze or aluminum into which the blocks are set. They can be dismantled and re-erected with a high percentage of salvage.

The term structural glass also embraces the opaque glass so much employed as partitions and wainscotings in baths, toilet rooms, kitchens,

dairies, lunch rooms, operating rooms and wherever a smooth, impervious and sanitary material is required. With the modern trend in design, structural glass is likewise used, on account of its variety of color and highly polished surface, for decorative features such as wall and ceiling linings in vestibules of office buildings and theatres, in show windows and shop fronts. Its thickness varies from  $11/32''$  to  $1\frac{1}{4}''$ , and, although larger slabs may be obtained for toilet partitions and table tops,  $24'' \times 24''$  is the practical maximum size for interior wainscoting and  $24'' \times 36''$  for exterior wall lining units. Some translucent types, when illuminated from the rear, present evenly luminous surfaces of great decorative quality. Structural sheets are available consisting of a layer of spun glass pressed between two lights of flat glass, thus presenting an obscure but diffusing surface of high insulating properties. They are effective where protection against the passage of heat with privacy and diffused light is desired, as in skylights, interior partitions and ceiling panels. Clear plate glass has likewise been tempered to increase its strength and resistance to shock, thereby extending its value for shelves, fire screens, showcases and modern fixtures. Doors of  $\frac{3}{4}''$  glass of this type are made with the hinges and locks cast on the glass in the factory. The maximum size is  $4'0''$  wide and  $9'0''$  high.

Lustrous opaque glass slabs  $11/32''$  thick are likewise backed with  $4''$  or  $8''$  of light-weight concrete at the factory to form masonry wall units. They are made in sizes having a surface area up to  $12 \text{ ft.}^2$  in  $4''$  thickness and  $8 \text{ ft.}^2$  in  $8''$  thickness and may be erected as load-bearing walls for one-story buildings, as a bonded or anchored facing for taller buildings and as interior partitions. The glass edges are protected by a metal binder which is not apparent when the units are set in mortar. The face joints are  $5/16''$  wide, and the units possess good insulating qualities, light weight and fire-resistance.

### Article 3. Glazing

**General.** Glass is fastened into wood and steel sash by putty or by wood or metal beads. With wood sash the glass is further held in place by small triangular pieces of metal called glaziers' points driven into the sash about  $8''$  apart close to the glass to force it against the rebates. Glass should be cut to fit the rebated opening of the sash with a slight play especially in connection with metal sash. The rebate to receive the glass should be about  $\frac{1}{4}''$  wide. In the best type of metal sash the glass is secured by metal strips or mouldings.

**Putty.** Putty for wood sash should consist of whiting (powdered chalk) and linseed oil with about 10% of white lead paste to harden it. The addition of more lead will cause the putty to set too hard and adhere too firmly to the rebates so that re-glazing is very difficult without damaging the sash and muntins. For use with steel sash 5% of litharge may be added to ordinary putty to assist the oxidation of

the oil, or special metal sash putty which is very satisfactory may be obtained from reliable manufacturers.

**Setting Glass.** All wood sash should receive a priming coat of lead and oil paint to prevent absorption by the wood of the oil in the putty and consequent crumbling of the putty. **BEDDING:** A layer of putty is spread upon the rebate to provide an even bed for the glass and for waterproofing. The glass is then applied and glazier's points are driven into the wood to hold the glass firmly against the putty bed. **FACE-PUTTYING:** The entire rebate is filled with putty beveled back against the sash and muntins. **BACK-PUTTYING:** When bedding is omitted putty should be forced between the back surface of the glass and the rebate, after the face-puttying is done, to fill any voids between the glass and the wood (Fig. 1,*a*).

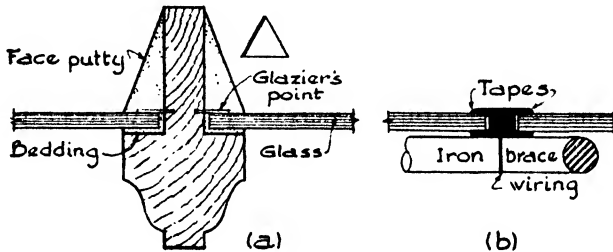

FIG. 1.—Muntins and Tapes.

Heavy plate glass, especially in doors and casement windows, is bedded and back-puttied, but instead of face-puttying, is held in place by wood beads screwed to the wood sash to withstand slamming. Plate glass in large sheets, as in store front construction, should be supported upon resilient pads such as felt, lead or leather, one at each end. The glazing beads should not be drawn too tight, especially when of metal, on account of expansion and contraction from heat and cold.

Leaded glass consists of small lights of clear or colored glass held together by strips of lead in section similar to the letter H, the flexible and usually flat arms of which extend on either side well over the edges of the glass, and the cross bar serves as a connecting and stiffening core between them. The glass is cemented or puttied into the flanges or tapes, and iron rods, called saddlebars, are usually let into the sash or into the masonry on each side of the window opening to which the leading is attached by copper wires soldered into the lead (Fig. 1,*b*).

Sheet or cylinder glass is set with the bowed or convex side outward to resist wind pressure and to lessen distortion of vision. Drawn sheet glass may be set with either side out. Wire glass has the twist of the wire running vertically. It is usual to place figured rolled glass in office doors with the smooth side toward the corridor for lettering and in windows with the figured side outward for better light transmission.

Prism glass must, however, be installed according to the requirements of light diffusion as designed for each case.

**Mirrors.** The mirror as most generally used consists of a clear sheet of polished plate glass upon the back of which has been precipitated a layer of a solution of silver nitrate and ammonia. The back of the layer is protected from dampness with a coat of shellac or varnish and two coats of lead or of tar paint. Special methods of depositing a layer of copper by electrolytic process upon the silver back are also employed. To give a variety of effects, mirrors are likewise backed with a deposit of gold chloride, of lead or of dull silver to give gold, gunmetal and dull silver tones to the mirrors in harmony with modern decoration.

Until about 1840, mirrors were made by pouring mercury upon a smooth sheet of tinfoil and laying a sheet of glass upon the mercury. Pressure was applied, forcing most of the mercury from under the glass and leaving a thin film of mercury and tin amalgam upon the surface. Such mercury-backed mirrors were very lasting and, although slow and expensive to make, showed a depth and softness of tone much more agreeable than the hard metallic luster of the silver-backed mirrors.



PART II  
*METHODS OF CONSTRUCTION*



CHAPTER XVI  
MECHANICS OF MATERIALS

Article 1. Statics

**General.** Architecture employs in its structures only forces which are at rest. All the forces which act upon the structural framework of a building or upon any of its parts are consequently in equilibrium. It is well, then, first to consider briefly the laws of statics or the science which treats of forces in equilibrium.

A **FORCE** is that which tends to change the state of rest or motion of a body. It may be considered as pushing or pulling a body at a definite point and in a definite direction. Such a push or pull tends to give motion to the body but this tendency may be neutralized by the action of another force or forces. A force is completely determined when its **MAGNITUDE**, **DIRECTION**, **LINE OF ACTION** and its **POINT OF APPLICATION** are known.

Forces are said to be **CONCURRENT** when they have a point in common on their lines of action. A system of forces not having a point in common on their lines of action are called **NON-CONCURRENT** forces. A force may be indicated graphically by a line with an arrowhead. The length of the line, drawn to scale, represents the magnitude; the direction of the line and the arrowhead show the direction in which the force acts, and the intersection of the line with a body gives its line of action and point of application.

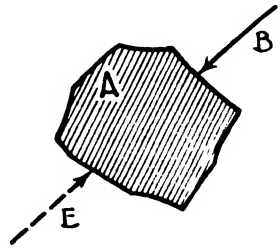

FIG. 1.

If a body *A* (Fig. 1), which is free to move, be acted upon by the force *B* it will move along the line of action of the force. It is possible to apply another force *E* at such a point, in such a direction and of such magnitude, that the body will not move but will be held in equilibrium. The force *E* is called the **EQUILIBRANT** of force *B*. An equilibrant is the force or system of forces which holds in equilibrium a single force or a system of forces.

The simplest system of forces, usually a single force, having the same effect as a number of forces acting together, is called the **RESULTANT** of the system of forces. Any one of the forces comprising the system is a **COMPONENT** of the resultant.

Consider the forces *A*, *B* and *C*, Fig. 2, acting upon a mass. These forces are concurrent because, if their lines of action are continued, they



meet in a common point. The force  $R$  is the resultant of the system. If the force  $E$  is applied, opposite in direction to  $R$ , equal in magnitude and having the same line of action, the system will be held in equilibrium.  $E$  is called the **EQUILIBRANT** of the system; it is equal to the resultant in magnitude, is opposite in direction and has the same line of action.

The process of finding the resultant of any given system of forces is called the **COMPOSITION OF FORCES**. The process of determining two or more forces which together are equivalent to a single given force is called the **RESOLUTION OF FORCES**.

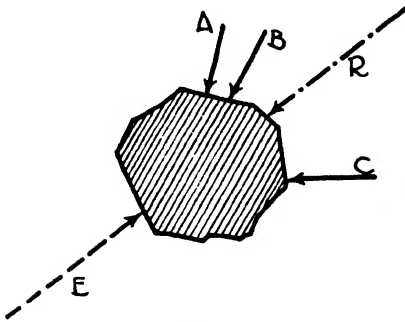

FIG. 2.

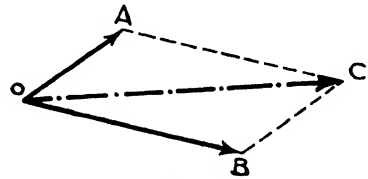

FIG. 3.

**Composition of Concurrent Forces.** Let  $OA$  and  $OB$ , Fig. 3, represent two concurrent forces acting at the point  $O$ . To find their resultant, draw  $AC$  parallel to  $OB$ , and  $BC$  parallel to  $OA$ , and connect  $O$  with the point of intersection,  $C$ . Then  $OC$  represents the resultant of the forces,  $OA$  and  $OB$ , its direction is from  $O$  to  $C$ , and its magnitude is represented by its length.  $OC$  is the force which would produce the same effect as the forces  $OA$  and  $OB$  acting together. If the two forces be drawn to a scale of so many pounds to the inch, the magnitude of the resultant may be

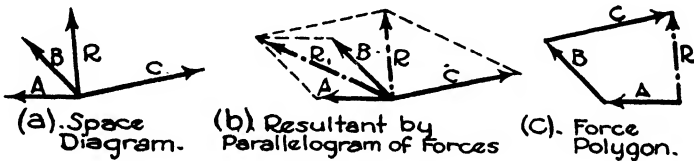

FIG. 4.

found by measuring the length of  $OC$  and reading it at the same scale used in drawing  $OA$  and  $OB$ . In this case the force diagram is called a **PARALLELOGRAM OF FORCES**.

In the case of a number of concurrent forces, the resultant may be found by first finding the resultant of any two forces, called  $R$ , then the resultant of  $R$ , with another force, and continuing until all the forces have been considered. The last resultant found will be the resultant of the given system. In Fig. 4 (a) let it be required to find the resultant,  $R$ , of the concurrent forces  $A$ ,  $B$  and  $C$ . In Fig. 4 (b), the resultant  $R_1$

of  $A$  and  $B$  is found; next find the resultant of  $R_1$  and  $C$ . This is  $R$ ; it is the resultant of forces  $A, B$  and  $C$ .

Another method of finding the resultant of a system of concurrent forces is by constructing a force diagram or force polygon, Fig. 4 (c). To do this, draw a system of lines, one after the other, equal in magnitude, parallel and in the direction of the respective forces. The line

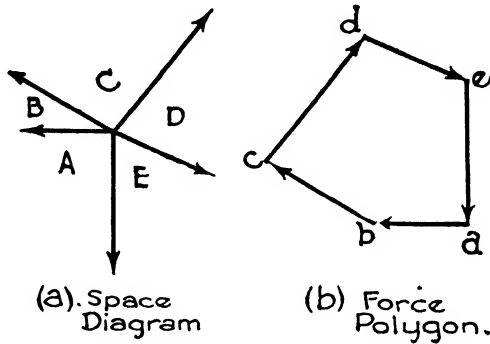

FIG. 5.

required to complete the polygon, DRAWN FROM THE STARTING POINT, represents the resultant in magnitude and direction. Its line of action is through the point in common of the given system of forces. If the forces in the given system are concurrent and the force polygon closes, that is, no closing line is required, the system is in equilibrium and the resultant may be said to equal zero.

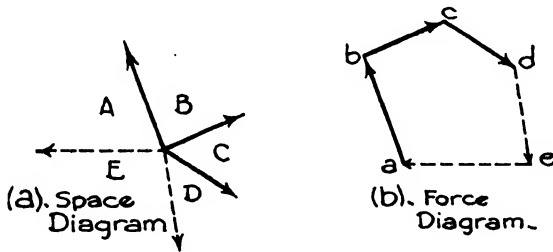

FIG. 6.

**Notation:** The notation generally used in the discussion of graphical solutions of problems is shown in Fig. 5. Fig. 5 (a) shows the space diagram, the five forces being represented by  $AB, BC, CD, DE$  and  $EA$ . In the force polygon lower-case letters are used, placed at the extremities of the forces. This system of forces is in equilibrium since they are concurrent and the force polygon closes.

**Finding Unknown Forces.** When a system of forces is in equilibrium, but all the forces are not completely known, the unknown forces may,

in certain cases, be determined. The most usual case is that in which two forces are unknown except in their lines of action, the other forces being known completely. In Fig. 6,  $AB$ ,  $BC$  and  $CD$  are completely known but only the lines of action of  $DE$  and  $EA$  are known. Construct the force diagram for  $AB$ ,  $BC$  and  $CD$ . From  $d$  draw a line parallel to the line of action of  $DE$ , and from  $a$  draw a line parallel to the line of action of  $EA$ . Their intersection determines the point  $e$ , and  $de$  and  $ea$  represent the required forces in magnitude and direction. The complete force polygon is  $abcdea$ .

**Resolution of Concurrent Forces.** The resolution of a given force into any number of components, which together have the same effect as the given force, may readily be accomplished by drawing a closed polygon with the given force as one side. The other sides of the polygon will then represent the component forces. But an infinite number of such polygons may be drawn, consequently in most cases occurring in practice the components are required to satisfy certain specified conditions. The most usual case is that of resolving a force into components parallel or perpendicular to established lines or surfaces.

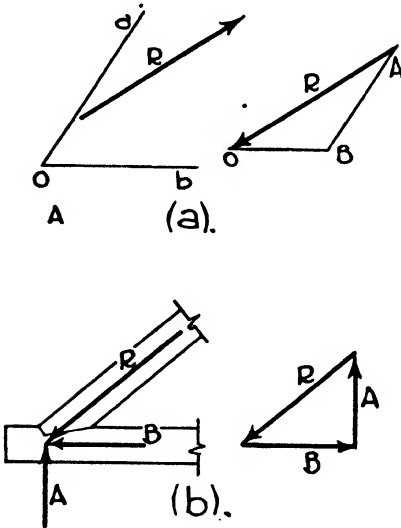

FIG. 7.

of the components may then be scaled from the diagram.

A situation often arising is that of resolving a force into two components, one parallel to a given surface and one perpendicular to it. These requirements are easily satisfied as shown in Fig. 7 (b). For instance, if  $R$  be the stress in the upper chord of a truss, the vertical component of  $R$  is the vertical force to be resisted by the lower chord, and the horizontal component is the horizontal force that must be resisted by the lower chord.

**Composition of Non-Concurrent Forces.** The effect of a force upon a rigid body is the same at whatever point in its line of action it is applied. The resultant of a system of non-concurrent and non-parallel forces may consequently be found in the same manner as for concurrent forces by prolonging two forces until they meet and, by a triangle of

forces, determining their resultant. This resultant is prolonged until it meets the third force and their resultant determined. This same method may be continued until the final resultant is obtained.

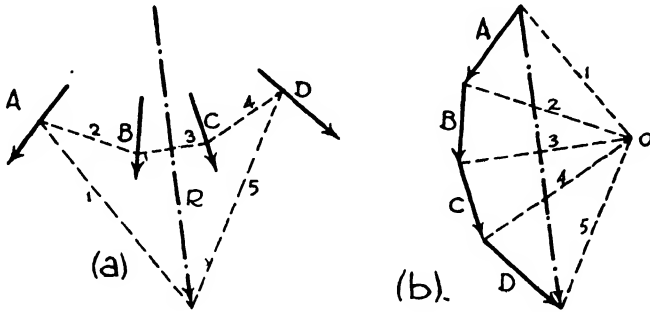

FIG. 8.

This method cannot be used when the forces are parallel, or nearly so, and for most cases the use of a FUNICULAR or EQUILIBRIUM POLYGON, together with a force polygon, as shown in Fig. 8, is more convenient.

Consider the four forces *A*, *B*, *C* and *D* shown on the space diagram, Fig. 8 (a). The force diagram is constructed, and the closing line *R* gives the magnitude and direction of the resultant. To find the line of action of the resultant, a funicular or equilibrium polygon is constructed. In Fig. 8 (b) any convenient point *O*, called the pole, is selected and from it the lines or rays, 1, 2, 3, 4 and 5, are drawn.

On the space diagram, Fig. 8 (a), select any point on force *A* and draw the lines 1 and 2 parallel to the rays 1 and 2 in Fig. 8 (b). From the point where 2 intersects *B*, draw 3 parallel to ray 3, and from the point where 3 intersects *C* draw 4 parallel to ray 4. From the point where 4 intersects *D* draw 5 parallel to ray 5 until it intersects 1, previously drawn. This point of intersection gives a point in the line of action of the resultant *R*. This is true because it will be observed that, in the force polygon, *R* is held in equilibrium by rays 1 and 5, and any three forces in equilibrium which are not parallel must have a point in common. Through this point draw the resultant parallel to *R* of the force diagram.

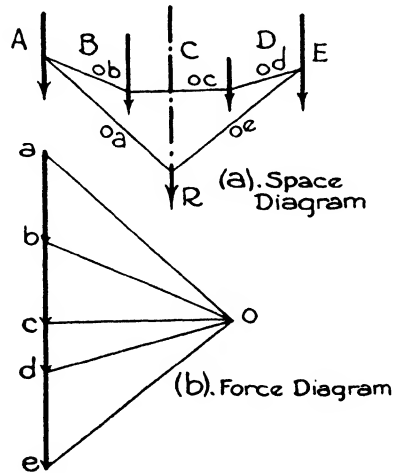

FIG. 9.

**Composition of Parallel Forces.** Fig. 9 (a) shows four parallel forces

*AB, BC, CD and DE.* Draw the force diagram, (b), all the forces forming an unbroken straight line. Construct the equilibrium polygon in the manner described for Fig. 8. Then the intersection of *oa* and *oe* gives a point on the line of action of the resultant. Its direction will be parallel to the component forces, and its magnitude will be the sum of the magnitudes of the component forces as shown by the line *ae* of the force diagram.

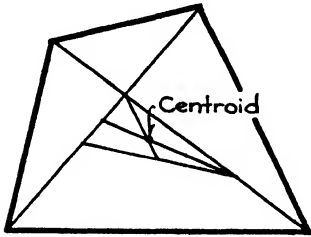

FIG. 10.

**Center of Gravity. Centroids.** All the particles of a body are attracted to the earth in parallel lines of action and with forces proportional to their masses. The resultant of these forces is the WEIGHT of the body, and the line of action of the resultant passes through the CENTER OF GRAVITY of the body.

The center of gravity is the same for any position of a body, and if a force equal to the resultant but opposite in direction be applied in a line passing through the center of gravity, the body will be held in equilibrium.

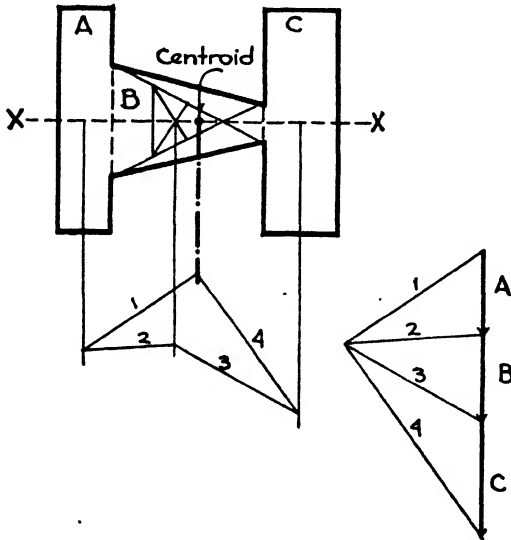

FIG. 11.

The CENTROID of a plane area is a point which corresponds to the center of gravity of a thin homogeneous plate of the same shape and area. The centroids of circles, parallelograms and triangles are readily found by graphical methods. The centroid of a quadrilateral, Fig. 10, may be found graphically by drawing the two diagonals and laying off

from the end of each diagonal furthest from the intersection, the length of its shorter segment. By connecting these two points a triangle is formed whose centroid is the centroid of the quadrilateral.

The centroid of any irregular figure may be determined by dividing the figure into convenient areas. The centroid of each area is then found. These sectional areas are treated as a system of parallel forces acting through their respective centroids with respect to a selected axis. The line of action of the resultant of these parallel forces is then found by means of a force diagram and an equilibrium polygon; it will pass through the centroid of the figure. If the figure be symmetrical about one axis, as  $X-X$ , Fig. 11, the centroid will be at the intersection of the line of action of the resultant with this axis. If the figure be unsymmetrical, resultants must be found in reference to two axes perpendicular to each other. The point of intersection of their lines of action determines the centroid.

### Article 2. Unit Stresses

**Axial Loads.** When a load is placed on a structural member in such a manner that its line of action coincides with the axis of the member, the load is said to be axial, and the stresses are assumed to be equally distributed over the cross-section. If  $P$  be the load,  $A$  the area of the cross-section, and  $f$  the unit stress, then  $P = fA$ . For instance, if a short 10" x 10" timber post be subjected to an axial load of 120,000 lbs., the unit stress may be found by the formula

$$P = fA, \text{ or } f = \frac{P}{A}$$

$$f = \frac{120,000}{100} = 1200 \text{ lbs./in.}^2$$

It is obvious that, if any two of the terms of the equation are known, the third may readily be found.

**Kinds of Stresses.** A stress may be defined as an internal resistance that balances an external force. A unit stress is a stress per unit of area. When a force acts upon a member, a change in shape or volume of the member results. This alteration is called **DEFORMATION**. The word **STRAIN** is used synonymously with **DEFORMATION**, but since the latter is more generally used, it will be adopted in these discussions.

The stresses which occur most frequently in structural members are **TENSION**, **COMPRESSION** and **SHEAR**.

If a member of a roof truss be subjected to forces that tend to lengthen it, the stress is tensile and the deformation is an elongation.

If a column be subjected to a load tending to compress the fibers, the member is in compression and the deformation accompanying the stress is a shortening.

Assume a beam to be loaded with equal loads placed near the supports as in Fig. 12. It is apparent that there is a tendency for the beam to be cut in vertical planes between the supports and the loads. The stresses resulting from such forces are called shearing stresses; they result from parallel forces acting in opposite directions, not having the same line of action.

Figs. 13 and 14 illustrate shearing stresses in rivets. In the former, the rivets are in single shear; in the latter, they are in double shear. It is evident that the steel plates in these two figures are in tension, and sufficient material must be provided so that the unit stress will not exceed the allowable tensile unit stress of the material.

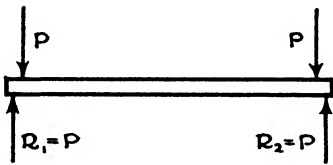

FIG. 12.

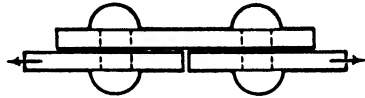

FIG. 13.

Fig. 15 indicates a simple beam having a concentrated load at the center of the span. The stresses in the fibers of the beam are compressive at the top of the beam and tensile at the bottom. The beam is in bending, and such stresses are discussed in Article 4.

**Elastic Limit.** Testing laboratories have machines for stressing specimens to rupture. During the tests, accurate records are kept of the deformations which occur as the loads are applied. Suppose we have a bar of wrought iron, 1 in.<sup>2</sup> in cross-section, to test for tension. It is

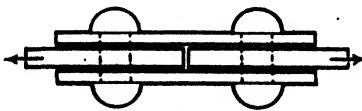

FIG. 14.

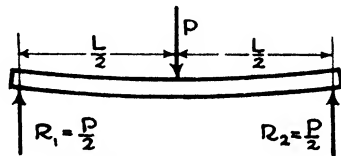

FIG. 15.

placed in a testing machine and a tensile force is gradually applied. When 5000 lbs. has been reached, it is observed that a certain elongation has been produced. The total elongation, or deformation, depends upon the length of the specimen. The unit elongation equals the total elongation divided by the number of units in the length of the specimen. Call the total elongation  $x$  inches. When the next 5000 lbs. has been applied, making a total unit stress of 10,000 lbs., we find the deformation to be twice as great as it was after the first 5000 lbs. The loads are increased again, and it is noticed that for each 5000 lbs. the

bar has lengthened  $x$  inches. When 20,000 lbs. has been reached, the deformation is  $4 x$  inches, but at 30,000 lbs., instead of  $6 x$  inches, the deformation is greater. Up to the load of about 26,000 lbs./in.<sup>2</sup> there has been a uniform lengthening for each unit of load applied. This unit stress, 26,000 lbs./in.<sup>2</sup>, is called the ELASTIC LIMIT; it is the unit stress beyond which the deformations increase in a faster ratio than the applied loads. If the results of the test were plotted as in Fig. 16, the curve up to 26,000 lbs./in.<sup>2</sup> would be a straight line; that is, within this limit, the ratio of stress to deformation would be constant.

If, while testing the specimen up to the elastic limit, the loads had been removed, the bar would have returned to its original length. This is not true if the unit stress exceeds the elastic limit, for we then find

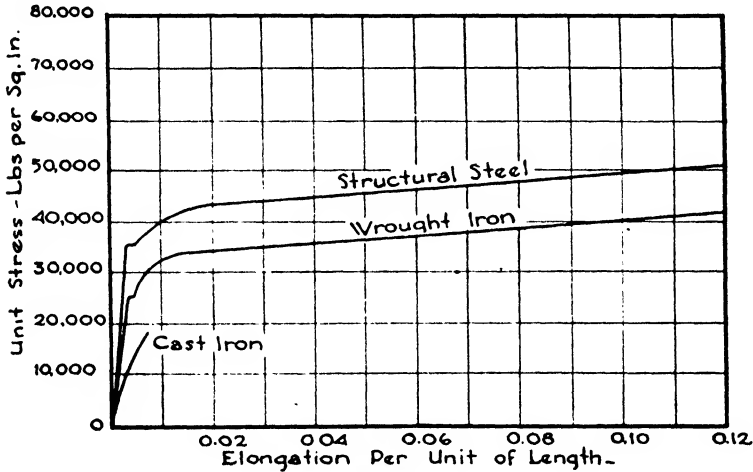

FIG. 16.

that upon removing the load the bar has increased its length; and this elongation is called the PERMANENT SET. It is seen that the elastic properties of a bar are injured if the unit stress exceeds the elastic limit, and hence in designing structural members it is essential that the unit stress be below the elastic limit.

**Table I. Average Values of the Elastic Limit for Various Materials**

Material	Elastic Limit, pounds per square inch	
	Tension	Compression
Structural Steel. . . . .	35 000	35 000
Cast Iron. . . . .	9 000	25 000
Wrought Iron. . . . .	25 000	25 000
Timber. . . . .	3 000	3 000



**Yield Point.** When ductile materials, as wrought iron, for example, are tested at a stress slightly greater than the elastic limit, it is noticed that there is an increase in deformation without the addition of any load. This unit stress is called the **YIELD POINT** and is indicated on the diagram as the short horizontal part of the curve. This yielding is only momentary and, if the test be continued, the specimen can again hold an increased load. It should be noted that non-ductile materials such as wood and cast iron have poorly defined elastic limits and no yield point.

**Ultimate Strength.** Assume the test to be continued and the stresses and deformation plotted. We find that the curve continues to rise but becomes flatter until the greatest unit stress is reached. This stress is the **ULTIMATE STRENGTH** of the material, and failure begins at this point. The curve now begins to slope downward and its end represents the **BREAKING STRENGTH**. See Fig. 17.

**Factor of Safety.** If the ultimate tensile stress of structural steel is 64,000 lbs./in.<sup>2</sup>, and the actual tensile stress of a member subjected to a load is 16,000 lbs./in.<sup>2</sup>, then  $\frac{64,000}{16,000} = 4$ , which is the **FACTOR OF SAFETY**.

It is the number which results from dividing the ultimate strength of the material by the allowable or the actual working stress. When a structural member is subjected to a load of  $P$  pounds and its cross-section area is  $A$  square inches,  $\frac{P}{A} = f$ , the actual unit stress. By comparing this unit stress with the ultimate strength of the material, the factor of safety may be determined. Determining the factor of safety of a member under a given load is called **INVESTIGATION**.

Owing to the difference in character of various materials, it is obvious that higher factors of safety are deemed advisable for some materials than for others. It can readily be understood that factors of safety for materials subject to steady stresses, such as are present in buildings, need not be as large as those required for varying stresses as in bridges or machines. When it is desired to know what allowable unit stress should be used in the design of structural members, the ultimate strength divided by the factor of safety determines this stress. But unless the factor of safety is set down by a building code, only engineering experience can determine what factor of safety to use. From what has been stated concerning the elastic limit, it can be seen that an allowable unit stress should be well within this stress. Allowable working stresses are today not determined by an arbitrary factor of safety but are rather the result of the engineering judgment of the authority specifying the stress. For the convenience of students, Table II is given as a guide. It is important to note that working unit stresses determined by this method are merely approximate, and that stresses used in the design of structures should be those set down by building codes or regulations.

Table II. Factors of Safety\*

Material	Steady Stress, Buildings	Variable Stress, Bridges	Shocks, Machines
Brick and Stone . .	15	25	40
Timber . . . . .	8-10	16	25
Cast Iron . . . . .	6	10	20
Wrought Iron . . . .	4	6	10
Structural Steel . . .	4	6	10

\* Taken from Merriman's 'Mechanics of Materials.'

Table III. Average Physical Properties of Various Building Materials

Material	Ultimate Strength lbs./in. <sup>2</sup>			Allowable Working Stress lbs./in. <sup>2</sup>				Modulus of elasticity lbs./in. <sup>2</sup>	Weight lbs./ft.
	Tension	Com-pression	Shear	Tension	Com-pression	Shear	Bend-ing		
Brick Masonry		2 000			100-250				125
Stone Masonry		2 500			400				145
Timber— forces paral- el to grain	10 000	8 000	600	1 000	1 000	110	1 000	1 000 000— 1 500 000	40
Timber— forces per- pendicular to grain . . . .			3 000		300	500- 1 000			
Cast Iron . .	25 000	80 000	20 000	3 000	12 000	3 000		12 000 000	450
Wrought Iron	43 000	48 000	40 000	12 000	12 000	8 000	12 000	27 000 000	485
Steel, Struc- tural . . . .	60 000	60 000	45 000	18 000	18 000	12 000	18 000	30 000 000	490

**Physical Properties of Materials.** Because of the various qualities and grades of materials it is obviously impossible to tabulate accurately their properties in one brief table. Table III is presented here merely as a guide, the figures given are approximate and designers should refer to the specific requirements set down by the building code under which they work. For timber stresses see Table I, Chapter XVIII.

**Masonry.** Brick masonry, for example, permits various stresses in accordance with the kind of brick and the mortar used. A typical specification is that for brick having an ultimate compressive strength of not less than 3000 lbs./in.<sup>2</sup>; 250 lbs./in.<sup>2</sup> is permitted if the mortar be Portland cement; 200 lbs./in.<sup>2</sup> if cement-lime mortar be used, and 100 lbs./in.<sup>2</sup> for lime mortar. In the same manner, the allowable unit stresses of stone masonry may vary, ordinary rubble ranging from 80 to 140 lbs./in.<sup>2</sup>

**Modulus of Elasticity. Deformation.** In stress-deformation diagrams we find that, for all unit stresses less than the elastic limit, there is a constant ratio between stress and deformation. Fig. 17 is a stress-deformation diagram of a steel specimen stressed to the point of rupture. The diagram is distorted to show more clearly the phenomenon of deformation. The tangent of angle  $\theta$  is the MODULUS OF ELASTICITY

of the material. The more nearly vertical this part of the curve, the greater the modulus of elasticity. This ratio represents the degree of stiffness of the material and may be defined as the unit stress divided by the unit deformation. If  $P$  = the applied load,  $f$  = the unit stress,  $A$  = the area of the cross-section,  $s$  = the unit deformation,  $e$  = the total deformation,  $l$  = the length of the specimen and  $E$  = the modulus

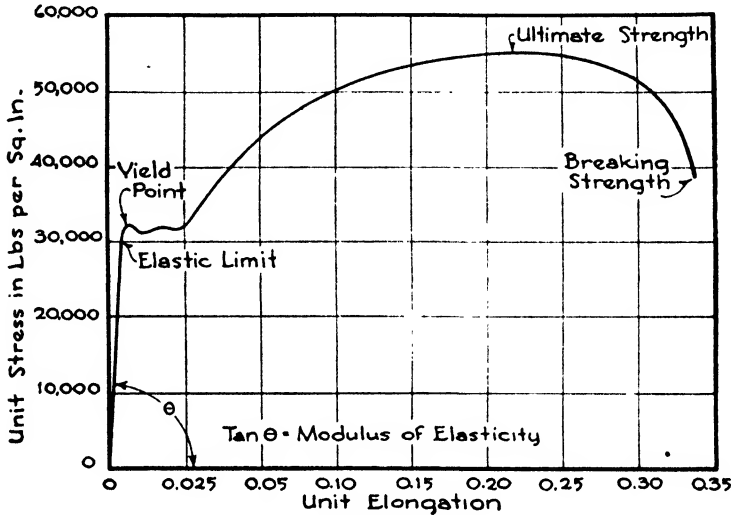

FIG. 17.

of elasticity of the material, then by definition,  $E = \frac{f}{s} = \frac{P/A}{e/l} = \frac{Pl}{Ae}$  or

$$e = \frac{Pl}{AE}$$

It must be borne in mind that this relation is true only when the unit stress is less than the elastic limit of the material.

**Example.** Compute the elongation of a steel bar 2 in.<sup>2</sup> in cross-section, 30'' long, under a tensile stress of 30,000 lbs. Assume  $E$  to be 30,000,000 lbs./in.<sup>2</sup>,

$f = \frac{P}{A}$  or  $f = \frac{30,000}{2} = 15,000$  lbs./in.<sup>2</sup> Since this unit stress is less than the

elastic limit of the material, the formula is applicable. Hence  $e = \frac{Pl}{AE}$  or  $e =$

$\frac{30,000 \times 30}{2 \times 30,000,000}$  or  $e$ , the deformation = 0.015''. There are five terms in this equation, and if any four are known, the fifth may be found.

### Article 3. Moments and Reactions

**Moments.** A moment of a force is the tendency of the force to cause rotation about a certain point or axis. The moment of a force is always

considered in connection with some fixed point or axis called the **ORIGIN** or **CENTER OF MOMENTS**, and the moment of a force in respect to that point is the measure of the tendency of the force to produce rotation about the point. The moment of a force is equal to the magnitude of the force multiplied by the perpendicular distance from the line of action of the force to the point or axis, or, in other words, the product of the magnitude of the force by the **LEVER ARM** of the force. When the force tends to cause rotation in the direction of the hands of a clock, called clockwise, the moment may be considered as **POSITIVE**, and **NEGATIVE** when the tendency is to rotate counter-clockwise.

Thus in Fig. 18 the moment of the force  $F$  with respect to the point  $O$ , is  $F$  multiplied by the perpendicular distance from  $O$  to  $F$ , or  $F \times Oa$ . If the magnitude of the force  $F$  were 100 lbs. and the distance  $Oa$  were 3'0", the moment of the force would be  $100 \times 3 = 300$  ft.-lbs., or  $300 \times 12 = 3600$  in.-lbs.

If a body be in equilibrium, the sum of the moments of the forces tending to rotate the body in a clockwise direction around a given

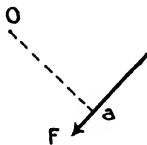

FIG. 18.

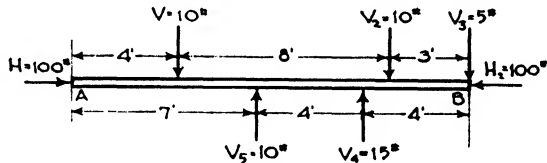

FIG. 19.

point must equal the sum of the moments of the forces tending to turn the body in the opposite direction around the same point. The algebraic sum of the moments, considering the positive moments as **PLUS** and the negative moments as **MINUS**, must equal zero,  $\Sigma M = 0$ .

Likewise for equilibrium, the sum of all the vertical forces acting upon a body must equal zero. The same is true with respect to the horizontal forces. If the forces acting downward were greater than those acting upward, or if the forces pushing or pulling to the right were greater than those acting toward the left, there would be movement in the body.

In Fig. 19 the beam  $AB$  is in equilibrium because the sum of the vertical forces is  $10 + 10 + 5 - 10 - 15 = 0$  or  $\Sigma V = 0$ ; and the sum of the horizontal forces is  $100 - 100 = 0$  or  $\Sigma H = 0$ ; and the sum of the moments around the end  $A$  is

$$(10 \times 4) + (10 \times 12) + (5 \times 15) - (10 \times 7) - (15 \times 11) = 0 \text{ or } \Sigma M = 0.$$

In this instance the sum of moments was taken about the point  $A$ , but the algebraic sum of the moments of the vertical forces would be zero regardless of the point taken, since the forces are in equilibrium.

These principles are constantly used in the designing of beams and other structural members.

**The Lever.** The principle of the lever has an important place in architecture and occurs particularly in the design of beams, girders and foundations. The lever is constantly employed in the erection of buildings and was probably the chief means by which great weights were moved in the construction of ancient monuments. The principle concerns the relation between any three parallel forces, in the same plane, which hold a body in equilibrium.

Assume that the force *A* on the beam in Fig. 20 is 60 lbs. The magnitudes of *C* and *B* are unknown but their positions are determined. If we wish to know the magnitude of the force *B* to balance, or hold *A* in equilibrium, we can apply the principle of moments. If we write an equation of the moments of forces *A* and *B* about the point of the beam in the line of action of *C*,

$$60 \times 4 = 6 \times B \text{ or } B = \frac{60 \times 4}{6} = 40 \text{ lbs.}$$

This is true because the moment of the force tending to revolve the beam in a clockwise direction about the point *C* must equal the

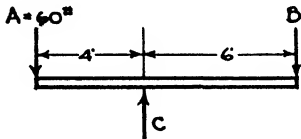

FIG. 20.

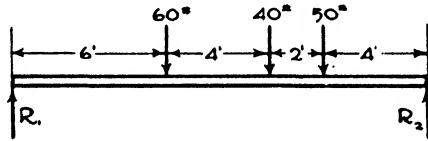

FIG. 21.

moment of the force tending to revolve the beam in a counter-clockwise direction about the same point.

If the algebraic sum of the vertical forces equals zero, the downward forces must equal the upward forces. Hence  $A + B = 60 + 40 = 100$  lbs., the downward forces; and *C* the upward force must also equal  $A + B = 60 + 40 = 100$  lbs.

**Reactions.** The beam represented in Fig. 21 may be considered as five vertical forces in equilibrium. The three downward forces are known, the supporting forces *R*<sub>1</sub> and *R*<sub>2</sub>, called reactions, have unknown magnitudes but their locations are determined. This type of problem is common in engineering. How may we determine the magnitude of *R*<sub>1</sub> and *R*<sub>2</sub>? First apply the principle of moments, taking their sum about *R*<sub>2</sub>. Then  $R_1 \times 16 = (60 \times 10) + (40 \times 6) + (50 \times 4) = 1040$  or  $R_1 = 65$  lbs.

The moment of the force *R*<sub>2</sub> is ignored because its lever arm is zero, and  $R_2 \times 0 = 0$ .

The sum of the downward forces must equal the sum of the upward forces, therefore  $60 + 40 + 50 = 150$  lbs. or the total downward forces. If  $R_1 + R_2 = 150$  lbs.,  $65 + R_2 = 150$  lbs., and  $R_2 = 150 - 65$  or 85 lbs.

If we had wished to compute *R*<sub>2</sub> by moments, we could have written an equation of moments about *R*<sub>1</sub>.

**Overhanging Beam.** The two types of loadings which occur in practice are CONCENTRATED LOADS and UNIFORMLY DISTRIBUTED LOADS. A column resting on a girder is an example of a concentrated load; a wall supported by a beam illustrates a load uniformly distributed. Fig. 22 represents a beam extending beyond one support, the loads consist of two concentrated loads, and one uniformly distributed load of 1000 lbs. extending over a length of 4'. In computing the reactions or supports for beams having uniformly distributed loads no difficulty is encountered if we remember that a uniformly distributed load is assumed to act at its center of gravity. In this example the uniformly distributed load is 1000 lbs. and extends over a distance of 4'. We may consider, then, that it affects the reactions in the same way as a concentrated load of the same magnitude acting at 2' from the left end of the beam.

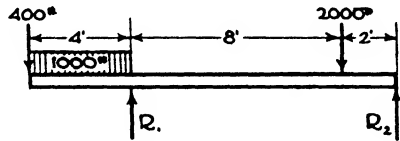

FIG. 22.

First let us write an equation of moments about the right support,  $R_2$ . The moments on the left-hand side of the equation tend to turn the beam in a clockwise manner about  $R_2$ , and those on the right-hand side tend to turn the beam in a counter-clockwise manner.

$$10R_1 = (400 \times 14) + (2000 \times 2) + (1000 \times 12) = 21,600$$

$$R_1 = 2160 \text{ lbs.}$$

Since the sum of the downward forces equals the sum of the upward forces,  $400 + 2000 + 1000 = 2160 + R_2$ . Therefore  $R_2 = 1240$  lbs.

If we had taken the moments about  $R_1$  the equation would be

$$(2000 \times 8) = 10 R_2 + (400 \times 4) + (1000 \times 2) \text{ or } R_2 = 1240 \text{ lbs.}$$

#### Article 4. Bending Moments and Shear

**Classification of Beams.** Primarily, a beam is a horizontal or inclined structural member which resists bending, the forces acting on the beam tending to bend rather than to shorten or elongate it. Beams are classified in accordance with the manner in which they are supported. A beam resting on two supports is called a SIMPLE BEAM, Fig. 23(a.) A beam which projects from a single support is a CANTILEVER BEAM, Fig. 23(b). A simple beam projecting over one or both supports is termed an OVERHANGING BEAM, Fig. 23(c). Examples of CONTINUOUS and FIXED beams are shown in Fig. 23(d) and (e), and are discussed in Article 8.

**Stresses within a Beam.** If a beam be subjected to loads and the beam be in equilibrium, it is obvious that at any section the stresses in the fibers of the beam hold in equilibrium the external forces on each side of the section. The external forces are the loads, including the weight of the beam, and the supporting forces, called the reactions

In the beam shown in Fig. 24(a), consider the section shown by the dotted line. Imagine the beam to be cut at this section and the two parts of the beam separated as in Fig. 24(b). It is seen that forces as indicated by arrows must be applied at the section cut if equilibrium is to be maintained. These are the forces which existed in the fibers before the beam was cut.

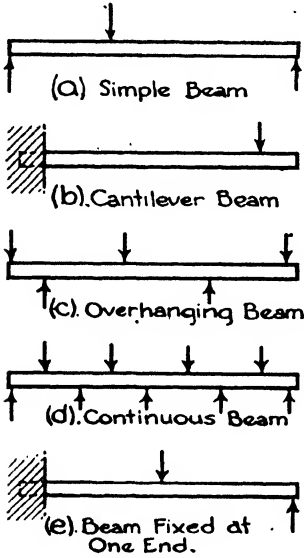

FIG. 23.

When a simple beam, as shown in Fig. 24, is stressed by loads, the beam tends to become concave on the top and convex at the bottom. The upper fibers are in compression and tend to shorten, while those at the bottom are in tension and tend

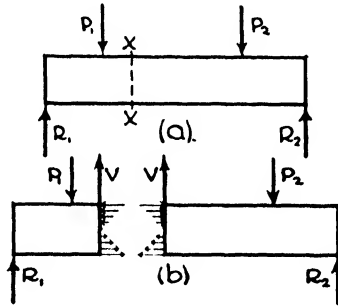

FIG. 24.

to elongate. It can be shown that the fibers in a plane between the upper and lower surfaces have no stress in bending, and this plane is called the **NEUTRAL SURFACE**. Provided the fiber stresses do not exceed the elastic limit of the material, they are directly proportional to their distances from the neutral surface, those at the top and bottom surfaces being the maximum in compression and tension respectively.

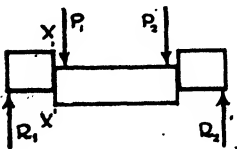

FIG. 25.

**Shearing Stresses.** Short beams with heavy loads may fail by a cutting action, as indicated in Fig. 25. Whether or not the beam fails, the tendency exists in all beams. If we consider the section X-X, this tendency is equal in magnitude to the forces on either side of the section

and is called the **VERTICAL SHEAR, V**. If the beam be in equilibrium there is no cutting, or motion, and the internal vertical stresses balance or equal the vertical shear. The sum of these internal vertical stresses resisting the vertical shear is called the **RESISTING SHEAR**. It follows, then, that the vertical shear must equal the resisting shear. If  $f_v$  = the shearing unit stress,  $V$  = the vertical shear and  $A$  = the area of the

cross-section,  $f_s = \frac{V}{A}$ , which is the fundamental equation given in Article 2. This formula assumes that the vertical shear is distributed equally over the entire cross-section. Such an assumption is true for parts under direct stress, as in rivets, but is not true for shearing stresses in beams.

**Horizontal Shear.** If a number of boards are laid one upon the other as shown in Fig. 26, there is a tendency for them to slide one on the other, as indicated. This tendency is present in beams but is restrained by the fibers. The name given to it is HORIZONTAL SHEAR, and at any section in a beam the sum of the horizontal shearing unit stresses is equal to the sum of the vertical shearing unit stresses.

The horizontal shearing unit stresses are not distributed equally over the cross-section of a beam; they are maximum at the neutral surface and zero at the outer surfaces. In an I-beam the fibers receiving the greatest stress in shear are in the web where there is a relatively small amount of material, the flanges being stressed a minimum amount. For these reasons, the depth of the I-beam multiplied by the thickness of the web gives the area considered as resisting shear.

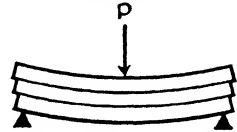

FIG. 26.

Wooden beams are rectangular in cross-section. The maximum horizontal shearing unit stress is at the neutral surface and may be computed by the equation

$$f_s = \frac{3V}{2A}$$

$A$  being the area of the cross-section.

**Example.** A 10" x 12" wooden beam has a concentrated load of 16,000 lbs. at the middle of a 12' span. What is the maximum horizontal shearing unit stress?

If the load is 16,000 lbs. the maximum vertical shear is 8000 lbs. Substituting in the above formula,  $f_s = \frac{3 \times 8000}{2 \times 120}$  or  $f_s = 100$  lbs./in.<sup>2</sup>

It is observed from the formula that the maximum horizontal shearing unit stress is one and one-half times the average stress,  $\frac{V}{A}$ . If the allowable maximum shearing unit stress on this beam were 110 lbs./in.<sup>2</sup>, the average shearing stress would be  $\frac{2}{3} \times 110 = 73.3$  lbs. Since the area = 10 x 12 = 120 in.<sup>2</sup>, the allowable resisting shear will be 120 x 73.3 lbs. = 8796 lbs. The concentrated load in this case, ignoring the weight of the beam, which causes this shearing stress will be 2 x 8796 lbs. = 17,592 lbs.

**Vertical Shear.** From the foregoing discussion it is seen that vertical shear may be defined as the tendency of one part of a beam to move vertically with respect to an adjacent part. The magnitude of the vertical shear is equal to the algebraic sum of the external vertical



forces on either side of the section. In finding the vertical shear either the forces to the right or to the left of the section may be considered, since the result is the same in either case. For convenience, however, the forces to the left of the section are usually considered, and we may say: **The vertical shear at any section of a beam is equal to the reactions to the left of the section minus the loads to the left of the section.** It is of the utmost importance that the student remember this exactly and not confuse shear with the bending moment which will be discussed later. Also, if the reactions and loads be in pounds, the magnitude of the vertical shear will be in similar units, namely pounds.

**Bending Stresses.** We have just discussed the tendency of the various parts of a beam to move up and down vertically; this is vertical shear.

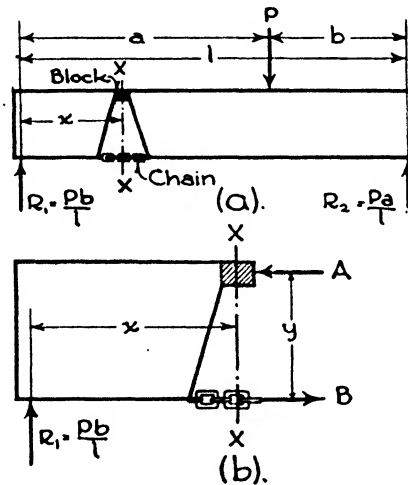

FIG. 27.

Now let us consider the tendency of forces to cause rotation in the different parts of a beam; this tendency is called the **BENDING MOMENT**. To understand the theory of beams, it is highly important that the student keep separate and distinct in his mind the tendency to move vertically and the tendency to rotate.

Consider the beam shown in Fig. 27(a). A portion has been cut away on the axis  $X-X$ , a block is inserted at the top and a chain at the bottom of the beam. We know from observation that the block will be in compression—call this force  $A$ ; the chain is in tension,  $B$ . If there is to be equilibrium, the sum of the compressive forces must equal the sum of the tensile forces, or  $A = B$ . If the beam had not been cut, these stresses would have been distributed, in compression on the fibers above the neutral surface, and in tension on the fibers below the neutral surface. But the sum of all the compression stresses would equal  $A$ , and the sum of all the tensile stresses,  $B$ .

If we write an equation of the moments of the external forces about  $R_2$ ,  $R_1 l = Pb$  or  $R_1 = \frac{Pb}{l}$ . Similarly,  $R_2 = \frac{Pa}{l}$ .

At the section  $X-X$  there is a tendency for the force  $\frac{Pb}{l}$  to cause a clockwise rotation about this section. The moment of  $\frac{Pb}{l}$  about the section  $X-X$  is  $\frac{Pb}{l}$  multiplied by its lever arm  $x$ , or the tendency to rotate is expressed by  $\frac{Pb}{l} \times x$ . This tendency of the external forces to cause rotation about a section of a beam is called the **BENDING MOMENT**. It varies in magnitude at different sections of the beam. For instance, at the distance  $a$  from the left support it is  $\frac{Pb}{l} \times a$ . The bending moment is indicated by  $M$ , or  $M = \frac{Pb}{l} \times x$  at distance  $x$ , and  $M = \frac{Pb}{l} \times a$  at distance  $a$ .

But the beam is in equilibrium; it does not rotate. The forces which prevent motion are forces  $A$  and  $B$ , Fig. 27(b). These forces tend to rotate the beam in a counter-clockwise direction about the section  $X-X$ .  $A$  = the sum of all the compressive stresses, and  $B$  = the sum of all the tensile stresses. The sum of the moments of the internal stresses at any section of a beam is called the **RESISTING MOMENT** because it resists the bending moment. Obviously, then, if a beam be in equilibrium, the resisting moment equals the bending moment.

The sum of the moments of the horizontal forces  $A$  and  $B$  about a point midway between their lines of action is  $A \frac{y}{2} + B \frac{y}{2}$ , and this equals the resisting movement. But  $A = B$ ; therefore substituting the value of  $B$ ,  $A \frac{y}{2} + A \frac{y}{2} = 2A \frac{y}{2} = Ay$ , the resisting moment. If we had taken the sum of moments of forces  $A$  and  $B$  about the line of action of force  $B$ , then  $Ay + 0 =$  the resisting moment, because  $A$  has a lever arm of  $y$ , and  $B$  has a lever arm of zero.  $B \times 0 = 0$ .

**Bending Moment.** The bending moment at any section of a beam is equal to the algebraic sum of the moments of the external forces on either side of the section. For convenience, the forces to the left are generally considered; therefore: **The bending moment at any section of a beam equals the moments of the reactions minus the moments of the loads to the left of the section.** This statement must be borne in mind constantly in the design of beams. Since a moment is the product of a force by a distance, the bending moment is in units of foot-pounds, inch-pounds, etc., depending upon the units employed.

**Shear and Moment Diagrams.** It is of great convenience to make diagrams of the shear and bending moments. They are drawn directly below the beam, the shear diagram first, because, as will be seen, it is of assistance in drawing the bending moment diagram. It can be shown that the bending moment approaches a maximum at the point where the shear passes through zero, and in complex loadings it is often necessary to draw the shear diagram to determine this point. In drawing the shear diagram, a horizontal line is laid off parallel to and directly below the beam, a convenient scale is adopted and the diagram is plotted. The ordinates or vertical distances represent the magnitude of

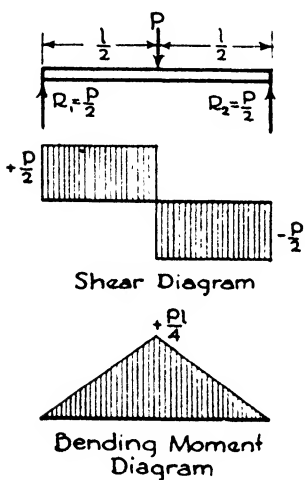

FIG. 28.

the shear at corresponding points along the beam. If the shear be a positive quantity it is plotted above the horizontal line, and a negative shear is plotted below. The bending moment diagram is constructed in a similar manner.

A case frequently occurring in practice is a simple beam having a concentrated load at the center of the span, Fig. 28. Call the load  $P$ , and the span  $l$ . Then  $R_1 = \frac{P}{2}$

and  $R_2 = \frac{P}{2}$ . A convenient way to write an

equation for the shear,  $V$ , and the bending moment,  $M$ , at any specific point in a beam is to designate as  $x$ , the distance from the point to the left end of the beam. For instance, the shear at a point  $\frac{l}{4}$

be written,  $V_{(x=\frac{l}{4})} = \frac{P}{2} - 0 = \frac{P}{2}$ , because the shear at any section of a beam equals the reactions minus the load to the left of the section. The reaction to the left of this particular point is  $\frac{P}{2}$  and the loads to the

left are zero. Similarly  $V_{(x=\frac{3l}{4})} = \frac{P}{2} - P = -\frac{P}{2}$ . The shear diagram is plotted in Fig. 28. It is obvious that the value of the shear at the supports is equal in magnitude to the respective reactions. In this instance the shear passes through zero at  $x = \frac{l}{2}$ , that is, at the center

of the span where the sign of the shear changes from plus to minus. The bending moment at this point is maximum and may be written,

$M_{(x=\frac{l}{2})} = \left(\frac{P}{2} \times \frac{l}{2}\right) - 0$  or  $M = \frac{Pl}{4}$ . This is true since the bending mo-

ment at any section of a beam equals the moments of the reactions to the left of the section, minus the moments of the loads to the left. The reaction to the left is  $\frac{P}{2}$  and its lever arm is  $\frac{l}{2}$ . The force  $P$  at this section has a lever arm of zero, hence its value is  $P \times 0 = 0$ . Since this loading, a concentrated load at the center of a simple beam, occurs so frequently, it is well to remember the maximum bending moment,

$$M = \frac{Pl}{4}$$

Another common occurrence is a simple beam having a uniformly distributed load over its entire length, Fig. 29.

Call the span  $l$  and the load  $w$  pounds per foot. The total load  $= wl$ , and  $R_1 = R_2 = \frac{wl}{2}$ ;

$$V \left( x = \frac{l}{2} \right) = \frac{wl}{2} - \frac{wl}{2} = 0, \text{ and}$$

$$M \left( x = \frac{l}{2} \right) = \left( \frac{wl}{2} \times \frac{l}{2} \right) - \left( \frac{wl}{2} \times \frac{l}{4} \right) = \frac{wl^2}{4} - \frac{wl^2}{8} = \frac{wl^2}{8}$$

The reaction to the left of the section is  $\frac{wl}{2}$ , and its lever arm is  $\frac{l}{2}$ . The load to the

left is  $\frac{wl}{2}$  and its lever arm is  $\frac{l}{4}$ , because the uniformly distributed load is considered as a force acting at its center of gravity. Sometimes the TOTAL uniformly distributed load is represented by  $W$ , in which case  $W = wl$  and

$$M = \frac{wl^2}{8}, \text{ which is the same as } M = \frac{Wl}{8}$$

The bending moment just found is the maximum. If we wish to find its value at any distance,  $x$ , from the left reaction, then  $M_x = \left( \frac{wl}{2} \times x \right) - \left( wx \times \frac{x}{2} \right)$ , since  $x$  is the lever arm of the reaction and  $\frac{x}{2}$  is the lever arm of the load  $wx$ .

Fig. 30 shows a cantilever beam having a concentrated load of 1000 lbs. at the free end, and a uniformly distributed load of 500 lbs. per linear foot extending over a distance of 8' from the wall. The shear at the wall equals  $- [1000 + (8 \times 500)] = - 5000$  lbs. The bending moment at the wall equals  $- [(1000 \times 10) + (500 \times 8 \times 4)] = - 26,000$  ft.-lbs.

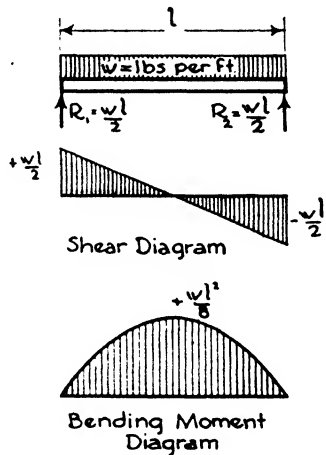

FIG. 29.

An illustration of a simple beam with a uniform load and two concentrated loads is shown in Fig. 31. To find the reactions:

$$8R_1 = (2000 \times 6) + (4000 \times 4) + (400 \times 8 \times 4) \text{ or } R_1 = 5100 \text{ lbs.}$$

$$8R_2 = (2000 \times 2) + (4000 \times 4) + (400 \times 8 \times 4) \text{ or } R_2 = 4100 \text{ lbs.}$$

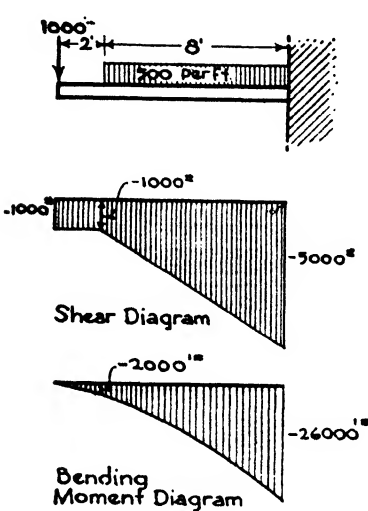

FIG. 30.

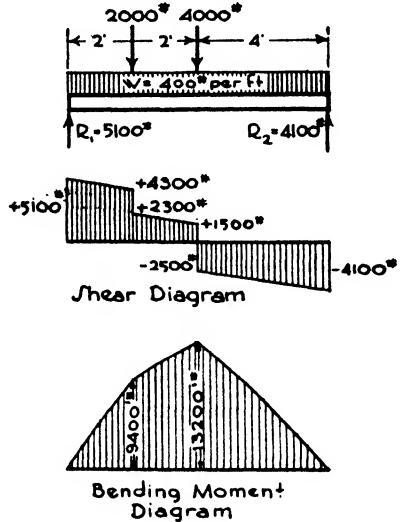

FIG. 31.

From the shear diagram it is seen that the shear passes through zero under the 4000-lb. load, at  $x = 4$ , and the bending moment will be maximum at this point. To find its magnitude:

$$M_{(x=4)} = (5100 \times 4) - [(2000 \times 2) + (400 \times 4 \times 2)] \text{ or } M = 13,200 \text{ ft.-lbs.}$$

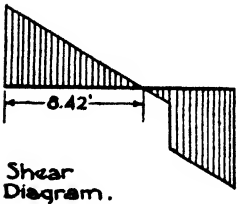
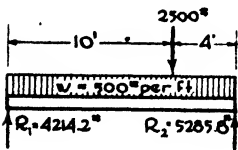

FIG. 32.

In order to draw the bending moment diagram it is necessary to compute the bending moment at several sections in the beam.

It sometimes happens that the bending moment is not a maximum under a concentrated load, that is, the shear does not pass through zero under a concentrated load. Fig. 32 is an example of this condition. In order to find this point, the reactions are first computed. In this particular case it is seen from the shear diagram that there is zero shear at some point between  $R_1$  and the concentrated load of 2500 lbs. Call this distance  $x$  from the left support. Then  $V = 0 = 4214.2 - (500 \times x)$  or  $500x = 4214.2$ , and  $x = 8.42'$ . The value

of the bending moment at this point is:  $M_{(x=8.42)} = (4214.2 \times 8.42) - (500 \times 8.42 \times \frac{8.42}{2})$  or  $M = 17,759 \text{ ft.-lbs.}$

**Article 5. Flexure Formula. Properties of Sections**

**Flexure Formula.** In the discussion of bending stresses, we found that the stresses in the fibers at any section of a beam hold in equilibrium the tendency of the external forces on either side of the beam to cause rotation. The sum of the moments of these stresses, about the neutral axis, is called the resisting moment and is equal to the bending moment in magnitude. Let us find an expression for the resisting moment.

Consider the portion of the beam shown in Fig. 33 cut at section *AB*. We know that all the stresses above the neutral surface are in compression and those below are in tension. If the greatest fiber stress does not exceed the elastic limit of the material, the stresses are directly proportional to their distances from the neutral surface. Call the distance of the fiber most remote from the neutral surface *c*.

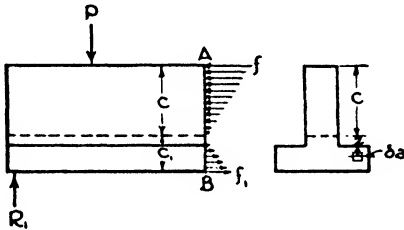

FIG. 33.

Then,  $f$  = the unit stress on the fiber most remote from the neutral surface and  $\frac{f}{c}$  = the unit stress on the fiber at unit distance from the neutral surface. Let us imagine an infinitely small area,  $\delta a$ , at  $z$  distance from the neutral surface. The unit stress on a fiber at  $z$  distance will be  $\frac{f}{c} \times z$ , and the stress on all the fibers in the area  $\delta a$  will be the unit stress multiplied by the area or  $\frac{f}{c} \times z \times \delta a$ . The moment of the stress on fibers in  $\delta a$ , about the neutral axis, will be the stress multiplied by its lever arm  $z$ , or  $\frac{f}{c} \times z^2 \times \delta a$ . If we consider the sum of the moments of the stresses of all the fibers in the section *A-B* about the neutral axis, the sum is, of course, the resisting moment at that section. The letter  $\Sigma$  is a symbol used to indicate the summation of an infinite number of parts, hence the resisting moment =  $\Sigma \frac{f}{c} \times \delta a \times z^2$ , and this quantity is equal to the bending moment,  $M$ . This may be written,  $M = \frac{f}{c} \Sigma \delta a z^2$ .

The quantity  $\Sigma \delta a z^2$  may be read as the sum of the products of all the elementary areas multiplied by the squares of their distances to the neutral surface, and the name given to this quantity is **MOMENT OF INERTIA**, represented by the letter  $I$ . By using the letter  $I$ , the above equation may be written,

$$M = \frac{f}{c} I.$$

Other forms of this equation are  $\frac{M}{f} = \frac{I}{c}$  and  $f = \frac{Mc}{I}$ . This equation is known as the **FLEXURE FORMULA** and is applicable to all beams composed of one material.

**Moment of Inertia.** In the expression  $\Sigma \delta a z^2$ ,  $\delta a$  is an area and, although infinitely small, is measured in square units, generally inches. If we multiply square inches by a distance squared we get inches to the fourth power, that is, biquadratic inches, since the linear unit is contained four times. Hence the moment of inertia of a 6'' x 6'' cross section may be written:  $I = 108 \text{ in.}^4$

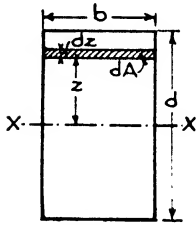

FIG. 34.

The neutral axis of a beam passes through the centroid of the cross-section. It can be seen from the definition, that the moment of inertia might be taken about any axis, but for beams it is convenient to consider that  $I$  is taken about an axis through the centroid, parallel to the base of the beam. The  $I$  of a section is a quantity which depends upon the size of the area and its shape and form with respect to the neutral surface.

It can be shown\* that, for a rectangular cross-section of width  $b$  and depth  $d$ , the moment of inertia about an axis through its centroid, parallel to the base, is:

$$I = \frac{bd^3}{12}.$$

For instance, for a 3'' x 12'', using actual sizes,  $2\frac{5}{8}'' \times 11\frac{1}{2}''$ ,  $I = \frac{2.625 \times 11.5^3}{12} = 332.69 \text{ in.}^4$ . See Table IV.

Let it be required to find the moment of inertia of the I-shaped

\* The simplest method of finding the value of  $I$  for a rectangular cross-section is by means of the calculus. To find  $I$  for a rectangular cross-section of breadth  $b$  and depth  $d$  about an axis through its centroid parallel to the base, Fig. 34, select an elementary strip  $dz$  at  $z$  distance from the axis  $X-X$ . Its area is  $b \times dz$ , and  $I$  for the entire area will be

$\int z^2 b dz$  with the limits of  $+\frac{d}{2}$  and  $-\frac{d}{2}$ . Then:

$$I = b \int_{-\frac{d}{2}}^{+\frac{d}{2}} z^2 dz = b \left[ \frac{z^3}{3} \right]_{-\frac{d}{2}}^{+\frac{d}{2}} = \frac{bd^3}{12}$$

cross-section shown in Fig. 35. If such a section were used as a beam it might be placed with either the  $X-X$  or the  $Y-Y$  axis in a horizontal position. For the greatest strength it is obvious that the beam should rest on a flange, that is, the  $X-X$  axis should be horizontal. Consider first the moment of inertia about the axis  $X-X$ .  $I$  for the rectangle  $8'' \times 8'' = \frac{8 \times 8 \times 8 \times 8}{12} = 341.3 \text{ in.}^4$  This includes the spaces on each side of the web, which is equivalent to a rectangle of width  $7''$  and depth  $6''$ , and its  $I$  equals  $\frac{7 \times 6 \times 6 \times 6}{12} = 126 \text{ in.}^4$

Since both of these moments of inertia are taken about the same axis, we may subtract one from the other to obtain the true  $I$  for the section, or  $341.3 - 126 = 215.3 \text{ in.}^4$

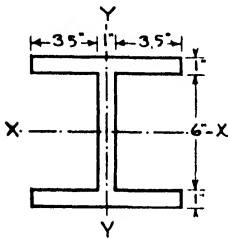

FIG. 35.

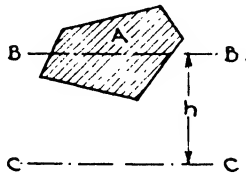

FIG. 36.

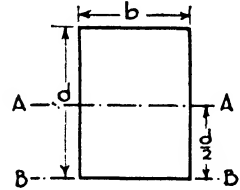

FIG. 37.

To find  $I$  for the section about the  $Y-Y$  axis, divide the section into three rectangles, the two flanges,  $1'' \times 8''$ , and the web,  $6'' \times 1''$ . Adding the moments of inertia of the three parts we get  $I$  for the actual section, or  $(2 \times 42.6) + 0.5 = 85.7 \text{ in.}^4$

Let  $I$  be the moment of inertia of the section, whose area is  $A$ , about the axis  $B-B$  which passes through its centroid, Fig. 36. Call  $I_1$  the moment of inertia of the same section with respect to the axis  $C-C$  which is parallel to  $B-B$  and at  $h$  distance.

$$\text{Then } I_1 = I + Ah^2$$

This equation, used for transferring moments of inertia from one axis to another, is employed in finding  $I$  for built-up sections. It may be stated thus: The moment of inertia of a plane surface with respect to any axis is equal to the moment of inertia with respect to a parallel axis through its centroid plus the area of the surface multiplied by the square of the distance between the two axes.

Let us find, by use of this formula, the moment of inertia of a rectangle of breadth  $b$  and depth  $d$  about an axis,  $B-B$ , taken through the base of the rectangle, Fig. 37. Since  $I_1 = I + Ah^2$ ,

$$I_1 = \frac{bd^3}{12} + \left[ bd \times \left( \frac{d}{2} \right)^2 \right] \text{ or } I_1 = \frac{bd^3}{12} + \frac{bd^3}{4} \text{ or } I_1 = \frac{bd^3}{3}$$



Table IV. Properties of American Standard Yard Lumber and Timber Sizes\*

Size	American Standard Dressed Size	Area of Section	Weight per Linear Foot†	Moment of Inertia	Section Modulus
(Nominal in inches)	In.	$A = bd$ In. <sup>2</sup>	Lbs.	$I = \frac{bd^3}{12}$	$S = \frac{bd^2}{6}$
2X 4	1 <sup>5</sup> / <sub>8</sub> X 3 <sup>5</sup> / <sub>8</sub>	5.89	1.6	6.45	3.56
2X 6	1 <sup>5</sup> / <sub>8</sub> X 5 <sup>5</sup> / <sub>8</sub>	9.14	2.5	24.10	8.57
2X 8	1 <sup>5</sup> / <sub>8</sub> X 7 <sup>1</sup> / <sub>2</sub>	12.19	3.4	57.13	15.32
2X 10	1 <sup>5</sup> / <sub>8</sub> X 9 <sup>1</sup> / <sub>2</sub>	15.44	4.3	116.09	24.44
2X 12	1 <sup>5</sup> / <sub>8</sub> X 11 <sup>1</sup> / <sub>2</sub>	18.60	5.2	205.04	35.82
2X 14	1 <sup>5</sup> / <sub>8</sub> X 13 <sup>1</sup> / <sub>2</sub>	23.62	6.5	333.15	49.36
3X 4	2 <sup>5</sup> / <sub>8</sub> X 3 <sup>5</sup> / <sub>8</sub>	9.51	2.6	10.42	5.75
3X 6	2 <sup>5</sup> / <sub>8</sub> X 5 <sup>5</sup> / <sub>8</sub>	14.76	4.2	38.03	13.84
3X 8	2 <sup>5</sup> / <sub>8</sub> X 7 <sup>1</sup> / <sub>2</sub>	19.63	5.7	92.28	24.60
3X 10	2 <sup>5</sup> / <sub>8</sub> X 9 <sup>1</sup> / <sub>2</sub>	24.93	7.2	187.55	30.48
3X 12	2 <sup>5</sup> / <sub>8</sub> X 11 <sup>1</sup> / <sub>2</sub>	30.18	8.8	332.69	57.85
3X 14	2 <sup>5</sup> / <sub>8</sub> X 13 <sup>1</sup> / <sub>2</sub>	35.43	10.3	538.21	79.73
4X 4	3 <sup>5</sup> / <sub>8</sub> X 3 <sup>5</sup> / <sub>8</sub>	13.14	3.6	14.38	7.04
4X 6	3 <sup>5</sup> / <sub>8</sub> X 5 <sup>5</sup> / <sub>8</sub>	20.30	5.7	53.76	19.11
4X 8	3 <sup>5</sup> / <sub>8</sub> X 7 <sup>1</sup> / <sub>2</sub>	27.13	7.5	127.44	33.98
4X 10	3 <sup>5</sup> / <sub>8</sub> X 9 <sup>1</sup> / <sub>2</sub>	34.43	9.6	258.00	54.52
4X 12	3 <sup>5</sup> / <sub>8</sub> X 11 <sup>1</sup> / <sub>2</sub>	41.68	11.6	459.42	79.00
4X 14	3 <sup>5</sup> / <sub>8</sub> X 13 <sup>1</sup> / <sub>2</sub>	48.93	13.6	743.23	110.11
4X 16	3 <sup>5</sup> / <sub>8</sub> X 15 <sup>1</sup> / <sub>2</sub>	56.18	15.6	1,124.00	145.15
6X 6	5 <sup>1</sup> / <sub>2</sub> X 5 <sup>1</sup> / <sub>2</sub>	30.25	8.4	76.25	27.73
6X 8	5 <sup>1</sup> / <sub>2</sub> X 7 <sup>1</sup> / <sub>2</sub>	41.25	11.4	193.35	51.50
6X 10	5 <sup>1</sup> / <sub>2</sub> X 9 <sup>1</sup> / <sub>2</sub>	52.25	14.5	392.06	82.73
6X 12	5 <sup>1</sup> / <sub>2</sub> X 11 <sup>1</sup> / <sub>2</sub>	63.25	17.5	697.06	121.23
6X 14	5 <sup>1</sup> / <sub>2</sub> X 13 <sup>1</sup> / <sub>2</sub>	74.25	20.6	1,127.66	167.06
6X 16	5 <sup>1</sup> / <sub>2</sub> X 15 <sup>1</sup> / <sub>2</sub>	85.25	23.6	1,706.76	220.22
8X 8	7 <sup>1</sup> / <sub>2</sub> X 7 <sup>1</sup> / <sub>2</sub>	56.25	15.6	263.67	70.31
8X 10	7 <sup>1</sup> / <sub>2</sub> X 9 <sup>1</sup> / <sub>2</sub>	71.25	19.8	535.85	112.81
8X 12	7 <sup>1</sup> / <sub>2</sub> X 11 <sup>1</sup> / <sub>2</sub>	86.25	23.9	950.55	165.31
8X 14	7 <sup>1</sup> / <sub>2</sub> X 13 <sup>1</sup> / <sub>2</sub>	101.25	28.0	1,537.73	227.81
8X 16	7 <sup>1</sup> / <sub>2</sub> X 15 <sup>1</sup> / <sub>2</sub>	116.25	32.0	2,327.42	300.31
10X 10	9 <sup>1</sup> / <sub>2</sub> X 9 <sup>1</sup> / <sub>2</sub>	90.25	25.0	678.75	142.80
10X 12	9 <sup>1</sup> / <sub>2</sub> X 11 <sup>1</sup> / <sub>2</sub>	109.25	30.3	1,204.01	209.39
10X 14	9 <sup>1</sup> / <sub>2</sub> X 13 <sup>1</sup> / <sub>2</sub>	128.25	35.6	1,947.78	288.56
10X 16	9 <sup>1</sup> / <sub>2</sub> X 15 <sup>1</sup> / <sub>2</sub>	147.25	40.9	2,948.04	380.39
12X 12	11 <sup>1</sup> / <sub>2</sub> X 11 <sup>1</sup> / <sub>2</sub>	132.25	36.7	1,457.50	253.47
12X 14	11 <sup>1</sup> / <sub>2</sub> X 13 <sup>1</sup> / <sub>2</sub>	155.25	43.1	2,357.85	340.31
12X 16	11 <sup>1</sup> / <sub>2</sub> X 15 <sup>1</sup> / <sub>2</sub>	178.25	49.5	3,568.70	460.48
12X 18	11 <sup>1</sup> / <sub>2</sub> X 17 <sup>1</sup> / <sub>2</sub>	201.25	55.9	5,136.49	586.08

\*Compiled from data published by the United States Department of Agriculture, Forest Products Laboratory.

†Based on assumed average weight of 40 lbs./ft.<sup>3</sup>

**Centroids. Center of Gravity.** The centroid of a plane surface is a point which corresponds to the center of gravity of a very thin homogeneous plate of the same area and shape. We have stated that the neutral surface of a beam passes through the centroid of the cross-section of the beam, and also that  $c$  in the flexure formula is the distance of the fiber most remote from the neutral surface. It is obvious that for rectangular cross-sections the centroid is located at a point one-half the distance between the upper and lower surfaces, or  $c = \frac{d}{2}$ . This is true for all symmetrical surfaces;  $c$  for a 10" I-beam, for instance, equals 5". However, for surfaces that are unsymmetrical the position of the centroid must be computed.

The **STATICAL MOMENT** of a plane area, with respect to an axis, is the product of the area by the normal distance of its centroid to the axis. If an area be divided into parts, the statical moment of the entire area, with respect to a given axis, is equal to the sum of the statical moments of the parts with respect to the same axis. It is generally possible to divide areas into elementary parts of which the centroid is known, and by this means the position of the centroid of the given area may be found.

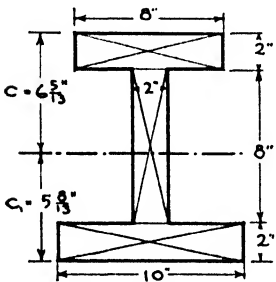

FIG. 38.

Suppose we wish to determine the position of the neutral surface for the section of a beam shown in Fig. 38. This means that we must find the distance  $c$ , of the centroid from the top flange of the beam. For convenience, divide the section into three rectangles—the two flanges and the web. The sum of the statical moments of these areas ABOUT AN AXIS THROUGH THE TOP OF THE UPPER FLANGE is  $(16 \times 1) + (16 \times 6) + (20 \times 11)$ . This is equal to the statical moment of the entire area, 52 in.<sup>2</sup>, multiplied by the distance of its centroid from the same axis. This is distance  $c$ . Therefore  $16 + 96 + 220 = 52c$  and  $c = 6 \frac{5}{13}$ ". Since the depth of the beam is 12",  $c_1 = 12 - 6 \frac{5}{13}" = 5 \frac{8}{13}"$ .

**Section Modulus.** The flexure formula may be written  $\frac{M}{f} = \frac{I}{c}$ . Very often the quantity  $\frac{I}{c}$  is represented by the letter  $S$ . It is called the **SECTION MODULUS**. Since  $I$  is in units of inches to the fourth power, inches<sup>4</sup>, and  $c$  is a linear dimension, usually inches,  $\frac{I}{c}$ , the section modulus, is in units of inches to the third power, inches<sup>3</sup>. For rectangular cross-sections, the moment of inertia about an axis through the centroid parallel to the base is  $\frac{bd^3}{12}$ , and  $c = \frac{d}{2}$ . Therefore  $\frac{I}{c}$  or  $S = \frac{bd^3}{12} \div \frac{d}{2} = \frac{bd^2}{6}$

Manufacturers of steel sections publish the properties of the various sections which they roll, and  $I$  and  $S$  are always given. See Table IV.

**Radius of Gyration.** The value of the moment of inertia has been expressed as,  $I = \Sigma \delta a z^2$ .  $\Sigma \delta a$  is really the sum of all the elementary areas and equals  $A$ , the area of the entire section.  $z$  is a variable. If we imagine a point at which the entire area might be concentrated so that the moment of inertia would be the same as it is when the area is distributed, we may write:

$$I = Ar^2 \text{ or } r = \sqrt{\frac{I}{A}}$$

This point is called the CENTER OF GYRATION, and the distance from the center of gyration,  $r$ , to a given axis, is called the RADIUS OF GYRATION.

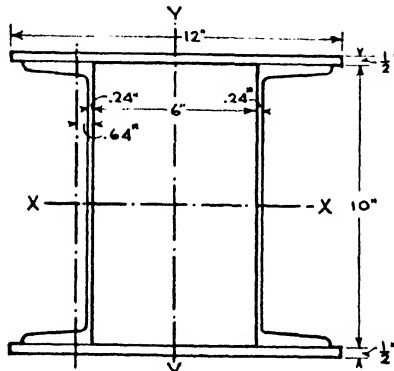

FIG. 39.

This property of structural shapes is used most frequently in the study of columns. Unless the sections are symmetrical about both major axes, there are two major moments of inertia and consequently two radii of gyration. In the design of columns, the least radius of gyration is the one used in computations.

Let it be required to find the moment of inertia, section modulus and radius of gyration of the built-up section shown in Fig. 39. This section is composed of two 12" x 1/2" plates and two 10"—15.3# channels. This type of section is used as a column, and as the least radius of gyration is the one used in column design we will consider it in this instance, that is, the three properties which we seek will be found with respect to the Y-Y axis.

The area of the two plates equals  $2 \times 12 \times .5 = 12 \text{ in.}^2$ , and the area of the two channels is  $2 \times 4.47 = 8.94 \text{ in.}^2$ . The area of the entire cross-section is, therefore,  $12 + 8.94 = 20.94 \text{ in.}^2$ . By referring to tables of steel sections we find the area of a 10"—15.3# channel to be 4.47 in.<sup>2</sup>, the moment of inertia of the channel about an axis parallel to the web is 2.3 in.<sup>4</sup>, and also that this axis is 0.64" from the back of the web.

First let us find the value of the moment of inertia of one channel with respect to the  $Y-Y$  axis of the column. The equation for transferring moments of inertia is  $I_1 = I + Ak^2$ . Therefore  $I_1 = 2.3 + (4.47 \times 3.64^2)$  or  $I_1 = 61.53 \text{ in.}^4$ ;  $3.64''$  is the distance between the centroid of the channel and the axis  $Y-Y$ . The moment of inertia of the two channels about the  $Y-Y$  axis will be  $2 \times 61.53 = 123.06 \text{ in.}^4$   $I$  for one  $12 \times 0.5$  plate will be:  $I = \frac{0.5 \times 12^3}{12} = 72 \text{ in.}^4$ , and for both plates will be  $2 \times 72 = 144 \text{ in.}^4$  We may now add together the moments of inertia of the four parts, or  $123.06 + 144 = 267.06 \text{ in.}^4$ , which is  $I$  for the entire section about the  $Y-Y$  axis.

The section modulus  $S = \frac{I}{c}$ . Therefore  $S = \frac{267.06}{6} = 44.51 \text{ in.}^3$ , since  $\frac{12}{2} = 6'' = c$ , which is the distance of the most remote fiber from the axis  $Y-Y$ .

The value of the radius of gyration is  $r = \sqrt{\frac{I}{A}}$ , or

$$r = \sqrt{\frac{267.06}{20.94}} = 3.57''.$$

### Article 6. Design, Safe Loads and Investigation of Beams

**Design of Beams.** The flexure formula may be written  $\frac{M}{f} = S$ , in which  $M$  is the bending moment,  $f$  the extreme fiber unit stress and  $S$  the section modulus. It may be used directly in the design of beams.

Let it be required to design for flexure a steel I-beam having a span of 18' with the concentrated load of 10,000 lbs. at the center of the span, extreme fiber stress not to exceed 18,000 lbs./in.<sup>2</sup> The maximum bending moment for a simple beam with a concentrated load at the center of the span is,  $M = \frac{Pl}{4} = \frac{10,000 \times 18}{4} = 45,000 \text{ ft.-lbs.}$ ;  $45,000 \times 12 = 540,000 \text{ in.-lbs.}$ ;  $\frac{M}{f} = S$ . Then  $\frac{540,000}{18,000} = S$ , or  $S = 30 \text{ in.}^3$  Referring to tables giving the properties of beams, we find that a 12'' WF 25# has a section modulus of 30.9 in.<sup>3</sup> and therefore is acceptable. Generally the lightest-weight section is the most economical.

Suppose that the load of 10,000 had been uniformly distributed over the entire length of the beam instead of concentrated at the center. Then the maximum bending moment would be  $M = \frac{Wl}{8}$  or  $M = \frac{10,000 \times 18}{8}$

$$= 22,500 \text{ ft.-lbs.} = 270,000 \text{ in.-lbs.}; \frac{M}{f} = \frac{270,000}{18,000} = 15 \text{ in.}^3$$

A 10" WF 21# has a section modulus of 21.5 in.<sup>3</sup> and therefore is acceptable.

**Safe Loads.** A 10"-25.4# I-beam has a span of 15' with two equal concentrated loads, one at 5' from the left reaction and the other at 5' from the right reaction. Let it be required to find the magnitudes of the loads if the extreme fiber stress is 18,000 lbs./in.<sup>2</sup>. The maximum bending moment is  $M = 5 \times 12 \times P = 60 P$  in.-lbs. Referring to manufacturers' tables we find  $S$  for a 10"-25.4# I-beam to be 24.42 in.<sup>3</sup>  $\frac{M}{f} = S$ . Therefore  $\frac{60P}{18,000} = 24.42$ , or  $P$ , the magnitude of each load = 7326 lbs.

**Investigation of Beams.** The investigation of beams for flexure consists in computing the extreme fiber stress of a beam of given dimensions, material, span and loading. By comparing this stress with the ultimate tensile or compressive strength of the material, the factor of safety is determined, or the actual stress may be compared with the stress permitted by a building code.

A 10" x 12" long-leaf Southern yellow pine beam has a span of 12' and a uniformly distributed load of 15,000 lbs. Is the beam safe in flexure? The maximum bending moment is  $M = \frac{15,000 \times 12}{8} = 22,500 \text{ ft.-lbs.}$

or 270,000 in.-lbs. A timber of 10" x 12" nominal size has actual dimensions of 9.5" x 11.5".  $S = \frac{bd^2}{6}$  or  $S = \frac{9.5 \times 11.5^2}{6} = 209.39 \text{ in.}^3$ ; see Table IV.

$\frac{M}{f} = S$  or  $f = \frac{M}{S}$ . Therefore  $f = \frac{270,000}{209.39} = 1290 \text{ lbs./in.}^2$  Building codes permit as high as 1400 lbs./in.<sup>2</sup> for the No. 1 Structural Grade of long-leaf Southern yellow pine, and hence the beam is amply strong.

**Modulus of Rupture.** If a beam is loaded until it fails and the bending moment inserted in the flexure formula,  $f = \frac{Mc}{I}$ , the resulting value of  $f$  is called the MODULUS OF RUPTURE. Since the flexure formula is valid only when the extreme fiber stress is less than the elastic limit of the material, the modulus of rupture cannot be considered the unit stress in the outermost fibers of the beam. It is used in comparing the bending strength of different materials and also to determine the probable breaking load on the beam. Approximate values in pounds per square inch are: steel, 50,000; cast iron, 35,000; timber, 9000; and stone, 1500.

Article 7. Deflection of Beams

**Elastic Curve.** When loads are applied to a beam it changes shape or bends. The vertical distance moved by a point on the neutral surface during the bending of a beam is the DEFLECTION of the beam at that point. The trace of the neutral surface on a vertical longitudinal plane



FIG. 40.

is called the ELASTIC CURVE OF THE BEAM. The resistance to deflection is called STIFFNESS. Generally it is necessary that a beam be STIFF enough as well as strong enough. A floor beam may be sufficiently strong to carry the load upon it, but its deflection may be so great that a plastered

ceiling would crack or the floor would vibrate. The general requirement for the deflection of beams is that the deflection does not exceed

$$\frac{1}{360}$$

of the span. For instance, the maximum deflection permitted in a beam having a span of 30' would be 1". It is necessary, therefore, that the deflection of beams be computed. Formulae used to find the deflection of beams are valid only when the stresses caused by bending are below the elastic limit of the material. A convenient method of deriving formulae for the deflection of beams is by means of the calculus. Another method commonly employed is that known as the MOMENT-AREA-METHOD. It is not intended in a volume of this character to discuss in detail the derivation of formulae used to find the deflection of beams, but a brief explanation of the moment-area-method is presented to show its simplicity.

**Moment-Area-Method.** Assume *M* and *N* to be two points on the elastic curve of a beam which was originally horizontal and straight, Fig. 40. Then the vertical displacement,  $\Delta$ , of point *M* from the tangent to the elastic curve at point *N*, equals the statical moment, with respect to *M*, of the area of the moment diagram between the points *M* and *N*, divided by *EI*.

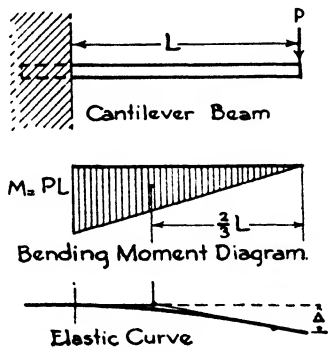

FIG. 41.

Fig. 41 represents a cantilever beam with a concentrated load, *P*, at the free end. The maximum bending moment is at the support and equals *PL*. The area of the moment diagram is  $\frac{PL}{2} \times L$  or  $\frac{PL^2}{2}$ . The centroid of the area of the moment diagram is  $\frac{2}{3}L$  from the free end.

Therefore, applying the proposition given in the preceding paragraph, the maximum deflection,  $\Delta$ , =  $\frac{PL^2}{2} \times \frac{2}{3}L \times \frac{1}{EI} = \frac{PL^3}{3EI}$

For a uniformly distributed load,  $W$ , on a cantilever beam of length  $L$ , the maximum deflection,  $\Delta$ , =  $\frac{WL^3}{8EI}$ . The maximum deflection of a

simple beam having a uniformly distributed load  $W$  is  $\Delta = \frac{5}{384} \frac{WL^3}{EI}$ .

For a simple beam with a concentrated load,  $P$ , at the center of the span, the maximum deflection is  $\Delta = \frac{PL^3}{48EI}$ . Another common type of

loading is a simple beam of span  $L$  with two concentrated loads,  $P$ , each, one  $\frac{L}{3}$  from the left reaction and the other  $\frac{L}{3}$  from the right reaction.

The maximum deflection is  $\Delta = \frac{23}{648} \frac{PL^3}{EI}$ .

### Article 8. Overhanging, Fixed and Continuous Beams

#### Overhanging Beam, Inflection Point, Negative Bending Moments.

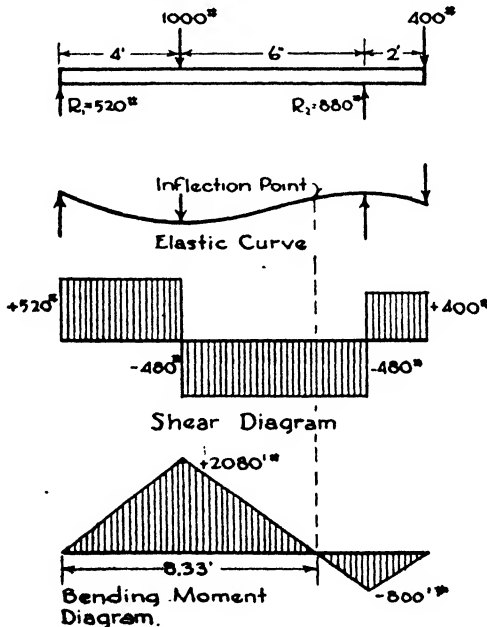

FIG. 42.

Fig. 42 illustrates an overhanging beam with two concentrated loads. By the methods previously described,  $R_1$  and  $R_2$  are computed and the

shear and bending moment diagrams drawn. We observe that the shear passes through zero at two points, first under the 1000-lb. load and again at the right support. We know that the bending moment approaches a maximum at these points and this is verified on the bending moment diagram. At a point between the 1000-lb. load and  $R_2$ , we see that the bending moment passes through zero; this is called the **INFLECTION POINT**. To find its position, call it  $x$  distance from  $R_1$  and write an equation for the value of the bending moment, equating it to zero. Therefore,  $M = 0 = 520x - [1000 \times (x - 4)]$ ,  $480x = 4000$  or  $x = 8.33'$ . An exaggerated form of the elastic curve is also shown, Fig. 42. In this instance, as in most overhanging beams, the member is concave up to a certain point and convex for the remainder of its length. The point or points where the curvature reverses is the inflection point. It

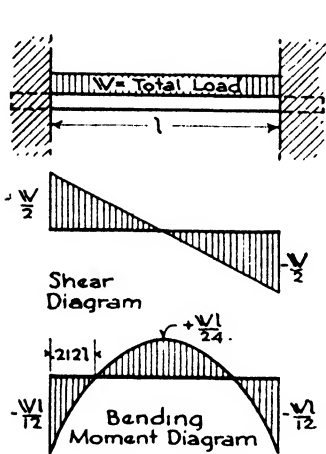

FIG. 43.

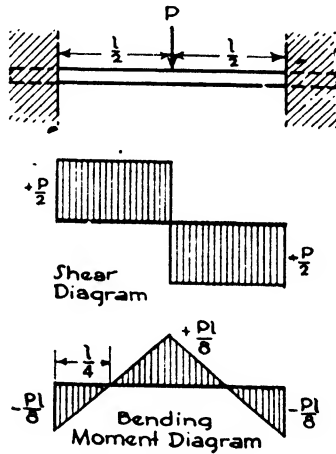

FIG. 44.

is obvious that all fibers on the top of this particular beam, to the left of the inflection point, are in compression, and the fibers at the top of the beam to the right of the inflection point are in tension. This is an example of a **NEGATIVE BENDING MOMENT**, the maximum negative bending moment being at the right support, and its magnitude is  $-800$  ft.-lbs.

**Restrained Beams.** In simple beams the shortening of the fibers above the neutral surface, and the lengthening of the fibers below, result in a curvature of the same character throughout the length of the beam, generally concave on the top surface of the beam. A **RESTRAINED BEAM** is one in which constraint is introduced at or by a support sufficient to reverse the character of the curvature which would exist if the beam were simply supported.

A **FIXED BEAM** is one which is fully restrained, or one in which the tangent to the elastic curve is horizontal at the point of support. Beams may be fixed at one or both supports.



The reactions for beams fixed at one end and supported at the other are not computed by the same method employed for beams simply

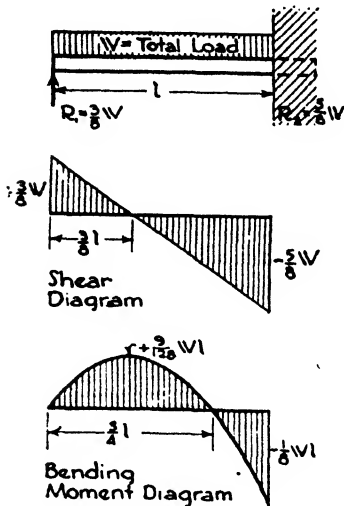

FIG. 45.

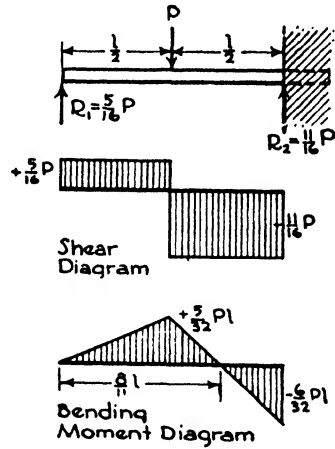

FIG. 46.

supported, owing to the mechanical couple which exists at the fixed end. These beams are said to be statically indeterminate, and their

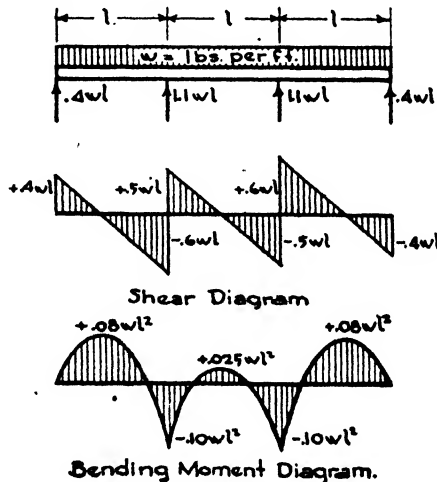

FIG. 47.

design is accomplished by means of equations supplied by the conditions of restraint and deflection. Four of the most common types are shown in Figs. 43, 44, 45, and 46. It should be noted that a negative

bending moment occurs at the point where beams are fixed, and in some instances its magnitude exceeds the maximum positive moment.

**Continuous Beams.** A CONTINUOUS BEAM is one which rests upon more than two supports. They frequently occur in modern construction, particularly in reinforced concrete, and a certain economy of material is effected as compared with simple beams having the same spans. CONTINUOUS beams are indeterminate structures, and their reactions cannot be found by the conditions of static equilibrium alone. An example of a continuous beam of three equal spans with a uniformly distributed load is shown in Fig. 47. Theoretical bending moment diagrams for the usual spans and types of loading are given in Chapter XXII.

### Article 9. Columns

**General Considerations.** A short axially loaded post or strut, whose length does not exceed about 10 times its least transverse dimension, is considered as stressed uniformly in compression. The unit stress is therefore assumed as  $\frac{P}{A}$ , or the load divided by the cross-sectional area.

In the case of longer columns, however, tests show that failure is due to bending stresses rather than to direct compression. This condition is due to the fact that it is generally impossible to attain a perfectly concentric loading in practice, owing to some imperfection in workmanship or a slight crookedness in the column. Such inaccuracies cause bending, and the bending moment increases with the slenderness of the column.

**Slenderness Ratio.** In the design of columns, therefore, the element of slenderness must be taken into consideration. In wooden columns the ratio of length of the member to its least lateral dimension or diameter should not exceed about 35. This limiting ratio varies with different building codes. The SLENDERNESS RATIO,  $\frac{l}{r}$ , is the ratio of the length of the column in inches, between adjacent points of lateral support, to the least radius of gyration of the cross-section of the column with respect to the centroidal axis about which the column can bend. If the slenderness ratio of a member in compression is less than about 30 it is called a SHORT COLUMN. In practice, most columns have a slenderness ratio between the limits of 30 and 150. Some codes permit ratios of 150 to 200 only in secondary members having no calculated stress due to loads, or which resist wind loads only.

**End Conditions.** A column having no restraint at the ends may bend in an arc as shown in Fig. 48 (a). When an end condition permits freedom of rotation the column is said to have a ROUND END. The opposite of the round end is the FIXED END. A column which has its ends rigidly riveted to girders is an example of a column with fixed

ends, Fig. 48 (c). If the ends of a column are fixed, the strength is increased since the deflection is decreased. A combination of both round and fixed end conditions is shown in Fig. 48 (b), and columns of this type have strengths which are intermediate between cases (a) and (c). In cases (a), (b) and (c) it is assumed that the ends are prevented from moving laterally. Fig. 48 (d) is an example of a column fixed at one end and free to move in any direction at the other. The end conditions of a column determine the length of the curve which the column tends to assume, and consequently affect the strength of the column. The conditions just given are theoretical, and column formulae, by means of which columns are designed, generally include a constant which provides for various end conditions.

**Column Formulae.** To allow for both the direct compressive and the bending stresses, formulae have been derived which determine an aver-

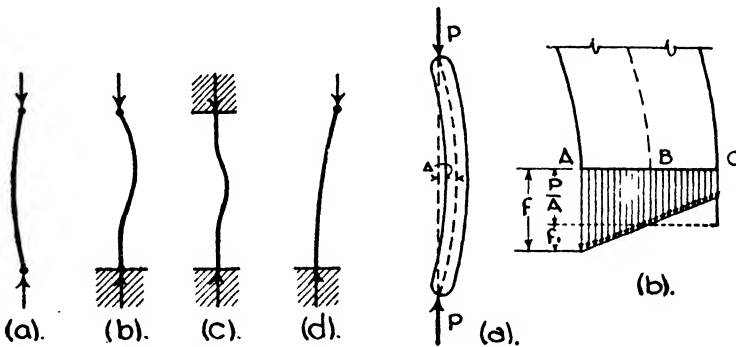

FIG. 48.

FIG. 49.

age working stress such that the column will not be overtaxed by direct compression and bending acting together. In the Rankine formula the basic compressive stress is reduced by dividing by a number greater than unity. In the straight-line formula the basic stress is reduced by subtracting a number. Both the divisor and the subtrahend increase with the slenderness ratio.

**Rankine's or Gordon's Formula for Columns.** Assume  $P$  to be the concentric load upon a column of cross-section area  $A$ ;  $\Delta$  is the deflection, Fig. 49 (a). An enlarged portion of the column is shown at (b); section  $A-C$  is the plane cut at the mid length. The arrows drawn below the section  $A-C$  represent the stresses along the section. Let  $f$  equal the stress on the concave side of the column.  $f$ , then, is composed of the average compressive stress,  $\frac{P}{A}$ , plus  $f_1$ , which is the stress due to bending. It should be noted that the stress on the concave side is increased by  $f_1$ , and the stress on the opposite side is decreased by the same amount. Therefore  $f = \frac{P}{A} + f_1$ .  $f_1$  is the stress due to bending as

given in the flexure formula,  $f_1 = \frac{Mc}{I}$ . The value of  $M$  is  $P\Delta$ , and  $I = Ar^2$ , or  $f_1 = \frac{P\Delta c}{Ar^2}$ . Therefore,  $f = \frac{P}{A} + \frac{P\Delta c}{Ar^2}$  or  $f = \frac{P}{A} \left( 1 + \frac{\Delta c}{r^2} \right)$ . It is assumed, from the study of deflections, that the deflection,  $\Delta$ , varies directly as the square of the length of the column divided by  $c$ , or  $\frac{l^2}{c}$ , and hence  $f = \frac{P}{A} \left( 1 + \phi \frac{l^2}{r^2} \right)$ . So far, the end conditions of the column have not been considered, consequently a constant  $\phi$  is added to the formula, and it becomes

$$f = \frac{P}{A} \left( 1 + \phi \frac{l^2}{r^2} \right), \text{ or } \frac{P}{A} = \frac{f}{1 + \phi \left( \frac{l^2}{r^2} \right)}$$

This is known as Rankine's or Gordon's formula for columns.  $\phi$ , the constant, is a quantity, determined by experiment, depending upon the end conditions of the column and the elastic properties of the material. Table V shows the value of  $\phi$  for different materials and various end conditions as given in Merriman's "Mechanics of Materials."

**Table V. Values of  $\phi$  Used in Rankine's Formula**

Material	Both Ends Fixed	Fixed and Round Ends	Both Ends Round
Timber.....	$\frac{1}{3\ 000}$	$\frac{1.78}{3\ 000}$	$\frac{4}{3\ 000}$
Cast-iron....	$\frac{1}{5\ 000}$	$\frac{1.78}{5\ 000}$	$\frac{4}{5\ 000}$
Wrought Iron	$\frac{1}{36\ 000}$	$\frac{1.78}{36\ 000}$	$\frac{4}{36\ 000}$
Steel.....	$\frac{1}{25\ 000}$	$\frac{1.78}{25\ 000}$	$\frac{4}{25\ 000}$

A form of Rankine's formula for steel columns is

$$f = \frac{18,000}{1 + \frac{l^2}{18,000 r^2}}$$

with a maximum fiber stress not to exceed 15,000 lbs./in.<sup>2</sup> Slenderness ratios of main members must not be greater than  $\frac{l}{r} = 120$ , and for secondary members must not exceed  $\frac{l}{r} = 200$ . This formula and limita-

tions appear in many building codes. Certain codes, however, modify the slenderness ratio limit.

**Straight-line Formula.** Investigators in testing laboratories throughout the country have tested numerous columns to failure. The columns varied widely in material, shape of cross-section, length and end conditions. When the results of these tests were plotted, with  $\frac{P}{A}$  as the ordinate and  $\frac{l}{r}$  the abscissa, it was found that the points formed a fairly broad band. A straight line was then drawn through the approximate center line of the band and an equation written representing the line. If  $f$  be the unit stress on the concave side of the column, and  $C$  a quantity varying with the material and the condition of the ends, the STRAIGHT-LINE FORMULA may be written

$$\frac{P}{A} = f - C \frac{l}{r}$$

The straight-line formula which is widely used for steel columns is:

$$\frac{P}{A} = 16,000 - 70 \frac{l}{r}$$

with a maximum fiber stress of 14,000 lbs./in.<sup>2</sup> The limiting values of  $\frac{l}{r}$  for main members is 120, and for struts for secondary members, 150.

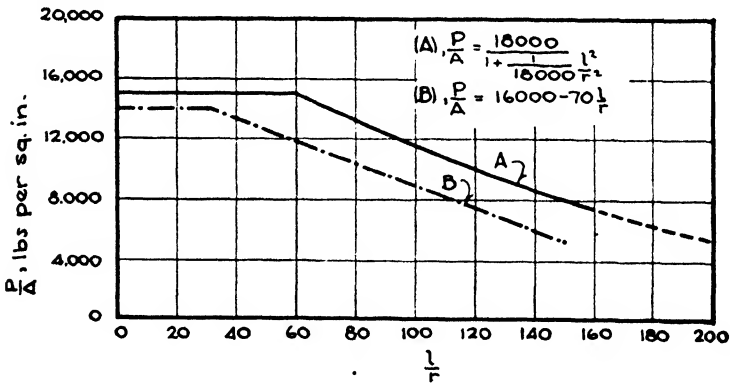

FIG. 50.

Fig. 50 shows the curves of two of the column formulae which are frequently used in structural design. Many different column formulae are used and all are more or less empirical. In actual practice, loads may have slight eccentricities and the columns may not be exactly straight. It is also probable that the exact end conditions are not known. In tests, these items may be controlled to a greater degree than in actual building conditions. In view of this, it would not seem ad-

visible to use the more complicated formulae which are advised by some authorities.

**Example.** Let it be required to design a steel column 13' long to support a concentric load of 120,000 lbs. using the formula  $f = \frac{18,000}{1 + \frac{P^2}{18,000 r^2}}$ .

Unlike beams, columns are designed by the trial method. A particular section is selected and the safe load it will support is computed by means of the formula. If it is found that the assumed section is too large or too small, a second section is tried and tested in a like manner. With experience in the use of the formula, one trial is generally sufficient.

In this problem, we know, for instance, that columns of this length and load have unit stresses approximately 13,000 lbs./in.<sup>2</sup>;  $\frac{120,000}{13,000} = 9.23$ , the approximate number of square inches required in the column. By consulting the manufacturers' tables we find that an 8"WF31# has an area of 9.12 in.<sup>2</sup> Its least radius of gyration is 2.01". Testing this assumed section by the formula, the stress per square inch,  $\frac{P}{A} = \frac{18,000}{1 + \frac{1}{18,000} \left( \frac{13 \times 12}{2.01} \right)^2}$  or  $f = 13,487$  lbs./in.<sup>2</sup> The total load permitted on this column will be, then,  $13,487 \times 9.12 = 123,000$  lbs. Therefore the trial section is acceptable.

If it is required that the straight-line formula,  $\frac{P}{A} = 16,000 - 70 \frac{l}{r}$ , be used, try an 8"WF40#. From tables,  $A = 11.76$  in.<sup>2</sup>, and the least radius of gyration is  $r = 2.04$ . Then  $\frac{P}{A} = 16,000 - 70 \frac{13 \times 12}{2.04} = 10,652$  lbs./in.<sup>2</sup> Since the area contains 11.76 in.<sup>2</sup>, the safe load will be  $11.76 \times 10,652 = 125,000$  lbs. The 8"WF40# section is acceptable.

**Timber Columns.** Although timber columns may be circular in cross-section, most of those used in practice are solid rectangular cross-sections. Instead of  $\frac{l}{r}$ ,  $\frac{l}{D}$ , the unsupported length in inches, divided by the dimension of the least side, is used. Building codes vary greatly in the formulae used in the design of columns; the following, however, is typical and may be used with safety:

$$\frac{P}{A} = C - 20 \frac{l}{D}$$

in which  $C$  is the compressive stress in pounds per square inch for various species of wood.  $\frac{l}{D}$  shall not exceed 40. See Table VI.

**Table VI. Values of C for Various Species of Timber in Pounds per Square Inch**

Southern Yellow Pine, Structural Grade.....	1200
Southern Yellow Pine, No. 1 Common.....	1000
Douglas Fir, Structural.....	1200
Douglas Fir, Common.....	1100
Red and White Oak, Common.....	800
West Coast Hemlock, Common.....	720
Eastern Hemlock, Common.....	560
Spruce, Common.....	640

**Example.** Let it be required to design a Southern yellow pine, structural grade column, 12' in length, to support a concentric load of 75,000 lbs. Assume a 10" x 10" column, the actual size of which is 9½" x 9½", having an area of 90.25 in.<sup>2</sup>

Then the allowable unit stress,  $\frac{P}{A} = 1200 - 20\left(\frac{12 \times 12}{9.5}\right)$ , or  $\frac{P}{A} = 900$  lbs./in.<sup>2</sup>

If there are 90.25 in.<sup>2</sup> in the assumed cross-section, 90.25 x 900 = 81,225 lbs., the load which may be placed on the column. This is in excess of the 75,000-lb. load required, but the next stock size smaller, an 8" x 8", would support only 45,900 lbs. by use of this formula.

**Eccentric Loads.** If a rectangular member in compression has a length which does not exceed about 10 times the dimension of the least side, it is called a short column or strut, and if the applied load is axial or concentric, it is assumed that the stresses are equally distributed over the cross-section and that there is no tendency towards bending.

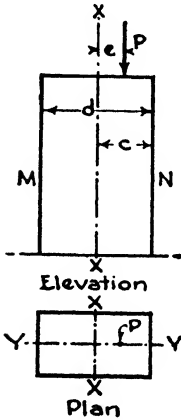

FIG. 51.

Fig. 51 represents a short post, shown in plan and elevation. If the load  $P$  is axial, the unit stress on each unit of cross-section will be  $f = \frac{P}{A}$ . Assume, however, that the load  $P$  is applied at  $e$  distance from the vertical axis,  $X-X$ ;  $e$  is called the eccentricity, and the load is said to be eccentric as opposed to axial. The load is axial with respect to axis  $Y-Y$ . We know that the stresses are not now equally divided and that the unit stresses on the side  $N$  are greater than those at the side  $M$ . Call  $f$  the unit stress at  $N$ . It is equal to the average stress,  $\frac{P}{A}$ , plus the stress due to the eccentricity of the load and its consequent bending. Let  $X-X$  be the neutral axis of the cross-section;  $c$ , the distance of side  $N$  to this axis;  $I$ , the moment of inertia, and  $r$ , the radius of gyration of the cross-section. Call  $f'$  the flexural unit stress at  $N$ . The flexure formula is

$f' = \frac{Mc}{I}$ , and the bending moment in this instance is  $M = Pe$ . Substitut-

ing its value in the flexure formula,  $f' = \frac{Pec}{I}$ . Since  $I = Ar^2$ ,  $f' = \frac{Pec}{Ar^2}$ .

Adding this stress due to bending to the average unit stress,  $\frac{P}{A}$ ,  $f = \frac{P}{A} + \frac{Pec}{Ar^2}$

or  $f = \frac{P}{A}\left(1 + \frac{ec}{r^2}\right)$ , which is the compressive unit stress on the side nearest the eccentric load,  $P$ . In a similar manner it can be shown that the stress on the opposite side of the column, at  $M$ , has been reduced in magnitude and equals  $\frac{P}{A}\left(1 - \frac{ec}{r^2}\right)$ . For rectangular cross-sections,  $r^2 = \frac{I}{A} = \frac{bd^3}{12} \times \frac{1}{bd} =$

$\frac{d^2}{12}$ , and  $c = \frac{d}{2}$ . Substituting the values of  $r^2$  and  $c$  in the above formulae, and calling the stress at  $N$ ,  $f_1$ , and at  $M$ ,  $f_2$ ,

$$f_1 = \frac{P}{A} \left( 1 + 6 \frac{e}{d} \right)$$

and

$$f_2 = \frac{P}{A} \left( 1 - 6 \frac{e}{d} \right)$$

Figs. 52 (a), (b), (c) and (d) illustrate the effect of the force  $P$  applied at various degrees of eccentricity with respect to the axis  $X-X$ , Fig. 52 (a) shows the load  $P$  as axial, and since there is no eccentricity, the unit stresses are equally distributed over the cross-section; consequently  $f_1$  and  $f_2$  are equal. In Fig. 52 (b) the eccentricity is slight and  $f_1$  is greater than the average,  $\frac{P}{A}$ , while  $f_2$  has been reduced. In Fig. 52 (c)

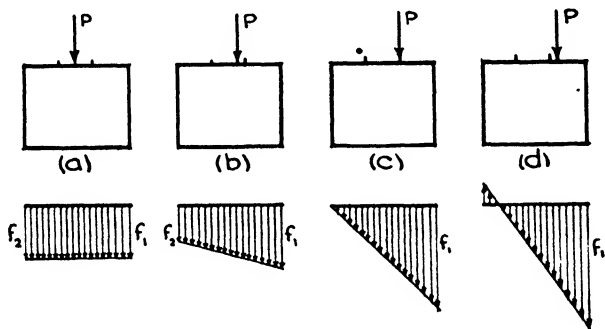

FIG. 52.

the load  $P$  occurs at the outer edge of the middle third, that is, the eccentricity,  $e = \frac{d}{6}$ . Substituting this value in  $f_1 = \frac{P}{A} \left( 1 + 6 \frac{e}{d} \right)$ ,  $f_1 = 2 \frac{P}{A}$

In a similar manner we find for an eccentricity of  $e = \frac{d}{6}$ ,  $f_2 = 0$ . This illustrates the PRINCIPLE OF THE MIDDLE THIRD. So long as the resultant force remains within the middle third, there is pressure over the entire cross-section. When it occurs at the outer edge of the middle third the pressure on the edge of the prism nearest the load is 2 times the average, and the pressure at the opposite side is zero. Fig. 52 (d) shows  $P$  outside the middle third. This results in tension at the opposite side as is indicated by the arrows pointing upward. If the condition illustrated in (d) exists, the stress  $f_1$  may be found by considering it twice the average stress, over the area of the base which is in compression. This area, of course, will be less than the total cross-section area.

In the previous discussion it should be noted that the force  $P$  lies at some point on the  $Y-Y$  axis. (See Fig. 51.) However, it may happen



that the force is eccentric with respect to both the  $X-X$  and the  $Y-Y$  axes. The hatched areas in Fig. 53 (a) and (b) indicate the portions of the base within which the resultant of the forces must occur in order to have compression over the entire area of the base. These areas are called **KERNS**.

The equation  $f_1 = \frac{P}{A} \left( 1 + \frac{ec}{r^2} \right)$  applies only to short columns or those in which  $\frac{l}{r}$  does not exceed about 40. For longer columns it is necessary to consider not only the unit stresses due to direct compression and to bending from intentional eccentric loads, but also the unit stress due to the accidental eccentricity already discussed in the derivation of formulae for columns with nominally axial loads. The sum of these unit stresses must not exceed the basic allowable unit stress.

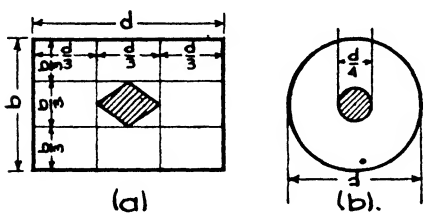

FIG. 53.

and to accidental bending is expressed as follows:

$$\frac{P}{A} = \frac{f}{1 + \phi \frac{l^2}{r^2}} \text{ and } f = \frac{P}{A} \left( 1 + \phi \frac{l^2}{r^2} \right) \text{ or } \frac{P}{A} + \frac{P \phi l^2}{Ar^2}$$

According to the values recommended by the American Institute of Steel Construction,  $\phi = \frac{1}{18,000}$  for steel columns.

Therefore, 
$$f = \frac{P}{A} + \frac{Pl^2}{18,000 Ar^2}$$

As discussed previously, the unit stress due to an intentional eccentric load is expressed as follows,  $f' = \frac{P^1 ec}{I}$ .

The sum of the three unit stresses may then be written as follows:

$$f = \frac{P}{A} + \frac{Pl^2}{18,000 Ar^2} + \frac{P^1 ec}{I}$$

in which  $f$  is the basic allowable unit stress (18,000 lbs./in.<sup>2</sup>),  $P$  is the sum of the axial and the eccentric loads and  $P^1$  is the eccentric load. This formula is frequently used in the design of columns having both concentric and eccentric loads.

**Bending Factor.** The **BENDING FACTOR** is a term frequently employed in designing columns having eccentric loads. It is indicated by the letter  $k$  and is equal to the section modulus with respect to a given axis, divided by the area of the cross-section,  $k = \frac{S}{A}$ . This quantity is also called the **KERN DISTANCE**. It is a constant, for a section, by which

moments on the section may be divided to find equivalent axial loads. For a rectangular cross-section where  $d$  is the dimension of the side perpendicular to the axis considered,  $k = \frac{S}{A} = \frac{bd^2}{6} \times \frac{1}{bd}$  or  $k = \frac{d}{6}$ .

$$Af = \Sigma P + \frac{M_x}{k_x} + \frac{M_y}{k_y}$$

- in which  $A$  = the area of the cross-section in square inches;
- $f$  = maximum fiber stress in pounds per square inch permitted by the column formula used;
- $\Sigma P$  = sum of all the loads on the column in pounds;
- $M_x$  = moment of eccentric load about the axis  $X-X$  in inch-pounds;
- $M_y$  = moment of eccentric load about the axis  $Y-Y$  in inch-pounds;

$k_x$  and  $k_y$  = the bending factors for the axes  $X-X$  and  $Y-Y$ .

Let it be required to find the maximum fiber stress on a column 6" x 10" in cross-section, with a concentric load of 20,000 lbs. and an eccentric load of 10,000 lbs. having an eccentricity of 1" about the  $Y-Y$  axis (perpendicular to the 6" dimension), and an eccentricity of 2" about the  $X-X$  axis (perpendicular to the 10" dimension). Then  $A = 6 \times 10 = 60$ ;  $\Sigma P = 20,000 + 10,000 = 30,000$ ;  $M_x = 10,000 \times 2 = 20,000$ ;

$$k_x = \frac{10}{6} = 1.6; \quad \frac{M_x}{k_x} = \frac{20,000}{1.6} = 12,500, \quad \text{and} \quad M_y = 10,000 \times 1 = 10,000;$$

$$k_y = \frac{6}{6} = 1; \quad \frac{M_y}{k_y} = \frac{10,000}{1} = 10,000.$$

Substituting these values in the above formula:

$60 f = 30,000 + 12,500 + 10,000$ , or  $f = 875$  lbs./in.<sup>2</sup>, the maximum fiber unit stress.

Let it be required to find the maximum fiber stress for a steel column section subjected to an axial load of 80,000 lbs. and an eccentric load of 40,000 lbs., the eccentricity being 7" with respect to the  $X-X$  column axis. The column is a 10" WF 60# section.

Referring to the table of properties of a steel handbook, we find, for this column section,  $A = 17.66$  in.<sup>2</sup> and  $S_{x-x} = 67.1$  in.<sup>3</sup> Then  $\Sigma P = 80,000 + 40,000 = 120,000\#$ ,  $M = 40,000 \times 7 = 280,000\#\#$

and 
$$k = \frac{S}{A} = \frac{67.1}{17.66} = 3.79''.$$

$$Af = \Sigma P + \frac{M}{k} = 120,000 + \frac{280,000}{3.79} = 193,700\#$$

$$f = \frac{193,700}{17.66} = 10,950\#/\text{in.}^2, \text{ the maximum fiber stress.}$$

It should be noted that by use of the section factor we have converted the eccentric load to an equivalent axial load. In this instance 193,700 lbs., is the total equivalent axial load on the column.

## CHAPTER XVII

### BRICK AND STONE CONSTRUCTION

#### Article 1. Brick Construction

**General Considerations.** Brick masonry should be stressed only in direct compression and in shear since the character of its composition does not adapt it to bending or tensile stresses. Consequently, the tests made to determine the strength of brick masonry are loading tests in direct compression. Many such tests have been made on individual brick and upon small sections of brickwork laid up in mortar, but the results have not always been particularly instructive because the conditions and consequently the ultimate strength in the high walls and piers of actual construction have proved very different, on account of variations in material and workmanship, from those of the small test samples. However, tests have been made at the Bureau of Standards in Washington on large brick piers and large sections of walls in which the specimens approached much more closely the true conditions in building.

**Tests.** The Bureau of Standards test on brick piers were performed upon piers uniformly 10'0'' high with areas varying from 79 in.<sup>2</sup> to 1024 in.<sup>2</sup> The bricks were of three varieties: (1) Best hard burned, (2) medium burned, (3) soft burned, inferior qualities, and were selected from four districts, Pittsburgh, New York, Chicago and New Orleans.

The average results of the tests are presented in Table I.

The conclusions from the tests may be briefly summarized as follows:

1. The primary failure of brick piers is caused by transverse failure of the individual bricks rather than by crushing the bricks. Therefore the component parts of the pier should be made as deep as possible, by laying the bricks on edge and by breaking joints every few courses instead of every course. Likewise the mortar joints should be as thin as possible and of uniform thickness, and for this reason regularity in the shape of the bricks is important.

2. The kind of mortar used is important. Pure lime mortar gave the weakest results but it was found that, in a mortar of 1 part Portland cement to 3 parts sand, 25% by volume of the cement could be replaced by hydrated lime without affecting the strength of the piers. The workability of the mortar was likewise improved, and smoother, and more even beds and fuller joints resulted. Equal parts by volume of cement and lime, however, caused a decrease in the strength of the piers.





*Frohman, Kobb and Little, Architects.*

STONE CONSTRUCTION, WASHINGTON CATHEDRAL.

3. Varying the number of header courses does not appreciably affect the ultimate strength of the pier, but its strength is slightly increased by the introduction of wire mesh in all horizontal joints. This increase did not take place, however, when the mesh was introduced in every fourth joint only.

Table I

PITTSBURGH DISTRICT

Mortar	Grade of Brick	Compressive Strength lbs./in. <sup>2</sup>	Compressive Strength One Brick lbs./in. <sup>2</sup>	Modulus of Elasticity	Per Cent Absorption
1 Cement, 3 Sand . . . . .	1	2 783	11 990	2 970 000	4.08
" " " . . . . .	2	1 647	6 070	1 700 000	10.00
" " " . . . . .	3	573	1 659	655 000	16.28
1 C. (15% lime), 3 S. . . . .	1	3 540	11 965	3 350 000	1.28
" " " " . . . . .	2	1 463	6 070	1 308 000	10.00
1 Lime, 6 Sand . . . . .	1	1 360	11 990	630 570	4.08
" " " . . . . .	2	907	7 880	642 300	7.46
" " " . . . . .	3	171	1 659	290 000	16.28

NEW ORLEANS DISTRICT

1 C. (15% lime), 3 S. . . . .	1	1 605	7 340	533 000	16.80
" " " " . . . . .	2	1 710	6 880	1 104 000	16.40
" " " " . . . . .	3	1 743	6 510	1 666 300	17.10

NEW YORK DISTRICT

1 C. (15% lime), 3 S. . . . .	1	1 243	5 630	875 000	16.40
" " " " . . . . .	2	1 260	4 430	939 000	18.60
" " " " . . . . .	3	1 050	2 710	583 600	19.30

CHICAGO DISTRICT

1 C. (15% lime), 3 S. . . . .	1	813	3 200	777 000	16.20
" " " " . . . . .	2	720	3 150	687 000	16.20

The Bureau of Standards tests on brick walls deal with the central loading of 168 walls each 6'0" long and about 9'0" high and of 129 wallettes or small walls each about 18" long and 34" high, each walette corresponding in kind of brick, method of laying, mortar mixture and workmanship with one of the large walls. It was found that the wallettes gave a much more consistent measure of the strength of a proposed construction than do tests upon individual bricks, the solid walls averaging about 86% of the strength of the wallettes and the hollow walls about 77%.

The workmanship was divided into two types. In the first the walls were built by contract on a lump sum basis without supervision, the longitudinal vertical joints being very short of mortar and the hori-

zontal beds deeply furrowed with the trowel. In the second type the walls were laid up by day's work with careful supervision. The vertical joints were filled and the horizontal mortar beds smoothly spread.

The first type were built of Chicago brick, and the average strengths of the walls with various mortars were as follows, the ultimate strength of a half-brick flatwise being 3280 lbs./in.<sup>2</sup>

Lime Mortar Walls . . . . .	287 lbs./in. <sup>2</sup>
Cement-Lime Mortar Walls . . . . .	587 lbs./in. <sup>2</sup>
Cement Mortar Walls . . . . .	661 lbs./in. <sup>2</sup>

For the second type the average results were as follows:

Table II

Kind of Brick	Compressive Strength of Half-Brick Flatwise	Average Compressive Strength of Solid Walls	
		Cement-Lime Mortar	Cement Mortar
	lbs./in. <sup>2</sup>	lbs./in. <sup>2</sup>	lbs./in. <sup>2</sup>
Chicago . . . . .	3 280		895
Detroit . . . . .	3 580	945	1 145
Mississippi . . . . .	3 410	1 300	1 550
New England . . . . .	8 600	1 875	2 850

It is seen that both the kind of mortar and the workmanship very materially affect the strength of the walls. Those in which the beds were smooth and the vertical joints well filled were stronger by from 24% to 109% than walls in which the mortar beds were furrowed.

**Factor of Safety.** The figures given above denote the maximum loads which the piers and walls were capable of supporting without failure. It is customary, however, when designing, to make allowances for accidental inferiorities in brick, mortar and workmanship and for unknown stresses arising through abnormal circumstances which cannot be foreseen. Such allowances consist in dividing the ultimate strength as obtained from tests by a factor, usually 6 or 10 in the case of brickwork, and in using the value thus obtained as an allowable unit stress in place of the ultimate strength. This reduced value is called the **ALLOWABLE WORKING STRESS** or the **SAFE LOAD**.

**Building Codes.** As has been mentioned in Chapter I, the building codes of the various cities differ as to their requirements for the allowable working strengths of the several building materials. The following table summarizes the requirements in regard to brickwork and also gives recommended safe loads based on the recent tests.

Table III

Hard-Burned Brick and Mortar	Boston 1930	New York 1938	Chicago 1939	Phila- delphia 1941	Denver 1898	San Fran- cisco 1928	Recom- mended
	Allowable pressure in lbs./in. <sup>2</sup>						
Brick in Portland cement mortar	275	325	250	300		200	300
Brick in cement and lime mortar	165	250	200	225		140	200
Brick in lime mortar.....	100	100	100	100	110	100	100

The recommended values are intended for brickwork laid with good workmanship and with the following mortar mixtures:

- Portland cement mortar.. 1 cement, 1/10 lime, 3 sand.
- Cement and lime mortar.. 1 cement, 1 lime, 4 sand.
- Lime mortar..... 1 lime, 3 sand.

**Weight.** Brickwork is generally considered as weighing 125 lbs./ft.<sup>3</sup>

**Walls.** Because of the greatly increased use of steel frame construction in recent years, independent bearing walls of brick are now almost never built over eight stories in height and very rarely over four or six stories, steel frame with enclosing walls supported at each story on the steel proving a more economical type of construction for the taller buildings. The proper thicknesses for bearing walls depend upon the loads and are consequently determined by the safe stress allowed per square inch on the brickwork. The building codes, however, publish tables and rules of wall thicknesses which are required as safe for the various heights of walls. The following table gives the thicknesses in inches fixed by the codes of several cities for buildings from one to six stories high.

In addition to the tables of wall thicknesses, laws are included in most codes regulating the extent of wall both horizontally and vertically which may be constructed of the given thicknesses without providing reinforcement of piers, cross walls and buttresses or without tying the wall by means of cross floor beams. The object is to provide stability and lateral stiffness in the walls independently of the consideration of direct compressive strength. The tables and rules must be consulted when designing buildings to be erected in districts where a building code has been established.



Table IV. Wall Thickness

Height and Location		Stories					
		1st	2nd	3rd	4th	5th	6th
One Story	New York	8					
	Chicago	12					
	Philadelphia	13					
	San Francisco	13					
Two Stories	New York	12	8				
	Chicago	12	8				
	Philadelphia	13	13				
	San Francisco	17	13				
Three Stories	New York	12	12	8			
	Chicago	12	12	8			
	Philadelphia	18	13	13			
	San Francisco	17	17	13			
Four Stories	New York	12	12	12	12		
	Chicago	16	12	12	8		
	Philadelphia	18	18	13	13		
	San Francisco	17	17	17	13		
Five Stories	New York	16	12	12	12	12	
	Chicago	16	16	12	12	12	
	Philadelphia	22	18	18	13	13	
	San Francisco	21	17	17	17	13	
Six Stories	New York	16	16	12	12	12	12
	Chicago	16	16	16	12	12	12
	Philadelphia	22	22	18	18	13	13
	San Francisco	21	21	17	17	17	13

The Building Code Committee of the Department of Commerce, in its efforts to harmonize and standardize the building codes of the various municipalities of the country, has published recommendations for the construction of brick walls, of which a summary follows:

The minimum thickness for solid brick exterior bearing and party walls shall be 12'' for the uppermost 35' and shall be increased 4'' for each successive 35' or fraction thereof measured downward from the top of the wall. Where solid brick exterior bearing and party walls are stiffened at distances not greater than 12' apart by cross walls or by internal or external offsets or returns, at least 2' deep, they may be 12'' thick for the uppermost 70' measured downward from the top of the wall, and shall be increased 4'' in thickness for each successive 70' or fraction thereof. In the case of one-story buildings, or of three-story buildings

not over 40' high, 8" walls are permitted when having unsecured heights of not over 12' and horizontal roof beams with no outward thrust.

The Building Code Committee permits non-bearing brick walls to be 12" thick for the uppermost 70' of height with an increase of 4" for each successive 35' or fraction thereof, measured downward from the top of the wall.

**Openings.** It is undoubtedly true that an excessive number of door and window openings weakens a wall. Most municipal building codes therefore require that the wall be increased 4" in thickness when the openings exceed a certain percentage of the wall section in any horizontal plane. The Building Code Committee, however, considers that it is not necessary to require an increase in wall thickness on account of openings if the compressive stresses are kept within the prescribed limits and if serious eccentricity in loading of piers and short wall sections is avoided. A logical basis of design is thereby attained in place of an arbitrary thickening of the entire wall.

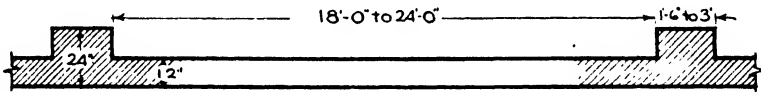

FIG. 1.—Brick Wall with Piers.

**Chases.** In order that plumbing and heating pipes and ducts may not project into the interior of a building, grooves called chases are commonly left on the inside of brick walls to accommodate them within the thickness of the wall. Such chases, if too large, may seriously weaken a wall, and their extent is consequently restricted in most building codes. The Code Committee recommends that no chases shall be deeper than  $\frac{1}{3}$  the wall thickness, that no horizontal chase shall exceed 4' in length and that no diagonal chase shall exceed 4' in horizontal projection. It also recommends that the aggregate area of chases shall not exceed  $\frac{1}{4}$  the whole area of the face of the wall in any story and that there shall be no chases in the required area of any pier or buttress.

**Piers** (Fig. 1). Brick piers may be incorporated in walls or may be isolated and stand alone. When incorporated in walls they signify a thickening of the brickwork to at least 2' to give lateral support and stability to the wall itself or to receive the concentrated loads of girders or roof trusses. By their presence they permit a reduction in the thickness of the wall between them. The clear distance between piers is limited in the codes to 18 to 24 times the wall thickness, and the width of piers varies from  $\frac{1}{8}$  to  $\frac{1}{12}$  the clear distance. When piers receive the loads of girders or roof trusses their dimensions should be sufficient so that the allowable compressive working stress per square inch is not exceeded.  $A = \frac{P}{f_c}$ , in which  $A$  is the required area of cross-section in

square inches,  $P$  the load and  $f_c$  the allowable compressive working stress in pounds per square inch.

Isolated brick piers are used to support beams, girders or trusses and their area of cross-section is determined by the formula just stated,

$A = \frac{P}{f_c}$ . Since they are not supported on each side by a wall, however,

they may fail from bending if their load should become eccentric. Their height is, therefore, generally limited by the codes to 6 or 10 times their least dimension since brickwork is weak in flexure. Diagonal thrusts, as from arches and trusses, are treated in Article 2 of this chapter.

**Buttresses** (See Fig. 5). A buttress differs from a pier in that it serves to counteract a diagonal thrust as well as bear a vertical load. It is used to take the thrusts from arches, vaults and roof trusses and to transfer these diagonal forces to the ground. Buttresses are most commonly employed in large buildings such as churches, armories and auditoriums where the walls are of considerable height unsupported laterally by floors and where an outward thrust on the walls is derived from the roof construction. The reaction of the arch or roof construction must first be determined in magnitude and direction, this thrust then being combined with the weight of the uppermost section of the buttress, the resultant of these forces with the weight of the next section and so continuing to the footing. Such buttresses must be carefully bonded with the wall so that they will act together. See Article 2 of this chapter.

**Basement Walls and Footings.** Common brick are very little used at the present time below grade because they do not withstand the moisture and frost as well as stone or concrete. For light buildings in dry soil, basement walls of brick may still be built, but only the hardest and soundest brick should be used, laid up in Portland cement mortar, thoroughly slushed and grouted so that all joints are filled.

Brick basement walls should be at least as thick as the walls above them and never less than 12". Many building codes require them to be 4" thicker than the wall above, but the Code Committee considers this thickening unnecessary, since fewer openings render the unit compressive stress less than in the superimposed walls. Also as a retaining wall it owes its stability to the weight above, and the addition of 4", except in very thin walls, increases its resistance to side thrust very little. If, however, upon investigation it be found that the stresses due to earth pressure and superimposed building exceed the specified safe working stress, then the thickness of the basement wall must be increased to bring the stresses within the specified limit.

Footings are now almost never made of brick, concrete being more satisfactory even under a brick basement wall.

**Corbeling Action.** If brickwork be properly laid in good cement mortar and well bonded it will have certain corbeling or arching properties, that is, each brick will act as a small cantilever supporting with its projecting portion the brickwork above it. Thus the brickwork

over a window or door opening will support itself to a certain extent since each brick starting from the corners of the opening projects slightly over the opening and carries the upper wall. The overlapping brick on the two sides of the opening gradually approach each other from course to course until they meet in a point over the center of the opening. Consequently only the brick inside the triangle thus formed will impose their weight upon the lintel or arch which spans the opening itself.

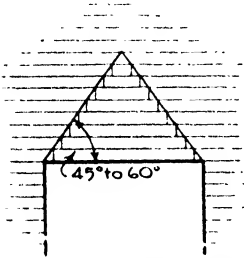

FIG. 2.—Corbeling Action in Brickwork.

The angle at which the corbeling action functions is variously taken at 45° or 60° with the horizontal. Allowance is made for this property of brickwork in calculating the loads upon lintels and arches and in the process of underpinning walls and foundations (Fig. 2).

**Arches.** The bonding of brick arches is described in Chapter V on Brick. Such arches are usually either flat, segmental or full-centered, that is semicircular, in form. Flat arches are generally supported upon steel angle lintels and have less strength than the other types (Fig. 3,*a*). Segmental arches, though strong, exert a considerable thrust, and with wide spans or heavy loads cast-iron or stone skew-backs and steel tie rods are frequently required (Fig. 3,*b*). The thrust must first be determined and the rods proportioned in size to the thrust. A fairly close value for the thrust may be determined for a uniform load by the following formula:

$$\text{Horizontal thrust} = \frac{\text{load on arch} \times \text{span in feet}}{8 \times \text{rise of arch in feet}}$$

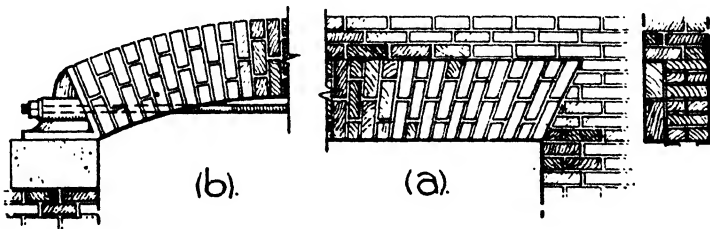

FIG. 3.—Flat and Segmental Arches.

For a load concentrated at the crown of the arch the thrust found by this formula should be multiplied by 2.

The required area of the rod in square inches is found by dividing the total thrust by 16,000, 18,000 or 20,000, whichever tensile strength per square inch is employed for the steel. The table of safe loads at 16,000 lbs. for round rods with plain and upset ends is found in Chapter XVIII, Article 1. Two or three rods may be used if one be insufficient.

**Example.** What tie rod is required for a segmental arch with a rise of 1'6" and a span of 16'0" supporting a brick wall 16" thick?

Assume the load to be composed of the brickwork inside an equilateral triangle with 16'0" sides. The height of the triangle is 13.8', the area is 110.4 ft.<sup>2</sup> and the cubical contents 143.52 ft.<sup>3</sup>

Weight of brick masonry = 125 lbs./ft.<sup>3</sup> Load = 143.52 × 125 = 17,940 lbs.

Thrust =  $\frac{17,940 \times 16}{8 \times 1.5} = 23,520$  lbs. From Table VII, Chapter XVIII, it is found that one 1 5/8" round rod with plain ends, or one 1 3/8" with upset ends, will resist the thrust.

The methods of designing semicircular brick arches are the same as those for stone arches and will be considered in the next article of this chapter, Stone Construction. The various types of arches and bonds are described in Chapter V, Brick.

## Article 2. Stone Construction

**In General.** The strength of stone depends upon its structure, the hardness of its particles and the manner in which the aggregates are interlocked or cemented together. If cemented, the character of the cement, whether of lime, clay, iron oxide or silica, affects the strength of the stone. Generally the more dense and durable stones are the stronger, although this is not always the case. Tests show that all the stones usually employed in building are many times stronger in compression than required by the loads imposed upon them even in the case of the heaviest buildings and monuments. Very few failures in direct compression have occurred in construction although failures from bending, as in lintels or as caused by settlements of bed, are not uncommon. Stone is strong, then, in compression but weak in flexure and shear, and these characteristics must always be remembered in design. The strength of the mortar has an important part in the resistance of masonry to forces, as have also the size and regularity of the stones and the workmanship of the masons. Stones of the same kind may also vary widely in their strength, those from one quarry or district being much more resistant than those from another.

**Tests.** Many compression tests, extending over a long period of years, have been made upon building stones, and from the values derived it would appear that the average crushing strength of any class of stone may be misleading because of the wide range of results for the same kind of stone. If an exact working strength be desired tests should be made upon samples from the actual quarry furnishing the stone.

The following examples of the variation as shown by tests in the ultimate strength of stones in pounds per square inch may be noted:

Granite.....	10,000 to 28,000.
Sandstone.....	3,000 to 14,000.
Limestone.....	9,000 to 18,000.
Dolomite.....	16,000 to 24,000.
Marble.....	10,000 to 23,000.

Below is given a summary of the allowable working stresses specified by several cities.

Table V

Building Stone	Boston 1930	New York 1938	Chicago 1939	Phila- delphia 1941	Denver 1898	San Fran- cisco 1928	Recom- mended
	Allowable pressure in lbs./in. <sup>2</sup> (cement mortar)						
Granite, cut	1 000	800	400		560	400	800
Marble and limestone, cut	560	500	350				500
Sandstone, hard, cut	420	300	350		170		400
Rubble stone		140	100	140			140

Some cities omit stone entirely from their tables of unit stresses apparently considering that whatever passed the inspectors would be sufficiently strong to support any compressive loads put upon it in modern building construction. This position appears logical in view of the fact that steel and concrete have taken the place of stone as supports of heavy loads, the latter being used now in most cases only for the bearing walls of low buildings or for the facing and decoration of tall ones. Mr. I. O. Baker has compiled a list of some of the heaviest masonry structures with their existing maximum pressures. These structures include large European churches, the Washington monument and the Brooklyn and St. Louis bridges, and the pressures range from 400 to 600 lbs./in.<sup>2</sup> It is unlikely that such stresses in stone will ever be approached by architectural structures of the present day.

The allowable unit stress of stone in shear should not be taken at more than  $\frac{1}{4}$  the allowable compressive unit stress. In tension a safe working stress with lime mortar is 5 lbs./in.<sup>2</sup>, and with cement mortar 15 lbs./in.<sup>2</sup>

**Weight.** The weight of stone masonry is usually taken at 155 lbs./ft.<sup>3</sup> for sandstone, 165 lbs. for limestone and marble, and 170 lbs. for granite.

**Walls.** The minimum thicknesses for walls and piers of stone masonry are the same as those prescribed for brick under the same conditions and have been explained in Article 1 of this chapter. The only exception is rubble stone work which is required to be 4" thicker than brick walls of the same heights with a minimum of 16" to 18". Ashlar facing with brick backing is generally 4" thick and is tied back to the brickwork with built-in metal anchors. In this case it cannot be counted when

calculating the thickness of the wall. Sometimes the facing stones are alternately 4'' and 8'' thick, the deeper stones being built into the brickwork. With this method of bonding the stone facing may be counted as an integral part of the wall in determining its thickness. The requirements for lateral support for stone walls by means of piers, buttresses, cross walls or floor beams is the same as for brick walls, as are also the limits placed upon the extent of chases. Details of stone construction are described in Chapter VII, Stone.

**Piers** (Fig. 4). A stone or brick pier under a vertical load is subjected only to direct compression, and its area,  $A$ , should be equal to the load,  $P$ , divided by  $f_c$ , the allowable compressive stress per square inch, or  $A = \frac{P}{f_c}$ . Thus a pier built of limestone subjected to a load of 179,000 lbs.

should have an area of  $\frac{179,000}{560}$  or 320 in.<sup>2</sup> and might have a cross-section area of 16'' x 20''. A pier to support the same load, built of brick and cement mortar, should have an area of  $\frac{179,000}{300}$  or 597 in.<sup>2</sup>, the cross section area being 20'' by 30''.

If, however, the pier were subjected to a horizontal pressure or thrust in addition to the vertical load, the resultant of the two forces would tend either to overturn the pier or to cause it to slide laterally on its base or at some bed joint or plane of weakness. Suppose the horizontal force  $P$  (Fig. 4) tends to overturn a rectangular pier and that  $W$  represents the weight of the pier acting through its center of gravity. Then  $R$  will be the resultant of  $P$  and  $W$  and will cut the base  $CD$  at  $E$ . There would then be a tendency for the pier to overturn by rotating around the point  $C$ . As the force  $P$  decreases, the resultant  $R$  would cut the base at points nearer to the vertical line through the center of gravity and there would be less tendency for the pier to overturn.

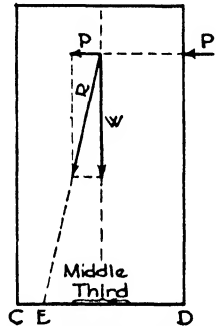

FIG. 4.—Effect of Thrust.

It is shown in Article 3, Chapter XXIV, under Eccentric Footings that when the resultant,  $R$ , cuts the base within its middle third, all the foundation bed is in compression, the entire width of the base acts in support, and the pier is considered stable if the maximum compressive stress does not exceed the allowable compressive stress of the material. If, however,  $R$  cuts the base outside the middle third, only a part of its surface is in compression and assists in giving support. Hence it is customary to assume that the base is divided in three equal sections and to limit the point, at which the resultant should cut the base, to the middle section or MIDDLE THIRD (Fig. 4).

As has been said, the horizontal component of the forces will likewise

tend to cause the pier to slide laterally on its base or at some horizontal joint. This tendency is counteracted by the friction between the surfaces. The amount of friction varies with the material and is measured by the angle with the horizontal, called  $\phi$ , at which two surfaces will naturally slide upon each other. For horizontal joints the tangent of the angle  $\phi$  is known as the COEFFICIENT OF FRICTION. For brick and stone,  $\phi$  is about  $33^\circ$ , and  $\tan \phi$ ,  $f$ , is 0.65. Sliding will occur between

two horizontal surfaces when the horizontal components of the forces acting above the joint equal the weight upon the joint multiplied by the coefficient of friction, or when  $H = fW$ . In design, a safety factor of 2 should be used to avoid all possibility of sliding, especially in the case of footings upon slippery soil such as clay.

**Buttresses.** The diagonal thrusts transmitted by arches, vaults and trusses are frequently transferred to the ground by means of masses of masonry whose vertical weight, when combined with the diagonal thrust, forms a resultant force which should cut the base of the buttress within its middle third. A pinnacle is often placed on top of the buttress above the point of application of the thrust to add weight, thereby increasing the vertical component and bringing the resultant nearer the axis of the pier.

In Fig. 5, *a*, the center of gravity of each section of masonry is first found to give the line of action of the weight of that section. The weight  $W_1$  of the pinnacle, section I, is laid off at a convenient scale on a vertical line passing through the centroid of the pinnacle.

$W_1$  must now be combined with the weight of the next section below,  $W_2$ , and since the centroids of this section and of the pinnacle are not on the same vertical line, the resulting line of action of the two weights must be determined. (See Fig. 5, *b*.)

We have, then, the lines of action of the diagonal thrust  $T$  and of the resultant weights. Produce these two lines until they meet, and construct a parallelogram of forces, laid off at a scale indicating their intensities. If the buttress be sufficiently deep for stability, the diagonal of the parallelogram, which is the resultant of  $T$  and  $W_1$  and  $W_2$ , should

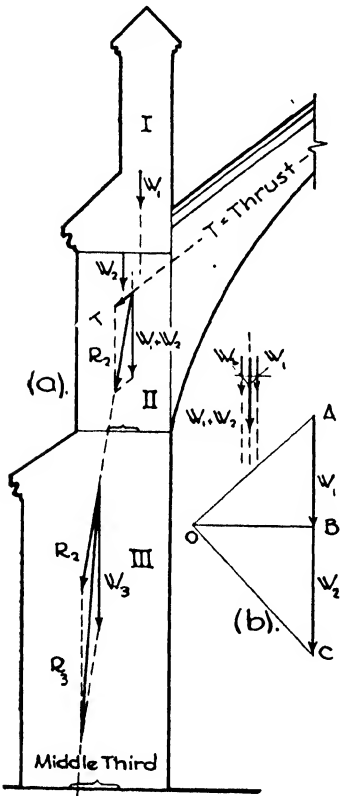

FIG. 5.—Buttresses.



cut the base of the second section within its middle third. This resultant is then combined with the weight  $W_3$  acting through the centroid of the third section in the same manner as before, and the last should cut the base of section III within its middle third. While it is considered desirable to keep the resultant of the forces within the middle third, stability may still be maintained if the resultant passes outside this section. In any case the maximum compressive stress should be investigated.

In ordinary practice the architectural design determines the preliminary proportions of the pier or buttress. A sketch of the structure so designed is tested as here described to determine the position of the resultant, or line of pressure, in reference to the middle third of the base and its intensity. The weakest joint is also tested to determine the factor of safety against sliding. If the results are unsatisfactory the buttress must then be modified in design by increasing the width, the

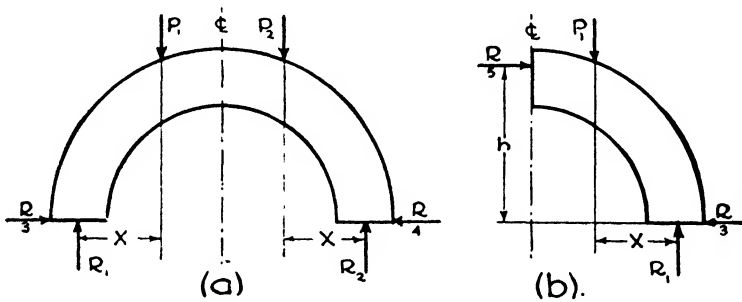

FIG. 6.

depth or the superimposed load or, in the case of sliding, by inclining the joints. As elsewhere in masonry design, however, good architectural proportions instinctively follow stability of construction.

**Arches.** The stability of brick and stone arches is based upon the same theory as that already applied to piers and buttresses, that is the line of pressure should fall within the middle third at all cross-sections of the ARCH RING, the space between the intrados and the extrados of the arch. The investigations are best made graphically. In order to arrive at a graphical representation of the line of pressure in an arch, the following convention is employed.

Since in architecture the majority of arches are symmetrically loaded upon the right and left halves of the arch, the values of the forces and stresses acting in the two portions will be the same. In Fig. 6,  $a$ , if  $P_1$  and  $P_2$  be the resultants of all the loads on the two halves,  $R_1$  and  $R_2$  the vertical reactions and  $R_3$  and  $R_4$  the horizontal components of the thrusts, then

$$P_1 = P_2, R_1 = R_2, R_1 = P_1, R_2 = P_2 \text{ and } R_3 = R_4.$$

Now if the right-hand half of the arch were removed as in Fig. 6,  $b$ , in order to preserve equilibrium in the left-hand half, a force,  $R_4$ , must be

applied at the crown equal and opposite in direction to  $R_3$ , and the algebraic sum of the horizontal forces, the vertical forces and the moments must each equal zero.

Therefore in Fig. 6,  $b$ ,  $P_1 = R_1$ ,  $R_3 = R_5$ , and  $R_5 h = P_1 x$  or  $R_5 = \frac{P_1 x}{h}$

The force  $R_5$  is the same as the thrust from the left half of the arch.

The line of pressure is represented by the successive resultants obtained from the actions of the thrusts and the loads of the various sections. The line of pressure should coincide as nearly as possible with the center line of the arch ring to produce compression throughout the surfaces of the joints and to avoid rotating or overturning of the voussoirs. Consequently, according to the theory of eccentric loading, if a line of pressure be obtained within the middle third of the arch ring, it is regarded as sufficiently close to the true line and the arch is considered stable.

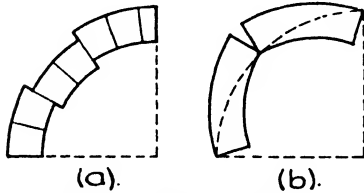

FIG. 7.—Failure of Arches.

Semicircular and segmental arches may fail because the line of pressure is inclined at an angle to the joints between two or more voussoirs greater than the angle of friction, causing the surfaces to slide over each other as in Fig. 7, *a*, or because the line of pressure falls so far outside the middle third that

the voussoirs rotate upon each other as in Fig. 7, *b*.

In building construction the width of the arch ring is generally a matter of design, and the problem consists in investigating the arch, as designed, to determine the course of the line of pressure and the degree of stability of the arch. The voussoirs of an arch almost invariably carry a superimposed load, and consequently this load as well as the weight of the voussoirs must be included in testing the arch. The triangular corbeling or arch action of masonry described in Article 1 of this chapter is sometimes considered in determining the superimposed load, but in the following procedures, which accord with the usual methods, the weight of the full load over the arch will be employed.

The graphic solution considers one half the arch only, it being assumed that the loads are symmetrical and equally distributed and therefore the stresses in each half-arch are identical. The arch ring and superimposed load are divided into a convenient number of imaginary sections since, for the purposes of the investigation, it is not necessary to preserve the keystone and voussoir arrangement of the actual design. Arcs are then drawn representing the limits of the middle third.

**Example.** Investigate the stability of the arch shown in Fig. 8. Radius of intrados 11'6", radius of extrados 14'6". Height of wall above crown of extrados 2'6". Top of wall horizontal.

(1) **LOADS.** Divide the superimposed load and the arch ring into any convenient number of vertical sections, as I, II, III, IV and V, it not being necessary

that these sections have any relation to the voussoirs. Next compute the areas of the sections. Since the areas are directly proportional to the weights of the sections, assuming the arch and the surcharge to be one unit in thickness the weights of the sections are proportional to their areas.

From experience it has been found that the greatest pressure lies nearer the extrados at the crown and spring line of a semicircular arch with a superimposed load. For this reason assume the horizontal thrust,  $H$ , from the left side of the arch to be at the outer edge of the middle third of the arch ring as shown at  $E$ . Similarly assume the resultant thrust,  $T$ , at  $L$  on the spring line.

(2) CENTROIDS. By graphical methods find the centroids of the assumed sections as  $c_1, c_2, c_3, c_4$  and  $c_5$ , and also the centroid of the whole area,  $W$ .

**DATA:**

Span = 23'-0"  
 Radius = 11'-6"  
 Ring = 3'-0"

**AREAS & WEIGHTS:**

- I.  $\frac{5.5+5.8}{2} \times 2.15 = 12.1$
  - II.  $\frac{5.8+7}{2} \times 2.15 = 13.8$
  - III.  $\frac{7+9.3}{2} \times 2.15 = 17.5$
  - IV.  $\frac{9.3+17}{2} \times 2.15 = 28.3$
  - V.  $17 \times 3 = 51.0$
- 
- 122.7

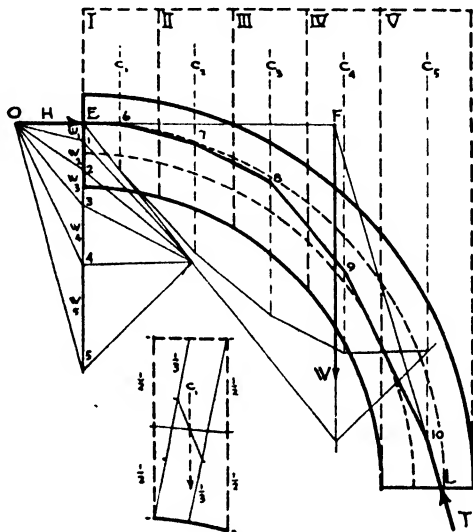

FIG. 8.—Line of Pressure in Arches.

(3) LINE OF PRESSURE. From  $E$  lay off vertically downward  $w_1, w_2, w_3, w_4$  and  $w_5$ . The length of this line represents the weight or area of the entire section. There are three fundamental forces in equilibrium:  $H, W$  and  $T$ . Their common point is  $F$ . A line joining  $L$  and  $F$  determines the direction of  $T$ . Since  $H, W$  and  $T$  are in equilibrium, the force polygon closes. This polygon is drawn about the point  $E$ , and a line drawn from the lower extremity of the load line, 5, parallel to  $T$ , determines the magnitude of the thrust  $H$ . Designate the thrust  $H$  by  $OE$  and draw  $O1, O2, O3$  and  $O4$ . The thrust  $H$  meets the weight line of section I at point 6. The resultant of  $OE$  and  $w_1$  is  $O1$ . Draw a line parallel to  $O1$  from point 6 to the centroid of section II. The resultant of  $w_2$  and  $O1$  is  $O2$ . Continue in like manner to the spring of the arch. The broken lines thus found represent the line of pressure in the arch ring.

More than one trial is often required to find the true line of pressure. The center of the crown and spring may be used in the first trial as points of application of the thrust and resultant and the outer limits of the middle third in later trials.

If a satisfactory line of pressure cannot be found, the weights upon the wall or the width of the arch ring must be increased. When, however, the requirements of the architectural design will permit of no alterations of this sort, heavier weights over the abutments of the arch may be introduced to resist thrusts falling too far beyond the limit of stability: It would seem, however, that a stone or brick arch if designed according to satisfying masonry proportions should, for that very reason, be stable and capable of successful analysis.

## CHAPTER XVIII

### HEAVY TIMBER CONSTRUCTION

**Introductory.** The subject of wood construction naturally divides itself into two classes, HEAVY TIMBER CONSTRUCTION and LIGHT WOOD FRAMING. The first class is a direct descendant from the early methods of our ancestors in this country and in Europe and is founded upon the basic principles of heavy floor beams and girders supported on walls and posts finished off with sturdy roof beams and trusses. The result is a stout, self-supporting, well-braced framework capable of sustaining the severe stresses resulting from heavy loads and long spans, but slow and unwieldy to put together. The second class arose in the United States toward the middle of the nineteenth century inspired by the demand for quickly built dwellings composed of light members readily turned out by local sawmills and easily handled in erection without the aid of derricks and hoists. The parts consist of many light joists and rafters spaced near together instead of few heavy beams and trusses far apart, and of slender studs at small intervals to form walls and bearing partitions in place of thick posts and girders. Construction of the first class is used for our mills, factories, hangars, garages and large barns because of the wide spans, heavy loading and slow-burning properties required, and the second class is employed for dwellings both large and small and for small shops, stables and apartments. This chapter will treat of the first class, Heavy Timber Construction; Light Wood Framing will be described in Chapter XIX.

#### Article 1. Floor Framing

**General Principles.** In general, heavy timber construction is based upon the demands of heavy floor loads and long spans, and the floor system consequently consists of stout beams supporting thick plank floors or closely spaced joists, the beams in turn resting upon girders, posts or walls. The posts, girders, beams, joists and planks must therefore be of adequate size to support their respective loads, and the methods of Mechanics and Strength of Materials are called upon to determine what these adequate dimensions must be. But in order to make use of the methods of calculation deduced through Mechanics the allowable unit fiber stresses of the wood employed must first be considered.

**Allowable Unit Stresses.** As has been explained in Chapter IV the strength of wood varies widely according to its species and its quality or grade. The two species most widely used for the heavy timbers of building

construction are Douglas fir in the West and Southern yellow pine together with Douglas fir in the East. Red and white spruce and Eastern hemlock are also used for light framing in the East and Sitka spruce and West Coast hemlock in the West. The following table gives the allowable unit fiber stresses for the standard grades of these six species conforming with the American Lumber Standards. These stresses are for dry locations such as exist in the interior structure of buildings.

**Nominal and Actual Sizes.** Attention is called to the fact that the nominal cross-sectional sizes of timber are given in whole inches while the actual stock sizes are generally  $\frac{1}{2}$ " less in depth and from  $\frac{3}{8}$ " to  $\frac{1}{2}$ " less in width. Thus a 2" x 10" timber measures actually  $1\frac{5}{8}$ " x  $9\frac{1}{2}$ "; a 4" x 10" timber,  $3\frac{5}{8}$ " x  $9\frac{1}{2}$ ", and a 6" x 12" timber,  $5\frac{1}{2}$ " x  $11\frac{1}{2}$ ". Flooring nominally 1" thick is actually  $25/32$ ". In practice, the actual

Table I. Allowable Unit Stresses in Pounds per Square Inch

Species of Timber	Grade	Ex- treme Fiber in Bend- ing	Maxi- mum Horiz- ontal Shear	Compression		Modulus of Elasticity
				Paral- lel to Grain	Perpen- dicular to Grain	
Douglas Fir Coast Region	Dense Select Structural	1 800	120	1 466	380	1 600 000
	Select Structural	1 600	100	1 200	345	
	1200# Framing and Joist	1 200	100	1 100	325	
	900# Framing and Joist	900	100	880	325	
Long-Leaf Southern Pine	Select Structural	2 000	100	1 450	380	1 600 000
	Prime Structural	1 800	100	1 300	380	
	Structural Square Edge and Sound	1 600	100	1 200	380	
	No. 1 Structural	1 400	100	1 000	380	
Short-Leaf Southern Pine	Dense Select Structural	2 000	100	1 450	380	1 600 000
	Dense Structural	1 800	100	1 300	380	
	Dense Square Edge and Sound	1 600	100	1 200	380	
	Dense No. 1 Structural	1 400	100	1 000	380	
Eastern Hemlock	Select	1 100	70	700	300	1 100 000
	900# Common	900	52	560	300	
West Coast Hemlock	Select	1 300	75	900	300	1 400 000
	No. 1 Dimension	1 040	75	720	250	
Eastern Spruce	1200# Select	1 200	90	800	250	1 200 000
	1000# Common	1 000	80	600	250	
Larch	Select Structural	1 800	120	1 466	380	1 300 000
	Structural	1 600	100	1 200	345	
	Common Structural	1 200	100	1 100	325	

stock dimensions should be employed in all computations, but for simplicity the nominal dimensions will be used in most of the following problems.

The unit stresses specified in the building codes are, in some of the older ordinances, less than those given in this table, no distinction of grade being recognized. The tendency in the newly revised ordinances, however, is to distinguish between the grades and allow higher stresses in the better grades of each species.

The grades of timber generally used for heavy framing of buildings are Structural and Common Structural Douglas fir and Structural

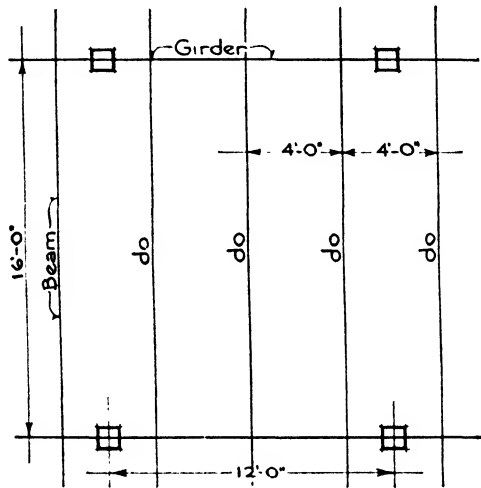

FIG. 1.

Square Edge and Sound and No. 1 Common yellow pine, the denser grades being confined to the construction of trestles, bridges and wharves, where the loads, exposure, impact and vibration are more severe. For light framing and studding in Eastern and West Coast hemlock and in red, white and Sitka spruce the Common grade is usually employed, although the Select grade is sometimes considered best for joists and rafters of long span or heavy loading.

When considering the deflection of timber joists and beams, allowance is sometimes made for the fact that under a continuous load such as dead load a slight increase in deflection will take place in time without an increase in load. In this respect the effect of continuous loading on wood is different from that on steel. Consequently a modulus of elasticity is used for the dead load of  $\frac{3}{4}$  the modulus for the live load. In other words, the dead load is increased by  $\frac{1}{8}$  before combining it with the live load to arrive at the total load. This allowance has not been considered necessary, however, in presenting the following illustrative problems.

The following notation is used throughout this chapter:

$L$  = span in feet.

$W$  = total uniform load =  $wL$ .

$l$  = span in inches =  $12L$ .

Max.  $D$  = allowable deflection in

$w$  = load per lineal foot.

$$\text{inches} = \frac{l}{360} = \frac{12L}{360} = \frac{L}{30}$$

**Beams and Girders.** In the designing of wood beams and girders the shear and deflection are important considerations as well as the bending. Especially for deep beams of short span the horizontal shear may be the determining factor, and likewise, members may be sufficiently strong to withstand bending stresses but if the deflection be more than  $1/360$  of the span the floors will shake and vibrate and plastered ceilings may crack. Beams and girders must therefore be examined for horizontal shear and deflection as well as for bending. For good proportions the breadth of a beam or girder should be  $1/3$  to  $1/2$  the depth or  $b = \frac{d}{3}$  to  $\frac{d}{2}$  approximately.

**Example 1.** Design the beam shown in Fig. 1.

*Data*

Live load = 110 lbs./ft.<sup>2</sup>

3" plank floor.

$7/8$ " finished floor.

Southern Yellow Pine

Structural Square Edge and Sound.

$f$  = 1600 lbs./in.<sup>2</sup>

$v$  = 100 lbs./in.<sup>2</sup>

$E$  = 1,600,000 lbs./in.<sup>2</sup>

*Loads*

Live load = 110 lbs./ft.<sup>2</sup>

3" plank floor = 10

$7/8$ " finished floor = 3

123 lbs./ft.<sup>2</sup>

*Load on Beam,*  
*per foot of span*

Floor  $123 \times 4 = 492$  lbs.

6" x 12" beam = 20

512 lbs.

*Beams*

Total load,  $W = 512 \times 16 = 8192$  lbs.

Reaction,  $R_1 = \frac{8192}{2} = 4096$  lbs.

1. MOMENT.  $M = \frac{WL \times 12}{8} = \frac{8192 \times 16 \times 12}{8} = 196,600$  in.-lbs. Assume  $d = 12''$ ;

$$M = \frac{fbd^2}{6}; b = \frac{6M}{df} = \frac{6 \times 196,000}{12 \times 12 \times 1600} = 5.1'' \text{ Try } 6'' \times 12''.$$

2. HORIZONTAL SHEAR.  $V = R_1 = \frac{W}{2}; v = \frac{3V}{2bd}$  or  $\frac{3W}{4bd} = \frac{3 \times 8192}{4 \times 6 \times 12} = 85$  lbs./in.<sup>2</sup> Allowable shear = 100 lbs./in.<sup>2</sup>

3. DEFLECTION. MAX.  $D = \frac{L}{30} = \frac{16}{30} = 0.53''$ .

Actual  $D = \frac{5WL^3}{384EI}$  for distributed load.

Since  $l = 12L; D = \frac{5W \times 1728L^3}{384EI} = \frac{22.5WL^3}{EI}$ . But  $I = \frac{bd^3}{12}$ .

Therefore  $D = \frac{22.5WL^3 \times 12}{Ebd^3} = \frac{270WL^3}{Ebd^3} = \frac{270 \times 8192 \times 16 \times 16 \times 16}{1,600,000 \times 6 \times 12 \times 12 \times 12} = 0.54''$ .

A 6" x 12" beam is satisfactory.



Nominal instead of actual timber sizes are used in this problem. Since the actual dimensions of a 6" x 12" beam are 5½" x 11½", it will be seen that a 6" x 14" beam with actual size of 5½" x 13½" is safer for the allowable deflection.

**Girders. Example 2** (Fig. 2). The loads from the beams on both sides of the girder are concentrated as shown in Fig. 2; they consist of the reactions of the beams amounting to 4096 lbs. each or 8192 lbs. for the two beams. Call the load 8200 lbs. at each point of loading.

Assume the girder to be 10" x 16". Weight =  $\frac{10 \times 16}{144} \times 40 = 44$  lbs./lin. ft.

$$R_1 = \frac{3 \times 8200}{2} + \frac{44 \times 12}{2} = 12,564 \text{ lbs.}$$

1. MOMENT.  $M_{max}$  at center of span =  $(12,564 \times 6) - (8200 \times 4) - \left(\frac{44 \times 6 \times 6}{2}\right) = 41,792$ , say 42,000 ft.-lbs.

$M = 42,000 \times 12 = 504,000$  in.-lbs.

$$b = \frac{6M}{d^2f}. \text{ If } d = 16, b = \frac{6 \times 504,000}{16 \times 16 \times 1600} = 7.3. \text{ Try } 8'' \times 16''.$$

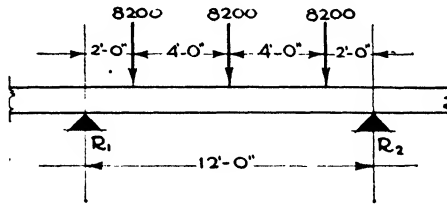

FIG. 2.

2. HORIZONTAL SHEAR.

$$V = 12,564 \text{ lbs. } v = \frac{3V}{2bd} = \frac{3 \times 12,564}{2 \times 8 \times 16} = 147 \text{ lbs./in.}^2 \left. \begin{array}{l} \\ v \text{ (allowable)} = 100 \text{ lbs./in.}^2 \end{array} \right\} \text{ not safe.}$$

$$bd = \frac{3V}{2v} = \frac{3 \times 12,564}{2 \times 100} = 188. \text{ If } b = 8'', d = 24''. \\ \text{If } b = 10'', d = 18.8''. \text{ Use } 10'' \times 20'' \text{ girder.}$$

3. DEFLECTION.  $M = 42,000$  ft.-lbs. =  $\frac{WL}{8}$  for an equivalent uniform load to produce the same bending moment.

$$\text{Therefore } 42,000 = \frac{W \times 12}{8}; W = \frac{42,000 \times 8}{12} = 28,000 \text{ lbs.}$$

$$D = \frac{5WL^3}{384EI} = \frac{5 \times 28,000 \times 12 \times 12 \times 12 \times 12 \times 12 \times 12 \times 12}{384 \times 1,600,000 \times 10 \times 20 \times 20 \times 20} = 0.102''.$$

$$D \text{ (allowable)} = \frac{12 \times 12}{360} = 0.4''. \text{ Deflection is satisfactory for } 10'' \times 20'' \text{ girder.}$$

Nominal instead of actual timber sizes are used in this problem.

**Example 3.** Design a girder with a span of 16'0" and a concentrated load of 30,000 lbs. at its center. Use Douglas fir, Select Structural Grade.  $f = 1600$  lbs./in.<sup>2</sup>  $v = 100$  lbs./in.<sup>2</sup>  $E = 1,600,000$  lbs./in.<sup>2</sup>

1. REACTION.  $R_1 = \frac{30,000}{2} = 15,000.$

2. MOMENT.  $M = \frac{WL}{4} = \frac{30,000 \times 16}{4} = 120,000$  ft.-lbs. or 1,440,000 in.-lbs.

$b = \frac{6M}{d^2f}$  Assume  $d = 20''$ ; then  $b = \frac{6 \times 1,440,000}{20 \times 20 \times 1600} = 14''$  Try 14'' x 20'' girder.

3. HORIZONTAL SHEAR.  $v = \frac{3W}{4bd} = \frac{3 \times 30,000}{4 \times 14 \times 20} = 80$  lbs./in.<sup>2</sup>, acceptable.  
 100 lbs./in.<sup>2</sup>, allowable.

$v = \frac{3V}{2bd}$ ; but  $V = \frac{W}{2}$ . Therefore  $v = \frac{3W}{4bd}$ .

4. DEFLECTION. MAX.  $D = \frac{L}{30} = \frac{16}{30} = 0.53''$ .

$D = \frac{WL^3}{48EI} = \frac{30,000 \times 16 \times 16 \times 16 \times 12 \times 12 \times 12 \times 12}{48 \times 1,600,000 \times 14 \times 20 \times 20 \times 20} = 0.29''$ .

Use 14'' x 20'' girder.

Nominal instead of actual timber sizes are used in this problem.

**Bearing of Beams upon Girders.** The simplest method of connecting a beam to a girder is to rest it on top of the girder. Headroom under the girder, however, is sacrificed by this method; flames have free play to surround the girder, and there is more depth for shrinkage of wood. The resistance of the wood fibers of the girder must be investigated to make sure that they will not be crushed by the compression across their grain exerted by the beam. The beam may extend across the full width of the girder, or two beams may be butted at the center line of the girder.

For the 10'' x 20'' yellow pine girder in Example 2, the load imposed by the beam is 4096 lbs. The allowable fiber stress for compression across the grain for structural square edge and sound grade of Southern yellow pine is 380 lbs./in.<sup>2</sup>

Area of bearing required = 4096/380 = 11 in.<sup>2</sup> The beam is 6'' wide. Therefore a bearing 2'' deep upon the girder would be safe. In this case the beams may carry across the girder or their ends may butt at the center line of the girder with safety since the girder is 10'' wide.

When it is desired to frame the tops of the beams and girders on the same level the beam is usually supported by WOOD CLEATS bolted to the sides of the girders or by STEEL HANGERS. With wood cleats the safe area of the wood against crushing by the beam load must be determined. The 6'' x 12'' beam of Example 1 will impose a load of 4096 lbs. The required bearing area is  $\frac{4096}{380} = 11$  in.<sup>2</sup> The width of the beam is 6''; therefore the cleat should be 2'' thick. Some clearance is usually allowed between the beam and the girder. Use a cleat 3'' thick by 4'' wide.

With steel hangers the bearing seat for the beam and the thickness of the metal must be adequate for the loads imposed. By calculating the maximum allowable bending moment, shear and deflection for yellow pine beams of varying cross-sections, the maximum end reaction may be obtained and the dimensions of the corresponding hanger determined. Tables of hangers for beams of a wide range of dimensions

have thus been prepared by the manufacturers, and it is more economical of time to use a maximum standard size hanger to suit the conditions than to calculate the actual theoretical size of seat and thickness of metal in each case. Table II gives a few beam cross-sections with corresponding hanger sizes.

Table II. Hanger Sizes

Beam Sections	Hanger Size
2 x 8 to 3 x 10	$2\frac{1}{2} \times \frac{1}{4}$
4 x 10 to 4 x 12	$2\frac{1}{2} \times \frac{3}{8}$
6 x 12 to 3 x 14	$3 \times \frac{3}{8}$
8 x 12 to 4 x 14	$3\frac{1}{2} \times \frac{1}{2}$
6 x 14	$4 \times \frac{1}{2}$
8 x 14 to 10 x 14	$4 \times \frac{5}{8}$

There are several types of steel beam hangers, some of which hook over the top of the girder whereas others are furnished with a lug or nipple which enter holes bored in the girder. The arms of the first type are likely to crush the edges of the girder, and, with single hangers on one side of the girder only, the arms sometimes lift up from the back edge of the girder. The second type is usually preferred. It is designed so that the lug enters the girder on the compression side above the neutral surface so that there is no weakening of the tensile strength. When beams occur opposite each other on both sides of the girder a bolt passing through the girder binds the hangers together (Fig. 3).



FIG. 3.—Joist Hanger.

Some arrangement should always be made to insure the action of beams as ties or struts across the building to stiffen the construction. When the beams rest on top of the girders they usually butt end to end and are anchored together with iron straps called fish straps on the sides of the beams or by iron anchors called timber dogs let into the tops of the beams. When the beams are placed side by side, overlapping each other without butting, they are bolted together. If hangers are used, a lug or ridge in the beam seat of the hanger let into a notch in the under side of the beam anchors the beam in place.

**Bearing on Walls.** When beams and girders bear on brick walls the allowable crushing stresses in the wall must not be exceeded. The wood member may either be built into the wall, in which event a metal bearing plate is used under its seat, or it may be supported in a steel wall hanger. If built into the wall a thickness of at least 4" of brickwork should be maintained beyond the end of the beam.

**Example 4.** The 10" x 20" girder in Example 2 has an end reaction of 12,564 lbs. If it rests upon a 12" brick wall what bearing should be provided? The allowable compression on yellow pine of the grade mentioned across the grain

= 380 lbs./in.<sup>2</sup> The allowable compression on a good brick wall = 200 lbs./in.<sup>2</sup> Maximum depth of bearing on 12" wall = 12" - 4" = 8".

The area required under the girder to prevent crushing of wood is

$$\frac{12,564}{380} = 33.0 \text{ in.}^2 \text{ Area available} = 10 \times 8 = 80 \text{ in.}^2$$

The area required on wall to prevent crushing of brick is

$$\frac{12,564}{200} = 62.8 \text{ in.}^2 \text{ Area available} = 10 \times 8 = 80 \text{ in.}^2$$

It is seen that the brick is capable of bearing the load but on account of the concentration of the load and possibilities of inferior workmanship it is considered more practical to use a bearing plate. In this case a steel plate projecting 1" on each side of the girder would be used. Its dimensions are 8" x 12" x 3/4".

Wall hangers are similar to the beam hangers already described except that they are furnished with flanges at the back which are built into the brickwork. They are sometimes preferred because they do not break the bond of the masonry, they require shorter lengths of timber and they permit beams and girders to be easily replaced if necessary.

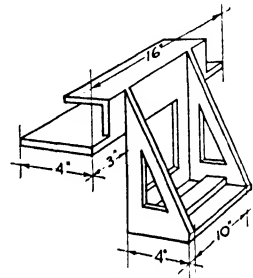

FIG. 4.—Wall Hanger.

**Example 5.** (Fig. 4). What beam seat and what wall bearing area are required for a hanger to support from a brick wall a 10" x 20" yellow pine girder with an end reaction of 12,564 lbs.?

1. BEAM SEAT.  $\frac{12,564}{380} = 33.0 \text{ in.}^2$  Width of girder = 10";  $\frac{33}{10} = 3.3$ ". Use 4".

2. BEARING ON WALL.  $\frac{12,564}{200} = 62.8 \text{ in.}^2$  Width of one brick course = 4".  
 $\frac{62.8}{4} = 15.7$ " = length of bearing; 15.7 - 10 = 5.7" = total projection beyond girder, or a lug of 3" on each side of hanger beyond the girder. A rib in the beam seat over which the girder is notched ties the girder to the wall.

**Post Caps.** At the posts and columns the girders and beams are supported upon cast iron or steel brackets which are part of the post caps. They will be treated under Article 2, Wood Columns.

**Floor Construction.** The floor systems used with heavy wood framing consists of 7/8" to 1 3/4" flooring supported upon joists which span across the beams or the girders, or of heavy plank flooring 3" or more thick which itself spans across the beams or the girders, the joists and, in standard mill construction, the cross beams being omitted.

**Joists.** These members are 2" or 3" thick and are spaced 12" and 16" apart. They may rest on top of the beams or they may be hung in steel joist hangers similar to the beam hangers already described. The means of determining their depth will be considered in Chapter XIX, "Light Wood Framing," since they are light members and are not a part of true heavy wood construction.

**Plank Floors.** Plank floors are composed of heavy plank 2" or more thick laid close together on the flat to span from one beam or girder to the

**Table III.\* Properties of Yellow Pine Mill Floors**

Nominal Thickness inches	Actual Thickness inches	Area of Section square inches	Weight per square foot, pounds	Moment of Inertia inches <sup>4</sup>	Section Modulus inches <sup>3</sup>
2	1 <sup>5</sup> / <sub>8</sub>	19.5	5.4	4.3	5.28
2 <sup>1</sup> / <sub>2</sub>	2 <sup>1</sup> / <sub>8</sub>	25.5	6.9	9.6	9.03
3	2 <sup>3</sup> / <sub>8</sub>	31.5	8.7	18.1	13.78
4	3 <sup>5</sup> / <sub>8</sub>	43.5	12.0	47.6	26.28
5	4 <sup>5</sup> / <sub>8</sub>	55.5	15.4	98.9	42.78
6	5 <sup>1</sup> / <sub>2</sub>	66	18.3	166.3	60.5

\*-Tables III, IV and V are taken by permission from the Southern Pine Manual published by the Southern Pine Association.

**Table IV. Maximum Spans for Yellow Pine Plank Floors**

$E = 1,600,000 \text{ lbs./in.}^2$

Nominal Thick-ness	Actual Thick-ness	Fiber Stress Lbs./in. <sup>2</sup>	Span in Feet. Live Loads in Lbs./Ft. <sup>2</sup>											
			50 lbs.	100 lbs.	125 lbs.	150 lbs.	175 lbs.	200 lbs.	225 lbs.	250 lbs.	275 lbs.	300 lbs.	350 lbs.	400 lbs.
3"	2 <sup>5</sup> / <sub>8</sub> "	1 200	13-8	10-1	9-1	8-4	7-9	7-3	6-10	6-6	6-3	6-0	5-7	5-2
		1 300	14-3	10-6	9-6	8-8	8-1	7-7	7-2	6-10	6-6	6-3	5-9	5-5
		1 500	15-4	11-3	10-2	9-4	8-8	8-2	7-8	7-4	7-0	6-8	6-2	5-10
		1 600	15-10	11-8	10-6	9-7	8-11	8-4	7-11	7-7	7-2	6-11	6-5	6-0
		1 800	16-9	12-4	11-2	10-3	9-6	8-11	8-5	8-0	7-8	7-4	6-9	6-4
		Deflection	9-0	7-4	6-10	6-6	6-2	5-11	5-8	5-6	5-4	5-2	4-11	4-9
4"	3 <sup>5</sup> / <sub>8</sub> "	1 200	18-5	13-8	12-4	11-5	10-7	10-0	9-5	9-0	8-7	8-3	7-7	7-2
		1 300	19-2	14-3	12-11	11-10	11-0	10-4	9-10	9-4	8-11	8-7	7-11	7-5
		1 500	20-7	15-4	13-10	12-9	11-10	11-2	10-6	10-0	9-7	9-2	8-6	8-0
		1 600	21-3	15-10	14-4	13-2	12-3	11-6	10-11	11-4	9-11	9-6	8-10	8-3
		1 800	22-7	16-9	15-2	13-11	13-0	12-2	11-7	11-0	10-6	10-1	9-4	8-9
		Deflection	12-3	10-1	9-4	8-11	8-6	8-2	7-10	7-7	7-4	7-2	6-10	6-6
5"	4 <sup>5</sup> / <sub>8</sub> "	1 200	22-10	17-8	15-7	14-5	13-5	12-7	11-11	11-4	10-10	10-5	9-8	9-1
		1 300	23-10	17-11	16-3	14-11	13-11	13-1	12-5	11-10	11-4	10-10	10-1	9-5
		1 500	25-7	19-3	17-5	16-1	15-0	14-1	13-4	12-8	12-2	11-8	10-10	10-2
		1 600	26-5	19-11	18-0	16-7	15-6	14-7	13-9	13-1	12-6	12-0	11-2	10-6
		1 800	28-0	21-1	19-1	17-7	16-5	15-5	14-7	13-11	13-4	12-9	11-10	11-1
		Deflection	15-4	12-8	11-10	11-3	10-9	10-4	9-11	9-7	9-4	9-1	8-8	8-3
6"	5 <sup>1</sup> / <sub>2</sub> "	1 200	20-3	18-4	16-11	15-10	15-1	14-1	13-5	12-10	12-4	11-6	10-9	
		1 300	21-1	19-1	17-8	16-5	15-8	14-8	14-0	13-4	12-10	11-11	11-2	
		1 500	22-7	20-9	18-11	17-8	16-10	15-9	15-0	14-4	13-9	12-10	12-0	
		1 600	23-4	21-3	19-7	18-3	17-5	16-4	15-6	14-10	14-3	13-3	12-5	
		1 800	24-9	22-6	20-9	19-4	18-5	17-3	16-5	15-9	15-1	14-0	13-2	
		Deflection	14-11	14-0	13-3	12-8	12-2	11-9	11-5	11-1	10-9	10-3	9-10	

next without the support of intermediate joists. Their edges are either tongued and grooved or they may be held together with strips of hard wood, called splines, let into grooves in the edges of the planks. The thickness of the planks depends upon the span and the load which is generally considered as a live load uniformly distributed. The planks are usually continuous over two bays, and their thickness is consequently calculated like a continuous beam over two spans. The formula  $M = \frac{wl^2}{8}$  is used, this being the negative moment at the middle support.

**Table V. Maximum Spans for Laminated Floors**  
 Planks on Edge laid close together  
 $E = 1,600,000 \text{ lbs./in.}^2$

Nominal Thickness	Actual Thickness	Fiber Stress Lbs./in. <sup>2</sup>	Span in Feet Live Loads in Lbs./Ft. <sup>2</sup>										
			100	125	150	175	200	225	250	275	300	350	400
6"	5 1/2"	1 200	20-8	18-9	17-4	16-2	15-3	14-5	13-9	13-2	12-8	11-9	11-0
		1 300	21-6	19-6	18-0	16-10	15-10	15-0	14-3	13-8	13-1	12-2	11-5
		1 500	23-1	21-0	19-4	18-1	17-0	16-1	15-4	14-8	14-1	13-1	12-3
		1 600	23-10	21-8	20-0	18-8	17-7	16-7	15-10	15-2	14-7	13-6	12-8
		1 800	25-3	23-0	21-2	19-10	18-8	17-8	16-10	16-1	15-5	14-4	13-6
		Deflection	15-3	14-4	13-7	13-0	12-6	12-0	11-8	11-4	11-0	10-6	10-1
8"	7 1/2"	1 200	26-10	24-6	22-8	21-2	20-0	19-0	18-1	17-4	16-7	15-6	14-7
		1 300	27-11	25-6	23-7	22-1	20-10	19-9	18-10	18-0	17-4	16-1	15-2
		1 500	30-0	27-5	25-4	23-9	22-4	21-2	20-3	19-4	18-7	17-4	16-3
		1 600	31-0	28-3	26-2	24-6	23-1	21-11	20-10	20-0	19-2	17-10	16-9
		1 800	32-10	30-0	27-9	26-0	24-6	23-3	22-2	21-2	20-4	19-0	17-10
		Deflection	20-0	18-10	17-11	17-1	16-6	15-11	15-5	14-11	14-7	13-10	13-4
10"	9 1/2"	1 200									20-10	19-5	18-3
		1 300									21-9	20-3	19-1
		1 500									23-4	21-9	20-5
		1 600									24-1	22-5	21-2
		1 800									25-7	23-10	22-5
		Deflection								18-4	17-6	16-10	
12"	11 1/2"	1 200											22-0
		1 300											22-11
		1 500											24-7
		1 600											25-4
		1 800											26-11
		Deflection										20-3	

**Example 6.** What thickness of floor plank is required for a span of 12'0" between center lines of girders with a live load of 150 lbs./ft.<sup>2</sup>? Use yellow pine with an allowable unit stress of 1600 lbs./in.<sup>2</sup>

Live load = 150 lbs./ft.<sup>2</sup>

$L = 12'0''$

" flooring = 3

$M = \frac{wl^2}{8} \times 12 \text{ in.-lbs.}$

W.P. lining = 1

4" plank =  $\frac{11 \text{ (assumed)}}{165} \text{ lbs./ft.}^2$

$M = \frac{165 \times 12 \times 12 \times 12}{8} = 35,640 \text{ in.-lbs.}$

Section modulus =  $\frac{M}{f} = \frac{35,640}{1600} = 22.2 \text{ in.}^3$

Referring to Table III it is found that a 4" plank with actual thickness of  $3\frac{5}{8}$ " has a section modulus of 26.28 in.<sup>3</sup> It therefore fills the requirements.

Since the load on a plank floor is generally considered as uniformly distributed, the following table may be used directly.

**Laminated Floors.** The planks instead of being laid flat are sometimes set on edge and nailed solidly to each other. Such floors are called LAMINATED FLOORS. They are stiffer on wide spans than the flat plank floors and are consequently sometimes used, especially in standard mill construction, when the design calls for wider-spaced columns and girders. Since the loads are generally considered as uniformly distributed the following table may be used to determine the proper depth of plank. Details of their installation will be explained in Article 3, Slow-burning Construction.

**Compound Beams.** The most economical beam or girder is composed of a single piece. However, when no single pieces of the required dimensions are obtainable two or more pieces may be fastened together,

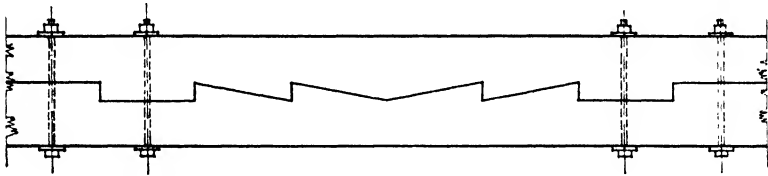

FIG. 5.—Scarfed Beam.

either side by side or one on top of the other. When two beams are placed side by side their combined strength is equal to the sum of the strengths of each beam. When two equal beams are placed one on top of the other their combined strength is equal theoretically to four times the strength of one beam, because their depth is doubled and the section modulus increases as the square of the depth. It would therefore seem far more effective to superimpose one beam upon another, but experience has shown it to be impossible to fasten the pieces so securely together that the upper beam does not slip to some degree in horizontal shear upon the lower beam. A lesser value than the ideal strength must therefore result, depending upon the effectiveness of the method of fastening the beams together. All compound beams are subject to shrinkage and consequent slip of fastenings which may lessen their efficiency and increase their deflection.

**Superimposed Beams.** Beams formed of two members one on top of the other may be fastened together by spikes, common screws, lag screws or bolts either alone or together with keys, scarfed joints or diagonal wood braces on the sides of the beam. When used alone, spikes, bolts, etc., have not given satisfaction owing to their bending and the crushing of the wood surrounding them. Keyed beams, scarfed beams

and diagonally braced beams called Clark beams have, however, proved more efficient.

**Scarfed Beams** (Fig. 5). Beams may be superimposed one upon the other and fastened together by a scarf joint and by bolts. This method is more satisfactory than when bolts alone are employed, but its efficiency in flexure is only 70% of that of a solid beam of equivalent size. In designing such a beam, 70% only of the allowable unit load is therefore used. The scarf joint gives butt end bearings to resist the horizontal shear. These butt ends are usually cut from  $\frac{3}{4}$ " to  $1\frac{1}{2}$ " into each beam, giving total depths of scarfing of  $1\frac{1}{2}$ " to 3". The bending moment and the depth and width of the combined beam are found in the usual manner with the reduced allowable fiber stress. The unit vertical shear and the horizontal shear per lineal inch of beam are then determined and also the bearing resistance of the scarf. By dividing the bearing resistance by the horizontal shear per lineal inch the length of the scarf is found. Scarfed beams are the least efficient of the compound

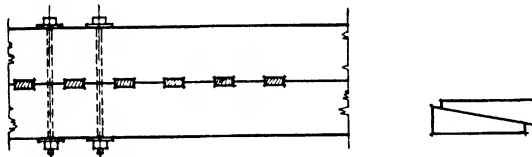

FIG. 6.—Keyed Beam.

beams, are costly to fabricate and are wasteful of material. They are very seldom employed at the present time.

**Keyed Beams** (Fig. 6). Beams in which oak or cast-iron keys are used to prevent sliding between the upper and lower members are the most satisfactory and the most often used compound beams. Bolts are employed to bind the two parts together and counteract the separating tendency of the keys but are not counted in the calculations. The keys are generally of oak and are shaped like two wedges fitting against each other. They should be about twice as wide as they are thick and are usually all of the same size with their spacing varied according to the varying intensity of the horizontal shear at different points of the span. The efficiency of a compound beam with wood keys is about 90% of that of an equivalent solid.

Table VI. Key Sizes

Depth of Beam	Size of Key	Size of Bolt	Washer
16"	$1\frac{1}{2}$ " x 3"	$\frac{3}{4}$ "	3 " diam.
20"	$1\frac{1}{2}$ " x 3"	$\frac{3}{4}$ "	3 " "
24"	2 " x 4 "	$\frac{7}{8}$ "	$3\frac{1}{2}$ " "
28"	$2\frac{1}{4}$ " x $4\frac{1}{2}$ "	$\frac{7}{8}$ "	$3\frac{1}{2}$ " "



The horizontal shear is considered greatest at the supports and equal to the vertical shear. It is zero at the center of the span where the bending moment is maximum. The spacing of the keys is therefore minimum near the supports and becomes greater in approaching the middle of the beam. The following practical rule for a beam uniformly loaded is derived from the parabola of the moment diagram of which the shear is a function.

- At  $\frac{1}{8}$  span from the supports, spacing =  $\frac{4}{3}$  minimum spacing.
- At  $\frac{1}{4}$  span from the supports, spacing = twice minimum spacing
- In middle quarter of span no keys are usually required.

For a single load concentrated at the center of the beam the minimum spacing is used from the supports up to a point  $\frac{1}{8}$  of the span on each side of the center.

The bolts are inserted at the ends of the beam, between every two keys and beyond the last key. A diameter of  $\frac{3}{4}$ " or  $\frac{7}{8}$ " is generally used, the bolts being placed in one row for beams 10" or less wide and in two staggered rows for larger beams.

The width of a compound beam should be at least  $\frac{2}{5}$  the depth or  $b = \frac{2d}{5}$ .

**Example 7.** A keyed beam is uniformly loaded with 1800 lbs./lin. ft., ( $w$ ). The span is 20'0" and the keys are of oak. Design the beam. Allowable fiber stress in bending of structural square edge grade of yellow pine = 1600 lbs./in.<sup>2</sup> Efficiency of keyed beam is 90%. Use  $0.90 \times 1600 = 1440$ . Timber sizes nominal.

1. MOMENT.  $M = \frac{wL^2}{8} \times 12 = \frac{1800 \times 20 \times 20 \times 12}{8} = 1,080,000$  in.-lbs.

Assume  $b = 12''$ ;  $bd^2 = \frac{6M}{f}$ ;  $d^2 = \frac{6 \times 1,080,000}{1440 \times 12} = 375$ ;  $d = 19.3''$ .

Try 2 - 10" x 12".

2. SHEAR.  $V = \frac{wL}{2} = \frac{1800 \times 20}{2} = 18,000$  lbs.;  $v = \frac{3V}{2bd} = \frac{3 \times 18,000}{2 \times 12 \times 24} =$

95.5 lbs./in.<sup>2</sup>

100 lbs./in.<sup>2</sup> allowable.

3. DEFLECTION.  $D = \frac{270WL^3}{Eb d^3} = \frac{270 \times 1800 \times 20 \times 20 \times 20 \times 20}{1,600,000 \times 12 \times 24 \times 24 \times 24} = 0.29''$ .

$D = 0.29''$  for a solid beam.

$0.29 \times 1.25 = 0.362''$  for keyed beam.

Multiply by 1.25 (deflection factor) to find  $D$  for keyed beam.

$D$  (allowable) =  $\frac{l}{360} = \frac{20 \times 12}{360} = 0.67''$ .

Deflection is not excessive.

4. Shear per linear inch of width =  $95.5 \times 12 = 1146$  lbs.;  $d = 24''$ .

Use 2" x 4" keys. See Table VI.

Bearing area in one beam =  $1 \times 10 = 10$  in.<sup>2</sup> Allowable bearing = 1200 lbs./in.<sup>2</sup>

Resistance of one key =  $12 \times 1200 = 14,400$  lbs.;  $\frac{14,400}{1146} = 12.5''$ .

∅ Minimum spacing of keys = 12".

Spacing at eighth span =  $\frac{4 \times 12}{3} = 16''$ .

Spacing at quarter span =  $2 \times 12 = 24''$ .

Use  $\frac{7}{8}''$  bolts,  $3\frac{1}{2}''$  washers (Table VI).

**Clark Beams.** (Fig. 7). A compound beam easily built up and having an efficiency of about 75% of an equivalent solid beam is known as the Clark beam. It consists of two component beams with diagonal boards nailed to each side in opposing directions to fasten the beams together and prevent them from slipping on each other. The vertical and horizontal shearing stresses in a beam cause stresses inlined to the horizontal. At the supports these diagonal stresses are at a maximum and their inclinations are at 45° to the horizontal. The diagonal braces are therefore nailed to the beams at an angle of 45°, with their inclinations in opposite directions on the two sides to form a shear-resisting couple. Ten or twelve penny nails are used with  $1\frac{1}{4}''$  battens and twenty to

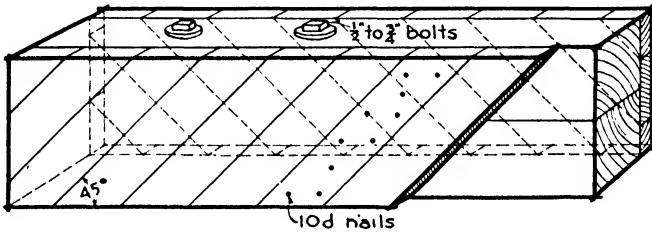

FIG. 7.—Clark Beam

thirty penny nails with 2'' battens. Bolts from  $\frac{1}{2}''$  to  $\frac{3}{4}''$  diameter are also used to bind the beams together but are not considered in the calculations. The allowable shearing stress in the battens is an average of the allowable shearing stress across the grain and with the grain. The deflection is usually twice that of a solid beam. They are rarely used with plastered ceiling.

**Example 8.** Design a Clark beam to carry a distributed load of 1000 lbs. per ft. on a span of 18'0". Use nominal timber sizes, yellow pine.

1. MOMENT.  $M = \frac{wL^2}{8} \times 12 = \frac{1000 \times 18 \times 18 \times 12}{8} = 486,000$  in.-lbs.

Beam 75% efficient.  $0.75 \times 1600 = 1200$  lbs.

Assume  $b = 8''$ ;  $bd^2 = \frac{6M}{f}$ ;  $d^2 = \frac{6 \times 486,000}{1200 \times 8} = 304$ ;  $d = 17.4''$ . Try 2 - 8'' x 10''.

2. SHEAR.  $V = \frac{wL}{2} = \frac{1000 \times 18}{2} = 9000$  lbs.;  $v = \frac{3V}{2b \times d} = \frac{3 \times 9000}{2 \times 8 \times 20} =$

84.7 lbs./in.<sup>2</sup> Allowable 100 lbs./in.<sup>2</sup>

3. SHEAR per linear inch of beam =  $8 \times 84.7 = 677.6$  lbs.;  $\frac{677.6}{2} = 339$  lbs./in. on each facing.

Allowable shear with grain = 100 lbs./in.<sup>2</sup>  
 " " across " 1300 " "

Required thickness of battens =  $\frac{339}{700} = 0.48''$ .

Average  $\frac{2)1400}{700}$  " "

Use 8" x 1/8" boards.

4. DEFLECTION allowable =  $\frac{18 \times 12}{360} = 0.6''$ .

$D = \frac{270WL^3}{Ebd^3} = \frac{270 \times 1000 \times 18 \times 18 \times 18 \times 18}{1,600,000 \times 8 \times 20 \times 20 \times 20} = 0.27''$  for solid beam; multiply

by 2 for Clark's beam.  $0.27 \times 2 = 0.54''$ . Deflection satisfactory.

**Built-up Beams.** Planks tied together side by side are usually known as built-up beams, their total strength being theoretically the sum of the strengths of the individual planks. As a matter of fact, a built-up beam may actually be stronger than a solid piece of the same dimensions because the quality of each component part may be inspected, whereas a solid beam may have hidden defects which cannot be detected. The planks are also better seasoned and less likely to check than large sections of wood. This possibility is not, however, considered in the calculations. The planks may be spiked, lag-screwed or bolted together, bolts being considered the best means. Planks 2" thick are generally used with a depth not exceeding 14". The depth is usually assumed and the number of beams calculated to obtain the required width.

The standard practice calls for two bolts 1'0" from each end and two lines of intermediate bolts staggered about 2'0" on centers. The bolts are 5/8" or 3/4" in diameter.

**Example 9.** Design a built-up beam for a span of 20'0", the beams being 8'0" on centers. Use actual timber sizes.

Live load = 75 lbs.

1/8" finished floor = 3 "

3" plank floor = 10 "

88 lbs./ft.<sup>2</sup>

Load per linear foot  $88 \times 8 = 704$

Weight of beam, assumed = 26

Total

= 730 lbs./ft.

1. MOMENT.  $M = \frac{wL^2}{8} \times 12 = \frac{730 \times 20 \times 20 \times 12}{8} = 438,000$  in.-lbs.

Use  $d = 13\frac{1}{2}''$ ;  $bd^2 = \frac{6M}{f}$ ;  $b = \frac{6 \times 438,000}{1600 \times 13.5 \times 13.5} = 9''$ . Use 6-1 5/8" planks.  
 $b = 9\frac{3}{4}''$

2. SHEAR.  $V = 7300$  lbs.;  $v = \frac{3V}{2bd} = \frac{3 \times 7300}{2 \times 9.75 \times 13.5} = 100$  lbs./in.<sup>2</sup>

100 lbs./in.<sup>2</sup> allowable.

3. DEFLECTION.  $D = \frac{270WL^3}{Ebd^3}$ ;  $\frac{270 \times 730 \times 20 \times 20 \times 20 \times 20}{1,600,000 \times 9.75 \times 13.5 \times 13.5 \times 13.5} = 0.82''$

Allowable deflection =  $\frac{l}{360} = \frac{20 \times 12}{360} = 0.67''$ ; 0.82'' allowable with unplastered ceiling.

**Trussed Girders** (Fig. 8). When spans are too long or loads too great for solid beams, trussed girders are found to be effective if there be sufficient space to permit their use. In this type shrinkage of wood does not lessen the efficiency.

There are four classes of trussed girders as follows:

- (a) King post.
- (b) Queen post.
- (c) Reversed king post.
- (d) Reversed queen post.

Classes (c) and (d) are more easily constructed and permit better joints. They are used as floor girders; classes (a) and (b) are available

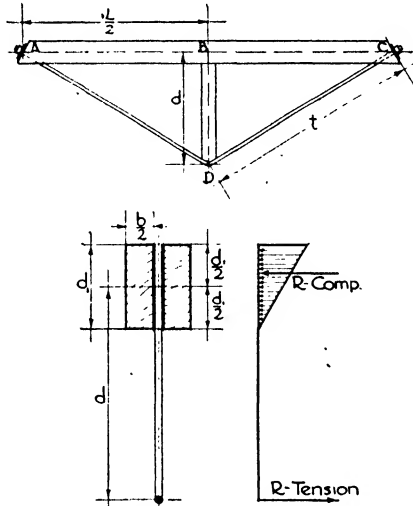

FIG. 8.—Trussed Girder.

only for the support of ceilings and roofs. The reversed king post and queen post girders, which are more often employed, will be considered in this chapter. The other two classes are simple roof trusses and are designed according to the methods explained in Chapter XXI.

Reversed king post and queen post girders are generally composed of two or three horizontal wood beams called chords, placed side by side, with one or two diagonal steel tension rods passing between them. The rods are held in place by iron bearing plates or washers on the ends of the chords, which are beveled to a plane perpendicular to the direction of the tie rods. The strut is a compression member acting like a column; it may be of either wood or cast iron. Wood separators of 2'' x 4'' stock are placed between the timbers of the chords held in place by 5/8''

or  $\frac{3}{4}$ " bolts. They are set at the struts and at intervals of about 2'0" on centers to the ends of the chords.

Steel rods may have plain ends threaded, in which case the area at the root of the thread must be used in determining the required size of rod, or the ends may be upset or enlarged so that the area at the root of the thread is approximately equal to the area of the plain rod.

The following table presents the full and net areas of round rods and the safe loads for plain and upset ends.

Table VII. Safe Loads on Round Rods in Lbs.

Dimensions			Stress 18,000 lbs./in. <sup>2</sup>
Diameter, in inches	Full Area, square inches	Net Area at root of thread, square inches	Plain Rods. Load based on net area
$\frac{3}{4}$	0.441	0.302	5 436
$\frac{7}{8}$	0.601	0.402	7 560
1	0.785	0.550	9 900
$1\frac{1}{8}$	0.994	0.694	12 492
$1\frac{1}{4}$	1.227	0.893	16 074
$1\frac{3}{8}$	1.484	1.057	19 026
$1\frac{1}{2}$	1.767	1.295	23 312
$1\frac{5}{8}$	2.073	1.515	27 270
$1\frac{3}{4}$	2.405	1.746	31 428

To be effective a trussed beam should be as deep as conditions will permit, in order to reduce the stresses. The greater the distance  $d$  and the nearer it approaches the length  $l$  the less will be the tension in the tie rod and the compression in the chord. The following standards are sometimes used:

- (a)  $d \geq 1\frac{1}{2} d_1$ ;
- (b)  $b = \frac{1}{2}$  to  $\frac{2}{3} d_1$ ;
- (c)  $d_1 = \frac{1}{2}$ " per foot of span approximately.

By trigonometry the following formulae are derived. Compression

$$AB \text{ and } BC = \frac{5WL}{32d}; \text{ compression } BD = \frac{5W}{8}; \text{ tension } AD \text{ and } DC = \frac{5Wt}{16d};$$

$$\text{length } t = \sqrt{d^2 + \left(\frac{L}{2}\right)^2}.$$

**Example 10.** Design a trussed girder with span of 24'0" carrying a live load of 200 lbs./ft.<sup>2</sup>, the girders being 8'0" on centers. Finished floor 1", plank 3". Available space 4'4" or 52." Use nominal timber sizes.

Assume  $d = 16''$ .

$$= \sqrt{(12)^2 + (3.33)^2} = 12.4'$$

Live load = 200 lbs.  
 Finished floor = 3 "  
 Plank =  $\frac{12}{215}$  "

Finished floor 1'' 52'' - 12'' = 40''  
 Plank 3''  $d = 2d_1 = 2 \times 16 = 32''$ ;  
 1/2 beam  $\frac{8''}{12''}$   $d = 2 \frac{1}{2}d_1 = 2 \frac{1}{2} \times 16 = 40''$ .  
 Use  $d = 40''$  or 3.33'.  
 Load per linear foot on truss =  $215 \times 8 = 1720$  lbs.  
 Weight of truss  $\frac{50}{215}$   
 Total load per foot = 1770 lbs.

Total load on truss =  $1770 \times 24 = 42,500$  lbs.

1. DIRECT STRESS.  $AB = BC = \frac{5WL}{32d} = \frac{5 \times 42,500 \times 24}{32 \times 3.33} = 47,900$  lbs. (C).

2. STRESS IN STRUT.  $BD = \frac{5W}{8} = \frac{5 \times 42,500}{8} = 26,500$  lbs. (P).

3. STRESS IN ROD.  $AD = DC = \frac{5Wl}{16d} = \frac{5 \times 42,500 \times 12.4}{16 \times 3.33} = 49,500$  lbs. (T).

4. SIZE OF ROD.  $A_s = \frac{T}{f_s}$ ;  $A_s = \frac{49,500}{18,000} = 2.7$  in.<sup>2</sup> Use 2-1 5/8'' rods.  
 $f_s = 18,000$  lbs./in.<sup>2</sup> Area 3.03 in.<sup>2</sup>

5. SIZE OF CHORD. In addition to the direct compression stresses in the chord, flexural stresses will exist owing to the uniform loads upon the chord.

$$M = \frac{\frac{W}{2} \times \frac{L}{2}}{8} \times 12 = \frac{WL}{32} \times 12 \text{ in.-lbs.}; M = \frac{42,500 \times 24}{32} \times 12 = 382,500 \text{ in.-lbs.}$$

The total stresses in the chord =  $\frac{6M}{bd^2} + \frac{C \text{ (direct comp.)}}{bd}$  which must not exceed 1200 lbs./in.<sup>2</sup>, the allowable unit stress in compression with the grain.

$$1200 = \frac{6 \times 382,500}{b \times 16 \times 16} + \frac{47,900}{b \times 16}, \text{ or } 1200b = 11,958; b = 9.9, \text{ say } 10''.$$

6. SIZE OF STRUT. The allowable compression parallel to the grain on the strut (1200 lbs./in.<sup>2</sup>) must not be exceeded nor the allowable compression across the grain on the chord (380 lbs./in.<sup>2</sup>);  $\frac{P}{1200} = \text{area on strut}$ ;  $\frac{P}{380} = \text{area on chord}$

$$A = \frac{26,500}{1200} = 22 \text{ in.}^2; A_1 = \frac{26,500}{380} = 70 \text{ in.}^2 \text{ A } 6'' \times 6'' \text{ strut would be sufficient}$$

for the bearing on the strut, but a 8'' x 10'' must be used to limit the bearing on the chord to the allowable unit stress.

TIMBER CONNECTORS are devices which are used in bolted timber joints and which give a greater rigidity and higher efficiency to the connections. By means of timber connectors, joints are made two to three times stronger than the ordinary bolted joint and thereby permit the use of smaller-size members for a given load. They consist of steel or malleable iron plates, grids or rings, from 2'' to 8'' in diameter, embedded into the adjacent timbers to be joined, and having holes in

their centers through which the bolts pass. The connectors fit into pre-cut grooves in the timber faces or are furnished with teeth and spikes driven into the wood so that the back of the connector is flush with the timber face. Tables are published by National Lumber Manufacturers Association giving the allowable loads in pounds per connector for the various grades and thicknesses of wood and the different diameters of connectors and bolts. The number of connectors required at each joint may then be calculated from the total applied load. See Chapter XXI.

## Article 2. Wood Columns

**General Considerations.** Wood columns may be solid sticks or built up of several pieces. Built-up columns may consist of planks spiked or bolted close together or may be constructed of two outside planks separated by spacer and blocks joined with metal timber connectors. The second kind, called SPACED COLUMNS, are designed by the use of special formulae. The strength of bolted built-up columns should never be considered more than 80% that of solid columns of the same dimensions because of the impossibility of fastening together the component planks so rigidly that they do not slip upon each other, owing to the flexure in the bolts or spikes and the crushing of the wood when the column bends. The same situation has been explained for compound girders consisting of two superimposed beams spiked or bolted together without keys. Solid wood columns are usually square in section to give equal resistance to bending in all directions.

**Formulae.** On account of accidental eccentricities of bearing caused by inequalities in loading, workmanship or the structure of the material, most columns fail ultimately by bending. Consequently although wood columns are generally comparatively short with a small ratio of length ( $L$ ) to least transverse dimension ( $d$ ), they should be designed according to the usual column formulae if their  $\frac{L}{d}$  is more than 11. A greater slenderness ratio than  $\frac{L}{d} = 50$  is not used with timber. Since the strength of wood varies greatly with the species, the value of  $f_w$  in compression is changed in the column formulae to conform with the kind of timber used.  $f_w = C$ . For columns whose  $\frac{L}{d}$  is 11 or less the direct compression formula  $C = \frac{W}{A}$  is used.

There are several formulae in use to determine the maximum safe stress in columns, based upon the results of tests and experience.

The most recent formula is one recommended by the Forest Products Laboratory of the U. S. Department of Agriculture at Madison, Wisconsin, as follows:

$$p = C \left[ 1 - \frac{1}{3} \left( \frac{L}{Kd} \right)^4 \right]$$

In the above formulae:

$A$  = cross-sectional area of column in inches;

$p$  = allowable unit compression in pounds per square inch for the column;

$C$  = allowable direct compressive strength of species and grade of wood parallel to grain, pounds per square inch =  $f_w$ ;

$L$  = length of column, in inches;

$E$  = modulus of elasticity;

$K$  = a constant depending upon  $E$  and  $C$  of the wood employed,

$$= \frac{\pi}{2} \sqrt{\frac{E}{6C}} = 0.64 \sqrt{\frac{E}{C}} \text{ for solid columns;}$$

$K_1$  for spaced columns = 1.58  $K$ ;

$d$  = least dimension of column section, in inches.

**Example 11.** Design a square yellow pine column, dense structural grade, 16'0" long, to carry 200,000 lbs.

$$K = 0.64 \sqrt{\frac{1,600,000}{1300}} = 22.5.$$

$$\text{Try } 12'' \times 12''. \quad p = 1300 \left[ 1 - \frac{1}{3} \left( \frac{16 \times 12}{22.5 \times 11.5} \right)^4 \right] = 1170;$$

$$pA = 1170 \times 11.5 \times 11.5 = 154,732 \text{ lbs. Not satisfactory.}$$

$$\text{Try } 14'' \times 14''. \quad p = 1300 \left[ 1 - \frac{1}{3} \left( \frac{16 \times 12}{22.5 \times 13.5} \right)^4 \right] = 1232;$$

$$pA = 1232 \times 13.5 \times 13.5 = 224,605 \text{ lbs. Satisfactory. Use } 14'' \times 14'' \text{ column.}$$

Dressed instead of rough sizes are used in the above example.

The following table is selected from the values recommended by the National Lumber Manufacturers Association. These values were determined by the use of the formula derived by the U. S. Forest Products Laboratory. It is generally simpler to apply this table than to calculate the column section by means of the formulae.

**Bases.** Steel or cast-iron bases are used with wood columns to distribute their load over the footings and to protect the end of the column from dampness. Cast-iron bases were formerly much used, but of late years rolled-steel plates have been considered more dependable. There are several patented types, and the available sizes may be found in the manufactures' catalogues. The base must have sufficient area so that the allowable unit compression on the footing is not exceeded. The material of the plate also must be sufficiently thick to withstand bending at the edge of the column, the plate acting as a short symmetrical cantilever (Fig. 9).



Table VIII. Safe Load in Pounds per Square Inch of Cross-sectional Area of Square and Rectangular Timber Columns

Species of Timber	Grade	Ratio of Length to Least Dimension ( $\frac{L}{d}$ )										
		1 and less	L/d 12	L/d 14	L/d 16	L/d 18	L/d 20	L/d 25	L/d 30	L/d 35	L/d 40	L/d 50
		lbs.	lbs.	lbs.	lbs.	lbs.	lbs.	lbs.	lbs.	lbs.	lbs.	lbs.
Douglas Fir Coast Region	$E = 1,600,000$											
	Dense Select Structural	1 466	1 357	1 319	1 263	1 179	1 064	701	487	358	274	175
	Select Structural	1 200	1 172	1 148	1 112	1 060	986	701	487	358	274	175
	Framing and Joist 1200# Framing and Joist 900#	1 100 880	1 078 887	1 060 876	1 032 850	991 833	935 798	701 652	487 457	358 358	274 274	175 175
Southern Yellow Pine	$E = 1,600,000$											
	Select Structural	1 450	1 357	1 319	1 263	1 179	1 064	701	487	358	274	175
	Prime Structural	1 300	1 265	1 235	1 190	1 123	1 030	701	487	358	274	175
	Structural Square Edge No. 1 Structural	1 200 1 000	1 172 984	1 148 970	1 112 949	1 060 918	986 876	701 701	487 487	358 358	274 274	175 175
Larch	$E = 1,300,000$											
	Select Structural	1 466	1 333	1 275	1 189	1 061	891	570	396	291	223	142
	Structural Common Structural	1 200 1 100	1 158 1 068	1 122 1 041	1 068 990	980 938	877 854	570 570	396 396	291 291	223 223	142 142
Eastern Hemlock	$E = 1,100,000$											
	Select No. 1 Common	700 560	688 593	678 587	664 577	641 563	610 544	481 463	335 335	246 246	188 188	121 121

**Example 12.** Design a steel plate base upon a concrete footing for a 14" x 14" column carrying a load of 200,000 lbs.

$f_c$  for concrete in compression = 500 lbs./in.<sup>2</sup>

$f$  for steel in flexure = 20,000 lbs./in.<sup>2</sup>

1.  $A = \frac{200,000}{500} = 400 \text{ in.}^2$  Use a 20" x 20" plate.

2.  $M = \left( \frac{200,000}{4} \times \frac{2}{3} \times 10 \right) - \left( \frac{200,000}{4} \times \frac{2}{3} \times 7 \right) = 100,000 \text{ in.-lbs.}$

The section modulus  $S = \frac{M}{f} = \frac{100,000}{20,000} = 5$ , but  $S = \frac{bd^2}{6}$ . Therefore  $5 = \frac{20d^2}{6}$

$d^2 = 1.5$ ;  $d = 1.22$ . Use a plate 20" x 20" x 1 1/4".

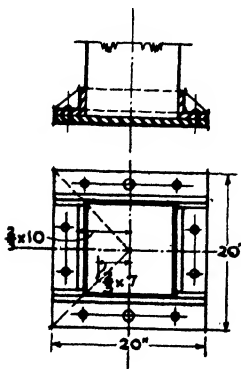

FIG. 9.—Steel Base.

The top of the concrete footing is often set a few inches above the finished floor to raise the column above any moisture upon the floor. The base should be well painted and the end of the column treated with wood preservative.

**Caps.** Column caps are made of cast iron or steel, their chief function being to support and give sufficient seats to the girders framing into the column on one or two sides. A bearing must also be provided for the column of the story above so that it will properly transfer its load to the column beneath it. Such caps are called two-way caps. When, however, cross beams also frame into the column, seats must likewise be supplied for them. The beams are

generally of less depth than the girders and therefore their seats will be at different levels from the girder seats, which tends to produce a complicated cap and one awkward to construct. An uneven floor also results since the beams framing into the girder will settle by the shrinking of the girders while those resting upon the column cap settle only through their own shrinkage. Such caps, called four-way caps, should therefore be avoided and the framing so designed that the cross beams stagger the columns and all frame into the girders. Pressed steel post caps are made by various manufacturers; their sizes may be obtained from the catalogues. The architect must always assure himself that the projection of the girder seats and the thickness of the metal are sufficient.

**Example 13** (Fig. 10). Design a cast-iron column cap for a 12" x 12" column with a 10" x 10" column above it and 10" x 16" girders with end reaction of 15,000 lbs framing into it on two opposite sides. Let  $f_w$  for compression across grain = 300 lbs./in.<sup>2</sup> and  $f$  for flexure of cast iron = 3000 lbs./in.<sup>2</sup>

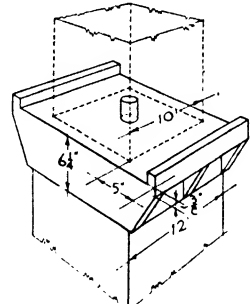

FIG. 10.—Cast Iron Column Cap.

The seat must contain  $\frac{15,000}{300} = 50$  in.<sup>2</sup> The effective cap is 10" wide and the seat will be  $\frac{50}{10} = 5''$  long.

1. DEPTH OF SIDES.  $M$  on post cap at face of upper column =  $\frac{W \times L}{2} = \frac{15,000 \times 5}{2} = 37,500$  in.-lbs. to be resisted by two sides of cap acting as cantilevers  $\frac{37,500}{2} = 18,750$ ;  $S = \frac{M}{f} = \frac{18,750}{3000} = 6.25$  in.<sup>3</sup> Let  $b$  = thickness of side = 1";  $\frac{bd^2}{6} = S$ ,  $d^2 = 37.50$ ,  $d = 6.12''$ , say  $6\frac{1}{4}''$ .

2. THICKNESS OF SEAT. Projection beyond lower column = 5" - 1" = 4". Seat acts as beam 13" long to center of sides and 4" wide with fixed ends.

Load =  $\frac{4}{5} \times 15,000$  lbs. = 12,000 lbs.;  $M = \frac{12,000}{12} \times 13 = 13,000$  lbs.;  $S = \frac{13,000}{3000} = 4.33$ ;  $\frac{bd^2}{6} = 4.33$ ;  $d^2 = \frac{25.98}{4} = 6.49$ ;  $d = 2.52$ . Too thick, and a rib is introduced under center of seat. The span then =  $\frac{13}{2} = 6\frac{1}{2}''$ .  $M = \frac{6000 \times 6\frac{1}{2}}{12} = 3250$  in.-lbs.;  $S = \frac{3250}{3000} = 1.08$ ;  $d^2 = \frac{6.48}{4} = 1.62$ ;  $d = 1.27''$ . Use  $1\frac{3}{8}''$ . The rib has the same depth as the sides =  $6\frac{1}{4}''$ .

**Wood Bolsters** (Fig. 11). Instead of metal caps, wood pieces are sometimes used to give bearing for the girders. Such construction is not now considered as desirable as metal caps because of shrinkage of wood and projection of bolsters when a finished ceiling is desired. However, a brief description will be included. There are two methods

of arranging the bolsters. In the first, the piece is set over the lower column with the grain running horizontally—a poor arrangement because of the crushing across the grain in the bolster by the heavy loads in the columns. By the second method the blocks are set into the column with their grain running vertically. All bearings of bolster and column are consequently on end grain with greater compressive strength and less shrinkage resulting. The bolsters are held to the column by through bolts, and steel plates or wood pads are bolted from girder to girder and from upper to lower column to tie the members together. If a joist is set against the column on each side and spiked to it, additional stiffness across the building will result.

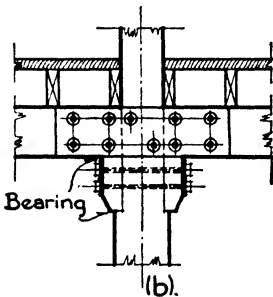
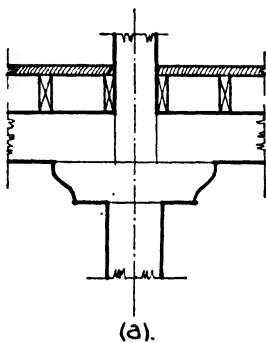

FIG. 11.—Wood Bolsters.

**Metal Columns.** In heavy wood construction metal columns of cast iron or steel are sometimes employed in place of wood posts. At one time, hollow round cast-iron columns were much used in connection with wood beams and girders because they were capable of carrying larger loads on smaller sections than wood posts and could be concealed in partitions more easily. They likewise occupied much less space in the open areas of factories and shops. The casting of the metal produces internal strains, rifted seams, inequalities in thickness of shell and other flaws which tend to render the columns unreliable. In case of fire, cast iron often cracks from rapid and irregular contraction if struck by water when hot.

Structural steel columns, when not protected, will distort and fail in high temperatures while heavy wood beams only char. To surround the steel in fireproof material is not economical in connection with the cheaper wood members.

Steel pipes filled with concrete have been developed which combine very satisfactorily economy of space, good bearing capacity and fire-resistance. The pipe is clamped in a vertical position at the factory and filled

with a 1:1½:3 mix of concrete, the sides of the pipe being tapped with an electric hammer to compact the concrete and eliminate air holes and cavities. The sections may be plain or reinforced with a round bar, a second central pipe or a combination of four angles.

The following table gives the safe loads of steel concrete-filled columns made by the Lally Columns Companies.

**Long-span Roof Arches.** Several types of wood arches and trusses are in the market for use in hangars, garages, churches, fair buildings, playing courts or wherever wide unobstructed floor space and height are required. Some of these systems which have been patented consist either of laminated glued-up arches and trusses or of short diamond-shaped sections forming a continuous arch without trusses. Laminated trusses of conventional shapes for shops and churches and where clear floor space is more important than unobstructed height are also factory built upon engineering principles and are easily obtainable. Spans of 75' to 400' are claimed for the various types of long-span arches. See Chapter XXI.

Table IX. Safe Loads in Thousands of Pounds

Diameter of Columns, inches		Thick-ness of Metal, inch	Unbraced Length of Column, feet							
			6	8	10	12	14	16	18	20
Light weight	3½	.0120	26.1	22.2	18.3	14.5				
	4	.134	35.6	31.2	26.8	22.4				
Heavy weight	3½	.216	37.9	32.3	26.7					
	4	.226	49.2	43.1	37.0	30.9				
	4½	.237	61.8	55.3	48.8	42.3	35.8			
	5	.247	75.6	68.6	61.7	54.7	47.8	40.9		
	5½	.258	92.1	84.6	77.1	69.6	62.1	54.6	47.1	
	6⅝	.280	128.3	120.0	111.7	103.4	95.0	86.7	78.4	70.1
	7⅝	.301	166.0	156.9	147.8	138.6	129.7	120.5	111.4	102.3
	8⅝	.322	211.1	201.1	191.0	181.0	170.9	160.8	150.8	140.7
	9⅝	.342	259.2	248.3	237.4	226.5	215.6	204.6	193.7	182.8
	10¾	.365	319.1	307.2	295.4	283.5	271.6	259.7	247.9	236.0
	12¾	.375	421.9	408.8	395.8	382.8	369.7	356.7	343.6	330.6

**Article 3. Slow-burning Construction**

An important type of framing with heavy timbers is that used in the erection of mills and factories. This type was developed in New England in an effort to produce a structure which would carry the loads of machinery and materials and at the same time be economical to erect and fairly resistant to fire. The aim was not to design a fireproof building, a costly undertaking in either wood or steel construction, but one which would ignite slowly, char without bursting into flame and so be easily extinguished by means of sprinklers and fire hose without much damage to the structure.

**Standard Mill Construction** (Fig. 12). To attain this end, the exterior walls are built of brick or concrete and the floor and roof construction of heavy timbers supported on stout posts with flooring and roofing of thick planks. No enclosed spaces forming flues are permitted, and all

the wood members are of large dimension and widely spaced. The plank floors span from girder to girder without cross beams, the flat under side of the planks being very slow to kindle. There is no lath or plaster, and the posts and girders have chamfered or rounded edges, sharp projecting corners which readily ignite being avoided. Stairways and beltways are enclosed in brick or other incombustible material. The absence of cross beams not only presents fewer sharp edges to ignite but greatly facilitates the installation of sprinkler pipes and the free sweep of water streams from fire hose throughout the ceilings. It also permits the advantageous raising of the window heads. No girders less than 6" or posts less than 8" in width are permitted, irrespective of the loads. (See also Chapter IX, Fig. 4, and Chapter X, Fig. 3.)

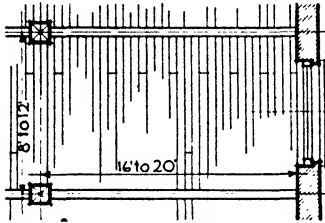

FIG. 12.—Standard Mill Construction.

The girders are spaced 8'0" to 12'0" on centers, generally run the shortway of the building, and are carried by the outside walls and by posts set 16'0" to 20'0" apart. The girders cannot well be spaced farther apart because of the floor planking which spans across them. The most important joint is at the point where the columns and girders are connected. It has been found to be a safer and more rigid construction if the girders butt against each other

and are anchored together, thus forming both struts in compression and ties in tension and firmly bracing the building from wall to wall. Likewise it has been proved by experience that a much surer bearing is afforded if the girders rest on top of the column itself rather than upon overhanging iron cap brackets which may fail under high temperature. But it is well known that columns must rest one upon another from the top to the bottom of the building; consequently a short cast-iron post, called a *PINTLE*, has been devised. The pintle generally has a round cross-section about 4" in diameter and can therefore be set into a 2" half-round groove in each of the adjoining ends of two girders and still permit the girders to butt against each other and to be tied together on top by iron straps, called *DOGS*, passing over each side of the pintle. The dogs are covered by the plank floor over them, and the post of the pintle is embedded in the ends of the girders, the ironwork thereby being insulated on all sides by the wood. Above the girders in the space occupied by the plank flooring the pintle flares out into a base for the column above and it rests on a plate serving as the cap of the column below (Fig. 13).

Although pintles are considered far better structurally and are, indeed, one of the fundamental elements of Standard Mill Construction, cast-iron and steel caps are sometimes used as illustrated in Article 2. They permit the column of the upper tier to rest directly upon the

column below, but in so doing the column intervenes between the ends of the girders, lessening their efficiency both as struts and as ties. Moreover, the girders must rest upon the projecting brackets of the cap, and these brackets may break from flaws or bend from heat before the girders themselves are weakened.

All woodwork is planed in order to present large smooth masses with the least possible total surface to a fire. In sizes up to 14" x 16" single sticks are preferred for girders, but timbers 6" x 16" or 8" x 16" are often used in pairs bolted together without an air space between them, the surfaces in contact being treated with creosote or other water-repellent material to prevent decay. The two sections are held together by bolts staggered in two lines at equal spaces not exceeding four times

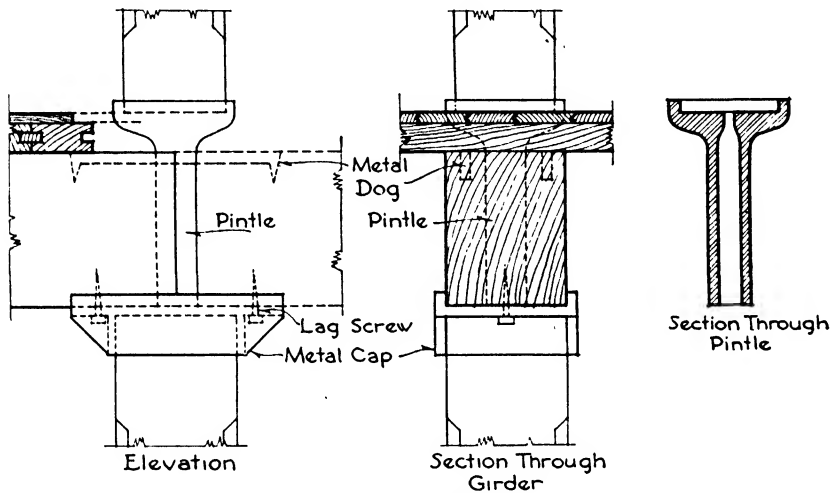

FIG. 13.—Pintos.

the depth of the girder, 3'0" being a common spacing. Steel beams are sometimes used for girders in place of wood where the spans must be greater than 25'0". They should be protected with fireproofing, such as wire lath and plaster, the lath being attached to 1/4" rods bent around the beams and fastened to a wood sleeper or nailing strip on top of the beam.

The methods of designing wood girders and columns explained in Articles 1 and 2 of this chapter apply also to the calculations of members in standard mill construction.

The most general type of floor planking is spruce or dense Southern pine, laid with the grain flat, the thickness being not less than 4" to permit a certain amount of charring on the under surface without dangerously weakening the planks. The thickness must, however, be calculated in each case for bending moment as of a continuous beam. The planking is usually laid with each piece bearing on three girders, the

joints breaking every 4'0" transversely. The planks may be tongued and grooved or fastened together with long strips called splines let into grooves in the edges of the planks, splined flooring being considered better than tongued and grooved especially in the thicker pieces. A space 1" wide is left around the edges of the planking next to the walls to obviate bulging of the floor in the event of swelling from water. Waterproof felt is then placed over the planks, and a  $\frac{7}{8}$ " tongued and grooved under-floor is nailed down diagonally to brace the construction and to permit the upper floor to be laid in any direction desired. The upper floor is usually of edge-grain tongued and grooved maple or birch  $\frac{7}{8}$ " thick. See Table IV for safe spans of yellow pine plank floors.

**Girder Wall Supports** (Fig. 14,*a*). The outer ends of girders bearing upon walls in standard mill construction should be supported by WALL BOXES made of malleable iron or steel. An air space has been found necessary around the ends of wood girders built into masonry walls to provide ventilation and avoid decay. Likewise no type of bearing or anchoring should be used which prevents the girders from being self-

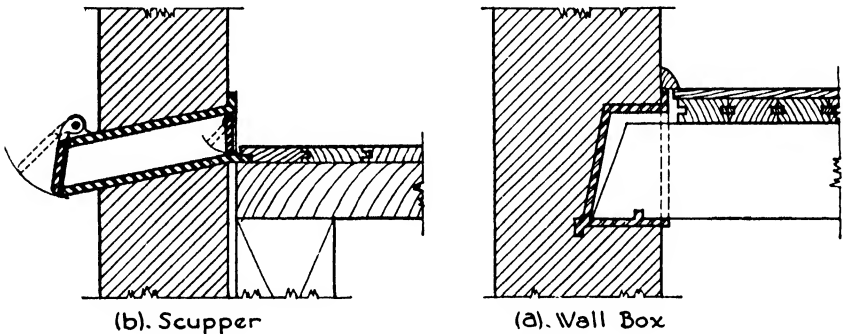

FIG. 14.—Scupper and Wall Box.

releasing in case the middle portion burns through and drops down, thus prying the wall apart. Wall boxes are keyed into the wall; they provide an air space and they hold the girder by a lug in the bottom of the box, which releases the end if the girder falls. In slow-burning construction, the use of wall boxes is preferred to metal beam hangers, which may fail and bend through the effects of heat as described for post cap brackets.

**Laminated Floor Construction.** When heavy loads occur or when wider spans are desired laminated floors are often employed. These consist of planks laid on edge instead of on the flat, thereby producing a stiffer and stronger construction. The planks are either 2" or 3" thick and from 6" to 10" deep, each plank being nailed to the adjoining plank with 60d. nails at intervals of 18" alternately at the top and bottom throughout its length. The planks are not spiked to the supporting girders so that expansion in the floor due to dampness will not cause

movement in the girders at the walls. It is often difficult to obtain plank long enough to span two wide bays in the continuous manner already described for splined plank laid on the flat in narrower bays. The laminated floor permits joints not over girders because the planks are all spiked together and mutually support each other. Every third or fourth plank extends from center to center of adjoining girders and the intermediate planks butt at about  $\frac{1}{4}$  span. The planks used in laminated floors are often not planed on the sides but only on the edges, the roughnesses on the sides left by the saw forming minute air spaces between the planks which prevent decay from starting as might happen if the smooth even sides of planed planks were brought tight together. See Table V for safe spans for laminated floors.

**Scuppers** (Fig. 14,*b*). Buildings of slow-burning standard mill construction are provided on all floors with scuppers to lead water from the sprinklers and fire hose outside the exterior walls; otherwise, unless the water finds a ready means of escape, more damage may result from the water than from the fire. Scuppers are made of cast iron with bronze weather valve on the outside, and a brass wind shield, grating and fender on the inside. One scupper is installed for every 500 ft.<sup>2</sup> of floor surface if the building is equipped with sprinklers and one for every 1000 ft.<sup>2</sup> if without sprinklers.

**Roofs.** Mill roofs are usually flat, that is, with a pitch of  $\frac{1}{2}$ " to the foot, and are framed and planked like the floors, using large timbers, none less than 6" in minimum dimension for fire protection, even if such sizes are unnecessary to sustain the roof loads. The roofs are usually covered with layers of tarred felt laid in hot pitch, known as the membrane method, and finished with a coating of gravel or slag for protection.

**Plaster.** If plastered ceilings be anywhere desired as a finish, metal lath and plaster should be used, without air space, the plastering following the contour of the girders and wood ceiling.

**Painting.** Paint should not be applied to the interior wood surfaces in mill construction until at least 3 years after the completion of the building, to allow the timbers to dry out and to avoid dry rot.

**Semi-mill Construction** (Fig. 15). In some instances transverse floor beams are used between the girders, making possible a wider spacing of the columns and a more open floor area. This method, called SEMI-MILL CONSTRUCTION, departs radically from the ideal of standard construction in that more timber surface is exposed to fire and the members are considerably lighter. The beams are spaced from 4'0" to 8'0" apart to work out well with the lengths of flooring. They may be placed either to occur at a column or to come on each side of a column and frame into the girders. The second arrangement is considered better because the awkward detail of the column cap, resulting from the differing depths of beams and girders, is avoided. The floor beams are placed parallel to the long side of the panel, and the girders span the short direction, thus gaining economy in the relative sizes of the mem-



bers and in the reduced number of columns. Spans of floor beams are from 12'0" to 20'0" and of girders from 12'0" to 16'0". The inner ends of the floor beams may be supported by resting them on top of the girders or by hanging them to the girders by steel hangers. If resting on top of the girders the beams have greater bearing surface, but the method is undesirable for every other reason. It necessitates less head-room under the girders and gives a free passage for flames all around them. Also, by the interposition of so much wood, unevenness of floors may arise caused by a difference in shrinkage between the ends of beams

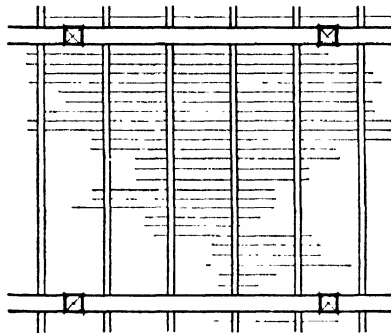

FIG. 15.—Semi-mill Construction.

resting upon girders and those bearing upon exterior masonry walls. Steel hangers may extend over the top of the girder, which sometimes crushes the fibers of the upper surface. A very good type of hanger has a lug inserted in a hole in the girder above the neutral axis. Its sides are ventilated to prevent dry rot, and by its position it reduces the amount of wood shrinkage. The beams are notched over projecting ridges in the bottom of the hangers and are thus held in position and can act as ties across the building. (See Fig. 4). The details of the plank and upper floors are the same as for standard mill construction, but the planking is often less than 4" thick.

## CHAPTER XIX

### LIGHT WOOD FRAMING

**Introductory.** As stated in Chapter XVIII, light wood framing denotes a method of erecting the smaller types of wood buildings with light floor loads, such as dwellings, shops, stables and apartments. The frame is composed of many light members spaced close together, each member thereby carrying a relatively small load, as contrasted with heavy timber construction in which the pieces are larger but more widely spaced and consequently are more heavily loaded. The light members are quick and easy to handle and transport, and the rate of erection is rapid. Light wood framing, also, usually refers to the use of wood for the enclosing walls as well as for the floors and partitions, although wood floor joists and wood stud partitions are often used with enclosing walls of masonry.

A wood frame is composed of a **SILL** laid level upon the top of the cellar wall and bedded in mortar. The **CORNER POSTS** and the **STUDS** are vertical members fastened to the sill and supporting at their upper ends the horizontal **PLATE** which carries the ends of the roof **RAFTERS**. The first-story floor beams or **JOISTS** rest upon the sill, and the second and third-story joists upon **GIRTS** or **RIBBONS** which are horizontal pieces supported by the studs or fastened to them at the floor levels.

There are two methods of constructing the exterior walls of a wood frame building: the **BRACED FRAME** and the **BALLOON FRAME**.

#### Article 1. The Braced Frame

**In General.** The braced frame, sometimes called the combination frame, is a modification of the heavy timbered frame which our ancestors used in Europe and in America until the middle of the nineteenth century. This heavy frame was composed of big pieces spaced at wide intervals, many of the joints being cut with mortise and tenon and fastened together with wood pins. The entire frame was thoroughly braced with diagonal braces, and the floor beams and roof beams were heavy pieces set wide apart. The loads bearing on each piece, the reducing of sections caused by the cutting of mortises and the uncertainty as to the true strength of the wood necessitated heavy timbers of large sections which were unwieldy to handle and slow to erect. The resulting structure was, however, a strong and rigid framework capable in itself of carrying its imposed weights and of withstanding, without vibrations, wind pressure and the impacts of moving loads.

**Braced Frame.** A demand for a more rapid method of erecting houses led to the development of the braced or combination frame which employs lighter pieces more easily handled without derricks and readily

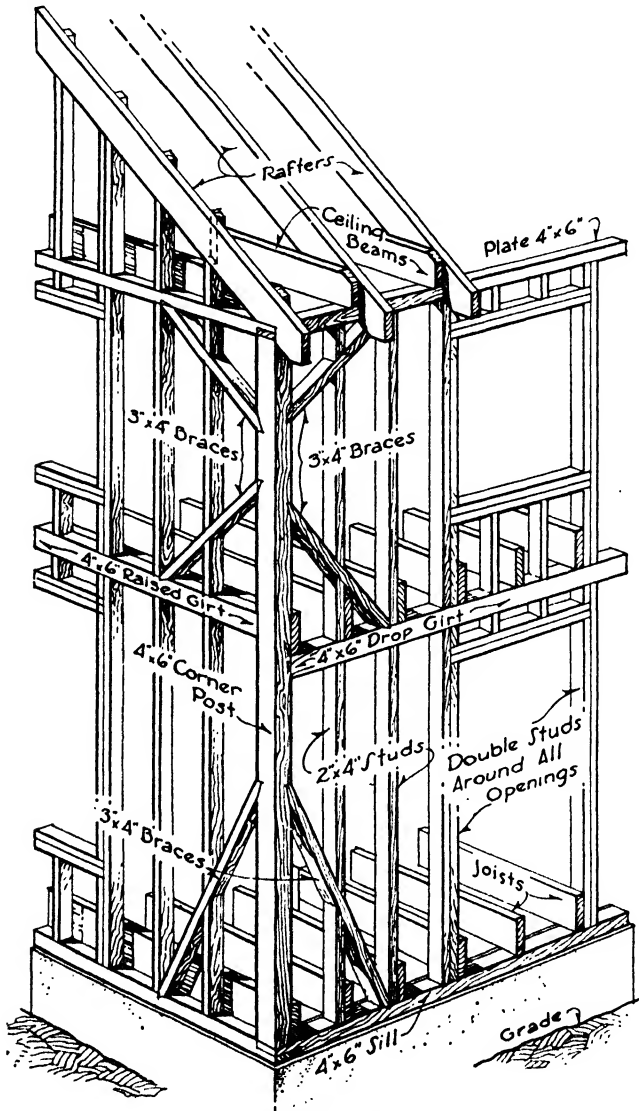

FIG. 1.—Braced Frame.

obtainable from local sawmills or transported from large lumber yards. The members are set more closely, thus reducing the load on each piece; they are spiked together or hung in metal hangers, and mortise and

tenon joints were almost completely eliminated. One characteristic of the original heavy construction should, however, always be maintained: the ability of the framework to stand in itself as a competent and rigid structure without the necessity of depending upon outside sheathing or inside lathing, plastering and flooring to achieve its resistance to stress (Fig. 1).

The framework consists of the sill upon which are fastened the corner posts at each angle. These posts are fairly heavy timbers extending up two or more stories to the plate, a horizontal member surrounding the building at the top as does the sill at the bottom and tying it together. The roof rafters also rest upon the plate. The framework is further tied together by the horizontal girts, which are of the same size as the corner posts and are framed into them at the second-story level. Diagonal pieces extend from the sill and the girts to the corner posts and from the corner posts to the plate to brace the framework rigidly in a lateral direction. It will be seen that the framework is firm and rigid in its own construction and capable of sustaining the weights of its loads and of resisting wind pressure without deflections or vibrations. The first-story joists rest upon the sill, the second-story joists upon the girts and the attic joists upon the plate or a ledger board. The first-story studs of the exterior walls run from the sill to the girts, the second-story studs resting upon the girts and extending to the plate.

The following cross-sectional dimensions are generally accepted for the various members of the braced frame, the rafters, joists, girders and collar beams being the only pieces usually calculated from the loads and spans. It may be necessary at times, however, to study the size and spacing of studs in partitions and walls when carrying unusual loads. The size of the purlins in a gambrel roof depend upon the dimensions of the rafters.

Sill—4" x 6" or 6" x 8".

Plate—4" x 4" or 4" x 6".

Corner Post—4" x 6".

Raised Girt—4" x 6".

Dropped Girt—4" x 6".

Ledger Board—1" x 8".

Braces—4" x 4".

Studs—2" or 3" x 4" or 6".

Joists—2", 3" or 4" x 6", 8", 10", 12" or 14".

Girders—4", 6", 8", 10", or 12" x 6", 8", 10", 12", or 14".

Rafters—2" or 3" x 4", 6", 8", 10" or 12".

Collar Beam—2" x 4", 6" or 8".

Purlin—4" x 4", 6", 8" or 10".

**Framing Details.** SILLS are usually 4" x 6", but for heavy buildings or where spanning wide openings in the cellar wall they should be 6" x 8". They are always set level in mortar and in the best work are bolted to the cellar wall with  $\frac{3}{4}$ " bolts 24" long built into the masonry.

They should not be spliced in their length and should be set 1" back from the outside face of the wall to allow room for the sheathing. Sills are never butted or mitered at the corners but are halved together and pinned or spiked (Fig. 2, *a, b*).

STUDS are most often 2" x 4" spaced 16" on centers but may be 3" x 4" or spaced 12" on centers to carry special loads or for walls of unusual height. It is also usually necessary in every house to use 6" studs in some of the partitions or walls to conceal plumbing and heating pipes and conduits. Studs are doubled at the heads, sides and sills of all openings. For openings over 4'0" wide triangular trussing is used, the head pieces being set side by side on edge or one above the other flatwise. When on the flat a 1" space is left between the pieces so that any sag developed in the upper piece will not be transmitted to the lower piece causing the window or door to bind (Fig. 2, *c*). The inside edges of studs should be brought to an even plane by furring

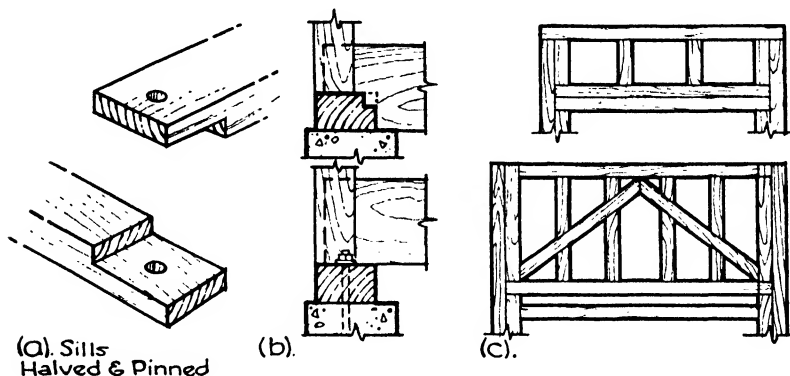

FIG. 2.—Framing Details.

out or dressing down to furnish proper bearing and nailing for the plaster lath.

CORNER POSTS are 4" x 6" or 6" x 8", one dimension being the same as a dimension of the wall studs. They extend from sill to plate in one continuous piece. A 2" x 4" furring stud is set against the post to give a nailing for the lath.

GIRTS have the same dimensions as the corner posts, to which they should be fastened by a framed joint in order to give proper support for the girt and to stiffen the entire framework, this being the one position in which the mortise and tenon joint with oak pin should still be maintained. If such a joint cannot be attempted the girt should be supported on a block of wood spiked to the corner post or by a steel angle lag-screwed in place. The girts running parallel to the joists are set with their tops level with the tops of the joists and are called raised girts. The girts running at right angles to the joists are lowered so the joists may rest upon them and are known as dropped girts (Fig. 3).

BRACES are most effective when at an angle of  $45^\circ$  and should be  $3'' \times 4''$  or  $4'' \times 4''$ . Strips  $1'' \times 4''$  let into the outside of the stud faces under the sheathing also make very efficient diagonal braces but should not take the place of the heavier braces in a true braced frame. The studs are cut in above and below the braces.

PLATES. The thrust of the rafters is best resisted by a  $4'' \times 6''$  plate, although  $4'' \times 4''$  plates may be used if the projection beyond the inner face of the studs be objectionable. Some architects prefer to build up the plate of two pieces each  $2''$  thick, rather than to use a solid  $4''$  member, because they consider that warping and twisting are less likely to occur in built-up plates and that splices will be stronger when the two pieces overlap by several feet.

JOISTS. The joists support the flooring at each story level. The first-story joists either rest upon the sill, are hung from it with metal hangers or are framed into mortises cut in the sill. If the last method be used the sill should have larger dimensions to balance the material cut away. At the second-story level the joists rest upon the dropped girt and are

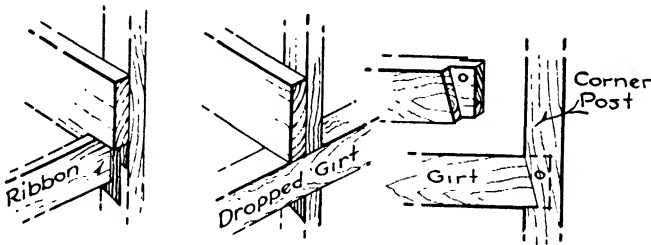

FIG. 3.—Ribbon and Girt.

spiked to the girt and to studs when occurring next to the joists (Fig. 3). The attic joists rest upon the plate or upon a  $1'' \times 8''$  ledger board let into the inner faces of the studs below the plate. When the exterior walls are of wood the joists are usually  $2''$  thick, but in the case of masonry walled buildings within the fire limits of cities the building codes often insist on a thickness of  $3''$ . Joists are set on edge  $12''$  or  $16''$  apart depending upon the required stiffness and upon the loads. Their depth varies from  $6''$  to  $14''$  as necessary to resist the stresses or avoid deflection, depths over  $14''$  being uneconomical. In the latter event a rearrangement of the framing scheme and the introduction of cross girders will effect a saving when spanning wide spaces or carrying heavy loads.

The inner ends of first-story joists rest upon girders, stud partitions or masonry walls, those of the second and upper-story joists upon girders or stud bearing partitions. By adjusting the ends when setting the joists or by dressing down high spots all the top edges are brought to a level plane surface to receive the flooring. The lower edges are

prepared for plastered ceilings by leveling and nailing furring strips across them, called cross furring.

At stair wells and chimneys doubled joists or heavier beams called TRIMMERS must be used at each side of the opening parallel to the floor joists. From one trimmer to the other is framed a cross piece composed also of a heavier beam or of doubled joists called a HEADER which supports the short joists or TAIL BEAMS (Fig. 4,*a,b*). Headers and tail beams should rest upon steel joist hangers (Fig. 4,*d*). A header should always be set across a chimney breast at least 2'' away from the masonry to receive the joists which are never built into a chimney even at story levels where no fireplaces occur.

When discontinuous or non-bearing partitions run parallel to the joists they are carried on two joists set close together, but separated by at least 2'' to give nailing for the finished flooring (Fig. 5,*a*). If pipes

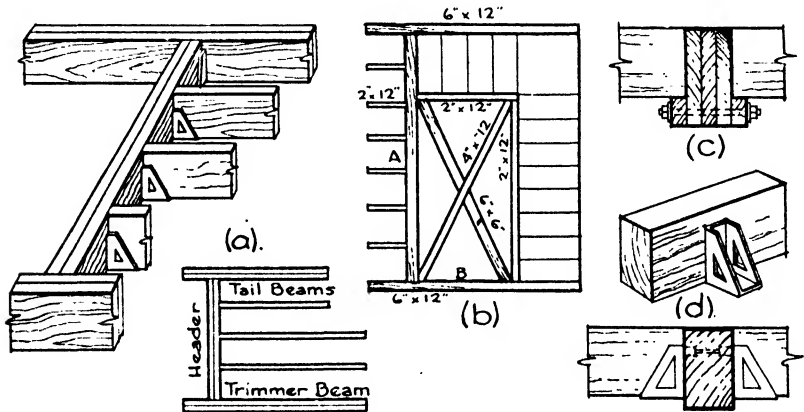

FIG. 4.—Headers and Trimmers

or ducts pass up the partition the joists are spaced far enough apart to accommodate them, pieces of 2'' x 6'' plank being cut in between the joists to support the partition (Fig. 5,*b*). When bearing or non-bearing partitions run across the joists, the joists themselves must provide sufficient strength to carry the concentrated load of the partition. This may be done by using deeper joists, by spacing the joists at 12'' instead of 16'' intervals or by introducing a girder under the partition.

**Bridging** (Fig. 5,*c*). Lines of diagonal braces about 6'0'' apart consisting of 1'' x 3'' or 2'' x 3'' pieces should be cut in between all the joists. The braces are cut on the miter to the exact length and nailed to the joists. This bridging stiffens the entire floor and reduces vibration. It does not render a floor any stronger to support distributed loads but does assist in spreading a concentrated load to the adjacent joists.

**Joist Tables.** The following tables of maximum spans for joists are selected from those prepared by R. G. Kimbell and published by the

National Lumber Manufacturers Association. These tables are based upon the latest tests and upon the latest methods of grading lumber. Two spans are given for each size and spacing of joist, one where bending only is considered as in warehouses and factories with unplastered ceilings, and the other and smaller span depending upon the modulus of elasticity and deflection of the joist as necessary in buildings with plastered ceilings. The deflection in these spans is limited to  $1/360$  of the span length.

The procedure in using the tables is as follows:

(1) In the case of buildings with plastered ceilings. (a) Determine by reference to the building code of the locality the required live load for the type of building in consideration and the allowable modulus of elasticity in pounds per square inch ( $E$ ) for the species of timber used. If no building code covers the locality of the building and in the case of typical problems 40 lbs./ft.<sup>2</sup> live load may be assumed for residences, apartments and small office buildings, and  $E$  may be determined by reference to Table I, Chapter XVIII. (b) Refer to the column :

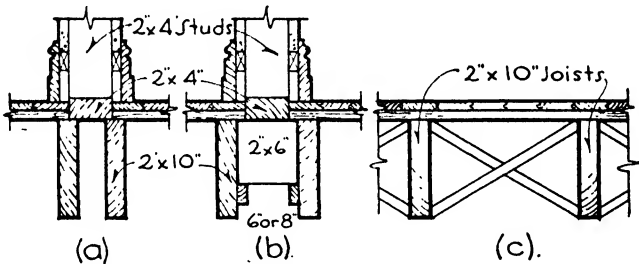

FIG. 5.—Double-Joist and Bridging.

following tables headed by the selected value for  $E$  and find the nearest span to that in the problem. The corresponding size of joist and the spacing required will be found in the column to the left.

(2) In the case of buildings without plastered ceilings. (a) Determine by reference to the building code of the locality the required live load for the type of building in consideration and the allowable extreme fiber stress in bending in pounds per square inch for the species and grade of lumber used. If no building code covers the locality of the building and in the case of typical problems, 50 lbs. or 60 lbs./ft.<sup>2</sup> live load may be assumed for light barns, storehouses or garages, and the allowable stress in bending may be determined by reference to Table I, Chapter XVIII. (b) Refer to the column in the following tables headed by the selected value for bending and find the nearest span to that in the problem. The corresponding size of joist and the spacing required will be found in the column to the left.

The spans should be checked for horizontal shearing strength when the loads exceed 80 lbs./ft.<sup>2</sup>



The following weights per square foot have been used in determining the dead load.

- Weight of joist at average of 40 lbs.
- Weight of lath and plaster ceiling (10 lbs.).
- Double thickness of 13/16" flooring (5 lbs.).

The spans for the various sizes and spacings of joists under the values of  $E$  and  $f$  for each loading are determined in the following manner:

DETERMINED BY BENDING.

(a) Case in which  $f = 900$  lbs./in.<sup>2</sup> for 2" x 6" joists with a 12" spacing. Live load = 30 lbs./ft.<sup>2</sup> Actual size of joist 1 5/8" x 5 5/8".

Loading. 
$$M = \frac{fbd^2}{6} = \frac{900 \times 1.62 \times 5.62 \times 5.62}{6} = 7677 \text{ in.-lbs.}$$

Live load 30 lbs. 
$$M = \frac{wl^2}{8}. \text{ Therefore } l^2 = \frac{8M}{w}.$$

Floor 5  
Ceiling 10  
Joist 2.5 
$$l^2 = \frac{8 \times 7677 \times 12}{47.5} = 15,515.$$

Total 47.5 lbs./ft.<sup>2</sup> 
$$l = \sqrt{15,515} = 124'' = 10'4''.$$

(b) Same conditions except spacing = 16". Load = 30 + 5 + 10 = 45.

Loading. 
$$45 \times 4/3 = 60. \quad l^2 = \frac{8 \times 7677 \times 12}{62.5} = 11,791$$

$$60 + 2.5 = 62.5 \quad l = \sqrt{11,791} = 109'' = 9'1''.$$

DETERMINED BY DEFLECTION.

Same conditions, determined by deflection of  $\frac{L}{30}$  or  $\frac{l}{360}$ .

$E = 1,000,000$  lbs./in.<sup>2</sup> Spacing = 12".

$$D = \frac{5WL^3}{384EI}; \text{ but } I = \frac{bd^3}{12} \text{ and } l = 12L; \text{ therefore}$$

$$D = \frac{5WL^3 \times 1728 \times 12}{384Ebd^3} = \frac{270WL^3}{Ebd^3}.$$

$$D = \frac{L}{30}; \text{ therefore } \frac{L}{30} = \frac{270WL^3}{Ebd^3} \text{ or } Ebd^3L = 8100 L^3W \text{ and } L^2 = \frac{Ebd^3}{8100W}$$

But  $W = wL$ ; therefore  $L^3 = \frac{Ebd^3}{8100w}$ .

Then 
$$L^3 = \frac{1,000,000 \times 1.62 \times 5.62 \times 5.62 \times 5.62}{8100 \times 47.5} = 751+.$$

$$L = \sqrt[3]{751+} = 9.09' = 9'1''.$$

**Table I. Maximum Spans for Floor Joists—Uniformly Loaded**  
 Live Load 30 lbs./ft.<sup>2</sup> with Plastered Ceiling or 40 lbs./ft.<sup>2</sup> with Unplastered Ceiling  
 Maximum Allowable Lengths between Supports (Clear Span)

Nominal Size of Joists, inches	Spacing of Joists Center to Center, inches	Limited by Deflection of $\frac{1}{360}$ of the Span						Determined by Bending					
		E = 1 000 000	E = 200 000	E = 1 400 000	E = 1 000 000	E = 600 000	f = 900	f = 1 000	f = 1 100	f = 1 200	f = 1 300	f = 1 600	f = 1 800
2 x 6	12	9-10	10-5	11-0	11-6	10-11	10-4	10-11	11-6	12-0	12-6	13-10	14-8
	16	9-0	9-7	10-1	10-6	9-6	9-1	9-6	10-0	10-6	10-10	12-1	12-10
2 x 8	12	13-0	13-10	14-7	15-3	14-6	13-9	14-6	15-3	15-11	16-6	18-4	19-5
	16	11-11	12-8	13-4	13-11	12-8	12-0	12-8	13-4	13-11	14-5	16-0	17-0
2 x 10	12	16-4	17-5	18-4	19-2	18-3	17-3	18-3	19-1	19-11	20-8	23-0	24-4
	16	15-0	15-11	16-9	17-6	15-1	15-1	15-11	16-8	17-4	18-2	20-1	21-4
2 x 12	12	19-9	20-11	22-0	23-0	21-10	20-8	21-10	22-11	23-11	24-10	27-7	29-3
	16	18-1	19-2	20-2	21-1	19-3	18-1	19-3	20-1	20-11	21-10	24-3	25-8
2 x 14	12	22-11	24-4	25-7	26-9	25-5	24-1	25-5	26-6	27-10	28-11	28-3	29-11
	16	21-1	22-5	23-7	24-8	22-4	21-2	22-4	23-5	24-5	25-5	28-3	29-11
3 x 6	12	11-5	12-1	12-9	13-4	13-8	13-0	13-8	14-4	15-0	15-7	17-4	18-4
	16	10-5	11-1	11-8	12-2	12-0	11-4	12-0	12-6	13-1	13-8	15-2	16-1
3 x 8	12	15-0	15-11	16-9	17-7	17-11	17-1	17-11	18-10	19-8	20-6	22-9	24-2
	16	13-9	14-8	15-5	16-1	15-9	15-0	15-9	16-7	17-4	18-0	20-0	21-2
3 x 10	12	18-9	20-0	21-0	22-0	22-5	21-3	22-5	23-6	24-7	25-7	28-5	30-3
	16	17-4	18-5	19-4	17-11	19-9	18-9	19-9	20-9	21-8	22-7	25-0	26-6
3 x 12	12	22-6	23-11	25-2	26-3	26-11	25-5	26-11	28-1	29-4	30-8	30-0	
	16	20-9	22-1	23-3	24-3	23-8	22-5	23-8	24-10	25-11	27-0		
3 x 14	12	26-11	27-9	29-2	30-6	31-2	29-7	31-2	28-10	30-3			
	16	24-2	25-8	27-0	28-3	27-6	26-1	27-6					

**Table II. Maximum Spans for Floor Joists—Uniformly Loaded**  
 Live Load 40 lbs./ft.<sup>2</sup> with Plastered Ceiling or 50 lbs./ft.<sup>2</sup> with Unplastered Ceiling

Nominal Size of Joists, inches	Spacing of Joists Center to Center, inches	Maximum Allowable Lengths between Supports (Clear Span)										
		Limited by Deflection of $\frac{1}{360}$ of the Span					Determined by Bending					
		$E=1\ 000\ 000$	$E=200\ 000$	$E=1\ 400\ 000$	$E=1\ 600\ 000$	$E=1\ 800\ 000$	$f=900$	$f=1\ 000$	$f=1\ 100$	$f=1\ 200$	$f=1\ 300$	$f=1\ 600$
2 x 6	12	9-1	9-8	10-2	10-8	9-6	10-0	10-5	10-11	11-4	12-7	13-5
	16	8-4	8-10	9-3	9-8	8-3	8-8	9-1	9-6	9-10	11-0	11-7
2 x 8	12	12-1	12-10	13-1	14-1	12-6	13-2	13-10	14-5	15-0	16-8	17-8
	16	11-0	11-8	12-4	12-11	10-11	11-6	12-0	12-7	13-1	14-6	15-5
2 x 10	12	15-2	16-1	17-0	17-9	15-9	16-7	17-4	18-2	18-11	21-0	22-3
	16	13-11	14-9	15-6	16-3	13-9	14-6	15-2	15-10	16-6	18-4	19-5
2 x 12	12	18-4	19-5	20-5	21-4	18-11	19-11	20-11	21-11	22-8	25-2	26-9
	16	16-9	17-9	18-9	19-7	16-6	17-5	18-3	19-1	19-11	22-0	23-5
2 x 14	12	21-4	22-7	23-10	24-11	21-11	23-2	24-3	25-4	26-6	29-4	27-3
	16	19-7	20-9	21-10	22-10	19-3	20-3	21-3	22-3	23-2	25-8	27-3
3 x 6	12	10-7	11-3	11-10	12-4	11-10	12-5	13-1	13-8	14-3	15-9	16-9
	16	9-8	10-3	10-10	11-3	10-4	10-11	11-5	11-11	12-5	13-9	14-9
3 x 8	12	13-11	14-10	15-7	16-4	15-7	16-5	17-3	18-0	18-9	20-9	22-0
	16	12-9	13-7	14-4	14-11	13-8	14-5	15-1	15-9	16-5	18-3	19-4
3 x 10	12	17-5	18-7	19-7	20-6	19-6	20-7	21-7	22-6	23-3	26-0	27-7
	16	16-1	17-1	18-0	18-10	17-2	18-1	18-11	19-9	20-8	22-10	24-3
3 x 12	12	21-0	22-3	23-6	24-6	23-4	24-7	25-9	26-11	28-0	27-5	29-1
	16	17-1	18-2	19-2	20-0	20-6	21-8	22-9	23-9	24-8	27-5	29-1
3 x 14	12	24-5	25-11	27-4	28-7	27-2	28-8	30-0	27-7	28-9	27-5	29-1
	16	22-6	23-11	25-2	26-4	23-11	25-2	26-5	27-7	28-9	27-5	29-1

**Table III. Maximum Spans for Floor Joists—Uniformly Loaded**  
 Live Load 50 lbs./ft.<sup>2</sup> with Plastered Ceiling or 60 lbs./ft.<sup>2</sup> with Unplastered Ceiling

Nominal Size of Joists, inches	Spacing of Joists Center to Center, inches	Maximum Allowable Lengths between Supports (Clear Span)										
		Limited by Deflection of 1/360 of the Span					Determined by Bending					
		E=1 000 000	E=200 000	E=1 400 000	E=1 000 000	E=1 600 000	f=900	f=1 000	f=1 100	f=1 200	f=1 300	f=1 600
2 x 6	12	8-6	9-1	9-6	10-1	8-9	9-3	9-8	10-0	10-6	11-7	12-4
	16	7-9	8-3	8-8	9-1	7-8	8-0	8-4	8-9	9-1	10-1	10-9
2 x 8	12	11-4	12-0	12-8	13-3	11-7	12-2	12-9	13-4	13-10	15-5	16-3
	16	10-4	11-0	11-7	12-1	10-1	10-8	11-2	11-8	12-2	13-5	14-3
2 x 10	12	14-3	15-2	15-11	16-9	14-7	15-4	16-1	16-10	17-6	19-5	20-7
	16	13-0	13-10	14-7	15-3	12-8	13-4	14-0	14-8	15-3	16-11	18-0
2 x 12	12	17-2	18-3	19-3	20-1	17-6	18-5	19-4	20-2	21-0	23-4	24-9
	16	15-9	16-9	17-7	18-5	15-3	16-2	16-11	17-8	18-5	20-5	21-8
2 x 14	12	20-1	21-4	22-5	23-6	20-4	21-5	22-6	23-6	24-6	27-3	28-9
	16	18-5	19-6	20-7	21-6	17-10	18-9	19-8	20-7	21-5	23-9	25-3
3 x 6	12	9-11	10-1	11-1	11-7	10-11	11-6	12-1	12-7	13-2	14-7	15-6
	16	9-1	9-8	10-2	10-7	9-6	10-0	10-6	11-0	11-6	12-8	13-5
3 x 8	12	13-1	13-11	14-8	15-4	14-5	15-2	16-0	16-8	17-4	19-3	20-5
	16	12-0	12-9	13-5	14-1	12-7	13-4	14-0	14-6	15-2	16-10	17-10
3 x 10	12	16-6	17-1	18-5	19-3	18-1	19-1	20-0	20-11	21-9	24-2	25-7
	16	15-2	16-1	16-11	17-8	15-11	16-9	17-6	18-4	19-1	21-2	22-5
3 x 12	12	19-10	21-1	22-2	23-2	21-8	22-10	24-0	25-0	26-2	29-0	30-9
	16	18-2	19-4	20-4	21-3	19-0	20-1	21-1	22-0	22-11	25-5	27-0
3 x 14	12	23-1	24-6	25-10	27-8	25-2	26-7	28-0	29-1	30-5	34-8	
	16	21-3	22-7	23-9	24-10	22-2	23-5	24-6	25-8	26-9	29-8	

**Table IV. Maximum Spans for Floor Joists—Uniformly Loaded**  
 Live Load 60 lbs./ft.<sup>2</sup> with Plastered Ceiling or 70 lbs./ft.<sup>2</sup> with Unplastered Ceiling

Nominal Size of Joists, inches	Spacing of Joists Center to Center, inches	Maximum Allowable Lengths between Supports (Clear Span)										
		Limited by Deflection of $1/360$ of the Span					Determined by Bending					
		$E=1\ 000\ 000$	$E=200\ 000$	$E=1400\ 000$	$E=1\ 600\ 000$	$E=1\ 600\ 000$	$f=900$	$f=1\ 000$	$f=1\ 100$	$f=1\ 200$	$f=1\ 300$	$f=1\ 600$
2 x 6	12	8-1	8-7	9-1	9-6	8-1	8-6	9-0	9-5	9-9	10-10	11-6
	16	7-4	7-10	8-3	8-7	7-1	7-5	7-10	8-1	8-6	9-5	10-0
2 x 8	12	10-9	11-5	12-0	12-4	10-9	11-4	11-11	12-5	13-0	14-5	15-3
	16	9-9	10-5	11-0	11-5	9-5	9-11	10-4	10-10	11-3	12-6	13-3
2 x 10	12	13-6	14-5	15-2	15-10	13-7	14-4	15-0	15-8	16-4	18-1	19-2
	16	12-4	13-2	13-10	14-6	11-10	12-6	13-1	13-8	14-3	15-9	16-9
2 x 12	12	16-4	17-4	18-3	19-1	16-4	17-3	18-1	18-11	19-8	21-10	23-2
	16	14-11	15-10	16-8	17-5	14-3	15-1	15-9	16-6	17-2	19-0	20-2
2 x 14	12	19-1	20-3	21-4	22-4	19-1	20-1	21-1	22-0	22-11	25-5	26-11
	16	17-6	18-7	19-6	20-5	16-9	17-6	18-5	19-3	20-0	22-3	23-7
3 x 6	12	9-5	10-0	10-6	11-0	10-3	10-10	11-4	11-10	12-4	13-7	14-6
	16	8-7	9-2	9-7	10-1	8-11	9-5	9-10	10-4	10-9	11-11	12-7
3 x 8	12	12-6	13-3	13-11	14-7	13-6	14-3	14-11	15-7	16-3	18-0	19-1
	16	11-5	12-1	12-9	13-4	11-10	12-5	13-0	13-7	14-3	15-9	16-9
3 x 10	12	15-8	16-8	17-7	18-4	17-0	17-11	18-10	19-7	20-5	22-7	24-0
	16	14-4	15-3	16-1	16-10	14-10	15-9	16-5	17-1	17-11	19-10	21-0
3 x 12	12	18-10	20-1	21-1	22-1	20-4	21-5	22-6	23-6	24-6	27-1	28-10
	16	17-4	18-5	19-4	20-3	17-11	18-10	19-9	20-7	21-5	23-10	25-4
3 x 14	12	22-0	23-5	24-7	25-9	23-9	25-0	26-3	27-4	28-6	31-0	32-5
	16	20-3	21-6	22-7	23-8	20-10	21-11	23-0	24-0	25-0	27-10	29-5

**Table V. Maximum Spans for Floor Joists—Uniformly Loaded**  
 Live Load 70 lbs./ft.<sup>2</sup> with Plastered Ceiling or 80 lbs./ft.<sup>2</sup> with Unplastered Ceiling

Nominal Size of Joists, inches	Spacing of Joists Center to Center, inches	Maximum Allowable Lengths between Supports (Clear Span)										
		Limited by Deflection of 1/360 of the Span					Determined by Bending					
		E=1 000 000	E=1 200 000	E=1 400 000	E=1 600 000	E=1 800 000	f=900	f=1 000	f=1 100	f=1 200	f=1 300	f=1 600
2 x 6	12	7-9	8-3	8-8	9-0	7-8	8-1	8-6	8-9	9-2	10-2	10-9
	16	7-0	7-6	7-10	8-3	6-8	7-0	7-5	7-8	8-0	8-10	9-5
2 x 8	12	10-3	10-11	11-6	12-0	10-1	10-8	11-2	11-8	12-2	13-7	14-5
	16	9-4	9-11	10-6	10-11	8-9	9-4	9-9	10-2	10-7	11-9	12-6
2 x 10	12	12-11	13-9	14-6	15-2	12-9	13-6	14-2	14-9	15-5	17-1	18-1
	16	11-10	12-7	13-3	13-10	11-2	11-9	12-4	12-10	13-5	14-10	15-9
2 x 12	12	15-7	16-7	17-6	18-3	15-5	16-4	17-0	17-9	18-6	20-7	21-9
	16	14-3	15-2	15-11	16-8	13-5	14-2	14-10	15-6	16-2	18-0	19-0
2 x 14	12	18-3	19-5	20-5	21-4	18-0	19-0	19-11	20-10	21-7	24-0	25-5
	16	16-8	17-9	18-8	19-6	15-9	16-7	17-5	18-3	18-11	21-0	22-4
3 x 6	12	9-0	9-7	10-1	10-6	9-7	10-1	10-9	11-1	11-7	12-11	13-7
	16	8-3	8-9	9-2	9-7	8-5	8-11	9-4	9-9	10-1	11-3	11-11
3 x 8	12	11-11	12-8	13-4	13-11	12-10	13-6	14-1	14-9	15-5	17-0	18-0
	16	10-11	11-7	12-2	12-9	11-1	11-9	12-4	12-10	13-6	14-10	15-9
3 x 10	12	15-0	16-0	16-10	17-7	16-0	16-11	17-9	18-6	19-4	21-5	22-9
	16	13-9	14-7	15-5	16-1	14-0	14-10	15-6	16-3	16-11	18-9	19-10
3 x 12	12	18-1	19-3	20-3	21-2	19-3	20-3	21-4	22-3	23-1	25-9	27-3
	16	16-7	17-7	18-6	19-5	16-11	17-10	18-9	19-6	20-4	22-6	23-11
3 x 14	12	21-1	22-5	23-7	24-8	22-5	23-7	24-10	25-11	26-11	29-11	31-10
	16	19-4	20-7	21-8	22-8	19-9	20-9	21-9	22-9	23-7	26-3	27-10

**Table VI. Maximum Spans for Floor Joists—Uniformly Loaded**  
 Live Load 80 lbs./ft.<sup>2</sup> with Plastered Ceiling or 90 lbs./ft.<sup>2</sup> with Unplastered Ceiling

Nominal Size of Joists, inches	Spacing of Joists Center to Center, inches	Maximum Allowable Lengths between Supports (Clear Span)										
		Limited by Deflection of 1/360 of the Span					Determined by Bending					
		E=1 000 000	E=200 000	E=140 000	E=1 600 000	E=	f=900	f=1 000	f=1 100	f=1 200	f=1 300	f=1 600
2 x 6	12	7-5	7-11	8-4	8-8	7-2	7-7	8-0	8-4	8-8	9-8	10-2
	16	6-9	7-2	7-7	7-11	6-4	6-7	6-10	7-2	7-6	8-5	8-11
2 x 8	12	9-10	10-6	11-0	11-6	9-7	10-1	10-7	11-1	11-6	12-9	13-7
	16	9-0	9-7	10-1	10-6	8-4	8-9	9-2	9-8	10-1	11-1	11-9
2 x 10	12	12-5	13-3	13-11	14-7	12-1	12-9	13-5	14-0	14-7	16-2	17-1
	16	11-4	12-1	12-8	13-3	10-6	11-1	11-8	12-2	12-8	14-1	15-0
2 x 12	12	15-0	15-11	16-9	17-7	14-7	15-5	16-1	16-10	17-7	19-6	20-8
	16	13-9	14-7	15-4	16-0	12-8	13-5	14-1	14-8	15-4	17-0	18-0
2 x 14	12	17-7	18-8	19-8	20-6	17-1	18-0	18-11	19-9	20-6	22-10	24-3
	16	16-1	17-1	17-11	18-9	14-11	15-9	16-6	17-3	17-11	19-10	21-1
3 x 6	12	8-8	9-2	9-8	10-1	9-1	9-7	10-1	10-7	11-0	12-3	12-11
	16	7-11	8-5	8-10	9-3	7-11	8-5	8-10	9-3	9-7	10-7	11-4
3 x 8	12	11-6	12-2	12-10	13-5	12-1	12-10	13-5	14-0	14-7	16-3	17-1
	16	10-6	11-2	11-9	12-3	10-7	11-1	11-9	12-3	12-8	14-1	14-11
3 x 10	12	14-6	15-4	16-2	16-11	15-3	16-1	16-10	17-7	18-4	20-4	21-6
	16	13-3	14-1	14-9	15-6	13-4	14-0	14-9	15-5	16-0	17-9	18-10
3 x 12	12	17-5	18-6	19-6	20-4	18-4	19-4	20-3	21-1	22-0	24-5	25-11
	16	15-11	16-11	17-10	18-8	16-0	16-11	17-9	18-6	19-3	21-5	22-7
3 x 14	12	20-4	21-7	22-9	23-9	21-4	22-6	23-7	24-7	25-7	28-5	30-3
	16	18-8	19-10	20-10	21-9	18-9	19-9	20-9	21-7	22-6	24-11	26-5

**Table VII. Maximum Spans for Floor Joists—Uniformly Loaded**  
 Live Load 90 lbs./ft.<sup>2</sup> with Plastered Ceiling or 100 lbs./ft.<sup>2</sup> with Unplastered Ceiling

Nominal Size of Joists, inches	Spacing of Joists Center to Center, inches	Maximum Allowable Lengths between Supports (Clear Span)										
		Limited by Deflection of $\frac{1}{360}$ of the Span					Determined by Bending					
		$E=1\ 000\ 000$	$E=200\ 000$	$E=1\ 400\ 000$	$E=1\ 000\ 000$	$E=600\ 000$	$f=900$	$f=1\ 000$	$f=1\ 100$	$f=1\ 200$	$f=1\ 300$	$f=1\ 600$
2 x 6	12	7-2	7-7	8-0	8-4	6-10	7-2	7-7	8-0	8-4	9-2	9-9
	16	6-6	6-11	7-3	7-7	6-0	6-4	6-7	6-10	7-2	8-0	8-5
2 x 8	12	9-6	10-1	10-8	11-1	9-1	9-8	10-1	10-6	11-0	12-2	13-0
	16	8-8	9-3	9-8	10-2	8-0	8-5	8-9	9-2	9-6	10-7	11-2
2 x 10	12	12-0	12-9	13-5	14-1	11-6	12-2	12-9	13-4	13-10	15-5	16-4
	16	10-11	11-8	12-3	12-10	10-1	10-7	11-1	11-7	12-1	13-5	14-2
2 x 12	12	14-6	15-5	16-3	16-11	14-0	14-8	15-5	16-1	16-8	18-7	19-8
	16	13-3	14-1	14-9	15-6	12-1	12-9	13-5	14-0	14-7	16-2	17-2
2 x 14	12	17-0	18-0	19-0	19-10	16-4	17-3	18-0	18-10	19-7	21-9	23-0
	16	15-6	16-6	17-4	18-1	14-3	15-0	15-9	16-5	17-1	18-11	20-1
3 x 6	12	8-4	8-10	9-4	9-9	8-9	9-3	9-7	10-0	10-6	11-7	12-4
	16	7-7	8-1	8-6	8-11	7-7	8-0	8-5	8-10	9-1	10-1	10-9
3 x 8	12	11-1	11-9	12-5	13-0	11-6	12-3	12-10	13-4	14-0	15-5	16-4
	16	10-1	10-9	11-4	11-10	10-0	10-7	11-1	11-7	12-1	13-5	14-3
3 x 10	12	14-0	14-10	15-8	16-4	14-6	15-4	16-1	16-10	17-6	19-5	20-6
	16	12-9	13-7	14-3	14-11	12-9	13-4	14-0	14-9	15-3	16-11	17-11
3 x 12	12	16-10	17-11	18-10	19-8	17-6	18-5	19-4	20-3	21-0	23-4	24-9
	16	14-11	15-10	16-9	17-3	15-4	16-1	16-11	17-7	18-5	20-5	21-7
3 x 14	12	19-8	20-11	22-0	23-0	20-5	21-6	22-6	23-6	24-6	27-3	28-10
	16	18-0	19-2	20-2	21-1	17-10	18-10	19-9	20-7	21-5	23-10	25-3



**Table VIII. Maximum Spans of Floor Joists—Uniformly Loaded**  
 Live Load 100 lbs./ft.<sup>2</sup> with Plastered Ceiling or 110 lbs./ft.<sup>2</sup> with Unplastered Ceiling

Nominal Size of Joists, inches	Spacing of Joists Center to Center, inches	Maximum Allowable Lengths between Supports (Clear Span)										
		Limited by Deflection of $1/360$ of the Span					Determined by Bending					
		$E=$ 1,000,000	$E=$ 200,000	$E=$ 140,000	$E=$ 100,000	$E=$ 60,000	$f=$ 900	$f=$ 1,000	$f=$ 1,100	$f=$ 1,200	$f=$ 1,300	$f=$ 1,600
2 x 8	12	9-3	9-9	10-4	10-9	8-8	9-2	9-9	10-1	10-6	11-8	12-5
	16	8-5	8-11	9-5	9-10	7-7	8-0	8-5	8-9	9-1	10-1	10-9
2 x 10	12	11-8	12-4	13-0	13-7	11-0	11-8	12-2	12-9	13-4	14-8	15-7
	16	10-7	11-3	11-10	12-5	9-7	10-1	10-7	11-1	11-6	12-9	13-7
2 x 12	12	14-0	14-11	15-9	16-5	13-4	14-1	14-8	15-5	16-0	17-9	18-10
	16	12-10	13-7	14-4	15-0	11-7	12-2	12-11	13-5	14-0	15-6	16-5
2 x 14	12	16-5	17-6	18-5	19-3	15-7	16-6	17-4	18-0	18-10	20-10	22-1
	16	15-0	15-11	16-9	17-7	13-7	14-5	15-1	15-9	16-5	18-1	19-4
3 x 6	12	8-1	8-7	9-1	9-6	8-5	8-10	9-3	9-7	10-0	11-1	11-10
	16	7-4	7-10	8-3	8-7	7-3	7-9	8-0	8-5	8-9	9-9	10-3
3 x 8	12	10-9	11-5	12-0	12-7	11-0	11-9	12-3	12-10	13-5	14-9	15-9
	16	9-9	10-5	11-0	11-6	9-7	10-1	10-7	11-1	11-7	12-10	13-7
3 x 10	12	13-6	14-5	15-2	15-10	13-11	14-9	15-5	16-1	16-9	18-7	19-9
	16	12-4	13-2	13-10	14-6	12-3	12-10	13-5	14-0	14-7	16-3	17-3
3 x 12	12	16-4	17-4	18-3	19-1	16-9	17-9	18-6	19-4	20-1	22-4	23-9
	16	14-11	15-10	16-8	17-5	14-7	15-5	16-3	16-11	17-7	19-6	20-9
3 x 14	12	19-1	20-3	21-4	22-4	19-6	20-7	21-7	22-7	23-6	26-1	27-7
	16	17-6	18-7	19-6	20-5	17-1	18-0	18-11	19-9	20-6	22-10	24-3

**Table IX. Maximum Spans for Ceiling Joists and Attic Floor Joists—Uniformly Loaded**

Nominal Size of Joists, inches	Spacing of Joists Center to Center, inches	Maximum Allowable Lengths between Supports (Clear Span)											
		Limited by Deflection of 1/360 of the Span						Attic Floor Joists, Live Load 20 lbs./ft. <sup>2</sup>					
		Ceiling Joists, No Live Load			Ceiling Joists, No Live Load			E = 1 000 000		E = 1 200 000		E = 1 400 000	
•	12 16	E = 1 000 000	E = 1 200 000	E = 1 400 000	E = 1 600 000	E = 1 000 000	E = 1 200 000	E = 1 400 000	E = 1 600 000	E = 1 000 000	E = 1 200 000	E = 1 400 000	E = 1 600 000
		9-4 8-7	10-0 9-2	10-6 9-8	11-0 10-0	6-6 5-11	7-0 6-3	7-4 6-8	7-8 6-11				
2 x 6	12 16	E = 1 000 000	E = 1 200 000	E = 1 400 000	E = 1 600 000	E = 1 000 000	E = 1 200 000	E = 1 400 000	E = 1 600 000	E = 1 000 000	E = 1 200 000	E = 1 400 000	E = 1 600 000
		14-2 13-1	15-1 14-0	15-10 14-8	16-7 15-4	10-0 9-1	10-9 9-8	11-3 10-2	11-9 10-8				
2 x 8	12 16	E = 1 000 000	E = 1 200 000	E = 1 400 000	E = 1 600 000	E = 1 000 000	E = 1 200 000	E = 1 400 000	E = 1 600 000	E = 1 000 000	E = 1 200 000	E = 1 400 000	E = 1 600 000
		18-6 17-2	19-8 18-3	20-8 19-3	21-8 20-2	13-4 12-1	14-2 13-0	14-11 13-8	15-7 14-2				
2 x 10	12 16	E = 1 000 000	E = 1 200 000	E = 1 400 000	E = 1 600 000	E = 1 000 000	E = 1 200 000	E = 1 400 000	E = 1 600 000	E = 1 000 000	E = 1 200 000	E = 1 400 000	E = 1 600 000
		23-0 21-4	24-5 22-9	25-8 24-0	26-10 25-0	16-9 15-3	17-9 16-4	18-9 17-2	19-7 17-11				
2 x 12	12 16	E = 1 000 000	E = 1 200 000	E = 1 400 000	E = 1 600 000	E = 1 000 000	E = 1 200 000	E = 1 400 000	E = 1 600 000	E = 1 000 000	E = 1 200 000	E = 1 400 000	E = 1 600 000
		27-2 25-6	28-11 27-0	30-5 28-6	29-9	20-0 18-6	21-4 19-7	22-6 20-8	23-6 21-7				

**Concentrated Loads.** The above tables are based upon loads uniformly distributed throughout the length of the joist. If a concentrated load such as the weight of a cross partition be imposed upon any portion of the joist, a simple method of determining the total load upon the joist is to change the concentrated load to an equivalent uniformly distributed load and to add this value to the true distributed load. The equivalent distributed load may be found by multiplying the concentrated load by a factor depending upon the point of the span at which the concentrated load is applied.

The weight of a stud partition plastered both sides is 20 lbs./ft.<sup>2</sup> of surface.

**Table X. Factors for Equivalent Distributed Loads**

For a concentrated load applied at	Factor
Middle of span . . .	Multiply by 2
1/3 span . . . . .	" " 1.78
1/4 span	" " 1.5
1/5 span . . . . .	" " 1.28
1/6 span . . . . .	" " 1 1/9
1/7 span . . . . .	" " 0.98
1/8 span . . . . .	" " 7/8
1/9 span . . . . .	" " 0.79
1/10 span . . . . .	" " 0.72

**Example 1.** What size joists are required for a span of 16' with a uniform live load of 40 lbs./ft.<sup>2</sup> and concentrated load of a stud and plaster partition 9' high at 1/4 span? Space joists 12" on centers and use red spruce lumber.

Distributed Load—16 × 40 = 640 lbs.

Concentrated Load—9 × 20 = 180 lbs. Factor = 1.5; 180 × 1.5 = 270 lbs.

Total Load on strip 12" wide = 640 + 270 = 910 lbs. Load per square foot =  $\frac{910}{16} = 57$  lbs.

From Table IV for live load of 60 lbs. we find a span of 17'4" in column headed by E = 1,200,000. The size of joist for 12" spacing is 2" x 12".

For 16" spacing the size of joist may be 2" x 14" or 3" x 12".

**Wood Girders.** Wood girders are used to span wide openings, to support partitions, and to furnish bearing for joists. They are more satisfactory when composed of one solid piece, especially when a dependable structural grade of Southern yellow pine, Douglas fir or white oak is employed. Oak is not always obtainable, the other two species mentioned providing our most practical heavy timber. The Structural grade of Douglas fir and the Structural Square Edge and Sound grade of yellow pine are commonly used for girders in light wood framing. Steel joist hangers provide the best means of supporting joists upon girders. The lug of the hanger is inserted in the girder as near the neutral surface as possible, thereby causing no weakening of the girder and

reducing shrinkage to a minimum. Joists may also be supported for light loads upon hardwood bearing strips bolted along the lower edge of the girder (Fig. 4,c). To rest the joists on top of the girder reduces the headroom under the girder and presents greater combined depth of wood for shrinkage. If one end of a joist bear upon a masonry wall or metal hanger and the other end upon a wood girder the difference in shrinkage may cause serious sagging in the floor.

Built-up or trussed girders as described in Chapter XVIII may be used when necessary in light frame construction.

**Steel Girders.** In order to save headroom steel girders may be used on long spans in light wood framing. The joists may be attached to the girders by stirrups, hangers or shelf angles. Stirrups hook over the upper flange of the girder; hangers are bolted to the web and rest upon the lower flange with a shelf to carry the joist. Both hangers and stirrups are furnished in various sizes to carry any depth of joist. Shelf angles are riveted to the web of the girder in the shop and are the most common means of carrying the joists (Fig. 6,a).

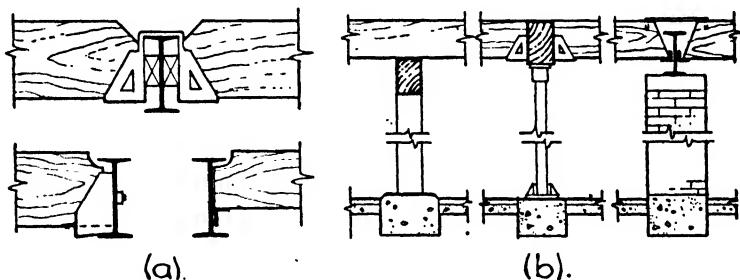

FIG. 6.—Joist Framing and Girder Supports.

It is not good practice to rest the joist upon the sloping lower flange of a Standard I-beam. Sufficient level bearing may, however, sometimes be obtained upon the flanges of the Bethlehem and the new Carnegie beams, but the relative depths of the I-beam and the joist must be favorable to this arrangement.

The wood joists should be set with their tops  $\frac{5}{8}$ " above the upper flange of the steel I-beam to allow for shrinkage in the wood.

**Girder Supports.** Girders at the first-story level may be supported in the cellar at intervals according to the design by masonry piers, wood posts or pipe columns. Masonry or pipe columns are preferred because of freedom from shrinkage. The pipe columns consist of wrought-iron or steel pipe filled with concrete. They are strong for their diameter, easily handled and cheap. Wood posts should be set above the cellar floor on concrete bases to avoid dampness (Fig. 6,b).

Girders at levels above the first story are set upon wood posts or pipe columns concealed in the exterior wood walls, or upon the masonry when the exterior walls are of stone, brick or concrete.

**Partitions.** Like the exterior walls, partitions are built generally of 2" x 4" studs set 16" on centers. Bearing partitions often require studs to be set 12" on centers, and when the partitions are over 9'6" high or the loads are heavy 2" x 6" studs are used. Heating ducts and plumbing pipes sometimes necessitate 2" x 6" studs to conceal them. Wood and metal lath are of proper dimensions to work out evenly with either 12" or 16" spacing (Fig. 7,a).

There should be as little horizontal grain wood as possible in the total extent of a bearing partition from cellar to attic to reduce the wood shrinkage and the settling of floor joists which cause plaster to crack and doors to bind. The studs should therefore extend down between the joists and rest on the cap of the partition below rather than be set upon a sole placed over the flooring on top of the joists. The spaces between the studs where they pass through the joists should be filled with brick or concrete to act as a fire stop. An equally unyielding bearing

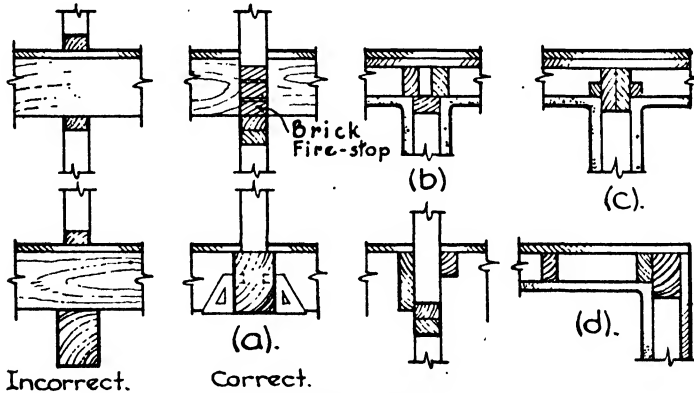

FIG. 7.—Framing Details.

may be obtained for the outer and inner ends of the joists when the exterior walls are of masonry by using steel girders instead of wood.

A horizontal stud called a CAP is used to terminate the top of stud partitions, and a similar piece known as a SOLE is sometimes used as a base for the studs to rest upon. As explained above, however, it is generally better practice to start the studs upon the cap of the partition below, thereby combining the cap and sole in one piece. When partitions run at right angles to the joists the cap is spiked across the under side of the joists and the studs nailed to the cap. When the partition runs parallel to the joists good construction demands that the joists be arranged so that one can be set directly against the studs for nailing and bracing. The cap is then set upon the studs between the joists and the studs of the partition above rest upon it. Caps are sometimes double for greater strength.

Bracing consisting of 2" x 4" horizontal bridging should be cut in between the studs, one row of bridging to each story height. Where

floor space must be saved and the wall area is small, as in closet partitions, the studs may be set the 2'' way and the partition well bridged.

**Corners.** Intersections of partitions with each other or with the outside wall should be solid and give a nailing for the lath. This may be effected by doubling the studs but setting them 2'' apart to give nailing for the lath. The first stud of the abutting partition is then set close against the edges of the doubled studs (Fig. 7,b). Two 2'' x 6'' studs set close together and extending 2'' into the abutting partition make a very solid corner. Nailing strips for the lath are fastened against the sides of the 6'' studs (Fig. 7,c). At exterior corners 2'' x 4'' studs are also set against the 4'' x 6'' corner posts to give a bearing for the lath (Fig. 7,d).

**Trussed Partitions.** When a partition of wide span runs parallel to the joists with no support below it is sometimes trussed to prevent sagging. The truss is composed of a stout bottom member, diagonal braces and steel vertical rods, and can support floors or partitions above. The supports under the ends must be capable of supporting the reactions (Fig. 8).

The following table of safe loads on yellow pine stud partitions is taken by permission from the Southern Yellow Pine Manual of the Southern Pine Association. The weight and strength are based on actual size and the board measure on nominal size. A single cap is included and the studs are assumed to be bridged at the center.

Table XI. Safe Loads on Stud Partitions

Nominal Size, inches	Actual Size, inches	Distance on Centers, inches	Height, feet	Per Lineal Foot of Partition		
				Safe Load, pounds	Weight, pounds	Board, feet
2 x 4	1 5/8 x 3 5/8	12	8	3 723	16.3	6.66
"	"	12	10	3 180	19.56	8.00
"	"	12	12	2 631	22.82	9.33
"	"	16	8	2 793	13.04	5.33
"	"	16	10	2 385	15.50	6.33
"	"	16	12	1 974	18.00	7.33
2 x 6	1 5/8 x 5 5/8	12	8	5 757	25.30	10.00
"	"	12	10	4 226	30.56	12.00
"	"	12	12	4 076	35.42	14.00
"	"	16	8	4 326	20.24	8.00
"	"	16	10	3 699	24.03	9.50
"	"	16	12	3 057	27.83	11.00

The above loads are calculated by the U. S. Forest Products Laboratory formula for wood columns given in Chapter XVIII.

**Example.** A bearing partition 10'0'' high and 18'0'' long carries a total distributed load of 53,100 lbs. What size studs and what spacing should be used?

$$\frac{53,100}{18} = 2950 = \text{load per lineal foot}$$

From Table XI, 2" x 4" studs 12" on centers will support a load of 3180 lbs./lin. ft. on a partition 10'0" high. Select 2" x 4" yellow pine studs, 12" on centers.

**Outside Sheathing.** The outside of exterior stud walls is usually covered with 25/32" tongued and grooved wood sheathing boards from 6" to 8" wide. The narrower boards are less likely to warp and twist than wider pieces. The sheathing is sometimes, in cheap work, nailed on the studs horizontally, but by far the stronger method, though somewhat more costly in labor and material, is to set the boards diagonally. Building paper or felt is then fastened to the outside of the sheathing, and the finished siding, clapboards, shingles or stucco is applied.

Tests by the U. S. Forest Products Laboratory show very definitely the importance of diagonal sheathing, let-in bracing, intelligent nailing, wood lath and plaster and reasonably dry lumber. From investigation it appeared that typical wood framed and sheathed walls are sufficiently strong to resist any pressure of wind blowing directly against them, but

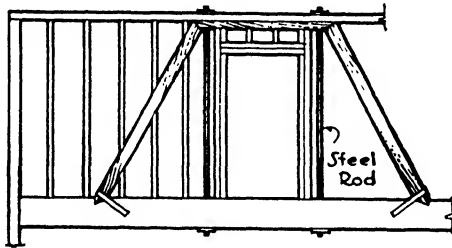

FIG. 8.—Trussed Partition.

that wall resistance to end thrust caused by the transmission of pressure from the front to the side walls is very questionable unless the side walls are properly constructed. It is this end thrust which causes vibration and trembling of the building under moderate winds and distortion and possible collapse under severe winds or earthquakes. The Laboratory subjected to test nearly fifty frame walls, 8'0" and 9'0" high and 12'0" and 14'0" long built of 2" x 4" studs spaced 16" on centers and 4" x 6" corner posts. Pressure was applied horizontally at the top plate in the plane of the wall surface. The sill was bolted to the base.

The conclusions may be summarized as follows:

(a) Diagonally sheathed walls are from 4 to 7 times as stiff and 7 to 8 times as strong as if horizontally sheathed.

(b) Diagonally sheathed walls are improved by 30% to 100% in stiffness by using three or four nails instead of two, but horizontally sheathed walls are improved but little.

(c) A wall horizontally sheathed with green lumber and allowed to dry

before testing lost 50% in stiffness and 30% in strength compared to a dry sheathed panel.

(d) Herringbone or bridge bracing between the studs has little value. Bracing by 2" x 4" diagonal corner braces cut in between studs adds 60% to stiffness and 40% to strength.

(e) 1" x 4" strips, let into the stud faces diagonally under the sheathing, make horizontally sheathed walls 2½ to 4 times stiffer and 3½ to 4 times stronger.

(f) Plaster on wood lath made an unsheathed wall 90% stiffer and gave it about half the strength of a diagonally sheathed wall. It increased the stiffness of a horizontally sheathed panel with window and door openings over 200%. However, if the plaster begins to crack from shrinkage, settlement or other causes, the rigidity of sheathing comes into play and is all-important in violent winds. On this account, and because of insulation and the distribution of concentrated loads, sheathing should never be omitted.

**Exterior Wall Surface.** Outside the sheathing of the walls is placed the final exterior finish, which may consist of shingles, siding or stucco.

**WALL SHINGLES** are the same as those used for roofs and are made of Western cedar, redwood and cypress. (See Chapter XI, Article 1.) They are laid in horizontal rows, each row overlapping the one below so that about 6" is exposed to the weather.

The term **SIDING** includes several varieties with different cross-sections. They consist of long strips from ⅜" to ¾" thick and 6" to 8" wide, so formed as to give weather-tight joints.

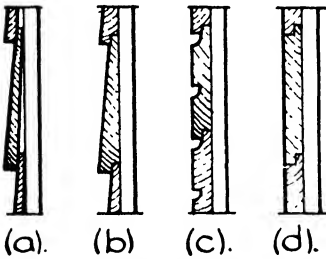

FIG. 9.—Siding and Clapboards.

**BEVEL SIDING** or **CLAPBOARDING** is tapered in cross-section like shingles and is laid with overlapping joints (Fig. 9,a). **DROP SIDING** is also tapered in section and is provided with a rabbet on the bottom edge to fit over the upper edge of the row below (Fig. 9,b). **NOVELTY SIDING** has a rabbet on the bottom edge and a tongue on the upper to fit into the rabbet (Fig. 9,c). **SHIP-LAP** has a rabbet on both the top and bottom edges (Fig. 9,d).

The application of **STUCCO** is considered in Chapter XII.

**Building Paper.** Tests made at the University of Wisconsin show a reduction in air leakage from 12.3 ft.<sup>3</sup> per hour per square foot of surface to 0.3 ft.<sup>3</sup> when good quality building paper was stretched over the sheathing in vertical strips. The air leakage through shingle roofs laid upon 1" x 4" shingle lath was reduced from 69.5 ft.<sup>3</sup> to 0.4 ft.<sup>3</sup> when building paper was introduced under the shingles. It is evident that at slight cost a practically air-tight wall or roof may be secured by the use of building paper linings. The joints between the strips of paper should be well lapped.



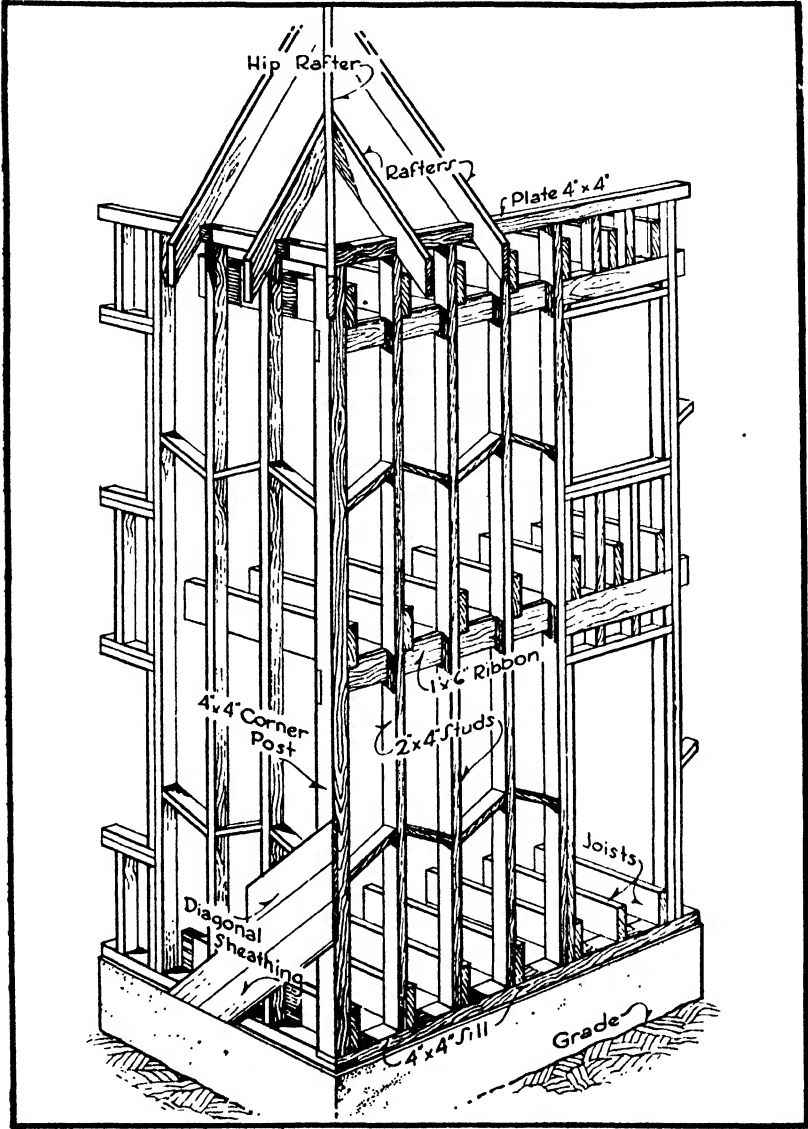

FIG. 10.—Balloon Frame.

Article 2. The Balloon Frame

The balloon frame is the cheaper, quicker and more fragile method of light frame construction, but it is less rigid and permanent and is more readily consumed by fire. The sills, rarely more than 4" x 4" or 2" x 6", are bedded in mortar on the cellar walls and halved at the corners. The first-story joists are spiked in place on the sill, the corner posts, 4" x 4", set and held by temporary braces, and the studs, which run through in one piece from sill to plate, are spiked in position to the sill and held near their upper ends by temporary boards nailed across

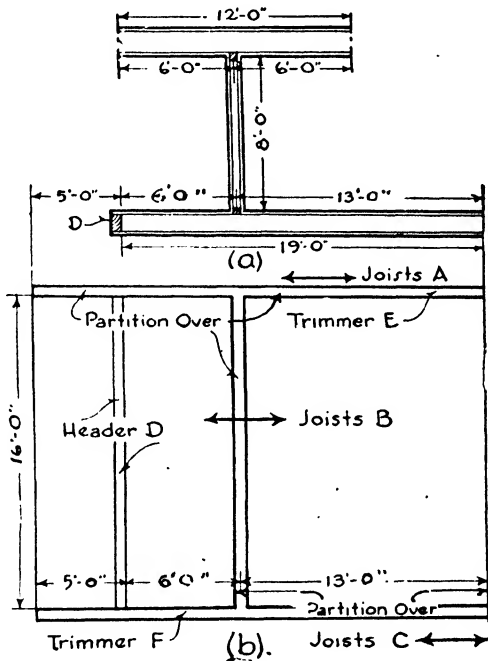

FIG. 11.

them. A horizontal 1" x 6" or 1" x 8" board, called a ribbon, is notched into and nailed to the inner faces of the studs and corner posts at the proper height to support the second-story joists, which are next nailed in place, a joist being brought against a stud wherever possible. The tops of the studs and corner posts are then sawed off level, and the plate, consisting of a 2" x 4" piece, or two 2" x 4" pieces fastened one on top of the other, is nailed on top of the studs and halved together over the corner posts (Fig. 10).

It may be seen that the long, slender studs, the light sill, plate and corner posts, the thin ribbon and the omission of bracing, except that

derived from the outside sheathing, all tend to produce a frame lacking in rigidity and liable to sway, creak and tremble in heavy winds. The necessity of diagonally set sheathing is very apparent since it furnishes the only bracing in the building. Unless fire stops of brick or concrete are introduced at the floor levels, the long unencumbered spaces between the studs extending from sill to roof eaves provide excellent flues for the passage of flame and render the balloon frame readily inflammable.

Modifications to obtain greater rigidity consist in using 3'' x 4'' studs and 4'' x 6'' sills, in introducing horizontal bridging between the studs of the outer walls and in cutting 1'' x 6'' boards diagonally into the faces of the studs under the sheathing from sill to corner posts to act as braces.

**Example 2** (Fig. 11). Design joists *A*, *B* and *C*, header *D* and trimmers *E* and *F*.

(1) JOIST *A*. Live load = 40 lbs./ft.<sup>2</sup> Use spruce common.  $E = 1,200,000$ . Span = 24'0''. From Table II, 3'' x 14''—12'' o.c. are good for 25'11''. Use 3'' x 14'' spruce. 12'' o.c.

(2) JOIST *B*. Supports (a) live load, (b) attic floor, (c) partition.

(a) Live load =  $40 \times 19 = 760$  lbs.

(b) Attic floor.

4.5	lbs. joist
2.5	floor
10.0	ceiling
17.0	lbs.
20.	lbs. L.L. attic
37.0	lbs./ft. <sup>2</sup>

$37 \times 12 = 444$  lbs. load on strip of floor 12'' wide.

(c) Partition.  $8 \times 20 = 160$  lbs.  $444 + 160 = 604$  lbs. Concentrated at 1/3 point of span. For equivalent distributed load multiply by 1.78.

$604 \times 1.78 = 1075$  lbs.

$760 + 1075 = 1835 =$  total load on strip of floor 12'' wide.

$\frac{1835}{19} = 96$  lbs. = load per foot.

Use yellow pine.  $E = 1,600,000$ . Span = 19'0''. From Table VIII, 2'' x 14''—12'' o.c. are good for 19'3'' span. Use 2'' x 14'' yellow pine. 12'' o.c.

(3) JOIST *C*. Same as joist *A*. Use 3'' x 14'' spruce 12'' o.c.

(4) HEADER *D*. Supports (a) floor load, (b) partition load.

(a) Floor Load.

Live Load	= 40
Floor	= 5
Ceiling	= 10
Joist	= 11.5

$\frac{66.5}{66.5}$  lbs./ft.<sup>2</sup>

(b) Partition.

$8 \times 16 = 128$  ft.<sup>2</sup>

$128 \times 20 = 2560$  lbs.

$9.5 \times 16 = 152$  ft.<sup>2</sup>

$152 \times 66.5 = 10,108$  lbs.

Since the partition is 1/3 span from header, the header will support 2/3 the load.

$\frac{2560}{3} \times 2 = 1707$ ;  $10,108 + 1707 = 11,815$  lbs. = total distributed load on header.

MOMENT.  $M = \frac{WL}{8} = \frac{11,815 \times 16 \times 12}{8} = 283,600$  in.-lbs. Assume  $d = 14''$ ,

actual  $13'5''$ .

Use Southern yellow pine, Structural Square Edge grade.  $f = 1600$  lbs./in.<sup>2</sup>

$$M = \frac{fbd^2}{6}; b = \frac{6M}{d^2f} = \frac{6 \times 283,600}{13.5 \times 13.5 \times 1600} = 5.8.$$

Use  $6'' \times 14''$  header.

SHEAR.  $V = R = \frac{W}{2} = \frac{11,815}{2} = 5908$ ;  $v = \frac{3V}{2bd} = \frac{3 \times 5908}{2 \times 6 \times 13.5} =$

109 lbs. actual.

100 lbs. allowable.

Permissible.

DEFLECTION.  $D = \frac{L}{360} = \frac{16 \times 12}{360} = 0.53''$  allowable.

Rule of thumb.  $L = 1.1d$ ,  $13.5 \times 1.1 = 14.85$ , but  $L = 16$ . Try deflection.

$$D = \frac{5WL^2}{384EI}; I = \frac{bd^3}{12}; D = \frac{5 \times 11,800 \times 16 \times 16 \times 16 \times 12 \times 12 \times 12 \times 12}{384 \times 1,600,000 \times 5.5 \times 13.5 \times 13.5 \times 13.5} = 0.57.$$

$$D = \frac{5 \times W \times L^3 \times 12}{384 \times E \times b \times d^3}$$

0.57'' actual

0.53'' allowable

} Permissible.

(5) TRIMMER *E*. Supports (a) partition, (b) reaction of header.

(a) Partition.  $8 \times 24 = 192$  ft.<sup>2</sup>;  $192 \times 20 = 3840$  lbs.

(b) Header  $R = \frac{W}{2} = \frac{11,815}{2} = 5908$  lbs. at  $1/5$  span. Multiply by

$\sqrt{.28}$ ,  $5908 \times 1.28 = 7563$  lbs.;  $3840 + 7563 = 11,403$  lbs. = total distributed load.

Moments.  $M = \frac{WL}{8} = \frac{11,403 \times 24 \times 12}{8} = 401,500$  in.-lbs. Assume  $d = 14''$ .

Use Southern yellow pine, Structural Square Edge grade,  $f = 1600$  lbs./in.<sup>2</sup>

$$M = \frac{fbd^2}{6}; b = \frac{6M}{d^2f} = \frac{6 \times 401,500}{13.5 \times 13.5 \times 1600} = 8.3. \text{ Use } 10'' \times 14'' \text{ trimmer.}$$

(6) TRIMMER *F*. Supports (a) partition, (b) reaction of header.

Since the partition extends over only part of the trimmer a load diagram should be constructed to determine the point of zero shear and maximum bending moment. Weight of partition =  $20 \times 8 = 160$  lbs./lin. ft.

Total load =  $5908 + (160 \times 13) = 7988$  lbs.

The reactions at the supports are first determined. Taking moments around  $R_2$ ,

$$24 R_1 = (19 \times 5908) + (160 \times 13 \times 6.5) = 112,252 + 13,520 = 125,774.$$

$$24 R_1 = 125,774$$

$$R_1 = 5240 \text{ lbs.}; R_2 = 7988 - 5240 = 2748 \text{ lbs.}$$

Load Diagram (Fig. 12). The shear will be the same from the left-hand support to the point of application of the concentrated load and will equal the left-hand reaction.

$$V = R_1 = 5240 \text{ lbs.}$$

At the concentrated load the shear will equal  $5240 - 5908 = -668$ .

It therefore changes sign at this point and continues equal to  $-668$  until the beginning of the distributed load, when it increases at a regular rate until at the right-hand support the shear is equal to the right-hand reaction.

$$V = R_2 = 2748 \text{ lbs.}$$

The shear therefore equals zero at the point of application of the concentrated load, and at this point the bending moment will be maximum.

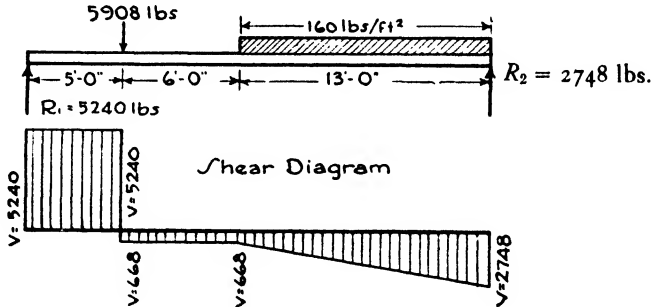

FIG. 12.

$M_{max.} = 5240 \times 5 \times 12 = 314,400 \text{ in.-lbs.}$  Assume  $d = 14''$ ,  $13.5''$  actual.  
 Use Southern yellow pine, Structural Square Edge grade.  $f = 1600 \text{ lbs./in.}^2$

$$M = \frac{fb^2}{6}; b = \frac{6M}{d^2f} = \frac{6 \times 314,400}{13.5 \times 13.5 \times 1600} = 6.4.$$

Use  $8'' \times 14''$  trimmer.

### Article 3. Roof Construction

**Pitch of Roofs.** A certain inclination from the horizontal is desirable in all roofs in order to shed rainwater, but the amount of this inclination may vary from that of a virtually flat roof to an extreme pitch conceived as an element of architectural design and far greater than necessary for the disposal of water. Advantage is taken of the space enclosed by roofs of steep pitch to install attic stories for living quarters or for storage. Certain types of roofs such as gambrel and mansard roofs are designed with two slopes, a steep pitch below and a flatter slope above to produce an extra story and yet keep the eaves or cornice line at a desired low level. The pitch of the roof is expressed in degrees of inclination with the horizontal or in inches of vertical rise to a horizontal foot.

As a matter of practical construction, roofs should have the following minimum rises to the horizontal foot as determined by the kind of roofing material applied:

Wood and Asbestos Shingles.....	6''
Tile.....	4'' to 7''
Slate.....	6''

Flatter slopes than the above should be covered with sheet metal or built-up roofing. Chapter XI treats the subjects of roofing materials and roof drainage.

**Types of Roofs.** Roofs may in general be divided into six types as follows:

- (1) Lean-to Roofs having one slope (Fig. 13,*a*).
- (2) Gable or Pitched Roofs having two slopes and a triangular or gable end (Fig. 13,*a*).
- (3) Gambrel Roof with a break in each slope, the lower portion being steeper than the upper (Fig. 13,*b*).

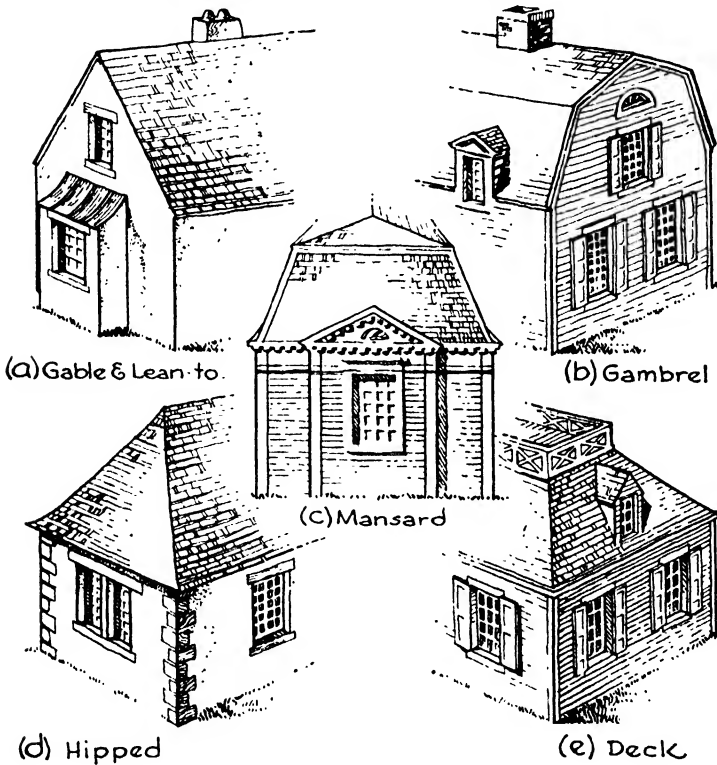

FIG. 13.—Types of Roofs.

- (4) Mansard or French Roof with breaks in the slopes like a gambrel roof but with steeper pitch and slopes from all sides of the building (Fig. 13,*c*).
- (5) Deck Roof with sloping sides below and a flat deck on top (Fig. 13,*e*).
- (6) Hipped Roof with slopes running back from the eaves at the ends of the building as well as at the sides (Fig. 13,*d*).

The roof boarding upon which the roofing material is attached is supported in light frame construction upon members 2" thick and from 4" to 14" deep called **RAFTERS**. They are spaced from 12" to 24" apart, depending upon the loads, and are similar in character to floor joists

except that they are set in an inclined position. The usual spacings are 16'' and 24''. The lower ends of the rafters rest upon the plate, and their upper ends meet the upper ends of opposing rafters and are supported by the ridge or by hip or valley rafters. The hips and valleys

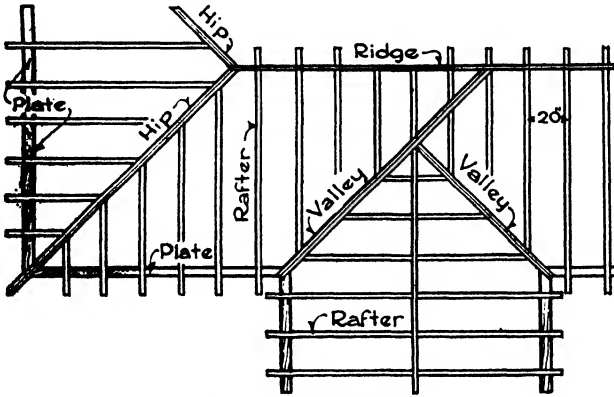

FIG. 14.—Roof Framing.

are the lines of intersection of opposing roof planes, and they should be framed with heavier and deeper timbers than the rafters to give solidity and stiffness to the roof. Hips form the salient and valleys the re-entrant intersections of the roof surfaces (Fig. 14). Where dormers, chimneys or

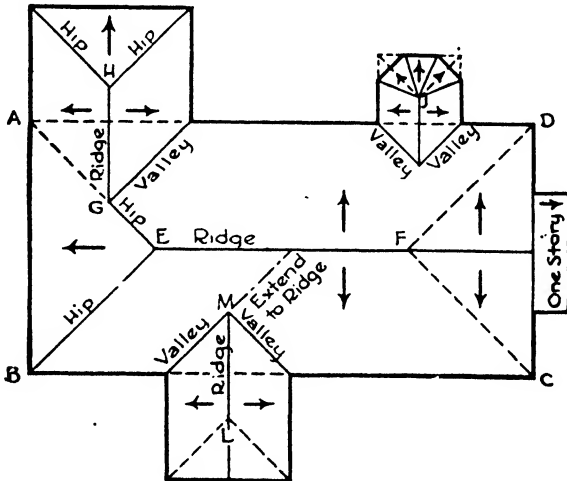

FIG. 15.—Roof Plan.

other projections through the roof surface occur, the rafters and headers framing around the openings are doubled.

The usual method of laying out a roof plan may be illustrated as follows (Fig. 15):

An outline of the building including ells and porches is drawn and the largest rectangle contained in this outline is indicated *ABCD*, representing the main roof. The  $45^\circ$  lines are then drawn from the corners of the main roof and the ell roofs.

Their intersections as at *EF*, *GH*, *JK* and *ML* determine the positions in plan of the ridges of the main roof and the ells. Then draw the  $45^\circ$  hip and valley lines for the main roof and ells. A hip roof throughout is thus obtained, but if gable ends be desired the hip lines are erased and the ridge lines extended to the exterior wall lines. If a gambrel roof be desired the longitudinal lines are drawn in by taking off their positions from the elevations. A deck can be introduced if wanted.

**Rafters.** The loads upon a roof tend to produce an outward thrust or push by the heels or lower ends of the rafters against the plate. When the attic joists rest upon the plate they are securely spiked to it and thereby act as ties across the building to counteract the thrust of

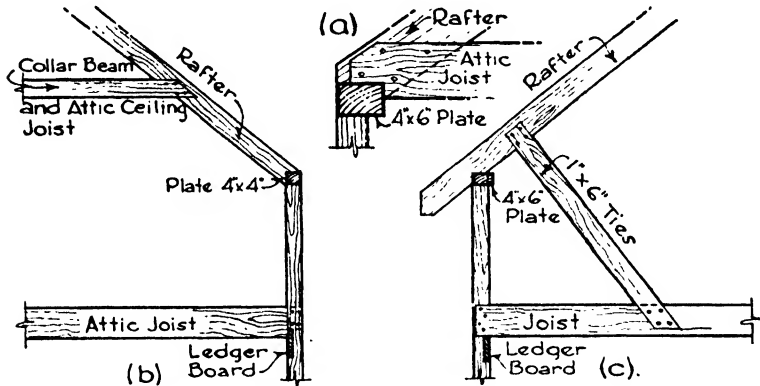

FIG. 16.—Roof Construction.

the rafters (Fig. 16,*a*). If the attic joists are secured to the rafters above the plate they act as ties or collar beams to restrain the rafters from spreading at that point and so reduce the thrust upon the plate. When the attic joists are held by the exterior wall studs below the plate, they serve to tie the walls together and so assist in counteracting the thrust, but in this case it is good practice to add collar beams to tie the rafters above the attic ceiling line (Fig. 16,*b*). Such collar beams may also serve as attic ceiling beams.

Ties from rafter to floor joist may be used to restrain the rafters when such ties do not occupy valuable space (Fig. 16,*c*).

Like floor joists, rafters are subject to bending under their loads and may require intermediate support between the plate and the ridge. If the span be less than 30'0" no such support is usually necessary, but for greater spans either trusses or interior vertical supports should be used since rafters heavier than 3" x 12" are rarely economical. In



residences, attic partitions or posts can generally be employed for support as in Fig. 17,*a*, but where a clear floor area is desired under the roof it is necessary to use trusses. The design of such trusses is described in Chapter XXI.

The upper rafters of gambrel roofs extend from the ridge to the purlin, a 4" x 6" horizontal member extending the entire length of the roof. The lower rafters extend from the purlin to the plate (Fig. 17,*b*).

All rafters should have firm bearing of from  $2\frac{1}{2}$ " to 4" depending upon the depth of the rafter, the end being accurately cut to fit the plate and securely spiked to it. At the ridge the rafters are nailed to a longitudinal plank generally  $\frac{3}{8}$ " thick called the RIDGE OR RIDGE POLE. The ends of corresponding rafters on opposite slopes of the roof are butted against each other to balance their thrusts.

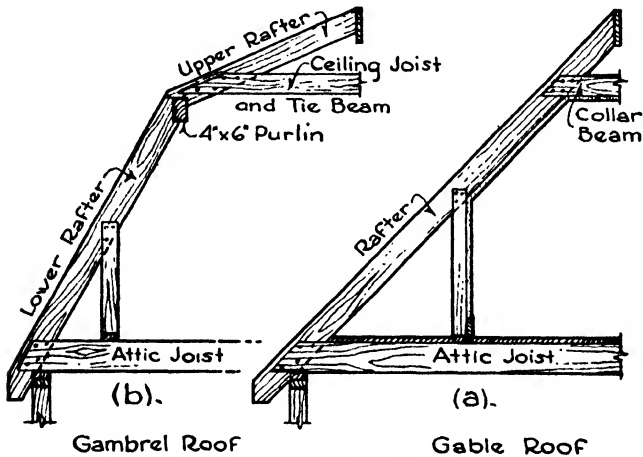

FIG. 17.—Roof Construction.

Hip rafters for simple roofs of moderate span and rigid plate need not be more than 2" thick but should be 2" deeper than the common rafters to give space for beveling the upper edge and for nailing. The hip rafters for heavy roofs of wide span should be 3" thick or may be composed of two pieces each 2" thick.

Valley rafters support nearly all the roof above them, and one of each pair should extend to the main ridge or to a hip rafter. They often consist of two 2" rafters spiked together. (See Fig. 14.)

**Dormers.** Fig. 18. Dormer windows are of a great variety of forms but may generally be classed as those constructed entirely upon the roof, those with fronts resting upon the exterior wall of the building, those with pitched roofs and those with roofs of one slope. In all cases the trimmer rafters along the sides of the opening and the header across the top should be doubled to carry the weight of the window

The sides of the dormer are framed with 2" x 4" studs notched over the trimmer rafters to prevent sagging away or shrinking. The dormer roof is framed with 2" x 4" or 2" x 6" rafters. When the dormer rests

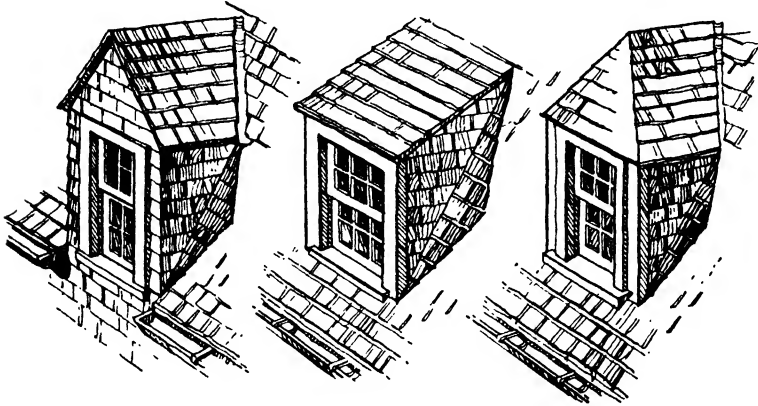

FIG. 18.—Dormers.

entirely upon the roof a 2" x 4" is set between the trimmer rafters to carry the window sill and front (Fig. 19, a, b).

**Wood Roofs on Masonry Walls.** When rafters rest on masonry walls the wood wall plate is anchored to the wall with steel or iron anchors

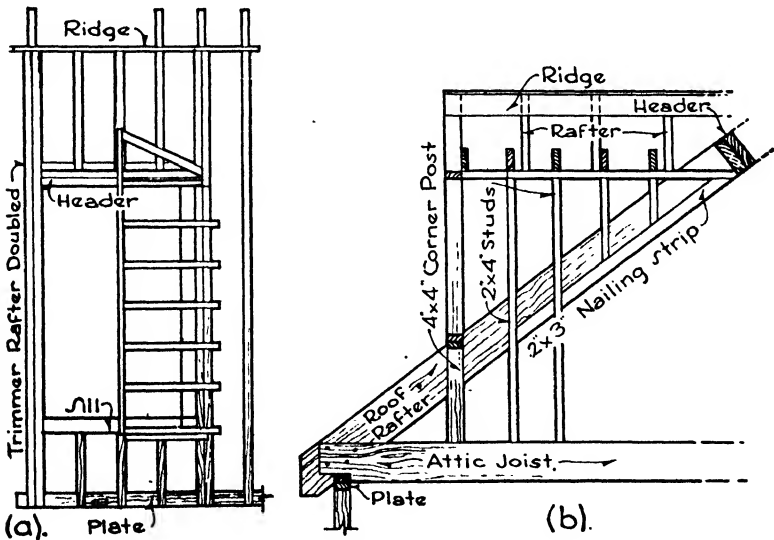

FIG. 19.—Framing of Dormer.

spaced about 6'0" apart and extending down into the masonry at least 2'0". This anchoring is necessary so that the plate may withstand the outward thrust of the rafters without bowing out of line.

**Design of Rafters.** In the design of rafters the total wind and snow loads are seldom used, it being considered improbable that a heavy snow would cling to a sloping roof under a high wind. Two possibilities are consequently assumed:

- (a) Action of dead load and total snow load.
- (b) Action of dead load, total wind load and one-half snow load.

Both possibilities should be investigated to determine in which case the combined load is the greater.

**Example 2.** What size of select grade spruce rafters spaced 16" o.c. is required for a roof of 40° slope, sheathed and shingled on top? Unsupported span from plate to ridge 20'0". Snow load 15 lbs./ft.<sup>2</sup> Wind load 15 lbs./ft.<sup>2</sup> perpendicular to roof.  $f = 1200$  lbs./in.<sup>2</sup>  $E = 1,200,000$  lbs./in.<sup>2</sup>

$$\text{Wind load} = \frac{15}{\cos 40^\circ} = \frac{15}{0.766} = 20 \text{ lbs./ft.}^2 \text{ vertical load.}$$

(1) LOADS.

Shingles = 2 1/2 lbs.	Dead load = 10 1/2 lbs.
7/8" sheathing = 3	1/2 snow load = 7 1/2
Rafters = 5	Wind load = 20
Total dead load = 10 1/2 lbs.	38 lbs./ft. <sup>2</sup>
Snow load = 15	
25 1/2 lbs./ft. <sup>2</sup>	Greater load.

Load per foot of rafter length =

$$38 \times \frac{16}{12} = 50 \text{ lbs.}$$

(2) MAXIMUM MOMENT.

$$M = \frac{Wl}{8}; \text{ but } W = wl \text{ and } l = 12L.$$

$$\text{Therefore } M = \frac{wL \times L \times 12}{8} = \frac{3wL^2}{2} = 1.5 wL^2.$$

$$M = 1.5 \times 50 \times 20 \times 20 = 30,000 \text{ in.-lbs.}$$

$$M = \frac{fbd^2}{6}; \quad d^2 = \frac{6M}{bf}. \text{ Assume } b = 1 \text{ 5/8"}, \text{ then } d^2 = \frac{6 \times 30,000}{1.625 \times 1200} = 100 \text{ approx}$$

$$d = \sqrt{100} = 10". \text{ Try } 2" \times 12" \text{ rafter. Actually } 1 \text{ 5/8" } \times 11 \text{ 1/2"}.$$

(3) DEFLECTION.

$$\frac{l}{360} = \frac{20 \times 12}{360} = 0.67" = \text{allowable deflection. } W = 20 \times 50 = 1000 \text{ lbs.}$$

$$D = \frac{270WL^3}{Ebd^3} = \frac{270 \times 1000 \times 20 \times 20 \times 20}{1,200,000 \times 1.625 \times 11.5 \times 11.5 \times 11.5} = 0.73", \text{ which is excessive.}$$

Try 2" x 14" rafter. Actually 1 5/8" x 13 1/2".

$$D = \frac{270 \times 1000 \times 20 \times 20 \times 20}{1,200,000 \times 1.625 \times 13.5 \times 13.5 \times 13.5} = 0.45", \text{ which is allowable.}$$

Therefore 2" x 12" rafters will satisfactorily resist bending, but 2" x 14" rafters should be used when the deflection is to be limited to 1/360 of the span.

**Rafter Tables.** It is more usual in the case of simple rafters, as in the case of the simple joists already considered, to use prepared tables

**Table XII. Maximum Spans for Rafters—Uniformly Loaded**  
Slope of 20° or More. Live Load 15 lbs./ft.<sup>2</sup>

Nominal Size of Rafters, inches	Spacing of Rafters Center to Center, inches	Allowable Unsupported Lengths from Plate to Ridge, without Collar Beams										
		Limited by Deflection of 1/360 of the Span					Determined by Bending					
		E = 1 000 000	E = 200 000	E = 1 400 000	E = 1 600 000	E = 1 800 000	f = 900	f = 1 000	f = 1 100	f = 1 200	f = 1 300	f = 1 600
2 x 4	16	6-11	7-5	7-8	8-1	8-8	9-1	9-6	10-0	10-5	11-7	12-4
	24	6-1	6-9	6-9	7-1	7-1	7-6	7-11	8-2	8-7	9-6	10-1
2 x 6	16	10-8	11-4	12-0	12-6	13-2	14-0	14-8	15-4	15-10	17-8	18-9
	24	9-5	10-0	10-6	11-0	11-0	11-7	12-2	12-8	13-2	14-7	15-6
2 x 8	16	14-1	15-0	15-9	16-6	17-5	18-5	19-4	20-1	20-10	23-4	24-7
	24	12-6	13-2	14-0	14-7	14-6	15-4	16-0	16-8	17-5	19-4	20-6
2 x 10	16	17-8	18-9	19-9	20-8	21-9	22-10	24-0	25-1	26-1	29-0	30-9
	24	15-8	16-8	17-6	18-4	18-2	19-1	20-1	21-0	21-9	24-2	25-8
2 x 12	16	21-2	22-6	23-8	24-9	26-0	27-5	28-8	30-0	26-2	29-0	
	24	18-10	20-0	21-1	22-1	21-9	23-0	24-1	25-1	26-2	29-0	
2 x 14	16	24-7	26-3	27-6	28-10	30-1	26-9	27-11	29-3	30-6		
	24	22-0	23-5	24-7	25-9	25-3	26-9	27-11	29-3	30-6		
3 x 6	16	12-4	13-1	13-10	14-5	16-5	17-4	18-3	18-11	19-9	21-11	23-3
	24	10-11	11-7	12-3	12-10	13-9	14-6	15-3	15-10	16-6	18-4	19-5
3 x 8	16	16-3	17-3	18-1	18-11	21-5	22-6	23-7	24-9	25-11	28-6	30-0
	24	14-5	15-4	16-1	16-10	18-0	18-11	19-11	20-10	21-9	24-0	25-5
3 x 10	16	20-3	21-5	22-7	23-7	26-6	27-11	29-4	30-8	26-11	30-0	
	24	18-0	19-3	20-3	21-1	22-5	23-7	24-10	25-11	26-11	30-0	

**Table XIII. Maximum Spans for Rafters—Uniformly Loaded**

Slope of 20° or More. Live Load 20 lbs./ft.<sup>2</sup>

Nominal Size of Rafters, inches	Spacing of Rafters Center to Center, inches	Allowable Unsupported Lengths from Plate to Ridge, without Collar Beams										
		Limited by Deflection of $\frac{1}{360}$ of the Span					Determined by Bending					
		E = 1 000 000	E = 200 000	E = 1 400 000	E = 1 000 000	E = 600 000	f = 900	f = 1 000	f = 1 100	f = 1 200	f = 1 300	f = 1 600
2 x 4	16	6-6	6-11	7-2	7-6	7-9	8-4	8-7	9-0	9-4	10-5	11-0
	24	5-7	6-0	6-4	6-7	6-5	6-8	7-0	7-5	7-8	8-6	9-1
2 x 6	16	10-0	10-7	11-1	11-7	12-0	12-7	13-2	13-9	14-5	16-0	17-0
	24	8-8	9-4	9-10	10-4	9-11	10-5	10-10	11-5	11-10	13-1	14-0
2 x 8	16	13-2	14-0	14-8	15-5	15-8	16-7	17-5	18-2	19-0	21-0	22-4
	24	11-7	12-4	13-0	13-7	13-0	13-8	14-5	15-1	15-8	17-5	18-5
2 x 10	16	16-7	17-7	18-6	19-5	19-8	20-9	21-9	22-9	23-8	26-4	27-10
	24	14-7	15-7	16-5	17-1	16-5	17-4	18-1	19-0	19-8	21-10	23-2
2 x 12	16	19-10	21-1	22-4	23-4	23-7	24-10	26-1	27-2	28-5	30-8	31-10
	24	17-7	18-8	19-8	20-7	19-8	20-9	21-9	22-8	23-8	26-4	27-10
2 x 14	16	23-3	24-7	25-11	27-1	27-4	28-10	30-4	30-5	31-6	34-8	35-10
	24	20-7	21-11	23-1	24-1	23-1	24-3	25-4	26-5	27-6	30-8	31-10
3 x 6	16	11-6	12-4	12-11	13-6	14-11	15-9	16-6	17-3	17-10	19-10	21-0
	24	10-3	10-10	11-5	11-11	12-5	13-0	13-9	14-4	14-11	16-6	17-6
3 x 8	16	15-3	16-3	17-0	17-10	19-5	20-6	21-6	22-6	23-6	25-11	27-6
	24	13-6	14-4	15-1	15-10	16-4	17-1	18-0	18-10	19-7	21-9	23-0
3 x 10	16	19-0	20-3	21-4	22-3	24-3	25-6	26-9	27-11	29-1	31-6	33-10
	24	16-11	18-0	18-11	19-10	20-4	21-5	22-6	23-6	24-6	27-1	28-10

**Table XIV. Maximum Spans for Rafters—Uniformly Loaded**  
Slope of 20° or More. Live Load 30 lbs./ft.<sup>2</sup>

Nominal Size of Rafters, inches	Spacing of Rafters Center to Center, inches	Allowable Unsupported Lengths from Plate to Ridge, without Collar Beams											
		Limited by Deflection of 1/360 of the Span						Determined by Bending					
		E=1 000 000	E=1 200 000	E=1 400 000	E=1 600 000	E=1 800 000	900	f=1 000	f=1 100	f=1 200	f=1 300	f=1 600	f=1 800
2 x 4	16	5-10	6-2	6-6	6-10	6-8	7-0	7-4	7-8	7-11	8-10	9-5	9-8
	24	5-1	5-5	5-8	6-0	5-5	5-9	6-0	6-3	6-7	7-3	7-8	7-8
2 x 6	16	9-0	9-7	10-1	10-6	10-2	10-9	11-3	11-9	12-3	13-8	14-6	14-6
	24	7-11	8-5	8-10	9-3	8-4	8-10	9-3	9-8	10-1	11-2	11-11	11-11
2 x 8	16	11-11	12-9	13-4	14-0	13-6	14-3	15-0	15-7	16-3	18-0	19-1	19-1
	24	10-6	11-2	11-9	12-3	11-2	11-9	12-4	12-10	13-4	14-10	15-9	15-9
2 x 10	16	15-0	15-11	16-10	17-6	17-0	17-11	18-9	19-7	20-5	22-8	24-0	24-0
	24	13-4	14-0	14-10	15-6	14-0	14-10	15-6	16-3	16-11	18-8	19-10	19-10
2 x 12	16	18-1	19-3	20-3	21-2	20-4	21-6	22-6	23-6	24-6	27-2	28-10	28-10
	24	15-11	17-0	17-10	18-8	16-11	17-10	18-8	19-6	20-3	22-6	23-11	23-11
2 x 14	16	21-1	22-6	23-7	24-8	23-9	25-1	26-2	27-4	28-6	31-0	32-10	32-10
	24	18-7	19-10	20-10	21-10	19-9	20-9	21-9	22-9	23-7	26-3	27-10	27-10
3 x 6	16	10-5	11-1	11-9	12-3	12-10	13-6	14-1	14-10	15-5	17-1	18-1	18-1
	24	9-3	9-10	10-4	10-10	10-7	11-1	11-9	12-3	12-9	14-1	15-0	15-0
3 x 8	16	13-10	14-7	15-5	16-1	16-10	17-9	18-7	19-5	20-4	22-5	23-9	23-9
	24	12-3	12-11	13-7	14-3	14-0	14-9	15-5	16-1	16-11	18-7	19-9	19-9
3 x 10	16	17-4	18-4	19-4	20-3	21-0	22-1	23-3	24-3	25-3	28-0	29-9	29-9
	24	15-4	16-4	17-1	17-11	17-6	18-6	19-5	20-3	21-0	23-4	24-10	24-10

**Table XV. Maximum Spans for Rafters—Uniformly Loaded**  
Slope of 20° or More. Live Load 40 lbs./ft.<sup>2</sup>

Nominal Size of Rafters, inches	Spacing of Rafters to Center, inches	Allowable Unsupported Lengths from Plate to Ridge, without Collar Beams										
		Limited by Deflection of 1/360 of the Span					Determined by Bending					
		E = 1 000 000	E = 200 000	E = 1 400 000	E = 1 600 000	E = 1 800 000	f = 900	f = 1 000	f = 1 100	f = 1 200	f = 1 300	f = 1 600
2 x 4	16 24	5-4 4-8	5-8 5-0	6-0 5-2	6-2 5-5	5-10 4-9	6-3 5-0	6-5 5-4	6-10 5-6	7-0 5-9	7-9 6-5	8-4 6-9
2 x 6	16 24	8-4 7-2	9-3 7-8	8-10 8-1	9-8 8-6	9-0 7-5	9-6 7-9	10-0 8-2	10-5 8-7	10-10 9-10	12-0 9-10	12-9 10-6
2 x 8	16 24	11-0 9-7	11-8 10-2	12-4 10-9	12-11 11-4	12-0 9-10	12-7 10-5	13-2 10-10	13-9 11-5	14-5 11-9	16-0 13-1	17-0 14-0
2 x 10	16 24	13-11 12-2	14-8 13-0	15-6 13-7	16-2 14-2	15-1 12-5	15-10 13-1	16-8 13-8	17-5 14-4	18-1 15-0	20-1 16-7	21-4 17-7
2 x 12	16 24	16-8 14-8	17-8 15-7	18-8 16-5	19-6 17-2	18-1 15-0	19-1 15-9	20-0 16-7	21-0 17-4	21-9 18-0	24-2 20-0	25-7 21-2
2 x 14	16 24	19-6 17-3	20-10 18-4	21-10 19-4	22-10 20-1	21-1 17-6	22-3 18-6	23-4 19-5	24-5 20-3	25-5 21-0	28-3 23-5	29-10 24-10
3 x 6	16 24	9-7 8-6	10-4 9-0	10-10 9-6	11-4 9-11	11-5 9-5	12-0 9-11	12-7 10-5	13-1 10-11	13-9 11-4	15-3 12-6	16-1 13-4
3 x 8	16 24	12-10 11-3	13-6 12-0	14-4 12-7	14-11 13-3	15-0 12-5	15-10 13-1	16-7 13-9	17-4 14-5	18-1 15-0	20-0 16-7	21-3 17-6
3 x 10	16 24	16-1 14-3	17-0 15-1	17-11 15-10	18-10 16-7	18-10 15-7	19-10 16-6	20-10 17-4	21-9 18-0	22-7 18-10	25-0 20-10	26-7 22-1

rather than to calculate the rafters as explained in Example 2. Tables XII-XV are prepared in the same manner as the joist tables in Article 1, and the method of using them is the same

The weight of the rafter is included together with weights per square foot of 2.5 lbs. for wood sheathing and 2.5 lbs. for shingle, copper or 3-ply ready roofing.

In Example 2, spruce rafters were used spaced 16" on centers, and the unsupported length of rafter was 20'0". The allowable unit fiber stress in bending for select grade spruce is 1200 lbs./in.<sup>2</sup>, and its moment of elasticity is 1,200,000. The live load was 20+7.5 or approximately 30 lbs./ft.<sup>2</sup> By entering Table XIV in the column headed  $f = 1200$  it is found that, for a span of 23'6" and spacing of 16", a 2" x 12" rafter is required to withstand the bending. Under  $E = 1,200,000$  it is seen, however, that a 2" x 14" rafter is necessary to limit the deflection to 1/360 of the span for a span of 22'6". A 2" x 12" or a 2" x 14" rafter is therefore chosen, depending upon the necessity of limiting the deflection.



## CHAPTER XX

### STEEL CONSTRUCTION

#### Article 1. Structural Shapes and Their Properties

**Structural Shapes.** The rolled shapes of steel most employed in building construction are I-beams, channels, T-beams, angles and plates. Rods are used for hangers and ties and round and square bars for concrete reinforcement.

The most common structural form is the beam with an I-shaped section. It is economical for its weight because a large porportion of material is concentrated in the top and bottom flanges where the bending stresses are greatest, and it is adaptable to many purposes on account of its symmetry about the vertical and the horizontal axes.

Channels are convenient for use in certain parts of a skeleton frame, as at elevator shafts and stair-wells, and as lintels and roof purlins. Two channels placed back to back are often employed in grillage foundations under columns, the increased web thickness of the two channels being stiffer against buckling.

Angles may be used as beams for short spans and light loads, especially as lintels over openings supporting brick or stone masonry. They have a further important place as components of built-up columns, trusses and girders, also in connecting members to each other, as beams to girders and girders to columns.

T-sections are extensively employed as supports for gypsum roof-slabs and clay book-tile, the tee being inverted to receive the slabs. They are cut from both WF and Standard Sections.

Plates are used for a variety of purposes but especially as the webs of built-up girders and columns and as flange and web reinforcement.

Rolled-steel slabs are now largely employed for column bases instead of cast iron or built-up steel. They are often known as BILLETS and are dependable and economical, requiring little or no fabrication.

**Types of Beams.** Beams may be classed as regular sections or those of popular sizes for which there is constant demand and ready supply, and special sections or those rolled at irregular intervals because of fluctuating supply. Therefore the use of the special sections should be avoided unless in sufficient amounts to call for a rolling.

Beams may be further grouped as WF (wide flange) beams and American Standard beams. Regular WF beams are produced by the Bethlehem Steel Company and the Carnegie-Illinois Steel Corporation. American Standard beams are rolled by all beam manufacturers.



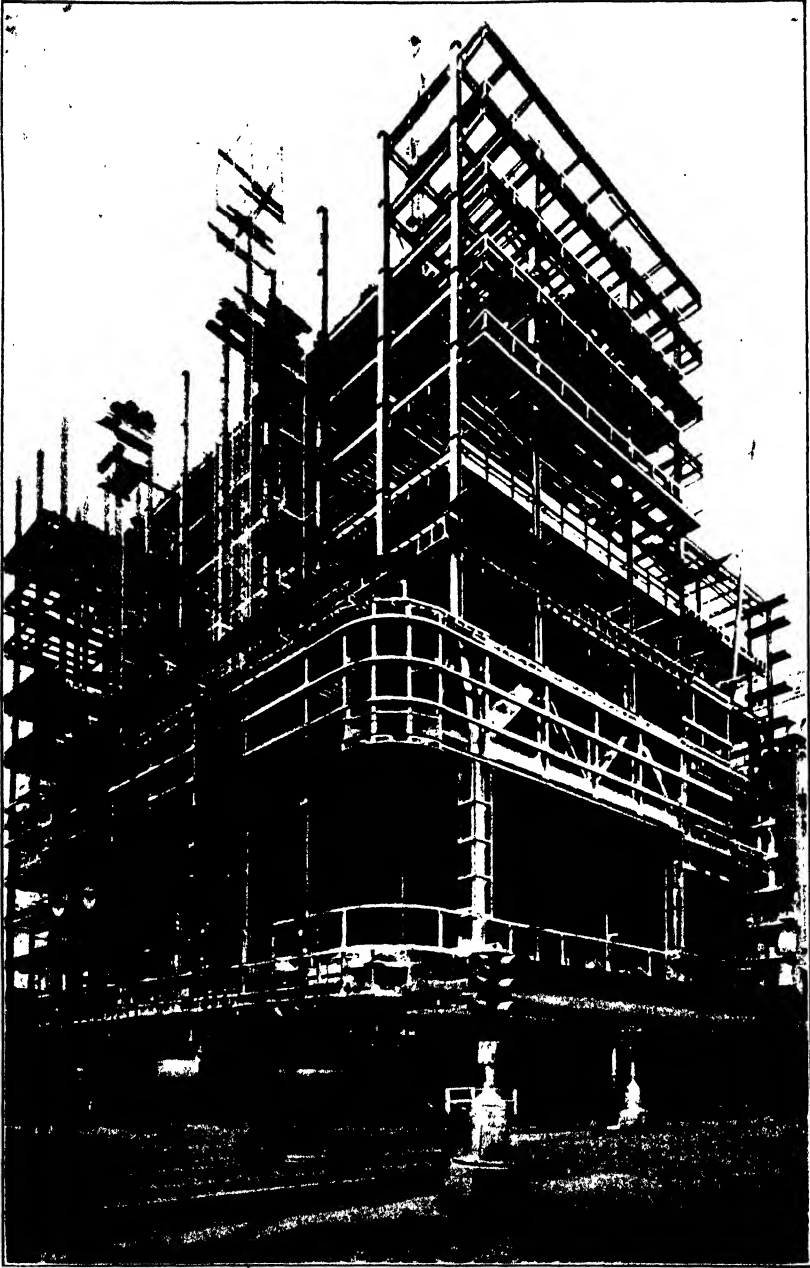

*Howe and Lescaze, architects*

STEEL CONSTRUCTION, PHILADELPHIA SAVING FUND BUILDING.

All WF beams have parallel face flanges of uniform thickness throughout and no slope (Fig. 1,c), except that the following Bethlehem beams have a 5% slope on the inside face of the flange: all sizes with nominal depths from 36" to 16" inclusive; 14 WF 42 to 30; 12 WF 36 to 25; 10 WF 29 to 21; 8 WF 21 to 17 (Fig. 1,b). The properties of certain WF sections as produced by the different mills are, therefore, not absolutely the same, but the differences are so small as to be negligible. The properties given in the tables are based on the lesser values.

The sizes increase from 8" to 36" in depth. The different weights for each depth are obtained by spreading both the horizontal and the vertical rolls, thus thickening the webs and widening the flanges and thickening the flanges. The actual depths therefore differ slightly for each nominal depth, as for instance the 16" I-beams, which vary from 16<sup>5</sup>/<sub>8</sub>" to 15<sup>7</sup>/<sub>8</sub>" in depth and from 78 lbs. to 36 lbs./lin.ft. in weight (Fig. 1,b,c).

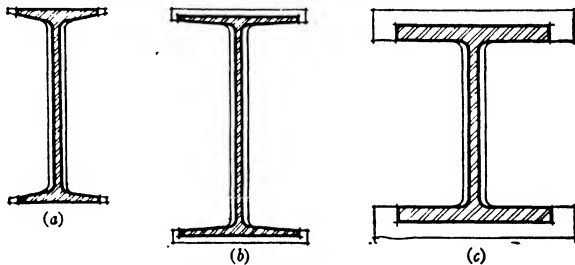

FIG. 1.—Types of Rolled Beams.

American Standard beams are fabricated in sizes of 3" to 24" in depth. For each depth several weights are rolled. The increased weight is obtained by spreading the horizontal rolls and thereby thickening the web and widening the flange but not increasing the depth of the beam. Less weight is added proportionately to the flanges than to the web, and consequently the resistance to bending does not increase in the same ratio as the weight. The lighter weights for a given depth of beam are therefore the more economical and more in demand. The thicker webs, however, have greater resistance to shear and buckling (Fig. 1,a).

Miscellaneous WF light columns, light beams and joists and Standard light columns, mill beams and junior beams are also fabricated and are readily procurable.

**Angles and Channels.** Angles and channel beams are rolled by all mills according to the American Standard. The angles vary in size from 1<sup>3</sup>/<sub>4</sub>" x 1<sup>1</sup>/<sub>4</sub>" to 8" x 8", some sizes having equal legs and some unequal. The channels vary in size from 3" to 15" in depth, the weights for each depth being increased by spreading the horizontal rolls only, thus thickening the web but maintaining a constant depth, similar to the Standard I-beams.

**Built-up Beams and Girders.** Where a single beam or girder would not be adequate to carry the loads, where headroom is insufficient for

a deep member, or where greater width is required as in the support of a wall, two or more beams may be set side by side connected with separators or diaphragms and angles (Fig. 2, a, b). Wall girders and

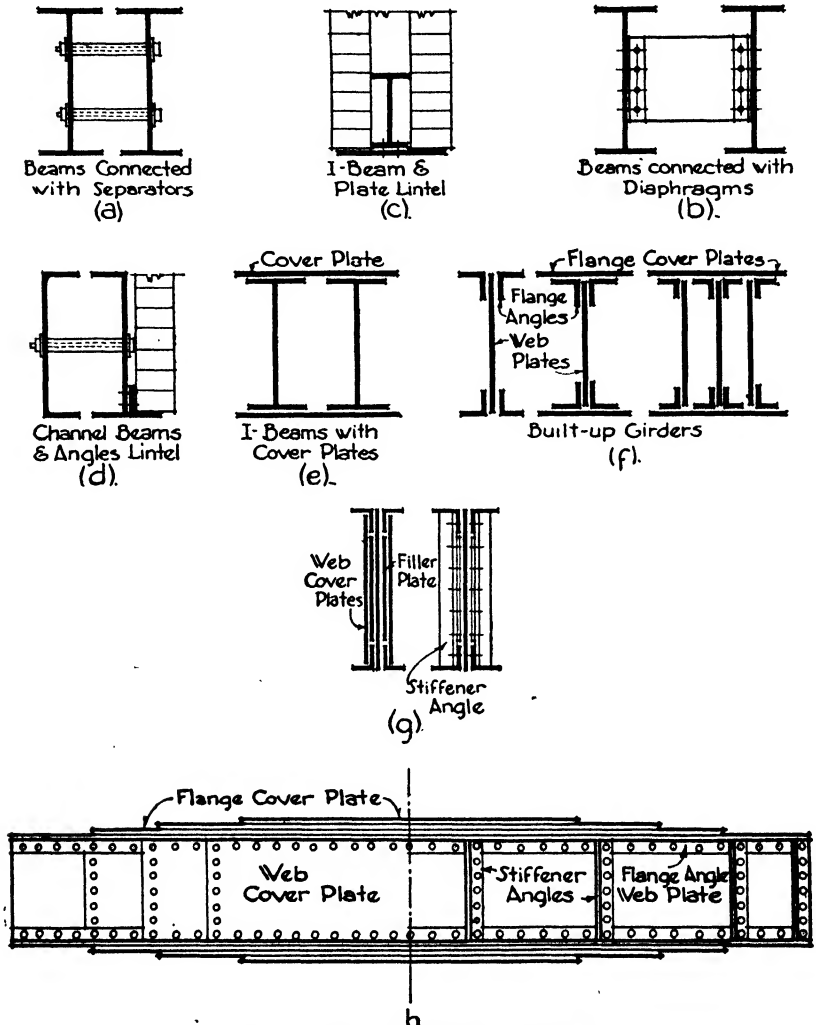

FIG. 2.—Built-up Beams and Girders.

lintels are made up in a variety of ways by connecting I-beams and channels with plates and angles (Fig. 2, c, d, e).

**Plate Girders.** For loads too heavy for rolled sections of beams, members called plate girders can be built up of a plate forming the web and four angles forming the top and bottom flanges. Additional

plates may be added to the angles to strengthen the flanges, and when greater resistance to buckling or shear is required two or more web plates may be used. When the web plate must be made heavier at certain sections of the girder it is more economical to use reinforcing plates on each side of the web plate along the highly stressed portions of the girder than to thicken the web plate throughout its entire length. Flange plates may be strengthened with reinforcing plates in the same manner. Vertical stiffener angles acting like columns are often riveted along the web plate at points of maximum stress and at intervals of 7'0" when the depth of web plate is more than 70 times its thickness. The stiffeners are used in pairs, one on each side of the plate (Fig. 2, *f, g, h*).

**Columns.** An economical column section should, as far as practicable, concentrate its area near its exterior surface to increase its radius of gyration and should be symmetrical about its two major axes for equal resistance to bending in all directions. A hollow circle for these reasons would be an ideal section, but it cannot be rolled and does not fulfill certain other requirements which are likewise of much importance, such as convenience of beam connecting and splicing and of field painting, economy of fabrication and simplicity of fireproofing. It is evident that single I-beams, channels or angles with narrow flanges, although capable of sustaining loads, have not suitable distributions of metal in their sections to act as economical columns. Many combinations of these shapes have consequently been devised, but objections of one sort or another have eliminated most of them from frequent use. At the present time the two types which are most generally employed are the rolled H-column and the built-up plate and angle column.

H-columns are similar to I-beams except that the flanges are much wider and therefore the section has more nearly equal strength about both the *X-X* and the *Y-Y* axes. They are now included in the tables of WF beams. For great loads they may be reinforced with flange plates or boxed out with web plates and angles. The columns of the Empire State Building in New York were built up in this manner. Under ordinary conditions, they are amply strong to be used without reinforcement and are, therefore, simpler to design and to fabricate than the plate and angle columns (Fig. 3, *a, b, c*).

Plate and angle columns consist of a web plate and four flange angles, with or without flange plates, riveted together as described for plate girders. They are comparatively cheap, not difficult to fabricate, offer good beam connections and are readily field painted. They are the most-used type of column next to the H-columns (Fig. 3, *d*). The web plate is usually made  $\frac{1}{2}$ " narrower than the back-to-back distance between the flange angles to allow for irregularities in the edges of the plate and to permit even seating for flange plates and beam connections (Fig. 3, *e*).

**Properties or Elements of Structural Shapes.** All I-beams, chan-

nels, angles, tees, plate girders, H-columns and built-up columns have certain properties or elements which must be known in order to select the members intelligently to carry their imposed loads. These properties are listed by the manufacturers in their handbooks, and an understanding of the meaning and usefulness of the properties is essential in the designing of structural frames. The properties most generally employed in the design of members are as follows:

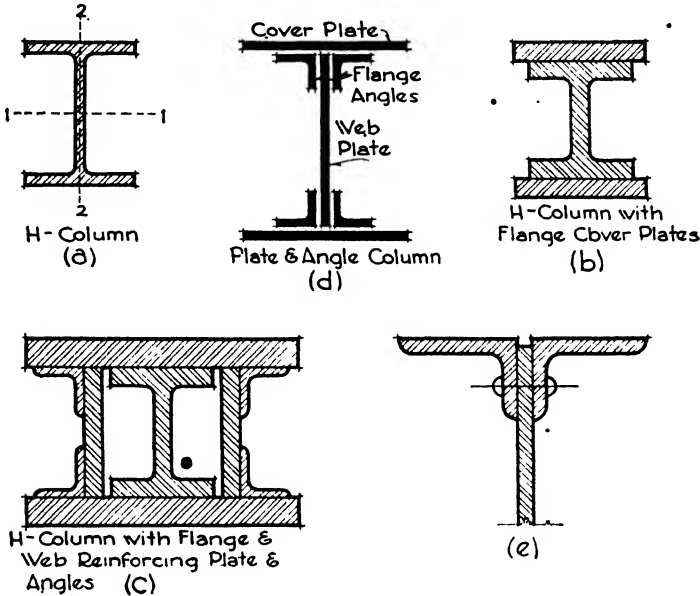

FIG. 3.—Steel Columns.

1. Depth of member; the distance from back to back of the flanges; of angles; the lengths of the legs.
2. Weight of member; the weight in pounds per linear foot.
3. Area of section; the actual area of the steel in square inches.
4. Width of flange in inches.
5. Thickness of web in inches.
6. Moment of inertia ( $I$ ) of the section in inches to the fourth power.
7. Radius of gyration ( $r$ ) of the section in inches.
8. Section modulus ( $S$ ) of the section in inches to the third power.

It is a measure of the strength of a section, and is equal to  $\frac{I}{c}$  (moment of inertia divided by distance from neutral axis to extreme fiber), and also to  $\frac{M}{f}$  (maximum bending moment divided by extreme fiber unit stress).

Beams and H-columns are classified and identified by their depth in

inches and by their weight per linear foot. Angles are grouped by the length and thickness of their legs in inches.

For example:

Wide-flange I-beam . . . . .	24	WF 74
American Standard I-beam . . . . .	15	I 42.9
Channel section . . . . .	9	□ 13.4
Equal-leg angle . . . . .	3	3 x 3 x 1/4
Unequal-leg angle . . . . .	7	7 x 4 x 1/2

The various properties of structural shapes have many uses but are principally employed as follows:

The area of the section affects its strength and weight. The calculation of the area is also necessary to determine the moment of inertia and the radius of gyration of the section.

The width of the flange influences the detailing of connections and the spacing of grillage beams.

The thickness of the web must be known, in many cases, to determine the resistance of beams to shear and buckling and the necessity of stiffening angles and reinforcing plates.

The moment of inertia is required for the calculation of the radius of gyration and section modulus (*I*).

The radius of gyration is employed in the design of columns (*r*).

The section modulus is the property most used in consulting the manufacturers' lists of sections when designing beams. In a specific problem it is generally calculated by the formula  $S = \frac{M}{f}$ , in which *M* is the maximum bending moment in inch-pounds and *f* the allowable extreme fiber stress per square inch. A section is selected from the tables having a section modulus equal to or greater than that computed by the formula.

The following tables give the properties most often employed in the design of beams and columns. Additional properties such as thickness of flange, depth of web and spacing of rivet holes in the flange may be found in the manufacturers' tables. Many other sizes and weights rolled in the mills are not included in the tables here shown. The handbooks of the manufacturers should be consulted for complete lists of their products, the sizes here set forth being largely for purposes of illustration. The minimum weight for a calculated section modulus is generally the most economical to select, although it may necessitate a deeper beam or larger column. The beams of minimum weight in each class of depths are usually those most generally found in stock in the mills, and consequently are most readily obtained. The tables comprise selections from the handbook issued by the American Institute of Steel Construction.



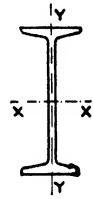

Table I. Properties of Selected Standard I-Beams

Depth of Beam	Weight per Foot	Area of Section	Width of Flange	Thick-ness of Web	Axis X-X			Axis Y-Y		
					<i>I</i>	<i>S</i>	<i>r</i>	<i>I</i>	<i>S</i>	<i>r</i>
In.	Lbs.	In. <sup>2</sup>	In.	In.	In. <sup>4</sup>	In. <sup>3</sup>	In.	In. <sup>4</sup>	In. <sup>3</sup>	In.
24	110.0	32.18	7.925	0.675	2 869.1	239.10	9.44	80.6	20.3	1.58
	100.0	29.25	7.247	.747	2 371.8	197.68	9.05	48.4	13.4	1.29
	90.0	26.30	7.124	.624	2 230.1	185.84	9.21	45.5	12.8	1.32
	79.9	23.33	7.000	.500	2 087.2	173.93	9.46	42.9	12.2	1.36
20	81.4	23.74	7.000	.600	1 466.3	146.63	7.86	45.8	13.1	1.39
	65.4	19.08	6.250	.500	1 169.5	116.95	7.83	27.9	8.9	1.21
18	75.6	22.04	7.000	.560	1 141.8	126.87	7.20	46.3	13.2	1.45
	54.7	15.94	6.000	.460	795.5	88.39	7.07	21.2	7.1	1.15
15	60.8	17.68	6.000	.590	609.0	81.20	5.87	26.0	8.7	1.21
	42.9	12.49	5.500	.410	441.8	58.91	5.95	14.6	5.3	1.08
12	40.8	11.84	5.250	.460	268.9	44.82	4.77	13.8	5.3	1.08
	31.8	9.26	5.000	.350	215.8	35.97	4.83	9.5	3.8	1.01
10	40.0	11.69	5.091	.741	158.0	31.6	3.68	9.4	3.7	0.90
	25.4	7.38	4.660	.310	122.1	24.42	4.07	6.9	3.0	0.97
8	18.4	5.34	4.000	.270	56.9	14.22	3.26	3.8	1.9	0.84
7	15.3	4.43	3.660	.250	36.2	10.34	2.86	2.7	1.5	0.78
6	12.5	3.61	3.330	.230	21.8	7.27	2.46	1.8	1.1	0.72

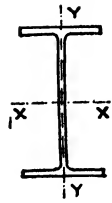

Table II. Properties of Regular WF I-Beams

Nominal Size	Weight per Foot	Area of Section	Actual Depth	Flange Width	Web Thickness	Axis X-X			Axis Y-Y		
						I	S	r	I	S	r
In.	Lbs.	In. <sup>2</sup>	In.	In.	In.	In. <sup>4</sup>	In. <sup>3</sup>	In.	In. <sup>4</sup>	In. <sup>3</sup>	In.
36x16½	300	88.17	36.72	16.65	0.945	20 290	1 105.1	15.17	1 225.2	147.1	3.73
	230	67.73	35.88	16.47	.765	14 988	835.5	14.88	870.9	105.7	3.59
36x12	170	49.08	36.16	12.02	.680	10 470	570.1	14.47	300.6	50.0	2.45
	150	44.10	35.84	11.97	.625	9 012	502.9	14.29	250.4	41.8	2.38
33x15¾	240	70.52	33.50	15.86	.830	13 585	811.1	13.88	874.3	110.2	3.52
	200	58.79	33.00	15.75	.715	11 048	669.6	13.71	691.7	87.8	3.43
33x11½	152	44.71	33.50	11.56	.635	8 147	486.4	13.50	256.1	44.3	2.39
	125	36.78	33.00	11.50	.805	6 354	385.1	13.14	188.2	34.7	2.26
30x15	210	61.78	30.38	15.10	.775	9 872	649.9	12.64	707.9	93.7	3.38
	172	50.65	29.88	14.98	.655	7 891	528.2	12.48	550.1	73.4	3.30
30x10½	132	38.83	30.30	10.55	.615	5 753	379.7	12.17	185.0	35.1	2.18
	108	31.77	29.82	10.48	.548	4 461	299.2	11.85	135.1	25.8	2.06
27x14	177	52.10	27.31	14.09	.725	6 728	492.8	11.36	518.9	73.7	3.16
	145	42.68	26.88	13.96	.600	5 414	402.9	11.26	406.9	58.3	3.09
27x10	114	33.53	27.28	10.07	.570	4 080	290.2	11.03	149.6	29.7	2.11
	91	26.77	26.84	9.98	.483	3 129	233.2	10.81	109.0	21.8	2.02
24x14	160	47.04	24.72	14.09	.656	5 110	413.5	10.42	492.6	69.9	3.23
	130	38.21	24.25	14.00	.565	4 009	330.7	10.24	375.2	53.6	3.13
24x12	110	32.36	24.16	12.04	.510	3 315	274.4	10.12	229.1	38.0	2.66
	24x 9	87	25.58	24.16	9.02	.480	2 467	204.3	9.82	92.9	20.6
74		21.77	23.87	8.97	.430	2 033	170.4	9.67	73.8	16.5	1.84
21x13	132	38.81	21.31	13.08	.614	3 141	294.8	9.00	353.8	54.1	3.02
	112	32.93	21.00	13.00	.527	2 620	249.6	8.92	289.7	44.6	2.96
21x 9	96	28.21	21.14	9.03	.575	2 088	197.6	8.60	109.3	24.2	1.97
	82	24.10	20.86	8.96	.499	1 752	168.0	8.53	89.6	20.0	1.93
21x 8¾	68	20.02	21.13	8.27	.430	1 478	139.9	8.59	60.4	14.6	1.74
	59	17.36	20.91	8.23	.390	1 246	119.3	8.47	49.2	12.0	1.68
18x11¾	124	36.45	18.64	11.88	.651	2 227	239.0	7.82	281.0	47.4	2.78
	96	28.22	18.16	11.75	.512	1 674	184.4	7.70	206.8	35.2	2.71
18x 8¾	85	24.97	18.32	8.83	.526	1 429	156.1	7.57	99.4	22.5	2.00
	64	18.80	17.87	8.71	.403	1 045	117.0	7.46	70.3	16.1	1.93
18x 7½	50	14.71	18.00	7.50	.358	800	89.0	7.38	37.2	9.9	1.59
16x11½	105	30.87	16.48	11.58	.584	1 407	181.7	6.96	230.7	39.8	2.73
	88	25.87	16.16	11.50	.504	1 222	151.3	6.87	185.2	32.2	2.67
16x 8½	71	20.86	16.16	8.54	.486	936	115.9	6.70	77.9	18.2	1.93
	58	17.04	15.86	8.46	.407	746	94.1	6.62	60.5	14.3	1.88
16x 7	45	13.24	16.12	7.03	.346	583	72.4	6.64	30.5	8.7	1.52
	36	10.59	15.85	6.99	.299	446	56.3	6.49	22.1	6.3	1.45

Table II (Continued). Properties of Regular WF I-Beams

Nominal Size	Weight per Foot	Area of Section	Actual Depth	Flange Width	Web Thickness	Axis X-X			Axis Y-Y		
						I	S	r	I	S	r
In.	Lbs.	In. <sup>2</sup>	In.	In.	In.	In. <sup>4</sup>	In. <sup>3</sup>	In.	In. <sup>4</sup>	In. <sup>3</sup>	In.
14x16	426	125.25	18.69	16.69	1.875	6 610	707.4	7.26	2 359.0	282.7	4.34
	300	88.20	17.00	16.17	1.350	4 140	488.2	6.86	1 546.0	101.2	4.10
	202	59.30	15.03	15.75	0.930	2 538	324.9	6.54	979.7	124.4	4.06
	142	41.85	14.75	15.50	.680	1 672	226.7	6.32	660.1	85.2	3.97
14x14½	127	37.33	14.62	14.69	.610	1 476	202.0	6.29	527.6	71.8	3.76
	103	30.20	14.25	14.57	.495	1 165	163.0	6.21	419.7	57.6	3.72
	87	25.56	14.00	14.50	.420	966	138.1	6.15	349.7	48.2	3.70
14x12	78	22.94	14.06	12.00	.428	851	121.1	6.09	206.9	34.5	3.00
14x10	61	17.94	13.91	10.00	.378	641	92.2	5.98	107.3	21.5	2.45
14x 8	53	15.50	13.94	8.06	.370	542	77.8	5.00	57.5	14.3	1.92
	43	12.05	13.68	8.00	.308	429	62.7	5.82	45.1	11.3	1.89
14x 6¾	38	11.17	14.12	6.77	.313	385	54.6	5.87	24.6	7.3	1.49
	30	8.81	13.86	6.73	.270	289	41.8	5.73	17.5	5.2	1.41
12x12	190	55.86	14.38	12.67	1.060	1 892	263.2	5.82	580.7	93.1	3.25
	120	35.31	13.12	12.32	0.710	1 071	163.4	5.51	345.1	56.0	3.13
	65	19.11	12.12	12.00	.390	533	88.0	5.28	174.6	29.1	3.02
12x10	53	15.59	12.06	10.00	.345	426	70.7	5.23	96.1	19.2	2.48
12x 8	40	11.77	11.94	8.00	.516	310	51.9	5.13	44.1	11.0	1.94
12x 6½	32	9.41	12.12	6.53	.273	246	40.7	5.12	20.6	6.3	1.48
	25	7.39	11.87	6.50	.240	183	30.9	4.98	14.5	4.5	1.40
10x10	136	40.03	11.88	10.57	.915	917	154.4	4.79	295.9	56.0	2.72
	77	22.67	10.62	10.19	.535	457	86.1	4.40	153.4	30.1	2.60
	49	14.40	10.00	10.00	.340	272	54.0	4.35	93.0	18.6	2.54
10x 8	41	12.06	10.00	8.00	.328	222	44.5	4.29	47.7	11.9	1.99
	33	9.71	9.75	7.96	.292	170	35.0	4.20	36.5	9.2	1.94
10x 5¾	26	7.65	10.12	5.76	.259	139	27.6	4.27	13.4	4.6	1.32
	21	6.19	9.90	5.75	.240	106	21.5	4.14	9.7	3.4	1.25
8x 8	67	19.70	9.00	8.28	.575	271	60.4	3.71	88.6	21.4	2.12
	40	11.76	8.25	8.07	.365	146	35.5	3.53	49.0	12.1	2.04
	31	9.12	8.00	8.00	.288	109	27.4	3.47	37.0	9.2	2.01
8x 6½	24	7.06	7.93	6.50	.245	82	20.8	3.42	18.2	5.6	1.61
	17	5.00	8.00	5.25	.230	56	14.1	3.36	6.7	2.6	1.16

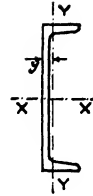

Table III. Properties of Standard Channels

y = distance in inches from center of gravity to back of channel

Depth of Beam	Weight per Foot	Area of Section	Width of Flange	Thick-ness of Web	Axis X-X			Axis Y-Y			
					I	S	r	I	S	r	y
In.	Lbs.	In. <sup>2</sup>	In.	In.	In. <sup>4</sup>	In. <sup>3</sup>	In.	In. <sup>4</sup>	In. <sup>3</sup>	In.	In.
15	40.0	11.70	3.52	0.520	346.3	46.17	5.44	9.3	3.4	0.89	0.78
	33.9	9.90	3.40	.400	312.6	41.68	5.62	8.2	3.2	.91	.79
12	30.0	8.70	3.17	.510	161.2	26.87	4.28	5.	2.1	.77	.68
	20.7	6.03	2.94	.280	128.1	21.35	4.61	3.9	1.7	.81	.70
10	25.0	7.33	2.89	.526	90.7	18.14	3.52	3.4	1.5	.68	.62
	15.3	4.47	2.60	.240	66.9	13.38	3.87	2.3	1.2	.72	.64
9	13.4	3.89	2.43	.230	47.3	10.51	3.49	1.8	0.97	.67	.61
8	11.5	3.36	2.26	.220	32.3	8.08	3.10	1.3	0.79	.63	.58
7	9.8	2.85	2.09	.210	21.1	6.03	2.72	0.98	0.63	.59	.55
6	8.2	2.39	1.92	.200	13.0	4.33	2.34	0.70	0.50	.54	.52

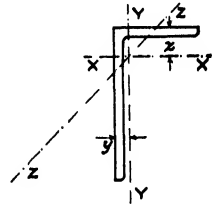

Table IV. Properties of Standard Angles

Size	Thick-ness	Weight per Foot	Area	Axis X-X				Axis Y-Y				Axis Z-Z	
				I	S	r	x	I	S	r	y	r	
In.	In.	Lbs.	In. <sup>2</sup>	In. <sup>4</sup>	In. <sup>2</sup>	In.	In.	In. <sup>4</sup>	In. <sup>2</sup>	In.	In.	In.	In.
6x6	3/8	14.9	4.36	15.39	3.53	1.88	1.64						1.10
	1/2	19.6	5.75	19.91	4.61	1.86	1.68						1.18
	3/4	28.7	8.44	28.15	6.66	1.83	1.78						1.17
	1	37.4	11.00	35.46	8.57	1.80	1.86						1.16
6x4	3/8	12.3	3.61	13.47	3.32	1.93	1.94	4.90	1.60	1.17	0.94	0.88	
	1/2	16.2	4.75	17.40	4.33	1.91	1.99	6.27	2.08	1.15	0.99	0.87	
	3/8	20.0	5.86	21.07	5.31	1.90	2.03	7.52	2.54	1.13	1.03	0.86	
	7/8	27.2	7.98	27.73	7.15	1.86	2.12	9.75	3.39	1.11	1.12	0.86	
6x3 1/2	3/8	11.7	3.42	12.86	3.24	1.94	2.04	3.34	1.23	0.99	0.79	0.77	
	1/2	15.3	4.50	16.59	4.24	1.92	2.08	4.25	1.59	0.97	0.83	0.76	
	3/8	18.9	5.55	20.08	5.19	1.90	2.13	5.08	1.94	0.96	0.88	0.75	
	1/4	22.4	6.56	23.3	6.10	1.89	2.18	5.80	2.30	0.94	0.93	0.75	
5x3 1/2	3/8	10.4	3.05	7.78	2.29	1.60	1.61	3.18	1.21	1.02	0.86	0.76	
	1/2	13.6	4.00	9.99	2.99	1.58	1.66	4.05	1.56	1.01	0.91	0.75	
	3/8	16.8	4.92	12.03	3.65	1.56	1.70	4.83	1.90	0.99	0.95	0.75	
	1/4	19.8	5.81	13.92	4.28	1.55	1.75	5.55	2.22	0.98	1.00	0.75	
4x4	3/8	9.8	2.86	4.36	1.52	1.23	1.14					0.70	
	1/2	12.8	3.75	5.56	1.97	1.22	1.18					0.78	
	3/4	18.5	5.44	7.66	2.81	1.19	1.27					0.77	
4x3 1/2	3/8	9.1	2.67	4.18	1.49	1.25	1.21	2.99	1.17	1.06	0.96	0.73	
	1/2	11.9	3.50	5.32	1.94	1.23	1.25	3.79	1.52	1.04	1.00	0.72	
	3/4	17.3	5.06	7.32	2.75	1.20	1.34	5.18	2.15	1.01	1.09	0.72	
4x3	3/8	8.5	2.48	3.96	1.46	1.26	1.28	1.92	0.87	0.88	0.78	0.64	
	1/2	11.1	3.25	5.05	1.89	1.25	1.33	2.42	1.12	0.86	0.83	0.64	
	3/4	13.6	3.98	6.03	2.30	1.23	1.37	2.87	1.35	0.85	0.87	0.64	
3x3	1/4	4.9	1.44	1.24	0.58	0.93	0.84					0.50	
	3/8	7.2	2.11	1.76	0.83	0.91	0.89					0.58	
	1/2	9.4	2.75	2.22	1.07	0.90	0.93					0.58	
3x2 1/2	1/4	4.5	1.31	1.17	0.56	0.95	0.91	0.74	0.40	0.75	0.66	0.53	
	3/8	6.6	1.92	1.66	0.81	0.93	0.96	1.04	0.58	0.74	0.71	0.52	
2 1/2 x 2	1/8	2.75	0.81	0.51	0.29	0.79	0.76	0.29	0.20	0.60	0.51	0.43	
	1/4	3.62	1.06	0.65	0.38	0.78	0.79	0.37	0.25	0.59	0.54	0.42	

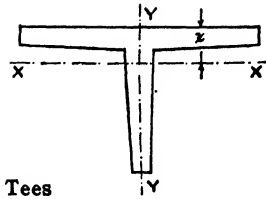

Table V. Properties of Structural Tees

Cut from Standard Beam Sections

Depth	Weight per Foot	Area	Flange		Stem Thickness	Axis X-X			Axis Y-Y			
			Width	Average Thickness		I	S	r	z	I	S	r
In.	Lbs.	In. <sup>2</sup>	In.	In.	In.	In. <sup>4</sup>	In. <sup>3</sup>	In.	In.	In. <sup>4</sup>	In. <sup>3</sup>	In.
6	27.5	8.09	5.60	0.660	0.810	28.3	6.98	1.87	1.95	8.52	3.04	1.03
	20.4	5.99	5.25	0.660	0.460	18.8	4.26	1.77	1.57	6.77	2.58	1.06
	15.9	4.67	5.00	0.544	0.350	14.9	3.31	1.78	1.51	4.68	1.87	1.00
5	20.0	5.88	5.09	0.491	0.741	14.6	4.39	1.58	1.67	4.67	1.83	0.89
	12.7	3.73	4.66	0.491	0.310	7.81	2.05	1.45	1.20	3.39	1.46	0.95
4	12.75	3.75	4.26	0.425	0.532	5.75	2.08	1.24	1.24	2.33	1.09	0.79
	9.2	2.70	4.00	0.425	0.270	3.50	1.14	1.14	0.94	1.86	0.93	0.83
3½	10.0	2.94	3.86	0.392	0.450	3.36	1.36	1.07	1.04	1.58	0.82	0.73
	7.65	2.24	3.66	0.392	0.250	2.18	0.81	0.99	0.81	1.32	0.72	0.77
3	8.62	2.53	3.56	0.359	0.465	2.13	1.02	0.92	0.91	1.15	0.65	0.67
	6.25	1.83	3.33	0.359	0.230	1.27	0.55	0.83	0.69	0.93	0.56	0.71

## Article 2. Design of Simple and Cantilever Beams

**Application of Mechanics.** In order to select a beam section capable of supporting safely the loads imposed under given conditions, the principles of mechanics are directly applied in determining four essentials: (1) the reactions of the supports; (2) the kinds and intensities of the stresses produced in the beam by the loading; (3) the allowable unit stresses of the material; (4) the amount and distribution of the material necessary to withstand the combined effects of the loading.

**Reactions.** In a beam supported at both ends, which is the most general case in steel building construction, each support reacts with an upward pressure called the reaction. The sum of the two reactions equals the total load on the beam plus its own weight.

In cantilever beams the reaction at the support is equal to the total load on the beam plus its own weight.

**Stresses.** All beams are subjected to both bending and shearing stresses. If the usual beam is loaded to the full value of allowable bending stress, it seldom occurs that the shearing stress has also reached its allowable limit. It may be said, then, that usually the bending stresses govern the design. The section is therefore calculated to withstand the bending and is then investigated for shear. In special beams, such as short grillage foundation beams supporting the load of a column, and in girders carrying heavy concentrated loads near their supports, the shearing stresses may be found excessive although the bending stresses are allowable. A new section must then be selected which combines sufficient shearing strength with requisite bending strength. Buckling or the sideways bending of the web must also be examined for these special cases, and reinforcing plates or stiffening angles applied as required.

**Bending Moment.** The algebraic sum of the moments of the external forces to the left of any section of a beam is the bending moment at that section. Its value may be computed by taking the moments of the reactions and subtracting the moments of the loads to the left of the section. The bending moment varies in value from one part of the beam to another. Its maximum value is reached at a point where the shearing stress is zero or where it changes from a positive to a negative value or from a negative to a positive. When beams are loaded with a uniformly distributed load, a concentrated load at the center of the span or by equal symmetrically placed concentrated loads, the formulae for the maximum bending moment and its position are easily remembered through practice.

Often, however, the loads are not equal or symmetrically placed, or they are combinations of distributed and concentrated loads. Then it is generally more convenient to construct shear and moment diagrams by calculating the shears and bending moments at the points of applica-

tion of the loads, and at intermediate points if necessary, and by laying off to scale their values above or below a horizontal line whose length is the span of the beam. The sign of the shear is generally considered plus if the resultant of the forces to the left of a section of a beam is upward, and minus if the resultant of the forces on the left is downward (Fig. 4,*a*). For bending moments the sign is commonly considered plus when the beam is bent downward with the top fibers in compression, positive bending moment; and as minus when the beam is bent upward and the top fibers are in tension, negative bending moment (Fig. 4,*b*).

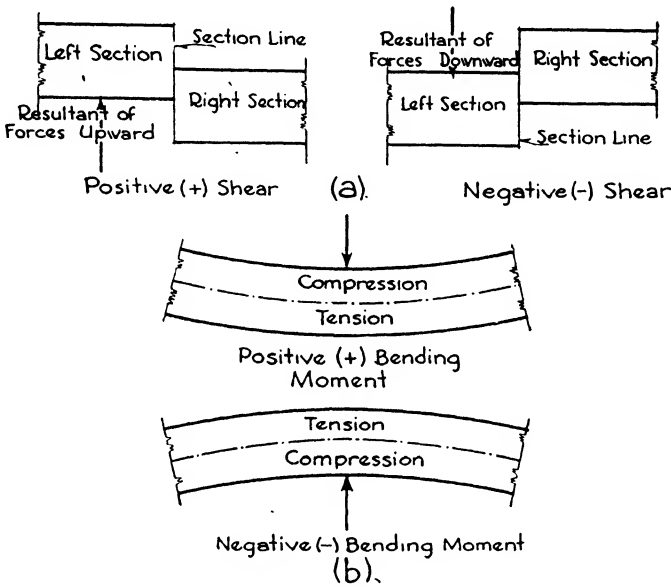

FIG. 4.

In constructing the shear and moment diagrams the positive or plus shear and moment values are laid off above the horizontal line and the negative or minus values below the line. A point where the shear becomes zero or changes its sign will be seen to be the point where the bending moment is maximum. By scaling this distance from one of the supports, the section of maximum bending moment may be determined. The shear diagram is, therefore, constructed first. The bending moments are found by multiplying the external forces to the left of the section by their distances from the section. If the moments of forces acting upward are given plus signs and of those acting downward minus signs, the algebraic sum of the moments will give the magnitude and sign for the bending moment at that section.

**Shear.** The shear at each support is equal to the reaction at that support. At any section between the supports it is equal to the difference



between the reaction at a support and the loads between the section and that support. Consequently if the reactions acting upward are considered positive and the loads acting downward negative, the shear at any point is the algebraic sum of the vertical forces acting between the point and either support. As in computing the bending moment, the shear is determined by considering the forces to the left of the section. Therefore the value of the shear at any section of a beam is equal to the sum of the reactions minus the sum of the loads to the left of the section.

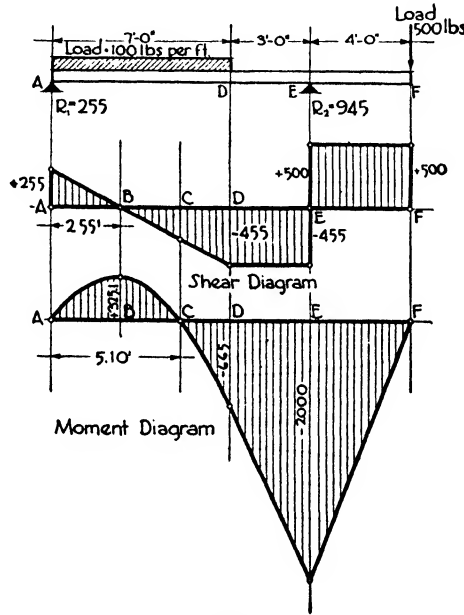

FIG. 5.

**Example 1.** Construct shear and moment diagrams for the beam illustrated in Fig. 5.

1. REACTIONS. Taking the moments of the forces about  $R_2$ , and considering that a uniformly distributed load acts at its center of gravity,  $10R_1 = (700 \times 6.5) - (500 \times 4) = 2550$ ;  $R_1 = 255$  lbs.

Taking the moments about  $R_1$ ,  $10R_2 = (700 \times 3.5) + (500 \times 14) = 9450$ ;  $R_2 = 945$  lbs. These results check because  $R_1 + R_2 = 1200$  lbs. and equals the sum of the loads,  $700 + 500$ .

2. SHEAR.  $V$ , at left support  $= R_1 = 255$  lbs. Lay off this value to scale above the datum line.

$V$ , at a point  $1'0''$  to right of left support  $= 255 - 100 = 155$  lbs.

$V$ , at a point  $4'0''$  to the right of  $R_1 = 255 - 400 = -145$  lbs.

It will be seen that the shear has passed through zero between  $R_1$  and a section  $4'$  to the right. To find this point, call the distance from  $R_1$   $x$ .

Then, since the shear at this point is zero,  $Y = 0 = 255 - 100x$ .

$$x = 2.55'$$

$V$  at 7' from the left support =  $255 - (100 \times 7) = -445$  lbs. The sign being minus, the value 445 is laid off below the datum line.

$V$  is constant to the right of the uniform load up to the right support because no loads intervene to alter its value.

$V$ , at the right of the right support =  $(255 + 945) - 700 = +500$  lbs. Lay off this value above the datum line. The shear continues constant to the end of the beam.

3. BENDING MOMENTS.

$M = 0$  at the left support because there are no forces to the left.

$M$  at 2.55' from left support =  $(255 \times 2.55) - (255 \times 1.275) = +325.1$  ft.-lbs.

The bending moment is zero somewhere between  $R_1$  and the point  $D$ . Call this distance  $x$ .

$$\text{Then } M = 0 = 255x - \left(100 \times x \times \frac{x}{2}\right); 255x - 50x^2 = 0 \text{ or } x = 5.1'$$

The moment curve for a uniform load is a parabola. Lay off the curve above the datum line with values of 0 at  $A$ , 325.1 at  $B$  and 0 at  $C$ .

$M$ , at right end of uniform load =  $(255 \times 7) - (700 \times 3.5) = -665$  ft.-lbs.

This moment being negative is laid off below the datum line.

$M$  at right support =  $(255 \times 10) - (700 \times 6.5) = -2000$  ft.-lbs.

This negative moment is laid off below the datum line.

The moments increase directly from the end of the overhang to the right support, and the moment curve is therefore a straight line. From  $D$  to  $E$  it is also a straight line since the moments increase directly between these points.

Since the shear passes through zero at points  $B$  and  $E$ , the bending moment approaches a maximum at these points, the maximum positive moment being 325.1 ft.-lbs. and the maximum negative moment 2000 ft.-lbs.

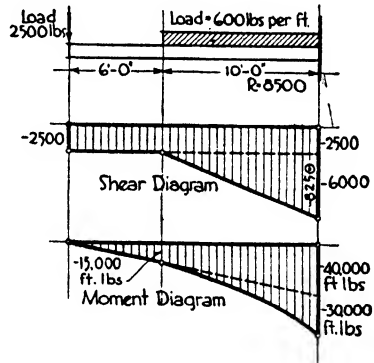

FIG. 6.

**Example 2.** Construct shear and moment diagrams for the cantilever illustrated in Fig. 6.

1. REACTION.  $R = (600 \times 10) + 2500 = 8500$  lbs.

2. SHEAR.  $V$ , at all points between left end of beam and uniform load =  $-2500 - 0 = -2500$  lbs.

$V$ , at support =  $-(2500 + (600 \times 10)) = -8500$  lbs.

3. BENDING MOMENTS.  $M$ , at left end of beam = 0, since there are no reactions or loads to the left.

$M$ , at 6' from left end of beam =  $-(2500 \times 6) = -15,000$  ft.-lbs.

$M$ , at support =  $-(2500 \times 16) - (600 \times 10 \times 5) = -70,000$  ft.-lbs.

The maximum bending moment is at the support; it equals 70,000 ft.-lbs.

The moment line of the uniform load is a portion of a parabola which is tangent to the straight sloping moment line of the concentrated load at the point where the uniform load ceases.

The diagrams for the uniform load and for the concentrated load might have

been constructed separately, as shown by the dotted lines, and their areas combined to determine the total shear and moment stresses.

**Guides.** It is of assistance in constructing shear and moment diagrams to remember the following general principles:

**SIMPLE BEAMS:**

A uniformly distributed load gives a straight sloping shear line and a parabolic moment line.

Concentrated loads give straight horizontal shear lines which change in value at each load by an amount equal to the load.

The difference in value of the bending moment between two points is equal to the area of the shear diagram between the points.

A maximum ordinate of the moment diagram is established at any point where the shear line crosses the datum line.

**CANTILEVER BEAMS:**

A uniformly distributed load gives a straight shear line sloping from the support to the end of the datum line. The moment line is parabolic, curving from the support to the end of the datum line.

A concentrated load gives a straight horizontal shear line from the support to the point of application of the load. The moment line is straight, sloping from the support to the datum line at the point of application of the load.

**Vertical and Lateral Deflection.** In addition to bending and shearing stresses, the loading of a beam produces deflection both vertically and laterally. Vertical deflection is the measure of deformation which the beam has undergone through flexure or bending. Within the allowable limits of stress this deflection does not seriously affect the endurance of the beam. It may, however, be sufficient to crack other substances, such as plaster, which may be supported by the beam. To avoid such an occurrence the vertical deflection of a beam is limited to  $1/360$  of the span when carrying plastered ceilings or other easily disrupted material.

The formula derived by mechanics for the deflection in inches for a uniformly distributed load is

$$D = \frac{5}{384} \times \frac{Wl^3}{EI}; \text{ but } M = \frac{WL}{8} \text{ and } WL = 8M. \text{ Also } M = \frac{fI}{c} \text{ and } l = 12 L.$$

$$\text{Therefore } WL = \frac{8fI}{c}.$$

$$\text{Then } D = \frac{5 \times 8 \times f \times I \times l^3}{384 \times c \times EI} = \frac{40f l^3}{384Ec} = \frac{15fL^2}{Ec} \text{ inches.}$$

The formulae for other cases of frequent loading are given in the succeeding paragraphs on formulae.

The tensile stresses within a loaded beam tend to draw the beam out in a straight line between the supports while the compression stresses tend to bend it laterally. Usually the compressive flanges of beams are secured against lateral bending by the stiffness of the floor systems or by tie rods, and the existence of such bending may be neglected. In

end beams or spandrel beams, the thrust of the floor construction may tend to produce lateral deflection which, if not neutralized by tie rods, may be resisted by combining a channel with the I-beam or by a single beam designed to resist the thrust. For this latter purpose a permissible ratio of flange width to unsupported length has been determined together with formulae for reduction in allowable compressive stress in the upper flange when the ratio exceeds the normal. Several such ratios and formulae have been advanced, those of the American Institute of Steel Construction being now the most generally accepted. The formula is based upon Rankine's column formula. The Institute recommends that it is unnecessary to reduce the full allowable stress of 20,000 lbs./in.<sup>2</sup> until the length of the unsupported flange is more than 15 times its width.

For greater ratios of length of flange to width than 15 to 1, the reduced allowable compressive stress is determined by the following formula, no ratios of more than 40 to 1 being permitted.

$$f_c = \frac{22,500}{1 + \frac{l^2}{1800b^2}}$$

**Buckling.** When relatively short beams are submitted to heavy concentrated loads, the web may cripple or bend sidewise, similar to column action, although the beam may be amply strong to withstand flexure and shear. Intermediate buckling between points of concentrated loads or reactions may also occur. Many tests have shown that shearing stresses, when at their maximum, may be properly resolved at 45° to the axis of the beam into equal compression and tension stresses acting at right angles to each other. The compressive stresses tend to buckle the web, acting, as in a column, at 45° to the neutral axis, and the tensile stresses tend partially to counteract the buckling.

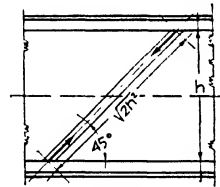

FIG. 7.

The length of the column would be  $\sqrt{2}h$ , where  $h$  is the height between flanges (Fig. 7). Experience has shown that, until  $h$  is over 70 times the thickness of the web, buckling is not to be feared and therefore may generally be neglected in rolled beams, but is important in plate girders. By applying the column formula to the web of a beam and making the proper substitutions the following formula is obtained for determining the safe unit stress to withstand buckling when  $h/t$  is greater than 70. See Article 5 of this chapter.

$$f_b = \frac{18,000}{1 + \frac{h^2}{7200t^2}}$$

For values of  $h/t$  less than 70, a safe unit stress of 13,000 lbs./in.<sup>2</sup>, the same as the safe shearing stress, is now generally accepted.

**Weight of Beam.** The weight of a beam carrying a heavy load over a short span is a very small percentage of the total load, while the weight of a beam carrying a light load over a long span may amount to 4% or more of the total load. Unless its proportion of the total load is 2 or 3%, the weight of the beam is generally neglected. In calculating the weight of floor systems per square foot, the weight of the steel beams or joists is naturally included in arriving at the dead load.

**Formulae for Maximum Bending Moment, Shear and Deflection.** The following formulae and diagrams are adapted to simple and cantilever beams with the most frequent types of loading. Special calcula-

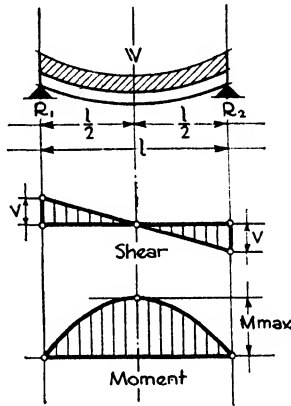

FIG. 8.

tions and diagrams should be made for unusual conditions, the principles, however, always being the same as those already described.

BEAM SUPPORTED AT ENDS

I. UNIFORMLY DISTRIBUTED LOAD (Fig. 8.)

R. Reaction,  $R_1 = R_2 = \frac{W}{2}$ .

V. Shear (max.) =  $R_1 = R_2 = \frac{W}{2}$ .

V. Shear (min. at center) =  $\frac{W}{2} - \frac{W}{2} = 0$ .

M (distance  $a$ ) =  $\frac{Wa}{2} \left( 1 - \frac{a}{l} \right)$ .

M (max. at center) =  $\left( \frac{W}{2} \times \frac{l}{2} \right) - \left( \frac{W}{2} \times \frac{l}{4} \right) = \frac{Wl}{8}$ .

D. Deflection (max. at center) =  $\frac{5Wl^3}{384EI}$ .

2. CONCENTRATED LOAD AT CENTER (Fig. 9).

R. Reaction,  $R_1 = R_2 = \frac{W}{2}$ .

V. Shear (at any point) =  $R_1 = R_2 = \frac{W}{2}$ .

V changes sign at center.

M (distance  $a$ ) =  $\frac{Wa}{2}$ .

M (max. at center) =  $\frac{W}{2} \times \frac{l}{2} = \frac{Wl}{4}$ .

D. Deflection (max. at center) =  $\frac{Wl^3}{48EI}$ .

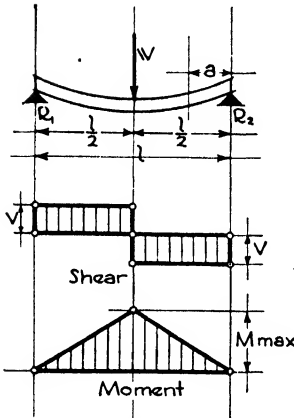

FIG. 9.

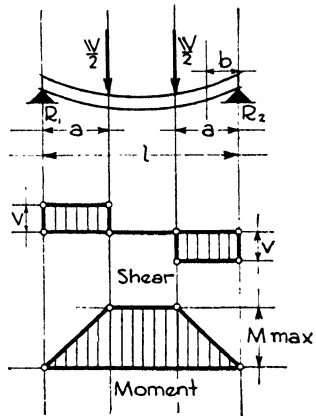

FIG. 10.

3. TWO EQUAL LOADS SYMMETRICALLY PLACED (Fig. 10).

R. Reaction,  $R_1 = R_2 = \frac{W}{2}$ .

V. Shear (max.) =  $R_1 = R_2 = \frac{W}{2}$ .

No shear between loads.

M (at distance  $b < a$ ) =  $\frac{Wb}{2}$ .

M (max. at and between loads) =  $\frac{Wa}{2}$ .

D. Deflection (max. at center) =  $\frac{Wa}{12EI} \left( \frac{3l^2}{4} - a^2 \right)$ .

4. THREE EQUAL LOADS AT QUARTER POINTS OF SPAN (Fig. 11).

R. Reaction,  $R_1 = R_2 = \frac{3W}{2}$ .

V. Shear (max.) =  $R_1 = R_2 = \frac{3W}{2}$ .

V (distance  $a < \frac{l}{4}$ ) =  $\frac{3W}{2}$ .

V (distance  $a > \frac{l}{4}$  and  $< \frac{l}{2}$ ) =  $\frac{W}{2}$ .

M (distance  $a = \frac{l}{4}$ ) =  $\frac{3W}{2} \times \frac{l}{4} = \frac{3Wl}{8}$ .

M (max. at center) =  $(\frac{3W}{2} \times \frac{l}{2}) - (W \times \frac{l}{4}) = \frac{Wl}{2}$ .

D. Deflection (max. at center) =  $\frac{19Wl^3}{384EI}$ .

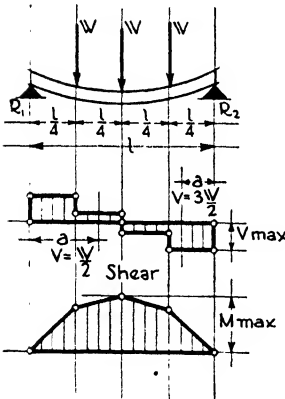

FIG. 11.

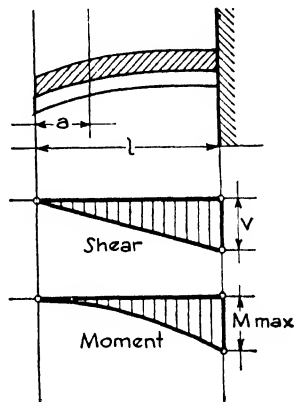

FIG. 12.

CANTILEVER BEAM

I. UNIFORMLY DISTRIBUTED LOAD (Fig. 12).

R. Reaction,  $R = W$ .

V. Shear (max.) =  $R = W$ .

V (at distance  $a$ ) =  $\frac{Wa}{l}$ .

M (distance  $a$ ) =  $\frac{W}{l} \times a \times \frac{a}{2} = \frac{Wa^2}{2l}$ .

M (max. at support) =  $\frac{Wl}{2}$ .

D. Deflection (max. at end) =  $\frac{Wl^3}{8EI}$ .

2. CONCENTRATED LOAD AT FREE END (Fig. 13).

R. Reaction,  $R = W$ .

V. Shear (at any point) =  $R = W$ .

M (distance  $a$ ) =  $Wa$ .

M (max. at support) =  $Wl$ .

D. Deflection (max. at end) =  $\frac{Wl^3}{3EI}$ .

**Allowable Working Unit Stresses.** Allowable working unit stresses have been somewhat increased in value during recent years owing to improvements both in manufacture of steel, in the methods of testing and in the practical deductions from the tests. Although 16,000 lbs./in.<sup>2</sup> for tension and compression and 10,000 lbs./in.<sup>2</sup> for shear are still prescribed in the building codes of some communities, the engineering

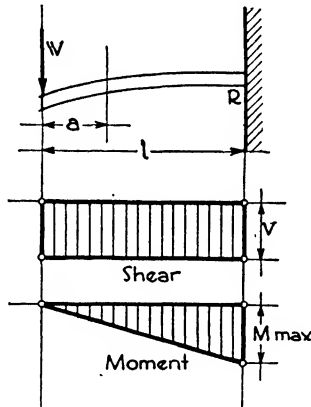

FIG. 13.

societies, the manufacturers and most of the revised codes have now adopted the following permissible stresses:

Structural Steel

Tension and compression.....	20,000 lbs./in. <sup>2</sup>
Shear.....	13,000 lbs./in. <sup>2</sup>
Buckling.....	13,000 lbs./in. <sup>2</sup>
Bearing, steel on steel.....	27,000 lbs./in. <sup>2</sup>

The following properties for the structural grade of steel are generally accepted:

Modulus of elasticity.....	29,000,000 lbs./in. <sup>2</sup>
Elastic limit.....	31,000 lbs./in. <sup>2</sup>
Yield point.....	33,000 lbs./in. <sup>2</sup>
Ultimate strength.....	63,000 lbs./in. <sup>2</sup>

The American Society for Testing Materials specifies that structural steel shall have an ultimate tensile unit stress of 60,000 to 72,000 lbs./in.<sup>2</sup>



and a yield point 0.5 of the tensile strength, but in no case less than 33,000 lbs./in.<sup>2</sup>

**Types of Loads.** In Chapter I the two types of loads, live loads and dead loads, were described, and a table of live loads, depending upon occupancy, was inserted. Before proceeding to the actual design of beams and columns the subject of dead loads will be briefly discussed.

**Dead Loads.** The dead load includes the weight of the permanent structure, such as the steel frame, and floor and wall systems. In the design of beams the weight of the floor construction as well as the loads imposed by permanent partitions play important parts. Movable partitions should also be considered, particularly in office buildings where 15 to 20 lbs./ft.<sup>2</sup> is often added to floor loads to allow for random installations of this kind.

**Table VI. Weights of Floor Materials in Pounds per Square Foot**  
Finished Floors

Wood floors per inch thick . . . . .	3	Asphalt mastic per inch thick . . . . .	12
Cement " " " " . . . . .	12	Linoleum (1/4" standard thickness) . . . . .	1 1/2
Floor tile " " " " . . . . .	10	Rubber tile (3/8" standard thickness)	4

Fills

Cinders per inch thick . . . . .	6	Sand per inch thick . . . . .	8
Screeds (nailing strips) . . . . .	2	Nailcrete " " " " . . . . .	8

Structural Floors

Wood sub-floor per inch thick . . . . .	3	Terra cotta blocks per inch depth . . . . .	4
Plank flooring " " " " . . . . .	3 1/2	Gypsum blocks " " " " . . . . .	3
Gypsum slab " " " " . . . . .	4 1/2	Structural steel per sq. ft. . . . .	8-10
Cinder concrete " " " " . . . . .	9	Reinforcing steel " " " " . . . . .	4-6
Stone concrete " " " " . . . . .	12 1/2		

Ceilings

Plastered direct (2 coats) . . . . .	5	Metal lath (direct) . . . . .	10
Plaster on wood lath (direct) . . . . .	6	Metal lath (suspended) . . . . .	15
Plaster on wood lath (suspended) . . . . .	10	Wood ceiling boards . . . . .	2 1/2

**Design of Beams.** The procedure in designing simple and cantilever beams follows:

1. Make a sketch of the beam showing reactions and locations and magnitudes of loads.
2. Calculate reactions.
3. Calculate shearing stresses and construct shear diagram when the loadings depart from simple types.
4. Determine bending moments at the points where the shear is equal to zero or where it changes sign.

5. Calculate the section modulus,  $S = \frac{I}{c} = \frac{M}{f}$ .

6. Select, from the tables of properties, a beam section having a section modulus equal to or slightly larger than that required by the problem. When two sections have approximately the same section modulus the less heavy section will be more economical and should be chosen unless other considerations govern.

7. Test the section for shear.

8. Test the section for web buckling. This examination is necessary only if there are heavy concentrated loads on relatively short spans.

9. Test for deflection.

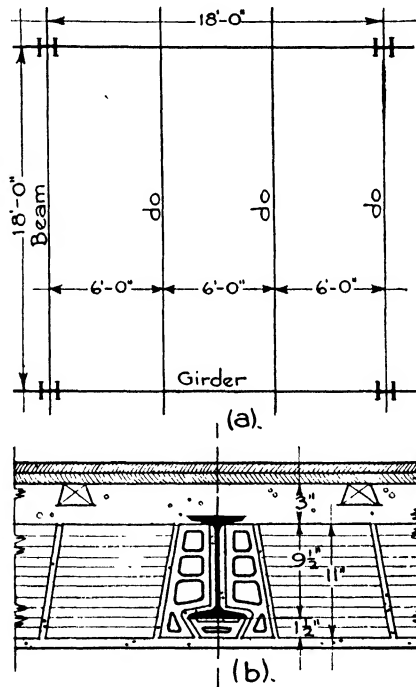

FIG. 14.

**End Conditions.** In steel design with riveted connections, the ends of beams are generally considered to be freely supported and not restrained or fixed, as they may be in reinforced concrete construction. Continuous beams are likewise seldom employed. With welded connections, continuity and restraint may be involved; these will be discussed in Article 3 of this chapter.

**Example 3** (Fig. 14). Floor Beams. A floor panel, between columns, measures 18'0" x 18'0". Girders connect the columns in one direction, and floor beams, on 6'0" centers, supporting the floor system, frame into the girders. The floor arch is of hollow structural clay tile 11" deep, serving to support the beam laterally. Design the floor beam.

1. LOADS. The tile are set  $1\frac{1}{2}$ " below the bottom flange of the beam for fireproofing. It is generally required that  $1\frac{1}{2}$ " depth of tile arch be provided for each foot of span, not including the fireproofing.\* A depth of  $9'+1\frac{1}{2}"$  or  $10\frac{1}{2}"$  is therefore required and a 11" tile is used. The cinder fill will be 3" thick, and the sub-floor and finished floor  $1\frac{3}{4}"$ . A plastered ceiling is applied directly to the under side of the arch. Assume a live load of 60 lbs./ft.<sup>2</sup>

Live load.....	60
Finished floor.....	3
Sub-floor.....	3
3" cinder fill.....	18
11" T. C. arch.....	42
Ceiling.....	<u>5</u>
Total load.....	131 lbs./ft. <sup>2</sup>

The load per linear foot of beam will be  $131 \times 6 = 786$  lbs.

Assume a 10"—25.4# I.  $S = 24.42$ . Add the weight, 25.4 lbs., to 786, and the total load per linear foot is 811 lbs.

Total load on beam,  $811 \times 18 = 14,598$  lbs.

2. REACTIONS.  $R_1 = R_2 = \frac{14,598}{2} = 7299$ , say 7300 lbs.

3. MOMENT.  $M$ , in foot-pounds  $= \frac{WL}{8} = \frac{14,598 \times 18}{8} = 32,845.5$  ft.-lbs.

$32,845.5 \times 12 = 394,146$ , say 394,200 in.-lbs.

4. SECTION MODULUS.  $S = \frac{M}{f} = \frac{394,200}{18,000} = 21.9$  in.<sup>3</sup>

5. SHEAR.  $V = R_1 = 7300$  lbs.  $v = \frac{V}{h \times t} = \frac{7300}{8 \times 0.31} = 2943$  lbs./in.<sup>2</sup>, in which  $h =$

height of web,  $t$  its thickness and  $v$  the shearing unit stress. Since the allowable shearing stress is 13,000 lbs./in.<sup>2</sup>, this section is amply strong to resist shear. This is an example of the fact that, when a beam of long span and comparatively light load is sufficiently strong to resist bending, it is generally amply strong to withstand the shearing stress. The web without the flanges is regarded as resisting shear and buckling.

The crippling stress will be disregarded for the same reason and also because the load is uniformly distributed.

6. DEFLECTION. To avoid the use of the moment of inertia the formula for the deflection of uniformly loaded beams,  $\frac{5WL^3}{384EI}$ , may be changed by substitutions as already described in this chapter to  $D = \frac{15fL^2}{Ec}$ . In the present problem the allowable deflection should not exceed

$$\frac{L}{360} \text{ or } \frac{18 \times 12}{360} = 0.6''.$$

$D = \frac{15 \times 18,000 \times 18 \times 18}{29,000,000 \times 5} = 0.6''$ . The beam is therefore just deep enough not to deflect unduly under its load.

\*When the codes permit the fireproofing to be included in the effective depth of the arch, a tile 10" deep is usually adequate for a 6'0" span between beams.

The deflection coefficient found in the manufacturers' handbooks for each span of every beam may also be used. The deflection is found by dividing the coefficient by the depth of the beam in inches. The coefficients are calculated from the above-mentioned formula.

Use 10"—25.4# Standard I-beams.

**Example 4 (Fig. 15). Girders.** Design the girder illustrated in Example 3. The girder has equal loads of 14,598 lbs., say 14,600 lbs., concentrated at  $\frac{1}{2}$  points of span, the beams of the adjoining panel being assumed to contribute the same loads upon the girder and at the same points as those of the panel in question.

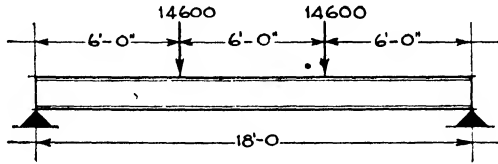

FIG. 15.

1. REACTIONS.  $R_1 = R_2 = 14,600$  lbs.;  $W = 14,600 + 14,600 = 29,200$  lbs.

2. MOMENT.  $M = \frac{Wa}{2} = \frac{29,200 \times 6 \times 12}{2} = 1,051,200$  in.-lbs.

3. SECTION MODULUS.  $S = \frac{M}{f} = \frac{1,051,200}{18,000} = 58.4$ .

Try a 15"—42.9# Standard I with  $S = 58.9$ .

4. Deflection for a girder of 18'0" span should not exceed 0.6".

$D = \frac{Wa}{12EI} \left( \frac{3l^2}{4} - a^2 \right) = \frac{29,200 \times 6 \times 12 \times 207 \times 12 \times 12}{12 \times 29,000,000 \times 441.8} = 0.41''$ , which is less than 0.6".

5. SHEAR.  $v = \frac{V}{h \times t} = \frac{14,600}{12.5 \times 0.41} = 2848$  lbs./in.<sup>2</sup> The beam is safe with respect to shear since the unit shearing stress is less than 13,000 lbs./in.<sup>2</sup>, which is allowable.

### Article 3. Beam Connections. Riveting and Welding

**Types of Connections.** Beams are connected to girders and girders to columns by means of angles which are secured in place by welding or by riveting. Bolts may also be used under certain conditions. Welding has probable advantages in cost, simplicity and quietness of erection which have led to its rapid development. Riveting is by far the most generally employed method of connecting the members in a steel structure and of building up the parts of compound girders, beams, columns and trusses. Unfinished bolts are not so effective a means of fastening for main connections or where vibration from wind or machinery may occur. They are used in low or temporary buildings and are generally permitted in higher buildings for securing beams to beams and beams to girders and for framing subordinate parts such as penthouses, roof purlins and

stairs. They should never be used in the connections of beams and girders to columns, for column splices and braces or for any framing within 3'0" of a column. They do not contribute the stiffness, rigidity and efficiency of rivets, and their use is therefore limited. It is very important that the nuts be prevented from loosening. Turned bolts in reamed or drilled holes are used where it is impossible to drive satisfactory rivets. Washers are used under all nuts.

**Welded Connections.** Two methods of welding are used, as follows:

(a) **RESISTANCE WELDING**, in which an electric current is passed across the joint between two members, the high resistance at the imperfect junction melting the metal so that when pressure is applied a welded connection is obtained. This type of welding is adaptable only to light structural shapes, as in the fabrication of trussed joists and metal lumber.

(b) **ELECTRIC-ARC WELDING**, in which an electric arc is formed between an electrode and the pieces to be welded, both the electrode and the pieces being parts of the circuit.

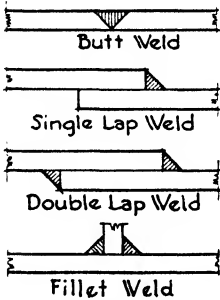
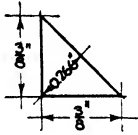

FIG. 16.—Welded Joints.

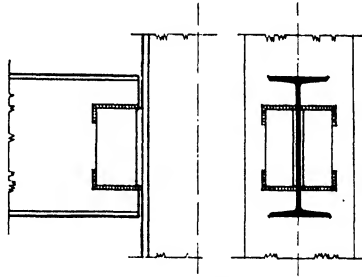

FIG. 17.—Girder Welded to Column.

The electrode, which is held in the workman's hand, contains a  $\frac{3}{16}$ " rod about 14" long which melts off gradually and supplies metal to form the weld. The arc also softens the base steel at the joint so that a perfect union with good penetration is formed. The steel of the electrode, containing about 0.15% carbon and 0.50% manganese, is especially adapted for the purpose.

Several kinds of welded joints are made, such as lap, butt and fillet welds (Fig. 16). In joining beams, girders, columns and trusses, a fillet weld is commonly used to attach connecting angles to the members in much the same combination as when they are secured by rivets (Fig. 17). There is an economy in the elimination of hole punching and drilling, and frequently in the reduction in number of connecting angles and gusset plates. With proper study a greater simplicity of structure is usually possible than in riveted design. On the other hand, the electric

welding equipment is expensive and time is consumed in preparation at each new connection.

The field equipment consists of direct-current generators driven by electric motors or gas engines. For buildings less than 100'0" high the equipment generally remains on the ground with wires running up to the operator. For taller buildings the generators are sometimes raised to the upper floors to reduce the voltage drop in the long circuits.

Some fabricators find welding cheaper than riveting for shopwork, under favorable conditions and careful superintendence. For this reason many roof trusses and built-up girders are now welded in the factory. In field work the conditions are more inconvenient and inspection difficult, and welding is not yet upon an entirely practical basis for the ordinary contractor in the matters of cost and speed. A considerable number of 10- to 20-story buildings have, however, been constructed with welded connections throughout.

In welded work the beams and girders are often designed to run through continuously, and the columns are fitted in above and below them for greater dependability of the welds. A welded joint is always rigid; a riveted joint is not. Welded beams are therefore either continuous or have fixed ends; consequently they must be designed as such and not as riveted beams. The rigid connections made possible by welding are adaptable to the bents and panels introduced in high buildings for wind bracing.

A working stress in a  $\frac{3}{8}$ " fillet weld of 3000 lbs./lin. in., based upon an allowable shearing stress of 11,300 lbs./in.<sup>2</sup>, is recommended by Professor McKibben,\* and this limit is generally accepted. The critical throat dimension for a  $\frac{3}{8}$ " fillet is 0.266". Careful specifications have been compiled by the American Welding Society to cover the design and erection of welded buildings.

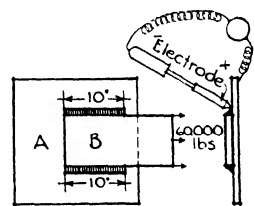

FIG. 18

The following advantages may be regarded as established for welding as compared to riveting:

- (a) Reduction of noise in erection.
- (b) Ease of connection to existing structures and in repairs.
- (c) Rigidity of frame.
- (d) Simplicity of connections and elimination of parts.
- (e) Saving of metal, especially in plate girders, because the elimination of rivet holes permits a greater effective depth and reduced flange areas. Stiffeners consist of plates with one edge welded against the web and flanges instead of angles, thereby discarding one leg of the angle and the filler plates and reducing weight.

The required length of a fillet is determined by dividing the load to be transmitted by 3000. For example, if a load of 60,000 lbs. is to be

\**Civil Engineering*, October, 1930.

transferred from plate *B* to plate *A* the total length of fillet =  $\frac{60,000}{3000} = 20''$  or  $10''$  on each side of plate *B* (Fig. 18).

The following table gives the allowable stresses for various sizes of weld.

**Table VII. Allowable Stresses, Pounds per Linear Inch**

Size of Weld in.	Allowable Stress	Size of Weld in.	Allowable Stress
$\frac{1}{4}$	2000	$\frac{1}{2}$	4000
$\frac{5}{16}$	2500	$\frac{5}{8}$	5000
$\frac{3}{8}$	3000	$\frac{3}{4}$	6000

**Riveted Connections.** Rivets are generally manufactured from round rods of soft steel by upsetting one end into the shape of a hemispherical button head and cutting off the rod to the proper length for the shank. Holes are punched or drilled in the members to be connected, and the rivets after being heated to a light yellow color are inserted through the holes. A second button head is formed upon the shank end by a pneumatic hammer called a riveter to hold the rivet tightly in place and render the joint effective. The work done in the shop, called FABRICATING, is performed in heavy machines which drive the rivet and form the head in one operation, as much of the framing as possible being accomplished in this way. Many connections must, however, be performed in the field, and this work, called ERECTING, is done according to the same principles as the shopwork except that the pneumatic riveter or GUN and the holding tool or DOLLY are hand implements. Air-pressure machines are also used for field drilling and reaming and for grinding and chipping the rivet heads.

It was formerly considered that field riveting was not so efficient as shop riveting, and lower allowable stresses were specified. In modern practice, however, all machine riveting, whether in the shop or field, is regarded as equally effective, the only distinction made in recent specifications being between machine and hand riveting.

Hand riveting, which signifies driving with a hand hammer instead of a pneumatic machine, has almost completely gone out of use except on small jobs not warranting the expenses of the compressed-air equipment. The heating of the rivet causes it to be expanded while the head is formed; the subsequent contraction due to cooling shortens the shank and sets up tensile stresses which draw the plates tightly together. Rivets should not be heated above 1950°F. nor should they be driven when below 1000°F.

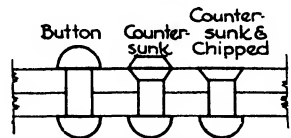

FIG. 19.—Types of Rivets.

**Rivet Holes.** The rivet holes in plates and structural shapes are punched unless the metal is too thick, in which case they are drilled. Punching is cheaper and quicker but is restricted to steel not over  $\frac{3}{4}$ " or  $\frac{7}{8}$ " thick. In building construction, holes are punched  $\frac{1}{16}$ " larger in diameter than the size of the cold rivet to permit its entering when expanded by heat. The process of punching is considered to injure the steel around the hole to the extent of another  $\frac{1}{16}$ ". In design, therefore, the diameter of the hole is taken as  $\frac{1}{8}$ " larger than the nominal diameter of the rivet. Round button heads are the strongest and should be maintained wherever possible. Occasionally, to obtain clearance or for purposes of even bearing, the heads may be countersunk, presenting a slightly convex surface, or countersunk and chipped, which grinds the head level with the adjoining steel. The heads are shaped by the form of the hammer face in the riveter, and for countersunk rivets the holes are beveled out at the surface with a reamer (Fig. 19).

**Size and Spacing of Rivets.** Although rivets are obtainable in a great variety of diameters, only the  $\frac{3}{4}$ " and  $\frac{7}{8}$ " sizes are generally used in building construction with  $\frac{5}{8}$ " for special light framing and 1" for heavy work. The standard connections as published in the steel handbooks are all made with  $\frac{3}{4}$ " rivets. It is difficult to drive rivets over  $\frac{7}{8}$ " in diameter with a hand machine, and to introduce smaller rivets than  $\frac{3}{4}$ " complicates the fabrication and erection. Consequently the practice has become quite general to confine rivets to  $\frac{3}{4}$ " and  $\frac{7}{8}$ " and impose a minimum limit of 8" on the depths of ordinary beams and channels, and of  $2\frac{1}{2}$ " on the widths of angles. The economy in fabrication and erection more than offsets any waste in material. The diameter of the head of a  $\frac{3}{4}$ " rivet is  $1\frac{1}{4}$ "; and of a  $\frac{7}{8}$ " rivet,  $1\frac{7}{16}$ ".

The spacing of rivets depends primarily upon the stresses, but certain guiding rules are generally recognized. Rivets may be driven in one or more rows, the distance between centers of rivets in the same row being called the **PITCH**, and the distance between the rows the **GAUGE**. The minimum pitch should not be less than 3 diameters of the rivet, but the distances should preferably be not less than 3" for  $\frac{7}{8}$ " rivets,  $2\frac{1}{2}$ " for  $\frac{3}{4}$ " rivets and 2" for  $\frac{5}{8}$ " rivets. For  $\frac{3}{4}$ " rivets an average spacing is 3". The maximum pitch is generally limited to 6", although 8" for  $\frac{7}{8}$ " rivets is sometimes used. The minimum distance from the sheared edge of any plate to the center of a rivet hole should be  $1\frac{1}{2}$ " for  $\frac{7}{8}$ " rivets,  $1\frac{1}{4}$ " for  $\frac{3}{4}$ " rivets and  $1\frac{1}{8}$ " for  $\frac{5}{8}$ " rivets, with a maximum of not over 6". The distances of flange rivet holes from the webs of I-beams and channels are fixed in the handbooks for each beam, in order to allow sufficient clearance for the riveting tools. The positions of the holes in the legs of angles are determined for the same reason. See the following table and Fig. 20.

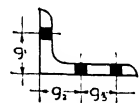

FIG. 20.—Gauge Lines for Angles.



**Table VIII. Gauges for Angles in Inches**

Leg	2	2½	3	3½	4	5	6	7	8
g1. . . . .	1 ⅜	1 ⅜	1 ¾	2	2 ½	3	3 ½	4	4 ½
g2. . . . .						2	2 ¼	2 ½	3
g3. . . . .						1 ¾	2 ½	3	3
Max. rivet	⅝"	¾"	⅞"	⅞"	⅞"	⅞"	⅞"	1"	1 ⅛"

When calculating the resistance of a web plate to shear, the net area of the section is required, that is, the area of the section after deducting the rivet holes. The following table gives the amount of metal subtracted by one hole for ¾" and ⅞" rivets in various plate thicknesses. The holes are ⅛" greater in diameter than the rivets. To obtain the total area subtracted, a corresponding amount here given is multiplied by the number of rivets. For example, if the stiffener legs, at the bearing of a girder, require 14—¾" rivets in a ⅝" web plate, the metal deducted by their holes is 14 × 0.33 = 4.62 in.<sup>2</sup>

**Table IX. Reductions of Area**

Thickness of Plate, inches	Diameter of Hole, inches	
	⅞"	1"
5/16. . . . .	0.27	0.31
3/8. . . . .	.33	.38
7/16. . . . .	.38	.44
1/2. . . . .	.44	.50
9/16. . . . .	.49	.56
5/8. . . . .	.55	.63
11/16. . . . .	.60	.69
3/4. . . . .	.66	.75
13/16. . . . .	.71	.81
7/8. . . . .	.77	.88
15/16. . . . .	.82	.94
1. . . . .	.88	1.00

**Conventional Signs.** The following signs are used on steel drawings to indicate the finish of a rivet. It will be noticed that shop rivets are shown

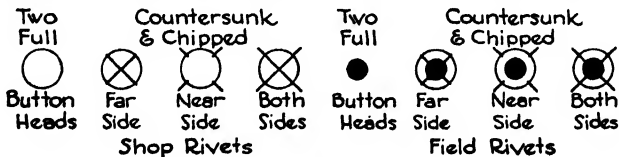

**FIG. 21.—Conventional Signs for Rivets.**

in plan as circles the size of the head; field rivets are indicated as circles the size of the shank. The field rivets are filled in with black (Fig. 21).

**Failures in Riveted Joints.** Riveted joints may fail by the shearing of the rivets or by the crushing of the plates in bearing. If two plates are joined, the rivet is said to be in single shear and is likely to be cut through upon one cross-section. If three plates are joined the rivet is said to be in double shear and is exposed to shearing upon two cross-sections (Fig. 22).

If the plate is thin or the rivet too near the edge, the plate may be crushed by the rivet before the rivet itself gives way to shearing stresses. When the plate is enclosed laterally by angles, as in double shear, it has greater resistance to crushing and a higher bearing value is allowed.

The strength of a riveted joint, then, depends upon the ability of the rivets to withstand the shearing and bearing stresses. The smaller resistance governs the strength of the joint.

**Allowable Unit Stresses.** The following unit stresses in rivets are recommended by modern practice:

SHEARING	LBS./IN. <sup>2</sup>
Power-driven rivets.....	15,000
Turned bolts in reamed or drilled holes..	15,000
Unfinished bolts.....	10,000
	LBS./IN. <sup>2</sup>
BEARING	<i>Single Shear</i> <i>Double Shear</i>
Power-driven rivets.....	32,000      40,000
Turned bolts in reamed or drilled holes..	32,000      40,000
Unfinished bolts.....	20,000      25,000

**Formulae.** SHEAR. The allowable value for a rivet in shear is equal to the product of its cross-sectional area and the allowable unit shearing stress, or

$$\frac{\pi d^2}{4} \times 15,000$$

BEARING. The allowable value for a rivet in bearing is equal to the product of its resisting cross-section and the allowable unit bearing stress, or

$$d \times t \times 32,000$$

in which *d* = diameter of the rivet and *t* = thickness of the plate.

For a 3/4" rivet the safe resistance to shear would be

$$\frac{3.1416 \times (0.75)^2}{4} \times 15,000 = 0.4418 \times 15,000 = 6627 \text{ lbs.}$$

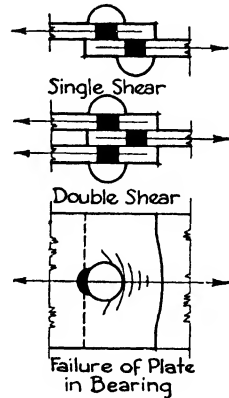

FIG. 22.—Failures in Riveted Joints.

For a  $\frac{3}{4}$ " rivet the safe resistance to bearing on a  $\frac{3}{8}$ " plate would be  $\frac{3}{4} \times \frac{3}{8} \times 32,000 = 9000$  lbs.

The following tables gives the values of  $\frac{3}{4}$ " and  $\frac{7}{8}$ " rivets in single and double shear and their bearing values upon plates of various thicknesses. The unit bearing value of 32,000 lbs./in.<sup>2</sup> is for open or unenclosed bearing, and the value of 40,000 lbs./in.<sup>2</sup> is for enclosed bearing.

**Beam and Girder Connections.** Beams and girders are connected to each other by angles which are generally riveted to the beams in the shop. After the girders are in place in the building, the beams are se-

Table X. Shearing and Bearing Values of  $\frac{3}{4}$ " and  $\frac{7}{8}$ " Rivets

$\frac{3}{4}$ " Rivets. Area 0.442 in. <sup>2</sup>						
Shear	Unit pounds per square inch . . . . .		10 000	12 000	13 500	15 000
	Single shear per rivet . . . . .		4 418	5 301	5 964	6 627
	Double shear per rivet . . . . .		8 836	10 603	11 928	13 254
Bearing	Unit pounds per square inch . . . . .		20 000	25 000	32 000	40 000
	Thickness, inches	$\frac{3}{16}$ . . . . .	2 813	3 515	4 500	5 625
		$\frac{1}{4}$ . . . . .	3 750	4 687	6 000	7 500
		$\frac{5}{16}$ . . . . .	4 688	5 860	7 500	9 375
		$\frac{3}{8}$ . . . . .	5 625	7 030	9 000	11 250
		$\frac{7}{16}$ . . . . .	6 563	8 203	10 500	13 125
		$\frac{1}{2}$ . . . . .	7 500	9 374	12 000	15 000
		$\frac{9}{16}$ . . . . .	8 438	10 547	13 500	16 875
		$\frac{5}{8}$ . . . . .	9 375	11 720	15 000	18 750
		$\frac{11}{16}$ . . . . .	10 313	12 890	16 500	20 625
		$\frac{7}{8}$ " Rivets. Area 0.601 in. <sup>2</sup>				
Shear	Unit pounds per square inch . . . . .		10 000	12 000	13 500	15 000
	Single shear per rivet . . . . .		6 013	7 216	8 118	9 020
	Double shear per rivet . . . . .		12 026	14 432	16 236	18 040
Bearing	Unit pounds per square inch . . . . .		20 000	25 000	32 000	40 000
	Thickness, inches	$\frac{1}{4}$ . . . . .	4 375	5 468	7 000	8 750
		$\frac{5}{16}$ . . . . .	5 469	6 836	8 750	10 932
		$\frac{3}{8}$ . . . . .	6 563	8 203	10 500	13 125
		$\frac{7}{16}$ . . . . .	7 656	9 633	12 250	15 312
		$\frac{1}{2}$ . . . . .	8 750	10 936	14 000	17 500
		$\frac{9}{16}$ . . . . .	9 844	12 305	15 750	19 687
		$\frac{5}{8}$ . . . . .	10 938	13 672	17 500	21 864
		$\frac{11}{16}$ . . . . .	12 031	15 040	19 250	24 062
		$\frac{3}{4}$ . . . . .	13 125	16 405	21 000	26 250

cured to them by field-riveting the angles to the girders. Since an angle is riveted on each side of the beam the shop rivets are in double shear and the field rivets in single shear.

Because several arrangements of connections may be devised to connect one beam safely to another under the same conditions, the steel mills and the American Institute of Steel Construction have developed standard connections so that all beams of the same depth are supplied with the same size connecting angles with the same arrangement of rivets. Much special work is avoided in this way and quicker and cheaper fabrication results, although occasionally the angles may be heavier than necessary. Under unusual conditions, as when short beams have heavy loads, or loads are very near one end, the connections must be calculated, but the standard connections should be used whenever possible. The same angle,  $4'' \times 3\frac{1}{2}'' \times \frac{3}{8}''$ , is always used except for beams under 8'' when  $6'' \times 4'' \times \frac{3}{8}''$  angles are specified. For heavy girders,  $6'' \times 6'' \times \frac{3}{8}''$  angles are generally used for all depths. The length of the angle and the number of rivets vary to suit the individual conditions.

When the tops of the two members to be framed together must be on the same level, it is necessary to cut out or cope the flange of the beam so that its web may fit up close to the web of the girder, (Fig. 23).

Beams and girders are usually ordered 1'' short for clearance to permit the framing of the members without difficulty and to give good bearing for the connecting angles which must be set to exact dimensions (Fig. 23).

The rivet holes are punched or drilled with great precision so that the rivets may be easily inserted without distorting the holes. A tapered steel rod called a DRIFT-PIN is a necessary tool in assembling the members, but to drive it with a sledge hammer through holes in order to line them up is most injurious to the metal. Reaming the holes which do not match is permissible, however.

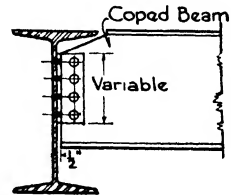

FIG. 23.—Beam and Girder Connection.

**Example 5.** A 16''—50# WF I-beam carries a distributed load of 60,000 lbs. on an 18'0'' span. What angle connection is required?

The reaction on each connection =  $\frac{60,000}{2} = 30,000$  lbs.

From Table II, thickness of web = 0.380 =  $\frac{3}{8}''$ . Use  $\frac{3}{4}''$  rivets. Area = 0.44 in.<sup>2</sup>

Single shear on each rivet, 15,000 × .44	= 6,600 lbs.
Double shear, 2 × 6600	= 13,200
Enclosed bearing, $\frac{3}{8} \times \frac{3}{4} \times 40,000$	= 11,250
Unenclosed bearing, $\frac{3}{8} \times \frac{3}{4} \times 32,000$	= 9,000

Try 2—4'' × 3½'' × ⅜'' angles with 4 rivets in each leg.

**WEB**

Double shear on rivets, $4 \times 13,200$	= 52,800 lbs.
Enclosed bearing on web, $4 \times 11,250$	= 45,000
Unenclosed bearing on angles, $2 \times 4 \times 9000$	= 72,000

**OUTSTANDING LEG.**

Single shear on rivets, $8 \times 6600$	= 52,800
Unenclosed bearing on angles, $8 \times 9000$	= 72,000

The bearing upon the web, 45,000 lbs., controls the strength of the connection and is sufficient for the reaction, 30,000 lbs.

The value of the bearing on the angles is not generally calculated in practice because it is always greater than the shear on the rivets and the bearing on the web.

**Plate Girder Flanges.** The rivets connecting the flange angles to the web plate in plate girders are in horizontal shear since they resist the tendency of the angles to slide over the web. The most exact method for determining the pitch of the rivets to withstand this shearing stress is cumbersome, and the following approximate but sufficiently accurate solution is in general use.

In Fig. 24,  $V$  = the total shear at any section of the girder;

$p$  = the pitch of the rivets;

$P$  = the shearing value of a rivet;

$d$  = effective depth of the girder.

The section is in equilibrium under the action of two balancing couples  $P \times d$  and  $V \times p$ . Then  $V \times p = P \times d$  and  $p = \frac{Pd}{V}$ .

**Example 6.** Calculate the minimum pitch required for the rivets of the flange angles of a plate girder consisting of a  $50'' \times \frac{3}{8}''$  web plate, two  $6'' \times 6'' \times \frac{3}{4}''$  angles and one  $14'' \times \frac{5}{16}''$  cover plate. End reaction, 200,000 lbs. Load, 8000 lbs./ft. Use  $\frac{3}{4}''$  rivets. Distance,  $x$ , from back of angle to axis through center of gravity = 1.78''.

The effective depth,  $d = 50.5 - 3.56 = 46.94''$ , since  $2 \times 1.78 = 3.56$ . Assume the center of the first panel to be 3'0'' from the support; then the shear at this point  $V = 200,000 - (8000 \times 3) = 176,000$  lbs.

The value of a  $\frac{3}{4}''$  rivet in double shear is  $2 \times 6627 = 13,254$ .

Then  $p = \frac{Pd}{V} = \frac{13,254 \times 46.94}{176,000} = 3.5$ . Use  $3\frac{1}{2}''$  pitch.

No cover plate at this section.

The pitch is calculated at the center of each panel throughout the length of the girder, the spacing of the rivets becoming less as the point of zero shear is approached. A maximum pitch of 6'' is, however, generally specified. When there are angle stiffeners they naturally divide the web into panels. In the absence of stiffeners the panels should not be more than 6'0'' long.

**Erection.** Beams and girders are raised and swung into place by steam or electric derricks. They are received by the erectors who secure them with a few temporary bolts through the rivet holes. The riveters then

follow after with their portable heating furnaces and drive in the hot rivets, upsetting the shank to form a head and drawing the steel members tight together. Before riveting is started plumbing of the columns may be necessary, especially those on the corners of the structure and at the elevator shafts. The plumbing is done by means of wire ropes supplied with turn buckles which maintain the columns at the vertical until the riveting on the tier of beams is finished.

The erection of the steelwork generally sets the pace for the other trades, and its systematic progress is very important. On large buildings the steel is raised at one time for two stories above the one upon which the derrick is placed, called the working floor. The steel for the two tiers is sorted upon this floor, swung up and bolted in position. The riveters first rivet the second tier above the working floor, rendering it serviceable for a new working floor. Then while the derricks are being shifted and the steel sorted for the succeeding two tiers above, the riveting of the intermediate story is accomplished. By the time the steel is sorted and bolted in position the riveters are ready to proceed upon the new second tier. Columns are usually fabricated in 2-story lengths. The progress from one 2-story section to the next should require about 4 days, and during this period neither the men nor the derricks are ever idle. The centering for the floor arches follows directly behind the derricks, and the floors are consequently begun before the steel erection is finished. The wall and partition work proceeds close after the floors. The rapid continuity of steel installation is consequently necessary to avoid loss of time in all the trades.

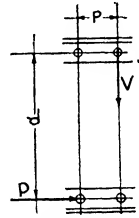

FIG. 24.

#### Article 4. Plate and Box Giders

**General.** For very long spans and heavy loads, rolled sections of beams may not be sufficiently strong and girders built up of plates and angles must be used in their place. Such girders have the general shape of rolled I-sections consisting of plate webs and angle flanges and are known as PLATE GIRDERS. The members must be riveted together so securely that they will act in unison and no joints be overstressed. Because they are composed of several parts any sizes may be obtained, rendering them readily adaptable to a variety of conditions.

**Types.** The simplest type of plate girder consists of a plate for the web and four angles for the flanges (Fig. 25,*a*). Angles with unequal legs, the long leg being horizontal, are more efficient in resisting bending than equal angles because more steel in a given area of angle is at a maximum distance from the neutral axis. If the angles do not contribute sufficient flange area, cover plates are added (Fig. 25,*b*). These plates can be proportioned in length to the intensity of the bending moment and are, therefore, not all required over the entire length of the girder.

It is, consequently, often more economical to resort to flange plates than to use heavy 8"×8" angles which must continue from end to end. If, however, only one flange plate is necessary, it is given the full girder length, as is also the plate next to the angles if two or three plates are used. More than three or four are rarely used, and it is not generally economical to employ flange plates with angles smaller than 5", because of the cost of fabricating.

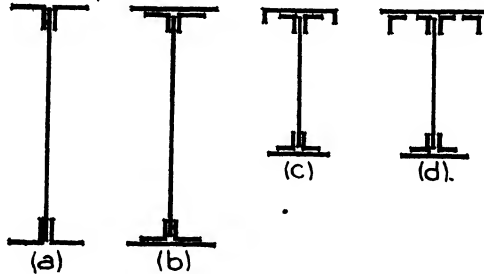

FIG. 25.—Plate Girders.

When girders are unsupported laterally for excessive distances, the upper flange is sometimes reinforced with a channel or with a plate and edge angles to withstand buckling under the compressive stresses.

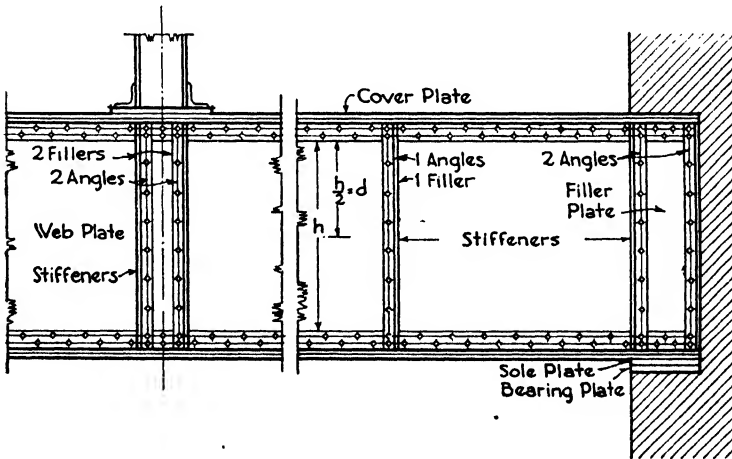

FIG. 26.—Plate Girder.

Such reinforcement has also been employed to support thick masonry walls or columns, but box girders are usually preferred for such columns (Fig. 25, c, d).

The web plate may be strengthened by plates riveted over the por-

tions under greatest shearing stress in the same manner as the flange. The resistance of the web plate to buckling at the end of the girder and under concentrated loads is increased by the addition of stiffener angles acting as columns. They are used in pairs, one on each side of the web plate, and should be milled at the ends to fit tight under the horizontal legs of the flange angles. Filler pieces are usually set under them along the web for even bearing, which is considered better practice than crimping the stiffener angles to fit against the web and the flange angles.

**Length and Depth.** Plate girders are rarely used for spans of more than 100'0", lattice girders or trusses being resorted to for greater distances. The span is counted from center to center of bearing when resting on masonry walls or running over the tops of columns, and as total length of girder when connected between columns.

The economical depth for plate girders is about  $1/12$  of the span or  $\frac{L}{12}$ . Some of the handbooks recommend  $\frac{L}{15}$  as a minimum. Greater proportions of depth to span may call for less material in the flanges but increase the thickness of the webs and the weight of the stiffeners. Girders are very rarely made more than 10'0" or less than 2'0" deep, the usual depths being from 3'0" to 6'0".

**Web.** (Fig. 26). Vertical shear and buckling are withstood by the web alone; its thickness and sectional area must, therefore, be sufficient for its task. The thickness should be at least  $1/170$  of the clear distance between the flange angles and not less than  $5/16$ " to allow for corrosion and to resist buckling under ordinary loads. A shear of 13,000 lbs./in.<sup>2</sup> is generally allowed upon the net web area if the depth is less than 70 times the thickness. If the depth is more than 70 times the web thickness, stiffener angles should be used at the end bearings, under concentrated loads, between concentrated loads and adjacent to the bearings. The net area is equal to the gross area after deducting the rivet holes; it may be found by multiplying the number of rivets by the product of the hole area and the thickness of the web. See Table IX. Because of the slight irregularities in the edges, the web plates are usually made  $1/2$ " narrower than the back-to-back distance between the flange angles, thus giving sufficient clearance for good bearing of cover plates.

**Stiffeners.** There are two classes of stiffener angles: (a) those at concentrated loads and end reactions, and (b) those placed between these points to withstand buckling when the web depth is more than 70 times its thickness.

(a) Stiffeners of the first class evidently act under direct compression and may be considered either as columns, combining flexure with compression, or as struts taking the load in direct bearing. If they are considered columns, the basic column formula may be used. See Article 5 of this chapter.



$$f \text{ (allowable unit stress)} = \frac{18,000}{1 + \frac{18,000}{9,000} \frac{l^2}{r^2}}$$

Because of end restraint by the flange angles,  $l$ , the length, is taken as  $\frac{h}{2}$ , or half the depth between flanges. Then

$$f = \frac{18,000}{1 + \frac{d^2}{9,000} \frac{r^2}{r^2}}$$

in which  $d$  is the effective depth. See Fig. 25. If stiffeners are considered to be struts, the value of  $f$  is fixed at 20,000 lbs./in.<sup>2</sup>, and the area of the stiffeners is found by the formula  $A = \frac{P}{f}$ . Both these formulae produce theoretical results which are generally less in value than the areas of angles required by practical considerations. To obtain good riveting, the leg next to the web should be 3" wide and the outstanding leg still wider to stiffen the web and support the flange, its width generally being 1" less than that of the flange angle. Consequently, if the stiffeners are selected according to the rules of good practice there is little need to calculate them. It is well, however, to check them by the formula

$$A = \frac{P}{f}$$

(b) Stiffeners of the second class occur between the points of concentrated loading and between these points and the end reactions; they are called intermediate stiffeners. They assist in resisting buckling caused by the 45° compressive stresses acting where the shear is high and the bending moments low, and are generally not needed unless the web thickness is less than 1/70 of its height. There is no accurate way to determine the size of the intermediate stiffeners, but the methods of modern practice have proved safe. They are made the same size as the end stiffeners but of thinner metal, and they have a maximum spacing of 7'0".

The following table illustrates appropriate stiffeners for a few generally used flange angles.

Table XI. Dimensions of Stiffener Angles

Flange Angles	Stiffener Angles	
	At Concentrations and Ends	Intermediates
4".....	3 x 3 x 1/2	3 x 3 x 3/8
5".....	4 x 3 x 1/2	4 x 3 x 3/8
6".....	5 x 3 1/2 x 5/8	5 x 3 1/2 x 1/2
8".....	6 x 6 x 3/4	6 x 6 x 1/2

**Flanges.** The upper and lower flanges have different functions, the lower flange resisting tension stresses and the upper flange compression and buckling. Theoretically they might, therefore, have different sections, but for reasons of symmetry and simplicity of fabrication they are both given the larger required area. The flanges are designed to resist the bending moment, and if the compression flange has a laterally unsupported length of more than 15 times its width a reduced compressive stress should be used in determining its section. The following formula, based on the column formula, gives the allowable unit stress as explained in Article 5 of this chapter.

$$f_c = \frac{22,500}{1 + \frac{l^2}{1800 b^2}}$$

The unsupported length should never be more than 40 times the flange width.

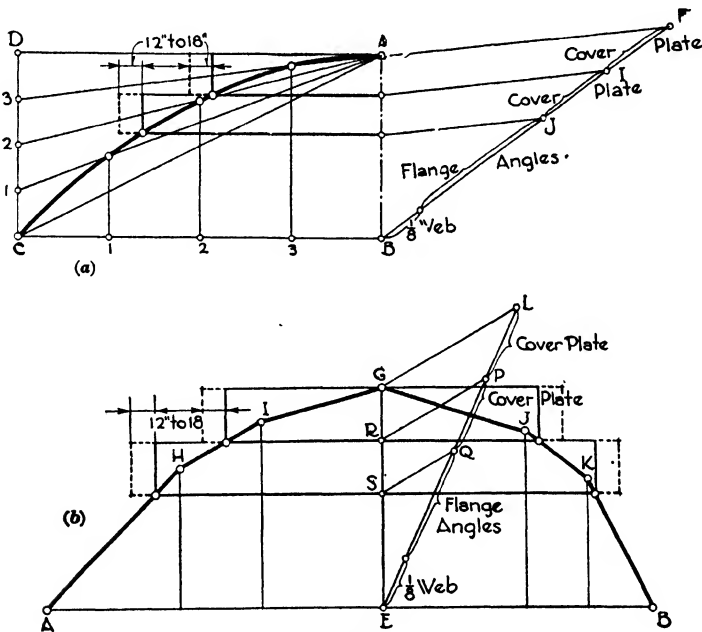

FIG. 27.

In building up flange sections of angles and cover plates, at least  $\frac{1}{2}$  the total area should be included in the angles; otherwise the center of gravity may fall outside the backs of the flange angles, which is not good practice. The most generally used angles are  $4'' \times 3''$ ,  $5'' \times 3\frac{1}{2}''$ ,  $6'' \times 4''$ ,  $6'' \times 6''$  and  $8'' \times 8''$ , with varying thicknesses of metal. Cover plates are not used with the  $4'' \times 3''$  angles because of expense, and may

or may not be used with the larger angles. When used, they are generally 2" wider than the two horizontal legs of the flange angles, that is, 12" coverplates are used with 5" angles, 14" plates with 6" angles and 18" or 20" plates with 8" angles. The portion of the web plate between the flange angles is usually considered as withstanding bending stresses, and its area, frequently taken as  $\frac{1}{8}$  the web section area, is included in calculating the flange section.

**Cover Plates.** The lengths of the cover plates are proportioned to the intensity of the bending moment as already described; they may be determined graphically as follows.

**FOR UNIFORM LOADS (Fig. 27,a).** The moment diagram is a parabola. It can be readily constructed by laying off, to scale,  $AB$  equal to the maximum bending moment and the horizontal  $CB$  equal to  $\frac{1}{2}$  the span. Complete the rectangle  $ABCD$ , divide  $CB$  into a convenient number of equal parts, and  $CD$  into the same number of equal parts. From  $A$  draw the lines  $A-C$ ,  $A-1$ ,  $A-2$ ,  $A-3$ , and from  $CB$  erect perpendiculars from points 1, 2 and 3. The points of intersection of the perpendiculars with the corresponding radiating lines give points on the parabola. The bending moment curve can then be drawn with sufficient accuracy by connecting these points. On any measuring line,  $BF$ , drawn at an angle from  $B$ , lay off the area of  $\frac{1}{8}$  the web section, the area of the flange angles and the areas of the cover plates. Connect  $F$  and  $A$  and draw from  $J$  and  $I$  lines parallel to  $FA$ . From the points of intersection of these lines with  $AB$ , draw horizontal lines cutting the moment curve. The points of intersection on the curve give the theoretical points where the cover plates may be stopped. In practice, 12" or 18" is added at each end of the plate to provide sufficient riveting to develop the efficiency of the plate before it is actually needed as a part of the girder.

**FOR CONCENTRATED LOADS (Fig. 27,b).** The same method may be used for concentrated loads, except that the moment line is found by calculating the moments at the several points of concentration and erecting perpendiculars at these points with lengths proportional to the values of the moments. A measuring line,  $EL$ , is then drawn from the point  $E$  of maximum moment, and the areas of the sections laid off.  $LG$  is drawn, and  $PR$  and  $QS$  parallel to it. The intersections of the horizontal lines drawn through  $R$  and  $S$  with the moment line give the theoretical lengths of the two cover plates.

**Design.** It has been explained that the flanges of plate girders are considered as resisting the bending, and the web the shear and buckling. The thickness and depth of the web plate are selected by rules established by good practice together with the investigation for shear and buckling and the necessity for stiffener angles. The following formula for shear stress is applied:

$$v = \frac{V}{A}$$

in which  $A$  is the net area of the web;  $V$ , the maximum vertical shear; and  $v$ , the shearing unit stress.

The flanges may be calculated by two methods, the MOMENT OF INERTIA method and the CHORD-STRESS method. The first is the more laborious but more accurate, especially for shallow girders. The chord-stress method, however, is usually sufficiently exact. It may be checked for shallow girders by finding the moment of inertia of the established section and testing it by the flexure formula given in the next paragraph.

By the moment of inertia method the moment of inertia of the entire net section including flanges and web plate is calculated, and the moment of resistance and section modulus is determined by the formula

$$M = \frac{fI}{c} \quad \text{or} \quad S = \frac{M}{f}$$

By the chord-stress method, also called flange area method, the tensile and compressive stresses are assumed to be distributed uniformly over the entire area of the tensile and compressive flanges respectively. The effective depth, or the distance between the centers of gravity of the flanges, is then the moment arm of the couple. This method is very generally followed and is permitted by most building codes; it will, therefore, be adopted in this chapter. As already mentioned,  $\frac{1}{8}$  the gross web section area is generally considered as part of the flange section. The formula for the chord-stress method is  $M = fAd$ .

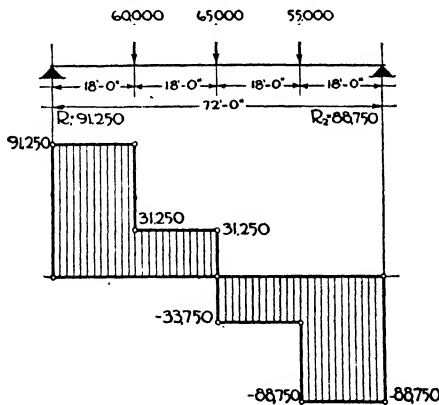

FIG. 28.

The web is first calculated to withstand the shear. The maximum bending moment is determined and the effective depth assumed. By dividing the moment by the effective depth, the flange stress is found. This stress divided by the allowable unit stress gives the required flange area. The flange angles and cover plates are then selected to equal this area after deducting  $\frac{1}{8}$  the gross web section. The lengths of the cover plates can be found by the graphic method previously described.

**Example 7** (Fig. 28). Design a plate girder with span of 72'0" loaded as shown in Fig. 28. Allowance is made in the loads for the weight of the girder, and depth is limited to 6'0".

1. REACTION.  $72 R_1 = (60,000 \times 54) + (65,000 \times 36) + (55,000 \times 18) = 6,570,000$ .  
 $R_1 = 91,250$ ;  $R_2 = 180,000 - 91,250 = 88,750$ .

2. WEB. The thickness should not be less than 1/170 of the clear distance between angles. A total depth of 6'0" will give a web plate 71.5" deep. Assume 6" x 6" x 11/16" flange angles. The clear distance between angles is then 59.5".

$$\frac{59.5}{170} = 0.35", \text{ say } \frac{3}{8}" - \text{thickness of web.}$$

3. SHEAR.  $V = 91,250$ . Bearing value of a 3/4" rivet on a 3/8" plate =  $\frac{3}{8} \times \frac{3}{4} \times 32,000 = 9000$ ;  $\frac{91,250}{9000} = 12$ . To take the bearing on the end support, 12 rivets are required.

The net web area =  $71.5 \times 0.375 = 26.81 \text{ in.}^2$

less (3/8" hole for a 3/4" rivet)  $12 \times 0.875 \times 0.375 = 3.93$

Net web area =  $22.88 \text{ in.}^2$

Total resistance to shear =  $22.88 \times 13,000 = 297,440 \text{ lbs.}$

Since the actual maximum shear is only 91,250 lbs., the assumed web thickness, 3/8", is adequate.

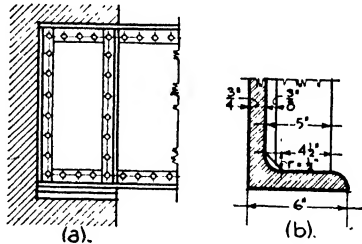

FIG. 29.

4. MOMENT. The maximum bending moment occurs where the shear changes sign, or at the 65,000-lb. load, 36'0" from the supports (Fig. 28).

$$M = (91,250 \times 36) - (60,000 \times 18) = 2,205,000 \text{ ft.-lbs.}$$

5. FLANGE AREA. Assume as effective depth the distance between the centers of gravity of the angles,  $71.5 - 3.5 = 68"$ . Then the stress in the flange or the force of the couple =

$$\frac{M}{d} = \frac{2,205,000 \times 12}{68} = 395,000 \text{ lbs.}$$

The flange area required =  $\frac{395,000}{18,000} = 21.94 \text{ in.}^2$

1/8 web plate =  $\frac{71.5 \times .375}{8} = 3.35$

2 angles, 6" x 6" x 11/16" (less 4 - 3/8" holes) = 13.16

1 plate 14" x 1/2" (less 2 - 3/8" holes) 1/8 = 6.125  
 22.635 in.<sup>2</sup>

Since 21.94 in.<sup>2</sup> is required, the assumed section area of the flange is adequate.

The required length of the flange plate may be found graphically as described in a preceding paragraph. It is general practice, however, when there is only one flange plate to continue it the entire length of the girder.

6. STIFFENERS (Fig. 29,*a*). Stiffener angles will be required under the concentrated loads and at the end reactions. The necessary bearing area of the outstanding leg of the stiffener angle upon the horizontal leg of the flange angle

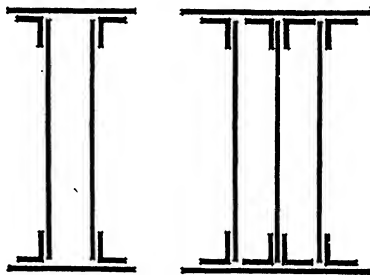

FIG. 30.—Box Girders.

is found by the formula  $A = \frac{P}{f}$ ;  $A = \frac{65,000}{20,000} = 3.25 \text{ in.}^2$  for two angles, one on each side of the web. The radius of the fillet of a 6" x 6" x  $\frac{3}{4}$ " angle is 0.5". True bearing can therefore be obtained on 5" - 0.5" or a 4.5" length of the stiffener leg. The thickness of the leg =  $\frac{3.25}{2 \times 4.5} = 0.36$ ", say  $\frac{1}{2}$ " for practical reasons (Fig. 29,*b*).

For concentrated loads use 2-5" x 3  $\frac{1}{2}$ " x  $\frac{1}{2}$ " angles.

The ends of the beams are reinforced with stiffeners to assist the web in transferring the loads to the bearing plates. The usual method is to rivet a pair

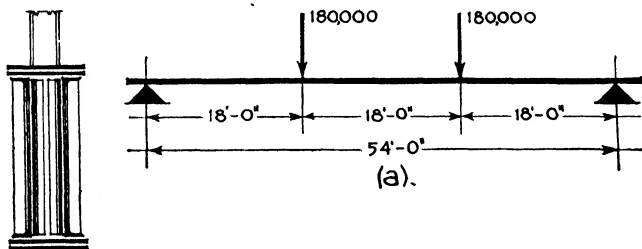

FIG. 31.

of angles at the outer and at the inner edges of the bearing plate, or 4 angles altogether. The method of calculating is the same as just described for the concentrated loads (Fig. 29,*a*).

$$A = \frac{91,250}{20,000} = 4.56 \text{ in.}^2$$

For 4-5" angles the thickness of outstanding leg will be  $\frac{4.56}{4 \times 4.5} = 0.25$ ", say  $\frac{3}{8}$ " for practical reasons. Use 4-5" x 3  $\frac{1}{2}$ " x  $\frac{3}{8}$ " angles.

Because the thickness of the web is less than  $1/70$  the depth, intermediate stiffeners should be introduced to resist buckling in the panels between the concentrated loads and adjoining the supports. The angles should be the same size as those just calculated but of lighter metal, say  $5/16''$ . They should be spaced not more than  $7'0''$  apart.

**Box Girders** (Fig. 30). When heavy concentrated loads, such as those of columns, must be supported, wide flanges and great stiffness are required, and the box girder composed of two or more web plates with plate and angle flanges is often employed. These girders are also used when, for any cause, a large amount of resistance to shear or lateral deflection is necessary.

**Example 8** (Fig. 31). Design a box girder supporting two  $10''$  H-columns each loaded with  $180,000$  lbs. The loads include an allowance for the dead weight of the girder.

1. REACTIONS.  $R_1 = R_2 = 180,000$  lbs. Total load =  $360,000$  lbs.

2. MOMENT.  $M = 180,000 \times 18 \times 12 = 38,880,000$  in.-lbs.

3. SHEAR. Depth of web may equal  $\frac{L}{12} = 54''$ . The box girder will have two web plates, one under each flange of the column or  $10''$  apart.

$$\text{Area of section} = \frac{180,000}{12,000} = 15 \text{ in.}^2$$

The shearing value on a  $3/4''$  rivet is found in the table to be  $6627$ . To take shear in end bearing,  $\frac{180,000}{2 \times 6627} = 14$ , the number of rivets required in each web. To find the net width of web plate,  $54 - (14 \times .875) = 41.75$ , allowing  $1/8''$  hole for each rivet.

Then total web thickness =  $\frac{14}{41.75} = 0.34''$  or  $0.17''$  for each plate. But the minimum thickness of a web plate is  $5/16''$  or  $0.31''$ . Therefore each web plate will be  $5/16''$  thick and  $54''$  deep.

4. FLANGE AREA. Assume  $6'' \times 6'' \times 3/4''$  angles. The effective depth between centers of gravity is  $54 - 3.5 = 50.5''$ . Then the stress in the flange will be

$$\frac{M}{d} = \frac{38,880,000}{50.5} = 769,900 \text{ lbs.}$$

$$\text{The flange area required} = \frac{769,900}{18,000} = 42.77 \text{ in.}^2$$

$$1/8 \text{ gross area of web plates, } \frac{54 \times 0.312 \times 2}{8} = 4.21 \text{ in.}^2$$

$$2 \text{ angles, } 6 \times 6 \times 3/4 \text{ (less four } 1/8'' \text{ holes)} = 14.25$$

$$2 \text{ plates, } 24 \times 9/16 \text{ (less four } 1/8'' \text{ holes)} = 25.04$$

$$43.50 \text{ in.}^2$$

The required flange area being  $42.77 \text{ in.}^2$ , the assumed section is sufficiently large.

5. COVER PLATES. One cover plate will extend the entire length of the girder to connect the two web plates. The upper plate may be stopped off at points where it is no longer needed to resist the bending moment. These points may be determined graphically as already explained or may be found analytically as follows:





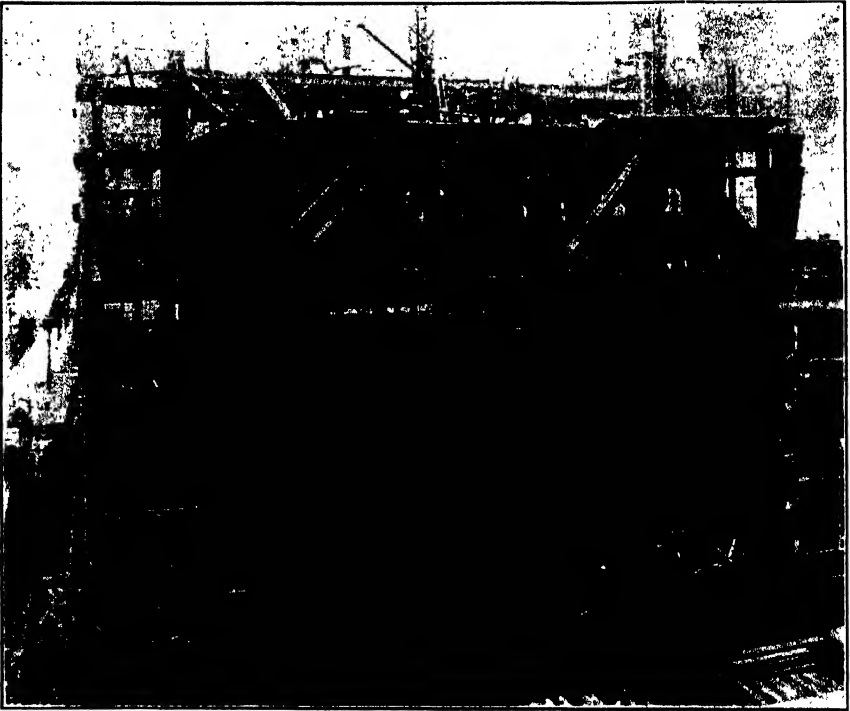

*Howe and Lescaze, Architects*

**OFFSET COLUMNS, PHILADELPHIA SAVING FUND BUILDING.**

(a) Calculate the bending moment developed by the flange section less the top plate.

Flange section area less top plate =  $4.21 + 14.25 + 12.52 = 30.98 \text{ in.}^2$

Flange stress in this area =  $30.98 \times 18,000 = 557,640 \text{ lbs.}$

Resisting moment =  $557,640 \times 50.5 = 28,160,820 \text{ in.-lbs.}$

(b) Determine the distance from the left reaction where the bending moment will equal this value.

$x$  (distance from the reaction)  $\times 180,000 = 28,160,820$ .

$x = 157'' = 13'0''$ .

Over this distance at each end the top cover plate will not be needed. Its length will therefore be  $54'0'' - 26'0'' = 28'0''$  plus  $12''$  or  $18''$  at each end to develop a rivet stress equal to the stress in the plate.

6. STIFFENERS (Fig. 31): The section area of the angles =  $\frac{P}{f} = \frac{180,000}{20,000} =$

$9 \text{ in.}^2$  For reactions use four  $5'' \times 5'' \times \frac{1}{2}''$  angles (area =  $9 \text{ in.}^2$  for outstanding legs). Under each concentrated load use eight  $3\frac{1}{2}'' \times 3'' \times \frac{5}{16}''$  angles, two on the outside and two on the inside of each web plate under both column flanges. Stiffener angles should also be used at intervals of  $7'0''$  and between the concentrated loads and the supports.

### Article 5. Columns

**Loads.** The first and most important consideration in the designing of columns is an accurate calculation of the imposed loads. In a regular floor panel as shown in Fig. 32, column *A* will support on its four sides

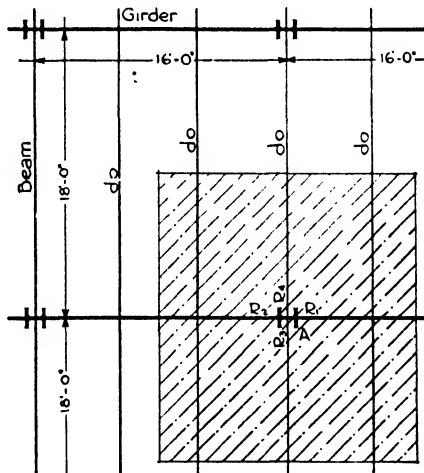

FIG. 32.—Floor Load on Column.

an area equal to the area of a full panel. In the usual procedure the floor loads, beams and girders are determined before the columns, and their weights are used directly in designing the columns. However, when great speed is essential, the columns are designed before the floor

framing, and allowances of loads per square foot of floor area are made for the weight of beams and girders. But the type of floor system and flooring must always be determined before the columns can be designed. In Fig. 32 if the floor system and flooring, including the live load, weigh 186 lbs./ft.<sup>2</sup>, the load upon column *A* would be  $18 \times 16 \times 186 = 53,568$  lbs. If the beams weigh 48.5 lbs./lin. ft. and the girders 96 lbs. per lin. ft., including fireproofing, the load from the steel would be  $[3 \times 48.5 (18 - 1)] + [96 (16 - 1)] = 3913.5$  lbs., supposing the columns to be 12" square. The total floor load on column *A* would then be  $53,568 + 3913.5 = 57,481.5$  lbs. It is customary to express such loads to the nearest 100 lbs., which is sufficiently accurate and presents simpler calculations. The load of 57,481.5 lbs. may then be called 57,500 lbs. It is sometimes more convenient to use the beam and girder reactions, when they have been determined, in ascertaining the load. Column *A* would then support the end reactions of two beams and two girders or the sum of  $R_1, R_2, R_3$  and  $R_4$ . The assumed weight of the column itself and its fireproofing must be added to the floor load, as must also the load from the column above, if one exists, to arrive at the full design load on the column in question.

When the floor-framing adjoining a column is irregular or unsymmetrical, as happens when stair-wells and shafts occur, or when the panel is of unusual shape, it is simpler and more accurate to calculate the column load from the beam and girder reactions than to use the floor-area method.

Besides the floor and superimposed column loads, wall columns also carry the exterior wall loads consisting of the weight of the brick, terra cotta or stone masonry of which they are composed.

**Reductions in Loads.** In Chapter I the theory of reductions in live loads as approved by building codes and engineering societies is discussed. The subject may be reviewed here by stating that roof loads and the loads transferred to a column by its own floor are not reduced, nor are the loads in single-story buildings. But when a building consists of several stories it is allowable to reduce the loads imposed upon a column by the columns above it, according to certain percentages. The following table, recommended by the Building Code Committee of the U. S. Department of Commerce, illustrates these reductions.

**Table XII. Reduction of Live Loads**

Reduction of total live loads permitted upon a column carrying

One floor.....	0%
Two floors.....	10
Three floors.....	20
Four floors.....	30
Five floors.....	40
Six floors.....	45
Seven or more floors.....	50
No reduction being greater than 50%.	

A column on the eighth floor of a 16-story building would consequently carry the following live load:

Floor panels 18'0" x 18'0". Live loads, floor, 100 lbs./ft.<sup>2</sup>; roof, 40 lbs./ft.<sup>2</sup>

Roof	324 × 40 lbs.	= 12,960 lbs. (No reduction)
16th floor	324 × 50	= 16,200
15th	324 × 50	= 16,200
14th	324 × 55	= 17,820
13th	324 × 60	= 19,440
12th	324 × 70	= 22,680
11th	324 × 80	= 25,920
10th	324 × 90	= 29,160
9th	324 × 100	= 32,400

Total live load on eighth-story column = 192,780 lbs.

These reductions are permissible only in stores, office buildings, apartments and places of habitation or refuge, and not in warehouses, storehouses and buildings in which all floors may probably be loaded to their full capacity at the same time.

**Design.** Two types of columns are most generally employed at the present time in building construction, rolled H-columns and built-up plate and angle columns. Both types of columns may be reinforced with cover plates and additional flange angles to render them capable of bearing excessive loads. The H-columns are preferred to the plate and angle type because of simpler fabrication.

**Column Formulae.** Two steel column formulae are in general use, one based on the Rankine formula and the other called the straight-line formula. The Rankine formula is recommended by the American Institute of Steel Construction for a slenderness ratio,  $\frac{L}{r}$ , of more than 120, and the straight-line formula for  $\frac{L}{r}$  not exceeding 120. The derivation of these formulae is explained in Chapter XVI on Mechanics.

From the Rankine formula, the American Institute of Steel Construction has evolved the following formula:

$$\text{The average stress } \frac{P}{A} \text{ shall not exceed } \frac{18,000}{1 + \frac{L^2}{18,000 r^2}}.$$

For main compression members the slenderness ratio  $\frac{L}{r}$  must not exceed 120, and for bracing and other secondary members  $\frac{L}{r}$  must not exceed 200.

The straight-line formula is so called because, if plotted, the result will be a straight line, whereas the Rankine formula will be a curve. Its form is as follows:

$$\frac{P}{A} = 17,000 - 0.485 \frac{l^2}{r^2}$$

$\frac{l}{r}$  for columns must not exceed 120.

It is explained in Chapter XVI on Mechanics that columns of length more than approximately 30 times the radius of gyration always fail under tests by bending and crippling rather than by crushing, it being impossible to obtain conditions of perfect concentric loading. The two column formulae serve to determine an average working stress by decreasing the stress permitted upon short compression members, so that the column will not be overtaxed by both compression and bending. The A. I. S. C. formula reduces the basic stress, 18,000 lbs./in.<sup>2</sup>, by dividing by a number larger than 1, this number increasing as the slenderness ratio increases. The straight-line formula reduces the basic stress, here 17,000 lbs./in.<sup>2</sup>, by subtracting a quantity to obtain the allowable unit stress.

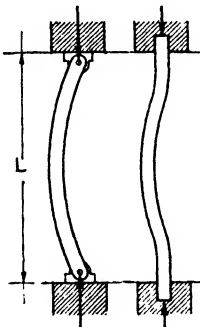

FIG. 33.—End Conditions of Columns.

The end conditions of columns, whether fixed or free to turn, have an important influence upon their manner of bending and upon the constants in the column formulae (Fig. 33). In machine design the end conditions may be definitely recognized, but in structural work the ends are neither entirely free nor entirely fixed. The constants in the Rankine and straight-line formulae used in building construction are determined for intermediate conditions between no restraint and complete restraint. Modern wind bracing, however, often demands rigid connections which must receive especial attention.

**Procedure.** The procedure in designing columns is trial-and-error. By considering the magnitude of the load and the length of the column, a section is selected which is tested by the column formula to ascertain whether or not its unit fiber stress exceeds the allowable stress. If the stress is exceeded, then a larger section must be tried. Experience is naturally of great assistance in selecting a proper section. The steel handbooks are also valuable with their tables of areas, radii of gyration and safe loads.

A stress 15,000 to 13,000 lbs./in.<sup>2</sup> is allowable for columns of slenderness ratio below 60, and of 15,000 to 7,000 lbs./in.<sup>2</sup> for columns with ratios from 60 to 120. By assuming an approximate unit stress, the load can then be divided by the stress to arrive at a probable area of section.

**Example 9.** Design a column 20'0" long to carry a load of 475,000 lbs.

(1) Assume a 12"—120# WF section. The properties as given in Table II are: area of section = 35.31 in.<sup>2</sup>;  $r_{x-x} = 5.51$ ;  $r_{y-y} = 3.13$ . The least radius of gyration is used in the slenderness ratio. Then

$$\frac{l}{r} = \frac{20 \times 12}{3.13} = 76.6$$

$$\text{Allowable unit stress, } \frac{P}{A} = \frac{18,000}{1 + \frac{L^2}{18,000r^2}} = \frac{18,000}{1 + \frac{(76.6)^2}{18,000}} = 13,584 \text{ lbs./in.}^2$$

Since  $\frac{L}{r}$  is less than 120 the formula  $\frac{P}{A} = 17,000 - 0.485 \frac{l^2}{r^2}$  could have been used here. Total allowable load =  $13,584 \times 35.31 = 479,000$  lbs. The assumed section is adequate.

**Eccentric Loading.** Interior columns with beams and girders framing to them on opposite sides are seldom so unsymmetrically loaded as to necessitate special design. Certain eccentricities may exist, as when the beam on one side of the column is more heavily loaded than the one on the other side, or when a beam is framed on only one side of a column, as at an elevator shaft. Under these conditions, however, the eccentricity is usually neglected for the following reasons: (a) a basic stress is used well below the elastic limit; (b) the column formula provides a further reduction of the basic stress; (c) the axial load of the upper tier column minimizes the tendency toward bending due to eccentricity in the column in question.

Exterior or wall columns, on the other hand, very frequently receive loads of sufficient eccentricity to exercise serious bending stresses. Examples are girders framing into the flanges of the columns and wall or spandrel beams framed to one side of the column axis or carried upon brackets outside the column. Members framed into the web of an H, or plate and angle column, have bearings so close to the column axis that the eccentricity is negligible. It is often difficult to fit large beams into the web, however, and the connections are awkward. Wall columns are, therefore, generally set with their flanges parallel to the wall, and the girders are framed against the flanges. This arrangement involves an eccentric load with a moment arm equal to the distance from the center of the beam seat to the axis of the column (Fig. 34).

For formula for the eccentric loading is derived from Rankine's column formula as explained in Chapter XVI by adding the stress caused by the eccentric load,  $\frac{P'ec}{I}$

$$f = \frac{P}{A} + \frac{PL^2}{18,000Ar^2} + \frac{P'ec}{I}$$

in which  $r$  = least radius of gyration;  $I$  = moment of inertia with respect to the axis about which the bending occurs;  $e$  = the eccentricity;

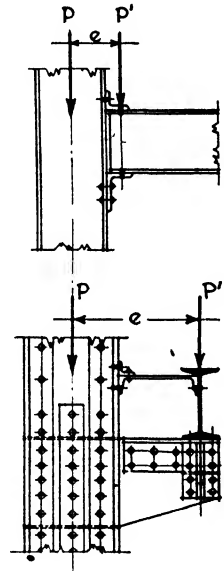

FIG. 34.—Eccentric Column Loading.

$c$  = distance from column axis to extreme fiber;  $P$  = sum of axial and eccentric loads, and  $P^1$  = the eccentric load.

The column tables in the handbooks give bending factors,  $B_x$  and  $B_y$ , for each section. If the bending moment caused by the eccentric load is multiplied by the bending factor for the axis, the product is the equivalent axial load on the column producing the same compressive stress as the eccentric load.

**Example 10** (Fig. 35). Design a column 25'0" long to support a concentric load of 418,000 lbs. and a load of 50,000 lbs. whose eccentricity is 10".

(1) Assume a 14"—WF 142 column whose properties are as follows:  $b = 15\frac{1}{2}"$ ;  $d = 14\frac{3}{4}"$ ;  $r_{x-x} = 6.32$ ;  $r_{y-y} = 3.97$ ;  $A = 41.85$ ;  $c = 7.37"$ ;  $I_{1-1} = 1672$ .

$$f = \frac{468,000}{41.85} + \frac{468,000 \times (300)^2}{41.85 \times 18,000 \times (3.97)^2} + \frac{50,000 \times 7.37 \times 10}{1672} =$$

11,182 + 3,547 + 2,204 = 17,000 lbs. The assumed section is adequate since the allowable unit stress is 18,000 lbs./in.<sup>2</sup>

**Plate and Angle Columns.** Columns consisting of plate webs and angle flanges, with or without flange plates, may be built up with a great range of section areas and to suit a variety of conditions. There are a few guides which may be followed in the preliminaries of the design, but in general the procedure is the same as for rolled columns. These guides are as follows:

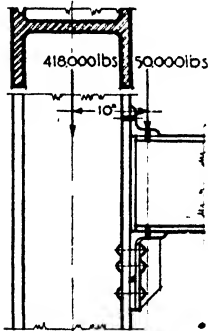

FIG. 35.

(a) Plate and angle columns are seldom made with web plates less than 8" wide, and for ordinary web connections a 12" plate is more convenient.

(b) Angles with unequal legs are generally used with the longer legs outstanding, to obtain a larger radius of gyration. The shorter legs should not be less than 3", and the longer ones are usually at least 5" or 6". The least radius of gyration is generally about the axis running longitudinally through the web, and its approximate value for

this type of column, about this axis, may be derived from the formula  $r = 0.22 \times b$ .

(c) The thicknesses of metal in the web plate, flange angles and flange plate should be approximately the same, to conform with good practice.

(d) The diameter of a rivet should not be less than  $\frac{1}{4}$  the total thickness of the metal through which it is driven.

The handbooks of the steel mills contain data as to the properties and load-bearing capacities of plate and angle columns made up in a great variety of sizes. It is a convenience to refer to these lists for the  $A$ ,  $I$ ,  $S$  and  $r$  of various combinations of angles and plates.

**Example 11.** Design a plate and angle column, having flange cover plates, 14'0" long to support 500,000 lbs.

1. ASSUMPTIONS. Since the load is fairly heavy a 14" x 14" column will be assumed. Approximate radius of gyration of this type of column is  $14 \times 0.22 = 3.08''$ , say 3. The slenderness ratio will then be approximately  $\frac{14 \times 12}{3} = 56$ , consequently 15,000 lbs./in.<sup>2</sup> will be tried as allowable fiber stress.

2. AREA.  $\frac{500,000}{15,000} = 33.3 \text{ in.}^2$  Try four 6" x 4" x 1/2" angles 19.00 in.<sup>2</sup>  
 one 14" x 3/8" web plate 5.25  
 two 14" x 3/8" flange plates 10.50  
 34.75 in.<sup>2</sup>

3. MOMENT OF INERTIA (I) Axis y - y.

I of four 6 x 4 x 1/2 angles,  $4 \times 17.4 = 69.6$

$A d^2$  of four 6 x 4 x 1/2 angles,  $4 \times 4.75 \times (2.17)^2 = 89.4$

I of one 14 x 3/8 web plate,  $1 \times \frac{14 \times (0.375)^3}{12} = .06$

I of two 14 x 3/8 cover plates,  $2 \times \frac{0.375 \times (14)^3}{12} = 171.50$   
 330.56, say 331 in.<sup>3</sup>

4. RADIUS OF GYRATION,  $r = \sqrt{\frac{I}{A}} = \sqrt{\frac{331}{34.75}} = 3.09'' = \text{least radius.}$

5. ALLOWABLE UNIT STRESS.

Slenderness ratio  $= \frac{L}{r} = \frac{14 \times 12}{3} = 56; \frac{L^2}{r^2} = 56^2 = 3,136.$

$f = \frac{18,000}{1 + \frac{L^2}{18,000r^2}} = \frac{18,000}{1 + \frac{3,136}{18,000}} = \frac{18,000}{1.17} = 15,384 \text{ lbs./in.}^2$

But the stress is limited by specifications to 15,000 lbs./in.<sup>2</sup>

6. ALLOWABLE TOTAL LOAD.

$P = Af = 34.75 \times 15,000 = 521,250 \text{ lbs.}$

### Article 6. Column Connections

**Column Splicing.** Columns usually are fabricated in two-story lengths, this being the most convenient practice. One-story lengths require an unnecessary number of connections, and three-story lengths are awkward to handle. The splicing is done with plates riveted to the flanges, covering the joints, with smaller plates on the webs of the columns. The joints should occur 2'0" or 3'0" above the floor level so as not to complicate the connections of the beams and girders. Columns should be milled to accurate bearings at the joints, and the splice plates should have sufficient length to hold the sections in line and to resist bending stresses from wind pressure or other causes. The plates are not intended to transfer the load (Fig. 36).

It is a convenience, in many ways, to vary the width of the columns from story to story as seldom as possible, the differences in required bearing capacity being obtained by increasing or decreasing the area and weight of the section. Built-up sections called constant-dimension



columns are especially fabricated by the steel companies to fulfill this condition. When a column section of smaller dimension must be spliced to one of larger section below, as a 10" section to a 12" section, horizontal bearing plates are used between the sections, and filler plates are inserted under the splice plates to take up the difference in dimensions. Splice plates are riveted to the lower section in the shop and to the upper section in the field.

**Column and Beam Connections.** There are two methods of connecting beams and girders to columns, namely, seated connections and framed connections. The former is used whenever possible because of greater ease of erecting.

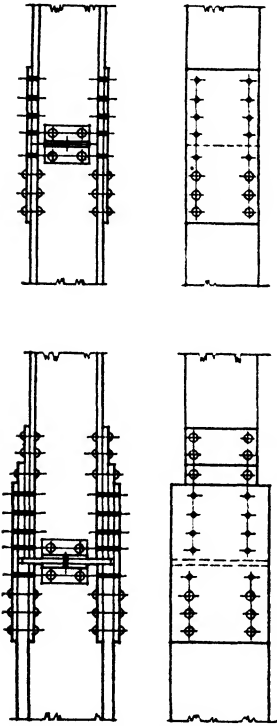

FIG. 36.—Column Splicing.

**SEATED CONNECTIONS** are made with seat angles, the standard size being 6" x 4" with the 4" leg outstanding to give bearing for the beam, and the 6" leg riveted against the column flange or web (Fig. 37). A clearance of  $\frac{1}{2}$ " is maintained in shop practice between the column and the end of the beam, thus giving a seat of  $3\frac{1}{2}$ ". For light reactions, up to 26,400 lbs., the angle alone is generally sufficient, the thickness being  $\frac{1}{2}$ " for loads up to 15,000 lbs., and  $\frac{5}{8}$ " from 15,000 to 26,400 lbs. The controlling value is the single shear on the rivets through the vertical leg. Since only four rivets, two in each gauge line, can be contained in a 6" leg, and the shear value of a  $\frac{3}{4}$ " rivet at 15,000 lbs./in.<sup>2</sup> is 6620 lbs., then the total shear sustained by the four rivets will be  $4 \times 6620 = 26,480$  lbs. When the reactions are larger than 26,400 lbs., a stiffener is used. This consists of an angle riveted against the 6" leg of the seat angle and acting as a bracket under the outstanding leg. Since its purpose is to provide more

riveting space to withstand the shear, it is longer than the 6" leg and must be provided with a filler plate. The stiffeners also assist in resisting bending in the seat. They are generally used in pairs with their backs together under the center of the beam. The lower ends are clipped at 45° for better appearance, and the upper inside corners are ground off to clear the fillet of the seat angle. A field-riveted angle also secures the top flange of the beam to the column and gives it lateral rigidity.

When the projection of the stiffeners is objectionable because of interference with interior finish, **FRAMED CONNECTIONS** are used consisting of an angle on each side of the beam, one leg riveted to the web

and the other to the column. Because of the difficulty of swinging the girder into place and catching the holes of the connection, an angle,

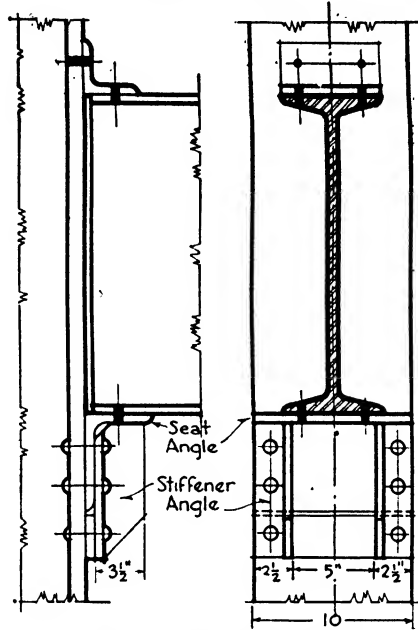

FIG. 37.—Seated Connection.

called an erection seat, is often bolted to the column about 1/4" below the true level of the bottom of the lower flange. The girder is then

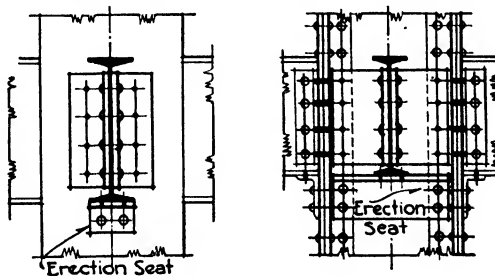

FIG. 38.—Framed Connection.

raised on to the seat, shimmed up until the rivet holes are opposite each other and riveted into place. The erection seats are then removed (Fig. 38).

**Example 12** (Fig. 37). What is the proper seat connection to a 10" column for a 20"—65.4# I-beam with an end reaction of 35,000 lbs.? Use 3/4" rivets. Assume that seat extends width of column.

1. To find the thickness of the angle seat, assume that it is to resist bending. The center of bearing of the beam reaction on the angle seat is considered to be at the  $\frac{1}{2}$  point of the bearing length or  $0.5'' + \frac{3.5''}{3} = 1.67''$  from the column face. The arm of the moment ( $a$ ) is the distance from the center of bearing to the face of the angle less the fillet radius, or  $(0.5 + \frac{3.5}{3})'' - 0.5'' - 0.5'' = 0.67''$ , using an average value of  $\frac{1}{2}''$  for the thickness of the angle.

Then  $M = R \times a = 35,000 \text{ lbs.} \times 0.67'' = 23,450 \text{ in.-lbs.}$

$S$  (section modulus) =  $\frac{bt^2}{6}$ , and  $M = Sf$ . Then  $M = \frac{fbt^2}{6}$  and

$$i = \sqrt{\frac{6M}{fb}} = \frac{6 \times 23,450}{24,000 \times 10} = 0.76'', \text{ say } \frac{3}{4}''$$

$f = 24,000 \text{ lbs./in.}^2$  because of the restraint in the vertical leg and the fillet.

2. To find the number of rivets to resist shear,  $\frac{35,000}{6620} = 5.4$ , say 6 rivets. A

$6'' \times 4'' \times \frac{3}{4}''$  angle seat will accommodate only four rivets, therefore two stiffener angles are required, each  $3\frac{1}{2}'' \times 2\frac{1}{2}'' \times 5/16''$  with the  $3\frac{1}{2}''$  leg outstanding.

Use  $6'' \times 4'' \times \frac{3}{4}''$  angle seat and two  $3\frac{1}{2}'' \times 2\frac{1}{2}'' \times 5/16''$  stiffeners.

When wind bracing is necessary, the joints between the columns and girders are made more rigid by means of heavy connection angles, gusset plates and brackets as discussed in Article 7 of this chapter.

**Column Bases.** The foot of a column transfers the entire load to the footing, which in turn transfers it to the foundation bed. The footing is generally a concrete slab or pier even when the foundation bed is rock. If the end of the steel column rested directly upon the concrete, the concrete would be crushed because the allowable unit compressive stress in steel is much greater than the ultimate compressive stress of concrete. The column load must, therefore, be distributed by some means so that the allowable unit bearing stress in the concrete is not exceeded. For fairly light loads the column is flared out at the bottom by adding wide plates, cut at an angle, to carry the dimensions of the column out to the extremities of the base plates, which are of sufficient size to distribute the load to the concrete (Fig. 39,a). Bases of this type, and cast-iron bases, were formerly used also for heavy loads, but at the present time the rolled-steel slab, or billet, is preferred. It can be ob-

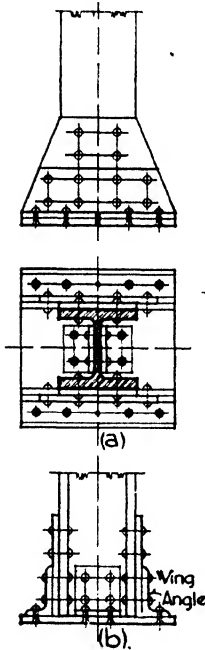

FIG. 39.—Column Bases.

is flared out at the bottom by adding wide plates, cut at an angle, to carry the dimensions of the column out to the extremities of the base plates, which are of sufficient size to distribute the load to the concrete (Fig. 39,a). Bases of this type, and cast-iron bases, were formerly used also for heavy loads, but at the present time the rolled-steel slab, or billet, is preferred. It can be ob-

tained in greater thickness than a plate, to resist the bending moments, and it requires only a pair of 6'' x 4'' wing angles for securing the column during erection, therefore greatly simplifying fabrication. The end of the column should be milled, and the surface of the slab is sometimes planed for perfect contact in bearing. When the slab rests on steel grillage beams, both sides may be planed (Fig. 40).

Billets are considered economical up to 6'' in thickness, grillage beams being employed when a greater thickness is required. The size of the slab or billet is determined by the bearing power of the material upon which it rests, or upon the outside dimensions of the column. When the billet rests on concrete, its area is determined by dividing the column load by 500, the allowable stress per square inch for concrete in direct bearing. When it rests upon grillage, the actual necessary area is determined by the bearing of steel upon steel, 27,000 lbs./in.<sup>2</sup>, or by compression in the webs of the grillage beams, 18,000 lbs./in.<sup>2</sup> But, for practical reasons, the slab must be larger than the column area, and this necessity, and other requirements of good practice, often result in an area much larger than the actual compressive-stress requirement of the steel.

The thickness of the slab is determined by the maximum bending moment caused by the uniform resistance of the footing. The usual method is to consider the slab as a cantilever because of the inflexibility of the column.

If  $P$  = column load,

$f_c$  = allowable unit compression on concrete, 500 lbs./in.<sup>2</sup>,

$f_s$  = allowable unit fiber stress in bending in steel, 18,000 lbs./in.<sup>2</sup>,

$w$  = unit pressure upward on slab, in pounds per square inch,

then  $A$ , area of slab =  $\frac{P}{f_c}$ ;  $w = \frac{P}{A}$ ;  $M = \frac{w(D-d)^2}{8}$  or  $\frac{w(B-b)^2}{8}$

$S$ , section modulus =  $\frac{bt^2}{6}$ ; for  $b = 1''$ ,  $S = \frac{t^2}{6}$ ; but  $S = \frac{M}{f} = \frac{M}{18,000}$ .

Therefore

$$t^2 = \frac{6M}{18,000} = \frac{M}{3,000} = \frac{w(D-d)^2}{24,000} \text{ or } \frac{w(B-b)^2}{24,000}, \text{ whichever is greater.}$$

Some of the steel manufacturers' handbooks consider it more accurate, because of the shape of an H-column, to use the values  $(D-0.95d)$  and  $(B-D.8b)$  instead of  $(D-d)$  and  $(B-b)$ , but the method first given above is sufficiently exact and is in very general use.

**Example 13** (Fig. 40). A 14'' H-column carries a load of 1,200,000 lbs. upon a concrete pier. Design a square steel billet base.

1. Area.  $A = \frac{P}{f_c} = \frac{1,200,000}{500} = 2400 \text{ in.}^2$  Use a 50'' x 50'' slab.

2. Unit load.  $w = \frac{P}{A} = \frac{1,200,000}{2500} = 480 \text{ lbs./in.}^2$

3. Thickness.  $D - d = B - b = 50 - 14 = 36''$ .

$$t^2 = \frac{w(D-d)^2}{24,000} = \frac{480 \times (36)^2}{24,000} = 25.91; t = 5.09''.$$

The finished slab would be  $5\frac{1}{4}''$  thick and would be planed down from a  $5\frac{1}{2}''$  rolled slab.

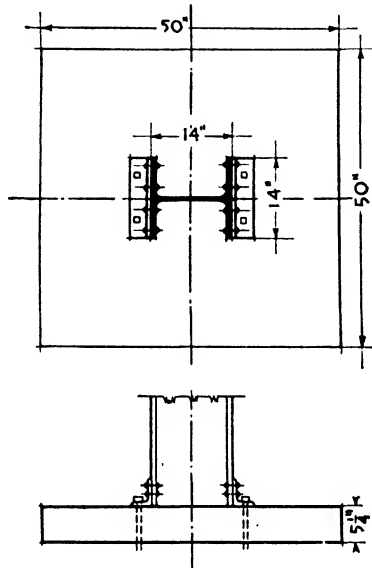

FIG. 40.—Steel Billet Base.

Further discussion of rolled steel slab bases in their relation to grillage beam footings will be found in Chapter XXIV, Foundations.

### Article 7. Wind Bracing

**General.** Buildings with masonry supporting walls are generally sufficiently solid and rigid to render additional precautions against the pressure of the wind unnecessary. For structures of skeleton steel, however, both of the mill and the skyscraper types, the stiffness of the walls is negligible and the steel frame itself must be rendered sufficiently rigid to resist the horizontal forces produced by the wind.

**Intensity of Wind Pressure.** The velocity of the wind varies greatly in the different parts of the United States. At Miami, Florida, in 1926 it was measured as reaching 128 miles/hr., and squalls around New York have attained 96 miles. These velocities are for 5-minute periods, and for sudden gusts of wind they may well be greater. It is quite possible, then, that anywhere along the Atlantic coast 100 miles/hr. may be reached during the life of a modern building. Many experiments have shown that a velocity of 100 miles/hr. produces a pressure of 30 lbs./ft.<sup>2</sup>

of surface, and this force is adopted by the New York Building Department for tanks, high chimneys and exposed signs. For the vertical surfaces of buildings in ordinary situations, the New York Code specifies a pressure of 20 lbs./ft.<sup>2</sup>, and for an isolated structure exposed to the full force of the wind throughout its entire height, 25 lbs./ft.<sup>2</sup>

Experiments show that wind increases in velocity with height up to the level of the gradient wind, that is, wind free from surface disturbances. It is also reasonable to consider the lower portions of tall buildings, situated in built-up areas, to be shielded by surrounding structures and consequently exposed to less wind pressure. The Sub-Committee of the American Society of Civil Engineers recommended in its report submitted January 22, 1931, "that for the first 500' of height the prescribed wind force be 20 lbs./ft.<sup>2</sup> From the 500' level up, it is recommended that it be increased by 2 lbs./ft.<sup>2</sup> for each 100' of height, thus amounting to 30 lbs./ft.<sup>2</sup> at the 1000' level and to 40 lbs./ft.<sup>2</sup> at the 1500' level."

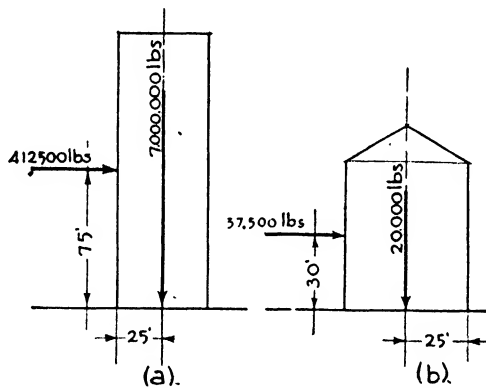

FIG. 41

**Effects of Wind Pressure.** Wind pressure produces (a) a tendency to overturn the building as a unit, (b) a tendency to distort or collapse the building and (c) a tendency to cause vibration by movement in the joints.

The tendency for a building to overturn must be resisted either by the weight of the building or by anchorage to the foundations. In high buildings, or those of extensive area, the possibility is slight because of great dead weight or of large ground area compared to height. In mill buildings, which may be narrow with a sheet-metal enclosure and few interior supports, the possibility of overturning should be investigated.

**Example 14** (Fig. 41, a). A building 50'0" x 110'0" in plan and 150'0" high weighs 7,000,000 lbs. What is the possibility of its overturning under a wind pressure of 25 lbs./ft.<sup>2</sup>?

1. **OVERTURNING MOMENT.** The tendency to overturn is evidently greatest in the direction of the least horizontal dimension. The resultant of the wind pressure will act at the middle point of the height.

Then  $M = 110 \times 150 \times 25 \times 75 = 30,937,500$  ft.-lbs.

2. **RESISTING MOMENT** = weight  $\times \frac{\text{least dimension}}{2} = 7,000,000 \times 25 = 175,000,000$  ft.-lbs.

The building will not overturn.

To care for emergencies, the ratio of the moment of resistance to the overturning moment should not be less than 1.5 to 1.

**Example 15** (Fig. 41, *b*). A steel mill building 50'0" wide and 60'0" high is framed of panels 25'0" wide between columns. Dead load of one panel is 20,000 lbs. What is the possibility of overturning under a wind pressure of 25 lbs./ft.<sup>2</sup>?

1. **OVERTURNING MOMENT.**  $M = 60 \times 25 \times 25 \times 30 = 1,125,000$  ft.-lbs.

2. **RESISTING MOMENT** = 20,000  $\times$  25 = 500,000 ft.-lbs.

The building will overturn unless anchored.

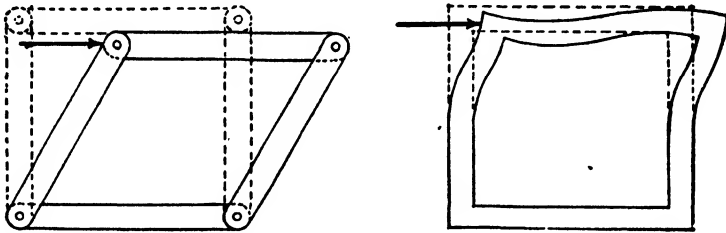

FIG. 42.

**General Theory.** To resist distortion and vibration, the junctions of the girders and columns must be rigid. If all the joints of a bent were hinged it is evident that the effect of the horizontal wind pressure would be to fold the bent down upon the horizontal. If all the joints are rigid, the tendency will be to distort the vertical members as shown in Fig. 42 with points of contraflexure at their mid-lengths. Excessive bending would result in unsafe conditions in the framework, while even a moderate bending in the members or movement in the joints, although not dangerous to the structure, might cause undue deflection in girders and columns, and vibrations throughout the building. Such vibration or tendency to sway, when exceeding certain values, is uncomfortable for the occupants and has a most unfavorable effect upon office rentals. To render a building safe against collapse from wind pressure is not difficult, but to arrive at exact allowable deflections, correctly chosen with regard to the human nervous system, requires more experiments and tests of actual horizontal movements in buildings of various types and proportions than have yet been made.

“Only experience will reveal the relation between computed maximum deflection and comfortable occupancy. By reason of the present

impossibility of appraising in advance the restraining or dampening effect of the non-skeleton parts of a building on deflection, it is convenient to employ, as a measure of stiffness, the relation between the maximum deflection of the top of a frame and its height under maximum wind load, assuming the frame to carry the entire lateral force. This might, perhaps, be called, for ease of reference, the 'deflection index' or 'deflection characteristic.' Owing to inertia and to the dampening effect of walls, partitions and floors it does not represent the actual deflection that will arise, but some multiple of the quantity. Nevertheless, it is a convenient standard by which to judge the probable stiffness of a building and its probable freedom from disturbing vibrations.

"Making use of this deflection index as a basis of rating or judgment, some guidance may be afforded the designer. Thus it has been found that tall buildings . . . with a maximum deflection . . . amounting to 0.002 times the height have a satisfactory behavior in the matter of deflection and vibration. In very high buildings this figure represents not only a satisfactory occupancy basis but about the upper practicable limit of attainable stiffness without liberal additions to columns and other main members for wind effect only."\*

**Route of the Wind Stress.** The wind pressure acting upon the vertical walls and windows is transferred to the spandrel beams and from them to the girders and columns which in turn carry it to the foundations. The curtain walls and windows and the interior partitions, often light and movable, cannot be depended upon to absorb any part of this stress. The steel frame must therefore be designed to withstand the entire wind pressure. To accomplish this purpose effectively, the connections must be rigid and the girders and columns capable of resisting the distortion. Not necessarily all the panels are reinforced to carry this stress, but certain lines of columns and girders are selected because of their relations to the structure as a whole. These groups are called wind bents and should, if possible, run completely across the least dimension of the building. Frequently bents are also introduced in the longitudinal direction. The framing of the outside walls forms convenient bents for wind bracing, but if this is not practicable lines of interior columns may be used. When towers occur the bents are often in the outside walls of the towers and extend down in interior vertical planes through all the stories below the tower. The elevator shafts, stairways, and service often occupy a central position and extend up into the tower. Their partitions are, therefore, favorable locations for braced wind bents which stiffen the entire structure.

The ideal wind bent would consist of columns in straight rows horizontally and directly over each other vertically with no intervening openings to interfere with the cross bracing. Such conditions are rarely encountered, however, for architectural necessities introduce offset

\* Report of the Sub-Committee of the American Society of Civil Engineers, *Civil Engineering*, March, 1931.



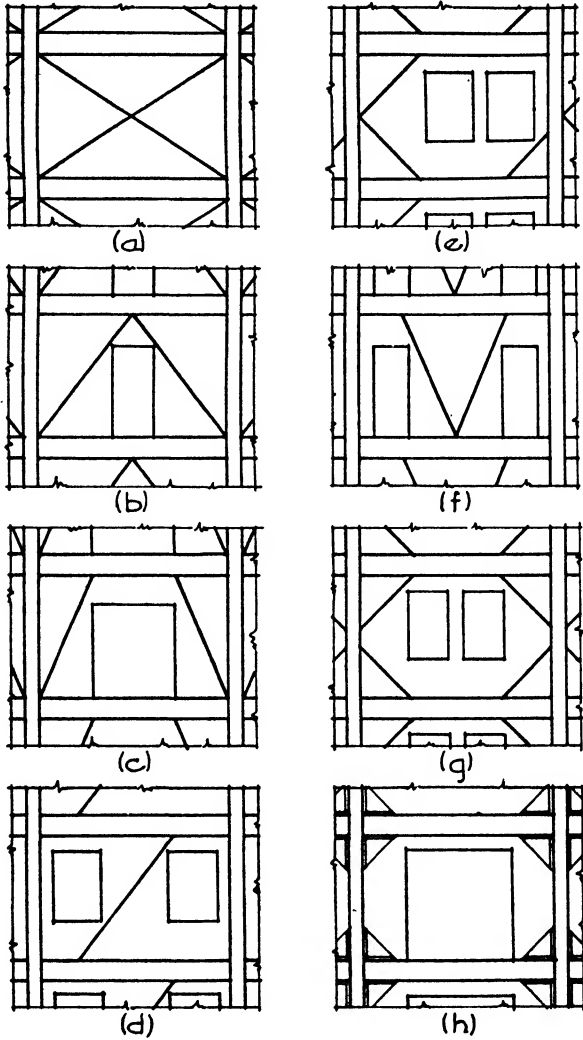

FIG. 43.—Types of Wind Bracing.

columns, door and window openings, intersecting corridors, columns supported on trusses and irregularly shaped building sites. It may not always be possible, therefore, to carry an interior wind bent completely across a building in one vertical plane. In such a condition the wind loads can be transferred laterally to bents in other planes through the floor system made rigid by horizontal bracing at the floor levels. The bents should be arranged symmetrically to avoid twisting or distortion of the building because of greater rigidity on one side than the other.

**Types of Bracing.** The most effective bracing between girders and columns is obtained by full diagonals from one column to the next, but this type is seldom possible because of necessary doors, windows and corridors. Modifications of complete diagonal bracing, however, as shown in Fig. 43, can often be arranged to avoid such openings. Gusset plates and heavily riveted clip angles and I-beam sections on the top and bottom of the horizontal member are also effective in stiffening the joints but are not equal to diagonal bracing.

**Design.** The chief elements of design to resist vibration, horizontal movement and sway consist, then, of braced bents so placed that they will act as stiffening influences for the entire framework, and the rigid construction of these bents to reduce the deflection at the top of the building to a predetermined relation to the height. To obtain a rigid construction, the joints between the girders and the columns must be unyielding, and the girders and columns themselves must be capable of resisting the bending moments produced by the unyielding joints.

Except in very tall buildings, the stress due to the wind load does not as a rule exceed 50% of that from the direct load. Furthermore the wind load is intermittent, of short duration and seldom reaches its maximum force. Unit stresses for combined live, dead and wind loads are therefore permitted amounting to 50% more than the stresses allowed for live and dead load alone, but this combined stress should not exceed 75% of the elastic limit of steel. It is seldom necessary, therefore, to increase column and girder sizes, capable of withstanding safely the stresses from the direct loads, in order to render them sufficiently stiff to resist the wind load stresses. In very high buildings the bending in the columns caused by the wind may, however, be serious and should be investigated. The thickness of the masonry spandrel walls is sometimes increased to provide sufficient dead weight for rigidity.

A wind bent acts as a vertical cantilever truss fixed in the ground, the columns representing the chords and the girders the web. The resistance of the truss to distortion and to deflection at its upper end depends upon the cross bracing of the web and the stiffness of the chord and web joints. Since cross diagonal braces are generally impracticable, rigidity must be attained by knee braces and gusset plates. These braces should be made as deep as architectural requirements permit, in order to reduce the bending moments in the columns and girders. The wind shear and moment stresses in the joints vary with the distances of the columns from the axis of the cantilever truss. The stresses in the braces of the joint are derived from the stresses in the column and girder forming the joint. The limit of deflection or horizontal movement in the top of the truss (0.001 or 0.002 of the height) must be considered.

In the Bank of Manhattan Co. building, New York, "the general intent of the wind bracing was to secure in the web system a rigidity equivalent to a lateral movement of 0.001 of the height of the building

with an average wind pressure of 15 lbs./ft.<sup>2</sup> taken in the structural frame."\* The results indicate that the intention has been well carried out.

The expense of adequate wind bracing is a very small portion of the total cost of construction, and the precautions required to render a building not only safe but also comfortable under the action of the wind should never be neglected.

### Article 8. Light Steel Framing

**Description.** Light copper-bearing sheet steel shapes are now fabricated for the complete framework of dwellings and other buildings with small loads and not more than three stories in height. The structural design is the same as for light wood framing, steel members merely being substituted for wood members.

The architects' drawings are prepared as for wood construction. The steel manufacturers then make framing and erection drawings, and the material is fabricated in the shops to the exact lengths required. In the field, therefore, it is only necessary to bolt or screw the members together according to the erection drawings, each piece being numbered for identification. Units are employed corresponding to the common structural elements of wood frame construction: sills, studs, girders, joists and rafters.

**Sills.** Sills, girts and plates are identical; they consist of two standard steel channels  $3\frac{1}{8}$ " deep, their flanges perforated on 1" centers.

**Studs.** Studs are made up of two  $3\frac{3}{4}$ " channels with 2" flanges welded back to back.

**Girders.** Girders and posts are standard steel shapes of size as required by the loads.

**Joists and rafters** are 8" deep with 2" flanges. They are made in five gauges of steel for varying loads and spans. For unusual loads standard I-beam sections are used.

**Erection.** The various members are assembled with self-tapping screws through the holes in the flanges of the studs, sills, girts and plates. Special clips are provided for making the connections and for hanging the joists and rafters. Diagonal cross bracing in the walls is attained with wire cables attached to the sills, girts and plates with U-bolts and tightened with turn-buckles. The joists are cross-bridged with steel straps hooked over the flanges and bolted together. The walls are braced horizontally with  $\frac{7}{8}$ " channels bolted to the studs. An entire wall panel is usually assembled upon the ground and then raised into place as a unit.

The floor construction generally consists of a 2" concrete slab poured upon metal lath or fibrous-backed wire fabric. The exterior walls may be of stucco upon metal lath or of brick or stone veneer. The interior faces of walls, ceilings and partitions are covered with the usual plaster bases

\* Henry V. Spurr, *Civil Engineering*, March, 1931.

or wall boards clipped to the studs and joists and then plastered. Wood or metal window and door frames and interior trim are attached to wood nailing blocks and grounds as in wood frame construction.

The fact that the members are accurately fabricated to size in the shop renders the field construction simple and speedy. The advantages of the system lie in its durability, sturdiness, speed of erection and fire-resistance.

## CHAPTER XXI

### ROOF TRUSSES

#### Article 1. Definitions

**Definitions.** A **FRAMED STRUCTURE** is composed of a number of straight members so arranged and fastened together at their ends that the stresses in the members, due to loads at the joints, are direct stresses. A **TRUSS** is a framed structure. Theoretically, the stresses are either tension or compression.

Since a triangle is the only geometrical figure which cannot change its shape without a change in the length of one of its sides, trusses or framed structures are composed of a number of triangles framed together.

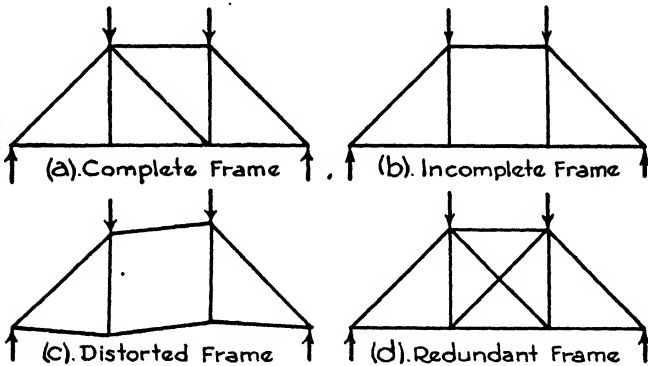

FIG. 1.

A **COMPLETE FRAME**, Fig. 1 (a), is one which is made up of the least number of members required to form a structure entirely of triangles.

An **INCOMPLETE FRAME**, Fig. 1 (b), is one which is not wholly made up of triangles. Such a truss is stable if loaded symmetrically, but if the loads be unsymmetrical the frame may be distorted as shown in Fig. 1 (c). Such a frame is not strictly a truss. A **REDUNDANT FRAME** is one containing more members than would be required to form a structure entirely of triangles, Fig. 1 (d). It is seen that two diagonals are inserted in the quadrilateral; one would be sufficient. Occasionally both diagonals are added, but they are of such dimensions, rods, for instance, as to resist only tension. In this case only one diagonal acts at a time.

The terms **UPPER AND LOWER CHORDS**, **WEB MEMBERS**, **SPAN**, **PITCH** and **RISE** are indicated in the **PRATT TRUSS** shown in Fig. 2.

A **PANEL** is that portion of a truss which occurs between two adjacent joints of the upper or lower chords.

A **BAY** is that portion of a roof which occurs between two adjacent trusses.

A **JOINT**, sometimes called a **PANEL POINT**, is the point of intersection of two or more members of a truss.

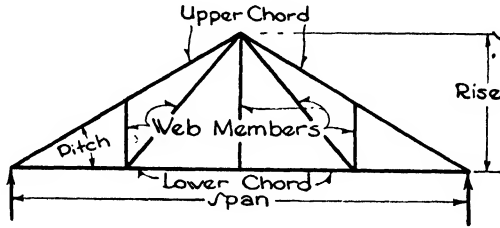

FIG. 2.

A **PURLIN** is the beam spanning from truss to truss, resting on the upper chords, usually at panel points.

## Article 2. Types of Roof Trusses

**Types of Roof Trusses.** The type of roof truss used in a building is determined by the length of span, the material of which it is constructed and the manner of loading. Several types of trusses are shown in Fig. 3 and 3a. Both timber and steel are used in their construction.

**TIMBER CONNECTORS**, noted in Chapter XVIII and shown in Fig. 3a, provide a more efficient utilization of timber, since their use results in stronger joints than are obtained by the usual bolted connection and smaller timber sizes are permitted. Long-span trusses in the past were possible only when steel was used. Flat Pratt trusses constructed with modern timber connectors have been successful for spans up to 120' although 80' is considered to be the maximum span for efficiency in economy and fabrication. The bowstring truss is probably the most efficient type for spans exceeding 80'. It results in economical construction for spans of 50' to 150'.

Timber connectors are employed extensively in many types of buildings. They are of particular value in the framing of roof trusses, and Fig. 3a indicates a number of trusses in which they have proved advantageous.

The National Lumber Manufacturers Association, Washington, D. C., and the U. S. Forest Products Laboratory, Madison, Wis., have published valuable data concerning timber connectors, and complete information is readily obtainable.

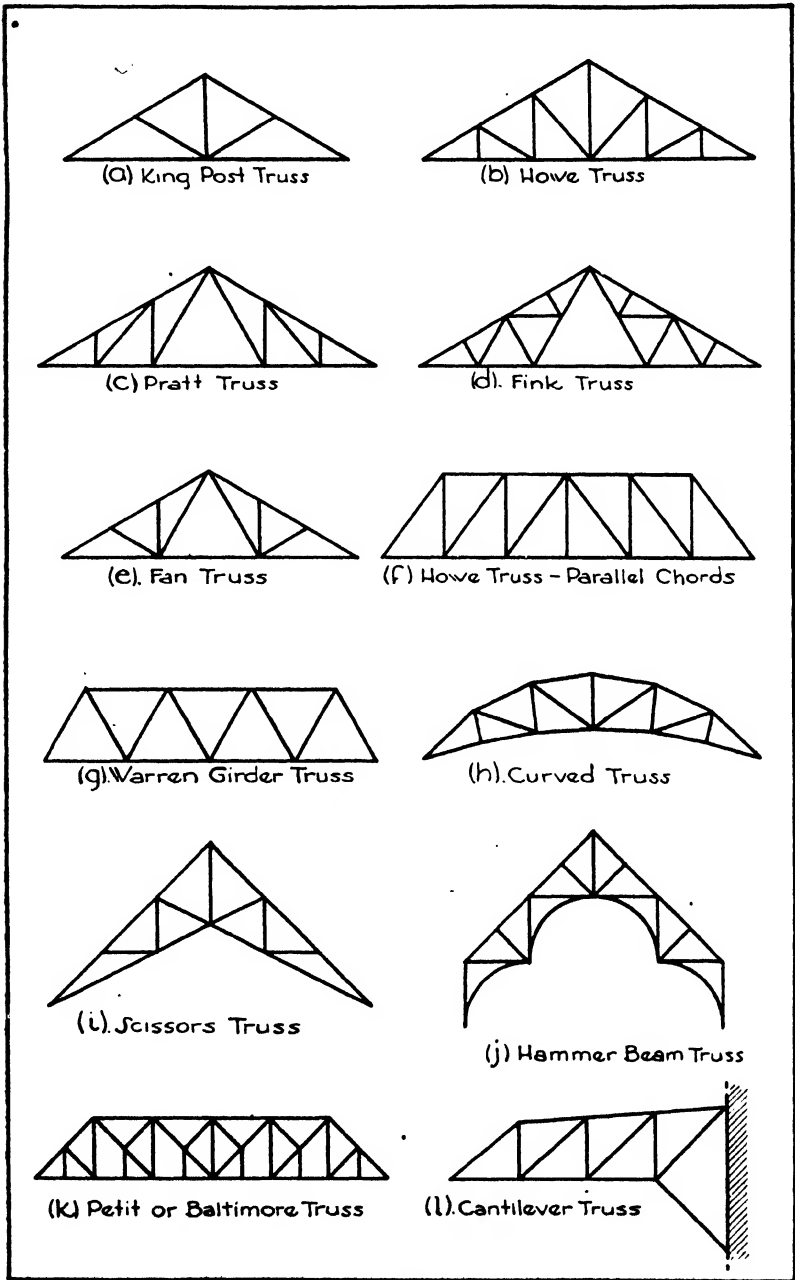

FIG. 3.—Types of Roof Trusses.

Article 3. Roof Loads

The three loads to be considered in computing the stresses in roof trusses are: (1) DEAD LOADS, (2) SNOW LOADS and (3) WIND LOADS.

**Dead Loads.** The dead load consists of (a) the weight of the roof covering, such as sheathing, slate, tile, concrete slab, etc.; (b) weights of

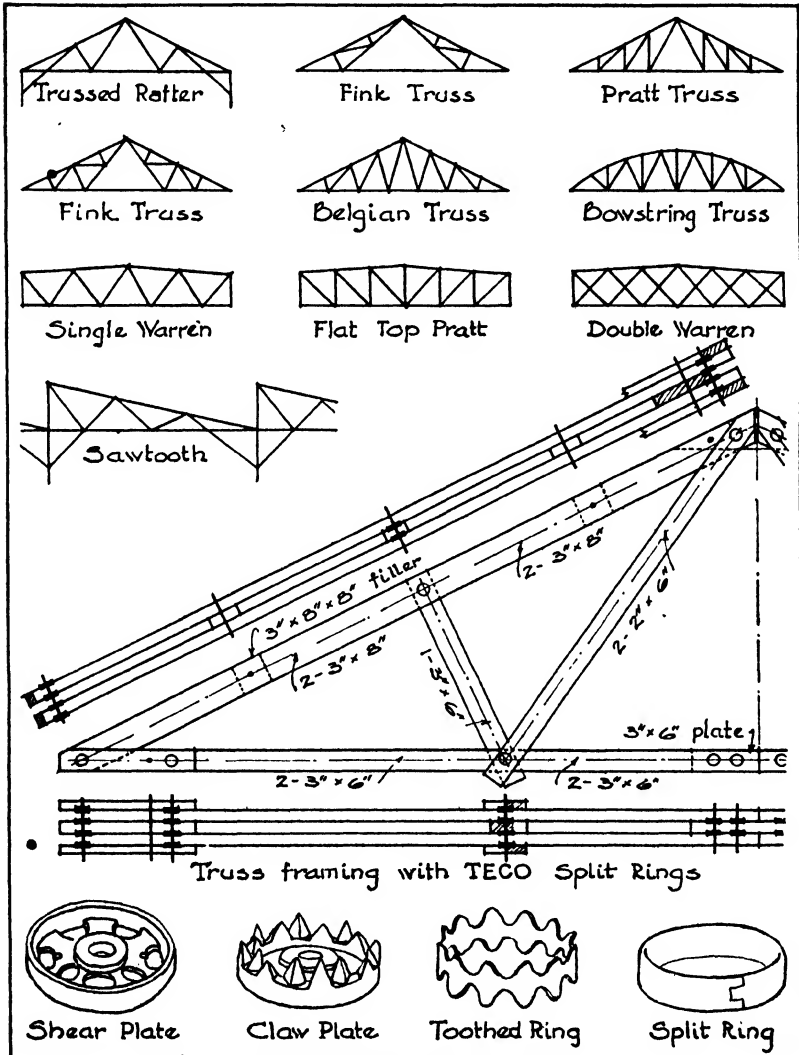

FIG. 3a—Types of Roof Trusses.



purlins, rafters and bracing; (c) weight of truss, and (d) weight of suspended loads, such as ceilings, balconies and mechanical equipment.

The approximate weight of a wooden truss may be found by Merri-man's formula,  $W = \frac{1}{2}SL\left(1 + \frac{1}{10}L\right)$ , in which  $W$  = the weight of one truss in pounds;  $S$  = the distance between adjacent trusses in feet, and  $L$  = the span of the truss in feet.

For steel trusses, the approximate weight may be found by Fowler's formula,  $W = 0.4 SL + 0.04 SL^2$ , in which the terms are similar to those in the formula for computing the weight of wooden trusses.

**Snow Loads.** The magnitude of the snow loads to be used in the analysis of roof trusses varies with the pitch of the roof and the latitude of the locality. It is probable that the maximum snow load and maximum wind load will never occur simultaneously; therefore, if a maximum wind load is assumed, the snow load used should be a minimum. Dry snow weighs about 8 lbs./ft.<sup>3</sup>; wet or packed snow may weigh from 10 to 15 lbs. Table I, taken from Kidder-Parker "Architects' and Builders' Handbook," gives snow loads that may be used with safety.

Table I. Snow Loads for Roof Design in Pounds per Square Foot of Roof Surface

Locality	Slope of Roof				
	45°	30°	25°	20°	Flat
Northwestern and New England States.....	10-15	15-20	25-30	35	40
Western and Central States.....	5-10	10-15	20-25	25-30	35
Southern and Pacific States.....	0-5	5-10	5-10	5-10	10

**Wind Loads.** The wind may be considered as acting in a horizontal direction, exerting its greatest pressure when blowing at right angles to the side of a building. The pressure on a flat vertical surface is generally assumed to be about 30 lbs./ft.<sup>2</sup>, which is equivalent to a velocity of 87 miles/hr. The maximum wind pressure is probably not more than 40 lbs./ft.<sup>2</sup> In the design of roof trusses, the wind is assumed to act in a direction perpendicular to the pitch of the roof, and the magnitude of this load is computed from various formulae. Of the three generally used, Duchemin's, Hutton's and the straight-line, Duchemin's gives larger values and may be used with safety. If it is assumed that the wind exerts a pressure of 40 lbs./ft.<sup>2</sup>, the normal pressure on roofs of various pitches will be as given in Table II.

Table II. Wind Pressure in Pounds per Square Foot

Pitch of Roof, degrees	Normal Pressure, pounds
10	9.6
15	14.0
20	18.3
25	22.5
30	26.4
35	30.1
40	33.4
45	36.1
50	38.1
55	39.6
60	40.0

Article 4. Reactions

**Expansion and Contraction of Roof Trusses.** Because of changes in temperature, the length of a truss does not remain constant. In trusses of short span, the expansion and contraction are relatively slight and no particular provision need be made for them. In trusses supported on masonry walls having spans of more than about 45', it is essential that one end be rigidly secured and the other be so arranged that it is free to move laterally. For spans up to about 75' a joint as indicated in Fig. 4 is frequently used. The bearing plate, upon which the truss rests, contains slotted holes in which the anchor bolts pass. The slotted holes permit a longitudinal movement at that end of the truss.

For trusses greater than 75', **ROCKER BEARINGS OR ROLLERS** are used at one end, and the truss is secured laterally at the opposite end.

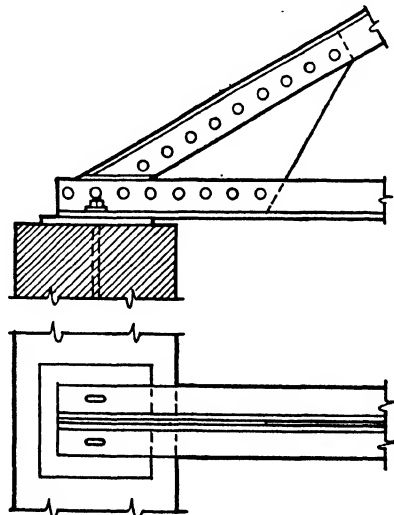

FIG. 4.

If the loads on a truss are only vertical, such as the dead or snow load, the **REACTIONS** or pressure at the supports will also be vertical and there will be no tendency for the truss to move laterally. When a roller or rocker bearing is used at one end, the reaction at that end must be vertical regardless of the

direction in which the load acts. The wind is assumed to act in a direction normal to the pitch of the roof. This means that there is a tendency for the roof to move horizontally, and the horizontal component of the wind load must be resisted by the end of the truss which is secured, since the roller end can resist only vertical forces.

**Force Polygon.** In the graphical analysis of roof trusses, it is first necessary to draw, to some suitable scale, the FORCE POLYGON OF THE EXTERNAL FORCES. The external forces consist of the loads on the truss and the supporting reactions, Fig. 5 (a) illustrates the loads and reactions on a king post truss. The total load is 8000 lbs., and, since the loads are symmetrical with respect to the truss, the supporting reactions are equal and each is one-half of 8000 lbs. or 4000 lbs. If we read the forces in a clockwise manner, the loads are *AB*, *BC*, *CD*, *DE* and *EF*; they are laid off in the same sequence in the force polygon, Fig. 5 (b), to any convenient scale. This is called the LOAD LINE. Continuing in a clockwise manner, the next force is *FG*. This is an upward force of 4000 lbs., and the point *g* will occur midway between the points *c* and *d* on the load line. Next comes *GA*, also an upward force of 4000 lbs. Points *g* and *a* are both located on the load line, and the force polygon is complete. It reads: *ab*, *bc*, *cd*, *de*, *ef*, *fg* and *ga*.

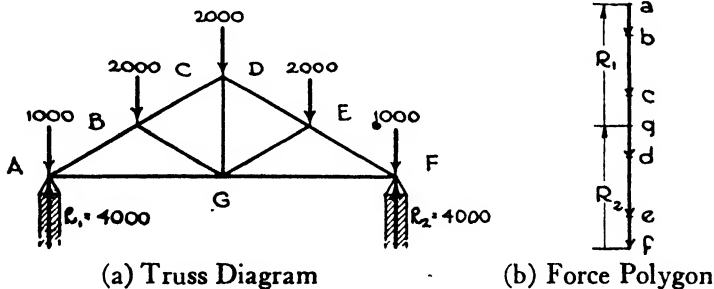

FIG. 5.

In analyzing roof trusses the student should always try to complete the force polygon of external forces before attempting to construct any part of the stress diagram. This may not always be possible, but most stress diagrams are readily constructed if the complete force polygon has been drawn.

**Notation.** The system of notation throughout this discussion is shown in Fig. 5. Capital letters in the truss diagrams identify forces or members, and these letters are placed one on each side of the force or member. In the force polygon and stress diagram, lower-case letters are used. In the stress diagram the letters are placed at the extremities of the lines, and the length of the lines indicates the magnitudes of the forces or stresses. In order that no member may be overlooked, it is a good plan

to see that every letter shown on the truss diagram appears on the stress diagram.

It should be noted that the force polygon, Fig. 5 (b), was drawn and lettered by reading the forces in the truss diagram in a clockwise manner. It is of the utmost importance that the student remember the direction selected, as this is of primary importance in determining the character of the stresses. If a counter-clockwise direction had been adopted for the truss shown in Fig. 5 (a), the force polygon would have read: *fe*, *ed*, *dc*, *cb*, *ba*, *ag* and *gf*. Unless otherwise noted, the direction adopted for reading forces in this chapter will be clockwise.

**Trusses Symmetrically Loaded.** It is obvious that, when trusses are symmetrically loaded, the reactions are of the same magnitude, and

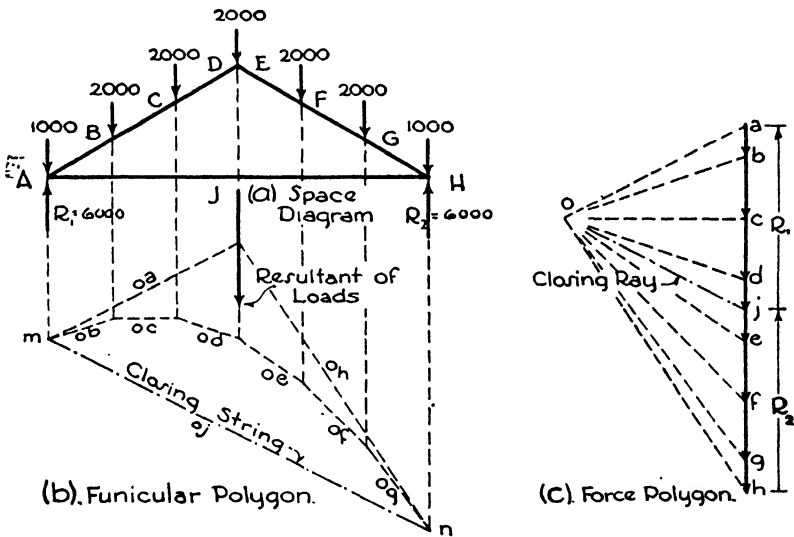

FIG. 6.

consequently each is equal to one-half the total load. This applies generally to dead and snow loads. The wind, however, blows from only one side at a time and hence produces reactions which may not be equal.

Fig. 6 (a) represents the upper and lower chords of a truss with a total vertical load of 12,000 lbs. symmetrically placed. The web members are omitted to avoid confusion, and the dotted lines under the forces show their lines of action. Obviously  $R_1$  and  $R_2$  will each be equal to 6000 lbs., but, if they had not been known, their magnitudes could have been found by means of the FUNICULAR or EQUILIBRIUM POLYGON. To construct this, first draw the load line, Fig. 6 (c), *ab*, *bc*, *cd*, *de*, *ef*, *fg* and *gh*. Select any point, *o*, and draw the rays *oa*, *ob*, *oc*, etc. In Fig. 6 (c) it is seen that force *ab* is held in equilibrium by *oa* and *ob*; therefore on any point on the line of action of *AB* in the truss diagram,

as  $m$ , draw the strings  $oa$  and  $ob$  parallel respectively to the rays  $oa$  and  $ob$ . Where the string  $ob$  intersects the force  $BC$ , draw the string  $oc$  parallel to the ray  $oc$ . Continue in a similar manner until the string  $og$  intersects the force  $GH$ . From this point,  $n$ , draw the CLOSING STRING,  $oj$ , and then the closing ray from  $o$  to the load line parallel to the closing string. This determines the point  $j$ . The intersection of the strings  $oa$  and  $oh$  determines a point which lies in the line of action of the resultant of the vertical loads because the load line  $ah$  is held in equilibrium by the rays  $oa$  and  $oh$ , and three forces, not parallel, must have a point in common. Since the point  $j$  has been determined on the force polygon, the magnitudes of  $HJ$  and  $JA$ ,  $R_2$  and  $R_1$ , are determined, their direction of course being vertical.

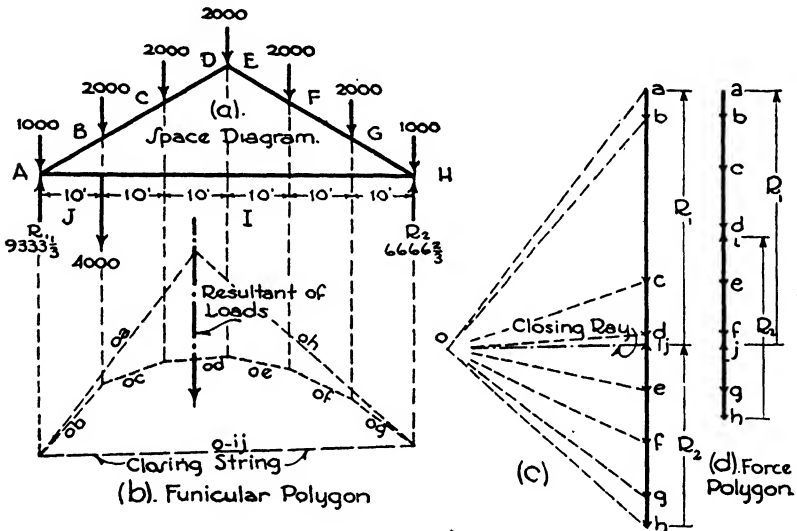

FIG. 7.

**Unsymmetrical Loads.** The truss shown in outline in Fig. 7 (a) is an example of unsymmetrical loading. A load of 12,000 lbs. is symmetrically placed upon the upper chord, but there is an added load of 4000 lbs. suspended from the lower chord in the line of action of the force  $BC$ .  $HI$  and  $JA$ , the reactions, cannot be equal.

$R_1$  and  $R_2$  may readily be found by the principle of moments. If the sum of moments is taken about  $R_1$ , then  $60 R_2 = (12,000 \times 30) + (4000 \times 10)$  or  $R_2 = 6666\frac{2}{3}$  lbs. Since the total load is 12,000 + 4000 or 16,000 lbs.,  $R_1 = 16,000 - 6666\frac{2}{3}$  or  $9333\frac{1}{3}$  lbs. To draw the force polygon Fig. 7 (d), begin with the force  $ab$ , continue with  $bc$ ,  $cd$ ,  $de$ ,  $ef$ ,  $fg$  and  $gh$ . The next force is  $HI$ , ( $R_2$ ) an upward force of  $6666\frac{2}{3}$  lbs., therefore locate the point  $i$ . Then draw  $Ij$ , a downward force of 4000 lbs., locating point  $j$ .  $JA$ , which is  $R_1$ , is next drawn; since  $a$  is already located, the force polygon is complete.

A simple method of determining  $R_1$  and  $R_2$  graphically is by means of the funicular polygon as previously explained for Fig. 6. To do this, begin with force  $ab$ , Fig. 7 (c); the next force is  $BC$ , but  $IJ$  is in the same line of action; therefore, call the force in this position  $BC+IJ$  or 6000, and  $bc$ , instead of being laid off 2000 lbs., has a length equivalent to 6000 lbs. Continue with forces  $cd, de$ , etc., and draw the closing string and ray. This determines the point marked  $ij$ , and the magnitude of  $R_1$  and  $R_2$  may be found by scaling the lines  $h-ij$  and  $ij-a$ . It should be distinctly understood that the line of loads shown in Fig. 7 (c) is *not* the force polygon. It is a diagram used in finding the magnitudes of  $R_1$  and  $R_2$  and aids us in completing the force polygon, Fig. 7 (d).

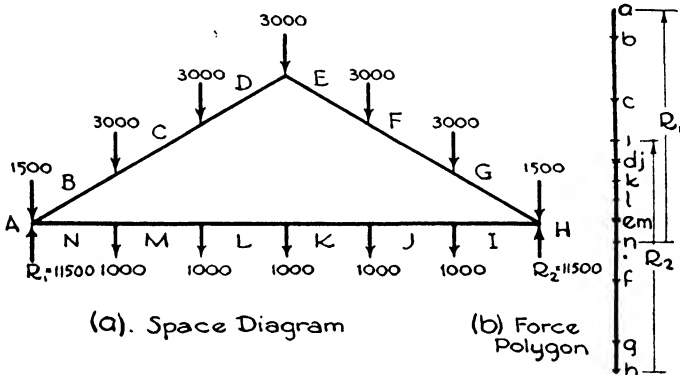

FIG. 8.

If the funicular polygon is drawn accurately,  $R_1$  and  $R_2$ , found graphically, will have the same magnitudes as were previously determined by mathematics, namely,  $9333\frac{1}{3}$  and  $6666\frac{2}{3}$  lbs.

**Suspended Loads.** Fig. 8 (a) illustrates symmetrical loads on the upper and lower chords of a truss. Since it is obvious that  $R_1$  and  $R_2$  will be equal, it is unnecessary to construct a funicular polygon. The total loads are  $18,000 + 5000$  or  $23,000$  lbs.  $R_1$  and  $R_2$  will each equal  $\frac{1}{2} \times 23,000$  or  $11,500$  lbs. To construct the force polygon, first draw  $ab, bc, cd, de, ef, fg$  and  $gh$ , Fig. 8 (b). The next force in order is  $HI$ , an upward force of  $11,500$  lbs. After locating point  $i$ , draw the downward forces  $ij, jk, kl, lm$ , and  $mn$ . The last force to complete the force polygon is  $NA$ , an upward force of  $11,500$  lbs.

**Wind Loads.** It is assumed that the wind acts in a direction normal to the pitch of the roof. The problem of finding the direction of the reactions due to the wind load is indeterminate. If the roof is comparatively flat it is permissible to assume that the reactions are parallel to the direction of the wind, but this assumption is not logical if the roof is steep. The assumption that the horizontal components of the reactions are equal is generally considered to be more nearly true for average trusses.

Consider the wind loads shown on the truss in Fig. 9 (a). Each end of the truss is secured to the wall, and, if the direction of the wind is oblique with the vertical, the reactions due to the wind cannot be vertical. The two general assumptions in this respect are (a) that the wind load reactions are parallel and (b) that the horizontal components of the reactions are equal.

**Reactions Parallel.** First assume the reactions to be parallel. Draw the load line  $ab, bc, cd$  and  $de$  parallel to the direction of the wind, Fig. 9 (c). Next select the point  $o$ , draw the rays and construct the funicular polygon, Fig. 9 (b). The closing ray determines the point  $f$ , and hence  $ef, R_2$ , and  $fa, R_1$ , are determined.  $R_1$  and  $R_2$  have been determined by means of the funicular polygon.

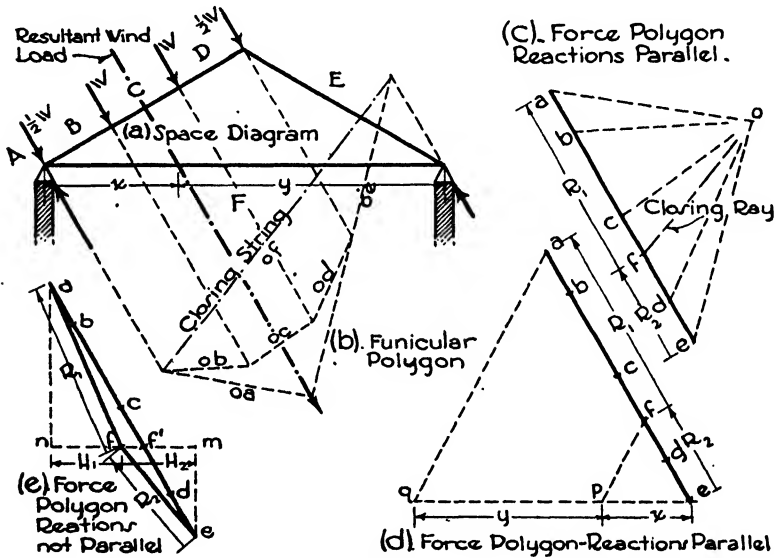

FIG. 9.

Another method of determining  $R_1$  and  $R_2$  is as follows: Draw the load line  $ab, bc, cd$  and  $de$ , Fig. 9 (d). The resultant of the wind loads, since the loads are symmetrical on the windward side of the truss, will be at the mid-point as shown in Fig. 9 (a). It can be shown that reactions are proportional to the sections of the span cut by the resultant wind load. The span is cut into two sections,  $x$  and  $y$ , as shown. It is only necessary, then, to divide the load line  $ae$  into two parts, proportional to  $x$  and  $y$ . To do this, from the point  $e$  draw any line of convenient length  $eq$  and divide it into parts  $ep$  and  $pq$ , proportional to  $x$  and  $y$  in Fig. 9 (a). Connect points  $q$  and  $a$ , and draw a line from  $p$  to the load line parallel to  $qa$ . This determines the point  $f$ , and consequently the reactions  $ef$  and  $fa$ . In using this simple method of determining the

reactions, care must be taken in placing the divisions  $ep$  and  $pq$  in their proper positions. In this instance it is known from observation that  $ef$  will be smaller than  $fa$ , and, therefore,  $ep$ , corresponding to distance  $x$ , will occur adjacent to point  $e$ .

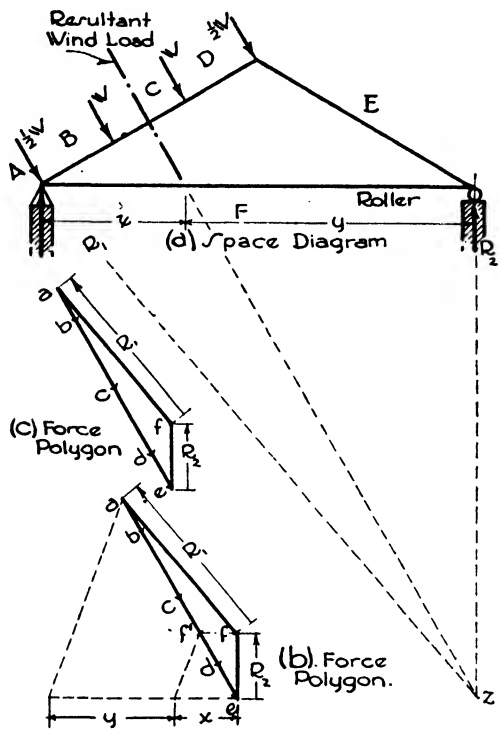

FIG. 10.

**Horizontal Components of Reactions Equal.** The second assumption, and that which is generally adopted, is to assume that the horizontal components of the reactions are equal. Draw the load line  $ab, bc, cd$  and  $de$  Fig. 9 (e). Next determine the reactions, assuming them to be parallel to the directions of the wind. Call this point  $f^1$ ; it may be determined by either of the two methods just described. Through  $f^1$  draw a horizontal line, and draw vertical lines through points  $a$  and  $e$  intersecting the horizontal line at points  $n$  and  $m$ . The horizontal component of the wind load is, therefore,  $nm$ . Divide  $nm$  into two equal parts,  $H_1$  and  $H_2$ , and these will be the horizontal components of  $R_1$  and  $R_2$  respectively. This determines the point  $f$ , and we can now draw  $ef$  and  $fa$ , the reactions  $R_2$  and  $R_1$ .

**Roller Support.** Trusses of large span frequently have one end supported on rollers as shown diagrammatically in Fig. 10 (a). This figure



represents the wind coming from the left and the roller at the right. Since the roller is used to permit unrestrained horizontal movement, it is apparent that the reaction under the roller can be only vertical, and all the resistance to horizontal movement must be supplied by the fixed end of the truss.

To draw the force polygon, first draw the load line  $ab, bc, cd$  and  $de$ , Fig. 10 (b). Next find  $f^1$ , which determines the reactions assuming them to be parallel to the direction of the wind. Since  $R_2, ef$ , the reaction at the roller, can be only vertical; it cannot be  $ef^1$  but will be the vertical component of  $ef^1$ . Therefore, through  $f^1$  draw a horizontal line and extend a vertical line from the point  $e$ . The intersection of these two lines determines the point  $f$ , and  $ef$  will be  $R_2$ , the reaction under the

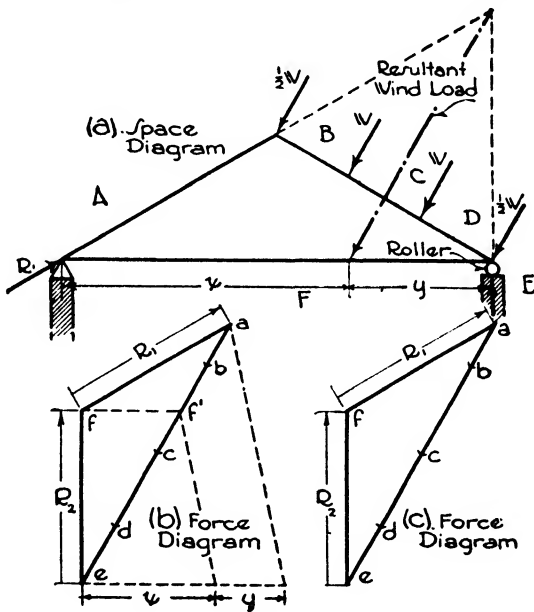

FIG. 11.

roller, since it is the vertical component of  $ef^1$ . The reaction at  $R_1$  will be  $fa$ . It will be noticed that  $ff^1$ , the horizontal component which would have been resisted by  $R_2$  if the reactions had been parallel, is now resisted by  $R_1$ .

Another method of drawing the force polygon for a wind load and roller reaction is as follows: Draw the load line  $ae$ , Fig. 10 (c). We may consider that there are three external forces, Fig. 10 (a), namely, the wind load,  $R_1$  and  $R_2$ . The line of action of the resultant wind load acts at the mid-point of the roof as shown. If three forces, not parallel, are in equilibrium, they must have a point in common. The direction of the reaction  $EF$  must be vertical owing to the roller. Therefore the point

common to  $R_1$ ,  $R_2$  and the wind load will be the intersection of the lines of action of the resultant wind load and  $R_2$  as at  $z$ . By drawing a line from  $z$  to the support at which the truss is fixed, we determine the direction of the reaction at this support. Having drawn the load line  $ae$ , Fig. 10 (c), erect a vertical line from  $e$ , and draw, through point  $a$ , a line parallel to the line of action of  $R_1$ . The intersection of these two lines determines the point  $f$  and consequently the reactions  $ef$  and  $fa$ . This completes the force polygon.

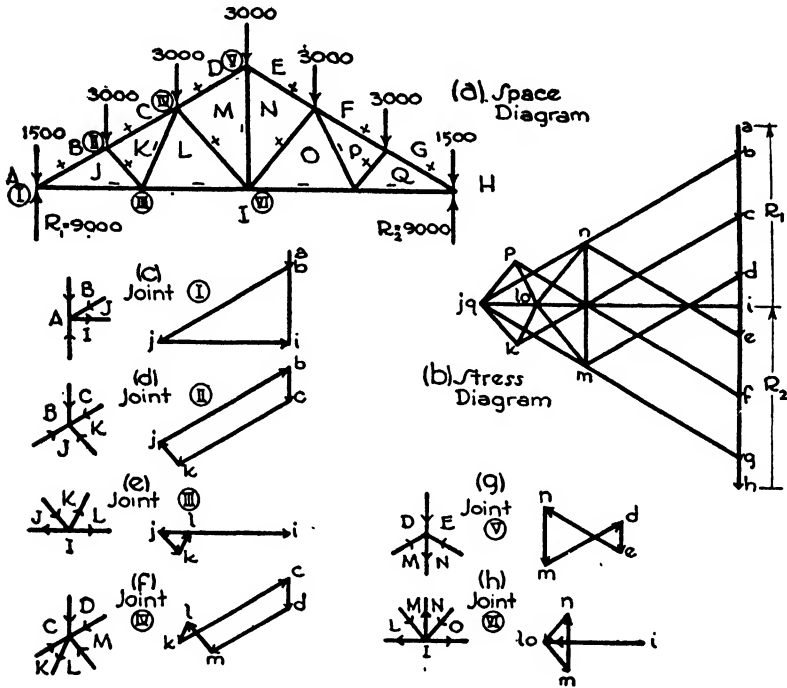

FIG. 12.

Fig. 11 (a) is an illustration of the wind coming from the right with the roller at the right. The force polygon is completed in a manner similar to that just described for Fig. 10. Figs. 11 (b) and (c) show the two methods.

### Article 5. Stresses in Roof Trusses

**Force Polygon of External Forces.** A truss with loads on the upper chord only is illustrated in Fig. 12 (a). The total vertical load is 18,000 lbs., and, since the truss is symmetrically loaded,  $R_1$  and  $R_2$  will each equal  $\frac{1}{2}$  of 18,000 or 9000 lbs. As has been previously stated, it is first necessary to draw the complete force polygon of the external forces.

Draw the load line,  $ab, bc, cd, de, ef, fg$  and  $gh$ , Fig. 12 (b). The next force is  $HI$ , an upward force of 9000 lbs. This determines point  $i$ , and  $ia$ , which is  $R_1$ , completes the force polygon.

**Joint I.** Consider now the joint I, which, reading in a clockwise manner, is joint  $ABJI$ . At this point we have four forces in equilibrium which are concurrent. Of the four forces we know the magnitude and direction of  $IA$  and  $AB$ ; we also know the directions of  $BJ$  and  $JI$ . Since these forces are in equilibrium, their force polygon will close. First draw, at some suitable scale,  $ia$  and then  $ab$ , Fig. 12 (c). The next force in order is  $BJ$ ; therefore through point  $b$  draw a line parallel to  $BJ$ ; the point  $j$  will lie somewhere on this line. The next force is  $JI$ . Since we have point  $i$ , draw a line through  $i$  parallel to  $JI$ . Point  $j$  will be on this line. Since the point  $j$  is on a line through  $b$  parallel to  $BJ$ , and also on a line through  $i$  parallel to  $JI$ , it must be at their point of intersection. This completes the force polygon about the point  $ABJI$ , and the magnitude of the stresses in the members  $BJ$  and  $JI$  may be found by scaling the lengths of  $bj$  and  $ji$  in the force polygon, Fig. 12 (c), using the scale at which  $ab$  and  $ia$  were drawn.

**Joint II.** Next consider joint II, which is  $BCKJ$ . Of the four forces  $BC, CK, KJ$  and  $JB$ , we know  $JB$  and  $BC$  since  $JB$  was found in constructing the force polygon for the forces at joint I, and  $BC$  is a load of 3000 lbs. Draw  $jb$  and  $bc$ , Fig. 12 (d), two sides of the force polygon, representing equilibrium of the four forces at joint  $BCKJ$ . Next draw a line through  $c$  parallel to  $CK$ , and through  $j$  a line parallel to  $KJ$ . The intersection of these two lines determines the point  $k$  and therefore the magnitude of the stresses in members  $CK$  and  $KJ$ .

**Joint III.** There are four forces about joint III,  $JKLI$ , of which  $IJ$  and  $JK$  are now known. Draw  $ij$  and  $jk$ , Fig. 12 (e). The intersection of a line through  $k$  parallel to  $KL$ , and a line through  $i$  parallel to  $IL$ , determines the point  $l$  and hence the stresses in  $LI$  and  $KL$ .

**Joint IV.** At joint IV,  $LKCDM$ , there are five forces, three of which are known. Draw  $lk, kc$  and  $cd$ , Fig. 12 (f). A line through  $d$  parallel to  $DM$ , and a line through  $l$  parallel to  $ML$ , determine the point  $m$ , giving us stresses in  $DM$  and  $ML$ .

**Joint V.** Joint V,  $MDEN$ , has four forces of which we know  $MD$  and  $DE$ . Draw  $md$  and  $de$ , Fig. 12 (g), and construct a line through  $e$  parallel to  $EN$ , and another through  $m$  parallel to  $NM$ , thus determining point  $n$ . This gives us the stresses in  $EN$  and  $NM$ .

**Stress Diagram.** In a similar manner we could continue with the remaining joints of the truss until separate force polygons had been drawn for the forces at each joint. However, we have found the magnitudes of the stresses in all the members on the left-hand side of the truss, and those on the right-hand side, which are similarly located, will be the same. It should be noted that it is impossible to complete the polygon for any joint where more than two members are unknown or where more than one letter is sought. This makes it necessary that

we choose the joints in a sequence that gives us not more than two unknowns at a joint. In this particular truss the joints were taken in this order, I, II, III, IV and V. We could, however, have started at joint  $GHIQ$  and worked toward the left.

Thus far we have drawn separate force polygons for the various joints. Considerable time may be saved by combining all the force polygons on one diagram called the **STRESS DIAGRAM**, Fig. 12 (b). First the force polygon of the external forces is drawn, and then force polygons for the various joints. In the stress diagram, Fig. 12 (b), we note that points  $j$  and  $q$ , also points  $l$  and  $o$ , occur at the same place. This has no particular significance and happens in this truss because the truss and loads are symmetrical and the letters on the truss diagram occur in similar places.

**Character of Stresses.** Theoretically, the stresses in the members of a truss are either in compression or tension, since the loads occur at the joints, that is, at the ends of the members. As well as determining the magnitude of the stresses, it is equally important that we know their character. A member which had been designed to resist a compressive force may probably be of ample dimensions to resist the same force in tension, but a member designed for a tensile load will probably fail if the load is compressive.

To determine the character of the stresses in the members of the truss shown in Fig. 12 (a), consider first the member  $BJ$  about joint I,  $ABJI$ . Referring to the force polygon Fig. 12 (c),  $bj$  reads downward toward the left. If in the truss diagram we read  $BJ$  downward toward the left we read **TOWARD THE JOINT  $BJIA$** , and hence the member is in compression (+).

Member  $JI$  about joint  $BJIA$  reads from left to right in the force polygon,  $ji$  Fig. 12 (c). If we read the member  $JI$  from left to right in the truss diagram we read **AWAY FROM  $BJIA$** , and, therefore, the member  $JI$  is in tension (-).

Member  $CK$  about the joint  $BCKJ$  reads downward toward the left in the force polygon for this joint,  $ck$ , Fig. 12 (d).  $CK$ , downward toward the left about the joint  $BCKJ$  in the truss diagram, reads toward the joint and is, therefore, in compression (+).

Member  $KJ$  about joint  $BCKJ$  reads upward toward the left in the force polygon,  $kj$ , Fig. 12 (d).  $KJ$ , upward toward the left about joint  $BCKJ$ , reads **TOWARD the joint** and is in compression (+).

In the same manner we may consider each member of the truss. Thus far, in determining the character of stresses, we have used the separate force polygons as at Figs. 12 (c) and (d), but the results would be the same if the stress diagram Fig. 12 (b) were used. It must be distinctly understood and remembered that in this instance the force polygons and stress diagram were constructed by reading the forces in a **CLOCKWISE** manner. This is of the utmost importance in reading the

character of stresses. For instance, we read the member *BJ* about joint I, but the same member is read *JB* about joint II.

Another point to bear in mind is that the magnitude of the stress in a member is determined by the length of the line, corresponding to the member, in the stress diagram and not in the truss diagram. In the truss diagram the length of a member bears no relation to the magnitude of its stress.

The plus and minus signs, corresponding to compressive and tensile stresses respectively, marked on the members of the truss, Fig. 12 (a), indicate the character of stress due to vertical loads on the upper chords. To find the character of stress due to wind loads, with or with-

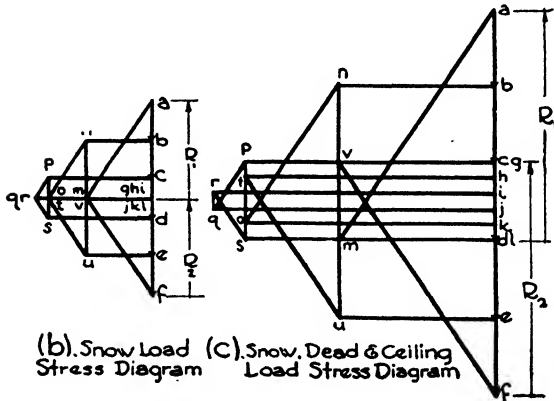
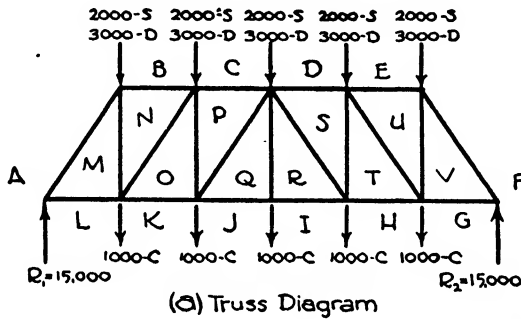

FIG. 13.

out roller bearings, it is necessary to draw separate stress diagrams. The members of the truss are designed to take the maximum load that may occur in them, whether it is due to dead, snow or wind loads, or a combination of loads.

**Howe Truss.** Fig. 13 (a) shows a Howe truss with parallel chords, having suspended or ceiling loads. The letters adjacent to the loads, *S*, *D* and *C*, indicate snow, dead and ceiling loads. Fig. 13 (c) is the stress diagram for all the loads. To draw the force polygon, first draw the

loads on the upper chord, *ab*, *bc*, *cd*, *de* and *ef*. Since the loads are symmetrically placed, *FG* and *LA*,  $R_1$  and  $R_2$ , are each equal to  $\frac{1}{2}$  the total load or 15,000 lbs. Therefore, the next force is *fg*, an upward force of 15,000 lbs. Having determined the point *g*, draw the downward forces *gh*, *hi*, *ij*, *jk*, and *kl*. The last external force is *la*, which completes the force polygon of external forces. The stress diagram presents no difficulties and is drawn as described for the truss in Fig. 12.

Fig. 13 (b) is the stress diagram for snow loads only. Note that the letters *g*, *h*, *i*, *j*, *k* and *l* occur at the same point since the ceiling loads are not considered when drawing the snow load diagram. In this stress

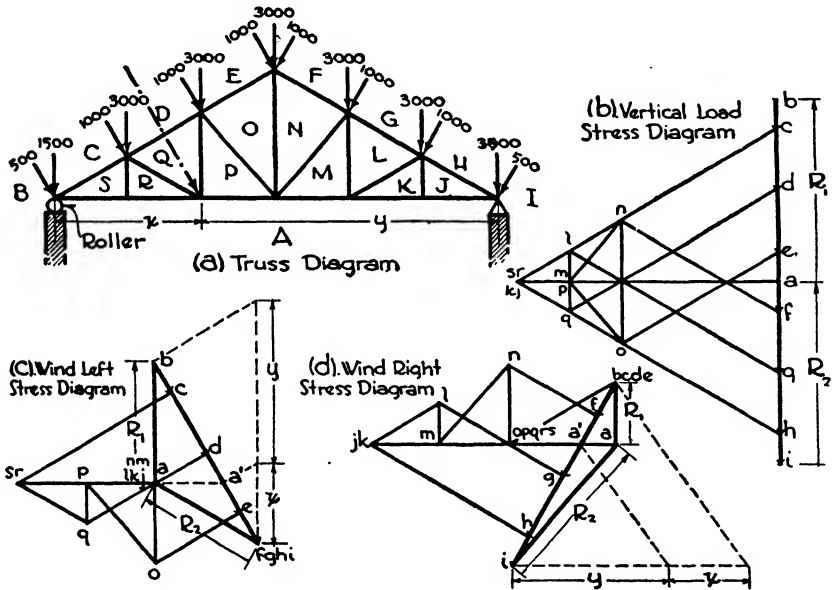

FIG. 14.

diagram the *q* and *r* occur at the same point. This means that *qr* in the stress diagram has no length and, therefore, no stress due to the snow load.

**Wind Load Stress Diagram.** Fig. 14 (a) is an example of a Howe truss with wind and vertical loads, having a roller at the left end. The vertical loads, due to dead and snow loads, produce vertical reactions each equal to one half the total load. The stress diagram for these loads is shown in Fig. 14 (b). Since letters *s* and *r*, also *k* and *j*, occur at the same points, there is no stress in members *SR* and *KJ*.

Fig. 14 (c) is the stress diagram for the wind coming from the left. First draw the force polygon of external forces. The load line is *bc*, *cd*, *de* and *e-fghi*. The letters *f*, *g*, *h* and *i* occur at the same point, since

no loads occur on the right-hand side of the truss when we assume only the wind coming from the left. Next come  $R_2$  and  $R_1$ , which are found as previously described,  $R_1$  being vertical because the roller is located at that support. The force polygon of external forces having been completed, the stress diagram presents no difficulties. It should be noted that letters  $n, m, l, k$  and  $j$  occur at the same point, showing that there are no stresses in members  $NM, ML, LK$  and  $KJ$  due to wind coming from the left. It is well to show all letters on the truss in the stress diagrams in order to prevent error.

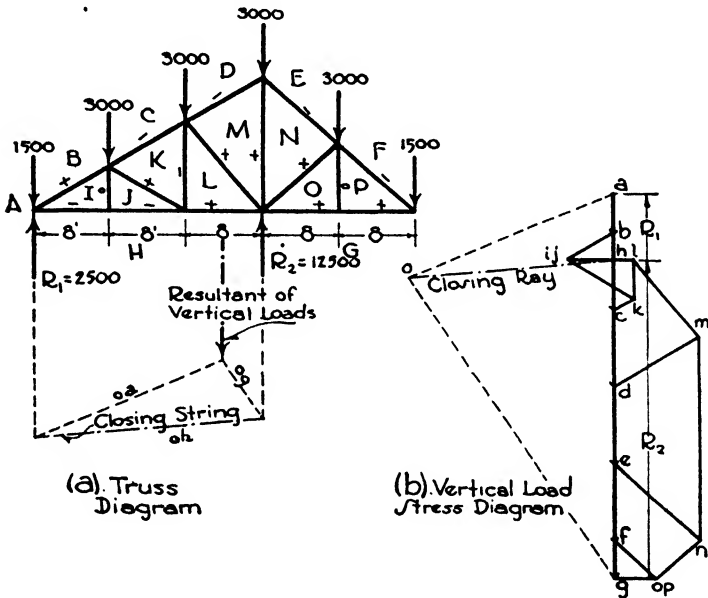

FIG. 15.

The stress diagram for wind right is shown in Fig. 14 (d). It is completed as described for wind left, and we find that members  $SR, RQ, QP$  and  $PO$  have no stress due to the wind coming from the right.

**Grandstand Truss.** A grandstand truss is shown in Fig. 15 (a); it is loaded with vertical loads. To draw the stress diagram, first draw the load line,  $ab, bc, cd, de, ef$  and  $fg$ , Fig. 15 (b). Since  $R_2$  is placed 16' from the right-hand end of the truss, the reactions cannot be equal in magnitude. To find the reactions a funicular polygon could be drawn considering each load separately. The work may be shortened, however, by assuming the resultant vertical load to act at a point 20' from  $R_1$ , since the loads are symmetrically placed on the truss, and the span is 40'. The three external forces are the total vertical load,  $R_1$  and  $R_2$ , their lines of action are known and the funicular polygon is completed as shown. The closing ray in Fig. 15 (b) determines the

reactions  $gh$  and  $ha$ . This completes the force polygon of external forces.

Sometimes it is more convenient to compute  $R_1$  and  $R_2$  by mathematics. In this instance, write an equation of moments about  $R_2$ . Then  $24R_1 = 15,000 \times 4$ , or  $R_1 = 2500$  lbs., and  $R_2 = 15,000 - 2500 = 12,500$  lbs.

The stress diagram is readily drawn, Fig. 15 (b), and the character of stresses for the vertical loads is marked on the truss.

**Fink Truss.** The Fink truss, Fig. 16 (a), is one of the most common types of steel trusses used today. Its stress diagram, however, presents a problem requiring explanation. The diagram shows a roller at the right-hand end which, of course, means that the reaction at  $R_2$  will be vertical regardless of the direction in which the loads act.

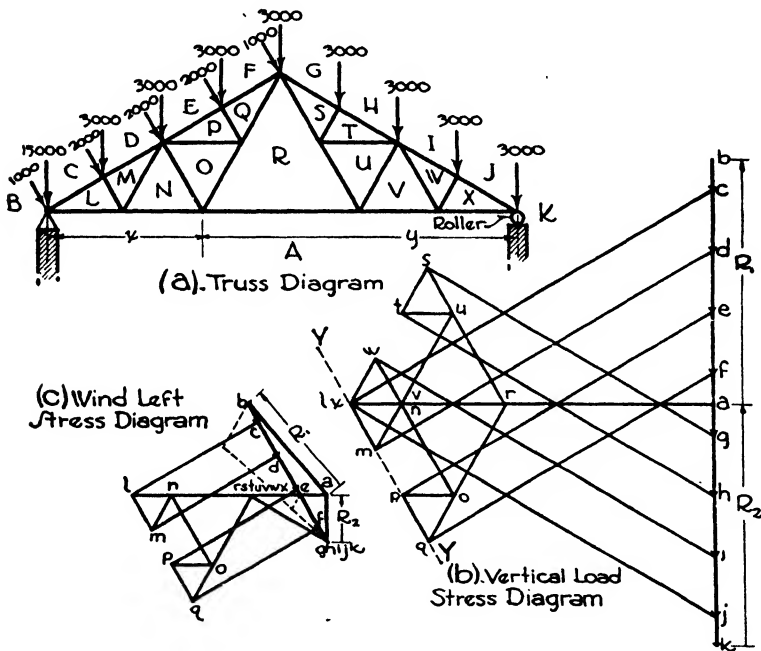

FIG. 16.

First consider the stress diagram for vertical loads, Fig. 16 (b). The load line  $b-k$  is drawn, and, since the reactions will be equal and vertical, the point  $a$  is established. The force polygon for the joint  $BCLA$  is completed and then  $CDML$  and  $LMNA$ . We then find that at joint  $DEPONM$  there are six forces of which but three are known, leaving three unknown. At joint  $NORA$  there are also three unknown forces since we have determined only  $AN$ . Several different methods may be employed to determine the remaining stresses. It can be shown for a Fink truss of this type, having equal divisions of the upper chord, that each successive member of the upper chord, beginning with the one



nearest the reaction, has the same rate of decrease in stress. In this instance the stress in *CL* has been established, likewise the stress in *DM*. By examining the stress diagram the decrease in stress is observed. Since, by the foregoing statement, the stresses in *EP* and *FQ* will have the same rate of decrease, draw line *Y-Y*, passing through points *l* and *m*, and also lines through *e* and *f*, parallel to *EP* and *FQ* respectively. The points *p* and *q* will be at the intersection of these lines with line *Y-Y*. We can now find points *o* and *r*, thus completing the left-hand side of the truss. The stress diagram for the right-hand side is completed in a similar manner.

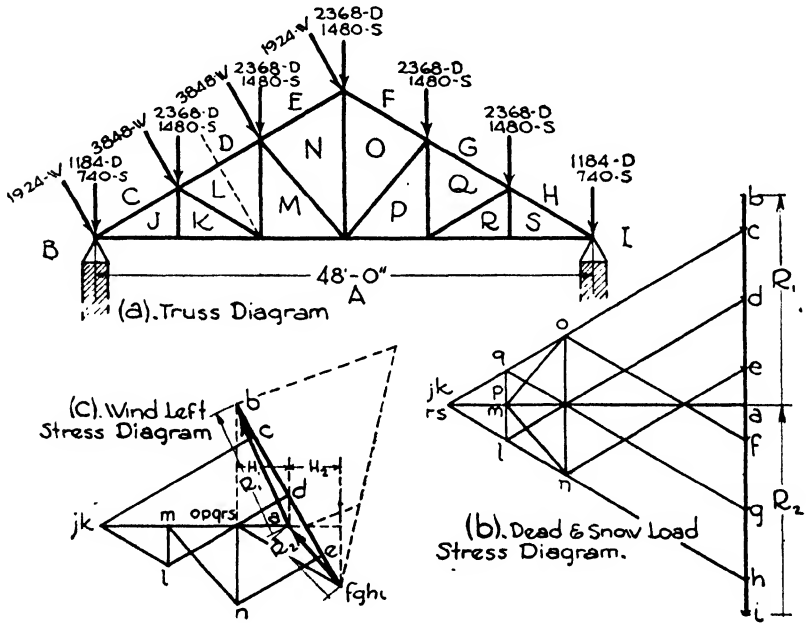

FIG. 17.

### Article 6. Design of Roof Trusses

**A Timber Howe Truss.** Let it be required to design the Howe truss indicated in Fig. 17 (a). The truss has a span of 48', and the trusses are placed 16' on centers. The length of the upper chord is 27'9"; therefore, there are 444 ft.<sup>2</sup> of roof surface supported by each half of the truss or a total of 888 ft.<sup>2</sup> of roof supported by the entire truss.

The dead load consists of the weight of the exposed roofing material, sheathing, roof rafters, purlins and the truss itself. In this instance the load is 16 lbs./ft.<sup>2</sup>;  $888 \times 16 = 14,208$  lbs. the total dead load. There are seven joints, five of which receive  $\frac{1}{5}$  of 14,208 or 2368 lbs., and  $\frac{1}{2}$  of 2368 or 1184 lbs. is the load at each joint.

A load of 10 lbs. has been assumed to be the snow load on each square foot of roof surface;  $888 \times 10 = 8880$  lbs., the total snow load, resulting in 1480 lbs. at each joint except the two ends which are each 740 lbs.

There are 444 ft.<sup>2</sup> of roof surface on each side of the truss. Since the truss has a pitch of about 30° with the horizontal, we will assume a wind load of 26 lbs./ft.<sup>2</sup>;  $444 \times 26 = 11,544$  lbs., the total wind load;  $\frac{1}{2}$  of 11,544, or 3848, is the wind load at each joint, except the ends which are each 1924 lbs.

To construct the stress diagram, Fig. 17 (b), for the vertical loads, the dead load and snow load will be combined, the total dead and snow loads being  $14,208 + 8880$  or 23,088 lbs. This will be the load line *b-i*, and since the reactions are vertical and equal, each will be  $\frac{1}{2}$  of 23,088 or 11,544 lbs. This determines the point *a*, and the stress diagram may be completed.

Since the truss is fixed at each end, it will be necessary to draw a wind load stress diagram for one side only. The load line, Fig. 17 (c), will be *b-fghi*, 11,544 lbs. We will assume that the horizontal components,  $H_1$  and  $H_2$ , of the reactions are equal. By the methods previously described, the point *a* is determined. The remaining part of the stress diagram presents no difficulties. In the stress diagram, Fig. 17 (c), we find that letters *opqr* and *s* occur at the same point. This means that no stress exists in *OP*, *PQ*, *QR* and *RS* due to wind coming from the left, but the conditions are reversed when the wind blows from the right.

Table III is a tabulation of the stresses in the various members of the truss and also the sections of timbers and rods which may be used in constructing a truss for the loads assumed. Only the members on the left-hand side of the truss are shown, for those similarly situated

Table III. Stresses and Sections Required for Howe Truss

Member	Stress in Pounds			Section, Nominal Size
	Dead and Snow	Wind	Maximum	
<i>CJ</i> .....	+19 300	+10 300	+29 600	6" x 8"
<i>DL</i> .....	+15 400	+ 8 000	+23 400	6" x 8"
<i>EN</i> .....	+11 500	+ 5 800	+17 300	6" x 8"
<i>JA</i> .....	-16 700	-10 900	-27 600	6" x 8"
<i>KA</i> .....	-16 700	-10 900	-27 600	6" x 8"
<i>MA</i> .....	-13 300	- 6 900	-20 200	6" x 8"
<i>JK</i> .....	0	0	0	$\frac{1}{2}$ " round rod
<i>LK</i> .....	+ 3 800	+ 4 500	+ 8 300	4" x 6"
<i>LM</i> .....	- 1 800	- 2 300	- 4 100	$\frac{3}{4}$ " round rod
<i>MN</i> .....	+ 5 200	+ 5 900	+11 100	6" x 6"
<i>NO</i> .....	- 7 800	- 4 500	-12 300	1 $\frac{1}{4}$ " round rod

on the opposite side will have the same stresses and the same sections will be used.

It is obvious that the greatest stress that may occur in a member

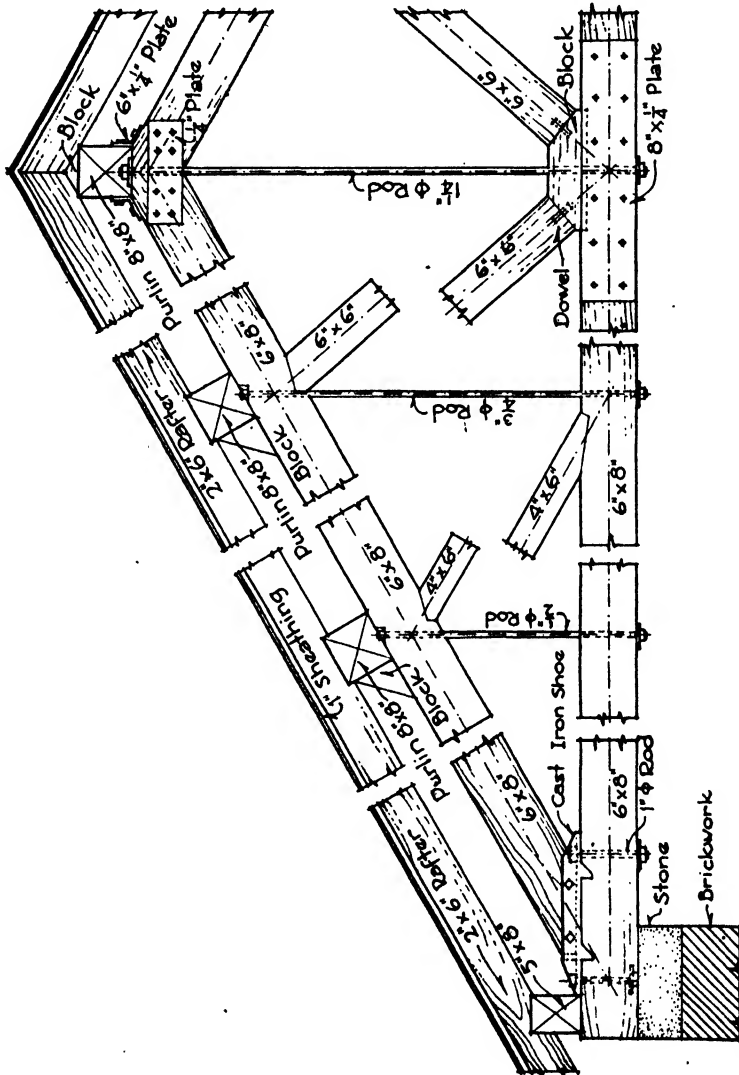

FIG. 18.

is that due to a wind load when snow rests on the roof. Consequently, the column in the table marked "maximum" is the stress resulting from adding together the dead and snow load and the wind load stresses. This is the stress used in designing the members. The upper and lower chords are of wood in this type of timber truss although the lower chord

is in tension. The vertical web members are in tension and are of wrought iron. The allowable tensile stress of wrought iron is assumed to be 16,000 lbs./in.<sup>2</sup>, and the area is taken at the root of the thread. There is no stress in members *JK* and *RS* due to loads on the upper chords. Rods are generally used, however, to prevent deflection of the lower chord. If there had been a suspended load, a ceiling for instance, these members would have been stressed.

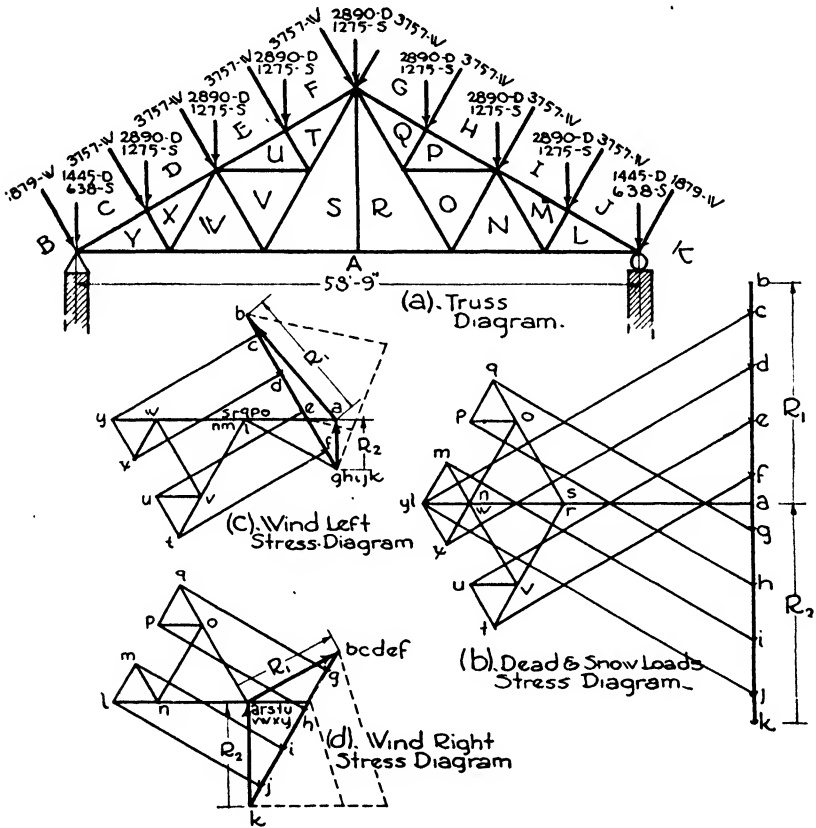

FIG. 19.

The timber used for the design of this truss is the #1 structural grade of Southern yellow pine. In computing sizes it is considered good practice to select members having an excess area of 20 to 25% due to cutting and framing of the joints. Practical considerations also make it advisable to select sizes larger than the stresses might seem to warrant. For example, the greatest stress in the upper chord is in the member nearest the support, *CJ*, but the upper chord is made of a uniform section throughout its length. See Fig. 18. This is true also for

the lower chord. Some designers prefer to have all the timber members of the truss of the same lateral dimensions to facilitate framing. This also results in larger sections than those actually required.

**A Steel Fink Truss.** To design a steel Fink truss as shown in Fig. 19 (a), it is first necessary to compute the loads. The trusses are spaced 17'0" on centers, and the length of the upper chord is 34'0". Therefore,  $17 \times 34 = 578$ , the number of square feet of roof surface supported by one half of the truss;  $578 \times 2 = 1156$ , the total number of square feet supported by one truss. The dead load, composed of exposed roofing material, sheathing, rafters, purlins and the truss itself, is 20 lbs./ft.<sup>2</sup> Hence the total dead load is  $1156 \times 20$  lbs. = 23,120 lbs.;  $\frac{1}{8} \times 23,120$  lbs. = 2890 lbs., the load at each joint, except the two end loads which are  $\frac{1}{2} \times 2890$  or 1445 lbs. each.

The snow load is assumed to be 10 lbs./ft.<sup>2</sup> of horizontal projection of the roof. If the horizontal projection is 60', then  $60 \times 17 \times 10 = 10,200$  lbs., the total snow load to be supported by the roof. This produces loads of 1275 lbs. at each joint except the two ends which are 638 lbs. each.

There are 578 ft.<sup>2</sup> of roof surface supported by each side of the truss. Since the truss has a pitch of 30° we may assume a wind pressure of 26 lbs./ft.<sup>2</sup>, and the total wind pressure from either the right or left will be  $578 \times 26 = 15,028$  lbs. This results in loads of 3757 lbs. at each joint, except the ends which are each 1879 lbs.

Since the snow and dead loads are vertical, they are considered in the same stress diagram, Fig. 19 (b). The total dead and snow loads will be  $23,120 + 10,200$  or 33,320 lbs., and this is represented by the load line *b-k*. The character and magnitude of the stresses for these loads are shown in Table IV.

A roller is placed under the right support, resulting in a vertical reaction at *R*<sub>2</sub>. Separate stress diagrams are drawn for wind left and wind right, Figs. 19 (c) and (d), and stresses for each are given in Table IV.

The column in the table marked "maximum" is the greatest stress that occurs in a member as a result of the dead and snow loads and wind right or wind left. These are the stresses used in designing the members of the truss. There is no stress in the vertical member *SR*, but  $2\frac{1}{2}'' \times 2'' \times \frac{1}{4}''$  L is used to prevent possible sagging in the lower chord. If a ceiling were suspended from the lower chord this member would receive a stress. See Fig. 20.

In steel trusses, both tension and compression members are generally made up of two angles separated by the thickness of a gusset plate. For intermediate joints in trusses of this character  $\frac{3}{8}''$  gusset plates are commonly used.

For rivets,  $\frac{3}{4}''$  and  $\frac{7}{8}''$  are the sizes generally employed. Since the stresses in this truss are relatively small,  $\frac{3}{4}''$  rivets with  $\frac{5}{16}''$  holes are used. The minimum distance, called *PITCH*, between centers of rivet

Table IV. Stresses and Sections for Fink Truss

Member	Stress in Pounds				Section
	Dead and Snow Loads	Wind Left	Wind Right	Maximum	
CY	+29 100	+14 300	+ 8 800	+43 400	2- 4'' x 3'' x 5/16''  S
DX	+27 100	+14 300	+ 8 800	+41 400	2- 4'' x 3'' x 5/16''  S
EU	+25 000	+14 300	+ 8 800	+39 300	2- 4'' x 3'' x 5/16''  S
FT	+22 900	+14 300	+ 8 800	+37 200	2- 4'' x 3'' x 5/16''  S
GQ	+22 900	+ 8 800	+14 300	+37 200	2- 4'' x 3'' x 5/16''  S
HP	+25 000	+ 8 800	+14 300	+39 300	2- 4'' x 3'' x 5/16''  S
IM	+27 100	+ 8 800	+14 300	+41 400	2- 4'' x 3'' x 5/16''  S
JL	+29 100	+ 8 800	+14 300	+43 400	2- 4'' x 3'' x 5/16''  S
YA	-25 200	-18 900	0	-44 100	2-3 1/2'' x 2 1/2'' x 5/16''  S
WA	-21 600	-15 200	0	-36 800	2-3 1/2'' x 2 1/2'' x 5/16''  S
SA	-14 400	- 7 600	0	-22 000	2-2 1/2'' x 2'' x 1/4''  S
RA	-14 400	- 7 600	0	-22 000	2-2 1/2'' x 2'' x 1/4''  S
NA	-21 600	- 7 600	- 7 600	-29 200	2-3 1/2'' x 2 1/2'' x 5/16''  S
LA	-25 200	- 7 600	-11 400	-36 600	2-3 1/2'' x 2 1/2'' x 5/16''  S
YX	+ 3 620	+ 3 800	0	+ 7 420	2-2 1/2'' x 2'' x 1/4''  S
WV	+ 7 200	+ 7 600	0	+14 800	2-3 1/2'' x 2 1/2'' x 1/4''  S
UT	+ 3 620	+ 3 800	0	+ 7 420	2-2 1/2'' x 2'' x 1/4''  S
QP	+ 3 620	0	+ 3 800	+ 7 420	2-2 1/2'' x 2'' x 1/4''  S
ON	+ 7 200	0	+ 7 600	+14 800	2-3 1/2'' x 2 1/2'' x 1/4''  S
ML	+ 3 620	0	+ 3 800	+ 7 420	2-2 1/2'' x 2'' x 1/4''  S
XW	- 3 620	- 3 800	0	- 7 420	2-2 1/2'' x 2'' x 1/4''  S
VU	- 3 620	- 3 800	0	- 7 420	2-2 1/2'' x 2'' x 1/4''  S
PO	- 3 620	0	- 3 800	- 7 420	2-2 1/2'' x 2'' x 1/4''  S
NM	- 3 620	0	- 3 800	- 7 420	2-2 1/2'' x 2'' x 1/4''  S
VS	- 7 200	- 7 600	0	-14 800	2-2 1/2'' x 2'' x 1/4''  S
TS	-10 800	-11 400	0	-22 200	2-2 1/2'' x 2'' x 1/4''  S
RQ	-10 800	0	-11 400	-22 200	2-2 1/2'' x 2'' x 1/4''  S
RO	- 7 200	0	- 7 600	-14 800	2-2 1/2'' x 2'' x 1/4''  S
SR	0	0	0	0	1-2 1/2'' x 2'' x 1/4''  L

holes is 3 diameters of a rivet. The maximum pitch in the line of stress is 16 times the thinnest plate or shape connected, or 20 times the thinnest enclosed plate.

Theoretically, the working lines of the truss members should coincide with the center of gravity axes of the members. See Fig. 20. The working lines should be concurrent at the joints, and the rivets should be driven on these lines to prevent eccentricity. In smaller members, the center of gravity line is too near the back of the angle to permit rivets being driven on it. Consequently the working lines in practice are made to coincide with the gauge lines of the sections.

If a member is continuous at a joint, as at *CDXY*, the stress to be resisted by riveting is the difference in the adjacent stresses. Frequently, the placing of all the rivets in line results in too large a gusset plate, and it is common practice to employ a clip angle when the required number of rivets exceeds seven in a single gauge member. The rivets at a joint in the upper chord should be sufficient in number to resist the force exerted by a purlin. In general, the required number of rivets at the end of a member is determined by dividing the stress in the member by the controlling value of the rivet. Often, because of the size of the

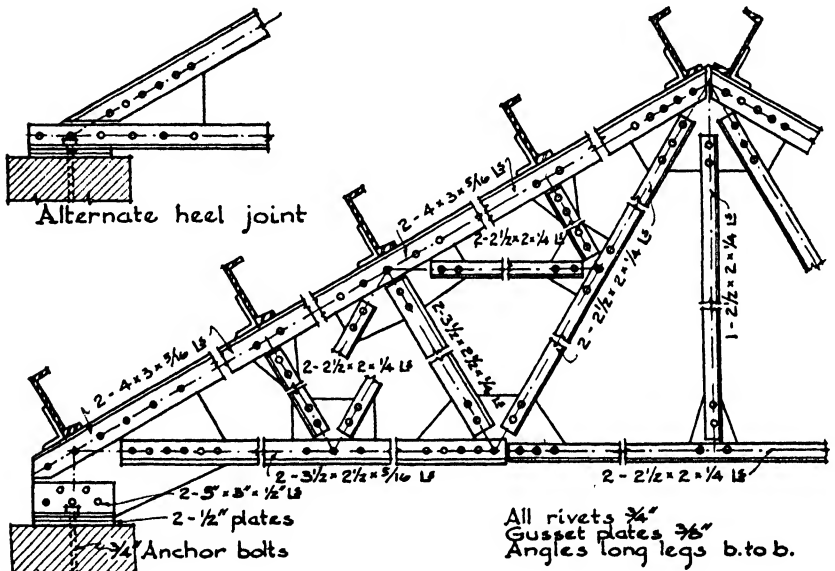

FIG. 20.

gusset plate, or in order to prevent eccentricity, a greater number of rivets is employed than the number theoretically required. Two is the minimum number of rivets for connecting a member to a gusset plate. The smallest allowable angle used in the design of this truss is 2 1/2" x 2" x 1/4".

In order to have angles act together, it is necessary to place **STITCH RIVETS** between joints. For compression members they should not be placed more than 2'0" on centers, nor more than 3'0" on centers in tension members. When stitch rivets are used, washers, the thickness of the gussets, are placed between the angles.

The column formula used in the design of the compression members of this truss is  $f = \frac{18,000}{1 + \frac{p^2}{18,000 r^2}}$ ,

in which  $f$  = the allowable unit stress, in pounds per square inch;  
 $l$  = the unsupported length of the column, in inches;  
 $r$  = the least radius of gyration of the cross section, in inches.

The limiting value of  $\frac{l}{r}$  will be 120.

For this truss we will use  $\frac{3}{4}$ " rivets and  $\frac{3}{8}$ " gusset plates.

The upper chord will be made of one continuous member, the greatest stress occurring in  $CY$ , a compressive stress of 43,400 lbs., its length being 8'6". For a trial section assume the member to be composed of two 4" x 3" x  $\frac{5}{16}$ " angles, long legs back to back, separated by  $\frac{3}{8}$ " for the gusset plates.

The least radius of gyration of this section is  $r = 1.27$ ", and the cross-section area is 4.18 in.<sup>2</sup> Then  $\frac{l}{r} = \frac{102}{1.27} = 80.3$ , the slenderness ratio. This ratio is within the limiting value of 120. Substituting the values of  $l$  and  $r$  in the above column formula, we find that  $f = 13,250$  lbs./in.<sup>2</sup> As there are 4.18 in.<sup>2</sup> in the cross section, the allowable load on the column is  $13,250 \times 4.18$  or 55,380 lbs. We find that the allowable load is greater than the design load, 43,400 lbs.; therefore the trial section is acceptable. It will be used as a continuous member for the upper chord.

The member  $WV$  is also in compression, its stress being 14,800 lbs. As its length is 10', a section made up of two  $3\frac{1}{2}$ " x  $2\frac{1}{2}$ " x  $\frac{1}{4}$ " angles will be used, for any smaller section would have a slenderness ratio in excess of 120. In accordance with the column formula this section has an allowable load of 31,000 lbs.

The minimum section, two  $2\frac{1}{2}$ " x 2" x  $\frac{1}{4}$ " angles, will be used for the short struts  $YX$  and  $UT$  since their allowable loads are greater than the design loads of 7420 lbs.

A continuous member will be used for  $YA$  and  $WA$ , the controlling tensile stress, occurring in  $YA$ , being 44,100 lbs. As two angles will be used for the section, each angle will be required to resist a tensile stress of 22,050 lbs. Assume the angle to be  $3\frac{1}{2}$ " x  $2\frac{1}{2}$ " x  $\frac{5}{16}$ ". Its gross area is 1.78 in.<sup>2</sup> As the legs of the angle are  $\frac{5}{16}$ " in thickness, the effective area to be deducted for a  $\frac{3}{4}$ " rivet is  $\frac{5}{16} \times \frac{1}{8}$  or 0.273 in.<sup>2</sup> Then the net area is  $1.78 - 0.273$  or 1.507 in.<sup>2</sup> If the allowable tensile unit stress is taken as 18,000 lbs./in.<sup>2</sup>, the allowable tensile load on one angle will be  $18,000 \times 1.507$  or 27,126 lbs. This is in excess of the design load, 22,050 lbs., and therefore the member consisting of two  $3\frac{1}{2}$ " x  $2\frac{1}{2}$ " x  $\frac{5}{16}$ " angles is acceptable. The other tension members are designed similarly.

To determine the number of rivets required to connect a member to a gusset plate, divide the stress in the member by the controlling value of one rivet. A common specification for the allowable stresses for power-driven rivets is as follows: unit shearing stress = 13,500 lbs./in.<sup>2</sup>, single bearing unit stress = 24,000 lbs./in.<sup>2</sup> and double bearing unit stress = 30,000 lbs./in.<sup>2</sup>.



Consider first the member *CY* at the joint over the support. The angles are  $\frac{5}{8}$ " thick, the gusset is  $\frac{3}{8}$ " and the rivets are  $\frac{3}{4}$ " in diameter. In accordance with the above stresses, the allowable working values of one rivet are: double shear = 11,930 lbs., double bearing = 8440 lbs. and single bearing = 11,260 lbs. Of these three values, 8440 lbs. is the smallest and therefore is the controlling value of one rivet. As the stress in member *CY* is 43,400 lbs.,  $43,400 \div 8440 = 5 +$ , use 6 rivets.

Similarly, for the member *YA* about the same joint,  $44,100 \div 8440 = 5 +$ , and 6 rivets are required.

The stress in *CY* is 43,400 lbs., and the member *DX* has a stress of 41,400 lbs. These two members, however, are continuous about the joint *CDXY*, and the stress to be transferred to the gusset plate is their difference in magnitude. Then  $43,400 - 41,400 = 2000$  lbs. As the con-

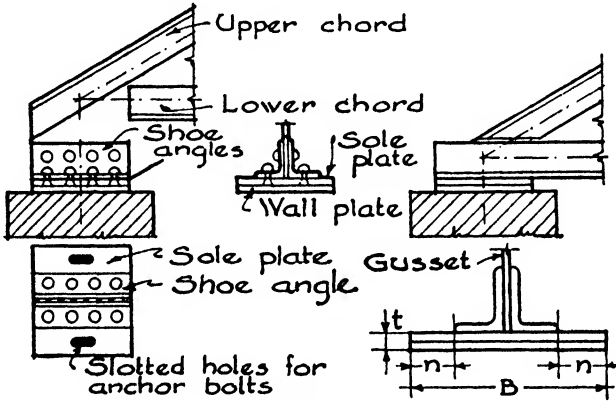

FIG. 21.

trolling value of one rivet is 8440 lbs., less than one rivet is required theoretically. However, a minimum of two rivets is always used, and frequently a greater number are employed when the dimensions of the gusset plate so demand. This condition is illustrated at the joint *DEUVWX*.

The area of the bearing plate is determined by dividing the vertical load transferred by the truss to the supporting wall by the allowable bearing capacity of the masonry. It is customary to extend the bearing plate at least 6" beyond the center line of the bearing and to provide a total length of at least 12" parallel to the length of the truss. To help to distribute the load uniformly a sole plate is riveted to the angles of the lower chord or shoe angles, the sole plate resting on the wall plate; see Fig. 21. Both the sole plate and wall plate should have thicknesses of at least  $\frac{1}{2}$ " each. For economy they should not project beyond the sides of the angles more than 3" or 4". Slotted holes are made in the sole plate through which the anchor bolts are passed. These slotted holes

provide for variations in the length of the truss for expansion and contraction due to temperature changes. The anchor bolts should be at least  $\frac{5}{8}$ " in diameter.

To determine the thickness of the plates the following formula may be used:

$$t = \sqrt{\frac{3 \times w \times B \times n}{2 \times f}}$$

in which  $t$  = the combined thickness of the sole and wall-plate, in inches;

$w$  = the actual bearing stress on the masonry, in pounds per square inch;

$B$  = the length of the plates normal to the length of the truss, in inches;

$n$  = the projection of the plates on each side of the angles, in inches;

$f$  = the allowable flexural stress of the steel plates, 18,000 lbs./in.<sup>2</sup> or 20,000 lbs./in.<sup>2</sup>

To design the plates for this truss, let us assume the allowable bearing stress of the masonry to be 200 lbs./in.<sup>2</sup> and the shoe angles to be 5" x 3" x  $\frac{1}{2}$ ". The vertical component of the combined vertical and wind loads is 25,360 lbs.; hence the required area is  $25,360 \div 200 = 126.8$  in.<sup>2</sup> Accept an area of 12" x 12". Then  $B = 12$ " and  $n = [12 - (3 + 3 + 0.375)] \times \frac{1}{2} = 2.8125$ ". As the area of the plates, 144 in.<sup>2</sup>, has been made somewhat larger than required, the actual bearing stress will be less than 200 lbs./in.<sup>2</sup>, or  $w = 25,360 \div 144 = 175$  lbs./in.<sup>2</sup>

Substituting in the above formula to determine the thickness of the

plates,  $t = \sqrt{\frac{3 \times 175 \times 12 \times 2.8125}{2 \times 18,000}} = 0.7$ ", the combined thickness of the

plates. Since  $\frac{1}{2}$ " plates are generally considered to be a minimum thickness, the sole and wall plate will each be  $\frac{1}{2}$ " thick, 12" x 12" in area and slotted to receive anchor bolts.

## CHAPTER XXII

### REINFORCED CONCRETE

#### Article 1. General Considerations

Plain concrete was used in ancient times by the Egyptians and the Romans and probably by the Mayas in Central America. Sewers, roads, aqueducts, water mains and foundations were constructed of mass concrete by the Romans, who also employed it as a filling between the brick and stone ribs of their vaults and arches. The knowledge of the use of natural cement and consequently of concrete seems to have been lost during the Middle Ages, and it was not until the eighteenth century that its value was rediscovered.

The reinforcing of concrete was first introduced in France in 1861 by Joseph Monier, who constructed flower pots, tubs and tanks, and François Coignet who published theories of reinforcing for beams, arches and large pipes. Very little was actually accomplished in building construction until twenty-five years later when German and Austrian engineers developed formulae for design and Hennebique in France began the use of bent-up bars and stirrups. Between 1880 and 1890 several reinforced concrete buildings were erected in the United States by E. L. Ransome, G. W. Percy and others, and since 1896 the increase in the amount of construction with this material has been remarkable.

Until recent years there has been a tendency among architects to consider reinforced concrete as a method of construction suited only to heavy and massive structures, to foundations, bridges, dams, factories, warehouses and industrial buildings. This feeling was perhaps due to the apparent bulkiness of the material and to the fact that the wooden forms for plain flat surfaces, beams and columns cost less than for curves, arches and domes. The characteristics of the architecture were limited by the economical restrictions of the centering. Much study and experiment have, however, led to vast improvements in the manufacture of the concrete, in the ingenuity, efficiency and simplicity of formwork, and in the development of plastic moulds and of self-centering reinforcement such as ribbed fabrics. Indeed at the present time unlimited possibilities in flexibility, slenderness and aesthetic qualities of design appear to be in the hands of the creators of concrete buildings. The capacity of reinforced concrete is, in the opinion of many architects, not yet realized. Both in Europe and in this country the birth

of a new architectural style conceived by this new material is widely heralded. The potentialities of a substance which can be poured into any form or shape from delicate ornament to huge cantilevers and parabolic arches and which is monolithic throughout its mass should indeed inspire methods of expression distinctive of its structure, and quite different to those called forth by the disjointed elements of steel, wood, brick and stone.

**Design.** Buildings of reinforced concrete may be constructed with load-bearing walls or with a skeleton frame. According to the first method, the exterior walls are designed of sufficient strength to carry the loads of the girders, beams, floors and roofs which rest upon them, the interior supports consisting also of load-bearing walls or of columns. By the second method, the floors and roofs rest directly upon exterior and interior columns or are carried upon beams and girders which, in turn, rest upon the columns. The walls and partitions are simple enclosures of brick or reinforced concrete supported by the beams and girders. Most concrete buildings of any size are now designed according to this second or skeleton frame method.

For the usual types of concrete structures continuity in beams and girders is desirable since the bending moments are thereby less in value than for freely supported beams, with consequent economy of material. Such continuity is reasonable to assume and simple to attain because the concrete of the beams can be poured at the same time as that of their supporting columns and true integral connections attained. In order to assume such continuity in the beams, there should be at least three bays in each direction, and for the most economical design the bays should be nearly square in plan and contain about 400 ft.<sup>2</sup> of floor area.

Exterior columns are generally square or rectangular in cross-section, but interior columns may have any section desired, round, square or octagonal being most employed with beam-and-slab and ribbed-slab floor systems, while a round section is generally selected for girderless flat slab construction.

There should not be a great variety in the specified sizes of reinforcing steel for the beams, girders and slabs. It is often more economical to use a slightly larger bar or a closer spacing than necessitated by the calculations in order to attain uniformity, rather than to require a diversity of sizes and intervals which complicates the fabricating and placing of the steel. The same forms should also be employed as far as practicable, since a small excess of concrete or of lumber is less costly than the labor to alter forms to carry out unimportant differences in dimensions.

The details of live and dead loads are included in Chapters I and XX, and the proportioning of column loads on footings is described in Chapter XXIV, Foundations.

The selection between round rods and square bars is most often governed by the requirements of the suitable cross-sectional area, although round rods are considered easier to bend.

Steel rods amounting in cross-sectional area to 0.003 or 0.004 the cross-sectional area of the concrete should be introduced at right angles to the main reinforcement in floor slabs and especially in roof slabs to provide against temperature variation and shrinkage. Vertical expansion joints are often provided in buildings 200' or 300' long to furnish a plane of separation so that free movement due to changes of temperature may take place between the two adjacent parts.

When the plan and character of a building permit their adoption, the foregoing principles will lead to economy in design. In every case, however, the constructive details must necessarily be determined by the architectural requirements.

## Article 2. Reinforcement

**Material.** Either steel or iron may be used for the reinforcing of concrete, iron being largely used in Europe and steel almost exclusively in the United States.

The steel may be of either Bessemer or open-hearth manufacture and should not contain over 0.10% phosphorus for the Bessemer or 0.05% for the open-hearth.

The American Society for Testing Materials requires the following properties in reinforcing steel.

Table I. Tensile Properties

Properties	Plain Bars			Deformed Bars			Cold-twisted Bars
	Structural Grade	Intermediate Grade	Hard Grade	Structural Grade	Intermediate Grade	Hard Grade	
Tensile Strength lbs./in. <sup>2</sup>	55 000 to 70 000	70 000 to 85 000	80 000 min.	55 000 to 70 000	70 000 to 85 000	80 000 min.	Recorded only
Yield Point lbs./in. <sup>2</sup>	33 000	40 000	50 000	33 000	40 000	50 000	55 000
Elongation in 8 in. Minimum %	1 400 000 Ten. str.	1 300 000 Ten. str. but not less than 16%	1 200 000 Ten. str.	1 250 000 Ten. str.	1 125 000 Ten. str. but not less than 14%	1 000 000 Ten. str.	5

A deduction from the percentages of elongation shall be made for plain and deformed bars of 0.25% in bars over 3/4" in thickness for each increase of 1/32" of the diameter above 3/4", and of 0.5% in bars under 7/16" in thickness for each decrease of 1/32" of the diameter below 7/16".

**Table II. Bend-Test Requirements**

Thickness or Diameter of Bar	Plain Bars			Deformed Bars			Cold-twisted Bars
	Structural Grade	Inter-mediate Grade	Har.1 Grade	Structural Grade	Inter-mediate Grade	Hard Grade	
Under 3/4"	180° $d = t$	180° $d = 2t$	180° $d = 3t$	180° $d = t$	180° $d = 3t$	180° $d = 4t$	180° $d = 2t$
3/4" or over	180° $d = t$	180° $d = 2t$	180° $d = 3t$	180° $d = 2t$	180° $d = 3t$	180° $d = 4t$	180° $d = 3t$

$d$  = diameter of pin about which the specimen is bent.  
 $t$  = thickness or diameter of the specimen.

The bars shall bend cold around the pin without cracking on the outside of the bent portion.

It is very important that reinforcement should conform to this test because all bars are subject to being bent before placing and the inclined and curved portions must be as efficient to withstand stresses as are the straight portions.

Until recent years reinforcing steel was generally selected from the structural grade with an allowable working stress of 16,000 lbs./in.<sup>2</sup> in tension and compression. Engineering societies and the revised building codes are now, however, recommending the use of a smaller factor of safety for structural grade steel or the employment of the intermediate grade in order to permit working stresses of 18,000 and 20,000 lbs./in.<sup>2</sup> Very definite economies in the cost of building are naturally the result of the higher allowable stresses especially since the intermediate grade is very little dearer than the structural.

The Joint Committee of 1940 recommends the following working stresses per square inch for steel reinforcement:

Tension in flexural members, with or without axial loads:

- Structural grade bars and shapes..... $f_s = 18,000$  lbs.
- Intermediate grade bars..... $f_s = 20,000$  lbs.
- Hard-grade bars (billet, rail or axle steel)..... $f_s = 20,000$  lbs.
- Wire mesh or bars not exceeding 1/2" diam. for one-way solid slabs only..... $f_s = 50\%$  of min. yield point but not to exceed 25,000 lbs.

Tension in web reinforcement:

- All grades of steel..... $f_s = 16,000$  lbs.

Compression in column verticals:

- Intermediate grade bars..... $f_s = 16,000$  lbs.
- Hard-grade bars (billet, rail or axle steel)..... $f_s = 20,000$  lbs.

**Types of Reinforcement.** Reinforcement may be divided generally into five types:

- (a) Round rods and square bars.
- (b) Wire fabric.
- (c) Expanded metal fabric.
- (d) Self-centering fabric.
- (e) Spirals.

**RODS AND BARS** (Fig. 1, *a*). Rods and bars are either plain or deformed, the plain having smooth surfaces and the deformed being provided with projections or irregularities formed during the process of rolling. These deformations increase the adhesion between the steel and the concrete by adding the mechanical bond of the projections to the surface bond of the plain bars. Higher unit bond stresses are, therefore, allowed for the deformed than for the plain bars. There is little to choose between round and square bars except the matter of obtaining the proper cross-sectional area. Round rods are generally easier to bend and for that reason stirrups are formed from the rounds rather than the squares. As a rule, in localities where deformed bars are not distinctly more costly than plain bars, their use should be preferred because of the higher factor of safety obtained.

Deformed bars and rods are regularly rolled in the following sizes only, other sizes being special and more expensive.

Round rods, 1/4, 3/8, 1/2, 5/8, 3/4, 7/8, and 1 in.  
Square bars, 1/2, 1, 1 1/8, and 1 1/4 in.

**WIRE FABRIC** (Fig. 1, *b*). This material is made by crossing wires so as to form a fabric with square or triangular mesh. The heavier wires run lengthwise and are called carrying wires; the lighter wires, called tie wires, cross the heavy wires and are attached to them by welding or winding. The size and spacing of the wires vary to provide a series of effective cross-sections suitable to meet the ordinary run of conditions. Wire fabric, called floor lath, is furnished with a heavy water-resisting paper backing to be used on light steel joists without other centering. Concrete is poured directly upon the fabric and is held in place by the backing.

**EXPANDED METAL** (Fig. 1, *c*). This type of reinforcement is formed by slitting a sheet of soft steel and then cold drawing the metal in a direction normal to the axis of the sheet, pulling the slits into diamond-shaped meshes. By varying the thickness of the sheets and the width of the strands a series of effective cross-sections is obtained suitable to general requirements as in the case of wire fabric, both types being much used in cinder concrete floor arches. The uniform spacing of the steel is maintained in both wire fabric and expanded metal, which is a distinct advantage.

**SELF-CENTERING FABRIC** (Fig. 1, *d*). This fabric is made from sheets with deep rigid corrugations or foldings lengthwise of the sheet. The

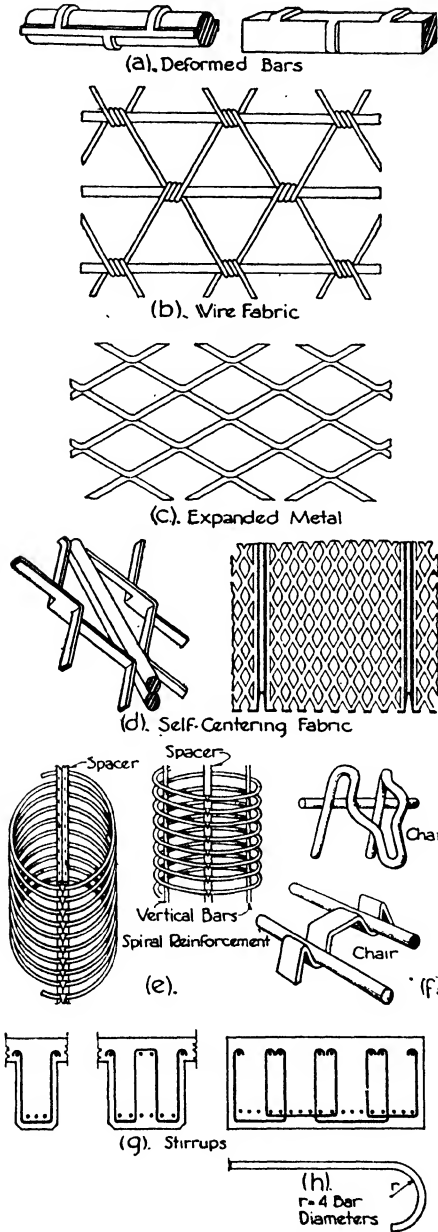

FIG. 1.—Types of Reinforcement



metal between the ribs is slit and expanded into small mesh, and a stiff reinforcing material is obtained which does not require forms or centering. The fabric is stretched over steel beams, concrete is poured on top and the under side is plastered. A suspended ceiling may be hung beneath the beams if preferred, but in either case the fire-protection is not of the highest order. Self-centering fabric likewise provides a means of constructing concrete members, walls and domes in modernistic character and of any desired shape or curve without the expense or the limiting influences of wood forms and centering.

**SPIRALS** (Fig. 1, *e*). Spiral reinforcement for columns is generally made at the factory and shipped flat, together with the necessary spacing rods. It may be obtained in a variety of wire sizes, coil diameters and pitch. The wire usually ranges from  $\frac{1}{4}$ " to  $\frac{1}{2}$ " in diameter, the coil from 12" to 36" and the pitch from  $1\frac{1}{2}$ " to 3".

**Support for Reinforcement** (Fig. 1, *f*). It is very necessary that the reinforcing steel be held in its proper position laterally and above the forms so that it will be maintained in its designed position during the pouring of the concrete. Metal chairs resting upon the bottom of the formwork for beams and slabs provide a satisfactory resting place for the bars. These chairs are also combined with spacing rods to hold the bars at the proper distances apart.

Column spirals are held in place by the notches of vertical spacers, three or four to a column.

The clear distance between bars should not be less than 1" and should be  $2\frac{1}{2}$  times the diameter of the bars if round or 3 times the side of the bars if square. They should be far enough apart for the coarse aggregate to pass through with ease.

**Stirrups** (Fig. 1, *g*). Stirrups should pass under the bottom longitudinal bars and be hooked over the top bars or over longitudinal spacer bars. In wide beams and footings where stirrups of more than 4 legs are required it is better practice to use several U's or W's than to increase the number of legs on a single stirrup. Rods larger than  $\frac{5}{8}$ " should not be made into stirrups because of the difficulty of bending. Stirrups should be securely wired or welded to the longitudinal bars in their exact designed positions.

**Anchorage** (Fig. 1, *h*). In order that sufficient surface of steel at the support of a beam be in contact with the concrete to transmit the stresses in the steel to the support it is customary to extend the steel over the support into the concrete of the adjoining span. The amount of overlapping is usually taken as  $\frac{1}{5}$  or  $\frac{1}{4}$  of the span. This extension is practical at interior supports but not at end supports, and here the bar is provided with a hook at its end to obtain sufficient anchorage in the concrete. The hook should have a radius of 4 bar diameters and if possible should pass over a cross bar to distribute the pull upon the concrete.

Article 3. Beams and Slabs

**General Theory.** Concrete is strong to resist compressive stresses but weak against tension; therefore to render it a practical material for the construction of beams, columns and other structural members, steel rods or bars are combined with the concrete while the latter is still soft, to resist the tensile stresses, the concrete itself being depended upon to take care of the compression. Upon hardening or setting, a fairly strong bond is formed between the concrete and the steel, the

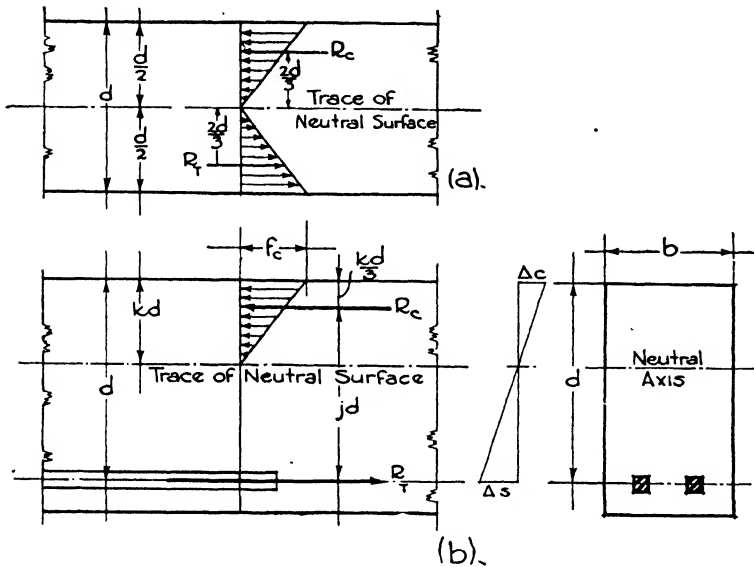

FIG. 2.

rods becoming, as a matter of fact, a part of the aggregate of the concrete. The rods are, of course, very carefully placed in those parts of the concrete member, be it beam girder or column, where the tensile stresses will occur.

It is well known that, when a beam supported at each end is loaded, there is a tendency for the beam to bend, the fibers in the upper part being compressed together and those in the lower part elongated. The fibers at the extreme top and bottom of the beam are in the greatest stress, and the stress diminishes in the fibers as they become more remote from the top and bottom surface, until at a plane called the neutral surface there is no stress either compressive or tensile. In the cross-section of a rectangular beam of homogeneous material the neutral surface is at the center, the fibers above the neutral surface being in compression and those below in tension. The resisting moments of the

portions of the beam in tension and in compression are determined in relation to this neutral surface (Fig. 2, *a*).

In a reinforced concrete beam, however (Fig. 2, *b*), there are two materials, the concrete and the steel, and the position of the neutral surface is not at the centroid of the beam but depends upon the relative moduli of elasticity of the concrete and the steel. The modulus of elasticity of steel does not vary with the strength of the steel but is substantially the same for all grades, namely 30,000,000 lbs./in.<sup>2</sup> In the case of concrete, however, the modulus of elasticity varies with the strength of the concrete, that is upon the proportioning of the ingredients and the water and upon the age, and may be fairly taken as equaling 1000 times the ultimate strength of the concrete or  $1000 f'_c$ . The ratio known as  $n$  of the modulus of elasticity of the steel to that of the concrete,  $\frac{E_s}{E_c}$ ,

changes in direct proportion to the change in the modulus of the concrete and with it changes the position of the neutral surface. The value of  $n$ , then, equals  $\frac{E_s}{1000f'_c} = \frac{30,000}{f'_c}$ . For these reasons it is found to be

more convenient to compute the resisting moments of compression in the concrete and of tension in the steel as a couple with lever arm equal to the perpendicular distance between them. The compressive stresses may be depicted as a triangle with the base representing the greatest stress in the extreme fiber and with the apex, carrying no stress, at the neutral surface. The resultant of the compressive stresses will then be situated at the centroid of the triangle, that is, at a point  $1/3$  of the distance from the base or extreme fiber to the neutral surface. The resultant of the tensile stresses will be in the centroid of the steel reinforcement, any tensile strength in the concrete, below the neutral surface, being disregarded. If  $j$  represent the ratio of the distance between the compressive and the tensile resultants to the depth of the beam, and  $k$  represent the ratio of the distance between the extreme fiber in compression and the neutral surface to the depth of the beam, then  $jd$  is the distance between the compressive and the tensile resultants and  $kd$  is the distance between the extreme fibers in compression and the neutral surface. The resisting moment of the steel is then equal to the unit tensile stress times the sectional area of the steel, times its lever arm,

$$M_s = f_s A_s j d \quad (1)$$

The resisting moment of the concrete equals the average unit compressive stress  $\frac{f'_c}{2}$ , times the area of the cross-section of the concrete in compression, times its lever arm,

$$M_c = \frac{1}{2} f'_c \times k d b \times j d = \frac{1}{2} f'_c j k b d^2 \quad (2)$$

These two moments must be equal, and by equating them we may de-

rive the fundamentals upon which are based the working formulae for the design of beams, slabs and columns in reinforced concrete. It is evident that  $kd$  must be used to determine the cross-sectional area of concrete in compression and that  $jd$  is the lever arm of the couple.

For the most economical beam the ratio of the respective sectional areas of steel reinforcement and of concrete should be such that each develops its full working stress simultaneously with the other. This ratio of area of steel to area of concrete is designated by  $p$ . Such a beam is called a balanced beam.

The formulae for determining the values of  $j$ ,  $k$  and  $p$  may be derived by the following methods.

(1) In Fig. 2,  $b$ ;  $\Delta_c$  and  $\Delta_s$  represent the respective maximum deformations in the concrete and the steel when a beam is bent by loading. By similar triangles:

$$\frac{\Delta_s}{\Delta_c} = \frac{d - kd}{kd}$$

Now the modulus of elasticity of steel and of concrete each equals the unit stress in the material divided by the corresponding unit deformation, or  $E_s = \frac{f_s}{\Delta_s}$  and  $E_c = \frac{f_c}{\Delta_c}$ .

Then  $\Delta_s = \frac{f_s}{E_s}$ ;  $\Delta_c = \frac{f_c}{E_c}$ , and  $\frac{\Delta_s}{\Delta_c} = \frac{f_s}{E_s} \times \frac{E_c}{f_c} = \frac{f_s}{nf_c}$ .

Therefore  $\frac{\Delta_s}{\Delta_c} = \frac{d - kd}{kd} = \frac{f_s}{nf_c}$ ; or  $\frac{f_s}{nf_c} = \frac{1 - k}{k}$ .

Then  $k(f_s + nf_c) = nf_c$ ; and  $k = \frac{nf_c}{f_s + nf_c} = \frac{1}{1 + \frac{f_s}{nf_c}}$  or  $\frac{n}{n + \frac{f_s}{f_c}}$ . (3)

(2) In Fig. 2,  $b$ ;  $jd = d - 1/3 kd$ ; and  $j = 1 - \frac{k}{3}$ . (4)

(3) For a balanced beam  $M_s = A_s f_s jd = p f_s j b d^2$  and  $A_s = p b d$ . Then from formulae (1) and (2):

$$f_s p b d \times jd = 1/2 f_c k b d \times jd \text{ or } p f_s = 1/2 f_c k$$

Therefore  $p = \frac{1/2 f_c k}{f_s} = \frac{f_c k}{2 f_s}$ . (5)

Since the values of  $jd$ ,  $kd$  and  $p$  are dependent upon the ratio  $n$  between the moduli of elasticity of steel and concrete and the value of the modulus of elasticity of concrete varies with its strength, it is evident that, in order to arrive at working formulae, we must first decide upon values for the ultimate strength of steel and concrete and so upon a value for  $n$ .

Until recently, limits of 16,000 lbs./in.<sup>2</sup> for steel and 650 lbs./in.<sup>2</sup> for concrete have generally been required by municipal building codes and employed by most designers. Because of the improvements in the pro-

duction of steel and concrete of late years, however, greater strength and dependability have been assured. Consequently the engineering societies, the Concrete Institute and the revised building codes have now raised the values of the allowable working stresses to 18,000 lbs./in.<sup>2</sup> for tension in steel and 900 lbs./in.<sup>2</sup> for compression in flexure of concrete. The stress for concrete is based upon an ultimate compressive strength of 2000 lbs./in.<sup>2</sup> at 28 days, a value which can be relied upon with intelligent mixing and economical proportioning. When higher strength than 2000 lbs./in.<sup>2</sup> can be shown by tests, building codes gen-

Table III. Allowable Unit Stresses

Description	Allowable Unit Stresses			
	For Any Strength of Concrete	Strength Fixed by Water Cement Ratio		
		$n = \frac{30,000}{f'_c}$	$f'_c = 2000 \text{ lbs.}$	$f'_c = 2500 \text{ lbs.}$
	% of $f'_c$	lbs./in. <sup>2</sup>	lbs./in. <sup>2</sup>	lbs./in. <sup>2</sup>
		$n = 15$	$n = 12$	$n = 10$
<b>Flexure: <math>f_c</math></b>				
Extreme fiber stress in compression, $f_c$ .....	$0.45f'_c$	900	1 125	1 350
Extreme fiber stress in tension (for plain concrete footings only) $f_t$ .....	0.03	60	75	90
<b>Shear: <math>v</math></b>				
Beams without web reinforcement or anchorage of longitudinal steel.....	0.02	40	50	60
Beams without web reinforcement but with anchorage.....	0.03	60	75	90
Beams with web reinforcement but without anchorage.....	0.06	120	150	180
Beams with web reinforcement and anchorage.....	0.12	240	300	360
Flat slabs at distance $d$ from edge of column cap or drop panel.....	0.03	60	75	90
Footings where longitudinal bars have no anchorage.....	0.02	40	50	60
Footings where longitudinal bars have anchorage.....	0.03	60	75	75
Combined footings and Raft foundations designed as beam elements with web reinforcement and anchorage.....	0.06	120	150	180
<b>Bond: <math>u</math></b>				
In beams and slabs and one-way footings				
Plain bars.....	0.04	80	100	120
Deformed bars.....	0.05	100	125	150
In two-way footings				
Plain bars (not anchored).....	0.03	60	75	90
Deformed bars (not anchored).....	0.0375	75	94	113
Plain bars (anchored).....	0.045	90	113	135
Deformed bars (anchored).....	0.056	112	140	168
<b>Bearing: <math>f_s</math></b>				
On full area.....	0.25	500	625	750
On one-third area or less.....	0.375	750	938	1 125
<b>Axial Compression: <math>f_c</math></b>				
On pedestals.....	0.25	500	625	750

erally permit increased working stresses in the concrete. Chapter III on concrete describes the methods of proportioning by water-cement ratio now largely adopted to produce economical mixtures of reliable strength.

Table III presents the percentages of the ultimate strength of concrete recommended by the American Concrete Institute for allowable stresses in compression, shear and bond. These percentages and values form the basis upon which many municipalities are revising their building codes and were specified by the Joint Committee on Standard Specifications for Concrete and Reinforced Concrete.\*

In this table  $f'_c$  is the ultimate compressive strength of the concrete at an age of 28 days when tested in cylinders according to the recommendations of the American Society for Testing Materials.

Stirrups used as web reinforcement are of softer steel than the longitudinal bars and 16,000 lbs./in.<sup>2</sup> is usually taken as the working stress.

In Table IIIA are given the values of  $n$ ,  $f_c$ ,  $j$ ,  $k$  and  $p$  for three classes of concrete with ultimate strengths of 2000-2400, 2500-2900 and 3000-3900 lbs./in.<sup>2</sup> respectively. The values of  $n$  are based on the formula

$$n = \frac{30,000}{f'_c}$$

and are for normal weight aggregates. For light-weight concrete the values of  $n$  should be doubled. The values of  $k$ ,  $j$  and  $p$  are derived by formulae 3, 4 and 5.

Table IIIA. Values of  $n$ ,  $f_c$ ,  $j$ ,  $k$ , and  $p$

	$f'_c = 2000 - 2400$	$f'_c = 2500 - 2900$	$f'_c = 3000 - 3900$
$n$	15	12	10
$f_c$	900	1 125	1 350
$j$	0.857	0.857	0.857
$k$	0.428	0.428	0.429
$p$	0.01	0.013	0.016

It will be noticed that the values of  $j$  and  $k$  are approximately the same for the three strengths of concrete. For ordinary purposes 0.86 may be used for  $j$  and 0.43 for  $k$ .

**Working Formulae. Effective Depth.** The usual procedure in designing a concrete beam is first to assume the width,  $b$ , and then to compute the effective depth,  $d$ , required to resist the compressive stresses in the con-

\* This committee is composed of five members from each of the following societies; American Society of Civil Engineers, American Society for Testing Materials, American Railway Engineering Association, American Concrete Institute, American Institute of Architects, Portland Cement Association. Its last report was submitted in June, 1940.

crete produced by the tendency toward bending under the load. The effective depth is the distance from the upper surface of the beam to the centroid of the steel reinforcement. For this purpose the above formula (2) involving the compression resisting moment is used.

$$M_c = \frac{1}{2} f_c j k b d^2$$

or

$$d = \sqrt{\frac{M}{\frac{1}{2} f_c j k b}} \tag{6}$$

**Area of Steel.** The effective depth is an essential in computing the necessary cross-sectional area of the steel reinforcement to resist the tensile stresses produced by bending. When the areas of concrete and steel are in such relation that their full working stresses are simultaneously developed the formula involves the ratio  $p$ .

$$A_s = p b d \tag{7}$$

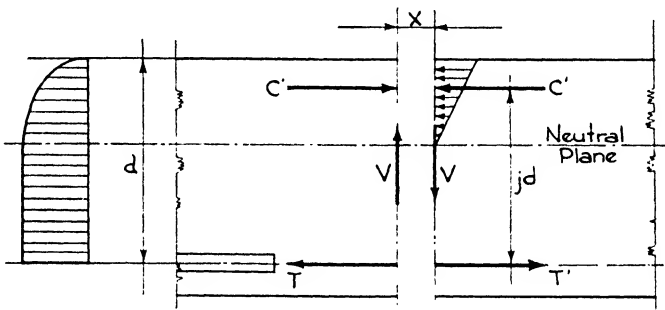

FIG. 3.

If, however, it is not feasible to balance the reinforcement a second formula, derived from formula (1) involving the bending moment, is used:

$$A_s = \frac{M}{f_s j d} \tag{8}$$

Besides the stresses caused in concrete by bending, stresses also arise from shear and from diagonal tension.

**Shear.** The variation in shearing stresses in a reinforced concrete beam differs from that in a homogeneous beam because the steel reinforcement takes all the tensile stress. The intensity of the shearing stress is therefore considered to be constant from the neutral surface to the centroid of the reinforcement. On the compression side, however, the intensity of the shear is greatest at the neutral surface and varies according to the curve of a parabola from the neutral surface to the extreme fiber of the compressive face.

Fig. 3 represents a beam cut by two vertical planes separated by the distance  $x$  so small that the vertical shears in the two planes may be

considered equal.  $T$  and  $T'$  represent the tensile forces on the two adjacent sections acting in the steel, and  $C$  and  $C'$  are the resultants of all compressive stresses acting above the neutral surface. Since the tensile and compressive forces are in equilibrium,  $C = T$  and  $C' = T'$ . The total horizontal shearing stress upon any horizontal plane of the two vertical sections  $x$  distance apart, situated between the steel and the neutral surface, is equal to  $T - T'$ . This horizontal shear is resisted by the concrete over an area equal to  $bx$ , when  $b$  is the width of the beam

The unit shearing stress is then

$$v = \frac{T - T'}{bx} \tag{9}$$

Since the section must be in equilibrium under the various moments and couples,

$$Vx = (T - T')jd \text{ or } T - T' = \frac{Vx}{jd}$$

Substituting this value of  $T - T'$  in equation (9) there follows:

$$v = \frac{Vx}{jd} \times \frac{1}{bx} \text{ or } v = \frac{V}{jbd}$$

In a symmetrically loaded simple beam the maximum positive bending moment is at the center of span, and at this point the shear passes through zero. As the moment decreases while approaching the supports, so the shear is increasing until at the support the moment is zero and the shear is maximum. Therefore for some distance on each side of the center of span the shear can be resisted by the concrete itself, but adjacent to the supports, steel is generally required to take care of the shearing stress in excess of that which the concrete can withstand.

**Diagonal Tension.** (Fig. 4,a). Diagonal cracks occur on the tension side of unreinforced beams under testing loads. They are nearly vertical at the center of the beam and arise from failure in flexural stress. Near the supports, the cracks become more inclined in direction from the bottom of the beam toward the top. These cracks arise from a combination of flexural stress and vertical shear, called diagonal tension. Although the exact determination of diagonal tension stress is impossible, tests show that the shearing unit stress may be accepted as a convenient measure of diagonal tension; that is, the diagonal tension may be assumed as proportional to the direct shearing stress. Therefore by adopting proper working stresses based on tests producing diagonal tension failures, formulae for vertical shearing stresses may be used for diagonal tension. The formula for shear as a measure of diagonal tension then is

$$v = \frac{V}{jbd} \tag{10}$$

in which  $V$  is the total vertical shear in pounds and  $v$  is the unit shearing stress in pounds per square inch. The amount of shear per linear inch



would be  $v_1 = \frac{V}{jd}$ . Since the value of  $j$  varies but slightly for different percentages of steel, the approximation 0.875 or  $\frac{7}{8}$  is generally employed in shear computations, or

$$v = \frac{8V}{7bd} \text{ and } v_1 = \frac{8V}{7d} \tag{11}$$

Most building codes limit the allowable unit shearing stress in diagonal

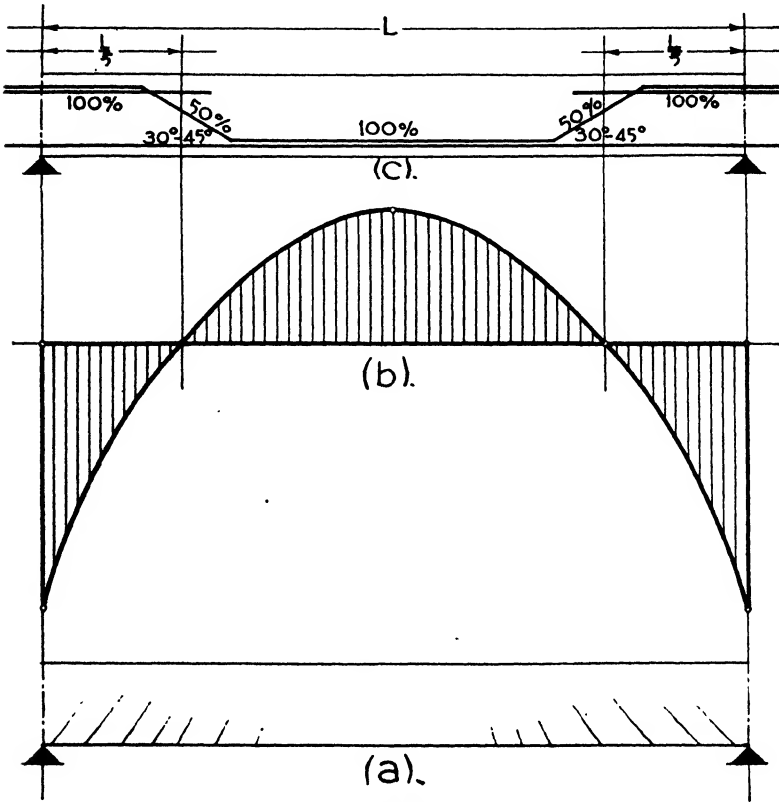

FIG. 4.

tension for 2000 lb. concrete to 40 lbs./in.<sup>2</sup>, when there is no special reinforcement against shear, called web reinforcement, and to 120 lbs. when such web reinforcement is provided.

$v'$  = shearing stress at 40 lbs./in.<sup>2</sup>

Web reinforcement generally consists of bent-up longitudinal bars or of rigidly fixed vertical U-shaped stirrups hooked at the upper end and spaced at computed distances, or of a combination thereof. The

stirrups are usually round in section,  $\frac{3}{8}$ " or  $\frac{1}{2}$ " in diameter. In wide girders or footings it is sometimes necessary to have several legs or prongs on each stirrup. The radius of the hook should not be less than 4 times the diameter of the web bar, or where more convenient the ends may be bent around the longitudinal reinforcement or welded to it.

As has been said, in symmetrically loaded beams the maximum positive bending moment is at the center of the span, and the full amount of longitudinal reinforcement is needed at this point. Since the positive bending moments decrease as the supports are approached and the diagonal tension increases, it is the custom to bend up 30% to 50% of the longitudinal positive moment reinforcement at angles of  $30^\circ$  to  $45^\circ$  to resist the diagonal tension. The bars are then bent horizontally again and pass over the supports near the top of the beam to resist the negative bending moment at the support. In continuous beams the bending changes, causing a positive moment at the center of the beam and a negative moment over the supports. This point of change or inflection is generally assumed to be at a distance from the support equal to  $1/5$  of the clear span, and at this point the moment is zero. It is through this fifth point that the reinforcing bars are bent up (Fig. 4,*b*). When necessary accurate determinations of the points of inflection may be made by constructing moment diagrams.

For simplicity of designing and of placing reinforcement, the positive moment is generally considered equal to the negative moment. By bending up 50% of the longitudinal reinforcement on each side of a support, the full amount or 100% is obtained over the support (Fig. 4,*c*).

To design the web reinforcement it is first necessary to find the distance  $x$  out from the support to the section where the shear can be carried by the concrete alone.

$$V = \frac{wl}{2} - wx; v = \frac{V}{bjd}, \text{ and } V = bjd v$$

where  $V$  equals the total shear at the point  $x$ ,  $v$  = the unit shear at that point and  $w$  = load per linear foot.

$$\text{Then } x = \frac{l}{2} - \frac{vbjd}{w}. \quad (12)$$

In actual design  $x$  may often be found by the simple proportion  $\frac{L}{2} : (\frac{L}{2} - x) = v : v'$ ; or  $x = \frac{L}{2} \left( \frac{v - v'}{v} \right)$ , where  $\frac{L}{2}$  = the half span,  $v' = 40$  lbs. and  $v$  = unit shear stress.

The next step is to determine the spacing of the stirrups. The web reinforcement, whether consisting of vertical stirrups or bent-up bars, contributes resistance to diagonal tension only in that component of its total resistance which is directed at an angle of  $45^\circ$  with the longitudinal

axis of the beam. The stirrup spacing or effective length of a bent-up bar is therefore:

$$s = \frac{A_s' f_s j d (\cos \alpha + \sin \alpha)}{V'} \quad (13)$$

where  $s$  = the horizontal distance along the axis of the beam between stirrups;  $\alpha$  = angle of the stirrup or bars with the longitudinal axis of the beam;  $A_s'$  = total cross-sectional area of web reinforcement;  $V'$  = total vertical shear in excess of the part, generally 40 lbs./in.<sup>2</sup>, resisted by the concrete,  $= (v - v') j b d$ .

The natural sine for 90° is 1 and the cosine 0; the sine and cosine for 45° are both 0.71. Therefore for vertical stirrups formula (13) becomes

$$s = \frac{A_s' f_s j d}{V'}, \text{ or } s = \frac{A_s' f_s}{(v - v') b} \quad (14)$$

and for bars inclined at 45° it becomes

$$s = \frac{A_s' f_s j d}{0.7 V'} \quad (15)$$

The Joint Committee recommends that the effective length  $s$  for bent-up bars shall not exceed  $\frac{3}{4}d$  and it shall be measured  $\frac{1}{2}$  each way from the bar at the mid-depth of the beam.

**Bent-up Bars.** A portion of the longitudinal reinforcement bars of uniformly loaded beams is generally bent up through the point of inflection which is assumed to be at a distance of  $\frac{1}{5}$  the clear span from a support. Care should be taken, however, that the bends are not made so near the points of maximum positive and negative bending moment as to reduce the efficacy of the bars in tension; that is, a sufficient horizontal length of bar must be maintained on each side of these points to resist the tension stresses present and to produce the required bond. Theoretically it is more reasonable to bend up the bars in sequence as the moments decrease in approaching the point of inflection, and some architects prefer this method as providing a better distribution of steel. It produces, however, a more complicated system of reinforcement and a puzzling number of types of bent bars on the job. Consequently for all except the largest girders, especially those with bars in two tiers, the longitudinal reinforcement is generally bent up in one plane (Fig. 5,a).

The bars must not be bent so near the center of a uniformly loaded beam as to weaken unduly the horizontal reinforcement for positive bending moment nor so close to the support that the reinforcement for the negative moment is too much reduced.

For concentrated loading a diagram (Fig. 5,b) may be constructed and the point determined at which the moment is 50% of the maximum

moment at the load nearest to the support. The bend at the bottom can properly be made at this point. The bars are generally first bent up from the bottom point using a selected angle, which of itself fixes the top point. This top point should then be checked, and if found too near the section of maximum negative moment a steeper angle must be used. Some codes recommend that only  $\frac{3}{4}$  of the inclined por-

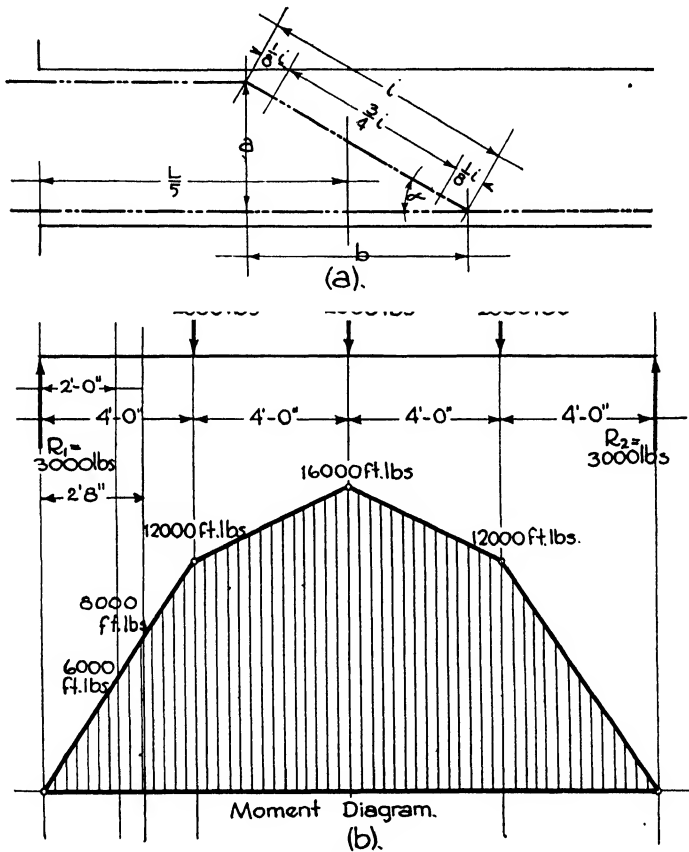

FIG. 5.

tion of bent bars be considered effective in resisting shear and diagonal tension. The horizontal projection of the inclined portion may be found by the formula

$$b = a \cot \alpha \tag{16}$$

when  $a$  is the effective depth less 2" for fireproofing at top of beam and half upper bar diameter or  $d - 2''$ ;  $b$  is the desired projection, and  $\alpha$  is the angle of the bars.

The area of the bent-up bars may be checked for the shearing stress which they will be called upon to resist by the formula

$$A_v = \frac{V'}{16,000 \sin \alpha}$$

in which  $A_v$  is the total area of the bent-up bars, and  $V'$  is the excess of total shear over that permitted in the concrete.

Table IV. Natural Sines, Cosines, and Cotangents

Angle	Sine	Cosine	Cotangent
45°.....	0.71	0.71	1.0
40°.....	0.64	0.76	1.19
35°.....	0.57	0.81	1.43
30°.....	0.50	0.86	1.73

Tables V and VI give the areas and perimeters of the rods and bars most generally employed for reinforcement both as longitudinal steel and as stirrups.

Table V. Areas and Perimeters of Round Rods

Diameter in inches	¼	⅜	½	⅝	¾	⅞	1	1⅛	1¼
Area in sq. in.	0.049	0.11	0.19	0.30	0.44	0.60	0.78	0.99	1.22
Perimeters in in.	0.78	1.18	1.57	1.96	2.35	2.75	3.14	3.53	3.93

Table VI. Areas and Perimeters of Square Bars

Side in inches	¼	⅜	½	⅝	¾	⅞	1	1⅛	1¼
Area in sq. in.	0.062	0.14	0.25	0.39	0.56	0.76	1.00	1.26	1.56
Perimeters in in.	1.00	1.50	2.00	2.50	3.00	3.50	4.00	4.50	5.00

The most-used sizes for longitudinal steel are ¼, ⅜, ½, ⅝, ¾, ⅞ and 1" round, and ½, 1, 1⅛ and 1¼" square. Other sizes are considered special and are more expensive. Stirrups are generally selected from the ¼", ⅜" and ½" round rods because of ease of bending and placing. Since softer steel is employed for stirrups, an allowable working stress of 16,000 lbs./in.<sup>2</sup> will be assumed. Stirrups should be held in place by passing under the bottom horizontal steel to which it is wired or welded and by hooking over the top reinforcement.

**Bond.** The resistance of the steel reinforcement to tension can function only through the adhesion between the concrete and the steel called the **BOND**. This perfect adhesion is one of the fundamental assumptions in the design of reinforced concrete. If the reinforcement should slip through the concrete its power of resistance is lost and tensile stresses are brought upon the concrete, which has little ability to with-

stand them. The examination of the reinforcement for bond stress after it has been designed to resist tension and shear is therefore very important. The adhesion between the two materials is caused by the shrinkage of the concrete in setting and by the frictional resistance of the bar or rod. The steel should never be polished since the friction is thereby reduced and a slight rust adds to the bond. In order to increase the anchorage, deformed bars are rolled with closely spaced lugs or projections on their surface to engage the surrounding concrete, and also the ends of the bars may be formed in a hook for situations where sufficient longitudinal contact cannot be obtained. The hook should be bent in a full semi-circle with a radius not less than 3 bar diameters, plus an extension at the free end of at least 4 bar diameters. Right-angle bends should be avoided.

The critical section for bond stress is at the face of the support for simple beams, for freely supported end spans of continuous beams and for negative reinforcement. The Joint Committee recommends that, for continuous and restrained beams, the critical section be taken at the point of inflection. Bent-up bars within a distance of  $d/3$  from the horizontal reinforcement under consideration at the critical section may be included with the straight bars in computing the sum of the perimeters.

The bond stress is the horizontal shear between the steel and the concrete. The bond per LINEAR inch is  $V/jd$ , as may be seen from formula (10), and the bond per SQUARE inch of steel surface is  $V/jd$  divided by the sum of the perimeters of the bars.

Then 
$$u = \frac{V}{\Sigma o j d} \tag{17}$$

when  $u$  = bond stress per square inch and  $\Sigma o$  = the sum of the perimeters.

The length of embedment necessary to develop full working stress in the steel equals

$$l = \frac{f_s i}{4u}$$

in which  $i$  is the diameter of the rod or bar.

If the bond stress is found excessive, a larger number of smaller bars are used, having the same  $A_s$ , or area of steel, but a greater total perimeter. Deformed rods may also be employed to increase the bond, or the ends of the rods may be hooked.

For 2000-lb. concrete the following allowable bond stresses are recommended (see Table III):

Beams, slabs and one-way footings:	
Plain bars.....	80 lbs./in. <sup>2</sup>
Deformed bars.....	100 " "
Two-way footings:	
Plain bars, not anchored.....	60 " "
Deformed bars, not anchored.....	75 " "

**Résumé of Working Formulae for Beams**

$f_s = 18,000 \text{ lbs./in.}^2$

Formulae	$f'_c = 2000/\text{in.}^2$	$f'_c = 2500/\text{in.}^2$	$f'_c = 3000/\text{in.}^2$
Depth, $d = \sqrt{\frac{M}{1.5 f_s j k b}}$	$\sqrt{\frac{M}{450 \times 0.86 \times 0.43 \times b}}$ $= \sqrt{\frac{M}{177b}}$	$\sqrt{\frac{M}{562 \times 0.86 \times 0.43 \times b}}$ $= \sqrt{\frac{M}{208b}}$	$\sqrt{\frac{M}{675 \times 0.86 \times 0.43 \times b}}$ $= \sqrt{\frac{M}{250b}}$
Area of steel, $A_s = \rho b d$	$A_s = 0.01bd$	$A_s = 0.013bd$	$A_s = 0.016bd$
Area of steel, $A_s = \frac{M}{f_s j d}$	$A_s = \frac{M}{18,000 \times 0.86d}$		
Diagonal tension, $v$ $v = \frac{V}{jbd}$			$v = 0.86bd$
Distance for stirrups, $x$ $x = \frac{l}{2} \frac{v b j d}{w}$			$x = \frac{l}{2} \frac{0.86bd}{w}$ OR $x = \frac{l}{2} \left(1 - \frac{v'}{v}\right)$
Spacing vertical stirrups $s = \frac{A_s f_s d}{V'}$			$s = \frac{0.86 A_s f_s d}{V'}$ OR $s = \frac{A_s f_s}{(v-v')b}$
Bars bent at $45^\circ$ , $s$ $s = \frac{A_s f_s d}{0.7 V'}$			$s = \frac{0.86 A_s f_s d}{0.7 V'}$
Bond - $u$ and $o$ $u = \frac{V}{\Sigma o j d}$ $\Sigma o = \frac{V}{u j d}$			$u = \frac{V}{0.86 \times \Sigma o d}$ $\Sigma o = \frac{V}{0.86 u d}$

$j = 0.875$  is often used in all shear computations

Where special anchorage is provided,  $1\frac{1}{2}$  times these values may be used.

**Bending Moments** (Fig. 6). The following shear and moment diagrams show the variations in simple and continuous beams and the differences in the conditions at the end supports and the interior supports of continuous beams. It will be noted that, although the actual bending moment over the interior supports is  $\frac{wl^2}{12}$ , and at the center of the span is  $\frac{wl^2}{24}$  for continuous beams, the same value,  $\frac{wl^2}{12}$ , is used in practice at both points. The values are made equal to provide sufficient steel to approximate uniform resisting moments at the critical bending sections.

The span length of a freely supported beam or slab is the center-to-center distance between supports but shall not exceed the clear span plus the distances to centers of bearing areas.

The span length for a continuous or restrained beam or slab, built to act integrally with supports, is the center-to-center distance between supports.

**Uniformly Distributed Loads.** The moment formulae for uniformly loaded beams or slabs are divided into two classes:

- (a) Those for beams with freely supported or slightly restrained ends.
- (b) Those for beams with fully restrained ends.

(a) **FREELY SUPPORTED ENDS.** Beams and slabs of approximately equal spans freely supported or built to act integrally with beams, girders or other slightly restraining support, or built into brick or masonry walls so as to develop only partial end restraint.

1. One span.

Positive moment at center:

$$M = \frac{wl^2}{8}$$

Negative moment at end supports:

$$M = \frac{wl^2}{24}$$

2. Continuous for two spans only.

Positive moment near center:

$$M = \frac{wl^2}{10}$$

Negative moment over interior support:

$$M = \frac{wl^2}{8}$$

Negative moment at end supports:

$$M = \frac{wl^2}{24}$$



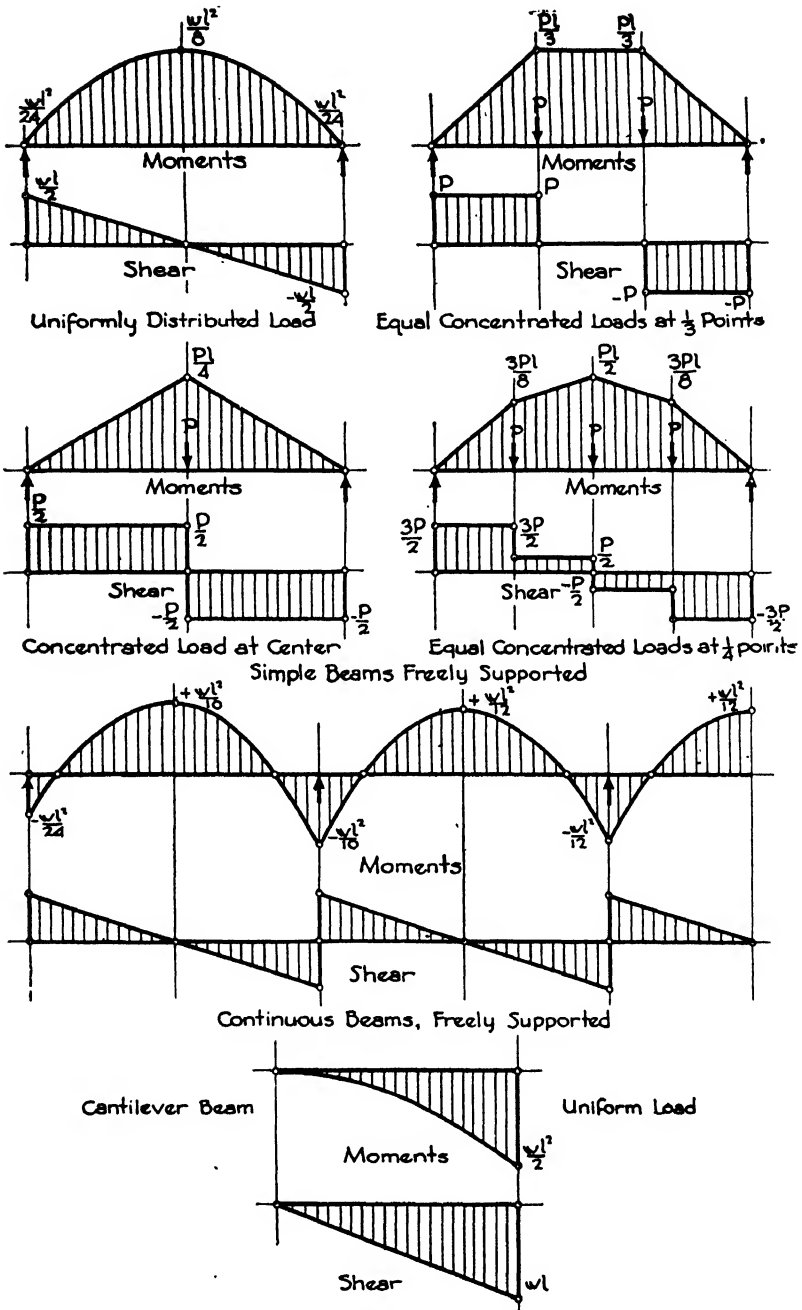

FIG. 6.—Moments and Shear for Common Types of Loading.

3. Continuous for more than two spans.

Positive moment near center and negative moment at support of interior spans:

$$M = \frac{wl^2}{12}$$

Positive moment near center of end spans and negative moment at first interior support:

$$M = \frac{wl^2}{10}$$

Negative moment at end supports:

$$M = \frac{wl^2}{24}$$

(b) **FIXED ENDS.** Beams and slabs of approximately equal spans built to act integrally with columns, walls or other restraining supports so as to develop full restraint.

1. Interior Spans.

Positive moment near centers of interior spans:

$$M = \frac{wl^2}{16}$$

Negative moment at interior supports except the first:

$$M = \frac{wl^2}{12}$$

2. One Span and End Spans of Continuous Beams.

Where  $\frac{l}{l}$  is less than twice the sum of the values of  $\frac{l}{h}$  for the exterior columns above and below built into the beams.

Positive moment near center of span and negative moment at first interior support:

$$M = \frac{wl^2}{12}$$

Negative moment at exterior supports:

$$M = \frac{wl^2}{12}$$

where  $\frac{l}{l}$  is equal to or greater than twice the sum of the values of  $\frac{l}{h}$  for the exterior columns above and below built into the beams.

Positive moment near center of span and negative moment at first interior support:

$$M = \frac{wl^2}{10}$$

Negative moment at exterior supports:

$$M = \frac{wl^2}{16}$$

$I$  is the moment of inertia computed as if the member were homogeneous, neglecting the reinforcement, but including the full depth of the beam with fireproofing.  $l$  and  $h$  are the span length and column height respectively.

**Concentrated Loads on Beams.** The following points of concentrated loading are the most usual in building construction as represented by the bearing of beams upon girders. Framing at the  $\frac{1}{3}$  points is considered the most economical by reducing the bending moment and the formwork. In these formulae  $P$  is the concentrated load and  $L$  the span from center to center of supports in feet.

1. Single concentrated load at middle of span:

$$M = \frac{PL}{4}$$

2. Equal concentrated loads at  $\frac{1}{3}$  points of span:

$$M = \frac{PL}{3}$$

3. Equal concentrated loads at middle and  $\frac{1}{4}$  points of span:

$$M = \frac{PL}{2}$$

The bending moment from the uniformly distributed load caused by the weight of the member should be added to the moment from the concentrated loads. The above formulae are for simply supported beams; for fully continuous beams the moment as computed by these formulae may be reduced by multiplying by  $\frac{2}{3}$  and for semi-continuous by multiplying by  $\frac{1}{2}$ .

**Cantilever Beams.** Cantilevers have long been used for carrying the overhanging balconies in theatres. Also in modern design they are taking an important place in the support of exterior walls and projecting upper stories when the main columns of the building are set well back of the building line. Vaults and domes have also been constructed as a combination of two upright cantilevers meeting at the crown.

In order to avoid torsion in the girder acting as a fulcrum, an anchor beam is provided to function as an arm carrying the uplift back to a structural wall or column. The principle is then that of the lever, and the net reaction at the end support may be upward or downward depending upon the loads on the cantilever, the anchor beam and the position of the fulcrum. The bending moments in the cantilever and in the anchor beam near the fulcrum will be negative, and the main longitudinal reinforcement in these locations will consequently be placed

in the top of the beam. There are usually positive bending moments also in the anchor beam, and part of the steel must be bent down to take care of them. If there is an uplift at the end support there will be no negative moments in the anchor beam. Cantilevers are generally rectangular in section and are cast monolithically with the fulcrum girder and the anchor beam. (See Fig. 23, Example 9, Article 8).

**Reinforcement for Compression.** If, because of structural or architectural limitations, it is impossible to supply sufficient cross-sectional area of concrete above the neutral axis to withstand the compressive stresses, steel reinforcement in the form of rods or bars is provided in the compressive portion of the beam to take care of the moment in excess of the carrying capacity of the concrete. (Fig. 7.)

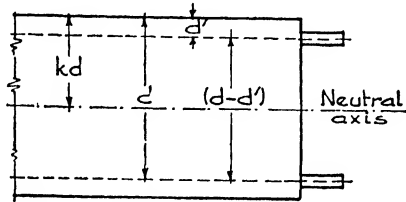

FIG. 7.—Reinforcement for Compression

The following formulae are used to determine the amount of compressive steel required:

$$M_1 = \frac{1}{2} f_c j k b d^2; M_2 = M - M_1; A_{s_2} = \frac{M_2}{f_s j d}$$

Since  $d - d'$  = the arm of the couple formed by tensile and compressive steel, it may replace  $jd$  (see Art. 3). Therefore

$$A_{s_2} = \frac{M_2}{f_s (d - d')} \text{ and } A_s = A_{s_1} + A_{s_2}$$

Because the beam must be in equilibrium and the unit stresses vary as their distances from the neutral axis,

$$A'_s f'_s = A_{s_2} f_s \tag{a}$$

and 
$$\frac{f_s}{f'_s} = \frac{d - kd}{kd - d} \text{ or } f'_s = f_s \frac{k - \frac{d'}{d}}{1 - k}$$

Substituting in (a)

$$A'_s f_s \frac{k - \frac{d'}{d}}{1 - k} = A_{s_2} f_s \text{ or } A'_s = A_{s_2} \frac{1 - k}{k - \frac{d'}{d}}$$

$M_1$  = moment developed by concrete section without reinforcement;

$M_2$  = moment to be developed by compression reinforcement;

$M$  = total moment =  $M_1 + M_2$ ;

$f_s$  = unit stress in tensile steel;  $f'_s$  = unit stress in compressive steel;

$A_{s_1}$  = tensile steel to develop  $M_1$ ;

$A_{s_2}$  = additional tensile steel to develop  $M_2$ ;

$A'_s$  = required compressive steel;

$A_s$  = total tensile steel =  $A_{s_1} + A_{s_2}$ .

Compression reinforcement should be secured against buckling by ties or stirrups anchored in the concrete and spaced not more than 16 bar diameters apart.

**Example 1. Compression Reinforcement.** Simply supported beam limited to 8" x 18" cross-section. Span 20'0". Load 550 lbs./lin. ft.;  $f_s = 18,000$ ;  $f_c = 900$ ;  $n = 15$ ;  $k = 0.43$ ;  $j = 0.856$ ; insulation 2". Find compression steel.

$$\text{Weight of beam } \frac{8 \times 8}{144} \times 150 = 150 \text{ lbs./lin. ft.}$$

$$\text{Total load} = 550 + 150 = 700 \text{ lbs./lin. ft.}$$

$$M = \frac{wl^2}{8} = \frac{700 \times 20 \times 20 \times 12}{8} = 420,000 \text{ in.-lbs.}$$

$$M_1 = 450 \times 0.856 \times 0.43 \times 8 \times 16 \times 16 = 339,222 \text{ say } 340,000 \text{ in.-lbs.}$$

$$M_2 = 420,000 - 340,000 = 80,000 \text{ in.-lbs.}$$

$$A_{s_1} = \frac{340,000}{18,000 \times 0.856 \times 16} = 1.38 \text{ sq. in.}$$

$$A_{s_2} = \frac{80,000}{18,000 \times (16 - 2)} = 0.30 \text{ sq. in.}; A_s = 1.38 + 0.30 = 1.68 \text{ sq. in.}$$

$$A'_s = 0.30 \times \frac{1 - 0.43}{0.43 - \left(\frac{2}{16}\right)} = 0.56 \text{ sq. in.}$$

#### Article 4. Concrete Floor Construction

**Types.** Fireproof buildings demand fireproof floor construction, and the efforts to fulfill this demand have led to the development of many types of floor systems, some of which have proved to be of practical importance and some of which have vanished. Those which have persisted and are now in general use may be divided into six classes as follows:

- (a) Structural hollow tile arches.
- (b) Pre-cast gypsum slabs.
- (c) Stone concrete beam and slab.
- (d) Stone concrete joists and slab with tile fillers (Combination).
- (e) Cinder concrete and gypsum slabs cast in place.
- (f) Flat stone concrete slabs (Girderless).

(a) STRUCTURAL HOLLOW TILE ARCHES are not computed according to the principles of reinforced concrete; they are described in Chapter

IX, Floor Systems; and their design in Chapter XX, Steel Construction. They are employed only with steel beams.

(b) PRE-CAST GYPSUM SLABS, also used only in steel construction, are treated in Chapter IX.

(c) STONE CONCRETE BEAM AND SLAB construction (Fig. 8,a) consists of concrete cross beams running between girders and columns, enclosing floor panels which are covered over with reinforced stone concrete slabs. An economical arrangement of beams is at the  $\frac{1}{3}$  points of the girder span giving spacing of 4'6" to 8'0" center to center for the beams. The methods of computing concrete beams and slabs is explained

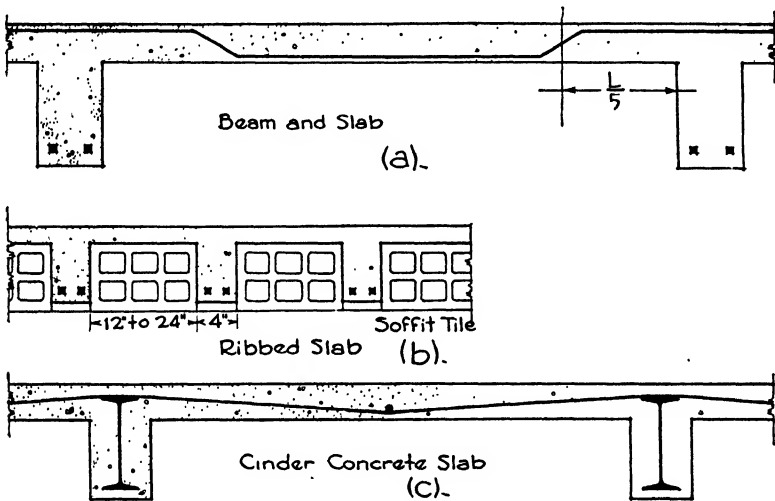

FIG. 8.

in Article 8 of this chapter in connection with T-beams and girders. Long-span slabs running between girders with beams omitted are also used when the loads are light.

(d) JOIST OR RIBBED construction, also called the COMBINATION SYSTEM (Fig. 8,b), consists of a concrete slab supported on concrete ribs running in either one or two directions cast between fillers of hollow terra cotta or gypsum blocks or of metal pans. The ribs are spaced from 16" to 25" apart, depending upon the size of the fillers. The system is light in weight and is adapted to the lesser floor loads. It may be used with either steel or concrete beams.

(e) CINDER CONCRETE AND GYPSUM SLABS cast in place (Fig. 8,c) are slabs with one-way reinforcement. Their spans are usually limited to 8'0". They are very light in weight and are used in steel buildings with small live loads.

(f) FLAT SLAB construction (Fig. 9) consists of a slab only, supported by the columns without the introduction of beams and girders. The

columns have wide capitals, and the slab in the vicinity of the capitals is generally thickened into a dropped panel. This system is economically adapted to live loads of more than 100 lbs./ft.<sup>2</sup> and to column spacings up to 30'0". It is not used with steel construction. The methods of computing flat slabs is discussed in Article 5 of this chapter.

The beam and slab system may be designed with reinforcement running in either one or two directions. The ribbed system may likewise be constructed with ribs in one direction or in two at right angles to each other. The selection between the one- and two-way systems

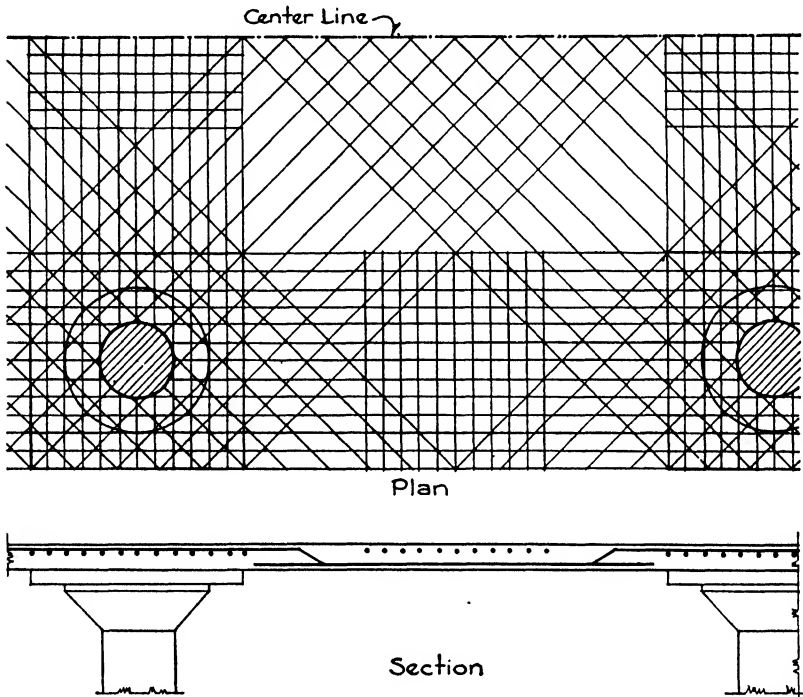

FIG. 9.—Flat Slab Construction.

depends upon the shape of the panel between the structural beams. When this panel is a square or an oblong with the longer side less than  $1\frac{1}{3}$  times the shorter, the load is equally or nearly equally distributed in both directions. When the longer side of an oblong panel is more than  $1\frac{1}{3}$  times the shorter the proportion of the load carried on the lesser span is so great that two-way reinforcement is uneconomical. (See Table VII.) The reinforcement for the entire load is then designed as spanning the shorter way. The one-way system necessitates a thicker floor slab because of its longer spans but is simpler to install and requires less centering. The two-way system results in a thinner slab and is more

economical in concrete but more costly in centering and in placing reinforcement.

**Choice of System.** When the live loads exceed 100 lbs./ft.<sup>2</sup> the beam and slab system or the girderless type is generally a more economical method of reinforced concrete floor construction than the lighter forms. The beam and slab system is adaptable for any kind of building and may be used with steel or concrete frame, with regular or irregular panels and with long or short spans. However, it is most often employed with concrete T-beams. The girderless type is appropriate for industrial buildings and warehouses where the panels are square or nearly square and where the large columns and capitals do not interfere with the architectural design.

When the live loads are moderate, from 40 lbs. to 80 lbs./ft.<sup>2</sup>, as in office buildings, hotels, schools and institutions, some type of ribbed slab or of cinder or gypsum concrete is more economical because the dead weight of the construction is far less and consequently the sections of the structural frame will be reduced. Ribbed slabs may be chosen for both steel or concrete building frames, but the cinder and gypsum slabs are used only with steel.

The choice in joist construction between terra cotta blocks, gypsum blocks and metal pans or domes depends upon the relative cost of labor and materials, the ease and speed of erection and the dead weight of the construction. These elements vary with different localities; consequently each building must be studied individually. Metal pans and domes furnish a lighter dead load, while terra cotta blocks add materially to the strength and stiffness of the floor. It is necessary to apply metal lath to the under side of the metal pans and domes for plastering; with terra cotta and gypsum blocks, the plaster is applied directly to the under side. Thin blocks are often set into the soffits of the concrete beams to present a uniform clay base throughout, the concrete sometimes causing dark bands to appear when plaster is applied directly to it.

**Terra Cotta Tile and Concrete Joists.** The one-way system consists of reinforced concrete ribs 4" to 5" wide, running in one direction between lines of hollow tile 12" x 12" in plan and from 4" to 12" thick. Tile 16" and 20" wide are also available to lighten the loads and produce a more economical slab. A concrete floor slab 2" or 3" thick is poured on top of the tile monolithically with the ribs, forming T-beam construction. The tile are laid with their cells parallel to the ribs and their joints close together. The centering is of the open type with a plank under each rib soffit supporting also the edges of the adjoining tile. This system is used to span the short way of oblong panels and is safe for spans up to 25'0".

The two-way system consists of ribs running in two directions forming square voids which are filled by hollow tile. The tile are usually 12" x 12" in plan and the ribs 4" wide. This system is used on large square or



nearly square panels with light loads. The centering is generally a solid deck. The load is proportioned in two directions depending upon the relative lengths of the sides of the panel. It is not used when the long side is more than 1.3 times the short side. Special tile with closed ends are produced to prevent concrete from entering the cores.

The following table gives the proportion of load carried upon the shorter span of rectangular panels according to the ratio of the lengths of the panels to their widths.

Table VII. Load Distribution

Ratio of Length to Width of Panel	Ratio of Load Carried by Shorter Span $m$
1.00	0.50
1.05	0.55
1.10	0.60
1.15	0.65
1.20	0.70
1.25	0.75
1.30	0.80
1.35	0.85
1.40	0.90
1.45	0.95
1.50	1.00

Table VIII gives the weights per square foot of floor area for ribbed slabs of the one-way system with varying depths of terra cotta and metal tile and 2" and 2½" concrete tops.

**Example 2** (Fig. 10). Joists and Slab. One-way system. Span 16'0" center to center. Live load 50 lbs./ft.<sup>2</sup> Weights: finished floor, 3 lbs./ft.<sup>2</sup>; nailcrete sub-floor, 10 lbs./ft.<sup>2</sup>; plaster ceiling, 5 lbs./ft.<sup>2</sup> Ends fully continuous;  $f_c = 16,000$ ;  $f_s = 1125$ ;  $n = 12$ ;  $j = 0.86$ ;  $k = 0.43$ .

It is not practicable to use stirrups in the ribs, and the shear must therefore be withstood by the concrete alone. A unit fiber stress of 60 lbs./in.<sup>2</sup> for shear in the concrete is generally permitted with ribbed slabs. The vertical shells of terra cotta tile fillers in contact with the ribs may be included in  $b$  for computing the shear.

Assume 6" tile with a 2" concrete floor slab. Ribs 4" wide, 16" on centers. From Table VIII the weight of tile and concrete is 60 lbs./ft.<sup>2</sup>

1. LOADS.

Live load.....	50 lbs.
Floor.....	3 lbs.
Nailcrete.....	10 lbs.
Ceiling.....	5 lbs.
	<hr/>
	68 lbs.
Slab.....	60 lbs.
	<hr/>
	128 lbs./ft. <sup>2</sup>

**Table VIII. Weights of Ribbed Slabs**  
**Pounds per Square Foot of Floor Area**

TERRA COTTA TILE, 12" X 12"

Depth of Tile.....	4"	6"	8"	10"	12"
2" Concrete Top. 4" Joists—16" on centers					
Weight.....	50	60	70	80	90
2½" Concrete Top. 4" Joists—16" on centers					
Weight.....	56	66	76	86	96

METAL TILE, 20" WIDE

Depth of Tile.....	4"	6"	8"	10"	12"
2" Concrete Top. 5" Joists—25" on centers					
Weight.....	36	42	50	57	65
2½" Concrete Top. 5" Joists—25" on centers					
Weight.....	42	48	55	63	71

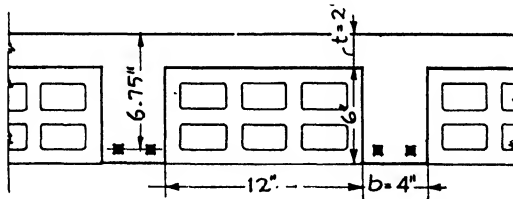

FIG. 10.—Joist Construction with Tile Fillers.

Load per linear foot on each rib =  $128 \times \frac{16}{12} = 171$  lbs.

Total load on each rib =  $171 \times 16 = 2736$ , say 2800 lbs.

2. MOMENT.  $M = \frac{WL}{12} = \frac{2800 \times 16 \times 12}{12} = 44,800$  in.-lbs.

3. AREA OF STEEL. The area of steel is computed in the same manner as for T-beams. (See Article 8.)  $A_s = \frac{M}{f_s \left( d - \frac{t}{2} \right)}$ ;  $jd = \left( d - \frac{t}{2} \right)$ ;  $d = (6 + 2) - 1.25 = 6.75$ , in which the depth of slab and rib =  $(6 + 2)$ , and 1.25 is allowed for fireproofing and ½ diameter of steel.  $t =$  thickness of slab = 2";  $\frac{t}{2} = 1$ ".

$A_s = \frac{44,800}{16,000 \times 5.75} = 0.48$  in.<sup>2</sup> Use two ½" square rods, area = 0.50 in.<sup>2</sup>

4. SHEAR.  $V = \frac{2800}{2} = 1400 \text{ lbs.}; v = \frac{V}{bjd} = \frac{1400}{4 \times 0.86 \times 6.75} = 60 \text{ lbs./in.}^2$   
 60 lbs. allowable.

The rods should be anchored by hooks at the ends. One rod is raised at 1/5 span and carried over the supports to at least 1/5 point of the adjacent span.

5. BOND.  $u = \frac{V}{\Sigma ojd} = \frac{1400}{2 \times 2.00 \times 5.8} = 60 \text{ lbs./in.}^2, 100 \text{ lbs. allowable.}$

Perimeter of 1/2" square rod = 2".

**Example 3.** Ribbed Slab. Two-way system. Panel 18'0" x 22'0". Live load 40 lbs./ft.<sup>2</sup> Weights of double wood floor 6 lbs./ft.<sup>2</sup>, fill 21 lbs./ft.<sup>2</sup>, ceiling 5 lbs./ft.<sup>2</sup> Short span fully continuous, long span semi-continuous.  $f_s = 16,000$ ;  $f_c = 900$ ;  $n = 15$ ;  $j = 0.875$ ;  $k = 0.43$ .

Assume 6" tile with a 2 1/2" concrete floor slab. Ribs 4" wide, 16" on centers. Assume the weight of tile and concrete to be 78 lbs./ft.<sup>2</sup>

1. LOADS.

Live load.....	40 lbs.
Floor.....	6
Fill.....	21
Ceiling.....	<u>5</u>
	72
Slab.....	<u>78</u>
Total load.....	150 lbs./ft. <sup>2</sup>

Ratio long side to short side  $\frac{22}{18} = 1.2$ .

From Table VII

Load carried by short span  $150 \times 0.70 = 105 \text{ lbs./ft.}^2$

Load carried by long span  $150 \times 0.30 = 45 \text{ lbs./ft.}^2$

2. SHORT SPAN.

Load per linear foot on each rib =  $105 \times \frac{16}{12} = 140 \text{ lbs.}$

Total load on each rib =  $140 \times 18 = 2520 \text{ lbs.}$

$M = \frac{WL}{12} = \frac{2520 \times 18 \times 12}{12} = 45,360 \text{ in.-lbs.}$

$A_s = \frac{M}{f_s \left( d - \frac{t}{2} \right)} = \frac{45,360}{16,000 (7.25 - 1.25)} = 0.47 \text{ in.}^2$

in which  $d = (6 + 2.50) - 1.25$  (fireproofing and 1/2 diameter of steel) = 7.25 and

$\frac{t}{2} = \frac{2.50}{2} = 1.25$ .

Try two 1/2" square bars (area each bar, 0.25) = 0.50 in.<sup>2</sup>

$V = \frac{2520}{2} = 1260; v = \frac{V}{bjd} = \frac{1260}{4 \times 0.875 \times 7.25} = 49 \text{ lbs./in.}^2$   
 60 lbs./in.<sup>2</sup> allowable.

$u = \frac{V}{\Sigma ojd} = \frac{1260}{2 \times 2 \times 0.875 \times 7.25} = 49 \text{ lbs./in.}^2$   
 80 lbs./in.<sup>2</sup> allowable.

3. LONG SPAN.

Load per linear foot on each rib =  $45 \times \frac{16}{12} = 60$  lbs.

Total load on each rib =  $60 \times 22 = 1320$  lbs.

$M = \frac{WL}{10} = \frac{1320 \times 22 \times 12}{10} = 34,848$  in.-lbs.

$A_s = \frac{34,848}{16,000 (6.75 - 1.25)} = 0.39$  in.<sup>2</sup>

Try two 1/2" round rods (area each rod, 0.19) = 0.38 in.<sup>2</sup>

The steel in this direction passes above the short span steel. Fireproofing of 1" and 0.75" for 1 1/2 diameters of steel is required.

6" + 2 1/2" has been assumed as the total depth and is therefore satisfactory.

8.50 - 1.75 = 6.75" = effective depth.

$V = \frac{1320}{2} = 660$  lbs.;  $v = \frac{660}{4 \times 0.875 \times 6.75} = 28$  lbs./in.<sup>2</sup> Satisfactory.

$u = \frac{660}{2 \times 1.57 \times 0.875 \times 6.75} = 36$  lbs./in.<sup>2</sup> Satisfactory.

1.57 = perimeter of one 1/2" round rod.

It should be noticed that a slab thickness of 2 1/2" instead of 2" and a 6" tile increase the amount of concrete and decrease the area of steel. The economy of such a design depends upon the relative cost of steel and concrete in each locality.

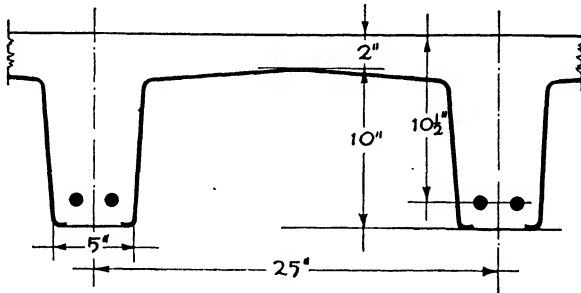

FIG. 11.—Joist Construction with Metal Pans.

**Gypsum Tile and Concrete Ribs.** Gypsum tile are 19" x 18" in plan and 6", 8", 10" and 12" deep. They are used in both one- and two-way rib construction in the same manner as terra cotta tile, and, being lighter in weight and larger, they are claimed to be more economical. The design procedure is the same as for terra cotta except that due consideration is given to the lighter dead load and the wider spacing of the steel and the shells are not included in computing the shear. The ribs are 4" to 5" wide, and the top slab 2" to 2 1/2" thick.

**Metal Tile and Concrete Ribs.** The tile consist of metal pans 4" to 12" deep with sloping sides. They are made of #14 or #16 gauge for the heavy removable type and of #26 gauge for the permanent tile. The metal is often corrugated to give greater stiffness, the pans being laid end to end and lapping one corrugation. They are 20" across the bottom

and are 30" to 48" long. The concrete ribs are usually 5" wide at the bottom and slightly wider at the top owing to sloping sides of the pans. The center-to-center distance between the ribs is consequently 25". The floor slab over the top is 2" or 2½" thick. Pans with closed ends called domes are also made for two-way ribs.

**Example 4** (Fig. 11). The procedure for metal tile is very similar to the design of ribbed slabs with clay tile.

Span 20'0". Live load 75 lbs./ft.<sup>2</sup> Weights per square foot: floor, 3 lbs.; nailcrete sub-floor, 10 lbs.; hung ceiling, 12 lbs. One-way reinforcement. Ends fully continuous.  $f_s = 16,000$  lbs./in.<sup>2</sup>;  $f_c = 900$  lbs./in.<sup>2</sup>;  $n = 15$ .

1. LOADS. Assume tile 10" deep and a 2" slab on top with a weight of 57 lbs./ft.<sup>2</sup> (See Table VIII.)

**DEAD LOADS**

Floor.....	3 lbs.
Nailcrete.....	10
Ceiling.....	12
Slab.....	57
	82 lbs.
Live load.....	75
Total load.....	157 lbs./ft. <sup>2</sup>

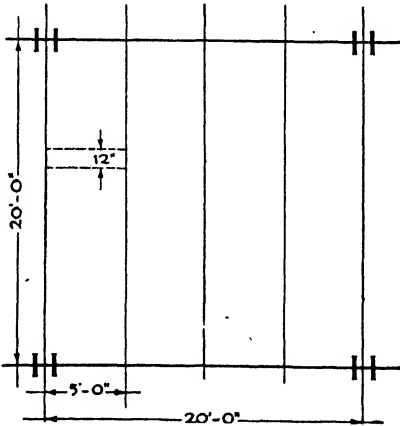

FIG. 12.

Load per linear foot of rib =  $157 \times \frac{25}{12} = 327$  lbs., say 330 lbs. Total load on rib =  $20 \times 330 = 6600$  lbs.

2. MOMENT.  $M = \frac{WL}{12} = \frac{6600 \times 20 \times 12}{12} = 132,000$  in.-lbs.

3. AREA OF STEEL.  $A_s = \frac{M}{f_s \left( d - \frac{t}{2} \right)} = \frac{132,000}{16,000 (10.50 - 1)} = 0.86$  in.<sup>2</sup>

Total depth =  $10 + 2 = 12$ ; effective depth =  $12 - 1.50 = 10.50$ ;  $\frac{t}{2} = \frac{2}{2} = 1$ .

Use two  $\frac{3}{4}$ " round rods (area each rod = 0.44) = 0.88 in.<sup>2</sup>  
 Perimeter one  $\frac{3}{4}$ " round rod = 2.25.

4. SHEAR.  $V = 3300$  lbs.  $v = \frac{V}{bjd} = \frac{3300}{6 \times 0.86 \times 10.50} = 60$  lbs.; allowable; 6" is the average width of rib.

5. BOND.  $u = \frac{V}{\Sigma ojd} = \frac{3300}{2 \times 2.35 \times 0.86 \times 10.50} = 77$  lbs./in.<sup>2</sup>; 80 lbs./in.<sup>2</sup> allowable.

At the continuous supports the straight steel is stopped at the center line of the girder, and at the non-continuous support it is anchored by a hooked end. One rod, 50% of the steel, is bent up at  $\frac{1}{5}$  span and is carried over the supports. At the non-continuous end it is anchored by a hook, and on the continuous side it is continued over the  $\frac{1}{4}$  point of adjoining span. The slab should have a 4" bearing on masonry at the end support.

**Cinder Concrete Slabs.** These slabs are light in weight and are easily and quickly constructed, the centering being hung by wires from the structural beams. They are used with steel frame only and not with concrete. Some form of metal lath or wire fabric is used for reinforcing instead of rods and bars. The slab cannot be less than 4" thick according to most codes, and the unit compression stress is limited to 300 lbs./in.<sup>2</sup> A hung ceiling is generally necessary to cover the bottom flanges of the beams. The weight of cinder concrete is taken as 108 lbs./ft.<sup>3</sup>, and the mixture should never be leaner than 1:2:5. Spans should not exceed 8'0".

**Example 5** (Fig. 12). A panel is 20'0" x 20'0" with steel beams at center and quarter points or 5'0" on centers.

Live load.....	60 lbs.
Flooring.....	6
2" Fill.....	16
4" Slab.....	36
Hung ceiling.....	15
Total load.....	<u>133 lbs./ft.<sup>2</sup></u>

Since the reinforcement is of wire mesh,  $f_s$  is taken at 20,000 lbs./in.<sup>2</sup>,  $f_c = 300$  lbs./in.<sup>2</sup>,  $n = 30$ ,  $K = 41.3$ ,  $j = 0.91$ . Slab is fully continuous. Consider the slab as divided into a series of concrete beams 12" wide and 5'0" long.

$$1. M = \frac{wl^2 \times 12}{12} = \frac{133 \times 5 \times 5 \times 12}{12} = 3325, \text{ say } 3300 \text{ in.-lbs.}$$

$$2. d = \sqrt{\frac{M}{\frac{1}{2}f_c j k b}} = \sqrt{\frac{M}{K b}} = \sqrt{\frac{3300}{41.3 \times 12}} = 2.59'$$

But the slab must be 4" deep; therefore  $d = 3''$  with 1" for fireproofing.

$$3. A_s = \frac{M}{f_s j d} = \frac{3300}{20,000 \times 0.91 \times 3} = 0.06 \text{ in.}^2$$

By referring to manufacturers' tables the area of steel for various types of mesh may be found. The American Steel and Wire Co.'s triangular mesh, style 067R, has an effective sectional area in longitudinal steel of 0.067 in.<sup>2</sup>/ft. of width. The longitudinal wires are #9 gauge spaced 4" on centers, and the cross wires, of #12  $\frac{1}{2}$  gauge, are spaced 8" on centers.

**Continuous Beams and Slabs.** When concrete beams and floor slabs are poured integrally so that they form one monolithic structure they are shown by tests to act together rather than as separate members. The widely used systems of one- and two-way concrete floor slabs supported on concrete beams and girders are common examples of this principle of continuity. In these systems part of the slab is assumed to assist the upper part of the beam in resisting compressive stresses. The two acting together constitute what is known as a T-BEAM. The special formulae and characteristics of T-beams are given in Example 11, Article 8, of this chapter.

**Table IX. Maximum Moment Coefficients for One-Way Slabs of Equal Spans and Uniformly Distributed Loads**

No. Spans	End Span				Interior Span				
	End Support	Mid-Span		First Interior Support		Mid-Span		Typical Support	
	Neg.	Pos.	Neg.	Pos.	Neg.	Pos.	Neg.	Pos.	Neg.
Dead Load									
1	-0.040	0.125							
2	-0.040	0.075			-0.125				
3	-0.040	0.085			-0.100	0.030			
4 or more	-0.040	0.080			-0.110	0.040 }*			-0.080
						0.046 }			
Live Load									
1	-0.040	0.125	-0.000						
2	-0.040	0.100	-0.030	0.000	-0.125				
3	-0.040	0.105	-0.025	0.017	-0.120	0.080	-0.050		
4 or more	-0.040	0.105	-0.020	0.015	-0.120	0.085	-0.045	.036	-0.115

\*For five or more spans, 0.046.  
 The numerical values given are coefficients of  $W_1L^2$  and  $W_2L^2$  respectively, in which  $W_1$  = the dead load and  $W_2$  = the live load per unit of area.

One- and two-way solid or ribbed slabs built monolithically with supporting beams or walls may be designed as continuous beam elements as illustrated in the examples in Articles 4 and 8. This method, however, does not consider the position of the slab in the series of panels, the conditions of continuity along its edges or the relative stiffness of the beams and of the adjoining slabs. The Joint Committee has made studies based upon analysis and tests which show that the inclusion of these considerations produces moments considerably less than those derived on the basis of independent beam elements. In the 1940 Report the Committee recommends the following tables of coefficients for one- and two-way slabs. These coefficients when multiplied by  $WL^2$  give the bending moment per unit width of slab. Tables IX and X.

The value of *m* refers to the proportion of load carried by the short span of rectangular slabs. See Table VII, Article 4.

In some types of reinforced concrete buildings there may be an economy in an exact analysis of the moments in the beams, girders and slabs. This arises from the fact that the full live load is seldom applied on all portions of the building at the same time. The Joint Committee recommends that bending moments be computed for the following arrangements of loaded spans:

**Table X. Bending Moment Coefficients for Rectangular Slabs Supported on Four Sides and Built Monolithically with Supports**

Coefficients are for moments in middle strips

Moments	Short Span						Long Span. All values of <i>m</i>
	Values of <i>m</i>						
	1.0	0.9	0.8	0.7	0.6	0.5 and less	
Case 1. Interior panels. . . . .							
Neg. moment at continuous edge . . .	0.033	0.040	0.048	0.055	0.063	0.083	0.033
Neg. moment at discontinuous edge . . .							
Positive moment at mid-span. . . . .	0.025	0.030	0.036	0.041	0.047	0.062	0.025
Case 2. One edge discontinuous. . . . .							
Neg. moment at continuous edge . . .	0.041	0.048	0.055	0.062	0.069	0.085	0.041
Neg. moment at discontinuous edge . . .	0.021	0.024	0.027	0.031	0.035	0.042	0.021
Positive moment at mid-span. . . . .	0.031	0.036	0.041	0.047	0.052	0.064	0.031
Case 3. Two edges discontinuous . . . . .							
Neg. moment at continuous edge . . .	0.049	0.057	0.064	0.071	0.078	0.090	0.049
Neg. moment at discontinuous edge . . .	0.025	0.028	0.032	0.036	0.039	0.045	0.025
Positive moment at mid-span . . . . .	0.037	0.043	0.048	0.054	0.059	0.068	0.037
Case 4. Three edges discontinuous . . . . .							
Neg. moment at continuous edge . . .	0.058	0.066	0.074	0.082	0.090	0.098	0.058
Neg. moment at discontinuous edge . . .	0.029	0.033	0.037	0.041	0.045	0.049	0.029
Positive moment at mid-span. . . . .	0.044	0.050	0.056	0.062	0.068	0.074	0.044
Case 5. Four edges discontinuous . . . . .							
Neg. moment at continuous edge . . .	0.033	0.038	0.043	0.047	0.053	0.055	0.033
Neg. moment at discontinuous edge . . .							
Positive moment at mid-span. . . . .	0.050	0.057	0.064	0.072	0.080	0.083	0.050

These coefficients when multiplied by  $wS^2$  give the moment per foot of width.  
 $w$  = load per square foot;  $S$  = short span.

For Beams. (a) Alternate spans loaded, with a maximum of three loaded spans. (b) Two adjacent spans loaded, other spans unloaded.

For One-Way Slabs. (a) The maximum negative moment at the support for two adjacent spans loaded. (b) The maximum positive moment near the middle of a loaded span when adjacent spans are not loaded. (c) The resultant moment (positive or negative) near the middle of an unloaded span when adjacent spans are loaded.

For the purposes of this textbook and because the methods of the more exact analysis have not yet been adopted by the building codes,



the above simpler moment formulae will be used in the examples contained herein. Although these formulae do not consider so many possible conditions as the later formulae and recommendations of the Joint Committee, they are approximately accurate. They are conservative in their application and cover the uncertainties in the distribution of the live load.

### Article 5. Flat Slabs

**Flat Slab Construction.** Flat slab construction is also called GIRDERLESS FLOORS. The term refers to concrete slabs built monolithically with the supporting columns without beams or girders to carry the loads, and having reinforcement bars extending in two or four directions. Normally, slabs extend in each direction over at least three panels and have approximately equal dimensions and a ratio of length to width

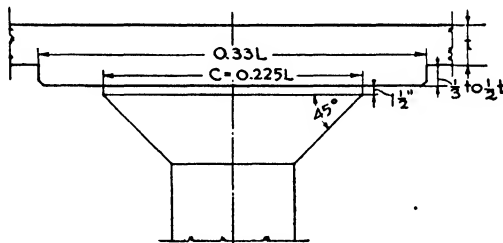

FIG. 13.—Drop Panel and Capital.

of panel not exceeding 1.33. The advantages of the flat slab type of floor over the beam and girder type are as follows:

- (a) Greater load-carrying capacity for a given amount of concrete and steel.
- (b) Flat ceiling with greater fire-resisting qualities and better accommodations for sprinklers, piping and wiring.
- (c) Cheaper formwork.
- (d) Floor height saving of 12" to 18" per story or a saving of one story in nine stories.

Flat slabs are best adapted for spans under 30'0" and for live loads greater than 100 lbs./ft.<sup>2</sup> They are most used for warehouses, factories and garages, where the panels are regular and nearly square and where the large columns and flaring capitals are not objectionable. Other types are more economical for light loads and varying spans as in hotels, office buildings and apartments. There are two methods of arranging the reinforcement: the two-way and the four-way systems.

**DROP PANELS AND COLUMN CAPITALS.** Drop panels are a thickening of the slab around the column capital; they are usually square in outline. The purpose is to decrease the unit shearing stresses at the column head

and to strengthen the negative moment portion of the column strip (Fig. 13).

Column capitals or column heads usually have the shape of truncated cones. The function of the capital is to reduce the unit shearing stresses and to decrease the net span and thereby the critical bending moments. Standard diameters of round capitals for use with metal column forms range from 3'6" to 6'0" in increments of 6".

It is more economical to use drop panels if architectural considerations permit. Capitals should never be omitted except with very light loading.

The diameter of the column cap should not be less than 0.20  $L$  or greater than 3 times the column diameter. The edge of the cap should be at least 1½" thick, and from the edge the sides of the cap should not slope at an angle greater than 45° with the vertical.

The width of interior drop panels should never be less than 0.33  $L$ . The offset forming the drop should not be less than ⅓ or more than ½ the slab thickness in depth.

The width of drop panels at the wall is the same as for the interior panels, and their projection from the wall 50% of their width.

**Thickness of Slab.** The minimum thickness of slab without drops may be found by considering the column strip as a rectangular beam according to the formula:

$$t_1 = 0.038 \left( 1 - 1.44 \frac{c}{l} \right) l \sqrt{w} + 1\frac{1}{2}'' , \tag{18}$$

and of a slab beyond the drop in a panel with drops by the formula:

$$t_2 = 0.02 l \sqrt{w} + 1'' \tag{19}$$

in which  $c$  = the diameter of the column capital in feet;

$w$  = dead and live load per square foot;

$l$  = length center to center of columns on long side of panel.

The above formulae are based upon 2000-lb. concrete. For concretes with other ultimate compressive strengths the values of  $t$  and  $d$  may be

modified by multiplying by the factor  $\sqrt[3]{\frac{2000}{f'_c}}$

So that there may not be undue deflection in the slab, and to provide sufficient depth for the several bands of reinforcement, the thickness at the center of the panel should not be less than the following:

1. Floor slabs with drop panels, 4½ in.  
    Floor slabs without drop panels, 5 in.
2. Roof slabs with drop panels, 3½ in.  
    Roof slabs without drop panels, 4 in.
3. Floor slabs; 2500-lb. concrete
  - (a) End panels, 0.030 $l$ .
  - (b) Interior panels. 0.026 $l$ .

## 4. Roof slabs; 2500-lb. concrete

(a) End panels, 0.025*l*.(b) Interior panels, 0.023*l*.

## 5. For concrete having a 28-day compressive strength other than

2500 lbs./in.<sup>2</sup> multiply the coefficients in 3 and 4 by  $\sqrt[3]{\frac{2500}{f'_c}}$ ,in which  $f'_c$  = compressive strength at 28 days.

**Columns.** Interior columns are usually round in section; the wall columns are rectangular. In the building codes their diameter is generally limited to  $1/15$  the average span ( $L$ ) of the slabs which they support with a minimum of 16" for round columns and 14" for square.

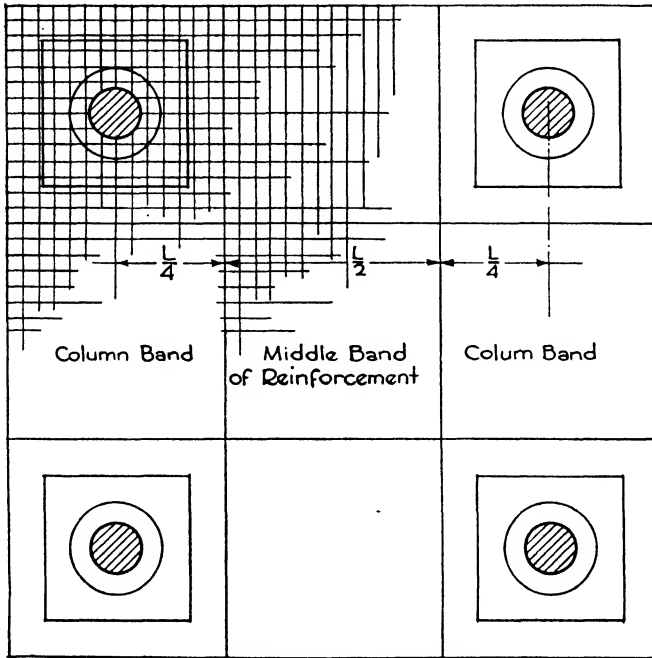

2-Way Reinforcement  
FIG. 14.—Two-Way System.

**Choice of System.** The TWO-WAY SYSTEM (Fig. 14) consists of two bands of reinforcement, each one parallel to a side of the panel. Additional bars are placed over the column heads and between the columns to take care of the negative bending moment and shear in these areas.

The FOUR-WAY SYSTEM (Fig. 15) has, in addition to the longitudinal and transverse bars, two bands of diagonal bars passing across the panel and over the column heads. The choice is largely one of economy, for

certain loadings and spans the four-way proving cheaper than the two-way, and vice versa. The relative cost of concrete and steel is also a factor. The four-way is theoretically more efficient as the load is carried in a more direct line from the slab to the column. The two-way is simpler in computation and is less complicated, and consequently more accurate in the placing and inspecting of the steel.

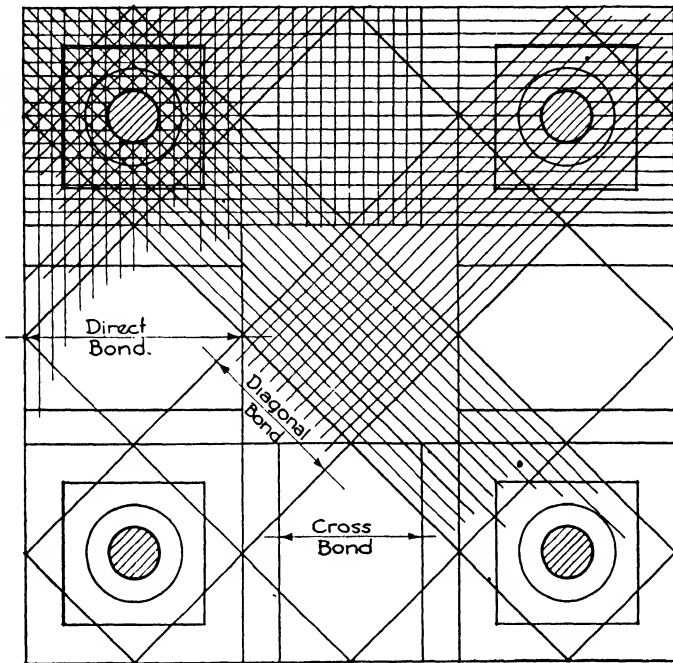

4-Way Reinforcement

FIG. 15.—Four-Way System.

**Bending Moments** (Fig. 16,*a*). The differing stresses in the continuous slabs cause many varying bending moments, positive in certain portions and negative in others. The portion over a column, when deflected, assumes a mushroom shape with negative bending moments; the middle part of the slab is deflected into the shape of a bowl with positive bending moments. Lines of inflection, where the moments change from positive to negative, surround each column at about the  $\frac{1}{4}$  to  $\frac{1}{3}$  points of span. In each portion there are two sets of bending moments acting at right angles to each other. Each set produces bending in one direction only, and the two sets together cause the actual deflection in the slab. To simplify the computations, a sufficiently accurate approximation has been generally adopted avoiding unnecessary complications. The panel is divided into three strips running at right angles to the section

of the maximum bending moments for one of the sets above mentioned. The stresses in this set can then be computed separately and the rein-

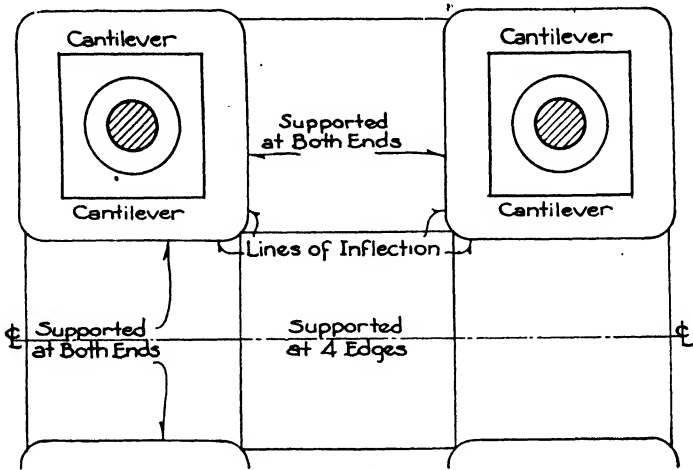

FIG. 16a.

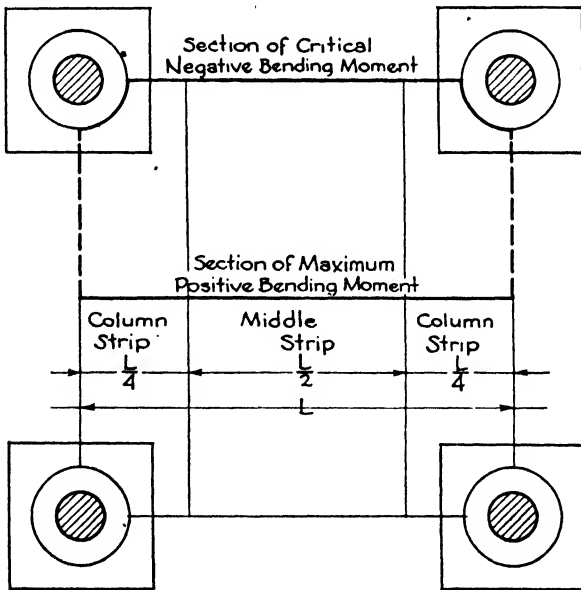

FIG. 16b.

forcement determined. For square panels the set of moments in the other direction will be equal to those in this set. For rectangular panels moments should be taken in both directions (Fig. 16b).

The three strips perpendicular to the section of maximum bending moment are the MIDDLE STRIPS equal in width to  $\frac{1}{2}$  the span upon the column axis or  $\frac{L}{2}$ , and the two COLUMN STRIPS each equal in width to  $\frac{L}{4}$ . The distribution of positive and negative bending moments in the direction of either side of the panel is not uniform. For average conditions approximately  $\frac{3}{8}$  of the total moment may be considered positive and  $\frac{5}{8}$  negative. Slabs with drops have about 5% more negative moment than slabs without drops and an equal decrease in positive moment.

The sum of the maximum positive moment and the average of the negative moments in a continuous beam is equal to the maximum moment in a corresponding simply supported beam. The span of a simply supported beam corresponding to a flat slab panel is considered to be  $l - \frac{2c}{3}$ , in which  $l$  is the center-to-center span and  $c$  is the diameter of the capital. The total moments,  $M_o$ , in the panel may then be considered equal to  $\frac{1}{8}wl_1\left(l - \frac{2c}{3}\right)^2 = \frac{1}{8}wl_1\left(1 - \frac{2c}{3l}\right)^2$ , in which  $l_1$  = span center to center of columns perpendicular to direction for which moments are computed;  $l$  = span center to center of columns in the direction in which moments are computed.

Tests on full-sized panels have shown the actual stresses in the steel to be somewhat less than those obtained by means of the above equation. By comparing the results of theoretical analyses and tests the following formula for determining the total positive and negative moments,  $M_o$ , in a panel has been derived which is rational and generally accepted:

$$M_o = 0.09\left(l - \frac{2c}{3}\right)^2 l_1 w \tag{20}$$

The distribution of this sum of bending moments through the three strips at their sections of positive and negative maximum moments is made according to the percentages as recommended by the Joint Committee and shown in Table XI.

Table XI. Distribution of Bending Moments, Interior Panels

Strip	Flat Slabs without Dropped Panels		Flat Slabs with Dropped Panels	
	Negative	Positive	Negative	Positive
Slabs with Two-way Reinforcement				
Column strip.....	$-M = 46\%M_o$	$+M = 22\%M_o$	$-M = 50\%M_o$	$+M = 20\%M_o$
Middle strip.....	$-M = 16\%M_o$	$+M = 16\%M_o$	$-M = 15\%M_o$	$+M = 15\%M_o$
Slabs with Four-way Reinforcement				
Column strip.....	$-M = 50\%M_o$	$+M = 20\%M_o$	$-M = 54\%M_o$	$+M = 19\%M_o$
Middle strip.....	$-M = 10\%M_o$	$+M = 20\%M_o$	$-M = 8\%M_o$	$+M = 10\%M_o$

The moments in the three strips may be computed directly from the foregoing formulae. The local building codes vary slightly in their formulae according to the preferred manner of distributing the moments in the strips, but the principles as above described are generally accepted in all the codes.

**Moments in Discontinuous Panels.** For end or side panels where the slab is not continuous and is fully restrained by a beam supported upon rigid columns, the Joint Committee recommends the following modifications of the moments given in Table XI.

1. First line of interior columns.
  - Column strip. Increase negative moment by 15%.
  - Increase positive moment by 15%.
  - Middle strip. Increase negative moment by 30%.
  - Increase positive moment by 30%.
2. Perpendicular to discontinuous edge.
  - Column strip. Reduce negative moment by 20%.
  - Middle strip. Reduce negative moment by 20%.
3. Adjacent and parallel to supported edge.
  - Half column strip. Reduce all moments by 75%.

To possess adequate rigidity a column (or two superimposed columns) should have a stiffness factor  $\left(\frac{I}{h}\right)$  of at least  $1\frac{1}{2}$  times the stiffness factor  $\left(\frac{I}{l}\right)$  of the slab. The moment of inertia ( $I$ ) of the slab should be based upon a width equal to the column spacing and a depth equal to the slab thickness plus  $\frac{1}{3}$  the depth of the drop.

**Diagonal Tension and Shear.** In flat slab construction the two critical sections for which it is customary to compute the unit shearing stress as a measure of diagonal tension are those about the peripheries of the column capitals and of the dropped panels.

The shear,  $V$ , is the total load on the panel less the load on the area enclosed by the periphery of the column head or of the drop as the case may be.

For the column head ·

$$V = w\left(L^2 - \frac{\pi c^2}{4}\right) \text{ and } v = \frac{V}{bjd}$$

in which  $c$  = diameter of column capital and  $b$  = perimeter of capital =  $\pi c$ .

For drops:  $V = w(L^2 - b^2)$ , in which  $b$  = side of drop; and  $v = \frac{V}{bid}$ , in which  $b$  = periphery of drop.

In the New York code the formula for  $v$  is specified as

$$v = \frac{V}{bd}$$

**Reinforcement.** In calculating the moments at any section all the bars crossing the section are generally used, provided that they extend far

enough on each side of the section to develop their full stress by bond. The effective area of the bars at any moment section is taken as the area of the bars multiplied by the sine of the angle which the bars make with the plane of the section. The bars running at right angles to the section are therefore counted at their full area; those running at an oblique angle, as in the diagonal bands of the four-way system, are counted at a reduced area depending upon the sine of the angle.

The steel is laid in the bottom of the slab in the sections of positive bending moment and is bent up at the lines of inflection to receive the negative bending moments. The bends should be sharp and the bars placed with care because of the relative thinness of the slab.

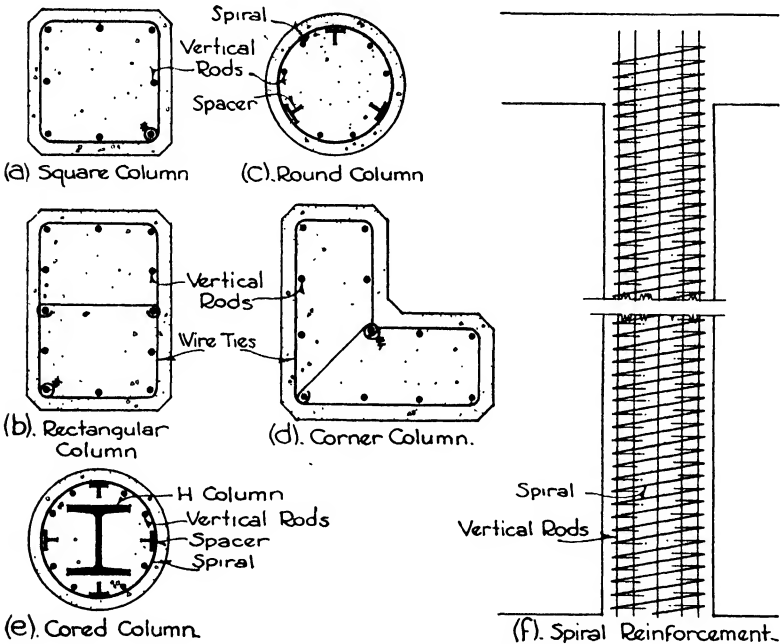

FIG. 17.—Types of Reinforced Columns.

In the middle strip of slabs with dropped panels the point of inflection is assumed at  $0.3L$ , and in the column strips at  $0.3(L - c)$ .

### Article 6. Columns

**In General.** When columns or piers are not longer than 3 or 4 times their least lateral dimension they may be constructed of plain concrete without reinforcement, and their area of cross-section is equal to the load divided by the allowable unit compressive stress. This allowable stress, being in direct compression, is generally taken as 25% of the ultimate crushing strength or 500 lbs./in.<sup>2</sup> for 2000-lb concrete. Such



short piers are often used as pedestals between a longer column and its footing, the load being applied concentrically about the axis of the pier.

When columns are longer than 3 or 4 times their least lateral dimension accidental eccentricity of loading may cause flexure and tensile stresses; consequently reinforcement should be introduced. The Joint Committee report recommends that the length of a concrete column should not exceed 10 times its least lateral dimension. Some building codes, however, permit a length of 15 times the least dimension. When required to be of greater slenderness ratio the column is designed according to the special formulae for long columns involving the radius of gyration. The minimum diameter of the main columns of a building should not be less than 10" and posts extending not more than one story, such as the supports of stairs, should be at least 6" in minimum thickness. A layer of concrete  $1\frac{1}{2}$ " or 2" thick should surround the steel reinforcement to act as fireproofing. The portion of the column inside the reinforcing bars, called the core, is the effective area of the cross-section.

Interior columns are very often round in section although square and octagonal columns can easily be constructed when required by the architectural design. They are, however, less economical in concrete. Wall columns may have square, rectangular, round or angular sections as made necessary by the arrangement of the walls (Fig. 17).

**Measures of Length.** The following methods of determining the unsupported lengths of columns are generally accepted.

The unsupported lengths are taken:

- (a) In flat slab construction, as the clear distance between the floor and the lower extremity of the capital.
- (b) In beam and slab construction, as the clear distance between the floor and the under side of the deepest beam framing into the column at the next higher floor level.
- (c) In floor construction with beams in one direction only, as the clear distance between floor slabs.
- (d) In columns restrained laterally by struts, as the clear distance between consecutive groups of struts in each vertical plane. To be considered adequate support, two such struts should meet the column at approximately the same level, and the angle between vertical planes through the struts should not vary more than  $30^\circ$  from a right angle.

**Steel Percentage.** The total cross-sectional area of the vertical reinforcement in concrete columns is specified as a percentage of the gross cross-sectional area of the concrete and is limited between a minimum and a maximum percentage. For spiral columns the percentages range from 1% to 8%, and for tied columns from 1% to 4%. Also the factor of safety in the concrete may vary in spiral columns from 3.6 for 1% of steel to 2.75 for 8%, and in tied columns from 4.5 for 1% to 4.0 for 4%. By this means both the concrete and the steel are more nearly stressed at their full values.

**Types of Columns.** Concrete columns may be divided into five types:

(a) **SPIRAL COLUMNS**, in which the reinforcement consists of vertical rods together with lateral spirals. The lateral reinforcement is made of coiled wire forming, when stretched out, a long spiral from the bottom to the top of the column encircling the concrete core. The spiral serves to resist lateral pressure in the concrete and is consequently under tensile stress.

(b) **TIED COLUMNS**, reinforced with vertical rods alone, held together at intervals with horizontal wire ties.

(c) **COMPOSITE COLUMNS**, consisting of a structural steel column encased in concrete reinforced both longitudinally and spirally.

(d) **COMBINATION COLUMNS**, consisting of a structural steel column encased in concrete at least 2½" thick reinforced by welded wire mesh.

(e) **PIPE COLUMNS**, which consist of steel pipe filled with concrete.

**SPIRAL COLUMNS.** Columns are never designed with spiral reinforcement alone, the vertical steel always being included to withstand the compressive stresses and tendency toward bending. A concrete column under direct compression is shortened longitudinally and expanded laterally. If this lateral expansion is resisted, as by spiral wire, lateral stresses are produced which tend to neutralize the effect of the longitudinal compressive stress. For this reason the spiral reinforcement raises the ultimate strength of the column. Shortening of the column and spalling of exterior concrete may take place, however, before final failure occurs. The Joint Committee Report of 1940 recognizes "the fact that the strength produced by spirals is accompanied by spalling of the column shell and excessive column shortening, hence the spiral is utilized only as a toughening element or an insurance against a sudden and complete collapse of the column." A formula is recommended by the Committee which is stated in terms of the gross area of the column and the area of the vertical steel reinforcement and omits any reference to the spiral reinforcement. The formulae for spiral and tied columns are made identical except that a 20% greater load-bearing capacity is permitted to the former column, because, if the outer shell should spall, the spiral is present to carry part of the load.

The maximum allowable axial load,  $P$ , is given by the following formula:

$$P = 0.225f'_c A_g + A_s f_s \tag{21}$$

in which  $A_g$  = gross area of the column;  $f'_c$  = compressive strength of the concrete;  $f_s$  = allowable working stress in the vertical reinforcement;  $A_s = p_g A_g$ ;  $p_g$  = ratio of the effective cross-sectional area of vertical reinforcement to the gross area.

The vertical reinforcing bars should have total cross-sectional areas of 1% to 8% of the gross area of the concrete. The minimum number of bars should be 6 and the minimum diameter ⅝". The center-to-

center spacing of bars within the periphery of the core should be at least  $2\frac{1}{2}$  times the diameter for round bars or 3 times the side dimension for square bars, with a minimum clear spacing between bars of  $1\frac{1}{2}$ " or  $1\frac{1}{2}$  times the greatest size of the coarse aggregate.

Where the vertical steel is spliced, the amount of lap for deformed bars with 3000-lb. concrete should be 24 diameters of bar for intermediate grade steel and 30 bar diameters for hard steel. For concretes of less than 3000 lbs./in.<sup>2</sup> the amount of lap should be  $\frac{1}{3}$  greater. For plain bars the amount of lap should be 25% greater than for deformed bars. Butt welding of the bars instead of lap splicing is recommended when the bar diameter exceeds  $1\frac{1}{4}$ ". The weld should develop in tension at least the yield-point stress of the reinforcing steel.

Where changes in the cross-section of superimposed columns occur the vertical bars should be sloped the full length of the lower column, or they may be offset at the floor levels or wherever lateral support in the form of concrete capital, floor slab, metal ties or spirals is present.

The amount of spiral reinforcement is expressed as a ratio of the concrete core as follows:

$$p' = 0.45 \left[ \frac{A_g}{A_c} - 1 \right] \frac{f'_c}{f'_s} \quad (22)$$

where  $p'$  = ratio of volume of spiral reinforcement to the volume of the concrete core (out to out of spirals);

$\frac{A_g}{A_c}$  = ratio of gross area to core area of column;

$f'_s$  = useful limit stress of spiral reinforcement at 40,000 lbs./in.<sup>2</sup> for hot-rolled intermediate grade, 50,000 lbs./in.<sup>2</sup> for hard grade and 60,000 lbs./in.<sup>2</sup> for cold-drawn wire.

Minimum diameter of spiral wire should be  $\frac{1}{4}$ " for columns up to 18" core diameter and  $\frac{3}{8}$ " for larger columns. Splices should be welded or have a lap of  $1\frac{1}{2}$  turns, and anchorage at each end of spiral should consist of  $1\frac{1}{2}$  extra turns. The pitch or center-to-center spacing of the

Table XII. Diameters and Areas of Spiral Wires

Nominal Diameter, inches	Actual Diameter, inches	Area, Square inches
5/8	0.63	0.31
9/16	0.56	0.246
1/2	0.49	0.189
7/16	0.43	0.145
3/8	0.36	0.110
5/16	0.30	0.074
1/4	0.24	0.049

spirals should not exceed 1/6 the core diameter and is often limited to 1 3/8" minimum and 3" maximum. At least three vertical spacer bars should be used to hold the wire firmly at a uniform pitch. The spacers are usually small T-bars and are notched on one leg at proper intervals to receive the wire.

**Example 6.** Design a round concrete column 20'0" long reinforced with vertical rods and spiral wire to carry a load of 200,000 lbs.  $f'_c = 2500$ .

Assume a column with core diameter of 20" and over-all diameter of 23" and 1% of vertical steel.

$$A_g = 415 \text{ in.}^2; A_s = 4.15 \text{ in.}^2; f_s = 20,000; \text{ seven } 3/8'' \text{ round bars; } A_s = 7 \times 0.60 = 4.20 \text{ in.}^2 \quad A_c = 314.2 \text{ in.}^2$$

$$P = 0.225 f'_c A_g + A_s f_s = (0.225 \times 2500 \times 415) + (4.15 \times 20,000) = 316,437 \text{ lbs.}$$

Weight of column =  $\pi r^2 \times 150 \times 20 = 8700$ ;  $200,000 + 8700 = 208,700$  lbs. Satisfactory.

$$\text{SPIRAL STEEL. } p' = 0.45 \left[ \frac{A_g}{A_c} - 1 \right] \frac{f'_c}{f'_s} = 0.45 \left[ \frac{415.5}{314.2} - 1 \right] \frac{2500}{60,000} = \frac{0.45 \times 0.32}{24} = 0.006 = \text{ratio of volume of steel to volume of core.}$$

$$\text{Volume of core} = \pi r^2 \times 240'' = 3.14 \times 100 \times 240 = 75,360 \text{ in.}^3$$

$$\text{Volume of steel} = 75,360 \text{ in.}^3 \times 0.006 = 452 \text{ in.}^3 \quad \text{Pitch} = 5''.$$

Therefore 4 turns in 1 ft. of height; 1 turn =  $\pi d = 3.14 \times 20 = 62.8''$ ; 4 turns = 251.2''.

$$\text{Total length of wire} = 251.2 \times 20 = 5024'', \quad \frac{452}{5024} = 0.09 \text{ in.}^2 = \text{area of wire.}$$

3/8" round wire has area of 0.11 in.<sup>2</sup>

Try 22" column with 1% vertical steel.

Maximum diameter 22",  $A_g = 380.1$ . Core diameter 19".  $A_c = 283.5$ ;  $A_s = 3.8$

$$P = 0.225 f'_c A_g + A_s f_s = (0.225 \times 2500 \times 380) + (3.8 \times 20,000) = 213,750 + 76,000 = 289,750$$

Weight = 7890. Total load  $200,000 + 7890 = 207,890$ . Satisfactory. Use seven 3/4" square bars  $A_s = 3.92 \text{ in.}^2$

A smaller column would exceed the 11 to 1 ratio of height to diameter.

Use same spiral wire.

**TIED COLUMNS.** The maximum allowable axial load,  $P$ , is 80% of that found by formula 21 for spiral columns. The vertical reinforcing bars should have a total cross-sectional area of 1% to 4% and should consist of at least 4 bars with a minimum diameter of 5/8". The reinforcement should be placed not less than 1 1/2", plus the thickness of the tie, from the column face. Splices are made as set forth under Spiral Columns.

The lateral ties should have a minimum diameter of 1/4 in. and a vertical spacing of not more than 16 bar diameters, 48 tie diameters or the least column diameter.

**COMPOSITE COLUMNS.** The allowable load,  $P$ , is found by the following formula:

$$P = 0.225 A_c f'_c + f'_s A_s + f_r A_r \tag{23}$$

where  $A_c$  = the net area of the concrete section =  $A_g - A_s - A_r$ ;  
 $A_s$  = the cross-sectional area of vertical bar reinforcement;  
 $A_r$  = the cross-sectional area of the structural steel core;  
 $f_r$  = allowable unit stress in the steel core, not to exceed 16,000 lbs./in.<sup>2</sup>

The amounts of vertical and spiral reinforcement are found by formulae 21 and 22 for spiral columns. The cross-sectional area of the steel core should not be greater than 20% of the gross area of the column. The spacing and splicing of the bars and the thickness of concrete shell are as set forth for spiral columns. A clearance of at least 2 in. should be maintained between the spiral and a steel H-column and of at least 3 in. between the spiral and any other type of steel core.

COMBINATION COLUMNS. The allowable load,  $P$ , is found by the following formula:

$$P = A_r f'_r \left[ 1 + \frac{A_c}{100 A_r} \right] \quad (24)$$

where  $A_r$  = the cross-sectional area of the steel column;  
 $f'_r$  = the allowable stress for unencased steel column;  
 $A_c$  = the total area of concrete section, =  $A_g - A_r$ .

The welded wire mesh reinforcement should have minimum size wire of No. 10 gauge with a maximum spacing of 4 in. vertically and 8 in. horizontally. The mesh should extend entirely around the column, 1 in. inside the outer concrete surface, and should be lap-spliced at least 40 wire diameters. The compressive strength of the concrete should not be less than 2000 lbs./in.<sup>2</sup>

PIPE COLUMNS. The allowable load,  $P$ , on steel pipe filled with concrete is given by the following formula:

$$P = 0.225 f'_c A_c + f'_r A_r \quad (25)$$

$$f'_r = \left[ 18,000 - 70 \frac{h}{R} \right] F$$

where  $f'_r$  = allowable stress in the steel pipe section;  
 $h$  = unsupported length of column;  
 $R$  = radius of gyration of steel pipe;  
 $F = \frac{\text{tensile yield point of pipe steel}}{45,000}$ .

## Article 7. Walls

**In General.** Walls of basements, pits and areas require special reinforcement because of the pressure of the earth against one side. Basement wall panels are generally supported either at the top and bottom by the first-story and basement floor slabs or at each side by the wall columns. The first method with vertical reinforcement is employed unless there

Table XIII. Areas and Perimeters of Round Columns

Diameter, inches		Core Area, square inches	Gross Perimeter, feet inches	
Gross	Core			
14	10	78.5	3	8
	11	90.0		
16	12	113.1	4	2
	13	132.7		
18	14	153.9	4	9
	15	176.7		
20	16	201.0	5	3
	17	227.0		
22	18	254.5	5	9
	19	283.5		
24	20	314.2	6	3
	21	246.4		
26	22	380.1	6	10
	23	415.4		
28	24	452.4	7	4
	25	490.9		
30	26	530.9	7	10
	27	572.6		
32	28	615.8	8	5
	29	660.5		
34	30	706.9	8	11
	31	754.8		
36	32	804.2	9	5
	33	855.3		
38	34	907.9	10	0
	35	962.1		
40	36	1017.9	10	6
	37	1075.2		

are wide openings in the panel which would interrupt the continuity of the steel. The second method uses horizontal reinforcement and transfers the loads to the columns. The pressure of the earth acts upon the wall in two ways: (a) it tends to slide it forward as a whole, and (b) it tends to tip it forward about its base. In order to be impervious to ground water, the wall is required by many codes to be at least 12" thick.

Exterior concrete curtain and spandrel walls may be theoretically 6" or 8" thick with steel reinforcement, but for practical reasons they are seldom made less than 12". Curtain walls are not bonded to the floor slab and are often reinforced with 3/8" square bars 12" on centers horizontally and 12" to 18" on centers vertically, set 2" from the outside face of wall. Spandrel walls are usually bonded to the floor construction by anchoring the floor steel into the wall and by forming the vertical steel into stirrups or hoops around the horizontal steel. Recesses should be provided in the columns to receive the wall, which acts as a beam (Fig. 18).

**Earth Pressure.** Water pressure per square foot both vertically and

horizontally is equal to the weight of a cubic foot times the depth. Water weighs  $62\frac{1}{2}$  lbs./ft.<sup>3</sup>, and its vertical and horizontal pressure at a depth of 10' would be 625 lbs./ft.<sup>2</sup> Any material not a fluid has less

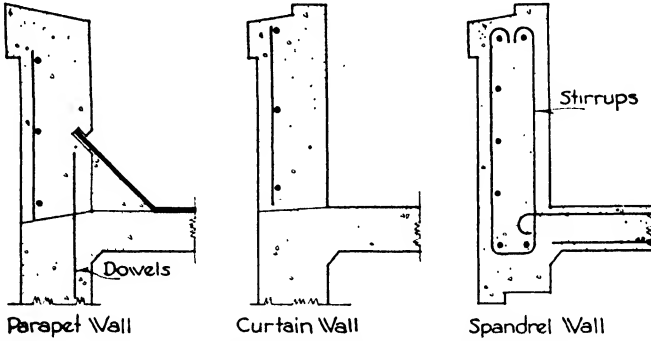

FIG. 18.—Parapet, Curtain and Spandrel Walls.

horizontal than vertical pressure or weight, but the horizontal pressure is proportional to the vertical in ratios which differ according to the angle of repose of the material. The term EQUIVALENT FLUID PRESSURE for a given soil, therefore, means the horizontal pressure per square foot at a depth of 1'. The values of equivalent fluid pressure vary from 15 to 80 lbs. according to the kind of soil and its condition. The following table gives recommended values in pounds per square foot for five soils.

Table XIV. Equivalent Fluid Pressures

Well-drained gravel.....	20
Average earth.....	33
Wet sand.....	50
Water-bearing soil.....	62.5
Fluid mud.....	80

For ordinary conditions the equivalent fluid pressure is taken as 30 lbs./ft.<sup>2</sup>

**Basement Wall.** When the basement wall is supported at top and bottom by the first-story and the basement floor slabs, the reinforcement consists of vertical rods placed 2" from the inside face of the wall. The force diagram takes the form of a triangle with the greatest pressure acting at the bottom and with no pressure at the surface of the ground (Fig. 19).

Let  $P$  = the total pressure;  $p$  = the equivalent fluid pressure = 30 lbs./ft.<sup>2</sup>;  $h$  = height of wall;  $P'$  = pressure at any section, and  $h_1$  = distance of any section from top of wall.

Then  $P = ph \times \frac{h}{2} = \frac{ph^2}{2}$  and acts at  $\frac{h}{3}$  above the base of the wall.

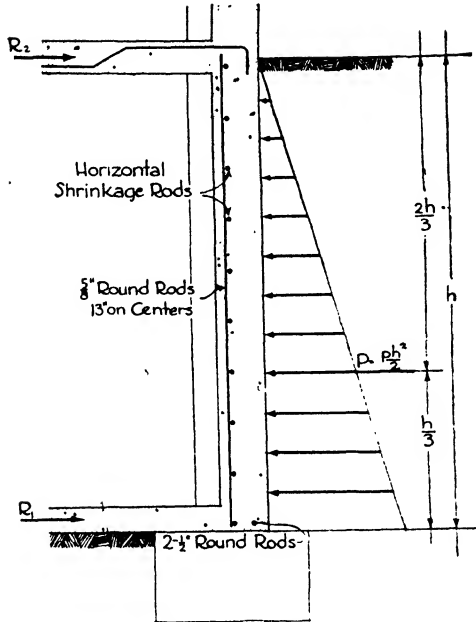

FIG. 19.—Wall without Surcharge.

The reactions for a linear foot of wall are

$$R_1 \text{ at the bottom} = \frac{2P}{3} \tag{26}$$

and

$$R_2 \text{ at the top} = \frac{P}{3} \tag{27}$$

The maximum bending moment per linear foot will be at the section of zero shear, that is at the section where the reaction minus the load equals zero, or where  $R_2 - P' = 0$ .

Substituting  $R_2 = \frac{P}{3} = \frac{ph^2}{6}$ ;  $P' = \frac{ph_1^2}{2}$ ;  $\frac{ph^2}{6} - \frac{ph_1^2}{2} = 0$ .

Then  $\frac{ph_1^2}{2} = \frac{ph^2}{6}$  and  $h_1^2 = \frac{h^2}{3}$ ;  $h_1 = \frac{h}{\sqrt{3}} = 0.58h$ , and the depth of the

section of zero shear and maximum bending moment below the top of the wall =  $0.58h$ .

The maximum bending moment =  $M = R_2(0.58h) - P'(\frac{0.58h}{3})$

$$M = \frac{ph^2}{6} \times 0.58h - p \frac{(0.58h)^3}{6} = 0.064ph^3 \text{ ft.-lbs.} \tag{28}$$

When there is no basement floor at the bottom of the wall to resist the thrust of the soil, the base of the wall or the wall footing should be converted into a horizontal beam spanning between the columns. When



the adjoining panels are similar the beam will be continuous and both the positive and negative moments will be equal to  $\frac{wl^2}{12}$ . But

$$w = R_1 = \frac{2P}{3} = \frac{\rho h^2}{3}. \text{ Therefore } M = \frac{\rho h^2 l^2}{36} \quad (29)$$

For wall panels supported at each side by columns, the design is similar to that of a continuous slab spanning from column to column and the reinforcement is horizontal. The panel is considered as a number of horizontal strips, each 1' high, and the pressure on each strip varies according to its height from the bottom. The pressure at the base is equal to  $\rho h$  per square foot of wall surface and diminishes to zero at the top. Both the positive and negative moments are equal to

$$\frac{wl^2}{12}$$

$w$  = the pressure per square foot at the height under consideration and  $l$  = the clear distance between columns.

The positive reinforcement is placed near the inside of the wall, and the negative reinforcement, at the columns, near the outside face.

Two-way reinforcement, both horizontal and vertical, is sometimes economical when the wall panel is nearly square as described for floor slabs, and for conditions of semi-continuity or of simple support without continuity the moment factors are increased in the same manner as in floor design.

**Example 7** (Fig. 19). Design a basement wall of concrete 12'0" high supported by the basement floor slab and the floor slab at the first story. Equivalent fluid pressure of soil = 30 lbs./ft.<sup>2</sup>;  $f_s = 16,000$  lbs./in.<sup>2</sup>;  $f_c = 650$  lbs./in.<sup>2</sup>,  $n = 15$ .

$$1. P = \frac{\rho h^2}{2} = \frac{30 \times 12 \times 12}{2} = 2160 \text{ lbs./lin. ft.}$$

Section of maximum moment is at distance  $h_1$  from top of wall.

$$2. h_1 = 0.58h = 0.58 \times 12 = 6.96'$$

$$3. \text{ Then } M = 0.064\rho h^3 = 0.064 \times 30 \times 12 \times 12 \times 12 = 3318 \text{ ft.-lbs./lin. ft.}$$

$$4. \text{ SHEAR } = V = R_1 = \frac{2P}{3} = \frac{2 \times 2160}{3} = 1440 \text{ lbs./lin. ft.}$$

$$5. \text{ Depth - thickness of wall } = \sqrt{\frac{M}{107.6 \times b}} = \sqrt{\frac{3318 \times 12}{107.6 \times 12}} = 5.5''.$$

$b = 12'' = 1$  lin. ft. of slab. Thickness of 5.5" sufficient to resist bending, but most codes require 12" for practical reasons. Effective depth = 10".

$$6. \text{ Area of Steel. } A_s = \frac{M}{f_s j d} = \frac{3318 \times 12}{14,000 \times 10} = 0.28 \text{ in.}^2/\text{lin. ft.}$$

Use one  $\frac{5}{8}''$  round rod. Area = 0.30 in.<sup>2</sup> Spacing =  $\frac{30}{27} \times 12 = 13''$ .

Set the bars vertically 13" on centers, 2" from inside face of panel,

7. The wall panel acts as a beam 12'0" deep to support its own weight.  
 $W = 12 \times 16 \times 150 = 28,800$  lbs. Assume the panel to be 16'0" long.

$$M = \frac{WL}{8} = \frac{28,800 \times 16 \times 12}{8} = 691,200 \text{ in.-lbs.}$$

$$A_s = \frac{M}{f_s j d} = \frac{691,200}{14,000 \times 12 \times 12} = 0.34 \text{ in.}^2$$

Place two 1/2" round rods horizontally 3" above base of panel.

Area two 1/2" rods =  $2 \times 0.19 = 0.38 \text{ in.}^2$

Horizontal rods of about 0.3% of the concrete sectional area should be added to counteract shrinkage and to brace the vertical bars.

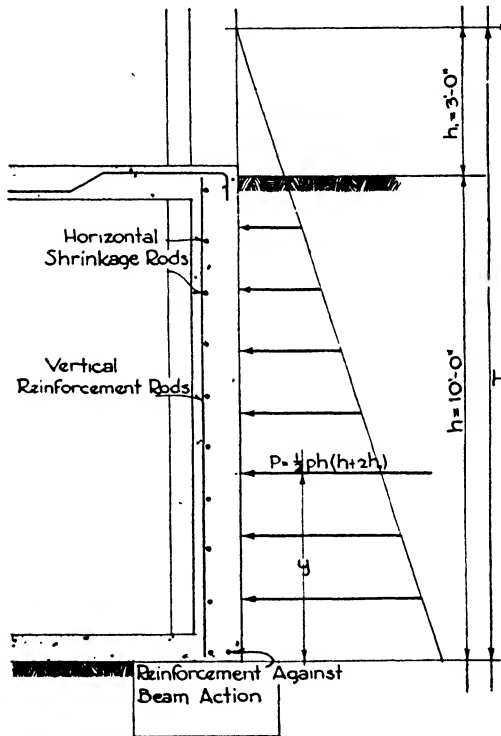

FIG. 20.—Wall with Surcharge.

**Surcharge.** When the ground outside a basement wall is loaded, as when merchandise is stored on sidewalks or platforms, an additional pressure is brought upon the outside of the basement wall. Ordinary soil is generally considered as weighing 100 lbs./ft.<sup>3</sup> The applied loads are calculated in terms of weight of soil, thus giving an additional height to the triangle of pressure. If a surcharge of 300 lbs./ft.<sup>2</sup> is applied to the ground surface outside a basement wall 10'0" high it would be equivalent to three more feet of earth with an equivalent fluid pressure of 30 lbs./ft.<sup>2</sup> (Fig. 20).

The load diagram becomes a trapezoid, and the center of gravity of the applied pressures or the point of application of the resultant is found by the formula

$$y = \frac{h}{3} \times \frac{h + 3h_1}{h + 2h_1}$$

in which  $y$  = distance in feet from base to center of gravity of pressures;  $h$  = height of wall in feet, and  $h_1$  = height of surcharge in feet.

Let  $H = h + h_1$ . Then the resultant pressure on  $H$  is

$$P_2 = \frac{1}{2}\rho H^2$$

and the resultant pressure on  $h_1$  is

$$P_1 = \frac{1}{2}\rho h_1^2$$

Then the resultant pressure on the wall with height  $h$  will be the difference, or

$$P = P_2 - P_1 = \frac{1}{2}\rho(H^2 - h_1^2) = \frac{1}{2}\rho h(h + 2h_1)$$

At a distance equal to  $0.6h$  from the wall the effect of any loads upon the soil may be neglected.

**Pits.** Elevator, boiler and machinery pits below the basement floor often require walls reinforced against soil pressure and sometimes against the surcharge of loads upon the basement floor and against the head of water pressure in the soil. The walls vary from 8" to 12" thick, and the main reinforcement is usually placed horizontally to avoid the necessity of bond in top and bottom of the wall.

**Areas.** Small area walls are seldom over 6" thick, and the reinforcement often consists of  $\frac{3}{8}$ " horizontal rods, 10" on center, and  $\frac{3}{8}$ " vertical rods 1'6" on center. When the area extends across several bays of the building, concrete struts are run from the area wall back to the columns. The wall can then be designed like the basement wall supported at top and bottom, as already described.

### Article 8. Illustrative Cases

**Procedure.** The usual procedure in design for rectangular beams is as follows:

1. Assume a width and depth for the beam in order to arrive at a trial weight. Widths may be taken as  $1/20$  to  $1/24$  of the span and depths as  $1\frac{1}{4}$ " to  $1\frac{3}{4}$ "/ft. of span, depending upon the loads. The width must be sufficient to contain the probable reinforcement with  $1\frac{1}{2}$ " of fire-proofing on each side and at least 1" between the longitudinal bars or rods together with a possible  $\frac{1}{2}$ " on each side for stirrups. Calculate the weight of the beam with these assumed dimensions. The weight of stone concrete is generally taken as 144 or 150 lbs./ft.<sup>3</sup> When it is considered at 144 lbs. the formula for the weight of a beam or slab reduces to the product of the width by the depth in inches by the length in feet. For a beam 10" wide, 24" deep and 18'0" long,

$$W = \frac{10 \times 24 \times 18 \times 12 \times 144}{1728} \text{ or } W = 10 \times 24 \times 18$$

2. Determine the reactions and maximum shear.
3. Determine the maximum bending moment.
4. Compute the depth.

5. Find the area of reinforcing steel.  $A_s = pbd$  for a beam in which the compressive strength of the concrete will be balanced by the tensile strength of the steel. If other requirements than the compressive strength, such as a depth regulated by the building code, call for an unnecessary area of concrete, then it is more economical to use the formula:

$$A_s = \frac{M}{f_s j d}$$

6. Compute the maximum unit shearing stress:  $v = \frac{V}{jbd}$ .
7. Design the web reinforcement:  $x = \frac{L}{2} \left( 1 - \frac{v'}{v} \right)$ .

$$V' = (v - v')bjd, \quad s = \frac{A'_s f_s j d}{V'} \quad \text{or} \quad s = \frac{A'_s f_s}{(v - v')b}$$

8. Test the bond stress:  $u = \frac{V}{\Sigma o j d}$ .

If the assumed width and depth of beam are not satisfactory, another trial with new assumptions must be made.

**Example 8** (Fig. 21, a). A continuous beam of 18'0" span between faces of supports has a uniform load of 30,000 lbs. and fully continuous end conditions. Design the beam.  $f_c = 800$ ;  $j = 0.875$ ;  $p = 0.0089$ .

1. WEIGHT OF BEAM. Assume width = 10" and depth = 22", plus 2" for fireproofing and  $\frac{1}{2}$  the diameter of steel or a total depth of 24". Concrete weighs 150 lbs./ft.<sup>3</sup>

$$\text{Then } W = 30,000 + \frac{10 \times 24 \times 18 \times 12}{1728} \times 150 = 34,500 \text{ lbs.}$$

$$2. \text{ SHEAR. } V = R = \frac{34,500}{2} = 17,250 \text{ lbs.}$$

$$3. \text{ MAXIMUM MOMENT. } M = \frac{W L}{12} = \frac{34,500 \times 18 \times 12}{12} = 621,000 \text{ in.-lbs.}$$

$$4. \text{ DEPTH. } d = \sqrt{\frac{M}{138.7 \times b}} = \sqrt{\frac{621,000}{138.7 \times 10}} = 21.2''.$$

Total depth = 21.2 + 2 = 23.2". Use 24" as total depth.

$$5. \text{ AREA OF STEEL. } A_s = pbd = 0.0089 \times 10 \times 21.1 = 1.8779 \text{ in.}^2$$

Use two  $\frac{3}{4}$ " square bars and two  $\frac{5}{8}$ " square bars.

$$\text{From Table VI, area two } \frac{3}{4}'' \text{ square bars} = 2 \times 0.56 = 1.12$$

$$\text{area two } \frac{5}{8}'' \text{ square bars} = 2 \times 0.39 = 0.78$$

$$1.90 \text{ in.}^2$$

Raise one  $\frac{3}{4}$ " and one  $\frac{5}{8}$ " bar at  $\frac{1}{8}$  point of span at an angle of 30° to the horizontal. To verify the relations of the points of upper and lower bend to the points of maximum positive and negative bending moments the following data may be determined (Fig. 23, b):

$$\frac{1}{5}L = \frac{18}{5} = 3.6' = 43.2''$$

Horizontal projection of bent-up bars =  $a \cot \alpha$  (formula 15) =  $19 \times 1.73 = 32.9''$   
 $\frac{32.9}{2} = 16.45''$ ,  $43.2 - 16.45 = 26.75''$  = distance from face of support to upper bend;  $26.75 + 32.9 = 59.65$ , say  $60''$ .  $\frac{L}{2} = 108''$ ,  $108 - 60 = 48''$  = distance of lower bend from center of span.

With 1" of concrete between the bars and 1½" of fireproofing at the sides, the width 10" is sufficient including the stirrups.

6. SHEAR.  $v = \frac{V}{jbd} = \frac{8V}{7bd} = \frac{8 \times 17,250}{7 \times 10 \times 21.2} = 93$  lbs.

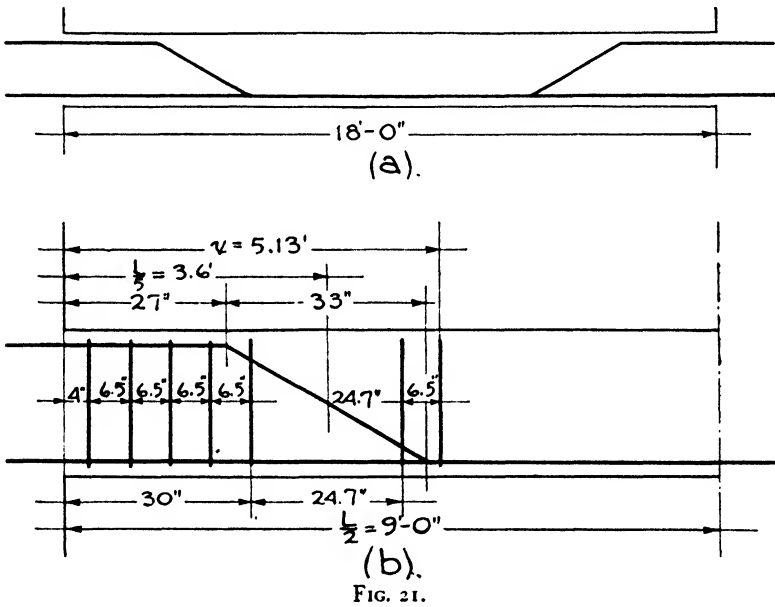

FIG. 21.

Web reinforcement of stirrups must be provided since the unit shear is more than 40 lbs./in.<sup>2</sup>

7. STIRRUPS.  $x = \frac{L}{2} \left( 1 - \frac{v'}{v} \right) = 9 \left( 1 - \frac{40}{93} \right) = 5.13'$

Use ¾" stirrups with 2 legs,  $A_s = 2 \times 0.11 = 0.22$  in.<sup>2</sup> (Table II).

$$s = \frac{A_s f_j d}{V'} = \frac{0.22 \times 16,000 \times 0.867 \times 21.2}{9700} = 6.5''$$

The horizontal projection of the bent-up bars = 32.9". If only 75% of this distance is considered available for web reinforcement,  $0.75 \times 32.9 = 24.675$ . By placing the first stirrup 4" from the support, spacing 4 more stirrups 6.5" apart, omitting all stirrups through a space of 24.675" covered by the bent-up bars and then placing 2 more stirrups 6.5" apart, the required distance,  $x = 5.13'$ , is supplied with web reinforcement and 7 stirrups are used at each end of the beam.

8. BOND.  $u = \frac{V}{\Sigma o j d} = \frac{17,250}{[(2 \times 2.5) + (2 \times 3)] \times .875 \times 21.2} = 84 \text{ lbs./in.}^2$

Perimeter of  $\frac{5}{8}$ " bar = 2.5".

Perimeter of  $\frac{3}{4}$ " bar = 3.0".

The above bond stress acts upon the negative reinforcement at the face of the support.

For the bond stress at the point of inflection at  $1/5$  span:

$V'$  - vertical shear at  $1/5$  point =  $17,250 - \frac{34,500}{5} = 10,350$ . Since only the 2 bent-up rods resist this stress,  $\Sigma o = 2.5 + 3.0 = 5.5$ .

$u = \frac{10,350}{5.5 \times 0.867 \times 21.2} = 101 \text{ lbs./in.}^2$  Use deformed bars.

The straight bars are carried to the center line of the column, and the bent bars are lapped to the  $1/5$  points of adjacent spans.

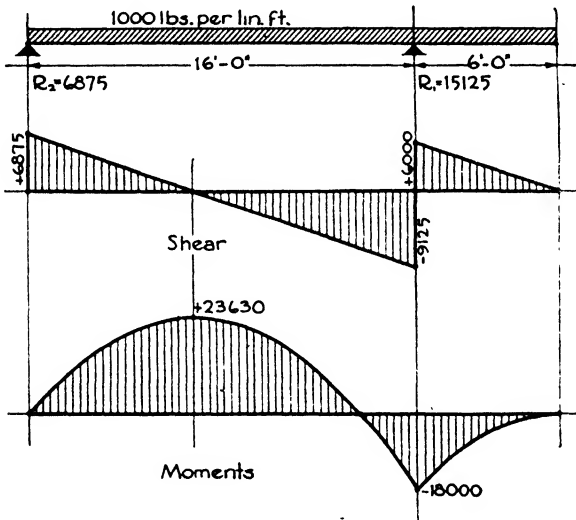

FIG. 22.

**Cantilever Beams. Example 9** (Fig. 22). A cantilever beam 6'0" long is supported upon a fulcrum girder and is tied back to a wall by an anchor beam 16'0" long. Both the cantilever and the anchor beam are uniformly loaded with 1000 lbs./lin. ft. Design the beams.  $f_s = 16,000 \text{ lbs./in.}^2$ ;  $f_c = 650 \text{ lbs./in.}^2$ ;  $n = 15$ ;  $j = 0.875$ ;  $p = 0.0077$ .

Reactions.

$16R_1 = (16,000 \times 8) + (6000 \times 19) = 242,000$ ;  $R_1 = \frac{242,000}{16} = 15,125 \text{ lbs.}$

$16R_2 = (16,000 \times 8) - (6000 \times 3) = 110,000$ ;  $R_2 = \frac{110,000}{16} = 6875 \text{ lbs.}$

**Anchor Beam.**

I. SHEAR, AT FULCRUM.  $V_1 = 6875 - 16,000 = -9125 \text{ lbs.}$

AT WALL.  $V_2 = R_2 = 6875 \text{ lbs.}$

From the shear diagram (Fig. 24) the section of zero shear may be scaled and found to be 6.9' or 6'10½" from the wall. Or from the formula  $V=0=R_2-1000x$ ;  $6875-1000x=0$ ;  $1000x=6875$ ;  $x=6.875'=6'10½''$ .

2. MOMENTS.  $M_{max}=(6875 \times 6.9)-(1000 \times 6.9 \times 3.45)=23,630$  ft.-lbs. or 283,560 in.-lbs.

$M$  at fulcrum  $=(16 \times 6875)-(16,000 \times 8)=-18,000$  ft.-lbs. or -216,000 in.-lbs.

3. DEPTH. Assume width = 9".

$$d = \sqrt{\frac{M}{107.6 \times b}} = \sqrt{\frac{283,560}{107.6 \times 9}} = 17''; 17 + 0.5 + 1.5 = 19''.$$

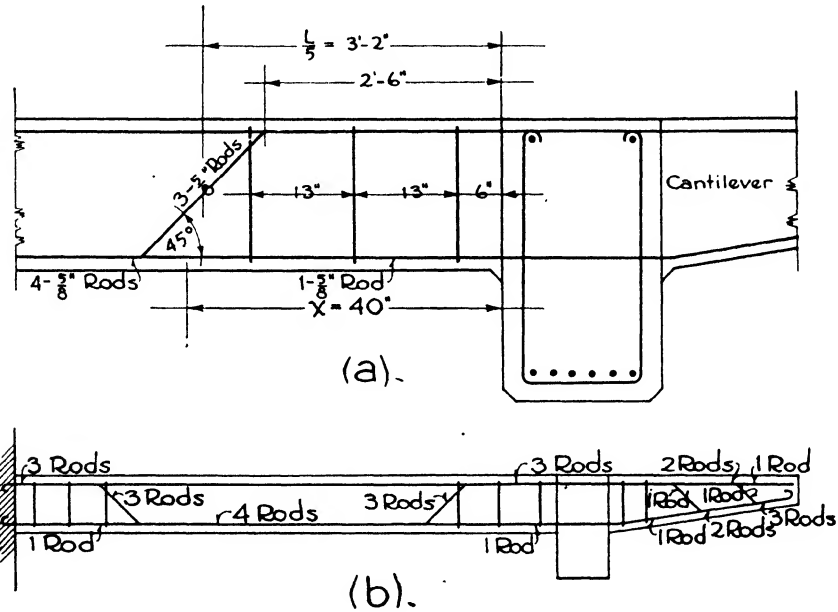

FIG. 23.

4. AREA OF STEEL.  $A_s = pbd = 0.0077 \times 9 \times 17 = 1.18$  in.<sup>2</sup>

Use four ½" round rods. Area = 4 × 0.30 = 1.20 in.<sup>2</sup> Perimeter = 1.96".

5. SHEAR.  $V = 16,000 - 6875 = 9125$  lbs.

$$v = \frac{V}{jbd} = \frac{9125}{0.875 \times 9 \times 17} = 68 \text{ lbs./in.}^2 \text{ Over 40 lbs. Use stirrups.}$$

6. BOND.  $u = \frac{V}{\Sigma ojd} = \frac{9125}{4 \times 1.96 \times 0.875 \times 17} = 78 \text{ lbs./in.}^2$  Allowable 80 lbs./in.<sup>2</sup>

7. WEB REINFORCEMENT.  $x = \frac{L}{2} \left( 1 - \frac{v'}{v} \right) = 8 \left( 1 - \frac{40}{68} \right) = 3.3'$  or 3'4".

Use ⅜" stirrups,  $A = 0.11$ . Spacing,  $s = \frac{A_s f_s j d}{V} = \frac{0.22 \times 16,000 \times 0.875 \times 17}{3750}$

13.9", say 13".

Bend-up 3 rods at 45° at 1/8 span. Place first stirrup 6" from the girder and space 2 more stirrups 13" apart, making 3 stirrups at each end of the anchor beam.

The 3 bent-up rods give the required steel area for the negative moment in the anchor beam near the fulcrum and also the necessary area for negative moment in the top of the cantilever (Fig. 25).

**Cantilever Beam.**

1. NEGATIVE MOMENT.  $M = \frac{WL}{2} = \frac{6000 \times 6}{2} = 18,000 \text{ ft.-lbs. or } 216,000 \text{ in.-lbs.}$

The greater moment is the positive moment in the anchor beam.

2. SHEAR.  $V = 6000 \text{ lbs.}; v = \frac{V}{jbd} = \frac{6000}{0.875 \times 17 \times 9} = 45 \text{ lbs.}$  Acceptable with 2 stirrups.

For practical reasons, to avoid torsion in the fulcrum girder, the same depth will be employed for the cantilever at the fulcrum as calculated for the anchor

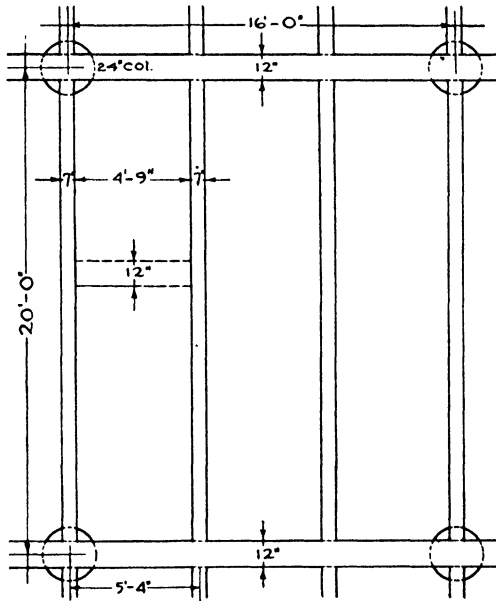

FIG. 24.

beam, although the maximum bending moment is less in the cantilever than in the anchor beam. This depth may be maintained uniformly throughout the cantilever or the depth may be decreased as the bending moments decrease.

3. AREA OF STEEL.  $A_s = \frac{M}{f_s j d} = \frac{216,000}{14,000 \times 17} = 0.90 \text{ in.}^2$

Use three 5/8" round rods.  $A = 3 \times 0.30 = 0.90 \text{ in.}^2$  Perimeter = 1.96".

4. BOND.  $u = \frac{6000}{3 \times 1.96 \times .875 \times 17} = 70 \text{ lbs./in.}^2$  Allowable 80 lbs./in.<sup>2</sup>



One rod is continued throughout the top of the cantilever, the other two being bent down at intervals to resist diagonal tension. A stirrup 4" from the fulcrum and another at a space of 8" should be added because of the high shearing stress in the cantilever (Fig. 23).

At a section 3'0" from the end:

$$M = 1000 \times 3 \times 1.5 = 4500 \text{ ft.-lbs. or } 54,000 \text{ in.-lbs.; } d = \sqrt{\frac{54,000}{107.6 \times 9}} = 7.4''.$$

**Example 10. Solid Slabs. One-Way Reinforcement.** The floor panels between the columns may be constructed in a variety of ways, the most generally used being (a) the solid slab with beams, (b) the flat slab without beams also called the girderless type and (c) the combination or ribbed slabs with terra cotta or metal fillers. The solid slab with beams will be considered first.

The following panel arrangement will be used in the next four examples covering the slab, the beams, the girders and the columns (Fig. 24).

The columns in a building are 16'0" x 20'0" on centers, and the girders run the short way. Panels 20'0" wide are formed which are supported upon cross beams, 5'4" on centers framing into the girders. Design the concrete floor slabs between these beams, the live load being 200 lbs./ft.<sup>2</sup> In square slabs and in rectangular slabs with the long side not more than 1.5 times the width the load is distributed in both directions and two-way reinforcement is used. In this example, however, the load is transferred to the longer side, and short-span one-way reinforcement will be employed.

The computations are similar to those for a continuous beam with a uniformly distributed load, and the slab may therefore be considered as divided into a series of adjoining beams 12" wide. Each imaginary beam is therefore 4'9" long and is continuous.  $f_c = 800$ ;  $j = 0.875$ ;  $n = 15$ .

1. **WEIGHT.** Most building codes require a minimum thickness for floor slabs of 4".

$$w = \frac{4 \times 12 \times 12}{1728} \times 150 = 50 \text{ lbs./ft.}^2$$

Live load . . . . . 200 lbs./ft.<sup>2</sup>

Weight . . . . . 50

Total load . . . . . 250 lbs./ft.<sup>2</sup>

Total load on slab =  $4.75 \times 250 = 1187.50$  lbs., say 1188 lbs.

2. **MOMENT.**  $M = \frac{Wl}{12} = \frac{1188 \times 4.75 \times 12}{12} = 5643 \text{ in.-lbs.}$

3. **DEPTH.**  $d = \sqrt{\frac{M}{138.7 \times b}} = \sqrt{\frac{5643}{13.87 \times 12}} = 1.8''.$

The total depth must, however, be at least 4". Allowing 1" for fire protection and 0.25" for half diameter of steel,  $d$ , the effective depth, must be 2.75" to the center of reinforcement.

4. **SHEAR.** Shear is not a determining factor in solid slabs, except for very heavy loads, and need not be investigated here.

5. **AREA OF STEEL.** Since the steel need not balance the compressive strength

of the concrete the formula  $A_s = \frac{M}{15,600 \times d}$  will be used.

$$A_s = \frac{5643}{15,600 \times 2.75} = 0.131 \text{ in.}^2$$

Use  $\frac{3}{8}$ " round rods, area each rod = 0.11 in.<sup>2</sup>

6. SPACING.  $\frac{0.131}{0.11} = 1.2$  rods/ft.;  $\frac{12}{1.2} = 10'' =$  spacing of rods.

The Joint Committee recommends that the spacing of the principal reinforcement in solid slabs shall not be more than 3 times the slab thickness, in this case 12".

7. BOND. The bond stress is often high in solid slabs and should be tested at the point of inflection at  $\frac{1}{8}$  span.

$$V = \frac{1188}{2} = 594 \text{ lbs.}$$

$$u = \frac{V}{\sum ojd} = \frac{594 - \left(\frac{1188}{5}\right)}{1.2 \times 1.23 \times 0.875 \times 2.75} = 100 \text{ lbs./in.}^2 \text{ Allowable for deformed bars.}$$

In this equation 1.2 = number of rods per foot and 1.23 = perimeter of one rod.

The Joint Committee recommends that reinforcement for shrinkage and temperature stresses should be provided at right angles to the main reinforcing rods in floor and roof slabs where the principal reinforcement extends in one direction only. Table XV gives ratios of cross reinforcement area to concrete area which should be followed.

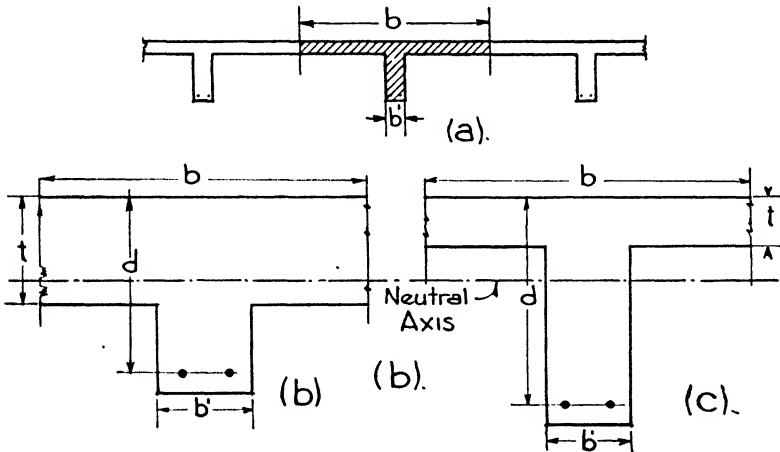

FIG. 25.—T-Beams.

The concrete area is  $12'' \times 2.75'' = 33 \text{ in.}^2$ ;  $33 \times 0.0025 = 0.0825 \text{ in.}^2$ . If two rods were placed parallel to the beams, they would be about 18" apart, which is the maximum spacing permitted. Two  $\frac{3}{4}$ " plain round rods with a combined area of 0.098 in.<sup>2</sup> are selected.

The steel of the main reinforcement is bent up at  $\frac{1}{8}$  span to act as reinforcement against negative bending moment and, when not of one continuous length, splices with a lap of 40 diameters of the rod or 15" are made.

**Solid Slabs. Two-Way Reinforcement.** The methods of calculation are similar to those for one-way slabs except that the load must be apportioned to the long and short spans. When the slabs are square, half the load is carried on each span; but when the slabs are oblong,

more load is carried upon the short than upon the long span. Table VII gives the distribution in such cases. See Article 4 for illustrative problem on two-way ribbed slabs.

Table XV. Ratios of Temperature Reinforcement

Plain bars	
Floor slabs.....	0.0025
Roof slabs.....	0.003
Deformed bars	
Floor slabs.....	0.002
Roof slabs.....	0.0025
Wire fabric having welded intersections not more than 12" apart in direction of stress.	
Floor slabs.....	0.0018
Roof slabs.....	0.0022

**Example 11. T-Beams and Girders** (Fig. 25,*a*). When solid slabs are poured integrally with the cross beams and girders, economy is gained by considering a certain width of slab on each side of the beam as the upper flange of the beam, thereby producing a T-section strong in compression above the neutral surface. The Joint Committee recommends that the width of slab considered as acting as the flange shall not exceed  $\frac{1}{4}$  the span length of the beam, nor its overhanging width on either side be more than 8 times the thickness of the slab or  $\frac{1}{2}$  the clear distance to the next beam. Some building codes specify  $\frac{1}{6}$  span and 6 times thickness of slab instead of the limits set by the Committee.

Where the principal reinforcement of the slab is parallel to the beam, as is usual with T-girders in connection with one-way slab reinforcement, short transverse bars should be provided in the top of the girder projecting well into the slab on both sides to carry the load in the girder flange.

The overhanging portion of the flange of the beam is not considered effective in computing the shear and diagonal tension of T-beams.  $b$  = width of flange;  $t$  = thickness of flange;  $b'$  = width of web.

Two cases arise in practice: A, in which the neutral axis of the cross-section is located in the flange; and B, in which the neutral axis is located below the flange.

**CASE A** (Fig. 25,*b*). This case occurs only when the flange is very thick in comparison with the depth of the beam. The T-beam is considered as a rectangular beam of the same depth and with a width equal to the flange width. The formulae for rectangular beams therefore apply, the width,  $b$ , in the formulae denoting the flange width.

**CASE B** (Fig. 25,*c*). This case with the neutral axis located below the flange is the usual one in practice. The compression in the web is small compared with that in the flange and is not considered. The exact formulae are derived in a manner similar to that for the rectangular beam formulae. They are complicated to use, and consequently the following simplified approximate formulae which err slightly on the safe side are generally employed in practice.  $M_c$  is the resisting moment of the concrete.

$$M_o = \frac{1}{2} f_s b t \left( d - \frac{t}{2} \right) \tag{30}$$

$$A_s = \frac{M}{f_s \left( d - \frac{t}{2} \right)} \tag{31}$$

In the layout of the panel in Fig. 24, the girders are considered to be 12" wide and 20'0" on centers and the beams to be 7" wide and 5'4" on centers. For the uniformly loaded beams, then, the thickness of the flange, *t* will be 4", equal to thickness of the slab, and the width *b'* is assumed as 7". To assume the depth, 1" for every foot of span may be used as a trial. The web must be sufficiently wide to accommodate the reinforcement.

1. WEIGHT (Fig. 26,a). The width, *b'* is usually taken as 1/2 to 1/3 the effective depth *d*. Here *d* will be assumed as 17", and *b'* = 7".

17 + 1 1/2 + 1/2 = 19". The clear span = 19'0".

$$W_1 = \frac{7 \times 19 \times 19 \times 12}{1728} \times 150 = 2632 \text{ lbs.} = \text{weight of beam.}$$

*W*<sub>2</sub> = 1188 (load from slab per linear foot of beam) × 19 = 22,572 = load from slab.

Total load = 2632 + 22,572 = 25,200 lbs.

2. WIDTH OF FLANGE. 1/4 span = 19/4 = 4.75' = 57". Use 7" + 25" + 25" = 57".

3. DEPTH. Because the wide flanges give an excess of concrete at the top to withstand compression, shear is generally the critical stress. The assumed depth may then be checked directly from the allowable unit shearing stress, 120 lbs./in.<sup>2</sup>, with web reinforcement, as follows:

From formula (10):  $v = \frac{V}{b_j d}$  or  $d = \frac{V}{v_j b}$ .

$$\text{When } v = 120 \text{ lbs.}, d = \frac{V}{120 \times 0.875 \times b} = \frac{V}{105b}$$

$$V = \frac{25,200}{2} = 12,600; d = \frac{12,600}{105 \times 7} = 17"$$

Then 17 + 1 1/2 + 1/2 = 19" = total depth.

$$4. \text{ MOMENT. } M = \frac{Wl}{12} = \frac{25,200 \times 19 \times 12}{12} = 478,800 \text{ in.-lbs.}$$

The beam is considered fully continuous for the span in question.

$$5. \text{ AREA OF STEEL. } A_s = \frac{M}{f_s \left( d - \frac{t}{2} \right)} = \frac{478,800}{18,000 \times 15} = 1.77 \text{ in.}^2$$

Use one 1" round rod, area = 0.78

one 1 1/8" round rod, area = 0.99  
1.77 in.<sup>2</sup>

Bend up the 1 1/8" rod at 30° at the 1/5 point of span, or 3.8' from the girder.

6. WEB REINFORCEMENT (Fig. 28,b).  $x = \frac{L}{2} \left( 1 - \frac{v'}{v} \right)$ ; *v'* = 40, *v* = 120.

$$\text{Therefore } x = \frac{L}{3} = \frac{19}{3} = 6.33'$$

$$s = \frac{A_s' f_s d}{v'} = \frac{0.38 \times 16,000 \times 0.875 \times 17}{8330} = 10". \text{ Using } 1/2" \text{ round stirrups.}$$

Horizontal projection of sloping portion of bar =  $a \cot \alpha = 15'' \times 1.73 = 25.95'' = 2.16'$ ;  $2.16' \times \frac{3}{4} = 1.62' = 19.5''$ . The first stirrup is placed 6'' from the girder, then 3 stirrups 10'' apart and, omitting stirrups for  $19\frac{1}{2}''$ , set 3 stirrups with 10'' spacing giving a total of 7 stirrups at each end of the beam.

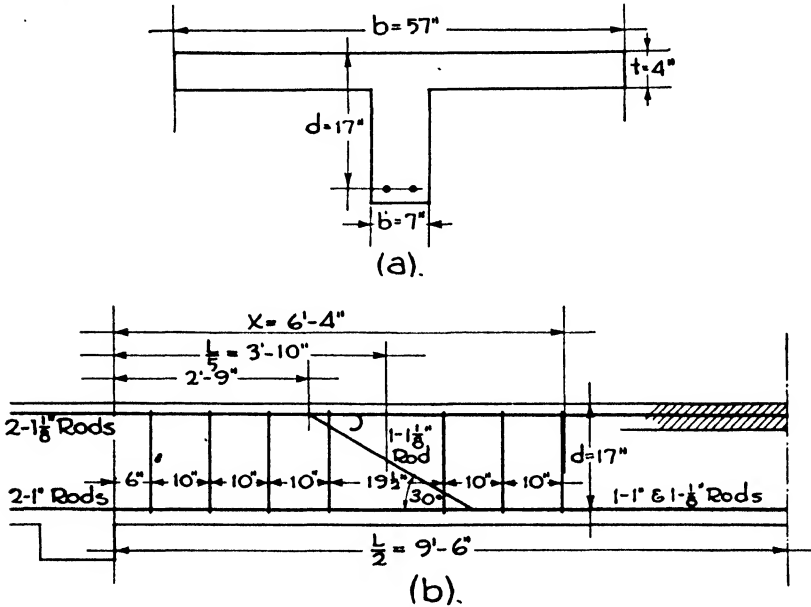

FIG. 26.

7. BOND.  $u = \frac{V}{\Sigma o_j d}$ . At the face of the girder for negative bending moment,  
 $u = \frac{12,600}{2 \times 3.53 \times 14.87} = 120 \text{ lbs./in.}^2$ , in which 3.53 = the perimeter of the  $1\frac{1}{8}''$  rod.

At the point of inflection,  $u = \frac{12,600 - \frac{22,572}{5}}{1 \times 3.53 \times 14.87} = 154 \text{ lbs./in.}^2$

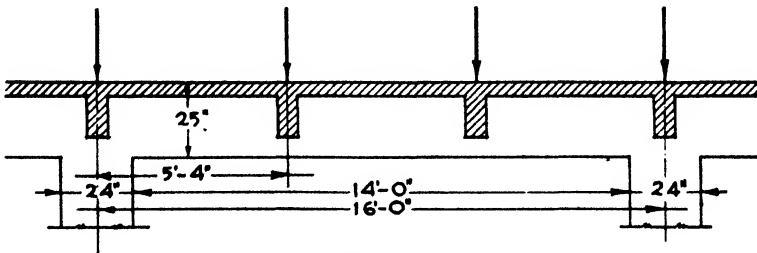

FIG. 27.

Because the stress is high, the rods should be deformed and anchored by a hook at the end. (See Table III.)

**Example 12. T-Girder (Fig. 27).** The method of designing the T-girder is similar to that for the T-beams except that the loads from the cross beams are concentrated at the  $\frac{1}{3}$  points of span of the girder instead of being uniformly distributed. The thickness of the flange is determined by the slab thickness. Therefore  $t = 4''$ . The width of the web ( $b'$ ) has already been assumed as  $12''$ . The columns are assumed to be  $24''$  in diameter; therefore, the clear span of the girder is  $14'0''$ . The width of the flange is  $16/4 = 4'0''$ .

1. WEIGHT. Assume effective depth  $= 22''$ , with 2 tiers of reinforcing bars. Allow  $1\frac{1}{2}''$  for fireproofing and  $1\frac{1}{2}''$  from the centroid of the two tiers to the bottom of the lower tier. Then the total depth of beam  $= 22 + 3 = 25''$ .

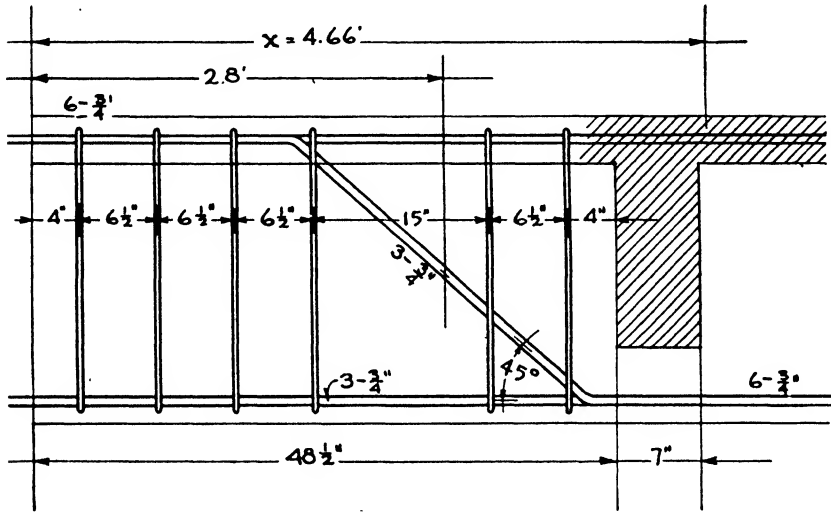

FIG. 28.

$$W = \frac{14 \times 12 \times 25 \times 12}{1728} \times 150 = 4375, \text{ say } 4400 \text{ lbs.}$$

2. DEPTH.  $V = \frac{25,200 + 25,200 + 4400}{2} = 27,400 \text{ lbs.}$

$$d = \frac{V}{105b'} = \frac{27,400}{105 \times 12} = 21.74, \text{ say } 22''; 22 + 3 = 25'', \text{ the total depth.}$$

3. MOMENT.  $M = \frac{PL}{3}$  for concentrated loads at  $\frac{1}{3}$  span. Multiply by  $\frac{2}{3}$  for fully continuous beam. Use center-to-center span.

$$M = \frac{WL}{12} \text{ for weight of beam uniformly distributed.}$$

$$M = \frac{25,200 \times 16 \times 12}{3} = 1,612,800 \times \frac{2}{3} = 1,075,200 \text{ in.-lbs.}$$

$$M = \frac{4400 \times 16 \times 12}{12} = 70,400 \text{ Adding both moments, } 1,145,600 \text{ in.-lbs.}$$

4. AREA OF STEEL.  $A_s = \frac{M}{f_s \left( d - \frac{t}{2} \right)} = \frac{1,145,600}{18,000 \times 20} = 3.1 \text{ in.}^2$

Use six  $\frac{3}{4}$ " square bars. The smaller size of bar is chosen to increase the total perimeters for the bond. One  $\frac{3}{4}$ " bar has area = 0.56 in.<sup>2</sup>

and perimeter = 3.0 in.

Total area = 6 × 0.56 = 3.36 in.<sup>2</sup>

Arrange bars in two tiers because the beam must be widened to accommodate one tier.

Bend up 3 bars at 45° through the  $\frac{1}{8}$  point of span or 2.8' from the column.

5. WEB REINFORCEMENT (Fig. 28).  $x = \frac{L}{2} \left( 1 - \frac{v'}{v} \right)$ ;  $v' = 40$ ;  $v = 120$ ;  $x = \frac{L}{3}$ .

$$x = \frac{14}{3} = 4.66'; s = \frac{A_s' f_s d}{V} = \frac{0.38 \times 16,000 \times 0.875 \times 22}{18,480} = 6.3''.$$

Using  $\frac{1}{2}$ " round stirrups.

The horizontal projection of the sloping portion of the horizontal bars,  $b = a \cot \alpha = 20 \times 1 = 20''$ ;  $20 \times \frac{3}{4} = 15'' =$  extent of sloping bars to be used for web reinforcement. Stirrups are required throughout distance from column to nearest cross beam. No stirrups are necessary between cross beams. Place first stirrup 4" from column and space 4 more stirrups  $6\frac{1}{2}''$  apart omitting 15" covered by sloping bars. Sixth stirrup is 4" from first cross beam.

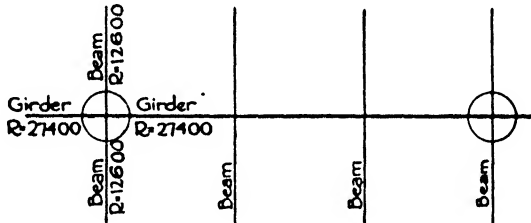

FIG. 29.

6. BOND.  $u = \frac{V}{\Sigma o_j d}$ . At face of column,  $u = \frac{27,400}{6 \times 3 \times 0.875 \times 22} = 78 \text{ lbs./in.}^2$

$$\text{At point of inflection, } u = \frac{27,400 - \left( \frac{4400}{5} \right)}{3 \times 3 \times 0.875 \times 22} = 153 \text{ lbs./in.}^2$$

Because the stress is high the rods should be deformed and anchored by a hook at the end.

COLUMNS. Each column of the panel shown in Fig. 24 will carry loads from two girders and two beams of the floor which it directly supports, together with the load transmitted to it from the columns above it. The reaction of each girder is 27,400 lbs. and of each beam is 12,600 lbs., making a total load from the floor framing of 80,000 lbs. Assume the transmitted load and the weight of the column itself to amount to 140,000 lbs. Then the total load is 220,000 lbs. =  $P$ . Assume the height of the column to be 12'0" and that a 2500-lb. concrete is used.

**Example 13. Tied Column (Fig. 29).** Design a tied column with vertical reinforcement only. Load is 220,000 lbs.

Try a column with 22" gross diameter and 1% of steel. Gross area of column ( $A_g$ ) = 380.1 in.<sup>2</sup> Area of steel = 3.8 in.<sup>2</sup> The allowable load will equal 80% of the following formula:

$$P = 0.225f'_c A_g + A_s f_s$$

OR

$$P = (0.225 \times 2500 \times 380) + (3.8 \times 20,000) = 213,750 + 76,000 = 289,750; 0.8 \times 289,750 = 231,800.$$

Allowable load 231,800 lbs.  
Applied load 220,000 lbs.  
Satisfactory.

Use nine  $\frac{3}{4}$ " round rods; area =  $9 \times 0.44 = 3.96$  in.<sup>2</sup>

**Example 14. Spiral Column.** Assume the column to be located upon a lower story of the building considered in the preceding examples and to carry a load of 400,000 lbs.  $f_s = 20,000$  lbs./in.<sup>2</sup> for rods and 60,000 lbs./in.<sup>2</sup> for spiral.

Try a column with 24" gross diameter and 20" net diameter.

$A_g = 452$  in.<sup>2</sup>;  $A_c = 314$  in.<sup>2</sup> Use 2% of vertical steel.

Area of steel =  $0.02 \times 452 = 9.04$  in.<sup>2</sup>

$$P = 0.225f'_c A_g + A_s f_s = (0.225 \times 2500 \times 452) + (9.04 \times 20,000) = 254,250 + 180,800 = 435,050 \text{ lbs.}$$

Weight of column =  $\pi r^2 \times 150 \times 12 = 3.14 \times 1 \times 150 \times 12 = 5652$  lbs.

Total load =  $400,000 + 5652 = 405,652$  lbs. Satisfactory.

Use ten  $1\frac{1}{8}$ " round rods; area  $10 \times 0.99 = 9.9$  in.<sup>2</sup>

The ratio of volume of spiral steel to volume of column core is found by the formula:

$$p' = 0.45 \left( \frac{A_g}{A_c} - 1 \right) \frac{f'_s}{f'_c}$$

$$p' = 0.45 \left( \frac{452}{314} - 1 \right) \frac{2500}{60,000} = \frac{0.0165}{2} = 0.008$$

Volume of core =  $314 \times 144 = 45,216$  in.<sup>3</sup>

Volume of steel =  $45,216 \times 0.008 = 361.7$  in.<sup>3</sup>

Pitch = 3", 4 turns to 1' of height; length of 1 turn =  $3.14 \times 20 = 62.8$ ";

total length of wire =  $4 \times 62.8 \times 12 = 3024.4$ ". Area of wire =  $\frac{361}{3024} = 0.11$  in.<sup>2</sup>

$\frac{3}{8}$ " round wire has area of 0.11 in.<sup>2</sup>

**Example 15. Flat Slab.** A square flat slab panel has a span of 20'0" center to center of columns and carries a live load of 200 lbs./ft.<sup>2</sup> Design the slab with drops and four-way reinforcement. Ultimate strength of concrete 2500 lbs./in.<sup>2</sup>  $n = 12$ .

1. THICKNESS OF SLAB. Assume an 8" slab.

Weight of slab/ft.<sup>2</sup> =  $\frac{3}{8} \times 150 = 100$ . Total load =  $200 + 100 = 300$  lbs./ft.<sup>2</sup>

$$t_2 = 0.02l \sqrt{w + 1}; t_1 = 0.02 \times 20 \sqrt{300} + 1 = 7.9, \text{ say } 8"$$

Multiply by 0.93 for 2500-lb. concrete,  $7.9 \times 0.93 = 7.3$ . (For practical purposes 8" slab will be retained.)

2. CAPITAL. Diameter =  $\frac{l}{5} = 4'0"$ .

3. DROP. Width =  $\frac{l}{3} = 6'8" = b$ . Depth =  $1.5t_1; 1.5 \times 8 = 12"$ .

Weight of drop =  $6\frac{3}{4} \times 6\frac{3}{4} \times \frac{1}{2} \times 150 = 2217$  lbs.

Total load of panel =  $20 \times 20 \times 150 + 2217$  lbs. = 122,217 say 123,000 lbs.



4. MOMENTS.  $M_0 = 0.09Wl \left(1 - \frac{2c}{3l}\right)^2$ .

$M_0 = 0.09 \times 123,000 \times 20 \left(\frac{13}{15}\right)^2 = 166,296 \text{ ft.-lbs.} = 1,995,000 \text{ in.-lbs.}$

	Negative	Positive
Column strip.....	$0.54M_0 = 1,077,300$	$0.19M_0 = 379,050$
Middle strip.....	$0.08M_0 = 159,600$	$0.19M_0 = 379,050$

5. SHEARING STRESS. Allowable stress =  $0.03f'_c = 75 \text{ lbs./in.}^2$

At plane at distance  $d_1$  from capital:  $d_1 = t_1 - 1\frac{1}{2}'' = 12 - 1\frac{1}{2} = 10\frac{1}{2}''$ .

$v = \frac{V}{bjd}$ ; weight of capital, drop and load =  $350/\text{ft.}^2$

$V = 123,000 - 350 \frac{\pi \times 5.75^2}{4} = 123,000 - 9100 = 113,900 \text{ lbs.}$

$v = \frac{113,900}{\pi \times 68 \times \frac{1}{8} \times 10.5} = 58 \text{ lbs. Satisfactory.}$

At plane at distance  $d_2$  from edge of drop:  $d_2 = t_2 - 1\frac{1}{2} - 8 - 1\frac{1}{2} - 6\frac{1}{2}''$ .

$b_2 = 80'' + (2 \times 6\frac{1}{2}) = 93'' = 7.75'$ ;  $V = (20^2 - 7.75^2)300 = 102,000 \text{ lbs.}$

$v = \frac{102,000}{\frac{1}{8} \times (4 \times 93) \times 6.5} = 48 \text{ lbs. Satisfactory.}$

6. AREA OF STEEL, FOUR-WAY BARS.  $A_s = \frac{M}{f_s \times jd}$ ;  $j = 0.875$ ;  $f_s = 18,000 \text{ lbs./in.}^2$

(a) *Column Strip*. Direct bars:  $+M$ ,  $d = 8 - 1\frac{1}{16} = 6\frac{15}{16}''$ ;  $A_s = \frac{379,050}{18,000 \times 0.875 \times 6.93} = 3.47 \text{ in.}^2$  using  $\frac{3}{8}''$  bars and  $\frac{3}{4}''$  insulation; 12 -  $\frac{3}{4}''$  round bars furnish  $3.6 \text{ in.}^2$

(b) *Middle Strip*. Cross band bars:  $-M$ ,  $d = 8 - 1\frac{1}{2} = 6\frac{1}{2}''$ ;  
 $A_s = \frac{159,600}{18,000 \times 0.875 \times 6.5} = 1.6 \text{ in.}^2$  using  $\frac{1}{2}''$  bars and  $\frac{3}{4}''$  insulation; seven  $\frac{1}{2}''$  square bars furnish  $1.7 \text{ in.}^2$

Diagonal bars:  $+M$ ;  $d = 8 - 1\frac{1}{16} = 6\frac{5}{16}''$ ;  $A_s = \frac{379,050}{18,000 \times 0.875 \times 6.93} = 3.47 \text{ in.}^2$

Effective area in each band =  $\frac{A_s}{2(\sin 45^\circ)}$ ;  $\sin 45^\circ = 0.71$ ;  $A_s = \frac{3.47}{2 \times 0.71} = 2.4 \text{ in.}^2$  using  $\frac{3}{8}''$  bars and  $\frac{3}{4}''$  insulation; eight  $\frac{3}{8}''$  round bars furnish  $2.4 \text{ in.}^2$

(c) *Column Strip*. Column head bars:  $-M$ ;  $d = 12 - 1\frac{1}{16} = 10\frac{5}{16}$ ;  
 $A_s = \frac{1,077,300}{18,000 \times 0.875 \times 10.3} = 6.63 \text{ in.}^2$

Diagonal bars are extended across the column head and provide  $3.47 \text{ in.}^2$  of steel. Additional steel required equals  $6.63 - 3.47 = 3.16 \text{ in.}^2$ . Raise six  $\frac{3}{8}''$  round bars from direct column strip on each side or 12 bars altogether.  $12 \times 0.30 = 3.6 \text{ in.}^2$ . The remaining 6 direct bars of the column strip continue horizontally and stop off near the drop.

## CHAPTER XXIII

### STAIRS

#### Article 1. General Discussion

Stairs are provided for access to and descent from the upper stories of a building. They should, therefore, be so designed that the climb may be made with ease and comfort and the descent with safety and expedition. The proper ratio of riser to tread and the provision of sufficient intermediate platforms insure the first requirement, and the second is fulfilled by a suitable proportion between the persons to be accommodated and the number and width of the stairways and their fire protection.

Stairs may be classed as STANDARD, MONUMENTAL, EMERGENCY and SERVICE according to their use.

STANDARD STAIRS are those intended for constant and every-day use in structures where there are no elevators and for access to the first story above the street floor in elevator buildings. Such stairs should have a comfortable yet practical ratio of riser to tread and should insure passage from one story to another with least labor and delay. They include the stairways in dwellings, schools, factories, libraries, public buildings and railroad stations and all structures where the stairs are the habitual means of access to the stories above the ground.

MONUMENTAL STAIRS are those intended for architectural effect as well as use and include the stairways in all buildings of monumental character and those in the finer type of residences. They suggest dignity and ease of movement and consequently are designed with less rise and wider tread than standard stairs. In high buildings the stairs from the street floor to the first story are sometimes given a monumental character with the expectation that to reach the upper stories the elevators only will invariably be used.

EMERGENCY STAIRS are those in high structures such as office buildings, hotels and apartment houses where the elevators are resorted to for all ordinary travel but where stairs must be provided from top to bottom to conform with the law and with the dictates of common sense. They are rarely used except in emergency and are consequently simple in design and of standard pitch or ratio of riser to tread. In case of fire they may become the only means of escape for the occupants and should consequently be adequate and safe. Fire towers or smoke-proof towers are one type of emergency stairways.

SERVICE STAIRS are those in residences and hotels intended for use in

the domestic service of the establishment. They may be narrower and steeper than standard stairs and are often unduly so.

**Terms.** The terms generally used in stair design may be defined as follows:

**RISE.** Total height from floor to floor.

**RUN.** Total length of stairs including platforms.

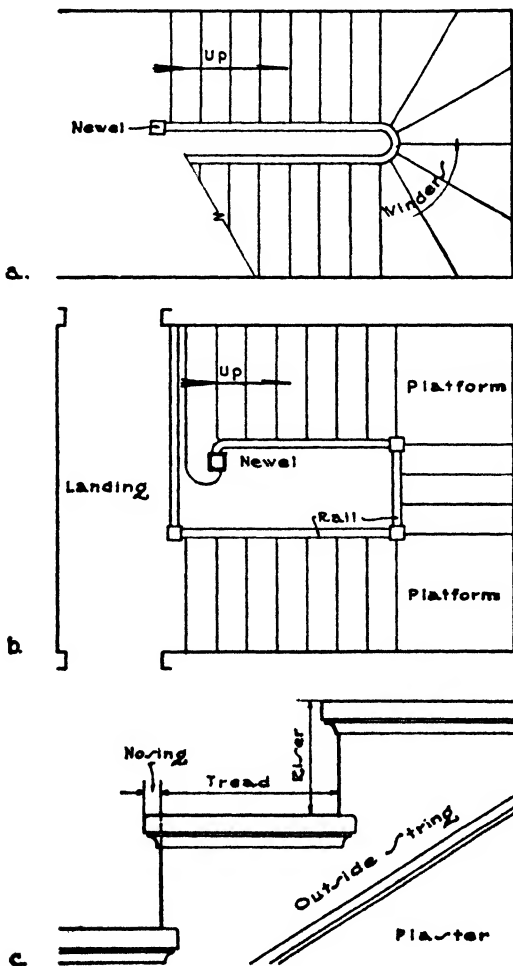

FIG. 1.

**RISE.** Vertical face of a step (Fig. 1, c).

**TREAD.** Horizontal face of a step (Fig. 1, c).

**NOSING.** Projection of tread beyond face of riser (Fig. 1, c).

**CARRIAGE.** Rough timber supporting the treads and risers of wood stairs. Sometimes called **STRINGERS**.

**STRINGS.** In steel stairs this term denotes the inclined steel members on the outside and inside of the stairway which support the treads and risers. In very wide stairs there may also be an intermediate string. The inside string when set against a wall is called the **WALL STRING**.

In a wood stairs the strings are distinguished from the carriages in that they refer to boards placed outside the carriage, the outside string, and against the wall, the wall string, to give a finish to the staircase. Open strings are cut to follow the lines of the treads and risers. Closed strings have parallel sides, the risers and treads being housed into them (Figs. 1, c, and 4, a).

**NEWEL.** The main post of the railing at the start of the stairs and the stiffening posts at the angles and platforms (Figs. 1, a, and 4, a).

**RAILING.** The protection on the open sides of a run of stairs. The inclined parts are generally 2'6" high measured from the tread at face of riser. The horizontal portions on platforms and landings are 2'10" high (Figs. 1, a, b, and 4, a).

**HAND RAIL.** The top finishing piece on the railing intended to be grasped by the hand in ascending and descending (Fig. 4, a).

**BALUSTERS.** The vertical members of the railing supporting the hand rail (Fig. 4, a).

**WINDERS.** Radiating or wedge-shaped treads at turns of stairs (Fig. 1, a).

**LANDING.** Floor at top or bottom on each story where a flight ends or begins (Fig. 1, b).

**PLATFORM.** The intermediate area between two parts of a flight (Fig. 1, b).

**Ratio of Risers to Treads.** The riser is the vertical face of a step and the tread the horizontal. If the risers be too high the climb will naturally be a strain to the muscles and heart, and if too low the discomfort will be almost as great because of the multiplied repetition of movement. Likewise if the tread be too short the stairs will be too steep, and if too long the forward reach will be excessive, both conditions inducing fatigue. Experience has proved that a riser 7" to 7½" high combines both comfort and expedition, and these limits therefore determine the standard height. Monumental stairs may have a riser of 6" to 7" with a good average at 6½". The risers of emergency stairs can have a height up to 7¾", and service and attic stairs are sometimes given risers of 8".

As the height of the riser is increased the width of the tread must be decreased for comfortable results. Very good ratios are provided by either of the following rules:

Tread plus twice the riser equals 24 or 25.

Tread multiplied by the riser equals 70 to 75.

A riser of 7½" would therefore require a tread of 10" and a riser of 6½" a tread of 11". Treads are rarely made less than 9" or more than 12" wide.

**Width of Stairways.** In residences, main stairways should not be less than 3'6" wide in the clear of hand rails, service stairs being somewhat narrower. The width of monumental stairs should be ample and is largely a matter of architectural design, 6'0" or more not being unusual. The stairways of industrial buildings, schools, courthouses, office buildings and hotels should be of sufficient width to serve their varying needs, depending upon the type and number of occupants. Industrial buildings should have easy access and exits for all occupants at stated hours of the day; schools and courthouses need sufficient width to vacate the corridors without crowding or confusion when required, and office buildings and hotels, although depending upon elevators for ordinary travel, should have emergency stairs wide enough to empty the structure in a few moments in case of fire. Stairs to theatre galleries are generally required to be at least 4'0" wide for the first 50 people to be accommodated and 6" wider for every additional 50 people. Not all types of buildings have the same number of inmates per unit of floor space. The square foot area specified by the New York Building Law for one occupant in buildings of various uses is as follows:

Table I

Places of Assembly .....	10
Schools and Courthouses.....	15
Stores.....	25
Factories.....	32
Office Buildings.....	50
Hotels and Apartments.....	100
Warehouses.....	150

**Number of Stairways.** In residences it is always more convenient to have two sets of stairs: the main stairs, easy and comfortable, which are often made a feature of the design; and the service stairs, usually somewhat narrower and steeper and hidden from general view. In other buildings the number of stairways should be sufficient so that no portion of the structure is unduly remote from a means of descent. For this reason two sets of stairs 3'6" wide but well distributed represent better practice than one set 7'0" wide.

In many types of buildings the horizontal distance from any part of a floor to the stairway is limited. For open floor areas as in lofts and factories the New York Law restricts this distance to 100'0" and for subdivided areas as in hotels and office buildings to 125'0". The New York Law also has the following requirement as to the capacity of staircases.

"The aggregate width of stairs in any story of the building shall be such that the stairs or the stairways may accommodate at one time the total number of persons ordinarily occupying or permitted to occupy the largest floor area served by such stairs or stairways above the flight or flights of stairs under consideration, on the basis of one person for

each full 22" of stair width and  $1\frac{1}{2}$  treads on the stairs, and one person for each  $2\frac{3}{4}$  ft.<sup>2</sup> of floor area on the landings and halls within the stairway."

It is also stated in the New York Code that only  $\frac{1}{2}$  the aforesaid number of persons need be accommodated if the building be equipped with an automatic sprinkler system,  $\frac{1}{3}$  if there be a horizontal exit to the floor, and  $\frac{1}{4}$  if both a sprinkler system and a horizontal exit be provided. Sprinkler systems are usually installed only in lofts, industrial buildings, warehouses and theatre stages.

From the number of occupants upon the floor and the number which may be accommodated upon a stairway the required number of stairways may be determined. Building codes generally require that every floor area above the ground floor shall have at least one interior stairway serving it, and when the floor area exceeds 2500 ft.<sup>2</sup> there shall be at least two interior stairs. The restriction as to distance between any part of the floor area and a stairway also influences the number of stairs required. There are often special provisions in regard to theatres and moving-picture houses.

**Types of Stairs.** Stairways may have a straight continuous run with or without an intermediate platform or landing or they may consist of two or more runs at angles to each other (Fig. 2, *a, b, c, d*). In the best and safest practice a platform is introduced at the angle, but the turn may be made by using radiating risers called winders. The natural path, called the line of travel, taken in climbing the stairs with a hand on the outer rail is at a distance of 1'8" to 2'0" from the rail. The width of the treads at the line of travel upon winders is, of course, less than the normal width upon the straight run. For this reason they are considered unsafe and are prohibited in theatres and in fireproof buildings generally (Fig. 2, *g*).

Stairways may also be circular in plan or have semicircular turns instead of square (Fig. 2, *e, f*). Such stairs often use winders radiating from the center from which the stair circle is struck. If the radius of the inner stair line be sufficiently large the treads of the winders will have a safe width at the line of travel, but if the radius be small the winders will be narrow and dangerous. A method, called balanced steps, produces very easy and safe travel for residences and the first flight of monumental stairs but is not allowed for the upper flights. The winders, instead of radiating from the center, are arranged so that the width of each tread upon the line of travel is the same as that of the treads upon the straight portion of the stairs (Fig. 2, *h*).

The intermediate platforms are often called landings, but it is less confusing to confine this term to the approaches at the bottom and top of the stairs and to use the term platform only for the intermediates. Platforms are often required in fireproof buildings, since their presence contributes to the safety of the occupants in case of fire.

**Design of Stairways.** The location and the width of a stairway together with the platforms having been determined, the next step is to fix the

height of riser and the width of tread. A suitable height of riser is chosen, and the exact distance between the finished floors of the two stories under consideration is divided by this riser height. If the quotient be an even number the number of risers is thereby determined. It very often happens, however, that the result is uneven, in which case the story height is divided by the whole number next above or below the quotient.

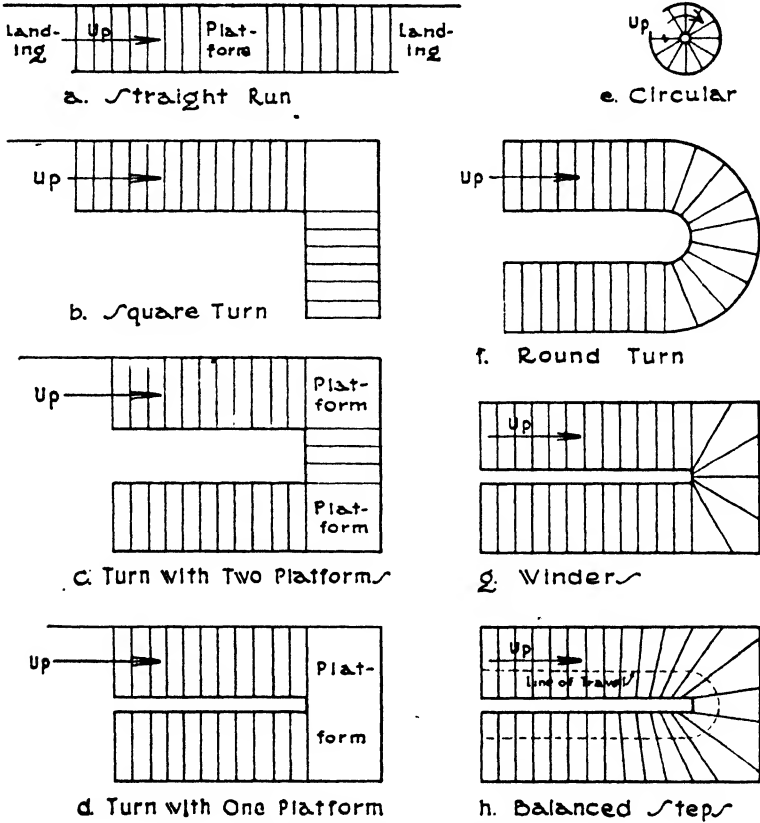

FIG. 2.—Types of Stairways.

The result of this division gives the height of the riser. The tread is then proportioned to the riser by one of the above-mentioned rules.

**Example 1.** The distance between the finished floors of two stories in a residence is 12'3". Find proper height of riser. A riser 7½" high is first selected.

$$7 \frac{1}{2}'' = \frac{15''}{2}; \quad 12'3'' = 147'' = \frac{294''}{2}; \quad \frac{294}{15} = 19 \frac{3}{5}$$

Since it is evidently necessary to have an even number of risers, divide 147" by 20, the nearest whole number.

$$\frac{147}{20} = 7 \frac{7}{20}$$

The number of risers is 20 and the exact riser height is then  $7 \frac{7}{20}$ ". This mixed fraction would be used by the stair-builders, who are necessarily in the habit of working with unusual fractions. If it were preferred to use a height as near as possible to 7", 147" would be divided by 7.

$$\frac{147}{7} = 21$$

Since the result is an even number, 7" can be used as the exact height and the risers will be 21 in number.

By the rule: (tread) + 2 (riser) = 25, the tread with a  $7 \frac{7}{20}$ " riser is found to be 10.3" and with a 7" riser, 11".

**Enclosed Stairs.** In buildings of over three or four stories occupied by more than 50 persons above the first story, required interior stair-

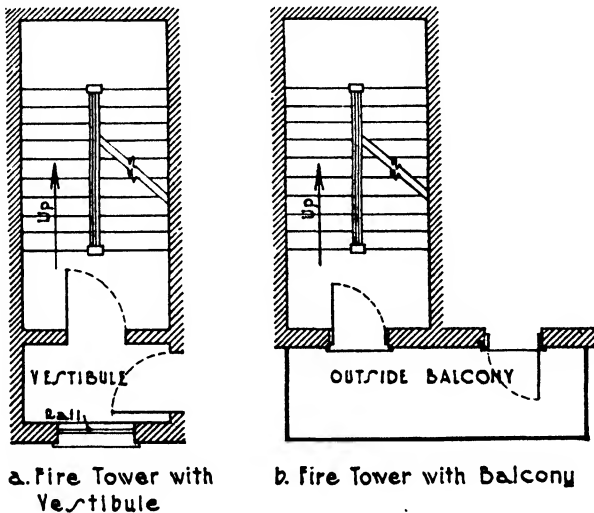

FIG. 3.—Fire Towers.

ways should be enclosed with fireproof partitions. Such a requirement has been found necessary in order to cut the stairway off from any flame and smoke in other parts of the building and so render it a fairly safe means of escape for the occupants. The doors and window sash and frames are made of metal, and the glass is wired glass. The doors should open from the floors into the stair enclosure and at the bottom exit from the enclosure outward to street or yard.

**Fire Towers** (Fig. 3, a, b). Fire towers are stair enclosures with special provisions for excluding smoke and fire and are sometimes called smoke-proof towers. Some building codes require fire towers in all business buildings exceeding 85'0" in height. They have no openings except into fireproof vestibules or exterior balconies and extend from the roof to the street or to a court of at least 100 ft.<sup>2</sup> area. The doors from the floor areas to the fire vestibules and exterior balconies and the doors between the



fire tower and the vestibules and balconies are fireproof and self-closing. Fire vestibules have an opening to the outside air without window sash and the outside balconies are of wrought iron, steel or concrete. There are no locks on the fire-tower doors, and the locks on doors to vestibules and balconies are always capable of operation by the knob from the building side. Steel stairs without fireproofing are permitted in fire towers.

**Materials.** Stairs in wood frame and non-fireproof buildings of moderate size may be of wood, but in all high and fireproof buildings the stairs must be of incombustible material. Wood stairs are, therefore, confined to wood frame buildings and to low buildings with masonry walls and wood floor beams. The stairs in all other buildings should be

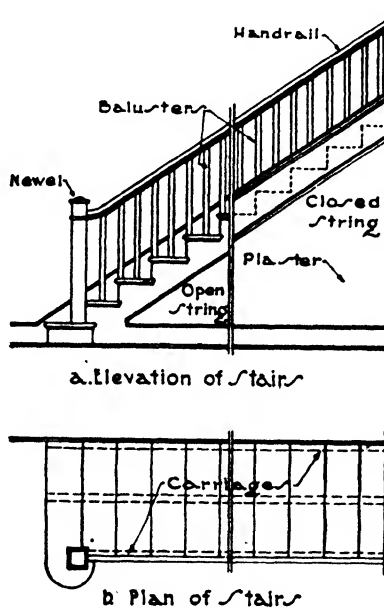

FIG. 4.—Wood Stairway.

of iron, steel or concrete. Iron and steel stairs are generally confined to steel frame buildings and concrete stairs to concrete buildings. Concrete stairs are, however, used to some extent with steel construction, since they can be readily adapted to a variety of conditions and types of support.

### Article 2. Wood Stairs

**Construction.** There are several methods of constructing wood stairs, depending somewhat upon the general custom of the locality. The ideal stairway is one which is stiff and firm under load and does not sag, vibrate, creak or squeak. One method will be described which is generally considered as good construction but is not always followed in the cheapest work (Fig. 4,a).

The treads and risers are supported upon rough, 2" x 12" plank carriages which are solidly fixed in place level and true, upon the framework of the building. Their upper edges are cut like steps to fit the outline of the treads and risers. One carriage is set near the wall and one on the outside of the stairs, with intermediate carriages at distances of 12" to 18" on centers. Rough treads are nailed across the carriages for the convenience of the workmen until the building is plastered and

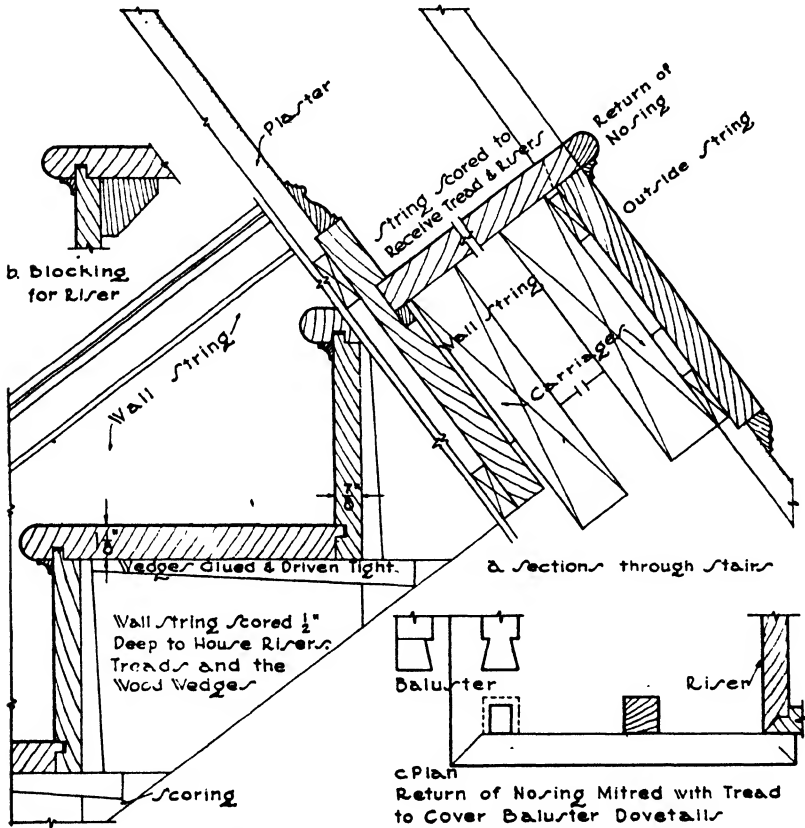

FIG. 5.—Wood Stairway Construction.

ready for the interior trim, thereby saving the finished stairs from damage (Fig. 4,b).

When the plastering is completed, the finished stairs, which have been got out in the shop, are erected in place by the stair-builders, who constitute a separate trade of mechanics. The wall string is ploughed out to the exact profile of the treads, risers and nosings with sufficient space at the back to take the wedges. The tops of the risers are tongued into the front of the treads, and the back of the treads into the bottom

of the risers. The wall string is spiked to the wall inside the wall carriage, and the treads and risers are fitted together and forced into the wall string housing, where they are set tight by driving and gluing wood wedges behind them. The wall string thus shows above the profiles of the treads and risers as a finish against the wall and is often made continuous with the baseboard of the upper and lower landings (Fig. 5, *a,b*).

If the outside string be a curb or closed string it is housed out and the treads and risers are wedged and glued into it as into the wall string. If the outside string be an open string it is cut to fit the risers and treads and nailed against the outside carriage. The edges of the risers are

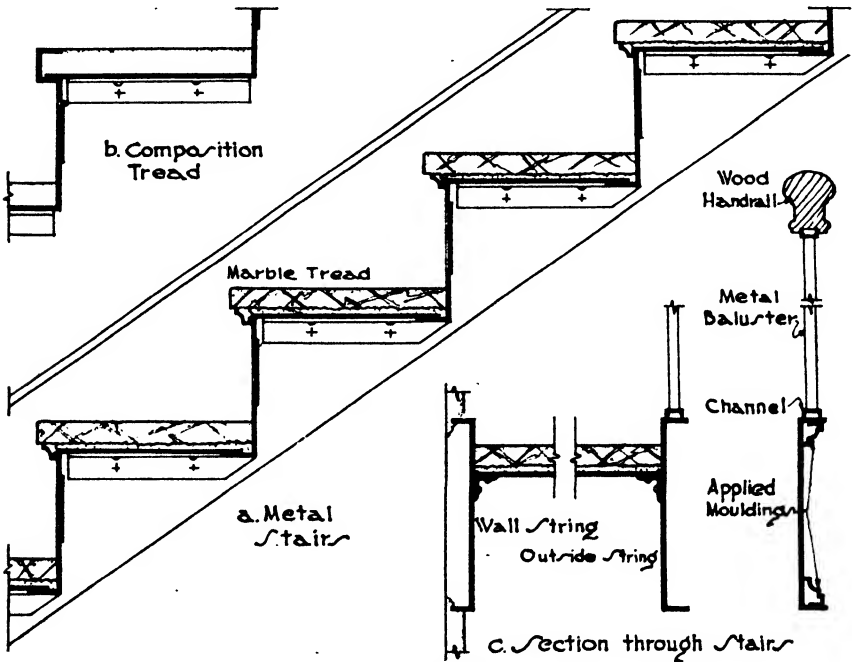

FIG. 6.—Steel Stair Details.

mitered with the corresponding edges of the string, and the nosing of the tread is returned upon its outside edge along the face of the string (Fig. 5, *c*).

The rails, newels and balusters are matters of design and appearance and may be extremely plain and simple or decorated with elaborate carving. The balusters are doweled or dovetailed into the treads and covered by the return of the nosing.

### Article 3. Steel Stairs

**Description** (Fig. 6, *a,b,c*). Metal stairs were first constructed of cast-iron strings and treads, then of angles, channels and other structural

steel shapes, but since both these methods have proved heavy and unwieldy a pressed-sheet steel stair has now been developed which is much lighter in weight and can readily be erected. This sheet steel type of stairs is now almost exclusively used in fireproof stair enclosures and fire towers. The steel sheets are at least  $3/16''$  thick and are formed into the shapes of the risers and sub-treads or pans. The strings are of closed type and are of pressed steel, usually in channel shape, and often have angles welded to them to receive the treads. Sometimes tie rods bind the stringers in place. The outside string may be finished with applied mouldings if desired. If marble or slate treads be used they are set in cement on top of the metal sub-treads so that their under sides are protected from heat in case of fire. Otherwise the stone treads are liable to crack and fall under the action of high temperatures. If cement,

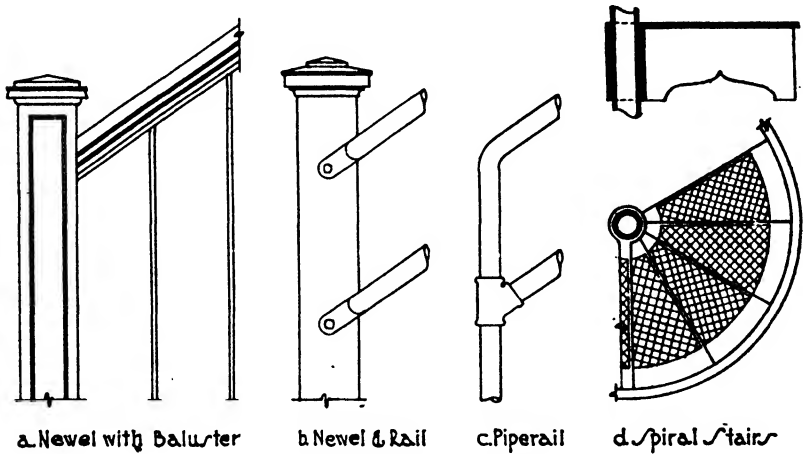

FIG. 7.—Steel Stair Details.

concrete or composition treads are to be installed, the sub-tread is bent into a nosing or has a metal nosing welded to it, which acts as a mould for the composition and later protects it from wearing down or breaking. "Carborundum" chips are often mixed with the composition to prevent slipping. Steel stairs are usually obtained in stock patterns from the manufacturers. The methods of pressing differ somewhat, but the basic scheme is the same. The stairs are generally designed for an allowable load of 125 lbs./ft.<sup>2</sup> The stringers are firmly attached at top and bottom to the steel structural framework, and platforms are often hung by concealed rods to overhead beams.

Pre-cast treads are also made of iron, bronze, aluminum and nickel upon the outer surface of which silicon carbide ("Carborundum") is incorporated during casting to give a non-slip surface. They span the distance from the outside to the inside string and are exceedingly strong

and durable. Treads of this material are used on the stairs to the New York subway where the wearing conditions are very severe.

**Monumental Stairs.** Stone and marble stairs of a monumental character are now generally constructed with a steel frame upon which the marble string, balustrades, treads and risers are attached by bronze clamps and bolts. The treads are set in a bed of mortar or composition on metal sub-treads. The soffits may be plastered or covered with stone slabs.

**Railings and Newels.** Except in decorative stairways, the railings are generally composed of  $\frac{1}{2}$ " square bars set vertically about 6" apart into the upper flange of the steel outer string. These bars support a steel channel top rail which in turn carries a wood hand rail (Fig. 7,a).

In fire towers and other localities where a simple appearance is not objectionable, the rails consist of 2" pipes running with the rake of the stairs and fastened to the newels, using standard pipe fittings (Fig. 7,b).

The newels may be of pressed steel or cast iron with a cross-section 4" to 5" square. With pipe rails the newels are often formed by bending the pipe to a vertical position and attaching to the string (Fig. 7,c). The railings should be stoutly constructed and capable of withstanding any strain put upon them in the event of crowding or confusion. Broad stairs in places of assembly should have an intermediate rail in the center of their width.

**Spiral Iron Stairs** (Fig. 7,d). Spiral stairs are very economical in space and are often used in banks, libraries, offices, power-houses and pumping stations. They consist of a central post, generally a 3" or 4" steel pipe, upon which the wedge-shaped, cast-iron treads are mounted. The rail consists of a 1" pipe with 1" pipe supports. The stair diameters vary from 42" to 96". To give headroom the risers should generally be from 8" to 9" high with 12 to 16 treads to a complete turn of the stairs. Each tread usually has a circular opening at its narrow end which fits around the central post.

#### Article 4. Reinforced Concrete Stairs

**Steps.** When the treads are few in number, as in exterior steps to entrances or between area and terrace levels, it may be possible to construct them without reinforcement. This should not be attempted unless the steps are poured as a solid mass or block resting upon a firm foundation below frost and are incorporated by steel dowels into the wall against which they are placed. This method naturally calls for an uneconomical amount of concrete (Fig. 8,a). A second method often used when steps occupy a position outside cellar or area walls consists in compacting the earth to a proper slope to act as a form for the under side of the slab and in pouring the concrete upon this slope using suitable wood forms to obtain the faces of the treads and risers. It is far better practice, however, to use reinforcement in the form of rods or wire

mesh in this case, since without it, any settlements in the earth bed will cause cracks in the concrete (Fig. 8,*b*).

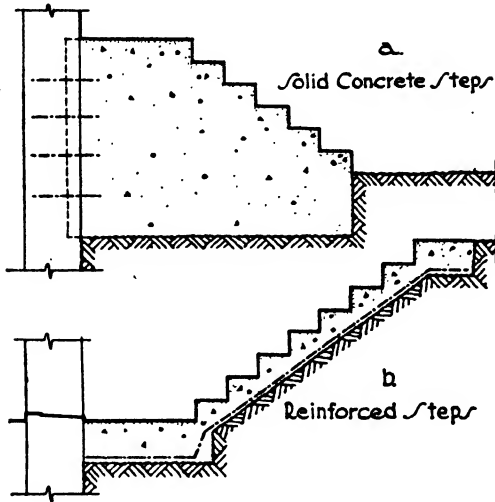

FIG. 8.—Outside Steps.

As a rule, then, reinforcement should always be incorporated in all concrete steps to join them properly to their abutments and to avoid cracking from settlement or from unforeseen tension stresses. When the steps cannot rest upon earth through their entire length they become inclined beams supported at the top and bottom and are reinforced in the manner of stairways as next described.

**Stairs.** Concrete stairs may generally be regarded as a simple non-continuous inclined beam or slab with the treads, risers, platforms and landings formed upon its upper surface. The span is taken as the horizontal distance between the centers of the supports and includes the width of any platform and landing, each run of stairs being considered as a separate member. The slab may rest at the bottom upon the floor construction if sufficiently sturdy to receive the concentrated load, but more generally

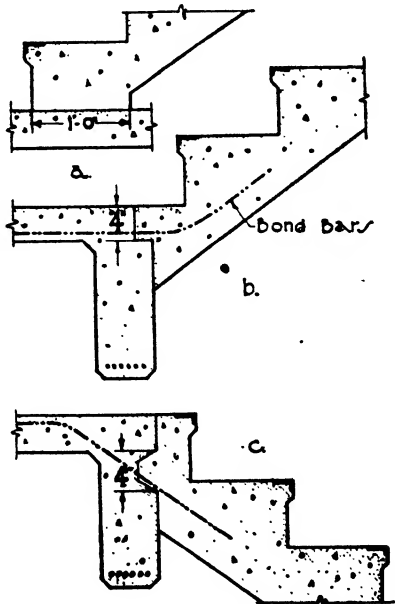

FIG. 9.—Concrete Stair Details.

more generally

it is supported upon a girder or header beam (Fig. 9, *a, b, c*). If the landing at the top of straight-run stairways abuts against an exterior wall it may be supported at its outer end by a spandrel beam or by the wall itself when of load-bearing construction. When the stairway is entirely in the interior of a building the landing is supported directly upon a cross beam between columns or hung by steel rods from a cross beam above. The rods should be fireproofed or else embedded in the surrounding walls. The intermediate platforms of double run stairs are supported at their outer ends as described above for landings, and sometimes a header beam is introduced at their inner edge to carry the lower end of the second run of stairs.

In triple-run stairways with two platforms the intermediate stair slab is supported upon the first and third stair slabs and their platforms, the load of the slab being added to their own dead and live loads.

Pipe rails supported on pipe stanchions are generally used with concrete stairs, or if a solid rail be preferred a reinforced concrete slab 3" or 4" thick may be constructed upon the treads.

Live loads upon stairs vary with the character of occupancy of the building, those for theatres, schools and places of assembly being greater than for office buildings, hotels or warehouses. The usual loads required by building codes range from 40 to 100 lbs./ft.<sup>2</sup>

It is generally more convenient to install the concrete for the stairs after the frame and floor slabs are in place. For this reason rabbets are left in the header beams to receive the stair slab, and  $\frac{3}{4}$ " steel dowels 3'0" long are inserted about 12" apart to create the proper bond between the slab and the headers. The stair slab together with the platforms is then poured monolithically.

Since the slab is simply supported the bending moment is found by the formula

$$M = \frac{wl^2}{8}$$

The total thickness,  $s$ , of the slab is the perpendicular distance from the bottom surface to the foot of a riser. It is obtained by the formula

$$d = \sqrt{\frac{M}{107.6 \times 12}}^*$$

The reinforcement is placed in the bottom of the slab and runs longitudinally, a portion of it being bent up over the header beam supporting the platform to prevent cracks due to negative bending moment. Cross reinforcement consisting of a  $\frac{3}{8}$ " bar is often placed in each riser and 3 or 4 bars in each platform and landing to prevent shrinkage and temperature cracks:

$$A_s = \frac{M}{14,000d}^*$$

\* In these formulae  $f_s = 16,000$  lbs./in.<sup>2</sup> and  $f_c = 650$  lbs./in.<sup>2</sup>

The weight of the steps at 144 lbs./ft.<sup>3</sup> equals

$$\frac{r \times t}{2} \times 12 \times \frac{12}{t} \times \frac{144}{1728} = \frac{r \times t}{2} \times \frac{12}{t}$$

The weight of the slab at 144 lbs./ft.<sup>3</sup> equals

$$s\sqrt{r^2 + t^2} \times 12 \times \frac{12}{t} \times \frac{144}{1728} = s\sqrt{r^2 + t^2} \times \frac{12}{t}$$

where  $r$  = height of riser,  $t$  = width of tread,  $s$  = total thickness of slab.

The live load is specified as 100 lbs./ft.<sup>2</sup> by the New York Code. The span is taken as the horizontal distance between supports. The design procedure is the same as that for one-way solid slabs as explained in Chapter XXII, Article 8.

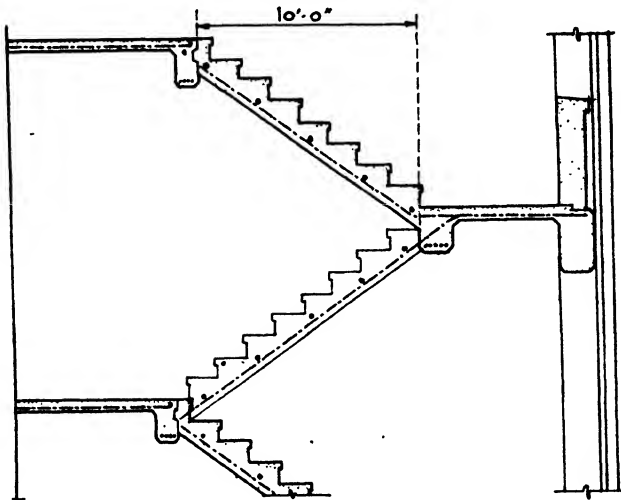

FIG. 10.

**Example 2** (Fig. 10). The horizontal length of a run of concrete stairs is 10'0", the risers are 7½" high and the treads 10" wide. Design the stair slab, using a live load of 100 lbs./ft.<sup>2</sup>

$$f_c = 16,000 \text{ lbs./in.}^2 \quad \text{Weight of concrete} = 144 \text{ lbs./ft.}^3$$

$$f_s = 650 \text{ lbs./in.}^2$$

DEAD LOAD PER SQUARE FOOT. Assume total depth of slab,  $s$ , = 7".

$$\text{Steps} = \frac{(r \times t)}{2} \times \frac{12}{t} = \frac{7.5 \times 10}{2} \times \frac{12}{10} = 45 \text{ lbs.}$$

$$\text{Slab} = s\sqrt{r^2 + t^2} \times \frac{12}{10} = 7\sqrt{7.5^2 + 10^2} \times \frac{12}{10} = 105 \text{ lbs.}$$

$$\text{Total Dead Load } 45 + 105 = 150 \text{ lbs./ft.}^2$$

$$\text{Live load} = 100$$

$$\text{Total load} = 250 \text{ lbs./ft.}^2$$



MOMENT.  $M = \frac{wl^2}{8}$ . Span length = clear span plus depth of slab.

$$\text{Then } M = \frac{wl(12l + s)}{8} = \frac{250 \times 10 \times (120 + 7)}{8} = 39,690 \text{ in.-lbs.}$$

$$\text{DEPTH. } d = \sqrt{\frac{M}{107.6 \times 12}} = \sqrt{\frac{39,690}{107.6 \times 12}} = 5.5''.$$

Total thickness of slab = 5.5 + 1.5 (fireproofing) = 7''.

$$\text{AREA OF STEEL. } A_s = \frac{M}{14,000d} = \frac{39,690}{14,000 \times 5.5} = 0.51 \text{ in.}^2$$

Use  $\frac{1}{2}$ '' square rods. Area each rod = 0.25 in.<sup>2</sup>

$$\text{Spacing} = \frac{0.51}{0.25} = 2 \text{ rods per foot of width of slab or } 6'' \text{ on centers.}$$

## Article 5. Escalators

**Description.** Moving stairways or escalators have met with much success because of their convenience and comfort to passengers, their large capacity and the small amount of electric current required. They are continuous in motion and are, therefore, always ready to receive passengers.

Escalators are composed of the running gear or moving steps which carry the passengers, the fixed balustrade on each side of the running gear and a hand rail on top of the balustrade which moves at the same speed as the steps. This equipment is supported on a track and a steel truss and is operated by electric power. Since the stairway is in continuous movement the amount of current required for each passenger is small.

**Types.** There are two types of escalators, the **FLAT-STEP TYPE** and the **CLEAT-STEP TYPE**. Both these types have standard steps with horizontal treads and vertical risers gradually formed as the running gear moves upward. The chief difference is in the method of entering and leaving the escalator. In the flat-step type, the entrance consists of 6 or 8 treads with their top surfaces on the same level forming a moving platform upon which the passenger enters. The steps then gradually form as the escalator moves upward until perfect steps are formed. At the top the steps again flatten out into a moving platform from which the passenger walks on to the floor, leaving from one or both sides, depending upon building conditions. The moving platforms occupy considerable space at the top and bottom of the stairway.

In the cleat-step type the treads are furnished with longitudinal cleats and by means of a combing they appear and disappear directly without the introduction of a moving platform. The longitudinal cleats and the combing make it possible for the passenger to step directly on and off the first tread of the stairs with ease and safety. The cleat-step type occupies less room than the flat-step type and is now more generally installed.

**Capacity.** Escalators are made in 3 sizes, 2', 3' and 4' wide respectively, which have passenger capacities of 4000, 6000 and 8000 persons per hour. They are widely used in department stores, railway stations, elevated railways, subways and industrial buildings. In department stores they relieve the elevators to a great extent from short floor-to-floor traffic.

## CHAPTER XXIV

### FOUNDATIONS

#### Article 1. General Considerations

**Purpose of Foundation.** If the weight of any building exceed the bearing resistance of the material, either soil or rock, upon which it rests, the material will give way and the building will sink. The amount of this sinkage may be the same under all walls and columns, in which case the building will settle uniformly; or it may be greater under some portions than under others due to greater loads or to less resistance of the foundation bed, in which event the building will settle unevenly. The walls will no longer be plumb nor the floors level, and more or less serious fractures may appear under the diverse stresses involved. The cracking of plaster and binding of doors are common results of uneven though perhaps slight settling of the structure.

Those portions of a building resting upon the soil or rock are known as the FOUNDATIONS or FOOTINGS, and careful study must be given to their area and strength and also to the characteristics and resistance of the bed upon which they rest to avoid all settlement if possible but in any case to escape the perils of unequal settlement.

Three general methods are in use to procure a firm non-settling bed upon which to erect the building.

(a) The foundations are spread out to distribute the load over the bed so that the safe bearing power of the bed per square foot is not exceeded.

(b) Excavations are made down through unstable materials until a stratum of soil or a bed of rock is reached whose bearing power is sufficient to sustain the loads. The foundations as a whole or the footings under individual walls and columns are then built upon this satisfactory base. Such footings may also be spread to distribute the load as in the first method.

(c) Long shafts of wood or concrete called piles are driven into the ground until they are sufficiently embedded to carry the loads without further sinkage or until their lower ends rest upon rock. The footings and column bases are then built upon the tops of the piles.

The first two methods will be described in this chapter. The description of pile foundations will be included in Chapter XXV.

It will be seen that an exact knowledge must be obtained of the characteristics and strength of the material upon which it is proposed to lay a foundation before starting such work. Several ways of testing are in

common use by which not only the nature of materials may be ascertained even at great distances below the surface, but also what underlies them and at what depths water, rock or hardpan may be encountered.

**Test.** The four most general methods of testing are by test pits, auger borings, wash borings and core borings. **TEST PITS** may be dug in the ground to explore the actual conditions. The strata are exposed and the true characteristics examined. Loading tests may also be made upon the soil by erecting a 12" x 12" post resting upon the bottom of the pit and by fastening a platform to the top of the post. The platform is then loaded with weights and the settling of the post under the load is read until it comes to rest. A fair knowledge of the bearing power per square foot of the soil in the bottom of the pit and its compressibility may thus be obtained. The cost of excavating such pits to any depth is high and they are rarely sunk below water level. Certain allowances are usually made in fixing the working pressure since settlement over large areas is generally found to be greater than on the small test area.

**AUGER BORINGS** are made with an ordinary 2" or 2½" auger fastened to a long pipe or rod, the whole often being encased in a larger pipe. The auger is removed after a few turns, bringing up samples of the strata encountered. Such borings give fairly good evidences of the character of the soil but the auger is stopped at the first obstruction, which may be hardpan or rock or a boulder or stump. They are most practical in fine sand or clay and can extend downward from 50' to 100'.

**WASH BORINGS** are used when the material is too compact for good results with an auger. They consist of a pipe, 2" to 4" in diameter, driven into the soil and containing a smaller jet pipe through which water is forced. The flow of water washes the material at the bottom up to the surface, where it is collected and tabulated. The finer materials, such as clay, sometimes disappear in the washing, and the heavier materials separate from each other, which reduces the dependability of the samples. Wash borings may also be stopped by boulders or stumps rather than bedrock. They can penetrate all other materials, however, can be carried downward 100' or more and are often sufficiently reliable.

**CORE BORINGS**, also known as **DIAMOND DRILL BORINGS**, are more costly than the other methods of testing but are the most dependable. They can penetrate to great depths, through all materials including rock, and bring up complete cores or cylinders of the material through which they pass. A definite section can then be drawn showing the successive material with accurate dimensions of all the strata under the proposed building site. A diamond drill consists of a hollow cylinder similar to a pipe with a cutting edge in which carbons called borb or black diamond are fitted, sufficiently hard to cut rock. Shot and fragments of cut chilled steel are also used for cutting. An annular groove is thus sunk into the bed surrounding a cylindrical core about 1½" in diameter, which is lifted to the surface in lengths varying from an inch to several feet.

Test borings should be made at enough points over the building area to ascertain the distance to rock or good bearing material, and the thickness of the beds, at all parts of the site. Strata are often steeply inclined so that rock may be found near the surface at one point and many feet below grade at others. The locations of subterranean springs or streams and of soft sand holes and rifts in the rock formation are also important items of information which should always be obtained by borings before any foundation work is designed. The costs of many important buildings have been greatly increased by lack of proper exploration of the material, characteristics and condition of the foundation beds beneath the site. It must be remembered that the presence of water not only complicates the difficulties of excavating and of laying foundations but may also change a good bed into a very poor one. Water must always be the most carefully considered and the most continually combated of all the elements in the design and construction of foundations.

Besides the information obtained from tests and borings the general characteristics of the site should be thoroughly studied together with the possibilities of future modifications of the conditions. If the projected building will be near the foot of higher ground or situated between hills, water may be encountered either at once or at some later time. When the site is upon the slope of a hill the architect must thoroughly assure himself not only of a sound foundation bed but also that the material under this stratum is not of such a nature that the whole bed may slip as one mass down the slope after the building is finished. Likewise in cities the influences of present or future excavations for deep sub-basements or subways must be considered, for it is very evident that the digging of deep pits or tunnels near a building may cause movements and slips in the soil or may lower the water level and radically change the nature of the bed. For this reason the foundations of tall and heavy buildings are now preferably brought down to solid rock wherever the distance is not prohibitive in order to escape the hazards connected with footings on soil.

**Nature of Rocks and Soil.** In order to determine the supporting ability of foundation beds a brief study should be made of the characteristics of the rocks and soils most commonly encountered. Minerals and the composition of rocks have already been considered in Chapter VII.

**Rock.** Any sound rock such as granite, traprock, sandstone and limestone is proverbially a solid foundation and capable of supporting any load placed upon it. Granite is very hard, is without stratification or cleavage and consequently is an excellent foundation bed. Limestones and sandstones will support great loads and make excellent foundations except when the cementing material between the grains of lime or sand is easily soluble. In such cases the rock disintegrates under the influence

of water and weak acids. Dolomite, a magnesian limestone, is affected only by strong acids and consequently serves very satisfactorily. Schists are finely foliated, and the large amount of mica in their composition often causes disintegration. Shale is a consolidation of clay occurring in thin layers and uneven structure. It consequently is not a good foundation stone.

If the stratification of a good rock be very inclined or tilted, as happens under the sites of several of our large cities, there is danger that the strata break apart on their cleavage planes, causing serious slips and settlements to the buildings constructed upon them. This danger becomes more acute in view of the deep excavations on all sides for subways, tunnels and the basements of tall buildings.

Drainage should be installed to prevent water from penetrating to easily soluble rocks and so causing their disintegration.

A good rock should require blasting to remove it.

**Decayed Rock.** Certain good rocks such as granite, limestone and traprock are sometimes changed to a broken or rotten condition by a variety of influences. The rotten stone may be only a few inches thick overlying the solid rock or it may have a depth of several feet. It should always be removed down to sound bedrock.

**Gravel.** A mixture of rock particles larger than sand and smaller than boulders is called gravel. The particles generally vary greatly in size, the smaller filling the interstices between the larger. It forms, then, a very desirable foundation bed when well compacted and undisturbed by adjoining excavations or by pumping. It is usually the result of glacial action and contains no animal or vegetable matter. Pick and shovel are required for its removal.

By geological action gravel is sometimes so compacted together and at the same time united by a clayey cement that it resembles a good concrete. It is then called **HARDPAN** and presents the most reliable foundation bed after rock. The architect must assure himself, however, of the thickness of the layer and of what underlies it, since it is sometimes found resting directly on rock and sometimes upon quicksand. Although it may be a difficult job, hardpan can usually be removed with pick and shovel.

**Sand.** Rocks may be decomposed under the action of water, heat, freezing and attrition, the broken fragments being transported by water, ice and wind until they arrive at the locations and are reduced to the size in which we find them. The processes of decomposition and transportation also act as segregating and collecting agencies, and we meet with great deposits of the finer particles without the admixture of larger stones. The harder particles when under  $\frac{1}{4}$ " in diameter are known as **SAND**. Since quartz is the most abundant rock mineral and has great hardness and insolubility it is the chief constituent of sand, but particles of feldspar, mica and other minerals also occur. Clay, loam and

decayed vegetable matter are likewise found in sand, and it may be very dry or contain large amounts of water. When confined, both wet and dry sand will bear heavy loads, but the action of a head of water will cause it to flow if the confinement be insufficient. Fine sand is more liable to be carried by water than coarse sand, which presents greater opportunity for the water to drain through it without disturbance of the grains. Fine sands mixed with clay and mica scales often flow very readily under the influence of water and are called **QUICKSANDS**. Such sands are very difficult to drain without a movement of the whole mixture. It is evident, then, that strata of quicksand may be drained away from under layers of better material with great danger to any constructions placed upon the latter. Before setting foundations upon a bed of sand, the character of the underlying strata should therefore be investigated and the probabilities of continued confinement of the sand or of change in water level carefully examined. Wet sand is considered as having less bearing power than dry sand and fine sand than coarse sand. Loose sand can be readily shoveled, but firm compact sand requires picking for removal.

**Clay** is formed largely from the mineral feldspar, a silicate of alumina, together with many impurities. The particles are much more finely divided than sand and are more easily dissolved. Its physical character is greatly altered by the admixture of water. Thus clay may be capable of bearing heavy loads when firm, dry and compact but will become soft, plastic, slippery and incapable of carrying weight upon the admission of water. On the other hand, if water be drained from wet clay the drying mass will shrink in volume from 10% to 20% and often crack into small fragments. For these reasons clay cannot be considered a reliable foundation bed unless the water present in the clay can be maintained at a constant amount. The movement of underlying strata of clay is often in large masses from areas of greater to less pressure, on the sides of hills or upon tilted strata of rock. Modern practice tends toward sinking the foundations of heavy buildings to underlying bedrock rather than depending upon the hazards of a clay bottom whose instability may be increased at any moment by the excavation, flooding or draining of adjacent areas.

**Silt and Fill.** Silt is the very soft and finely divided material brought down by rivers or left behind by receding lakes. It is most compressible and undependable. Artificially filled land has little compactness and is consequently highly compressible, causing dangerous settlements. With either silt or fill the foundations should go down to rock or good bottom, or be supported upon clusters of piles.

The following table, taken from the Building Code of the National Board of Fire Underwriters, presents a fair average of the pressures per square foot allowed upon various foundation beds by the municipal codes of the country.

**Table I. Allowable Pressures on Soil and Rock**

Material	Tons per Square Foot
Soft Clay.....	1
Firm Clay, Fine Sand, wet.....	2
Clay or Fine Sand, dry.....	3
Hard Clay, Coarse Sand, dry.....	4
Gravel.....	6
Hardpan.....	8 to 15
Rock.....	15 to 75

**Article 2. Classes of Footings**

In the past, large and very heavy buildings have been erected with masonry bearing walls necessitating wide and massive footings throughout their entire length. These walls supported not only their own weight but also the weight of the roof and floors. Such walls were, of course, very thick and the footings were generally of stone. Later tall buildings were constructed with self-sustaining masonry walls but with the floor and roof loads supported on iron and steel columns set inside these walls. The World Building in New York, built in 1890, is an example. It is about 200'0" high with a tower 75'0" higher. The walls increase in thickness from 2'0" at the top to 12'0" at the bottom with continuous footings 15'0" wide. It is evident that walls of such thickness occupied a tremendous amount of valuable space, were very slow and expensive to construct and required uninterrupted foundations throughout their entire length.

The introduction of skeleton steel construction has, however, not only made possible our extraordinary development of skyscraper construction but has also concentrated the loads on footings at isolated points thereby greatly economizing space, labor and expense. Our present method is to erect a steel cage or skeleton consisting of columns and floor beams and to hang the enclosing wall, which becomes a mere curtain, upon this skeleton. We see, then, that for large buildings we have a problem of column footings and not one of wall footings.

In the case, however, of light buildings, that is, buildings under four or five stories in height, bearing walls and consequently wall footings are still generally used and the problems of light wall footings therefore remain.

Stone is now very seldom used for footings because concrete is far cheaper and easier to handle and by the addition of steel reinforcement will resist high bending and shearing stresses.

We may then divide footings and foundations into the following classes:



- A. LIGHT BUILDINGS. Wall Bearing.
  - (a) Slab Wall Footing.
  - (b) Slab Wall and Pier Footing.
  - (c) Stepped Wall Footing.
  - (d) Eccentric Wall Footing.
- B. HEAVY BUILDINGS. Column Bearing.
  - 1. Rock and Incompressible Soil.
    - (a) Concrete Base Slab.
    - (b) Concrete Piers to Rock or Hardpan.
    - (c) Steel Cylinders to Rock.
  - 2. Compressible Soil. Spread Footings.
    - (a) Independent Column Footing.
      - (1) Reinforced Concrete.
      - (2) Steel Grillage.
    - (b) Continuous Column Footing.
      - (1) Reinforced Concrete.
      - (2) Steel Plate or Box Girders.
    - (c) Combined Column Footing.
      - (1) Reinforced Concrete.
    - (d) Cantilever Column Footing.
      - (1) Reinforced Concrete.
      - (2) Steel Plate or Box Girders.
    - (e) Mat or Raft Footing.
      - (1) Reinforced Concrete.
  - 3. Compressible Soil. Pile Foundations.
    - (a) Wood Piles.
    - (b) Concrete Piles.
      - (1) Pre-Cast.
      - (2) Cast in place.

### Article 3. Footings for Light Buildings

**Slab Wall Footings.** By this term is meant a simple slab of plain un-reinforced concrete under the wall to lend stability and to distribute the weight of the wall over the ground. The depth of the slab should not be less than 12" and its projection on each side of the wall at least 6". The projection should never be more than  $\frac{1}{2}$  the depth in order to avoid undue bending moments or shearing or punching stresses, which would necessitate reinforcement and too great expense for a building of moderate size. All footings should be placed below the frost line to prevent heaving and settling due to freezing of the underlying soil.

**Example 1** (Fig. 1, a). Design a plain concrete footing under a stone wall 24" thick bearing a load of 16,000 lbs./lin. ft. Soil is a firm wet clay.

From Table I the allowable pressure upon firm wet clay is 2 tons/ft.<sup>2</sup> or 4000 lbs.;  $\frac{16,000}{4000} = 4$ . The footing must therefore be 4'0" wide, giving a projection

of 1'0" on each side of the 2' wall. Since the projection should not exceed 1/2 the depth the footing will be 4'0" wide and 2'0" deep.

**Slab Pier Footing.** When girders or roof trusses are supported on a wall it is often necessary to thicken the wall at the bearing points to provide sufficient strength to carry the concentrated loads. Such thickenings form piers, and the footing must be enlarged to give sufficient spread around the pier. The additional areas required on each side of the wall to support the pier together with the footing area for the wall lying between them should be arranged as a square around the center of gravity of the pier. The side of this square may be found from the

formula,  $l = \frac{b}{2} + \sqrt{A + \left(\frac{b}{2}\right)^2}$  in which  $l$  = side of square,  $b$  = width of wall footing and  $A$  = required area of pier footing.

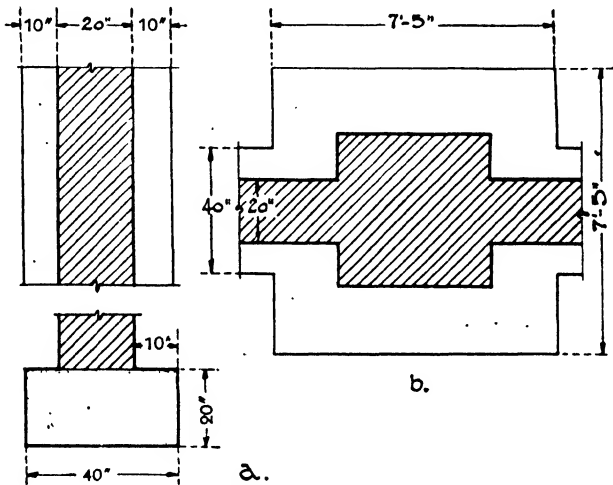

FIG. 1.—Wall Footings and Pier.

**Example 2** (Fig. 1, b). A wall 20" thick has a footing 40" wide. A pier in the wall carries a concentrated load of 120,000 lbs. The allowable soil pressure is 4000 lbs./ft.<sup>2</sup> Find the size of the square footing required for the combined pier and wall.

$$A = \frac{120,000}{4000} = 30 \text{ ft.}^2 \quad l = \frac{b}{2} + \sqrt{A + \left(\frac{b}{2}\right)^2}; \quad l = \frac{3.3}{2} + \sqrt{30 + \left(\frac{3.3}{2}\right)^2} = 7.37'$$

$$b = 40'' = 3.3'$$

The length of the combined square footing for wall and pier is 7.37' or about 7'5".

**Stepped Wall Footing.** It may be found that a fairly wide footing is required to distribute the load from a wall so that the bearing capacity of the soil per square foot will not be exceeded. To avoid the use of reinforcement and yet to escape undue bending moments and at the

same time an excess of concrete in the projecting portions the footing may be stepped from the width of the wall to the width required for the footing.

**Example 3** (Fig. 2, *a*). A basement wall is 20" thick and carries a load of 42,000 lbs./lin. ft. The allowable soil pressure is 6000 lbs./ft.<sup>2</sup> Design an adequate stepped concrete footing without reinforcement.

$$\frac{42,000}{6000} = 7'0'' = \text{required width of footing. } 84'' - 20'' = 64'' \text{ or } 32'' \text{ projection}$$

on each side of wall. The projection of the first step is often taken as  $\frac{1}{2}$  the thickness of the wall. Two projections of 10" and one of 12" on each side will give the required width of footing. The 10" steps must have depths of 20" and the 12" step a depth of 24".

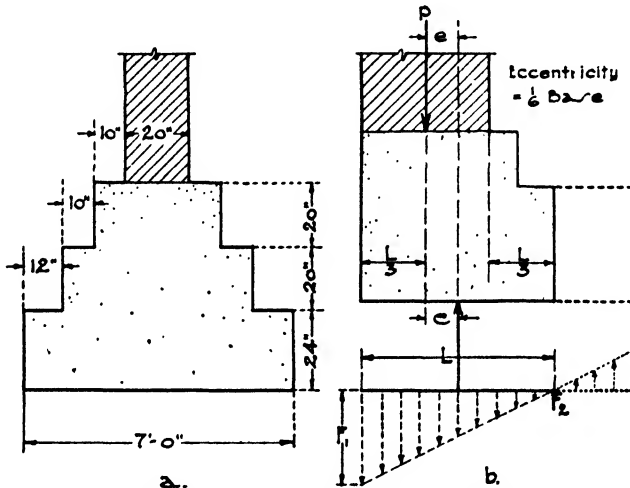

FIG. 2.—Stepped and Eccentric Wall Footing.

**Eccentric Wall Footing** (Fig. 2, *b*). Often when the wall is on a party line or on a street building line it is not permissible to extend the footing on both sides of the wall. An important principle of all foundation work is that the center of gravity of the load must coincide with the center of gravity of the footing. If the footing project on one side only of the wall the two centers of gravity will not coincide and an eccentric footing involving the turning action of a couple will be the result. With heavy loads no eccentricity is ever allowed.

With light loads an eccentricity may be permitted if not excessive, but an extreme eccentricity would be dangerous. When the two centers of gravity coincide, the downward pressure is the same on all parts of the footing. But when the resultant of the upward thrust of the soil, acting through the center of gravity of the footing, falls inside the resultant of the downward loads on the wall, the maximum unit pressure

on the soil will be at the outer edge and the unit pressures will decrease in approaching the inner edge of the footing. If the resultant of the wall loads fall within the middle third of the width of the footing the tendency of the footing to turn about the inner edge of the wall is not considered dangerous for light loads. In this case the eccentricity,  $e$ , does not exceed  $1/6$  the length of the footing,  $L/6$ . If it fall outside the middle third there will be an uplift on the inner edge of the footing which combined with the maximum downward pressure on the outside edge tends to upset the footing. The eccentricity exceeds  $L/6$ . For light loads the restraining power of the soil against the cellar wall, the inherent rigidity of the masonry and the tying action of the floor beams may sometimes be depended upon to counteract the effects of the eccentricity. Such construction is, however, contrary to the theories of stability.

The pressures  $F_1$  and  $F_2$  on the outer and inner edges of the footing, respectively, are found by the following formulae. (See Chapter XVI, Article 9.)

$$F_1 = \frac{P}{L} \left( 1 + \frac{6e}{L} \right); \quad F_2 = \frac{P}{L} \left( 1 - \frac{6e}{L} \right)$$

in which  $P$  = the total load per linear foot on the footing. If the center of downward pressure coincide with the center of upward pressure there will be no eccentricity:

$$e = 0 \text{ and } F_1 = F_2 = \frac{P}{L}$$

If  $e$  be less than  $\frac{L}{6}$ , the values of  $F_1$  and  $F_2$  are found by the above formulae.

If  $e = \frac{L}{6}$ ,  $F_1 = \frac{2P}{L}$  and  $F_2 = 0$ .

If  $e$  be greater than  $\frac{L}{6}$ , for instance  $\frac{L}{3}$ ,  $F_1 = \frac{3P}{L}$  and  $F_2 = -\frac{P}{L}$ .  $F_2$  is negative and would create an uplift upon the inner edge of the footing.

#### Article 4. Footings for Heavy Buildings

**Description.** Whenever a building, through its walls, piers or columns, transmits such loads to the foundations that it is no longer economical or practical to employ simple plain concrete footings, then the structure may be considered as a heavy building. More complications arise, footings may be combined or counterbalanced and steel beams or reinforced concrete must be used as a material.

Footings are considered as failing by shearing and bending. These failures may take place in plain concrete footings, but such footings are now used only for comparatively light loads, and stability in the

wall and the bearing capacity of the soil determinè their dimensions rather than failure through internal stresses. It is particularly in the case of REINFORCED CONCRETE footings that these tendencies to failure must be investigated because of the greater loads involved and the more exact calculations required (Fig. 3).

By the use of reinforced concrete to support the heavy loads great economies are effected over the amounts of plain mass concrete and the accompanying excavation necessary if reinforcement were not employed. The various problems arising from the placing of heavily loaded columns close to property lines, often necessitating combined and cantilever footings, require the reinforcing of the concrete. Such footings were formerly and still are to some extent composed of steel girders and grillage beams, but the use of reinforced concrete for all manner of footings and foundations is increasing every day.

Although the walls may at times be so loaded as to require reinforcement in the wall footings, heavy buildings are generally constructed in such a way that they transmit their loads to the foundations through columns, and it is with column footings, then, that we are chiefly concerned.

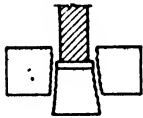

Shearing

Column footings may be sub-divided into three groups according to the bottom upon which they rest, as follows:

(a) Slab and Pier Footings. Rock and Incompressible Soils.

(b) Spread Footings. Compressible Soils.

(c) Pile Foundations. Compressible Soils.

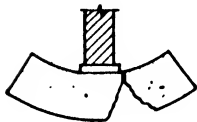

Bending

FIG. 3.

**Slab Footings.** Concrete slabs are usually set under columns even when they bear upon rock or incompressible soil where no spreading or distributing of

the column load is necessary. The slabs, being wider than the column and the column base plate or billet, lend stability and prevent the corrosive action of water. They furthermore contribute an even bearing for the column and transmit the load to the rock, thereby avoiding the necessity of dressing the face of the rock to true bearing surface. The slabs must be designed so that the allowable unit stress for direct compression in concrete, generally limited to 500 lbs./in.<sup>2</sup>, is not exceeded.

**Concrete Piers.** When the rock or hardpan lies at some depth below the basement level of a building, necessitating extended excavation, it is far more economical and practical not to carry the columns themselves down to the bedrock but rather to sink shafts, with or without enclosing steel cylinders, to the rock or hardpan and to fill them with concrete. Piers or caissons are thus formed extending from the rock up to the basement level, and the columns are set upon them, usually one column to each pier or caisson. The surrounding earth is generally sufficiently

firm to give lateral support so that the piers are designed for direct compression upon the concrete. The tops of the piers are often reinforced to give greater rigidity, and sometimes vertical rods are introduced throughout the entire length of the pier. When resting upon hardpan instead of rock the lower end of the pier may be enlarged into a bell to distribute the load according to the bearing power of the soil. The angle of the side of the bell with the horizontal should never be less than  $60^\circ$  in order to avoid caving in of the soil while excavating. Methods of sinking the shafts for concrete piers and caissons will be described in Chapter XXVI under Excavation.

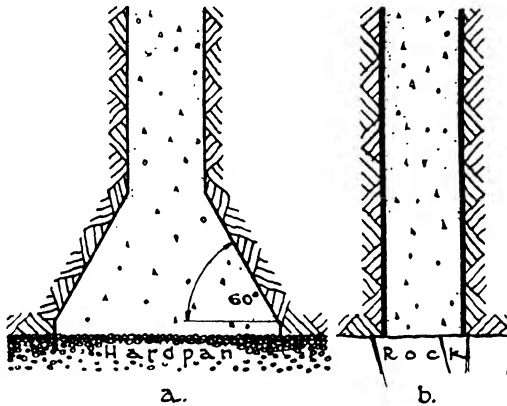

FIG. 4.—Concrete Piers.

**Example 4** (Fig. 4, a). A load of 400,000 lbs. is transmitted by a column to a circular concrete foundation pier 40'0" deep. What should be the diameter of the pier and of the bell at its foot if the allowable bearing on the soil be 20,000 lbs./ft.<sup>2</sup>?

Allowable unit compression = 500 lbs./in.<sup>2</sup>

Weight of stone concrete = 150 lbs./ft.<sup>3</sup>

$$\text{Area of pier} = \frac{400,000}{500} = 800 \text{ in.}^2 \text{ or } 5.5 \text{ ft.}^2; \quad r^2 = \frac{800}{\pi} = 254;$$

$$r = 16''; \quad d = 32'' = 2'8''.$$

Volume of pier =  $5.5 \times 40 = 220 \text{ ft.}^3$

Weight of pier =  $220 \times 150 = 33,000 \text{ lbs.}$

Total load upon soil =  $400,000 + 33,000 = 433,000 \text{ lbs.}$

$$\text{Area of bell} = \frac{433,000}{20,000} = 21.65, \text{ say } 22 \text{ ft.}^2 \text{ or } 3168 \text{ in.}^2$$

$$r^2 = \frac{3168}{\pi} = 1009; \quad r = 32''; \quad d = 64'' = 5'4''.$$

**Steel Cylinders** (Fig. 4, b). Another very generally used method of transmitting the column loads down to a bed of rock which may lie at some distance below the column base is by the use of steel cylinders filled with concrete. The strength of the steel shell as well as of the

concrete is included in calculating the capacity of the cylinder to support its load. The thickness of the shells may vary from  $\frac{3}{8}$ " to  $\frac{3}{4}$ ". The cylinders may be obtained in lengths up to 20'0" and in diameters of 10" to 16" and are often referred to as Hercules or steel pipe piles. The methods of sinking the cylinders and their capacities will be considered in Chapter XXV, Piling.

**Spread Footings.** When the footings rest upon a compressible soil rather than upon rock or a practically incompressible soil such as hardpan, then the loads must be distributed by spreading out the footing so that the load per square foot will not exceed the bearing capacity of the soil per square foot. In order to resist economically the bending and shearing stresses arising in the footings, reinforced concrete or steel beams and girders are employed instead of plain mass concrete.

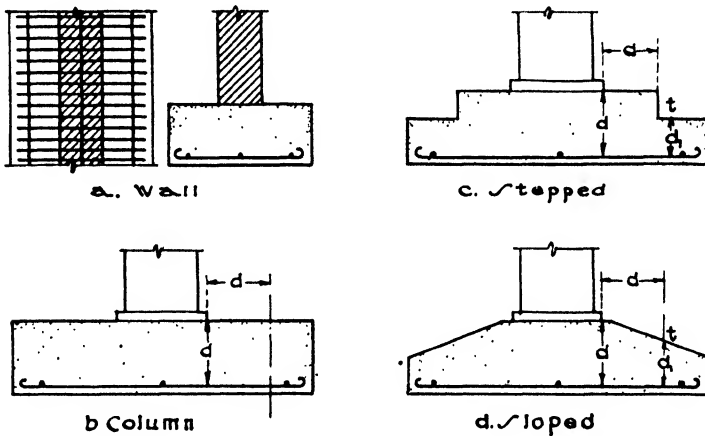

FIG. 5.—Spread Footings.

The generally accepted method of design is to assume that reinforced concrete footings may be divided into combinations of simple, continuous or cantilever beams and their properties computed accordingly. The projecting portions of all footings, whether isolated, continuous or combined, are treated as simple cantilever beams in which the moment of the forces over the entire area on one side of any section is included in the bending moment of that section.

For isolated column footings a method is extensively used which considers the footing projection at each face of the column to be a cantilever beam trapezoidal in shape. This beam is divided into a rectangle and two triangles, and the bending moment is taken at the face of the column.

**Spread Wall Footing** (Fig. 5,*a*). The simplest type of spread footing is the wall footing, in which the projection on each side of the wall is considered an inverted cantilever beam uniformly loaded by the upward reaction of the soil and supported by the wall. It is not practicable to

introduce stirrups in a long wall footing as web reinforcement. The footing must consequently be made deep enough for the plain concrete to resist the shear and diagonal tension. The maximum bending moment is at the face of the wall, and reinforcing rods are placed across the footing at right angles to the wall to counteract the tension in bending. The extreme fibers in bending will be at the bottom of the footing, and those in compression at the top. A layer of concrete 3" or 4" thick should extend below the rods for insulation against moisture, which layer is not included in the effective thickness of the footing. There should also be 3" or 4" of concrete beyond the ends of the rods, which should be bent to a hook for anchoring.

**Spread Column Footings.** The simplest type of column footing is an individual square or rectangular footing for each column called an **ISOLATED OR INDEPENDENT COLUMN FOOTING**. It may be constructed of concrete or of steel grillage beams. The latter type is used only with steel columns and is becoming obsolete (Fig. 5, *b, c, d*).

**Isolated Column Footings, Concrete.** When constructed of concrete, an isolated footing is considered an inverted cantilever, uniformly loaded by the upward reaction of the soil and supported by the column. The reinforcement consists of square bars or round rods laid in one or two directions on the lower or tension side of the footing.

The footings may be either **FLAT**, **STEPPED** or **SLOPED**. It has been found from tests that the critical section for bending and bond is at the face of the column or pedestal and for diagonal tension at a distance out from the face of the column or pedestal equal to  $d$ , the effective depth of the footing. The greatest thickness of concrete is, therefore, needed at or near the face of the column or pedestal to resist the bending moment and diagonal shear, both of which diminish as the distance from the column increases. If the excess concrete in the upper portion of the footing is discarded by stepping down the footing beyond the critical sections or by sloping the top, a real saving of material is effected. There should be a minimum thickness of 6" at the edge of the footing above the reinforcement. In determining the amount of saving, however, the extra cost of the more complicated framework must be considered. The top of the footing should be flat for a distance of at least 3" all around the column base before beginning the slope which

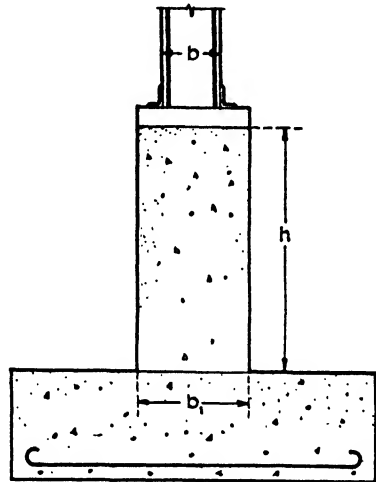

FIG. 6.—Pedestals.



should not exceed a ratio of 1 vertical to 2 horizontal in order to avoid special treatment as a wedge-shaped beam.

Stirrups are not used in isolated footings, and the resisting power in the concrete must be sufficient to counteract the shear and diagonal tension. For 2000-lb. concrete an allowable unit fiber stress of 40 lbs./in.<sup>2</sup> is generally employed, or 60 lbs./in.<sup>2</sup> when horizontal reinforcement is hooked at both ends.

**Pedestals.** Pedestals or caps are now generally used between the column base and the footing, to distribute the column load over a greater surface of the footing and to catch up any differences of level in the tops of the various footings so that the columns may be of the

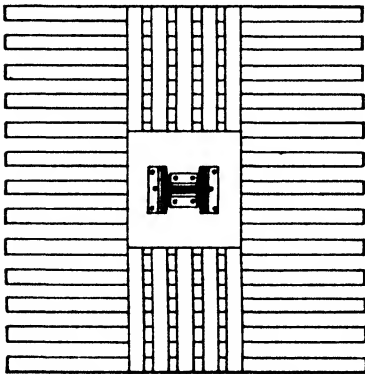
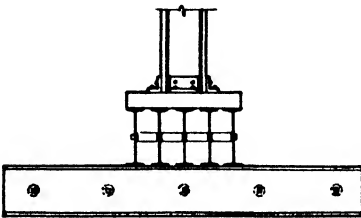

FIG. 7.—Grillage Footing.

same length. The area of the pedestal or cap is often made twice that of the column, and the height should not be over 3 times the least width in order to avoid reinforcement against bending. The allowable unit stress for direct compression in this case is generally taken at 500 lbs./in.<sup>2</sup> for concrete with an ultimate strength of 2000 lbs./in.<sup>2</sup>, instead of 900 lbs./in.<sup>2</sup> as allowed for compression in flexure (Fig. 6).

**Bases.** Rolled-steel slabs, called billets, are now very generally used under steel columns instead of cast-iron or built-up bases to distribute the concentrated column load to concrete or grillage footings or to pier foundations. These billets are rolled in listed thicknesses, widths and lengths, and the nearest available dimensions should be chosen after the sizes have been calculated. The surfaces in contact with steel column or grillage should be milled

for perfect bearing; those resting on concrete need not be milled but should be grouted.

**Isolated Column Footings, Grillage.** Independent grillage column footings are now largely supplanted by reinforced concrete. They consist of horizontal steel beams placed side by side in one, two or three tiers, the direction of the beams being at right angles in adjoining tiers. The upper tier receives the concentrated load of the column and distributes it to the lower tiers which in turn distribute it to the soil. The upper tier, which is not wider than the base of the column and distributes the load only in one direction, is therefore composed of relatively

few deep and heavy beams to withstand bending and web buckling. The lower tiers which can distribute the load in both directions are composed of a larger number of shallower beams. The number of tiers depends upon the load and the bearing power of the soil, since one tier might require very long and deep beams, less economical than two or three tiers of shorter and lighter beams. The clear distance between the flanges of the beams in each tier should not be less than  $2\frac{1}{2}$ " or more than 3 times the flange width. Recently the tendency has been to use closer spacing, a minimum of 1" and a maximum of  $\frac{3}{4}$  the flange width. The spaces between the beams in all tiers are filled with concrete, and all the beams are enclosed with at least 4" of concrete on ends, bottoms and sides, 5" to 9" being often preferred. The bond between the steel and the concrete assists in distributing the load

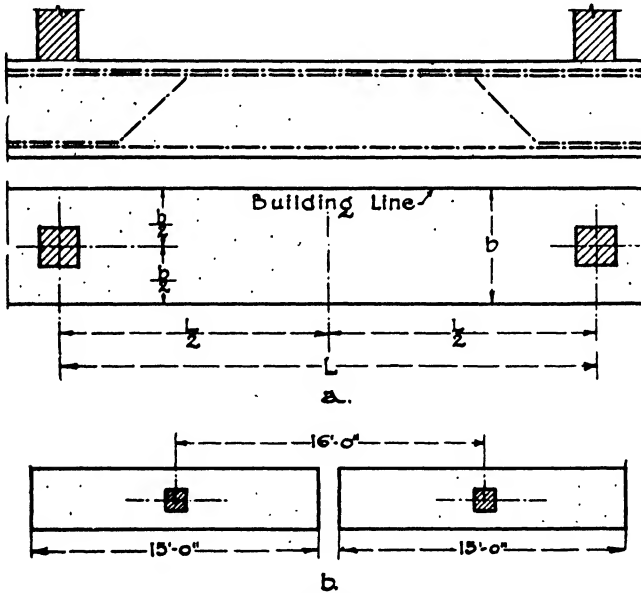

FIG. 8.—Continuous Footing

throughout the entire footing and also protects the steel from corrosion. Gas pipe separators are used to hold the beams in position. Grillage is calculated in the usual manner for simple beams under a uniformly distributed load with the maximum bending moment at the center (Fig. 7).

For very heavy column loads, grillage beams are often found lighter and more economical than thick solid steel base plates or billets to distribute the column load upon concrete pier and steel cylinder foundations.

**Continuous Spread Column Footings** (Fig. 8). Usually in constructing buildings in cities it is desired to cover as much of the lot as possible;

consequently the columns are set upon or close to the property lines and street building lines. On this account space is often not available on all sides of a column to employ an isolated footing concentric with the column. If the columns are set back a short distance from the building line it is sometimes possible to use the space from the line to the center of the column as one-half the width of the footing and to extend the footing an equal amount inside the column axis, thereby obtaining a footing concentric with the column in the direction of its width. Then if the footing is extended by required equal amounts along the building

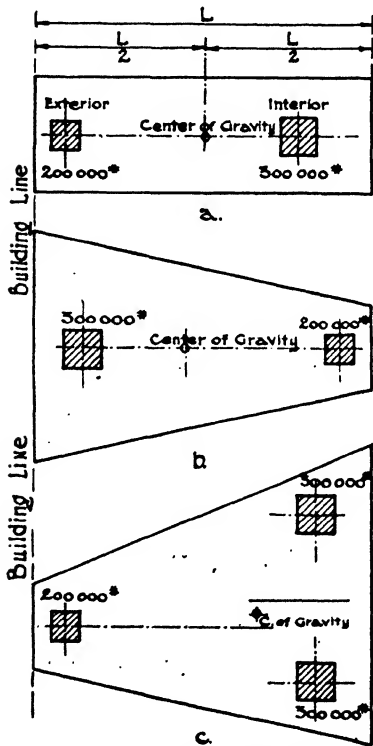

FIG. 9.—Combined Footing.

line on each side of the column a concentric footing in the direction of its length is obtained. By the same procedure with regard to the adjacent exterior column, a series of rectangular footings result parallel to the building line and approaching each other more or less closely (Fig. 8, b). If these footings are joined together a continuous footing is formed resembling an inverted continuous beam supported by the columns and uniformly loaded by the upward action of the soil. The basement wall between the columns is also sometimes designed as a beam to distribute the column loads upon the footing. Suppose that two adjacent exterior 20" columns spaced 16'0" apart with their axes 18" from the building line carry loads of 270,000 lbs. each on a soil of 6000 lbs./ft.<sup>2</sup> allowable pressure. The area of the footing must be 45 ft.<sup>2</sup>, and if the conditions restrict the width to 3'0" the length must be 15'0". The footings may therefore be readily joined and a continuous footing 3'0" wide under both columns be constructed. If, however, the load on each column were 360,000 lbs. the area of each footing must be 60 ft.<sup>2</sup> and the length 20'0". The footings would consequently overlap and an impossible condition result. Also if the face of the column coincided with the building line the footing could be only 1'8" wide, which would be unstable. In both these cases a continuous footing cannot be used and we must resort to a third type, the COMBINED FOOTING.

**Combined Spread Column Footings (Fig. 9).** The term generally refers

to the combining of the footings of exterior and interior columns so that two or three and sometimes four columns are resting upon one footing. Such footings are employed when isolated and continuous footings can not be used without eccentricity or without overlapping. The combined footing must be so proportioned that the center of gravity of the reactions on the footing will coincide with the resultant of the column loads. A combined footing may be rectangular or trapezoidal, depending upon the area available for the footing. If the load upon the interior column is greater than that upon the exterior column, which is the usual condition, the footing can be rectangular unless its projection beyond the interior column is limited by pits, sub-basements or other restrictions (Fig. 9,a). When, however, such restrictions upon the interior column exist or when the load upon the exterior column is greater than that upon the interior then a trapezoidal combined footing must be used

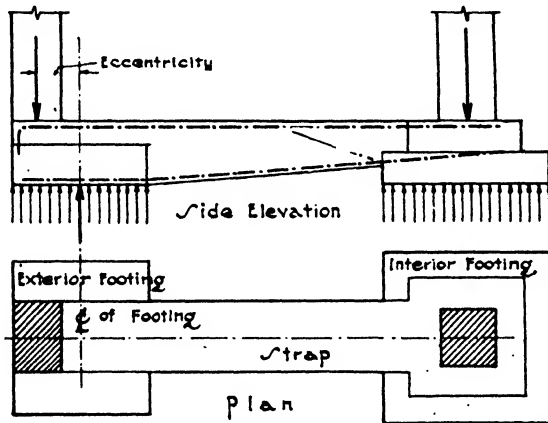

FIG. 10.—Cantilever Footing.

(Fig. 9,b). Trapezoidal footings are also employed when the spacing of the interior columns is different from that of the exterior or at irregular intervals, in which cases three columns are often combined upon one footing (Fig. 9,c). In all trapezoidal footings the required area is first found, then the center of action of the resultant of the column loads. The length of the footings is assumed from the conditions and the widths of the two parallel sides determined for a trapezoid of the required area and with a center of gravity coinciding with the center of the resultant of the column loads.

**Cantilever Footings** (Fig. 10). In restricted situations where a concentric footing cannot be used cantilever footings are sometimes more economical when the bearing power of the soil does not require the wide spread of combined footings. They consist of two independent footings each one designed of the required area to distribute the load of its column upon the soil. The footing under the interior column is

proportioned to be concentric with the line of action of the column load, while the conditions in the exterior restricted area will cause an eccentricity between the lines of action of the column load and the soil pressure on the exterior footing. This eccentricity tending to overturn the footing is resisted by a connecting strap of concrete joining the two footings and acting as a lever arm between them. The lever is assumed

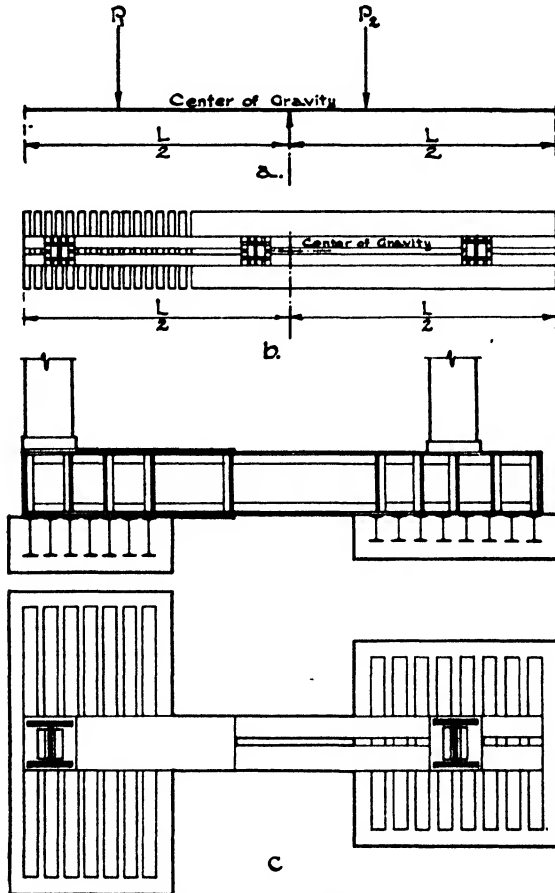

FIG. 11.—Girder Footings

to rest upon the center of gravity of the exterior footing. The upward pressure or uplift of the lever's inner end is counterbalanced by the downward pressure of the interior column. The maximum bending moment will be at the inner edge of the exterior footing, and the maximum shear, equal to the uplift, at the outer edge of the interior footing. Cantilever footings may be constructed of reinforced concrete or steel girders and grillage beams.

**Steel Girder Footings.** Before the development of reinforced concrete, heavy column loads were commonly carried on steel plate and box girders to distribute the pressure when limited areas rendered independent grillage footings impracticable. Such construction is seldom used at the present time (Fig. 11).

**Mat or Raft Foundations.** It has sometimes been found to be less economical to use piles upon a very deep bed of soil of low bearing power than to construct a raft or mat of reinforced concrete over the entire building site. The common types are the beam and slab and the flat slab construction. The **BEAM AND SLAB TYPE** is composed of beams running from column to column in both directions and slabs spanning from beam to beam, similar to a beam and slab floor construction except that the forces are inverted. The slabs consequently lie on the under

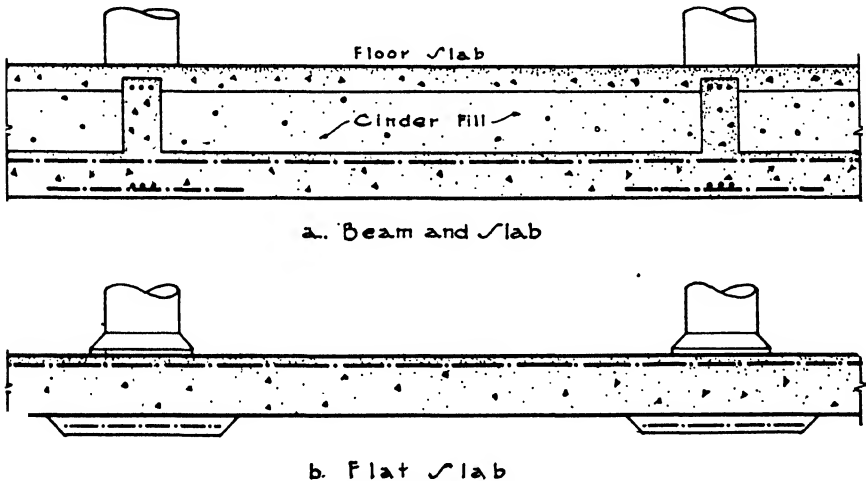

FIG. 12.—Raft Foundations.

side of the beams and may be calculated as the flanges of inverted T-beams. An additional slab is constructed upon the upper sides of the beams to serve as basement floor. The space between the slabs may be used for the passage of pipes, conduits and ducts (Fig. 12,*a*). The **FLAT SLAB TYPE** is similar to an inverted flat slab floor construction except that the drop is placed under the slab instead of above it. No beams are used and the slab is designed to span from column to column with two-way or four-way reinforcement. The drops reduce the spans, moments and shears and therefore the thickness of the slab. Since the top of the slab may be used for the basement floor this type is somewhat less costly than the beam and slab but is more inconvenient for piping (Fig. 12,*b*).

Mat or raft foundations reduce the extent of damage in the event of uneven settlement in an unstable foundation bed, because the building

will settle and tip as an entity and may be jacked back again to a perpendicular position without serious harm. If, however, the columns rested upon independent footings, some of which sank more than others, it is evident that severe racking and contortions would take place throughout the structure with much resulting injury. Since raft foundations are intended only for very compressible soils settling is considered inevitable, architects often allowing for a uniform sinkage of 5" to 8" in determining their grade and first-floor levels. But the exact amount of settlement, even when uniform, cannot always be foretold, and the encroachment of neighboring cellars and subways causes constant unforeseen conditions. Consequently, of late years piers or caissons sunk to rock, even when lying at great distances below the grade level, are preferred to the problematical results of depending upon raft or mat foundations.

**Selection of Foundations.** If satisfactory rock is found near the surface of the ground the natural procedure would be to rest the foundations upon the rock either by setting the columns themselves upon it with concrete slabs between or by building up short piers upon which to rest the columns. When, however, rock lies at some distance below the ground the selection of the type of foundation needs careful study, the question of cost as well as that of safety requiring consideration. If hardpan or good soil capable of bearing 6000 to 8000 lbs./ft.<sup>2</sup> is encountered at levels above the rock, and if this is sufficiently thick and not resting upon soft clay or quicksand, then spread footings may be used for moderate loads. The effects of future excavations and of changing water levels and of the possible slipping of strata should be investigated, however.

With the very heavy loads imposed by the tall buildings developed in recent years, the tendency has been to sink concrete piers and caissons to solid rock, thereby attaining a perfect support and avoiding possible disturbances in the future. In New York City, although a great variety of conditions exist and the strata are often sharply tilted, rock is generally encountered at no great depth, but often overlaid with quicksand. The foundations of the heaviest buildings are here almost invariably carried down to rock by means of pits and pneumatic caissons or open cofferdams, while the lighter loads are often supported upon concrete piles because of underground streams and changing water levels. The piers and caissons supporting the Empire State and Bank of Manhattan buildings all extend down to rock.

In St. Louis, limestone lies from 50'0" to 80'0" below street level and is overlaid with strata of soft clay gradually becoming harder as the rock is approached. The heavier buildings are generally carried on concrete caissons sunk to the rock, while spread footings and piles are employed for the more moderate loads. The soil in Chicago is generally a blue clay of low bearing power with rock in some places 130'0" below the surface. Because of this great depth to rock heavy buildings were

formerly placed upon mat or raft foundations, also called floating foundations, distributing the load over the clay with more or less settlement as the usual result. Since the amount of settlement can seldom be foretold, and also on account of the dangerous effects of neighboring excavations for cellars and subways, the later-erected structures have been placed upon concrete piers extending down to hardpan or to rock. Lighter buildings are carried on piles and independent or combined spread column footings.

In Cleveland, it is often necessary to penetrate to even greater depths than in Chicago to reach bedrock. The clay soil can generally, however, be safely loaded with 6000 to 10,000 lbs./ft.<sup>2</sup>, and concrete piers with bottoms widened into bells resting upon satisfactory clay strata are often used. However, it was considered safer, for the 52-story tower of the Union Terminal, Graham, Anderson, Probst and White, Architects, to sink piers 204'0" to rock to support the columns rather than depend upon the bearing power of the clay.

Besides the question of present and future safety, economical considerations naturally enter very largely into the selection of the type of foundation. Suppose that the bottom consists for instance, of a stratum of clay, then gravel and then hardpan or rock, all with different bearing power but each one satisfactory for a bed under footing areas adequate for proper distribution

of the loads. From the point of view of economy alone the question to be decided would be the relative cost of shallow excavations and wide footings on the clay, deeper excavation and narrower footings on the gravel and much deeper excavation and no footings on the hardpan or rock. The difficulty of the excavation, the presence of underground water and the relative expense of excavations and finished concrete would all be factors in the decision (Fig. 13).

Ingenuous methods have been developed in recent years for installing the foundations of a new building upon a site still occupied by an existing structure or of putting in the foundations of a building while the construction of its superstructure is progressing. The foundations of

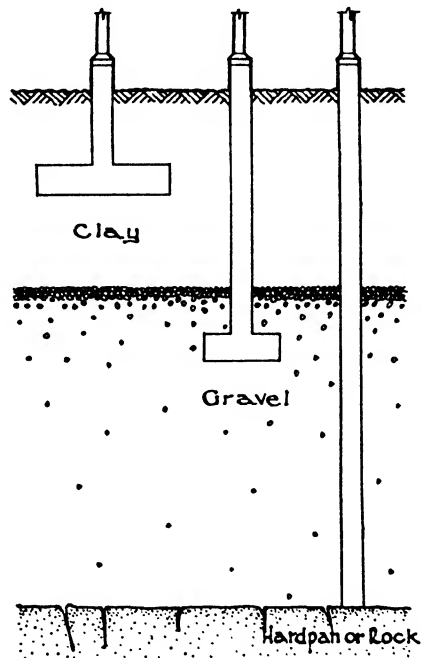

FIG. 13.—Selection of Foundations.



the new Bank of Manhattan Co. in New York, Severance and Matsui, Associated Architects, were begun before the demolition of the existing buildings on the site. Temporary circular piers, consisting of steel cylinders driven or jacked down to hardpan and excavated to rock, were installed to carry about 25 stories of the new steel framing and cinder floor slabs. Large square steel billets were installed upon these temporary round piers extending beyond them on all sides and of sufficient size to spread the completed column loads upon the permanent piers. These permanent piers were either square or rectangular and were constructed by excavating around the temporary cylindrical piers within steel sheet piling driven to refusal. They were concreted to within a few inches of the bottom of the billet, this intervening space later being dry packed with quick-setting mortar. By the time the steel frame had reached the twenty-fifth story the foundations were ready for the entire steelwork 70 stories high.\*

**Proportioning the Areas of Footings.** In Chapter I DEAD LOADS were defined as the permanent weight of the structure itself and LIVE LOADS as the intermittent weights of occupants, furniture, merchandise, machinery, stored material, snow and wind. These weights are ultimately transferred to the footings and must be supported by the foundation bed. When this bed is rock, hardpan or other reasonably incompressible soil no settlements will take place, but when the bed consists of a compressible soil a certain amount of settling is generally expected. The effort must therefore be to design the footings so that the settling will be uniform not only under the constant weight of the dead loads but also under the shifting and intermittent weights of the live loads. The dead loads begin to act when construction first starts; they increase as the building progresses, and after completion they act continually throughout the life of the structure. They constitute therefore an unchanging compressive force upon the soil. The live loads, however, being almost non-existent before a building is occupied and irregular in amount and period of action after occupation, will distribute upon the soil varying occasional rather than continuous maximum pressures. Since it is not probable that all the floors of a building will at any one time be carrying the maximum live load, an effort is made to approximate the probable average live load bearing upon each column and footing. This probable load evidently depends upon the use of the building, a residence, office building or apartment house averaging a smaller percentage of the maximum live load than a warehouse or storage building, which may at times be nearly completely filled with merchandise. Most building codes therefore permit a reduction in live loads on footings in the same manner as on columns and will make special rulings depending upon individual conditions after approval of the architect's designs. See Chapter XX, Article 5.

\* H. V. Spurr, *Civil Engineering*, March, 1931.

**Article 5. Spread Footings. Illustrative Problems**

Unless otherwise indicated, the following values, which are those still generally specified by the building codes, will be used in these problems. They will afford exercise in the varying elements as often met with in practice.

- $f_s = 16,000 \text{ lbs./in.}^2$                        $j = 0.875$ .
  - $f_c = 650 \text{ lbs./in.}^2$                        $k = 0.38$ .
  - $n = 15$ .                                       $b = 12e$  ( $e$  being base of column in feet).
  - $v$  for shear, not more than  $40 \text{ lbs./in.}^2$  without reinforcement.
  - $60 \text{ lbs./in.}^2$  with reinforcement anchored.
  - $120 \text{ lbs./in.}^2$  with web reinforcement.
  - $u$  for bond, not more than  $80 \text{ lbs./in.}^2$  for plain bars.
  - $100 \text{ lbs./in.}^2$  for deformed bars.
  - $150 \text{ lbs./in.}^2$  for deformed bars anchored.
- $d_1 = \text{depth at critical section}; f_e = \frac{M}{1.99cd^2}; s = \frac{A_s f_s}{(v - c')b}$ .

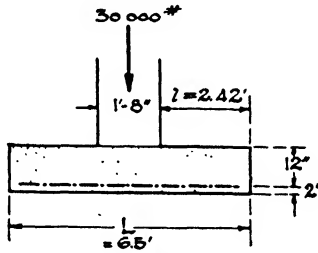

FIG. 14.

**Example 1. Wall Footing** (Fig. 14). Wall 1'8" wide loaded with 30,000 lbs./lin. ft. Allowable soil pressure 5000 lbs./ft.<sup>2</sup>

1. Divide load per linear foot plus assumed weight of footing by soil pressure to find width of footing.  $L = \frac{\text{Load} + \text{Weight}}{\text{Soil pressure}}$ .

Estimated weight of footing 1200 lbs.

$$L = \frac{31,200}{5000} = 6.24', \text{ say } 6.5'. \text{ Projection} = l = \frac{6.5 - 1.66}{2} = \frac{4.84}{2} = 2.42'.$$

2. Divide load per linear foot by width of footing to find net design load.

$$w = \frac{\text{Load}}{L} = \frac{30,000}{6.5} = 4600 \text{ lbs./ft.}^2$$

3. Find maximum bending moment for cantilever beam 12" wide uniformly loaded.

$$M = \frac{wl \times l \times 12}{2} \text{ in.-lbs.} = 6wl^2 \text{ in.-lbs.}; l = \frac{L - a}{2}$$

$$M = 6 \times 4600 \times 2.42 \times 2.42 = 161,600 \text{ in.-lbs.}$$

4. Find depth of footing as governed by maximum bending moment.

$$d = \sqrt{\frac{M}{\frac{1}{2}f_c j k b}} = \sqrt{\frac{M}{325 \times 0.875 \times 0.38 \times b}} = \sqrt{\frac{M}{107.6b}}$$

$$d = \sqrt{\frac{161,600}{107.6 \times 12}} = 11.2'', \text{ say } 12''.$$

5. Check depth for diagonal tension.  $v = \frac{V}{b_j d}$ ;  $V = wx = w \left( l - \frac{d}{12} \right)$ ;  
 $v = \frac{(2.42 - 1)4600}{12 \times .875 \times 12} = 51.8 \text{ lbs./in.}^2$  Acceptable for anchored bars.

6. Find area of steel.  $A_s = \frac{M}{f_s j d} = \frac{M}{16,000 \times 0.875 \times d} = \frac{M}{14,000d}$

$$A_s = \frac{161,600}{14,000 \times 12} = 0.96 \text{ in.}^2$$

Try  $\frac{5}{8}''$  square bars. Perimeter = 2.5". Area = 0.39 in.<sup>2</sup>

$$\frac{96}{39} = 2.4 \text{ bars/lin. ft. Spacing} = \frac{12}{2.4} = 5'' \text{ on centers.}$$

7. Test bond stress.  $u = \frac{V}{\Sigma o_j d} = \frac{2.42 \times 4600}{2.4 \times 2.5 \times 0.875 \times 12} = 176 \text{ lbs./in.}^2$

Stress is too high.  $u$  should not be more than 150 lbs./in.<sup>2</sup> anchored.

$o$  = perimeter of one bar.

Number of bars per linear foot =  $\Sigma = \frac{V}{o_j d u} = \frac{2.42 \times 4600}{2.5 \times 0.875 \times 12 \times 150} = 2.8$  bars per foot.

$$\text{Spacing} = \frac{12}{2.8} = 4.2'', \text{ say } 4'' \text{ on centers.}$$

**Example 2 (Fig. 15). Isolated Column Footing.** A column 30'' square supports a load of 550,000 lbs. Allowable soil pressure 6000 lbs./ft.<sup>2</sup> Design an independent concrete footing.  $a$  = side of square column;  $c$  = projection of footing;  $f_s$  = 20,000 lbs./in.<sup>2</sup>;  $f_c$  = 1000 lbs./in.<sup>2</sup>;  $v$  = 75 lbs./in.<sup>2</sup>;  $u$  = 141 lbs./in.<sup>2</sup>;  $n$  = 12;  $f_c' = 2,500$  lbs./in.<sup>2</sup>

1. Divide column load plus assumed weight of footing by soil pressure to find area of footing.

$$A = \frac{\text{Load} + \text{Weight}}{\text{Soil pressure}}$$

Assume weight of footing = 50,000 lbs.\*

Total load = 550,000 + 50,000 = 600,000 lbs.

$$A = \frac{600,000}{6000} = 100 \text{ ft.}^2 \text{ or } 10'0'' \times 10'0'' \text{ footing.}$$

2. Divide column load by area of footing to find net design load.

$$w \text{ (Net design load)} = \frac{550,000}{100} = 5500 \text{ lbs./ft.}^2; 2c = 10 - 2.5 = 7.5; c = 3.75.$$

3. Find maximum bending moment for uniformly loaded cantilever beam, assuming a square footing. The beam is trapezoidal and may be divided into a rectangle and two right triangles. The moments in inch-pounds at face of column

\*When the soil is fairly compact, some designers consider that, since the concrete weighs but little more than the earth which it displaces, it is unnecessary to add an assumed weight of footing to the column load.

$$= 12w \left[ \left( a \times c \times \frac{c}{2} \right) + 2 \left( c \times \frac{c}{2} \times \frac{2c}{3} \right) \right] = 6w(a + 1.33c)c^2.$$

For a round column,  $a$ , in this formula = the diameter of the column in feet  $\times 0.886$ .

For footings not square, moments are taken on each side to determine the greater.

$$M = 6w(a + 1.33c)c^2 = 6 \times 5500 \times 3.75^2 [2.5 + (1.33 \times 3.75)] = 3,471,187 \text{ in.-lbs.}$$

4. Determine the effective depth required to resist compression in flexure,

from the formula  $d = \sqrt{\frac{M}{Kb}}$ .

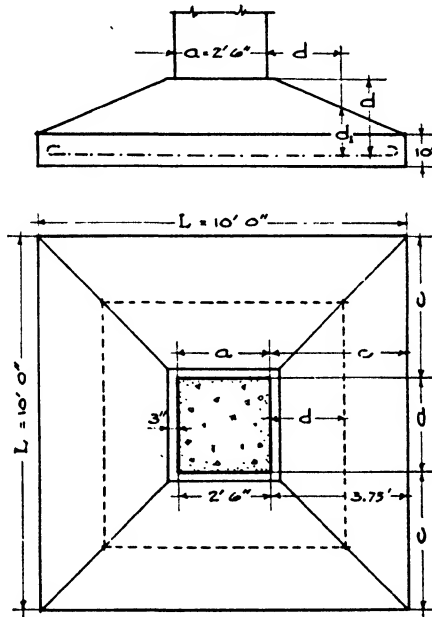

FIG. 15.

The width,  $b$ , must be assumed; it is often considered to be equal to the width of the column or pedestal plus the effective depth. Subsequent investigations for shear and bond stresses, usually the governing factors in the design of footings, may necessitate altering the depth until a satisfactory value is found.

Assuming an effective depth of 24", the width,  $b$ , equals  $30 + 24$  or 54" and

$$d = \sqrt{\frac{3,471,187}{164 \times 54}} = 19.7''$$

required to resist compression in bending. A depth of 24" is consequently more than sufficient for this purpose.

5. Check this depth of 24" for shear and diagonal tension. The critical section

for diagonal tension occurs at a distance out from the column equal to the effective depth of the footing and is shown by the dotted square in Fig. 15.

The total shear on one side of the square,  $V' = \frac{L^2 - (a + 2d)^2}{4} \times w$ , or

$$V' = \frac{10^2 - 6.5^2}{4} \times 5500 = 79,500 \text{ lbs.}$$

$$s' = \frac{V'}{jbd} = \frac{79,500}{0.875 \times 78 \times 24} = 49.2 \text{ lbs./in.}^2$$

78 =  $a + 2d$  in inches; 75 lbs. allowable.

Find effective depth,  $d_1$ , at this section for allowable stress of 75 lbs./in.<sup>2</sup>

$$d_1 = \frac{V'}{jbs} = \frac{79,500}{0.875 \times 78 \times 75} = 15.5'', \text{ say } 16''$$

6. AREA OF STEEL.  $A_s = \frac{M}{f_s j d} = \frac{3,471,187}{20,000 \times 0.875 \times 24} = 8.25 \text{ in.}^2$

Use nineteen  $\frac{3}{4}$ " round rods.  $19 \times 0.44 = 8.36 \text{ in.}^2$

Perimeter  $\frac{3}{4}$ " round rod = 2.36".

7. BOND STRESS. The critical section for bond is assumed to be at the face of the column. For one side,

$$V' = \frac{L^2 - d^2}{4} \times w \text{ or } V' = \frac{10^2 - 2.5^2}{4} \times 5500 = 129,000 \text{ lbs.}$$

Then  $u = \frac{V'}{\Sigma o j d} = \frac{129,000}{19 \times 2.36 \times 0.875 \times 24} = 137 \text{ lbs./in.}^2$

Acceptable since allowable bond stress is 141 lbs./in.<sup>2</sup>

The footing will be 10'0" square and have an effective depth of 24" at the faces of the column. The top of the footing may be stepped down or sloped from a 24" thickness to a 16" thickness at a point at 24" from the column face. The edge of the footing should have a thickness of at least 6" above the steel, and 4" should be added below the steel throughout for protection.

The reinforcement consists of two bands of 19  $\frac{3}{4}$ " round deformed rods each, placed at right angles with each other. Both ends of all rods will be hooked to provide anchorage.

**Example 3. Continuous Column Footing (Fig. 16).** Four wall columns each carrying a load of 250,000 lbs. are spaced 20'0" apart on centers. They are 24" square, and their centers are 1'8" from the building line. Allowable soil pressure = 6000 lbs./ft.<sup>2</sup> Design a continuous footing for the four columns. Length of footing =  $(3 \times 20) + 2 = 62'0''$ .

1. The total load on the soil = the sum of the loads on the columns plus the weight of the footing. Divide the area by the length to find the width of the footing.

$$A = \frac{\text{Load} + \text{Weight}}{\text{Soil pressure}}; b = \frac{A}{L}; \text{ assume weight of footing} = 100,000 \text{ lbs.}$$

Total load on soil =  $(4 \times 250,000) + 100,000 = 1,100,000 \text{ lbs.}$

$$A = \frac{1,100,000}{6000} = 183 \text{ ft.}^2; b \text{ (width of footing)} = \frac{183}{62} = 3'0'' = 36''.$$

2. Divide the total load on columns by the length of the footing to find net design load.  $w = \frac{1,000,000}{62} = 16,500$  lbs./lin. ft.

3. Find maximum bending moment at mid-span for a continuous beam with a uniformly distributed load.  $M = \frac{wl^2}{12}$ . The positive bending moment under the columns is considered as equal to the negative moment at mid-span.

$$M = \frac{16,500 \times 400 \times 12}{12} = 6,600,000 \text{ in.-lbs.}$$

4. Find depth required by maximum bending moment.

$$d = \sqrt{\frac{M}{\frac{1}{2}f_j k b}} = \sqrt{\frac{M}{107.6b}} = \sqrt{\frac{6,600,000}{107.6 \times 36}} = 42''.$$

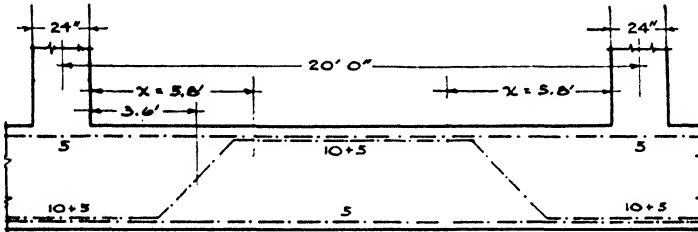

FIG. 16.

5. Check depth for diagonal tension.  $d = \frac{V}{f_v' b}$ . The fiber stress,  $\sigma$ , is generally taken as 120 lbs./in.<sup>2</sup> with web reinforcement of stirrups.

$$V = 16,500 \times 9 = 148,500 \text{ lbs.}$$

$$d = \frac{148,500}{0.875 \times 36 \times 120} = 39''. \text{ Accept } 42'' \text{ determined in step 4.}$$

6. Find area of steel.  $A_s = \frac{M}{14,000d}$ . The bars are placed in the top of the footing in the central part of the span to resist the negative bending moment and are bent down to the bottom of the footing under the columns to withstand the positive bending moments.

$$A_s = \frac{6,600,000}{14,000 \times 42} = 11.2 \text{ in.}^2$$

Try fifteen 1" round bars. Area one bar = 0.79 in.<sup>2</sup>; 15 × 0.79 = 11.9 in.<sup>2</sup> Lay 15 bars at depth  $d$  under columns, bending up 10 bars at 1/5 point of clear span. Continue 5 straight bars through the bottom of the footing and add 5 straight bars throughout the top of the footing. This arrangement provides required reinforcement for both positive and negative bending moments and also security throughout the bottom of the footing against possible settlement.

7. BOND STRESS.  $u = \frac{V}{\Sigma o j d} = \frac{148,500}{15 \times 3.14 \times 0.875 \times 42} = 86 \text{ lbs./in.}^2$

Acceptable for deformed bars anchored.

8. WEB REINFORCEMENT. The concrete without reinforcement will resist shear up to 40 lbs./in.<sup>2</sup> in the vicinity of mid-span where shear is low. The distance,  $x$ , from the column must be determined, over which space the shear exceeds 40 lbs./in.<sup>2</sup> and web reinforcement in the form of stirrups is required.

$$x = \frac{L}{2} \times \left(1 - \frac{v'}{v}\right) = \frac{18}{2} \times \left(1 - \frac{40}{112}\right) = 5.8'$$

$$s \text{ (spacing of stirrups)} = \frac{A_s f_s}{(v - v') b}$$

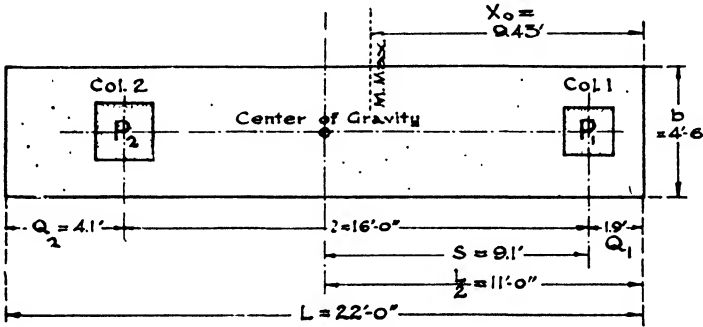

FIG. 17.

$$\text{Spacing of stirrups} = \frac{16,000 \times 1.52}{(112 - 40) \times 36} = 9''.$$

Use 1/2" round stirrups with 8 prongs. Area one prong = 0.19 in.<sup>2</sup>; area 8 prongs = 1.52. The first stirrup is placed  $\frac{l}{2}$  or 4" from the column. Then place stirrups 9" apart to a distance of 6'0" from the column omitting the space covered by the bent bars.

The bent portions of the longitudinal bars generally provide sufficient web reinforcement for the area through which they pass. Stirrups are therefore omitted in the space covered by the bent bars.

**Example 4. Combined Column Footings (Fig. 17).** Rectangular Footing. Wall column 1, 20" x 20", load  $P_1 = 225,000$  lbs. Interior column 2, 24" x 24", load  $P_2 = 300,000$  lbs. Distance between columns on centers ( $l$ ) = 16'0". Soil pressure = 6000 lbs./ft.<sup>2</sup> Axis of wall column 1'11" from building line.

$S$  = distance from axis of column 1 to center of gravity.

$Q_1$  = distance from axis of column 1 to edge of footing = 1.9'.

$Q_2$  = distance from axis of column 2 to edge of footing.

$x_0$  = distance from edge of footing to section of greatest moment between columns.

$b$  = width of footing.

1. Find distance from column  $P_1$  to point of application of resultant of column loads which must coincide with center of gravity of footing.

$$S = \frac{300,000 \times 16}{525,000} = 9.1'; \quad S + Q_1 = 9.1 + 1.9 = 11'0'' = \frac{L}{2}; \quad L \text{ (length of footing)} = 22'0''. \quad Q_2 = 4.1'.$$

2. Find width of footing. Divide total load on footing by soil pressure per square foot times length of footing. Estimated weight of footing = 65,000 lbs.

$$b = \frac{590,000}{6000 \times 22} = 4.5' = 54''. \quad A = 22 \times 4.5 = 99 \text{ ft.}^2$$

2. Find net design soil pressure. Divide total column loads by area of footing.

$$w = \frac{525,000}{99} = 5300 \text{ lbs./ft.}^2$$

4. Find section of maximum bending moment between columns, which occurs where  $V = 0$ . At any section at  $x$  distance from right-hand edge of footing.

$$V = bw x - P_1. \quad \text{Where } V = 0, \quad bw x_0 - P_1 = 0 \quad \text{and } x_0 = \frac{P_1}{bw}, \quad x_0 = \frac{225,000}{4.5 \times 5300} = 9.43'$$

5. Find maximum bending moment between columns, which is the algebraic sum of the bending moments of the vertical forces to the right of the section distant 9.43' from the edge of the footing.

$$M = P_1(x_0 - Q_1) - bw x_0 \times \frac{x_0}{2} = 225,000 \times (9.43 - 1.9) - \left( \frac{4.5 \times 5300 \times 9.43^2}{2} \right) = 633,820 \text{ ft.-lbs.}$$

$$= 7,606,000 \text{ in.-lbs.}$$

6. Find depth of footing between columns which must be sufficient to withstand bending moment, and diagonal tension.

(a) For Bending Moment.  $d = \sqrt{\frac{M}{107.6 \times b}} = \sqrt{\frac{7,606,000}{107.6 \times 54}} = 36.2$ , say 37".

(b) For Diagonal Tension.  $d = \frac{V}{bjv}$ .

Column 1. Distance from right edge to face of column = 1.9' + 10" = 2.75'.

$$d = \frac{225,000 - (2.75 \times 4.5 \times 5300)}{12 \times 4 \times 0.875 \times 120} = 31''$$

Column 2. Distance from left edge to face of column = 4.1' + 12" = 5.1'.

$$d = \frac{300,000 - (5.1 \times 4.5 \times 5300)}{12 \times 4 \times 0.875 \times 120} = 35.4''$$

Accept  $d = 37''$ . Total depth of footing = 37 + 0.5 + 4 = 41.5, say 42".

Effective depth = 37" + 0.5 (1/2 probable diameter of bars) = 37.5".

7. AREA LONGITUDINAL STEEL BETWEEN COLUMNS.  $A_s = \frac{M}{14,000 \times d}$ .

$$A_s = \frac{7,606,000}{14,000 \times 37.5} = 14.4 \text{ in.}^2 \quad \text{Try } \frac{3}{8}'' \text{ round rods.}$$

$$\begin{cases} \text{Area one } \frac{3}{8}'' \text{ rod} = 0.60. \\ \text{Perimeter } \frac{3}{8}'' \text{ rod} = 2.75. \end{cases}$$

$$\frac{14.4}{0.60} = 24. \quad \text{Try twenty-four } \frac{3}{8}'' \text{ round rods.}$$

8. BOND STRESS.  $\Sigma$  = number of rods.  $o$  = perimeter of one rod.

$$\Sigma = \frac{V}{o j d u}; \quad u = 100 \text{ lbs./in.}^2, \quad \text{allowable for deformed rods.}$$

$$\text{Maximum shear is at face of column 2. } V = 300,000 - (5.1 \times 4.5 \times 5300) = 178,400 \text{ lbs.}$$

$$\Sigma = \frac{178,400}{2.75 \times 0.875 \times 37.5 \times 100} = 20 \text{ deformed rods. Therefore twenty-four } \frac{3}{8}'' \text{ round rods will be used, allowing 4 rods to be bent down for cantilever.}$$



•9. Find maximum bending moments for cantilevers or those portions of the footing projecting longitudinally beyond the columns at each end.  $M$  is maximum at column 2. Length =  $4.1' - 1.0' = 3.1'$  (col. 2).

$$" = 1.9' - 0.9' = 1.0' \text{ (col. 1).}$$

Column 2.  $M = (3.1 \times 4.5 \times 5300) \times \frac{3.1}{2} = 114,600 \text{ ft.-lbs. or } 1,375,200 \text{ in.-lbs.}$

Column 1.  $M = (1.0 \times 4.5 \times 5300) \times \frac{1}{2} = 11,925 \text{ ft.-lbs. or } 143,100 \text{ in.-lbs.}$

10. Check depth of footing for moment in cantilever.

$$d = \sqrt{\frac{M}{107.6 \times b}} = \sqrt{\frac{1,375,200}{107.6 \times 54}} = 15.3". \text{ It is evident that the depth } 37.5"$$

as computed for the section between the columns is more than adequate for the cantilevers.

11. Find area of longitudinal steel in cantilevers.  $A_s = \frac{M}{14,000 \times d}$ .

Column 1.  $A_s = \frac{143,100}{14,000 \times 37.5} = 0.27 \text{ in.}^2$

Column 2.  $A_s = \frac{1,375,200}{14,000 \times 37.5} = 2.62 \text{ in.}^2$

12. Test for bond stress. Cantilever steel =  $\frac{V}{\Sigma o_j d u}$ ;  $u = 100 \text{ lbs.}$  Try  $\frac{1}{8}"$  round rods or perimeter =  $2.75"$  and area =  $0.60 \text{ in.}^2$

Column 1. Distance column face to edge of footing =  $1.9 - 0.83 = 1.07'$ .

$$V = 1.07 \times 4.5 \times 5300 = 25,520 \text{ lbs.}$$

$$\Sigma = \frac{25,520}{2.75 \times 0.875 \times 37.5 \times 100} = 2.82, \text{ say } 3 \text{ rods.}$$

Column 2. Distance column face to edge of footing =  $4.1 - 1.0 = 3.1'$ .

$$V = 3.1 \times 4.5 \times 5300 = 73,935 \text{ lbs.}$$

$$\Sigma = \frac{73,935}{2.75 \times 0.875 \times 37.5 \times 100} = 8.19, \text{ say } 9 \text{ rods.}$$

As explained in paragraph 8, three  $\frac{1}{8}"$  rods may be bent down at  $45^\circ$  at column 1, which takes care of the reinforcement required. At column 2, four  $\frac{1}{8}"$  rods may be bent down and five more  $\frac{1}{8}"$  rods added to make up the required 9 rods.

13. CROSSWISE STEEL UNDER COLUMNS. The tendency of the footing to bend and shear as a distributing beam in a crosswise direction must be investigated. The width of the beam is considered to be the distance between the end of the footing and the section of zero shear.

$$M = \frac{P}{b} \times \frac{(b - \text{width of column})}{2} \times \frac{(b - \text{width of column})}{4}$$

Column 1.  $M = \frac{225,000}{4.5} \times \frac{4.5 - 1.66}{2} \times \frac{4.5 - 1.66}{4} \times 12 = 604,920 \text{ in.-lbs.}$

Column 2.  $M = \frac{300,000}{4.5} \times \frac{4.5 - 2}{2} \times \frac{4.5 - 2}{4} \times 12 = 625,000 \text{ in.-lbs.}$

14. AREA OF CROSSWISE STEEL.  $A_s = \frac{M}{14,000d}$ .

Column 1.  $A_s = \frac{604,920}{14,000 \times 37.5} = 1.15 \text{ in.}^2$

$$\text{Column 2. } A_s = \frac{625,000}{14,000 \times 37.5} = 1.19 \text{ in.}^2$$

15. BOND STRESS. Find vertical shear and, assuming size of bar, determine number of bars required to be safe with a bond stress of 100 lbs./in.<sup>2</sup>

$$V = \frac{P}{2} \times \frac{(b - \text{width of column})}{b}$$

$$\text{Column 1. } \frac{225,000}{2} \times \frac{4.5 - 1.66}{4.5} = 70,875 \text{ lbs.}$$

$$\text{Column 2. } \frac{300,000}{2} \times \frac{4.5 - 2}{4.5} = 83,500 \text{ lbs.}$$

Assume  $\frac{5}{8}$ " square bars. Perimeter = 2.5".  $\Sigma = \frac{V}{o_j d \times 100}$

$$\text{Column 1. } \frac{70,875}{2.5 \times 0.875 \times 37.5 \times 100} = 8.6, \text{ say 9 bars.}$$

$$\text{Column 2. } \frac{83,500}{2.5 \times 0.875 \times 37.5 \times 100} = 10.1, \text{ say 10 bars.}$$

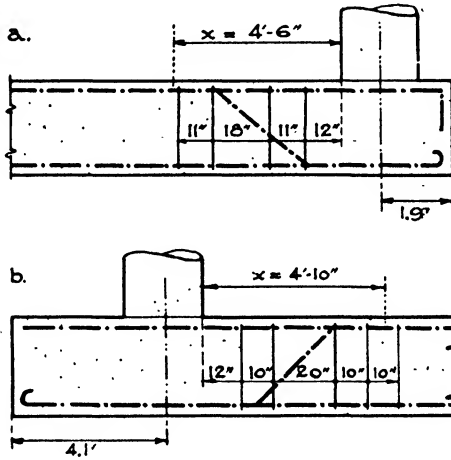

FIG. 18.

Nine  $\frac{5}{8}$ " square deformed bars under column 1.

Ten  $\frac{5}{8}$ " square deformed bars under column 2.

Also  $\frac{5}{8}$ " square crosswise bars are spaced 12" apart throughout the length of the footing.

16. WEB REINFORCEMENT. The portions of the footing in the vicinity of each column and projecting a certain distance,  $x$ , toward the center of the footing must be reinforced against diagonal tension by stirrups, since the value  $v = 120$  lbs./in.<sup>2</sup> was used in computing the depth, while 40 lbs. only can be considered as the resistance of plain concrete.

$$x = \frac{l}{2} \times \left( 1 - \frac{v'}{v} \right); \quad v' = 40 \text{ lbs. allowable unit shear for plain concrete.}$$

$$v = 120 \text{ lbs. allowable unit shear with stirrups.}$$

$$\text{Column 1. } v = \frac{V}{jbd} = \frac{225,000 - (2.8 \times 4.5 \times 5300)}{0.875 \times 12 \times 4.5 \times 37.5} = 89.3, \text{ say 90 lbs./in.}^2$$

$$1.9' + 0.9' = 2.8'; x = \frac{14.2}{2} \times \left(1 - \frac{40}{90}\right) = 7.1 \times \frac{5}{9} = 4.00'$$

Use  $\frac{1}{2}$ " round stirrups for ease of bending. Area of one leg = 0.19 in.<sup>2</sup> Use 10 legs.

$$\text{Column 2. } v = \frac{300,000 - (5.1 \times 4.5 \times 5300)}{0.875 \times 12 \times 4.5 \times 37.5} = 100.6, \text{ say } 101 \text{ lbs./in.}^2$$

$$4.1' + 1.0' = 5.1'; x = \frac{14.2}{2} \times \left(1 - \frac{40}{101}\right) = 7.1 \times \frac{61}{101} = 4'4''$$

Use  $\frac{1}{2}$ " round stirrups with 10 legs.

17. SPACING STIRRUPS.  $A_s f_s = \frac{2}{3} \times \frac{V \times s}{f_d}$ ;  $A_s = \frac{2}{3} \times \frac{V \times s}{f_d}$ ;  $s = \frac{3}{2} \times \frac{f_d A_s}{V}$ , considering the steel as resisting  $\frac{2}{3}$  shear and concrete  $\frac{1}{3}$  shear.

$$\text{Upward pressure per foot of length} = \frac{300,000 + 225,000}{22} = 23,863 \text{ lbs.}$$

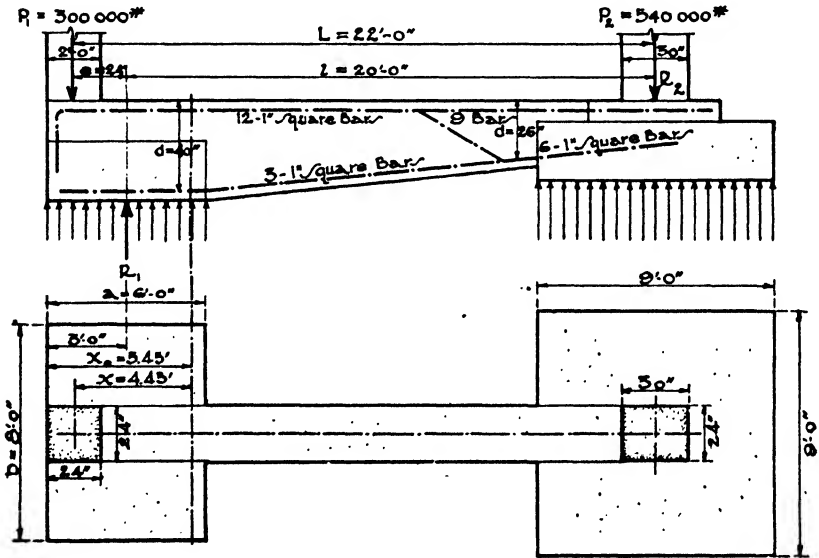

FIG. 19.

Set first stirrup  $d/3$  or approximately 12" from the faces of both columns.

Column 1. Set first stirrup 12" from face of column and find spacing required by diagonal tension to left of that section (Fig. 18,a).

$V$  = the algebraic sum of the forces to the right of the section, or  $225,000 - (3.7 \times 23,863)$ .

$$s = \frac{3}{2} \times \frac{f_d A_s}{V} = \frac{3}{2} \times \frac{16,000 \times 0.875 \times 37.5 \times 1.9}{225,000 - (23,863 \times 3.7)} = 10.9, \text{ say } 11''$$

$$3.7' = 1.9 + 0.8 + 1.0 = \text{distance from section to end of footing.}$$

$$\text{Column 2. } s = \frac{3}{2} \times \frac{16,000 \times 0.875 \times 37.5 \times 1.9}{300,000 - (23,863 \times 6.1)} = 9.62, \text{ say } 10'' \text{ (Fig. 18,b).}$$

$$6.1' = 4.1 + 1.0 + 1.0 = \text{distance from section to end of footing.}$$

The tension bars are bent so that they cross the neutral axis at the  $\frac{1}{3}$  point

of the clear span as for continuous beams. The angle varies from 30° to 45° with the horizontal depending upon the ratio of the span to the depth of the footing, the thicker footings having the larger angle of bending.

**Example 5. Cantilever Footing** (Fig. 19).

Column  $P_1$  24" x 24". Load = 300,000 lbs.

Column  $P_2$  30" x 30". Load = 540,000 lbs.

Soil pressure = 8000 lbs./ft.<sup>2</sup>

Columns, 22'0" on centers.

1. AREA OF EXTERIOR FOOTING. Add 25% for weight of footing and strap.

$$300,000 + 75,000 = 375,000 \text{ lbs.}; \frac{375,000}{8000} = 46.8, \text{ say } 48 \text{ ft.}^2 \text{ or } 6'0'' \text{ by } 8'0''$$

AREA OF INTERIOR FOOTING. Add 20% for weight of footing.

$$540,000 + 108,000 = 648,000 \text{ lbs.}; \frac{648,000}{8000} = 81 \text{ ft.}^2 \text{ or } 9'0'' \text{ by } 9'0''$$

2.  $R_2$  must equal the uplift. Center of gravity of exterior footing is 3'0" from edge. Then  $e$  (eccentricity) = 3'0" - 1'0" = 2'0". Then  $R_2 \times l = -P_1 \times e$  for equilibrium.

$l$  = distance between footing centers = 22'0" - 2'0" = 20'0".

$$R_2 = \frac{300,000 \times 2}{20} = 30,000 \text{ lbs.}$$

3. If the exterior footing were considered to be balanced upon the point of application of  $R_1$  as upon a fulcrum, the maximum bending moment would occur at this point. But the pressure upon the soil is assumed to be uniformly distributed over the area of the footing, and consequently the section of maximum bending moment and zero shear will be situated near the inner edge of the footing. The distance of this section from the outer edge of the footing is

found by the formula  $x_0 = \frac{P_1}{bw}$ .

$$w = \text{pressure per square foot on soil} = \frac{R_1}{\text{area of footing}};$$

$b$  = width of footing = 8'0";  $a$  = length of footing = 6'0".

Reaction  $R_1$  = column load + uplift = 300,000 + 30,000 = 330,000 lbs.

$$w = \frac{330,000}{48} = 6875 \text{ lbs.}; x_0 = \frac{300,000}{6875 \times 8} = 5.45'$$

$x$  = distance from column center to section of  $M_{max.} = 5.45 - 1.00 = 4.45'$ .

4. MAXIMUM BENDING MOMENT.  $M = -P_1 \times x_1 + \left( w \times bx_0 \times \frac{x_0}{2} \right)$ , but  $wbx_0 = -P_1$ .

Substituting,  $M = -P_1x_1 - \left( P_1 \times \frac{x_0}{2} \right) = -P_1 \left( x_1 - \frac{x_0}{2} \right)$ .

$$M = -300,000 \left( 4.45 - \frac{5.45}{2} \right) = 519,000 \text{ ft.-lbs.}$$

5. DEPTH OF STRAP.  $d = \sqrt{\frac{M}{\frac{1}{2}f_s j k b}} = \sqrt{\frac{M}{107.6 \times b}}$ . Assume 36" as width of strap.

$$d = \sqrt{\frac{519,000 \times 12}{107.6 \times 36}} = 40''.$$

6. AREA OF STEEL TO RESIST BENDING.  $A_s = \frac{M}{14,000d} = \frac{519,000 \times 12}{14,000 \times 40} = 11.12 \text{ in.}^2$

$40 + 3 + \frac{1}{2} = 43\frac{1}{2}$ , say 44" = total depth of strap adjacent to inner face of exterior footing. Use twelve 1" square bars.

7. SHEAR. The maximum shear usually occurs at the outer face of the interior footing.  $V = R_1 - P_1$ . But  $R_1 l = P_1(l + e)$ ,  $R_1 = \frac{P_1(l + e)}{l}$ .

$$\text{Then } R_1 = \frac{P_1(l + e)}{l} = P_1 + \frac{P_1 e}{l}.$$

$$\text{Therefore } V = P_1 + \frac{P_1 e}{l} - P_1 = \frac{P_1 e}{l} = \frac{300,000 \times 2}{20} = 30,000 \text{ lbs.}$$

8. DEPTH OF STRAP FOR SHEAR.  $d = \frac{V}{vjb}$ . To avoid stirrups use  $v = 40 \text{ lbs./in.}^2$

$$d = \frac{30,000}{40 \times .875 \times 36} = 23.8, \text{ say } 24''$$

This depth should be checked for a positive bending moment caused by the restraint of the interior column. Experience shows this moment to be  $\frac{1}{3}$  to  $\frac{1}{2}$  the maximum bending moment at the exterior footing. Using  $\frac{1}{3}$  the moment found in paragraph 4,

$$d = \sqrt{\frac{519,000 \times 12}{107.6 \times 36 \times 3}} = 23.8, \text{ say } 24''$$

Use  $24'' + 3'' + \frac{1}{2}'' = 27\frac{1}{2}''$ , say 28" total depth.

The strap will therefore be 44" deep at the inner edge of the exterior footing and 28" deep at the outer edge of the interior footing.

9. Area of steel to resist bending moment at interior footing.

$$A_s = \frac{M}{14,000d} = \frac{519,000 \times 12}{14,000 \times 24 \times 3} = 6.18 \text{ in.}^2 \text{ Use six 1" square bars.}$$

10. ARRANGEMENT OF STEEL. In paragraph 6 it was found that twelve 1" square bars were required in the top of the strap to resist the maximum bending moment at the inner edge of exterior footing. Bend down 3 bars at the  $\frac{1}{4}$  point of span. Add three 1" square longitudinal bars in the bottom of the strap to resist possible reversal of stress due to unequal settlement of the footings. These 3 bars together with the 3 bent bars provide the 6 bars required at the outer edge of the interior footing.

The interior footing is designed with its reinforcing steel as an independent footing under a column load of 540,000 lbs. without considering the uplift.

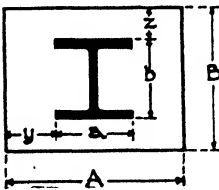

FIG. 20.

**Calculation of Base Slab (Fig. 20).** The base slab may distribute the column load to masonry as upon a concrete pier or to steel grillage. When the slab rests upon concrete, unless other considerations require greater dimensions, its area is found by dividing the column load by the allowable unit pressure in direct bearing on concrete, which is generally limited to 500 lbs./in.<sup>2</sup> The slab is considered an inverted cantilever loaded by the upward pressure of the concrete and with maximum bending moment at the edge of the column.

$P$  = column load.

$f_c$  = allowable unit compression on concrete, lbs./in.<sup>2</sup> = 500.

$f_s$  = allowable unit flexure in steel, lbs./in.<sup>2</sup> = 18,000.

$w$  = unit pressure upward on slab, lbs./in.<sup>2</sup>

$t$  = thickness of slab.

$$y = \frac{A - a}{2}, z = \frac{B - b}{2}.$$

Area of slab =  $\frac{P}{f_c}$ ;  $w = \frac{P}{\text{area}}$ ;  $M_{max} = w \times \frac{A - a}{2} \times \frac{A - a}{4} = w \frac{(A - a)^2}{8}$ ; or

using values  $y$  and  $z$ ,  $M_{max} = \frac{wy^2}{2}$  or  $\frac{wz^2}{2}$ .

The determining maximum bending moment will occur on that side where  $y$  or  $z$  is greater.

$S$  = Section modulus =  $\frac{bt^2}{6}$  or for 1" width of slab =  $\frac{t^2}{6}$ .

Also  $S = \frac{M}{f_s} = \frac{wy^2}{2 \times 18,000}$ . Therefore  $t^2 = \frac{6wy^2}{36,000} = \frac{wy^2}{6000}$ ;

$$t = \sqrt{\frac{wy^2}{6000}} \text{ or } \sqrt{\frac{wz^2}{6000}}$$

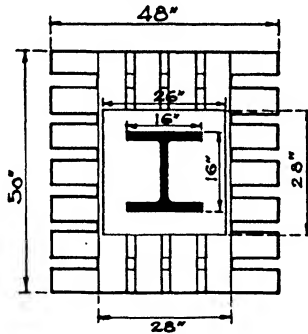

FIG. 21.

When the column and its base or slab rests upon steel grillage the dimensions of the slab are determined by considerations of good practice. The width should extend at least  $\frac{3}{4}$ " beyond the center lines of the outside grillage beams, and the length should be from 20% to 30% of the length of the grillage. The slab should not distribute more than 18,000 lbs./in.<sup>2</sup> in compression to the webs of the beams.

**Example 6** (Fig. 21). Design a grillage footing to distribute a load of 1,200,000 lbs. from a 16" x 16" column to a concrete pier having an allowable bearing capacity of 500 lbs./in.<sup>2</sup>

1. Area of grillage =  $\frac{1,200,000}{500} = 2400 \text{ in.}^2 = 48'' \times 50''$ .

Upper tier 50" long, lower tier 48" long. Assume base plate, 26" x 28".

2.  $\frac{28 - 16}{2} = 6$ ;  $t = \sqrt{\frac{1,200,000 \times 6 \times 6}{6000 \times 26 \times 28}} = \sqrt{\frac{900}{91}} = 3.1$ .

Use 26" x 28" x 3 1/2" plate.

## UPPER TIER.

$$1. l = 50 - 28 = 22''. \text{ Assume 4 beams. } S \text{ for each beam} = \frac{1,200,000 \times 22}{8 \times 18,000 \times 4} = 45.8.$$

Try four 12''—45# I's.  $S = 47.3$ ; flange width =  $5\frac{3}{8}''$ ;  $t = 0.565$ ;  $7\frac{1}{2}''$  on center.

$$2. \text{ Shear. } V = \frac{1,200,000 \times 11}{50 \times 4 \times 12 \times 0.565} = 9,735 \text{ lbs./in.}^2 \text{ Allowable } V = 12,000 \text{ lbs./in.}^2$$

3. Buckling stress =  $\frac{1,200,000}{(28+6) \times 4 \times 0.565} = 15,625 \text{ lbs./in.}^2$  Allowable stress =  $15,000 \text{ lbs./in.}^2$  Stress too high, try four 12''—50# I's; flange width =  $5\frac{1}{2}''$ ;  $t = 0.687$ ;  $7\frac{1}{2}''$  on centers.

$$\text{Buckling stress} = \frac{1,200,000}{34 \times 4 \times 0.687} = 12,842 \text{ lbs./in.}^2 \text{ Satisfactory.}$$

## LOWER TIER.

Width of upper tier 28''.  $l = 48 - 28 = 20''$ .

1. Try 7 beams.

$$S \text{ for each beam} = \frac{1,200,000 \times 20}{8 \times 18,000 \times 7} = 23.8.$$

Try seven 9''—35# I's; flange width =  $4\frac{3}{4}''$ ;  $t = 0.724$ .

$$2. \text{ Shear } V = \frac{1,200,000 \times 10}{48 \times 7 \times 9 \times 0.724} = \frac{125,000}{22.8} = 5482 \text{ lbs./in.}^2 \text{ Satisfactory.}$$

$$3. \text{ Buckling stress} = \frac{1,200,000}{(28+4.5) \times 7 \times 0.724} = 7300 \text{ lbs./in.}^2 \text{ Satisfactory.}$$

## CHAPTER XXV

### PILING, SHORING AND UNDERPINNING

#### Article 1. Piles and Piling

**In General.** Piles are long straight shafts of wood or concrete extending down through soft or fluid material until their ends rest upon rock or hardpan below, or else penetrating far enough into fairly firm soil to support, by frictional or skin resistance, the load permitted upon the pile. The employment of trunks of trees set into soft or wet soil to support buildings dates from prehistoric times, as evidenced by the lake dwellings of Switzerland where whole villages were constructed over the water resting upon piles driven into the lake bottoms. In many places, where continually covered by water, these piles still remain. Timber has been used for such purposes in many parts of the world since those earliest days through the Roman, Mediaeval and Renaissance periods, Venice and the Dutch cities being familiar examples of the use of piles in large areas for the support of buildings. At the present day, piles are employed generally in many parts of our country and constitute a very important type of building foundations.

Piles are best adapted for soft ground, silt, clay or filled land where a firm bearing bed is at so great a depth that it is not economical to carry the concrete footings down to it. When the soil consists of hard ground or gravel it would probably be better practice to use spread footings unless it were desired to penetrate to rock.

**Spacing.** Piles must not be driven so close together that they are pushed out of the vertical during driving or that the bearing value of the soil is exceeded. If, for example, the allowable bearing value of the soil is 5 tons/ft.<sup>2</sup> and the capacity of the pile is 20 tons, 4 ft.<sup>2</sup> of area is required to support each pile and a spacing of at least 24" is necessary. Most building codes specify a minimum spacing of 30".

One pile may sometimes be sufficient to support a column, but a cluster is generally required because of the loads. A bearing wall should be set on at least two rows, the piles often being staggered. Clusters may be of 3, 4, 5 or a greater number, depending upon circumstances. It is best to arrange the piles in a cluster symmetrically about the two axes, and whenever possible the center of gravity of the cluster should coincide with the center of gravity of the load (Fig. 1).

As in the case of spread footings on soil as described in Chapter XXIV, Article 4, the numbers of piles in the clusters may be proportioned



according to the ratios of live load to dead load so that the amount of settlement in all clusters will be as nearly equal as possible.

**Driving Piles.** The driving is done by a drop hammer or a steam hammer and requires expert direction. The **DROP HAMMER** mechanism (Fig. 2) consists of a vertical frame with two guides called leads between

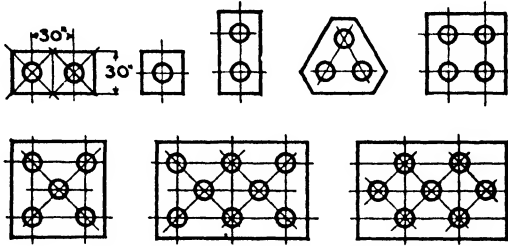

FIG. 1.—Arrangement of Piles.

which the hammer head falls by its own weight from the top of the frame to the top of the pile. The hammer is raised by a rope wound on a drum operated generally by a steam engine and is tripped automatically or by hand when it reaches the top of the frame. The hammers vary in weight from 2000 to 5000 lbs., 3300 lbs. being a generally used

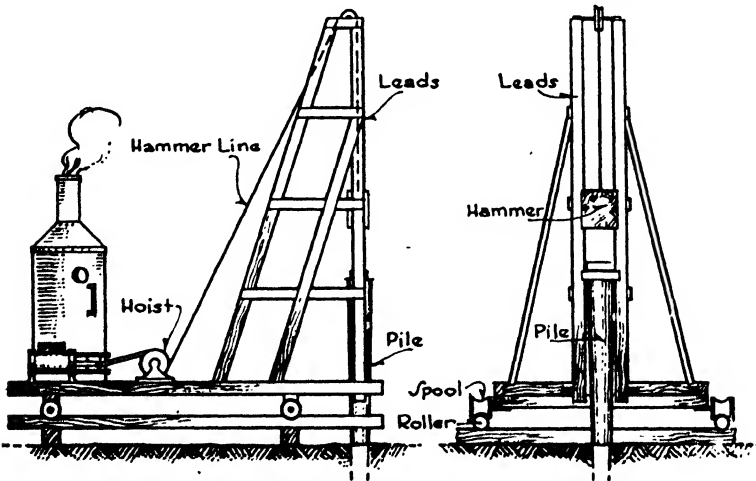

FIG. 2.—Pile Driver.

average, and the fall is often about 20'. The **STEAM HAMMER** consists of a steam cylinder resting on top of the pile, the stroke of the piston raising the weight and in some types also increasing the blow on the pile (Fig. 3). A **SINGLE-ACTING** hammer is lifted by the admission of steam to the bottom of the cylinder and falls of its own weight, whereas for the **DOUBLE-ACTING** hammer steam is admitted alternately below

and above the piston, raising the hammer and then adding to the force of the downward stroke. The weight of the moving part of single-acting hammers is about 5000 lbs., the stroke or fall about 3'0" and the speed of the strokes about 60 per minute. For double-acting hammers the moving weight varies from 1250 to 2550 lbs., but the force of the stroke is increased to about 7000 lbs. by the steam pressure. The heavier double-acting steam hammers strike about 100 blows per minute; the lighter hammers may act at a rate of 200 blows. As a result of the greater frequency of the blows from a steam hammer there is much less set to the pile between blows and much less initial resistance in getting the pile under way at each blow.

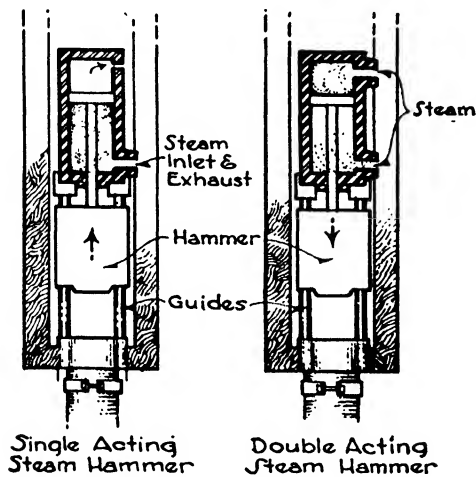

FIG. 3.—Steam Hammers.

Borings should always be used to test the character of the soil and the depth of the earth strata to determine before beginning the drive the distance to which the piles should be driven and their necessary length. Otherwise piles may be broken or bushed by too much driving on a hard bottom.

Piles may be of wood or concrete. Most building codes limit the load to 20 tons each for wood piles and 40 tons for concrete even under most favorable conditions.

**Wood Piles.** Wood has long been the natural material for piles, being easily obtainable in satisfactory lengths and sufficiently straight for most situations. It still is generally the cheapest material, but under certain conditions concrete piles are preferred. The timber may be either softwood or hardwood, depending upon the local supply, the necessary element being that the wood does not split or broom out unduly under the blows of the hammer. Any wood which can successfully withstand the punishment of driving may be considered capable of bearing the

allowable loads. The points are, however, often protected by conical iron shoes and steel straps and the butts confined by iron rings to avoid splitting and brooming. The wood should be straight and sound, not less than 6" in diameter at the point and not less than 10" at the butt for 25'0" piles or 12" for longer ones.

The ability of surrounding material to contribute lateral support has important influence upon the load-bearing capacity of a pile. When extending to rock or hardpan through firm soil the pile may be considered to act as a short column under direct crushing and may be loaded with 20 tons. When, however, the pile is driven through water, silt or soft mud, lateral support is lacking, bending may occur and the pile should be considered as a long column with a consequently reduced capacity.

When it is not practical or economical to drive piles down to rock or hardpan the frictional resistance of the surrounding soil upon the sides of the piles must be depended upon to hold the piles in place without further settlement under their loads. The allowable load or capacity of the piles under these circumstances is most reliably determined by actual tests upon a pile or a cluster of piles. Gradually increasing loads are placed upon the piles, and the amount of the penetration or settlement is measured. Factors of safety of 2 to 6 are employed to fix the allowable load. When such actual loading tests cannot be made the capacity of a pile may be fairly well computed by means of very generally used empirical formulae known as the Wellington or Engineering News formulae, as follows:

$P$  = capacity of pile with factor of safety of 6, in pounds.

$W$  = weight of hammer in pounds.

$h$  = fall of hammer in feet.

$s$  = average penetration of pile in inches under last 5 blows.

$w$  = weight of pile.

$A$  = area of piston in square inches.

$p$  = steam pressure in pounds.

The formulae are derived by equating the work done by the load to the energy of the hammer, both producing a certain penetration. The denominator is arbitrarily increased by 1 or 0.1 to allow for the extra initial resistance to starting the pile at each blow due to the setting of the pile between blows.

#### WOOD PILES.

$$\text{For drop hammer} \quad P = \frac{2Wh}{s + 1} \quad (1)$$

$$\text{For single-acting steam hammer} \quad P = \frac{2Wh}{s + 0.1} \quad (2)$$

$$\text{For double-acting steam hammer} \quad P = \frac{2(W + Ap)h}{s + 0.1} \quad (3)$$

**CONCRETE PILES.** Because of the greater weight more inertia is en-

countered in concrete piles, and the full force of the blow is not applied to penetrating the soil. The following formulæ have been proposed:

$$\text{For single-acting steam hammer } P = \frac{2Wh}{s + 0.1 \frac{w}{W}} \quad (4)$$

$$\text{For double-acting steam hammer } P = \frac{2(W + Ap)h}{s + 0.1 \frac{w}{W}} \quad (5)$$

When piles are designed for a certain allowable load they are driven until the final penetration,  $s$ , becomes small enough to give the required capacity by the appropriate formula. For example, a wood pile driven by a drop hammer weighing 4000 lbs. falling 10'0" is designed to carry 20 tons.

From formula (1), if  $P = \frac{2Wh}{s + 1}$ , then  $s = \frac{2Wh}{P} - 1$

$$s = \frac{2 \times 4000 \times 10}{40,000} - 1 = 2 - 1 = 1''$$

The pile should therefore be driven until the average penetration under the last 5 blows is reduced to 1".

By the term "driving to refusal" is meant driving the pile until no penetration results from the last blows. Such a condition may be produced by the point of the pile reaching bedrock or hardpan or else encountering a boulder or other obstruction. The advantage of test borings is evident in such cases, since they offer dependable information as to the depth at which bedrock or hardpan may be expected and also as to the thickness and character of the rock or hardpan. To continue driving after refusal often leads to splitting and cracking of the pile with great reduction in its capacity.

If it is impossible with a certain length of pile to obtain small enough penetrations, the capacity of the pile should be reduced in proportion to the amount of the final penetration and the proper number of piles added to the cluster to support the load destined for that cluster.

The number of piles in a cluster is determined by dividing the load on the footing by the capacity of one pile. Loading tests should, however, be made after the piles are in place to check calculations. The procedure in these tests has been greatly perfected in recent years and they are now considered to be the most reliable means of predetermining the action of piles under their final loads.

The tops of wood piles should be cut off below permanent low water, so that the entire length of the pile will always be wet, since alternate wetting and drying of wood will very quickly cause decay. Any likelihood of the future lowering of the low water level in the soil, also called the ground water level, by draining due to new construction in the vicinity must be borne in mind when the piles are cut.

Water jets are sometimes used especially through pure sand in driving

both wood and concrete piles to loosen the material at the point and along the sides and so facilitate the penetration.

**Concrete Piles.** The two most generally used types of concrete piles are the pre-cast and the cast-in-place.

**PRE-CAST PILES.** These piles are cast in the manufacturer's yard or at the site of the building where they are driven in the same manner as wood piles, often with the aid of a water jet. They are built as long reinforced concrete columns with special reinforcement at the butt and point and are designed to resist the strains of handling. Vibrators are frequently used to compact the concrete. The piles may be square or octagonal in cross-section and preferably have straight sides. The size and length are limited only by the difficulties of transporting and setting, excessively long or thick piles becoming very heavy and requiring costly equipment to handle them. A larger number of more slender piles may then be preferred.

If driven to a bearing upon rock or hardpan, the pile acts as a column and its capacity is equal to its crushing and flexural strength. If the carrying capacity is developed by frictional resistance, its value is determined by load tests or by one of the formulae set forth in the paragraph on wood piles.

Three sets of stresses must be considered in designing the reinforcement of pre-cast concrete piles: (a) those taking place after the pile is in place and supporting its load, (b) those arising during the handling of the pile and (c) those generated during driving.

(a) The pile acts as a short column when it has the lateral support of firm soil with resulting compressive stress only, and as a long column throughout those portions of its length where lateral support is lacking and flexural stresses consequently arise. The reinforcement should consist of longitudinal rods and spirals computed as for a reinforced column with the same ratio of slenderness.

(b) Piles are stored and transported in a horizontal position and are handled and set in their final vertical station by derricks, at which time they are subjected to bending moments from their own weight. Up to 40'0" long they are generally suspended from the derricks at their center of gravity. When over 40'0" long they are suspended at two points, each  $\frac{1}{3}$  the length of the pile from an end. This arrangement gives nearly equal bending moments at the point of suspension and at the end, thereby necessitating a minimum of reinforcement.

(c) The blows of the hammer tend to fracture the top of the pile unless it is protected by a cushion or by reinforcement. As cushions reduce the effectiveness of the blow and slow up the rate of penetration, reinforcement is preferable; it consists of closely spaced spirals and bands of steel. The point of the pile should also be reinforced against the accidents of driving, such as striking a boulder, with longitudinal bars and lateral bands or spirals.

We have, then, longitudinal and spiral reinforcement extending

throughout the length of the pile for the column stresses, additional tension bars as required at areas of suspension and at the middle, and increased spirals and bars at the top and at the point.

**PILES CAST IN PLACE.** Concrete piles of this type are poured in the positions which they are intended to occupy in the completed structure. A hole is driven into the soil to a predetermined depth by a steel point acting in a large pipe, and the hole is then filled by pouring in concrete from the top. As a rule these piles have no lateral reinforcement other than that provided by the steel shell. The two generally employed methods are as follows:

(a) A steel tube or shell, usually furnished with a tight-fitting collapsible steel core or mandrel, is driven into the soil, the collapsed core is removed and the steel shell is filled with concrete. The shell may be inspected before pouring by lowering down an electric light. A typical

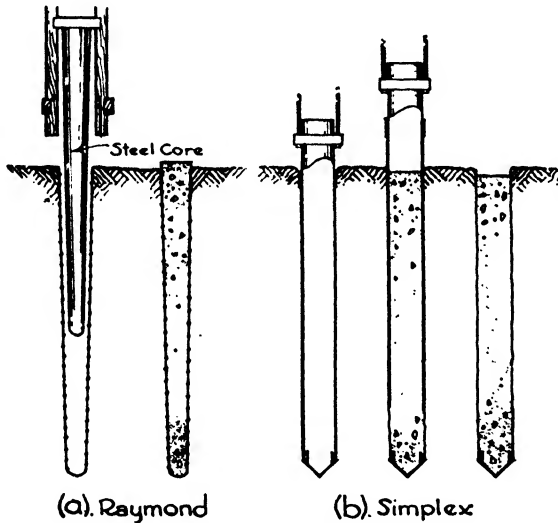

FIG. 4.—Concrete Piles.

pile of this kind is the Raymond pile in which the tube is tapered from the top down to a diameter of 8" at the bottom. The shell is usually 18 to 20 gauge sheet steel spirally corrugated and often laterally reinforced with a  $\frac{1}{4}$ " wire wound through the corrugations. The capacity of these piles may be calculated by the *Engineering News* formulae (Fig. 4,a).

(b) A steel tube is fitted at the bottom with a driving point and driven into the ground to the required depth. Concrete is then poured into the hole thus formed, the tube being gradually withdrawn as the hole is filled, the point remaining in the bottom. The Simplex pile is typical of this kind, in which the tubing is  $\frac{3}{4}$ " thick and about 16" in diameter with straight sides (Fig. 4,b).

A combination of wood pile below the permanent ground water level

and a Raymond pile above is sometimes used for economy. The top of the wood pile is turned down in a lathe to form a dowel with a shoulder over which the concrete of the Raymond pile is poured.

The capacity of Simplex piles or those driven by a water jet cannot be measured by the formulæ for hammer driving already given. The following formula, based upon the bearing power of the soil at the bottom of the pile and skin friction on the sides, is sometimes used:

$$P = B \times A + F \times S$$

- in which  $P$  = the capacity of the pile in pounds;
- $B$  = the unit bearing power of the soil;
- $A$  = the area of the bottom of the pile;
- $F$  = the frictional resistance in pounds per square foot;
- $S$  = the superficial area of the pile in square feet.

The frictional resistance is somewhat indefinite, but the following averages are proposed by Professor C. C. Williams.\*

Table I

Soil	Frictional Resistance lbs./ft. <sup>2</sup>
Silt and soft mud . . . . .	50 to 100
Silt compacted . . . . .	120 to 350
Clay and sand . . . . .	400 to 800
Sand with some clay . . . . .	500 to 1 000
Sand and gravel . . . . .	600 to 1 800

**Pile Caps.** Concrete column and wall footings similar to the spread footings described in Chapter XXIV are constructed to distribute the loads over the pile clusters.

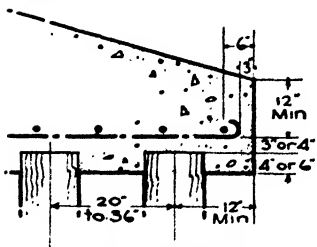

FIG. 5.—Pile Cap.

These footings are sometimes called pile caps. The critical section for diagonal tension is taken at a distance  $\frac{d}{2}$  from each face of the column.

Any piles whose centers are at or outside this section should be included in computing the shear. The butts of wood piles should extend up into the cap about 6", and of concrete piles 4". With grillage beams from 6" to 9" of concrete should extend over the tops of the piles to receive the grillage. When the cap is of reinforced concrete there should be 3" or 4" of concrete between the tops of the piles and the reinforcement of the footing (Fig. 5).

The exterior row of piles should be checked for punching shear by the formula:

$$d = \frac{V}{v_b}$$

\*"The Design of Masonry Structures and Foundations."

in which  $V$  = the pile load;  
 $b$  = the perimeter of the pile;  
 $v_2$  = allowable punching;  
 Shear = 120 lbs./in.<sup>2</sup>

**Steel Cylinders and Caisson Piles.** Besides the relatively slender piles already described which are driven in clusters and may be considered true piles, heavy  $\frac{3}{8}$ " to  $\frac{3}{4}$ " STEEL CYLINDERS in 20' lengths and of 10" to 18" diameter are widely used when it is desired to extend the foundations down to bedrock. They derive their support from end bearing and not from skin friction. These cylinders are driven by steam hammers or forced down with jacks, are excavated by compressed air or by small orange-peel buckets and are filled with concrete. They may be employed in clusters, or they may be individually designed of sufficient size to carry a full column load. They depend for their strength upon the heavy steel of the cylinders as well as upon the concrete filling. Steel cylinders in a succession of short lengths are much used for underpinning walls and columns. It is assumed that about  $1/16$ " of the thickness of the cylinder shell will be destroyed by rust. The effective thickness is therefore taken in computations as  $1/16$ " less than the actual thickness.

The New York Building Code permits the following loads on steel cylinders, upon the basis of 7500 lbs./in.<sup>2</sup> on the area of the steel shell and 500 lbs./in.<sup>2</sup> on the concrete filling.

**Table II. Capacity of Steel Cylinders in Tons**

Thickness of Steel in Inches	Outside Diameter of Cylinder				
	10"	12"	15"	16"	22"
$\frac{3}{8}$ .....	57.6	73.6	93.5	103.5	150
$\frac{1}{4}$ .....	65.5	83.0	103.2	113.4	165
$\frac{1}{2}$ .....	73.4	92.4	112.9	123.8	180

The cylinders have been used to depths of 155'0", the lengths being joined by steel inside sleeves. A cluster of several cylinders may be driven if required by the column load.

Steel billets or grillage beams are used to distribute the column load uniformly over the steel shell and concrete filling.

CAISSON PILES constitute another type of large pile sufficient to carry the entire load of a column. These are generally used on ground of fairly good bearing power and are flared out at 30° to the vertical, forming a bell at the bottom to distribute the load upon the soil. They are not driven but gradually sink of their own weight as the earth is excavated from under the cutting edge. To permit a man to work inside the tube the diameter must be at least 36" irrespective of the load.



They consist of short sheet steel cylinder sections, each one set directly upon the one below and bolted to it, and are filled with concrete. The cylinders are usually removed as the concrete is deposited. Air locks may be used with these piles if necessitated by excessive water in the soil. Since pile drivers are not employed to sink them, the green concrete of neighboring piles is not injured by vibration. A caisson pile 36" in diameter at 500 lbs./in.<sup>2</sup> will carry 508,000 lbs. Because 36" is the least practical diameter the same section must be used for lighter loads, but the area of the bell must vary as the load varies. Thus loads of 300,000, 400,000 and 500,000 lbs. would require bell diameters of 6'10", 8'5" and 9'0" respectively, while the shaft must always be 3'0" in diameter.

**Example 1.** Design a caisson pile to support a column load of 900,000 lbs. upon a soil of 10,000 lbs./ft.<sup>2</sup> bearing capacity. Allowable compression on concrete = 500 lbs./in.<sup>2</sup>

$\frac{900,000}{500} = 1800$  in.<sup>2</sup> Therefore a cylinder of 48" diameter is required. The weight of the pile with concrete is assumed to equal 75,000 lbs.

Therefore total load on the soil = 975,000 lbs.

Area of bearing = 97.5 ft.<sup>2</sup> Diameter of bell = 11'3"

**Selection of Type of Pile.** Wood piles are largely used for the lighter classes of buildings since they are generally cheaper and more easily handled than concrete piles. They have, however, less bearing power, they cannot be obtained in as great lengths and they will decay rapidly above ground water level where they are alternately wet and dry. For great depths and heavy loads, concrete piles are therefore generally preferred. Also when the ground water level is at some distance below the basement floor level it may be more economical even in the lighter buildings to use concrete piles throughout than to undertake expensive excavation to bring the concrete footings down to the top of wood piles.

Each type of concrete pile has some distinctive advantages which adapt it to certain soil conditions and for certain purposes. Wherever lateral pressure is combined with a vertical load or when the pile penetrates both firm and very soft strata the pre-cast pile is more generally employed because of its reinforcement against bending and general dependability. Some architects prefer it also because the concrete can be thoroughly inspected and seasoned before driving. On the other hand, pre-cast piles are expensive to fabricate and transport and difficult to handle and to store. Piles cast in place do not have these disadvantages, but the concrete cannot be poured or the reinforcement set with the same precision as in pre-cast piles.

The type of pile from which the casing is removed as the concrete is poured should not be used when water is present or through soft strata since the water may enter the hole and dilute and wash out the cement

or the soil may mix with the concrete and weaken it. This type of pile should be used only in the absence of water and in stiff soil capable of retaining the shape of the hole until the concrete is set.

When the casing is not removed from the ground the shell protects the green concrete from earth pressure and excludes water, soft soil and foreign matter. The casing with its reinforcing wire also furnishes a very definite resistance to bending and so increases the variety of conditions under which this type of pile may be employed.

Steel cylinders are used only for bearing on rock and in such situations may be found more economical than wood or concrete piles or pneumatic or open caissons.

Caisson piles are used in fairly good soil to carry loads to a satisfactory bed or to rock and are often more economical under favorable conditions than wood or concrete piles. They permit the inspection of the bed before pouring the concrete, cause little vibration during sinking and may therefore be employed inside existing buildings and close to adjoining structures.

## Article 2. Shoring, Needling and Underpinning

When new buildings with deep basements or foundations are erected adjoining existing structures with shallow basements and footings, it is necessary to support the footings and walls of the old building until the newer one is constructed or to bring the old footings down to the level of the new foundations. This work is called UNDERPINNING. The solution of the problems involved often demands much experience and discretion.

The walls and footings of the building in question must be undermined to some extent in order to insert the deeper foundations. This may sometimes be accomplished without temporary support but very often requires the assistance of posts, timbers and beams to carry the weight of the building until the new walls and foundations are in place. The ability of a bonded brick or masonry wall to form an arch over any moderate-sized breach made in the wall or gap excavated beneath it aids very materially in underpinning walls with average loads. The load over the breach or gap is carried to the soil on each side by the arching action of the wall. The two most-used types of temporary support are SHORES and NEEDLES.

**Shoring.** Shoring consists in setting long wood posts or SHORES in an inclined position against the wall to be supported (Fig. 6,*a*). The upper end of the shore is received in a niche cut in the masonry, and the lower end rests upon a wood platform with a face at right angles to the inclination of the shore. The post is forced into close bearing against the wall by driving steel wedges under its heel or by the introduction of a jack (Fig. 6,*b*). The shore should incline as little as possible, and its top should be set level with a tier of floor beams to reduce

the hazard of pushing over the wall. Greater strength may be contributed to the wooden member by bolting steel channels or I-beams to its sides

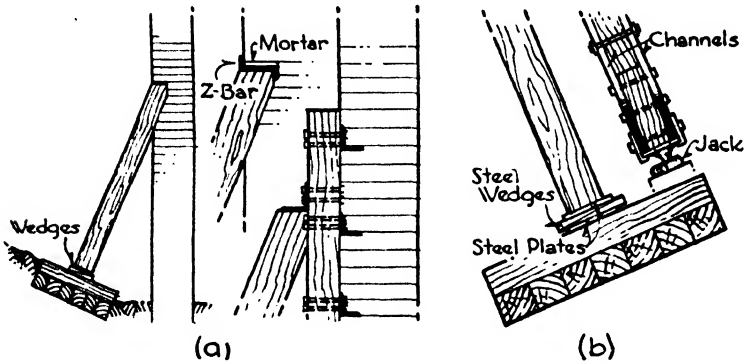

FIG. 6.—Shoring.

In general several small shores are better than a few large ones so that the lifting forces may be well distributed through the length of the wall. To support high walls two or more shores of different lengths may be placed in the same vertical plane

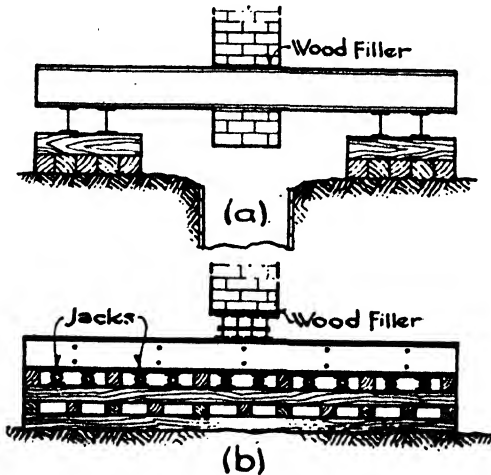

FIG. 7.—Needling

**Needling.** Horizontal wood or steel beams penetrating through holes cut in a wall or under a column and supported on both sides of the wall upon wood blocks or cribbing are called NEEDLES. Wedges are inserted between the beam and its supports to produce a tight bearing under the wall or column, which is then carried upon the beams. Steel I-beams

are now generally preferred to wood timbers for use as needles (Fig. 7, a, b).

When a building cannot be entered to place supports for the needles in the interior the FIGURE FOUR method of needling may be employed. The needle beam acts as a cantilever balance upon wood cribbing, and equal parts of the wall load are carried by the inner end of the needle and by the shore resting upon the outer end (Fig. 8, a).

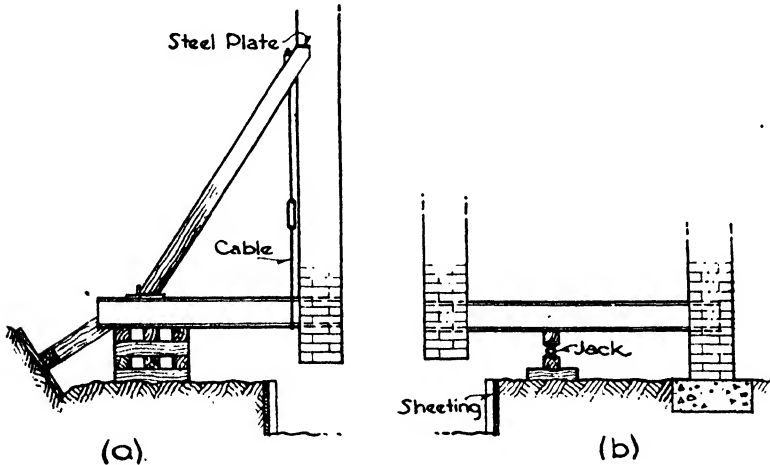

FIG. 8.—Needling

A SPRING NEEDLE also acts as a cantilever balanced upon cribbing with one end carrying the wall to be supported and the other end engaged in an adjacent wall. The cribbing is placed near the supported wall so that the proportion of uplift will be greater upon that wall (Fig. 8, b).

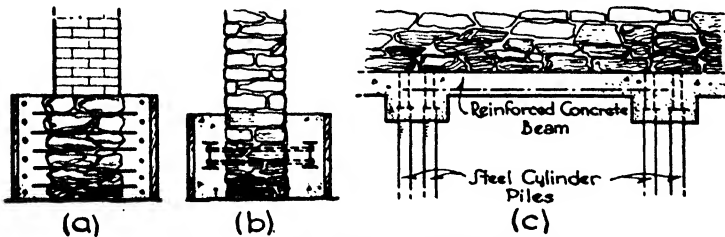

FIG. 9.—Strengthening and Underpinning.

**Strengthening Foundations.** Much progress has been made in recent years in the underpinning of foundations without resorting to the temporary support of shores and needles. Before employing these methods, however, it is often necessary to strengthen the bottom of the old wall or to tie together the footings of existing columns.

Walls may be strengthened by encasing their lower portions in concrete with or without reinforcing rods through the wall, or by placing horizontal I-beams along the wall on each side near its bottom tied together by dowel rods passing through the wall, the whole being encased in concrete (Fig. 9, *a, b, c*).

Isolated column footings are sometimes joined by continuous slabs of concrete and steel which also act as long spread foundations to carry the columns while the underpinning is progressing beneath them. Steel grillage footings may also be reinforced and connected by the introduction of additional steel beams between the existing grillages.

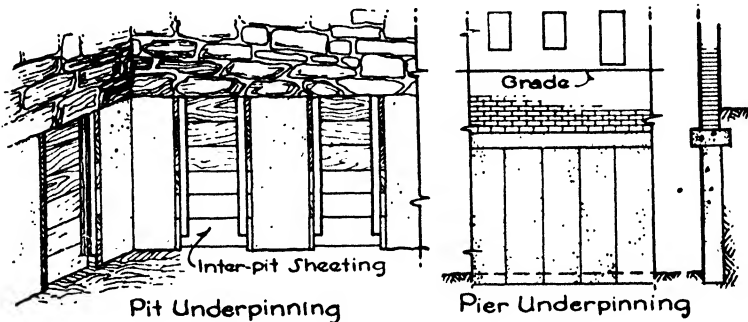

FIG. 10.—Underpinning.

**Underpinning.** There are two general methods of introducing new and deeper foundations under an old wall, the pit method and the pile method. The **PIT METHOD** consists in digging pits at intervals under the wall or under half the area of a column footing. The pit extends down to a good bearing stratum below the plane determined by the design and is filled with masonry up to the under side of the wall or column footing. This method is generally used with moderately light loads, the support for the wall being furnished by shores and needles or by the arching action of the old masonry over the pits. The new masonry, brick or concrete, erected in the pits acts as columns or piers and in turn supports the old structure until new masonry can be introduced in secondary pits between the first ones. Steel wedges and plates are driven in between the old and new masonry to bring the entire construction in perfect bearing so that the loads may be transferred to the new foundations without settlement. Short lengths of I-beams are also employed in conjunction with plates and wedges to produce a tight bearing (Fig. 10).

The **PILE METHOD** consists in driving or jacking piles in short sections under the old foundations and is adapted to heavy loads, great depths and the presence of water. Shallow pits are also dug in this method to give a working headroom of 3'0" to 7'0" under the old footings. Steel cylinder piles are most frequently used in sections 12" or 24" long with

sleeve connections. The usual diameters are 10" to 16", although, when conditions require larger piles, 36" diameter cylinders have been employed, permitting excavation by a workman within the cylinder and the installation of an air lock. The thickness of shell varies from 1/8" to 3/8". If there is sufficient space, the piles may be driven with a falling weight or by a pneumatic hammer, but the more usual method is to force the pile down with hydraulic jacks or rams thrusting against the under side of the old foundation above (Fig. 11, a, b, c). The cylinders sink much more readily if the sections are excavated as they are forced down, the excavating being done by earth augers, by small orange-peel buckets or by jetting. When the pile has reached the required depth and is completely cleaned the jacks are removed and the cylinders are filled with concrete (Fig. 11, d, e).

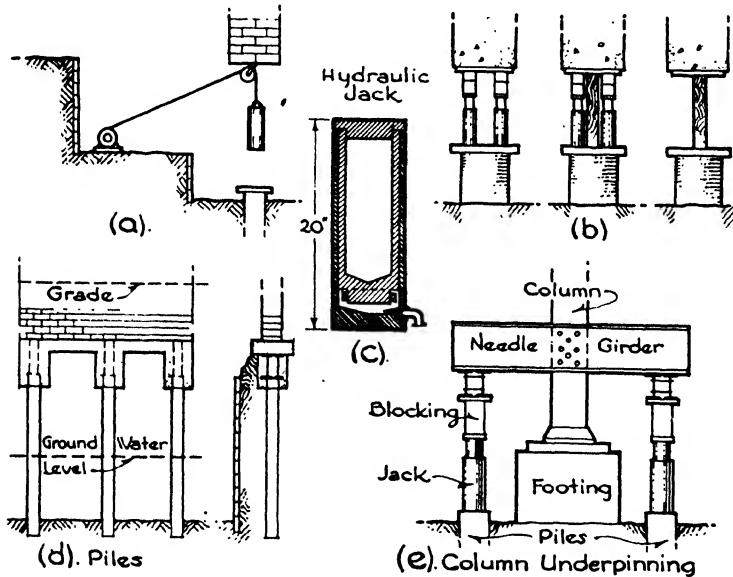

FIG. 11.—Details of Underpinning.

It has been found that the piles will rise up or rebound after the removal of the jacks owing to the release of pressure upon the compressed earth bulb at the foot of the pile, called the bulb of pressure. When the load of the foundations is again brought upon the pile by inserting beams, plates and wedges a settlement of a foot or two may take place. To avoid this rebounding and resettlement the patented PRE-TEST METHOD has been developed by which the pile is wedged under the foundations by means of short steel columns before the jacks are removed. The pile cannot rebound when the jacks are taken away because it is already tightly wedged against the foundations in its final

position. The piles are tested by means of the jacks to a 50% overload before the weight of the foundations are transferred to them. Much of the underpinning of tall buildings in New York and other larger cities has been done by this method preliminary to the construction of neighboring skyscrapers (Fig. 11,*b*).

Spread footings and clustered piles may be pre-tested by the above method before columns are set upon them, to determine their bearing capacity without settlement.

Piles are also sunk for underpinning by excavating short distances and then inserting steel shells in segments in the excavation, repeating the process until the desired depth is reached, when the entire shaft is filled with concrete.

It is often necessary to use some method to prevent the soil from flowing from under the cellar of an underpinned building into the new and deeper excavations. This protection may be obtained by driving sheet piling when the excavation is at some distance from the underpinned wall or columns, or by inserting horizontal sheeting of wood between the pits or piles when the new cellar is close to the wall. Such sheeting is called inter-pile or inter-pit sheeting. Vertical H-beams are sometimes driven first and the sheeting placed behind their flanges as the excavation proceeds.

## CHAPTER XXVI

### EXCAVATION AND WATERPROOFING

#### Article 1. Excavation in Dry Ground

**General Considerations.** In Chapter XXIV on Foundations several types of footings were described for both light and heavy buildings, and in all cases it was necessary to build the footings upon a foundation bed either of soil or rock which was adequate to carry the load without settlement. It was also seen that these foundation beds were always situated below the surface of the ground, either to avoid the action of frost, to permit the construction of cellars below grade or to arrive at a stratum of soil or rock with the required bearing value. To accommodate the foundations at the required level below grade the removal of soil is naturally necessary, and such removal or excavation may, according to the conditions of the case, be extremely simple or involve many difficulties.

The presence of water in quantity in the soil complicates the process of excavation and calls forth the employment of special methods and devices. The subject may then be subdivided under the two heads of EXCAVATION IN DRY GROUND and EXCAVATION IN WET GROUND. The first division will be treated in this article.

**Types of Dry Excavation.** The general types may be classified as the digging of cellars and the sinking of foundations. Excavation in dry ground, or in the dry as it is sometimes called, ranges in extent from hollowing out shallow cellars and foundation trenches for small buildings to digging great basements and sub-basements for large structures and sinking deep holes for the foundations of their heavy columns. In the case of shallow excavation of small lateral extent, hand tools, such as picks and shovels, may be used to advantage; but when the space is large horse scrapers and power shovels are more practical. The use of steam and gasoline excavators discharging into motor trucks has greatly expedited digging of cellars, and in recent years they are considered economical for all but the smallest work. When the excavation has become so deep that the power shovels cannot dump into trucks standing at grade level, timber runways are built into the cellar so that the trucks can be driven down to the shovels. If the ground be very hard, ploughs may be required to break up the soil for the excavators, or it may be necessary to resort to dynamite. Blasting is effective in crumbling the ground but care must be taken that the action does not extend to the strata selected for the foundation beds. Rock ledges when occurring above the desired basement floor are removed by blasting. Except in



this event, however, rock is seldom disturbed since it provides the best foundation bed for columns and walls.

As has been explained in Chapter XXIV, the loads of heavy buildings are almost invariably concentrated upon columns, these columns resting upon piles, spread footings or concrete piers extending down to hardpan or rock. Consequently dry excavation for foundations resolves itself into wide but comparatively shallow excavation for spread footings and narrow but relatively deep holes for piers. Pile driving is not considered as true excavation in this classification and is therefore treated separately in Chapter XXV.

**Blasting.** To be removed, rock must be broken into sizes which can be handled by man or by power shovels and trucks. For this purpose blasting with black powder or dynamite is now more generally employed than plug and feather wedges which were formerly used. Black powder is composed of 60 to 75% potassium nitrate, 15 to 20% charcoal and 10 to 15% sulphur. It is slow burning, the smaller-grained powders being, however, quicker than the large grains, and is fired by an electric battery or by a powder fuse. Straight dynamite contains nitroglycerine, wood meal and sodium nitrate and is very sensitive and quick acting. Blasting gelatine, made of nitroglycerine and nitrocellulose, is the strongest and most water-resisting of the explosives. Dynamite is generally preferred to black powder at the present time. It is fired by blasting caps containing a very sensitive and violent explosive such as fulminate of mercury. The cap is detonated by means of a fuse or by an electric current. When electricity is used, a copper wire circuit is embedded in the cap with the ends of the wire extending outside. Electric blasting machines consist of small portable generators in which the armature is rotated by the downward thrust of a handle, thereby generating a current. Blasting should be done only by licensed operators, for not only are care and experience required to guard against danger to life but also a high degree of skill is necessary to direct and control the charges especially in the confined quarters of crowded cities. Planks and rope mats are often spread over the area to prevent flying pieces of rock.

An important part of all blasting is the drilling, because the depth and direction of the fracture are largely controlled by the depth, direction and spacing of the holes in which the explosive is placed. Drilling on a small scale may be done by hand drills and sledge hammers, but for work of any magnitude pneumatic drills are more economical. A piston operated by compressed air strikes hammer blows upon the drill and turns it slightly at each stroke. Pneumatic drills are either held by hand or are set upon tripods. The hand drill can be used only for vertical holes, the tripod drill being required for slanting and horizontal holes.

**Sheet Piling.** The chief difficulty connected with dry soil excavation is the tendency of the earth sides to fall into the bottoms of the pits. This tendency is greater in loose sand and gravel than in cohesive soil

such as hard clay, but in all cases, when the digging extends to any depth, protection should be maintained against possible cave-ins. The type of protection depends upon the size and shape of the excavation.

For spread footings, which are generally rectangular or trapezoidal in plan and of some extent, sheet piling is employed consisting of wood planks or steel sheets driven on end into the soil ahead of the digging. The wood sheet piling is composed of 2" to 8" planks about 12" wide and may be used in single thicknesses side by side or may be bolted together in 3 layers so arranged that a tongue is formed on one side of the section and a groove on the other. This type, called the Wakefield pile, is less likely to buckle than the single planks and provides a tight joint between sections (Fig. 1,*a*). Steel sheet piling has come into general use

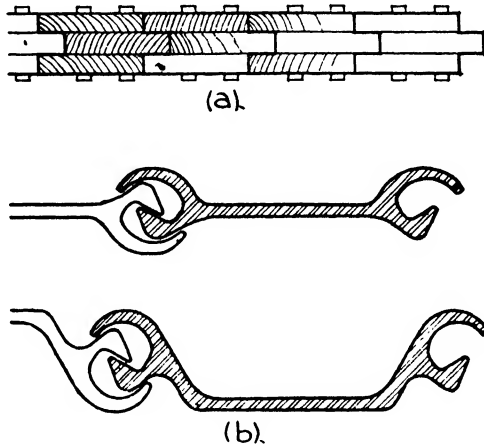

FIG. 1.—Sheet Piling.

in recent years. It consists of lengths of steel plate about  $\frac{1}{2}$ " thick and from 12" to 16" wide provided with interlocking joints along the sides. Two types of sections are made, the arched web and the straight web, the former being stiffer against buckling (Fig. 1,*b*). Steel sheeting is higher in first cost but is easier to drive and can be re-used more often. When the conditions are not too difficult and the piling is to remain in place wood sheeting is probably still the cheapest.

In all cases borings should be made to determine the depth to which the sheet piling is to be driven.

Wood and steel sheet piling is largely used for holding the banks of cellar and basement excavations. All such sheeting must be strongly braced to withstand the earth pressure, especially in crowded cities where any settlements or cave-ins would be most dangerous to adjoining buildings and streets. The bracing may be set horizontally between opposite banks or may consist of sloped shoring with the heels of the

braces held by temporary piles driven in the basement bottom (Fig. 2). If the pressure be very great, 2 lines of sheeting are sometimes used or a trench may be dug at the building line or the sidewalk curb line before excavation begins. This trench is then filled with concrete to form the cellar wall and the basement is dug inside. Bracing must be introduced to hold the walls in place as the excavation proceeds and before the columns and girders are in place.

Moderate amounts of water encountered in the excavation of basements and cellars may be drained to a sump pit from which it is pumped to the sewer. When the water occurs in so large quantities that it cannot be eliminated through sumps, the excavation is generally enclosed with some type of cofferdam or by well points as described in Article 2.

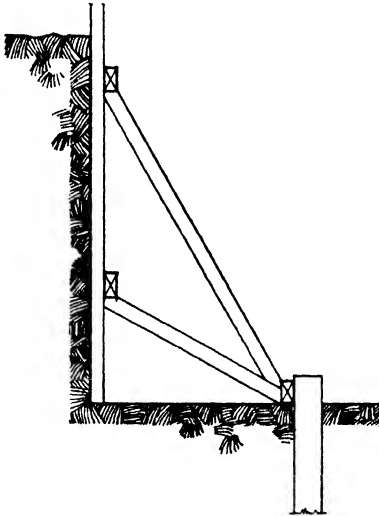

FIG. 2.—Bracing.

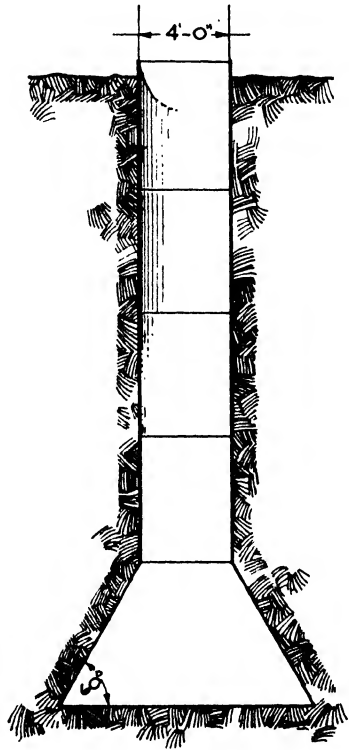

FIG. 3.—Caisson Pile.

Concrete piers to rock or hardpan are circular in plan and the protection is generally accomplished in one of three ways.

(a) **STEEL CYLINDERS.** Heavy steel cylinders are driven down to rock by pile drivers, the earth being cleaned out afterward with small orange-peel or clam-shell buckets. The cylinders are left in place and filled with concrete and, since the metal is heavy, they are included in the calculations as contributing to the compression strength of the pier.

(b) **CAISSON PILES** (Fig. 3). Light steel cylinders, sometimes called Gow piles, are sunk as the excavation proceeds and are either removed

or left in place when the concrete is poured but are not considered as contributing to the strength of the pier. Caisson piles are often used when an adequate foundation bed of soil is encountered before reaching

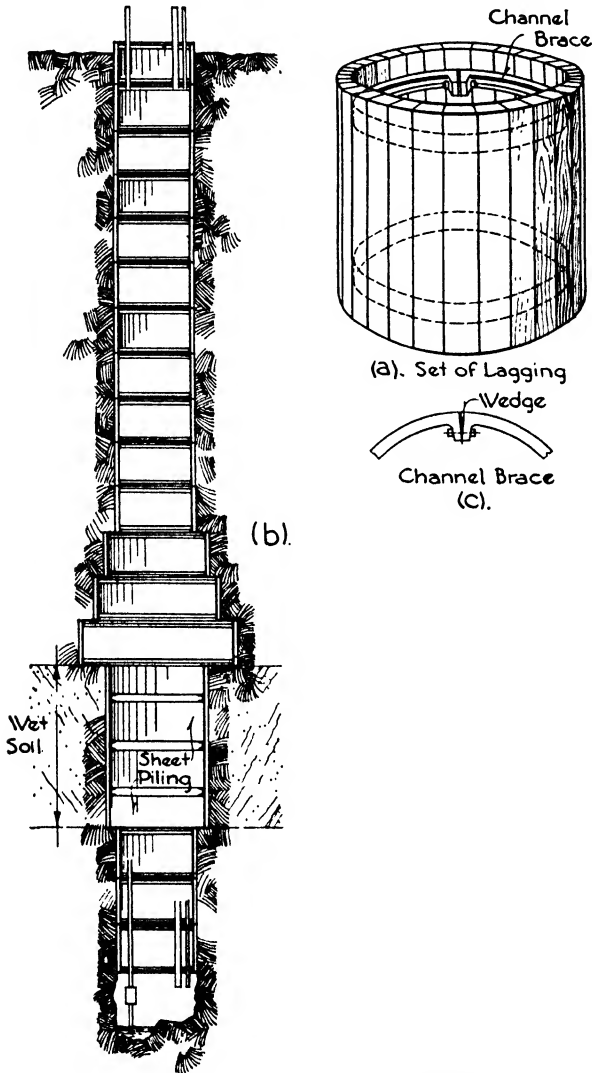

FIG. 4.—Poling Board or Chicago Method.

rock. In this case the cylinder is belled out at the bottom to give greater bearing area. The diameter of the caisson should be at least 3'0" or 4'0" to allow a man to remove the earth under its lower edge. Pneumatic picks and spades are employed for greater speed and economy of room,

and the caisson sinks without the use of a pile driver. The lengths of steel cylinders rest directly upon each other and are bolted together. As a rule, caisson piles are used in soil of sufficient cohesion to permit the undercutting for the bell without the use of wood shoring to support the earth, the angle with the horizontal being not less than  $60^\circ$ . The foundation bed may be inspected and leveled off before pouring the concrete. If water be encountered in sinking the cylinders, air pressure may be applied within the caisson and an air lock installed at the top as described in Article 2 for pneumatic caissons.

(c) **POLING BOARD METHOD** (Fig. 4,*a,b,c*). This type of excavating for piers, also known as the Chicago method because of its frequent use in that city, has been employed with success where the rock is at great depths below the surface. In the foundation work for the Union Terminal Buildings in Cleveland, wells for piers were sunk for a distance of 204'0". This method consists in assembling a cylindrical set of tongue and groove maple sheeting or lagging. The boards are 2" or 3" thick and have beveled edges. The height of the set depends upon the character of the soil and varies from 3'0" in non-cohesive sand to 6'0" in firm clay. The inside diameter is the diameter of the concrete pier, and the set is braced against outside earth pressure with steel bands on the interior. The bands are now generally composed of channels in semi-circular arcs, each arc provided with outstanding lugs for bolting together and wedging against the lagging. A shallow excavation of the proper diameter is made, and the first section of lagging is placed in position and carefully centered. The soil is then dug out for a depth equal to the height of the set and another section is placed directly under the first and centered. The digging and placing of the sets continues in this manner until rock is reached. Excavation is done by hand, generally with pneumatic tools, and the material is hoisted out in circular buckets. If wet soil be encountered, special widening out of the lagging is necessary to permit of driving wood or steel sheet piling ahead of the excavation. When the wet stratum is passed the original section diameter and method of digging are resumed. It is often necessary to furnish electric light in the tubes, and sometimes fresh air must be pumped in to neutralize gases from the soil.

Steel sheet piling is also used in much the same manner as the wood lagging just described in the sinking of open pits to rock.

It may be necessary to resort to pumping to free the wells of water. When large quantities of water are present, other methods of excavation such as caissons or cofferdams must be employed as described in Article 2.

## Article 2. Excavation in Wet Ground

**General.** The presence of water in large quantities in the soil creates a very serious condition and special methods are used to control it.

Water by its own presence not only renders the process of excavation difficult and often impossible for the workmen, but it also causes soil to flow, thereby converting it into a material most difficult to restrain or direct. In many cities upon the sea coast or near lakes and rivers the soil constantly contains large amounts of water up to a level called the ground water level. This level is often but little below the surface, and the water-soaked soil must be penetrated to arrive at good rock or adequate bearing below. Springs and underground streams are also sometimes encountered in excavating. Consequently it may be necessary to take special precautions to eliminate the water from the area where the digging occurs. The following general methods are now most used in conditions of this sort.

(a) The entire area is surrounded with a water-tight construction known as a **COFFERDAM**, ahead of the excavation, and the digging is then carried on in the dry.

(b) Water-tight compartments called **CAISSONS** are sunk as the excavation proceeds, the digging being done inside the compartment.

**Cofferdams.** Any water-tight construction such as sheet piling is a cofferdam, but the term is usually applied to the more elaborate structures on a large scale. In building construction they are employed especially to enclose either the whole or an appreciable part of a building site in order to prevent the water from entering. The cofferdams may consist of two rows of wood or steel sheet piling with clay puddled in between the rows, or of a series of caissons sunk side by side to the required depth. The caissons are usually of concrete and form part of the basement wall and waterproofing system, and act as footings for the exterior wall columns. Careful bracing must be applied as the excavation proceeds to withstand the earth pressure on the outside. Cross bracing composed of the structural girders can sometimes be employed, the interior columns being introduced after their footings are completed. Cofferdams are used in the excavation of basements and cellars or of large boiler and machinery pits below the basement floor level.

Column piers, when sunk in the presence of water to greater depths than the basement floor, may be laid through steel cylinders as described in Article 1, but especial attention must be given to sealing the bottom of the cylinder with concrete to prevent the entrance of water. The soil inside the cylinder may be loosened up with power-driven cutter heads on vertical shafts lowered into the tube. After the removal of the cutter head the soil is hoisted out with buckets. When the footings are of large size, either open or pneumatic caissons are used.

In sand, sheet piling is often slow and difficult to drive and pumping has proved more practicable. This is accomplished by laying a line of 3" to 6" pipe around the building site and tapping into this line, at regular intervals, 1½" vertical pipes with well points at their lower ends. The sand is softened with water jets, and the vertical pipes and points are then easily sunk to the required depth. A pump is connected

to the pipe line and clears the water from the sand. This method has been successfully used in Atlantic City, New Jersey, where the general excavation was 18'0" deep and machinery and elevator pits 42'0" deep while surface water was encountered at 3'0" and tide water at 10'0" below the street level. The well points are placed from 1'6" to 4'0" apart as required.\*

**Open Caissons.** The word caisson is derived from the French *caisse* and is virtually a box either without top or bottom or with a top but no bottom. Caissons have been used for a long period in the foundation work for piers and bridges, and in late years have come into general favor in heavy building construction in wet soil. The box is constructed of water-tight material, wood, steel or concrete, upon the spot where the excavation is to be started. The digging is then carried on inside the box, which sinks of its own weight as the earth is removed from under its lower edge. When the box has no bottom or top it is called an OPEN CAISSON. When a top is added, which is always for the purpose of confining compressed air within the box, it is called a PNEUMATIC CAISSON.

Open caissons are used when there is sufficient water running from the sides of the excavation to interfere with the progress of the work but when comparatively little enters under the lower cutting edge. They are usually circular or rectangular in form and when in place become a part of the foundation. The excavation is carried on by hand or by dredging machines, and pumps are used if necessary to remove surplus water.

The construction of caissons must be sufficiently strong to withstand torsion, bending and shearing due to the imposed loads, to uneven bearing at the bottom and to departure from a vertical position. Concrete or steel are now preferred in building caissons to wood which was the material originally used.

**Pneumatic Caissons** (Fig. 5). When the water pressure is so great that a large amount enters under the cutting edge, washing in quantities of soil along with it, the conditions demand other measures. The entrance of the water and soil greatly interferes with the progress of excavation and also draws material away from the surrounding areas thereby creating a danger to adjacent buildings. By introducing compressed air into the interior of the caisson the pressure is raised to a higher degree than that in the material upon the outside and water can no longer enter. Normal air pressure is about 15 lbs./in.<sup>2</sup>, and men are able to work for longer or shorter periods in pressures up to 50 lbs./in.<sup>2</sup> A limit of about 100'0" is therefore placed upon the depth at which pneumatic caissons can be effective.

In building construction, pneumatic caissons are now made of steel or concrete, the latter generally being the cheaper. They consist of a box called the working chamber, about 6'0" high, provided with a top

\* *Engineering News-Record*, Nov. 4, 1920.

or deck and no bottom. This chamber is sunk in the earth by excavating in the chamber and under the lower edges.

As the working chamber sinks, its sides are extended above the deck and the space between the walls is filled with concrete. It is an advan-

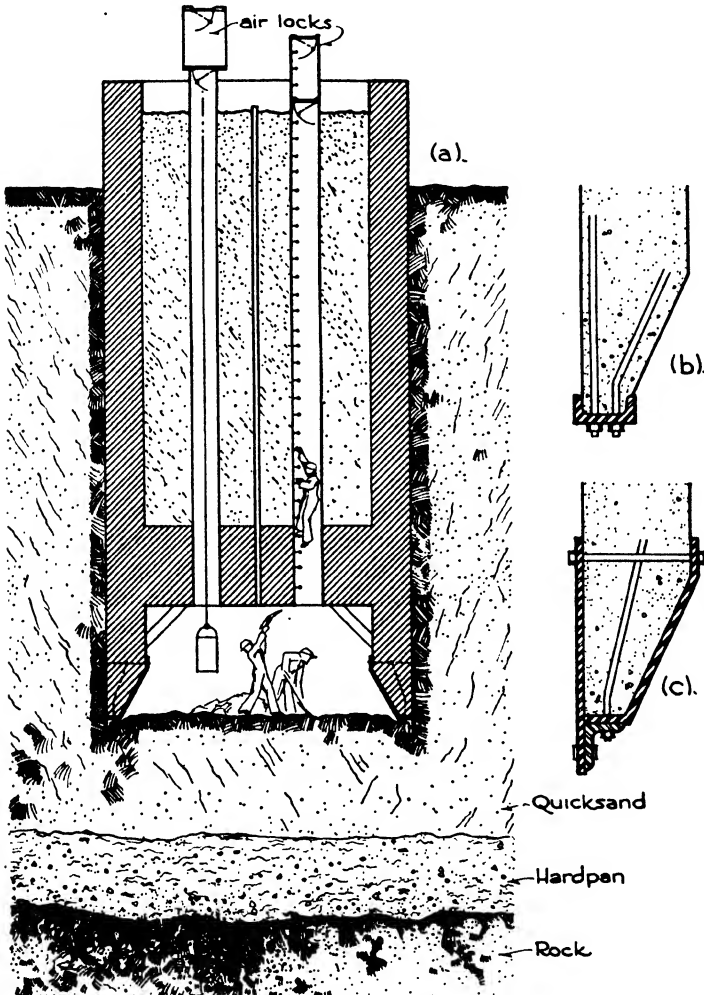

FIG. 5.—Pneumatic Caisson.

tage to provide for a continuous sinking of the caisson because the earth settles and binds around the structure during long stops, which necessitates adding pig iron or other weights to start it again against the increased friction. A light cofferdam of wood is often built on top of the deck permitting the concrete to be poured continuously as the caisson



sinks. The air pressure is maintained through a pipe from the working chamber to the surface of the ground where the compressor is situated.

The workmen enter and leave and materials are removed from the working chamber through shafts provided with air locks. The shafts are usually made up of sections of  $\frac{3}{8}$ " steel pipe and vary from 2'6" to 4'0" in diameter. The air locks are compartments in the top of the pipes fitted with air-tight doors in the top and bottom. To enter the shaft the upper door is opened while the bottom door is closed. The workman descends into the lock and shuts the top door. The air pressure is then raised in the lock to equal that in the shaft and working chamber and the lower door is opened. The workman then climbs down the ladder in the shaft to the chamber. The opposite procedure is carried out upon leaving the shaft. Heavy material such as boulders and wet clay may be hoisted out of the chamber in buckets, but sand and silt are generally blown out through pipes by the air pressure.

When the working chamber has reached the rock where it is to rest, the surface is dressed down to solid material and the working chamber is filled with concrete to about 12" from the top, thereby sealing the caisson against the entrance of water. The concrete is allowed to stand for 24 hours until all shrinkage has taken place and then, the air pressure being released, the remaining space is rammed full with comparatively dry concrete. The shafts are also filled and a solid concrete pier is obtained from the surface of the ground down to bedrock.

Pneumatic caissons must be strongly constructed in the same manner as open caissons to withstand the wracking, bending and shearing incidental to sinking into position. The deck over the working chamber must likewise be able to carry the load of concrete placed upon it. This load is, however, considered as including only the few feet of green concrete resting directly upon the deck. This layer of concrete is sometimes reinforced to act as a slab and when set serves as a support for the concrete of the pier above it.

**Cutting Edge** (Fig. 5, *b*, *c*). The cutting edges of both open and pneumatic caissons may be sharp or blunt. Although the sharp edge requires less excavation under it to cause the caisson to sink and by penetrating the soil gives a good seal against blow-outs, the blunt edge is more generally preferred because it is less likely to bend and gives better bearing in case of uneven support. The blunt edge is usually shod with a 6" or 8" channel.

### Article 3. Waterproofing

**General.** Unless some method of prevention be employed, moisture from the outside earth is liable to penetrate foundation walls and cause cellars and basements to be objectionably damp. Even in well-drained soils with no permanent moisture rainwater will often enter the walls with undesirable results. When there is a definite water content in the

soil from nearby ocean, rivers, lakes or springs, pressure results which causes continual leakage into the substructure.

The general conditions may then be classified as follows:

- (a) SURFACE WATER only with little or no hydrostatic pressure.
- (b) PERMANENT WATER in the soil with a definite hydrostatic pressure.

Different methods of preventing dampness in the substructure are employed in these two conditions.

**Surface Water.** Drainage of the foundation wall is usually all that is necessary in the case of rain and snow from the surface of the ground with no standing water in the soil. The drainage may consist simply of a back filling of loose rock to collect water, which would otherwise follow along the wall, and lead it away from the building, or a drain pipe with open joints may be laid in the bottom of a trench next to the wall. The water is carried to the sewer or, in the case of isolated build-

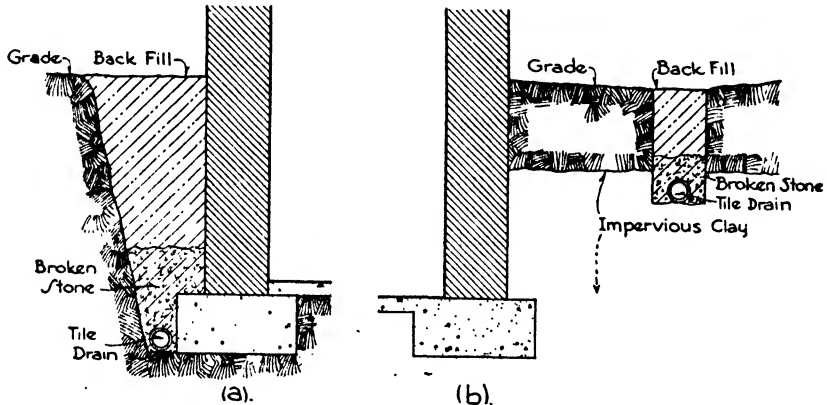

FIG. 6.—Drainage for Basement Walls.

ings, to a dry well (Fig. 6, a). A more effective but slightly more costly method is to lay drain pipe and loose rock fill in a trench several feet away from the basement wall thereby keeping the water entirely away from the building. If impervious clay be overlaid with porous gravel or sand the drain need not be deeper than 12" into the clay (Fig. 6, b). Hollow tile are sometimes laid all over the earth bottom, especially when wood finished flooring is used in rooms with no cellar under them as further described in Chapter IX. No actual waterproofing of the cellar walls and floor is usually necessary in the case of surface water only, the drainage of the foundations being sufficient. When a building is situated upon sloping ground, however, waterproofing may be required on the wall toward the increased flow of surface water.

**Ground Water with Pressure.** Now that the basements of large buildings often extend below ground water and tide levels, the question of

rendering the sub-structure water tight becomes very important. The systems of waterproofing may be classified as

(a) Absolute Pressure Waterproofing.

(b) Waterproofing with Drainage.

In ABSOLUTE PRESSURE WATERPROOFING the effort is to transform the basement walls and floor into an absolutely water-tight basin which will withstand the water pressure or hydrostatic head. This pressure may be very powerful and necessitates heavy concrete floors and even reinforced slabs to withstand the head. Many cases have occurred in which the entire basement floor has been raised in waves and sometimes has cracked and disintegrated under the pressure of the water in the soil beneath it. The amount of resistance required can be determined from the amount of hydrostatic head, which depends upon the position of the ground or tide water level in relation to the cellar bottom, or from the flow of subterranean springs when they are present. The absolute pressure method is usually adopted when the water pressure is moderate, and has been employed with success under great hydrostatic head. When caisson cofferdams have been installed to free areas from water during excavation their presence may also be made use of in an absolute pressure system of waterproofing.

In WATERPROOFING WITH DRAINAGE the water pressure under the basement floor is relieved by drainage pipes extending over the surface and emptying into the sewer or into a sump pit below the level of the floor. The water is then pumped from the sump pit up into the sewer. In some large buildings which generate their own power or use a large amount of electric current it is more economical to operate the automatic electric sump pumps than to pay for costly reinforcement of the basement floor. There may be, however, a question as to the permanence and reliability of such a drainage system.

**Waterproofing.** In both the above described cases waterproofing of the walls and floor is necessary because concrete is seldom water-tight in itself owing to character of mix or workmanship, working planes and settlement cracks.

There are three methods of waterproofing in general use: INTEGRAL, MEMBRANE and SURFACE COATING.

**INTEGRAL WATERPROOFING.** This method consists of incorporating certain compounds, in the form of powder, liquid or paste, with the concrete during the mix. Their effect is to render the concrete more impermeable by filling the voids, repelling the water or increasing the chemical activity of the cement. Many of the compounds are patented and their composition secret, but in general they consist of hydrated lime, iron filings, fatty acids and oils and aluminum, magnesium and zinc fluosilicates. Hydrated lime fills the pores and also lubricates the concrete, rendering it more dense; iron filings oxidize and expand, thereby closing up the pores. The fatty acids are generally mixed with lime, reacting to form a lime soap which is not soluble in water and

tends to repel it. Heavy oils have also been used with some success. The chemical admixtures act upon the cement to render it more waterproof and also harden the concrete.

Although integrally mixed compounds increase the water-resistant qualities of the concrete they cannot fill cracks or working joints or compensate for poor workmanship. They are often used with success in small constructions, but other methods of waterproofing are more dependable for work of any magnitude.

**MEMBRANE WATERPROOFING.** Membrane waterproofing is the oldest and still the most widely used type. It consists of layers of impregnated felt, jute or cotton covered with tar pitch or asphalt binder applied hot.

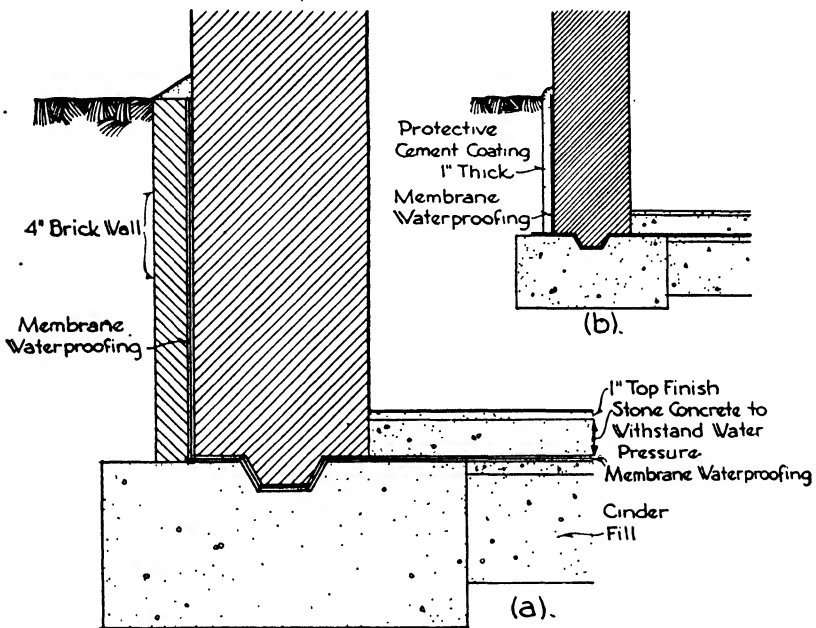

FIG. 7.—Membrane Waterproofing.

The material has a certain degree of elasticity which permits it to stretch slightly with settlement of the masonry and to cover small cracks in the wall occurring after the membrane is applied. Complete continuity is necessary, and the material must therefore be installed and superintended by experienced men to be effective. It is put on in alternate layers of membrane and hot pitch or asphalt. Asphalt is best where there are wide ranges of temperature, and it is more used on roofs than on walls and foundations. Pitch has greater chemical stability. Of the membranes, felt is the cheapest but jute and cotton are more elastic. An open-weave jute is now often used which acts as a toughened and moderately reinforced material. The membranes are saturated with

asphalt or coal tar pitch, the number of plies, from two to five, depending upon the water pressure in the surrounding soil (Fig. 7,*a*).

The waterproofing must always be applied on the surface of the wall or floor which is toward the water, the bond between the masonry and the tar and felt being but slight with little resistance to pressure. The water should therefore push the membrane against the wall and floor rather than pull it away. The waterproofing is generally applied to the basement floor before the exterior walls are built, and a key is made in the footings to bond the wall. Laps are left projecting beyond the outer edge of the footing to be turned up later and connected with the layers applied to the outside of the wall after it is built.

When possible to get at the outer surface of the wall to apply the tar and felt coatings a layer of cement is applied over the waterproofing for protection before the back-filling is finished (Fig. 1,*b*). It is, however, often impossible to reach the wall from the outside, in which event a 4"

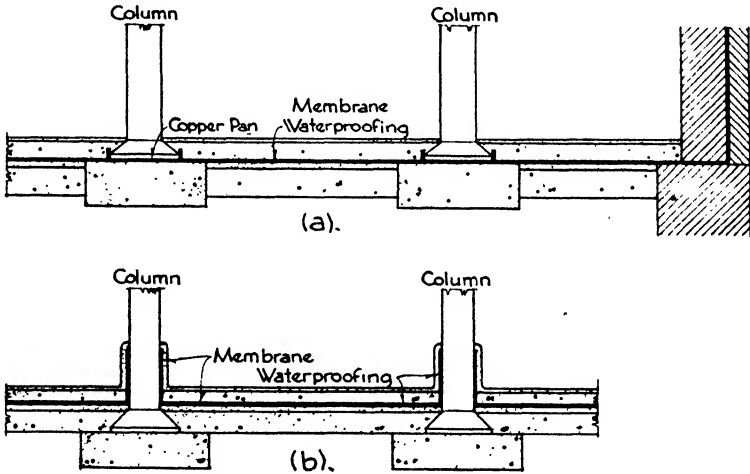

FIG. 8.—Membrane Waterproofing.

wall of brick or terra cotta blocks is first built from the footing up to grade outside the basement line before the basement wall is constructed. The membranes are applied to the inside of this wall and the basement wall is built up close against it, all the work being done from inside the basement (Fig. 7,*a*).

In constructing the basement floor a layer of cinders 10" to 12" thick is first put down for drainage and to give a firm and homogeneous bed for the concrete. If drain pipes are used to relieve the pressure they are laid in this bed. Upon the cinders 2" of concrete are spread as a preparation for the membrane waterproofing. Upon the waterproofing is poured the concrete floor slab or cellar bottom, which must be strong enough to withstand the water pressure. If no under drainage is used,

as in the absolute pressure system, it may be necessary to introduce steel reinforcement, calculating the bottom as a flat slab held down by the weight of the columns. Over the top of the cellar bottom is laid a 1" wearing surface of 1 to 2 concrete. Where columns occur the waterproofing may be connected to a copper pan under the column or it may be brought up the sides of the column, depending upon whether the waterproofing or the columns are first installed. The membranes must

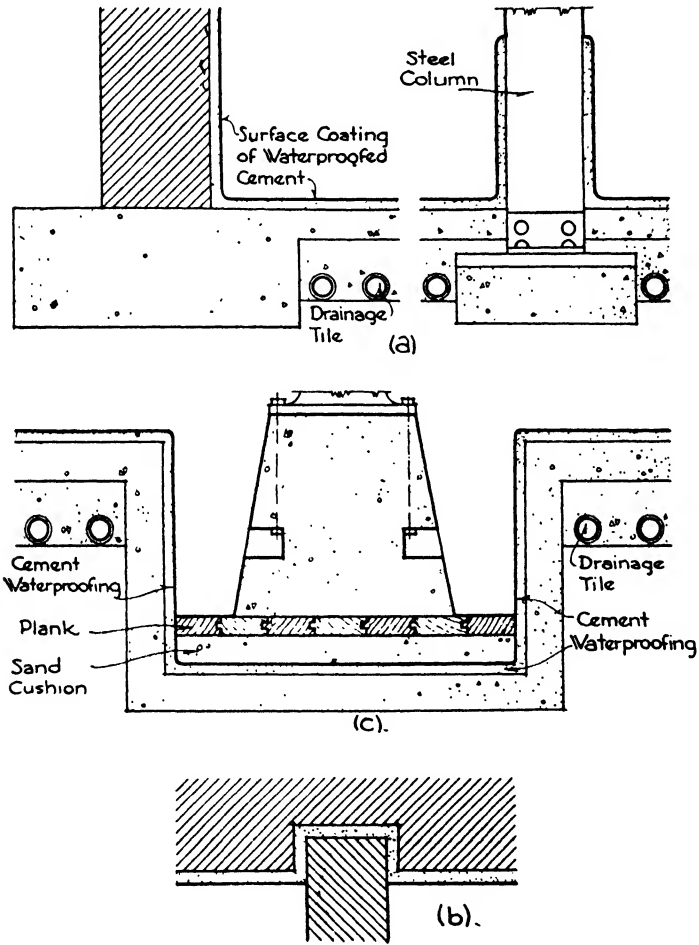

FIG. 9.—Surface Coating Waterproofing.

be insulated from the heat of steam boilers and oil burners (Fig. 8,a,b). The work must be done with great care because it is entirely covered from view by other construction and therefore cannot be repaired without difficulty and expense.

**SURFACE COATING WATERPROOFING** (Fig. 9). This type consists of

a coating of integrally waterproofed rich cement and lime mortar applied to the inner surface of the walls and on the top of the cellar bottom. Many large buildings have been waterproofed in this manner with perfect success. It is not elastic, but any cracks and leaks may be easily seen and repaired. The coatings are usually put on in two layers and total about  $\frac{3}{4}$ " thick on walls and 1" on floors where it also acts as the wearing surface. The essential consideration is a good bond with the wall and floor surfaces, and great care is taken to gain this end by scratching and roughening the faces upon which the waterproofing is to be applied and by working in a thin coat of neat cement before putting on the first layer (Fig. 9,a).

Niches are usually left in an exterior wall and the coating carried in and around them wherever interior partitions butt into exterior walls. The partition is then built into the niche (Fig. 9,b). The waterproofing on the floor may be carried under interior partitions or brought up on the sides to the required height. With columns the floor coating is usually continued up the side of the column. Under machinery foundations 2" cushions of sand and 2" planks are sometimes introduced between the foundation and the waterproofing to prevent vibration from cracking the cement coating. Both with membrane and surface coating methods, machinery foundations below the cellar floor are set in waterproofed pits, and the bolts should never be allowed to penetrate the waterproofing (Fig. 9,c). The cellar bottom must be sufficiently strong to resist the hydrostatic head as described for the membrane type, either the absolute pressure or drainage method being applicable.

It is generally best practice to keep all water out of the foundations and cellars by pumping until the waterproofing is entirely completed.

# INDEX

(Numbers refer to pages)

- Acoustical tile, 146
- Actinic glass, 237
- Admixtures, 28
- Aggregates, 27
  - bulking of, 30
  - grading of fine, 31
- Air furnace iron, 102
- Alca lime, 16
- Allowable stresses, for brickwork, 291
  - for concrete, 476
  - for reinforcement, 469
  - for steel, 393
  - for stonework, 297
  - for timber, 305
- Alloy steel, 105
- Alloys, non-ferrous, 111
- Aluminum, 111, 210
- Aluminum paint, 226
- Aluminum roofing, 159
- Aluminum windows, 201
- Anchoring of brickwork, 59
- Angles, gauges for, 402
  - properties of, 382
  - steel, 373
- Annual rings, 39
- Arch bond, 61
- Arches, brick, 60, 120, 295
  - centers for, 96
  - cinder, 123
  - elliptical, 95
  - failure of, 301
  - flat, 61, 95
  - gypsum, 124
  - hollow tile, 120
  - pointed, 95
  - relieving, 61
  - segmental, 61, 95
  - stability of, 300
  - stone, 95
  - wood, 327
- Architectural terra cotta, 67
- Area walls, 522
- Areas, of rods, 484
  - of steel, 478
- Asbestos roofing, 160
- Asbestos shingles, 153
- Ashlar, 92
  - thickness of, 97
- Asphalt flooring, 147
- Backer tile, 70
- Backing of stonework, 97
- Balloon frame, 357
- Bar joists, 128
- Barge boards, 207
- Bars, bent-up, 482
  - reinforcing, 470
- Base board, wood, 216
- Base slab, design of, 588
- Basement floors, 115, 116
- Basement walls, 294, 518
  - design of, 520
- Basement windows, 200
- Bases, column, 323, 426, 568
  - for stucco, 182
- Bastard sawed lumber, 45
- Battened doors, 185
- Bay of truss, 437
- Beads, corner, 178
- Beams, bearing on, 309
  - built-up, 318, 373
  - cantilever, 388, 489
    - design of, 525
  - ceiling, 219
  - Clark, 317
  - compound, 314
  - concrete, 132
  - connections for, 404, 424
  - continuous, 278, 279, 502
  - deflection of, 275, 307
  - depth of, 477
  - design of, 273, 307, 394, 395
  - end conditions, 395
  - erection of, 406
  - fixed, 277
  - formulae for, 491
    - deflection, 276
  - hangers, 310
  - investigation of, 274
  - keyed, 315



- Beams—(Continued)  
 overhanging, 259, 276  
 properties of structural shapes, 376  
 reinforced concrete, design of, 522  
 restrained, 277  
 safe loads for, 274  
 scarfed, 315  
 simple, 388  
 steel, 131  
 stiffness of, 275  
 stresses in, 259, 384  
 superimposed, 314  
 theory of, 473  
 timber, design of, 307  
 types of, 259, 372  
 weight of, 390  
 wood, 117, 130
- Bearing, on beams, 309  
 on walls, 310
- Bearing wall construction, 10
- Belt courses, 207
- Bending factor, 286
- Bending moment, 262, 263, 384, 486  
 formulae for, 390  
 negative, 276
- Bending stresses, 262
- Bent-up bars, 482
- Bessemer process, 107
- Billets, 426, 568  
 design of, 588
- Birch, 50
- Blasting, 608
- Blocks, concrete, 79  
 glass, 238  
 wood, 142
- Board, plaster, 19, 179  
 wall, 19
- Board foot, 46
- Bolsters, wood, 325
- Bond of reinforcement, 484
- Bonded cement flooring, 148
- Bonding of masonry, 57, 59
- Book tile, 72
- Borings, 555
- Boston hip, 154
- Boston lap, 154
- Box girder, design of, 416
- Braced frame, 334
- Braces, 337
- Brass, 112
- Brick arches, 60, 120, 295
- Brick masonry, 56, 57, 58
- Brick piers, 293
- Brick vaults, 61
- Brick veneer, 60
- Brick walls, 291, 294
- Bricks, 134  
 burning of, 52  
 drying of, 52  
 grades of, 52  
 ingredients of, 51  
 kinds of, 53  
 manufacture of, 51  
 selection of, 55  
 sizes of, 53
- Brickwork, 54, 232  
 allowable stresses for, 291  
 anchoring of, 59  
 arch bond, 61  
 centers for arches, 62  
 chases in, 293  
 cleaning of, 64  
 corbeling of, 294  
 damp-proofing of, 65  
 efflorescence of, 64  
 flat arches, 61  
 joints in, 55  
 mortar for, 66, 288, 291  
 openings in, 293  
 reinforced, 60  
 relieving arches in, 61  
 segmental arches, 61  
 strength of, 289  
 tests for, 288  
 weight of, 291
- Bridging, 338
- Bronze, 112
- Bronze windows, 200
- Buckling, 389
- Bucks, door, 81  
 pressed steel, 81  
 structural steel, 82  
 wood, 81
- Building codes, 6
- Building paper, 355
- Buildings, types of, 7
- Built-up beams, 318, 373
- Built-up furring, 181
- Built-up girders, 373
- Built-up roofing, 160, 161
- Bulking of aggregates, 30
- Bullet-proof glass, 237
- Burning of bricks, 52
- Butt joint, 213
- Buttresses, 294, 299
- Caisson piles, 599, 610
- Caissons, open, 614  
 pneumatic, 614
- Calcareous materials, 85

- Calcimine, 227
- Calcium lime, 14
- Cantilever beam, 489, 525
- Cantilever footings, 571
  - design of, 587
- Caps for columns, 324
- Carbon steel, 104
- Carbonate of lead, 225
- Casements, 193, 195
  - steel, 200
- Cast iron, 101, 102
- Cast stone, 82
- Castings, chilled, 102
- Cedar, 50
- Ceiling beams, 219
- Ceilings, coved, 181
  - furred, 177
  - suspended, 177
- Cellar windows, 193
- Cellular steel floors, 128
- Cement, high early strength, 24
  - hydraulic, 14
  - Keene, 18
  - masonry, 24
  - natural, 20
  - non-staining, 24
  - Portland, 20, 24
  - pozzuolan, 20
  - testing of, 25
- Cement floors, 147, 148
- Cementing materials, 14, 25
- Center, of gravity, 250, 271
  - of gyration, 272
- Centers, for arches, 95
  - for brickwork, 62
- Centroids, 250, 271
- Ceramic floors, 144
- Chain, sash, 193
- Chair rail, 219
- Chalk, 87
- Channels, 373
  - properties of, 381
- Chases, 293
- Checks, 41
- Cherry brick, 52
- Chilled castings, 102
- Chimneys, 62
- Chromium, 111
- Chromium trim, 211
- Cinder arches, 123
- Cinder concrete, 28
  - blocks, 80
  - floor slabs, 122, 501
- Clapboards, 355
- Clark beams, 317
- Clay, 558
- Cleaning, of brickwork, 64
  - of stonework, 97
- Coarse aggregate, 27
- Codes, building, 6
- Coefficient of friction, 299
- Cofferdams, 613
- Cold-drawn mouldings, 198
- Collar beam, 364
- Color pigments, 226
- Colored glass, 236
- Column bases, 323, 426
- Column caps, 324
- Column connections, 424
- Column footings, 567
  - design of, 578
  - grillage for, 568
- Column formulae, 280, 282, 419
- Column loads, 418
- Column splicing, 423
- Columns, bases for, 558
  - combination, 516
  - composite, 515
  - end connections of, 279, 420
  - metal, 326
  - plate and angle, 422
  - reinforced concrete, 511
    - length of, 512
    - types of, 513
  - spiral, 513
    - design of, 535
  - steel, 375
    - design of, 283
  - stone, 96
  - tied, 515
    - design of, 534
  - timber, design of, 284
    - formula, 283
  - used with flat slabs, 506
  - wood, 219
- Combination columns, 516
- Combined column footings, 570
  - design of, 582
- Commercial occupancy, 8
- Common bond, 57
- Common bricks, 53
- Components of forces, 245
- Composite columns, 515
- Composition flooring, 147
- Composition of forces, 246, 248
- Compound beams, 314
- Compression reinforcement, 490
- Concentrated loads, 350, 489
- Concrete, allowable stresses for, 476
  - cinder, 28

## Concrete—(Continued)

compressive strength of, 30  
 consistencies of, 32  
 construction joints, 36  
 controlled, 31  
 curing of, 37  
 definition of, 27  
 expansion joints, 36  
 light-weight, 81  
 mass, 27  
 painting of, 231  
 placing of, 35, 36  
 pouring of, 35  
 processed, 123  
 proportions of, 29  
 pumping of, 35  
 ready-mixed, 33  
 recommended mixes for, 32  
 reinforced, 27  
 transporting of, 34  
 used in fireproofing, 134  
 vibration of, 35  
 water-cement ratio, 30  
 water-content of, 30

Concrete beams, 132

Concrete blocks, 79  
 cinder, 80  
 structural, 79

Concrete joints, 36

Concrete joists, 124, 126, 495

Concrete mixers, 33

Concrete ribbed slabs, 499

Concrete solid slabs, 129

Concrete tiles, 145

Concurrent forces, 245

Conductors, 167

Connections, beam, 404, 424  
 riveted, 400  
 types of, 397  
 welded, 398

Connectors, timber, 321, 437

Consistencies of concrete, 32

Construction joints, 36

Continuous beam, 278, 279, 502

Continuous footing, 569, 580

Continuous slabs, 502

Continuous windows, 199

Controlled concretes, 31

Conversion of wood, 45

Copings, 96

Copper, 110

Copper roofing, 159

Copper trim, 210

Coquina, 87

Corbeling, 294

Cord, sash, 193

Core borings, 555

Cork flooring, 150

Corner beads, 178

Corner boards, 207

Corner posts, 336

Cornices, plaster, 181  
 wood, 219

Corrugated iron roofing, 160

Corrugated steel floors, 128

Counterbalanced steel doors, 202

Coved ceilings, 181

Cover plates, 412

Curing of concrete, 37

Curtain walls, 58

Cylinder glass, 234

Cylinders, steel, 565, 599, 610

Cypress, 49

Damp-proofing of brickwork, 65

Dead loads, 10, 394, 439

Decay of wood, 41

Deductions in live loads, 12

Defects in timber, 41

Deflection of beams, 275, 307, 359, 388  
 formulae for, 276, 390

Deformation, 251, 253, 255

Dense terra cotta, 73

Diagonal tension, 479

Distributed loads, factors for, 350

Dolomite, 85

Dolomite limestone, 88

Dome and vault tile, 72

Door bucks, 81

Door frames, 189

Door trim, 209, 217

Doors, battened, 185  
 counterbalanced, 202  
 hollow-metal, 196  
 ledged, 185  
 manufacture of, 186  
 metal-covered, 195  
 operation of, 187  
 paneled, 185  
 revolving, 188  
 rolling steel, 201  
 sliding steel, 202  
 stock, 187  
 thickness of, 187  
 types of, 185

Dormers, 364

Double-hung windows, 190, 200

Douglas fir, 48

Dovetailed joints, 215

Doweled joints, 215

- Dowels, 213  
 Drainage, of basement floors, 116  
   of basement walls, 617  
   of roofs, 163  
 Drawn glass, 234  
 Driers, 224  
 Drips, 93  
 Drop panel, 504  
 Dry-press process, 52  
 Dusting, 149
- Earth pressure, 517  
 Eaves, wood, 205  
 Eccentric loads, 284, 421  
 Eccentric wall footing, 562  
 Efflorescence, 64  
 Elastic curve, 275  
 Elastic limit, 252  
   of materials, 253  
 Elements of structural shapes, 375  
 Elliptical arches, 95  
 Enamel, 228  
 Encaustic tile, 144  
 End conditions, 279, 395  
 English bond, 57  
 English tile, 156  
 Entablatures, 96  
 Equilibrant, 245  
 Equivalent distributed load factors, 350  
 Equivalent fluid pressures, 518  
 Escalators, capacity of, 553  
   types of, 552  
 Excavation, types of, 607  
 Expanded metal, 470  
 Expansion joints, 36
- Face bricks, 54  
 Factor of safety, 254, 290  
   of materials, 255  
 Factory and shop lumber, 43  
 Faience tile, 144  
 Feldspar, 85  
 Fill for floors, 132  
 Fillers, 230  
 Fine aggregate, 27  
 Fink truss, 455  
   design of, 460  
 Fire brick, 54  
 Fire hazards, 8  
 Fire limits, 8  
 Fire protection, 135  
 Fire towers, 543  
 Fireplaces, 62, 64  
 Fireproof construction, 7  
 Fireproofing, selection of, 136
- Fireproofing tile, 71, 78  
 Fixed beam, 277  
 Fixtures, 220  
 Flagstone, 88  
 Flashing, 164  
 Flat arch, 61, 95, 295  
 Flat glass, 234  
 Flat slab, choice of system, 506  
   columns for, 506  
   construction, 504  
   design of, 535  
   diagonal tension in, 510  
   discontinuous panels, 510  
   moments in, 507  
   reinforcement in, 510  
   shear in, 510  
   thickness of, 505  
   types of, 129  
 Flemish bond, 57  
 Flexure formula, 267  
 Floor fill, 132  
 Floor framing, 113  
 Floor loads, 10  
 Floor slabs, cinder concrete, 122  
 Floor systems, 113, 114, 133  
 Floor tile, 70, 77  
   weights of, 71  
 Flooring, asphalt, 147  
   cement, 148  
   composition, 147  
   cork, 150, 151  
   laminated, 140  
   linoleum, 150  
   magnesite, 147  
   maple, 139  
   oak, 138  
   rubber, 151  
   veneered, 140  
   wood, 137  
   wood block, 142  
   yellow pine, 137  
 Floors, cement, 147, 148  
   dusting of, 149  
   granolithic, 149  
   gypsum, 122  
   laminated, 118, 313, 330  
   on soil, 115  
   parquetry, 140, 141  
   plank, 118, 312  
   reinforced concrete, types of, 492  
   ribbed, 124  
   sheet steel, 128  
   terrazzo, 149  
   with steel beams, 119  
   wood, 137, 141

- Flues, 62
- Footings, areas of, 576  
cantilever, 571, 587  
classes of, 559  
column, 567  
  design of, 578  
combined column, 570  
  design of, 582  
continuous, 569  
  design of, 580  
girder, 573  
grillage, 589  
isolated column, 567, 578  
pier, 561  
proportioning of, 576  
slab, 564  
spread, 566  
types of, 563  
wall, 560, 566, 577  
  stepped, 561
- Force, elements of, 245
- Force polygon, 246, 442
- Forms, 37  
  stripping of, 38
- Foundation beds, allowable pressures on, 559
- Foundations, mat, 573  
  purpose of, 554  
  selection of, 574  
  strengthening of, 603  
  tests for loads, 555
- Frame construction, 7
- Frames, door, 189  
  types of, 436
- Framing for floors, 113
- French tile, 155
- Furred ceilings, 177
- Furring, built-up, 181  
  for walls, 180
- Furring channels, 177
- Furring tile, 70, 77
- Gables, 207
- Gauges for angles, 402
- Girder footings, 572
- Girder supports, 351
- Girder wall supports, 330
- Girders, 117  
  box, 416  
  built-up, 373  
  design of, 397  
  plate, 374  
  steel, 351, 434  
  timber, design of, 308
- Girders—(Continued)  
  trussed, 319  
  wood, 350
- Girts, 336
- Glass, actinic, 237  
  bullet-proof, 237  
  colored, 236  
  composition of, 233  
  cylinder, 234  
  flat or drawn, 234  
  kinds of, 234  
  manufacture of, 234  
  obscured, 235  
  plate, 234  
  prism, 236  
  quartz, 237  
  roofing, 160  
  setting of, 240  
  shatter-proof, 237  
  structural, 238  
  wire, 235
- Glass blocks, 238
- Glass tile, 146
- Glazed bricks, 54
- Glazed tile, 144
- Glazing, 239
- Gneiss, 86, 89
- Gordon's column formula, 281
- Gothic construction, 5
- Grading, of aggregates, 31  
  of wood, 42
- Grain of wood, 40
- Grandstand truss, 454
- Granite, 86
- Granolithic floors, 149
- Graphite paints, 225
- Gravel, 557
- Gray cast iron, 101
- Greek construction, 5
- Grillage, 568  
  footing, 589
- Grounds for plaster, 179
- Guastavino vault, 72
- Gutters, 166
- Gypsum, 17, 85  
  structural, 19
- Gypsum arches, 124
- Gypsum floor slabs, 122
- Gypsum plaster, 18, 19, 173
- Gypsum tile, 75, 134  
  erection of, 79  
  manufacture of, 76
- Half timber, 208
- Hangers, 310

- Hard finish plaster, 18  
 Hazards, fire, 8  
 Headers, 338, 358  
 Hemlock, 49  
 High early strength cement, 24  
 Hollow brick walls, 59  
 Hollow metal doors, 196  
 Hollow tile arches, 120  
 Horizontal shear, 261  
 Hornblende, 85  
 Housed joints, 215  
 Howe truss, 452, 456  
 Human occupancy, 8  
 Hydraulic cement, 14  
 Hydraulic lime, 14, 17
- I-beams, properties of, 378  
 Igneous rocks, 86  
 Imitation wall tile, 145  
 Industrial windows, 198  
 Inflection point, 276  
 Insulation for roofing, 162  
 Integral waterproofing, 618  
 Investigation, 254  
   of beams, 274  
 Iron, air furnace, 102  
   malleable, 102  
   manufacture of, 99  
   ore, 98  
   pig, 98  
   smelting of, 99  
 Isolated column footing, 567
- Jambs, 93  
 Joints, brickwork, 55  
   failure of, 403  
   riveted, 403  
   stonework, 97  
   welded, 398  
   woodwork, 213  
 Joists, 117, 311, 337  
   bar, 128  
   concrete, 124, 126, 495  
   steel, 126, 434  
   tables for, 341-9  
   trussed, 128  
   wood, 118  
     design of, 358  
 Junior beams, properties of, 127
- Keene cement, 18  
 Kern distance, 286  
 Keyed beam, 315  
 Keyed joints, 215  
 Kiln-dried lumber, 40
- Kilns for bricks, 52  
 Knots in lumber, 41
- Lacquer, 228  
 Laitance, 29  
 Lally columns, 326  
 Laminated floors, 118, 140, 313, 330  
 Lath, metal, 176  
   selection of, 179  
   wood, 176  
 Lead, 111  
 Lead roofing, 159  
 Lead trim, 210  
 Leaders, 167  
 Ledged doors, 185  
 Lever, 258  
 Light frame construction, 118  
 Light-weight concrete, 81  
 Light wood framing, 333  
 Lime, 14  
   alca, 16  
   calcium, 14  
   hydrated, 15  
   hydraulic, 14, 17  
   magnesium, 14  
   setting of, 17  
   slaked, 15  
 Lime mortar, 15  
 Lime plaster, 170  
 Limestone, 14, 87  
 Linoleum flooring, 150  
 Lintels, 93  
 Live loads, 10, 11  
   reduction in, 12  
 Load-bearing tile, 68  
 Load distribution, 496  
 Loads, axial, 251  
   column, 417  
   concentrated, 350, 489  
   dead, 10, 394, 439  
   eccentric, 284, 421  
   floor, 10  
   live, 10, 11  
     reduction in, 418  
   roof, 10, 12  
   snow, 440  
   suspended, 445  
   types of, 394  
   unsymmetrical, 444  
   wind, 13, 440, 445  
 Logs, sawing of, 45  
 Lumber, bastard sawed, 45  
   checks in, 41  
   defects in, 41  
   factory and shop, 43

## Lumber—(Continued)

- knots in, 41
  - pitch pockets in, 41
  - qualities of, 44
  - shakes in, 41
  - strength of, 47
  - structural material, 43
  - units of measure, 46
  - yard, 43
- Magnesite flooring, 147
- Magnesite stucco, 184
- Magnesium lime, 14
- Mahogany, 50
- Malleable iron, 102
- Manufacture, of cast iron, 101
- of cast stone, 82
  - of doors, 186
  - of gypsum tile, 76
  - of iron, 99
  - of steel, 106, 107
  - of terra cotta, 74
  - of wrought iron, 103
- Maple, 50
- Maple flooring, 139
- Marble, 89
- Marble tile, 146
- Masonry, stresses in, 255
- Masonry cement, 24
- Mass concrete, 27
- Mat foundations, 573
- Materials, elastic limit of, 253
- factor of safety of, 255
  - physical properties of, 255
  - weights of, 394
- Matrix, 27
- Medullary rays, 39
- Membrane waterproofing, 619
- Metal columns, 326
- Metal connectors, 321, 437
- Metal-covered doors, 195
- Metal-covered windows, 196
- Metal lath, 135, 176
- Metal roofing, 157
- Metal trim, 221
- Metals, non-ferrous, 110
- Metamorphic rocks, 88
- Mica, 85
- Middle third, principle of, 285, 298
- Mill construction, 7, 118, 327
- Minimum live loads, 11
- Mirrors, 241
- Mission tile, 155
- Mitered joints, 213
- Mixers for concrete, 33

- Mixes for concrete, 32
- Mixing of paint, 230
- Modulus, of elasticity, 255
- of rupture, 274
- Moment-area method, 275
- Moment diagram, 264, 386, 487
- Moment of inertia, 268, 270
- Moments, 256
- for distributed loads, 486
  - statical, 271
- Mortar, for brickwork, 66, 288, 291
- lime, 15
  - Portland cement, 25
- Mouldings, cold-drawn, 198
- plaster, 175
  - wire, 219
  - wood, 215
- Mullions, 192
- Natural cement, 20
- Needling, 602
- Negative bending moment, 276
- Neutral surface, 260
- Newels, 548
- Non-concurrent forces, 245
- Non-ferrous alloys, 111
- Non-ferrous metals, 110
- Non-fireproof construction, 7
- Non-staining cement, 24
- Northern white pine, 48
- Oak, 50
- Oak flooring, 138
- Obscured glass, 235
- Oil paint, 223
- One-way slabs, 502
- design of, 528
- Oolitic limestone, 87
- Open caissons, 614
- Open-hearth process, 105
- Ores, iron, 98
- Ornamental plaster, 175
- Overhanging beam, 259, 276
- Oxide of zinc, 225
- Paint, 223
- application of, 231
  - mixing of, 230
  - oil, 223
  - on wood, 232
  - selection of, 233
  - spraying of, 232
  - water, 227
- Paint remover, 232
- Panel of truss, 437

- Panel point, 437
- Paneled doors, 185
- Paneling, 218
- Paper, building, 355
- Parallelogram of forces, 246
- Parquetry flooring, 140, 141
- Partition tile, 69, 76
  - weight of, 77
- Partitions, safe loads on, 353
  - solid plaster, 181
  - trussed, 353
  - wood, 352
- Pedestals, 568
- Perimeters of rods, 484
- Permanent set, 253
- Picture moulding, 219
- Pier footing, 561
- Piers, 293
  - concrete, 564
  - stone, 298
- Pig iron, 98
- Pigments, color, 226
- Pile caps, 598
- Pile driver, 592
- Piles, caisson, 599, 610
  - cast in place, 597
  - concrete, 596
  - driving of, 592
  - pre-cast, 596
  - selection of type, 600
  - spacing of, 591
  - wood, 593
- Piling, sheet, 608
- Pintle, 328
- Pitch of roofs, 163, 360
- Pits, 522
- Pivoted windows, 198
- Placing of concrete, 35
- Plank floors, 118, 312
- Plaster, 231
  - grounds for, 179
  - gypsum, 18, 19, 173
  - hard finish, 18
  - lime, 170
  - ornamental, 175
  - selection of, 175
- Plaster board, 19, 179
  - cornices, 181
  - partitions, 181
  - screeds, 175
- Plaster of Paris, 18
- Plastics, 146
- Plate and angle columns, 422
- Plate girder joists, properties of, 127
- Plate girders, 374
  - cover plates of, 412
  - design of, 412
  - flanges of, 406, 411
  - length and depth of, 409
  - stiffeners for, 409
  - types of, 407
  - web of, 409
- Plate glass, 234
- Plates, 337
- Pneumatic caisson, 614
- Pointed arches, 95
- Pointing of stonework, 97
- Poling board method, 612
- Poplar, 50
- Porous terra cotta, 73
- Portland cement, 20, 24
  - manufacture of, 22
  - setting of, 23
  - specifications for, 21
  - use of, 22
- Portland cement mortar, 25
- Post caps, 311
- Pozzuolan cement, 20
- Prepared roofing, 162
- Pressed steel bucks, 81
- Pressed wood, 146
- Pressure of earth, 517
- Prism glass, 236
- Processed concretes, 123
- Projected windows, 198
- Promenade tile, 155
- Properties, of junior beams, 127
  - of plate girder joists, 127
  - of standard timber sizes, 270
  - of structural shapes, 375
- Proportions of concrete, 29
- Protection against fire, 135
- Protective materials, 133
- Pulleys for sash, 193
- Purlins, 437
- Putty, 239
- Pyrites, 86
  
- Qualities of lumber, 44
- Quarry tile, 155
- Quarrying of stone, 90
- Quartz glass, 237
- Quicklime, 15, 17
- Quoins, 93
  
- Radius of gyration, 272
- Raft foundations, 573
- Rafter tables, 366



- Rafters, 363
  - design of, 366
  - steel, 434
- Railings, 548
- Rain conductors, 167
- Rankine's column formula, 281
- Reactions, 256; 258, 384
- Ready-mixed concrete, 33
- Recarburization, 107
- Red lead, 225
- Reductions in live loads, 418
- Redwood, 49
- Regeneration, 106
- Reinforced brickwork, 60
- Reinforced concrete, 27
  - formulae for, 491
  - types of floors, 492
  - uses for, 467
  - working formulae, 477
- Reinforced concrete beams, design of, 523, 525
- Reinforcement, allowable stresses for, 469
  - anchorage for, 472
  - area of, 478, 484
  - bond in, 484
  - for compression, 490
  - in columns, 512
  - in flat slabs, 510
  - perimeters of, 484
  - properties of, 468
  - spiral, 514
  - supports for, 472
  - temperature, 530
  - types of, 470
- Relieving arches, 61
- Removers, paint, 232
- Renaissance, 4
- Resisting moment, 263
- Resisting shear, 260
- Resolution of forces, 248
- Restrained beams, 277
- Resultant, 245
- Revolving doors, 188
- Ribbed slabs, 124, 129, 499
  - design of, 498
  - weight of, 497
- Ribbon, 337
- Risers and treads, 539
- Rivet holes, 401
- Riveted connections, 400
- Rivets, allowable stresses for, 403
  - failures of, 403
  - size of, 401
  - spacing of, 401
- Rivets—(Continued)
  - symbols for, 402
  - types of, 400
  - working values for, 404
- Rocks, classification of, 86
  - igneous, 86
  - metamorphic, 88
  - nature of, 556
  - sedimentary, 87
- Rods, reinforcing, 470
  - safe loads on, 320
- Roller support, 447
- Rolling of steel, 109
- Rolling steel doors, 201
- Roman architecture, 4
- Romanesque construction, 4
- Roof drainage, 163
- Roof gutters, 166
- Roof insulation, 162
- Roof loads, 10, 12
- Roof systems, 113
- Roof tile, 78, 156
- Roofing, aluminum, 159
  - asbestos, 160
  - built-up, 160
  - copper, 159
  - corrugated iron, 160
  - glass, 160
  - lead, 159
  - metal, 157
  - prepared, 162
  - selection of, 162
  - sheet metal, 158
  - tile, 155
  - tin, 157
  - zinc, 159
- Roofs, 331
  - flashing for, 164
  - materials for, 152
  - pitch of, 163, 360
  - types of, 361
- Rowlock arch, 61
- Rubber flooring, 151
- Rubble stonework, 92
- Rusticated stonework, 93
- Safe loads, for beams, 274
  - for lally columns, 326
  - for partitions, 353
  - for rods, 320
  - for timber columns, 324
- Salmon brick, 52
- Sand, 16, 557
- Sandstone, 88

- Sash, 192  
   pulleys for, 193  
   stock, 195  
 Sash chain, 193  
 Sash cord, 193  
 Sawing of logs, 45  
 Scarfed beams, 315  
 Schist, 90  
 Screeds, 175  
 Scribing, 215  
 Scuppers, 331  
 Seasoning, of stonework, 97  
   of wood, 40  
 Section modulus, 270, 271  
 Sedimentary rocks, 87  
 Segmental arch, 61, 95, 295  
 Semi-mill construction, 331  
 Semi-porous terra cotta, 73  
 Serpentine, 85  
 Set-backs, 9  
 Setting, of glass, 240  
   of Portland cement, 23  
   of stonework, 97  
 Shakes, 41  
 Shale, 88  
 Shapes, structural, 372  
 Shatter-proof glass, 237  
 Shear, 385, 478  
   formulae for, 390  
   horizontal, 261  
   resisting, 260  
   vertical, 261  
 Shear diagram, 264, 386, 487  
 Shearing stresses, 260  
 Sheathing, 354  
 Sheet piling, 608  
 Sheet-metal roofing, 158  
 Shellac, 228  
 Shingles, 355  
   asbestos, 153  
   tile, 155  
   wood, 152  
 Shoring, 601  
 Shrinkage reinforcement, 529, 530  
 Siding, 355  
 Silica minerals, 84  
 Silicate minerals, 85  
 Sills, 94, 335  
   steel, 434  
 Silt, 558  
 Skeleton-frame construction, 10  
 Skewbacks, 61  
 Skylights, 168  
 Slabs, cinder concrete, 501  
   concrete solid, 129  
 Slabs—(Continued)  
   continuous, 502  
   flat, 129, 535  
   footings, 564  
   one-way, 502  
     design of, 528  
   reinforced concrete, 121  
   ribbed, 124, 129, 499  
     weight of, 497  
   theory of, 473  
   two-way reinforcement, 503  
 Slag, 28  
 Slaked lime, 15  
 Slate, 89  
 Slate roofing, 154  
 Slate tile, 146  
 Slenderness ratio, 279  
 Sliding steel doors, 202  
 Slow-burning construction, 7, 327  
 Slumps of concrete, 32  
 Smelting of iron, 99  
 Snow loads, 440  
 Soft-mud process, 51  
 Soil, allowable pressures on, 559  
 Solid plaster partitions, 181  
 Southern yellow pine, 48  
 Spacing of rivets, 401  
 Spanish tile, 155  
 Species of timber, 44  
 Spiral columns, 513  
   design of, 535  
 Spiral stairs, 548  
 Spirals, 472  
   areas and diameters, 514  
 Splicing of columns, 423  
 Splined joint, 215  
 Spraying of paint, 232  
 Spread footings, 566  
 Spring wood, 39  
 Spruce, 49  
 Stability of arches, 300  
 Stains, 229  
 Stairs, concrete, 549  
   design of, 539, 551  
   enclosed, 543  
   spiral, 548  
   steel, 546  
   terms used with, 538  
   types of, 537, 541  
 Stairway, construction of wood, 545  
   design of, 539, 541, 551  
   width of, 540  
 Statical moment, 271  
 Steel, 232  
   allowable stresses in, 393

## Steel—(Continued)

- alloy, 105
- carbon, 104
- effect of heat on, 133
- manufacture of, 105, 107
- rolling of, 109
- structural, 109
- Steel beams, 119, 131
- Steel casements, 200
- Steel cylinders, 565, 610
- Steel doors, 202
- Steel framing, 434
- Steel girders, 351
- Steel joists, 126
- Steel windows, 198, 200
- Steps, 96, 548
- Stiff-mud process, 52
- Stiffeners, 409
- Stiffness of beams, 275
- Stirrups, 472
- Stock doors, 187
- Stock sash, 195
- Stone, composition of, 84
  - cutting of, 90
  - quarrying of, 90
  - selection of, 91
  - use of, 84
- Stone arches, 95
- Stone columns, 96
- Stone copings, 96
- Stone masonry, 92
- Stone piers, 298
- Stone steps, 96
- Stone trimming, 93
- Stone walls, 297
- Stonework, allowable stresses for, 297
  - backing of, 97
  - cleaning of, 97
  - joints in, 97
  - pointing of, 97
  - rusticated, 93
  - seasoning of, 97
  - setting of, 97
  - tests of, 296
  - weight of, 297
- Storm windows, 192
- Straight-line formula, 282
- Strain, 251
- Strength, of brickwork, 289
  - of lumber, 47
- Stresses, bending, 262
  - character of, 451
  - for materials, 255
  - in beams, 384
  - kinds of, 251

## Stresses—(Continued)

- shearing, 260
  - Stripping of forms, 38
  - Structural clay tile, 134
  - Structural concrete blocks, 79
  - Structural glass, 238
  - Structural gypsum, 19
  - Structural shapes, 109, 372
    - properties of, 375
  - Structural steel, 109
    - bucks, 82
  - Stucco, 182, 183, 231
  - Studs, 336
    - steel, 434
  - Summer wood, 39
  - Supports for girders, 330, 351
  - Surcharge, 521
  - Surface water, 617
  - Suspended ceilings, 177
- Tables, for joists, 338  
for rafters, 366
- T-beam, design of, 530
  - Tees, properties of, 383
  - Temperature reinforcement, 529, 530
  - Temperatures, in burning buildings, 133
    - effects of, 25
  - Terra cotta, architectural, 67
    - characteristics of, 74
    - colors of, 75
    - dense, 73
    - description of, 67
    - firing of, 75
    - fitting of, 75
    - manufacture of, 73, 74
    - porous, 73
    - raw materials for, 74
    - semi-porous, 73
    - structural, 67
    - uses of, 67
  - Terrazzo floors, 149
  - Testing cement, 25
  - Tests, for brickwork, 288
    - for foundation beds, 555
    - for stonework, 296
  - T-girder, design of, 533
  - Thrust, 298, 299
  - Tied columns, 515
    - design of, 534
  - Tile, acoustical, 146
    - backer, 70
    - book, 72
    - concrete, 145
    - dome and vault, 72
    - encaustic, 144

- Tile—(Continued)  
   English, 156  
   faience, 144  
   fireproofing, 71, 78  
   floor, 70, 77  
   French, 155  
   furring, 70, 77  
   glass, 146  
   glazed, 144  
   grades of, 145  
   gypsum, 75, 134  
   imitation wall, 145  
   load-bearing, 68  
   marble, 146  
   mission, 155  
   partition, 69, 76  
   promenade, 155  
   quarry, 155  
   roof, 78, 156  
   shingle, 155  
   slate, 146  
   Spanish, 155  
   structural clay, 134  
   unglazed, 143  
 Tile base, 116  
 Tile roofing, 155  
 Tile trim, 144  
 Timber, allowable stresses for, 305  
   commonly used, 47  
   grades of, 44  
   modulus of elasticity of, 305  
   properties of standard sizes, 270  
   sizes of, 305  
   species of, 44  
   varieties of, 46  
 Timber columns, design of, 284  
   formula for, 283  
   safe loads for, 324  
 Timber connectors, 321, 437  
 Tin, 111  
 Tin roofing, 157  
 Tongued and grooved joint, 213  
 Towers, fire, 543  
 Transoms, 192  
 Traprock, 86  
 Travertine, 87  
 Treads and risers, 539  
 Trigonometric functions, 484  
 Trim, aluminum, 210  
   chromium, 211  
   copper, 210  
   door, 209, 217  
   lead, 210  
   metal, 221  
   window, 209, 217  
 Trimmers, 338, 358  
 Trussed girders, 319  
 Trussed joists, 128  
 Trussed partitions, 353  
 Trusses, 436  
   character of stresses, 451  
   chords of, 436  
   expansion of, 441  
   Fink, 455, 460  
   grandstand, 454  
   Howe, 452, 456  
   notation for, 442  
   stresses in, 449  
   symmetrically loaded, 443  
   types of, 437  
 Two-way slabs, 503  
 Types, of buildings, 7  
   of doors, 185  
   of windows, 190  
  
 Ultimate strength, 254  
 Underpinning, 604  
 Unglazed tile, 143  
  
 Varieties of timber, 46  
 Varnish, 227  
 Varnish removers, 232  
 Vault lights, 236  
 Vaults, brick, 61  
   Guastavino, 72  
 Veneered flooring, 140  
 Vertical shear, 260, 261  
 Vibration of concrete, 35  
  
 Wainscoting, 217  
 Wallboard, 19  
 Wall box, 330  
 Wall footing, 560, 566  
   design of, 577  
   eccentric, 562  
   stepped, 561  
 Wall furring, 180  
 Walls, area, 522  
   basement, 518  
   bearing on, 310  
   brick, 291, 294  
   hollow brick, 59  
   reinforced concrete, 516  
   stone, 297  
   thickness of, 292  
 Walnut, 50  
 Washes, 93  
 Water, 29, 617  
 Water-cement ratio, 29

- Water content, 30
- Water paint, 227
- Waterproofing, 616, 618
  - integral, 618
  - membrane, 619
  - surface coating, 621
- Web members, 437
- Web of plate girder, 409
- Weights of materials, 71, 77, 291, 297, 394
- Welded connections, 398
- Welds, allowable stresses for, 400
- WF beams, properties of, 379
- Whitewash, 227
- Wind bracing, design of, 433
  - types of, 433
- Wind loads, 13, 440, 445
- Window sash, 192
- Window trim, 209, 217
- Windows, aluminum, 201
  - basement, 200
  - bronze, 200
  - casement, 193
  - cellar, 193
  - continuous, 199
  - double-hung, 190
  - industrial, 198
  - metal covered, 196
  - pivoted, 198
  - projected, 198
  - storm, 192
  - types of, 190
- Wire fabric, 470
- Wire glass, 235
- Wire mouldings, 210
- Wood, conversion of, 45
  - decay of, 41
  - grading of, 42
  - grain of, 40
  - growth of, 39
  - pressed, 146
  - seasoning of, 40
  - selection of, 46, 209, 212
  - varieties used, 48
  - workmanship for, 212
- Wood arches, 327
- Wood beams, 117, 130
- Wood blocks, 142
- Wood bolsters, 325
- Wood bucks, 81
- Wood column formula, 322
- Wood columns, 219
- Wood floors, 137, 139
- Wood girders, 350
- Wood joints, 213
- Wood joists, 118
- Wood lath, 176
- Wood mouldings, 215
- Wood partitions, 352
- Wood shingles, 152
- Wood trim, erection of, 221
- Wrought iron, 102, 103
- Yard lumber, 43
- Yellow pine flooring, 137
- Yield point, 254
- Zinc, 110
- Zinc roofing, 159
- Zoning, 9





