

# Birta Central Library

PILANI (Jaipur State)

Class No :- 677.

Book No :- W 284 T

Accession No :- 33777.





THE TEXTILES STUDENT'S  
MANUAL



*FROM THE SAME PUBLISHERS*

**A FIRST YEAR  
COTTON SPINNING COURSE**

By H. A. J. DUNCAN, A.T.I.

The book is divided into three sections: Cotton Spinning, Textile Mathematics, and Textile Drawing, and covers the requirements of the first-year student in a thoroughly practical manner.

In crown 8vo, cloth gilt, 240 pp. 5s. net.

**BLEACHING, DYEING,  
PRINTING AND FINISHING  
FOR THE MANCHESTER TRADE**

By J. W. McMYN, F.C.S.; and J. W. BARDSLEY.

A book intended for warehousemen, textile students, and others interested in cotton goods.

In crown 8vo, cloth gilt, 238 pp., with 41 illustrations. 6s. net. Second Edition.

**HANDBOOK OF  
WEAVING AND MANUFACTURING**

By HENRY GREENWOOD, A.T.I., *Head of the Textile Department, Municipal Technical School, Bury.*

A practical guide for students, weavers, overlookers, managers, and others engaged in the textile industry.

In crown 8vo, cloth gilt, 136 pp., illustrated. 5s. net.

**WORSTED CARDING AND  
COMBING**

By JOHN R. HIND, M.R.S.T., A.T.I.

Explains the fundamental principles underlying the processes of worsted carding and combing.

In crown 8vo, cloth gilt, 216 pp. 7s. 6d. net.

# THE TEXTILES STUDENT'S MANUAL

AN OUTLINE OF ALL TEXTILE PROCESSES,  
FROM THE ORIGIN OF THE FIBRE TO THE  
FINISHED CLOTH

A HANDBOOK TO ALL BRANCHES OF THE  
TEXTILES INDUSTRIES

BY

T. WELFORD

LECTURER ON TEXTILES TO THE LONDON COUNTY COUNCIL  
LONDON CHAMBER OF COMMERCE TEXTILES PRIZE, 1926



LONDON  
SIR ISAAC PITMAN & SONS, LTD.

1933

**SIR ISAAC PITMAN & SONS, LTD**  
**PARKER STREET, KINGSWAY, LONDON, W C 2**  
**THE PITMAN PRESS, BATH**  
**THE RIALTO, COLLINS STREET, MELBOURNE**  
**2 WEST 45TH STREET, NEW YORK**  
**ASSOCIATED COMPANY**  
**SIR ISAAC PITMAN & SONS (CANADA), LTD.**  
**70 BOND STREET, TORONTO**

**PRINTED IN GREAT BRITAIN**  
**AT THE PITMAN PRESS, BATH**

## PREFACE

IN the course of my studies of the fascinating subject of textiles, I have always felt the lack of a book written in non-technical language dealing with the fundamental facts which have to be mastered by every beginner. There are many excellent and expert treatises available, each of them describing one or more sections of the industry, but I have not yet seen a book written primarily for the student, giving him an outline of all textiles processes from the origin of the fibres to the finished cloth, and serving as a guide to his future studies.

This book is an attempt to fill the gap and to provide the student with a handy book of reference on all branches of the industry, whilst giving him the groundwork for a more detailed study of the subject. In compiling it I have endeavoured to avoid as much as possible lengthy descriptions of machinery or technical expressions, whilst at the same time giving all the essential details necessary for the proper understanding of each process. In the sections dealing with spinning and weaving only those parts of the mechanism which actually perform the operation under discussion are described, leaving the description of power supply, speeds, and general technical questions to the factory expert.

Although written for the student, *The Textiles Student's Manual* will also be found of assistance to anyone connected with the textiles trade who wishes to gain a general knowledge of the subject without going too deeply into the technicalities usually found in a work of this kind. The latest developments are all discussed in the book, and Rayon, the lusty infant of the textiles world, has a special chapter to itself. In the glossary of fabrics

will be found descriptions of cloths of every type, including those of our grandmothers' day, as well as the most recent of fashion's favourites.

In submitting this book to the approval of the reader, I should like to express my great appreciation of the assistance given me by those firms who have so kindly loaned the photographs and blocks from which many of the illustrations are reproduced. The generous way in which they have responded to my request is evidence of the fine spirit of co-operation which has always existed in this great industry.

T. W.

# CONTENTS

	PAGE
PREFACE . . . . .	V
SECTION I	
TEXTILE FIBRES AND YARNS	
CHAPTER I	
INTRODUCTION . . . . .	3
Vegetable and animal fibres—Characteristics of a good fibre	
CHAPTER II	
COTTON . . . . .	8
The plant—Insect pests—Sources of supply—Preparation for spinning	
CHAPTER III	
COTTON SPINNING . . . . .	24
Ring frame—Mule—Doubling—Gassing—Mercerizing—Yarn counts	
CHAPTER IV	
FLAX . . . . .	34
Sources of supply—Preparation of fibre—Wet spinning—Dry spinning—Yarn counts	
CHAPTER V	
MISCELLANEOUS VEGETABLE FIBRES . . . . .	41
Ramie—Jute—Hemp—Sisal hemp—Pita fibre—Manila hemp—New Zealand flax—Pineapple fibre—Bombax cotton—Kapok—"Vegetable silk"	
CHAPTER VI	
SILK . . . . .	48
Varieties of silk moth, cultivated and wild—Life of a silk moth—Preparation of raw silk—Silk throwing—Spun silk—Silk counts	
CHAPTER VII	
RAYON (ARTIFICIAL SILK) . . . . .	62
History of the rayon industry—World production—The raw materials and methods of production—Viscose, acetate, cuprammonium, nitro-cellulose—Rayon spinning—The Top-ham box—Celta—Staple fibre—Artificial horsehair—Yarn counts	

## CHAPTER VIII

	PAGE
WOOL . . . . .	81
Origin of breeds—The qualities necessary in a good wool fibre—Tops—Yield—Sources of supply, England, Australia, New Zealand, South Africa, South America, United States, etc.—Wool exchanges—Camel hair—Auchenia fibres—Mohair—Cashmere—Rabbit fur—Horsehair—Skin wools	

## CHAPTER IX

WOOL SPINNING . . . . .	104
Scouring—Carbonizing—Preparatory processes—Woollens—Worsted—Semi-worsted—Re-manufactured wools—Spinning—The Flyer—Ring frame—Cap frame—Mule—Yarn counts	

## CHAPTER X

FANCY YARNS . . . . .	120
-----------------------	-----

## CHAPTER XI

CONDITIONING . . . . .	122
Moisture content—Standards of regain	

## CHAPTER XII

METHODS OF DISTINGUISHING BETWEEN THE VARIOUS TEXTILE FIBRES . . . . .	125
Physical methods—Microscope examination—Chemical tests	

## SECTION II

## WEAVING

## CHAPTER XIII

WEAVING . . . . .	139
The plain loom—The Jacquard	

## CHAPTER XIV

STANDARD TYPES OF WEAVE . . . . .	152
Tabby—Twill—Satin—Gauze, etc.	

## CHAPTER XV

KNITTED FABRICS . . . . .	157
The latch needle—The beard needle—Hosiery—Warp-knitted fabrics	

## CONTENTS

ix

### CHAPTER XVI

	PAGE
LACE NET . . . . .	164
The lace machine	

### CHAPTER XVII

CARPETS . . . . .	169
Felted—Knotted pile—Plush woven—Double cloth	

### CHAPTER XVIII

GLOSSARY OF FABRICS . . . . .	172
-------------------------------	-----

## SECTION III

## BLEACHING, DYEING, AND FINISHING

### CHAPTER XIX

BLEACHING . . . . .	183
Cotton—Linen—Wool—Silk—Rayon	

### CHAPTER XX

THE DYEING OF TEXTILES . . . . .	186
Natural dyes—Mineral dyes—Acid dyes—Basic dyes—Mor- dant dyes—Direct cotton dyes—Sulphur dyes—Vat dyes— Dye faults and tests	

### CHAPTER XXI

CALICO PRINTING . . . . .	194
Direct method—Dyed style—Resist style—Discharged style	

### CHAPTER XXII

THE FINISHING OF TEXTILE FABRICS . . . . .	200
Wool—"Unshrinkable" process—Mercerized wool—Water- proofing—Silk—Silk weighting—Cotton—Flameproofing— Linen—Rayon—De-lustring	

### CHAPTER XXIII

CALENDAR OF TEXTILES HISTORY . . . . .	217
INDEX . . . . .	219





## ILLUSTRATIONS

FIG.	PAGE
1. Cotton . . . . .	16
2. Saw Gin with Feeder and Condenser . . . . .	17
3. Diagram of the Saw Gin Illustrated in Fig. 2 . . . . .	19
4. Revolving Flat Carding Engine for Cotton . . . . .	20
5. Card Clothing, Showing the Individual Wire Staple . . . . .	21
6. Flyer Roving Frame . . . . .	22
7. Ring Spinning Frame . . . . .	25
8. Self-acting Mule . . . . .	27
9. Ring Doubling Frame . . . . .	30
10. Diagram of Ring Doubling Frame, Showing Two Systems of Water Troughs and Two Systems of Creels . . . . .	31
11. Flax . . . . .	35
12. Ramie . . . . .	42
13. Kapok . . . . .	47
14. Cultivated Silk ( <i>Bombyx Mori</i> ) . . . . .	49
15. Wild Silk ( <i>Tussah</i> ) . . . . .	50
16. The Silkworm . . . . .	51
17. Diagram Showing the Fibroin Ducts of the Silkworm . . . . .	51
18. The Silk Moth ( <i>Bombyx Mori</i> ) . . . . .	52
19. Cross-section Through the Double Silk Filament . . . . .	53
20. Silk Cocoon . . . . .	53
21. Silk-reeling Machine . . . . .	55
22. Silk Spindle and Flyer . . . . .	57
23. Viscose Rayon . . . . .	67
24. Acetate Rayon . . . . .	68
25. Cuprammonium Rayon . . . . .	70
26. Nitro-cellulose Rayon . . . . .	71
27. Rayon Pump Unit, Showing the Spinneret from which the Filaments are Emitted . . . . .	72
28. Diagram of Rayon Spinning Machine . . . . .	73
29. Rayon Spinning Box, Electrically-driven . . . . .	74
30. Celta . . . . .	75
31. Cross-section of Celta Fibres . . . . .	77

FIG.		PAGE
32.	Cross-section of Celta Fibres . . . . .	77
33.	Wool, Merino . . . . .	82
34.	Wool, Cross-bred . . . . .	83
35.	Camel Hair . . . . .	96
36.	Alpaca . . . . .	97
37.	Llama . . . . .	98
38.	Vicuna . . . . .	98
39.	Mohair . . . . .	100
40.	Cashmere . . . . .	101
41.	Rabbit Hair (Angora) . . . . .	101
42.	Single Head Balling Intersecting Gill Box . . . . .	110
43.	"Noble" Comb . . . . .	111
44.	Wide Model Rectilinear ("Heilmann") Comb . . . . .	112
45.	Drawing Box . . . . .	113
46.	Roving Frame, with High-speed Spindles . . . . .	114
47.	Flyer Spinning Frame . . . . .	117
48.	Ring Spinning Frame . . . . .	118
49.	Conditioning Oven . . . . .	123
50.	Standard Pattern Wire Heald Frame, Showing Two Methods of Fixing Wires to Frame . . . . .	141
51.	Types of Shuttles and Bobbins in Modern Use . . . . .	143
52.	Warping Machine . . . . .	144
53.	The Action of a Plain Loom . . . . .	145
54.	Lightweight Automatic Loom . . . . .	146
55.	Heavyweight Automatic Sheeting Loom . . . . .	147
56.	Shuttle Magazine for Automatic Loom . . . . .	148
57.	Lightweight Automatic Loom with Jacquard Attach- ment . . . . .	149
58.	Linen Damask Loom . . . . .	150
59.	Plain or Tabby Weave . . . . .	152
60.	Tabby Weave on Point Paper . . . . .	152
61.	Hopsack . . . . .	153
62.	Weft-face Twill . . . . .	153
63.	Five-end Twill . . . . .	154
64.	Serge Twill . . . . .	154
65.	Herring-bone Twill . . . . .	155
66.	Herring-bone Twill . . . . .	155
67.	Weft-face Satin . . . . .	155

## ILLUSTRATIONS

xiii

FIG.		PAGE
68.	Honeycomb . . . . .	155
69.	Simple Gauze Structure . . . . .	156
70.	Another Type of Gauze Structure . . . . .	156
71.	The Latch Needle . . . . .	158
72.	The Beard Needle . . . . .	158
73.	Simple Automatic Seamless Knitting Machine for Ladies' Hosiery, Half-hose, etc. . . . .	160
74.	Interlock Knitting Machine . . . . .	160
75.	Circular Jacquard Knitting Machine . . . . .	162
76.	Lace Carriage and Bobbin . . . . .	165
77.	Dye Jiggers . . . . .	187
78.	Four-colour Calico Printing Machine, Turning Out about 50 Yards of Printed Cloth per Minute . . . . .	195
79.	Hydro-extractor ("Whizzer") . . . . .	201
80.	Cage of Hydro-extractor (Fig. 79) . . . . .	202
81.	Stenter Frame . . . . .	203
82.	Seven-bowl Calender . . . . .	205



**SECTION I**  
**TEXTILE FIBRES AND YARNS**



# THE TEXTILES STUDENT'S MANUAL

## CHAPTER I

### INTRODUCTION

VEGETABLE and animal fibres—Characteristics of a good fibre.

THE textiles trade is perhaps one of the most complicated in existence, containing within itself so many different sections, each a separate unit of the parent trade and each specializing in its own particular branch. At the same time it is one of the most interesting, and a study of the operations necessary to produce the finished cloth or garment is as fascinating as it is instructive. With the many new developments that are constantly taking place, nobody who is in any way connected with the sale or distribution of textiles can afford to be without some knowledge of the basic principles underlying the manufacture of the fabrics which pass through his hands. It is not sufficient to know what a cloth customarily looks like, or its approximate market price. The textiles assistant should know not only how the cloth itself is made but the yarn used in its manufacture and the raw material of which the yarn is composed. The quality of a finished cloth depends on so many factors that it is necessary to go right back to the production and preparation of the actual textile fibre in order to gain a real appreciation of what actually takes place before the length of calico, georgette, serge, or lace is offered for sale.

Fibres used in textiles to-day can be divided into two general classes, vegetable and animal. There is a further



section, necessitated by the introduction during the last fifty years of the artificial silks, but as these consist for the most part of a regenerated form of cellulose, a substance found in large quantities in cotton and wood pulp, they can quite justly be considered as an off-shoot of the class of vegetable fibres. Two other less important classes are the mineral and metallic fibres, but as these are not used to any great extent in the production of modern textile fabrics it has been thought best to leave them out of this work. Asbestos is the only mineral fibre connected in any way with textiles and its only claim to recognition is the fact that it has the power to resist extreme heat. The metallic fibres are not really fibres at all, but finely drawn wires of gold or silver which are sometimes twisted with textile yarns to obtain some special effect.

The principal varieties of vegetable and animal fibres in use to-day are the following—

*Vegetable—*

Cotton . . . .	<i>Gossypium</i>
Flax . . . .	<i>Linum usitatissimum</i>
Ramie . . . .	<i>Boehmeria</i>
Jute . . . .	<i>Corchorus</i>
Hemp . . . .	<i>Cannabis sativa</i>
Kapok . . . .	<i>Eriodendron anfractuosum</i>

Artificial silk :

Viscose  
Acetate  
Cuprammonium  
Nitro-cellulose

*Animal—*

Silk, cultivated . . . .	<i>Bombyx mori</i>
Silk, wild . . . .	<i>Tussuh</i>
Wool . . . .	<i>Ovis aries</i>
Camel hair . . . .	<i>Camelidae</i>
Alpaca . . . .	<i>Auchenia paco</i>
Vicuna . . . .	<i>Auchenia vicuna</i>
Llama . . . .	<i>Auchenia llama</i>
Guanaco . . . .	<i>Auchenia guanaco</i>
Mohair . . . .	<i>Capra hircus angorensis</i>
Cashmere . . . .	<i>Capra hircus laniger</i>
Rabbit hair . . . .	<i>Lepus</i>

In addition there are one or two lesser important fibres which have been called into use from time to time, and these will be mentioned in the appropriate section.

In their raw state the natural fibres are quite unsuitable for immediate conversion into yarn. Cotton when it is picked still has the seeds adhering to the tiny fibres, flax exists as the inner bark of the stem of the flax plant, wool is a matted greasy mass of crimped hairs, and they all contain impurities which must first be removed. Silk has to be wound off the hardened cocoon of a silk moth or chrysalis which must first be steamed or baked to prevent the moth eating its way out and spoiling the silk. The only fibre which in its raw state is practically ready for the weaver's loom is artificial silk, which is made in a continuous filament or thread.

It will be seen, therefore, that quite a considerable amount of preparation is necessary before a yarn can be made from these raw materials. All dirt and other impurities or irregularities must be removed, the fibres must be thoroughly cleaned and separated, and the short fibres laid side by side in parallel form ready for the spinning, which is really a twisting of the fibres round each other so that they hold together and form a strong, compact yarn. The continuous fibres, silk and artificial silk, are not so difficult to manipulate, but even they require to be doubled, several filaments together, and twisted to give a strong thread of suitable thickness for the fabric into which they are to be made.

Although by twisting a number of fibres together it is possible to make a compact, strong yarn, it is obvious that the twisting alone is not sufficient to make a short fibre like cotton, for example, which has a staple length of not more than 2 in. and averages only about 1 in., hold together without some other aid. Actually each of the fibres has some natural characteristic which creates a sort of

surface friction and so enables the fibres to interlock or hold together. In cotton this takes the form of a natural twist, the ribbon-like fibre turning first in one direction and then in the other. The flax fibre, which is rather longer than cotton, sometimes measuring as much as three feet, has swellings (nodes) at fairly regular intervals throughout its length. Wool and other animal hairs have an outer cuticle in the form of scales, which protrude for a fraction of an inch and, together with a crimpiness, help the fibres to interlock in the manner necessary for spinning. Silk has length, which is, of course, an asset in spinning, as well as a slightly irregular diameter and a natural gum on the surface.

Surface friction, then, is very necessary, especially in a short fibre. Other qualifications requisite in a good fibre are given below, and the reader is recommended to study these and by referring to them from time to time to judge for himself how many of them are possessed by each of the different fibres.

#### CHARACTERISTICS OF A GOOD TEXTILES FIBRE

1. *Tensile strength and length of fibre.*
2. *Uniformity in length.* This renders the spinning operations more easy.
3. *A small and even diameter.*
4. *Flexibility and elasticity.*
5. *Power to absorb and retain liquids.* Without this it would be impossible to produce a cloth in any other than the natural colour of the fibre. Wild silk, for example, is very difficult to dye owing to the presence of tannin, which resists the penetrating action of the dyestuffs.
6. *Lustre.* The natural lustre of silk gave it for a long time a distinct advantage over the other textile fibres, and experiments were constantly being made to improve the lustre of those fibres which were naturally dull. Mercerized cotton, for instance, is preferred to cotton which has not undergone this treatment, owing to the richer appearance of the finished cloth. Since the introduction of artificial silk, however, with its extremely high and almost metallic lustre, public taste has gone a little in the opposite direction, and many fabrics produced to-day are purposely dulled (de-lustred) in order to give the desired matt finish. Cloths of the suede and "angel-skin" type are well-known examples.

7. *Resistance to decay.* Flax and natural (unweighted) silk possess this characteristic in a marked degree, and linen mummy-cloths found in the tombs of the ancient Egyptians are in a remarkably good state of preservation.

8. *Abundance in quantity.* A fibre which cannot be produced in sufficient quantities to make the working of it a commercial proposition is obviously not worthy of consideration for the purpose of textiles.

9. *Facility in obtaining a clean fibre.* As already explained, all fibres require some preparation before they can be successfully turned into yarn, and a fibre which in its original state contains many impurities difficult of removal would not be so satisfactory as one which is easily separated and cleaned. Ramie is a fibre taken from the stalk of a variety of nettle, which gives several crops a year and is very easy to grow. Nevertheless, owing to the dirtiness of the fibre and the fact that it is full of a hard gum which is difficult to remove, ramie has not yet become as important as cotton or linen.

## CHAPTER II

### COTTON

THE plant—Insect pests—Sources of supply—Preparation for spinning.

COTTON is a ribbon-like fibre found in the seed pod of the cotton plant (genus *Malvaceae*) attached to the seeds. Its purpose in nature is twofold, to protect the seeds, and, when they are ripe, to carry them in the wind so that they shall be properly scattered, and so ensure the further sowing and continuation of the plant life. The pod does not open until the seeds are ripe, and the cotton fibres require the action of the sun and air to bring them to maturity. As the sun dries the fibre it twists first one way and then the other, these twists being greater in the best qualities. In a good Sea Island cotton, which is the finest cotton grown, the twists may be as many as 250 to the inch, whilst the average is about 150 to the inch. The edges of the fibre are rounded, and the length varies from  $\frac{1}{2}$  in. in the poorest Indian to  $2\frac{1}{2}$  in. in Sea Island. The average diameter of a medium size cotton fibre is about  $\frac{1}{2500}$  of an inch, although the finest Sea Island may measure only  $\frac{1}{5000}$  in. Some idea of its weight can be gathered from the fact that it takes nearly 150 million fibres to weigh 1 lb. avoirdupois.

Cotton fibres from all sources have approximately the same composition, consisting almost entirely of cellulose, of which the chemical formula is  $C_6H_{10}O_5$ .

The cotton plant is usually grown as an annual and requires a warm equable climate. Sharp frost before the cotton is ripe would be disastrous and is the principal cause of what is known as "dead" or "unripe" cotton, which has no density or body. It contains very little twist and when found among other cotton fibres it shows

up glossy. In the cross-section the difference between ripe and unripe cotton can be clearly seen. Unripe cotton is frequently found in the Indian variety.

In the early stages of growth an even temperature is best, and although a certain amount of moisture is necessary, too much rain would be a disadvantage. After the seed pod or "boll" has burst, the cotton appears at the top and excessive rain at that time would "stain" the cotton, and would also encourage the boll weevil and worm, which breed rapidly in warm, moist weather.

The boll weevil and boll worm are the two insect pests which are the principal dread of the cotton grower. The boll weevil, which first appeared in the U.S.A. in 1892, bores into the boll, deposits its eggs, and the grubs which hatch later feed on the contents of the boll. The boll worm feeds on the seeds and contents of the boll as well as on the plant itself. There are various methods used to prevent or destroy them, chiefly consisting of spraying the plants with chemicals, but they still exact their toll on the crop at different times according to weather conditions, and the cotton crop in the various cotton growing centres of the world is frequently affected by the ravages of these pests.

#### SOURCES OF SUPPLY

The largest producer of raw cotton is the United States of America which provides about 65 per cent of the world's output. Next in order come India with 15 per cent, other parts of the British Empire 8 per cent, Egypt 4 per cent, and South America, Russia, and the Far East with about 8 per cent between them. Production in the British Empire is being carefully fostered by the British Cotton-growing Association, and British cotton is becoming more and more important as the quality, yield, and methods of baling improve.

## UNITED STATES OF AMERICA

American cotton is grown as an annual. The land is ploughed in the autumn and the tops of the furrows split by a light plough so that when the seeds are planted in the following April the roots will grow in the soil just above the level of the bottom furrow and so avoid excessive moisture. The flowers mature at different times, starting at the bottom of the plant and giving three crops, bottom, middle, and top. The first crop is usually picked in August. The following are the principal types of American cotton—

**Orleans.**

A strong, elastic cotton of good colour with a staple of  $1\frac{1}{2}$  in., shipped from New Orleans and considered to be the best and most regular of the American cottons. It is grown in the Mississippi valley and Louisiana, and is sometimes referred to as Gulf cotton. Long-stapled varieties of this class are Benders, Peelers, and Allenseed.

**Texas.**

This is slightly stronger than Orleans cotton but is a little deeper in colour and has an average staple of about 1 in. It is most suitable for warps and twist yarns.

**Uplands.**

A soft, clean cotton with a staple of 1 in. but not so strong and more suitable for weft. Grown in the interior of Georgia, South Carolina, and South Alabama.

**Mobile.**

Mobile cotton is the poorest of the American cottons and, although similar to Uplands, is of a lower grade. With a staple of  $\frac{7}{8}$  in., it is used for weft.

**Sea Island.**

This is the famous *Gossypium Barbadosense* or "Black Seed," the finest cotton grown in the world. It has a staple length of  $1\frac{1}{2}$  to 2 in., fine diameter, is strong, elastic, and silky. The plant flourishes in a salty soil with sea air, and is grown in Florida, Georgia, and South Carolina.

**Meade.**

A substitute for Sea Island, but not quite so long, the staple being  $1\frac{3}{8}$  to  $1\frac{3}{4}$  in. It has the advantage of maturing a few weeks earlier than Sea Island, and usually gives a better crop, as it is easier to pick.

**Pima.**

An American-Egyptian cotton of good staple length,  $1\frac{5}{8}$  to  $1\frac{3}{4}$  in.

American cotton is sold under the following classification. The standard type is Mid (middling) on which "futures" are quoted. The grade depends on appearance, cleanliness, and freedom from impurity.

G.O.	.	.	.	Good ordinary
S.G.O.	.	.	.	Strict good ordinary
L.M.	.	.	.	Low middling
S.L.M.	.	.	.	Strict low middling
MID	.	.	.	Middling
S.M.	.	.	.	Strict middling
G.M.	.	.	.	Good middling
S.G.M.	.	.	.	Strict good middling
M.F.	.	.	.	Middling fair

**EGYPTIAN COTTON**

The production of cotton in Egypt is entirely dependent on irrigation. The fibre is of good quality, strong, uniform, clean, and fine in diameter, and commands a higher price than American cotton under normal conditions. Some trouble is experienced with the pink boll worm, which has reduced the yield in recent years.



**Mitafifi.**

Also known as Brown Egyptian. A very good quality, grown in Lower Egypt and the Delta and noted for regularity of staple and colour. Length  $1\frac{3}{8}$  in.

**Abassi.**

The whitest of the Egyptian cottons, with a staple length of about  $1\frac{1}{4}$  in.

**Sakellaridis (" Sakells ").**

A popular quality and the best of the Egyptians. It is soft and silky, and has a staple length of about  $1\frac{1}{2}$  in. Sakells have taken the place of Joanovitch.

**Joanovitch.**

This was at one time one of the best of the Egyptian cottons but is fast disappearing. It is a selection from Mitafifi and the staple is fine, strong, clean, and silky, with a length of about  $1\frac{1}{2}$  in.

**Ashmouni (" Upper Egyptian ").**

The poorest of the Egyptian cottons. It is dirty and irregular, and is only suitable for coarse wefts. Staple length about  $1\frac{1}{8}$  in.

**Nubari.**

This is a fairly new variety and is a selection from Joanovitch, but is rather irregular.

**Assil-Afifi.**

Another recent variety, selected from Mitafifi and fairly good in quality.

**BRITISH EMPIRE COTTONS****India.**

Indian cotton is produced under quite different climatic conditions from American and Egyptian. The main

centre of the cotton-growing industry is the Deccan. The cotton seed is scattered broadcast together with the seeds of other plants which are intended to grow to a small height in order to protect the roots of the cotton from hot sun. The great drawback is insufficient rainfall at the time when it is most needed. The methods of handling the cotton are rather primitive and it is frequently baled in a dirty condition, which has an adverse effect on the price. Generally speaking, only native crops can be grown. The cotton fibre is rather coarse and short in staple. Mention must be made of the British Cotton-growing Association, which is doing so much to improve the qualities and methods of production. Only a small proportion of the cotton grown in India is used in England. The bulk of it is consumed locally or shipped to Japan or some of the European countries where coarse counts of cotton are spun. The three principal Indian varieties offered in Liverpool are the Surats, Bengals, and Madras.

### **Surats.**

Broach and Oomra are both market qualities with staple  $\frac{3}{4}$  to  $\frac{7}{8}$  in. Another good quality is Surtee, staple  $\frac{7}{8}$  to 1 in. Comptah, a selection from Broach, has a staple  $\frac{3}{4}$  to  $\frac{7}{8}$  in. Dharwur is an American variety of good colour, length  $\frac{5}{8}$  to  $\frac{3}{4}$  in., but not very satisfactory. The poorest of the Surats is Scinde, which has a very short staple.

### **Bengals.**

Bengals are similar to Scinde, being very poor in quality, dirty, and with a staple length of  $\frac{5}{8}$  to  $\frac{3}{4}$  in. They are only suitable for the coarsest counts.

### **Madras.**

The best Madras cotton is sold under the name Tinnevely, and is clean and strong. Western is a cotton with

fairly long staple (about  $\frac{3}{4}$  in.), but is dull and somewhat harsh. Northern is softer but not so white. Red Coconada is a highly coloured cotton of moderate staple. An American cotton of the Tinnevely type is Cambodia, which is fine and strong and has a staple length of about 1 in.

### **Burma.**

A small amount of poor quality cotton with a staple length of  $\frac{1}{2}$  to  $\frac{3}{4}$  in. is exported from Rangoon.

### **British West Indies.**

This is the home of the Sea Island cotton, which is also grown in the United States. Owing to the smaller demand for Sea Island cotton in recent years it is quite possible that other qualities will also be produced in Barbados.

Other parts of the British Empire engaged in growing cotton are Sudan, Uganda, Kenya, Nigeria, Nyasaland, and Australia.

## OTHER COUNTRIES

### **Brazil.**

A fair quantity of Brazilian cotton is exported to England but not much progress has been made in recent years. The country is now spinning its own cotton yarns. The quality of the cotton is not quite so good as American, being somewhat dirtier and harsher. The type of cotton most favoured is tree cotton (*Gossypium Arboreum*), and sometimes a crop is taken from the plant in the second year of its growth, this method producing what is called Ratoon cotton. The three best known varieties of Brazilian cotton are Pernams, Ceara, and Maranhams.

### **Peru.**

Peru depends on irrigation. A type of Sea Island cotton is grown with a staple of  $1\frac{3}{4}$  in., but this is irregular in colour and length, and rather inferior to the American

Sea Island. Peruvian tree cotton is grown on a plant which reaches a height of ten feet and sometimes yields as many as six crops. The cotton from this plant, which is known as Rough Peruvian, has a harsh handle and a length of  $1\frac{1}{4}$  in., and is very useful for mixing with wool. Smooth Peruvian is a softer cotton similar to American, and is an important cropper with a length of  $1\frac{1}{8}$  in. Most of the cotton grown in Peru is exported to England.

### **China.**

A fair quantity of cotton of good average quality is grown in China, but is mostly used locally. It is clean and white and has a staple length of  $\frac{3}{4}$  in.

### **Russia.**

The production of cotton is being carefully fostered by the Soviet Government, and the aim is to provide the whole of Russia's raw cotton needs from home production. A native variety of cotton is grown, mostly in the Turkestan and Caucasus districts. It has a short staple, about  $\frac{7}{8}$  in. in length, and is rough and harsh. A curious feature of this native cotton is that the seed pods do not open when ripe in the same manner as American cotton, but have to be plucked off whole and broken open afterwards in order to extract the cotton fibre. Russian cotton growing depends on irrigation, and this is not very well maintained, with a consequent bad effect on the crop.

### **Spain.**

A small quantity of cotton is now being produced and used locally as a result of experiments commenced a few years ago.

### **Turkey.**

The production of cotton in Asiatic Turkey is increasing yearly. Both American and native varieties are grown.

**Iraq.**

A good quality American cotton called Meso-white is grown in Iraq, where the industry is making good progress. Irrigation is necessary to provide the cotton fields with sufficient moisture.

**THE PREPARATION OF RAW COTTON**

Cotton is picked from the plant by hand, as, although attempts have been made to effect the picking by suction, machine picking usually makes the cotton come off dirty.

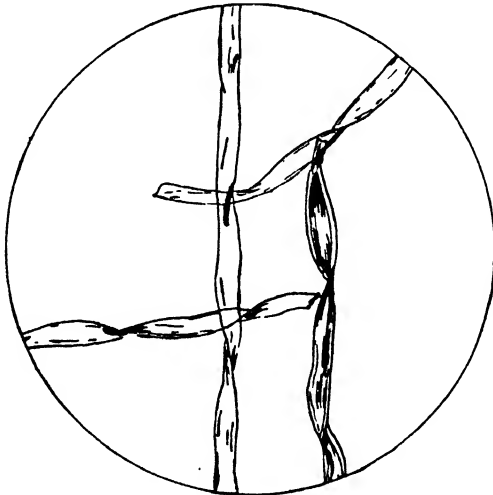

FIG. 1. COTTON

Flat, ribbon-like structure, fairly uniform in diameter. Characteristic twists, which are more numerous in the better-class cottons. Most of the twist is taken out when it is mercerized, and this is one of the reasons for the increased lustre of mercerized cotton. Length of staple varies from  $\frac{1}{2}$  in. in the poorest Indian cotton to  $2\frac{1}{2}$  in. in Sea Island

The seeds remain attached to the fibres and have to be removed before the cotton can be baled for shipment. This process is called ginning. There are two kinds of gin in use, the Saw Gin and the Macarthy Gin. The former is used in American cotton-growing districts whilst the latter is used practically exclusively for the better classes of cotton such as Sea Island and Egyptian.

### The Saw Gin.

The principal organ of this machine is a central shaft supporting a series of sixty or seventy close-gauge circular saws, revolving through a closely-set grid which prevents the seeds from passing forward while allowing



*By courtesy of*

*Messrs. Dobson & Barlow, Ltd.*

FIG. 2. SAW GIN WITH FEEDER AND CONDENSER

This machine contains 114 saws, and is used for the removal of cotton linters still remaining after the first ginning

the fibres to do so. This means that the fibres are literally sawn off the seeds. The treatment is therefore severe and causes quite a considerable proportion of broken fibres, which are described as "gin-cut." The fibres are removed from the saws by a revolving brush, and the current of air caused carries them down a chute and drops them into a receptacle. The seeds are thrown out on the other side of the machine.

### **The Macarthy Gin.**

This is more gentle in its treatment and consists of a revolving roller covered with leather and having a knife blade, known as the "doctor," pressing against the surface. The cotton fibre is drawn by friction between the leather roller and the doctor knife, and a beater knife knocks off the seeds.

After the ginning the cotton is pressed into bales and stored or shipped to its destination.

The processes immediately preceding the spinning all have as their object the opening up of the fibre, the removal of any dirt and impurities, and finally the laying of the fibres in parallel form slightly twisted into a loose open thread ready for spinning.

### **The Bale Breaker.**

This breaks down the solid mass of cotton taken from the bale, opens it up, starts to clean it, and facilitates the mixing or blending.

### **Mixing and Blending.**

The cotton is built up into a stack in horizontal layers but in being fed to the opener machine it is taken in *vertical* section so that a thorough mixing takes place. The object of the mixing is threefold—

1. To average the variations in cotton and so make for regularity in the yarn.
2. To allow the air to get into the cotton and help to open it. As it comes from the bale, cotton is in a hard, matted state, and stacking the cotton permits it to fall apart naturally.
3. To help the blending process.

In blending cottons, fibres are taken from different bales and sometimes different qualities are mixed together. This requires a good deal of skill to be done properly as

surfaces of card clothing moving against each other comb the cotton fibre in between them, and the length of time the cotton stays in this machine depends on the quality and cleanness of the fibre as well as on the ultimate purpose for which the yarn is required.

### Combing.

For the finer counts of cotton and the better qualities, the fibre is sometimes put through a combing machine.

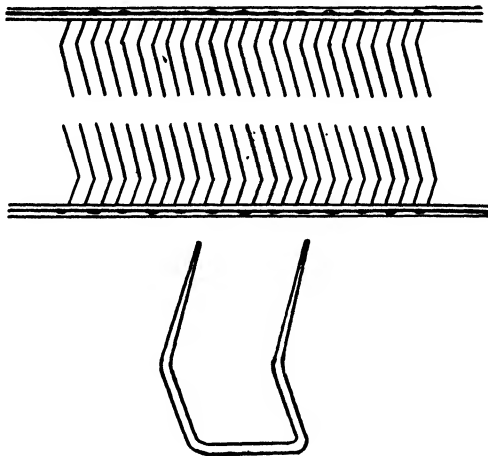

FIG. 5. CARD CLOTHING, SHOWING THE INDIVIDUAL WIRE STAPLE

There are several types of combs all working on a similar principle, the main part being a cylinder on which are set a number of rows of needles of different gauges. These comb out the fibres in a similar manner to the card clothing, but are more successful in removing the short staple fibres.

### Drawing.

The Drawing Frame unites several slivers and draws them out to the thickness of one. By this means a further blending takes place and any irregularities are evened out.



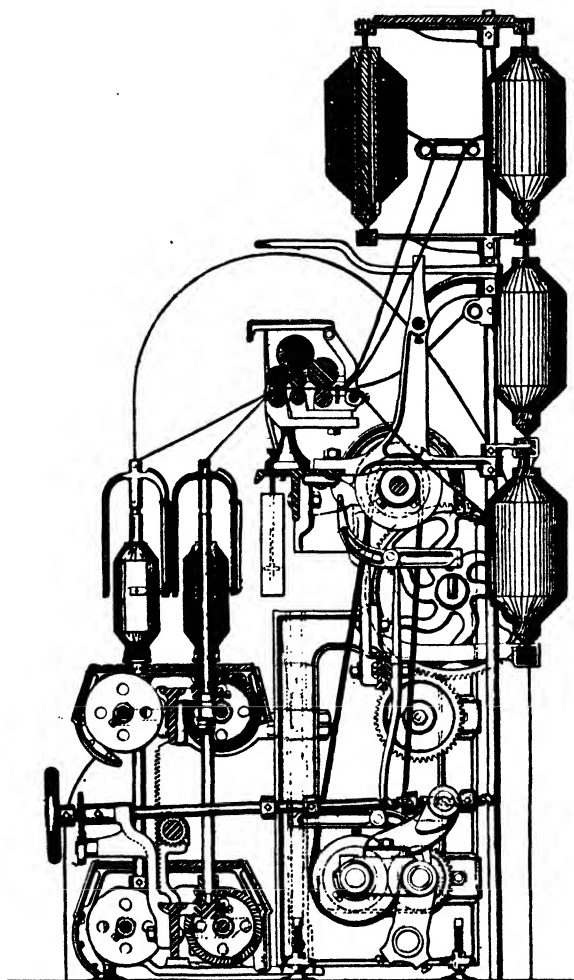

By courtesy of

Messrs. Platt Bros. & Co., Ltd.

FIG. 6. FLYER ROVING FRAME

The slivers are put through this process several times, according to the grade of cotton. Good-class cottons and long staples go through four or more times. The two or more slivers are passed through four pairs of rollers of which the second pair revolve at a greater speed than the first, the third faster than the second, and the fourth faster than the third. The speeds are carefully regulated in steps, otherwise the slivers might break or come out uneven.

### **Slubbing.**

From the drawing frame the sliver is still too thick for the spinning machines and is also in too loose a state to stand the strain of the high speed necessary. It must go through a further drawing in order to bring it down to the required weight and thickness, and it also has to be lightly twisted to give a little strength. The first of the machines designed to do this is the Slubbing Frame. The sliver passes through the drafting rollers and, after receiving a light twisting by means of what is known as the flyer, is wound on to large bobbins. The fibre is then said to be in the form of a "roving."

### **Intermediate.**

The bobbins of roving are placed on the intermediate frame, and two of them are twisted together after a further drafting. Slightly more draft and twist are imparted on this frame than in the slubbing.

### **Roving Frame.**

This is practically the same as the intermediate, and more twist and draft are inserted, delivering the roving ready to go on the spinning machines. For the better qualities, such as Egyptian or Sea Island, another machine is added called the Fine Roving Frame, on which additional twist and draft are given.

## CHAPTER III

### COTTON SPINNING

RING frame—Mule—Doubling—Gassing—Mercerizing—Yarn counts.

IN spinning cotton into yarn the drafting and twisting of the fibres are carried to the final stage by one of two systems. The first of these is by means of the Ring Frame, in which the drafting and twisting are performed simultaneously. The ring frame was originally used only for producing low or medium counts of yarns, but is now used also for finer counts and qualities. The other method is one in which the drafting is inserted first and then the twist. The machine used is the Spinning Mule, which spins any count of yarn but is specially suitable for fine and delicate yarns.

#### **The Ring Frame (Continuous System).**

The roving is first carried through a series of drafting rollers of which the last pair are revolving at a greater speed than the first. The size of the draft rollers and their distance apart depend on the length of staple of the fibre. From the draft rollers the roving is delivered to a guide eye exactly above the centre of the spindle.

The bobbin or tube on which the spun yarn is intended to be wound is fixed on the spindle, and both revolve together. Surrounding them is the metal ring, from which the machine gets its name, and which rests in the ring-board or rail. The ring is flanged round its upper circumference and a small loop-shaped piece of metal runs freely round this flange. This is called the Traveller, and its function is to maintain an even tension on the yarn and guide it on to the bobbin. The pull of the yarn as it is fed on to the bobbin carries the Traveller at a fast speed

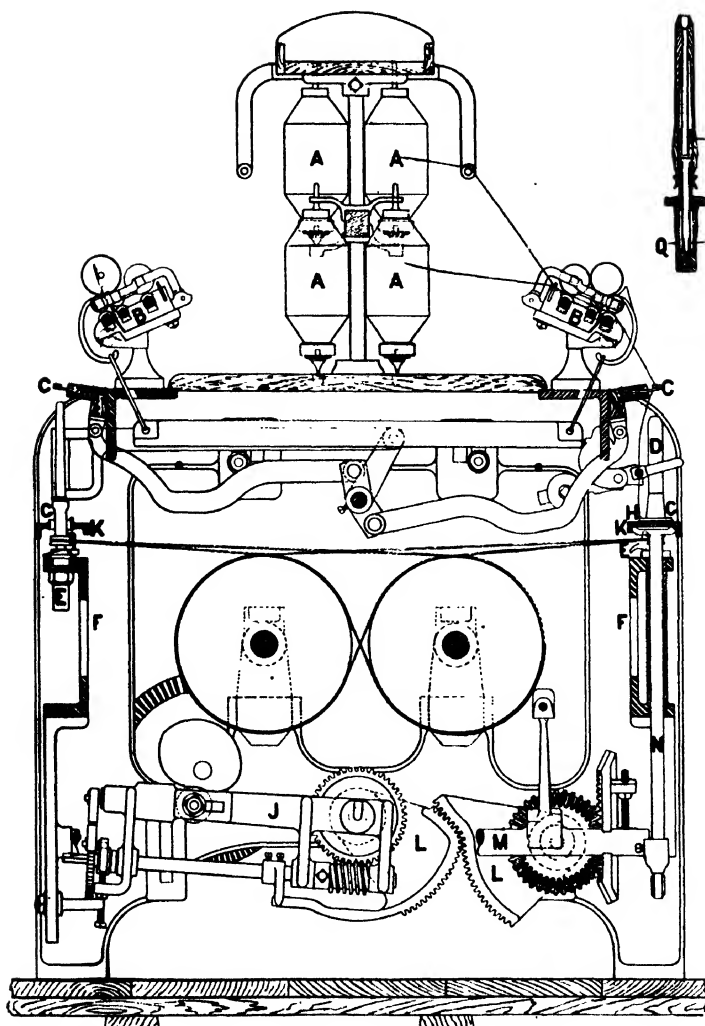

By courtesy of

Messrs. Platt Bros. & Co., Ltd.

FIG. 7. RING SPINNING FRAME

AA = bobbins of roving  
 BB = draft rollers  
 CC = guide eyes

D = bobbin for spun yarn  
 EE = spindles  
 KK = rings

round the flange of the ring. The ring-board moves up and down within the limits of the top and bottom of the spindle in order to distribute the yarn evenly on the bobbin. On the spindle being revolved, twist is inserted in the roving between the delivery rollers and the Traveller. The degree of twist varies with the speed at which the spindle revolves, this ranging from 5,000 to 10,000 revolutions per minute according to the quality and fineness of the yarn.

### **The Mule (Intermittent System).**

The difference between the Ring Frame and the Mule is that in the latter the various operations of drafting, spinning, and winding-on all take place separately, about two yards of yarn being dealt with at a time. In a cotton mule three pairs of drafting rollers put in the requisite draft as the roving is paid out on to the mule. At the same time the spindle inserts a slight drafting twist. The actual spinning twist is then thrown in from the spindle point whilst the length of yarn remains suspended in the machine. Winding-on is the last part of the operation, and is carried out only when the yarn has actually been spun.

The Mule consists of a wheeled carriage supporting the spindle, which is inclined in the direction of the delivery rollers. Roving is delivered from creels at the back of the frame, through the draft rollers, and on to the spindle. The carriage moves along a track about six feet in length, away from the back frame and at right angles to it. There are, of course, many carriages and spindles in one machine and they all move in unison.

The sequence of operations is as follows. Starting from the position with the carriage close to the rollers, as the roving is paid out through the drafting rollers the carriage retreats, whilst at the same time the spindles,

course, again reversed, and are running at much slower speed. When the carriage once more reaches the delivery rollers, the guide wires disengage from the yarn and the machine is ready to repeat the cycle.

For spinning cotton waste, that is, the small fibres thrown out from the various preparatory processes which are a preliminary to spinning, and for very short staple cotton such as the poorest of the Indian cottons, a slightly different mule is used in which there are no drafting rollers. The roving is delivered on to the machine through ordinary delivery rollers, and the draft is effected by stopping the delivery rollers when the carriage has completed only about two-thirds of its traverse. As the carriage continues it attenuates the roving, which also receives drafting twist at the same time. This is called Spindle draft. The spinning and winding-on movements are the same as on the roller draft mule.

### **Doubling.**

In order to produce a stronger or fuller yarn, two or more single yarns are doubled together by twisting them round each other in the opposite direction to the original twist. Doubled yarns are necessary for sewing threads, for warps of heavy materials owing to the greater strain (see chapter on Weaving), and for hosiery. Doubling can be effected either on the Twiner, a machine with intermittent action built something like a spinning mule, or on the Flyer and Ring Doublers. The latter, which are continuous in their action, are similar to spinning machines of the continuous type, but are without drafting rollers.

Both dry and wet doubling are practised. In the latter the threads are moistened before being twisted, which helps to form a more compact and clean thread. The doubling of yarns is also used to form fancy yarns of different types, described elsewhere in this book.

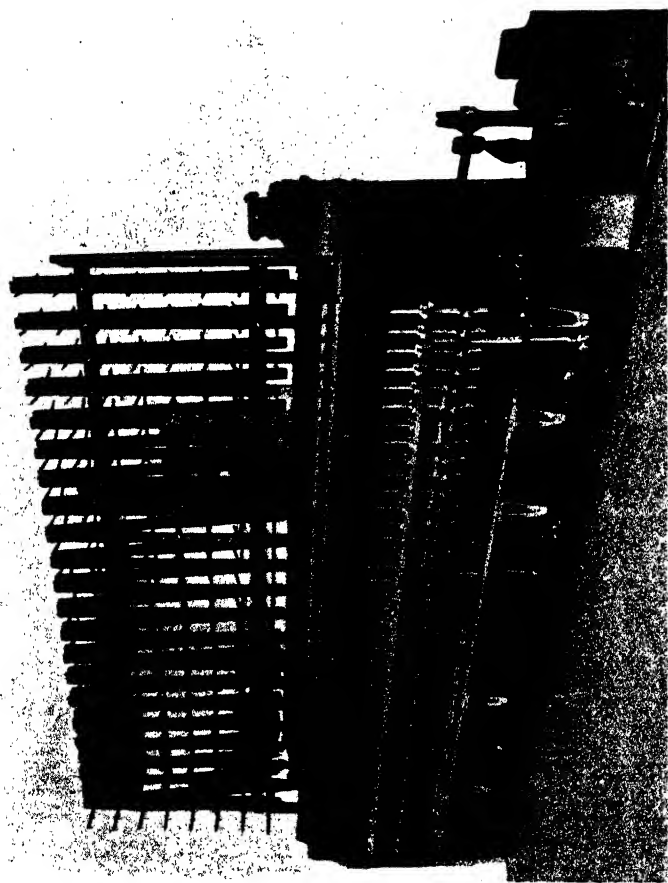

Messrs. Platt Bros. & Co., Ltd.

FIG. 9. RING DOUBLING FRAME

By courtesy of

is called the "count" of the yarn. Each class of textiles has its own method of arriving at the count of the yarn made from it, and in the case of cotton the count is the number of hanks of yarn, each measuring 840 yd., which are required to weigh 1 lb. avoirdupois. There are 7,000 grains in 1 lb., so that if we find the weight of a hank of yarn (840 yd.) and divide it into 7,000 we shall get the count of the yarn.

A hank contains 7 leas of 120 yd., and it would therefore be sufficient to divide the weight in grains of 1 lea into 1,000 to arrive at the same result.

Metric weights are used with most fine balances, but the conversion from grammes to grains is quite simple, 1 gramme being equivalent to 15.432 grains.

Where a length other than one hank or one lea is weighed, the following formula will be found useful—

$$\frac{\text{No. of yards} \times 7,000}{\text{Weight in grains} \times 840} = \text{Count of yarn}$$

or, more simply:  $\frac{\text{No. of yards} \times 100}{\text{Weight in grains} \times 12}$

*Example—*

150 yards of thread weigh 1 gramme.

$$\frac{150 \times 100}{15.432 \times 12} = \frac{15,000}{185.184} = 81\text{'s (nearest)}$$



## CHAPTER IV

### FLAX

SOURCES of supply—Preparation of fibre—Wet spinning—Dry spinning  
—Yarn counts.

THE flax fibres used to make linen fabrics are obtained from the inner bark or bast fibres of the flax plant *Linum Usitatissimum*. The best qualities of flax are produced in Belgium and Ireland, whilst France, Holland, Russia, Latvia, Germany, and America all produce a flax for commercial purposes.

The plant is grown as an annual, and has a straight narrow stalk about 36 to 40 in. in length. The flower is a pretty blue in colour and a flax field in full bloom is a scene worthy of any painter's brush. The seeds are contained in a round seed pod about the size of a small pea, this being set right at the top of the stalk. In order to produce a single straight stalk without branches and additional flowers, the seeds are sown very thickly; this causes the plants to grow quickly and spring up into a straight stalk in the endeavour to reach the air and sun. When a good crop of seed is required for further propagation the sowing is carried out rather more thinly. A rich, loamy soil is considered the best for flax, but the plant is very adaptable, although it is not considered good to grow flax in the same field two years in succession.

Belgian flax is the best flax in the world and gives a rich creamy-coloured fibre. This colour is thought to be due to the peculiar nature and suitability of the waters of the river Lys in which the stacks are retted (see later). Some of the best seeds come from Riga, Latvia, including a much favoured class.

The long fibres cut from the centre of the stalk are known as "cut line," whilst the shorter fibres thrown out in the preparation for spinning are called "tow." These require slightly different treatment.

A cross-section of the flax stalk shows that on the outside is an epidermis or bark, beneath which are the

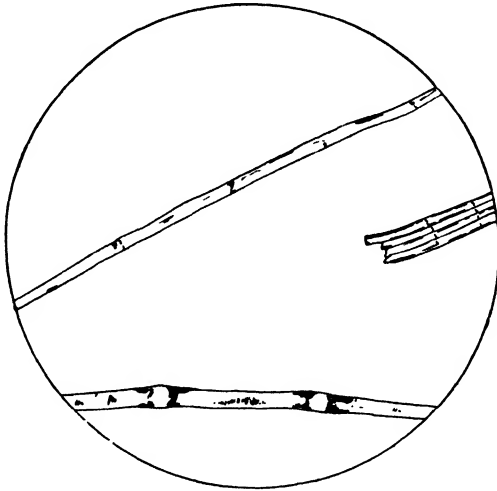

FIG. 11. FLAX

Fairly regular in diameter, with characteristic joint-like markings. Tapers gradually to a pointed end. Length varies from 8 or 12 in. to about 3 ft., according to quality and origin

bundles of bast fibres. Next there is an inner bark or layer, surrounding the woody core and pith tube.

#### PREPARATORY PROCESSES

##### **Pulling.**

Just before the seeds are fully ripe the stalks are pulled whole from the ground by hand and laid out to dry off. The reason they have to be pulled is that cutting would leave not only part of the stalk actually in the ground, but also several inches above the surface, and this would all be wasted. After about twenty-four hours the stalks

are gathered into sheaves ("beets") and left in the sun for a further period before being taken away for rippling.

### **Rippling.**

By passing the stalks through an iron comb set in a board the seed pods are ripped off. The seeds are crushed in order to extract the linseed oil, whilst the crushed pulp is used in the manufacture of cattle cake.

### **Retting.**

Retting is a forced decomposition of the bark and core of the stalk in order to free the fibres. There are several methods adopted to achieve this end. The chief method is by immersing the bundles of stalks in stagnant or slow-moving water for a period of two to four weeks, during which fermentation takes place. This has the effect of causing the outer bark to rot to some extent, as well as loosening the fibres from the inner stalk. A layer of reeds is placed at the bottom of the pool or stream, the flax being stacked in a vertical position under the water. Another layer of reeds is placed on top and weighted to keep them in position. In order to test the progress of the action, the flax worker takes out one or two stalks after the first two weeks and examines them to see if the woody matter is becoming brittle. He repeats this test until he judges that the process is complete. Care must be taken not to overdo it as the fibres may become affected and lose their strength and colour. The success of subsequent operations depends to a large extent on satisfactory retting, and under-retted flax is equally as unsatisfactory as flax which has been allowed to ferment too long. Owing to the putrefaction of the woody bark and cells of the plant whilst fermenting, an unpleasant odour is given off, and this is one of the principal objections to the cold water process.

In some flax-producing countries, e.g. Russia and the United States of America, dew retting is practised. This consists of subjecting the flax stalk to the action of atmospheric influences (dew, rain, wind, etc.), with the same object. Dew retting avoids the offensive smell to some extent but takes rather longer, about three to five weeks' exposure being necessary.

A combination of the two methods, called "mixed retting," is also used. The flax is first retted in water for a week or more and then laid out as for dew retting. The process takes from two to three weeks according to weather conditions.

Artificial methods have been introduced to quicken the process, and retting in tanks of warm water takes only a few days. Steam retting is still quicker, whilst the addition of dilute sulphuric acid to the water not only speeds up the action but reduces the odour. Such a delicate operation, however, can scarcely be hurried, and the old methods are still very widely practised.

### **Drying.**

After retting, the stalks are washed in clean water and laid out to dry in the sun.

### **Breaking.**

The breaking machine has a series of fluted rollers through which the stalks are passed to break up the woody core and split the bark.

### **Scutching.**

A bunch of flax stalks is held on a metal plate supported on springs which allow it to give slightly, while a series of wooden blades rotating on a common hub strike it glancing blows, which remove a large part of the woody substance and bark. Some of the short fibres are also taken out by the process.

**Hackling.**

The hackling machine combs out all the remaining particles of wood or bark, as well as any short fibres which may still be left, and divides the bundles of flax into separate fibres, laying them straight and parallel to each other. This is achieved by an arrangement of metal needles, which are drawn through the fibres, combing them into the desired form. In a dry stem there is about 25 to 30 per cent of good flax fibre, of which roughly one-fifth consists of good "line" flax with a length of 12 in. or more, and the balance tow.

**Gilling.**

This continues the combing-out process, and finally forms the fibre into a sliver. As flax has a longer staple than cotton, in addition to being more irregular in its length, this process is rather different from the corresponding process for cotton. The gilling machine contains a number of moving belts which are fitted with rows of sharp needles. At the end of the machine are drafting rollers which draw out the fibres and deliver them as a sliver into a can placed to receive them.

**Doubling and Drawing.**

Several slivers are united and drawn out to the thickness of one.

**Roving.**

The final process before spinning is to turn the sliver into a roving. A further drafting takes place and a small amount of twist is inserted by means of the Flyer.

**Flax Spinning.**

Flax fibres, being smooth and long, do not lend themselves easily to spinning by the mule or ring frames, but must be spun by means of the flyer machine. The part

of the machine from which it takes its name is the part directly concerned in the spinning of the yarn, and is the equivalent of the ring and traveller in the ring frame and the cap in the cap frame.

The flyer is a two-armed piece of metal, shaped something like a wishbone, which revolves on the top of the spindle and bobbin, with the two arms turning round the bobbin. In some flyer frames the thread is guided through an eye in the head of the flyer, and directed on to the bobbin through another eye at the end of one of the arms. In others, the thread is carried direct from the drafting rollers to the eye on the arm, and so on to the bobbin.

The spindle revolves and carries the flyer round with it, whilst the bobbin, which rests loosely on the spindle, is also carried round by the drag of the thread, but at a much slower speed. As the roving is paid out from the drafting rollers, it is taken up by the flyer and twist inserted by the arm as it revolves with the spindle. The winding-on is regulated by the bobbin moving up and down inside the flyer as the flyer arm delivers the spun yarn.

In spinning fine linen yarns and yarns to be used for warp, the roving is passed through hot water, which has the effect of softening the fibres and allowing them to slip over each other more readily. The bath of hot water is in between the roving creels and the drafting rollers, so that when the roving goes through the rollers the fibres are in a damp, softened condition, and yield themselves more readily to the action of the rollers. This process is known as "wet spinning." The dry spinning method is used for low counts of yarns, and the spindle runs at a speed of 2,500 revolutions per minute, as compared with nearly 5,000 revolutions per minute in wet spinning.

Although a lot of water is thrown out by the great speed of the spindles, wet spun yarn has to be dried off immediately after spinning, as otherwise it might rot. For this

purpose it is reeled off into hanks and hung in a heated room.

### **Tow.**

The short flax fibres, called tow, which are thrown out in the preparation of line flax are put through a carding engine of a similar type to the cotton card, but with somewhat coarser card clothing. Thereafter, they are spun on the flyer frame in the same way as ordinary line flax, with such adjustments as are necessary in view of the difference in the length of staple.

Flax is fairly hygroscopic and will absorb up to 20 per cent of its own weight in moisture. Its strength is considerably greater than that of cotton, but it is more easily injured by strong bleaching agents. Flax that has been over-retted is also inclined to be brittle. The flax fibre consists to a large extent of cellulose, which forms about 80 to 85 per cent of its composition.

### **Yarn Count.**

The count of linen yarn is determined by the number of "cuts," each measuring 300 yd., that it takes to weigh 1 lb. avoirdupois. The "cut" contains 120 "threads," a thread being one turn round a linen reel with a circumference of 90 in. Linen yarn is usually bought and sold in this country by the "bundle" of 200 cuts. The Belgian *pacquet* or bale of linen yarn contains three bundles totalling 600 cuts.

Linen can be mercerized either in yarn form or as a woven fabric in the same way as cotton.

## CHAPTER V

### MISCELLANEOUS VEGETABLE FIBRES

RAMIE—Jute—Hemp—Sisal hemp—Pita fibre—Manila hemp—New Zealand flax—Pineapple fibre—Bombax cotton—Kapok—"Vegetable silk."

#### RAMIE

(Rhea or China Grass)

RAMIE fibre is obtained from the stalk of a plant belonging to the nettle family, and grown in Eastern Asia and the United States of America. The plant grows rapidly, giving three or four crops a year without replanting.

Many attempts have been made to introduce ramie into this country as a commercial product, but all have failed. During the latter part of the nineteenth century seven firms are said to have lost over a quarter of a million pounds altogether over ramie. Attempts in North America have been more successful, but, up to the present, ramie is not used in England to any great extent.

In the natural state ramie is full of a hard gum, which is difficult to remove, and it is also rather dirty. The fibre is, however, much stronger than flax. Whilst flax is a solid fibre, ramie is a hollow hair-like tube, the walls of which vary in thickness. The fibres usually have a length of 6 to 10 in., but may measure up to 24 in. They are the broadest of the bast fibres, being more than twice the diameter of flax. Under the microscope they show striations crossed in places by transverse darker lines. The main constituent is cellulose of the same type as linen and cotton, forming about 70 per cent of the composition.

#### **Preparation of Ramie.**

I. DEGUMMING. The stripped stalks are steeped in strong soda lye to clear away the dirt. The material is



then left in a bath of hydrochloric acid and allowed to ferment. This is the equivalent of the retting process for flax. During this process the ramie must be carefully watched as the acid has a strong action. After this it is steeped again in soda lye. As a result, the gum will have been slightly softened and can be removed with the aid

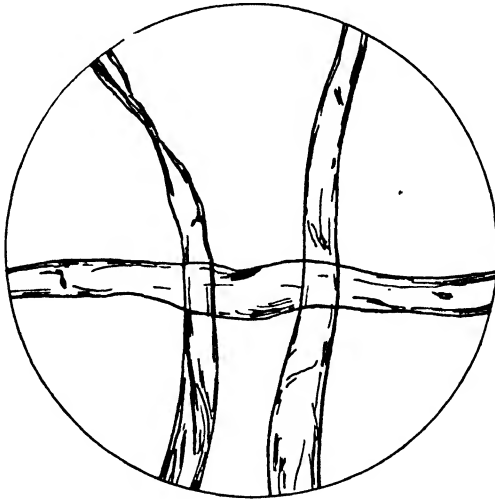

FIG. 12. RAMIE

Large, irregular diameter. Many striations, also some darker lines across the fibre

of a bath of permanganate of potash. The latter must then be washed out with hyposulphite of soda. The ramie is then washed in soapy water and hydro-extracted to remove the moisture.

Another method of degumming consists of steeping the ramie for seven hours in soda lye, washing in water, and then leaving in a solution of chloride of lime for ten hours. It is next retted in sulphuric acid and then washed clean.

Both processes of degumming also bleach the fibre, and it will be seen that great care is necessary as the fibres

might easily be damaged or destroyed. As it is, they are left bare and in a dry, harsh condition.

2. OILING. The fibres are sprinkled with oil and a mixture of water, glycerine, soap, white wax, and tallow.

3. SOFTENING. To soften the fibres they are passed through rollers.

4. FILLING. This is a sort of combing to make the fibres lie evenly together and parallel with each other. This is effected by means of a roller having a series of spikes in rows at intervals. The ramie fibres are then cut into lengths of about 3 or 4 in.

5. DRESSING. In order to separate the fibres into "drafts" of different lengths, they are subjected to a further combing which drops out the short noils, these being put aside for separate treatment.

6. SPINNING. Ramie is spun into yarn in a similar way to flax.

### JUTE

The chief source of supply of jute is India. The fibre is similar to flax and ramie but not as clean as either. In length the fibres measure from  $4\frac{1}{2}$  to 8 ft., whilst the plant from which they are stripped reaches a height of 10 or 12 ft. when the fruit has ripened.

In its raw state jute is very difficult to work owing to its great size, its harshness and intractability. The diameter of the fibres varies, those from the upper part of the stem being finer than those from the lower part. Grown from seed sown in April, the plants are cut down in September in order to extract the fibre. After the leaves have been removed, the stems are left for three or four days in the field, and are then retted for a period of three to thirty days in a sluggish stream. The fibres are then separated by hand or machinery, washed and dried. They are prepared for spinning in a similar manner to ramie.

The coarser fibres are usually spun and made up into sacks in India, but the finer and better fibres are exported in an unbleached condition, most of it being shipped from the port of Calcutta.

The centre of the jute spinning and weaving industry in Great Britain is Dundee, where the best classes of jute are made into coarse shirtings, sheetings, carpets, etc. The poorer fibres are used in the paper-making industry, whilst the extra strong fibres are used for cords and ropes.

Jute fibres differ from the fibres of cotton, flax, and ramie in consisting mainly of a compound of cellulose known as *lignocellulose*, which contains 46 per cent carbon, 6 per cent hydrogen, and 48 per cent oxygen. This forms the basis of one of the chemical tests for distinguishing between jute and the other two bast fibres.

### HEMP

Hemp is obtained from a plant belonging to the nettle family produced in Russia, China, Japan, Italy, France, Australia, and North America. The fibres have a length of 3 to 8 ft., and are much coarser than flax, but otherwise are very similar in appearance, being uneven in diameter and showing jointings and striations of the kind appearing on flax. The ends of the fibres are usually blunt, but they are occasionally pointed and sometimes forked. This forking is a characteristic of hemp and does not appear in flax; consequently, it is one method of distinguishing between the two under the microscope.

The male plant (summer hemp) yields better fibre than the female plant (winter hemp), and they are both cut before they have seeded. The fibres are separated from the stalk by a retting process, and have to be softened by passing through fluted rollers to break down the stiffness. They are then treated in a similar way to flax. It is difficult to bleach hemp to a good white.

Hemp is mainly used for the manufacture of twines, ropes, sailcloths, etc., for which it is specially suitable owing to its resistance against rotting when wet, and is said to have been cultivated in India as early as 800 to 900 B.C.

#### SISAL HEMP (Henequen)

This is grown principally in Mexico, but is also found in the West Indies, Florida, and parts of Africa. The fibre is obtained from the leaf of a species of Agave plant and is light yellow in colour, straight and smooth, with a length of  $2\frac{1}{2}$  to 4 ft. The leaves are taken from the plant at about the third year of its growth, scraped, and the fibres washed and dried in the sun. Sisal hemp is not very strong or flexible, and disintegrates more easily through the action of salt water than other fibres used for ropes.

#### PITA FIBRE

Pita fibre is similar to sisal hemp, and is taken from the leaves of a plant grown in Mexico. It is used for the manufacture of twine and cordage but is unimportant as a textiles fibre.

#### MANILA HEMP

The plant from which this is taken is cultivated in the Philippines, Java, and Queensland (Australia), and attains a height of 18 to 20 ft., whilst the stem has a diameter of 10 or 11 ft. The fibre is obtained from the stems of the leaves, and is chiefly used to make marine ropes and cordage owing to its great strength and durability. The finest grades are sometimes woven into muslin, and the coarser fibres are sometimes used for coarse textile fabrics. The fibres are a yellowish-brown colour and have a silky lustre, with a length of 4 to 6 ft.

### "NEW ZEALAND FLAX"

This fibre, which is not really a flax, is obtained from the leaves of a tree grown in New Zealand and Australia. The leaves are from 3 to 6 ft. in width, and the fibre obtained from them is smooth and silky, and stronger than real flax. It is mostly used for string and rope, but some of the finer fibres are woven into cloth and coarse mats.

### PINEAPPLE FIBRE

An exceedingly fine, strong, flexible, and silky fibre taken from the leaves of the pineapple, found wild in Mexico and Brazil, and cultivated in tropical countries. The fibre, which is also known as "silk-grass," is sometimes used in the Philippines for the manufacture of a fine fabric called "Piña cloth," which is supposed to be waterproof.

### BOMBAX COTTON

A fine vegetable down attached to the inner walls of the seed pods of plants belonging to the Bombaceae family, grown in the West Indies, Brazil, and other parts of South America. It has a fine silky appearance, but is weak and not very elastic. The fibre is very short, the longest not measuring much more than 1 in., and has not the characteristic twisted formation of real cotton. It is of little value as a textiles material but is sometimes spun mixed with cotton. Bombax cotton is chiefly used for stuffing cushions and for similar purposes.

### KAPOK

Kapok is a kind of Bombax cotton and is also used as a stuffing for cushions. Owing to the fact that in the compressed state it can support about thirty-six times its own weight in water, it is of especial value for the padding of lifebelts. Under the microscope kapok appears as a

tapering cylindrical fibre ending in a bulbous base, and by reason of this formation is easily distinguishable from the other vegetable fibres. It is lustrous and soft, but is

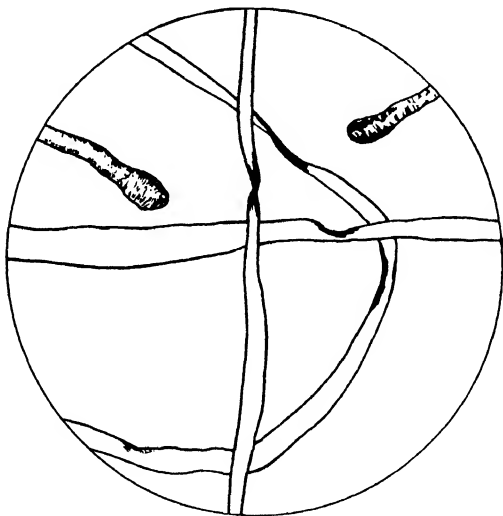

FIG. 13. KAPOK

Some fibres quite transparent, others very dense. Smooth, ribbon-like, almost devoid of structure, but broken and doubled over in some places. Characteristic bulbous root-like end

also brittle and inelastic. Like jute, the principal constituent of kapok is lignocellulose.

### “ VEGETABLE SILK ”

Vegetable Silk fibres are the seed hairs of certain plants of the *Asclepias* family. They are longer and stronger than the *Bombax* cottons, soft and lustrous, but rather brittle. Although they are occasionally mixed with cotton they are comparatively unimportant.

## CHAPTER VI

### SILK

VARIETIES of silk moth, cultivated and wild—Life of a silk moth—Preparation of raw silk—Silk throwing—Spun silk—Silk counts.

THE production and weaving of silk has been carried on for several thousand years and was first mentioned in Chinese history in 3,000 B.C. The secret of *Sericulture* was kept by the Chinese until about A.D. 300, but in the third century silkworm eggs were smuggled out of the country and found their way to Japan and thence to India. By similar methods silk was introduced into Europe in A.D. 550, and from that time sericulture and silk weaving spread over the whole of Eastern Europe. Italy commenced the cultivation of the domestic silkworm in the twelfth century, and to-day Italy produces over 10 million lb. of raw silk per annum, more than half as much as China, with its 18 to 20 million lb. Out of China's total, however, over 7 million lb. is of rather inferior grade, known as Canton silk. By far the largest producer of raw silk to-day is Japan, in which country nearly 74 million lb. of silk were produced in 1930-1931.

Attempts have been made to produce silk in England, but although the silk was quite satisfactory the experiment was not found to be profitable for various reasons, one of which was probably the cost of labour. India is the most important of the wild-silk producing countries.

There are several important firms preparing raw silk for weaving (throwing, etc.), and our silk yarns are considered to be some of the finest produced. Silk weaving is also carried on in this country and is rapidly making progress.

Silk, a continuous animal fibre, is produced by the

silkworm when spinning a cocoon in which to make the change from worm to chrysalis, and then to moth. The moth on emerging from its silken case lays its eggs on a leaf and dies. The eggs hatch into silkworms which continue the process.

### Principal Varieties of Silk Moth.

There are two main categories into which the different species of silkworm moths can be classed, the cultivated

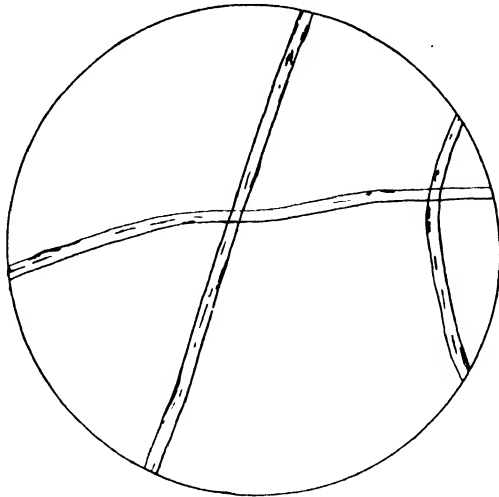

FIG. 14. CULTIVATED SILK (*BOMBYX MORI*)

A lustrous rod-like fibre. Fairly straight, but diameter varies, and irregularities in the form of swellings can sometimes be seen

moths and the wild moths. The best silk is obtained from the cultivated variety, which is bred in "filatures" or farms. The wild silk moth breeds in the open on trees, and although a certain amount of attention is given during the breeding the silk produced is rather coarse and irregular, and only suitable for rough materials of the Shantung type.

**BOMBYX MORI.** This is the cultivated silk moth which is fed on mulberry leaves. It is bred in China, Japan, Italy, and other silk-producing countries.



**YAMA-MAI.** A wild variety and a native of Japan. It feeds on oak leaves, and produces a cocoon about the size of a pigeon's egg from which a pale green silk is reeled. The moth is often 6 in. across.

**ATTACUS ATLAS.** Wild. A moth found in China, India, Burma, Ceylon, and Java, which feeds on various trees. The cocoon from this variety is also large.

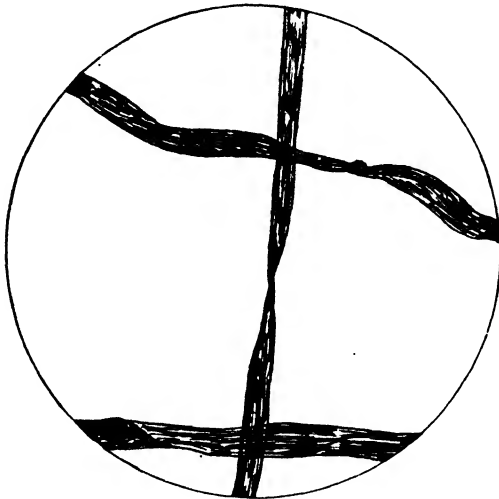

FIG. 15. WILD SILK (TUSSAH)

Large diameter. Occasional twists. Brownish lines running along the length of the fibre. Sometimes shows diagonal markings. Considerable variation of diameter

**ANTHEREA PERNYI.** An oak-feeding moth which is a native of China.

**TUSSER.** The silkworm of the Tusser moth is found on oak and other trees in the jungles of central and southern India. Not much care is taken in the breeding. During the time when the worms are feeding, heavy rains are of daily occurrence, and without these to keep them clean, the worms will not thrive. They have to be watched to protect them against bats, rats, and other vermin. Wild Tusser silk contains tannin, which has to be thoroughly discharged before the silk can be dyed.

There are probably about four or five hundred different varieties of silk moths, but the large majority of them are of no commercial value owing to the poorness of the silk, or the difficulty of collecting and reeling off the silk before the moth eats its way out.

THE LIFE STORY OF A SILKWORM MOTH—  
BOMBYX MORI

The moth lays its eggs in the summer. They are pink in colour, very minute, about 35,000 to 40,000 weighing

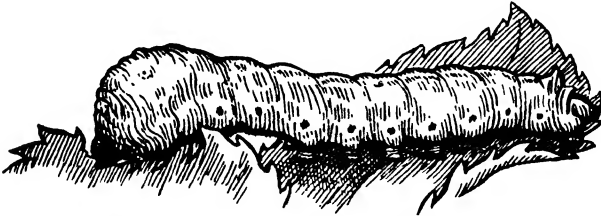

FIG. 16. THE SILKWORM

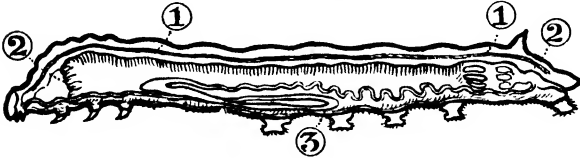

FIG. 17. DIAGRAM SHOWING THE FIBROIN DUCTS OF THE  
SILKWORM

1. The main artery of the organism
2. The alimentary canal or digestive tube
3. The fibroin reservoir and apparatus

only one ounce. This quantity would be enough to stock a silk filature for one season.

Soon after being laid, the eggs change to a dark grey colour, and in the following spring they are hatched. In temperate climates the *Bombyx Mori* only breeds annually.

As soon as it is hatched, the worm grows rapidly, feeding voraciously. In a few days it stops feeding to change its skin, moving backwards out of the old one, which has become too small for it. As soon as this is done, it

commences once more to feed. In about five or six weeks the worm has changed its skin four times and should be fully grown, measuring about 3 in. in length and weighing approximately one-ninth of an ounce.

When fully grown, the worm ceases feeding and appears to be restless. The skin changes colour to a semi-transparent pink, and from a hole in the lower lip there begins to appear the silk thread. The silkworm emits a small amount of gum with which it attaches itself to the nearest



FIG. 18. THE SILK  
MOTH (BOMBYX  
MORI)

leaf or twig. Then by a waving motion of the body it gradually envelopes itself in a cocoon of silk drawn out in a double thread, slightly twisted, and covered by silk gum. Once it starts spinning, the silkworm never leaves off until the silk is exhausted. The total length of silk given out is approximately 500 yd., but may measure up to 1,250 yd. It is continuous, i.e. in one unbroken length.

When the worm has completely enveloped itself in the cocoon and has given out all its silk, it commences to change from worm to chrysalis, and then to moth. This takes about two or three weeks. When fully formed, the moth eats its way out of one end, dries its wings in the sun, then flutters about. It has four wings, six legs, and two antennae. The moth does not eat, and only lives a few hours. The female lays its eggs and then dies.

When it breaks its way through the end of the cocoon, the moth cuts the silk thread in thousands of places, rendering it impossible to reel off. The cocoons are therefore gathered as soon as they have been spun, and then baked or steamed to kill the insect inside. This has to be done very carefully in order not to spoil the silk.

There is one variety of silkworm (*Fogara*) of the Atlas family grown in Eastern India, which spins a light brown cocoon, open at both ends, through which the moth can

emerge without eating its way. This is not a very important variety, however, and the cocoon is used for spun silk.

Some silk moths which grow in hot climates breed several times a year, and these are called *multivoltine*. The annually breeding moths are called *univoltine* and give the best silk.

### THE SILK FILAMENT

Most silk when reeled from the cocoon is yellow or green in colour, but Chinese silk is usually white.

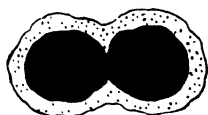

FIG. 19. CROSS-SECTION THROUGH THE DOUBLE SILK FILAMENT

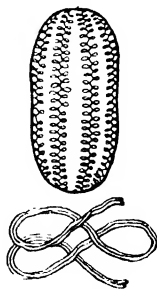
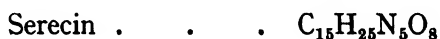

FIG. 20. SILK COCOON

The silk thread as it comes from the worm is double, consisting of two fibres side by side, surrounded by silk gum. The double filament is called the *bave*, whilst the single separated filament is called the *brin*. The thread is very fine and each filament measures only about  $\frac{1}{1000}$  part of an inch in diameter. One ounce of silk runs a hundred thousand yards in length. The cocoons of one hundred silkworms, weighing about 1 lb., yield about 1½ to 2 oz. of best silk. The remainder of the cases is made into spun silk.

The silk filament consists of two substances, fibroin, which is the core of the thread, and sericin, the silk gum on the surface of the fibre. About 75 per cent is fibroin and the balance sericin.

Silk is composed of carbon, hydrogen, nitrogen, and oxygen, the chemical proportions being—



so that serecin contains more hydrogen and oxygen. It is thought that serecin is formed by the oxidation of the outside surface of the fibroin when it comes into contact with the air on being exuded by the worm.

Serecin is soluble in boiling water, but fibroin is not. Although not soluble in water, fibroin is highly hygroscopic and will absorb as much as 33 per cent of water without feeling damp to the touch. Fibroin is also insoluble in alcohol or ether, but is freely acted upon by strong alkaline solutions, acids, and solutions of ammonia and oxide of copper.

In a silk filature the worms are watched carefully from the time they hatch to the time they spin the cocoon. Equable temperature is necessary, the worms must be kept clean and any diseased worms removed. As a general rule the strongest, finest, and most regular silk is produced by worms grown in temperate climates and bred annually. Silk produced in tropical countries is soft and bright but not so strong.

### **Diseases of Silkworms.**

These are of two kinds. The diseases of domestic (cultivated) worms are mostly forms of indigestion and are hereditary; it is therefore important to breed from healthy worms. Cultivated worms are also sometimes attacked by a kind of parasitic fly, which often proves fatal. Wild silkworms are not often subject to internal disease, but suffer greatly from insect and other pests.

## THE PREPARATION OF RAW SILK

**Reeling.**

In this process, which is a very important one, the silk filaments are reeled off the cocoons into hanks. The cocoons are steeped in hot water, which must be kept at constant temperature. This softens the silk gum and sets free the fibre. The outer web or case is brushed away and

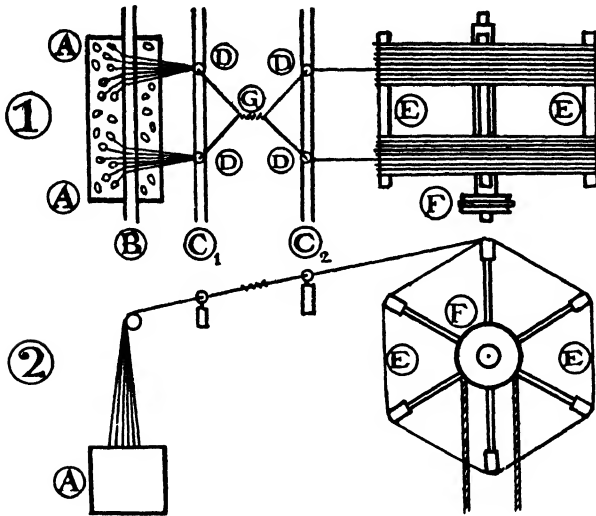

FIG. 21. SILK-REELING MACHINE

the end of the silk thread found. Owing to their great fineness the filaments from at least six cocoons have to be reeled off together.

Above the hot water tank (A) in which the cocoons are floating is a glass rod (B), over which the threads are taken. Two other fixed bars (C<sub>1</sub> and C<sub>2</sub>) have glass eyelet holes (D) set a few inches apart, and the two sets of threads, each containing the filaments from six cocoons, are carried through the first two eyes, crossed in the middle (G), and taken through the second pair of eyes to the swifts (E), where they are wound into skeins. The action of crossing

the two sets of threads is called the "crossieur," and is an essential part of the contrivance. The twisting together at the crossing consolidates the filaments and presses them into a compact thread. It also cleans them from any impurities, dries them, and tends to make them even. All reeling machines have the crossieur in one form or another.

It is essential to keep the same number of cocoons in action in order to give evenness of thread. If one of the threads breaks, the end must be caught up and joined to the others going through. Many of the faults which show themselves at a later stage are due to bad reeling. Some of these faults are enumerated below—

**WASTE.** This is a mass of tangled open fibre attached to the raw silk threads.

**NIBS AND SLUGS.** Thickened places several times the diameter of the thread.

**SPLIT THREADS.** Large loops, loose ends, or open places where one or more filaments are separated from the thread.

**KNOTS.** These appear where broken filaments are tied up. The ends should not exceed  $\frac{1}{8}$  in. in length.

### **Sorting.**

At the silk throwing mill, the "book" or bundle of raw silk, weighing several pounds and made up of a number of smaller bundles or "mosses," is opened up. The mosses consist of skeins which have come from many different reeling machines. These are sorted into different grades according to colour and cleanness, i.e. freedom from inequalities such as knots or loose ends.

### **Washing.**

This is done in warm water and is only intended to remove the outer dirt which may have been picked up. The gum is not removed in this process.

### Winding.

From the skeins the silk is wound on to bobbins or reels ready for the next process.

### Cleaning.

The silk thread is passed through a very sharp double knife with the edges practically touching, in order to clean off all unevenness and hairy filaments.

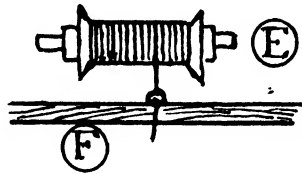

### The First Throwing.

The throwing of silk is the equivalent of the spinning operation for other textile fibres, and consists of twisting the filaments together by means of the flyer system. The amount of twist inserted depends on the purpose for which the yarn is to be used. Fig. 22 is a sketch showing the essential parts of a silk throwing machine, which works on the following principle.

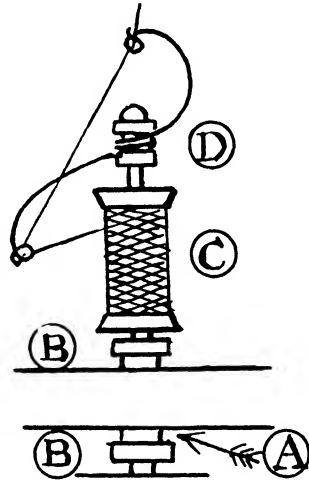

FIG. 22. SILK SPINDLE AND FLYER

The bobbin (C) containing the untwisted thread of several silk filaments is fixed on to a vertically set spindle (A), with which it revolves. On the top end of the spindle a small cylinder (D) rests loosely, and is kept in position by a screw cap. A wire is twisted round the groove in the cylinder, the two ends being bent into a sort of "S" with loop-eyes at each extreme. This is called the flyer.

Immediately above the spindle, and resting on a board (F), which also supports the other bobbins on the machine,



is a bobbin (*E*) intended to receive the twisted thread. From the lower bobbin the thread is taken through both eyes of the flyer and up to the horizontal bobbin overhead.

If the lower bobbin were loose and the silk were drawn from it in an upward direction to the other bobbin it would only be very lightly twisted. As, however, the lower bobbin is fixed to the spindle and revolves with it at a greater speed than the upper bobbin, the thread is literally "thrown" off faster than the upper bobbin can receive it. The difference in speeds causes a certain amount of slack thread. This is taken up by the flyer, which is running freely, and twisted round at great speed before it reaches the upper bobbin. In front of the upper bobbin is a guide eye which has a side-to-side movement in order to distribute the thrown silk evenly on the bobbin.

The amount of twist given to the thread in the throwing operation depends on the difference between the speeds of the upper and lower bobbins. Some silk yarns are given as many as sixty twists to the inch in the first throwing process.

The yarn from the first throwing is called "singles," although it contains twelve or more single filaments of fibre. The term "dumb singles" is applied to the silk thread before it has been thrown.

### **Doubling.**

This consists of winding two, three, or more thrown silk threads together to increase the thickness and strength, and it is effected without twist.

### **The Second Throwing.**

The second throwing is similar to the first, but twist is inserted in the opposite direction, thus binding the threads together into a compact yarn.

**Steaming.**

In order to set the twist the thrown silk is steamed.

**Sizing.**

The silk is graded for size and quality.

**Reeling.**

The thrown silk thread is next reeled on to large metal drums to be stored until required.

When silk leaves the throwing mill it is still in the gum and is called hard silk. It is still in this state when woven into cloth, the reason being that the gum strengthens and supports the thread during the weaving process. Part of the finishing process for silk cloths is the degumming or boiling-off of the silk gum. The gum liquor is afterwards used towards making up the dye bath, as it acts as an assistant, i.e. helps the silk to absorb the dye evenly.

**Spun Silk.**

There is a fair amount of silk waste resulting from the various preparatory processes, and this is made into spun silk, together with cocoons which have been broken open by the moth and any raw silk which for any reason cannot satisfactorily be reeled off in a continuous fibre. Waste silk is torn up into short filaments and treated in a similar manner to cotton, that is to say, carded and spun like any other short fibre.

**Silk Counts.**

Raw silk is known by its "title" or count, which is the weight in deniers of 450 metres of raw silk, one denier being equal to  $\frac{1}{53.15}$  of an ounce, or .05 gramme. The double thread produced by the silkworm counts about  $2\frac{1}{2}$  deniers when in the gum, so that a single filament would count approximately 1 denier after degumming. Net silk

is usually quoted as 12/14, 16/18, etc., and sold on the middle or average figure, i.e. 13, 17, deniers, etc., as it is very unusual to find two hanks weighing (i.e. counting) exactly the same. If the single filament counted exactly one denier then a silk thread with the title 13/15 would contain 13 to 15 filaments. In the case of Italian silk, for example, the double cocoon thread in the gum weighs 2.62 deniers and the percentage loss in boiling off the gum is approximately 25 per cent. This means that in 13/15 Italian silk there are actually 9/11 filaments. Japanese silk weighs 2.43 deniers for the double cocoon thread in the gum, and with a loss of 18 per cent in the boiling-off a 13/15 denier Japanese silk will have 10/11 filaments in one thread. Canton silk is the lightest, having a weight of 1.90 deniers in the gum, and with a loss of 22 per cent this gives 11/14 filaments in a 13/15 silk thread. It will be noticed that Canton has a wider variation in the diameter and weight of the filaments, in addition to containing more filaments than a silk thread of different origin in the same count. This makes Canton a rather fuller thread, but at the same time it is rather irregular and contains more reeling faults, such as thickened threads, knots, etc. Ordinary Chinese silk is much more regular, and is nearer to the Italian and Japanese silks in weight and filament count.

There are other methods of counting silk yarns, but the one outlined above is the most usual and is in fact the legal standard upon which other methods are based.

The count of spun silk is calculated in the same way as cotton, i.e. the number of hanks each measuring 840 yd. that it takes to weigh 1 lb. avoirdupois.

### **Silk Terms.**

The following terms are used in the silk trade—

**DUMB SINGLES.** Fine silk threads reeled without twist

and combined to form Tram or thrown weft silk. Also called Net Silk.

TRAM. Two or more dumb singles, doubled, and with just sufficient twist to hold them together. They are twisted as lightly as possible in order to retain the lustre and covering power. They are generally used for weft.

ORGANZINE. Two or more singles, doubled, and twisted, the amount of twist varying according to the purpose for which it is to be used. Chiefly for warps.

ECRU SILK. Thrown silk with only a little of the gum taken away. The term is also used to mean silk cloth before being degummed.

FLOSS SILK. A soft yarn with very little twist, used for embroidery. The name is also given to some silk waste.

BAVE. The double filament of raw silk.

BRIN. The single separated filament.

DUPIONS. Double cocoons.

KNUBS OR FRISONS. The waste from the outside of the cocoon. The outside layer is also called Waddings or Blaze. This is full of gum and consequently lacking in lustre.

NERI OR RICOTTI. A term used in the U.S.A. to denote the waste inside the cocoon.

SCHAPPE SILK. This term is sometimes used to-day to describe Spun Silk, but actually schappe silk takes its name from the "schappe" method of degumming. The silk is put into vats of warm water below boiling point and left for some days or even weeks, being allowed to ferment. This leaves the fibre strong but spoils the colour. The usual method of degumming is described in a later chapter. (See the Finishing of Silk.)

With the exception of Figs. 14 and 15, the illustrations in this chapter are reproduced from *Silk, its Production and Manufacture*, by Luther Hooper (Sir Isaac Pitman & Sons, Ltd.).

## CHAPTER VII

### RAYON (ARTIFICIAL SILK)

HISTORY of the rayon industry—World production—The raw materials and methods of production—Viscose, acetate, cuprammonium, nitro-cellulose—Rayon spinning—The Topham box—Celta—Staple fibre—Artificial horsehair—Yarn counts.

THE name Artificial Silk was first given to a fibre produced in an attempt to imitate real silk, and although it has not yet been possible to obtain in a synthetic fibre all the natural characteristics of the silken thread emitted by the silkworm, nevertheless the tremendous success which has attended the experiments of the pioneers of this new branch of textiles has justified its being placed in an entirely new class, and has earned for it a name which should prevent it from being confused with any other textile fibre. With this in mind, the leading firms engaged in its production have agreed to use the new name *Rayon* to cover all varieties of this new synthetic fibre. The manufacturers of the United States quickly realized the necessity of a separate name and have called it Rayon for some time, whilst other countries as well as Great Britain are now falling into line. Some large producers are still endeavouring to foster the old connection with the natural fibre which it was at first intended to copy, by calling their article "— silk," using their own name in conjunction with the word "silk," but it is to be hoped that in time they, too, will agree with the decision of the majority and allow their product to stand alone on its own merits in the new class of textile, which has certainly earned a place and name for itself in the textiles world.

Whilst real silk is an animal fibre, rayon, which is produced from vegetable substances by chemical means, really belongs to the vegetable fibres. It is a continuous

fibre and can be spun to almost any length. Its main constituent is cellulose, which is found to such a large extent in cotton and wood pulp.

As already mentioned, the original intention was to produce a yarn with the same properties as natural silk, but by artificial means. The natural lustre, strength and beauty of silk had long excited the envy of other sections of the textiles trade, and for years scientists pondered over the possibility of emulating the silkworm and producing by mechanical means a thread equal to that which the worm so patiently winds round itself before making the transformation from worm to chrysalis. The first attempt was with a gelatine thread in the seventeenth century. This was not a conspicuous success owing to the difficulty of winding off the thread. In 1740 a Frenchman worked up spiders' web into gloves, stockings, etc., but this was not taken as a serious move towards the solution of the problem.

The first real step was taken in 1855, when a patent was taken out for producing Nitro-cellulose in the form of a thread. The filaments were drawn out by the point of a needle and then wound on to a bobbin. Seven years later the action of the silkworm was imitated by forcing a solution through fine holes to form a thread.

The present rayon industry can be said to have started in earnest, however, in the year 1878, when three men commenced the experiments which laid the foundation of the work that has continued ever since. These were Count Chardonnet, and the Englishmen Cross and Bevan. Chardonnet concentrated on the production by the nitro-cellulose process. In its pure form nitro-cellulose is highly inflammable, and not only were the experiments dangerous but the yarn produced was not safe to be used as it was. A method of de-nitrating the material had to be found which did not affect the shape or nature of the thread.

In 1892 Cross and Bevan took out their first patent for what they called "Viscose Silk." Shortly after, the problem of a suitable means of winding off the spun yarn was solved by C. F. Topham, who invented the rotating yarn box now called the Topham Box.

The well-known English firm of silk manufacturers, Courtaulds, came into the field in 1904, when they started experimenting at Kew with a view to producing the fibre commercially, and a year later they opened a factory at Coventry.

In 1911 Dr. Dreyfus patented a method of producing cellulose acetate. This material was used to a large extent during the Great War in liquid form as "dope" for aircraft owing to its waterproofing powers, and a company was formed under the control of the British Government to produce it in large quantities. The Celanese Company is the successor to the organization concerned.

The marvellous progress made by this modern industry can be appreciated by the fact that in 1891 the estimated output was approximately 30,000 lb., whilst in 1931 the world production reached the enormous figures of over 450 million lb. The following figures, which are taken from the *Textile Mercury*, show how the industry has grown.

#### WORLD RAYON PRODUCTION

1891	.	.	.	30,000 lb.
1896	.	.	.	1,350,000 "
1903	.	.	.	6,700,000 "
1910	.	.	.	18,000,000 "
1913	.	.	.	27,000,000 "
1922	.	.	.	78,000,000 "
1923	.	.	.	97,000,000 "
1924	.	.	.	141,000,000 "
1925	.	.	.	187,500,000 "
1926	.	.	.	219,400,000 "
1927	.	.	.	270,368,000 "
1928	.	.	.	345,500,000 "
1929	.	.	.	442,200,000 "
1930	.	.	.	426,400,000 "
1931	.	.	.	451,500,000 "

The success which attended the pioneers of this industry attracted many speculators, and a year or two ago a number of mushroom firms sprang up with the object of producing this new fibre. As a result there was for a time a quantity of second grade and decidedly inferior yarn on the market which certainly did not help to popularize rayon in the eyes of the consuming public; but the newcomers soon found that it was not so easy to produce a satisfactory yarn as it at first appeared, and the old-established firms with their earlier years of experience are now left to continue their work with the full confidence of the trade. In addition to the viscose and acetate rayons in which this country has been so successful, there is now a third kind, Cuprammonium, produced in large quantities by most of the larger firms. A new factory recently established in Doncaster is now engaged in producing cuprammonium on a commercial scale, and incidentally providing work for large numbers of English workmen in this new industry.

There are four kinds of rayon produced to-day for the textiles trade. These are: (1) Viscose; (2) Acetate; (3) Cuprammonium; (4) Nitro-cellulose.

Of these, viscose is easily the most important from the viewpoint of quantity, over 88 per cent of the world's production of rayon being made by this method. Next in order come acetate with about 8 per cent, cuprammonium with about 3 per cent, and lastly nitro-cellulose, about 1 per cent. The United States of America is the largest rayon-producing country in the world, with an output of nearly 140 million lb. in 1931, most of which was viscose, although they also make all of the other three kinds. Italy comes next with 76½ million lb., and Great Britain takes third place with 54½ million lb. The production of Germany is not much less than that of Great Britain, whilst Japan and France also produce important



quantities. Practically every civilized country of any importance is making rayon by one or other of the four methods.

### RAW MATERIALS

Cellulose is a vegetable substance present in cotton, flax, and other vegetable fibres, as well as in wood pulp. Cotton is used for the better kinds of rayon, but it is usually only the linters or short fuzzy fibres remaining attached to the seeds after ginning. The principal source of the cellulose used for rayon is wood pulp. This comes from Norway, Sweden, Finland, and Canada. The logs are carefully trimmed, all bark and dirt removed, and the wood cut into chips, which are boiled in a solution of calcium bisulphite and sulphur dioxide. The resulting mass is strained, washed, and dried, and then bleached. Washed and dried again, the pulp is formed into sheets and packed in bales for export. Absolute cleanliness is necessary in this and all subsequent operations.

### METHOD OF PRODUCTION

In general the usual method is to make a solution of cellulose, clearing out all impurities, and to force it through tiny tubes or holes, which are called spinnerets, and have a diameter of from  $\frac{1}{300}$  to  $\frac{1}{100}$  of an inch. These are made of glass, porcelain, or platinum. If the ejected liquid does not set on coming into contact with the air by the solvent evaporating, then it must be passed through a liquid or gas to set the thread.

### VISCOSE RAYON

This is the most important process and is entirely British, having been discovered by Cross and Bevan. Cleaned wood pulp is steeped in a strong solution of caustic soda. The liquid is squeezed out of the material, which is

then dried and ground into "crumbs" of alkali cellulose. These are left to take up oxygen, this part of the process being known as "ageing." For this purpose the crumbs are left in closed boxes for several days in a constant temperature of 75° F. After this they are treated with carbon disulphide to form a brownish-looking solid called cellulose xanthate. This is dissolved in a weak solution

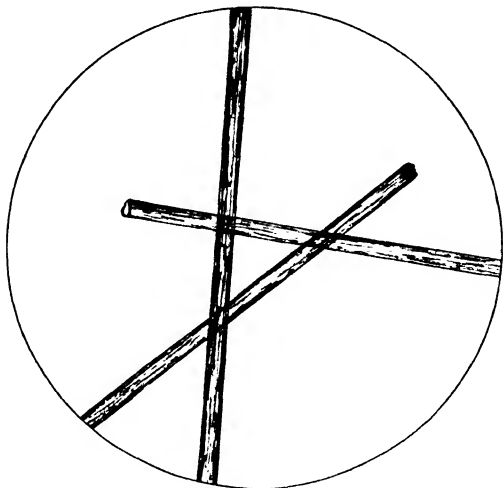

FIG. 23. VISCOSE RAYON

A glass-like rod, with characteristic lines down the length of the fibre. The broken end shows a serrated edge. Diameter fairly even

of caustic soda, which turns it into a viscous, treacly substance called viscose, which gives the name to the whole process. The viscose is carefully filtered to remove any impurities, such as fibres which have not been thoroughly dissolved, and to take out the air bubbles.

The viscose is then left to settle for about four days, during which further chemical changes take place, allowing the formation of the spinning solution.

The spinning solution is forced through spinnerets in the form of a thread, which is carried through a coagulating bath made up of dilute sulphuric acid, sodium sulphate,

and glucose, which solidify the thread. This spinning bath may, of course, be modified to suit the circumstances or any slight change in the chemicals previously used, but on the whole all viscose is made in more or less the same manner.

Poisonous gases are developed during the manufacture

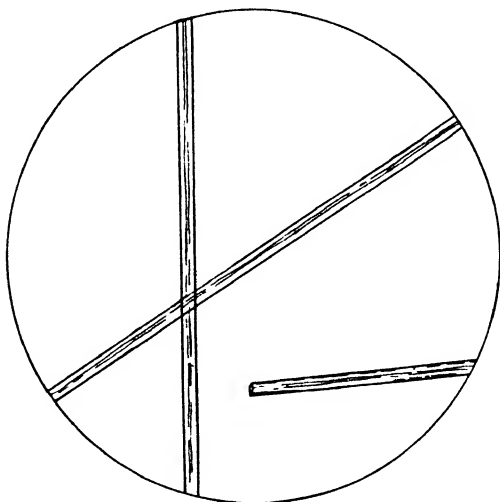

FIG. 24. ACETATE RAYON

Similar to viscose, but not so many longitudinal markings. Usually two lines down the centre

of viscose, and proper means of ventilation are necessary to carry these away.

Viscose is the cheapest and most popular class of rayon. It has a medium lustre and its strength, wet and dry, is about the average. The handle of viscose is not so good as acetate and cuprammonium, but is improving.

#### ACETATE RAYON (Acetyl-cellulose)

This is the only one of the four rayons which is not a pure form of cellulose. Acetate is a compound of cellulose

and acetic acid, the source of the cellulose being wood pulp or cotton linters. The cellulose is treated with acetic anhydride, which is a form of acetic acid, and the subsequent combination is called cellulose acetate. This is washed, dried, and dissolved in acetone. After filtering, the solution is forced through spinnerets, and the thread solidifies in a current of warm air, which evaporates the acetone.

In lustre and handle acetate rayon is claimed to be the nearest approach to silk. Its tensile strength in the wet and dry state is good, and it is resistant to the action of water. The cost of production is, however, high, and owing to the nature of the fibre the ordinary dyes used for other textiles are found to be unsatisfactory for acetate. A special range of synthetic dyes is now available for use in the dyeing of this material.

#### CUPRAMMONIUM RAYON (Cupra)

This process, used to a large extent by the Bemberg companies, and now by other manufacturers, is rapidly gaining in importance. The raw material used is either wood pulp or cotton linters. The cellulose is dissolved in a solution of ammoniacal copper oxide. When filtered this gives a blue-coloured viscous fluid, which is spun through a coagulated bath of strong caustic soda. Washed in weak acid to remove the copper, the thread then loses its blue colour.

In the cuprammonium process both direct and stretch spinning are used. In the latter the filaments are stretched whilst being spun in order to produce a fine even yarn. Cupra yarn is spun in very fine counts, in some cases as fine as, and even finer than, silk. As a consequence it has a subdued lustre and good covering power, besides being fairly strong.

### NITRO-CELLULOSE RAYON (Nitro)

This is the method discovered by Count Chardonnet, but for various reasons it has not achieved the popularity gained by the other processes. Another name for it is the Collodion method. Cotton linters are used for the cellulose, which is steeped in a bath of nitric and sulphuric acids.

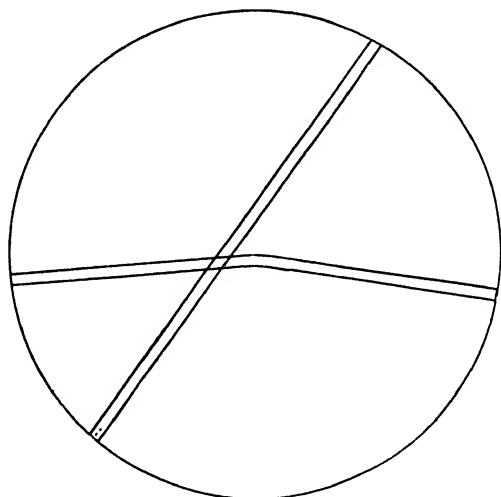

FIG. 25. CUPRAMMONIUM RAYON

Transparent, lustrous, almost devoid of structure. Even diameter, frequently as fine as real silk

These nitrate the cellulose, converting it into a powder. In this form it is similar to gun-cotton and is highly explosive.

The cellulose nitrate is dissolved in a solution of alcohol and ether, which produces a viscous mass called Collodion. This is carefully filtered and allowed to settle. Spun through worms (spinnerets), the thread solidifies at once by the alcohol and ether evaporating. The solid filament thus produced is actually nitro-cellulose, and has to be de-nitrated by treatment with ammonium sulphide. Bleached, washed, and dried, it is then ready for use.

This process is used on the Continent, but is, however, becoming less important. The filament has a high lustre and soft handle, but low tensile strength, especially when wet.

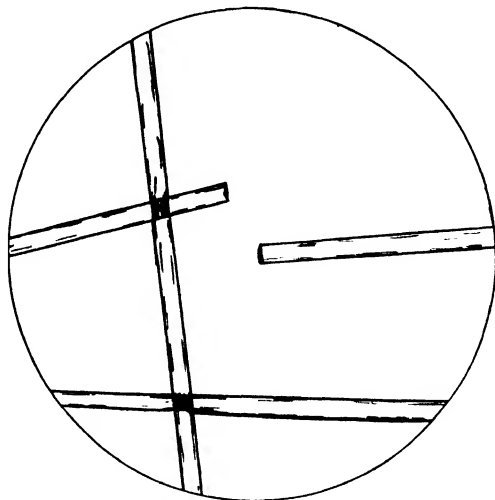

FIG. 26. NITRO-CELLULOSE RAYON  
Similar to cuprammonium, but not so fine in diameter

#### COMMERCIAL VARIETIES OF RAYON

The following are the principal varieties of rayon on the market at the present time—

VISCOSE. Courtaulds, Celta, Dulenza, Enka, Glanzstoff, Snia-Viscosa.

ACETATE. Celanese, Chatillon, Rhodioseta.

CUPRA. Bemberg, Napon, Zelloag.

NITRO. Tubize, Chardonize, Chacelon.

#### THE SPINNING OF RAYON

In this process the filaments emitted from the spinnerets or worms are wound off together, several being combined and twisted to form one composite yarn as in silk.

There are two methods, the bobbin system and the can

system. In the former the thread is wound on to glass bobbins without any twist. This entails washing and drying, and ultimate twisting as a separate operation. The

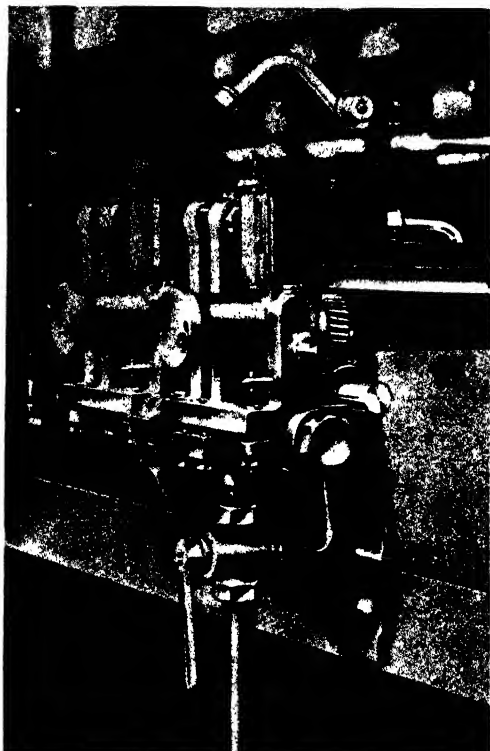

*By courtesy of*

*Messrs. Dobson & Barlow, Ltd.*

FIG. 27. RAYON PUMP UNIT, SHOWING THE SPINNERET FROM WHICH THE FILAMENTS ARE EMITTED

can system is the most modern, and effects all these operations at one time. The principal feature of the can system is the Topham Box.

### **The Topham Box.**

The filaments from the spinnerets are guided over a glass rod or wheel at the top of the machine and fall

vertically into a glass funnel, the end of which is moving up and down inside the box. The box itself is a perforated can inside a round bakelite case, and revolves at a speed

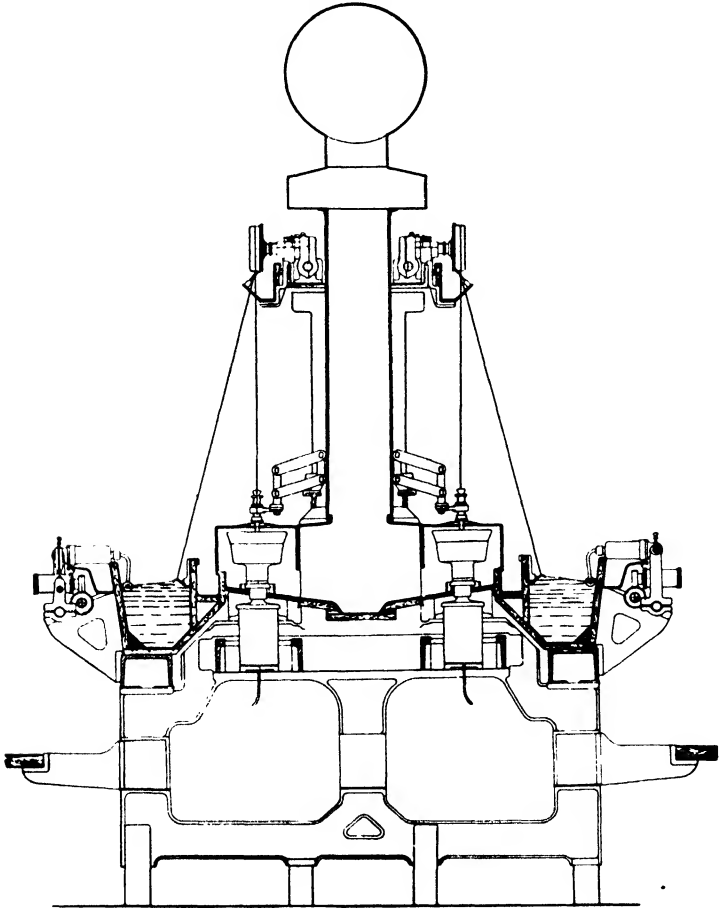

*By courtesy of*

*Messrs. Dobson & Barlow, Ltd.*

FIG. 28. DIAGRAM OF RAYON SPINNING MACHINE

of 5,000 revolutions or more per minute. The thread is thrown to the outside of the perforated can, the water or spinning solution being thrown off and forced out through the holes by the centrifugal force set up owing to the



high speed of the box. As the glass funnel moves up and down inside the can it deposits the thread evenly in the form of a "cake," which is easily turned out when the box

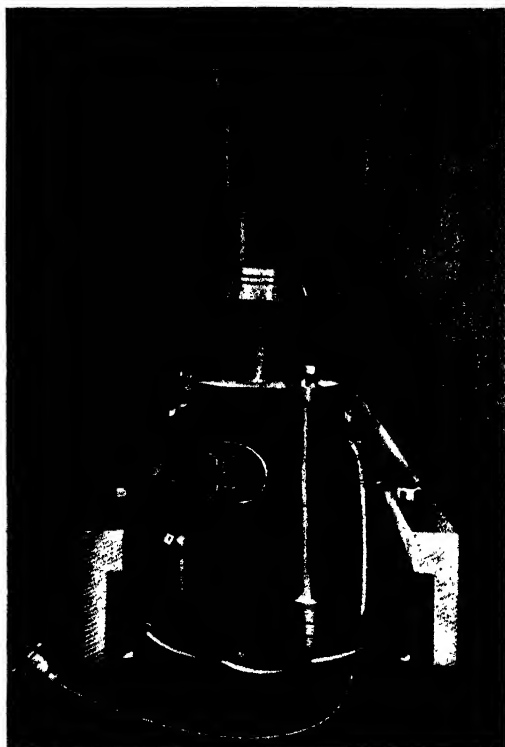

*By courtesy of*

*Messrs. Dobson & Barlow, Ltd.*

FIG. 29. RAYON SPINNING BOX, ELECTRICALLY-DRIVEN

is full. The thread is thus twisted and laid into such a form that it can be easily reeled into skeins without becoming entangled. Another advantage of this method is that there is no strain on the filaments. It takes about three hours to fill a box and less than a minute to replace the full box with an empty one. The skeins of rayon into which the "cakes" are then wound are washed again in warm water and dried.

**Celta (Viscose).**

During the ordinary processes of manufacturing viscose yarns precaution is usually taken to prevent air or gas

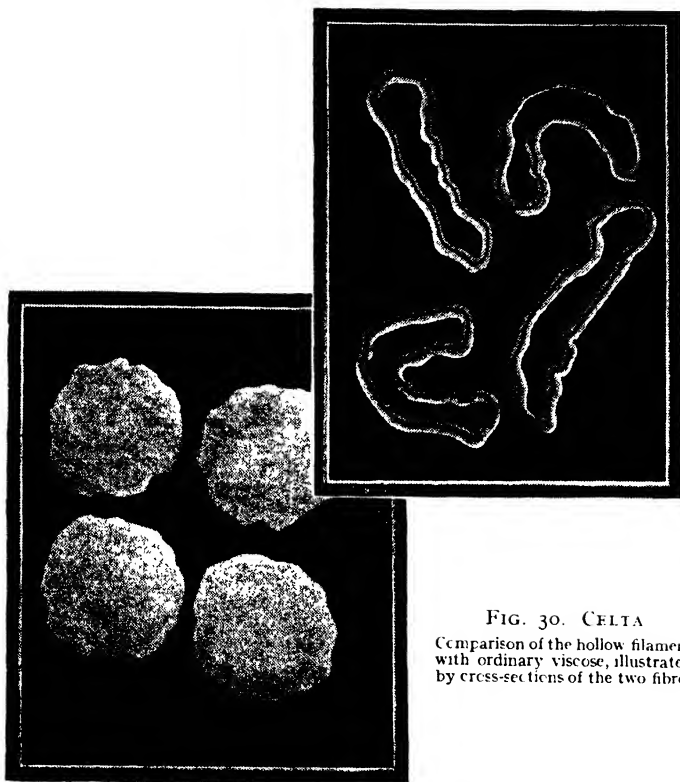

FIG. 30. CELTA

Comparison of the hollow filament with ordinary viscose, illustrated by cross-sections of the two fibres

*By courtesy of Messrs. Thos. Taylor & Co.*

bubbles from getting into the filament, as they would cause irregularity and weak places in the yarn. In the Celta process, however, bubbles are actually created and controlled so that the gases are imprisoned within the walls of the filaments, forming a hollow tube or fibre, similar to an inflated rubber tube. In this state the filament is rigid and not flexible. During the spinning process, part of the imprisoned gas is dissolved and the

hollow filament becomes deflated. The advantage of a hollow filament rayon is that the lustre is reduced by presenting a more uneven surface. The fibre is more ribbon-like than cylindrical, and is consequently softer, lighter, and bulkier. The manufacturers claim that it is very suitable for hosiery and underwear as it is warmer than ordinary rayon, and that garments made from Celta do not lose their shape after washing. It is also said that the shape of the fibre gives it extra covering power, and this would make it very suitable for velvets and plushes.

Under the microscope hollow-filament rayon appears as a continuous ribbon-like filament with prominent cell walls, not unlike cotton.

Celta is the name under which hollow-filament fibre is sold in England, but there are rayons of a similar type produced and sold on the Continent under different names.

### **Staple Fibre.**

A demand has sprung up in recent years for rayon filaments cut into short lengths. These are spun into yarn in a similar manner to cotton, and are frequently mixed with fibres of cotton, wool, or silk. From the spinner's point of view they have the distinct advantage of presenting an equal length in each staple. Most important rayon manufacturers produce one or more qualities of staple fibre. "Fibro," "Vistra," and "Sniafil" are typical examples.

### **Sniafil.**

Sniafil is made by the viscose process by the Snia Viscosa Company in Italy. The viscose yarn is cut into short, even lengths and treated to give the appearance of wool. It is not, however, so strong as wool, nor is it as warm. Sniafil is mixed with wool to make waterproof



FIGS. 31 AND 32. CROSS-SECTIONS OF CELTA FIBRES

fabrics and other kinds of cloth, and has also been used in yarn form as the weft for a fabric with cotton warp.

### **Artificial Horse Hair.**

Horse hair is used to a large extent in the tailoring and furnishing trades for stiffening purposes, and a very good substitute, which has the advantage of being cheaper and available in larger quantities, is now made from single filament rayon yarn. This is produced either by the viscose, acetate or cuprammonium processes and is sold under various names, e.g. Monosilk, Crinol, and Crinolene. It was first made in 1900 by the cupra process, but since 1923 great progress has been made and the article is now produced in large quantities in Nottingham. The counts range from 30 to 1,000 deniers single filament, that is to say, from the thickness of human hair to that of elephant's hair.

The processes are the same as for ordinary rayon, but as it is single filament slightly different treatment is necessary. It is essential that the fibre should be quite round and regular. Until properly coagulated the filament would be affected by any pressure. The spun yarn is taken through a long spinning bath, and there are over three yards of the filament in the bath at a time. The thread is not spun direct on to a bobbin or into the Topham Box as it has to be thoroughly hardened first. It is led into a receptacle where it lies in a loose state ready for hardening. While it is drying the thread shrinks considerably, becoming shorter and thicker without losing its roundness. It is quite possible for the shrinkage to be as high as 20 per cent, and this must be allowed for in spinning the yarn for a given count. For example, 9,000 metres of yarn counting 300 deniers in the wet state will shrink to between 7,000 and 7,500 metres counting 350 to 370

deniers. Consequently, if a count of 300 deniers is required the spinnerets must be fitted to spin 250 deniers.

Artificial horse hair can be used for any of the purposes to which real horse hair is put. It is also used in fine counts for making wigs, and the fact that it can be easily dyed in any colour makes it particularly suitable for this purpose. Attempts have been made to use it in the bristle and brush industry, but as it suffers from the disadvantage of losing its strength and appearance when wet, and does not regain these properties after drying, it will be seen that for this purpose it is quite unsuitable.

### **The Uses of Rayon.**

Rayon is used for many kinds of textile fabrics, including dress goods, plushes, tapestries, knit goods, stockings, linings, etc. It can be used alone or made up with cotton, wool, or spun silk, either spun together in the yarn or woven in the same cloth as a separate yarn. Fabrics with silk and rayon in the warp and weft are also made in order to obtain the appearance of a woven silk cloth at a lower cost. Shot effects can be obtained by cross dyeing, e.g. viscose and acetate, cotton and acetate, rayon and silk, etc.

Compared with silk, rayon is not so strong, elastic, warm, or durable. It loses strength in water or as a result of excessive heat. For this reason fabrics made of rayon must be ironed carefully and the iron should not be too hot. Rayon yarns have been known to melt and fuse into one another through the application of too hot an iron. Silk has a tensile strength of 3 to 3.5 grammes per denier and only loses about 25 per cent of its strength when wet, but rayon with a strength of less than 2 grammes per denier loses about 50 per cent when wet. The sensitiveness of rayon to moisture can be diminished to some extent by treatment with various substances such as formaldehyde and lactic acid.

**Rayon Counts.**

The yarn count of rayon is calculated in exactly the same way as silk, i.e. the weight in deniers of 450 metres of yarn, one denier being equal to  $\cdot 05$  gramme or  $\frac{1}{80}$  oz. In the rayon trade it is usual to increase these standards for ease in calculation, and by multiplying them by twenty the standards become 9,000 metres and 1 gramme. The denier count will therefore be found by taking the weight in grammes of 9,000 metres of yarn.

English methods of counting yarn are based on the denier system, and consist of converting from French into English weights and measurements.

Staple fibre, i.e. cut lengths of rayon, are counted like cotton, that is, by the number of hanks, each measuring 840 yd., that it takes to weigh 1 lb. avoirdupois.

## CHAPTER VIII

### WOOL

ORIGIN of breeds—The qualities necessary in a good wool fibre—Tops—Yield—Sources of supply, England, Australia, New Zealand, South Africa, South America, United States, etc.—Wool exchanges—Camel hair—Auchenia fibres—Mohair—Cashmere—Rabbit fur—Horse hair—Skin wools.

THE sheep as we know it to-day is said to be a development, through years of selection and acclimatization, of somewhat rough-haired animals, originally reared on the central plains of Asia. The Arabs who moved along the north coast of Africa into Spain probably took sheep with them, and these developed into the Spanish Merino sheep, the origin of the Merino breeds throughout the world. At the same time, it is thought that Asiatic tribes which wandered across the Central plains of Europe took with them sheep which ultimately reached England and formed the first flocks of English sheep. From these Merino and Mountain sheep have developed the Lustre, Mountain, and Down breeds (raised in England), the Pure Merinos (Spain, Australia, South Africa, South America), and the cross-breeds which are a cross between Merino and English (New Zealand, South America).

It is thought that the original sheep was double-coated, that is, it had an overcoat of long, strong *hair*, and an undercoat of fine *wool*. In the case of Merino the long, strong hair has been reduced by breeding and the fine wool developed, whilst with the others the fine wool has been reduced and the hair developed. The Scotch Blackface to-day has a strong hair about  $\frac{1}{40}$  in. in diameter and a fine wool of about  $\frac{7}{100}$  to  $\frac{1}{1000}$  in. in diameter. The finest Merino may have a diameter as fine as  $\frac{1}{3500}$  in.



The early sheep are thought to have had black or brown wool, but most of the wool produced to-day is white.

Climate plays a great part in determining what class of sheep is bred. Where the climate is equable and warm Merino sheep thrive well, but where the climate is variable, and very cold weather or drought is experienced,

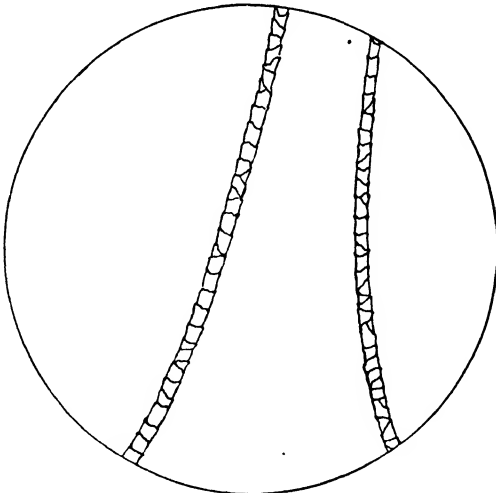

FIG. 33. WOOL, MERINO

Small and even diameter. Scale structure well marked, the scales in most cases being unbroken and crossing the fibre. Length of staple varies from about 1 in. to about 4 in., according to quality and breed

the hardier English or cross-bred sheep are better able to stand up to the weather conditions. Another factor is the meat trade. If sheep are grown for meat as well as for wool, cross-bred or English sheep, which are larger and hardier, are chosen. On the other hand, the sheep which is bred principally for its fleece is not so profitable as regards meat.

The long coarse hairs in wool are called "tops," and the shorter and softer hairs "noils."

Wool and hair always grow from the skin, so that once

the point at the tip is cut off the end does not become pointed again but remains blunt. Thus lamb's-wool or first clip, which has a pointed end, can always be distinguished from second and later clips.

Wool and hair both have an outer cuticle which is broken in the form of scales. These are more prominent in wool than hair, and can sometimes be felt by sensitive

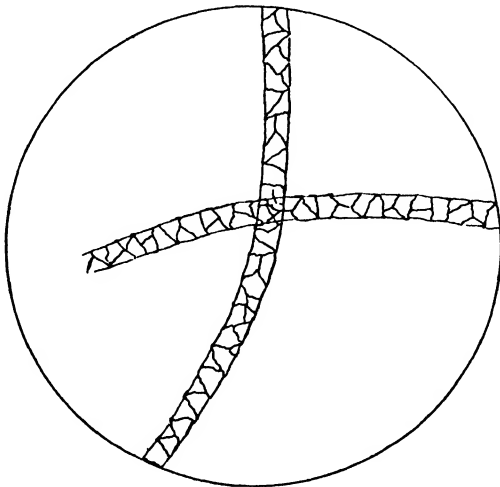

FIG. 34. WOOL, CROSS-BRED

Rather coarser in diameter than Merino wool. Scales well marked, but broken in appearance, so that they do not traverse the width of the fibre. Length up to 8 in., according to quality and breed

fingers by running the fibre through the finger and thumb. These scales are very minute, but can be seen under the microscope. In a good Merino wool the scales are unbroken and cross the fibre, there being about 1,000 to 1,200 per inch. In cross-bred wools the scales are broken, and there are about 500 per inch. The diameter of Merino is  $\frac{8}{10000}$  in. and of Lincoln (English)  $\frac{10}{10000}$  in. About 5,000 wool fibres grow on a square inch of skin, but the finest Merino may have up to 40,000 fibres per square inch.

If there is a drought the wool becomes affected and is very irregular in shape. Sometimes little lumps are seen or the fibre is narrow in places. This is because the wool is diseased, owing to ill-health of the sheep. The more uniform the fibres are, the better will the yarn be.

Kemps are fibres where the scale structure is not properly developed. When seen in bulk the wool shows white patches. This wool is brittle, and frequently the white patches do not take the dye.

The main differences between hair and wool are—

1. Hair has considerably less crimp than wool, and looks straighter under the microscope.
2. The scales of hair are less free, and more closely attached to the central cylinder, than those of wool.
3. Hair is shed every year, whereas wool has to be cut (unless pulled from the skin of dead sheep).

Camel hair is picked up along trade routes and collected at a central station. Black-faced mountain sheep have in their fleece a mixture of wool and hair. This fleece is *shed* yearly, but is sometimes plucked from the sheep.

### **The Qualities Necessary in Wool.**

1. **FINENESS.** No breed of sheep should be expected to produce a higher count of wool than the usual standard for that breed. Special breeding to improve counts spoils the quality.

2. **LENGTH.** Maximum lengths of wool are: Merino 4 in., Cross-bred 6 in. to 8 in., Lincoln and Leicester 8 in. to 12 in. An average length of  $2\frac{1}{2}$  in. over the whole fleece is satisfactory for a Merino.

3. **SOUNDNESS AND PURITY.** There must be no diseased wools, kemps, beard hairs, black hairs, dog-hairs, or grey hairs.

Beard hairs are produced by some Merino sheep in the wrinkles of the skin all over the body. They are much to be avoided. They appear also in Rambouillet, the French Merino. Black hairs appear in white-woolled sheep, the Down breeds being very liable. Dog-hairs, a name used in the Colonies, indicates a coarse class of hair which is always occurring on the lower part of the legs of cross-breeds. Grey hairs, i.e. wool of greyish hairy type, spoil wool if it is to be used for light colours.

4. UNIFORMITY. The best fleece of any grade is one where the better quality extends over the greatest part of the fleece. Length always tends to decrease towards the lower part of the animal (hinder end).

5. BRIGHTNESS IN COLOUR. Merino is the whitest.

6. SOFTNESS.

The impurities in wool are best enumerated as follows—

(a) Grease (wool fat), called Yolk.

(b) Dried perspiration (Potash), called Suint.

(c) Dirt, sand, etc.

Wool grease does not saponify (change to soap) but emulsifies. The perspiration part is soluble in water. Yolk is a misapplied term, generally used to mean the grease, but really embracing all matter, grease, perspiration, dirt, etc.

As Merino is dirtier and greasier owing to the finer fibres and better developed grease glands, there is a greater loss in scouring. A dirty Merino loses about 50 per cent in weight after scouring but an English wool will lose only about 30 per cent.

### **Top Numbers.**

The top number in wool is an indication as to the grade of yarn which can be spun from it and the following table shows the scale of counts with the kind of wool used.

## TOP NUMBER

80's	very fine indeed.	Merino			
70's	" "	" "			
64's	a good average yarn.	Merino			
60's	the lowest real	Merino			
58's	comeback, the best	cross-bred.	Cross-breds	and	English
56's	good	cross-bred			
50's	" "	" "	" "	" "	" "
48's	medium	" "	" "	" "	" "
46's	" "	" "	" "	" "	" "
44's	lower or	coarse	" "	" "	" "
40's	" "	" "	" "	" "	" "
36's	" "	" "	" "	" "	" "
32's	" "	" "	" "	" "	" "

Thus, Merinos make 60's to 80's tops, all below 50's being medium or lower grades.

**The Yield of Wool.**

The points to note in estimating the yield of a wool in the grease are as follows—

The yolk or grease at the tips.

Colour of the wool. If yellowish or dark it has more grease.

"Handle." By feeling between the fingers one can generally tell if there is much dirt, sand, burrs, etc.

Crimps, length, and fineness. The better-class wools usually have the shortest staple.

Merino wools have the best felting properties, are of the best colour, show little lustre, and are shortest in staple.

## SOURCES OF SUPPLY

## ENGLISH WOOLS

**Long Wools.**

I. LUSTRE. The Lustre wools have a staple with an average length of 10 to 12 in. The two principal breeds of sheep in this class are the Lincolns and the Leicesters. The former grow a wool which makes up to 36's tops and

is the longest and largest in diameter. Leicester wools are finer and shorter and produce 40's tops. These two are sometimes crossed to give New Lincoln. They are also crossed with other English breeds to improve the quality of the wool. The fleece from the Lustre sheep has an average weight of 10 to 12 lb.

2. DEMI-LUSTRE. These have a staple length of 7 to 9 in. The four most important breeds are Devon, 36-40's tops, Kent or Romney Marsh, 44-46's tops, Roscommon (Irish), 44's, and Border Leicester, 44's.

### **Short Wools.**

These are also called Down Wools, and the chief of them is the South or Sussex Down sheep. This is the best short wool sheep, the wool being "lofty," elastic, and with a good springy feel. With a staple length of 3 in., it makes a top of 56-58's count and is one of the best hosiery wools. South Down wool is as good as a low Merino.

Other important Down breeds are the Shropshire Down, a larger animal with a wool somewhat coarser than South Down, staple length  $4\frac{1}{2}$  in., top counts 46-50's; the Hampshire Down, which is the largest of the Down sheep, staple length  $4\frac{1}{2}$  in., top 50's; and the Dorset Down, which gives a fine close wool of 4 in. staple and makes up to 50's tops.

### **Miscellaneous English Wools.**

CHEVIOTS. A sheep bred in Northumberland, producing a good quality wool of 4 in. staple, fine, dense, and soft. Tops count 46-50's. Used for tweeds.

HERDWICK. Similar to Cheviot but thrives only in its native Cumberland and Westmorland. The wool is slightly kempy.

BLACKFACED SCOTCH. A sheep producing a fleece which contains a mixture of wool and hair which is kempy

and uneven and is used for homespuns and carpets. Tops 28-32's.

WELSH. A little better than Scotch Blackface, tops 36's.

SHETLAND. These sheep give a mixture of wool and hair which is usually combed off.

NORTH WOOLS. Taken from a group of cross-breds between the Border Leicesters and the Cheviots. A good class wool, similar to Demi-Lustres, with a 6 in. staple, tops 46's.

SCOTCH CROSS. 1. Leicester and Blackface.

2. Cheviot and Blackface. Both these crosses produce an inferior quality of wool.

Rubbings are the very short wools shorn or slipped from a sheep or its skin within a very short time of the last shearing. They are excellent for felting purposes. If they measure under  $\frac{1}{2}$  in. they are sometimes called "shearlings," and over  $\frac{1}{2}$  in. "headwool." Hog wool is the first clip from the yearling sheep, whilst the wool taken from the second or subsequent clip is called "wethers."

The sorting of English wool is very difficult owing to the large variety of counts on the same fleece. The wool taken from round the neck of the animal is usually a better quality than that from the lower part of the fleece. For example, in a Lincoln hog fleece, the wool round the neck would count from 44-48's tops, the centre part of the back 36's, farther down the back 32's and towards the hinder end 28's. Merinos and cross-breds are usually sorted before being sold but English wools are sold in bulk and sorted at the mill.

English wool is usually put up into bales of the following weights—

English pack . . .	240 lb.
English square . . .	700 „
Scotch bag . . .	225 „

### AUSTRALIAN WOOLS

The best sheep-producing districts in Australia are the Riverina and Darling Downs which between them give practically one half of Australia's wool. There are, however, sheep all over Australia.

Australian Merino is the finest and best in the world, and the best Australian Merino comes from Port Phillip, being known as "P.P's." The felting qualities of Australian Merinos are better than those of the South African variety.

A very important factor in the wool industry of Australia is the prevalence of drought. A drought year can make a difference of millions of wool-bearing sheep, and the number of sheep in Australia is therefore always fluctuating according to the yearly rainfall. The average number of sheep maintained in Australia is about 75 millions. The rain-bearing winds of Australia come from the East and lose a large proportion of their moisture on the highlands of the eastern coast of Australia, the shortlands between the hills and the sea receiving a satisfactory rainfall. By the time it reaches the centre and west of Australia, the wind is very dry. The animals subsist during the dry periods principally on Kangaroo grass, which, having tap roots, brings the available moisture to the surface, and on a species of scrub or prickly bush (in South Africa a similar kind of root plant helps the sheep over the dry periods).

#### **Qualities of Australian Wool.**

**MERINOS.** These are divided into three grades, fine, medium, and strong. The fine Merinos are extremely soft and a perfect white, with excellent felting properties. With a staple length of 3 in. and about 24 crimps to the inch, they can be made up into tops with a count of 64-80's. The medium Merinos are about 3½ in. in length,



have 18 to 22 crimps per inch, and yield a top of 60-70's count. The strong Merinos are the coarsest of the three grades. They have a soft handle, a good colour, are very strong, and felt well. Their staple length is 4 in., crimps per inch 14 to 20, top counts 58-64's.

CROSS-BREDS. These are also classified into three grades, fine, medium, and strong. The fine cross-breds are very strong, of good colour, and have fair felting properties. Staple length 6 in., top counts 50-58's. Medium cross-breds are strong and lustrous, but do not felt very well. Staple length 10 in., tops 40-50's. "Strong" cross-breds are not so strong as the others. They are very lustrous and are the poorest Australian wools from the point of view of felting. Staple length 12 in., tops 32-40's.

About seven hundred million pounds of wool are produced in Australia yearly, of which approximately 70 per cent is Merino and the balance Cross-bred. Australian wool is put up into bales weighing 250 lb. (scoured), or 330 lb. (greasy).

### NEW ZEALAND WOOLS

The wool produced in New Zealand is principally of the English and Cross-bred type, only about 5 per cent being pure Merino. Corriedale is a favoured breed produced by crossing a Lincoln and Merino.

New Zealand wool is clean, has few burrs, and is generally good, having excellent covering power. The climate is favourable for the breeding of sheep. There is more wool produced in the North Island than in the South, but that of the latter is better in quality, particularly Canterbury wools. New Zealand sheep, being Cross-breds, are bigger than Merinos, and have heavier fleeces weighing about 8 lb. About two hundred million pounds of wool are produced annually.

## SOUTH AFRICAN WOOLS

The chief wool-producing districts of South Africa are the Cape Colony, Natal, and Orange River Colony. There is a great lack of grading, and in some cases the whole fleece is put into the same bale without any separation of qualities. There is also a large percentage of waste as South African wool is always very dirty. The yield from scouring is about 40 to 45 per cent and sometimes even lower.

Owing to frequent clippings the wool is very fine and makes up into tops of 64-70's count. All South African wools are of a good colour, and the South African "Snow-white" is considered to be the best white obtainable. Although dirty when clipped, they scour up well in colour and appearance. Their felting qualities are, however, not very good.

All South African sheep are of the Merino type, as English and Cross-bred sheep do not thrive. The total annual production of wool is about two hundred million pounds, which is mostly shipped in the grease. One disadvantage of South African wool is that owing to its great fineness it is liable to become tender.

"Coarse and coloured" wools are from a cross between a Merino and a "Fat-tailed" sheep which is usually reared for the mutton. These wools are classified apart from South African wools, and consist mainly of coarse wool and hair.

South African wool is usually shipped in bales weighing 210 lb. (scoured) or 370 lb. (greasy).

## SOUTH AMERICAN WOOLS

**Argentine.**

About 75 per cent of the sheep grown in the Argentine are Cross-breds, and many English sheep of the Lincoln, Leicester, and Romney Marsh breeds are imported for

crossing the strains. The Argentine Merino, a hardier and stronger sheep than most other Merinos, is bred from the French Merino Rambouillet, which originated in Spain.

The average weight of an Argentine fleece is from 5 to 5½ lb. Most of the wool goes to the Roubaix district of France, as the methods of combing in the French woollen mills are more suitable for Argentine wool. The conditions in the Argentine are not too favourable, as rainfall and temperature are uncertain.

### **Uruguay.**

The Uruguay sheep are mostly of the Merino type, the conditions being good and the many streams providing suitable pasture lands.

### **Punta Arenas.**

A very good quality of hosiery wool is produced at Tierra del Fuego in the Western part of South America. The wool, which is nearly equal to the English Downs wool for hosiery purposes, is very bulky and has a full "springy" handle. It produces a top of 50-56's count. Nearly all the Punta Arenas wool comes to England.

## UNITED STATES OF AMERICA

There are about 40 million sheep maintained in North America. All wools produced to the west of the Mississippi are called Territory wools, and those east of the river Fleece wools. Delaines is a term used in the United States for fine Merino wools. The terms "half-blood," "quarter-blood," etc., are American terms denoting the proportion of Merino strain in the animal. Half-blood will therefore be a straight cross between, for example, a Merino and a Lincoln. To cross half-blood with Lincoln produces a quarter-blood and so on.

## MISCELLANEOUS WOOLS

**Germany.**

Silesian Merinos are reckoned to be one of the finest grades in the world, but the bulk of German wools are Cross-breds. Heide is a German hill sheep similar to Scotch Blackface.

**Russia.**

Donskoi wools are a class of coarse wools produced in South Russia in the neighbourhood of the River Don, and usually exported from Rostov. They are straight, hairy fibres, loose and white, and although coarse they are fairly good and free from kemps. Russian sheep are clipped twice yearly, in the spring and autumn. The spring crop is preferred to the autumn wools, which are more suitable for carpets. The best Russian wools come from Georgia, and are called Toucha (first class) and Nouka (second class). Toucha is a good white, springy, and altogether a fairly good staple. Georgian wools are usually exported from Tiflis.

**Spain.**

Spanish sheep are Merinos and Pyrenneans, the latter giving a rough, coarse, carpet wool. Many Spanish wools are used in France.

**India.**

All Indian wools are coarse, hairy fibres, with many grey hairs. The finest of them is Joria, which can be used for lower-class textiles. Kandahar is a good carpet wool consumed locally. Kelat (Baluchistan) is a short carpet wool not so good as Kandahar. Pac-Pathan is a low-grade carpet wool. Most of the Indian carpet wools are offered for sale in Liverpool and not London, and are exported from Bombay and Karachi.

**'Iraq.**

Carpet wools are produced from native sheep, some of them being very poor in quality. The qualities handled in Liverpool are Awassi, Karadi, Baghdad, and Basra.

**Persia.**

Great care is taken in sorting Persian wools, and the best Khorassan is used for low quality clothing. Two qualities of Persian carpet wools are Kurki and Meherjun.

**China.**

Some carpet wools are exported from Shanghai and Tientsin to the U.S.A.

**Chinese Turkestan.**

Kashgar wool, produced in this district, is a valuable white wool, soft and silky. It is usually sent to Russia. Camel hair also comes from Turkestan.

**Falkland Islands.**

A small quantity of wool is produced from Cheviot-Merino crosses. It is rather harsh and of low grade.

**Iceland.**

From Iceland is exported a mixture of wool and hair of poor quality and a very fine downy underwool. This goes to Denmark and the U.S.A.

The bale weights for the South American and miscellaneous wools are as follows—

Argentine and Uruguay . . . . .	} Scoured	800 lb.	
		} Greasy	1,000 ,,
Punta Arenas . . . . .		Greasy	450 ,,
China . . . . .		Greasy	500 ,,
Turkey . . . . .			200 ,,
Carpet wools (Asia, India, Persia, etc.) . . . . .			330 ,,

Wool is sold in the Wool Exchanges situated in the

chief ports of the world to which it is shipped. There are Wool Exchanges in the following ports—

London . . . .	All good class wools
Liverpool . . . .	} Carpets and coarse wools, } River Plate, alpaca, mohair, etc.
Dunkirk . . . .	
Bremen . . . .	Mostly S. American wools
Boston, U.S.A.	Mostly Australasian
Sydney	
Melbourne	
Adelaide	
Brisbane	
Hamburg	
Antwerp	
Amsterdam	
Marseilles	

#### CAMEL HAIR

The Camel hair used in textiles comes from the Bactrian or two-humped camel found in Central Asia. There is a plentiful supply in Southern Siberia, Manchuria, round the Caspian Sea, and on the Steppes of the Volga, but only a small quantity comes to England. It frequently contains vegetable matter as the animals rub off their coats against shrubs, etc., and consequently the hairs often want carbonizing.

The noils or undercoat are the hairs used for textiles, and these are made up into blankets, coats, dressing gowns, etc., and are sometimes mixed with a very small percentage of wool to make knitted garments. The coarse strong long hairs are used for making driving belts owing to their strength and elasticity.

The camel hair used in textiles has a very soft handle, is light in weight, and, owing to its slow conductivity of heat, has great warmth-retaining powers.

The fibre varies considerably in diameter, some hairs being four times as thick as others. The length of staple is from 4 to 10 in.

All hairs which in their natural state appear to be

coloured owe that colour to pigment cells, i.e. individual units of pigment. In camel hair the pigment cells are not evenly distributed as in other hairs, but are usually more on one side than on the other, and this can be seen under

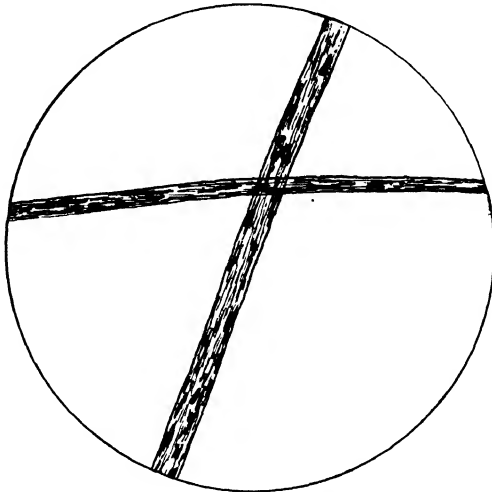

FIG. 35. CAMEL HAIR

Stiff and hairlike. Large but varying diameter. Pigmentation distinct, but not uniform. Oval patches of pigment here and there, which are occasionally transparent, and sometimes contain a dark red spot

the microscope. Camel hair of large diameter when examined under the microscope usually shows what appears to be an opaque medulla or central channel. This is because the central part is in disuse and the air has got into the empty cells. Small camel hairs show oval patches of pigment which look like a network sieve, and in some cases the oval contains a spot which is practically blood red in colour. This oval patch appears principally on "White" fibres, i.e. fibres with few pigment cells.

#### AUCHENIA FIBRES

This class of hairs is taken from an animal which is the South American equivalent of the camel. There are four breeds, all of them found on the west side of South

America (Chile and Peru) at high altitudes and in relatively small numbers. The fibres are very pigmented, and specks or pigment cells can easily be seen under a microscope. The length of staple varies from 7 to 15 in. The

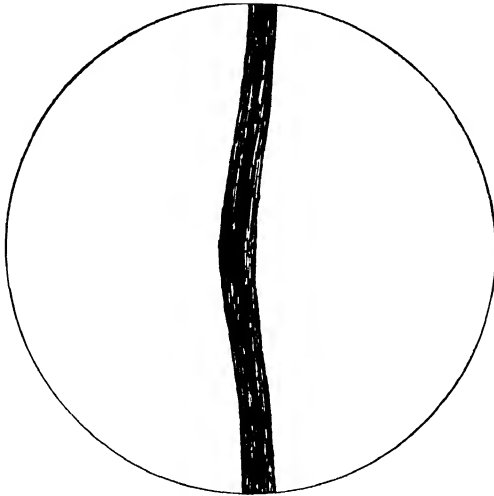

FIG. 36. ALPACA

Fairly large diameter, scales not very pronounced. Pigmentation varies, but medullary canal usually clearly marked

following are the four breeds from which these fibres are taken.

### 1. Alpaca.

This is a domesticated animal, and the hair, which has a very soft handle, shows great variation in colour, varying from white through grey and brown to black. The best alpaca is exported through the port of Arequipa. Second-grade alpaca is shipped from Mollendo, Callao, Tacna, and Chala.

### 2. Llama.

This animal is also domesticated. The fibre has a larger diameter than alpaca and is usually covered with pigment



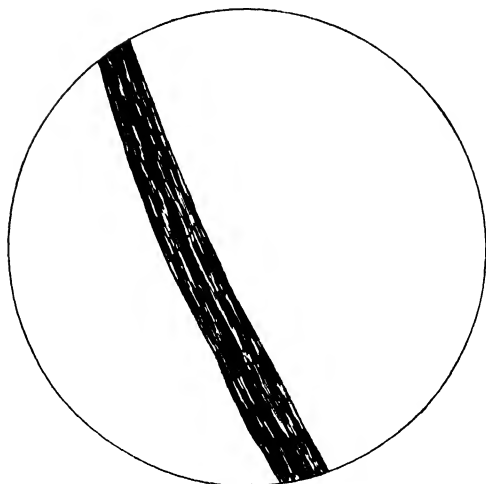

FIG. 37. LLAMA

Similar to alpaca, but usually larger in diameter

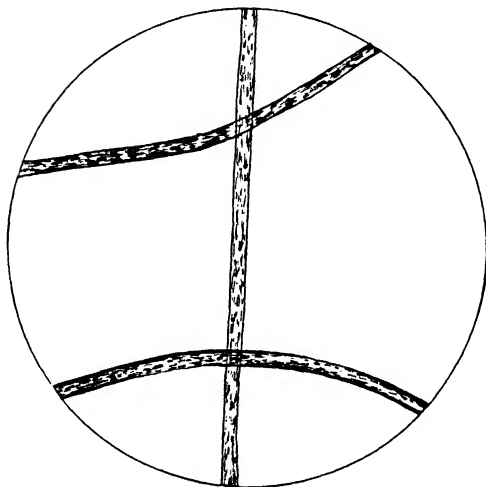

FIG. 38. VICUNA

Small, even diameter. Pigment clearly marked and evenly distributed. Scales not prominent

marks. It occasionally shows oval patches as in camel hair, but never the red spots.

### 3. Vicuna.

The vicuna animal runs wild and consequently has to be killed before the fleece can be obtained. As a result the hair is scarce and difficult to obtain, which makes it expensive. The brown colour and soft handle of vicuna are distinctive. The fibre is the finest of the four Auchenia fibres, and is in fact finer than 80's Merino. Vicuna and alpaca are very similar in appearance, and can only be distinguished by a comparison of the diameter.

### 4. Guanaco.

This is also a wild animal. The fibres are somewhat smaller in diameter than alpaca but not as fine as vicuna. In colour they are white and tawny.

## MOHAIR

Mohair is obtained from the Angora goat. This animal was originally bred exclusively in Angora, Asia Minor, but a number of goats were smuggled out and taken to South Africa, where, as a result of extensive breeding, there are now three times as many goats as there are in Angora.

The fibre is very soft and white in colour, with a fine handle. Compared with Merino it has a large diameter. The scales are not very prominent, and consequently the fibre is lustrous. Faint longitudinal striations can be seen on mohair under the microscope. The fibre is used for dress goods, linings, plushes, "alpacas," etc.

"Van mohair" comes from Asia Minor, and although it is of low grade it fetches a slightly better price than South African, principally owing to the length of staple, as it measures 5 to 8 in. as compared with 4 to 6 in. in South

Africa. "Blue mohair" from South Africa takes its name from the colour caused by the greyish-blue soil picked up by the goat in the hills.

The United States of America produce mohair with a length of 5 to 10 in., and this is all used locally. A very

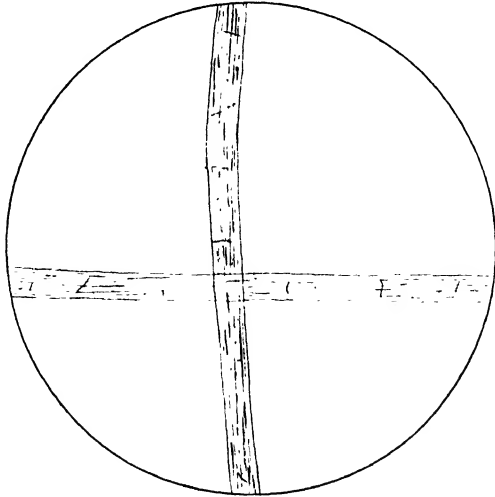

FIG. 39. MOHAIR

A straight, transparent fibre, with fairly large diameter, tapering to a blunt end. Longitudinal markings, but scales difficult to see. Length 8 in. or more

small quantity of mohair is also produced in Australia with a staple length of 6 to 7 in.

#### CASHMERE

This is a very soft and fine hair of a white or brownish-grey colour taken from the Cashmere goat, which is bred in North-West India. Only the undercoat is used and not more than three or four ounces of fibre are obtained from each goat in a year. Cashmere has a length of 2 to 4 in., and is about two-thirds the diameter of Merino. The fibres appear stiff and have a typical straight hair structure, but under the microscope the scales can usually be seen. Coarse hairs are always present and these can be seen on

## WOOL

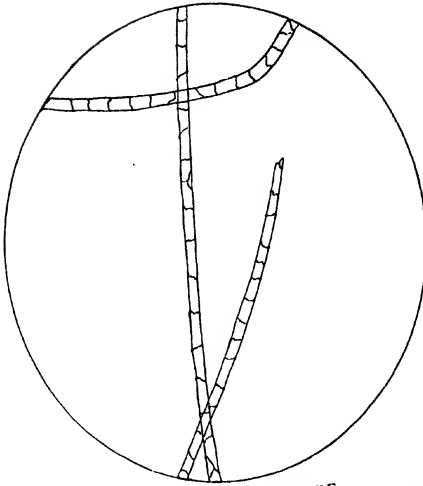

FIG. 40. CASHMERE  
 Fine, even diameter. Prominent scale structure, the scales being unbroken

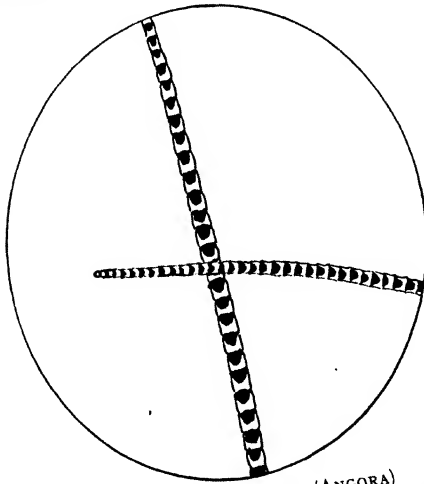

FIG. 41. RABBIT HAIR (ANGORA)  
 Medullary canal well developed, showing characteristic cell formation. Scales numerous and with sharp points, jointed something like a bamboo cane. Length about  $\frac{1}{4}$  in.

the surface of real cashmere fabrics. Owing to its softness and warmth cashmere is used for shawls, hosiery, etc.

### ANGORA RABBIT FUR

The Angora rabbit is bred for commercial purposes in Angora and also to some extent in Grenoble, France. The fur is very light and soft, has a staple of 5 in. in length, and is white or dark-grey in colour. It is about one half the diameter of Merino. Rabbit fur is disliked by manufacturers as in the spinning it flies about in the air owing to its extreme lightness. It has excellent felting properties, but this is rather a disadvantage in wet weather when the fibres become matted.

### HORSE HAIR

Under the microscope horse hair appears very opaque and no clear structure is visible. The long white hairs from the tail, etc., are used for violin bows, and the short white hair for bristles. The coarser hairs are used for upholstery and for the stiffening in coats. To some extent horse hair has now been replaced by a substitute made from rayon.

### SKIN WOOLS

Skin wools are the wools obtained from the skins of sheep which have been slaughtered. There are many of excellent quality, but there are also many which are unsatisfactory. During the pulling the fleece is mixed, making an assorted bale containing fibres of different lengths. They do not spin as well as shorn wools, and have a harsh handle, are not so springy, and do not dye as well. There are three kinds of skin wool according to the process used to remove the fibres from the skin—

#### **1. The Sweating Process.**

The skin is dried in the sun, moistened again, and hung up in a warm temperature. Putrefaction sets in, ammonia

is given off, and bacteria form, these acting upon the roots of the wool, which can then be pulled off by hand. The method is widely used, but the wool felts badly and requires plenty of oil in spinning.

## **2. The Chemical Process.**

The backs of the skins are painted with a weak solution of sodium sulphide and left overnight, the wool being pulled as usual. Scientifically the best method, it is not very much used, except in the Colonies.

## **3. Slipe Wools.**

A solution of lime is applied to the backs of the skins to loosen the fibres. This is a very widely-used process, but is really the least satisfactory owing to the lime left in the wool. Treatment with benzine or hydrochloric acid will remove the lime but is also likely to affect the wool. Benzine removes the internal grease from the fibres, whilst hydrochloric acid has a bad effect on the dyeing properties.

Skin wools are used for blending with fleece wools of Colonial growth in order to make medium-class worsteds and woollens, as they increase the "bulk" of the top. They are also mixed with Cross-breds to be made into yarns for the manufacture of serges, hosiery, etc.

Under the microscope skin wools can usually be distinguished by the bulb or swelling at the root end of the fibre.

## CHAPTER IX

### WOOL SPINNING

SCOURING—Carbonizing—Preparatory processes—Woollens—Worstedes—Semi-worstedes—Re-manufactured wools—Spinning—The flyer—Ring frame—Cap frame—Mule—Yarn counts.

### WOOL SCOURING

BEFORE wool can be put through the processes preparatory to spinning, the dirt and natural grease must be removed. There are four different methods—

#### **The Solvent Process.**

This is a method used in Belgium and the United States of America. A volatile solvent, crude naphtha, is passed through the wool, carrying with it the wool grease. The operation is performed in a circle as the naphtha is evaporated from the grease and passed through the wool several times. In this way there is very little waste, as the grease and naphtha can both be used after the process is finished. The potash in the yolk of the wool is washed out afterwards.

#### **The Emulsion Process.**

The most popular method is to steep the wool in a bath of water, soap, and a very weak solution of washing soda at a temperature of about 100° F. It is passed through several of these baths until it is clean. This is a wasteful method, as the by-products are taken off in one solution and usually thrown away.

#### **The Gas Process.**

Carbon dioxide is blown through the wool whilst it is in water. This separates the grease, which rises to the top

of the liquid in the form of a scum, leaving the water and potash to be washed off.

### **The Mixed Process.**

The potash is first washed out in clean water, the grease and dirt being cleaned out with soap and soda as in the Emulsion Process.

A modern method of scouring, used on the Continent, consists of passing the wool through two or more bowls containing a solution of wool grease. This makes the grease in the wool more easy to separate, and in the next bath, which is of weak soap, the grease comes away easily. The wool is then washed to remove the remaining impurities. By this method it is claimed that wool is rendered less harsh and more tractable. The probable reason is that other processes remove too much grease, including the natural grease in the fibre. The method is said to improve South African wools and also lime-pulled wools, which are frequently deficient in grease.

### THE CARBONIZATION OF WOOL

Some sheep whilst grazing pick up vegetable matter such as "burrs," seed pods  $\frac{1}{8}$  in. to  $\frac{1}{4}$  in. across, which become entangled in the fleece. This is not removed by the scouring process, and consequently very "burry" wools have to be put through what is known as the Carbonization process. The most important method is called the "wet" process, in which the medium is sulphuric acid.

### **The Wet Process.**

The wool is first steeped in cold dilute sulphuric acid for a period of two to twelve hours, according to the quantity of vegetable matter to be removed. The acid is then squeezed out and the wool dried at a temperature of



170° to 190° F. (well below boiling point), being kept in the dark owing to the action of light upon the acid. During this part of the process, which lasts about an hour and a half, the vegetable matter becomes carbonized. The acid and other matter is then washed out, and if necessary a bath of weak soda or ammonia is used to neutralize any acid remaining. What happens is that the sulphuric acid turns the cellulose in the vegetable matter into a brownish substance called hydrocellulose, which is easily washed out.

The wet process is used for raw wools. Two other methods of carbonizing wools are the alum chloride process and the "dry" process. These are used for manufactured wools, i.e. rags torn up to be made into shoddy. Such rags may contain some threads or fibres of cotton.

### **The Alum Chloride Process.**

The rags are impregnated with a solution of alum chloride and heated at a temperature of 230° to 250° F. (above boiling point); they are then washed, first with clean water and then with water containing fuller's earth to act as a softener. To free the alum oxide it is advisable to treat with a weak acid. In this process the chlorine in the alum chloride combines with the hydrogen in the cellulose to form hydrochloric acid, and the alum combines with the oxygen in the cellulose to form alum oxide. The method is dangerous owing to the great heat required, as any heat above boiling point weakens the fibres and affects their dyeing properties. It is also rather expensive.

### **The Dry Process.**

Hydrochloric acid is gently heated in a retort, and the gas given off is passed into a revolving drum containing the wool, which has previously been sprayed with steam.

When the cylinder is full of gas it is sealed. In the airtight drum is a revolving cage holding the wool, which is carried round to the top on a series of hooks from which it is dropped through the gas to the bottom of the cage. As the drum revolves, the wool is carried again and again to the top to fall through the gas, giving it the opportunity to act upon all the fibres. This takes about three hours. The wool is then removed, the carbonized matter crushed out, and the acid neutralized with a solution of soda.

#### THE PREPARATION OF WOOL FIBRES FOR SPINNING

The processes undergone by wool fibres in preparation for spinning can be divided into two groups. In the first group of processes, which are applied to practically all classes of wool, are the following—

(a) The removal of loose dirt, etc., by the aid of a machine called the "Battering Willie."

(b) Scouring.

(c) Drying.

(d) Burring or carbonizing.

(e) The opening of the fibres ready for the next processes.

The principal methods of scouring and carbonizing wool have already been described at the beginning of this chapter.

Group 2 comprises the processes designed to straighten out the fibres and form them into sliver or roving ready for spinning. These processes vary slightly in their application according to the length and grade of the fibres and the type of yarn into which they are to be spun. The following are the three main types of yarn spun from wool—

1. Woollen yarns.

2. Worsted yarns.

3. Semi-worsted yarns.

Generally speaking, the shorter wools are spun into a compact yarn in which the fibres do not necessarily lie parallel to each other, but are intended to felt together to produce a cloth with a more or less smooth surface, such as Melton. The longer wools are spun into a yarn in which the fibres lie parallel and are not felted together. An example of a fabric made from this class of yarn is Tweed. The yarns made from short and medium wools are called woollens and the long wools worsteds.

### WOOLLENS

Good felting fibres of short staple, not more than 4 in. average, with many crimps are best for this class of yarn.

#### **Willow.**

Wool which is still dirty or contains any loose impurities, such as sand, straw, etc., is passed through the willow. This consists of a spiked roller which carries the wool round and throws it against a grid. The sand, dirt, etc., drop through the grid. In some types there are beaters to knock the dirt out of the wool.

#### **Oiling.**

The wool is sprayed with olive oil to make it soft and pliable, and to prevent breakage of the fibres in the carding.

#### **Carding.**

There are three types of carding machine used for woollens: the Scribbler, the Intermediate, and the Finisher. All these work on the same principle, but with a variation in the size and position of the rollers and of the card clothing used. The card clothing consists of a number of wire staples set in a band of leather or linen, sometimes with a sheet of rubber or felt. The card clothing is placed round rollers, and the action of the wire staples moving

against each other whilst the wool is carried through loosens and separates the fibres and brings them into a more or less parallel condition. The Scribbler converts the wool into a fleece, which is fed to the Intermediate, from which it is delivered in the form of a longer fleece. This is converted by the Finisher into a thin lap or sheet of fibres.

### **Condenser.**

The sheet of wool fibres is then passed through the condenser, which divides it into bands of fleece. These are made into round slivers by the aid of "rubbers," which are endless leather belts, and the untwisted slivers are wound on to bobbins.

## WORSTEDS

With worsteds, the chief object is to produce a smooth round yarn of parallel fibres, and one that is not capable of felting. The short fibres (or noils) are therefore dropped out in one of the early processes.

### **Oiling.**

As for woollens.

### **Carding.**

There are two carding machines used for worsteds, the Breaker and the Finisher. Sometimes these are combined in the Double Card Machine. From this process the wool is delivered in the form of sliver.

### **Preparing Gill Box.**

This machine prepares the wool for the combing processes. Several slivers are doubled together and drawn out to the thickness of one. This helps to straighten out the fibres, and sometimes the wool is put through as many

as three or four Gill boxes. The wool is delivered in the form of sliver.

### Combing.

Combing removes all the short fibres below a given length, and also any foreign matter still remaining, such as

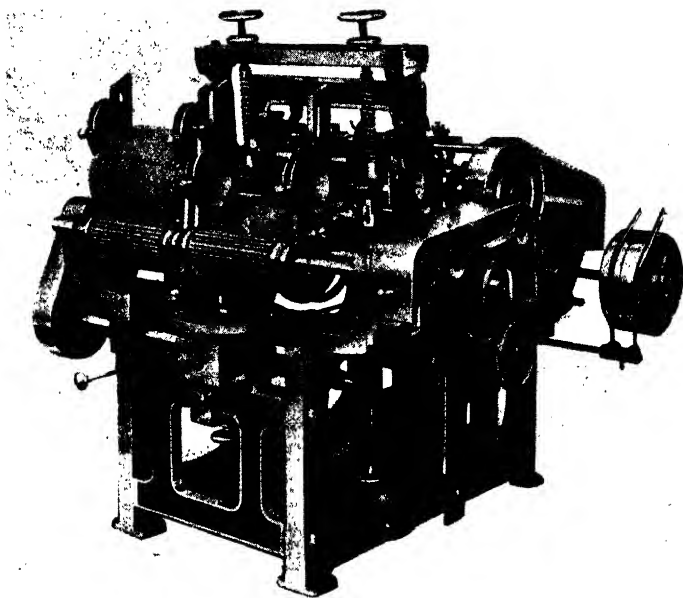

*By courtesy of*

*Messrs. Prince-Smith & Stells, Ltd.*

FIG. 42. SINGLE HEAD BALLING INTERSECTING GILL BOX

fragments of burrs, bits of straw, grit, etc. This is effected by a system of mechanical metal combs and brushes. There are several combing machines of different types in use, designed to treat different kinds of wool. The most important are the Noble, Lister, Holden, and Heilmann combs.

After the combing, worsteds are taken through other processes intended to continue the straightening out of

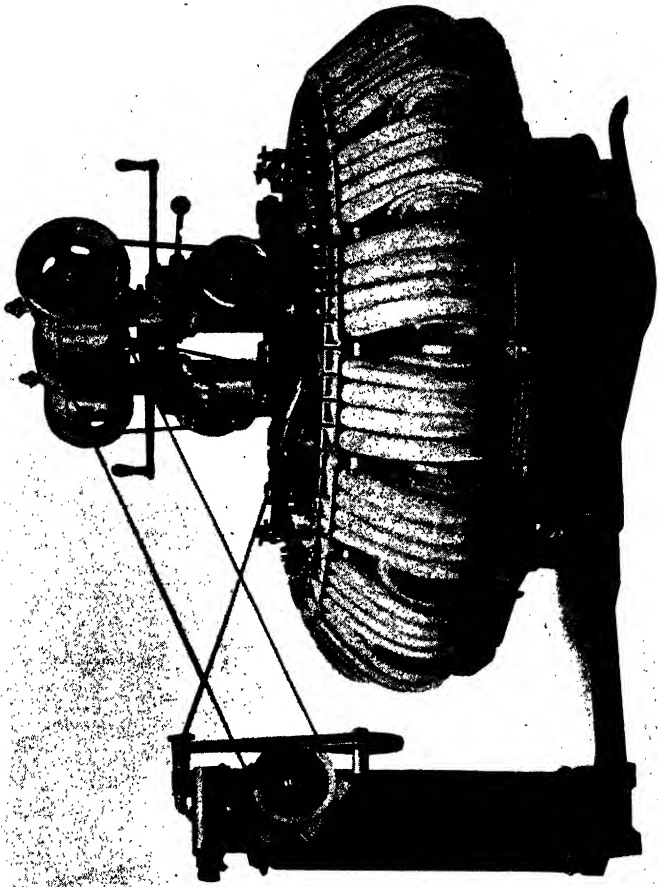

Messrs. Prince-Smith & Stells, Ltd.

FIG. 43. "NOBLE" COMB

By courtesy of

the fibres, including further drafting operations. The slivers are also put through a machine called a Back-

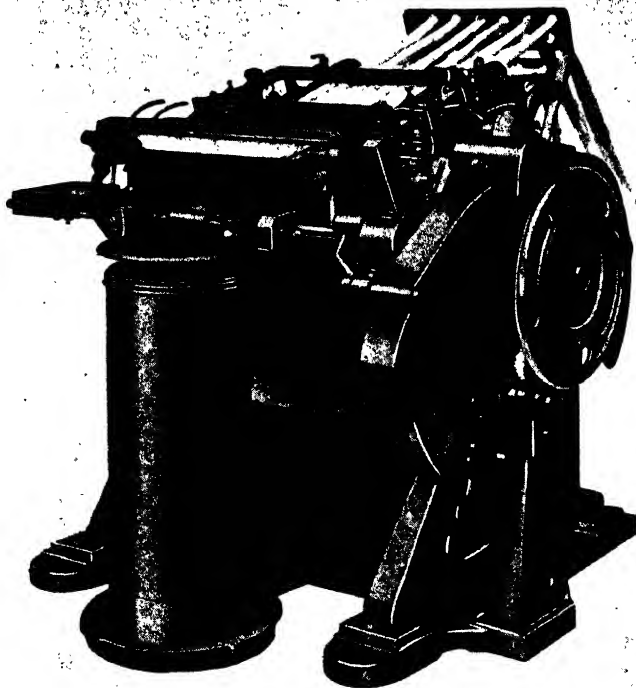

*By courtesy of*

*Messrs. Prince-Smith & Stells, Ltd.*

FIG. 44. WIDE MODEL RECTILINEAR ("HEILMANN") COMB

The most efficient type of combing machine for short wools

washer, to remove the oil which was sprayed on the wool to help it in the carding.

### **Roving Frame.**

This builds the slivers on to bobbins ready for the spinning. Some twist is inserted on the Roving Frame.

Fine twisted yarns for lace, knitted goods, and for weaving into smooth fabrics are gassed in order to burn

off any loose or projecting fibres and to give a clean, smooth yarn.

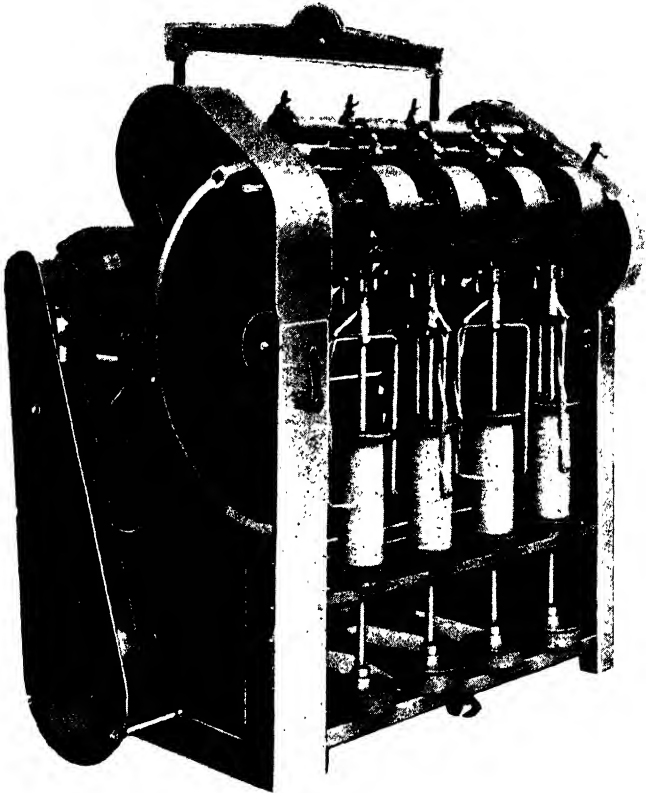

*By courtesy of*

*Messrs. Prince-Smith & Stells, Ltd.*

FIG. 45. DRAWING BOX

### SEMI-WORSTEDS

These are made from the medium-length wools in a similar manner to worsteds, but omitting the processes which remove the noils or short fibres. Consequently, the yarns are not so smooth or solid as real worsteds, although they are smoother and more lustrous than woollens.

Semi-worsted yarns are used principally for knitted



goods, hosiery, embroidery, etc., and not so much for woven cloths. In the case of hosiery and knitted goods, the yarns are frequently made up of a mixture of cotton and wool.

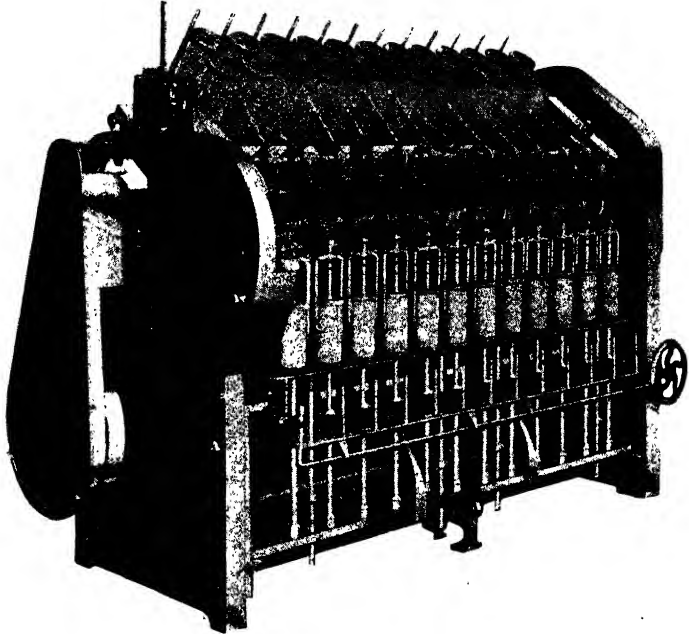

*By courtesy of*

*Messrs. Prince-Smith & Stells, Ltd.*

FIG. 46. ROVING FRAME, WITH HIGH-SPEED SPINDLES

### RE-MANUFACTURED WOOLS

- |             |            |
|-------------|------------|
| 1. Mungo.   | 2. Shoddy. |
| 3. Extract. | 4. Noils.  |

The re-manufactured wools trade is an important industry which is centred in the west of Yorkshire, the districts of Dewsbury and Batley turning out large quantities of wool fibres which have been recovered from old rags, factory waste, etc., by literally tearing the

materials to pieces. The fibres are spun up again, usually mixed with ordinary new wool, to make cheap cloths for the lower class trade. The cloths made from this class of wools are naturally poorer in quality and cannot give the same wear, as the fibres of which they are composed have already seen considerable service before the rags were discarded.

### **Mungo and Shoddy.**

Mungo is produced from the short soft wools, whilst shoddy comes from the longer and firmer wools. Their methods of treatment are similar and include the following processes—

#### *Cleaning.*

The rags are beaten in a shaker or duster to free them from loose dirt and dust.

#### *Sorting.*

The different classes of rags are sorted, the white rags being specially separated as they can be made up into yarn to be used either in a dyed or undyed condition. All seams, button holes, buttons, hooks, eyes, etc., are cut out, and sometimes the rags are cut into smaller pieces. If necessary, the rags are lightly washed, but this is avoided if possible.

#### *Grinding.*

They are then torn to pieces by the grinder or "devil." Another type of machine used is the "Garnet." Some of these machines have rollers with steel spikes; in others the rollers are covered with card clothing. They all have roller brushes to draw the fibres off the worker rollers. In some machines there is an oiling attachment to soften the fibres and help them withstand the severity of the process.

*Blending.*

The fibres are blended with other wools as necessary, and are then ready for spinning.

**Extract.**

Extract is prepared from materials containing a mixture of wool and cotton or other vegetable fibres, from which the vegetable matter is extracted by the carbonization process. The cleaning, sorting, and tearing-up processes are the same as for mungo and shoddy with the addition of the carbonization.

**Noils.**

These are the very short fibres thrown out during the combing operations of English or cross-bred wools, mohair, alpaca, etc. They are not so good as the original material, but are certainly better than mungo, shoddy, or extract. Noils are spun on their own, or mixed with other fibres to make second-grade yarns.

### WOOL SPINNING

In an earlier chapter we have described in detail the spinning of cotton by means of the Ring Frame and Mule. The spinning of wool fibres is carried out on very much the same lines, the process entailing a further drawing out of the roving, the insertion of twist to give strength and form a solid yarn, and winding on to bobbins or spools. As in cotton, the amount of twist depends on the class of yarn and fabric required. There is usually less twist in a weft thread than in a warp thread. Some wools need slightly different treatment from others in the spinning according to their length and structure, and consequently all four types of spinning machines are called into use for wool, viz. the Flyer, Ring Frame, Cap Frame, and Mule.

### The Flyer.

This machine, which runs comparatively slowly, is used for some worsted yarns, that is to say, for long fibres and lustre wools suitable for hosiery, carpets, etc. The

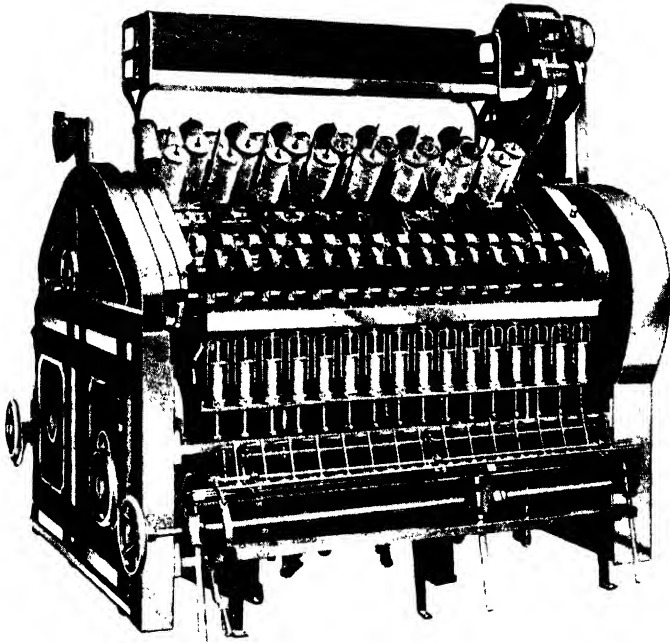

*By courtesy of*

*Messrs. Prince-Smith & Stells, Ltd.*

FIG. 47. FLYER SPINNING FRAME

principle is similar to the flyer described in the chapter on Flax Spinning, except that the worsted flyer usually has a hollow arm through which the roving is taken, emerging through a hole at the bottom of the arm.

### The Ring Frame.

For soft and smooth yarns made from the finest merinos the ring frame is found very suitable. It is also used to a

large extent for doubling. The ring frame is very popular in the United States of America. It is very much the same as the ring frame used in the cotton industry.

### The Cap Frame.

This is a variation of the ring frame, and is used for fine cross-breds and for merinos. It has a rapid action and

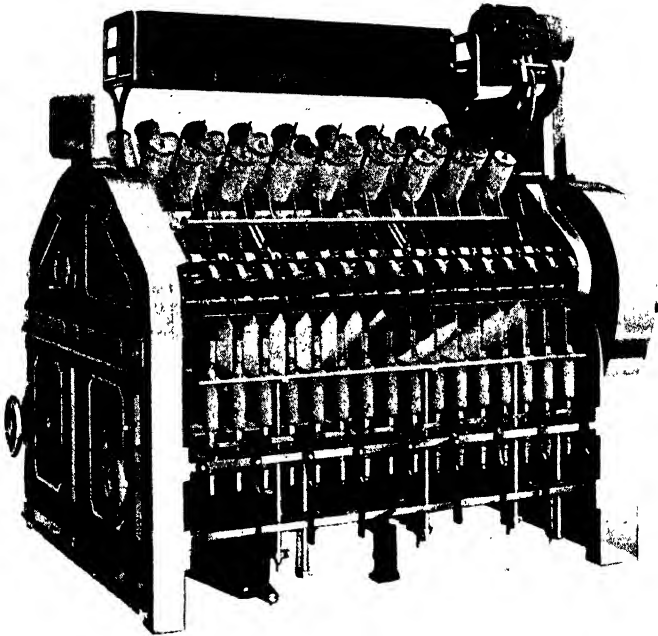

*By courtesy of*

*Messrs. Prince-Smith & Stells, Ltd.*

FIG. 48. RING SPINNING FRAME

produces a very good type of yarn. The yarn is guided on to the bobbin by a metal cap which rests on the top of the spindle. Instead of the spindle revolving it is fixed in the framework of the machine, whilst the bobbin itself, supported on a hollow tube, revolves at a great speed and moves up and down inside the cap to effect even distribution of the spun yarn.

### The Mule.

The mule is used for both woollens and worsteds, but is best for the short fibres. A feature of mule spun yarns is their softness and fullness, making them suitable for hosiery, etc. On a woollen mule the draft and twist are effected together on the spindle, this being called Spindle Draft. The worsted mule first inserts draft by means of a set of four drafting rollers ("Roller Draft") and then the twist from the spindle in the ordinary way.

### Yarn Counts.

There are several methods of arriving at the count of wool yarns, according to the type of yarn and the district in which it is spun. The most general are the following—

**WORSTED YARNS.** The number of hanks, each measuring 560 yd., that it takes to weigh 1 lb. avoirdupois.

**WOOLLEN YARNS.** The number of skeins, each made up of six pieces of 256 yd., that it takes to weigh 6 lb. By this method the number of yards that weigh 1 dram gives the same result.

**DEWSBURY.** The number of yards to one ounce.

**WEST OF ENGLAND.** The number of hanks, each measuring 320 yd., which weigh 1 lb.

**U.S.A.** The number of runs of 100 yd. to weigh 1 oz.;  
or

The number of cuts of 300 yd. to weigh 1 lb.; or

The weight in grammes of 20 yd.

**FRANCE.** The number of hanks of 1,000 metres that weigh half a kilogramme.

## CHAPTER X

### FANCY YARNS

SOME variation in yarns can be obtained by twisting together two yarns of different colour (*grandrelle*); by spinning together different coloured fibres which have previously been dyed in the raw material or sliver, so that they form one single yarn (*marl*); or by mixing two different textile fibres. A further example is the *melange* yarn, which has two or more colours printed at intervals on the surface. Strictly speaking, these are not fancy yarns, of which the following are some of the principal types—

#### **Corkscrew.**

Two yarns of unequal diameter twisted together. The twists may be equal or unequal, and either in the same direction or reversed. Modifications of the corkscrew are the spiral, gimp, and chain yarns.

#### **Spot.**

Similar to corkscrew, but having one of the ends wound round the other at intervals a greater number of times than the normal twist.

#### **Snarl.**

One end of ordinary twist and one end of hard twist. The hard twist causes the yarn to form kinks.

#### **Slub.**

One or more ends of roving with a hard-twisted single or two-fold end. In the twisting the roving is retarded at intervals and at the same time twist is inserted. Where

the roving thickens, the hard-twisted end acts as a binding thread.

**Loop.**

A yarn containing loops at more or less regular intervals.

**Chenille.**

This type of yarn is described in the section dealing with gauze fabrics.



## CHAPTER XI

### CONDITIONING

MOISTURE content—Standards of regain.

As textile fibres contain a variable amount of moisture, the selling price of the material will be largely affected by this factor. This applies particularly to wool, which will absorb 30 or 40 per cent of its own weight in water without feeling damp to the touch.

Sales are based upon the proportion of moisture in the fibre, and the official process of determining this amount is called "conditioning." The method consists of mixing three samples together, about  $\frac{1}{2}$  lb. to 1 lb. from each bale or consignment, weighing the total, then drying it at a fairly high temperature, 220° to 230° F., until constant in weight, i.e. when all the moisture is removed. The loss gives the proportion of moisture, and the resulting weight is the weight of the dry wool.

The amount of moisture that would be present in air-dried wool (or other fibre according to the sample under examination) under normal conditions of atmospheric moisture and temperature is then calculated and added to the weight of the dry substance. This is termed the "regain," and is fixed officially as a percentage of the dry weight. The Bradford Conditioning House has fixed the following standards of regain—

Worsted yarn . . . . .	18 $\frac{1}{4}$ per cent
Wool fabric . . . . .	16 "
Silk . . . . .	11 "
Cotton . . . . .	8 $\frac{1}{2}$ "
Linen . . . . .	12 "
Jute . . . . .	13 $\frac{3}{4}$ "
Hemp . . . . .	12 "

The apparatus by which the examination is carried out is called a Conditioning Oven. This is usually circular in

shape, about  $3\frac{1}{2}$  ft. high and  $2\frac{1}{2}$  ft. in diameter. The weighed sample is suspended in a wire basket inside the oven, and a hot current of air passes upwards through the oven and escapes from an outlet at the top, carrying with it the moisture in the form of steam. The wire holding the basket passes through the floor of a balance case fixed above it and is attached to one arm of the scale. From the other end of the arm is suspended a weight pan, which counterbalances the wire basket.

The weight of the sample is first taken by the balance, and as the moisture is expelled the weights are gradually removed until finally the weight becomes constant. A fresh reading of the weight is then taken, this representing the actual dry weight.

The standard amount of the regain is then added to the dry weight, and, by comparison of the result with the original weight of the sample before drying, the excess or deficiency of moisture content can be ascertained.

A second method of measuring the loss in weight is to have a small scale pan fixed to the top of the arm from which the sample basket is suspended. The total of the

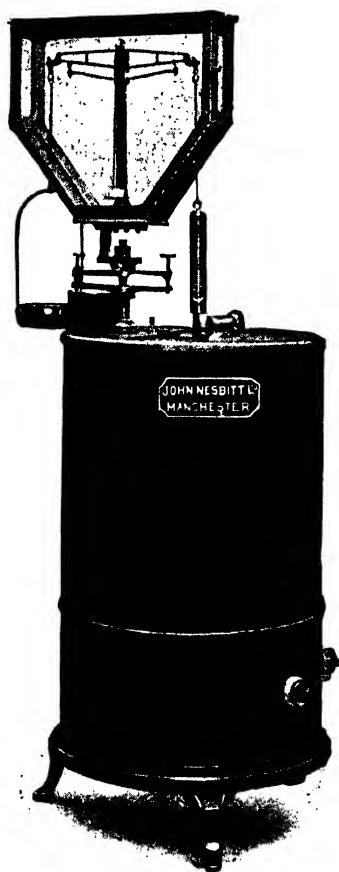

*By courtesy of Messrs. John Nesbitt, Ltd.*

FIG. 49. CONDITIONING OVEN

weights which must be placed in the sampling pan to maintain even balance equals the amount of moisture expelled.

EXAMPLE OF CALCULATIONS

A sample of wool weighs	.	.	750	gram.
On being dried it loses	.	.	125	„
			<hr/>	
Leaving a dry weight of	.	.	625	„
16 per cent regain	.	.	100	„
			<hr/>	
Gives a total <i>normal</i> weight of	.	.	725	gram.
			<hr/>	

There was consequently an excess moisture content of 25 gm. in the sample. If the total weight of the purchase was 30 kg. there would be a total of 1 kg. of excess moisture, and this would have to be allowed for in the price.

## CHAPTER XII

### METHODS OF DISTINGUISHING BETWEEN THE VARIOUS TEXTILE FIBRES

PHYSICAL methods—Microscope examination—Chemical tests.

THERE are three fundamental ways of ascertaining the nature of the textile fibre contained in a yarn or piece of cloth. The first may be described as the physical method, that is to say, by noting its appearance to the naked eye, its handle, or reaction to a physical test like biting a fibre between the teeth or burning the fibre in a lighted match. The second method, which is more certain and can be used to confirm an impression already gained, is by examination under the microscope, and the third is by chemical test.

Each of these three methods is dealt with in this chapter, and in considering the points to look for under the microscope the reader is recommended to refer to the sketches appearing on earlier pages of this book showing microscope drawings of all the principal fibres.

The burning test is an easy one to apply, and after some practice can be of great assistance. At the same time, too much reliability should not be placed upon it as a sole means of deciding the nature of a fibre, because all vegetable fibres will burn more or less the same, as will all animal fibres. If there is any doubt it is much safer to have resort to the microscope and, if need be, to one or more of the chemical tests.

In preparing fibres for the microscope, the yarn should be carefully untwisted between the thumb and forefinger of each hand and the individual fibres teased out with a needle or other sharp point. Placed on a glass slide, they should be quickly covered with another glass slide to keep them in position. It is sometimes of assistance to allow

a drop of water from a glass rod to drop on the fibres before they are covered with the second glass, as this keeps them in position and also helps them to stand out more clearly. It must be emphasized that it is of no use placing a length of yarn under the microscope in order to examine the fibres. All that will be seen is a rope-like mass of fibres tightly twisted round each other. Not more than two or three fibres are required, and these should be carefully separated on the glass.

If it is desired to mount a specimen and keep it for future reference, some mountant must be used. Fibres mounted in weak glycerine will keep for twelve months, whilst if glycerine jelly is used and the cover glasses be sealed with wax round the edges, the specimen can be kept for an even longer period.

Cross-sections of fibres can sometimes give useful information, and, although their preparation takes a little time, once the slide is ready it can be kept for some time without deterioration. To obtain cross-sections, a number of fibres are tied together in a small bundle and, after being soaked in pure alcohol to remove all air, they are covered with melted paraffin wax in xylol. The dish containing the fibres and the wax is gently heated for several hours. This evaporates the alcohol and causes the paraffin to soak right in and round the fibres. The contents of the dish are then poured into a mould, and the wax hardens with the fibres in the middle. The fibres can then be cut across quite easily with a microtome or razor blade. The cross-sections obtained are affixed to a glass slide by a solution of albumen and glycerine, dipped in xylol to remove the paraffin, and then covered with another glass.

As regards the chemical tests, these are of course fairly conclusive, and the only precaution necessary is to see that the cloth, yarn, or fibre is quite clean and free from oil, grease, or similar foreign matter which might affect

the result. It is also as well to dry off the sample under examination by placing it in a hot oven, and this is, in fact, necessary for some of the tests.

Generally speaking, it will be seen that strong alkalis, such as caustic soda, affect animal fibres, but not vegetable fibres. Acids, on the other hand, if not too strong, do not have a very harmful effect on animal fibres, whilst vegetable fibres definitely suffer. The rayons do not all behave the same under chemical tests and it should be remembered that viscose and acetate, the two chief classes of rayon, are distinct in their compositions, viscose being cellulose in a pure regenerated form, whilst acetate is a compound of cellulose and acetic acid.

### **Cotton.**

To the eye cotton looks dull, does not reflect the light, and is dead white in colour. If a cotton yarn is broken in two, the ends break short and show a flaring brush-like stump. If bitten between the teeth, it will crush. Cotton burns quickly with a flame and leaves practically no ash. The odour of burning cotton is similar to that of burning paper.

Under the microscope cotton appears as a flat ribbon-like fibre, fairly uniform in diameter, with a number of characteristic twists which are more numerous in the better-class cottons. Absence of twist, however, does not necessarily mean poorness of quality, as when cotton is mercerized many of the twists are removed. Mercerized cotton under the microscope has more body than ordinary cotton.

Cotton can be dissolved in concentrated sulphuric acid, whilst strong hydrochloric acid or strong nitric acid will decompose cotton rather quickly. When boiled in a 5 per cent solution of caustic soda, cotton is not affected. To test for mercerization, the sample should be steeped in a

strong solution of zinc chloride to which a few crystals of iodine have been added. The sample will turn blue. If it is now washed in water the colour will come out if not mercerized, but remain fast if mercerized.

### **Kapok.**

In appearance kapok is softer and silkier than cotton, and rather creamier in colour. It burns in a similar manner to cotton.

When examined under the microscope, kapok looks flat and smooth, without twists, and in places transparent and almost devoid of structure. The main thing to look for in kapok is a characteristic bulbous root-like end, and when this is found it is a certain proof of identity.

Chemically, kapok contains lignocellulose, which can be detected by treatment with phloroglucinol and weak acid. This solution turns the fibre red if lignocellulose is present, but other fibres are not affected.

### **Linen.**

Linen threads look lumpy and uneven. They are stiffer, more lustrous, and often creamy in colour. If the yarn is untwisted and drawn apart, it will show the fibres ending in a long point and of various lengths. The fibres can be seen lying straight in the yarn.

Linen cloth is cold to the touch. If a small piece of linen fabric is laid flat on the surface of water, it will soak through immediately without changing its position. Cotton would curl up or under. Another test is to soak the sample thoroughly in pure oil, such as olive oil. If it is linen the fabric assumes a transparent appearance, but cotton will still be opaque.

Linen burns like cotton, but rather more slowly.

Under the microscope the individual cells of linen can be distinguished by the nodes or swellings at the joints

between them. The shape of the fibre might also be likened to bamboo. A thin regular lumen or central channel can also be seen in some fibres.

If treated with sulphuric or hydrochloric acids, linen will be dissolved, but it is not affected as quickly as cotton. A boiling solution of caustic soda of 5 per cent strength has no effect on linen.

### **Ramie.**

Ramie is much stronger than flax. It is the broadest of the bast fibres, being twice as broad as flax, and this can be seen under the microscope. In addition ramie is marked with striations and some transverse darker lines. In the burning test ramie behaves like linen.

Ramie will resist the action of acids a little more than linen.

### **Jute.**

Jute contains lignocellulose, and this can be detected by the phloroglucinol test.

A weak solution of sulphuric acid colours jute dark brown.

### **Silk.**

Silk has a characteristic subdued lustre and a soft handle, which also has a certain amount of "life" in it. If bitten between the teeth silk threads will cut clean and not crush like cotton. As a general rule the individual filaments are much finer and lighter than those of the rayons.

Silk burns quickly with scarcely any flame, melting to a bead of brittle ash. Whilst burning it gives off an odour of burning horn or feathers, similar to wool. If a fabric weighted with metallic salts is burnt, it will not melt in the flame but retains its form as a dark ash, and while



in the flame the individual threads will glow with the heat.

Under the microscope cultivated silk appears as a solid, rod-like fibre of fine diameter but slightly irregular, with small swellings here and there. Wild silk has a larger diameter and shows occasional twists as well as brownish lines running along the length of the fibre.

A hot 10 per cent solution of caustic soda will dissolve cultivated silk in twelve minutes, but wild silk takes nearly an hour to dissolve.

Concentrated hydrochloric acid dissolves cultivated silk almost immediately and wild silk in a few hours. Zinc chloride dissolves cultivated silk very quickly, but wild silk slowly. A similar result is obtained by using chromic acid.

### **Rayon.**

1. **VISCOSE.** Rather more lustrous than silk unless it has been delustred, when it appears very dull. It is somewhat stiff in appearance, and breaks fairly easily if wetted.

Under the microscope viscose has the appearance of a glass-like rod, sometimes having well-defined lines running down the length of the fibre. The broken end (and cross-section if available) shows a serrated edge. Celta, the hollow-filament viscose fibre, is more flat in appearance and has a cross-section looking somewhat like a deflated tube.

Viscose burns like cotton, fairly quickly, and with a bright flame, leaving very little ash.

If heated in a 1 per cent solution of ammoniacal silver nitrate, viscose turns brown. Treated with iodine and concentrated sulphuric acid, viscose turns dark grey.

2. **ACETATE.** Acetate is a little softer and finer than viscose and does not lose its strength so readily when wet. Its appearance under the microscope is similar to viscose,

but instead of having many markings in the length it sometimes has two well-defined parallel lines running down the centre. The cross-section of acetate is fairly round.

The burning test is one of the best methods of distinguishing acetate from the other rayons. Acetate burns somewhat like silk, melting and forming a dark globule of ash, which is not brittle like silk but very hard. When burning, it gives off an odour quite different from the other rayons, and one can detect the odour of acetic acid.

Acetate is the only rayon that can be dissolved in acetone. When treated with iodine and concentrated sulphuric acid, acetate turns yellow.

3. CUPRA. Cuprammonium rayon is very fine in diameter and under the microscope looks like a glass tube with very few markings. It burns like viscose.

In a solution of iodine and concentrated sulphuric acid, cupra turns blue.

4. NITRO. Nitro-cellulose rayon is not met with very often in England and is made principally on the Continent. It is similar in appearance to cupra, but larger in diameter.

Nitro burns like viscose, but rather more quickly.

The standard test for detection of nitro is to treat it with a solution of diphenylamine sulphate, when the material will turn a dark blue if nitro, and finally dissolve into a blue solution. Other rayons are not affected by this test. In a solution of iodine and concentrated sulphuric acid nitro turns a reddish-purple.

## Wool.

Wool has a springiness of handle which is not possessed by any of the vegetable fibres. It is an unruly fibre which can usually be seen to project from the surface of a material or yarn, especially in the case of woollens. The

scales, which are a characteristic of wool, can usually be felt by running the thumb and finger up the wool. Wool is harsh and gritty if taken between the teeth. A woollen thread can be distinguished from a worsted thread by noting the direction of the fibres in the yarn, either with the naked eye or by the aid of a magnifying glass, and observing whether they are parallel. In a woollen thread, which is composed of wool of short staple, the fibres lie at all angles and project from the edge, whilst in a worsted thread they are well twisted round each other and lie fairly parallel in the direction of the yarn.

Wool burns fairly slowly with little or no flame, forming a bead at the end of the fibres or edge of the cloth, and giving off an odour like burning horn or feathers.

Under the microscope wool can be distinguished by its scale structure, which is more prominent than other animal fibres. The scales on a merino wool appear to cross the fibre from side to side, but in a cross-bred or English wool they are broken and more irregular. Raw wool has a wavy or crimped appearance, the finest merino wool having the most crimps.

A weak solution of caustic soda will entirely dissolve wool. Hydrochloric acid solution causes wool fibres to swell up but not dissolve. Wool becomes yellow if treated with nitric or sulphuric acids.

### **Camel Hair.**

This has a soft handle but no crimps, and is usually of a brownish colour, but varies in shade. Camel hair burns like wool.

Under the microscope the hair shows great variation in diameter. The fibres are well pigmented, most of the pigment being to one side. Small hairs sometimes show oval patches of pigment like a network sieve, and occasionally have inside a blood-red spot.

**Mohair.**

Mohair is very soft and lustrous and a characteristic grey-white or blue-grey in colour. The fibre burns like wool.

The scale structure is not very prominent under the microscope, but many striations can be seen. Mohair has a medium to large diameter, and the fibre tapers gradually from the base to the apex.

**Rabbit Fur.**

This is a very soft, fine hair which felts easily when wet. The quickest way to distinguish rabbit fur is by microscopic examination, owing to the peculiar "jointed" medulla (see Fig. 41).

**Cashmere.**

Cashmere is a straight hair without any crimps, but with a fairly prominent scale structure. It is soft and finer in diameter than most wools.

## TESTS FOR MIXTURES

**Detection of Wool in Fabrics.**

If a sample of the fabric is boiled for one minute in a weak solution of potassium plumbate, the wool present will become brown or black and show up distinctly.

**Wool and Cotton Mixture.**

To find the proportion of each of the fibres present either of the following three methods can be used—

1. After taking the dry weight of the sample, boil it in a strong solution of caustic soda. The wool will dissolve and leave the cotton, which should be strained off, dried, and weighed.

2. If the dried sample is steeped in weak sulphuric acid the cotton will dissolve, leaving the wool, which can then be dried and weighed.

3. A strong solution of hydrochloric acid will destroy the cotton, leaving the wool untouched.

### **Wool and Silk Mixtures.**

1. A weak solution of sulphuric acid breaks up the silk into a brownish mass, which can be precipitated by a little tannic acid, leaving the wool intact.

2. Schweitzer's solution will dissolve the silk and leave the wool. (Schweitzer's solution is cuprammonium hydroxide, obtained by dissolving copper hydrate in ammonia. This solution is used in the manufacture of cuprammonium rayon, and when cotton fibres are placed in it they swell up and then slowly dissolve.)

3. Boiling hydrochloric acid dissolves the silk, leaving the wool.

### **Silk and Cotton Mixtures.**

Dissolve 16 grammes of copper sulphate in 150 c.c. of distilled water, add 10 grammes of pure glycerine, then add a solution of caustic soda in drops until the precipitate in the liquid dissolves.

If the fabric is steeped in the mixture the silk will dissolve and leave the cotton untouched.

This test can also be used for silk and wool, as wool is not affected by the mixture.

### **To Find the Amount of Metal Weighting in Loaded Silks.**

Silk will absorb 30 per cent of its own weight in water without showing signs of dampness. The sample must therefore be carefully dried in a hot oven until constant in weight. Comparison of weights will give the amount of the moisture content.

To test for the presence of silk gum which may not previously have been boiled off, boil in two separate soap

solutions, for one hour each, rinse out, dry, and weigh again.

In order to ascertain the proportion of weighting matter in the silk (if any), boil the sample in a solution of binoxalate of potash after taking the dry weight. Rinse the sample, dry, and weigh again, comparing the two dry weights. If it is thought that there is still some weighting matter left in the sample, place it in successive baths of weak caustic soda, hydrochloric acid, and water. Dry and weigh.

A quicker method is to dry the sample after boiling off any silk gum, and to burn it in a crucible. The weight of the remaining ash will be approximately the weight of the metallic loading.



SECTION II  
WEAVING





## CHAPTER XIII

### WEAVING

THE plain loom—The Jacquard.

WEAVING by hand is thought to have been practised as long ago as the first period of Egyptian civilization, about 8000 B.C., and right through the ages there exist records of fabrics being produced by the interlacing of two or more sets of threads at right-angles to each other. The principle of plain weaving is very simple. One set of threads, which are intended to run in the length of the cloth, and which are known to-day as the warp, are mounted on a frame so that another set, called the weft, can be passed across from side to side, over and under certain of the warp threads in some definite order, the whole forming altogether a fairly solid fabric.

The passing of the weft thread was first done by hand, and it would soon occur to the weaver that his work would be made easier if he had a continuous supply of thread suitably wound round a piece of wood which could unwind as he went along. From this idea developed the bobbin, and eventually, when weaving became mechanical, the shuttle to contain the bobbin. The inventive weaver would then devise some means of parting the warp threads in some regular order, so that the weft could be passed across in one movement instead of having to cross under and over alternate warp threads. This would take the form of lifting every alternate warp thread and depressing the others.

#### **The Hand-loom.**

These two ideas form the basis of the ordinary hand-loom, and it is easy to understand how the hand-loom

weaver soon became proficient in throwing the shuttle from hand to hand across a narrow-width loom whilst controlling the movement of the warp threads by a system of treadles operated by the foot and connected by rods to an ingenious arrangement called the "harness," placed over the centre of the loom. The harness contained a number of wires or threads which passed down the centre of the loom, with eyes or loops through which the warp threads were threaded. These were called the healds, and by having half the healds (i.e. every alternate heald and warp thread) connected over a pulley to one foot treadle, and the other half to the other treadle, the weaver could depress one half of the warp threads at a time. This would form an opening, called the shed, between the two sets of warp threads, between which the shuttle would be thrown. Before returning the shuttle across the fabric the position of the two sets of warp threads would be reversed.

### **The Fly Shuttle.**

The first important speeding-up of the weaving process was the invention of the fly shuttle in 1733 by John Kay. In this invention, the bobbin with its thread was set in a boat-shaped shuttle which was beaten across the loom on a board specially designed to take it. The weft thread, after being thrown across the loom, was beaten up into the cloth by a comb on the same board.

### **The Power Loom.**

The invention of the power loom in 1785, three years after Watt patented the steam-engine, revolutionized the whole of the textiles industry, and paved the way for many improvements and additions to the loom. Of these, some of the most recent enable the weaving to be practically automatic, so that empty shuttles are replaced

without stopping the machine, shuttles with different-coloured yarns come into action as required and without attention, and special attachments stop the loom should a break occur in either the warp or weft threads. Thus what is known as the stop-rod mechanism stops the loom if the shuttle fails to reach the box on the other side of the loom, and avoids broken warp threads. The weft-fork mechanism comes into action if there is no weft in

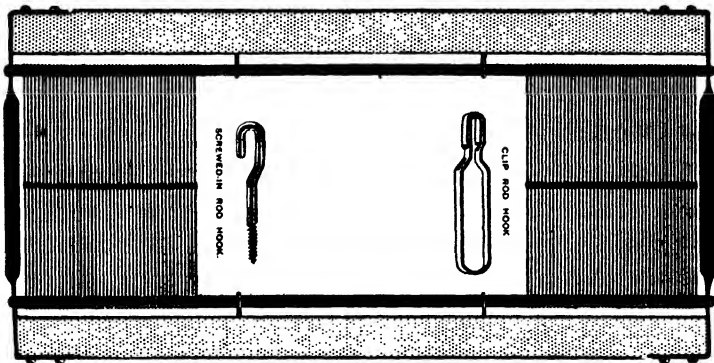

FIG. 50. STANDARD PATTERN WIRE HEALD FRAME, SHOWING TWO METHODS OF FIXING WIRES TO FRAME

the shed, and stops the loom. The warp-stop mechanism does the same if any of the warp threads break. As a result, it is now possible for one man to look after four and sometimes more looms at a time. In the case of Northrop Automatic Looms, this number is increased to twenty-four or more looms per weaver.

In setting-up a loom, certain preparatory processes are necessary. These are chiefly concerned with the warp threads. Threads to the required number are very carefully wound on a beam or roller, called the warp beam. Owing to the great strain which the warp threads have to bear, they must first be treated with starches, gums, etc. This is called sizing, and the material is applied in paste form. It strengthens the threads, creates even

tension, and makes them smooth, so that the shuttle will pass across without injuring them. The warp beam is then set up at the back of the loom, and the individual warp threads are "drawn-in" through the eyes in the healds, being passed across to the front of the loom. Here they must be passed through the *dents* or apertures in the reed or comb, this being called sleying. After going through the reed, the warp threads are tied up to the cloth beam, and when the shuttle containing its supply of weft thread is in position at the side of the machine, the loom is ready to commence weaving.

### The Plain Loom.

On page 145 will be found a diagram giving the essential parts of a plain loom, and the reader is recommended to study this diagram in conjunction with the following description.

At the back of the loom is the warp beam, with its supply of sized warp threads. These have been passed over the back roller and turned round two rods called the lease rods, whose functions are to keep an even tension on the warp threads and form one of the extremes of the *shed*. In the centre of the loom are suspended the healds, and through the eyes in these healds the warp threads are taken. All the "odd" healds are controlled by one harness and the "even" healds by another, the harnesses being worked automatically so that as one rises the other falls. The opening between the two sets of warp threads caused by this separation and movement of the healds is called the *shed*, and the action of the healds is described as shedding. Towards the front of the loom, i.e. to the left of the diagram, the next part requiring our attention is the sword. This works on a pivot, and the top moves backwards and forwards in a small arc. At the top of the sword is the going-part, or "slay sole," across which

the shuttle is thrown. Immediately behind the slay sole is the reed. The reed is like a comb, consisting of many narrow strips of metal placed in a vertical position and

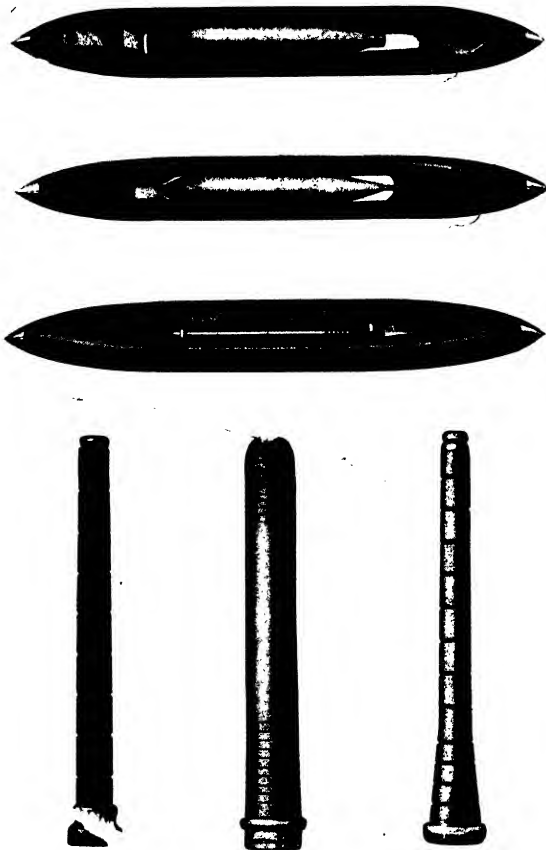

By courtesy of

Messrs. Wilson Bros. Bobbin Co., Ltd.

FIG. 51. TYPES OF SHUTTLES AND BOBBINS IN MODERN USE

fixed in a frame so that a small opening is left between each. It is through these openings or "dents" that the warp threads are passed before being fastened to the cloth beam. Usually one warp thread passes through each

opening in the reed, but sometimes two or perhaps three are taken through together. After being carried under a small roller to maintain the tension and form the front limit of the shed, the warp thread (and eventually the woven cloth) is carried over the breast beam to the cloth beam.

Now we are in a position to follow the loom through the motions of weaving. There are five movements. First,

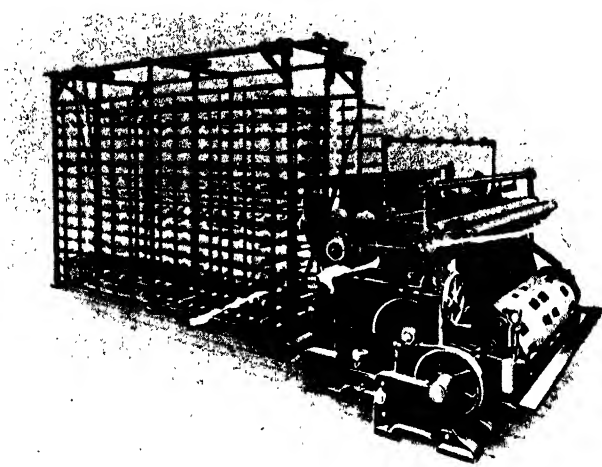

By courtesy of

Messrs. Platt Bros. & Co., Ltd.

FIG. 52. WARPING MACHINE

the shedding, during which the healds move up and down to part the two sets of warp threads and form a shed. Second, the picking, whereby the shuttle, with its bobbin of yarn, is beaten across the slay race by the action of the picking strap or stick, of which there is one at each side of the loom. The shuttle leaves behind it a weft thread, which lies in the open shed. The third movement is the beating-up. This is effected by the sword moving forward and causing the deposited weft thread to be beaten-up into the "fell" of the cloth by the reed. In the next two

movements, which take place simultaneously, the woven cloth is taken up by the cloth beam, and the warp beam lets off further warp ready for the next pick. Of course, the five movements do not take so much time as it does to describe them, and as the action of the loom is continuous, once the machine is started the warp beam

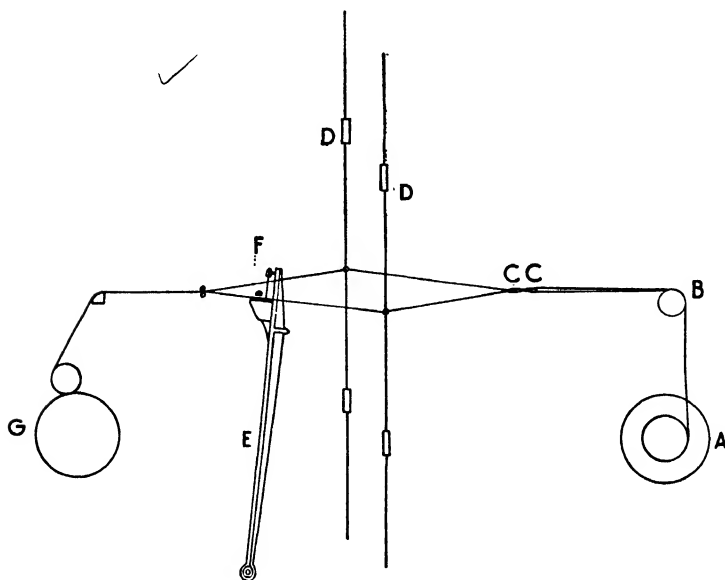

FIG. 53. THE ACTION OF A PLAIN LOOM

<i>A</i> = warp beam	<i>DD</i> = healds	<i>F</i> = comb
<i>B</i> = back roller	<i>E</i> = sword	<i>G</i> = cloth roller
<i>CC</i> = leash rods		

steadily gives off warp, whilst the cloth beam as steadily takes up cloth.

The warp threads are sometimes described as “ends,” and the weft as “woof” or “picks,” each “pick” or blow of the picking strap placing one “pick” of weft in the cloth. The edges of the woven cloth are called “selvedges.”

It must be understood that the loom described is a plain loom, and the parts are not necessarily identical in



all machines. At the same time, any variations introduced are usually for the purpose of weaving cloths of perhaps heavier or lighter weight and, of course, for the production of fancy weaves. Some looms are run with coloured warp and weft, the yarn having been previously dyed, and by using different-coloured threads in definite

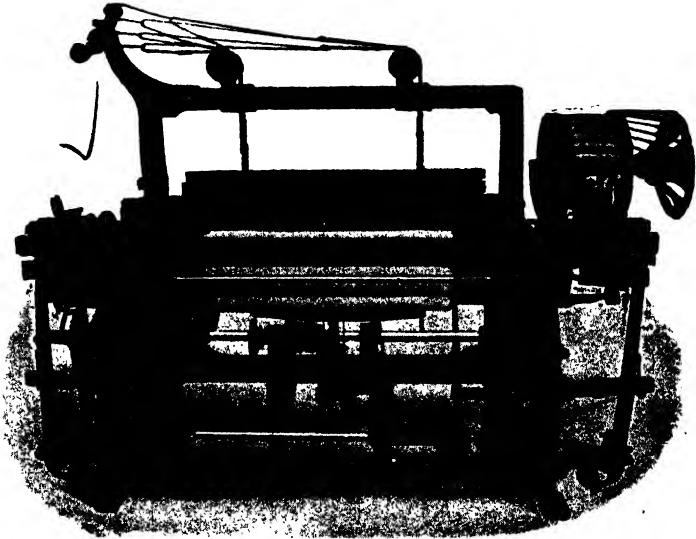

*By courtesy of*

*The British Northrop Loom Co., Ltd.*

FIG. 54. LIGHTWEIGHT AUTOMATIC LOOM

order many pleasing designs can be woven, although the cloth is of the plain type.

Looms for the production of fancy cloths are merely adaptations of the plain loom, with attachments altering the control of the warp threads or introducing a different order of picking the weft. Although it is not intended in this book to give more than an outline of the principles of weaving, there is, however, one development of the plain loom which must be mentioned. This is the Jacquard, named after the man who perfected it in 1798.

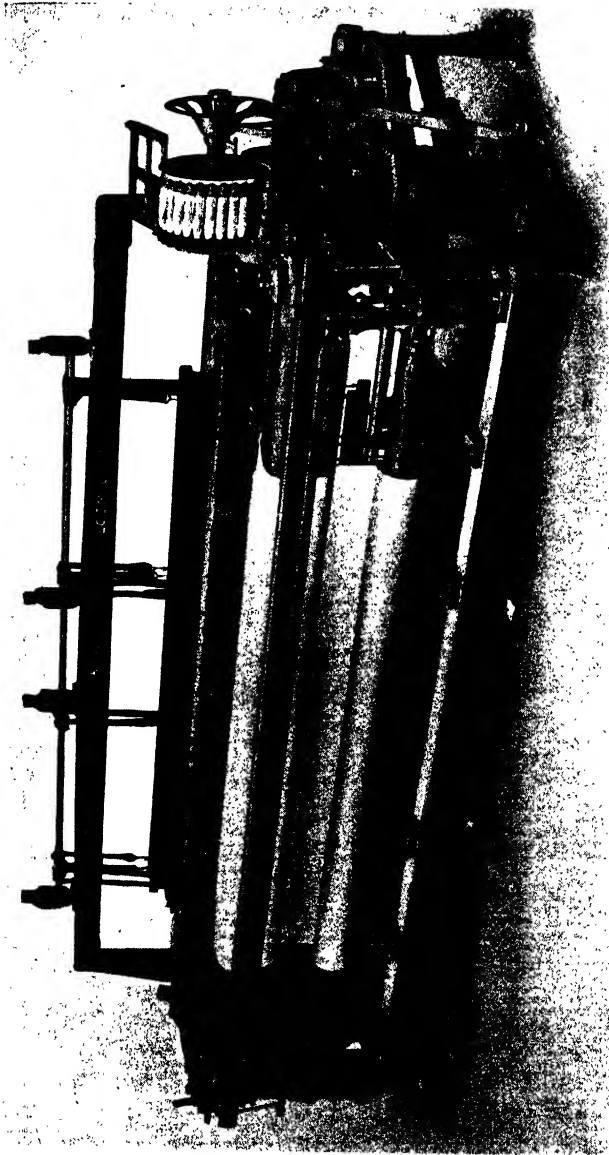

*By courtesy of*

**FIG. 55. HEAVYWEIGHT AUTOMATIC SHEETING LOOM**

*The British Northrop Loom Co., Ltd.*

### The Jacquard.

Machines worked on the Jacquard principle produce intricate patterns by a special method controlling the warp threads and raising them at will in many different combinations. Each warp thread is threaded through an "eye" at the bottom of a harness cord, and several of these cords are tied up to a wire in the upper part of the

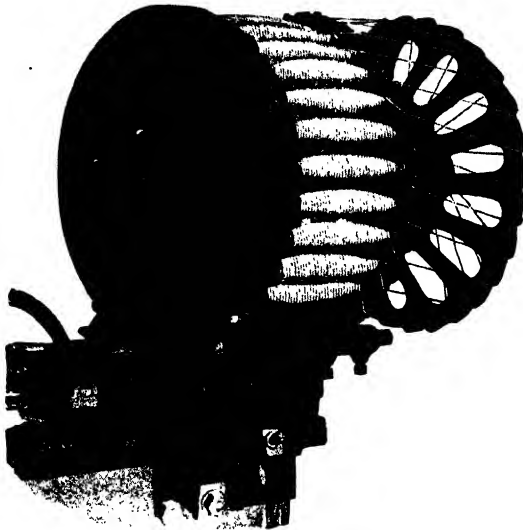

By courtesy of

The British Northrop Loom Co., Ltd.

FIG. 56. SHUTTLE MAGAZINE FOR AUTOMATIC LOOM

loom. There are many wires, the top of each being shaped like a hook, and the hooks are controlled by an equal number of needles. The needles press against a four-sided metal box called the *griffe*, which is pierced with rows of holes in regular order. These holes would allow all the needles to rise at the same time, but a sheet of stiff card the same size as the side of the *griffe* is interposed between the *griffe* and the needles. The card is pierced with holes in an order arranged to permit only a certain number of the needles to rise. As the needles move they

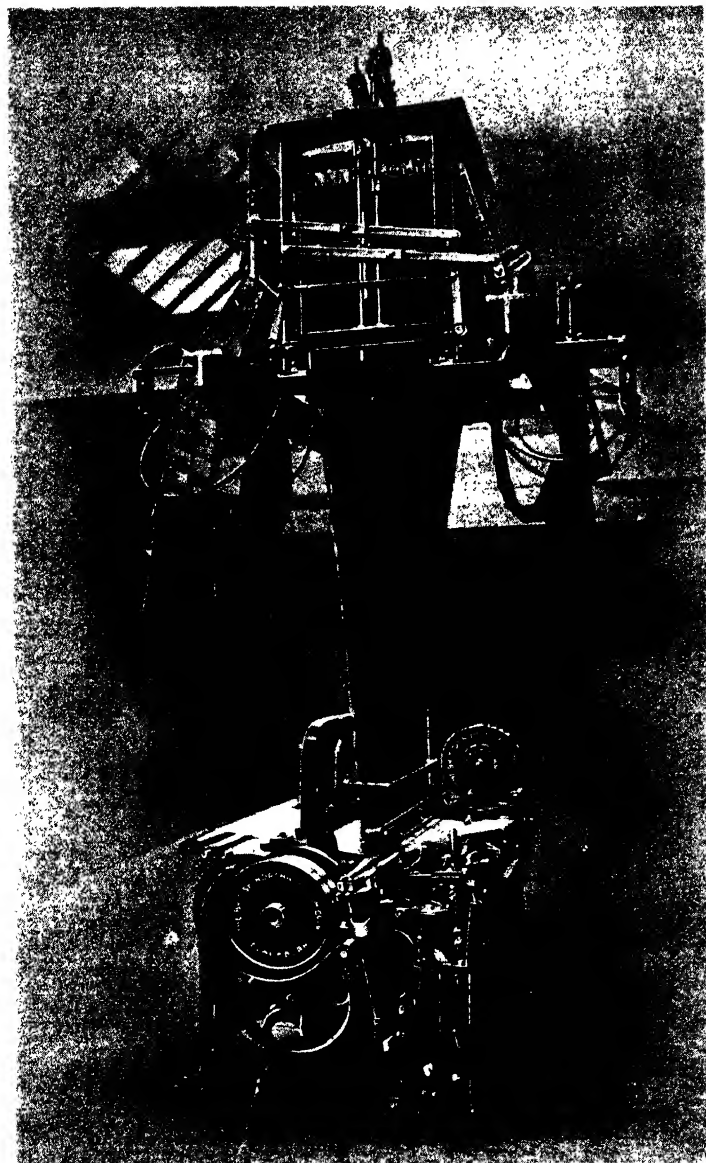

*By courtesy of*

*The British Northrop Loom Co., Ltd.*

**FIG. 57. LIGHTWEIGHT AUTOMATIC LOOM WITH JACQUARD ATTACHMENT**

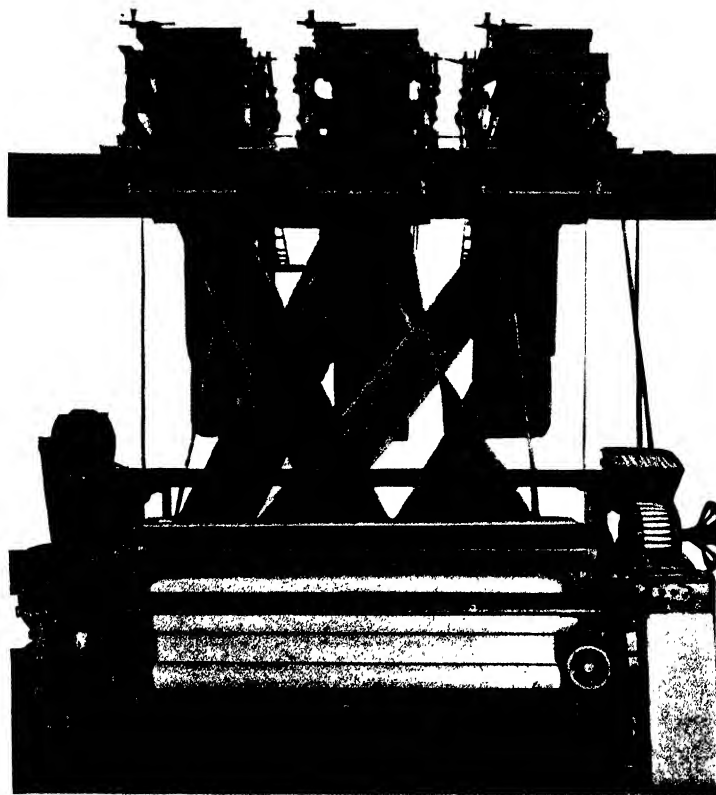

*By courtesy of*

*The British Northrop Loom Co., Ltd.*

FIG. 58. LINEN DAMASK LOOM

pull up the corresponding hooks with their harness cords attached, and so raise a number of the warp threads, forming a shed through which the shuttle is thrown. The card therefore decides the pattern of the weave for one pick of weft. The actual design of the fabric is produced by having a number of these cards strung together, each card perforated with holes in a different order. After every pick a fresh card comes into position over the face of the griffe, and thus the warp threads move up in a different formation for each shed. For a repeat of the design, the first card comes into position again, and the same sequence of cards crosses the griffe. The movement of the cards is effected by the four-sided griffe turning round a quarter of a revolution and bringing the next card into position for each pick.

Fabrics of the damask type, such as serviettes, tablecloths, quilts, and soft furnishings, are all made on Jacquard machines.

## CHAPTER XIV

### STANDARD TYPES OF WEAVE

TABBY—Twill—Satin—Gauze, etc.

THE simplest cloth structure is the plain or "tabby" weave in which the two sets of threads, warp and weft, cross each other at right-angles and interlace in the regular manner of one thread over and one thread under, alter-

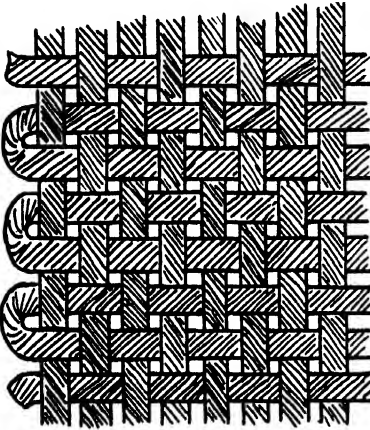

FIG. 59. PLAIN OR TABBY WEAVE

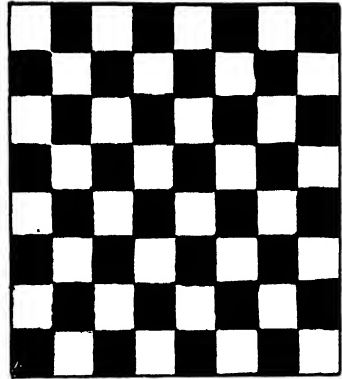

FIG. 60. TABBY WEAVE ON POINT PAPER

nately. This weave is used for all plain fabrics, such as handkerchief cloths, shirtings, calicoes, etc., where a pattern is not required to be woven in the cloth and where the strength is to be evenly distributed.

An examination of the sketch will illustrate this structure and also show the design as it will appear on the textile designer's "point paper." In the point paper the squares represent the crossings of warp and weft threads of the woven cloth. The warp threads are shown vertically and the weft threads horizontally. Where a warp

thread comes to the front the square is filled in black. Where a weft thread is on top the square is left blank. (This system may be reversed if desired, and some designers fill in the squares representing the threads, warp or weft, which appear least on the surface, as this saves time and the design still shows up as clearly.)

### Hopsack.

A variation of the tabby weave. One design of this type is shown in the sketches. (*N.B.* This is *not* a twill.) In the hopsack weave the warp and weft both work in pairs (or 3's or 4's, etc.).

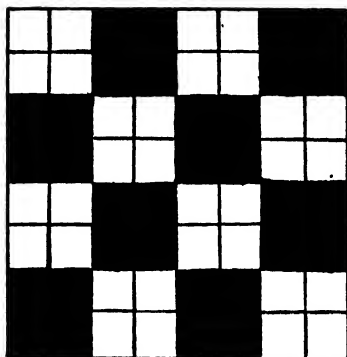

FIG. 61. HOPSACK

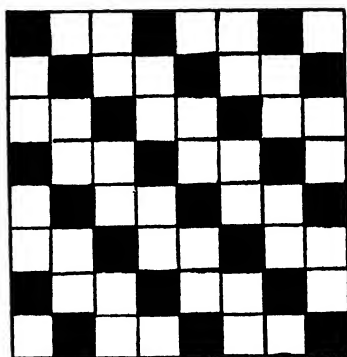

FIG. 62. WEFT-FACE TWILL

### Twill.

If weight is required and a thick yarn is used, plain weave is not so suitable, and a twill weave must be used. A five-end twill is one where the design is complete on five "ends" (warp threads). Owing to the direction of twist in ordinary cotton yarns, the twill lines are bolder when they run from right to left.

### Satin.

The satin weave is derived from twills by a changing round of the pattern. In satin weave one set of threads



is made to "float" on the surface. If the warp threads predominate on the surface, the cloth is called a warp satin; if the weft threads, a weft satin. The satin weave is used where a bright shiny surface is required and where friction is to be avoided, as in linings.

### Herring-bone.

An important example of broken twill.

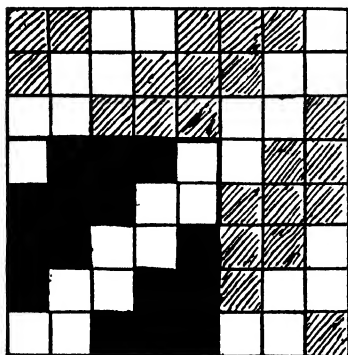

FIG. 63. FIVE-END TWILL

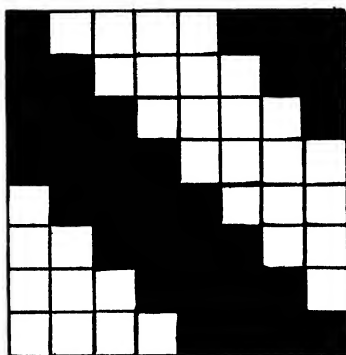

FIG. 64. SERGE TWILL

### Poplins.

Originally of pure silk. Later a worsted weft was introduced (marocain), and the material is now made entirely of cotton. It is a plain weave with a weft thread of greater diameter than the warp, to form a rib.

### Repp.

Similar to poplin, but alternate thick and thin warp and weft threads. The thick warp always comes over the thick weft, producing a double rib.

### Gauze or Leno Structure.

This is an important variation of the plain warp and weft weave used chiefly for light open fabrics of the muslin

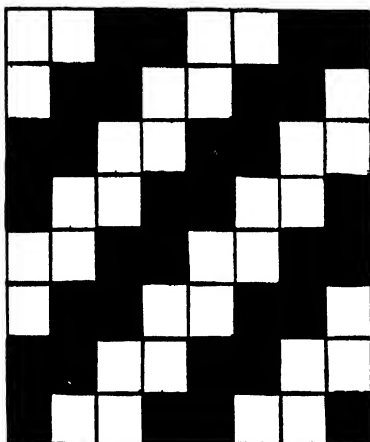

FIG. 65. HERRING-BONE TWILL

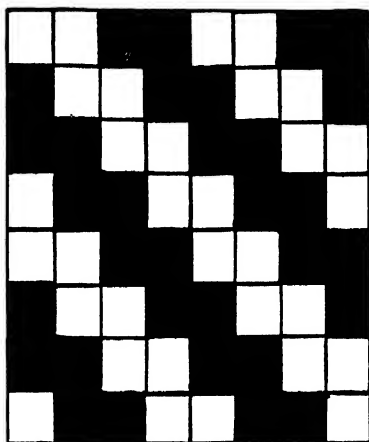

FIG. 66. HERRING-BONE TWILL

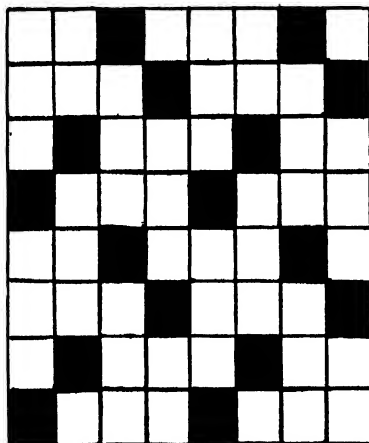

FIG. 67. WEFT-FACE SATIN

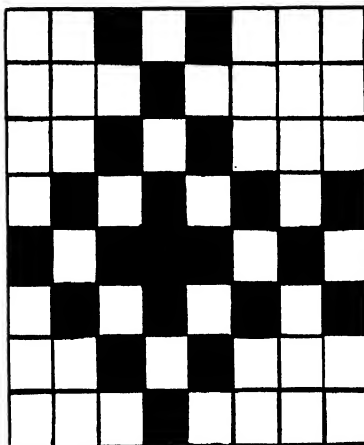

FIG. 68. HONEYCOMB

and curtain type, and also for cellular cloths used for underwear and light dress materials. By their special construction, gauze fabrics impart that firmness of texture which could not be obtained in an open fabric produced in the ordinary weave, as this would not stand a moderate strain without slipping. The main feature of this weave is the introduction of an additional set of warp threads

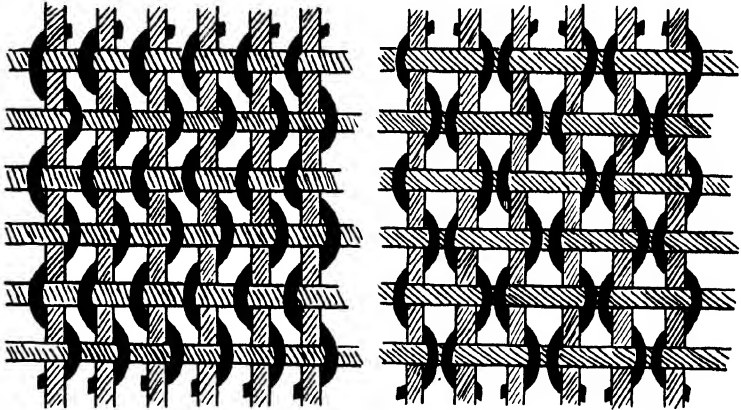

FIG. 69. SIMPLE GAUZE STRUCTURE

FIG. 70. ANOTHER TYPE OF GAUZE STRUCTURE

known as "crossing-ends," binding together the foundation of warp and weft threads, which are not interlaced but lie one on top of the other. Two simple examples of gauze materials are shown in Figs. 69 and 70 and other designs include squared patterns and also the introduction of coloured stripes.

The chenille yarn used for chenille Axminster carpets is produced by this method. After the dyed yarns have been suitably woven into an open gauze fabric they are cut in the direction of the warp, leaving a coloured chenille yarn which can then be used without further preparation.

## CHAPTER XV

### KNITTED FABRICS

THE latch needle—The beard needle—Hosiery—Warp-knitted fabrics.

INSTEAD of the two sets of threads lying at right-angles to each other that go to make up woven cloth, the structure of ordinary knitted fabrics consists of a series of loops made from a single thread running continuously through the fabric, which can be described as a weft fabric. Each row of loops is linked up with the preceding row, and every stitch is dependent on the stitches which surround it. Should the thread become broken in any place, it will "run" for several stitches and leave a hole.

Owing to the nature of the texture, knitted goods are very elastic and yield readily to any movement of the body, taking the shape of the wearer without causing discomfort. This makes it particularly suitable for underwear. The fabric should not be knitted too tightly, as this would reduce the elasticity, nor too loosely, as this would permit the fabric to stretch excessively without returning to its original shape. Owing to the air spaces between the loops, knitted garments are usually warmer than garments made from ordinary woven material.

The knitting process is especially suitable for footwear. In this case a woven fabric could not be used owing to the disadvantage of seams and the problem of absorbing and releasing perspiration, which in knitted goods is given off in the form of vapour. Seams present some difficulty in the knitting trade, but improvements in late years have got over the problem of the bulky seam to some extent. One modern method consists of inserting additional threads in the seaming process to join up the two edges.

There are two kinds of needle used in the knitting industry, the "latch" needle and the "beard" needle.

### The Latch Needle.

This is used largely on the flat knitting machine, which makes plain and fancy fabrics and is also used with a



FIG. 71  
THE LATCH  
NEEDLE

Jacquard attachment to produce numerous designs. The needles are arranged in two rows along the machine, and the knitted fabric passes from them down through the centre of the machine, being weighted at the bottom so that each row of loops drops clear of the needles as soon as released. One or other of the rows of needles comes into play according to the style of knitting, and for rib stitch both are used. By a special arrangement of the machine, in which both rows of needles are working at the same time but independently of each other, circular fabric can also be made on

the flat frame. In latch-needle knitting, each needle works individually, and in rapid succession to its neighbour, right across the width of the machine. It will be seen therefore that the latch needle is independent in its action. The latch needle is also used on the circular machine for footwear, etc.

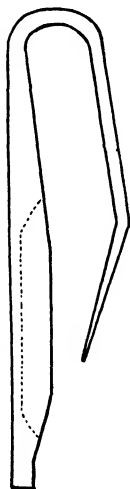

FIG. 72  
THE BEARD  
NEEDLE

### The Beard Needle.

The second type of needle used in the knitting industry is called the beard needle. This differs from the latch needle in that it requires other parts to help form the loop or stitch. It is made so that after the open needle has been pulled

down over the delivered yarn, a part called the presser forces the needle point back into the slot in the needle shank to enable the needle to carry the yarn through the loop previously formed. On the needle rising it opens again, retaining on its shank the new loop through which the freshly delivered yarn will be carried. This needle is used on hand frames and on the automatic types, flat and circular, and particularly for the full-fashioned trade.

### **Knitting Machines.**

The two main types of knitting machine in use are the flat and the circular frames. The circular frame is more regular than the flat machine, in which the action moves from side to side. As the name implies, the material produced on the flat machine is in one flat piece with edges. On this machine also is made the class of articles known as "fully-fashioned." These are made to the shape of the body in separate pieces and afterwards joined up without the waste which would be entailed in cutting. The edges of the fabric have special loops which can easily be joined together by what is known as a seaming thread, of the same colour as the garment. This method is, however, somewhat costly and the machinery required very expensive.

The circular frame produces what is called "seamless knitting," i.e. fabric in tubular form. Socks, stockings, gloves, and some types of underwear are made by this method. Pullovers and jumpers are also turned out on this machine, the sleeves being made separately and fitted in afterwards.

Some cheap stockings are made in the circular form with a slight reduction in the width towards the ankle, the shape being obtained by "boarding." The stocking is stretched on flat boards in the shape of a leg and dried

by heat, when the part round the ankle contracts and the wider part at the top stretches, this shape being retained. After a little wear, however, the lower part begins to stretch again and loses its shape.

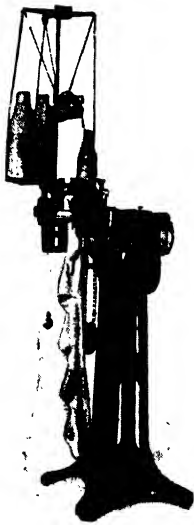

FIG. 73. SIMPLE AUTOMATIC SEAMLESS KNITTING MACHINE FOR LADIES' HOSIERY, HALF-HOSE, ETC.

The output of this machine is from 3 to 4 doz. pairs per day

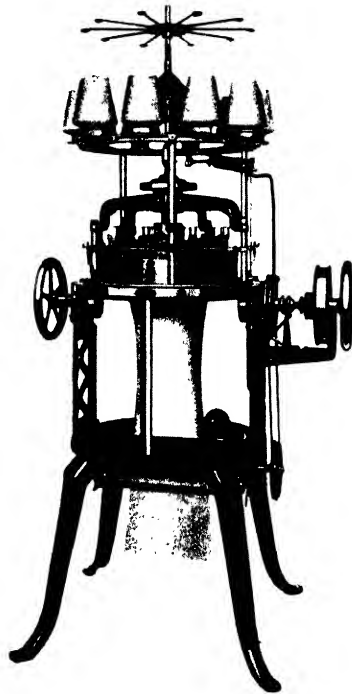

FIG. 74. INTERLOCK KNITTING MACHINE

Either cotton or wool yarns can be used on this machine without any adjustment. Produces about 20 lb. of fabric per day

*By courtesy of Messrs. Wildt & Co., Ltd.*

Full-fashioned stockings are made in flat pieces to the shape required, and joined up by a seam at the back of the leg. The heel has to be made in two sections at each side, and the sole of the foot is made separately and worked on afterwards. French stockings have the foot made in

one width without a special sole, and the seam runs along the middle of the sole. The seams in the English foot run along each side and down the back of the heel.

Yarns for hosiery must be wound perfectly even and be of equal tension throughout, otherwise the fabric may show defects. Knots and missing threads are to be avoided, as they are more noticeable in a knitted fabric than in a woven one. Imperfections of this type should be looked for on the back, which shows more clearly the character and design of the fabric. The face side shows the straight portions of the loops, whilst the reverse or back shows the curved loops of the knitting.

### **Warp-knitted Fabrics.**

As already indicated, the ordinary type of knitted texture has the threads running in a series of loops *across* the fabric, being described as weft-knitted. There are, however, other types in which the loops are made in such a way that the thread travels lengthwise in the material. These are termed warp-knitted, and the more intricate designs of this class are produced with the object of preventing "laddering." The simplest type of warp-knitted fabric will ladder if a thread becomes broken, but a more complicated kind made up of two sets of warp threads which cross in opposite directions to each other and interlace to form one complete fabric is practically ladderproof.

An even more strongly constructed warp-knit fabric is the well-known *Milanese*, in which each of the two sets of warp threads travels diagonally right across the width of the material, one to the right, one to the left, reversing as they reach the selvedge. This is one of the most compact and ladderproof of the knitted fabrics, and is in effect almost the equivalent of a double cloth. The



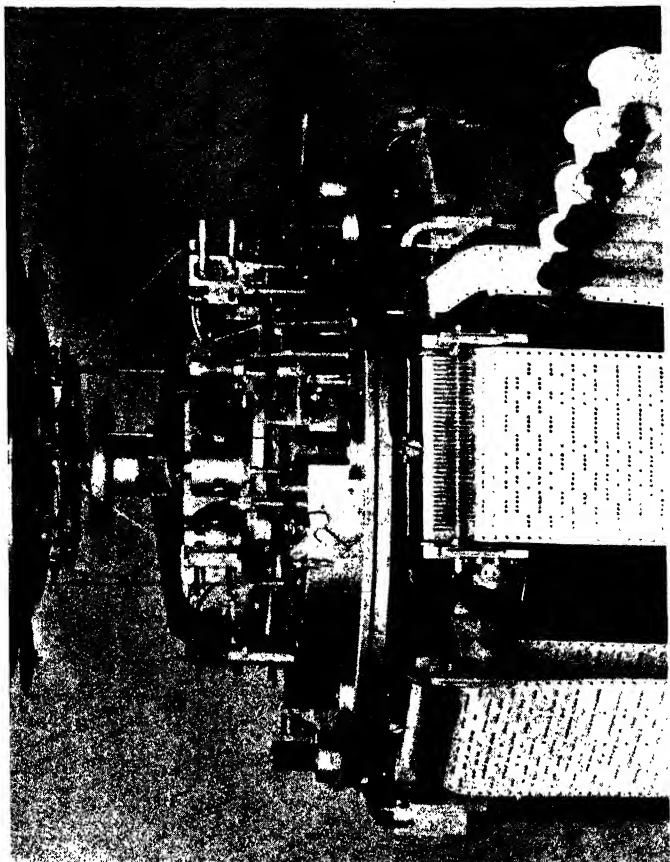

*Messrs. Wildt & Co., Ltd.*

**FIG. 75. CIRCULAR JACQUARD KNITTING MACHINE**

The action of the needles can be seen, also the "automat" cards controlling the pattern of the fabric

*By courtesy of*

structure of a Milanese fabric can easily be seen by holding it up to the light and looking through it.

Laddering is one of the chief disadvantages of knitted fabrics, and in testing such cloths should always be looked for, as it is a real guide to the value and serviceability of the article under test.

## CHAPTER XVI

### LACE NET

THE lace machine.

LACE has been made by hand in many and varied designs for centuries. As a form of decoration for wearing apparel it has always held a place in textiles, although its use depends to a large extent on the trend of fashion. One of the most popular forms of hand-made lace is that known as "Pillow-lace," invented in 1561 by a Saxon housewife. As the name implies, it is made on a pillow, the threads being carried across on gaily-coloured bobbins tossed from hand to hand. The pattern is obtained by laying on the cushion, below the threads, a sheet of stout paper punched with holes in a definite order. Pins are inserted in these holes, round which the threads are twisted to form the mesh.

#### The Lace Machine

From pillow-lace has sprung the machine-made net and lace of to-day, fashioned on a machine entirely different from any other mechanical form of weaving in the textiles trades. Early in the last century a young man named John Heathcoat, son of a farmer, acquired a few stocking frames and set himself the task of making "bobbin net" by machinery. He took as his model a piece of pillow-lace, and tracing the threads through the lace he discovered that whilst one set of threads appeared to run in a more or less straight direction through the piece, the rest of the threads, which were further divided into two halves, travelled diagonally across the width, one half to the left and the other half to the right.

Having isolated the *warp* threads, his next task was

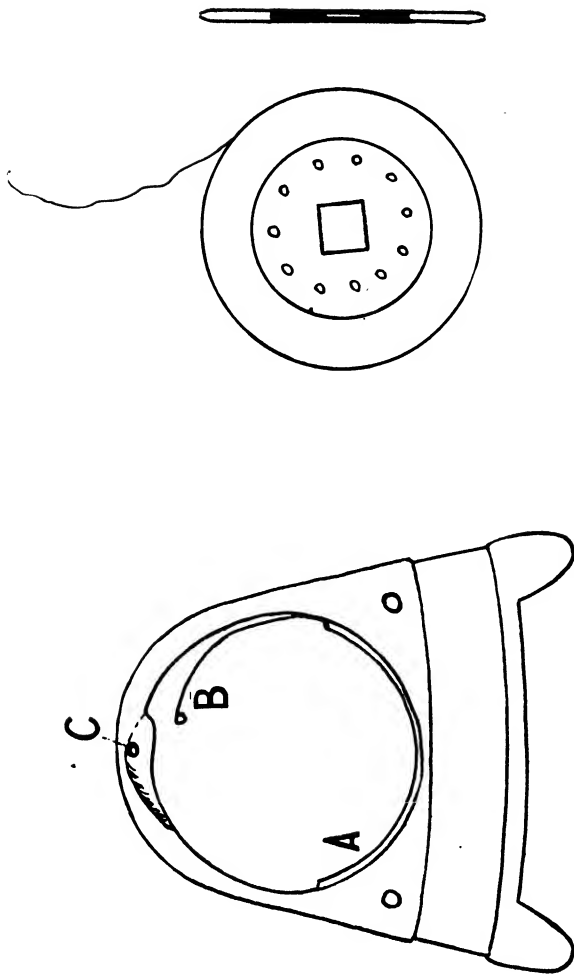

FIG. 76. LACE CARRIAGE AND BOBBIN

A = ridge on which bobbin rests

B = spring to hold bobbin in position

C = hole through which the thread passes

to find a way of twisting the others round them from side to side. This he achieved in the Heathcoat Bobbin-net Machine, the first lace machine invented, and the fore-runner of all modern lace machines.

The principle of the bobbin-net machine is as follows—

The warp threads are carried up from a warp beam at the bottom of the frame to the lace beam or roller at the top, and are separated into two sets by guides at the bottom of the machine. In between the warp threads hang the "wheel" or "bobbin" threads supported in "carriages." The bobbins (or wheels) are made of two discs of metal held together by a central pin or hub, and made extremely thin to enable them to pass to and fro between the warp threads. The thread is wound round the hub *inside* the bobbin, that is to say between the two discs. Each bobbin runs freely in its carriage, also made extremely thin, and the release of the thread is kept at an even tension by means of a spring on the carriage. The bobbins in their carriages are ranged across the width of the machine, resting on a part called the comb. The comb, which is in two sections, one each side of the warp threads, is shaped like an arc and slotted to hold the carriages upright and enable them to move freely. There are two sets of bobbins, one behind the other, one moving to the right and the other to the left. An attachment below the comb, called the shifting or conducting bar, catches in the lower projecting parts of the carriages to push them across from one half of the comb to the other, where they are received by a second shifting bar which pulls them on to the comb on the opposite side of the warp threads. After the bobbin has moved across from one bar to the other, i.e. through the warp threads, the latter move sideways to enable the bobbins to be returned on the other side of each warp thread.

By continuing this movement, the bobbin threads

are twisted round the warp threads. After being taken round one warp thread the bobbin is carried sideways ("shogged") by the comb into a position from which it can be twisted round the next warp thread. Before the actual twisting movements take place, the two sets of bobbin-threads are crossed at the top by the aid of an attachment called the *point-bar*. This also moves in an upward direction to carry the formed mesh on to the lace roller. In all it takes twelve motions of the lace machine to make a hole or mesh of ordinary bobbin net. When each bobbin has travelled across the width of the machine, it passes round the last warp thread and then commences the return (or "traverse") to the other side.

The first lace machine could only make narrow breadths of lace, but the machines in use to-day make various widths up to 324 in., the most usual being 216 in., so that the machine itself will be over 6 yd. long.

By twisting the bobbin thread round the same two warp threads several times at regular intervals, spots can be formed on the mesh.

The gauge of the machine and the net produced by it are denoted by the number of wheels or bobbins held in one inch of the comb. If there are ten wheels per inch, the gauge is called "10 point," from the points on the point-bar, of which there are the same number as there are wheel threads. The larger the mesh of the net it is intended to make, the fewer the points required to pick up the mesh. Ordinary bobbin or mosquito nets vary from 6 to about 15 points.

Longitudinally the gauge of the machine is not fixed, and the number of meshes per inch in the length of the net can be varied. In stating the gauge in the direction of the length, the meshes are called "holes."

During the manufacture of a piece of net, therefore, if the net has, for example, ten meshes per inch, counting

across the width in a straight line, and ten meshes in the length, then it is called a 10-point 10-hole net.

This method of counting, however, is not used outside the manufacturing section of the trade, and, furthermore it must be understood that after a net has been "dressed" and finished, the holes may have become slightly stretched in one direction or another. The true round shape of the bobbin-net mesh does not show itself while the net is on the machine, or, indeed, until it has been finished. The finishing consists of brushing on a mixture of starches and gums whilst the net is stretched taut on a frame, and all the time watching the net to see that the shape and size of the mesh do not vary in different parts. A piece of net measuring perhaps three or four yards in the width and forty or fifty yards in the length is not an easy thing to handle.

It will be seen that some other method of counting the holes is necessary for the finished net. Actually, the mesh count of a finished net is calculated by adding the number of holes lengthwise in one inch to the number of holes across the width in a similar space, and the total is reckoned to be the number of holes "per inch" of the net.

There are several different kinds of net made on the plain net machine: Cotton Bobbin or Bretonne net, cotton Spot or Point d'Esprit net, silk Cambay or "Illusion" net for bridal veils, silk Alencon and Brussels nets, and silk Mechlin net or "Tulle," the latter being fashioned slightly differently from the ordinary net. Some very attractive nets are also made to-day in rayon.

Fancy lace in various designs is made on rather more complicated machines, although the principle is much the same.

## CHAPTER XVII

### CARPETS

FELTED—Knotted pile—Plush woven—Double cloth.

CARPETS have been made by hand for thousands of years, and there are many in existence which are veritable works of art. Some of these products of the hand-loom took years to make, and the amount of care and skill which they embody is really marvellous. The methods of preparing the yarn and dyeing it were undoubtedly primitive, but the carpets produced have never been equalled by machinery. Practically all the materials—yarns, dyes, and framework—were prepared laboriously by hand, and the design jealously guarded and handed down from father to son.

In some hand-worked carpets there are said to be as many as 400 tufts to the square inch, all inserted separately. Small wonder that a genuine hand-made carpet of known origin can command a high price, and that this value increases with the age of the carpet.

The home of the hand-made carpet is Asia, each district having its own special styles. In modern times, carpets are also tufted by hand in England, but nothing like the same amount of work is put into them, and English hand-made carpets seldom have more than 30 tufts to the square inch.

A study of carpets would, however, need a volume much larger than the present one, and the object of this chapter is to give merely an outline of the principal types of carpets produced to-day on a commercial scale and their structural differences.

The four main divisions are as follows—

I. Felted carpets.



2. Knotted pile.
3. Plush woven.
4. Double cloth.

In the first class would be included all carpets made of felted fibres, and either dyed in one colour or printed on the surface with coloured designs. These have been largely superseded by linoleum, and are not sufficiently important to merit more than passing consideration.

### **Knotted Pile Carpets.**

This is the most important class of carpets, and includes the hand-made types produced in the East. The pile consists of short worsted threads inserted in the fabric in tufts which are either knotted by hand or woven into the cloth by machinery. The chief types of knotted pile carpets, apart from the Oriental carpets, are Axminster, Moquette, Crompton, and Patent Axminster. Genuine Axminster carpets are made on the hand-loom. Patent Axminster and Moquette are machine-made tufted pile carpets, woven with chenille yarn and plain yarn, either in alternate picks or in a pre-arranged sequence according to the design.

### **Plush Woven Carpets.**

The carpets of this class are actually woven fabrics. Instead of the material for the pile being cut up into small sections, it is woven into the cloth in the form of warp (called "pile warp"). The surface pile is made by inserting wires underneath the lifted pile threads which are selected to form the pattern. The wires may be constructed in a way that will leave the pile in loop form, or they may cut the loops when withdrawn, so creating a dense plush surface. The Brussels carpet belongs to this class, and has a surface made up of loops. The tapestry carpet is an imitation of a Brussels, but has the pattern

printed on the warp before it is woven. The Wilton carpet has a cut pile, longer than the pile in a Brussels carpet, and necessarily bound more firmly. Velvet pile tapestry should also be included in this group.

### **Double Cloth Carpets.**

Carpets of this type consist of two fabrics woven together in the same loom, one above the other. By changing the positions of the two main warps at different stages of the pattern during the weaving process, a wide variety of designs and colourings can be produced at will. The chief types of carpets made on this principle are Ingrain, Scotch Kidderminster, and Art Squares.

## CHAPTER XVIII

### GLOSSARY OF FABRICS

#### **Fabrics Made from Silk and Rayon.**

**TAFFETA.** Made in plain weave from net silk yarns, closely woven and generally weighted (sometimes only one way, i.e. warp or weft). Shot effects are obtained by weaving from dyed yarns of different colour in warp and weft.

**JAP SILKS.** Plain weave from net silk yarns, unloaded. A characteristic of Japs is irregularities in the weave or in the yarn, especially in the weft yarn.

**SHANTUNGS** (Tussore, etc.). Made of wild net silk, woven in the gum. Rather harsh in handle, but after washing several times the cloth becomes softer, lighter, and thinner. Uneven in yarn and weave.

**CRÊPE DE CHINE.** Plain weave, but with "crêpe-twisted" weft. The twist is set by steam, but is released when the silk is boiled off, causing the fabric to shrink or "cockle" weft-way, which gives the crêped effect. The warp is composed of ordinary silk yarns lightly twisted to give lustre. Both net and spun silk are used. The lower qualities of *crêpe de Chine* are always loaded, but spun silk crêpes are usually pure. Loading prevents "slipping," and therefore spun crêpes are inclined to "slip" if not closely woven. Many qualities of *crêpe de Chine* are now made from rayon, which is not loaded.

**CRÊPE GEORGETTE.** Made from net silk only, similar to *crêpe de Chine*, but with hard twist yarns in both warp and weft, giving a crêped effect described as "pebble." It should be noted that if the twist in crêpes were all the same way, the shrinkage would be uneven and result in a fabric similar to chiffon. The crêpe yarns are, therefore,

woven two right-hand twist and two left-hand twist alternately.

**MAROCAIN.** Similar to *crêpe de Chine*, but with heavier yarns. Sometimes made with crêpe-twisted warp and plain weft, giving a weft rib effect. Can also be made with weft of spun silk, cotton, wool, or rayon. Is sometimes loaded, especially the all-silk types.

**VELVETS.** Cloths of this type are made with two warps called pile and ground warps. The pile threads are drawn up into loops by means of wires in the loom, these loops being afterwards cut to form a pile surface. The pile may be of spun silk or rayon, lustre being desirable. The ground can be net silk, spun silk, or cotton.

**SATIN.** Made from net silk yarns, the warp or weft threads predominating on the surface in the usual satin weave. In crêpe satin the threads carried to the back of the fabric are of crêped yarn. *Satin Beauté* is of this type.

### **Fabrics Made from Wool.**

**WORSTEDS.** Made from worsted yarns (long wool fibres straightened out and laid parallel). The fabrics are strong in relation to their weight, have a clean appearance, and the nature of the weave can plainly be seen. *Examples* : Serges, gabardines, repps, worsted taffetas, cashmeres.

**WOOLLENS.** Made from woollen yarns (short wool fibres which lie crossed in all directions and form a hairy yarn). The fabrics show a naturally fibrous surface which can be raised into a nap if desired by brushing or "teazing." This would conceal the structure of the weave. Woollen cloths are felted and "milled," which causes further interlocking of the fibres and adds materially to the strength. *Examples* : Flannels, velours, meltons, tweeds.

**LIGHT PLAIN WORSTEDS.** Nuns' veilings, crêpe flannels, etc., made of light yarns or in an open weave of thicker

yarns. A special finishing process gives a crêpe effect, by causing the yarns to shrink or cockle.

**SERGES.** The best serges are made from worsted yarns in the twill weave  $2/2$  reversible. Where the number of threads per inch in warp and weft are equal, the twill will have an angle of 45 degrees. This will produce a well-balanced cloth equally strong and durable both ways.

**LUSTRE CLOTHS.** Alpacas, brilliantines, sicilians, glacés, etc. These are made with a fine cotton warp and a weft of thick alpaca, mohair, or lustre worsted yarns. If they are to be used for dress materials or high-grade linings, they are woven plain. The lower qualities are woven in the twill fashion. A special finishing process, called "crabbing," increases the lustre. Schreinerling is another process used for this type of cloth in order to increase the lustre, and this is described in the chapter on "Finishing."

### **Fabrics Made from Cotton.**

**CALICOES.** Longcloths, cambrics, nainsooks, lawns, muslins, etc. These vary in weight and finish, and are all in the plain weave. The best cloth is obtained where the warp and weft threads are as near as possible equal in quality, count, and number.

**POPLINS.** Made in the plain weave, usually of two-fold yarns, and mercerized. Repps are similar to poplins. Slub repps are made with yarns of uneven diameter obtained by variations in the spinning process. Rayon slubs are now an established feature of the furnishing trade.

**SATEENS.** Cotton Italians, Venetians, glissades, etc. Made in the satin weave, giving a smooth, even lustrous surface. Used for linings and other cloths where friction is to be avoided. Not so strong as cloths made in the plain weave.

**RAISED COTTON FABRICS.** Flannelettes, winceyettes, cotton molletons, Canton flannels, etc. These are finished

with a raised fibrous surface to produce softness and warmth in imitation of woollen fabrics. They are mostly made with fine warp and thick soft-spun weft which is brushed up. The raising of the nap weakens the soft-spun yarns and consequently these cloths are weaker in the weft than in the warp.

**LIGHT, OPEN CLOTHS.** Voiles, organdies, muslins, etc. Plain weave, fine yarns, open structure.

**CRETONNES.** Woven plain. "Cloth-printed" cretonnes are printed in the piece. "Warp-printed" cretonnes have the design printed on the warp, and have a weft of white or light-coloured threads. These latter cloths are reversible and are called "shadow" or "chine" cretonnes.

**VELVETEENS.** Plain or "corduroy." They have a pile surface similar to velvets, but are made entirely of cotton. The ground is in plain or twill weave.

### **Fabrics Made of Linen.**

**PLAIN LINENS.** Cambrics, lawns, sheetings, handkerchief cloths, towellings, etc. Plain or twill weave. Very hard wearing.

**LINEN DAMASKS.** This class of fabric is used to make table covers and serviettes. The cloths are woven in five- or eight-end sateen designs and are reversible. Eight-end sateen damasks are known as "Double damasks." Rayon is also being used in the weft for damasks.

### **Miscellaneous Fabrics.**

**AMERICAN CLOTH.** A cotton material covered with a solution of cellulose. This has a smooth surface printed in various designs.

**ARMURES.** Weaves which show a broken or irregular surface like crêpe, but coarser. These are chiefly worsted dress fabrics.

**ASTRAKHAN FABRIC.** An imitation of the astrakhan

fleece. It has a curly pile surface of lustre worsted or mohair yarn on a foundation of cotton or worsted yarns in plain weave.

BARATHEA. Medium and heavyweight suiting and dress fabrics with worsted yarns in the weave.

BATISTE. Plain weave, lightweight cotton, or linen yarns.

BOUCLÉ. Fabrics with curls, loops, or knots on the surface.

BUCKRAM. A plain cloth made from flax, cotton, or jute yarns. Piece-dyed and stiffened. For hat shapes and inside linings.

BUNTING. A plain cloth of thin texture made from mohair, lustre worsted or cotton yarns. Used for flags and outdoor decorations.

CRÊPE CORONA. (Proprietary name.) *Crêpe de Chine* with cotton warp and silk weft. The cotton has crêpe twist, the silk being only lightly twisted.

CRÊPE SUÈDE. Ordinary *crêpe de Chine* structure but with very dull and soft finish. Made from silk and rayon or all rayon. "Angel Skin" is a kind of crêpe suède.

CRINKLE CRÊPES. Several new types of crêped materials have recently been offered under the names "Crinkle Crêpe" and "Elephant Skin." They are made either of all silk, all rayon, silk and wool, or rayon and cotton, on the same principle as *crêpe de Chine*. The difference in the surface appearance is obtained by varying the number of weft threads of the same twist (right-hand or left-hand) which are thrown across the loom in sequence.

DIMITY. A cotton fabric with fine, light texture ground, and having a stripe or check of thick cord yarns.

DOESKIN. A fine dress fabric made from high quality woollen yarns in five-end warp sateen weave. Milled and raised to give a fibrous surface.

FAILLE. Plain weave from net silk yarns. Faille has a large number of warp threads to the inch and fewer

weft threads, giving a warp rib similar to a poplin. Generally loaded.

**FELT.** In the true felt there is no woven structure. The short wool fibres, sometimes mixed with cotton, are scoured and blended, then worked up on a carding machine into laps. Successive layers of the carded fibres are laid one on the top of the other until the desired thickness is attained, when the whole is pressed under heat by means of rollers. The mass of fibres is amalgamated by the aid of soap, water, acids, heat, and pressure.

**FOULARD.** A cloth made of net silk yarns woven 2/2 twill. Printed in spotted and other designs. Imitations of foulard are made from rayon.

**HARRIS TWEEDS.** Homespun made from thick woollen yarns, in plain or twill weave. The fabrics have a fibrous surface but the weave can be seen. The yarns contain a fair amount of kemps.

**HESSIANS.** Jute fabrics woven plain.

**INGRAIN.** Fabrics which are called "Ingrain Dyed" have been dyed in the yarn.

**JAPSHAN.** A proprietary name for a spun silk fabric in plain weave with two-fold yarns. Used for underwear, shirts, pyjamas, etc.

**LUVISCA.** (Proprietary name.) A weft-faced fabric made in various weaves, principally 3/1 weft twill, with cotton warp and viscose rayon weft. Used for shirts, blouses, pyjamas, etc.

**MELTONS.** All-wool, or wool and cotton, milled and raised. The nap is then cut to the required density and hides the weave entirely. A cloth used for overcoatings.

**MOIRE.** Ribbed cloths made of silk, rayon, or cotton, in which the "watered" effect is obtained by pressing two cloths together in the damp state, or folding the cloth in the width and pressing. These two methods give an irregular moire effect. A third method is by using pressure



from an engraved roller, the pattern in this case being regular and repeated at intervals.

**NINONS.** Lightweight silk fabrics in plain weave.

**OMBRES.** Fabrics in which the colour gradually shades from light to dark or from one colour to another. This is done either in the dyeing or by arrangement of the coloured yarns.

**ONDULE.** To obtain the ondule effect in plain cloths, the warp threads are drawn through and controlled by a special reed, the wires of which are set in a diagonal manner instead of perpendicular. The reed moves up and down so that the number of threads per inch varies. As a result the warp threads run in wavy lines down the piece. This style is not popular with manufacturers owing to the cost of the special reeds and the difficulties of manufacture.

**ORGANDIE.** Plain weave. A transparent cloth made from very fine single cotton yarns and in a stiff finish. Used for collars, cuffs, etc.

**PANNE VELVET.** A velvet with a flat pile.

**PIQUE.** A corded cotton fabric with the cords running from selvedge to selvedge instead of lengthwise, as in Bedford cords.

**PONGEE.** A plain silk fabric made from wild silk yarns.

**RIPPLE CLOTH.** An all-wool fabric with raised surface in which a rippled effect is obtained in the finishing. Cheaper qualities sometimes contain a little cotton. Used for dressing gowns.

**SATIN BEAUTÉ.** Five-end warp satin with crêpe back. Made from net silk and usually loaded. Also made in rayon.

**SATIN GRENADINE.** Net silk warp and spun silk weft. Woven in eight-end warp satin structure and given a dull finish.

**SCHAPPE SILK.** A term sometimes applied to ordinary

spun silks, but really meaning a fabric woven from spun silk yarns which have not been fully degummed. Made in plain weave.

**SCHREINERED FABRICS.** Chiefly cotton. The cloth is subjected to great pressure from rollers engraved with many fine parallel lines, which may be as many as 400 to the inch. This produces a highly lustrous surface.

**SHOT FABRICS.** Woven with yarn dyed warp and weft of different colours, usually in the plain weave.

**TULLE.** A fine net made from pure silk yarns.

**TWEEDS.** Plain or twilled fabrics made from fibrous woollen yarns, sometimes with a mixture of cotton. The fibre is occasionally dyed before spinning.

**UMBRELLA CLOTHS.** The best qualities are made from net silk yarns, unweighted. Lower qualities are made from Egyptian yarns. They are mostly in the plain weave but are sometimes twilled.

**VELOURS.** Plain or twill weave. Woven from woollen yarns which are raised to a dense nap, hiding the structure of the weave. Low grades contain some cotton.

**VICUNA CLOTH.** A fabric with a close fibrous surface which conceals the design of the weave. Made with worsted warp and woollen weft, sometimes with the admixture of a little cotton.

**VIYELLA.** (Proprietary name.) A union fabric made from worsted and cotton yarns, mostly in 2/2 twill.

**VOILES.** Light open fabrics in the plain weave made from fine cotton yarns.

**WORSTED GEORGETTE.** Plain weave with hard-twisted worsted yarns in the warp and weft, woven one-and-one in different twists. The crêpe finish is obtained by the irregular shrinking of the yarns in the finishing process.

**ZEPHYRS.** Cotton fabrics of plain weave, with coloured stripes or cords in the warp. These are sometimes woven with check colourings. Used for shirts and cotton frocks.



SECTION III  
BLEACHING, DYEING, AND  
FINISHING



## CHAPTER XIX

### BLEACHING

COTTON—Linen—Wool—Silk—Rayon.

THERE are two fundamental ways of bleaching textiles—

1. *Oxidation*, in which oxygen is added.
2. *Reduction*, in which oxygen is taken away.

In each case there is a possibility of the oxygen content returning towards the normal, and this leads to a “yellowing” of the fabric. There is also a danger of over-bleaching, with a consequent bad effect on the strength, durability, and dyeing properties of the fibre.

#### Cotton Bleaching (“Bowking”).

After thorough scouring to remove impurities, the cotton is put into a solution containing the bleaching powder, which is composed of *calcium*, *oxygen*, and *chlorine*. The chlorine is set free in the process, and acts upon the fibres.

There are two other methods which are not so widely used. In the first the bleaching agent is hypochlorite of soda. In the second, which is called the “electrolytic bleach,” chlorine is set free by passing a current of electricity through a solution of sodium chloride. Both are oxidizing methods.

Bleaching can very easily be overdone, and the fabric will then become yellow and tender in time. Over-bleaching of cotton produces what is known as *oxycellulose*, and this can be detected by the following two methods—

1. Half per cent solution methylene blue (cold). The oxycellulose turns a strong shade of blue.
2. Congo red solution. After being steeped and washed, then dipped in dilute hydrochloric acid, the fabric turns

black. If washed off, the affected parts remain black and the remainder regains the red colour of the original solution.

### **Linen Bleaching.**

This is as for cotton, but sun bleaching is also practised. The linen fabrics are exposed to the sun and air for definite periods, this process being known as "grassing." Certain chemicals are also used to assist the process. Linen loses about 20 to 25 per cent of its weight in bleaching, owing to the removal of impurities.

### **Wool Bleaching.**

The process most favoured in England is the reduction of oxygen by *stoving*. The wool is put into an airtight chamber with wooden or glazed brick walls, and a brazier fed with sulphur is burnt. The sulphur fumes act on the wool, which has previously been damped. What happens is that the sulphur fumes combine with the oxygen in the air to form sulphur dioxide  $\text{SO}_2$ . This joins with the water in the material, forming sulphurous acid  $\text{H}_2\text{SO}_3$ , and this latter, having an affinity for oxygen, withdraws it from the goods, forming sulphuric acid  $\text{H}_2\text{SO}_4$ . In this process it is wise to avoid iron nails, etc. It is difficult to remove all traces of the acid (which affects the dyeing properties), and the fumes are unpleasant. When wool blankets are new they frequently have an unpleasant smell, caused by bleaching with sulphur dioxide.

The oxidation process for wool is carried out with hydrogen peroxide,  $\text{H}_2\text{O}_2$ , at a temperature of approximately  $100^\circ\text{F}$ . Oxygen is taken up by the goods, leaving  $\text{H}_2\text{O}$  (water). The addition of a small quantity of dilute ammonia shortens the process from 24 hours to  $1\frac{1}{2}$  hours. To obtain a finishing bloom, the wool is sometimes put through the stoving process for a short time afterwards. This is a more permanent process, but rather expensive,

A variation of this method is by using sodium peroxide (which must be added to the water very slowly to avoid violent action). This combines with the water to form caustic soda and  $H_2O_2$ . The caustic soda must afterwards be neutralized with sulphuric acid. Mixture cloths (wool and cotton) can be bleached first with ordinary chlorine bleach (for the cotton) and then stoving (for the wool). Great care must be taken not to overdo the chlorine treatment, as this might affect the wool.

### **Silk Bleaching.**

Silks are bleached by one of three methods—

1. Hydrogen peroxide, assisted by sodium silicate and soap, at boiling-point, 8 to 10 hours.
2. Sodium peroxide, assisted by magnesium sulphate and sulphuric acid, 8 to 10 hours.
3. Sulphur dioxide (stoving).

Weighted silk piece goods are usually bleached by steeping them in a bath of oxygenated water after the weighting process, as sulphur would be harmful to them. Tussore silk is difficult to bleach a good white, owing to the presence of tannin, and is often sold in its natural colour.

### **Rayon Bleaching.**

The three principal methods of bleaching rayon are—

1. Sodium hypochlorite.
2. Calcium hypochlorite.
3. Sodium peroxide.

The last one is very good for whites.

Most rayon which is to be dyed in light shades must first be bleached.



## CHAPTER XX

### THE DYEING OF TEXTILES

NATURAL dyes—Mineral dyes—Acid dyes—Basic dyes—Mordant dyes  
—Direct cotton dyes—Sulphur dyes—Vat dyes—Dye faults and tests.

ALTHOUGH it has been possible to colour textile materials about as long as it has been possible to make them up into cloth, it is only during the last hundred years that the art of dyeing has made such wonderful progress. The earlier colouring substances, known as natural dyes, were obtained from vegetable and mineral sources, and in one instance (cochineal) from crushed insects. Some of these dyes were very lasting, and produced pleasing effects, but on the whole they were very irregular in their action and results, owing to the difficulty of producing them in a sufficiently pure form. They were also limited in supply, and consequently expensive.

With the discovery about the middle of the nineteenth century of coal-tar dyes, however, a great change came over the industry. These dyes, known as synthetic dyes, opened up a new field for the textile dyer, and after the discovery by Perkin in 1856 of *aniline*, which is obtained from the by-products of the coal-gas industry, chemists began their experiments with coal tar which have led to the production of the many synthetic dyes which are now in general use, and which have almost entirely replaced natural dyes owing to their cheapness, purity, and reliability.

Among the by-products of coal tar are the following—

Benzene.	Toluene.	Phenol.
Cresol.	Naphthaline.	Anthracene.

All these are used in the modern dye industry. By

converting benzene into nitrobenzene and then into *aniline*, a substance is produced which forms the basis for many dyes. By a process known as *diazotization*, aniline is changed into a compound which is the source of a large range of dyes known as "Azo" dyestuffs. Another dye, called *alizarin* (discovered 1869), is identical in its composition with madder (a natural dye produced

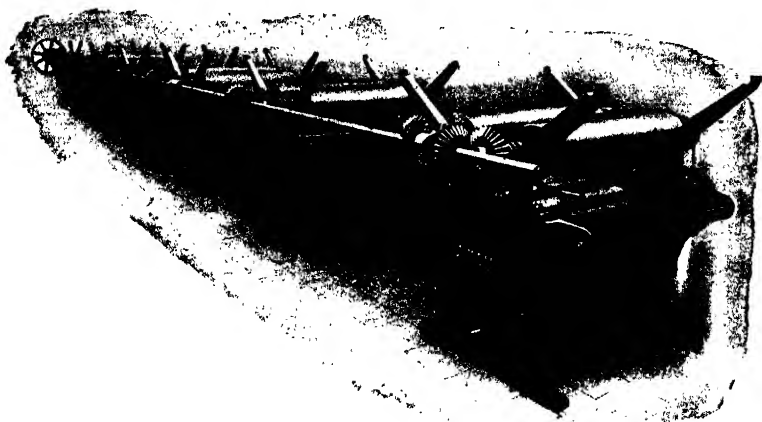

By courtesy of

Sir James Farmer Norton & Co., Ltd.

FIG. 77. DYE JIGGERS

The cloth runs backwards and forwards through the dye liquor until the required shade is obtained. Each jigger can be worked independently

from the root of a plant), and has now replaced it. Synthetic *indigo* (discovered 1897) is now produced in large quantities, and is widely used in place of real indigo. Sulphur dyes are made by treating coal-tar products at a high temperature with sulphur and compounds of sulphur. These are the direct cotton dyes. Another class of synthetic dyes, discovered in 1901, are the *vat* dyes, made from *anthracene*. These are very fast, but expensive in their production and application.

In its original state, *aniline*, the first of all coal-tar dyestuffs, is not in a suitable form for the extraction of

dyes. It has to be oxidized with a strong oxidizing agent such as potassium bichromate. This converts it into a dark-coloured solid from which dyes are extracted by means of a solvent (e.g. methylated spirit).

Nearly all dyestuffs contain carbon, hydrogen, and oxygen, as well as sulphur or nitrogen (sometimes both). According to the proportion in which these elements are present, so is it possible to find out the colour, affinity to different fibres, and fastness to light and washing, of a particular dye. Synthetic indigo, for instance, has the chemical formula  $C_{16}H_{10}N_2O_2$ .

The different textile fibres do not all have the same reaction towards the same dyestuffs. A dye which may be suitable for cotton may be quite useless for the dyeing of silk. Some dyes which are readily absorbed by two different textile fibres may remain fast in one but be easily washed out of the other. In other cases the fibre may not take up the dye at all, or absorb it too quickly or too slowly. For this reason the dyer frequently has to make use of other chemicals to enable him to give satisfactory results. These are called *assistants*, their function being to control the process of dyeing in order to obtain evenness of effect.

In those cases where a fibre will absorb a dye but not retain it, some form of fixing agent must be used, either before, during, or after the dyeing, and this is called a *mordant*. Generally speaking, vegetable fibres, being composed mainly of cellulose (i.e. carbon, hydrogen, and oxygen), will require different treatment from animal fibres, which have in addition nitrogen and sulphur. The different reactions of these two groups of textiles to alkaline or acid solutions must also be kept in mind when preparing the dye-bath.

Before dyeing woven textile fabrics they must be thoroughly cleansed to free them from any size, starch,

or other matter which may have been applied during the spinning or weaving, and also to remove any of the natural impurities which may prevent clear dyeing. In the case of light and clear shades, the fabric must also be bleached. Cotton and linen both lose weight in these processes. Silk is degummed (boiled-off), thereby losing from 20 to 25 per cent of its weight, but the silk gum or "boiled-off" liquor is used in making up the dye-bath and acts as an assistant.

The following are the principal classes of dyes—

### **Natural Dyes.**

Not very important, as they have been largely replaced by synthetic dyes. Usually require a mordant. Logwood and fustic are still used.

### **Mineral Dyes.**

Really pigments of metallic origin. Only used in special circumstances.

### **Acid Dyes.**

Chiefly for wool and silk, for which they are substantive dyes, requiring no mordanting or special preparation of the fabric. The *Azo* dyes belong to this class.

### **Basic Dyes.**

A class of dyes noted for their bright colours, but unfortunately not very fast to light and washing. Used for silks where brilliance is of more importance than fastness: Also largely used on cotton with a tannic acid mordant.

### **Mordant Dyes.**

Fairly fast dyes used for wool fabrics, sometimes for silk. This class of dye requires a mordant, which is usually metallic, i.e. *chromium*, *iron*, *tin*, or *copper*. Not

used for ordinary cotton dyeing, but sometimes for the printing of cotton.

### **Direct Cotton Dyes.**

Applied direct to cotton, linen, and viscose rayon fabrics without any preparation. Very easy to use. Fairly fast to light and washing, but inclined to bleed if the dyed fabric be placed in very hot soapy water. Also used for wool and silk, and for union fabrics. A very important class of dyes.

### **Sulphur Dyes.**

Mostly blacks, blues, and browns on cotton. Very fast. When applied, the dye is colourless, but on exposure to the air it oxidizes and resumes its correct colour, becoming fixed in the cloth at the same time.

### **Vat Dyes.**

Some of the fastest dyes in existence are vat dyes. They are also expensive. Oxidized on the fabric in a similar manner to sulphur dyes. At present used chiefly for cotton, as the dye liquor has to be strongly alkaline. The continental dyes known as *indanthrene* are of this type.

### **Dyes Used for Wool.**

**ACID DYES.** Assisted by Glauber's salt and sulphuric acid. The wool is put into a warm dye-bath, the temperature then being raised gradually to boiling-point. Time, about 1 to 1½ hours boiling.

**MORDANT DYES.** Mordanted with chromium salt, usually *sodium bichromate*.

**DIRECT COTTON DYES.** Also used for wool. Applied in similar way to the acid wool dyes.

**VAT DYES.** For indigo and general vat dyeing. (See "Cotton.")

### **Dyes Used for Cotton.**

**DIRECT COTTON DYES.** Applied boiling.

**BASIC DYES.** Applied in cold solution after mordanting the cotton with tannic acid.

**SULPHUR DYES.** Applied at boiling-point, assisted with Glauber's salt. (See above.)

**VAT DYES.** Used in similar way to sulphur dyes, but assisted by *sodium hydrosulphite*. The colour is developed by oxidizing with hydrogen peroxide or a bleaching powder (i.e. not by exposure to air).

### **Dyes Used for Silk.**

**BASIC DYES.** Moderate temperature, assisted by boiled-off liquor.

**ACID DYES.** Warm dye-bath made up with boiled-off liquor, assisted by sulphuric acid. Temperature kept below boiling-point.

**DIRECT COTTON DYES.** Not all of these have affinity for silk. They are used in conjunction with boiled-off liquor and acetic acid.

**LOGWOOD.** One of the natural dyes which is still used, as it produces a very satisfactory black. The process, which is a rather complicated one, commences with mordanting the silk with iron and tannic acid. This adds weight to the fabric, which is then dyed in a hot bath of logwood, iron and copper salts, and soap.

### **Dyes Used for Linens.**

Practically all the dyes used for cotton are suitable for linen.

### **Dyes Used for Rayon.**

Viscose, cupra, and nitro are dyed with very much the same dyes as cotton, but a special range of synthetic dyes has been prepared for acetate.

**Cross-dyeing.**

This can be achieved by steeping mixture cloths in separate dye-baths for the two different kinds of fibres, and sometimes by mixing the dyestuffs together in one bath, each of the two textile fibres taking up the dye for which it has an affinity. In some cases, of course, the two textile fibres will take up the same dye.

**Some Common Dye Faults.**

If the fabric is made from yarns in very different twists, they may take the dye unevenly. Oil spots on the cloth, or oil deposited on the yarn during spinning, will hinder good dyeing and also render the dyestuff loose. If wools from two widely-different breeds of sheep (e.g. Australian and South African) are mixed together, this may cause uneven dyeing. Shoddy does not take new dye very well owing to the presence of old dye matter and chemicals remaining. Should the temperature of the dye-bath not be carefully regulated, the dye may be loose in the cloth.

**Dye Tests.**

To test for loose dye, the material is immersed in a test tube containing a solution of Knight's Primrose Soap (a neutral salt), and this is placed in a bath of hot water, temperature 50° C., for half an hour. The liquor from the test tube is then poured into a white porcelain dish and examined for discoloration. Another test is to leave the fabric in tap water for 24 hours.

“CROCKING” OR RUBBING TEST. A piece of calico is moistened and rubbed across the material. If the dye is loose it will show on the calico.

FASTNESS TO LIGHT. This is tested by exposing the material in a frame covered with a dark paper stencil. Tests are taken for differing periods of exposure.

**FASTNESS TO PERSPIRATION.** The fabric is treated with a 10 per cent solution of acetic acid for 1 hour at body heat. After being ironed dry between white cloth, the fabric is then compared with a piece which has not undergone the treatment.

**TEST FOR MUD SPOTS.** The fabric is spotted with a weak lime solution containing a little ammonia. When the spots are dry they should brush off without leaving any marks.



## CHAPTER XXI

### CALICO PRINTING

DIRECT method—Dyed style—Resist style—Discharge style.

HAND-BLOCK printing was at one time the only method of imposing coloured designs on the surface of cloths, and is still carried on to a large extent for the better and more exclusive fabrics. Block-printed silks show a wealth of colour and clearness of design which has not yet been entirely equalled by roller printing. Nevertheless, printing by hand is a laborious and costly process, and the introduction of printing by machinery, "Calico Printing" as it is known, has made it possible to produce an enormous range of printed cloths at prices more within the reach of the slender purse. Cottons are the most popular cloths for printing, and cotton "prints" for shirtings, overalls, frocks, furnishings, etc., are available in seemingly unlimited variations of design. In recent years the introduction of rayon cloths has supplied the printer with a new material for the rollers, and cheap printed rayons are offering serious competition to the better-class hand-block printed silks.

Roller printing, as the name implies, is carried out on a large roller, called the "impression cylinder" or "pressure bowl," against which other rollers, with engraved surfaces, are pressing. The cloth to be printed is carried round the pressure bowl whilst underneath it is the "back grey," which is intended to soak up any surplus dye penetrating the cloth. Underneath both these cloths, and wrapped round the pressure bowl, is a blanket cloth to give the necessary resiliency to the printing action.

The engraved copper printing rollers, of which there is one for each colour to be printed, are placed in position

round the pressure bowl so that each runs lightly on the surface of the cloth. The colouring matter is contained in small troughs placed below the printing rollers, and the dye is transferred to the latter by means of a "furnisher" roller running half in the liquid with its upper surface touching the printing roller.

In order to remove any excess of dyestuff before it reaches the cloth, a knife-edge, called the "colour doctor,"

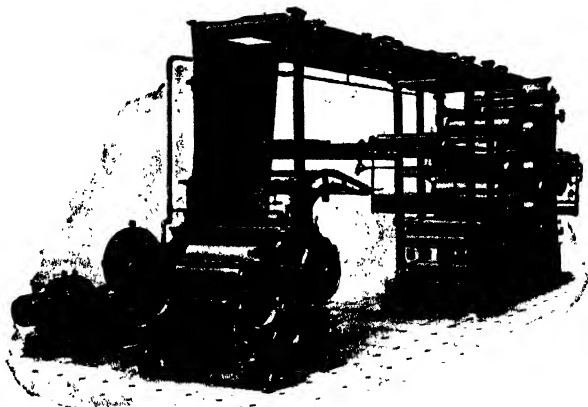

*By courtesy of*

*Sir James Farmer Norton & Co., Ltd.*

FIG. 78. FOUR-COLOUR CALICO PRINTING MACHINE, TURNING OUT ABOUT 50 YARDS OF PRINTED CLOTH PER MINUTE

The heated drying rollers are shown at the back of the machine

presses against the surface of the printing roller before it comes into contact with the cloth. The colour doctor also presses the dyestuff into the engraved part and promotes even printing. The part of the printing roller which has just been in contact with the cloth is scraped by another knife, called the "lint doctor," to take away any threads or other adhesions picked up from the cloth.

Although some fabrics are printed direct by the colouring matter, the process is not quite so simple as it seems. Some colours may require mordanting or assisting in order to make them fast in the cloth, and consequently

there have developed four methods of printing which are used according to the circumstances and the effect which it is intended to achieve on the material. These are called (1) the "Direct" or "Steam" style, (2) the "Dyed" style, (3) the "Resist" style, and (4) the "Discharge" style.

### **The "Direct" Method.**

The material is printed with the required design, the dyestuff and mordants being mixed together and deposited on the cloth by the engraved rollers. After printing, the cloth is subjected to the action of steam, which fixes the mordants and develops the colours. Prints produced by this method are not so fast to light and washing as the other methods.

### **The "Dyed" Style.**

The design is printed on the cloth with a thickened mordant, dried and steamed to fix the mordant, and then placed in an ordinary dye-bath of the required colour. The dye is only taken up by the parts of the cloth actually printed with the mordant, and, after washing, the unmordanted parts resume the original ground-colour.

### **The "Resist" Style.**

Sometimes called "Resist-padded." This is a reversal of the "Dyed" style. The parts of the cloth which are required to remain white or a ground-colour are printed with a substance capable of resisting the dye. After this has been properly absorbed and dried, the cloth is then placed in a dye-bath, when the colour is taken up only where the cloth is not coated with resistant.

### **The "Discharge" Style.**

A cloth dyed in the ordinary way is printed with certain chemicals which discharge the dye from those parts required to be white or a ground-colour.

## COLOURING MATERIALS

The colouring materials of the dyer and the printer are very much the same, although some dyes which are suitable for ordinary dyeing may not be suitable for printing, and *vice versa*. The chief difference lies in the fact that the dyer must always make a liquid, whilst the printer makes what is really a paste of the colouring matter, plus thickening materials and, if for the direct style, a mordant. For printing purposes the colours must be very well and uniformly mixed, smooth and free from grit or other impurities. Owing to the pressure which is used in printing, the cloth may be badly marked if a piece of grit or unmixed colour finds its way on to the rollers.

VEGETABLE COLOURS require a mordant (usually an acid) to fix them in the cloth. Perhaps the most important of the vegetable colours is logwood, which is obtained from the core of a tree. This is oxidized to form *haematin*, which is the actual colouring base for this dye. Haematin is combined with different metallic oxides, and these not only act as mordants, but also decide the colour. A useful range of colours is the result. The well-known logwood black is obtained by using chromic oxide. Pure indigo is another important vegetable dye. It is extracted from the leaves of an East Indian plant by fermentation. By oxidation of the liquid, indigo is precipitated in the form of a sandy-looking powder.

The MINERAL COLOURS, usually called pigments, are generally in solid form. The best white is obtained from zinc oxide. Chrome iron produces good yellows. Sulphate of iron gives reds, whilst the once popular Prussian blue comes from ferrocyanide of iron.

SYNTHETIC (COAL TAR) COLOURS are equally useful for printing or for dyeing. The anilines include reds, blues, violets, greens, and yellows. Magenta, methyl blue, methyl violet, malachite green, and auramine yellow are

examples of the aniline dyes. The naphthaline or azo dyes, of which congo red and benzopurpurine are two important examples, are used in large variety for wool and silk, but are not so suitable for cotton. Another class of synthetic dyes comprises the anthracene colours, which require a mordant to fix them in the cloth. They are fairly fast to light. From the anthracene colours are obtained by oxidation another range, known as alizarine, which includes some good yellows and black. Alizarine black is a jet black, fast to light and washing.

#### OTHER MATERIALS USED IN CALICO PRINTING

##### **Thickeners.**

These are required to give consistency to the colouring matter, to thicken it up, and so prevent the liquid "running" and spreading over the cloth outside the outline of the design. The chief materials used for thickening are best wheat starch (starch from other sources is not so pure), china clay, albuminoids, dextrin (a gum made from starch) and various other gums.

##### **Assistants (or "Astringents").**

Cotton absorbs tannic acid rapidly and very thoroughly. Dyes have an affinity for it in the pure state, and it is therefore an ideal assistant or conductor of colours.

##### **Resistants.**

Citric, tartaric, and oxalic acids all resist the penetration of dyes, and are used in the "resist-padded" and "discharge" methods of printing. For blacks, the principal resistant is acetate of lime.

##### **Solvents.**

For reducing the dye to a semi-liquid form suitable for printing, the following chemicals are used: Acetic acid,

glycerine, acetin (a mixture of the two), and ethyl tartrate.

### **Mordants.**

The purpose of mordants has already been explained. Various acids and salts are used for this purpose. Chrome and iron mordants are suitable for many of the coal-tar colours. Other mordants include tin salts, stannic oxide, stannic chloride, stannous acetate, lead acetate, bichromate of soda, phosphate of soda, carbonate of lime, etc. Two important mordanting salts are the aluminium and iron salts, called respectively red liquor and black liquor. Red liquor, which is acetate of alumina, is very soluble, and the acid goes off the fibre quickly, leaving the insoluble alumina behind. It is used in the "dyed" process. Black liquor, which is composed of ferrous acetate, is not now used so much for blacks as it is for purples and lilacs. The red and black liquors are sometimes combined to form what is known as "chocolate" liquor, because with it alizarine produces a chocolate colour.

After the printing operations, the cloth will require "finishing" in a similar way to ordinary dyed goods, the processes being described in the chapter dealing with this subject.

## CHAPTER XXII

### THE FINISHING OF TEXTILE FABRICS

WOOL—"Unshrinkable" process—Mercerized wool—Waterproofing—  
Silk—Silk weighting—Cotton—Flameproofing—Linen—Rayon—  
De-lustring.

THE textile fabric, as it comes from the loom and after it has been bleached or dyed, is not yet in a suitable condition for use. The many chemical baths, washings and dryings, and the constant handling leave the woven fabric in a state much different from that in which it is passed over the counter to the ultimate consumer. It has to be straightened out, pulled this way and that, smoothed, polished, trimmed, or cut. According to the purpose for which it is to be used, it may have to be rendered waterproof or fireproof. Finally it must be measured, folded or rolled, and packed in a parcel ready for dispatch to the textile warehouse in this country or abroad.

Each class of textile fabric requires special treatment, as follows—

### THE FINISHING OF WOOL FABRICS

All wool fabrics shrink in the finishing, and consequently they must be woven wider than the width ultimately required. Yarn-dyed cloths will not shrink so much as piece-dyed, because the yarns will already have shrunk to some extent when being dyed. Yarn-dyed cloths will shrink about  $12\frac{1}{2}$  per cent to 15 per cent, and piece-dyed about 20 per cent, but this varies according to the class of wool used.

Woollens and worsteds do not undergo quite the same treatment in finishing, but many processes are common to both.

### Perching.

The cloth taken from the loom is thrown over a roller and examined for imperfections such as burrs, straws, hairs, knots, etc., and for missing threads.



*By courtesy of*

*Messrs. Thos. Broadbent & Sons, Ltd.*

FIG. 79. HYDRO-EXTRACTOR ("WHIZZER")

Centrifugal drying machine, in which the material to be dried is thrown round at great speed in a perforated circular cage. (See Fig. 80)

### Picking and Burling.

The irregularities are picked out or removed from the face or back of the cloth.

### Mending.

Any broken or missing threads are attended to.

### Scouring.

The dirt, grease, etc., picked up in spinning and weaving is washed out in the "dolly" machine.



### **Milling or Fulling.**

The cloth is pounded by a machine having an arrangement of wooden mallets which fall on the material whilst it is immersed in a solution of soap and water. Any degree of weight, length, width, etc., can be obtained in

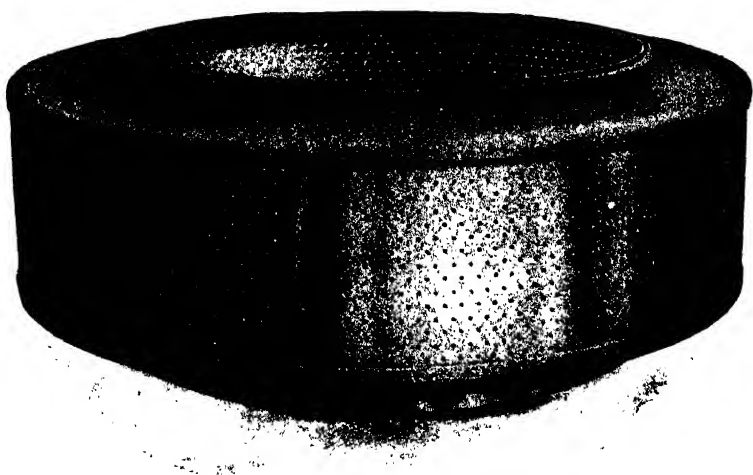

*By courtesy of*

*Messrs. Thos. Broadbent & Sons, Ltd.*

FIG. 80. CAGE OF HYDRO-EXTRACTOR (FIG. 79)

this process, which is sometimes performed by means of rollers.

### **Crabbing.**

The material is passed round a roller in very hot water to fix it in the length and width obtained from the milling.

### **Steaming and Decatizing.**

A method of setting the cloth by passing it over perforated rollers through which steam is blown.

### **Drying.**

By hot air, care being taken not to remove all the moisture.

### Tentering or Stentering.

The cloth, in a damp state, is carried through a frame which holds it taut in the length whilst stretching out the width. Whilst stretched out it is taken over heated plates or gas jets or through a heated chamber to dry it and set it in the required width.

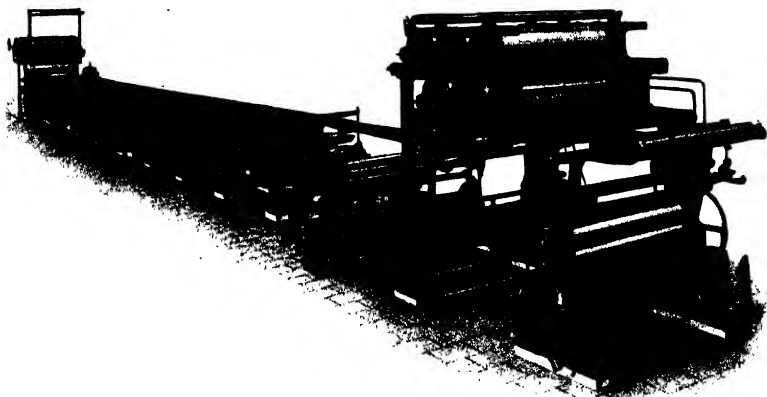

FIG. 81. STENTER FRAME

*By courtesy of H. Ostheide, Esq.*

### Teazling.

Teazles are the hook-like parts of a plant which are arranged on cylinders. They act on the cloth to raise a nap. A quicker method is by using steel wire hooks something like card clothing, but although these are widely used to-day they are not really as satisfactory as teazles.

### Cropping.

The raised fibres are cut by circular revolving knives to a required length in order to give a perfectly level surface.

### Calendering.

Roller pressing by heated rollers makes the cloth more uniform and breaks up any lumps.

**Conditioning.**

Moisture is added to the standard regain should the fabric be too dry. (This is also called "dewing.")

**Cuttling.**

Folding.

**Rigging.**

Folding half-width, selvedge to selvedge, if the cloth is a double-width material.

The foregoing are the principal processes in the finishing of wool fabrics, but there are some other minor operations which may be necessary according to the type of cloth and any special finish which may be required. The "unshrinkable" process and the waterproofing of wool are two examples, and these are explained separately.

In some cases the machinery used for finishing worsteds differs from the machinery for woollens, and sometimes additional processes are necessary in order to produce some particular finish, but on the whole the processes outlined are common to both classes of wool fabrics.

**"Unshrinkable Process."**

Shrinkage occurs in the fibre, in the yarn, and in the piece. One method of preventing this is to soak the wool in a very weak solution of hydrochloric acid and then in a bath of sodium hypochlorite. The hydrochloric acid sets free the chlorine, which acts on the fibres, causing them to lose their scale structure to some extent. The goods should not be in the second bath more than a few minutes. Cross-bred wools, which have a less prominent scale structure, would not require so strong a treatment as merinos.

Another method is by using ordinary bleaching powder, calcium hypochlorite.

As a result of this process, wool fibres lose weight and

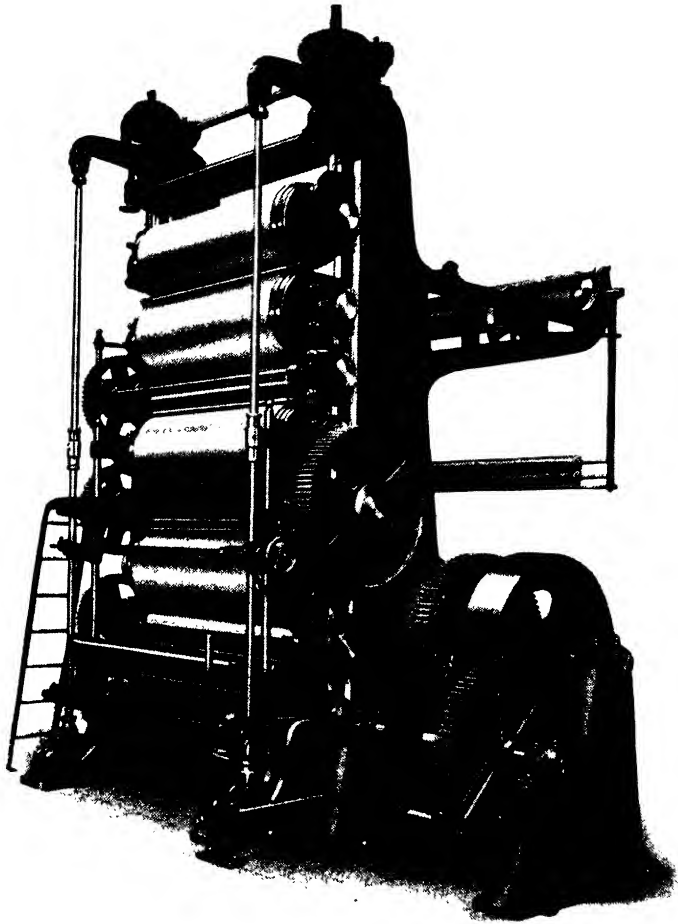

*By courtesy of*

*H. Ostheide, Esq.*

FIG. 82. SEVEN-BOWL CALENDER

their elasticity diminishes. The wool will also take up water more readily unless treated with dilute ammonia.

High-class suitings are sometimes deliberately shrunk in water before being sold, and are then termed "London Shrunk."

### WATERPROOFING

There are two fundamental ways of rendering a fabric waterproof—

1. Physical means.
2. Chemical means.

#### Physical Means.

1. By weaving a cloth very closely and shrinking it, the interstices may be closed up. In the case of wool the cloth is subjected to pressure after being treated with superheated steam.

Two closely-woven fabrics are sometimes superimposed with the weaves in the opposite direction.

2. Paraffin wax can be applied in various ways—

(a) By dusting on the wax and passing the cloth over heated rollers to melt the wax in the cloth.

(b) By drawing the goods through a bath of liquid wax and drying.

(c) By putting the goods into a bath of wax and benzine. The benzine then evaporates, leaving the wax in the cloth.

3. Fabrics to be used for macintoshes can be coated with a solution of rubber. Acetyl-cellulose is a modern preparation used on surface of fabrics to render them waterproof.

#### Chemical Means.

Practically all chemical methods rely upon precipitating upon the fabrics an insoluble compound of aluminium. The most popular is by saturating the goods in a solution of alum acetate and drying at a temperature of 100° F. This leaves a deposit of alum acetate on the material,

but, as it is liable to rub off, the method is sometimes combined with the wax method. Another method of depositing alum on the cloth is by electrolysis. This is very effective but probably more expensive.

### MERCERIZED WOOL

The mercerizing of wool is not widely practised. It is carried out by soaking the wool yarn for five minutes in a bath of bisulphite of soda at a high temperature. This causes the yarn to shrink, and it is then stretched back to normal length while still in the solution. Afterwards it is placed in a boiling bath of weak acid for one hour, during which time the tension is gradually released. The object of this process is to increase the lustre, but the scale structure is also affected.

### THE FINISHING OF SILKS

All silks made in the crêpe fashion shrink both in the warp and the weft owing to the tension of the twist being released during the boiling-off. It is in this shrinkage that the crêpe effect is given to the cloth. *Crêpe de Chine* shrinks from 5 to 8 per cent in the warp and 10 to 16 per cent in the weft.

Georgettes shrink 10 to 16 per cent in the warp and 8 to 12 per cent in the weft. The shrinkage is controlled by treatment on the Stenter frame.

Most silks of low to medium quality are weighted with tin before being dyed, and consequently require special treatment in the finishing.

After dyeing, the fabric is dried and then passed through rollers running in the "finishing mixture." This consists of oils, fats, glycerine, and other substances designed to soften the cloth, impart brightness, and bring out the inherent qualities of silk. With the finishing

mixture in it, the cloth is stretched out on the Stenter frame and dried by heat whilst being held taut. The frame is adjusted so that the fabric can be stretched out in the length or width whilst drying. The cloth, which is then somewhat stiff, is passed through "calender" rollers which break down the finishing substances and give the cloth a soft, supple handle. The finish of silks can be varied in stiffness or brightness according to the purpose for which they are to be used. At the same time it will be appreciated that the style of weave will to a large extent govern the ultimate appearance of the cloth. A closely-woven cloth will look different from one with a more open weave and, furthermore, the latter will take up more tin weighting. If a *crêpe de Chine* contains more weft threads (highly twisted) per inch than warp threads, the cloth will not be so bright as a cloth in which the warp (loosely twisted) predominates. Plain silks do not, of course, shrink so much in the finishing as crêped cloths.

### **Silk Weighting.**

In recent years the weighting of silk fabrics has become a general practice and has made it possible to produce a cloth with the appearance, handle, weight, and draping qualities of an expensive silk, but at a price within the reach of a much wider consuming public. Providing the weighting is not carried to excess, no real harm is done, but as silk will take up about twice its weight in metal there was for a time considerable abuse of this curious property of silk.

To-day, practically all silks of low to medium quality are weighted (also described as "loaded" or "charged"), chiefly with tin. Silk manufacturers have realized the harm done to their trade by excessively weighted silks quickly becoming weak, and the weighting is now controlled within safe limits.

The most usual method is with tin salts, and is carried out as follows—

The woven silk fabric is boiled off in a soap solution to remove most of the gum, rinsed out, and then passed through a cold solution of bichloride of tin. It is next passed through a bath of pure water, in which tin oxide forms on the silk. The next bath, which is hot, contains phosphate of soda, which turns the tin oxide to a tin phosphate. A weak acid bath neutralizes the phosphate, leaving the tin in the silk. In order to "fix" the tin the cloth then goes through a bath of silicate of soda. When the piece is dyed, part of the weighting matter comes out, but it is fast to subsequent washing.

Other weighting media which are not widely used are aluminium, iron, and chromium. The logwood dye used for blacks also adds weight.

Weighted silks will not last so long as pure silks. In time the action of air, sun, and heat will rot the fabric, the length of service depending on the amount of charge.

Perspiration and sea air also affect weighted silks in time, but under modern conditions of cheap fabrics and changing fashions, moderately-weighted silks give satisfactory wear for a sufficient length of time and the added advantage of an attractive fabric at a reasonable price. Weighting also prevents the threads from "slipping" at the seams of garments or at other places where this is likely to occur.

Silks which are to be used for embroidery purposes should always be more lightly loaded than ordinary dress fabrics, because of the extra strain to which the cloth is put in the embroidery machines.

### THE FINISHING OF COTTON

The finishing of cotton is a complicated and highly developed section of the trade, and the many processes



vary according to the type of cloth and the purpose for which it is to be used. They have as their object the improvement of the appearance of the cloth, the modification of the handle, and sometimes the increase of its strength and weight. Some cheap types of cotton cloth may consist almost entirely of filling, whilst others depend for their appearance upon careful treatment by lengthy calendering processes.

The materials used for filling and weighting differ according to the type of finish required, but in the main consist of wheat starch, potato or rice starch, china clay, and tallow. Common salt, borax, or alum is used to impart the crisp handle required in some cloths, whilst Glauber's salt is added if the cloth is to finish up with a high lustre. In order to produce softness, fats are used.

Mercerization is one of the important finishing processes for cotton, and produces a silky appearance as well as improving the dyeing properties.

The following are the principal processes—

### **Singeing or Gassing.**

The cloth is passed over hot plates to burn off any loose or projecting fibres and to give a clean appearance. This applies particularly to lace, net, and open fabrics.

### **Raising and Shearing.**

For flannelettes and similar cloths requiring a brushed surface. The surface fibres are raised by means of rollers covered with a special kind of wire card clothing.

### **Starching.**

To stiffen the fabric or fill up the interstices between the threads.

### **Calendering.**

Machines consisting of two heavy rollers similar to a mangle, which may be heated. There are various types

of calenders. In some cases the rollers are engraved with very fine lines on the surface, which causes the surface of the cloth to be stamped with impressions of the lines, thereby giving a highly lustrous finish (*Schreinered*).

### **Embossing.**

This is carried out by a method similar to schreinerer, with engraved rollers.

### **Stentering and Stretching.**

This process is much the same in all textile fabrics, and has already been described under the headings of wool and silk finishing.

### **Beetling.**

The "beetling" machine contains a number of wooden-headed hammers which give the fabric a rapid succession of blows. This helps to consolidate the cloth and beats in the filling, closing up the interstices of the weave.

### **Back-filling.**

Some fabrics are starched on one side and these are described as "back-filled." The starch is applied to one side only, by means of a roller running in the mixture.

### **Fireproofing ("Non-Flam").**

Cotton fabrics of light texture (such as muslins, tulle, etc.), and those with a raised fibrous surface (e.g. flannel-ettes) easily catch fire if brought into contact with a flame, and sometimes means are adopted to resist this as far as possible. Particularly in the case of theatrical clothing and drapings is it necessary to avoid the danger of fire, which would very quickly spread. It should be understood that up to the present it has not been possible to render cotton *absolutely* fireproof, only to slow

up the action and prevent the fabric from flaring up rapidly.

There are several methods of varying degrees of effect, but with many the proofing material will not withstand washing. For instance, a quick method of rendering cotton non-inflammable is by soaking in a solution of ammonium sulphate and drying. This will, however, come out in the first washing. The most satisfactory method consists of precipitating the substance on the cloth in an insoluble state.

A popular process is by treating first with stannate of soda and, when thoroughly impregnated, drying over heated drums. The fabric is next passed through a solution of ammonium sulphate, squeezed, and dried once again. Stannic oxide is precipitated on the cloth, leaving sodium sulphate, which is washed out. After drying, the fabric can then be finished off in the usual way. This treatment is fast to washing and gives fair protection from flame.

Other methods entail the use of silicate of soda, tungstate of soda, alum, borax, ammonium carbonate, etc., in different combinations and proportions.

Some methods of treatment affect the appearance, handle, and properties of the cloth, and may even make the cloth liable to become weak if subjected to heat, such as ironing. Great care must therefore be taken that in attempting to avoid one disadvantage the cloth does not acquire another.

#### THE FINISHING OF LINEN

Linen is finished in a similar manner to cotton, except that, being a naturally better-class fibre and cloth, it does not require so much artificial aid in providing a pleasing appearance. The filling and starching of cotton usually has as its object the imitating of linen.

## THE FINISHING OF RAYON

To some extent rayon cloths are finished in a similar manner to silk, except that it is not the practice to load rayons with metallic compounds. Due regard must be given to the characteristic weakening of rayon while in a damp state, and the treatment must be modified accordingly. The cloth, after bleaching or dyeing, is dried, conditioned, treated with a finishing mixture composed of gums, oils, glycerine, etc., and after being stretched on a tenter frame it is taken through one or more calendering machines. In the past few years great strides have been made in experimenting with new finishes for rayons, and to-day almost any degree of lustre or dullness can be obtained. The delustring of rayon is now an established part of some finishing processes, and it is quite possible to see the same rayon cloth in several totally different finishes, both as regards handle and appearance.

**Delustring.**

Rayon is naturally lustrous and modern taste requires this lustre to be reduced. The thinner the diameter of the fibre the less surface there is to reflect light, and consequently the lower the lustre. One solid fibre of 100 denier count would be considerably more lustrous than 5 fibres of 20 deniers twisted together to give the same count.

Various chemical methods are used to reduce lustre. Unfortunately these processes have other effects on the fibres. The laundering of acetate fibres which have been delustred by boiling is far more difficult than that of lustrous material. As a rule, delustring on viscose is more permanent. The boiling of acetate affects the actual substance of the fibre, and the surface becomes pitted with minute marks which may be seen under the

microscope and in the cross-section. Delustred acetate may be relustred by acetic acid.

Material delustred by means of soap solutions is slightly weaker than lustrous material. The great disadvantage of delustring acetate rayon by soap solutions is the difficulty of ironing without reviving the lustre. If the material is sprinkled with water before ironing, the lustre is restored in patches. Ironing in a dry state would not remove the creases. Other methods of delustring acetate are—

1. By a solution of phenol.
2. By a solution of acetone and water, not too strong, as it would dissolve the rayon.
3. By acetone and xylene (a solvent) at high temperature. The rayon is impregnated or sprayed.
4. By dilute nitric acid. (This affects the strength of the fibre.)

Lustre can also be reduced by rubbing the surface with rough material, but this also reduces the strength of the fibre.

The most permanent delustring effect on acetate and viscose is obtained by including various constituents in the spinning dope. Barium sulphate is deposited on viscose in this manner, in order to reduce the lustre of the finished yarn.

White pigments, such as titanium oxide (acetate), and also oil (viscose) have been used. With pigments, care must be taken not to block the spinning jets. Under the microscope the particles of pigment can clearly be seen embedded in the fibre, not only on the surface. These scatter the light rays by breaking up the smoothness of the surface. This also reduces the strength of the fibre.

If fabrics of low lustre are dyed black, or in a dark colour, they appear to regain their lustre. This is due to optical effects. The black dye absorbs all the light which

passes through the fibre and the broken surface is no longer effective.

Low lustre in rayon is therefore almost entirely a physical effect.

#### ANTI-CREASE PROCESS FOR COTTON AND RAYON <sup>1</sup>

One of the most recent developments is an additional finishing process which is claimed to reduce the susceptibility to creasing of cotton, linen, and viscose rayon. Fabrics made from vegetable fibres all suffer from this defect, and one of the principal disadvantages of rayon as compared with silk is the fact that garments made of rayon crease badly as soon as worn. An important British textiles manufacturing firm have been conducting experiments to get over this trouble and they have now discovered a method of overcoming the defect by impregnating the fibres with a synthetic resin in such a way that the material is actually deposited inside the fibres. This process is carried out after bleaching, dyeing or printing the fabric, and is therefore one of the final finishing processes.

As a result the fabric is less liable to crease, and when crushed recovers more fully its original condition. In addition, the strength of viscose rayon is considerably improved, both in the wet and dry state.

The addition of resin increases the weight of the fabric, and the manufacturers state that they consider 15 per cent increase a good average figure. It is suggested that the process would also be useful as a medium for loading silks. At present the process is not being applied to acetate rayon, but cotton and viscose fabrics of the improved types are already on the market.

The following is a summary of the principal advantages claimed by the manufacturers—

<sup>1</sup> From information supplied by Messrs. Tootal, Broadhurst, Lee.

1. Woven and knitted fabrics of cellulose material can be made more nearly like wool or silk in their resistance to and recovery from creasing, without detracting from their draping qualities or handle.

2. The strength of viscose rayon is increased, particularly in the wet state. The latter point means that they will be less liable to damage in the laundry.

3. The weight of the fabric is increased by an average of 15 per cent.

4. There will be less tendency for rayon yarns in a fabric to slip—one of the disadvantages associated with all rayon fabrics.

5. Shrinkage as a result of laundry operations is reduced.

6. Rayon fabrics and garments are rendered less liable to stretch out of shape, as the extensibility is reduced.

7. In the case of fabrics composed of spun viscose (staple fibre), the individual cut fibres are more firmly held as a result of the anti-crease process.

It is interesting to note that, although the word "creaseless" has been used in the Press in connection with the process, this is not claimed by the company, as completely creaseless materials would not have the requisite textile properties. The new property is briefly described by the inventors as "a combination of resistance to and recovery from creasing."

## CHAPTER XXIII

### CALENDAR OF TEXTILES HISTORY

#### B.C.

- 8000. Spinning and weaving practised during the first period of Egyptian civilization.
- 5000. According to Chinese tradition silk culture was first taught in that country.

#### A.D.

- 400 (about). Silk culture introduced into Japan and India.
- 550 (about). Silk culture introduced into Europe.
- 1200 (about). Cultivation of silkworms and manufacture of silk commenced in Italy.
- 1561. Pillow lace invented.
- 1685. The Huguenots (including many textiles workers) driven from France and settled in England.
- 1696. Calico printing first introduced into England.
- 1733. Invention of the fly shuttle by John Kay.
- 1738. Invention of mechanical carder by Lewis Paul.
- 1750. Brussels carpet weaving introduced into England.
- 1755. Axminster carpets first woven in England.
- 1764. Invention of spinning jenny by James Hargreaves.
- 1767. Invention of roller spinning frame by Arkwright.
- 1779. Invention of spinning mule by Samuel Crompton.
- 1782. James Watt patented the steam engine.
- 1785. Invention of power loom by Edmund Cartwright.
- 1793. Invention of saw gin for cotton by Eli Whitney.
- 1798. Jacquard loom appliance perfected.
- 1808. Invention of first lace machine for making bobbin net by John Heathcoat.
- 1813. Invention of a different type of lace machine by John Levers.
- 1832. Jute manufacture established in Dundee.
- 1845. Ramie first introduced into England.
- 1850. John Mercer patented his mercerizing process.
- 1856. Discovery by Perkin of aniline, the basis for many synthetic dyes.
- 1884. Count Chardonnet took out a patent for the preparation of nitro-cellulose.
- 1892. Cross and Bevan took out patent for viscose.
- 1904. Courtaulds commenced the manufacture of viscose rayon.
- 1911. Dreyfus took out a patent for the manufacture of cellulose acetate.





# INDEX

- ALPACA, 97  
Artificial horsehair, 78  
— silk (see Rayon)
- BAVE, 53  
Beard needle, 158  
Bleaching, 183 *et. seq.*  
— cotton, 183  
— linen, 184  
— rayon, 185  
— silk, 185  
— wool, 184  
Boll weevil, 9  
— worm, 9  
Bombax cotton, 46  
Brin, 53  
Burning test, 125
- CALENDAR of textiles history, 217  
Calico printing, 194  
— —, direct method, 196  
— —, discharge, 196  
— —, dyed style, 196  
— —, dyes used, 197  
— —, resist, 196  
Camel hair, 95, 132  
Cap frame, 118  
Card clothing, 21  
Carding, 20, 108, 109  
Carpets, 169  
Cashmere, 100, 133  
Celta, 75  
Chenille yarn, 156  
Combing, 21, 110  
Conditioning, 122  
Cotton, 8  
  carding, 20  
  combing, 21  
  composition, 8  
  counts, 32  
  drawing, 21  
  examination, 127  
  growth, 8  
  intermediate frame, 23  
  mixing and blending, 18  
  roving, 23  
  scutcher machine, 20  
  slubbing, 23  
  sources of supply, 9  
  spinning, 24
- Crossieur, 56  
Cross-sections, mounting for  
  microscope, 125
- DELUSTRING of rayon, 213  
Doubling, 29  
Drawing frame, 21  
Dumb singles, 60  
Dye faults, 192  
— tests, 192  
Dyes and dyeing, 186
- EXTRACT wools, 116
- FABRICS, glossary, 172  
Fibres, animal, 4  
—, characteristics, 6  
—, vegetable, 4  
Fibroin, 53  
Finishing of textiles, 209  
  cotton, 209  
  linen, 212  
  rayon, 213  
  silk, 207  
  wool, 200  
Fireproofing, 211  
Flax, 34  
  composition, 40  
  cut line, 35  
  growth, 34  
  preparatory processes, 35  
  sources of supply, 34  
  spinning, 38  
  tow, 35, 40  
Floss silk, 61  
Flyer, 39, 117
- GASSING, 31  
Gauze structure, 156  
Ginning, 16  
  Macarthy gin, 18  
  Saw gin, 17  
Guanaco, 99
- HEALDS, 141, 142  
Hemp, 44  
Hog wool, 88  
Horsehair, 102  
Hosiery, 159

- JACQUARD looms, 148  
 Jute, 43, 129
- KAPOK, 46, 128  
 Kemps, 84  
 Knitted fabrics, 157
- LACE net, 164  
 Latch needle, 158  
 Lignocellulose, 44, 47, 128  
 Linen, examination of, 128  
 Llama, 97  
 Loaded silks, 134, 208  
 Loom, action of the, 142
- MANILA hemp, 45  
 Mercerized cotton, 32  
 ——— wool, 207  
 Microscope, examination of fibres, 125  
 Milanese, 161  
 Mixtures, tests for, 133  
 Mohair, 99  
 Mule, cotton, 26  
 ———, wool, 119  
 Multivoltine, 53  
 Mungo, 115
- NET, lace, 164  
 New Zealand flax, 46  
 Noils, 82, 116
- ORGANZINE, 61
- PINEAPPLE fibre, 46  
 Pita fibre, 45  
 Point paper, 152  
 Printing, 194
- RABBIT fur, 102, 133  
 Ramie, 41  
 examination of, 129  
 preparation, 41  
 sources of supply, 41  
 Rayon, 62  
 acetate, 68, 130  
 artificial horsehair, 78  
 Chardonnet, 63  
 commercial varieties, 71  
 counts, 80  
 Cross and Bevan, 63  
 cuprammonium, 69, 131  
 examination, 130  
 history of production, 63  
 method of production, 66  
 nitro-cellulose, 70, 131
- Rayon (*contd.*)—  
 raw materials, 66  
 spinning, 71  
 staple fibre, 76  
 uses, 79  
 viscose, 66, 130  
 world production, 64
- Reed, 143  
 Regain of moisture, 122  
 Retting, 36  
 Ring frame, 24, 117  
 Roving frame, 23, 112
- SCHAPPE silk, 61  
 Semi-worsted, 113  
 Sericulture, 48  
 Serecin, 53  
 Shedding, 142  
 Shoddy, 115  
 Silk, 48  
 cocoons, 52  
 counts, 59  
 diseases of silkworms, 54  
 examination, 129  
 origin, 48  
 preparation of raw silk, 55  
 reeling faults, 56  
 throwing, 57  
 varieties of moths, 49  
 world production, 48
- Sisal hemp, 45  
 Skin wools, 102  
 Sleying, 142  
 Slipes, 103  
 Sniafil, 76  
 Spindle draft, 29  
 Spun silk, 59  
 Staple fibre, 76
- TESTS, 125  
 Topham box, 72  
 Tops, wool, 82, 85  
 Tram silk, 61
- UNIVOLTINE, 53  
 Unshrinkable process for wool, 204
- VEGETABLE silk, 47  
 Vicuna, 99
- WARPING, 141  
 Waterproofing, 206  
 Weaving, 139  
 action of loom, 142  
 jacquard, 148

- Weaving (*contd.*)—**  
preparatory processes, 141  
standard types of weave, 152
- Wool—**  
carbonization, 105  
diameter of fibre, 81  
examination, 131  
preparation for spinning, 107  
remanufactured, 114  
rubbings, 88  
scales, 83  
scouring, 104
- Wool (*contd.*)—**  
sources of supply, 86  
spinning, 116  
yarn counts, 119  
yield, 86  
Wool exchanges, 95  
Woollens, 108  
Worsted, 109
- YARNS, fancy, 120**  
Yolk, wool, 85



# A SELECTION FROM THE LIST OF COMMERCIAL HANDBOOKS

PUBLISHED BY  
**SIR ISAAC PITMAN & SONS, LTD.**

The following Catalogues will be sent post free on application: COMMERCIAL, EDUCATIONAL, TECHNICAL, LAW, SHORTHAND, FOREIGN LANGUAGES, ARTS and CRAFTS, and GENERAL

*Obtainable through any Bookseller or direct from the Publishers*

**LONDON:** PITMAN HOUSE, PARKER STREET, KINGSWAY, W.C.2  
**BATH:** The Pitman Press. **MELBOURNE:** Pitman House, Little Collins Street.

*Associated Companies*

**NEW YORK:** Pitman Publishing Corporation, 2 West 45th Street.  
**CHICAGO:** 205 West Monroe Street  
**TORONTO:** Sir Isaac Pitman & Sons (Canada), Ltd., (Incorporating the Commercial Text Book Company) 381-383 Church Street.  
**INDIA:** A. H. Wheeler & Co., Hornby Road, Bombay; 11 Clive Street, Calcutta; and 15 Elgin Road, Allahabad.

*The Prices contigned in this List apply only to Great Britain.*

## CONTENTS

	PAGE		PAGE
ADVERTISING AND COMMERCIAL ART . . . . .	20-21	ENGLISH AND COMMERCIAL CORRESPONDENCE . . . . .	8-9
ARITHMETIC, ETC. . . . .	2	FOREIGN LANGUAGES . . . . .	29
"ART AND LIFE" SERIES . . . . .	28	GEOGRAPHY AND HISTORY . . . . .	9-10
BANKING AND FINANCE . . . . .	11-13	INCOME TAX . . . . .	15-16
BOOK-KEEPING AND ACCOUNTANCY . . . . .	3-5	INDUSTRIAL ADMINISTRATION . . . . .	17-18
BUSINESS ORGANIZATION AND MANAGEMENT . . . . .	18-19	INSURANCE . . . . .	13-15
CAREERS . . . . .	6	LAW . . . . .	23-25
CIVIL SERVICE . . . . .	6-7	MUNICIPAL WORK . . . . .	19-20
COMMERCE, ETC. . . . .	7-8	REFERENCE BOOKS . . . . .	26-27
COMMON COMMODITIES AND INDUSTRIES . . . . .	31-32	SALESMANSHIP . . . . .	21-22
"ECONOMICS SERIES" . . . . .	27-28	SECRETARIAL WORK, ETC. . . . .	16-17
ECONOMICS . . . . .	10-11	SHIPPING . . . . .	15
		SHORTHAND . . . . .	30
		TRANSPORT . . . . .	22-23
		TYPEWRITING . . . . .	30-31

## ARITHMETIC, ETC.

	PRICE
<b>Arithmetic and Accounts</b>	
By NORMAN ROGERS, M.Com., and REGINALD W. WALLS, B.Sc., B.Com., etc. . . . .	2/6
Answers . . . . . Net	3/6
<b>Arithmetic and Book-keeping</b>	
By THOS. BROWN, F.S.S., and VINCENT E. COLLINGE	2/6
<b>Arithmetic Class Book</b> By W. R. BARHAM, L.C.P.	2/6
<b>Arithmetic Class Book</b>	
Advanced. By W. R. BARHAM . . . . .	3/6
<b>Arithmetic Exercises for Professional Examinations</b> By W. BENNETT, M.Sc. . . . .	2/-
<b>Arithmetic for Grocers</b> By C. C. HARRINGTON . . . . .	2/-
<b>Arithmetic of Commerce</b>	
By P. W. NORRIS, M.A., B.Sc. (Hons.) . . . . .	3/6
<b>Business Calculations</b> By F. HEELIS . . . . .	2/-
<b>Commercial Mathematics</b>	
By L. H. L. DAVIES, B.A., and E. G. H. HABAKKUK . . . . .	5/-
<b>Complete Business Arithmetic.</b> Revised by IVOR T. PLANT . . . . .	4/-
Answers . . . . . Net	2/6
<b>Complete Mercantile Arithmetic</b>	
By H. P. GREEN, F.C.Sp.T. (With Key) . . . . .	6/-
<b>Concise Senior Commercial Arithmetic</b>	
By W. CHANIN, M.R.S.T. . . . .	4/-
<b>First Year Commercial Mathematics</b>	
By H. HARMAN, B.Com. . . . .	2/6
With Answers . . . . .	3/6
<b>Logarithms in Commerce</b> By W. CHANIN, M.R.S.T.	2/-
<b>Logarithms Simplified</b>	
By ERNEST CARD, B.Sc., and A. C. PARKINSON, A.C.P. . . . .	2/-
<b>Modern Arithmetic Course</b> By E. N. MOTTS . . . . .	3/6
<b>Practical Commercial Arithmetic</b>	
By H. WATSON, B.Sc. (Econ.) . . . . .	4/-
<b>Principles and Practice of Commercial Arithmetic</b> By P. W. NORRIS, M.A., B.Sc. . . . .	7/6
<b>Rapid Methods in Arithmetic</b>	
By JOHN JOHNSTON. Revised and Edited by G. K. BUCKNALL, A.C.I.S. . . . . Net	1/-
<b>Slide Rule Applied to Commercial Calculations, The</b> By R. M. SHIREBY . . . . . Net	2/6

## BOOK-KEEPING AND ACCOUNTANCY

	PRICE
<b>Accountancy</b>	
By WILLIAM PICKLES, B.Com. (Vict.), F.C.A., A.S.A.A. (Hons.). Key 12/6 . . . . .	15/-
<b>Accountants' Dictionary</b>	
Edited by F. W. PIXLEY, F.C.A. In Two Vols. Net	67/6
<b>Accounts of Executors, Administrators, and Trustees</b>	
By WILLIAM B. PHILLIPS, F.C.A., A.C.I.S. Revised by F. T. WRIGHT, A.C.A. . . . .	5/-
<b>Advanced Accounts</b>	
Edited by ROGER N. CARTER, M.Com., F.C.A. . . . .	7/6
<b>Key to Advanced Accounts</b>	
By R. A. GOODMAN . . . . .	20/-
<b>Advanced Book-keeping Exercises for Commercial Schools</b>	
By A. J. FAVELL, B.Sc. (Econ.), A.C.I.S. . . . .	2/6
<b>Audit Programmes</b>	
By E. E. SPICER, F.C.A., and E. C. PEGLER, F.C.A. Net	4/6
<b>Book-keeping, A Course in</b>	
By R. W. HOLLAND, O.B.E., M.A., M.Sc., LL.D. . . . .	4/-
<b>Book-keeping, Advanced</b>	
By HENRY J. CLACK, F.C.R.A., F.R.S.A. . . . .	4/-
<b>Book-keeping for Beginners</b>	
By W. E. HOOPER, A.C.I.S. . . . .	2/-
<b>Book-keeping for Retail Classes</b>	
By JOHN MILLER ANDERSON, F.L.A.A. . . . .	5/-
<b>Book-keeping for Retailers</b>	
By H. W. PORRITT and W. NICKLIN, A.S.A.A. Net	2/-
<b>Book-keeping, Stage I</b>	
By A. J. FAVELL, B.Sc. (Econ.), A.C.I.S. . . . .	2/-
<b>Book-keeping, Stage II</b>	
By A. J. FAVELL, B.Sc. (Econ.), A.C.I.S. . . . .	2/6
<b>Book-keeping, Modern Methods of</b>	
By R. H. EPPS, <i>Chartered Accountant</i> . . . . .	4/6
<b>Builders' Accounts and Costs</b>	
By ROBERT G. LEGGE . . . . . Net	3/6



## Book-keeping and Accountancy—contd.

	PRICE
<b>Business Accounts</b>	
By L. A. TERRY, B.Com. and W. T. SMITH, M.Com. . . . .	3/6
<b>Business Accounts and Finance</b>	
By W. CAMPBELL, <i>Chartered Secretary</i> . . . . . Net	1/-
<b>Business Book-keeping</b>	
By J. ROUTLEY . . . . .	3/6
<b>Key to Business Book-keeping</b>	
By R. A. GOODMAN . . . . . Net	8/6
<b>Company Accounting</b>	
By H. A. R. J. WILSON, F.C.A., etc. . . . . Net	12/6
<b>Company Accounts</b>	
By ARTHUR COLES. Revised by W. C. WOOD, A.C.I.S. . . . . Net	10/6
<b>Constructing Accounts from Deficient Records</b>	
By W. J. BACK . . . . . Net	5/-
<b>Cost Accounting, The Fundamentals of Process</b>	
By L. A. WIGHT, A.C.W.A. . . . . Net	7/6
<b>Cost Accounts in Principle and Practice</b>	
By A. CLIFFORD RIDGWAY, F.C.A. . . . . Net	5/-
<b>Cost Accounts for the Metal Industry</b>	
By H. E. PARKES, M.Com., A.C.W.A. . . . . Net	10/6
<b>Cost Accounts in Rubber and Plastic Trades</b>	
By T. W. FAZAKERLEY . . . . . Net	5/-
<b>Costing and Price Fixing</b>	
By J. M. SCOTT MAXWELL, B.Sc., F.C.W.A. . . . . Net	6/-
<b>Costing, A Primer of</b>	
By R. J. H. RYALL, F.C.R.A. . . . .	5/-
<b>Costing, Dictionary of</b>	
By R. J. H. RYALL . . . . . Net	12/6
<b>Costing, Theory and Practice of</b>	
By E. W. NEWMAN, F.C.A. . . . . Net	8/6
<b>Currency Accounts in Sterling Books</b>	
By C. RALPH CURTIS, <i>Fellow of the Institute of Bankers</i> . . . . . Net	2/6
<b>Depreciation and Wasting Assets</b>	
By P. D. LEAKE, F.C.A. . . . . Net	15/-
<b>Dictionary of Book-keeping, Pitman's</b>	
By R. J. PORTERS, F.C.R.A. . . . . Net	5/-

## Book-keeping and Accountancy—contd.

	PRICE
<b>Elementary Graded Book-keeping Exercises</b> By A. J. FAVELL, B.Sc., A.C.I.S. . . . .	1/-
<b>Full Course in Book-keeping</b> By H. W. PORRITT and W. NICKLIN, A.S.A.A. . . . .	5/-
<b>Graded Book-keeping Exercises for Commercial Schools</b> By A. J. FAVELL, B.Sc., A.C.I.S. . . . .	2/-
<b>Goodwill, A New Theory of</b> By H. KANER, B.Sc., A.S.A.A. . . . . Net	5/-
<b>Hotel Book-keeping</b> By M. E. PITCHER . . . . .	2/6
<b>Investigations : Accountancy and Financial</b> By J. H. BURTON . . . . . Net	5/-
<b>Manual of Cost Accounts</b> By H. JULIUS LUNT, F.C.A., F.C.I.S., F.C.W.A. and A. H. RIPLEY, F.C.W.A. . . . .	8/6
<b>Modern Methods of Stock Control</b> By N. GERARD SMITH, M.I.P.E. . . . . Net	3/6
<b>National Defence Contribution</b> By H. E. SEED, A.C.A., A.S.A.A. . . . . Net	7/6
<b>Principles and Interpretation of Accounts</b> By H. L. ELLIS, M.Com. . . . .	3/6
<b>Principles of Accounts</b> By J. STEPHENSON, M.A., M.Com., D.Sc. . . . . Part I	3/6
Part II . . . . .	5/-
<b>Principles of Auditing</b> By F. R. M. DE PAULA, O.B.E., F.C.A. . . . .	8/6
<b>Principles of Bank Book-keeping</b> By HERBERT G. HODDER, Cert. A.I.B. . . . . Net	5/-
<b>Secretarial Book-keeping and Accounts</b> By H. E. COLESWORTHY, A.C.A., A.S.A.A.. . . . . Net	5/-
<b>Charles's Elementary Book-keeping</b> By F. F. CHARLES, F.S.A.A., F.C.I.S. . . . .	2/6
<b>Sinking Funds, Reserve Funds, and Deprecia- tion.</b> By J. H. BURTON . . . . . Net	3/6
<b>Trade Union Accounting and Financial Ad- ministration</b> By A. E. WARD and C. R. SWEETINGHAM . . . . . Net	3/6

## CAREERS

	PRICE	
<b>Dictionary of Careers</b>		
By L. H. TURNER, M.R.S.T. . . . .	Net	3/6
<b>Banking as a Career</b>		
By F. A. WILLMAN, Cert. A.I.B. . . . .	Net	3/6
<b>Commercial Art as a Career</b>		
By CECIL WADE . . . . .	Net	5/-
<b>How to Become an Auctioneer and Estate Agent.</b>		
By W. F. NOKES, F.A.I. Revised by D. McINTYRE, B.A., LL.B. . . . .	Net	3/6
<b>How to Become a Company Secretary</b>		
By E. J. HAMMOND . . . . .	Net	3/6
<b>How to Become a Private Secretary</b>		
By J. E. McLACHLAN, F.I.P.S. (Hons.) . . . . .	Net	2/6
<b>How to Become a Qualified Accountant</b>		
By R. A. WITTY, F.S.A.A. . . . .	Net	3/6
<b>How to Choose Your Career</b>		
By W. LESLIE IVEY, M.C., M.S.M.A. . . . .	Net	3/6
<b>How to Secure a Good Job</b>		
By W. LESLIE IVEY, M.C., M.S.M.A. . . . .	Net	3/6
<b>How to Secure Promotion</b>		
By W. LESLIE IVEY, M.C., M.S.M.A. . . . .	Net	2/6
<b>Insurance as a Career.</b>	By F. H. SHERRIFF	Net 3/6
<b>Journalism as a Career</b>		
Edited by W. T. CRANFIELD . . . . .	Net	5/-

## CIVIL SERVICE

<b>Arithmetic for Civil Service Students</b>		
By T. H. TEARE, B.Sc., and F. W. TEARE, B.Sc. . . . .	4/-	
<b>Civil Service Guide</b>	By A. J. T. DAY . . . . .	Net 3/6
<b>Civil Service Essay Writing</b>		
By W. J. ADDIS, M.A. . . . .	2/-	
<b>Civil Service Shorthand Writers' Phrase Book</b>		
Compiled by ALFRED MARSHALL, P.C.T. . . . .	2/-	
<b>Civil Service Test Papers—English : Junior</b>		
By GORDON S. HUMPHREYS, M.A. . . . .	1/9	
<b>Civil Service Test Papers—English: Senior</b>		
By W. B. FARRER, M.A. . . . .	2/6	
<b>Civil Service Test Papers—French Clerical Class</b>		
By F. J. BARTLETT, B.A. (Lond.) . . . . .	2/6	
<b>Civil Service Test Papers—Geography</b>		
By R. J. FINCH, F.R.G.S. . . . .	2/6	
<b>Civil Service Test Papers—History</b>		
By W. R. McAULIFFE, B.A. . . . .	2/6	

## Civil Service—contd.

	PRICE
<b>Civil Service Test Papers—Mathematics :</b>	
<b>Clerical Class</b>	
By JAMES READER, B.A., B.Sc. With Answers . . . . .	2/6
<b>English for Civil Servants</b> By WALTER SHAWCROSS	2/6
<b>Mathematics for Civil Service Candidates</b>	
<b>Part I</b>	
By J. READER, B.A., B.Sc. and H. WATSON . . . . .	5/-
<b>Typewriting Examination Tests—Civil Service</b>	
By ALBERT POTTS and MAXWELL CROOKS . . . . .	5/-
<b>Women and the Civil Service</b>	
By DOROTHY EVANS, M.A. . . . . Net	3/6

## COMMERCE, ETC.

<b>Boy's Book of Business, The</b>	
By STANLEY TOWNSEND, LL.B. . . . .	3/-
<b>Business Handwriting.</b> By W. BURTON . . . . .	1/6
<b>Commerce and Accounts</b>	
By ALONZA JAMES, F.F.T.Com., F.R.Econ.S. . . . .	2/6
<b>Commerce for Commercial and Secondary Schools</b>	
By A. J. FAVELL, B.Sc. (Econ.), A.C.I.S. . . . .	3/6
<b>Commerce, Stage I</b>	
By A. JAMES, F.F.T.Com., F.R.Econ.S. . . . .	1/6
<b>Course in Business Economics and Commerce,</b>	
By F. P. TUSHINGHAM, B.Com.Sc. . . . .	3/-
<b>Day Commercial School, The</b>	
By C. H. KIRTON, F.F.T.Com. . . . . Net	7/6
<b>Manual of Business Training</b>	
By A. STEPHEN NOEL, F.R.Econ.S. . . . .	5/-
<b>Modern Business and Its Methods</b>	
By W. CAMPBELL, <i>Chartered Secretary</i> . . . . .	7/6
<b>Office Practice</b> By W. CAMPBELL,	3/6
<b>Office Training for Girls</b>	
By MARGARET RYAN . . . . . Net	3/6
<b>Principles and Practice of Commerce</b>	
By JAMES STEPHENSON, M.A., M.Com., D.Sc. . . . .	8/6
<b>Principles of Business</b>	
By JAMES STEPHENSON, M.A., M.Com., D.Sc.	
Part I, 2/6; Part II . . . . .	3/6
<b>Questions and Answers on Commerce. Stage I</b>	
By A. J. FAVELL, B.Sc. (Econ.), A.C.I.S. . . . .	2/6

## Commerce, etc.—contd.

	PRICE
<b>Questions and Answers on Commerce. Stage II</b>	
By A. J. FAVELL . . . . .	3/6
<b>Self-Promotion</b> By COURTNEY D. FARMER . . . . .	Net 2/6
<b>Theory and Practice of Commerce</b>	
Edited by G. K. BUCKNALL, A.C.I.S. (HONS. . . . .	7/6
<b>Wholesale and Retail Trade</b> By W. CAMPBELL . . . . .	2/6

## ENGLISH AND COMMERCIAL CORRESPONDENCE

<b>Business Letters in English</b>	
By W. J. WESTON, M.A., B.Sc. . . . .	3/6
<b>Commercial Correspondence and Commercial English</b> . . . . .	3/6
<b>Commercial Dictionary</b> . . . . .	Net 1/6
<b>Dictionary of Correct English, A</b>	
By M. A. PINK, M.A. . . . .	Net 2/6
<b>English and Commercial Correspondence</b>	
By H. NAGAOKA and D. THEOPHILUS, B.A. . . . .	3/6
<b>English Composition and Business Correspondence</b>	
By J. F. DAVIS, D.Lit., M.A., LL.B. (Lond.) . . . . .	Net 2/-
<b>English Course, Stage I</b>	
By JOHN BENNETT . . . . .	1/9
<b>English Exercises. A Book of Homonyms</b>	
By B. S. BARRETT . . . . .	3/6
<b>English for Commerce</b>	
By J. GURNEY LAWRIE, M.A. . . . .	2/-
<b>English for Commercial Students</b>	
By H. W. HOUGHTON, A.C.I.S. . . . .	2/-
<b>English Grammar and Composition</b>	
By W. J. WESTON, M.A., B.Sc. (Lond.) . . . . .	3/6
<b>English Mercantile Correspondence</b> . . . . .	3/6
<b>Guide to Commercial Correspondence</b>	
By W. J. WESTON, M.A., B.Sc. (Lond.) . . . . .	2/6
<b>Higher Business Correspondence</b>	
By R. Skelton . . . . .	Net 6/-
<b>How to Teach Commercial English</b> . . . . .	
By WALTER SHAWCROSS, B.A. . . . .	Net 3/6
<b>Improve Your English</b>	
By W. J. WESTON, M.A., B.Sc. . . . .	Net 7/6

## English and Commercial Correspondence—contd.

	PRICE
<b>Manual of Commercial Correspondence</b>	
By ROLAND FRY, B.Com. . . . .	3/6
<b>Manual of Commercial English</b>	
By WALTER SHAWCROSS, B.A. . . . .	3/6
<b>Manual of Punctuation.</b> By W. O. WEBSTER . . . . .	1/-
<b>New Era Spelling Manual.</b> By H. J. BOWER . . . . .	2/6
<b>Principles and Practice of Commercial Corre-</b> <b>spondence.</b> By J. STEPHENSON, M.A., M.Com. . . . .	6/-
<b>Punctuation as a Means of Expression</b>	
By A. E. LOVELL, M.A. . . . . Net	1/-
<b>Self-Expression in English</b> By JOHN BENNETT . . . . .	2/-
<b>Standard English</b>	
By EDWARD H. GROUT, B.Sc., A.C.I.I. . . . . Net	7/6
<b>Synonyms and Antonyms</b> . . . . . Net	2/6
<b>Textbook of English for Foreign Students</b>	
By W. O. VINCENT . . . . .	6/-
<b>Using the King's English</b>	
By W. J. WESTON, M.A., B.Sc. . . . . Net	7/6

## GEOGRAPHY AND HISTORY

<b>Commercial Atlas of the World, Pitman's</b> Net	5/-
<b>Commercial Geography of the British Isles</b>	
By W. P. RUTTER, M.Com. . . . .	4/6
<b>Commercial Geography of the World</b>	
By W. P. RUTTER, M.Com. . . . .	6/-
<b>Economic Geography</b>	
By John McFARLANE, M.A., M.Com. . . . .	10/6
<b>Economic Geography, The Principles of</b>	
By R. N. RUDMOSE BROWN, D.Sc. . . . .	6/-
<b>Economic History of England</b>	
By H. O. MEREDITH, M.A., M.Com. . . . .	7/6
<b>Elements of Commercial History</b>	
By FRED HALL, M.A., B.Com., F.C.I.S. . . . .	2/-
<b>Geography of Commerce, The</b>	
By W. P. RUTTER, M.Com. . . . .	5/-
<b>History of Commerce, The</b>	
By T. G. WILLIAMS, M.A., F.R.Hist.S., F.R.Econ.S. . . . .	3/6
<b>Main Currents of Social and Industrial Change</b> <b>Since 1870</b>	
By T. G. WILLIAMS, M.A. . . . . Net	5/-

## Geography and History—contd.

	PRICE
<b>Principles of Commercial History</b>	
By J. STEPHENSON, M.A., M.Com., D.Sc. . . . .	5/-
<b>Rise of British Commerce, The</b>	
By K. G. LEWIS, B.A., and N. BRANTON . . . . .	3/6
<b>Statistical Atlas of the World, A</b>	
By J. STEPHENSON, M.A., M.Com., D.Sc. . . . .	Net 7/6

## ECONOMICS

<b>Dictionary of Economic and Banking Terms</b>	
By W. J. WESTON, M.A., B.Sc., and A. CREW . . . . .	Net 5/-
<b>Economics for Business Men</b>	
By W. J. WESTON, M.A., B.Sc. . . . .	Net 3/6
<b>Economics of Private Enterprise, The</b>	
By J. H. JONES, M.A. . . . .	7/6
<b>Economics of Production and Exchange</b>	
By JAMES STEPHENSON, M.A., M.Com., D.Sc.; and N. BRANTON, B.Com. . . . .	7/6
<b>Economics of the Import and Export Trade</b>	
By HIROMU NAGAOKA . . . . .	5/-
<b>Economics of the Industrial System</b>	
By H. A. SILVERMAN, B.A. . . . .	Net 7/6
<b>Economics of the Wholesale and Retail Trade</b>	
By JAMES STEPHENSON, M.A., M.Com., D.Sc. . . . .	5/-
<b>Elements of Political Economy</b>	
By H. HALL, B.A. . . . .	2/-
<b>Exercises in Economics</b>	
By A. PLUMMER, B.Litt., M.Sc. (Econ.), LL.D. . . . .	2/-
<b>Guide to Economics</b>	
By F. H. SPENCER, D.Sc., LL.B. . . . .	3/6
<b>International Combines in Modern Industry</b>	
By ALFRED PLUMMER, B.Litt., M.Sc. (Econ.), LL.D. . . . .	Net 7/6
<b>International Organization</b>	
By R. YORKE HEDGES, LL.D. . . . .	Net 10/6
<b>International Trade and Tariffs, An Introduction to</b>	
By R. A. HODGSON, B.Com. (Lond.) . . . . .	Net 6/-
<b>Introduction to Business Economics</b>	
By J. STEPHENSON, M.A., M.Com., D.Sc. . . . .	3/6

## Economics—contd.

PRICE

<b>New British Industries in the Twentieth Century</b>	
By ALFRED PLUMMER, B.Litt., M.Sc. (Econ.), A.S.A.A.	Net 15/-
<b>Substance of Economics, The</b>	
By H. A. SILVERMAN, B.A. (Econ.)	6/-
<b>Tourist Industry, The</b>	
By A. J. NORVAL	Net 12/6

## BANKING AND FINANCE

### Answers to Questions Set at the Examinations of the Institute of Bankers

By L. L. M. MINTY, Ph.D., B.Sc., Econ., B.Com.		
Foreign Exchange. Part I & Part II	Each	Net 3/6
Economics. Part I	Net	5/-
English Grammar and Composition. Part I	Net	3/6
" " " "	Part II	Net 5/-

### Balance Sheets : Explained, Analysed, and Classified

By H. KANER, B.Sc., A.S.A.A.	Net 7/6
------------------------------	---------

### Balance Sheets: How to Read and Understand Them

By PHILIP TOVEY, F.C.I.S.	Net 3/6
---------------------------	---------

### Banker as a Lender, The

By F. E. STEELE	Net 5/-
-----------------	---------

### Bankers and the Property Statutes of 1925 and 1926.

By R. W. JONES	Net 6/-
----------------	---------

### Bankers' Credits. BY W. F. SPALDING

Net 10/6

### Banker's Place in Commerce, The

By W. F. SPALDING	Net 3/6
-------------------	---------

### Bankers' Tests. BY F. R. STEAD

Net 10/6

### Banking for Advanced Students

By PERCY G. H. WOODRUFF	7/6
-------------------------	-----

### Bank Organization, Management, etc.

By J. F. DAVIS, M.A., D.Lit., LL.B. (Lond.)	Net 6/-
---	---------

### Bills, Bullion, and the London Money Market

By W. K. DUKE	Net 5/-
---------------	---------

### Bills of Exchange Acts, A Practical Examination of the.

By C. H. H. FENNELL	Net 7/6
---------------------	---------

### Book of the Stock Exchange

By F. E. ARMSTRONG	Net 10/6
--------------------	----------

### Capital Underwriting

By DAVID FINNIE, M.A., C.A.	Net 10/6
-----------------------------	----------



## Banking and Finance—contd.

	PRICE
<b>Dictionary of Banking.</b> By W. THOMSON . . . . .	Net 30/-
<b>Dictionary of the World's Currencies and Foreign Exchanges</b>	
By W. F. SPALDING . . . . .	Net 30/-
<b>Discount Market in London, The</b>	
By H. W. GREENGRASS . . . . .	Net 6/-
<b>Economics of the English Banking System</b>	
By W. J. WESTON, M.A., B.Sc. . . . .	Net 2/6
<b>English Banking Methods</b>	
By L. LE M. MINTY, Ph.D., B.Sc., B.Com. . . . .	Net 10/6
<b>English Composition and Banking Correspondence</b>	
By L. E. W. O. FULLBROOK-LEGGATT, M.C., B.A. . . . .	3/6
<b>Finance, Concise Dictionary of</b>	
By W. COLLIN BROOKS . . . . .	Net 12/6
<b>Foreign Exchange and Foreign Bills in Theory and in Practice.</b> By W. F. SPALDING . . . . .	Net 10/6
<b>Foreign Exchange : An Introductory Outline</b>	
By H. C. F. HOLGATE, B.Sc. (Econ.), Honours Cert. A.I.B., etc. . . . .	Net 2/6
<b>Foreign Exchange, A Manual of</b>	
By H. E. EVITT, <i>Fellow of the Inst. of Bankers</i> , etc. . . . .	Net 7/6
<b>Foreign Exchange, A Primer of</b>	
By W. F. SPALDING . . . . .	Net 3/6
<b>Foreign Exchange, Introduction to the Practice of</b>	
By H. E. EVITT, <i>Fellow of the Institute of Bankers</i> . . . . .	Net 3/6
<b>Foreign Exchanges, Arithmetic and Practice of the.</b> By A. G. SUGG, Cert. A.I.B. . . . .	2/6
<b>Foreign Trade, The Finance of</b>	
By W. F. SPALDING . . . . .	Net 7/6
<b>Functions of Money.</b> By W. F. SPALDING . . . . .	Net 7/6
<b>Investment, A Short History of</b>	
By PERCY RIPLEY . . . . .	Net 7/6
<b>London Money Market, The</b>	
By W. F. SPALDING . . . . .	Net 10/6
<b>Organization and Management of a Branch Bank.</b> By F. J. LEWCOCK . . . . .	Net 5/-
<b>Practical Banking</b> By H. E. EVITT . . . . .	Net 5/-
<b>Practical Branch Banking</b>	
By A. FORRESTER FERGUS . . . . .	Net 8/6

## Banking and Finance—contd.

	PRICE
<b>Principles of Currency, Credit and Exchange</b> By WILLIAM A. SHAW, Litt.D. . . . . Net	3/6
<b>Profits from Short-Term Investment and How to Make Them.</b> By COLLIN BROOKS . . . . . Net	3/6
<b>Property Investment</b> By REGINALD M. LESTER . . . . . Net	7/6
<b>Securities Clerk in a Branch Bank, The</b> By F. J. LEWCOCK, Cert. A.I.B., A.C.I.S. . . . . Net	7/6
<b>Theory and Practice of Finance, The</b> By W. COLLIN BROOKS . . . . . Net	10/6

## INSURANCE

<b>Accident Risks, The Surveying of</b> By J. B. WELSON, F.C.I.I., and FENWICK J. WOODROOF, A.C.I.I. . . . . Net	5/-
<b>Actuarial Science, The Elements of</b> By R. E. UNDERWOOD, M.B.E., F.I.A. . . . . Net	5/-
<b>Average Clauses and Fire-Loss Apportion- ments.</b> By E. H. MINNION, F.C.I.I. . . . . Net	8/6
<b>Building Construction, Plan Drawing, and Surveying in Relation to Fire Insurance</b> By D. W. WOOD, M.B.E. . . . . Net	6/-
<b>Compound Interest, Principles of</b> By H. H. EDWARDS . . . . . Net	5/-
<b>Dictionary of Accident Insurance</b> Edited by J. B. WELSON, I.L.M., F.C.I.I., F.C.I.S. Net	60/-
<b>Fire Insurance, Dictionary of</b> Edited by B. C. REMINGTON, F.C.I.I., and HERBERT G. HURREN, F.C.I.I. . . . . Net	30/-
<b>Fire Insurance, Principles and Practice of</b> By F. GODWIN . . . . . Net	5/-
<b>Fire Insurance, The Law of</b> By SANDFORD D. COLE, <i>Barrister-at-Law</i> . . . . . Net	6/-
<b>Fire Policy Drafting and Endorsements</b> By W. C. H. DARLEY . . . . . Net	7/6
<b>Guide to Marine Insurance.</b> By HENRY KEATE Net	3/6
<b>How Shall I Insure ?</b> By F. G. CULMER . . . . . Net	2/6
<b>Industrial Assurance Organization and Routine</b> By R. DINNAGE, F.I.A., and T. HILLS, A.C.I.I. Net	7/6

## Insurance—contd.

	PRICE
<b>Industrial Insurance Salesmanship</b>	
By ALBERT E. SHARP and CHARLES TAYLOR . . . . . Net	5/-
<b>Insurance Companies' Accounts</b>	
By G. H. ROBERTSON, A.C.I.S., A.L.A.A. . . . . Net	10/6
<b>Insurance Companies' Investments</b>	
By HAROLD E. RAYNES, F.I.A., F.C.I.I. . . . . Net	7/6
<b>Insurance Organization and Management</b>	
By J. B. WELSON, LL.M., F.C.I.I., F.C.I.S., and F. H. SHERRIFF, F.I.A. . . . . Net	7/6
<b>Insurance of Public Liability Risks</b>	
By S. V. KIRKPATRICK, F.C.I.I. . . . . Net	5/-
<b>Law and Practice as to Fidelity Guarantees</b>	
By C. EVANS and F. H. JONES . . . . .	5/-
<b>Law of Accident and Contingency Insurance</b>	
By F. H. JONES . . . . . Net	7/6
<b>Law of Negligence</b>	
By J. B. WELSON, LL.M., F.C.I.I., F.C.I.S. . . . . Net	5/-
<b>Law Relating to Insurance Agents and Brokers</b>	
By J. B. WELSON, LL.M., F.C.I.I., F.C.I.S. . . . . Net	5/-
<b>Life Assurance from Proposal to Policy</b>	
By H. HOSKING TAYLER, F.I.A., A.C.I.I., and V. W. TYLER, F.I.A. Revised by H. NOEL FREEMAN, B.A., F.I.A. . . . . Net	6/-
<b>Life Assurance, Dictionary of</b>	
Edited by G. W. RICHMOND, F.I.A., and F. H. SHERRIFF, F.I.A. . . . . Net	40/-
<b>Life Assurance, Guide to</b>	
By S. G. LEIGH, F.I.A. . . . . Net	5/-
<b>Marine Insurance of Goods, The</b>	
By F. W. S. POOLE . . . . . Net	10/6
<b>Motor Insurance.</b> By G. W. GILBERT . . . . . Net	7/6
<b>National Health Insurance</b>	
By W. J. FOSTER, LL.B. <i>Barrister-at-Law</i> , and F. G. TAYLOR, F.I.A. . . . . Net	10/6
<b>Pension and Superannuation Funds, Their Formation and Administration Explained</b>	
By BERNARD ROBERTSON, F.I.A., and H. SAMUELS Net	5/-
<b>Pension, Endowment, Life Assurance, and Other Schemes for Employees</b>	
By H. DOUGHARTY, F.C.I.I. . . . . Net	6/-
<b>Personal Accident, Disease, and Sickness Insurance</b>	
By J. B. WELSON, LL.M. . . . . Net	6/-

## Insurance—contd.

	PRICE
<b>Principles and Practice of Accident Insurance</b> By G. E. BANFIELD, A.C.I.I. . . . . Net	6/-
<b>Principles and Practice of Industrial Assurance</b> By R. B. WALKER, F.I.A., and D. R. WOODGATE, B.Com., F.I.A. . . . . Net	7/6
<b>Successful Insurance Agent, The</b> By J. J. BISGOOD, B.A., F.C.I.S. Revised by JOHN B. CUSHING, F.C.I.I. . . . . Net	2/6
<b>Workmen's Compensation Insurance</b> By C. E. GOLDING, LL.D., F.C.I.I., F.S.S. . . . . Net	5/-

## SHIPPING

<b>Charter Parties of the World</b> By C. D. MACMURRAY and MALCOLM M. CREE. With a Foreword by R. S. DALGLIESH . . . . . Net	15/-
<b>Exporter's Handbook and Glossary, The</b> By F. M. DUDENEY . . . . . Net	7/6
<b>How to Export Goods.</b> By F. M. DUDENEY. Net	2/-
<b>How to Import Goods.</b> By J. A. DUNNAGE . Net	2/6
<b>Importer's Handbook, The.</b> By J. A. DUNNAGE Net	7/6
<b>Manual of Exporting</b> By J. A. DUNNAGE . . . . . Net	7/6
<b>Shipbroking, Introduction to</b> By C. D. MACMURRAY and M. M. CREE . . . . . Net	3/6
<b>Shipping.</b> By A. HALL, F.I.C.S. and F. HEYWOOD, F.C.I.S. . . . . Net	2/-
<b>Shipping Office Organization, Management, and Accounts.</b> By ALFRED CALVERT . . . . . Net	6/-
<b>Shipping Practice.</b> By E. F. STEVENS . . . . . Net	6/-

## INCOME TAX

<b>Burn's Income Tax Guide</b> By JOHN BURNS, W.S. . . . . Net	5/-
<b>Income Tax Law, Practice, and Administration</b> By F. F. SHARLES, F.S.A.A.; R. P. CROOM-JOHNSON, LL.B., K.C.; L. C. GRAHAM-DIXON, <i>of the Inner Temple,</i> <i>Barrister-at-Law,</i> and W. J. ECCOTT, Three Volumes Net	84/-
<b>Dictionary of Income Tax and Sur-Tax Practice</b> By W. E. SNELLING. . . . . Net	25/-
<b>Income Tax for Professional Students</b> By W. T. BAXTER, B.Com., C.A. . . . . Net	7/6

## Income Tax—contd.

	PRICE
<b>Income Tax, Introduction to</b>	
By E. D. FRYER, A.L.A.A. . . . .	Net 2/6
<b>Income Tax and Sur-Tax, Snelling's Practical</b>	
By C. W. CHIVERS . . . . .	Net 3/6
<b>Pitman's Income Tax Tables, 1937-38</b>	
Compiled by CHARLES W. CHIVERS . . . . .	Net 6d.

## SECRETARIAL WORK, ETC.

<b>Alteration of Share Capital</b>	
By P. LEA REED, A.I.S.A., and C. WRIGHT, A.C.A. . . . .	Net 5/-
<b>Chairman's Manual</b>	
By GURDON PALIN, and ERNEST MARTIN, F.C.I.S. . . . .	Net 5/-
<b>Company Secretarial Work</b>	
By E. MARTIN, F.C.I.S. . . . .	Net 2/-
<b>Company Secretary's Vade Mecum</b>	
Edited by P. TOVEY. Revised by C. W. ADAMS, A.C.I.S. . . . .	Net 3/6
<b>Dictionary of Secretarial Law and Practice</b>	
Edited by PHILIP TOVEY, F.C.I.S. Revised and Edited by ALBERT CREW, <i>Barrister-at-Law</i> . . . . .	Net 30/-
<b>Formation and Management of a Private Company.</b>	
By F. D. HEAD, B.A. . . . .	Net 7/6
<b>Guide for the Company Secretary.</b>	
By ARTHUR COLES. Revised by W. CECIL WOOD, A.C.I.S. . . . .	Net 6/-
<b>Higher Control</b>	
By T. G. ROSE, M.I.Mech.E., M.I.P.E., F.I.I.A. . . . .	Net 12/6
<b>How to Take Minutes</b>	
Edited by E. MARTIN, F.C.I.S. . . . .	Net 2/6
<b>Issue of Shares, Debentures, and Bonds</b>	
By H. W. BATTY, F.S.A.A., F.C.I.S. . . . .	Net 7/6
<b>Meetings.</b>	
By F. D. HEAD, B.A. . . . .	Net 5/-
<b>Oldham's Guide to Company Secretarial Work</b>	
By G. K. BUCKNALL, A.C.I.S. (Hons.) . . . . .	3/6
<b>Practical Directorship</b>	
By H. E. COLESWORTHY, A.C.A., A.S.A.A. . . . .	Net 7/6
<b>Practical Secretarial Work</b>	
By H. I. LEE, A.I.S.A., and W. N. BARR . . . . .	Net 7/6
<b>Private Company, The</b>	
By R. W. L. CLENCH, F.C.A., F.C.I.S. . . . .	Net 6/-
<b>Private Secretarial Work</b>	
By DOROTHY PARRY THOMAS . . . . .	Net 5/-
<b>Prospectuses: How to Read and Understand Them.</b>	
By PHILIP TOVEY, F.C.I.S., and H. LAMBERT SMITH, B.Sc. . . . .	Net 3/6

## Secretarial Work, etc.—contd.

	PRICE
<b>Questions and Answers on Secretarial Practice</b> By E. J. HAMMOND. Revised by G. K. BUCKNALL, A.C.I.S. (Hons.) . . . . . Net	5/-
<b>Secretarial Practice of Public Service Companies</b> By E. G. JANES, A.C.I.S. . . . . Net	10/6
<b>Share Transfer Audits.</b> By R. A. DAVIES, A.C.I.S. Net	3/6
<b>Transfer of Stocks, Shares, and Other Marketable Securities.</b> By F. D. HEAD, B.A. Net	7/6

## INDUSTRIAL ADMINISTRATION

<b>Business Rationalization</b> By CHARLES S. MYERS, C.B.E., M.A., Sc.D., F.R.S. Net	3/6
<b>Case for Vocational Guidance, The</b> By ANGUS MACRAE, M.A., M.B. . . . . Net	3/6
<b>Causes of Accidents, The</b> By ERIC FARMER, M.A. . . . . Net	3/6
<b>Engineering Factory Supplies</b> By W. J. HISCOX . . . . . Net	5/-
<b>Estimating.</b> By T. H. HARGRAVE . . . . . Net	5/-
<b>Factory Administration in Practice</b> By W. J. HISCOX. Revised by JOHN R. PRICE, A.C.A., A.C.W.A., etc. . . . . Net	8/6
<b>Factory Lay-Out, Planning and Progress</b> By W. J. HISCOX . . . . . Net	7/6
<b>Factory Organization</b> By C. H. NORTHCOTT, M.A., Ph.D., O. SHELDON, B.A., J. W. WARDROPPER, B.Sc., B.Com., A.C.W.A., and L. URWICK, M.A. . . . . Net	7/6
<b>Foundry Organization and Management</b> By JAMES J. GILLESPIE . . . . . Net	12/6
<b>Industrial Organization, The Evolution of</b> By B. F. SHIELDS, M.A. . . . . Net	7/6
<b>Industrial Psychology Applied to the Office</b> By W. SPIELMAN RAPHAEL, B.Sc., C. B. FRISBY, B.Com., and L. I. HUNT, B.A. . . . . Net	3/6
<b>Industrial Psychology in Practice</b> By HENRY J. WELCH, and G. H. MILES, D.Sc. . . . . Net	7/6
<b>Introduction to Industrial Administration, An</b> By J. LEE, C.B.E., M.A., M.Com.Sc. . . . . Net	5/-
<b>Labour Organization.</b> By J. CUNNISON, M.A. . . . . Net	7/6
<b>Modern Foremanship</b> By T. H. BURNHAM, B.Sc., A.M.I.Mech.E. . . . . Net	7/6

## Industrial Administration—contd.

		PRICE
<b>Modern Works Management</b>		
By G. SAMUEL MASON, B.Sc., M.I.Chem.E., etc.	Net	8/6
<b>Muscular Work, Fatigue, and Recovery</b>		
By G. P. CROWDEN, M.Sc., M.R.C.S., L.R.C.P.	Net	3/6
<b>Principles of Industrial Welfare</b>		
By J. LEE, C.B.E., M.A., M.Com.Sc.	Net	5/-
<b>Principles of Rational Industrial Management</b>		
By JAMES J. GILLESPIE	Net	10/6
<b>Problem of Incentives in Industry, The</b>		
By G. H. MILES, D.Sc.	Net	3/6
<b>Production Planning.</b>	By OLIFTON REYNOLDS	Net 10/6
<b>Selection of Colour Workers, The</b>		
Edited and with a Preface and a Chapter by CHARLES S. MYERS, C.B.E., F.R.S.	Net	5/-
<b>Sharing Profits With Employees</b>		
By J. A. BOWIE, M.A., D.Litt.	Net	10/6
<b>Welfare Work in Industry</b>		
Edited by E. T. KELLY	Net	5/-

## BUSINESS ORGANIZATION AND MANAGEMENT

<b>Business Organization and Routine</b>		
By W. CAMPBELL, <i>Chartered Secretary</i>	Net	1/-
<b>Clubs and Their Management</b>		
By F. W. PIXLEY	Net	7/6
<b>Commercial Management</b>		
By C. L. BOLLING	Net	10/6
<b>Economy and Control Through Office Method</b>		
By E. W. WORKMAN, B.Sc. (Lond.)	Net	7/6
<b>Filing Systems.</b>		
By E. A. COPE. Revised by C. RALPH CURTIS, M.Sc. (Econ.), F.I.S.A.	Net	3/6
<b>Grocery Business Organization, Management, and Accounts</b>		
By C. L. T. BEECHING, O.B.E.	Net	7/6
<b>Hire Purchase.</b>	By HAROLD W. ELEY	Net 1/-
<b>Hire Purchase Organization and Management</b>		
By V. R. FOX-SMITH	Net	7/6
<b>Hire Purchase Trading</b>		
By CUNLIFFE L. BOLLING	Net	10/6

## Business Organization and Management—contd.

	PRIOR
<b>Hotel Organization, Management, and Accountancy</b>	
By G. DE BONI, and F. F. SHARLES, F.S.A.A., F.C.I.S. Revised by F. F. SHARLES . . . . .	Net 10/6
<b>Management of an Enterprise</b>	
By C. CANBY BALDERSTON, VICTOR S. KARABASZ, and ROBERT P. BRECHTE. . . . .	Net 21/-
<b>Modern Office Management</b>	
By H. W. SIMPSON . . . . .	Net 7/6
<b>Multiple Shop Organization</b>	
By A. E. HAMMOND . . . . .	Net 6/-
<b>Office Organization and Management, Including Secretarial Work</b>	
By the late LAWRENCE R. DICKSEE, M.Com., F.C.A., and SIR H. E. BLAIN, C.B.E. Revised by STANLEY W. ROWLAND, LL.B., F.C.A. . . . .	Net 7/6
<b>Retail Shop, The</b>	
By C. L. T. BEECHING, O.B.E., F.G.I. . . . .	Net 1/-
<b>Running a Tearoom and Catering for Profit</b>	
By HELEN JEROME, M.C.A. . . . .	Net 3/6
<b>Self-Organization for Business Men</b>	
By MORLEY DAINOW, B.Sc.(Hons.), Lond. . . . .	Net 5/-
<b>Selling by Post</b> By HAROLD W. ELEY . . . . .	Net 1/-
<b>Solicitor's Office Organization, Management, and Accounts</b>	
By E. A. COPE and H. W. H. ROBINS . . . . .	Net 6/-
<b>Stockbroker's Office, The</b> By J. E. DAY . . . . .	Net 7/6
<b>Stores Accounts and Stores Control</b>	
By J. H. BURTON . . . . .	Net 10/6

### MUNICIPAL WORK

<b>Local Government of the United Kingdom, and the Irish Free State, The</b>	
By J. J. CLARKE, M.A., F.S.S. . . . .	Net 15/-
<b>Municipal Accounting Systems</b>	
By S. WHITEHEAD, A.S.A.A. . . . .	5/-
<b>Municipal Audit Programmes</b>	
By S. WHITEHEAD . . . . .	Net 5/-
<b>Municipal Book-keeping</b>	
By J. H. MCCALL, F.S.A.A. . . . .	Net 7/6
<b>Municipal Cost and Works Accounts</b>	
By G. A. BRYANT, F.C.W.A. . . . .	Net 10/6



## Advertising and Commercial Art—contd.

	PRICE
<b>Poster Designing</b>	
By W. S. ROGERS . . . . .	Net 7/6
<b>Poster, The Technique of the</b>	
Edited by LEONARD RICHMOND, R.B.A., R.O.I. . . . .	Net 21/-
<b>Routine of the Advertising Department</b>	
By REGINALD H. W. COX . . . . .	Net 10/6
<b>Ticket and Showcard Designing</b>	
By F. A. PEARSON . . . . .	Net 5/-
<b>Training in Commercial Art</b>	
By V. L. DANVERS . . . . .	Net 10/6
<b>Types and Type Faces</b> By C. M. TREGURTHA	Net 2/6
<b>What the Press Artist Should Know</b>	
By JOHN R. TURNER . . . . .	Net 7/6

## SALESMANSHIP

<b>Administration of Marketing and Selling</b>	
By HAROLD WHITEHEAD, B.B.A., F.I.I.A. . . . .	Net 15/-
<b>Craft of Silent Salesmanship</b>	
By C. MAXWELL TREGURTHA and J. W. FRINGS . . . . .	Net 3/6
<b>Direct Mail Advertising for the Retail Trader</b>	
By H. DENNETT . . . . .	Net 7/6
<b>Modern Sales Correspondence</b>	
By D. M. WILSON . . . . .	Net 3/6
<b>More Sales Through the Window</b>	
By C. C. KNIGHTS . . . . .	Net 3/6
<b>Next Steps Forward in Retailing</b>	
By EDWARD A. FILENE, with the collaboration of W. K. GABLER and P. S. BROWN . . . . .	Net 5/-
<b>Organizing a Sales Office</b>	
By L. URWICK, O.B.E., M.C., F.I.I.A.; E. ASTON; F. H. CORDUKES; and C. H. TUCKER . . . . .	Net 10/6
<b>Outline of Sales Management, An</b>	
By C. C. KNIGHTS, <i>Sales Consultant</i> . . . . .	Net 3/6
<b>Personal Salesmanship.</b> By R. SIMMAT, M.A.	Net 3/6
<b>Practical Aids to Retail Selling</b>	
By A. EDWARD HAMMOND . . . . .	Net 3/6
<b>Practical Commercial Travelling</b>	
By RONALD T. LEWIS . . . . .	Net 3/6

## Salesmanship—contd.

	PRICE
<b>Practical Salesmanship</b>	
By N. C. FOWLER, Junr. . . . .	Net 7/6
<b>Principles of Store Practice</b>	
By FRANK CHITHAM and S. A. WILLIAMS, M.A. . . . .	5/-
<b>Psychology as a Sales Factor</b>	
By A. J. GREENLY . . . . .	Net 7/6
<b>Retail Distribution, Principles of</b>	
By S. A. WILLIAMS, M.A. . . . .	Net 5/-
<b>Retail Management.</b> By C. L. BOLLING . . . . .	Net 15/-
<b>Retail Salesmanship.</b> By C. L. BOLLING . . . . .	Net 7/6
<b>Sales Management.</b> By C. L. BOLLING . . . . .	Net 10/6
<b>Salesmanship</b>	
By W. A. CORBION and G. E. GRIMSDALE . . . . .	Net 3/6
<b>Salesmanship.</b> By WILLIAM MAXWELL . . . . .	Net 5/-
<b>Salesmanship, Technique of</b>	
By C. C. KNIGHTS . . . . .	Net 5/-
<b>Shop Fittings and Display</b>	
By A. E. HAMMOND . . . . .	Net 5/-
<b>Successful Retailing.</b> By E. N. SIMONS . . . . .	Net 5/-
<b>Training for More Sales</b>	
By C. C. KNIGHTS, <i>Sales Consultant</i> . . . . .	Net 5/-
<b>Training for Travelling Salesmen</b>	
By F. W. SHRUBSALL . . . . .	Net 2/6

## TRANSPORT

<b>Canals and Inland Waterways</b>	
By GEORGE CADBURY and S. P. DOBBS, B.A. . . . .	Net 5/-
<b>Commercial Motor Road Transport</b>	
By L. M. MEYRICK-JONES . . . . .	Net 15/-
<b>Elements of Transport</b>	
By R. J. EATON . . . . .	Net 2/6
<b>History and Economics of Transport, The</b>	
By A. W. KIRKALDY, M.A., B.Litt., M.Com., and A. D. EVANS . . . . .	Net 18/-
<b>How to Make the British Railways Pay</b>	
By M. F. FARRAR . . . . .	Net 3/6
<b>Modern Dock Operation</b>	
By D. ROSS-JOHNSON, C.B.E., V.D., M.Inst.I. . . . .	Net 5/-

## Transport—contd.

	PRICE
<b>Modern Railway Operation</b>	
By D. R. LAMB, M.Inst.T. . . . .	Net 5/-
<b>Port Economics</b>	
By B. CUNNINGHAM, D.Sc., B.E., F.R.S.E. . . . .	Net 5/-
<b>Railway Electrification and Traffic Problems</b>	
By P. BURTT, M.Inst.T. . . . .	Net 5/-
<b>Railway Rates : Principles and Problems</b>	
By P. BURTT, M.Inst.T. . . . .	Net 5/-
<b>Railway Statistics : Their Compilation and Use.</b>	
By A. E. KIRKUS, O.B.E., M.Inst.T. . . . .	Net 5/-
<b>Rights and Duties of Transport Undertakings</b>	
By H. B. DAVIES, M.A., and F. M. LANDAU, <i>Barrister-at-Law</i> . . . . .	Net 10/6
<b>Road Making and Road Using</b>	
By T. SALKIELD, M.Inst.C.E. . . . .	Net 7/6
<b>Road Passenger Transport</b>	
By R. STUART PILCHER, F.R.S.E., M.Inst.T. . . . .	Net 10/6
<b>Transport Management, Practical</b>	
By ANDREW HASTIE . . . . .	Net 10/6

## LAW

<b>Administration of Estates, The</b>	
By A. H. COSWAY . . . . .	Net 5/-
<b>Bankruptcy, Deeds of Arrangement, and Bills of Sale</b>	
By W. VALENTINE BALL and DONALD GEDDES . . . . .	Net 15/-
<b>Business Tenant, The</b>	
By EDWARD S. COX-SINCLAIR, and T. HYNES . . . . .	Net 7/6
<b>Business Transfer Agent and Trade Valuer</b>	
By J. OTWAY CAVE . . . . .	Net 7/6
<b>Pitman's Commercial Law</b>	
By J. A. SLATER, B.A., LL.B. Revised by R. H. CODE HOLLAND, B.A., <i>of the Middle Temple, Barrister-at-Law</i> . . . . .	3/6
<b>Companies and Company Law</b>	
By A. C. CONNELL, LL.B. (Lond.). Revised by W. E. WILKINSON, LL.D. . . . .	6/-
<b>Company Law</b>	
By D. F. DE L'HOSTE RANKING, M.A., LL.D., and ERNEST EVAN SPICER, F.O.A. Edited by H. A. R. J. WILSON, F.C.A., F.S.A.A. . . . .	Net 10/-
<b>Commercial Law Cases.</b> By ALBERT CREW . . . . .	Net 6/-

Law—contd.

	PRICE
<b>Company Law</b>	
By H. GOITEIN, LL.D., <i>Barrister-at-Law</i> . . . . .	7/6
<b>Concise Handbook of the Law Affecting Land- lord and Tenant</b>	
By R. BORREGAARD, M.A. . . . . Net	8/6
<b>Dictionary of Legal Terms and Citations, A</b>	
By H. A. C. STURGESS and ARTHUR R. HEWITT . Net	5/-
<b>Elements of Commercial Law, The</b>	
By A. H. DOUGLAS, LL.B. (Lond.) . . . . .	2/-
<b>Examination Notes on Commercial Law</b>	
By R. W. HOLLAND, O.B.E., M.A., M.Sc., LL.D. . Net	2/6
<b>Examination Notes on Company Law</b>	
By R. W. HOLLAND, O.B.E., M.A., M.Sc., LL.D. . Net	2/6
<b>Examination Notes on Criminal Law</b>	
By J. A. BALFOUR, <i>Barrister-at-Law</i> . . . . . Net	3/6
<b>Guide to Bankruptcy Law and Winding Up of Companies</b>	
By F. PORTER FAUSSET, M.A., <i>Barrister-at-Law</i> Net	5/-
<b>Guide to Company Law</b>	
By R. W. HOLLAND, O.B.E., M.A., M.Sc., LL.D. . . . .	3/6
<b>How to Patent and Commercialize Your Inventions</b> By D. B. MILLER . . . . . Net	2/6
<b>Industrial Assurance Law</b>	
By A. J. SUENSON-TAYLOR, O.B.E., M.A., F.C.I.I. Net	6/-
<b>Law for Journalists</b>	
By CHARLES PILLEY, <i>Barrister-at-Law</i> . . . . . Net	5/-
<b>Law for the House-Owner</b>	
By A. H. COSWAY . . . . . Net	3/6
<b>Law of Gaming and Betting</b>	
By C. F. SHOOLBREAD, B.A., LL.B., <i>Barrister-at-Law</i> Net	15/-
<b>Law of Inland Transport</b>	
By W. H. GUNN, LL.B. (Lond.), <i>Barrister-at-Law</i> Net	8/6
<b>Law of Joint Stock Companies</b>	
By W. J. WESTON, M.A., B.Sc., <i>Barrister-at-Law</i> . . . . .	7/6
<b>Law of Master and Servant</b>	
By F. R. BATT, LL.M. . . . . Net	12/6
<b>Law of the Sale of Goods</b>	
By C. G. AUSTIN, B.A. (Oxon.) . . . . . Net	5/-
<b>Law Relating to Industry</b>	
By H. SAMUELS, M.A., <i>Barrister-at-Law</i> . . . . . Net	10/6
<b>Law Relating to Restraint of Trade</b>	
By R. YORKE HEDGES, LL.M., <i>Barrister-at-Law</i> Net	7/6

## Law—contd.

	PRICE
<b>Law of Trusts, The</b>	
By GEORGE W. KEETON, M.A., LL.D. . . . . Net	25/-
<b>Liquidator's Index and Summary of the Companies Act and Winding Up Rules, 1929</b>	
By JOHN H. SENIOR, F.C.A., and H. M. PRATT . . . . . Net	7/8
<b>Manual of Company Law and Practice</b>	
By LESLIE MADDOCK, <i>Barrister-at-Law</i> . . . . .	10/6
<b>Patents for Inventions</b>	
By REGINALD HADDAN . . . . . Net	3/6
<b>Partnership Law and Accounts</b>	
By R. W. HOLLAND, O.B.E., M.A., M.Sc., LL.D. . . . . Net	6/-
<b>Preparation of Schemes and Orders under the Town and Country Planning Act</b>	
By S. PASCOE HAYWARD, B.A. . . . . Net	10/6
<b>Poley's Law and Practice of the Stock Exchange</b>	
By R. H. CODE HOLLAND, B.A., <i>of the Middle Temple, Barrister-at-Law</i> , and JOHN N. WERRY . . . . . Net	15/-
<b>Public Rights in the Seashore</b>	
By H. GALLIENNE LEMMON, M.A., L.L.M., Cantab. . . . . Net	30/-
<b>Questions in Mercantile Law</b>	
By W. J. WESTON, M.A., B.Sc. . . . .	2/6
<b>Settled Land Acts</b>	
By J. C. ARNOLD, LL.B., <i>of the Inner Temple, Barrister-at-Law</i> . . . . . Net	25/-
<b>Slater's Bills, Cheques, and Notes</b>	
Revised by L. LE M. MINTY, Ph.D., B.Sc., B.Com., LL.B. . . . . Net	5/-
<b>Slater's Mercantile Law</b>	
Revised by R. W. HOLLAND, O.B.E., M.A., M.Sc., LL.D., and R. H. CODE HOLLAND, B.A., <i>Barrister-at-Law</i> . . . . .	7/8
<b>Solicitor's Clerk's Guide</b>	
By E. A. COPE. Revised by F. G. W. LESTER . . . . . Net	4/-
<b>Tax Saving Deeds and the Finance Act, 1936</b>	
By T. J. SOPHIAN, <i>Barrister-at-Law</i> . . . . . Net	3/8
<b>Trade Mark Law and Practice</b>	
By A. W. GRIFFITHS, B.Sc. (Eng.), Lond. . . . . Net	10/6
<b>Wills, A Complete Guide for Testators, Executors, and Trustees</b>	
By R. W. HOLLAND, O.B.E., M.A., M.Sc., LL.D. . . . . Net	2/8
<b>Wills, A Handbook on.</b> By A. H. COSWAY . . . . . Net	2/6

## REFERENCE BOOKS

	PRICE
<b>Annuity and Loan Redemption Tables</b>	
By T. K. STUBBINS, F.C.A. and HAROLD DOUGHARTY, F.C.I.S., A.I.A. . . . .	Net 6/-
<b>Art of Conference, The</b>	
By FRANK WALSER . . . . .	Net 10/6
<b>Business Budgets and Budgetary Control</b>	
By A. W. WILLSMORE, F.R.Econ.S. . . . .	Net 10/6
<b>Business Charts</b>	
By T. G. ROSE, M.I.Mech.E. . . . .	Net 7/6
<b>Business Forecasting and Its Practical Appli- cation.</b> By W. WALLACE, M.Com. (Lond.) . . . . .	Net 7/6
<b>Business Man's Guide, Pitman's</b> . . . . .	Net 6/-
<b>Business Statistics</b>	
By R. W. HOLLAND, O.B.E., M.A., M.Sc., LL.D. . . . .	Net 3/6
<b>Business Terms, Phrases, etc.</b> . . . . .	Net 3/6
<b>Buying and Selling a Business</b>	
By A. H. COSWAY . . . . .	Net 3/6
<b>Commercial Credits and Accounts Collection</b>	
By CUTHBERT GREIG . . . . .	Net 10/6
<b>Charting, Manual of</b> . . . . .	Net 6/-
<b>Commercial Self-Educator</b>	
Edited by R. W. HOLLAND, O.B.E., M.A., M.Sc., LL.D. Three Vols. . . . .	Net 45/-
<b>Commodities of Commerce</b>	
By J. H. VANSTONE, F.R.G.S. . . . .	Net 5/-
<b>Course in Business Statistics</b>	
By CHARLES H. BAYLISS, B.Com. (Lond.) . . . . .	3/6
<b>Documents of Commerce</b>	
By F. A. WILLMAN, Cert. A.I.B. . . . .	Net 5/-
<b>Handbook of Commercial and Technical Educa- tion, Pitman's</b>	
Edited by HAROLD DOWNS . . . . .	Net 15/-
<b>How to Grant Credit.</b> By CUTHBERT GREIG . . . . .	Net 3/6
<b>How to Buy Timber (Including Plywood)</b>	
By R. R. RIVERS . . . . .	Net 3/6

## Reference Books—contd.

	PRICE
<b>How to Make a Speech</b>	
By RICHARD JOHNSON, M.A. . . . .	Net 2/6
<b>How to Run a Copying Office</b>	
By GLADYS C. MENZIES . . . . .	Net 5/-
<b>How to Speak Effectively</b>	
By Charles Seymour. . . . .	Net 7/6
<b>Human Psychology</b>	
By JUDSON REA BUTLER and THEODORE FRANCIS KARWOSKI . . . . .	Net 10/6
<b>Markets of London.</b> By CUTHBERT MAUGHAN .	Net 6/-
<b>Mercantile Terms and Abbreviations</b> .	Net 1/6
<b>Money Making in Stocks and Shares</b>	
By SYDNEY A. MOSELEY . . . . .	Net 7/6
<b>Office Desk Book, Pitman's</b> . . . . .	Net 2/6
<b>Personal Psychology</b>	
By MORLEY DAINOW, B.Sc. . . . .	Net 5/-
<b>Public Speaking</b>	
By ARCHIBALD CRAWFORD, K.C. . . . .	Net 6/-
<b>Raw Materials of Commerce</b>	
In 2 vols. Edited by J. H. VANSTONE, F.R.G.S.	Net 20/-
<b>Simplified Statistics</b>	
By LEONARD J. HOLMAN, B.Sc. (Lond.) . . . .	Net 3/6
<b>Speak in Public, How to</b>	
By C. F. CARR and F. E. STEVENS . . . . .	Net 3/6
<b>Statistics for Professional Students</b>	
By R. L. A. HOLMES, B.Com. . . . .	Net 5/-
<b>Statistics in Theory and Practice</b>	
By L. R. CONNOR, M.Sc. (Econ.), <i>Barrister-at-Law</i>	Net 12/6
<b>Unit Trusts and How They Work</b>	
By C. L. ROSENHEIM, M.A., and C. O. MERRIMAN, A.C.A. . . . .	Net 7/6

### PITMAN'S ECONOMICS SERIES

General Editor: PROFESSOR J. H. JONES, M.A.

<b>A Primer of Economic Geography</b>	
By L. W. LYDE, M.A., F.R.G.S., F.R.S.G.S. . . .	Net 5/-
<b>British Economists</b>	
By FRANCIS C. HOOD, M.A. . . . .	Net 2/6

## Pitman's Economics Series—contd.

	PRIOR
<b>Business Forecasting</b>	
By J. H. RICHARDSON, M.A., Ph.D. . . . .	Net 2/6
<b>Currency and Banking</b>	
By D. T. JACK, M.A. . . . .	Net 5/-
<b>Economic Functions of the State</b>	
By R. H. SOLTAU, M.A. . . . .	Net 5/-
<b>Finding Capital for Business</b>	
By DAVID FINNIE, M.A., C.A. . . . .	Net 2/6
<b>International Trade</b>	
By D. T. JACK, M.A. . . . .	Net 2/6
<b>Methods of Remuneration</b>	
By R. WILSON, M.A., B.Sc. . . . .	Net 2/6
<b>Overhead Costs</b>	
By SIR HENRY N. BUNBURY, K.C.B. . . . .	Net 2/6
<b>Production</b>	
By HUBERT PHILLIP, M.A. (Oxon) . . . . .	Net 5/-
<b>Socialism</b>	
By ROBERT RICHARDS, M.A. . . . .	Net 2/6
<b>Transport and Communications</b>	
By K. G. FENELON, M.A., Ph.D . . . . .	Net 2/6
<b>Value and Distribution</b>	
By HUBERT PHILLIPS, M.A. (Oxon) . . . . .	Net 5/-

## PITMAN'S "ART AND LIFE" SERIES

General Editor: WRIGHT WATTS MILLER, B.A., London  
(First Class Honours), M.Ed., Manchester

<b>Art : An Introduction to Appreciation</b>	
By RAYMOND COXON, A.R.C.A. . . . .	Net 5/-
<b>Books : An Introduction to Reading</b>	
By WRIGHT WATTS MILLER, B.A. (Lond.), M.Ed. (Manchester) . . . . .	Net 5/-
<b>Economics : The Study of Wealth</b>	
By A. L. GORDON MACKAY, M.Litt., M.A., M.Econ. . . . .	Net 5/-
<b>Films : The Way of the Cinema</b>	
By ANDREW BUCHANAN . . . . .	Net 5/-
<b>Music: An Introduction to Its Nature and Appreciation</b>	
By W. J. TURNER . . . . .	Net 5/-
<b>Theatre, The.</b> By MALCOLM MORLEY . . . . .	Net 5/-



## FOREIGN LANGUAGES

	PRICE
<b>FRENCH</b>	
<b>Progressive French Grammar</b>	
By DR. F. A. HEDGCOCK, M.A. . . . .	5/6
<b>Commercial French Grammar</b>	
By F. W. M. DRAPER, M.A., L.ès.L. . . . .	2/6
<b>French-English and English-French</b>	
<b>Commercial Dictionary</b>	
By F. W. SMITH . . . . . Net	7/6
<b>Handbook to French Examinations</b>	
By E. DONALD NISBET, B.A., HONS. (Lond.) . . . .	1/6
<b>GERMAN</b>	
<b>Commercial German Grammar, Pitman's</b>	
By J. BITHELL, M.A. . . . .	3/6
<b>German-English and English-German</b>	
<b>Commercial Dictionary</b>	
By J. BITHELL, M.A. . . . . Net	16/-
<b>Commercial Correspondence in German.</b>	3/6
<b>SPANISH</b>	
<b>Spanish Commercial Grammar</b>	
By C. A. TOLEDANO . . . . .	4/6
<b>Spanish-English and English-Spanish</b>	
<b>Commercial Dictionary</b>	
By G. R. MACDONALD, F.I.L. . . . . Net	12/6
<b>Manual of Spanish Commercial Correspondence</b>	
By G. R. MACDONALD, F.I.L. . . . .	4/6
<b>ITALIAN</b>	
<b>Italian Commercial Grammar</b>	
By LUIGI RICCI . . . . .	4/-
<b>Italian-English and English-Italian</b>	
<b>Commercial Dictionary</b>	
By G. R. MACDONALD, F.I.L. . . . . Net	30/-
<b>Mercantile Correspondence, English-Italian</b>	5/-
<b>PORTUGUESE</b>	
<b>Portuguese-English and English-Portuguese</b>	
<b>Commercial Dictionary</b>	
By F. W. SMITH . . . . . Net	16/-
<b>Mercantile Correspondence, English-Portu-</b>	
<b>guese.</b>	3/6

## PITMAN'S SHORTHAND

	PRICE
New Course in Pitman's Shorthand . . . . .	4/6
Pitman's Shorthand Instructor . . . . .	4/6
Pitman's Shorthand Commercial Course . . . . .	4/6
Pitman's Shorthand Rapid Course . . . . .	4/6
Shorter Course in Pitman's Shorthand . . . . .	1/-
Shorthand Dictionary . . . . .	7/6

## TYPEWRITING

<b>Pitman's Commercial Typewriting</b>	
By W. and E. WALMSLEY . . . . .	5/-
<b>Pitman's Commercial Typewriting—Part I</b>	
By W. and E. WALMSLEY . . . . .	1/6
<b>Pitman's Typewriter Manual</b> . . . . .	5/-
<b>Business Typewriting.</b> By F. HEELIS . . . . .	2/-
<b>Advanced Typewriting.</b> By F. HEELIS . . . . .	3/6
<b>Business Typewriting in Irish</b>	
By MRS. K. C. O'BRIEN . . . . .	3/-
<b>Dictionary of Typewriting</b>	
By H. ETHERIDGE, Revised by MAXWELL CROOKS and FREDERICK DAWSON, F.C.T.S. . . . .	5/-
<b>Theory of Typewriting, The.</b> By FLORENCE LOCKEY.	
Part I (only) . . . . .	2/-
<b>One Hundred and One Exercises in Typewriting</b>	
<b>Being the First Part of "Typewriting, Touch and Tabular"</b>	
By A. W. YOUNG, F.I.P.S. (Honours), F.F.T.Com., and JENNY C. YOUNG, F.Inc.T.T. . . . .	2/-
<b>Typewriting in Legal Offices</b>	
By WINIFRED HYNDS, F.I.P.S. (Hons), A.C.T.S. . . . .	Net 5/-
<b>Typewriting : Touch and Tabular</b>	
By A. W. and JENNY C. YOUNG . . . . .	6/-
<b>Typist's Companion, The</b>	
By MAXWELL CROOKS, . . . . .	2/-
<b>Typist's Desk Book</b>	
By PHYLLIS DRURY and H. L. PEARCE . . . . .	Net 2/6
<b>Book of the Underwood Typewriter, The</b>	
By MAXWELL CROOKS . . . . .	Net 2/6
<b>Book of the Remington Typewriter, The</b>	
By MAXWELL CROOKS . . . . .	Net 2/6

## Typewriting—contd.

	PRICE
<b>Notes of Lessons on Typewriting</b>	
By MAXWELL CROOKS . . . . . Net	5/-
<b>Touch Typewriting Exercises</b>	
By T. J. SIMONS, F.C.T.S., F.I.P.S. . . . .	1/6
<b>Shorthand-Typist's Senior Course, The</b>	
By A. C. MARSHALL, B.Com., and AGNES M. MILLS, B.A.	4/-
<b>Short Course in Typewriting</b>	
<b>Being the Third Edition of "New Course in Typewriting"</b>	
By MRS. SMITH CLOUGH, F.Inc.S.T. (Hon.) . . . . .	2/-
<b>Pitman's Keyboard Mastery Course</b>	
By MAXWELL CROOKS. The book is prepared for use with Pitman's <i>Gramophone Course of Keyboard Instruction</i> . In large post 4to . . . . .	1/6
<b>Pitman's Gramophone Course of Typewriter Keyboard Instruction</b>	
Arranged by MAXWELL CROOKS	
Complete, in strong case, together with one copy of <i>Instruction Book</i> . Comprising twelve 10-in. records (six discs) . . . . . Net	35/-
<b>Typewriting Manuscript and Accuracy Tests</b>	
By MAXWELL CROOKS . . . . .	2/6

## COMMON COMMODITIES AND INDUSTRIES

Each book in crown 8vo, illustrated. 3s. net

In each of the handbooks in this series a particular product or industry is treated by an expert writer and practical man of business. Beginning with the life history of the plant, or other natural product, he follows its development until it becomes a commercial commodity, and so on through the various phases of its sale in the market and its purchase by the consumer.

**Asbestos (SUMMERS)**

**Bookbinding Craft and Industry (HARRISON)**

**Books—From the MS. to the Book-seller (YOUNG)**

**Boot and Shoe Industry The (HARDING)**

**Brushmaker, The (KIDDIER)**

**Carpets (BRINTON)**

**Clocks and Watches (OVERTON)**

**Clothing Industry, The (POOLE)**

**Cloths and the Cloth Trade (HUNTER)**

**Coal (WILSON)**

**Coal Tar (WARNES)**

**Coffee—From Grower to Consumer (KEABLE). (Revised by PARHAM)**

**Concrete and Reinforced Concrete (TWELVETREES)**

## Common Commodities and Industries—contd.

<b>Cordage and Cordage Hemp and Fibres</b> (WOODHOUSE and KILGOUR)	<b>Rubber</b> (STEVENS and STEVENS)
<b>Cotton Spinning</b> (WADE)	<b>Silk</b> (HOOPER)
<b>Engraving</b> (LASCELLES)	<b>Soap</b> (SIMMONS)
<b>Explosives, Modern</b> (LEVY)	<b>Sponges</b> (CRESSWELL)
<b>Furs and the Fur Trade</b> (SACHS)	<b>Sugar</b> (MARTINEAU). (Revised by EASTICK)
<b>Glass and Glass Manufacture</b> (MARSON). Revised by L. M. ANGUS BUTTERWORTH	<b>Sulphur and Sulphur Derivatives</b> (AUDEN)
<b>Gums and Resins</b> (PARRY)	<b>Tea</b> (IBBETSON)
<b>Jute Industry, The</b> (WOODHOUSE and KILGOUR)	<b>Textile Bleaching</b> (STEVEN)
<b>Linen</b> (MOORE)	<b>Timber</b> (BULLOCK)
<b>Locks and Lock Making</b> (BUTTER)	<b>Tin and the Tin Industry</b> (MUNDEY)
<b>Meat Industry, The</b> (WOOD)	<b>Tobacco</b> (TANNER). (Revised by FAIRWEATHER)
<b>Paper</b> (MADDOX)	<b>Weaving</b> (CRANKSHAW)
<b>Photography</b> (GAMBLE)	<b>(Wool)</b> (HUNTER). (Revised by KERSHAW)
<b>Pottery</b> (NOKE and PLANT)	<b>Worsted Industry, The</b> (DUMVILLE and KERSHAW)

*The following Complete Catalogues will be sent, post free, on application—*COMMERCIAL EDUCATIONAL, TECHNICAL, LAW, SHORTHAND, FOREIGN LANGUAGES, ARTS AND CRAFTS, AND GENERAL.

Sir Isaac Pitman & Sons, Ltd. Parker Street, Kingsway, London, W.C.2





