

Birla Central Library

PILANI (Jaipur State)

Engg College Branch

Class No :- 624.062

Book No :- 11796F

Accession No :- 32362

Acc. No

ISSUE LABEL

Not later than the latest date stamped below.

--	--	--

FOUNDATIONS, ABUTMENTS
AND FOOTINGS

*The quality of the materials used in the manufacture
of this book is governed by continued postwar shortages.*

Books by **GEORGE A. HOOL**

HOOL—Reinforced Concrete Construction

Volume I—Fundamental Principles
Volume II—Retaining Walls and Buildings
Volume III—Bridges and Culverts

With **CHARLES S. WHITNEY**

HOOL AND WHITNEY—Concrete Designers' Manual

With **NATHAN C. JOHNSON**

HOOL AND JOHNSON—Concrete Engineers' Handbook

HOOL AND JOHNSON—Handbook of Building Construction
Two Volumes.

With **W. S. KINNE**

HOOL AND KINNE—Foundations, Abutments and Footings,
2d ed.

HOOL AND KINNE—Structural Members and Connections,
2d ed.

HOOL AND KINNE—Stresses in Framed Structures, 2d ed.

HOOL AND KINNE—Steel and Timber Structures, 2d ed.

**HOOL AND KINNE—Reinforced Concrete and Masonry
Structures, 2d ed.**

HOOL AND KINNE—Movable and Long-span Steel Bridges,
2d ed.

With **H. E. PULVER**

HOOL AND PULVER—Concrete Practice

HOOL AND PULVER—Reinforced Concrete Construction
Volume I—Fundamental Principles, Fourth Edition

Foundations, Abutments and Footings

Compiled by a Staff of Specialists

EDITORS-IN-CHIEF

GEORGE A. HOOL, S.B.

CONSULTING ENGINEER, FORMERLY PROFESSOR
OF STRUCTURAL ENGINEERING, THE UNIVERSITY OF WISCONSIN

and W. S. KINNE, B.S.

PROFESSOR OF STRUCTURAL ENGINEERING
THE UNIVERSITY OF WISCONSIN

REVISED BY

R. R. ZIPPRODT, B.S.

PRINCIPAL CIVIL ENGINEER, OFFICE OF THE QUARTERMASTER GENERAL
WASHINGTON, D.C.; FORMERLY ASSOCIATE PROFESSOR OF
CIVIL ENGINEERING, COLUMBIA UNIVERSITY; MEMBER
AMERICAN SOCIETY OF CIVIL ENGINEERS

and E. J. KILCAWLEY, M.C.E.

PROFESSOR OF SOIL MECHANICS AND SANITARY ENGINEERING
RENSSELAER POLYTECHNIC INSTITUTE

SECOND EDITION
SIXTH IMPRESSION

McGRAW-HILL BOOK COMPANY, INC.

NEW YORK AND LONDON

1943

FOUNDATIONS, ABUTMENTS AND FOOTINGS

COPYRIGHT, 1923, 1943, BY THE
MCGRAW-HILL BOOK COMPANY, INC

PRINTED IN THE UNITED STATES OF AMERICA

*All rights reserved. This book, or
parts thereof, may not be reproduced
in any form without permission of
the publishers.*

Preface to the Second Edition

This, the Second Edition of this volume—one of the six in the Structural Engineers' Handbook Library—has been prepared with the object of giving both the practicing engineer and the student a reference work that deals thoroughly with many of the problems involved in the design of foundations and footings.

All errors in the First Edition, of which there is any record, have been corrected. The editor-in-chief of the present revision will be grateful to those who, finding other errors, bring them to his attention for correction.

Numerous changes from the First Edition have been made. Section 1 on Soil Investigation has been almost completely rewritten to incorporate the latest developments in devices for the investigation of soil conditions. Practically all illustrations have been replaced by new ones depicting recent practice and procedure.

Essentially all the original material in Sec. 2 on Excavation has been replaced by new matter that includes many new illustrations descriptive of modern excavation equipment and processes.

Section 3 on Foundations has also been very largely rewritten. Many new illustrations serve to direct attention to the various types of foundations that are available today.

Much new material has been added to Sec. 4 on Spread Footings. The design of isolated spread footings is in accordance with the 1941 Building Regulations for Reinforced Concrete of the American Concrete Institute.

Section 5 on Underpinning and Sec. 6 on Foundations Requiring Special Consideration have been revised, as necessary, by the inclusion of considerable new material and new illustrations.

Section 8, now entitled "The Application of the Law Relative to the Engineer," completely replaces the former section on a similar subject.

Appendix A on Characteristics of Soils and Appendix B on Formulas for Bearing Power of Piles have been completely rewritten.

Credit has been given in the text of this volume for all data, illustrations, or parts of specifications used for the purpose of supplementing the technical matter. Mention is made here of the participation of the following Associate Editors in the preparation of the First Edition: F. H. Avery, Horace S. Baker, Walter Cahill, T. J. Ferrenz, P. G. Lang, Jr., W. R. Matheny, A. B. McDaniel, J. C. Meem, Chas. H. Paul, E. A. Prentis, Jr., J. C. Sanderson, S. E. Slocum, R. C. Smith, Earl G. Swanson, Lazarus White, A. M. Wolf, and Hugh E. Young.

Special acknowledgment is made to Dr. J. S. Kinney, Assistant Professor of Civil Engineering, Rensselaer Polytechnic Institute, for the preparation of the problems and relative data in Sec. 4; to Robert Murray, Attorney, Troy, N.Y., for the preparation of Sec. 8 in its entirety; and to Stanley V. Best, Instructor of Soil Mechanics, Rensselaer Polytechnic Institute, for checking sections of the manuscript and for many valuable suggestions during the preparation of the revision of this volume.

The senior author, who prepared the Preface to the Second Edition, acknowledges the continued and very helpful cooperation of his collaborator, Professor E. J. Kileawley, and thanks all others who have in any way contributed in the preparation of this revision.

R. R. ZIPPRODT.

BETHESDA, MD.,
May, 1943.

Preface to the First Edition

This volume is one of a series designed to provide the engineer and the student with a reference work covering thoroughly the design and construction of the principal kinds and types of modern civil engineering structures. An effort has been made to give such a complete treatment of the elementary theory that the books may also be used for home study.

The titles of the six volumes comprising this series are as follows:

Foundations, Abutments and Footings
Structural Members and Connections
Stresses in Framed Structures
Steel and Timber Structures
Reinforced Concrete and Masonry Structures
Movable and Long-span Steel Bridges

Each volume is a unit in itself, as references are not made from one volume to another by section and article numbers. This arrangement allows the use of any one of the volumes as a text in schools and colleges without the use of any of the other volumes.

Data and details have been collected from many sources, and credit is given in the body of the books for all material so obtained. A few chapters, however, throughout the six volumes have been taken without special mention, and with but few changes, from Hool and Johnson's Handbook of Building Construction.

The Editors-in-Chief wish to express their appreciation of the spirit of cooperation shown by the Associate Editors and the Publishers. This spirit of cooperation has made the task of the Editors-in-Chief one of pleasure and satisfaction.

G. A. H.
W. S. K.

MADISON, WIS.
September, 1923.

Contents

	PAGE
PREFACE TO THE SECOND EDITION.....	v
PREFACE TO THE FIRST EDITION.....	vii

Section 1. Soil Investigation

TESTS TO DETERMINE SOIL CONDITIONS		ART.	PAGE
ART.			
1.	Disturbance due to sam- pling.....		2
2.	Methods of investigation..		3
3.	Sounding rods.....		4
4.	Auger borings.....		5
5.	Wash borings.....		7
	a. Equipment.....		7
	b. Methods in detail.....		9
		c. Records and samples....	13
		6. Geophysical methods.....	14
		7. Test pits and bore holes...	14
		8. Samplers and sampling methods.....	15
		9. Core sampling.....	20
		10. Core borings.....	21
		a. Diamond drill method..	22
		b. Shot drill method.....	25
		11. Load tests.....	28

Section 2. Excavation

1.	General considerations.....	34	20.	Wagon drill.....	61
2.	Bulldozers.....	35	21.	Abrasion drills.....	63
3.	Scrapers.....	37	22.	Explosives.....	64
4.	Rooters.....	41		a. Blasting powder.....	65
5.	Power shovels.....	41		b. Pellet powder.....	65
6.	Elevating graders.....	44		c. High explosives.....	66
7.	Mobiloader.....	45		d. Nitroglycerin.....	66
8.	Draglines.....	46		e. Dynamite.....	66
9.	Derrick and hoist buckets.	47	23.	Rock breaking.....	70
10.	Cableway excavators.....	49	24.	Subaqueous rock excava- tion.....	71
11.	Walking draglines.....	51		a. Rock cutters.....	72
12.	Transporting equipment...	53		b. Drill boats.....	73
13.	Rock excavation.....	57	25.	Wet or subaqueous excava- tion.....	75
14.	Jackhammer drills.....	58		a. Dipper dredges.....	75
15.	Jackhammer mountings...	59		b. Clamshell or dragline dredges.....	78
16.	Drifter drills.....	60		c. Hydraulic dredge.....	79
17.	Stope-hammer drills.....	61		d. Ladder dredge.....	81
18.	Other hand-operated tools.	61			
19.	Well drills.....	61			

Section 3. Foundations

INTRODUCTION TO FOUNDATIONS		4.	Bearing power of soils.....	85
1.	General.....	COFFERDAMS		
2.	Types of foundations.....	5.	Types of cofferdams.....	86
3.	Preliminary investigation..			

ART.	PAGE
6. Soil pressure on cofferdams	87
7. Hydrodynamics of cofferdams.....	91
8. Earth cofferdams.....	91
9. Puddle cofferdams.....	92
10. Rock-fill cofferdams.....	93
11. Rock-filled cribs.....	93
12. Steel sheet pile cells.....	94
13. Land cofferdams.....	100
14. Pit sinking.....	101
15. Deep pits or wells.....	103
16. Movable cofferdams.....	104
17. Removing cofferdams.....	105

CAISSONS

18. General.....	107
19. Box caisson.....	108
20. Open caissons.....	108
21. Depth to which open caissons may be sunk....	108
22. Metal caissons.....	109
23. Amount of skin friction developed.....	110
24. General design.....	111
25. Wooden caissons.....	112
26. Concrete caissons.....	113
27. Cutting edges.....	113
28. Landing the caisson.....	114
29. Sinking caissons.....	114
30. Sealing caissons.....	118
31. Rate of sinking.....	119
32. Cost of sinking.....	119

PNEUMATIC CAISSONS

33. Pneumatic caissons.....	120
34. Depth limitation.....	121
35. Skin friction developed....	122
36. General design.....	122
37. Wooden caissons.....	123
38. Concrete caissons.....	124
39. Steel caissons.....	124
40. Cutting edges.....	125
41. Sinking caissons.....	125
42. Sealing caissons.....	127
43. Rate of sinking.....	127
44. Cost of sinking caissons....	128
45. Caisson diseases.....	128

ART.	PAGE
CAISSON DETAILS	
(Six examples)	
Pages 128 to 138 inclusive	

PILES AND PILE FOUNDATIONS

46. "Pile" defined.....	138
47. Earlier uses of piles.....	139
48. Types of piles.....	139
49. Pile foundations in modern construction—General features of design and construction.....	140

TIMBER PILES

50. Kinds of wood commercially available for foundation piling.....	143
51. Sizes of piles.....	144
52. Pile driving procedure.....	145
53. Pile drivers.....	146
54. Drop hammers.....	151
55. Steam hammers.....	153
56. Drop and steam hammers compared.....	156
57. Reducing tendency to lateral movement of pile.	158
58. Protecting pile head.....	158
59. Followers.....	159
60. Blunt vs. pointed piles....	160
61. Pile shoes.....	160
62. Driving piles with butt downward.....	161
63. Splicing piles.....	161
64. Cutting off piles.....	161
65. Preservation of piling....	162
66. Order in which piles should be driven.....	163
67. Lateral springing of pile...	164
68. Use of water jet in driving piles.....	164
69. Number of piles that can be driven in a day.....	166
70. Cost of pile driving.....	167
71. Driving foundation piles for bridge piers.....	168
72. Use of batter piles in foundations.....	168

ART.	PAGE	ART.	PAGE
CONCRETE PILES			
73. Advantages of concrete piles as compared with timber piles.....	170	82. Choice of type of concrete piles.....	200
74. Precast piles (patented types).....	173	83. Steel pipe piles.....	204
75. Unpatented precast concrete piles.....	175	STEEL PILES	
76. Construction of precast piles.....	178	84. Steel piles.....	205
77. Designing precast piles....	180	85. Driving and loading test piles.....	206
78. Driving of precast concrete piles.....	183	SHEET PILES	
79. Cast-in-place piles.....	187	86. Wood sheet piling.....	208
80. Objections to cast-in-place piles.....	197	87. Steel sheet piling.....	212
81. Composite types and combination piles.....	198	88. Driving sheet piling.....	215
		89. Removing sheet piling.....	217
		90. Watertightness.....	217
		91. Durability.....	218
		92. Reinforced concrete sheet piling.....	218

Section 4. Spread Footings

FOOTING AREAS		8. Cantilever footings.....	235
1. Relative allowable pressure on soil.....	219	9. Continuous footings.....	235
2. Proportioning footings.....	220	10. Illustrative problems in the design of isolated, combined, and cantilever footings of reinforced concrete.....	238
3. Eccentricity in footings....	224	11. Design of plain concrete footings.....	253
CONCRETE FOOTINGS		12. Footings supported on piles	254
4. Wall footings.....	225	GRILLAGE FOOTINGS	
5. Types of column footings..	227	13. Steel grillage footings.....	257
6. Single or isolated column footings.....	227	14. Timber grillage footings....	261
a. Plain concrete footings.	227	TRANSFERENCE OF COLUMN LOADS TO FOOTINGS	
b. Advantages of reinforced concrete footings.....	228	15. Methods.....	263
c. Summary of Professor Talbot's tests.....	229	16. Cast-iron and wood columns	264
d. Design of isolated footings.....	232	17. Masonry or concrete piers.	264
7. Combined column footings	233		

Section 5. Underpinning

1. Support of existing structures.....	268	menting existing foundations.....	272
a. Shoring.....	268	3. Underpinning proper.....	275
b. Needling.....	270	4. Piles used in underpinning.	276
2. Strengthening and supple-		5. Design of underpinning....	282

Section 6. Foundations Requiring Special Consideration

DEEP BASEMENTS AND MACHINERY

PITS

ART.	PAGE
1. Design.....	284
2. Construction.....	285

WATERPROOFING OF SUB-STRUCTURES

3. Methods of waterproofing.	292
4. Integral method of waterproofing.....	292
5. Membrane method of waterproofing.....	293
6. Surface coating method of waterproofing.....	294

RETAINING WALL FOUNDATIONS

7. Main considerations.....	297
8. Foundations on piles in plastic soil.....	299
9. Settlement of retaining wall foundations.....	300

DAM FOUNDATIONS

ART.	PAGE
10. Main requirements.....	300
11. Design depends on kind of foundation material..	300
12. Meaning of the term "foundation".....	301
13. Foundation material.....	301
14. Examination of foundations	303
15. Preparation of foundation.	305

MACHINERY FOUNDATIONS

16. Kinetic reactions of machinery.....	315
17. Weight required in massive foundations.....	317
18. Design of beam supports...	321
19. Design of column supports.	324
20. Marine installations.....	328
21. The Akimoff foundation...	332
22. Foundation dampers.....	335

Section 7. Bridge Piers and Abutments

GENERAL CONSIDERATIONS

1. Selection of site.....	338
2. Survey of local conditions..	338
3. Foundations, borings, etc..	338
4. Outside interests—effect on design.....	339
5. Economic balance of cost..	340
6. Concrete construction.....	340
7. Bridge seats.....	341
8. Protection of pier surfaces.	341

ORDINARY BRIDGE PIERS

9. External forces.....	342
10. Location.....	344
11. Top dimensions.....	344
12. Foundation dimensions....	345
13. Batter.....	345
14. Pier ends.....	345
15. Nose protection.....	345
16. General.....	346
17. Pier dimensions.....	346
18. Quantities.....	346

ABUTMENTS

19. Structural elements.....	346
20. Breast abutment.....	349
21. T abutment.....	349
22. U abutment.....	350
23. Pulpit abutment.....	350
24. Wing abutment.....	350
25. General.....	351
26. External forces.....	353
27. Retaining wall characteristic.....	353
28. Dimensions.....	354
29. Wings.....	355
30. Backwall.....	355
31. Toe.....	356
32. Dimensions.....	356
33. Coping.....	357
34. Quantities.....	357
35. Hollow and arch abutments	357
36. Buried abutments.....	362
37. Reinforced concrete abutments.....	362

CONTENTS

xiii

ART.	PAGE	ART.	PAGE
BASCULE BRIDGE PIERS			
38. Counterweight pits in general.....	362	43. Unit stresses.....	371
39. Types and sizes of counterweight pits.....	364	44. Materials.....	371
40. Clearances.....	367	a. Concrete mixture.....	371
41. Watertightness.....	368	45. Construction.....	372
42. Loading conditions.....	369	46. Testing.....	373
a. Pit proper.....	369	CYLINDER AND PIVOT PIERS	
b. Foundations.....	370	47. Hollow and cylinder piers..	373
		48. Pivot piers.....	374

Section 8. Application of the Law Relative to the Engineer

1. General.....	375	4. Texture.....	385
2. Common law.....	376	5. Structure.....	386
3. The common law of lateral and subjacent support	377	6. Relationship of texture and structure.....	387
4. Independent contractor... ..	378	7. Soil factors.....	388
5. Duty to employ a competent contractor.....	379	8. Defining and identifying terms.....	389
6. Injunctions.....	379	a. Texture.....	389
7. Blasting.....	379	b. Structure.....	390
8. Statutory legislation.....	380	c. Consistency.....	391
9. Ordinance requiring notice.	380	d. Compactness.....	391
10. Conclusion.....	381	e. Cementations.....	391
		f. Chemical composition..	392

Appendix A

CHARACTERISTICS OF SOILS

1. General.....	383
2. Soil profiles.....	384
3. Characteristics and properties.....	384

Appendix B

FORMULAS FOR BEARING POWER OF PILES

Limitations of formula.....	400
Static formula.....	401

INDEX.....	403
------------	-----

FOUNDATIONS, ABUTMENTS AND FOOTINGS

SECTION 1

SOIL INVESTIGATION

TESTS TO DETERMINE SOIL CONDITIONS

The extent of subsurface exploration and the methods used in its procedure will depend upon the purpose for which it is to be made. Studies of subsurface conditions may be divided into two main classes: (1) those made for preliminary or general data and (2) those made for data to be used in final designs for foundations or earth structures. The extent of each will also depend upon the importance, size, and type of the proposed structure and upon the soil conditions both at the immediate site and in the surrounding area.

In preliminary study, it is desired to obtain a general idea of the soil profile and the location of rock. This information aids in the selection of possible types of foundation and also determines the necessary extent of final exploration. For final study, suitable final samples should be taken. These samples should be obtained from points well distributed over the proposed area and at a depth that is consistent with the size of the proposed foundation. Samples should be representative of the natural conditions and should be secured with the minimum of disturbance.

The use of samples to establish and to evaluate the characteristics of the types of soil that determine its probable behavior under load is a comparatively recent practice. It has led to securing the so-called "disturbed" and the "undisturbed" sample. Characteristics of soil will be considered in Appendix A.

An adequate consideration of the art and science of soil sampling is beyond the scope of this work. In a plan to study and devise better methods of sampling, the American Society

of Civil Engineers has created an official committee on Sampling and Testing. As a first step in this tremendous task, Dr. M. Juul Hvorslev, Research Engineer to the committee, has prepared a report entitled, "The Present Status of the Art of Obtaining Undisturbed Samples of Soils." This report is highly recommended for a detailed study of soil sampling. Much of the data appearing under consideration of soil disturbance, methods of subsurface investigation, samplers, and sampling methods, was taken from this report.

Dr. Hvorslev recommends the terms "preliminary undisturbed sample" and "final undisturbed sample." The preliminary sample is taken with a modern sampler, 2 to 3 in. in diameter. Care should be exercised to create a minimum of disturbance, and continuous samples should be taken. When intermittent samples are taken, the danger of missing thin layers of soil types is probable. These layers may be of structural importance and, because of their absence in the record, erroneous conclusions may and often do result. If continuous samples are taken, accurate representation of the soil profile can be made. Furthermore, these samples are suitable for many laboratory tests but are unsuitable for consolidation, shear, and permeability determinations.

The final undisturbed sample is taken with a modern sampler having a diameter varying from 4 to 8 in. The samples should be taken preferably in test pits or bore holes. They therefore represent the most expensive method of soil investigation. The required number of samples can be materially reduced if adequate preliminary sampling and study have been completed. The establishment of a reliable soil profile will show conclusively where the large-diameter samples are necessary. The demand for such samples for the final design of large important foundations and earth structures is increasing.

1. Disturbance Due to Sampling.—The basic disturbances to which a soil sample may be subjected during the sampling operation are

- Changes in stress conditions.
- Changes in water content or voids ratio.
- Disturbance of the soil structure.
- Changes in thickness of soil layers.
- Mixing of the soil layers.

The changes in stress condition due to sampling are unavoidable. In cohesive soils, the release of the external stress results in an adjustment of the internal stress. The change in stress conditions within the sample is affected by the types of soil and types of samples and methods of sampling. The extent and the permanence of these changes have an effect upon the results of certain laboratory tests.

Changes in water content result from the variation in stress distribution during the sampling process. This change will affect the results of certain rapid tests. Where the original stress condition is approximately restored, laboratory test results on slow shear, or triaxial tests, are only slightly affected, provided the capillary pressure has not been changed in the sample.

Changes in thickness of soil layers result from swelling of the soil when the stress is released or from displacements below the edge of the sampler. Samples disturbed to an appreciable extent are suitable only for grain size, liquid, and plastic limit determination. Unless correction is made in plotting for the change in layer thickness, the soil profile will not be representative of actual conditions.

The mixing of soil layers results in serious disturbance. It makes the sample practically worthless. These samples may be used for the determination of the average character of the soil penetrated, provided that only the layers in close proximity have been mixed.

The disturbance of the soil structure cannot be wholly avoided. In any method of sampling, even the so-called "undisturbed sample," some disturbance of the structure results. In seriously disturbed samples, the soil structure is ruined. For laboratory tests, the value of the sample is reduced according to the degree of disturbance. The original structure cannot be restored in the laboratory. In obtaining the final undisturbed sample, careful workmanship and the use of large-diameter samplers tend to confine the disturbance to a thin layer over the surface of the sample.

2. Methods of Investigation.—The methods used to study sub-surface conditions are sounding rods, auger borings, wash borings, geophysical methods, test pits, and core borings. Soil samples are taken in some of these methods; in others, no samples are secured. The method best suited for a particular investigation

will depend upon its purpose, upon the extent and importance of the proposed construction, upon the extent of reliable data available, and upon the uniformity of soil deposits within the immediate area. For preliminary study, methods where no samples are taken are sometimes used. However, in other cases, continuous samples of small diameter are often taken for important or intensive preliminary study. For final study to establish design data, methods that produce samples with a minimum of disturbance should be used. In general these are continuous samples of large diameter and may be taken from the surface to ordinary depths or from test pits or bore holes at greater depths. Certain methods suitable for preliminary study may, when used in conjunction with undisturbed sampling, be useful in final investigation and study.

3. Sounding Rods.—The sounding rod is made from a solid bar of tool steel $\frac{5}{8}$ to $\frac{7}{8}$ in. in diameter, depending on the material to be penetrated. The bottom section should be pointed at one end and threaded for an outside coupling at the other. Where the earth is of such a nature that the bar can be churned down 6 or 8 ft. by hand, as is usually the case, the bottom rod should be from 10 to 12 ft. in length. This will eliminate one coupling and will decrease the friction for both driving and pulling of the rods. Additional sections 4 to 5 ft. in length, threaded at both ends, should be provided in sufficient number to reach the desired depth. After being worked down as far as possible by hand, the rods are driven with a 10- to 12-lb. maul or hammer. The drive end of the rod should be provided with a special drive cap fitting over the rod and cushioned with hard wood to prevent injuring the threads. Fourteen-inch Stillson wrenches are used to add additional sections and in taking them apart.

Driving resistance is difficult to interpret. In the past, records were taken only at intervals, and the amount of resistance was further affected by resistance between the side of the rod and the soil mass penetrated. Modern test rods are enclosed within a pipe, which eliminates the friction on the drive rod. Point resistance is therefore the only recorded resistance to driving. When this resistance is continuously recorded, a fairly good idea of the soil profile and an indication of the bearing capacity or the necessary length of piles may be obtained.

In general no samples are taken. However, in some cases, a pipe used instead of the cone point recovers material. Modern sounding rods, if properly handled, can furnish fairly reliable data on the approximate location of various strata, the required length of piles, or the approximate location of bedrock. The method does not, however, supply data necessary for final design.

4. Auger Borings.—The earth auger is much used in investigating soil conditions. Its field is limited, however, to such materials as will stay in the helix of the auger until brought to the surface; thus its use is confined to dry earth, clays, and other combinations in which there is sufficient clay to make the material cohesive. It is especially difficult, if not impossible, to make auger borings in earth other than clays, where water cannot be kept out of the borehole. The earth auger is very often used to advantage in combination with other methods of making borings, especially in starting the boring where better speed can be made with the auger than with the chopping bit.

For some purposes the ordinary 6-in. posthole auger will suffice to secure the desired information. Although it is adapted to shallow holes only, holes to a considerable depth can often be drilled with such an auger by welding a short piece of gas pipe on the stem and adding additional sections of pipe. The posthole auger is especially adapted for examining the soil to a depth of from 4 to 6 ft. below the bottom of proposed footings, after the excavations for the footings have been made.

Earth auger outfits consist of a derrick and hoist (similar to the derrick and hoist described later for wash borings), auger bits adapted to the soils to be drilled, pipe or drill rods in sufficient quantity to reach the desired depths, drive pipe casing having a drive shoe at the bottom and a drive head at the top, a ram for driving the casing, pulling block for pulling casing, and such small tools as may be required in the work.

In drill operations three to six men are used, depending on the depth to be drilled. The derrick and hoist are used to raise and lower the auger and drill rods, in driving the casing or drive pipe, and sometimes in pulling the casing after it has begun to pull easily. The auger is turned down by the men with levers or wrenches attached to the rods. When the auger bit has been turned its length into the material being drilled, it is pulled out

and cleaned, then lowered again, and the operation repeated. So long as the material is of such a nature that it will cling to the bit and be brought to the surface, good progress can be made by this method of drilling to a depth of 50 or 60 ft. Below this depth much time is required in taking out and replacing the rods. For larger diameter holes of comparatively shallow depths, special boring rigs using the rotary table are available. The rigs are capable of boring holes of 24 to 30 in. in diameter. Larger samples and the opportunity for visual inspection are offered.

If sand or gravel, or wet material that will not stand, is encountered, then the hole should be cased. This is done by removing the bit and drill rods and driving a casing of such diameter that the bit and rods will pass freely through it. On the bottom of the casing is a drive shoe having a beveled cutting edge to cut the earth as the casing is driven down. The casing or drive pipe should be made in sections about 5 ft. in length, and consists of ordinary pipe threaded at each end and connected together with ordinary outside couplings. After driving until a low penetration per blow is reached, the bit is put back, the casing cleaned out, and the bit worked ahead of the casing. The operation from this point on now consists of alternately drilling and driving the casing until the need of the casing is past or the boring completed. Better time will usually be made by drilling only a few feet ahead of the casing before pulling the rods and driving the casing.

When sand or gravel, or other material that will not be brought up by the auger, is encountered, the casing should be cleaned with a water jet; sometimes a sand pump is used. The sand pump is an ordinary piece of pipe, small enough in diameter to go down the casing and having at its bottom end a special valve. It is lowered into the hole by a rope and churned up and down until filled, when it is brought to the surface and emptied and the operation repeated. Often water must be poured into the hole to make the material "soupy" so that the sand pump will fill. Clean, heavy, compact sands cannot be removed with a sand pump, and when such material is encountered it must be washed out with a water jet. For this purpose a line of $\frac{3}{4}$ -in. pipe, open at the lower end, is lowered into the hole. The top of this pipe line is connected with a force pump, or with a water supply under pressure. The pipe then being lowered to the sand

and the pressure turned on, the sand is brought to the surface by the force of the jet. Under these circumstances, the so-called "dry sample" is taken. This is also sometimes practiced in wash boring operations and will be taken up in the consideration of that method.

Where boulders are encountered, they should be broken up by using a chopping bit on the bottom of the drill rods, in the place of the auger bit, or by the use of dynamite, both of which processes are described under wash borings.

Samples are obtained by removing the soil from the threads of the auger. Soil layers may be identified but the sample is very much disturbed. Furthermore, when uncased holes are used, there is great danger of mixing the layers. Samples obtained by this method are therefore suitable only for classification purposes. They cannot give reliable information regarding the soil structure, its water content, or its degree of compaction.

5. Wash Borings.—In the past, wash borings have been extensively used to study subsurface conditions. The method essentially consists of forcing or sinking a jet pipe into the soil. The displaced soil is washed to the surface. Because of this, one soil layer is thoroughly mixed with another and the whole is mixed with drilling mud. Samples are taken from the sediment collected in a stilling basin or wash-water tub at the surface. Much if not all of the fine material is washed away. Only a very approximate depth of most widely varying soils can be determined provided they are of considerable thickness. Thin layers may not be detected at all. Very little if any more reliable information can be gained by this method than by the use of sounding rods. It is essentially useful to locate bedrock but it is more costly than the use of test rods.

In making test borings it is often necessary to start with a larger diameter casing and drill rods, going as far as possible with these, then telescoping a smaller diameter casing inside, and continuing the hole with the smaller casing and smaller rods. The method may be suitable for preliminary investigation under suitable soil conditions to depths of 100 ft. or more.

5a. Equipment.—The necessary equipment consists of drill rods, the casing, chopping bits, derrick, drive weight, water pump, hoists for raising and lowering the rods, standard

couplings, and necessary accessories. This equipment may be secured from manufacturers of well-drilling or diamond-drill materials and units.

The drill rods should be made up of extra heavy pipe. They may be cut to a diameter of $1\frac{7}{8}$ in. or of 1 in. and are usually made in lengths of 4 to 5 ft. The pipe or rods are threaded on the inside with square threads into which are screwed special couplings, about 6 in. long, of sufficiently heavy metal to make the joints as strong as the rods themselves. These joints are flush throughout their length and should be very accurately fitted together so that a full bearing of the rod with the coupling is secured when they are screwed together. This is an important feature and should not be overlooked.

The casing should be made from lap-welded steel pipe and, for the $2\frac{1}{2}$ -in. casing, may be made from extra heavy pipe if the work to be done is of a difficult nature. Extra heavy pipe cannot be used for the $1\frac{1}{2}$ -in. casing as there would not be clearance for the 1-in. rods. The $2\frac{1}{2}$ -in. and the $1\frac{1}{2}$ -in. casings are made from $2\frac{1}{2}$ - and $1\frac{1}{2}$ -in. pipe, respectively.

The $1\frac{1}{2}$ -in. casing should be flush jointed to telescope inside the $2\frac{1}{2}$ -in. casing. It is advisable, although not necessary, that the larger size also be flush jointed. If outside couplings are used, the friction of the earth against the pipe will be much greater and the casing will have to be driven. With outside couplings, the casing is also more difficult to pull.

Flush-joint casing should have square threads, each piece, except the bottom one, having a male thread at one end and a female thread at the other. The bottom section should be plain pipe, square cut at the bottom, with a female connection at the top to protect the threads. These connections should be accurately milled at both top and bottom of the connection so that a full bearing will be obtained at both ends of the thread when the pieces are screwed together.

It will be of great advantage to have both the drill rods and the casing cut to length, so that it will not be necessary to measure each piece as it is added in the drill operations. The combination lifting and water swivel is used in raising and lowering the rods, and allowing them to be worked back and forth or around in drilling, with the water passing through to wash up the choppings from the bit.

The cross chopping bits are made of hardened steel and may be of the chisel, fishtail or X-shaped types for chopping and breaking up the earth. Four holes near the bottom of the bit allow the water to escape and are so drilled as to throw the force of the jet downward to the cutting edges.

An ample water supply under strong pressure is essential in the wash boring process. In city work where access to the city supply may be had, the hand force pump will usually not be necessary. In such cases sufficient water hose, or a pipe line, will be required to reach the supply, in addition to the equipment enumerated. Where such supply does not exist and where there is no pond or stream in the vicinity of the boring, it will be necessary to haul the water. This at times is a costly undertaking.

The derrick should be strong and substantial, and should be so constructed that it can be quickly taken apart or put together, if subject to numerous long moves. It may be made of wood or pipe.

Very often a "jack plank" is used in drilling. This consists of two 2 × 12-in. planks, one 16 ft. long and the other 12 ft. long, bolted together in the form of a T, the 16-ft. plank being the stem of the T. The two legs of the derrick stand upon the top of the T and the single leg on the far end of the stem. This jack plank gives a firm support for the derrick and also provides a support for the tongs in operating the casing.

Four to six or more men are required in drill operations by hand, depending on the depth of the hole and other difficulties attending the work.

The drill and pump may also be operated by power, a 3- to 5-hp. gasoline motor being the most satisfactory outfit for such purposes. The engine should be equipped with a hoist for raising and lowering the rods, and should have a special "nigger-head" on which the rope is operated, in churning the rods in drilling. Two men are required to operate a power outfit.

5b. Methods in Detail.—In starting a bore hole, it is of considerable advantage, where the ground will stand, to drill as far as possible either with a larger chopping bit, or with an earth auger slightly larger than the casing to be inserted. This reduces the friction and is often of great help in difficult work. As soon as caving or running ground is encountered,

the casing should be started. This is done by inserting the plain end of the bottom piece of 2½-in. casing in the hole that has been started. A pair of Brown's No. 4 pipe tongs are then clamped to the casing by means of one of the sections of 2-in. gas pipe, 3 in. long, driven over the handles of the tongs. The casing and tongs are then lowered until the tongs rest upon the jack plank, or other support if a jack plank is not used. Another piece of casing is then screwed into the lower section, the tongs raised to the top of the added section, and the two sections lowered as before. This process is repeated until the casing reaches the depth drilled before the casing was started, or until it binds in the hole. If not down to the depth previously drilled, the casing can usually be worked down still farther by turning on the tongs; when it cannot be advanced any farther by turning, the drill rods are inserted. In adding the sections of casing, should they become too heavy to handle by hand, the bushing is screwed into the top section and the casing then lowered by the derrick and hoist.

In starting the drill rods the cross chopping bit is screwed to the end on a drill rod. As the bit and rods are worked down, sections of drill rod are added until the bit has been forced some distance ahead of the casing; the rods are then raised until the bit is up in the casing, and the casing then turned down as before. The rods are supported, raised, and lowered by the rope attached to the bail of the water swivel and passing up over the sheave wheel and down to the drum of the derrick to which it is fastened. By means of the handles the men can hoist the rods with ease.

In drilling, the drum is made fast, with the bit resting on the earth, a few inches of slack being provided to allow the bit to advance into the earth. The rods and bit are then given a churning motion, by the men alternately pulling back on the rope and suddenly releasing it, causing the bit under the impact of the rods to hit the earth with considerable force, the drop usually being from 6 to 12 in. As the bit strikes, the foreman, who has hold of a pair of tongs clamped to the rods, gives the rods a turn of about 90 deg., loosening the earth into which the bit has sunk, which is then washed to the surface between the rods and the casing by the jet from the force pump. In some material, as sand or gravel, the rods cannot be churned down ahead of the casing on account of the sand filling in as

fast as the rods are pulled out of it. In such situations the rods and casing should be worked down together, this being done by turning both rods and casing at the same time, the bit being at about the level of the bottom of the casing.

When the casing becomes tight it can often be loosened by pulling it up a few feet and working it down again, repeating the operation several times if necessary. When the casing cannot be worked ahead any farther, the drill rods should be pulled out and the smaller casing and rods inserted, when drilling can be continued as before. If the drilling is in hard material that stands well when the larger casing stops, the larger rods should be worked ahead as far as possible before the smaller casing is put in. The rods and casing being of the same diameter, the smaller casing can often be worked many feet ahead of the larger casing without the friction that would result if the smaller rods were inserted as soon as the larger casing becomes stuck. It may happen in some localities that it will not be possible to reach the rock or the desired depth with two sets of casing; in such situations 3-in. casing may be used at the top, with a larger-sized bit on the $1\frac{7}{8}$ -in. drill rods. Owing to the increased area of the space between the rods and the casing, the volume of water will have to be much increased; if this cannot be accomplished by higher pressure by the pump, a larger pump will be required. Pump capacities vary from 20 to 60 gal. per min. The pressure should be at least 50 lb.

By the methods just described, the casing is always comparatively loose. When it becomes tight a smaller diameter casing is telescoped inside and the work proceeds with smaller casing and rods; in this way the friction of the earth against the casing is eliminated for the depth of the larger casing.

Another method for making wash borings, much used in some localities, is by driving the casing. Where the casing is to be driven, it is advisable to use ordinary pipe with outside couplings, as the flush-joint casing will not stand heavy driving. The casing is shod with a steel drive shoe with a beveled cutting edge. At the top is a steel drive head into which is screwed a hollow guide, the center of the drive head being drilled out to allow the drill rods to pass through. A heavy jar weight, about 300 lb., is raised by means of a rope over a sheave at the top of the derrick and dropped over the hollow guide; striking the drive head forces

the casing into the earth. Flush drill rods, such as already described, are used in drilling, the bit being pulled up in the casing while the casing is being driven. A short top piece of perforated casing should be used to allow the escape of the water and should be taken off of the casing in place and added to the new sections as they are put on. Two ropes, one operating the drill rods and the other the jar weight, are used in this method of drilling.

The casing can often be pulled by the use of the derrick and hoist alone; often a block and tackle are used, and the chain hoist is sometimes employed. The lever and chain, however, are probably used more often than anything else. When the casing becomes stuck and cannot be pulled by any of the above methods, casing clamps are fastened to the casing and jack screws used to start it. After it has been loosened a little it can be pulled much more rapidly by one of the methods already described. A more satisfactory appliance than the bolted casing clamps is the pipe puller. This is a cast-steel block with a hole through it considerably larger than the pipe to be pulled; this block is set over the casing to be pulled and wedge sections made to fit the casing are inserted. Jack screws are used under the pulling block to start the casing. When the jacks are loosened a blow of a hammer causes the wedges to drop out and the block to become loosened.

In making investigations of the soil under rivers, lakes, and other bodies of water, a scow or catamaran may be used if the holes are comparatively shallow, and the casing can be pulled without the use of jack screws. In deeper and more difficult work under water, piles are driven, a working platform constructed, and drill operations carried on from this platform as on land.

When obstructions are encountered in drilling that cannot be broken up and passed by the chopping bit, the hole is thoroughly washed out and a charge of 40 per cent dynamite lowered to the spot and exploded. If the obstruction is a small boulder, a single charge will usually suffice to clear it. If it is a large boulder, several charges may have to be used before any impression is made upon it. If it is a very large boulder, or bedrock, any number of charges will have but little effect. In working through hard clay or hardpan, it will be found impossible to force the casing through it by the methods described above. In

such cases the drill rods are worked ahead of the casing a few feet, 6 to 8 ft. perhaps, and a string of dynamite used. This is made by connecting a number of sticks of dynamite end to end separated by small sticks of wood 12 to 18 in. long. The exploder is usually inserted in the lower stick, the others being exploded by concussion. In using dynamite, the casing should always be pulled up several feet above the charge to be exploded, otherwise the casing will be damaged, perhaps so badly as to require the abandonment of the hole. For a single stick of dynamite, the casing should be raised 3 to 4 ft., but for the very heavy charges it may have to be raised 6 to 8 ft., or more.

To determine accurately the depth to, and the thickness of, the various strata encountered and for the proper placing of dynamite, it is necessary to know at all times the exact amounts of drill rods and casing that are in the hole. A record should be kept and each piece of rod and casing entered as it is put on, and the totals extended so that the drill foreman knows instantly the exact location of both rods and casing with respect to the surface. As stated before, if the rods and casing are cut to length, the matter of measurements is much simplified.

5c. Records and Samples.—Since sounding rods and wash borings are extensively used, a further comparison of these methods will be made. In wash borings the cuttings are caught in a bucket as they are washed to the surface and allowed to settle; but, although such samples show the kind of earth passed through, they do not show the nature of the material in place as to its hardness and suitability for foundations.

Such samples are therefore hopelessly mixed. Furthermore, the fine materials are washed away and larger material may not be forced up by the wash water. At best, they can only furnish data on the approximate depth of different soil layers provided each is of sufficient thickness. Because of the mixing of layers and the materials lost in the wash water, the existence of thin layers may not be detected. Although some idea of the bearing capacity may be shown by the resistance to jetting or sinking, the samples are worthless for soil tests. The chief information obtainable from this method is the location of rock, provided care is taken to ascertain that boulders are not encountered.

In an attempt to obtain a better sample, the so-called "dry sample" method is sometimes used. This sample is obtained by

withdrawing the jetting pipe and forcing a sampling tube into the soil. Generally no precaution is taken to reduce disturbance and, even though a representative section may be obtained, the sample is useful for classification purposes only. Furthermore, since they are taken only at intervals, thin but important soil layers may not be detected. Again an indication of bearing capacity is obtained by recording the force required to push the sampler in the soil.

The dry sample method is extensively used. In the hands of experienced and careful operators, it can furnish dependable data. The method is relatively cheap and can be carried on rapidly. It is inferior to modern methods of continuous sampling. When samples and records are not carefully taken, erroneous conclusions very often result.

Wash borings are more costly than the use of modern sounding rods and the information is seldom, if ever, any more adequate. Neither wash borings nor dry sampling will furnish data suitable for the final design of an important structure.

6. Geophysical Methods.—Geophysical methods of subsurface exploration were developed for use in geologic and mining investigations. For foundation purposes, investigation of large areas may be quickly and economically completed by use of these methods. Reliable information can be obtained for the location of rock and the approximate depth of different soil layers. The layers are located by the measurement of the varying rates of transmission of vibrations through them. The vibrations may be caused by artificial explosions or by continuous vibrations of known frequency. Since only the general character of the soil and the approximate location of rock can be determined, these methods are suitable for preliminary investigation only. They are practical for preliminary study of dam sites and highway location. Obviously no samples are taken. The methods cannot, therefore, serve for final design.

7. Test Pits and Bore Holes.—The test pit affords the most complete means of subsurface exploration. It is, however, the most expensive, especially where deep pits are necessary. For depths over approximately 25 ft., holes 24 to 36 in. in diameter may be bored by power core drills or augers.

These methods make possible the visual inspection of soil layers in place, and the conditions to be met in actual building

operation may be studied in their true relation. The firmness of the material, its water content, the tendency to run or cave, and the necessity for sheeting and bracing become evident as excavation proceeds. Test pits are often 4×6 or 5×10 ft. in plan. They will in general cost about \$10 per foot, depending on the cost of excavation and sheeting.

On work involving large quantities of excavation where but little is known of the earth stratification, test pit examinations should be made in connection with sounding or boring tests. Usually only an occasional test pit will be necessary, but test pits are invaluable in giving a complete understanding of the difficulty of foundation construction in an unknown locality. Usually one test pit to 12 or more borings or soundings will be all that is required. Materials excavated may be piled in the order in which they are taken from the pit. A better idea of the amount and kinds to be handled may be determined because the effect of disturbance and the possible amount of swelling will be shown.

The necessity for bracing and sheeting will depend upon the depth and kinds of materials encountered. The danger of failure increases as the depth below the water table increases. In these cases well points may be used to lower the ground-water table. Well points should not be placed within the pit unless it is certain that instability will not result from the up flow. In cases where samples are taken, positive assurance against up flow should be made.

Test pits provide an opportunity to secure laboratory samples at various depths by the use of surface sampling methods. It should not, however, be assumed that the soil at the sides and bottom of a test pit is entirely undisturbed, before sampling is done. There may be considerable disturbance.

Bore holes are essentially small test pits. They are made to be used above or below ground-water level. The stress condition of the sample is dependent upon whether the sample is taken above or below ground-water level and whether the bore hole is dry or filled with water, or if drilling fluid is used. In general it is possible to take samples with less disturbance in test pits than in bore holes.

8. Samplers and Sampling Methods.—The method used in obtaining preliminary or final undisturbed samples will depend

upon the conditions under which they must be taken. In surface or open-pit sampling, large samples of cohesive or slightly cohesive soils may be cut free and enclosed in a suitable box. The space surrounding the sample is filled with compacted damp sand or paraffin and the box sealed to preserve the sample in its

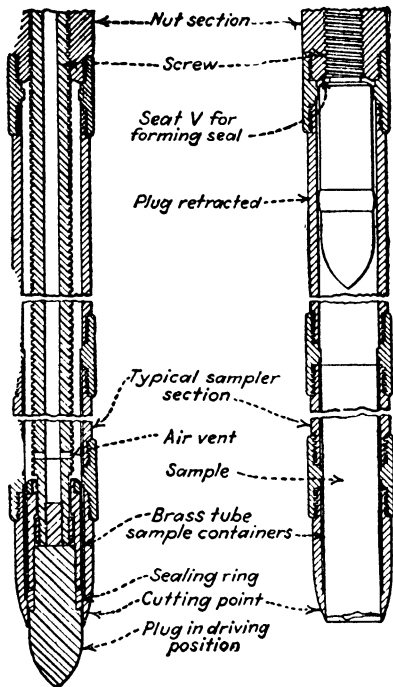

FIG. 1.—Lower end of Porter soil sampler. *Jacoby and Davis, "Foundations of Bridges and Buildings," 3d ed.*)

original condition. In very soft or cohesionless soil, short tubes may be forced into the soil. Details of samplers of this type vary widely. One type consists of beveled steel tubing held in a suitable frame by exterior lugs. After being removed, the tube containing the sample may be sealed by use of suitable caps and adhesive tape.

Subsurface sampling may be done by procuring samples from test pits or bore holes and from cased or uncased test holes. In the first case, it may be done by methods suitable for surface sampling unless samples from depths greater than that of the test or bore hole are desired.

For deep samples the piston sampler is commonly used in uncased holes or in holes cased for a certain part of their total depth. To procure samples from great depths with a minimum of disturbance, modern composite samplers are used in cased holes.

Several types of piston samplers have been developed. The Proctor sampler may be chosen as representative of this type. Figure 1 shows the lower end of the Proctor sampler with the piston in the driving position. The sampler is attached to a drive head, extension tubes, and piston rod assembly and is driven to the desired depth by hand or by the use of a light power hammer. Jetting methods are sometimes used. When the

desired depth is reached, the piston is retracted and the open tube is forced into the soil. A vent allows the escape of air and water as the soil sample enters the tube. The piston is then retracted further to close the vent, thus producing an airtight seal above the sample. The sampler is then withdrawn to the surface by the use of a hand jack.

This sampler usually obtains samples 3 to 4 ft. long. The sampling tube is divided into sections varying in length from 2 to 6 in. Samplers are made in diameters of 1, 2, and 5 in. In the small diameter the sampling tube is not divided but is fitted with a liner that consists of 6-in. sections. The 5-in. sampler is used in cased holes and for the sampling of coarse materials. The 1-in. sampler is suitable for preliminary study for depths up to 50 ft.

This sampler has been widely used since 1933. It is reported to give good results in all classes of materials, ranging from loose cohesionless soils to those having a hardness of soft rock.

Cased bore holes should be used when taking final samples in cohesive and plastic soils. Since the soils do not offer excessive resistance to penetration, drive samplers are most commonly used. By proper care in driving the casing and sampler and in clearing the bore hole, suitable samples may be obtained.

The simplest type of continuous sampler that has been widely used in the past is a piece of sharpened steel pipe fastened to a drill rod. Because of the difficulty of removing the samples, this method was abandoned. The substitution of strong thin-walled steel tubing for the heavy steel pipe has again brought this method into practice especially for preliminary investigation. The steel tubing is used only once and is cut into the desired length in the laboratory.

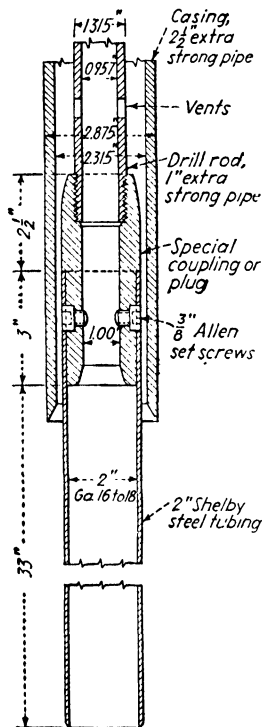

FIG. 2.—Shelby tubing sampler, by H. A. Mohr. (Jacoby and Davis "Foundations of Bridges and Buildings," 3d Ed.)

Several methods are used to fasten the tubing to the drill rods. A method suggested by H. A. Mohr and shown in Fig. 2 consists of a special coupling. The coupling fits into the tubing and is provided with a collar that transmits the driving force to the tubing. The pulling force for withdrawing the sampler is transmitted to the tubing by two Allen setscrews.

During the last decade many changes have been made in samplers. These changes are primarily to provide for the removal of the sample and to control the forces acting on it. A few examples taken from the work of Dr. M. J. Hvorslev will be given. The Moran and Proctor sampler is shown in Fig. 3.

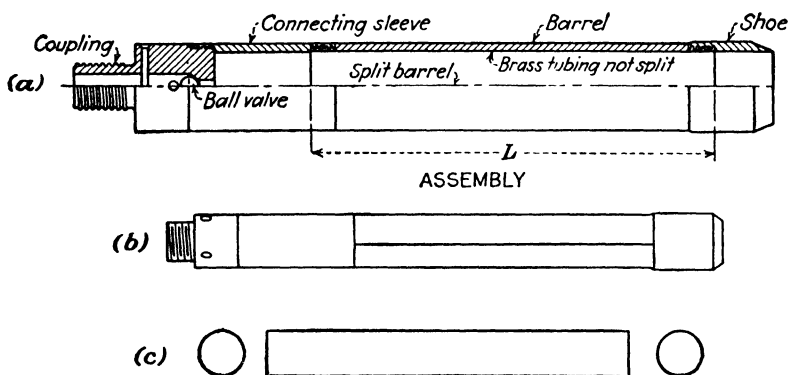

FIG. 3.—Moran and Proctor sampler. (*Krynine, "Soil Mechanics."*)

This apparatus has a split sampling barrel, which holds a brass tube. The barrel is held by the sampler shoe and a short piece of heavy pipe. The cutting edge is beveled to provide an inside clearance. This sampler is manufactured by Sprague and Henwood and by the American Instrument Company. Two sizes are available, one 1.5 in. in diameter and the other 3 in. in diameter. The lengths of samples obtained are 12 and 16 in., respectively. This sampler has been used to depths of 273 ft.

The M.I.T. sampler introduced the use of a piano wire to cut the sample free from the soil below. This eliminates the necessity of rotating the sampler in order to free the sample. This sampler was designed by members of the faculty of the Massachusetts Institute of Technology to secure samples 4.76 in. in diameter and 24 in. long. It was later modified by Casagrande, Mohr, and Rutledge and is shown in Fig. 4. Provision

is made to pull the cutting wire free of the sample during removal. This eliminates the danger of damaging the specimen during the withdrawing process. Two air lines or ports are used. One introduces pressure at the bottom of the sample and a vacuum is placed at the top of the specimen by the other during the withdrawing process.

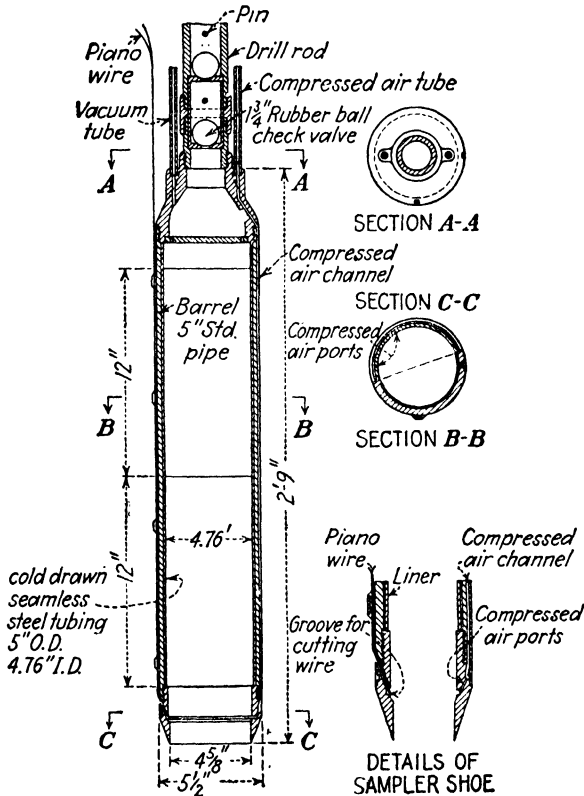

FIG. 4.—Casagrande-Mohr-Rutledge sampler. (Krynine, "Soil Mechanics.")

For sampling in cohesionless soils several types of samplers using core retainers in the form of flap valves are used. Suitable samples are very difficult to obtain. Because of the lack of cohesion, samples will not stay in the sampler without support. Sampling tubes can be forced only a comparatively short distance in coarse material by steady pressure. Driving causes vibrations that disturb the soil structure. For details of samplers, reference

is made to the catalogue of Sprague and Henwood. The Sand Pump, the Door, the Split-barrel, or the Maine type sampler is suitable where samples are used for visual inspection and classification.

To reduce disturbance, emulsions or chemicals are injected, or a method of freezing is sometimes used. Either method may be applied to the lower part of the sample within the tube, or the soil mass at the sampling points may be solidified. The latter method is sometimes used as deep-seated stabilization to improve bearing capacity.

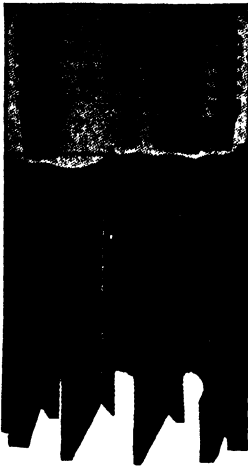

FIG. 5.—Davis cutter. (Jacoby and Davis, "Foundations of Bridges and Buildings," 3d ed.)

9. Core Sampling.—For obtaining samples in highly compacted, moderately hard or brittle materials, core drilling methods are used. The Davis cutter, shown in Fig. 5, consists of a steel cylinder of special composition. Teeth forged to the cylinder are set for clearance inside and out. The core is not touched by the teeth because of the inside clearance. The water and the cuttings rise in the clearance provided outside of the bit. The latest development in the toothed cutter is the calyx cutter which is provided with removable steel teeth. This cutter is shown in Fig. 6. The steel teeth may be sharpened on any ordinary emery wheel or grinder.

The double core barrel, shown in Fig. 7, is designed for drilling in soft or friable formations. The inner core barrel is hung from a rotation plug by means of a spindle. The inner core barrel can, therefore, remain stationary while the outer core barrel and cutting bit rotate. The core is thus protected against damage. The core lifter consists of a light steel ring, split in halves and held together by a steel snap spring resting in a taper on the bottom of the core-lifter shell. During the drilling process, the core passes into the inner core barrel through this ring. When the tool is withdrawn, the ring grips the core owing to the wedging effect of the taper of the shell. The core will be firmly held until it is broken off and lifted to the surface.

10. Core Borings.—Rock drilling may be necessary for excavation or exploration purposes. Methods and machinery used in rock drilling for excavation will be covered in the following section. For exploration purposes, rock is drilled for some distance to prove that boulders or thin rock layers are not

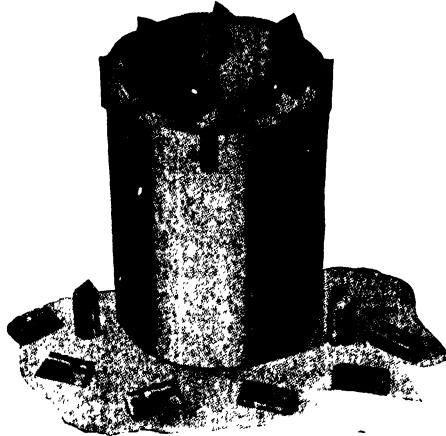

FIG. 6.—Calyx cutter. (*Jacoby and Davis, "Foundations of Bridges and Buildings," 3d Ed.*)

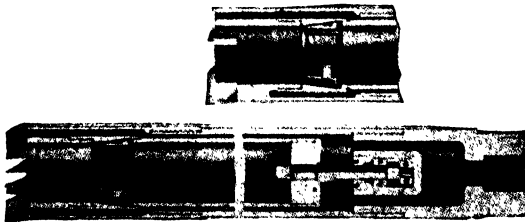

FIG. 7.—Double-core barrel.

mistaken for bed or ledge rock. To establish the character of the rock, samples are taken by core drills.

As the name implies, the core drill produces an exact core sample of the material penetrated, so that the information obtained by core drilling is accurate and reliable.

The essential equipment for this work consists of drill rods and casing, a rotary power plant, derrick and hoisting apparatus, force pump, and an automatic feed for forcing the drill bit into the rock.

Before core drilling operations can start, it is necessary to drive the standpipe or casing down to rock and to seat it in the rock and thus effectually shut out all sand and earth that would tend to enter the bore hole from the surface of the rock if the casing were not driven. This often proves a difficult and costly operation, especially if it must be driven through sand, gravel, and boulders. This standpipe or casing is the same, in essential details, as that used and described for wash borings and is driven to rock by one of the methods there described. There is one difference from wash borings, however, and that is that in core drill work the casing must be seated into the rock, whereas in wash borings holes are often completed without driving the casing all the way to rock.

There are two principal types of core drills: (1) the diamond drill, using black diamond or carbon as an abrasive to cut the rock, and (2) the shot drill, in which chilled shot is the abrasive agent. The essential features of the two operations are practically the same.

10a. Diamond Drill Method.—In making diamond drill borings, the drill rods carry a soft steel bit at their lower end, into which are set small pieces of black diamond or carbon, which, as the bit is rotated, cut an annular hole into the rock, leaving a center core undisturbed. Water, forced through the drill rods by the force pump, washes the cuttings to the surface and keeps the bit cool. Just above the bit is a core barrel, usually about 10 ft. in length, having at its bottom end a core lifting device, which passes smoothly over the rock core as the rods are fed downward but automatically grips and breaks the core when the rods are raised. When the core barrel becomes filled, or oftener if desired or conditions require, the rods with the core barrel are pulled to the surface and the core removed.

By keeping a careful record of the drilling process and of the core as it is removed, the location of the different rock strata, the thickness of the various strata, and the nature of the rock are known. Separating layers of clay or soft rock will be indicated by a loss of core, and the amount of this loss will be indicated by the ratio of the core obtained to the depth drilled to obtain it. Solid rock will usually give from 90 to 100 per cent of core.

Core samples, as they are taken from the core barrel, should be placed in order, in boxes especially made for the purpose, and properly marked for identification. For ordinary purposes in foundation work the size of hole drilled will be about $1\frac{3}{8}$ in.,

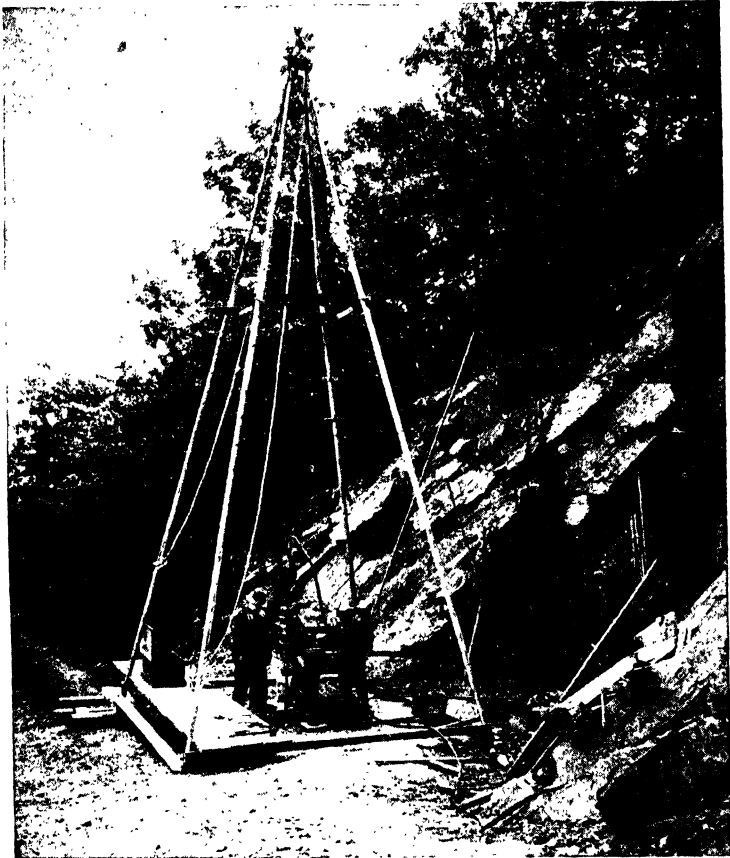

FIG. 8a.—Explorer diamond drill on surface mounting. (Courtesy of Ingersoll-Rand Company.)

the core being $1\frac{5}{16}$ in. in diameter. In drilling this size hole, the smaller size rods described for wash borings are used.

Successful operation of the diamond drill requires that a skilled mechanic, with experience in this class of work, be in charge of drill operations at all times. Although the operation of the drill mechanism itself is simple and requires no special knowledge over that required for other machinery and engines,

the action of the bit in drilling varies greatly with different formations, and there is the possibility of serious loss through breakage of carbon in broken rock; also it is usually necessary to reset the bits at the job. The setting of a diamond bit calls for skill, practice, and a knowledge of the best arrangement of the diamonds for different formations, to prevent loss by breakage or by the stones becoming loose and being lost.

Two kinds of diamonds are used in making diamond drill borings, namely, carbons and bortz. Carbons are opaque and noncrystalline, while bortz is semitransparent and crystalline. Bortz, although very hard, will not stand pressure, owing to its crystalline nature, and is used only in the softer rocks. Carbon now costs about \$50 per carat. Since a bit requires eight stones averaging about 2 carats each for a $1\frac{1}{2}$ -in. hole, it is seen that a diamond bit is a very costly affair. However, except in the case of breakage, the loss of carbon in

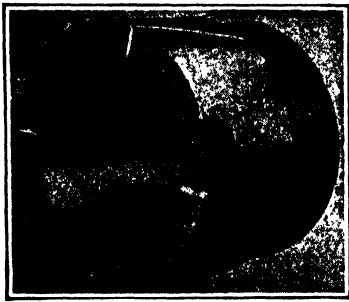

FIG. 8b.—Diamond bit. (*Jacoby and Davis, "Foundations of Bridges and Buildings," 3d ed.*)

drilling is not excessive, even in the case of the harder rocks. Bortz bits usually contain 35 to 40 stones. The stones are sized 2 to 7 stones per carat and cost about \$8 per carat.

A modern Explorer diamond drill, manufactured by the Ingersoll-Rand Company and mounted upon a light steel plate frame for surface drilling, is shown in Fig. 8a. The diamond bit is shown in Fig. 8b. The drill head is the screw-feed type and affords three feed rates and neutral by use of an external gear selector. It may be powered by a gasoline, an air, or an electric motor. Units driven by steam engine are also available. The standard feed rate is 1 in. per 200, 400, and 600 revolutions of the drill spindle. The drill head may be rotated through 360 deg. to permit drilling at any angle. Cores having diameters of $\frac{7}{8}$, $1\frac{1}{8}$, and $1\frac{5}{8}$ in. may be obtained at depths of 400, 300, and 200 ft., respectively, for surface mountings. A pneumatic rod puller is available for pulling up to 300 ft. of the $\frac{7}{8}$ -in. core rod. A hand-operated, portable 2-ton hoist having a positive internal brake is also available.

10b. Shot Drill Method.—Core borings by the shot method require equipment very similar to that used in diamond drill work except that a shot bit instead of the diamond bit is used. The bit is made of special carbon steel, of heavier wall than the core barrel. A slot is cut at the bottom of the bit to allow the circulation of water. Chilled steel shot are used to cut the rock and are fed as needed to the bit through the drill rods, by a special valve at the water swivel. In the place of a special device for lifting the core, a handful of coarse sand or fine gravel is forced down through the drill rods and acts to wedge in between the core and the sides of the core barrel and locks the core so that it can be brought to the surface. In shot borings the size of hole varies from $1\frac{1}{2}$ to 36 in. in diameter.

This method of drilling has the disadvantage that inclined holes, making an angle of more than about 70 deg. with the vertical, cannot be drilled, because of the shot that gathers on the low side of the hole as the bit is fed into the rock. Speed of drilling is also slower than with diamond drilling; in very hard rock it is difficult to make any headway. The initial cost of shot core drills is much less than that of diamond drills. On the other hand, diamond drill cores of a diameter greater than 2 or 3 in. are not often made, whereas cores of from 8 to 36 in. are not unusual by the shot method. Cores up to 72 in. in diameter may be taken if required.

The shot bit of the calyx drill shown in Fig. 9 is a smooth steel cylinder. It is attached to the core barrel and rotated with it by the drill rods. A narrow slot cut into the sides of the bit affords an outlet for the water and also aids the cutting material to get under the bit. The cutting material, calyxite (chilled shot), is manufactured by atomizing molten iron or steel and chilling it suddenly. The resulting material is very hard and consists of particles having an average size of $\frac{3}{32}$ in. Under the pressure of the shot bit this material shatters into sharp-edged hard-wearing fragments, which by rotation and contact mill away the rock beneath the bit. The rate of flow of water,



FIG. 9.—Shot bit of the calyx drill.

shot, and grout is under full control of the operator at all times. The flow of water is adjusted to wash the rock cuttings from the bit but not to disturb the shot. Cuttings are carried past the

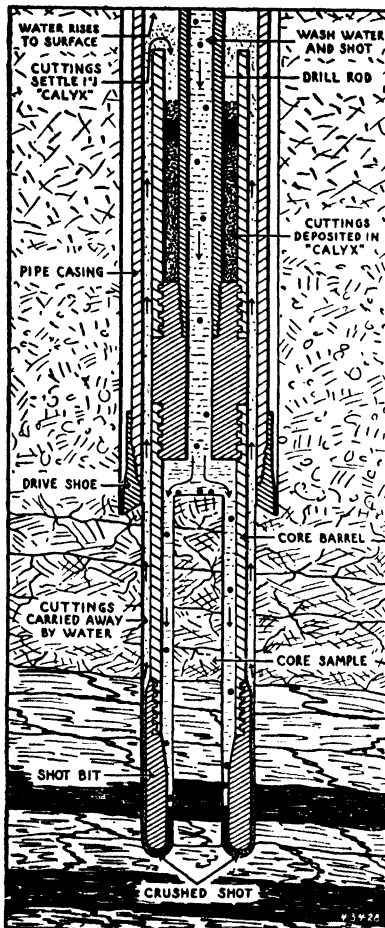

FIG. 10.—Shot drill showing calyx shot bit, drive shoe, and core sample. (Jacoby and Davis, "Foundations of Bridges and Buildings," 3d. ed.)

outside clearance of the core barrel and enter the region of larger water area just above the calyx. The cuttings settle out and the water rises to the surface. These features are shown in Fig. 10. In materials too soft to crush the shot, they may

become embedded in the walls. Crushed steel is often used to replace the shot under these circumstances.

The driving equipment for calyx drills may be powered by a gasoline engine or by electric or air motors. The type of mount-

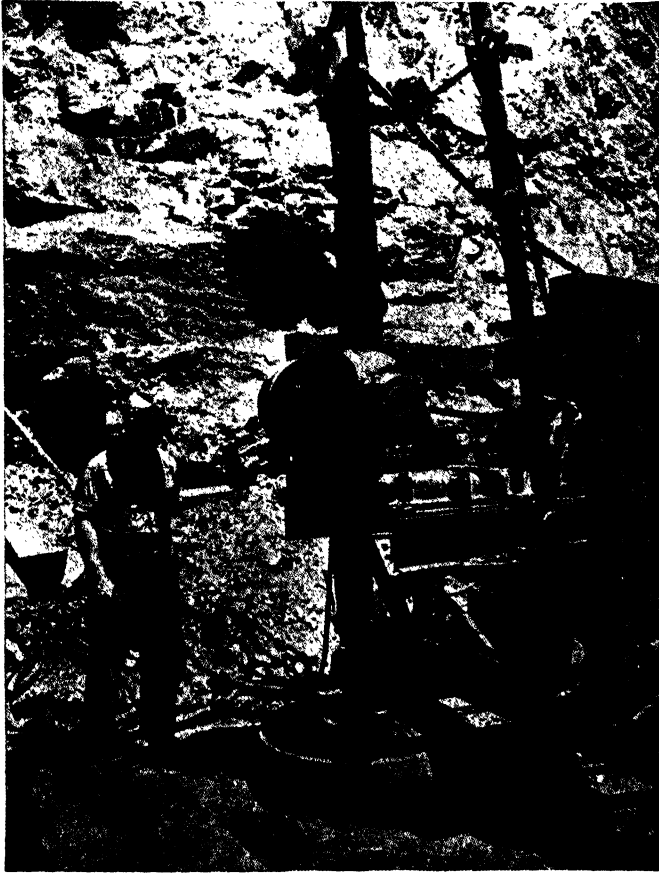

FIG. 11.—Mounting for 36-in. calyx drill. (Courtesy of Ingersoll-Rand Company.)

ing used is dependent upon the size of core and the depth of drilling. Figure 11 shows the mounting for a 36-in. core drill suitable for relatively shallow depths. For greater depths a smaller diameter core and hoist may be used with this mounting. A heavier mounting with hoisting equipment for deep drilling of large-diameter cores at Bonneville Dam is shown in Fig. 12a.

A section of core is being fastened to the hoist cable. Figure 12b shows 36-in. cores removed for the inspection and study of grouting operations at Norris Dam, for the Tennessee Valley Authority.

A special calyx core drill, 72 in. in diameter, is shown in Fig. 26 of Sec. 2. The operation of this unit without the use of drill rods is shown in Fig. 25 of the same section.

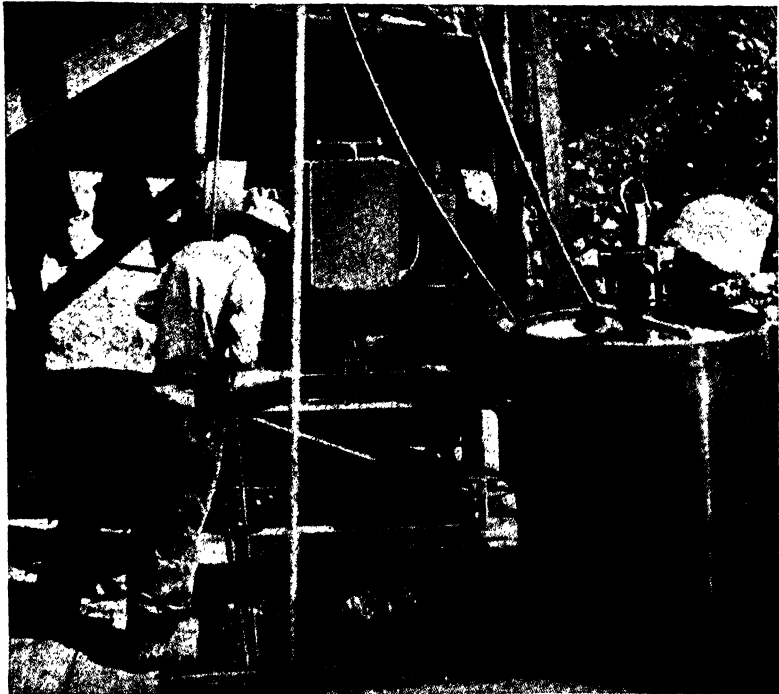

FIG. 12a.—Removing section of core. (Courtesy of Ingersoll-Rand Company.)

11. Load Tests.—Load tests are made to determine the bearing or carrying capacity of a soil. This ultimate strength is usually determined from the “critical loading.” Loadings are generally placed in predetermined increments and the settlement produced is recorded.

During the first increments of loading, after the initial settlement is complete, the settlement will have a straight-line relationship to the loading. At the point of sudden break in the relationship the “critical loading” is reached. This loading

represents the ultimate bearing capacity. The safe loading is determined as a percentage of the ultimate. The percentage is determined by the value of the safety factor desired. It should, however, be emphasized that the actual value of this factor is dependent upon the accuracy of test results and the accuracy of any assumptions used in the interpretation of test results to determine the "critical loading."



FIG. 12b.—Thirty-six-inch calyx cores. (Courtesy of Ingersoll-Rand Company.)

There is no standardization in the methods of making load tests. Most large cities specify methods in their building code. In general, both the necessity of making the test and the interpretation of test results are left to the commissioner or superintendent of buildings. Test pile loadings are considered in Sec. 3 and pile load tests are shown in Figs. 42 and 49 of that section. Before attempting load or pile loading tests, the building code and regulations of the commissioner or superintendent of buildings should be studied.

Modern building codes generally require that measurements of settlement be taken hourly for the first 6 to 8 hr. after loading and at 12-hr. intervals thereafter. The loading is placed inter-

mittently in increments of 25 to 50 per cent of the design loading. Each increment should remain undisturbed until no measurable settlement occurs in a 24-hr. period. In some cases it is required that the design load be placed and that it remain undisturbed until no settlement occurs during a period of 24 hr. After this is satisfied, a 50 per cent excess load should be applied and the total load remain undisturbed until no settlement occurs during a period of 24 hr. Tests are considered unsatisfactory if the proposed safe load shows a settlement of more than $\frac{3}{4}$ in. or if the increment of settlement obtained under the 50 per cent overload exceeds 60 per cent of the settlement under the proposed load.

The area loaded, in making load tests, varies from 1 sq. ft. to areas approaching and occasionally equal to the area of the proposed footings. In general, the larger the area loaded, the more representative the test will be of the sustaining power of the soil.

In loading tests on 1 sq. ft. of area, a single post, usually 12×12 in., is set on end on the soil to be tested, or upon a bearing plate of practically undeformable material such as cast iron, steel, concrete, or hard wood. On top of this post is constructed a platform on which the testing weights are balanced. Often four such posts are used, on which a platform or loading bin is constructed. Settlements are determined by making observations with a level and level rod, on a pin or bolt set in the top of the post under the load. Sand, cement, brick, pig iron, steel rails, or other materials convenient to the test, are used for loading the platform. In placing the load, care should be taken to cause as little vibration of the load as possible, since vibration, transmitted through the post to the soil under test, will cause additional settlement.

The hydraulic jack is occasionally used in making load tests. Where used, a reaction for the top of the jack should be provided. For this reaction a load may be built up on blocking or cribbing, centered over the area to be tested. This load should be slightly in excess of the test load and should be balanced on timber or steel beams under which there is a cross girder to take the reaction of the jack. In using the hydraulic jack for making load tests, slight leakages of oil from around the piston or plunger, and settlement of the plate under load, will cause a drop in the pressure of the jack, so that careful supervision is necessary in

making such tests to keep the pressure pumped up to the test requirements so that it will remain constant.

Too much emphasis cannot be placed upon the importance of the area tested. The nearer the tested area is to the actual area of the proposed footing the greater the value of the test. Although the test on a small area can produce the same vertical or shearing intensity of stress as the foundation, the distribution of these stresses is generally different. Furthermore, the larger areas produce greater settlement than the smaller ones. According to the theory of elasticity, the ratio of the relative settlements is equal to the square root of the ratio of the respective

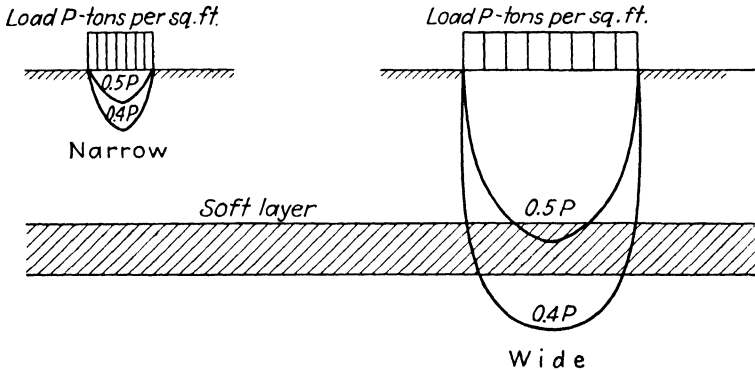

FIG. 13.—Isobars under a narrow and under a wide loaded area.

areas. Practice has, however, shown that this represents a possible maximum, and that actual settlements of building foundations are less than this value.

The settlement of a structure may be due to the consolidation of underlying strata or to lateral movements. Lateral movement is due to shearing stresses.

The amount of consolidation produced in a soil is directly proportional to the load intensity. The distribution of vertical intensity of stress in the soil mass supporting a foundation is also a function of the dimensions of the loaded area. This is shown diagrammatically in Fig. 13. It may be seen that a deep-seated cohesive soil layer may not be affected by the narrow loading of the test while considerable settlement may result from the loading of the full-sized foundation. Rate of consolidation is a function of the rate at which water is squeezed from the soil. In

cohesive soils of low permeability a considerable time is required. The comparatively short duration of load tests would not allow development of this process.

The intensity of shearing stress is proportional to the vertical intensity. Under the same unit loadings, the shearing stress intensity produced in the soil under the test loading and under the foundation may or may not be equal at a given point. This is dependent upon the relative dimensions of the loaded areas.

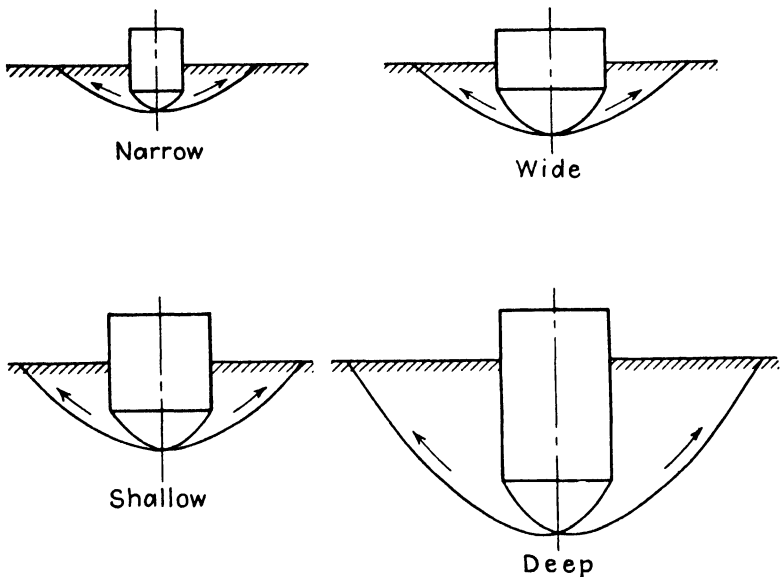

FIG. 14.—Possible shear planes under narrow, wide, shallow, and deep loaded areas.

The areas offering shearing resistance are different. Possible shearing planes under the larger loaded area will provide more shearing resistance. It follows, therefore, that the ultimate bearing capacity as determined by the test load will be on the side of safety. The amount of shearing resistance offered by the underlying soil mass is also affected by the depth at which the foundation or test area is placed. These effects are shown diagrammatically in Figs. 14a and 14b. Displacements may occur along failure lines without actual failure occurring. This results in a bulging of the earth mass around the structure and allows some settlement.

The safe load, as determined by a permissible amount of settlement, is therefore dependent upon the depth of the foundation below the surface and the dimensions of the loaded area, provided uniform soil conditions exist to an indefinite depth. The permissible settlement may be determined by the type of superstructure and the limits of allowable secondary stresses.

The new Boston Building Code specifies a required test area of 1 sq. ft. for rock and residual deposits. For gravels and sands and for hard, medium, and soft clays, the loaded area should be the full size of the pit and at such depths that the ratio of the width of the loaded area to the depth below the immediately adjacent ground surface is the same as the larger of (1) the ratio of the width of any footing to its depth below the immediately adjacent ground surface, (2) the ratio of the width of the entire foundation or group of footings to its depth below the average surrounding ground surface.

This code further specifies that whenever proposed foundations rest on medium or soft clay, rock flour, shattered shale, or any deposit of unusual character, test results must be interpreted in conjunction with accurate soil profiles that show the magnitude and variation in thickness of these strata. If, in the opinion of the commissioner, this information is not sufficient to determine whether the design load may cause excessive or dangerous differential settlement, he may require an analysis of the probable magnitude, rate, and distribution of settlement of the proposed structure. This analysis may be based upon settlements of near-by structures having essentially the same foundation conditions or upon consolidation tests and other investigations of undisturbed samples of the compressible materials.

bulldozer furnishes probably the cheapest method of earth moving. As auxiliary machines with other excavating and transporting machines, they provide invaluable service.

The angle dozer has an adjustable blade, which can be set at an angle either to right or left for side-casting the excavated material and can also be tilted so that one end is 12 in. below the other. This feature allows deeper digging on one side than on the other. This dozer is particularly suitable for opening cuts



FIG. 2.—La Plant-Choate treedozer mounted on Caterpillar Diesel D8 tractor.
(Courtesy of Caterpillar Tractor Company.)

and for sidehill cuts of certain types. If desired, the blade may be set for head-on dozing.

For good performance and the highest efficiency, a dozer should have a sturdy but lightweight bowl curved to roll material; perfect balance and weight distribution to keep the tracks of the track-type tractor in full contact with the ground in order to develop full traction and power; and power applied directly to the blade when it is at the digging angle.

In the LeTourneau mechanically controlled dozer the tractor power is transmitted to the dozer blade by the operation of cables,

which are designed for a 4,000-lb. pull per line. Since four cables are used, a lifting pull of 16,000 lb. can be transmitted to the blade. This high pull is particularly advantageous in uprooting trees and stumps and in moving or lifting boulders.

Figure 1 shows a LeTourneau bulldozer and a Caterpillar Diesel RD7 tractor. This model tractor will operate the bulldozer for efficient short hauls at a fuel cost of about 32 cents per hour. The machine is working on the upstream seal of Mad River Dam at Korbel, California. Note the sheep's-foot roller

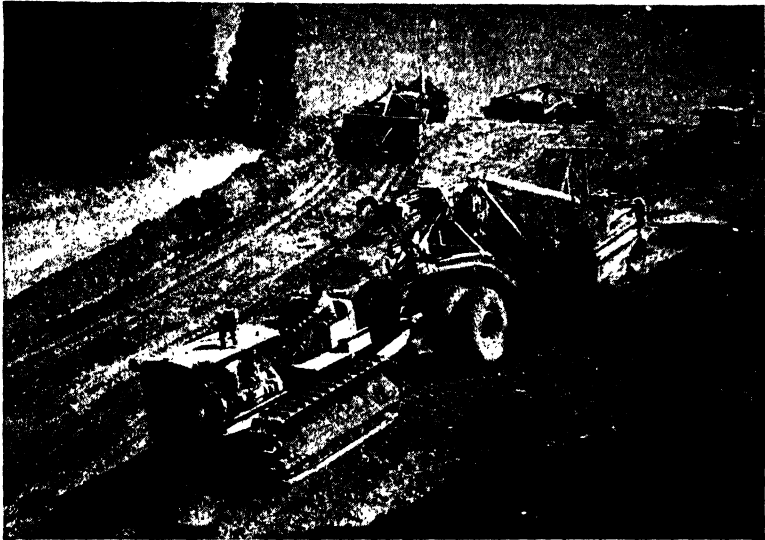

FIG. 3.—Carryall scraper. Loading operation. (Courtesy of R. G. LeTourneau, Inc.)

pulled by another tractor operating in the background to compact the soil after it is spread in thin layers by the bulldozer.

A Caterpillar Diesel D8 tractor equipped with a La Plant-Choate treedozer is shown in Fig. 2. This model will operate on a fuel cost of about 40 cents per hour and is reported to be able to clear from $\frac{3}{4}$ to 1 acre per hour.

3. Scrapers.—The modern scraper is another example of combination equipment. These machines combine the process of excavation and loading and also serve as transporting vehicles. They have been developed from the simple drag, two-wheel and four-wheel horse-drawn scraper used at the turn of the century.

They are widely used and can be efficiently operated in any material other than hard rock. Modern scrapers having heaped capacities varying from $3\frac{1}{2}$ to 60 cu. yd., are available. They are generally powered by a heavy-duty track-type tractor and can therefore act as a single unit. The scrapers are controlled by either cable or hydraulic pressure, from a power take-off on the tractor.

The carryall scraper shown in Fig. 3 is selected to represent these modern machines. They are made in two types: the single and the double bucket. The single-bucket machine has a single



FIG. 4.—Carryall scraper. Unloading operation. (*Courtesy of R. G. LeTourneau, Inc.*)

rigid bowl that is designed for maximum carrying capacity. In loading, the cutting blade angle is such that the material acquires a boiling action as it enters the bowl. Part goes to the rear of the scraper and part falls forward into the large carrying apron. This latter material assists in closing the apron when the loading is completed. High density results, which makes greater pay loads possible. When spreading, the controlled movement of the tail gate produces the positive ejection, as shown in Fig. 4.

In the double-bucket type the material is loaded in a shortened bowl, which expands to the rear as loading proceeds. The bucket moves on roller bearings to reduce both the loading resistance and the time required.

Every model has the same cable control, the same cutting and loading control, and the same positive ejection control. These single units therefore serve as an excavator, as a loading mechanism, as a transporting vehicle, and as a spreading machine.

The single-bucket models in 4- to 11-yd. capacities are suitable for the smaller earth-moving contracts. They are widely used for grading, sloping, finishing, basement excavations, ditching, trenching, and leveling. As auxiliary equipment on large jobs they are economical for hauls up to 2,400 ft. In these capacities, carryalls may be loaded without pusher help in ordinary operating conditions. The units from 15 to 33 yd. heaped capacities are suitable where considerable volume of earth moving is involved. Because of the large tires these models are capable of traveling rough, sandy, or muddy ground. Those with capacity below 20 yd. may be loaded without pusher help but the pay yardage will be increased if pusher help is used. The economical length of haul for this capacity is 4,000 ft. Two scrapers may be used in tandem. This practice materially increases the output of a single tractor. Pusher help, however, is advisable for loading where there is a lack of grade.

The double-bucket types are made in 16- to 60-cu. yd. heaped capacities. In effect these machines are the same as loading two small scrapers at the same time. Their initial cost is higher, but yardage gains due to more rapid loading will reduce the yardage cost and increase the length of economic haul. Double-bucket models are therefore best suited for large-scale earth moving, and are economical for hauls up to 6,000 ft. These larger machines should have additional tractors for loading. Under difficult loading conditions a pusher and a snatch tractor, one furnishing additional pull, are used. For economical operation these units should be operated in groups of three or four scrapers per pusher-loading tractor to distribute pusher cost over several machines.

An important factor limiting this economical length of haul was the slow speed of the tractor. The modern Tournapull, a powerful automotive-type rubber-tired machine, overcomes this difficulty. These units are built in six power sizes and, when used with carryalls, are capable of hauling large loads over good roadways at high speeds. They are subject to the draft limitation of all trucks. For loading, push helpers are necessary. A complete unit is shown loading in Fig. 5. With the introduction of this

Tournapull, the only factor now limiting the economical length of haul is that of keeping the loading costs spread over enough units to produce the lowest over-all cost.

Under proper planning for spreading costs it is reported that "pusher" loading can be reduced to about $1\frac{1}{2}$ cents per cubic yard. It is impossible to give complete production figures for all types of modern equipment under all working conditions. The manufacturers base the ownership and operation cost on an operating hour of 50 min., in which an efficiency of 83 per cent is assumed. According to the LeTourneau Company, a 15-yd.



FIG. 5.—Carryall scraper with Tournapull and pusher tractor. (Courtesy of R. G. Le Tourneau, Inc.)

heaped capacity carryall powered by a super "C" Tournapull will cost about \$5 to \$5.50 per operating hour. This figure includes depreciation. This model and power equipment has a maximum economic length of haul of 4,000 ft. The pay yards per 50-min. hour at one-way haul lengths of 800, 1,600, 2,400, 3,000, and 4,000 ft. are given as 140, 108, 87, 75, and 63, respectively.

Because of the controlled methods of loading and unloading, these machines furnish an invaluable means of earth moving where placement is a primary factor, as in the building of earth dams. They have made the great modern earth dams possible. Excavation can be controlled to produce the degree of mixing required; by use of automotive power the length of hauls is

limited only by the balancing of over-all costs, and the placement in fills can be easily controlled to thin layers to produce maximum ultimate compaction. The expense of spreading operation is calculated to be about 0.6 cent per cubic yard.

4. Rooters.—The heavy-duty roter is an important auxiliary tool for the scraper. It extends the use of the scraper into materials which would otherwise require blasting and shovel handling. A heavy-duty LeTourneau roter drawn by a Caterpillar Diesel D8 tractor is shown in Fig. 6 ripping limestone rock. Design strength is of greatest importance in these tools. A special



FIG. 6.—Heavy-duty LeTourneau roter and Caterpillar tractor. (*Courtesy of Caterpillar Tractor Company.*)

heavy-duty roter is built to take the fuel power of two D8 tractors. Rooters are made with three and five teeth. The selection of the one best suited for a particular job is dependent upon the hardness of the material and the depth of breakage desired. All units are of all-welded construction using heat-treated steels. The teeth enter the ground at angles that tend to pull deeper. The depth is controlled by the cable action. For breaking hard materials the teeth are raised by the action of the cables.

5. Power Shovels.—Power shovels are important excavating machines. They are suitable for close work and can be operated in any material, including hard rock that has been broken up.

These machines also serve as loading mechanisms. At present there is no standardization in design. The various makes differ in the types of power machinery, control, methods of transmission, and in the maximum speed and torques that can be developed. Various lengths of dipper sticks and designs of dippers are also used on the different makes. All these factors have an effect upon the performance and control. Modern power shovels use a steam, gasoline, or oil engine, or an air or electric motor as a prime mover. They may be mounted on standard railroad cars, on



FIG. 7.—Northwest shovels in heavy rock cut for approach to George Washington Bridge, New York City. (Courtesy of Northwest Engineering Company.)

trucks, or on a crawler base. Present-day shovels provide a full 360-deg. horizontal swing or operating angle. The general range of dipper capacities varies from $\frac{3}{8}$ to 3 cu. yd. The heavier machines may have dipper capacities up to 5 cu. yd. or larger. Special machines designed for coal stripping or other specific purposes may have dipper capacities as high as 30 cu. yd.

Power shovels provide good digging control and are speedy excavating machines. In general, for dipper capacities up to 2 cu. yd., they can operate at two to three cycles per minute. The determination of the proper size to use for a given job should be related to the other job factors. Shovel capacity and trans-

porting equipment capacity should be so balanced that the shovel can operate at full capacity for the maximum time. The single unit and total capacity of the transporting equipment should therefore be provided in accordance with shovel capacity, working conditions, and length of haul.

Figure 7 shows two Northwest shovels working in a heavy rock cut for the approach to the George Washington Bridge, New York, New York. These shovels are mounted on a specially

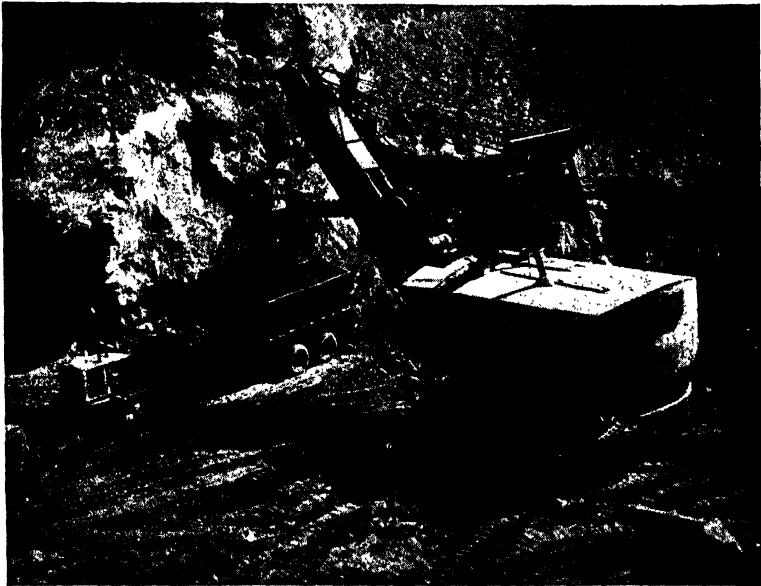

FIG. 8.—Electric shovel, 5 cu. yd. capacity, at site of Grand Coulee Dam.
(Courtesy of U. S. Department of the Interior.)

designed rotating base, which is in turn mounted on a crawler base. This make of shovel is, according to the manufacturer, powered by rugged heavy-duty power plants, especially designed to provide fuel economy and ease of control. The dippers are designed to fill quickly and to empty easily. The heavy all-welded boom and dipper stick will resist the high twisting stresses that are developed.

A heavy electric shovel with a dipper capacity of 5 cu. yd. is shown in Fig. 8 excavating at the site of West Side Power House at Grand Coulee Dam.

One of the principal advantages of the modern shovel is the possibility of various uses. Most makes can be converted into a trench hoe, or pull shovel, a dragline, a derrick, or a crane for clamshell operation. A pull shovel is shown in Fig. 9 excavating a sewer trench



FIG. 9.—Pull shovel in trenching work. (Courtesy of Northwest Engineering Company.)

6. Elevating Graders.—The elevating grader is another type of excavating and loading machine. It is also applicable where large areas must be excavated, such as stripping operations at the sites of large dams. An elevating grader includes a cutting blade, which may be controlled for cutting depth, and a means of deflecting and elevating the excavated material to the transporting vehicle.

Like all other excavating equipment, modern elevating graders represent a great improvement over the older models. They are usually tractor-drawn and are capable, under good loading conditions, of handling as much as 300 cu. yd. per hr. The smaller sizes are powered by a take-off on the tractor, but in the larger sizes a power unit is mounted on the grader. The development of the modern scraper has replaced this apparatus to a great extent.

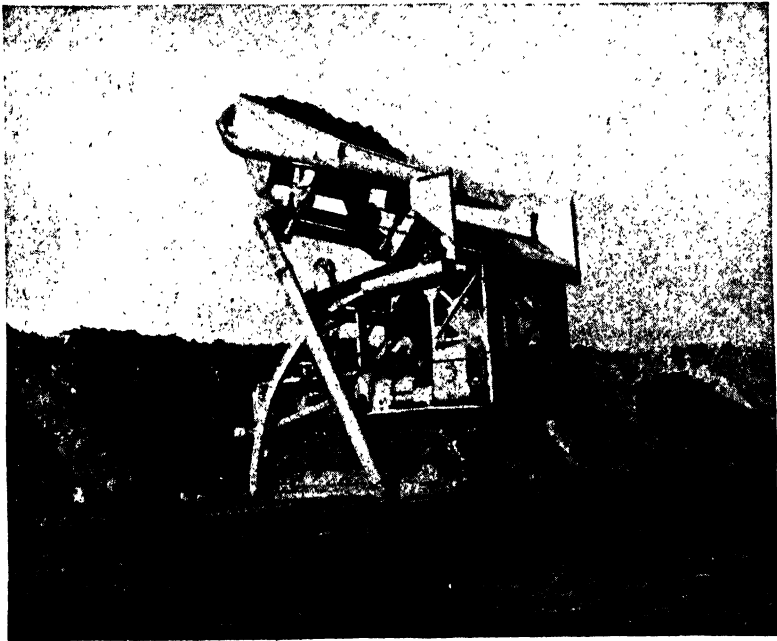

FIG. 10.—Mobiloader. (Courtesy of Athey Truss Wheel Company.)

7. Mobiloader.—A recent development in excavating and loading equipment is illustrated by the Mobiloader, shown in Fig. 10. These machines, which are designed and built by the Athey Truss Wheel Company, are available in two sizes and are mounted on Caterpillar D8 and D4 tractors. Bucket capacities range from $2\frac{1}{2}$ to $4\frac{1}{2}$ cu. yd., but larger buckets may be used when light materials are to be moved. The machine excavates in front and dumps overhead to the rear. The bucket on either model may be removed and replaced by a bulldozer blade. According to the manufacturers, in the two years of actual opera-

tion these machines have shown time savings and proved their suitability to handle sands, gravels, clays, crushed stone, ore, coal, or any stock-piled materials.

8. Draglines.—The dragline excavator also combines the functions of excavating and loading. It is a flexible excavating tool and can operate efficiently under conditions unsuitable for dipper shovels. It is applicable for trench excavation, in drainage work, in levee work, and on many other earth-moving jobs. A North-

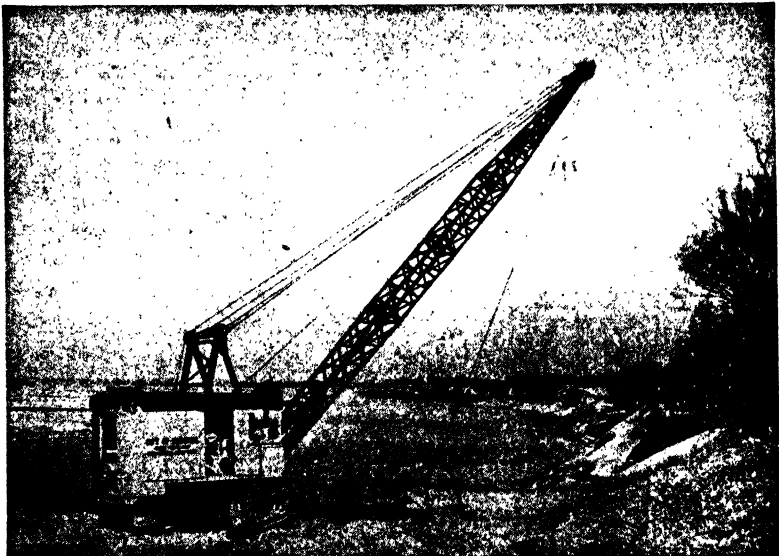

FIG. 11.—Dragline in moderate depth excavation. (Courtesy of Northwest Engineering Company.)

west dragline is shown in Fig. 11. Such a machine can excavate below its base. It has a longer reach than a shovel and can elevate the excavated material to transporting equipment or to storage piles as shown in Fig. 12.

Draglines cannot handle hard materials as efficiently as a dipper shovel. An important factor in producing maximum efficiency is the selection of the correct size and shape of bucket for particular soil conditions, length of boom, and other machine characteristics. Under certain easy digging conditions, bucket capacity is sometimes increased over the rated capacity. However, this usually requires a movement of the boom, which

decreases the range of operation. In general operation, the boom is fixed at an angle of 30 to 37 deg., as shown in Figs. 11 and 12.

9. Derrick and Hoist Buckets.—Two classes of buckets may be used with a derrick: the nondigging dump bucket and the digging or grab bucket. The first class include skips, trunnion buckets,

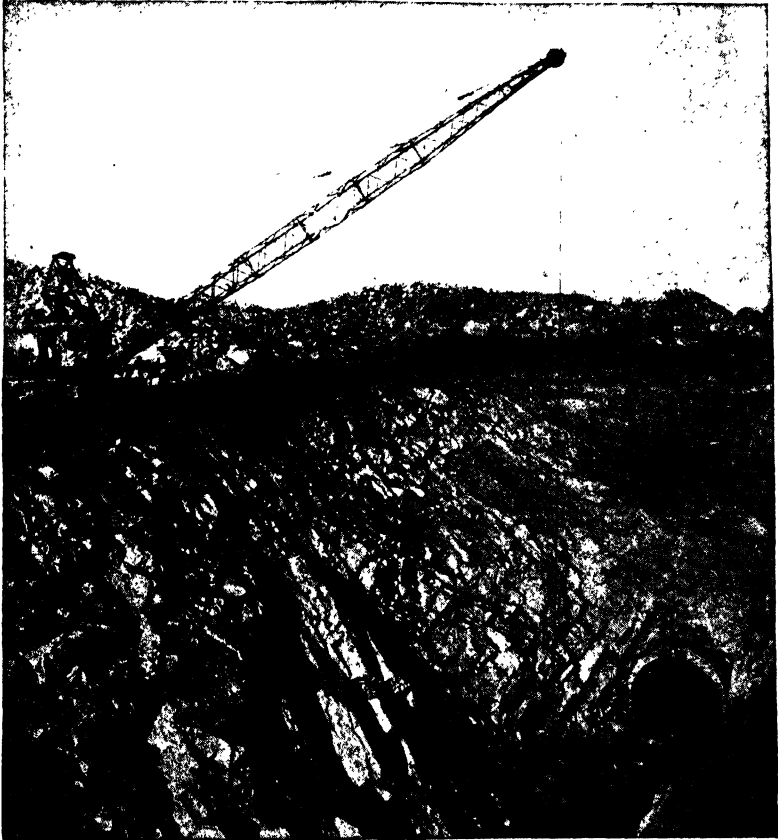

FIG. 12.—Dragline in deep excavation. (Courtesy of Northwest Engineering Company.)

and bottom-dump buckets. The second class comprises the orange-peel and the clamshell buckets. The skip is a tray-shaped box with one side open. It may be made of wood or steel and is suspended from three points by chains leading to a ring that engages the hook on the end of the derrick cable hoist line. The trunnion bucket consists of a steel tray, the front side of which

slopes sharply toward the outer or upper edge. The bucket is supported from the hoist line by a bail, which is attached to the sides by trunnions so placed as to keep the bucket upright when loaded. The bucket is easily dumped by tilting. Bottom-dump buckets are steel boxes with the bottoms hinged so that their

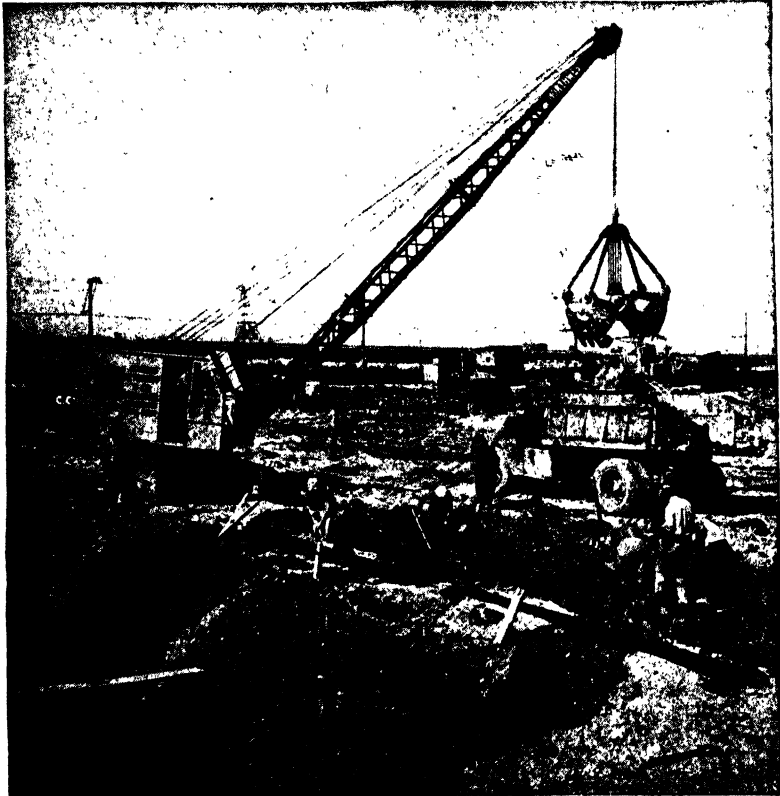

FIG. 13.—Clamshell bucket in trench excavation. (*Courtesy of Northwest Engineering Company.*)

contents may be automatically dumped. This type of bucket is better suited for handling concrete than earth and possesses no advantages over the skip for the removal of hand excavation.

The buckets may be hoisted with tractor or track-mounted cranes or by a converted shovel. The portable cranes are particularly suitable for trench excavation. For deep pits and deep foundations the fixed derrick may be used. The clamshell

bucket is widely used in handling materials in material storage yards and batching plants. Figure 13 shows a clamshell bucket used in trench excavation.

10. Cableway Excavators.—Cableway excavators are classified as tower machines and power drag scrapers. Both are essentially slack-line cableway excavators. They combine the four essential operations of excavation, loading, transportation, and disposal. They are very flexible machines and are built in a wide range of sizes having output capacities up to 1,000 tons per hour and in spans up to 1,500 ft. They can excavate to a depth equal approximately to one-third of the span and, depending on the

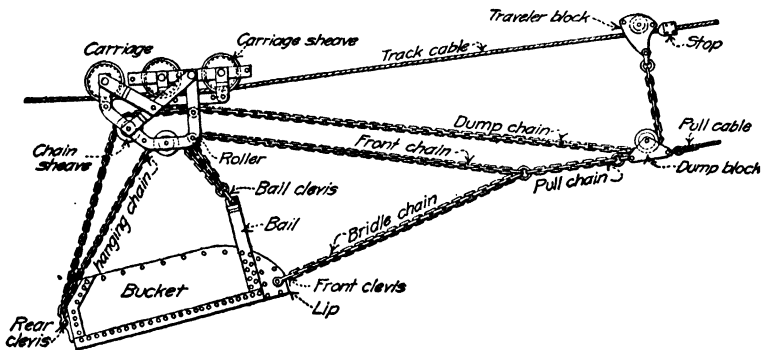

FIG. 14.—Dragline cableway bucket.

height of the tower, can pile excavated materials to a height of 50 to 90 ft. above the tower base.

Among the advantages claimed for these machines are one-man operation, low power and maintenance costs, reliable, speedy, steady service, a minimum of elaborate machinery with few moving parts, and adaptability to unusual soil conditions and excavation location.

The control of the bucket on a slack-line cableway during operation is shown diagrammatically in Fig. 14. The track cable is supported on one end by the tail tower and at the other in the head or control tower. When the track cable is slackened, the bucket runs down by gravity to the low point. This back haul may also be powered. The travel may be checked at any time by lengthening the cable. A pull is then placed on the load cable until the bucket is filled. The filled bucket is raised by a further

tightening of the track cable, and the load cable pulls it toward the head tower. The bucket may be dumped at any point along the cable. The height to which the material may be piled is dependent upon the height of the tower. It is evident that these machines are particularly suitable for excavating to considerable depths below the surface, where the excavated material must be transported to the edge or rim of the excavation and deposited.

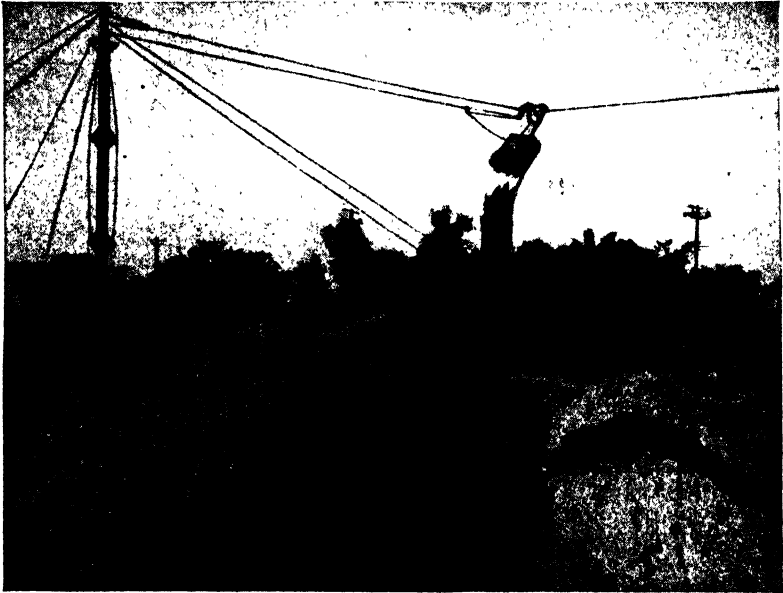

FIG. 15a.—Slack-line cableway excavator. (Courtesy of Sauerman Bros.)

Bucket capacities generally vary from 1 to 3 cu. yd. The output in cubic yards per hour is dependent upon the bucket size and the length of span. A slack-line cableway excavator having a span of 800 ft. and a bucket capacity of $\frac{1}{2}$ cu. yd. is shown in Fig. 15a.

In the operation of the power drag scraper the bucket is not raised from the ground surface. It is dragged from the pit on the surface, over the rim, and up the side of the spoil or storage piles. Both head and tail towers may be supported on wheel or crawler bases and are moved along as the work progresses. The bases are usually powered to propel themselves forward. The drag scraper is particularly suitable for levee and canal work or where excavated material may be dumped directly on the bank of the

pit. The output in cubic yards per hour is dependent upon the bucket size and the length of the span. Bucket sizes vary from 4 to 14 cu. yd., and economical spans vary from about 500 to 800 ft. A drag scraper with a self-propelled head tower is shown in Fig. 15*b*. Excavated material from an area 1,250 × 350 ft. and 30 ft. deep is dumped into a hopper at the top of the ramp and passed into cars underneath it.



FIG. 15*b*.—Dragline scraper with self-propelled head tower. (Courtesy of Saucerman Bros.)

11. Walking Draglines.—Another type of mobile excavator is the walking dragline. The machine, shown in Fig. 16, is also known as the Bucyrus-Monighan. The outstanding features of this machine as an excavator are its long boom, simplicity of construction, ability to handle large-capacity buckets, mobility, and the very low bearing load on its base, which makes its use possible on soft bottom. The machine is moved by a process of steps produced by the rotation of cams. Both shoes are lowered simultaneously and part of the weight of the machine is transferred from the base to the shoes. The base then tilts and the whole machine skids forward. The whole base is never off the ground at any one time and the movement is therefore accom-

plished without shock or damage to the machine or frame. The eccentric cams rotate inside the track frame and are driven by the walking shaft, which is rotated by a large gear, driven through a pinion connected to the drag drum shaft. Since no rotating or moving part comes in direct contact with the ground, very little wear results. No steering mechanism is necessary. The machine moves in whatever direction the walking shoes point. Direction is changed by swinging the revolving frame. Back-

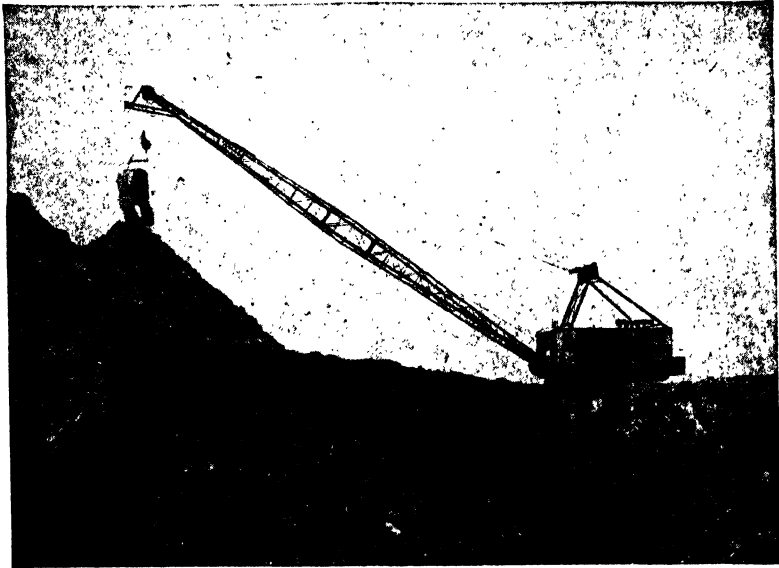

FIG. 16.—Walking dragline. (Courtesy of Bucyrus, Erie.)

and-forth or side-step movement, which permits advantageous working at most digging and dumping positions, is easily and quickly accomplished.

Walking draglines are built in standard sizes having bucket capacities of 2, 3, 5, 6, and 10 cu. yd. with corresponding boom lengths of 60, 70, 90, 100, and 160 ft. A model having a bucket size of 6 cu. yd. and a 160-ft. boom is also standard. Special models may be had with bucket capacities up to 20 cu. yd. and boom lengths up to 250 ft.

These draglines are designed for fast hoisting and swinging, which results in a minimum time cycle and high output. They

are powered by Diesel engines or electric motors. Remote-control levers are electric- or air-powered.

12. Transporting Equipment.—The need for efficient and fast-moving transporting vehicles has been pointed out in the consideration of power shovels, elevating graders, and draglines. This is a very important factor in connection with any excavating tool that serves as an excavator and a loader.

Trucks are widely used as high-speed transporting vehicles. They are offered in a wide range of type, capacity, and speed.



FIG. 17.—Crawler-type wagons drawn by Caterpillar tractor. (*Courtesy of Caterpillar Tractor Company.*)

They are usually provided with rear-dump bodies that are operated by hydraulic hoists. Tractor-drawn wagons of the crawler type, shown in Fig. 17, are available in capacities varying from 6 to 15 cu. yd. A recent trend is toward pneumatic-tired wagons of approximately equal capacities. Larger wagons, having heaped capacities up to 30 cu. yd., are termed "buggies." These buggies are usually tractor-drawn and may be dumped while in motion.

Truck- or tractor-drawn trailers are coming into wide use. A three-compartment side-dump trailer having a total capacity of 24 cu. yd. is available with Mack trucks. An all-welded steel

body trailer made by the LeTourneau Company is shown in Fig. 18a. These units are available in 10, 20, and 30 cu. yd.,



FIG. 18a.—Tournatrailer. (Courtesy of R. G. LeTourneau, Inc.)



FIG. 18b.—Tournatrailer in action. (Courtesy of R. G. LeTourneau, Inc.)

heaped capacity, and may be drawn by either the crawler or the pneumatic-tired tractor. In emptying, the body slides back off

the bed, forcing material out of the rear opening. The unit can be emptied while in motion as shown in Fig. 18b.

Dependent upon the magnitude of the excavation and the amount of materials to be hauled, special transporting equipment may be either designed or selected for a particular undertaking.

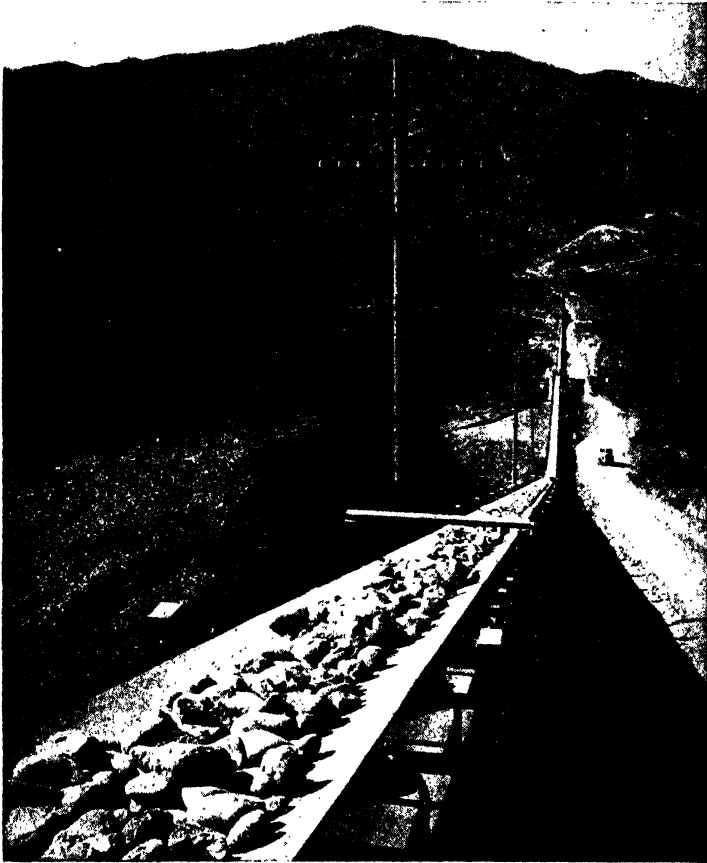

FIG. 19.—Belt conveyor at Shasta Dam. (Courtesy of U.S. Department of Interior.)

These methods may include railroad trains, tramways, belt conveyors, cableways, and others.

Railroad trains are suitable only for very large volumes over long hauls. They are used only if no other feasible methods can be adopted. Tramways are used to transport materials over

mountainous or very rough country where sufficient volume to justify the high cost of installation is involved. Loaded and empty buckets are moved by power-driven cables. The buckets cannot be loaded directly from excavating equipment and special loading and discharge equipment must be arranged for particular job conditions. A belt conveyor is shown in Fig. 19 delivering concrete aggregate at Shasta Dam, Central Valley Project,



FIG. 20.—Tail towers for cableway at Shasta Dam. (Courtesy of U.S. Department of the Interior.)

California. Belt conveyors are extensively used for the transportation of excavated material over both short and long distances where large volumes are to be moved to a definite delivery point.

The cableway is especially adapted for the hoisting and removal of excavated material when it is to be transported across a great open space, such as a valley or stream. The principal parts of a cableway are the towers, the power equipment, and the operating equipment. The cableway terminates in the towers.

One is called the "tail" tower, the other the "head" or operating tower. A main cable serves as a track over which the traveler moves and is controlled by hoisting and traversing cables operated from the head tower. Figure 20 shows the tail towers and Fig. 21 the head tower used at Shasta Dam, California.



FIG. 21.—Head towers for cableway at Shasta Dam. (Courtesy of U.S. Department of the Interior.)

13. Rock Excavation.—The excavation of deep foundations for buildings, walls, dams, piers, and other similar structures often involves the removal of solid rock. The rock should be broken up into fragments of a size that can be handled and removed by either hand or power excavators. Blasting, the universal

method of breaking up rock, consists in the drilling of holes into the rocks, the charging of the holes with a suitable explosive, and the firing or explosion of the charge. As the breaking up of rock in the foundation of many structures such as buildings, piers, and walls must often be done in restricted areas and adjacent to existing structures, the work should be executed with great care to secure the required results without injury to life and property.

Except for very small jobs rock drilling is no longer done by hand. The power-driven rock-drilling equipment now available covers such a wide range of sizes and is so adaptable to various power sources that it is almost universally used.

Power drills may be divided into two general groups: the percussion and the abrasion drill. The first type is represented by the jackhammer, the well, and the wagon drill. Abrasion drills are essentially core drills and are represented by the diamond drill and the shot core drill.

In general, power is furnished by gasoline, compressed air, or electric motors. Gasoline or electric motors may be used as prime movers for air compressors. Dependent upon the size of the job, air compressors vary from truck- or trailer-mounted units using gasoline, oil, or convertible engines to drive two-stage air-cooled compressors having capacities of 60 to 500 cu. ft. per min. to large station plants housing units up to 7,500 cu. ft. per min. capacity. These large units may be gasoline or oil, Diesel- or electric-motor-driven.

14. Jackhammer Drills.—The jackhammer drill is a portable, unmounted, hand-operated power drill. Since its introduction in 1912, there has been a steady improvement in its design and construction. It probably is the most popular drill now in use. It is relatively light in weight but has a fast drilling speed and is in general use in construction, quarry, mining, and in maintenance work. These drills are efficient tools for down-hole drilling for depths up to 10 ft. and can be mounted for horizontal drilling.

Jackhammer drills are made in the dry, wet, or blower type. Their weight varies from 35 to 75 lb.; the drill hole varies from 1 to 3 in. in diameter. Heavier hammers, sometimes called "sinkers," are used for large sizes in heavy down-hole drilling. Both the thrust and the rotation are produced by compressed air conducted to the drill through a flexible rubber hose. The air pressure generally used is between 70- and 80-lb. gage at the

drill. The jackhammers of various manufacturers differ in control and weight and other details. Typical hammers are those of Ingersoll-Rand Company and the Sullivan Machinery Company and reference is made to their catalogues for details. They are of all-steel construction and are automatically lubricated. The dry types use solid drill rods while the wet and blower types use hollow rods. To clean drill holes, air is used in the blower models and water in the wet models. Figure 22 shows a front view of a jackhammer drill of the 62-lb. class, with a removable jack bit. The use of these drills is shown in Fig. 3, of Sec. 6, preparing abutment foundations for Shasta Dam, California.

In practice, the use of jack rods and jack bits is replacing the use of forged drill rods. The bits are held to the jack rod by a coarse thread, which makes the bit readily detachable. The bits are made of especially uniformly hardened steel in various sizes and types

to meet all rock drilling conditions and can be resharpened two or three times. A 4- and 6-point center-hole jack bit and a jack-rod thread are shown in Fig. 23.

15. Jackhammer Mountings.—For horizontal or inclined holes, the jackhammer may be mounted. A representative type of mounting clamps the jackhammer in a carriage, which may in turn be mounted on a column, a horizontal bar, or a tripod. In drilling, the carriage is moved forward by hand or by an automatically operated feed screw. The jackhammer may also be mounted on a jack leg. The jack leg is a steel rod weighing about 35 lb. One end is pointed and the other contains an air piston. The hammer is attached to the piston. The pointed end of the jack leg is pushed in the ground and the drill bit resting against

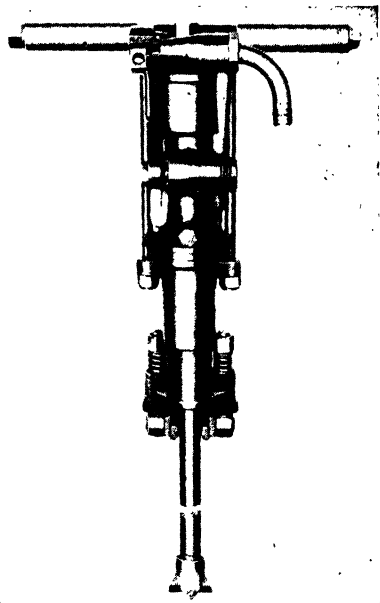

FIG. 22.—Front view of a jackhammer. (Courtesy of Ingersoll-Rand Company.)

the rock forms the other point of support. An adjustment of the feeding pressure against the jack-leg piston regulates the rate at which the hammer and drill are pushed forward, thereby regulating the drilling speed.

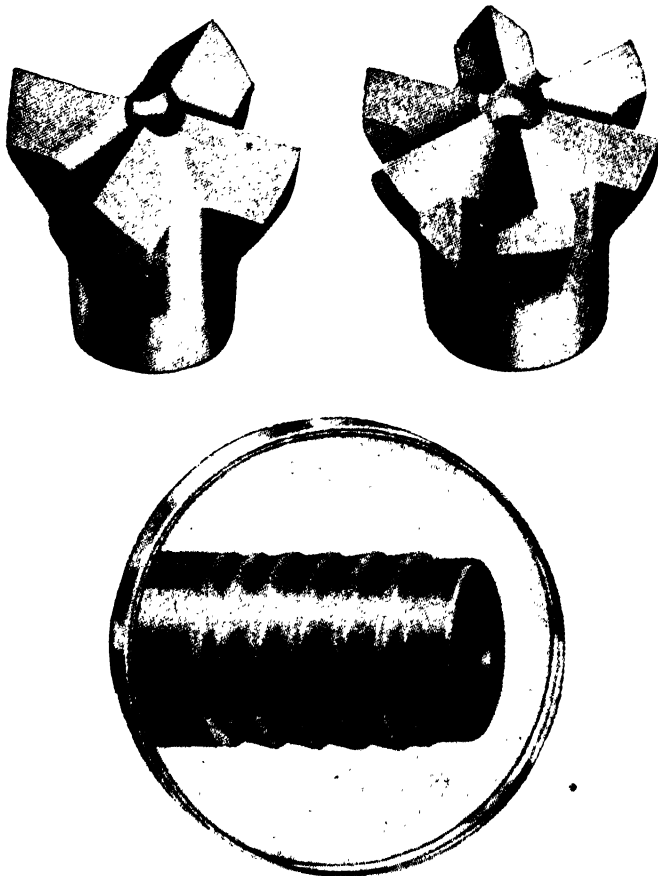

FIG. 23.—Jack bits and jack-rod thread. (Courtesy of Ingersoll-Rand Company.)

16. Drifter Drills.—The tripod mounting is generally used with drifter drills. The complete unit is sometimes called a “tripod drill.” Drifter drills weigh from 125 to 300 lb. The tripod legs are usually telescopic, with adjustable weights generally attached to them. These drills may also be mounted on columns, quarry bars, drilling units, or wagons. They are used

for heavy drilling work and for deeper holes in hard rock or where powerful rotation and high blowing are needed.

17. Stope-hammer Drills.—Essentially, a stope-hammer drill is a modification of a jackhammer. These drills are made in weights ranging from about 65 to 116 lb. and are usually mounted on a thrust rod and used principally for up-hole drilling. The lighter models are hand fed while the heavier models are usually automatically fed. Both types have high drilling speeds and are extensively used in tunnel and mining work.

18. Other Hand-operated Tools.—Many other hand-operated air tools are used in excavation work. They are adaptable to loosening soft rock, trimming rock surfaces, breaking concrete pavement, cutting hardpan or hard clays, tamping embankments, and many other operations. These powered tools have been developed to high degrees of efficiency and have done much to expedite work and to lower costs. For detailed information reference is made to manufacturers' catalogues.

19. Well Drills.—Well drills depend entirely upon the weight of the bit and heavy drill rod to produce a crushing action on the rock when the drill is dropped into the drill hole. In raising and lowering, a churning action is produced. This method is sometimes called the "churn drill." This churning action produces a slurry of displaced soil and rock fragments, when water is used in drilling. The hole is cleaned by bailing, washing, or with a sand pump.

Well or churn drills are best suited for large-diameter holes of considerable depth. They are used in quarry work for holes up to 8 in. in diameter. Because the rate of drilling is directly dependent upon the weight of the drill tools, small-diameter holes are not economical. Six-inch holes may be drilled at the rate of 1 to 6 ft. per hr. in rock having the hardness of limestone or trap.

20. Wagon Drill.—The wagon drill provides a flexible and portable drilling unit. A lighter model, as shown in Fig. 24, is adjustable for drilling at any angle. It is suitable for holes up to 24 ft. in depth and provides for change of drill rods in 6-ft. sections. The single-piece tubular frame furnishes rigidity with light weight and provides a means of obtaining many operating positions.

The heavier models will accommodate 10-ft. drill steel changes. The drill is fed down by its own weight plus a slab back with adjustable weights, which makes it adjustable for various ground conditions. It may be raised by a hand wrench or an air-operated hoist. The tower in these models may be tilted 15 deg. either side of the normal vertical position. The mounting

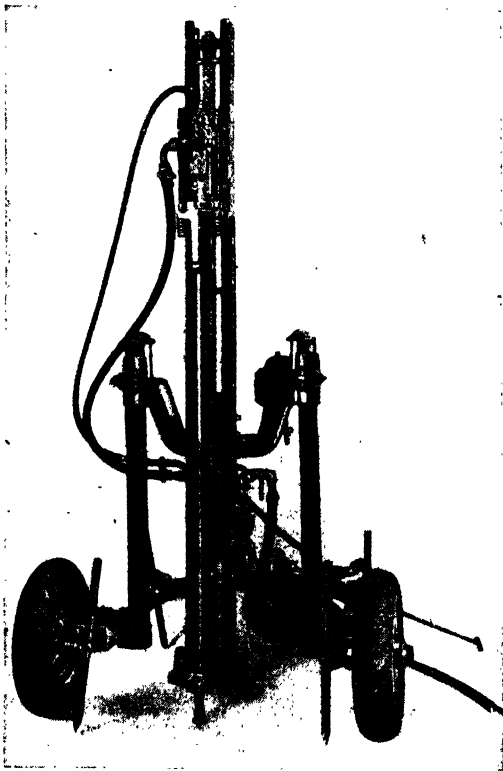

FIG. 24.—Wagon drill. (Courtesy of Ingersoll-Rand Company.)

frame is heavier and larger drills may be used. These heavy models are suitable for approximately vertical holes in soft and medium hard rock for depths up to 40 ft.

Compared with hand-operated drills, these wagon-mounted drills assure faster drilling speeds by permitting the use of heavier drills and longer feeds. Deeper holes may be drilled with fewer rod changes. The use of larger bits permits a wider spacing of holes. This produces a saving in drilling time and in quantity of

explosive necessary. In quarry work, holes may be so spaced that secondary drilling is unnecessary.

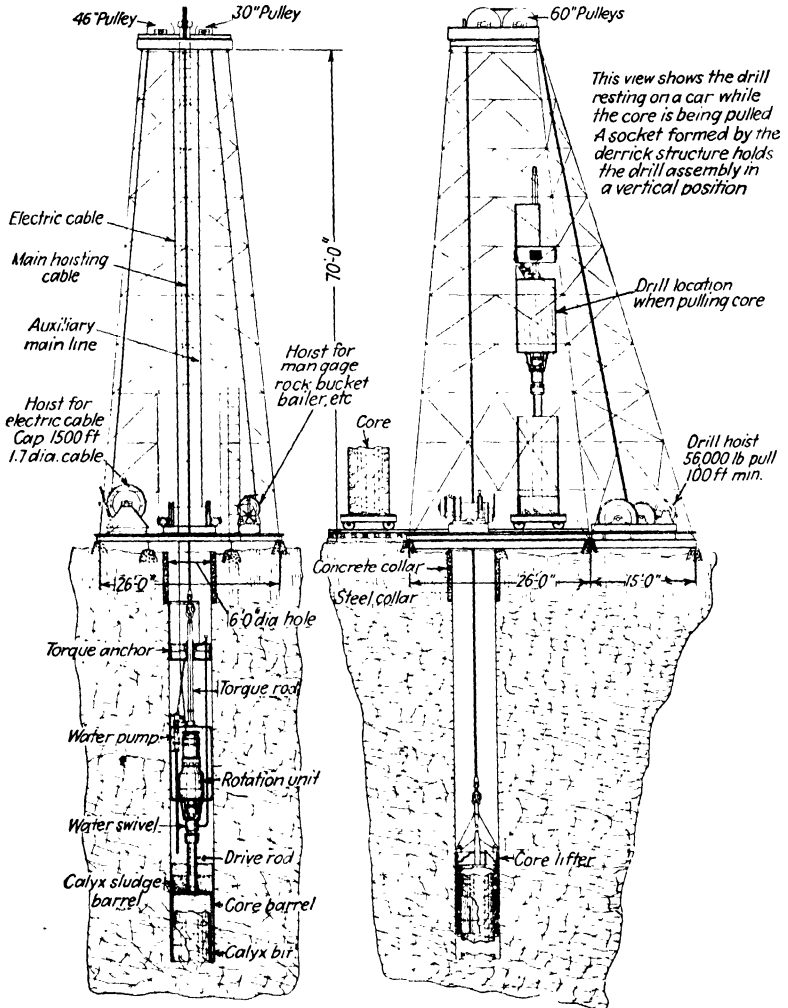

FIG. 25.—Rodless calyx bore unit. (Courtesy of Ingersoll-Rand Company.)

21. Abrasion Drills.—Abrasion drills are used where cores are to be taken. Core drilling done essentially for exploratory work was described in Art. 10.

Many large modern engineering undertakings require large-diameter deep holes. These holes are not primarily for investigation but may be used for ventilating shafts or in mining or tunneling work. The depth and diameter of the drill hole are limited by the length and weight of drill rods necessary. For small-diameter holes, the drill rod method is suitable for depths of 250 to 300 ft. For diameters up to 36 to 54 in., the calyx drill uses this method for depths of 50 ft.

To make large-diameter deep holes possible by core drilling methods without the use of drill rods, a rotative power unit that follows the drill tools down in the hole has been developed. This unit is shown diagrammatically in Fig. 25. The 72-in.-shaft core drill unit is shown in Fig. 26. A unit of this size was built for the Russian Government some years ago.



FIG. 26.—
Shaft-core
drill unit, 72-
in. diameter.
(Courtesy of
Ingersoll-Rand
Company.)

22. Explosives.—Explosives are substances used to generate power for the breaking up of masses of rock. The power is generated by an explosion, which is the chemical action between the elements of the explosive substance. This action takes place at a high temperature and results in the generation of a large volume of gas. The sudden expansion of the gas, which is confined in a relatively small space, produces the explosive force that ruptures or breaks up the rock. The strength of an explosive is the force or power generated by it. Fast explosion creates larger volumes of gas that quickly expand to produce a shattering blow. The slow explosion will produce an even blow. Explosive strength is usually expressed in terms of the percentage of nitroglycerin present. The gases generated in the explosion may be toxic and their heat may explode mixtures of pit gases and air, or mixtures of dust and air if used in confined places.

The strength of the explosive substances of the deflagrating type, such as blasting powder, which do not depend upon nitroglycerin for their strength, may be expressed in terms of a dynamite having

a percentage of nitroglycerin that will release an equal amount of energy.

Explosive substances may be classified as blasting powder, pellet powder, and high explosives, which include the permissible explosives.

22a. Blasting powder is the oldest and most widely known explosive. It consists of 70 to 75 per cent saltpeter, 10 to 15 per cent charcoal, and 10 to 15 per cent sulphur. In some grades the saltpeter may be replaced by nitrate of soda. The powders using saltpeter are much more expensive and are used only in difficult blasting, as in quarrying fine-dimension stone. The powder using nitrate of soda is not so water-resistant; hence, great care should be taken to keep the powder in an airtight container and stored in a dry place.

Powder comes in metal containers or kegs of about 25-lb. capacity. The powder is classified in grades depending on the size of the grain, which varies from about $\frac{1}{16}$ to $\frac{1}{2}$ in. in diameter. The rate of combustion varies with the size of grain, and thus a fine-grained powder is termed a *quick* powder, while a coarse-grained powder is called a *slow* powder. Powder grains should be uniform in size for any grade, be free from dust, and have no sharp edges or corners.

The grade using nitrate of soda is widely used in general quarrying, stripping, coal mining, and general excavating work. In blasting rock it is poured through a funnel into the hole or holes that have been previously drilled. In horizontal holes, the powder is placed by a long-handled scoop or shoved into the holes in paper bags. The powder is ignited by a cap or fuse, the lower end of which is buried in it. After the hole is loaded, clay or sand should be placed above the charge in layers well compacted by tamping with a wooden bar or rod. When powder is fired by electricity, a paper cap containing powder is placed in the charge and ignites the latter by a small flame.

22b. Pellet Powder.—Pellet powder is an improved deflagrating explosive. It is, basically, the same as the blasting powder containing nitrate of soda but has additional ingredients to control physical and explosive properties of the five grades manufactured. The powder is pressed in cylindrical pellets about 2 in. long and in diameters varying from $1\frac{1}{8}$ to $2\frac{1}{2}$ in.

Four pellets are paper wrapped to form a cartridge. The cartridges are dipped in paraffin and are packed in wooden boxes containing either 25 or 50 lb. This powder is suitable for use in wet holes.

22c. High Explosives.—High explosives include all the dynamites, permissible explosives, and the low powders. High explosives are all fired by a detonator, and the transformation from the solid to the gaseous form is much faster. A much greater volume of gas is generated. *Permissible explosives* are those which have been tested and approved by the U.S. Bureau of Mines for use in gaseous and dusty mines.

22d. Nitroglycerin.—Nitroglycerin is an unstable explosive liquid produced by the action of nitric or sulphuric acid on glycerin. The liquid will burn if ignited in open air, and explode at a temperature of 388°F. In explosion it generates about 1,500 times its volume in gas, which will in turn expand approximately 10,000 times in volume owing to the heat of combustion. Nitroglycerin will freeze at 41°F. and may be exploded by shock.

22e. Dynamite.—Dynamite is representative of the rapid explosive. It is made by soaking some absorptive material, usually called "dope," in nitroglycerin. The dope is called "inactive" if an inactive substance such as porous earth or wood pulp is used, and "active" if the absorbent material is gunpowder. The grades of *straight* dynamite are determined by the amounts, expressed in percentage by weight, of nitroglycerin contained in the explosives. Thus, if the weight of nitroglycerin is 60 per cent of the total weight of the compound (with inactive dope), the explosive is termed a 60 per cent dynamite. Dynamites with an active base are rated by comparison with a standard, inactive-dope brand. They are sometimes called "false" dynamites.

The classes of dynamite in general use are the straight nitroglycerin dynamite, the low-freezing dynamite, the ammonia dynamite, and the gelatin dynamite. The low-freezing dynamite will not generally freeze at temperatures above 32°F. In ammonia dynamite varying percentages of the nitroglycerin are replaced by nitrate of ammonia. In the gelatin dynamite the explosive base is a jelly made by dissolving nitrocotton in nitroglycerin. Some of the nitrocotton and glycerin may be replaced

by ammonia nitrate. The first is known as "straight gelatin" and the second as "ammonia gelatin" dynamite.

For a detailed consideration of the classification, transportation, storage, handling, and use of explosives, particular reference is made to "Blasters Handbook."¹

Dynamite comes in paper cartridges, $\frac{7}{8}$, 1, $1\frac{1}{4}$, to 2 in. in diameter and varying in length from 6 to 16 in. The common size is $1\frac{1}{4} \times 8$ in. and is shipped in wooden boxes holding 25 or 50 lb. Forty per cent dynamite is a common strength used in construction work. It is readily obtainable on the market and is suitable in any material except the very hard rocks.

The cartridges, which should be slightly smaller than the drill holes, are slit lengthwise with a knife and pressed well into the hole, successively, by a wooden rammer. The explosive charge is fired by a detonator or blasting cap. Blasting caps are copper cylinders, $\frac{1}{4}$ to $\frac{1}{2}$ in. or larger in diameter and about $1\frac{1}{2}$ in. long. They are closed on one end and contain varying charges of powerful explosive. They are fired by a safety fuse. The electric cap is equipped with wires of various lengths which may be interconnected by a series of parallel circuits to an electric source for firing. Series circuits are usually connected to a blasting machine which is a hand-operated dynamo consisting principally of two electromagnets and an armature. The pushing or pulling of a handle generates an electric current, which, transmitted to the detonator through the wires, explodes the charge.

Parallel circuits are usually connected to an electric source. Electric caps are generally safer than the ordinary firing caps and in addition give better control of the time of explosion.

Standard electric blasting caps used in construction work are insulated against water but are not made waterproof for firing under water. Delayed-action caps are available to fire as high as six intervals after the first impulse. This action is accomplished by placing a slow-burning substance between the ignition bridge and the explosive substance in the cap.

Field of Use.—The kind or strength of explosive to use in any particular case depends on several factors, such as the nature and condition of the material to be blasted, the amount of breaking up required, the size and spacing of the drill holes,

¹ Published by E. I. duPont de Nemours & Company, Inc., Explosives Department, Wilmington, Delaware.

and the nature of the excavation, such as bench, open cut, or tunneling.

The straight dynamites are generally the best to use in simple, open-cut work, where a quick, positive, shattering effect is desired. Gelatin dynamites are best adapted for wet work. In order to secure maximum efficiency from this class of explosive, the strongest detonator should be used. The ammonia dynamites are slower than straight dynamites, are not so sensitive, and should be used where too great a shattering effect is not desired.

Scope of Work.—The method of blasting to be used depends on many factors. In foundation or pit excavation it is generally done in sections or by the so-called "bench" method.

No rule can be given as to the spacing of the holes, as this depends largely upon the nature and condition of the rock, the required size of fragments, kind of explosive used, etc. In general practice, the holes are placed back from the face a distance about equal to their depth. The holes can often be spaced a distance apart considerably greater than their depth in stratified rock. When stratified rock has a dip, the spacing of the holes parallel and at right angles to the strike should depend on the kind of explosive used, the character of rock, the size and numbers of seams or fissures, and the method of loading or placing the charges. As a general rule, holes should never be more than 20 ft. apart, and in hard rock it is well to try out spacings of from 10 to 15 ft.

The amount of explosive to place in a charge depends on so many variable elements that no absolute rule can be given. It is common practice to fill the larger holes on heavy work to one-half their depth, and to bring the charge up to not less than 30 ft. from the surface. In hard material, the holes are often loaded up to within 20 ft. of the surface. In deep holes, two or more charges may be placed so as to secure greatest efficiency with economy in the use of the explosive. In ordinary rock 40 per cent dynamite will give satisfactory results; in hard rock, a combination of 60 per cent and 40 per cent dynamite is advisable—the 60 per cent placed in the bottom of the hole, and the 40 per cent on top. It is well to space caps or detonators about every 25 ft. in deep holes.

Usually the holes are exploded in lines equidistant from the face. The fractured material is then removed before the next

CUBIC YARDS OF ROCK REMOVED PER FOOT OF HOLE

Distance holes are set back from face (feet)	Distance apart of holes (feet)							
	5	6	7	8	9	10	11	12
5	0.92	1.11	1.3	1.49	1.66	1.85	2.04	2.22
6	1.11	1.33	1.55	1.77	2.0	2.22	2.44	2.65
7	1.3	1.55	1.81	2.0	2.33	2.7	2.85	3.11
8	1.49	1.77	2.0	2.37	2.65	2.96	3.26	3.55
9	1.66	2.0	2.33	2.65	3.0	3.33	3.66	4.0
10	1.85	2.22	2.7	2.96	3.33	3.7	4.1	4.44
11	3.26	3.66	4.1	4.48	4.88
12	4.0	4.44	4.88	5.33
13	4.81	5.3	5.77
14	5.18	5.7	6.22
15	5.55	6.11	6.66
16	7.11
17	7.55
18	8.0

Distance holes are set back from face (feet)	Distance apart of holes (feet)							
	13	14	15	16	17	18	19	20
10	4.81	5.18	5.55	5.92				
11	5.3	5.7	6.11	6.52				
12	5.77	6.22	6.66	7.11				
13	6.26	6.74	7.22	7.70				
14	6.74	7.26	7.77	8.30				
15	7.22	7.77	8.33	8.88	9.44	10.0	10.55	11.11
16	7.70	8.30	8.88	9.48	10.07	10.66	11.3	11.85
17	8.18	8.81	9.44	10.07	10.70	11.33	11.96	12.59
18	8.66	9.33	10.0	10.66	11.33	12.0	12.66	13.33
19	9.15	9.85	10.55	11.3	11.96	12.66	13.37	14.07
20	9.63	10.37	11.11	11.85	12.59	13.33	14.07	14.81
21	11.66	12.44	13.22	14.37	14.77	15.55
22	12.22	13.03	13.85	14.66	15.48	16.30
23	12.78	13.63	14.48	15.33	16.18	17.03
24	13.33	14.22	15.11	16.0	16.88	17.77
25	13.88	14.81	15.74	16.66	17.60	18.51
26	14.44	15.74	16.37	17.33	18.30	19.26
27	15.0	16.15	17.0	18.0	19.0	20.0
28	15.55	16.6	17.63	18.52	19.7	20.74
29	16.1	17.18	18.26	19.33	20.4	21.48
30	16.66	17.77	18.88	20.0	21.1	22.22

To reduce to tons

- For limestones..... multiply by 2.27
- For traps, syenites, etc..... multiply by 2.52
- For granites..... multiply by 2.3
- For shale..... multiply by 2.18
- For glass sand or gravel..... multiply by 1.55

blast is made. In very hard material good results are secured by staggering the holes. In some cases a second line of holes is shot down before the blasted material from the first line of holes is removed. This is the so-called "buffer" method of blasting and is especially adapted to loose stratified material that can be easily handled by an excavator in the cut.

The accompanying table gives the number of cubic yards of rock removed per foot of hole at different spacings.

23. Rock Breaking.—The blasted rock as it lies on the floor of the excavation may vary in size from a pea to fragments several feet in their least dimension. In order that the larger pieces of rock may be loaded into skips or buckets by hand or by some form of excavating machinery, it often becomes necessary to break them up into smaller fragments. The following methods are used:

1. Dropping of heavy weights.
2. Use of sledge hammers.
3. Block holing.
4. Mud capping.
5. Undermining.

1. The method of *dropping heavy weights* from a considerable height is practicable only when a derrick, locomotive crane, or cableway is available. The weight used is ordinarily a block of cast iron weighing about a ton. The height of the drop should be from 15 to 30 ft. The weight is released suddenly by a trip of a friction-drum engine. This method is applicable in a restricted space where a derrick is available.

2. The *sledge hammer* is one of the oldest and simplest methods of breaking up rock fragments. The sledge used should be of such proportions that a man of average strength can wield it efficiently. A lighter sledge of about 12-lb. weight, used with rapid blows, is much more effective than one weighing 16 lb. and used with slow strokes.

This method, though crude, is efficient for the breaking up of fragments to about 1 cu. yd. in volume, and for sedimentary and stratified rock. Every pit gang should be supplied with sledges for the breaking up of the rock fragments that are too small to be broken up economically by block holing or mud capping, and yet are too large and unwieldy to be handled by the power excavator.

3. *Block holing* is the simple application of the ordinary method of drilling and blasting to the breaking up of large rock fragments. The most efficient method is to drill a hole from a few inches to 2 ft. in depth and place the center charge of explosive in the hole. But the more common and quicker way is to drill a shallow hole and place a small part of the explosive on the rock above the hole and cover the entire charge with mud.

This method is the most effective one for the breaking up of rock larger than 1 cu. yd. in volume, and is in common use in open excavation work.

4. *Mud capping* is probably the most popular method of breaking up rock, especially with the average pit or blasting foreman. The placing of the explosive directly on the surface of the rock and covering it with a mud blanket is a simple but an expensive and uneconomical process. The resulting efficiency of the explosive is very low.

This method should not be used except when it is necessary to break up rapidly huge pieces of rock that are delaying the operation of the excavators.

5. The method of *undermining* is little used and not generally known. It resembles mud capping but differs essentially in that the explosive is under, rather than on top of, the rock. Where large masses of rock are piled up together, the charge of explosive can be placed on the upper surface of the lower fragments and thus have a bed. The same results can be attained by this method as by mud capping with the use of about one-half the amount of explosive.

24. Subaqueous Rock Excavation.—The earliest method of subaqueous rock excavation consisted of the use of explosives, which were lowered to the surface of the rock. This method proved to be uncertain and unsuccessful, especially in the case of ledges of hard rock. Large boulders and projecting rock can be broken up satisfactorily by this method. In some cases a drop bar was used to drill holes, into which charges were placed in the regular way. This method was slow and expensive.

The unwatering of the surface of the rock by constructing cofferdams can often be used to advantage if local conditions warrant such construction. Economic considerations and experience should decide the method best suited for given circumstances.

In general, subaqueous rock breaking is accomplished by some form of cutting or drilling and blasting, and removal is accomplished by dredging operations.

24a. Rock Cutters.—Rock cutters consist of a heavy chisel provided with a hardened steel cutting point. The cutters are usually mounted on a barge, which is rigidly braced.

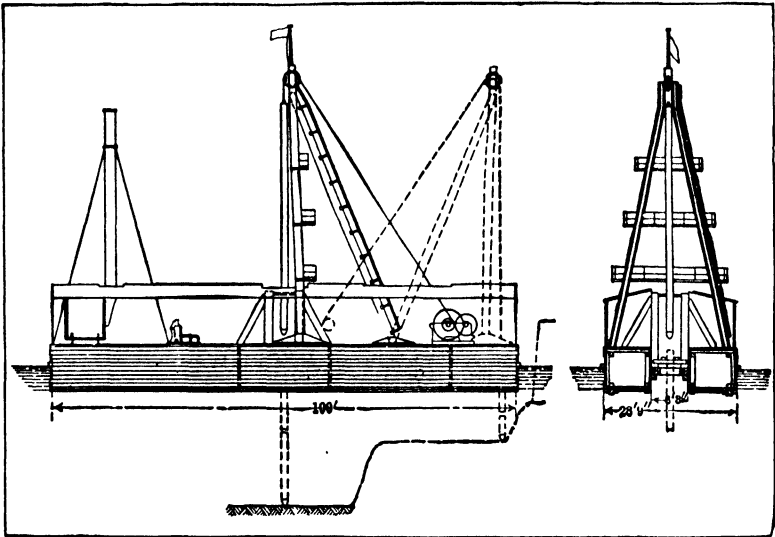

FIG. 27A.—Side elevation and cross section of Lobnitz rock cutter.

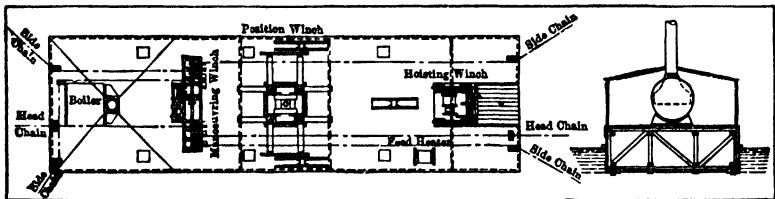

FIG. 27B.—Plan view of Lobnitz rock cutter.

The cutter, which may weigh from 4 to 20 tons, is operated by a steel cable, which is attached to the top of the cutter and then passed over a sheave suspended in an A-frame vertically above the cutter, and thence to the drum of a hoisting engine.

The operation of the cutter is similar to that of a drop-hammer pile driver, the fall varying from 5 to 10 ft. The impact of the falling point will fracture rock from 1 to 3 ft. in depth, depending on the nature and structure of the material. Figures 27A and

27*B* show the plan and elevation of a Lobnitz rock cutter. These cutters are sometimes termed "chisel boats."

The rock breaker has been in general use in European practice and is often combined with a ladder dredge. In this case, several cutters or chisels are located in a well alongside the ladder. The picks or chisels are placed about 2 ft. apart and can be operated singly or coordinately. The buckets of the dredge are provided with heavy steel teeth for the removal of the rock fragments.

24*b*. Drill Boats.—There are three forms of drill boats in general use:

1. A floating barge equipped with movable towers on which the drills are mounted.
2. A floating barge equipped with drilling frames, which are arranged to lower the drills to the rock surface.
3. A floating platform or barge equipped with tripod drills.

The drill boat consists essentially of a barge equipped with a spud at each corner and carrying one or more power drills. The details of construction depend on the uses to which the boat is to be put, and especially the character of the stream—tidal or nontidal.

The drilling equipment consists of power-operated drills which are either fixed or mounted on movable towers. The latter may be placed on a track and moved to any position along the length of the boat. The use of movable towers or drill frames will save considerable time since it is much quicker and easier to move the drill frame than the drill boat.

The drills are usually of the percussion type and are operated either by steam or by compressed air. Because of its economy, versatility, and increased performance the use of compressed air as a power source is increasing. Four modern submarine drills are shown in Fig. 28.

In operation, the drill boat is moved into position by means of four cables extending out from the four corners a distance of 300 to 500 ft. to an anchor. When the boat is in proper position, the spuds are lowered and the boat is raised 1 to 2 ft. in order to give more stability and prevent movements due to vibration of drills or to the tide.

The process of rock drilling consists of lowering the "sand pot," drilling the hole, and placing the dynamite charge. The

sand pot is a pipe 6 to 10 in. in diameter with a hopper top. This is placed upon the rock, and the drill having a hollow rod is placed on the rock through the pipe. Water forced through the drill rod washes the drilled rock materials from the hole through the sand pot as the drills are operated. The dynamite charge is placed through a hollow tube lowered to the bottom of the hole.

Drill holes vary in diameter from $1\frac{1}{2}$ to 4 in. Holes are spaced from 6 to 12 ft. on centers, dependent upon the type of rock and the depth of dredging. The dynamite charge will vary

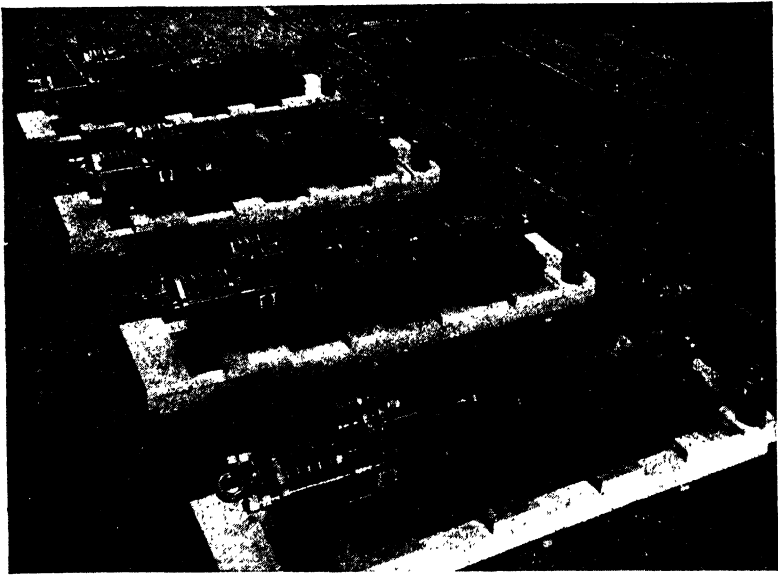

FIG. 28.—Submarine drills. (Courtesy of Ingersoll-Rand Company.)

from 1 to 3 lb. per lin. ft. of hole. Sixty per cent dynamite is generally used and the charge is exploded by an electric firing machine.

In general, dynamite will break rock on a slope of 45 deg. This determines the necessary depth of drilling for a given spacing and required depth of dredging. For example, if holes are spaced 10×10 ft. and it is required to remove rock to the 15-ft. plane, it would be necessary to drill 5 ft. below the 15-ft. plane in order to have the rock effectively broken up and economically removed by dredge.

The blasted rock is generally removed by a dipper dredge supplemented at times by derrick scows for the removal of large projecting pieces of rock, which were too large to be handled by the dredge.

Field of Work.—The excavation of rock for piers, docks, sea walls, and similar structures, the foundations of which lie under water, involves the breaking up of the rock and its subsequent removal. The method of breaking up depends on the nature of the rock. The rock cutter works most efficiently in shallow layers of soft, stratified rock, such as shale and sandstone. Hard rock, such as trap, gneiss, or granite, especially in layers over 3 ft. in thickness, can be handled more economically by the drill boat.

The output of the rock breakers will vary with the local conditions, such as depth of water, size of cutter, and nature of material. In ordinary rock, such as sandstone and limestone, a chisel weighing about 10 tons will deliver about 150 blows per hour and break up about 10 cu. yd. On the Panama Canal, during 1910-1911, a 19-ton ram, with a drop of 5 to 14 ft., broke up about 35,000 cu. yd. of rock in 3,535 working hours, or at the rate of about 10 cu. yd. per hr.

Rock cutters are not extensively used in American practice. They are not so efficient as the drilling and blasting process.

25. Wet or Subaqueous Excavation.—The excavation of earth and rock under water, as in the preparation of the foundations for docks, piers, sea walls, breakwaters, etc., can best be done by some type of floating excavator, if the work covers sufficient area and is of a sufficient magnitude to warrant it. The excavation of bridge piers, pits, and work of a similar type, where the area to be excavated is very limited and the depth is great, is usually done by some special form or method, such as the cofferdam, the pneumatic caisson, and dredging through wells. These methods will be discussed in other chapters of this volume. It is the purpose of this article to deal with the construction, operation, and use of the common types of floating excavator: the dipper or bucket dredge, the clamshell or dragline dredge, the hydraulic dredge, and the ladder dredge.

25a. Dipper Dredges.—Dipper dredges are built in three different types, depending on the use to which they are to be put: (1) the narrow-hull dredge with side or bank spuds for

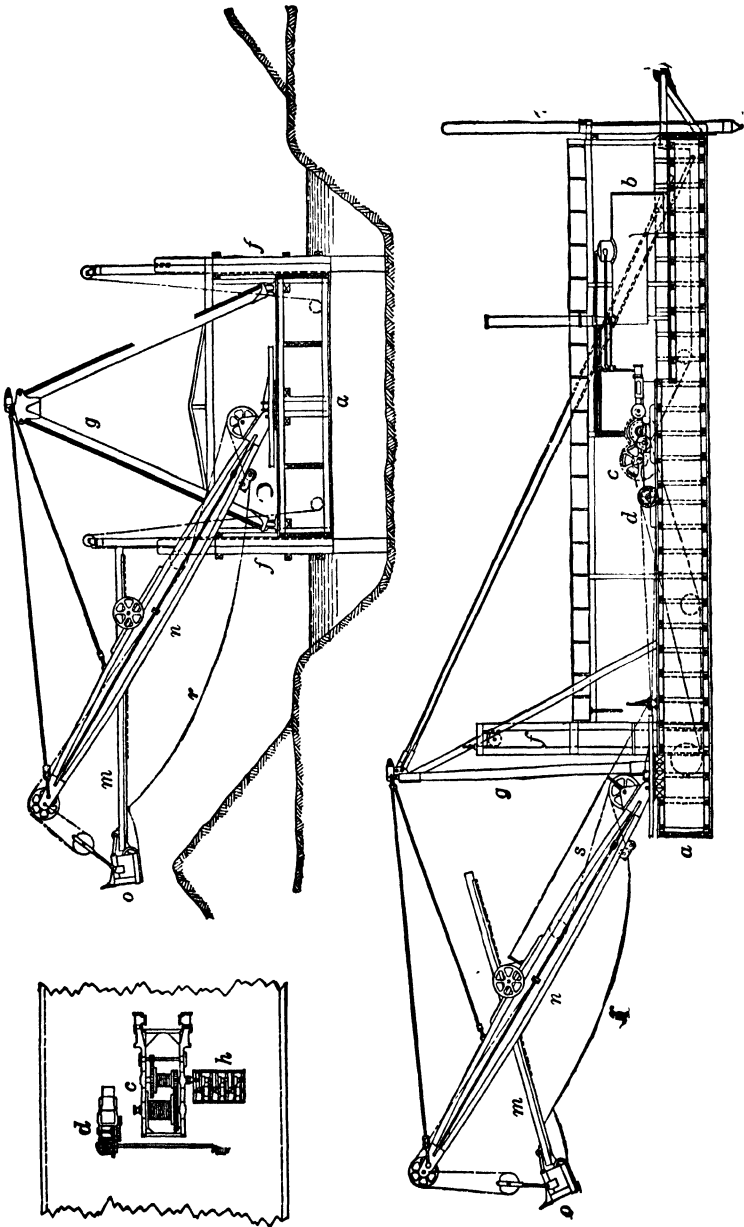

FIG. 29.—Diagram of floating dipper dredge. a, Hull; b, boiler; c, hoisting or main engine; d, swinging engine; e, rear spud; f, side spuds; g, A-frame; m, dipper handle; n, boom; o, dipper; r, latch rope; s, hoist line. (Courtesy of Marion Steam Shovel Co.)

ditch excavation, (2) the narrow-hull dredge with side floats for channel excavation and maintenance, and (3) the heavier, broad-hull dredges with vertical spuds for river and harbor work. The general features and essential parts of all three classes are the same and consist of the hull, the power equipment of hoisting engines and swinging engines, and the excavating equipment of A-frame, spuds, boom, and dipper or bucket.

The proportions of a dredge depend on its working capacity. The hull, power equipment, and boom must all be designed coordinately. In general, dipper dredges with vertical spuds have dipper capacities of 4 to 16 cu. yd.

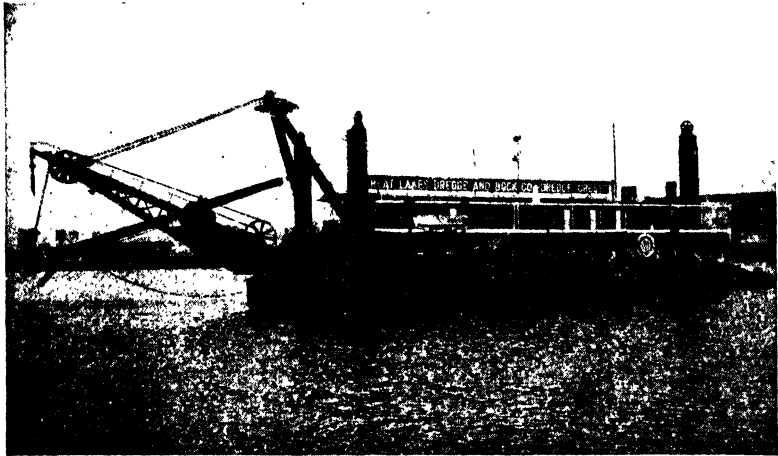

FIG. 30.—Dipper dredge "Crest." (Courtesy of Great Lakes Dredge & Dock Company.)

The essential parts of a typical dredge are shown in Fig. 29. The dipper dredge is operated by a steam plant, and a feed-water heater and purification system to provide suitable boiler water. In the larger sizes of dredge, the swinging engine is independent and swings the boom by a fixed turntable above the deck. The spuds are generally operated by separate engines, one at each spud.

The method of operation of a dipper dredge is similar to that of a steam shovel. The crew consists of an engineer, a cranesman, a fireman, and from two to four deck hands for each shift.

Field of Use.—The dipper dredge is one of the most universal and adaptable excavators for subaqueous work. In the prepara-

tion of a foundation for a dock or pier, it can pull stumps or piles, remove boulders, bridges, and other obstructions, drive piling, build temporary walls or dams, and excavate all kinds of soil from silt to loose rock. The great thrusting and prying power of the dredge makes it an especially efficient machine in the removal of the tougher materials that cannot be handled by the other types of floating dredge.

The output for a dipper dredge varies with the conditions, such as kind and condition of material, size and efficiency of dredge, climate, character and depth of excavation. A 4-yd. dredge will excavate from 1,500 cu. yd. of hard clay to 2,500 cu. yd. of soft clay, under average working conditions, in an 8-hr. shift.

The dipper dredge "Crest" owned by the Great Lakes Dredge and Dock Company is shown in Fig. 30. This dredge is powered by a 1,320-hp. Diesel electric motor and has a dipper capacity of 10 cu. yd. for rock and 16 cu. yd. for mud.

25b. Clamshell and Dragline Dredges.—Both the clamshell and the dragline dredge are similar to the dipper dredge. They consist of a hull with steam power equipment, hoisting engines, and excavating equipment of A-frame, spuds, boom, and dipper. The essential difference is that these types of dredges do not have the dipper "stick." They therefore do not have so accurate control of the dipper or bucket. The bucket capacities vary from 1 to 10 cu. yd., loose measurement. Either type may be mounted on a crawler base to move over the ground surface while carrying on subaqueous excavation adjacent to it, or on a barge as a floating excavator. Both types are adapted to the excavation of softer materials such as silt, muck, or clay.

The clamshell bucket equipped with teeth can be utilized for the excavation of the softer and lighter soils, while the orange-peel bucket may be used for the excavation of the harder and denser materials, such as sand, gravel, clay, and loose rock. The orange-peel bucket is especially efficient in the removal of boulders, blasted rock, tree stumps, and old piling from the bed of a stream or channel. The long boom on a grapple dredge is of especial advantage in the excavation of foundations lying under water, but adjacent to land, on which the dredge may operate.

The walking dragline shown in Fig. 16 is also used in subaqueous work on canals and other waterways.

25c. Hydraulic Dredge.—Hydraulic dredges may be classified as to the method of removal and deposition of material. Seagoing dredges are large self-propelled boats equipped with hoppers and are especially constructed to excavate hard materials in deep water. The smaller dredges are generally not self-propelled and dispose the excavated materials through a discharge pipe line, which is supported on pontoons and terminates on shore or in scows.

The essential parts of a hydraulic or suction dredge are the hull, the centrifugal pump, the revolving cutter, and the operating

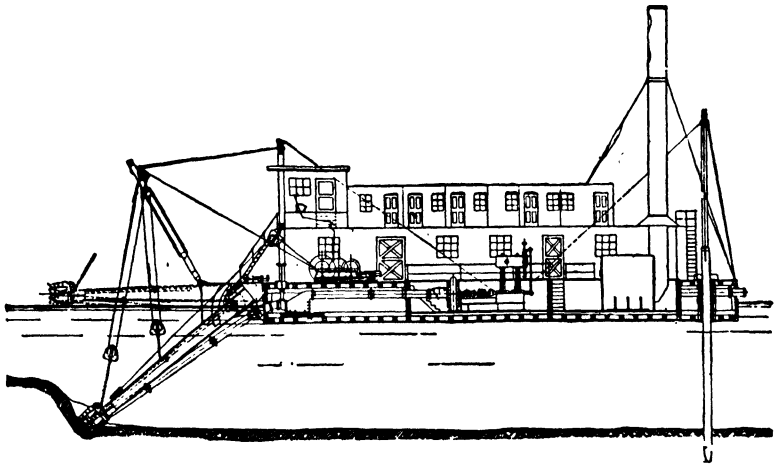
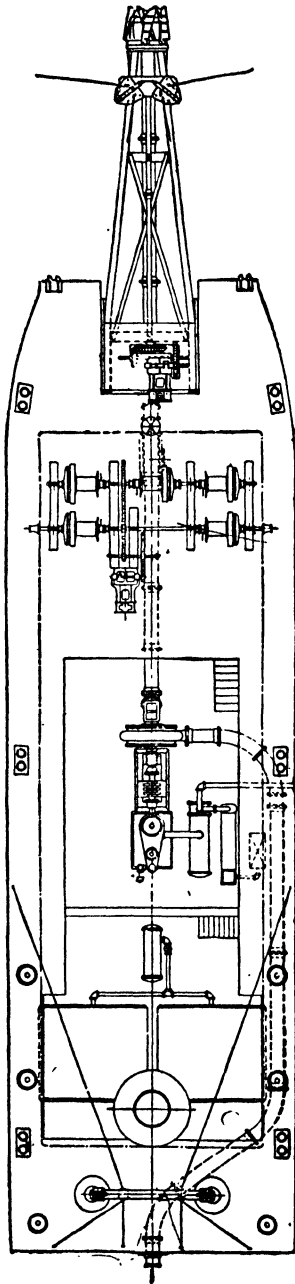

FIG. 31A.—Side view of hydraulic dredge. (Courtesy of Norbom Engineering Co.)

machinery. Attached to the pump is the suction pipe with a flexible movable joint, so that the outer and lower end can be raised or lowered to any desired depth. At the lower end of the suction pipe is placed the mouthpiece, or circular hood. On the periphery of the hood are generally placed a series of knives, which form a revolving cutter. The cutter is revolved by a shaft and gearing and loosens up the material to be excavated, which in dilution is drawn up through the suction pipe. The excavated material, when it passes through the pump, is forced through the discharge pipe, which is supported on pontoons, and discharges into scows or out upon an area to be filled in. Figures 31A and 31B show the essential parts and construction of a hydraulic dredge.



Field of Use.—The hydraulic dredge is the most economical machine for the excavation of large quantities of material under water that is easily removed and conveyed in dilution considerable distances. Generally the efficiency of this type of excavator is low on account of the high state of dilution of the excavated material. The solid content of the dilution may vary from 8 to 16 per cent. The maximum size of the solids largely determines the necessary pump size. The use of a stone box or of smaller slots to control the size particles entering the suction line has been found economical.

The Diesel electric hydraulic dredge "New Jersey" owned by the Great Lakes Dredge and Dock Company is shown in Fig. 32.

In general the life of a hydraulic dredge is 15 to 20 years. The chief factors that control the output of a dredge are type of material, suction pipe size, length and lift, size of discharge pipe and its length, and available power. The output is variable. According to O. P. Erickson of the Great Lakes Dredge and Dock Company, under like conditions of excavation and disposal for equal time intervals, the output may vary as much as six times the quantity when sand and mud are being removed as when gravel mixed with large clamshells is being removed.

FIG. 31B.—Plan view of hydraulic dredge.
(Courtesy of Norbom Engineering Co.)

25d. Ladder Dredge.—The principal feature of the excavating equipment is the steel ladder, which is a framework over which moves the bucket chain elevator. The buckets may have a capacity of from 3 to 15 cu. yd. each, and are placed at intervals of from 3 to 6 ft. along the chain. The ladder can be raised or lowered so that the buckets scrape the bottom and front of the excavation, removing and bringing up material, which is deposited at the top of the ladder, upon belt conveyors or into hoppers. Some ladder dredges are provided with a hydraulic

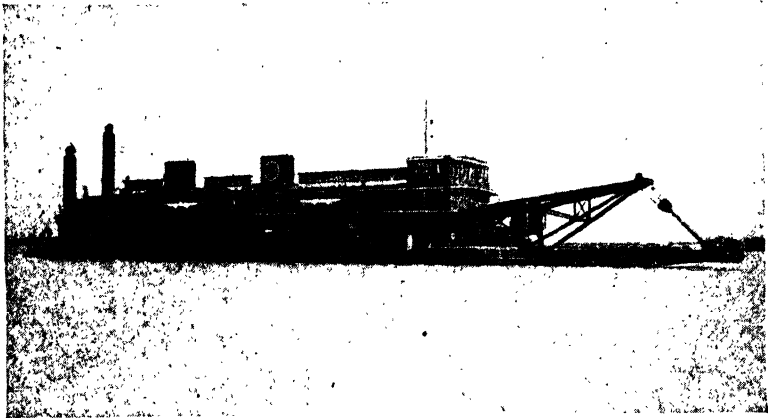

FIG. 32. Hydraulic dredge "New Jersey." (Courtesy of Great Lakes Dredge & Dock Company.)

monitor, which is useful in the washing down of high banks. The ladder dredge is sometimes provided with several cutters for the breaking up of rock, previous to its removal by the buckets. This arrangement is very efficient in the excavation of material too hard for the bucket chain to handle without loosening.

As the ladder dredge is generally a machine specially constructed to meet certain requirements of removal and disposition of material, it is impossible to give a definite statement as to output. On account of its high initial cost and relatively limited field of use, the ladder dredge has not and probably never will attain the general use and popularity of the dipper dredge. It does have the advantage of being able to work in deeper water than the dipper dredge and is particularly suited to the excavation of sands and gravels when the excavated materials may be processed on the same unit.

Field of Use.—The ladder dredge is efficient in the excavation of all classes of material from silt to the softer stratified rocks, in deep water, and over large areas where there is plenty of space for the maneuvering of the dredge from side to side. It cannot work to advantage in long narrow channels or overrestricted areas.

SECTION 3

FOUNDATIONS

INTRODUCTION TO FOUNDATIONS

1. General.—The art of foundation construction is as old as the art of building. In the past, however, the foundation has been considered only as the artificial structure which served to transmit the load of the structure to the soil or other supporting material. Foundations consist of two distinct parts: the substructure and the supporting material. The proper functioning of each depends upon the other and they should therefore be considered as a unit. The comparatively recent application of the results of the study of soil mechanics to the design and construction of substructures has done much to aid in developing a better understanding of this problem. The behavior of a supporting soil mass under load is of primary importance in estimating the relative values of various types of foundations that may be suitable for the particular field conditions.

Because of the many factors that control the behavior of soil under load, no definite answer can be given to a general problem. Each foundation is a specific problem and should be considered in relation to local conditions. Professor Terzaghi has repeatedly pointed out that soil mechanics cannot now and probably never will be directly and indiscriminately applied to the solution of foundation problems. The proper interpretation and use of soil test data require both experience and engineering judgment.

The function of a foundation is to support the structure and its live loading throughout its useful life without detrimental or costly damage resulting from settlement. Good engineering practice demands that this be accomplished economically. In modern practice, the failures of substructures have been few. In most cases where failure has occurred or where considerable damage has been done, the cause has been the failure of the supporting earth mass. Any structure not founded on rock will settle to some appreciable extent. The problem of the modern

foundation engineer is to determine the amount of settlement that can take place without damage to the structure, as well as the nature and the probable amount of settlement with the various types of foundations for the specific soil conditions. This is dependent upon the type of superstructure, the type of foundation, and its relation to surrounding foundations and soil characteristics. In the complete settlement analysis, soil mechanics plays an important part. It therefore follows that the final selection of the type of foundation should not be made until all the possible types have been investigated.

2. Types of Foundations.—Foundations may be divided into two classes: those constructed on land and those constructed under water. In the first class no particular precaution need be taken to exclude water although a moderate amount of pumping may be necessary. The underwater foundation may be below a body of water or below the ground-water table. Each class may be subdivided according to the type of the finished structure or to the methods used in its construction.

Land foundations constructed in essentially dry soil may be classified according to the method used to distribute the load to the supporting soil; for example, spread foundations, mat or floating foundations, and pile foundations. Footings or piers constructed in open excavation are termed "open-well" or "pier" foundations. When foundations, piers, or footings extend below ground-water level and when special provisions have to be made to exclude water, or water and soil, land cofferdams, or open or pneumatic caissons, are used. The methods commonly used to construct foundations below a body of water are similar to those used below the ground-water table. These include various types of cofferdams and of open, box, and pneumatic caissons.

Spread footing and grillage foundations will be considered in Sec. 4, and foundations requiring special consideration are given in Sec. 6. Cofferdams, piles, and pile foundations are considered under separate captions in this section.

3. Preliminary Investigation.—One of the primary problems in the design of substructures is the determination of the bearing capacity of the supporting soil. When soils of low bearing capacity, high permeability, or high cohesion are expected, a knowledge of soil structure and moisture conditions is essential. Subsurface investigation is therefore valuable. Lack of knowl-

edge of subsurface conditions has proved very costly in many instances. This is due to reluctance on the part of owners to expend the funds necessary for adequate preliminary investigations. Although all the uncertainties may not be eliminated by subsurface exploration and study, they can be greatly reduced. The owner should assume the responsibility. Otherwise the contractor is forced to gamble. This, in the final analysis, may be even more costly to the owner.

Substructures should be designed for the particular soil conditions at the site. Before the foundation is designed, a systematic investigation of subsurface conditions and the location of rock

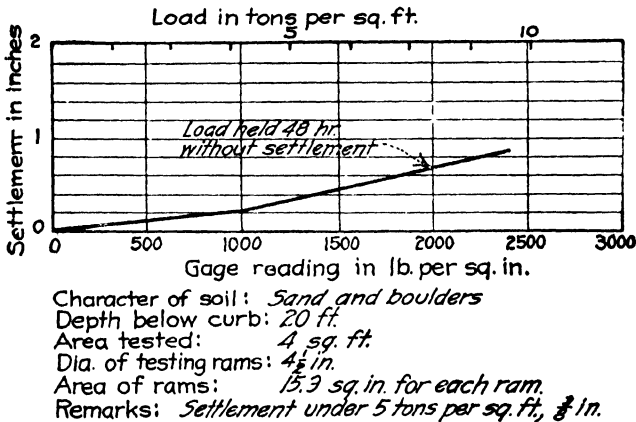

FIG. 1.—Record of soil test made under direction of Bureau of Buildings of Manhattan, New York City.

should be made. Complete records showing the character and extent of materials encountered should be made. Adequate and properly cared-for samples should be taken at suitable intervals. These samples should be tested and the results evaluated to determine the probable settlement under the proposed foundation loading.

4. **Bearing Power of Soils.**—The bearing capacity of a soil may be defined as the maximum load that it will support without producing progressive or detrimental settlement. Except for hard rock, cemented gravel, or hard dry clay, knowing the name and class of material in advance of tests does not help much. Assigning bearing values merely by name is very dangerous. The results of field tests made under the direction of the New

York Bureau of Buildings are shown in Fig. 1. Such tests, if carefully conducted, furnish valuable information. When supplemented by laboratory tests on soil samples, a more reasonable and a safer value for the allowable bearing capacity may be determined.

The bearing values used should have some relation to the allowable settlement which will not damage the superstructure.

COFFERDAMS¹

5. Types of Cofferdams.—A cofferdam is a temporary structure used to exclude water or earth and water from a specific area. The area is enclosed by the structure. Then the water or water and soil within it are removed. The chief purpose of the structure is to uncover an area at a desired elevation and to maintain it in such a condition that the work planned may be carried on within it. When these structures are used in subaqueous work, they are termed “water cofferdams,” and when they are used in soil excavations carried below ground-water level, they are termed “land cofferdams.”

There are four primary requirements of a cofferdam. It must be sufficiently strong to resist the external forces of water and earth pressure and of shock due to the impact of floating objects. It must have sufficient flexibility to enable it to pass obstructions during the sinking process without damage to the structure. It must be watertight to a degree that is consistent with stability and the job requirements. The cost including maintenance, water pumping, and removal, minus the salvage, should be a minimum.

In practice there are many types of cofferdams. Some of these have, through long use, become somewhat standard. However, the type of cofferdam finally selected is dependent upon the site conditions. To secure stability and to satisfy the time or economic requirements many changes in both types and methods of construction are found in practice.

The more common types of water cofferdams used under various conditions may be classified as earth embankment or dike, puddle cofferdams, rock dike or rock fill, rock-fill cribs, and steel sheet pile cells.

¹ See also discussion of sheet piles, p. 208.

6. Soil Pressure on Cofferdams.—Since cofferdams are usually of large area and depth, the pressure of the soil on their walls constitutes a very considerable factor in their design and a short discussion will therefore be given, relating to the pressure of dry and water-bearing soils against cofferdams or other walls.

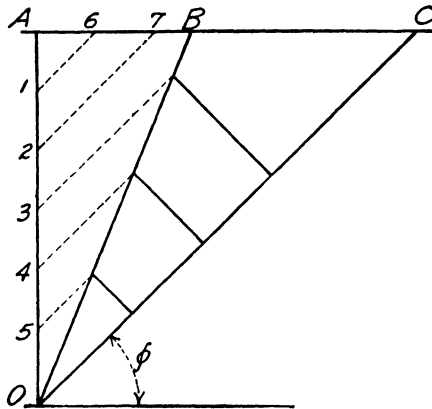

FIG. 2.

If in Fig. 2 we assume that AO is the braced wall of a trench or cofferdam, and that if it is removed, the normally dry sand behind it will slide away to the line or plane OC , then OC is the line or plane of repose of this soil. If then the face AO is restored and the area AOC is again back-filled, it is undoubtedly true that no soil below OC can exert any pressure on AO , but that all of the soil in the area AOC , being restrained from sliding by the wall, does exert some pressure on it. If the boards $A-1, 1-2, 2-3$, etc., are removed, one at a time, the areas or volumes above the slope line at these points tend to slide away, and therefore before removal must exert pressure proportional to their areas.

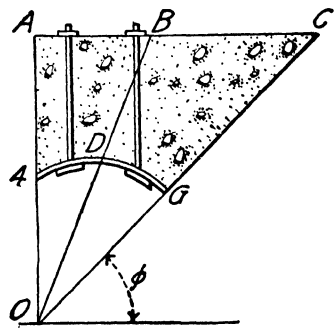

FIG. 3.

With the boards or wall in place, the tendency of the soil is, normally, to move toward the operating face when some small movement or leakage is probably occurring. When a sufficient depth

has been reached, as $A-4$ (Fig. 3), the soil tends to establish itself by forming a natural arch between $A-4$ and CG . If, for instance, the line or surface $4-D-G$ (Fig. 3) should be lagged and attached to the mass by bolts bearing through large washers on the surface, all the soil below $4-D-G$ could undoubtedly, and with perfect safety, be removed, the soil arching between $A-4$ and CG .

The soil pressure per linear foot of face on $A-1$ (Fig. 2) may be determined by multiplying the volume represented by the area $A-1-6$ by the weight of the soil per cubic foot and dividing by the tangent of the angle of repose (ϕ). In a like manner the

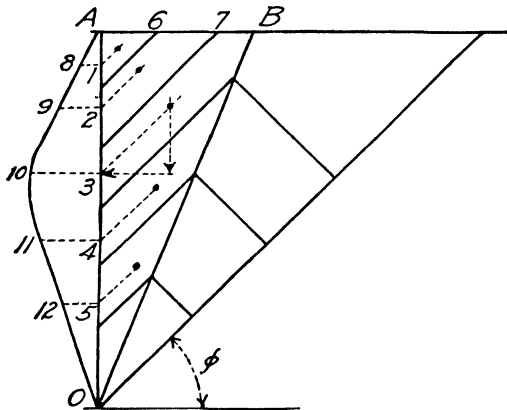

FIG. 4.

soil pressure on $1-2$ may be determined by considering the area $1-6-7-2$. The point of application of the pressure coming from each of these areas is where a line, parallel to the plane of repose and passing through the center of gravity, intersects the vertical face or wall.

The assumption is arbitrarily made that the line BO bisects the angle between the angle of repose and the vertical and therefore that all the soil in the area above presses against the wall and all below rests on the plane of repose. The actual determination of just where and what this line is has not been made, nor can it be except by experiments on a large scale, but it probably is not far from correct to assume it as noted. In any case it is believed that the error, if any, will be on the side of safety.

By determining the pressure for each area previously referred to (A-1-6, 1-6-7-2-, etc., Fig. 2) and plotting each result to the left of its point of application, a graphical curve of pressure is developed, as shown in Fig. 4, with its maximum thrust at a point slightly above the middle of the vertical wall.

Coming now to the question of the pressure of water and of aqueous or water-bearing soils, the pressure curve for water can first be plotted, as in Fig. 5, where *AO* is the wall of a cofferdam restraining water and *AB* is the graphical line of pressure, the pressure at *O* being represented by the horizontal ordinate *OB*.

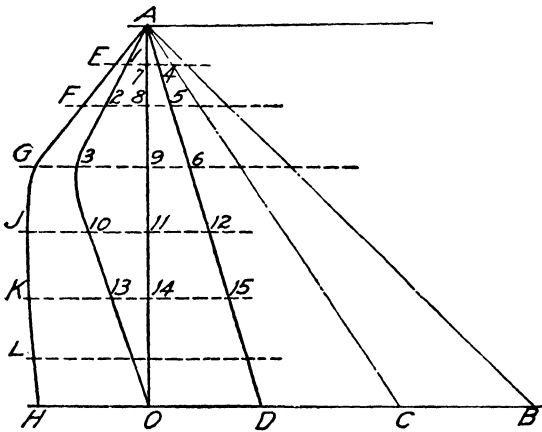

FIG. 5.

Since water weighs only $62\frac{1}{2}$ lb. and the weight of earth is approximately 90 lb. per cu. ft., the point *C* is located, in which *OC* is approximately 70 per cent of *OB*, *AC* being the relative pressure curve. If then, from Fig. 4, the curve A-1-2-3-10-13-0 is reproduced, the relative pressures of normally dry soil and of water are shown relatively and to the same scale.

In the case of semiaqueous or water-bearing soils—*i.e.*, where the voids of the soil are wholly filled with water which may be expelled by pumping, drainage, or air pressure—the pressures of the soil and water while acting in unison are wholly distinct. It is not correct to assume that the full pressure of the water is exerted plus the full pressure of the soil measured by its weight in water; nor is it correct to assume that the pressure is due to that of an aqueous mass of a specific gravity equal to the weight of a volume of the sand and water together.

It would appear, then, that as long as there is no movement of the water sufficient to cause hydraulic action or erosion of the soil, the presence of the water does not change its pressure effort, except to a relatively small degree in its cohesive element and also in reducing its pressure-weight element by the amount of its added buoyancy. If, however, it is realized that soil and water cannot produce pressure over the same area at the same time, it can be assumed that some areas of soil must be in contact with the wall and lead back through somewhat tortuous areas (which may be considered equivalent to solid columns) to beyond the pressure areas, and that between these areas are leads or areas of water giving full pressure equivalent to the hydrostatic head of each over this reduced area. Under this assumption the loss of weight of the soil due to the water is disregarded and the combined pressure is that of the soil of full weight as if normally dry, plus the water pressure acting through the voids of the soil. If it is assumed that these voids for safety are 50 per cent, then the intensity of pressure at any depth is represented by the horizontal distance between AO and AGH in Fig. 5. OD is made 50 per cent of OC , and AD is the curve or line of pressure due to the water in the soil. $A-1-2-3-10-13-0$, as noted, measures the soil pressure. By plotting $E-1$ equal to $7-4$, $F-2$ equal to $8-5$, etc., the curve of combined pressure $A-E-F-G-J-II$ is obtained. When the water is above or below the surface of the soil, the pressure curves may be separately plotted and combined as above.

The fallacy of attempting to measure the pressure of soils or the combined pressure of water and soil on cofferdam walls by means of gages through the walls should be apparent to anyone who realizes that in normally dry soils, areas as large as 1 ft. square may be frequently left or cut in the sheeting without any danger or any pressure being noticed, even though the braces and rangers over the whole area are under heavy stress. It is also true that the bottom plank of a horizontally sheeted trench in normally dry soil may be placed or removed without showing pressure stress. This may even be done in soils of firm sand or gravel where there is a seepage of water not sufficient to cause erosion. On the other hand, in aqueous soils such as stiff plastic clays, the gage may show a much larger pressure per area owing to the blanketlike action of the clay. In firm, sandy, or gravelly

soils, as just noted, the gage will ordinarily show water pressure due to the full hydrostatic head and very little else. The only possible way to measure these pressures correctly is by apparatus that will give the pressure on the whole area, as of a tunnel roof or the entire wall of a cofferdam. Until this is done on a scale sufficiently large to be conclusive, all earth pressure formulas will be largely theoretical instead of empirical or practical.

7. Hydrodynamics of Cofferdams.—In practice, cofferdams are not made watertight. A certain amount of leakage is expected and allowed. The cofferdam, in general, will be considered a success if it does not collapse and does not admit water faster than it can be pumped out or fast enough to cause "boils" within the structure. The danger of "boil" and the possible resulting instability can be determined by a study of the seepage conditions. From a scientific point of view, the only satisfactory method of seepage study is the use of the flow net. The graphic flow net method which was developed by Forchheimer, Terzaghi, Schaffernak, Casagrande, and others is a valuable tool in this work. It offers a method that is free from complicated details and has been proved by experience and test to be applicable to two-dimensional problems for steady laminar flow. Predictions of quantity, velocity, direction of flow, and seepage pressures may, by this method, be made with sufficient accuracy for direct application to design and construction. Thus a material reduction in cost may be effected.

8. Earth Cofferdams.—The earth embankment or earth dike cofferdam is the oldest and the simplest of all types used. Its use is, however, limited to shallow water having a low velocity of current. These dams have been successfully used for a depth of 4 to 5 ft. According to Fowler¹ the maximum economic depth is 6 to 7 ft. and the maximum possible depth is 8 to 10 ft. The side slopes used should correspond to the natural slope of the embankment material and the material should be a mixture of sand and clay to control permeability. When impervious materials are not easily obtainable, a core wall is sometimes used. These structures become unstable if overtopped.

To provide security against erosion, earth embankment cofferdams are sometimes protected by a single row of wood or steel sheet piling when exposed to flowing water.

¹ *Engineering and Contracting*, Mar. 23, 1921.

9. Puddle Cofferdams.—A puddle cofferdam consists of double rows of wood or steel sheet piling tied together and the space between the walls being filled with puddle. The piling may be supported on guide piles and wales. The guide piles spaced 6 to 8 ft. apart are driven deeper than the sheeting and are sometimes reinforced by spur or batter piles. The distance



FIG. 6.—Ohio River type cofferdam at Wheeler Dam.

between the rows of sheet piling is a function of the depth of water and the depth of penetration.

This type of cofferdam is suitable for depths over 20 ft. For very great depths, the walls must be correspondingly farther apart and are generally braced by bulkheads, thus forming cells.

For unbraced cofferdams, Jacoby and Davis¹ give the following rule, "make the width equal to the height above the ground up

¹ H. S. JACOBY and R. P. DAVIS, "Foundations of Bridges and Buildings," 3d ed. p. 244, McGraw-Hill Book Company, Inc., New York, 1941.

to 10 feet and for greater heights make it 10 feet plus $\frac{1}{3}$ of the height in excess of ten feet."

A special type of wood sheet pile cofferdam was developed for use on the Ohio River and is known as the Ohio or box type. Flexible wood frames are built on barges and dropped into place from the barge by a continuous process like a chain and cable. Sheet piling, usually wood, is then driven on each side of the frame and the filling material is placed. These dams are particularly suitable on a rock floor where no erosion problem exists. They are economical for depths of 15 to 20 ft. where low velocities exist during the period of construction. A dam of this type is shown in Fig. 6. By the use of a berm on the inside, this type may also be used on soft bottoms.

10. Rock-fill Cofferdams.—Essentially, the rock-fill cofferdam is a rock dike or embankment which is made watertight by a layer of impervious earth placed on the water side. This earth mat should also be protected against wave action at the water surface. Timber mats have been successfully used for this purpose.

This type of cofferdam has the advantage of low initial cost, provided sufficient rock is available at the site. It can be placed in comparatively swift water. Careful consideration should, however, be given to obtaining an effective seal. Leaks are difficult to locate and seal. They may cause delay and expense in dewatering, which would offset the economies of initial cost.

11. Rock-filled Cribs.—The rock-filled crib cofferdam is particularly well suited to placement in swift water and where overtopping may occur. This cofferdam is further particularly adaptable to rock bottom. The cribs are designed for internal bursting pressure due to the rock fill. To ensure against sliding and overturning, the width is taken equal to the height of water to be supported. The bottoms are made to fit the river bottom contours as determined by soundings. The crib base is usually built on shore or on barges and sunk at the site by further building up of the top. In some cases, chambers or cells for rock fill may be provided to aid in sinking. Where the current is swift, the cribs should be anchored. This is done by the use of cables to shore or other rock-filled cribs.

To provide watertightness, similar chambers or cells may be lined with vertical sheeting and filled with earth or sand-clay

mixtures. When the crib is exposed to very turbulent water, the outside may be covered by two layers of well-fitted planking. In cases where there is no danger of scour, sufficient watertightness may be obtained by an earth fill on the water side. The bottoms are sometimes sealed by using a heavy bituminized canvas nailed to the crib, spread on the stream bottom, and anchored by means of stone and sand.

Rock-filled cribs may be placed in double rows and the space between them filled with impervious material. This method is



FIG. 7.—Inside-rock-filled crib cofferdam at Bonneville Dam.

particularly suited to rough bottoms with varying depths of water and high velocity.

One of the most important crib cofferdams recently used was built at the Bonneville Dam and is shown in Fig. 7. These cribs were 61 ft. in width and were designed for a maximum height of 63 ft. Chambers for rock fill were provided and a single row of steel sheet piling driven on the river side provided watertightness. It also served as a seepage cutoff wall. The cribs were placed in water having a velocity of about 7 m.p.h., and a depth varying from 30 to 50 ft.

12. Steel Sheet Pile Cells.—The details of steel sheet piling will be given under a separate caption at the end of this section. Certain uses of both wood and steel sheet piles in the construction of various types of cofferdams have already been pointed out.

Cellular steel sheet pile cofferdams may be classified as the diaphragm type and the circular cell type.

The diaphragm type consists of a series of arcs connected by straight diaphragm walls or a series of connected bays. The circular cell type is made up of a series of complete circles connected by arcs, each having a radius of approximately 8 ft. In both types the spaces enclosed are filled with earth. Both types are used preferably where the area of the foundation is large and

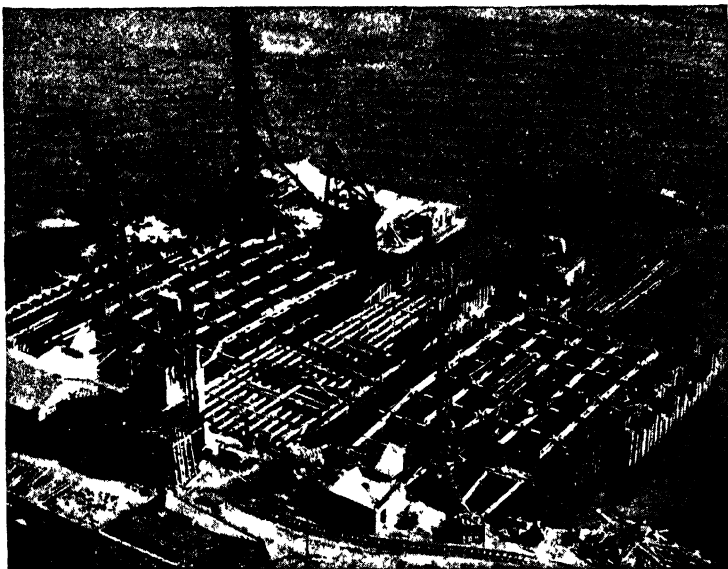

FIG. 8 — Deep cofferdam for George Washington Bridge pier

where a considerable percentage of the depth is through water alone.

For deep cofferdams that must go to rock, steel sheet piling in single or in spliced lengths may be driven when guided by frames supported on guide piles in either circular or rectangular form and then braced with steel frames. Bracing usually consists of framed I-beam cages or rings, which are lowered into place. Placing this bracing is a difficult job since it must be done in the water prior to pumping. Excavation is sometimes carried on with clamshell buckets. The rock bottom must be prepared by divers. Concrete for sealing is placed by the

tremie method to some predetermined elevation after which the cofferdam is dewatered. The remaining concrete is placed and pier construction carried on in the open. The sheet piling is pulled after the completion of the structure. All bracing below the section of tremie concrete must be left in place and, likewise, any bracing passing through the finished pier above this elevation is left in place. Much progress has been made in recent years in this type of construction.

Figure 8 shows an unusual cellular sheet pile cofferdam of great depth used in the construction of the foundations for the George Washington Bridge. Timber was used for internal bracing.

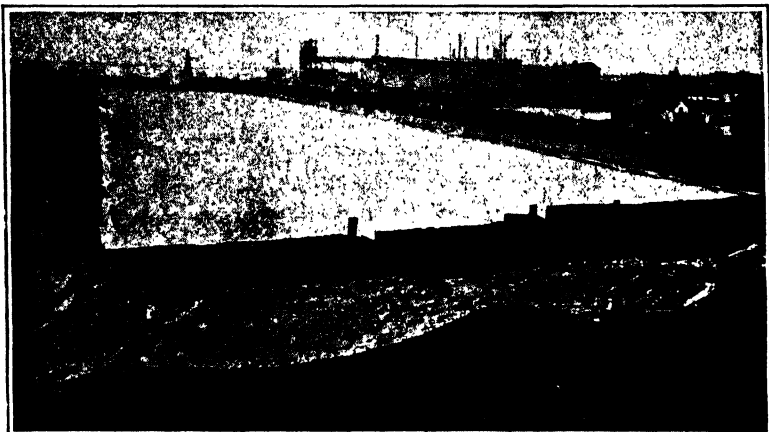

FIG. 9.—Cofferdam for the U. S. Government ship lock at Black Rock Harbor, Buffalo, N. Y.

A notable and one of the first examples of the diaphragm type was that used at Black Rock Harbor, Buffalo, New York, for the construction of a ship lock. Interlocking steel sheet piling was driven to conform to a plan of continuous connected bays as shown in Fig. 9.

The two important factors in the stability of cofferdams of this type are the inward pressure of the soil on the wall and the pressure of the natural or filled soil in the bays against the inner ring of piling. The outside pressure is measured by the stress diagrams already given for water and soil, and the wall is made sufficiently thick to resist by its own weight or inertia the tendency of these stresses to strain or distort it. The pressure of the soil (and water contained in the voids of the soil) in the bays is

measured in the same way as noted, but the inner ring of sheet piling should be considered in resisting these stresses, as the cables of a horizontal suspension bridge, and a specially designed or tested type of piling should be used in which the strength at the interlock is sufficient to resist the jaw pull. If this inside ring of piling is driven with a belly of 10 per cent of its length between cross walls, its resistance will of course be greater and more readily calculated than if driven "flat."

A specially designed and tested type of three-way pile should be driven at the end of each cross wall (see Fig. 10). The closures in each case are made by using specially designed closure piles or by designing the closure to be made at the back of each bay (when special care is not so requisite) and by setting the last several piles to close, before driving.



FIG. 10.

The walls were made up of sheet piling driven in square sets or bays—each 30×30 ft. The piling was driven to rock, and the bays, above the normal bottom, were back filled with dredged soil. When unwatering was begun, the inside sheet piling face of each bay belled more than 3 ft., and some alarm was at first felt for the stability of the structure. Under these conditions, however, the piling (with this belly) formed the equivalent of a horizontal suspension cable, and the strength at the jaw was found by tests to be more than sufficient to resist the stress due to the pressure of the soil contained in the bays. After a series of comparative tests of five types of sheet piling, 12-in., 40-lb. Lackawanna piling with a tested strength at the jaw of over 9,000 lb. per lin. in. was used in the cofferdam described.

Another interesting and unique type of braced wall cofferdam, also not entirely covered in any of the classes described, was that developed at the Staten Island end of the Narrows Siphon in New York City. In this a trench having a maximum depth of about 55 ft. and an approximate width of 19 ft. was sheet-piled, braced, and excavated in the bottom of the Narrows without unwatering. The walls were of steel sheet piling driven to form horizontal suspension members bellying some 2 ft. inwardly between master piles spaced about 15 ft. apart longitudinally and about 65 ft. long. As the excavation progressed by dredging, the 19-ft. trench between the master piles was braced by divers.

It is interesting to note that when the grade was reached, a trench was built, also by divers, and the pipes for the siphon were loaded on cars at the land end and run into place and caulked by the same divers. U.S. Steel piling ($12\frac{1}{2}$ in., 38 lb.) was used between the master piles in this work. As this structure was not unwatered, and as the soil back of the trench was of firm sand which would tend to stand up well when not subject to erosion, it is not probable that there was sufficient pressure to stress the jaws of the piling heavily, although it was found in two or three cases that the jaws had pulled apart at or near the bottom



Fig. 11.—Cofferdam for lock construction at Pickwick Landing Dam.

due to the heavy driving with a 7,500-lb. McKiernan-Terry hammer through unusually hard soil including riprap and boulders.

The first use of the circular cell type of cofferdam was in raising the Maine in Havana Harbor. The piling was driven in the form of continuous figure eights in bays to form the walls. The piling did not go to rock but to a depth in the harbor sufficient to prevent the inflow underneath it of soil during the process of unwatering and excavating for the skeleton of the Maine. The figure-eight section of wall is not believed to be so stable as the type shown in Fig. 10, which was used in the Black Rock cofferdam at Buffalo.

The circular cell cofferdam has an advantage over the diaphragm type in that each cell may be filled when completed

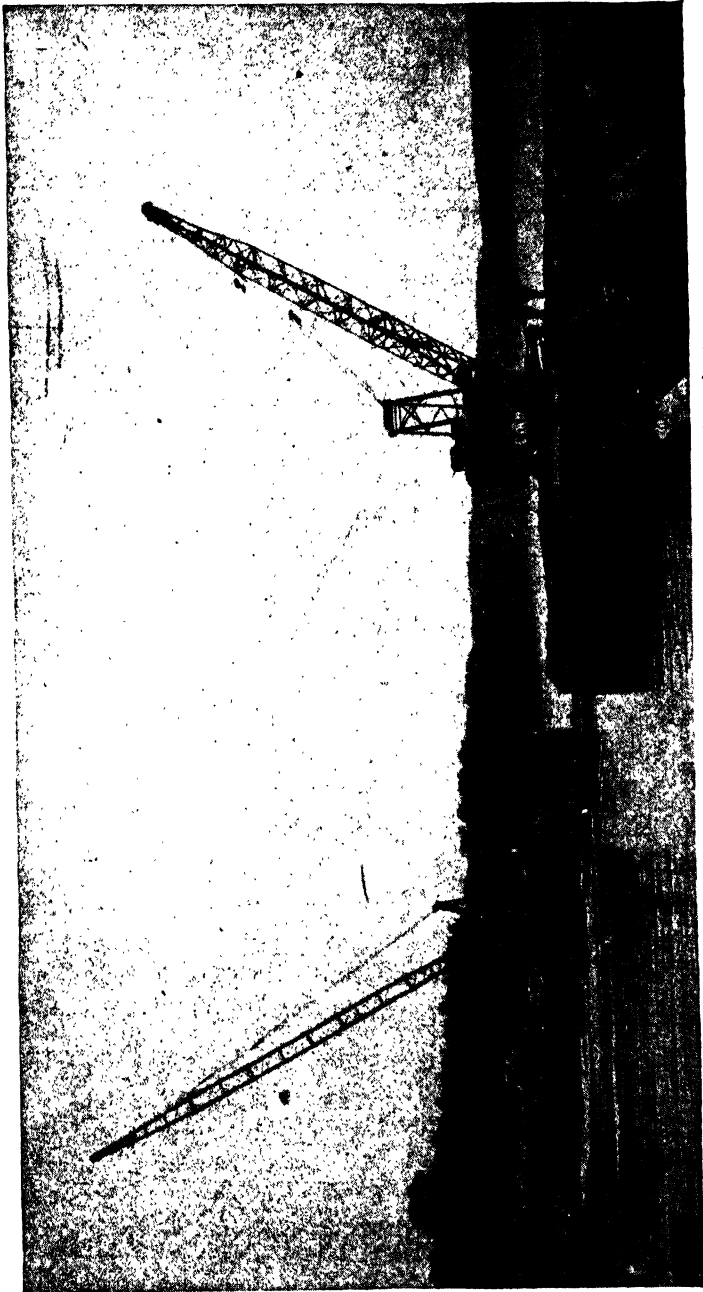

FIG. 12.—Circular-cell sheet-pile cofferdam, Delaware Aqueduct.

without undue distortion resulting. However, it requires more material for its construction.

The circular cell cofferdam used in the lock construction at the Pickwick Landing Dam of the Tennessee Valley Authority¹ is shown in Fig. 11.

Figure 12 shows the circular cell cofferdam under construction at Valhalla, New York, for the Board of Water Supply, City of New York.

13. Land Cofferdams.—The temporary structure or bracing used to retain soil in an excavation carried below ground water is termed a "land" cofferdam. Small self-contained structures serving this purpose are sometimes called cofferdams but when left in place are really caissons.

The simplest type of land cofferdam is an earth dike. Details of such a cofferdam used in a deep excavation and ground-water lowering at Atlantic City is given in Sec. 6.

In this operation the walls or protection were simply the natural slopes of the underlying soil, no sheeting, sheet piling, or other protection being used. The water was lowered progressively and held below the excavation requirements by a considerable number of well points, and the excavation was made by one high-power jet and two hydraulic dredges. This operation can be carried out successfully only in sandy soil which is free from a large percentage of clay or loam or large gravel.

Although the ordinary open trench is not, strictly speaking, a cofferdam, it often happens in large operations that the foundations of structures lie below the water line where the water is easily controlled by pumping, and ordinary sheeting and bracing may be used. In such cases rangers backed by light waling pieces are first laid in position in as deep an excavation as it is reasonable to make without protection, and ordinary sheeting planks (preferably 2-in.) are set and driven as the excavation proceeds, being well braced at the start to ensure being driven plumb. If the soil is granular and easily unwatered, this plain sheeting may be used to the bottom. * If, however, the soil is aqueous or plastic, light tongue-and-groove wooden sheet piling should be used, being driven in the same way as plain sheeting. Each set of sheeting (usually in 12- to 16-ft. lengths) is stepped in so that the last ranger of the upper set becomes the waling piece

¹ *Civil Eng.*, Vol. 9, p. 551, September, 1939.

of the next lower set. Short vertical pieces are set in or driven under the braces, in ordinary operations. Where it is necessary to ensure absolute tightness in the sheeting, the upper rangers should be set with the braces bearing against inside wales blocked out from the rangers, the blocking being split out as the sheeting is set and driven.

The pumping is done from a tight sump, preferably of sheet piling and circular in section. The water should flow or seep to this sump over its top where it can be watched and controlled, rather than through or under it, and the sump should be lowered as the work progresses.

This general type of cofferdam with braced walls also covers the method of driving interlocking steel or tongue-and-groove wood piling which is preferably driven in one continuous or spliced length and therefore does not require any offsetting.

In cofferdams or trenches of this type the piling is usually pulled as (or after) the structure is placed and backfilled. The pumping or unwatering and the placing of the foundation are carried forward as heretofore described.

14. Pit Sinking.—The simplest type or method of well sinking is the old well-digger's method. This consisted of excavating a square pit (about 6×6 ft.) as far as possible ahead of the protection, which was made of small tree trunks split or solid—those in the north and south ends alternating with those in the east and west walls, first as braces and then as rangers. When water was reached, bailing was resorted to and the method continued as long as was consistent with safety. After this, if it was necessary to go deeper, a square set of sheeting was set up and by driving this sheeting ahead of or with the excavation, the excavation was usually completed with safety, and was then walled up with dry rubble.

Contractors, more particularly those operating in lower New York, have adapted these methods of pit sinking from those of the well diggers, and, in connection with subway work in New York City, many thousand pits have been sunk in order to extend or deepen the foundations of buildings to be underpinned.

Briefly, the operations consist in excavating below the last set or ring for placing a new set. Ordinary 2×8 -in. rough board sheeting is used and the pits average 5 ft. square, the board lengths being alternately 5 ft. and 5 ft. 4 in. The north and

south sides alternately brace or are braced by the east and west sides as noted. The secret of both success and economy of operation by this method is in keeping the sheeting tight and well backed, and seeing that no voids or loose ground are left behind. For this reason the work should be entrusted to skilled workmen only, or men who have been properly instructed. When this is assured the method is safe, rapid, and economical.

One of the most common methods of protecting pits during excavation consists in driving 2-in. sheeting in short lengths of from 5 to 7 ft., through square sets, consisting of alternating rangers and braces backed by wales. The sheeting is driven with



FIG. 13.—Telescoped sheet-pile cofferdam, Tunkhannock Viaduct.

outward inclination sufficient to clear the next set. This method creates and leaves a very unsatisfactory condition at the corners, due to this outward inclination of the sides, which is usually cared for by makeshifts, as salt hay, or short light planking set in as a horizontal backing, or both. When the pit is sufficiently shallow to admit of driving sheeting or interlocking sheet piling for the full length in one set, very satisfactory results may be obtained by this method, even where water is present in the soil to a considerable extent. In the latter case, in water-bearing material, interlocking steel sheet piling gives better results than wood owing to the tendency of the latter to separate at the corners. The pit may be of square or preferably of round cross section. In this connection it may be well to note the difference between the terms "sheeting" and "sheet piling" as used here.

Sheet piling defines the tongue-and-groove wood or interlocking steel types driven entirely in advance of the excavation, while by sheeting is meant plain board or steel protection set in or driven as the excavation proceeds.

The telescoped steel sheet pile cofferdam, shown in Fig. 13, was used in the construction of the Tunkhannock Viaduct for the Delaware and Lackawanna Railroad. The total depth of excavation was approximately 75 ft. Each row of piling extended for about one-half the total depth of excavation. The outer row was placed from the ground surface to about half depth and the inner row from half to full depth. In placing, the inner row was first driven, excavated, and braced. Then the outside row was driven and the material between it and the inner row was excavated. The inner row was then driven to the desired depth as excavation and bracing proceeded.

The horizontal wood sheeting with bracing was used in subway construction in New York in 1914 and is described by White and Prentis.¹ The horizontal sheeting was supported on wood beams. Steel H-beams and concrete piles were also used. The sheeting is placed as the cut is deepened and should be tightly packed through slots left between the planks. Steel sheets and concrete planks have been used to replace wood sheeting. These materials present problems of handling and fitting. When used in very wet soil with comparatively high permeability, a berm and drainage ditch should be provided on the inside. The berm will aid in keeping the soil mass from becoming "quick" and the draining ditch will aid in the arrangement of pumping equipment.

15. Deep Pits or Wells.—In sinking deep pits or wells, various methods, each suitable for certain soil conditions, have been developed in various sections of the country. In permeable soils the preceding methods are applicable. If, however, clay is encountered, the methods used will depend upon the stiffness of the clay, which in turn is a function of the water content.

Caissons will be considered on page 107. A distinction between a cofferdam and a caisson may be made by considering that a cofferdam is not a permanent part of the finished structure while the caisson becomes an integral part of the permanent structure. The caisson does, however, act as a cofferdam during the sinking process.

¹ LAZARUS WHITE and E. A. PRENTIS, "Cofferdams," 1st ed., 1940, p. 79.

A process known as the Chicago method—sometimes termed both the “Chicago open caisson” and the “Chicago well” process—is shown in Fig. 14. This method consists of excavating in open pits, circular in cross section, in lifts up to 6 ft. and of placing lagging, usually 3 in. thick, which is held by braced



FIG. 14.—Chicago-type well shaft.

interior iron hoops or wood frames, depending upon the depth. The usual diameter varies from 4 to 10 ft. depending upon the load. This process is suitable for penetrating stiff clays and has been widely used. The concrete is usually placed by bottom drop buckets. A notable example is found in the pier foundations of the Cleveland Terminal building, which reach a depth of 250 ft. below the street level.

When the clay is too soft to permit excavation before placing the lagging, the Chicago method should be modified.

Where conditions permit, boring machines using spud drills may be used.

Where self-contained cylinders or squares can be used, and sunk in one length, or as built up, it is usually cheaper and more satisfactory to use them. They may be of steel or concrete, or a combination of the two.

Very satisfactory results have been obtained, especially in lower New York City, in driving steel cylinders in one or more short lengths in the bottom of an excavation or pit, below which ground water is present. Since these cylinders remain as a permanent part of the foundation, they are, according to definition, caissons and will be considered under that caption.

In Boston, the Gow pile, shown in Fig. 15, has been widely used to penetrate soft clays and sands overlying hard clay or cemented gravel. This pile is really a caisson.

16. Movable Cofferdams.—Where conditions are such that a cofferdam or a part of it may be used over again, it may be

termed a "movable cofferdam." The sides and ends may be made of braced sections held together by rods running through the walls. They may be used open-ended or may have a bottom. These are often used in grillage foundations or foundations supported on piles. In the first case a layer of concrete may be placed in the bottom. The cofferdam is dewatered and the pier



FIG. 15.—Gow caisson piles.

or other permanent structure built. The sides are then released and float free for reuse. Where the bottoms are used, these remain as a part of the permanent structure.

17. Removing Cofferdams.—Both steel sheet and wood piling may be used more than once, provided that care in driving has been exercised and that they are not driven too deep. Special rigging may be arranged to produce a pull of 25 to 50 tons. This is generally suitable for carefully driven piling, moderate in

length. For greater lengths pile extractors or special pulling rigs should be used. It is sometimes necessary to develop a pull of 225 tons. The pulling of long steel sheet piling should be carefully done to avoid damage to the interlocks. Such damage would of course render the piling useless.

A pile extractor manufactured by McKiernan-Terry Corporation is shown in Fig. 16 withdrawing heavy steel sheet piling.

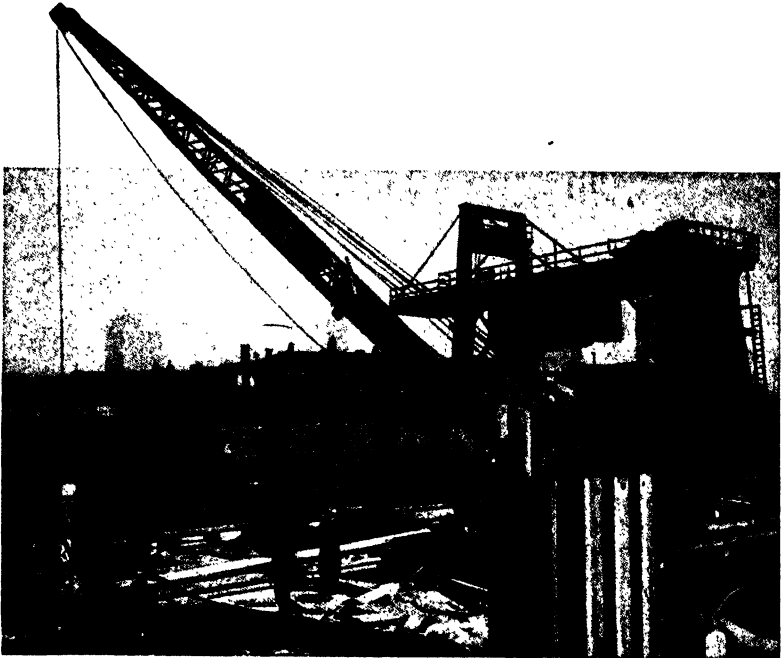

FIG. 16.—Pile extractor.

This piling had been driven to a penetration of 75 ft. and was bonded to concrete for a length of 35 ft. on one side. An inverted steam hammer used to pull piling is shown in Fig. 17.

In cases where piling cannot be pulled, it may be either cut off or bent over and allowed to remain on the stream bed, provided it does not interfere with navigation. The cofferdam sheet piles used in the construction of the Marine Parkway Bridge crossing Jamaica Bay, Long Island, New York, were cut off at the level of the pier base. The pier base was about 30 ft. below water level. The piles were cut by a diver operating an acetylene

torch. The piling below the pier base was left as a protection against scour.

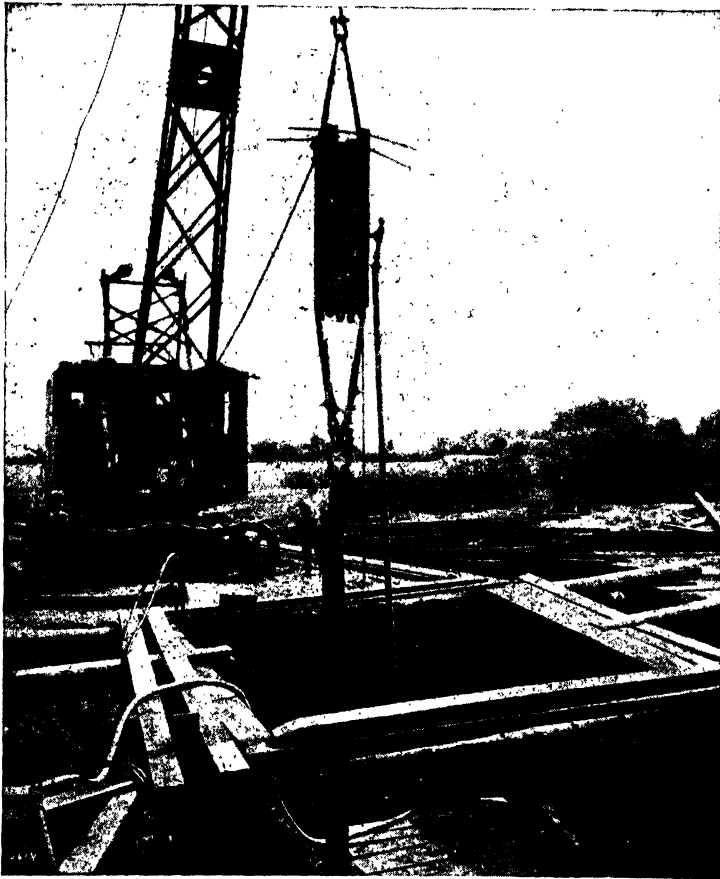

FIG. 17.—Inverted pile hammer.

CAISSONS

OPEN CAISSONS

18. General.—A caisson is a structure used for the purpose of placing a foundation in position. It differs from a cofferdam in that it becomes an integral part of the permanent structure. However, in the sinking process and during the construction period the caisson has the function of a cofferdam.

Caissons are divided into three general types: box, open, and pneumatic. These types may be designated as timber, metal, or concrete, dependent upon the materials used in their construction. Further details of construction and use will be given under separate captions.

✓ **19. Box Caisson.**—A box caisson is a watertight box having a bottom but no top. Box caissons are built of timber and reinforced concrete. The concrete, because of its weight, aids in sinking and furthermore is immune to the action of the wood borer. This type of caisson is suitable where no excavation is necessary and is therefore often used in the construction of breakwaters, jetties; wharves, and piers for light bridges. The caissons are constructed on shore, floated to the site, and sunk to rest upon the stream bed or on piles.

✓ **20. Open Caissons.**—An open caisson is a self-contained box structure made of timber, metal, or concrete and may be wholly or partly open at both top and bottom. Open caissons may be divided into three types: the single-wall rectangular caisson, the cylindrical caisson, and the dredging well caisson.

These structures are sunk by dredging out the enclosed material. The use of removable weights and water jets aids in the sinking process. They can be sunk more rapidly and economically than the pneumatic caisson and have the advantage that work may be carried on at atmospheric pressure. The preparation of the bottom should be done by divers and the concrete seal should be placed under water.

This type of caisson has been used for years in subaqueous work and has in recent years come into general favor for heavy building foundations, especially for great depths in wet ground. However, it cannot always be used because of material from the outside running into the excavation.

21. Depth to Which Open Caissons May Be Sunk.—Theoretically there is no limit to the depth to which an open caisson may be sunk. The world record for depth of bridge caissons was attained in the construction of the San Francisco-Oakland Bridge crossing the west channel. These caissons were developed by the late Daniel E. Moran and were cellular structures having vertical steel cylinders as dredging wells. The cylinders were capped with removable steel domes and were equipped with removable false bottoms. Concrete was placed at a maximum

depth of 242 ft. below the sea level. Figure 18 shows a caisson being lowered.

22. Metal Caissons.—In American practice, steel is used almost exclusively for metal caisson construction. Its advantage over both timber and concrete is in its greater strength. A more watertight structure is produced and less frictional resistance is developed during the sinking process. Metal caissons may be rectangular, square, or cylindrical in cross section. In the latter case they are termed "cylinder caissons" and are used extensively for both bridges and building founda-

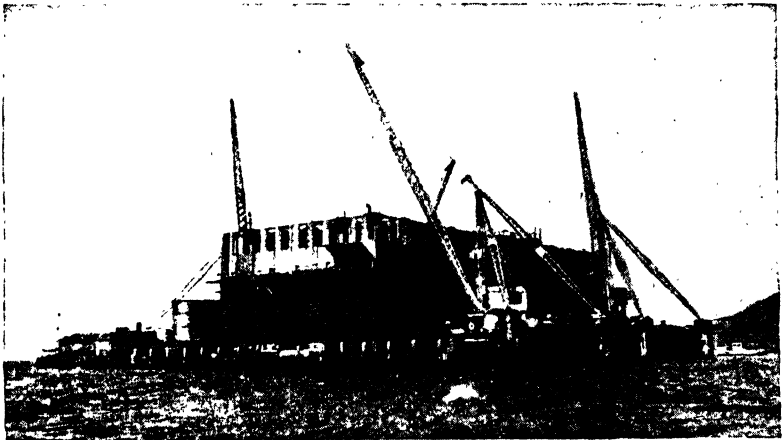

FIG. 18.—Caisson for San Francisco-Oakland Bay Bridge pier.

tions. Steel cylinder caissons are usually built in sections. These sections are ordinarily in lengths of from 2 to 6 ft. and made up of steel from No. 12 gage to $\frac{1}{2}$ in. in thickness, according to the requirements, and from 9 to 50 in. or more in diameter. They are connected by an overlapping inside ring of steel or by special inside collars of steel or cast iron. They are driven by a winch-actuated hammer or by a hydraulic pump (if reaction may be had) actuating independent rams; they are cleaned out, as the work progresses, by augers, scoops, or more rapidly by dwarf orange-peel buckets.

Telescopic cylinders have been used more or less successfully, the principal advantage apparently being found in overcoming additional skin friction. As this additional skin friction is relatively small, this advantage is minimized by the additional cost

of the larger top section of the telescope. Where the cross section is larger than 30 in. and the depth too great for driving steel piling in one length, an open reinforced concrete cylinder may prove best adapted to the requirements, providing the ground is soft enough to allow the cylinder to be sunk as built up under its own or small additional weight, when cleaned out. Gow pile caissons are shown in Fig. 15.

Large square or rectangular caissons are usually braced by cross walls or bulkheads, which form the dredging wells.



FIG. 19.—Open steel-cylinder caisson.

Figure 14 shows a Chicago type of well shaft and Fig. 19 shows an open steel cylinder caisson.

23. Amount of Skin Friction Developed.—The skin friction developed varies with the character of the material penetrated, the amount of moisture present, the surface of the caisson walls, and the depth sunk. The unit intensity of skin friction does not increase so rapidly with the depth sunk as might be expected. The passage of the lower part of the caisson smooths the material and brings the moisture to the surface of the caisson, which acts

as a lubricant. There is no method of calculating skin friction and the amount that may be developed in each instance is a matter of experience and judgment. In general, skin friction in the various materials varies in intensity in the following order: boulders and clay, gravelly clay, moist clay, gravel, sand, and silt.

The skin friction for each material varies over a wide range and usually increases with the depth. For depths up to 100 ft., the skin friction for sand may generally be taken at 250 to 500 lb. per sq. ft., gravel 300 to 600 lb., moist clay and gravelly clay 500 to 1,000 lb. These figures are not likely to be exceeded for average conditions. The skin friction for quicksand is somewhat higher than for building sand. The skin friction for

so-called quicksand around New York City varies from 250 to 650 lb. per sq. ft. The run-in under the cutting edge is much larger for quicksand than for other materials. The skin friction in boulders and clay may be very high.

Jacoby and Davis record a skin friction of 1,912 lb. per sq. ft. for the pivot pier of the Grand Trunk Bridge at Black Harbor on the Niagara River. The material was a very sticky red clay. The caisson was of concrete. The same authors give the maximum friction for one pier in the Cairo Bridge as 932 lb. per sq. ft. in sand.

The Foundation Company of New York City gives the skin friction for a concrete gun pit, sunk 130 ft. in clay and boulders at Washington, D.C., as 3,500 lb. per sq. ft.

Friction as high as given in the foregoing examples is seldom encountered.

24. General Design.—Caisson design is largely a matter of experience and judgment. The earth and water pressure, as determined by formula for pressure, is very easily provided for. However, in large and deep caissons that are pumped out, the stresses in the walls due to earth or water pressure may be high.

The unit stresses used in designing for loads to be carried after sinking should be very conservative. The process of sinking the caisson may so rack and twist it that its original calculated strength may be impaired. The indeterminate stresses due to sinking are the ones most likely to be inadequately provided for. It is possible to get almost any conceivable condition of loading on a caisson during sinking, owing to the variation of the skin friction over the surface, the moisture, the hardness of the bottom, the tipping of the caisson, logs or boulders under the cutting edge, or the nature of the run-in of material under the cutting edge.

A caisson should be designed with a shearing strength equal to at least one-half its weight. A rectangular caisson should be assumed to be supported on diagonally opposite corners. In a caisson supported at the corners, torsion produces heavy bending stresses at wall intersections. The earth pressure is usually not balanced around the caisson; at such times the caisson is acting as a beam or cantilever. In a caisson out of plumb, which has penetrated materials of different stiffnesses, this bending stress may be very high, especially if the material flows more readily

under the cutting edge on one side than on the other. The lower portion of the caisson should be made especially strong to withstand pressure of material flowing under the cutting edge, extra load from tilting, impact from a sudden drop on logs or boulders, or shock from blasting. There should also be sufficient strength to prevent pulling in two, in case the top is friction bound.

The sides of the caisson should be straight. Sloping the sides to reduce friction makes the caisson more difficult to guide and may increase the friction by material falling into the crevices and jamming the caisson. The Chicago, Burlington & Quincy R.R., however, experienced but little difficulty in sinking in sand in the Platt River a pier that had a base 16 ft. square for 12 ft. above the cutting edge and a cylindrical shaft 11 ft. in diameter above the base. The general experience with tapered caissons would indicate that this form would be much more likely to give trouble than a straight caisson.

25. Wooden Caissons.—Wooden caissons are built up of double walls of square 6- to 12-in. timbers with concrete between the walls to provide sinking weight. The caisson should be heavy enough to follow down as fast as the material is excavated. To get enough weight it is usually necessary to leave as much space as possible between the inside and outside walls, thereby reducing the dredging wells to a minimum. The dredging wells should be 7 or 8 ft. square although caissons have been sunk with dredging wells as small as 5 ft. in diameter. Excavation is more expensive and slower with the small dredging wells, because such small buckets must be used.

The outside walls are built of square timbers driftbolted together on 2- to 3-ft. centers. The inside walls are built of square timbers spaced 3- to 4-ft. centers. Large caissons are generally built of 12 × 12 timbers; small and shallow caissons may be made of 6 × 6, 8 × 8, or 10 × 10 timbers according to the size and depth. At the corners and intersections of cross walls the timbers may be halved, dovetailed, or alternate sticks run through. The latter method is the cheapest and gives equally good results. The outside of the caisson and the dredging wells are sheathed with 2-in. surfaced plank laid vertically. Care should be taken to lay the sheathing smoothly to reduce friction and to avoid projections that might catch on obstructions.

The few lower feet of the caisson are laid solid in triangular form, bolted through horizontally from the outside to the dredging well and driftbolted vertically. The lower edge, 8 to 12 in. wide, should be protected by a steel shoe.

26. Concrete Caissons.—Concrete is a satisfactory material for caissons and is sometimes used for that purpose. It is heavy, economical, and with steel reinforcement has the required strength. The first consideration should be to get the walls heavy enough to sink without loading. The interior walls should be strong enough to transfer their load to the outer walls, when undermined, or to carry a considerable part of the weight of the outer walls in case of an unusually hard bottom under a part of the caisson. The caisson should be reinforced for bending in all

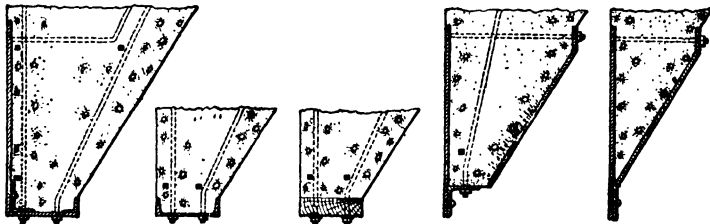

FIG. 20.—Cutting edges. FIG. 21.—Cutting edges. FIG. 22.—Cutting edges. FIG. 23.—Cutting edges. FIG. 24.—Cutting edges.

directions. Special care should be taken to make the corners and wall connections especially strong. When a caisson is racked out of plane, the cross walls produce a bending moment in the side walls instead of bracing them. Cylinder caissons are sometimes built of reinforced concrete.

The cutting edge should be protected by a steel shoe and be heavily reinforced for some distance above the bottom.

27. Cutting Edges.—The cutting edges of caissons should be strong enough to withstand the strains of the sinking operations as well as to allow excavation to be carried on under them and to prevent the escape of air. They may be made of tough wood and covered with a steel shoe or entirely of steel. The width used in practice varies from 4 to 18 in. Figures 20 to 24 show the usual forms of cutting edges. Figures 20 and 21 are the forms most frequently used and in general the most satisfactory. Figure 22 gives very little protection to the lower edge

of the caisson. Figures 23 and 24 lack stiffness and should not be used where obstructions may be encountered or when blasting may have to be resorted to. With the thin cutting edges, it is thought that the caisson follows the excavation more closely, thereby reducing the amount of material that runs in under them.

28. Landing the Caisson.—The site should be leveled off and cleared of all obstructions which would interfere with the free movement of the caisson. When the caisson is on land, it is customary to dredge the site down 15 to 20 ft. before setting the cutting edge.

The cutting edge is set level on blocking. The blocking should not be longer than required to sustain the weight. The projection of the blocking on the outside of the caisson should be as short as possible. When the caisson is ready to sink, all material except the blocking should be cleared away. As the dredging progresses, the blocking will be carried into the caisson by the material running in under the cutting edge.

Caissons in deep water are built on ways on the bank and floated to position. Guide piles are driven around the site so the caisson can be controlled until it is landed on the site. When the water is too shallow to float the caisson, it may be built on barges and floated to place. A framework may be built up on the barges to support the caisson, which is lowered by rods or by sinking the barges, or the caisson may be built directly on single or double barges and lowered by sinking the barges. As the caisson sinks, the barges are dragged from under the cutting edge. When the water is too shallow for a floating method, the caisson may be built on a platform at the site. One or two rows of piles are driven on each side of the site and capped. Crossties resting on the caps support the cutting edge. After completing the caisson, blocking is arranged on the platform and the caisson lowered to place by rods. In shallow water the site is sometimes dried up by a cofferdam.

29. Sinking Caissons.—Before dredging is started, the caisson should be built as high as practicable. The heavier the caisson the more closely it follows the excavation, and the less material will run in under the cutting edge. A caisson that is narrow for its height may be unstable at the beginning and require bracing until it is deep enough into the ground to prevent overturning. In very soft ground a caisson may be difficult to control at the

start. A caisson that is tilted can frequently be straightened by setting braces against the low side or by taking a heavy pull with a block and tackle.

The method chosen for sinking the caisson will to a great extent depend upon the character of the soil it must penetrate. Ordinarily, open caissons are sunk by dredging with a clamshell or orange-peel dredge bucket, the clamshell generally being the more satisfactory. The mud-sand pump or ejector is sometimes used. Water jets to reduce the side friction and temporary loading are sometimes used. Small caissons may be driven, pulled down, or placed by boring or jacking methods. The latter is used in building foundations where headroom is lacking. For large caissons that must penetrate unstable subaqueous soil, the sand island¹ method is advantageous.

The excavation should be made as uniform as possible. If the caisson is out of plumb, the excavation on the high side should be carried ahead of the excavation on the low side. But excavating on the low side should not be entirely omitted as it is not practicable to plumb the caisson without lowering it as a whole. The general level of the bottom should be kept in a plane, tilting the plane as may be required to plumb the caisson.

The excavation may be but a short distance below the cutting edge or it may be as much as 10 to 15 ft. When the excavation is carried very far below the cutting edge, there is always the likelihood of a sudden drop, which may wreck the caisson. When the excavation is carried very far below the cutting edge and there is a sudden run of material under the cutting edge with an accompanying drop of the caisson, the material packs around the caisson, making it difficult to start the caisson again. In such cases it is generally advisable to load the caisson enough to get a uniform movement as the excavation is made.

Jet pipes may be built into both the inside and outside walls or may be used as free jets operated from the surface. These usually discharge at an angle of 45 deg. and may be pointed either upward or downward. The outside jets tend to reduce surface friction while the inside jets tend to loosen material under the cutting edges. However, jet pipes built into the caisson walls have not proved very successful. They are generally plugged

¹ See p. 117 for description of sand island method.

with mud and cannot be used when wanted. A jet free of the caisson and operated from the surface is much more satisfactory. The water jet should be used with caution. It is likely to cause a sudden drop in a deep-dug caisson and also has a tendency to cause the material to pack around, making it increasingly difficult to start the caisson after each application of the jet.

The mud-sand pump consists of an outside pipe toothed to penetrate the soil and an inside pipe perforated at the end. Compressed air is conducted through the inside pipe. This churns the sand and water and causes it to rise in the outside or ejector pipe.

The excavation should be carried on continuously. It is harder to start a caisson than it is to keep it moving. Caissons to be landed on rock stop a short distance above the rock. They usually can be brought to a fair bearing by pumping them down rapidly and washing the material from under the cutting edge.

When the caisson is not heavy enough to overcome the skin friction, it is loaded with bags of sand, railroad rails, or cast weights of concrete or iron. The necessity of loading a caisson slows up the sinking operations and materially increases the cost of the work. Blasting may be resorted to on especially stubborn caissons, where the material is very hard to dig, or where the boulders and logs are hard to break up. The most economical method of loading caissons is to use the permanent concrete filling. This offers a great advantage to double-walled caissons. The usual method is to explode from one-half to a whole stick of dynamite inside the caisson. The Foundation Company reports a very remarkable case of blasting a caisson down in boulder clay. After the bottom had been dug 10 to 15 ft. below the cutting edge, a series of holes were drilled about 40 ft. deep all the way around the caisson and about 30 ft. back from it. Each hole was loaded with a stick of dynamite and all were fired at the same time. A few minutes after each series of simultaneous explosions the caisson would sink 6 to 8 ft. The caisson was sunk by the above method about 90 ft.

The open caisson cannot be so easily controlled as the pneumatic caisson nor so accurately located. Generally, the larger the caisson, the easier it is to keep plumb and the more accurately it can be landed. To keep small caissons plumb it is usually necessary to use shores.

Small steel-cylinder caissons may be driven with a drop or steam hammer. In some cases they may be pulled down by use of block and tackle attached to piles driven around them. Where reaction support is available, as in the underpinning of a building, small caissons may be sunk by the use of hydraulic jacks placed between the caisson and the building wall or similar support. The boring method was adopted from the process of large churn drills and has been used successfully.

Recently a new process, which is applicable to cylinders of large diameter, has been developed and is called the Montee patented caisson. This process has been applied to steel cylinders 4 to 8 ft. in diameter and 78 ft. high. The lower edge is cut to form a toothed cutting edge and is coated with a layer of tungsten carbide to resist wear. The top of the cylinder is held to a rotary head by a watertight clamp, which is driven by an electric motor with a worm-gear reducer mounted on a skid rig having vertical leads. Usually a 125-hp. motor is used and a torque of about 1,000,000 ft.-lb. is developed. In operation the cylinder is filled with water and kept under pressure by pumping. Pipes welded to the inside of the cylinder feed water to the cutting edge. Cylinders may be rotated at 4 to 10 r.p.m. and be spun down at the rate of 12 to 20 ft. per hr. This method has been used for penetrating sand, gravel, clay, and boulders. To reduce the friction on the sides, the rotating head is set with a slight eccentricity.

Where large caissons are to be sunk in swift water, great care and skill should be exercised. This is especially true in sinking large reinforced concrete caissons. The sand island method, a patented process, consists of creating an artificial island, which furnishes lateral stability and frictional resistance and thus reduces the danger of tipping and of blowouts. This method is particularly advantageous where caissons have to penetrate soft unstable materials and was used for pier construction on modern bridges on the Mississippi River at New Orleans and on the Missouri River Bridge at St. Charles.

Figure 25 shows the construction of piers for the Mississippi River Bridge. The river bottom was first covered with a willow mattress. Timber pile bents were sunk to about 25 ft. penetration and extended about 4 ft. above the water level. Steel rings 120 ft. in diameter and 10 ft. high were assembled in sections

30 ft. high on the falsework and then sunk. Similar sections were placed as the sinking process continued. When the shell reached the mattress, the latter was cut at the inside edge of the shell. The shell was then filled with sand to the water level. Concrete caissons 65×102 ft. in section were then sunk through the sand by the dredging method. The steel shells varied in length from 70 to 100 ft. The caissons were 135 ft. in length. A 50-ft. timber cofferdam was constructed on the caisson and pier construction was carried on within it. The sand between

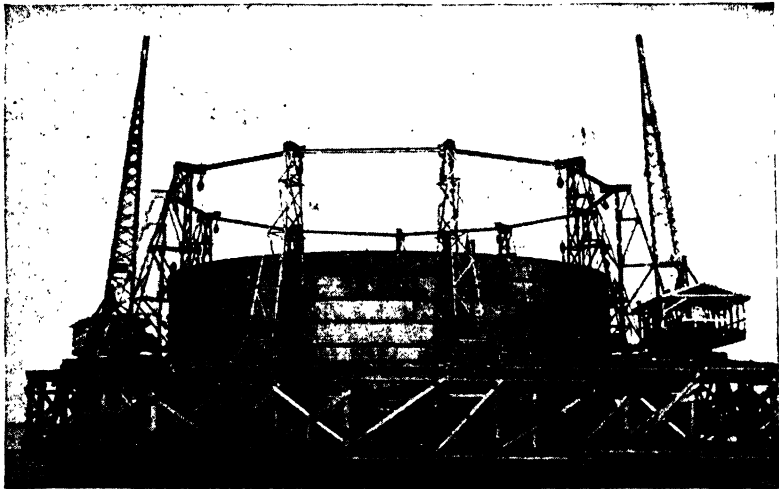

FIG. 25.—Lowering steel shell to provide sand island.

the finished pier and the steel shell was dredged out and the shell was detached at the lowest point accessible by diver for reuse.

30. Sealing Caissons.—When the caisson has been sunk to the required grade, the bottom should be dredged to a uniform surface. If the bottom is under water, as is usually the case, careful soundings should be taken to see that the surface slopes uniformly from center of the dredging well to the cutting edge. A diver should be put down to clean the material from under the steps at the cutting edge. The concrete may be deposited by either a tremie or bottom-dump bucket. The tremie is usually heavy and difficult to handle. The bottom-dump bucket is more easily handled and for deep work will give the best results. The concrete should be placed continuously and carried through the full thickness to avoid laminations.

The sealing concrete is not generally reinforced, as it is not practicable in most cases to reinforce it. It should not be leaner than a 1:2:4 mix, as concrete placed under water is not likely to be so good as concrete placed in the dry. Concrete placed through water has, in addition to a deposit of mud and laitance, a layer of porous concrete on top which may be from a few inches to a foot thick. A reduction in the allowable unit stresses for concrete placed through water should be made. The depth of seal for small dredging wells varies usually from a thickness equal to the smallest dimension of the well to a thickness of one-half that amount. If the foregoing rule were followed in large dredging wells, it would be quite expensive; consequently the thickness of seal is reduced to one-fourth the least dimension of the well, or even less. When the dredging well is round or nearly square, the seal may be figured as a flat slab supported at the edges. At the completion of the excavation the bottom is more or less in the form of a dome. If there is strength enough in the cutting edge to carry the ring tension, the seal may be figured most economically as a dome.

31. Rate of Sinking.—When the caisson is heavy enough to overcome the skin friction, the rate of sinking is dependent upon the amount of material that can be excavated. The amount of material excavated exceeds the displacement of the caisson. In sand and gravel with a light caisson the run-in may amount to 50 per cent of the displacement. With a heavy caisson the run-in should not be over 25 per cent. In quicksand with a light caisson the run-in may be over 100 per cent of the displacement. The run-in for clay is usually negligible. In sinking the four special-type open caissons for the San Francisco-Oakland Bay Bridge an average of six months was required.

In order to reduce the time of construction metal cylinder caissons are usually sunk at a high rate when used in congested high-value districts of large cities. Various means are used to accomplish this even though they may prove expensive.

32. Cost of Sinking.—The cost of excavation is practically the only indeterminate variable for a caisson that is heavy enough to sink by its own weight. It varies with the location of the work, the character of material to be excavated, the size and depth of the caisson, the size of the dredging wells, and the method of disposing of the excavated material. The cost of

dredging increases with the depth of water through which the dredging is done. Ordinarily, excavation may be carried on cheaper in caissons having large dredging wells than in those having small ones.

The increase in cost is due to reduction in speed, to material being washed out of the bucket, to difficulty in placing the bucket, and to the weight of the water compacting the material. The amount of material washed out by the water is a large item after orange-peel buckets have been in service for some time.

The total cost of sinking caissons should be determined for each individual job.

√PNEUMATIC CAISSONS

33. Pneumatic Caissons.—Where it is not practicable to dig through wet ground in the open in order to reach rock or better

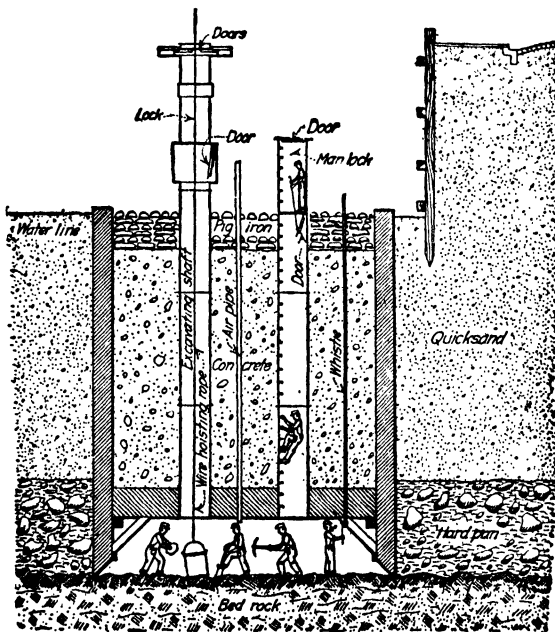

FIG. 26.—Pneumatic caisson sunk to bed rock.

material below the main excavation, pneumatic caissons are used. These structures may be made of timber, steel, or concrete. They are sunk to the desired depth by excavating in the

working chamber. Sufficient air pressure is maintained within the working chamber to balance the soil and water pressure and therefore aids in the control of the amount of material entering the working chamber. The structure should be strong enough to allow the building of a crib and a cofferdam and the pier or other structure upon it. It should also resist the stresses resulting from the sinking process. A typical pneumatic caisson is shown in Fig. 26.

The caisson is built aboveground and sunk in place as an inverted box. The lower section of the box consists of a working chamber usually 6 or 7 ft. high. Shafts for the passage of men and materials connect this chamber with the working deck and contain the air locks within which air pressure is raised from atmospheric to the working pressure when workmen are entering, and the opposite when leaving. A crib built above the roof is filled with concrete as the caisson sinks. The cofferdam is built above the crib. It is shown in Fig. 26. Removable weights to aid in sinking are shown within it.) When the caisson reaches bedrock or other suitable strata, the working chamber and shafts are filled with concrete and the pier or other construction is started within the cofferdam at the top of the crib. When the structure is complete, the cofferdam is removed. The caisson and the crib remain as integral parts of the permanent structure.

34. Depth Limitation.—The pneumatic caisson method is limited practically to a depth of not over 110 ft. below water level or an air pressure of 50 lb. per sq. in. There are a few instances where pneumatic caissons have been sunk a few feet deeper than 110 ft. and have had an air pressure of a few pounds above 50 lb. per sq. in., but a pressure of about 50 lb. per sq. in. is the recognized limit of endurance for the human system.

The cost of pneumatic work increases very rapidly as the air pressure increases on account of the shorter shifts the men can work and the longer rest periods required. There is also a decided increase in the number of cases of caisson disease when the pressure reaches 40 to 50 lb. per sq. in.

In cases where a stratum of highly tenacious soils such as Mississippi gumbo or the so-called Hudson River silts are encountered, the actual air pressure required may differ from the theoretical. Usually under these conditions the actual pressure required is lower than the theoretical and consequently allows

the use of pneumatic caissons to a greater depth without exceeding the maximum allowable air pressure.

35. Skin Friction Developed.—One of the most indefinite factors of caisson design and installation is the determination of the probable friction that may develop during sinking operations. As shown under the open caisson, this value may in general vary from 250 to 1,000 lb. per sq. ft. of surface in contact with the soil. Values lower than 250 lb. may be encountered but, on the other hand, values much higher than 1,000 lb. may under certain circumstances be developed. In general, pneumatic caissons used for building foundations develop higher frictional resistance than when used in underwater construction. This reduction is probably due to the development of a water film along the sides. In either case the escaped air may follow up along the caisson side and will act as a lubricant to reduce the frictional resistance to sinking.

36. General Design.—All the statements in regard to stresses under open caissons apply with equal force to pneumatic caissons. In the pneumatic caisson, however, the pier above the working chamber is usually solid masonry, except for the comparatively small shafts left for access to the working chamber. The walls of the working chamber are subjected to stresses of the same character and intensity as the lower part of an open caisson. They should be designed for the increased load of a caisson out of plumb, unbalanced lateral pressure, the pressure of material flowing under the cutting edge, and the impact when striking logs or boulders.

In the early designs the roofs of caissons were made of very heavy timber construction. In the more recent designs the roof timbers are made only strong enough to carry 4 to 6 ft. of wet concrete. The concrete should be well reinforced and allowed to set fully before sinking operations are started. It should be strong enough to transmit the weight of the pier or shaft to the cutting edges and be made sufficiently rigid to resist distortion while being landed. Rigidity is furnished by anchors to the side walls. The side walls should be as nearly airtight as possible. They should also be sufficiently strong to transmit the roof load to the cutting edge and to withstand the horizontal thrusts and the impact stresses built up when the cutting edges strike boulders, logs, or other material during the sinking operation. The

air pressure cannot be relied upon to carry a part of the load, as the pressure may be reduced quickly to zero for short intervals. The working chamber should be made as near airtight as possible, and should be from 6 to 7 ft. high. Higher walls afford more working space when the caisson is partly filled with sand. Although the higher walls make the excavating more economical, they increase the cost and difficulty of building the caisson.

37. Wooden Caissons.—There have been three general designs for the side walls of wooden caissons. The early designs, originated in the days of cheap lumber, had V-shaped side walls laid up of solid timbers driftbolted together. Alternate timbers were extended through the course instead of halved. An adaptation of the above design is to build the outside face of the wall of a single course of timber either 6×12 or 12×12 , and a single course of timber for the 45-deg. sloping wall. The space between the walls is filled with reinforced concrete. The straight-walled caisson is built of two courses of 12×12 's horizontally, driftbolted together vertically and bolted through and through horizontally, alternate timbers being cut at the corners.

The straight-walled caisson may also be made of one or two horizontal courses and a vertical course. The outside course is usually made of 12×16 's and extended several feet above the roof. The roof timbers are gained into the vertical timbers to transmit the roof load to the caisson walls. The foregoing sizes of timber are for large and deep caissons. For small and shallow caissons the size of the timbers may be reduced.

The walls of the straight-walled caisson should be braced at intervals of about 10 ft. by struts and rods extending across the caisson. The V-shaped walls require much less bracing than the straight wall. The straight caisson wall is more frequently used than the V-shaped because it is less difficult to excavate under the cutting edge. The lower course of timber should be protected by a steel shoe. The roofs of timber caissons formerly used for pier construction were very heavy. This was particularly true when the piers were built of stone masonry. The roofs were usually built of 12×12 -in. timbers thoroughly driftbolted and laid in courses alternating in direction to furnish a thickness of from 8 to 22 ft. The use of bulkheads within the working chamber and of concrete to replace stone masonry in pier construction has greatly reduced the required roof thickness.

In large caissons the wall bracing may take the form of bulkheads with tie and truss rods. In such cases the bulkheads with trusses may be used as a support for the roof.

The entire inside of the working chamber and the outside of the walls should be sheathed with 2- or 3-in. sheathing, which should be surfaced on one face and planed on the edges for caulking or should be tongued or grooved. To get a uniform surface, all caisson timbers should be surfaced on one side and one edge.

The cofferdam, built from the top of the caisson to a few feet above the water line, must carry the water load until the masonry is put in. When concrete is used, it is customary to utilize the cofferdam as a form. When the pier is of stone masonry, the cofferdam is braced to the pier or the space between the pier and the cofferdam is filled with sand.

38. Concrete Caissons.—Concrete caissons for bridge piers have not been used to any great extent in this country. On account of their weight they are difficult to build and to land on the pier site. Also, it is necessary to allow a considerable time for hardening before the sinking is started. The necessary thickness of wall to give the required strength reduces working space and thereby limits the use of this material for small caissons. Concrete caissons have the advantage of forming a monolithic pier structure. Concrete is a good material for a caisson that can be built on the site and a considerable depth of pier added before sinking. Under such conditions concrete caissons are very extensively used around New York for building foundations. Later practice tends toward the use of steel cylinder caissons for this purpose. Concrete cylinder caissons are sometimes used for bridge piers and are often sunk part way by open dredging methods. The final placing of the foundation is done by pneumatic methods.

39. Steel Caissons.—On account of their cost, steel caissons are not extensively used in American practice. In a vertical walled steel caisson the side walls are built of plates and angles, knee-braced to the roof beams. The knee braces are spaced 4 or 5 ft. on centers. The V-shaped walled caisson has a vertical and inclined wall of plates and angles with diaphragms at intervals of 6 to 8 ft. The space between the walls is filled with concrete. The roof is made of beams or girders with a plate riveted to the bottom flange. The cutting edge should be reinforced for stiff-

ness. All-metal cylinder caissons are used in New York City for building and bridge foundations. These are similar to those used for the open caissons but are equipped with a diaphragm door to form air locks. They are usually 6 to 12 ft. in diameter and are built up in sections of 6 to 10 ft. Open dredging methods are often used throughout part of the depth and the final placing of the foundation is done by the pneumatic process.

As given before, the advantage of the metal caissons is that the same strength can be furnished by a thinner wall, thus leaving more working space available. They generally form a more watertight structure.

40. Cutting Edges.—The cutting edge best adapted to pneumatic caissons is that shown in Figs. 23 and 24, page 113. The sharp edges permit the material to be dug out close to the side wall without allowing a great quantity of air to escape.

41. Sinking Caissons.—The site should be cleared of mud and leveled. In swift streams with soft bottoms the bottom on the upstream side of the caisson is sometimes paved with sand bags to prevent scouring and undermining of the caisson before the sinking is well started.

The best and most economical method of sinking a pneumatic caisson is to have just enough weight to keep the caisson moving as fast as the material is excavated from under the cutting edge. The excavation should be carried on continuously because after a caisson has stopped there is always difficulty in again starting it.

It is usual to excavate the material about a foot below the cutting edge, except close to the cutting edge. In clay the excavation can be carried somewhat deeper. The material under the cutting edge is then removed, and the air pressure reduced enough to let the caisson settle to the bottom of the excavation. In sinking caissons for building foundations large frictional resistance is usually developed. Weighting the caisson is often necessary as an aid in sinking. Large caissons when sunk to great depths have required as much as 1,000 tons of loading. Loading of the order of 300 to 400 tons may represent an average condition. If the caisson is much heavier than required to overcome friction, the working chamber may be practically filled with material that makes it difficult for the men to clear away a space large enough to work in. When passing through hard material or boul-

ders, it is important to see that the excavation is made amply wide so that the caisson will not jam. The excavated material is removed by buckets working through air locks or by a blowout pipe.

The blowout pipe is simply an iron pipe about 5 in. in diameter extending from the deck to the working chamber. There is an elbow at the top and a piece of flexible hose with a flap valve at the bottom. The excavated material is shoveled around the end of the hose and the valve opened. All of the material in front of the valve is very quickly blown out. The process is so rapid that the valve need be opened but a short time. Material is not generally blown out until the air reaches a pressure of about 20 lb. per sq. in. The abrasion of the sand on the elbow of the blowpipe wears it out very rapidly.

Clay and rocks are best removed by a bucket. The air locks now in use permit the bucket to be taken out of the caisson without disconnecting the bucket from the rope.

As the caisson is sunk it is rarely quite plumb nor is it exactly in the correct location. The caisson can usually be made to move in the direction desired, provided the material penetrated is not extremely hard. To move the caisson laterally the side of it opposite the direction to be moved should be undercut and the other side banked. The caisson is then allowed to sink out of plumb. The cutting and banking are then reversed and the caisson is brought to a vertical position. The caisson cannot be moved laterally without sinking it at the same time.

One of the land piers of the Missouri River Bridge at Omaha was moved 5 ft. laterally in sinking 8 or 10 ft. In addition to the cutting and banking, a heavy pull was put on the pier by a block and tackle. Inclined shores also were set in the working chamber to assist in the movement.

Where, owing to lack of headroom or for other reasons, it is sometimes not possible to sink a caisson by this method even though compressed air is required, a fixed lock may be used. The preferred method in this case is to sink to the water-bearing soil a small cofferdam or pit in the open, somewhat larger than required for the air work. Above this a roof or bulkhead is placed with a vertical or horizontal lock or locks in place. This bulkhead is then backfilled or weighted to more than balance the requisite pressure. From this working chamber under

compressed air, the smaller caissons may be sunk as in the open as described.

42. Sealing Caissons.—If the caisson when sunk to grade is in sand, gravel, or hardpan, the bottom should be leveled and the material dug from under the cutting edge. If the caisson lands on sloping rock overlaid by coarse sand or gravel, it is usually better to excavate the rock and continue the sinking until the cutting edge reaches the low point of rock. If the sloping rock is overlaid by fine compact sand or clay, the excavation may be carried below the cutting edge to rock by banking the sides of the excavation with bags of sand plastered over with clay, or the excavation may be carried to rock by jacking sheeting down. When hardpan, which is free of pockets of soft or loose materials, is encountered, caissons for building foundations are sometimes sunk a few feet into it and excavation to rock is carried on ahead of the cutting edge. Under the conditions the base is sometimes dug outward from the cutting edge to form a bulge at the base to increase the bearing area. The risk of excavating below the cutting edge increases as the air pressure increases. All loose rock should be cleaned off, all rotten rock removed, and all crevices cleaned out. Sloping rock should be stepped to give horizontal surfaces. Filling the working chamber with concrete is a very important part of the finishing work on a caisson and requires a great deal of care. It is customary to fill in concrete to 2 or 3 ft. above the cutting edge, and then build the concrete up in steps to within 6 in. of the roof by bulkheading. The last 6 in. is filled by ramming in comparatively dry concrete. This process is slow, tedious, and expensive. Another method is to fill the working chamber to within a foot of the roof with medium wet concrete. After the concrete has had time to set, the air pressure is released and the remaining 12 in. are filled with concrete wet enough to flow. The air is forced out at 2-in. air pipes placed near the corners of the caisson.

43. Rate of Sinking.—Primarily, the rate of sinking a pneumatic caisson depends upon the rate at which excavation can be made. Interference by logs, boulders, and other obstructions and the amount of skin friction developed also affect the rate. Consequently there is a wide variation in sinking rate. Rates accomplished in sinking building caissons in New York City vary from 1 ft. per hr. to $4\frac{1}{2}$ ft. per day as an average. The

Foundation Company reports the sinking of 87 caissons, all exceeding 75 ft. in length, for building foundations in New York City in a period of 60 days.

44. Cost of Sinking Caissons.—The cost, like the rate, of sinking caissons varies over a wide range. It is dependent upon many factors that are characteristic of the particular site. An estimate in which each item of cost is carefully considered should be made in each particular case.

45. Caisson Diseases.—As the air pressure in a caisson is increased, the fluids of the body absorb increasing quantities of air in accordance with Dalton's Law of Solution of Gases in Fluids: the amount of gas dissolved in a fluid is proportional to the pressure of the gas surrounding the fluid.

When the air pressure is lowered too rapidly, the absorbed gases are thrown out of solution more rapidly than the body can eliminate them and bubbles are formed in the blood, tissues, or joints. The decrease in pressure allows the entrained gases—principally nitrogen—to expand. This expansion interferes with the flow of blood and may cause the blood vessels to burst. The formation of these bubbles in the joints produces the "bends." Paralysis results when the bubbles are formed in the spinal cord. The treatment is to put the patient under pressure and decompress more slowly. Most states have laws regulating the rate of decompressing and the length of shift, which vary according to the intensity of pressure. They also require that a hospital compression lock be provided on the work for the treatment of caisson diseases. To prevent caisson disease, only comparatively young men of good habits and in good physical condition should be employed. Special attention should be given to the strength of the heart and condition of the circulatory system. Good circulation aids in the rate of desaturation. The final selection of workmen should be made only after a thorough examination by a competent physician.

CAISSON DETAILS

Example 1.—Figure 26A shows details of one of the boilerhouse piers of the Kansas City Power and Light Company's power stations on the Missouri River at Kansas City, Missouri.

The seal and cap were of 1:2:4 concrete; the walls of 1:2½:5 concrete reinforced as shown. The space between the seal and

The water tunnels for this power station were sunk in sections—16 ft. wide, 29 ft. deep, and 43 ft. long—as open dredging caissons. The sections were sunk 1 ft. apart. The space between caissons was closed on the outside by driving sheet piling,

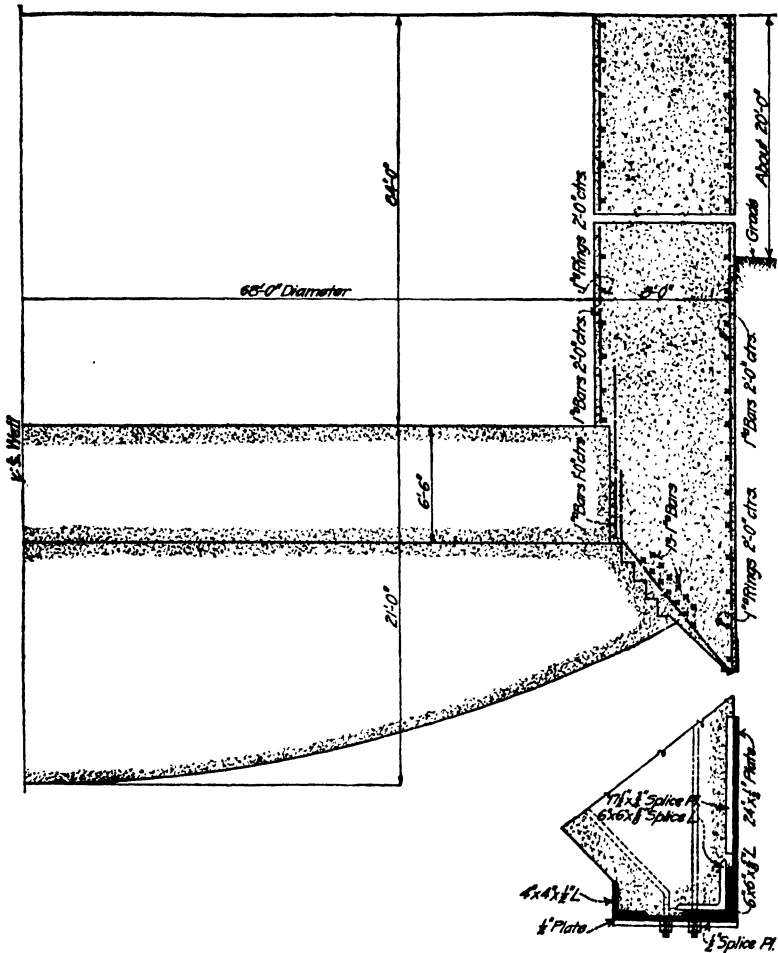

FIG. 26B.

on the inside by bracing a form against the concrete, the sand cleaned out, and the opening filled with concrete.

The seal was cast through the water; the top, which was above low water, was cast in the dry.

Example 2.—Figure 26B shows details of an open dredging caisson sunk on the Ohio River for the Union Gas & Electric Co. of Cincinnati, Ohio, for a condenser pit. The caisson was 68 ft. inside diameter with wall 8 ft. thick. The requirements of sinking weight determined the wall thickness. The caisson was sunk 60 ft. by open dredging through a cinder fill containing stone, clay, refuse from a gas plant, piles, etc., and 20 ft. into river gravel. The caisson was designed to resist a 70-ft. head of water. The walls were of 1:2½:5 concrete reinforced both ways with 1-in. bars spaced 2 ft. on centers on the inside and outside of the wall.

The seal was 1:2:4 concrete cast by bottom-dump bucket through about 30 ft. of water. The seal was in the form of a section of a sphere and figured as a dome without reinforcing. The side walls were reinforced for ring tension. After the caisson was pumped out, a finished bottom 6½ ft. thick containing the intake and discharge water tunnels was installed. Before the finished bottom was installed, the sealing plug carried a 50-ft. head of water with practically no leaks. The caisson was built up in 7-ft. lifts as the sinking progressed. The weight of the caisson was just enough to overcome the skin friction, which amounted to about 1,000 lb. per sq. ft. The caisson was landed 4 in. off center and 2 in. out of vertical.

Example 3.—Figure 26C shows details of a pneumatic wall caisson for the Federal Reserve Bank at New York. On account of the excessive run-in under the cutting edge when sinking piers by the open dredging method, it is necessary in cities to use the pneumatic caisson. The caissons are sunk in contact. After sinking, the hexagonal opening between caissons is cleaned out and filled with concrete, thus making a watertight retaining wall around the building site.

After the caissons are sunk and sealed, the basement excavation is made, the permanent struts being installed as the excavation progresses.

Example 4.—Figure 26D shows details of Pier No. 4 of the McKinley Bridge across the Mississippi River at St. Louis. The caisson was of timber and concrete construction. The walls were constructed of 6 × 12-in. timbers laid edgewise. The cross struts were of 6 × 8 and 10 × 10 timbers spaced 11 and 12 ft. horizontally and 3 to 4 ft. vertically. The wall timbers were laid

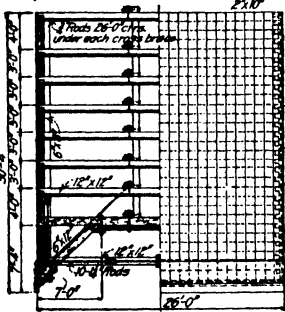
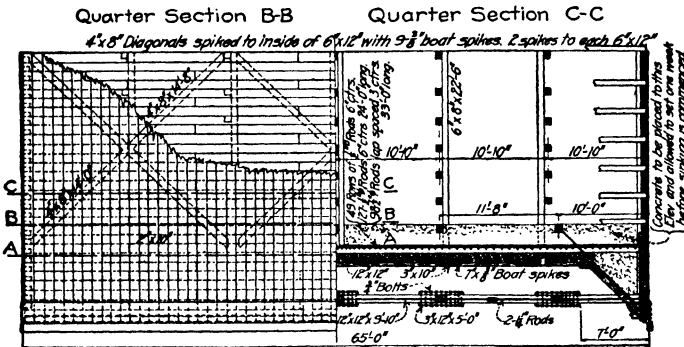
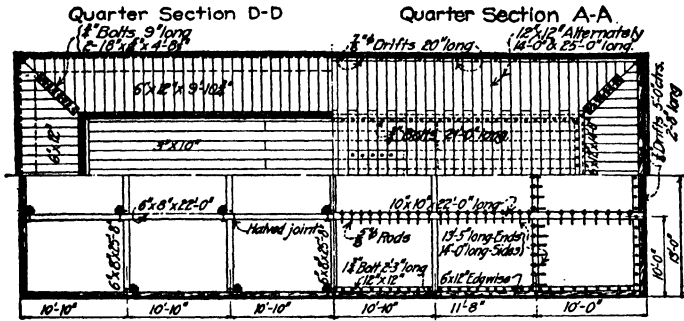

Sectional Side Elevation

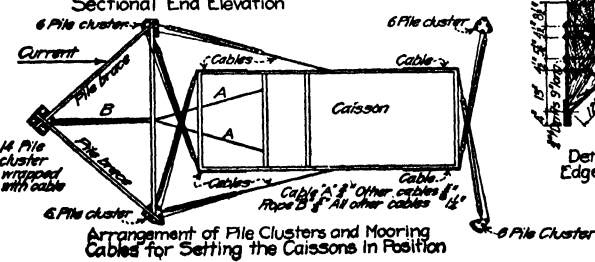
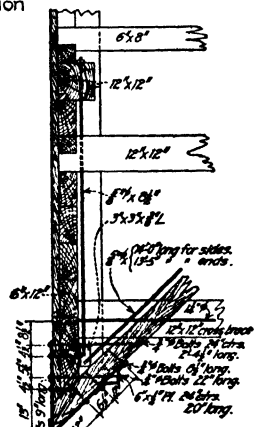

FIG. 28 D.

with intermediate butt joints and halved corner joints and were driftbolted together with $\frac{7}{8}$ -in. drifts, 2 ft. 8 in. long, spaced 5 ft. on centers in every course. Posts, 6 × 8 in., were put at intersections of struts with the side wall and $\frac{3}{4}$ -in. tension rods were used under each brace. The side walls were stiffened by 4 × 8-in. diagonals spiked on the inside. The working chamber was 7 ft. high with the sides and ends sloped at 45 deg. The roof of the working chamber was made of a single course of 12 × 12-in. timbers. Alternate timbers were halved into the side walls; the other roof timbers were stopped at the 45-deg. slope timbers which were 6 × 12 in., laid solid. The walls of the working chamber were braced by one longitudinal and five transverse struts extending from wall to wall. There were two $1\frac{1}{4}$ -in. rods with turnbuckles at each strut. The outside of the caisson was sheathed with 2-in. plank, the inside with 3-in. All sheathing was thoroughly caulked and all joints in iron plates coated with asphaltum.

The cutting edge consisted of two $\frac{3}{8}$ -in. plates outside, 8 and 33 in. wide, and a 36-in. plate on the inside bent to fit the 45-deg. slope. The steel plates extended 4 in. below the caisson timbers. Lug plates were bolted to the inside timbers of the cutting edge to take the weight during construction.

The concrete in the V-shaped cutting edge was reinforced with $\frac{5}{8}$ -in. rods spaced 1 ft. on centers along both the vertical and the inclined walls. These $\frac{5}{8}$ -in. rods were anchored to the lugs on the cutting edge.

The concrete on the timber roof was reinforced with two layers of $\frac{1}{2}$ -in. round rods in each direction spaced 6 in. on centers.

The caisson was built on shore on landing ways and landed in position by guide piles shown.

The material penetrated was mainly coarse sand, quicksand, gravel, and small boulders.

Excavated material was blown out by air pressure.

The skin friction was from 300 to 600 lb. per sq. ft. at the starting of the caisson. After the caisson was started, the friction was considerably less.

Example 5.—Figures 26E and 26F are plans and sections of a reinforced concrete gun pit sunk near Washington, D.C. for the Government by the Foundation Company of New York City.

Borings taken on the site of this caisson showed a comparatively stiff clay for a depth of 130 ft.

The ground was excavated to a depth of 20 ft. as an open cut before the cutting edge was set. The sinking progressed satisfactorily for the first 20 ft. when a layer of boulders 15 ft. thick was struck. The caisson, which had been designed for a friction of

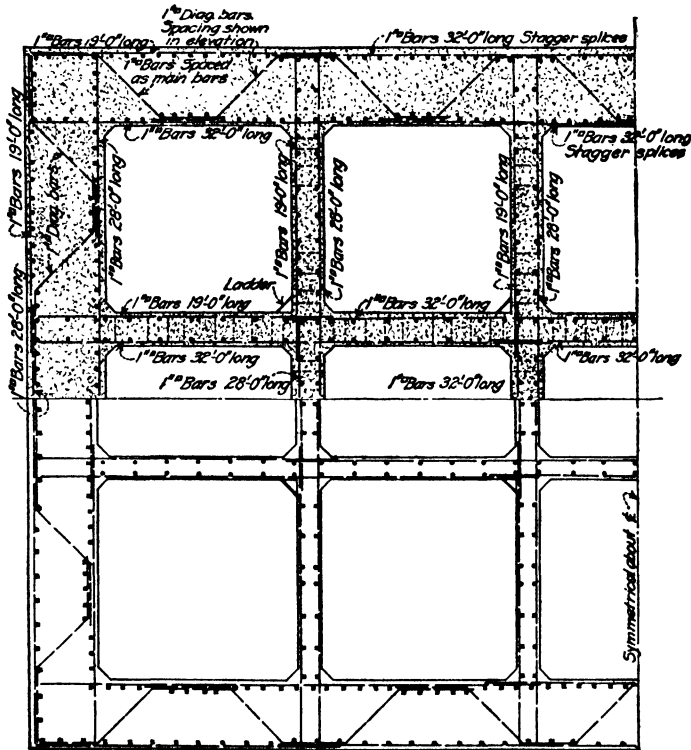

FIG. 26F.

500 lb. per sq. ft., would not penetrate the boulder strata when loaded to overcome a friction of 3,500 lb. per sq. ft. The caisson was dynamited by drilling a series of holes into the boulder strata 10 ft. apart and 30 ft. away from the caisson all the way around. Each hole was loaded with a stick of dynamite and all discharged at once. A minute or two after the explosion, the caisson would drop suddenly 6 or 8 ft. By repeating this process the caisson was sunk 90 ft. to the required depth. The caisson was landed

Pierre, South Dakota. The caisson was of timber construction. The walls were constructed of an outside course of 12×16 -in. timbers laid vertically and two courses of 12×12 -in. timbers laid horizontally. The vertical timbers extended to the top of the roof and were notched 6 in. into the roof for bearing. Alternate timbers of the horizontal timbers were run through at the corners. The roof was constructed of two courses of 12×18 -in. timbers laid transversely and two courses of 12×12 -in. timbers laid longitudinally. The cross struts were 6×12 -in. timbers at the top and 12×12 -in. at the bottom. The bottom timbers were halved at intersections. At the intersection of struts and at the intersection within the wall, 12×12 -in. posts were put between the top and bottom timbers. There were two 2-in. rods with turnbuckles at the bottom chord of each strut. There were three transverse struts and one longitudinal one.

The cofferdam was laid solid of 12×12 -in. timbers and braced by three lines of 12×12 -in. timbers laid transversely and two lines longitudinally. Bracing timbers were spaced on 4-ft. centers vertically, halved into the side walls and driftbolted at intersections.

All timbers were driftbolted together with $\frac{7}{8}$ -in. driftbolts the full depth of the timbers driftbolted together and spaced 4 ft. on centers along each timber. The outside of the caisson was sheathed with 2-in. plank, the inside with 3-in. All sheathing was thoroughly caulked. All timbers were sized to dimension. The cutting edge consisted of an $8 \times 8 \times \frac{3}{4}$ -in. angle and a $20 \times \frac{1}{2}$ -in. plate. The horizontal leg of the angle was fastened by 8×12 -in. plates spaced on 1-ft. centers. The caisson was sunk through 40 ft. of sand and gravel, and 5 ft. into gray clay shale.

PILES AND PILE FOUNDATIONS

46. "Pile" Defined.—The word pile is derived from the Anglo-Saxon "pil," meaning an arrow or sharp stake. Also from the Latin *pilum*, meaning javelin, and from the Latin *pila*, meaning a pillar.

In an engineering sense a pile may be defined as an element of construction composed of timber, concrete, or iron, or a combination of these that is either set, driven, or screwed into the ground vertically, or nearly so, for the purpose of increasing the

power of the pile to sustain the weight that is to rest upon it, or for resisting a lateral force.

47. Earlier Uses of Piles.—Historically considered, archaeologists and ethnologists recognize that piles were used in Europe by prehistoric races to form rude foundations for supporting their dwellings in lakes, a short distance from shore, and generally in shallow water. Whole villages were built this way. Some piles were driven and some were merely set with stone placed around them afterward to compact the ground. These piles were of wood $2\frac{1}{2}$ to 10 in. thick and up to 25 ft. long. Their relics are common in the lakes of Switzerland. On account of its manifest protective features, this type of lake or lacustrine dwelling is still used by many savage tribes in different parts of the world.

Caesar's "Commentaries" describes pile bridges built by his soldiers previous to the Christian Era.

In medieval ages Venice and the cities of Holland used wooden piles for foundations, these being driven by mallets or by metal hammers lifted by men or by animals. Piles, in the form of the trunks of small trees, were placed not by being driven but by being wiggled or rocked to and fro into place in soft ground, as is still done by farmers in northern Europe to establish platforms for drying hay, etc.

Timber piles have been used in Europe continuously since medieval times, the trunks of trees from their forested districts naturally suggesting themselves for the purpose. Iron shoes or points were later employed. Metal piles were first used about the middle of the nineteenth century, mainly in England, in the form of cast-iron screw piles, and disk piles to provide large bearing area. Their use has been very limited, such as for light-houses, ocean piers, and other marine work.

48. Types of Piles.—In modern practice piles may be classified into two main groups: bearing piles and sheet piles. The bearing piles may again be divided into four subdivisions: timber, concrete, composite, and steel. Each of these may again be divided according to treatment or method of placing or by various attachments for a certain purpose. Sheet piles may be divided into three groups: wood, steel, and concrete.

Piles are also classified according to their use. Either bearing or sheet piles may be used to control scour. The use of guide

piles in cofferdam work has already been pointed out. Piles are sometimes used as a means of compacting ground to increase its bearing power. Under suitable conditions, the short timber piles driven for this purpose may be withdrawn and the hole filled with sand. This column of sand acts as a pile and is termed a "sand" pile. Sand piles have been used up to 3 or 4 ft. in diameter. In this case the cavities were prepared by a suitable excavation method. When these piles rest on a dense stiff layer and the sand is well compacted, they will support loads of approximately 10 to 15 tons per square foot. A pile placed in an inclined position to resist horizontal load is known as a "spur" or "batter" pile. Piles placed singly about 10 to 15 ft. center to center along a dock line are termed "fender" piles. They are sometimes placed in clusters and lashed together to serve as fenders and are termed "dolphins." In water-front work, piles often serve as anchors to furnish lateral support, and are sometimes used to resist upward pressure.

Further consideration of the four classifications of bearing piles and the three classifications of sheet piles will be given under separate captions.

49. Pile Foundations in Modern Construction—General Features of Design and Construction.—In modern engineering construction, pile foundations are employed where the soil is manifestly improper for spread foundations; for example, where the ground is too soft to support the load without compressing or compacting, or where it is desired to support the load on hardpan or rock that is overlaid by very soft or fluid material.

In driving piles into hardpan, it is therefore essential not to drive through the hard stratum and into soft material that may be underneath. Some Chicago conditions are cases in point.

Pile foundations, in general, consist of a base of timber, steel, stone, brick, or concrete masonry, or a combination of these, supported by piles, which distribute the load of the structure resting upon it, through a considerable depth, to the earth, hardpan, or rock below.

In cases where the pile is employed to consolidate soft ground, the so-called "pile action" occurs, and the limiting condition of load is either the adhesion of the ground to the surface of the pile, namely, the friction, or the compressive resistance of the material in the pile itself. The tip of the wooden pile in such

cases may be as small as 6 in. Where a pile is used to go through soft material to hardpan or rock, it receives considerable lateral support even though the ground may be soft. As a consequence, the pile does not act entirely as a column and is capable of supporting a higher loading. It may, however, be suitable to use a larger tip diameter to increase the bearing area. A 9- to 10-in tip is desirable, though somewhat difficult to obtain in the ordinary market.

In either case, the pile so employed is called a "bearing" pile, which is a general term applying to any pile that carries a superimposed load. Examples of bearing piles are found in foundations of bridges and buildings, elevator foundations, power plants, and ore and coal storage docks. In the cases of storage docks and power plants on river banks, and particularly where compressible material rests on a harder stratum that slopes toward the boat channel, wooden piles are often driven closely together over large areas and well into the hard stratum to prevent disastrous slips into the water later, when the dock itself is completed and loaded. Such foundation piles are generally cut off and made to act as a unit by a continuous layer or mat of concrete, plain or reinforced, several feet in thickness around the heads of the piles.

TIMBER PILES

From an economical standpoint, the most favorable use of bearing piles occurs when a practically unyielding stratum can be reached by timber or wooden piles of ordinary or market lengths, roughly 20 to 50 ft. long, and the overlying material is compressible, such as soft clay, so as to be readily penetrated by piles, but sufficiently compact to prevent the piles from bending or from being displaced laterally. Commercially speaking, the available lengths and kinds of wooden piles are generally limited by the cost of railroad transportation and by the length of railroad cars, although long piles are often shipped in double loads, *i.e.*, with their ends lapping over on another car. Except on our coasts, piling is seldom shipped by boat, since its length and heaviness make it difficult to handle through hatches and to stow.

The chief advantage of timber piles is their low cost. They are, however, subject to decay and to the attack of marine borers. To prevent decay, wooden piles used in foundations are cut off

below the level of ground water. When this is done, they apparently have an indefinite life. This is shown by many instances of piles in service for hundreds of years. On the other hand, unprotected or untreated piles may be destroyed in a period of a few months if attacked by marine borers.

The first step in the design of the foundation for any structure is to ascertain the condition of the soil. As a general rule, the making of borings is valuable, but if the engineer depends upon others to obtain this information for him, he is soon confronted with a great deal of conflicting evidence. In the absence of definite knowledge by previous pile-driving experience at the site, or adjacent to it, borings certainly should be made or test piles driven.¹ The driving of test piles, although generally more expensive, is the more advantageous of the two. Even though it does not give samples of the material, *i.e.*, the character of the soil, it does give good information with which to decide upon the capacity of the soil.

It is evident, for the purpose of design and economical construction, that the length of piles to go in a pile foundation should be determined in advance. This is where the driving of test piles is additionally valuable. Wooden piles cannot be designed but must be taken as they grow.

If other methods are used to determine the supporting power of the earth and it is desired to compute the size of the pile, it should be remembered that "with the usual methods in effect, in which large initial stresses are to be expected, it is not safe to use piles of diameters which would be just large enough to support the developed supporting power of the earth, nor would it be practicable to secure or drive them." In ordinary pile-driving operations, design is not so absolute as in steel structures, for instance, and some little elasticity is advisable, particularly after the driving of the foundation itself is started and observations are being made. In systematic pile-driving operations over large areas, soft and hard spots in the ground often evidence themselves in a manner that is not always developed by the test piles driven previously at regular, but scattered intervals. For example, in case of doubt, on an ordinary pile-driving job, when a little easier

¹ A formula is sometimes used to express the relation between the safe bearing capacity of a pile and the variable factors that can be observed during its driving.

driving is encountered, it is better to drive a few additional piles such as are immediately available, rather than to wait for an exact number of larger piles to take the same individual loading.

The life of wooden piles above water, where exposed to air and alternate wetting and drying, is largely affected by the time of year the piles are cut. This feature has not always received the attention it deserves. Scientific experiment shows that it affects not only the durability of the timber but also its strength. This is also borne out by the observation of practical men who handle and drive piles in large quantities. They state that they would depend more on an inferior kind of timber that is cut in winter when the sap is down, than on the higher grades of timber, not excepting white oak, if cut in summer.

Also, although there are many specifications as to the kinds of wood permissible for use as piles, the well-established rule is that any kind of pile that successfully stands modern pile-driving methods with heavy machinery, will support the safe load that it is designed to receive in an ordinary pile foundation. The quality of a pile can usually be judged by the behavior of its head under moderate driving. As driving progresses, the condition of the head also gives some indication of the action of the pile below the surface.

The Building Code of New York City requires that the distance between the centers of wooden piles shall be at least 24 in. Piles shall, except when they are used as foundations for wooden frame structures over submerged or marsh lands, be cut off below the permanent water level. The maximum allowable load on a wooden pile having a 6-in. point shall be 15 tons; on a pile having a point of 8 in. or over, the maximum allowable load shall be 20 tons.

50. Kinds of Wood Commercially Available for Foundation Piling.—The kinds of wood commercially available for foundation piling varies in different portions of the country. In the Middle West, cypress, tamarack, and mixed hardwood may be obtained in lengths up to 50 and even to 60 ft. In yellow pine, piles may be obtained generally in rather limited quantities up to 90 ft. long. Oregon fir piles, which come in long lengths, are seldom used in the Middle West as the freight rate for the long haul is prohibitive.

In the East, yellow pine is easily obtainable in the longer lengths from the Southern states. For shorter piling various woods from the middle Southern states are often employed.

The hardest piles are white oak and some collateral varieties.

Mixed hardwood piles stand second in the list. These comprise oak, gum, elm, maple, beech, birch, hickory, pecan, ash, sycamore, locust, and chestnut.

The semihard woods comprise cypress, tamarack, and long-leaf yellow pine.

The soft woods include cottonwood, willow, poplar, cucumber, basswood, hemlock, and white pine.

Yellow pine and cypress, in addition to their availability in the market, are most suitable for pile foundations, as they are straight, well bodied, and free from large branches, and can be obtained in long lengths.

Oak piles are hard and tough, and stand driving well, but are not so straight and smooth and generally not so well bodied, as they usually do not hold their diameters in proportion to the lengths as pine piles do, being generally overlarge at the bole or butt end as compared to pine piles and having a tendency to run under size at the top. They have the added disadvantage of sinking in water unless rafted to lighter piles or timbers. They are chiefly used for dock work, trestles, etc., as in addition to durability against weather they stand boring and holding by anchor rods, driftbolts, and screw bolting better than the softer woods allowable for pile foundations.

51. Sizes of Piles.—Although large, full-bodied piles are more and more difficult to obtain, owing to the exhausting of our forest products, minimum specifications naturally receive most attention. As to maximum specifications, the diameter that piles may not exceed is generally given at 20 in. since the clearance between the leads of the pile driver is about 22 in. The 1936 specifications of the American Railway Engineering Association divide wooden piles into two classes: first and second. The first group includes white oak, the cedars, cypress, redwood, longleaf pine, and Douglas fir. The second class includes any suitable timber that will stand driving. Second-class piles are limited in use to foundations where they will be continuously submerged or to cofferdams and other temporary structures.

First-class piles should be cut from sound trees, above the ground swell and, unless otherwise specified, should be cut when the sap is down. They should be free from ring shakes, unsound spots or knots, and short bends. All knots should be trimmed close to the body and the piles peeled soon after cutting. The minimum tip diameter for lengths under 50 ft. should be 7 in.; for greater lengths, at least 9 in. The minimum diameter at one-quarter of the length from the butt should be 12 in.; the maximum butt diameter should be 20 in. The piles should have a uniform taper. A line drawn from the center of the tip to the center of the butt shall lie within the body of the pile.

For second-class piles the same requirements of butt and tip diameter, straightness, and taper apply. Unless specified, piles in this class do not have to be peeled.

The question of removing bark from piles has been much discussed. Many experienced men feel that the bark, because of its roughness, develops more frictional resistance. An extreme case was cited of pulling piles some years ago from the foundations of the burned Iowa Elevator on the Chicago River. Between 800 and 900 hardwood foundation piles that had been in place for about 30 years were pulled out clean, leaving the bark in the ground. This was mentioned to indicate the intense friction developed between the bark and the ground.

The 1937 Standard Specifications of the American Society for Testing Materials divide timber piles into three classes according to their use. Class *A* piles are for heavy railroad bridges and trestles. Class *B* piles are used for docks, wharves, highway work, and general construction. Class *C* are for use in cofferdams and other temporary work or in foundation work where they will always be completely submerged.

Ordinarily, the length of piles used in construction varies from 20 to 40 ft. Under certain circumstances much longer lengths are used. Single sticks 175 ft. long have been used in marine work on the West coast, and similar piles 135 ft. long were used on work in the Columbia River. Piles 135 ft. long having a butt diameter of about 30 in. were used on the Baton Rouge Bridge.

52. Pile-driving Procedure.—The operation of pile driving may be defined as forcing a pile into a definite position in the ground without previous excavation. This is accomplished by

the use of either drop hammers or steam hammers. The steam hammer may be either single or double acting. The pile, together with the necessary equipment, is termed a pile driver.

The operation may be most readily illustrated by the case in which a timber pile is driven vertically into the ground by a drop hammer. When piles have been delivered to the site within reach of one of the hoisting lines of the pile driver, this pile line is made fast to a pile at its head and first dragged, if necessary, near the front of the pile driver, and then hoisted until it is suspended in air. It is then placed and held between the high parallel members of the pile driver, known as the "leads" or "guides," in which the hammer slides and is guided in its movements. Next the pile is lowered till its tip rests on the ground, and the pile hammer, which had been hoisted out of the way, is now lowered gently to rest on the head of the pile. Generally in soft ground the pile runs a little under the weight of the hammer. The pile line is then released and actual driving begins; that is, the hammer is raised and released, and at each fall strikes the head of the pile, continuing until the required penetration is reached.

It is evident that some of the work done by the falling hammer is consumed in friction, in crushing or brooming and hitting the head of the pile, and in compressing the pile and the soil at its point and the hammer itself, while the remainder causes the penetration of the pile. When steam hammers are used, the hammer rests on the top of the pile or may be held in place by cable lines from a crane or other equipment (see Fig. 31a).

53. **Pile Drivers.**—A pile driver is an outfit or apparatus for driving piles. It is characterized by the leads—sometimes called "leaders"—which are upright parallel members supporting the pulleys or sheaves used to hoist the hammer and piles and to guide the movements of the hammer. Leaders may be of steel or wood. In the latter case the inside surface is generally lined with iron channels to reduce friction and wear. Steel leaders are not used so much as wooden leaders, although they answer satisfactorily for special work, such as cast-in-place concrete piles. In the more usual type of work the dragging and hoisting of a heavy pile over rough ground sometimes causes the pile to strike the leaders violently. This will deform steel leads more quickly than the more springy wooden ones. The steel leaders

are also more apt to shake loose at the joints from hard driving than the wooden frames and are not so much favored for general utility purposes.

Pile drivers designed primarily for pile driving alone may be divided into three groups: the floating pile driver, the skid pile driver, and the track pile driver.

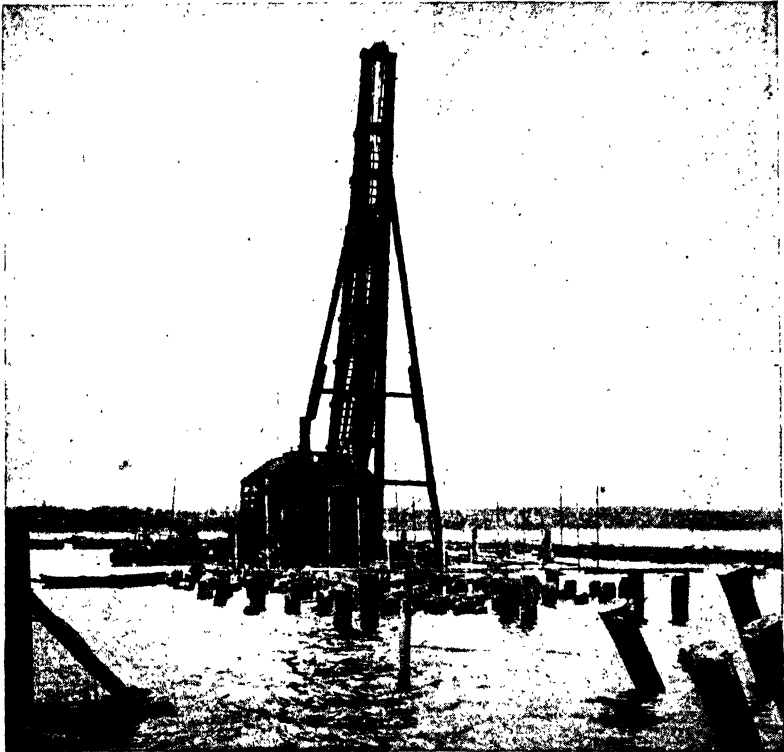

FIG. 27.—Floating pile driver.

On floating pile drivers the tops of the leads are usually arranged so that pulling blocks or falls may be set in place for the purpose of pulling round timber piles and wood or sheet piles, as in cofferdams for bridge foundations or for removing old docks. The buoyancy of the hull of the pile driver is thus employed to pull out piles. A standard type of floating pile driver fitted with a large McKiernan-Terry double-acting steam hammer for driving foundation piles for pier construction is shown in Fig. 27.

The pile-driver leads are braced in position by back stays and by horizontal and diagonal members to form the tower, the whole resting on a bed frame of horizontal sills, which generally extend far enough back to carry the hoisting engine and boiler. This whole outfit is then mounted direct either on rollers or on a

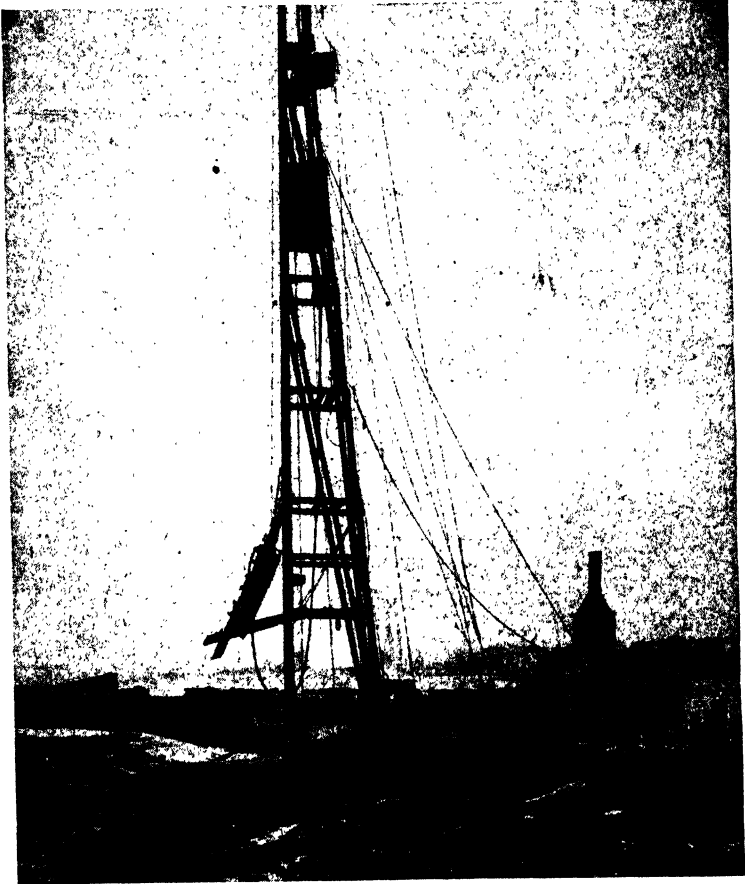

FIG. 28A.—Skid pile driver.

turntable set on rollers. When mounted on rollers, the driver is moved sidewise on rollers by winding with the engine on the chains shown at the ends of rollers. To move forward or back, the chain is run to some intervening object in the direction of proposed travel and beyond it, so that when the engine winds the

chain, it slues the end roller around as desired. This operation is then repeated for the other end of the roller.

When the skids are mounted on a turntable, the driver is known as a turntable pile driver. Figure 28A shows a turntable rig equipped with outrig batter leads suspended from the main

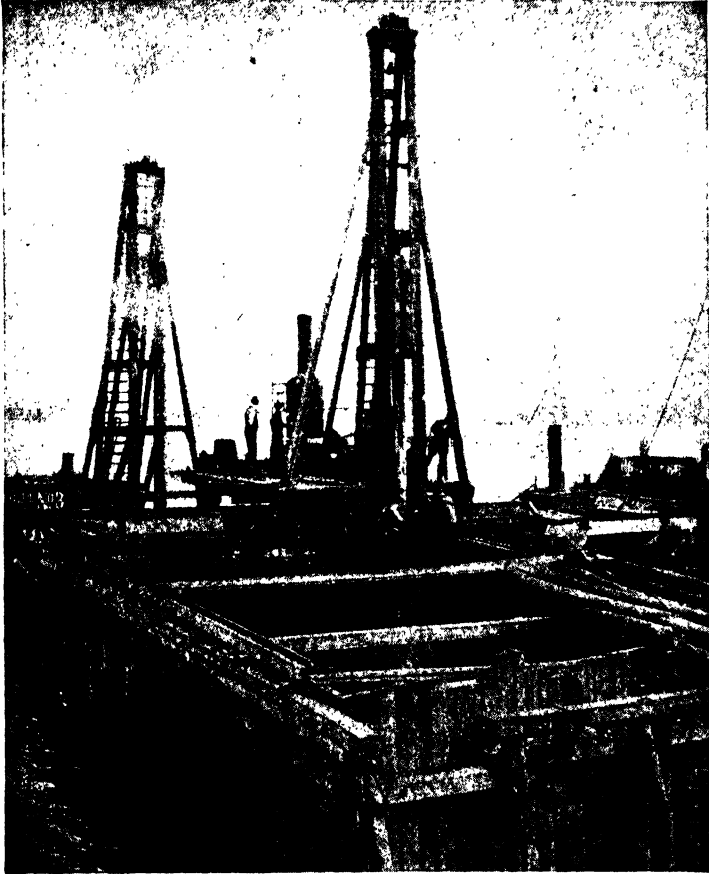

FIG. 28B.—Skid pile driver on cofferdam.

vertical fixed leads and the hammer arranged to drive batter piles. Figure 28B shows a land pile driver mounted on rails on top of a cofferdam driving foundation piles within the cofferdam. Both these drivers are equipped with heavy McKiernan-Terry hammers.

Track pile drivers for railroad service have been developed to a high degree of efficiency. They are usually the turntable or swiveling type and are mounted on a railroad car. A crane using hanging leads is shown driving monotube piles in Fig. 28C. They are used largely on trestlework and track elevation projects for

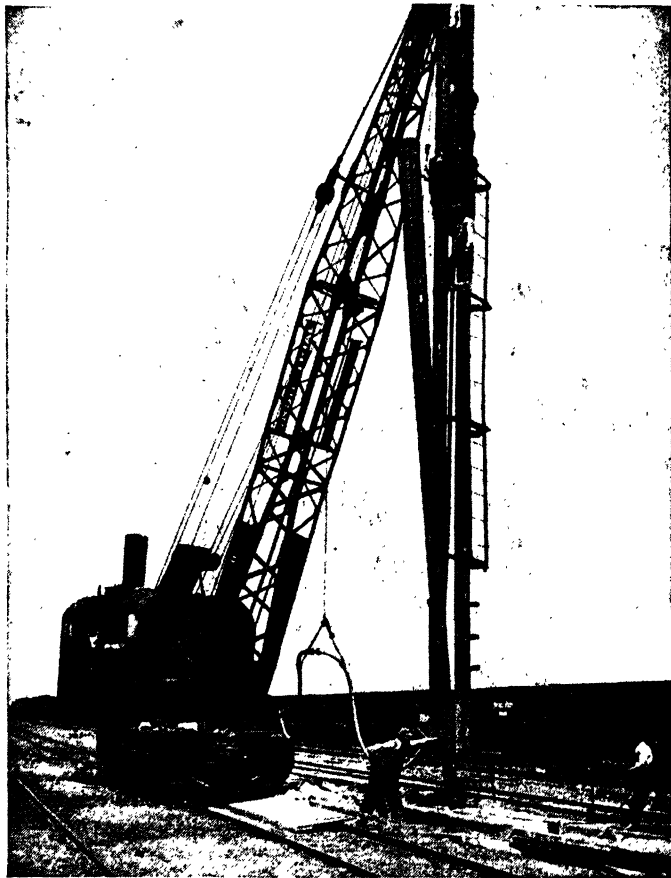

Fig. 28C.—Car-mounted crane with hanging leads.

railroads, and for bridge and culvert foundations, but are not used to any great extent on foundations for other structures. The present-day trend in pile-driving practice, especially in driving timber piles, seems to be toward the use of more mobile machinery that can be equipped with hanging leads. Such

equipment may serve many other purposes in the construction field when not employed in pile driving.

A crane equipped with wooden hanging leads and mounted on a barge for driving steel sheet piling is shown in Fig. 29A. A crawler crane equipped with steel hanging leads is shown in Fig. 29B driving concrete piles for an overpass foundation. Both these drivers are equipped with McKiernan-Terry double-acting steam hammers.

54. Drop Hammers.—The drop hammer is that type of pile hammer which is raised by a rope or steel cable and then allowed

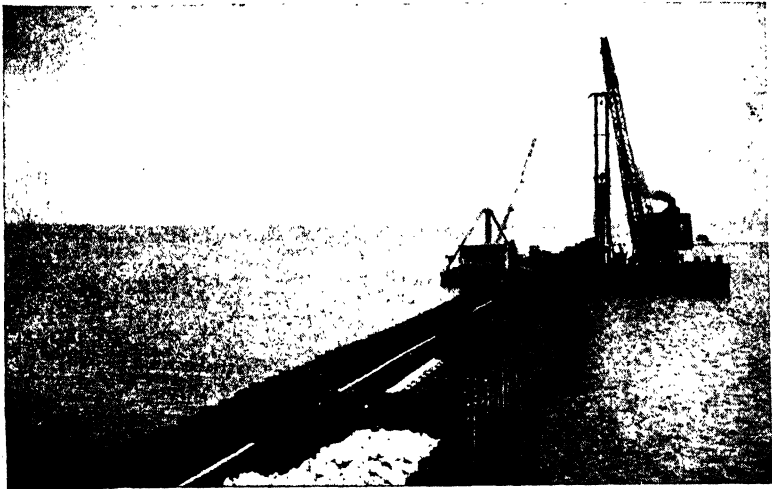

FIG. 29A.—Crane with wooden hanging leads.

to drop. Its essential features consist of the following: a solid casting with jaws on each side that fit into the guides of the pile-driver leads; a pin near the top for attaching the hoisting rope or nippers, as the case may be; a broad base on which it strikes the pile, the idea being to keep the center of gravity of the hammer as low as possible.

In modern drop-hammer design the hammer is made as long as practicable to increase the bearing in the leads, and all corners are rounded. The jaws are given as little play as practicable in order to reduce the jar on the driver when a blow is delivered to the pile. The bottom of the base of the hammer is made slightly concave when the hammer is to be used to strike the head of the

pile directly. When a pile cap is to be used, the base of the hammer is made flat.

The weight of drop hammers used in the United States to drive wooden piles varies from 2,000 to 4,000 lb., the latter weight of hammer being about 7 ft. high. For very short piles a weight

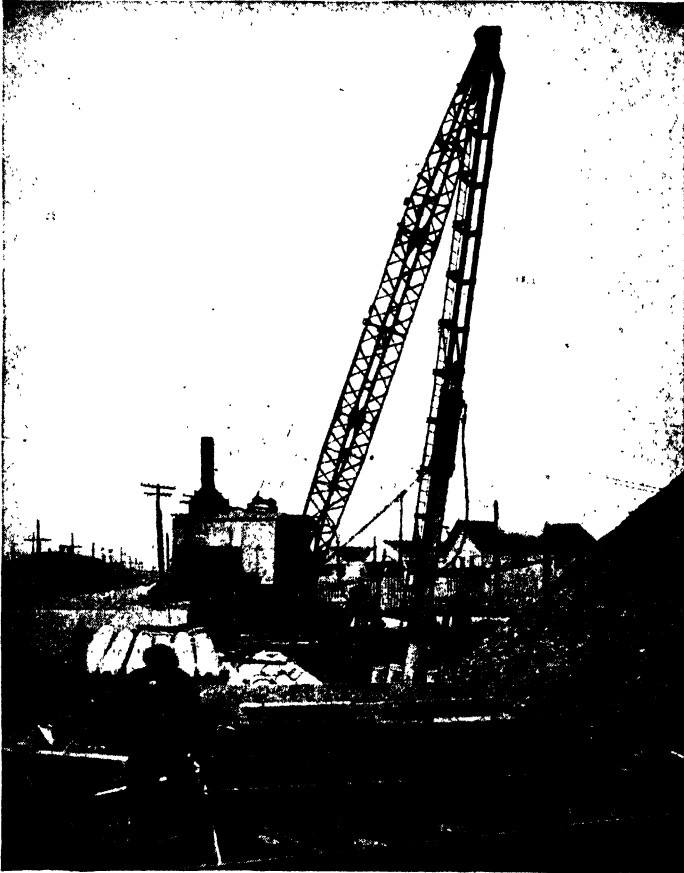

FIG. 29B.—Crane with steel hanging leads.

as low as 500 lb. is sometimes used. The weight of hammer to be used depends upon the length and size of the piles and the character of the ground to be driven through. Most contractors have a number of sizes to select from for the varying conditions of their work. Hollow hammers are sometimes used, so that

they may be loaded within a limitable range to give the varying weights. The fundamental considerations in the selection of a hammer are its weight in relation to the weight of the pile, its resistance to penetration, and the velocity of the ram at the instant of contact with the pile. A low velocity is more effective in transferring kinetic energy to the pile. The trend in modern manufacture is toward heavier hammers that develop sufficient energy with lower velocities. Some city building codes specify the allowable foot-pounds per blow.

55. Steam Hammers.—The steam pile hammer is one that is automatically raised and then dropped a short distance by means of a steam cylinder and piston held in a frame in the leaders of the pile driver so that it follows the pile down in driving. James Nasmyth of England invented the first steam hammer about 1850. In the United States the Vulcan Iron Works of Chicago has been building the steam hammer now known as the Warrington Vulcan hammer for more than half a century with continuous improvements.

Steam hammers are of two general classes: single-acting and double-acting. The single-acting is the older and better known type. Steam pressure conveyed from the boiler of the pile driver by a steam hose is used to raise the striking part of the hammer, which then falls by gravity. The force of the blow depends upon the length of the stroke and the weight of the movable part. The number of blows per minute depends upon the steam pressure, varying from 50 to 60 per minute.

In the second class of hammers—the double-acting—steam pressure raises the hammer and also assists the action of gravity on the down stroke. The force of the blow and its rapidity depend upon the steam pressure. The double-acting hammer is lighter, more compact, takes up less room in the leads, and operates with more rapidity than the single-acting steam hammer. Examples of double-acting steam hammers are the McKiernan-Terry, Industrial, Brownhoist, and the Warrington Vulcan. The super vulcan hammer is similar to the double-acting hammer but differs in that the steam below the piston is not exhausted and the pressure is held constant. Most modern hammers utilize compressed air as well as steam. Figure 30 shows a section of a McKiernan-Terry Corporation double-acting pile hammer. The smaller sizes are used mostly for driving light piling and have no

place in foundation piling work where the largest hammer practicable is generally the most efficient. The double-acting hammer in general delivers 100 to 120 blows per minute, or about double the number of the single-acting hammer.

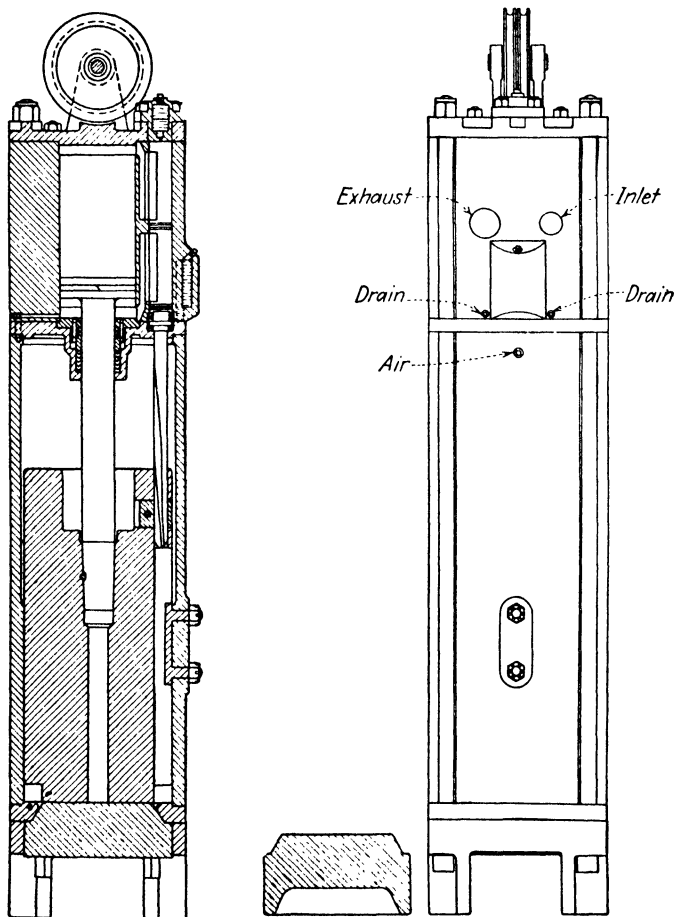

FIG. 30.—Cross section of a pile hammer.

In driving wooden piles, the steam hammer rests with its frame upon the pile, the pile head being trimmed to fit into the recess or base of the frame, the frame having on its sides angles or channels that engage the leads in the driver. In turn, the frame guides the hammer movement. In some makes of hammer the

frame entirely encases the striking part. The dead weight of the frame generally is many times the weight of the striking part and also much heavier compared to a drop hammer used under the same circumstances; hence it helps to keep the pile in motion

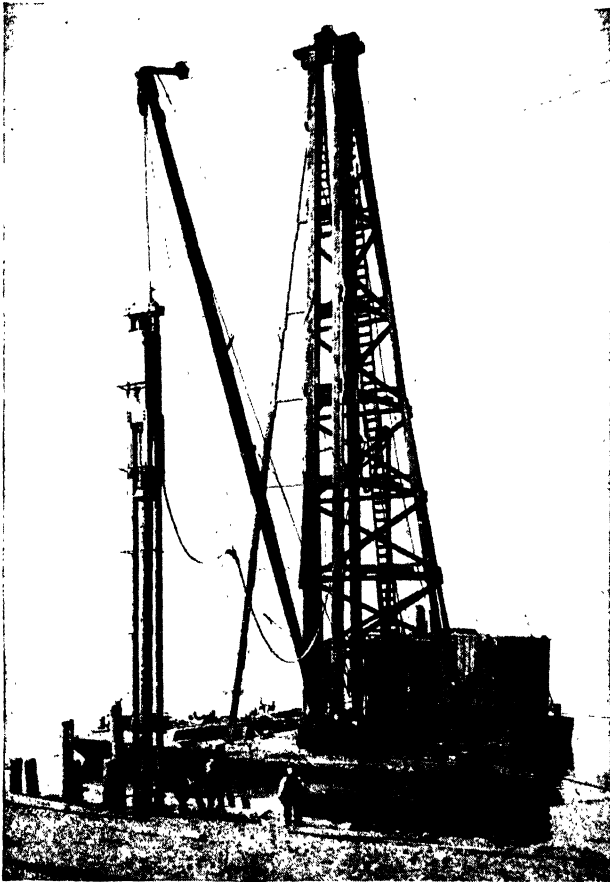

FIG. 31A. —Large double-acting steam hammer with pipe-sleeve attachment.

after it is started by the blow. As the blows follow rapidly, the pile is kept in continual motion, which is an important aid. The small vibration set up in the pile also assists its penetration.

Figure 31A shows a large McKiernan-Terry double-acting steam hammer, suspended from the boom attachment of a pile

driver and equipped with a pipe sleeve extension bolted to the bottom of the hammer for driving long wooden piles.

A close-up view of an especially built McKiernan-Terry hammer is shown in Fig. 31B. The total weight of this hammer is 16 tons, and the weight of the ram is 14,000 lb. It delivers 37,500 ft.-lb. per blow. This hammer was especially mounted



FIG. 31B.—Special heavy double-acting McKiernan Terry steam hammer.

to drive large H-piles during the construction at the Ludlow Ferry Bridge on the Potomac River. Some of these piles were 175 ft. long and were driven to a penetration of 165 ft. The hammer was submerged as much as 80 ft. when driving these long sections.

56. Drop and Steam Hammers Compared.—The advantages of the steam hammer over the drop hammer are as follows:

1. The pile is kept in position more firmly and guided better in driving.
2. Damaging the pile by brooming and splitting is more apt to be avoided, as piles must be headed more often with a drop hammer owing to this cause. The use of softer woods for piling is thus allowed with a steam hammer.
3. Driving is equally effective for any position of the piling in the leads.
4. A pile may be driven several feet (with some hammers 7 or 8 ft.) below the bottom of the fixed leads without the use of extension leads or a follower. This often saves several feet of pile length. This is important when material is expensive, since in the longer lengths of piles the owner pays not alone for the extra length, but an additional price for every foot of the pile as compared to a shorter pile. This also saves the expense of cutting off piles.
5. The rapidity of action keeps the pile in motion in all but the hardest driving, and as in foundation work almost every foot of the pile must be driven, compared to driving a pile in water, it means faster work. In a foundation three piles can usually be driven with a steam hammer while one is being driven with a drop hammer, because much time is lost in hoisting the drop hammer between blows.
6. It can be used in places and under conditions where a drop hammer cannot be used successfully.
7. Less injury is caused to adjacent foundations and less breaking of glass and cracking of plaster in near-by buildings.
8. Less wear occurs on the leads and less injury to machinery on the track and other mounted pile drivers.

In the Great Lakes district, where thick layers of clay cover bed-rock or hardpan, steam pile hammers are used almost exclusively.

In lake work, however, or generally in water work, the drop hammer is preferred for several reasons. Among these are the following:

The drop hammer is best on easy driving. This is usually the case in water work, as the distance driven into the ground is less than in foundations. Also, on water work the tops of the piles are generally left at 4 to 5 ft. above the water surface; hence the advantage of a steam hammer that can drive below the leads is not necessary. In fact, the steam hammer is so heavy, weighing generally about 5 tons as against 2 tons for a drop hammer, that its position of leverage in the leads when on a hull puts the ordinary pile-driver scow down by the head, so that it is impossible to leave piles standing 5 to 6 ft. out of water. Also, in varied work, where it is often necessary to take the steam hammer in and out of the leads and substitute a drop hammer, or vice versa, the weight of the steam hammer (generally about 5 tons for

driving wooden piles) is required to be handled, and a safe and strong place must be provided to receive the hammer. For these reasons, changing from a steam hammer to a drop hammer generally consumes 1 to 1½ hr. of a crew's time and is therefore expensive and hence objectionable.

Another objection to the steam hammer in such work as pile piers is that it generally consists of close-driven lines of piles on which the sides of the steam hammer will catch unless the work is done by backing away instead of working the driver sideways, as is the usual practice. In driving foundation piles, the spacing of piles, which is never closer than 2½ to 3 ft., does not render this feature of the steam hammer objectionable.

57. Reducing Tendency to Lateral Movement of Pile.—The butt of a pile should always be cut off square, so that the impact of the hammer may be distributed uniformly over the surface. Since the butt end tends to change its position slightly in the leads during driving, it has been found advantageous to make the lower surface of the drop hammer slightly concave. This provision counteracts the tendency toward lateral movement of the pile to some degree.

58. Protecting Pile Head.—To prevent splitting and reduce brooming, the head of a pile may be hooped with a pile ring, to receive which the pile is neatly chamfered down so that the first blow of the pile hammer puts the ring in place. The rings range in size from 2 × ¾ in. to 4 × 1 in. The diameters, of course, vary to suit the different sizes of piles. They are made of the best quality of wrought iron and generally last to drive about 100 oak piles and about twice that many soft wood piles. To remove the ring, a cant hook is used alone, or with the pile line attached to apply steam power. When a pile brooms too much in spite of the ring, the remedy is to saw off the broomed portion to a solid surface and replace the ring.

A more modern, more effective, and less expensive method of protecting a pile head is the use of a device known as Casgrain's pile cap. The chamfered head of the pile fits into a tapered recess in the bottom of a separate casting below the drop hammer, and a short cushion block of wood, preferably oak, is fitted into an upper recess. A rope mat is sometimes used. The cap has jaws on its sides to engage the pile-driver leads like the hammer itself, and so holds the head of the pile in position and guides

it in driving. After the pile is driven, the cap is hooked to the hammer casting and is raised with the hammer.

In pile pier and pile breakwater work in the Great Lakes district, neither a ring nor the more modern cap or bonnet is used with a drop hammer, as the use of the bonnet consumes a lot of time. When a pile is dropped to the bottom to begin driving, it generally is easily controlled by the two loader men using toggles or car stakes to pry the pile into line for driving. Another disadvantage is that the Casgrain caps or similar styles of bonnet have a tendency to jump off a pile and are easily lost in lake work. On river work where dock lines are to be driven, a bonnet is often used to control the driving of a pile. In such cases, in addition to its usual hooking arrangement, a line is put around it, passing over the top of the hammer, so that if the bonnet or cap jumps off into the water it can be reclaimed. A bonnet is similarly employed when piles are driven on a slope and have a tendency to drive away from the hammer.

Sometimes a flat steel plate is spiked on the pile head to receive the blow. Another device is a dished or cup striking plate for the same purpose. A still better arrangement is used with some makes of steam hammers; for example, the well-known Warrington steam hammer is often provided with a so-called "McDermid patent base" in which a recess is provided for a forged plate about 2 in. thick, called a "beating plate," which is inserted through a slot in the side, covered by a slide to hold it in place, thus avoiding the danger to the crew that occurs with a separate plate. As the slot that takes the beating plate is 4 in. high and as the plate is pushed to the top of the slot in driving, the top of the pile sometimes brooms up, particularly in hard driving, and fills the lower part of the slot with wood fiber, which makes it difficult to get the base off the pile.

Some makes of steam hammers are equipped with an anvil block in their base, which rests upon the pile.

59. Followers.—If a pile is to be driven below the leads or below the ground or water surface, a follower is usually employed. Briefly, it is a member interposed between the hammer and the pile to transmit blows to the pile when the latter is out of the leads. One of the simplest forms is a short pile or dolly of white oak, with a projecting band of iron on its lower end to keep it on the pile head. A cylindrical casting, with a horizontal division

or web in the middle is often employed, one portion of the casting being bolted to the follower or sometimes having an extra strong pipe cast in it to avoid the use of bolts, while the other end fits over the pile head. The upper end of the follower is held in position by the recessed base of the steam hammer, or by a pile cap if a drop hammer is being used. A follower absorbs a considerable portion of the energy of the hammer—sometimes as much as 50 per cent. As a follower is apt to stick in the ground, particularly in clayey soils, the practical limit of following is about 5 ft. Some patented followers have built-in pipes by which steam or compressed air may be introduced to release them.

The driving of piles for the bridge piers in the Maumee River at Toledo, by means of a long wooden follower working inside a large iron pipe used as a guide, is a rather unusual illustration of the use of a simple follower.

60. Blunt vs. Pointed Piles.—The foot of a timber pile should be cut off perpendicular to its axis to facilitate driving it true to line or position. In soft ground where driving is easy, it is hardly necessary to sharpen or point the pile. If it penetrates soft material and rests upon hard stratum so as to act as a column, a blunt end has the additional advantage of providing larger bearing area. Great care should be used in the latter case to prevent overdriving, which will shatter or crush the foot of a pile and seriously impair its supporting power.

In driving a pile with a blunt end, a cone of compressed earth forms under it and acts to a large extent as if the foot were pointed. Some experienced pile-driving men claim that even in driving through hard material, a blunt pile will keep more nearly to position than a pointed one. In hard material or in driving on a slope, pointing is necessary. The pile should be sharpened to the form of a truncated pyramid, the end being 4 to 6 in. square. The length of the point should be about twice the diameter of the foot. In compact material, the bearing power is practically the same with a point as without. In driving through debris or old grillage, etc., it is well to point piles for successful driving or even to use metal shoes.

61. Pile Shoes.—Many engineers and contractors condemn the use of pile shoes on the basis that they are not needed in soft driving, and that in difficult material the shoe strips off from the

unevenness of the point of application in hard driving. Pileshoes are difficult to fit properly to a pile and probably are condemned mostly as a loss of time. Metal pile shoes, so attached that they act as an integral part of the pile, are sometimes used on piles that are driven in soils containing boulders, riprap, deposits of coarse gravel, or very hard clay. They likewise prove advantageous in furnishing grips for falsework piles on rock bottom.

62. Driving Piles with Butt Downward.—Although it is the general practice to drive piles with the tip downward, special conditions occasionally make it advisable to drive them with the butt downward. In very soft ground, the larger area afforded by the butt of the pile will often be found to carry the load. Another condition occurs when it is difficult to keep a pile down after being struck by the hammer. The pile begins at once to rise, lifting the hammer with it, and may even shoot up into the air when the hammer is raised. A typical instance is in driving range piles in deep water for dumping of stone core for break-water projects, etc.; in such cases the range piles are so affected by the buoyancy of the deep water as to make it necessary to drive them butt down.

63. Splicing Piles.—It is sometimes necessary to use longer piles than can be obtained in the single sticks. For this purpose, two piles may be spliced together end to end by timber fishplates bolted on four sides of the piles, or a metal sleeve may be used in the form of a heavy pipe. Half lap joints fastened with bolts generally prove unsatisfactory because of the lack of lateral strength and stiffness. However, in swampy ground, one pile is sometimes driven on top of another with only an iron dowel pin connecting the two.

Pile splices are sometimes used where piles can be driven only in short sections owing to limited headroom. But in general, this is more apt to be the case with steel sheeting inside of buildings, for pits, wells, shafts, etc., than for foundation piles.

To increase the area of contact and the cross section of the pile timber, sticks may be bolted around the circumference of the pile. Such a pile is termed a "lagged pile." It is believed that settlement is less where lagged piles are used.

64. Cutting Off Piles.—In water work, the cutting off of piles is done with a circular saw mounted on a vertical shaft, which

may be operated in the leads of a pile driver by the pile-driver equipment.

In the average land foundation, also in cofferdams, where the piles are cut off after the excavation and pumping are done, the ordinary crosscut saw, cut into half lengths, tending to make it short enough not to interfere with adjacent piles and to work in the corners, is found to be economical. Where piles are subjected to tide water, they are usually cut off at half-tide level. This practice assumes that the pile will be kept continuously wet by the rise and fall of the tide. Piles in land foundations should be cut off below ground-water level. Serious damage to pile foundations has resulted from the lowering of the ground-water table, and many pile foundations have had to be replaced.

65. Preservation of Piling.—Chemical preservation of piles usually is not a factor in pile foundations for buildings, where the wooden piles can generally be cut off at ground-water level and thereby indefinitely preserved. There is a tendency, however, to use creosoted piles in dock foundations and there is, of course, in general, urgent necessity for creosoting in ocean districts where the teredo is active—for instance, on the Pacific, the South and East Atlantic, and the Gulf coasts and tributaries. The higher the water temperature, the more active the teredo. As knots cannot be well creosoted, the teredo is likely to enter the pile at such places and damage it. Hence, the tendency lately is toward a concrete armor on untreated wooden piles, this outer covering of concrete extending from just below the ground line to the high-water line. Where piles are to be placed entirely by jetting and hence are not jarred by driving, a protection made by cement-gun work on wire-mesh reinforcement around a wooden pile is found effective. Sectional jackets of concrete or vitrified clay pipe are sometimes used. Jackets may also be applied to piles already capped by using half sections held together with special clamps. The space within may be filled with sand or concrete. Protective pipes, such as corrugated iron pipe, may be placed over the pile and forced into the mud bottom, and the space between it and the pile filled with concrete or sand. Various kinds of metal sheeting have also been used.

Inasmuch as the marine borers are active only in salt water, there seems very little reason for employing creosoted piles in foundations in other districts, considering also the delay and

additional expense of the process. But railroad companies seem to favor creosoted piles for docks and foundations in various districts through the United States. Although a creosoted round pile behaves the same as an untreated pile in driving, experience shows that pine sheeting for docks when creosoted breaks more easily under the hammer than if untreated. The brittleness appears to be due to the creosoting process. In the Great Lakes district the portion of timber docks above water, *i.e.*, the round piles, timber, and sheet piling, is often treated with several applications of crude oil. This appears to lengthen the life of the timber considerably. The life of untreated and unprotected timber piles in waters where the *Teredo* and *Limnoria* are active varies from one to two years dependent upon the temperature of the water, kind of wood, and other factors. The effective or useful life may be much less. For more detailed information and specifications for chemical treatment and other methods used for preservation of wood, reference is made to the *Proceedings of the American Railway Engineering Association*. An exhaustive study of marine borers and their relation to marine construction was made by the San Francisco Bay Marine Piling Committee in cooperation with the National Research Council and the American Wood Preservers Association.¹

66. Order in Which Piles Should Be Driven.—In driving a foundation, particularly when it contains a large number of piles rather closely spaced, driving should always progress toward the line of least resistance; for instance, away from an existing building—not toward it—and toward a river or lake—not away from it. Instances may be recalled of pile foundation piers near rivers that were driven first and the main foundation landwards of them driven later. In such cases, it was generally found that the river piers were forced outward by the later driving.

Where there is no apparent direction of least resistance, say for instance in driving the foundation of a large gas holder in an inland situation, the inner circle of piles should be driven first and progress made outward over the entire area. A possible exception to this general rule may be the case of such soft ground that the outer piles should, of necessity, be driven first and the

¹ Copies of the final report are sold by the University of California Press, Berkeley, California.

inner piles last, in order to develop all the friction possible. In such cases, this will be recognized as a combination of driving and setting piles. In ordinary cases, however, this procedure would show its effect by the heaving of the enclosed ground and the possible raising of piles already driven. The heaving of ground between piles is a different proposition, and allowance should be made for this in elastic soil, such as potter's clay or water-bearing clay that has no outlet for water. The amount of heaving is, of course, more or less a guess and depends upon the number of piles driven, their spacing, and also the character of the soil as shown by previous experience in similar cases. But it is generally customary to make the general excavation about 1 to 2 ft. deeper than shown on the plans to allow for heaving and to avoid the expense of excavating later the soil compacted by driving, and particularly from digging out between piles, which means hand labor.

67. Lateral Springing of Pile.—In driving piles in some kinds of clay, the lateral springing of the pile under the hammer blows makes a hole slightly larger than the diameter of the pile; in a foundation this allows surface water to find its way to the foot of the pile and thus reduces both the skin friction and the bearing value of the clay under the foot of the pile. At times it causes settlement of piles under heavy loads, particularly moving loads. A point very important and often overlooked in bridge foundation work is that comparatively small leaks from river water, etc., following down a pile often make trouble in a cofferdam or shaft.

68. Use of Water Jet in Driving Piles.—The use of a water jet in pile-driving operations differs radically in principle from driving with a hammer. Briefly, it consists in displacing the material at the proposed location of the pile by means of one or more water jets.

Although the water jet may be used to advantage in any material that will settle around the pile after the jet is withdrawn, the best results are obtained in pure river, lake, or ocean sand. The simplest form of single jet under moderate pressure will generally answer in such conditions. It takes but little time to sink the jet and the pile, the sand packs around the pile quickly after it is in place, and very little driving with the hammer is needed except in the case of a clay or harder bottom beneath the sand, wh—

driving by the usual methods is necessary to penetrate these lower strata.

Although the water jet gives good results in driving piles in mixtures of sand, silt, and gravel, and also gives fair results in loam, marl, and even in some clays and harder materials, contractors continuously using the water jet find that its greatest field is in pure sand. When it is considered that sand offers a high resistance to a pile driven with a hammer alone, the principle of the water jet is therefore highly valuable in this material. With a jet a pile may be sunk in sand without injury, while, on account of the long and heavy pounding necessary to get it down, it is difficult to avoid injuring a pile driven into sand without the aid of a jet. The time saved as against the slow process of driving with a hammer in sand is astonishing. The energy saved is also considerable.

In using a water jet the quantity of water is more important than the velocity. The velocity should be enough to excavate the sand and make it alive and quick, while the volume of water should be sufficient to force the water to escape by rising to the surface and bringing material with it. As one pile-driver operator expressed it, the trick is to make a hole in the sand the length and the diameter of the pile, then pull out the jet and drop the pile into the hole. In pure sand most experienced operators of the jet never drop the pile with the jet. They shove the jet down first, haul it up, and then drop the pile in place. If clay underlies the sand, they do not try to jet into the clay stratum. As soon as the nozzle of the jet strikes the clay, it jumps. This is the operator's signal to pull it up, as it is no use to pump farther, because the clay will clog the jet. Straight driving into the clay is then resorted to after the pile is set in the sand.

The single jet equipment for water-jetting successfully in sand generally consists of a straight iron or steel pipe about $2\frac{1}{2}$ in. in diameter, connected by a flexible hose of the same diameter to the discharge end of a force pump, which provides water under pressure of about 100 lb. The pump is operated by steam generated from the boiler of the pile driver or in some cases by a separate steam supply.

To increase the velocity of the water and thus loosen the sand or earth, the lower or free end of the pipe is generally drawn down to form a nozzle. Nozzling down to $1\frac{1}{2}$ to $1\frac{3}{4}$ in. in diameter is

found to get the best results. One of the great mistakes in the use of a water jet is to employ too small a pipe or to nozzle it down too much. Often the using of too small a pump spoils the results, as quantity of water is essential. It is also important that the pile and the jet be kept in motion to avoid "freezing." This is due to material settling around the pile or the jet pipe. Some jets are equipped with pressure controls that enable the operator to lower, raise, or hold the jet in a given position by controlling the direction of pressure. Inadequate equipment is probably one of the main reasons why the water jet process has not come into more extensive use in pile-driving practice. In driving through gravel greater water pressures are needed than mentioned for sand. In such cases the water jet often washes out any sand and small gravel and leaves the larger material—often cobbles—to settle in the hole and interfere with the driving of the pile. Sometimes this can be remedied by increasing the volume and pressure of the water. The movement of water in jetting appears to be confined to a small radius horizontally—much less than the usual $2\frac{1}{2}$ - to 3-ft. spacing allowed by good practice for the driving of wooden piles in foundations; this is, of course, important as it does not affect adjacent piles during construction.

For jetting concrete piles the jet pipe is often cast in the center of the pile to deliver water to the foot of the pile in order to displace material there; also, side jets running from the center edges are often cast in the pile to assist further in floating the material and in reducing surface friction.

The use of a water jet is especially valuable in driving concrete piles, not only to save the energy and time required to drive long and heavy piles but also to avoid possible injury to the pile by the use of the hammer. It is evident that this method is particularly suitable where precast concrete piles are placed in sand, quicksands, or light gravels.

69. Number of Piles That Can Be Driven in a Day.—The number of timber piles that can be driven in a day by one pile-driver crew depends upon many factors. The result is affected by the size of the piles; the distance apart the piles are driven; the depth to which the piles are driven; the kind of ground encountered; whether soft driving or hard; the kind of hammer used; whether drop hammer or steam hammer; the weight of hammer relative to the weight of pile; whether a water jet is employed or not; the

training and experience of the crew; the kind and condition of the pile-driving equipment; and the experience or nonexperience of the inspectors directing the pile driving for the owners.

The spacing of the piles is not usually given the attention it deserves in considering pile-driving output, as moving of the pile driver from one position to another where the piles are spaced far apart consumes a large part of the working time. This and the snaking of piles to the leader, setting the driver in exact position, placing the pile in the leads, etc., also take more time than is usually realized unless time studies are made.

As to maximum performance per day in pile driving, many records can be cited of 100, and even in exceptional cases as high as 200, piles driven by one outfit and crew in a 10-hr. day. During the First World War it was reported that 220 piles, each 65 ft. long, were driven during one shift of 9 hr. at one of the shipyards constructed on the Atlantic coast.

The maximum performance is, however, grossly misleading as compared to the average number of piles driven per day over a long period. A large contracting organization that drives thousands of piles every year and operates over a large territory with varying conditions of ground formation gives 30 to 35 foundation piles as its average output per day of 8 hr. This is under average conditions from clay driving to jetting and driving. On many days 40 to 60 piles are driven, but the one or two days in the month when only 20 piles, or perhaps fewer, are driven, cuts down the average to the 30 or 35 piles stated, which they consider good progress and can be exceeded only under exceptional conditions. Within ordinary limits the length of piles does not greatly affect the number of piles that can be driven in a day. Ordinarily speaking, about as many 40-ft. piles can be driven in a day as 35-ft. piles; in other words, the driving of the additional length is not the limiting cause, but rather the moving around and the setting of driver in exact position for driving, the getting of piles to the driver, and other delays, exclusive of the actual driving.

70. Cost of Pile Driving.—On account of the varying features that have been outlined previously and the great number of elements entering into progress in pile driving, it is difficult to give costs that are of real value in estimating work. Statements of the cost of driving piles are given in the engineering periodicals and in

handbooks of cost data but are apt to be misleading unless the local conditions, the methods, the pile-driving equipment, and other factors are given in detail. Estimates on foundation piling are generally stated in a price per linear foot of pile driven, the length of pile being considered as that measured in the leads just before driving.

A rough estimate of cost of foundation piles is sometimes made by doubling the cost of the piles delivered at the site.

71. Driving Foundation Piles for Bridge Piers.—In driving foundation piles for bridge piers inside of cofferdams the work is often done from the top of the cofferdam. This is not considered good practice by the best constructors, if it can possibly be avoided, as it is apt to cause damage or even collapse to the interior bracing of the dam. It is considered much better practice to drive the foundation piles before the dam is closed in. Often the back line of the dam, consisting of piles and sheeting, is driven and also the sides of the dam are brought out partly or the entire distance; then the foundation piles are driven with a floating driver, if possible, but otherwise by a land driver and then the front or remaining sides of the cofferdam are driven and the bracing placed. The additional cost of excavating around the driven piles under this method is generally a saving in the end as compared to the damage that might be done to a large and deep cofferdam by driving from a machine placed on top of the bracing or by hanging leads.

72. Use of Batter Piles in Foundations.—Batter piles, sometimes called "spur" piles and in Europe called "slanting" piles, are often driven in the foundations of abutments for arch bridges to resist the horizontal components of the reaction. For simple truss or girder spans a few batter piles at each side of the pier are sometimes used when the weight of the pier itself does not provide sufficiently for effective traction. Dock walls are a more common illustration of the employment of batter piles. They are used in addition to the tie rods with anchor piles, and sometimes, although infrequently, are depended on entirely in place of anchorage.

Accidents often occur by failure to provide batter piles to relieve vertical piles from such stresses. Vertical piles in permanent structures should be protected against the action of lateral

forces by the use of batter piles or other devices. The following is an illustration.

The large powerhouse on the bank of St. Mary's River at Sault Ste. Marie, Michigan, was supported by vertical foundation piles of timber, which later showed lateral deflection, the whole structure moving toward the river owing to a 20-ft. difference of waterhead; the Lake Superior water level being brought to the land side of the powerhouse by means of a canal, and the water when released at the river side being at the lower level or that of St. Mary's River. As it was necessary to keep the powerhouse in operation during the reinforcing of the pile foundation, it was decided to drive a number of inclined shafts or struts to take up the heavy horizontal load. Tubular steel piles were jacked by sections into the river bottom and filled with concrete to form large batter piles. A pile driver equipped with outrig batter leads is shown in Fig. 28A. Some pile drivers are equipped with leads supported on a horizontal pin. These leads may be swung latterly and are termed "swinging" or "pendulum" leads. Generally, the heavy steel pile drivers are equipped to drive both vertical and batter piles.

CONCRETE PILES

Concrete piles came into use in the late years of the last century and their use has steadily increased since that time. They may be divided into two main groups: precast, or premolded, piles and cast-in-place piles.

The precast pile is one that is cast in a regular mold above the ground. After proper curing it is driven or jettted into place similarly to a wooden pile. These piles were first introduced in Europe toward the close of the last century. In modern practice they may be divided into two general groups: the tapered pile and the parallel-sided pile.

In order to withstand handling and driving stresses, precast piles are always reinforced with longitudinal rods in combination with lateral reinforcement of wire hoops or spiral wrapping. They are generally designed for a particular job and specific conditions. Large users of concrete piles, such as railroads and highway departments, have standard designs; in many cases, under unusual conditions, particular designs are made. Precast piles

are made in casting yards situated as near the work as possible. The cross section may be square, circular, hexagonal, or octagonal. The circular section is usually made without taper. Parallel-sided precast piles are available in lengths well over 100 ft. and in effective diameters up to and over 30 in. Tapered piles are limited to about 40 ft. in length.

Cast-in-place piles are those cast in the ground in the position for use in the foundation. This type of concrete pile was invented by A. A. Raymond and was first used in America in 1901 for a building foundation in Chicago. Since this type of pile is not subjected to handling and driving stress, it is not reinforced provided it is used as an ordinary foundation pile and is completely submerged in the soil. If, however, the pile is to act as a column or is to be subjected to lateral forces, reinforcement is used.

Cast-in-place piles are divided into two types depending upon whether or not the shell is left in place. The concrete may be placed in a tapered, driven-in shell or in a parallel-sided shell, which is dropped into the driving tube. The shell-less type may be placed as a parallel- or corrugated-sided shaft. They may be formed with a pedestal at the bottom. The shell may be driven with or without the use of a mandrel.

A composite pile is usually a combination of a timber pile and a cast-in-place concrete pile. These are combined so that advantage may be taken of the good qualities of both materials.

The fields of use of these types somewhat overlap. However, in general, precast piles are used almost exclusively in marine work in both fresh and salt water for docks, bulkheads, trestle structures, and anchorage work. Cast-in-place piles are used in ordinary foundation work and are sometimes used in the anchorage systems for marine work.

73. Advantages of Concrete Piles as Compared with Timber Piles.—As timber piles should be kept constantly submerged to remain preserved from the decay that results from alternate wetting and drying, they are generally cut off below the permanent ground-water level in the usual run of foundation work. This often involves the cost of additional or deeper excavation. When the water level is lowered by changes in drainage, lowering of sewers, or construction of subways in large cities, the

exposed portion of wooden piles becomes liable to rot and, by weakening, may possibly cause settlement of foundations, involving changes expensive to correct.

The most important advantage of concrete piles is that they are equally durable in dry or wet soil, their durability being independent of ground-water level and the rise and fall of the tides. Also they can be driven through rotted vegetation without the misgivings as to timber piles so employed. A concrete pile is not subjected to the ravages of the teredo worm; in salt water, infested by the limnoria or teredo, timber piles require chemical or mechanical protection, either of which is expensive. They also have a considerable advantage over timber piles owing to their larger size, thus enabling a material reduction to be made in the number of piles required to support a given structure. Engineers consider the approximate loading of timber piles to range from 10 to 25 tons each, while concrete piles may be loaded from 20 to 75 tons each. However, concrete piles are more expensive in first cost and generally are more troublesome and expensive to handle and drive, on account of their greater weight and relatively less flexural strength. They cannot be driven so rapidly as timber piles, but the number required may be enough smaller to save time as well as cost. Their use, being independent of ground-water level, avoids extra excavation and, as a direct consequence, effects a saving in masonry walls and footings. This is often the largest factor of saving, particularly if the tops of the concrete piles can be placed more than 3 ft. higher than for timber piles. Less excavation and smaller footings also save time in construction. Also, they sometimes have a secondary influence on the cost of the foundation by reducing the weight to be supported. The reduction in excavation, especially in depth, may lessen the amount of shoring, sheeting, pumping, and backfilling—items that are often difficult to estimate. Therefore contractors as well as engineers prefer to eliminate them as far as possible. When reinforcement is used, concrete piles may be bonded in the concrete cap or grillage to form a monolithic substructure. All these advantages can be considered adequately only in the detailed design and estimate of cost for a given structure; but numerous examples, given in the engineering journals from time to time, indicate a general saving in first cost, ranging from 10 to 25 per cent in the ordinary

foundation by using concrete piles instead of timber piles. In special cases savings as high as 50 per cent are shown.

Cement, sand, and stone being generally available all over the country, there is generally less probability of delay with concrete piles than in waiting for the shipment of timber piles to the site. This time factor is often a considerable one. As our forest resources are reduced, it is increasingly difficult to get the larger sizes of timber piles, and the quality of wood is getting poorer all the time. Engineers realize how difficult it is to find a fair percentage of timber piles to fill all the requirements of the specifications, particularly when the length is 50 ft. or over. However, with reasonable care every concrete pile can be made to comply fully with the specifications, and the strength improves with age. It should be noted that although the safe allowable compression for concrete is less than for wood on the ends of the fibers, the loading of a pile depends more frequently upon the supporting capacity of the earth than on the strength of the pile itself. Concrete piles can often be driven through filled material, such as brick, stone, slag lumps, old timber crib work, or sunken canal boats, through which it is impossible to drive timber piles without injury. Even where timber piles can be driven for some little depth into very hard material, concrete piles can generally be driven at least several feet farther. An adequate exploration of the soil should always be made to determine the proper length of piles, whether of timber or concrete, as failure to do so leads, in the first case, to waste of timber by excessive cutoffs and, in the second case, to even more serious waste of time, labor, and material.

In some cities the use of concrete piles for the foundations of retaining walls for track elevation walls has effected a large saving by reducing the required width of new right of way at the high rates that have to be paid for such real estate.

Examples are cited of concrete piles showing unusual flexural strength. During the completion of a terminal pier at Brunswick, Georgia, for steamships, a boat of 4,800 tons displacement was the first to arrive. In order to bring the steamer to her berth in a rapidly running tide, a hawser 9 in. in circumference was fastened around the tenon of one unsupported concrete pile, about 32 ft. of which was above ground level, and hence was compelled to act as a cantilever. It successfully withstood this

severe test. At another time a steamer ran into a pier, owing to misunderstanding of signals in the engine room, and broke a number of pine piles; but the concrete piles successfully withstood the shock.

74. Precast Piles (Patented Types).—Precast piles are of several distinct types; some are patented but most are unpatented. Among the patented types, four different examples are the Chenoweth, the Cummings pile, the Hennebique pile, and the Bignell pile.

The Chenoweth pile (Fig. 32) was one of the earliest constructed in America, being the invention of A. C. Chenoweth of Brooklyn, New York. It is a rolled pile and is made in a special machine. No forms are used. The reinforcement is arranged to show a spiral form in completed cross section. This rein-

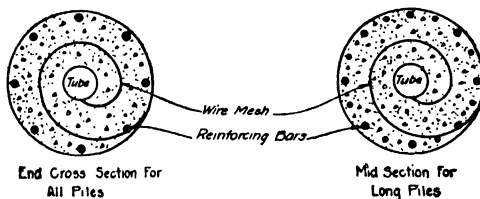

FIG. 32.—Chenoweth pile.

forcement, consisting of longitudinal bars and wire netting, is assembled on a wire platform and attached by wire clips to a mandrel or winding shaft. The concrete is spread over the reinforcement and then, by moving the platform and at the same time turning the mandrel, the pile is rolled or coiled into cylindrical form, which is compacted and shaped by adjustable rollers. The head and point are afterwards finished with concrete around projecting reinforcement, when the concrete pile is removed to a drying table. A very dry mixture of concrete should be used in making this type of pile to avoid squeezing out the water in rolling, as well as the deformation of the pile into an oval shape on the drying table. The diameter of the finished pile is generally about 15 in. Piles of this type up to 60 ft. in length have been successfully used in railroad trestles, bridge foundations, docks, etc. They are often cast with a central hole to permit the use of a water jet.

The Cummings pile distinguishes itself by the type of its reinforcement, generally of wire fabric, which is electrically welded to

longitudinal rods and handled as a unit. Grooves or corrugated surfaces are sometimes molded in its surface to increase the pile surface for skin friction and also as an outlet for the escape of jetting water to reduce friction in the operation of sinking. A hole or central bore cast in the concrete permits the use of a water jet, as in the Chenoweth pile. The corrugated type of pile, which is said to have been developed by Frank B. Gilbreth, is distinguished by the semicircular corrugation of its outer surface, which greatly increases the surface area for frictional resistance.

The Hennebique pile is a European type and is usually constructed as a square pile without taper and with the longitudinal

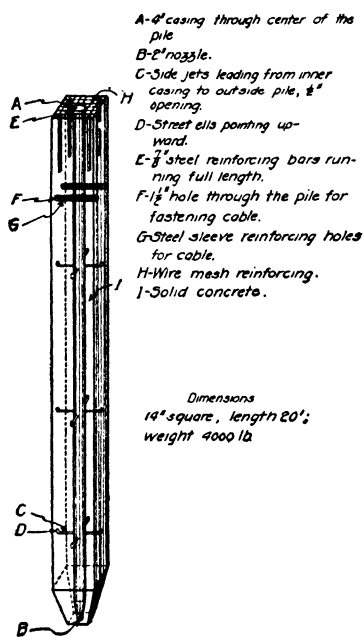

FIG. 33.—Bignell pile.

reinforcing bars near the four corners, which are slightly beveled or chamfered. Wire binders tie the longitudinal bars together at short intervals, and a cast-steel shoe, forming an integral part of the pile at its foot, is generally employed. An instance of the use of this type of pile is in the concrete quay at Key West, Florida. These piles were 16 to 20 in. square and 25 to 60 ft. in length, driven through marl and sand into coral rock.

The Bignell pile (Fig. 33) is called a self-sinking pile, the principle of jetting being employed to a high degree and without the aid of a hammer. This type of pile has its own place as a foundation pile for structures; it has been developed and extensively used in a novel and successful way in the Missouri River district to connect permeable dikes in connection with river bank protection for the preservation of bottom lands, where rigid dikes have not been successful in preventing erosion during floods on account of the soft and shifting ground in the river banks and river bottom.

The pile is sunk hydraulically as one member of a system of current retards, constructed upstream or alongside the river bank that is to be protected or built up. The top of the pile is sunk below the bed of the river to give a permanent anchorage below the scouring effect of the river bed. To this anchor is attached, by steel cables, a system of interlaced brushwood, or even large trees, which float in the water next to the bank and are tied to deadmen in the bank. The brush and trees act as current retards and cause the deposit of stream-borne sediment where it will protect the river bank instead of depositing in the channel. The general theory followed is to use the natural tendencies of such rivers to form sand bars, instead of constructing dikes and other forms of obstruction which attempt to change the flow of the channel.

For the foundations of bridges and culverts the Bignell pile is built as long as 50 ft. and 16 in. square. It consists, as for the river work already mentioned, of a reinforced concrete column with a 4-in. pipe running its entire length through the center and reduced to a 2-in. outlet at the nose or point. At intervals on each of the four sides small upturned jets are connected with this center pipe. A hose connection is made with the 4-in. pipe at the top of the pile. Water is forced through under a pressure of from 150 to 200 lb. The jet at the nose of the pile tends to dig downward, and the pile of its own weight sinks rapidly into the hole dug by the water pressure from the nozzle. The side jets, which are intended to form a complete film of water around the pile, carry away the sand and sediment dug by the point and overcome the skin friction that is formed by the material being penetrated. Although it is evident that this type of pile and sinking is most successful in sandy and silty material, it is claimed that it can also be successfully sunk through clay by the intense jetting action that is obtained. Sand or silt immediately settle around the pile when jetting ceases, but it probably takes months for clay to settle close enough against the pile to develop its full value.

75. Unpatented Precast Concrete Piles.—The Chicago, Burlington & Quincy Railway, through its bridge department, was a pioneer in the design of low reinforced concrete piles for trestles for its railroads. Concrete piles have been extensively

used by that railroad. Other railroads have also adopted designs to fit their purposes.

A good example of unpatented precast concrete piles is that designed by the Pennsylvania Lines for their extensive ore docks on the shore of Lake Erie at Cleveland, Ohio, as constructed by the Great Lakes Dredge & Dock Company (see Fig. 34).

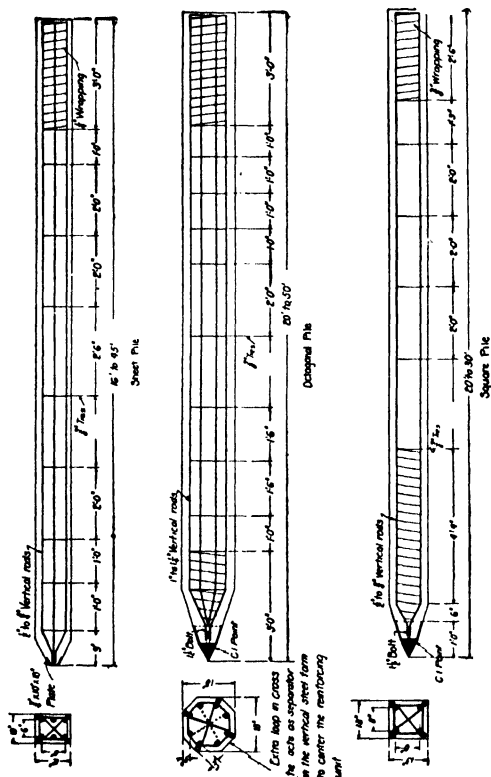

FIG. 34.—Details of piles used in ore-dock construction at Cleveland.

Note the good lines to which these piles can be driven (see Fig. 35). They are octagonal in shape without taper to give increased friction area, as well as for ease in handling and storing. They are pointed at the foot and furnished with a cast-iron shoe, which is made an integral part of the pile. The reinforcement consists of eight longitudinal rods bound together and spaced at regular intervals by tie rods. Spiral wrapping is also employed at the head

and foot to reinforce the pile against shock in hard driving. Over 3,500 of these piles, 18 in. in diameter and 30 to 40 ft. long,

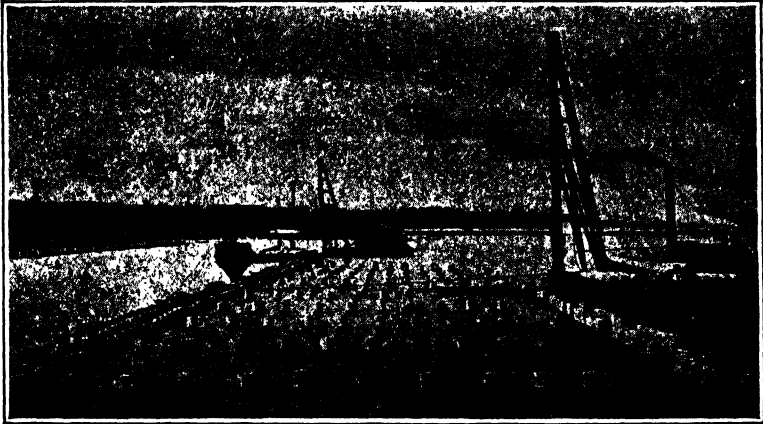

FIG. 35.—Concrete piles driven for the Pennsylvania Railroad ore dock at Cleveland, Ohio.

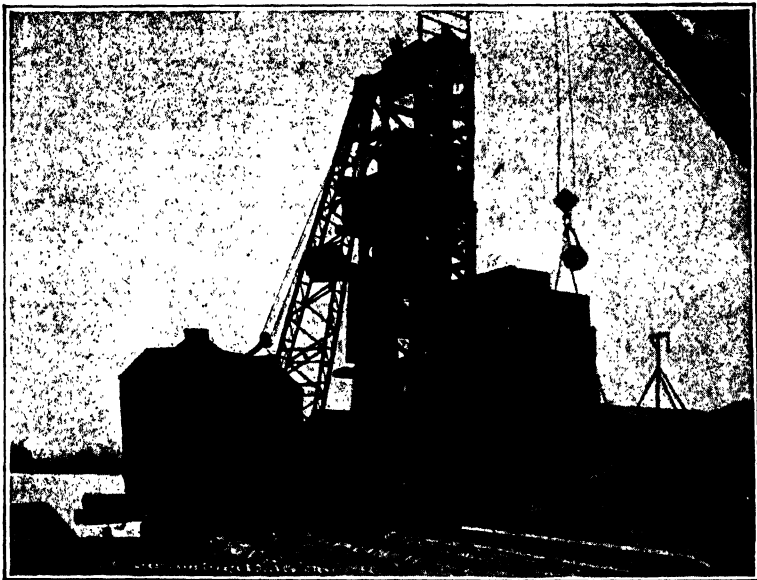

FIG. 36.—Casting concrete piles vertically in steel forms.

were driven for the dock foundation. The largest weighed 6 tons. Concrete sheeting, also reinforced, was driven at the channel line

of the dock. All these piles were cast in vertical molds (see Fig. 36).

76. Construction of Precast Piles.—The piles for the ore dock of the Pennsylvania Lines were cast vertically in steel forms, as shown in Fig. 36, and placed continuously in order to obtain dense concrete and so that the surface of the concrete, as deposited in the piles, should be perpendicular to the direction of the load supported by the pile and to its driving. A wet mix was used, and sections weighed later showed that dense concrete was obtained particularly at the point end where it was most needed.

The hardening of the concrete was hastened by curing the piles with live steam under cover.

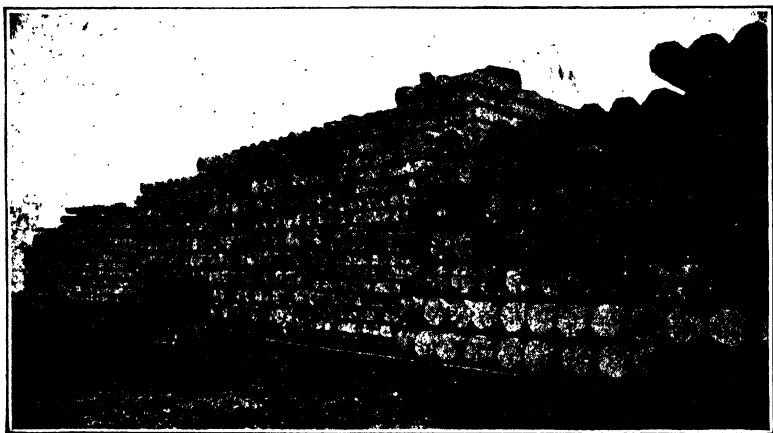

FIG. 37.—Concrete piles kept in storage 30 days before driving.

After being cast vertically, they were closed at the top and placed horizontally on a floor of cross timbers, and as the season was late, artificial curing was employed. This was done by stacking up the newly made piles, covering them with canvas, and introducing a steam pipe with an outlet pipe discharging steam under the canvas cover, maintaining a temperature of about 80°. Forms were removed in 10 to 18 hr., and the concrete piles were exposed direct to the steam for 3 or 4 days afterwards, by which time they were set sufficiently to be handled by a derrick. They were then kept in storage at least 30 days before being driven (see Fig. 37).

On other work concrete piles have been allowed to set 5 or 6 days in the ordinary manner and then carefully hoisted to a

curing bed and stacked with wooden separator blocks between them, and subjected to live steam for 2 or 3 days. This procedure permitted them to be driven in summer within 4 or 5 days afterward, and in winter within 10 to 12 days afterward. When cast in horizontal molds, the side forms may be removed in 1 to 2 days after placing, but the pile is allowed to remain on its base about a week longer. In summer it should be showered to permit complete chemical action for the setting of the cement. In very warm weather protection from the sun is advisable. After this the piles are removed and stacked to complete the seasoning, 3 to 4 weeks usually being allowed before being driven.

As soon as precast piles are driven, they are ready to receive their load from the superstructure above.

In best practice the reinforcement is fabricated as a unit so that it can be handled easily and quickly in the form for casting. The reinforcement unit should be held in accurate position in the molds or forms by suitable separators or hangers, so that the conditions assumed in designing the pile shall be realized in its construction.

The composition of the concrete is generally designed to produce a given compressive strength. For example, the American Railway Engineering Association specifies a strength of 3,500 lb. per sq. in. when not more than 5 gal. of water is used per sack of cement. Sizes of coarse aggregate are limited to a maximum of 1 in. with the further requirement that aggregate must not be larger than three-fourths of the clear distance between reinforcing bars or the minimum distance from reinforcement to forms. The concrete mix should be workable to assure complete embedment of reinforcement and to prevent honeycombing. During the curing period, which is specified as the time required for the concrete to attain a strength of 2,500 lb. per sq. in., the concrete should be kept moist. Piles cannot be handled or driven until the full strength of 3,500 lb. per sq. in. is obtained. Special provisions are made to reduce handling stresses. Piles may, under certain circumstances, be handled after the curing period.

The use of high early-strength cement materially reduces the time required to attain full strength. The use of vibrators is strongly recommended in both types of casting.

Sea water is found to have a somewhat deteriorating effect on reinforced concrete. When concrete piles are used in locations

where they will be subject to direct contact with sea water, such as in exposed trestles and boardwalks on beaches, the insistence on three simple precautions will be found of value: unusual care in mixing and placing the concrete, the use of a rich mixture, and the covering of the reinforcing steel with at least 3 in. of concrete. A coating or covering of gunite is sometimes placed on the piles.

Precast piles of circular cross section may be obtained in diameters from 10 to 25 in. Because these piles must be cast vertically, they are not extensively used. The most common section is octagonal. This or square sections having lateral dimensions as high as 24 in. may be obtained in lengths over 100 ft. They are cast in horizontal forms. These piles are usually made without taper but have a pyramidal tip. Precast piles 24 × 24 in. in cross section and 115 ft. long, weighing about 33 tons, have been driven by the Raymond Concrete Pile Company. When taper is used, it generally does not exceed $\frac{1}{4}$ in. per ft. and is confined to piles about 40 ft. long. Some specifications require certain least diameter relative to the length of the pile.

77. Designing Precast Piles.—The steel reinforcement of a concrete pile is intended to resist the stresses due to handling and driving the pile and to the load that may come upon it in its final position. The longitudinal bars receive their greatest stresses when the pile is lifted from a horizontal position. Piles are generally picked up near the middle, or a line may haul them by one end to the pile driver. In the first case the pile should be strong enough to resist the flexure due to its own weight. In the latter case the pile must carry not only its own weight but also any shock or impact from contact with obstacles. When so handled, cracks sometimes develop on the tension side, perhaps due to the reinforcing rods slipping, the concrete merely failing by compression. Exceptionally long and heavy piles are handled in slings or bridles (see Fig. 38), and extra longitudinal reinforcing is sometimes provided in the middle of the length. The stresses due to handling may be controlled by increasing the number of pickup points. For piles of large cross section and great lengths as many as six points of pickup have been used. However, in general the use of three points is satisfactory. Some designs add 100 per cent to the weight of the pile to provide for shock

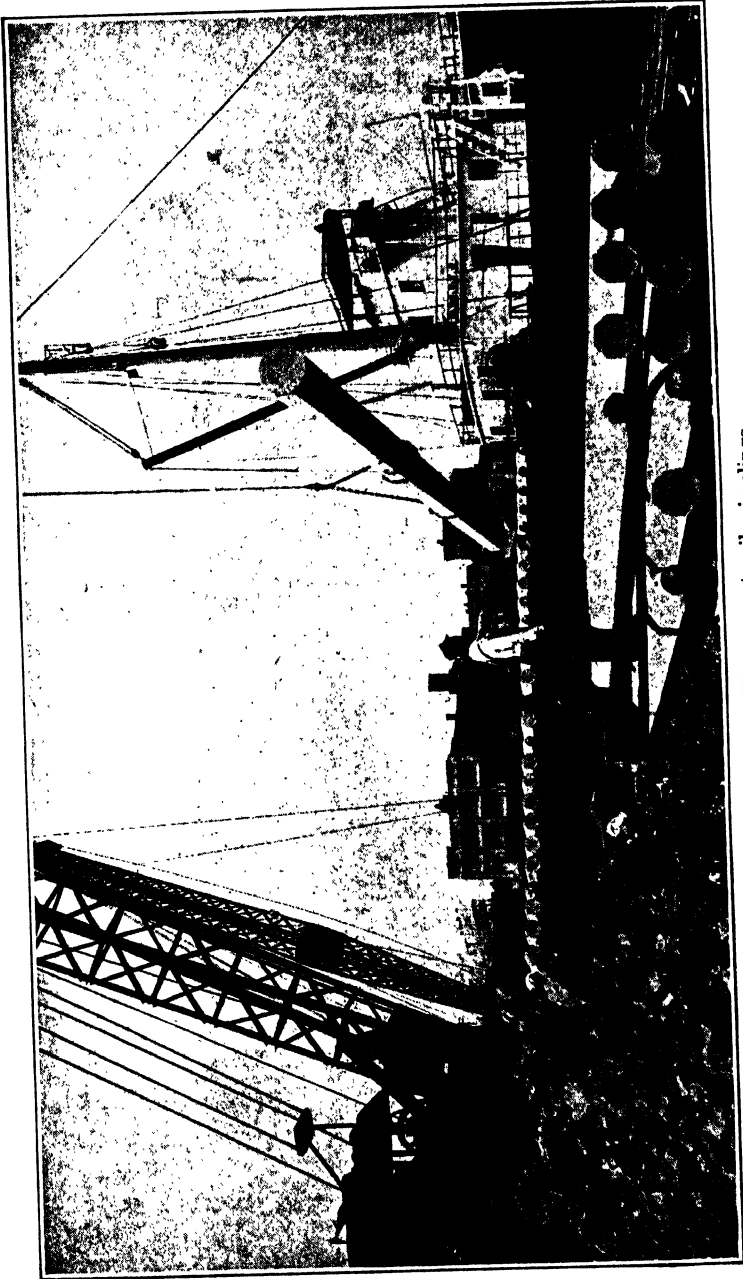

FIG. 38.—Handling concrete piles in slings.

due to handling. Fifty per cent is probably sufficient where proper and experienced handling is the rule.

The percentage of steel in the section area of the pile varies in practice from 0.6 to 2.8 per cent. Experiments show that hair cracks are likely to develop in handling when the reinforcing is less than 1 per cent. This is, therefore, looked upon as good practice. A minimum of 2 per cent is required by the building codes of New York and Boston, while the American Railway Engineering Association requires a minimum of 1 per cent and a maximum of 4 per cent.

Continuous spiral wrapping or separate wire hoops are used for lateral reinforcing. The hoops are spaced at varying intervals along the pile and the spirals are placed with varying pitches. Specifications usually require a spacing of 8 to 12 in. except for a distance of about 2 ft. at each end where the spacing is reduced to 3 in. Lateral reinforcement consists of quarter-round bars or No. 7 steel wire.

The carrying or load capacity of concrete piles is largely dependent upon the conditions between the pile and the soil. Usually both the cross-sectional area and the reinforcement are more than are required for the loading; consequently, the stresses are low. Some building codes allow additional loads based on the amount of reinforcement and others do not.

The sectional area of the head should be sufficient to support in compression the safe load for which the pile is designed. The safe unit stresses used should depend upon the quality of the concrete, the percentage of reinforcement, and its arrangements, as well as upon the character of the loading. If a tapered pile is used, the critical section for compression is, of course, not at the head, but at some distance below. Additional allowance for hard driving in special cases is made by enlarging the sectional area, or adding extra cement, particularly at the head of the pile. When a pile is to act as a column, it is, of course, to be designed as a column. Under retaining walls or other places where the piles receive a lateral thrust, as well as a vertical load, it is necessary to use reinforced piles to resist the flexure produced.

Figure 39 shows precast concrete piles in the foundation of the Detroit-Superior Bridge.

Illustrated catalogues published by construction companies also give much valuable information as to sizes and disposition

of reinforcement, methods of construction, and handling and driving of piles.

78. Driving of Precast Concrete Piles.—The driving of concrete piles requires strong equipment on account of the great weight to be handled and the heavy hammers used. Because of the additional stiffness and greater durability, steel pile drivers are widely used for handling and driving precast concrete piles.

Wherever possible, concrete piles should be driven with the aid of the water jet, so that the duty of the hammer becomes secondary. This not only avoids possible injury to the pile head by driving with a hammer but also saves time and energy. The equipment and methods for the water jet, as described for timber piles, apply in general to precast concrete piles. In ground that is not so advantageous for jetting, it is necessary for the hammer to do very effective work, either with or without the aid of the jet. A light hammer that answers for driving timber piles is found uneconomical for the heavier concrete pile, and a bad tendency results, namely, to use too high a fall of hammer and expend too much of its energy in useless and even in destructive work.

Experience in the use of both drop and steam hammers for driving concrete piles demonstrates that the steam hammer drives them in less time and with less injury to the pile. However, excellent results have been obtained with the drop hammer, the heavier hammers being the more efficient. Hammers weighing less than 4,000 lb. have given good results, although the time required was unnecessarily long. Drop hammers weighing from 7,000 to 12,000 lb. do the work much more quickly. These very large hammers are handled by three-part crucible steel cables roved over sheaves set in the hammer casting. The fall of these long hammers is not more than 8 ft. and usually less. Examples are cited of equipment fitted with such hammers driving an average of 15 concrete piles a day to 30-ft. penetration, a maximum of 25 piles a day being obtained with one outfit. To drive concrete piles 24 in. square and 45 to 75 ft. long at Halifax, Nova Scotia, an Arnott steam hammer of the double-acting type was built of special design with a total weight of 28,000 lb., the striking part weighing 4,000 lb. The stroke was 36 in. The selection of the proper weight of hammer for a specific driving job is dependent upon the weight of the pile and the resistance

to driving. In general, the heaviest hammer that will not unduly damage the pile should be selected. Due consideration should, however, be given to the foot-pounds of energy developed per blow.

When jetting cannot be used as an aid to driving, the successful driving of precast piles without injury is due mainly to the various driving caps and forms of protection used. Sometimes a hardwood block in a cast-iron cap is used on top of a concrete pile. Other types of hammers provide for mats of rope or rubber belting, or bags of sawdust, under blocks to make a cushion effect, in order to avoid damaging the head of the pile. The main point is to distribute the blow uniformly over the head of the pile to prevent spalling. The tendency during the past few years is to use less protection in driving precast concrete piles than in the days of their early introduction, because experience has shown that even where a water jet cannot be used with success, a well-seasoned precast pile usually stands a remarkable amount of pounding with the hammer, and that if the hammer blow is properly controlled, very little damage results. In driving into hard clay in one instance, the material became so compacted from driving successive piles that 5,000 blows of the steam hammer were necessary to put some of the piles down 20 ft. In the few piles that were broken, the crushing extended only 18 in. below the top of the head. A test was made at the Watertown Arsenal of the upper portion (about 9 ft. long) of a pile that failed owing to hard driving and probably striking a large boulder about 18 ft. below the surface. The pile had been given 735 blows with a 4,700-lb. hammer, with drops varying from 18 to 30 in., and the head was badly crushed. The test calls attention to the fact that the pile failed at the small end by opening oblique and longitudinal cracks, and not at the end that received the hammer blows. This indicates that the pile was not materially damaged by the hammering it received, except at the immediate point of contact. The ultimate strength of the section tested was found to be considerably larger than the average strength of similar concrete columns of the same age tested with it and made of the same proportions of concrete and reinforcing. In general, the spalling of the head of a concrete pile is not considered such bad practice, since the cracked concrete is removed to expose the reinforcing rods, which are then straight-

ened and bonded in with the concrete that is run for the footing.

Well-seasoned concrete piles will stand several hundred blows of a 3,000-lb. drop hammer, the drop increasing from 10 to 30 ft. as driving progresses, without appreciable injury. Comparatively green piles should be handled very carefully and the drop limited to 6 or 8 ft. Such work is slow and expensive, and it is better to season all piles thoroughly.

Concrete piles cannot be driven as rapidly as timber piles on account of the care necessary in handling the greater weights and the larger sizes of the concrete piles, as well as the greater amount of moving of the heavy driving outfit, since concrete piles are ordinarily spaced farther apart than timber piles. Roughly speaking, where the organized gait for foundations on land is 30 to 40 timber piles in a day, about one-fourth to one-half that many, or even less if the water jet cannot be used with effect, is considered good progress in driving concrete piles. On water work, such as dock foundations, a larger number of piles can generally be driven, because the floating pile driver can move more easily than a land driver and the comparative penetration of piles is often less considering the depth of water into which they are driven.

Concrete piles can be driven in any soil in which timber piles can be driven, and usually with much less danger of overdriving. A Chenoweth pile 13 in. in diameter and 61 ft. long was driven 8 ft. into compact gravel at Greenville, New York Harbor, where oak piles could not be driven.

It sometimes is found necessary to cut off the head of a concrete pile that cannot be driven to full depth. To do this, a V-shaped channel is cut around the pile at the desired level. The bars are exposed and cut off with an acetylene torch and the head is snapped off either by wedging or pulling with a line from a crane. Cutoffs on piles 18 to 24 in. in diameter may be normally made in about 30 min.

For splicing or connecting to caps or footings, the bars may be stripped for the desired length or holes may be drilled to the required depth, and dowels placed and grouted. In splicing a pile, a split sectional form is clamped on the sides, the bars are set, the top of the pile is wet, and the surface slushed with grout. The concrete is then placed. The use of vibrators is recom-

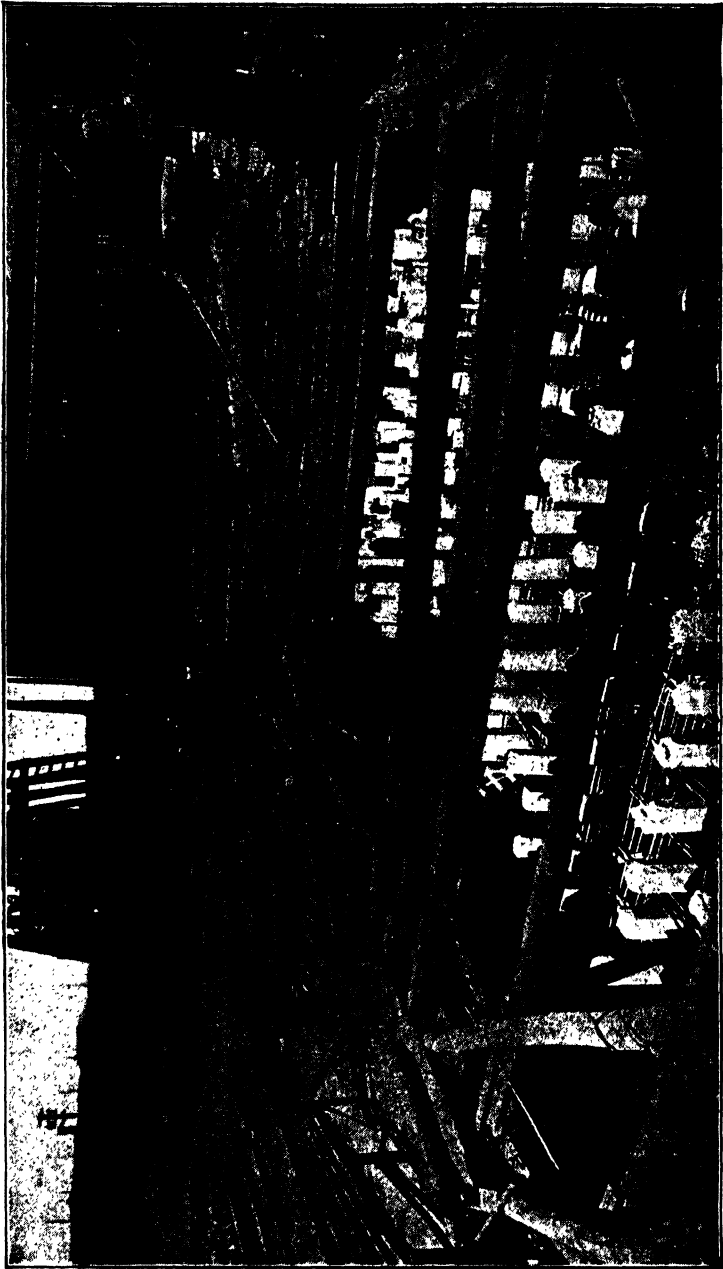

FIG. 39.—Concrete piles in foundation of Detroit-Superior bridge.

mended. Particular care should be taken to use the same quality of concrete as in the pile itself.

79. Cast-in-place Piles.—Cast-in-place concrete piles are constructed in their permanent position in holes in the ground prepared for the purpose. They are, as noted before, of the two

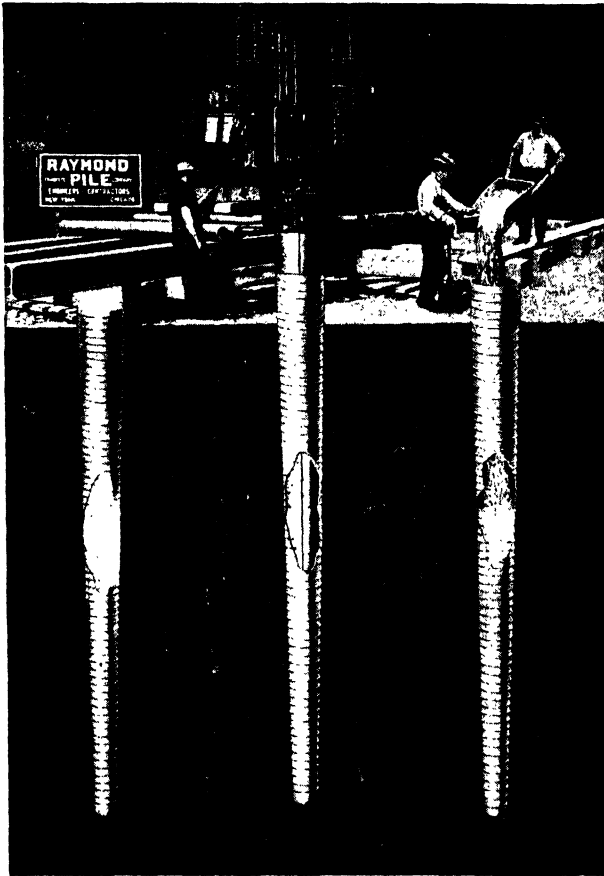

FIG. 40A.—Installing Raymond standard-taper piles.

general types: the shell pile and the shell-less pile. The shells may be tapered or have parallel sides and may be driven with or without a core or driving mandrel. These piles are suitable for land foundation work and are very extensively used. They are usually not reinforced, but if reinforcement is used it should be built and placed as a unit.

Examples of the shell-type pile are the Raymond standard tapered pile and the Raymond step-tapered pile, the monotube pile, the standard MacArthur concrete pile, the Franki pile, and the steel pipe pile. All these are patented. In general, the patents are based upon either the method of construction or the appliances used in construction.

The shell prevents the soil and ground water from mixing with the fresh concrete. Concrete having a strength of 2,500 lb. per sq. in. is usually used. It is placed in a continuous operation.



FIG. 40B.—Raymond standard-taper piles.

The standard Raymond tapered pile has a continuous taper equal to $\frac{4}{10}$ in. in diameter per foot and is available in lengths of 20 to 38 ft. The top diameter of the 20-ft. pile is 16 in. and that of the 38-ft. pile is 23 in. The shell is made of a tough grade of steel and has a thickness consistent with the length, diameter, and the soil conditions. The shell is reinforced throughout its length with a heavy, hard, drawn wire placed on a spiral having a pitch of 3 in.

In placing the pile, the shell is placed over a collapsible mandrel having the same taper as the pile and both are driven to the desired penetration. The mandrel is withdrawn, leaving the shell clean and dry. The shell is then filled with concrete.

Figure 40A shows the installation of Raymond standard tapered piles. Figure 40B shows a cutaway view of the shell to indicate the spiral reinforcing and concrete.

For lengths up to about 40 ft., it is claimed that the Raymond standard tapered pile offers the advantages of ease and speed of driving, economy due to taper in providing larger carrying capacity, the opportunity of inspecting and testing each pile, and the placing of the pile above the ground surface without the use of special forms.

For use in lengths over those of the standard tapered pile, the Raymond step-tapered pile was developed in 1931. It has been very extensively used. This pile consists of a spirally corrugated shell that offers high resistance to external pressure.

The steps are formed by the use of 8-ft. lengths, each of which increases in diameter from the tip to the top. The increase in diameter is usually 1 in. in the 8-ft. section.

A double-flange plow ring is welded to the bottom of each section. A short spirally corrugated inner sleeve is welded to

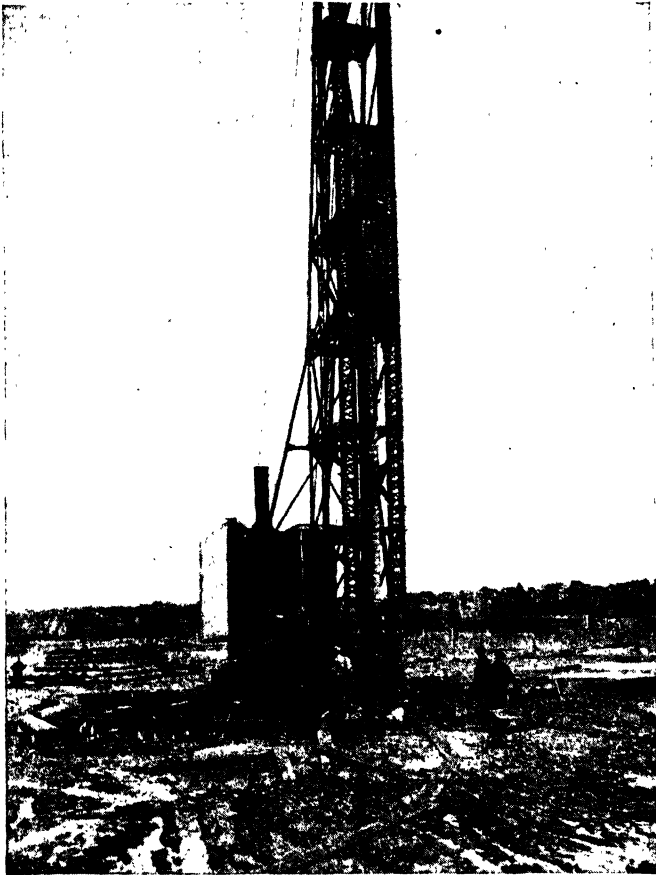

FIG. 41A.—Driving Raymond step-tapered piles.

the lower flange of the plow ring so that each section may be screw-connected to the lower section. A heavy-gage hemispherical boot is welded to the plow ring on the lowest section to form the point of the shell.

The shells are ordinarily made of No. 20 to 14 gage metal, although metal as heavy as No. 10 and as light as No. 24 is

sometimes used. The weight of metal is dependent upon the driving conditions and the pressure to be resisted. The sections are shipped in a nested or telescoped condition. This has the advantage of both protecting the shells and saving shipping and storage space.

In driving, a heavy-walled hollow core that has beveled steps bearing directly upon the inner surfaces of the plow rings for each section is used. Figure 41B shows the shell and driving core and the lower section of a pile after the concrete is placed. The driving of a step-tapered pile is shown in Fig. 41A.

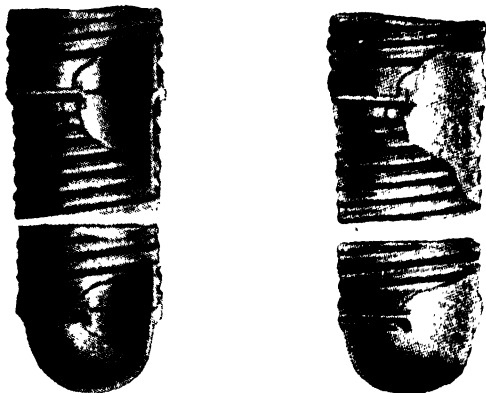

FIG. 41B.—Detail of step-tapered pile.

The advantages claimed for the step-tapered pile are the same as those for the standard tapered pile. In cases where good bearing strata are covered by soft material or with alternate layers of hard and soft material, step-tapered piles furnish an economical foundation. At La Guardia Field, New York, where marshy and filled ground had to be penetrated to reach firm bearing, 380,000 ft. of standard and step-tapered piles were used.

Where mandrels or cores are not used for driving, the shell must be of sufficient strength to withstand the driving stresses. The Union Metal fluted-steel monotube pile is an example of this type. The shell is fabricated by a cold-rolling process and has a fluted surface that furnishes greater surface area to provide greater frictional resistance and increased bearing power. The fluted design also furnishes stiffness and rigidity to resist driving stresses and structural strength to resist loading. It is claimed

that the shell has sufficient strength to support the pile loads without the concrete filling. A loading test made on a 60-ft. fluted shell is shown in Fig. 42A. Figure 42B shows 80-ft.



FIG. 42A.—Loading test.

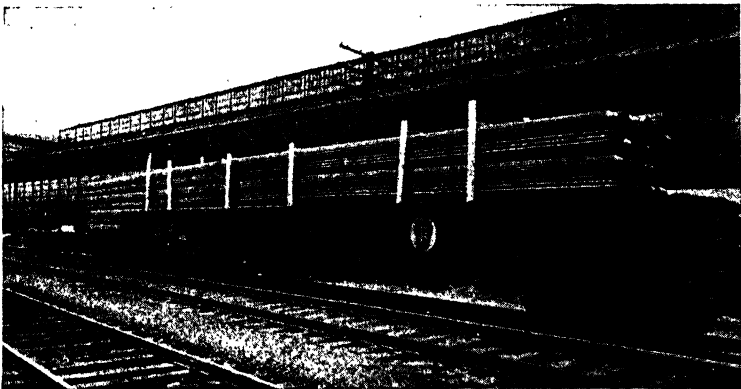

FIG. 42B.—Monotube piles loaded for shipment.

monotube piles assembled in two 40-ft. sections, loaded for shipment. These piles were for use in dry-dock construction.

Monotube piles are furnished in any desired length with point diameters varying from 6 to 16 in. with standard tapers of

1 in. in 7 ft., 1 in. in 4 ft., or 1 in. in 2 ft. 6 in. Other tapers can be furnished. Piles without taper are also available. Sections having taper may be used with parallel-sided sections. The shells are usually made of No. 11 gage steel plate but are available in No. 7 and No. 3 gage. The piles of No. 11 gage are



FIG. 43.—Sixty-foot monotube pile being placed in leads.

recommended for a driving resistance of about 30 tons; the No. 7 gage for a driving resistance of 45 to 55 tons. For all lengths over 40 ft., piles are made in sections that are welded together. This may be done in the shop or in the field. The steel point is welded to the lowest section and a driving collar is

welded to the butt. By this fabricating method, a one-piece continuous shell is furnished.

It is claimed that no special or heavy driving equipment is necessary because no heavy core is used. It is further claimed that these tubes may be sunk by the jetting method. Ease and speed of driving and inspection are also claimed by the manufacturers. Ease and economy in handling and the possible use in pier, dock, and marine work are also pointed out.



FIG. 44.—Monotube piles in foundation.

Figure 43 shows a 60-ft. pile being placed in the leads of a pile driver. Figure 44 shows monotube piles in the foundation for a reinforced concrete chimney.

In the construction of the foundations for the National Gallery of Art in Washington, D.C., 7,000 No. 7 and No. 11 gage piles, varying in length from 18 to 40 ft., were driven by six driving rigs within the stipulated 90-day period allowed for the driving. These piles required 1,750 tons of steel and represent a total length of 32 miles.

The standard MacArthur cased concrete pile is formed by driving a core and a heavy steel casing into the ground. The bottom of the casing is sealed by a pan to prevent water from

entering the casing. When the desired penetration is reached, the core is withdrawn and the casing inspected. A permanent casing of corrugated steel is then inserted within the driving casing. This corrugated steel casing is then filled with concrete and the driving casing is withdrawn.

The shell-less type of cast-in-place concrete pile is shown in the well-known Simplex pile, the standard MacArthur uncased compressed concrete pile, and the pedestal pile.

The Simplex pile, introduced in 1903, is constructed by driving into the ground a steel pipe, generally 16 in. in diameter and $\frac{3}{4}$ in. thick. The pipe is fitted at the driving point with a special shoe that completely closes the bottom; the hole thus made is filled with concrete as the pipe is withdrawn (see Fig. 45). The pipe should be extra heavy, as long as the pile to be formed, and the pile-driving equipment should be strong enough to pull out the pipe. The shoe remains in place; hence a new one is needed for each pile. To save the cost of a point for each pile, in very firm earth a device called an "alligator point" is used, which opens automatically when the pipe is pulled out and permits the concrete to flow through it.

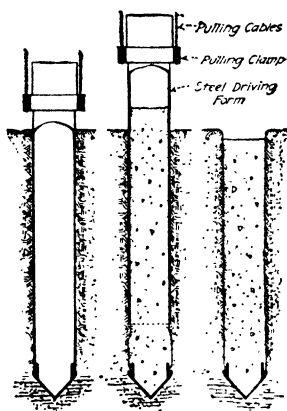

FIG. 45.—Method of constructing Simplex concrete piles.

In some work the pipe is filled with concrete, at the same time slowly withdrawing it. In other cases, as each batch of concrete is dumped in the hole, it is rammed to force it against the surrounding earth, in order to fill the hole completely. This increases the diameter of the pile and the bearing area.

The advantage claimed for this type of pile is that the concrete is forced into the irregularities of the compressed earth, giving a frictional resistance greater than for any other pile of equal proportions. However, the compressed earth sometimes becomes a part of the pile section and changes the frictional surface to a more regular form. In very soft ground where the earth does not hold its form as the pipe is withdrawn, this type of pile cannot be used without modification. In such cases a light casing of smaller diameter is generally used by lowering it into the hole

as soon as the first batch of concrete is placed. When this form is filled, the driven pipe is withdrawn. It is evident that this leaves some voids outside the light sheet-metal casing, which will fill only by the adjustment of the surrounding earth.

Piles as long as 45 to 48 ft. have been placed by the Simplex method, the practical limit being the ability of the equipment to pull out the pipe. In firm dry soils it is claimed to be the cheapest method of installing concrete piles. In ground that has any tendency to flow, there is always the question as to what extent the strength of the pile may be reduced by an admixture of earth, as it is impossible to inspect the integrity of the pile during construction.

The standard MacArthur uncased compressed concrete pile is placed by first driving a casing and core to the desired penetration. The apparatus is sealed at the bottom to prevent water from entering the casing. The core is then withdrawn and the casing is filled with concrete. The core is then placed upon the concrete in the casing and the casing is steadily withdrawn while the concrete is under a pressure of 7 tons. Under this pressure, the concrete moves instantly to the earth walls of the hole directly under the

bottom edge of the casing and develops an exceptionally good bond between the concrete and the earth. By this method, an exceptional frictional resistance is developed and a pile of uniform diameter is formed. Figure 46 shows the casing being withdrawn while the concrete is subjected to a loading of 7 tons,

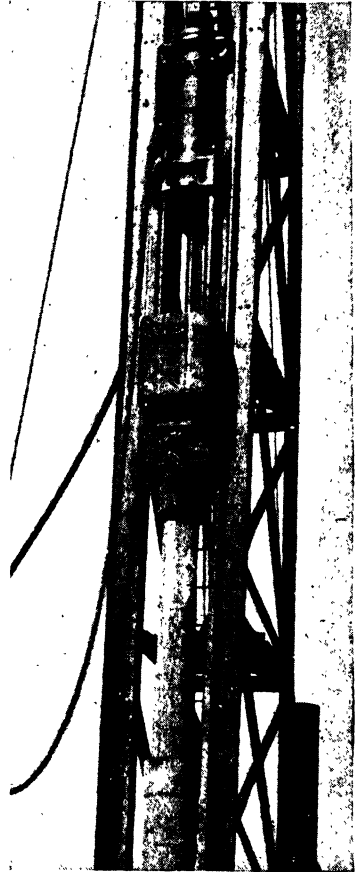

FIG. 46.—Withdrawing casing of the MacArthur pile.

The forming of the MacArthur pedestal pile is similar to that of the standard uncased pile. The steps are shown in Fig. 47. This pile was invented by Hunley Abbott. The core and casing, without the sealing pan, are driven. The core is removed and a charge of concrete is dropped to the bottom of the casing. The casing is then pulled up a distance of 18 to 36 in. while the 7 tons pressure of the core and the hammer remains on the concrete. This rams the concrete out. The core is then removed, another charge of concrete is placed, and the process is repeated. After the desired bulb is formed at the bottom, the casing is withdrawn to form a stem of constant diameter.

The intent of its form of construction is to take greater advantage than the ordinary form of piles does of the higher bearing

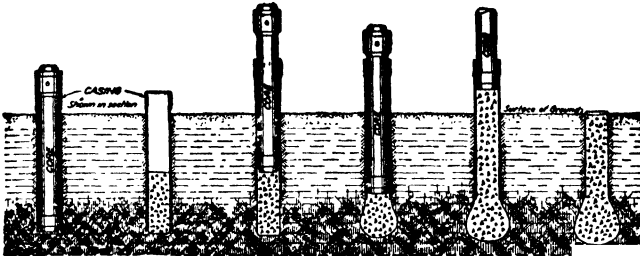

FIG. 47.—The process of forming a pedestal pile.

capacity generally existing in the lower strata of earth. This increasing of the bearing area at the foot doubtless was suggested by the older form of metallic screw and disk piles whose action it imitates.

Equipment similar to that used for the Simplex pile is used to construct the pedestal pile, except that a bottom shoe or jaw is not used, and that a steel core is added, which fits inside the pipe with its lower end projecting 4 or 5 ft. below the pipe and with its upper end enlarged into a head which fits over the pipe for driving. The pipe is usually about 16 in. in diameter and made of $\frac{3}{8}$ -in. metal. The pipe and core are first driven into the ground as a unit. The core is then withdrawn and a batch of concrete is dumped into the pipe, and the core is then used as a rammer to enlarge the hole below the pipe and to push aside the concrete laterally. When the concrete base is given the required volume by this method, the pipe is filled with concrete and gradually pulled out. A 1:2:4 mix of concrete is generally used.

The finished pile is usually about 17 in. in diameter if a 16-in. pipe is used, and the base is about 3 ft. in diameter and contains about half a yard or a little more of concrete, depending upon the nature of the ground. Should the earth for any reason resist unequally on opposite sides of the hole, the form of base resulting would make its reaction eccentric.

The Franki pile, which was developed in Europe, has an enlarged base and a corrugated shaft. To place the Franki pile, the concrete is put in the casing and struck with the hammer. The friction developed between the concrete and the inner surface of the casing pulls the casing down. The pedestal is formed by raising the casing and forcing the concrete to flow out and downward by striking it with the hammer. The shaft is formed by striking each charge of concrete with the hammer when the casing has been pulled up a short distance. This repeated action produces a series of corrugations on the surface.

Hollow concrete cylinders of large diameter are often sunk to considerable depth by excavating within them. Sectional telescoping steel cylinders may also be used. Both these methods are similar to open caisson work. In either case, the base may be stepped out to increase the bearing area if the end of the pipe is in good bearing material. When steel pipe is used, the pipe may be withdrawn after the concrete is placed. This method is known as the Gow caisson pile and is shown in Fig. 15. Because of the saving of the cylinders and the lack of heavy driving equipment, this process is considered the least expensive of any of the caisson methods.

A rotary drilling process using spud drills is sometimes used to excavate for caisson piles. This drill utilizes water fed through the drill stem under high pressure and creates a semifluid condition in the soil. The caisson pipe is then driven, and the bottom sealed off. It is then unwatered and mucked out and filled with concrete. This is an expensive method, which may in certain cases be economically substituted for the caisson method.

80. Objections to Cast-in-place Piles.—The chief objection to all cast-in-place piles is based upon the probability of injury to the green concrete from the back pressure set up by driving the forms for adjacent piles.

Even if the casing left in the hole, or the weight of the concrete without the casing, is able to resist an outside pressure until the

concrete is set, it is probable that the green concrete will be injured by the vibration and additional earth pressure from driving adjacent piles after the cement has started to set and before the setting has been completed.

Numerous tests to determine conditions have been made by excavating. In one example failure was due to fluid soil penetrating between batches of concrete, separating the pile into sections about 5 ft. long, and destroying its value as a pile. In other cases piles were found bent out of line. In still other cases the section areas were reduced from 20 to 100 per cent. In one case, as ascertained later by analysis, the cement failed to set owing to chemical constituents in the ground water. It was also found that the liability of green concrete to suffer injury from adjacent driving is increased when hard and soft strata alternate. Unless protected by a casing, there is always danger of some of the cement being washed out by underground flowing water; contrawise, absorbent earth may deprive cement of some of the water it requires to set completely.

The construction of cast-in-place piles requires more careful supervision than for precast piles, in order to get good results, on account of the manner in which concrete is deposited and the surrounding conditions, which preclude inspection of the pile after the concrete is in place. To protect piles against damage, specifications often require that no concrete may be placed until all shells within a radius of at least 5 ft. are driven to the required resistance. After the concrete is placed, no shell or pile may be driven within a radius of 15 ft. for a period of at least 4 days.

The chief advantage of shell-less cast-in-place piles is that they are usually the cheapest of all types of concrete piles.

81. Composite Types and Combination Piles.—Hollow precast piles are sometimes driven and filled with lean concrete after driving. Such hollow piles are generally of large sizes for economy and should be carefully handled by special slings or bridles to avoid bending stresses. A type of concrete pile called the Peerless has also been used. It consists of a reinforced concrete shell made in sections and slipped into a steel driving pipe, both of which bear on a pointed cast-iron shoe, which is left in the ground. The steel pipe protects the concrete shell from stresses due to driving, and when the steel pipe is pulled out, the concrete shell is inspected and filled with tremie concrete.

Combination piles have been made for foundations of docks on the Pacific coast by driving a hollow, reinforced, concrete pile 4 in. thick and 24 in. in diameter over the top of a wooden pile which had already been driven into the channel bottom, so that the head of the wooden pile projected a few feet above the

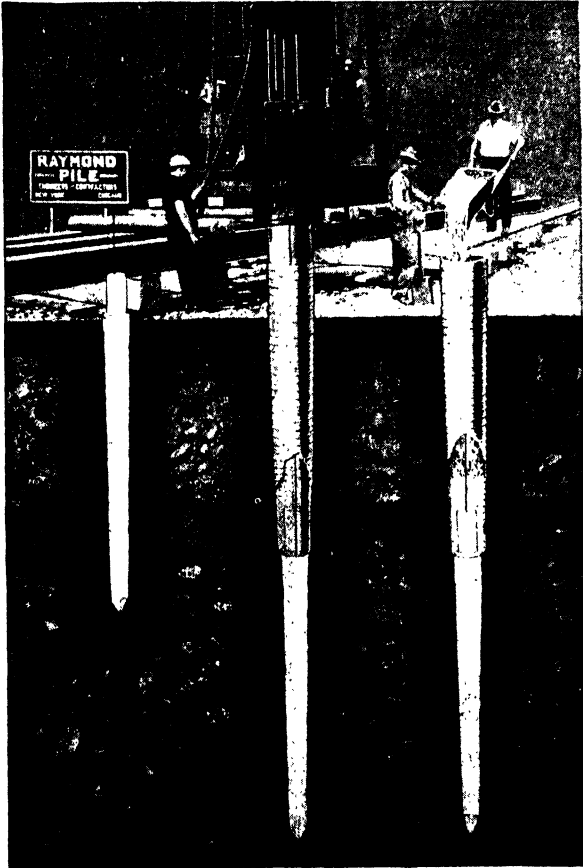

FIG. 48.—Placing Raymond composite pile.

mud line. When a good bearing was obtained on the bottom with a concrete pile, the inside was pumped out to remove the mud and water, and the hollow space was filled with concrete. It is feasible to use such combination piles for foundations on land, and they are cheaper than very long concrete piles.

At times the durability of concrete piles is combined with the lesser weight and cost of timber piles by placing concrete piles on top of timber piles, which are driven below ground-water level to resist decay.

The composite pile used by the Raymond Concrete Pile Company is placed by first driving the wood pile to the ground surface. Before driving, the head of the pile is turned down to a diameter of 7 to 8 in. for a length of about 18 in. This section is termed the "tenon." A collapsible mandrel is fitted inside a reinforced sheet steel shell and placed over the tenon on the wooden pile. This combined unit is then driven to its final depth. The mandrel is then withdrawn and the shell is filled with concrete. Figure 48 shows the process of placing a Raymond composite pile.

The placing of composite piles requires very careful workmanship. Care should be taken to form a watertight joint between the wood and the concrete and to supply a joint that has sufficient strength to resist both transverse and upheaval stresses. Several methods are used to develop strength in this joint. Vertical reinforcing bars may be placed around the tenon or into holes drilled in its top. Horizontal bars are sometimes placed through holes cut in the tenon and bent to extend upward into the concrete.

Precast concrete piles are sometimes used with a wooden pile to form the composite pile. The cast-in-place pile is usually preferred.

The use of a composite pile combines the advantage of the low cost of the wooden pile for the section below permanent ground-water level with the advantage of having a concrete pile above the permanent water level. This eliminates the necessity for cutoff. The need of cutting off timber piles at water level usually involves extra excavation, which in many cases makes the use of sheeting and pumping necessary. For lengths up to about 100 ft. these piles, when properly installed, furnish a secure foundation at a cost between that of timber and concrete piles.

82. Choice of Type of Concrete Piles.—In any case where it has been decided that the use of concrete piles is more economical than timber piles, durability also being given full consideration and the conditions at the site and the nature of the ground are known, the question then remaining is to determine the type of

pile especially adapted to the existing conditions, so that adequate strength may be secured for the proposed structure at the most reasonable cost. As each type of concrete pile has some distinctive advantages that are adapted more or less closely to certain conditions of ground where piles are necessary, to use a type of pile under conditions that are not favorable to it means either lack of economy or less security, or both. Some types cover a wider range of conditions than others, and the engineer's duty is to make a special study of each situation.

For supporting a structure above open water, as in docks, piers, wharves, and pile trestles, in addition to acting as columns, the piles are required to resist flexure. Precast piles are the only ones adapted for this service. They should be made without taper, at least for the part that is not in the ground. Taper is valuable in sand where the supporting power is due almost entirely to friction; if the piles are to penetrate sand, that portion may be tapered. However, if the sand is subject to scour or if sufficient total penetration and friction can be obtained without taper, then a pile with uniform cross section should be employed.

The precast pile has special advantages in ordinary sand and quicksand, or in such combinations of sand with gravel or clay as produce porous masses, because in such cases the water jet can be used successfully. When a pile is to be driven through soft material into a harder stratum, and so that it is expected to act as a column, it should be reinforced. Frequently the precast pile is the only one that can be so used.

It is important to remember that after plain concrete piles are driven in some kinds of stiff clay, if the adjacent ground should be heavily loaded, lateral pressure will be developed and cause serious bending moments that piles without longitudinal reinforcement may be unable to resist safely.

Conditions are sometimes met with where deep beds of clay require pile foundations because the upper strata become soft during the flood season, while during the dry season they are favorable for construction work and the clay is so hard that it is impracticable to drive piles into it. In such cases the problem often may be worked out satisfactorily by excavating a hole of proper diameter in the hard clay by means of an earth auger and driving a precast pile well into it, so as to fill the hole so completely that the surface water will not follow down the pile and

impair its value. Where investigation of the subsurface shows a stratum of quicksand or other soft material, which indicates that it will not retain its form until the pressure of the concrete can resist the external pressure, then no cast-in-place pile should be employed unless it leaves a casing in the ground which will retain its form until the concrete sets. The casing should have a uniform diameter, instead of a taper, so as to secure a larger bearing area at the foot. If the upper strata are of such nature as to retain their form temporarily until the concrete is in place, the type of pile may be used in which the pipe is gradually withdrawn. If a considerable part of the load is to come on a bottom stratum that is not well defined on its upper surface, the enlarging of the base of the pile to increase the bearing surface is often desirable, as is done in the pedestal pile method. But as the method of making the pedestal pile requires the ground adjacent to the base to be displaced by the ramming of the concrete, if the ground material is not homogeneous, the base may be unsymmetrical with reference to the vertical axis, and a dangerous stress may be produced in the stem of the pile, owing to the eccentric reaction of the pile column. In general, whenever the load is carried mainly at the foot of the pile, the pile should be reinforced unless the upper strata afford good lateral support.

All cast-in-place piles require precautions as to the order in which they are placed, so that no core or pipe is driven for another pile within a prescribed distance of a completed pile during the setting of its cement.

Where the nature of the ground is tough and leathery so as to cause upheaval when adjacent piles are driven, it would be disastrous to use some types of cast-in-place piles. As far as form is concerned, any piles used should be without taper. In ground that is compressible but not soft in the upper layers and gradually increases in density downward, almost any of the different types of piles may be used with proper precautions, but without taper, so that advantage may be taken of greater bearing value at the foot, as well as to obtain the greater frictional resistance of the lower surface of the pile.

To go a little further with this general illustration—if the ground is soft to a considerable depth; but the density increases slowly with the depth so that the bearing power depends almost entirely on skin friction, two factors will decide whether a tapered

or an untapered pile should be used. As the pile with uniform section has a slightly larger superficial area for a given volume, it has the additional advantage of having a larger proportion of its surface in the lower part of the pile, where friction is greater. On the other hand, the tapered pile has a larger sectional area of concrete at the top to transmit the load, and that factor may govern in some cases. In general, as the load is gradually transferred to the surrounding earth in passing downward through the pile, the decreasing sectional area of the tapered pile makes it conform more closely to one of universal strength throughout.

The precast pile is favored by many engineers over the cast-in-place types, because the concrete can be made, seasoned, and inspected thoroughly before any driving is begun.

The building code of the City of New York requires that precast piles shall be reinforced with longitudinal reinforcing equal to at least 2 per cent of the volume of the concrete. The *diameter* or *least lateral dimension* of precast concrete piles shall be 10 or more inches at the point and shall average at least 12 in. throughout the length of the pile for piles up to 20 ft., 14 in. for piles up to 30 ft., and 15 in. for piles up to 40 ft. In the case of piles over 40 ft. long, the diameter or least lateral dimension shall be one thirty-fifth of the length, provided that all piles shall be at least 15 in., but may be less than 24 in., in diameter or least lateral dimension. The maximum allowable load on precast piles varies from 24 tons for an average diameter of 12 in. to 40 tons for piles having an average diameter of 20 in. or over. For piles driven to ledge rock, the foregoing maximum allowable loads may be increased by 10 per cent. Concrete piles cast in place shall be made and placed so as to ensure the exclusion of any foreign matter and so as to ensure a continuous and full-sized pile. Piles shall be driven in such order and with such spacing as to ensure against distortion or injury to such piles when finished. Concrete shall be placed in the dry, and it shall be unlawful to place concrete in a pile form containing water. The diameter of any cast-in-place pile shall be at least 14 in. at the top; the diameter at the half length of the pile shall be at least 11 in.; the diameter of the point shall be at least 8 in. The maximum load for cast-in-place piles shall be 30 tons, except that when the point diameter of such piles exceeds 15 in., an additional allowance of 2 tons may be made for each inch of

increased diameter, until a maximum total load of 40 tons per pile has been reached.

It should be kept in mind, however, with all that has been said in favor of concrete piles as a class, that there are some limitations that still leave a field for timber piles. For example, in marshy land, timber pile trestles are found superior to concrete trestles, owing to less settlement, etc., and a combination of the timber pile with concrete top can often be used to reduce loads and also costs.

83. Steel Pipe Piles.—Steel pipe piles, sometimes called “tubular piles,” consist of standard steel pipes varying from 10 to 22 in. in diameter. The wall thicknesses usually vary from $\frac{5}{16}$ to $\frac{5}{8}$ in. These pipes are usually driven open-ended by steam or air hammers to rock or hardpan and are excavated by means of a compressed-air blowpipe or a water jet. The compressed air under 85 to 100 lb. per sq. in. pressure is introduced by the blowpipe, which is usually $2\frac{1}{2}$ in. in diameter. The impact and expansion of the air loosen and carry out the material within the pipe. After cleaning and inspection, the pipe is filled with concrete. Steel pipe piles may be used in any length and have been driven to depths as great as 155 ft. Where headroom is not available, short sections connected by internal sleeve couplings are used.

Experience has shown that the amount of corrosion of the steel pipe in the ground is negligible. However, some building codes require that in computing the loading area a deduction of $\frac{1}{16}$ in. in the thickness of the metal be made to allow for deterioration. Piles that have been in the ground for over 25 years have shown upon removal that corrosion did not penetrate more than $\frac{1}{64}$ in. into the metal. The iron oxide formed by the first deterioration serves as a protective coating.

The building code of the City of New York requires that concrete-filled steel piles when driven open-ended to rock have a center-to-center spacing of at least 2 ft. and at least the diameter of the tube plus 10 in. A base loading computed on pipes of $\frac{3}{8}$ in. wall thickness varies from 55 tons for a 10-in. pipe to 150 tons for a 22-in. pipe. Pipes larger than 22 in. in diameter are considered reinforced concrete piers.

When these piles are driven open-ended to refusal in hardpan, 70 per cent of the base loading just shown is allowed, but

a maximum load of 70 tons is specified. A spacing of at least 30 in., center to center, is required. For piles driven to boulders or a mixture of gravel and boulders, a loading of 50 per cent of the base loading may be used. A maximum loading of 50 tons is established for this condition provided no softer layer is underlying. A spacing of at least 20 in., center to center, is required.

When these piles are driven with closed ends or when their ends are in materials of less bearing capacity, they are considered as precast concrete piles. A spacing of $2\frac{1}{2}$ ft. is required.

A typical steel pipe pile foundation is shown in Fig. 17 in Sec. 5.

STEEL PILES

84. Steel Piles.—The use of rolled structural sections as piles has been practiced to some extent for years. In the early years of this practice, I-beam sections were used, but since the introduction of the H-beam section, they have been extensively used. At present, sections having equal web and flange thickness are specially rolled for piling. These sizes vary from 8 to 14 in. with corresponding weight of 33 to 117 lb. per ft. The sections are commonly 40 ft. in length but may be effectively spliced by the use of steel plates welded or bolted to the webs. The contact areas should have full bearing. Further details may be found in structural steel handbooks.

This type of pile has proved very successful in cases where driving conditions are difficult and where the piles extend above the ground surface to act as a column. The comparatively small cross-sectional area offers little resistance to driving and close spacing of piles is therefore possible. These piles can be driven to a high penetration in dense gravel deposits where other types could be placed only with great difficulty by either the driving or jet methods. The section between low ground water and a point above ground surface where piles are usually cut off is often encased in concrete. In the part below permanent ground-water level corrosion is slight. The section exposed to the air is subject to the same corrosive action as any other exposed steel structure and can be protected accordingly.

Steel H-piles are usually driven with a steam hammer having sufficient weight to develop from 7,000 to 15,000 ft.-lb. per

blow. The use of a driving cap or helmet protects the pile and also aids in controlling alignment.

The load capacity of steel H-piles is usually determined by the use of a modified column formula. For sections wholly within the soil, lateral support may be considered effective throughout. Good practice seems to indicate that loads are limited to 8,000 to 10,000 lb. per sq. in., with a reduction of 5 per cent for each splice above one per pile.

For piles resting upon rock the character of the rock will determine the possible loading. Although a structural failure may not occur, the rock may shatter under repeated loading. Loadings are therefore often decreased to 6,000 lb. per sq. in. of bearing area.

Where steel piles do not reach rock, dependence should be placed upon side friction and point resistance. To increase the resistance, horizontal stiffeners and vertical steel lagging are sometimes welded to the flanges. Timbers may be fitted between the flanges and bolted to the web. Any pile-driving formula for the determination of static resistance should be used with caution when driving is done in cohesive or semicohesive soil. Loading tests are resorted to in many cases.

This steel piling is often used for bridge piers and abutment foundations and particularly in trestlework where the sections aboveground act as a column.

A combination of a steel pipe and a rolled H-piling section, known as a drilled-in caisson or a Western pile, is placed as follows:

Steel pipes 24 to 30 in. in diameter and reinforced with a heavy tempered-steel cutting shoe are driven into intimate contact with the rock. This forms a seal that prevents the inflow of material. The rock is then drilled to any desired depth and may be examined as the drilling proceeds. A core that may be an H-piling section or a reinforcing cage is introduced through the pipe and extends into the socket drilled into the bedrock. The pipe and the socket are then filled with concrete.

These piles are constructed by the Western Foundation Company. The load is considered to be transferred from the core to the concrete and then to the washed walls of the bedrock socket.

85. Driving and Loading Test Piles.—Data essential to the design of pile foundations may be obtained from pile-loading

tests. Where foundations cover large areas, it is well to drive test piles at frequent intervals. Whenever practicable, test piles and the pile-driving equipment should be identical with those proposed for use in the final construction.

Test loadings are usually made on single piles or on groups of three or four piles. It is only in rare cases that larger groups of

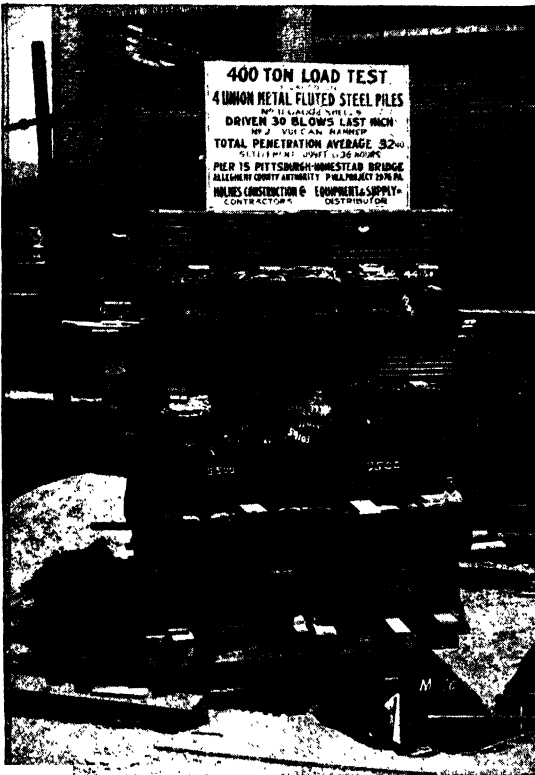

FIG. 49.—Pile-loading test on a pile group.

piles are used for test purposes because of the great expense involved. Reference is made to the report on such tests in connection with the work on Morganza Floodway in Louisiana, in an article entitled "Timber Friction Pile Foundation."¹

The static resistance of a pile may be a very different quantity from the dynamic resistance shown in driving operations.

¹ FRANK M. MASTER, *Proc. Am. Soc. Civil Eng.*, November, 1941. pp. 1659-1682.

Furthermore, the resistance of a pile group is a very different thing from the resistance of a single pile. Further reference is made to the bearing capacity of piles and pile-driving formulas in Appendix B.

Test pile loadings are usually required by building codes where, in the opinion of the superintendent, a question or doubt of the bearing power of the soil exists. Careful records of the driving operation should be kept. Static loads in the form of steel or iron castings, sand bags, or water tanks are placed upon platforms built on the pile heads. Where sufficient reactions are available to take the thrust, hydraulic jacks are sometimes used. A load of 100 tons is shown on a single monotube pile in Fig. 42A. Figure 49 shows a load of 400 tons on a group of four monotube piles.

The patented methods of pretest foundation given in Sec. 5 test-loads every pile to 150 per cent of its proposed service loading.

Building codes generally require that test piles sustain a loading of 150 per cent of the design load for a period of 24 hr. without settlement and that the total net settlement, after deducting rebound, be not more than 0.01 in. per ton of total test load.

Test loadings, even when made upon groups of piles, can at best be considered only as a model. The problem of predicting the probable behavior of larger groups or of entire pile foundations is largely a question of similitude. So many variable factors affect the results in both cases that certain assumptions are necessary. For example, there is at present no rigid mathematical method for the determination of stress distribution in the soil surrounding a pile or a pile group. Consequently results can be only as accurate as the original assumptions.

SHEET PILES

Sheet piling differs from any other type of piling in that it is rarely used to furnish vertical support but is used as a retaining wall. This use is either permanent, as in docks and piers, or temporary, as in cofferdams.

Wood, steel, or reinforced concrete may be used for sheet piling—the latter, of course, in permanent work only.

86. Wood Sheet Piling.—The simplest form of sheet piling consists of a single row of planks driven with their edges touching.

Properly braced this will support a bank of earth but will not keep out water (see Fig. 50a). Sometimes lighter pieces, called "battens," are driven on the outside over the joints (see Fig. 50b). Tongue-and-groove sticks, 3 in. or 4 × 6 in., are sometimes used for small cofferdams (see Fig. 50c). A double row of planks of the same thickness may be driven with joints broken and is called "shiplap sheet piling" (see Fig. 50d). This type of piling is often used for the outer wall of puddle cofferdams.

Before the introduction of steel sheet piling, piles were sometimes made of timbers for deep cofferdams by forming rectangular or dovetailed tongues and grooves by nailing wooden strips on the edges of the timbers (see Fig. 50e). These timber sheet piles sometimes had the grooves planed out of both edges of the timbers and a hardwood spline driven in to make the joint (see Fig. 50f).

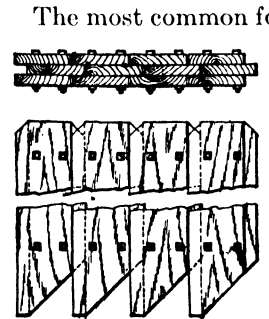

FIG. 51.—Wakefield sheet piling.

The most common form of timber sheet piling is that known as Wakefield, originally patented, but on which the patents have expired. It is made of three thicknesses of plank with the middle plank offset to form a tongue and groove (see Figs. 50g and 51).

Wakefield piling is usually made of 2-, 3-, or 4-in. pine or fir, surfaced on four sides. The piles are generally made at the site, with either wire nails, boat spikes or bolts. The planking is nailed with the center plank forming a tongue and groove by nailing a portion to the weather as follows:

- 2-in. plank makes tongue 2½ to 3 in.
- 3-in. plank makes tongue 3½ to 4 in.
- 4-in. plank makes tongue not over 4 in.

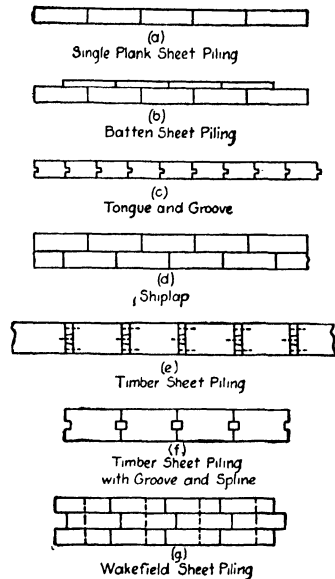

FIG. 50.—Types of timber sheet piling.

This gives piling about 5, 8, and 11 in. thick. The length of nails should be 6, 9, and 12 in. respectively. This will allow $\frac{1}{2}$ in. for clinching. Bolts $\frac{1}{2}$ to $\frac{5}{8}$ in. diameter are used.

When nails are used, one-half should be driven from one side of the pile and then the pile should be turned over and the remaining half driven. The nails should be driven on 1-ft. centers for 3 to 6 ft. at each end of the pile and 3 to 4 ft. apart in the center portion of the pile. Thus, in a short pile 12 to 15 ft. long, the first three nails from either end are on 1-ft. centers, while in a 27- or 30-ft. pile the end 6 ft. would have nails driven on 1-ft. centers. Bolts are sometimes used at 6-ft. intervals and spikes at 18-in. intervals throughout the length of the pile. The pile is completed

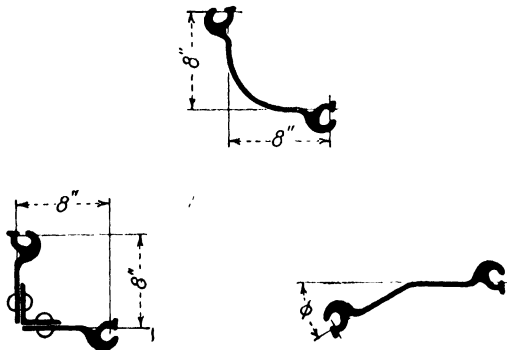

FIG. 52.—Standard rolled and fabricated corners.

by making a 45-deg. cut on the lower end beginning about 3 in. from the tongue and by cutting off the upper corners at 45 deg. for about 3 or 4 in. to prevent brooming. Wakefield piling is usually made on the job and may be used more than once, provided reasonable care is taken in the driving and pulling.

87. Steel Sheet Piling.—The oldest form of metal sheet piling was made of cast iron. Steel sheet piling was introduced in American practice about the turn of the century. The early practice consisted of the use of standard structural forms such as plates, channels, Z-bars, and I-beams, which were fabricated to form the piling. Locking bars and various other devices were used to form the interlocks.

Corners for steel pile cofferdams were made by riveting structural angles to the webs of the two halves of a standard sheet pile.

Sometimes the web was bent to an angle of 90 deg. It was usually possible to complete a closed dam by the use of standard sections only by using care in the driving of the last few sections and sometimes assembling several sections and driving them together. When necessary, a closing piece was made by splitting a standard pile and riveting the pieces together to give the desired width. Tapered closing pieces were made in the same way. Sometimes closing pieces were bolted together with slotted holes to give the necessary flexibility.

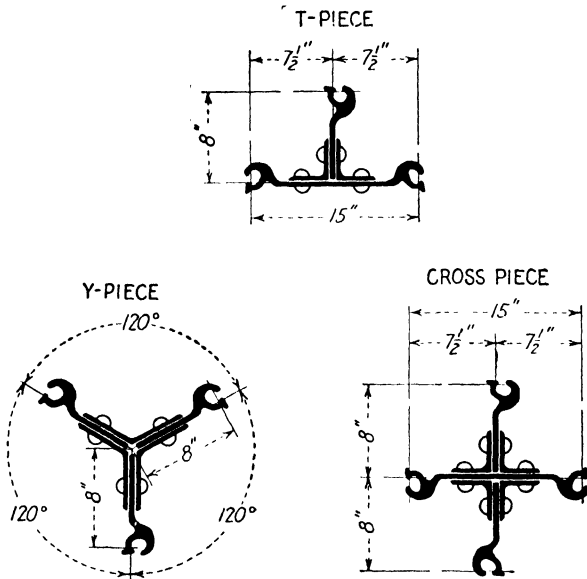

FIG. 52b.—Standard fabricated connections.

The introduction of specially rolled shapes provided a great impetus to the use of metal piling. This piling is now almost universally used. In American practice the standard types of sheet piling differ but slightly. This difference is principally in the interlock and the general dimensions. The sheet piling of one manufacturer may be used with that of another, but the interlocking strength is usually reduced.

The modern forms of steel sheet piling as manufactured by the Carnegie-Illinois Steel Corporation are shown in Fig. 53. The arch section is used in straight-wall installations and bulkheads where high lateral strength is required. Where a higher sec-

U.S.S. STEEL SHEET PILING SECTIONS¹

Profile	Section index	Driving distance per pile, inches	Weight, pounds		Web thickness, inches	Section modulus of single piece, inches ³		
			Per foot	Per square foot of wall		Per pile	Per foot of wall	
	Interlock with each other	M 108	15	43.8	35.0	$\frac{1}{2}$	3.8	3.1
		M 107	15	38.8	31.0	$\frac{3}{8}$	3.7	3.0
		M 117	15	38.8	31.0	$\frac{3}{8}$	8.9	7.1
		M 106	14	36.2	31.0	$\frac{3}{8}$	10.3	8.9
	Interlock with each other	M 113	16	37.3	28.0	$\frac{1}{2}$	3.3	2.5
		M 112	16	30.7	23.0	$\frac{3}{8}$	3.2	2.4
		M 110	16	42.7	32.0	$\frac{3}{16}$	20.4	15.3
		M 116	16	36.0	27.0	$\frac{3}{8}$	14.3	10.7
		M 115	19 $\frac{3}{8}$	36.0	22.0	$\frac{3}{8}$	8.8	5.4

¹ Minimum interlock strength in direct tension, based on a test piece approximately 3 in. long, in pounds per inch of interlock:

- M 107, M 108, M 112 and M 113..... 12,000 lb.
- M 106 and M 117..... 10,000 lb.
- M 110, M 115 and M 116..... 8,000 lb.

FIG. 53.—Newer forms of steel sheet pile sections.

U.S.S. STEEL SHEET PILING SECTIONS—Z PILES¹

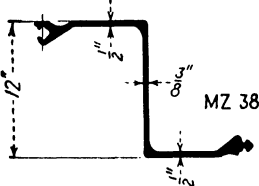
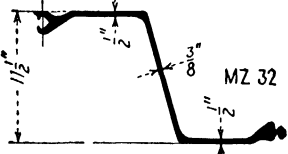
Profile	Driving distance per pile, inches	Weight, pounds		Web thickness, inches	Section modulus, inches	
		Per foot	Per square foot of wall		Per pile	Per foot of wall
 <p>MZ 38</p>	18	57.0	38.0	3/8	70.2	46.8
 <p>MZ 32</p>	21	56.0	32.0	3/8	67.0	38.3

¹ Minimum interlock strength, based on a test piece approximately 3 in. long, in pounds per inch of interlock..... 8,000 lb.

FIG. 53.—(Continued).

tion modulus is essential, a Z-section may be used. Standard rolled and fabricated corners are shown in Fig. 52a and standard fabricated connections are shown in Fig. 52b. For the details of sheet piling sections the reader should consult manufacturers' catalogues and bulletins. The 1941 reprint of the 1938 edition of the U.S.S. Steel Sheet Piling Bulletin published by the Carnegie-Illinois Steel Corporation is especially recommended.

Figure 54 shows an example of the use of Z-section piling. The use of other standard sections in cofferdam work is shown in Figs. 11 to 13.

A standard and an interlock section of corrugated steel sheet piling manufactured by the Corrugated Steel Sheet Piling Corporation, Chicago, Illinois, is shown in Fig. 56a and 56b. This piling is rolled from open-hearth steel and has a tensile strength of 35,000 lb. per sq. in. The corrugations have a depth of 1 3/4 in.

on 4-in. centers. The metal used varies from 8 to 12 gage and sections are rolled in lengths up to 40 ft. The weights vary from 6.84 to 10.74 lb. per ft. for the standard section and from

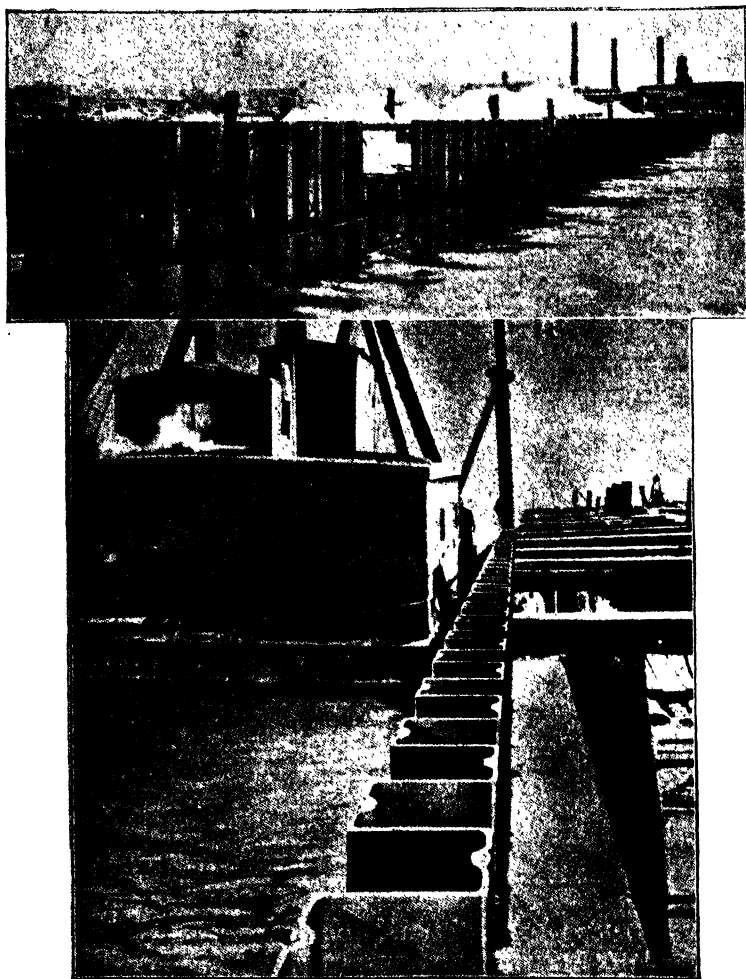

FIG. 54.—Z piling used in freight terminal.

8.66 to 13.61 lb. per ft. for the interlock section. Corner pieces can also be furnished. Interlocking clips are electrically welded to the standard section.

The standard section is recommended by the manufacturers for temporary work, the interlock section for permanent installations. It is claimed that maximum strength and rigidity are furnished, with a minimum of weight.

88. Driving Sheet Piling.—Wakefield piling is still driven to quite a large extent by drop hammers as it stands up well under

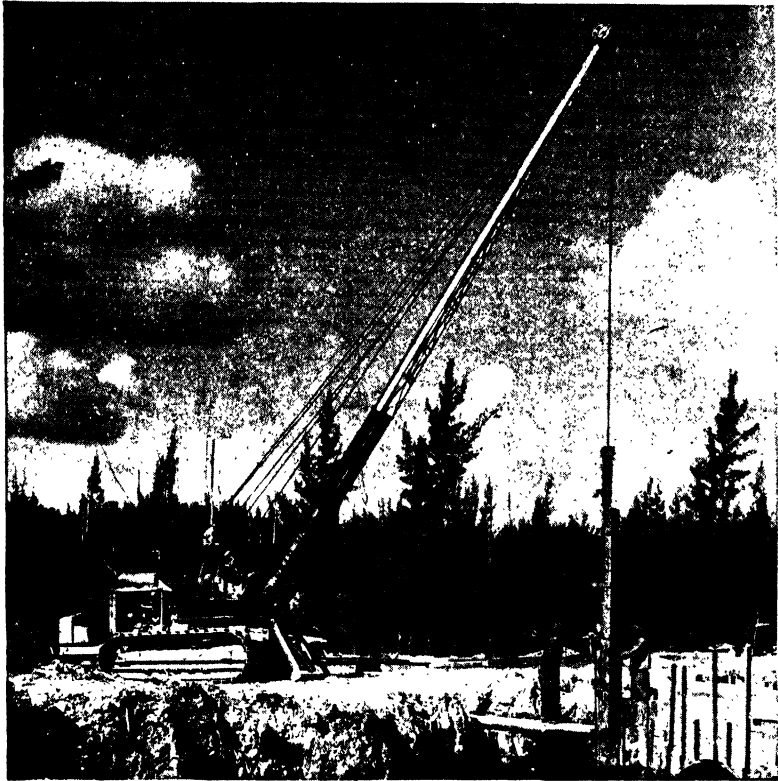

FIG. 55.—Caterpillar Diesel-powered speeder pile driver.

impact. The piles are pressed tight into the groove by means of a snub line, the loop end of which is dropped over a piece of piling left about 1 ft. high and several feet back of the driving face; the other end is kicked down 3 or 4 ft. on the pile and then taken to a niggerhead and a strain taken on it. The line can be greased to prevent cutting. After the pile is driven to place it should be toenailed to the cap and then a face nail driven close

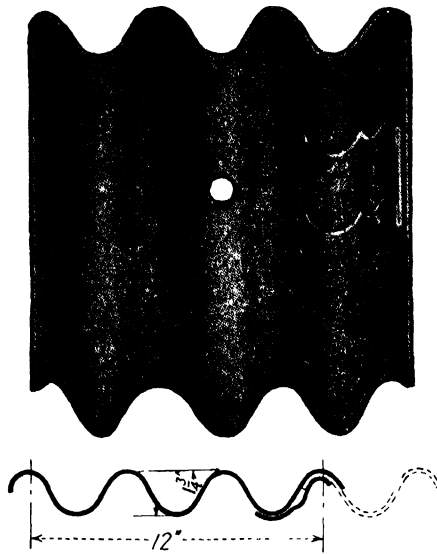

FIG. 56a.—Standard section, corrugated sheet piling.

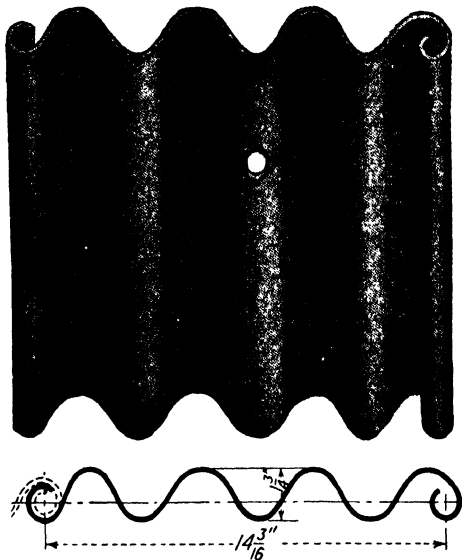

FIG. 56b.—Interlocking section, corrugated sheet piling.

to the back or grooved side to prevent the pile from springing until the cap and liners are nailed.

Steel sheet piling is driven almost entirely with steam hammers. Modern hammers are equipped with removable bases that fit into the lower part of the hammer and over the pile head. Driving caps of cast or structural steel with wooden cushion blocks are used when the driving is hard. When piles are driven under water, a follower usually made of a 6- to 7-ft. length of sheet piling is used. Steel channels and plates are riveted to its sides and fit over the pile section. The makers of the various kinds of steel piling have caps designed to fit their piles. Standard handling and pulling holes are provided at each end of sheet piling sections. These sections can be driven through sunken logs, old timber cribs, and materials such as brick and small stones usually found in made ground. Light steam hammers have been developed for driving small sheet piles. They can be handled by one man and are so arranged that the weight of the man is added to that of the hammer. Care should be exercised in handling steel sheet piling because small bends will damage the interlock and may produce excessive driving and pulling resistance. To provide protection for the piling or to procure good alignment or to effect a quick closure, sheet piles are not usually driven to final penetration singly. Several piles are fixed in the driving position. Then each is driven a short distance in turn until the desired penetration of all the piles is reached. A Caterpillar Diesel-powered Speeder pile driver is shown in Fig. 55 driving piling for a dam in a drainage canal. Wooden sheet piling on small jobs is often driven by hand with heavy wooden mauls. Corrugated steel sheet piling may be driven either by hand or by light air or steam hammers.

89. Removing Sheet Piling.—Steel sheet piles are pulled by use of special tackle, pile extractors, or inverted steam hammers. When inverted steam hammers are used, a steady pull on the cables is also maintained. Figure 16 shows a pile extractor pulling steel sheet piling. Figure 17 shows an inverted steam hammer used for this purpose. Corrugated steel sheet piling may be pulled either by hand or by light power equipment.

90. Watertightness.—Various methods are used to make steel sheet piling watertight. In the driving operation the interlock space is filled with the material penetrated. In highly imper-

meable soils this serves to seal the piling. Leaks may be closed by pouring cinders into the water on the outside of the piling close to the leaking joint. The interlock space may be filled with impervious materials. This practice may, however, increase the driving or pulling resistance or damage the interlock.

91. Durability.—Experience has proved that the economic life of steel sheet piling warrants its use for permanent structures. Its use for such structures as docks, wharves, sea walls, core walls for dams, retaining walls, and for building and pier foundations is now common practice. Recommendations for the design of cantilever sheet piling and for sheet piling gravity bulkheads are contained in the manufacturers' catalogues.

92. Reinforced Concrete Sheet Piling.—Concrete sheet piles are precast piles usually made square or rectangular in cross section. A tongue-and-groove interlock is used and the foot is usually beveled in order that the pile will be forced against an adjacent one when driven. Sheet piles should be driven in good alignment and in some cases guide frames are used for this purpose. Changes in alignment should be made on easy curves.

To secure watertightness the grooves are thoroughly cleaned by use of a water jet and are then grouted by the use of a small tremie. Expansion and contraction may be provided for by the use of a flexible filler at intervals of 25 to 50 ft. A special split section, having a solid section below ground level and a slit section above it, is sometimes used. The slit is filled with flexible joint filler. This joint, when used, should be continued through the cap.

Concrete sheet piles are used extensively as cutoff walls and for bulkheads, retaining walls, and other harbor structures.

They may also be used for docks, jetties, breakwaters, or piers. In this work they are usually driven in parallel rows tied at the top. The space between the rows is filled with soil or rock and a concrete slab placed on the top. For lateral reinforcement diaphragms of piles may be placed and tied to the walls at intervals of about 50 ft.

When conditions permit, the water jet is used to sink concrete sheet piling. Jet pipes may be built in the piles or external pipes may be used.

For methods of design for cutoff walls, bulkheads, and breakwaters, the reader is referred to the bulletin, *Concrete Piles*.¹

¹ Published by the Portland Cement Association, Chicago, Illinois.

SECTION 4

SPREAD FOOTINGS

FOOTING AREAS

1. Relative Allowable Pressure on Soil.—The bearing power of various soils has been discussed in a general way in Sec. 1, but in actual foundation design for a building it will be necessary to modify or discount these values in accordance with the height and character of loading of the building. That is, for the same soil conditions a smaller bearing value should be used for a high building than for a low (one- or two-story) building since any inequality in the loading of the building, or in the bearing value of the soil, might result in a serious overload on the soil in that section and possible failure due to unequal settling of the high structure, while the low one under the same circumstances might be little harmed. Then again, the relative bearing value of the same soil should be taken as less for a large multistoried warehouse designed for heavy floor loads, than for a low (three- or four-story) building with comparatively light floor loads. Briefly, this means that any table of bearing values for various soils should be used with a great deal of discretion and modified to correspond with what experience has taught to be safe values for any certain district.

If the soil on which the footings are to rest is likely to flow under load, or be disturbed by other foundation work adjacent, or by seepage or drainage into sewers, special precautions should be taken to retain the soil. This is especially necessary where the foundation bed is of wet sand that might be pumped out in keeping the water out of excavations. Lines of sheet piling of concrete, steel, or wood, driven down to a depth below which any subsequent excavation is unlikely to go will usually give the desired results.

For the footings of buildings without basements the footings need be carried down only below the maximum frost line. This

rule holds good for footings on solid rock as well as in earth since much damage can be done by the freezing of water, which may find its way into fissures in the rock under footings. After getting below the frost line, in general it will not be economical to excavate deeper unless a soil of greater bearing capacity can be found at such depth as will make the saving in concrete and steel in the footing, due to the lesser area, greater than the extra cost of excavation. However, in compressible soils, such as various clays, and in wet sands, the footings should be carried down below the line of possible danger of disturbance or lateral displacement of the soil by adjacent building operations, or to such depth that the weight of the soil above will prevent heaving at the periphery of footings under load.

The bearing power of the soil under many buildings has been improved by drainage of the foundation bed by means of lines of drain tile laid adjacent to the exterior or wall footings and slightly below the bottom of these footings. In this way any ground or surface water, which may find its way to the level of the bottom of the footings and tend to lower the bearing value of the soil by the attendant softening thereof, is conducted away from the foundations. Where such drains are laid in sand, the joints of the tile should be carefully wrapped with burlap to prevent the entrance of the sand, for the movement of the sand might undermine the footings.

Sometimes heavy layers of sand or gravel have been placed in bottoms of excavations in poor soils in order to improve the bearing capacity, but this method is of extremely doubtful value if the undersoil is soft, for when put under load the tendency is for the added material to squeeze into the natural soil and so cause settlement. The better method of increasing the allowable bearing on compressible foundation beds such as clays, is to drive short piles as close to each other as possible over the foundation area, thereby compressing the soil and raising its bearing power.

2. Proportioning Footings.—The aim in all footing design where the foundation bed is at all compressible is to have the unit bearing pressure as nearly uniform under various conditions of loading as is possible, in order that the settlement, if any, may be uniform. The present-day methods of monolithic reinforced concrete construction greatly reduce the possibilities of unequal

settlement since the strength of the connecting units—columns, slabs, beams, or girders, or all combined—acts as a stiff framework, transferring some or the load to adjacent column footings, where one footing tends to settle unequally, thus relieving the situation.

To have the bearing pressure under all footings uniform or very nearly so, is impossible of attainment under all conditions of loading because of the fact that the interior columns carry a greater percentage of live load than the exterior columns. The problem, therefore, resolves itself into approximating equality of soil pressure by making the footing areas proportional to loads that include only a part of the live load—say 50 per cent or less, or none of the live load—depending on the character of the occupancy. This results in relatively larger footing areas for exterior columns (for a given bearing value) as compared with the interior than would be the case if the full live load were considered in proportioning the areas of footings.

The loads to be considered on building foundations are (1) the dead load of the building, (2) the live or movable loads to which the floors may be subjected, and (3) the wind loads. The latter loads are in general neglected on buildings having a width as great or greater than the height, or where the side walls are protected by other buildings. For very narrow and high buildings it is essential that the wind loads be considered, for in buildings only two or three bays wide the loads on the leeward footings may be considerably increased by wind loads and unless they are proportioned accordingly, unequal settlement is very likely to occur.

The dead load, or the weight of the structure itself including walls and partitions, can be readily computed. The maximum allowable load can also be readily computed, but it is evident that a building very seldom carries the maximum allowable live load over the entire area of each floor at the same time. Aisle spaces, unloaded areas, and partly loaded areas generally considerably reduce the actual live loads on the various floors. It would therefore be wrong to proportion the columns and footings for the full allowable live load for which the floors may be designed.

The usual practice in building design, therefore, is to design the floor slabs for the full allowable live load per square foot, the girders for 85 per cent of this allowable or assumed live load, and to make a further reduction on the amount of live load carried by

the building columns. The reduction of live load for columns varies with different city ordinances, the idea in general being to design the columns as nearly as possible for the probable actual loads they will receive owing to the conditions mentioned in the preceding paragraph.

The 1939 Building Code of the City of New York fixes roof loads as follows: Roofs having a rise of 3 in. or less per foot of horizontal projection shall be proportioned for a vertical live load of 40 lb. per sq. ft. of horizontal projection applied to any or all slopes. With a rise of between 3 and 12 in. per ft., a vertical live load of 30 lb. on the horizontal projection shall be assumed. If the rise exceeds 12 in. per ft., no vertical live load need be assumed, but provision shall be made for a wind force of 20 lb. per sq. ft. of roof surface acting normal to such surface on one slope at a time.

This same code provides that live loads may be reduced as follows: In structures intended for storage purposes all columns, piers, or walls and foundations may be designed for 85 per cent of the full assumed live load. In structures intended for other uses the assumed live load used in designing all columns, piers, or walls and foundations may be as follows:

- 100 per cent of the live load on the roof.
- 85 per cent of the live load on the top floor.
- 80 per cent of the live load on the next floor.
- 75 per cent of the live load on the floor next below.

On each successive lower floor, there shall be a corresponding decrease in the percentage, provided that in all cases at least 50 per cent of the live load shall be assumed.

Other column load reduction formulas are used, the most common being that recommended by the National Board of Fire Underwriters, namely,

Except in buildings used for storage purposes, in designing a column, girder, truss, wall, pier, or foundation, carrying more than one floor, the live loads of the floors dependent for support on such column, girder, truss, wall, pier, or foundation may be reduced, but shall not be taken at less than the following percentages of live load for which such floors were designed, to wit: 100 per cent for the topmost floor, 90 per cent for the floor next below that, and at correspondingly decreasing percentages for lower floors, but in no case at less than 50 per cent for any floor.

The lower story column live load, as arrived at by the foregoing or similar reduction formulas, is the load for which the maximum stresses in the footing should be computed. For interior column footings this load should be used together with the dead load to find the area of footing required, using the maximum allowable bearing pressure on the soil in question.

After having found the footing area required, divide the sum of the dead load and 30 per cent of the lower story column live load (as reduced) by said area, and a new bearing value will be found. Now take the exterior column dead load plus 30 per cent of the lower story column live load (as reduced) and divide by the new bearing value already found. The result will be the area for exterior footings. In computing stresses in the exterior footings, however, the lower story column live load as reduced (not 30 per cent of said live load), plus the dead load, should be used.

Illustrative Problem.—Determine column footing areas for a six-story and basement office building with panels 20×20 ft. Roof pitch is 2 in. per ft. Roof live load is 40 lb. per sq. ft., floor live loads are 50 lb. per sq. ft., and basement load is 200 lb. per sq. ft. Floor loads are to be reduced in accordance with the New York City code for office buildings. Maximum allowable soil pressure is 4,000 lb. per sq. ft., neglecting weight of footing.

A summation of the reduced live-load intensities on roof and floors and full basement load gives 458 lb. per sq. ft.

Interior column load:

$$\begin{aligned} \text{Dead load} &= 257,000 \text{ lb.} \\ \text{Live load} &= 20 \times 20 \times 458 = \underline{183,000 \text{ lb.}} \\ \text{Total} &= 440,000 \text{ lb.} \end{aligned}$$

Dead load plus 30 per cent of live load = 312,000 lb.

Exterior column load:

$$\begin{aligned} \text{Dead load} &= 197,000 \text{ lb.} \\ \text{Live load} &= 20 \times 10 \times 458 = \underline{92,000 \text{ lb.}} \\ \text{Total} &= 289,000 \text{ lb.} \end{aligned}$$

Dead load plus 30 per cent of live load = 225,000 lb.

$$\text{Interior column footing area required} = \frac{440,000}{4,000} = 110.0 \text{ sq. ft.}$$

Make footing 10.5 ft. square = 110 sq. ft.

$$\begin{aligned} \text{Pressure on soil for dead load plus 30 per cent of live load} \\ = \frac{312,000}{110} = 2,840 \text{ lb. per sq. ft.} \end{aligned}$$

$$\text{Area of exterior footing required} = \frac{225,000}{2840} = 79 \text{ sq. ft.}$$

Make footing 8 ft. 11 in. square = 79 sq. ft.

In computing stresses in the exterior footing, the pressure for the entire reduced live load and dead load must be used, and this is

$$\frac{289,000}{79} = 3,660 \text{ lb. per sq. ft.}$$

From this it will be noted that, while under total reduced live and dead load the pressure under the interior footings is 4,000 lb. per sq. ft., under the exterior footings it will be only 3,660 lb. This indicates that the design is such as to preclude any marked difference in settlement of the exterior and interior footings. For dead load only the pressure under the exterior footing is 2,500 lb. per sq. ft.; under the interior column footing it is 2,340 lb. per sq. ft.

In cases where the assumed live load is somewhat larger—say 200 lb. per sq. ft.—it would probably be well to proportion the footings by using 50 per cent of the reduced live loads instead of 30 per cent as illustrated.

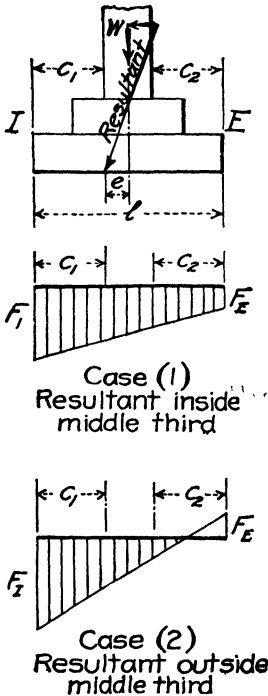

FIG. 1.

3. Eccentricity in Footings.—Whenever possible, footings should be so designed as to have the center of pressure coincide with the center of the base of the footing. This, however, is not always possible of attainment since under some conditions a combination of wind or earth pressure (or both) with the dead and live loads may be such as to make the line of resultant pressure depart from the vertical and intersect the base of the footing at some point beyond the center. In such a case the footing is said to be loaded eccentrically and the pressure on the soil is not uniform, but varies from a minimum at one side to a maximum at the other.

If the line of resultant pressure lies within the middle third of the footing (in which case e , the eccentricity, is less than $\frac{1}{6}l$, where l equals the dimension of the footing base in the plane under consideration), the pressure on the soil will vary from a minimum at the edge farthest from the point of intersection of the resultant with the base to a maximum at the opposite side. The variation in the pressure for this condition is shown in Fig. 1, Case (1).

The actual intensities of pressure at the interior and exterior edges of the footing, marked I and E , respectively, are given by the formulas

$$F_I = \frac{W}{l} \left(1 + \frac{6e}{l} \right)$$

$$F_E = \frac{W}{l} \left(1 - \frac{6e}{l} \right)$$

in which the footing is assumed to be square or rectangular, and W equals the total vertical load on the footing, or the total load per linear foot on a wall footing. To obtain the unit bearing pressure, the value of F_I or F_E should be divided by the width of footing (1 ft. in the case of the wall footing).

If the resultant of pressure intersects the base outside the middle third, the eccentricity will be greater than $\frac{1}{6}l$ and the pressure on the base will vary from a condition of no pressure or an uplift on the side farthest away to a maximum at the side nearest to the point of intersection of the resultant with the base. This condition is shown in Fig. 1, Case (2), where

$$F_I = \frac{2W}{3 \left(\frac{l}{2} - e \right)}$$

The condition of pressure shown in Case (2), however, should never be allowed in good design especially in buildings. When investigation indicates a footing to be so stressed, it should be redesigned.

CONCRETE FOOTINGS

4. Wall Footings.—A building of the wall-bearing type (that is, where no exterior columns are used—the floor slabs resting directly on the exterior brick or concrete walls) will usually require the footing for the exterior wall to be reinforced as a balanced cantilever projecting beyond each face of the wall an equal distance. In residence work or in large buildings where the bearing power of the soil is high, the wall footings will have a small projection and are usually constructed of plain concrete, the usual practice being to make the thickness of each footing course twice the projection of the course beyond the course above.

In designing a reinforced concrete wall footing the bending moment at any section of the footing at a distance x from the end (Fig. 2) will be

$$M = \frac{1}{2}wx^2$$

where w = the uniform bearing pressure per linear foot of footing for a given width of section. Now if l is the extreme width of footing and a is the thickness of wall, the bending moment at the face of the wall will be

$$M = \frac{1}{8}w(l - a)^2$$

For a section at the center of wall the bending moment will be a maximum and equal to

$$M = \frac{1}{8}w(l^2 - la)$$

However, since the resisting moment will be much greater at this point than at any in the footing projection, owing to the greater depth of wall, the critical section will be at the face of wall. That this is actually the case is borne out by Talbot's tests on reinforced concrete footings.¹ These tests indicate that the maximum tensile stresses developed at the face of wall are somewhat less

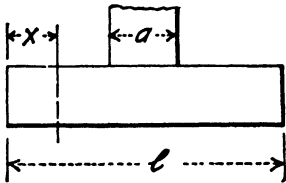

FIG. 2.

than the calculated stresses even when the wall and footing were not cast at the same time.

In designing reinforced concrete cantilever footings for walls, special consideration should be given to the ascertaining of bond stress and diagonal tension. In computing the maximum bond stress on bars, Talbot's tests show that the total external shear at the face of the wall should be used in the formula for unit bond stress. In computing the shear for diagonal tension, however, it should be taken on a line at a distance away from the wall equal to the effective depth of the footing. In view of this fact diagonal tension is quite likely to govern in the design of footings composed of a number of steps or with a sloped top, since the depth is generally less at a distance d from the face of the wall than at the wall. As a general rule it will be found

¹ *Univ. Ill. Eng. Exp. Sta. Bull.* 67.

better practice, from the standpoints of design and construction, to keep down the amount of diagonal tension reinforcement by making the footing courses relatively thick. In any event the reinforcement for diagonal tension should be bent to template and proper supports provided to ensure its correct placement and location in the finished work.

5. Types of Column Footings.—Column footings may be divided into four principal types depending on the number of columns the footing supports, namely, (1) isolated or single footings supporting one column; (2) combined footings to carry two or more columns; (3) cantilever footings, usually supporting one exterior and one interior column; (4) continuous footings, supporting a line of columns, or all the columns of a building on continuous strips of footings at right angles to (and integral with) each other, or on a mat covering the entire lot area.

6. Single or Isolated Column Footings.

6a. Plain Concrete Footings.—Plain concrete footings are the natural outgrowth of the now almost obsolete stone masonry footings in which each of the courses forming the footing act as cantilever beams projecting beyond the next course above and are uniformly loaded. Since no reinforcement is used, the design should be such that all projections will have a thickness sufficient to keep the tensile stress in the concrete well within the allowable under the maximum condition of loading.

The University of Illinois tests on plain footings gave results showing considerable variation that did not permit a method of determining the effective width of resisting section to be established or to obtain a formula for resisting moment. Based upon the full section of the footing, the moduli of rupture obtained were considerably less than the moduli of rupture of control beams made with the same concrete.

In view of these facts it seems that the better practice to follow in the design of such footings is to proportion them so as to eliminate all bending stresses.

In a reinforced concrete footing the load is transmitted to the soil over its entire area by virtue of the deflection or deformation of the footing under load, while in a plain concrete footing on a hard soil or rock the load tends to distribute only over such area as lies within the base of a pyramid or cone formed by the lines of stress from the base of the column to the bottom of the footing.

The general practice is, therefore, based on the assumption that the load is carried through the concrete at an angle of 30 deg. with the vertical. If all the projections lie outside of a line drawn at 30 deg. with the vertical from the edge of column to the bottom of the footing, no bending stresses will exist. The simplest form of a plain concrete footing would therefore seem to be a pyramid or cone, but owing to the difficulty of holding the forms on footings of this shape, stepped or coursed footings are used with all projections lying outside of the above-mentioned line of stress. To design a plain concrete footing on this basis, first find the area of footing required, and from one-half the width of the bottom course subtract one-half the column size, and divide the result by the $\tan 30$ deg. This will give the required height of footing. Then divide the footing into as many vertical steps as desired, keeping the projections entirely outside of a 30-deg. line with the vertical from edge of footing to edge of column.

In stepping off plain concrete footings the steps should be at least 12 in. high and preferably more. The area of the top course should be such as will allow the maximum bearing value on the footing concrete directly under the column base.

For footings on rock or on soil capable of sustaining relatively high unit loads, plain concrete footings should be used rather than reinforced concrete since, owing to the unyielding character of the foundation, the reinforced concrete footing could not act as designed.

Where excavation must be carried to a considerable depth below the ground-floor line, it will often be found more economical to use plain concrete footings since no saving can be made in excavation, which generally makes for economy in reinforced footings. Also the footing concrete will usually be cheaper than the extra length of reinforced concrete column required if reinforced footings without plinth blocks are used.

6b. Advantages of Reinforced Concrete Footings.—

Except in certain cases as already mentioned where plain concrete footings can be used to advantage, reinforced concrete footings will in normal times be found the most economical, since a saving in excavation, material, and weight of footing itself can be made.

A study made a few years ago as to the relative cost of various shapes of reinforced concrete footings developed the conclusions

that footings with sloping tops are most expensive to build, single course footings next, and then a decreasing range of cost as more courses, for a given depth, were used in the footings.

6c. Summary of Professor Talbot's Tests.—The fact that the tests made under the direction of Professor Talbot at the University of Illinois were the first made on column footings makes the phenomena of the tests and data of their action of especial interest to engineers and designers. It is, therefore, deemed advisable to quote in full the summary of conclusions drawn. Much information as to weaknesses in footings to be guarded against and as to methods of calculation of bending and resisting moments for square footings is given. This information is of special value in design of footings of any character if properly used.

1. A square column footing under load may be expected to take a bowl-shaped form. In slabs subject to bending in two directions, the stress in a fiber cannot differ from that in an adjoining fiber at the same level without setting up longitudinal shear; and as there is considerable resistance to variation from equality of stress in adjoining fibers, it may be expected that in stiff thick pieces (as are footings of ordinary design, where the thickness is large in comparison with the length of the projection) the deformations and consequent stresses will be distributed over the width of a cross section and that considerable stress will be developed even in the fibers at the edge of the footing.

2. For footings having projections of ordinary dimensions, the critical section for the bending moment for one direction (which in two-way reinforced concrete footings is to be resisted by one set of bars) may be taken to be at a vertical section passing through the face of the pier. In calculating this moment, all the upward load on the rectangle lying between a face of the pier and the edge of the footing is considered to act at a center of pressure located at a point halfway out from the pier, and half of the upward load on the two corner squares is considered to act at a center of pressure located at a point six-tenths of the width of the projection from the given section. By equating this bending moment and the resisting moment that is available at the given section, the maximum tensile stress in the concrete or in the reinforcing bars may be calculated.

3. As is usually the case when plain concrete is used in flexure, the unreinforced footings show considerable variation in results. The variations were such as not to permit a method of determining the effective width of resisting section to be established or to obtain a formula for resisting moment. Based upon the full section of the footing, the moduli of rupture obtained were considerably less than the moduli of rupture of control beams made with the same concrete.

4. In reinforced concrete column footings, resistance to nonuniformity of stress in adjoining bars will be given by bond and by longitudinal shear

in the concrete, and the amount of variation from uniformity of stress in the various bars will depend upon the spacing of the bars as well as upon the relative dimensions of the footing. With two-way reinforcement evenly spaced over the footing, it seems that the tensile stress is approximately the same in bars lying within a space somewhat greater than the width of the pier and that there is also considerable stress in the bars that lie near the edges of the footing. For intermediate bars stresses intermediate in amount will be developed. For footings having two-way reinforcement spaced uniformly over the footing, the method proposed for determining the maximum tensile stress in the reinforcing bars is to use in the calculation of resisting moment at a section at the face of the pier the area of all the bars that lie within a width of footing equal to the width of pier plus twice the thickness of footing, plus half the remaining distance on each side to the edge of the footing. This method gives results in keeping with the results of tests. When the spacing through the middle of the width of the footing is closer, or even when the bars are concentrated in the middle portion, the same method may be applied without serious error. Enough reinforcement should be placed in the outer portion to prevent the concentration of tension cracks in the concrete and to provide for other distribution stress.

5. The method proposed for calculating maximum bond stress in column footings having two-way reinforcement evenly spaced, or spaced as noted in the preceding paragraph, is to use the ordinary bond stress formula, and to consider the circumference of all the bars that were used in the calculation of tensile stress, and to take for the external shear that amount of upward pressure or load which was used in the calculation of the bending moment at the given section.

An important conclusion of the tests is that bond resistance is one of the most important features of strength of column footings, and probably much more important than has been appreciated by the average designer. The calculations of bond stress in footings of ordinary dimensions where large reinforcing bars are used show that the bond stress may be the governing element of strength. The tests show that in multiple-way reinforcement a special phenomenon affects the problem and that lower bond resistance may be found in footings than in beams. Longitudinal cracks form under and along the reinforcing bar due to the stretch in the reinforcing bars, which extend in another direction, and these cracks act to reduce the bond resistance. The development of these cracks along the reinforcing bars should be expected in service under high tensile stresses, and low working bond stresses should be selected. An advantage will be found in placing under the bars a thickness of concrete of 2 in., or better 3 in., for footings of the size ordinarily used in buildings.

Difficulty may be found in providing the necessary bond resistance, and this points to an advantage in the use of bars of small size, even if they must be closely spaced. Generally speaking, bars of $\frac{3}{4}$ -in. size or smaller will be found to serve the purpose of footings of usual dimensions. The use of large bars, because of ease in placing, leads to the construction of footings that are insecure in bond resistance. In the tests the column footings that were reinforced with deformed bars developed high bond

resistance. Curving the bar upward and backward at the end increased the bond resistance, but this form is awkward in construction. Reinforcement formed by bending long bars in a series of horizontal loops covering the whole footing gave a footing with high bond resistance.

6. As a means of measuring resistance to diagonal tension failure, the vertical shearing stress calculated by using the vertical sections formed upon the square that lies at a distance from the face of the pier equal to the depth of the footing was used. This calculation gives values of the shearing stress, for the footings that failed by diagonal tension, which agree fairly closely with the values that have been obtained in tests of simple beams. The formula used in this calculation is

$$v = \frac{V}{bjd}$$

where V is the total vertical shear at this section taken to be equal to the upward pressure of the area of the footing outside of the section considered, b is the total distance around the four sides of the section, and jd is the distance from the center of reinforcing bars to the center of the compressive stresses. This stress is somewhat larger than the average vertical shear over the section that is sometimes used. The working stress that was frequently specified for this purpose in the design of beams, 40 lb. per sq. in., for 1:2:4 concrete, was at that time applied to the design of footings.

The shear at the critical section may be calculated for the vertical sections that enclose the pier footing, although it may be expected that shear failure may not be produced exactly on this section. The value now generally accepted for shear at the critical section, 120 lb. per sq. in. for 1:2:4 concrete, may be used for the working stress in this case.

7. No failures of concrete in compression were observed, and none would be expected with the low percentages of reinforcement used. The compressive stresses in the pier of the footing were in some cases very high. In a few instances the pier failed and was replaced by a cube of concrete. In frequent cases there were signs of distress near the intersection of pier and footing where there is an abrupt change in direction of surfaces and where the combined stresses are very high.

8. In stepped footings, the abrupt change in the value of the arm of the resisting moment at the point where the depth of footing changes may be expected to produce a correspondingly abrupt increase of stress in the reinforcing bars. Where the step is large in comparison with the projection, the bond stress must become abnormally large. It is evident that the distribution of bond stress is quite different from that in a footing of uniform thickness. The sloped footing also gives a distribution of stress that is different from that in a footing of uniform thickness. However, for footings of uniform thickness, the bond stress is a maximum at the section of the face of the pier; in a sloped footing, the bond stress at the section at the face of the pier would be less accordingly than in a footing of uniform thickness, and a moderate slope may be found to distribute the bond stress more uniformly throughout the length of the bar. This is not of advantage if the full embedment of the bar is effective in resisting any pull due to bond.

9. The use of short bars placed with their ends staggered increases the tendency to fail by bond and cannot be considered as acceptable practice in footings of ordinary proportions. In footings in which the projection is short in comparison with the depth the objection is very great.

10. Footings having reinforcement placed in the direction of the diagonals as well as parallel to the sides (four-way reinforcement) gave good tests. The significance of the results is so obscured by the variety of manner of failure (bond, diagonal tension, and perhaps tension) and by variations in the quality of the concrete, that a comparison with two-way reinforcement on the basis of loads carried would not be of value. This type of distribution of reinforcement should be included in further tests. Measurements of deformation in the bars are needed to determine the division of stress among the four sets of bars.

6d. Design of Isolated Footings.—The 1941 Building Regulations of the American Concrete Institute will be followed in the design of all reinforced concrete and plain concrete footings discussed herein.

Maximum Bending Moment.—According to the regulations the external moment on any section should be determined by passing through the section a vertical plane that extends completely across the footing, and computing the moment of the forces acting over the entire area of the footing on one side of this plane. The greatest bending moment to be used in the design of an isolated footing should be the moment so computed at sections located as follows: for footings supporting a concrete column, pedestal, or wall, at the face of the column, pedestal, or wall; for footings under masonry walls, halfway between the middle and the edge of the wall; and for footings under metallic bases, halfway between the face of the column or pedestal and the edge of the metallic base.

The width resisting compression at any section should be taken as the entire width of the top of the footing at the section.

In one-way reinforced footings, the total tensile reinforcement at any section should provide a moment of resistance at least equal to the moment computed in the manner already described, and the reinforcement so determined should be distributed uniformly across the full width of the section.

In two-way reinforced footings, the total tensile reinforcement at any section should provide a moment of resistance equal to at least 85 per cent of the moment as already computed, and the total reinforcement so determined should be distributed across the full width of the footing.

Bond Stresses.—Critical sections for bond should be assumed at the same planes as those indicated for moment, and also at all other vertical planes where changes of section or of reinforcement occur. The total tensile reinforcement at any section should provide a bond resistance at least equal to the bond requirement as computed from the following percentages of the external shear at the section:

1. In one-way reinforced footings, 100 per cent.
2. In two-way reinforced footings, 85 per cent.

The allowable bond stresses, as specified by the regulations, are as follows: for plain bars, in one-way footings, $0.06f'_c$; in two-way footings $0.045f'_c$; for deformed bars, in one-way footings, $0.075f'_c$; in two-way footings, $0.056f'_c$. All bars in footings should be hooked at the ends. However, at no time may the allowable bond be taken at a value greater than 160 lb. per sq. in. for plain bars and 200 lb. per sq. in. for deformed bars.

Shearing Stresses.—The critical section for shear to be used as a measure of diagonal tension should be assumed as a vertical section obtained by passing a series of vertical planes through the footing, each of which is parallel to a corresponding face of the column, pedestal, or wall and located a distance therefrom equal to the depth d for footings in soil, and one-half the depth d for footings on piles. Each face of the critical section so obtained should be considered to resist an external shear equal to the load on an area bounded by said face of the critical section for shear, two diagonal lines drawn from the column or pedestal corners and making 45-deg. angles with the principal axis of the footing, and that portion of the corresponding edge or edges of the footing intercepted between the two diagonals. The allowable shear to be used as a measure of diagonal tension is $0.03f'_c$ but should not exceed 75 lb. per sq. in. The quantity f'_c is, in all cases, the ultimate compressive strength of concrete at the age of 28 days, expressed in pounds per square inch.

7. Combined Column Footings.—Where the exterior building columns are so located with respect to the property lines that sufficient bearing area cannot be obtained for a symmetrical isolated footing, a combined footing can be used. In such a footing, the exterior column in question is carried on a common footing with the adjacent interior column, the footing being of

such size and shape as to give the required bearing area and to make the center of gravity of the loads coincide with the center of the upward reaction. This is essential in order that, if any settlement should occur, it will be as nearly uniform as the character of the soil will allow and also to avoid dangerous transverse stresses in columns. At corners of buildings it often becomes necessary, owing to the above-mentioned restrictions, to place four columns on a combined footing, which may be solid or with a portion of the center omitted if the bearing value of the soil is relatively high.

Various shapes of combined footings can be used depending upon the relation of the column loads, the allowable projection of the footing beyond the respective column center lines, and whether or not relatively high shearing stresses are allowed.

From the standpoint of economy the rectangular-shaped footing with a greater thickness under columns (to take care of punching and diagonal shear) is the best. In such a footing fewer different lengths of bars are required, the transverse bending stresses are reduced to a minimum and also the amount of diagonal tension and the direct moment reinforcement. The two latter reductions are possible because of the greater thickness of slab at columns, which in turn cuts down the span of slab, in the same manner as the flaring heads in flat-slab construction.

If a footing of uniform thickness is used, the span-producing moment is greater and the shearing stresses will either be higher or the depth for moment excessive. Such footings should, therefore, not be used except for small footings or where it is necessary to keep the footings relatively shallow because of soil conditions.

From a construction standpoint the simpler the reinforcement and the shape of footing the cheaper will be the cost. The construction engineer detests nothing more than an irregular-shaped footing loaded with stirrups and bent bars of different lengths, for, when working below ground level, many difficulties are met with that militate against obtaining a first-class job if the layout of reinforcement is complicated.

In general, no limitation is placed on the allowable projection of footing beyond the interior column. Therefore, an illustrative example of a rectangular combined footing is given in Art. 10 since it represents the best and most common practice.

8. Cantilever Footings.—The type of footing described in Art. 7—the combined footing in which two columns are carried on the same footing so proportioned as to have the center of gravity of the loads coincide with the center of gravity of the upward reaction—is sometimes confused with, or even called, a cantilever footing, which, of course, is not correct. A cantilever footing is a construction connecting the footings of an interior and of an exterior column, the latter because of obstructions or local conditions being so placed as to have its center of gravity eccentric with the center of gravity of the column. This necessitates a strap or beam connection with the interior footing, which transfers the uplift, caused by cantilevering the exterior column beyond the center of the footing area supporting it, to the interior column footing. This construction is used where it is necessary to avoid encroachment on adjacent property or streets.

In this type of footing the uplift created at the footing for the interior column is found by multiplying the exterior column load by the eccentricity of the footing and dividing by the distance between the center of gravity of the exterior footing and the interior column. The strap connecting the two footings should be sufficiently strong to resist the bending moment caused by the eccentricity and the shear at the interior column. In construction the strap beam should be built so as not to bear on the foundation bed, which would complicate the action of the footing. This requirement can be met by excavating below the line of the bottom of the strap and building forms above. The space underneath should be boxed off so as to prevent filling in under the strap beam form (see Fig. 9, p. 252).

9. Continuous Footings.—Continuous footings may be divided into two main classes depending upon whether or not they are continuous between one or more lines of columns in one line and at right angles thereto. Where they are continuous between columns in one row only, as is often the case for wall columns where it is necessary to keep the projection beyond the building to a minimum owing to building code or property line restrictions, they are usually called “continuous” footings. If they cover the entire lot or are composed of several strips at right angles to each other built monolithic and supporting all the columns, they have generally been called “raft” footings. This latter name has been applied since such footings should be used only where the

bearing power of the soil is very low and the function of the footing is literally to "float" the building on a raft covering the entire ground area—or a large part of it—occupied by the building. They may also be used where the soil conditions require pile foundations, and the building loads are so heavy as to require a large number of piles that make it necessary to cover practically the entire building area with a "raft."

When soil conditions seem to warrant the use of continuous footings, the engineer should, by very careful study and tentative design, determine whether or not this type will be more economical and satisfactory than pile foundations, the next logical choice. Where investigation of the soil conditions shows a soil stratum of greater carrying capacity underlying the one in which the footings would be placed under ordinary circumstances, at a depth not to exceed 25 or 30 ft. below the latter, and there is any danger of the upper strata being disturbed or settling materially owing to adjacent building operations, it will usually be found more economical and a more stable foundation will be secured by using concrete or wood pile foundations or circular piers carried down to the solid stratum in wood-sheeted wells.

Continuous footings are best adapted to clay soils of low bearing power where the tendency to unequal settlement due to unequal loading of various parts of the building can be counteracted by tying the entire structure together as a large box, thus making adjoining portions of the footing aid the overloaded one in carrying the load. The action of such a footing under load is analogous to what tests show happens in a flat-slab floor under unequal loading.

In cases where it is necessary to load the entire foundation area, the footing slab can be designed as a flat-slab floor. In designing, however, it will be well to guard against undue bending stresses in the exterior columns produced by eccentricity of loading if the slab or mat does not project beyond the building lines sufficiently to balance the load. It should be remembered, however, that, where the exterior columns act as buttresses or supports for the basement walls, the pressure against these will relieve or counteract a certain amount of the bending induced by the eccentricity of the footing load.

Instead of using the ordinary sloping column head, so common in flat-slab construction, as a base for the column resting on the

footing slab, it will be found more economical to use a square or oblong pedestal consisting of one or more courses of sufficient size and depth to meet the requirements of accepted flat-slab design. For cases where the column spacing is over 20 ft. it may be found more economical to use a paneled slab for the mat, *i.e.*, one with greater thickness for the portions of the slab

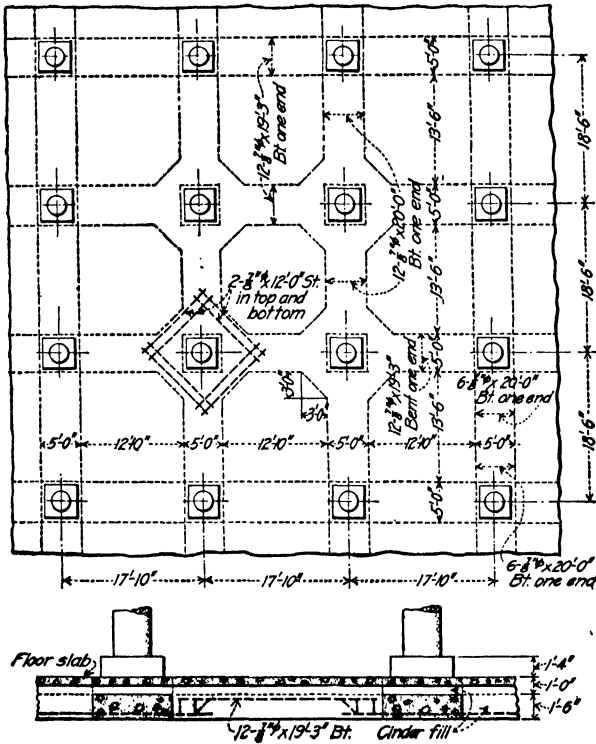

FIG. 3.

containing the main reinforcing running direct between columns. A considerable saving in concrete may thus be effected by such footing slabs, which should be designed by the same methods as used for "paneled ceiling" construction.

An example of a continuous footing supporting all columns of the building on several strips of reinforced concrete slabs at right angles to each other is shown in Fig. 3. Note the method of obtaining additional bearing area for columns supporting the sprinkler tank in addition to the regular building loads.

An example of a raft foundation composed of beams or girders at right angles to each other with a relatively thin slab underneath to distribute the load over the entire area is shown in Fig. 4.¹ This raft was designed as a T-beam structure and, although a saving in the design was effected in this respect, it requires an extra fill and another slab for the basement floor over the footing slab proper. A raft of flat-slab construction eliminates the necessity of another slab for the basement floor provided

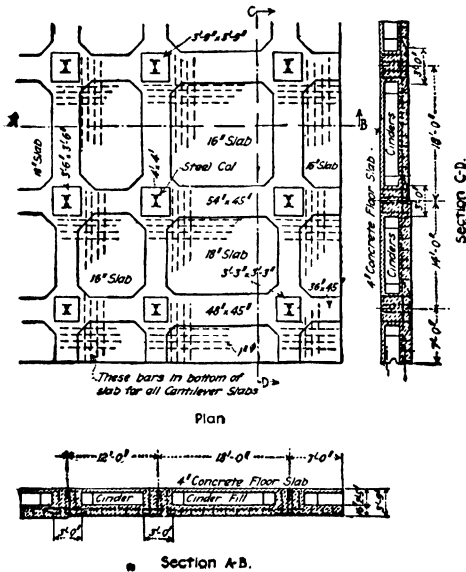

FIG. 4.

the column bases required for shear and moment considerations are not so large as to take up a considerable added area in the basement.

10. Illustrative Problems in the Design of Isolated, Combined, and Cantilever Footings of Reinforced Concrete. *Design Data.*—Design the necessary interior and exterior column footings for a three-story and basement building with interior panels 20×20 ft., center to center of columns, and with exterior exposed columns placed so that the distance from the center of the first row of interior columns to the outside face of the exterior columns

¹ W. A. HOYT, *Eng. News*, Aug. 26, 1909, p. 212.

is 20 ft. (Fig. 5). Floor loads are 200 lb. per sq. ft. The building is to occupy a lot 80 ft. wide by 200 ft. long with street on one side and one end, alley at the other end, and an inside lot line on the other side. On the long street side, footings can project only

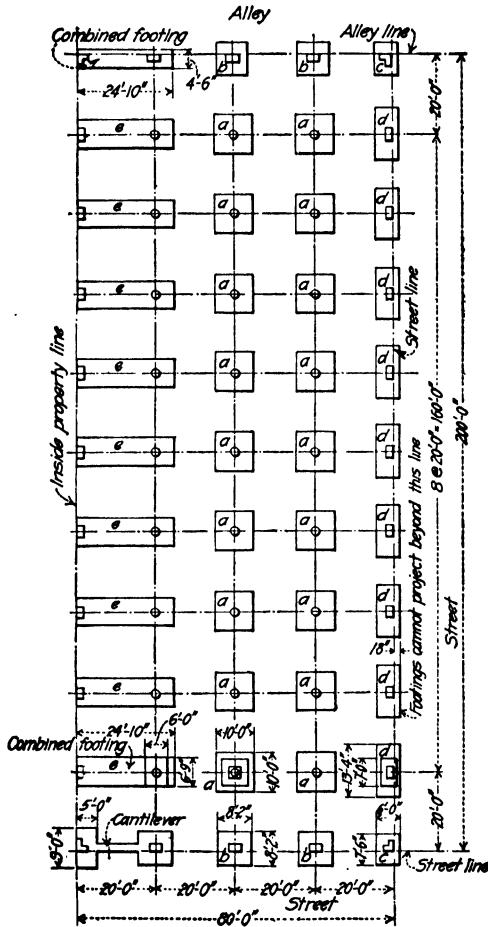

FIG. 5.

18 in. beyond the lot line by city ordinance because of future proposed subways. On the other street there are no restrictions. On the inside property line, outer faces of columns are to be on the line. Maximum allowable soil pressure is 4,000 lb. per sq. ft., neglecting weight of footing. Sizes of columns are as follows:

interior columns, 24 in. in diameter; exterior columns, 24 × 36 in.; corner columns, 18 × 36 in. The stresses to be used in the design of all footings will be

- Reinforcing steel: $f_s = 20,000$ lb. per sq. in.
 Ultimate strength of concrete: $f'_c = 2,500$ lb. per sq. in.
 $n = 12$
 Working stress in concrete: $f_c = 1,000$ lb. per sq. in.
 Allowable shear: $v = 75$ lb. per sq. in.

All reinforcing bars are considered to have end anchorage. The American Concrete Institute Building Regulations for 1941 will be followed in the design. The column loads are as follows:

Column	Dead load	Live load	D.L. + L.L.	D.L. + 50% L.L.
Typical interior.....	193,000	202,000	395,000	294,000
Typical ext. column.....	143,000	106,000	249,000	196,000
Corner column.....	127,000	54,000	158,000	131,000

Areas of Footings.—Interior column footing area = $\frac{395,000}{4,000} = 99$ sq. ft.

Use a 10 × 10-ft. footing = 100 sq. ft.

With a footing of this size the pressure on soil for dead load plus 50 per cent of the column live load is $\frac{294,000}{100} = 2,940$ lb. per sq. ft.

Exterior column footings should be proportioned for dead load plus 50 per cent of the live load, hence the bearing value of 2,940 lb. should be used in determining the area required, which equals $\frac{196,000}{100} = 66.6$ sq. ft.

Use a footing 8 ft. 2 in. square on alley and short street side. On the longer street side the limitation of 18-in. projection beyond building line and column thickness of 24 in. restricts width of footing to 5 ft. [2 ft. + (2 × 18 in.)]. Therefore the length of footings must be 13 ft. 4 in. For full live load plus dead load the pressure under exterior footings will be $\frac{249,000}{66.6} = 3,740$ lb. per sq. ft. This pressure must be used in design of reinforcement for footing.

The corner column footings require an area equal to $\frac{131,000}{2,940} = 44.5$ sq. ft. Owing to the fact that the limitation of projection of footing on the longer street side is 18 in. beyond building line and the center line of column is 18 in. in from building line (exterior columns have 36-in. exposed faces) the corner footings on street and alley corners can be 6 ft. wide and the length 7 ft. 6 in., giving an area of 45 sq. ft. For full live load and dead load the pressure equals $\frac{158,000}{45} = 3,500$ lb. per sq. ft. This pressure should be used in analyzing stresses in corner footings.

The footings along the inside property line will have to be combined with those in the next row away from the property line because of the eccentricity of column as regards the possible footing area. For a typical exterior and interior column the combined area required equals 166.6 sq. ft. The center of gravity of the combined footing must coincide with the center of gravity of loads. The center of gravity of loads equals $\frac{(294,000)(19)}{490,000} = 11.4$ ft. from the center of exterior column (taking moments about center of exterior column). Hence the footing must be $2(11.4 + 1) = 24.8$ ft. or 24 ft. 9½ in. long. Use 24 ft. 10 in. in computations. The width equals $\frac{(100 + 66.6)}{24.8} = 6.72$ ft. Use width of 6 ft. 9 in. The dimensions of footing are shown in Fig. 8.

At the street and alley ends adjacent to the property line, a corner and an exterior column must be combined and an area of $66.6 + 44.5 = 111.1$ sq. ft. is required. The center of gravity of loads equals $\frac{(196,000)(19)}{327,000} = 11.4$ ft. from center of corner column. It so happens for the loads given that the length of this footing will be the same as the one just proportioned carrying an interior and an exterior column, but this, of course, is not always the case. Using a length of $2(11.4 + 1) = 24.8$ ft., the width required is $\frac{111.1}{24.8} = 4.5$ ft. The size of the various footings for the building as above determined are shown in Fig. 5.

Detailed Design of Typical Interior Footing.—As already determined, the typical interior footings are to be 10 ft. square and will have two-way reinforcing.

According to the regulations, for a round or octagonal concrete column or pedestal the face of the column, used in footing design, shall be taken as the side of a square of an area equal to the area enclosed within the perimeter of the column or pedestal.

$$\text{The equivalent column} = \sqrt{\frac{\pi \times 24^2}{4}} = \sqrt{452} = 21 \text{ in.}$$

Assume an effective depth of footing of $20\frac{1}{2}$ in. with a distance of $3\frac{1}{2}$ in. from center of steel to the bottom of the footing.

The shear as a measure of diagonal tension is measured at a distance from the face of the column equal to the depth of the footing to steel, or $20\frac{1}{2}$ in. in this case. The area between the square formed by lines $20\frac{1}{2}$ in. from face of column and the edge of footing produces shear on the vertical planes through the square $EFGH$ (Fig. 6).

$$\text{Total shear on } EFGH, \frac{100 - 5.17^2}{100} (395,000) = 290,000 \text{ lb.}$$

The intensity of shear on $EFGH$ = $\frac{V}{bjd}$, in which j may be taken as 0.875 with sufficient accuracy.

$$v = \frac{290,000}{4 \times 62 \times 0.875 \times 20.5} = 65 \text{ lb. per sq. in.}$$

The allowable v is 75 lb. per sq. in.; so the assumed d is satisfactory from the standpoint of shear as a measure of diagonal tension.

The bending moment on each set of rods is

$$M = (3,950)(10) \frac{(4.125)^2}{2} (12) = 4,030,000 \text{ in. lb.}$$

The d required for moment is

$$d = \frac{M}{Kb} = \frac{4,030,000}{164 \times 120} = 14.3$$

and the concrete stress is seen to be satisfactory.

The area of steel required is

$$A_s = \frac{0.85M}{f_s j d} = \frac{0.85 \times 4,030,000}{20,000 \times 0.875 \times 20.5} = 9.56 \text{ sq. in.}$$

Twenty-four $\frac{3}{4}$ -in. round bars have an area of 10.6 sq. in. and a total perimeter of 57.6 in.

The bond stress is checked on the same section as the moment.

$$V = (3,950)(10)(4.125) = 163,000 \text{ lb.}$$

$$u = \frac{0.85V}{\Sigma ojd} = \frac{0.85 \times 163,000}{57.6 \times 0.875 \times 20.5} = 134 \text{ lb. per sq. in.}$$

This is satisfactory, provided we use deformed bars. The footing is shown in Fig. 6.

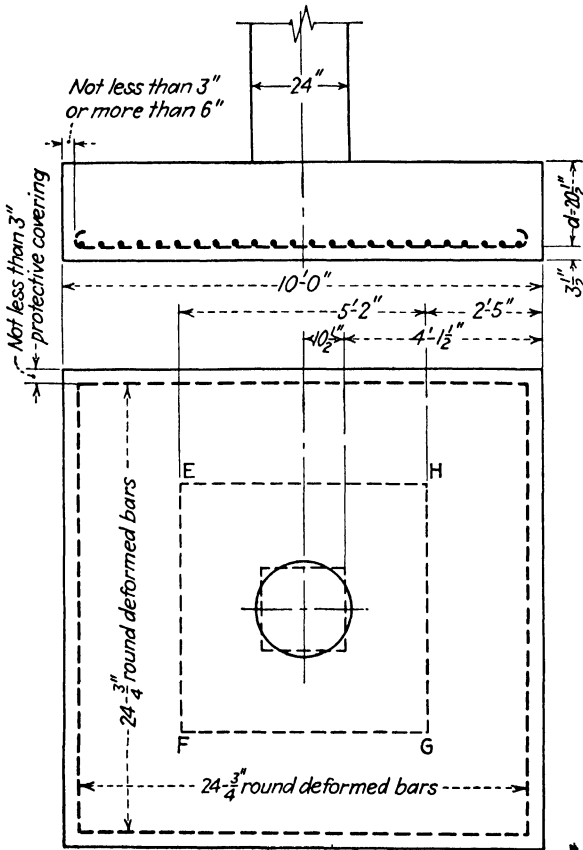

FIG. 6.

Some saving in concrete could be realized by using a stepped footing. This, however, would increase the cost of form work. If other considerations do not exist, the decision as to whether or

not to use a stepped footing would be based on a comparison of the saving in concrete and increased cost of form work. This would also be true if a sloped footing were used.

If a sloped or stepped footing is used, the angle of slope or depth and location of steps should be such that the allowable stresses are not exceeded at any section. The effective cross section in compression should be limited by the area above the neutral plane and its width should be taken as the width of the

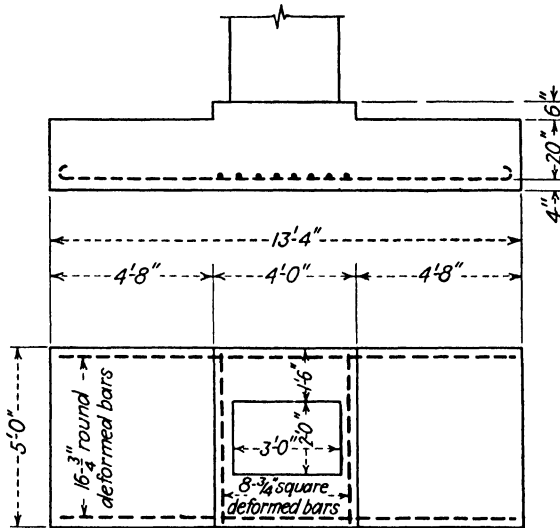

FIG. 7.

top of the footing at the section being considered. Sloped and stepped footings should be cast as a unit.

Dowels are used to transfer the stress in the longitudinal steel at the base of a reinforced concrete column to the footing. The regulations specify that there should be at least one dowel for each reinforcing bar in the column, and the total sectional area of dowels should not be less than the area of column reinforcing. These dowels should extend into the column and into the pedestal or footing the distance required to transfer to the concrete, by allowable bond stresses, their full working strength. It is often necessary to increase the depth of the footing under the column to provide sufficient thickness to receive these dowels. This is

done by placing a pedestal on top of the footing proper, of a thickness sufficient to make up the deficiency in the footing thickness. The pedestal may be of plain concrete (except for the dowels) provided the compressive unit stress on the gross area does not exceed the allowable, as explained subsequently under the general heading Transference of Column Loads to Footings, page 263. When this stress is exceeded, reinforcement should be provided and the pedestal designed as a reinforced concrete column. The pedestal should be placed monolithically with the footing.

Design of Rectangular Exterior Column Footing.—The square footings of exterior columns on alley and short street side will not be designed in detail here, but the rectangular footings along the long street side will be, in order to indicate the procedure with footings of this type.

These footings are to be 5 ft. wide by 13 ft. 4 in. long (Fig. 7). It will be considered that the column load is to be carried by a transverse beam 4 ft. wide, which in turn is supported by the main footing acting as a longitudinal beam.

The pressure on the soil is $\frac{249,000}{66.6} = 3,740$ lb. per sq. ft.

Design the longitudinal beam:

Moment at edge of transverse beam is

$$M = 5 \times \frac{(4.67)^2}{2} \times 3,740 \times 12 = 2,450,000 \text{ in.-lb.}$$

$$M = \frac{1}{2} f_c k j b d^2$$

in which for an ideal beam and for the stresses we are using $k = 0.375$; $j = 0.875$.

Therefore,

$$\begin{aligned} d &= \sqrt{\frac{2M}{f_c k j b}} \\ &= \sqrt{\frac{2 \times 2,450,000}{1,000 \times 0.375 \times 0.875 \times 60}} = \sqrt{249} = 15.8 \end{aligned}$$

Subsequent checks indicate that a 20-in. depth is preferable. j may still be used as 0.875 with sufficient accuracy. The critical section for shear is therefore 20 in. from the edge of the transverse beam.

$$V = 5 \times 3.0 \times 3,740 = 56,000 \text{ lb.}$$

$$v = \frac{56,000}{60 \times 0.875 \times 20} = 54 \text{ lb. per sq. in.}$$

Allowable $v = 75$ lb. per sq. in.

$$A_s = \frac{M}{f_s j d} = \frac{2,450,000}{20,000 \times 0.875 \times 20} = 7.0 \text{ sq. in.}$$

Use sixteen $\frac{3}{4}$ -in. round bars spaced evenly across entire width, leaving 4-in. covering on each side. This gives an area of steel = 7.05 sq. in. and each bar has a perimeter of 2.4 in. The critical section for bond being at the edge of the transverse beam

$$V = 4.67 \times 5 \times 3,740 = 87,500 \text{ lb.}$$

$$u = \frac{V}{\Sigma o j d} = \frac{87,500}{16 \times 2.4 \times 0.875 \times 20} = 130 \text{ lb. per sq. in.}$$

Permissible bond is 140 lb. per sq. in. for deformed bars; so deformed bars should be used.

Design of transverse beam:

The load per foot of transverse beam is

$$13.33 \times 3,740 = 50,000 \text{ lb.}$$

The critical section for moment is at the face of the column

$$M = 50,000 \times \frac{1.5^2}{2} \times 12 = 675,000 \text{ in.-lb.}$$

The shear to use in checking bond stress is

$$V = 50,000 \times 1.33 = 66,600 \text{ lb.}$$

Extend transverse beam 6 in. above top of footing

$$A_s = \frac{675,000}{20,000 \times 0.875 \times 25.5} = 1.5 \text{ sq. in.}$$

$$\Sigma o = \frac{66,600}{141 \times 0.875 \times 25.5} = 21.2 \text{ in.}$$

Eight $\frac{3}{4}$ -in. square deformed bars will be used to satisfy the bond requirement giving a total perimeter of 24 in. and a total area of 4.5 sq. in. These bars should be bent up around the ends of the transverse beam.

No check is necessary on shear as a measure of diagonal tension since the critical section for shear would fall outside the footing.

The foregoing method of design is recommended for rectangular footings having a length greater than $1\frac{1}{2}$ times the width. When the length is $1\frac{1}{2}$ times the width, or less, it is recommended that the moments on the critical sections be computed as for square footings and that both the longitudinal and transverse steel be designed for 85 per cent of the respective moments. The longi-

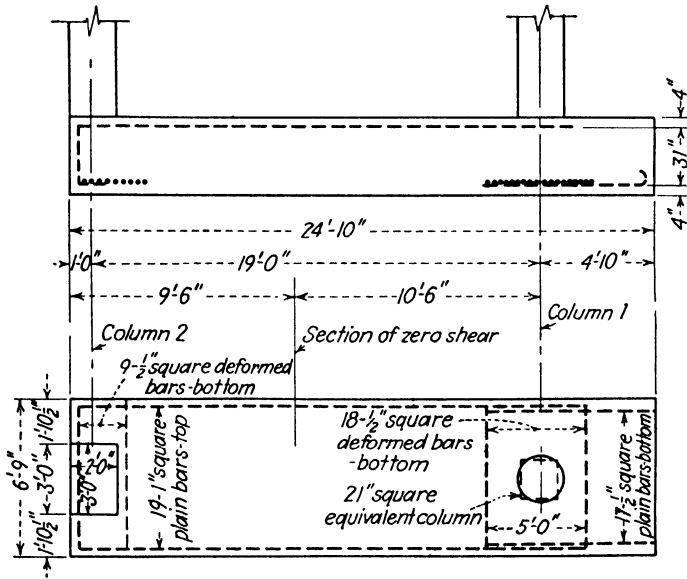

FIG. 8.

tudinal steel should be spaced uniformly over the entire width of the footing. A part, A_{s1} , of the transverse steel, should be distributed uniformly in a strip equal in width to the short side of the footing and symmetrical with respect to the column.

A_{s1} is given by the formula

$$A_{s1} = A_s \left(\frac{2}{1 + R} \right)$$

in which A_s is the total area of transverse steel required and R is the ratio of the length to the width of the footing. The

remainder of the transverse steel is distributed uniformly over the two outer end strips of the footing.

Combined Footings—Rectangular.—The size of the rectangular combined footing for one interior and one exterior column was found to be 24 ft. 10 in. long by 6 ft. 9 in. wide (Fig. 8).

Since the total load on the interior column is 395,000 lb. and on the exterior column is 249,000 lb., the average pressure on the soil for full live load will be

$$W = \frac{644,000}{166.6} = 3,860 \text{ lb. per sq. ft.}$$

This pressure will be used in the detail design of footing. In this, as in the other examples, the maximum allowable soil pressure has been assumed at 4,000 lb. per sq. ft. and the weight of footing neglected in the computations. In other words, the soil has been assumed to be capable of bearing the additional load due to weight of footing.

The columns will be supported on transverse beams within the footing, which in turn will be supported by the entire footing acting as a longitudinal beam. The maximum negative moment in the footing between the columns will occur at the section of zero shear. The distance from the outside of the building to this section of zero shear is given by

$$\frac{249,000}{6.75 \times 3,860} = 9.5 \text{ ft.}$$

The value of this moment is

$$\left[(6.75) \frac{(9.5)^2}{2} (3,860) - (249,000)(8.5) \right] 12 = 11,300,000 \text{ in.-lb.}$$

The depth required for moment is then

$$d^2 = \frac{M}{Kb} = \frac{11,300,000}{164 \times 6.75 \times 12} = 850$$

$$d = 29.2 \quad \text{Say 30 in.}$$

Checking this depth for shear as a measure of diagonal tension, the critical section is a distance of 30 in. from the edge of the 21-in. square equivalent interior column, or a total distance of 40½ in. from the center line of the interior column. Since the

section of zero shear is 10 ft. 6 in. from this same center line, the shear on the critical section is

$$V = (6.75)(10.5 - 3.4)(3,860) = 185,500 \text{ lb.}$$

$$\frac{V}{bjd} = \frac{185,500}{6.75 \times 12 \times 0.875 \times 30} = 88 \text{ lb. per sq. in.}$$

The allowable $v = 75$.

Increasing d to 35 in. will reduce v to 75 lb. per sq. in.

The longitudinal steel required in the top of the footing to care for the negative moment is given by

$$A_s = \frac{11,300,000}{20,000 \times 0.875 \times 35} = 18.5 \text{ sq. in.}$$

Use nineteen 1-in. square bars spaced 4 in. center to center.

Check bond at face of 21-in. square equivalent interior column.

$$V = (6.75)(10.5 - 0.9)(3,860) = 250,000 \text{ lb.}$$

$$u = \frac{250,000}{19 \times 4 \times 0.875 \times 35} = 108 \text{ lb. per sq. in.}$$

Allowable bond is 113 lb. per sq. in. for plain bars with end anchorage in 2,500-lb. concrete; so plain bars may be used.

The positive moment due to the projection of the footing beyond the interior column is

$$M = (6.75) \frac{(4)^2}{2} (3,860)(12) = 2,500,000 \text{ in.-lb.}$$

$$A_s = \frac{2,500,000}{20,000 \times 0.875 \times 35} = 4.1 \text{ sq. in.}$$

Use seventeen $\frac{1}{2}$ -in. square bars.

Check on bond:

$$V = (6.75)(4)(3,860) = 10,400 \text{ lb.}$$

$$u = \frac{10,400}{17 \times 2.0 \times 0.875 \times 35} = 100 \text{ lb. per sq. in.}$$

Plain bars may be used. No check on shear is necessary. Consider the transverse beam under the interior column. The load per foot on this beam will be

$$\frac{395,000}{6.75} = 58,500 \text{ lb.}$$

$$M = \frac{(2.5)^2}{2} (58,500)(12) = 2,195,000 \text{ in.-lb.}$$

We shall arbitrarily take the effective width of this beam as 5 ft. Then d for moment is given by

$$d = \sqrt{\frac{2,195,000}{164 \times 60}} = \sqrt{223} = 14.95 \text{ in.}$$

Actual d is 34 in., 1 in. less than d of longitudinal steel.

$$A_s = \frac{2,195,000}{20,000 \times 0.875 \times 34} = 3.7 \text{ sq. in.}$$

The required perimeter for bond, taking the critical section for bond at the face of the 21-in. square equivalent column and assuming deformed bars, is

$$\Sigma o = \frac{(2.5)(58,500)}{141 \times 0.875 \times 34} = 34.9 \text{ in.}$$

Use eighteen $\frac{1}{2}$ -in. square deformed bars, giving an area of 4.5 sq. in. and a perimeter of 36 in. Spacing these bars within the assumed effective width of 5 ft., we see that a spacing of $3\frac{1}{2}$ in. would be satisfactory. Consider the transverse beam under the exterior column.

The load per foot is

$$\frac{249,000}{6.75} = 37,000 \text{ lb.}$$

$$M = \frac{(1.9)^2}{2} (37,000)(12) = 800,000 \text{ in.-lb.}$$

Obviously, from a comparison with the previously designed transverse beam under the interior column, the d of 34 in. will be satisfactory from the standpoint of moment.

$$A_s = \frac{800,000}{20,000 \times 0.875 \times 34} = 1.35 \text{ sq. in.}$$

At the face of the column

$$\Sigma o = \frac{(1.9)(37,000)}{141 \times 0.875 \times 34} = 16.8 \text{ in.}$$

Use nine $\frac{1}{2}$ -in. square bars giving an area of 2.25 sq. in. and a perimeter of 18 in. These must be deformed bars. They will be spaced at 3 in. center to center, placing the outside bar 4 in. from the end of the footing.

Combined Footing—Trapezoidal.—Using the same spacing of columns and load as in the previous example, but limiting the projection to 1 ft. beyond column 1 a trapezoidal footing will be required. As determined previously, the center of gravity of the column loads is located 11.4 ft. from the center line of column 2. The center of gravity of the footing should coincide with the center of gravity of the loads. The length of footing is 22 ft. Now the area required for footing is 166.6 sq. ft., and the average width must be such as to give this area.

If C_1 and C_2 be taken as the width of footing at columns 1 and 2, respectively, then

$$\frac{(C_1 + C_2)(22)}{2} = 166.6$$

or

$$C_1 + C_2 = 15.14 \text{ ft.}$$

From the common equation for center of gravity, the distance from end of footing at column 1 to center of gravity equals

$$x_1 = \left(\frac{22}{3}\right) \left(\frac{C_1 + 2C_2}{C_1 + C_2}\right) = 9.6 \text{ ft.}$$

Solving these equations

$$C_1 = 11.14 \text{ ft. and } C_2 = 4 \text{ ft.}$$

For full live load and dead load

$$w = \frac{644,000}{166.6} = 3,860 \text{ lb.}$$

This pressure should be used in the design of the footing, which from this point is similar to the problem just illustrated except that the small positive moment at column 1 may be neglected. The line of maximum moment will be at the line of zero shear.

Cantilever Footing.—As an example of a cantilever footing take the corner footing at the property line and the adjacent exterior column footing and connect them with a strap to resist the uplift moment caused by the eccentricity of the footing slab for corner column (see Fig. 5).

The center of gravity of the corner column is located 15 in. from either face. The area of footing required for the corner

column is 44.5 sq. ft. Assume a width of 5 ft. for the corner column footing, making the eccentricity 1 ft. 3 in. (Fig. 9). This will require a length of 9 ft. For the typical exterior column use a footing 8 ft. 2 in. square as required by previous computation.

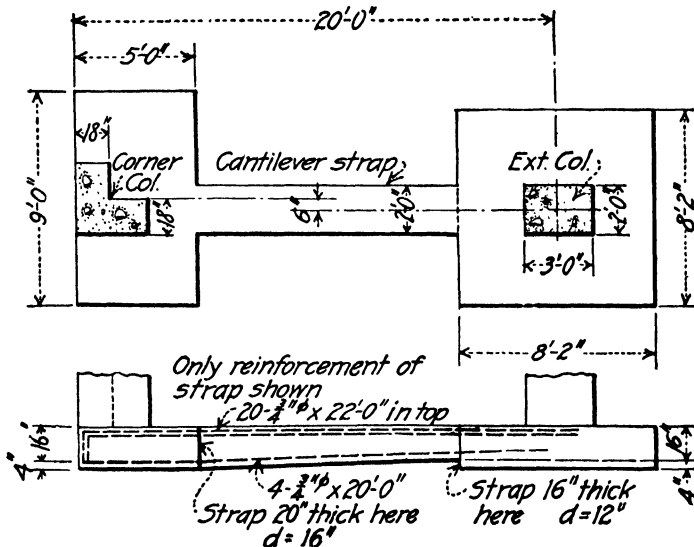

FIG. 9.

By taking moments about the center of gravity of the exterior footing, the uplift at the exterior column for full live and dead load on the corner column is found to be

$$\frac{(158,000)(1.25)}{17.5} = 11,300 \text{ lb.}$$

This is the value of the vertical shear carried by the strap. The total load on the exterior footing is decreased, and the total load in the corner footing is increased, by this amount. The total pressure (exclusive of weight of footing, which is neglected owing to its consideration in fixing the allowable bearing on soil) to be provided for in the corner footing will be

$$158,000 + 11,300 = 169,300 \text{ lb.}$$

For the footing size used, this gives a unit bearing of 3,760 lb. per sq. ft.

The corner footing should be designed for this soil pressure in a manner similar to the exterior footings along the long street side of the building. These computations will not be given here.

The maximum moment in the strap beam equals

$$M = (158,000)(1.25)(12) = 2,370,000 \text{ in.-lb.}$$

The shear, as previously noted, is 11,300 lb.

The strap may then be designed by the usual methods. The main reinforcing steel must, of course, be placed in the top of the strap and the ends at the corner column should be hooked down at the edge of the footing as shown. The section of the strap at the corner column will be determined by shear. It would be advisable to design the strap so as to make stirrups unnecessary. A nominal amount of reinforcement should be placed in the bottom of the strap (see Fig. 9).

11. Design of Plain Concrete Footings.—In the design of plain concrete footings the area of the base required is found in the usual way, *i.e.*, by dividing the total load on the footing, including its own weight if the supporting power of the earth has not been reduced by the weight of the footing, by the allowable unit earth pressure.

The area of the top of the footing should be such that the unit compressive stress on the loaded area will not exceed the bearing stress allowable for the quality of concrete in the footing as limited by the ratio of the loaded area to the supporting area. If the entire supporting area, *i.e.*, the entire footing top, is loaded, the allowable unit compressive stress is $0.25 f'_c$. If only one-third or less of the footing top is loaded, then the allowable is $0.375 f'_c$. Where the loaded area varies between one-third and the full supporting area, the allowable unit compressive stress is found by interpolating between the above values.

The critical section for moment is the same as for reinforced concrete footings, *i.e.*, at the face of the column, pedestal, or wall for footings supporting a concrete column, pedestal, or wall; and halfway between the middle and edge of the wall, for footings under masonry walls. The footing is considered to be a homogeneous beam in resisting this bending, and the dimensions should be such that the tension in the concrete will not exceed $0.03 f'_c$.

The critical section for shear is the same as for reinforced concrete footings, *i.e.*, a section parallel to the face of the wall,

pedestal, or column, and located a distance therefrom equal to the depth of the footing. The average shearing stress on this section must not exceed $0.02f'_c$.

Illustrative Problem.—Design a footing for a concrete wall of a storage building carrying 21,000 lb. per lin. ft.; allowable bearing in the soil is 3,000 lb. per sq. ft.; wall 24 in. thick; $f'_c = 2,500$. Assume weight of footing at 375 lb. per sq. ft. and a footing 8 ft. wide.

$$\text{Total load per foot} = 21,000 + 3,000 = 24,000 \text{ lb.}$$

$$\text{Width of footing} = \frac{24,000}{3,000} = 8 \text{ ft.}$$

$$M = \frac{(3)^2}{2} (3,000 - 375)(12) = 142,000 \text{ in.-lb.}$$

$$d^2 = \frac{6M}{bf'_c} = \frac{6 \times 142,000}{12 \times 75} = 948$$

$$d = 30.8$$

Evidently a d of 31 in. is required for moment. The assumed weight is sufficiently close.

This d is checked for shear:

$$V = (3,000 - 375)(0.4) = 1,050 \text{ lb.}$$

$$v = \frac{V}{bd} = \frac{1,050}{12 \times 31} = 3 \text{ lb. per sq. in.}$$

The plain concrete footing for the wall in question would be 8 ft. wide and 31 in. deep.

12. Footings Supported on Piles.—Where the bearing value of the soil is so low as to necessitate very large spread footings to distribute the load properly (with the ever attendant danger of movement of the soil under the footing), it will generally be found advisable to use either concrete or wood piles driven down to a firmer stratum, or deep enough to give the required bearing capacity due to skin friction.

Pile footings may be of the same general types as the plain and reinforced concrete footings previously described and illustrated, the difference in design being that instead of assuming a uniform bearing of the soil over the area of the footing, the reaction of each pile is considered as a concentrated load equal to the safe allowable load for the pile.

Most building codes require that the concrete footing capping the piles be carried down 6 in. below the top of the piles and that this concrete be neglected in computing the strength of the footing. Then, also, the spacing of piles is usually limited to 2 ft.

6 in. for wooden piles and 3 ft. for concrete piles, except where driven in staggered rows, when the spacing of rows may be reduced 2 or 3 in. for wooden and concrete piles, respectively. For wooden piles, the cutoff line, or top, should be below the natural ground-water level to avoid decay. Where the meeting of this requirement means added expense, concrete piles should be used.

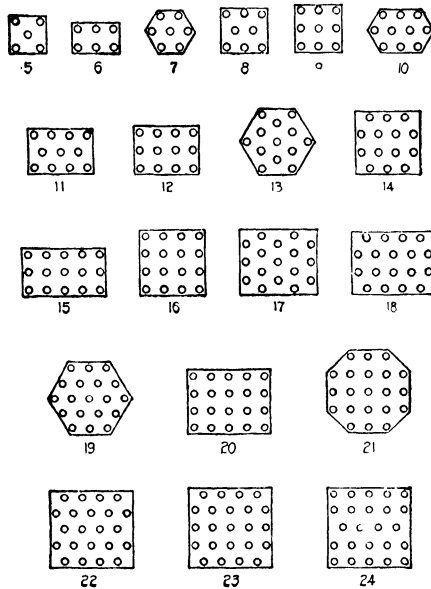

FIG. 10.

The most economical arrangement of piles in footings for various numbers of piles is shown in Fig. 10, the spacing of piles being as required by the particular code followed.

The critical sections for moment are the same as for footings resting on soil, and the required tensile reinforcement is determined in the same manner and placed according to the same rules. The critical sections for bond also are the same as for footings resting on soil and the allowable stresses are the same.

However, for footings resting on piles the critical section for shear to be used as a measure of diagonal tension is assumed as a vertical section obtained by passing a series of vertical planes, each of which is parallel to a corresponding face of the column,

pedestal, or wall, and located a distance therefrom equal to one-half the depth d of the footing.

In computing the external shear on any section through a footing supported on piles, the entire reaction from any pile whose center is located 6 in. or more outside the section should be assumed as producing shear on the section; the reaction from any

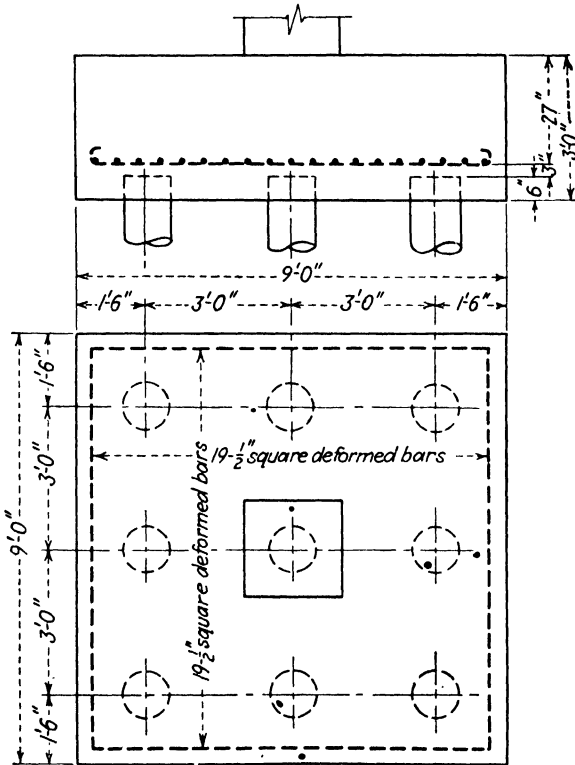

FIG. 11.

pile whose center is located 6 in. or more inside the section should be assumed as producing no shear on the section. For intermediate positions of the pile center, the portion of the pile reaction to be assumed as producing shear on the section should be based on a straight-line interpolation between full value at 6 in. outside the section and zero value at 6 in. inside the section.

Illustrative Problem.—A 24-in. square column supports a load of 325,000 lb. Design a footing resting on piles, if the safe bearing load of each pile is

20 tons, using the 1941 Regulations of the American Concrete Institute. $f'_c = 2,500$.

Assuming that the footing will weigh 35,000 lb., the number of piles required = $\frac{360,000}{40,000} = 9.0$.

Use nine piles spaced 3 ft. each way, with 1 ft. 6 in. from center of outer rows to edge of footing. This will make the footing 9 ft. square (see Fig. 11). The assumed weight then would be consistent with a total thickness of about 3 ft. Since the footing extends 6 in. below the tops of the piles and the steel should be at least 3 in. above the pile tops, we have actually assumed a d of 27 in.

The critical section for shear is a concentric square, each side being $12 + 13\frac{1}{2} = 25\frac{1}{2}$ in. from the column center. Since the centers of all piles, except that in the middle, are more than 6 in. outside of this section, the net reactions of eight piles will cause shear on the critical section. The net reaction per pile is $40,000 - 9 \times 450 = 35,950$ lb.

The intensity of shear on the critical section is, therefore,

$$v = \frac{8 \times 35,950}{4 \times 51 \times 0.875 \times 27} = 60 \text{ lb. per sq. in.}$$

The allowable shear is 75 lb. per sq. in., so the assumed d of 27 in. is satisfactory. The maximum moment on the vertical section through one face of the column is

$$M = 35,950 \times 3 \times 24 = 2,590,000 \text{ in.-lb.}$$

The effective depth required for this moment is

$$d = \sqrt{\frac{2,590,000}{108 \times 164}} = 12.1 \text{ in.}$$

Consequently, the concrete stresses are satisfactory.

The moment to be used in designing the steel is, according to the regulations,

$$A_s = \frac{0.85 \times 2,590,000}{20,000 \times 0.875 \times 27} = 4.66 \text{ sq. in.}$$

Assuming that deformed bars will be used we have

$$\Sigma o = \frac{3 \times 35,950}{141 \times 0.875 \times 27} = 32.3 \text{ in.}$$

Nineteen $\frac{1}{2}$ -in. square bars will be used, giving an area of 4.75 sq. in. and a perimeter of 38 in. They will be spaced uniformly across the entire width of the footing.

GRILLAGE FOOTINGS

13. Steel Grillage Footings.—In the early days of the skyscraper and until replaced in more recent years by reinforced

concrete, steel grillage footings were used very extensively in large buildings to distribute the column loads over relatively large areas with a minimum required depth of footing.

The beams forming the grillage are encased in concrete. This, however, is not assumed as adding to the strength of the footing but rather serving as a protection for the steel beams against rust. The steel beams in the grillage should be designed to resist the maximum bending moment, the shearing stresses, and with a spacing of beams that will readily admit the placing of concrete between them and at the same time allow the concrete filling to distribute the load. Some designers do not assume that the concrete between beams helps to resist any tendency of the webs to buckle under load. It would seem, however, that where properly encased in concrete and with separators placed between beams at frequent intervals, buckling would be impossible. On this basis, the webs should be figured for bearing steel on steel.

The bottom beams of a grillage footing should rest on a bed of concrete not less than 4 in. thick and preferably 6 to 9 in., and be completely surrounded at ends by at least 6 to 9 in. of concrete, while the space between beam flanges should never exceed $1\frac{1}{2}$ times the flange width or be less than $2\frac{1}{2}$ in. to allow proper tamping of the concrete. The assembled grillage is usually blocked up in position and leveled, and the concrete placed around it so as to give bearing on all flanges.

The beams in a grillage should not be painted. To prevent them from spreading and to make them act as a unit, gas-pipe separators (not cast iron since they break the continuity of the concrete) should be placed at the ends and under all points where concentrated loads occur. For beams over 8 in. deep, two lines of separators should be used.

The bearing area of a grillage is generally assumed as equal to the length of beams times the out-to-out width of the flange edges. Some codes allow an additional width equal to the width of the upper outer flanges on both sides. This latter additional area is allowed on the basis that the concrete tamped between the flanges will distribute the bearing to the concrete adjacent to the lower outer flanges.

Illustrative Problem.—Design a steel grillage footing for a 14-in. WF 136-lb. column carrying a total load of 600,000 lb., the bearing value of the soil being 6,000 lb. per sq. ft.

The area of footing required is 100 sq. ft. and a square footing will be used. A base plate $27 \times 27 \times 3$ in. will be used to transfer the load from the column to the top tier of the grillage. Two tiers of beams will be used, and the beams of each tier will be 10 ft. long.

The upward reaction per foot of top tier is 60,000 lb. Taking moments about a section $6\frac{1}{2}$ in. within the edge of the plate, *i.e.*, nearly under the edge of the column, we have

$$M = 60,000 \times \frac{(4.4)^2}{2} \times 12 = 6,970,000 \text{ in.-lb.}$$

Allowing 20,000 lb. per sq. in. for steel, the total section modulus required for the top tier is

$$S = \frac{6,970,000}{20,000} = 349 \text{ in.}^3$$

If four beams are used, each beam should have a section modulus of about 84 in.³ Four 15-in. 70-lb. I-beams will be used. In general, I-beams are more satisfactory than WF sections for grillage work because of their relatively narrow flanges and thick webs. The shear on each beam web will be

$$\frac{4.4 \times 60,000}{3} = 88,000 \text{ lb.}$$

The web of a 15-in. 70-lb. I-beam, at 13,000 lb. per sq. in., will support a shear of 150,000 lb.

Web crippling is checked, under the base plate. The load per beam is 150,000 lb. The crippling value for the web of a 15-in. 70-lb. I-beam is figured, allowing 24,000 lb. per sq. in. on the web. The length of bearing is $27 + 2k$ for the beam, or $27 + 2 \times 1\frac{1}{8} = 30.25$ in. The beam web is 0.77 in. thick, and the web crippling value is

$$30.25 \times 0.77 \times 24,000 = 560,000 \text{ lb.}$$

Inasmuch as the webs of the beams are connected by gas-pipe separators and are completely surrounded by concrete, no buckling check on the webs will be made. The four 15-in. 70-lb. I-beams will be spaced 9 in., center to center, the two outside beams being centered under the edge of the plate. This arrangement leaves a space of $2\frac{3}{4}$ in. clear between flanges of adjacent beams, which is sufficient to permit tamping of concrete between them. Since gas-pipe separators should be spaced not more than 5 ft. apart along the beam, three vertical rows of separators should be used, two separators per row.

The moment on the lower tier of beams at a section under the center line of column (the use of this section is conservative) is

$$M = 60,000 \times \frac{5^2}{2} \times 12 = 9,000,000 \text{ in.-lb.}$$

Total S for the bottom tier is

$$S = \frac{9,000,000}{20,000} = 450 \text{ in.}^3$$

If 10 beams are used, the section modulus per beam would be 45 in.³ Try 15-in. 42.9-lb. I-beams. If these beams are spaced 1 ft. 1 in., center to center, the out-to-out distance of the flanges will be 10 ft. 2½ in., which is satisfactory. The clear distance between flanges will be 7½ in., which is not excessive.

The maximum shear in each beam web is

$$6,000 \times 1.08 \times 4 = 26,000 \text{ lb.}$$

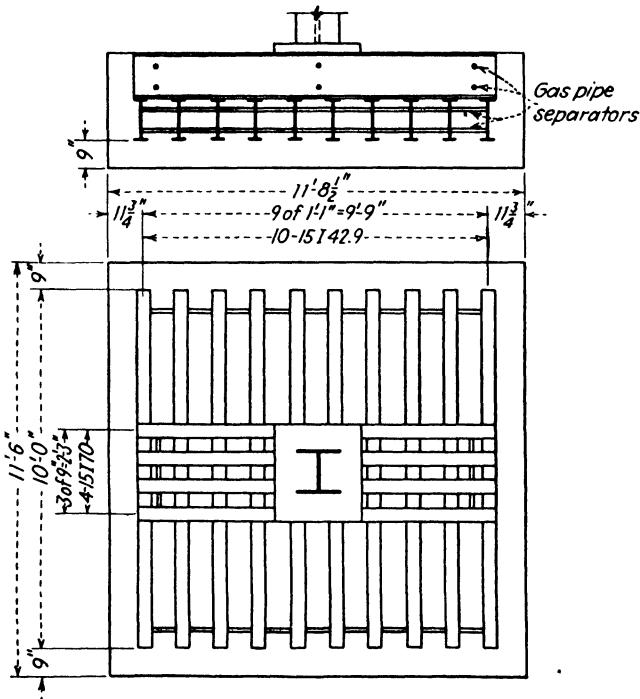

FIG. 12.

The allowable shear, at 13,000 lb. per sq. in. is 80,000 lb. The total upward load on each beam of the lower tier is 60,000 lb. The load transmitted from the lower tier beam to the upper tier beam is therefore 15,000 lb. The web crippling should be checked for each beam. The length of beam web effective in either tier in resisting crippling is $2K$ of the upper tier beam plus $2k$ of the lower tier beam, which is

$$(2 \times 1\frac{5}{8}) + (2 \times 1\frac{1}{4}) = 5\frac{3}{4} \text{ in.}$$

The web crippling value per inch of web of the 15-in. 70-lb. I-beam is 18.5 kips and of the 15-in. 42.9-lb. I-beam is 9.8 kips. Obviously, both beams are satisfactory as to web crippling. As before, web buckling will

not be checked, because of the support given the web by the concrete and gas-pipe separators.

The grillage is as indicated in Fig. 12.

14. Timber Grillage Footings.—For temporary construction in buildings on poor soil or for permanent construction where the footings are always under water, timber grillage footings can be used. Where they support bearing walls, these footings are usually made up of three courses of timber under the wall, the top and bottom courses being 2- or 3-in. planking laid longitudinally, with heavy cross timbers at frequent spacing between them to take care of the cantilever moment developed due to the projection beyond the face of the wall supported (see Fig. 13). The planking distributes the load over the transverse beams, which

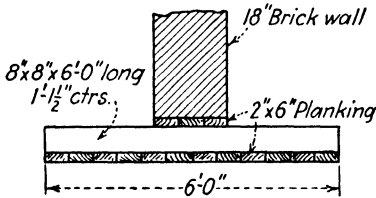

FIG. 13.

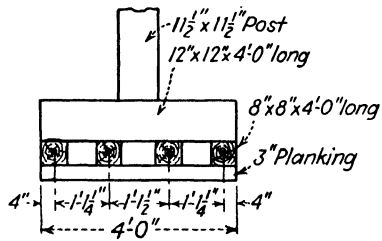

FIG. 14.

should be designed so that the stresses developed do not exceed the allowable. The spacing of the transverse beams will be determined by the strength of the planking and also by the projection of the beams.

For column footings of ordinary size, the load from the column is first transmitted to a sill made up of one or more timbers, which in turn transfer the load to timbers laid transverse to the first and resting on planking to guard against unequal settlement of any of the timbers due to inequalities in the soil. Such a footing is shown in Fig. 14. As footings increase in size, additional layers of timbers laid at right angles to each other may be necessary to distribute the load properly.

In designing timber footings it should be remembered that they will be more or less continuously wet or damp. The allowable stresses in the timber used should therefore be reduced in accordance with a good timber handbook.

Illustrative Problem.—Design a continuous timber grillage to support an 18-in. brick wall with a total load of 12,000 lb. per ft., the allowable bearing on the soil being 2,000 lb. per sq. ft. Use southern pine timber with unit stress of 1,600 lb. per sq. in. The working stresses will be: flexure, $1,600 \times 0.71 = 1,130$; bearing perpendicular to grain, $380 \times 0.58 = 220$; horizontal shear = 120.

$$\text{The width of footing required} = \frac{12,000}{2,000} = 6 \text{ ft.}$$

The wall being 18 in. wide, the timber footing will project 2 ft. 3 in. beyond it on each side.

The maximum vertical shear is

$$V = (2,000)(2.25) = 4,500 \text{ lb.}$$

Horizontal shear will usually rule in a design of a short timber beam. For a rectangular beam this maximum horizontal shear is $\frac{3}{2} \frac{V}{A}$ in which A is the cross-sectional area of the beam. Therefore

$$A = \frac{3V}{2v} = \frac{3 \times 4,500}{2 \times 120} = 56.3 \text{ sq. in.}$$

Using the nominal size, since footing timber would probably not be dressed, an 8×8 timber would be required. Greatest economy would be realized by spacing these timbers as far apart as possible. So,

$$V = \frac{2vA}{3} \times \frac{2}{3} \times \frac{120}{3} \times \frac{64}{3} = 5,120 \text{ lb.}$$

$$\text{Maximum spacing} = \frac{5,120}{4,500} = 1.14 \text{ ft.} = 13 \frac{1}{2} \text{ in.}$$

So space timbers 1 ft. $1\frac{1}{2}$ in. center to center along wall.

The maximum moment is

$$M = (1.14)(2,000)(2.25)(13.5) = 69,100 \text{ in.-lb.}$$

The bending stress is

$$S = \frac{69,100 \times 6}{8^3} = 810 \text{ lb. per sq. in.}$$

The bearing stress is

$$\frac{12,000 \times 1.14}{8 \times 18} = 96 \text{ lb. per sq. in.}$$

Planking 2 in. thick will be used under these beams.

Illustrative Problem.—Design a timber grillage footing for a $11\frac{1}{2} \times 11\frac{1}{2}$ in. timber column supporting a load of 29,000 lb. Stresses are to be the same as in previous example. The sill beam should be 12 in. wide, to give full width of bearing under the post. The bearing stress under the post is

$$\frac{29,000}{11\frac{1}{2} \times 11\frac{1}{2}} = 220 \text{ lb. per sq. in.}$$

This is the allowable for the sill beam. The bearing parallel to the grain in the post need not be checked since the allowable is considerably higher than across the grain. The base area required is

$$\frac{29,000}{2,000} = 14.5 \text{ sq. ft.}$$

Use a footing 4 ft. square.

Assuming three cross beams in the bottom tier, the maximum shear in the sill is

$$\begin{aligned} \frac{29,000}{3} &= 9,700 \text{ lb.} \\ A &= \frac{3 \times 9,700}{2 \times 120} = 121 \text{ sq. in.} \end{aligned}$$

A 12 × 12 undressed timber will be used for the sill. Assuming that the bottom-tier beams will be 8 × 8 and taking moments under the center of the column, the sill moment is

$$\begin{aligned} 9,700 \times 20 &= 194,000 \text{ in.-lb.} \\ S &= \frac{194,000 \times 6}{12^3} = 675 \text{ lb. per sq. in.} \end{aligned}$$

The bearing unit stress between the sill and the bottom tier beam will be

$$\frac{9,700}{12 \times 8} = 101 \text{ lb. per sq. in.}$$

The maximum vertical shear in each bottom tier beam will be approximately

$$\begin{aligned} \frac{9,700}{2} &= 4,850 \text{ lb.} \\ A &= \frac{3 \times 4,850}{2 \times 120} = 61 \text{ sq. in.} \end{aligned}$$

The assumed size of 8 × 8 is satisfactory as to horizontal shear. Taking moments about the center of the sill beam

$$\begin{aligned} M &= 4,850 \times 12 = 58,200 \text{ in.-lb.} \\ S &= \frac{58,200 \times 6}{8^3} = 685 \text{ lb. per sq. in.} \end{aligned}$$

Planking 3 in. thick will be used under the bottom tier beams.

TRANSFERENCE OF COLUMN LOADS TO FOOTINGS

15. Methods.—The load carried by a column may be transferred from the column to the footing by (1) direct bearing or (2) by a combination of direct bearing and bond stress developed on bars embedded in the column and the footing.

16. Cast-iron and Wood Columns.—The loads on steel, cast-iron, or wood columns can be transmitted to a column footing only by direct bearing, the requirement being that the column must have a base large enough to keep the bearing on the footing material (usually concrete) within the allowable. For wood columns the base plate may consist of a steel plate of sufficient thickness to resist the bending due to the projection beyond the face of column, a cast-iron base, or a fabricated steel base. For steel columns carrying relatively light loads, the column base is usually made an integral part of the column by riveting angles and plates to the bottom of the column. When very heavy loads are carried, steel billet slabs, steel or cast-iron castings, or grillages of steel beams, should be used. These should be designed so as to allow the blocking and leveling up of the base and anchoring these to the footing. The space between the bottom of the base and the concrete footing is then filled with cement grout. This cannot be done with steel slabs and the grout should therefore be spread over the footing top, leveled off, and the steel slab set and leveled thereon.

The area of base required for a column = $\frac{\text{total column load}}{\text{allowable bearing}}$.

The bearing stress on the concrete is therefore the determining factor. Good practice, as exemplified by the ACI Regulations, requires that the unit compressive stress on the loaded area shall not exceed the bearing stress allowable for the quality of concrete in the footing as limited by the ratio of the loaded area to the supporting area. If the entire supporting area, *i.e.*, the entire footing or pedestal top, is loaded, the allowable unit compressive stress is $0.25f'_c$. If only one-third, or less, of the footing or pedestal top is loaded, then the allowable is $0.375f'_c$. Where the loaded area varies between one-third and the full supporting area, the allowable unit compressive stress is found by interpolating between the foregoing allowable values.

17. Masonry or Concrete Piers.—The loads from brick, stone, or plain concrete piers can be transmitted to the footings only by direct bearing, the allowable bearing value of the pier materials being the limiting factor.

The allowable unit compressive stresses in spirally and tied reinforced concrete columns being relatively high, the critical section for bearing will be the top course of the footing. In some

cases the average bearing over the gross area of the column base will be within the allowable for the top of the footing. The design can be made for direct bearing only. In other cases the load may be transferred by direct bearing by putting in a top course of a richer mixture of concrete. In other cases a spirally reinforced cap or pedestal may be used, designed in the same manner as the column, but of larger diameter.

According to the ACI Regulations, the stress in the longitudinal reinforcement of a column or pedestal should be transferred to its supporting pedestal or footing either by extending longitudinal bars into the supporting members, or by dowels. If the transfer of stress in the reinforcement is accomplished by extension of the longitudinal bars, they should extend into the supporting member the distance required to transfer to the concrete, by allowable bond stress, their full working value.

In cases where dowels are used, their total sectional area should be not less than the sectional area of the longitudinal reinforcement in the member from which the stress is being transferred. In no case should the number of dowels per member be less than four and the diameter of the dowels should not exceed the diameter of the column bars by more than $\frac{1}{8}$ in.

Dowels should extend up into the column or pedestal a distance at least equal to that required for lap of longitudinal column bars and down into the supporting pedestal or footing the distance required to transfer to the concrete, by allowable bond stress, the full working value of the dowels.

The allowable compressive stress in the concrete of the pedestal or footing is as already outlined.

In sloped or stepped footings, the supporting area for bearing may be taken as the top horizontal surface of the footing, or assumed as the area of the lower base of the largest frustum of a pyramid or cone contained wholly within the footing and having for its upper base the area actually loaded, and having side slopes of one vertical to two horizontal.

SECTION 5

UNDERPINNING

Underpinning may be defined as the placing of new permanent supports under existing foundations. The necessity for underpinning work may result from the following: inadequate or improper type of foundation; the need to strengthen foundations in order to provide for additional loadings or different use of structures; the desire to protect existing buildings from damage during the process of deep excavation for other structures close to their foundations; the need to provide deeper foundations for existing buildings and to repair foundations that have been damaged owing to a change in condition since their construction. Where timber pile foundations were used, considerable damage has often resulted from the lowering of the ground-water table. This may result from the building of sewers, subways, or other deep subsurface construction.

Underpinning, like foundation work, is as old as the building art. Records show many examples of its early use. The great building projects of the present have not only increased the need for underpinning but made it necessary to develop more improved methods. When we consider the necessity of constructing new subways in the most congested districts of great cities like New York, Boston, and Chicago without interruption to street and sidewalk traffic, the importance of underpinning operations is apparent. Deep open excavations or tunneling operations must be carried on close to and below the foundations of many large heavy buildings. These buildings must be underpinned to protect them against both settlement and lateral movement and allow both their continuous and full use during the operation.

The underpinning of heavy structures requires great skill and care. The operations must be carried on under adverse or difficult circumstances and must be completed with a minimum of inconvenience to others and without damage to either the

building being underpinned or to the adjoining property. This phase of subsurface design and construction is a highly specialized field. Because of the many and varied factors that cannot be scientifically evaluated and must therefore be evaluated by experience and the exercise of engineering judgment, this work is considered an art rather than a science.

Before any underpinning operations are begun, complete and adequate preliminary investigations should be made. Too much emphasis cannot be placed upon this point. The neglect of adequate study and proper interpretation generally proves very costly. Soil samples should be taken properly. The results of tests performed should be interpreted by trained engineers and geologists. It is important that the depth and character be determined. It should be further shown that a suitable stratum is not underlaid by a softer material. To this end records of near-by excavations and building operations and the records of the behavior of the structures after construction should be carefully studied. The first records cited are often available at the offices of engineers, architects, and contractors. Unfortunately the practice of observing the behavior of structures after construction is not yet common and only comparatively few of these records are available. Old maps showing the existence of swamps, ponds, or streams provide a source of valuable information as an aid to the proper interpretation of sampling and testing operations and should not be overlooked.

For a thorough consideration of the subject of underpinning the reader is referred to the work of two eminent authorities in this field, E. A. Prentis and L. White.¹

The type of underpinning best suited depends upon the type of foundation, the conditions under which it must be carried out, and the soil and water conditions at the site. The work may be divided into two operations, (1) providing adequate support for the structure, the foundations of which are to be extended or replaced, and (2) installing the new permanent foundation or the underpinning proper. The first requires the use of shoring, needles, or a grillage. The second generally involves the building of concrete pits, piers, or steel cylinder caissons, which must be wedged to join them with old foundations or walls.

¹ "Underpinning," Columbia University Press, New York.

1. Support of Existing Structures.—This portion of the work especially requires good judgment and experience in order that no damage may result and that the expense of the operation may be as small as possible. From the necessities of the case only very general information can be given.

Buildings are much stronger than is commonly supposed. They are usually designed with a large factor of safety and consequently can stand more abuse than one would imagine (see Fig. 1). For instance, consider an ordinary case—a six-story building, 50 ft. wide and 100 ft. long. Assume that it is necessary to underpin the long side of such a structure resting on a mixture of sand and clay. As built, it is resting on a spread foundation

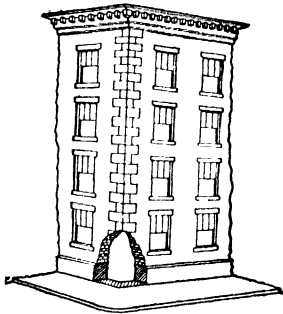

FIG. 1.—Building with portion of wall removed showing arching action developed.

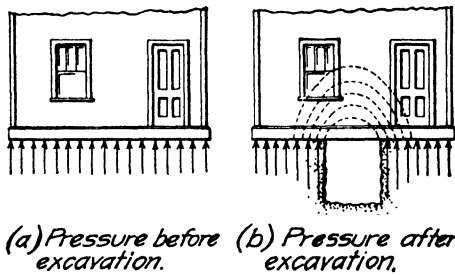

FIG. 2.—Length of arrows indicates relative intensities of soil loads.

uniformly loaded. The moment a small excavation is made under any part of this wall, the load formerly carried by that part of the soil is carried to the ground on either side of the excavation, as shown in Fig. 2, by the arching action of the wall.

Of course this is almost the simplest example that can well be imagined, but the principle is the same in more complex cases. In the example cited, assuming a slight settlement of the structure permissible, no additional support would be required during the underpinning operations.

1a. Shoring.—When additional or preliminary supports are required in underpinning, the easiest and most commonly used are called “shores.” These may be used when the loading is not excessive. Shores, as shown in Fig. 3, are usually long wooden posts placed in an inclined position against the wall

of a building in suitable niches in the masonry and adequately supported at the bottom, usually by a wooden crib. It is good practice to keep shores as nearly vertical as is expedient in order to minimize the side thrust against the wall. It is also advisable to place the head of the shore opposite a floor line in order to minimize the danger of pushing the wall in.

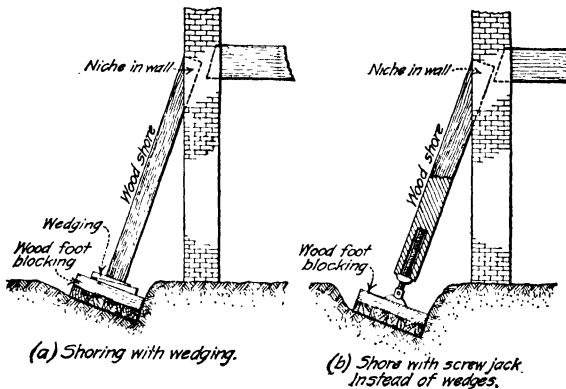

FIG. 3.—Typical shoring.

For heavy loads, care should be taken to have the head of the shore bear uniformly in the masonry work. Sometimes grouting with cement is the easiest thing to do and the wedges should always be well and truly driven until the shore is carrying the load desired. The shore itself may be reinforced by means of steel channels or I-beams bolted to it, as shown in Fig. 3A. Saddle plates and steel wedges are used where greater loads are to be supported. For lateral support, shores may be tied by lateral bracing.

Loads are transferred to the shores by use of screw jacks, which may be used up to 75 tons. Special attention should be given to the bearing areas at both ends of the shore. A short 12 × 12-in. timber shore reinforced by steel channels bolted to both sides, having a hole to receive the screw of the jack with any required length of upper timber, may be used up to a load of 50 tons.

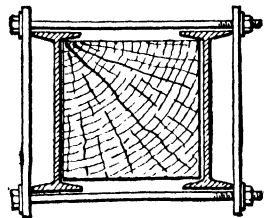

FIG. 3A.—Method of reinforcing wood shore for heavy loads.

The only load carried by the shore comes from the part of the structure above its head—except so far as the tensile strength of

The only load carried by the shore comes from the part of the structure above its head—except so far as the tensile strength of

the structure comes into play, which, in the case of brickwork, is a very small amount. Shores may be combined with needles (described in Art. 1b), the needles carrying the part of the wall from head of the shore to the ground. The combination shown in Fig. 4 has been used to advantage. The needle is sometimes termed a "springing needle."

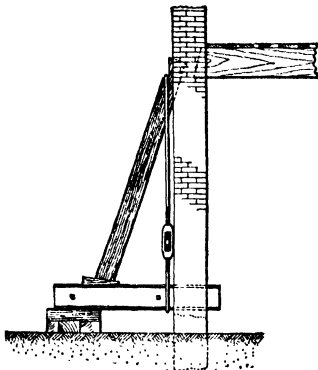

FIG. 4.—Shoring with support for wall below shore.

1b. Needling.—Another method of temporarily carrying structures is by "needling," which merely means that temporary beams called "needles" are installed to carry the structure until the underpinning is completed. This method is suitable for comparatively light loads. I-beams acting as simple beams and resting on suitable blocking and wedging are used. The necessary weight of the beams increases rapidly with the span. Consequently, for heavy loads and long spans built-up sections are necessary. The method is illustrated in Fig. 5.

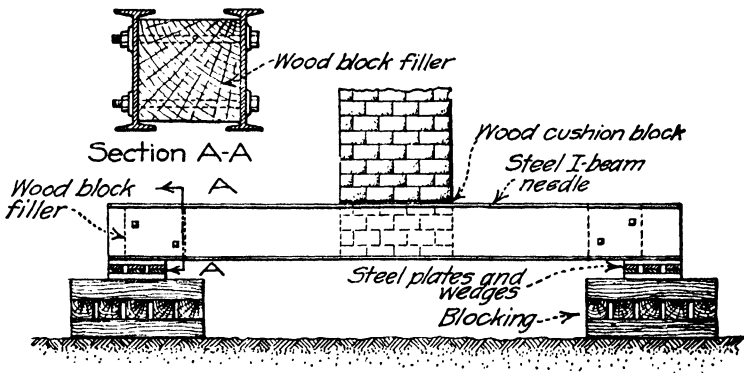

FIG. 5.—Simple needling operation.

There are several points to be noted in needling. In the first place, when carrying brick walls or piers it is wise to put in wood fillers above the beams, as these crush while the wedges are being driven in, thus putting a uniform bearing on the masonry and helping to prevent it from acquiring a crushing stress at the edges.

Then, as with shores, particular attention should be given to the footings that carry the needles. These should be adequate; otherwise, when the needles are wedged up, the footings will settle as the needles acquire the load and necessitate rewedging. Hydraulic jacks may be used in the footing.

A third thing to watch is the possibility of the needles flopping over on their sides while in use. This particularly applies to I-beams and can be prevented by using beams in pairs with wood fillers and lashings, as shown in Fig. 5.

The various combinations that can be resorted to are limitless. Wooden towers instead of cribwork for the supports of the ends

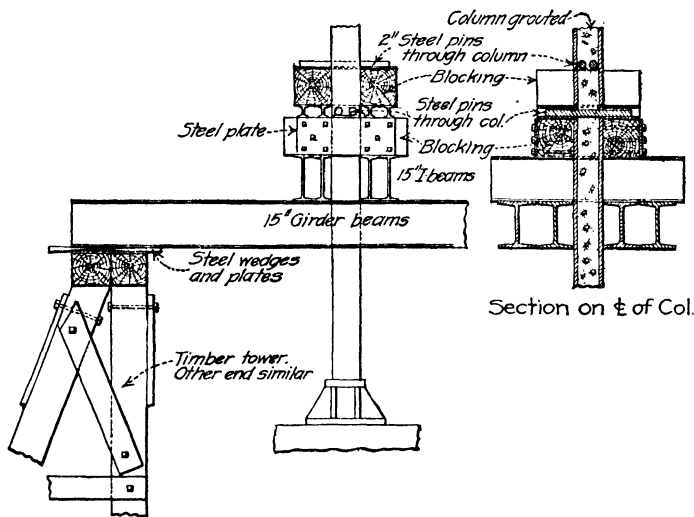

FIG. 6.—Needling for 12-in. cast-iron column. Load, 250 tons per column.

of the needles can be resorted to, or even temporary concrete or pile foundations in important cases. Two beams might be concreted together for a short distance at each end in order to prevent their wobbling. When I-beams are used, special care should be taken against lateral or tipping failure. Because of their greater stability H-beams are coming into more common use for this work. In any event, a spreader between the beams and the tie rods with turnbuckles should be used for safety.

Figure 6 shows the needling used to carry 10 × 10-in. cast-iron columns of a ten-story building with column loads of 250 tons each. The needles were carried by wooden towers resting on a

continuous row of 6 × 12-in. timbers, 6 ft. long. In this particular instance there was a serious problem in devising a suitable grip in the cast-iron column, and the one devised is shown in Fig. 6. Where steel columns are underpinned, holes may be bored through them or suitable brackets may be riveted to them.

Needle beams are usually placed in niches made for them in the walls. A combination of the needle beam and the shore is shown in Fig. 4. Where an interior column may be used as an anchor or reaction, a cantilever beam supported on a suitable fulcrum can be used to support an outside wall.

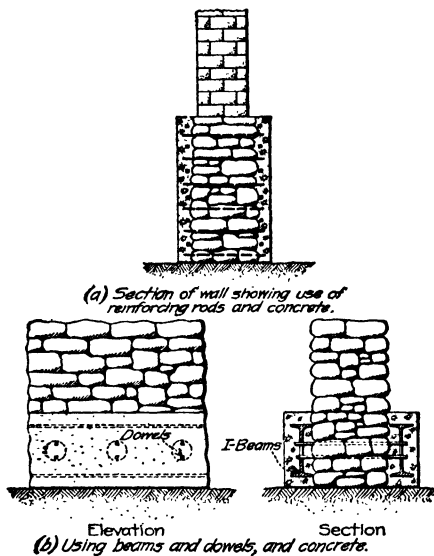

FIG. 7.—Strengthening old walls.

2. Strengthening and Supplementing Existing Foundations.—

In many cases, shores, needles, and their combinations are not needed, though often it may be necessary to strengthen or supplement the existing footings before excavating beneath them. Owing to the necessity of occupying space inside and outside the building walls to install needles and shores, their use is somewhat limited.

Where buildings rest on continuous dry rubble walls, the foundation may be effectively strengthened by merely cleaning out and washing the joints, building a tight form, and filling it with liquid grout. These conditions are frequently found in old

buildings. This method produces an effective bond and will in most cases produce a good masonry wall.

When poor rubble masonry walls are found, reinforcing rods may be used to advantage.

Sometimes I-beams can be substituted to advantage by cutting holes 2 or 3 in. in diameter in the webs in order to prevent voids in the concrete or mortar. Typical uses of these methods are shown in Fig. 7.

Very often when underpinning the columns of buildings, it is economical to join them together with continuous foundation

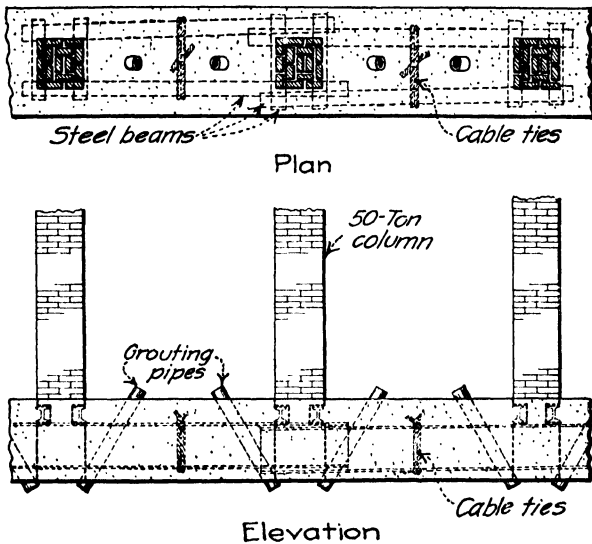

FIG. 8.—Foundation reinforced with grillage for underpinning.

slabs called "grillages." This not only ties the footings together but also gives a large spread foundation that carries columns while the excavation is going on underneath them.

Many ingenious combinations can be made, generally using steel and concrete, the steel being in the shape of I-beams as well as reinforcing rods. Secondhand steel is often used and generally is of such size as to fit the local conditions in the field rather than computed sizes.

Figure 8 shows such a grillage, including ties (usually a tourniquet of steel wire cable) and grout pipes for pouring in grout to

make a snug joint between the grillage and the new underpinning when installed.

Another application of steel and concrete for reinforcing foundations of an extremely heavy old-fashioned building is shown in Fig. 9.

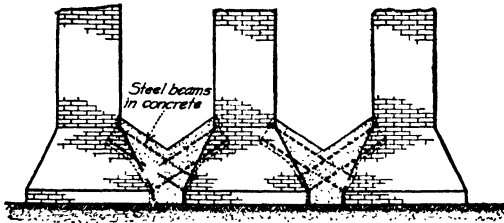

FIG. 9.—Foundation reinforced for underpinning without grillage.

For more modern buildings, grillages may be reinforced, as shown in Fig. 10.

The foregoing types of reinforcement are mentioned merely to give an idea of how some previous problems have been solved. The number of combinations to be used is limitless. Much

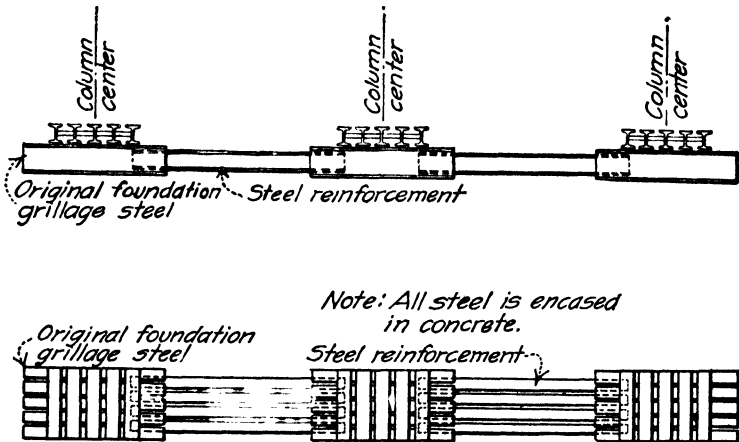

FIG. 10.—Reinforcing steel foundation of modern building.

depends on the ingenuity of the constructor. The grillage used should, however, be sufficiently strong to carry the column loads or to allow the placement of underpinning under the footings. It should also provide sufficient resistance to prevent lateral movement.

3. Underpinning Proper.—Assuming now from the foregoing that the building is in proper condition to have the underpinning installed, it is well to direct the attention to two important points.

The first is that every effort should be made not to lose or loosen the earth or ground beneath the footings. The second is that it is of primary importance to wedge up properly between the underpinning and the structure—in other words, actually to put the underpinning to work by bringing the load to it. If special care is not taken in this regard, the load will be carried to the underpinning subsequently by settlement of the structure itself.

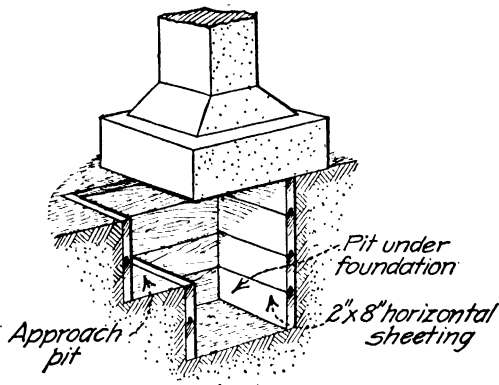

Fig. 11.— Foundation with underpinning pit.

When moderate loads only are being handled in connection with needles and shores, the wedges may be driven until they are relieved of all or part of their load. With heavier loads this cannot be done and the work should be so installed as to regulate the ensuing settlement so as to have it uniform. When the work is properly handled, even in the most difficult cases, settlements should usually not exceed $\frac{1}{4}$ to $\frac{1}{2}$ in. Settlements of over 1 in. are likely to prove troublesome.

Underpinning usually consists of pits filled with masonry, or piles, or combinations of both. Pits are generally used where possible, the limiting factor usually being water level. They may be dug to the required depth with or without sheeting, depending on the quality of the soil. Where sheeting is required, the usual vertical tongue-and-groove sheeting may be used if enough head-

room is available. Usually, however, it is more economical to use horizontal sheeting, say 2×8 in., as shown in Fig. 11.

When the pits are completed, they are filled with brick or concrete and, when set, are ready for wedging.

In case a light wall is being underpinned, perhaps with a brick or concrete wall, wedging stones were formerly used. Now steel plates and wedges are more commonly used, as shown in Fig. 12.

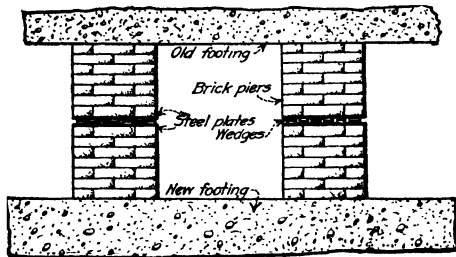

FIG. 12.—Wedging in brick underpinning piers.

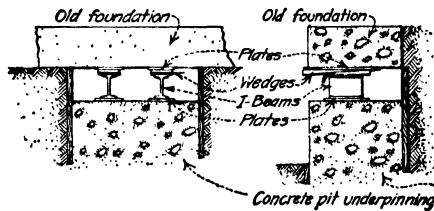

FIG. 13.—Wedging of a typical underpinning pit.

A very convenient method of wedging is by the use of short pieces of I-beams either resting on end or on their flanges and wedged with steel wedges, as shown in Fig. 13.

4. Piles Used in Underpinning.—Piles used in underpinning are generally steel shells, driven in the ground, usually in short sections, excavated, and concreted. They are used generally when it is necessary to go below ground-water level, to avoid the possible loss of ground or the use of pneumatic methods. The diameters and thickness of shells vary widely. Sometimes piles 3 ft. or more in diameter are driven by compressed air as in caissons, having a man in the working chamber. Generally, however, the sizes are smaller, varying from 10 to 16 in. in diameter and in thickness of shell from $\frac{7}{64}$ to $\frac{3}{8}$ in. using sleeve connections.

In case headroom is available, they may be driven down by means of a winch and a falling weight, as shown in Fig. 14, or by means of one of the many pneumatic hammers, such as the McKiernan-Terry.

Generally, however, the headroom is limited to from 3 to 7 ft., in which case 1- or 2-ft. sections of pipe are driven by means of hydraulic rams, as shown in Fig. 15.

These hydraulic jacking outfits are very efficient but require careful mechanical attention and a good bit of discretion in their use because of the large upward thrust they give when the pile offers sufficient resistance. The working pressures run up to 5,000 lb. per sq. in. It is rather unwise to use higher pressures because the leather gaskets become so compressed that they then have to be frequently renewed, which is an inconvenience. The most common diameter of the rams is $4\frac{1}{2}$ in. With this size,

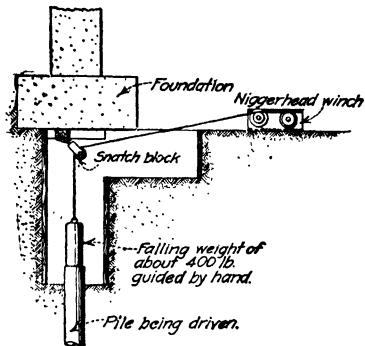

FIG. 14.—Driving pile with falling weight.

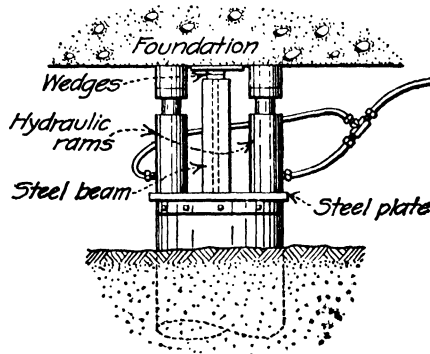

FIG. 15.—Method of driving pile by hydraulic rams. This illustration also shows method of wedging. "Pretest Method" (patented).

each 1,000 lb. on the gage indicates a thrust of about 8 tons, or, with 5,000 lb. per sq. in., a 40-ton reaction. For thrusts greater than this, two rams are connected up in parallel and with 5,000 lb. of pressure each would, of course, give 80 tons thrust. With

these great loads easily obtained, it is obvious that care must be used not to damage the structure that is used as a reaction.

As the pile is jacked into the ground, resistance to its progress increases rapidly. Every few feet the earth is excavated from within the cylinder. Earth augers and miniature orange-peel buckets attached to suitably jointed rods are used, also jetting, and with the pile excavated, the resistance to driving generally disappears. A convenient rig sometimes employed consists of putting the suction of a diaphragm pump down the pile, keeping the pile full of water, and jacking at the same time. By this method, progress is more or less uninterrupted by the excavating process but care should be taken not to let the suction of the pump get too near the bottom of the pile as this would cause a loss of ground.

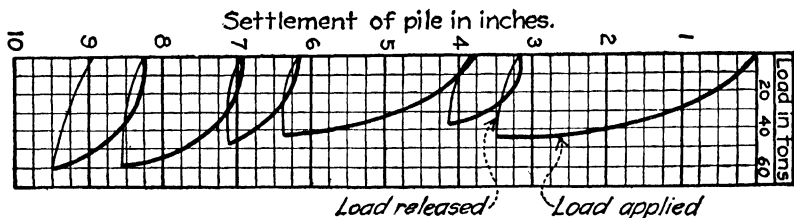

FIG. 16.—Loading test on jacked pile.

The skin friction of these cylindrical piles is always very small, around 50 lb. per sq. ft. of surface—in other words, a 25-ft. pile, 14 in. in diameter, requires only 4 or 5 tons to thrust it into the ground, provided, of course, that the pile is excavated to within a few inches of its bottom.

When driven the required depth and excavated, the pile is then concreted, using bottom-dumping buckets, if necessary. The hydraulic rams are again placed on the cylinders and the piles tested by reapplication of the load, well in excess of the load the pile is designed to carry. In coarse sand or gravel such a pile will give a reaction of 80 tons with a settlement of a foot or two, or with greater settlements in finer grained soils. The reason for this is that the soil at the base of the pile is compressed, forming a bulb. While the pressure is maintained, this bulb will generally remain intact but is partly or entirely destroyed if the load is lost, so that further settlement would be required for the pile to sustain its load. A settlement curve of such a cylinder is shown in Fig. 16.

To prevent this resettlement the "pretest method," patented by Lazarus White in 1915 and shown in Fig. 15, may be used. By this method the pile is wedged up by means of I-beams and wedges while the load is still on the pile. When the jacks are removed, an enormous load is immediately taken up by the beams because of the attempt of the pile to rebound. A typical pretest foundation is shown in Fig. 17.

The "pretest method" may be used in both new construction and underpinning work. It has the advantage of testing each cylinder, and it permits piling to be carried down while the building is being erected or during the construction of the

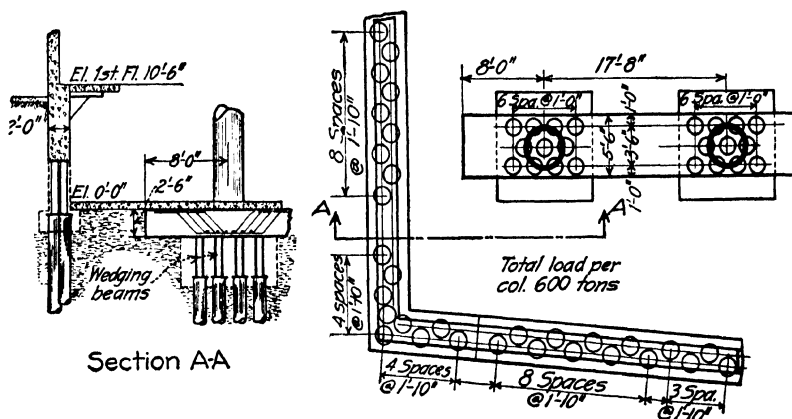

FIG. 17.—Typical pretest foundation (patented) as used for 17-story reinforced concrete building. Diameter of cylinders—14 to 20 in. Loading—350 to 500 lb. per sq. in. of cylinder cross section.

foundations for a new building while the old buildings are being demolished.

If this method is not used, the jacks are removed after testing and the piles wedged up by means of beams, plates, wedges, etc.

Example of Underpinning.—An interesting case of a very unusual underpinning operation was made necessary by the failure of the foundation of a grain elevator belonging to the Canadian Pacific Railway located at Winnipeg, Canada. The structure consisted of a workhouse 70 × 23 ft. and 180 ft. high, of a bin house 77 × 195 ft., containing 65 circular bins 92 ft. high placed in five rows, a penthouse located on top of the bins, and the necessary conveyors below them. The storage capacity was 1,000,000 bu. The bin house was constructed on a concrete

mat foundation resting on clay. The clay had a high water content and covered limestone bedrock to a depth of 54 ft.

Shortly after being loaded with 875,000 bu. of grain, the bin house started to settle with a marked inclination to the west. It finally came to rest at an inclination of $29^{\circ}53'$, as shown in Fig. 18. The west, or lower, side of the mat was 29 ft. below the original clay and the east or upper side was 5 ft. above the orig-

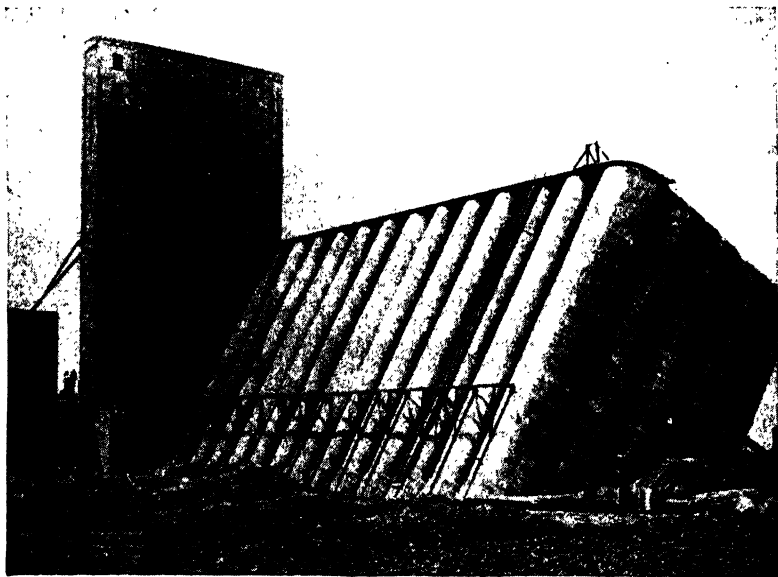

FIG. 18.—Winnipeg grain elevator after foundation failure. (Courtesy of Foundation Company.)

inal clay. On the north end the mat was 4 ft. lower than the south end.

The underpinning work was done by the Foundation Company, of New York, New York. After the grain had been emptied, suitable blocking and shores were installed to prevent further settlement and lateral movement of the structure during underpinning pier construction. Seventy open wells each 7 ft. in diameter and arranged in five rows were sunk through the clay to rock and concreted to the levels indicated in Fig. 19. Blocking jacks, indicated on the piers in rows *J* and *K* in Fig. 19, raised the structure and caused it to rotate about piers *I* as a fulcrum. When the inclination of the structure had been reduced to about

8°30', the H-piers were used as a fulcrum in order to raise the entire structure vertically. The jacking operations are shown in Fig. 20. Four hundred twenty jacks were used in the final jack-

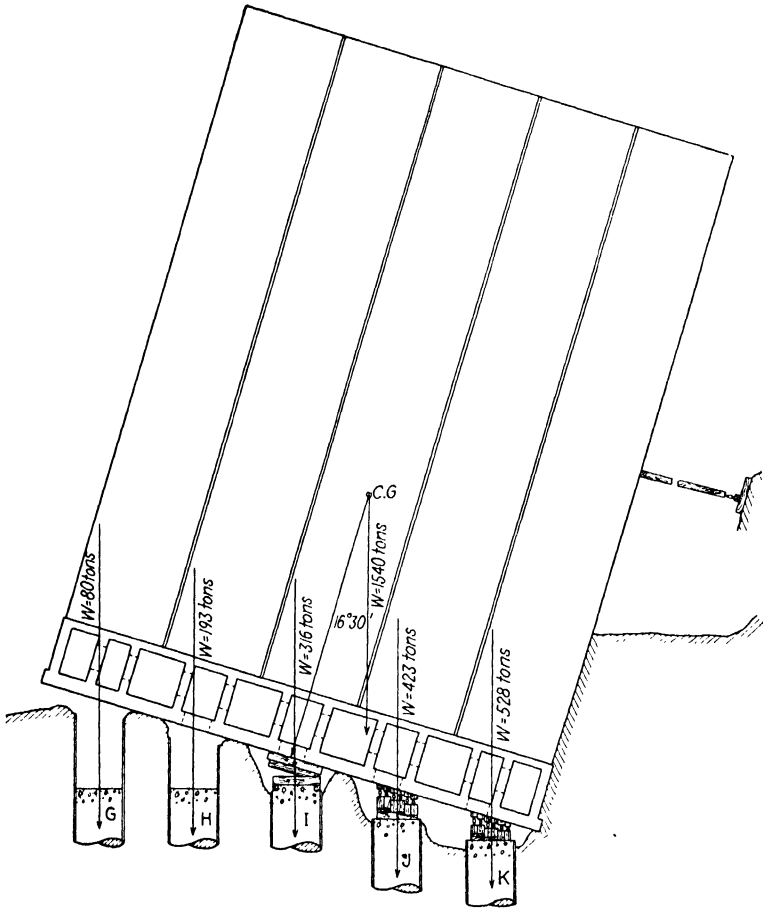

FIG. 19.—Section through the binhouse of the Winnipeg elevator. (Courtesy of Foundation Company.)

ing operation. When the structure was level in an east-west direction, isolated jacks and blocking were removed and the top of the pier was concreted. This process was repeated until the structure rested upon its new foundations.

5. Design of Underpinning.—The design of underpinning is based upon column loads computed from building plans. The same general principles that apply to foundation work are used.

In general the allowable bearing value given in building codes will apply on floating or spread underpinning; permissible pile loads may vary from 25 to 40 tons. It should, however, be emphasized that the possible safe use of these or any other gener-



FIG. 20.—Jacking operations, Winnipeg grain elevator. (Courtesy of Foundation Company.)

ally established values should be determined from a study of the soil and water conditions at the site, the character and loadings upon surrounding building foundations, and the proposed methods to be used in conditioning the building for underpinning and in the installation of the underpinning proper.

Although some settlement may be expected and allowed, the amount should be a minimum. This demands that both vertical and horizontal earth movements be controlled. To control earth movements, pits and trenches should be braced in such a manner as to resist the earth stresses without dangerous distortion or

deflection. The extent of the deflection and displacement of the restraining structures will determine the volume change that allows subsidence. The extent of subsidence can then be determined from the characteristics of the restrained materials. This is an important factor in determining the effect upon interior columns of underpinning building foundations.

Because of the many variable factors that determine the success of underpinning operations, its practice is considered a highly specialized field. The successful design and construction of underpinning involve in many cases not only great financial responsibility but also responsibility for the safety of many persons. It therefore requires a thorough technical knowledge of the engineering materials and their behavior under loads, together with the knowledge gained from a wide experience in this field of engineering practice.

SECTION 6

FOUNDATIONS REQUIRING SPECIAL CONSIDERATION

DEEP BASEMENTS AND MACHINERY PITS

The construction of deep basements and pits may involve all the methods of foundation construction from open unsheeted excavation to the use of cofferdams and caissons. This is especially true in wet ground where such construction is almost always troublesome and expensive. This kind of work is slow at the best and many progress schedules that seemed liberal to the designing engineer have been entirely disarranged by water under the ground.

Ground water is not detected by the common method of wash borings. Test pits are much more reliable in this matter. Wherever deep pits are contemplated, especial attention should be paid to this point in the preliminary explorations and, if water is encountered, it is always advisable to give serious consideration to the possibility of omitting the pits if the same purpose can be served by a modification of the design. This may mean the raising of the basement floor, or perhaps all the floors of a building, or the adoption of a different type of conveying machinery.

After it is determined that the pits are a necessary part of the building, their design should be worked out carefully with regard to possible construction methods and the necessity of making them tight and waterproof. They must be borne in mind also in preparing cost estimates and progress schedules.

1. Design.—During all stages of the design, underground conditions and construction methods should be considered. If the ground is dry, concrete walls (plain or reinforced) to suit the depth can be supported on ordinary footings; floors can be laid after the walls are finished.

The careful designer can often make considerable savings by observing closely the behavior of test pits to determine the proper angle of repose for the earth that he has to support.

Particularly in the more shallow pits, engineers are often extravagant with reinforcing steel in walls and floors. Architects and builders who work by the accumulated experience of the building craft rather than by mathematical analysis seem to understand the strength of plain masonry walls better than many engineers, and their confidence is justified by thousands of successful examples.

In wet ground, walls and floor are preferably monolithic and usually thicker than required to withstand earth pressure and the loads to be carried. If a special system of waterproofing is to be used, the method should be determined early and shown on the plans.

2. Construction.—Basements and pits in dry ground are no different from any other form of foundation construction. The excavation, bracing, and concreting are done by the ordinary methods and, with correct design and careful construction, good results are certain. Pits in wet ground are an entirely different matter. The ordinary foundation troubles are magnified by the fact that instead of digging a hole to be filled up with good ordinary concrete and earth, the builder is making a box with comparatively thin walls, which is to remain permanently open and is to house expensive machinery and goods that must be protected from water at all times. Sometimes the most careful builders do not secure watertight pits, and large sums have to be expended for waterproofing the finished work with more or less satisfactory results. This is usually due to failure to appreciate the difficulties during the period of design and to starting the work without adequate preparation and equipment.

Pits of any considerable size should be sheeted solid from near the top unless the ground is unusually firm and remains so upon exposure to air and water. This sheeting should be thoroughly braced. A careful and experienced contractor usually knows how to do this without any instruction, using good judgment based on experience, but it is well for the young engineer to check up the sheeting and bracing by calculations of earth pressure and to make a careful daily inspection of the sides of the hole. Danger can usually be detected by deflection of the timbers and movement of the walls. In this way the engineer will also add to his theory practical knowledge of the lateral pressure exerted by various kinds of earth. The most experienced are apt to be the

most careful in this respect as there is nothing much worse on a job than a big hole filled with caved-in earth, bracing, and sheeting with possibly some men buried under it.

The permeability of concrete decreases with increasing density. It can be made watertight against high heads of water. Dense concrete can be made from well-graded aggregate and good cement well mixed with the right proportion of water and placed with the aid of vibrators in tight forms that are clean and free from running water. These conditions can all be assured by ordinary careful work except the last one, which is sometimes very difficult. If a pit can be kept dry while the concrete is being placed and until it has thoroughly set, a watertight job can be practically guaranteed. If water is allowed to run or seep through the green concrete, leaks are almost certain to show. The problem is then: how to keep the pit dry until the concrete has set.

When conditions are not too bad, this can often be done by ordinary pumping from a sump. The sump should be located where it can remain in service until the concrete is set. Sometimes the sump has to be dug outside the line of finished work to a depth below the subgrade. If water flows across the bottom of the hole, it is sometimes possible to dry the subgrade for the concrete by digging it 6 in. or a foot lower and backfilling to the proper elevation with crushed stone or coarse gravel through which the water can flow to the sump without disturbing the concrete above.

Tile drains are sometimes laid on the subgrade to lead the water away and can usually be plugged at their connection with the sump after the floor has set hard. There are a number of basements in Chicago where such subdrains were used and the floors were not tight enough to withstand the water when the pressure increased after these pipes were plugged. In these cases the drains were left permanently connected to the sumps. This method is not recommended, but the basements are kept perfectly dry at the cost of continual pumping.

At the Samson Tractor works in Janesville, Wisconsin, in 1919, an ash pit and conveyor pit had to be sunk 10 ft. below the basement floor and nearly the same distance below ground-water level. The soil was coarse sand and gravel. Several large pumps were installed and a tight cofferdam was constructed and

driven down as the excavation progressed. When the bottom was reached, the flow of water amounted to several thousands of gallons per minute. The plans showed a 12-in. floor but the excavation was carried 2 ft. deeper and 2 ft. of concrete was placed all over the bottom except for a channel around the outside left to conduct the water to the sump. When this floor had hardened, little springs of water came up through it in a number of places and it was apparent that the top floor would be no better unless it could be protected from the water while soft. A large piece of heavy canvas was cut to fit the floor and to turn up 18 in. all around in the walls. This canvas was soaked in paraffin oil and was spread on top of the subfloor. Floor reinforcing rods were placed, wall forms and reinforcing bars were set up, and the waterproofing sheet was carefully turned up in the center of each wall. The concrete of the top floor was placed on top of the canvas and the walls were placed monolithic with the floor. This pit was practically dry when completed and was better than any of the other pits at this location that were constructed by different methods.

An accepted method of drying a pit of this kind is the method of lowering ground water by the use of well points. By this method well points are driven down around the area to be dried and are connected by pipes to a pump that is kept in continuous operation. The first application of this method of which the writer knows is recorded in the report of the Metropolitan Sewerage Commission for 1901. It was used on Section 69 by Beckwith and Quackenbush of Mohawk, New York, as follows:

For a length of 300 ft. near Mount Hope Station, the fine sand in which the lower part of the trench was excavated moved under the head of ground water. Five tubular wells were driven through the stratum of fine sand into the underlying gravel 19 ft. below. Pumping was continued for about a month when the soil was dried enough for the masonry to be placed.

This method was used on a large scale in all kinds of underground work during the construction of the city of Gary, Indiana. It has been extensively used on sewer work about Chicago with uniform success. During 1921 it was used for the basement of the Cornelia Garage on Broadway in Chicago and was successful as far as it was possible to use it. The south basement wall was adjacent to the next building and it was necessary to remove all

the points on one side before the floor could be placed. The other single row of points was not sufficient to keep down the water, and other means had to be adopted to finish the job.

A well-known instance of ground-water lowering by the use of well points is in excavating for the foundations of the Ambassador Hotel and the Ritz Carlton Hotel at Atlantic City and described as follows in the *Engineering News-Record* of Jan. 13, 1921):

In both cases the sand was excavated in the open without sheeting to depths exceeding 15 ft. below mean tide in spite of the fact that in one case the work was situated within 100 ft. of the water's edge. This result was made possible by encircling the work with lines of driven wells and pumping down the water in the sand to a level below the floor of the excavation. The fineness of the sand and its stability when dry made the method particularly effective as the pumping capacity required was moderate, changes in ground water level were comparatively slow, and the excavation stood with vertical banks that showed no tendency to crumble.

In applying well point pumping to the Ambassador a single cofferdam was constructed around the whole site by encircling it with a ring of wells pumped as a single unit. The Ritz Carlton work is distinguished by extensive subdivision of pumping and construction work through the use of many local rings of well points forming separate cofferdams. This expedient permitted progressive working from one end of the site towards the other, gave remarkable flexibility and adaptability to changing conditions, and, together with the practice of lowering the ground water in successive stages by using several tiers of wells as excavation proceeded, gave marked economy in both plant cost and pumping cost.

The wells consisted of lengths of 1½-in. pipe fitted with well points 30 to 36 in. long wrapped with 60-mesh screen, which were jetted down into the sand at intervals of from 3 to 4 ft. to as close as 18 in., usually closest in the lowest tier. The top of each well pipe connected through 1½-in. wire covered hose to a 4-in. steel pumping main, to which were connected one, two, three or four electrically driven pump units of capacity from 75 to 200 gal. per minute discharging by pipe line to the beach. Each of these units was mounted on a platform to form a portable unit that could be shifted around by the derrick.

In jetting down a well point a 1½-in. pipe supplied with water at 40-lb. pressure was pushed down into the ground and moved around or churned as necessary to loosen up an area large enough for the well pipe; the well pipe with point was then dropped into the soft sand loosened by the jet.

Generally the points were put down to depths of 10 to 20 ft. However, the details of the well point work throughout as to depth, spacing, pumping capacity, and the like, were fixed as experience dictated, the system adapting itself flexibly to any required changes. When a particular area of the site was to be excavated to a lower level, for example, a ring of points was sunk around the area, at possibly 4 ft. spacing, to 5 or 6 ft. depth, and pumping and excavation were started simultaneously. If these wells did not draw down the water rapidly enough, or if the ground proved wet in excavating, a set of points was jetted down between those already in place. If the pumps were not able to hold the vacuum, another pump was cut in. Hose and pipe connections were checked for tightness frequently, this being vital to good results. When the excavation was down 4 or 5 ft. a set of points was jetted in around the bottom of the pit to lower the water level farther, excavation then continuing inside this smaller ring.

On the whole, experience at this site was that the ground water level could be lowered 10 ft. in about 4 hr. (with 10 to 12 ft. of lift and about 30 ft. from foot of well to discharge). The return of the water was relatively slow, so that when pumping was stopped it would be half an hour before water came up through the floor of the excavation. The pumpage is fairly represented by the experience with the longest continuous line of wells, whose total length was something over 300 ft. and the pumpage averaged 300 gal. per minute. A vacuum of 12 to 20 in. of mercury was carried at the pump. This was at a distance of less than 200 ft. from the edge of mean tide.

Work was started at the beach end of the site, first on the right hand half of the front wall, the other half being started only after the deep wall footing of the first half had been constructed and the principal hazard of interruption of the pumps was over. Then the side wall and parts of the rear wall were taken in hand. When the next sections of side wall were started, the entire front section was cut off by a line of wells and general excavation of the forward portion continued down to floor level. Underdrains, concrete in base, waterproofing, and final concrete floor were then put in, which took care of further drainage in this section and released the wells and pumps.

It is not always practicable to use this satisfactory method of drying a pit and some other method must be adopted to prevent water from flowing through the green concrete of walls and floor. The caisson method is sometimes used on a small scale by constructing a tight box of dressed and matched lumber having walls and floor, which is set down in the pit and the concrete placed within it using the box as an outside form. Sometimes a box of

sheet steel is used for small pits such as those for elevators. This is a reliable method where practicable. The reinforced concrete caisson has been used with marked success for large pits and there seems to be no good reason why it could not be used equally well for small pits by weighting down the caisson sufficiently.

In the construction of the Quabbin Dam and Dike for the Quabbin Reservoir of the Metropolitan District Water Extension, Boston, Massachusetts, an extensive pumping system to lower the ground-water level was used. These dams are located about 65 miles west of Boston in the valleys of the Swift River and Beaver Brook. The foundations are in glacial materials. To secure watertight core walls, a concrete wall consisting of concrete caissons sunk to ledge rock was selected. A lowering of the ground-water table was desired so that a lower air pressure could be used in the pneumatic caissons.¹

An exploratory caisson equipped with intakes and pumps was sunk to a depth of 75 ft. below river level. Ground water was pumped at an average rate of about 650 gal. per min. This accomplished a lowering of the ground-water level in the vicinity of the caisson of about 7 ft. Additional pumps were installed and the intake capacity was increased by forcing well points into the surrounding material through holes drilled in the caisson sides. Pumping at a pumping rate of about 2,100 gal. per min. over a period of 11 months lowered the ground water in the vicinity of the caisson about 30 ft.

The river was diverted and the area of the dam site was closed off by upstream and downstream embankments. Two additional exploratory caissons were installed at points where the overburden was thicker. In general, pumping was carried on from two caissons while the third was being excavated under air pressure. Following this method these caissons were sunk to ledge rock about 120 ft. below river level and 100 ft. below ground-water level.

These caissons were then sealed off, and special intakes constructed under the cutting edge were connected to pumping units through the seal. During the construction of the core wall, temporary portable pumping units lowered into the working

¹ For a complete and detailed report of this work, reference is made to "Permeability Determinations, Quabbin Dams" by Stanley M. Dore, *Trans. Am. Soc. Civil Eng.*, 1937, pp. 682-711.

chambers of other caissons aided these pumping units in removing ground water.

Ground water was pumped at the rate of approximately 5,000 gal. per min. for several months during the construction of the core wall. The ground-water level was lowered about 75 ft. Nearly all the other core wall caissons were sunk by the use of an air pressure of approximately 18 lb. per sq. in. Approximately 82 per cent of the caisson sinking was accomplished under atmospheric pressure conditions. All the exploratory caissons became part of the finished core wall.

Sometimes the bottom may be sealed by placing a thick mat of dry mixed concrete all over it. The aggregate and cement are mixed without water and the water is drawn up through the mass by capillary attraction. If the flow of water from the bottom is too violent to allow this treatment, the water may be permitted to rise to its normal level and the mat of concrete placed in still water through a tube or be placed by a dumping bucket. The water can be pumped out after the concrete is thoroughly set and the bottom will usually be sealed.

The application of mixtures, membranes or other coatings for waterproofing is discussed in Arts. 3, 4, 5, and 6. The grouting method of waterproofing is practically a part of the concreting and has been used in many tunnels and is applicable to basements. It was used with marked success on the tunnels of the New York Aqueduct and also in the new Delaware River Aqueduct. Sheet-iron pans were placed against the wall of the excavation to catch the infiltrating water and to lead it to a drain pipe extending out through the face of the form. Grout pipes also extended into the space between the pans and the outer wall. The wall was concreted in the ordinary way and the green concrete was not disturbed by water, which was intercepted by the pans and carried away through the drain pipes. After the concrete had thoroughly hardened, thin grout was forced in to fill the voids by the pressure of compressed air. By repeated applications of grout, remarkably good results were attained and in most cases the walls were left entirely dry. Grouting was also practiced on the La Salle Street and Washington Street tunnels in Chicago to dry finished walls that leaked. Holes were drilled through the walls and a grouting nozzle was inserted with a collar, which was jacked tight against a thick gasket that surrounded the nozzle.

Grout was then forced in behind the wall. Upon hardening, it effectually sealed the leaks.

WATERPROOFING OF SUBSTRUCTURES

The question of waterproofing, especially of the substructure of a building, is a subject that has been given comparatively little consideration by the majority of architects, engineers, and contractors. The natural result is that in many cases some system is used that does not fit the conditions.

The necessity for deeper foundations and the use of basement floors, which are often below ground-water level, have increased the need for waterproofing. As practically all the foundations of today are being built of concrete, this discussion will be limited to the waterproofing of that material.

It is almost generally conceded that concrete can be made watertight without the aid of waterproofing agents provided (and there is the whole secret) that 100 per cent workmanship be obtained in all steps. The fact that we often see examples of concrete that are not so good as can be made shows that the personal equation cannot be neglected. It also proves that results cannot be guaranteed without some special agent. Every waterproofing system has its value, but some of them are not applicable to certain cases; the choice therefore depends entirely upon the conditions to be met.

3. Methods of Waterproofing.—In general there are three main classes of waterproofing: the integral method, the membrane method, and the surface coating method.

4. Integral Method of Waterproofing.—The integral method consists of incorporating in the concrete some material, either as a paste, powder, or liquid. This material is added during the mixing and the theory is that it will act as a void filler. It is because of the voids in concrete that leaks occur; if these are filled there can be no leakage. If an integral system is used on a job, strict superintendence must ensure that all precautions are taken to secure an A-1 concrete. It should be remembered that a void filler will not prevent construction joints or porous spots, both of which are the results of poor workmanship. It is possible to secure waterproof concrete without a waterproofing agent, provided that a proper selection of materials is made, that the

mix is properly graded and designed, and that careful workmanship is obtained.

A subdivision can be made in the integral method: inert fillers, water repellents, and chemical combinations.

Among the inert fillers, hydrated lime is the best known. Probably its most valuable advantage is its plasticizing property, which allows a reduction in the amount of mixing water without a reduction in the workability. It likewise aids in placing, particularly when chutes are used.

Clay is another inert filler. If it is used, care should be taken that the material is in a finely divided state and that it is evenly distributed throughout the mass. Clays having high expansion coefficients will expand and fill the voids, thus producing a more dense mix. If the clay is added to replace a part of the cement, the strength of the concrete will be reduced.

The water repellents generally have, as a base, lime to which is added a percentage of fatty acids. The theory is that the acids react with the lime to form a lime soap. This is not easily soluble in water and therefore tends to repel it. Heavy oils have also been used with more or less success.

Many waterproofing compounds are now available under such trade names as Puzzolith, Steabox, Omicron, Masterseal, and Truscon waterproofing. In general, these products are a lime or stearate base. Manufacturers assert that these products will produce a puzzolithic or a plasticizing effect that increases workability and decreases permeability, absorption, and shrinkage.

In the class of chemical combinations are those which have a chemical action on the cement. Whereas these agents fill or help to fill the voids, there is also the advantage of the chemical reaction by which is formed a chemical with waterproofing properties, which also assists in the hardening of the concrete.

Summing up the integral method, the main advantage is that it makes possible the use of a lower quantity of mixing water for the same workability. It should be remembered that it will not compensate for poor workmanship, poor materials, etc. If the forms allow passage of water, this waterproofing will be washed out and make the concrete weaker than if it had not been used.

5. Membrane Method of Waterproofing.—Membrane waterproofing, although really a surface coating, is now so extensively used that it is listed as a special method. It consists of alternate

layers of fabric and tar or asphalt applied either to the exterior or interior surfaces (see Fig. 1). The fabric is usually either felt or burlap impregnated with tar or asphalt. The surfaces are first mopped with hot tar or asphalt and, while that is still soft, covered with the fabric. Usually from three to five layers of fabric are required for a waterproof job. The application of this system is very important as is also the choice of the material;

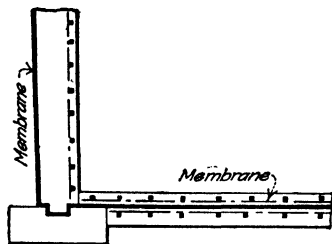

FIG. 1.—Membrane water-proofing method.

too often it is done by a roofing contractor who knows nothing about waterproofing and who uses ordinary roofing paper instead of fabric.

By the membrane system there are covered up the defects in the concrete due to poor workmanship in leaving porous spots and construction joints. Another advantage is that the fabric is slightly elastic and can, without breaking, bridge structural cracks that are small and prevent leaks at these points.

Although this system has these decided advantages, it also has serious disadvantages that are possibly of greater weight. It cannot be applied to a wet or cold wall as the tar or asphalt will not hold. If it is applied to the exterior of the walls, extra excavation is required; if applied to the interior of the walls, a special concrete or brick wall is needed to hold the membrane in place and prevent sloughing. It is good practice to place a protecting wall even when the membrane is applied to exterior surfaces. If large or even medium cracks occur, the fabric will not span it and will crack. Expenses involved in repairing leaks in a membrane system are often so high that they are out of the question.

Membrane to secure the best results should be applied while the structure is being built. It should be run over the floor and footings to the exterior of the wall, leaving enough to run part way up the wall. This tends to destroy the bond between the wall and the footing and the weight of the wall should be sufficient to prevent slipping.

6. Surface Coating Method of Waterproofing.—The surface coating method (Fig. 2) comprises all materials used to coat the

surface after the structure is completed. To secure good results with this method all porous spots should be chipped out and replaced with good concrete.

Sodium silicate and magnesium silicate have been used with a certain amount of success. The silicates act on the free lime in the concrete to form a hard insoluble coating. The life of this coating is limited, requiring periodic treatment.

The Annapolis mix is a combination of Portland cement, coal-tar pitch, and kerosene. This has given excellent results when applied to exterior surfaces.

Paraffin has also been used to some extent but its use has been limited because of the high cost. It is applied in the melted state and forced into the concrete with a blowtorch, thereby

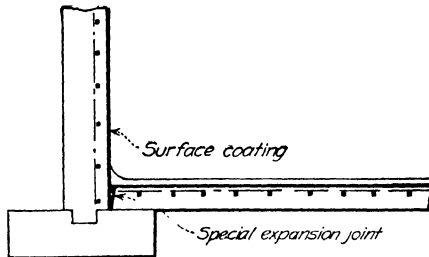

FIG. 2.—Surface waterproofing method.

filling the surface pores; a final surface coat is usually applied. This is also limited so far as life is concerned and should be renewed.

The plaster coat method is a system that has been used to a great extent, especially in the East. Briefly, this method consists of a dense mortar coat applied either to interior or exterior surfaces. The surfaces are all chipped and roughened so as to secure a mechanical bond for the coating. All bad spots are chipped out and replaced with good dense mortar. Often an integral waterproofing is used in the coating to make it more workable and give a denser mortar.

The main objection to this method is that the plaster obtains the bond with the concrete only because the concrete is roughened. In cases in which it is applied to the interior surfaces where there is much pressure, the coat is liable to be blown off. It has the advantage that it can be easily repaired if leaks develop

and will last as long as the structure itself, often prolonging the life of the structure by preventing passage of water through the concrete. It may, however, be difficult to locate the leak. Often large sections of wall have to be removed and repaired. The extended improvement in cement quality and the newer processes used in the application during recent years have greatly improved this method.

The most used of the surface coatings, especially in the Middle West, is the ferrous method. It consists of coating the surfaces with a finely pulverized iron to which has been added an oxidizing agent. These particles are forced into the pores of the concrete by brushing and, in oxidizing, swell and fill those pores, also forming a bonding coat for additional coats. Each coat should be thoroughly developed before another is applied, if the best results are to be obtained. Usually one or two straight coats of the pulverized iron are applied, followed by alternate coats of slush and iron, the number depending upon conditions. The final coat consists of a cement wash to which has been added a certain percentage of the iron, thereby giving the finished surface the gray concrete color. If a white finish is wanted, white cement is used.

The objection has been raised that this material becomes only a rust and will not be permanent. It is correct that it forms an iron oxide, of which class rust is one, but that oxide takes the form of limonite which is a combination that is very stable. Records show that waterproofing placed by this method has given good service over long periods of time.

On wall work no protecting or restraining wall is needed. The bond is obtained through the swelling action of the iron and is so perfect that on interior surfaces it has stood a pressure of 70 ft. of water. What it will stand on exterior surfaces has never been reached. On floor work it is placed under the topping as a protection against abrasion. This topping becomes an integral part of the floor on account of the bonding action of the iron.

This system is applicable to both exterior and interior surfaces, and is applicable to old as well as to new work. It can be successfully applied to walls that are wet or through which water is flowing. This system does not involve the expense of extra excavation, of a protection wall, or of back plastering. Should structural cracks develop, they can be seen and repaired. If

desired, paint can be applied directly upon surfaces so treated without any effect on the paint.

The principal objection to this system is that of cost, which depends upon the character of the work but, generally, is higher than that of the other systems. This is due to the fact that it must be applied by experienced labor to ensure success. It is not a method that can be used by the ordinary layman.

During recent years there has been a great advance in the waterproofing of structures until at present the main problem is to secure a method that will prevent leakage through structural cracks. As yet no such method has been developed so that under the circumstances the best method is that best adapted to the type of construction.

RETAINING WALL FOUNDATIONS

Although foundations for retaining walls do not differ in essential detail from those of other structures, there are several points that present themselves for special consideration. Ordinarily the largest horizontal area of a retaining wall is its base, and therefore the design of its foundation is relatively simple, provided there is no settlement problem involved. Because of the uneven distribution of loading, retaining wall foundations are liable to show differential settlement. This causes the wall to move out of plumb. This in turn changes the stress condition in both the backfill and in the foundation soil masses. Sufficient resistance to overcome sliding should also be provided. Drainage conditions and the behavior of the backfill under wet and dry conditions are very important factors and should be considered in design and construction.

7. Main Considerations.

1. Whether or not the pressure of the bank or soil to be restrained by the wall is to be relieved during construction (as in building an independent wall and backfilling), or whether the pressure is to be held with sheeting and bracing during construction.

The placing of the foundation for a retaining wall, while the bank with its pressure load is in position, is not radically different from placing it in a trench except that the braces are inclined props or rakers. If the wall is designed for such operation, the lower tiers of sheeting and bracing may be removed as the wall is

built up. Otherwise the sheeting may remain in place and holes may be left in the wall through which the struts or rakers may later be removed.

2. Whether any action counter to the foundation load should be assumed as coming from the overturning moment against the wall.

Since many ordinary retaining walls at some time in their history, for some portion if not all of their length, probably stand alone or nearly so and, further, since the ordinary masonry of such walls is not sufficiently unified to render this moment fully effective at the foundation, it is perhaps safer to eliminate this item from consideration—at least as a helpful factor, as noted later, except in specially designed reinforced concrete walls. In such walls where the pressure may not be expected to be relieved or reduced—as, for instance, clay becoming dry and solidified—and when the economy thereby effected is worth considering, the overturning moment may offset the action of the foundation load.

3. What action counter to the foundation load should be assumed as coming from the presence (if any) of water under pressure in the soil directly below the foundation.

In the matter of uplift due to the buoyant effort of the water in the soil three typical cases should be considered: (a) foundation resting on piles, (b) foundation resting on water-bearing soil, and (c) foundation resting on rock.

In the first case where a retaining wall foundation rests entirely on piles, a condition may easily, and probably almost always does, arise in which the soil tends to settle slightly away from the foundation bottom, forming a water pocket over the whole area not actually in contact with the piling. The buoyant effort or uplift acting on the bottom is then

$$P = (A - a)h$$

where P = total pressure in pounds on foundation bottom.

A = total area in square feet of foundation bottom.

a = total area in square feet of piling.

h = pressure per square foot due to the hydrostatic head of the water.

In the second case the condition is different, as although the foundation may be considered as resting on the equivalent of

solid columns of sand, any settlement or subsidence of the soil carries the foundation with it; therefore, a water pocket over a large percentage of the area cannot form. Nor can there be, over those areas which are actually supporting the foundation, any water pressure. There may be, however, and probably are, small areas of water pressure corresponding roughly to the voids. In this case the buoyant effort is

$$P = AVh$$

where P = total pressure in pounds on foundation bottom.

V = percentage of voids in sand.

h = pressure per square foot due to hydrostatic head of the water.

Where this factor is a helpful one, *i.e.*, favorable to the design or to economy, the designer should be very sure of the value he attaches to V , owing to the fact that even coarse soil such as gravel or coarse sand may become clogged with finer soil shutting off practically all water pressure.

With due regard to the safety factor, therefore, it is suggested that, where P tends to exert a helpful pressure, V be made to equal zero; where the pressure is harmful or against the design, V should be made to equal one-half, or 50 per cent. This of course is in the absence of satisfactory tests or positive information as to the true value of V for each special case.

In the last case—foundation resting on rock—the conditions are practically the same as on soil, except that there can be practically no settlement of the support, and the value of V or percentage of voids is normally much smaller and not infrequently is zero.

Where, however, a critical examination of the rock cannot be made, and again when P acts against or is a factor harmful to the design, a value of at least 20 or 30 per cent should be assigned to V for safety.

8. Foundations on Piles in Plastic Soil.—A possible condition may arise in which a retaining wall foundation is carried by piles making a firm foundation although their tops are in soil so soft and plastic as to flow under normal pressure—as plastic clay. In this remotely possible case the wall and its foundation are stable while the fill behind it tends to subside and cause the soil around the piles to flow outwardly.

To render such a condition stable, sheet piling should be driven flush with the inside face of the foundation. If the top stringer, or wale, bears against the inner face of the foundation, the piling need not necessarily be driven to firmer soil but only to a sufficient depth so that the pressure on the soil is dissipated laterally.

When the inside face of the foundation cannot be uncovered or exposed, the sheet piling may be driven flush with the outer toe of the wall, bearing against a rafter anchored to the wall foundation by expansion bolts, or reinforced concrete ties or caps, or by any satisfactory anchorage.

It will ordinarily be found in practice, however, that no matter how soft the ground, the bearing piles will act to prevent the flow of soil past them even though the piling is not continuous nor more than normally close.

9. Settlement of Retaining Wall Foundations.—It is usually true that a small amount of settlement is not serious so long as it is not continuous or cumulative. Where this latter is expected or found to exist, piling or the equivalent should be used; but if it is known that the maximum settlement for the proposed foundation load is not beyond the safe limit set, no further action is necessary, provided there is no danger of a deep-seated soil failure.

DAM FOUNDATIONS

10. Main Requirements.—The main requirements to be considered for a dam foundation are as follows: bearing power; water tightness or control of seepage; prevention or control of upward pressure; prevention of sliding of the dam on its foundation or in the foundation itself; and protection against scour below the downstream toe or apron.

11. Design Depends on Kind of Foundation Material.—The type of dam to be built and its design depend on the character of foundation available. Inasmuch as dams are being built successfully on such material as light river silt, it is evident that almost any material, however unfavorable, may be used for a dam foundation, provided it is properly prepared and provided, further, that a suitable design is worked out to fit the foundation conditions. In other words, some type of dam may be built on almost any foundation. On the other hand, failure to understand foundation conditions or to appreciate their importance

has often resulted in disaster, as at Austin, Texas, or in greatly increased cost and delay, as at Hales Bar, Tennessee.

12. Meaning of the Term "Foundation."—It should be remembered that the entire area upon which the dam rests is included in the term "foundation." It is not sufficient to examine only the lower portion of the foundation, but the examination should be continued all the way to the ends of the dam and out into the abutments, to make sure that the higher portions of the foundations, and the abutments also, meet the requirements. There are cases on record where this precaution has been neglected, with unfortunate results, as at the Cedar Lake Dam at Seattle.

13. Foundation Material.—*Solid rock* is the only suitable foundation for a high masonry dam, say about 200 ft. or higher. By solid rock is meant firm hard rock, without open seams, fissures, or faulting. Obviously such rock is also suitable for dams of any other type. Its bearing is sufficient, and the requirements as to watertightness, upward pressure, sliding, and scour are more easily controlled than with any other foundation material. Even with solid rock, however, surface indications should not be relied upon entirely, and the importance of subsurface examination and thorough preparation of foundation should not be overlooked. These subjects are discussed in Arts. **14** and **15**.

Soft rock, or *rock of poor quality*, if not too badly fissured, and *hard shale*, are suitable foundation material for masonry dams of moderate height, say less than 150 to 200 ft. as well as for reinforced concrete, rock fill, earth, or timber dams. Although any ordinary rock and the harder shales are usually sufficient as to bearing power, the other requirements are not so easily satisfied, particularly as to watertightness, upward pressure and scour in the case of the softer rock, and as to sliding and scour in the case of shale. *Cavernous rock*, for any dam foundation, should be avoided if possible, as it is extremely unreliable, even after the most careful grouting or other treatment. The difficulties encountered at the Hales Bar Dam illustrate this. Subsurface examinations become increasingly important as the character of the material is less reliable, and special treatment is often necessary to meet the various foundation requirements. Many of the softer rock and shales deteriorate rapidly upon

exposure, and that feature should be kept in mind, not only in the design of the structure but also in preparing the foundation to receive it.

Clay is usually regarded with suspicion for a dam foundation, although with proper treatment the harder clays may be suitable for most types of dams, except masonry dams of considerable height. The clays vary so much in character and are so affected by changes in moisture conditions that great care should be used in determining their suitability in any case. By going to greater depth, by confining the material with curtain walls or sheet piling, by loading the material outside of the structure itself, or by drainage, a clay foundation, which otherwise would be unsatisfactory, may be made to meet the requirements. Short piles are sometimes driven for the purpose of compacting a soil to increase its bearing capacity. They may also be used as bearing piles. Before piles are driven into a clay deposit for either purpose, a careful study of its characteristics should be made. The disturbance created by pile-driving operations may cause certain clays to become unstable because of the breakdown or destruction of their structure. Further reference is made to this consideration in Appendix B. When the necessary bearing capacity is assured, the requirements as to sliding and scour are the ones to consider most carefully. Clay foundations should always be protected from overflow, or discharge from outlets or spillways, until velocities have been reduced to the point where scour or wash will cause no damage.

Gravel and *sand* are commonly used as foundations for low masonry dams, say 50 ft. or less in height, and for other types of dams of any reasonable height. Such foundations should be studied carefully, however, inasmuch as few if any of the requirements are satisfied without special treatment of the foundation or special design of the structure to meet the conditions. Bearing power is usually sufficient, except for masonry dams, where piling or a widened base may be necessary. Seepage may be controlled by a cutoff wall, a core wall, or an impervious upstream blanket. Upward pressure should be provided for in the design. Scour may be prevented by a timber or rock apron.

Sand and *silt* have been used successfully in many cases as foundation material for earth dams and for low dams of most any other type, including reinforced concrete dams of special

design. All the precautions mentioned in the preceding paragraph should be considered even more carefully in the case of these lighter materials; in addition, it is usually necessary to make some modifications in design to meet the unfavorable foundation conditions. The Gatun Dam (Panama) and the Laguna Dam (Arizona) are cases in point.

Generally speaking, any dam is an important structure, and the selection of type and design to suit the foundation available should be based on sound judgment and experience, with questions of doubt always decided on the conservative side. In the case of any dam of considerable size, the best advice that can be obtained should be secured. Failure to observe good engineering practice accounts for practically all the failures that have ever occurred in dams.

14. Examination of Foundations.—For dams of importance it is desirable, whenever possible, to have a careful geological examination of the foundation conditions. An investigation and report by a reputable geologist are very much worth while in most cases. Such reports should deal with the geological characteristics of the rock, its reliability as to bearing power, deterioration, etc., as well as the probability of fissures and faulting, or former upheavals or disturbance. Even slight settlement is not permissible in foundations for a masonry dam, except possibly for low dams specially designed with that in view. For earth or rock-fill dams, however, slight settlement of the foundation during construction may not be objectionable, provided there is no danger of further settlement after the construction is finished. But unequal settlement near outlets or spillways, due to unequal loading, should be guarded against by special design.

Where the bearing power is questionable, a field test may be made by clearing off a small space and loading it by means of a platform or box supported on a base of known area and loaded with sand, pig iron, rails, etc., of known weight. Unfortunately such tests, for practical reasons, are limited to an area of only a few square feet at most, and the results are difficult to interpret correctly. The completed foundation will affect the stress distribution in the soil to greater depths than the test load. If a soft, deep-seated stratum exists below the finished foundation, considerable settlement may result. For these reasons adequate subsurface explorations should be made over the entire area.

The methods of subsurface exploration are given in Sec. 1. They may be classified as soundings, borings, and test pits.

It is impossible to state exactly what soil investigations should be made because each case is different and each should be thoroughly investigated. The extent of soil sampling and testing should be determined for each case. Sounding rods may be used in light shallow soils to locate rock surfaces. In cohesive soils, earth augers may be used for considerable depths.

Wash borings, or well-drilling methods, are employed to determine the character of deep substrata. This method is unreliable and furnishes unsatisfactory results. It can give no dependable information concerning the structure of the substrata even when the so-called "dry sample" method is used. Wash borings, followed by core drilling, will usually give fairly accurate information as to the surface of bedrock, provided they are spaced closely enough. Wash borings alone, however, may stop on boulders and thus be misleading.

Core drilling should be resorted to for examination of rock foundation. The holes should be carried into the rock to a depth of 20 ft. or more, and a careful record should be kept of the amount of core obtained. A few holes should be put down to a considerably greater depth, in order to make sure that there are no faults in the foundation below the rock surface. At the Shoshone Dam (Wyoming) and also at the Arrowrock Dam (Idaho) some of the core drill holes passed through an overhanging shelf of rock, where the side of the cliff had once been undercut and afterwards filled in by the deposition of gravel. The final surface of the rock was found at a greater depth than was at first indicated. Had the core drillings been confined to shallow holes, the result in these cases would have been misleading. It is not uncommon to encounter immense boulders lying on top of the bedrock. Here again core drilling to a considerable depth is necessary in order to make sure of the foundation conditions.

Open test pits afford the only opportunity to inspect the material in place. Even though they are comparatively expensive, a few of them, at least, are very desirable, especially in the case of important structures, or where foundation conditions are at all questionable. Recent developments in methods of geophysical prospecting have made it possible to study geologic structures. In order to apply these methods, the logs of near-by

wells or other excavations should be available and the geologic structures should not be too complex.

15. Preparation of Foundation.—The preparation of the rock foundation for a high masonry dam is one of the vital features of construction. All loose or soft rock should be carefully cleaned off and removed, and the surface scrubbed clean with water and stiff brooms or wire brushes. This scrubbing should be continued until the foundation is absolutely clean, even to the extent of sopping up and disposing of the dirty water with sponges and



FIG. 3.—Cleaning up bedrock foundation for the Arrowrock, Idaho, dam.

buckets (see Fig. 3). The foundation should then be slushed with a thin neat cement grout and scrubbed in with brooms, just in advance of the placing of the concrete or masonry. This tends to take up any loose particles and incorporate them in the masonry. A layer of rich mortar, say 1:2, an inch or more in thickness, should be applied and kept just ahead of the concrete or masonry construction. If the dam is of concrete, it is good practice to make the first placings in as thick layers as is practicable, say 6 or 8 ft., so that the weight of the fresh concrete will help to make a good bond with the foundation.

Often there are seams of softer material running through a foundation of hard rock. Such seams should be excavated or cleaned out to sufficient depth and filled with concrete or grout. At the Arrowrock Dam (Idaho) a seam of porphyry running diagonally across the foundation was cut off by a shaft 40 ft. deep, sunk down the porphyry seam, and filled with concrete, which was keyed into the granite on either side of the shaft.

Blasting near neat lines should be done with great care, so as not to disturb or loosen the rock. Short holes and very light charges should be used, where such blasting is necessary in trimming up a foundation; for the final trimming, the use of bars or picks or wedges is much to be preferred. Where heavy excavation is necessary in material that requires blasting, this precaution should be kept in mind in drilling and shooting the primary holes, especially in seamy material where the effect of a blast may be felt at some distance from the hole.

Grouting of rock foundations for masonry dams is often resorted to as a matter of precaution. In fact, it is standard practice in the construction of high masonry dams, as at the Arrowrock Dam (Idaho), Elephant Butte Dam (New Mexico), Kensico Dam (New York), and in many of the later dams, such as Boulder, (on the Colorado River on the boundary lines between Nevada and Arizona), Grand Coulee (Washington), Shasta (California) and others.

Grouting, in order to be effective, should follow a carefully prepared plan involving the use of test holes, as the work proceeds, to show whether the desired results are being accomplished. The grout holes are usually drilled in two or more parallel lines, with the test holes between. Each grout hole should be drilled and grouted before another hole is drilled, otherwise the grout is likely to escape through the open holes, instead of being forced into the seams. All holes should be thoroughly washed out and tested for leakage under water pressure before the work starts. Neat cement grout should be used, unless the seams in the rock are open and take the grout very freely. In that case, some sand may be added until the hole begins to tighten up. Grout is usually mixed in proportions 1 cement and 3 water, to 1 cement and 5 water, depending on the tightness of the holes. The idea, of course, is not to seal the hole as quickly as possible, but on the contrary, to force in as much grout as the foundation will take. When the grouting of a hole has started, the flow of

grout should be continuous, until it will take no more. Grouting machines with two tanks, or a combination of two machines properly connected to the discharge line, are used to accomplish this. The grout is driven home by air pressure or water pressure, depending on the type of machine used. Usually it is best to begin with a low pressure and work up gradually to the maximum. The maximum pressure to be used depends on local conditions. In rock with horizontal seams care should be taken not to lift the rock. It is good practice to bring the grout holes up through the first layer of masonry and do the grouting after the foundation is covered. This also tends to grout the joint between the dam and its foundation. Grouting as a precautionary measure is excellent treatment for the foundation of a dam of any considerable size, but at best the results are uncertain, and where the safety of the structure depends on the success of the grouting operations, it is better to look elsewhere for a foundation. In other words, grouting as a precaution is to be recommended. Where absolutely necessary for the safety of a proposed dam, it is a doubtful expedient.

Grouting of sand and gravel has been attempted at various times, but no satisfactory method has yet been worked out, for dam foundations at any rate. In the light of present knowledge it should not be considered for such purpose. What is usually accomplished is simply to get a small mass of grouted material just at the end of the pipe. The results are of course dependent upon the permeability of the soil and the pressure used in the grouting process.

To key the dam into its foundation, it is customary to excavate a cutoff trench or keyway across the foundation along the heel or upstream face of the dam. The depth of this keyway will depend on the character of the rock. It should be at least 3 or 4 ft. deep in any case and should be continued up the abutments and along the full length of the dam. Figure 4 shows high rock scalars at work preparing the abutments for Shasta Dam, (California). It may be as narrow as is economical to excavate. Its sides should be nearly vertical, with clean square corners. Wherever practicable, the use of a channeling machine is recommended. In some cases one or more additional keyways may be desirable, in which case they should be parallel to the first and located within the upstream third of the dam. If the rock

is bedded in horizontal layers, the matter of keyways or cutoffs is of great importance, and they should be carried to sufficient depth to cut off any seams that might permit seepage or sliding.

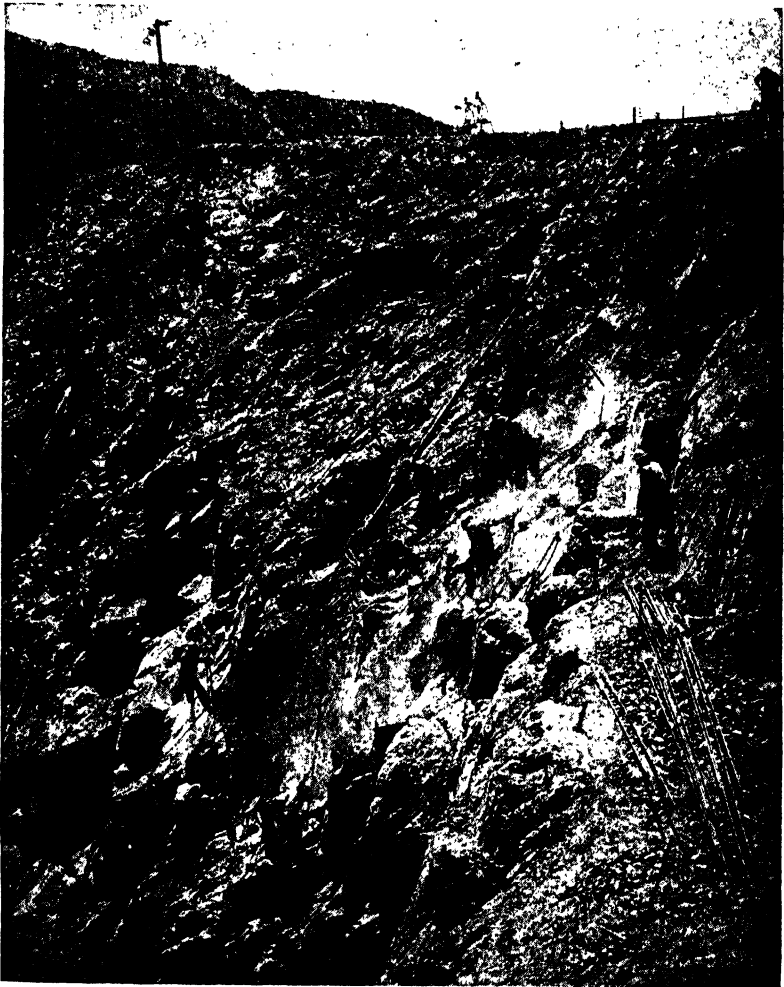

FIG. 4.—High scalers at work preparing abutments for Shasta Dam. (Courtesy of the Bureau of Reclamation, Department of Interior.)

Exposed foundation rock, the diversion channel, and completed sections of Shasta Dam are shown in Fig. 5.

It is sometimes thought desirable to scarify the rock foundation of a masonry dam. This is seldom necessary, as the work of



FIG. 5.—Diversion channel at Spasta Dam. (Courtesy of the Bureau of Reclamation, Department of Interior.)

cleaning off the foundation usually leaves it sufficiently rough to furnish a good bond and prevent sliding. Even when the rock is clean and waterworn, it is seldom so smooth and level that sliding is possible without actually shearing the masonry or the foundation itself.

The foregoing discussion of the preparations for foundations refers particularly to solid rock foundations for masonry dams. *For the softer rocks, shale, or clay* a similar procedure should be followed, with such modifications as may be suggested by the character of the foundation material or the size or importance of the structure. Clay, shale, or rock that might decompose rapidly when exposed should not be excavated to neat lines when the bulk of the excavation is being removed. It is best to excavate such material only to within a few inches, or perhaps a foot or more, of final depth, and then trim to neat lines just ahead of the placing of the concrete or the masonry, so that the foundation may be covered as soon as possible after being exposed. Anchoring the dam to its foundation is sometimes resorted to in the case of rock with horizontal clay seams, or shale, to guard against sliding or the effect of upward pressure.

The purpose of this is to make the foundation material, for a certain depth, an integral part of the dam structure. It is usually accomplished by drilling holes, properly spaced, to the depth required, and grouting in reinforcing bars, which will be carried up and tied in to the masonry in such a manner as to tie the dam and the foundation together effectually. Or, if protection against sliding only is required, these bars may project into the masonry only far enough to act as dowels. Shale and clay foundations should not be scrubbed with water or grout, for obvious reasons, but should be treated with a layer of rich mortar as the masonry is being placed. In such foundations, too, it is necessary to go to sufficient depth to ensure against sliding or the softening of the foundation by the action of water. Deep cutoffs or curtain walls of concrete are also desirable at both upstream and downstream faces of the dam. A well-designed drainage system may be required at the downstream toe.

Overflow dams on the softer foundations should be protected downstream by aprons of concrete, rock, or timber, carried to sufficient distance to prevent any possible erosion that would endanger the structure. The design of a suitable apron in such

cases is fully as important as the design of the dam itself. Aprons should be so designed that the standing wave will always occur well back of the apron and should be protected at the downstream end by heavy rock, paving, or riprap. Discharges from outlets and spillways may be handled in a similar manner. Hydraulic jump pools, as used in the Miami Conservancy Dams (Ohio), are very satisfactory for reducing the velocities and thus preventing scour. For vertical drops, water cushions are effective, provided they can be given a depth of 20 to 40 per cent of the drop. Even hard rock is not proof against the destructive action of falling water, the water in the seams acting as a wedge taking the impact of the falling water and eventually rupturing the rock. A water cushion or a heavy concrete apron will prevent this trouble.

A *clay foundation*, which is doubtful as to bearing power, may be improved by several of the expedients suggested heretofore, namely, spreading foundation, deeper excavation, use of piling, or confining by cutoffs or curtain walls. A soft clay may sometimes be greatly improved by driving short piles fairly close together. Such piles, however, must be below permanent water level or otherwise protected against rotting. Loading the foundation outside of the structure proper may also be successful. At one of the embankments forming the Deer Flat reservoir (Idaho), the downstream toe of the embankment was extended by means of a heavy blanket of gravel, which served the purpose of loading the partly saturated clayey material just outside the embankment foundation, which otherwise might have squeezed out and allowed settlement. This blanket served another useful purpose of providing drainage for any seepage that might find its way through the foundation material under the embankment.

Prevention or control of upward pressure in masonry dams is a subject that has been under lively discussion for many years. Although there is wide divergence of opinion as to how such pressure should be computed, all are agreed that it should not be disregarded and should be reasonably provided for. As a matter of fact, its prevention or control is usually not difficult. In most masonry dams it is feasible to construct drainage galleries lengthwise of the dam, close to the upstream face, and high enough above the downstream water surface to afford drainage to the

downstream face. A line of open drainage holes or weep holes may be drilled into the foundation and carried up to the drainage gallery to provide relief for any upward pressure that may exist. This has been done at many important dams including the Elephant Butte Dam (New Mexico), Arrowrock Dam (Idaho), and several others. The drainage galleries should be located near the upstream face so that the weep holes may be placed just downstream from the upstream cutoff, or the grout holes if any. In a grouted foundation the weep holes should not be driven, of course, until the grouting has been completed.

Cutoff and curtain walls in the upstream third of the foundation, impervious upstream aprons, and drainage of the down-

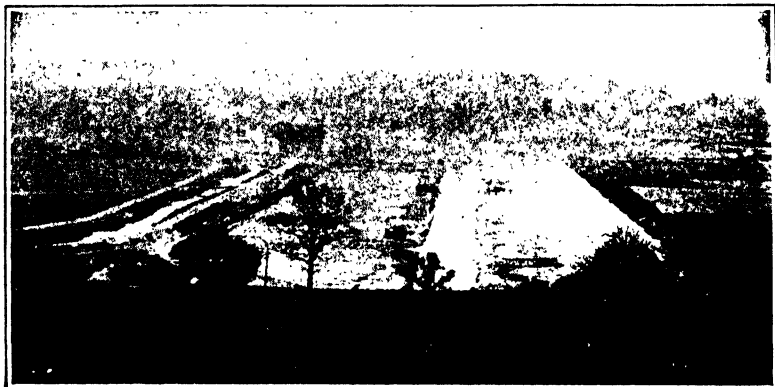

FIG. 6.—The foundation for the Huffman dam, Ohio, cleaned off, and cutoff-trench excavated, ready for beginning of hydraulic fill.

stream toe, all tend to prevent the action of upward pressure. Arching the dam in plan, or even building it on only a slight curve, will also help to take care of the uplift stresses. Any treatment of the foundation that leaves the upstream third more impervious than the downstream will be effective in reducing or preventing upward pressure. But the combination of weep holes and drainage galleries (which will also serve as inspection galleries) is the simple and positive method to be used whenever practicable.

Gravel and sand, or sand and silt foundations for earth or rock-fill dams should be stripped of all light loamy topsoil, peat, vegetable matter, or other perishable matter, and roots more than an inch or so in diameter should be grubbed out. One or

more cutoff trenches, or core trenches, of reasonable depth should be excavated across the valley and up the abutments, to be filled with impervious material. This should be done for exploration purposes, even if not required to prevent seepage. Springs encountered in the foundations should be controlled by diversion or by proper drainage. Bearing power of such foundations is usually sufficient for earth or rock-fill dams of reasonable height, because of the relatively wide base required; at any rate, slight settlement during the construction of such dams does not matter. The importance of the loss of water will determine to what extent measures for the prevention of seepage should be carried out. Where even slight loss of water is objectionable from an economic standpoint, the core trench should be carried to rock or impervious material, or, if the depth is too great for proper handling of a core trench, a concrete sheet pile or caisson cutoff may be substituted. If neither of these is practicable, the next best thing is a blanket of impervious material connecting with the impervious section of the dam and extending for some distance upstream. Where it is necessary and when conditions permit, foundation materials may be consolidated to provide increased bearing capacity. Simultaneous explosions of small charges of dynamite placed at suitable depths provide an effective method.

Even where loss of water is not objectionable, seepage must always be controlled to the extent that flow through the foundation material will not have enough velocity to wash out the finer particles. Lengthening the line of seepage travel by means of cutoffs, or by an impervious upstream blanket, will accomplish the result desired. A conservative rule, in ordinary porous sand and gravel, is that the ratio of length of travel to head shall be not less than about 8 or 9:1. It often happens in wide river valleys that there is an overburden of impervious material on top of the porous sand and gravel. In such cases, the thickness of this impervious layer should be determined by means of suitable subsurface exploration at various points upstream from the impervious portion of the dam. The thin spots, if any, may then be reinforced by artificial "patches" of rolled material, until the thickness of the impervious blanket at any point will be not less than 3 to 6 ft., depending on the head of water to which it will be subjected.

The foundations of the five hydraulic fill dams of the Miami Conservancy District (Ohio) were all prepared in this way. The length of the line of seepage may not be the only consideration necessary to control the amount of seepage under a dam. Should sufficient velocity develop, colloidal erosion may start at the point of exit of the seepage water in the lower sections. From this, progressive piping may result. Harza,¹ who has studied this problem extensively, concludes, "There seems to be no logical basis for expressing safety against toe flotation in terms of 'short path' of seepage or any functions thereof." A method of protection against piping is the use of inverted filters at the toe or the use of blanket filters as proposed by Casagrande.² Protection against scour from discharge of outlets and spillways may be secured by means of riprap, paving, aprons, water cushions, or hydraulic jump pools, as mentioned heretofore. Whenever practicable, outlets and spillways should be located on the same side of the river, to save expense in protecting against scour. Strange to say, this is a detail that is sometimes overlooked.

Foundations of gravel and sand for low masonry dams should be prepared in the same manner as for earth or rock-fill dams, special attention being given to the requirements as to bearing power, sliding, and upward pressure. As masonry dams on such foundations are usually of the overflow type, the design of the downstream apron is especially important, and too much care cannot be taken in protection against scour at that point. All that has been said heretofore concerning aprons, paving, riprap, etc., should be called to mind in this connection. Here again the best of judgment is required to obtain satisfactory results.

The use of *piling*, to meet the requirements as to bearing power, is often necessary, and in such cases the piling should be designed to carry all the load. A sheet pile cutoff at the upstream edge of the dam is usually desirable, and at the downstream toe a row of round piles driven close together, or of sheet piles with openings to permit drainage, will act to retard undercutting in case the apron is not fully effective. The impervious upstream apron is also desirable if practicable. Upward pressure should be reckoned with to an extent dependent on the porosity

¹ L. F. HARZA, "Uplift and Seepage under Dams on Sand," *Trans. Am. Soc. Civil Eng.*, Vol. 100, p. 1352.

² A. CASAGRANDE, "Seepage through Dams," *Harvard Univ. Pub.*, 208,

of the foundation material. As a matter of fact, in cases of this sort, the preparation of the foundation and the design of the structure are so interdependent that it is hardly possible, here, to do more than suggest general precautions to be observed.

A word ought to be said about *pump sumps*. It is important that sumps be set low enough, before the final cleaning up of the foundation is attempted, so that the water may be kept out of the way during that process, and also while the first courses of masonry are being laid. Very often the location of a pump sump may mean the difference between a good foundation job and a poor one. It is a good paying investment, on any wet foundation work, to give special attention to the location of sumps, so that the water level in the pit may always be under proper control, within the limits required. This in turn emphasizes the importance of determining the permeability of the foundation materials. Due consideration should be given to the rate of pumping in order that colloidal erosion or progressive piping does not occur.

No two foundations are alike in all respects. Rocks of different kinds and of different quality, as well as various combinations of gravel, sand, clay, and silt, each require special study and proper treatment. In some cases two or more entirely different materials will be present in the same foundation. An attempt has been made to discuss a few typical cases, leaving it to the judgment of the engineer to work out the best solution for his own particular problem.

MACHINERY FOUNDATIONS

16. Kinetic Reactions of Machinery.—Foundations are subjected to two general classes of loading: static and kinetic. A static load is one that does not vary with the time, such, for example, as the dead weight of a building or machine. In structural design, live loads, such as the weight of a train on a bridge, the weight of merchandise in a storehouse, or of an assembly of people in a building, are also classified under this head. The characteristic feature of static loading is that for a given structure the load carried by the foundation at any given time is constant in magnitude and direction. Consequently for static loading, the main purpose of the foundation is to provide adequate resistance to the force of gravity.

In designing foundations to carry static loads, two general principles are followed:

1. Provision of sufficient bearing area to prevent permanent settlement or deformation of the supports.
2. Equality in the distribution of pressure.

The application of these two principles is fully treated in other parts of this volume and will not be considered further here.

In machinery, the static loads due to the dead weights of the machine and its attachments are usually of minor importance as compared with the kinetic reactions produced by the motion of the various moving parts. Each moving part when accelerated or retarded gives rise to inertia forces in accordance with Newton's law,

$$\text{Force} = \text{mass} \times \text{acceleration}$$

In general, such forces are periodic and give rise to vibration. When there are several moving parts, these in general set up a corresponding number of separate vibrations in the machine, so that the resultant effect is usually very complex. The problem of designing a foundation to take care of the inertia forces set free by machinery in motion must therefore be solved by entirely different methods from those used in designing foundations for static loads.

The requirements that any particular foundation must satisfy depend largely on the kind of machine it is intended to support. For example, in machine tools the principal requirement is rigidity, in order to maintain accuracy of operation. Machines of this type are therefore usually of rugged construction with massive foundations.

At the opposite extreme are such machines as aircraft, in which the motor has practically no foundation so far as its mass is concerned. This requires an absolutely different type of mounting, the proper design for the support in this case being such as to minimize dynamically the effects of vibration, so far as this is possible, and to absorb the residual energy of vibration by some form of damping.

In designing the foundation for electrical machinery, and in fact for all types of modern high-speed machinery, the elimination of vibration is an important factor. This can be partly accom-

plished in the machine itself, but there is always an appreciable amount of residual vibration that must be taken care of by the foundation.

When the kinetic reactions caused by operating a machine do not occur with such frequency as to produce vibration, they are frequently of such amount and nature as to cause excessive shock and noise, often to such an extent as to endanger the building by the jar or to produce nervous fatigue in the operatives by the noise. A familiar example of this kind of machine is a battery of looms in a textile factory. Usually such machines are mounted directly on the floor, the result being that it is necessary to house them in specially reinforced buildings and also to relieve the operatives at frequent intervals. With properly designed foundations, it would be possible to relieve such conditions very materially.

The three main principles underlying the design of foundations for machinery are, therefore:

1. To overcome dynamically the effects of free inertia forces and couples by balancing such kinetic reactions within the foundation itself so as to cause them wholly or partly to cancel.
2. To prevent synchronism with adjoining machines or structures, by proper location or distribution of loads, by correct proportioning of structural members, or by insulation.
3. To absorb residual vibration by means of dampers incorporated in the foundation.

17. Weight Required in Massive Foundations.—The use of heavy foundations under machinery is the simplest and most primitive means of providing resistance to the kinetic reactions arising from the moving parts of the machine. In many cases, as for example in marine installations, power plants for aircraft or automobiles, and factories located on the upper floors of buildings, the use of a massive foundation is out of the question, and more scientific means must be resorted to for preventing vibration or for damping the effect of unbalanced inertia forces. Where a massive foundation can be used, however, it is effective as an inertia damper, although never efficient from the standpoint of power losses and strain on the machine.

There is no standard practice in designing heavy foundations for machinery, and so far as the writer is aware, no general method for designing such foundations has ever been given.

Each designer is a law to himself and lays out his foundation by eye, usually with the simple requirement of making it fit in the space available. It is evidently unscientific as well as uneconomical to mount a highly fabricated machine on a foundation that is largely guesswork. The following method of analysis may serve as a basis for determining the weight required in a massive foundation.

Consider a single-cylinder horizontal engine, say of the Corliss type (Fig. 7). As in the case of all internal-pressure engines, the steam pressure in the cylinder produces equal and opposite forces on the piston and cylinder head. Consequently these forces cancel out as regards the machine as a whole, and therefore

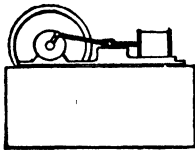

FIG. 7.

have no effect on the foundation. The moving parts, however, possess mass and hence inertia and, when accelerated or retarded, give rise to inertia forces or kinetic reactions, in accordance with the fundamental law $force = mass \times acceleration$. The resultant of all these inertia forces at any given instant is, then, the free force transmitted to the foundation at that instant. These inertia forces are in general harmonic, or approximately so, and therefore periodic; consequently, their resultant is also periodic.

In the present case, in order to express the required relations mathematically, let

W_1 = weight of eccentric rotating parts, including crankpin, crank cheeks, and crank end of connecting rod.

W_2 = weight of reciprocating parts, including piston head, wrist pin, piston rod, cross head, and reciprocating end of connecting rod.

W_3 = total weight of engine.

W_4 = weight required in foundation.

l = length of connecting rod between centers of pins.

r = crank radius.

$$q = \frac{l}{r}$$

n = speed of engine in revolutions per minute.

$$\omega = \text{angular velocity of crank} = \frac{2\pi n}{60}$$

For uniform speed of revolution the rotating parts have a constant central acceleration of amount $r\omega^2$; hence their inertia

produces a centrifugal force of amount

$$C = \frac{W_1}{g} r\omega^2$$

directed radially outward from the center of rotation.

The maximum acceleration of the reciprocating parts occurs at the ends of the stroke where the direction of motion is reversed. If the connecting rod were infinitely long, the motion of the reciprocating parts would be harmonic, and their maximum acceleration would be $r\omega^2$. For a connecting rod of finite length, however, the acceleration depends on the ratio of the length of the connecting rod to the crank radius, namely, on $q = \frac{l}{r}$. In this case it is easily shown that at the out end of the stroke the acceleration is $r\omega^2 \left(1 - \frac{1}{q}\right)$, whereas at the in end of the stroke it is $r\omega^2 \left(1 + \frac{1}{q}\right)$. The inertia force due to this acceleration or retardation is

$$F = \frac{W_2}{g} r\omega^2 \left(1 \pm \frac{1}{q}\right)$$

Consequently the maximum kinetic reaction exerted on the shaft is

$$\frac{W_1}{g} r\omega^2 + \frac{W_2}{g} r\omega^2 \left(1 + \frac{1}{q}\right)$$

This periodic inertia force is resisted jointly by the inertia of the masses to which it is transmitted, including the mass of the machine, the mass of the foundation, and the mass of that part of the soil or subfoundation which may be assumed to act as a unit with it. In other words, the practice of rigidly anchoring a machine to a massive foundation is based on the principle of using the relatively small accelerations set up in a large mass, namely, foundation and underpinning, to balance the large accelerations of relatively small masses, namely, the moving parts of the machine. For this reason the soil on which a foundation rests usually adds greatly to its effectiveness, for the mass of the soil is also accelerated just as far as the disturbance transmitted to it by the foundation extends.

Let k denote the ratio of the mass of soil accelerated to the mass of the foundation proper, and let a denote the average acceleration for the entire mass set in motion. Then the condition for equilibrium against horizontal translation in the present case is

$$\frac{W_3 + W_4 + kW_4}{g} (a) = \frac{W_1}{g} r\omega^2 + \frac{W_2}{g} r\omega^2 \left(1 + \frac{1}{q}\right)$$

Since the motion of the foundation is periodic with the same period as the engine, it is a sufficiently close approximation to assume that it is harmonic. If the amplitude of this harmonic motion is $2b$, then $a = b\omega^2$. Substituting this value, canceling out the common term $\frac{\omega^2}{g}$, and solving for the required weight of foundation W_4 , we have

$$W_4 = \frac{r}{b(1+k)} \left[W_1 + W_2 \left(1 + \frac{1}{q}\right) \right] - \frac{W_3}{1+k}$$

The horizontal reaction applied to the bed plate of the engine is of course accompanied by a vertical overturning couple acting on the foundation in the plane of the motion. In the present case, however, the effect of this couple is unimportant in comparison with the lateral motion due to the horizontal reaction.

Illustrative Problem.—In an engine of the Corliss type assume the following approximate weights and dimensions:

- Weight of rotating parts = 150 lb.
- Weight of reciprocating parts = 400 lb.
- Total weight of engine = 12 tons.
- Speed = 120 rev. per min.
- Length of connecting rod = 5 ft.
- Length of stroke = 20 in.

Find required weight of foundation to limit its lateral motion to 0.005 in. in either direction from a position of rest.

In the foregoing formula, k is an empirical factor, the value of which depends on the nature of the soil or subfoundation. In the present case assume $k = 10$ as an average value. Substituting the given numerical values in the above formula, the result is

$$W_4 = 55 \text{ tons}$$

as the actual weight required in the foundation under the assumed conditions to limit its motion to the amount specified.

18. Design of Beam Supports.—As mentioned in Art 16, in designing supports for machinery, their dimensions cannot be determined from the strength required to support the dead weight of the machine. Evidently the supports must be designed to offer adequate resistance to the kinetic reactions developed by the moving parts of the machine, but this requirement usually resolves itself into the condition that the supports shall be so designed as to prevent any possibility of synchronizing with the operating speed of the machine. In other words, foundations for machinery cannot be regarded as safe or efficient unless they are reasonably free from vibration.

When a machine is supported on an elastic framework of any kind, the motion of the machine in general will produce vibration of the support. Every elastic framework, however, possesses a certain definite natural frequency of vibration. When the speed of the machine reaches the same numerical value as this natural frequency of the support, the vibrations of the latter become excessive. This is the so-called "critical speed" for the given construction. The existence of vibration in a structure is never in itself a sign of weakness. In any structure, vibrations are sure to arise whenever its natural frequency synchronizes with the frequency of the exciting force, while a weaker structure under the same conditions would not vibrate to the same extent because of lack of synchronism. In designing supports for machinery it is therefore always essential so to proportion them as to make certain that the running speed of the machine never approaches very closely to the natural frequency of the support.

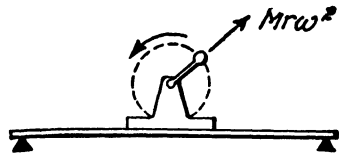

FIG. 8.

To explain the method of dimensioning beams to avoid synchronism, suppose that a machine of weight W rests at the center of a simple beam of length l (Fig. 8). As a first approximation neglect the weight of the beam itself in comparison with the load. Then the maximum deflection d of the beam occurs at the center and is of amount

$$d = \frac{Wl^3}{48EI}$$

where E is the modulus of elasticity for the material of the beam,

and I is the static moment of inertia of its cross section. The natural period P of free vibration of the beam is then

$$P = 2\pi \sqrt{\frac{d}{g}}$$

where g denotes the acceleration due to gravity. Inserting in this the value of the deflection d , we find

$$P = 2\pi \sqrt{\frac{Wl^3}{48EIg}}$$

Let n denote the speed of the machine in revolutions per minute. Then since the period P is expressed in seconds, we have

$$n = \frac{60}{P}$$

Consequently the lowest critical speed for the machine, *i.e.*, the speed at which the amplitude of vibration will be a maximum is

$$n_{\text{critical}} = \frac{30}{\pi} \sqrt{\frac{48EIg}{Wl^3}} = 1,300 \sqrt{\frac{EI}{Wl^3}}$$

E , I , and l being expressed in inch units, W in pounds weight, and n in revolutions per minute. If the actual running speed of the machine is likely to approach this value, it will be necessary to change the dimensions of the beam. Strengthening the beam by increasing its moment of inertia I raises its natural frequency, whereas weakening the beam by decreasing I lowers its natural frequency.

If the operating speed were considerably higher than the natural frequency of the beam, there might be little vibration at this speed, but in starting and stopping the machine, it would always have to pass through this critical speed, which might prove dangerous. It is therefore desirable that the operating speed should lie well below the lowest critical frequency of the support.

If it is desired to include the weight of the beam in the formula for critical speed, this may be done approximately as follows: The load carried by the beam in this case is the weight W of the machine and the weight wl of the beam itself, where w denotes its weight per unit of length. The deflection at the center therefore

consists of two parts: that due to the concentrated load W , which is

$$d_1 = \frac{Wl^3}{48EI}$$

and that due to the uniformly distributed load wl , which is

$$d_2 = \frac{5wl^4}{384EI}$$

Therefore, the total deflection at the center is

$$d = d_1 + d_2 = \frac{l^3}{48EI} \left(W + \frac{5}{8} wl \right)$$

which is the same as for a single concentrated load of amount $W + \frac{5}{8}wl$. Assuming that the natural frequency of vibrations of the beam is the same for a single concentrated load as when part of the load is uniformly distributed, the formula for critical speed becomes in this case

$$n_{\text{critical}} = \frac{30}{\pi} \sqrt{\frac{48EIg}{(W + \frac{5}{8}wl)l^3}}$$

This analysis is only approximate and the fraction $\frac{5}{8}$ is, therefore, not exact. A rigorous analysis shows that the proportion of the weight of the beam that should be added to W is $\frac{17}{35}$ instead of $\frac{5}{8}$.¹ Therefore, the required formula for practical use becomes

$$n_{\text{critical}} = \frac{30}{\pi} \sqrt{\frac{48EIg}{(W + \frac{17}{35}wl)l^3}} = 1,300 \sqrt{\frac{EI}{(W + \frac{17}{35}wl)l^3}}$$

To illustrate how this formula is used, suppose we assume as our working condition that the lowest critical frequency for the beam shall be ten times as great as the actual speed of the machine or

$$n_{\text{critical}} = 10n$$

and determine the size of the beam accordingly. As a first approximation neglect the weight of the beam. Then

$$n_{\text{critical}} = 10n = \frac{30}{\pi} \sqrt{\frac{48EIg}{Wl^3}}$$

¹ The correct analysis of this problem has been given by S. Timoshenko in Russian

whence

$$I = \frac{n^2 W l^3}{1,690 E}$$

Using this value of I , the dimensions of the beam may be determined and its weight calculated. As a check its critical speed may be redetermined, using $W + 17/35 wl$ for the concentrated central load.

The above considerations also indicate that it is desirable to distribute the load over the beam nonuniformly, as in general this has the effect of raising the critical frequency of the beam.

19. Design of Column Supports.—When a machine is supported on columns, as for example when machinery is installed on the upper floors of a building, it is of course just as essential as in the case of beams that the operating speed of the machine shall not synchronize with the natural frequency of vibration of the columns.

To explain how synchronism may be avoided in this case, consider a weight W supported on a column of length l , and as a first assumption neglect the weight of the column itself in comparison with W

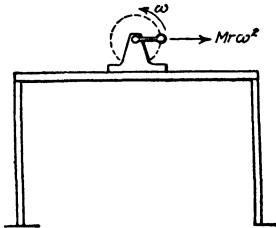

FIG. 9.

(Fig. 9). Under the action of a horizontal force applied to the top of the column, it will deflect like a cantilever beam. This horizontal force is made up of the horizontal components of the kinetic reactions produced by the motion of the machine. Denoting the

horizontal force acting on one column by H , the lateral deflection of the upper end of the column will be

$$d = \frac{Hl^3}{3EI}$$

where I denotes the moment of inertia of a cross section of the column. Therefore d is proportional to H , which is a sufficient condition that the lateral motion of the column shall be harmonic. The fundamental equation for simple harmonic motion is

$$m \frac{d^2x}{dt^2} = -kx$$

where k denotes the value of the disturbing force at unit distance from the position of rest. In the present case, k is the value of H for $d = 1$; consequently

$$k = \frac{3EI}{l^3}$$

The period of the harmonic motion is

$$P = 2\pi \sqrt{\frac{m}{k}}$$

where m denotes the mass of the body, and the frequency f is

$$f = \frac{1}{P} = \frac{1}{2\pi} \sqrt{\frac{k}{m}} = \frac{1}{2\pi} \sqrt{\frac{3EIg}{Wl^3}}$$

The critical speed for the structure, namely, the operating speed of the machine, which synchronizes with the natural frequency of the column, is then

$$n_{\text{critical}} = \frac{30}{\pi} \sqrt{\frac{3EIg}{Wl^3}} = 325 \sqrt{\frac{EI}{Wl^3}}$$

where E , I , and l are expressed in inch units and W in pounds weight.

At first glance it might seem that there is something peculiar about this expression, since it implies that the critical frequency for a column is the same as for a cantilever beam. The reason for this is that, in the general formula for the period of a harmonic motion, namely,

$$P = 2\pi \sqrt{\frac{m}{k}}$$

m denotes the mass of the vibrating body, while k denotes the unit restoring force, which in this case is the flexural rigidity of the column considered as a vertical cantilever beam with its lower end fixed.

In order to make this still clearer, the following alternative proof may be given: When the weight W is vibrating laterally with a simple harmonic motion, the maximum value of its velocity v is at mid-position and is of amount

$$v = r\omega$$

where in the present case the amplitude $r = d$. Since the motion is harmonic, $\omega = \sqrt{\frac{f}{m}}$. The kinetic energy of W in this mid-position is, therefore,

$$K.E. = \frac{1}{2} mv^2 = \frac{1}{2} mr^2\omega^2 = \frac{1}{2} md^2 \frac{f}{m} = \frac{1}{2} d^2f$$

This energy should be equilibrated by the resilience of the column, *i.e.*, by its internal work of deformation or potential energy. If d is the amplitude of lateral deflection and F is the force required to produce this deflection, then since the column deflects laterally like a cantilever beam fixed at the lower end, we have

$$d = \frac{Fl^3}{3EI}$$

Consequently, the potential energy stored in the beam at either extreme position is

$$P.E. = \frac{1}{2} Fd = \frac{3EI d^2}{2l^3}$$

Equating these two expressions, we find

$$P.E. = \frac{3EI d^2}{2l^3} = K.E. = \frac{1}{2} d^2f$$

whence, as before,

$$f = \frac{3EI}{l^3}$$

and, consequently,

$$P = 2\pi \sqrt{\frac{m}{f}} = 2\pi \sqrt{\frac{Wl^3}{3EIg}}$$

The effect of including the weight of the column in the calculations may be determined approximately as follows: Since the deflection of a cantilever beam under uniform load is

$$d = \frac{wl^4}{8EI}$$

where w denotes the uniform load per unit of length, the total deflection of such a beam under both a concentrated load W and

a uniform load wl will be

$$d = \frac{Wl^3}{3EI} + \frac{wl^4}{8EI} = \frac{l^3}{3EI} \left(W + \frac{3}{8} wl \right)$$

It is, therefore, the same as for a single concentrated load of amount $W + \frac{3}{8}wl$. Assuming that the frequency of the column is the same for a single concentrated load as when part of the load is uniformly distributed, we have approximately in this case

$$n_{\text{critical}} = \frac{30}{\pi} \sqrt{\frac{3EIg}{l^3(W + \frac{3}{8}wl)}}$$

A rigorous analysis of this problem shows that the fraction of the uniform load wl , which should be added to the concentrated load W to obtain the true frequency, is $\frac{33}{140}$ instead of $\frac{3}{8}$.¹ Consequently the corrected formula for critical speed becomes

$$n_{\text{critical}} = \frac{30}{\pi} \sqrt{\frac{3EIg}{l^3(W + \frac{33}{140}wl)}} = 325 \sqrt{\frac{EI}{l^3(W + \frac{33}{140}wl)}}$$

- where W = total load in pounds supported by one column.
- w = average weight of column in pounds per linear inch.
- l = length of column in inches.
- wl = total weight of one column in pounds.
- I = static moment of inertia of cross section of column in inches⁴.
- E = Young's modulus for the material.

To determine the required size of column so as to avoid synchronism, we may assume its natural frequency n_{critical} to be a certain multiple of the operating speed n assumed to be known, say

$$n_{\text{critical}} = 10n$$

Neglecting the weight of the column as a first approximation, we have in this case,

$$n_{\text{critical}} = 10n = \frac{30}{\pi} \sqrt{\frac{3EIg}{Wl^3}}$$

whence

$$I = \frac{n^2 W l^3}{1,057 E}$$

¹ *Ibid.*

The dimensions of the column may then be determined so as to give approximately this value of I . Its weight may then be computed and its critical frequency recomputed using $W + \frac{33}{140}wl$ for the load.

20. Marine Installations.—The hull of a vessel is a compound beam, made up of the sides, decks, and bulkheads as component girders. It therefore vibrates in the same manner as a massive beam having the same distribution of mass and moment of inertia.

In order that the motion of the engine shall not set up forced vibrations in the hull, two conditions must be fulfilled:

1. The combined center of gravity of all the moving masses must always remain at rest relative to the hull of the vessel.
2. The algebraic sum of the moments of momentum of the moving masses must be zero at each instant for every arbitrary center of moments.

The first condition is taken care of in the design of certain types of motors. For example, in a 6- or 12-cylinder gas engine,

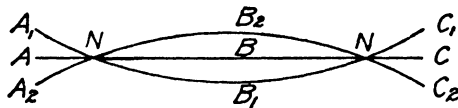

FIG. 10.

like the Liberty motor, the combined center of mass of the reciprocating parts is a fixed point; consequently, in this type of motor no vibration is set up by the motion of the reciprocating parts. Both of the foregoing conditions may be satisfied simultaneously for an engine with not less than four cylinders by applying the method of inertia balancing devised by Schlick.

For an ordinary marine engine with any number of cylinders these conditions may be so applied as to minimize vibration by properly locating the engine in the hull.

Consider first the effect of placing a single-cylinder vertical engine at or near the center of the vessel, represented by the point B in Fig. 10. Let ABC represent a straight line in the vessel when the engine is at rest. When the engine attains a certain critical speed, namely, when its speed becomes the same as the natural frequency of vibration of the hull, strong vibrations will appear, causing the line ABC to vibrate between the two extreme positions $A_1B_1C_1$ and $A_2B_2C_2$. If the speed is

increased beyond the critical point, the vibrations die away. The same phenomenon will occur if the engine is placed near the ends *A* or *B*, *i.e.*, near the bow or stern. However, if placed at either of the points lettered *N* in Fig. 10, which represent the nodes of the vibration for this frequency, the vibrations will not appear at this speed but may occur at higher speeds, provided of course that it is possible for the engine to reach these speeds. In other words, the simple form of vibration shown in Fig. 10. corresponds to the fundamental or lowest natural frequency of the hull, which is usually the only one that lies within the range of engine speeds in the case of steam engines. Any beam, however, has a whole sequence of higher natural frequencies, called harmonics of the lowest or fundamental frequency, each of which possesses its own characteristic form, as well as a fixed number and location of nodes or stationary points. In high-speed motors these harmonics may be the critical frequencies to be avoided.

For a two-cylinder vertical engine with cranks 180 deg. apart, the vertical inertia forces cancel, but the opposition of the cylinders gives rise to an inertia couple. Consequently, the best location for such an engine is at the center or ends of a vessel where the couple will have the least effect. If placed at a node, with the cylinders on opposite sides of the node and equidistant from it, the couple will have the greatest effect, producing vibrations of the first order at the lowest critical speed. As the engine is moved away from the node, the effect becomes less marked.

Any system of forces whatever can always be reduced to an equivalent system consisting of a single resultant force and a single resultant couple. This of course applies equally to the inertia forces in a machine. From what precedes, then, it is apparent that there are two general rules for avoiding vibrations of the first order in marine installations:

3. For an engine placed at the center of a vessel the resultant vertical force must be zero (*i.e.*, the algebraic sum of the vertical inertia forces must be zero) but for this particular location the resultant inertia couple has its least effect in producing vibration.

4. For an engine placed at or near a node, the resultant fore-and-aft couple must be zero, but it is not so important that the resultant of the vertical inertia forces shall be zero.

Consider next a three-cylinder vertical engine, say a triple-expansion steam engine with cranks 120 deg. apart (Fig. 11). The usual location of such an engine is aft of the center of the vessel, and therefore near one of the nodes of the fundamental frequency. Let W_1, W_2, W_3 denote the weights of the reciprocating parts for the three cylinders, respectively, and let a, b, x denote the distances of these three cylinders, respectively, from the node (Fig. 11). Let φ denote the angular displacement of the

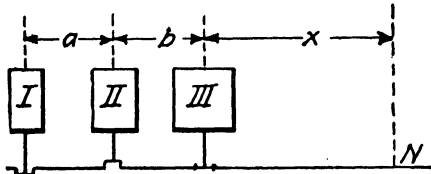

FIG. 11.

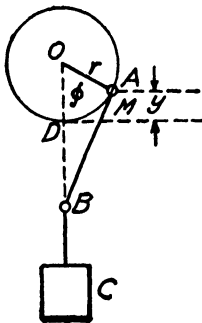

FIG. 12.

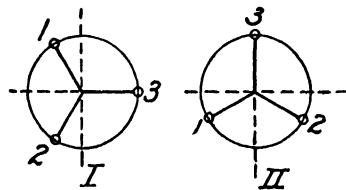

FIG. 13.

crank OA from the inner dead center D (Fig. 12). Then its vertical displacement is

$$y = r - r \cos \varphi$$

Consequently its vertical velocity is

$$v = \frac{dy}{dt} = r \sin \varphi \frac{d\varphi}{dt} = r\omega \sin \varphi$$

where ω denotes the angular velocity of the shaft, assumed to be constant. For a simple approximate solution, neglect the angularity of the connecting rod. Then this expression for v will also

denote the velocity of the reciprocating parts. If M denotes the mass of these parts, their linear momentum is

$$Mv = Mr\omega \sin \varphi$$

Now consider two positions of the crank as indicated in Fig. 13. Finding the momentum of each of the three sets of reciprocating weights W_1 , W_2 , W_3 , and taking moments about the node we obtain from the fourth rule, given above, for these two positions the two following relations:

$$\left\{ \begin{aligned} \frac{W_1}{g} r\omega \sin 210^\circ (a + b + x) + \frac{W_2}{g} r\omega \sin 330^\circ (a + x) \\ \qquad \qquad \qquad + \frac{W_3}{g} r\omega \sin 90^\circ (x) = 0 \\ \frac{W_1}{g} r\omega \sin 300^\circ (a + b + x) + \frac{W_2}{g} r\omega \sin 60^\circ (a + x) \\ \qquad \qquad \qquad + \frac{W_3}{g} r\omega \sin 180^\circ (x) = 0 \end{aligned} \right.$$

Canceling the common factor $\frac{r\omega}{g}$ and substituting the values of the trigonometric functions, these reduce to the following:

$$\left\{ \begin{aligned} -\frac{1}{2}W_1(a + b + x) - \frac{1}{2}W_2(a + x) + W_3x = 0 \\ -\frac{1}{2}\sqrt{3}W_1(a + b + x) + \frac{1}{2}\sqrt{3}W_2(a + x) = 0 \end{aligned} \right.$$

Further reduction shows that these two equations are equivalent to the simple conditions

$$W_1(a + b + x) = W_2(a + x) = W_3x$$

For a triple-expansion steam engine we have approximately

$$W_1 : W_2 : W_3 = 0.71 : 0.83 : 1$$

Assuming for simplicity that $a = b$, substituting the numerical values of these ratios, and solving for x , we have approximately

$$x = 5a$$

If, then, the engine is installed in this location, it will produce a minimum of vibration in the hull.¹

¹ This criterion for locating a triple-expansion marine engine is due to Schlick.

In practice, engines are frequently installed in approximately this location. This accounts for the fact that some installations show very little vibration.

21. The Akimoff Foundation.—The usual method of supporting machinery consists in anchoring the machine down firmly to a foundation designed to be as rigid and massive as circumstances permit. As already explained, the effect of massiveness in a foundation is to reduce the amplitude of motion. However, a large mass vibrating with even a small amplitude absorbs energy that can come only from the machine; consequently, this practice results in considerable power losses. In addition to power losses, vibration is likely to cause failure of certain parts, owing to the fatigue of the material under repeated stress. There are many other undesirable effects, such for instance as the disintegration of concrete foundations under heavy machinery such as turbogenerators, producing trouble by allowing the machine to settle out of alignment.

It is a fact of common experience that there are certain critical speeds for any machine at which vibration is greatly intensified. A partial explanation of this effect and means for avoiding it are given in what precedes. The following supplementary explanation may serve to make the matter clearer.

Every elastic body, or system of elastic members, if displaced from its position of equilibrium and then released, will oscillate about this position with a certain definite frequency depending on the distribution of mass and stiffness of the system. Such oscillations performed by a body of itself are called natural or free oscillations, and their frequency is called the natural frequency of the system. Free vibrations absorb very little power, as practically the only energy dissipated is a very slight amount due to molecular friction. On the other hand, any elastic body or system of members may be forced to oscillate with any given frequency by the action of an external periodic force. Such forced vibrations, however, require the expenditure of power, the amount of power required depending of course on the mass and rigidity of the system as well as on the frequency of the forced vibration.

Whenever the frequency of the forced vibration happens to be the same as the natural frequency of the system, we have what is called synchronism between the two. The result of synchronism

is naturally excessive vibration, since the power required to maintain vibration with the natural frequency of the system is very slight; consequently, the excess energy received from the exciting force is manifested in greater amplitude of motion, often to such an extent as to produce fracture of some part.

The critical speed then is simply that at which synchronism occurs between the frequency of the impressed force and the natural frequency of the system on which it acts, the resistance in this case dropping to a minimum; consequently, the amplitude of motion shows a corresponding increase so as to keep their product sensibly constant and proportional to the rate at which work is being done on the system.

In designing foundations for machinery it is usually very important to prevent synchronism between the operating speed of the machine and the natural frequency of adjacent structures or machines. Vibration is frequently transmitted through the walls, partitions, and floors of a building, and through the soil for long distances, making itself felt unpleasantly and perhaps dangerously whenever it extends to any structure that synchronizes with it. For example, the blades of a turbine rotor have been found in vibration although the turbine was not running, due simply to synchronism between the natural frequency of the blades and the operating speed of adjacent machinery. The function of a foundation should be therefore not only to support weight and damp out vibration, but also to prevent the occurrence of synchronism.

The Akimoff patented foundation is designed to accomplish all three of these results simultaneously. It consists primarily in interposing a three-point support between the machine and the foundation proper, one of these supports being rigid and of the nature of a universal joint and the other two being resilient. The three main features of this type of mounting may be briefly summarized as follows:

1. *Concentrates Loads at Three Definite Points and Maintains Alignment.*—A three-point support localizes the loads transmitted to the foundation at these three points. This simplifies the design of the foundation since when the exact amount and point of application of a load are known it is a simple matter to provide adequate support. Most of the difficulties in foundation design are due to uncertainty as to the distribution of the load. By

making one of the three supports adjustable as to height, this provides means for leveling the machine and maintaining its alignment. A three-point support also prevents the occurrence of the twisting strains that often occur in certain types of machines, such for instance as automotive apparatus.

2. *Permits Damping.*—The resilient supports may be so designed as to serve as dampers for absorbing the energy of vibration. The function of dampers and their construction are

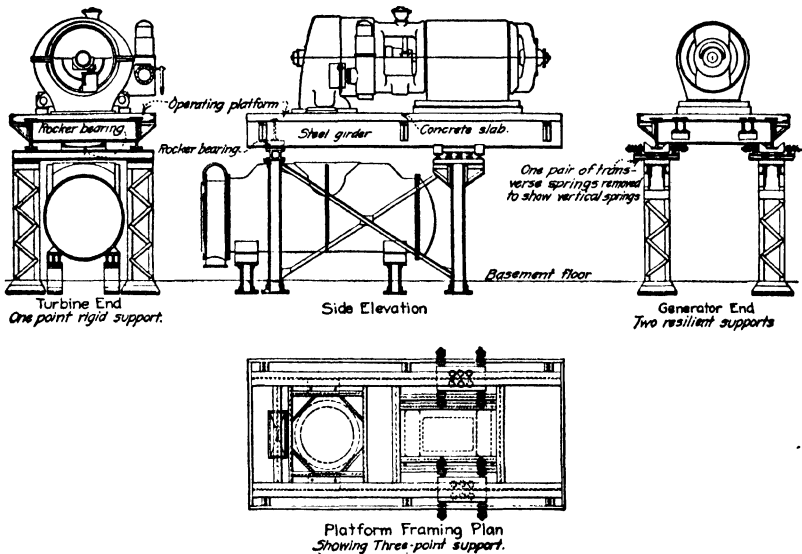

FIG. 14.

explained more fully in Art. 22. It may be mentioned in this connection, however, that by constructing the resilient supports so as to have a large coefficient of internal friction, the energy of vibration may be largely dissipated in the damper itself and consequently disappear before it reaches the foundation. This is evidently the most effective means of disposing of vibration since the disturbance is given no chance to extend to adjacent structures.

3. *Prevents Synchronism.*—The principle on which the effectiveness of this foundation depends consists not merely in using a three-point support, but in making one of these points rigid and the other two elastic. The single fixed point prevents linear

motion of the machine in any direction, whereas the elasticity of the resilient supports leaves it free to rotate very slightly about any axis through the fixed point. The effect of this is to allow the machine three degrees of freedom, of course within very small limits, instead of attempting the impossible task of providing an absolutely rigid anchorage. A means is thereby provided for controlling the motion of the machine through the agency of the resilient supports so as to prevent the possibility of synchronism between the operating speed of the machine and the natural frequency of the foundation or substructure.

Figure 14 is a sketch of the Akimoff foundation applied to a 3,000-kw. turbogenerator mounted on a structural steel framework.

22. Foundation Dampers.—In a machine anchored rigidly to a heavy fixed foundation, the mass of the foundation acts as an inertia damper to limit the displacement due to vibration, as explained in Art 16. The smaller the ratio of the mass of the moving parts of the machine to the mass of its fixed parts, including the foundation anchored to it, so much the less will be the amplitude of vibration, since the whole question is one of transferring the kinetic energy of vibration to the foundation. From what precedes it is also apparent that not only are the size and density of the moving parts concerned, but also their position relative to one another and to the foundation on which the machine is supported. The ideal procedure in designing foundations for machinery is then to begin with the machine itself and, by proper arrangement and design of the moving parts, cancel the free inertia forces so far as possible. The location of the machine with respect to the foundation should next be considered, as for instance in the case of marine installations considered in Art. 20. The weight and distribution of mass in the foundation itself should then be so proportioned relative to the machine as to offer the most effective resistance to the kinetic reactions that are finally transmitted to the foundation.

In most cases, however, this procedure cannot be followed, as the type of machine and the foundation are both fixed by other considerations. For instance, in automotive apparatus, the motor and its support are designed for compactness, lightness, and appearance; or, when installing standard machinery on the upper floors of old buildings, where it is impossible to build up a

massive foundation, it is necessary to resort to other means for disposing of the free kinetic energy of vibration, say by transferring it to an elastic system where it can be absorbed or damped out by internal frictional resistance.

A method frequently employed for this purpose consists in placing the machine on a layer of some resilient material, such as cork or felt, called an "insulating" layer. This of course is a very simple method to apply, but it is only partly effective. In fact this should not be called "insulation" since this term by reason of its common use in electrical work has come to mean a layer that is impenetrable by a certain type of wave motion. The first fact to observe is that a resilient layer is effective only in proportion to its capacity to absorb work by internal or molecular friction. As this capacity for any given layer is limited, it is capable of absorbing only a certain fraction of the energy of vibration, and it is usually not practicable to introduce sufficient volume to absorb all of it. Furthermore, this damping layer may not be inserted at any arbitrary place for, as shown above, the amplitude of vibration depends on the ratio of the mass of the moving parts to that of the foundation and fixed parts. Since inserting a resilient layer diminishes the effective mass of the foundation, these layers should therefore be placed at such a depth that the machine will still be attached to a sufficiently-heavy foundation mass. Moreover, inserting a resilient layer has the effect of raising the center of gravity of the machine and therefore affects its stability, which must also be taken into account in determining the position of such a layer. This leads to the principle that when practicable, instead of isolating each machine separately, several machines should be built on a common support, and this support isolated from its surroundings by resilient layers or some form of damper as described below.

In order to be effective as a vibration damper, a resilient layer should be lightly loaded, the allowable weight per square inch depending of course on the nature of the material used for this purpose, as the damping action depends entirely on preserving the elasticity of the material and preventing permanent deformation. The layer should also be impregnated with some preservative so as to make it impervious to water, oil, acids, etc., in order that it may permanently retain its damping properties. The use of a simple resilient layer is shown in Fig. 15.

Naturally, absorption of vibration is not limited to entire machines. Absorption dampers may also be applied to separate parts such as machine feet, brackets, and other kinds of supports. As such dampers are intended for special purposes, they must be constructed in a special manner. Figures 16 and 17 illustrate two simple types of dampers for machine feet. These are so designed as not to change the height of the machine, and also to act as an anchorage against vertical upward pull as well as

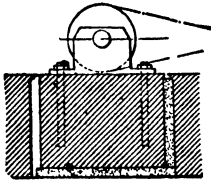

FIG. 15.

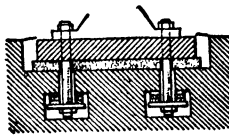

FIG. 16.

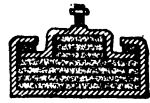

FIG. 17.

downward compression. The use of a metal housing as shown in Fig. 17 is important, as it prevents the resilient material from lateral deformation and thereby increases its efficiency.

It is often advisable to use springs in connection with absorbent material. One form of combination damper of this type is shown in Fig. 18. The springs in such dampers absorb very little energy as their molecular friction is very slight provided the load does not exceed the elastic limit of the steel. The spring, however, does decrease the intensity of vibration since it extends the action of the force over a greater period of time. For this reason a combination damper should be used in a machine subject to shocks. For instance, in an automobile, in addition to the vibration caused by the motor, there are also severe road shocks to be considered. Therefore, a combination damper is desirable in this case since the action of the spring serves to relieve shocks as well as to reduce the intensity of vibration, while the resilient material dissipates the energy of vibration in proportion to its volume and specific damping properties. Whenever springs are used, however, care should be taken that the speed of the machine does not synchronize with the natural frequency of the spring, as in this case the effect will be exactly the reverse of that desired.

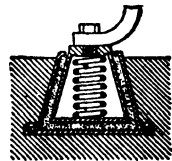

FIG. 18.

SECTION 7

BRIDGE PIERS AND ABUTMENTS

GENERAL CONSIDERATIONS

1. Selection of Site.—The selection of the site of a bridge is necessarily regulated, to a large extent, by the topographic and geologic features of the vicinity, as these will influence the selection of an economic crossing and the general type of construction. The proposed location should be subjected to a careful and intelligent examination and all local conditions should be ascertained and recorded. In the case of highway bridges, adequate traffic surveys should be made on all main arteries from which traffic to the proposed bridge may flow. Maximum loading will occur if the bridge is a part of a main traffic route or furnishes access to a parallel route.

2. Survey of Local Conditions.—The profile of the ground and also the bottom of the stream should be carefully plotted, the rate of stream flow determined, the periods and elevations of high and low water as indicated by the records of the past ascertained, and the area of the waterway determined for which it is necessary that provision be made. The channel proper should be located and, in the case of bridges consisting of two or more spans, the location of the channel span should be so fixed as to provide minimum obstruction.

3. Foundations, Borings, Etc.—Special attention should be given to the determination of the character of the natural foundations on which the substructure will rest. When small bridges are under consideration, the digging of test pits usually supplies adequate and reliable data. Where large and costly structures are contemplated, test borings should be made. This work requires equipment of a class whose possession is usually restricted to firms actually engaged in this class of work, and the most economic and satisfactory results can usually be obtained by contracting for borings of this nature. Core borings to any desired depth can usually be contracted for at prices ranging

from \$1 per foot upward, depending upon the character of the soil, the depth to which it is necessary to bore, and whether the site of the boring is on land or water.

4. Outside Interests. *Effect on Design.*—Where the proposed bridge involves the crossing of a navigable stream, it is necessary that the navigation interests be consulted, their wishes and needs ascertained. Where the proposed structure is to cross a highway or tracks, the desires of the interests whose right of way is crossed must receive due consideration, and suitable agreement covering the rights of each party to the crossing should be formulated. In such cases, the general economic considerations that fix the location of the substructure units and the superstructure span lengths are frequently modified by the demands of the interests controlling the property crossed. Frequently the desire to avoid or minimize the obstruction upon such property requires an arrangement of piers and abutments that is not the most economical from the standpoint of bridge costs. The angle of the crossing is also an element that cannot be neglected. It is probably needless to say that the most economical arrangement is a right-angle crossing. Where, for any controlling reason, this is impossible, the intersection should be made as near a right angle as possible.

In the case of bridges crossing interstate navigable streams, the approval of the U.S. War Department must be obtained, prior to the beginning of actual construction. Governmental regulations covering such instances require that the application for War Department permit be made on standard form, accompanied by the plans and supporting documents enumerated in the instructions therein printed. The most satisfactory method of conducting negotiations for the issuance of a War Department permit is usually by personal conference with the Engineer Officer of the War Department in whose district the proposed work lies.

In many parts of the United States, public regulatory bodies of various kinds exist, exercising statewide or local jurisdiction over various phases of bridge construction: the capacity of the proposed new structure, its adaptability to the local conditions and the traffic which it is to carry, the waterway provided, aesthetic features, etc. In some cases, the formal approval of such bodies is required by law. Under any circumstances, it is a matter of sound policy that these bodies be consulted.

5. Economic Balance of Cost.—When all the factors influencing the character of structure to be adopted have been fully considered, it may be worthy of note, as a statement frequently repeated, that the most economical type of bridge is that in which the cost of the piers and abutments, *i.e.*, the substructure, approximately equals the cost of the superstructure. This general statement, however, is subject to wide variations. The ratio between the cost of the substructure and that of the superstructure varies considerably. The cost of the superstructure, exclusive of the floor system, will vary approximately as the square of the span. In general, the cost of the substructure is constant for a comparatively large range of span. Extremes may be represented by the profile of the crossing, *i.e.*, its characteristics may vary between a broad, low crossing or a crossing that is narrow and high. A further factor to be considered is the anticipated life of the superstructure and that of the substructure. In general, it may be assumed that the substructure will have an anticipated life at least twice that of the superstructure.

6. Concrete Construction.—The discussions in this section treat only of concrete construction, whose economy over stone masonry has been clearly established by engineering experience. This fact is attributable to the large labor cost involved in the latter class of construction, the current scarcity of expert stone cutters, and the impossibility, in many localities, of securing a satisfactory quality of stone except at prohibitive cost, in which transportation is a factor. Concrete as a material of mass construction has been in use for such a length of time that its nature and composition are matters of common and thorough knowledge. The plant and equipment required for such construction do not necessitate the employment of highly skilled labor, and all material may be readily transported and handled. In many instances, sand and stone are secured locally, and, after mixing, the concrete may, with proper plant arrangement, be placed in final position by chutes, or other means, at comparatively small labor cost.

Only mass or monolithic concrete, in contradistinction to reinforced concrete construction, will be discussed in detail. The external forces acting on piers and abutments for bridge substructures are identical, whether the structure is of the mono-

lithic or reinforced type. A reinforced pier or abutment may be considered a framed structure, consisting of columns, beams, slabs, counterforts, etc., all of which must be designed in accordance with the principles laid down for framed reinforced concrete construction, and, except as previously mentioned for external forces, such piers and abutments differ radically from the type under consideration. Furthermore, it is desired to call attention to the fact, that, in the case of reinforced concrete construction, it is vitally essential that great care be taken in the design to provide proper drainage and, in addition, thoroughly waterproof the structure, in order to prevent deterioration of the reinforcing material. Integral waterproofing will not do this satisfactorily, and it becomes necessary to resort to membrane waterproofing, which must, in turn, be protected.

7. Bridge Seats.—The tops, *i.e.*, the bridge seats, of piers and abutments provide the immediate bearing surface for the support of the superstructure. The superstructure, especially in the case of railroad bridges and, to a somewhat minor degree, in the case of highway bridges subject to the movement of heavy trucks or trolley traffic, is subject to vibration, which must be absorbed by the supporting masonry. It is essential that the bridge seats be composed of a good quality of concrete, certainly not leaner than 1:2:4 mixture.

8. Protection of Pier Surfaces.—In the case of bridges crossing waterways, it is necessary to consider especially that portion of the substructure located “between wind and water,” *i.e.*, the portion of the masonry surface that lies between extreme high and extreme low water. This surface is subject to injury and consequent deterioration, owing to impact of objects floating on the water, the erosive action of the current, waves, frost, and possibly, in the case of salt water, the action of the saline content. In regions where industrial plants or coal mines abound, this danger to the masonry is further increased by the introduction of chemical agents, especially sulphuric acid, into the water, very small quantities of which will cause comparatively rapid deterioration of the concrete.

It is recommended that, where a leaner mixture is used for the bodies of piers or abutments, the surface for at least an approximate thickness of 2 ft., between a line 2 ft. above ordinary high water and 2 ft. below ordinary low water, be composed of a

concrete not leaner than 1:2:4 mixture, thoroughly spaded, and the forms left in place at least 30 days before the concrete is exposed.

In cases where conditions are unusually adverse, the surface of the substructure between a line 2 ft. above ordinary high water and 2 ft. below ordinary low water should be formed of precast concrete blocks, 1:2:4 mixture, which have set at least 30 days before being placed. Mechanical bonds should be provided to bond the blocks together properly, and to the monolithic concrete forming the bulk of the masonry. The joints between the blocks should be thoroughly and completely grouted. If it is possible to obtain a satisfactory grade of stone at reasonable cost, stone may be substituted for the concrete blocks.

The use of a stone masonry facing has the advantage of saving form work and of solving the surface cracking problem. The finished pier will present a more pleasing appearance. The stone facing should be adequately tied by the use of rods to the concrete of the pier.

ORDINARY BRIDGE PIERS

9. External Forces.—The external forces to which a pier will be subjected, and to resist which it will be designed, must be determined in advance. Some of these forces are susceptible of absolute mathematical determination—the source, effect, and disposition of others are matters of engineering judgment and experience. In pier construction these forces are

1. The dead load of the superstructure.
2. The live load of traffic passing over the bridge.
3. The dead load of the pier itself.
4. Lateral forces, acting in a direction parallel to the center line of the pier, *i.e.*, those which act in a transverse direction with respect to the longitudinal axis of the bridge. Among these forces may be enumerated the wind on traffic passing over the bridge, the wind on the superstructure, centrifugal force in the case of a railroad bridge on a curve, force of the water current, the force due to large fields of floating ice, and the effect of impact of objects floating upon the water surface.
5. Longitudinal forces, acting in a direction transversely to the center line of the pier, *i.e.*, those which act in a direction parallel to the longitudinal axis of the bridge. In the case of a railroad bridge, it is necessary to consider the forces that are caused by the stopping and starting of trains.

The impact produced by the live load of traffic passing over the bridge can usually, in the case of substructures, be neglected.

In any event, it will be a small portion of the total load, even though the impact effect is not entirely dissipated in the superstructure and substructure before it reaches the foundations.

Buoyancy should be considered in the design, particularly if there is any possibility of a combination of forces whereby the stability of the pier, considering buoyancy, may be compromised. It rarely happens that such is the case, and generally the neglect of buoyancy will be on the side of safety, as such neglect will increase the calculated loading on the foundation.

The American Railway Engineering Association Specifications, 1940, require that the wind force shall be considered as a moving load acting in any horizontal direction. On the train, it shall be taken at 300 lb. per lin. ft. on one track, applied 8 ft. above the top of the rail. On the bridge, it shall be taken at 30 lb. per sq. ft. of the following surfaces:

1. For girder spans, $1\frac{1}{2}$ times the vertical projection of the span.
2. For truss spans, the vertical projection of the span plus any portion of the leeward trusses not shielded by the floor system.

Centrifugal force, in the case of railroad bridges, should be provided for in accordance with the American Railway Engineering Association Specifications, 1940, as follows: on curves, the centrifugal force (assumed to act 6 ft. above the rail) shall be taken equal to a percentage of the live load, according to the following table, which is based upon a maximum speed of 100 m.p.h. and a maximum superelevation of 7 in. resulting in a maximum centrifugal force of 17.5 per cent for the formula

$$C = 0.00117S^2D,$$

where C = the percentage of live load.

S = speed, miles per hour.

D = the degree of the curve.

Degree of curve	20'	40'	1°	2°	3°	4°	5°	6°	8°	10°	15°	20°
Percentage.....	3.90	7.80	11.7	17.5	17.5	17.5	17.5	17.5	17.5	17.5	17.5	17.5
Speed (m.p.h.).	100	100	100	87	71	61	55	50	43	39	32	27

In the case of highway bridges, it is unnecessary to make provision for centrifugal force.

The force due to the water current is assumed to be equal in pounds per square foot to $P = 1.5v^2$, v being the velocity of the current in feet per second. This is to be used for flat surfaces; for rounded surfaces, use one-half of the above quantity.

The pressure due to a floating field of ice may, as an extreme, be taken equal to the crushing strength of ice, which varies from 300 to 800 lb. per sq. in., 43,200 to 115,200 lb. per sq. ft. It is unnecessary to consider ice as more than 1 ft. thick.

The longitudinal force on railroad bridges resulting from the starting and stopping of trains is required by the specifications already quoted to be taken as "the larger of

1. Force due to braking:
Fifteen percent of the live load without impact.
2. Force due to traction:
Twenty-five per cent of the weight on the driving wheels, without impact."

All the foregoing forces should, in each case, be carefully determined, the effect of each calculated, and the resultant computed, so that the most severe effect on the foundations may be obtained. The pier, in any event, should be designed so that there is no uplift, as the masonry cannot be anchored in a satisfactory manner to the natural foundation encountered. The effect of this is that, in the case of rectangular areas, the resultant of all possible forces must fall within the middle third. These forces are ultimately resisted by the natural foundations encountered. Spread or stepped footings should be provided where necessary for their distribution to the underlying material, and where pile foundations are used. Adequate provision should be made for protection against scour. The stepping should preferably be at an angle of 60 deg. with the horizontal—never less than 45 deg.

10. Location.—The pier should be so located with respect to the superstructure that the center of gravity of the superimposed load, *i.e.*, the live and dead load of the superstructure, will be coincident with the center line of the pier.

11. Top Dimensions.—In pier design, the top dimensions are the first to be fixed. These dimensions are determined by the character, width, and length of the bridge. The width of the pier is dependent upon the size of the bearing plates or shoes upon which the superstructure rests and should not be less

than 2 ft. more than the out-to-out dimension of the bearing plates or shoes, measured along the longitudinal axis of the superstructure.

The length of the pier should in no case be less than 4 ft. in excess of the extreme width of the supported superstructure, measured from out to out of bearing plates. The bearing of the superstructure on the substructure should be such that the dead and live load of the superstructure does not exceed 800 lb. per sq. in. on granite masonry, 600 lb. per sq. in. on concrete, or 400 lb. per sq. in. on sandstone and limestone, as required by the American Railway Engineering Association Specifications, 1940.

12. Foundation Dimensions.—The dimensions of the foundations are primarily dependent upon the character of the underlying material, *i.e.*, the load in tons per square foot which it has been determined in advance this material will be capable of supporting, not only safely but without undue settlement. For deep piers, dependent upon the character of the soil penetrated, certain reductions may be made in the computed net load upon the base area. The first is a weight equivalent to the displaced water and soil; the second is that equal to the skin friction acting upon the sides of the pier.

13. Batter.—The surfaces of the piers should be battered $\frac{1}{2}$ in. per ft. This may, in extraordinary cases, be increased as necessary, in order to secure proper stability.

14. Pier Ends.—Piers in streams constitute an obstruction to the waterway and increase the liability to scour. This tendency can be materially reduced by due attention to the form of pier end, which should, in general, be so shaped as to afford the minimum obstruction to the stream flow. Experience and tests indicate that, for both the upstream or nose end and the downstream or tail end of piers, the half-round, *i.e.*, semicircular shape, affords the minimum obstruction to the waterway consistent with practical construction. As a second choice, a 45-deg. nose and tail are recommended.

15. Nose Protection.—In localities where heavy ice movement occurs, where exceptionally rapid stream flow exists, or where a combination of both conditions may be anticipated, it is advisable to build a 45-deg. nose, this nose to be protected from a point not less than 4 ft. above extreme high water to 4 ft. below extreme low water by an angle iron, with properly designed bent bolts

inserted at intervals not greater than 2 ft., these bolts being embedded in the concrete, and the angle iron nose protection thus held in place.

16. General.—The body of the pier should be composed of a mixture not leaner than $1:2\frac{1}{2}:5$ concrete. One-man stones may be used in the foundations, if they are thoroughly cleaned, completely embedded, and entirely surrounded by concrete. It will be found advantageous to use a small amount of reinforcing near the surface of the pier as a framework for the attachment of wire mesh. This will have the effect of providing a mechanical bond in the concrete and reduce the probability of surface cracks, due to temperature or other causes.

The disposition and treatment of piers that support bridges crossing public highways, steam, or electric railroad tracks are necessarily governed by local conditions and the wishes of local authorities or other interests having jurisdiction. It is advisable that, where piers are placed between tracks, they be protected by a nose or buffer to prevent damage to the structure in the event of derailment.

17. Pier Dimensions.—For piers supporting railroad bridges, the following sizes represent good practice:

Square End Piers (Dimensions taken at undercoping):

Single-track deck plate girders— 6×16 ft. and 8×16 ft.

Double-track deck plate girders— 6×29 ft. and 8×29 ft.

Single-track through plate girders— 6×24 ft. and 8×24 ft.

Double-track through plate girders— 6×37 ft. and 8×37 ft.

Round End Piers (Width at undercoping—length center to center of ends at undercoping):

Single-track deck plate girders— 6×14 ft. and 8×14 ft.

Double-track deck plate girders— 6×27 ft. and 8×27 ft.

Single-track through plate girders— 6×22 ft. and 8×22 ft.

Double-track through plate girders— 6×35 ft. and 8×35 ft.

18. Quantities.—The following tables give the quantities for square-end and round-end piers, as shown by Figs. 1 and 2, in various widths, lengths, and heights, and include quantities for 5-ft. foundations, as indicated.

ABUTMENTS

19. Structural Elements.—Every abutment is, in general, composed of three distinct structural elements, namely,

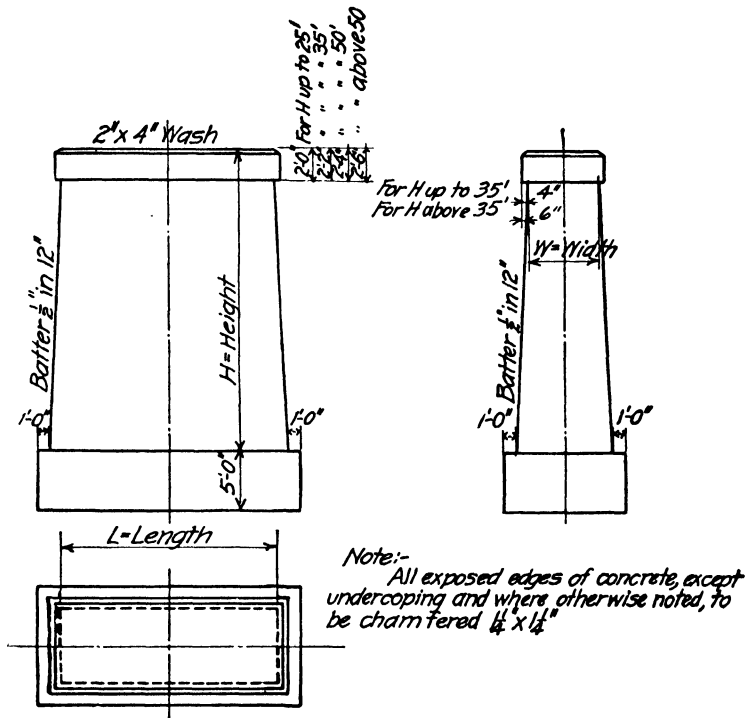

FIG. 1.

SQUARE-END PIERS—CUBIC YARDS OF MASONRY
(See Fig. 1)

Height (H)	Width (W) × length (L)							
	6 × 16 ft.	6 × 29 ft.	6 × 24 ft.	6 × 37 ft.	8 × 16 ft.	8 × 29 ft.	8 × 24 ft.	8 × 37 ft.
8	60	105	88	133	77	135	113	170
14	88	153	128	194	112	197	164	249
20	118	206	172	260	151	263	220	332
26	151	263	220	331	192	333	279	421
32	187	323	271	409	236	408	342	513
38	226	389	327	490	283	488	410	613
44	268	459	385	577	334	572	481	718
50	313	534	450	670	388	662	558	821

1. The breast, which directly supports the dead and live loads of the superstructure and serves for the retention of the material deposited in its rear.

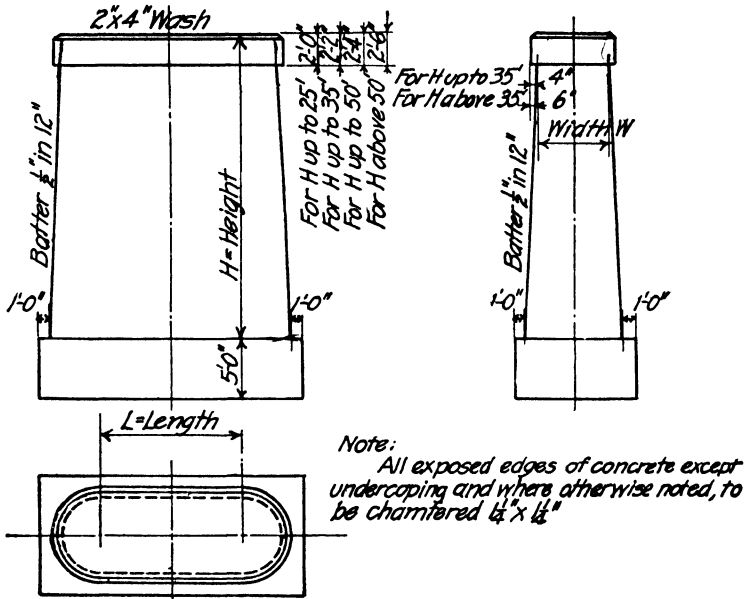

FIG. 2.

ROUND-END PIERS—CUBIC YARDS OF MASONRY
(See Fig. 2)

Height (H)	Width (W) × length (L)							
	6 × 14 ft.	6 × 27 ft.	6 × 22 ft.	6 × 35 ft.	8 × 14 ft.	8 × 27 ft.	8 × 22 ft.	8 × 35 ft.
8	72	117	100	145	99	157	136	194
14	104	170	145	210	143	227	196	280
20	138	227	193	280	190	302	260	372
26	176	288	245	357	240	382	328	470
32	217	353	300	437	293	456	400	573
38	260	423	360	524	350	555	478	681
44	307	496	424	615	411	650	560	798
50	356	577	492	712	474	748	644	917

2. The wings, which are, in reality, extensions of the breast and furnish no support for the superstructure, but act as retaining walls to prevent the encroachment of the material deposited behind the abutment upon the area or passageway in front.

3. The backwall, or parapet wall, which is a small retaining wall, preventing the material in back of the abutment from flowing on to the bridge seat, that part of the orest which supports the superstructure.

20. Breast Abutment.—The simplest form of abutment is that without wings, composed solely of the breast and backwall. Such an abutment may be likened to a pier, whose thickness has been increased to resist the lateral thrust of the material in

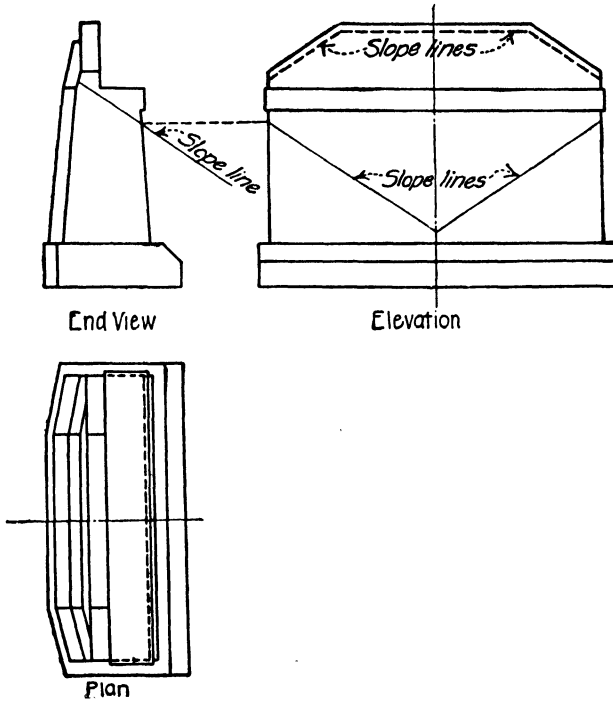

FIG. 3.—Breast abutment.

back of it and which has been provided with a suitable toe in front, for the purpose of increasing its stability. Some of the retained material flows around in front of the abutment (see Fig. 3).

21. T Abutment.—The T abutment is essentially a pier, reinforced in the rear by a stem, which supports the superimposed load and whose length is made such that the toe of the slope of the retained material is at or behind the front face of the pier (see Fig. 4).

22. U Abutment.—This form may be considered a T abutment, whose stem has been divided along the center line of the bridge, and the two halves shifted to the ends of the pier; or it may be considered a wing abutment, whose wings have been folded back parallel to each other and parallel to the longitudinal axis of the bridge. The walls in this case are made of sufficient

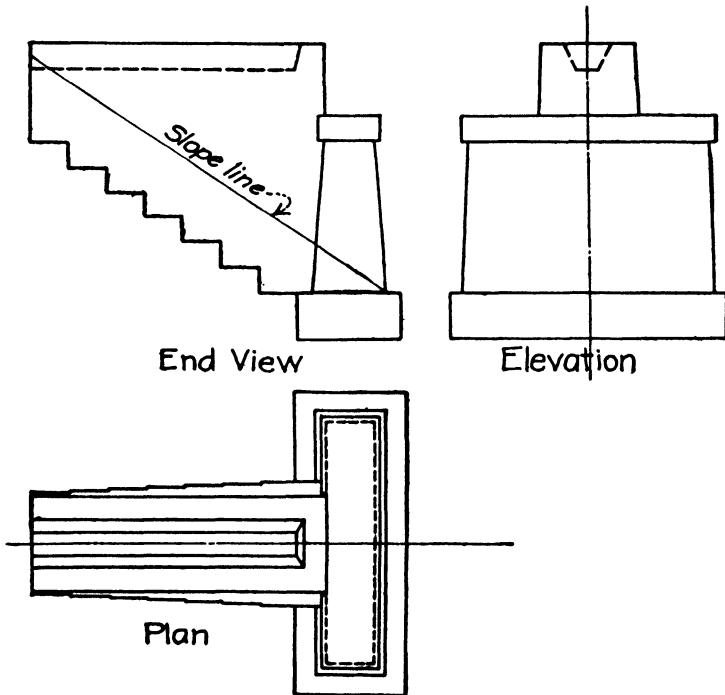

FIG. 4.—T abutment.

length so that the toe of the slope is at or in the rear of the front face of the abutment (see Fig. 5).

23. Pulpit Abutment.—This is a modified form of the U abutment, which is sometimes adopted in the case of high abutments. In this form, the wings are made only of sufficient length to prevent the retained material from flowing on the bridge seat, but not of sufficient length to prevent it from flowing in front of the abutment (see Fig. 6).

24. Wing Abutment.—In this type, the tops of the wings are sloped to conform to the natural slope of the retained material,

and the angle of the wings with respect to the normal to the longitudinal axis of the bridge made to conform to the local conditions. The most economic form is obtained when the wings are made normal to the longitudinal axis of the bridge. The most common form, perhaps, is that in which the angle of the wings to the normal is 30 deg. (see Fig. 7).

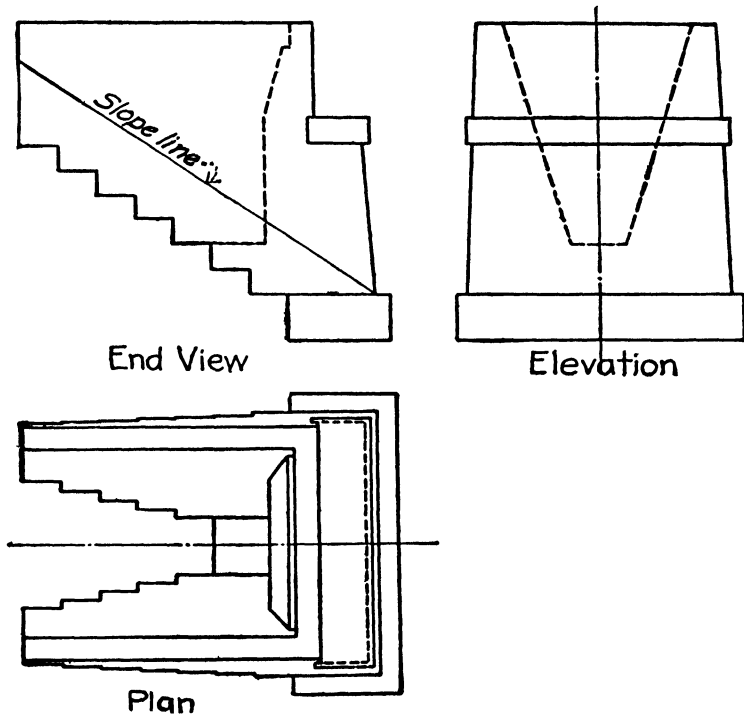

FIG. 5.—U abutment.

25. General.—Of these forms of abutments, the wing abutment is the most generally used. The pulpit abutment is used to a limited extent, principally at the ends of steel viaducts, where fill is made for the approaches and where there is no objection to the material flowing in front of the abutment. The U abutment finds a limited use. Its use under certain local conditions is very satisfactory. This is especially the case where good rock foundation is found near the surface of the ground and particularly where the rock slopes, in which case the

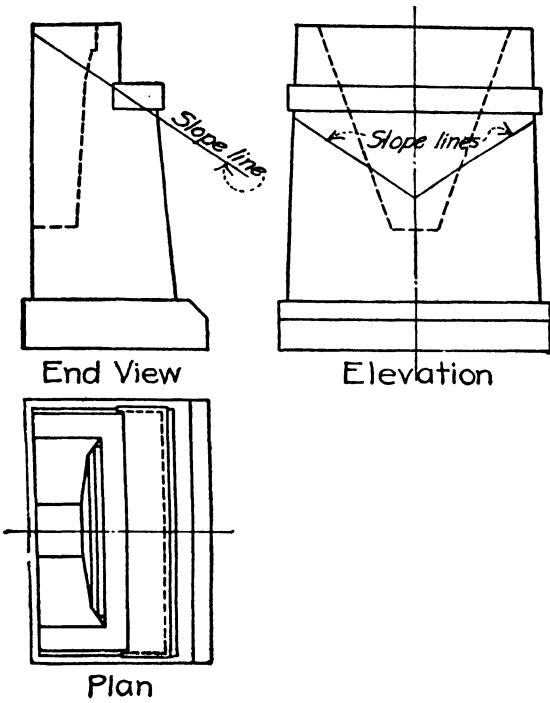

FIG. 6.—Pulpit abutment.

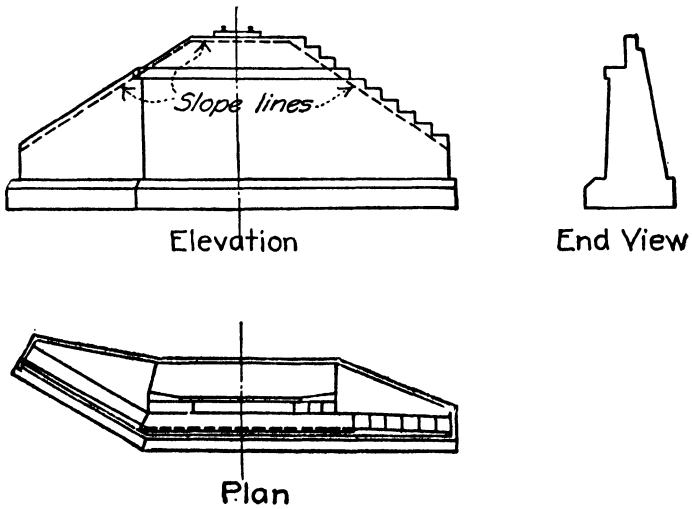

FIG. 7.—Wing abutment.

foundation for the wings of a U abutment can be readily stepped to conform to the natural slope line, thus making a material saving in the quantity of masonry. The T abutment was widely used during the early period of railroad construction. Since 1880, however, it has gradually ceased to be used and, at present, is rarely, if ever, constructed. The solid stem of the T abutment introduces undesirable conditions, particularly as far as the riding of the track in the case of a railroad is concerned.

26. External Forces.—The external forces to which an abutment will be subjected, and to resist which it will be designed, should be determined in advance. Some of these forces are susceptible of absolute mathematical determination. The source, effect, and disposition of others is a matter of engineering judgment and experience.

In abutment construction, these forces are

1. The dead load of the superstructure.
2. The live load of traffic passing over the bridge.
3. The dead load of the abutment itself.
4. Thrust, *i.e.*, the thrust of the material retained by the abutment, in conjunction with which must be considered a surcharge allowance equivalent to the effect of the live load on the fill at the rear of the abutment.
5. The thrusts due to longitudinal traction and braking forces and to wind loads.

27. Retaining Wall Characteristic.—The most troublesome factor in connection with the design of an abutment is the determination of the magnitude, direction, and point of application of the thrust of the retained material against the abutment. The varying character of the material deposited behind and retained by an abutment introduces an element of uncertainty; in addition, the change in character of material, due to varying amounts of moisture in it, should be considered; that is, it is conceivable that, under certain conditions of moisture, the material retained will act as a semifluid. On the other hand, good stiff clay, under certain conditions, may act as a solid. An attempt to reduce to a matter of mathematics the thrust exerted originated with Coulomb, who published the theory that bears his name in 1784. This was followed by Weyrauch, Rankine, and others. In general, all theories involving mathematical investigation of earth pressures rest upon three postulates, namely,

1. That the surface of rupture is a plane.
2. That the application of the lateral thrust occurs at a point one-third of the height of the wall from its bottom.
3. That this lateral force is exerted in a certain direction, actually unknown, but as a factor in mathematical process variously assumed as an essential hypothesis to the demonstration of the theory.

The entire theory of earth pressures is based, to a certain extent, upon the consideration or contemplation of the action of a liquid. The liquefaction of the retained material not only increases its weight but very materially increases the thrust, and, in the case of a liquid, the thrust is horizontal. Owing to these considerations, material in back of abutments should be carefully placed and properly drained. A good drainage system may be constructed by placing rock fill immediately back of the abutment and proper drain pipes at the bottom.

In the construction of retaining walls and in the solution of this problem as a part of abutment design, the results of past experience should be carefully considered. An abutment the thickness of which at any horizontal section is made 0.45 of the height from that section to the top of the abutment will give a safe structure.

It should be borne in mind, in this connection, that sub-structures are to be considered as permanent works and that it is false economy to use a minimum of material, based upon a purely theoretical design. In the interest of real economy and considering the long anticipated life of such a structure, the designer should plan an abutment with a thickness perhaps in excess of the theoretical requirements, since but a small additional first cost will be incurred. Due consideration should also be given to load distribution upon the supporting foundation material. Unequal distribution of load may cause differential settlement.

Further, he should visualize all the conditions surrounding the reconstruction of an abutment which has, for any cause, failed in service, realizing that, in that event, it will be necessary to provide temporary supports for the existing superstructure, remove the useless masonry, and properly reconstruct it. In view of these circumstances, it is believed that a thickness equal to 0.45 of the height is not excessive.

28. Dimensions.—The length of an abutment, *i.e.*, the length of the breast, is determined by the width of the approach road-

way to be retained and the width of the bridge superstructure that is to be supported. In no case should the length of the bridge seat be less than the width of the superstructure, measured over the sole plates or shoes, plus 4 ft. The width of the bridge seat is the distance from the face of the backwall to the under-coping line and should be not less than 1 ft. 6 in. more than the length of the shoes or sole plates. The front face of the abutment should have a batter of not less than $1\frac{1}{2}$ in. per ft., preferably 1 in. per ft. A plumb face is not desirable and should be avoided wherever possible, although in the case of an abutment the face of which is coincident with the building line of a street, or under other exceptional conditions, its adoption may be necessary.

29. Wings.—The width of the wing walls at the top should be made not less than 2 ft., preferably 2 ft. 6 in. The thickness at the neat line should be made 0.45 of the height from that line to the top. From a practical standpoint, it is preferable that the tops of the wing walls be stepped to conform to the slope, although, in the case of concrete walls under discussion, the objection is often advanced that this involves an apparent attempt to imitate stone masonry, whereas concrete readily lends itself to the formation of a sloped surface. Cases may occur, especially where the face of the abutment coincides with the building line of a street, or other thoroughfare, in which it is desirable that the surface of the wall be sloped. It is to be noted, in this connection, however, that such a surface is a constant invitation to children to use it as a sliding board. This condition, has, in some instances, resulted in serious accidents. On the other hand, a stepped wall is of practical utility in the event that it becomes necessary to renew the superstructure, in which case a stepped wall affords a very suitable foundation for any falsework that may be necessary.

30. Backwall.—The backwall should be straight, in order that longitudinal access to the bridge seat may be unobstructed. This arrangement is of special utility in cases where renewal of the superstructure is necessary, in which event the old span may be removed and the new one placed without interference with the masonry or undue interruption to traffic. The width of the backwall at the top should not be less than 2 ft., preferably 2 ft. 6 in. The thickness of the backwall at the bridge seat elevation should be made 0.50 of the height from the bridge seat to the top. In no case should this be less than the thickness at

the top plus 8 in. In railroad bridges, and also highway bridges, it will be found convenient to place a step on the back at the top of the backwall. This step should be not less than 8 in. wide and 2 ft. 6 in. below the top of the backwall. This arrangement will provide a footing for any temporary structures that it may be desired to place in order to support traffic before the fill is placed, or if, in future, it should become necessary to remove the fill (see Fig. 8).

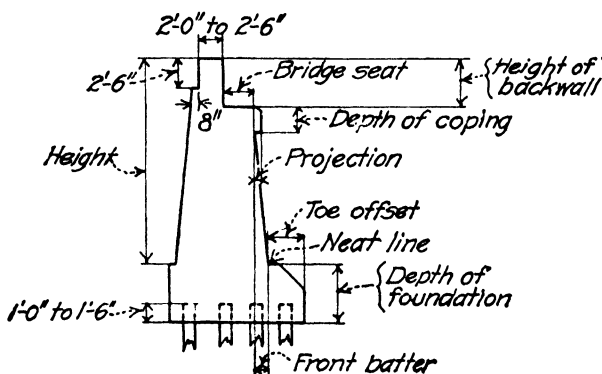

FIG. 8.

31. Toe.—A properly designed toe should be used in front of the abutment breast and in front of the wing walls. It is, perhaps, needless to state that, in any event, the resultant of all forces at the foundation must fall within the middle third, otherwise uplift will be produced, and, since masonry cannot be anchored to the natural foundation encountered, masonry will be wasted. A good toe will, to a large extent, remedy this condition.

32. Dimensions.—The following dimensions for depth of foundation and offset for toe have been extensively used, and found to give satisfactory results (see Fig. 8):

Distance from top of abutment to neat line	Horizontal offset for toe	Depth of foundations
1' to 20'	2'6"	4'6"
20. 1' to 25'	3'0"	4'6"
25. 1' to 30'	4'0"	5'6"
30. 1' to 40'	4'6"	6'0"

Where rock foundation is available, the toe may be omitted. For abutments less than 20 ft. in height, the toe may be modified, if conditions justify. Abutments over 40 ft. in height should be the subject of special investigation. Where rock is less than 4 ft. from the neat line, a 12-in. offset should be used, and a 12-in. offset introduced for each additional 4 ft. of foundation. The tops of all piles should project at least 1 ft., preferably 1 ft. 6 in., into the bottom foundations.

33. Coping.—The following practice is recommended with respect to the depth of coping on concrete abutments and piers:

Height of abutment or pier	Depth of coping
Up to 25 ft.....	24 in.
25 to 35 ft.....	26 in.
35 to 50 ft.....	28 in.
50 ft. and over.....	30 in.

For heights up to 35 ft. use 4-in. projection; for heights in excess of 35 ft., use 6-in. projection.

34. Quantities.—The following tables give the volumes of wing abutments in cubic yards, as shown by Figs. 9 and 10, and should be used in conjunction with the accompanying sketches.

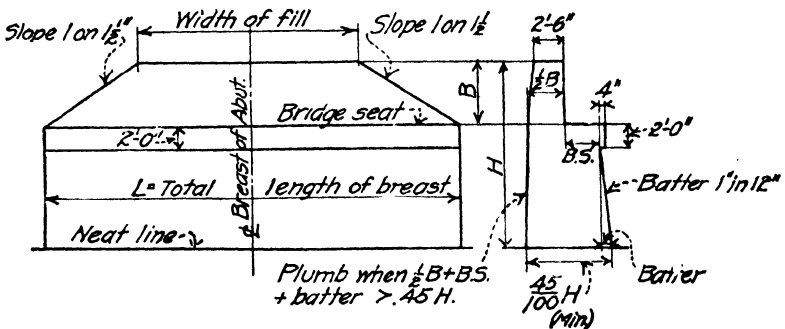

FIG. 9.

35. Hollow and Arch Abutments.—This type is exemplified by abutments in which arch openings are placed in the breast or the stem, in order to economize in the quantity of masonry. Hollow abutments are also of the cellular type. Hollow or cellu-

ABUTMENT QUANTITIES
 18' 6" Width of Fill. Volumes in Cubic Yards. One Abutment with Back-wall Exclusive of Foundation and Wings

Height = H, ft.	B = 4 ft. 0 in. B = 5 ft. 0 in. B = 6 ft. 0 in. B = 7 ft. 0 in. B = 8 ft. 0 in. B = 9 ft. 0 in. B = 10 ft. 0 in. B = 11 ft. 0 in. B = 12 ft. 0 in.			Height = H, ft.						
	$L = 28.5$ ft. Volume in back-wall = 8 cu. yd.	$L = 31.5$ ft. Volume in back-wall = 11 cu. yd.	$L = 34.5$ ft. Volume in back-wall = 15 cu. yd.		$L = 37.5$ ft. Volume in back-wall = 20 cu. yd.	$L = 40.5$ ft. Volume in back-wall = 26 cu. yd.	$L = 43.5$ ft. Volume in back-wall = 34 cu. yd.	$L = 46.5$ ft. Volume in back-wall = 43 cu. yd.	$L = 49.5$ ft. Volume in back-wall = 53 cu. yd.	$L = 52.5$ ft. Volume in back-wall = 64 cu. yd.
	3 ft. 0 in. Br. St.	4 ft. 0 in. Br. St.	3 ft. 0 in. Br. St.	4 ft. 0 in. Br. St.	3 ft. 0 in. Br. St.	4 ft. 0 in. Br. St.	3 ft. 0 in. Br. St.	4 ft. 0 in. Br. St.	3 ft. 0 in. Br. St.	4 ft. 0 in. Br. St.
10	48	54	63	71	80	89	96	104	112	120
12	61	70	83	96	110	123	138	151	166	183
14	75	86	101	117	134	151	170	189	210	224
16	91	102	119	138	158	180	203	226	252	267
18	112	120	141	162	183	207	234	266	299	312
20	135	143	167	192	218	243	278	310	342	356
22	159	168	195	222	254	285	324	356	392	406
24	185	195	224	254	291	324	363	403	437	450
26	213	225	257	289	334	374	416	453	490	503
28	243	255	292	321	368	412	453	490	527	540
30	275	288	329	354	400	446	484	521	558	571
32	310	323	369	391	439	481	516	547	583	596
34	344	358	411	429	485	526	558	589	624	637
36	381	398	454	473	526	565	596	626	661	674
38	421	439	499	519	568	608	638	668	702	715
40	462	481	546	568	612	654	684	714	748	761
42	505	525	594	618	658	700	730	760	794	807
44	550	572	647	671	714	757	787	817	851	864
46	597	620	701	726	764	808	838	868	902	915
48	646	670	756	782	821	864	894	924	958	971
50	697	721	812	841	882	912	942	972	1,002	1,015

For skewed abutments, multiply respective quantities by secant of skew angle. Abutments above heavy line have a base greater than 0.45H.

ABUTMENT QUANTITIES
31' 6" Width of Fill. Volumes in Cubic Yards. One Abutment with Back-wall Exclusive of Foundation and Wings

Height = H, ft.	B = 4 ft. 0 in. B = 5 ft. 0 in. B = 6 ft. 0 in. B = 7 ft. 0 in. B = 8 ft. 0 in. B = 9 ft. 0 in. B = 10 ft. 0 in. B = 11 ft. 0 in. B = 12 ft. 0 in.			Height = H, ft.																																																																																																																																																																																																																																																																																																																																																																																																																																																																																																																																																																																																													
	Volume in back-wall = 13 cu. yd.	Volume in back-wall = 17 cu. yd.	Volume in back-wall = 22 cu. yd.		Volume in back-wall = 29 cu. yd.	Volume in back-wall = 38 cu. yd.	Volume in back-wall = 48 cu. yd.	Volume in back-wall = 59.5 ft. in 39 cu. yd.	Volume in back-wall = 72 cu. yd.	Volume in back-wall = 87 cu. yd.																																																																																																																																																																																																																																																																																																																																																																																																																																																																																																																																																																																																							
10	70	68	77	92	102	124	136	159	181	203	238	277	324	380	437	504	574	652	738	831	898	936	1,032	1,132	1,237	1,346	1,459	1,577																																																																																																																																																																																																																																																																																																																																																																																																																																																																																																																																																																																					
12	90	102	89	110	124	115	134	124	136	129	139	159	181	203	238	277	324	380	437	504	574	652	738	831	898	936	1,032	1,132	1,237	1,346	1,459	1,577																																																																																																																																																																																																																																																																																																																																																																																																																																																																																																																																																																																	
14	110	126	111	126	148	138	151	143	167	153	161	176	181	203	238	277	324	380	437	504	574	652	738	831	898	936	1,032	1,132	1,237	1,346	1,459	1,577																																																																																																																																																																																																																																																																																																																																																																																																																																																																																																																																																																																	
16	134	149	137	148	170	170	181	179	190	186	203	214	223	238	277	324	380	437	504	574	652	738	831	898	936	1,032	1,132	1,237	1,346	1,459	1,577																																																																																																																																																																																																																																																																																																																																																																																																																																																																																																																																																																																		
18	164	175	168	179	202	214	206	218	217	229	228	240	238	252	295	307	362	421	484	551	623	697	738	831	898	936	1,032	1,132	1,237	1,346	1,459	1,577																																																																																																																																																																																																																																																																																																																																																																																																																																																																																																																																																																																	
20	197	209	202	214	239	245	256	259	273	272	286	286	307	307	362	421	484	551	623	697	738	831	898	936	1,032	1,132	1,237	1,346	1,459	1,577																																																																																																																																																																																																																																																																																																																																																																																																																																																																																																																																																																																			
22	232	246	239	253	287	293	303	319	319	319	335	334	350	362	421	484	551	623	697	738	831	898	936	1,032	1,132	1,237	1,346	1,459	1,577																																																																																																																																																																																																																																																																																																																																																																																																																																																																																																																																																																																				
24	270	285	279	293	332	332	349	351	369	370	388	388	406	421	484	551	623	697	738	831	898	936	1,032	1,132	1,237	1,346	1,459	1,577																																																																																																																																																																																																																																																																																																																																																																																																																																																																																																																																																																																					
26	301	327	322	339	387	380	399	403	422	424	445	446	466	484	551	623	697	738	831	898	936	1,032	1,132	1,237	1,346	1,459	1,577																																																																																																																																																																																																																																																																																																																																																																																																																																																																																																																																																																																						
28	354	373	358	387	437	432	453	456	479	483	505	507	529	551	623	697	738	831	898	936	1,032	1,132	1,237	1,346	1,459	1,577																																																																																																																																																																																																																																																																																																																																																																																																																																																																																																																																																																																							
30	400	420	417	437	492	484	505	509	539	545	568	573	597	623	697	738	831	898	936	1,032	1,132	1,237	1,346	1,459	1,577																																																																																																																																																																																																																																																																																																																																																																																																																																																																																																																																																																																								
32	452	471	469	491	554	542	569	572	602	610	636	642	670	715	713	743	781	821	859	898	936	1,032	1,132	1,237	1,346	1,459	1,577																																																																																																																																																																																																																																																																																																																																																																																																																																																																																																																																																																																						
34	501	521	524	548	617	605	631	642	670	679	709	715	743	781	821	859	898	936	1,032	1,132	1,237	1,346	1,459	1,577																																																																																																																																																																																																																																																																																																																																																																																																																																																																																																																																																																																									
36	556	581	581	607	695	681	710	739	751	781	821	859	898	936	1,032	1,132	1,237	1,346	1,459	1,577																																																																																																																																																																																																																																																																																																																																																																																																																																																																																																																																																																																													
38	613	639	642	669	766	756	786	813	827	859	871	906	946	989	1,037	1,085	1,132	1,185	1,237	1,289	1,346	1,401	1,459	1,517	1,577																																																																																																																																																																																																																																																																																																																																																																																																																																																																																																																																																																																								
40	673	701	706	735	836	828	857	890	906	946	989	1,037	1,085	1,132	1,185	1,237	1,289	1,346	1,401	1,459	1,517	1,577																																																																																																																																																																																																																																																																																																																																																																																																																																																																																																																																																																																											
42	723	756	772	803	897	898	927	970	990	1,043	1,085	1,132	1,185	1,237	1,289	1,346	1,401	1,459	1,517	1,577																																																																																																																																																																																																																																																																																																																																																																																																																																																																																																																																																																																													
44	802	833	848	875	977	977	1,007	1,053	1,076	1,114	1,132	1,171	1,231	1,289	1,346	1,401	1,459	1,517	1,577																																																																																																																																																																																																																																																																																																																																																																																																																																																																																																																																																																																														
46	871	903	918	949	1,053	1,053	1,083	1,130	1,166	1,206	1,231	1,271	1,331	1,389	1,448	1,507	1,566	1,625	1,684	1,743	1,802	1,861	1,920	1,979	2,038	2,097	2,156	2,215	2,274	2,333	2,392	2,451	2,510	2,569	2,628	2,687	2,746	2,805	2,864	2,923	2,982	3,041	3,100	3,159	3,218	3,277	3,336	3,395	3,454	3,513	3,572	3,631	3,690	3,749	3,808	3,867	3,926	3,985	4,044	4,103	4,162	4,221	4,280	4,339	4,398	4,457	4,516	4,575	4,634	4,693	4,752	4,811	4,870	4,929	4,988	5,047	5,106	5,165	5,224	5,283	5,342	5,401	5,460	5,519	5,578	5,637	5,696	5,755	5,814	5,873	5,932	5,991	6,050	6,109	6,168	6,227	6,286	6,345	6,404	6,463	6,522	6,581	6,640	6,699	6,758	6,817	6,876	6,935	6,994	7,053	7,112	7,171	7,230	7,289	7,348	7,407	7,466	7,525	7,584	7,643	7,702	7,761	7,820	7,879	7,938	8,000	8,059	8,118	8,177	8,236	8,295	8,354	8,413	8,472	8,531	8,590	8,649	8,708	8,767	8,826	8,885	8,944	9,003	9,062	9,121	9,180	9,239	9,298	9,357	9,416	9,475	9,534	9,593	9,652	9,711	9,770	9,829	9,888	9,947	10,006	10,065	10,124	10,183	10,242	10,301	10,360	10,419	10,478	10,537	10,596	10,655	10,714	10,773	10,832	10,891	10,950	11,009	11,068	11,127	11,186	11,245	11,304	11,363	11,422	11,481	11,540	11,599	11,658	11,717	11,776	11,835	11,894	11,953	12,012	12,071	12,130	12,189	12,248	12,307	12,366	12,425	12,484	12,543	12,602	12,661	12,720	12,779	12,838	12,897	12,956	13,015	13,074	13,133	13,192	13,251	13,310	13,369	13,428	13,487	13,546	13,605	13,664	13,723	13,782	13,841	13,900	13,959	14,018	14,077	14,136	14,195	14,254	14,313	14,372	14,431	14,490	14,549	14,608	14,667	14,726	14,785	14,844	14,903	14,962	15,021	15,080	15,139	15,198	15,257	15,316	15,375	15,434	15,493	15,552	15,611	15,670	15,729	15,788	15,847	15,906	15,965	16,024	16,083	16,142	16,201	16,260	16,319	16,378	16,437	16,496	16,555	16,614	16,673	16,732	16,791	16,850	16,909	16,968	17,027	17,086	17,145	17,204	17,263	17,322	17,381	17,440	17,499	17,558	17,617	17,676	17,735	17,794	17,853	17,912	17,971	18,030	18,089	18,148	18,207	18,266	18,325	18,384	18,443	18,502	18,561	18,620	18,679	18,738	18,797	18,856	18,915	18,974	19,033	19,092	19,151	19,210	19,269	19,328	19,387	19,446	19,505	19,564	19,623	19,682	19,741	19,800	19,859	19,918	19,977	20,036	20,095	20,154	20,213	20,272	20,331	20,390	20,449	20,508	20,567	20,626	20,685	20,744	20,803	20,862	20,921	20,980	21,039	21,098	21,157	21,216	21,275	21,334	21,393	21,452	21,511	21,570	21,629	21,688	21,747	21,806	21,865	21,924	21,983	22,042	22,101	22,160	22,219	22,278	22,337	22,396	22,455	22,514	22,573	22,632	22,691	22,750	22,809	22,868	22,927	22,986	23,045	23,104	23,163	23,222	23,281	23,340	23,399	23,458	23,517	23,576	23,635	23,694	23,753	23,812	23,871	23,930	23,989	24,048	24,107	24,166	24,225	24,284	24,343	24,402	24,461	24,520	24,579	24,638	24,697	24,756	24,815	24,874	24,933	24,992	25,051	25,110	25,169	25,228	25,287	25,346	25,405	25,464	25,523	25,582	25,641	25,700	25,759	25,818	25,877	25,936	25,995	26,054	26,113	26,172	26,231	26,290	26,349	26,408	26,467	26,526	26,585	26,644	26,703	26,762	26,821	26,880	26,939	26,998	27,057	27,116	27,175	27,234	27,293	27,352	27,411	27,470	27,529	27,588	27,647	27,706	27,765	27,824	27,883	27,942	28,001	28,060	28,119	28,178	28,237	28,296	28,355	28,414	28,473	28,532	28,591	28,650	28,709	28,768	28,827	28,886	28,945	29,004	29,063	29,122	29,181	29,240	29,299	29,358	29,417	29,476	29,535	29,594	29,653	29,712	29,771	29,830	29,889	29,948	30,007	30,066	30,125	30,184	30,243	30,302	30,361	30,420	30,479	30,538	30,597	30,656	30,715	30,774	30,833	30,892	30,951	31,010	31,069	31,128	31,187	31,246	31,305	31,364	31,423	31,482	31,541	31,600	31,659	31,718	31,777	31,836	31,895	31,954	32,013	32,072	32,131	32,190	32,249	32,308	32,367	32,426	32,485	32,544	32,603	32,662	32,721	32,780	32,839	32,898	32,957	33,016	33,075	33,134	33,193	33,252	33,311	33,370	33,429	33,488	33,547	33,606	33,665	33,724	33,783	33,842	33,901	33,960	34,019	34,078	34,137	34,196	34,255	34,314	34,373	34,432	34,491	34,550	34,609	34,668	34,727	34,786	34,845	34,904	34,963	35,022	35,081	35,140	35,199	35,258	35,317	35,376	35,435	35,494	35,553

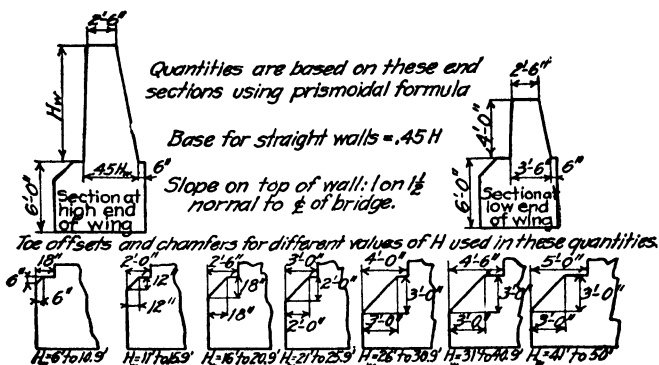

FIG. 10.

ABUTMENT FOUNDATIONS
Volumes in Cu. Yd.

Height = H, ft.	Toe offsets, ft. in.	Cham- fers, ft. in.	Founda- tion 6 ft. deep per lin. ft. of breast ¹	Founda- tion per addi- tional foot of depth per ft of breast
10	1 6	0 6	1 44	0 25
12	2 0	1 0	1 74	0 30
14	2 0	1 0	1 94	0 33
16	2 6	1 6	2 23	0 38
18	2 6	1 6	2 43	0 42
20	2 6	1 6	2 63	0 45
22	3 0	2 0	2 91	0 50
24	3 0	2 0	3 11	0 53
26	4 0	3 0	3 44	0 60
28	4 0	3 0	3 64	0 64
30	4 0	3 0	3 84	0 67
32	4 6	3 0	4 15	0 72
34	4 6	3 0	4 35	0 76
36	4 6	3 0	4 55	0 79
38	4 6	3 0	4 75	0 82
40	4 6	3 0	4 95	0 86
42	5 0	3 0	5 26	0 91
44	5 0	3 0	5 46	0 94
46	5 0	3 0	5 66	0 97
48	5 0	3 0	5 86	1 01
50	5 0	3 0	6 06	1 04

¹ No chamfer allowance in this column.

QUANTITIES IN ONE WING
Volumes in Cu. Yd.

Base at Neat Line = 0.45 H_w
Slope of top 1 on 1 1/2

Straight wings			
H _w , ft.	Neat con- crete	Founda- tion 6 ft. deep	Founda- tion addi- tional per ft.
6	1.7	4.3	0.8
8	4.1	8.0	1.4
10	7.7	12.7	2.2
12	12.7	19.1	3.3
14	19.2	25.3	4.3
16	27.4	33.6	5.8
18	37.6	41.2	7.0
20	50.0	49.4	8.4
22	64.6	60.2	10.4
24	81.9	70.0	12.1
26	101.8	84.5	15.1
28	124.7	95.8	17.0
30	150.7	107.6	19.1
32	180.1	124.7	22.0
34	213.0	138.0	24.3
36	249.7	152.0	26.7
38	290.3	166.6	29.2
40	335.0	187.7	32.8
42	384.1	203.8	35.6
44	437.7	220.6	38.5
46	496.1	237.9	41.4
48	559.4	255.7	44.5
50	627.8	274.2	47.7

For played wings, multiply res-
pective quantities by secant of
play angle.

lar abutments should be so designed as to withstand the pressure of the fill in the rear, together with the superimposed load,

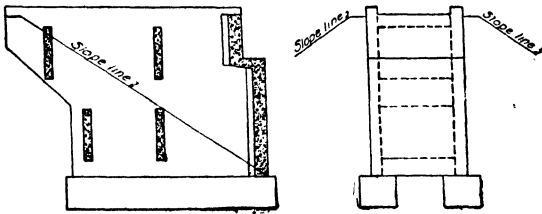

FIG. 11.—Hollow U abutment, cellular type.

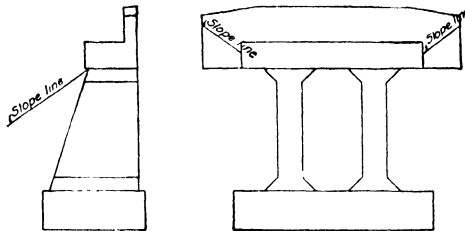

FIG. 12.—Buried abutment.

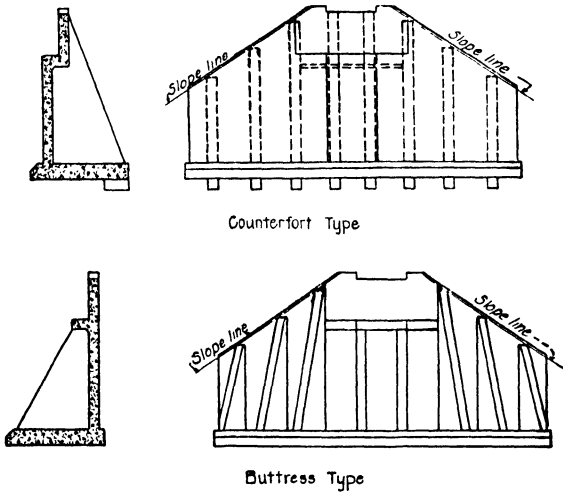

FIG. 13.—Reinforced concrete abutments.

including the relieving pressure caused by any fill that may be placed in front of the abutment.

Abutments of this character are indicated by Fig. 11.

36. Buried Abutments.—This term applies to abutments that are of sufficient dimensions to support the superstructure and prevent the fill from encroaching on the bridge seat. They are not provided with wings to retain the filling material, and the fill is permitted to flow around the abutment. Such abutments are of varied detail in construction and may be plain, arch or cellular.

A representative type of this abutment is shown in Fig. 12.

37. Reinforced Concrete Abutments.—The distinguishing characteristic of this type consists in the fact that the stability as a whole is not dependent primarily on gravity action, as is the case in the ordinary abutment, but is due to the weight of the filling material. Such abutments are of the buttress or

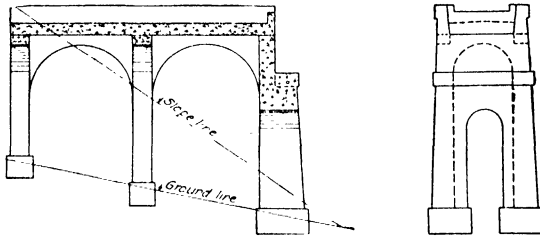

FIG. 14.—Reinforced concrete arch abutment.

counterfort type, in which the earth thrust is resisted by counterforts or buttresses.

A typical abutment of this character appears in Fig. 13, and a typical arch abutment in Fig. 14.

BASCULE BRIDGE PIERS

38. Counterweight Pits in General.—The piers and abutments of bascule bridges do not differ materially from those for stationary bridges, unless the tail ends of the bascule girders, or the counterweight, or both, go below the water line for any angle of opening of the bridge, in which case it becomes necessary to provide a watertight "counterweight pit" or "tail pit." Some early examples of bascule bridges (Langebrog, Copenhagen, Denmark—now replaced by a modern bridge—and Honig Bridge, Koenigsburg, Germany) dispensed with the use of pits by employing counterweights which were suspended from the tail ends of the bascule girders by means of rods or chains and which were at all times submerged in water. Such an arrangement should, however, be considered only for temporary or semipermanent

structures owing to the rapid deterioration of the counterweight suspensions and the danger arising from ice conditions, etc.

Counterweight pits are, as a rule, required only when the distance from high water to the bridge floor is relatively small and when the counterweight is below the floor. The Knippels Bridge at Copenhagen, built in 1909, and the B. & O.C.T. R.R.'s bascule bridge over the South Branch of the Chicago River are, however, examples of bascule bridges with overhead counterweights in which tail pits are required.

Counterweight pits are also used for certain types of lift bridges, as in the Brockport lift bridge built over the New York Barge Canal and the Pretoria Avenue Bridge over the Rideau Canal at Ottawa, Ontario, built in 1918. Hollow piers of similar construction are used for many European swing bridges in which the lower end of the center pivot forms the plunger in a hydraulic cylinder while the pit affords the necessary room for the hydraulic machinery and the accumulators by means of which the swing span is lifted bodily before it is swung.

Counterweight pits are considered by many as being expensive, as requiring much attention, and as involving an element of risk. The City of Chicago has built 20 to 25 double-leaf bridges (a total of some 50 pits) and has had little or no trouble in keeping the pits dry and clean. Counterweight pits are often the means of developing a structure of attractive appearance and one that is an asset to the community where otherwise an overhead counterweight bridge would be the only alternative, which would be an eyesore and would be out of harmony with the present-day demand for civic beauty.

In such a case the advantages and disadvantages should be given careful consideration. The cost of a counterweight pit is not excessive when cofferdams must be used for the foundation construction in any event. When the subsoil is bad, the cost of the pit may be of less importance than the cost of the subpiers.

The matter of keeping the pit clean, *i.e.*, free from dirt and refuse, is largely a matter of so designing the superstructure that the dirt from the roadway will not be dumped into the pit when the bridge is raised, and this condition is fulfilled in most modern bascule bridges of the trunnion type.

To keep the pit dry under ordinary conditions it is necessary to have unyielding supports, to give proper consideration in the

design to the hydrostatic pressure, and to provide for the necessary waterproofing. These problems have been solved and in each individual case are certain of a satisfactory solution at the hands of an experienced bascule bridge engineer.

To guard against accidents, such as the ramming of the pit by a boat out of control, the pit should be guarded by protection piling or fenders, as required for the protection of the piers of all

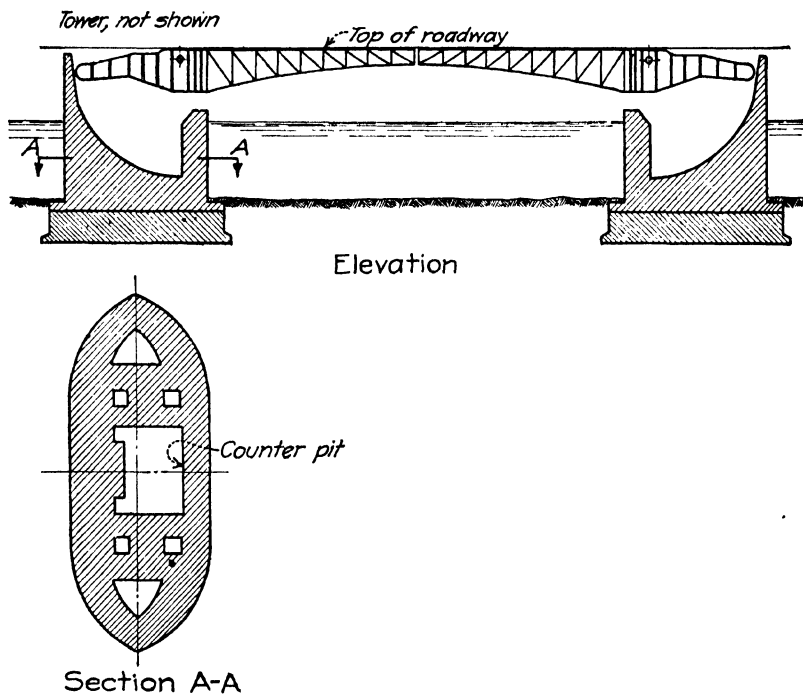

FIG. 15.—Tower Bridge, London, built 1892.

movable bridges. As an important part of such protection, clusters of an effective number of piles are recommended. Besides, it is good practice to make the front wall of the pit of somewhat larger dimensions than required merely to sustain computed loads, this being, under ordinary conditions, the only part of the pit that is liable to be struck by a vessel.

39. Types and Sizes of Counterweight Pits.—To illustrate the types of construction used, counterweight pits may be classified, in general, as follows:

1. The pit is in the nature of a recess or chamber in a large massive pier. (Example.—Tower Bridge, London, built 1892. See Fig. 15.)

2. The pit consists of four concrete walls of approximately the same thickness—except as noted for the front wall—and a concrete floor, all resting directly on hardpan or rock. (Example.—Phoenix Bridge, built

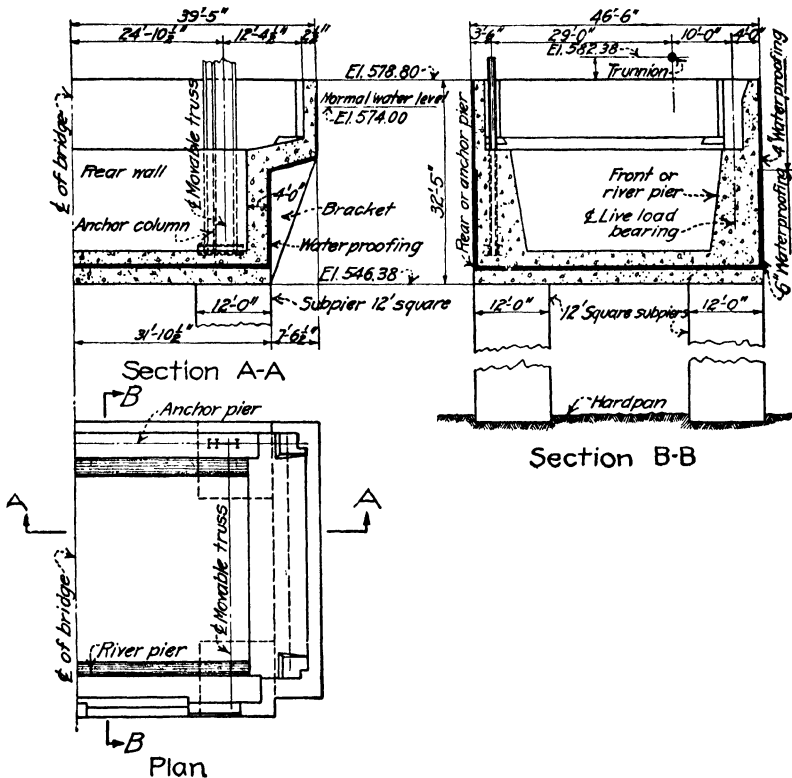

FIG. 16.—General design of Jefferson Avenue and Fort St. Bridge, Detroit; also the railroad bridge for the Detroit, Toledo & Ironton R. R. over the Short Cut Canal at Detroit.

over the New York State Barge Canal, see Fig. 17, also 35th Street Bridge, Chicago, built in 1914.)

3. The pit consists of a heavy reinforced concrete box resting on subpiers, the walls being designed to carry and transmit the superstructure loads to the subpiers. (Example.—Jefferson Avenue Bridge, Detroit¹ and the railroad bridge for the Detroit, Toledo & Ironton R.R. over the Short Cut Canal at Detroit, see Figs. 16 and 18).

¹ Jefferson Avenue and Fort Street Bridge over the River Rouge built in 1922 for Wayne Co. Road Commissioners, Chicago Bascule Bridge Co., Engineers.

Each of the two pits for the double-deck Michigan Avenue or the Boulevard Link Bridge in Chicago¹ (see Fig. 22) has the following inside dimen-

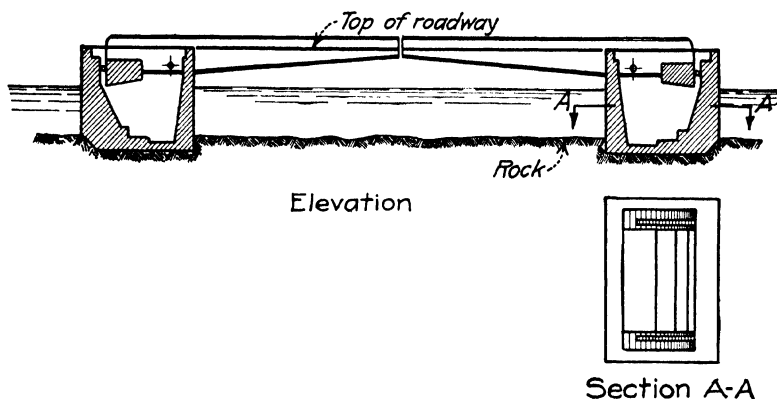

FIG. 17.—General design of Phoenix Bridge, built over the New York State Barge Canal; also 35th Street Bridge, Chicago, built 1914.

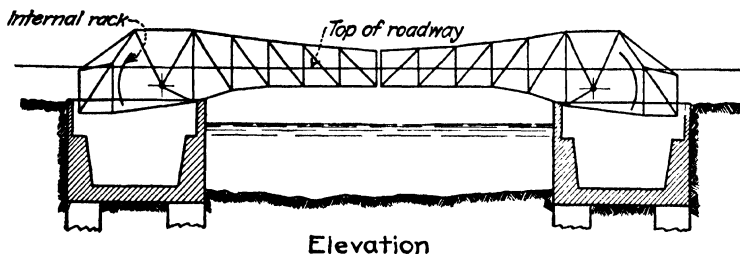

FIG. 18.—General design of Jefferson Avenue and Fort St. Bridge, Detroit; also the railroad bridge for the Detroit, Toledo & Ironton R. R. over the Short Cut Canal at Detroit.

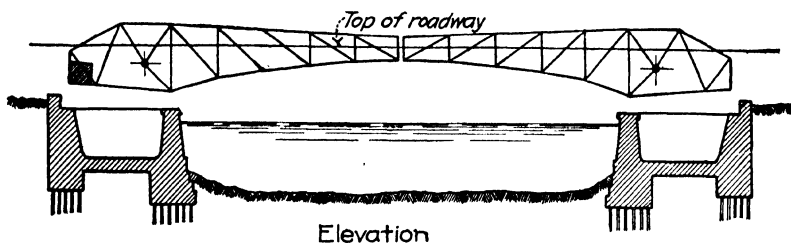

FIG. 19.—Erie Street Bridge, Chicago, built 1910.

sions: width 66 ft.; length (parallel with center line of bridge) 52 ft.; depth 34 ft. 5 in. below water line.

¹ Michigan Avenue Bridge over Chicago River, built in 1920 for the Board of Local Improvements, City of Chicago, Hugh E. Young, Engineer of Bridge Design.

4. The pit consists of a relatively light reinforced concrete box, suspended between two rectangular piers, which may be founded on rock, on piles, or on subpiers and which carry the superstructure loads, while no loads whatever are carried by the pit with the exception of its own weight and the outside hydrostatic pressure. (*Example*.—Erie Street Bridge, Chicago.¹ See Fig. 19.)

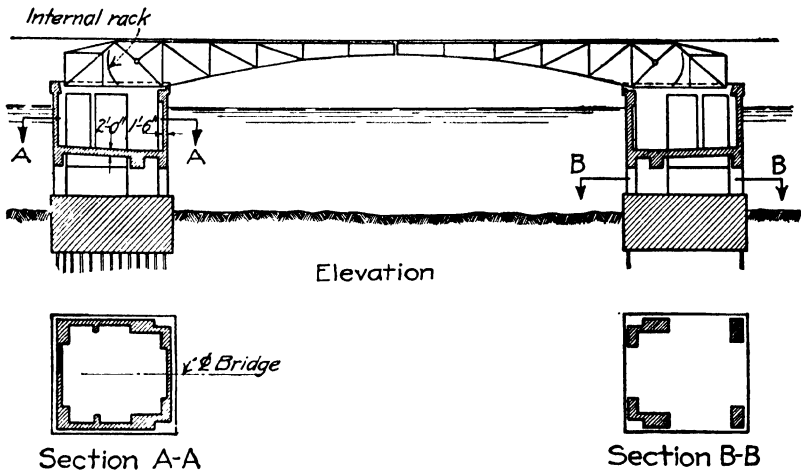

FIG. 20. —Bascule Bridge over Young's Bay, Astoria, Oregon, built 1920.

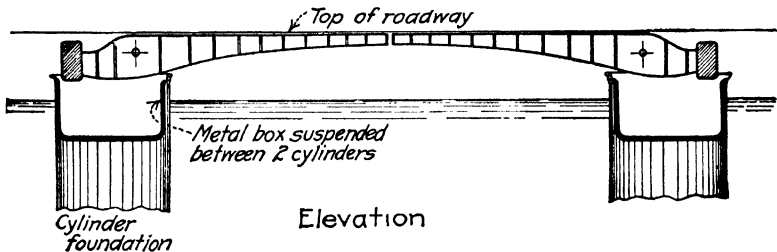

FIG. 21. —Old Knippels Bridge at Copenhagen, built 1869 (now removed).

5. The pit consists of a light reinforced concrete box suspended on large corner piers carried down to a subfoundation. (*Example*.—Bascule Bridge over Young's Bay, Astoria, Oregon, built in 1920. See Fig. 20.)

6. The pit consists of a sheet-metal or cast-iron box suspended between two piers. (*Example*.—Old Knippels Bridge at Copenhagen, built in 1869, and now torn down. See Fig. 21.)

40. Clearances.—In laying out a counterweight pit the question of clearances should be given careful consideration from the

¹ Erie Street Bridge over North Branch Chicago River, built 1910 for City of Chicago, Alexander von Babo, Engineer of Bridge Design.

start. The clearance between the counterweight in any position and the pit walls should never be less than 6 in.; a clearance of 12 in. is to be preferred.

In case the bridge is to be erected in the open position, sufficient clearance should also be provided for riveting up the field connections in the tail ends of the bascule trusses and in the counterweight boxes. In large and important structures it is sometimes required that there be sufficient clearance to enable a man to save himself if the bridge should be set in motion while he is down in the pit for one purpose or another.

In general, ample clearance is desirable, (1) because it facilitates the erection and the placing of the counterweight material,

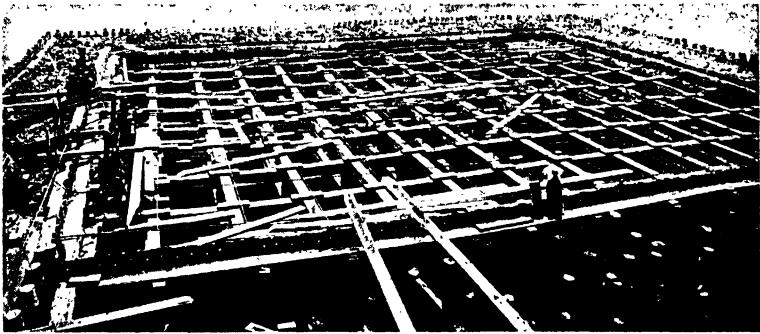

Fig. 22.—Cofferdam of the Boulevard Link Bridge in Chicago.

(2) because it will allow for a slight change in the location of the pit necessitated by a movement of the cofferdam work, and (3) because it permits a future increase in the size of the counterweight. Such an increase in the size of the counterweight may be necessary in order to compensate for a heavier bridge floor that may be demanded by an increase in the traffic requirements during the life of the bridge.

41. Watertightness.—The design of a counterweight pit presents no particular difficulties once the governing loading conditions have been established, but in addition to having sufficient strength the pit must also be watertight. This requires not only special provisions for waterproofing but also that the pit walls be so designed as to have sufficient rigidity to support and protect the waterproofing material properly and to preclude cracks.

This consideration may, in many cases, determine the thickness of the pit walls rather than the consideration of strength to resist computed loads. In no case should the thickness of a reinforced concrete pit wall be less than 12 in. even for a small and shallow pit.

When the concrete itself cannot be relied upon for watertightness, waterproofing methods as given in Sec. 6, Art. 3 to 6, may be applied. However, the use of the membrane method is not favored in this work where the pressure is from without the structure. Excellent results have been obtained by the use of a continuous layer of cement mortar, varying in thickness from 4 to 6 in., depending upon the size of the pit and the pressure. This is shown in Fig. 16.

42. Loading Conditions.

42a. Pit Proper.—The critical loading conditions depend on the type of the pit and must be established by a careful consideration of all the contributing factors. The maximum stress in any one part of the pit will result from the proper combination of the following loads:

1. Superimposed loads due to bridge closed, no live load.
2. Superimposed loads due to bridge closed, full live load.
3. Superimposed loads due to bridge open, no wind.
4. Superimposed loads due to bridge open, maximum wind pressure.
5. Dead load of pit itself.
6. Water pressure from outside, pit empty.
7. Water pressure from inside and no water pressure from outside.

Loads 1 and 3 will, as a rule, be identical, but in certain rolling and other patented bridges there is a horizontal translation of the superstructure load as the bridge opens and closes, and the critical position of this load should be investigated. Also a certain impact should be added to this load, varying between 0 and 50 per cent, depending on the general arrangement and, particularly, on the smoothness with which the movement takes place.

In determining loads 2, it will, as a rule, be permissible to disregard impact and to figure only a fraction of the full live load varying, say, from 50 per cent for a large and wide highway bridge to 80 per cent for a single-track railroad bridge.

The loads under 6 are easily determined, except the upward hydrostatic pressure on the bottom of a pit of type 2 where only

a direct examination of the underlying rock can decide whether it is necessary to consider full, reduced, or no hydrostatic pressure.

The loads under 7 obtain only while the pit is being tested for watertightness with the cofferdam still in place. For this condition it is customary to use unit stresses 25 to 50 per cent in excess of those used otherwise.

In addition to the foregoing loads, which can easily be established, the pit should be strong enough to resist wave action, ice thrust, and the impact from a boat drifting against the pit after having demolished the pier protection. These forces do not lend



FIG. 23.—Completed counterweight pit, Franklin-Orleans Street Bridge, Chicago, Ill.

themselves to accurate calculations and are generally provided for by arbitrarily increasing the thickness of the pit walls where this seems advisable, and particularly by increasing the mass of the channel pier or the front wall of the pit.

42b. Foundations.—In the design of the pile foundations or subpiers for counterweight pits the same loads as already enumerated are to be taken into account. But for this part of the structure it is common practice to disregard live load impact and to reduce the percentage of the live load still further, except when the dead load of the superstructure and pit combined is small as compared with the live load.

When subpiers are used, four such piers will generally suffice. When the pit is unusually large, however, the number should be increased, each pit of the Michigan Avenue Bridge, referred to above, for instance, being founded on 9 circular piers varying from $7\frac{1}{2}$ to 12 ft. in diameter.

An increase in the number of subpiers may also be necessary where utilities, tunnels, or other obstructions interfere with the regular spacing of the subpiers. In the pit for the Franklin-Orleans Bridge,¹ shown in Fig. 23, two additional subpiers, each 5 ft. in diameter, were placed under the house foundations.

The subpiers are generally circular and vary in size from 6 to 14 ft. in diameter, but in a series of bascule bridges constructed over the River Rouge at Detroit it was found necessary to use 12×12 -ft. square subpiers, these piers being sunk by the pneumatic process and through very bad bottom.

43. Unit Stresses.—The unit stresses employed in the design of counterweight pits should conform with standard practice.

44. Materials.—The material most commonly used and, under ordinary conditions, most suitable for counterweight pits is reinforced concrete in rather heavy sections and so reinforced as to preclude cracks. A veneer of cut stone is sometimes used and is very desirable in salt water. In many Chicago and Detroit bridges a distinction is made between the pit proper, which is built entirely of concrete and extends only a few feet above the water line, and the enclosure walls built on top of the pit and extending up to the bridge floor. These walls are of stone masonry—either granite or limestone—with brick backing. In this manner, utility, economy, and appearance are duly served.

Steel or cast-iron boxes and suspended reinforced concrete pits with thin walls have been used but are not considered standard practice. The pit is a part of the substructure and should be designed so as to possess the same degree of permanence, without maintenance, as is requisite in the foundations for any permanent structure.

44a. Concrete Mixture.—The concrete should be a 1:3:5 mixture or, when the walls are rather thin, a 1:2:4 mixture to which should be added about 10 lb. of hydrated lime for each bag (94 lb.) of cement.

¹ Franklin-Orleans Bridge, over the Chicago River, built in 1920 for the City of Chicago, Hugh E. Young, Engineer of Bridge Design.

45. Construction.—Construction methods vary greatly with the size and the design of the pit and with local conditions. Only a few points of special interest and importance will be mentioned.

When piles are used in the foundation, they are generally driven before the cofferdams. The cofferdam is then built and as the water is pumped out, bracing is put in, and the piles are cut off as necessary to give room for the bracing.

When subpiers are used and conditions are favorable for building them in open wells, as in Chicago, the cofferdams are as a rule completed and pumped out before the wells are sunk, while the reverse is found more convenient when the subpiers are sunk by the pneumatic process, as at Detroit.

The particular difficulties that are met with in the construction of a counterweight pit arise from the boxlike shape of the structure, from the necessity for watertightness, and from the fact that the dimensions of the cofferdam are generally large and require heavy cofferdam bracing, which must at all times be supported without interfering with the placing of the concrete bottom and walls. To overcome this difficulty the following procedure was carried out in many of the Chicago bridges.

Four to six piles were driven on the longitudinal or transverse center line of the pit for the support of the cofferdam bracing.

The bottom of the pit was placed in two layers, separated by a 4- to 6-in. layer of cement mortar.

While the bottom layer was being placed, the piles were surrounded, where they pass through the floor, by a wooden box, shaped as a truncated pyramid.

When the concrete had set, the pile was cut off 3 or 4 ft. above the concrete and supported on a horizontal timber, which, in turn, was supported on two blocks resting on the concrete.

The pile stump was then cut off, the box removed, and the hole filled with concrete—the tapered form of the concrete plug ensuring tightness under outside water pressure.

The mortar layer was then deposited and the upper half of the floor slab was placed—the blocks or stub posts supporting the pile being surrounded by wooden boxes as before.

When the concrete in the second layer had set, the blocking was shifted, the wooden boxes removed, and the holes filled with concrete.

It may be advisable to do such work in three operations instead of in two so that the breaks in the bottom layer, the mortar layer, and the top layer would be offset, one in relation to the other, but experience does not seem to indicate that this is necessary.

Watertight work is essential and to this end concreting should proceed as rapidly as possible. Each layer of the floor should be placed in one operation and no more than 3 hr. should elapse between the placing of two batches coming in contact with each other.

The walls from the pit floor to the water line should also be built in one continuous operation except for such short interruptions as may be necessary in order to allow for the removal and reframing of the cofferdam bracing.

Particular attention should be paid to the joint between the floor and the walls. The joint should be trenched. The bottom reinforcement should be bent and continued well up into the wall and, before the concreting of the walls is begun, the surface of the joint should be roughened, cleansed of scum, laitance, and foreign material and then wetted down and slushed with neat Portland cement.

The waterproofing course of cement mortar in the pit bottom should be placed in one continuous operation. The waterproofing course in the walls should be carried up with the concrete and this is conveniently done by means of forms consisting of steel plates, about 12 in. wide, to which are riveted vertical angles that bear against the inside of the outside wall of the wooden forms. The thickness of the layer, 4 or 6 in., will determine the size of the angles to be used. These steel forms are easily pulled up as the concreting progresses and are held in place by the pressure of the concrete, which is deposited so as always to be slightly ahead of the mortar layer.

46. Testing.—Before the cofferdam is removed, the pit may be tested for watertightness by filling the space between the cofferdam and the pit with water after the concrete in the pit has had sufficient time to set.

If leaks appear, the water should again be pumped out and the leaks—if necessary—traced to the outside of the pit by filling the pit with water. After the leaks have been carefully sealed, the pit should be pumped out and the cofferdam again flooded. These operations should be repeated until a satisfactory job is obtained. In practice, however, the pit is generally found to be tight from the beginning and with proper design, proper materials, and proper construction methods, it is now possible to ensure a watertight job without the necessity of repeated tests.

CYLINDER AND PIVOT PIERS

47. Hollow and Cylinder Piers.—This type of pier decreases the volume of concrete but increases the form work necessary. Care should be taken that good high-strength concrete is used and that it is well reinforced. Because of the decreased weight

of concrete, more vibration may result. These piers are a compromise between the solid and the cylinder pier.

Cylinder piers are formed of two or more cylindrical columns, usually consisting of a steel shell filled with concrete. These cylinders should be properly strutted and tied together to form a pier unit, and to provide the necessary lateral stability. This braced structure is essentially a rigid frame and should be analyzed as such.

48. Pivot Piers.—This designation is used for piers supporting the center of a swing drawbridge. The horizontal section of such a pier is usually circular, of sufficient diameter properly to support and anchor the rack used in turning the bridge and, in the case of a rim-bearing bridge, the track. This requires a large diameter and in a solid pier would result in a very heavy structure. To reduce the weight, pivot piers are often built hollow and covered with a reinforced concrete slab. Pivot piers are sometimes made octagonal in horizontal cross section.

Incidentally, it may be stated that, in the case of a draw span, both the pivot pier and the end piers or abutments should be protected by timber fenders, to prevent damage to the substructure by water-borne traffic.

SECTION 8

APPLICATION OF THE LAW RELATIVE TO THE ENGINEER

1. General.—This chapter is designed to set forth briefly a few of the legal principles that relate to the engineer in the field of excavation, underpinning, and subsurface construction.

Only a few engineers are employed with any regularity as expert legal witnesses; a few more come in contact with the law as specialists only a few times in their lives; while the great majority never have any direct employment as specialists in litigation. To the last class this chapter is devoted. The attempt will be, with little regard for a detailed development of the law as such, to set forth the particular fields of the law that the engineer meets most often in his professional life in that highly specialized field of excavation, foundations, and underpinning work.

An engineer who has a working knowledge of the law in its application to this field of engineering will save money for himself, the contractor, or the owner by avoiding the loss of time imposed upon him (1) by an injunction proceeding restraining an illegal building activity, or (2) by reason of a judgment in a court of civil jurisdiction because of an illegal activity or wrongful act. A few paragraphs found later in this section will develop in greater detail injunctions and civil liability resulting in judgments.

Another branch of the law, namely, *criminal law*, will not be treated here except to state broadly and in the nature of a platitude that an engineer will not render himself criminally responsible except where he violates a Federal or state penal statute, or a local ordinance prohibiting him from the doing of a specified act, or where his conduct in his work is so reckless and heedless that it evinces a complete and total disregard of human rights.

Law is divided into two classes: *substantive* and *adjective*, or *procedural*. The latter field does not concern the layman, as

it is the branch of law that deals with the relevancy of testimony and the rules and regulations governing the beginning, continuance, and finishing of a cause of action.

We are concerned with substantive law, and then with only a few of its many subdivisions.

Substantive law comes to us in two forms:

1. Common law, derived from antiquity.
2. Statute law, derived by legislative enactment.

2. Common Law.

2a. The *common law* of the United States and of the states of the union is a heritage from England which through the years from the time of the Norman Conquest to colonial days had developed a great body of laws for the guidance of the English people and the colonies. These laws were established in England and were transplanted here by the colonial judges, who owed their appointment to the crown and to the colonial governors. These judges and governors promulgated the same jurisprudence in this country that had been established in the mother country. After our independence the previously established law of the colonies remained in most part the same and became the law for later states of the union.

2b. Common law at its inception was predicated upon no previously written rules or regulations, but rather upon the custom and usage of the people in their acts and conduct toward one another. Whether or not an individual deviated from the usually accepted habit and custom and injured another to his damage and rendered himself liable became a question that the English judges and a jury would decide. Eventually, a decision was written, which concerned a breach of duty or a negligent act and which became the norm for cases with similar facts. Thousands of decisions were handed down involving all branches of human conduct and man's legal relationship with man. These decisions became the established law of the land and the guiding sign for the future. Occasionally injustices seemed to exist in a few cases, but usually the decisions were founded upon good judgment, reason, and inherent justice. This doctrine of accepting and following previously established decisions became known in the law as the doctrine of *stare decisis*, or "the written decision remains." Later, when it was

deemed advisable and when natural justice required an abrogation of the common law, this was accomplished by legislative enactment known as statutory legislation. That subject will be treated in subsequent paragraphs.

2c. Common law is the law in 47 states and in the United States. The one exception is Louisiana, which was colonized by the French and has the Napoleonic Code. However, one must remember that upon appeal to the highest court in one state, similar facts in the highest court of another state might be interpreted differently. As a result there sometimes exists a conflict in the law of these states.

2d. The common law is the law of the land except where it has been necessary to abrogate or abridge it to meet changed social conditions, when, without a change, injustices and inequities would result from its application. The abridgment or abrogation of the common law is designated as statute law. Such laws are created by the legislative bodies of the state or nation, when new rights, duties, and liabilities are concerned. Later, some of these statutes are set forth briefly as they relate to the engineer engaged in excavation, underpinning, and sub-surface construction work.

3. The Common Law of Lateral and Subjacent Support.

3a. As a fundamental principle, an owner of land is entitled to have his land remain in its natural state. The owner of an adjoining piece of realty who excavates his own land or digs a tunnel under it, thereby disturbing his neighbor's land and causing it to fall, slide away, or cave in, is responsible in money damages for the injury caused. This rule of law applies to the land at the surface or below it. This principle applies regardless of the fact that the adjoining owner exercised the highest degree of care in the excavation of his own land. It is only necessary to prove that the adjoining property owner did an act that resulted in the subsidence of his neighbor's land.

3b. However, the engineer or contractor engaged in foundation work should carefully examine the topography, soil, etc., and, having done so, should provide such artificial support or shoring as to preclude the subsidence of the adjoining land.

3c. The doctrine of lateral and of subjacent support does not extend so far as to give rise to a cause of action for

damages, where the excavator in excavating his own land causes a neighbor's house or buildings to fall away. In this event it is necessary to establish the fact of negligence—that the one who caused the injury did something he should not have done or failed to do something he should have done.

3d. In a minority of the states and in England it is the rule of law that if a landowner withdraws the lateral support of his land, causing a falling away of the abutting owner's land and building, there is liability for the falling away not only of the land but also of the buildings if the land would have fallen away without the buildings.

3e. Where a landowner withdraws the lateral support from a street or road, thereby causing a caving in of the road, he is liable in damages for the injury caused.

3f. Where an abutting owner in the excavating of his land withdraws percolating water from his neighbor's land, which removal results in a sinking of the land, there is no liability imposed upon him.

3g. However, where one excavates or drains his land, thereby causing wet sand, loam, or silt to run off his neighbor's land, and resulting in a sinking of that land, there is a liability imposed.

4. Independent Contractor.

4a. A contractor or owner is liable for his own negligence and the negligence of his employees and servants.

4b. A contractor ordinarily is not liable for his subcontractor's negligence unless the general contractor exercises dominion or control over the actual doing of the work. Likewise, an owner is not responsible for his contractor's negligence unless the owner exercises dominion or control over his contractor.

Exception 1: Power to hire and fire the subcontractor's employees.

Exception 2: General contractor directing a subcontractor or his employees in the manner or method of doing the work.

4c. However, a general contractor is not liable for his subcontractor's negligence if he exercises only a general power of supervision, seeing that the work is done according to plan or specification. A similar relationship between an owner and his contractor exists.

4d. However, an owner is responsible in certain cases, as well as the contractor:

1. Where the work done is illegal or constitutes a nuisance.
2. Where the work being done is in its nature inherently dangerous.

5. Duty to Employ a Competent Contractor.

5a. Courts hold, and decisions indicate, that it is the duty of an owner to use reasonable care to employ a competent contractor to do the work if the owner is to avoid liability for a contractor's negligence.

6. Injunctions.

6a. Courts will grant an injunction restraining an owner, contractor, or subcontractor from doing illegal acts that are repetitious. This is to avoid a multiplicity of lawsuits, or a recurrence of an injury where there is no adequate remedy at law for money damages.

6b. An injunction proceeding stops a wrongdoer in his tracks and is resorted to on behalf of the aggrieved party where money damages could not compensate him adequately for the anticipated injury.

6c. Very often an injunction would serve no useful purpose—as where the wrong has been done and the damage has occurred, and it is obvious that it will not recur.

6d. The courts will grant injunctions where an irreparable injury is threatened, although the damages would be slight and be compensated for in money.

6e. Injunctions are also granted in cases involving blasting where the work is being done without the safeguards employed by prudent and careful men.

7. Blasting.

7a. The results of blasting operations are usually divided into two classes.

1. Where the blasting operation causes a direct invasion of a person or property. *Example.*—Where flying stone or debris strikes a person or property and causes injury to either. A cause of action lies against the person who caused the blasting operation. Negligence is presumed against the blaster by the very fact that a person was struck by flying stone.

2. Where the blasting operation causes an indirect injury. *Example.*—Concussion caused by the blasting, which results in damage to a building. In this case, in order to permit a recovery against the one causing the blasting, the injured must show that the blaster was negligent in performing the blasting operation; that is, the blaster failed to do some act which an ordinarily prudent man would have done under the same circumstances.

8. Statutory Legislation.

8a. In this day, with great areas of congested territory necessitating skyscrapers, a few states and many municipalities have enacted legislation in the form of statutes, building codes, and ordinances that permit the availability of all of a man's land for building purposes but require him to use certain safeguards and precautionary measures. These ordinances and building codes can usually be secured by anyone from the department of a city having jurisdiction of the subject matter, free or at a small cost. These departments are known by many names: Department of Plants and Structures, Department of Public Works, Bureau of Water Supply, Board of Planning and Construction, etc.

8b. An engineer, particularly a young engineer, should spend a few hours talking with a qualified engineer in the municipal employ under whose supervision his operations come, and he will be given many valuable tips respecting the requirements of an ordinance, or building code, and its application.

8c. A failure on the part of an owner, engineer, or contractor to observe a building code or ordinance is usually sufficient evidence of negligence in the doing of the work to permit a recovery for the damages caused to an adjoining owner's building. In any event it is evidence of neglect that would be a question for a jury's determination and possibly result in a judgment of liability; or if not, in costly litigation.

9. Ordinance Requiring Notice.

9a. Many municipalities require an owner of real property, before starting building operations, to notify adjoining property owners that it is his intention to excavate below the surface of the earth. Each municipality having this ordinance has established the depth of excavation necessary before notice is given; the depth varies, usually starting with a depth of 8 ft. This notice enables an adjoining property owner to take the necessary precautions to shore up his structure.

9b. A failure to observe this notice is sufficient grounds to establish a prima-facie case of negligence against the wrongdoer and to permit the adjoining property owner to recover for the damages caused to his structures.

9c. This notice is also necessary in order to permit the excavator to receive a license or permit to go on the property

of another, in order to take the necessary safeguards enabling him to do his excavating in a competent and careful manner.

9d. Raising Level.—An owner who raises the level of his land must provide reasonable protection to prevent damage to adjoining land.

9e. Encroachments.—An owner whose property encroaches on that of another may be required by court order to remove such encroachments. There is no natural right to the support for land by underground water.

9f. Light and Air.—In this country there is no right to receive light and air over the land of another. The rule is to the contrary in England. Such a right may be acquired by an express grant. Pollution of air may give rise to a right for damages as a nuisance clause of the *sic utere* theory rather than as an interference with light and air.

9g. Trees.—Trees belong to the land on which they stand. Trees actually on the boundary line are owned jointly.

9h. Water.—An owner of land has the exclusive right to the use and enjoyment of standing water and to water that percolates beneath the surface.

A riparian owner who owns land adjacent to flowing water, either on or below the surface, has a right only to the use of such water consistent with the similar rights of other riparian owners. To constitute a stream so that riparian rights may be acquired there must be a regular flow of water in a well-defined manner.

The setting back of water by a lower owner to the land of an upper owner is an unreasonable use.

9i. Highways, Street and Alleys.—The ownership of roads and highways in this country is usually in the adjoining landowner. Streets and alleys dedicated to the public use are usually the property of the municipality. This is true in most of the Western states. In the older states of the East the public easement theory is more generally followed. Local statutes and rules should be consulted.

10. Conclusion.—An engineer should know that, although everyone is charged with a knowledge of the whole of the law, the legal system has become so intricate that the services of a specialist, one trained in the law, are necessary for the safeguarding of the interests of those whose rights are threatened or who have interfered with the rights of others.

APPENDIX A

CHARACTERISTICS OF SOILS

1. General.—Soil is the unconsolidated mantle covering base rock. It is the result of the disintegration and decomposition of rock.

Soil deposits are divided into two general types: residual and transported. Residual deposits are those which overlie the base rock from which they were formed. Transported soils are composed of rock fragments and debris that have been redeposited by the action of water, wind, or glacial ice. In the transportation process, fragments of many kinds of rock are mixed. Hence a heterogeneous mixture with respect to particle sizes and chemical composition results.

Each of the transporting agents will produce deposits that are characteristic although there is some overlapping. The alluvial deposit produced by sedimentation from water as the velocity is reduced exhibits the effect of the sorting action of the water. Material is therefore placed in various sizes corresponding to the decreasing velocity of the transporting water. Flood plains, deltas, alluvial fans, and lake deposits are examples. Aeolian or wind deposits are all characterized by the uniformity of the particle size. Sand dunes, adobe, and loess deposits are typical. Glacial action, in general, is responsible for the great deposits, known as glacial drift or glacial till and characterized by the heterogeneous mixtures of debris and rock fragments of all sizes, of which moraines are examples. Water formed by the melting of the ice and flowing either within the glacier or away from it forms deposits that exhibit characteristics similar to the alluvial deposits. Eskers and alluvial fans are examples.

Residual deposits, those formed in place, may be characterized by gravels, sands, or clays depending upon the composition of the parent rock and the degree of disintegration, or they may be formed by the decay of organic matter and rock fragments. Peat and muck deposits formed in old ponds and lakes are examples.

Weathering action continues to act upon the deposit of "parent material" and as a consequence both the physical and chemical characteristics continually change. Ranges of temperature change, quantity of rainfall, quantity and rate of decomposition of organic matter affect the disintegration and decomposition so that typical deposits result within regions where definite sets of conditions predominate.

The soil mass or body as encountered in natural deposits consists of a mixture of mineral and organic matter together with solutions, water, and air. The mineral content of the deposit exists in various stages of decomposition, depending upon the resistance of the primary rock minerals to

the direct and reverse action of the chemical agents of oxidation, solution, hydration, and carbonation. These reactions are further complicated by the formation of colloids, which in turn bring surface phenomena into action and under certain conditions promote base exchange. Except for truly organic deposits, such as peat bogs and muck soils, the amount of organic matter found in soils is relatively low. In general it is of importance only as it enters or affects the chemical processes.

A vast amount of data relative to the character of the great soil deposits has been gathered and studied for agricultural purposes. These data may be shown on a soil profile.

2. Soil Profiles.—A soil profile is a vertical section through a soil deposit. Dependent upon the action of weathering agents and the time of their operation, a soil profile will show layers or strata that exhibit certain definite characteristics. Vertical sections having like characteristics are termed "horizons." Soil profiles are generally divided into four horizons, designated by the letters *A*, *B*, *C*, and *D*. Variations within each are designated by numerical subscripts. Horizons may or may not be definitely defined.

The *A horizon* extends from the surface to a depth that may vary from a few inches to several feet. This section is highly leached. The upper portions may contain large quantities of organic matter and humus. Soluble material and the fine particles have been carried downward by the percolating water. In mature soils, a coarse-textured soil results in this horizon.

The *B horizon* is a zone of deposition. Materials carried by the percolating water accumulate and may become cemented in varying degrees. Dependent upon pressure, the percentage of clay particles, and materials possessing cementing properties, these deposits result in clay pan when compressed and in hardpan when fully cemented.

The *C horizon* consists of unweathered parent materials such as rock fragments, residual, or transported soil, which may extend to considerable depth.

The *D horizon* designates rock or other impervious materials which underlie the materials of horizon *C* and which differ in character.

Soil profiles, originally used by the agronomist, usually made use of only the *A* and *B* horizons. The horizons *C* and *D* have been added to aid in the consideration of the engineering problems of soil mapping and classification.

In undrained, arid regions and perpetually frozen areas soil profiles are not normally developed.

For details of the soil-forming process and geologic classification reference is made to the many excellent texts on geology.

3. Characteristics and Properties.—The characteristics of a soil are expressed in descriptive terms that are intended to reflect the origin, history, and present condition of the deposit. These qualities are sufficient to aid in a general classification but of necessity cover wide ranges. To define the variation more closely within these ranges the term "properties" has been introduced. The "properties" of a soil may be expressed in physical or in chemical terms and are intended as a guide to evaluate its use better for a

particular purpose. The terms used for both classification and properties are obviously interrelated; therefore, a certain amount of overlapping and repetition is to be expected in their use.

In foundation engineering the ultimate interest in any soil deposit is its probable behavior under load. The manner in which the soil body resists the external forces determines its value as an engineering material for that purpose. In general, soils are studied for texture and structure. Soil properties are used to study one or both of these general characteristics, in order to evaluate the soil as an engineering material for a particular use. Two distinct types of texture and structure result in the two main classes of soils: granular and cohesive. Gravels and sands are examples of the first and clays represent the second. Within the classes various descriptive terms have come into use and have, in general, developed in a designation of types. In the hope of more clearly and definitely fixing the scope or range of the type with respect to its behavior under load or for other engineering purposes, certain terms and factors to study the properties were introduced. Unfortunately neither the designation of many of the terms nor their definitions have been standardized. Some of the important terms and definitions used to designate characteristics and properties together with descriptive names applied to soil types as related to texture and structure are given here. These may be considered tentative and approximate at this time.

4. Texture.—The *texture* of a soil is a descriptive term relating to the particle size of a given soil. The range of particle size may vary from the fine particles of clay to a coarse gravel. Dependent upon the percentages of coarse or fine grains present, soils are classified according to texture as gravels, sands, clays. The comparatively coarse or sandy materials are termed "light-textured" soils, while the extremely fine-grained, such as clays, are termed "heavy-textured."

Texture is determined by mechanical analysis, which consists of sifting a given sample through a set of sieves that separate the particles into groups of definite maximum and minimum sizes. Subsieve sizes are separated by wet analysis, which is based upon the time of settlement. One method is that introduced by Professor Bouyoucos of the Michigan Agricultural College in 1926.

The data from mechanical analysis are represented by plotting the percentage retained against the particle size on semilogarithmic paper. Grading, or distribution of particle size, the range of particle size, the effective diameter, specific area, and other pertinent information in comparing soil samples may be obtained from this graph. Ideal grading will produce smooth curves; conversely, the lack of certain sizes will produce characteristic skews in the grading curve. Grading is associated with density, which in turn affects other important soil factors. Essentially, textural grading curves are the same as the well-known grading curves introduced by Fuller for studying concrete aggregate mixtures.

The Bureau of Chemistry and Soils, U.S. Department of Agriculture, introduced the following ranges of particle size in millimeters to correspond to the descriptive names.

	Millimeters
Fine gravel.....	2.0 -1.0
Coarse sand.....	1.0 -0.5
Medium sand.....	0.5 -0.25
Fine sand.....	0.25 -0.10
Very fine sand.....	0.10 -0.05
Silt.....	0.05 -0.005
Clay.....	Below 0.005

A triaxial textural chart, developed by A. C. Rose of the U.S. Bureau of Public Roads and showing the classification of soil types dependent upon texture, is shown in Fig. 1. Descriptive terms for the types are shown in Art. 8. It is pointed out that these types, as shown, limit the percentage of the particle sizes within a given range allowable for a given type. Furthermore, the term "loam" represents particle size, not the presence of organic matter. For example, sandy clay loam may have the following percentages of particle size group: sand 50 to 80; silt 0 to 30; clay 20 to 30. Other limiting percentages are shown in the following table.

SOIL TEXTURES

Class	Sand, per cent	Silt, per cent	Clay, per cent
Sand.....	80-100	0-20	0-20
Sandy loam.....	50-80	0-50	0-20
Loam.....	30-50	30-50	0-20
Silty loam.....	0-50	50-100	0-20
Sandy clay loam.....	50-80	0-30	20-30
Clay loam.....	20-50	20-50	20-30
Silty clay loam.....	0-30	50-80	20-30
Sandy clay.....	55-70	0-15	30-45
Clay.....	0-55	0-55	30-100
Silty clay.....	0-15	55-70	30-45

Texture and the corresponding grading and range of particle size are not sufficient to predict the ultimate value of the soil as an engineering material. As previously pointed out, texture is related to density, which in turn affects such soil properties as surface area, capillarity, permeability, and others. For final evaluation as an engineering material, these factors should be considered.

5. Structure.—The *structure* of a soil mass or body refers to the arrangement of the individual soil particles. It is obvious that the possible arrangements for all the particle sizes contained in soil masses are innumerable. It includes a range that varies from that exhibited by the loose flocculent structure of fine-grained clay particles, which have not been subjected to loading, through that shown by all possible arrangements exhibited by the

mixtures of granular soils, to that of the dense, highly cemented structure shown in hardpan

The foundation engineer is interested in evaluating the variable properties of soil, within the range of general types, which may be identified by texture. In this evaluation, structure is an important characteristic, but is not in itself sufficient completely to determine the probable behavior of a soil under load. Furthermore, the present structure of a soil mass is so closely associated with many physical and chemical soil properties that the origin and history of the deposit cannot be disregarded. Some of the properties associated with structure can be directly measured, others must be measured by indirect means. In the interpretation and correlation of test results, a clear idea of the origin and of the various processes by which the deposit is placed and its subsequent history is essential. Leaching water may alter the physical character by either removing or depositing fine materials of the silt or colloidal range. The character of the water will also affect the type and the rate of chemical reactions. The resulting mineral content may therefore be predominantly a single, chemically stable primary rock mineral or any probable mixture of primary and secondary rock minerals. The clay minerals, unlike other soil minerals, are materially affected by pressure. Consequently, clay deposits will show a varying range of structure dependent upon the intensity and duration of vertical loading. Deposits of clay or those which contain sufficient percentages of clay to impart some of its properties will therefore show the effect of overburden loads. The overburden load may have been the ice sheets or deposits that are now eroded.

Descriptive terms that are intended to designate in general the various types of structures with respect to compactness, consistency, and chemical composition have been applied. These terms are relative. Compactness is associated with porosity, degree of consolidation, and degree of cementation. Both texture and density, in a measure, determine "specific surface" which in turn is associated with "capillarity," water-holding capacity, and permeability. The percentage and chemical composition of colloids in part define the degree of adhesion and possible base exchange, which again affect possible shrinkage, swelling, and permeability. Consistency refers to the degree of cohesion. This is associated with origin, chemical composition, particle sizes, and water content. Degree of compaction and consistency are associated with, and at least in part define, internal stability or resistance to deformation and are therefore associated with shearing strength, bearing capacity, and rate of volume change.

The evaluation of structure as a factor in defining the suitability of a particular soil for a given purpose may, therefore, be represented by an integration of the physical and chemical properties between limits fixed by local geology and conditions for the intended use.

6. Relationship of Texture and Structure.—Texture and structure are perhaps the most important characteristics by which soils are identified. Both are, however, interrelated and interdependent. Neither serves as a sufficient means for the evaluation of soil masses for engineering purposes. The physical and chemical properties of a soil mass are, therefore, expressed

in terms of soil factors that can be more or less directly measured. Some of these may properly appear under the study of both texture and structures. For example, particle size and gradation are primarily a textural study but they also contribute to and, to a large extent, control density but do not sufficiently define it. Density in turn is associated with compaction, permeability, and other important properties. Structure is a property of the mass, which is not only determined by particle size or gradation but is dependent upon chemical composition and the history of the deposit relative to the physical, chemical, and mechanical actions to which it has been subjected and by which it has acquired certain mechanical properties of a processed engineering material.

7. Soil Factors.—Some of the more important soil factors that are used to define and evaluate soil properties more clearly will be briefly described. These definitions are approximate. For details relative to the interrelated functions of these factors in determining important soil properties together with methods of their determination, reference is made to texts on soil mechanics and to the current literature upon that subject.

Density.—The density of a soil is its weight per unit volume. Its value is, therefore, dependent upon the state of compaction. The term “mass density” is sometimes used and refers to the density or unit weight of the soil mass or body.

Specific Gravity.—The specific gravity of a material is the ratio of its weight per unit volume to the weight of a unit volume of water.

True specific gravity refers to the specific gravity of the soil particles themselves, while *mass specific gravity* refers to the specific gravity of the soil mass or body.

Porosity.—The porosity of a soil mass is the ratio of the volume of voids to the total volume expressed as a percentage.

Specific Surface.—The specific surface of a soil is the surface area of the soil particles per unit of absolute volume.

Capillarity.—The capillarity of a soil refers to its ability to raise water in thin films above the level of the water table. Both particle size and the physicochemical properties of the soil, particularly adhesion, influence its value.

Water-holding Capacity.—The water-holding capacity of a soil refers to its ability to retain water in thin films against the action of forces tending to drain it. A centrifugal force, usually 1,000 times gravity, is generally used. The results are evaluated as *centrifugal moisture equivalent*, which is the moisture content expressed as a percentage of the dry weight of the soil.

Colloids.—A colloid is a particle of such size that it will exhibit Brownian movement when suspended in water.

Adsorption.—The concept of adsorption, in physical chemistry, is that phenomenon which causes all solids to adsorb or condense on their surface any gas or vapors with which they are in contact.

Base Exchange.—In physical chemistry, base exchange is defined as adsorption that involves reactions that are essentially chemical or ionic in character.

Shrinkage.—The shrinkage of a soil is the loss of volume due to a decrease in the moisture content and to forces resulting from tension in the water films.

Swell.—The swell of a soil mass is the increase in volume caused by a change in water content.

Cohesion.—The cohesion of a soil is the property by which resistance to displacement of particles is developed by the forces of attraction that act between them.

Internal Stability.—The internal stability of a soil mass is that property by which particles too large to be affected by molecular attraction attain mechanical stability through the mutual support of the particles.

Compressibility.—The compressibility of a soil mass is that property by which a decrease in volume results when an external pressure is applied.

Plasticity.—The plasticity of a solid is the ability continuously to deform without rupture under a force greater than that which caused yield. It follows that a force less than that which caused yield can be sustained without deformation resulting.

Elasticity.—Elasticity of a solid is the ability to return to its original shape and size when the external force causing deformation is removed, provided the deforming force is within the elastic range.

Permeability.—The permeability of a soil mass is that property which allows a fluid under a hydrostatic head to flow through it.

Shearing Strength.—The shearing strength of a soil mass is that property by which the individual particles resist displacement with respect to one another when an external force is applied.

Bearing Capacity.—The ultimate bearing power of a soil mass is defined as the minimum load that causes failure of the mass. The safe-bearing capacity is evaluated by the use of a safety factor. Failure of the mass may, however, be determined by a specified settlement. Consequently, both the dimensions and the value of the bearing area and the depth at which it is located should be specified.

8. Defining or Identifying Terms.—The following terms describing textures, structure, consistency, compactness, and chemical composition are used primarily for identification in the soil profile and represent a partial list of those designated by the committee on terminology of the American Soil Survey Association. Neither terms nor definitions have been standardized nor have they been accepted by the Bureau of Chemistry and Soils. Consequently they may be considered as tentative and approximate.

8a. Texture. Sands.—Sands are composed of loose granular grains, containing less than 20 per cent of silt and clay.

Sills contain less than 20 per cent of sand and clay.

Clays contain more than 50 per cent of silt and clay, or clay and sand, and more than 30 per cent of clay.

Loams contain more than 50 per cent of silt and clay, or sand and clay, but less than 20 per cent of clay.

Clay is a fine-textured soil, which forms hard lumps or clods when it is dry.

Varying percentages of sands and silts result in the designation of "sandy loam," "sandy clay loam," "clay or silty loam," "silty clay loam," or "silty clay." The table of soil textures shown with the textural chart in Fig. 1 defines the permissible percentages.

8b. Structure. *Granular Structure.*—Aggregates varying in size to 2 in. in diameter, of medium consistency, and more or less subangular or rounded in shape

Amorphous Structure.—A soil of fine texture having a massive or uniform arrangement of particles. The individual grains cannot be recognized.

Class	%Sand	%Silt	%Clay
Sand	80-100	0- 20	0-20
Sandy loam	50- 80	0- 50	0-20
Loam	30- 50	30- 50	0-20
Silty loam	0- 50	50-100	0-20
Sandy clay loam	50- 80	0- 30	20-30
Clay loam	20- 50	20- 50	20-30
Silty clay loam	0- 30	50- 80	20-30
Sandy clay	55- 70	0- 15	30-45
Clay	0- 55	0- 55	30-100
Silty clay	0- 15	55- 70	30-45

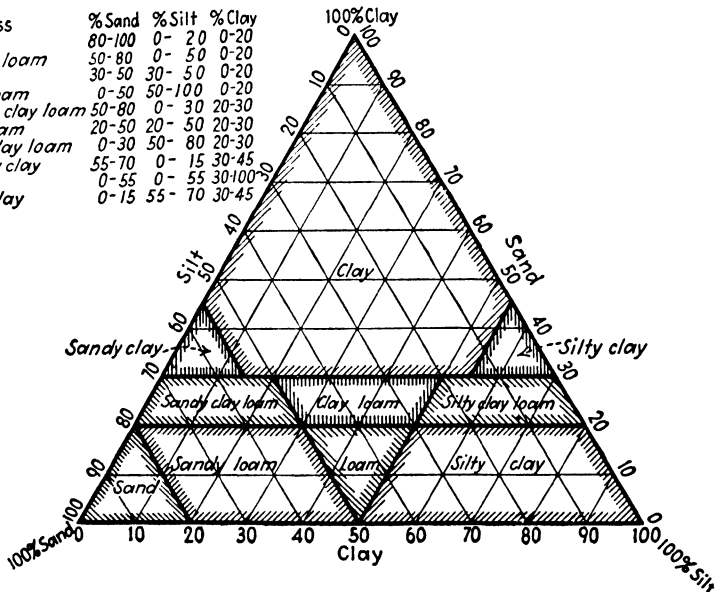

FIG. 1.

Dense Structure.—A soil mass having a minimum of pore space and an absence of any large pores or cracks.

Honeycomb Structure.—A natural arrangement of the soil mass in more or less regular five- or six-sided sections separated by narrow or hairline cracks. This is usually found as a surface structure arrangement.

Laminated Structures.—An arrangement of the soil mass in very thin plates or layers, less than 1 mm. in thickness, lying horizontal or parallel to the soil surface.

Single-grained Structure.—An incoherent condition of the soil mass with no arrangement of individual particles into aggregates. This type is usually found in soils of coarse texture.

Clay Pan.—An accumulation or stratum of stiff, compact, and relatively impervious clay. The clay is not cemented and, if immersed in water, can be worked into a soft mass.

Hardpan.—An accumulation that has been thoroughly cemented into a rocklike layer that will not soften when wet. True hardpan definitely and permanently limits the downward movement of water in nature. The distinction between hardpan and clay pan is an important one in soil classification.

8c. Consistency. *Brittle*.—A soil that will break with a sharp, clean fracture, when dry. If struck a sharp blow, it will shatter into cleanly broken, hard fragments.

Plastic.—A soil that may be readily deformed without rupture. It is pliable but cohesive. This term applies to those soils in which, at certain stages of moisture, the grains will readily slip over each other without the masses cracking or breaking apart.

Soft.—Yielding to any force causing rupture or deformation.

Sticky.—This term is applied to soils showing a decided tendency, when wet, to adhere to other materials and foreign objects.

Firm.—A soil that is moderately hard. It shows a resistance to forces tending to produce rupture or deformation.

Friable.—A structure that may be easily pulverized to a granular. The aggregates of a friable soil are readily crushed or ruptured with the application of a moderate force.

Hard.—A soil structure, resistant to forces that tend to cause rupture or deformation.

Tough.—A soil that is tenacious or shows a decided resistance to rupture. The soil mass adheres firmly.

8d. Compactness. *Loose*.—A soil mass in which the soil particles are independent of each other or cohere very weakly with a maximum of pore space and a minimum resistance to forces tending to cause rupture.

Compact.—A soil packed together in a dense firm mass but without any cementation. Relative degree of compaction may be expressed by terms such as "slightly compact," "very compact," etc.

Impervious.—A soil that is highly resistant to the penetration of water and usually resistant to penetration by air and plant roots. In field practice the term is applied to strata or horizons that are very slowly penetrated by water and that retard or restrict root penetration.

8e. Cementations. *Firmly Cemented*.—Cementing materials of considerable strength and requiring considerable force to rupture the mass. They usually break with clean, though irregular, fractures into hard fragments.

Indurated.—Cemented into a very hard mass which will not soften or lose its firmness when wet and which requires much force to cause breakage. Rocklike.

Weakly Cemented.—This term is applied when the cementing material of a soil mass is not strong, and the aggregates can be readily broken into fragments with a more or less clean fracture.

Softly Cemented.—This term is applied when cementing material is not strong or evenly diffused through the mass. The aggregates are readily crushed but do not break with a clean fracture.

8f. Chemical Composition. *Peat Soil.*—A soil composed predominately of organic material, highly fibrous, with easily recognized plant remains.

Muck Soil.—A soil composed of thoroughly decomposed black organic material, with a considerable amount of mineral soil material, finely divided, and with few fibrous remains.

Leaf Mold.—The accumulation on the surface of more or less decomposed organic remains, usually the leaves of trees and remains of herbaceous plants.

Alkaline Soil.—A soil containing an excessive amount of the alkaline salts.

Saline Soil.—A soil containing excessive amounts of the neutral or non-alkaline salts.

Calcareous Soil.—A soil containing sufficient calcium carbonate to effervesce when tested with a weak (0.1N) hydrochloric acid.

Acid Soil.—A soil which is deficient in available bases, particularly calcium, and which gives an acid reaction when tested by standard methods. There is no full agreement on the most satisfactory test for acidity or as to the actual character of an acid soil. Qualifying terms, such as “strongly,” or “moderately,” may be applied to express the degree or intensity of acidity.

APPENDIX B

FORMULAS FOR BEARING POWER OF PILES

Pile driving is not now and probably never can be an exact science. It is not, therefore, subject to so precise mathematical analysis as many other phases of design and construction in which only processed materials are involved. An important and one of the most indeterminate factors involved in the behavior of a pile both in driving and in resisting static loading is the soil surrounding it. The supporting soil mass is, therefore, a structural element if the pile is to perform its function. Since the physical properties of materials composing the pile itself are well established, its behavior under both dynamic and static loading can be calculated within a fair degree of accuracy. The soil is a natural material. It has been formed by natural processes; hence it may, and often does, exhibit wide variations in character in short distances within natural deposits.

The characteristics of the soil are evaluated by suitable tests upon representative samples. If the sampling process does not secure samples that show all changes in character, the values determined do not represent the true subsurface conditions. Serious errors may, therefore, result in the determination of the probable behavior of the soil under the pile loading.

Since these two materials must act together, a serious indeterminate problem results. The analysis is further complicated by the fact that piles are placed by dynamic forces and, in most cases of service, must resist static loading.

The statement that the best results in pile driving are obtained as a result of practical experience and the exercise of good judgment is often seen in engineering literature on this subject. Many, perhaps most, experienced pile-driving men state that pile-driving formulas should be used with caution. This statement is entirely correct. However, the warning in itself implies that the ability to evaluate the factors determining the behavior of driven piles and of pile groups has been acquired by those who apply them. Doubtless, many pile foundations have been built that successfully perform their purpose. On the other hand there are many that do not. The need for supporting data as to just how various formulas and results are evaluated for driving equipment, kinds of piles, and subsurface conditions is evident if suitable dependable guides are to result. Such a procedure would leave records of the valuable information and experience gained by pile-driving men throughout a lifetime of effort. Unless records of these experiences are kept in a form suitable for later reference, the experience is lost to the profession in the years to come.

Pile-driving formulas will fail to give consistent results dependent upon the consideration of all the factors involved and upon the accuracy of their determination. Some dynamic formulas attempt to evaluate factors as

a whole. Others provide for separate determination. The first method, in general, results in a simple formula, the latter in a more complicated one.

The development of testing apparatus to determine the physical and mechanical properties of soil has furnished an important tool for the evaluation of the fundamental soil factors pertinent to the problem. Although these values may vary over a considerable range for given soil types, they can be determined within reasonable and practical limits, provided the samples are representative. However, soil factors so determined can fail in their purpose if the test results are misinterpreted for particular conditions. Carefully determined soil factors, properly applied and interpreted with pile-driving data, the results of test pile loadings, and the behavior of pile groups in resisting static loading could furnish data for a comparison and evaluation of existing formulas.

There is much controversy in engineering literature about the relative values of simple and complex formulas. Except for uniform soil conditions, it is doubtful if any formula that considers all the factors involved can be expressed in simple form. Furthermore, it is not understood why a simple formula to express the safe bearing capacity of a pile should be more necessary than it is for any other element of a structure or other engineering work. Certainly no formula, either dynamic or static, should be blindly applied. In the design of a pile foundation, formulas are but one of the necessary and available tools. They, like the other tools, should be properly used if a safe and economic foundation is to result.

It is beyond the scope of this book to attempt to present either a complete review of dynamic pile-driving formulas or the mathematical derivation of the many formulas that have resulted from various assumptions made to evaluate the variable factors involved. The relationship between the well-known formulas and the assumptions made in their derivation will be pointed out. All dynamic formulas are based upon the assumption that pile driving is a problem of Newtonian impact and that the static resistance can be expressed in terms of dynamic resistance.

The most thorough and scientific study of pile-driving formulas yet published appeared in the *Journal of the Boston Society of Civil Engineers*, Vol. 27, January, 1940, entitled "Dynamic Pile Driving Formula" by A. E. Cummings. The special committee of the American Society of Civil Engineers on the Bearing Value of Pile Foundations published a progress report in the *Proceedings* of the society for May, 1941, Vol. 67. These papers, together with a discussion of the latter as published in the succeeding numbers of the *Proceedings*, represent current opinion of pile-driving formulas, as expressed by the leaders of the pile and allied industries. These references are especially recommended for detailed study.

Practically all dynamic pile-driving formulas are based upon the fundamental energy equation,

$$WH = RS \tag{1}$$

where W = the weight of the hammer or ram.

H = the height of fall.

R = the resistance to penetration.

S = the distance the pile penetrates under one hammer blow.

Accordingly, R in Eq. (1) represents the so-called "ultimate load," or bearing capacity, of the pile. The following formulas will be written in this form and the safety factors will not, except where noted, be included. The dimensions of all units or quantities should be such that all equations are dimensionally consistent.

This equation assumes no loss of energy. It states that all the energy acquired by the hammer in falling through a distance H is utilized in producing a pile penetration of S by overcoming the resistance R through a distance equal to S . The value of R must, therefore, be assumed to be constant or to vary along the pile according to a definite law. Neither of these seems likely nor is there any conclusive evidence that any such assumption is justified. Likewise the term S is not clearly defined. The impact of the hammer causes a temporary compression of the pile and the surrounding soil. Permanent penetration of the pile is therefore reduced and the energy required to produce these deformations is lost energy.

The energy losses during impact may be represented by Q and the fundamental equation rewritten as

$$WH = RS + Q \quad (2)$$

To evaluate this equation, the Newton theory of impact has been applied. In this theory, the elastic properties of bodies in direct central impact are represented by the coefficient of restitution e , which is evaluated by

$$e = \sqrt{\frac{h_2}{h_1}}$$

where h_1 is the height of the fall and h_2 the height of the rebound. For perfectly elastic bodies, e is equal to 1; for perfectly inelastic bodies, e is equal to zero. The energy loss of two bodies of masses M and m having a velocity of V before impact and v after impact is given by

$$\text{Energy loss} = \frac{1}{2} (1 - e^2) \frac{Mm}{M + m} (V - v)^2 \quad (3)$$

Assuming M as the mass of the hammer and V its velocity before impact, m represents the mass of the pile and v its velocity, which, after impact, will equal zero. By substitution, Eq. (3) becomes

$$\text{Energy loss} = WH \frac{P(1 - e^2)}{W + P} \quad (4)$$

Substituting for Q its value, Eq. (2) becomes

$$WH = RS + WH \frac{P(1 - e^2)}{W + P} \quad (5a)$$

or,

$$RS = WH \left(\frac{W + Pe^2}{W + P} \right) \quad (5b)$$

If perfectly inelastic impact is assumed, Eq. (5b) reduces to

$$RS = WH \left(\frac{1}{1 + \frac{P}{W}} \right) \quad \text{or} \quad R = \frac{WH}{S \left(1 + \frac{P}{W} \right)} \tag{6}$$

This is Eytelwein's formula, which was first published about 1820.

If perfectly elastic impact is assumed, Eq. (5a) reduces to

$$WH = RS \quad \text{or} \quad R = \frac{WH}{S} \tag{7}$$

This is Saunders' formula, which was published about 1850. Saunders used this equation with a safety factor of 8.

Referring again to Eq. (5a), the quantity $\frac{W}{W+P} + \frac{Pe^2}{P}$ represents the energy loss due to impact, determined by the theory of Newton, and is represented by the factor k . This term then represents the efficiency of the hammer blow. The relative values of the weights of the hammer and the pile together with the value of the coefficient of restitution will determine the behavior of the hammer upon striking the pile. Theoretically, when Pe^2 is greater than W , no rebound of the hammer will occur. Hammer rebound reduces the energy transferred to the pile and, in this case, the efficiency k is represented by

$$k = \left(\frac{W + Pe^2}{W + P} \right) - \left(\frac{W - Pe^2}{W + P} \right) \tag{8}$$

Since k is a factor multiplying WH , consideration of Eq. (8) will show the importance of the relative weights of the hammer and the pile being driven and of the control of hammer rebound.

The temporary compression of the pile may be expressed in terms of load R , cross-sectional area A , length L , and modulus of elasticity E for perfectly elastic bodies by static theory as follows:

$$\text{Energy loss} = \frac{R^2L}{2AE} \tag{9}$$

The energy available may be equated to pile resistance plus the energy lost in compressing the pile, assuming no rebound of the hammer, as follows:

$$WH \left(\frac{W + Pe^2}{W + P} \right) = RS + \frac{R^2L}{2AE} \tag{10}$$

from which

$$R = \frac{AE}{L} \left(-S \pm \sqrt{S^2 + WH \left(\frac{W + Pe^2}{W + P} \right) \frac{2L}{AE}} \right) \tag{11}$$

Assuming perfectly inelastic impact, e is equal to zero and Eq. (11) reduces to

$$R = \frac{AE}{L} \left(-S \pm \sqrt{S^2 + \frac{2WH}{E(W+P)} \frac{L}{A}} \right) \tag{12}$$

which is Redtenbacher's formula. This formula was first published about 1850 and is extensively used in European practice.¹

If, in addition to perfectly inelastic impact, no loss in compression or rebound of the pile is assumed, Eq. (11) reduces to

$$R = \frac{W^2H}{(W + P)S} \quad (13)$$

This is the Dutch formula. It is to be noted that as the value of S approaches zero, the value of R approaches infinity. These values of R are of no significance and hence the formula will not hold for small penetrations per hammer blow. This formula is widely used in Holland, Belgium, and France.¹

Equation (10) is the basic equation of many pile-driving formulas. When terms are added to represent the energy loss due to temporary compression of the driving head and the surrounding soil, the so-called "complete" pile-driving formula results. This formula seems to have been developed by Redtenbacher according to Cummings.²

A modification of the complete pile-driving formula was introduced by A. Hiley³ in 1930. The energy equation is written as follows

$$kW^2H = RS + \frac{RC}{2} \quad (14)$$

in which k is the efficiency of the hammer blow and C represents the energy loss. The factor C is composed of three parts, namely, C_1 , the temporary compression of the driving head, C_2 , the temporary compression of the pile, and C_3 , the temporary compression of the ground. A safety factor of 3 is recommended.

The efficiency of the hammer blow may be computed by the bracketed term in Eq. (5a) or by Eq. (8), provided they are modified to evaluate the effect of the driving cap. For wood-driving caps values for e of 0.25, 0.40, and 0.50 for fresh, medium, and well-compacted wood cushions are recommended. Using these values, the coefficient k may be computed for various values of the ratio of the weight of the pile to the weight of the hammer. It is also recommended that the k values be further adjusted to compensate for equipment efficiency. When drop hammers are used, the values of k are multiplied by 0.8; for steam hammers, a factor of 0.9 is used. For double-acting steam hammers the additional energy developed by the steam pressure is added to the energy developed by $W \times H$.

Values of C_1 and C_2 may be determined for assumed cross-sectional areas and lengths of piles and driving caps under various conditions of driving by calculating the stresses produced, assuming the modulus of elasticity

¹ Portland Cement Association, "Concrete Piles," p. 19.

² A. E. CUMMINGS, "Dynamic Pile Driving Formula," *Jour. Boston Soc. Civil Eng.*, Vol. 27, January, 1940.

³ A. HILEY, "A Rational Pile Driving Formula and Its Applications," *Engineering*, Vol. 119, pp. 657 and 721, 1925.

and substituting in the static formula for the deformation produced. The value of C_3 is determined from the formula

$$C_3 = 0.2 \frac{R}{A} \quad (15)$$

where R is the pile load and A is the cross-sectional area of the pile.

The Portland Cement Association¹ recommends the following method of measuring the values of C_2 and C_3 . A board, covered by a sheet of paper, is fastened or clamped on the pile. A straightedge is held on a separate frame directly in front of the board and free of the pile. During driving, a pencil drawn over the straightedge records a diagram or trace on the paper. The permanent set and the elastic compression of the soil below the pile point are measured directly on this trace. Field measurements have been made by Hiley and Ackerman in England and by Goodrich in the United States.²

To use this formula, the conditions at the site of the work, the equipment to be used, and the type of soil must be known. It does not seem likely that any formula can be expected to express the temporary compression of the ground. This factor will vary with both driving conditions and soil characteristics, and the latter may vary over a wide range within the area where piles are to be driven.

In a discussion of pile-driving formulas Professor Terzaghi³ points out that there is at present no tangible evidence that the variation between calculated and real values for bearing capacity can be reduced by the determination of the factors contained in this formula, when they are compared on a statistical basis. Furthermore, the "act of making the observations places a burden on the engineer."³ A further significant fact is repeatedly pointed out by Cummings⁴ that formulas derived from the complete pile-driving formula are based upon Newtonian impact. The complicated impact conditions that prevail in pile-driving operations are incompatible with the basic conditions upon which this theory was developed. Furthermore, in the so-called "complete" pile-driving formula, the coefficient of restitution, by the theory of Newton, represents all the energy losses. Certain parts of these losses are, therefore, deducted twice.

In 1888, the late A. M. Wellington, then editor of *Engineering News*, introduced a formula, which has since been commonly known in both its original and its modified form as the *Engineering News* formula. Although it is generally thought that this formula is entirely empirical, its author

¹ See footnote 1, p. 397.

² See footnotes 1 and 2, p. 397. Reference is also made to "Piles and Foundations" by J. Stuart Crandall, *Jour. Boston Soc. Civil Eng.*, Vol. 18, pp. 176-189, 1931.

³ C. TERZAGHI, Discussion of Progress Report, Committee on Bearing Value of Pile Foundations, *Proc. Am. Soc. Civil Eng.*, Vol. 68, No. 2, pp. 311-323, February, 1942.

⁴ See footnote 2, p. 397. Also A. E. CUMMINGS, "Discussion of Progress Report, Committee on Bearing Value of Pile Foundations," *Proc. Am. Soc. Civil Eng.*, Vol. 68, No. 1, pp. 172-181, January, 1942.

states, "The general form was first deduced as a theoretically perfect equation of the bearing power of piles, barring some trifling and negligible elements."¹

Wellington assumed that all the energy available in the hammer blow was consumed in overcoming pile resistance and that this produced the maximum or ultimate bearing load M . The safe bearing load was considered to be one-sixth of the ultimate; in other words, a safety factor of six was introduced into the formula. The energy of the hammer was expressed in inch-pounds. Equating these terms,

$$\frac{M}{6} = \frac{12WH}{S} \quad \text{or} \quad M = \frac{2WH}{S} \quad (16)$$

In this formula as the value of S approaches zero, the value of safe bearing load approaches infinity. This condition was likewise shown in the Saunders formula, Eq. (7), where no allowance is made for energy losses. To adjust this condition the factor C was introduced, which is evaluated as 1 for drop hammers and as 0.1 for steam hammers.

With the introduction of the factor C , this equation is fundamentally the same as Eq. (2). The general form is

$$\text{Safe load} = \frac{2WH}{S + C} \quad (17)$$

For drop hammers the formula is

$$\text{Safe load} = \frac{2WH}{S + 1} \quad (18)$$

For single-acting steam hammers

$$\text{Safe load} = \frac{2WH}{S + 0.1} \quad (19)$$

For double-acting steam hammers

$$\text{Safe load} = \frac{2(W + Ap)H}{S + 0.1} \quad (20)$$

where A is the area of the piston and p is the steam pressure.

Experience has shown that the value of 0.1 is too low for steam hammers and that, in many cases, wood piles have been ruined in attempting to produce the required penetration for an indicated safe bearing capacity. A value of 0.3 is sometimes used.

To adjust for the inertia of heavy piles and for the relative weights of the pile and the hammer, Eqs. (19) and (20) have been modified as follows for single- and double-acting steam hammers, respectively:

$$\text{Safe load} = \frac{2WH}{S + 0.1 \frac{P}{W}} \quad (21)$$

$$\text{Safe load} = \frac{2(W + Ap)H}{S + 0.1 \frac{P}{W}} \quad (22)$$

¹ A. M. WELLINGTON, "Pile and Pile Driving," *Eng. News* (reprint).

in which P is the weight of the pile. All other symbols are as before defined. It is, however, reiterated that in Eqs. (16) to (21) *II*, the height of the hammer fall, is expressed in inches.

In the original work¹ on this formula, Wellington places limits upon hammer weight, height of fall, and bouncing effect and requires a reduction in the energy developed by the hammer fall for wind resistance, guide friction, conditions of pile head, retardation of velocity due to hoisting rope, etc. He also specifies that S be taken as the mean of the penetrations for several blows, provided that "the penetration is uniform or uniformly decreasing," that "the same conditions would continue if the pile were driven for several feet further (which may be known from test pile driven to an extra depth or from knowledge or evidence as to the nature of the soil, as that it is all sand, gravel or alluvial deposits)" and that "penetration must be relatively quick."

The *Engineering News* or Wellington formula is probably the most widely used of the dynamic formulas. The erratic results for small penetrations have been pointed out. It is doubtful if any formula should be applied to a pile where the principal resistance is at the point. When calculated results are compared with real values as determined by test loading, wide variations are shown for both wood and concrete piles driven with a single-acting steam hammer in cohesive soil and for steel piles driven with various types of hammers and soil types.² Based upon the results of 30 tests, Professor Terzaghi shows that the real factor of safety obtained by the use of this formula is approximately 4 instead of the theoretical 6.² Since it is generally agreed that a real safety factor of 2 is adequate, the use of this formula would result in placing twice the number of piles necessary. In other cases, the number used may be inadequate.

Limitations of Formula.—All dynamic pile-driving formulas are limited because of the questionable application of the impact theory of Newton. Questionable assumptions regarding impact are introduced, and in formulas based upon the complete pile-driving formula certain portions of energy losses are deducted twice. None of these formulas provide for vibrations set up in the pile. Unless exact subsurface conditions are known, the value of pertinent soil factors must be assumed. It seems to be the opinion at present³ that any change in dynamic pile formulas should have a different basis than Newtonian impact. Cummings⁴ points out that pile driving is more nearly associated with the theory of longitudinal impact of rods. This theory was derived by St. Venant and Boussinesq and covers the analysis of transmission of stress within rods subjected to longitudinal impact. It was applied to pile driving by Dr. V. Isaacs.⁵ The British

¹ See footnote 1 on p. 399.

² See footnote 3, p. 398.

³ See footnote 2, p. 397 and footnote 4, p. 398. Also, H. A. MOHR, "Discussion of Progress Report, Committee on the Bearing Value of Pile Foundations," *Proc. Am. Soc. Civil Eng.*, Vol. 68, no. 1, January, 1942.

⁴ See footnote 2, p. 397.

⁵ See footnote 4, p. 398.

Building Research Board has demonstrated that the behavior of piles under field conditions can be predicted with considerable accuracy. Field data have also shown that the stress transmission characteristics of the pile have a bearing upon its behavior during driving and upon its ability to resist static loading.¹

In 1929 Professor Terzaghi² fully explained the factors of driving and static resistance of piles in cohesive soils and proved the inadequacy of dynamic formulas. The static resistance of a pile consists of point resistance and side friction. There is no reason to assume nor data to prove that the sum of these resistances is equal to the sum of the point and side friction resistance during the driving process. In noncohesive soils where conditions are not complicated by hydrodynamic lags and excesses, the total static and dynamic resistances may be more nearly equal. It is, however, difficult to drive piles into dense noncohesive soils and jetting methods are often used. Under these circumstances, static formulas are more applicable.

Static Formula.—The static resistance of a pile is composed of point resistance and side friction developed between the pile and the surrounding soil. It may be expressed as follows

$$R = ap + A_s f \quad (23)$$

where R = pile resistance.

a = cross section of the pile at the point.

p = the bearing capacity of the soil at the pile point.

A_s = the surface area of the pile.

f = the frictional resistance of the soil, per unit of area.

The point resistance is dependent upon the resistance of the soil to compression and the side friction is dependent upon the character of the pile surface and the shearing strength of the soil. These soil factors are directly related to both the nature and the state of the soil.

The degree of disturbance caused by driving will alter the value of these soil factors. In some cases, a so-called "remolding" is said to take place. Settlements of the pile would also affect the value of both soil factors.

For the greatest benefit, both factors should have their maximum values at the same time. Therefore, stress conditions in the soil surrounding the pile cannot be ignored.

To secure an evaluation of this or any static formula involving compressive and shearing resistance the determination of these soil factors is pertinent. According to Professor Terzaghi, no dependable method is as yet available to evaluate correctly the factors that determine side friction nor is the rate of variation with depth accurately known.³ The so-called "remolding" produced in driving cannot be evaluated by laboratory tests because the conditions cannot be reproduced. The disturbance that the soil undergoes during driving occurs under the pressure of the overburden while any disturbance of a laboratory sample takes place at atmospheric pressure.

¹ See footnote 3, p. 397.

² C. TERZAGHI, "The Science of Foundations—Its Present and Future," *Trans. Am. Soc. Civil Eng.*, Vol. 93, pp. 270–301, 1929.

³ See footnote 3, p. 398.

A method of evaluation is quoted from practice, "Although the soil pressure on the side of a pile may not increase in direct proportion to the depth, it would be reasonable to expect the pressure to increase in proportion to the shearing strength of the soils, thus enabling these pressures to be at least approximately evaluated.

"The calculations for bearing capacity are based on the results of tests on core samples which tests determine the shearing strength and the friction of the penetrated soils on the particular pile materials proposed. It is assumed that the failure of a pile may occur as the result of either a shearing failure in the surrounding soil, a frictional failure on the surface of the pile, or a combination of both, whichever is least.

"For piles of small displacements, such as steel H-piles, it is assumed that the lateral pressure on the surface of the pile is equivalent to the natural over-burden of the soil mass. In the case of displacement piles, during the driving of which the soils are pushed aside and remolded or compacted, it is assumed that the lateral pressure on the surface of the piles is equal to the ultimate permanent passive pressure of the soil as limited by its shearing strength. This passive pressure is taken as equal to a quantity between π and $(\pi + 2)$ times the shearing strength depending upon the character of the soil.

"The results of the calculations based on this method of analysis are usually presented in the form of curves showing the lengths of various types of piles required to carry a range of loads for each site. The factor of safety to be selected for determining the design loads from these curves depends upon the type, flexibility, and importance of the structure as well as upon the extent and completeness of the investigations and the uniformity of the soil conditions. The accuracy of the capacities calculated by this method has repeatedly been verified by loading tests to failure."¹

In the design of a foundation, the decision that the use of piles is the proper solution is far more important than the determination of which pile formula to use. Once the decision to use piles is made, the safety of the pile group and of the pile foundation as a whole is paramount. The fact that the pile and the pile groups are but elements of the foundation and that the soil is the real supporting or resisting medium must not be overlooked. The pile foundation is much more likely to fail in its purpose from settlement than from a material failure. The behavior of the pile group will depend primarily upon how the soil takes the load. This in turn is dependent upon the stress-strain relationship of the soil body. To evaluate these factors, complete and accurate knowledge of the subsurface conditions, together with results of test pile loadings and records of driving must be known. Under these conditions, a pile-driving formula can be a useful tool to aid in accomplishing comparable results throughout the area where piles are driven. Such a complete record can also serve as a basis for adequate evaluation of pile-driving formulas.

¹ TRENT R. DAMES and WILLIAM W. MOORE, "Discussion of Progress Report, Committee on the Bearing Value of Pile Foundations," *Proc. Am. Soc. Civil Eng.*, Vol. 67, no. 10, pp. 1939-1946, December, 1941.

Index

A

Abbott, Hunley, 196
Abutment quantities, 357-359
Abutments, 346
 and bridge piers, 338
 breast, 349
 buried, 362
 dam, 300
 dimensions of, 354, 356
 forces on, 353
 hollow and arch, 357
 parts of, 355-357
 pulpit, 350
 reinforced concrete, 362
 Shasta Dam, 307
 structural elements, 346
 T, 349
 toe dimension and depth of
 foundation, 356
 types of, 349-350, 357, 362
 U, 350
 wing, 350
Adjective law, 375
Adsorption of soils, 388
Aeolian soils, 383
Air lock, 121, 126
Akimoff foundation for machinery,
 332
Alligator point for Simplex pile, 194
Allowance for shocks due to han-
 dling concrete piles, 180
Alluvial soils, 383
Ambassador Hotel, Atlantic City,
 288
Anchoring dam to foundation, 310
Annapolis mix for waterproofing,
 295
Apron, dam, 310
Aqueduct, New York, 291

Arch abutments, 357
Arching action, 268
Arching dam, 312
Area, of concrete pile, 182
 for load tests, 33
Areas for footings, 219
Areas problem, 223
Armor, concrete, to protect piles
 from teredo, 162
Arnott steam hammer, 183
Arrowrock Dam, Idaho, 304-306
Asphalt for waterproofing, 294
Auger borings, 5

B

Backwall, 349, 355
Bark, removing from piles, 145
Bascule bridge, counterweight pits,
 372
 materials for, 371
Bascule bridge piers, 362
Base exchange, 388
Basements, 284
Bases for columns, 263
Batter of bridge piers, 345
Batter piles, use of, in foundations,
 168
Beam supports for machinery, 321
Bearing capacity of soil, 389
Bearing piles, 131
Bearing power, of concrete piles, 171
 of dam foundation, field test, 303
 of soils, 304
Bignell pile, 174
Black Rock cofferdam at Buffalo,
 N.Y., 96
"Blasters' Handbook," 67
Blasting, 67, 379
 damages from, 379

- Blasting, for sinking caissons, 116
 Blasting caps, 67
 Blasting handbook, 67
 Blasting holes, spacing of, 68
 Blasting powder, 65
 Blasting rock dam foundation, 306
 Block holing, 71
 Blowout pipe, 116
 Blunt vs. pointed piles, 160
 Bond resistance of reinforced foot-
 ings, 230
 Bond stresses in reinforced footings,
 230
 Bonnet to protect pile head, 159
 Boreholes, 14
 Borings, auger, 5
 for bridge piers, 338
 core, 21
 cost of, 14
 diamond drill, 22
 methods, 9
 samples, 13
 shot-drill method, 25
 wash, 7
 Bortz, 24
 Boulder dam, 306
 Boulevard Link Bridge, Chicago,
 368
 Braced cofferdams, 95
 Breaking rock, 70
 Breast abutment, 349
 Bridge piers and abutments, 338
 bascule, 362
 dimensions of, 344, 346
 driving foundation piles for, 168
 foundation, depth of, 345
 top dimensions, 344
 Bridge seats, 341
 Bridles to handle concrete piles, 198
 Brittleness of creosoted sheet piles,
 163
 Brockport lift bridge, 363
 Buckets, clamshell, 47
 digging, 47
 for excavation, 48
 field of use, 48
 hoist, and derrick, 47
 nondigging, 47
 orange-peel, 47
 and clam-shell, for dredging
 caissons, 115
 Buffalo, N.Y., 96
 Bulldozers, 35
 Buried abutments, 362
- C
- Cableway excavators, 49
 advantages, 49
 operation of, 49
 output, 49
 types of, 49
 Cableways, capacity of, 49
 Caisson details, 128
 Caisson disease, 128
 Caisson method of sinking deep pits,
 291
 Caissons, 107
 box, 108
 metal, 109
 Montee, patented, 117
 open, 108
 pneumatic, 120
 wooden, 112
 Calyx cutter, 21
 Calyx drill, 25
 Cantilever footings problem, 251
 Cap, Casgrain's pile, 158
 Caps, driving, for concrete piles, 184
 Capacity of
 cableways, 49
 clam shell and dragline dredge, 78
 dipper dredge, 77
 hydraulic dredge, 80
 ladder dredge, 81
 power shovels, 42
 Capillary water content of soils, 388
 Carbons, for diamonds, 24
 Casagrande, A., 314
 Casagrande — Mohr — Rutledge,
 Sampler, 18
 Casgrain's pile cap, 158
 Casing, 5
 for core drilling, 22
 for wash borings, 8
 Cast-in-place piles, 170, 187

- Cavernous rock for dam foundations, 301
- Cedar Lake Dam, Seattle, 301
- Cementation of soil, 391
- Centrifugal force on bridge piers, 343
- Characteristics, soil, 383
- Charge of explosive, amount, 68
- Chenoweth, A. C., 173
- Chenoweth pile, 173, 185
- Chicago, bascule bridges, 363
- Chicago, Burlington, & Quincy Railway concrete piles, 175
- Chicago open caisson, 110
- Choice of type of concrete piles, 200
- Cinders for sealing cofferdams, 218
- Clamshell bucket, 47, 115
for dredging caissons, 115
- Clay, for dam foundation, 302, 311
as inert filler for concrete, 293
pan, 390
- Cleaning counterweight pits of bascule bridges, 363
- Clearances, bascule bridge, 367
- Closing pieces for steel sheet piles, 212
- Cofferdams, 86
for bascule bridge, 372
- Colloids, 388
- Column bases, 264
footing, design of plain concrete, 223
load, transference to footings, 264
supports for machinery, 315
- Column footings, 227
- Combination piles, 198
timber and concrete, 198
- Combined column footings, 233, 248
footings, rectangular, problem, 245
trapezoidal, problem, 251
- Common law, 377
- Compressive strength of concrete pile, 179
- Concrete armor to protect piles from teredo, 162
- Concrete caissons, sinking, 119
pneumatic, sinking, 128
- Concrete construction of bridge piers, 340
- Concrete footings, 227-228
- Concrete gun-pit caisson, Washington, D.C., 134
skin friction of, 122
- Concrete piles, 169
advantages over timber piles, 170
cast-in-place, 187
choice of type, 200
combination, 198
composite types, 198
compressive strength, 198
cutting off, 185
introduced, 169
Peerless, 198
precast, 173, 178
driving of, 183
rate of driving, 166
average number driven per day, 183
safe load, 208
sectional area, 182
specifications, 182
unit pressure, 203
piles, water jet for driving, 164
- Concrete-protected steel sheet piles, 218
- Concrete sheet piling, 218
- Concrete test piles, driving and loading, 206
- Condenser pit, Union Gas & Electric Co., Cincinnati, Ohio, 131
- Consistency of soil, 391
- Consolidation of ground by piles, 140
- Continuous footings, 235
- Contractor, independent, 378
liable for damages from his excavation, 378
- Coping of abutment, 357
- Core barrel, 22
- Core borings, 21
for bridge piers, 338
equipment for, 21
by the shot drill, 25
- Core drilling, 20
- Core drills, types, 22

- Core samples, 23
 Core sampling, 20
 Core trench for dam foundation, 312
 Corliss engine foundation, 318
 Corners for steel sheet piles, 212
 Corrugated sheet piling, 213
 Coulomb, 353
 Counterweight pits, in general, 362
 types and size, 364
 Crandall, J. Stuart, 398
 Creosoted piles, 162
 Critical speed of machinery, 321
 Crude oil, treatment for piles and
 timbers, 163
 Cummings, A. E., 394, 397-398
 Cummings pile, 173
 Curing of concrete piles with steam,
 178
 Curtain walls in dams, 312
 Cut-off trench, for dam, 307
 foundation, 312
 Cut-off walls in dams, 312
 of wooden piles, 162
 Cutting edges, of caissons, 113
 Cutting off, concrete piles, 185
 wood piles, 161
 Cylinder and pivot piers, 373
 C.&N.W. Ry. bridge pier caisson,
 Pierre, S.D., 137
 C.B.&Q.R.R. Platt River bridge
 pier caisson, 112
- D
- Dam, Arrowrock, 305-306
 foundations, 300
 material for, 301
 examination of site, 303
 meaning of term, 301
 preparation of, 305
 Dames, Trent R., 402
 Dampers, to absorb residual vibra-
 tion, 317
 foundation, 335
 Damping, 333-334
 Dams, earth or rock-fill, 312
 overflow, on softer foundations,
 310
- Dead load, on abutments, 353
 on bridge piers, 342
 Deep basements and machinery
 pits, 284
 Deep excavation, 48
 Deer Flat Reservoir, Idaho, 311
 Defining or identifying terms for soil,
 389
 Delaware River Aqueduct, 291
 Derrick and hoists, buckets, 47
 field use, 48
 power for, 48
 types, 47
 for wash borings, 9
 Design, of beam supports for
 machinery, 321
 of caissons, 111, 122
 of column footing, problem, 245
 of column supports for machinery,
 324
 of isolated footings, 227, 232
 of plain concrete footings, 227
 of pneumatic caissons, 122
 of rectangular exterior, 245
 of underpinning, 282
 Designing precast piles, 180
 Details of caissons, 128
 Detroit-Superior bridge, Cleveland,
 Ohio, 182
 Detroit, Toledo and Ironton R.R.
 bridge, Detroit, 365-366
 Diamond drill, 22
 operation, 22
 cost of, 24
 Diamonds, for drills, 24
 Dikes, permeable, Missouri River,
 174
 Dipper dredge, 75
 Disease, caisson, 128
 Draglines, 46
 excavation by, 46
 walking, 51
 Drainage, of foundation bed, 219
 of pits, 286
 for reinforced concrete piers, 341
 Drainage galleries in dams, 311
 Dredge, clamshell and dragline, 78
 capacity of, 78

- Dredge, clamshell and dragline, field
of use, 78
dipper, 75
capacity of, 77
field of use, 77
hydraulic, 79
capacity of, 80
field of use, 80
ladder, 81
capacity of, 81
field of use, 82
sea-going, 79
Dredging out caissons, 115
Dredging wells of caissons, 110
Drill boat, 73
Drilling, churn, 61
core, 22, 304
rock, 58
for wash borings, 8
Drills, 58
abrasion, 63
compressed air, 58
core, 22
diamond, 22
drifter, 60
explorer, 24
jackhammer, 58
prime movers for, 58
slope-hammer, 61
submarine, 74
wagon, 61
well, 61
Driving caps for concrete piles, 184
Driving concrete piles, number per
day, 166
Driving core and shell of Raymond
pile, 188
Driving foundation piles for bridge
piers, 183
Driving and loading test piles, 145,
206
average rate, 167
with butt downward, 161
precast concrete piles, 183
sheet piling, 208
sounding rod, 4
with water jet, 164
Drop hammers, 151
Drop hammers, and steam hammers
compared, 156-157
Dry counterweight pits for bascule
bridges, 362
Dutch pile formula, 397
Dynamite, 66
- E
- Earth auger, 5
Earth fill dams, 312
Earth pressure, against abutment,
353
theory, 354
Eccentricity in footings, 224
Economic balance of cost of bridges,
340
Ejector pipe, 116
Elephant Butte Dam, New Mexico,
306
Elevating graders, 44
field of use, 44
output, 45
power for, 45
Eminent domain, 381
Encroachments, 381
Engineer and the law, 375
Engineering News pile formulas,
399-400
Eriksen, O. P., 80
Erie Street Bridge, Chicago, 366
Examination of foundation area for
dam, 303
Excavation, 34
by bulldozers, 35
by cableways, 49
in caissons, 108
Chicago method, 104
by derrick and hoist buckets, 47
by draglines, 46
by elevating graders, 44
legal requirements, 380
by mobiloader, 45
rock, 57
by scrapers, 37
subaqueous, 71
by walking draglines, 51

- Excavation, well-point method, 100
 wet or subaqueous, 71
- Excavators, cableway, 49
 field of use, 40
 scraper, 37
- Existing foundations, strengthening, 272
 structures, support of, 208
- Explosives, 64
 amount in charge, 68
 field of use, 67
 scope of work, 68
- External forces, on abutments, 353
 on bridge piers, 342
- Eytelwein's pile formula, 396
- F
- Factor of safety for retaining wall, 299
- Fenders for bascule bridge counterweight pits, 364
- Ferrous method of waterproofing, 296
- Flexural strength of concrete piles, 180
- Flexure due to weight of concrete pile, 198
- Follower for pile-driving, 159
- Footing areas, 219
- Footings, advantages of reinforced concrete, 228
 bond stresses, 233
 cantilever, 235
 combined column, 233, 248
 rectangular, 248
 trapezoidal, 251
 concrete, 225
 continuous, 235
 depth of, with regard to frost, 219
 design of isolated, 232, 238
 problems, 238
 eccentricity in, 224
 grillage, 257
 steel, 257
 timber, 261
 isolated, 232
- Footings, pile spacing for, 254
 plain concrete, 227
 problems in design of, 253-254
 and reinforced, compared, 228
 proportioning, 220
 raft, 238
 reinforced concrete, problems in design of, 238
 Talbot's tests of, 229-232
 reinforcement and stirrups, 224, 257
 on rock, 228
 shearing stresses, 233
 spread, 219
 supported on piles, 254
 transference of column load to, 263
 types of column, 227
 wall, 225
- Forces, external, on abutments, 353
 on bridge piers, 342
- Formulas for bearing power of piles, 393
- Fort Street Bridge, Detroit, 365
- Foundation Company of New York, 116
- Foundations, for bascule bridges, 370-371
 dam, 300
 preparation of, 305
 dampers, 335
 deep basement, 284
 dimensions of bridge piers, 346
 existing, supplemented, 275
 in general, 83
 loads, 221
 machinery for, 315
 machinery pit, 284
 pile, 138
 pretest, 208
 retaining wall, 297
 steel piles, 208
 wooden piles, 141
- Franklin-Orleans Street Bridge, Chicago, 370-371
- Friction, skin, of open caissons, 111
 of pneumatic caissons, 125

G

- Galleries, drainage, in dams, 311
- Gary, Indiana, well-point construction, 287
- Gatun Dam, Panama, 303
- Geological report on dam foundation, 303
- Geophysical methods of soil investigation, 14
- Gilbreth, Frank B., 174
- Glacial drift, definition, 383
- Glacial soils, 383
- Gow pile, 197
- Grand Coulee Dam, 306
- Gravel, for dam foundation, 302
- Great Lakes Dredge and Dock Company, 77, 80
- Greenville, New York Harbor, pile driving, 185
- Grillage, footings, 257
- Ground water, 284
 - lowering by well points, 288
- Grouting, method of waterproofing, 291
 - of rock dam foundations, 306
 - sand and gravel, 307
- Guide piles for caissons, 114

H

- Hales Bar, Tennessee, dam, 301
- Hammer, Arnott, steam, 183
 - drop, 151
 - for driving precast concrete piles, 151
 - overhanging, for pile driving, 152
 - steam, for driving precast concrete piles, 153
 - industrial works, 153
 - McKiernan-Terry, 155-156
 - Warrington Vulcan, 153
- Hand-operated tools for rock excavation, 57-61
- Hanging leads for driving piles, 150
- Hard-shale dam foundation, 301
- Hardpan, 391
- Harza, L. L., 314

- Head of pile, protecting, 158
- Height and character of building, affecting bearing value of soil, 219
- Hennebique, pile, 174
- Highways, streets, and alleys, 381
- Hiley, A., 397
- Hiley pile formula, 397
- Hoist buckets and derrick, for excavation, 47
 - field of use, 48
- Holes, blasting, spacing of, 69
- Hollow abutments, 357
- Honig Bridge, Koenigsburg, Germany, 362
- Huffman Dam, Ohio, 312
- Hvorslev, M. Juul, 2, 18
- Hydrated lime for waterproofing concrete, 293
- Hydraulic dredge, 79
 - capacity, 80
 - field of use, 80
- Hydraulic jack, for load tests, 30
- Hydraulic jump pool, 311
- Hydraulic rams, for underpinning, 277

I

- Ice pressure on bridge piers, 344
- Impact ice on bridge piers, 342
- Independent contractor, 378
- Industrial Works steam hammer, 153
- Inert fillers, 293
- Injunctions, 379
- Insulating layer in foundation, 336
- Integral method of waterproofing, 292
- Investigations, preliminary, 1
 - of soil under water, 12
 - of soils, 1
 - subsurface, 1
- Isolated column footings, 232

J

- Jack plank, for drilling, 9
- Jacoby and Davis, 92

- Jefferson Avenue Bridge, Detroit, 366
- Jet pipes in caissons, 115
- Jetting piles, 164
 precast concrete piles, 183
- K
- Kensico Dam, New York, 306
- Keyway for dam foundation, 307
- Kinetic reactions of machinery, 315
- Knippels Bridge, Copenhagen, Denmark, 363
- L
- Ladder dredge, 81
 capacity of, 81
 field of use, 82
- Laguna Dam, Arizona, 303
- Landing the caisson, 114
- Langebrogade Bridge, Copenhagen, Denmark, 362
- LaSalle Street Tunnel, Chicago, 291
- Lateral building operations, disturbance of soil, 220
 forces, on bridge piers, 342
 against vertical piles, 164
 of pile, 164
 springing of pile, 164
 support, right to, 377
- Law and engineer, 375
 classes of, 375
 common, 376
 general, 375
- Leaders, pile driver, 148
- Leads, hanging, 152
 of pile driver, 146
- Level, raising, 381
- Liability for negligence, 378
 contractor, 378
 by owner, 378
 subcontractor, 378
- License to excavate, 380
- Light and air, right to, 381
- Lime soap for waterproofing, 293
- Live load, on abutments, 353
 on bridge piers, 342
- Live load, reduction on foundations, 221-222
- Load, safe, on concrete pile, 171
 testing apparatus for soils, 30
 tests, with hydraulic jack, 30
 on piles, 206
 of soils, 28
- Loading, allowable, for soils as a function of settlement, 33
- Loading conditions, bascule bridge pits, 369
- Loading test of piles, 206
- Loads on building foundations, 221
- Lobnitz rock cutter, 73
- Location of bridge piers, 344
- Longitudinal forces on bridge piers, 342
- Lowering ground water by well points, 288
- Ludlow Ferry Bridge, 156
- M
- McDermid patent base for steam hammer, 159
- Machinery foundations, 315
 kinetic reactions of, 315
- McKiernan-Terry steam hammer, 153
- McKinley bridge, St. Louis, pier caisson, 131
- Magnesium silicate for waterproofing, 295
- Maine, battleship, cofferdam for raising, 98
- Marine installations of machinery, 328
- Masonry or concrete piers, transference of load to footings, 264
- Massive machinery foundations, 317
- Membrane method of waterproofing, 293
- Metropolitan District Water Extension, Boston, 290
- Metropolitan Sewerage Commission, 287
- Miami Conservancy Dams, Ohio, 311

- Miami Conservancy District, Ohio, 314
- Michigan Avenue Bascule Bridge, Chicago, 366
- Missouri River bridge of Omaha, 126
- M.I.T. Sampler, 18
- Mobiloader, 45
- Mohr, H. A., 400
- Moore, William W., 402
- Mountings, jackhammer, 59
- Mud capping, 71
- N
- Narrows Siphon, Staten Island, 97
- Nasmyth, James, 153
- National Board of Fire Underwriters, building code, 222
- Navigation interests, effect on design of bridge piers, 339
- Needling, 270
- New York Aqueduct, 291
- New York City building code, 143, 182
- New York requirements for load tests, 143
- Newton's law applied to foundations, 316
- Nitroglycerin, 66
- Nose protection of bridge piers, 345
- O
- Open caissons, 108
test pits, 304
- Orange-peel bucket, 47
for dredging caissons, 115
- Ordinance requiring notice, 380
- Ordinary bridge piers, 342
- Ore dock, Pennsylvania R.R., Cleveland, Ohio, 176
- Overflow dams on softer foundations, 310
- P
- Pan, definition, 390-391
- Paraffin for waterproofing, 295
- Paraffin oil for waterproofing concrete pit, 287
- Parapet wall, 349
- Patented precast concrete piles, 173
- Pedestal pile, 196
- Peeling piles, 145
- Peerless pile, 198
- Pennsylvania R.R. ore dock, Cleveland, Ohio, 176
concrete piles, 176
- Percentage of steel in precast piles, 182
- Periodic forces, 318
- Permeable dikes, Missouri River, 174
- Phoenix Bridge over New York State Barge Canal, 366
- Piers, bridge, 342
bascule bridge, 342
batter, 345
bridge seats, 341
construction of, 340
dimensions, 344, 346
ends, 345
foundations, 338
 boring for, 338
 dimensions, 345
location, 344
nose protection, 345
sites for, 338
surface protection, 341
survey for, 338
quantities, 346-348
- Pile cap, Casgrain's, 158
defined, 138
- Pile driver, 146
followers, 159
with hanging leads or crane, 150
track, 150
- Pile driving, 145
average rate, 166
with butt downward, 161
cost of, 167
with drop hammer, 151
number per day, 166
precast concrete, 183
procedure, 145
steam hammer, 153

- Pile driving, with water jet, 164
- Pile formulas, 393
- Pile foundation for retaining wall, 298
- Pile foundations, 138
 - in medieval times, 139
 - limitations of, 400
- Piling in dam foundation, 302
 - preservation of, 162
 - protection for bascule bridge counterweight pits, 364
- Piles, bascule bridge, 372
 - bearing capacity, 141
 - Bignell, 174
 - cast-in-place concrete, 170, 187
 - Chenoweth, 173, 185
 - combination, 198
 - concrete, 169
 - choice of type, 200
 - composite types, 198, 200
 - cutting off, 185
 - precast, 173, 178
 - specifications, 203
 - Cummings, 173
 - cutting off, 161
 - Franki, 188, 197
 - Gow, 104
 - head, protecting, 158
 - Hennebique, 174
 - lateral springing of, 164
 - monotube, 188, 190
 - number driven per day, 166
 - pedestal, 196
 - Peerless, 198
 - precast, 173, 175
 - composition of concrete for, 179
 - construction of, 178
 - design of, 180
 - Raymond, 170
 - standard tapered, 188
 - step-tapered, 188
 - ring, 158
 - safe load for, 208
 - sheet, 208
 - shoes, 160
 - Simplex, 194
 - spacing for footings, 254
 - splicing, 161
- Piles, steel, 205
 - steel pipe, 204
 - supporting footings, 254
 - test, 206
 - timber, 141
 - for underpinning, 276
 - wooden, 141
- Pits, deep, and basements, construction of, 284
 - for machinery, etc., 284
 - test, 14
 - for underpinning, 272
- Pivot piers, 374
- Plaster coat for waterproofing, 295
- Pneumatic caissons, 120
 - limitation of depth, 121
 - wall caisson, Federal Reserve Bank, N. Y., 131
- Porphyry seam in dam foundation, 306
- Porter Soil Sampler, 16
- Portland Cement Association, 397
- Powder, blasting, 65
 - pellet, 65
- Power drills, 58
 - method of mounting, 59
- Power shovels, 41
 - capacity, 42
 - field of use, 44
- Precast concrete piles, 173, 175
- Preparation of dam foundation, 305
- Pressure, on all footings, desired
 - uniform, 220
 - distribution of, below foundations, 31
 - of earth against abutment, 353
 - below foundations, distribution of, 31
 - relative allowable, on soil, 219
 - on soil, relative allowable, 219
 - upward, in dams, 311
 - of water on cofferdams, 90
- Pretest foundations, 208
 - method of underpinning, 279
- Pretoria Avenue bridge, Ottawa, Ontario, 363
- Procedural law, 375
- Profile soil, 384

Properties of soil, 384
 Proportioning footings, 220
 Protected steel sheet piling, 218
 Protecting pile head, 158
 Protection of pier surfaces, 341
 piling for bascule bridge counter-
 weight pits, 364
 Pulpit abutment, 350
 Pump, mud-sand, 116
 Pyramidal concrete footing, 228

Q

Quabbin Dam & Dike, 290
 Quantities of material, in abutments,
 358
 in bridge piers, 347-348

R

Raft footings, 238
 Raising level, 381
 Rams, hydraulic, for underpinning,
 277
 Rankine, 353
 Ratio of grain sizes, 390
 Raymond, A. A., 170
 Raymond piles, 170
 Reinforced concrete, abutments, 362
 footings, advantages of, 228
 Talbot's tests of, 229-232
 sheet piling, 218
 Reinforcement for cast-in-place con-
 crete piles, 257
 Reinforcing steel, percentage of, in
 precast piles, 182
 Removing bark from piles, 145
 Requirements, for dam foundations,
 300
 Residual soils, 383
 Retaining wall, characteristic of
 abutments, 353
 Retaining wall, for abutments, 353
 foundations, 297
 on piles, 298
 on rock, 298
 settlement, 299
 on water-bearing soil, 298

Redtenbacher pile formula, 397
 Right to lateral support, 377
 Ring, pile, to protect head, 158
 Riparian rights, 381
 Rock, breaking, 70
 Rock cutter, field of work, 73
 Lobnitz, 73
 for dam foundation, 301
 Rock drills, 58 to 63
 Rock drilling, 58
 excavation of, 57
 subaqueous, 71
 footings on, 228
 removed per foot of blast hole, 69
 Rock foundations, 228
 for retaining wall, 298
 Rolled concrete pile, Chenoweth
 type, 173, 185
 Rooters, 41

S

Safety factor for retaining wall, 299
 Samplers for soils, 15
 Samples, of core drilling, 13
 from drill holes, 13
 Sampling methods, 15
 Sand, for dam foundation, 302
 or gravel to improve bearing value
 of soft soils, 220
 Sand dunes, 383
 Sand piles, 140
 Saunders' pile formula, 396
 Scarifying rock foundation of dam,
 308
 Scope of work, of drills, 58
 of explosives, 68
 Scraper excavators, 37
 field of use, 40
 Scrapers, 37
 field of use, 40
 Scrubbing of rock-dam foundation,
 305
 Sea-going dredge, 79
 Sealing caissons, 118
 pneumatic caissons, 127
 Seams in rock foundation of dam,
 306

- Seepage under dams, 313
- Selection of site for bridge piers, 338
- Settlement, initial, in load tests, 29
- permissible in dam foundations, 303
- of retaining wall foundations, 299
- Shale, for dam foundation, 301
- Shasta Dam, 306-308
- Shear, in reinforced footings, 231
- on stepped footings, 229
- Sheet piles, 208
- Sheet piling, 208
- in dam foundation, 302
- driving, 215
- to protect foundations, 219
- reinforced concrete, 218
- steel for cofferdam, 94, 212
- Shelby Tubing Sampler, 17
- Shoes, pile, 160
- Shoring, 268
- Shoshone Dam, Wyoming, 304
- Shot-drill method, 25
- Shovel, power, 41
- field of use, 44
- working capacity, 42
- Simplex pile, 194
- Single-acting steam hammer, 153
- Single-column footings, 227
- Sinking caissons, open, 114
- pneumatic, 125
- Site for bridge piers, selection of, 338
- Skin friction, of open caissons, 110
- of pneumatic caissons, 122
- Slackline Cableway, 49
- bucket capacity, 50
- operation of, 49
- output, 51
- power drag scraper, 50
- span of, 50
- Slings to handle concrete piles, 181
- Sodium silicate for waterproofing, 295
- Softer rock for dam foundation, 301
- Soil, compactness, 391
- disturbance by sampling, 2
- investigations, 1
- methods of, 3
- records of, 13
- Soil, samplers and sampling methods, 15
- shearing stress in, 32
- terms of identification, 389
- Soil factors, 388
- adsorption, 388
- base exchange, 388
- capillarity, 388
- cementation, 391
- chemical composition, 392
- compactness, 391
- composition of, 392
- consistency, 391
- characteristics and properties, 384
- density, 388
- deposits, 383
- residual, 383
- transported, 383
- horizons, 384
- investigations, 1
- underwater, 12
- mass, 383
- mineral content, 383
- porosity, 388
- profiles, 384
- samplers, 15
- sampling methods, 15
- specific gravity, 388
- surface, 388
- structure, 386, 390
- texture, 385, 389
- water-holding capacity, 388
- weathering, 383
- Solid rock dam foundation, 301
- Sounding rods, 3
- Spacing of blasting holes, 69
- Splicing piles, 161
- Spread footings, 219
- Springing, lateral, of pile, 164
- Springs for absorbing vibration, 337
- Stability of buildings, 272
- Static loads on foundations, 221
- Static pile formula, 401
- Statute law, 376
- Statutory legislation, 380
- Steam hammer, 153
- Steel caissons, 109
- pneumatic, 124

- Steel cylinders, 204
 Steel grillage footings, 257
 Steel piles, 205
 H Section, 205
 pipe, 204
 western, 206
 Steel sheet piling, 208
 Stepped concrete footings, 228
 Stirrups in footings, 257
 Stone masonry, compared to concrete, 317, 340
 Strengthening existing foundations, 272
 Structural elements of abutments, 346
 Structure of soils, 386, 390
 Structures, existing, support of, 268
 Subaqueous rock excavation, 71
 Subdivisions of the law, 375
 Sub-drains, 286
 Subjacent support, 377
 Submarine soil investigations, 12
 Sub-piers, bascule bridge, 372
 Subsurface investigations, 1
 Substantive law, 375
 Support, of existing structures, 268
 lateral, right to, 377
 subjacent, 377
 Surface coating method of waterproofing, 294
 Survey of local conditions for bridge piers, 338
 Synchronism, prevention of, 317, 332-334
- T
- T abutment, 349
 Tail pit for bascule bridge, 362
 Talbot's tests on reinforced concrete footings, 229-232
 Tar for waterproofing, 294
 Tension, diagonal, in footings, 226, 230, 242
 Teredo, 162
 Terzaghi, C, 398, 401
 Testing watertightness of bascule bridge pit, 373
- Tests, bearing power of dam foundation, 303
 borings for bridge piers, 338
 cast-in-place piles, 198
 holes in grouting dam foundations, 306
 load, for soil, 28
 loading of piles, 206
 piles, 206
 driving and loading, 206
 pits and bore holes, 14
 for bridge piers, 338
 rod, 8
 soil, 28
 Talbot's, on reinforced concrete footings, 229-232
 University of Illinois on plain footings, 227
 Texture of soils, 385, 389
 Thirty-fifth Street Bridge, Chicago, 366
 Three-point support, 353
 Thrust on abutments, 353
 Tile, drain, for foundation beds, 220
 Timber Caissons, 112
 Timber grillage, footings, 261
 piles, 141
 sheet piles, 208
 Timoshenko, S., 323
 Top dimension of bridge piers, 344
 Tower, 364
 cableway excavators, 49
 Track pile drivers, 150
 Tractors, 35
 Transference of column load to footings, 264
 Transporting equipment, belt conveyors, 55
 buggies, 53
 cableways, 49, 55-56
 draglines, 46, 51
 trailers, 53
 tramways, 55
 trucks, 53
 railroad trains, 55
 wagons, 53
 Tree dozers, 36

Trees, legal provisions concerning, 381

Trench, cut-off or core, for dam foundation, 312

Trenches, sheeting and bracing, 100

Tunnel, LaSalle Street, Chicago, 291

New York Aqueduct, 291

Washington Street, Chicago, 291

Tunkhannock Viaduct cofferdam, 102

U

U abutment, 350

Undermining, method of, 71

Underpinning, 266, 275

design of, 282

example of, 279

Uniform pressure on all footings desired, 220

Union Gas and Electric Co., Cincinnati, Ohio, condenser pit, 131

Unit pressure on concrete piles, 182

Unit stresses, for counterweight pits, 371

United States sheet piling, 212

United States War Department, approval of bridge, 339

University of Illinois tests on plain footings, 227

Unpatented precast concrete piles, 175

Uplift on cantilever footing, 235

Upward pressure in dams, 311

V

Venetian medieval pile foundations, 139

Vertically reinforced columns, transference of load to footings, 264

Vibrations, 316

Volume of water in water jet, 164, 183

Von Babo, Alexander, 367

W

Wakefield sheet piling, 209

Walking draglines, 51

Wall caisson, Federal Reserve Bank, N. Y., 131

Walls, cut-off or curtain, in dams, 312

War Department permit for bridge, 339

Warrington Vulcan steam hammer, 153

Wash borings, 7, 304

equipment for, 7

methods, 9

Washington Street Tunnel, Chicago, 291

Water, current pressure on bridge piers, 344

around pile from lateral springing, 164

beneath retaining wall, 298

right to, 381

Water pressure, on cofferdams, 89

Water repellents, 293

Water-bearing soil foundation for retaining wall, 298

Water supply, for wash borings, 9

Water jet, use of, in driving piles, 164

for driving precast concrete piles, 183

volume of water in, 164, 183

Waterproofing, of bascule bridge counterweight pits, 369

by grouting, 291

methods of, 292

for reinforced concrete bridge piers, 341

of substructures, 292

Waterproofing compounds, 293

Watertight concrete, 286

Watertightness, of counterweight pits, 368

of sheet piling, 217

Watertown Arsenal pile test, 184

- Wayne County Road Commissioners, 365
- Wedges, for underpinning, 275
- Well drill, 61
points for lowering ground water, 287-288
- Wellington, A. M., 398-399
- Wellington formula for piles, 399-400
- Well-point method, of unwatering soil, 288
- Wells, or caissons sunk with compressed air, 125
dredging, of caissons, 110
- Western pile, 206
- Weyrauch, 353
- White, Lazarus, 279
- Wood, commercially available for foundation piling, 143
suitable for piles, 143
- Wing abutment, 350
- Wings of abutment, 348
- Wooden caissons, 112
pneumatic, 123
- Wooden pile foundations, 142
- Y
- Young, Hugh E., 366
- Young's Bay Bascule Bridge, Astoria, Oregon, 367

