

BIRLA CENTRAL LIBRARY

PILANI [RAJASTHAN]

Class No. 5391

Book No. P835 E

Accession No. 45788

Fluorescence and Phosphorescence

FLUORESCENCE AND PHOSPHORESCENCE

by PETER PRINGSHEIM

Argonne National Laboratory, Chicago, Illinois

1 9 4 9



INTERSCIENCE PUBLISHERS, INC., NEW YORK
INTERSCIENCE PUBLISHERS LTD., LONDON

All Rights Reserved

This book or any part thereof must not be reproduced without permission of the publisher in writing. This applies specifically to photostatic and microfilm reproductions.

INTERSCIENCE PUBLISHERS, INC.
215 Fourth Ave., New York 3, N.Y.

For Great Britain and Northern Ireland:

INTERSCIENCE PUBLISHERS LTD.
2a Southampton Row, London, W.C. 1

PRINTED IN THE NETHERLANDS BY
MEIJER'S BOEK- EN HANDELSDRUKKERIJ, WORMERVEER

To my Friend JAMES FRANCK
A Pioneer in the Field
of Fluorescence

PREFACE

The manuscript of this book was forwarded to the publishers on New Year's Day 1946, which proved to be most unfortunate timing. Within a few weeks from this date the investigations that had been kept secret or had been published in books and journals inaccessible during the war began to flow freely in ever-increasing numbers. They partly corroborated my earlier judgments and partly corrected them, or provided completely new facts and viewpoints. It must have been as trying for the patience of the publishers as it was exciting and even tantalizing for the author, when one section after the other, especially in the second part of the book, had to be revised or even rewritten.

The manuscript that was finished in December, 1945, was already based on an earlier one whose intended publication in England had been prevented by the outbreak of the war. This genesis and stepwise growth may be recognizable in the present form of the book but, as I hope, not entirely to its disadvantage. It is probable that, if one were to start today to compile the material for a treatise on fluorescence and phosphorescence, one would be tempted to put much more emphasis on the latest developments, especially in the field of crystal phosphors, and to neglect not only the chapters dealing with the luminescence of gases and vapors but also the earlier work on the crystal phosphors themselves. It is curious to see how inclined one is to assume that research did not begin much before 1936; and the programs of three major congresses show in a very striking way to what extent the general interest has been shifted since 1936 from one end of the field to the other. In the reports of the first international luminescence congress held in Warsaw in 1936, papers on the fluorescence of vapors and gases still take more than fifty per cent of the space, and most of the other papers treated the luminescence of organic compounds. In the luminescence discussion of the Faraday Society at Oxford in 1938, the luminescence of solids takes about three times more space than the luminescence of liquids and vapors combined; and in the volume in which the papers presented at the meeting in Ithaca in October, 1946, are collected (it bears the title *Luminescence of Solids*), gases and vapors do not occur at all and the so-called organophosphors are mentioned in a single discussion remark.

This trend is due, of course, to the growing importance crystal phosphors have attained in numerous technical applications, whereas on the other hand the fluorescence of gases, which contributed so much to the earlier development of the theory of atomic and molecular spectra, has become almost a closed chapter of classical optics. The intention in writing this book has been to give, for the first time in more than twenty years, a *complete* survey of the field of photoluminescence. All types of practical applications have been left aside, since recent publications dealing with the various fields of this kind are available in sufficient numbers. Notwithstanding the fact that its title might suggest a more general content, the subject of the book has been restricted to photoluminescence. Luminescence excited by other means has not been included, although the luminescence excited by electrically charged particles at least is highly interesting and important. The main reason for this exclusion was the desire not to make the book too voluminous. But it cannot be denied that the principal importance of electroluminescence lies in its manifold technical applications and that the investigation of these phenomena up to now has contributed far less to the theoretical understanding of the processes occurring in luminescence than has the study of photoluminescence.

As pointed out above, I tried during the period in which the book was edited and printed to take care as far as possible of newly published papers and also of the earlier publications that had previously escaped my attention. This was possible, of course, only within certain limits. Although *Solid Luminescent Materials*, edited by Fonda and Seitz, appeared in 1948, I was able to make use of some of the papers contained in the volume because I had been present at the meeting at Ithaca. On the other hand, Kroeger's exceedingly interesting volume, *Some Aspects of the Luminescence of Solids*, came too late and only insofar as its content had been published previously in various journals could some of his numerous new data be inserted.

However, as may be seen from the great number of references with a, b, c, etc. in the bibliography, the latter lists every paper about photoluminescence of which I became aware up to May, 1948, again disregarding all papers dealing exclusively with technical applications. It is probable that, although containing well over two thousand items, the bibliography is not free of omissions, even for the years preceding the war, for the list of references that I kept continuously from 1908 on was not at my disposal and I had to start the collection all over again.

I have already mentioned that the publishers — the president and vice president of Interscience Publishers, Inc., as well as their whole staff — were exceedingly patient and helpful in the production of the book, and I want once more to thank them for their kindness. I want moreover to thank those of my colleagues who assisted me in various ways: my old friend J. Franck, with whom I discussed many a problem; S. Simon, who kindly corrected the galleys; F. Urbach, who not only read the page proofs but also suggested several important improvements, especially in the chapter on crystal phosphors for which he is one of the best authorities; Miss M. M. Tippet, who helped in correlating the bibliography; J. Biegeleisen, who was the first to draw my attention to the recently declassified report on the uranyl spectra and thus made it possible to bring this very important chapter up to date; and many others who helped me by putting at my disposal original photographs and sending me reprints of their papers.

Chicago, December 1948

PETER PRINGSHEIM

CONTENTS

Preface	vii
Introduction	1
A. General Theory	1
1. Postulates of Bohr's Quantum Theory	1
2. Energy Levels	2
3. Duration of the Luminescence Process	3
4. Effects of Perturbations	5
5. Coherence of the Secondary Radiation	7
6. Comparison with Other Excitation Processes	9
B. Experimental Technique	10
7. Phosphoroscopes and Fluorometers	10
8. Measurement of the Intensity and of the Degree of Polarization	17
9. Light Filters and Light Sources	19
10. Containers	23
PART I. FLUORESCENCE OF GASES AND VAPORS	
I. Monatomic Gases and Vapors	27
A. Nomenclature of Series Spectra	27
11. Quantum Numbers	27
12. Energy Terms	28
13. Series Lines	30
B. Fluorescence Lines	32
14. Resonance Lines	32
15. Multiple Ground States	34
16. Excitation by Absorption of Lines Leading to Higher Energy States	36
17. Stepwise Excitation	38
18. Combined Electrical and Optical Excitation	44
C. The absorption and Emission Process	48
19. Absorption of Primary Radiation	48
20. Fluorescence Yield and Width of Resonance Lines	51
21. Hyperfine Structure	54
22. Experimental Determination of Lifetime τ	58
23. "Imprisoned Radiation." Recoil of Excited Atoms	61
D. Polarization of Resonance Radiation in Magnetic Fields	63
24. Classical and Quantum-Mechanical Interpretation	63
25. The Mercury Line 2537A as Most Simple Example	64
26. Anomalous Zeeman Effects	68
27. Negative and Circular Polarization	70

28. Vanishing Magnetic Fields	74
29. Influence of Hyperfine Structure on Polarization of the Resonance Radiation	75
E. Determination of τ from the Degree of Polarization in Weak Magnetic Fields	79
30. Principle of the Method	79
31. Experimental Results	81
32. Alternating Magnetic Fields	85
F. Stark Effect in Resonance Radiation	86
33. Direct Demonstration of the Effect	86
34. Polarization of Resonance Radiation in Electric Fields	88
G. Perturbations of Resonance Radiation by Collisions	89
35. Effective Cross Sections	89
36. Collision-broadening. Flame Fluorescence	92
37. Transfer of the Excited Atom into Adjacent Quantum States	96
38. Effect of Collisions on the Polarization of Resonance Radiation	102
39. Quenching of Resonance Radiation by Collisions	108
40. Mechanism of Energy Transfer in Quenching Collision	116
H. Sensitized Fluorescence	124
41. Nature of the Phenomenon and Importance of Energy Resonance	124
42. Influence of Foreign Gases and of Magnetic Fields	131
II. Diatomic Gases and Vapors	134
A. Theory of Band Spectra and Interpretation of Resonance Spectra	134
43. Energy Levels	134
44. Rotational Doublets and the Complete Resonance Spectrum	138
45. Electronic Terms	142
46. Shape of the Potential Curves	145
47. Franck-Condon (F. C.) Principle	147
B. Fluorescence of the Halogen Vapors	151
48. The Visible Band System of I_2	151
49. Ultraviolet Resonance Spectra of Iodine Vapor	161
50. McLennan Bands	165
51. Other Halogen Vapors	167
C. Vapors of the Alkali Metals	169
52. Existence of Diatomic Molecules	169
53. Resonance Spectra of Na_2	170
54. KNa , K_2 , Li_2 , Rb_2 , and Cs_2	175
D. Elements of the Sixth Column of the Periodic System	177
55. Oxygen	177
56. Resonance Spectra of S_2 , Se_2 , and Te_2	177
57. Predissociation and Fluctuations	181
E. Fluorescence of Other Diatomic Molecules	184
58. Elements of the Fifth Column of the Periodic System	184
59. Various Metal Vapors	185
60. Light and Heavy Hydrogen	186

61. Metal Halide Vapors	187
62. Fluorescence of Diatomic Radicals	189
F. Effect of Collisions and of Magnetic Fields on the Resonance Spectra of Diatomic Molecules	191
63. Various Effects Produced by Collisions	191
64. "Transferring Collisions" in Iodine Vapor	192
65. Quenching of Iodine Fluorescence by Foreign Gases	196
66. Quenching of Iodine Fluorescence by Magnetic Fields	199
67. Transferring Collisions and Induced Predissociation in Other Diatomic Molecules	201
68. Atomic Fluorescence Caused by Induced Predissociation	207
G. Photodissociation of Diatomic Molecules Followed by Atomic Fluorescence	208
69. Products of Photodissociation	208
70. Dissociation of Metal Halides and Their Heat of Dissociation	208
H. Lifetime of the Excited States and Polarization of the Resonance Spectra	212
71. Lifetime	212
72. Theory of the Polarization of Resonance Spectra	213
73. Experimental Results	215
I. Sensitized Fluorescence of Diatomic Molecules	218
74. Fluorescence Bands Excited in Hg- and Cd-Vapors on Addition of Foreign Gases	218
75. Rare Gas-Mercury Bands	222
J. Luminescence of Diatomic Metal Molecules That Are Stable Only in Excited States	224
76. Fluorescence Bands of Hg ₂	224
77. Some Properties of the Individual Hg ₂ -Bands	227
78. Lifetime of the Bands and Their Sensitivity to Collisions	230
79. Sensitized Fluorescence Induced by Hg ₂ -Molecules	234
80. Fluorescence Bands of Cd ₂ , Zn ₂ , and of Mixtures of Various Metal Vapors	235
K. Re-emission of Exciting Lines and Rayleigh Scattering	238
81. Re-emission of Exciting Lines by Molecules	238
82. Rayleigh Scattering	240
III. Polyatomic Gases and Vapors	244
A. Types of Fluorescence Spectra and the Energy Relations	244
83. Some Distinguishing Properties of Polyatomic Molecules	244
84. Stokes' Law and the Selection Rules	247
B. Fluorescence Spectra of Polyatomic Molecules	250
85. Inorganic Compounds	250
86. Introductory Remarks Concerning the Fluorescence of Organic compounds	253
87. Nonaromatic Organic Compounds	254
88. Benzene	261
89. Simple Derivatives of Benzene	266
90. Condensed Aromatic Hydrocarbons	270

91. Heterocyclic Compounds; Dyes	273
92. Sensitized Fluorescence of Aromatic Compounds	274
C. Fluorescence of Radicals Produced by Photodissociation of Polyatomic Molecules	275
93. Metal Halides	275
94. Other Polyatomic Molecules	279

PART II. FLUORESCENCE AND PHOSPHORESCENCE OF CONDENSED SYSTEMS

IV. General Survey	285
A. Nature of Luminescent Substances	285
95. Conditions for the Occurrence of Photoluminescence	285
96. Most Important Types of Luminescent Substances	286
97. Energy Transfer from the Absorbing to the Emitting Mechanism	287
B. Course of the Emission Process	290
98. Fluorescence and Phosphorescence	290
99. Decay Curves	293
100. Luminescence Intensity and "Light Sum" L	297
C. Emission, Absorption, and Excitation Spectra	299
101. Band Width, Stokes' Law, and the Franck-Condon Principle	299
102. So-called Mirror Symmetry	302
103. Fluorescence Intensity as a Function of Absorbed Energy	306
104. Absorption by Molecules in the Excited State	311
D. Luminescence Yield as a Function of Experimental Conditions	313
105. Definition of Yield and Methods of Measuring It	313
106. Efficiency, Lifetime, and Solvent Quenching	315
107. Quenching of Luminescence by Foreign Molecules of Low Concentration	322
108. Specific Properties of Quenchers	328
109. Mechanism of Quenching by Foreign Molecules	335
110. Fluorescent Compounds as Photosensitizers	338
111. Fluorescence of Living Plants	343
112. The "Optimum Concentration"	346
113. Self-quenching	349
114. Polymerization and Self-quenching	353
115. Polymers with New Fluorescence Bands	359
E. Fluorescence and Ionization	361
116. Fluorescence of Neutral and Ionized Molecules	361
117. Fluorescence and Photoelectric Effect	364
F. Polarization and Angular Intensity Distribution of Fluorescence Radiation	366
118. Polarization Caused by the Anisotropy of Oscillators	366
119. Polarization of Fluorescence in Liquid Solutions and Influence of Molecular Rotation	370
120. Negatively Polarized Fluorescence of Isotropic Solutions	379
121. Polarized Fluorescence of Partially Oriented Molecules	383

122. Polarized Fluorescence of Crystals	385
123. Angular Intensity Distribution of the Fluorescent Radiation	389
V. Fluorescence of Organic Compounds	392
A. The Luminescent Systems	392
124. Chromophors and Fluorogens	392
125. Influence of Isomerism	395
126. Influence of State of Aggregation	397
127. Influence of Solvent	400
B. Aromatic Hydrocarbons and Heterocyclic Compounds	402
128. Benzene	402
129. Derivatives of Benzene	404
130. Condensed Aromatic Hydrocarbons	405
131. Heterocyclic Ring Compounds	415
C. Dyes	420
132. Synthetic Dyes	420
133. Natural Dyes	424
D. Polyenes, Aliphatic Compounds	429
134. Aromatic and Aliphatic Polyenes	429
135. Various Aliphatic Compounds	432
E. Afterglow of Organic Compounds in Solid Solutions	434
136. Phosphorescence and Slow Fluorescence	434
137. Spectra of Dyes in Solid Solutions	445
138. "Progressive Phosphorescence" and Related Phenomena	448
139. Boric Acid and Similar Compounds as Bases of "Organophosphors"	453
VI. Luminescence of Pure Inorganic Compounds	458
A. The Rare-Earth Metals	458
140. Fluorescence Spectra of the Trivalent Ions	458
141. The Crystalline State	465
142. Solutions in Liquids and Glasses	474
143. Fluorescence of Divalent Ions	478
B. Uranyl Salts	480
144. Band Spectra of UO_2^{++} -Ions	480
145. Fluorescence Spectra of Individual Crystalline Uranyl Salts	489
146. Liquid Solutions and Glasses	494
C. Various Complex Inorganic Ions	498
147. Metal Salts in Aqueous Solutions	498
148. "Pure" Inorganic Salts	501
149. Complex Platinous Salts	502
150. Unsaturated Silicon Compounds	505
151. Glasses	505
VII. Crystal Phosphors	508
A. Nature of the Phosphors and Fundamental Processes	508
152. Monomolecular and Bimolecular Processes	508
153. Crystalline Structure of the Phosphors	516

154. Activating and Quenching Impurities	521
155. Absorption and Emission Bands	526
156. Photoconductivity and the Zone Theory of Crystals	532
157. Phosphorescence Centers and Electron Traps	543
158. Processes of Excitation and Emission	556
159. Periods of Induction and Decay	566
160. Phosphorescence Yield	582
B. Properties of the Most Important Synthetic Crystal Phosphors	594
161. Alkaline Earth Sulfide Phosphors and Related Phosphors	594
162. "Pure" Sulfide and Oxide Phosphors	605
163. Silicate Phosphors	610
164. Halide Phosphors	616
165. Phosphors with Various Base Materials	628
166. Tungstates and Molybdates	634
167. Chromium as Activator	637
C. Luminescence of Natural Minerals and of Crystals Discolored by Irradiation	646
168. Minerals and Gems	646
169. Radioluminescence and "Radiophotoluminescence"	655
170. Fluorites	660
Bibliography	671
Author Index	761
Reference Number Index	761
Subject Index	773

INTRODUCTION

A. General Theory

1. Postulates of Bohr's Quantum Theory. By absorption of light the energy of the absorbing system is increased. According to the laws of thermodynamics the inverse process, emission of energy in the form of radiation, must be possible. This inverse process *must* occur, if no other way of returning the system to its initial state of lower energy is available. Light emission excited by light absorption is called *photoluminescence*. For a long time photoluminescence was supposed to be an exceptional phenomenon characteristic of relatively few substances. The real problem is, however, to understand why so many substances are *not* photoluminescent.

Bohr's theory, first developed for interpretation of the spectra of the H atom and later adapted to more and more complicated systems, postulates that energy can be taken up by such a system only in certain definite steps; the system is stable only in discrete, more or less sharply defined energy levels. The lowest of these levels is the ground level or the ground state of the system. For all atoms and for many diatomic molecules the energy levels are perfectly known. For polyatomic molecules and for still more complicated systems like crystals, knowledge of the energy levels is still far from complete. Even for these systems however, the assumption of the existence of such energy levels has proved itself very fertile in developing an understanding of all processes connected with light absorption and light emission.

Only if the energy absorbed by a molecule is so large that one part of the system is completely separated from the remainder, as in a process of ionization or dissociation, can the separating particles take up undetermined amounts of kinetic energy, so that no discrete energy levels exist for the system as a whole.

In quantum mechanics a system in a given state is characterized by a "wave function" ψ which is the product of the wave functions ψ_i of all individual particles composing the system. These functions ψ_i determine the probability with which a particle is found at a point in space.

Apart from the introduction of discrete energy levels, Bohr's

theory postulated the following relation for a transition between two levels N and F with the energies E_N and E_F :

$$\nu_{FN} = 1/h \cdot (E_F - E_N) \quad (1)$$

h being Planck's constant = $6.63 \cdot 10^{-27}$ erg sec and ν_{FN} the frequency of the radiation which is emitted or absorbed by the transition.

In general, the wave number $\tilde{\nu} = 1/\lambda$ is used instead of the frequency ν , which has the dimension of sec^{-1} . $\tilde{\nu}$ is measured in cm^{-1} and is related to the frequency by the equation $\tilde{\nu} = \nu/c$. Hence a "term" T , which is characterized by its wave number $\tilde{\nu}$, has the energy $\tilde{\nu}hc$, but for the sake of brevity energies are frequently expressed in cm^{-1} . On the other hand, it is customary to measure energies in electron volts (eV), one electron volt being the energy which an electron acquires under the acceleration produced by a potential difference of one volt.

$$1 \text{ eV} \approx 8.11 \cdot 10^3 \text{ cm}^{-1} \approx 1.59 \cdot 10^{-12} \text{ ergs} \approx 23 \text{ kcal/mole}$$

2. Energy Levels. In the diagram of Figure 1 several energy levels of an atom or a more complicated system are represented by horizontal lines. The vertical distance between two of these lines is proportional

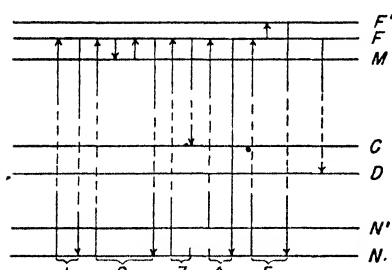

FIG. 1. Energy level diagram for the representation of fluorescence and phosphorescence.

- 1: resonance radiation.
- 2: phosphorescence.
- 3: fluorescence.
- 4 and 5: anti-Stokes fluorescence.

to the corresponding difference in energy; the level N represents the ground state. By absorption of light of frequency ν_{FN} the atom is raised to the level F and if no other energy levels exist between N and F , the atom can return to N only by re-emission of light of the same frequency ν_{NF} : theoretically this is the simplest case of photoluminescence; it is called "resonance radiation." In the diagram of Figure 1, however, several levels C, D, \dots are located between N and F . Under these conditions other transitions from F to C, D, \dots can

occur, resulting in the emission of spectral lines of frequency ν_{FC} , ν_{FD}, \dots . These frequencies are smaller than ν_{NF} . The law according to which the wavelength of fluorescence is always greater than, or in the limiting case equal to, the wavelength of the exciting light was first found empirically by Stokes (1585); the quantum theoretical expla-

nation was given by Einstein more than fifty years later (344). Small deviations from Stokes' law are possible if other energy levels N' or F' are located immediately above N or F respectively, so that the system can be raised by transfer of thermal energy either into N' before the exciting light is absorbed, or into F' during the lifetime of the system in the excited state F . Under these conditions the frequency of the exciting light $\nu_{FN'}$ is smaller than the frequency of the fluorescence ν_{FN} , or the frequency of the absorbed light ν_{FN} is smaller than the frequency of the fluorescence $\nu_{F'N}$: anti-Stokes fluorescence.

Such deviations from Stokes' law, by which additional energy is supplied by a body of low temperature to the radiation from a source of much higher temperature, of course in no way invalidates the second law of thermodynamics, as was suggested erroneously by Lenard (1284, 1293b, 1726, 1762b, 1762c).

3. Duration of the Luminescence Process. In the classical Lorentz-Drude theory the emission of monochromatic light by an atom or molecule originates from the oscillation of an electron which is bound to its position of equilibrium by a quasi-elastic force. The decrease in energy of the oscillating electric dipole which is caused by the emission of radiation, and the corresponding decrease in intensity of the radiation itself, follow an exponential law. The average duration of the emission, or the time after which the intensity has dropped from its initial value I_0 to $(1/e)I_0$, is:

$$\tau = \frac{3}{8\pi^2} \frac{mc}{e^2\nu^2} \text{ with } I_t = I_0 e^{-\frac{t}{\tau}} \quad (2)$$

For visible light, with $\nu \approx 5 \cdot 10^{14} \text{sec}^{-1}$, τ is of the order of 10^{-8} sec.

In the absence of all external perturbations the lifetime of an excited state is determined, according to quantum theory, by the total probability of all possible transitions to lower energy levels. These transition probabilities A_{FK} can be calculated if the wave functions ψ' and ψ'' of the combining levels E_F and E_K are known:

$$A_{FK} = \left\{ \int_0^\infty \Psi' \Psi''^* r dv \right\}^2$$

The lifetime of a molecule in the excited state F is then:

$$\tau = \frac{1}{\sum_K A_{FK}} \quad (2a)$$

As in radioactive decay, the number of transitions per unit of time is at every instant proportional to the number of excited molecules and

thus the decay of the luminescence intensity again follows an exponential law, exactly as in the older theory.

The transition probabilities between various levels of one and the same molecule are of widely different magnitudes. While the Lorentz-Drude theory dealt only with electric dipole radiation, with a mean lifetime depending exclusively on the frequency of the oscillator, much weaker radiation of much longer duration can also be explained on the ground of classical electrodynamics by assuming electric quadrupoles or multipoles or magnetic dipoles or multipoles as sources of radiation. The emission by an electric quadrupole or a magnetic dipole lasts about 10^6 times longer than that of an electric dipole. In the quantum-mechanical models, however, an electric dipole can have a much smaller moment than the oscillating electron of the Lorentz theory and thus the decay of its radiation also can be much slower. Several experimental methods have been found which allow a discrimination between the radiation of electric and magnetic dipoles and multipoles (280a, 435, 1491, 1492, 1761a).

Transitions which have a very small probability because they correspond to the radiation of an electric dipole of small moment or of an electric multipole or a magnetic pole are called "forbidden" and the corresponding spectral lines are "forbidden lines." If no "allowed transition" from an excited state M to any lower energy level exists, the system, once brought into this state, must remain in it for a relatively long period. Such states are termed "metastable." If the system is absolutely unperturbed (as, for instance, in the highly rarefied atmospheres of stellar nebulas) light emission nevertheless occurs, but with very small intensity and slow decay. On the other hand, the transition from the ground state to the state M is also forbidden and the corresponding absorption line, if at all observable, is very weak. However, M can be reached indirectly; in the level scheme of Figure 1, this can occur by absorption of the line corresponding to the transition $F \leftarrow N$,* and by the subsequent transition $F \rightarrow M$. If M is separated by only a small amount of energy from F and if the excited system is in thermal equilibrium with the surrounding molecules a sufficient amount of energy can be provided to the system so that it can return to F . From there the emission of the lines corresponding to the transitions $F \rightarrow N$, $F \rightarrow C$, etc., may again take place. A photoluminescence

* The symbol for the higher level always precedes the symbol for the lower level; the direction of the transition is indicated by the arrow. This principle, which is generally used for the description of the spectra of diatomic molecules, is applied here similarly to the representation of atomic spectra.

process of this type, involving the passage through a metastable level, is called *phosphorescence*.

In the older literature fluorescence and phosphorescence were distinguished only by the criterion of an observable afterglow: if the luminescence did not last longer than the irradiation, it was called fluorescence; if it was visible for an appreciable length of time after the end of the excitation, it was called phosphorescence. Modern experimental technique however, permits the measurement of the finite duration of any emission process, even if it is as short as 10^{-9} sec, and, on the other hand, the spontaneous transition probabilities, even in atomic processes, correspond to lifetimes which vary continuously from 10^{-8} sec to several seconds. Therefore, it is no longer possible to define some arbitrary duration of the emission process as the boundary between fluorescence and phosphorescence. (For a more complete definition of fluorescence and phosphorescence, see chapter IV.)

While, according to the definition given above, fluorescence and phosphorescence are first-order processes and follow exponential laws of decay, another kind of luminescence is a typical bimolecular reaction. If an electron is completely separated from its molecule by photoelectric ionization and if its recombination with any other ion produces the emission of light, the process is of the second order and decays, therefore, according to a hyperbolic law. Luminescence caused by recombination is observed in electrical discharge through gases or metal vapors under especially favorable conditions. These cannot be achieved in the case of excitation by light absorption. However, a phenomenon of the same kind occurs in certain phosphorescent crystals; it will be called "recombination afterglow" in the following treatment.

4. Effects of Perturbations. An excited system can be transferred to neighboring energy levels by outside perturbations, for instance by collisions or other interactions with surrounding molecules, and from these new levels transitions occur which produce emission lines not contained in the primary fluorescence spectrum. Furthermore, such perturbations may cause a momentary displacement of an energy level and if these displacements fluctuate with time and in space, broad and diffuse bands appear instead of sharp lines in the absorption and fluorescence spectra. This is true in particular for all condensed systems which are capable of luminescence (with the exception of certain crystals, especially at low temperatures). Under such conditions the peak of the emission band must be shifted with respect to the peak of the corresponding absorption band in the direction of greater

wavelengths. This consequence of Stokes' law will be dealt with in more detail in a later chapter.

If the whole energy of excited molecules can be lost as the result of collisions or other perturbations, the mean life of all excited molecules is shortened and the fluorescence yield is decreased.

The quantum yield of fluorescence is:

$$Q = I/A \quad (3)$$

where the fluorescence intensity I and the radiant energy A absorbed per unit time are measured by the number of light quanta contained in the emitted and absorbed radiation. In the case of resonance radiation, the quantum yield Q can be replaced by the "energy yield" Φ (I and A being given in ergs or calories), since in this case $Q \equiv \Phi$ (compare Section 105). [In general (namely in the case of Stokes fluorescence), the energy yield is smaller than the quantum yield, while in the case of anti-Stokes fluorescence Φ is slightly larger than Q .]

If no perturbations occur, the fluorescence intensity I_0 is equal to A when equilibrium is reached during the irradiation, and $Q = 1$. Under these conditions, the spontaneous transition probability a_0 alone determines the lifetime τ_0 , and the number n_0 of excited molecules in equilibrium is given by the equation:

$$A = I_0 = a_0 n_0 = n_0 / \tau_0 \text{ with } \tau_0 = 1/a_0 \text{ and } n_0 = A/a_0 \quad (4)$$

If the excitation energy can be lost by a second competing process with a probability a_1 , Equation (4) is replaced by:

$$A_1 = n_1 (a_0 + a_1) = n_1 / \tau_1 \text{ where } \tau_1 = 1/(a_0 + a_1) \text{ and } n_1 = A_1 / (a_0 + a_1) \quad (5)$$

n_1 is smaller than n_0 . Supposing that the absorbing power of the molecules is not altered by the perturbations ($A_1 = A_0 = I_0$), the fluorescence intensity becomes:

$$I_1 = a_0 n_1 = n_1 / \tau_0 = I_0 / (1 + a_1 \tau_0) \quad (6)$$

and the yield:

$$Q_1 = I_1 / A = a_0 n_1 / a_0 n_0 = \tau_1 / \tau_0 \quad (7)$$

$$\text{The "quenching constant" } \alpha_1 \text{ is: } \alpha_1 = \frac{a_0(1-Q_1)}{Q_1} \quad (7a)$$

In the same way the yield is reduced by another perturbation with the probability a_2 to:

$$Q_2 = \tau_2 / \tau_0 \text{ where } \tau_2 = 1/(a_0 + a_2) \quad (7b)$$

Hence the general relation:

$$Q_1 \cdot Q_2 = \tau_1 \cdot \tau_2 \quad (8)$$

The fluorescence yield of a given system is directly proportional to the actual lifetime of the excited state (*I22I, I57I*).

If several processes compete simultaneously with the radiating transition and if their probabilities are $\alpha_1, \alpha_2 \dots \alpha_n$, the lifetime of the excited state becomes:

$$\tau_n = \frac{1}{\alpha_0 + \alpha_1 + \alpha_2 + \dots + \alpha_n} \quad (9)$$

and the intensity of the luminescence:

$$\begin{aligned} I_n &= \frac{I_0}{1 + \tau_0(\alpha_1 + \alpha_2 + \dots + \alpha_n)} = \frac{I_1}{1 + \tau_1(\alpha_2 + \alpha_3 + \dots + \alpha_n)} \\ &= \frac{I_{n-1}}{1 + \tau_{n-1}\alpha_n} \end{aligned} \quad (10)$$

According to the classical theory, the width of a spectral line is proportional to the damping coefficient or inversely proportional to the mean life of the excited state. Qualitatively the same law holds in quantum theory. All perturbations by which the fluorescence is quenched increase the width of the corresponding emission line. The latter is determined, however, not only by the action of the perturbation on the excited state from which the emission process originates, but also by the action on the final state to which the system is transferred.

5. Coherence of the Secondary Radiation. The only photoluminescence process for which the classical wave theory of light could account without the introduction of rather artificial hypotheses was the excitation of resonance radiation. Existence of this phenomenon had been predicted on theoretical grounds by Lord Rayleigh long before its discovery by R. W. Wood. Resonance radiation was understood as special case of light scattering in which the scattering resonators were exactly in tune with the frequency of the primary radiation.

According to the original quantum theory only the average lifetime τ of an excited state could be determined, while for the individual molecule the time elapsing between the absorption and the re-emission of light obeyed the laws of statistics. Hence it seemed impossible that a definite phase relation could exist between the wave trains of the primary and the secondary light. Resonance radiation was considered to be incoherent. On the other hand Rayleigh scattering, which was known to be coherent, was ascribed to forced vibrations of "virtual oscillators" within the molecules. There was no

connection between the two phenomena. It was even assumed, for a time, that for radiation in resonance with the characteristic frequency of the scattering oscillators both processes might occur simultaneously and that it might be possible to separate them experimentally (e.g., by observing a different decay period for either of them) (129).

In the quantum-mechanical treatment, however, the electromagnetic field produced by the interaction of the primary radiation and the virtual oscillators of a molecule is exactly the same as that of the classical wave theory, and thus the steady transition from Rayleigh scattering to resonance radiation is restored. If various energy levels $C, D \dots$ exist in the molecule between the ground state N and the level F to which the molecule is raised by the absorption of the primary light, the resulting electromagnetic field surrounding the excited molecule is the same as if it contained a number of vibrating oscillators of frequency $\nu_{FC}, \nu_{FD} \dots$ in addition to the absorbing oscillator of frequency ν_{FN} . The "strength" of each oscillator is proportional to one of the transition probabilities $F \rightarrow C, F \rightarrow D \dots F \rightarrow N$. All phenomena related to the wave nature of the secondary radiation (coherence, interference, polarization) are to be derived from this model. However, the energy of the radiation is no longer spread continuously over the whole wave field and proportional everywhere to the square of the wave amplitude. The square of the amplitude determines only the probability for a photon of the corresponding frequency to be found at a given instant at a particular point. The absorption and emission of radiant energy occurs exactly as in Bohr's original theory, in quanta within practically infinitely short periods of time (1813).

Insofar as the problem of coherence is determined by the phase relation between primary and secondary radiation, only Rayleigh scattering and resonance radiation can be considered (1529). The existence of such coherence is not revealed by any experimental facts. Resonance radiation is observed exclusively in gases and vapors at low pressures. Under these conditions the coherence of the "classical" Rayleigh scattering with the primary radiation cannot be proved either, because of the random distribution of the molecules in a perfect gas.

If the fluorescence spectrum of a monatomic gas contains lines of wavelengths different from that of the exciting light, a constant phase relation between the waves of the primary and the secondary radiation is out of the question. However, a constant phase relation might still exist between the secondary wave trains originating at

different atoms; this kind of coherence could again only be observed by the angular distribution of the fluorescence intensity if the fluorescing atoms were fixed in space in a regular lattice.

Every kind of coherence between the radiation coming from different molecules must disappear in the fluorescence of molecules in which nuclear vibrations and rotations occur simultaneously with the electronic transition and independently in each individual molecule. The same is true if the molecules undergo external perturbations during their lifetime in the excited state. This is the case for the fluorescence of all liquids and solids. On the other hand, it has been proved by wide-angle interference experiments that the radiation emanating in different directions from an individual molecule of a liquid solution is coherent, exactly as the radiation emitted by a dipole as a spherical wave is coherent in itself according to the classical wave theory (435, 1489-1492, 1817).

6. Comparison with Other Excitation Processes. The radiation emitted by an atom or a molecule depends only on its state of excitation and on the probabilities of transitions from this state to those of lower energy. It does not depend on the mode of excitation by which the system has been brought into the excited state. In this sense there is no difference between fluorescence and any other kind of light emission by the same atoms or molecules caused by collisions with electrons, by chemical processes, or by thermal agitation. The characteristic properties of a spectral line or a band (for instance, the dependence on temperature and pressure or the sensitivity to magnetic and electric fields) must be the same in every case.

A system emitting luminescence is not, however, in a state of thermal equilibrium; some of its molecules contain a much higher electronic energy than that corresponding to the actual temperature of the system and this is the essential feature of every luminescence process. It follows that the "excited" molecules can lose their excessive energy by collisions with other molecules: luminescence, for instance the photoluminescence of iodine vapor, can be suppressed or "quenched" by the addition of relatively small quantities of oxygen. If the same quantity of oxygen is added to iodine vapor heated in a quartz tube to a temperature of 1000° C at which it emits its characteristic bands as temperature radiation according to Kirchhoff's law, no appreciable change in the emission occurs, because now, in thermal equilibrium, the quenching collisions must be compensated by an equal number of exciting collisions (1284).

Photoluminescence is distinguished furthermore by an almost

complete control of the excitation process, since, among all atoms or molecules which are present, only those in a well-defined initial state are transferred into an equally defined excited state by the absorption of light of a given frequency. The complete spectrum of all atoms and molecules, modified within certain limits by the temperature, is emitted by a flame or an arc. By means of electron collisions in a gas at low pressure it is possible to exclude from the spectrum all lines which require an excitation energy surpassing the energy of the electrons under the applied voltage, but all levels lying below this energy are excited simultaneously. Besides, the accuracy of the method is not great enough to differentiate between the excitation of closely adjacent lines. On the other hand, the possibility of separately exciting neighboring energy states of a molecule by the absorption of monochromatic light is limited only by the degree to which the primary light can be made monochromatic. Even the state of polarization which is characteristic for a certain transition can be determined by this method of excitation; thus it becomes possible to ascertain the existence of the various Zeeman levels in very weak magnetic fields which are separated by such small intervals that they cannot be distinguished by other spectroscopic methods.

The same is still true, although to a smaller degree, for condensed systems; there, also, a much finer differentiation is obtained in the excitation of individual emission processes by light absorption than by any other mode of excitation.

B. Experimental Technique

7. Phosphoroscopes and Fluorometers. The experimental methods applied to the investigation of photoluminescence are, in general, very simple. The most important types of apparatus which have been especially designed for this purpose are the phosphoroscopes and fluorometers. These serve for measuring the duration of short or almost instantaneously decaying emission processes. All of these instruments are based on the principle of permitting the observation of the luminescence a short, and if desired, a variable time after the end of the excitation period.

The first phosphoroscope was invented by E. Becquerel (4,78); in a "Becquerel phosphoroscope" the luminescent substance is placed between two discs *M* and *N* (Figure 2), which are mounted on a common axis and have sector-shaped apertures *A* and *D* shifted with

respect to each other by an angle φ . The exciting light enters the phosphoroscope by the apertures in one of the discs and the luminescence light reaches the eye of the observer through the apertures in the other disc. The time interval between excitation and observation and the duration of the excitation itself can be varied within certain limits by altering the speed of rotation of the discs, the angle of aperture Θ of the sectors (which in the original apparatus was identical in the two discs), and the angle φ separating the sectors A from the sectors D . It is plausible that with decreasing "lifetime" the

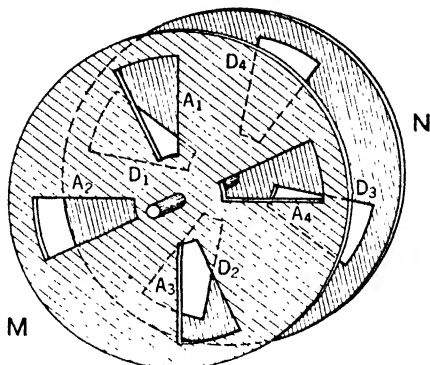

FIG. 2. Becquerel phosphoroscope.

speed of rotation must be increased or the angle φ decreased in order to observe the afterglow. For quantitative observations the intensity of the luminescence must be measured by means of a photometer. For a correct interpretation of these observations, however, it is not sufficient to plot the measured intensities I as a function of the average time elapsed between excitation and observation, for instance as a function of the speed of rotation of the discs. The formula derived by Becquerel under this assumption was:

$$\tau = \frac{T_1 - T_2}{2n(\log I_1 - \log I_2)} \quad (11a)$$

T_1 and T_2 are the durations of a revolution of the discs at two different frequencies, I_1 and I_2 the corresponding intensities of luminescence, and n the number of sectors in one of the discs. Equation (11) yields values of τ which in some cases are more than twice as large as the true values. The equation does not take into account the fact (1) that the apertures A and D open and close only gradually, (2) that a luminescence with a

finite decay period has also a finite period of growth, and (3) that the emission of light observed during each passage of a sector D is caused not only by irradiation in the last preceding period of excitation but possibly by that in many previous periods. Delorme and Perrin have published a method which permits an exact determination of τ from the data obtained with a Becquerel phosphoroscope; it necessitates a rather inconvenient graphical approximation of a theoretical curve to the curve which has been obtained experimentally. However the different corrections are made very nearly negligible by the introduction of some modifications in the original instrument: each disc has only one aperture, the aperture D for the observation of the luminescence being a narrow slit and the aperture A for the excitation a much larger one; the two apertures and the speed of rotation are kept constant during a whole set of observations and only the angle φ between A and D is varied (272).

It will be discussed later that a luminescence process which has a certain decay period τ has also a corresponding period of growth or "induction". In general this induction period will not have reached its end at the end of an illumination period t_1 in a phosphoroscope. If the luminescence decays exponentially and if a stationary state is attained after a certain number of revolutions, the peak intensity of luminescence reached at the end of each illumination period is:

$$I_m = I_0 \frac{1 - e^{-t_1/\tau}}{1 - e^{-t/\tau}} \quad (11b)$$

In this equation I_0 is the luminescence intensity obtained under continuous illumination, $t = t_1 + t_2$ is the time of one revolution of the phosphoroscope, t_1 the duration of each illumination period, and t_2 the corresponding dark period. τ is the mean decay time of the luminescence. I_m approaches I_0 the more, the larger t_1 and the smaller t is compared with τ .

By means of a Becquerel phosphoroscope mean lifetimes as short as 10^{-4} sec can be determined. The instrument can be used, however, only if the luminescent substance is transparent to some degree for either the exciting or the secondary radiation. If this is not the case, the apparatus must be altered so that the phosphor is excited and observed from the same side. This can be accomplished by fastening the phosphor to a cylinder rotating within a coaxial tube; the exciting light is admitted through a slit on one side of the tube and the luminescence observed through a slit on the opposite side. Lenard has devised an apparatus in which a fast-moving diaphragm periodically

screens the phosphor from the observer and simultaneously actuates a spark discharge exciting the luminescence (*X*). In still another setup, a pinpoint image of the primary light source is thrown on the phosphor which uniformly covers a rotating disc; if luminescence is persistent, the point is drawn out into a bright streak and the length of the luminescent streak in conjunction with the known speed of rotation provides a measure of the duration of the afterglow (*187, 1766, 1884*). The latter arrangement has the advantage that at low frequency of rotation slow decay periods of the order of 1 sec can be observed; this is not possible with phosphoroscopes of the Becquerel type. With high speed of rotation, on the other hand, it is claimed that periods of afterglow of less than 10^{-5} sec can be measured. The device by means of which the shortest decay periods are observed with a mechanical shutter seems to be the one proposed by Vavilov and Levshin: the fluorescence is excited by the light from a spark discharge and the luminous spot is drawn out into a long band by means of a fast-revolving mirror, the spark always being started in the same position of the mirror by a synchronizing apparatus. The limit of the resolving power of this phosphoroscope is claimed to be 10^{-8} sec (*1766*). A resolving power of a microsecond is reached also if a cathode-ray oscillograph is used for analyzing the fluctuating potential of a photoelectric cell which is excited by the luminescence. The primary radiation impinging on the luminescent substance must be interrupted by a rotating disc shutter which is in phase with the alternating voltage applied to the second pair of electrodes in the oscillograph tube. In phosphoroscopes of this type the intensity curve of the exciting radiation is made as nearly rectangular as possible so that the irradiation is nearly constant through a time interval of the order of 5 millisecc. The period of the oscillograph and of the shutter is about ten times as long and thus the complete rise ("induction") and decay of the luminescence are visualized in a single curve, if the luminescence has decayed to zero at the end of every oscillograph period. Otherwise, the emission processes originating from previous excitation processes will overlap in the same way as with other phosphoroscopes (*266, 459e, 1335a, 1432c, 1433*).

An oscillograph phosphoroscope described by Lord and Rees differs from the more usual type in that the exciting radiation has a sinusoidal intensity curve. The light source and the time base of the oscillograph are actuated by the same alternating voltage so that they are synchronized automatically. The intensities of the primary radiation and of the luminescence as functions of time are recorded by

means of the oscillograph and the phase shift between the minima of the two curves is measured (957*a*).

For the measurement of the very shortest decay periods down to 10^{-9} sec so-called fluorimeters are used. They are, in principle, nothing else than modifications of the Becquerel phosphoroscope with practically no inertia. For this purpose the mechanical shutters are replaced by an electric device. Such shutters are either Kerr cells operated by a high-frequency alternating voltage and placed between crossed Nicols or they are systems in which the impinging light beam is diffracted periodically by means of supersonic waves. In contradistinction to the Becquerel phosphoroscope the time interval between

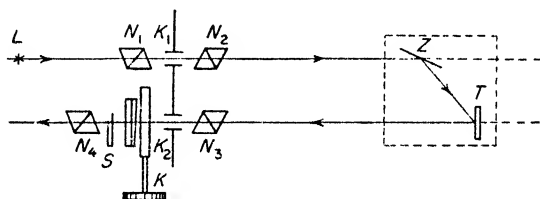

FIG. 3. Kerr-cell fluorimeter [Szymanowski (1623)].

L : light source.	K and S : compensating
K_1 and K_2 : Kerr cells.	arrangement for the
Z : mirror.	measurement of elliptic
$N_1, N_2, N_3,$ and N_4 :	polarization.
Nicols.	T : fluorescent substance.

excitation and observation is not produced by a phase difference between the periods of the first and the second shutter, but by the variation of the distance between the luminescent substance and the two shutters, and thus by the time in which the light traverses this distance. If this time is equal to one-half the period of the shutters, no light is transmitted through the second shutter, unless the luminescence has a duration which is not infinitely short compared to the period of the shutters.

The first fluorimeters which yielded useful results were of the Kerr-cell type. A somewhat improved modification of the original apparatus designed by Gaviola is shown schematically in Figure 3. L is the light source, T the fluorescent substance and K_1 and K_2 the two Kerr cells placed between the two pairs of crossed Nicols $N_1, N_2,$ and $N_3, N_4,$ respectively. Instead of measuring the intensities of the luminescence for variable distances K_1-T-K_2 , the degree of elliptical polarization of the radiation transmitted through the second Kerr

cell is determined. The fluorescent substance T and a diffusely reflecting surface R (not shown in the figure) are mounted on a movable carriage and in every position of the carriage T and R are interchanged. Thus two complete curves of the measured ellipticities can be plotted, one for the instantaneous reflection process and the other for the luminescence process (main curve and fluorescence curve in Figure 4). The value of τ is, in the first approximation, derived directly from the distance between the minima in the two curves. For accurate calculations several corrections must be introduced; the complete theory of the method has been discussed by Duschinsky. According to Szyma-

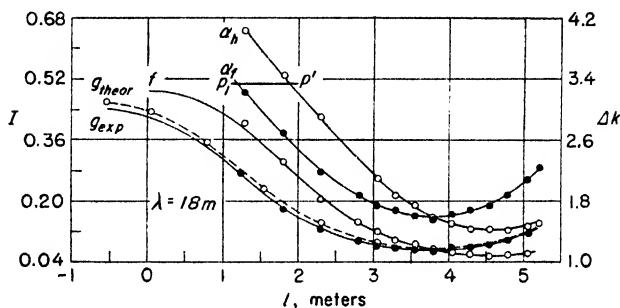

FIG. 4. Curves obtained with the Kerr-cell fluorometer [Szymanowski (1623)].

α_h and α_f : ellipticity of reflected and of fluorescent light as a function of path length.

g_{theor} : calculated according to Duschinsky's theory.

f and g_{exp} : intensities derived from α_h and α_f , respectively.

l : distance K_1-T-K_2 in Fig. 3.

nowski it is possible to measure decay periods as low as 10^{-9} sec with an error of $\pm 0.2 \cdot 10^{-9}$. The theory assumes that the decay is exponential. In principle it should even be possible to verify the validity of this assumption by analyzing the shape of the curves of Figure 4 (328, 460b, 1622-1625).

In some instances the fluorescence radiation is partially plane polarized if it is excited by plane-polarized light; this is always the case in Kerr-cell fluorometers. Under these conditions different values of τ are obtained according to whether the Nicols N_2 and N_3 are crossed or parallel, both positions being admissible. A partial or even total depolarization of the fluorescence light is caused by the Brownian rotation of the luminescent molecules during their decay period. Hence the measurements average different portions of the decay curve with crossed or with parallel Nicols N_2 and N_3 . The genuine average

is obtained if the planes of polarization of N_2 and N_3 form an angle of 54.72° . The validity of this consideration has been checked experimentally (669,676,771).

In supersonic-cell fluorimeters a single cell serves for both shutters: it is traversed by the exciting radiation and by the fluorescence light in two directions perpendicular to each other, as shown in Figure 5. The supersonic waves are produced by means of high-frequency oscillating voltages in a solid quartz block to which the electrodes are directly applied, or in a vessel filled with a liquid. In the latter case the oscillations are generated by means of a thin quartz plate which is in contact with the liquid. Either arrangement has its advantage. The liquid cells require very little energy and low voltage, while a peak voltage of several thousand volts is needed for the quartz

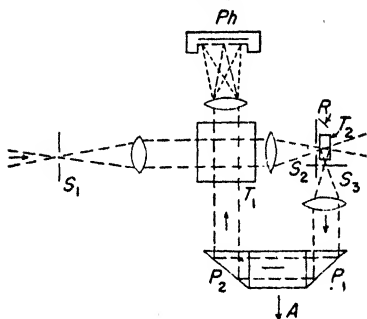

FIG. 5. Supersonic fluorimeter (Maercks).

- Light source to the left
- T_1 : supersonic cell as shutter.
- P_1 and P_2 : totally reflecting prisms, mounted on carriage movable in direction A .
- T_2 : fluorescent solution, exchangeable with reflecting surface R .
- Ph : differential photometer cell.
- S_1 - S_3 : slits.

block. On the other hand, it is much more difficult to obtain exactly plane parallel wave trains in a liquid than in a good crystal. At the moment when the amplitude of the standing wave passes through zero, light beams traversing the cell are not deflected; when the amplitude of the supersonic wave reaches its maximum a large part of the light is diffracted into the spectra of the first order. With good adjustment the modulation is almost complete. In the main these fluorimeters are operated in the same way as the Kerr-cell instruments, with the exception that the light intensities must be measured photometrically. Maercks uses for this purpose a differential photoelectric cell in which the intensities of the directly transmitted and of the diffracted light beams are compared, thus eliminating the influence of intensity fluctuations of the primary light source (168,780,970,1708).

Kerr-cells filled with nitrobenzene do not transmit the violet and u.v. Besides, they are rapidly heated by the great energy input of about 100 watts so that the measurements must be interrupted after a short time. On the other hand, the exact theoretical treatment has not yet been worked out for the supersonic shutters, because the "time

function" which determines the transmitted energy during a full oscillation period as a function of the time is not known. In the first approximation it has been supposed to be sinusoidal, but the deviations may be rather large.

Both instruments have the property in common that with the shutter frequencies of 10^7 which are needed for the measurement of short decay times, the paths over which the fluorescent substance must be moved in order to obtain a complete curve, as in Figure 4, are of the order of five meters. Thus the whole arrangement is rather cumbersome. Kirchhoff has overcome this drawback by a device which is somewhat complicated and seems to reduce the accuracy of the measurements.

8. Measurement of the Intensity and of the Degree of Polarization.

Any photometer can be used for the measurement of the intensity of fluorescence. It is true that a number of photometers are advertised as fluorometers or fluorimeters (for better distinction the name "fluoro-photometer" would be preferable), but they have no features by which they differ from similar instruments constructed for other purposes. Visual photometers, photographic methods, or photoelectric cells, both of the emission and the barrier-layer type, are in general use. For the measurement of weak intensities Geiger-Mueller counters or "photo-multipliers" can replace the photocells. A visual photometer for the very small intensities which occur frequently in the investigation of fluorescence has been designed by Vavilov. In this apparatus the fluorescence radiation and the comparison light are weakened by means of a neutral wedge to the threshold value of the dark adapted eye (183).

As in all photometric work, it is of the greatest importance that any variations in the intensity of the primary light source are automatically compensated for and, therefore, it is advisable to use as comparison light the radiation of a fluorescent substance which is excited by the same primary source. The human eye and all photoelectric cells and photographic plates are characterized by a more or less selective response to light of different wavelengths. Therefore they cannot be used for comparing radiation of different color or different wavelength if the spectral distribution of their sensitivity is not known. The fact that the fluorescence yield of many fluorescent compounds is independent of the wavelength of the exciting light over a wide spectral range can be used for heterochromatic photometry. E. J. Bowen recommends as "integrating screens" mosaics made of uranyl sulfate or of cells filled with an esculin solution. Radiation,

the intensity of which is to be determined, excites the fluorescence of an integrating screen which covers the entrance window of a photoelectric cell and thus stimulates a current in the cell proportional to the unknown intensity (Figure 6) (140).

Photoelectric cells are particularly suitable if the total amount of light which is stored in a phosphor after the end of the excitation is to be determined. This "light sum" is proportional to the electric charge

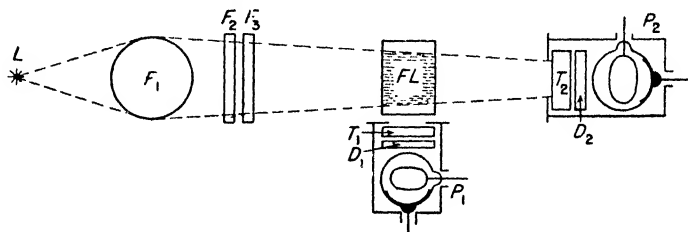

FIG. 6. Heterochromatic photometer (Bowen).

F_1 , F_2 , F_3 , D_1 , and D_2 : light filters. T_1 and T_2 : integrating fluorescent screens.
 P_1 and P_2 : photoelectric cells. FL : fluorescent solution.

produced in the photoelectric cell, which is connected to an electrometer and a capacitance of known capacity. A light counter operating a mechanical counting device (telephone counter) is even more useful for the same purpose. Complete decay curves covering long periods of time are obtained with a photo-multiplier tube connected through an amplifier with a recording galvanometer. The curve can be followed over a very wide range of intensities, if the amplification can be altered by known steps every time the galvanometer deflection has reached a certain low value (733,837*a*,1293).

The degree of polarization of fluorescence radiation is frequently of great importance. For partially plane-polarized light the degree of polarization is defined by the equation:

$$p = \frac{(I' - I'')}{(I' + I'')} \quad (12a)$$

I' and I'' are the maximum and the minimum intensities of the fluorescence if it is observed through a Nicol which is gradually rotated around its axis. The azimuths of maximum and minimum intensity are often known a priori, otherwise the preferential orientation of the electric vector has to be determined in order to obtain the real degree of polarization. The relation between the degree of polarization p and the degree of depolarization:

$$\rho = I''/I' \quad (12b)$$

is determined by the equations:

$$\rho = (1-p)/(1+p); \quad p = (1-\rho)/(1+\rho) \quad (12c)$$

Sometimes the "apparent" degree of polarization p_z is obtained experimentally instead of p :

$$p_z = \frac{(I_z - I_x)}{(I_z + I_x)} \quad (12d)$$

where I_z and I_x are the intensities of the components with electric vectors parallel to two directions Z and X which are perpendicular to each other (as a rule, the vertical and the horizontal). p_z can be zero even if p is equal to 100% if the radiation is plane polarized parallel to a direction forming an angle of 45° with Z and X . In the following the term "light polarized parallel to a direction" is always used in the sense that the electric vector of the radiation is parallel to this direction; "light partially polarized parallel to a direction" means that the electric vector has its greatest amplitude in this direction.

In general, one of the following methods is used for the determination of the degree of polarization. Either a double image of the luminescent light source is produced by means of a Wollaston prism and an analyzing Nicol adjusted to the angle at which the brightnesses of the two images become equal; or the partial polarization of the radiation is made visible by the interference fringes produced in a quartz-wedge combination (Savart plate, etc.) and the fringes are made to disappear by means of a compensating set of glass plates; or the radiation enters a photoelectric cell through a polarizing prism and its intensity is measured for various azimuthal orientations of the prism. The quartz-wedge method is particularly suitable for visual measurements; the "Cornu method", or double-image method with photographic registration, and the photoelectric method, serve mainly for the u.v. (466).

9. Light Filters and Light Sources. Colored screens, monochromators and spectrographs of usual types serve for the spectral resolution of the exciting radiation as well as of the luminescence light. Colored glasses of many shades are provided by several manufacturers (Corning, Schott, and others) and gelatin filters stained with organic dyes are also available (Kodak, Wratten). By a combination of such screens almost any spectral region can be isolated, though, in general, with great loss of luminosity. "Black" glass, stained with nickel oxide, is almost completely opaque for all visible light except the

extreme red,* while its absorption coefficient is small between 4000 and 3000Å. The transparency reaches its maximum value of about 80% at 3500Å. Special glasses of this kind are even transparent as far as 2300Å, but they are not quite so opaque for the violet part of the spectrum.

Some other filters which have proved useful for isolating spectral regions in the u.v. may be mentioned. A solution of 1.75 molar nickel sulfate and 0.5 molar cobalt sulfate in distilled water contained in a quartz cuvette of 3 cm thickness, absorbs all light of wavelengths greater than 3500Å, but transmits 73 % of 3130Å, 80 % of 2600Å, and almost as much of 2300Å. Similarly a quartz cell filled with bromine vapor completely cuts off all light from the yellow down to 3500Å and chlorine vapor at saturation pressure at room temperature is opaque between 4400 and 2650Å; both freely transmit the Hg-line 2537Å. On the other hand, the short wavelength radiation is absorbed by an aqueous solution of potassium nitrate from 4000Å downward, by a solution of potassium phthalate from 3000Å downward, and by a thiophene solution from 2500Å downward. The Hg-lines 3132Å and 2537Å, respectively, are still well transmitted by the two latter solutions. The Hg-line 1849Å, which is transmitted through good crystalline quartz and moderate distances of atmospheric air, is completely absorbed by distilled water, while the Hg-line 1940Å is transmitted. Adding acetic acid dropwise to distilled water shifts the limit of transparency continuously from 1940 to 2400Å.

Occasionally closely adjacent components of almost monochromatic radiation are to be separated without the use of a spectrograph and the corresponding loss of intensity. R. W. Wood has devised the following setup for the separation of the sodium D-lines (Figure 7). The radiation containing both D lines ($\Delta\lambda = 6\text{Å}$), which has been polarized by means of a first Nicol P_1 , is passed through a crystalline quartz plate Q . The optical axis of the crystal lies in the plane of the plate and forms an angle of 45° with the electric vector of the incident radiation. The thickness of the plate, about 32 mm, is determined so that after leaving the plate the ordinary and the extraordinary rays

* In order to eliminate this long wavelength radiation, which is often disturbing for visual observation, a cell containing a copper sulfate solution is frequently inserted in the path of the exciting light. However, it should not be overlooked that if this filter is sufficiently concentrated to eliminate the red completely, the near ultraviolet is also appreciably weakened. If the luminescence is not red itself, it is therefore better to insert the filter in the path of the secondary radiation. For the absorption of infrared radiation a cell filled with distilled water suffices to protect the luminescent substance against heat.

have a phase difference which is larger by $\frac{1}{2}\lambda$ for D_2 than it is for D_1 . A second Nicol P_2 of suitable orientation transmits only one of the two lines (470, 1879).

For the partial isolation of components of the hyperfine structure of the Hg-line 2537A, which have an even closer spacing ($\Delta\lambda \sim 10^{-2}\text{\AA}$), Mrozowski uses a polarizing prism and an absorption cell filled with mercury vapor which is placed in a magnetic field. If the strength of the magnetic field has a certain value, the absorption lines of the hyperfine structure are shifted so much that they absorb some of the components of the incident radiation while transmitting some of the others (1067).

Frequently, and especially if the exciting light is strongly scattered by the luminescent substance, it is advantageous to use the

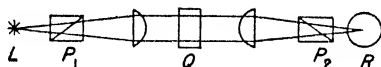

FIG. 7. Wood's method for the separation of the D-lines.

L : light source. P_1, P_2 : Nicols.
 Q : quartz plate. R : resonance lamp.

method of "crossed" or complementary filters. The first filter transmits only those parts of the primary radiation which serve for the excitation of the luminescence; the second filter is placed between the luminescent substance and the eye of the observer and transmits the luminescence light, while it is opaque for the exciting radiation. (For instance, in Figure 6, the filters D_1 and D_2 are complementary to the filter combination F_1, F_2, F_3 .) This device, which has already been used by Stokes can, of course, be applied only if the spectral region of the exciting light does not completely overlap that of the emission band. If this condition is fulfilled, it becomes possible to observe the fluorescence, during the excitation, in the direction of the primary radiation, a procedure which is often convenient, and, in certain cases, of especial interest. If the first filter is a "black glass" transmitting only u. v., the second filter can be dispensed with (594).

More detailed information concerning the specific action of exciting light of different wavelengths (the so-called "excitation spectrum") is provided by the method of "crossed spectra," which also has already been employed by Stokes (1585). The real image of a continuous spectrum is formed on the luminescent surface; only certain parts of this spectrum excite luminescence. A second "ana-

lyzing" spectrograph, with its slit perpendicular to the slit of the first spectroscope, deviates the light belonging to the primary spectrum as well as the luminescence light and thus permits the determination of the regions of the primary spectrum by which the various parts of the fluorescence spectrum have been excited. The method has also been applied, with slight modifications, to the investigation of the volume fluorescence of vapors. Furthermore, the method can be applied to the determination of the "excitation spectrum" of a slowly decaying phosphorescence: when the primary radiation is interrupted, the phosphorescent surface remains luminescent only where the spectrum of primary radiation has been able to excite phosphorescence (*F, 1631*).

Sources of light with a continuous spectrum are the sun, the carbon arc, tungsten filament lamps, and electric discharges in hydrogen gas of about 1 mm pressure. The choice is frequently influenced by the spectral region required for a specific experiment; thus the hydrogen discharge alone provides a continuum below 2500Å. The light source is of particular importance if the resonance radiation of a gas or vapor is to be investigated. Since the absorption lines are extremely narrow in this case, the primary radiation must have a high intensity at the center of the lines and these must be free of self-reversal. Spark discharges or high pressure arcs are therefore quite inadequate. In the earlier stages of this kind of research, sodium chloride flames and mercury arcs of the Hanau type were almost exclusively used. In order to keep the vapor pressure at a low value, the mercury lamps, or at least their electrodes, were cooled by running water, following a suggestion by Kerschbaum (767). Furthermore, the arc was pressed close to one of the walls of the tube by a magnetic field so that the reabsorption of the lines by a layer of nonluminous vapor was minimized (1867). At present these lamps have been almost completely supplanted by hot cathode discharge lamps containing argon or neon with an admixture of a small quantity of a metal; by the heat generated by the discharge the metal is evaporated and becomes the carrier of the light emission. By a suitable choice of voltage and current density, 90 % of the total radiation of such mercury lamps can be concentrated in the line 2537Å, practically without self-reversal. Sodium, cadmium, zinc, thallium, and magnesium lamps of this type are also available.

For further suppression of line reversal, Cario and Lochte-Holtgreven have constructed a metal-vapor lamp in which the hot metal vapor is prevented from distilling out of the high-temperature discharge chamber by a continuously circulating stream of a rare gas. Simultaneously this gas stream protects the window of the lamp,

which must be kept at a low temperature, against corrosion by the vapor or deposit of solid metal (204).

If it is important for an investigation that the width of the line in the primary radiation be narrow and absolutely constant, a "resonance lamp" is used as light source. This is a highly evacuated tube containing the vapor of the metal in question and kept at a well-defined temperature. The resonance lamp is excited to emit its characteristic radiation by one of the light sources which have been described above.

10. Containers. The fluorescence of gases and vapors is investigated, in general in carefully cleaned and highly evacuated glass or quartz vessels. If pressure and temperature of a vapor have to be varied independently, a side tube is attached to the observation chamber and both are heated by separate electric ovens. The side tube must always be kept at the lower temperature in order to regulate the vapor pressure. Many metal vapors attack the glass at high temperatures; for some metals, e.g. sodium, special resisting glasses have been developed. If such glasses are not available, metal vessels with sealed-on water-cooled windows can be used occasionally. However, they are not suitable for precision measurements, partly because of the bad definition of the vapor pressure in a volume of varying temperature, partly because of the unavoidable impurities which are released by the hot metal walls.

For special purposes a molecular beam which is projected from an oven through a narrow diaphragm into the observation chamber is excited to fluorescence. This method has proved useful, for instance, in the excitation of the resonance radiation of lithium vapor, which is extremely corrosive for almost all materials. Other applications of the method are mentioned in Sections 20, 22, and 23 (323).

The fluorescence of liquids is observed in cuvettes with plane windows for the admission of the exciting light. In order to avoid scattering of the primary radiation in the direction of observation by multiple reflection, the vessels containing a fluorescent gas or liquid frequently have the horn-like shape which Strutt (Lord Rayleigh) used for the investigation of molecular light scattering (Figure 8a).

The mode of illuminating a fluorescent gas or liquid depends on the problem under investigation. If the luminescence is weak and the highest possible intensity must be obtained for spectrographic research, a tubular mercury lamp is placed side by side with the horn-shaped tube, both are surrounded by a cylindrical reflector, and an image of the luminescent volume is formed on the slit of a spectrograph

which is screened from direct lamp radiation by a suitable set of diaphragms (Figure 8*b*).

If, on the other hand, specific properties of the fluorescence are to be determined, as, for instance, its angular intensity distribution or its polarization, the exciting light must enter the luminescent medium

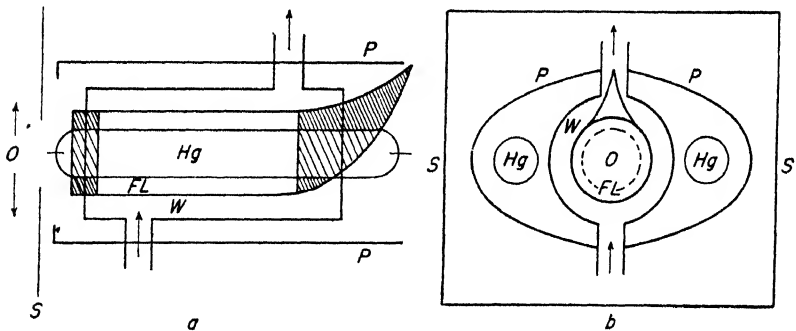

FIG. 8. Wood's device for high intensity excitation of fluorescence.

FL: container of fluorescent solution with hornshaped end ("Rayleigh horn").

W: concentric tube for filter and cooling liquids.

Hg: mercury arc lamps.

P: elliptical cylindrical aluminum reflectors.

S: screen with circular diaphragm *O*.

as a parallel beam produced by a suitable lens system from a point source of light.

With the exception of glasses, photoluminescent solids are seldom available in large transparent pieces. In most cases they form microcrystalline powders. For the investigation of the emission by a single microcrystal, the fluorescence must be observed under a microscope. In general, the powder is spread out on a porcelain dish or a glass or metal plate, and frequently it is fastened to the support by means of a binder. Sometimes it is advisable to keep the luminescent screen in an evacuated chamber in order to avoid photochemical reactions with the surrounding gas.

PART I
Fluorescence of Gases and Vapors

CHAPTER I

MONATOMIC GASES AND VAPORS

A. Nomenclature of Series Spectra

II. Quantum Numbers. Only the most loosely bound electrons of an atom participate in the optical absorption and emission processes. For practically all spectra which are treated in this chapter, a single electron acts as "emission electron" ("Leuchtelectron" in Sommerfeld's terminology). The energy contributed by an individual electron to the total internal energy of an atom is determined by 5 quantum numbers $n, l, f, j,$ and m . In Bohr's original atomic model, the "principal quantum number" n defines the length of the major axis of the elliptical orbit on which the electrons move around the positive nucleus. The values of n are 1, 2, 3, 4 . . . The secondary quantum number l measures the orbital angular momentum of the electron in units of $h/2\pi$ and can be equal to any integral number between 0 and $n-1$. If an atom contains several electrons outside its outermost closed electron shell, the secondary quantum number of the atom L is obtained by vectorial addition of the l values of the individual electrons.* For all spectra occurring in this chapter, l differs from zero only for the emission electron; hence L is always equal to l . (The total contribution of all electrons in the inner shells toward L is zero.)

Every individual electron has a spin quantum number $s = 1/2$; vectorial addition of these individual spin values yields the total electronic spin of the atom S , so that $S = 1/2$ for one outer electron, $S = 0$ or $S = 1$ for two electrons, $S = 1/2$ or $S = 3/2$ for three electrons, etc.

By vectorial addition of l and s or L and S , respectively, the "inner" quantum number j of the individual electron or J of the atom (measuring the resultant electronic angular momentum) is obtained

$$|L-S| \leq J \leq L+S \quad (13)$$

There are, in general, $(2S + 1)$ different values of J for $L > S$ and $(2L + 1)$ values of J for $L < S$.

* This so-called Russell-Saunders coupling prevails for all spectra which are considered in the following sections.

f is the "hyperfine structure" quantum number. It is the vectorial sum of J , as defined above, and of i , the momentum of the nuclear spin, and corresponds to the total angular momentum of the atom. For elements of even atomic number, i is, with very few exceptions, equal to zero; but for "odd elements," $i = 1/2, 3/2, \text{etc.}$, according to the number and nature of the elementary particles (protons and neutrons) constituting the nucleus. Thus:

$$|J-i| < f < J + i \quad (14)$$

and there are $(2i + 1)$ different values of f , if $J > i$ and $(2J + 1)$ values if $J < i$.

Finally, the "magnetic quantum number" m determines the angular momentum which is produced by the precession movement of an atom revolving around the lines of force of a magnetic field and therefore m determines the orientation of the atom in space. Since:

$$-f < m \leq f \quad (15)$$

there are always $(2f + 1)$ values of m . For even elements with no nuclear spin, f is equal to J and, therefore:

$$-J \leq m \leq J \quad (15a)$$

with $(2J + 1)$ different values of m . Relation (15a) replaces (15) quite generally, even for atoms with $i > 0$, if the applied magnetic field is so strong that its influence prevails over the influence of the magnetic field produced by the nuclear spin ("Paschen-Back effect" of the hyperfine structure).

12. Energy Terms. The major part of the energy characterizing an atom in a specific state (n, L, J, f, m) is determined by the value of n . An energy level corresponding to a given value of n splits into several sublevels originating from the fact that the other quantum numbers can contribute an additional energy. These additional energies decrease, in general, in the order in which the quantum numbers are enumerated above. The magnetic quantum number causes the splitting of an energy level into various "Zeeman levels" only if an external magnetic (or electric) field acts on the atom. In the absence of such fields, the atom is "degenerate" with respect to spatial quantization. However, although the sublevels corresponding to various possible values of the quantum number m coincide energetically, their multiplicity determines the statistical weight of the state.

The energy differences between the sublevels corresponding to the hyperfine structure are so small in many cases that they need not

be considered for most spectroscopic research work. Therefore, the first three quantum numbers are sufficient, in general, for the construction of the energy term scheme of an element. Each term is characterized by a symbol of the form: n^rS_J , n^rP_J , etc. n and J have the meanings explained in the preceding section and r indicates the multiplicity of the term, i.e., the greatest number of values which J can assume according to Equation (13). Instead of stating the quantum number L explicitly, the symbols S^* , P , D , F , etc., are used for $L = 0, 1, 2, 3$, etc. Thus the various terms are denoted as 1S -terms (singlet S -terms), 3P -terms (triplet P -terms), etc. J has only a single possible value in a singlet term, it has two possible values in a doublet term, etc. According to the definition, J is an integer number ($J = 0, 1, 2, 3 \dots$) for odd values of r (singlets, triplets, etc.) and a half-number ($J = 1/2, 3/2, 5/2 \dots$) for even values of r (doublets, quartets, etc.). L being equal to zero for S -terms, these are always single, even if they belong to a doublet or triplet system, since for $L < S$ the multiplicity is: $2L + 1$.

The monovalent elements in the first column of the periodic system have only doublet terms, those in the second column, with two external electrons, have singlet and triplet terms, those in the third column have doublet and quartet terms, etc.

Since the principal quantum number n must always be larger than L , only the series of S -terms begins with $n = 1$, the P -series begins with $n = 2$, and the D -series with $n = 3$. At first it was usual to designate the lowest state of an atom, if it was an S -state, by the symbol $1S$, and the following states were then called $2P$, $2S$, $3D$, etc. Similarly, the ground state was called $2P$ if it corresponded to a P -term. In more recent papers on spectroscopy, however, the correct notation is used exclusively and the principal quantum number n of the emission electron in the ground state is determined by the number of electrons that are contained in the interior shells. Only the ground state of the hydrogen atom and of the helium atom is called $1S$, the ground state of lithium is $2S$, and that of sodium $3S$. In Table 1, the two modes of designations are collected for all elements dealt with in this book; it may serve for comparing earlier publications with more modern papers.

Instead of the energy-level diagrams of Figure 1, diagrams like those of Figure 13, 15a, 17 (so-called Grotrian diagrams) are used for representing the complete set of terms of an atom. The series of terms

* The generally accepted use of the same symbol S for the total electronic spin and for terms with $L = 0$ can never be misleading.

TABLE 1
 MAIN QUANTUM NUMBERS FOR THE LOWEST *S*-, *P*- AND *D*-TERMS
 OF ALL ATOMS FLUORESCING IN THE GASEOUS STATE

Old designation	1S 2P 3D			1S 2P 3D			1S 2P 3D			2P 3S 3D						
Correct designation	Li	2S	2P	3D	He	1S	2P	3D	Ca	4S	4P	4D	In	5P	6S	5D
	Na	3S	3P	3D	Ne	2S	2P	3D	Zn	4S	4P	4D	Tl	6P	7S	6D
	K	4S	4P	4D	A	3S	3P	3D	Cd	5S	5P	5D	Pb	6P	7S	6D
	Cu	4S	4P	4D	H	1S	2P	3D	Hg	6S	6P	6D				
	Ag	5S	5P	5D												
	Rb	5S	5P	5D												
	Cs	6S	6P	6D												

for which n increases, while L and J are kept constant, are plotted in a vertical column as short horizontal lines; the various columns for different values of J and L are plotted side by side. The vertical distances between the individual short lines are again proportional to the energy differences between the terms, measured in eV or cm^{-1} .

13. Series Lines. A spectral line is determined by two terms, for instance, 3^1S_0 and 5^1P_1 . If only the frequency of the line is to be stated, it is given by the difference $5^1P_1 - 3^1S_0$; if the direction of the transition is to be made clear, the dash is replaced by an arrow. According to the footnote on page 4, $n''P \rightarrow n'S$ represents an emission process and $n''P \leftarrow n'S$ represents an absorption process.

For deriving the lines which actually occur in the spectrum of an atom, knowledge of the terms does not suffice: it must be supplemented by knowledge of the "selection rules." Only transitions are "allowed" for which:

$$\Delta n = 0, 1, 2, 3 \dots, \text{ and simultaneously:}$$

$$\Delta L = \pm 1 \text{ and } \Delta J = 0 \text{ or } \pm 1.$$

The selection rules for the hyperfine-structure quantum numbers and for the magnetic quantum numbers are:

$$\Delta j = 0 \text{ or } \pm 1 \text{ and } \Delta m = 0 \text{ or } \pm 1.$$

Only if $J = 0$, transitions with $\Delta J = 0$ are forbidden; under these conditions, $\Delta J = +1$ is the only allowed transition. This is particularly important because of the resulting metastability of the 6^3P_0 -state of mercury and of the corresponding states of other elements. $\Delta m = 0$ is forbidden for the magnetic quantum number if $\Delta J = 0$ for the line under consideration, as, for instance, for a $3^1P_1 - 3^1S_1$ transition. It has already been mentioned in the introduction that forbidden transitions

do actually occur, though with very small probability. (The transition $\Delta J = 0$ for $J = 0$ practically does not occur at all.)

It follows from the selection rule $\Delta L = \pm 1$ that the only allowed transitions from an S -term are those to a P -term, from a P - to an S - or a D -term, and, generally, from one vertical column in a Grotrian diagram to the neighboring columns, if terms which differ only by their J -values are classified as belonging to the same column.

[This simple formulation of the selection rule for ΔL suffices for all atomic spectra if l differs from zero for only one electron outside of the completely closed shells (for instance, the spectra of Na, Hg, Tl and other elements of the first three columns of the periodic system, and also for the spectra of the rare gases). If several electrons have l -values greater than zero for instance, if an atom contains two or more p -electrons (with $l = 1$) one must apply the more general quantum-mechanical law according to which only transitions between "even" and "odd" states are allowed. A state is even when the algebraic sum Σl is even, and the state is odd when this sum is odd, odd states being characterized by a superscript $^{\circ}$ as in $^3P_1^{\circ}$, in contrast to an even state 3P_1 . The atom of lead has two $6p$ electrons in its even ground state 3P_J ; if one of these electrons is raised to the level $7s$, an excited odd $^3P_J^{\circ}$ state is formed. Transitions between these two 3P -triplet states are allowed if they agree with the selection rules for ΔJ . The fluorescence spectrum of lead vapor (Figure 10) provides the only instance mentioned in this chapter for a transition of this kind.]

If a term combines successively with all terms of a neighboring column in the Grotrian diagram so that the L -value of the latter is kept constant while the n -values vary, a "series" of lines is obtained, as, for instance, the series $6P-6S$, $7P-6S$, $8P-6S$, etc. If, on the other hand, all quantum numbers with the exception of J are kept constant in the initial and the final-state, while all possible values are assigned successively to J in both states, the resulting lines form a multiplet, as, for instance, $6^3D_{1,2,3}-6^3P_{0,1,2}$.

"Intercombination transitions," as, for instance, those from a triplet state to a singlet state, have small probabilities, in general. They are strictly forbidden in the spectra of the lightest elements, but become more probable with increasing atomic number of the elements. In the spectrum of mercury the intercombination resonance line $^3P_1-^1S_0$ is relatively strong, the analogous lines in the spectra of Cd and Zn are much weaker, and, in the spectrum of helium, intercombination lines between the triplet and singlet systems (ortho and parhelium spectrum) do not occur at all. Simultaneously, the sepa-

ration of the individual triplet terms becomes smaller as compared with their mean distance from the corresponding singlet term.

The series originating from the transitions $P-S$ (S being the ground state of the atom) are called the principal series, those corresponding to transitions $D-P$ are the *diffuse*, and those corresponding to the transitions $S-P$ are the *sharp* secondary series.

At moderate temperatures, at which practically all atoms are in the ground state, only the principal series or the two secondary series appear in the absorption spectrum, if the ground state is characterized by an S - or a P -term, respectively.

Each series of terms converges towards an upper limit corresponding to the energy needed for the ionization of the atom in a given initial state. In the same way, every absorption series converges towards a short wavelength limit, beyond which a region of continuous absorption begins. Absorption of light in this continuous region leads to the photoelectric ionization of the atom.

B. Fluorescence Lines

14. Resonance Lines. Pure resonance radiation, as exclusive re-emission of absorbed monochromatic light, occurs only if there is no other possible spontaneous transition from an excited state than the return to the ground state. Therefore, the ground state must be single, a condition always fulfilled if the ground state is a S -state. This is the case for all metals of the first and second columns of the periodic system. It is not necessary, on the other hand, that no other levels exist between the excited and the ground states, as long as spontaneous transitions of the electron into any existing intermediate levels are forbidden by the selection rules. Excited states of this type are characterized for the alkali metals by the term symbols $P_{1/2}$ and $P_{3/2}$, and for the metals of the second column of the periodic system by 1P_1 and $^3P_{0,1,2}$; transitions $^2P_{3/2} \rightarrow ^2P_{1/2}$, $^1P_1 \rightarrow ^3P_{0,1,2}$ or $^3P_1 \rightarrow ^3P_0$ are forbidden (compare Figures 13 and 15). It follows that an atom can have more than one genuine resonance line. Thus, either of the D -lines of sodium is a resonance line; if the primary radiation contains in its spectrum only one of these lines, and if the vapor pressure is sufficiently low so that no collisions occur during the lifetime of the excited state, only this component of the doublet is re-emitted by the vapor (1895). Resonance emission of the first doublet of the principal series has also been observed in the vapors of lithium (6708A, without

resolution of the two components which are separated by a distance of only $\frac{1}{4}\text{A}$), as well as in the vapors of potassium (7699 and 7645A) and of silver (3382 and 3280A) (127,1133). (Compare Section 94 concerning the excitation of resonance radiation of copper.)

The two resonance lines corresponding to the transitions $^3P_1 \rightarrow ^1S_0$ and $^1P_1 \rightarrow ^1S_0$, which have been observed in the vapors of several metals of the second column of the periodic system, are collected in Table 2. The mercury line 1849A coincides with the first strong

TABLE 2
 RESONANCE LINES OF METALS BELONGING TO THE SECOND COLUMN OF
 THE PERIODIC SYSTEM
 (Wavelength in A)

"	Hg 6	Cd 5	Zn 4	Ca 4
$n^3P_1 - n^1S_0$	2537	3261	3076	6537
$n^1P_1 - n^1S_0$	1849	2288	2139	4227

absorption bands of O_2 ; therefore, it is observed only if the primary and the secondary radiation do not have to pass through more than a few centimeters of atmospheric air. Resonance excitation of this line so far, has been treated only in one paper (1395). On the other hand, the intensities of the long-wavelength resonance lines of Cd, and even more of Zn, are rather weak because of the small transition probabilities (111-113, 1251, 1524, 1531, 1540).

While the metals enumerated above are the only ones in whose vapors resonance radiation has actually been observed, there is no doubt that the other elements of the first columns of the periodic system would behave the same way under adequate conditions. The experimental difficulties are caused either by the high temperatures needed for the production of sufficient vapor pressure (as in the case of gold or barium and strontium), or by the fact that the resonance lines are situated in the far u.v., which is accessible only to vacuum spectroscopy (as in the case of the rare gases or

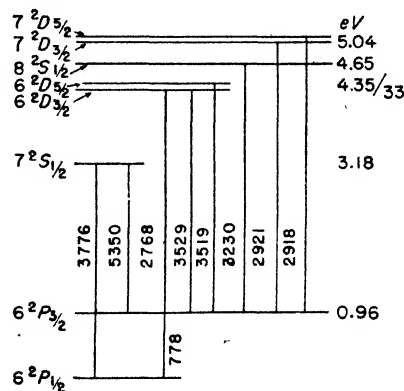

FIG. 9. Level diagram for the fluorescence of Tl [Mueller (1084)].

atomic hydrogen).

15. Multiple Ground States. If the ground state of an element is a doublet state, resonance radiation, in the strict sense of the word, cannot occur. A typical example is provided by thallium. The lowest energy level of the thallium atom is characterized by the symbol $6^2P_{1/2}$. By absorption of the lines 3776 and 2768A, the atom is raised into the states $7^2S_{1/2}$ and $6^2D_{3/2}$, respectively (Figure 9). Transitions between these two levels are forbidden, but transitions from either are possible to $6^2P_{3/2}$ as well as to $6^2P_{1/2}$. Therefore, the lines 5350 or 3529A, respectively, appear simultaneously with the exciting lines in

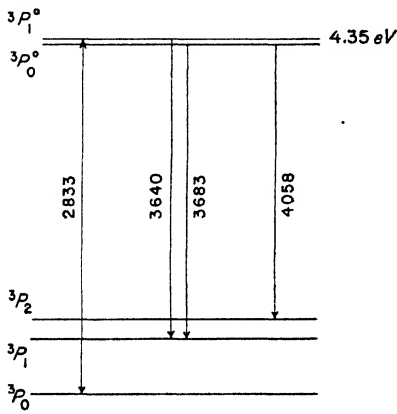

FIG. 10. Level diagram for the fluorescence of Pb (Winans).

the fluorescence spectrum. At high temperatures some atoms are in the state $6^2P_{3/2}$, when thermal equilibrium is established, though the relative concentration is low (about 10^{-4} at 800°C) because of the large energy difference of 0.96 eV between the two doublet P -levels. Nevertheless, the fluorescence emission of the lines 5350 and 3776A can be excited under these conditions by irradiating Tl-vapor with the green thallium line as well as with the ultraviolet line 3776A. In either case, the absorbing atoms are raised to the level $7^2S_{1/2}$ while the initial state is $6^2P_{3/2}$ or $6^2P_{1/2}$. The relative intensities of the two emission lines are, as might be expected, independent of whether the vapor is excited by the green or the u.v. line. At temperatures below 500°C , irradiation with the green line is practically ineffective in producing any fluorescence, as has been shown by Terenin (1631).

The term system of indium is strictly analogous to that of thallium (Figure 53). The resonance radiation of indium has never been investigated in laboratory experiments. However, the great intensity of the indium line, 4511A ($6^2S_{1/2}-5^2P_{3/2}$), in the spectra of certain variable stars has been interpreted by Thackeray as being caused by resonance excitation: the hydrogen line H_γ (4101.735A) coincides almost exactly with the indium absorption line, 4101.7A ($6^2S_{1/2}-5^2P_{1/2}$), and the Balmer lines of hydrogen are always very strong in the spectra of these stars (1650).

Results similar to those obtained with thallium vapor were found

by Terenin for the vapors of lead, bismuth, and antimony; the term schemes of these metals were then not completely analyzed and the investigation of their fluorescence made it possible to decide which lines were able to excite luminescence and were therefore absorption lines of the atoms in the ground state, and which lines occurred simultaneously in the fluorescence spectra and were therefore emitted from the same excited level. By means of the method of "crossed spectra" all these problems could be solved in a single experiment. The absorption and emission lines found by Terenin in this way are shown in Figures 9-12 (1631).

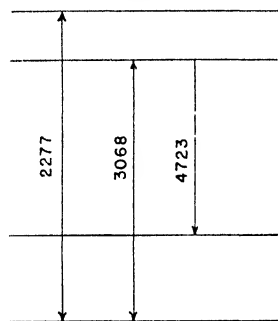

FIG. 11. Level diagram for the fluorescence of Bi (Terenin).

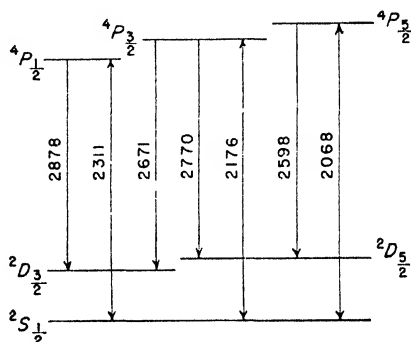

FIG. 12. Level diagram for the fluorescence of Sb (Terenin).

Furthermore, Terenin observed the As-lines 2288 and 2381 A, when As-vapor was irradiated with the full radiation of an As-arc; however, he was not able to determine the wavelength of the light which was responsible for the excitation. Finally, re-emission of atomic Mn-lines was observed, when manganese vapor was illuminated with the light from a manganese spark (437). The fluorescence spectrum consisted of two narrow triplets at 4032 and 2798A; the former could even be resolved into its components (4030.76, 4033.07, 4034.49A). According to Catalan, these triplets are caused by the transitions $3P_{0,1,2} \rightarrow 1S_0$ and $3P'_{0,1,2} \rightarrow 1S_0$ (437). However, the exciting lines emitted by the Mn-spark were probably self-reversed, and since the same fluorescence could be produced by the radiation from sparks between copper, zinc, or chromium electrodes, it must be assumed that in this, as perhaps also in some of the other cases mentioned above, the fluorescence was not due to a direct excitation of the atoms but to excitation of diatomic molecules with subsequent emission of atomic lines (compare Section 69).

16. Excitation by Absorption of Lines Leading to Higher Energy States.

It has been assumed, so far, that the vapors were excited by absorption of the first line of their absorption series. If other lines of this series are used for the excitation, a number of energy levels must exist between the excited and the ground states, so that the "emission electron" need not return to the ground state by the same way by which it reached the excited state; the return can be achieved in

several steps, and consequently several new lines may be observed in the emission spectrum. This phenomenon has been investigated most thoroughly in cesium vapor by Boeckner. The Cs-line 3889A, corresponding to the transition $8^2P_{1/2} \leftarrow 6^2S_{1/2}$, coincides so closely with a strong line of the helium spectrum that this transition can be stimulated by irradiating cesium vapor with the light from a helium discharge tube. Apart from the re-emission of the same line, a number of other lines are obtained under these conditions in the fluorescence spectrum of the vapor. These lines, among which the resonance line is to be found, are marked in the diagram of Figure 13 by heavy arrows. The missing lines which are necessary for completing the transition from $8^2P_{1/2}$ to the ground state via the intermediate levels 7S and 7D are marked in the diagram by dotted arrows. They do not appear on the spectrograms because of their great wavelengths, but they are certainly present in the emission spectrum. This is also true for the second component of the resonance doublet 8943.5A ($6^2P_{1/2} \rightarrow 6^2S_{1/2}$), while the second component of the doublet $8^2P_{3/2} \rightarrow 6^2S_{1/2}$ actually cannot be emitted, because the transition $8^2P_{3/2} \leftarrow 8^2P_{1/2}$ does not occur (125).

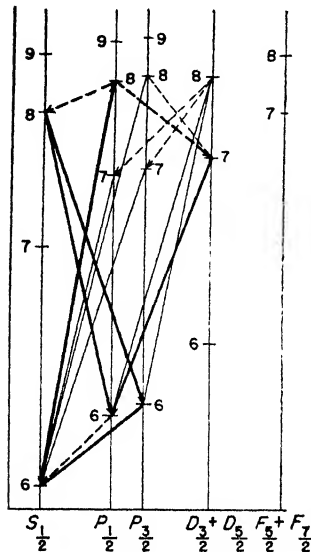

FIG. 13. Grotrian diagram for the fluorescence of Cs.

The presence of the D-lines in the fluorescence spectrum of sodium vapor irradiated with the line 3303A had been observed by Strutt (Lord Rayleigh) much earlier (1593, 1594). This line is one of the components of the second doublet of the main series of sodium and corresponds to the transition $4^2P_{1/2} - 3^2S_{1/2}$. It coincides sufficiently closely with the zinc line 3303.7A, which could be used for the purpose of exciting the sodium vapor. It was this observation which induced

Bohr to assume that a stepwise return to the ground state is not effectuated directly over a forbidden transition ($4P \rightarrow 3P$), but via intermediate levels like $4S$ or $4D$. In Strutt's experiment, which was executed in vapor of relatively high pressure, the transition $4P \rightarrow 3P$ might have been caused by collisions and this explanation seemed even to be made plausible by the great width of the D-lines, which would then have been caused by the Doppler effect. However, such an interpretation can no longer be upheld from the theoretical viewpoint, and later experiments which were performed at lower vapor pressures gave the same results with regard to the emission of the D-lines without showing an unusual broadening of the lines ($I340$).

If thallium vapor is illuminated with the full radiation emitted by a thallium lamp, many higher series lines are observed in the fluorescence spectrum. These lines and the corresponding transitions are collected in Table 3. Since the spectrograms were obtained without

TABLE 3

FLUORESCENCE SPECTRUM OF THALLIUM EXCITED BY THE RADIATION FROM A THALLIUM LAMP

Wavelength in A ..	5350	3775	3529
Transition	$7^2S_{1/2}-6^2P_{3/2}$	$7^2S_{1/2}-6^2P_{1/2}$	$6^2D_{1/2}-6^2P_{1/2}$
Wavelength in A ..	3519	3230	2922
Transition	$6^2D_{5/2}-6^2P_{3/2}$	$8^2S_{1/2}-6^2P_{3/2}$	$7^2D_{3/2}-6^2P_{3/2}$
Wavelength in A ..	2918	2768	2580
Transition	$7^2D_{5/2}-6^2P_{3/2}$	$6^2D_{3/2}-6^2P_{1/2}$	$8^2S_{1/2}-6^2P_{1/2}$
Wavelength in A ..	2380		
Transition	$7^2D_{3/2}-6^2P_{1/2}$		

spectra, resolution of the primary radiation, it is impossible to determine which of the individual lines were stimulated by light of the same wavelength and which were due to stepwise emission.

Fluorescence can be excited in He by the radiation from a hot cathode discharge in helium gas at a pressure of about 1 mm; the observation chamber must be separated from the discharge tube by a window which is transparent to short-wavelength u.v. Lee's and Skinner's earlier experiments have been confirmed by Maurer and Wolf. They obtained numerous lines of the parhelium spectrum (singlet spectrum of He; compare the term diagram of Figure 17). The lines 5015 and 2964A are the strongest in the fluorescence spectrum, the line 3819 is somewhat weaker (3^1P_1 , 4^1P_1 and $5^1P_1 \rightarrow 2^1S_0$); in this case atoms can be transferred by absorption of light

exclusively to 1P_1 -states because deviations from the selection rules do not occur. The fact that a few rather weak lines starting from D -levels and a few lines belonging to the orthohelium system were also observed, was, according to the authors, due to collisions of the second kind (876,877,990,991). (Compare also Section 19).

In the emission spectra of particular stars in nebulae, the orthohelium lines have an anomalously large intensity as compared to the parhelium lines. It is assumed that this abnormal intensity distribution is due to the fact that only the lines of the singlet system are excited to fluorescence by absorption of the underlying continuous radiation. When the emission is due to recombination of helium ions with electrons, the singlets are much weaker than the triplets (147-149).

Lau and Reichenheim ascribe a strong emission of the Balmer lines $H\alpha$ and $H\gamma$ ($2P \rightarrow 2S$ and $3P \rightarrow 2S$) in a hydrogen discharge tube to a fluorescence excitation caused by the absorption of the corresponding Lyman lines ($2P \rightarrow 1S$ and $3P \rightarrow 1S$) in normal hydrogen atoms. An excitation by collision with electrons seemed to be impossible under the experimental conditions. Phenomena of this type may be rather frequent in gas discharge tubes, if light emission is observed in the space outside of the path of the discharge itself (corona) (869).

Astrophysics provides other examples of a stepwise return from an excited state reached by irradiation, and of the correspondent emission of several lines by the excited atoms. The spectra of nebulae contain certain groups of lines of relatively high intensity, the origin of which was unexplained until Bowen realized that they belong to doubly ionized oxygen and nitrogen (O III and N III). The line producing the excitation of oxygen is the He II-line 303.78A. The complete course of the absorption and emission processes can be easily understood by means of the diagram of Figure 14, in which all actually observed oxygen lines are rendered by heavy arrows. The resonance between the He-line and the absorption line of O III is complete if the Doppler width is taken into account. A similar resonance exists between the emission line 374.436 of O III and the absorption doublet 374.434/442A of N III, which explains the subsequent excitation of the lines of N III indicated in the right-hand part of the diagram of Figure 14 (148).

17. Stepwise Excitation. If an atom is raised to an excited level by some mechanism for instance, by the absorption of the resonance line, or by the collision of the atom with an electron it is able to absorb lines belonging to new series starting from that excited state, before it returns spontaneously to the ground state. These new absorption

lines do not occur in the normal absorption spectrum of the atom, and from the higher excited states reached by this process a great number of "secondary" lines can be emitted as fluorescence. This process can even be repeated several times: the levels reached by the emission of the secondary lines become the starting points of new absorption processes which, in turn, lead to the emission of tertiary fluorescence

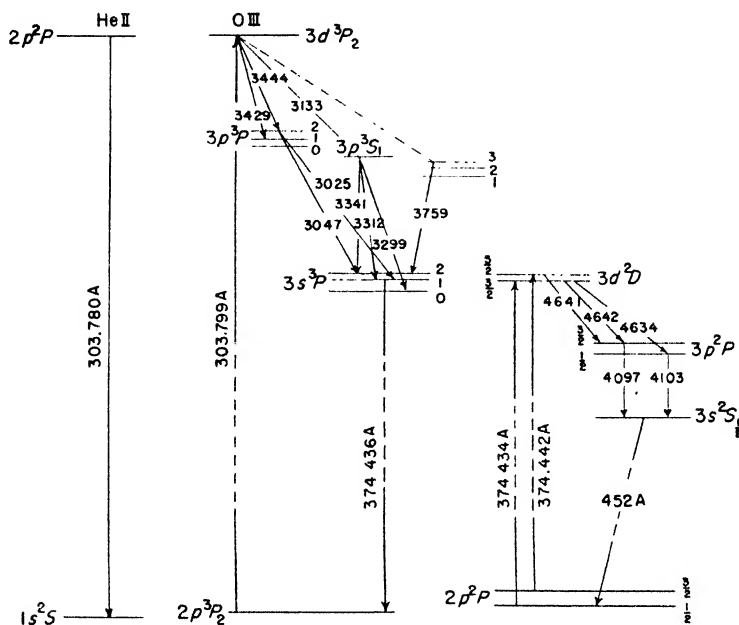

Fig. 14. Energy level diagram of O III and N III-lines in the spectra of stellar nebulae.

lines. The intensities of the tertiary lines are small, in general, unless the secondary emission brings the atom into a metastable state, as, for instance, the states 6^3P_0 or 6^3P_2 of mercury (Figure 15). In the absence of other perturbations the atoms must remain in these metastable states until they are dislodged from them by the absorption of radiation.

Stepwise excitation was discovered by Fuechtbauer in mercury vapor (452) and has been investigated extensively by Wood, who used a much improved experimental setup. The mercury vapor is contained in the quartz tube *R* (Fig. 16a) and is excited by the resonance radiation of a cooled mercury arc lamp I. The second mercury lamp II

is not cooled and is unable to excite resonance radiation because of the self-reversal of the line 2537A in its emission spectrum. As Fuechtbauer has shown, lamp II produces no effect at all in tube *R*, unless some of the mercury atoms in *R* are transferred into the state 6^3P_1 by

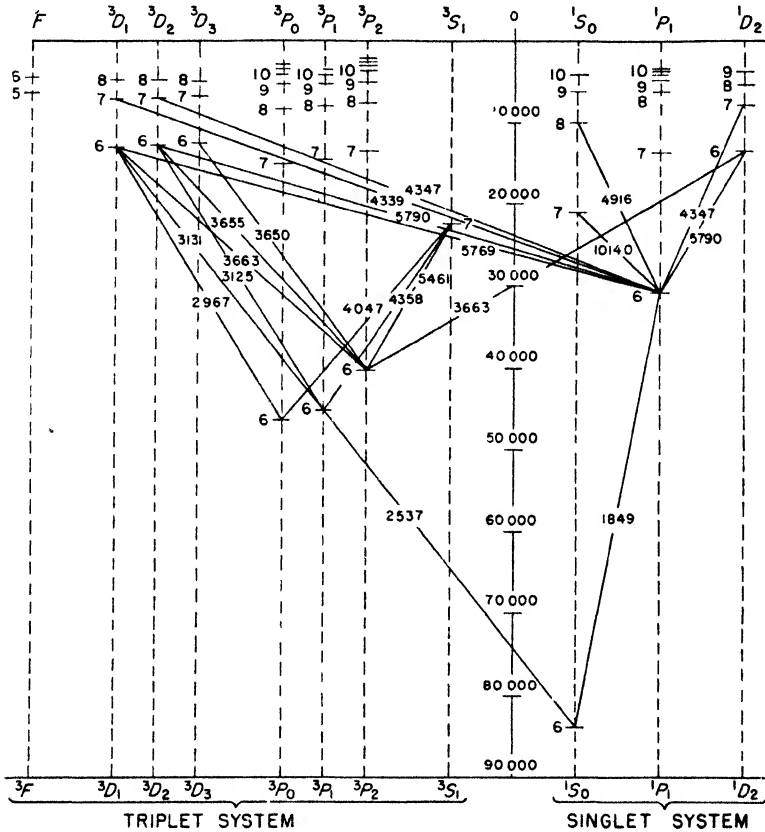

Fig. 15. Grotrian diagram for Hg.

the radiation from lamp I. If, on the other hand, the total radiation of lamp I alone is used for excitation, all transitions shown in Figure 15 by solid lines are observed in the fluorescence of *R*. Various combinations of exciting lines can be selected by interposing filters between *R* and the two lamps; as soon as the resonance line is contained in the spectrum of the primary light, all lines which can be expected are present in the fluorescence spectrum. The relative in-

tensities of these lines depend to a large extent on the nature of the lines which are transmitted by the combination of filters used. The triplet $6^3D_{1,2,3} \rightarrow 6^3P_2$, with the wavelengths 3663, 3655, and 3650A, may be discussed as an example. For producing secondary fluorescence of any appreciable intensity, the exciting radiation must contain, in addition to the resonance line, at least one of the lines 3131, 3126, or

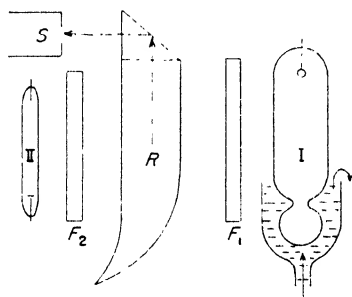

Fig. 16a. Wood's setup for the observation of stepwise excitation of mercury fluorescence.

I: water-cooled Hg-lamp. *R*: resonance lamp. *S*: slit of spectrograph. *II*: hot Hg-lamp. *F*₁ and *F*₂: filters.

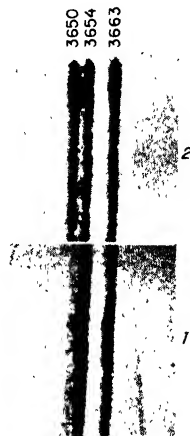

Fig. 16b. Stepwise excitation of the u.v. Hg-triplet (R. W. Wood).

(1) excited by Hg-radiation of $\lambda < 4000\text{\AA}$. (2) excited by Hg-radiation including the line 4358A

4358A, all starting from the level 6^3P_1 . Other transitions starting from this level correspond to absorption lines of relatively small intensity. If light of all wavelengths above 4000A is removed from the spectrum of the primary radiation by means of filters, "secondary absorption" of the lines 3131 and 3126 raises the atoms from the state 6^3P_1 to the states 6^3D_1 and 6^3D_2 , from where the triplet lines 3663 and 3655A can be emitted. By these emission processes, atoms reach the metastable state 6^3P_2 and are now able to absorb in a tertiary process all three of the triplet lines and eventually to re-emit them again. This tertiary emission, however, is very much more improbable than the secondary processes, and, furthermore, the initial state from which it starts is produced by the secondary emission of the two other Pringsheim 2*

triplet components only. Therefore, the intensity of the third component of the triplet (3650A) is very low as compared with the two others. If the line 4358A is transmitted through the filters, atoms are raised by absorption of this line to the level 7^3S_1 and subsequently drop by secondary fluorescence emission of the line 5461A to 6^3P_2 . From there, they are able to absorb any one of the three triplet lines and thus to reach the states 6^3D_1 , 6^3D_2 , or 6^3D_3 ; the only possible transition from 6^3D_3 is to 6^3P_2 , while the atoms can leave the two other 6^3D -levels by several allowed transitions. Accordingly, the line 3650A is now the strongest of the triplet in the fluorescence spectrum (462,1889,1903) (Fig. 16 b).

These theoretical results, as well as other conclusions derived from the selection rules, are in good agreement with Wood's photometric measurements. Simultaneously with the triplet component 3663A, the "intercombination line" 5769A, corresponding to the possible, though little probable, transition $6^3D_1 \rightarrow 6^1P_1$, was obtained by Wood, with relatively small intensity. Other intercombination lines, $6^1D_2 \rightarrow 6^3P_2$ (3662.9A) or $7^1S_0 \rightarrow 6^3P_1$ (4078A), were observed in the secondary fluorescence spectrum of mercury vapor by Terenin, who employed an experimental arrangement similar to the one used by Wood (1637).

If fluorescence is excited stepwise, the intensity distribution in the emission spectrum must depend on the relative intensity of the lines in the primary radiation and its modification by the use of selective screens. If the total intensity of the primary radiation is altered, for instance, by increasing the distance between the arc lamp and the fluorescence tube, or by interposing a wire-gauze filter, only the intensity of the primary resonance radiation is proportional to the first power of the intensity of the exciting radiation, while the intensity of the "secondary lines" (e.g. 3655A) varies with the square, and that of the "tertiary lines" (e.g. 3650A) varies with the third power of the primary intensity.

In the presence of foreign gases, especially of nitrogen, mercury atoms which have been raised to the state 6^3P_1 by absorption of the resonance line are transferred into the contiguous state 6^3P_0 by collisions with the molecules of the foreign gas. (The mechanism of this process is dealt with in Section 37). The state 6^3P_0 being metastable, a relatively large number of atoms remains in this state. Therefore, the absorption lines which originate from 6^3P_0 have great intensity and the fluorescence excited stepwise by the full radiation of a mercury arc is much stronger under these conditions than in pure mercury vapor. Table 4 reproduces some of the values published by

Wood comparing the intensities of lines obtained in pure mercury vapor and in the presence of about 2 mm of nitrogen (1889).

TABLE 4
RATIO OF INTENSITIES (k) OF MERCURY FLUORESCENCE LINES EXCITED BY THE TOTAL RADIATION OF A MERCURY ARC IN PURE MERCURY VAPOR AND IN THE PRESENCE OF 2 MM NITROGEN

Final state	6^3P_2		6^3P_1		6^3P_0	
	λ (Å)	k^{-1}	λ (Å)	k^{-1}	λ (Å)	k^{-1}
Initial state						
7^3S_1	5461	32	4358	16	4046	8
8^3S_1	3341	5	2894	8	2753	16
$6^3D_1 + 6^1D_2$	3663	4	3131	16	2967	4
6^3D_2	3654	1	3126	2	—	—
6^3D_3	3650	16	—	—	—	—

For a complete interpretation of these intensity ratios, a very thorough discussion of the experimental conditions prevailing in every instance is necessary. Gaviola, who treated the problem, found that the observed results could be explained in every case by plausible assumptions (462, 1716, 1903). For instance, an increased emission of the line 5641Å increases the number of atoms in the metastable state 6^3P_2 ; the 6^3P_2 -atoms can be excited once more and thus contribute to some new emission process with an intensity proportional to a higher power of the primary radiation. Furthermore, the reabsorption of some of the fluorescence lines by the mercury vapor is not quite negligible; and finally, a certain amount of genuine quenching (complete loss of energy) caused by multiple collisions of metastable atoms with the foreign molecules may occur. With pure nitrogen, however, such collisions do not seem to be of great importance, since Wood was able to observe fluorescence emission of the "forbidden" line 2665.8Å ($6^3P_0 \rightarrow 6_1S_0$) in the presence of several mm of nitrogen. Because of the low transition probability, this line can be emitted only if the unperturbed life of the metastable atoms is comparatively long. The intensity of the forbidden line is proportional to the intensity of the resonance line in the primary light; its appearance is caused by a single process of absorption (1902). (For more details concerning the forbidden line compare Section 22).

Bender observed stepwise excitation of fluorescence in cadmium vapor: the results were analogous to those obtained by Wood in pure mercury vapor. When excited by the total radiation of a cadmium lamp, the fluorescence spectrum contained, apart from the resonance Pringsheim 2**

line 3261A ($5^3P_1 \rightarrow 5^1S_0$), many lines originating from the higher excited states. Among these, the secondary lines starting from the levels which are reached directly from 5^3P_1 were again much more intense than the tertiary lines. It is noteworthy that in Bender's Cd-spectra all lines belonging to the singlet system are missing: because of the small probability of intercombinations in the case of cadmium, these lines should be emitted almost exclusively, if cadmium atoms undergo stepwise excitation after having reached the state 5^1P_1 . However the short life of that state, caused by the great transition probability $5^1P_1 \rightarrow 5^1S_0$, reduces the probability of absorption processes which otherwise would originate from it (91).

This interpretation does not agree with Bender's observation that in zinc vapor excited by the total radiation of a zinc arc, the blue-green triplet $5^3S_1 \rightarrow 4^3P_{0,1,2}$ (4810, 4722, 4680A) and the red singlet line $4^1D_2 \rightarrow 4^1P_1$ (6362A) have practically the same intensities. It is possible, however, that in this case the short lifetime of the state 4^1P_1 is compensated by the very small probability of the transition $4^3P_1 \leftarrow 4^1S_0$. The primary stages in the stepwise excitation of the triplet lines and of the singlet line can only be the states 4^3P_1 and 4^1P_1 , respectively.

If thallium vapor is irradiated with the line 3776A at a temperature low enough so that there are practically no $6^2P_{3/2}$ -atoms in thermal equilibrium, the excited atoms are partially transferred into this metastable state by the emission of the green line 5350A (Figure 9). However, the vapor cannot be excited, under these conditions, to secondary fluorescence by absorption of the lines 3519 and 3529A ($6^2D_{1/2,3/2} \leftarrow 6^2P_{3/2}$), nor do these lines acquire an appreciable intensity in the absorption spectrum of the vapor. Thus, the life of the metastable state $6^2P_{3/2}$ of thallium seems, even at low vapor pressure of the order of 10^{-4} mm, to be short as compared with that of other metastable atoms. (1084). (Compare footnote, page 45).

18. Combined Electrical and Optical Excitation. In principle it makes no difference whether in stepwise excitation the first stage is attained by light absorption or by electron collision. An electric low-voltage discharge produces in mercury vapor not only atoms in the state 6^3P_1 but also atoms in the metastable states 6^3P_0 and 6^3P_2 , and because of their long lifetimes these metastable atoms attain relatively high concentrations. Therefore, the vapor shows particularly strong absorption for the lines starting from the metastable levels, and the fluorescence of the visible triplet $7^3S_1 \rightarrow 6^3P_{0,1,2}$ can be stimulated not only by absorption of the line 4358A, as before, but as well and even

more efficiently by absorption of the lines 4047 and 5416A. The relative intensities of the three components of the triplet do not depend on which of the three lines served for the secondary excitation: there is no evidence for the existence of a separate scattering process apart from fluorescence (447). (See Section 33 for further conclusions to be drawn from these experiments). Gaviola has shown that the relative intensities of the triplet components do not depend, either, on the relative concentrations of atoms in the various 6^3P_j -states. This was to be expected according to Bohr's theory, while an erroneous interpretation of wave mechanics led to a different conclusion.*

The term systems of the rare gases are very similar to the system of mercury: they consist of singlet and triplet series. The true resonance lines are situated in the far u.v. and can be observed only with vacuum apparatus. However, the levels nearest to the ground state are metastable. In helium the lowest of these is the state 2^3S_1 , which is the ground state for the orthohelium spectrum. Since intercombination lines between the triplet and the singlet system of helium do not exist at all, the state 2^3S_1 can become the ground level for genuine resonance radiation exactly as the normal ground state n^1S_0 of an unexcited metal atom. Because of the high degree of their metastability the concentration of the metastable helium atoms can become rather high in an electric discharge (Figure 17).

The resonance lines of orthohelium, as discovered by Paschen, form a doublet (instead of a triplet), because only two of the three 2^3P_1 -levels can be resolved. If helium of a few mm pressure is excited by a weak electric discharge, it absorbs the two infrared emission lines 10830 and 10829A ($2^3P_2 \leftarrow 2^3S_1$ and $2^3P_1 \leftarrow 2^3S_1$) of a helium Geissler tube. The two lines are re-emitted by the absorbing gas without appreciable loss of energy, according to Paschen's measurements. The state 2^1S_0 of parahelium is also metastable, but the atoms can be raised from this level to 2^1P_1 or 3^1P_1 by absorption of light and from there they can return directly to the ground state 1^1S_0 . Therefore, the concentration of atoms in the state 2^1S_0 remains relatively small in the electric discharge, and absorption of the line 20582A ($2^1P_1 \leftarrow 2^1S_0$) is rather weak; it is even much weaker in emission because of the competition of the much more probable transition to 1^1S_0 (the true resonance line of helium). The line 20582A has never been observed

* G. Hoffmann observed the absorption of the lines originating from the levels $5^3P_{0,1,2}$ in electrically excited vapors of cadmium and zinc and the absorption of the green line in electrically excited thallium vapor. However he made no mention of any fluorescence emission of these lines.

in the fluorescence spectrum of electrically excited helium (1193). (The experimental conditions are particularly unfavorable for observations of low intensities, since they cannot be made visually or

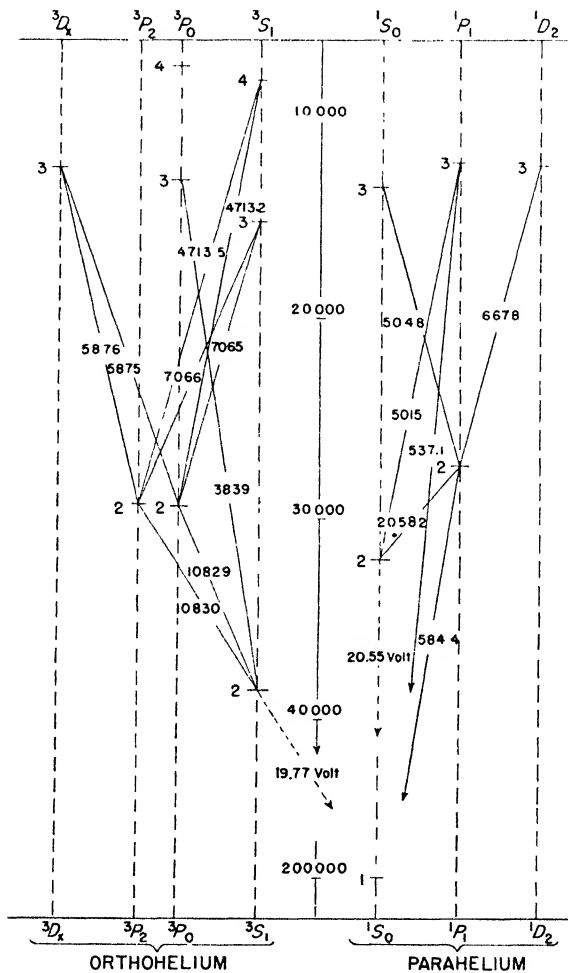

Fig. 17. Grotrian diagram for He.

photographically, but must be performed by means of thermopiles or bolometers).

On the other hand, the second doublet of the main series of orthohelium at 3839A ($3^3P_J \rightarrow 2^3S_1$) has been obtained by McCurdy

in fluorescence, while the analogous line of parhelium at 5015A was again missing. However, a number of orthohelium lines were observed by Maxwell in a tube in which, as in Lees' and Skinner's experiment (see Section 18), helium was excited by a concentrated beam of electrons, while the spectral observations were restricted to the space outside of the path of the electrons. According to Maxwell, helium atoms which have been raised by electron collisions into the higher states of the parhelium term system leave the path of the electric discharge by diffusion and are then able to absorb and re-emit other lines of the parhelium spectrum (876,877,997,992,995). [The reasons brought forward by Maurer and Wolf to disprove Maxwell's explanation of his experiments are far from being convincing (990).]

Lau and Reichenheim, also, admit the possibility of stepwise excitation in their experiments mentioned at the end of Section 16. In this case, the first stage of the process would not be due to an electron collision but to the absorption of the Lyman resonance line $2P \leftarrow 1S$ of hydrogen. The short life of the $2P$ -atoms is supposed to be compensated by their high concentration. Ladenburg had shown much earlier, that the lines of the Balmer series are absorbed with high efficiency by electrically excited hydrogen (869).

However, stepwise excitation is, in general, important only when metastable states come into play as in the case of mercury and the rare gases. The system of the lower terms of neon is in all respects analogous to that of mercury, although the energy differences between the ground state and the lowest excited levels are much larger. Like mercury, neon has two genuine resonance lines corresponding to the transitions from the ground state 2^1S_0 to 2^3P_1 , 2^1P_1 ($1s_4 1s_2$ in Paschen's older notation). They are situated in the far u.v. and have, so far, been observed only under electric excitation. Two further $2P$ -levels, 2^3P_0 and 2^3P_2 ($1s_3$ and $1s_5$, according to Paschen), are metastable, as in the case of mercury; neon atoms can be raised into these states from the ground state by electron collisions and comparatively large concentrations of such metastable atoms are present in equilibrium in an electric discharge through neon. If the total radiation of a neon-filled Geissler tube is focused into the space adjoining the path of the electric discharge in a neon glow lamp, this radiation excites a secondary fluorescence which is completely analogous to the secondary fluorescence of mercury, described previously. All those lines occur which are emitted from levels reached by absorption of atoms in the four P -states and particularly in the metastable states. Line 6402A ($3^3D_3 \rightarrow 2^3P_2$) is of especially great intensity. This line is the genuine

resonance line of the metastable state 2^3P_2 . In commercial neon glow lamps, the discharge proper is surrounded by a red luminescence; De Groot explained it as a phenomenon of secondary fluorescence in the electrically excited gas. The stepwise-excited fluorescence of neon can be demonstrated even better in a "Hertz lamp." This is a tube filled with neon of low pressure and equipped with a hot filament cathode; the electrons from the cathode are accelerated through a grid into a field-free observation chamber. If the accelerating voltage on the grid is large enough, the visible neon lines are stimulated by electron collision in the observation chamber. If the voltage is below 18 volts but larger than 16, the P -states alone are excited and red and orange lines appear as secondary fluorescence, if the Hertz lamp is irradiated with light from another neon discharge tube. If, under these conditions, the exciting radiation contains only the line 6402A, this resonance line is also the only one emitted in fluorescence (265,311, 453,1008). If the grid voltage drops below 16 volts, fluorescence is produced neither by electron impact nor by optical excitation.

By the same method, the emission of a great number of red and infrared argon lines and of some xenon lines was observed as secondary fluorescence in electrically excited argon and xenon, corresponding to transitions between terms analogous to those in neon (475,1008).

C. The Absorption and Emission Process

19. Absorption of Primary Radiation. Resonance radiation has been discovered by Wood in the vapors of mercury and sodium, and the phenomenon has been investigated in these two vapors more thoroughly than in any other vapors or gases. This is due rather to the fact that adequate light sources were available, than to the relatively high vapor pressures of the metals at low temperatures. The vapor pressures needed for the excitation of resonance radiation are so low that they can be obtained for many other metals without great difficulties. Mercury resonance radiation is already very strong at 0°C ($p = 1.9 \cdot 10^{-4}$ mm) and can be observed down to temperatures of -50°C ($p < 10^{-6}$ mm). In sodium vapor all measurements can easily be performed visually at 100°C ($p \sim 10^{-7}$ mm) if a suitable source of primary light is used. Since low vapor pressure is essential for obtaining pure experimental conditions, the absorption lines of the vapor are exceedingly narrow and only the central parts of the lines emitted by the primary light sources contribute to the excitation. If great

amounts of sodium chloride are injected into a Bunsen flame, its yellow radiation becomes much brighter without increasing the intensity of the resonance radiation which it excites in sodium vapor. It is well known that higher sodium concentration in the flame increases only the width of the D-lines, but not the intensity in the center of the lines (1860, 1866).

[The occurrence of the D-lines in the light of the night sky is greatly enhanced during a short period immediately after sunset and before sunrise and has been interpreted by Bernard, Bricard and Kastler, and others as resonance radiation excited by sunlight in a layer of sodium vapor at an altitude of about 75 km. Because of the improbability of the presence of free atomic sodium in the high atmosphere, others ascribed the phenomenon to the photodissociation of NaCl into $\text{Cl} + \text{Na}$ (3^2P) with subsequent emission of the atomic sodium lines (see Sect. 70). An argument in favor of the first hypothesis is seen in the sharpness of the lines: their width is, according to their absorbability in sodium vapor, far less than 0.03\AA and corresponds to the Doppler effect at 240°K . If produced by photodissociation of sodium chloride the lines would have an appreciably greater width, because some of the molecules would absorb light quanta of an energy exceeding the heat of dissociation of NaCl. This argument is not quite convincing, however, because the energy distribution in the spectrum of the sun must slope very steeply at the wavelength of 1700\AA which is needed for the dissociation process, so that light of still smaller wavelengths would contribute very little to the reaction. An unequivocal solution of the problem would be provided by a determination of the altitude at which the phenomenon takes place: light of wavelengths equal to, or smaller than, 1700\AA cannot penetrate to an altitude below 100 km. On the other hand, it may be possible to explain the existence of atomic sodium in the atmosphere at an altitude of 75 km by the presence of atomic oxygen, which would automatically maintain a certain concentration of sodium atoms by the continuous reaction (94, 167, 195, 196, 205, 216, 269, 427, 730a, 730b, 1769):

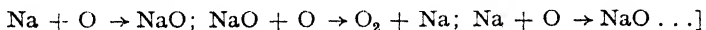

When, in his earliest experiments, Wood used a commercial high-pressure mercury lamp, resonance radiation was excited in mercury vapor only during the first few seconds after striking of the arc. With rising temperature of the lamp its radiation, including the line 2537\AA , became stronger, but the intensity at the center of this

line decreased and dropped, because of self-reversal, eventually to zero (1866).

At very low vapor pressures in the resonance tube, the absorption of the primary radiation is small and the resonance emission can, therefore, be observed over a relatively long path of the exciting beam. Since the secondary absorption of the resonance radiation in the vapor is insignificant, a sharply delimited beam of light is produced, with slowly diminishing intensity along its path ("beam fluorescence"). The intensity of the mercury resonance decreases to about 50% after the exciting ray has passed through 0.5 cm of mercury vapor at room temperature ($p \sim 10^{-3}$ mm). From these data, Wood derived an approximate absorption coefficient of the exciting radiation, but he himself pointed out that the absorption does not follow a strictly exponential law. According to Goos and Meyer, the apparent "absorption coefficient k " determined by this method decreases continuously with increasing distance d from the entrance window. From one of their photographs, for instance, k was calculated to be 1.8, 1.5, and 1.2 cm^{-1} for distances $d = 3, 6,$ and 9 cm respectively. The different parts of the exciting line are not equally absorbed in the vapor, the absorption being much stronger for the center of the line than for the outer parts. The width of, and the intensity distribution in, the exciting line are of decisive importance for its absorbability (520, 1023, 1654, 1867).

If the vapor pressure in the resonance tube is increased, the absorption of the primary and of the secondary radiation becomes stronger. Therefore, the resonance intensity along the exciting beam decreases more rapidly and, at the same time, the luminosity becomes more and more diffuse, until it fills the whole volume of the tube (volume fluorescence). Eventually the phenomenon is concentrated within a narrow layer adjoining the entrance window; the "volume fluorescence" is transformed into "surface fluorescence." This state is reached in saturated sodium vapor at about 300° C and in mercury vapor somewhat below 100° C (322, 1874).

If the fluorescence of thallium is excited by lines which are absorbed by atoms in the ground state $6^2P_{1/2}$ (for instance, the line 3776A), surface fluorescence is observed exclusively in vapor saturated at 900° C ($p \sim 1$ mm), while the green thallium line is still able to produce fluorescence well inside of the tube; under these conditions, only about one per cent of the atoms are in the state $6^2P_{3/2}$ and are thus able to absorb the green line.

In volume and surface fluorescence, the main part of the radiation

leaving the tube is not emitted by atoms which have been directly excited. In general, the absorbed energy is transferred several times from one atom to another before it leaves the fluorescing gas. This energy transfer is due not only to reabsorption and re-emission, but also to so-called collisions of the second kind, which will be dealt with in a later chapter.

20. Fluorescence Yield and Width of Resonance Lines. The yield or efficiency of resonance radiation is the ratio of the energy emitted by a given volume to the energy absorbed in the same volume. In the absence of all perturbations, the whole energy taken up by an atom can be re-emitted only in the form of radiation; hence, the efficiency $\Phi = 1$ is to be expected. The experimental results, which were obtained with resonance radiation of different gases and vapors, have confirmed this expectation. Paschen's measurements on the infrared orthohelium lines are probably the most accurate. He determined at first, by means of a thermopile, the intensity emitted by his helium resonance lamp in a certain solid angle; then he focused an image of the resonance lamp, by means of a spherical mirror of known aperture into the lamp itself, thus increasing the intensity of its radiation, and repeated the measurement with the thermopile. Finally, he determined the absorption coefficient of the resonance lamp for its own radiation. The total yield was thus found to be 95 % (1193). The same method was used by Gerlach for the resonance radiation of mercury, employing a photoelectric cell instead of a thermopile. The yield was of the order of 100 % in this case also, although the precision was less than in Paschen's experiment, since the reflection coefficient of the mirror for the line 2573A was not exactly known. The same result had already been obtained by Wood in a more qualitative way. Finally, Dunoyer and Wood proved by a very simple and convincing method that sodium vapor re-emits absorbed light energy completely as resonance radiation. If surface fluorescence is excited in sodium vapor at 300° C by the radiation from a sodium resonance lamp, the luminous layer has the same brightness as an adjoining perfectly white surface. If the exciting resonance lamp is replaced by a sodium chloride flame which emits D-lines of much greater width, the white area appears far brighter than the surface fluorescence (324, 1874, 1881). [A criticism by Vavilov which was brought forward against this conclusion does not seem to be justified (compare chapter IV, Section 123).]

The width of the resonance lines is determined mainly by the temperature of the vapor or rather by the Doppler effect resulting from the thermal agitation, as long as the excited atoms are not

appreciably perturbed by interaction with other atoms or molecules. If, as in most experiments, the resonance emission is observed in a direction perpendicular to the exciting beam, the width and intensity distribution of the line in the primary light have no influence: each atom absorbs radiation only of the frequency which, in a system moving with the atom, coincides with the center of the line. On the other hand, the line width, as seen by a stationary observer, is determined exclusively by the Maxwell velocity distribution of the excited atoms with respect to the observer. Rump has shown that the width of the mercury resonance line increases according to theoretical prediction if the temperature of the vapor is altered, while the density in the resonance tube and the intensity of the primary radiation are kept constant. In these experiments the source of primary radiation was another resonance lamp and the relative values of the line width were obtained by measuring the absorption of the resonance radiation in a cell filled with mercury vapor of constant temperature and pressure. However, the width of the resonance line leaving the resonance tube does not, in general, correspond exactly to the width of the absorption line as postulated by theory; even under the most favorable conditions a slight re-absorption of the central parts of the line cannot be avoided. The intensity distribution of the line resembles very closely a Gaussian distribution, but the greater the density and the depth of the re-absorbing layer, the more the apparent width of the line exceeds the true Doppler width (1394, 1928).

If the resonance radiation is observed in a direction parallel to the direction of the primary radiation, the intensity distribution in the resonance line is closely related to the intensity distribution in the exciting line; if the exciting line is self-reversed, the fluorescence line is also reversed. Under these conditions, the intensity of the resonance radiation is less diminished by absorption in a layer of mercury vapor when it is observed in the direction of the primary beam than when it is observed in a perpendicular direction (1055).

If the line width is essentially determined by some sort of perturbations and not by the Doppler effect, the intensity distribution in the resonance line is independent of the exact wavelength and of the energy distribution of the exciting line, as long as the wavelength of the exciting line coincides with a part of the broadened absorption line, and as long as the perturbations at the moment of absorption and at the moment of emission are independent of each other. If an atom is perturbed by interaction with another molecule and, therefore, preferentially absorbs light of a frequency different from the resonance

frequency, it emits afterwards light corresponding to the center of the resonance line if it has left the sphere of the perturbation before the emission sets in. The angle formed by the direction of observation and the direction of the exciting beam is, in this case, of no importance for the "restoring" of the normal intensity distribution in the resonance line. The validity of these conclusions has been proved experimentally for the mercury resonance line, which was broadened by the addition of an inert gas (1183).

This "restoring" of the normal intensity distribution in the line may be considered as the distinctive feature of resonance radiation as compared with Rayleigh scattering-notwithstanding the continuous transition between the two phenomena. If the frequency ν of the primary radiation does not coincide with the characteristic frequency ν_0 of the unperturbed atom at rest the "virtual oscillators" of all atoms perform forced oscillations of relatively small amplitudes and thereby scatter the impinging radiation with low intensity and unchanged frequency. If ν is within the Doppler width or within the width of the absorption line caused by a perturbation, the characteristic frequency of comparatively few atoms having high velocities or being strongly perturbed will coincide with ν and they will be excited to vibrate with large amplitudes. The resonance radiation emitted by these atoms will be much stronger than the light of frequency ν scattered by the other atoms. The Rayleigh scattering prevails only in those parts of the spectrum where the absorption caused by Doppler-broadening or collision-broadening of the resonance line practically vanishes. (Compare Section 82).

The half-width of the D-lines in the resonance radiation of sodium vapor at 300° C has been determined by Dunoyer and Wood and by Strutt, both using interferometric methods. The value of 0.02A which they obtained is in good agreement with the value computed for the Doppler width at 600° K under the assumption that the line would be infinitely narrow at absolute zero. Under the prevailing conditions, the line width was exclusively determined by the thermal Doppler effect and not by radiation-damping nor by external perturbations (324,1591).

The Doppler width becomes almost negligible if an atomic beam of the vapor is excited by a light beam perpendicular to the atomic beam and if the fluorescence is observed in a direction perpendicular to either. By using suitable diaphragms for the limitation of the atomic ray, the thermal agitation of the atoms in the directions perpendicular to the ray can be reduced to a value corresponding to

a few degrees K (307). If the mercury resonance line is excited under these conditions, its width is of the order of 10^{-5}A and is probably caused by radiation-damping alone; 93.5 % of its intensity is absorbed in a layer of 5 mm thickness of mercury vapor saturated at 20°C ($p = 1.3 \cdot 10^{-3}\text{ mm}$) (1919).

21. Hyperfine Structure. The hyperfine-structure components of the D-lines are separated from each other by distances not exceeding 0.01A. If the temperature of the vapor is sufficiently high for the

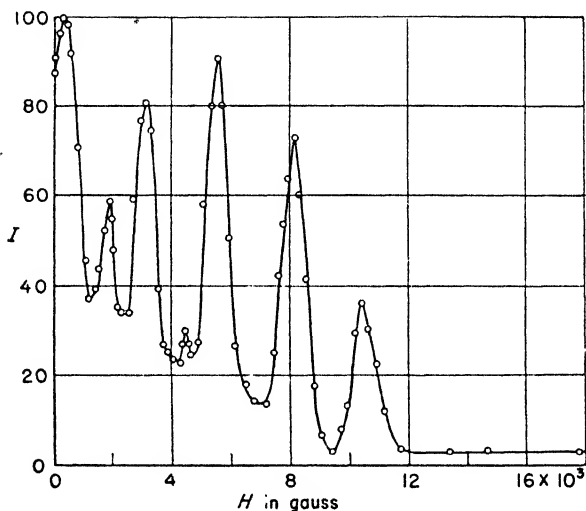

Fig. 18. Magnetic resolution of the hyperfine structure of the Hg-resonance line by the Schein method (Buhl). I = transmitted energy.

observation of resonance radiation, the hyperfine structure of the lines is hidden, under normal conditions, by the Doppler width of the lines. However, if the resonance radiation is excited in an atomic beam, the hyperfine structure can be resolved (307).

The Doppler width of the mercury resonance line is smaller owing to the greater atomic weight of Hg and, furthermore, the vapor pressure becomes greater at lower temperatures than in sodium vapor. Therefore, spectrographic methods of sufficient resolving power show the hyperfine structure of the mercury resonance line 2537A in a tube containing the vapor at room temperature. Malinowski was the first to prove that the line consists of more than one component. In his experiments, radiation emitted by a mercury resonance lamp passed

through an absorption tube which contained mercury vapor and which was placed between the pole pieces of an electromagnet. Stepwise increase of the magnetic field shifted the Zeeman components of the absorption line. Measuring the absorption of the unshifted resonance line in the absorption cell for every field strength, Malinowski obtained several maxima and minima of transmitted energy and concluded that the line consisted of two or more components with a width of about $2.3 \cdot 10^{-4} \text{A}$ and a mutual distance of $3 \cdot 10^{-3} \text{A}$ (972). Later, Wood succeeded in analyzing completely the line emitted by an electric discharge in mercury vapor; he used two crossed Lummer-

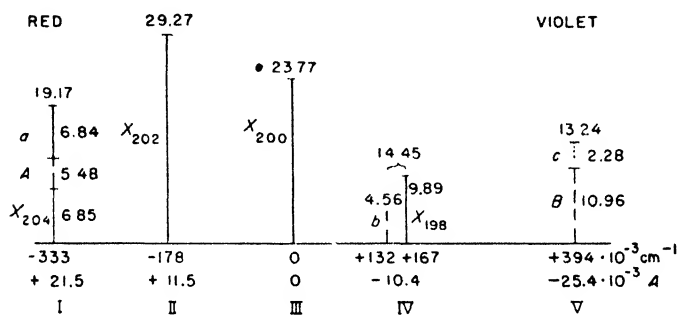

Fig. 19. Hyperfine structure of the Hg-resonance line (Schueler and Keyston).

Gehrke quartz plates and found five approximately equidistant components of equal width (1890).

Several investigators confirmed Wood's results concerning the structure of the line also when the radiation was excited by resonance. Schein came to the same conclusion by improving Malinowski's method, and Buhl improved it even further by using, as primary radiation, a single hyperfine-structure component which was isolated by a "Mrozowski filter" (Section 9). Figure 18 shows the intensity transmitted through the resonance lamp as a function of the applied magnetic field (185,645,1078,1420-1422).

The complete hyperfine-structure scheme of the mercury line 2537A is reproduced in Figure 19, in which the distances from the central component are plotted as abscissas, the units being thousandths of an Angstrom. The existence of hyperfine structure is due to two causes. The energy levels of the seven mercury isotopes, which are listed in Table 5 according to Schueler and Keyston, have slightly

TABLE 5
THE ISOTOPES OF MERCURY

Atomic weight	Relative amount in %	Nuclear spin i	Atomic weight	Relative amount in %	Nuclear spin i	
204	6.85	0	201	13.67	3/2	
202	29.28	0		16.45	1/2	
200	23.27	0		30.12		
198	9.89	0				
196	0.10	0				
	69.39					

different energies. Furthermore, the terms of the mercury isotopes of odd atomic weight ("odd isotopes"), consist of $2i + 1$ or $2J + 1$

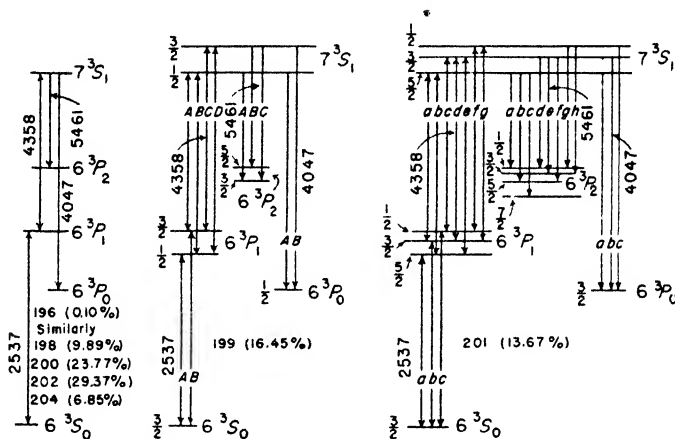

Fig. 20. Hyperfine-structure levels of the lower electronic states of Hg [Boggs and Webb (126)]

sublevels (compare Section 13). The hyperfine-structure terms of the lower levels of the mercury isotopes are represented in the diagram of Figure 20. The term schemes for the five even isotopes are similar, but the absolute heights of the levels differ. Some of the energy differences, however, are so small that the corresponding lines cannot be separated even with instruments of highest resolving power. In Fig. 19, components of line 2537A which belong to even isotopes are designated by the symbols X_{204} , X_{202} , etc., those belonging to Hg²⁰¹ by a , b , c , and those belonging to Hg¹⁹⁹ by A and B . Lengths of the lines in the diagram correspond to the intensities of the components. The diagram shows, furthermore, why the line was resolved into only

five components by Wood and other investigators. All details concerning the width and the intensity distribution of the lines apply without alteration to the individual components of the hyperfine structure.

Mrozowski succeeded in exciting some of the hyperfine-structure components of the line 2537 separately by resonance, using the "filter method" described in Section 9. According to the magnetic field strength and the orientation of the polarizers, he obtained practically only the component -25.4 ,* or the components -10.4 and $+21.5$, or the components 0 and $+11.5$. The various components which have unequal intensities in the emission spectrum also have different absorption coefficients in mercury vapor of constant density. (This is a further reason for the nonexistence of a homogeneous absorption coefficient of the resonance radiation in mercury vapor). The relative intensities of the hyperfine-structure components vary in a resonance lamp, along the beam of the primary light, since at sufficiently low vapor pressures (so that collisions during the life of the excited states are excluded) every component is emitted only insofar as it is directly excited by absorption (*I07I*).

Figure 20 shows, furthermore, that the hyperfine structure of the triplet lines $7^3S_1 \rightarrow 6^3P_J$ ($J = 0, 1, 2; 5461\text{\AA}$, etc.) which can be excited by stepwise absorption is much more complicated. The relative excitation probabilities are now different for all components in each of the two stages ($6^3P_1 \leftarrow 6^1S_0$ and $7^3S_1 \leftarrow 6^3P_1$), and thus the relative intensities of the hyperfine-structure components can differ widely in the exciting and in the fluorescence radiation (*I26*). The weaker components, in particular, are apt to be practically missing in the fluorescence spectrum because they are little absorbed in the resonance lamp. If the radiation from a mercury lamp passes through a tube containing a mixture of Hg-vapor and N_2 in which metastable mercury atoms are produced at a high concentration by irradiation with the resonance line, the absorption of the lines 4047 and 2752\text{\AA}, both originating from the state 6^3P_0 , does not obey an exponential law with increasing length of the absorbing layer because of the unequal absorbability of the various hyperfine-structure components of these lines (five components in the case of 4047, two in the case of 2752) (*231a, I254, I255*).

Terenin was the first to mention these relations. Later, Boggs and

* According to Ellett it is impossible to isolate completely this component by the Mrozowski method; the filter always transmits simultaneously the component $+21.5$ with about the same intensity.

Webb computed the relative intensities of all hyperfine-structure components of the lines 5461, 4358, and 4047A under the assumption of stepwise excitation and they obtained excellent agreement with the experimental results. They supposed the intensity distribution in the primary radiation to be completely free from self-reversal and the primary radiation to be completely absorbed in the fluorescing vapor (126).

Apart from the extensive observations on mercury vapor, the only investigation of the hyperfine structure of a line excited by resonance dealt with the zinc line 3076A. It was not possible to resolve the individual components of the line by means of the Malinowski-Scheibe method; however, the line width was found to be about twice as large as the Doppler width of a single line. Billeter assumed that the components belonging to the three even isotopes (Zn^{64} , Zn^{66} , and Zn^{68}) overlap, because the distance of the outer components from the central line does not exceed $1.75 \cdot 10^{-3}A$. The relative abundance of the only odd component is not more than 4% and, therefore, it can practically be neglected so far as its contribution to the resonance radiation is concerned (33,110-112).

22. Experimental Determination of Lifetime τ . The mean lifetime τ of the excited state of an atom has been defined in the Introduction as the time during which the intensity of its radiation decreases from I_0 to $1/e \cdot I_0$. I_0 is the intensity at the moment when the excitation process is ended. τ can be computed from the natural width of the line ("radiation-damping") or from the absolute intensity of the line in the absorption spectrum ("oscillator strength"), using the theory of dispersion. These calculations are based essentially on absorption measurements, even if resonance lamps are used for the production of radiation, and, therefore, are not to be discussed here.* Some of the values obtained in this way are given for comparison in Table 11.

Since the lifetime of a resonance line in the visible part of the spectrum may be expected to be of the order of 10^{-8} sec, it is obvious that no afterglow could be observed in optically excited sodium or mercury vapor by any of the earlier methods. Not only did the mechanical phosphoroscopes fail, but Dunoyer was also unable to observe a shift of the luminescent spot in an atomic beam of sodium, in which resonance radiation was excited by irradiation (Figure 21) (323). The average atomic velocities at the temperature which he used

* For a full discussion of these and other methods, the reader may be referred to Mitchell and Zemansky's *Resonance Radiation and Excited Atoms*, chapter III.

are of the order of 10^4 or 10^5 cm per sec, and since a displacement of the upper edge of the luminous spot by less than 10^{-2} cm could not be detected, his experiment proved that 10^{-6} sec was the upper limit of τ . The lifetime of the very "improbable" intercombination resonance line of cadmium (3261A, $5^3P_1 \leftarrow 5^1S_0$) is larger than this value; it was actually possible to obtain the lifetime $\tau = 2.5 \cdot 10^{-6}$ sec for this line by means of Dunoyer's method, while the singlet resonance line of cadmium (2288A, $5^1P_1 \leftarrow 5^1S_0$) is far too short-lived for an experiment of this kind. The lifetime of the intercombination line of zinc (3076A, $4^3P_1 \rightarrow 4^1S_0$) is considerably longer (compare Section 14) but its transition probability is very low and the efficiency of resonance excitation is so small that the failure to detect an afterglow in an atomic ray of zinc vapor is easily explained (I532, I533).

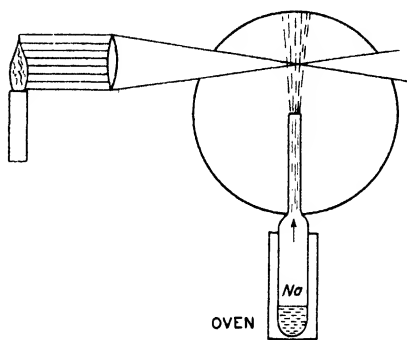

Fig. 21. Excitation of resonance radiation in an atomic beam (Dunoyer).

The mean life of the metastable state 6^3P_0 into which mercury atoms are transferred by the absorption of the resonance line and a subsequent collision with a nitrogen molecule is so long that it is accessible to measurements with a Becquerel phosphoroscope. It is possible to determine the period during which the visible triplet $7^3S_1 \rightarrow 6^3P_{0,1,2}$ can be excited "stepwise" in the vapor after the irradiation with light of wavelength 2537A has been interrupted. Furthermore, the line 2537A itself shows a measurable afterglow originating from atoms which are raised from the metastable state to the level 6^3P_1 by a renewed collision with a nitrogen molecule (27, 28, I252, I253). The values of τ determined in this way are of the order of magnitude of 10^{-3} to 10^{-2} sec; however, they do not correspond to the genuine "natural lifetime" of the metastable state, but only to its lifetime under the specific experimental conditions, such as quenching collisions, diffusion to the walls, etc. The true life of the state 6^3P_0 of the even mercury isotopes in the absence of all perturbations would be infinite. Mrozowski proved by observation of its hyperfine structure that the emission of the "forbidden line" 2656A ($6^3P_0 \rightarrow 6^1S_0$) occurs exclusively in the odd mercury isotopes. For these, the strict selection rule mentioned in Section 13 is invalidated so some extent by the

influence of the nuclear spin, so that the natural lifetime of their metastable state is of the order of magnitude of one second. Considering the great effective cross section of energy transfer between excited states of nearly equal energy (see Section 35), the energy stored in the 6^3P_0 -atoms of the even mercury atoms has a hundred percent probability of being transferred to an odd isotope even at low vapor densities and thus the lifetime of all mercury isotopes in the 6^3P_0 -state is only of the same order of magnitude as that of the odd isotopes (1071, 1081).

Experiments on the lifetimes of metastable states of other elements yielded similar results, but since these experiments consisted in absorption measurements in electrically excited gases, they are beyond the scope of this book.

The equation for the relation between fluorescence yield and lifetime (Section 4) was derived by Stern and Volmer originally with the purpose of determining the lifetimes of excited states. In order to obtain quantitative results, they assumed that every "gas-kinetic collision" between an excited and a quenching molecule* is a "quenching collision." It was shown later that this assumption is not correct in general, and, therefore, the principle is better adapted for finding the "effective quenching cross sections" of molecules if the values of τ have been determined by other measurements (1275, 1571).

The measurement of the degree of polarization of resonance radiation in magnetic fields provides a method which has been applied most frequently and successfully for the determination of the lifetimes of excited atoms in fluorescent vapors; this method is treated in Part E of this chapter. As far as the fluorescence of monatomic vapors is concerned, fluorimeters have been used only in the case of the D-lines of sodium, for which Hupfeld obtained a lifetime $\tau = 1.5 \cdot 10^{-8}$ sec, while Duschinsky found by the same method the appreciably smaller value of $\tau = 0.8 \cdot 10^{-8}$ sec. Duschinsky performed his experiments at a vapor pressure of $2 \cdot 10^{-6}$ mm (saturated at 135° C); he assumed that at the higher vapor pressure of $8 \cdot 10^{-5}$ mm (saturated at 190° C) which subsisted in Hupfeld's experiments the resonance radiation was partially "imprisoned," thus increasing the apparent duration of the emission process. Such an effect must actually occur, as will be discussed in the next section, but it is doubtful whether it can be made responsible for the discrepancy between the two measurements. All other methods by which the lifetime of the $3P$ -states of sodium can be

* α , in Equations (5)-(7), section 4, is in this special case the probability of quenching, i.e., the number of quenching collisions per second.

determined, produce values of τ which are in much better agreement with Hupfeld's than with Duschinsky's results (326,642).

Gaviola, and in more detail Weisskopf and Duschinsky, have discussed the question whether the results obtained by means of a fluorometer correspond to the real lifetimes of the excited states in resonance radiation; they all come to the conclusion that, under the prevailing experimental conditions, the method can be applied (327, 328, 1813, 1815).

23. "Imprisoned Radiation". Recoil of Excited Atoms. K. T. Compton, H. W. Webb, and at greater length E. A. Milne, have treated the problem of a radiation which is "imprisoned" in a volume of vapor because of multiple reabsorption and re-emission processes. It is a typical diffusion problem (232, 457, 590, 765, 766, 1030a). The result of the mathematical treatment is that when the number N of atoms per unit cross section between the entrance window for the exciting radiation and the exit window for the fluorescence radiation is increased, the apparent lifetime also increases. N is proportional to the vapor pressure p and thickness d of the layer of vapor and, under the simplest assumptions, the apparent value of τ is directly proportional to N . The theory has been tested by Hayner and by Zemanski for the mercury resonance line and has been corroborated, at least in a qualitative way, by the latter.* In his experiments the mercury vapor, saturated at different temperatures (60 to 130°C), was contained in plane parallel quartz cells 1.3 and 1.95 cm thick; the cells were placed between the rotating discs of a phosphoroscope, and values of τ were obtained which were of the same order of magnitude as those calculated according to Milne's theory. However, a comparison of the figures collected in Table 6 shows that increasing p or d does not have the same influence on the value of τ . Above a certain pressure, τ even drops again: collisions of excited atoms with other mercury atoms are able to quench the fluorescence. There are other reasons why the use of the mercury line 2537A makes the results of these observations rather ambiguous; as a matter of fact, the observed times of the afterglow may be caused by a number of complications quite unrelated to the "imprisonment" of radiation, for instance, the transfer of excited atoms into the metastable state 6^3P_0 , or the formation of Hg_2 -Molecules and the subsequent emission of the resonance line

* According to measurements by Webb and Messenger on electrically excited mercury vapor, the time during which the resonance radiation is imprisoned in the vapor becomes about ten times longer if the vapor pressure is increased from 10^{-4} to 10^{-3} mm. [*Phys. Rev.*, **33**, 319 (1929)].

following the dissociation of these molecules. These phenomena will be dealt with in a later section (206,590,1923).

Zehden confirms that the phenomenon of imprisoned radiation also begins to be noticeable in saturated sodium vapor above 170° C, but quantitative measurements are not available for this case (1921).

It has been suggested that the center of a resonance line should be displaced appreciably by the effect of many repeated processes of reabsorption and re-emission (Compton effect of optical radiation). An individual scattering process would produce a change in wavelength of the order of only 10^{-7}\AA , but the cumulative effect of a great number of such processes was supposed to produce a measurable change in the wavelength of a resonance radiation which had been imprisoned in a

TABLE 6
THE TIME OF AFTERGLOW τ OF IMPRISONED MERCURY RESONANCE RADIATION AS A FUNCTION OF VAPOR PRESSURE p AND OF THICKNESS OF VAPOR d

T (°C)	p (mm)	$d = 1.30$ cm		$d = 1.95$ cm	
		$N \cdot 10^{-15}$	$\tau \cdot 10^4$	$N \cdot 10^{-15}$	$\tau \cdot 10^4$
60	0.026	—	—	1.50	0.376
70	0.050	1.82	0.356	2.73	0.704
80	0.092	3.25	0.518	4.88	1.13
90	0.163	5.72	0.827	8.59	1.41
100	0.279	9.44	1.06	14.2	1.45
110	0.466	15.3	1.11	23.0	1.30
120	0.756	24.4	0.941	36.7	1.04
130	1.197	37.9	0.74	56.6	0.76

volume of vapor. It can easily be proved, however, that as long as the width of the line is determined by the Doppler effect or by collision-damping and not by radiation-damping (and this is the case for all experiments under discussion), a phenomenon of this type cannot occur, because on the average the successive Compton effects will not add up, but will compensate each other (413, 1032, 1181b, 1185, 1753).

Fritsch has shown experimentally that actually every absorption and emission process causes a recoil of the atom and, therefore, must also produce a Compton effect. He excited the resonance radiation in a narrowly defined atomic beam of sodium vapor by a light beam perpendicular to it, as in Dunoyer's older experiment (Figure 21). The atomic ray broadens symmetrically in the plane which is perpendicular to the direction of the exciting radiation, because the emission processes occur with equal probability in all directions within this plane. In the

direction of the exciting radiation, however, an unsymmetrical shift of the atomic beam is superimposed upon this broadening, because the absorption processes take place only from one side. The effects are very minute; they were rendered visible by the displacement of the spot where the atomic beam impinged on the receiving instrument, 20 cm distant from the point of excitation, using the exceedingly sensitive methods which have been developed for the investigation of molecular beams (440).

D. Polarization of Resonance Radiation in Magnetic Fields

24. Classical and Quantum-Mechanical Interpretation. The existence of a partial polarization of the resonance radiation which is excited by plane-polarized light has been the subject of some controversy. Eventually, Wood and Ellett found that it depended to a large extent on the presence of external magnetic fields which may be very weak and quite accidental, as well as on the direction of observation and, finally, on the nature of the individual resonance lines (351, 1344, 1888, 1896).

The vibrations of the electrical oscillators of the Lorentz theory must always follow the direction of the electric vector E of the exciting radiation, and thus the resonance light emitted by the oscillator must be polarized in the same direction as the primary radiation. This holds for any azimuth under which the fluorescence is observed. On the other hand, the intensity of the fluorescence is a function of the angle of the azimuth; it has its maximum in the direction perpendicular to E and tends, theoretically, towards 0 for the direction parallel to E .

Even excitation with unpolarized light should produce the emission of totally polarized fluorescence in the direction exactly perpendicular to the primary beam. In this case, the degree of polarization drops to zero if the fluorescence is observed in the direction of the exciting ray, while simultaneously its intensity becomes twice as large.

The absorption and emission of light by an anisotropic oscillator having the same frequency in all directions could not be treated by means of the classical theory without the introduction of rather artificial assumptions (compare Section 118).

The quantum theory in its original form was able to solve the problem of the polarization of resonance radiation only for atoms

which are subjected to the action of an external directional force, for instance, a magnetic field. In the absence of such fields the atoms are degenerate with respect to the quantum numbers which determine their orientation in space.

Hanle was the first to publish a short note in which he showed that Wood's and Ellet's striking observations could be interpreted in principle as caused by Zeeman effects in the absorption and emission processes. Making use only of the classical Lorentz model, he could not explain why the behavior of the mercury resonance line and of the D-lines differed so widely (570,571). Some time later, several investigators were able almost simultaneously, to give a complete interpretation of the experimental observations by means of quantum theory* (159,348,351,695,1142,1180,1282,1339). However, they made the assumption that the spectral terms split in the magnetic field according to the inner quantum number J , without taking into account the influence of the hyperfine structure. While this supposition yields, in general, correct results for the even isotopes, important discrepancies occur for odd isotopes, if the magnetic fields are not strong enough to produce a Paschen-Back effect of the hyperfine structure. In the following sections, this condition is supposed to be realized. However, many experiments have been executed with weak or even vanishing magnetic field strength; hence, the results sometimes seemed to disagree with the theory. These cases are dealt with in Part E (576).

25. The Mercury Line 2537A as Most Simple Example. Corresponding to the classical model, the ideal case would be a line showing the "normal Zeeman effect," a line of the type $^1P_1 \rightarrow ^1S_0$, for instance, the singlet resonance line of mercury (1849A). A line of this class has not yet been thoroughly investigated. No observations dealing with the polarization of the mercury line are available, and the publications on the corresponding lines of cadmium and zinc are far from being complete. However, for all questions to be considered here, the type represented by the mercury line 2537A is practically equivalent. The Zeeman triplet of this line in a strong magnetic field differs from the Lorentz triplet only by the "splitting factor" $g = 3/2$; the distances $\Delta\nu$ between the outer components and the undisplaced line are $3/2$ of those in the normal triplet for which $\Delta\nu = 4.7 \cdot 10^{-5}c \cdot H$ (c is the velocity of light in vacuo and H the magnetic field strength in gauss).

If a line of this type is excited by resonance in a magnetic field,

* As a matter of fact, a large part of this explanation was already contained in an earlier paper by Foot, Ruark, and Urey, but without applying it to Wood's and Ellett's experiments (406).

its behavior can be visualized easily by the assumption that each atom carries three oscillators of equal frequency: a linear oscillator e , vibrating parallel to H , and two rotors r_1 and r_2 , rotating in opposite directions, with their plane of rotation perpendicular to H . In Figure 22, E is the electric vector of the exciting light and H the vector of the magnetic field. The direction of the primary radiation is supposed to be parallel to the X -axis. The figure shows, for certain orientations of E and H (case I and case II), how only e or only the rotors r are excited, and how, in consequence,

the resonance radiation should be completely plane polarized if the direction of observation is parallel to the Y -axis. Wood's and Ellett's measurements yielded for the degree of polarization p of the mercury resonance line the values

$p = 90\%$ in case I and $p = 60\%$ in case II. Keussler obtained 80% in case I and 67% in case II. The discrepancy between theory and

experiment, at least as far as the large differences between cases I and II are concerned, is partly explained by the fact that the beams of primary and of secondary radiation are never strictly parallel. Hence, E is never exactly parallel to e or to the plane of the r 's. It is easily proved that case II is more influenced by this circumstance than case I (468). Keussler's measurements were made by a photoelectric method and were probably more accurate than the older photographic determinations, inasmuch as he he tried to eliminate all causes which might tend to decrease the degree of polarization. He assumed the discrepancies between his results and the theoretical values to be real (80% in case I instead of 100%), and was the first to propose the hypothesis that they were caused by the hyperfine structure of the line. A degree of polarization of nearly 100% (98.8%) could be obtained only when the magnetic field strength was raised to 700 gauss (773,774,1067,1896-1898).

Similarly, degrees of polarization much below 100% were found in weak magnetic fields for the resonance lines of cadmium, zinc, and calcium. And again, the polarization of the cadmium line 3261A increased in a strong magnetic field to 95% or nearly the theoretical value. Soleillet has shown that the polarization of this cadmium line is the same in stationary vapor or in an atomic ray, if the conditions

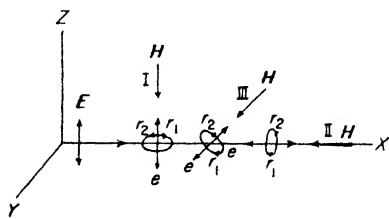

Fig. 22. Orientation of electric oscillators in a magnetic field H .

Y = direction of observation.

TABLE 7
DEGREE OF POLARIZATION p OF THE RESONANCE LINES OF
Cd, Zn, AND Ca

Metal.....	Cd .		Zn		Ca
Wavelength in Å	3261	2288	3076	2139	4227
p in %	87	76	67	74	76.5

of excitation are otherwise the same (1538). The measurements for the calcium line were made under rather unfavorable technical conditions (badly defined vapor pressure, presence of 3 mm of helium). It is, therefore, very doubtful whether the author was justified in extrapolating the experimental results to infinitely low vapor pressures, so as to arrive at a limiting value of polarization equal to 95% (354, 968, 1526, 1539, 1567).

Case II is cylindrically symmetrical with respect to the X -axis; therefore, the polarization of the fluorescence is in this case independent of the polarization of the exciting radiation.

If the orientation of H is varied continuously from position I to position II, it passes through a position III, in which the vector E excites the oscillators e and r with equal strength; hence, they emit radiation of equal intensity and the fluorescence light is completely depolarized. For orientations of H between I and III, and between II and III, respectively the azimuth of polarization is rotated continuously from the direction of the X -axis or of the Z -axis, respectively, into the direction III, while the degree of polarization drops simultaneously from its maximum value down to $p = 0$. Figure 23 shows the excellent agreement between the calculated and the observed values of p . The points on the curve are the measured values at the angle φ between H and Z ; the curve itself is derived from the equation:

$$p = (7.5 \cos^2 \varphi - 3.75 \sin^2 \varphi) / (9.5 \sin^2 \varphi - 5.75 \cos^2 \varphi) \quad (16)$$

The numerical coefficients are chosen so that for $\varphi = 0^\circ$, 55° , and 90° , $p = 79\%$, 0% , and 65% , corresponding to the values which had been observed for these angles (1176).

Similarly, the degree of polarization of the resonance radiation can be worked out for any other relative orientation of H and E , in good agreement with the experiments.

Case IV, in which H is parallel to the direction of observation (parallel to the Y -axis in Figure 22), is of particular interest for small

values of H . Only the two circularly polarized waves which have opposite directions of revolution and are emitted by the two rotors r_1 and r_2 are observed under these conditions. In a weak magnetic field, these two components cannot be resolved by ordinary spectroscopic methods; none the less, their frequencies are slightly different. Therefore, the relation between their phases is not constant and the fluorescence is more or less depolarized. If, however, the radiation emitted

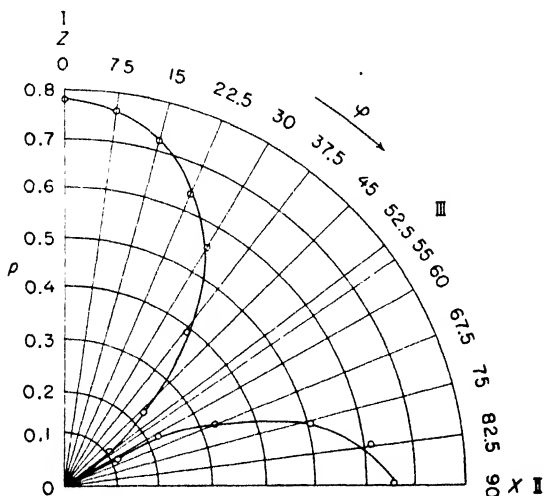

Fig. 23. Polarization of Hg-resonance radiation as a function of φ , the angle between H and E (Olsen).

in the direction of the Y -axis by a resonance lamp (with E parallel to Z and H parallel to Y , according to case IV) is passed through an absorption cell containing mercury vapor, the resonance radiation is not absorbed if this cell is subjected to a magnetic field H' , of equal strength but antiparallel to H ; the radiation is strongly absorbed if H and H' are parallel. This experiment proves that the apparently unpolarized fluorescence of case IV really consists of two circularly polarized, very close components. If the same experiment is repeated with H and H' parallel to X (as in case II), a reversal of the direction of H' has no effect on the absorption of the fluorescence radiation; this last observation shows that no angular momentum is transferred from the circular oscillators to the field of radiation, if the quanta are

emitted in a direction perpendicular to the lines of force of the magnetic field* (transversal Zeeman effect) (439).

Kastler has repeated these experiments with the same results for the D-lines of sodium vapor. It should be mentioned that the principle of the method had been independently suggested by Ruark and Urey (725,1388).

26. Anomalous Zeeman Effects. The simple model used in the last section does not avail for the representation of more complicated Zeeman effects and of the resulting polarization of fluorescence

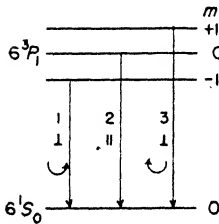

Fig. 24.
Magnetic sublevels
for the Hg-line 2537A.

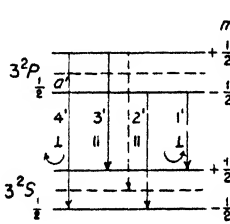

Fig. 25.
Magnetic sublevels
for the Na-line D_1 .

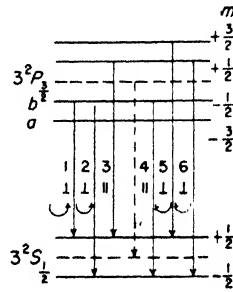

Fig. 26.
Magnetic sublevels
for the Na-line D_2 .

radiation. Experimental observations are easily interpreted, however, by introducing the well-known Landé schemes of magnetic energy sublevels into which the various levels of a Grotrian diagram split under the action of a magnetic field. Zeeman schemes of this type are reproduced in Figures 24 to 27 for the mercury resonance line, for the two D-lines, and for the green thallium line. Transitions in which the magnetic quantum number m remains constant correspond in these schemes to emission or absorption of radiation plane polarized parallel to H (π -components); transitions in which m is altered by ± 1 correspond to circular polarization (σ -components). If, by an absorption process, the atom is raised to a Zeeman level from which only π - or only σ -transitions originate, the secondary radiation is totally polarized (as in Figure 24). If transitions of both kinds can originate from the

* It is not yet possible to decide whether some qualitative experiments communicated by Yen are connected with Fritsch's experiments, which have been related above. Yen found that the intensity of the resonance radiation emitted by an atomic ray of mercury varied according to whether a magnetic field was oriented parallel or antiparallel to the exciting beam (1919).

excited level (as in Figures 25 to 27), the secondary radiation is partially or completely depolarized, even if the exciting light is completely plane polarized. The degree of polarization can be computed from the relative probabilities of the individual transitions which occur from the various excited levels. Thus, the fluorescence of the D_1 -line should, according to Figure 25, always be completely unpolarized, as has been confirmed experimentally. On the other hand, the D_2 -line is partially polarized in cases I and II (467, 1282). If the theoretical values for the relative intensities of the Zeeman components are used for the evalu-

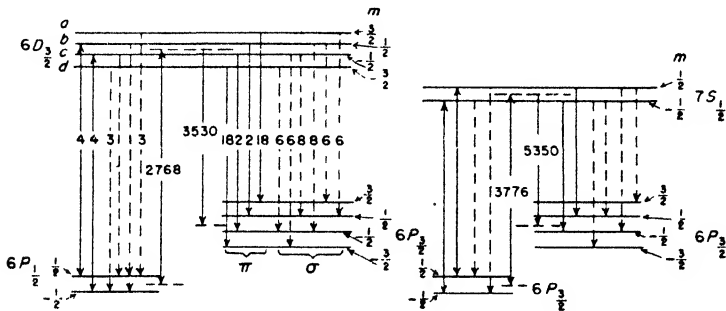

Fig. 27. Magnetic sublevels for the Tl-line 5350A [Guelke (547)]. The numbers indicate the relative intensities of the components.

ation of p , without taking into account the influence of hyperfine structure, the degree of polarization of D_2 is 60 % in case I and 42 % in case II.

If, as in most experiments, the two D-lines are not separated, and if it is assumed that the ratio of the intensities of D_1 and D_2 is 1:2 in the spectrum of the exciting radiation as well as in the absorption spectrum of the resonance lamp, the intensity of D_1 would be only $1/4$ of the intensity of D_2 in the resonance radiation. The resulting polarization of the total resonance radiation would be 50 % in case I (351, 352).

In strong magnetic fields (H larger than 150 gauss), Datta obtained $p = 58 \%$, using D_2 alone for excitation, and Larrick obtained $p = 46.25 \%$ under excitation with both D-lines in a magnetic field of 350 gauss. The agreement with the theoretical values is good, inasmuch as in Larrick's experiments the intensity of D_1 was probably greater than has been assumed, thus decreasing the observed value of p . In weak magnetic fields ($H = 10$ gauss), however, Ellett and his collaborators never succeeded in finding a degree of polarization greater

than 16.3 % under excitation with both D-lines, corresponding to $p = 21$ % under excitation with D_2 alone.

The degree of polarization of the resonance radiation is greatly dependent on the vapor pressure. According to Datta, the polarization of the D_2 -line resonance tends with decreasing sodium vapor pressure toward 60 % even in vanishing magnetic fields. The lowest pressure at which he was actually able to make a measurement was $3 \cdot 10^{-7}$ mm at 115° C and the correspondent p value in magnetic fields below 1 gauss was 33 %. Ellett's and Larrick's latest measurements, however, were made at an even lower vapor pressure (10^{-8} mm at 80° C), with the results mentioned above (259,353,866).

At the time of their publication Datta's results were in closer agreement with the theoretical expectations. However, because of the influence of the hyperfine structure, these were correct only for strong magnetic fields. In a field of 12,000 gauss Ellett even obtained a degree of polarization of 100 % for the resonance emission of the D_2 -line. With the lines of force parallel to the exciting beam (case II), only the two inner σ -components (2 and 5) were excited, while the two outer σ -components (1 and 6) were displaced so much that they were not covered by the narrow line in the primary radiation. Thus, no atoms were brought into the magnetic levels corresponding to $m = +\frac{1}{2}$ and $m = -\frac{1}{2}$ and the π -components were completely missing in the secondary emission. (Compare Figure 26).

For the second unresolved doublet of the main series of sodium excited with nonpolarized radiation, Ellett and Heydenburg found the polarization to be 30 % in a magnetic field of 80 gauss oriented as in the last experiment. This is again in satisfactory agreement with theory. In a vanishing magnetic field the polarization dropped to 10 %.

27. Negative and Circular Polarization. If the exciting absorption and the fluorescence emission correspond to different electronic transitions, the polarization of the fluorescence can become negative: the fluorescence can be partially polarized in a direction perpendicular to the polarization of the primary light. Of the four lowest electronic levels of thallium shown in Figure 9, $^2S_{1/2}$ splits into two magnetic sublevels according to the rules of Section 12. Hence, the emission lines originating from $^2S_{1/2}$ must always be completely depolarized, like the D_1 -line of sodium. $^2P_{1/2}$ splits also into two sublevels, while $^2P_{3/2}$ and $^2D_{3/2}$ are resolved into four magnetic levels. The line $6^2D_{3/2} \rightarrow 6^2P_{1/2}$ behaves, therefore, as far as the Zeeman effect and the polarization are concerned, like the sodium D_2 -line. If thallium vapor is excited by the absorption of the line 2768A under the conditions of case I, transitions

occur only to the magnetic levels *c* and *b* of the state ${}^2D_{3/2}$ (Figure 27). The intensity of the σ -components of the line 3530A, which originates from these magnetic levels, is much larger than that of the π -components, and thus the fluorescence line 3530A is, under these conditions, partially polarized parallel to *X*, while the exciting light is polarized parallel to *Z* (547).

TABLE 8
DEGREE OF POLARIZATION OF THALLIUM LINES
IN A MAGNETIC FIELD (CASE I)

Wavelength in Å	p in %			
	p , observed	p , computed without h.f.s.	p , computed with h.f.s.*	
2768	+ 35	+ 60	+ 33.3	+ 35.1
3530	- 60	- 75	- 41.8	- 48.8
3776	0	0	0	0
5350	0	0	0	0

* h.f.s. = hyperfine structure.

The lines of the visible mercury triplet show a behavior similar to that of the thallium lines, though the case is still further complicated by stepwise excitation. If the resonance lamp contains nitrogen, the ground level for the second absorption process is almost exclusively the metastable state 6^3P_0 , which does not split up in a magnetic field. Under excitation by the isolated line 4047A, only the magnetic level $m = 0$ of the state 7^3S_1 is reached in case I. In the subsequent fluorescence emission the line 4047A should theoretically (and disregarding the h.f.s.) show a positive polarization of 100%. The polarization of the line 4358A should, under similar conditions, also be 100%, but negative, since only the two σ -components *f* and *g* of Figure 28 contribute to the emission (the transition $\Delta m = 0$ being forbidden for $\Delta J = 0$); finally, the polarization of the line 5461A should, under these conditions, be + 14.3%. Table 9 shows a comparison between the experimental results obtained by Richter and the theoretical values. In case II, which has not been investigated quantitatively, the line 4047A should again have a positive polarization of 100%, while the line 4358A should show a partial negative polarization because of the relatively greater intensity of the π -components (578,729,1037,1357,1530,1531).

If no nitrogen is present, the state 6^3P_1 , which is directly reached by the absorption of the resonance line, becomes the starting level for

TABLE 9

DEGREE OF POLARIZATION OF THE MERCURY TRIPLET LINES $7^3S_1 \rightarrow 6^3P_{0,1,2}$
IN A MAGNETIC FIELD (CASE I), EXCITED STEPWISE,
IN THE PRESENCE OF NITROGEN

p in %

Wavelength in Å	p , observed	p , calculated without h.f.s.	p , calculated with h.f.s.
4047	+ 77	+ 100	+ 84.7
4358	- 48	- 100	- 44.6
5461	+ 13	+ 14	+ 3.4
2957	+ 75	+ 100	+ 84.7
3131	- 22	- 100	- 44.6
3663	+ 45	+ 14.3	+ 3.4

the second absorption process. 6^3P_1 splits into three magnetic levels (Fig. 28), of which (because of $\Delta m = \pm 1$) only the levels $m = +1$ and $m = -1$ are populated in case II. From there, level $m = 0$ of the state 7^3S_1 alone can be reached by absorption of the line 4358

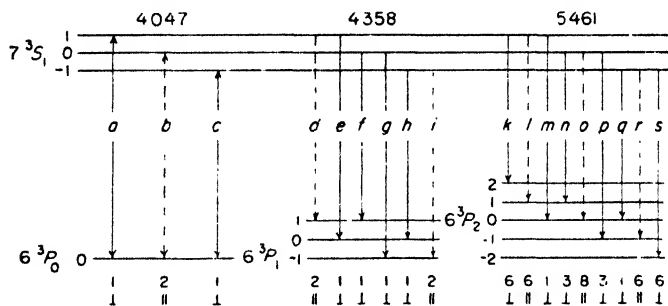

Fig. 28. Magnetic sublevels for stepwise-excited Hg-fluorescence [Richter (1357)]. The numbers below the diagram indicate the relative intensities of the components.

under the condition that, again, $\Delta m = \pm 1$. Only the σ -components f and g of the line 4358 and the π -component of the line 4047 originate from this level, so that now the line 4358 is positively, and the line 4047 is negatively, polarized. This was actually observed by Kastler; if nitrogen was admitted into the observation chamber, the sign of the polarization of the two lines was reversed (728).

The phenomena would be still further complicated if pure mercury vapor were excited stepwise by the two lines 2537 and 4358A,

polarized with their electric vectors perpendicular to each other. This problem has been suggested by Kastler, but, so far, no measurements have been made (726).

Richter measured the degree of polarization of the line 4358A under stepwise excitation in the presence of nitrogen for various orientations of the vectors E and H . He investigated, also, the polarization of the ultraviolet triplet $7^3D_1 \rightarrow 6^3P_{0,1,2}$ (2967, 3131, and 3663A) (compare Table 9). The result of all these investigations was that the observed polarization agreed qualitatively with values predicted by theory, especially as far as the sign was concerned, while there were numerous and considerable quantitative discrepancies (7357).

The excitation of resonance radiation by circularly polarized light produces results of particular simplicity if the direction of observation, the direction of the magnetic field, and the direction of the primary radiation coincide. Under these conditions, only the transitions corresponding either to $\Delta m = +1$ or to $\Delta m = -1$ are excited, depending on the sense of rotation of the electric vector of the primary light. From the magnetic levels populated by these transitions the same σ -components which were absorbed are re-emitted. A π -component, which may also be emitted, contributes no radiation in the direction of observation.* Hanle obtained complete circular polarization of the mercury resonance line excited under these conditions and a circular polarization of 87% for the two D-lines of sodium vapor in a longitudinal magnetic field of 600 gauss. The unimportant deviation from the theoretical value in the second case was due to the incomplete parallelism of the primary and the secondary radiation (573).

The analogue to "negative" polarization is provided also in this instance by the green thallium line, when it is excited by absorption of the ultraviolet line 3776A. If the exciting light is polarized circularly clockwise, the partial polarization of the fluorescence is counterclockwise and vice versa (574). Stepwise excitation of the triplet lines of mercury by circularly polarized light produces, again, similar effects. Kastler has investigated the phenomena arising when circular polarization is applied in both stages of the excitation process in the absence of nitrogen. In his experiments, circularly polarized radiation of wavelength 2537 and 4358A entered a resonance lamp through opposite windows; a magnetic field of 10 gauss was applied with its lines of force parallel to the exciting beams. If the circular polarization of

* This is correct only if $J = 0$ or $J = \frac{1}{2}$ for the ground state; the condition is, however, fulfilled in all cases which are treated in this section.

the primary radiation of wavelength 2537 is counterclockwise, corresponding to $\Delta m = +1$, the excited level of 6^3P_1 has the magnetic quantum number $m = +1$, since the magnetic quantum number of the ground state is 0. No magnetic level with the quantum number $m = 2$ exists in the state 7^3S_1 to which the atom is raised from 6^3P_1 by the subsequent absorption of the line 4358A. Hence, no stepwise excitation is possible under these circumstances if the circular polarization of the primary radiation of wavelength 4358A is also counterclockwise. If, however, the polarization of this radiation is clockwise, stepwise excitation does occur, since, because $\Delta m = -1$, the atom is raised into the actually existing magnetic level of the state 7^3S_1 with the quantum number $m = 0$.* These oversimplified theoretical predictions are not quite correct, due to the influence of hyperfine structure. However, Kastler found experimentally that the emission of the line 4358A was very much stronger if the circular polarization of the two exciting lines had opposite signs (727-729).

28. Vanishing Magnetic Fields. It has already been mentioned that quantum theory was at first unable to make any predictions regarding the polarization of resonance radiation in the absence of an external force which determines the spatial orientation of the atoms. Since the conditions prevailing for $H = 0$ can be arrived at by the adiabatic disappearance of a field of fortuitous orientation, it seemed natural to expect that with no magnetic field the degree of polarization should be lower than with a magnetic field oriented as in case I or II. If the local magnetic fields caused by the surrounding atoms are oriented at random, one should, according to Heisenberg, obtain for the mercury resonance line $\rho = 27\%$ (instead of 100%), for D_2 , $\rho = 14\%$ (instead of 60%), and for D_1 , $\rho = 0$ (595). This calculation did not take the hyperfine structure into account. However, Wood and Ellett had found, in their earliest experiments, the same degree of polarization of the mercury resonance line for case I in strong magnetic fields and with $H = 0$. Keussler confirmed this result and measured the angular intensity distribution of the resonance radiation in the plane perpendicular to the direction of the exciting radiation (plane $Y-Z$) under the same conditions. If the fluorescence emitted in the direction Y were totally plane polarized, its intensity should drop to zero in the direction Z . Actually, it drops to about $1/10$ of the maximum intensity. The total intensity distribution can be represented by the superposition of an unpolarized radiation I_n , which does not depend on the direction

* The light emitted from this level has partially clockwise and partially counterclockwise circular polarization, resulting in complete depolarization.

of the observation, and a plane-polarized radiation I_p , according to the equation:

$$I = I_n + I_p \sin^2 \varphi \quad (17)$$

φ is the angle between the direction of observation and E. Neglecting the term I_n , which could not be explained at that time, Equation (17) represents exactly the angular intensity distribution of the radiation which an isotropic oscillator would emit under the action of an incident plane-polarized wave. This distribution would not be changed by the presence of a magnetic field with lines of force parallel to the oscillations (H parallel to E). Therefore, Bohr introduced the new hypothesis into quantum theory that, in the absence of space quantization by an external field, the radiation of an atom should have the same polarization as the radiation emitted by a corresponding classical oscillator under the action of a magnetic field which would not influence the vibration of the oscillator (128).

In this form the rule cannot be applied to atoms with anomalous Zeeman effects, since no classical oscillator with corresponding properties exists. Heisenberg generalized the rule in the following way: in the absence of an external field, the polarization of the radiation of an atom is the same as in the presence of a magnetic field which leaves the total symmetry unaltered. If the primary radiation is plane polarized, H should be parallel to E; if the primary light is unpolarized or circularly polarized, H should be parallel to the direction of the exciting light ray (595). This law of "spectroscopic stability" holds, of course, only if the auxiliary magnetic field is not strong enough to produce a Paschen-Back effect of the hyperfine structure. Only then the complete disappearance of the magnetic field leaves the conditions unaltered.

29. Influence of Hyperfine Structure on Polarization of the Resonance Radiation. Ellett and McNair proved that the anomalous Zeeman effects of individual hyperfine-structure components of the mercury resonance line cause the difference between the polarization which is observed in a field-free space and the expectation of the primitive theory (355,358,969,1040). On spectrograms obtained with a Lummer-Gehrke plate, the degree of polarization of components $-10.4, 0,$ and $+11.5$ appeared to be practically 100% for vanishing values of H under the conditions of case I. Simultaneously, the degree of polarization of components -24.5 and $+21.5$ was certainly below 60%. Figure 19 shows that component -24.5 is exclusively, and component $+21.5$ mainly, due to the odd isotopes Hg^{199} and Hg^{201} . The nuclear momenta of these components are $i = 1/2$ and $3/2$, re-

spectively, and their magnetic quantum numbers are, therefore, not to be derived from J but from $f = J + i$. The f -values in Figure 20 show that component A of Hg^{199} has a Zeeman effect of the same type as D_1 , and component B one of the same type as D_2 (Figures 25 and 26, in both cases neglecting the h.f.s. of the D-lines). Hence, $p = 0$ for component A and $p = 60\%$ for component B . Making use of similar considerations, the degree of polarization of components a , b , and c of the isotope Hg^{201} can be determined. b coincides with the single line of the isotope Hg^{198} , which is thereby slightly depolarized. The total polarization of the unresolved mercury resonance line can be computed from these data if the relative concentration of the isotopes and the intensity distribution of the h.f.s.-components in the exciting radiation are taken into account. Two limiting cases are relatively easy to deal with. Either the resonance line in the primary radiation is so broad that its intensity can be regarded as being constant over the whole width of the hyperfine structure of the absorption line, or the primary light source is itself a resonance lamp, and the intensity distribution of the exciting line is the one represented in Figure 19. In the first case the degree of polarization of the unresolved radiation is, according to the calculation of Larrick and Heydenburg, 84.7%, while in the second case it is 88.7%. This explains the decrease of the degree of polarization of the mercury resonance line which Olson observed with increasing current density in the exciting mercury arc.

Table 10 lists the calculated degree of polarization of the individual components for the first case.

TABLE 10
DEGREE OF POLARIZATION CALCULATED FOR THE H.F.S.-COMPONENTS OF
THE MERCURY RESONANCE LINE

Component	+ 21.5	+ 11.5	0	-- 10.4	-- 25.4
p in %	55.9	100	100	84.8	51.4

If the lines in the spectrum of the primary light source are more or less self-reversed, the intensities of the single components belonging to the most abundant isotopes, Hg^{200} and Hg^{202} , are much more reduced than those of the components belonging to the odd isotopes. Under such conditions, the resulting polarization of the unresolved resonance radiation may be much smaller than the values calculated by Larrick and Heydenburg (358,867*a*,969,1176,1936).

The agreement between the observed degree of polarization and the values calculated from the hyperfine structure is much less

satisfactory for the stepwise-excited Hg-triplets $7^3S_1 \rightarrow 6^3P_{0,1,2}$ and $7^3D_1 \rightarrow 6^3P_{0,1,2}$ (compare Table 9). The discrepancies, which are particularly large for the transitions leading to 6^3P_2 (the lines 5461 and 3663A), certainly exceed the errors which can occur even in the determination of rather small degrees of polarization. Nor is it probable that they are caused by anomalous intensity distribution in the exciting line, for instance, by strong self-reversals and it seems likely that still unknown factors have to be taken into account.

The cadmium lines 2288 and 3261A differ from the mercury resonance line in that most of their h.f.s.-components are exceedingly close. The components of the line 2288A have not yet been resolved spectroscopically; the line 3261A has three components ($\Delta\lambda = \text{---}18.0, 0, +17 \cdot 10^{-3}\text{A}$), which are evidently due to the splitting of the upper level 6^3P_1 , since the ground state 6^1S_0 is common to both lines. However, the fact that the degree of polarization of the line 2288A never exceeds 76.3% for $H = 0$ proves that also for this line an influence of hyperfine structure has to be considered (357). According to Schueler, the nuclear spin of the odd isotopes of Cd is $i = 1/2$. Taking this value for granted, it is possible to work out the relative concentration γ of the even and the odd isotopes from the measured degree of polarization of the line 2288A. From the value $\gamma = 2.6$ which is obtained by this method, the degree of polarization of the other resonance line can be computed; the value thus calculated (86.4%) is in excellent agreement with the observed values (86 to 87%)* (1525, 1534).

Because of the small separation of the components of the cadmium h.f.s.-levels, the Paschen-Back effect occurs in relatively weak magnetic fields. Table 11 shows p as a function of H . For $H = 563$ gauss, the influence of the hyperfine structure is practically eliminated and the theoretical value of $p = 100\%$ is almost reached (609, 1039, 1536).

From the curve representing p as a function of H , separation of the h.f.s.-levels of the term 5^3P_1 , which has not yet been determined directly, can be derived; the calculated value is $12.6 \cdot 10^{-3}\text{A}$.

The influence of the hyperfine structure causes a relatively strong depolarization of the resonance radiation of Tl and Na, which consist exclusively of odd isotopes. From the nuclear spin $i = 1/2$ which is

* From the relative intensities of h.f.s.-components of other Cd-lines, Schueler derived $\gamma = 3.34$. The corresponding values of $p = 80.5\%$ for the line 2288A and $p = 89\%$ for the line 3261A can hardly be brought into agreement with the observations.

TABLE 11
 INCREASING POLARIZATION OF RESONANCE RADIATION IN STRONG
 MAGNETIC FIELDS CAUSED BY THE PASCHEN-BACK EFFECT OF HYPERFINE
 STRUCTURE

Cd 2288A		Na D ₁ + D ₂	
H in gauss	p in %	H in gauss	p in %
0	76.7	0	16.48
75	77.3	10	16.3
149	79.9	20	21.37
200	82.5	50	34.54
255	86.2	70	38.86
315	89.1	90	43.0
375	92.1	170	45.7
563	95.0	315	46.25
(\sim)	(100)	(\sim)	(50)

ascribed to both Tl-isotopes, Tl²⁰³ and Tl²⁰⁵, the degrees of polarization which are listed in Table 8 were derived by Ellett. For the figures under *a*, the exciting line is assumed to be resolved into its h.f.s.-components, while for those under *b*, the intensity is supposed to be constant over the whole width of the absorption lines. If a value of *i* larger than $\frac{1}{2}$, for instance $i = \frac{3}{2}$, were to be ascribed to one of the isotopes, the depolarization of the Tl-lines in Table 8 would become even larger. The agreement between the calculation and the experimental results is very poor; the latter would actually fit best with the nuclear spin number $i = 0$ (as in the case of no h.f.s.), which is certainly not correct (355).

Sodium is known as a "pure" element with atomic weight 23. It should, therefore, be possible to derive the nuclear spin momentum *i* directly from the observed degree of polarization of the resonance radiation, without the introduction of any additional hypothesis. The value found by Datta for the maximum polarization in the absence of a magnetic field is in complete contradiction with all other measurements (259). Leaving it out of consideration, the best value for the unseparated D-lines seems to be $p = 16.3\%$ or, for D₂ alone, 21%. This leads directly to $i = 1$. From other experiments (Stern-Gerlach effect and analysis of the Na₂-bands), the momentum $i = \frac{3}{2}$ is obtained. This, in turn, would correspond to $p = 15.4\%$ for the unresolved D-lines, which differs from the experimental value by more than the possible error. However, the h.f.s.-separation of the $3^2P_{3/2}$ -state of sodium is small, even in comparison to the natural width of the line which corresponds to the lifetime of the excited state $3^2P_{3/2}$.

($\tau = 1.6 \cdot 10^{-8}$ sec). Therefore, the h.f.s.-levels overlap and a resulting degeneration of the quantization must be taken into account. Doing this, Larrick obtained $p = 16.25$ for $i = 3/2$, in complete agreement with the observations (356,611,612,866,867). As in the case of cadmium, above, the distance between the h.f.s.-levels of Na $3^2P_{3/2}$ can be calculated from the change of the degree of polarization with increasing magnetic field strength; the value thus obtained is $\Delta\nu = 1.45 \cdot 10^{-4} \text{ cm}^{-1}$ (compare Table 11).

The observed degree of polarization of 9.2% for the second doublet of the main series of sodium also does not agree with the nuclear momentum $i = 3/2$, if no correction corresponding to the natural width of the lines is introduced. Assuming a line width corresponding to the plausible lifetime $\tau = 3.05 \cdot 10^{-8}$ sec for 4^2P , the theoretical value of p becomes exactly 9.2%.

The degrees of polarization of the resonance radiation of rubidium (second doublet at 4202/15Å) and cesium (first and second doublets at 8521 and 4555Å) correspond to nuclear momenta which agree approximately with the values derived from other experiments (32,610).

Summarizing, it can be said that the disagreements between the observed degrees of polarization and the original calculations are in the main caused by the influence of hyperfine structure. However, a number of discrepancies are still unexplained and the deviations can be completely accounted for only in those rare cases in which the nuclear momentum is known from other sources and in which the conditions are otherwise fairly simple as, for instance, for sodium.

E. Determination of τ from the Degree of Polarization in Weak Magnetic Fields

30. Principle of the Method. In case IV, with the exciting radiation plane polarized parallel to Z and the magnetic field in the direction of observation, parallel to Y, the secondary radiation was assumed to consist of two incoherent circularly polarized components. This cannot remain true for very small field strengths, because, otherwise, the weakest magnetic field in the direction of observation would be sufficient for complete depolarization of the fluorescence. With vanishing field strength the degree of polarization must always tend towards the same limiting value, irrespective of the direction of the field. Actually, the depolarization of the resonance radiation is small in case IV, as long as the magnetic field is weak, and this depolarization Pringsheim 3**

is accompanied by a rotation of the plane of polarization. Both effects increase with increasing field strength, and the last remainder of linear polarization disappears only when H exceeds a critical value, which differs greatly for various lines.

Hanle explained this phenomenon on a semiclassical theoretical basis. Though his model cannot be claimed to be rigidly correct, it has the great advantage of being easily visualized. Hanle assumed that a linear "virtual oscillator" is excited instantaneously with maximum amplitude by the absorption of one quantum $h\nu$. From there on, the amplitude of the oscillator decreases continuously according to classical radiation-damping. If an oscillator of this nature is placed in

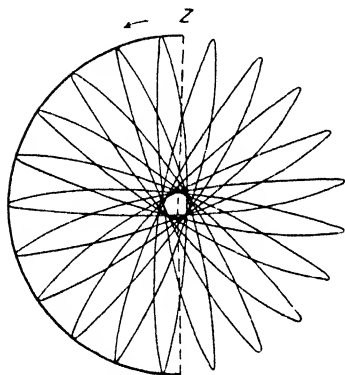

Fig. 29. Precession of linear electric oscillator in a strong magnetic field perpendicular to E (Hanle).

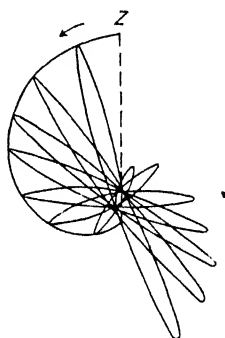

Fig. 30. Precession of a damped linear electric oscillator in a weak magnetic field perpendicular to E (Hanle).

a magnetic field H , the lines of force being perpendicular to the vibrations of the oscillator, it precesses like a spinning top around the lines of force. The resulting movement is a rosette of the type shown in Figure 29. The rotational frequency of this "Larmor precession" is:

$$O = H \cdot e / 2c \cdot m \quad (18)$$

If the frequency of the precession is so small that the amplitude of the oscillation decreases appreciably during a complete revolution, the rosette does not retain its circular symmetry (Figure 30). A preferential orientation of the electric vector prevails which is, however, rotated by an angle d with respect to the initial direction of polarization Z . The larger the lifetime τ , the smaller is the field strength

which causes a complete rotation of the oscillator without appreciable loss of amplitude, and thus effects complete depolarization (571).

It has since been shown that the strictly classical treatment of the behavior of an isotropic oscillator with normal Zeeman effect and the quantum-theoretical treatment of the general case lead to the same results (159-161, 164, 1742).

In general, the left side of Equation (18) must be multiplied by the "splitting factor" g , which is, as already mentioned, $3/2$ for the mercury resonance line 2537A and for the analogous lines of other metals (Cd, Zn, Ca); it is $2/3$ for the line D_2 of sodium.

If p_0 is the degree of polarization in the absence of a magnetic field, a magnetic field H in the direction of observation reduces the degree of polarization to:

$$p = p_0 / \sqrt{1 + (2og\tau)^2} \quad (19)$$

Simultaneously, the angle d , by which the plane of polarization is rotated, becomes:

$$d = \frac{1}{2} \arctan 2o\tau \quad (20)$$

If the "apparent degree of polarization" p_z is measured instead of p (compare Section 8), Equation (19) has to be replaced by:

$$p_z = p_0 / [1 + (2og\tau)^2] \quad (19a)$$

31. Experimental Results. The validity of these formulas has been checked quantitatively by Keussler and by Olson for the mercury

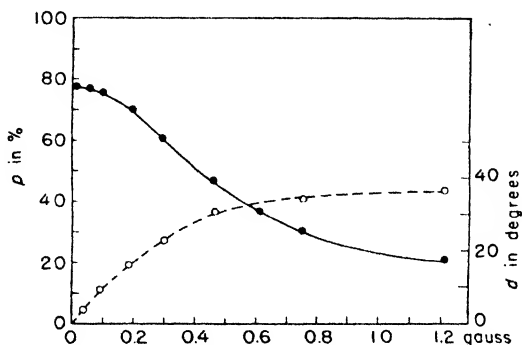

Fig. 31. Depolarization (continuous line) and rotation of plane of polarization (broken line) of Hg-resonance radiation observed in the direction parallel to the magnetic field H (Keussler).

resonance line. Here also, the influence of the h.f.s. must be taken into account. Assuming that the value of τ was identical for all h.f.s.-levels of the state 6^3P_1 Mitchell derived a theoretical curve which agrees within the limits of error with the curve of Figure 31, which was obtained under the assumption that there is only one kind of isotope with $i = 0$, and that, for reasons unknown, the polarization is only 80 % instead of 100 % for $H = 0$ (772,1176).

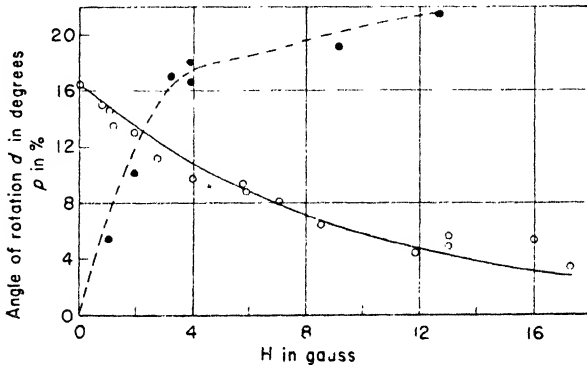

Fig. 32. Depolarization (continuous line) and rotation of plane of polarization (broken line) of sodium resonance radiation observed in the direction parallel to the magnetic field H .

Mrozowski determined the angle d as a function of H for the h.f.s.-components of the mercury line excited separately, and derived from these measurements lifetimes for the various levels of 6^3P_1 , which differed from each other by almost 50 %. It must, however, be taken into consideration that the splitting factor for the Zeeman effect of the isotope Hg^{199} is not $3/2$ but 1; introducing this correction, Mitchell has shown that Mrozowski's measurements prove directly that all h.f.s.-levels have the same lifetime (1040,1071).

Olson used a second method for the determination of the value of τ for the mercury resonance line. The exciting light was polarized parallel to the direction of observation Y , and H was parallel to Z . For reasons of symmetry p , under these conditions, must be zero for $H = 0$, and the observed fluorescence intensity must be due exclusively to the odd isotopes. With increasing field strength, the σ -components of all isotopes are increasingly excited and a maximum degree of polarization parallel to X is obtained at high field strengths. The value $\tau = 0.98 \cdot 10^{-7}$ sec obtained by Olson is appreciably below

Keussler's value: $\tau = 1.1 \cdot 10^{-7}$ sec, but Mitchell showed that Olson's results can be represented satisfactorily by a value of $\tau = 1.08 \cdot 10^{-7}$ sec (1176).

If the lifetime of an excited state is shorter, stronger magnetic fields must be applied to obtain a certain degree of depolarization or a certain angle of rotation d . A comparison of the scales of abscissas used in Figures 31 and 32 shows at once that the life of the D-lines is considerably shorter than the life of the mercury resonance line, which is an intercombination line with a smaller transition probability. The lifetimes of the intercombination resonance lines of cadmium and zinc are longer still, and, therefore, much weaker magnetic fields in the direction of observation suffice for a complete depolarization of the fluorescence (1533, 1535, 1540, 1791b). On the other hand, the lifetimes of singlet resonance lines which originate from the states 1P_1 are a great deal shorter.

TABLE 12
LIFETIMES OF EXCITED STATES OF Hg, Cd, Zn AND Ca
(τ in sec.)

Combining terms	$^3P_1-^1S_0$			$^1P_1-^1S_0$		
	Hg	Cd	Zn	Cd	Zn	Ca
Resonance line (in Å) .	2537	3261	3076	2288	2139	4227
H^* in gauss .	0.4	0.02	$5 \cdot 10^{-4}$	150	?	17
τ derived from H^* . .	$1.1 \cdot 10^{-7}$	$2.3 \cdot 10^{-6}$	10^{-5}	10^{-8}	?	$3.5 \cdot 10^{-9}$
τ derived from other methods . .	$1.08 \cdot 10^{-7} \dagger$ $1.14 \cdot 10^{-7} \dagger$	$2.5 \cdot 10^{-6} \S$ $2.14 \cdot 10^{-6} \parallel$		$2 \cdot 10^{-8} \%$	$< 10^{-7} \dagger \dagger$	

† Garrett, alternating voltage method; Kopfermann and Tietze, absorption.

‡ Ladenburg and Wolfsohn, anomalous dispersion.

§ Kuhn, magnetic rotation; Koenig and Ellett, atomic beam method.

|| Webb and Messenger, alternating voltage method.

% Kuhn, magnetic rotation; Zemansky, absorption.

†† Soleillet, atomic beam method.

All observations concerning measurements of lifetimes by fluorescence methods are collected in Table 12. The "half-value field strength" H^* is the field strength by which the degree of polarization is reduced to one half of its value in the absence of a magnetic field.

The relation between H^* and τ according to Equations (18) and (19), is:

$$\tau = \sqrt{3} mc/gH^*e \quad (21)$$

Accurate measurements of lifetimes below 10^{-7} sec are very difficult because of the minuteness of the magnetic fields by which depolarization is produced, and hardly more than the order of magnitude of τ can be warranted.

As already mentioned, the fluorescence excited by the line 3261A in an atomic beam of cadmium is "carried along" by the beam. Under these conditions the distance over which an atom travels before it emits the fluorescence line is proportional to the time elapsed since the moment of excitation. If a magnetic field parallel to the direction of observation and perpendicular to the atomic ray is applied, the Larmor rosette of Figure 30 is drawn out along the atomic ray. If τ is determined directly from the decrease of intensity along the ray, the splitting factor g can be calculated according to Equation (21) from the angle of rotation of the direction of polarization, which is measured on different points of the ray. Soleillet obtained $g = 1.75$ by this method. Considering the difficulty of the observations, the result is in satisfactory agreement with the theoretical value of $g = 1.5$ (1533-1535).

Hanle and Richter have tried to derive the half-value period of the fluorescence of the mercury triplet 5461, 4358, 4047A from the depolarization of the lines in a longitudinal magnetic field. They excited the fluorescence stepwise in the presence of nitrogen and obtained the surprising result that the green line seemed to provide a value of τ four times as long as the two other lines, despite the fact that they all originate from the same excited level. R. H. Randall confirmed this result independently, using a different method. However, Randall's experiments have since been repeated by several investigators, most thoroughly by Mitchell, and his conclusions have been proved to be erroneous. Richter also admitted, in a later publication, that his measurements were not sufficiently reliable for sustaining his earlier statement. Hence, the assumption seems justified that the lifetime of the mercury atoms in the state 7^3S_1 is the same for the emission of each of the three visible triplet lines; it is probably of the order of $5 \cdot 10^{-9}$ sec (441, 578, 1042, 1336, 1357).

Eq. 19 can be applied if in a magnetic field the excited state splits into three levels, while the ground state is unaffected, so that the resulting Zeeman triplet differs from the normal Lorentz triplet by not more than a g -value different from 1. If, however, the Zeeman effect is more complicated, involving several values of g for the excited

and the unexcited states, or if lines with unequal Zeeman effects are not resolved (D_1 and D_2 of sodium, h.f.s.-components of mercury, etc.), Equations (19) and (19a) must be replaced by the following more general equation:

$$P_z = \frac{\sum_i \sum_k p_0^{(i,k)}}{1 + \sum_i [\sigma \cdot g_k(i)]^2} \quad (22)$$

in which the indices i refer to the various components and the indices k to the Zeeman subcomponents of each component.

Using Equation (22), the lifetime of excited sodium in the states $3^2P_{1/2}$ and $3^2P_{3/2}$ can be determined by measuring the depolarization or the rotation of the plane of polarization of the unresolved D-line resonance radiation in longitudinal magnetic fields. The experimental curves are reproduced in Figure 32; the values of τ which were derived from these curves, and also those obtained by several other methods, are listed in Table 13. The relatively large deviations of Duschinsky's measurements from the others have already been mentioned in Section 22.

TABLE 13
LIFETIME OF EXCITED SODIUM EMITTING THE D-LINES, OBTAINED BY
VARIOUS METHODS

Method	Fluorometer		Depolarization in magnetic field	Magnetic rotation*	Average †
	Hupfeld	Duschinsky			
$\tau \cdot 10^8$	1.5	0.82	1.35	1.6	1.48

* Compare footnote to Table 12.

† Computed by Ladenburg from all available measurements.

32. Alternating Magnetic Fields. The results produced by a magnetic field are not changed if, instead of a constant field, an alternating field is applied by means of an alternating electric current in a solenoid, as long as the period of the alternating field is long compared with the period of the Larmor precession, which is determined by the field strength. If the frequency of the alternating field exceeds the frequency of the Larmor precession, the latter no longer produces a complete rotation during a half-period of the magnetic field; the sense of revolution is reversed after each half-period and with increasing frequency the motion degenerates into an oscillation of decreasing amplitude around the direction of the vector E . If the fluorescence is observed in the direction of the magnetic field, the degree of polari-

zation is eventually the same as without a magnetic field. The larger the effective strength of the applied field, the larger is the Larmor frequency ω and the higher becomes the frequency at which the limiting state is reached.

For the mercury resonance radiation, Fermi and Rasetti found practically no depolarizing action by a field of 1.13 gauss at a frequency of $5 \cdot 10^6 \text{ sec}^{-1}$. With 1.87 gauss, the action of the magnetic field on the polarization was already appreciable, while with 2.13 gauss, the degree of depolarization was the same in the alternating and in a constant magnetic field. From the relation between the field strength, the frequency of the alternating field, and the corresponding depolarization of the resonance radiation, the frequency ω of the Larmor precession can be calculated. Satisfactory agreement between theory and experiment is obtained only if the splitting factor $g = 3/2$ is introduced into the calculation. Assuming a normal Lorentz triplet with $g = 1$ for the mercury line 2537A, the alternating field of frequency $5 \cdot 10^6$ should become ineffective in depolarizing the resonance radiation only at a field strength of 3.2 gauss, and not, as is actually true, at $2/3 \cdot 3.2 = 2.14$ gauss (385).

Fermi's and Rasetti's results were confirmed qualitatively by Breit and Ellett. These observations show why Wood could not influence the polarization of the mercury resonance radiation by the alternating magnetic field of a strong beam of sunlight: the magnetic field of the sun radiation, which according to Wood's calculation was of the order of 3 gauss, was much too small, considering the high frequency of infrared and visible light (163).

F. Stark Effect in Resonance Radiation

33. Direct Demonstration of the Effect. The splitting of a resonance line in an electrostatic field by the so-called Stark effect is, in general, very difficult to observe, because resonance lines correspond to transitions between the lowest electronic states of an atom; with the exception only of the hydrogen atom, these states are very insensitive to the action of electric fields. Paschen and Gerlach were unable to find conclusive evidence of a shift exceeding the limit of error ($5 \cdot 10^{-5} \text{ \AA}$) for the mercury resonance line in a field of 14,000 volts per cm (1194).

Brazdziunas used the much more sensitive Schein-Malinowski method for the investigation of the Stark effect of the mercury

resonance radiation. A mercury resonance lamp was exposed alternately to the action of a transversal magnetic and electric field and the lines of the absorption cell were displaced gradually, either by a second magnetic field or by the admission of small quantities of atmospheric air into the cell. Brazdziunas was thus able to show that the σ -components of the Stark effect are shifted as much in a field of 100,000 volts per cm as one of the σ -components of the Zeeman effect by a magnetic field of 1.2 gauss, the displacement being in either case $5.4 \cdot 10^{-4} \text{ \AA}$ toward greater wavelengths. The displacement of the π -component is not larger in a field of 140,000 volts per cm than the displacement of the σ -components in a field of 60,000 volts per cm. Assuming that the shift is proportional to the square of the field strength, the displacement of the σ -components is five times larger than that of the π -component. It was not possible to determine whether the π -component was displaced in the direction of greater or smaller wavelength (157).

Ladenburg investigated the Stark effect in the absorption spectrum of sodium vapor by means of an interferometer. Applying a field of more than 100,000 volts per cm, he obtained a shift of the D-lines of about 0.01 \AA . At least qualitatively, he succeeded also in proving the occurrence of an effect of the same order in the resonance radiation of sodium vapor; the light emitted by a sodium resonance lamp was appreciably less absorbed in a second cell containing sodium vapor if the resonance lamp was under the action of the electric field. By inserting a Nicol prism into the path of the resonance radiation, it could further be shown that the σ -components (polarized in the plane perpendicular to the lines of force) as well as the π -component (polarized parallel to the lines of force) are both more or less influenced by the electric field. The exciting radiation and the direction of observation were both perpendicular to the lines of force in these experiments (806,856).

The higher electronic states of most atoms are much more sensitive to the action of external electric fields and, therefore, series lines corresponding to transitions between such states show Stark effects which are much easier to demonstrate. When a field of 5,000 volts per cm was applied by Terenin to a mercury resonance lamp which was excited stepwise by the full radiation of a water-cooled mercury arc, all lines which originated from the levels $6^3D_{1,2,3}$ and 6^1D_2 (compare Figure 17) were missing in the fluorescence spectrum, although they were present when the electric field was not applied. The resonance line and the lines originating from the state 7^3S_1 were not affected by the field. The suppression of certain lines is obviously

due to the fact that they are displaced in the absorption spectrum of the resonance lamp by more than their width in the primary radiation. This width was of the order of 10^{-2}\AA and thus the Stark effect must have produced a displacement of at least the same order. The effect is due almost exclusively to the action of the electric field on the upper states of excitation (6^3D_J and 6^1D_2) (1632).

34. Polarization of Resonance Radiation in Electric Fields. According to classical electrodynamics as well as to quantum theory, an electric field parallel or perpendicular to the vibrations of an oscillator

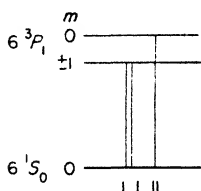

Fig. 33. Level diagram for Stark effect of Hg-line 2537A.

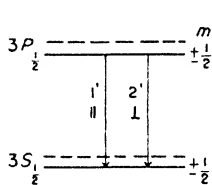

Fig. 34. Level diagram for Stark effect of Na-line D_1 .

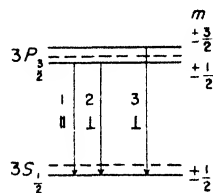

Fig. 35. Level diagram for Stark effect of Na-line D_2 .

does not influence the polarization of the radiation emitted by the oscillator.

The quantum numbers m which determine the spatial quantization have the same absolute values for each electronic state of an atom in an electric and in a magnetic field. However, in an electric field the energies of the levels $+m$ and $-m$ coincide and, therefore, the Zeeman level schemes of Figures 24–26 have to be replaced, for the Stark effect, by those of Figures 33–35. Thus, the transitions from the levels $m = +1$ and $m = -1$ of the state 6^3P_1 to the level $m = 0$ of the state 6^1S_0 produce radiations which are circularly polarized with opposite signs but have the same frequency. If both components are excited simultaneously by absorption of plane-polarized light, their radiation, of identical frequency, is coherent and combines into a single wave which is plane polarized in the same direction as the exciting radiation. The phenomenon is exactly the same as if the two rotors r_1 and r_2 introduced into the model for the Zeeman effect (Section 25) were replaced by a single linear oscillator e' perpendicular to the oscillator e and to the lines of force F and having a frequency slightly different from the frequency of e .

Consequently, an electric field F either parallel or perpendicular to the electric vector E of the exciting radiation, should not alter the

polarization of resonance radiation; the polarization should remain the same in the presence or in the absence of the field. Earlier experiments by Hanle and by Richter on the resonance radiation of mercury and of sodium seemed to disagree with these theoretical predictions. However, Suppe later showed that these results were erroneous and that if all necessary precautions were taken, an electric field had no influence whatsoever on the state of polarization of the mercury resonance radiation, as long as F and E were oriented so that only e or only e' was excited (as in cases I, II or IV) (572,576,1597,1856).

If the angle ϑ between F and E differs from 0 or 90°, the two virtual oscillators e and e' are excited simultaneously, their amplitudes being equal for $\vartheta = 45^\circ$. Since the frequencies of the oscillators are not quite the same, a slowly increasing difference of phase must arise in their radiation and the wave resulting from their superposition becomes increasingly elliptically polarized. In a weak electric field, this process is so slow as compared with the duration of the emission that the polarization of the observed fluorescence is partially elliptical. (The phenomenon is observed at its best in the direction parallel to the exciting radiation, where the oscillators e and e' contribute equal intensities to the total fluorescence). In stronger electric fields, the depolarization is complete, as in the somewhat similar case of a longitudinal magnetic field.

In combined electric and magnetic fields the polarization or depolarization caused by the magnetic field alone is not altered by the presence of an electric field up to 150,000 volts per cm, as long as the latter is oriented so that it would not influence the polarization in the absence of the magnetic field. If, on the other hand, the resonance radiation is depolarized by an electric field of adequate orientation and strength, the polarization is not restored by a magnetic field of any orientation. (This result obtained by Suppe is also in contradiction with Hanle's earlier publication).

G. Perturbations of Resonance Radiation by Collisions

35. Effective Cross Sections. Resonance radiation is unperturbed only if the excited atoms are not subjected to collisions or, more generally speaking, to any interaction with other molecules during the time interval between the absorption and the emission process. If this condition is not fulfilled, the consequences are of two kinds. On the one hand, the state of the *excited atom* is altered so that, if an

emission occurs at all, the emitted light has a different frequency. On the other hand, the corresponding energy difference must be balanced somehow by the *perturbing molecule*, which in most cases will gain energy but sometimes also may lose energy to the excited atom. Collisions by which excited atoms or molecules transfer their electronic excitation energy to the colliding particles are called "collisions of the second kind." The fluorescence which would be observed in the absence of collisions is quenched by collisions of the second kind (418, 786).

If the "competing process" characterized in Equation (6), Section 4, by the probability α_1 is due to collisions, and if every collision of an excited atom quenches its fluorescence, α_1 is equal to the number z_k of collisions and since z_k is proportional to the partial pressure p of the quenching gas, the equation takes the form in which it was published by Stern and Volmer (1571):

$$I = I_0 / (1 + z_k \tau_0) = I_0 / (1 + \beta p) \quad (\beta \text{ being a constant}) \quad (23)$$

or with several quenching gases of partial pressures p_1, p_2, \dots :

$$I = I_0 / (1 + \beta_1 p_1 + \beta_2 p_2 + \dots) \quad (24)$$

If the intensity of the fluorescence is reduced from its maximum value I_0 to a value I'_0 by the partial pressure p_1 of the first gas, the intensity I'_0 is not quenched by the partial pressure p_2 of the second gas as much as the intensity I_0 would be quenched by the same quantity of the second gas in the absence of the first gas. For, by the quenching action of the first gas, the natural lifetime of the excited state τ_0 has already been reduced to the value τ_1 according to Equation (5) Section 4. Only qualitative observations are available concerning the simultaneous quenching action of two gases on the resonance radiation of monatomic vapors. The mercury resonance radiation is reduced to $1/20$ by 4 mm of hydrogen. If the intensity of the fluorescence is already quenched considerably by 100 mm of nitrogen, the addition of 4 mm of hydrogen reduces the intensity only to about $1/5$ of the value observed in the absence of hydrogen. The quenching efficiency of atmospheric air can be calculated correctly using Equation (24) and taking into account the individual quenching efficiencies of nitrogen and oxygen. However, quantitative measurements on the fluorescence of iodine vapor show that, at least in this instance, the conditions are more complicated than was assumed in deriving Equation (24). (Compare Section 65) (93,203,1167).

By variation of the value of p in equation (23), a state can be

attained, corresponding to a pressure p^* , in which $I = \frac{1}{2}I_0$ or $\tau_0 = 1/z_k$. Since $1/z_k$ is equal to the average time between two collisions, the lifetime τ_0 of the unperturbed excited atoms is equal to the time at the "half-intensity pressure" p^* . If τ_0 has been determined by another method, the number of quenching collisions z can be worked out from Equation (23). If this number is found to be smaller than the value z_k which is derived from kinetic theory, it is to be assumed that not every gas-kinetic collision is actually quenching, and an "efficiency ϵ " smaller than unity can be introduced. However, if z is found to be larger than z_k , one is forced to assume that the "effective quenching cross section" for the perturbation under consideration is larger than the gas-kinetic cross section.

An atom in a certain excited state can have different effective cross sections for different kinds of interactions with other molecules. Thus, it is clear that these interactions are not collisions in the sense of mechanics, according to which a collision is defined as an approach to a well-determined distance. The interaction reaches, theoretically, into infinity, while its strength decreases according to laws which may be widely different in different cases. These laws determine for every distance r a probability $W(r)$ according to which the energy transfer in question will occur within the unit of time.

If an effective cross section σ (or an effective radius ρ) is defined by the equation:

$$\sigma = \pi \rho^2 = \int_0^{\infty} r W(r) dr \quad (25)$$

it can be shown that this value plays the same part for the "optical collisions" as the gas-kinetic cross section σ_k plays for the mechanical collisions. σ can be considerably larger than σ_k , if $W(r)$ is still large for great values of r ; if, on the other hand, $W(r)$ decreases rapidly with increasing r , the effective cross section can become much smaller than the kinetic cross section. This means only that not every kinetic collision produces the reaction under consideration, or that the yield of the collisions is below 100% — it does not pretend that a molecule actually approaches the excited atom in a quenching collision to a distance smaller than the gas-kinetic radius.

In determining the probability $W(r)$ of an energy transfer from an excited atom in a collision process, a principle which was introduced by Franck in connection with problems of this type, and which has since been extensively applied by him and others, is of great importance: during the exceedingly short time of an electronic transition,

the location and the momentum of atomic nuclei cannot be altered appreciably because of the relatively large mass of the nuclei. Therefore, only a small part of the electronic excitation energy of an atom can be transferred directly into kinetic energy of the colliding particles. Either the excited atom loses only a small fraction of its energy and is transferred by the collision into a closely neighboring quantum state, or, if the atom loses a large fraction or all of its excitation energy, this energy must be converted almost completely into some kind of excitation energy of the perturbing molecule. The nearer the energy of a quantum state of the latter is to the excitation energy of the former, the better is the "energy resonance" between the two, and the greater is the probability $W(r)$ for large values of r . The energy resonance reaches a maximum if the two particles are of the same kind, one atom being transferred from the excited state to the ground state and the second atom from the ground state to the very same excited state. This process, however, cannot be observed directly (412b).

Kallman and London have treated the interaction between an excited atom and another atom almost in resonance with the first applying the laws of quantum mechanics. If δ is the difference between the excitation energies of the two systems and if the corresponding transitions are allowed (dipole radiation), the effective cross section increases proportionally with $\delta^{-2/3}$. However, for very small values of δ , σ does not increase infinitely but tends towards a limiting value, which depends mainly on the relative velocity of the two atoms; the higher the temperature, the smaller is σ in the case of sharp energy resonance (707).

36. Collision-Broadening. Flame Fluorescence. Increase in width of spectral lines with increasing gas pressure has been known for a long time and has been interpreted by H. A. Lorentz as caused by "collision-damping"; according to the Fourier analysis, the lines become broader because the phase of the emitted wave is altered or the wave is completely interrupted every time the vibrating oscillator is perturbed by a collision. The equivalent of this explanation could not be found in Bohr's original theory, in which every individual emission process was instantaneous and strictly monochromatic, without any mention of phase relations. Collision-broadening was interpreted, according to the principle of correspondence either, by the shortening of the lifetime of the excited state, or it was ascribed to the perturbation of the excited level caused by the small distance between the colliding molecules (molecular Stark effect) at the moment of emission. If the second assumption were correct, collision-broadening would

become a pure configuration effect and would depend on temperature only insofar as due to the higher average kinetic energy, a close approach of two atoms occurs more frequently. The number of collisions per unit of time would be without importance; if the configuration of the molecules at a high temperature could be suddenly "frozen," the width of the line would remain unchanged. This hypothesis was suggested by Einstein for an experimental test in the early days of Bohr's theory, and was taken up again much later by Jablonski, after the introduction of "potential curves" for representing the energy relations between two atoms at variable distances (658,980, 1181a, 1814, 1925).

In Figure 36, the abscissa is the distance r between two atoms; the ordinate is the potential energy U as far as it depends on the electronic configuration within the atoms and on the interaction between them. For $r = \infty$, U is determined exclusively by the electronic energy, which is assumed to be 0 if both atoms are in their ground state, and E if one of the atoms is excited. For the present considerations, it is assumed that with decreasing distance

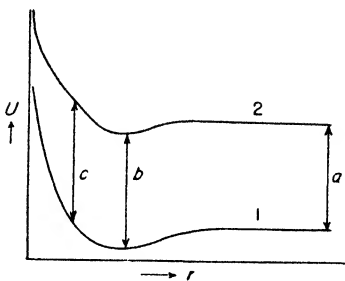

Fig. 36. Potential curves for collision-broadening (Jablonski).

only repulsion forces between the two atoms need to be taken into account, apart from the weak Van der Waals forces, which cause a flat trough in the potential curves, with its lowest point at a certain value of $r = r^*$. For distances smaller than r^* , the slope of the potential curves becomes rapidly steeper, because of the strong repulsive forces. According to Franck's principle, an emission process can be due only to vertical transition (such as a , b , and c) between points of the upper curve and points of the lower curve. Since the two curves are not strictly parallel, the quantum $h\nu$ which corresponds to such a transition has a different value from the quantum $h\nu_0$ emitted at $r = \infty$. The superposition of many processes of this kind causes a broadening of the spectral line, which, in general, will be asymmetrical. However, this type of broadening of spectral lines becomes important only at relatively high gas pressures; at the low pressures which generally prevail in experiments on resonance radiation, the broadened lines remain almost completely symmetrical and this effect must be due to another collision-damping theory, according to which the number of collisions

during the lifetime of the excited state determines the width of the line, while it is of no importance whether the emission is quenched or only changed in phase by a collision (900,901,1814).

The greatest part of the investigations on collision-broadening deals with absorption processes and therefore, is not within the scope of this book. Even the broadening of emission lines excited by resonance has, in general, been determined by the change of absorbability of the line in a cell containing the same vapor as the resonance lamp. By this method, it could be shown that the mercury resonance line is broadened by the same amount whether the number of collisions in a mixture of mercury vapor and a foreign gas is increased by an increase of temperature at constant density or by an increase of pressure at constant temperature (1187a). Furthermore, it has been demonstrated that as long as the number of collisions is the same gases with a strong quenching action broaden the lines no more than other gases. The broadening effect of helium and hydrogen on mercury vapor or of argon and nitrogen on sodium vapor are respectively equal, though the rare gases have a very small, the others a very strong quenching efficiency. By means of fluorometric measurements, Duschinsky proved that the broadening of the resonance lines by rare gases is not caused by a shortening of the life of the excited states without simultaneous quenching. If nitrogen or helium were added to sodium vapor in such quantities that their respective vapor pressure produced the same amount of collision-broadening of the D-lines, the duration of the resonance emission was reduced by nitrogen to about one-half, with the corresponding decrease of fluorescence intensity; the fluorescence was neither quenched appreciably, nor was the lifetime τ_0 shortened to a measurable extent by the addition of helium. Hamos obtained the same result in a more indirect way, by showing that the quenching efficiency of nitrogen on the resonance radiation of sodium was not changed by the addition of helium. If the lifetime of the excited atoms were shortened by the action of the rare gas without simultaneous quenching, the quenching efficiency of nitrogen should be diminished as well according to the Stern-Volmer Equation (23) (326,569).

Thus, collision-broadening by rare gases is not due to induced radiating transitions causing a shortening of lifetime of the excited state. If, on the other hand, the atom radiates spontaneously at the moment of collision, the frequency of the radiation will be noticeably altered, according to the potential-curve diagram of Figure 36; the consequence must be the appearance of an emission band in the vicinity of the normal atomic line. Oldenberg has actually observed a

narrow diffuse band on the long-wavelength side of the mercury resonance line which was produced, apart from the resonance line itself, by irradiating a mixture of mercury vapor and inert gases with the radiation of a mercury lamp (1168). Simultaneously, bands with a well-defined structure occurred in the fluorescence spectrum; they were ascribed by Oldenberg to excited rare gas-mercury molecules and are treated in a later chapter (Section 75). It is to be assumed that the transition probability between the upper and the lower potential curves of Figure 36 is altered and probably increased for small values of r . This would shorten the lifetime of the excited mercury atoms participating in these perturbed emission processes. However, their number is relatively small and neither the average lifetime of the other atoms (which is obtained by the fluorometric measurement) nor the width of the line emitted by them would be influenced by such processes.

By an increase of the pressure of the fluorescent vapor itself, the resonance lines are broadened much more than by the addition of a foreign gas, if the number of kinetic collisions is the same in both cases. The effective cross sections are much larger when the energy resonance between the colliding atoms is complete (1184, 1478, 1479, 1480).

If the absorption line of a vapor is broadened by collisions, the resonance line has the same width in the fluorescence spectrum as the absorption line, even when the exciting line is narrow (1183).

The intensity of the resonance fluorescence of a vapor is frequently increased when the absorption line is broadened by collisions. The exciting line in the spectrum of the primary light source has nearly always a greater width than the absorption line of the resonance lamp and, therefore, a larger fraction of the incident energy is absorbed, if the width of this absorption line is increased. The intensity of the resonance fluorescence of mercury or sodium vapor may become several times stronger by addition of helium of 100 mm. (The intensity decreases, however, under otherwise equal conditions, if the narrow line of a resonance lamp is used for excitation). Even if the foreign gas quenches the resonance radiation considerably, this effect can be overcompensated by the broadening of the line, especially if the line is more or less self-reversed in the primary radiation. According to Badger, the mercury resonance radiation is almost completely quenched by a few cm of nitrogen if a resonance lamp is used for excitation, while under excitation by a mercury arc the fluorescence intensity is almost independent of the nitrogen pressure, up to 760 mm (35, 1167, 1867).

Badger ascribes to the same cause the phenomenon which Nichols and Howes called "flame fluorescence" and which they observed at first only in flames colored by the evaporation of a thallium salt. If a Bunsen flame is supplied with a metal vapor (Tl, Mg, Ag; also with, less efficiency, Cd, Hg, Na) and if it is irradiated with light containing the resonance line of the metal, the resonance line and possibly, by

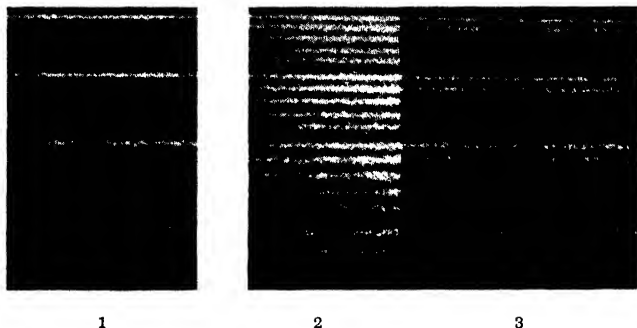

Fig. 37. Transfer of Hg-hyperfine-structure component - 25.4 by collisions of excited Hg-atoms with He-atoms (Mrozowski).

1. No helium present. 2. complete hyperfine structure of Hg-line 2537A. 3. with 0.7 mm He.

stepwise excitation, some of the other series lines are re-emitted by the flame, often with considerable intensity. Special experiments showed that neither the temperature nor any other specific conditions prevailing in the flame were responsible for this phenomenon (35, 977, III 8).

37. Transfer of the Excited Atom into Adjacent Quantum States.

The smaller the energy difference between two electronic states of an atom, the greater becomes the probability that a transfer of the atom from one state to the other will be produced by a collision. The condition of smallest energy difference is fulfilled for the h.f.s.-levels of the state 6^3P_1 of mercury. Mrozowski observed that if the mercury fluorescence is excited by the isolated component - 25.4 (see Figure 19) of the resonance line 2537A in the presence of a foreign gas, the other components of the hyperfine structure belonging to the isotopes Hg^{199} and Hg^{201} are emitted together with the exciting line. The components belonging to the even isotopes are missing in the fluorescence spectrum (Figure 37). The addition of 0.1 mm helium or

nitrogen is sufficient to produce this effect. On increasing the mercury pressure itself, however, all h.f.s.-components appear in the fluorescence spectrum, even if a single component is used for the excitation. In this case it is not the primarily excited atom which is transferred into a neighboring quantum state by a collision; the excitation energy is transferred to another atom, which is in almost complete energy resonance with the first one (the energy difference being of the order of $2 \cdot 10^{-5}$ eV): it is thus an instance of "sensitized fluorescence" (see Section 43). According to Mrozowski, the half-pressure p^* is about 0.1 mm for this energy transfer; because of the smaller atomic velocities, the frequency of collisions is about ten times smaller than in the case of energy transfer due to collisions with helium which has been mentioned above. Mrozowski's statements are not sufficient for more quantitative conclusions with respect to the increase of the effective cross sections (1072).

Decreasing the energy differences between the mercury h.f.s.-levels still further by the action of a magnetic field, Buhl finds that the effective cross section for the energy transfer from one mercury isotope to another can be more than one thousand times larger than the gas-kinetic cross section (185).

The energy difference between the two $3P$ -levels of sodium ($3^2P_{1/2}$ and $3^2P_{3/2}$) is equivalent to about $2 \cdot 10^{-3}$ eV. If the exciting light contains only one of the D-lines, the other D-line appears also in the emission spectrum if hydrogen, nitrogen, or a rare gas is added to the sodium vapor in the resonance lamp. If the partial pressure of the foreign gas is increased to a few mm, the relative intensity of the D-lines tends towards the normal ratio 1:2, corresponding to the statistical weights of the two 2P -levels, irrespectively of whether D_1 or D_2 is used for excitation; because of the smallness of the energy difference, transitions in both directions are almost equally probable even at a temperature of 100° C. However, the half-pressure of 3 mm of argon is > 10 times larger than that obtained for transitions between the h.f.s.-levels of mercury, corresponding to the considerably larger energy difference which must be bridged. Increase of the sodium vapor pressure itself has, again, a particularly strong effect: at a sodium vapor pressure of $2 \cdot 10^{-3}$ mm, transitions between the two 2P -levels are as frequently induced by collisions as at an argon pressure of 0.6 mm. The effective cross section is about 200 times larger in the first case than in the second (944, 1895, 1911).

The appearance of the violet line 4058A in the fluorescence spectrum of lead vapor (see Section 15) can also be explained only by a

transfer of atoms from the excited state ${}^3P_1^o$ to ${}^3P_0^o$, since a direct exciting transition from the ground state 3P_0 to ${}^3P_0^o$ is strictly forbidden ($\Delta J \neq 0$ for $J = 0$). The energy difference between the two ${}^3P^o$ -states is only $4 \cdot 10^{-2}$ eV, and it is probable that the lead vapor pressure in Terenin's experiment was sufficiently high for the occurrence of transferring collisions (1631, 1849).

According to Paschen, the resonance doublet of orthohelium has its normal intensity ratio in the fluorescence spectrum, although the short-wavelength component, 10829.11A, is much weaker in the primary radiation and is less absorbed by the metastable helium atoms in the fluorescence chamber. Also, in this instance, the equilibrium was re-established by collisions between the excited and the normal helium atoms; the helium pressure was of the order of magnitude of 0.1 mm in Paschen's experiments (1193).

If cesium vapor is excited by the absorption of the line 3989A ($8^2P_{1/2} \leftarrow 6^2S_{1/2}$) in the presence of a few mm of helium, not only the lines which are excited directly or in steps (compare Section 16), but numerous further lines are re-emitted, among them, also, the second doublet component originating from the state $8^2P_{3/2}$. The emission of most of these lines is due to the transfer of excited atoms by collisions from the state $8^2P_{1/2}$ into the closely adjacent $8D$ -levels. The transitions corresponding to the observed new lines are marked in Figure 13 by thin lines; the thin dotted lines are, again, the transitions corresponding to spectral lines which are missing in the spectrograms only because of their long wavelengths. The lines originating from $8^2S_{1/2}$ show relatively small intensities, owing to the greater energy difference between this level and the state $8^2P_{1/2}$ — 0.043 eV as compared to 0.01 eV for the transfer to the $8D$ -levels (125).

The emission of the D-lines by sodium vapor, which is excited by absorption of the second doublet of the main series, has been explained by Bohr by a spontaneous stepwise return into the ground state (see Section 16). Franck assumed at first that the phenomenon was due, at least partially, to a transfer by collisions. This interpretation appeared admissible, because in Strutt's original experiment the sodium vapor pressure was sufficiently high, and because in the later repetitions of the experiment at low vapor pressure, the effect was appreciably increased by the addition of argon of a few mm. The D-lines emitted under these conditions are not noticeably weakened by passing through a thick layer of sodium vapor, while the resonance radiation excited in the same tube by irradiation with the D-lines is completely absorbed by such a cell. The greater line width in the first

case was ascribed by Franck to the Doppler effect resulting from the surplus energy which would be liberated by a collision transfer from 4^2P to 3^2P . The transfer of so much electronic energy (1.64 eV) into kinetic energy of the colliding particles is not compatible with Franck's principle. Berry and Rollefson supposed, therefore, that the collisions transfer the excited atoms from the state $4P$ to $4D$ with a surplus energy of only 0.14 eV, which still leaves to the atoms a velocity sufficient to explain the greater line width in the subsequent stepwise emission of the lines $4D \rightarrow 3P$ and the D-lines ($3P \rightarrow 3S$) (96).

A relatively small energy difference separating the metastable state 6^3P_0 from the state 6^3P_1 is characteristic of the mercury atom. If atoms which have been raised to 6^3P_1 by absorption of the resonance line are subsequently transferred into the metastable state by collisions, the resonance radiation is quenched. The presence of metastable atoms in the vapor is proved by the appearance of the lines 4047 and 2967 in the absorption spectrum (1889).

If mercury vapor is irradiated with strong light containing the resonance line, the absorption of the line 4047A becomes noticeable at a partial nitrogen pressure of 0.1 mm and is very conspicuous at a pressure of 2 mm. At still higher pressures, the absorption line is assymmetrically broadened. However, the strength of the absorption cannot be used as a quantitative measure for the number of atoms in the metastable state, since the absorption tends towards a limiting value which depends on the shape of the line in the transmitted radiation.

The energy difference of 0.218 eV between 6^3P_1 and 6^3P_0 is so large that, at room temperature, only every 2,000th collision has the energy necessary to reverse the process. An admixture of a fraction of one per cent of quenching impurity is, therefore, sufficient to stop almost completely any return to the higher level. On the other hand, the energy of 4.7 eV separating the metastable state from the ground state is so large that the quenching transition to the ground state cannot be induced by a collision without some kind of energy resonance. Hence, the concentration of the metastable atoms can become rather large if such collisions are improbable. The equilibrium concentration depends on the intensity of the primary radiation, on the probability of diffusion and of quenching collisions, on the return to 6^3P_1 , and, as far as the odd isotopes are concerned, on the emission of the forbidden line 2656A (465,789).

Even the energy difference of 0.218 eV is great enough to render the transfer from 6^3P_1 to 6^3P_0 by a collision with an inert gas very

improbable. However, the transfer can be produced with great efficiency if the excited mercury atoms collide with diatomic or polyatomic molecules. This, again, is explained by resonance effects; the quantized nuclear vibrations of the molecules are assumed to take up the balance of the electronic energy of the mercury atom. The closer the energy of the first vibrational quantum of the colliding molecule to 0.218 eV, the better is the energy resonance and the larger should be the effective cross section for the "transferring collisions." The data which were published as proof for the validity of this hypothesis are listed in the first vertical column of Table 14 (Sect. 39). However, most of these "effective cross sections" were not obtained by measuring the equilibrium concentration of metastable atoms in the presence of the various gases, but by their quenching efficiency for the resonance radiation, which may also be due to genuine quenching, i.e., to transfer to the ground state (67,317,369,1924). Nitrogen, which ranks rather low in Table 14, is the gas which produces by far the greatest equilibrium concentration of metastable mercury atoms. At small nitrogen pressures, the yield is still increased by the addition of an inert gas which, in itself, is inactive, but which decreases the diffusion to the walls. In a specific case, the equilibrium concentration of the metastable atoms measured by the absorption of the line 4047A was reached at a nitrogen pressure of 2 mm; if neon of 12 mm was added, it occurred, under otherwise unaltered experimental conditions, at 0.8 mm of nitrogen (465,789).

If other gases are more efficient than nitrogen in transferring mercury atoms from the state 6^3P_1 to 6^3P_0 , they must also have a much greater efficiency in real quenching. This is proved for nitric oxide by the different influence which a rise in temperature produces in the quenching efficiency of this gas and of nitrogen. If a mercury resonance lamp, in which the fluorescence is almost completely suppressed by nitrogen of sufficient pressure, is heated to 750° C, the intensity of the radiation is restored nearly to the value which it had in the absence of nitrogen. At this temperature, collisions causing the retransfer from 6^3P_0 to 6^3P_1 are sufficiently frequent, while genuine quenching collisions practically do not occur. It cannot be assumed that the first part of the process (the transition $6^3P_1 \rightarrow 6^3P_0$) is suppressed at high temperatures: while at 750° C the mercury resonance radiation is as strong in the presence of nitrogen of 40 mm as without nitrogen, it is much more strongly quenched by an addition of hydrogen in the first case than in the second (203,1167). By the intermediate transition into the metastable state the total lifetime of the excited

atoms is lengthened and thus they have a greater probability of being quenched by a collision with a hydrogen molecule. (This observation shows that the metastable mercury atoms, also, lose their electronic energy by collisions with hydrogen molecules. According to E. Meyer, the probability of such a process is practically the same for mercury atoms in the states 6^3P_1 and 6^3P_0) (1022a).

Nitric oxide of 6 mm quenches the mercury resonance radiation at room temperature to 15% of its value in the absence of a quenching gas. At 650°C the intensity increases only to 25% of this value; in this case the major part of the loss is caused by genuine quenching and cannot be reversed by an increase of temperature. It is true that a relatively small quenching efficiency can be sufficient for producing this result because of the long lifetime of the state 6^3P_0 , and thus the direct quenching of the atoms in the state 6^3P_1 may be negligible.

Nevertheless, the "resonance curve" which has been derived from the figures of Table 14 still has a somewhat hypothetical character. The ordinate in this curve (Figure 38) represents the quenching cross section of each gas and the abscissa the difference between the lowest vibrational energy of the molecules and 0.218 eV. The peak of the curve corresponds to the gas with the best energy resonance. The two vertical lines at the center of the figure indicate the "unsharpness of energy" caused by the thermal agitation. For a quantitatively satisfactory treatment of the problem, the quenching of the resonance radiation, its dependence on temperature, and the number of metastable atoms in equilibrium should be known for every gas as a function of its pressure. In not a single case are all these data available. (Compare Section 40).

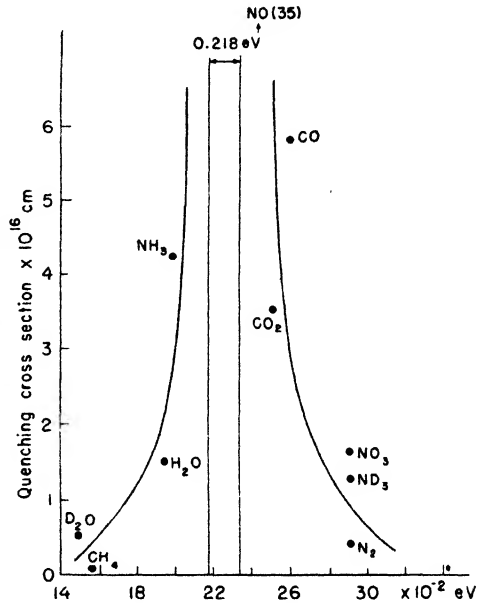

Fig. 38. "Resonance curve" for the quenching of Hg-resonance radiation by various gases (Bates).

Interaction with mercury atoms in the ground state seems also to induce the transition of excited mercury atoms into the metastable state with great efficiency. An increase of the mercury vapor pressure from 10^{-3} to 1 mm causes a decrease of the fluorescence yield by 50%. It is not yet possible to determine whether metastable atoms in the state 6^3P_0 are directly produced in this process, or whether intermediate Hg_2 -molecules are formed (compare Section 76). At any rate, the metastable modification originating from a collision between an excited and an unexcited mercury atom has an energy not below 4.65 eV and is able to retain it through a great number of further collisions with mercury atoms (1182).

The energy-level scheme of cadmium is completely analogous to that of mercury, but the distance between the levels 5^3P_1 and 5^3P_0 is equivalent to only 0.07 eV. Transitions between the two states are, therefore, almost equally probable in both directions, even at the lowest temperatures of observation (about 250° C), so that the concentration of metastable atoms never becomes very large. Because of their small number, it is difficult to prove their presence by the observation of the characteristic new absorption lines. However, Bender was able to demonstrate the transfer $5^3P_1 \rightarrow 5^3P_0$ due to collisions with N_2 or CO-molecules by the appearance of new lines in the fluorescence spectrum which was caused by stepwise excitation. In contradistinction to the similar phenomenon in mercury vapor, the transfer cannot be ascribed to resonance with the vibrational frequencies of the molecules, and it is to be expected that it would be produced with not much smaller efficiency by collisions with monatomic gases (66,91).

38. Effect of Collisions on the Polarization of Resonance Radiation.

The considerations which were applied in the last section to the transfer between closely neighboring levels retain their validity for the effect of collisions on the polarization of resonance radiation. The complete or partial polarization of radiation is caused by the exclusive or preferential population of some of the magnetic levels of an electronic state. If, by collisions, the relative population of the several magnetic levels is brought closer to the statistical equilibrium, the polarization decreases and is eventually destroyed. Since the energy difference between the magnetic levels is proportional to the field strength, the depolarization by collisions is expected to become noticeable at very low pressures in weak or vanishing magnetic fields.

Figure 39 shows the degree of polarization of the mercury resonance radiation as a function of the pressure of various foreign gases,

after Keussler's measurements. Similar curves were obtained by Hanle for the D-line resonance in sodium vapor excited by circularly polarized light. The main difference between the two sets of curves consists in the order of magnitude of the "half pressures" p^* at which the degree of polarization drops to one-half of its maximum value. p^* is considerably larger for sodium than for mercury, in accordance with the shorter lifetime of the excited state of sodium. With an inert gas, which is the most likely to give comparable results in both vapors, p^* is 0.77 mm for mercury and 3 mm for sodium. For the singlet resonance line of cadmium, the value of p^* is even 10 mm. The pre-

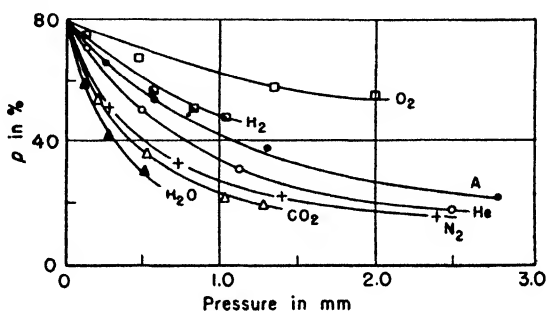

Fig. 39. Polarization of Hg-resonance radiation as a function of the pressure of foreign gases (Keussler)

sence of 1.5 mm of nitrogen, by which most of the mercury atoms are transferred after absorption of the resonance line into the metastable state, has practically no influence upon the polarization of the lines originating from the state 7^3S_1 , which is reached by stepwise excitation; as already mentioned, the lifetime of this state is only of the order of $5 \cdot 10^{-9}$ sec (571,574,728,729,773).

The "depolarizing cross section" of the molecules of various gases cannot be derived directly from curves like those of Figure 39, because the quenching action of a foreign gas may partially compensate its depolarizing action. For this reason, hydrogen or oxygen, which are good quenchers for the mercury resonance radiation, decrease its polarization much less than the inert gases at the same pressure. Measuring the quenching and the depolarization of the mercury resonance radiation by hydrogen or deuterium separately, Suppe has calculated the genuine depolarizing efficiency of these gases, which is compared in Figure 40 with their apparent depolarizing efficiency (773,1598).

The competition between depolarizing and quenching action be-

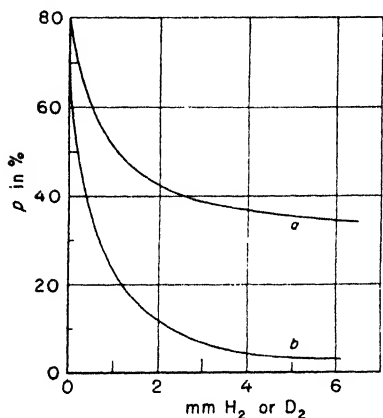

Fig. 40. Apparent (*a*) and real (*b*) depolarization of Hg-resonance radiation by hydrogen and deuterium (Suppe).

comes particularly evident if the decrease in polarization is brought about independently of the collisions by a magnetic field of appropriate orientation. The magnitude of both effects (quenching and depolarization) is determined by the lifetime of the excited state. If the lifetime is shortened by the addition of hydrogen to excited mercury vapor, not only is the intensity of the emitted radiation reduced but, simultaneously, the depolarization and the rotation of the plane of polarization by a longitudinal magnetic field decrease (1229).

A magnetic field parallel to the direction of the primary radiation is not able to compensate the depolarizing action of collisions with the molecules of a foreign gas. Beyond a field strength of 200 gauss, the curves of Figure 41 run almost parallel to the abscissa; the probability of the transfer into another magnetic level is very little influenced by the exact value of the energy difference between these levels, which remains small for all magnetic fields in this series of experiments. The slope of the first part of the curves, for H below 200 gauss, can be attributed to the fact that depolarization, which is caused by the interaction with other sodium atoms, is compensated to a much higher degree by the magnetic field.

This depolarization by interaction with atoms of the same kind is, again, a resonance effect, with the very large effective cross sections which are characteristic of atoms with good energy resonance. If, for instance, an excited sodium atom passes from the magnetic level $m = -\frac{1}{2}$ of the state $3^2P_{1/2}$ to the level $m = +\frac{1}{2}$ of the ground state, another atom may be raised from the level $m = -\frac{1}{2}$ of the ground state to the level $m = -\frac{3}{2}$ of the excited state. In weak magnetic fields, the energy difference between these transitions becomes exceedingly small and the energy resonance is correspondingly sharp (1142, 1480).

The strong depolarizing effect of atoms of the same kind at even rather low vapor pressures on the resonance radiation of Hg and Na

has actually been realized from the beginning. In later quantitative investigations, however, a few discrepancies have not yet been elucidated. Ellett et al. find no appreciable influence of the vapor pressure on the polarization of the D-line fluorescence in sodium vapor saturated at temperatures below 135° C. They obtain the same degree of polarization of 16.4 % in the absence of a magnetic field, no matter whether the observations are made at 135° C ($1.6 \cdot 10^{-6}$ mm) or at 85° C (10^{-8} mm). Datta, on the other hand, reports a continuous and increasingly steep rise of the degree of polarization with decreasing vapor pressure down to 115° C, and Hanle confirms this result in his experiments with circularly polarized light. It can hardly be assumed that these discrepancies are to be explained by measuring errors alone (259,351,356,467,573).

Figure 42 shows the degree of polarization of mercury resonance radiation excited by plane-polarized light as a function of the mercury vapor pressure, and Figure 43, the polarization of the D-lines excited by circularly polarized light as a function of the sodium vapor pressure.

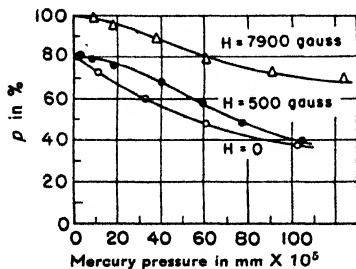

Fig. 42. Polarization of Hg-resonance radiation as a function of Hg-vapor pressure (Keussler).

Pringsheim 4

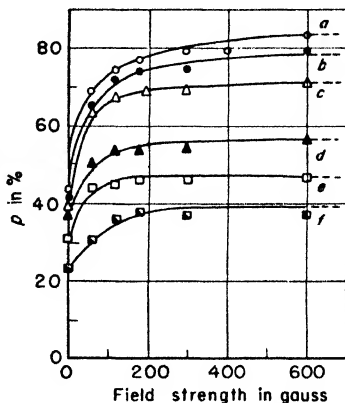

Fig. 41. Depolarization of circularly polarized Na-resonance radiation by He-Ne mixture at various magnetic field strengths (Hanle).

Pressure of He-Ne

a: 0.0 mm	d: 1.2 mm
b: 0.2	e: 2.3
c: 0.4	f: 3.7

The scales of the abscissas of the two figures prove that, in contradistinction to the effect of perturbations by foreign gases, the sodium lines are much more sensitive than the mercury line to increasing vapor pressure. According to wave mechanics, the interaction between atoms of the same kind depends not only on the sharpness of resonance but also on the dipole moment of the oscillations which correspond to a transition between two electronic

states. The dipole moment corresponding to the mercury intercombination line, with its smaller transition probability, is weaker and, therefore, an energy transfer by resonance becomes less probable. The intercombination resonance line of cadmium, with its still longer lifetime, has attained its highest degree of polarization at a saturation temperature above 170° C (about $2 \cdot 10^{-5}$ mm),* while the polarization

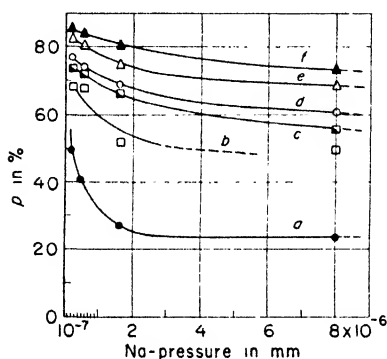

Fig. 43. Circular polarization of Na-resonance radiation as a function of Na-vapor pressure at various magnetic field strengths (Hanle).

a: 0 gauss *d*: 180 gauss
b: 60 *e*: 300
c: 120 *f*: 600

polarized perpendicularly to the direction of observation, and if no perturbations occur during the process. Under these conditions the even isotopes cannot reach the excited state 7^3S_1 in two successive π -transitions, since m would have to remain zero and ΔJ would be zero in the second step from 6^3P_1 to 7^3S_1 (see selection rules for m in Section 13). Thus, only the odd isotopes for which $m = \pm \frac{1}{2}$ and $\pm \frac{3}{2}$ in the ground state would participate in the emission of the blue line. If, however, all magnetic levels of the state 6^3P_1 are populated in consequence of the interaction between the excited atoms and other mercury atoms (or, in other words, if the resonance line itself is depolarized by the vapor pressure of the mercury), the line 4358A should show a positive polarization of 26.9%. The resonance line is already appreciably depolarized in saturated mercury vapor at 0° C ($2 \cdot 10^{-4}$ mm) (see Figure 42) and, accordingly, the degree of polarization of the line 4358A is +20% under these conditions. It increases

* At 210° C (about $3 \cdot 10^{-4}$ mm) the degree of polarization of this cadmium line is about one-half of the maximum value.

of the singlet resonance line of cadmium increases continuously down to pressures below 10^{-6} mm. The second doublet of the principal series of sodium, which has a much smaller intensity in the sodium absorption spectrum and a much smaller oscillator strength than the D-lines, shows a measurable decrease of its polarization only if the vapor pressure exceeds $2.4 \cdot 10^{-5}$ mm (35*f*).

The polarization of the mercury line 4358A is expected to be negative and its intensity weak (compare Section 27) if both lines serving for the stepwise excitation (2537 and 4358A) are plane

to + 26% if the temperature is raised to 18° C and the vapor pressure to 10^{-3} mm. This exceptional behavior (the enhancement of the polarization of fluorescence by increasing vapor pressure) is due to the fact that even at the higher pressures the number of atoms in the state 6^3P_1 is negligibly small. Therefore, the state 7^3S_1 from which the line 4358A originates is not perturbed by resonance effects, since transitions between 7^3S_1 and the ground state 6^1S_0 are not to be considered either. An increase of the vapor pressure thus destroys the polarization of the resonance line by resonance interaction, but leaves the polarization of the line 4358A unaffected (729).

The points of Figure 43 are replotted in a different way in Figure 44. The curves of Figure 44 show that the depolarization caused by the interaction with atoms of the same kind is counteracted to a large extent by magnetic fields. The higher the vapor pressure, the stronger the magnetic fields that must be applied. The separation of the magnetic levels is greater in a strong field; therefore, the resonance between the transitions from these various levels to the ground state becomes less and less sharp and, corresponding to the theory developed by Kallman and London (Section

35), the effective radius for the depolarizing perturbations becomes smaller. Hanle has tested this theory quantitatively by measuring the circular polarization of the D-line fluorescence of sodium vapor in magnetic fields of increasing strength and, on the whole, he found a good agreement between theory and experiments. The effective cross section was approximately proportional to $\delta^{-2/3}$ [$\delta = h(\nu - \nu_0)$], even at smaller values of δ than predicted by the theory (577).

According to Buhl, the depolarizing cross section of mercury atoms for the mercury resonance radiation does not follow Kallmann's and London's law but is proportional to δ^{-2} . Buhl interprets his result by the assumption that, in this case, the coupling between the reso-

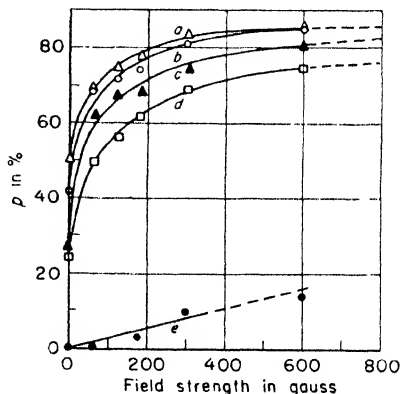

Fig. 44. Circular polarization of Na-resonance radiation as a function of the magnetic field strength at various vapor pressures (Hanle).

- a: 115°, $2 \cdot 10^{-7}$ mm
- b: 120°, $5 \cdot 10^{-7}$
- c: 135°, $1.6 \cdot 10^{-6}$
- d: 165°, $8 \cdot 10^{-6}$
- e: 195°, $5 \cdot 10^{-5}$

nators is due mainly to the electromagnetic field of the radiation and not to the dipole moment of the resonators (185).

From Hanle's experiments, the effective depolarizing radius of sodium atoms for the D-line fluorescence was calculated to be 10^{-4} cm or about one thousand times as large as the gas-kinetic radius. The effective depolarizing radius of mercury atoms for the Hg-resonance line is only $0.75 \cdot 10^{-8}$ cm or 50 times the gas-kinetic radius. However, even if the energy differences between the magnetic levels of the excited atoms become relatively large in strong magnetic fields, the depolarization caused by the interaction with atoms of the same kind

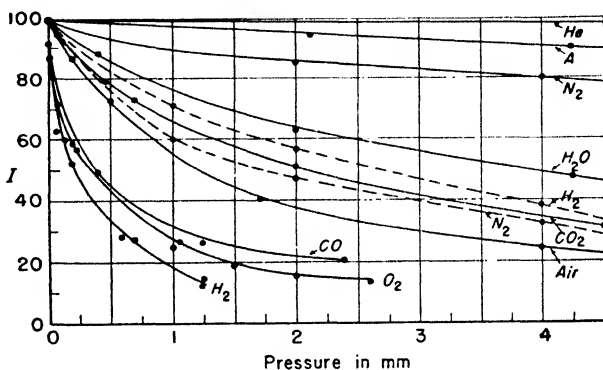

Fig. 45. Quenching of Hg- (continuous lines) and Na-resonance (broken lines) radiation by various gases (Mannkopf and Stuart).

does not completely disappear; the curves of Figure 44 do not tend asymptotically toward the same limiting value. This has also been proved by Schuetz; in a field of 18,000 gauss he still obtained a noticeable depolarization of the mercury resonance line at a vapor pressure of 10^{-3} mm, and, using the Malinowski method, he proved that the σ -components are still excited under experimental conditions (case I) under which the π -components alone should be excited in the absence of perturbations (1478, 1479).

39. Quenching of Resonance Radiation by Collisions. While in "transferring" collisions, which were dealt with in the foregoing sections, the main part of the electronic energy remains in the primarily excited atoms, genuine "quenching" collisions are characterized by the complete loss of the excitation energy. (If both processes occur simultaneously, it is difficult to separate them).

The quenching of the fluorescence of vapors by the addition of

foreign gases (atmospheric air, oxygen, chlorine, etc.) has been described by Wood in one of his first papers dealing with resonance radiation. The first systematic measurements on quenching were published by Stuart and by Mannkopf for the resonance radiation of sodium and of mercury, respectively (Figure 45) (976, 1595). Zemanski has brought forward a number of objections to the lack of precision of these early observations. In the case of mercury, no distinction had

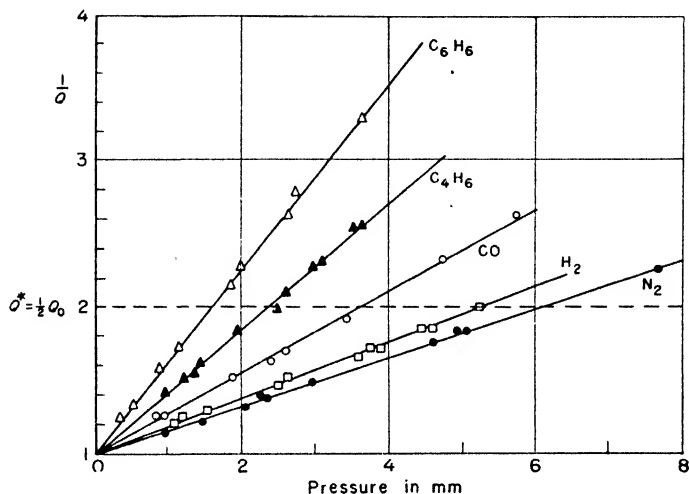

Fig. 46. Quenching of Na-resonance radiation by various gases (Norrish and Smith).

been made between the transfer into the metastable level and genuine quenching. The possibility of an increase of intensity caused by the broadening of the absorption lines has already been mentioned. If, on the other hand, the exciting line is very narrow — for instance, if it is emitted by a resonance lamp — it is absorbed less if the absorption line is broadened; thus, the intensity of the fluorescence becomes weaker without any real quenching action by the foreign gas. According to Zemanski, the quenching of the mercury resonance by inert gases, shown in Figure 45, is due to this cause alone. To avoid these effects, the measurements must be limited to pressures of the quenching gases so low that the width of the lines is still essentially determined by the Doppler effect. Another possible source of error is a chemical reaction of the metal vapor with the foreign gas — for instance, of mercury with oxygen or of sodium with nitrogen — by which the pressure of the metal vapor can be altered in an uncontrollable manner (463). Because

of the latter effect, Mannkopf's and Hamos' values for the quenching of sodium resonance radiation are probably too high. Norrish and Smith took special precautions for avoiding this source of error (see Tables 19A and B). Some of their results are represented in Figure 46, in which the reciprocals of the fluorescence yield are plotted versus the pressure of the quenching gas as straight lines, thus proving the validity of the Stern-Volmer equation (1147). Finally, the quenching efficiency can be increased if the resonance radiation is

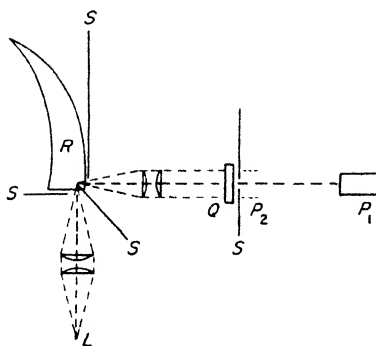

Fig. 47. Zemanski's apparatus for the determination of quenching cross sections.

L: light source. *R*: resonance lamp. *Q*: cell containing Hg-vapor and quenching gas. *P*₁: photocell in position 1. *P*₂: photocell in position 2. *S*: screens.

the quenching efficiency of oxygen was assumed to be 100% in Stuart's experiments, an effective radius had to be ascribed to the mercury atoms in the state 6^3P_1 which was 3.3 times larger than the gas-kinetic radius. (According to more recent measurements, the effective radii seem to differ less from the kinetic radii in this particular case.)

Zemanski's own method for measuring the quenching of the mercury resonance radiation is claimed to avoid all the objection

"imprisoned" in a metal vapor of relatively high pressure; because of the longer lifetime of the excited states, the probability of a quenching collision becomes larger.

In spite of all these objections, Stuart's and Mannkopf's papers already contained most of the principal results, to which only some quantitative corrections had to be introduced afterwards*: (1) various foreign gases differ widely in their action on a given excited atom, and the same gas acts very differently on various excited atoms; (2) if the quenching process is to be described by the Stern-Volmer equation, "effective" radii must be introduced instead of the gaskinetic radii. If, for instance,

* It may be mentioned here that even more recent measurements cannot claim absolute quantitative reliability. Thus, the quenching cross section of hydrogen for the Cd resonance line 3261A is listed in two papers as 0.67 and $3.54 \cdot 10^{-16}$ cm²; in both determinations the same method was used and no reason could be found to explain the discrepancy. (See Table 15).

mentioned above. It was later applied by Bates and Evans to a great number of quenching gases. In Figure 47, mercury vapor contained in a thin plane-parallel cell Q is excited by a parallel beam coming from another resonance lamp R . The intensity of the total radiation leaving Q in the direction of the primary beam is measured by means of a photoelectric cell P . In order to separate the resonance radiation emitted by Q from the primary light, P is placed either immediately in front of Q (position P_2) or at so great a distance from Q that practically only the parallel primary beam enters P (position P_1). Increasing quantities of the quenching gas are successively admitted into Q . An exact mathematical treatment of the problem can be given. The effective cross sections obtained by this method are, in general, smaller than those given in the earlier papers. Zemanski's results are listed in Table 14 together with some data published by Bates and Evans (67,369,1924,1926).

TABLE 14
QUENCHING CROSS SECTIONS OF VARIOUS GASES FOR MERCURY
RESONANCE RADIATION*

Gas	σ in $\text{cm}^2 \cdot 10^{16}$	Gas	σ in $\text{cm}^2 \cdot 10^{16}$	Gas	σ in $\text{cm}^2 \cdot 10^{16}$
H ₂ O	1.43	H ₂	8.6	CH ₄	0.085
D ₂ O	0.46	D ₂	11.9	C ₂ H ₆	0.6
NH ₃	4.2	O ₂	19.9**	C ₃ H ₈	2.26
NO	35.3	He	negligible	C ₄ H ₁₀	5.88
CO ₂	3.54	Ne	0.325	C ₇ H ₁₆	34
N ₂	0.27	A	0.223	C ₂ H ₄	48
				C ₆ H ₆	59.5

* Many of the figures contained in this table are taken from Mitchell and Zemanski's *Resonance Radiation and Excited Atoms*; in some cases they deviate considerably from the figures published by the authors in their original papers. Mr. Zemanski was kind enough to inform me that the deviations are caused by corrections which he found necessary to introduce in his calculations.

** It is difficult to understand why the value $59 \cdot 10^{-16} \text{ cm}^2$, derived from Mannkopf's curve, is so much larger. At the corresponding half-pressure of O₂, the broadening of the absorption line by collisions is still negligible. The values for the rare gases are taken from a paper by Olsen (1175a).

For comparison's sake, the gas-kinetic cross sections of normal mercury atoms may be mentioned: they are $11 \cdot 10^{-16} \text{ cm}^2$ in nitrogen and of the same order of magnitude (between 9 and $11 \cdot 10^{-16} \text{ cm}^2$) in all other gases listed in the table. According to Samson, the diffusion coefficient of metastable mercury atoms in oxygen is between 15.1 and $18.4 \cdot 10^{-16} \text{ cm}^2$ — about as large as the quenching coefficient in oxygen

— so that, in this case, the gas-kinetic and the quenching coefficients would seem to be practically identical. The size of mercury atoms in the metastable state, measured by their coefficient of diffusion in nitrogen, is also nearly the same as the size of normal mercury atoms derived from the kinetic theory of gases (1252, 1408, 1789, 1791a).*

Two independent determinations of the quenching of the mercury resonance radiation by H_2 and D_2 have been published; it is very striking that both papers reproduce curves plotting the fluorescence

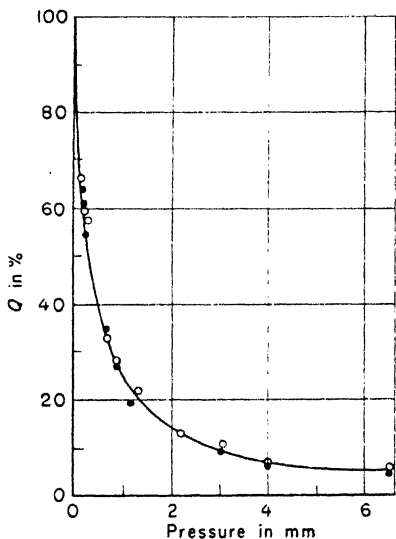

Fig. 48. Quenching of Hg-resonance radiation by H_2 (closed circle) and D_2 (open circle) (Suppe).

intensity versus the gas pressure which coincide exactly for hydrogen and deuterium. Since the numbers of kinetic collisions are inversely proportional to the square roots of the molecular masses, the effective quenching cross sections of H_2 and D_2 derived from the curve of Figure 48 are directly proportional to these square roots. As a matter of fact, the values given in Table 14 for D_2 and H_2 correspond to the ratio $11.9/8.6 = 1.4 = \sqrt{2}$. Thus, the smaller number of collisions is exactly compensated by the smaller velocities of the molecules or by the longer duration of the individual collision. While, in general, a law of this type governs the interaction of particles in nuclear physics, this is the only case where it has been found to be valid for the interaction between excited atoms and quenching molecules (369, 1598).

Even for the quenching of the corresponding resonance line of cadmium 3216A by D_2 and H_2 , the ratio of the cross sections is quite different, about $1/2$ instead of $\sqrt{2}$. (The second pair of values mentioned in Table 15 even yields a ratio below $1/3$). The quenching cross sections of other gases and vapors for the cadmium resonance line are collected in Table 15. As mentioned, some of the values published by different investigators do not agree very satisfactorily. The results marked

* From measurements of the diffusion in mercury vapor Couliette derived an effective cross section of metastable Hg (6^3P_0) which was 1.5 times as large as that of normal mercury atoms [*Phys. Rev.* 32, 636 (1928)].

with one asterisk seem to be the more reliable ones (66,91,943,1561).

TABLE 15
 QUENCHING CROSS SECTIONS OF VARIOUS GASES AND VAPORS FOR
 THE Cd RESONANCE LINE 3261A

Gas	$\sigma \cdot 10^{16}$	Gas	$\sigma \cdot 10^{16}$	Gas	$\sigma \cdot 10^{16}$
H ₂	3.54* (0.67**)	CH ₄	0.012**	C ₂ H ₄	24.9*
D ₂	1.80* (0.19**)	C ₂ H ₆	0.024**	C ₃ H ₆	29.1*
CO	0.14**	C ₃ H ₈	0.012*	C ₄ H ₈ (1)	35.2*
NH ₃	0.052* (0.041**)	C ₄ H ₁₀	0.46*	C ₄ H ₈ (2)	30.6*
N ₂	0.021**	C ₆ H ₆	28.4*	C ₂ H ₂	27*

* After Steacy and Leroy (1561).

** After Lipson and Mitchell (943).

Winans has developed a method for investigating the quenching of atomic fluorescence by foreign gases, which provides the possibility of observing the quenching cross sections at different relative velocities of the colliding molecules. The vapor of a metal halide --- for instance, of sodium chloride --- is dissociated by the absorption of ultraviolet light into an excited metal atom and a halide atom according to the equation:

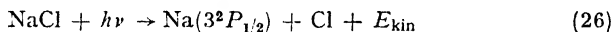

If the frequency of the absorbed radiation corresponds to a quantum $h\nu$ larger than the minimum energy needed for the dissociation, the surplus energy E_{kin} is distributed between the two separating atoms according to the law of the conservation of momentum. It is thus possible, within certain limits, to impart to the excited metal atoms any desired velocity larger than the velocity of thermal equilibrium (627,781,800,1267a,1644,1848). (Processes of this kind are discussed in more detail in the following chapter, Section 73).

The method has the advantage of avoiding most of the difficulties mentioned by Zemanski. Since the primary absorption occurs in the continuous band of the molecules, the absorption of the exciting light is not appreciably influenced by collision-broadening, even at considerable pressures of a quenching gas. On the other hand, as practically no unexcited atoms of the metal are present in the observation chamber, reabsorption and imprisonment of the resonance radiation are out of the question. (However, if the quenching gas has an absorption band in the spectral region of the exciting light or of the resonance radiation, adequate corrections must be introduced into

the calculations). Finally, it is possible to investigate the quenching action of vapors which would react strongly with the metal vapor itself.

Tables 16 and 19A list the values obtained by means of this method for the D-lines of sodium: σ is the effective cross section calculated from the "half-pressure" p^* , and v_1 the additional velocity of the excited atoms due to the surplus energy, according to Equation (26). Compared with the thermal velocities, v_1 is, in general, large and, therefore, the calculation of σ can be appreciably simplified by neglecting the thermal velocities. Under this assumption, the number of collisions z is given by the equation:

$$z = \sigma n v_1 \psi(x) \quad (27)$$

where $x = v_1 \sqrt{m/2kT}$

$$\psi(x) = (c^{-1/2}/x) + (2 + 1/x^2) \cdot \int_0^x e^{-\xi^2} d\xi$$

n is the number of quenching molecules per cm^3 and
 m is their mass

TABLE 16
 EFFECTIVE QUENCHING CROSS SECTION OF VARIOUS GASES FOR THE Na
 RESONANCE RADIATION AS A FUNCTION OF THE EXCITING WAVELENGTH
 AND THE MOLECULAR VELOCITY

Wavelength in A	2400	2380	2311	2300	2232	2082	2026	1990
v_1 in $\text{cm}/\text{sec} \cdot 10^{-4}$	0.7	0.7	1.3	1.4	1.7	2.4	2.6	2.8
Nitrogen $\sigma \cdot 10^{16}$	58.5	—	—	—	—	24.9	—	38.2
Iodine $\sigma \cdot 10^{16}$	75	60	40	48	28	12	15	17

The gas-kinetic cross sections of sodium in the gases mentioned in Tables 16, 18, and 19A lie between 31 and $41 \cdot 10^{-16} \text{ cm}^2$, for sodium in I_2 it is $50 \cdot 10^{-16}$. Thus, the quenching cross sections do not differ much from the gas-kinetic cross sections, with the exception of argon, for which the ratio between quenching and kinetic cross sections is about one-to-ten. But even for argon, σ is not vanishingly small as has been assumed by Zemanski for the inert gases colliding with excited mercury atoms. With argon as the quenching gas, each sodium atom suffers a number of collisions before it is quenched, so that it has acquired the average thermal velocity when the quenching collision occurs; therefore, an influence of the exciting wavelength on σ is neither to be expected nor is it observed. If molecular iodine is the quenching gas, σ decreases continuously with increasing v_1 ; only for

the greatest value of v_1 does σ show a slight increase again. The results obtained with nitrogen are similar, while the influence of v_1 on σ is rather doubtful with atomic iodine as quencher (803,1267b,1268).

Winans' method has the disadvantage that it is practically impossible to extrapolate the quenching cross sections characteristic of the atoms with normal thermal velocities from values like those of Table 16 and, thus, to compare the results with those obtained by other methods. A very arbitrary extrapolation from the three points, given in Table 16 for the quenching efficiency of nitrogen leads to $\sigma = 83 \cdot 10^{-16}$ for $v_1 \sim 0$. This value was obtained by Hamos for excited sodium atoms of thermal energy, but it is certainly much too high and disagrees widely with the value found by Norrish and Smith which must, at present, be considered to be the most reliable (compare Table 19A).* The quenching cross sections found by Norrish for the quenching of the sodium resonance radiation by hydrogen and carbon monoxide are also hardly consistent with those obtained by Winans' method. They are inserted for comparison in Table 19A; Table 19B lists the effective quenching cross sections of a number of organic compounds for the D-lines (569,1147).

The quenching efficiency of hydrogen and nitrogen for the second doublet of the principal series of sodium ($4^2P \rightarrow 3^2S$) was found by Berry and Rollefson to be of the same order of magnitude as that for the D-lines (96).

Prileshajewa measured the quenching of the green thallium line by various gases using Winans' method of excitation. Table 17 gives the relation between σ and the nature of the quenching gas for excitation with the radiation of a zinc spark. The complete lack of quenching by hydrogen is particularly remarkable (1267b,1268,1644).

Table 18 lists all examples for which the quenching cross section has been investigated as a function of the relative velocities of the colliding particles. It is not possible to find any connection with the various processes which are assumed to produce the quenching (compare the following section).

It must be mentioned, however, that in several instances other authors disagree with Prileshajewa in regard to the quenching processes (1270).

* On the other hand, the values of Tables 16 and 19A are in fairly good agreement with those obtained by other authors using the same method under similar conditions. Hamos' result, and also the earlier ones published by Stuart, are probably caused by the fact that the sodium vapor pressure in the observation vessel was lowered by the reaction of the metal with the quenching gas. Norrish took special precautions in order to avoid this source of error.

TABLE 17
 QUENCHING OF THE GREEN THALLIUM FLUORESCENCE
 BY VARIOUS FOREIGN GASES

Quenching gas	p^* in mm	$\sigma \cdot 10^{18}$ cm ²	σ/σ_k	Quenching gas	p^* in mm	$\sigma \cdot 10^{18}$ cm ²	σ/σ_k
O ₂	20	86	1.67	A	300	2.6	0.07
CO ₂	35	21	0.56	H ₂	?	0.01	10 ^{-2*}
N ₂	—	11	0.29	I ₂	4.9	17	—
H ₂ O	100	1.0	0.39	I	30	63	—
				TII	5	50	—

40. Mechanism of Energy Transfer in Quenching Collisions.

According to Franck's principle, the electronic energy of an excited atom cannot be transferred directly into kinetic energy of the colliding particles. If the excitation energy has to be taken over almost completely as internal energy of the quenching molecules, these must have some sort of excited states which are in energy resonance with the primarily excited atom. The most direct process of this type occurs if the quenching atom has among its electronic levels one of nearly the same energy as the primarily excited atom. Under these conditions,

TABLE 18
 VARIATION $\Delta\sigma$ OF THE QUENCHING CROSS SECTION WITH INCREASING
 RELATIVE VELOCITIES OF THE COLLIDING PARTICLES

Fluorescing vapor	Na		Tl	
	$\Delta\sigma$	Quenching process	$\Delta\sigma$	Quenching process
H ₂	irregular	reaction?	0	?
N ₂	negative	collision of the 2d kind	0	collision of the 2d kind
O ₂	—	—	negative	reaction
CO	irregular	collision of the 2d kind	0	collision of the 2d kind
CO ₂	negative	reaction	positive	reaction
H ₂ O	—	—	0	collision of the 2d kind
Br ₂	negative	reaction	—	—
I ₂	negative	reaction	negative	reaction
I (atomic)	irregular	collisions of the 2d kind	irregular	collision of the 2d kind
TII	—	—	positive	collision of the 2d kind

the second atom is able subsequently to emit its characteristic radiation as "sensitized fluorescence." This very important phenomenon is treated separately in the last part of this chapter.

The hypothesis of energy resonance between electronic transitions and nuclear oscillations of diatomic molecules has proved its usefulness in the discussion of the induced transfer of excited mercury atoms into the metastable state. Several authors have tried to apply the same hypothesis to genuine quenching, assuming that the colliding molecule takes up a great number of oscillation quanta at once. Table 19A provides an example of this kind for the quenching of the sodium resonance radiation. Δ is the difference between the electronic energy of the atom and the vibrational energy of the molecule containing v quanta of oscillation.

Using the figures of Table 19A, Kondratiev and Siskin plotted a "resonance curve" of the same type as the curve of Fig. 38; they obtained similar results for the quenching of the green thallium line. However, the authors themselves point out that the quenching cross

TABLE 19A

EFFECTIVE CROSS SECTIONS FOR THE QUENCHING OF SODIUM RESONANCE RADIATION AS A FUNCTION OF THE ENERGY RESONANCE

Quenching gas	N ₂	NO	O ₂	CO	H ₂
Number of oscillation quanta v	8	10	12	8	4
Oscillation energy in eV	2.24	2.18	2.12	2.03	1.93
Δ in eV	0.08	0.02	-0.04	-0.13	-0.23
σ_q in cm ² · 10 ¹⁶	24.9	31.6	52.2	13.4	15.7
(The same after Norrish)	(14.5)			(28)	(7.4)

TABLE 19B

EFFECTIVE CROSS SECTIONS FOR THE QUENCHING OF THE SODIUM RESONANCE RADIATION BY HYDROCARBONS

Saturated compounds	$\sigma \cdot 10^{16}$	Nonsaturated compounds	$\sigma \cdot 10^{16}$
CH ₄	0.11	C ₂ H ₄	44
C ₂ H ₆	0.17	C ₃ H ₆	52
C ₃ H ₈	0.2	C ₄ H ₈	58
Cyclohexane	0.4	C ₆ H ₆	75
Iso-octane	0.8	Hexadiene	76

section $\sigma = 0$ found for the quenching of the thallium fluorescence by hydrogen is in complete disagreement with the hypothesis, and they draw the conclusion that the interpretation of the curves as resonance curves cannot be upheld. Moreover, the transfer of electronic energy into nuclear vibrations of such great amplitudes would be in contradiction to Franck's principle in no lesser degree than the direct transfer into translation energy of the molecules. Thus, other possible processes producing these quenching actions must be looked for (803).

The first instance in which at least the overall reaction of a quenching collision could be determined was the weakening of the mercury resonance radiation by hydrogen. Franck and Cario proved that if a mixture of mercury vapor and hydrogen is irradiated with the mercury resonance line, hydrogen molecules are dissociated. The formation of atomic hydrogen can be proved by the reduction of a metal oxide such as copper oxide or tungsten oxide, or, if oxygen is present in the vessel, by the formation of water. The rate of dissociation can be followed by measuring the decrease in gas pressure, all newly formed water vapor being frozen out. If oxygen is present at too high a pressure the reaction is inhibited by the strong quenching action of oxygen itself. On the other hand, the rate of reaction becomes small at low hydrogen pressures and correspondingly low probabilities of a collision between a hydrogen molecule and a short-lived excited $\text{Hg}(^3P_1)$ -atom. The curves representing the quenching of the mercury fluorescence and the hydrogen dissociation as functions of the hydrogen pressure are exactly parallel: the number of quenching collisions is proportional with the number of dissociation processes and probably the latter occur with a yield of 100%. The dependence of the reaction rate on the hydrogen pressure disappears almost completely if nitrogen is added to the gaseous mixture; under these conditions the excited mercury atoms, which by collisions with nitrogen molecules have been transferred to the metastable state 3P_0 , have a high probability of colliding during their long lifetime with hydrogen molecules even at low hydrogen pressures. Mercury atoms in the states 3P_1 and 3P_0 seem to be about equally efficient in dissociating hydrogen molecules (202a, 301, 1022a).

The most obvious interpretation of the mechanism of this typical sensitized photochemical reaction, which is represented by the equation:

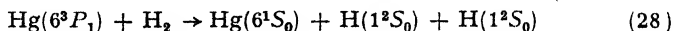

must probably be discarded. From the theoretical viewpoint, it is

prohibited by Wigner's law of the conservation of spin angular momentum, according to which the loss of electronic spin in the triplet-singlet transition of the Hg-atom must be compensated by a corresponding increase of spin in the other partners of the process. This question has been discussed at length by Laidler (857).

Furthermore, the heat of dissociation of hydrogen is only 4.46 eV, so that the relatively large energy of 0.4 eV must be transferred into kinetic energy of the colliding particles. Conditions are only slightly more favorable for deuterium, with a heat of dissociation equal to 4.54 eV. The cadmium resonance line 3261A is quenched by hydrogen almost as strongly as the mercury resonance radiation, although the excitation energy of the cadmium atom is only 3.78 eV and is thus insufficient for the process described by Equation (28). The appearance of HgH- and CdH-bands, respectively, in the fluorescence spectra (see Section 74) proves that these compounds are formed in the mixture of the metal vapors with hydrogen under the influence of the irradiation (91,92,1562,1630). Thus, one must assume that the primary quenching process follows the equation:



In the case of cadmium, the available energy is just sufficient for this process; in the case of mercury, the surplus energy can be taken over by the HgH-molecules as nuclear vibration and rotation energy. Beutler and Rabinowitch have shown that a high rotational energy results with great probability from this type of reaction if the metal has a high atomic weight (106). The concentration of the HgH-molecules remains small, however; because of their small heat of dissociation and their great vibrational energy, they dissociate almost instantaneously.

If the fluorescence of zinc vapor is excited by the full radiation of a zinc arc, the intensity of the triplet lines is much more reduced in the stepwise-excited fluorescence spectrum by an addition of 0.02 mm of hydrogen than the red singlet line (Section 17). Bender concludes that a reaction of Zn(4^3P_1) with H_2 is more probable than that of Zn(4^1P_1), because of better energy resonance; the energy of the singlet state is 5.77 eV or larger by 1.31 eV than the heat of dissociation of H_2 . However, it must also be taken into account that the lifetime of the singlet state is more than ten thousand times shorter than that of the triplet state (92).

The quenching of the mercury and cadmium resonance radiation by saturated hydrocarbons is followed by polymerization and other

transformations of the organic molecules. The primary process is supposed to be of the same type as in the quenching by hydrogen (compare Section 74):

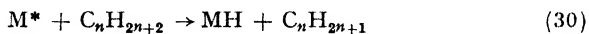

The subsequent chemical reactions of the radicals need not be dealt with in this connection. The effective cross sections are relatively small (see Tables 14 and 15), with the exception of the heaviest compound (257,589,1063,1558,1559,1561,1563-1565).

The effective quenching cross sections of the unsaturated hydrocarbons are much larger. In this case, the primary process is not connected with a photolysis of the compounds; the electronic energy of the mercury atoms is transformed into excitation energy of the colliding molecule. For instance, for ethylene:

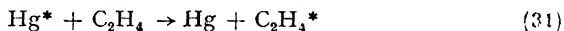

with subsequent reactions of the type: $C_2H_4^* \rightarrow C_2H_2 + H_2$; $H + C_2H_4 \rightarrow C_2H_5$; etc. (699,903-905,1054,1560). However, ethylene absorbs only about 20% of the total energy as electronic excitation energy; the remnant must be transferred into vibrational energy of the molecule. (This would not be at variance with the Franck-Condon principle, since the molecules are transferred simultaneously to a different electronic state). Because of this great internal energy, it is not improbable that the primary reaction is followed by a dissociation of the excited molecule before the polymerization can occur. Such an event is much less probable if the process is sensitized by the presence of excited Cd (5^3P_1) or Zn (4^3P_1) atoms, because of the appreciably smaller excitation energies of cadmium and zinc (548a,548b,558,589,904).

The quenching of the mercury resonance radiation by acetylene is ascribed to the analogous mechanism followed by a polymerizing chain reaction:

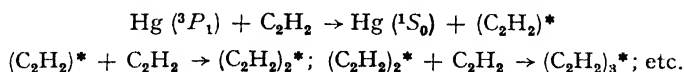

This polymerizing process is inhibited by the presence of NO, perhaps due to the formation of C_2H_2NO (697,905,1012).

Hydrogen-deuterium exchange reactions in mixtures of the vapors of ammonia, phosphene, or methane and heavy water are photosensitized by mercury vapor irradiated with the mercury resonance line (380,1013).

Chemical reactions are known to occur in many processes by

which the mercury resonance radiation is quenched but, in general, it is difficult to ascertain the mechanism of the primary energy transfer. When the resonance radiation is quenched by oxygen, the gas disappears gradually, while solid HgO is deposited on the walls; simultaneously the fluorescence regains its initial intensity if a sufficient supply of mercury is available (463,882,1148). If mercury vapor is excited in the presence of oxygen through a Mrozowski filter transmitting the hyperfine-structure components II and III of the line 2537A (Figure 19), only even isotopes are transferred into the state 6^3P_1 and react subsequently with oxygen. In this way, a partial separation of the mercury isotopes can be achieved (1935).

If NO is the quenching gas, the gas pressure drops slowly to one-half of its original value (67,1629). According to Noyes, this is due to the formation of N_2 , while the oxygen reacts again with the mercury to form Hg₂O. The sensitized photolysis of NH_3 and ND_3 by collisions with excited mercury atoms occurs, according to Melville, in two steps: by a first collision, the mercury atoms are transferred into the metastable state (see Section 37); by another collision of the metastable atom, an ammonia molecule is dissociated. This second process has a relatively small probability and is, therefore, very sensitive towards minute admixtures of hydrogen which "quenches" the metastable atoms before a second effective collision with an NH_3 - or ND_3 -molecule takes place (1011,1041,1150).

While the quenching cross section of ND_3 for the mercury resonance radiation is appreciably smaller than that of NH_3 , corresponding to the greater energy deficiency $\Delta\epsilon$ of -0.072 eV against 0.016 eV (Figure 38), the quenching efficiencies of PH_3 and PD_3 are nearly the same, although, in this case too, the vibrational frequency of the ground state of PH_3 is in much better energy resonance with the transition $6^3P_1 \rightarrow 6^3P_0$ of the mercury atoms ($\Delta\epsilon = 0.012$ eV for PH_3 as compared with 0.07 eV for PD_3). Moreover, the quenching cross sections of the phosphines are much larger than that of ammonia (26 and $29 \cdot 10^{-16}$ against $4 \cdot 10^{-16}$ cm²) and, finally, the mercury-sensitized decomposition of the phosphines is very little inhibited by the presence of hydrogen. It must be assumed, therefore, that, in this instance, a collision with an excited mercury atom produces the direct transition $6^3P_1 \rightarrow 6^1S_0$ and the decomposition of the colliding molecule with much greater probability than the transition $6^3P_1 \rightarrow 6^3P_0$, which would be due to the intake of vibrational energy by the phosphine molecules (1014).

It is very improbable that the quenching of the sodium and

thallium fluorescence is primarily due to chemical reactions of the excited atoms. If the foreign gas is monatomic, the formation of a molecule in a simple collision is impossible because of the conservation of momentum, even if the two partners are able to form a stable molecule. This applies, for instance, to the quenching of the sodium resonance radiation by atomic iodine: the two atoms approach each other along a potential curve with a deep potential minimum, but, at the point of closest approach, they have sufficient potential energy to separate again along the same curve. This is true for the unexcited state as well as for the excited state of the sodium atom. However,

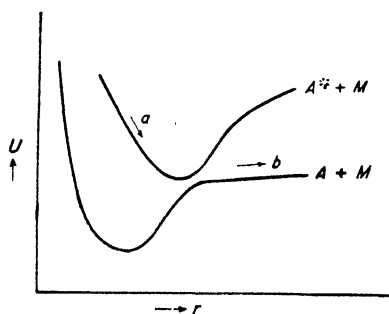

Fig. 49. Potential curves for quenching without transfer of excitation energy (Laidler).

Laidler has pointed out that the potential curves representing these two states may draw so near to each other at some point (Figure 49) that a transition from one to the other would no longer disagree with the Franck-Condon principle.

If the same considerations are applied to the quenching of the sodium resonance radiation by molecular hydrogen and nitrogen, or by hydrocarbons, the two-dimensional potential curves must be replaced by three-dimensional or polydimensional surfaces, since the relative positions of the individual atoms within the quenching molecules are also influencing the interaction with the excited atom. In this case, curves like that of Figure 49 would represent a cross section of such a potential surface (857).

These statements are only a more elaborate formulation of a general idea which has been enunciated at a much earlier date by Franck and Eucken and has been repeated since by several authors in slightly different ways. The probability of the transfer of any kind of energy into vibrational energy of a molecule by a collision is large only if the potential curves of the molecule undergo a strong deformation by the interaction between the colliding particles, and this always occurs if one of the colliding particles is a radical or a chemically reacting atom or, more generally speaking, a particle with a strong external electric field. According to Eucken, every exchange of energy between two molecules must be treated as the beginning of a chemical reaction (414).

While the quenching of the mercury resonance radiation by saturated hydrocarbons is accompanied by a photosensitized reaction, this cannot be assumed for the quenching of the sodium resonance by the same compounds. Neither is the available energy sufficient, nor have such reactions actually been observed. Nevertheless, the quenching cross sections are of the same order of magnitude for the resonance radiation of mercury and sodium, and they are in both cases much smaller for the saturated hydrocarbons than for the nonsaturated compounds. The strong external fields of the latter have a much larger influence on the probability of the energy transfer than the possibility of an actual chemical process (698).

The rare gases, like argon, are very weak quenchers, but they are not quite ineffective. They cannot take part in a chemical reaction nor take up electronic or vibrational energy. Attraction curves with a potential minimum do not exist either; but, at small nuclear distances r , the two repulsion curves I and II of Figure 50 can cross at b , or at least can come so close together at $y-y'$ that a transition from one to the other becomes possible. At this point of close approach, the energy levels of the fluorescent atom are so much distorted by the interaction with even a rare-gas atom that there is practically no difference between the energy of the excited and the unexcited atom, a transition from one to the other consists only in a rearrangement of the electronic configuration. As these transitions occur at very small internuclear distances, the effective cross sections for quenching collisions of this type are very small and increase with increasing temperature. According to Oldenberg, the quenching efficiency of argon for the resonance radiation of mercury is very low at room temperature and becomes nearly four times larger when the temperature is raised to 750° C. In this case the quenching is not caused by the transfer to the metastable state but by direct transfer to the ground state of the excited atoms so that the electronic excitation energy is completely converted into kinetic energy of the separating atoms (658,1167).

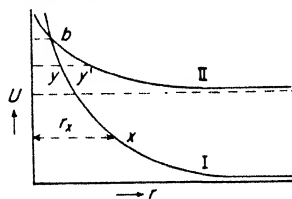

Fig. 50. Potential curves for quenching by a rare gas [Jablonski (658)].

I: metal atom in ground state. II: metal atom in excited state.

H. Sensitized Fluorescence

41. Nature of the Phenomenon and the Importance of Energy Resonance. The process which has been defined in the last section as sensitized fluorescence has the greatest probability of occurring if the foreign atoms colliding with the excited atoms have an electronic state with an energy very close to the excitation energy of the latter. The lines originating from this electronic state will have the greatest intensity in the spectrum of the sensitized fluorescence. In order to provide a sufficient number of collisions with the primarily excited atoms, the partial pressure of the second vapor must not be too low. Therefore, the lines leading to the ground state will be relatively weakened by reabsorption. If the energy resonance between the electronic states of the absorbing and the emitting atom is not very

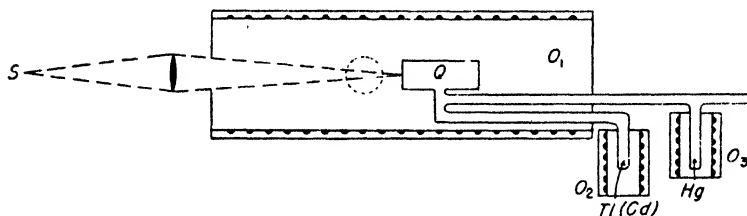

Fig. 51. Apparatus for production of sensitized fluorescence (Cario).
 S: light source. Q: resonance lamp. O_1 , O_2 , and O_3 : electric ovens.

good, the kinetic energy of the colliding atoms may be so much increased that the reabsorption is considerably reduced. These theoretical predictions which are due to Franck are in general agreement with the intensity distributions which were observed in the spectra of sensitized fluorescence.

The phenomenon was discovered by Cario in a mixture of mercury vapor and thallium vapor irradiated with the mercury resonance line 2537A (201,202b). The observation chamber and two side tubes were heated by three independent ovens so that the temperature of observation and the vapor pressure of the two metals contained in the side tubes could be adjusted separately (Figure 51); the pressure of the mercury vapor was 0.25 mm and that of the thallium vapor, 2 mm. The fluorescence spectrum obtained under these conditions consisted, apart from the mercury resonance line, of a great number of thallium

arc lines. The thallium lines disappeared, together with the mercury resonance line, if the exciting water-cooled arc lamp was replaced by a hot mercury lamp (316).

In the same way, sensitized fluorescence was later obtained in the vapors of the alkali metals, of silver, cadmium, zinc, lead, and indium, while experiments with antimony and arsenic gave negative results. In all these instances the primarily excited atoms were mercury atoms. Atomic fluorescence sensitized by light absorption in the vapor of another metal has not yet been observed (310, 805, 821, 959a, 1845, 1846).

The earlier papers of the Goettingen school give the impression that, in spite of the preferential excitation of electronic states with small energy differences, the secondary emission of lines for which the available surplus energy exceeded 1 eV was directly stimulated by collisions with excited mercury atoms. Beutler's and Josephy's investigation of the mercury photosensitized fluorescence of sodium showed unambiguously the extraordinary importance of energy resonance for the efficiency of the energy transfer in sensitized fluorescence (100, 103). (It must be emphasized, however, that even before the discovery of sensitized fluorescence J. Franck put forward, for the first time, the principle which bears his name).

TABLE 20
ENERGIES OF VARIOUS Na- AND Hg-TERMS

Na-term	4D	6S	5D	7S	6D	8S	7D	9S	8D	10S
Energy in eV . .	4.26	4.50	4.58	4.71	4.75	4.81	4.84	4.88	4.92	4.94
Hg-term					6^3P_0		6^3P_1			
Energy in eV . .					4.68		4.86			

Table 20 lists the energies of various terms of the sodium atom and, for comparison, the energy of two mercury terms. In general, the intensity of the lines of a series decreases rapidly with increasing order, so that the line $9S \rightarrow 3P$ is one of the weakest in the emission spectrum of sodium vapor under normal conditions. In the spectrum of sensitized fluorescence, however, this line is particularly strong, while the line $4D \rightarrow 3P$, which would be much stronger in a normal spectrum, is very weak. As shown in Table 19, the energy of the term 9S is very nearly the same as the energy of the mercury level 6^3P_1 and, thus, the sodium atoms are transferred with greatest probability into the level 9S by a collision with an excited mercury atom. On the other hand, the lines corresponding to the transitions $9S \rightarrow 3P$ (4423 and

4420A)* have the greatest intensity of all the lines originating from the state 9S. The effective radii, which were calculated from the intensity of the lines, the intensity of the primary radiation and the vapor densities, were several hundred times larger than the kinetic radii.

By an addition of nitrogen to the mixture of the metal vapors, most of the excited mercury atoms can be transferred into the metastable state 6^3P_0 before they collide with a sodium atom. The state 6^3P_0 of mercury is in almost complete energy resonance with the Na-term 7S and, therefore, the line $7S \rightarrow 3P$ (4750A) becomes prevalent in the sensitized fluorescence spectrum of sodium under these changed conditions.

Whichever of the two lines is emitted primarily, the emission of the D-lines must always follow as a second step in the return from the state $3P$ to the ground state. As far as estimates of the relative intensities permit one to draw a conclusion, the emission of the D-lines was not excited in these experiments by any other more direct mechanism. (That the D-lines were found to be abnormally broadened under these conditions of excitation is no proof for a Doppler effect due to the transfer of a great amount of kinetic energy in a direct excitation of the state $3P$. Because of the relatively low mercury vapor pressure, the fluorescence was excited in rather deep layers of the vapor, so that the D-lines were partially self-reversed on their way to the exit window).

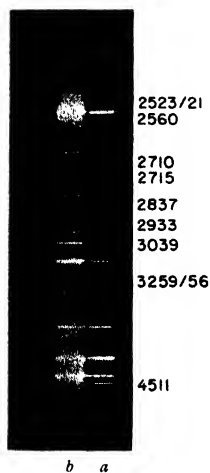

Fig. 52. Spectrum of Hg-sensitized fluorescence of indium (Donat). *a*: mercury spectrum. *b*: fluorescence spectrum.

These results lead to a more comprehensive interpretation of the sensitized fluorescence which was observed in other metal vapors. The fluorescence of indium may serve as a typical example (310). The lines obtained by Donat are listed in Table 21, the spectrum is reproduced in Figure 52 and, schematically, in the Grotrian diagram of Figure 53. The resonance between the indium terms $7P$ and $6D$, with energies of 4.78 and 4.80, and the mercury level 6^3P_1 is sufficiently good. From these two states, stepwise transitions lead to all lower levels of the Grotrian diagram from which the lines of Figure 52 and 53 originate. As far as the lines 2602 and 2521/23 are concerned, it must be considered that at an observation

* The doublets were not resolved on the spectrograms and, therefore, the corresponding indices were omitted in the designation of the terms in Table 20.

temperature of 900° C an appreciable number of indium atoms are in the metastable state $5^2P_{3/2}$, which lies 0.272 eV above the ground state. The transition $7^2D \leftarrow 5^2P_{3/2}$ in the indium atom is again in good resonance with the mercury line 2537A.

It is not possible to explain the line intensities observed in the sensitized thallium fluorescence spectrum by similar considerations. The only thallium term with an energy close to the energy of the mercury state 6^3P_1 is the term $8S$, its energy being 4.77 eV. There are some lines in the spectrum originating from this level. Furthermore, the level $7S$ can be reached from $8S$ via $7P$ and, thus, the occurrence of the strong lines 5350 and 3776A (see Figure 9) can be understood. However, the line 3529A originating from the level $6D_{3/2}$ (4.45 eV) is almost the strongest in the whole fluorescence spectrum. A spontaneous transition $8S \rightarrow 6D$ is forbidden and a primary excitation of the state $8P_{1/2}$, with an energy of 5.11 eV, is also out of the question. Thus, it was assumed by Cario that the thallium atoms were directly transferred by collisions with excited mercury atoms into the state $6D_{3/2}$ with the relatively high surplus kinetic

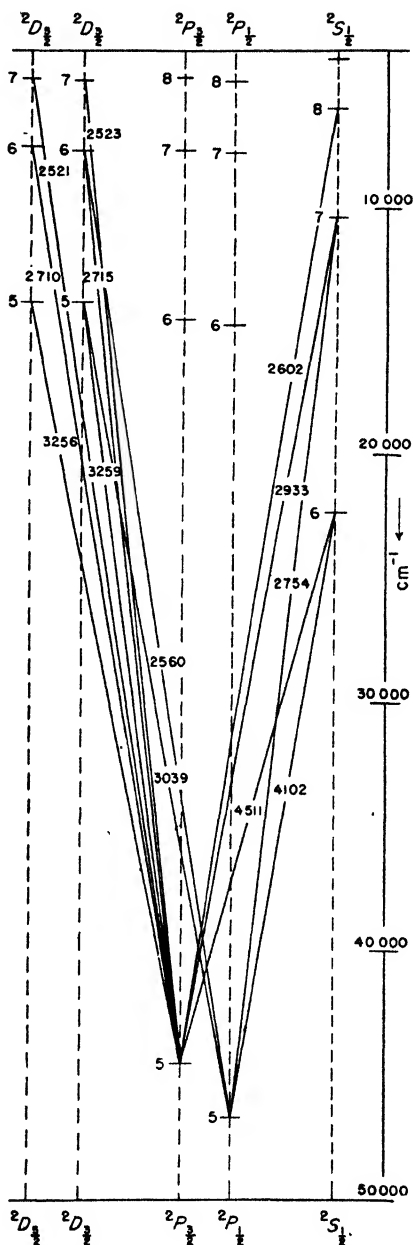

Fig. 53. Grotrian diagram of indium (Donat).

Pringsheim 5*

TABLE 21
THE SPECTRUM OF SENSITIZED FLUORESCENCE OF INDIUM

Wave length (Å)	Inten- sity	Terms involved	Energy eV of upper term	Wave length (Å)	Inten- sity	Terms involved	Energy eV of upper term
4511	v.st.	$6S_{1/2}-5P_{3/2}$	3.00	2754	Hg*	$7S_{1/2}-5P_{1/2}$	4.46
4102	st.	$6S_{1/2}-5P_{1/2}$	3.00	2715	w.	$6D_{3/2}-5P_{3/2}$	4.80
3259	v.st.	$5D_{3/2}-5P_{3/2}$	4.04	2710	st.	$6D_{5/2}-5P_{3/2}$	4.80
3256	n.s.	$5D_{5/2}-5P_{3/2}$	4.04	2602	v.w.	$8S_{1/2}-5P_{3/2}$	5.01
3039	st.	$5D_{3/2}-5P_{1/2}$	4.04	2560	w.	$6D_{3/2}-5P_{1/2}$	4.80
2933	st.	$7S_{1/2}-5P_{3/2}$	4.46	2523	v.w.	$7D_{3/2}-5P_{3/2}$	5.15
				2521		$7D_{5/2}-5P_{3/2}$	(4.88)†
							5.15

v. st. : very strong; st. : strong; w. : weak; v.w. : very weak; n.s. : not separated.

* Hidden by mercury line.

† $5.15 - 0.27 = 4.88$ ($5P_{3/2} - 5P_{1/2} = 0.27$ eV).

energy of 0.41 eV divided equally between the two atoms. Despite the resulting Doppler effect, the small intensity of the other line originating from $6D_{3/2}$ and leading to $6P_{1/2}$ was ascribed to the re-absorption of this line in the thallium vapor (202b).

However, it is very probable that many other processes have to be taken into account for a complete explanation of the phenomenon. Under the conditions of the experiment, a part of the excited mercury atoms may have been transferred into the metastable state by the interaction with other mercury atoms. Furthermore, excited Hg_2 -molecules can be formed by collisions of normal Hg-atoms with mercury atoms in the states 6^3P_0 or 6^3P_1 . The very complicated potential-curve system of these molecules is shown in Figure 81. Finally, excited mercury atoms may combine with thallium atoms to form excited $HgTl$ -molecules and these may dissociate later into normal mercury and excited thallium atoms.

Insofar as the second of these assumptions is concerned, Mrozowski has actually shown that sensitized thallium fluorescence can be produced by primary excitation of Hg_2 -molecules, although it is true that in his experiments the mercury vapor pressure was appreciably higher. Under these conditions, the sensitized thallium fluorescence was excited by primary lines which are not absorbed by monatomic mercury vapor (1079b). (This process will be dealt with in more detail in Section 79).

As mentioned in Section 39, the resonance radiation of mercury is almost completely quenched in mercury vapor saturated at $250^\circ C$;

simultaneously, the lines of the sensitized thallium fluorescence not only become stronger than at the mercury vapor pressure most favorable for the emission by the mercury atoms themselves, but the intensity of the thallium line 3776A does not decrease if the mercury vapor pressure is raised to more than an atmosphere (350°). The thallium vapor pressure need not exceed a few hundredths of a mm so that an excited mercury atom or molecule will, on the average, collide with a thallium atom only after 10,000 collisions with other mercury atoms. According to Mrozowski's later observations, it can hardly be doubted that in these experiments also, not only metastable Hg-atoms but Hg₂-molecules contributed, at least partially, toward the conservation of the excitation energy over so long a period (1182).

The third hypothesis mentioned above is supported by two facts. The formation of HgTl-molecules under favorable conditions has been proved by the appearance of emission bands characteristic of these molecules. On the other hand, the emission of the mercury resonance line following the dissociation of excited Hg₂-molecules has been observed in many experiments.

A few lines occur in the sensitized fluorescence of thallium which require excitation energies of up to 5.5 eV, since they originate from the levels 8D and 9S. Their appearance can be explained by the fact that at 800° C a small fraction of the thallium atoms is in the metastable state $6P_{3/2}$, as proved by noticeable absorption of the green line in the vapor. From $6P_{3/2}$, the thallium atoms can be raised with fairly good energy resonance into one of the higher *P*-states by collisions with excited mercury atoms (for instance $11P-6P_{3/2} = 4.81$ eV). (This mechanism cannot suffice to explain the appearance of the *strong* line 3529A in the fluorescence spectrum).

At a temperature of 800° C in the observation chamber, the lines of the Cd-triplet 5086-4800-4678A were obtained in the mercury sensitized fluorescence of cadmium vapor, though with very small intensity. These lines require an excitation energy of 6.3 eV. If the vapor pressure is kept constant while the temperature in the observation chamber is lowered to 400° C, the lines disappear. Thereby it is proved that the surplus energy actually is furnished by thermal agitation, and since the cadmium atoms have no metastable state of higher energy above the ground state like the thallium atoms, this energy must be provided either by the transferring collision itself or by a second collision during the life of the excited state. The average kinetic energy of the atoms is only 0.11 eV and, thus, collisions with a surplus energy of 1.4 eV would be exceedingly rare. The improba-

bility of a transfer of so large an amount of kinetic energy into electronic excitation energy has already been sufficiently discussed. One may, therefore, have to assume, in this instance also, a more complicated mechanism.

The same consideration applies even more convincingly to the appearance of lines with an excitation energy of 7.7 eV in the mercury sensitized fluorescence of zinc vapor at a temperature of only 720° C (for instance, the line 3302A, $4^3D_2-4^3P_1$). Since this energy surplus can under no circumstances be supplied from the thermal energy, Winans assumed that mercury atoms are raised by stepwise excitation into a higher level — for instance, by secondary absorption of the line 4358A into the state 7^3S_1 with an energy of 7.69 eV. This process was possible in Winans' experiments because the full radiation of a mercury arc was used for excitation. The same is true for all observations mentioned in this section. By inserting a filter which transmitted only the mercury line 2537A into the path of the exciting radiation, the zinc lines requiring a high energy were suppressed in the fluorescence spectrum. However, it is certain that, at least in part, the observed emission lines were not caused by any kind of absorption in mercury atoms; for, in contradistinction to Cario's original experiment with thallium vapor, some of the zinc lines were excited also by light of a hot mercury lamp which could not stimulate resonance radiation in pure mercury vapor, while another part of the zinc lines disappeared under these conditions. Furthermore, it was possible to excite the zinc fluorescence (the lines of the triplet $5^3S_1-4^3P_{0,1,2}$) by irradiating the mixture of mercury and zinc vapor with light of wavelengths below 1900A produced by an aluminum spark. Although Winans ascribed the absorption of this radiation to mercury atoms, it was probably caused by molecules of some sort, either Hg_2 or Zn_2 or $HgZn$. Actually, a band which belonged neither to pure Hg- nor to pure Zn-vapor was observed in the absorption and emission spectra of the mixed vapors. Winans' experimental conditions were particularly favorable for the formation of molecules of this type because the zinc vapor pressure was very high (16 mm) (1845-1847).

The investigation of the sensitized fluorescence of the other metals enumerated in the third paragraph of this section corroborated the foregoing conclusions, more or less, without providing further information of importance.

Winans devised a simplified method for the excitation of sensitized fluorescence, especially of metals such as iron and chromium which have very low vapor pressures at moderate temperatures. The metal is

crushed to a fine powder and introduced into a quartz tube containing some mercury. The tube is evacuated and the part containing the powder is heated with a blowtorch to the highest temperature which the tube stands without collapsing. The mercury pressure is adjusted to values between 1 and 150 mm by keeping the coldest part of the tube at an adequate temperature. When the radiation from a water-cooled mercury arc was focused on the hottest part of the tube, the two resonance triplets of chromium (at 3600 and 4300Å) and some thirty iron lines could be obtained in the sensitized fluorescence spectrum of these metals (1850, 1854).

Winans used the same method for the excitation of the sensitized fluorescence of lead and tin, and here it could be shown that, although with lesser efficiency than the energy resonance, a "partial selection rule," $\Delta J = 0$, is of importance for the transfer of energy; the probability of transfer is greater if the sum of the electronic angular momenta of the two colliding atoms, Hg* and M [$J = J(\text{Hg}) + J(\text{M})$], remains constant and is smaller if J changes. If the excitation of lead atoms is mainly due to collisions with Hg (3P_0)-atoms (e.g., if nitrogen is present in the tube) and thus the value of $J(\text{Hg})$ is zero before and after the collision, the lead line 3683Å originating from the level $^3P_0^o$ is much stronger than the line 3639Å originating from $^3P_1^o$ (Figure 10), while in the arc spectrum of lead the two lines have practically the same intensity. The energy difference between the two levels is so small that they are equivalent insofar as energy resonance is concerned. Similar considerations can be applied to a pair of lines in the spectrum of tin, in which altogether thirteen lines have been obtained by the excitation of sensitized fluorescence (1849, 1852, 1855).

42. Influence of Foreign Gases and of Magnetic Fields. If, by addition of nitrogen, the excited mercury atoms are transferred to the metastable state 6^3P_0 , the probability of collisions of the second kind is greatly increased. Donat has actually observed that in the sensitized fluorescence of thallium, the thallium lines were considerably enhanced if nitrogen was added to the mixture of the metal vapors. According to Donat, the various thallium lines behave very differently under these conditions: some of them (2920, 2580, 3230, 3530Å) reach an intensity maximum at 30 mm of N_2 and fade out rather rapidly at higher nitrogen pressures; others (3551, 3776Å) remain constant between 30 mm and one atmosphere, while the intensity of the line 2788Å, with a slower initial rise, continues to increase up to atmospheric pressure. However, these results were not confirmed by Loria, who states that all lines decline again with increasing nitrogen pressure Pringsheim 5**

after having reached a maximum intensity. Since no other observations are available, a discussion of these discrepancies is not possible. A decrease of the fluorescence intensity at high nitrogen pressures is plausible in itself because of the quenching action of the gas on the fluorescence of thallium (Table 16). Both authors agree that argon produces similar effects, although considerably higher pressures are necessary. However, it is very likely that the action of argon was due to traces of nitrogen, since it has been shown repeatedly that a transfer of excited mercury atoms into the metastable state practically never occurs by collisions with argon (310,960,1182).

The enhancement of the thallium lines by the addition of nitrogen is not only inhibited by the presence of the smallest traces of oxygen or hydrogen, but the light emission is completely quenched as soon as the probability of a collision of the metastable atoms with the molecules of these strongly quenching gases becomes larger than the probability of a collision with a thallium atom. The direct quenching action of oxygen (not of hydrogen) on the thallium fluorescence must also be taken into account (310).

The great influence of the presence of nitrogen and of the resulting production of metastable mercury atoms for the sensitized fluorescence of sodium vapor has already been discussed (Section 41). If mercury vapor is irradiated at room temperature in the presence of 3.7 mm of nitrogen with the resonance line alone and, thus, under conditions which exclude stepwise excitation, the lines 3662, 3665, and 3650A are observed in the fluorescence spectrum. Beutler and Rabinowitch consider this phenomenon to be due to a kind of sensitized fluorescence between mercury and mercury atoms and designate it as "energy enhancement in an elementary process" (105). The energy levels from which the lines mentioned above originate are $6^3D_{1,2,3}$, 8^3S_1 , and possibly 8^1S_0 (compare Fig. 15); they have excitation energies of 8.81, 9.13, and 9.20 eV, respectively. The last value corresponds almost exactly to the sum of the energies contained in two 6^3P_0 -atoms and can, therefore, be transferred with excellent energy resonance to one atom by a collision of two metastable atoms. The resonance would still be sufficiently good for the excitation of the state 8^3S_0 (9.13 eV), the small surplus energy being converted into thermal agitation. The 6^3D -states are probably produced by subsequent collisions of $8S$ -atoms with nitrogen molecules which are able to take up the energy difference of 0.27 eV as vibrational energy.

Beutler and Josephi suppose that even the photoelectric ionization of mercury vapor, which was discovered by Steubing and which

is produced by irradiating the vapor with the resonance line, may be due to another repetition of the same process. After being raised to the state 8^1S_0 , an atom is assumed to take up the energy of a third metastable atom in a collision of the second kind. Although a qualitative calculation proved that such processes might occur with sufficient abundance, it seems more likely, as has been discussed in detail by Houtermans, that, at least at higher vapor pressures, the formation of metastable excited Hg_2 -molecules and subsequently of Hg_2 -ions plays an important part in the process (103,105,630,1572).

Mitchell investigated the sensitized fluorescence of cadmium at a mercury vapor pressure of 10^{-3} mm and a cadmium vapor pressure of 0.5 mm, in the presence of 2 mm of helium; the observation chamber was placed in a magnetic field of 300 gauss with its lines of force parallel to the exciting radiation (case II). Under these conditions, the mercury resonance line was still appreciably polarized, while the cadmium line 3261A showed no sign of polarization. Mitchell draws the conclusion from his observation that the primarily existing orientation of the electric vector is completely destroyed in an energy transfer by a collision of the second kind. Although the conclusion may be correct in itself, this is not proved unambiguously by the experiment. The partial polarization of the mercury line might persist in spite of the relatively high pressures of helium and cadmium vapor, while the cadmium line is completely depolarized by the resonance interaction between excited and unexcited cadmium atoms (1038).

CHAPTER II

DIATOMIC GASES AND VAPORS

A. Theory of Band Spectra and Interpretation of Resonance Spectra

43. Energy Levels. The internal energy of a diatomic molecule is not completely determined by the configuration of its electrons; it depends also on the vibrations of the nuclei along the line connecting them and on the rotation of the molecule around its principal axis of inertia, which is perpendicular to this line. In a first approximation, the total energy is obtained by the addition of three terms corresponding to the electronic, the vibrational, and the rotational energy:

$$W = T + G + F \quad (32)$$

To the same approximation, the wave function describing the energy state of a molecule can be split into three factors:

$$\Psi = \Psi_e \cdot \Psi_v \cdot \Psi_r \quad (32a)$$

Ψ_e , Ψ_v , and Ψ_r depend *only* on the configuration of the electrons, on the nuclear vibration, and on the rotation of the molecule, respectively.

The vibrational energy* of a strictly harmonic oscillator is:

$$G(v) = (v + 1/2)\omega \quad (33)$$

where ω is the characteristic frequency of the oscillator and $v = 0, 1, 2, \dots$ is the "vibrational quantum number." For an anharmonic oscillator, a term quadratic in v (and for a more accurate description also a cubic term) must be introduced into the equation, so that:

$$G(v) = (v + 1/2)\omega_e - (v + 1/2)^2 x_e \omega_e + (v + 1/2)^3 y_e \omega_e + \dots \quad (34)$$

ω_e now being the frequency of the oscillator for vanishingly small

* In this chapter all energies are given in cm^{-1} , for the sake of simplicity; in order to obtain the actual energies, all equations must be multiplied by h/c (compare Section 1). Following the common practice the symbol ν is used instead of $\bar{\nu}$ for the wave number (compare Section 6).

amplitudes ($v = 0$). Even in the "vibrationless state" the energy of the oscillator is not zero but assumes the value:

$$G(0) = \frac{1}{2}\omega_e - \frac{1}{4}x_e\omega_e + \dots \quad (35)$$

The fraction of the molecular energy due to the rotation alone is:

$$F(J) = J(J + 1) \cdot h/8\pi^2 I = J(J + 1) \cdot B \quad (36)$$

I is the moment of inertia of the molecule with respect to its principal axis, and J is the rotational quantum number.†

The moment of inertia I and, therefore, also B , depend on the distance between the nuclei; they vary with the amplitude of the vibration and are functions of v :

$$B_v = B_e - \alpha(v + \frac{1}{2}) + \dots \quad (37)$$

α is the "coefficient of interaction" (between oscillation and rotation). The values x_e , y_e , B_e , and α are characteristic of a given electronic state of a molecule and vary with the transition from one state to another.

The frequency of a line corresponding to the transition from a state T' , v' , J' to a lower state T'' , v'' , J'' is thus determined by the equation:

$$\begin{aligned} \nu &= (T' - T'') + (G' - G'') + (F' - F'') \quad (38) \\ &= \nu_e + (v' + \frac{1}{2})\omega'_e - (v' + \frac{1}{2})^2 x'_e \omega'_e - (v'' + \frac{1}{2})\omega''_e \\ &\quad + (v'' + \frac{1}{2})^2 x''_e \omega''_e + J'(J' + 1) [B'_e - \alpha'(v' + \frac{1}{2})] \\ &\quad - J''(J'' + 1) [B''_e - \alpha''(v'' + \frac{1}{2})] \end{aligned}$$

In practical spectroscopy it is more convenient to use integer coefficients instead of the $(v + \frac{1}{2})$ values of the vibrational quantum numbers:

$$\begin{aligned} \nu &= \nu_e + v'\omega'_0 - v'^2 x'_0 \omega'_0 - v''\omega''_0 + v''^2 x''_0 \omega''_0 \\ &\quad + J'(J' + 1) (B'_0 - \alpha'_0 v') - J''(J'' + 1) (B''_0 - \alpha''_0 v'') \quad (38a) \end{aligned}$$

The constants occurring in Equation (38a) are derived easily from the constants of Equation (38) — for instance (neglecting y):

$$\omega_0 = \omega_e(1 - x_e), \quad x_0\omega_0 = x_e\omega_e, \text{ etc.} \quad (38b)$$

Taking into account the selection rules which are explained in the

* If the rotor is not rigid, so that the distance between the nuclei is increased by the centrifugal acceleration, a term $J^2(J + 1)^2 \cdot D$ must be added. However, this term can be neglected for the following considerations.

† Compare Section 45 on the general meaning of the quantum number J .

following sections, Equations (38) and (38a), respectively, describe the complete band spectrum of a diatomic molecule. The first term on the right-hand side of these equations corresponds, by itself, to a line in the visible or ultraviolet region and contributes by far the largest part of the total energy ($\nu_e \sim 20,000 \text{ cm}^{-1}$). If a single electronic transition is considered, ν_e is kept constant and its value determines the approximate position of a "band system" in the spectrum. In the second term, which corresponds to a variation of the vibrational energy, the frequencies ω' and ω'' are, in general, of the same order of magnitude (in most cases between 100 and 1,000 cm^{-1}). (In the spectra of H_2 , N_2 , O_2 and some other gases and vapors, the values of ω are considerably larger).

Infrared vibrational bands correspond to transitions from one v -level to another, if they occur without a simultaneous electronic transition.

If the rotational energy is disregarded [$F = 0$ in Eq. (32)], the energy levels of three electronic states are represented by the diagram of Figure 54. The intervals ΔG between the individual sublevels of a given electronic state are constant, to a first approximation, but they decrease slowly from the bottom towards the top because the binding force between the nuclei is not strictly linear. Therefore, $\Delta G = \omega$ must be replaced by:

$$\begin{aligned} \Delta G(v + 1/2) &= G(v + 1) - G(v) & (39) \\ &= \omega_e - 2(v + 1)x_e\omega_e \\ &= \omega_0 - 2(v + 1/2)x_0\omega_0 \end{aligned}$$

For high values of v which, however, cannot be extrapolated from Equation (38) without taking the cubic term and, possibly, even higher-order terms into account, ΔG converges towards zero; the vibrational levels converge towards an upper limit where they merge into a continuum corresponding to a complete separation of the two nuclei. The atoms or ions into which the molecule splits can acquire kinetic energies which are no longer quantized.

If all excited molecules of a vapor are in one definite vibrational level v' of an electronic state T' , they can return from there to all existing levels v'' of the ground state and thus produce an emission spectrum in which the lines corresponding to $v'' = 0, 1, 2 \dots$ form a regular "progression." The intervals between neighboring lines in the progression decrease according to Equation (39). Without a simultaneous electron jump, the vibrational number v of a harmonic oscillator can vary only by ± 1 ; values of Δv larger than one can

occur only to the extent to which the binding force of the oscillator is anharmonic; the probability of such transitions decreases rapidly with increasing Δv , if the anharmonicity of the oscillator is small ($x \ll 1$), a condition which holds for practically all diatomic molecules. Lenz

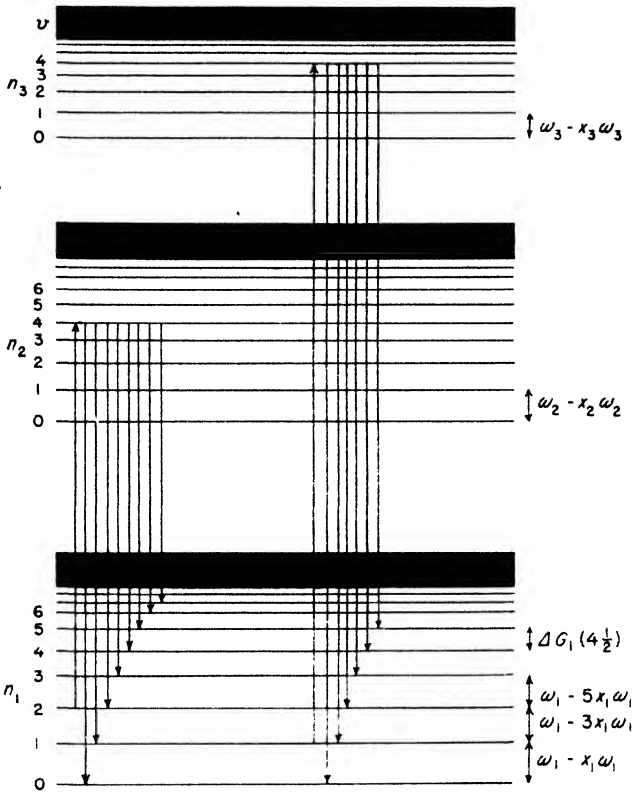

Fig. 54. Energy-level diagram for two band systems of a diatomic molecule.

has shown, however, that if an electronic transition (or, in the corresponding classical model, an electronic vibration) is superimposed on the nuclear vibrations, the two processes will influence each other even according to classical electrodynamics. Under quite plausible assumptions regarding this interaction, overtones of high order or transitions with large Δv may be expected to occur in the nuclear vibrations, although the binding force between the nuclei may be strictly linear. Under these conditions, the intensities of neighboring lines of the

progression can vary in a very irregular fashion, as has been actually observed. The quantum-mechanical interpretation of this phenomenon is discussed in Sections 47 and 48 (898,899).

44. Rotational Doublets and the Complete Resonance Spectrum.

The last term on the right-hand side of Equation (38) is due to molecular rotation. Thereby, every line corresponding to a transition $v' \rightarrow v''$ splits into a multitude of lines forming a "band." The scheme of Figure 54 does not take the molecular rotation into account; the energy levels are drawn for $J = 0$. If all levels caused by the variation of J were included in the diagram, a series of levels would be inserted above every horizontal line of the figure. The distances between these levels would steadily increase according to the following relation, which is derived from Equation (36):

$$\Delta F(J + \frac{1}{2}) = F(J + 1) - F(J) = 2(J + 1)B \quad (40)$$

The higher members of these series would stretch beyond the following vibrational levels, so that the ground would be covered almost con-

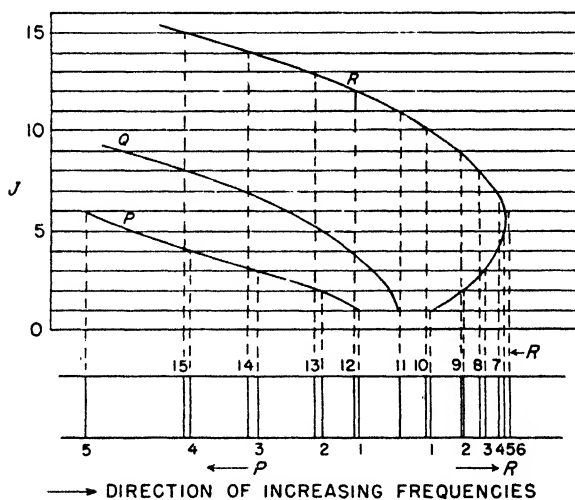

Fig. 55. Fortrat diagram for a band system with P -, Q -, and R -branches.

tinuously and the diagram would be completely blurred. It is better, therefore, to represent the subdivision of the energy levels caused by the molecular rotation by a different scheme, reproduced in Figure 55

— so-called Fortrat parabolas. The scheme is not quite as simple and obvious as that of Figure 54, but it has the advantage of showing only the allowed transitions, which occur by varying J and it makes possible a direct visualization of the relative position of the corresponding lines in the band.

The rotational quantum number follows the selection rule $\Delta J = 0$ or ± 1 strictly, so that always $J'' = J'$ or $J'' = J' \pm 1$. Thus, the last term in Equation (38) can assume the three following forms:

$$\begin{aligned}
 \text{a: } J'' = J' - 1: P(J'') &= J'^2(B'_v - B''_v) + J'(B'_v + B''_v) & (41) \\
 &= J'^2(B'_v - B''_v) + J'(B'_v - B''_v) - B''_v + (2J' + 1)B''_v \\
 \text{b: } J'' = J': Q(J'') &= J'^2(B'_v - B''_v) + J'(B'_v - B''_v) \\
 \text{c: } J'' = J' + 1: R(J'') &= J'^2(B'_v - B''_v) + J'(B'_v - 3B''_v) - 2B''_v \\
 &= J'^2(B'_v - B''_v) + J'(B'_v - B''_v) - B''_v - (2J' + 1)B''_v
 \end{aligned}$$

Each band is divided into three branches (P , Q , R), represented by parabolas in the diagram of Figure 55.* In all bands in which fluorescence spectra have been observed so far, ΔJ is *either* equal to 0 or to ± 1 ; therefore, either only one rotational line corresponds to a transition from a given excited state T' , v' , J' to a vibrational level of the ground state T'' , v'' , J'' with $J'' = J'$, or two rotational lines of the band appear, corresponding to $J'' = J' + 1$ and $J'' = J' - 1$ and forming a doublet. The separation between the components of the doublet is:

$$\delta\nu = (4J' + 2)B''_v = (4J' + 2)(B''_0 - \alpha''_0\nu'') \quad (42)$$

Within a series corresponding to transitions from the same excited state v' , J' to all vibrational levels $v'' = 0, 1, 2, \dots$ of the ground state, the doublet separation is approximately constant and decreases only slowly with increasing v'' because of $\alpha_0 \ll 1$. For various initial rotational states J' , however, the values of $\delta\nu$ vary considerably; to a first approximation, they are proportional with $4J'$.

If the initial state T' , v' , J' remains constant while the final state of an emission process assumes all possible values v'' , the terms of Equation (38a), which remain unaltered under these conditions, can be summed up into:

* According to whether B'_0 is larger or smaller than B''_0 , the parabolas follow the direction of increasing or decreasing ν with increasing values of J' ; in Figure 55 the latter assumption ($B'_0 < B''_0$) has been made, since this is the case for almost all the examples occurring in this book.

$$\nu^* = \nu_0 + \nu' \omega'_0 - \nu'^2 x'_0 \omega'_0 + J'(J' + 1) B'_0 (1 + \alpha'_0 \nu') \quad (43a)$$

ν^* is the frequency of the line which would correspond to a transition to the final state $\nu'' = 0$, disregarding the rotational energy. Introducing this frequency ν^* , a complete doublet progression is represented by the equation:

$$\nu = \nu^* + \nu'' \omega''_0 + \nu''^2 x''_0 \omega''_0 - (J' \pm 1)(J' + 1 \pm 1) B'_0 (1 - \alpha'_0 \nu''_0) \quad (43b)$$

If strictly monochromatic light is absorbed in a vapor consisting of diatomic molecules, its frequency must coincide with that of an individual line of the band spectrum described by Equation (38a). Only molecules which are in a definite initial state \bar{T}'' , $\bar{\nu}''$, \bar{J}''^* can take part in the absorption process and these are all transferred into the same excited state T' , ν' , J' . In the absence of perturbations by collisions, etc., this state becomes the initial level from which the emission of a singlet or doublet series originates according to the mechanism described above. These "resonance series" have a very simple structure as compared to a complete band system; thus, the analysis of the band system is materially facilitated if some resonance series can be isolated. If, for instance, the values of ν'' and J'' can be determined in a special case, the doublet interval in the series gives directly the molecular constants B'_0 and α'_0 , and, simultaneously, the moment of inertia I'_0 .

In practically all resonance spectra of diatomic molecules which have been observed so far, the molecule returns by the emission process to the electronic ground state. Under these conditions, the exciting line is also a line of the fluorescence spectrum. However, it is the first member of the progression only if $\bar{\nu}'' = 0$, or if the absorbing molecule contains no vibrational energy; otherwise, the emission spectrum exhibits a number of "anti-Stokes" lines with wavelengths smaller than that of the exciting line.

Line progressions of this type were discovered by R. W. Wood in the fluorescence spectra of sodium and iodine vapor and were called by him "resonance spectra." It seemed obvious that a preferential position in the series should be ascribed to the exciting line, which was designated as the *R*-line (resonance line) and characterized by the order number 0. The other lines were numbered with reference to the *R*-line so that the order of the anti-Stokes lines became negative:

* Terms and quantum numbers representing the state of a molecule previous to the exciting absorption process are designated by a bar above the symbol in the following chapters.

$$v = v_R - pa + p^2b$$

$$(p = 0, \pm 1, \pm 2, \pm 3 \dots \text{ is the "order number"}) \quad (44)$$

If a series is described correctly by Equation (43), it can also be represented by Equation (44); the constants occurring in (44) can be derived from those in (43) by simple transformations. However, the notation of Equation (43) has the advantage that ω_0^* is a genuine molecular constant and retains the same value for every progression of the band system, while the constant a in Equation (44) is different for every series. The interval between the R -line and the line which follows in the direction of greater wavelengths ($p = +1$) is determined by the relation:

$$\Delta G^*(v_R + 1/2) = \omega_e^* - 2(v_R^* + 1)x_K^*\omega_e^* \quad (45)$$

and since $b = x_K^*\omega_e^*$, it follows that $a = \omega_e^* - (2v_R^* + 1)x_K^*\omega_e^*$.

The relative position of the doublet components in a resonance spectrum is essentially determined by the fact that the exciting absorption line belongs either to the P - or to the R -branch of the band — i.e., that in the absorption process the rotational quantum number \bar{j}'' increases to $\bar{j}'' + 1$ or decreases to $\bar{j}'' - 1$. In the first case, the companion line of the resonance line corresponds to the transition $(\bar{j}'' + 1) \rightarrow (\bar{j}'' + 2)$ and appears on the long-wavelength side of the R -line; in the other case, the companion line corresponds to the transition $(\bar{j}'' - 1) \rightarrow (\bar{j}'' - 2)$ and appears on the side of smaller wavelengths. In other words; if the exciting line belongs to a P -branch, the companion line lies on the R -branch, and vice versa. This is repeated in all other doublets of the resonance spectrum.

If the exciting line is broad enough to cover several absorption lines with various \bar{j}'' s and belonging partly to P - and partly to R -branches, the fluorescence spectrum consists no longer of doublets, but of complicated groups of lines which surround the central line more or less asymmetrically.

If a further electronic level B exists above the excited state A , and if spontaneous transitions from B to the ground state N are allowed, resonance spectra of the same kind as in the band system $A-N$ can be stimulated in the system $B-N$. They will be shifted towards shorter wavelengths, according to the greater energy difference $B-N$; but the spacing $\Delta G(v + 1/2)$ within the series is the same as in the system $A-N$, since it is determined by the constants characterizing the ground state, which is common for both systems. The

occurrence of fluorescence spectra of diatomic molecules caused by stepwise transitions from a higher electronic state ($B \rightarrow A$, $A \rightarrow N$) has not been proved with any certainty.

45. Electronic Terms. The electronic terms of diatomic molecules are discussed here only insofar as necessary to understand the designations which are used for the description of actually observed fluorescence spectra. For more details, reference should be made to books dealing exclusively with this subject.*

The electronic quantum numbers l and s , or L and S , respectively, retain the same meaning as in Section 12. From these the new quantum numbers A and Σ are derived by projecting L and S upon the principal axis of the molecule. The molecular states $\Sigma, \Pi, \Delta, \dots$ are determined† by the quantum number $A = 0, 1, 2, \dots$. In the so-called "coupling case a ," which alone may be discussed here as one of the most important instances, A and Σ combine vectorially to a new quantum number Ω so that:

$$|A - \Sigma| \leq \Omega \leq |A + \Sigma|$$

Ω plays the same part as the inner quantum number in atomic spectra. In Sect. 43, J was characterized as the rotational quantum number of the molecule. Actually, J measures the total angular momentum of the molecule, which is determined by the superposition of the rotation of the nuclei around the principal axis of inertia, the orbital angular momentum of the electrons, and the spin of the electrons (and, in certain cases, of the nuclei). Thus, J is equivalent to the angular momentum M produced by the rotation of the molecule around the axis of inertia only for ${}^1\Sigma_0$ -states. In all other cases, J differs from zero even in the absence of molecular rotation ($M = 0$), and the lowest value which can be assigned to J is $1/2$ or 1 or $3/2$, etc., according to the nature of the electronic state and the values of L and S .

In the "coupling case b ," A and M combine by vectorial addition to a new quantum number K , and J is obtained by vectorial addition of K and the electronic spin S . These altered definitions of J do not alter the representation of the resonance spectra given in the preceding sections.

* Jevons, *Report on Band Spectra of Diatomic Molecules*, London, 1932; W. Weizel, *Bandenspektren*: (1), *Ergänzungsband des Handbuchs der Experimentalphysik*, Akademische Verlagsgesellschaft, Leipzig, 1934; G. Herzberg, *Molecular Spectra and Molecular Structure*, Prentice Hall, New York, 1939.

† Like S in the description of atomic spectra, Σ is used here in two different meanings: as a quantum number and as a term symbol.

The most important selection rules for transitions between electronic states are:

$$\Delta A = 0 \text{ or } \pm 1; \quad \Delta \Sigma = 0; \quad \Delta \Omega = 0 \text{ or } \pm 1; \quad \Delta S = 0 \text{ or } \pm 1$$

The multiplicity r of an electronic state, which is determined by the relation $r = 2S + 1$, can, therefore, change in an electronic transition by 0 or ± 2 . Allowed transitions are, for instance:

$${}^1\Sigma \rightarrow {}^1\Sigma; \quad {}^1\Pi_1 \rightarrow {}^1\Pi_1; \quad {}^3\Pi_0 \rightarrow {}^3\Pi_0; \quad {}^1\Sigma_0 \rightarrow {}^3\Sigma_1; \quad {}^1\Pi_1 \rightarrow {}^1\Sigma_0, \text{ etc.}$$

and forbidden transitions:

$${}^3\Pi_0 \rightarrow {}^3\Pi_3; \quad {}^3\Pi_0 \rightarrow {}^3A_1; \quad {}^1A_1 \rightarrow {}^1\Sigma_1, \text{ etc.}$$

Other selection rules, particularly for element molecules consisting of two atoms of the same kind, follow from the fact that certain symmetry properties of the molecules must be preserved.

1. A state may be positive (+) or negative (-). (See footnote at the end of 5).

2. A state of an element molecule (which may consist of two isotopes of different mass) is called even (g), if the total angular momentum of its electrons is even: $L = 0, 2, 4 \dots$; it is called odd (u) for odd values of L ($L = 1, 3, 5 \dots$). If necessary, g and u are added as subscripts to the term symbols:

$${}^1\Sigma_g, {}^2\Pi_u, \text{ etc.}$$

3. A state of a homonuclear molecule is symmetrical (s) or antisymmetrical (a). A symmetrical state is always either positive and even (+ and g) or negative and odd (- and u); an antisymmetrical state is always negative and even (-- and g) or positive and odd (+ and u). These relations and the corresponding selection rules are collected in Table 22.

TABLE 22
ALLOWED AND FORBIDDEN TRANSITIONS

s	a	Allowed	Forbidden
+ and g	+ and u	$s \rightleftharpoons s$	$s \rightleftharpoons a$
- and u	- and g	$a \rightleftharpoons a$	+ \rightarrow +
		+ \rightleftharpoons -	- \rightarrow -
		$g \rightleftharpoons u$	$g \rightarrow g$
			$u \rightarrow u$

4. If a Σ -state ($A = 0$) is produced by the action of two or more electrons with individual $\lambda > 0$ (e.g., $\lambda_1 = +1, \lambda_2 = -1$ or $\lambda_1 = +1, \lambda_2 = +1, \lambda_3 = -2$, etc.), the two sublevels Σ^+ and Σ^- have opposite symmetry properties and are, in general, separated by a rather large energy difference. In all other electronic states of a homonuclear molecule (Π, Δ , etc.), each rotational level is split into two sublevels c and d which coincide energetically for $J = 0$ and become gradually wider apart as J increases. c and d have opposite symmetry. This " A -type doubling" is caused by the magnetic field which is produced by the rotation of the molecule; according to whether A is parallel or anti-parallel to the lines of force of this field, the energy of the term is slightly different.

5. The rotational levels of a given electronic state are alternately $+$ and $-$ and, in a homonuclear molecule, alternately s and a ; if, for instance, in a Π -state c is positive and, therefore, d negative for a given value of J , the reverse is true for $J + 1$, where c is negative and d is positive.*

It follows from 1, 2, and 3 that two states which combine with a third state cannot combine with each other. However, this rule applies strictly only to homonuclear molecules. In molecules of this type, consecutive rotational levels which are alternately symmetrical and antisymmetrical have unequal statistical weights. Hence, the consecutive lines of a band have alternating intensities.

The diatomic molecules of even elements (without nuclear spin; compare Section 12) have only symmetrical terms; every second term with an odd value of K or J , respectively, is missing. For odd elements, the nuclear spin i is always different from zero, and the $(-, g)$ or the $(+, u)$ terms ("ortho terms") have a larger statistical weight than the $(+, g)$ and the $(-, u)$ terms ("para terms").

For $\Sigma \rightarrow \Sigma$ transitions, the Q -branches are missing in all bands, $\Delta J = 0$ being forbidden for $A = 0$; the resonance series consist of doublets exclusively (example: the green resonance spectra of I_2). In bands corresponding to transitions $\Sigma \rightleftharpoons \Pi$, Q -branches are not only

* The meaning of these symmetry relations can be explained only in terms of quantum mechanics. An electronic state is $+$ if the wave function Ψ corresponding to the motion of the electrons with regard to the nuclei does not change its sign on reflection in a plane through the axis of the molecule. A state is g (from the German *gerade*) if the electronic factor of Ψ [Ψ_e in Equation (32a)] does not change its sign on reflection in the midpoint of the line joining the two nuclei. A state is symmetrical if on interchanging the two nuclei Ψ_e does not change its sign. $-, u$, and a are determined by a change of sign in Ψ_e under the conditions mentioned above.

present, but their intensity is even greater than that of the P - and R -branches. It follows from 4 and 5 that if in this case Σ has the same symmetry as $\Pi(c)$ for a given value of $J = J_n$, and, therefore, a symmetry different from that of $\Pi(d)$, transitions from Σ to Π can lead only to c if $\Delta J = 0$, while for $\Delta J = \pm 1$ they must lead to d (Figure 56). Thus, *either* a singlet *or* a doublet progression, but never a triplet series, is produced by absorption of monochromatic light (example: the green to orange Na_2 resonance spectra).

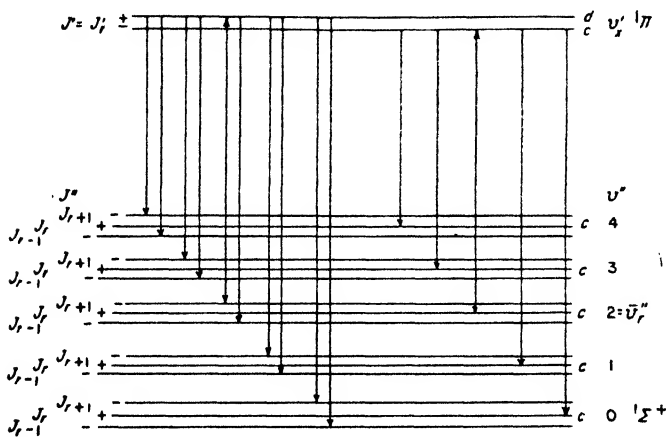

Fig. 56. Doublet and singlet progressions for $\Sigma \rightarrow \Pi$ transition.

The band spectra due to transitions between other electronic terms like $\Pi \rightarrow \Pi$, $\Pi \rightarrow \Delta$ show Q -branches as well as P - and R -branches, although the intensity of the former is relatively low; they are of little importance for the fluorescence spectra of the diatomic gases which have been investigated so far.

46. Shape of the Potential Curves. The term diagram of Figure 54 gives an accurate picture of the lines occurring in a resonance spectrum which results from the transition from a level $T'v'$ to the various levels v'' of the electronic ground state. The scheme, however, does not give any indications concerning the relative intensities of the individual lines. These can be obtained by using potential curves instead of the levelschemes for the representation of the electronic states and by applying the so-called Franck-Condon principle.

In Figure 57 the abscissa measures again the distance r between two atomic nuclei, and the ordinate the sum $U = T + V$ of the electronic excitation energy and of the potential energy of the nuclear

configuration, while the molecular rotation is neglected. If the nuclei are at infinite distance from each other V is zero and, as in Figure 36, 49 and 50, the vertical distance between the curves N and A is equal to the electronic energy of one of the atoms in an excited state. If (in contradistinction to the assumption on which the curves of Figures

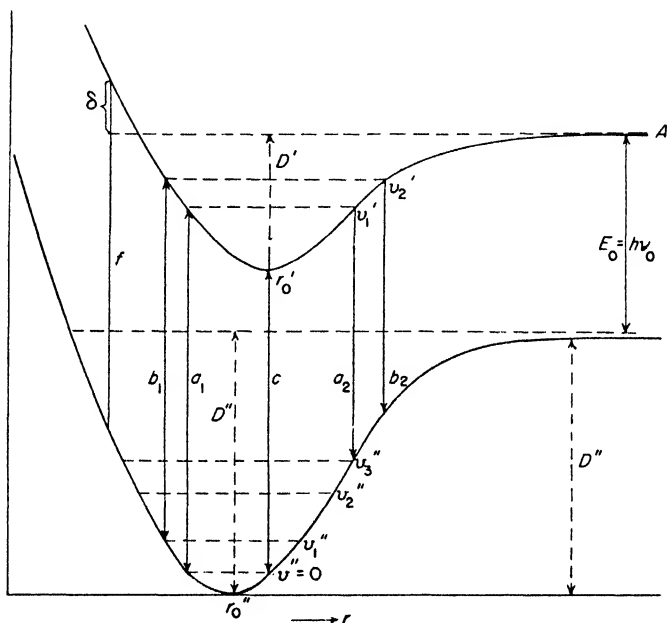

Fig. 57. Potential curves for the fluorescence of a diatomic molecule.

36 and 50 were based) an attractive force exists between the two atomic nuclei so that a stable molecule can be formed, U assumes negative values if the two unexcited atoms approach each other adiabatically. At very small distances between the two nuclei the repulsive force prevails, causing a steep rise of the curve. The minimum of U corresponds to the equilibrium of the nonvibrating molecule at the nuclear distance r_0 . The vertical distance between this point and the horizontal branch of the curve at great values of r corresponds to the work which must be applied to separate the nonvibrating molecule into two single atoms, or to the heat of dissociation D . For the sake of simplicity, the zero axis of energy is shifted in Figure 57 so that all

energies which occur (especially the energy of the nonvibrating unexcited molecule) assume positive values.

The function representing the potential energy of diatomic molecules in its relation to the interatomic distance has not yet been worked out in a generally valid form which can be numerically evaluated. The best approximation is probably still obtained by Morse's semi-empirical equation:

$$U(r) = E_{\min} + D(1 - e^{-a\varrho^2}) \quad (46a)$$

in which

$$a = 2\pi\omega_e c \sqrt{\frac{I_e}{2D}}$$

and $\varrho = r - r_0$, the deviation from the equilibrium position. If, in Equation (34), the coefficient ωx is very small, the oscillating molecule can be treated, in first approximation, as a classical harmonic oscillator, as long as the amplitudes are not too large, and its potential energy can be represented by the equation:

$$U(r) = E_{\min} + b\varrho^2 \quad (46b)$$

Under these conditions, the potential curve becomes a symmetrical hyperbola.

Since the vibrational energy of the molecule is quantized and since the energy is completely potential at the turning points of the oscillation, U can assume at these points only definite values which are determined by Equation (34) and which are indicated in Figure 57 by dotted horizontal lines. For a given value of the vibrational quantum number v , U oscillates according to the potential curve between the near and the far turning point. For $v = 0$, the vibrational energy of the molecule does not vanish, but it becomes $1/2\omega_e$ — $1/4\omega_e x_e$ [Equation (35)]; even the so-called nonoscillating state of the molecule does not correspond exactly to the lowest point on the potential curve, but to the undermost horizontal line in the diagram.

47. Franck-Condon (F.C.) Principle. If Franck's idea, according to which the position and the momentum of the nuclei cannot change appreciably during an electronic transition (cf. Section 35), is applied to the processes occurring in a diatomic molecule, only those transitions between the potential curves A and N have a reasonable probability which correspond to vertical arrows in the diagram. In the case represented by Figure 57, for instance, transitions from the ground state with $\bar{v}'' = 0$ can lead only to vibrational levels of the

excited state A between $v' = 0$ and $v' = v_1$ (a_1 and c in Figure 57). The molecules stay longest in the neighborhood of the turning points and, therefore, those transitions which are indicated by the arrows a_1 and a_2 have the greatest probability in the process of re-emission.

These considerations, based by Franck on plausible assumptions, later received a precise quantum-mechanical treatment by Condon and since then have been known as the Franck-Condon principle. The transition probability between the vibrational levels v' and v'' of two electronic states T' and T'' is defined, within the approximation of Equation (32a), by:

$$W = C \left\{ \int_0^{\infty} \psi'(v') \psi''^*(v'') dr \right\}^2 \quad (47)$$

$\psi'(v')$ and $\psi''(v'')$ are the eigenfunctions characterizing the vibrational states v' and v'' of the electronic states T' and T'' , respectively. C is a

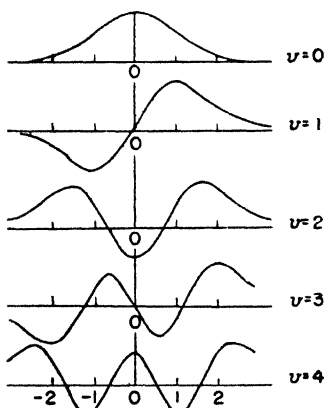

Fig. 58. Eigenfunctions of the five lowest vibrational states of a harmonic oscillator.

constant which contains the probability of the electronic transition $T' \rightarrow T''$, supposed to be independent of v' and v'' . In Figure 58 the first eigenfunctions of a harmonic oscillator are reproduced for $v = 0, 1, 2 \dots$; in general, the eigenfunctions have a number of nodes and antinodes and the probability of a certain transition, as defined by the integral of Equation (47), depends to a great extent on the relative position of the nodes and antinodes of the two functions ψ' and ψ'' . For greater values of v , the number and height of antinodes near the turning points increase; this is the reason why the first formulation of Franck's principle yielded useful results. For values of v near

zero, however, the deviations become considerable.

In principle, the eigenfunctions can be derived for each case from the potential curves, but the calculation — at least as far as the analysis of resonance spectra is concerned — has been carried through only for a very few examples. Even there, the problem was greatly simplified by the assumption that the oscillations could be considered as purely harmonic in both electronic states (Sections 53 and 60). The

application of the same method to the analysis of the resonance spectra of iodine lead to entirely erroneous results, probably because one or several erroneous assumptions were introduced into the calculation (24,175,1026).

For obtaining at least qualitative results, it is thus necessary to use the F.C. principle in its original formulation. It is easily realized that the type of the absorption spectrum, as well as the possibility of exciting fluorescence, depends not only on the shape but also on the relative position of the two potential curves, which represent the 2 combining electronic states. Also, the unexcited molecules are, at not too high temperatures, in low vibrational states ($\bar{v}'' = 0$ or $\bar{v}'' = 1$) and, on the other hand, a transition to a point higher than the level of dissociation of an electronic state leads to dissociation of the molecule. Since the kinetic energy of the separating atoms (corresponding to the surplus energy δ in the figure) is no longer quantized, all points on the potential curve above D' are virtual turning points and, therefore, absorption or emission processes leading to such points do not produce separate lines but continuous bands. If transitions from the lowest vibrational level of N into discrete levels of A are most probable on the basis of these considerations, the major part of the absorption spectrum will show bands with fine structure, and, in the absence of perturbations, the return from the excited state A to the ground state N will occur with the emission of fluorescence. Examples of this behavior are provided by the first absorption band systems of I_2 and Na_2 . If the values of r_0'' and r_0' are nearly equal and if the two potential curves between which the transitions take place have nearly the same shape, transitions with $\Delta v = 0$ are the most frequent. In the limiting case, the resonance spectrum would consist of only one strong line, possibly accompanied by a few others of rapidly decreasing intensities, and fluorescence would be excited practically only by the absorption of lines fulfilling the condition $\Delta v = 0$. If, on the other hand, r_0'' and r_0' differ widely, the resonance spectrum produced by the absorption of a line has two maxima of intensity, corresponding to transitions from the near and from the far turning points of the excited state. The second of these transitions can correspond to the continuous part of the emission spectrum. If,

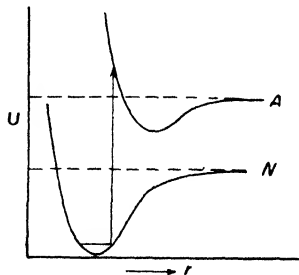

Fig. 59. Potential curves of a molecule with a continuous band prevailing in the absorption spectrum.

finally, transitions by which the molecule is transferred into the region of continuous energy of the state A have the greatest probability (Figure 59), or if *only* such transitions can occur, the part of the absorption spectrum showing fine structure is weak or completely missing and irradiation with monochromatic light produces no fluorescence because every absorption process leads to the dissociation of the absorbing molecule.

If transitions from an excited quantized state bring the molecule, according to the F.C. principle, to the part of a potential curve corresponding to a non-quantized state, the emission spectrum does not consist of separate lines but of a continuous band. Such emission bands must occur if the second state is characterized by a repulsion curve; they occur, also, if the transition leads to a point of an attraction curve lying either, for $r < r_0$, above the dissociation energy level or, for $r > r_0$, on the almost horizontal branch which corresponds to a complete separation of the nuclei. If (as, for instance, in the last case) the potential curve of the nonquantized state has a very small slope, the continuous band can exhibit a sequence of maxima and minima, so-called "fluctuations." The spacing of these maxima is of the order of magnitude of $\Delta G(v')$ or of ω' , because the energy of the lower electronic state is practically independent of the intranuclear distance, while the vibrational levels of the upper electronic state are separated by intervals $\Delta G(v')$. However, the spacing of the fluctuations may decrease in the direction of longer or shorter wavelengths according to the slope of the lower potential curve: "pseudoconvergence" of the fluctuations.

Analogous conditions can cause the inverse effect, the occurrence of fluctuation bands in the absorption spectrum, if a transition leads from a quantized electronic ground state to a nearly horizontal branch of the potential curve representing a nonquantized excited state. By absorption of light in such fluctuation bands, fluorescence cannot be excited, exactly as no fluorescence is excited by absorption in normal continuous bands.

Apart from the transition probabilities, the intensity of an emission line depends, of course, on the number of molecules which are in the state from which the line originates. The initial state is the same for all lines of a resonance spectrum excited by the same strictly monochromatic line; therefore, their relative intensities are independent of the number of excited molecules. This is no longer true if the absorbing molecules are raised to different levels of rotation and oscillation by irradiation with a primary line which is broad enough to cover several neighboring lines of an absorption band.

B. Fluorescence of the Halogen Vapors

48. The Visible Band System of I₂. The fluorescence spectrum of iodine vapor is treated here, without regard to any systematic order, as a first example because it was the first which has been investigated thoroughly, and because it provides the possibility of discussing almost every theoretical consideration mentioned in the last sections.

In the visible part of the spectrum iodine vapor, saturated at room temperature, shows an absorption band system which consists of numerous bands partially overlapping each other. By means of a powerful grating, these bands are resolved into a very large number of fine lines so that, for example, 100 individual lines can be counted in the interval between the two D-lines. Until recently, the band system which stretches from about 5000 to 7000Å was ascribed to a transition $^1\Sigma \leftarrow ^1\Sigma$. On the basis of theoretical considerations, Mulliken ascertained that the upper state is a $^3\Pi_0$ -state which is split into two levels by "A-doubling"; these two levels behave almost like independent $^1\Sigma$ -states and only one of them (designated by Mulliken as $^3\Pi_0^+$) combines with the ground state. Thus, practically all conclusions arrived at from the older assumption are preserved as correct (1992).

Lommel was the first to observe that when iodine vapor was irradiated with sunlight, it emitted a strong greenish-yellow fluorescence which, viewed through a spectroscope, looked like the reversal of the absorption spectrum. The fine structure of these fluorescence bands and the occurrence of resonance spectra under monochromatic excitation were later discovered by R. W. Wood (949, 1862).

The resonance spectrum which is produced by irradiating iodine vapor with the green mercury line 5461Å has been investigated in every detail (760, 820, 950, 1005, 1337a, 1870, 1875, 1877, 1883). If this line originates from a hot mercury arc, it covers at least nine iodine absorption lines. However, if the mercury arc lamp is water cooled, the green line becomes sufficiently sharp to coincide with a single iodine line and, thus, to excite only molecules of one definite initial state. A part of the resonance spectrum obtained under these conditions by Wood and Kimura is reproduced in Figure 60 and 61. Photograms obtained by means of an interferometer of high resolving power prove that the doublet components of this spectrum are devoid of any further structure (1907).

Wood derived empirically the law governing the spacing of the lines in the spectrum; later it was worked out in detail on the basis of

Fig. 60. Resonance spectrum of I_2 , order 1-3.Fig. 61. Resonance spectrum of I_2 , order 15-22.

the theory which had been developed in the meantime. According to Rank, who improved the precision of the measurements and whose figures are listed in Table 23, the progression of the main lines of the doublets is represented with high accuracy by the formula:

$$\nu = 18307.50 - 213.7977\nu'' + 0.614045\nu''^2 + 0.000931961\nu''^3 + 0.00001866\nu''^4 \quad (48a)$$

The doublet separation is given by:

$$\delta\nu = 5.168 - 0.194\nu'' \quad (48b)$$

and the molecular constants for the iodine molecule derived from Equation (48a) are: $\omega_e'' = 214.57$; $x_e''\omega_e'' = 0.6127$; $y_e''\omega_e'' = 0.000895$; $z_e''\omega_e'' = 0.0000187$; $B_e'' = 0.00375$; $\alpha'' = 0.000191$.

The resonance spectrum has been extended by Oldenberg, Loomis, and Rank as far as to the 39th member at 9097A by means of infrared sensitized plates (953,1165,1337a). It does not contain any "anti-Stokes" lines (with wavelengths shorter than that of the exciting line). Hence, the exciting line is absorbed by molecules in the lowest vibrational state ($\bar{\nu}'' = 0$). The vibrational quantum number of the excited state is $\nu' = 26$ as Kemble and Witmer, and Loomis, proved by a very thorough analysis of the complete absorption and fluorescence spectrum. Accordingly, the *R*-line is produced by the transition $\nu' \rightarrow \nu'' = 26' \rightarrow 0''$, and the following lines by $26' \rightarrow 1''$, $26' \rightarrow 2''$, etc. For the doublets with order numbers beyond 27, the vibrational energy increases in the emission process ($26' \rightarrow 27''$, $26' \rightarrow 28''$, etc.*) (760,950).

* The symbols $26''$, $27'$, etc., are used for $\nu'' = 26$, $\nu' = 27$, etc.).

TABLE 23
 RESONANCE SPECTRUM OF IODINE VAPOR EXCITED BY THE GREEN
 MERCURY LINE 5460.724A
 (Wavelengths λ in Å in atmospheric air; wave numbers ν in cm⁻¹ reduced
 to vacuum)

ν''	λ	ν	ν''	λ	ν	ν''	λ	ν
0	5459.2 5460.7	18312.68 18307.50	13	6394.4 6396.4	15634.49 15629.58	26	missing	
1	5525.1 5526.6	18094.30 18089.17	14	missing		27	7683.7 7686.6	13011.0 13006.0
2	missing		15	6558.8 6560.9	15242.6 15237.7	28	missing	
3	5657.2 5658.9	17671.66 17666.54	16	6643.2 6645.2	15048.9 15044.3	29	7896.8 7899.4	12659.9 12655.7
4	5725.1 5726.7	17462.20 17457.09	17	6729.3 6731.4	14856.4 14851.6	30	8006.4 8009.5	12486.5 12481.7
5	5794.2 5795.9	17253.9 17248.8	18	6816.8 6819.0	14665.7 14660.8	31	missing	
6	5864.5 5866.2	17047.03 17041.98	19	?	?	32	8231.9 8234.9	12144.6 12140.3
7	missing		20	6997.1 6999.4	14287.8 14282.8	33	missing	
8	6009.1 6010.9	16636.95 16631.95	21	missing		34	8465.4 8468.6	11809.5 11805.1
9	missing		22	7184.3 7188.7	13915.5 13910.7	35	8585.6 8588.7	11644.2 11640.0
10	6159.0 6160.9	16232.03 16227.05	23	7280.4 7282.9	13731.8 13727.0	36	8707.4 8710.3	11481.4 11476.9
11	6236.0 6237.9	16031.55 16026.59	24	missing		37	8831.8 8835.1	11319.6 11315.4
12	missing		25	7478.4 7480.9	13368.2 13363.8	38	missing	
						39	9087.3 9090.6	11001.4 10997.4

The intensity distribution of the observed lines is not only very irregular, but some lines, for instance the members 2, 7, 9 in Table 23, seem to be missing altogether. The theoretical explanation of this phenomenon, which occurs more or less pronouncedly in all resonance spectra, has already been given in the preceding section. For a reason which is not obvious, the intensity maximum of most resonance spectra lies near the *R*-line or in this line itself. It is probably due to a tendency to investigate the most brilliant fluorescence spectra. These are excited by the absorption of lines which are strong in the absorption spectrum and thus correspond to a great transition probability, $v' \leftarrow \bar{v}''$. The transition probability $v' \rightarrow v''$ and the intensity of the *R*-line in the resonance spectrum are, therefore, also great.

If the fluorescence of iodine vapor is excited by the green line from a hot mercury arc, the other absorption lines covered by the mercury line contribute to the excitation, and molecules in different levels of the ground state are raised into different vibrational and rotational levels of the excited state. From every one of these a complete series of doublets originates. For most of the series observed by Wood, it has been possible to determine the location of the *R*-line in the Fortrat diagram characterizing the bands. Three more series correspond to the transition $26' \leftarrow 0''$ in the absorption process, but with different rotational quantum numbers so that two of the four *R*-lines belong to the *P*-branch and two to the *R*-branch of the Fortrat parabola $26'-0''$. The differences between the *J*-values of these lines are not large (compare Table 24 and Figure 62) and the separations of the corresponding doublet components are nearly the same, according to Equation (42). For the first two doublets, the companion lines lie on the side of greater wavelengths; for the other two, on the short wavelength side of the main line (950,951,1875,1877,1883).

Among the other I_2 -absorption lines covered by the broadened green mercury line, five correspond to transitions from the "vibrationless" ground state to higher vibrational levels of the excited state; they belong to the bands $27'-0''$, $28'-0''$, and $29'-0''$. The "zero lines" of these bands (with $J'' = 0$) have much higher frequencies than the exciting mercury line, which is close to the zero line of the band $26'-0''$. A line belonging to a band with a greater v' can coincide with the broadened mercury line only if the rotational quantum number \bar{J}'' has a relatively high value [compare Equation (38)]. Under these conditions the doublet separation, which is proportional to J'' , becomes much larger. The transitions assumed by Loomis for the various *R*-lines excited by the green mercury line are listed in Table 24.

TABLE 24
DOUBLETS IN THE RESONANCE SPECTRA OF IODINE VAPOR EXCITED BY
THE GREEN MERCURY LINE

$\bar{\nu}''$	ν'	\bar{J}''	J'	Branch to which the R-line belongs	$\delta\nu$ Frequency difference of doublet components (cm ⁻¹)	Designation in diagram
0	26	28	29	P	4.3	0*
		29	30	P	4.4	0
		34	33	R	-5.0	0'
		35	34	R	-5.2	0*'
0	27	80	81	P	12.0	1
		85	84	R	-12.73	1'
0	28	108	109	P	16.13	2
0	29	129	130	P	19.26	3
		134	133	R	-19.9	3'
1	29	45	46	P	7.6	4
		50	49	R	-6.6	4'
		51	50	R	-8.3	4*'

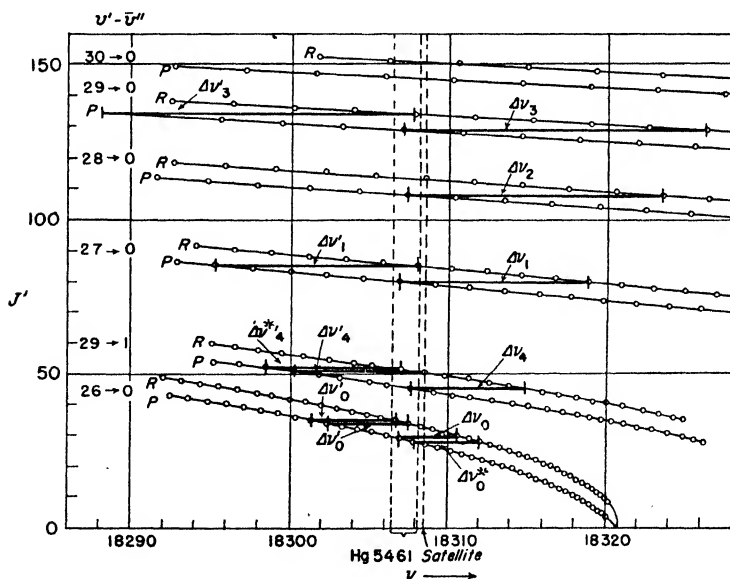

Fig. 62. Fortrat diagram for the doublets of zero order excited in I₂-vapor by the green Hg-line.

Figure 62 shows the complete Fortrat parabola for the band $26'-0''$: the curves for the other bands may be continued on the right-hand side down to the point where they cross the 0-axis. The ordinates are the values of J' ; they are the same for either component of every doublet. The distances separating the components of a doublet are indicated by a horizontal line joining the R -line and its companion.

The doublet separations $\delta\nu$ decrease in every progression linearly with increasing v'' , in agreement with Equation (42). Finally, it follows from Equation (43b) that if several series have one line in common (for instance, the various series excited by the green mercury line), all principal doublet components of these series (but not the companion lines) must also very nearly coincide, forming apparently a single series, if the analyzing spectroscope has a small resolving power. However, since each series belongs to another rotational quantum number J' , the separation becomes appreciable for higher values of v'' , where the last term in Equation (42) ($4J'\alpha''v''$) can no longer be neglected. This also is in complete agreement with Wood's experimental results.

In all iodine resonance spectra which are excited by the green mercury line and have no anti-Stokes lines, the intensity distribution is almost identical and, in particular, the same orders which are marked as missing in Table 22 are missing in every one of these series. This is not a self-evident conclusion to be drawn from any of the theoretical considerations put forward in the foregoing sections, since some of the series originate from different, although closely adjacent, vibrational levels. However, because of the relatively high values of v' , the eigenfunctions for all these levels have a great number of maxima near the turning points, so that the transition probabilities for the series depend essentially on the eigenfunctions of the lower states determined by v'' . (This is not the case for other resonance spectra — for instance, those of Na_2).

In resonance spectra having an anti-Stokes member ($\bar{v}'' = 1$), lines appear with wavelengths which are missing in the progressions corresponding to $\bar{v}'' = 0$. If the emission of a line of a given wavelength leads to a vibrational level v'' in one of these latter progressions, the emission of a line with almost the same wavelength will lead to the level $v'' + 1$ in a series containing an anti-Stokes member. Thus, the spectral location of the "missing line" $v'' = 2$ will now be occupied by the line $v'' = 3$ and the same holds for the other missing lines. Because they are not hidden by the much stronger lines of the series 0^*-3 in Table 24, Loomis was able to determine their exact frequencies in

spite of their low intensities. Whether in the progressions 4 (Table 24) the lines corresponding to $v'' = 2, 7, 9 \dots$ are also missing cannot be decided because of their coincidence with the lines corresponding to $v'' = 1, 6, 8 \dots$ of the progressions without anti-Stokes members.*

The high values of J'' occurring in Table 24 may seem to be remarkable; they suggest that unexcited iodine vapor contains considerable numbers of molecules with rotational quantum numbers up to 135. This is possible because of the relatively large moment of inertia of iodine molecules, which can be derived from the constant B_0 according to the relation: $B = h/8\pi^2I$. The analysis of the resonance spectra provides the value of $B_0 = 0.037$. Thus, $I_0 = 8 \cdot 10^{-38}$ g cm² and the quantum number $J'' = 135$ corresponds to the rotational energy $F = h \cdot B \cdot J(J + 1) = 0.08$ eV; this is about four times the average rotational energy at room temperature, so that an appreciable fraction of the molecules occupies rotational levels with those high quantum numbers.

On the other hand, the vibrational energy of the molecules is so large even for small values of v'' that most of the unexcited molecules are in the nonvibrating state and comparatively few in the first quantum state of vibration. Accordingly, resonance series without an anti-Stokes member, or with only one such member, have the greatest intensity. A series with a second anti-Stokes member is also stimulated by absorption of the broad green mercury line, but it is very weak and it has not been possible, so far, to assign definite order numbers to its lines. However, if iodine vapor of constant density is heated to 300° C, the intensity of this series increases very much in comparison to the intensity of the other series. Under conditions such as these, it is even possible to obtain a fourth and a fifth anti-Stokes line which belong to still other progressions excited by the green mercury line. An increase of temperature does not alter the intensity distribution within a homogeneous resonance spectrum, but it will alter the relative intensities of whole series, because the number of molecules in the corresponding initial states $v''J''$ increases or decreases. For the same reason, only the anti-Stokes and the first positive members of a progression are absorbed, if the fluorescence light produced by a monochromatic line is viewed through a layer of iodine vapor at room temperature. The lines of greater wavelengths ($v'' \geq 4$) remain practi-

* In resonance spectra without anti-Stokes members, Wood's original order numbers p coincide with the "rational" numbers v'' . For series with one, two or more anti-Stokes members, they differ by 1, 2... and negative values of p have to be introduced for the anti-Stokes members.

cally unaffected and, thus, the color of the fluorescence is shifted very appreciably towards the red. While there are practically no molecules with more than four vibrational quanta in the unexcited vapor at 20° C, the lines of higher order, at least up to $v'' = 6$, are weakened to an increasing degree if the temperature of the absorbing vapor is raised to 300° C (1276).

If the fluorescence of iodine vapor is excited by the absorption of white light, the resulting emission spectrum is very similar to the absorption spectrum, but it contains a great many more lines, for almost all absorption processes start from the levels $v'' = 0$ and $v'' = 1$, while the emission processes end partly at levels with much higher values of v'' . Therefore, the center of gravity of the total fluorescence spectrum is displaced towards longer wavelengths, compared to that of the absorption spectrum ("Stokes' law") (1278, 1875).

Argabiceanu, who excited the fluorescence of iodine vapor by means of a mercury arc emitting a very narrow green line, obtained a resonance spectrum with as many as six anti-Stokes members. The excitation of this series corresponds, according to his calculations, to the transitions $32' \leftarrow 2''$, $35' \leftarrow 3''$, $39' \leftarrow 4''$, and $43' \leftarrow 5''$. Since these bands are completely missing in the absorption spectrum, Argabiceanu believes that the occurrence of the anti-Stokes lines can be explained by a "quantum-mechanical resonance phenomenon" (24). It may happen that because of the shape of the potential curves the transition

$43' \rightarrow 1''$ has, in a special case, a much greater probability than the transition $43' \rightarrow 5''$, so that the fourth anti-Stokes line in the progression which is excited by the absorption process $43' \leftarrow 5''$. However, if this process is induced at all by irradiating the vapor with the green mercury line, the unexcited vapor must, under all circumstances, contain molecules in the vibrational state $v'' = 5$. If the corresponding band seems to be absent in the absorption spectrum, it proves only that it is, in general, much easier to find isolated weak emission

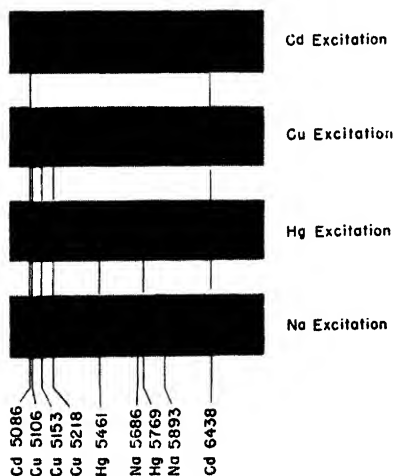

Fig. 63. Resonance spectra of I_2 excited by various lines.

lines than to find a weak absorption band on a background which is covered by many other, much stronger absorption bands (24).

Resonance spectra produced in the visible band system of iodine vapor by the absorption of the two yellow mercury lines and by several zinc, cadmium, and sodium lines have also been investigated, although less thoroughly (Figure 63). The resonance series excited by the yellow mercury lines show several anti-Stokes members and, while at room temperature their intensities are low compared with the fluorescence excited by the green mercury line, they increase considerably with increasing temperature* (1276,1786a).

TABLE 25
INITIAL STATE AND EXCITED STATE OF I₂ FOR THE ABSORPTION OF
VARIOUS EXCITING LINES

Light source	Wavelength in Å	$\bar{\nu}''$	ν'	J'
Na	5893	2	17	30
		1	15	47
Hg	5791	2	19	44; 37 and 38
		1	17	61 and 54
		1	20	169
		0	15?	72
Hg	5770	2	20	68
		1	18	80
		0	16	93 and 86
Hg	5461	0	26	35; 34; 29 and 28
		0	27	85 and 80
		0	28	108
		0	29	134 and 129
		1	29	51; 50 and 45
Cd	5086	0	50	8
		0	51	43

As far as they are known, the quantum numbers corresponding to the various resonance series are collected in Table 25. Each of the spectra is represented satisfactorily by Equation (48) which, originally, had been derived only for the resonance spectrum of Table 23. A

* The yellow Hg-lines cover 10 and 12 lines, respectively, in the iodine absorption spectrum. Hence, the corresponding resonance spectra do not consist of doublets, but of complicated groups of lines.

rescence is practically independent of the temperature. It begins to decrease only at the temperature at which the dissociation of the molecules becomes noticeable (858).

At 4990A, the band system converges and merges into a region of continuous absorption, the intensity of which drops rather rapidly with decreasing wavelength. Absorption of light in this part of the spectrum causes no fluorescence, but the optical dissociation of the molecules into a normal and an excited atom, according to the equation:

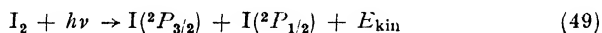

The theoretical prediction was corroborated experimentally by Turner, who observed, under these conditions, the appearance of atomic iodine lines in the absorption spectrum of the vapor. The excited state ($^2P_{1/2}$) of the iodine atom is metastable, so that the dissociation process is not followed by the emission of an atomic fluorescence (1715).

49. Ultraviolet Resonance Spectra of Iodine Vapor. A second band system is observed at room temperature in the absorption spectrum of iodine vapor between 1760 and 2000A. At greater vapor pressures and with temperatures increasing up to 1100 C°, it can be followed to ca. 3440A because of the increasing number of unexcited molecules in higher vibrational states. In the numerous resonance spectra which were obtained in this band system, the spacing ΔG between consecutive lines was found to be of the same order of magnitude as in the visible resonance spectra. Hence, the lower state into which the molecules are transferred by the emission of the u.v. bands is, again, the electronic ground state (332,1160,1787).

The analysis of the u.v. band system is less complete by far than that of the visible bands. Almost all data referring to the upper state are missing. Cordes' assumption that it is a $^1\Sigma$ -state agrees with the observation that, as far as they are analyzed, the resonance series seem to consist of doublets. It follows, furthermore, from the investigation of the absorption and the fluorescence spectra that transitions with large Δv have the greatest probability; this means that the potential curve of the upper state must be shifted considerably with respect to that of the ground state (cf. curve *C* in Figure 64). Finally, the vibrational levels of the upper state have ΔG values less than half as large as those of the ground state and converge very slowly, corresponding to a very large heat of dissociation.

At room temperature, fluorescence of appreciable intensity is

excited only by lines of wavelengths below 2100Å. Oldenberg, who discovered this fluorescence, obtained resonance spectra by irradiating the vapor with the mercury lines 1849 and 1943Å, the bismuth line 1903Å, and the zinc line 1900Å. For only the last of these spectra the wavelengths of the individual members, which were not resolved into doublets, have been published. They stretch from the fifth anti-Stokes

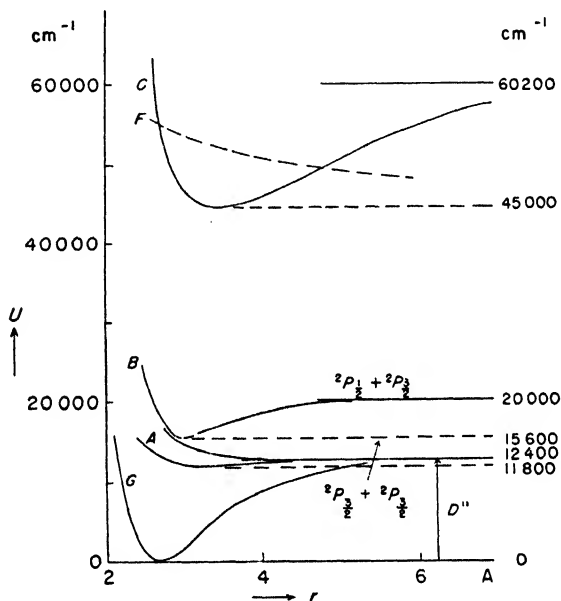

Fig. 64. Potential curves of the I_2 -molecule [after Curtis and Evans (254)].

member to the thirty-fifth member with a positive order number. Asagoe, and Kimura and Tonomura, have investigated, much more thoroughly, several resonance series which were produced by the iodine atomic lines 1830 and 1844Å (29,777). These lines were excited by means of an electric discharge through a tube containing iodine vapor saturated at 0° C and were reabsorbed by the I_2 -molecules contained in the same tube. This method of fluorescence excitation, which the authors called "auto-resonance", is very efficient, since the primary lines are produced in the same volume in which they excite the fluorescence and, moreover, all windows which might weaken the short-wavelength u.v. primary light are avoided. A disadvantage of the method is the attendant difficulty of deciding to what extent the

molecular emission is actually caused by the irradiation and not directly by the electric discharge or by collisions of the second kind. If, however, the emission spectrum consists only of a few v'' -progressions out of the whole band system, the conclusion seems to be justified that excitation is caused by the absorption of a few monochromatic lines.

One of the progressions (I in Table 27) originates from the line 1830A, the other (II to V) from the line 1846A. (Several series below 2000A excited by the atomic iodine lines 1783, 1799, and 1876A were also observed, but no numerical data are given). The spectrograms were obtained by means of a quartz spectograph of high dispersion and record no lines below 2055A, so that all members with $v'' < 31$ are missing. On the other hand, series I stretches as far as to the 85th order and series II and V even to the 96th order. This enables the authors to evaluate the constants of the ground state of the I_2 -molecule with an accuracy which they consider to be better than that obtained by using the data from the visible bands. Instead of Equation (48), they give the following equation for their resonance series:

$$r = \nu_0 - 214.328(v + 1/2) + 0.5805(v + 1/2)^2 + 0.00198(v + 1/2)^3 + 0.0000124(v + 1/2)^4 \quad (50)$$

while the "constant of interaction" is $\alpha'' = 0.000018$ instead of 0.000191 cm^{-1} . Table 27 contains the other data relating to these series; $\delta\nu$ is the doublet separation in the doublet of shortest wavelength observed in each series. The brackets following the J'' values indicate whether the exciting line belongs to a P - or an R -branch. It is impossible to derive the quantum numbers v' from these observations.

Resonance series which are excited in I_2 -vapor by lines of wavelengths larger than 2000A are very weak at room temperature, but attain great intensity when the vapor is heated; the longer the wavelength of the exciting radiation, the higher the minimum temperature at which the corresponding resonance spectrum can be observed with appreciable intensity. These minimum temperatures T_m are listed in the third row of Table 28. The fourth row of the same table shows under $\Delta G(v'' + 1/2)$, the distances of the first Stokes line from the exciting line; the approximate values of the v'' s are derived from these by means of Equation (48). All observed series are described satisfactorily within the limits of experimental error by inserting appropriate values for ν_0 into this equation. The doublet nature of the spectra could be ascertained in only a few cases; the analysis is difficult and, in general,

TABLE 27
ULTRAVIOLET RESONANCE SPECTRA OF IODINE VAPOR EXCITED BY
"AUTO-RESONANCE"

	I	II	III	IV	V
Exciting line (A)	1830	1846	1846	1846	1846
$\bar{\nu}''$	0	2	2	2	2
\bar{J}''	90(<i>R</i>)	48(<i>P</i>)	50(<i>P</i>)	24(<i>R</i>)	26(<i>P</i>)
$\delta \nu$ (cm ⁻¹)	11.3	6.6	6.6	?	?

TABLE 28
ULTRAVIOLET RESONANCE SPECTRA OF IODINE VAPOR EXCITED BY LIGHT
OF WAVELENGTHS ABOVE 2000Å

Exciting line (A)	Zn 2026	Zn 2062	Zn 3239	Cd 2265	Cd 2288	Hg 2537
Exciting line ν (cm ⁻¹)	49342	48481	46758	44136	43693	39409
T_m (°C)	20	20	100	250	250	500
ν''	(6)	(7)	9	13	14	25
$\Delta G(\nu'' + 1/2)$ (cm ⁻¹) <i>a</i>	205	204	202	198	197	184
$\Delta G(\nu'' + 1/2)$ (cm ⁻¹) <i>b</i>	—	—	188	176	177	146

not quite certain, because each of the exciting lines covers a large number of iodine absorption lines and, therefore, every resonance spectrum is composed of several superimposed series. Since the spacing ΔG is somewhat different for the individual overlapping series, they become farther separated with increasing order number, so that they form an inextricable "maze of lines" ("Liniengewirr") at the long-wavelength end of each resonance spectrum, as shown in Oldenberg's first paper. The fact that the individual series stimulated by "auto-excitation" could be followed up to such high values of ν'' must have been due to the particularly favorable sharpness and spectral location of the exciting lines (332,624,1160).

At temperatures about 200° C above T_m (Table 28), all resonance spectra which are excited by primary lines of wavelength greater than 2100Å begin to show a second progression *b* with appreciably smaller spacing than that of the original series *a*. The corresponding values of

b [REDACTED]

a [REDACTED]

↑
2139

Fig. 65. Double resonance spectrum excited in I₂-vapor at 200° C (*a*) 560° C (*b*) by Zn-line 2139Å.

$\Delta G(\nu'' + 1/2)$ are listed in the last row of Table 28, and a typical example is reproduced in Figure 65. The greater the wavelength of the exciting line, the larger is the difference between series *a* and *b*. With further increasing tempera-

ture, the intensity of series *b* exceeds that of *a*. This phenomenon, which occurs neither in the u.v. resonance spectra excited by light of wavelengths below 2100A nor in those of the visible band system, has not yet found a theoretical explanation (332).

Concerning the nuclear vibrational levels of the excited electronic state from which the various u.v. resonance spectra originate, one can say only that if v' is assumed (as a limiting case) to be equal to zero for the series excited by the mercury line 2537A, v' must be at least equal to 140 for the series excited by the line 1890A.

50. McLennan Bands. In addition to the resonance spectra described in the last section, absorption of light in the u.v. band system of iodine vapor causes the appearance of a sequence of partly broad, partly rather narrow bands and groups of bands in the fluorescence spectrum. These bands were discovered by McLennan and are frequently designated as "McLennan (or Mc) bands" (997). The mechanism of their emission can be explained only by assuming that some nonquantized molecular states take part in the process (Section 46). Furthermore, most of the Mc bands are never observed in the absorption spectrum, although their intensity in the fluorescence spectrum, and also under electrical excitation, is often very great. It is, therefore, improbable that the lower state is the electronic ground state of the molecules, unless highly excited nuclear vibrational levels come into play.

The fluorescence bands discovered by McLennan belong to several different types. A long regular sequence of fluctuations between 2000 and 2500A, with a spacing $\Delta\nu \sim 380 \text{ cm}^{-1}$, appears simultaneously with the resonance progressions, if the exciting lines have wavelengths smaller than 1900A so that vibrational levels with large v' are excited; they overlap the "maze of lines" into which the resonance series merge. A discussion of the energy relations proves that the electronic state reached by the emission of these bands lies below the dissociation limit of the unexcited molecules where no nonquantized energy states exist. Therefore, the emission process must start from an upper state *F* (Figure 64) which is not quantized, or the potential curve of which has only a very shallow minimum; and the molecules must be transferred to this state from the closely adjacent electronic level *C* which has been reached by the primary absorption of light. It is not possible to give an interpretation for the very large values of $\Delta\nu$ which are almost double the ω_0 characterizing the ground state. [The interpretation of similar fluctuation bands in the fluorescence spectra of tellurium and selenium vapor seems to be much less uncertain (compare Figure 70).]

The other types of Mc bands are excited by the absorption of all lines which coincide with parts of the u.v. band system of iodine vapor. They consist of a great number of symmetrical bands (half-width $\sim 130 \text{ cm}^{-1}$) which are distributed somewhat irregularly over the whole spectral region between 4700 and 2500A, and of several broader continuous bands which are superimposed upon the former. Although the main aspect of the bands is the same for all exciting lines, the exact location of each individual band and its relative intensity varies according to the frequency of the primary light. The group of bands between 3150 and 3290A, which is marked as *c* in Figure 66 and which occurs in all Mc-band spectra, is particularly characteristic in this respect.

The smaller the wavelength of the exciting light, the farther these

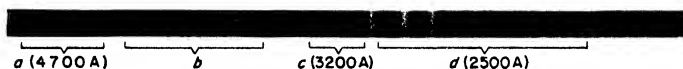

Fig. 66. McLennan bands in the u.v. fluorescence spectrum of I_2 excited by white light (Duschinsky and Pringsheim).

Mc bands stretch into the u.v. Several attempts have been made to divide the bands into regular sequences, but none of these agrees completely with the experimental results. In Figure 66 the bands are divided into four groups (*a-d*), an arrangement suggested by a superficial survey of the spectra and their dependence on the wavelength of the exciting light — but this, also, is rather arbitrary (254,333).

It is difficult to decide whether the occurrence of all Mc bands is due to a single upper and several lower states, or to more than one upper state. It seems rather probable that the upper state of the emission processes is quantized and that the lower state is continuous and lies above the limit of dissociation of the normal iodine molecules. The energy of the excited molecules in the state *F* from which the emission originates must depend to a certain extent on the quantum number v' of the vibrational level which is reached directly by absorption of the exciting line and from which the molecule passes over into *F*.

The frequency intervals between these bands are, on the average, 220 cm^{-1} and, thus, are of the same order as the nuclear vibration quantum ω_0'' of the unexcited molecule. However, it has already been mentioned that the ground state of I_2 cannot be the final level of the emission process. Using all known data about ultraviolet absorption

spectra of iodine vapor, Cordes has tried to build up a complete term scheme for the I_2 -molecule and to interpret the mechanism of the Mc bands on the basis of this scheme. However, this interpretation does not agree with a part of the results obtained in other investigations.

Several broader, apparently continuous bands are superimposed on the other bands in the fluorescence spectrum of iodine vapor which is excited by short wavelength u.v. The most conspicuous of these continua are located at 2520–2730, 3040–3210 (*Y*), 3360–3440 (*X*), 4040–4320, and 4400–4630Å. The bands *Y* and *X* may form a single system. Various mechanisms have been proposed for the production of some of these bands (electron affinity spectrum of the I_2 -molecule, recombination luminescence corresponding to the process $I + I \rightarrow I_2$, etc), but none has been satisfactory. At temperatures above 900° C, Warren succeeded in extending the discontinuous absorption band system from 2000Å up to 3440Å, where it merged into the band *X*; accordingly, he interpreted this band as the “dissociation continuum” belonging to the system (*1161, 1787, 1788*).

According to Elliott, it is extremely doubtful whether any genuine continua exist in the fluorescence spectrum of iodine vapor. It had been previously observed that several of the continua are replaced by bands with a conspicuous, though complicated, structure when foreign gases are added to the iodine vapor, and Elliott suggests that in the spectrum of pure I_2 -vapor at low pressure this structure is obliterated only because too many vibrational and rotational levels of the excited electronic state take part in the emission process. However, this interpretation, also seems, to involve certain inconsistencies, as will be discussed in Section 64 (*360*).

51. Other Halogen Vapors. The potential curves of the excited states are much more displaced with respect to those of the ground states for the other halogen vapors, and, therefore, the discontinuous parts of their first absorption band systems are much weaker as compared with the adjoining continua. Furthermore, the probability of the intercombination transition $^3\Pi \leftarrow ^1\Sigma$ producing these first absorption band systems is much smaller for the lighter molecules than for those of iodine.* According to Rabinowitch and W. C. Wood, the ratio of the total absorption in the bands of I_2 , Br_2 , and Cl_2 is 740:160:90. Thus, resonance spectra could be obtained only with much longer exposure in bromine vapor, and it has not been possible so

* This corresponds to the behavior of the atomic spectra of Hg, Cd, and Zn, respectively, in which the intercombination lines become less intense with decreasing atomic weight.

far to observe any resonance fluorescence in chlorine vapor. (Compare Section 93 for an indirect method of exciting fluorescence of Br_2 and Cl_2) (1318).

According to R. W. Wood and to Dunoyer, a weak yellowish fluorescence can be excited in bromine vapor by white light. Plumley obtained complete doublet progressions by irradiating the vapor with the light from a mercury arc and using high intensity apparatus and exposures of many hours. The progressions originated from the two yellow and from the green mercury lines. The resonance spectrum stimulated by the green line was about 300 times weaker than that excited in iodine vapor under similar conditions. Even if the relatively narrow line from a cooled mercury lamp is used, five resonance series of unequal doublet separation are excited in bromine vapor. They are ascribed by Plumley to various combinations of the two isotopes Br^{79} and Br^{81} . Table 29 gives the doublet separations $\delta\nu$ as positive or negative, respectively, according to whether the exciting line lies on a *P*- or a *R*-branch, so that the "companion lines" are displaced towards greater or smaller wavelengths. Series I is by far the strongest; it has no anti-Stokes member and can be followed up to the 17th member. However, the values of $\delta\nu$ decrease so rapidly that the doublet could be resolved only in the first order. The series can be described by the equation (260a, 1243, 1871):

$$\nu = 18307.5 - 322.67 \cdot v'' + 1.15 \cdot v''^2 \quad (51)$$

In a mixture of iodine and bromine vapor, IBr -molecules are formed. No fluorescence belonging to these molecules is excited by visible light, but, on irradiating the vapor with light of wavelengths below 2000A, the emission of a large number of rather diffuse bands is obtained in the region extending from 2890 to 4850A. Although they exhibit a certain likeness to the Mc bands of pure iodine, the two

TABLE 29
RESONANCE SPECTRUM OF BROMINE VAPOR EXCITED
BY THE MERCURY LINE 5461A

No. of series	Isotopes	$\bar{\nu}''$	ν'	\bar{J}''	$\delta\nu$ (A)
I	79-81	0	19	8(<i>R</i>)	— 3.0
II	81-81	1	23	17(<i>R</i>)	— 6.0
III	79-81	1	25	64(<i>P</i>)	20.5
IV	79-79	0	21	74(<i>P</i>)	24.0
V	79-81	0	21	76(<i>R</i>)	—25.0

spectra do not coincide. Furthermore, the IBr-bands do not stretch nearly as far towards the u.v. as the Mc bands, and the resonance series observed in the short wavelength region of the iodine fluorescence spectrum are completely missing from the IBr-spectrum (387, 954).

In a mixture of iodine and chlorine vapor, a new characteristic fluorescence could no more be obtained than in pure chlorine vapor. According to Cordes and Spöner, ICl exhibits a band absorption spectrum stretching from 1910Å toward smaller wavelengths, whereas the corresponding system of IBr reaches as far as 1974Å.

C. Vapors of the Alkali Metals

52. Existence of Diatomic Molecules. Typical "resonance spectra" were observed for the first time by R. W. Wood in the fluorescence of sodium vapor. Wiedemann had found that, if sodium vapor of sufficient density was irradiated with sunlight, an intense green fluorescence occurred along the whole length of the exciting beam; using a spectroscope, he was able to resolve the luminescence spectrum into a series of channeled bands in the green, and a second series of such bands in the orange and red. Besides, the D-lines occurred with high intensity in the spectrum. The absorption spectrum of the vapor showed bands of similar structure in the same region, apart from the well-known lines of the principal series of the sodium atom (1833). Wood analyzed these bands by means of a spectrograph of high resolving power and proved, furthermore, the existence of similar absorption bands in the neighborhood of the absorption lines of the sodium atom in the u.v. All these bands were at first ascribed to atomic sodium (1860). Only after Bohr's theory had provided the basis for a theoretical treatment of band spectra, were diatomic molecules recognized as the carriers of band absorption and emission in metal vapors, which before had always been regarded as monatomic.*

Dunoyer held the opinion that the bands in the fluorescence spectrum of sodium vapor were caused by an organic impurity and that they disappeared after careful purification of the metal, and he published experimental results which seemed to prove the validity of his hypothesis. Although the cause of these observations has never

* Na_2 -molecules as the carriers of the band spectra were suggested for the first time in the author's "*Fluorescenz und Phosphorescenz im Lichte der neueren Atomtheorie*," Springer, Berlin, 1921.

been cleared up properly, they were certainly not correct. For the intensity of the bands is exactly the same, no matter whether the vapor is produced by distillation of the technical metal preserved under benzene, or by decomposing sodium azide in vacuo, or whether the sodium is introduced into the observation chamber by electrolysis through the glass (Figure 67d). A further proof for the production of the bands by Na_2 -molecules can be seen in the fact that bands of the same type are not only observed in the absorption and emission spectra of the other alkali metal vapors, but that a new band system occurs in

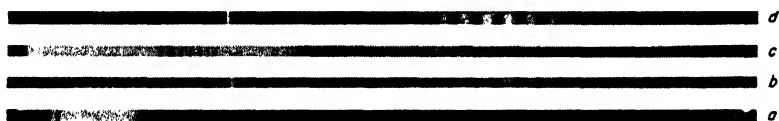

Fig. 67. Fluorescence spectra of diatomic alkali metal vapors.

a: pure potassium. *b*: pure sodium. *c*: mixed potassium and sodium. *d*: pure sodium prepared by disintegration of NaN_3

a mixture of sodium and potassium vapor. This system is missing from the spectra of the vapors of pure sodium and potassium and must, therefore, be ascribed to the formation of NaK -molecules. In mixtures of other alkali metal vapors similar characteristic band systems occur, but have been observed so far only in absorption spectra (319, 1283). (After these spectroscopic results had destroyed all doubt that diatomic molecules exist in the vapors of alkali metals, their presence was also proved by precision measurements of vapor pressures and by other methods).

The fact that the molecular bands are closely adjacent to the atomic lines in these and many other spectra is understood by the assumption that the potential curves of the ground state and the excited states are very nearly parallel over their whole length.

53. Resonance Spectra of Na_2 . The narrow spacing of the lines in the absorption spectrum of the Na_2 -molecules has the effect that within a wide spectral range practically every line produced by the arcs or sparks between any metal electrodes covers one or several absorption lines and, thus, is able to excite at least one resonance progression. Every progression produced in this way is confined either to the blue-green or to the orange-red bands; they belong to two independent systems and originate from different excited electronic states. Wood used a great many light sources (electric discharge through the

vapors of Hg, Cd, Zn, Mg, Pb, Ag, Bi, Cu, Li, Na, and Ba, and, furthermore, through hydrogen and helium) for the production of fluorescence in sodium vapor. In most instances he did not isolate individual primary lines, so that in many of his spectrograms several resonance series overlap one another. The spacing ΔG is approximately the same in all these series, and if the exciting light consists of a group of lines, this group is repeated over the whole fluorescence spectrum with only slight modifications. This, for instance, is the case for the excitation by the green Mg-triplet 5167.4, 5172.9, 5183.7A. The series due to the second of these lines is listed in Table 30. On the spectrograms, every line has a companion on either side corresponding to the two other triplet components. The figures of the last row of the table are calculated according to the empirical formula (1860, 1863, 1868, 1904):

$$\nu = 19329 - 142.3p + 0.845 \cdot p^2 \quad (p = 0, \pm 1, \pm 2 \dots) \quad (52)$$

TABLE 30
 RESONANCE SPECTRUM OF Na₂ EXCITED BY THE Mg-LINE 5172.9A

p	-6	-5	-4	-3	-2	-1
Wavelength (A)	4946	4948	5022	5060	5098	5136
Wave number (observed)	20219	20064	19912	19763	19615	19470
Wave number (calculated)	20214	20062	19912	19764	19617	19472

p	0	+1	+2	+3	+4
Wavelength (A)	5172.9	5212	5250	5288	5327
Wave number (observed)	19329	19187	19048	18911	18773
Wave number (calculated)	19329	19188	19048	18910	18774

Table 31 contains those of the numerous resonance spectra photographed by Wood and others in the blue-green system of Na₂ for which an unambiguous assignment to a certain exciting line is possible. The rule is again confirmed that with increasing wavelength of the exciting light, the number of anti-Stokes lines tends to increase. This number is, in general, larger than for the green resonance spectra of iodine vapor because the observations must be made at higher temperatures (frequently above 500° C), and also because the vibrational quantum of the ground state is smaller for Na₂ than for I₂.

TABLE 31
 RESONANCE SPECTRA OF Na₂

(N^- = number of anti-Stokes lines; N^+ = number of Stokes lines)

Exciting line (A)	Zn 4722	Cd* 4800	Zn 4811	Ba 4934	Li 4971	Pb 5006	Cd* 5086	Cu 5133	Mg 5157	Mg 5173	Mg 5184	Ag 5209	Cu 5218
N^-	1	0	0	2?	3	2	4	7	3	6	9	7	9
N^+	7	14	6	10	6	7	0	6	1	4	3	3	2
$\bar{v}''\dagger$	1	0	0	1?	3	2	4	7	7	8?	8	10	11
$v'\dagger$	9	5	4	?	?	?	0	1	1	2	2	5	4

* Compare pages 147 and 215.

† \bar{v}'' and v' not quite certain in several cases.

In Table 32, the constants characterizing the ground state of Na₂ and other diatomic alkali molecules are collected. By means of these constants, empirical Equation (52) can be transformed into the "rational" equation representing all resonance progressions of the blue-green Na₂-band system [compare Equations (43) and (44), Section 44].

TABLE 32
 CONSTANTS CHARACTERIZING THE GROUND STATE
 OF DIATOMIC ALKALI MOLECULES
 [I : moment of inertia (1519)]

Molecule	ω_e''	$\omega_e'' x_e''$	D'' (eV)	$I \cdot 10^{10}$
Na ₂	159.23	0.726	1.0	2.5
KNa	123.29	0.40	0.62	6.6
K ₂	92.3	?	0.61	18.4
Cs ₂	81.99	0.08	0.45	—

The values given under D'' for the heat of dissociation cannot be determined with any accuracy from the resonance spectra by extrapolation. The exact calculation became possible only by the analysis of the complete band systems carried through by Loomis and his collaborators. However, the task was considerably simplified by the previous investigation of the resonance spectra (952,956a).

According to this analysis, the ground state of the Na₂-molecule (and also that of the other alkali metal molecules) is characterized by

the symbol ${}^1\Sigma_r^+$; the excited state from which the emission of the blue-green band of Na₂ (and also the orange band of KNa and the red band of K₂) originates, by ${}^1\Pi_u$; and that for the orange-red band of Na₂, by ${}^1\Sigma_u^+$. The potential curves derived from the band analysis are reproduced for Na₂ in Figure 68A.

In agreement with the rules governing transitions ${}^1\Pi \rightarrow {}^1\Sigma$ (Section 45), the resonance spectra of Na₂ consist partly of doublets and partly of singlets. The resonance series show maxima of intensity at their long-wavelength and at their short-wavelength ends and a minimum of intensity in the middle. From every excited level n' , two transitions have the highest relative probability, namely, those from the two turning points on the potential curve of the excited state *A* in Figure 68. The one corresponds to a relatively small, the other to a large value of $h\nu$. These experimental facts, combined with the F.C. principle in its elementary form, prove that the minima of the

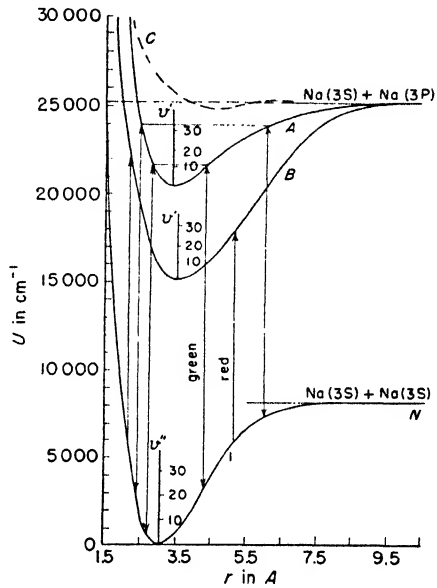

Fig. 68. Potential curves of Na₂ (Loomis and Nile).

potential curves of the excited state and the ground state (*A* and *N* in Figure 68) correspond almost exactly to the same internuclear distance r_0 . A striking result obtained by Wood in his earliest investigations is now easily understood: if the fluorescence was excited by light which was selected from a carbon arc spectrum by means of a monochromator and consisted of a narrow range in the blue-green, the fluorescence spectrum was divided into two parts: the first coincided very closely with the spectral range of the primary light, whereas the other, separated from the first by a dark interval, was situated at greater wavelengths. If the monochromator selecting the exciting light was set for greater wavelengths, the long-wavelength part of the fluorescence spectrum was displaced towards the violet until the two parts met in the middle. For the same reason, the resonance spectra

which are excited by strictly monochromatic radiation in the blue-green band system contain, in general, in addition to the nearly equidistant series starting from the exciting line, a great number of closely spaced weaker lines in the yellow-green. These belong to transitions to the highest vibrational levels of the ground state and are difficult to disentangle because of the small values of $\Delta G''$ (1860).

Brown has carried through a calculation of the intensity distribution on the basis of the wave-mechanical formulation of the F.C.

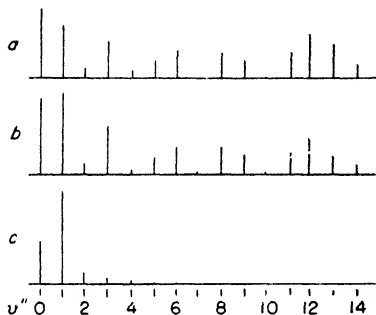

Fig. 69. Intensity distribution in the Na_2 resonance spectrum excited by Cd-line 4800A (Brown).

a: observed. *b*: calculated for $v' = 5$. *c*: calculated for $v' = 6$.

principle for the two Na_2 resonance spectra excited by Cd-lines 4800 and 5086A (*, Table 31). He made the simplifying assumption that the molecules in both electronic states can be represented by harmonic oscillators as long as the vibrational quanta v' and v'' are comparatively small. The effective frequency ω_v^* was assumed to be the mean of the fundamental frequency ω_e and the frequency of the vibrational state v : $\omega_v = (v + \frac{1}{2})\omega_e \dots (v + \frac{1}{2})^2\omega_e x_e$. According to an older analysis, the quantum number $v' = 6$ had been assigned to the upper level of the singlet resonance series which is excited by the Cd-line 4800A. Figure 69 shows a comparison between the experimental measurements and Brown's calculations for $v' = 5$ and 6, respectively. From the excellent agreement between *a* and *b* it follows with certainty that $v' = 5$ is the correct evaluation* (175, 675).

The agreement between calculation and observation is almost equally good for the doublet series excited by the line 5086A which consists, apart from the exciting line, only of four anti-Stokes members (see Table 31).

The red band system of Na_2 also forms a part of the absorption spectrum of the vapor and, accordingly, the spacing $\Delta G''$ of the resonance spectra excited in this system has the same value as in the resonance series of the blue-green band system. Apart from the fluo-

* The appearance of a very weak anti-Stokes line in the resonance spectrum excited by the line 4800 proves that transitions $6' \leftarrow 1''$ must also occur to some extent in the absorption process.

rescence produced by white light, Wood observed only the resonance spectra stimulated by the Li-lines 6102 and 6708A. In the absorption spectrum, the system stretches somewhat beyond the D-lines in the direction of smaller wavelengths. The corresponding transitions [indicated by the first arrow (from the left) in Figure 68] originate from high vibrational levels which are little populated at the temperatures of the experiments, and, therefore, this part of the band is weak. Nevertheless, irradiation of sodium saturated at 300°C with the intense light from a sodium arc produces, in addition to the atomic D-lines as surface fluorescence, the emission of two molecular resonance series originating from the D-lines and showing many anti-Stokes members. Even before this had been proved conclusively, Schueler suggested that the appearance of a series of bands close to the D-lines in the spectrum of glow discharges in sodium vapor and of chemical reactions with sodium was due to a secondary process: primarily, sodium atoms are raised into the 3^2P -states by electron impact and, in a second process, their energy is transferred on to Na₂-molecules. The question whether this transfer occurred by collisions of the second kind, or by radiation, was left open. This is the first instance of the mechanism which Kimura later called "auto-resonance" (see Section 49) (176, 1477, 1900, 1908, 1909).

Wood observed fluorescence in the band system adjacent to the second member of the principal atomic series of Na (3303A) caused by irradiation with the nonresolved radiation from a carbon arc. Later, Seidel succeeded in exciting resonance series by absorption of the Ag-lines 3391 and 3383A and also, of some Cu- and Zn-lines. By the emission of these resonance spectra, the excited molecules return to the ground state and, thus, the spacing ΔG in these progressions is again of the order of 150 cm⁻¹ (1201a, 1483, 1868). In the absorption spectrum of Na₂-vapor, the band system between 3600 and 3200A has been analyzed recently by Pearse and Sinha who were able to represent the progression of band heads with great accuracy using the constants listed in Table 32 although these were derived from the analysis of the blue-green bands (1201a).

54. KNa, K₂, Li₂, Rb₂, and Cs₂. Our knowledge of the fluorescence of the diatomic molecules of the other alkali metals is much less complete. Apart from the fluorescence caused by white light, a few resonance series have been photographed in the red band system of K₂ and in the orange system of KNa; both are produced by a mechanism analogous to that responsible for the blue-green system of sodium. In the case of K₂, the resonance spectra were excited by the two yellow

mercury lines and the two D-lines. The constants for the equations by which the spectra can be represented are contained in Table 32. Some additional molecular bands, corresponding to other electronic transitions, appear in the absorption spectrum of potassium vapor, but they have not been observed in fluorescence emission (1283, 1295, 1894).

The heat of formation of the K_2 -molecules was determined for the first time by using the intensity of the band fluorescence as a measure of the number of molecules present per unit volume and by varying the temperature of the vapor, either at constant pressure or at saturation pressure. The heat of formation was thus found to be about 14,000 cal per mole or 0.6 eV, in very satisfactory agreement with later, more accurate, determinations (211).

Fluorescence of Rb_2 and Li_2 was observed only under excitation with white light. Li_2 exhibits, under these conditions, a band in the red. According to Carter and to Dunoyer, the fluorescence spectrum of Rb_2 consists of three groups of bands, one in the red, one in the orange, and one in the green. At low temperatures the red group predominates; it stretches from 6700A into the infrared and its numerous bands coincide with those of the strongest absorption band system. Probably it is analogous to the blue-green bands of Na_2 and corresponds to the transition $^1\Pi-^1\Sigma$. Its intensity decreases at temperatures above 300° C, as compared with the intensity of the two other band groups (213, 320, 1917).

In the absorption spectrum of cesium vapor, five independent band systems were obtained by Loomis between 4800 and 9000A. A band with the maximum of intensity at 7667A is already very strong at 170° C and shows a long progression of band edges. Loomis ascribed it also to the transition from the ground state of the molecule $^1\Sigma$ to a state $^1\Pi$. While the band at 7667 could not be observed in fluorescence under excitation with white light, another band near 6250A appeared in the emission spectrum, probably only because of its more suitable spectral location. In the absorption spectrum this band becomes noticeable at 230° C; it shows an extremely complicated structure, so that Loomis was unable to analyze it or to assign it to a definite electronic transition. He succeeded, however, in exciting a resonance progression by means of the neon line 6402A; the series consisted of six "positive" lines with a spacing ΔG of the order of magnitude of 40 cm^{-1} . Since the lower state of a band system appearing in the absorption spectrum at such low temperatures must be the electronic ground state of the molecule, the constants obtained from the resonance spectrum are characteristic of the Cs_2 -molecules in the state $^1\Sigma$ (956, 998, 1375).

D. Elements of the Sixth Column of the Periodic System

55. Oxygen. Next to the vapors of iodine and sodium, the fluorescence and resonance spectra of diatomic molecules have been most extensively investigated in the vapors of the elements of the sixth group of the periodic system. The spectral regions in which the excitation and the emission of fluorescence occur in each of these elements are listed in Table 33.

TABLE 33
 APPROXIMATE LOCATION OF THE ABSORPTION AND FLUORESCENCE
 BANDS OF O₂, S₂, Se₂, AND Te₂
 (Wavelengths in Å)

Element	O ₂	S ₂	Se ₂	Te ₂
Absorption ..	< 1900	2548-4000	3238-4180	3831-6200
Fluorescence ..	< 2000-3870	2800-5650	3050-4910	4200-6600

On account of the light absorption by atmospheric air, the first strong absorption band system of oxygen is accessible only to the methods of vacuum spectroscopy. The bands below 1900Å, which are obtained on spectrograms if the light from a high-pressure mercury lamp is passed through a layer of atmospheric air before falling on the slit of a spectrograph, were interpreted erroneously by Steubing as produced by fluorescence of oxygen; they are, in reality, oxygen absorption bands visible on the continuous background of the lamp spectrum. However, Rasetti obtained a series of resonance doublets by irradiating pure oxygen of atmospheric pressure with the mercury line 1849Å, which coincides with one of the last bands of the O₂ band system. The series was photographed from the eighth positive member at 2364Å to the twenty-second member at 3870Å. According to the very complete analysis of the O₂ band system under consideration (the so-called Schumann-Runge bands) the excited state of this resonance series is $v' = 8, J' = 12$, whereas the ground state from which the excitation takes place corresponds to $\bar{v}'' = 0$ (1341, 1573).

A rather intense fluorescence was observed in oxygen at low pressure (0.5 mm) by R. W. Wood and others when they irradiated the gas with short-wavelength u.v. originating from various spark discharges. No attempt has been made to analyze this spectrum (1000, 1022, 1164, 1880, 1905).

56. Resonance Spectra of S₂, Se₂, and Te₂. According to Steubing, Pringsheim 7

the vapors of sulfur, selenium, and tellurium can be excited to fluorescence by the unresolved radiation from iron or carbon arcs and from various spark discharges. The fluorescence spectra consist of channeled bands which continue absorption band systems of a similar structure towards greater wavelengths and overlap them to a certain extent. Later investigations by Rosen and others showed that these fluorescence spectra produced by "white light" are also essentially an inversion of the absorption spectra, although stretching farther into the region of greater wavelengths (Table 33) (1001, 1378, 1379, 1575).

Under excitation with monochromatic light, doublet progressions again appear, instead of the complete band systems. In contradistinction to iodine vapor, the vapors of sulfur, selenium, and tellurium contain not only diatomic but also polyatomic molecules in equilibrium according to temperature and pressure. Since the band spectra which are here under consideration belong only to the diatomic molecules, their intensity depends essentially on the choice of those two parameters. In order to vary them independently, the temperature in the observation chamber and in a side tube containing the solid material must be regulated separately. Table 34 shows the relation between the intensity of the band fluorescence and the temperature at a constant vapor pressure of 10^{-1} mm for the three elements.

If, on the other hand, the temperature is kept constant at about 500° C, the fluorescence intensity begins to become appreciable at a pressure of 10^{-3} mm and thence increases nearly proportionally with density. At pressures > 1 mm, the fluorescent region contracts itself to the neighborhood of the entrance window for the primary radiation and remains observable as "surface fluorescence" up to rather high pressures — at least up to 250 mm in sulfur, to 50 mm in selenium, and to 30 mm in tellurium vapor. Since the various exciting lines are

TABLE 34.
FLUORESCENCE INTENSITY OF THE VAPORS OF SULFUR, SELENIUM,
AND TELLURIUM
(Pressure 10^{-1} mm)

Element	Sulfur	Selenium	Tellurium
Just noticeable at .	150°	350°	400°
Increases up to ..	400°	600°	800°
Constant up to ..	600°	800°	—
Decreases above ..	650°	—	—

absorbed to very different degrees in the vapors, according to whether the absorption process originates from vibrational level $\bar{v}'' = 0, 1, 2, \dots$, the state of surface fluorescence occurs for various progressions at widely different pressures. In tellurium vapor, for instance, the mercury line 5461A only begins to excite a faint "beam fluorescence" at a pressure of 10 mm, while a resonance series excited by the line 4358A appears exclusively as surface fluorescence under these conditions.

The absorption band systems of Table 33 correspond to transitions ${}^1\Sigma-{}^1\Sigma$ for all three of the elements and, therefore, the resonance spectra should consist of doublet series. However, this could be demonstrated only in very few cases. Generally, exceedingly complicated line groups were obtained instead of the expected doublets, because the exciting lines covered several absorption lines. This is caused, at least partially, by the existence of several isotopes of the elements which combine to a number of molecules with slightly different spectra (768, 1605, 1607, 1617, 1732).

In several resonance spectra of tellurium vapor, the individual components of such line groups or apparent multiplets could be assigned to various combinations of the tellurium isotopes with the atomic masses 124, 125, 126, 128, and 130. According to Rosen, a very intense resonance spectrum excited in tellurium vapor by the mercury line 4358A can be followed up to the group at 6530A which corresponds to $v'' = 36$. Since the exciting line lies close to the head of the band 8'-4'', the isotope effect is not strong enough in the first members of the series (corresponding to low v'' -values) to split them into distinct components; the apparently single lines are only broadened and made diffuse. However, for v'' greater than 22, each member consists of five well separated lines, and their separation increases with increasing values of v'' . The number of the observed components is smaller than 15 (the number of possible combinations of the five isotopes) not only because of the very small concentration of some of the isotopes, but also because the lines belonging to combinations with nearly equal reduced masses (like 128 + 128 and 130 + 126, or 126 + 128 and 124 + 130) coincide almost exactly (1383).

For sulfur vapor, the evidence for the existence of the isotope effect is less complete; however, Swings made the assumption at least very plausible that not only molecules made up from the most frequent isotope S³² contribute to the emission of some of the resonance spectra, but that also molecules containing an atom of the odd isotope S³³ take part in the process.

Diestelmeier, a group of emission bands is obtained by irradiating the vapor with the light from an iron spark. The fluorescence was suppressed by inserting a plate of glass into the path of the exciting light. Probably the same bands formed a part of the fluorescence spectrum reaching from 2229A to the limits of the visible region which was excited by McLennan and Wallerstein in selenium vapor saturated at 325° C by the unresolved radiation from a mercury arc (305,100I).

57. Predissociation and Fluctuations. In the band systems of S₂, Se₂, and Te₂, a phenomenon occurs which was discovered by V. Henri

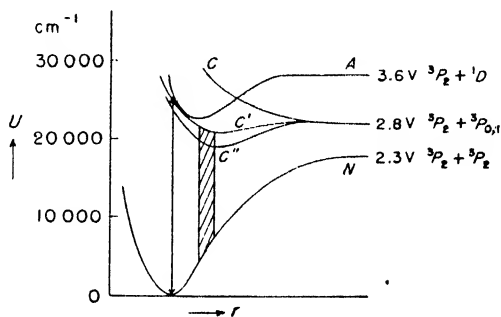

Fig. 70. Potential curves of Te₂ (Rosen).
Shaded area : region of fluctuation bands.

and was called by him “predissociation.” In the neighborhood of a certain vibrational state with $v' = v'_p$, the absorption bands become diffuse and the fine structure due to the rotation disappears. The phenomenon is explained by assuming that the potential curve of the excited state is crossed at the point v'_p by the potential curve of another electronic state, or at least that the two curves approach each other very closely. The potential curve of the “perturbing state” is frequently a pure repulsion curve (C in Figure 70) or an attraction curve with a very shallow trough (C' and C'' in Figure 70), corresponding to a loosely bound unstable molecule. The perturbing curve causing the predissociation may even have a deep minimum corresponding to a stable molecular state, if the point of intersection lies higher than the dissociation level of this state. The mechanism is very similar to that represented by Figure 48 for the quenching of an excited atom by a collision of the second kind.

If a spontaneous radiationless transition from curve A to curve C in Figure 70 is allowed, the lifetime of the excited state A becomes shorter and the absorption lines due to the transitions $A \leftarrow N$ are

broadened so that they overlap and render the band diffuse. In the emission spectrum, the corresponding lines are almost completely missing because the effect becomes noticeable only if a spontaneous transition from A to C has a much higher probability than the transition from A to N .

In the band system of tellurium, for instance, predissociation causes the bands to become diffuse in the neighborhood of wavelength 3895A; no resonance spectra can be excited by lines belonging to transitions with $v' > 20$ and, in the complete fluorescence band system excited by white light, all bands which originate from vibrational levels with $v' \geq 21$ are absent.

The fluorescence band systems of Se_2 and Te_2 (Table 33) are continued at their long-wavelength end by a sequence of more or less diffuse bands. These bands are also observed in the spectra excited by electric discharges and in thermal radiation; at high temperatures they appear even in the absorption spectra of the vapors. Evidently the emission process transfers the molecules into the higher vibrational levels of the electronic ground state. Since the bands are emitted at lower temperatures by thermal radiation than the bands listed in Table 33, the excited level from which they originate must be lower than the excited state for the latter bands. According to Rosen and his collaborators the new excited states are represented by shallow potential curves C' and C'' in Figure 70. Spontaneous transitions from A into C' and C'' must be allowed. The existence of two curves of this type is assumed because the bands seem to be divided into two groups each. Table 36 contains, under ΔG , the spacing of the principal maxima, and under $\Delta\nu$, the distances between secondary maxima superimposed upon most of the bands. These secondary maxima are apparently caused by the fact that the curves C' and C'' belong to weakly bound molecular states with closely spaced, but still quantized, vibrational levels. Spectrographs of small dispersion do not resolve these secondary maxima, so that the bands appear to be mere fluctuation bands. Bands of this type, with a "fluctuating intensity distribution", may be called pseudofluctuation bands. From the values of ΔG in the C' -bands of Te_2 , values of v'' between 12 and 15 are derived; v'' s between 15 and 20 are obtained for the C'' -bands of Te_2 ; and, for the bands of Se_2 , v'' is also larger than 12 (1033, 1380-1382).

The processes here under consideration differ from predissociation processes in that the states characterized by the curves C' and C'' must have a lifetime sufficient for the emission of fluorescence and that, furthermore, the probability of the transition from A to C' or C'' ,

and from there to N , must not be large compared with the probability of a spontaneous transition from A to N . It must be kept in mind that if the transition from A to C' or C'' is possible, the molecules are also able to return from C' or C'' to A . Thus, this transition probability is not essentially responsible for the relative intensities of the normal resonance fluorescence and the pseudofluctuation bands. If the fluorescence of Se_2 or Te_2 is excited by suitable lines — for instance, the Mg-triplet 3829, 3832, 3836A which is effective in both vapors — the typical resonance series and the pseudofluctuation bands are emitted with comparable intensities.

TABLE 36
PSEUDOFUNCTUATION BANDS OF Se_2 AND Te_2

Element	Te_2		Se_2	
Band group	C'	C''	C'	C''
Wavelength (A)	5250-6015	6022-6359	4770-5160	5380-6080
Number of fluctuations .	—	—	5	8
ΔG in cm^{-1} ..	250	220	360	330
$\Delta \nu$ in cm^{-1} ..	20	20	30	45

The intensity of the pseudofluctuation bands is practically independent of the temperature and the gas pressure; these parameters would have a strong influence if the transitions from A to C' and C'' were caused by collisions of the second kind. On the other hand, "radiating transitions" from A to C' (and C'') are out of the question because of the selection rules forbidding radiating transitions between two states from which radiating transitions to a common third state (the ground state) are possible. Thus, the transitions from A to C' and C'' must be spontaneous and direct.

The pseudofluctuation bands of selenium were also obtained by irradiating the vapor with white light of wavelengths 3600 to 4200A. The spectrum had essentially the same appearance as when excited by monochromatic light, but every fluctuation group contained more secondary maxima; the same is the case if the emission of the bands is caused by electrical or thermal excitation. Apparently the distribution over the closely spaced vibrational levels of the states C' and C'' depends on the vibrational quantum number ν' of the state A from which the molecules reach the states C' or C'' . As mentioned in

Section 50, the Mc bands of iodine show a similar behavior. It is not improbable that the short-wavelength bands designated in Section 50 as fluctuations have also a secondary structure which is covered by the superimposed "maze of lines" and that they belong, therefore, to the class of pseudofluctuation bands dealt with here.

E. Fluorescence of Other Diatomic Molecules

58. Elements of the Fifth Column of the Periodic System. The fluorescence of other diatomic molecules has been observed occasionally, but the data are not sufficient, in general, for the determination of the terms between which the corresponding transitions take place.

The first strong absorption band system of N_2 lies still farther in the u.v. than that of oxygen and has never been obtained in fluorescence. However, Oldenberg observed a number of bands between 3700 and 4700A by exciting nitrogen at 0.5 mm with light of short wavelength (probably less than 1500A) from a spark. The fluorescence spectrum consisted not of resonance progressions originating from a definite upper vibrational level, but of complete bands corresponding to transitions between two higher electronic states of the N_2 -molecule which are known also from other spectroscopic investigations. By the irradiation of atmospheric air with the light from a powerful spark between aluminum or copper electrodes, Wood and Meyer obtained the emission of the nitrogen bands at 3369, 3536, and 3778A; the last occurred with much higher intensity in pure nitrogen (in the absence of oxygen) (1000, 1021, 1022, 1163, 1164).

The principal results obtained with the other elements of this group are collected in Table 37. The figures in the last line of the table, which are marked with an asterisk, represent the fundamental vibrational frequencies ω_e^* derived from the observed values of ΔG ; in the other spectra, the available measurements do not suffice for the determination of this constant. Two widely different values of ΔG were found by Parys for the resonance series excited in Bi_2 -vapor by the blue and the green mercury lines; either the two progressions correspond to transitions to different lower electronic states, or the green fluorescence transfer the molecules into very high vibrational levels of the electronic ground state ($v'' > 50$). The series excited by the blue line has no anti-Stokes member and seems to consist of triplets which, however, are probably due to the superposition of two doublet series with $\delta\nu = +16$ and -20 cm^{-1} , respectively. The green doublet

series, with $\delta\nu = 12 \text{ cm}^{-1}$, has five anti-Stokes, and five positive members. Parys described several additional fluorescence bands excited in bismuth vapor by the green mercury line, but could not assign them to any known electronic transitions. While at lower temperatures and pressures only the atomic fluorescence lines are observed (cf. Section 15), the blue resonance series appears in the fluorescence spectra of the saturated vapor at 500°C and the green series above 800°C . By irradiation of Bi-vapor with white light at 1300°C , Narrajan and Row obtained twenty-four fluorescence bands between 5000 and 6600A which coincided with the absorption bands found by the same investigators (1096, 1192, 1338, 1610).

TABLE 37
FLUORESCENCE OF THE ELEMENTS OF THE FIFTH GROUP
OF THE PERIODIC SYSTEM

Element	P ₂ (078,685)	As ₂ (1618)	Sb ₂	Bi ₂
Temperature in °C ..	600-700	1100	900	500-1300
Vapor pressure	0.1 mm	saturated at 300° C	saturated at 600° C	saturated
Fluorescence spectrum in A ..	1900-3500	—	—	5000-6600
Exciting lines for resonance series in A ..	Al 1935, 1990 Cd 2144, 2195 Zn 2026, 2064 Zn 2101	Hg 2483 Hg 2537 Hg 2655 Hg 2806	Hg 2968, 3022 Hg 3126, 3132 Mg 2929, 2937	Hg 4358 Hg 5461
ΔG in cm^{-1} ...	770*	420	277*†	309; 173.2

† According to Genard; for Sb₂ Siksma gives $\omega_e^- = 269.5$

Similarly, the atomic resonance lines alone are excited in Sb₂-vapor saturated at 200° and superheated to 900°C . Only if the oven regulating the vapor pressure is heated to 600° do the molecular resonance series of Table 37 appear in the fluorescence spectrum (483). At somewhat lower pressures, Siksma observed the emission of some bands excited in antimony vapor by the light from Mg and Zn sparks; there are no data available concerning the origin and the structure of these fluorescence bands (1503).

59. Various Metal Vapors. — The vapor of lead has been investigated by Domaniewska-Krueger and Klokowska. By irradiation with white

light at 900° C, they obtained the emission of a band system stretching from 3200 to 5136Å in which 23 edges could be distinguished between 4216Å and the long wavelength end of the system. Resonance series were excited by the mercury lines 3287, 3345, 4358, and 5461Å. In the two latter spectra, the individual members could be resolved into doublets with $\delta\nu = 35$ and 24.4 cm^{-1} , respectively. For the u.v. series, the spacing ΔG is of the order of 430 cm^{-1} , corresponding probably to the approximate value of ω_e^* ; for the series in the visible, ΔG is only about 420 cm^{-1} . The authors give equations with a member quadratic in v'' for their resonance spectra; however, since their values of $\omega_e^* x_e^*$ vary between 0.7 and 2.07 for the various series, the measuring accuracy does not seem to have been sufficient for this calculation (309,788).

The vapors of thallium and indium exhibit a number of absorption bands at higher vapor pressures. These probably belong to diatomic molecules Tl_2 and In_2 . Absorption in these bands, however, leads only to the emission of atomic lines, according to a mechanism which is treated in a later section. The molecular bands themselves could never be obtained in the fluorescence spectra (1783).

60. Light and Heavy Hydrogen. The first absorption bands of molecular hydrogen are situated in the far u.v., in the neighborhood of, and below, 1060Å. They correspond to the transition of molecules from ground state $1s\sigma^1\Sigma_g^+$, to various electronic states A, B, C . In the emission spectrum of an electric discharge through argon with a small admixture of hydrogen, Beutler observed a doublet series consisting of fourteen members in addition to the normal Lyman bands ($A \rightarrow N$) which are excited by collision processes. The spacing ΔG of the series and the doublet separation $\delta\nu$ can be derived from the well-known constants of the ground state of H_2 , if it is assumed that the v'' 's progress from 1 to 14, while the rotational quantum numbers are $K'' = 1$ and 3, respectively, corresponding to the value $K' = 1$ for the excited state. According to Beutler, this series is produced by the absorption of the argon line 1066Å, which occurs with great intensity in the spectrum of the discharge and which transfers the hydrogen molecules from the ground state $\bar{v}'' = 2, \bar{K}'' = 1$ to the level $v' = 10, K' = 2$ of the electronic state $B (2p\pi^1\Pi_u)$. The calculated energy of this transition agrees with the $h\nu$ of the argon line within 2 cm^{-1} . The energy of the vibrational level $v'' = 2$ of the ground state is 8085 cm^{-1} or 2300 cal per mole; it is so high that the equilibrium concentration of the molecules in that level is only 10^{-8} and their partial pressure is not more than 10^{-10} mm at the temperature and the hydrogen pressure

in the discharge tube. This is far too little to provide sufficient absorption of the argon line; it must, therefore, be assumed that an adequate number of molecules in this state is produced by the discharge itself.

Similar resonance spectra originating from HD-molecules were obtained under the same conditions of excitation in mixtures of light and heavy hydrogen. In this case, the molecules are raised from the nonvibrating level of the ground state to the level $v' = 3$ of the electronic state A ; thus, the series forms a part of the band system analogous to the Lyman bands of normal hydrogen. The spectrum consists of twelve doublets without an anti-Stokes member; from the spacing ΔG , which decreases along the progression from 448 to 202 cm^{-1} , the rotational quantum number $K' = 2$ ($K'' = 1$ and 2) can be derived. A weaker companion line of these doublets is ascribed to a second series belonging to the same bands, with $K' = 1$ (104, 1026).

In the HD resonance spectrum, the doublets with $v'' = 3, 6$, and 9 have vanishingly low intensities, while those with $v'' = 5$ and 8 are the strongest. The theoretical intensity distribution could be derived from quantum mechanics and was found to be in good agreement with the experiments. A better approximation could be applied by Bewerndorff in the determination of the eigenfunctions of the vibrating hydrogen molecules than had been used by Brown for the resonance spectra of Na_2 (compare Section 53).

Apart from these Lyman band series, four doublets between 1050 and 1200A were found in the emission spectrum of HD. They originate from the argon line 1048A and are related to another band system (the so-called Werner bands). The only vibrational level of the ground state in which the line 1048A can be absorbed in $\bar{v}'' = 1$, with $\bar{K}'' = 2$. Since the relative intensity of this series increases appreciably with increasing temperature, it must be assumed that its appearance is favored by the thermal increase of the number of HD-molecules with $v'' = 1$.

Heavy hydrogen, D_2 , does not exhibit a phenomenon of this type; no electronic transitions which are in resonance with one of the argon lines exist in D_2 .

61. Metal Halide Vapors. The vapors of several metal halides provide practically the only examples of polar diatomic molecules which are known at present to be fluorescent.* AgCl, AgBr, AgI, and

* Terenin occasionally mentioned the emission of a fluorescence band between 5800 and 2400A which is excited in CO by light of wavelengths below 1600A. According to a casual remark of Sen Gupta, the so-called γ -bands of NO can be produced by irradiating nitric oxide with light of wavelengths somewhat greater than 2000A. (See also the following section).

III have so far been investigated. The absorption spectra of these vapors consist, in part, of bands showing a fine structure and corresponding to transitions from the ground states of the molecules to excited states with discrete vibrational levels. Typical resonance spectra can be produced by light absorption in these bands. The approximate spectral location of the bands and the vibrational frequencies of the electronic ground states obtained from the resonance spectra are collected in Table 38. The table contains, furthermore, the heat of dissociation D'' of the normal molecules and, in the last row, the "Reststrahlen" frequencies of the compounds. The latter vary in the same order as the ω_e'' s, but their absolute values are much smaller, indicating that the atoms are less strongly bound in the ionic crystal lattices than in the molecules of the vapor. T and p are the temperatures and pressures under which resonance spectra have been obtained, N^- and N^+ the numbers of anti-Stokes and positive members contained in the resonance series which were excited by various primary lines (422).

TABLE 38
RESONANCE SPECTRA OF METAL HALIDES

Compound	AgI	AgBr	AgCl	III
Absorption bands (Å)	3168-3350	3183-3394	3116-3485	3780-5360
T (° C)	800	900	—	500
p (mm)	0.5	1.5	—	6
Exciting lines (Å)	Cu 2374, Ag 3383	Cd 3261	Zn 3175	Pb 4062, Hg 4047
N^-	4 —	3	1	—
N^+	35 —	8	3	—
ω_e'' (cm ⁻¹)	205	245	340	150
D'' (eV)	3.1	2.6	2.1	—
ν_r (cm ⁻¹)	—	88.9	122.7	—

By irradiation with the unresolved light from an iron arc, a blue band fluorescence is excited in III-vapor. By using for excitation the cyanogen bands emitted by a carbon arc, the structure of the very complicated band system becomes considerably simpler, so that the bands can be resolved into series with the two periods $\Delta G_1 = 150$ and $\Delta G_2 = 30$ cm⁻¹. The first one occurs also in the resonance spectra excited by monochromatic light and corresponds to the vibrational

frequency of the ground state; the other period of about 30 cm^{-1} can be caused only by the vibrational frequency of the excited electronic state and, in this respect, TII differs widely from the silver halides. According to Franck and his collaborators, the bond between the two nuclei, in the case of the silver halides, is of nearly the same strength in the ground state and in the first excited state. On the other hand, Butkow found that the first excited state of thallium chloride must be represented by a very shallow potential curve in order to explain the structure of the absorption spectrum of the vapor. A weak fluorescence excited in TlCl-vapor consisted of a sequence of narrow bands between 3200 and 3350A which seemed to coincide with some of Butkow's absorption bands. In such cases, where the molecules are loosely bound in the excited state, the discontinuous part of the band system in which resonance radiation can be excited is relatively narrow, and transitions into the nonquantized region have a great probability. In the case of the alkali halides, the potential curves of all excited states are so shallow that light absorption always leads to the dissociation of the molecule (see Section 70) (191).

The fluorescence of TII-vapor can also be excited by light of wavelengths below 2100A, but the intensity distribution within the bands is quite different. It has been suggested that this fluorescence, and also the occurrence of some additional continuous bands excited by short-wave u.v. is due to a primary process in which the dissociation of a molecule is involved. [See Sections 74 and 78 (1637)].

If the vapors of cuprous iodide and cuprous chloride are irradiated at temperatures between 400 and 500° C with the light from sparks between aluminum, zinc, or cadmium electrodes, a weak visible band fluorescence is observed, green (about 4800–5000A) in the case of CuI, blue-violet (4300–4550A) in the case of CuCl. Since the frequency of the exciting light differs so widely from the frequency of the fluorescence and the emission spectrum is independent of the exact wavelength of the primary light, this fluorescence is not resonance radiation. Most likely the primary process is the dissociation of Cu_2Cl_2 or of Cu_2I_2 , which are also present in the vapors, into an excited and an unexcited diatomic molecule. This mechanism is treated, together with other similar phenomena, in Section 94 (1649).

62. Fluorescence of Diatomic Radicals. The fluorescence of various diatomic radicals can be excited by the collision of polyatomic molecules such as H_2O or NH_3 with excited mercury atoms, or by the dissociation of the molecules caused by the absorption of short-wave u.v. light. Under these conditions, the fluorescence of the radicals OH, NH,

and CN has been observed, and, moreover, the fluorescence of the diatomic molecules of the halides of mercury, cadmium, zinc, and lead. (See Sections 67, 74, and 94.) In these cases of indirect excitation, more or less complete bands appear in the emission spectra, although frequently with an anomalous intensity distribution.

The spectra of comet tails contain lines belonging to bands of the following radicals and ions: OH, CH, NH, CN, C₂, CO⁺, CH⁺, and N₂⁺ (1613, 1615, 1619). They owe their existence to the photodissociation of some polyatomic molecules by the short-wave radiation of the sun, but it seems certain that the emission of their characteristic bands is a primary fluorescence process caused by light absorption in the radicals themselves, which are relatively long lived because of the low gas pressure in the comets' atmosphere. Although the spectrum of the exciting sunlight is continuous, many of the emission spectra have almost the character of resonance series produced by the absorption of monochromatic radiation: they exhibit only a few rotational lines of each band. This is true mainly for those radicals which, because of their polar nature, are able to lose their rotational and vibrational energy by infrared radiation, so that they are in the very lowest energy levels when they absorb a fraction of the impinging sunlight. By every absorption process, the rotational quantum number can be increased only by unity. The most important examples of this type are the OH-bands between 3078 and 3211A corresponding to the vibrational transitions 0' → 0'', 1' → 1'', and 2' → 2'', and the NH-bands between 3350 and 3372A corresponding to 0' → 0'' and 1' → 1''; less prominent, but fairly well identified, are the bands of CH⁺ between 3972 and 4231A and those of NH⁺ between 4039 and 4051A. In all these bands, the rotational quantum numbers of the excited states are $K' \leq 2$.* If, on the other hand, a C₂-radical has acquired a high rotational energy, either in the primary dissociation process by which it is produced or by successive stepwise processes of light absorption, it remains indefinitely in this state. Accordingly, the intensity distribution of the rotational lines in the "Swan bands" of the comet-tail spectra corresponds to a temperature of about 3000°.

The CN-bands take an intermediate position, the rotational quantum numbers being in part as high as 25. However, the intensity distribution among the rotational lines differs widely from a normal temperature distribution: it shows two distinct maxima at about $K' = 3$ and $K' = 9$, the first corresponding to a temperature of 50° K

* In some of the OH-bands, weak lines with $K' = 3$ have been identified; in the bands of CH, K' even reaches 6.

and the other to 400° K. Various explanations have been proposed for this phenomenon, but none of them is quite satisfactory. The solar spectrum is not uniformly continuous but is interrupted by many dark Fraunhofer lines which cause deep intensity minima in the spectrum. If such minima coincide with specific lines of the absorbing molecules, the corresponding doublets are missing from the fluorescence spectrum. This effect must be taken into account for an interpretation of the intensity distribution in all comet-tail bands due to fluorescence excitation by the solar radiation. However, it is not sufficient for explaining the anomalous intensity distribution in the CN-bands which occurs equally in the violet sequence, $\Delta v = -1$ (4215-3572A), and in the ultraviolet sequences, $\Delta v = 0$ (3883-3852A) and $\Delta v = +1$ (3584-3572). It seems, therefore, more likely that the double maxima in the "rotational temperature" distribution of the CN-radicals occur either because the radicals originate from two different parent molecules, or because one type of parent molecules is photodissociated in two different ways. The last hypothesis may find some support in the results obtained in laboratory experiments on the photodissociation of C_2N_2 and ICN-molecules (compare Sections 67 and 94).

F. Effect of Collisions and of Magnetic Fields on the Resonance Spectra of Diatomic Molecules

63. Various Effects Produced by Collisions. If excited diatomic molecules collide with other molecules, the same effects can be expected which are produced by collisions in fluorescent monatomic vapors: the excited system can be transferred to a closely adjacent quantum state, losing only a small fraction of its energy, or it can be genuinely quenched and lose its excitation energy almost completely. However, in a diatomic molecule either of these effects can be produced not only by the same mechanism as in an isolated atom, but also by another process which is actually, in either case, the more important and the more common one. The molecule can not only be transferred into a neighboring electronic state but also into another rotational or vibrational level of the same electronic state; and, in addition to the quenching processes treated in Chapter I, the molecule can pass from the potential curve characteristic of the stable molecule into a repulsion curve intersecting it. If a transition of this type is allowed, it leads to spontaneous predissociation (see Section 57). If it is forbidden by one of the selection rules, it can be induced by a collision;

following this transition, the two atoms forming the molecule separate and the excitation energy is transformed into kinetic energy of the atoms (592).

There is no sharp boundary between spontaneous and induced predissociation. There are cases like that of the visible band system of iodine in which transitions from the excited electronic state to a repulsion curve do not occur spontaneously and are not even induced by collisions with helium atoms, whereas the somewhat stronger atomic fields of the heavier rare gases are sufficient for enforcing the transition. In the other limiting case, the spontaneous transition to the perturbing potential curve has a greater probability than the emission of radiation causing the return to the ground state -- as, for instance, in the predissociation bands of tellurium. However, there are intermediate cases in which spontaneous predissociation has a relatively small probability and the effect is greatly enhanced by external perturbations. Under these conditions, even collisions with helium atoms can become effective.

If collisions cause "transfers" as well as "induced predissociation" in a band system, the bands in the long-wavelength region of the system, which are due to transitions from the lower vibrational levels of the excited electronic state, are not only relatively less quenched than the others but may even be enhanced. Moreover, under these conditions the total quenching averaged over the whole band system does not obey the Stern-Volmer equation, because the quenching efficiency is not constant. It is larger for those molecules the vibrational levels of which are close to the point where predissociation occurs; it becomes smaller when more of the excited molecules are transferred by collisions into lower levels.

The effective cross section of a perturbing gas in its interaction with an excited molecule containing vibrational energy depends on two main factors. The first is the mass of the particles, because of the conservation of momentum as well as because of the influence of mass on the velocity of the molecules and on the duration of the individual collisions; the second is the strength of external molecular fields, by which the potential curves of the excited molecules are more or less distorted during the collisions.

64. "Transferring Collisions" in Iodine Vapor. If molecules are raised by the absorption of monochromatic light into the level $v'J'$ of an excited electronic state, and if they are transferred by collisions into other rotational levels, the singlets or doublets of the corresponding resonance spectrum give way to more or less complete bands; if the

vibrational quantum number v' is also affected by the collision process, new bands appear in the fluorescence spectrum until finally the whole band system is emitted. This phenomenon was first observed by Franck and Wood in the resonance spectrum of I_2 -vapor excited by the green mercury line. Bands were already noticeable in the intervals between the resonance doublets when 2 mm of helium were added to the iodine vapor; with increasing helium pressure, they became stronger and more numerous. At a helium pressure of 10 mm the members of the original resonance series no longer stood out from the background formed by the other band lines, which were now also extended much further into

the red region of the spectrum (Figure 71). This intensity shift in direction of greater wavelengths which is best observed if the fluorescence is excited by white light is caused by the fact that high vibrational energy is partially transferred from the excited I_2 -molecules to He-atoms, while the inverse process has a much smaller probability. However, the major

part of the excitation energy, which is stored in the excited electron, is not affected by the collisions, so that the total intensity of the fluorescence is not greatly altered. At a helium pressure of 20 mm the luminous intensity does not seem to have noticeably decreased, as far as the change of color makes the comparison possible, and even at 80 mm the fluorescence is still strong, although the color has now changed to red; under these conditions, every excited I_2 -molecule undergoes, on the average, thirty collisions during its lifetime (412, 1872, 1899).

The admixture of other foreign gases or an increase of the iodine vapor pressure itself produces similar results, but simultaneously the total fluorescence intensity is weakened to a much greater extent, the degree of quenching depending on the nature of the perturbing gas. With argon, the red shift in the intensity distribution is still plainly visible; with oxygen, it is practically suppressed by the much stronger quenching action (Fig. 72) (430, 1871)

A change of v' and of J' of the excited molecules is produced with Pringsheim 7*



Fig. 71. Transformation of a resonance spectrum of I_2 to the complete band spectrum (Franck and Wood).

1: pure I_2 -vapor. 2: 2 mm He.
3: 10 mm He.

about equal probability by a collision process; the appearance of a new line in the same band or in a neighboring band occurs with about the same intensity. The "transferring yield" in collisions of excited I_2 -molecules with rare-gas atoms is so high that the effective cross sections, which increase with increasing atomic weight of the rare gas, are in some cases twenty-five times larger than the gas-kinetic cross sections (325,349,1171,1369). (See Table 39). They are also much larger than those obtained from measurements of the sound velocity or from the heat of activation of the oscillations; this is probably due to the fact that the molecules are in highly excited vibrational levels with $v' \sim 26$ instead of $v' \sim 0$.

TABLE 39
TRANSFERRING CROSS SECTIONS σ OF RARE GASES FOR THE VISIBLE
IODINE FLUORESCENCE
(In cm^2)

Gas	He	Ne	A	Kr	Xe
$\sigma \cdot 10^{16}$	113	159	240	309	480

In general, Δv does not exceed 1 or possibly 2 in an individual collision process. Bands originating from levels which are separated by several vibrational quanta from the initial level occur only if the excited molecules suffer a large number of collisions during their lifetimes.

By using a spectrograph of very high resolving power, Wood and Loomis were able to prove that collisions with helium atoms always change the rotational quantum number J' by two units: every second line is missing in the bands of the fluorescence spectrum which is excited in iodine vapor by the green mercury line in the presence of helium at 10 mm. This is in perfect agreement with the theoretical expectations based on quantum mechanics (see Section 45) (1910).

The ultraviolet resonance series of iodine vapor are not transformed into the complete band system by the addition of foreign gases; the series are only weakened more and more by increasing pressure of the foreign gas until they disappear completely. The same is true with respect to the Mc bands. Simultaneously, the "continuous bands" mentioned in Section 50, which are relatively weak in pure iodine vapor, are replaced by much stronger bands with a typical vibrational structure. According to Elliott, the region corresponding to the continua Y and X is covered by a single system in which he was able to measure 72 band heads represented by the equation:

$$\nu = 33744 + 104(v' + \frac{1}{2}) - 0.2(v' + \frac{1}{2})^2 \\ - 214.26(v'' + \frac{1}{2}) + 0.592(v'' + \frac{1}{2})^2$$

with v' varying from 1 to 12 and v'' from 13 to 28.

The lower state is supposed to be the electronic ground state with the vibrational frequency characteristic of the unexcited I_2 -molecule. The potential curve of the upper state must be shifted appreciably with respect to that of the ground state since transitions to the lower vibrational levels of this state do not occur. The band system becomes very complicated in certain parts because ω'' is nearly equal to $2\omega'$.

Elliott assumes that molecules which were raised by light absorption to high vibrational levels of an electronic state ${}^1\Sigma_u^+$ are transferred by collisions to low vibrational levels of this state and pass from there to a part of the potential curve of an electronic state ${}^1\Sigma_g^+$, situated immediately below the minimum of the potential curve of ${}^1\Sigma_u^+$; the fluorescence bands originate at the various vibrational levels of the state ${}^1\Sigma_g^+$ (360).

Although it is certain that a mechanism of this kind must be assumed for the production of the bands with vibrational structure, this assumption does not seem to explain why, in the absence of a foreign gas, the band should appear as continuous. If the "continuum" corresponds to the same electronic transition, its emission must originate from approximately the same vibrational levels, since the wavelength range is the same in both cases. The band can be made continuous only by the fact that in the absence of a foreign gas, much more numerous and densely packed rotational levels of ${}^1\Sigma_g^+$ are populated; this is very improbable, because relatively sharp resonance spectra are emitted from the primarily excited state ${}^1\Sigma_u^+$. If, on the other hand, the apparently continuous band originates from another electronic state, the latter might correspond to a repulsion curve and the band be really continuous.

The intensity distribution in the band observed in the presence of a foreign gas is independent of the wavelength of the primary radiation, but is influenced noticeably by the nature and pressure of the foreign gas and by the temperature. While the intensity of the short-wavelength bands of the system, corresponding to great values of v' , decreases when the pressure of added nitrogen exceeds 10 mm, the intensity at the head of the system near 3450Å increases continuously up to 760 mm N_2 . If the temperature is raised to 800° C, the short-wavelength part with greater v' values is enhanced. The intensity of the band system is much weaker and the intensity

distribution corresponds to a relatively greater population of the higher vibrational levels, when nitrogen is replaced by helium of the same pressure; with helium, the distribution is about the same at room temperature as it is with nitrogen at 800° C. On the other hand, the u.v. resonance series and the Mc bands are less strongly quenched by helium, which also, in this instance, has only a small efficiency in "transferring collisions," both for the transfer from one electronic state to the other and for transfers between the various vibrational levels of a given electronic state (333).

On addition of nitrogen to iodine vapor, a structure similar to that of the band system at 3450A has been observed by Elliott in the other "continua" mentioned in Section 50; some of them are quenched again at higher N₂-pressures. Nothing is known concerning the electronic states from which they originate; apparently these states also lie somewhat below the state $^1\Sigma_u^+$ which is reached directly in the process of excitation and have quantized vibrational levels. According to Elliott's analysis, their vibrational frequencies do not coincide with that of the system at 3450A (360).

65. Quenching of Iodine Fluorescence by Foreign Gases. The quenching of the fluorescence of diatomic vapors may frequently be connected with chemical reactions, as was proved for the fluorescence of monatomic vapors. It is possible that the great quenching efficiency of gases such as oxygen and the halides is partly due to their chemical reactivity. However, very little is known about such processes and the particularly strong molecular fields of these electronegative gases also may favor induced predissociation.

The "self-quenching" due to an increase of the vapor pressure of the electronegative gases themselves has frequently been overrated. It has already been mentioned that oxygen at atmospheric pressure and sulfur vapor at 250 mm exhibit strong resonance spectra. While bromine vapor was at first expected to be fluorescent only at the very lowest pressures because of its electronegativity, the red part of its fluorescence spectrum is, according to Plumley, not appreciably weakened by increasing the pressure to 70 mm. In Wood's earlier experiments, it seemed that the visible iodine fluorescence was completely suppressed when the vapor pressure exceeded 1 mm; a considerable part of this apparent self-quenching was explained later by the fact that the effects caused by absorption processes were not taken into account. On the one hand, a smaller fraction of the incident light penetrates into the volume of the vapor, so that surface fluorescence becomes prevalent; and, on the other hand, the fluorescence light

coming from the interior of the vapor is absorbed on its way to the exit window.* Actually, the resonance spectra produced by the radiation from a mercury arc are still observed as surface fluorescence of considerable intensity in iodine vapor saturated at 150° C ($p \sim 100$ mm) (1275, 1913).

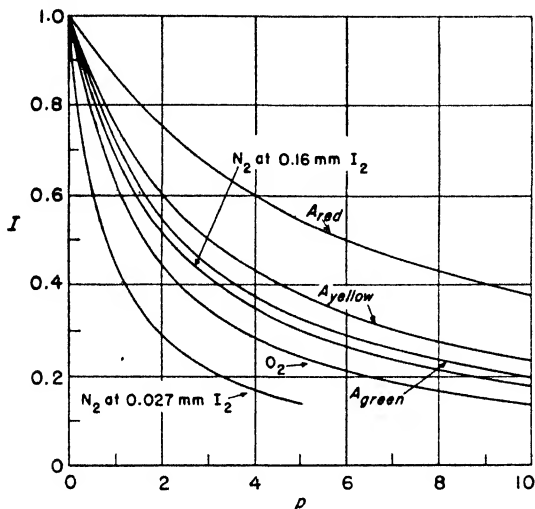

Fig. 72. Quenching of the I_2 -fluorescence by foreign gases (I_2 -pressure 0.16 and 0.027 mm) [Berg (93)].

Ared, *Ayellow*, *Agreen*, quenching by argon of the red, yellow, and green part of the spectrum.

Taking the absorption into account, the quenching half-pressure of the iodine fluorescence by iodine molecules is 0.08 mm. Because of the existence of this self-quenching action, the apparent quenching efficiency of foreign gases is largely dependent on the iodine vapor pressure itself: the higher the latter, the smaller the efficiency of the additional gas seems to be (Figure 72). The fluorescence intensities observed at increasing pressures of a foreign gas can be described by

* Plumley seems to be of the opinion that without reabsorption processes the fluorescence intensity would not decrease at all with increasing vapor pressure, because a quenching proportional to the pressure would be exactly compensated by the growing absorption of exciting light, which is also proportional to the pressure. However, the amount of primary energy absorbed in a certain volume is proportional to the vapor pressure only as long as this pressure is so low that the reabsorption of the fluorescence light is of little importance. Once the absorption becomes strong, the assumption that the quantity of absorbed radiation increases indefinitely with increasing pressure is erroneous (1243).

means of a Stern-Volmer equation, but the half-pressure derived from the equation is not related to the natural life time of the excited molecules unless it is extrapolated to the iodine pressure zero. This has been done for the values given in Table 40. It appears that the simultaneous quenching by increasing I_2 -pressure and by addition of a foreign gas are not additive, as should be expected according to Equation (24), Section 35 (93).

If the quenching of the visible iodine fluorescence is caused by a transfer of the excited molecules to a state represented by a repulsion curve, the relatively strong action of molecules of the same kind might, perhaps, again be explained by a quantum-mechanical resonance phenomenon in which the excited molecule returns to the ground state and another molecule is raised to the state of equal energy, but corresponding to the repulsion curve.

The ultraviolet resonance spectra of iodine and the Mc bands are slightly weakened by increasing vapor pressure; the self-quenching becomes less effective, with increasing wavelength of the exciting light. The resonance progression excited by the mercury line 2537A is still very strong and shows a practically unaltered structure at a saturation pressure of two atmospheres. Very few molecules are in the high vibrational state from which the line 2537 can be absorbed, and, therefore, the corresponding "resonance effect" which could produce quenching should be very weak.

The conclusion that the quenching of the visible iodine fluorescence is actually due to a predissociation process was derived by Loomis and Fuller from absorption measurements. The absorption in the bands corresponding to values of $v' \geq 12$ increases considerably on addition of argon or oxygen to the iodine vapor, and this phenomenon can be ascribed only to a broadening of the individual lines caused by the fact that the average life of the excited molecules is shortened by induced predissociation (801,955,1715,1717).

TABLE 40
QUENCHING OF THE VISIBLE IODINE FLUORESCENCE
BANDS BY COLLISIONS

Quenching gas	He†	A†	H ₂	O ₂	CO ₂	Ether	Cl ₂	I ₂
Half-value pressure p* in mm	70 (20)	6 (2.3)	5	3.5	1.2	0.3	0.2	0.08

† The first figures relate to the red, the second, in (), to the green part of the fluorescence spectra.

Furthermore, lines characteristic of atomic iodine appear in the absorption spectrum of a mixture of iodine vapor and argon under the action of strong irradiation with light from which all wavelengths below 5100A are filtered out, while these atomic lines occur in pure iodine vapor only if the vapor is directly photodissociated by light of wavelength below 5000A (1717).

According to Rabinowitch and W. C. Wood, the photodissociation of I_2 -molecules is produced with the same high yield of almost 100 % if it is caused by light absorption in the continuum adjoining the convergence limit, or if it is due to absorption in the different parts of the discontinuous bands between the blue-green and the yellow in the presence of a foreign gas of a few hundred mm (He, A, H_2 , or N_2). The relative number of dissociated molecules was determined by the decreasing absorption in the characteristic molecular bands, and every absorption process in the continuous band was assumed to produce dissociation. These experiments prove that the quenching action of the various gases is due almost exclusively to induced predissociation of the excited molecules, but considering the high pressure of the quenching gas at which each excited molecule undergoes many collisions during its lifetime, they do not answer the question whether the probability of a transfer from the excited state into the state of repulsion depends on the wavelength of the exciting light. This problem will be dealt with in the next section (1318).

66. Quenching of Iodine Fluorescence by Magnetic Fields. Further information regarding the mechanism of the quenching processes has been gained by experiments proving the influence of strong magnetic fields on the intensity of the fluorescence, and the interpretation of these experiments by Turner and van Vleck. According to Steubing's early investigations, the intensity of the iodine-vapor fluorescence excited by white light is considerably weakened by a magnetic field; the bands in the green part of the spectrum are more strongly affected than the red ones. It has since been proved repeatedly that this effect is not caused by a corresponding change in the absorption spectrum of the vapor (1162, 1170, 1576, 1577). If a resonance spectrum is excited in I_2 -vapor by monochromatic light, the two components of every doublet and the various members of a simple resonance progression are weakened to the same extent. However, the total intensities of resonance spectra excited by different primary lines are reduced in different degrees by a given magnetic field: the quenching efficiency is related to the vibrational quantum number v' of the excited electronic state. Fig. 73 shows the relative weakening I_m/I_0 as a function of the

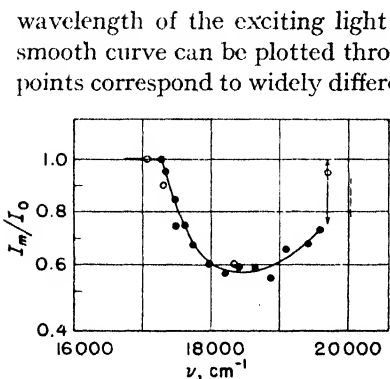

Fig. 73. Quenching of the I_2 -fluorescence by a magnetic field [Turner (1713)].

probability. Van Vleck's theory for predissociation induced by magnetic fields leads to the equation:

$$A = (I_0 - I_m)/I_0 = bH^2(\alpha + bH^2) \quad (54)$$

n which H is the magnetic field strength, b a constant depending on ν' , and $\alpha = 1/\tau$ the reciprocal lifetime of the excited state. Genard measured the effect for two doublets of the resonance series excited by the green mercury line and obtained a satisfactory agreement between his observations and Equation (54), at least for values of H larger than 20,000 gauss. Scholz confirmed his results also for weaker fields down to 10,000 gauss (482,484,1234,1475).

It might be expected that the induced predissociation of excited I_2 -molecules by collisions and by magnetic fields should show the same dependence on the wavelength of the exciting light, viz., the value of ν' . However, in contrast to the clean-cut results obtained for the magnetic effect, the influence of ν' on the quenching by collisions is very uncertain, according to investigations by several authors. An observation published by Ramsauer, according to which the individual members of a homogeneous resonance spectrum suffer unequal losses of intensity by collision-quenching, also needs confirmation (1330,1714).

Berg has investigated the simultaneous quenching by collisions and by magnetic fields. At increasing iodine vapor pressure the quenching action of a given magnetic field decreases continuously; it is much less noticeable at room temperature than at 0°C ($p = 0.03$

wavelength of the exciting light in a field of 12,500 gauss. A fairly smooth curve can be plotted through the observed points; since these points correspond to widely different values of the rotational quantum number J' , evidently only the values of ν' and not those of J' are decisive for the effect (1713, 1743).

The quenching reaches its maximum at the frequency 18,500 cm^{-1} . According to theory, this frequency corresponds to the value of ν' at which the potential curve A of the excited molecule intersects the repulsion curve C ; it is the point where the induced predissociation has the greatest

mm) and vanishes almost completely at 40° C ($p = 1.2$ mm). As in the case of simultaneous quenching by a foreign gas and by an increase of the I_2 vapor pressure, this result is explained by the shorter lifetime of the excited molecules in I_2 -vapor of great density. Actually, the effect of the magnetic field is even less reduced by the quenching interaction of the iodine molecules than would be expected according to an additive superposition of the two factors. The same is true if a magnetic field is applied to the iodine fluorescence already weakened

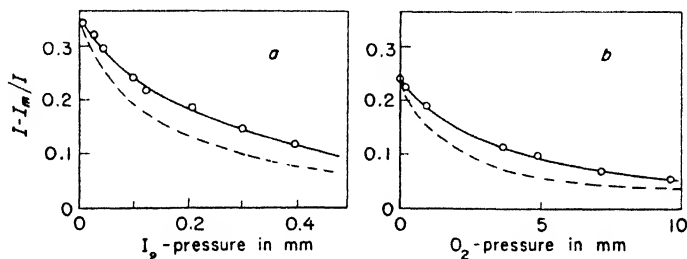

Fig. 74. Simultaneous action of collisions and a magnetic field on the I_2 -fluorescence (Berg).

a: variable I_2 -pressure

b: variable O_2 -pressure at I_2 -pressure of 0.17 mm.

H: 20,000 gauss. I : fluorescence intensity without field.

I_m : intensity with field.

by the presence of a foreign gas. This is shown in Figure 74, where the solid curve represents the measurements, while the broken curve is calculated by superposition of the two individual effects. It seems that the magnetic field, in addition to its own quenching action, deforms the potential curves of the excited molecules in such a way that the effective cross sections for the quenching collisions become larger (93).

67. Transferring Collisions and Induced Predissociation in Other Diatomic Molecules. The predominance of either transferring collisions or of induced predissociation depends mainly on the shape of perturbing potential curves and on their location with regard to the potential curve of the excited state (592). In the fluorescence of S_2 , for instance, the quenching is comparatively weak, and transferring collisions are frequent; the molecules of Se_2 and Te_2 show the opposite behavior.

Two characteristic regions of predissociation are produced in the absorption spectrum of S_2 by the existence of two perturbing curves

C and C' (Figure 75). Thus, the relatively weak quenching of the S_2 -fluorescence is not caused primarily by a selection rule (as in the case of the visible I_2 -fluorescence), but must be explained by the fact that the intersection point of curve A with curve C lies too high (near $v' = 19$) and, therefore, the energy necessary for raising a fluorescent molecule to this point is practically never available in a collision.* Curve C' , on the other hand, has a shallow minimum, and its intersection point with curve A lies below the dissociation level of the

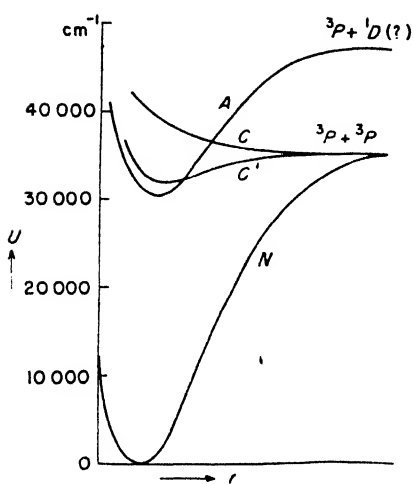

Fig. 75. Potential curves of S_2 (Rosen).

weakly bound state represented by C' . Radiating transitions from C' to the ground state have never been observed. Therefore, a transition from A to C' frequently will be followed, after a few oscillations, by a return to some vibrational level of A , and such collisions by which an excited molecule is transferred from A to the state C' would produce the same overall result as a normal "transferring" collision. Some quenching may occur nevertheless, because of the possibility of the dissociation of the loosely bound molecule in the state C' by a collision before its return to the state A . The fact

that transitions $A \rightarrow C'$ are induced by collisions is again proved by a change in the absorption spectrum; while the spontaneous predissociation bands are limited to the region close to $v' = 9$, the bands corresponding to values of v' down to 4 become diffuse in the presence of a foreign gas (I380).

According to Durand, the transferring and the quenching efficiency of all rare gases for S_2 -molecules in the vibrational level $v' = 8$ are of the same order of magnitude, and they are also about the same for a change in the rotational and the vibrational energy; the transferring efficiency of helium is greater than that of the heavier rare gases while its quenching efficiency is smaller. Finally, Durand finds

* No fluorescence is excited in S_2 -molecules by absorption of lines by which the molecules are raised into levels of the excited electronic state with $v' \geq 17$, e.g., by absorption of the Mg-line 2800Å.

that the apparent quenching cross section of all rare gases decreases considerably with increasing pressure of the rare gases or with increasing number of excited molecules which have already been transferred by a collision into a lower vibrational level. The half-pressure calculated from the quenching at a helium pressure of 8 mm is $p^* = 12$ mm; from the relative intensity observed at a helium pressure of 46 mm, the value $p^* = 37$ mm is derived. However, even this value is still so far below those obtained by earlier investigators, who found for the quenching of the S_2 -fluorescence by helium $p^* > 400$ mm, that it is doubtful whether the discrepancy can be explained by the fact that in these experiments the fluorescence was excited by white light and that, therefore, the bands belonging to small values of v' prevailed (325).

The far larger quenching efficiency of helium and other gases for the fluorescence of Te_2 (and similarly of Se_2) is easily understood from the potential-curve diagram of Figure 70. The transition probability corresponding to spontaneous predissociation is greatly enhanced by collisions. Induced predissociation prevails so strongly in comparison with transferring collisions that even at high helium pressures only the bands which originate from the level reached by a single transfer with $\Delta v = 1$ appear in the Te_2 fluorescence spectrum in addition to the resonance series which have been directly excited (473,592).

The action of magnetic fields on the fluorescence of the vapors of S_2 , Se_2 , and Te_2 is still somewhat doubtful. According to Genard, several resonance series of S_2 (for instance, the double progression excited by the mercury lines 3126 and 3131 Å) and of Se_2 are enhanced by the influence of a magnetic field, while others are weakened (484, 485, 1234, 1520). An increase in intensity of a series can be caused exclusively by a greater number of the molecules in the level $v'J'$ from which the emission of the series originates; either a smaller fraction of these molecules is deactivated by competing radiationless processes (this is out of the question since no quenching processes occur in the absence of the magnetic field), or more excited molecules are produced; this can occur if the absorption of the exciting line is increased by the Zeeman effect of the absorption band.* If an enhancement of a resonance series by a magnetic field must be explained by an effect of this type, the same interpretation can also be used to

* In a region of induced predissociation, the magnetic perturbation of the potential curves and, thus, the Zeeman effects of the band lines are particularly large. Due to the displacement or broadening of the lines caused by the Zeeman effect, the absorption of a given exciting line can be increased or decreased.

account for the weakening of other series. Nevertheless, the mechanism assumed for interpreting the magnetic quenching of the I_2 -fluorescence may also have a part in the weakening of some of the resonance spectra of Se_2 and Te_2 . Since most of the resonance series consist of complicated groups originating from a number of closely adjacent absorption lines, the changes in intensity can be different for various members of the spectrum because of an unequal "fine structure" of each group (25).

The fluorescence of the diatomic radicals $HgCl$, $HgBr$, and HgI can be excited by photodissociation of the mercuric halides by short-wavelength u.v. radiation. In the fluorescence spectrum of HgI a system of bands (the so-called *B*-bands) reaches from 4425Å more or less into the u.v., according to the wavelength of the exciting radiation; the corresponding vibrational levels of the excited radicals are characterized by lower or higher values of v' . In the absence of a foreign gas, the short-wavelength limit of the emission band lies at 3100Å, if the fluorescence is excited by an Al-spark ($\lambda \sim 1860\text{Å}$), and at 3800Å under excitation by a Zn-spark ($\lambda \sim 2150\text{Å}$). On addition of a foreign gas, both quenching and transferring collisions occur. With Al-spark excitation, all bands corresponding to $v' \geq 11$ are suppressed by the presence of argon or nitrogen, while in the other parts of the band system the effect of transferring collisions prevails so much that the visible fluorescence even becomes appreciably brighter. If only the long-wavelength bands are excited by the Zn-spark, the visible fluorescence is not affected noticeably by an admixture of A, N_2 , or CO, whereas it is strongly quenched by O_2 and H_2 . The bands below 4000Å are weakened also in this case by the "nonquenching" gases. Simultaneously, the structure of the spectrum, which is extremely complicated when many levels of the upper electronic state contribute to the emission, is greatly simplified and consists now in the main only of the progression $0' \rightarrow 0'', 1'', 2'' \dots$ so that the analysis becomes much easier (1836-1839).

Analogous effects are obtained with mercurous bromide and chloride. In the presence of nitrogen at 100 mm, even the weak bands of the isotope $HgCl^{37}$, which otherwise are completely submerged in the bands of the more abundant $HgCl^{35}$, can be clearly identified.

A second band system, *C* (3100-2800Å), showing fine structure, occurs in the fluorescence spectrum of HgI when it is excited by the Al-spark. Only quenching, and no transferring, collisions are produced in this system by foreign gases. The quenching cross sections of various gases for band *C* are listed in Table 41. The quenching efficiency of

O_2 is the same for the bands corresponding to $v' = 5$ and $v' = 1$. Table 41 shows that the quenching efficiency depends on the molecular fields as well as on the masses of the quenching molecules. On the other hand, the efficiency of all gases is largest for the fluorescence of HgI, smaller for HgBr, and smallest for HgCl. The abnormally great quenching cross section of NH_3 for the three halides is caused by a chemical reaction: the ammonia pressure decreases after strong irradiation, probably because of the formation of ammoniates (166r).

TABLE 41
 QUENCHING OF THE U.V. FLUORESCENCE OF Hg I

(p^* = half-value pressure in mm; σ_q and σ_k = quenching and kinetic cross sections)

Quenching gas		NH_3	O_2	CO_2	N_2	CO	H_2	A
	p^*	—	26	38	50	53	30	100
Band C	$\sigma_q \cdot 10^{16}$	37	28	22	14	13.4	0.4	—
	σ_q/σ_k	1.74	0.93	0.64	0.41	0.43	0.23	—
Band B	$\sigma_q \cdot 10^{16}$	185	31.5	—	0	0	0.35	—

The fluorescence band of the radical CN at 3883A exhibits widely different rotational-energy distributions according to the wavelength of the light by which the parent molecule ICN or C_2N_2 is dissociated; they correspond to a "rotational temperature" of the vapor of about $1500^\circ K$ ($K' \sim 16$) or $150^\circ K$ ($K' \sim 5$), respectively, as compared to the average temperature of the vapor of $380^\circ K$ ($K' \sim 8$). By the admixture of foreign gases, the normal distribution of the rotational energy is restored, and the curves of Figure 76 show that in this case the mass of the colliding particles plays the most important part. The relatively small difference between the curves for argon and for nitrogen and carbon monoxide may be due to the existence of a simultaneous quenching action of N_2 and and CO, of which no account has

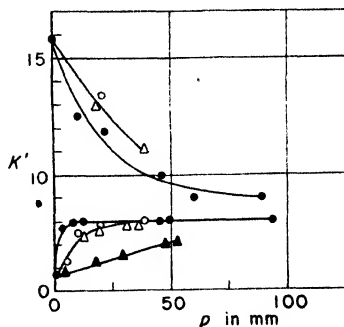

Fig. 76. Influence of foreign gases on the rotational structure of CN band at 3883A (Jakowlewa): A(●); N_2 (Δ); CO(○); H_2 (▲).

been taken in the measurements; the small efficiency of hydrogen is quite obvious (681,683,684).

Characteristic bands of the radicals HgH and OH can be excited as sensitized fluorescence in mixtures of mercury vapor with nitrogen and hydrogen or with water vapor. The OH-bands are also produced by photodissociation of various polyatomic compounds (see Sections 74 and 94). In all these cases, the bands show an abnormal rotational intensity distribution: the high rotational levels have not only a much larger population than corresponds to the actual temperature of the vapor, but the relative population of the various levels does not correspond to any Maxwellian distribution. For the HgH-bands, the addition of nitrogen increases the relative intensity of the tail of the band $v' = 0 \rightarrow v'' = 0$ and, accordingly, the number of molecules of high rotational energy in the level $v'' = 0$. The excitation process produces HgH-molecules in vibrational levels up to $v' = 5$, as is proved by the presence of the bands $5' \rightarrow 1''$ and $4' \rightarrow 0''$ (2878 and 2838A) in the fluorescence spectrum. These bands disappear completely at higher N_2 -pressures; the HgH-molecules are transferred by collisions into lower vibrational levels of the excited electronic state, and the vibrational energy is transformed into rotational energy in this process. Genuine quenching is negligible; it is hardly noticed at a N_2 -pressure of 160 mm. The higher vibrational levels of HgH* are depopulated also by collisions with H_2O -molecules. In this case, however, the lost energy is taken up, in the main, by the colliding H_2O -molecules, so that the increase of rotational energy in the HgH-band $0' \rightarrow 0''$ is relatively small; on the other hand, a direct decrease of rotational energy by collisions with water molecules does not seem to be considerable.

In the mercury-sensitized fluorescence of OH, the bands $0' \rightarrow 0''$ at 3064A, $1' \rightarrow 0''$ at 2811A, and $1' \rightarrow 1''$ at 3122A are observed, all with abnormally large quantum numbers J' . In this case, no enhancement of the rotational energy is caused by collisions with N_2 -molecules, but the weakening of the bands originating from the level $1'$ is relatively much greater than the decrease of intensity of the lines which correspond to high J' values in the band $0' \rightarrow 0''$; the collisions cause the transfer $1' \rightarrow 0'$ with greater probability than a decrease of J' . It is possible, however, that the latter effect is compensated for, in part, by the repopulation of the high rotational levels accompanying the loss of vibrational energy. At any rate, such processes are much less frequent in the collisions of OH* with N_2 than in the case of HgH* (106,963,964,1171,1365,a,b).

68. Atomic Fluorescence Caused by Induced Predissociation. Resonance series in the blue-green band system of Na_2 , in sodium vapor saturated at 300°C , are appreciably weakened by the addition of helium; the decrease of intensity is the larger, the higher the vibrational level v' from which a progression originates. For instance, the series excited by the Zn-line 4722 ($v' = 9$) is more strongly quenched than the series excited by the Zn-line 4811A ($v' = 4$); the effect is almost negligible for the fluorescence excited by the Mg-line 5183A ($v' = 2$). The weakening of the resonance spectra is not compensated by the emission of other bands of the system caused by the transfer of excited molecules into adjacent vibrational levels. Instead of this effect, the D-lines, which are absent from the monochromatically excited resonance progressions, appear in the fluorescence spectrum; their intensity is the stronger, the greater the value of v' and the more, accordingly, the corresponding resonance series is quenched. Apparently the sodium molecules in high vibrational levels of the excited electronic state are dissociated by the collisions into two sodium atoms Na (3^2S) and Na (3^2P), the latter subsequently being able to emit the atomic resonance lines. In an inelastic collision the helium atoms transfer, because of their small mass, 92% of the relative kinetic energy into internal energy of the Na_2 -molecule; at 300°C , 2% of all atoms have sufficient kinetic energy for dissociating Na_2 -molecules in the vibrational levels $v' = 4$; and 10% even have the energy for dissociating molecules with $v' = 9$. Since no stepwise transfer of vibrational energy with $\Delta v = 1$ seems to occur, it is very improbable that complete dissociation is produced by a summation of such processes. It is more likely that the effect is produced by a direct transition into another potential curve corresponding to a state of repulsion, as indicated by the dotted line C in Figure 68A (675).

Addition of argon or nitrogen causes, qualitatively, the same effect. However, while the molecular fluorescence is much more effectively quenched, especially in the case of nitrogen, the simultaneous emission of the D-lines is much weaker. This may be due to a direct quenching of the band fluorescence by another mechanism (for instance, dissociation into two unexcited Na-atoms or a chemical reaction), or to a secondary quenching action on the excited sodium atoms which have been produced by a first collision. An increase of the sodium vapor pressure itself to 50 mm (saturation pressure at 600°C) causes a very strong emission of the D-lines under otherwise identical conditions of excitation. It is possible that in this case the mechanism is of the same nature as the one produced by helium; but it can also

be a kind of sensitized fluorescence in which the excited Na_2 -molecules transmit their electronic energy to colliding sodium atoms (778).

G. Photodissociation of Diatomic Molecules Followed by Atomic Fluorescence

69. Products of Photodissociation. The products of photodissociation of diatomic molecules are either two neutral atoms in the ground state, or a positive and a negative ion, or, most frequently, two neutral atoms of which at least one is in an excited electronic state. In a molecular absorption spectrum each of these dissociation processes corresponds to a continuous band in a different spectral region; some of these bands may overlap.

The continuum adjoining the visible band system of I_2 is related to the dissociation of the molecule into $\text{I}(^2P_{3/2})$ and $\text{I}(^2P_{1/2})$. Since one of the atoms is in the ground state and the other in a metastable state, no emission of light follows the dissociation process (233,337). However, iodine vapor has other absorption bands reaching far into the u.v., and on irradiation with light of wavelengths below 1450A the vapor emits the resonance line of monatomic iodine at 2063A. Probably the molecules are dissociated into a normal atom and an atom in the state $^3S_{1/2}$.

The convergence limit of the blue-green band system of Na_2 lies at 4565A. R. W. Wood observed a strong emission of the D-lines by sodium vapor saturated at 400° C, when it was irradiated with light of wavelengths below 4500A. The dissociation process induced by light absorption in the continuum adjoining the blue-green band system is represented by the equations (1908):

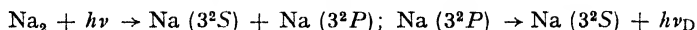

70. Dissociation of Metal Halides and Their Heat of Dissociation.

The excited electronic states of the halides of silver and thallium from which resonance fluorescence can originate dissociate into a normal and a metastable atom: AgI into $\text{Ag}(5S) + \text{I}(^2P_{1/2})$ and TlI into $\text{Tl}(6^2P_{1/2}) + \text{I}(^2P_{1/2})$ or $\text{Tl}(6^2P_{3/2}) + \text{I}(^2P_{3/2})$; $\text{Tl}(^2P_{3/2})$ and $\text{I}(^2P_{1/2})$ are metastable and have nearly equal energies. It has already been mentioned that, in contrast to the silver halides, the first excited state of thallium halides is very loosely bound. The alkali halides have no stable excited states at all; they form stable molecules only in the

ground state, as so-called ionic molecules. All higher electronic states are represented by pure repulsion curves (Figure 77). Accordingly, the absorption spectra consist exclusively of continuous bands in which no fluorescence can be excited. Light absorption in the first and in the second absorption band splits the molecules into two neutral atoms in the ground state or into a positive metal ion and a negative halide ion, respectively.

By light absorption in continuous bands situated in the far u.v., the halides of the heavier metals, as well as those of the alkali metals, are dissociated into a normal or a metastable halide atom and an excited metal atom. Several continua have been observed in the u.v. absorption spectra of every compound; Figure 77 shows six bands of this type for CsI which could all be ascribed to different dissociation processes (1093, 1461). However, not more than two atomic emission lines were obtained, so far, from any of the dissociated compounds. If the vapor of sodium iodide is irradiated with light of a wavelength near 2450A, only the D-lines are emitted in the fluorescence spectrum; under the action of light with $\lambda < 1850\text{A}$, the second member of the principal series at 3303A, also appears. The fluorescence of silver iodide vapor, irradiated with light of wavelengths between 2115 and 2060A, exhibits almost exclusively the long-wave component of the Ag resonance doublet (3383A), whereas with primary wavelengths below 2060A the short-wavelength component (3280A) predominates. In the first case, the dissociating silver atoms are all in the state $5^2P_{1/2}$; in the second, most silver atoms are in the state $5^2P_{3/2}$. The atomic lines (λ_F) excited in various vapors by this process and the maximum wavelengths (λ_m) of the exciting radiation are listed in Table 42 (191, 276, 800, 1267a, 1634, 1635, 1637, 1773-1776).

In general, the spectral region and the long wavelength limit within which the atomic resonance lines can be excited, have been determined using a number of spark lines between 2400 and 1850A. The yield as a function of the wavelength of the exciting light has been measured quantitatively only for the D-line fluorescence of NaI and the green

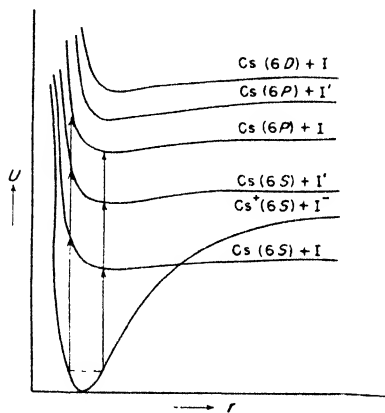

Fig. 77. Potential curves of CsI (Mulliken).

Tl-fluorescence of TII. Figure 78 shows that the curve for the fluorescence yield and the absorption curve do not coincide; one or several other processes must be produced by the absorption apart from the excitation of fluorescence. According to Terenin, one of these processes corresponds to the dissociation of TII into the ions Tl^+ and I^- . Curve II in Figure 78 represents the excitation spectrum of the green fluo-

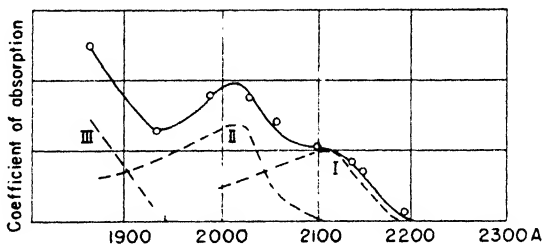

Fig. 78. Excitation spectra (broken line) of TII photodissociation (Frank). The continuous line in the absorption spectrum.

I: $Tl^* + I$. II: $(Tl^+ + I^-)$. III: undetermined.

rescence, and curve I the band in which the dissociation into ions occurs* (389,432,1643).

If the wavelength of the exciting light is appreciably smaller than λ_m in Table 42, the atomic fluorescence lines (for instance, the D-lines) are broadened by the increasing Doppler effect. If NaI-molecules are dissociated by irradiation with the Zn-line 2026Å, the width of the D-lines is 0.1Å as compared to the normal Doppler width of 0.03Å at the temperature of observation. (Compare Section 20.) The velocities of the excited atoms determined by the Doppler-effect broadening have no preferential angular distribution with respect to the direction of the primary light (627,1036).

The last two columns of Table 42 give the heat of dissociation D

* Terenin is of the opinion that some TII fluorescence bands mentioned in Section 61, which are excited by light absorption in the spectral region I, are caused primarily by this dissociation process and a subsequent recombination. However, this hypothesis is far from being convincing. The bands consist of two strong maxima at 4439 and 4084Å with adjoining fluctuations which are also observed in the normal absorption spectrum of TII. Absorption of light of wavelength $< 1900\text{Å}$ produces an additional continuous fluorescence band between 4000 and 5000Å (maximum at 4152Å) which coincides with the absorption bands mentioned in Section 61, and, finally, a narrow linelike band at 3475Å.

TABLE 42
PHOTODISSOCIATION OF DIATOMIC VAPORS OF METAL HALIDES

Compound	λ_F in Å	λ_m in Å	Heat of dissociation in eV	
			Calculated	Thermochemical
LiI	6706	2350	3.4	3.45(2.8)
NaI	5892	2450	2.95	3.1 (2.99)
	3303	1854	2.93	
RbI	7947/7800	2650	3.00	3.32(3.18)
	4261/01	2080	3.08	
CsI	4555/93	2085	3.22	3.31(3.6)
LiBr	6706	2040	4.2	4.45(3.6)
NaBr	5892	2144	3.65	3.78(3.7)
AgI	3383	2115	2.2	(2.0)
	3280	2060	2.1	
CuI	3274/47	2170	1.92	(1.4)
TlI	5351	2080	2.65	(2.0)
TlBr	5351	1915	3.21	(2.8)
TlCl	5351	1850	3.4	(3.4)
BiI	3068	2100	2.04	—

derived from the fluorescence experiments and from thermochemical data. The minimum energy needed for the photodissociation process is calculated from the value of λ_m ; the energy liberated by the emission of the fluorescence line λ_F is known. D is obtained as the difference of these two energies.

This method of determining the heat of dissociation is far less reliable than other spectroscopic methods and furnishes hardly more than a rough approximation. On the one hand, the minimum energy corresponding to λ_m may be appreciably larger than the dissociation energy if, according to the F. C. principle, the transition to the repulsion curve can occur only with a simultaneous transfer of kinetic energy (Figure 59). On the other hand, the experiments are performed, in general, at an elevated temperature in order to obtain a sufficient vapor pressure. The higher this temperature, and the greater the pressure, the more numerous are the molecules which are in higher vibrational levels of the electronic ground state and the smaller, therefore is the additional minimum energy which must be supplied for the dissociation. Thus, the following values of λ_m were obtained by Visser for the excitation of the green fluorescence in TlI-vapor (Table 43) (1775). In spite of these objections against the method, its results are in satisfactory agreement with the thermochemical data, inasmuch as

TABLE 43
 VALUES OF λ_m FOR THE EXCITATION OF THE
 GREEN FLUORESCENCE IN TII-VAPOR
 (T_1 and T_2 : temperature regulating the
 pressure and temperature of observation
 chamber, respectively)

T_1 (° C)	T_2 (° C)	λ_m in Å
385	401	2100
385	595	2144
385	720	2200
465	620	2313

the latter are not very consistent among themselves, if they are taken from different sources. The figures in parentheses in Table 42 are those listed in the International Critical Tables; the others come from more recent publications

H. Lifetime of the Excited States and Polarization of the Resonance Spectra

71. Lifetime. The lifetime of the excited state from which resonance spectra originate has been determined by means of a fluorometer for the green-yellow Na_2 -bands; the measurements, which do not seem to be quite reliable, gave a value of $\tau = 10^{-8}$ sec (642). All other experiments, dealing chiefly with the visible fluorescence of I_2 (e.g., displacement of the fluorescence in a vapor jet, broadening of a sharply defined fluorescent beam by Brownian movement, and also a fluorometric determination), gave no positive results, or, at best, an upper limit for τ which, in all experiments, was of the order of 10^{-6} sec. About the same value was obtained by applying the Stern-Volmer equation to the self-quenching of the iodine fluorescence and assuming a quenching efficiency of 100 % for gas-kinetic collisions. However, the calculations were based on measurements of the self-quenching in which the influence of increasing light absorption was not taken into account (see Section 65) and, therefore, have no great value. They lead to the conclusion that in order to obtain "reasonable" lifetimes of the order of 10^{-7} to 10^{-8} sec, one has to assume effective quenching cross sections which are much larger than the kinetic cross sections. On the other hand, Heil explained the high sensitivity of the excited

I_2 -molecules to self-quenching by their relatively long lifetime, which is due to the fact that the bands correspond to a triplet-singlet intercombination transition. This proves once more that one of the two independent parameters contained in the Stern-Volmer equation must be determined by another method (592,1571,1913).

Finally, it has been shown that data concerning the lifetime of excited diatomic molecules cannot be obtained by observing the influence of temperature or of magnetic fields on the polarization of the resonance radiation (compare the following section) (1275).

72. Theory of the Polarization of Resonance Spectra. While it remained doubtful for a long time whether the resonance radiation of monatomic vapors was polarized or not, Wood ascertained immediately after the discovery of the resonance spectra of iodine and sodium vapor that the radiation showed a partial polarization if the fluorescence was viewed in the direction perpendicular to the direction of the primary light. In the case of diatomic molecules perturbations by weak magnetic fields or neighboring molecules are almost negligible, and, therefore, the phenomenon could be observed without taking any special precautions (1864,1878).

In atoms, the electronic orbits have no preferential orientation in a field-free space; they are degenerate with regard to their spatial quantization and very weak external forces are sufficient for influencing their orientation in space. In a diatomic molecule, the electronic orbits have a well-determined orientation with respect to the line joining the atomic nuclei, from which they are only very little deviated even by large external forces; the Zeeman effects of band lines are very small. In order to alter the spatial orientation of the electronic orbits, the orientation of the whole molecule, including the heavy nuclei, must be changed.

As long as the problem could not be interpreted by quantum mechanics, the most plausible assumption was to treat the molecule as a more or less anisotropic classical oscillator. For complicated polyatomic molecules, this is still the only possible model and it will, therefore, be dealt with in more detail in a later section. In the simplest case, the oscillators are completely anisotropic (linear); the distribution of their spatial orientation is at random in a gas. If, under these conditions, the oscillators are irradiated with plane-polarized light, the fluorescence which they emit in a direction perpendicular to the primary light has a degree of polarization $p_p = 50\%$,* as long as the

* If the incident radiation is unpolarized, the polarization of the fluorescence light in the direction perpendicular to the primary light is

oscillators are at rest. The degree of polarization is reduced by the thermal agitation of the molecules.

The translational component of the thermal agitation obviously does not affect the orientation of the oscillators and the polarization of the fluorescence. The latter is reduced by the rotational component, but not completely destroyed, if the axes of rotation retain their direction, i.e., if no perturbing collisions occur during the emission process. The frequency of molecular rotation is, in general, of the order of 10^{11} sec⁻¹. Since the lifetime of the excited states is equal to or larger than 10^{-8} sec, each molecule performs a great number of rotations during its lifetime. Under these circumstances and with plane polarization of the primary light, the polarization corresponding to completely anisotropic oscillators is $p_p = 14.3\%$. A further increase of the rotational velocity by an increase of temperature has no influence upon these relations and, therefore, no conclusions can be derived from such experiments with regard to the value of τ (1275).

In the quantum-mechanical treatment of the problem, which was developed by Placzek and by Mrozowski, the principle of spectroscopic stability was again applied (compare Section 28): in a field-free space the polarization of the fluorescence is the same as in a strong magnetic field by which the symmetry of the system is not altered. Although the absolute values of the Zeeman separations of the magnetic sublevels remain very small even in a field of considerable strength, each term, with the exception of Σ -terms which are not affected, splits into $2J - 1$ sublevels with different magnetic quantum numbers m , J being the quantum number of the total angular momentum. As for atomic lines, the degree of polarization of the molecular fluorescence is derived from the relative population of the individual Zeeman levels of the excited state, which is determined by the special experimental conditions* and by the probability of the several transitions which can occur between these levels and the various Zeeman levels of the electronic ground state. Again, $\Delta m = 0$ corresponds to π -components and $\Delta m = \pm 1$ to σ -components. J depends on the nature of the electronic term and on the molecular rotation but is independent of the nuclear vibration. Therefore, the

$p_n = p_p / (2 - p_p)$; thus, for $p_p = 50\%$; $p_n = 33\%$. The relation holds, however, for every degree of polarization p_p . Where the distinction between p_p and p_n is not to be emphasized, the simple symbol p is used for p_p .

* These are the directions of the exciting radiation, the electric vector in this radiation, and the magnetic lines of force, with respect to each other (compare Section 28).

degree of polarization is the same for all members of a resonance progression; in the "classical" theory this has been taken for granted without a real proof. On the other hand, the degree of polarization can be widely different for two closely adjacent series, if they correspond to unequal values of J' , and it can also differ for the two components of a rotational doublet. For the polarization, in general, is not the same for a given value of J' if the absorption or the emission process corresponds to lines lying on a P - or an R -branch, or if both correspond to Q -branch lines. Figure 79 shows

the degree of polarization p as a function of J' for the five possible combinations of the two processes; the branch designation in brackets [P], [Q], or [R] refers to the excitation process. The curves for $R[P]$ and $P[R]$ are almost coincident, and it is noticeable that even for small values of J' all curves tend toward limiting degrees of polarization, which are 50% for $Q[Q]$ and 14.3% for the others, thus agreeing exactly with the degree of polarization calculated for the classical model of the rotating anisotropic oscillator. The points in Figure 79 have been worked out by

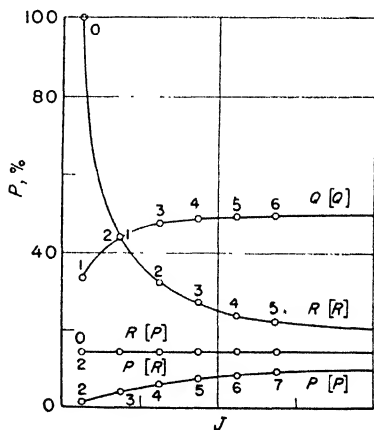

Fig. 79. Degree of polarization of the individual lines of a resonance spectrum (Mrozowski).

Mrozowski for the relatively simple case of a transition ${}^1\Pi \rightarrow {}^1\Sigma$, for instance, the one corresponding to the blue-green Na_2 -bands, where the ground state as a Σ -state does not split up into several Zeeman levels. According to Placzek, however, the same calculations can be applied to transitions between all types of electronic states (1077).

73. Experimental Results. The available quantitative experimental material suffices for testing all important predictions of the theory. The polarization has been determined separately for the two resonance spectra of Na_2 which are excited by the cadmium lines 4800 and 5086A (marked by an asterisk in Table 31). The first of these series consists of singlets ($Q[Q]$), the other of doublets ($P[R]$). The measured polarization was $p = 42\%$ for the singlets and $p = 13\%$ for the doublets, in satisfactory agreement with the theory. Even better is the agreement obtained by Mrozowski for the resonance spectra which are excited by the Hg-line 4358A in selenium and

tellurium vapor. He found $p = 14.4$ and 14.2% , respectively, and, since these spectra belong to bands corresponding to ${}^3\Sigma - {}^3\Sigma$ transitions, Mrozowski's results prove the validity of Placzek's generalization of the originally restricted theory (1082, 1290).

If a resonance spectrum is excited in the visible band system of iodine vapor by monochromatic light, p is the same for all members of the progression, and, in particular, Wood's R -line, which coincides with the exciting line, is in no way distinguished with respect to the others. This result, which seemed somewhat surprising at first, must be expected according to the theory developed in the last section. Furthermore, Wood found the degree of polarization to be the same for the two components of a rotational doublet excited by the green mercury line. Although one component is an $R[R]$ -line and the other an $R[P]$ -line, there is no discrepancy with the theoretical values represented by Figure 79, since $J' = 35$ (see Table 25). If, however, the fluorescence is excited by circularly polarized light and is observed in the direction opposite to the primary beam, the polarizations of the two doublet components differ. The "principal line" of the doublet for which $J'' = \bar{J}''$ shows circular polarization of a degree only little below 100% and of the same sense of rotation as the exciting line. The circular polarization of the "companion line"* for which $J'' = \bar{J}'' - 2$ is much smaller and the sense of rotation is reversed. This effect was predicted theoretically by Placzek and has been actually observed by Daure and Kastler in the first positive doublet of the I_2 resonance progression excited by the green mercury line (260b, 1878).

If the emission of the complete visible band system of I_2 is stimulated by the absorption of linearly polarized white light, the degree of polarization is about 13% at room temperature and is not altered appreciably by doubling the absolute temperature at constant vapor pressure (1275).† Since these iodine bands consist only of P - and R -branches, and since the average value of the rotational quantum number of the molecules at room temperature is of the order of 50 or more, p should be close to 14.3% according to Figure 79. The agreement seems to be satisfactory.

* Throughout this book \bar{J}'' and J'' are used for the quantum number of the ground state before the absorption process and after the emission process, respectively. Thus, $\bar{J}'' = J''$ is the $R[R]$ -component and $J'' = \bar{J}'' - 2$ the $R[Q]$ -component.

† The value of 18% given in earlier publications must undergo a correction because the multiple reflection in the compensating glass plates had been neglected. For the iodine fluorescence excited by the unresolved radiation of a hot mercury arc, Mrozowski obtained values of p between 15 and 20%.

When the fluorescence of iodine vapor is excited by plane-polarized light, the angular distribution of the fluorescence intensity shows a maximum in the direction perpendicular to the electric vector of the exciting radiation and a minimum in the direction parallel to this vector (421).

The visible fluorescence bands of the alkali vapors Na_2 , K_2 , and Rb_2 exhibit considerably higher degrees of polarization. According to Dunoyer, the values of p are between 36 and 38 % in all three cases. These bands contain Q -branches as well as P - and R -branches, and since all these branches overlap if they are excited by white light, the observed polarization represents an average value and can also be considered as a confirmation of the theory. Dunoyer assumed the existence of a connection between the degree of polarization of the fluorescence and the frequency of the molecular rotation, which is determined by the moment of inertia and the temperature. However, his conclusions were based on extrapolations which were certainly not correct. The apparent influence of temperature which he observed was caused most probably by the simultaneous increase of vapor pressure and the depolarizing action of collisions (379).

More extensive investigations of the influence of collisions on the polarization of the resonance fluorescence of diatomic molecules are available only for the visible bands of iodine. As may be expected, the depolarizing cross sections are, in contradistinction to the case of the atomic resonance radiation, relatively small; they are much smaller than the quenching cross sections. The depolarization is due mainly to collisions by which the spatial orientation of the molecular axis is altered, while a change of the rotational quantum number by one unit has a much weaker effect. "Transferring collisions" which affect only the vibrational energy produce no depolarization. In a fluorescence spectrum in which the primarily excited resonance progression has been partially transformed by collisions into the band spectrum, the lines belonging to the new bands are actually less depolarized than those for which v' has remained unchanged (1074). The depolarizing efficiency of various foreign gases increases continuously with their molecular weight, from H_2 through He, N_2 , and Ne to A. If the fluorescence is quenched by the foreign gas, its depolarizing action is reduced because the lifetime of the excited state is shortened, exactly as in the case of monatomic vapors. Due to this circumstance and to the strong self-quenching of the iodine fluorescence, its polarization is practically independent of the iodine vapor pressure. The polarization of the iodine fluorescence is not appreciably altered by

external magnetic fields. If, however, the fluorescence has been partially depolarized by addition of helium at a few mm, the polarization is largely restored by applying a strong magnetic field, because the average lifetime of the excited state is shortened by "induced predissociation" (Section 66) (*1079a*).

The ultraviolet Mc bands of iodine vapor differ essentially from the resonance bands which have been treated so far, in that a transition, probably without radiation, occurs between the absorption process and the final emission process. Since this transition is spontaneous in the absence of collisions, the spatial orientation of the molecular axis remains unaffected and the rotational quantum number does not alter by more than unity. Thus, the polarization of the fluorescence should be practically unaffected by the transition. Actually, the polarization of the Mc bands is very considerable; even with an addition of helium at 10 mm to the iodine vapor the bands still show a degree of polarization of 7%, if the primary light is plane polarized, and a similar degree of polarization is observed in the band at 3460Å which is strongly excited only by collisions with a foreign gas; the spatial orientation of the molecules is not completely destroyed by collisions which transfer them to another electronic state (*1075*).

I. Sensitized Fluorescence of Diatomic Molecules

74. Fluorescence Bands Excited in Hg-and Cd-Vapors on Addition of Foreign Gases. If excited mercury atoms are transferred to the metastable state by collisions with polar molecules like CO, the latter can re-emit the vibrational energy which they have taken up, as infrared radiation; this would be a typical case of sensitized fluorescence, but it would be almost impossible to observe an emission process of this kind. In genuine quenching processes, in which the excited mercury atoms lose their total electronic energy in a collision with a diatomic molecule, the molecules are not raised into excited electronic states and thus excited to emit their own characteristic fluorescence; instead, the energy is consumed in producing a chemical reaction — for instance, a dissociation process — and only a small surplus of energy is available sometimes for an increase of vibrational or rotational energy of the newly formed molecules. If these molecules are sufficiently stable, however, they can undergo a second collision

with another excited atom and this may eventually stimulate the emission of sensitized fluorescence.

As a matter of fact, the fluorescence spectra of mercury and cadmium vapor excited by the resonance lines of the metals contain in addition to the re-emitted resonance lines, bands of HgH, HgD, CdH, CdD, and, moreover, of OH and NH₃, respectively, if hydrogen, deuterium, nitrogen, water vapor, or ammonia are present in the vessel. Whenever hydrogen participates in the reaction, its concentration must be very low, because otherwise the strong quenching action of H₂-molecules would destroy all excited mercury or cadmium atoms before any other sensitizing energy transfer could occur. These small amounts of hydrogen are then probably completely dissociated by the interaction with excited atoms. On the other hand, the presence of nitrogen or NH₃ increases the intensity of mercury-sensitized fluorescence in general, even if the nitrogen has no actual share in the reaction, because the lifetime of the excited atoms is increased by the transfer to the metastable state (471, 1034, 1901).

The HgH-radicals are very unstable, as already mentioned in Section 40; they have practically no chance to survive more than one collision with an excited mercury atom. Therefore, the intensity of the HgH-bands (3100–4222Å) is proportional to the square of the intensity of the exciting line; two excited atoms are needed for every emission process. The CdH-molecules are comparatively stable; under constant illumination with the cadmium resonance line their concentration becomes so large that the intensity of CdH-bands (4198–4791Å) in the fluorescence spectrum can be greatly enhanced by irradiating the resonance lamp simultaneously with the light emitted by an electric discharge through a mixture of hydrogen and of cadmium vapor. Under these conditions, the CdH-bands are produced not only as sensitized fluorescence but also by direct resonance excitation. This enhancing effect is obtained in analogous experiments with CdD and ZnH-vapors, but it is not observed with HgH and HgD-molecules. On the other hand, the CdH-bands appear under the same conditions of excitation when the atomic fluorescence of cadmium vapor is quenched by an admixture of propane vapor at a pressure between 1 and 7 mm (92, 1173, 1562).

In the process of formation of the HgH-molecules by collisions of metastable Hg (³P₀)-atoms and H₂-molecules, a surplus energy of 0.62 eV is available, while there is an energy deficit of 0.1 eV if the hydrogen molecule is replaced in the process by a water molecule:

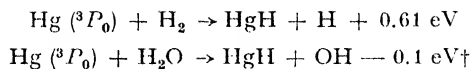

Beutler and Rabinowitch assumed that the surplus energy of the first process is transferred partly into rotational energy of the HgH-molecule and that it is preserved as such until the excitation occurs by a collision with another Hg (3P_0)-atom (106). This hypothesis has been proved to be erroneous by Rieke. Whatever their origin, the HgH-molecules attain the thermal equilibrium of their vibrational and rotational energy by collisions with N_2 or H_2O -molecules. In the ensuing excitation process, vibrational and rotational energy is transferred to the HgH-molecules. Subsequently, the vibrational energy is converted almost completely into rotational energy by collisions with N_2 -molecules, while collisions with H_2O -molecules are much less efficient, as pointed out in Section 67. Therefore, the HgH-bands show an abnormally high "rotational temperature" only when they are excited in the presence of nitrogen (1365a, 1365b).

In addition to the HgH-bands, OH-bands, the so-called water bands, with edges at 2811 and 3064A, always appear in the mercury-sensitized fluorescence spectrum if water vapor is present in the vessel. Since excited mercury atoms are transferred with great probability to the metastable state by collisions with water molecules, the first process which occurs is, in general:

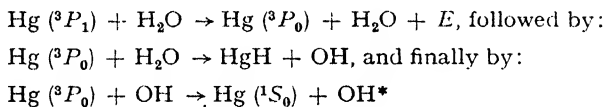

In the OH-band originating at the vibrational level $v' = 0$, the highest rotational quantum number observed is $J' = 17$, while in the band originating at the level $v' = 1$, J' reaches up to 12. These two levels of OH^* ($v' = 0, J' = 17$, and $v' = 1, J' = 12$) lie immediately below the energy level of the mercury atom 6^3P_0 (963,964).

The intensity of the OH-bands increases more than proportionally to the first power, but less than proportionally to the second power of the primary light intensity. Therefore, it must be assumed that after the OH-radicals have been formed, some of them can be excited more than once before they are destroyed. The processes leading to the emission of the NH-bands, when H_2 and N_2 are

† On the one hand, the dissociation energy of H_2O to $\text{H} + \text{OH}$ is 118 kcal or 5.14 eV; on the other hand, the energy of formation of HgH is 0.37 eV and the energy of Hg (6^3P_0) is 4.7 eV (336).

added to the mercury vapor, must be still more complicated, since the dissociation of N_2 cannot be effectuated by a single collision with an excited mercury atom. Gaviola assumes metastable mercury atoms to be present in such great concentration, because of the interaction with nitrogen molecules, that three-body collisions between two metastable Hg-atoms and an N_2 -molecule can occur and produce the dissociation of the latter. The heat of formation of NH from atomic hydrogen and nitrogen is supposed to provide the energy necessary for the excitation of the NH-bands. No special hypothesis has been proposed regarding the excitation of the NH-bands by collisions of excited mercury atoms with NH_3 -molecules. Whatever the mechanism of their production may be, the NH-radicals are also relatively long-lived, since the intensity of the NH-bands follows nearly the same law as that of the OH-bands in its relation to the energy of the exciting radiation. In the presence of N_2 , the red and violet CN-bands are frequently observed in the mercury-sensitized fluorescence. The carbon atoms are probably produced by dissociation of some organic stopcock-grease vapor. The phenomenon has never been investigated any further.

All bands mentioned in the last paragraphs show fine structure and can be ascribed unequivocally to their carriers. The origin of two additional continuous bands has not yet been explained satisfactorily. The first, between 2900 and 4000A, occurs only in the presence of NH_3 and the other, between 2537 and 3200A, in the presence of H_2O -vapor. They are produced by a single absorption process, since, in this case only, the intensity of the fluorescence is directly proportional to the intensity of the incident mercury resonance line. Wood and Gaviola suggest that a complex molecule of high energy is formed by a collision of an excited mercury atom and an NH_3 or H_2O -molecule, respectively, and that the emission of the bands is caused by the disintegration of these complexes (471,1901).

The HgI-bands at 4525A (compare Sections 65 and 93) form a part of the fluorescence spectrum which is emitted if a mixture of I_2 -vapor and nitrogen containing traces of mercury vapor is irradiated with the mercury resonance line at a temperature of 800° C. The bands disappear from the fluorescence if the exciting mercury line is self-reversed; the radiation by which they are excited is thus absorbed primarily by normal mercury atoms. The emission of the bands may be due either to the formation of excited HgI-molecules by collisions of excited iodine molecules with excited mercury atoms, or to the sensitized fluorescence of HgI-molecules present in the vapor (333).

If a mixture of iodine vapor and nitrogen is illuminated at room temperature with short-wavelength u.v., a deep green fluorescence is observed. It is caused by the emission of a band having a width of about 200Å and showing some fine structure. It cannot be obtained in pure iodine vapor nor in pure nitrogen, not even by an electric discharge, nor does it appear in iodine vapor if any other gas is added instead of nitrogen. The band begins to be noticeable at a nitrogen pressure of a few cm and its intensity increases continuously if the

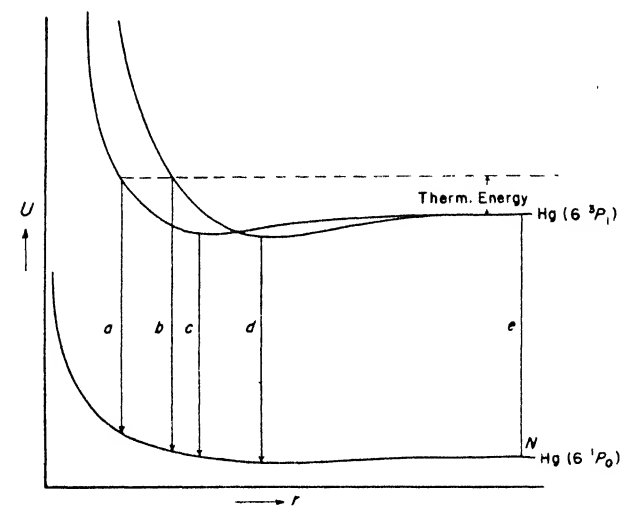

Fig. 80. Potential curves for the system rare gas-mercury (Oldenberg).

a: first short-wavelength max. *c*, *d*: long-wavelength bands.
b: second short-wavelength max. *e*: atomic line.

nitrogen pressure is raised to one atmosphere and more. Apparently the iodine molecules are able, in their highly excited state, to form iodine-nitrogen compounds of great energy which emit the green band. Such processes, including some of those mentioned in the preceding paragraphs, are perhaps better designated not as sensitized fluorescence but as photo-chemiluminescence: the energy of the primarily excited molecules induces a chemical reaction which, in turn, causes the emission of light (360,1161).

75. Rare Gas-Mercury Bands. Unexcited mercury atoms are not able to form stable molecules with the atoms of helium or other rare gases; if the mercury atoms are in the excited state 6^3P_1 or 6^3P_0 , however, such molecules can exist, though their heats of dissociation

are very low. Figure 80 shows the potential curves for the systems rare gas-Hg (6^1S_0) and rare gas-Hg($3P_1$). Two states of repulsion, which also occur in the second case, can be disregarded in this connection; the minima of the attraction curves are very shallow. The distance between the dotted horizontal line and the horizontal branches of the attraction curves corresponds to the average thermal energy of the atoms at room temperature. The points at which the dotted line intersects the potential curves determine, therefore, the distance to which, on the average, the two atoms approach each other, or the most probable turning points: they are located on both curves above the dissociation level of the loosely bound molecules and correspond to nonquantized states. Transitions from there to the potential curve N of the ground state cause the emission of two broad lines which are displaced in the direction of shorter wavelengths with regard to the normal mercury resonance line, as already mentioned in Section 36.

If, however, the excited mercury atom and the atom of the rare gas approach each other with low velocities, weakly bound mercury-rare gas molecules can be formed in three-body collisions. Because of the shallowness of the potential trough, the number of rather closely spaced vibrational levels of these molecules is small. By transitions from these levels to the almost horizontal potential curve N of the ground state, the molecules dissociate and, simultaneously, emit fluorescence bands which show fluctuations almost exactly reproducing the structure of the vibrational levels of the excited molecules.

Oldenberg observed the fluorescence excited at room temperature by the nonreversed Hg resonance line in mercury vapor to which rare gases (He, Ne, Ar, Kr, and Xe) of pressures up to one atmosphere were added, so that three-body collisions had a sufficient probability. In addition to the two "collision lines" on the short-wavelength side of the resonance line, which have been mentioned above, Oldenberg, in these experiments, obtained the emission of bands on the long-wavelength side of the resonance line. They appeared to be continuous in the case of helium and xenon and showed only traces of fluctuations with neon, but with argon and krypton they were resolved into a series of maxima converging in the direction of greater wavelengths: a first sequence of maxima stretches from 2541.7 to 2549Å, and from 2541.1 to 2548.5Å, respectively, and in both cases weaker and more closely spaced bands follow, reaching to 2554Å for argon and to 2557Å for krypton. At high mercury pressures these bands are also obtained

in the absorption spectra of the mixed vapors, but under conditions prevailing in Oldenberg's fluorescence experiments the mercury vapor pressure was low and the light absorption could occur only in normal mercury atoms (849,1166,1169).

J. Luminescence of Diatomic Metal Molecules That Are Stable Only in Excited States

76. Fluorescence Bands of Hg₂. The emission of various fluorescence bands by pure mercury vapor has been known for a long time and has been the subject of a large number of publications; the most important of these are due to the younger Lord Rayleigh. Similar fluorescence bands have been observed in the vapors of cadmium and zinc and in mixtures of these vapors. Contrary to the processes dealt with in the preceding sections, the bands which are under consideration here are, in general, *not* produced by absorption of the resonance line of the metal but by irradiation of the vapor with light belonging to other spectral regions. Furthermore, some of the bands occur in the absorption spectrum under the same experimental conditions under which the fluorescence is obtained.

Table 44 shows spectral location, type, and occurrence or non-occurrence in the absorption spectrum for all fluorescence bands which have been observed in Hg-vapor. An almost complete interpretation of their production and their complicated dependence on temperature and pressure has become possible on the basis of the potential-curve diagram reproduced in Figure 81.* The "dissociation products" in the second row of Table 44 can also be derived from the diagram (841, 897a, 1065, 1068, 1073, 1345-1348, 1735).

Aside from the weak polarization forces which cause a very shallow minimum at a relatively large internuclear distance in the potential curve, only repulsive forces exist between two unexcited mercury atoms. The heat of dissociation of the "van der Waals molecules" bound by the polarization forces is of the order of only 0.06 eV and these molecules are, therefore, very unstable even at room temperature (798, 1066). However, at the relatively high vapor pressures

* Bands which have been observed only in the absorption spectrum and do not seem to be related to the excitation of fluorescence are not mentioned in the table, but some of them are indicated in Figure 81. Concerning the designations used in the figure and their theoretical foundation, the original papers by Mrozowski and others must be consulted.

between several mm and one atmosphere at which the fluorescence bands are observed, the actual distance between many atoms is not

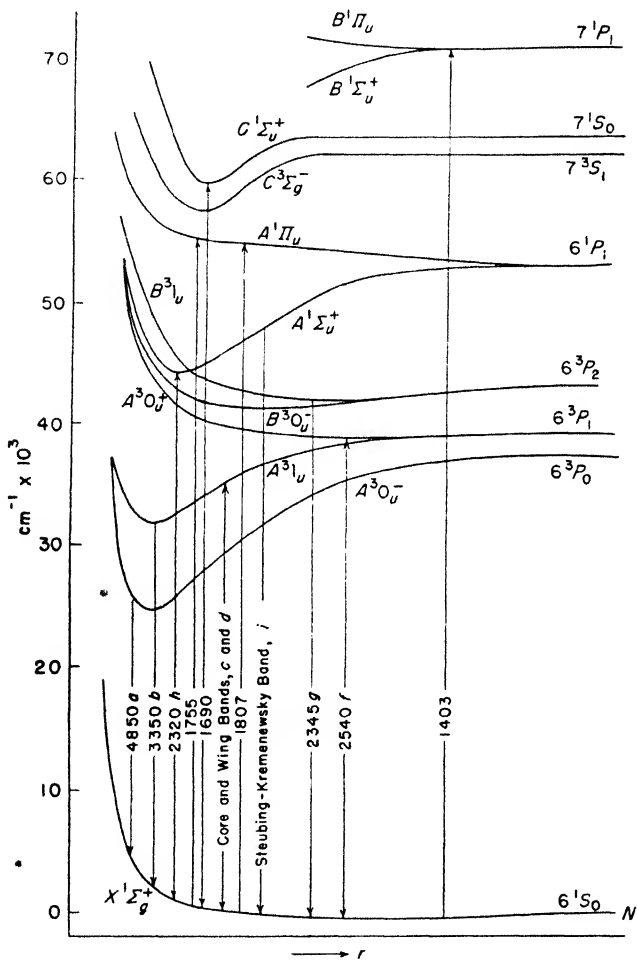

Fig. 81. Potential curves of Hg₂ (Mrozowski).

greater, or is even smaller, than the internuclear distance in the van der Waals molecules. On the other hand, mercury atoms in the excited states 6³P_{0,1,2}, 6¹P₁, 7³S₁, etc., are able to form stable genuine molecules with unexcited mercury atoms. The heat of dissociation of these

molecules in some cases exceeds 1 eV, and their vibrational and rotational energies are completely quantized. If the distance between two unexcited atoms is sufficiently small, they can be raised by absorption of light, in accordance with the F.C. principle, to one of the potential curves representing a stable molecular state, from which the emission of fluorescence subsequently originates.

The mercury bands listed in Table 44 can be divided into three groups: (1) the narrow bands (*e*), *f*, and *g* at (3650),* 2540, and 2345A, respectively; they are closely connected with the electronic transitions in the normal atoms and are ascribed to transitions between van der Waals molecules in the ground state and in higher electronic states. (2) Long sequences of typical fluctuations (bands *c*, *d*, and *h*) which can correspond only to transitions from excited molecular states to the nearly horizontal branch of the lower potential curve *N*. Even when excited with monochromatic light of different wavelengths, in general the whole sequence of fluctuations is emitted, because the same average distribution over the various vibrational levels of the excited state is produced by collisions. (3) Broad bands without any structure which probably also originate from excited stable molecules, but which correspond to transitions onto a part of the lower potential curve where its slope is already relatively steep. At moderate temperatures and vapor pressures these bands (and also band *h*) are missing in the absorption spectrum, because the relative thermal energies of the unexcited atoms are practically never so large that they can approach each other sufficiently closely (see Figure 81). However, in mercury vapor of high pressure (about one atmosphere), light of all wavelengths between 3750A and the far u.v. is completely absorbed and it is not possible to decide how much the individual processes contribute to the total absorption.

Since the possible transitions are very numerous and the energy differences between the individual potential curves are small, absorption bands caused by transitions between the ground state and various excited states will frequently overlap, so that two emission processes can be excited by primary light of one wavelength. If two such absorption processes originate from different parts of the potential curve *N*, the corresponding emission bands may show an unequal dependence on temperature and vapor pressure. On the other hand, an emission process may not originate at all from the directly excited electronic state, because the molecule is transferred into

* This so-called band at 3650A is, according to Mrozowski's latest publication, not a separate band but rather the short-wavelength edge of band *c* or *d*.

another potential curve before the emission occurs. If this is a repulsion curve, the molecules dissociate into atoms, some of them being in the metastable states 6^3P_2 or 6^3P_0 ; these can later recombine with other atoms to form some sort of excited molecules. Finally, the formation of such molecules can also follow the primary production of excited atoms by the absorption of the resonance line.

TABLE 44
FLUORESCENCE BANDS OF MERCURY VAPOR

Band designation	<i>a</i>	<i>b</i>	<i>c</i>	<i>d</i>	$e \frac{1}{1}$	<i>f</i>	<i>g</i>	<i>h</i>	<i>i</i>
Products of dissociation	6^3P_0	6^3P_1	6^3P_1	6^3P_1	?	6^3P_1	6^3P_2	6^1P_1	6^1P_1
Wavelengths of band (Å)	5500–3500*	3950–3020†	3020–2760	2930–2760	2650	2540	2345	2345–2100	2000–1810
Type of band	cont §	cont	fl	fl	narrow	narrow W	narrow	fl	cont ·
Occurs in absorption	—	—	—	+	+	+	+	+	+
Corresponding atomic line	2656	2537	2537	2537	2270	2537	2270	1849	1849
Excitation bands	<i>i, h, d,</i> to 3450	<i>C, W</i> to 3360	<i>C**</i>	<i>W**</i>	<i>f, C</i>	<i>f, C</i>	<i>i, C</i>	<i>i, h</i>	<i>i</i>

* Maximum at 4850. † Maximum at 3380. ‡ See footnote, page 226. § cont — continuous. || fl = fluctuation bands. ~~W~~ Possibly with some structure. ** *C* and *W* = “core and wing excitation,” according to Lord Rayleigh’s nomenclature (see Section 77).

77. Some Properties of the Individual Hg₂-Bands. The band designations in the first row of Table 44 correspond to those used in Figure 82. The last row shows that most of the fluorescence bands can be excited by light absorption in more than one of the absorption bands. It seems almost certain for instance, that at least four primary processes must be considered for the excitation of band *a*, with a maximum of intensity at 4850Å. The band is excited at a vapor pressure of 600 mm (320° C) by light of wavelengths up to 3200Å and at pressures above one atmosphere, even by light of 3450Å. It cannot be ascertained which of the original excitation regions has spread so far under these conditions. *C* and *W*, which are also mentioned in Table 44 as exciting band *a*, stand for Lord Rayleigh’s “core” and

“wing” excitation, respectively. The former is used for excitation by the almost nonreversed “core” of the Hg resonance line, while the latter designates excitation by the strongly self-reversed resonance line or by lines adjoining this line in the direction of greater wavelengths (1348).

The excitation spectrum of the continuum *b*, with maximum at 3380A, coincides very closely with that of band *a*. However, according to Rayleigh, the relative intensities of *a* and *b* depend very much on the vapor pressure and the temperature. With wing excitation, as

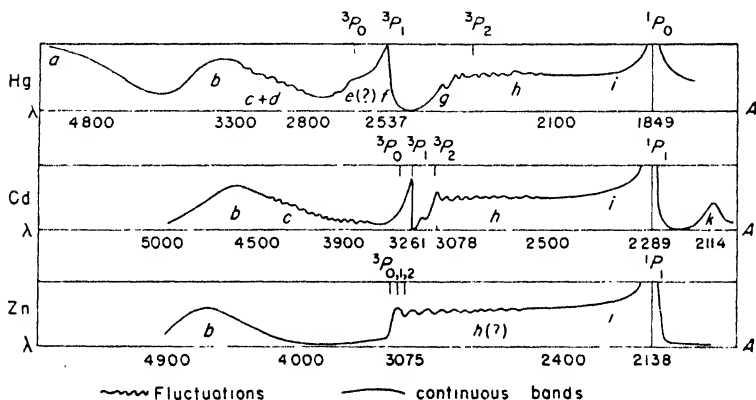

Fig. 82. The fluorescence bands of Hg_2 , Cd_2 , and Zn_2 (Mrozowski).

well as with core excitation, the green band *a* prevails at pressures above 20 mm; at pressures below 5 mm the u.v. band *b* is the stronger one. Since neither occurs in the absorption spectrum at these pressures, the change in relative intensities cannot be due to reabsorption. On overheating the vapor at a constant pressure of 60 mm, the intensity of band *b* increases steadily, while band *a* vanishes completely. Mrozowski explains this behavior by assuming that an increase of the number of collisions between Hg-molecules, due to higher temperature or higher pressure, increases the probability of a transfer from the long-lived metastable state A^30_u to the state A^31_u and thus favors the emission of band *b* in comparison with *a*.

The emission of the narrow band *g* is not only caused by excitation with light of $\lambda \sim 1850\text{A}$, but also by core excitation; in the latter case, *g* is followed by a further number of narrow bands at 2338, 2334, and 2330A which overlap band *h* but apparently do not belong to this system.

The fluctuation band *h* itself (2345 to 2100A)* overlaps a series of similar absorption bands reaching from 1849 to about 2260A and corresponding to the same electronic transition. The light absorption in these bands excites the emission of band *h*, which consists of a long sequence of maxima and minima. The spacing of the fluctuations is about 600 cm⁻¹ near the band head at 2300A, but decreases to 150 cm⁻¹ at 2100A. The intensity distribution within the band and the exact location of the individual maxima depend on the wavelength of the primary light: the shorter the latter, the farther the emission band stretches in the direction of greater wavelengths.† In this respect, the Steubing bands differ from all other Hg fluorescence bands. According to Mrozowski, this is due to the fact that the various levels from which the individual fluctuation maxima originate correspond to different rotational quantum numbers and not to different values of *v*'. The *J*'s are much less affected by collisions than the *v*'s. As shown in Figure 81, the wavelength of the light absorbed in band *h* is the greater, the smaller the interatomic distance at the moment of absorption, or the greater the relative energy of the two atoms before the collision. Therefore, the average angular momentum with respect to the common center of gravity and the ensuing rotational energy of excited molecule are the larger, the greater the wavelength of the exciting light (1073, 1572).

The band *i* adjacent to the singlet resonance line 1849A (6¹P₁-6¹S₀) is excited by light of wavelengths below 2000A. If the primary radiation consists of monochromatic lines - - for instance, the aluminum lines 1854, 1882, 1935, and 1990A - - these lines themselves appear with great intensity, superimposed on the continuous band in the fluorescence spectrum. The same phenomenon was first observed by Kapuscinski in the fluorescence of cadmium vapor and is treated in more detail in Section 81.

The two fluctuation bands *c* and *d* originally were called wing and core bands by Lord Rayleigh because he obtained the one by wing, the other by core excitation (1347). Both consist of long series of fluctuations with a spacing which decreases towards smaller wavelengths; in band *c* the distance between adjoining maxima is about 160 cm⁻¹ at 2900A and about 100 cm⁻¹ at 2780A. In spite of the differences in

* The fluorescence band *h* and the correlated absorption band was first observed by Steubing and is, therefore, frequently called the "Steubing band."

† The narrow band *g*, which is also strongly excited by light of wavelengths below 2000A, remains unaffected by these changes and is thus proved to be independent of the band system *h*.

location and spacing observed by Rayleigh in the two bands, they are so similar that it seems plausible to ascribe them to the same electronic transition. On the average, the spacing is slightly larger in band *c*, but also less regular, so that it may rather correspond to a superposition of several series. It is not improbable that *c* and *d* differ only by the amount of rotational energy which has been imparted to the molecules in the process of formation. This might be the reason why only one of them (*d*) is observed also in the absorption spectrum of the vapor. On the other hand, band *c* can be excited by an electric discharge through mercury vapor.

All processes of excitation listed in Table 42 lead directly to the formation of diatomic mercury molecules, with the sole exception, perhaps, of "core excitation," which Lord Rayleigh is inclined to ascribe to absorption by unperturbed normal Hg-atoms. However, experiments which will be described in Section 81 make it more probable that this so-called core absorption takes place in van der Waals molecules (1068, 1137, 1296).

The intensity of all mercury absorption bands of greater wavelengths increases with the square of the vapor pressure, in agreement with the assumption that two atoms participate in every absorption process. (Some deviations from this law have been reported by Mrozowski).

78. Lifetime of the Bands and Their Sensitivity to Collisions. The band fluorescence of mercury vapor is characterized by a distinctive property: some of the bands exhibit a very appreciable afterglow. From the point where the luminescence is excited, it is carried along by streaming mercury vapor over relatively large distances. Phillips was the first to observe the phenomenon, which has since been investigated frequently. In Phillips' experimental arrangement, the length of the luminous column was 50 cm; the rate of flow could be determined from the temperature gradient along the tube and, thus, the duration of the afterglow was calculated to be about 10 sec (1231). The afterglow can be produced by wing and core excitation and by irradiation of the vapor with the short-wavelength u.v. from an aluminum spark. The emission spectrum consists mainly of the bands *a* and *b* and the narrow band *f*; the other bands have never been mentioned in this connection. Lifetimes of that order can be explained only by assuming that metastable systems participate in the process: either the excited molecules themselves are partially in metastable states, as may be expected for configurations derived from atoms in the states 6^3P_0 and 6^3P_2 , or metastable atoms are produced by the

intermediate reactions which occur in most of the excitation processes. The production of metastable Hg-atoms at the point where band fluorescence is excited by the absorption of light of wavelength 2540A (band *f*) has been proved by Rayleigh; under these conditions of excitation, it was possible to obtain the emission of the higher atomic series lines by "stepwise excitation" and, furthermore, the emission of the "forbidden lines" 2656A ($6^3P_0 \rightarrow 6^1S_0$) and 2270A ($6^3P_2 \rightarrow 6^1S_0$). This is the only instance in which the second of these lines has ever been observed in fluorescence; even in this case its intensity was very weak. If the band fluorescence is excited by light of wavelength 2850A (band *d*), no metastable atoms are found in the vapor (I346a, I347).

On the other hand, the atomic resonance line 2537A occurs wherever the band fluorescence is excited by light of wavelengths $\leq 2537A$, and even as anti-Stokes fluorescence, if the primary radiation corresponds to the band *f* (2540A)*, but not on excitation by light of still greater wavelengths. If the band fluorescence is excited by the light from an aluminum spark, the resonance line is "carried along" by the vapor as far as the green band *a*; with core excitation this occurs only at low pressure (about 2 mm) and over relatively short distances. However, under these conditions the spectrum of the afterglow contains several other atomic lines of low intensity originating from higher electronic states (e.g., 7^3D_2 and 7^1S_0 , compare Figure 15); these lines could not be excited "stepwise" by light absorption, but only by collisions, since the corresponding lines were not present in the spectrum of the primary radiation. If mercury vapor at atmospheric pressure is irradiated with the light from an aluminum spark, the visible mercury triplet is also emitted in addition to the bands *g* and *f* (I348).

Wood made the observation that a dark space occasionally seemed to intervene in a mercury-vapor jet between the point of excitation and the beginning of the visible afterglow (I884). According to Rayleigh, who investigated this phenomenon extensively, the dark space is most pronounced if the fluorescence is excited by light of wavelengths below 2000A; it is less obvious with wing excitation and completely absent with core excitation. A similar dark interval has never been found in the emission of the continuum *b* and the other bands listed in Table 44. Both duration of the afterglow and the existence of the dark interval have been ascertained by Wood by

* The resonance line is missing at higher vapor pressures because of reabsorption, if the fluorescence originates from the interior of the vapor.

phosphorescopic methods. A slow increase of the fluorescence intensity after the irradiation period can be understood, if the excited state is not reached directly by the excitation process and if at least one of the intermediate states into which the molecule is transferred after the absorption of light is metastable. Under these circumstances, the conditions (as Kapuscinski has pointed out) are analogous to the production of a radioactive element from a parent substance, if several intermediate elements of not too short lifetimes are formed in the process. If some of the intermediate states are sufficiently long lived, the initial growth of the final product can be so slow that a genuine dark interval may seem to exist. The actual occurrence of a perfectly "dark" interval can hardly be explained on the basis of any theory (716, 1233, 1348).

It has already been mentioned that for most of the mechanisms under consideration, several collision processes must intervene between the absorption and the emission of light. Relatively large deviations from Stokes' law are not infrequent, as, for instance, the core excitation of band *g* (energy deficit $\Delta E = 0.4$ eV), the excitation of the complete band *b* (3950-3020Å) by light of $\lambda = 3450\text{Å}$ ($\Delta E \leq 0.3$ eV), and the core excitation of the higher atomic lines. The thermal energy is not sufficient to supply these "deficiencies" and it must be assumed that two or more primarily excited molecules or atoms partake in the collision processes.

The sensitivity of the fluorescence bands to quenching or enhancing collisions, particularly with hydrogen or nitrogen molecules, is closely connected with the lifetimes of the excited states. The influence of collisions is very weak for the bands near 1849Å, which do not occur in the afterglow and probably have a very short lifetime. The other short-wavelength band *h* is also little affected by the addition of foreign gases; nitrogen has a rather greater quenching efficiency than other gases, while the fluctuations retain their normal structure and intensity distribution. On the other hand, the bands *g* and *f* are considerably weakened by the presence of hydrogen, the H_2 half-value pressure being about 25 mm. On addition of nitrogen, the band *g* disappears completely and simultaneously the green band *a* is greatly enhanced. Probably both phenomena are caused by the well-known transfer of mercury atoms from the state 6^3P_1 into 6^3P_0 by collisions with nitrogen molecules.* Even in mercury vapor saturated

* If it is correct that the intensity of the band *b* is also increased to some extent by addition of N_2 , it must be explained by secondary transitions from A^30_u into A^31_u .

at room temperature ($p = 10^{-3}$ mm) to which nitrogen of atmospheric pressure has been added, the emission of the visible fluorescence band is excited by irradiation with the resonance line with considerable intensity. Under these conditions, the only possible process is the transfer of the excited 6^3P_1 -atoms into the metastable state and subsequently, probably in a three-body collision, the combination of the metastable atom with another mercury atom to form excited Hg₂-molecule. It is plausible to assume that analogous processes occur also in mercury vapor of high pressure in the absence of nitrogen (1073,1347).

The green fluorescence band is exceedingly sensitive to quenching by hydrogen; according to Pringsheim and Terenin, it is completely destroyed by hydrogen at a few thousandths of a millimeter. This observation provided the explanation of a phenomenon which, for a time, was the source of rather strange speculations. In certain experiments the green band failed to appear in the fluorescence spectrum of stagnant mercury vapor, while it reappeared as soon as a temperature gradient which caused the mercury to distill from one end of the tube to the other was established in the observation chamber. Apparently, traces of H₂ were present and were "pumped" by the distilling vapor to the cooler end of the tube. Wood and Voss also eventually interpreted their puzzling results by this assumption. According to Winans, the same interpretation cannot be applied, however, to a similar phenomenon observed in a mixture of mercury and zinc vapors, which will be mentioned in the last paragraph of Section 80 (1299,1847,1914).

Lord Rayleigh confirmed Pringsheim's and Terenin's results in the case of "core excitation" of the green band, while he found the visible fluorescence to be not noticeably weakened even at hydrogen pressures of several mm when "wing excitation" was used. This discrepancy has not yet been cleared up in a satisfactory manner. According to Section 38 a strong quenching by hydrogen should always be expected if metastable systems of an electronic energy near 4.5 eV are formed in the process of excitation. It is not surprising, therefore, that the green fluorescence is not quenched by hydrogen when it is excited by absorption of light in the band d or even by light of $\lambda > 3000\text{\AA}$ (1299,1347).

The long-wavelength bands a and b which are distinguished by their long lasting afterglow, and apparently, also, the fluctuation bands c and d , are always completely depolarized, even if they are excited by plane-polarized light. If the molecules are formed by the combination

of an excited and an unexcited atom, it is impossible that any preferential orientation of the primary electronic oscillator survives this process. Long life of the excited states is, of course, also apt to destroy an originally existing polarization. On the other hand, the fluctuation band h and the narrow band f are partially polarized if excited by absorption of short-wavelength u.v. ($\lambda < 2000\text{\AA}$). If the fluorescence is observed in the direction perpendicular to the unpolarized primary radiation, the degree of polarization p_n of either band is about 5%, corresponding to $p_p = 9.6\%$. The molecules emitting these bands are formed directly in the absorption process, and, since they are relatively short lived, they undergo only a small number of collisions during their lifetime. As stated in Section 73, the orientation of the molecular axes, which is determined by the absorption process, is not completely destroyed by a moderate number of collisions (1077, 1082, 1030).

The polarization and intensity of the Hg_2 fluorescence bands is not appreciably influenced by magnetic fields. An apparent weakening of the green band, when it is excited by the mercury resonance line, is, according to Mrozowski, a secondary effect; it is caused by the "magnetic filtering" of the primary radiation by the vapor layer adjacent to the walls of the vessel (see Section 9) (1080).

79. Sensitized Fluorescence Induced by Hg_2 -Molecules. It has been pointed out in Section 40 that, if sensitized fluorescence is excited in mercury vapor of high pressure, Hg_2 -molecules may play a part in the process. This has been proved with certainty by Mrozowski: he irradiated a mixture of mercury and thallium vapor with lines from aluminum or zinc sparks, which are not absorbed by mercury or thallium atoms, but only by Hg_2 -molecules. At temperatures above 275°C , he obtained the two thallium lines 5350 and 3776A in the fluorescence spectrum; the intensity of the lines increased continuously with increasing temperature up to 800°C , and additional lines originating from higher excited states of thallium appeared at the same time. This is caused only to a small degree by the higher thermal energy available; in the main, it is due to the greater density of the thallium vapor, which enhances the probability of collisions between thallium atoms and Hg_2 -molecules in highly excited states before these lose a part of their energy by collisions with other Hg_2 -molecules or Hg-atoms.

Under these conditions, the relative intensities of the various thallium lines are widely different from the intensity distribution in the sensitized thallium fluorescence excited by the mercury resonance line in mercury vapor of low pressure. The difference is explained by

the absence of the "energy resonance" which is known to play an important part in the energy transfer from Hg (6^3P_1)-atoms to other metal atoms (compare Section 40).

The fluorescence emission of the Hg₂-bands themselves is also affected to a certain degree by the presence of thallium vapor. In contrast to the results obtained in pure mercury vapor, the green band *a* remains stronger than the u.v. band *b* at temperatures up to 500° C, even if the vapor is overheated. Probably the Hg₂-molecules in high vibrational levels of the state A^{30}_u , which in the absence of thallium atoms would be transferred by collisions into the state A^{31}_n (origin of band *b*), transmit their energy with greater efficiency to thallium atoms because of energy resonance with the thallium term $7^3S_{1/2}$. The band *a* vanishes and is replaced by a narrow band at 4550A only if the temperature is raised above 500° C. The origin of this band is uncertain; it should perhaps be ascribed to a HgTl-molecule. (Concerning the occurrence of HgTl-bands, see next section). In Mrozowski's experiments the spectrum of the sensitized fluorescence also contained the cadmium line 3261A; apparently the thallium sample was contaminated with traces of cadmium (1079*b*).

80. Fluorescence Bands of Cd₂, Zn₂, and of Mixtures of Various Metal Vapors. After the detailed treatment of the band fluorescence of Hg₂-vapor, similar phenomena in the vapors of cadmium and zinc can be dealt with more briefly, inasmuch as the experimental data are much scantier; most of them are due to Jablonski, Kapuscinski, and their collaborators.

The potential curves for Cd₂ and Zn₂ can be assumed to be essentially the same as those of Hg₂ reproduced in Figure 81. The bands which have been observed are drawn schematically for the three vapors in Figure 82, after a representation given by Mrozowski. As far as possible, the designations of the bands correspond to those used for Hg₂ in Table 44 and in Figure 81. The absorption bands of the vapors again coincide, in general, with the bands in the fluorescence spectra, but again the long-wavelength bands which extend partially into the visible region are missing in the absorption spectrum (*b* and *c* in Figure 82) (242,244,657,710,712,715,717,1070,1076,1262,1601,1734).

The structure of the Cd₂-band *h* (2627–3050A) depends on the wavelength of the incident light, as in the case of the analogous Hg₂-band *h*; furthermore, the location of the individual fluctuation maxima is strongly influenced by the temperature. The spacing of the maxima corresponds to 460 cm⁻¹ at the long-wavelength end of the band and

decreases to 80 cm^{-1} at the short-wavelength end. In the overlapping region between 2640 and 2820A, the maxima in the fluorescence spectrum coincide almost exactly with the fluctuations in the absorption spectrum.

If the fluorescence is excited by the strong magnesium-line group between 2803 and 2936A, the short-wave part of the emission band is missing and the fluorescence spectrum consists only of seven fluctuation maxima between 2800 and 3000A. If, on the other hand, the fluorescence is excited by monochromatic lines of the spectral region, where the absorption and the emission bands overlap, the fluorescence spectrum shows a very pronounced and narrow maximum of intensity at the wavelength of the exciting line, almost as in a resonance re-emission. Under these conditions, the fluctuations are restricted to the "Stokes part" of the band *h*, while the "anti-Stokes part" is continuous and does not reach far beyond the exciting line (715).

The fluorescence of the Cd_2 -band *k*, which has no known analogue in the Hg_2 -spectrum, can be excited only by light of $\lambda \leq 2114\text{A}$. In the fluctuation bands *c* and *d*, which were obtained by irradiating the vapor with the light from a Cd-spark, the wavelengths of thirty-three maxima were measured by Kotecki in the spectral region between 4290 and 2633A with a spacing decreasing from 236 to 81 cm^{-1} . Irradiation with light of wavelengths below 2290A causes the emission of the visible band *b*. Kapuscinski proved, by means of a rotating mirror phosphoroscope, that this band shows an afterglow of about 10^{-4} sec and a period of growth $\sim 10^{-5}$ sec. In this respect, the band is analogous rather to band *a* than to band *b* of Hg_2 . The lifetime of the other Cd_2 -bands is very much shorter (714,716,812,813).

The fluorescence bands of Zn_2 are less easily observed; their intensity is always low and they are very sensitive to small traces of impurities. Their spectral location is shown in Figure 82. In the short-wavelength part between 2456 and 3073A, twenty-three fluctuation maxima could be identified; the intervals between them decrease (at an even greater rate than in the other vapors) from 700 cm^{-1} at 3000A to 200 cm^{-1} at 2450A. The phenomenon of "line re-emission" has been observed also in these bands.

The similarity between the Hg_2 -bands on one side and the Cd_2 and Zn_2 -bands on the other, also prevails with regard to their polarization. The visible Cd_2 and Zn_2 -bands are always unpolarized. The degree of polarization of the band *h* of Cd_2 is 5.5 %, if the fluorescence is excited by unpolarized light, and 11 % if the primary radiation is plane polarized. The polarization is very little influenced by the vapor

pressure. In consideration of a question occurring in the next section, it is important that the "re-emitted lines" in the Cd₂-band *h* are polarized to exactly the same degree as the underlying fluctuations. The degree of polarization of the Zn₂-band *h* is even supposed to be appreciably higher (14.5 %) than in the other instances, but this result may be due to errors in the rather difficult measurements (1158, 1541).

If the fluorescence of cadmium and zinc vapor is excited by short-wave u.v. at sufficiently great vapor densities, the spectra contain a considerable number of atomic lines in addition to the molecular bands, some of them originating from higher excited levels. Stepwise excitation is out of the question also in this case if the primary radiation is produced by sparks between iron or aluminum electrodes. The intensities of some of the lines, e.g., the triplet $5^3D_2 \rightarrow 5^3P_{0,1,2}$ of Cd, or the triplets $4^3D_2 \rightarrow 4^3P_{0,1,2}$ and $5^3S_1 \rightarrow 4^3P_{0,1,2}$ of Zn, are proportional to the square of the intensity of the primary light, while the intensity of the resonance lines of Cd and Zn, respectively, and that of some of the other lines is proportional to the primary intensity itself. The contribution of two excited molecules is needed for the production of the high atomic excitation states, while one excited molecule, in addition to the available thermal energy, suffices for exciting the lower states; when this is no longer the case at decreasing temperatures, the ratio between the primary and the secondary intensities, instead of being linear, tends to become quadratic even for the resonance lines (1847).

In a mixture of cadmium and zinc vapors, a fluorescence band has been observed which belongs neither to the Cd₂ nor to the Zn₂ band systems. It is excited by light of wavelengths between 2150 and 2300A and can be ascribed only to a CdZn-molecule (1544).

The fluorescence spectrum of a mixture of mercury and thallium vapors excited by the Hg-line 2537A contains, between 6580 and 4296A, four groups of bands showing fine structure. Since Winans and Davis obtained these bands with a mercury vapor pressure of the order of 100 mm and a very considerable thallium pressure, each of the following four processes may be responsible for their emission: a direct excitation of HgTl-molecules which are present in the vapor; fluorescence of such molecules sensitized by light absorption in Hg-atoms or Hg₂-molecules; formation of excited HgTl-molecules by light absorption in pairs of normal Hg and Tl-atoms during a collision; formation of excited HgTl-molecules by three-body collisions between normal Tl-atoms and excited Hg-atoms. The fact that the same bands are produced by an electric discharge through a mixture

of mercury and thallium vapors seems to be rather in favor of the first assumption (1851).

In mixtures of mercury and indium vapors and of mercury and zinc vapors, bands apparently originating from HgIn and HgZn-molecules occur in the absorption spectra. No corresponding fluorescence bands were observed, however, in addition to the fluorescence lines of atomic indium and zinc. Since this atomic fluorescence is excited by all spark lines of wavelengths below 2000Å, the excitation must be ascribed to light absorption by mixed molecules which subsequently dissociate into an excited and an unexcited atom. The zinc fluorescence lines (the triplet 4820, 4722, and 4688Å) and the characteristic HgZn absorption bands below 1900Å are observed only in distilling mixed HgZn-vapor. Winans states that one would not expect purification by distillation to introduce a new absorption band. However, the assumption that diatomic HgZn-molecules should be formed in distilling rather than in stagnant vapor can also hardly be accepted as valid. The most simple hypothesis would be that the zinc vapor pressure was increased by heating one part of the tube in which the distillation was produced (1847, 1853).

K. Re-emission of Exciting Lines and Rayleigh Scattering

81. Re-emission of Exciting Lines by Molecules. If the density of saturated sodium vapor is increased beyond the point at which the atomic resonance radiation contracts as "surface resonance" towards the wall of the observation chamber, and if the D-lines used for the excitation are broad or even slightly self-reversed, a well-defined "beam fluorescence" reappears along the path of the primary radiation in the interior of the vapor.* The intensity is weak at 250° C, but increases rapidly when the temperature is raised to 300° C. The phenomenon not only has the same outward appearance as the resonance radiation excited in sodium vapor of low pressure, but, when resolved by a spectrograph, the radiation seems to consist of the two normal D-lines. However, either the width of the lines must be a good deal greater than that of the resonance lines, or they must be slightly displaced in the spectrum — otherwise they would be completely reabsorbed by the intervening vapor and the beam fluorescence would

* The phenomenon can also be produced, though with low efficiency, by the yellow part of a continuous spectrum.

be transformed into volume fluorescence. If the primary light is plane polarized, the D_1 -line is, as usual, unpolarized in this new fluorescence, while the D_2 -line shows a degree of polarization of more than 30 % at 250° C and of 20 %, still, at 300° C. The normal atomic resonance radiation is already completely depolarized at 200° C in saturated sodium vapor. Furthermore, the polarization of the fluorescence is not noticeably affected by a magnetic field of 80 gauss with its lines of force parallel to the direction of observation. The polarization of the resonance radiation in sodium vapor of low pressure would be completely destroyed under these conditions (674).

Similar observations have been made when mercury vapor at a pressure of 10 mm (saturated at 80° C) was irradiated with the light of a mercury lamp emitting a broadened resonance line 2537A: a new "beam fluorescence" reappeared under these conditions; its wavelength practically coincided with the wavelength of the resonance line, its polarization amounted to 22 %, notwithstanding the high vapor pressure and the well-known depolarizing effect produced by atoms of the same kind, and the polarization was not altered by a longitudinal magnetic field of 20 gauss in the direction of observation (compare Section 25) (1296).

In both cases the fluorescence originates from very loosely bound diatomic molecules of the van der Waals type with energy levels which are only slightly different from those of the free atoms. The molecules must be sufficiently stable to survive the average lifetime of the excited states, since the absorption, as well as the re-emission, of the lines must occur in one and the same molecule in order to produce the observed polarization phenomena (840,1077).

The conditions are different if the lines which are re-emitted are not very nearly coincident with the atomic resonance lines but are absorbed by pairs of atoms in one of the processes described in Sections 76–80, by which excited diatomic molecules are formed. It has already been mentioned that the phenomenon was discovered by Kapuscinski in the Cd_2 fluorescence band h between 2600 and 2900A. Subsequently, it has been investigated in more detail by several authors in the same band, in the Hg_2 -bands i (1850–2000A) and f (2540A), and in a band excited in thallium vapor adjoining the thallium resonance line 2768A towards greater wavelengths.* (381,710, 713,715).

In the resonance spectra of genuine diatomic molecules, the

* It is obvious that reflection of the exciting light on the walls of the vessel or elsewhere was carefully avoided in these experiments.

exciting line (Wood's *R*-line) is not distinguished by an outstanding intensity from the other lines of the progression; the transition probabilities from the excited state to the vibrational levels of the ground state depend on the eigenfunctions by which these are characterized and which vary considerably in the distribution of their maxima with the values of v'' (Figure 58). If, however, the ground state *N* is represented by a repulsion curve, its eigenfunction has a strong maximum only at the turning point*;

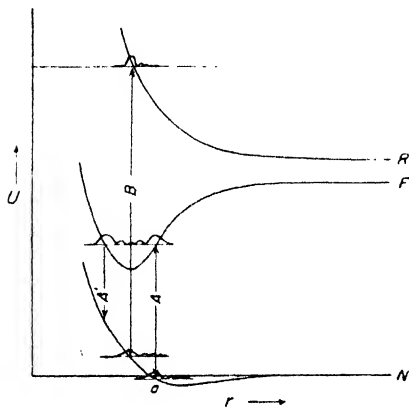

Fig. 83. Potential curves and eigenfunctions of molecules formed in a collision process [Finkelburg (393)].

only at the turning point*;

therefore, transitions from this point into an excited molecular state, or from the excited state to this point, have the greatest probability. Before a collision occurs, two atoms have a certain relative kinetic energy which enables them to approach each other to a certain distance (to the turning point *a* in Figure 83). At this point the pair can absorb a line of the frequency corresponding to the transition *A* according to the F.C. principle. The same line is re-emitted with greatest intensity by the vibrating stable molecule in state *F*. The emission of

the second line corresponding to the transition *A'* in Figure 83 has never been observed under these conditions (393).

If the *excited* state also corresponds to a repulsion curve (curve *R* in Figure 83), the absorption and re-emission of a line due to the transition *B* of Figure 83 is no longer a molecular fluorescence, but a perturbed atomic fluorescence, as explained in Section 36.

82. Rayleigh Scattering. It may seem to be questionable whether the observations described in the last section could not be interpreted by a mechanism of a different kind: instead of being part of a molecular fluorescence, the re-emission of the incident lines might be due to classical scattering by atoms; it would not be due to the strong emission by relatively few excited molecules, but to the forced vibrations induced in normal atoms. The amplitudes of these vibrations

* In the language of the classical theory, this corresponds to the fact that the colliding molecules remain longest at the point of their closest approach, where their relative velocity becomes zero.

remain small if the frequency of the scattered light differs appreciably from the resonance frequency of the atoms; on the other hand, the number of the atoms is exceedingly large in comparison to that of the excited molecules.

Rayleigh scattering must occur under all circumstances. The only question is whether its intensity is sufficient to explain the phenomena completely, or whether it is at least capable of providing a considerable contribution. The answer to both questions is negative for the re-emission of the D-lines and the mercury resonance line by sodium or mercury vapor of great density. The luminous intensity of the D-line re-emission is quenched by the addition of nitrogen to the sodium vapor as strongly as the normal sodium resonance radiation, whereas the intensity of scattered radiation would not be influenced by the addition of a small amount of a foreign gas by which the shape of the absorption line is not appreciably affected. Furthermore, the duration of the emission process has been measured by means of a fluorometer and has been found to be of the same order of magnitude as that of the resonance radiation, while a scattering process would be "instantaneous" or, at least, much shorter than 10^{-8} sec. Similar experiments concerning the re-emission of the mercury line 2537A lead to the conclusion that in either case the contribution of Rayleigh scattering is relatively very small and molecular fluorescence alone is to be taken into account.

Landsberg and Mandelstam have carried out very detailed quantitative investigations on the behavior of mercury vapor at a pressure of 123 mm (270° C) excited by the zinc line 2558A. They confirm the re-emission of the line superimposed on the fluorescence band *f*. The band and the line are considerably weakened by the addition of hydrogen, but, whereas the band is completely quenched at greater hydrogen pressures, the intensity of the line tends towards a limiting value amounting to about 25 % of its maximum intensity. Furthermore, this persistent radiation is polarized to almost 100 %, while the degree of polarization of the radiation is relatively small in the absence of hydrogen.

The intensity of the line, which is still observed at a hydrogen pressure of 400 mm, is in perfect agreement with the equation which is obtained by the classical theory for the light scattered by a gas of refractive index *n* and with a number *Z* of scattering atoms per cc:

$$I \cdot (n-1)^2 / Z\lambda^{4*} \quad (55)$$

* The so-called depolarizing coefficient *ρ* which occurs in the complete equation for light scattering is equal to 1 within the accuracy of the measurements.

As postulated by the equation, the observed intensity is proportional to the first power of the vapor density, while the intensity of the molecular fluorescence increases with the square of the density.

These joint data leave no doubt that the persistent part of the re-emission of the line 2558A by mercury vapor is actually due to Rayleigh scattering (859,860).

Also in agreement with the theory, the scattered intensity of the zinc line 2502A, on the short-wavelength side of the mercury resonance line, is about 12 times weaker when it is observed under identical experimental conditions. The value of the factor $(n - 1)^2$ for mercury vapor at a pressure of 123 mm is $6.8 \cdot 10^{-6}$ at wavelength 2558A, and only $0.55 \cdot 10^{-6}$ at 2502A; in the same wavelength range, the factor $1/\lambda^4$ varies by not more than 8%.

In this connection, a phenomenon which Wood observed at a much earlier date must be mentioned. The iron line 2535.6A is reflected geometrically and without change of frequency at the boundary between mercury vapor of high pressure and the quartz window of the tube containing the vapor. The geometrical reflection was also obtained with the short-wavelength half of a strongly self-reversed mercury resonance line 2537A. Rump later succeeded in showing that this phenomenon can be followed with decreasing intensity down to much smaller vapor pressures at which a diffuse surface-resonance emission already becomes noticeable, and Schmettler proved that the regular reflection is not quenched by the addition of hydrogen which suppresses the resonance fluorescence. The only difference between the reflection and the scattering consists in the fact that regular interference of the "scattered" secondary wavelets is caused by the greater density of the oscillators performing forced vibrations. The geometrical reflection is restricted to light of wavelengths slightly shorter than that of the resonance line because the difference between the refractivities of quartz and of the mercury vapor becomes large only in this spectral region on account of the existence of anomalous dispersion near the absorption line. It is of historic interest to note that Wood was led to the discovery of resonance radiation by looking for geometrical reflection by a vapor, which could be expected according to the laws of classical optics (190,1394,1440,1866,1874,1887,1906).

Landsberg and Mandelstam point out that the re-emission of lines mentioned in the preceding section can be partially due to Rayleigh scattering even in cases where the frequencies of the lines differ from the resonance frequencies of the absorbing vapors by much larger amounts. Equation (55) does not contain the difference

between the two frequencies, but the factor $(n - 1)^2$, which is related only indirectly to the difference between the frequencies of the scattered line and the absorption line. For mercury vapor of 100 mm, this factor varies between 5.1 and $4 \cdot 10^{-6}$ in the spectral region between 2100 and 2164A, in which Paterson observed the re-emission of a number of lines (the Zn-lines 2100, 2139, and 2164A and the Cd-line 2144A) and thus is of the same order of magnitude as for the line 2558A. The re-emission of the aluminum lines below 1990A becomes noticeable at much lower vapor pressures; the refractive index of the vapor has not been determined in this instance, but it must be expected to be very large considering the close neighborhood of the mercury resonance line 1849A, which is about ten times stronger than the line 2537A (350,433).

It is not improbable that a part of the line re-emission in cadmium and thallium vapors is due to the scattering process which has been proved to be effective at least for some lines re-emitted by mercury vapor. In the main, however, the phenomenon is caused by molecular fluorescence even in the case of mercury vapor, as long as the fluorescence is not quenched by the presence of hydrogen. In Cd-vapor, the contribution of scattering to the total re-emission must be still smaller if the observation concerning the equal polarization of the lines and the underlying bands is correct.

CHAPTER III

POLYATOMIC GASES AND VAPORS

A. Types of Fluorescence Spectra and the Energy Relations

83. Some Distinguishing Properties of Polyatomic Molecules. For many reasons the fluorescence spectra of polyatomic compounds are much more complicated than the resonance spectra of diatomic molecules, and, accordingly, their interpretation is much more difficult.

a. Instead of only one vibrational frequency, several frequencies and their possible combinations are superimposed on every electronic frequency. Therefore, the sum of all possible transitions, even from a single level of an excited state to the ground state, no longer corresponds to a progression of singlets or doublets, but to a sequence of more or less complex band groups showing little regularity.

b. Instead of a single principal axis of inertia, the molecule has three such axes and, therefore, three rotational frequencies, each with its separate rotational quantum numbers. The rotational doublet itself is thus replaced by a group of lines; for asymmetrical molecules, a further complication is caused by the fact that the selection rule for J is not strictly valid.

c. The electronic energy levels are, in general, more numerous and separated by smaller intervals. In compounds consisting of several radicals, the electronic states of the individual components are often preserved almost unaltered and independent of each other.

d. The possibility of a direct photodissociation is the greater, the larger the number of components forming the molecule; simultaneously, the number of possible predissociation processes increases. Therefore, continuous and diffuse bands without fine structure, in which light absorption produces no fluorescence,* are numerous in the absorption spectra of polyatomic molecules. The number of such molecules which have only continuous or diffuse absorption bands is very much larger than in the case of diatomic molecules. On the other

* Fluorescence which may occur in one of the dissociation products originating from a photodissociation is, of course, not considered here.

hand, the emission of continuous fluorescence bands is caused, again by transitions from an excited state into a state represented by a repulsion curve. It is, however, often impossible to decide whether an absorption or emission band of a polyatomic molecule is genuinely continuous, or whether it only appears as continuous because its overlapping individual lines cannot be resolved.

e. Bands showing fine structure occur in the absorption spectra of polyatomic molecules which are not excited to fluorescence by light absorption in these bands. If the absorption bands are relatively weak and the probability α_1 of the corresponding transition small (e.g., $1/\alpha_1 = \tau_1 = 10^{-6}$ sec), the light emission is practically suppressed by a competing radiationless process which has a probability α_2 with $\tau_2 = 10^{-8}$ sec. This lifetime of the excited state corresponds to the same natural line width as that of a normal "allowed" atomic line. Even by shortening the lifetime to 10^{-10} sec, the lines are not broadened appreciably beyond their width caused by Doppler effect at room temperature. If α_1 and α_2 are of the same order of magnitude, fluorescence is observed with considerable intensity, although its yield is more or less reduced by the competing process.

f. In diatomic molecules the only type of "competing radiationless processes" mentioned in paragraph (e) is predissociation. In polyatomic molecules "internal conversion" is even of greater importance. The existence of a second competing process is proved by the fact that neither fluorescence nor photolysis is produced by irradiating certain compounds, such as crotonaldehyde, which has discontinuous and continuous absorption bands in the near u.v.; in many other cases, the total yield of fluorescence plus photodissociation remains far below 100 %, so that the surplus energy must be lost by another process. As already stated under d, the vibrational and rotational levels of the electronic ground state and the excited state are frequently so tightly packed that a perfect energy resonance always exists between some high vibrational level of the ground state and a given level of the excited state. Because of the F.C. principle, this is, in general, by no means sufficient to allow a transition from one to the other. However, if a nuclear configuration which is common to both states can be attained, so that the transition can occur without changing the position and the momentum of the nuclei, then the transition can have a great probability. This means, in the representation by polydimensional potential surfaces which, for polyatomic molecules, replace the simple potential curves, that the surfaces belonging to the ground state and the excited state, respectively,

must intersect or at least touch each other; or, making use of the simplified representation by two-dimensional "configuration coordinates" (compare Section 38): the transition can take place only at the intersection of the two curves N and A (Figure 84). The probability of a passage from A into N depends chiefly on the average time δ within which the excited molecule reaches the crossing-point C in its motion along the curve A . When the molecule passes from A to N , the total excitation energy is transformed into vibrational energy of the ground state and is subsequently transferred by collisions to other

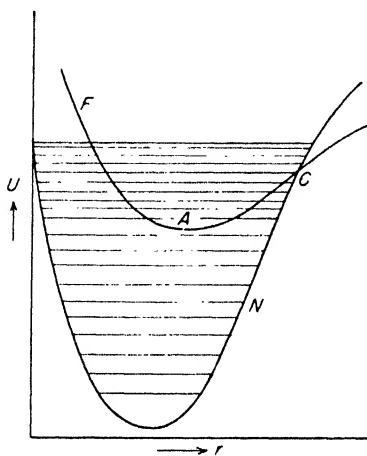

Fig. 84. Configuration potential curves for internal conversion.

molecules. Because of the part played by collisions in the final dissipation of the energy, internal conversion is of special importance for condensed media. If this final dissipation by collisions or infrared radiation does not take place, the energy must remain in the molecule, which can thus eventually return into the excited electronic state (414, 1145).

g. The light absorption by a molecule occurs at a moment at which its nuclei are in a certain fortuitous configuration; the excited state reached from this configuration with greatest probability is determined by the Franck-Condon principle. If the amplitude of one of the fundamental vibrations thus attained in the excited electronic state is large, due to its anharmonicity this vibration will be sufficiently coupled with the other fundamental vibrations of the molecule so that the repartition of energy between the various vibrational degrees of freedom varies constantly: the molecule performs a "Lissajous movement" on the polydimensional potential surface. While a diatomic molecule is found most probably at a turning point of its excited oscillation, it may take a long time before a polyatomic molecule comes back to a given point of its potential surface, or before the same phase relation of all its fundamental oscillations is again attained simultaneously. If the return from many points of the "Lissajous figure" in the excited state to corresponding nuclear configurations in the ground state is possible, the structure of the

emission band will be so complicated that it appears to be continuous and the exciting line, or a resonance series originating from this line, will not stand out on the continuous background. If, on the other hand, only one of the fundamental vibrations is strongly coupled with the electronic transition (in other words, if the strength of only one bond responsible for one of the vibrations differs widely in the two states) a considerable part of the oscillation energy may remain in the molecule when the electron returns to the ground state. This is another reason, not dependent on collisions but rather caused by a kind of internal conversion, why the fluorescence spectra of polyatomic molecules do not overlap the absorption bands; the whole vibrational structure of the two spectra may, for this reason, also be considerably different.

h. In diatomic vapors the quenching by induced predissociation becomes less effective if a part of the excited molecules is transferred into lower vibrational levels by the collisions; thus, the long-wavelength part of a fluorescence band can even be enhanced. In polyatomic molecules analogous processes occur with much greater efficiency because, in general, the time elapsing before the "crossing-point" is reached is longer. If the fluorescence of a vapor at low pressure is very little excited by the absorption of light which produces almost exclusively predissociation or internal conversion, the total fluorescence yield can be increased many times by the addition of a foreign gas of atmospheric pressure. This "stabilizing effect" of collisions is again of special importance in liquid solutions where, very frequently, the fluorescence of polyatomic molecules is excited by light of much shorter wavelengths than the fluorescence of the same compound in the vapor state (1648, 1745).

84. Stokes' Law and the Selection Rules. Frequently, the discontinuous absorption bands of polyatomic molecules which correspond to transitions into an excited state with quantized vibrational levels are relatively weak. Therefore, the vapor pressures must be high in order to provide absorption of sufficient intensity: in many vapors, fluorescence cannot be observed at pressures below 50 to 100 mm. Under these conditions, an almost complete exchange of vibrational energy between the excited molecules and the molecules of the surrounding gas is unavoidable; thus, the fluorescence does not originate from the vibrational level which has been directly reached by the absorption process, but from one of the lowest vibrational levels, or even from the nonvibrating state. For this reason, Stokes' law seems to be obeyed in a stricter sense in almost all fluorescence spectra of polyatomic

Pringsheim 9*

compounds than in those of diatomic molecules. The emission and absorption bands do not coincide over a large spectral region, but the former are shifted, as a whole, in the direction of greater wavelengths and overlap the absorption bands only slightly. The emission spectra consists essentially of the progression $0' \rightarrow 0'', 1'', 2'' \dots$, and the absorption spectra of the progression $0', 1', 2' \dots \leftarrow 0''$; only the band $0' \rightleftharpoons 0''$ is common to both. The fluorescence spectrum is practically independent of the wavelength of the exciting radiation.

Only if the intensity of the fluorescence is still sufficient for observation at low vapor pressures is the appearance of the emission spectrum essentially different: now, most of the emission bands originate from the higher vibrational level which has been directly excited and, moreover, the selection rules are, in general, not the same for $v' = 0$ and for $v' > 0$.

According to the main principle governing the selection rules, in a radiating transition between two states the symmetry properties of the eigenfunctions which characterize the various states of a polyatomic molecule must again remain unaltered with respect to the symmetry elements of the molecule (planes, axes, or centers of symmetry).

The nuclear vibrations of diatomic molecules are always parallel to the line joining the nuclei and do not affect the symmetry of the molecule. In polyatomic molecules the vibrations are either symmetrical (with quantum numbers v_s) or antisymmetrical (with quantum numbers v_a). If, for instance, a molecule is planar, the plane of the molecule is a plane of symmetry, since the mirror image of the molecule reflected on this plane is the molecule itself. In the model of the formaldehyde molecule drawn in Figure 85, not only the plane XZ of the molecule, but also the plane XY are planes of symmetry. An oscillation which is confined to the plane XZ is symmetrical with respect to this plane; the oscillation indicated in the figure by full arrows is also symmetrical with respect to XY and, thus, is "totally symmetrical" (symmetrical with respect to all existing elements of symmetry). Any oscillation with a component parallel to the Y -axis is antisymmetrical with respect to the plane XZ ; on the other hand, the oscillation lying in the plane XZ which is indicated by dotted arrows in Figure 85 is antisymmetrical with respect to the plane XY .

If a molecule is initially in a nonvibrating state, only the value of v_s can be altered in an allowed electronic transition which by itself leaves the symmetry of the molecule unaffected, while all Δv_a are

equal to 0. This follows clearly from the F.C. principle in its original form. If in the electronic transition the symmetry of the molecule as a whole is preserved, the positions of equilibrium of the individual atoms in the two electronic states can differ only insofar as the total symmetry of the molecule is not affected by such changes. If the equilibrium positions of the various nuclei were displaced in Figure 85 along the dotted arrows, which represent an antisymmetric vibration, the symmetry of the molecule with respect to the plane XY would be lost. On the other hand, a displacement of the equilibrium positions of the nuclei along the solid arrows would not alter the symmetry of the molecule. If, however, vibrational levels are already excited in the initial state of the molecules, v_a can alter by an even number of quanta ($\Delta v_a = 0, 2, 4 \dots$) simultaneously with an allowed electronic transition, since the eigenfunctions of antisymmetrical vibrations are all symmetrical for even values of v_a and antisymmetrical for odd values of v_a .

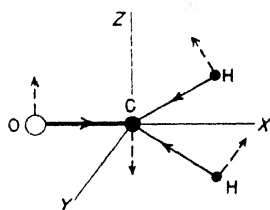

Fig. 85. Symmetrical and antisymmetrical vibrations of the formaldehyde molecule.

Because of these selection rules, a monochromatically excited "resonance spectrum" may appear to be more complicated in certain respects than the fluorescence spectrum which is obtained under the same conditions of excitation, if all molecules are transferred into the nonvibrating state by collisions before the emissions takes place. The individual bands contain more rotational lines in the second case, since new rotational levels are populated by the collisions, but only bands which correspond to a variation of the quantum numbers of the relatively few totally symmetrical oscillations appear in the fluorescence spectrum. The "resonance spectrum" contains, in addition to these, the numerous bands corresponding to $\Delta v_a = 2, 4 \dots$. The spacings of the progressions caused by the variations of v_a are twice as large as the fundamental vibrational frequencies.

If the electronic transition is forbidden, because by itself it would alter the symmetry of the molecule, it becomes allowed, to a certain degree, if it is combined with a vibrational transition which by itself would also change the symmetry. In particular, "forbidden transitions" from a nonvibrating initial state can occur, corresponding to $\Delta v_a = 1, 3, 5 \dots$, while the $0'-0''$ band is missing. Accordingly, the absorption and the fluorescence bands do not overlap but are separated by an interval. Considering the low intensity of many bands

which show fine structure in the absorption spectra of polyatomic molecules, it is probable that such bands frequently correspond to forbidden electronic transitions. In several instances this assumption is supported by the theoretical treatment of the spectrum.

In addition to the selection rules which are derived from the symmetry relations, the transition probabilities are again subjected to the Franck-Condon principle, as has been pointed out in Section 83g.

B. Fluorescence Spectra of Polyatomic Molecules

85. Inorganic Compounds. Fluorescence of the vapors of inorganic polyatomic compounds has been observed in a very few instances. This is only to a smaller degree due to the fact that the first absorption bands are usually situated in the far u.v., as in the case of CO_2 and NH_3 , and are accessible only to vacuum spectrography. The more general reason seems to be that, according to the tables compiled by Sponer and Teller,* most of the molecules have only continuous absorption bands, even fluctuations being relatively scarce.

Somewhat detailed data are available concerning the fluorescence of NO_2 and SO_2 . The absorption spectrum of nitrogen dioxide consists of a weak and very intricate system of bands between 5750 and 3520A, and a second system between 2600 and 2270A. Both systems show fine structure. Irradiation with light of wavelength below 3800A produces no fluorescence, but only dissociation. However, a fairly strong visible fluorescence is excited by irradiation with light of $\lambda > 4000\text{A}$. The emission spectrum consists of two bands at 6550–6250A and 6050–5600A,† followed by a few weaker narrow bands reaching into the blue region. The fluorescence intensity increases with the vapor pressure up to 1 mm, due to the increasing absorption of the exciting light, and drops very slowly at higher pressures; surface fluorescence remains visible even at pressures of 90–100 mm. The quantum yield, however, has its optimum Q_0 at the very lowest vapor density and has already dropped to $\frac{1}{2}Q_0$ at a pressure of 0.02 mm of NO_2 (Figure 86). A similar strong quenching is produced by the addition of CO_2 , while N_2 , O_2 , and H_2 are a little less effective, with half-value pressures p^* between 0.04 and 0.06 mm. The apparent quenching efficiency of the foreign gases is again dependent on the

* H. Sponer and E. Teller, *Rev. Modern Phys.*, **13**, 75–170 (1941) (1545a).

† A fine structure observed in the second of these bands seems to be caused, at least partially, by the overlapping absorption bands.

NO_2 -pressure itself, as in the case of the visible I_2 -fluorescence. The great sensitivity to collisions is caused not by anomalously large quenching cross sections (they correspond very nearly to the kinetic cross sections) but by a lifetime of the excited state of the order of 10^{-5} sec. This is in agreement with the low absorption coefficient characterizing the NO_2 -bands, which is about 100 times smaller than that of the visible I_2 -bands. Moreover, the long lifetime has been proved experimentally: at a low vapor pressure at which the mean

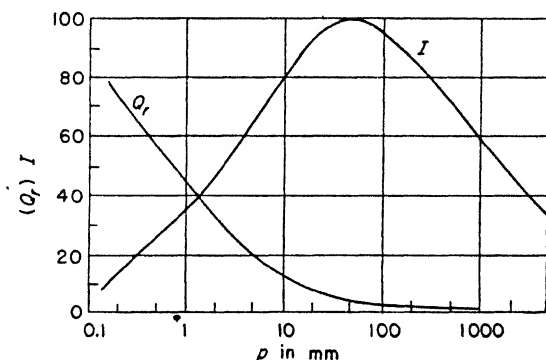

Fig. 86. Intensity and yield of the fluorescence of NO_2 as a function of the gas pressure (Baxter).

I : intensity. Q_r : relative yield

free paths are equal to 1 cm, the boundaries of the fluorescent beam became diffuse, while they were sharply defined at a pressure of 4 mm (74.593, II44).

The intensity distribution in the fluorescence spectrum depends on the wavelength of the exciting light: under excitation by the mercury line 4358A the red fluorescence band prevails, while under excitation by the mercury line 4047A higher vibrational levels of the upper electronic state are populated and the yellow-green band is emitted almost exclusively. Apparently the strong quenching action of collisions prevents a redistribution over the various vibrational levels. Notwithstanding this fact, the fluorescence is completely depolarized, as might be expected because of its slow decay. Irradiation with the violet mercury line produces predissociation in competition with the fluorescence; the blue line excites only fluorescence.

SO_2 -vapor exhibits, also, several u.v. absorption band systems. The first system between 3900 and 2600A is rather weak, and, although

the bands show a well-defined fine structure, they do not seem to be connected with the excitation of fluorescence. The second system stretches from 2440 to 2000A; the vapor is dissociated by the absorption of light of wavelengths below 2100A, but spark lines of greater wavelength (e.g., Cu 2136, 2190, and 2225A, Ni 2169 and 2207A, Cr 2171A, Cd 2195A, Pb 2204A, and Zn 2100A) excite long sequences of fluorescence line groups extending from the exciting line to the violet. Especially in their long-wavelength parts, they are very difficult to analyze. The complexity of the spectra may, in part, be due to the fact that every exciting line covers several absorption lines, but may be attributed even more probably to the various reasons mentioned in the preceding section. The fluorescence spectrum excited by the Zn-line 2100A has a relatively simple structure in which the three frequency differences of 1370, 1150, and 520 cm^{-1} recur periodically; they correspond to three fundamental frequencies of the unexcited molecule which have been observed in the SO_2 Raman spectrum. The same periods are found, although not so obviously, in some of the other resonance series and, furthermore, they agree with the analysis of the absorption spectrum (96I, 152I).

By the addition of foreign gases (A, H_2 , or O_2), the resonance progressions are not transformed into the complete band spectrum. The intensity of the fluorescence is very little reduced by argon of 100 mm and the quenching efficiency of hydrogen and oxygen is also relatively small. It is compensated for, in part, by increasing absorption of the primary light due to the broadening of the absorption lines. If this enhancing effect is taken into account, 400 mm of CO_2 quench the fluorescence to about $1/50$ of its initial value, if it is excited by the group of copper lines 2136–2225A, while the intensity is decreased only to $1/10$ by the addition of the same quantity of CO_2 , if the fluorescence is excited by the Zn-line 2100A. In the latter case the lifetime of the excited state is already shortened, apparently by predissociation, since the zinc line lies very near to the predissociation limit, beyond which no fluorescence can be excited. The Pb-line 2088A and the Ag-line 2066A are quite ineffective in producing fluorescence in SO_2 -vapor.

No fluorescence has been observed in the gases CO_2 and CS_2 . The question has been discussed, whether the infrared radiation of carbon dioxide at high temperatures should not be regarded as resonance radiation which is excited by the radiation coming from the walls of the oven. Quantitative measurements performed by Gerlach proved this assumption to be wrong (488). But even lacking this experimental

proof it could not be doubted that, at the high pressures under which alone the emission can be obtained with appreciable intensity, and considering the small probability of emission and absorption processes in the infrared, the temperature equilibrium is achieved practically only by heat conduction and convection, and not by radiation.

Absorption bands of ammonia and water vapor in the u.v. above 2500A are not tabulated by Sponer and Teller. During the investigation of the Raman effect of these vapors it was found, however, that they are excited to fluorescence by irradiation with the mercury line 2537A. The emission band of ammonia reaches from 2700A far into the visible, while the intensity of the water-vapor band has its maximum close to the exciting line and drops rapidly in the direction toward greater wavelengths. Beyond the fact that the bands are continuous, nothing is known concerning these last two instances of a fluorescence of polyatomic inorganic vapors (1342).

86. Introductory Remarks Concerning the Fluorescence of Organic Compounds. Organic compounds which are known to be fluorescent in the vapor state are numerous. However, these are, without exception, also fluorescent in liquid solutions or even as pure solids. Most investigations, in particular the earlier ones, deal primarily with the fluorescence of solutions, because of the smaller experimental difficulties; furthermore, many substances are decomposed at the temperature necessary for evaporation and others exhibit photoluminescence only when they are ionized. For this reason, all questions referring to the connection between constitution and fluorescence are treated in later chapters and only phenomena which are specifically characteristic of the vapor phase are mentioned in the following sections.

The preceding remarks refer mainly to aromatic compounds, while observations concerning the fluorescence of aliphatic or non-aromatic ring compounds are almost as scanty as those about inorganic polyatomic vapors. The reasons are essentially the same: the first absorption bands of many aliphatic compounds (methane, ethane, methanol, ethanol and other alcohols, hexane, etc.) lie in the far u.v., many others have only continuous absorption bands, or, if the absorption bands show structure, the absorption process leads nevertheless to predissociation or, perhaps, to internal conversion. The latter seems, for instance, to be exclusively the case for phosgene or thiophosgene with a fine-structure band between 5712 and 3950A within which neither fluorescence nor dissociation is produced. Even in the vapors of aliphatic compounds in which fluorescence can be obtained

the yield is, in general, relatively small and dissociation or internal conversion is competing with the emission process.

87. Nonaromatic Organic Compounds. All known instances of fluorescent aliphatic vapors are collected in Table 45. Probably it is only owing to too small intensities that in several cases the "excitation spectra" do not seem to reach as far into the red as the absorption bands. On the other hand, the short-wavelength limit of the excitation spectra is certainly due to the predominance of competing processes in the wavelength region beyond this limit.

In the absorption spectrum of formaldehyde a series of equidistant bands stretches from 3530A towards shorter wavelengths with a spacing of 1190 cm^{-1} ; they have been designated by Herzberg and Gradstein as "A" (3530A), "B" (3400A), "C" (3270A), etc. On the long-wave side of "A" follows, at the appreciably larger distance of 1225 cm^{-1} , a last, much weaker absorption band "a" at 3706A. Fluorescence is excited by absorption of light in the bands "A," "B," "C," with rapidly decreasing yield in passing from "A" to "C." The fluorescence spectrum begins with a relatively strong band which coincides with the absorption band "a" and extends from there far into the green in a long series of bands, some of which show fine structure (526,606).

The total strength of the absorption and fluorescence bands is rather low; the fluorescence has a noticeable intensity only at vapor pressures above 50 mm. It is probable, therefore, that the corresponding electronic transition is forbidden and occurs only when combined with a simultaneous jump $\Delta v_a = 1, 3, 5 \dots$ of an anti-symmetrical oscillation. Since at the temperature of observation most of the molecules are in the nonvibrating ground state, the absorption bands "A," "B," "C" . . . are caused by the v_a -transitions $1', 3', 5' \leftarrow 0''$. Only the weak band "a" originates from the electronic ground state with $v_a'' = 1$ and corresponds to the transition $0' \leftarrow 1''$. On the other hand, at the prevailing high pressure, all excited molecules are transferred by collisions into the nonvibrating level of the upper electronic state and the emission bands are caused by the v_a -transitions $0' \rightarrow 1''$ (coinciding with the absorption band "a"), $0' \rightarrow 3'', 5'' \dots$ If this interpretation is correct, the frequency difference of 1190 cm^{-1} is at first approximation equal to $2\omega'$, and, thus, $\omega' = 595\text{ cm}^{-1}$. The corresponding value of the vibrational frequency of the ground state is obtained (see Figure 87) from the equation:

$$A - a = \omega' + \omega'', \text{ or } \omega'' = 1225 - 595 = 630\text{ cm}^{-1} \quad (56)$$

A further period of 1700 cm^{-1} , which is known as the characteristic frequency of the C–O bond, can be found with some degree of certainty in the fluorescence bands, but a complete analysis of the spectrum has not yet been achieved.

The fluorescence of the vapors of acetone and biacetyl has been the subject of much discussion. A comparatively strong greenish fluorescence, which is observed when acetone vapor is irradiated with the mercury line 3132A, was ascribed at first to the acetone molecules; at present it is supposed to belong to biacetyl, which is formed under the action of the irradiation. If the newly formed biacetyl is continuously removed in streaming acetone vapor, only a weak blue fluorescence is excited under the same conditions. This blue luminescence also prevails alone in the emission spectrum, if the green fluorescence is quenched by the addition of oxygen (II-13,256a, 395,602,962a,987,1146,1188).

Since the blue acetone vapor fluorescence in the spectral region between 4860 and 4180A can be resolved into 26 bands with an average spacing of 120 cm^{-1} , this emission process does not seem to be directly related to the photodissociation of the acetone molecules (962a).

In pure biacetyl vapor the green fluorescence is excited by the absorption of blue and violet light which is quite ineffective in acetone vapor. The three emission bands listed in Table 45 show a somewhat irregularly spaced structure with $\Delta\nu \sim 55\text{ cm}^{-1}$ in the orange and $\Delta\nu \sim 85\text{ cm}^{-1}$ in the green which apparently is unrelated to the structure of the absorption bands. The absorption and the emission bands are separated by a gap (Figure 88). While the intensity of the absorption bands corresponds to a transition probability $\alpha_1 = 10^5\text{ sec}^{-1}$, the duration of the emission is of the order of 10^{-3} sec , with an exponential decay; this has been proved by phosphoroscopic measurements as well as by the method of observing the diffuseness of the fluorescence beam at low vapor pressures. Almy assumes, therefore, that the molecules pass from the directly excited state F (Figure 89) into a metastable state M from which they are enabled by the thermal fluctuations to return into the lowest vibrational levels of F ,

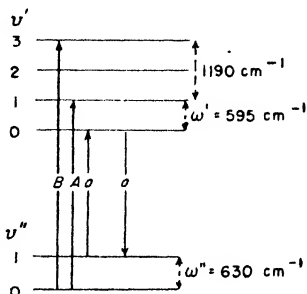

Fig. 87. Energy-level diagram for the fluorescence and absorption of formaldehyde (Gradstein).

with subsequent emission of fluorescence. If excited by blue or violet light, the fluorescence yield is practically constant, of the order of 15 %, in a pressure range between 1 and 50 mm. On the other hand, the yield is very small at low pressures if the wavelength of the primary light is 3650A, and increases gradually to about 13 % if the pressure is raised to 50 mm. This behavior suggests the additional hypothesis that predissociation occurs with very great probability from the high vibrational levels reached by the absorption of the u.v. line, and that

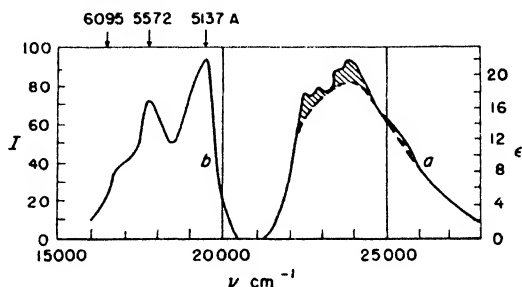

Fig. 88. Absorption and fluorescence spectrum of biacetyl vapor at room temperature (Lewis and Kasha).

a: absorption band ϵ : molar absorption coefficient
b: fluorescence band.
I: in arbitrary units

the molecules are "stabilized" to a certain degree by collisions at greater vapor pressures.

Lewis modified the energy diagram presented in Figure 89 in that he assumed that the luminescence of biacetyl vapor is not a "phosphorescence" due to the retransfer from state *M* to a low level of *F* with a subsequent "allowed" radiating transition to *N*, but a direct "forbidden" transition from state *M* to state *N*, the former being a triplet and the latter a singlet state. The hypothesis is based on an observation of Lewis and Kasha that biacetyl dissolved in a solidified organic solvent emits a fluorescence with a spectrum identical with that of the vapor* and with a mean life of $5 \cdot 10^{-3}$ seconds. Phenomena of this type are treated in Chapter V, E. The relatively small influence of the temperature on the lifetime is strongly in favor of Lewis' assumption that the luminescence is a "slow fluorescence" and not a phosphorescence (927*b*).

* The fluorescence spectrum of biacetyl in aqueous solution also practically coincides with that of the vapor.

[It must be pointed out here, however, that if the low transition probability $M \rightarrow N$ is due to the fact that N and F are singlet states and M is a triplet state, then the transition $F \rightarrow M$ must occur nevertheless, with a probability which is at least equal to 17.6 % of the sum of the probabilities of all others processes by which the molecules in the state F are quenched. If, in agreement with Almy's diagram (Figure 89), the competing predissociation occurs in state M , all excited molecules are transferred from F to M in a time shorter than 10^{-7} sec, since no normal fluorescence due to a direct return from F to N with a yield of more than 1 % is observed. If, on the other hand, Lewis' assumption is correct and the excited molecules which do not contribute to the luminescence are quenched while staying in state F , the lifetime of the latter cannot exceed 10^{-7} sec, and even in this case the probability of the transition $F \rightarrow M$ would be fairly high. However, if the transition probabilities are governed by the electronic selection rules, they are the same for the transition $F \rightarrow M$ in the vapor and in the solid solution; and if, furthermore,

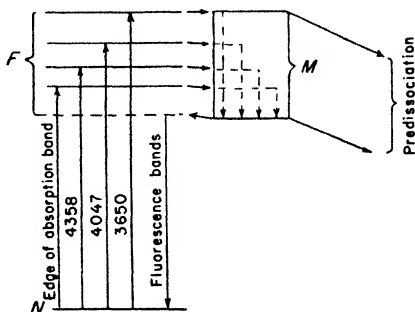

Fig. 89. Energy-level diagram for the luminescence of biacetyl (Almy).

the mean duration of the afterglow of $1.5 \cdot 10^{-3}$ and $5 \cdot 10^{-3}$ sec can be accepted as correct for the vapor and the solid solution, respectively, at least 70 % of the molecules which are transferred from F to M are quenched in the vapor, and, therefore, not 15 but at least 50 % of all excited molecules must pass from F to M . The corresponding transition probability is almost as large as the one derived from Almy's original assumption.

Finally, the transition is spontaneous, since the quantum yield of the vapor fluorescence (when excited by blue and violet light) does not depend on the vapor pressure. Thus, the selection rule forbidding the radiating transition from M to N does not appreciably influence the spontaneous radiationless transition from F to M .]

After a long-lasting irradiation the fluorescence of the vapor vanishes, because the biacetyl molecules are destroyed by photochemical processes which may be initiated by predissociation. It is probable, however, that this is not the only process competing with the re-emission of light, but that internal conversion plays an even more important part.

While self-quenching seems to be negligible, the green biacetyl fluorescence is extremely sensitive to quenching by oxygen. The oxygen half-pressure is $1.3 \cdot 10^{-2}$ mm; if the irradiation is continued after the admission of a small quantity of oxygen, the oxygen is eventually used up by oxidizing processes and the fluorescence recovers its initial intensity. The quenching efficiency of iodine is even greater; the original fluorescence intensity of biacetyl vapor is reduced to less than 3% by addition of iodine vapor of $2 \cdot 10^{-3}$ mm.

TABLE 45
FLUORESCENCE OF ALIPHATIC VAPORS
(Wavelengths in Å)

Compound	Formula	Fluorescence bands	Discontinuous absorption bands*	Excitation spectrum
Formaldehyde	COH_2	5100-3700 series of bands	3700-3100 (-2750)	3530-3200
Glyoxal (r655)	$(\text{CHO})_2$	5200-4200 continuous	4600-3400	4400-3600
Methylglyoxal		visible	?	?
Acetone	CH_3COCH_3	4750 and biacetyl bands	3340-2950 (-2200)	3300-3100
Biacetyl	$\text{CH}_3\text{COCOCH}_3$	broad bands with maxima: 6095, 5572, 5117	4670-3500	4400-3650
Acetaldehyde	CH_3COH	biacetyl bands	3485-2730	3400-2800
Ethyl methyl ketone	$\text{C}_2\text{H}_5\text{COCH}_3$	biacetyl bands	3200-2400	about 3132
Propionaldehyde	$\text{C}_2\text{H}_5\text{COH}$	5460-4360† continuous	?	about 3000
Diethyl ketone	$\text{C}_2\text{H}_5\text{COC}_2\text{H}_5$	5460-4360‡	?	about 3000
n-Butyraldehyde	$\text{C}_3\text{H}_7\text{COH}$	visible	3400-2850 (-2420)	3132
Ethylamine	$\text{C}_2\text{H}_5\text{NH}_2$	3600-2700 with max. 3435, 3285, 3140, 3005, 2880	2372-2300 (-1850)	3270-2300

* The figures in parentheses indicate the limit of the nondiscrete bands.

† Probably belonging to bipropionyl diketone, $\text{C}_3\text{H}_5\text{COCOC}_2\text{H}_5$.

‡ Possibly also belonging to a diketone.

If the biacetyl fluorescence is produced by irradiating acetone vapor with the mercury line 3132A, the intensity of the green luminescence grows slowly to a limiting value. Pure biacetyl vapor does not absorb the line 3132A and is not excited by it; if acetone vapor is added to biacetyl vapor, the green fluorescence appears immediately with its full strength when the vapor is irradiated with the line 3132A. These experiments prove that the emission of the biacetyl bands by acetone vapor is not caused by a direct formation of excited biacetyl molecules, but that the biacetyl molecules are first formed by a photochemical process, and their luminescence subsequently excited as "sensitized fluorescence." No green fluorescence is produced in acetone vapor by light of $\lambda < 2900\text{\AA}$, beyond which the discrete acetone absorption bands merge in to a continuum. This was assumed, at first, to prove that the fluorescence belongs to the chemically unaltered acetone molecules; in reality, the molecules are dissociated by light absorption in the discrete bands due to predissociation, probably according to the equation:

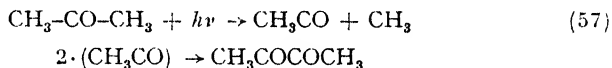

Absorption in the continuous band of acetone gives rise to another dissociation process, which cannot be followed by the formation of biacetyl — perhaps:



The whole complex of phenomena proves very convincingly that the appearance of fine structure in a band can well be connected with predissociation, while the nonexistence of fluorescence excitation beginning at a given wavelength is an absolutely unambiguous sign for the prevalence of a "competing process"* (11,12,13,602).

According to work of Rollefson and Graham, fluorescence is excited in the vapor of acetaldehyde at room temperature by means of irradiating it with the mercury line 3132A. The fluorescence yield

* The historical development of the biacetyl fluorescence illustrates, also, the danger of constructing elaborate energy levels for complicated molecules by the use of approximately agreeing numerical data. It seemed possible to represent the three fluorescence bands by combining the frequency of the exciting line with three infrared frequencies of acetone. The arbitrariness of this construction became evident when the fluorescence bands were proved to belong to another molecule.

does not vary during the irradiation, but decreases with increasing temperature and disappears completely when the temperature exceeds 150° C. The decrease in fluorescence intensity is roughly complementary to an increase in photodissociation which competes with the fluorescence at all temperatures. The authors conclude from this behavior that the fluorescence is characteristic of acetaldehyde itself and not of some product of photolysis (1372).

However, the spectrum of the fluorescence of acetaldehyde vapor, which Rollefson and Graham describe only as "visible," has been found to be identical with that of biacetyl vapor. It is true that this latter result was obtained by Matheson and Zabor and by Padmanabhan by irradiating the vapor with the nonresolved radiation from a quartz-mercury lamp and the photochemical production of biacetyl might have been due to the presence of light of shorter wavelengths. Thus, it is possible (although not very probable) that the fluorescence observed by the two groups of investigators was not of the same nature. Furthermore the biacetyl bands were observed in the fluorescence of the vapor of ethyl methyl ketone ($C_2H_5COCH_3$) (988, 1188).

Identical fluorescence spectra differing slightly from the biacetyl spectrum appear also upon irradiation of the vapors of diethyl ketone ($C_2H_5COC_2H_5$) and propionaldehyde (C_2H_5COH). Probably the mechanism is analogous in all these cases to the excitation of the biacetyl bands by irradiation of acetone. In the last instances mentioned above, the carrier of the fluorescence, according to this assumption, should be bipropionyl diketone. Terenin supposes that the fluorescence which he observed in the vapor of ethylamine should possibly also rather be ascribed to diethylamine. Although very little is known about the weak fluorescence of *n*-butyraldehyde, it seems plausible to assume that it also originates from a compound produced by a primary photochemical reaction. No fluorescence has been observed in the vapors of isobutyraldehyde, acrolein, or of methylamine. Thus, only a few of the not too numerous cases of fluorescence listed in Table 45 are caused by the direct excitation of an aliphatic vapor (62,454,988, 1188,1639,1656).

None of the nonaromatic heterocyclic single-ring compounds, pyrrole (C_4H_5N), furan (C_4H_4O), thiophene (C_4H_4S), and pyridine (C_5H_5N) can be excited to fluorescence in the vapor state, although at least the four last-named compounds have strong absorption bands with fine structure in the region between 3500 and 2000Å (390). Only when they are joined to a benzene ring, as in quinoline or indole, do the compounds become weakly fluorescent, notwithstanding the fact

that the absorption bands of quinoline are much more diffuse than those of pyridine, which is one of the components of the quinoline molecule.

88. Benzene. The fluorescence of benzene vapor is excited by light absorption in a relatively weak band between 2700 and 2200Å. Light absorption in the much stronger bands in the far u.v. always leads to photochemical disintegration. The production of hydrogen by irradiating benzene vapor with light of wavelengths below 2000Å actually was observed by Prileschajewa.

The great complexity of the band system with its 0"-0' band at $39,089\text{ cm}^{-1}$ (2557.5Å) is caused by the superposition of numerous vibrational frequencies and rotational fine structure. Various investigators who have undertaken the analysis of the system disagree among themselves, more or less, in the assignment of numerical values to the occurring frequencies and their interpretations, and more than one electronic transition has even been assumed to be responsible for the band structure. The most recent analysis is due to H. Spöner, Nordheim, Sklar, and Teller; it is followed here, although it may not represent the final solution of the difficult problem. In this analysis, the band system is ascribed to a single forbidden electronic transition (601,646,647,782,783,1500,1545).

The fluorescence has been observed both at high pressure ($p > 10\text{ mm}$) of the benzene vapor itself or of an inactive foreign gas, and at low pressure ($p = 0.3\text{ mm}$). In the first case, the emission spectrum is independent of the wavelength of the exciting light, because the excited molecules are always transferred into the lowest vibrational levels of the upper electronic state; identical fluorescence spectra have been obtained by irradiating the vapor with light from a quartz mercury arc, from a Cd- or Zn-spark, or from a hydrogen discharge tube. In the second case, the so-called resonance spectrum originates exclusively from the directly excited vibrational levels. However, the spectrum shows no likeness to the clear simplicity of iodine resonance progressions, because too many combinations of vibrational oscillations contribute to the emission process (646,647,1003,1294,1350).

Heavy benzene, or hexadeuterobenzene (C_6D_6), behaves exactly like ordinary benzene, with the sole exception that all frequencies are somewhat different. Therefore, it suffices to deal in the main only with normal benzene (255).

According to Spöner and her collaborators, the most important features of the absorption and fluorescence spectra can be represented

by taking into account only three vibrational carbon frequencies of the excited and of the ground state. In Table 46 and Figures 90 and 91, the frequencies ω and quantum numbers v of totally symmetrical vibrations are marked by even subscripts (0, 2...), those of anti-symmetrical oscillations by odd subscripts (1, 3...).

TABLE 46
ELECTRONIC AND VIBRATIONAL FREQUENCIES (ν_0 AND ω) CHARACTERIZING
THE FLUORESCENCE SPECTRA OF C_6H_6 AND C_6D_6

	ν_0	ω_0''	ω_0'	ω_1''	ω_1'	ω_2''	ω_2'	ω_3''	ω_3'	ω_4''	ω_4'
C_6H_6	38089	992	923	606	520	400	240	(1590)	(1480)	(3062)	(2565)
C_6D_6	38292	947	878	579	497	370*	230*				

* Only the difference $\omega_2'' - \omega_2' = 140$ is actually known.

At high pressures the excited molecules are supposed to be almost completely transferred into the vibrational levels $v_0' = 0$, $v_1' = 0$ or 1, and $v_2' = 0, 1, 2, 3, 4$. The lowest of these levels have the greatest populations. Since the electronic transition is forbidden, only bands with $\Delta v_1 = 1, 3, 5 \dots$ can have an appreciable intensity. Bands corresponding to any value of Δv_0 and Δv_2 (variation of the symmetrical

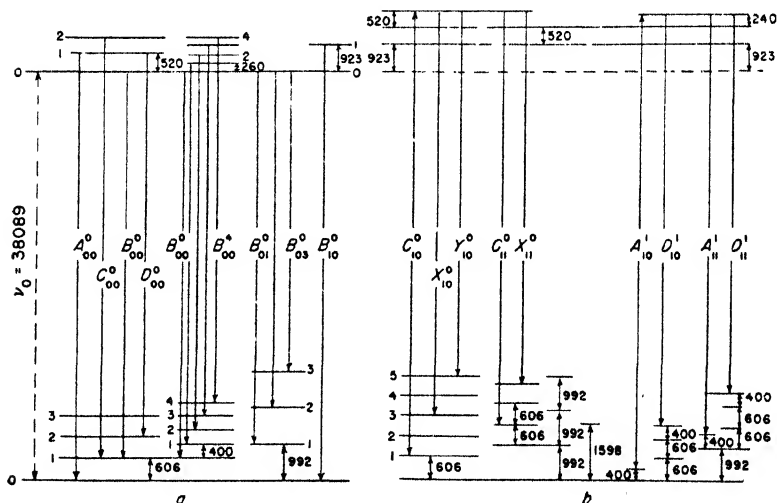

Fig. 90. Energy-level diagrams for fluorescence of benzene.

a: high-pressure fluorescence excited by Hg-line 2537A.

b: resonance spectrum excited by Hg-line 2537A at low vapor pressure.

vibration quanta) can be superimposed on the bands caused by the variation of v_1 . The level diagram of Figure 90a shows the principal types of bands resulting from this mechanism. The designations are, in the main, those of Spomer's paper: the bands designated by A , B , C , and D correspond to certain values of v_1' and v_2'' the subscripts in A_{00} , A_{01} , etc., in this figure, refer to the values of v_0' and v_0'' , respectively. Since, according to our assumptions all bands in the fluorescence spectrum start from the level $v_0' = 0$ and lead to numerous levels $v_0'' = 0, 1, 2, 3 \dots$, the bands $A_{0v''}$, and similarly the bands $B_{0v''}$, $C_{0v''}$, and $D_{0v''}$, form progressions with the spacing $\Delta\nu = 992 \text{ cm}^{-1}$.* They are the most outstanding feature of the fluorescence spectrum. (Right-hand part of Figure 90a). The bands B , which originate from the lowest vibrational level of the excited state, have the greatest intensity. The frequency differences between B and the other bands are (left-hand part of Figure 90a):

$$B - A = -1126; B - C = -1040; B - D = 114 \text{ cm}^{-1}$$

These frequency differences appear as regularly recurring periods in the spectrum. The same is true for the difference $A - D = 1212 \text{ cm}^{-1}$, which is twice the value of the fundamental antisymmetric frequency 606 cm^{-1} .

Finally, a small period of 160 cm^{-1} is produced by the transitions between the excited vibrational levels $v_2'\omega_2'$ and the levels $v_2''\omega_2''$ of the ground state. ω_2 is symmetrical and Δv_2 is always zero. This causes the appearance of sub-bands with a spacing $\Delta\nu = 400 - 240 = 160 \text{ cm}^{-1}$ in every one of the bands A , B , C , and D . The superscripts in B_{00}^0 , B_{00}^1 , etc., refer to the values of $v_2' = v_2''$ (Figure 90a, central part). Thus, the fluorescence spectrum can be represented by the equation:

$$\nu = 38039 + v_1' \cdot 520 - v_1'' \cdot 606 - v_0'' \cdot 992 - v_2'' (400 - 240)$$

with $v_1' = 0, 1, 2$; $v_1' - v_1'' = \pm 1$; $v_0'' = 0, 1, 2 \dots$; $v_2'' = 0, 1, 2, \dots 6$. (59)

Although this analysis explains most of the more conspicuous bands, it is far from disentangling the whole complexity of the spectrum. Transitions with $\Delta v_1 = 3$ and 5 , leading to the higher levels of the antisymmetrical oscillation 606 cm^{-1} of the ground state, must also occur, and the other vibrations of the ground state, e.g., the asymmetrical carbon vibration ω_3 (1590 cm^{-1}) which coincides almost exactly with the sum $992 + 606 = 1598 \text{ cm}^{-1}$, and the totally

* The corresponding progressions in the absorption spectrum have the spacing 923 cm^{-1} .

symmetrical hydrogen vibration 3062 cm^{-1} , cannot be neglected altogether.* Besides, the bands have a rotational fine structure which is, in general, not quite resolved. Figure 91a gives a schematic representation of the small region of the fluorescence spectrum between 2660–2700A and shows the great number of bands which are not accounted for by Equation (59).

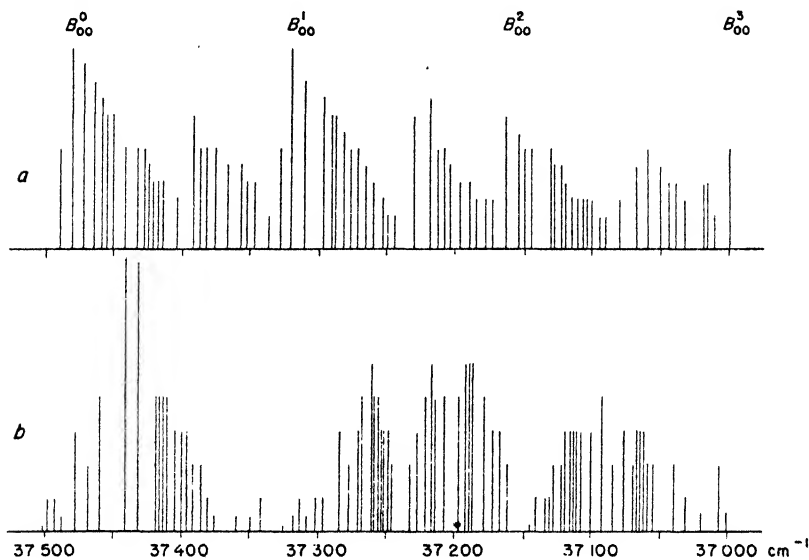

Fig. 91. Schematic representation of part of benzene fluorescence spectrum (Ingold and Wilson).

a: fluorescence spectrum at high vapor pressure.
b: resonance spectrum at low vapor pressure.

At high benzene pressures the first band group, between $38,600$ and $37,600\text{ cm}^{-1}$ ($2590\text{--}2659\text{A}$), containing the bands A_{00} , C_{00} , and B_{10} , is missing in the fluorescence spectrum on account of reabsorption. If, however, the "transferring collisions" are produced in benzene vapor of low pressure by addition of foreign gases, these bands appear with fairly great intensities, though with somewhat irregular intensity distribution, which is caused by the still-prevailing reabsorption of certain sub-bands (*10,1843*). (For instance, the band A_{00}^0 is more strongly absorbed than the band A_{00}^1 , etc.).

* Though not explicitly mentioned in the analysis of the fluorescence spectrum, the bands originating from the excited level $v' = 1$, also seem to be rather strong, as shown in Figure 6 of Sporer's paper.

The so-called resonance spectrum is by no means less complex, and shows rather less regularity in its structure (Figure 91*b*). It is unfortunate that, for technical reasons, resonance spectra in light and heavy benzene have been obtained only by excitation with the mercury line 2537A.* This line lies between two rather weak absorption bands of light benzene vapor; the two bands are indicated in Figure 90*b* as C_{10}^0 and A_{00}^1 . Their small intensity, especially at low vapor pressures, results from the fact that they originate from the vibrational levels 606 and 400 cm^{-1} , respectively. The periods 992 cm^{-1} (between C_{10}^0 and C_{11}^0) and of 1212 cm^{-1} (between C_{10}^0 and X_{10}^0) also appear in the resonance spectrum, while the period 160 cm^{-1} is missing because ν_2'' has the same value in all bands. On the other hand, the bands originating from the excited level (923 + 520 + 240) cm^{-1} , which is reached by the second possible absorption process, fall in between the first two progressions (left-hand side of Figure 90*b*). Besides, there are, again, transitions to additional levels of the ground state (e.g., 1598 or 3062 cm^{-1}), which make the appearance of the spectrum still more complicated.

In this respect heavy benzene is slightly more favorable: the mercury line coincides with the absorption band (2·479 + 230) ← (579 + 370) cm^{-1} , so that the emission bands originate almost exclusively from one and the same upper level; as a matter of fact, the resonance spectrum of heavy benzene is decidedly simpler than that of normal benzene.

The fluorescence of benzene vapor is affected very little by self-quenching, and the quenching efficiency of foreign gases (He, N₂, CO₂, cyclohexane, and even atmospheric air) is relatively small; transferring collisions by which the "resonance spectrum" is transformed into the "fluorescence spectrum" have by far the greater probability. If, however, the temperature is raised to 200° C at constant vapor pressure, the fluorescence becomes much weaker and its structure more diffuse; at 400° C, the fluorescence spectrum consists only of a faint continuous band. Simultaneously, the diffuseness characteristic of strong predissociation extends more and more from the short-wave absorption bands towards bands of greater wavelengths. Even at room temperature the mercury radiation produces considerable photodissociation competing with the excitation of fluorescence: after some time the walls of the container are covered with a deposit which is opaque to ultraviolet light.

* At low benzene vapor pressures, very long exposures are necessary and mercury arc lamps are practically the only light sources which burn steadily over many hours and emit a strong line in the spectral region of the benzene bands.

89. Simple Derivatives of Benzene. The optical properties of benzene derivatives in which one or several hydrogen atoms are substituted by other atoms or radicals are, in general, very similar to those of benzene vapor itself. However, the absorption bands, as well as the fluorescence bands, are always shifted to some extent in the direction of greater wavelengths, and, furthermore, the band structure, which in many cases is still visible in the absorption spectra, is frequently absent in the fluorescence spectra (Figure 92). In the most favorable instances (toluene, xylene, phenol), fluctuation maxima are superimposed on the continuous background, their spacing being, again, of the order of 1000 cm^{-1} . Even at the lowest vapor pressures

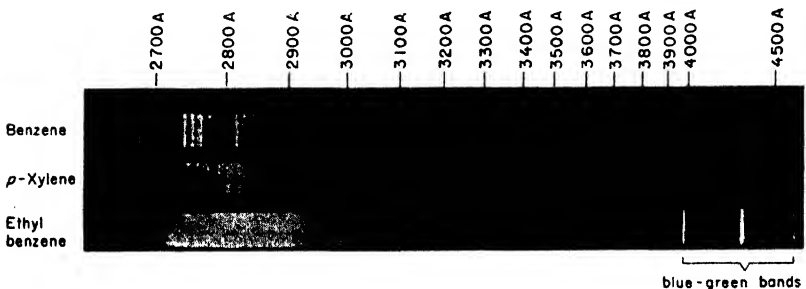

Fig. 92. Fluorescence spectra of benzene, *p*-xylene, and ethyl benzene (Marsh).

the conditions are not changed. This is caused not by the predominance of really continuous bands due to dissociation processes, but rather by the overlapping of ever more densely packed vibrational and rotational levels, and also by the fact that with increasing asymmetry of the whole molecule the selection rules forbidding certain transitions in benzene lose their strict validity. In many of these vapors a much greater fluorescence intensity can be obtained than in benzene vapor (984,985,1004).

Aniline vapor provides an especially instructive illustration for most of the statements made in the last paragraph. Its absorption power in the first absorption band and its fluorescence intensity are about ten times greater than that of benzene vapor under analogous conditions. The absorption bands show fine structure between 3026 and 2650Å; they are followed by a series of fluctuations and, finally, by a continuum beginning at 2520. At high vapor pressures, the fluorescence spectrum which reaches from 2850 to 4000Å is completely continuous with a maximum at 3150Å. The mean lifetime of the

excited state which can be derived from the half pressure of quenching by oxygen is of the order of magnitude of 10^{-8} sec.

Under excitation by light of wavelength below 2810A the fluorescence spectrum of aniline vapor does not show any structure even at a pressure of 10^{-2} mm (at room temperature) at which thermal equilibrium cannot be established in the excited molecules by collisions. Vartarian ascribes this behavior to the reasons discussed in Section 83g. The fluorescence spectrum is discontinuous, however, when the fluorescence is excited by the magnesium line 2937A; the line coincides with a strong band near the longwavelength end of the absorption spectrum which is supposed to be the $O' \rightarrow O''$ band of the system. Since under such conditions of excitation all excited molecules are in the nonvibrating state, the emission spectrum becomes a relatively simple "resonance spectrum." One of the principal spacings between band groups is 990 cm^{-1} in the emission spectrum and 950 cm^{-1} in the absorption spectrum, obviously corresponding to the wellknown characteristic frequencies of benzene. In the region between 2937 and 3027A the fluorescence bands coincide exactly with the absorption bands which are due to transitions from several levels of low vibrational energy in the electronic ground state.

Addition of foreign gases does not affect the sharpness of the "resonance bands", but it alters the relative intensities of the individual bands and stimulates the appearance of a number of anti-Stokes bands which are also present in the absorption spectrum. This redistribution of vibrational energy corresponds to the establishment of thermal equilibrium in the excited state (1648, 1745, 1746).

The complete fluorescence band reaching from about 3400 to 2800A can be excited, though with small intensity, by irradiating saturated aniline vapor at 200°C with light of wavelength 3900A. This wavelength not only lies far outside of the normal absorption band of the vapor, but the deviation from Stokes' law very much exceeds the Pringsheim 10*

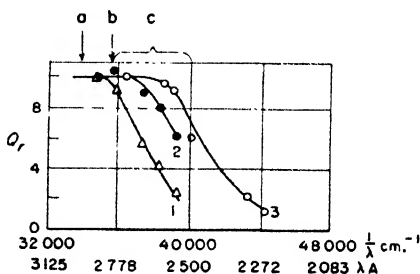

Fig. 93. Spectral distribution of relative quantum yield of aniline fluorescence [Terenin, Vartanian, and Neporent (1648)].

- 1: vapor in absence of foreign gas.
2: vapor with 700 mm of NH_3 added.
3: solution in hexane.

limit which should be expected from the available thermal energy. The phenomenon has been explained tentatively by Duschinsky, who made the following assumptions: the polyatomic molecule contains, on the average, in each of its $(3n - 6)$ vibrational degrees of freedom the thermal energy kT ; absorption of light in a band near the long-wavelength end of the absorption spectrum transfers the molecule to one of the lowest vibrational levels of the excited electronic state — in

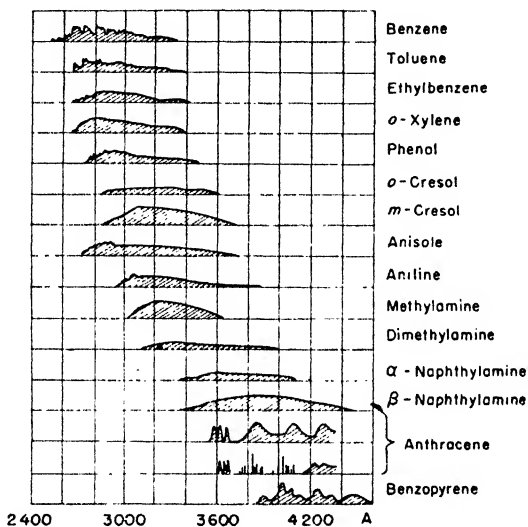

Fig. 94. Schematic drawing of the fluorescence spectra of various aromatic vapors.

the limiting case the molecule can lose all vibrational energy. In a molecule of 14 atoms this would amount to $36 \cdot kT$ or, at 200°C , to about 1eV . During the lifetime of the excited state, this energy is restored to the oscillations of the molecule by collisions and is subsequently available as additional energy for the emission process. The hypothesis has the shortcoming that the proposed transitions have an exceedingly small probability, but no better explanation of the phenomenon and of other similar ones mentioned in Section 96 has been brought forward so far (331,1269).

The fluorescence spectrum of fluorobenzene is weak and diffuse; the vapor of chlorobenzene is not fluorescent at all: apparently the light emission is completely suppressed by some competing process. The figures collected in Table 47, which gives only a selection of the

numerous fluorescent benzene derivatives, and the schematic drawings of Figure 94 need no further comment. It cannot be doubted that the

TABLE 47
FLUORESCENCE OF VAPORS OF AROMATIC COMPOUNDS

Compound	Formula	Limits of fluorescence spectrum, A	Type of bands
Benzene	C_6H_6	3100-2590	Series of complicated band groups showing fine structure
Toluene	$C_6H_5CH_3$	3400-2700	Many narrow bands superimposed on continuum
Ethylbenzene	$C_6H_5C_2H_5$	3600-2800	Continuum with two maxima
Propylbenzene	$C_6H_5C_3H_7$	3500-2850	Weak continuum
<i>p</i> -Xylene	$C_6H_4(CH_3)_2$	3850-2675	Diffuse maxima on continuous background
Mesitylene	$C_6H_3(CH_3)_3$	3800-2700	Three maxima on continuous background
Phenol	C_6H_5OH	3720-2810	Many irregularly spaced bands on continuous background
<i>o</i> -Cresol	$C_6H_4(OH)_2$	3610-2830	Continuum
<i>p</i> -Cresol	"	3680-2840	Five maxima on continuum
Aniline	$C_6H_5NH_2$	4000-2850	Fluctuations on continuum
Fluorobenzene	C_6H_5F	2880-2640	Four groups of bands on continuous background
<i>p</i> -Fluorotoluene	$C_6H_4CH_3F$	2950-2720	Groups of bands on continuous background
<i>o</i> -Chlorophenol	C_6H_4OHCl	3680-2850	Weak continuum
Benzaldehyde	C_6H_5CHO	5000-3940	Four band groups showing structure
Acetophenone	$C_6H_5CH_3CO$	4600-3900	Three diffuse maxima
Biphenyl	$(C_6H_5)_2$	3400-2800	Weak continuum
Benzidine	$(p-NH_2C_6H_4)_2$	4500-2950	Continuum
Diphenylamine	$C_6H_5NHC_6H_5$	4000-2400	Very weak continuum
Diphenyloctatetraene	$C_6H_5-(CH=CH)_4-C_6H_5$	7000-4000	Weak continuum with some indication of structure
Naphthalene	$C_{10}H_8$	4000-3080	Many narrow bands almost merged in strong continuum
Methylnaphthalene	$C_{10}H_7CH_3$	4500-3000	Continuum
Anthracene	$C_{14}H_{10}$	4300-3590	Sequence of bands (see Table 48)
Naphthacene	$C_{16}H_{12}$		Sequence of bands
Benzopyrene	$H_{20}H_{13}$	4550-3930	Sequence of bands (see Table 48)
Rubrene	$C_{16}H_8(C_6H_5)_4$	green	?
Octahydrofluorocyclene	$C_4F_8H_{36}$	5400-4100	Five discrete bands

fluorescence of most of these compounds is characteristic of the benzene ring itself, which is only slightly modified in its optical properties by the substitutions. In addition to their ultraviolet bands, Marsh and his collaborators observed in the fluorescence spectra of many benzene derivatives a series of bands in the blue-violet (see Table 90, Section 138) which always have the same appearance (984, 985, 1152, 1271). According to Terenin they belong to benzaldehyde, formed by a chemical reaction of the excited compounds, and are not characteristic of the benzene ring but of the carbonyl group in the molecule C_6H_5CHO . Since the absorption process takes place in the ultraviolet benzene band, the excitation energy must be transferred from one group to the other during the lifetime of the excited state, by a kind of "internal sensitization." Similar processes will be dealt with later. On the other hand, aniline vapor has a second u.v. absorption-band system which is ascribed to the NH_2 -group because of its analogy with the absorption spectra of other amines. The aniline fluorescence is not excited by light absorption in this band.

The fluorescence bands of biphenyl are very weak and diffuse; the same is true for the fluorescence bands of the diphenyl polyenes, while the fluorescence of these compounds in liquid solutions, and especially at low temperatures, shows a very definite structure (compare Section 134).

90. Condensed Aromatic Hydrocarbons. The aromatic hydrocarbons, consisting of from two to ten and more condensed benzene rings, are all fluorescent in liquid solutions and many of them have been found to be fluorescent in the solid crystalline state. It is very probable that this is also the case for the vapors of these compounds, although only relatively few instances are actually known. It was rather surprising that the simplest of these hydrocarbons, naphthalene, was not among them, while its fluorescence in liquid and solid solutions has been the subject of numerous investigations. Marsh obtained only a continuous emission band in the Tesla-luminescence spectrum of naphthalene vapor; he emphasized that it was the only case in which the fluorescence spectrum of the vapor showed less structure than that of the liquid solutions (985). However, a more recent report proved that by irradiating naphthalene vapor with monochromatic light of wavelengths below 3000A, the fluorescence emission of a long series of narrow bands is excited; bands which are superimposed between 3000 and 3340A on a strong continuum form the prolongation of a similar series of absorption bands; the two sets of bands coincide in the overlapping region. Vapor pressure and wave-

length of the primary radiation do not affect the aspect of the fluorescence spectrum (1292). V. Henri, who was very successful in investigating the spectra of polyatomic compounds, has derived a complete electronic energy-level scheme of naphthalene by combining the photo- and cathodoluminescence spectra of the vapor, of liquid solutions, and of the crystalline state with infrared bands of the vapor. Such constructions seem to lack a sound foundation, however, because the electronic energy levels are always strongly influenced by the surrounding medium, so that no conclusions can be drawn from apparent numerical relations between the frequency differences occurring in the spectra of the vapor and of solutions.

Publications dealing with the fluorescence of anthracene vapor are much more numerous. A strong violet fluorescence is excited by irradiating the saturated vapor at a temperature above 100° C with light of wavelengths below 3700Å; the spectrum consists of four rather diffuse bands with a spacing $\Delta\nu = 1370 \text{ cm}^{-1}$. Only the first of these bands is resolved into three sub-bands, which coincide exactly with the last long-wavelength band of the absorption spectrum. From there the absorption spectrum continues in the direction of smaller wavelengths with a series of diffuse bands. The spacing of the absorption bands of 1380 cm^{-1} is nearly the same as that of the emission bands; this seems to prove that the vibrational frequency responsible for its appearance is nearly identical in both electronic states. At a vapor pressure of 0.1 mm (110° C), the same fluorescence bands are excited by the radiation of various light sources (mercury, zinc, or carbon arc) as long as all wavelengths below 3100Å are eliminated by inserting a glass plate in the path of the primary light; a decrease of pressure to 0.02 mm (90° C) decreases only the intensity of the fluorescence, while the first group of the fluorescence bands is suppressed by self-absorption, if the pressure is raised to 1.5 mm (150° C).* Thus, even at the low density prevailing at the pressure of 0.02 mm, all molecules seem to be transferred into the same vibrational levels during the lifetime of the excited electronic state. This behavior may be due to the relatively long lifetime which F. Perrin found for anthracene dissolved in various viscous solvents. If his result can be applied to the vapor, it would not be surprising if the fluorescence of the vapor would be always completely depolarized, as has been stated in one of the papers dealing with the question. Under practically

* This is probably the reason why, in earlier papers, the short-wavelength group of anthracene fluorescence bands is not mentioned (362,996).

the same experimental conditions, however, Suppe obtained a degree of polarization $p = 33\%$; the reason for this discrepancy has not yet been cleared up (1292, 1599).

If anthracene vapor is irradiated with the cadmium line group near 3612A, which coincides with the last absorption band of the vapor, the fluorescence spectrum has a strikingly different aspect: the diffuse bands are replaced by groups of line-like narrow bands which are shifted with regard to the former by about 400 cm^{-1} in the direction of smaller wavelengths. The spacing between the groups is again 1370 cm^{-1} , while the distance between the individual sub-bands is of the order of 80 cm^{-1} . If the vapor pressure is increased from 110° to 150° C , the structure disappears and the fluorescence spectrum recovers its "normal" type. Although the behavior differs in several details, the phenomenon is very similar to that of aniline vapor described in the preceding section, and it must be explained, in the main, by the same assumptions (1292). It seems reasonable to expect that also the fluorescence spectra of other aromatic compounds which are continuous, in general, would exhibit the structure characteristic of their absorption bands, if a line coinciding with the $O' \rightarrow O''$ band were used for excitation.

Anthracene has a second absorption band system showing two diffuse maxima in the short-wavelength u.v.; it corresponds to another electronic transition. The violet fluorescence is excited by light absorption in these bands at even considerably lower vapor pressures because of the greater absorbing power of the vapor for the short-wavelength u.v. radiation. Since no light emission accompanies the transition from the higher electronic state to the emitting state, the transition must correspond to a process of internal conversion. In such a process very numerous vibrational levels of the emitting state must be populated and therefore the fluorescence band is under these conditions quite continuous between 3600 and 4400A.

The fluorescence of phenanthrene, which is an isomer of anthracene, has been the subject of several publications, in which it is described as being very similar to that of anthracene. It is very, likely, however, that this fluorescence was really due to admixtures of anthracene, as shall be pointed out in a later section, while the fluorescence of pure phenanthrene is exclusively ultraviolet (458c).

The only other instance of a polycyclic aromatic hydrocarbon of which the fluorescence spectrum has been investigated in the vapor state is represented by benzopyrene. The spectrum is similar to that of anthracene and is excited equally by the near-u.v. radiation of a

mercury and a carbon arc. The details of the spectrum, as well as of the fluorescence spectrum of anthracene vapor, are listed in Table 48. The bands show some structure and are separated by intervals of 1400 cm^{-1} (1292).

TABLE 48
FLUORESCENCE BANDS OF ANTHRACENE AND BENZOPYRENE VAPORS
(Wavelengths of band maxima in Å)

Compound	Wavelength of band maxima						
Anthracene	3595	3650	3695	3858	4074	4300	
Benzopyrene		3930		4050	4080	4150	4262 4320 4520

Only the color of the fluorescence is known for the vapors of a few additional compounds: dark blue for retene, orange red for naphthazarine, bright blue for perylene and rubrene. At higher vapor pressures the fluorescence of rubrene turns into a deep green because of the reabsorption of the blue and violet light by the vapor.*

91. Heterocyclic Compounds; Dyes. The number of heterocyclic aromatic compounds, and especially of dyestuffs, which are known to be fluorescent in solutions is almost unlimited. Only a few of them have been investigated in the vapor state. This may be due partly to the reasons mentioned in Section 86, but it is probable that the number of fluorescent vapors might easily be increased. The few examples which have been tested so far are listed in Table 49. While nothing is known about the fluorescence of acridine vapor, the acridine dye, acriflavine (tryptaflavine), can be heated up to 350°C without being destroyed, its vapor showing a bright blue fluorescence when irradiated with violet light. The fluorescence of the vapors of anthraquinone and of indigo was mentioned by Wiedemann and Schmidt in 1895; the fluorescence color of the vapor of the Kodak dye, 1,4-diaminoanthraquinone, turns from pure green into yellow with increasing vapor pressure. Considering the results obtained by Prileschajewa with the vapors of indigo blue and indigo red, it may be doubted whether this change of color is exclusively caused by reabsorption. The fluorescence spectra of the two indigo dyes is very similar, but a much greater intensity is obtained with indigo blue. If the vapor of the dye is irradiated with light of the near u.v. (2700–3800Å), the fluo-

* Unpublished observations; this holds also for most cases mentioned in the following section.

rescence is violet, its spectrum extending from 2800 to 5500A; by unresolved white light a blue fluorescence is excited, reaching from 3700 to 6000A. When a green filter is inserted in the path of the primary light, the fluorescence is yellow-green; it becomes orange by inserting a yellow filter, and red when the filter is orange. This is the only example known, at present, in which Stokes' law is obeyed in this strict manner (1274,1834).

TABLE 49
FLUORESCENCE OF VAPORS OF DYES

Compound	Fluorescence color	Compound	Fluorescence color
Acridine ..	blue to green*	Indigo red	blue
Anthraquinone	blue	Indigo blue	violet to red†
Diaminoanthraquinone ..	green to yellow*		

* Depending on vapor pressure.

† Depending on wavelength of exciting light.

92. Sensitized Fluorescence of Aromatic Compounds. The fluorescence of indigo vapor is not excited by light of wavelengths between 2700 and 2400A; if some aniline vapor is admitted into the observation chamber, the violet indigo fluorescence flashes up. Since the aniline vapor absorbs the incident light, the indigo fluorescence is excited, under these conditions, as sensitized fluorescence.

On the other hand, the excitation spectrum of aniline-vapor fluorescence is confined to the spectral region 2850–2500A; the zinc line 2500A produces only a very weak fluorescence in aniline vapor of 0.1 mm. After an exposure of half an hour, the photographic plate is not appreciably blackened. In the presence of benzene vapor of 15 mm, the aniline fluorescence excited by the zinc line is so much enhanced that it can be photographed in several minutes. In a mixture of aniline and benzene vapor, the benzene fluorescence, which is easily excited by primary light of wavelength 2500A, is very weak, while the aniline fluorescence is still noticeable at a partial aniline vapor pressure of 0.005 mm, at which it cannot be excited by light absorption in the long-wavelength absorption bands of aniline itself. Apparently the transfer of excitation energy from the benzene molecules to the aniline molecules has a very high efficiency (1273).

The phenomena described in the last two paragraphs are instances of typical sensitized fluorescence; they are interesting in themselves, because they are (apart from the case of the acetone-biacetyl

fluorescence) the only instances of sensitization by polyatomic molecules which have been observed so far in the vapor state. It is, however, even more surprising that either of the two processes is reversible. It has already been mentioned that the aniline emission bands can be excited with small intensity as anti-Stokes fluorescence by irradiating the vapor with light of wavelengths up to 3900Å. In the presence of indigo vapor, this anti-Stokes fluorescence is enhanced at least ten times. Similarly, the benzene fluorescence, which is not excited directly by the magnesium line 2800Å, appears in the emission spectrum, though only with small intensity, if aniline vapor is added to the benzene vapor. The excitation spectra of the three vapors and the fluorescence bands of indigo, aniline, and benzene are so distinct that any mistake is quite out of the question. A satisfactory explanation of the mechanism by which the energy for this anti-Stokes fluorescence is provided has not yet been suggested.

Another phenomenon may at least be mentioned in this connection. According to Prileshajewa, nitrogen, hydrogen, and carbon oxide quench selectively those parts of the fluorescence bands of the vapors of ethylbenzene, toluene, and aniline which are "in resonance" with some vibrational levels of the quenching molecules. Since the fluorescence bands are situated in the u.v., the quenching molecules must be transferred into very high vibrational levels of their electronic ground state, the corresponding quantum numbers v lying between 10 and 15. It has been pointed out in another section that such processes are exceedingly improbable from the theoretical viewpoint, and, since the effects obtained by Prileshajewa are little pronounced, her results must be confirmed by other investigations before they can be taken for granted (1272).

C. Fluorescence of Radicals Produced by Photodissociation of Polyatomic Molecules

93. Metal Halides. The photodissociation of the triatomic halides of Hg, Cd, and of Zn is quite analogous to that of diatomic metal halides, discussed in Section 69. The compounds can be dissociated by absorption of light in several continuous bands, and the only distinguishing feature is that one of the products of the dissociation process is not a metal atom but a metal halide radical, according to the equation:

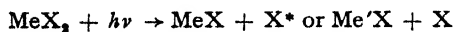

The wavelength of the primary light determines the excited state in which one of the two separating particles is found after the dissociation. Light absorption in the continuum of greatest wavelength produces, again, excited halogen atom X^* in a metastable state; if, by absorption of light of shorter wavelength, an excited radical $Me'X$ results from the dissociation, a molecular band is emitted subsequently instead of an atomic line. In Table 50 all results obtained with the halides of mercury, cadmium, and zinc are collected: $Me'X$, $Me''X$, and $Me'''X$ denote three excited electronic states of different energy; a , b , c . . . are the absorption or selective excitation bands; absorption of light in these bands excites the emission of the fluorescence bands A , B , . . . The fluorescence bands consist, in most cases, of long sequences of band edges or fluctuations which can be analyzed partially in accordance with the band theory for diatomic molecules, although this analysis frequently seems to be somewhat arbitrary. It is assumed that the lower electronic state which is reached by the emission of the bands B , C , and D is the ground state of the molecule MeX , because the spacings between the maxima in the three band systems have nearly the same values; taking this for granted, the heat of dissociation for the process $MeX_2 \rightarrow MeX + X$ can be derived from the wavelength of the exciting light and that of the fluorescence bands. Since the latter is much less well defined than the wavelength of an atomic line, this method of determining the heat of dissociation is even less accurate here than it was in the case of the diatomic metal halides.

The continuum of longest wavelength in which absorption of light produces the emission of a fluorescence band (e.g., C) is designated in the table by the corresponding small letter (e.g., c). However, the same fluorescence band may be excited with even greater efficiency by light absorption in a continuum of smaller wavelength; e.g., the violet fluorescence " B " of HgI , which can be excited by irradiation of HgI_2 -vapor with light of wavelength 2240 (absorption band b), becomes much stronger if the primary radiation contains light of $\lambda < 1870$, which is absorbed in band c (696, 1157, 1633-1636, 1661, 1836-1840).

Several additional processes occur in the photodissociation of the lead halides. By absorption of light in two different continua, only one band characteristic of the radical PbX is excited; therefore it is probable that the two absorption bands correspond to the two processes: $PbX_2 + h\nu \rightarrow PbX + X^*$ and $Pb'X + X$, X^* representing, again, the halogen atom in the metastable state $^2P_{1/2}$. Apart from the PbX -bands, the X_2 -bands and a number of atomic Pb -lines appear

in the fluorescence spectrum. Pb-lines are also observed in the absorption spectrum of the vapors. At the temperature and vapor pressure of the experiments (given in parentheses in Table 50), the vapors are dissociated thermally to a certain degree. However, since the intensities of the X_2 -bands and of the atomic lines are quadratic or even cubic functions of the primary light intensity, two or more individual absorption processes are contributing to their excitation, which, therefore, cannot be a case of normal sensitized fluorescence. The mechanism of the energy transfer from the excited PbX_2 -molecules

TABLE 50

ABSORPTION AND FLUORESCENCE BANDS OF POLYATOMIC METAL HALIDES (*a, b, c*... absorption bands; *A, B, C*... corresponding fluorescence bands; wavelengths in Å)

Products of dissociation	Band symbol	HgI ₂	HgBr ₂	HgCl ₂	CdI ₂	CdBr ₂	ZnI ₂	ZnCl ₂
MeX + X*	<i>a</i>	2600	2240	1850	2620	?	2200	?
Me'X + X	<i>b</i>	2240	1950	1810	2230	1970	1960	1750
	<i>B</i>	4450-3500	5040-3500	5660-3400	5670-5085	7000-?	6000-5300	5600-4900
Me''X + X	<i>c</i>	1820	1700	—	2070	—	—	1600
	<i>C</i>	3100-2800	2900-2700	—	3500-3250	—	—	3800-2850†
Me'''X + X	<i>d</i>	1730	1600	—	1820	—	—	—
	<i>D</i>	2800-2650	2700-2500	—	?	—	—	—
?	<i>e</i>	1600	2700-2500	—	—	—	—	—
		PbI ₂ (450°, 0.3 mm)		PbBr ₂ (250°, 1 mm)		PbCl ₂ (500°, 2 mm)		
PbX + X*	<i>b</i>	2326		2230		2050		
Pb'X + X	<i>b'</i>	2020		2080		1950		
	<i>B</i>	5000-4000 (12 broad bands)		4950-4433 (22 band edges)		4921-4098 (69 band edges)		
	<i>X₂</i>	5600-5350 (structure uncertain)		5600-5050 (13 band edges)		5258-4941 (48 band edges)		

† Three different excited states are ascribed, in a more complete analysis of the ZnCl₂-spectrum, to the bands listed here as fluorescence band *C*; if this is correct, the representation given in this table probably is too simple also for the other halides.

to the X_2 -molecules and the Pb-atoms has not yet found a satisfactory explanation. This holds also for the excitation of the mercury resonance line 2537A, which is always present in the fluorescence when HgI_2 is photodissociated.

The yellow-green iodine bands are emitted if the vapor of stannic iodide at a pressure of 110 mm (saturated at 60° C), is superheated to temperatures above 350° C and irradiated with light of wavelengths between 2500 and 2150A. In this case, the impossibility of a direct excitation of free I_2 -molecules has been proved experimentally: no fluorescence is produced by illuminating the vessel with green light, which is most effective in stimulating the visible iodine fluorescence (1103). Free iodine, which is actually produced by the photodissociation, must be frozen out carefully in order to prevent quenching of the fluorescence. The intensity of the I_2 -fluorescence is proportional to the intensity of the primary light and, therefore, cannot be caused by a recombination process of the type $I + I^* \rightarrow I_2^*$. On the other hand, the emission of the iodine bands is not observed at temperatures below 320° C and is continuously enhanced by raising the temperature to 550°, the limit reached in the experiments for technical reasons. In tin tetraiodide, the iodine atoms are not grouped in pairs, but form a tetrahedron symmetrically surrounding the central tin atom. Only if, at high temperatures, the amplitudes of the oscillations become sufficiently large, can two of them approach each other so closely that they can be separated in a single act from the parent molecule as an excited iodine molecule. Terenin calls this process "inner recombination in the photodissociation of a polyatomic molecule." Some of the I_2 -bands emitted under these conditions are anomalously enhanced, irrespective of the wavelength of the exciting light; according to Terenin, the abnormal intensity distribution is caused by a selective transfer of vibrational energy from the excited iodine molecule to the remainder of the original compound, SnI_2 (61,1103, 1647).

A yellow-green fluorescence which has been observed in superheated vapor of BiI_3 has been ascribed by Terenin to the analogous process $BiI_3 + h\nu \rightarrow BiI + I_2^*$, notwithstanding the fact that the fluorescence band is quite continuous.† Simultaneously, a number of atomic Bi-lines are emitted which may be due either to a secondary photodissociation: $BiI + h\nu \rightarrow Bi^* + I$, or to a direct excitation of Bi-atoms present in the vapor (1101).

† Therefore, the band had been ascribed previously to an excited molecule BiI_2 .

If the vapor of GaI_3 saturated at 300°C is irradiated with light of wavelengths below 2080\AA , the atomic gallium lines 4033 and 4172\AA appear in the fluorescence spectrum. A weak band at 3915\AA , which is excited by the radiation from a carbon arc, is ascribed by Petrowa to the undissociated molecule GaI_3 , while a much stronger yellow luminescence, which is excited only by light of wavelengths shorter than 1800\AA , is supposed to result from the photodissociation of the compound into $\text{Ga}^{\text{I}} + \text{I}_2$. The origin of a greenish fluorescence excited at 230°C by short-wavelength u.v. in the vapor of GaBr_3 has not been determined (*1230, 1818*).

The emission of the CuCl -bands due to the photodissociation of Cu_2Cl_2 by light of wavelengths below 2370\AA has already been mentioned in Section 61. Butkow's and Terenin's earlier experiments were repeated by Terrien, who obtained essentially the same results and succeeded no better than the Russian investigators in explaining the energy relations of the processes involved. If he illuminated the vapor simultaneously with u.v. light ($\lambda < 2370\text{\AA}$) and the lines of the Cu resonance doublet $3248/74\text{\AA}$, the resonance lines reappeared in the fluorescence spectrum in addition to the CuCl -bands. The intensity of the doublet dropped to $\frac{1}{4}$ if the total primary intensity was reduced to $\frac{1}{2}$ by means of a wire-gauze filter. Irradiation with the lines of the doublet alone was ineffective. Hence, it seems that the copper atoms are separated from Cu_2Cl_2 or CuCl -molecules by the absorption of ultraviolet light and are subsequently excited by absorption of the atomic lines while still in the gas phase, before they are precipitated (*191, 1649*).

Finally, a visible fluorescence is observed when the vapors of CH_3HgI and CH_3HgBr are illuminated by the light of strong sparks; the fluorescence is violet in the first, and blue in the second case. The color of the emission and the spectra are identical with those obtained in the vapors of HgI_2 and HgBr_2 . However, the fluorescence appears at much lower temperatures in the vapors of the organic compounds and the spectral range of the exciting light is different from that of the mercury halides. It is certain, therefore, that the primary process is a photodissociation of the compounds according to the equation: $\text{CH}_3\text{HgX} + h\nu \rightarrow \text{CH}_3 + \text{HgX}^*$ (*1646*).

94. Other Polyatomic Molecules. Terenin and his collaborators have observed the fluorescence of radicals which were produced by the irradiation of various polyatomic molecules with the Schumann u.v. of a hydrogen discharge lamp. By inserting very thin quartz plates and fluorite plates into the path of the exciting light they were

able to determine the short-wavelength limit of the processes qualitatively. From this limiting wavelength λ_m and the fluorescence wavelength λ_F , they calculated the electronic energy E of the excited radicals and the heat of dissociation D of the compounds (681,683, 684,1104,1638).

TABLE 51
PHOTODISSOCIATION OF MOLECULES CONTAINING THE RADICALS
OH, CN, NH₂, AND NO

Compound	Products of dissociation	D + E in eV	λ_m in Å	λ_F in Å
H ₂ O	H + OH*	5 + 4 = 9	1370	3062
CH ₃ OH	CH ₃ + OH*	3.9 + 4 = 7.9	1560	3062
C ₂ H ₅ OH	C ₂ H ₅ + OH*	3.9 + 4 = 7.9	1560	3062
HCOOH	HCO + OH*	3.9 + 4.6 = 7.9	1560	3062
HCOOH	HCO* + OH	3.9 + 3.6 = 7.5	1630	3400
CH ₃ COOH	CH ₃ CO + OH*	3.9 + 4 = 7.9	1560	3062
CH ₃ CN	CH ₃ + CN*	4.57 + 3.18 = 7.75	1600	3863
ICN	I + CN*			3863
C ₂ N ₂	CN + CN*			3863
NH ₃	H + NH ₂ *	5.1 + 2.4 = 7.5	1630	5000
N ₂ H ₄	NH ₂ + NH ₂ *	5.3 + 2.4 = 7.7	1580	5000
N ₂ O	N + NO*	4.1 + 5.6 = 9.7	1280	4000

The OH-band at 3062Å, corresponding to the vibrational quantum numbers $0' \rightarrow 0''$, is by far the strongest in all spectra in which the OH-radical is the carrier of the fluorescence and shows abnormally high rotational quantum numbers; the band at 2811Å ($1' \rightarrow 0''$) is much weaker, while the band at 3428Å ($0' \rightarrow 1''$) is noticeable only in the photodissociation spectrum of formic acid. In addition to the OH-bands, the fluorescence of formic acid contains a sequence of diffuse bands very similar to those of formaldehyde. However, the two sets of bands do not exactly coincide, and Terenin suggests that the new bands might belong to the radical HCO.

The band sequence with $\Delta v = 0$ ($0' \rightarrow 0''$, $1' \rightarrow 1''$, $2' \rightarrow 2''$) between 3883 and 3862Å has the greatest intensity in the CN-fluorescence following the photodissociation of various cyanogen compounds; the sequence $\Delta v = +1$ ($0' \rightarrow 1''$, $1' \rightarrow 2''$, $2' \rightarrow 3''$) between 4216 and 4181Å is much weaker and the sequence $\Delta v = -1$ ($1' \rightarrow 0''$, $2' \rightarrow 1''$) between 3590 and 3586Å is only just noticeable.

The emission bands of NH₂ exhibit a great number of narrow and closely spaced sub-bands; they are designated, in general as α -bands

of ammonia. The fluorescence has about the same intensity when the radical NH_2 is produced by dissociation of ammonia or hydrazine vapor; it is rather weak in the vapor of methylamine.

N_2O has a number of continuous absorption bands between 3000 and 1400A. The products of the dissociation processes corresponding to these bands are O- and N-atoms and NO- or N_2 -molecules in the ground state or in metastable states, so that no light emission follows the dissociation. By absorption of light in a very strong band at 1280A, however, the N_2O -molecules are split into a nitrogen atom in the ground state and an NO-molecule in the excited state $B^2\Pi$. From there the molecules can return to the ground state with emission of the so-called β -band of NO, which reaches from 5270 to 2185A; the great length of the band system is caused by the fact that the potential curve of the excited state, with an excitation energy of 5.6 eV, has its minimum at a much greater internuclear distance than the potential curve of the ground state. In Sen Gupta's experiments, only the long-wavelength part of the band was obtained by means of a glass spectrograph; the intensity distribution in this part of the system was normal, with the highest intensity in the bands at 4589, 4041, and 3800A. Light of wavelengths greater than 1800A, which would suffice for directly exciting the β -bands in NO-gas, was ineffective and thus it could be proved that the emission was really caused by the photodissociation of N_2O (1493).

The fluorescence of the OH-radicals is strongly quenched by addition of CO and H_2 ; the influence of foreign gases in reducing the abnormally high rotational energy in the OH- and CN-bands has been dealt with in Section 67. The fluorescence of CN is quenched by N_2 more effectively in the $O' \rightarrow O''$ band than in the $1' \rightarrow 1''$ band. For the NH_2 -fluorescence, nitrogen, carbon monoxide, and argon have about the same quenching efficiency. Most of these quenching processes seem to be caused by induced predissociation, but Terenin assumes that the OH-fluorescence is quenched by chemical reactions between the excited OH-radicals and hydrogen or carbon monoxide molecules.

PART II
Fluorescence and Phosphorescence
of Condensed Systems

CHAPTER IV

GENERAL SURVEY

A. Nature of Luminescent Substances

95. Conditions for Occurrence of Photoluminescence. Unperturbed fluorescence of gases and vapors is noted only at lowest pressures. At pressures at which collisions of excited molecules become sufficiently probable, either the secondary radiation is changed in frequency, or its intensity is weakened or even completely quenched. Polyatomic molecules seem to be less sensitive to quenching by collisions, in general, than monatomic vapors. In condensed states (pure liquid or solid, liquid or solid solution) the ability to fluoresce is lost, however, even in the majority of polyatomic compounds. The reasons for the absence of fluorescence due to the interaction of excited molecules with other molecules are, in principle, the same in condensed systems as in vapors: induced predissociation, chemical reactions, and "internal conversion." It is easily understood that the first of these processes has a greater chance of realization in condensed systems, where the excited molecules are in a constant state of collision.* In most instances no chemical reactions are produced by the absorption of light, and, especially if the nature of the surrounding molecules (of the solvent, for instance) has no marked influence on the optical properties of the absorbing substance, the re-emission of radiation must be suppressed by the third type of process (424).

The probability of internal conversion is greatly enhanced in condensed systems for two reasons. If, in a polyatomic vapor, the electronic excitation energy of an isolated molecule is converted to high vibrational energy of the electronic ground state, the inverse process must occur after some time. This fluctuation of energy from one form to the other may be repeated more than once, but as long as no collision takes place, the absorbed energy must eventually be re-emitted as radiation. Whenever a molecule has acquired a high

* It has already been pointed out that, on the other hand, the probability of spontaneous predissociation can be reduced by the stabilizing effect of collisions (see Section 83).

vibrational energy in a condensed system, this energy is almost immediately dissipated into thermal agitation of the surrounding medium and is never restored to the initially excited molecule. Also a molecule in a condensed system, especially in a solution, can never be treated as an isolated entity: in nearly every case it forms some sort of complex with surrounding molecules, e.g., of the solvent. Many metal ions exhibit, in aqueous solutions, absorption bands of much lower frequencies than those of the resonance lines in the vapor state and these may be due at least partially to electronic transitions between the dissolved molecules and the solvation envelope by which they are surrounded. In other instances the influence of the solvents on the absorption spectra of the dissolved molecules is relatively small, but none the less an interaction between the latter and the solvation envelope takes place and can greatly influence the fluorescence yield.

Since the existence of narrow absorption bands proves the corresponding electronic transitions to be well protected against perturbations from outside, one might assume that molecules exhibiting such bands should have a greater chance to be fluorescent than others. This is correct up to a point: among compounds with narrow absorption bands the number of fluorescing substances is relatively great, although fluorescence is by no means a general property of such compounds. For instance, the chromium alums and the uranous salts are not fluorescent. On the other hand, the absorption bands of many strongly fluorescent dye solutions are no less diffuse and broad than those of nonfluorescent dyes. Very small changes in the constitution of a molecule can have a great influence on the probability of internal conversion and, thus, on the occurrence or nonoccurrence of fluorescence without appreciably affecting the power of absorption.

96. Most Important Types of Luminescent Substances. If photoluminescence is a characteristic property of a compound as such, the molecules of this compound must be fluorescent under various conditions — for instance, when the compound is in the crystalline state, in a liquid solution, and in the vapor state. Practically all molecules which are photoluminescent in condensed states are more or less complex. The only exceptions are the positive ions of some rare-earth metals, the optical properties of which are so little perturbed by the surrounding medium that, even in crystals or in aqueous solutions, they behave almost like the atoms of a vapor. Among the complex inorganic molecules the positive ions UO^{++} are, with few exceptions, fluorescent in crystalline uranyl salts and in liquid solutions of such salts. A few other metallic ions (Tl^+ , Pb^{++} , and Sn^{++}) are able, in

aqueous solutions, to form complexes which can be excited to fluorescence (521,522,617,1304). In addition the cyanoplatinites are to be mentioned and, finally, some derivatives of siloxene which, owing to their ring structure, have much in common with aromatic compounds. It is doubtful whether the tungstates, molybdates, and some similar salts should be included in this class for, although many crystals containing these ions are strongly photoluminescent without being appreciably contaminated by an impurity, nothing is known about their fluorescence in other than the crystalline state. Thus, they may be classified as belonging to the mineral crystal phosphors.

Although only a relatively small number of inorganic compounds must be considered here, organic chemistry provides an almost unbounded wealth of examples, especially in the class of aromatic and polycyclic compounds, beginning with benzene and reaching to the most highly complex dyestuffs.

No less numerous are the substances belonging to the last main class of materials which are luminescent in the solid state. They are called "crystal phosphors."* As indicated by this designation, it is no longer an individual molecule which is luminescent by itself. The ability to re-emit absorbed radiation as light is intimately related to the condition that the molecules form a part of a crystal lattice; in most cases the luminescence is due to the incorporation of minute impurities into the "base material" of the crystal.

In general, only *fluorescence* is observed in liquids and most frequently it is a fluorescence of very short duration. Very weak phosphorescence has been obtained, however, with some liquid dye solutions (136,745,927b). Although a strong afterglow of considerable duration is observed with many solids (glasses as well as crystals), phosphorescence lasting many hours, and even days, after the end of the excitation seems to be a specific property of crystal phosphors "activated" by impurities.

97. Energy Transfer from the Absorbing to the Emitting Mechanism. In the isolated complex molecules of a vapor, radiant energy can be absorbed in one part of a molecule and pass into another part the characteristic fluorescence of which is subsequently emitted. If collisions occur, the electronic energy of an excited molecule can be transferred to the colliding molecule with subsequent emission of "sensitized fluorescence." Similar processes may take place in con-

* Many organic compounds are luminescent in the crystalline state, and so are uranyl salts and the platinous cyanides, but in these cases the crystalline form is not an essential condition for the occurrence of luminescence.

densed systems. The first type is observed at its best with certain complex rare-earth salts in liquid solutions.

The excitation and fluorescence spectra of crystalline or dissolved inorganic europium salts (nitrates, sulfates, etc.) are confined to several groups of narrow lines, and the fluorescence intensity which can be attained is weak. Organic salts of europium, such as the salicylaldehyde or the benzoyl acetate, have strong continuous absorption bands between 3200 and 4400A, and the characteristic europium line-fluorescence is excited with great intensity if the salt is irradiated with light of any wavelength between these limits. It is certain that the broad absorption bands which appear also in the absorption spectra of the organic compounds containing no rare earth are not connected with an electronic transition within the europium ion. The excitation of the internal electronic system of Eu^{+++} is caused by light absorption in another part of the complex molecule. The efficiency of the energy transfer seems to depend a great deal upon the nature of the bond between the rare-earth ion and the absorbing radical. It is best in the purely covalent, benzene-soluble benzoyl acetate, less good in the picrate, and completely missing in europium cyanoplatinite crystals with their purely ionic bonds (1816).

Probability of the energy transfer must also depend, however, on still other conditions, for the same compounds which provide the strongest europium fluorescence are quite inefficient with terbium. On the other hand, the green terbium line-fluorescence is excited with great brilliancy by light absorption in the u.v. bands of terbium acetoacetanilide, while the corresponding europium compound is very slightly fluorescent.

The converse effect has been obtained by Tomaschek. The excitation of the blue-violet fluorescence characteristic of organic acids by the Hg-lines at 3130A is greatly enhanced in the gadolinium salts of these acids (for instance, gadolinium salicylate) which in addition to the normal absorption bands of the acids show the typical absorption lines of the trivalent gadolinium ion in the vicinity of 3130A (Section 140). The violet fluorescence of the europium salts of the same organic acids is only very slightly excited by the Hg-lines at 3130A, while the fluorescence of the gadolinium and of the europium salts is excited with equal rather low intensity by the Hg-lines at 3650A which are not selectively absorbed by either of the rare-earth ions (1698c).

While the phenomena described in the last paragraphs may be designated as internally sensitized fluorescence, the experimental

proofs for the occurrence of externally sensitized fluorescence in liquid solutions are rather unconvincing.

In crystals still other means of energy transfer from an absorbing to an emitting center must be taken under consideration: "internal photoelectric effect" and "exciton migration." These might be regarded as belonging to the category of energy transfer within a complex molecule, insofar as a crystal can be treated as a huge polyatomic molecule. In the first instance, an electron is completely detached by light absorption from its normal location and, transporting a certain amount of energy, it travels across the crystal lattice until it excites light emission at another point within the crystal. Exciton migration is a purely quantum-mechanical resonance phenomenon; in a certain way it is similar to the diffusion of a resonance light quantum in the "imprisoned radiation" of mercury vapor. However, the total time during which the photon remains within the vapor as imprisoned radiation is the sum of the individual lifetimes of the single excited atoms, while, in a crystal, the total lifetime corresponding to exciton migration becomes shorter in the same ratio as the number of identical crystal elements which take part in the resonance process becomes larger. The excitation energy does not belong to an individual element at any moment, but simultaneously to all of them; the probability of emission increases correspondingly, and if the crystal is homogeneous it is not possible to determine whether the absorbing and the emitting centers are the same or not. If the crystal contains an impurity with a characteristic emission band of its own, light absorption may be due to the base lattice, through which the energy travels as an exciton until it reaches the impurity center where, finally, the radiation is emitted.

Both phenomena are of special importance for crystal phosphors. As these differ in many respects from other classes of luminescent liquids and solids, it seems advisable to treat their properties separately. But photoconductivity and exciton migration can also occur in luminescent crystals which do not belong to the class of "crystal phosphors" and, thus, they should be mentioned here (143b, 428, 1803). Leaving the crystal phosphors aside, the properties more or less common to all other photoluminescent solids and liquids are collected in the following sections, while in later chapters the principal classes of fluorescent substances are treated. This division of the material, although leading to some repetition or overlapping, seems to be the best way by which a more general understanding of the phenomena can be attained. The crystal phosphors are dealt with in the last chapter.

B. Course of the Emission Process

98. Fluorescence and Phosphorescence. It has already been mentioned in the introductory chapter that, in the present state of knowledge and experimental technique, the duration of the emission process does not supply an unequivocal method of distinction between fluorescence and phosphorescence. J. Becquerel held the opinion that no essential difference really existed between the two kinds of photoluminescence, and that there was a continuous transition from the first to the second. As we know now, the situation is complicated by the fact that typical fluorescence is not inconsistent with a relatively long afterglow. For phenomena of this kind, F. Perrin introduced the term "fluorescence of long duration," which, for the sake of brevity, will be replaced here by "slow fluorescence" (*A*,272,1221).

An instance in which all possible luminescence processes can be observed and which corresponds to the energy-level diagram of Figure 1 is provided by mercury vapor which is excited, at room temperature and in the presence of nitrogen, by the absorption of the resonance line 2537A. Some of the excited atoms re-emit the line as fluorescence within the normal lifetime (10^{-7} sec) of the state 6^3P_1 ; other atoms are transferred by collisions with nitrogen molecules into the metastable state 6^3P_0 . Some of these emit the forbidden line 2655A and thus return to the ground state by a relatively improbable transition which has a much longer decay period and must be designated as slow fluorescence. Other 6^3P_0 -atoms are brought back to the 3^1P_1 -state by collisions with nitrogen molecules of sufficient energy, and the final process is, once more, emission of the resonance line. The duration of this afterglow depends primarily on the frequency of collisions with sufficient energy (in other words, on the temperature) and is a typical phosphorescence.

For the complex molecules which have to be considered in these paragraphs, the energy levels and the corresponding transition probabilities are almost never as well known as they are in the example of the mercury atom. Nevertheless, it is possible also to give here general criteria for the discrimination between fluorescence and phosphorescence. Becquerel's hypothesis seemed, at first, to be corroborated by an experimental result. Wiedemann and Schmidt found that while liquid dye solutions showed only fluorescence with no measurable afterglow, a phosphorescence could be observed and its duration could be increased if the viscosity of the solution was increased by the

addition of gelatin (1454, 1835). A similar afterglow could be observed when the dye was dissolved in various solids such as sugar, benzoic acid, albumen, etc. Later, however, Vavilov and Levshin proved that there was no gradual increase of the duration of luminescence but that in the solid solutions the fluorescence retained the same short lifetime, of the order of magnitude of $5 \cdot 10^{-9}$ sec, and that a second process of much longer lifetime was superimposed on this fluorescence (1766). Boudin was the first to observe a phosphorescence lasting about 10^{-3} sec in a diluted eosin solution in glycerol free of oxygen which was placed in a Becquerel phosphoroscope. Kautsky obtained similar results with aqueous and alcoholic solutions of eosin, erythrosin, rose bengale, phloxin, and porphyrin; the relatively strong afterglow of chlorophyll could be observed only when the dye was dissolved in pure isoamylamine (136, 469, 750, 1453, 1454).

In every one of these cases the fluorescence and the phosphorescence are excited by light of the same wavelength and their emission spectra are identical: the light absorption leads to, and the emission starts from, the same excited level. It is obvious that the relatively stable state to which some of the excited molecules are transferred and which causes the appearance of phosphorescence is characteristic of the molecule itself; the phosphorescence is weak or completely missing in liquid solutions only because the probability of some sort of quenching process is much greater in this case. When phosphorescence occurs, the intensity of the luminescence drops to a much lower level at the moment when the primary radiation is cut off; from there on, it decays continuously to zero.

If an afterglow can be observed in a phosphoroscope or even without such an instrument, and if the intensity curve shows no discontinuous break immediately after the end of the excitation, the afterglow is not phosphorescence but a slow fluorescence [corresponding to the emission of the forbidden line by the Hg (6^3P_0)-atoms]. If this afterglow lasts only a few thousandths of a second or less, the bands corresponding to the same electronic transition are observable also in the absorption spectrum, and the slow fluorescence can be excited "directly" by light absorption in these bands (272 1218, 1227, 1767).

Many organic substances can be excited to emit a slow fluorescence different in color from their normal fluorescence and lasting several seconds. In general no band corresponding to the forbidden electronic transition which produces this slow fluorescence is found in the absorption spectrum; emission is excited by light absorption in

the normal absorption bands of the substance, exactly as emission of the forbidden Hg-line is excited by absorption of the mercury resonance line and a subsequent transfer of the atoms to the metastable state: it is an "indirectly excited" slow fluorescence. It has already been stated that the visible slow fluorescence of Eu^{+++} and Tb^{+++} which can be excited directly is excited indirectly, with much greater intensity, in certain complex organic compounds (1816).

The long lifetimes of the states M from which phosphorescence and indirectly excited slow fluorescence originate need not be due [as in the case of $\text{Hg}(6^3P_0)$], or at least may not be due exclusively, to electronic selection rules according to which certain transitions are forbidden or, rather, extremely improbable. Existence of longlived high-energy modifications of polyatomic molecules can also be explained by applying the Franck-Condon principle and by assuming that the atomic nuclei have an equilibrium configuration in state M which does not correspond to any configuration occurring in the electronic ground state. Under these conditions, a radiating spontaneous transition from M to N has an exceedingly small probability. Franck and Livingston, therefore, call the state M a tautomeric modification of the molecule. With a less specific designation, which may be applied also to the analogous phenomenon in crystal phosphors all states which owe their long life to the Franck-Condon principle will be classified as "quasi-stable," in contradistinction to those which are "metastable" because of an electronic selection rule (424).

The duration of a fluorescence process is essentially independent of external conditions insofar as this duration is determined by internal transition probabilities. If the mean life τ_0 of an excited state is shortened by a quenching process which might depend on the temperature this is, according to Equation (8), (compare Section 4, page 6) always accompanied by a proportional decrease in the total luminescence yield. Apart from such secondary effects, the temperature has no influence on the duration of fluorescence. As a matter of fact the afterglow of the uranyl salts or of the slow fluorescence bands of dyestuffs is very nearly the same at room temperature as at liquid-air temperature (927a, 1227, 1302). On the other hand, it follows from the energy-level diagram of Figure 1 that the duration of a real phosphorescence is fundamentally a function of temperature, since the energy deficiency $F - M = \epsilon$ must be provided by thermal fluctuations. The lower the temperature, the longer is the average time interval elapsing before the necessary energy is supplied to M . Below a certain temperature the return from M to F will practically not occur at all, while the

passage from N to F by light absorption and the transition from F to M is not impeded.

Thus, the phosphorescence is excited and "frozen in." If the temperature is subsequently raised, the absorbed energy is set free and re-emitted without new excitation as a brilliant flash. This phenomenon was discovered by Dewar when he immersed barium cyanoplatinite* in liquid air (283). Even if the platinite is kept after excitation in the dark at low temperature for an hour or more, a bright light emission takes place when the liquid air is removed. Similar phenomena occur in the phosphorescence of solid dye solutions, though with smaller efficiency. The most brilliant examples of "frozen-in" phosphorescence are found in certain crystal phosphors. All so-called thermoluminescence is nothing but phosphorescence which already is frozen in at room temperature.

99. Decay Curves. All emission processes treated in this chapter, normal and slow fluorescence as well as phosphorescence, are monomolecular (first-order) processes. Hence, according to theoretical expectation, their decay curves should all be simple exponentials:

$$I = I_0 e^{-at}, \text{ with } a = 1/\tau \quad (60)$$

From fluorometric measurements and other more indirect methods, the fluorescence of liquid dye solutions is known to have a lifetime usually not exceeding $5 \cdot 10^{-9}$ sec. The shape of the decay curve during so short a period has not yet been determined by direct experiments. However, the assumption of an exponential decay of the fluorescence of dye solutions is supported by the fact that calculations based on this hypothesis yield identical values for the lifetimes of excited dye molecules when widely differing shutter frequencies are used for obtaining the fluorometer curves, from which the τ -values are derived (compare Figure 4) (1623). Another result of fluorometric measurements, which was obtained by Cram and later confirmed by Thumerman, must be mentioned in this connection. Fluorometer curves corresponding to the fluorescence of various dye solutions at low temperatures could be interpreted only by supposing that a dark interval of the order of magnitude of 10^{-7} sec occurred between the end of the excitation and the beginning of the emission, while the latter proceeded from there on with the normal decay period of $5 \cdot 10^{-9}$ sec (243, 1709). The interpretation of several earlier experiments which seemed to prove the existence of a dark interval between the end

* At room temperature, this compound shows only a short-lived fluorescence.

of the excitation and the beginning of the emission in fluorescing solutions were based on erroneous assumptions concerning the methods used in these experiments (464,525,638,1884). Cram's and Thumerman's papers do not seem to contain any fallacies of this kind, but no theoretical interpretation of their unexpected results has been found so far (Compare Section 78).

For slower fluorescence processes a direct observation of the decay is possible and, in all cases in which measurements were made, the results were in satisfactory agreement with an exponential decay.

Nichols and Merritt, to whom we are indebted for much important research on the fluorescence of uranyl salts, were of the opinion that this luminescence originated from a bimolecular reaction and that its intensity after the end of the excitation should, therefore, be represented as a function of time by an equation of the type:

$$I = Ct^{-2} \quad (61)$$

From their experiments they derived for every uranyl salt several (in most instances, three) different values of the constant C for different intervals of time t , and so the curve representing $I^{-\frac{1}{2}}$ as a function of t was a broken line consisting of three straight branches (Figure 95).

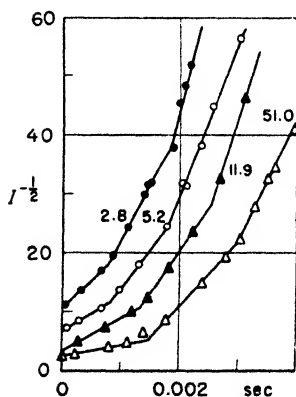

Fig. 95. Decay of fluorescence of uranyl salts at intensities varying from 2.8 to 51.0 (in arbitrary units) (Nichols and Merritt).

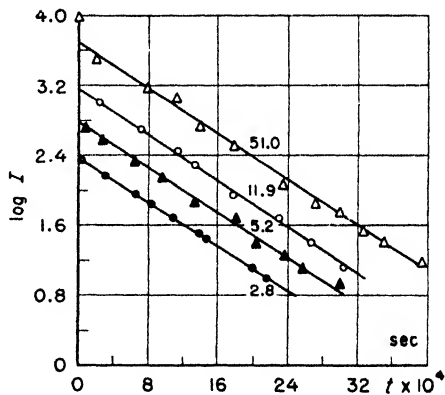

Fig. 96. The values of Figure 95 in a plot of $\log I$ versus t [Vavilov and Levshin (1767)].

Vavilov and Levshin showed, however, that all results published by Nichols and Merritt, as well as a great number of new observations of

their own, were represented without exception as straight lines on $\log I$ versus t diagrams, in accordance with Equation (60) (Figure 96) (*H, III3, III6, I767*).

The same has been proved by various authors for the phosphorescence and for the slow fluorescence of solid dyestuff solutions, platinum cyanides, canary glass, and other luminescent compounds with values of τ larger than 10^{-4} sec (Figure 97). Minor deviations from strictly logarithmic decay curves which were occasionally observed probably can be ascribed to secondary effects (*459f, 915, 927a, 930, 1302, 1428, 1772*).

For instance, if, in a solid solution with a luminescence yield less than 100 %, the solvent molecules surrounding the individual molecules of the luminescent compound do not have identical configurations, the excited molecules may have unequal probabilities of transferring their excitation energy to the solvent. Thus they would have slightly different mean life times and the decay curve would correspond to the superposition of numerous exponentials with slightly different exponents.

As mentioned in the foregoing section, the coefficient a in Equation (60) is a function of temperature for phosphorescence processes. In the first approximation the relation between a and the absolute temperature T is also exponential:

$$a = se^{-\epsilon/kT} \quad \text{or} \quad \log a = b + c \cdot T^{-1} \quad (62)$$

where $\epsilon = F - M$ or the heat of activation of the phosphorescence process. s is nearly constant but varies slightly with the temperature; it determines the probability with which the process occurs when the energy ϵ is provided by thermal fluctuations.

The decay of a simple band whether fluorescence or phosphorescence, is always uniform for all parts of the band. This has been proved by direct observation for the slow fluorescence of uranyl salts and rare-

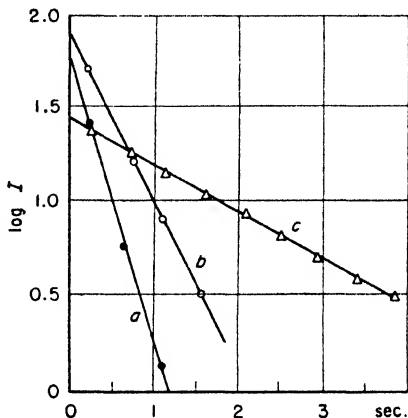

Fig. 97. Decay of the luminescence of tryptaflavine adsorbed on silica gel (Pringsheim and Vogels).
a: green phosphorescence at $+39^{\circ}\text{C}$. *b*: the same at -18° .
c: orange slow fluorescence at -180°C .

earth ions, and for the fluorescence and phosphorescence of dyes in solid solutions; it has been proved by indirect methods for the short-lived fluorescence of liquid dye solutions. In every instance where the color of the luminescence varies during the period of the afterglow, it could be shown that two emission bands of different spectral composition and with different lifetimes were superimposed. An example is the green phosphorescence band and the yellow band of slow fluorescence emitted by tryptaflavine in solid solution at -40°C (927*a*, 1302).

Any light emission which is excited by light absorption must have a certain period of growth or "induction" corresponding inversely to the decay period. With a long-lasting constant irradiation the luminescence reaches a limiting or equilibrium value I_0 when the number of molecules excited per second by light absorption is equal to the number deactivated by emission:

$$dn/dt = A - an_0 = 0; I_0 = an_0 = A; a = 1/\tau_0 \quad (63)$$

Absorbed energy A and emitted energy I are measured in quantum units, and no quenching processes of any kind are assumed to exist in this simple treatment.

In analogy to the mean lifetime τ_0 at the end of which the intensity has dropped from I_0 to $I = e^{-1}I_0$ after the termination of the excitation, the mean induction period ϑ can be defined as the time elapsed from the beginning of the excitation until the luminescence has attained the intensity:

$$I = (1 - 1/e)I_0 \quad (64a)$$

If the luminescence is due to the same electronic transition as the absorption and both have the same transition probability (an assumption which is valid for practically all directly excited fluorescence processes), τ_0 and ϑ are equal, irrespective of the absolute value of τ_0 . This follows from the integration of Equation (63) for $dn/dt > 0$:

$$n = n_0 (1 - e^{-t/\tau}) \text{ for } t = \tau_0 = \vartheta \quad (64b)$$

If, on the other hand, the duration of the luminescence depends partially on transition probabilities which have no influence on the absorption process, as in phosphorescence and indirectly excited slow fluorescence, the mean induction period can never be longer than the mean decay period, but it can be much shorter. Under these conditions, τ_0 and ϑ are no longer connected by a definite relation. Temperature determines the duration of phosphorescence because it determines the

transition probability from M to F , but it has no influence on the absorption process. If the intensity of the exciting irradiation is kept constant, a decrease in temperature increases the number of molecules which remain in the quasi-stable state; eventually, practically all molecules have been transferred into this state when equilibrium is reached. The phosphor is then "fully excited" or "saturated." Greater intensity of the exciting light produces saturation within a shorter time, while this leaves the decay period of the phosphorescence unaltered. Similar considerations are valid for indirectly excited slow fluorescence.

The existence of an induction period was discovered by Becquerel in luminescence processes which are now classified as slow fluorescence. The phenomenon is easily observed in the slow fluorescence of organic compounds at low temperatures (for instance, Kowalski's "progressive phosphorescence"; compare Section 136) and in the phosphorescence of many crystal phosphors (815).

100. Luminescence Intensity and "Light Sum" L . Under the conditions stated in the last section, according to which the periods of growth and decay of luminescence are equal, the relative number of excited molecules always remains small compared to the total number of unexcited molecules, even if the primary radiation has a very high intensity. Therefore, the fluorescence intensity is strictly proportional to the intensity of the exciting light over the widest obtainable range (582). This is no longer true if, in the course of a phosphorescence excitation process, a relatively great number of molecules is transferred into a quasi-stable state M . Under these conditions, the phosphorescence intensity reached at the end of the excitation process tends toward its saturation value I_m . A further increase of the primary intensity has no appreciable influence on this value. Figure 98 shows the phosphorescence intensity of fluorescein dissolved in vitrified boric acid at 18°C as a function of the strength of the primary radiation: if the intensity of the exciting light is reduced to one-half of its maximum value, the phosphorescence decreases by only about 12%. Similar curves were obtained for the slow fluorescence of the same solid solution at -185°C (930).

For any kind of fluorescence, regardless of its duration and its mode of excitation, the intensity of the secondary radiation is a direct measure of the number of excited molecules present at the moment of observation, according to Equation (63), in which constant α depends only on the nature of the luminescent molecule. On the other hand, the intensity of a phosphorescence can be very small or even zero at the

end of the excitation period in a fully excited phosphor. Hence, the number of excited molecules present at a given moment is no longer proportional to the actual intensity of luminescence but to the total

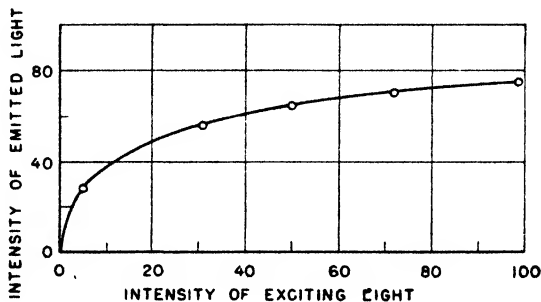

Fig. 98. Intensity of the phosphorescence of fluorescein in boric acid as a function of the exciting radiation at 18° C (Lewis, Lipkins, and Magel).

number of light quanta the substance is still able to emit without new excitation, or to the "light sum" L stored in the phosphor:

$$L_t = \int_t^{\infty} I dt \text{ or } I = -dL/dt \text{ and } I_0 = I_0 \int_0^{\infty} e^{-at} dt = I_0\tau \quad (65)$$

If a simple exponential decay is assumed for I , L is also an exponential:

$$L = I_0\tau e^{-at} \quad (66)$$

If τ is known, I_0 and L_0 can be derived from the measurement of I at any given moment after the end of the excitation. As long as τ is constant, I_0 and L_0 are proportional to I at any given time t , and in order to find, for instance, the relative change of I_0 or L_0 with varying intensities of the primary light it is sufficient always to measure I at the same time t after the end of excitation under the varying conditions of irradiation.

If the intensity of the primary radiation is far below the saturation value,* I_0 is equal to A [Equation (63)] as soon as the equilibrium state is reached and according to Equation (65) the light sum or the total energy stored in a phosphor at a given intensity of primary radiation increases proportionally with τ . If experimental results

* This condition is fulfilled in almost all cases of afterglow not exceeding a few seconds.

disagree with this conclusion, some kind of quenching process must compete with the luminescence emission. In the other limiting case, when saturation is reached either because the exciting radiation is extremely strong or because the lifetime τ is very long, L_0 has always the same value at the end of the excitation period, while I_0 decreases with increasing τ -- for instance, when the temperature is lowered.

In a saturated phosphor, L_0 is proportional to the total yield Q even in the presence of some quenching process, while I_0 , being a function of τ , is not directly connected with Q . If, on the other hand, the phosphor is far from being saturated, I_0 is proportional to Q , regardless of the value of τ , while L_0 would increase with an increase of τ according to Equation (66). (In the case of saturation, I_0 would decrease with decreasing temperature at a constant value of Q ; far below saturation, the luminescence intensity is always $I_0 = QA$ after equilibrium is reached).

C. Emission, Absorption, and Excitation Spectra

101. Band Width, Stokes' Law, and the Franck-Condon Principle.

The energy levels of a luminescent molecule are influenced in two different ways by the continuous and fluctuating interaction with the surrounding medium. Under this influence the energy of a level is not sharply determined, but varies at every instant for differently located molecules and varies with time for every individual molecule. The broadening of the energy levels is due to the electronic rather than to the vibrational part of the total energy, since the Raman lines due to intramolecular vibrations are nearly as narrow in liquids as in vapors. Equally sharp fluorescence lines are very infrequent in condensed media; they occur exclusively in crystals at low temperatures. As a second consequence of the continuous energy exchange with the surrounding medium, no vibrational energy transferred to a molecule by the absorption process can be retained by the molecule during the period elapsing before the re-emission takes place. Therefore, the emission process always originates from one of the lowest vibrational levels of the excited molecule.

Lenard was probably the first to ascribe the great width of the bands in the emission spectra of crystal phosphors to the fluctuation of the molecular fields. The problem of the band width and of the spectral displacement of the fluorescence bands with respect to the absorption bands has been treated by Jablonski on the basis of the

Franck-Condon principle. His considerations were essentially the same as those used for polyatomic vapors at high pressures. The energy of an individual state, however, no longer depends only on the electronic and vibrational energy of the molecule itself, but is affected by the configuration of the surrounding molecules which may have different equilibrium distributions if the electronic state of the molecule is changed. All these parameters are now included in the representation of the potential energy by "configuration potential curves." The latter admittedly give a rather incomplete picture of the real situation, but are easier to visualize than polydimensional potential surfaces. In general, the minima of the curves representing the ground state and the excited state do not have the same abscissas; due to zero-point energy and thermal fluctuations, the molecules do not occupy these minima but oscillate about them with a Maxwellian distribution. Because of this distribution in the ground state, the absorption band has an appreciable width and an approximatively symmetrical intensity distribution around a center, which corresponds to the vertical transition from the minimum of the lower curve to the upper curve. After re-establishment of thermal equilibrium in the excited state, which corresponds again to a Maxwellian distribution, the return to the ground state produces an emission band of about the same width and shape which were characteristic of the absorption band and with a center of gravity which must always be shifted in the direction of longer wavelengths (Figure 99) (659).

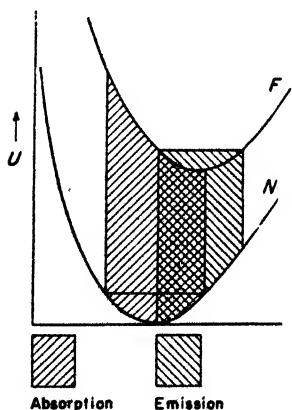

Fig. 99. Potential curves for fluorescence in a condensed system (Jablonski).

The intensity distribution within the emission band is independent of the exact wavelength of the exciting light (656). Only if thermal equilibrium should not be re-established during the lifetime of the excited state would the energy distribution in the luminescence band be more or less influenced by the wavelength of the exciting radiation. Experiments which seemed to show the existence of such an effect were performed by Starkiewicz on dye solutions in water-free glycerol and were explained by the slower energy exchange in a highly viscous medium. However, these experiments are not very conclusive (1555). [A similar effect was described by Gudden

in the fluorescence of certain crystal phosphors and was explained by the same assumption (536).]

Corresponding to the "anti-Stokes" terms in the resonance spectra of diatomic vapors, small departures from the strict form of Stokes' law also occur in the fluorescence of condensed systems. The question of the possibility of exciting fluorescence by light of wavelengths longer than that of the secondary radiation has been the subject of much discussion; eventually it was proved that the whole fluorescence band is emitted even if the luminescence is excited by a line which lies inside the range of the emission band. This means only that the absorption (or excitation) band and the fluorescence band overlap. Theoretically it is explained by the same assumption as every anti-Stokes fluorescence, namely, that a part of the excitation energy is supplied by the thermal energy of the surrounding medium. The center of the absorption band, however, is always displaced in the direction of shorter wavelengths with respect to the emission band (814).

The effect of temperature on the appearance of anti-Stokes fluorescence has been demonstrated very convincingly by Wood, who excited the fluorescence of an aqueous uranin solution by light of the longest wavelength capable of stimulating fluorescence at room temperature. The intensity of the fluorescence was enhanced considerably by heating the solution to 100° C; this is not due to an increase in fluorescence yield, but to an increase in absorption at the long-wavelength end of the absorption band. At higher temperatures a greater fraction of the molecules in the electronic ground state populate the higher vibrational levels and thus absorb light of greater wavelength. The gain in anti-Stokes fluorescence exceeds even the apparent gain in fluorescence intensity, because simultaneously and for analogous reasons the emission band stretches farther in the direction of shorter wavelengths (1892).

If the lowest points in the potential curves N and F of Fig. 99 have widely different abscissas, a broad interval separates the long-wavelength end of the absorption band and the short-wavelength end of the emission band. Otherwise the two bands overlap, and, if the secondary radiation has to travel a considerable distance before emerging from the fluorescent medium, a part of the fluorescence light is reabsorbed in this medium. An apparent displacement of the center of the emission band can be produced thereby, but such an effect is by no means able to explain the "Stokes shift," as was assumed by J. Stark; without the independent existence of the Stokes shift, a band

reversal and not a displacement of the center of the band would be the result of reabsorption.

In order to obtain the real spectral intensity distribution within a fluorescence band, either the emission by an infinitely thin layer or by a very dilute solution must be investigated, or the observations must be extrapolated to these limiting values by measuring the spectral distribution of the absorbing power of the fluorescing medium and integrating over the radiation coming from different depths.

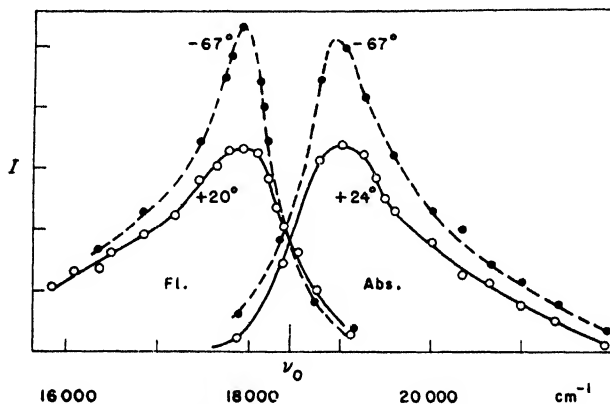

Fig. 100a. Mirror symmetry of absorption and fluorescence bands.

Rhodamine 6 G in ethanol (Levshin).

102. So-called Mirror Symmetry. The diagram of Figure 99 explains the general analogy between the absorption and emission bands and the fact that changes in temperature affect the two types of bands in a similar way. It also determines the limits beyond which the frequently quoted, so-called law of mirror symmetry loses its validity. This law was first stated by Levshin on purely empirical grounds. It contends that if the intensities of an absorption band and of the corresponding fluorescence band are plotted as functions of the frequency,* the two curves are symmetrical with respect to a frequency ν_0 lying halfway between the peaks of the two bands (Figures 100a and b) (912-914).

In the simple case of a diatomic molecule such a symmetry exists only if the shapes of the potential curves of the combining states are

* The intensities are measured in quanta ($I/h\nu$) and the peak of the emission curve is given the same value as the peak of the absorption curve.

the same and if, consequently, the vibrational frequencies ω_0'' and ω_0' as well as their anharmonicities $\omega''x''$ and $\omega'x'$ are identical in both electronic states. Under these conditions the center of symmetry corresponds to the $0'' \leftrightarrow 0'$ band which coincides with all other transitions $\Delta v = 0$ and has the greatest intensity in both the absorption and the emission spectrum. If, on the other hand, the potential curve of the excited state is appreciably shifted with respect to that of the ground state, the transition $0'' \leftrightarrow 0'$ has a vanishing probability and

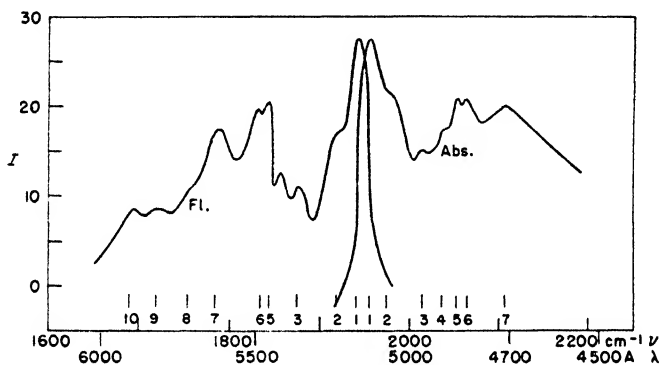

Fig. 100*b*. Mirror symmetry of absorption and fluorescence bands.

Triphenylmethyl in pentane-ether-ethanol mixture
at -190°C (Lewis, Lipkin, and Magel).

the two spectra no longer overlap. At the same time the vibrational frequencies and the values of the ωx 's differ in the two electronic states, and, if ω'' is larger than ω' , the absorption spectrum (represented by the progression $v'' = 0, v' = 0, 1, 2 \dots$) is compressed into a smaller frequency range than the fluorescence spectrum ($v' = 0, v'' = 0, 1, 2 \dots$): the symmetry law does not hold.

These considerations, which are strictly correct only for diatomic molecules, can be applied also to polyatomic molecules with several vibrational frequencies $\omega_1, \omega_2, \omega_3$, etc., if a progression of one of these frequencies (e.g., ω_1) is the predominant feature of their spectra. The spectra of benzene and of the uranyl salts, which have been quoted by Levshin as examples of the mirror symmetry, belong to this class. In the emission spectra of both, the spacings between the main band groups are appreciably larger than those in the absorption spectra. Moreover, the intensity distribution in the absorption and fluorescence

spectra of the uranyl salts differs widely. While the fluorescence spectrum consists of bands due to a single electronic transition, the corresponding band system in the absorption spectrum is overlapped by bands with slightly different spacings which are due to transitions to several higher electronic states; eventually these overlapping band systems merge into a continuum which probably is connected with a photodissociation process (Fig. 101) (1288,1289).

The conditions are essentially different if the first band in the

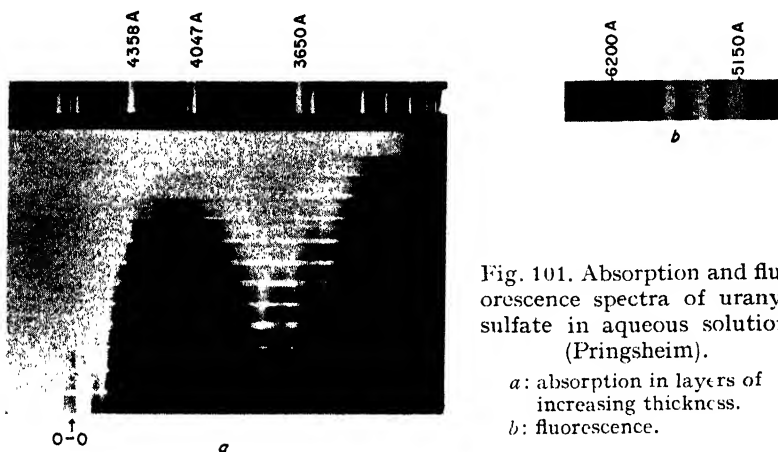

Fig. 101. Absorption and fluorescence spectra of uranyl sulfate in aqueous solution (Pringsheim).

a: absorption in layers of increasing thickness.
b: fluorescence.

absorption spectrum and the fluorescence band of a polyatomic molecule do not correspond to a progression of the type assumed above, but to a single vibrational transition $\bar{\omega}_1'' = 0 \rightarrow \omega_1' = 1$ and $\omega_1' = 0 \rightarrow \omega_1'' = 1$, respectively, on which vibrational frequencies $\omega_2, \omega_3, \dots$ are superimposed. The electronic excitation may affect only the frequency, ω_1 , while the internuclear bonds which determine the other vibrational frequencies remain practically unaltered. The band group is then represented in the absorption spectrum by the frequencies $\omega_1', \omega_1' + \omega_2, \omega_1' + \omega_3, \dots$ and in the fluorescence spectrum by the frequencies $\omega_1'', \omega_1'' - \omega_2, \omega_1'' - \omega_3, \dots$ (or $2\omega_1', 2\omega_1' + \omega_2$, etc., according to the relative displacement of the two potential curves) and the center of symmetry is no longer the missing band $0'' \leftrightarrow 0'$ but a point halfway between the two bands, which are separated by the frequency gap $\omega_1' + \omega_1''$ (compare Section 83, g).

An example of this kind seems to be represented by the absorption and fluorescence spectra of the radical triphenylmethyl (Figure 100*b*). Pauling pointed out that the frequency differences

occurring between the individual band maxima of these spectra were in fair agreement with Raman frequencies of other compounds containing the same bonds. Another case of a similar nature is discussed more fully in Section 134 (932,1201).

Levshin has collected a great many examples of dye solutions for which his symmetry postulate holds even if the absorption and fluorescence bands undergo appreciable changes by variation of temperature, choice of solvent, etc. (Figure 100*a*). In these examples, both bands are influenced in the same way by the changing conditions (914).

TABLE 52
WAVELENGTHS OF THE ABSORPTION AND FLUORESCENCE BAND PEAKS OF MEROCYANINE DYES IN DIFFERENT SOLVENTS

Solvent	$n = 1$		$n = 2$		$n = 3$	
	Abs.	Fl.	Abs.	Fl.	Abs.	Fl.
Cyclohexane	4920	5480	5380	6330	5700	(6470)
Alcohol	5240	5590	6000	6440	6340	7650
Pyridine + H ₂ O . .	5400	5627	6310	6510	7100	7830

For other types of dyes, the spectral shift of the absorption band can be much larger than the shift of the emission band; thus, the gap between absorption and emission bands is altered. Table 52 shows this effect for three merocyanines, as given by Brooker; n indicates the number of (CH = CH) groups present in the compound. Similar observations referring to the diphenylpolyenes will be mentioned in Section 134. Such a behavior can be explained by the assumption that, while the ground state and the equilibrium position of the excited state are less influenced by the nature of the solvent, the slope of the upper potential curve is appreciably changed. If A_1 and A_2 represent the potential curves of the excited state in two solvents, the absorption transitions $a \rightarrow b_1$ and $a \rightarrow b_2$ correspond to different frequencies, while the emission frequency of the transition $c \rightarrow d$ remains unaltered (Figure 102).

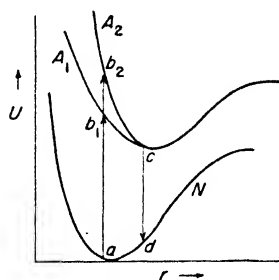

Fig. 102. Potential curves showing relative shift of absorption band by interaction with the solvent.

The intensity distribution within a simple absorption or emission band depends, in the first place, on Pringsheim 11*

the distribution of vibrational energy in the absorbing or the emitting molecules, and, in the second place, on the fluctuations in the configuration of the surrounding medium. Since both follow the laws of statistics, the spectral intensity-distribution curve of each band should also have the shape of a Gaussian error curve as was pointed out by Lenard with respect to the phosphorescence bands of crystal phosphors. The nearly symmetrical bell shape is lost if two adjacent bands, which may correspond to different electronic transitions,

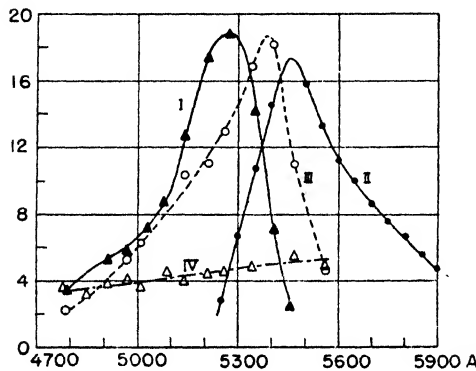

Fig. 103. Absorption, excitation, and emission spectra of eosin in aqueous solution (Nichols and Merritt).

- I. absorption
- II. fluorescence spectrum
- III. noncorrected excitation spectrum
- IV. excitation spectrum reduced to equal amounts of absorbed energy.

overlap. It may be doubtful, however, whether it is correct to analyze every intensity curve which is not exactly bell-shaped as the superposition of two or several Gaussian curves, as has been done by Lenard and his school.

103. Fluorescence Intensity as a Function of Absorbed Energy. Although, in general, every fluorescence band is associated with an absorption band corresponding to the same electronic transition, the *excitation* of the fluorescence of condensed systems is never restricted to this

narrow spectral region. The introduction of the term "excitation spectrum" or "excitation distribution" (translating Lenard's "Erregungsverteilung"), which is frequently mentioned in older publications, was due to the fact that the fortuitous superposition of the spectral energy distribution in the primary radiation and in the absorption spectrum of the fluorescent substance was not taken into account.* If these are determined by quantitative measurements and if the fluorescent intensities are reduced to the values corresponding to equal absorbed energies, all spectral selectivity in the exciting power of the primary light disappears.

* In his first important paper on fluorescence, Stokes states that fluorescence is excited *only* by light which is absorbed by the fluorescent substance (1585).

Nichols and Merritt were the first to prove this; in Figure 103, curves *I* and *II* represent absorption and fluorescence bands, respectively, curve *III* the relative intensities of the fluorescence excited by light of various wavelengths transmitted through a monochromator, and curve *IV* the specific exciting power as a function of the wavelength of the primary radiation (1018, 1123-1125). Nichols and Merritt's results were later corroborated and enlarged in two respects. Valentiner and Roessiger found that the efficiency of the exciting radiation decreased rapidly as soon as the wavelength of the primary light became larger than the wavelength corresponding to the peak

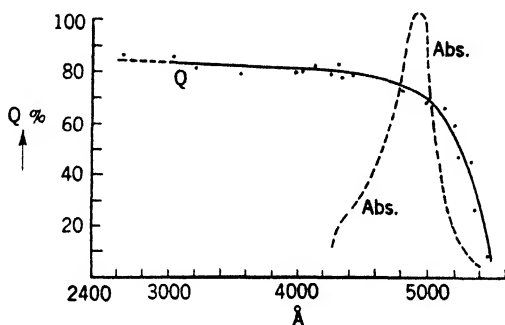

Fig. 104. Quantum yield of the fluorescence of an aqueous solution of fluorescein sodium as a function of the exciting wavelength (after Vavilov).

of the fluorescence band. For an aqueous fluorescein solution with the maximum of the emission band at 5250Å, the relative efficiency of excitation by the line Hg 5461Å was ten times smaller than the efficiency of excitation by Hg 4358Å. Such a turning point may be indicated by the last point of curve *IV* and in Figure 103 (1730, 1731). Vavilov, who extended the measurements over a wider spectral range of exciting radiation down to 2500Å, showed that the relative efficiency increased linearly with the wavelength or inversely with the frequency ν of the exciting light, the coefficient of proportionality being equal to Planck's constant h . Hence, the fluorescence intensity is proportional to the number of absorbed light quanta irrespective of the wavelength of the exciting light (Figure 104) (1747, 1748, 1750). This constancy of the quantum efficiency for exciting light of all wavelengths smaller than that of the emission band has since been proved for numerous substances (for instance, esculin, sodium salicylate,

chlorophyll, and uranyl salts). Most of these investigations were undertaken in order to test the possibility of applying "integrating fluorescent screens" to u.v. heterochromatic photometry (16,140,220, 271,315,579,581).

The steep drop of efficiency in the region of greater wavelengths which has been observed by Valentiner has also been confirmed in several instances. This phenomenon cannot be interpreted without introducing new assumptions. According to the potential curves of Fig. 99, the long-wavelength branch of the absorption band is ascribed to molecules having a relatively high vibrational energy in the electronic ground state. As the number of these molecules is small, the absorption intensity is weak in this part of the band. But there is no reason why these molecules, once they are lifted by light absorption into the excited state, should have a smaller probability of subsequent fluorescence emission than any other excited molecules. The fluorescence intensity excited by a given energy of incident light will be relatively small, but the quantum efficiency should still be the same. It can be assumed however, that the wings of the absorption bands are due mainly to molecules which are strongly perturbed by the interaction with adjacent molecules. According to Franck and Rabinowitch, this interaction can last considerably longer than a single collision in the gas phase, because of the so-called cage effect, and, thus, internal conversion can be made probable, inhibiting the eventual fluorescence re-emission of the absorbed energy. Jablonski has suggested that the decrease in fluorescence yield at greater wavelengths may be due to the fact that transitions from the ground state N to a quasi-stable state M contribute a considerable fraction to the absorption in the long-wavelength part of the normal absorption band. It will be shown in Section 136 that the transition from N to M has a probability almost 10^8 times smaller than that of the transition from the ground state to the fluorescent state F . On the other hand, the absorption coefficient of the dye solution at the wavelength at which the yield begins to decline in the curve of Figure 104 is still about one per cent of the absorption coefficient at the center of the absorption band. Therefore, Jablonski's hypothesis does not seem to provide an adequate interpretation of Figure 104 (compare Section 120) (660, 679).

Figure 103 and 104 show that the excitation of fluorescence is not restricted to the absorption band which corresponds to the same electronic transition, but reaches with unaltered quantum efficiency not only into the adjoining region of small absorption, which might

still be regarded as the tail of this band, but into a second absorption band of much shorter wavelength which corresponds to the transition into a higher electronic state ($N \rightarrow G$) (compare Figure 129). Under these conditions, the emission of the normal fluorescence band $F \rightarrow N$ can be only the second part of a stepwise return into the ground state. Since the emission of a second fluorescence band corresponding to the transition $G \rightarrow F$ has never been observed, this transition must be due to an internal conversion. It is rather astonishing that the quantum efficiency of the fluorescence is the same as when F is reached directly by light absorption; it must be assumed that all molecules raised to

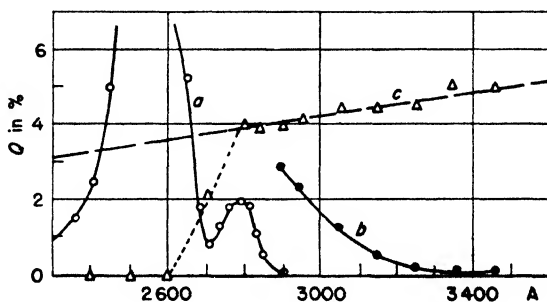

Fig. 105. Absorption and excitation spectra of magnesium platinocyanide in aqueous solution (Khvostikov).

- a*: absorption coefficient in arbitrary units
b: same with ordinate enlarged 30 times
c: fluorescence yield
 Straight line calculated according to Einstein's law.

the state G pass into a high vibrational level of F without any losses due to a direct return to the ground state. It should be remembered that the same behavior was observed with respect to the excitation of fluorescence in anthracene vapor.

While, in general, the fluorescence yield is independent of the wavelength of the exciting light, aqueous solutions of cyanoplatinites show a different behavior. Their absorption spectrum consists of a band in the near ultraviolet with peak at 2780A and long-wave limit at 3500A, and of a second much stronger and narrower band at 2500A. Fluorescence is excited with an energy yield decreasing linearly with the wavelength as long as the primary light is absorbed in the first band, but the yield drops sharply to zero at the boundary of the second

band. By light absorption in this band the molecules must be raised to a state from which fluorescence emission occurs neither directly nor indirectly (Figure 105) (775).

Not only the fluorescence yield but also the energy distribution in the fluorescence spectrum is independent of the wavelength of the exciting light for practically all fluorescent compounds (aromatic hydrocarbons, dye solutions, rare-earth salts, cyanoplatinites etc.) (656). Substances in which different emission bands are excited by light of different wavelengths are exceptional. The fluorescence of meldola blue in aqueous solution, for instance, is orange when excited by radiation corresponding to its main absorption band (5500–6100Å) and greenish under excitation by blue-violet light. It is probable that these two different fluorescence bands belong to two constituents of the commercial dye. The same explanation may be applied to the change of the fluorescence spectrum which Andant observed when he excited solid alkaloids with light of different wavelengths. In the afterglow of malachite green and crystal violet dissolved in glycerol at -100°C , G. N. Lewis obtained the emission of a red band when the solution was irradiated with light absorbed in the visible absorption bands of the dyes, while a green emission band appeared only under irradiation with near u.v. Lewis ascribed the latter to a pseudo-isomer formed by the addition of a solvent molecule of the type ROH, of which OR goes to the central C-atom and H to one of the nitrogens. As a matter of fact, the same green emission bands were obtained in the luminescence spectra of the carbinols of malachite green and crystal violet dissolved in a mixture of ether, pentane, and ethanol at -183°C^* (927a).

If the influence of various parameters, such as concentration, temperature, quenching by foreign molecules, etc., on the fluorescence yield is to be investigated, it is sufficient, in general, for the reasons stated in the preceding paragraph, to limit the measurements to a part of the emission band which is most convenient because of better visibility, easy separation from the exciting radiation by complementary filters, absence of reabsorption by the fluorescing medium, etc. The total fluorescence intensity can be derived from these measurements once the intensity distribution in the fluorescence band has been determined under favorable experimental conditions.

* Although not mentioned explicitly, it must be supposed that the red bands are missing in the emission spectra of the carbinols in glycerol at -100°C ; at the temperature of liquid air they would have disappeared also from the luminescence spectra of the normal dyes (see Section 136).

104. Absorption by Molecules in the Excited State. An excited mercury atom has absorption lines differing from those of the atom in the ground state. Broad absorption bands which originate from the groundstate N and an excited state F of a complex molecule in a condensed system may more or less overlap, so that light of the same frequency can be absorbed by molecules in either of these two states. Under any circumstances, however, light absorption by a molecule in state N or in state F transfers the molecule to a different upper state: either from N to F , or from F to a higher electronic level G . In general, the two bands $N \rightarrow F$ and $F \rightarrow G$ will belong to different spectral regions.

In most fluorescence processes the number of excited molecules which are to be found at any moment in the state F remains small compared to the number of molecules in the ground state, and, therefore, the absorption bands corresponding to transitions $F \rightarrow G$ remain below the limit of observability, while the intensity of the absorption band $N \rightarrow F$ is apparently constant. No trace of a change in the absorption coefficient of a dye solution could be obtained by Vavilov and Levshin, even when they used the very highest attainable intensities provided by a condensed spark as their source of excitation and, simultaneously, as background for their absorption measurements. When they replaced the dye solution by a canary glass with an appreciably slower decay of luminescence, they found an effect just outside the limit of probable error. It must be emphasized, however, that the lifetime of the excited state does not affect the relative number of excited atoms which are in equilibrium with a given primary radiation, as long as absorption and emission correspond to the same electronic transition, since a longer lifetime is compensated by weaker absorption (1766).*

The conditions are much more favorable if, as in the experiments performed by Lewis and his co-workers, a slow fluorescence is excited indirectly by light absorption in a strong absorption band. This, for instance, is the case when, at low temperatures, dye molecules in solid solution pass from the directly excited state F to a quasi-stable state M from which they return to the ground state under emission of a slow fluorescence. The normal absorption spectrum of fluorescein in boric acid is represented by curve 1 of Figure 106; curve 2 of the figure shows the absorption spectrum of the same solution irradiated with

* In canary glass the uranyl fluorescence may, perhaps, be excited indirectly by light absorption not taking place in the uranyl ions but in some other component of the glass.

the very strong light of a high-pressure mercury arc at -95°C . The maximum of curve 1 at 4365A has become much lower in curve 2, while an absorption band apparently consisting of two overlapping parts with maxima at 5050 and 6500A is greatly enhanced. It belongs, beyond doubt, to the excited state M , its small but measurable intensity in curve 1 being due to the weak radiation used for the absorption measurements. Figure 107 represents the decrease in absorption band 1 and the increase in absorption band 2 with increasing irradiation. It is to be noted that illumination of the excited molecules with light absorbed in band 2 has no influence on the fluo-

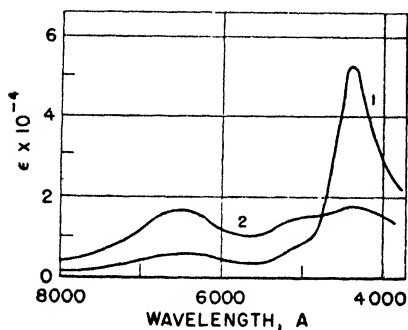

Fig. 106. Absorption spectrum of fluorescein in boric acid [Lewis, Lipkin, and Magel (930)].
1: in ground state N . 2: partially excited quasi-stable state M .

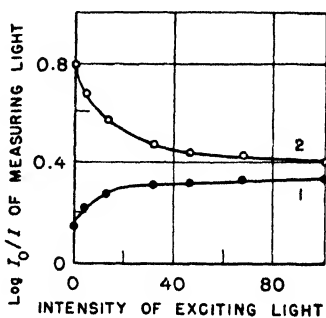

Fig. 107. Effect of intensity of exciting light on the absorption of fluorescein in boric acid [Lewis, Lipkin, and Magel (930)].
1: 6500A. 2: 4360A.

rescence process; all molecules raised from M by light absorption into some higher levels L or K return to M from where the emission process originates. Whereas this behavior differs from that of certain crystal phosphors, it corresponds to the observations which were described in the preceding section. It has been pointed out that all molecules of fluorescent organic molecules which are raised by light absorption in a short-wavelength absorption band to a higher electronic state are transferred from there by radiationless transitions to the excited state F and not directly to the ground state N (930).

During the first decade of this century the existence of a so-called fluorescence absorption was the subject of much discussion and of a good deal of experimental research. The concept was based on an erroneous analogy with Kirchhoff's and Bunsen's well-known ob-

ervation that a sodium flame absorbs the same lines (the D-lines) which it emits. This observations lead to the inference that the light absorption was due to the emitting atoms. However, sodium vapor absorbs the D-lines also at temperatures at which no emission occurs, and, as a matter of fact, the "emitting atoms," or the atoms in the excited state, are the only ones which have no part in the absorption process. The experiments in search of a new absorption band of fluorescence substances, which was assumed to appear during the emission of fluorescence and to coincide exactly with the fluorescence band, seemed partially to prove and partially to disprove the hypothesis, but eventually all apparently favorable results could be shown to be caused by experimental error. Perhaps the most convincing proof of the non-existence of fluorescence absorption was brought forward by J. Becquerel. The index of refraction and, thus, the absorption coefficient of ruby in the neighborhood of its exceedingly sharp fluorescence lines is not altered by a fraction of a per cent when the crystal is excited to strong fluorescence (84,1018,1126,1865).

D. Luminescence Yield as a Function of Experimental Conditions

105. Definition of Yield and Methods of Measuring It. The fluorescence yield has been defined for gases as the ratio of the total intensity emitted by a volume of gas in a certain time to the total light intensity absorbed by that volume in the same time. This definition remains correct for condensed systems as long as it is applied to states of equilibrium during the period of excitation. For phosphorescence processes it is not difficult to integrate the energy emitted after the end of the excitation, but it is not possible, in general, to determine which part of the absorbed energy has been immediately re-emitted as fluorescence and which part has been stored in the "phosphorescence centers," since both processes are excited by light of the same wavelengths.

If a part of the incident light is absorbed by molecules which do not contribute to the fluorescence — for instance, molecules of the solvent or of a second dissolved substance — this must, if possible, be taken into account in calculating the fluorescence yield.

The light intensities are measured either in energy units such as ergs or watt seconds or by the number of quanta comprising the radiation. In the first instance, the "energy yield" Φ , and, in the

second, the "quantum efficiency" Q , is obtained. The relation between Φ and Q is given by the equation: $Q = (\lambda_a/\lambda_e)\Phi$, where λ_a and λ_e are the wavelengths of the absorbed and emitted radiation, respectively. Q is always smaller than, or, in the limiting case of $\lambda_a = \lambda_e$ (resonance radiation), equal to Φ . When the terms efficiency or yield are used without qualification in the following paragraphs, they always refer to the quantum yield.

The same processes which completely inhibit the appearance of luminescence in most absorbing systems, according to Section 95, are responsible for values of Q smaller than 100% in fluorescent systems. All quenching processes which depend on the varying distances between excited and other molecules will obey the Stern-Volmer equation in their dependence on the number of "effective collisions," regardless of the specific mechanism by which the excitation energy is consumed.*

Processes such as spontaneous predissociation and internal conversion, which reduce the fluorescence yield regardless of external conditions, have been characterized as "internal quenching" or "quenching of the second kind" by some authors. These processes are constitutional features of the luminescent molecules themselves. In this book the term "quenching" is used only for processes by which the luminescence of a given compound is reduced below the intensity which the *same* compound would exhibit in the absence of the quenching agent (912).

In order to measure the yield experimentally, two methods are in general use. In the first method the depth of the fluorescing layer or the concentration of a fluorescent solution is made so great that the exciting radiation is completely absorbed in it. If the fluorescence is observed backward (from the same side from which the primary light enters the solution), the brightness of the fluorescence is directly proportional to the efficiency under variable conditions (temperature, nature of the solvent, etc.). This remains true, even if the concentration of the fluorescent molecules is changed, as long as Beer's law is valid, since in this case the absorption of the exciting radiation and the reabsorption of the fluorescence are determined only by the number of absorbing molecules in the paths of the two beams and this number

* It has been known since the early Franck-Cario experiment on the mercury-sensitized photodissociation of H_2 that the primary quenching process is frequently a chemical reaction. This long-established fact is merely reasserted by the recently repeated derivation of the Stern-Volmer equation for the quenching of the fluorescence in liquid solutions by chemical reactions (1806).

is not altered by a change in concentration. For the second method, fluorescent layers of such reduced thickness or small concentration are used that the intensity of the exciting light along the path within the fluorescing medium can be supposed to be constant. In this case the absorption coefficient of the fluorescent substance for the exciting radiation must be determined separately in order to calculate Q , and corrections for the reabsorption of the fluorescence must also be introduced.

While measurements of the relative efficiency Q , under variable conditions are comparatively simple, absolute values of Q are much more difficult to obtain and the corresponding data are scarce and not too reliable. For experiments of this kind the intensities of the exciting and of the secondary radiation must be measured in the same units and, therefore, the spectral sensitivity curve of the measuring instrument (photocell or photographic plate) must be known, or, in visual photometry, a spectrophotometer and a light source with known spectral intensity distribution must be used for comparison. Furthermore, the fluorescence intensity, which is measured directly only within a certain solid angle, has to be integrated over the whole sphere. The assumptions which have to be made for this purpose are not quite unequivocal, as will be discussed in Section 122.

Vavilov, who was the first to measure the absolute yield Q for a dye solution, used the method of visual photometry; his results cannot claim an accuracy greater than 10%. Within these limits they are in fairly good agreement with those obtained by Hellstroem who used a similar method for the determination of the fluorescence yield of various dye solutions. Among these was etioporphyrin dissolved in ether with the exceedingly low yield of 0.08%. Bowen determined Q for anthracene dissolved in benzene by means of his "heterochromatic photometer" (see Section 8). All other data concerning absolute fluorescence yields which are found in literature are derived from relative determinations and subsequent comparison with Vavilov's value for uranin or Bowen's result for anthracene (Table 53) (145,599,1748).

106. Efficiency, Lifetime, and Solvent Quenching. The yields obtained for different compounds in the same solvent and for one compound in different solvents, which are illustrated in Table 53, are scattered over a very wide range. In his first paper on the fluorometric measurement of the lifetimes of fluorescent dye solutions, Gaviola pointed out that the solutions with the weakest fluorescence were those for which he found the smallest τ -values, and he concluded that the probability of a radiating transition was of the same order for all

TABLE 53
 FLUORESCENCE YIELD Q OF VARIOUS COMPOUNDS IN DIFFERENT
 SOLVENTS* AT ROOM TEMPERATURE

Compound	Solvent	Q in %	$\tau \cdot 10^8$ (sec)	Compound	Solvent	Q in %	τ (sec)
Uranin . . .	Water	71	5	Anthracene	Paraffin	23	—
	Ethanol	71	5		Benzene	25	—
	Glycerol	71	5		Acetone	21	—
Eosin . . .	Water	15	1.9	Hexane	18†	—	
	Ethanol	40	—		Trichloro-	17	—
	Glycerol	60	—		methane		
Erythrosin ..	Water- acetone	2	0.08	Naphtha- cene ..	Cryst. †	~100	—
		18	—		Xylene	6	—
		50	—		Cryst.		—
Rose bengale.	Water	1	—	anthra- cene	~100	—	
		40	—		Cryst. †	2(?)	—
Rhodamine B	Water	25	0.94	Rubrene ..	Benzene	70	—
		42	1.6		Acetone	~100	—
Potassium cyano- platinitite ..	Water	4.5	2.5	Cryst. †	10(?)	—	
		~100			Canary glass§	20-100	3-10 · 10 ⁻⁴
				Uranyl .. sulfate	Water	1	10 ⁻⁴
					H ₂ SO ₄	26	10 ⁻²

* All data listed in this table refer to measurements made in the presence of atmospheric air, so that the solvents were not free of oxygen.

† According to Samburski and Wolfsohn, the fluorescence yield of anthracene is larger by about 50% in hexane than in benzene. The discrepancy may be due to the fact that the anthracene concentration was 25 times larger in Bowen's experiments and that self-quenching is much stronger in hexane than in benzene (compare Table 66) (145,1407b).

‡ Cryst.: in the pure crystalline state.

§ Varying with composition of canary glass.

of these compounds and that short lifetimes and small efficiency were both due to quenching or another competing process (462a).

The equation:

$$\tau/\tau_0 = I/I_0 = Q \quad (67)$$

was derived in Section 3 from the Stern-Volmer formula; $1/\tau_0 = a$ is the probability of a radiating transition and I_0 the fluorescence intensity corresponding to a yield of 100%. This value of I_0 cannot be found, in general, even in the absence of all intentional quenching,

because of the existence of internal conversion. If the transition probability α_0 or the intensity of the absorption band remains unchanged, Equation (67) can be replaced by:

$$\tau_1/\tau_2 = I_1/I_2 = Q, \quad (68)$$

where I_1 , τ_1 , I_2 , τ_2 , are the fluorescence intensities and lifetimes under two different conditions and Q , is the relative efficiency.

Thus, Gaviola's qualitative conclusions were well founded theoretically, since the absorption coefficients of the dyes which he investigated were of the same order of magnitude while the fluorescence yields differed widely. With small transition probabilities and correspondingly weak absorption bands (e.g., for aqueous uranyl-salt solutions) however, a small fluorescence yield can be consistent with relatively long lifetimes.

Whatever the nature of the competing mechanism which causes a low fluorescence yield, its chance of weakening or eventually completely destroying the luminescence will be the greater, the longer the natural lifetime τ_0 of the excited state. Thus, slow fluorescence and phosphorescence have a much greater probability of being quenched than normal fluorescence. On the other hand, long-lived luminescence processes can occur with an appreciable yield only if all competing processes are avoided. If a compound cannot be excited to fluorescence under any circumstances, although it is able to absorb light, the most probable interpretation is that it has a very high tendency to undergo internal conversion. Many dyes which are not fluorescent in liquid solutions become fluorescent and even phosphorescent when they have lost a part of their free mobility by being dissolved in a solid (sugar, boric acid, formic acid, etc.) or when they are absorbed on a rigid gel — for instance, silica gel, alumina, or gelatin (the system dye-gelatin is frequently spoken of as a solid solution). Apparently the loss of certain degrees of freedom renders the process of internal conversion less probable. Examples of dyes of this type are discussed in Section 137. Their formulas show distinctly that their structure is less rigid than that of other dyes of similar nature and similar absorption properties which are fluorescent in liquid solutions. Dyes of the latter type also become phosphorescent under the conditions which were described above (1454, 1835).

Although the ability of fluorescing in a liquid solution is to some degree a property of the dissolved molecules as such, the fluorescence yield of a solution in which the excited molecules are in permanent contact with some other molecules depends greatly on the nature of

interaction with these molecules which may or may not quench the fluorescence. If the quenching probability is small, or, in other words, if some specific configuration in two colliding molecules (the excited and the quenching molecule) must be reached so that the excitation energy can be converted to heat or can initiate a chemical reaction, the fluorescence will not be quenched completely, even if a collision between two complex molecules lasts a relatively long time and the excited molecules are continuously in contact with one or the other of the quenching molecules. If one does not assume, however, that an excited molecule, once in contact with a quencher cannot react with a second quencher approaching from another direction, the quenching will still be increased by an increase in the quencher concentration, although it will no longer obey the Stern-Volmer equation. In the limiting case the excited molecules (and all other molecules of the fluorescent compound) are permanently and completely surrounded by "quenching molecules," namely, the molecules of the solvent. Nevertheless the probability of an energy transfer from excited molecules to solvent molecules is not large in comparison with the probability of fluorescence emission. Thus there is a continuous transition from the quenching by specific quenchers to the general case of "solvent quenching" which may be negligible in some cases and almost complete in others.

Examples illustrating the different influence of solvent quenching of various solvents on similar fluorescent compounds are listed in Table 53. The number of such examples can be increased indefinitely. For instance, the fluorescence yield of benzopyrene is practically identical in solutions in petroleum ether, acetone, and pyridine; in the same solvents it varies for anthracene in the proportion of 4 : 5 : 9, and for 1,2-benzanthracene in the proportion 4 : 7 : 14 (1029).^{*} Still other examples are mentioned on the following pages.

Substitution of halides for H-atoms in aromatic compounds reduces their fluorescence yield. The fluorescein series (fluorescein, eosin, erythrosin, and rose bengale) in Table 53 provides a characteristic example. However, a comparison of the fluorescence yields of fluorescein and erythrosin in water, on the one hand, and in acetone, on the other, proves the important part which the interaction between the fluorescent molecules and the solvent plays also in this instance.

The figures listed in Table 53 refer to room temperature only. If

^{*} These figures were obtained with solutions completely free of oxygen and, therefore, are not distorted by the unequal solubility of oxygen in the various solvents; compare Section 108.

an alcoholic solution of uranin or rhodamine is cooled, Q increases at temperatures below 0°C by about 3% per 10 degrees so that at -80°C the yield is very nearly 100%, all internal conversion or quenching reactions having disappeared. In the case of erythrosin and rose bengale, which have an exceedingly low yield in alcohol at room temperature, the efficiency does not increase in the same way at low temperatures: the probability of internal conversion always remains large for these dyes, and this may be connected with their tendency to go over into a quasi-stable state (912).

The yield of the slow fluorescence of uranyl sulfate in sulfuric acid increases from 26% to almost 100% when the temperature is lowered from $+20^{\circ}\text{C}$ to -40°C , and the duration of the afterglow increases simultaneously by a corresponding amount. The fluorescence of an alcoholic solution of barium cyanoplatinite, which has an extremely short lifetime, becomes about four times stronger if the solution is cooled from room temperature to -21°C . In all these instances the direct influence of low temperature was not separated from that of increasing viscosity. The fluorescence yield of anthracene dissolved in solid paraffin does not vary appreciably when the temperature varies from the melting point to -42°C (535,775,1754).

On the other hand, the fluorescence yield practically always drops if a solution is heated above room temperature. (Concerning an important exception, compare Section 114). For uranyl sulfate in sulfuric acid the values of Q and τ are shown for a considerable temperature range in Table 54. The existence of a similar parallelism between Q and τ was proved for the same solution when the sulfuric acid was gradually diluted with water. Aqueous solutions of uranyl salts lose

TABLE 54

YIELD AND DURATION OF THE FLUORESCENCE OF URANYL SULFATE IN SULFURIC ACID AS A FUNCTION OF TEMPERATURE

Temp. in $^{\circ}\text{C}$	18.5	27	45	52	67
Q	26	21	13	11	7.3
$\tau \cdot 10^4$	1.08	0.81	0.58	0.46	0.33
$Q/\tau \cdot 10^4$	24	25	22	23	22

TABLE 55

FLUORESCENCE YIELD OF RHODAMINE B IN GLYCEROL AS A FUNCTION OF TEMPERATURE

Temp. in $^{\circ}\text{C}$	16	20	30	35	40	55	60	70	75	85	90
Q	75	70	64	60	55	44	40	32	28	25	21

their fluorescence power, completely at temperatures which are always below the boiling point and, frequently, even much lower. The same is true for the solutions of the cyanoplatinites, in both cases with no important change in the absorbing power.

Most dye solutions obey the same law. As an example, Table 55 shows the relative fluorescence yield of rhodamine B in glycerol for the temperature range between 16° and 90° C, the absorption power again remaining constant. In other solvents, like isobutyl alcohol, the absorption spectrum of this dye varies greatly with increasing temperature, so that a loss of fluorescence yield might be ascribed to a change in the structure of the molecules.

The fluorescence yield of quinoline red in aqueous or alcoholic solutions however is practically independent of temperature in the wide range from 0° to 100° C. Measurements of the corresponding lifetimes have not been performed (339,732).

In principle, the heat of activation of the process causing the quenching can be derived, irrespective of the nature of the process, from the temperature dependence of the fluorescence yield.

The decrease in the fluorescence yield of rubrene dissolved in aliphatic solvents from nearly 100% at -60°C to a much lower value at +60°C has been ascribed to an increasing probability of internal conversion, and from the slope of the curves representing the log of the quenching constant (Eq. 7a) versus $1/T$ the "heat of activation" corresponding to the height of point *C* above point *A* in Figure 84 has been calculated to be about 7 kcal. This heat of activation is not a characteristic constant of the molecule itself, however, but is apparently determined by the fact that the rubrene molecules are surrounded by specific solvent molecules, for the fluorescence of rubrene dissolved in hexane shows an almost constant yield of nearly 100% in the entire temperature range from -60 to +60°C; thus, no internal conversion does occur in the rubrene molecules under these conditions.

When dissolved in an aromatic solvent (benzene, toluene), rubrene exhibits a fluorescence yield well below 100% even at low temperatures. The fluorescence yield of anthracene at room temperature is also lower by 35% when the solvent is benzene than when it is hexane. This behavior has been interpreted as due to the tendency of the aromatic solvent molecules to form complexes with the solute molecules, with the additional assumption that internal conversion has a relatively high probability in these complexes. With rising temperature the complexes dissociate and the resulting gain in fluorescence yield is claimed to compensate partially the increasing

probability of internal conversion in the nonassociated rubrene molecules. Therefore, the fluorescence yield decreases less rapidly with rising temperature in aromatic solvents than in aliphatic solvents.

It must be kept in mind, however, that increasing internal conversion is not the only possible interpretation of a temperature-dependent fluorescence yield. The decrease in yield can be explained also by some reversible photochemical reaction (such as the exchange of a hydrogen atom) between excited molecules and the molecules of the solvent. In order to explain the behavior of rubrene in the different solutions by such a mechanism one would only have to introduce the very simple and plausible assumption that the heat of activation of the photochemical reaction is so high, when the solvent is a paraffin, that the reaction practically does not occur at all in the temperature range under consideration; it is of the order of 7 kcal per mole for the aliphatic solvents and essentially smaller for the aromatic solvents, so that in the latter the reaction has an appreciable probability even at -60°C (143c, 1407b).

If the rate of the back reaction is not too high, the occurrence of the chemical reaction may become observable by a reversible bleaching such as has been obtained in solutions of chlorophyll. If, on the other hand, the back reaction follows the reaction within an extremely short interval, the process might be represented by the transient formation of a complex in which the electronic excitation energy is converted with very high probability to vibrational energy. This concept differs from the one discussed above in that the hypothetical complexes are not permanently present but exist only during the short period during which an *excited* rubrene molecule combines with a solvent molecule.

The parallelism between Q and τ (see Table 54) is destroyed if the processes of absorption and emission occur in different parts of a complex molecule. In the organic europium compounds mentioned in Section 97, the duration of the emission process is determined in the main by the transition probability in the electronic system of the rare-earth ion and is influenced very little by temperature. On the other hand, the fluorescence yield depends on the probability of the energy transfer from the organic radical in which the light absorption takes place to the europium ion. The yield decreases if this probability is smaller than the probability of converting the energy into heat, and the latter probability is a function of temperature. Thus, the intensity of the fluorescence of europium picrate dissolved in a mixture of ethanol, ether, and isopentane is over fifty times as strong at -190°C

as at room temperature, although the decay constant changes by not more than 30 %. Furthermore, the probability of internal conversion of the absorbed energy depends to a great extent on the nature of the salt and of the solvent. At room temperature the fluorescence intensity of the salicylaldehyde in alcoholic solution is only about 13 % of the intensity emitted by the benzoylacetate, while at liquid-air temperature they are practically equal. At room temperature the fluorescence of the salicylaldehyde in alcoholic solution is much less bright than when the same compound is dissolved in toluene; at -80°C the fluorescence of the two solutions shows the same brightness. At low temperatures the fluorescence yield of all europium salts is close to 100 % (at least 85 %) (1816).

The formation of complexes can favor the appearance of fluorescence in liquid solutions quite as well as it can favor the processes of internal conversion. Certain metallic ions (Pb^{++} and Zn^{++}) which are not fluorescent when dissolved in pure water form fluorescent complexes of the type $(\text{PbCl}_4)^{-}$ if an alkali halide of high concentration is added to the solution. The relatively weak fluorescence of the hydrated Tl^{+} -ion in aqueous solution is also enormously enhanced by the addition of halide ions, while the nature of the added cations is of slight importance (521, 522, 617, 1304).

107. Quenching of Luminescence by Foreign Molecules of Low Concentration. The earliest observations of the quenching effect of certain salts, especially halides, on the fluorescence of dye solutions are due to Herschel and Stokes (1585). While in solvent quenching the luminescent molecules are in permanent contact with molecules of low quenching efficiency, the concentration of the quenching molecules is now so low that a specific reaction must be assumed to take place between them and the excited molecules in the relatively short periods during which the distance between them is sufficiently small. The frequency of these events, which may be called collisions, is proportional to the concentration c of the quencher. As pointed out in Section 105, the quenching efficiency as a function of c must obey the Stern-Volmer equation in its most general form:

$$I = I_0/(1 + z\tau_0) \quad (69)$$

τ_0 is the lifetime of the excited state in the absence of the quencher and z is the number of "effective collisions" per second.

A first qualitative proof of the validity of this statement can be seen in the fact that, under otherwise similar conditions, the efficiency of a given quencher like KI is, in general, the greater, the longer the

natural lifetime τ_0 of the excited molecule (Table 56). The much longer-lasting weak phosphorescence of some dyes in liquid solutions disappears at quencher concentrations which have no visible influence on the fluorescence intensity of the solution.* On the other hand, the duration of the emission becomes shorter with increasing concentration of the quencher; this has been shown to be true in many instances.

TABLE 56
 QUENCHING EFFICIENCY OF POTASSIUM IODIDE IN AQUEOUS SOLUTIONS OF FLUORESCENT COMPOUNDS

(τ : lifetime of excited state; c^* : concentration of KI in mole per liter at which $Q^* = \frac{1}{2}Q_0$; k : "reaction rate")

Compound	Uranyl sulfate	Quinine sulfate	Uranin	Eosin	Anthracene†	Naphthalene†
τ	10^{-6}	$4 \cdot 10^{-8}$	$4 \cdot 10^{-9}$	$1.9 \cdot 10^{-9}$	$2.5 \cdot 10^{-7}$?
c^*	10^{-4}	10^{-2}	10^{-1}	$2.7 \cdot 10^{-1}$	$6 \cdot 10^{-2}$	0.5
k	10^4	100	10	3.7	17	2

† In ethanol.

The values of τ , c^* , and k depend to a certain degree on the concentration of the fluorescent compounds and differ, therefore, within certain limits, in the papers by various investigators.

A quantitative verification of the equation is much more difficult. For a gas, all factors determining the number of effective collisions are known, with the exception only of the "effective cross section," and the Stern-Volmer formula can be used to calculate its value if the lifetime τ_0 is found by some other experiment. In a liquid solution a great number of variables are to be considered and several of them are interdependent. The most important among these parameters are the temperature T , the viscosity η , the ionic strength μ , and the dielectric constant D . Within the temperature range obtainable with most liquids the direct effect of a variation of T will be negligible in comparison to its influence on η and μ . Finally, the nature of the solvent is not only important because it determines η , D , and μ , but also because the value which Q_0 and τ_0 have in the absence of the quencher depends on it. Thus, if one studies the influence of the viscosity by varying the solvent (diluting glycerol with water) the simultaneous change of τ_0 must be taken into account.

* See also Section 109 concerning the quenching of the phosphorescence of dyes absorbed on silica gel.

If all other parameters are kept constant, the number of effective collisions is proportional to the concentration c of the quencher:

$$Q_r = 1/(1 - kc) \quad (70)$$

the value of τ_0 now being included in the constant k . k is the "reaction rate" and is the reciprocal of the half-value concentration c^* at which the yield $Q^* = \frac{1}{2}Q_0$. Hence, the points in a diagram plotting $1/Q_r$ versus c should lie on a straight line which intersects the zero axis at the point $1/Q_r = 1$.

For values of $1/Q_r$ not exceeding 5, the experimental results agree fairly well with Equation (70) (Figure 108), while for greater concentrations of the quencher the deviations become much larger than the possible errors.

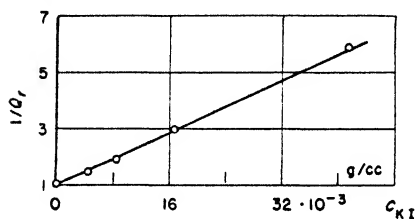

Fig. 108. Quenching of the fluorescence of fluorescein sodium in aqueous solution by KI of various concentrations (Vavilov).

Only within the same range of concentrations does Equation (68) hold for the relation between Q_r and τ (434,1755).

Vavilov tried to interpret these deviations by assuming a "configuration-quenching" to be superimposed on the collision-quenching. Those molecules in the "effective volume" of which a quenching molecule is present at the moment of absorption are assumed to lose their excitation energy by this configuration-quenching. In the absence of any collisions (with all molecules at rest in a very viscous medium) the relative yield is, therefore:

$$Q_r = e^{-\omega Nc} \quad (71)$$

where $\omega = \pi^{\frac{4}{3}} \rho^{\frac{2}{3}}$ is the effective volume of the excited molecules and Nc the number of quenching molecules per cc.† By superposition of the two effects the relation between Q_r and c become; now:

$$Q_r = \frac{e^{-\omega Nc}}{1 + kc} \quad (72)$$

Vavilov's own measurements of the quenching of the fluorescence of various dye solutions seem to be in good agreement with this last equation.

The denominator in the fraction representing Q_r does not contain $\dagger c$ is the number of g/cc and N the number of molecules per g.

the parameter τ and, thus, the linear relation between $1/\tau$ and c is preserved. Szymanowski, who determined τ and Q_r for several fluorescent solutions at various concentrations of KI as quenching agent, found $1/Q_r$ to be represented as a function of c by a curve corresponding to Equation (72), while $1/\tau$ was represented within the same range of c by a straight line (Figure 109) (434,1600a).

Rollefson and Stoughton have shown that a formula of the type of Equation (70) or (72) can be correct only if the fluorescent molecules

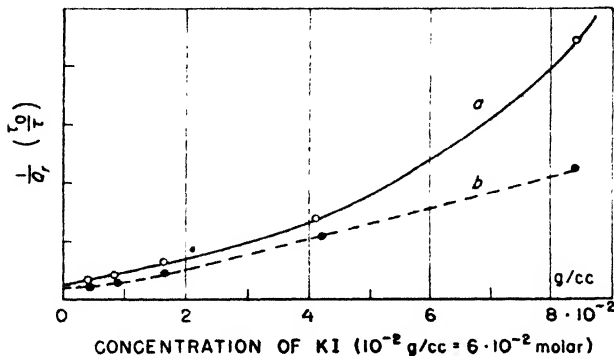
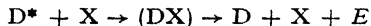

Fig. 109. Yield and lifetime of fluorescence of fluorescein sodium in water quenched by KI (Szymanowski).

$a: 1/Q_r$. $b: \tau_0/\tau$.

carry no electric charge or if the ionic strength is kept constant. According to these authors, the quenching process must be treated as a normal bimolecular reaction between the excited molecule and the quencher, regardless of the mechanism of the quenching reaction:



where D is the fluorescent and X the quenching molecule, and E is the excitation energy which is set free and which may appear in any form. If D and X are ions, as is very frequently the case, the reaction rate k depends on the ionic strength of the solution, which is appreciably changed if the concentration of the quencher becomes large. On the other hand, the quenching efficiency of a given quencher at constant concentration varies a good deal if the ionic strength of the solution is changed by addition of an ionized salt which alone has no influence on the fluorescence yield of the solution. Table 56A shows the change of k at constant KI concentration when the ionic strength

Pringsheim 12

of a fluorescein solution is varied by addition of sodium perchlorate. In the case of acridone which is electrically neutral, the addition of potassium nitrate is practically without influence on k .

TABLE 56A
QUENCHING RATE k OF KI IN FLUORESCENT SOLUTION
OF VARYING IONIC STRENGTH μ

	Fluorescein + sodium perchlorate					Acridone + potassium nitrate			
μ	0.031	0.51	0.101	0.201	0.301	0.01	0.05	0.11	0.21
k	11.4	12.2	14.0	16.4	16.8	92	92	94	93.5

Similar effects should be brought about by variations of the dielectric constant, but no quantitative measurements are available (1587).

Respecting the influence of the viscosity η , Vavilov and others assumed that, since the velocity of diffusion decreases with increasing viscosity, k should be inversely proportional to η . The following equation was derived by Vavilov for the relation between k and η :

$$k = \frac{\tau_0 RT}{3\eta} \frac{(\rho + \sigma_2) (\sigma_1 + \sigma_2)}{\sigma_1 \cdot \sigma_2} \quad (73)$$

σ_1 and σ_2 are the kinetic radii of the excited and the quenching molecules which, together with the viscosity, determine the velocity of diffusion; ρ is the effective radius of the excited molecules which depends on the nature of the solvent, even for the reaction between a specific fluorescent compound and a specific quencher.

The figures in the first columns of Table 60 show that the efficiency of various quenchers is greater in methanol than in water, and greater in water than in ethanol, in the same order as the viscosities of these solvents vary. However, not even in this qualitative way is the rule valid in all instances. Thus, the quenching efficiency of potassium iodide for the fluorescence of fluorescein is greater in water ($\eta = 0.011$) than in acetone ($\eta = 0.004$).

As a matter of fact, the fundamental assumption from which Equation (73) is derived is valid only in a very restricted sense. The number of collisions in a solution is *not* proportional to the velocity of diffusion and inversely proportional to the viscosity. In a viscous medium an individual quenching molecule has a reduced probability of hitting a second excited molecule after a collision with a first excited molecule, but it has an increased probability of making a second collision or even a whole group of collisions with the first molecule within a short period of time (so-called cage effect); it may even happen

that such a group merges into a single collision of relatively long duration. Thus, the probability of quenching the fluorescence of this individual molecule is enhanced if the quenching efficiency of a single collision is less than 100%. The lower the quenching efficiency, the less it is affected by the viscosity of the solution.

Moreover, the latter can be varied only by either mixing two liquids of widely different viscosities or by using solvents which differ in viscosity and otherwise have similar properties, or by varying the temperature. The duration τ_0 of the fluorescence which would prevail

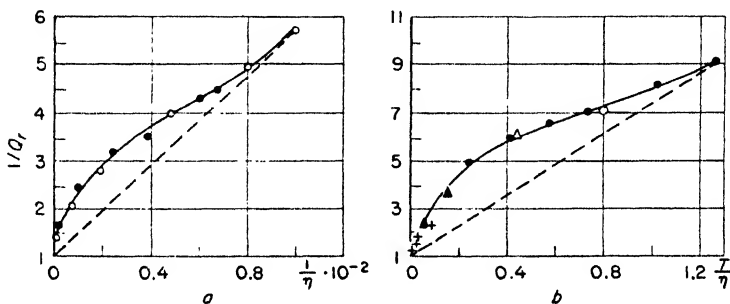

Fig. 110. Quenching of the fluorescence of fluorescein (a) by potassium iodide and (b) by aniline as a function of viscosity [Sveshnikov (1600)]

- | | |
|-----------------------------------|--|
| (a) | (b) |
| ○ sugar solution | ● isobutyl alcohol |
| ● mixtures of glycerol with water | ○ ethyl alcohol |
| | △ mixture of isobutyl alcohol with ethyl alcohol |
| | ▲ mixture of glycerol with isobutyl alcohol |
| | + glycerol |

in the absence of the quencher can be altered by such variations and this must influence the value of k in Equation (73), irrespective of simultaneous changes in viscosity. The formation of solvate envelopes protecting the fluorescent molecules against the action of a quencher will also depend on the nature of the solvent.

Sveshnikov discussed these various influences which, in general, are difficult to separate.* However, plotting $1/Q$ versus $1/\eta$ and T/η , respectively, for a variety of solutions and quenchers, he obtained a series of curves which closely resembled those reproduced in Figures

* These problems have been treated recently in a more quantitative manner by LaMer and co-workers (625a, 1723a, 1843).

110*a* and *b*. In the experiments, η was varied by changing the concentration of aqueous sugar solutions, by adding water to glycerol, by using a series of alcohols, and by altering their temperature; potassium iodide, the organic compounds listed in Table 60, and copper sulfate served as quenchers, and the fluorescent compounds were sodium naphthionate, rhodamine B, fluorescein, and rhoduline red. All points belonging to a given pair of fluorescent compound and quencher were situated on smooth curves of similar shape. They prove the existence of general parallelism between $1/Q$ and $1/\eta$ and of systematic deviations from the linear relation between the two parameters, especially at high viscosities (1600*a*).

108. Specific Properties of Quenchers. Quenching substances can be divided into several classes with widely differing quenching efficiencies for different groups of fluorescent solutions. In the first systematic research of this kind Jette, West, and Muller found that if potassium salts were added to aqueous solutions of uranin, quinine sulfate, and uranyl sulfate, the quenching efficiency of various anions for every one of these three solutions followed the order (689,1091,1823):

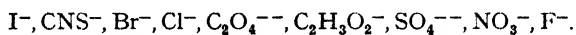

The efficiency of the ions to the right of Cl^- is very small. These results were confirmed for solutions of eosin, rhodamine, and other dyes. It has been pointed out that the order of the quenching efficiencies is the same as the order of the deformabilities of the ions. It is also the order of many other of their properties, however, and a direct relation between the quenching capacity and the deformability of an ion is not obvious. Besides, the relative efficiency of two quenchers, even when they are as closely related as I^- and Br^- , depends a great

TABLE 57
RELATIVE QUENCHING EFFICIENCY (HALF-VALUE CONCENTRATION c^*)
OF THE HALIDE IONS IN AQUEOUS SOLUTIONS
($c^* = 1$ for I^- as quencher)

Fluorescing compound	Color of fluorescence	Quenching ion		
		I^-	Br^-	Cl^-
		c^*		
Quinine sulfate	blue	1	1.4	3.9
Uranin	green-yellow	1	20	100
Esculin	blue	1	20	100
Pinacryptol yellow . .	green-yellow	1	1	1.5

deal on the nature of the fluorescent compound. The examples listed in Table 57 show that there is no general connection between the sensitivity of a quencher and the color of fluorescence, which is a measure of the energy stored in the fluorescent molecules.

Rollefson and Stoughton have shown that for another group of fluorescent compounds the order of quenching efficiencies is exactly reversed, so that NO_3^- and BrO_3^- are much stronger quenchers than I^- . Sodium naphthionate, α -naphthol, and sodium sulfanilate belong to this group (1588).

TABLE 58
QUENCHING EFFICIENCY (HALF-VALUE CON-
CENTRATION c^* AND "REACTION RATE" k) OF
VARIOUS NEGATIVE IONS FOR SODIUM
NAPHTHIONATE

Quencher. . . .	NO_3^-	BrO_3^-	I^-
c^*	0.061	0.057	2.4
k	16.4	17.5	0.42

The colorless cations K^+ , Na^+ , Ca^{++} , Ba^{++} , etc., have no quenching effect and can be interchanged in the salts used as quenchers without appreciable influence on the fluorescence yield. Small effects are produced in some cases by the ions of rare-earth metals such as Sm^{+++} and Pr^{+++} , while the colored ions Cu^{++} , Ni^{++} , and Fe^{++} act as strong quenchers in most fluorescent solutions. The values collected in Table 59 were calculated taking into account the fraction of the incident light which is absorbed by the quenching ions. The very high efficiency of

TABLE 59
QUENCHING OF FLUORESCENCE BY POSITIVE IONS
(Half-Value Concentration c^* and k)

Fluorescent compound	Quinine sulfate		Esculin		Sodium naphthionate		Thalious chloride	
	c^*	k	c^*	k	c^*	k	c^*	k
Solvent	$\text{H}_2\text{SO}_4\text{-H}_2\text{O}$		Ethanol		Water		$\text{H}_2\text{O-KCl}(10^{-3})$	
Quencher:								
$\text{CuSO}_4..$	0.275	3.6	0.028	35.7	0.007	143	—	—
$\text{NiSO}_4..$	0.189	5.3	0.100	10	0.050	20	—	—
$(\text{VO})\text{SO}_4$	0.099	10.1	0.070	14.3	—	—	—	—
$\text{FeSO}_4..$	0.036	28	0.136	7.3	—	—	10^{-3}	1000
$\text{CoSO}_4..$	0.021	48	0.016	62.5	0.010	100	—	—
$\text{Cr}_2(\text{SO}_4)_3$	0.0063	158	0.0062	159	0.005	200	—	—
$\text{MnSO}_4..$	2.05	0.49	1.16	0.86	—	—	—	—

the chromium ions and the relatively small effect produced by manganese is noteworthy (1792).

The fluorescence of the complex ions which are formed when thalious salts are dissolved in pure water and in solutions of KCl and KBr is also quenched by Fe^{++} and by I^+ ; the effect is strongest in the chloride solutions, a good deal weaker in pure water, and weakest for the complexes formed in bromide solutions, while the fluorescence yield (and probably the lifetime of the excited state) is about equal for the halogen complexes and much smaller for the Ti^+ -ions in pure water (1521,1522).

Many organic compounds are powerful quenchers for practically all fluorescent solutions. A few examples are given in Table 60. The strong fluorescence of uranyl sulfate in sulfuric acid is almost completely suppressed by the presence of traces of ethanol, while the fluorescence yield of dyes dissolved in ethanol is relatively high in most cases (272,346).

TABLE 60
THE QUENCHING OF FLUORESCENT SOLUTIONS BY ORGANIC COMPOUNDS
(Molar half-value concentration c^*)

Fluorescent compound.....	Quinine sulfate		Pinacrytol yellow		Sodium naphthion-ate	Esculin
	Methanol	Water	Water	Ethanol	Water	Ethanol
η	0.006	0.011	0.011	0.012	0.011	0.010
	c^*					
Quencher:						
Phenol	0.010	0.013	0.071	0.098	0.60	0.40
<i>o</i> -Cresol	—	0.012	0.39	0.070	1.0	2.03
Hydroquinone .	0.0046	0.010	0.042	0.076	0.041	0.13
Resorcinol ..	0.0067	0.011	0.031	0.068	2.90	0.505
	0.0063	0.011	0.049	0.052	0.20	0.188
Pyrogallol ..	—	0.100	0.037	0.050	0.082	0.108
α -Naphthol ..	—	—	—	0.042		0.081

An exceptional behavior is shown by an alcoholic solution of rhodamine B to which increasing quantities of nitrobenzene are added. In the right-hand part of Figure 111e, the initial rise of $1/Q_r$ is of the usual type, but, after reaching a maximum at a nitrobenzene content of 4 moles per liter of solution, the curve slopes downward again, so that the fluorescence yield in pure nitrobenzene is restored to nearly one-half of its value in pure ethanol. The fluorescence and absorption spectra of rhodamine are practically identical in both solutions. The

parallelism between the curves for $1/Q_r$ and $1/\tau$ indicates a quenching obeying the Stern-Volmer law (1600a).

If only the left-hand or only the right-hand branch of the curves were known, one would assume that one of the two liquids is a solvent

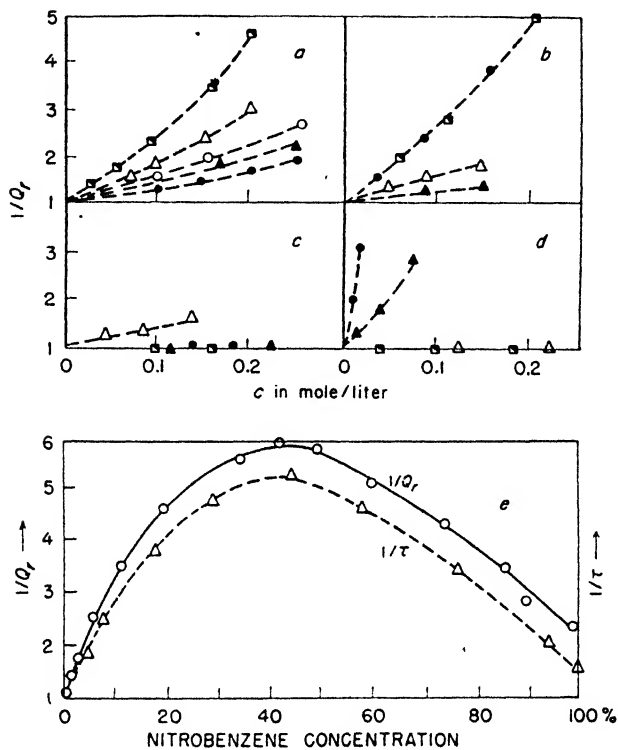

Fig. 111. Specific quenching power of various substances (Sveshnikov): (a) rhodamine B, (b) anthracene, (c) sodium naphthionate, (d) quinine sulfate, (e) rhodamine B in ethanol-nitrobenzene mixture.

□: aniline; ●: KI; △: hydroquinone;
▲: guaiacol; ○: nitrobenzene.

in which the fluorescence yield is fairly good, while the other is a strong quencher. The complete curves suggest, however, that while neither of the two solvents strongly quenches the fluorescence, in mixtures of alcohol and nitrobenzene some sort of complexes are formed with a peak equilibrium concentration in a mixture of 70% alcohol and 40% nitrobenzene, and that the excited rhodamine mole-

cules are quenched by collisions with these complexes rather than by interaction with the molecules of the individual solvents themselves.

Quenching curves which were obtained by Banderet appear, at first sight, to be very similar to the curve of Figure 111*l*, but correspond probably to an essentially different mechanism. The quenchers were organic compounds consisting of long chains such as gardinol $[\text{CH}_3-(\text{CH}_2)_{15}-\text{SO}_3]^- \text{Na}^+$, sodium stearate $[\text{CH}_3-(\text{CH}_2)_{15}-\text{COO}]^- \text{Na}^+$, and saponine $[\text{CH}_3-(\text{CH}_2)_7-\text{CH}=\text{CH}-(\text{CH}_2)_7-\text{CO}-\text{NH}_2-(\text{CH}_2)_2-\text{N}(\text{C}_2\text{H}_5)_2]^+ \text{Cl}^-$ which were added to aqueous solutions of rhodamine, pyronine, and quinine sulfate or of fluorescein, eosin, and iris blue. With increasing concentration of the quencher the fluorescence of the solutions was almost completely suppressed, but when the concentration of the quencher exceeded 10 volume per cent, the intensity of the fluorescence increased again and reached about 60 to 70 % of its initial value, when the concentration of the quencher attained 50 volume per cent. Simultaneously, the solution was converted into a gel and this is apparently the reason for the vanishing quenching effect. The recovery of the fluorescence yield is best observed at very low dye concentrations, but occurs also at higher concentrations of the fluorescing molecules. A second very striking peculiarity is characteristic of these quenchers. Only positive fluorescent ions (rhodamine, quinine sulfate) are strongly quenched by the compounds which form negative ions (gardenal, sodium stearate), while negative fluorescent ions (fluorescein, eosin) are quenched by the compounds which form positive ions (saponin and similar substances) (49). In these cases quenching becomes effective only when the dye molecules are adsorbed on the long chains of the quenching compounds.

The quenching of fluorescence by molecular oxygen is of special interest for more than one reason. It is to be kept in mind that the O_2 -concentration in atmospheric air is less than 0.01 mole per liter, and that it is very low in all liquid solutions, even if they are saturated with oxygen under an oxygen pressure of 760 mm (Table 61). Therefore, even relatively small decreases in fluorescence yield of oxygen-saturated solutions correspond to rather high values of $k(\text{O}_2)$. These

TABLE 61
OXYGEN CONCENTRATION c IN LIQUIDS UNDER 760 MM O_2 (MOLE/LITER)*

Liquid	Hexane	Acetone	Toluene	Benzene	Alcohol	Water
$c \cdot 10^8$	15	9	7.5	7.15	6.3	1.3

* These are not the units found in most tables.

values are, again, widely different for different fluorescent compounds. For the fluorescence of uranin, eosin, erythrosin and rhodamine G extra in water $k(\text{O}_2)$ is practically zero (1476). However, the *phosphorescence* of eosin, erythrosin, phloxin, and other dyes in liquid solutions is completely quenched by small traces of O_2 (136,745). According to Kautsky, the fluorescence of tryptaflavine is quenched only slightly by oxygen when the dye is dissolved in water; it is quenched a little more in alcoholic and still more in acetonic solutions. This order corresponds to the increasing solubility of oxygen in these solvents. The fluorescence of chlorophyll dissolved in alcohol or acetone is from 20 to 40 per cent weaker when the solutions are saturated with oxygen in atmospheric air than in the absence of O_2 ; the corresponding values of $k(\text{O}_2)$ are 250 and 700, respectively.

Under continuous illumination most dye solutions are slowly bleached, if all oxygen is not carefully removed. The photo-oxidation may be due mainly to the reaction of molecules in quasi-stable states, as will be explained in the next section.

An earlier hypothesis, which at present is interesting merely from the historical point of view, supposed that every fluorescence process was only a secondary phenomenon accompanying a permanent photochemical conversion of the luminescent molecule (1202-1206, 1210, 1211, 1279, 1281). However, it could be shown that such conversions, as a rule, occur only in the presence of oxygen or another quencher, and that the fluorescence is strongest when the solution does not undergo any chemical reaction (1799). In many cases a direct photochemical transformation of a fluorescent compound is brought about by light of shorter wavelengths. Thus, esculin loses its fluorescence power under the action of near-ultraviolet radiation in solutions containing oxygen, while in a solution free of oxygen a loss of fluorescence is observed only after irradiation with light of wavelengths below 3000Å (999). The same is true for certain aromatic compounds dissolved in solid boric acid (1691).

Oxygen quenches the fluorescence of many aromatic hydrocarbons in liquid solutions. The third column of Table 61A lists the quenching constant k of oxygen for hydrocarbons dissolved in hexane; the values of k are spread out over a wide range without showing any systematic order. A comparison between naphthalene and anthracene is striking: naphthalene, which is almost immune to I^- -ions, is exceedingly sensitive to the quenching by oxygen; the fluorescence of anthracene, much less sensitive to oxygen, is very appreciably quenched by iodine ions. No relation can be established between the

TABLE 61A

FLUORESCENCE YIELD Q AND QUENCHING CONSTANT k OF AROMATIC HYDROCARBONS DISSOLVED IN HEXANE AND EXCITED BY THE Hg-LINE 2537A

Compound	Q in %	k	Compound	Q in %	k
Benzene	10.9	600	Naphthalene ..	37.6	2400
Toluene	22.7	1100	Anthracene .. .	46.3	178
<i>o</i> -Xylene	28.7	1060	Phenanthrene ..	27	960
<i>m</i> -Xylene	30	800	Fluorene	100	530
<i>p</i> -Xylene	41.5	1050	Acenaphthene ..	70.4	2200
Trimethylbenzene .	16.4	850	Biphenyl	22.8	440
Tetramethylbenzene	52.3	980	Triphenylmethane	23.2	580

quenching efficiency of oxygen and the number of fused rings of which a compound consists; the sensitivity of benzanthracene and benzo-pyrene is intermediate between those of anthracene and naphthalene (144-146).

Nitric oxide quenches the fluorescence of aromatic hydrocarbons with about the same efficiency as oxygen. In both instances the quenching is completely reversible. When the quenching oxygen or nitric oxide is flushed out by some inert gas, such as nitrogen or hydrogen, the solution recovers its full fluorescence intensity (1805, 1806).

The phosphorescence of dyes adsorbed on silica gel is observed only in a very high vacuum or in an atmosphere in which the partial pressure of oxygen does not exceed 10^{-3} mm.* The phosphorescence is weakened appreciably even by oxygen at 10^{-5} mm; in the case of tryptaflavine, the intensity drops to one-half at a partial oxygen pressure of $5 \cdot 10^{-5}$ mm (426,748).

The fluorescence of the adsorbed dye is also quenched to a certain extent by oxygen, but since the lifetime of the excited state is less than 10^{-8} sec (compared to nearly 1 sec for the phosphorescence), much higher oxygen pressures are needed for producing an appreciable effect. The fluorescence of tryptaflavine adsorbed on silica gel is almost half as large in atmospheric air as in a high vacuum. The fluorescence

* Nitric oxide and certain vapors may also act as quenchers for this phosphorescence. Kautsky's observation, according to which the tryptaflavine phosphorescence is quenched by water vapor, however, has been proved to be caused by a secondary effect. Traces of oxygen which are adsorbed on the gel are dislodged by the vapor and then quench the phosphorescence. If they are removed, the vapor itself has no influence on the afterglow (426).

of eosin, erythrosin, and rhodamine B is as little affected by the presence of oxygen when the dyes are adsorbed on either aluminum oxide or silica gel,* as they are in aqueous solutions; on the other hand, the fluorescence of chlorophyll is considerably more sensitive to the action of oxygen than the tryptaflavine fluorescence, also under these conditions (426,749).

The blue fluorescence of organic compounds that can be prepared in the form of aero-gels, such as palmitic acid and the solid polymers of formaldehyde, is very strongly and reversibly quenched by the vapors of nitrobenzene and quinone; the vapors of dimethylaniline and diacetyl are appreciably less efficient, and the vapors of monobromoethane, benzene, and ammonia, and all permanent gases, including oxygen, produce practically no quenching in this instance (1640b).

109. Mechanism of Quenching by Foreign Molecules. If addition of foreign molecules to a fluorescent solution converts the fluorescent molecules by a dark reaction into molecules of another kind which are nonfluorescent, the foreign molecules do not "quench" the fluorescence in the sense in which the term is employed here. If the newly formed molecules do not absorb the exciting light, the fluorescence *intensity* will be altered because of the decrease in concentration of fluorescent molecules, but the fluorescence *yield* will remain unchanged. If, on the other hand, the newly formed molecules absorb a part of the exciting light, an apparent decrease in fluorescence yield will result exactly as if some other kind of inactive light-absorbing molecules had been introduced into the solution. However, this apparent loss of yield would not be accompanied by the corresponding decrease in τ which is the distinctive characteristic of genuine quenching (as it was in the case of fluorescent vapors) and which follows from the laws expressed by the Stern-Volmer equation.

The overall result of a genuine quenching reaction can consist in the chemical transformation of the excited molecule, of the quencher, or of a third kind of molecule — for instance, of the solvent. If no permanent change is produced in the solution by the quenching process, the excitation energy must eventually have been converted into heat. These overall effects, however, do not provide much knowledge concerning the elementary quenching processes.

. If the phosphorescence of tryptaflavine adsorbed on silica gel is

* The negative ions of the fluorescein derivatives are adsorbed on alumina, but not on silica, while the opposite is true for the positive ions of basic dyes, e.g., tryptaflavine and rhodamine.

quenched by oxygen at low pressure, the oxygen will disappear after a period of continuous irradiation and the dye will be discolored and no longer luminescent; it will be oxidized. This oxidation is probably not the primary quenching process, as Kautsky seems to have proved by a very clever experiment: if a colorless and nonfluorescent leuco dye, e.g., leucomalachite green, is absorbed together with tryptaflavine on the gel, the tryptaflavine phosphorescence is quenched by oxygen as before, but it is the leuco dye which is oxidized to malachite green with its characteristic blue-green color. This oxidation does not occur under conditions which are identical, except that no tryptaflavine is present. Thus, the primary quenching process must consist in the formation of some highly reactive gas which is able in a subsequent collision to oxidize a tryptaflavine or leucomalachite-green molecule, the second reaction having by far the greater probability (740,745,749). Kautsky assumed that the intermediate product was a metastable oxygen molecule, but this hypothesis must be discarded for many reasons (455,456,742,743,746). According to Franck, the primary reaction is represented by the equation: $DH^* + O_2 \rightarrow D + HO_2$, DH being the dye in its normal state and the radical HO_2 the oxidizing agent.

The relatively weak photo-oxidation by which many dyes are discolored in liquid solutions saturated with oxygen is reduced by the addition of other foreign molecules which are able to quench the fluorescence of the dye. According to J. and F. Perrin, the negative halide ions and organic compounds such as hydroquinone, phenol, and aniline are examples of "antioxidants" of this type. Their efficiency in inhibiting the oxidation is much greater than their efficiency in quenching the fluorescence of the dyes. Quantitative measurements comparing the two effects are available only for a solution of eosin in glycerol (136). They seem to prove that the antioxidant efficiency is equal to the efficiency in quenching the *phosphorescence* of the dye solution and it may be concluded from this experiment that molecules in the quasi-stable state contribute most to the photo-oxidation process (1219,1777).

The chemical reaction which is directly correlated to the quenching process may be so speedily reversible that it is not observed under normal circumstances. The fluorescence of a large class of dye solutions is quenched by iodide ions. For thionine ("Lauth's Violet"), J. Weiss was able to observe an appreciable, though weak, bleaching effect under strong illumination when the fluorescence of the dye solution was partially inhibited by an addition of potassium

iodide. This discoloration is due to the conversion of the dye into its leuco base:

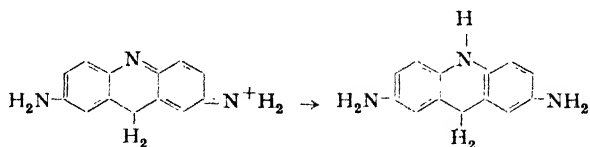

Immediately after the end of the irradiation, the normal absorbing power of the solution was restored spontaneously. A similar, but still weaker, effect was obtained with an eosin solution, and it is not improbable that reversible conversions of the same kind with an even higher rate of reversibility occur in many other dye solutions.

However, even in these apparently simple cases the conversion into the leuco dye was not supposed to be the primary quenching process; the latter, according to Weiss, is characterized by the reaction: $D^* + I^- \rightarrow D^- + I$. The subsequent chemical reactions are beyond the scope of this discussion. In the same way, Weiss explains the quenching of a fluorescent solution by ferrous ions: $D^* + \text{Fe}^{++} \rightarrow D^- + \text{Fe}^{+++}$. His hypothesis that the electron transfer which is supposed to be the primary cause of the quenching should be due to a "resonance" is not acceptable on any theoretical grounds. The mechanism itself may be effective in some cases but is by no means as general as Weiss asserts (1809-1812).

F. Perrin assumed that the energy of excitation of a fluorescent molecule is spent in separating the extra electron from a halogen ion in a collision of the second kind; the efficiency of a quencher was supposed to depend to a certain extent on the nature of the solvent because the energy of the electron affinity is a function of the dielectric constant of the surrounding medium. The energy, of the order of magnitude of 2.5 eV, which is stored in an excited molecule with visible fluorescence is, however, never sufficient for separating an I^- ion from its electron, and, therefore, Franck and Livingston replaced this process by a reaction in which additional energy is supplied by the formation of a semiquinone DH, which, according to Weiss' hypothesis, would occur only in a secondary reaction of D^- and H_2O ; the quenching particle is not the isolated ion I^- , but the complex ion $I\text{-OH}_2$. The primary reaction: $D^* + I\text{-OH}_2 \rightarrow \text{DH} + I + \text{OH}^-$ is followed, in general, by a recombination: $\text{DH} + I + \text{OH}^- \rightarrow D + I\text{-OH}_2$. DH reacts with O_2 to give $D + \text{HO}_2$ only if oxygen is present

in the solution at a sufficient concentration, and molecular iodine is formed, as was proved experimentally (423, 424, 1219, 1221, 1463).

The quenching efficiency of oxygen in solutions of aromatic hydrocarbons is ascribed to the formation of peroxides of the type

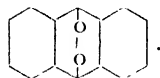

The existence of peroxides of this type has been proved by Moureau and Duffraisse. Weil-Malherbe and Weiss obtained small quantities of analogous compounds in which O_2 was replaced by NO ("nitroxides") by intensive irradiation of solutions of anthracene and dimethylbenzanthracene in an atmosphere of nitric oxide (1805, 1806).

Only in some instances (benzene, toluene, the xylenes, and other methylbenzenes) is the decrease in fluorescence yield caused by the action of oxygen compensated by a corresponding yield of peroxides. For other hydrocarbons the rate of photo-oxidation is much smaller than the quenching of fluorescence would indicate; the production of peroxides is below the limit of experimental error for naphthalene, a compound with a very large quenching constant $k(O_2)$, and for fluorene, which has a relatively small value of $k(O_2)$. Thus, no general simple relation between the quenching efficiency of O_2 and the rate of photo-oxidation exists (143a, 146). In certain cases the complex formed by the collision of the excited hydrocarbon and the oxygen molecule must dissociate immediately after the quenching process has occurred. Hence, it is reasonable to assume that quenching processes are very frequently not connected with a chemical reaction in the ordinary sense of the word, but involve the formation of unstable intermediates which are able to convert the electronic energy by internal conversion into thermal energy according to the equation*: $D^* + X \rightarrow (DX)^* \rightarrow D + X + E_{kin}$.

110. Fluorescent Compounds as Photosensitizers. The probability of a connection between the fluorescence of certain dyes like eosin or erythrosin and their usefulness in the sensitization of photographic emulsions was pointed out by J. Stark long ago. All quenching processes mentioned in the last section in which, ultimately, some molecules other than those of the absorbing dye undergo a chemical

* Compare the analogous considerations concerning the quenching of the fluorescence of vapors (Section 42) and the quenching by solvents (Section 106).

reaction might be quoted as further examples in favor of this hypothesis. It need hardly be repeated that it is not the fluorescence itself but the quenching of the fluorescence which is essential for the transfer of energy to the reacting molecule. The parallelism between the two phenomena is caused by the ability of the compounds to store the excitation energy which they have acquired by light absorption, for a relatively long period without dissipating it into heat. The best sensitizers, however, are not the dyes with the highest fluorescence yield, such as fluorescein, but rather those which show comparatively weak fluorescence and are able to phosphoresce even in liquid solution. (Compare Section 131). Their great inclination to pass into a quasi-stable state would cause their small fluorescence yield as well as their greater propensity to act as sensitizers. The dyes which, at present, are used as the best sensitizers for photographic emulsions, the various cyanine dyes, are not fluorescent at all in liquid solutions. Some of these dyes are brightly fluorescent, however, when they are dissolved in aqueous gelatin, and they retain a part of this fluorescence even when they are adsorbed as sensitizers to the silver salt in a photographic emulsion. If the emulsion is supersensitized by addition of another dye not absorbing in the same spectral region [for instance, 1-(*p*-diethylaminostyryl)benzothiazole], the fluorescence of the cyanine dye is completely quenched and its sensitizing efficiency is enormously enhanced; under these conditions the whole excitation energy is made available for the sensitizing process. Addition of the "super-sensitizing" dye to the silver-free cyanine solution in gelatin quenches also the much stronger fluorescence of this solution with exceedingly high efficiency (*r822a*). It seems that the primary process in the interaction between the molecules of the supersensitizing dye and the excited molecules of the sensitizing dye consists of an internal conversion by which the excitation energy is transformed into vibrational energy of the whole complex and thus becomes available for the ejection of an electron from a Br⁻-ion in the silver bromide emulsion. (For the very interesting fluorescence of cyanine dyes in a state of high polymerization compare Section 115.)

The acceleration of the photolysis of ethyl iodide in alcoholic solution by the addition of naphthalene may be discussed as a typical example of a photochemical reaction which can be sensitized in a liquid solution by a fluorescent compound. C₂H₅I has a diffuse absorption band between 2300 and 3200A; absorption of the Hg-lines at 3130A decomposes the molecules into an ethyl radical and a free I-atom with a quantum yield of 30%. The fluorescence of naphthalene in

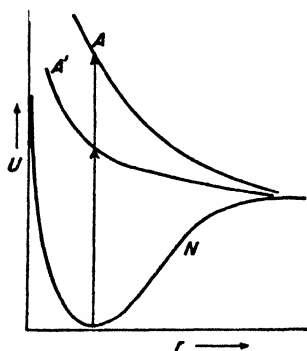

Fig. 112. Potential curves for the photosensitized decomposition of ethyl iodide.

The energy which is needed for the transition from the lower vibrational levels to the repulsion curve may be much larger than the dissociation energy, as shown in Figure 112. In a collision between an excited naphthalene molecule D^* and an ethyl iodide molecule Et , either the shape of the normal repulsion curve can be altered to A' so that the distance from the nonvibrating state of Et to the repulsion curve is reduced to a value not exceeding the energy stored in D^* , or by a process of internal conversion occurring in the "complex" $(DEt)^*$ this energy is converted directly into high vibrational energy of the ground state N of Et which suffices to dissociate the latter. In either case the ethyl iodide molecules in the low vibrational states corresponding to thermal equilibrium can take part in the process (which, therefore, acquires a high degree of probability). (The same consideration applies to all sensitized photochemical reactions and especially to those which cannot be produced directly by light of the wavelength which is active in the sensitized process.)

In a solvent of great viscosity the quenching power of ethyl iodide for the naphthalene fluorescence and the photosensitizing power of naphthalene for the photolysis of ethyl iodide become smaller.

The fluorescence of β -naphthol is very little quenched by ethyl

alcoholic solution is strongly quenched by ethyl iodide, k_q being 180. If the fluorescence is almost completely quenched by an iodide concentration above 0.01 molar, the increase of the rate of decomposition of the iodide is directly proportional to the absorption caused by the sensitizer. If the absorption of the mercury line is trebled by the addition of an adequate quantity of naphthalene to the solution, the

rate of photolysis also becomes three times as large as in the solution free of naphthalene. The photochemical yield remains unaltered at 30%; this means that the total energy which is absorbed by the naphthalene molecules, including the fraction which does not appear as fluorescence under any conditions because of internal conversion, is transferred to the ethyl iodine molecules. The relatively low photochemical yield is ascribed to the probability of initial recombination of the radical and the iodine atom (1822b).

The energy which is needed for the transition from the lower vibra-

iodide ($k_q = 14$) and β -naphthol has a very small sensitizing effect on the photolysis of ethyl iodide. On the other hand, the naphthalene fluorescence is only very slightly quenched by potassium iodide ($k_q = 2$), which makes it certain that the quenching is not caused by I^- -ions. Finally, the total light absorption in a solution containing naphthalene and ethyl iodide is the sum of the absorption by each of the two compounds and, therefore, it is not to be assumed that the two compounds form a complex which would be responsible for the increase in the rate of decomposition. In this case all observations agree with the assumption that the sensitization is caused by collisions of the second kind.

Not every sensitization of a photochemical process by a luminescent compound, however, can be treated as an energy transfer in a collision process. The sensitized photolysis of oxalic acid in aqueous solution in the presence of uranyl sulfate is a typical example of a process of this kind. The fluorescence of the uranyl salt is weakened by the addition of oxalic acid and simultaneously the acid is decomposed by the action of the light which is absorbed by the uranyl salt. KI, with a much higher quenching efficiency, also inhibits the photolysis of the acid if both are present in the solution. However, the photochemical process is reduced to about one-fourth of its maximum value by a 0.1 molar KI concentration, while the uranyl fluorescence is almost completely quenched by a KI concentration which is about a hundred times smaller. Hence, the energy transfer from excited uranyl molecules to the acid molecules is practically uninhibited by a concentration of I^- -ions sufficient to deactivate every excited uranyl radical during its relatively long lifetime. Apparently, uranyl-oxalic acid complexes are formed independently of the irradiation, and light absorbed by the uranyl radicals in these complexes is transferred to the other part of the complex within a time which is short compared to the lifetime of the isolated excited uranyl ions. Thus, it can also be understood why the yield of the photochemical reaction is of the order of magnitude 60 %, while the fluorescence yield in the aqueous uranyl salt solution scarcely exceeds 1 %. The existence of complexes in this case is made even more probable by a very marked influence of the addition of oxalic acid on the absorption spectrum; although the latter retains the structure characteristic of all uranyl salt spectra, the absorbing power in the near-ultraviolet region is more than doubled by addition of an equimolecular quantity of oxalic acid, while oxalic acid itself shows no absorption at all in this spectral region (212, 1288, 1808).

There are other instances of the sensitization of photochemical processes by fluorescing compounds which are ascribed to the formation of complexes. Schpolsky and Sheremetiev mention the oxidation of sodium sulfite in an aqueous solution of rhodamine, and Eder's reaction, $2\text{HgCl}_2 + (\text{NH}_4)_2\text{C}_2\text{O}_4 \rightarrow \text{Hg}_2\text{Cl}_2 + 2\text{NH}_4\text{Cl} + 2\text{CO}_2$, in the presence of eosin under irradiation with light absorbed by the dyes as belonging to this class. If a dye is absorbed on some foreign molecules in a solid solution, it is especially difficult to draw a sharp limit; some authors are of the opinion that in photographic emulsions which are sensitized with dyes of the fluorescein series, the silver atoms and the dyes form complexes such as silver erythrosinates and that a reaction of this type is greatly favored if the acidity of the dye is increased by the substitution of halogens for hydrogen atoms (1476).

Very little is known concerning the existence of sensitized fluorescence in liquid solutions. In general, the absorption bands are so broad that it is difficult to prove that the fluorescence of an additional dye is not excited by light absorption in the "tail" of its own absorption band rather than by energy transfer from another dye the absorption peak of which has a wavelength coinciding with that of the primary radiation, while its fluorescence band corresponds to the absorption band of the "sensitized" dye. The excitation of the red fluorescence of fluorescent blue in an aqueous solution of phenosafranin is the only example quoted in the literature; the fluorescence of the latter dye is yellow and is excited, together with the red fluorescence of the former, by absorption of green light. A case of sensitized dye fluorescence in which the primary energy is provided by a chemical reaction instead of irradiation has been described by Kautsky and Zocher. If siloxene is oxidized by potassium permanganate, it emits a weak bluish chemiluminescence. If dyes such as rhodamine and eosin are absorbed on the gel, the characteristic fluorescence of the dye is emitted with great intensity as long as the process of oxidation lasts (755,1214).

Quenching of the fluorescence of one dye by the addition of another dye to the solution has been observed more frequently. According to Perrin, the efficiency is greater the more closely the absorption band of the second dye coincides with the fluorescence band of the first dye, and he therefore ascribes the energy transfer to a "resonance induction" without giving a very clear idea of the mechanism by which the excitation energy is converted into heat. However, a reabsorption of the fluorescence light would produce the same effect, and it is difficult to distinguish between these two causes of decreasing fluo-

rescence intensity. Examples quoted by Perrin are the quenching of the fluorescence of uranin and of fluorescent blue by eosin and by methylene blue, respectively (1207, 1209, 1212).

A phenomenon which might be called sensitized fluorescence occurs with naphthacene and some other colored hydrocarbons dissolved in small concentrations in crystalline anthracene, when the fluorescence of the dissolved compound is excited by light which is absorbed by the molecules of the solid solvent. These cases will be treated in Section 117.

As a last type of reaction which can be sensitized by fluorescent dyes, the coagulation of colloids such as arsenic sulfate may be mentioned. If such a solution is irradiated in the presence of an electrolyte (e.g., lithium chloride) and a dye (e.g., eosin), the rate of coagulation is highly increased. The sensitization is inhibited by addition of an "antioxidant" which, under other circumstances, would quench the fluorescence of the dye (132).

111. Fluorescence of Living Plants. Photosynthesis, the assimilation of carbon dioxide by green plants under the action of light, is by far the most important of all photochemical reactions which are sensitized by a fluorescent dye. Chlorophyll, which exhibits fluorescence when it is dissolved in organic liquid solvents, is also fluorescent when adsorbed on the proteins of a plant leaf. The very characteristic luminescence spectrum is nearly the same in both cases; however, the yield, which in alcoholic solutions is of the order of ten per cent, is far below one per cent in plants. This small fluorescence yield is not exclusively due to the energy transfer in sensitizing photosynthesis, but is caused to a considerable degree by other competing "inactive" quenching processes according to the generalized Stern-Volmer equation:

$$Q_f = \frac{\alpha}{\alpha + \beta + \gamma} \quad (74)$$

where Q_f is the fluorescence yield and α, β, γ are the relative probabilities of fluorescence, inactive quenching, and sensitization.

Photosynthesis is a highly complicated process with the overall reaction:



The reaction takes place in a series of successive steps in which several catalysts cooperate. Several [probably $x = 8$ in Equation (75)] of these steps require an activation energy which is provided by light

absorption in the chlorophyll molecules.* Under normal conditions, about one-third of the absorbed light energy is lost by inactive quenching. The chemical reactions themselves are not within the scope of this discussion, which is concerned only with the fluorescence phenomena associated with photosynthesis (415,739,744,750,751,753).

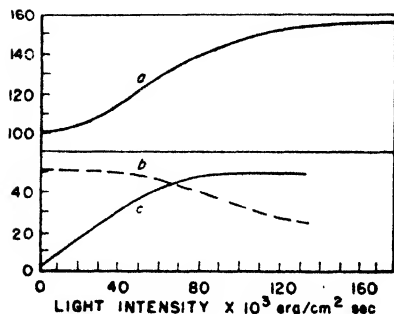

Fig. 113. Yield of fluorescence and photosynthesis in a leaf as a function of the intensity of illumination (Franck, French, and Puck).

- a: relative fluorescence yield.
 b: relative yield of photosynthesis.
 c: rate of photosynthesis.

photochemical process is limited by the limited supply of the catalyst which is needed for the reaction. If a leaf is subjected to a steady irradiation and if the light input is not too large, fluorescence *intensity* and the *rate* of the photochemical reaction are proportional to the intensity of the impinging light: fluorescence *yield* and the *yield* of photosynthesis are independent of the intensity of the exciting light under these conditions. With increasing light intensity, however, photosynthesis tends toward a saturation value corresponding to the total quantity of catalyst available for one of the reaction stages. Simultaneously, the fluorescence yield increases and approaches a value which is about 70% higher than the yield obtained at low light intensities. From there on the fluorescence intensity is again

* A part of the energy which is supplied in successive steps by the transfer of a photon is not used up for the reactions and, therefore, appears on the right side of the overall equation as "Energy." This has nothing to do with the "inactive quenching processes" which are characterized by the probability coefficient β in Equation (74).

Once more the fluorescing molecules are those which have no part in the sensitizing action: fluorescence yield and rate of photosynthesis are antiparallel, although because of the contribution of inactive quenching, they are not strictly complementary. If photosynthesis is slowed down by external conditions -- for instance, by low temperature or small CO₂-concentration in the surrounding atmosphere -- the fluorescence output is enhanced; every increase of the photosynthesis rate is accompanied by decreasing fluorescence. The maximum output of at least one stage of the

proportional to the intensity of the exciting light, the yield now remaining constant at the higher level (Figure 113). Not all of the energy which is withheld from the photochemical process is gained for the fluorescence process, but if one of the principal paths by which excitation energy can be lost is blocked by the saturation of the catalyst, the number of excited molecules in equilibrium with absorbed radiation becomes larger and the fluorescence intensity, therefore, increases.

Inhibition of photosynthesis by a poison, such as hydrogen cyanide, or by low temperature, causes the rise of fluorescence yield to occur at much lower light intensities. Under very weak and very strong illumination, the fluorescence of inhibited and uninhibited leaves is the same. In the first case, the very low rate of the photochemical reaction is carried on even in an inhibited leaf, while, in the second case, the fraction of the absorbed radiation needed for the saturation of photosynthesis in the uninhibited leaf is practically negligible.

Much additional understanding of the whole problem is gained by the observation of leaves during the so-called induction period. If a leaf which has been kept in the dark for some time is irradiated, the fluorescence starts at the same intensity level which is characteristic of the state of equilibrium under continuous irradiation. Its intensity increases rapidly during the first second until it reaches a value which is about three times as large as the initial value. The absolute magnitude of this fluorescence outburst depends on the intensity of the exciting light. It is proportional to the primary intensity if the latter is not too high, but above a certain critical limit a further increase in exciting light intensity produces only a small increase in the fluorescence outburst. The *rate* of this initial rise of fluorescence also increases with the light intensity and approaches an upper limit which

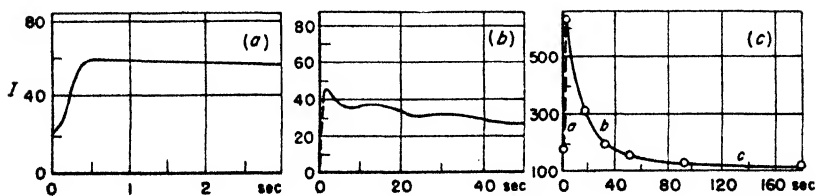

Fig. 114. Fluorescence intensity of a leaf as a function of the time of illumination (Franck, French, and Puck): (a) during the first 3 sec.; (b) during the first 50 sec.; and (c) during the first 3 min.

it can not exceed. The temperature and the CO_2 -concentration of the surrounding atmosphere do not influence the rate or the intensity of the outburst (Figure 114) (415,431,740,749,751,753).

When the fluorescence has reached its maximum intensity at the end of the outburst, it decays again, under normal conditions during several minutes, until it has dropped to the initial level. From there on it remains steady for a practically indefinite time. The decay from the peak of the outburst is inhibited by high concentration of carbon dioxide; it is slowed down by low temperature, by poisoning the leaf with hydrogen cyanide, and by a shortage of oxygen in the surrounding atmosphere. Every one of these treatments impedes not only photosynthesis but also the respiration process. Evidently the decay of fluorescence is due to the second of these effects, since it also occurs when the leaf is kept in the dark after the end of the fluorescence outburst. If the illumination is interrupted for a short time at the peak of the outburst, fluorescence starts at a higher level when the irradiation is renewed; it takes a dark period of about 10 sec before the normal "dark state" of the leaf is restored.

The whole course of the fluorescence intensity during the induction period under various conditions is represented in a plausible manner by Franck and Herzfeld's theory of photosynthesis, which cannot be discussed here at length (420). As far as the fluorescence phenomena are concerned, the theory explains how the coefficient γ of Equation (74) decreases at first during the induction period and, after having reached a minimum, increases again, until an equilibrium state is attained.

The quantitative measurements of the fluorescence intensity during the induction period show that the "inactive quenching" is also influenced by the distribution of the intermediate products of photosynthesis, or that the probability coefficient β in Equation (74) is not constant. The fluorescence peak at the end of the "outburst" is almost twice as high as the fluorescence intensity observed during the steady state, when photosynthesis is inhibited. Apparently the molecules in direct contact with the chlorophyll molecules are not the same in both cases and the probability of a quenching energy transfer is altered. This inconstancy of β renders the relation between fluorescence yield and photosynthesis rate more complicated and increases the difficulty of finding any quantitative correlation between the two processes.

112. The "Optimum Concentration". In many publications the concentrations of fluorescent compounds are given in g per cc of the

solvent, while other authors refer their measurements to molar concentrations. The following Table 62 may be useful for the conversion of the various data from one system to the other. The figures are of the same order of magnitude in either system and this may lead to misunderstandings.

TABLE 62

CONVERSION OF THE CONCENTRATIONS OF FLUORESCENT COMPOUNDS
FROM GRAM PER CUBIC CENTIMETER TO MOLE PER LITER

(10^{-3} g/cc = $x \cdot 10^{-3}$ mole/liter; 10^{-3} mole/liter = $y \cdot 10^{-3}$ g/cc)

Compound	Molecular weight <i>M</i>	<i>x</i>	<i>y</i>
Fluorescein	370	2.7	0.37
Eosin	692	1.44	0.69
Erythrosin	879.4	1.14	0.88
Rose bengale	1017.2	0.98	1.02
Rhodamine B extra	446.5	2.24	0.446
Rhodamine 6G	450.5	2.22	0.45
Trypaflavine	259.5	3.85	0.26
Euchrysin	301.5	3.31	0.30
Rhoduline orange	401.5	2.95	0.40
Magdala red	486.5	2.06	0.49
Thionine	263.5	3.79	0.26
<i>ψ</i> -Isocyanine	362	2.76	0.36
Malachite green	346.5	2.88	0.35
Crystal violet	390.5	2.54	0.39
Quinine sulfate (+ 7H ₂ O)	492	2.07	0.49

The fluorescence strength *F* in a solution is determined by the number of photons emitted by a unit volume when light of unity intensity enters the volume through one of its surfaces. If Beer's law is assumed to be valid, it follows that:

$$F = (1 - e^{-\epsilon c})Q \quad (76a)$$

ϵ being the molar absorption coefficient, *c* the concentration in moles per liter, and *Q* the quantum yield. For small values of *c* the equation can be replaced by:

$$F = \epsilon c Q \quad (76b)$$

As long as this is permissible, the fluorescence strength increases proportionally to the concentration. The exact proportionality between *F* and *c* was proved, for instance, by quantitative measurements

performed with aqueous rhodamine solutions in a range of concentrations between 10^{-9} and 10^{-6} g per cc. Uranin can be traced by its fluorescence at concentrations as low as 10^{-14} g per cc at which there are only a few thousand molecules in a cubic millimeter. In such dilute solutions, the fluorescence strength can be used directly for quantitative analysis.

On the other hand, Equation (76a) tends toward the limit:

$$F = Q \quad (76c)$$

when the value of c becomes very large; the fluorescence strength is equal to the yield at concentrations at which practically all incident

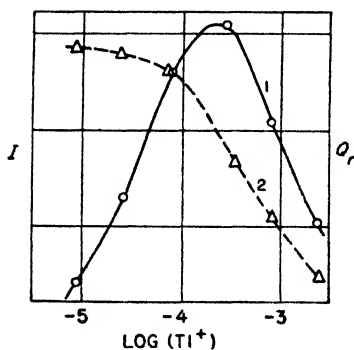

Fig. 115. Yield and apparent fluorescence intensity I (1), and relative fluorescence Q_r (2) of Tl^+ in a concentrated KCl solution as a function of the Tl -concentration (Pringsheim and Vogels).

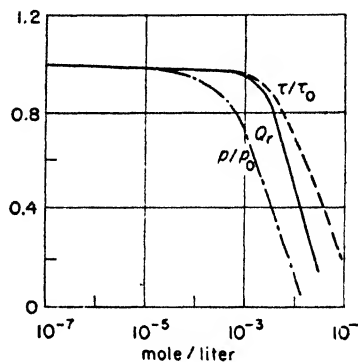

Fig. 116. Yield, (Q_r), lifetime (τ/τ_0), and polarization (p/p_0) of the fluorescence of fluorescein sodium in glycerol as a function of the dye concentration (Vavilov).

light is absorbed in the volume under observation. F should asymptotically approach this limiting value, and simultaneously the light-emitting volume should contract itself with increasing brightness into a thin surface layer. This is almost never the behavior which is actually observed in a fluorescent solution, when the concentration of the fluorescent molecules is increased gradually. After having reached a maximum, F decreases again and frequently the solution does not fluoresce at all at very high concentrations (Figures 115–118) Such a behavior can be due only to the fact that Q itself is not constant, but is a function of c . It cannot be explained by the assumption that at

high concentrations a part of the fluorescent light is reabsorbed in the solution if the luminescence is observed backward or from the side from which the exciting light enters (compare Section 105).

The existence of an "optimum concentration" is a very general phenomenon in fluorescent solutions. It even occurs quite regularly in solutions of substances which, like the uranyl salts and anthracene, are strongly luminescent in the pure solid state. Compounds as widely different as most dyes in water, in alcohol or in sugar; uranyl sulfate in H_2SO_4 or in water; benzene in alcohol or in hexane; and Tl^+ -ions in aqueous KCl solutions, may be mentioned as examples of "self-quenching" (Figure 115). Pekerman states, however, that alcoholic solutions of numerous aromatic hydrocarbons and their derivatives, such as anthracene, naphthionic acid, quinine, esculin, etc. are free of self-quenching in a very wide range of concentrations (1200b). If an afterglow is observable in a solution, it is even more sensitive to this effect. Thus, the phosphorescence of eosin in glycerol attains its greatest strength at a concentration of $5 \cdot 10^{-5}$ g per cc, while the fluorescence strength increases up to a concentration of 10^{-3} g per cc. Similarly, the afterglow of hematoporphyrin in alcohol can be observed only at the very highest dilution. For uranin in solid boric acid, the fluorescence intensity and the initial brightness of the afterglow decrease at the same rate with increasing concentration of the dye. The duration of the afterglow decreases as well, however, and thus the total phosphorescence output is more strongly quenched than the fluorescence (178,750,911,1201b).

113. Self-quenching. Two widely different theories have been put forward for the explanation of self-quenching.* Both are supported by some experimental evidence, but neither is sufficient to explain all observed facts and it is probable that each contains a part of

* A third hypothesis which, at its best, can be applied only to a very few specific cases will be mentioned in Section 116.

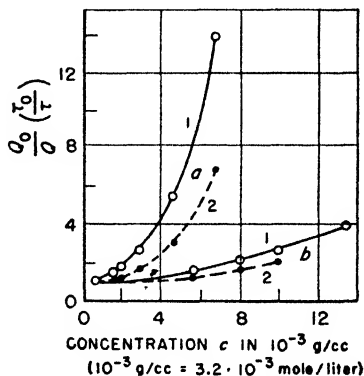

Fig. 117. Yield and lifetime of the fluorescence of fluorescein sodium in water (a) and in glycerol (b) as a function of the dye concentration (Szymanowski).
1: yield. 2: lifetime.

truth. Vavilov and F. Perrin were the first to apply the hypothesis of collisions of the second kind to these quenching processes, assuming that because of some resonance phenomenon the effective cross-sections were particularly large for interactions between molecules of the same kind (1215, 1216, 1221, 1224, 1749, 1758, 1762a). A specific mechanism by which this resonance should produce quenching has never been proposed. The other theory has been asserted by Walter at a very early date; more recently, Levshin and Rabinowitch have been its principal champions (911, 1317a). According to these authors, the

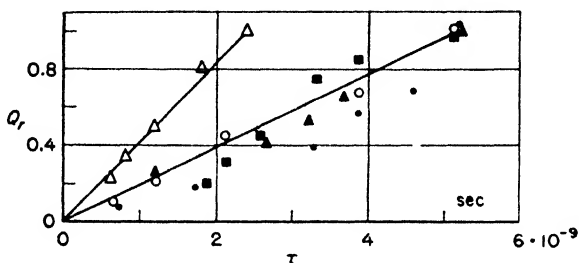

Fig. 118. Fluorescence yield Q_f as a function of the lifetime τ of fluorescein and rhodamine fluorescence at various dye concentrations (Szymanowski).

- fluorescein in water; c from 0.175 to $6.8 \cdot 10^{-3}$ g/cc
- fluorescein in ethanol; c from 2.1 to $23 \cdot 10^{-3}$
- fluorescein in isobutanol; c from 0.37 to $10.9 \cdot 10^{-3}$
- ▲ fluorescein in glycerol; c from 0.11 to $12 \cdot 10^{-3}$
- △ rhodamine in methanol; c from 1.0 to $21.5 \cdot 10^{-3}$

decrease in fluorescence yield with increasing concentration of the fluorescent compound is due to the formation of dimers or polymers which are not fluorescent. Such an effect would not be equivalent to genuine quenching, however, as was pointed out in the first paragraph of Section 109, and the apparent decrease in fluorescence yield would not be accompanied by a decrease in the lifetime τ of those excited molecules which are not polymerized and which are the only molecules contributing to the fluorescence.

The strongest argument in favor of the collision theory of self-quenching is the existence of the parallelism between the decrease in Q_f and τ with the increase in concentration of the fluorescent molecules. This parallelism appeared very clearly in a set of curves that were published by Gaviola and Pringsheim, who used Gaviola's first measurements of the lifetimes of the fluorescein fluorescence.

Szymanowski's later, more accurate measurements enabled Vavilov to replot these curves with slightly greater precision (Figure 116) (461, L).

The self-quenching of uranyl sulfate in concentrated sulfuric acid follows the Stern-Volmer Equation (11) up to the highest concentrations of the fluorescent molecule and Q_r and τ are proportional in the same range of concentrations. The problem is complicated by the increasing viscosity of the concentrated solutions, which has to be taken into account. The self-quenching of anthracene in benzene excited by near u.v. also obeys the Stern-Volmer law, but no τ -values are available for these solutions (1291, 1754).

While $1/Q_r$ and $1/\tau$ plotted versus c are well represented by straight lines for rhodamine B extra dissolved in methanol, the deviations from the Stern-Volmer law greatly exceed the possible errors for the same dye dissolved in glycerol, for uranin dissolved in water, ethanol, and isobutanol, and for many other dye solutions (Figure 117). An obvious discrepancy between the curves for Q_r and τ appears also in Figure 116. Nevertheless, Figure 118, in which the Q_r -values of Table 63 are represented as a function of the corresponding τ -values proves that, to the first approximation at least, a linear relation prevails between these two variables, and this is even more striking because the dye concentration are spread over a very wide range (1624).

TABLE 63

LIFETIMES (IN 10^{-9} SEC) AND RELATIVE QUANTUM YIELD Q_r OF THE FLUORESCENCE OF FLUORESCEIN AS A FUNCTION OF THE DYE CONCENTRATION c (IN MG PER CC) IN VARIOUS SOLVENTS

Solvent											
Water			Ethanol			Isobutanol			Glycerol		
c	τ	Q_r	c	τ	Q_r	c	τ	Q_r	c	τ	Q_r
0.175	5.07	1.00	2.1	5.07	1.00	0.37	5.07	0.98	0.12	5.13	0.98
0.66	5.07	0.96	7.0	3.87	0.67	4.5	3.87	0.67	0.36	5.13	1.00
1.57	4.60	0.69	11.0	2.13	0.45	6.0	3.33	0.57	4.60	3.67	0.66
2.00	3.87	0.57	16.6	1.20	0.21	7.4	1.65	0.45	6.9	3.2	0.52
2.82	3.26	0.39	23	0.67	0.11	9.0	2.13	0.31	9.0	2.67	0.40
4.6	1.73	0.18	—	—	—	10.9	1.87	0.21	12.4	2.1	0.26

Since, in many instances, the experimental values did not fit the collision theory of self-quenching, F. Perrin replaced it by a hypothesis which considered only the influence of the average configu-

ration of the molecules and not their relative motion. This hypothesis led to the equation:

$$Q = Q_0 e^{-kc} \quad (77a)$$

k is a constant depending mainly on a function $f(r)$ which determines the quenching probability of an excited molecule by an unexcited molecule of the same kind at the mutual distance r (1215, 1224). In order to explain the existence of an "optimum concentration," Bruninghaus and, later, Ewles have put forward a similar formula for the fluorescence strength: $F = A c e^{-nc}$; however, a theoretical foundation for introduction of the exponential which causes the decrease in F after passing the optimum is not mentioned by either of the authors. Ewles postulates that a dye molecule is luminescent only when it is separated from the next dye molecule by some smallest number n of solvent molecules (178, 181, 371). Bouchard states that numerous measurements which he performed under varying experimental conditions with various dye solutions are in good agreement with Perrin's equation (133-135). Other investigators do not confirm this statement.

As I pointed out incidentally, introduction of a quenching probability determined by the function $f(r)$ instead of the rigid "effective volume" of Eq. 71, restores the interdependence of Q and τ , although, in general, the relation would not be linear; at any rate the molecules remaining longest in the excited state would have the greatest probability of being quenched (329, 330). This principle is the basis of Vavilov's latest theory of self-quenching, which represents the self-quenching of dye solutions in the concentration range from 10^{-4} to 10^{-1} mole per liter, but fails to interpret the behavior at lower concentrations which all previous theories also were unable to explain: in the curves plotting the yield and lifetime as functions of the concentration, the decrease in Q and τ sets in with a sharp bend at a certain "limiting concentration" c_0 , while at lower concentrations the curves are nearly horizontal. This behavior has been observed in many instances, the value of c_0 varying with the nature of the dye and of the solvent (Table 64). The polarization of the fluorescence, which will be discussed in Sections 118 and 119, decreases also with increasing concentration and is even more sensitive in this respect than Q and τ (Figure 116) (1201b).

Vavilov assumes the existence of two independent probabilities of energy transfer by resonance from an excited molecule to another molecule of the same kind, the one leading only to depolarization, the

TABLE 64
LIMITING MOLAR CONCENTRATION c_0 AT
WHICH SELF-QUENCHING BEGINS

Dye	Uranin	Eosin	Rhodamine 6G	Trypa- flavine	Coriphos- phine
Solvent:					
Water ..	$5 \cdot 10^{-4}$	$5 \cdot 10^{-4}$	$5 \cdot 10^{-5}$	$3 \cdot 10^{-3}$	$3 \cdot 10^{-4}$
Ethanol .	$3 \cdot 10^{-3}$	—	$1 \cdot 10^{-3}$	—	—
Acetone .	—	—	$1.4 \cdot 10^{-3}$	—	—
Glycerol .	$1 \cdot 10^{-3}$	—	$1 \cdot 10^{-3}$	—	—

other to quenching, the first being much larger than the second. In addition to these time-dependent interactions, a static sphere of influence is assumed for the quenching, in the same way as in Equations (71) and (72). From these assumptions the following equation is derived:

$$Q = e^{-\Omega_0 c} \left\{ 1 + c \left(\frac{\tau_0}{k_1} + \frac{\tau_0}{k_2} + \frac{\tau_0}{k_2} e^{-\Omega_0 c} \right) \right\}^{-1} \quad (77b)$$

τ_0 is the lifetime of the excited molecules at lowest concentrations, Ω_0 the sphere of static influence, and $1/k_1$ and $1/k_2$ determine the probabilities of quenching and depolarizing energy transfers. The equation represents with great accuracy the observed dependence of Q , τ , and ρ on the concentration of four dyes dissolved in glycerol. It must be emphasized, however, that the theory is purely formalistic in that it fails also to interpret the mechanism by which the energy is converted into heat in the "quenching" transfers (1762a).

114. Polymerization and Self-quenching. The absorption spectra of many dyes in solutions undergo a continuous change with increasing concentration, and this change is connected with the self-quenching of fluorescence by an unmistakable parallelism. Both effects depend in the same way on the nature of the dye and the solvent. For certain dyes the deviations from Beer's law in the normal absorption band (M) of the dissolved molecules are appreciable even at very low concentrations, especially in aqueous solutions (for instance, for rhodamine at $5 \cdot 10^{-5}$ moles per liter and for thionine at $2 \cdot 10^{-7}$ moles per liter); at higher concentrations new bands appear in the absorption spectra and eventually these prevail almost alone. In alcoholic solutions the new bands ("D-bands") are observed only at greater dye concentrations and they may be completely missing in

acetic solutions in which no self-quenching occurs (Figure 119) (13, 1523).

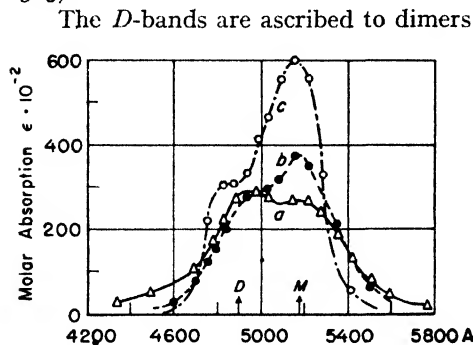

Fig. 119. Absorption bands of eosin in aqueous solutions at various dye concentrations (Soederberg).

a: $2.5 \cdot 10^{-1}$ g/cc. *b*: $2 \cdot 10^{-2}$. *c*: $3 \cdot 10^{-6}$.

The *D*-bands are ascribed to dimers of the dye molecules. From the relative areas under the curves representing the absorption bands the relative concentrations of monomers and dimers in the solution can be calculated. The results obtained by Rabinowitch and Epstein with aqueous solutions of thionine and methylene blue (Figure 120) were in good agreement with the equation for a partially dissociated molecule:

$$k = 2cx^2/(1 - x) \quad (78)$$

where *c* is the total concentration of the dye and *x* the fraction of monomeric molecules or "dissociated polymers" (1317*a*).

If a thionine solution is irradiated with light of a wavelength which is equally absorbed in the two overlapping bands *M* and *D*, the fluorescence yield decreases at very nearly the same rate as the concen-

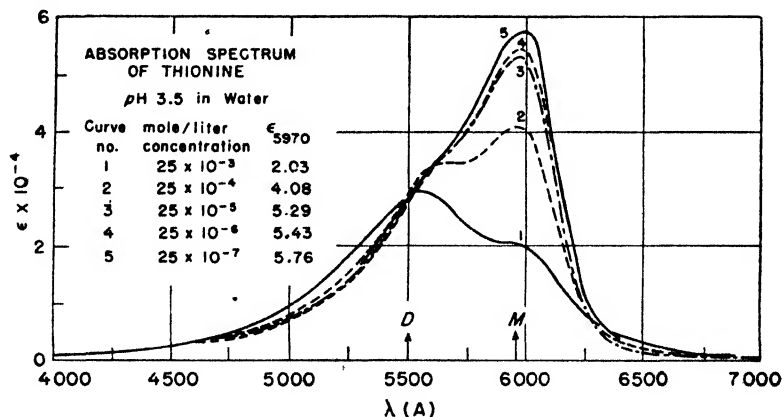

Fig. 120. Molar extinction coefficient of thionine in water [Rabinowitch and Epstein (1317*a*)]

tration of monomeric molecules x . In ethanol, thionine does not polymerize and Q remains constant.

TABLE 65
SELF-QUENCHING AND DIMERIZATION OF THIONINE
IN DIFFERENT SOLVENTS

Concentration	In water			In ethanol	
	x	Q_f	Q_f/x	x	Q_f
$2.5 \cdot 10^{-5}$	0.995	10	10.5	1.0	20
$2.5 \cdot 10^{-4}$	0.732	6.8	9.3	1.0	19
$2.5 \cdot 10^{-3}$	0.359	2.7	7.5	1.0	20

If, on the other hand, the fluorescence of an aqueous rhodamine solution which is excited by light of wavelength 5461A is compared with the fluorescence excited by light of wavelength 6000A, the decrease in *yield* with increasing concentration is much smaller in the first than in the second case: 6000A and 5461A correspond very nearly to the peaks of the *D* and the *M*-band of the solution (Figure 121) (913).

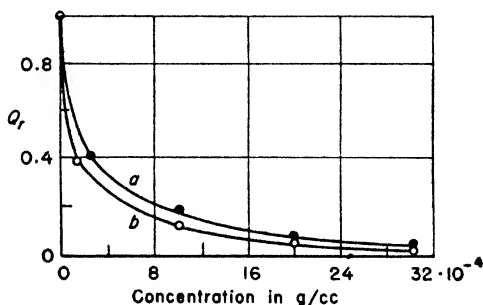

Fig. 121. Self-quenching of the fluorescence of rhodamine in aqueous solution with increasing concentration (Levshin).

a: exciting light of wavelength 5460A.
b: exciting light of wavelength 5900A.

If a solution is heated, the *D*-band in the absorption spectrum becomes weaker and the fluorescence yield simultaneously becomes larger, while all losses of excitation energy due to internal conversion or to collision processes are increased by the increase in temperature. Only when a certain critical temperature is exceeded does the fluorescence yield begin to drop again, because the diminishing polymerization is overcompensated by other quenching processes (Figure 122).

Notwithstanding so much evidence, polymerization alone cannot be made responsible for self-quenching, as was pointed out in the last section. In some instances, as for thionine in water, polymerization may be the main cause, only the relatively small deviations shown in Table 65 being due to genuine quenching. In other instances, where the

parallelism of Q and τ has been proved to exist, some sort of collision-quenching must prevail and only the deviations from the theoretical equations can be caused by polymerization. It has been suggested that the polymerized molecules, apart from not being fluorescent themselves, might have a large specific quenching efficiency for the non-associated molecules; no reason is known why this should be any more probable than a strong quenching of the excited molecules by non-excited monomeric molecules.

As a matter of fact, the latter possibility and the polymerization process might well be related. If, in a given solvent, polymerized molecules exist in a certain equilibrium concentration, this concentration can be shifted towards higher values if the solution is irradiated, or, in other words: dye molecules which are excited by light absorption are quenched by forming a dimer in a collision with a nonexcited molecule. The conversion of anthracene into dianthracene under the action of near-ultraviolet light is a well-known fact, and Weigert has shown that, in this case, dimerization and quenching of fluorescence are complementary (1799).

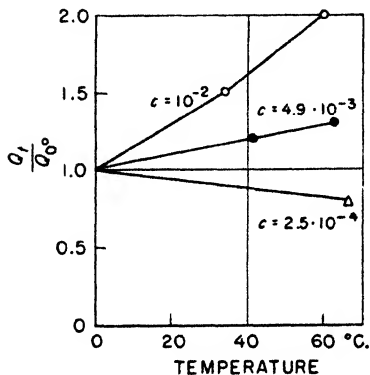

Fig. 122. Influence of temperature on the self-quenching of fluorescein in aqueous solutions (Levshin).

Concentration c in g per cc.

With respect to the self-quenching of anthracene and other aromatic hydrocarbons, however, statements are found in the literature which seem to be completely contradictory. According to different authors the self-quenching of anthracene in benzene, hexane, and other solvents is very pronounced (Table 66). According to Pekerman the fluorescence of anthracene dissolved in benzene shows typical self-quenching, while this phenomenon is completely lacking in alcoholic solutions in the concentration range from 10^{-6} to $2 \cdot 10^{-2}$ g per cc (1201b).

The figures of Table 66A are taken from a paper by Bowen, the value of k_s for anthracene in benzene being in complete agreement with that found by another author (144,1291). The relatively great difference of the corresponding value in Table 66B (after Weil-Malherbe and Weiss) cannot well be ascribed to the strong prequenching by

TABLE 66

QUANTUM YIELD Q_0 AND SELF-QUENCHING CONSTANT k_s OF AROMATIC HYDROCARBONS IN SOLUTION EXCITED BY NEAR U.V.

A. ANTHRACENE IN THE PRESENCE OF ATMOSPHERIC AIR

(Concentration range: $1.8 \cdot 10^{-3}$ – $4.5 \cdot 10^{-2}$)

Solvent	Benzene	Hexane	Acetone	Biacetyl ether	Paraffin
$Q_0(\%)$	21.5	23	21	21.4	29
k_s	26	90	53	75	3

B. VARIOUS HYDROCARBONS IN THE ABSENCE OF O_2 (1806)

(Concentration range: 10^{-5} – 10^{-2})

Compound	Solvent	k_s	Compound	Solvent	k_s
Anthracene	Benzene	60	Pyrene	Benzene	< 10
Anthracene	Hexane	100	1,2,5,6-Dibenz- anthracene	Benzene	20
3,4-Benzopyrene	Benzene	70	Methylchol- anthrene	Benzene	77
9,10-Dimethyl- 1,2-benz- anthracene	Benzene	83	Ethylchloro- phyllide	Ethanol	10^5
1,2-Benz- anthracene	Benzene	40			

O_2 in the first case, since the solubility of oxygen is much smaller in benzene than in hexane. According to a later paper by Bowen, the self-quenching constant k_s for benzene, anthracene, and all other hydrocarbons enumerated in Table 61A (Section 108) is smaller than 0.5, when the solutions in oxygen-free hexane are excited by the mercury line 2537A. Moreover, under these conditions the much higher value of $Q_0 = 46\%$ (instead of 23%) was obtained for the fluorescence yield of anthracene. The discrepancy in the values of Q_0 might perhaps be explained by the smaller depth in which the exciting radiation of wavelength 2537A is completely absorbed and by a corresponding difference in the reabsorption of the fluorescence radiation. It was pointed out in Section 105, however, that this explanation cannot be applied to the disagreement between the k_s values. In the case of anthracene, Bowen's later data refer to so low a concentration range (from 0.7 to $2.8 \cdot 10^{-4}$), that they may still correspond to the horizontal branch of the yield curve (Figure 125). It is doubtful how far this consideration can be extended to the other compounds listed in Table 61A (146,1806).

While no quantitative data are available for the self-quenching
Pringsheim 13

of benzene in alcohol, it has been stated by various investigators that the fluorescence strength at first increases with concentration, then reaches a maximum at a volume concentration of about 2% (corresponding to $2.3 \cdot 10^{-2}$ mole per liter), and finally drops almost to zero in pure liquid benzene. The fluorescence reappears strongly when the liquid crystallizes (1350).

The fluorescence yield of dyes becomes smaller also at high concentrations, when they are dissolved in a solid; for instance, in sugar the Q -value of uranin is constant at concentrations between 10^{-5} and 10^{-4} , it drops rapidly at concentrations above 10^{-4} , and is only about 7% of its highest value at the concentration of $2 \cdot 10^{-2}$.* In media of such great viscosity, no collisions occur and dimerization due to the interaction of an excited and an unexcited molecule is possible only if the two are immediate neighbors. Otherwise, self-quenching in a solid solution must be ascribed either to "configuration-quenching" or to the production of dimers by a dark reaction preceding the solidification of the solution. The latter phenomenon alone would not suffice, however, for an interpretation of Levshin's observation that the duration of the phosphorescence of fluorescein in boric acid is reduced to about one-half when the concentration of the dye is increased from 10^{-2} to $3 \cdot 10^{-1}$ % (911).

All the foregoing remarks refer to directly excited fluorescence and phosphorescence of solutions, as it is observed, in general, at room temperature. G. N. Lewis found the duration of the indirectly excited slow fluorescence of fluorescein in glycerol at -180° C to be independent of the dye concentration in the range from $5 \cdot 10^{-5}$ to $5 \cdot 10^{-2}$ moles per liter. It is not impossible that, nevertheless, the apparent *yield* is appreciably smaller at the higher concentrations if its decrease were due exclusively to the formation of nonluminescent dimers (929, 930).

If the concentration of a dye in aqueous solution is just below the critical value c_0 of Table 63, the quenching efficiency of foreign ions, such as I^{-} and Br^{-} , is much larger than in solutions of lower dye concentration. Moreover, the D -band appears in the absorption spectrum under these conditions when the quencher is added to the solution. Both effects become weaker with increasing temperature. Banow supposes, therefore, that, because of the tendency of the halide ions to hydration, the number of solvent molecules at the disposal of each dye molecule is lessened and thus the "real concentration" of

* These concentrations are given in gram dye per cc solvent (Table 62).

the dye is increased. It would be a first step toward salting out. Similar effects are not observed at the same concentration in alcoholic solutions in which no polymerization takes place. In these solutions, an increase in temperature enhances the quenching by foreign ions as in the other instances described in Section 107 (60,1723a).

115. Polymers with New Fluorescence Bands. There is, of course, no reason in principle why polymerized molecules should always be non-fluorescent. Pseudoisocyanine chloride exhibits relatively broad and diffuse "molecular" absorption bands M_1 at 5300A and M_2 at 4820A in alcoholic solutions and if the concentration is low, also in aqueous solutions. If dye concentration exceeds 10^{-3} molar in aq. solution, a new narrow absorption band P appears in the yellow, and, simultaneously, a weak fluorescence. By increasing the concentration to about 10^{-2} molar, the fluorescence and absorption band P are greatly enhanced, the absorption in the other bands becomes weaker, and the liquid solution is converted into a gel (Figure 123). If the temperature is lowered, the P -band in the absorption spectrum and the fluorescence begin to be observable at lower dye concentrations. The phenomenon as a whole is caused by the formation of highly polymerized molecules which consist of large numbers of parallel planar dye molecules piled upon each other face to face so that long chains are built up (685,1414-1418).

The fluorescence of these solutions is exceedingly sensitive to the presence of quenchers of very low relative concentrations. Addition of 10^{-5} mole per liter of pyrocatechol to a solution containing 0.2 mole per liter of pseudoisocyanine chloride quenches the fluorescence to 80% of its maximum value: a single quenching molecule is able to affect the light emission originating from a very large number of dye molecules which obviously form a unit. The molar concentration of the *polymers* is far below the calculated concentration of the non-associated dye molecules and the light emission by the entire poly-

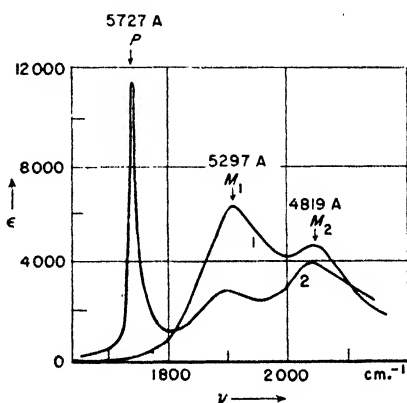

Fig. 123. Molar absorption coefficients of ψ -isocyanine chloride in aqueous solution (Scheibe).

1: 10^{-4} mole per liter. 2: 10^{-2} .

merized molecule is inhibited if any of the dye molecules forming the chain are in contact with a quenching molecule.

Various cyanine dyes behave similarly. For the dye mentioned above, the wavelength of the *P*-band is 7287Å and the center of the fluorescence band which overlaps the *P*-band is shifted only slightly toward greater wavelengths. The fluorescence can be excited as "resonance radiation" by light absorption in the *P*-band or by absorption in one of the other bands which are characteristic also of the nonpolymerized molecules ("molecular bands"). The fluorescence yield rises rapidly in the concentration range in which the gelation occurs and remains constant at higher concentrations up to the point at which only very little water is left in the solution. With complete dehydration the *P*-band and the corresponding fluorescence disappear. The pure crystalline dye shows a deep red fluorescence.

The exact location of the *P*-band depends on the amount of water which is present in the gel. The water molecules play an important part in the cementing of the polymerized aggregates. In alcoholic solutions no polymerization of this kind occurs, the *P*-band does not appear in the absorption spectrum and the solution is not fluorescent at any dye concentration (339,989*a*).

Different dyes of this class have *P*-bands more or less shifted in wavelength with regard to each other. In a mixture of two such dyes — for instance, diethyl- ψ -cyanine and diethyl- ψ -thiacyanine which have individual *P*-bands at 5790 and 5450Å — the dyes together form "heteropolymerized" molecules with a *P*-band which is intermediate between the bands of the two isolated dyes and cannot be explained by a mere superposition of the two individual bands.

In solutions of dinaphtho-substituted ψ -isocyanine, the *P*-band appears in the absorption spectrum at dye concentrations about 100 times smaller than in the solutions of the other dyes; the solution, however, does not turn into a gel, nor does it become fluorescent. Only the high degree of polymerization at which the solution is solidified brings about the fluorescence. The less complete polymerization by which the solution is not converted into a gel does not suffice, though it is sufficient for the appearance of a *P*-band.

On the other hand, some dyes of similar structure become gels at high concentration in aqueous solution without the appearance of a new narrow absorption band; nevertheless, they too become fluorescent in the gel state, although they are not fluorescent as long as the solution is liquid. Thus, the highly polymerized molecules of mono-

naphtho- ψ -thiacyanine can be excited to a green fluorescence by irradiation with near-ultraviolet light (732).

Instead of increasing the concentration of an aqueous solution, the fluorescent dye polymers can also be "salted out" by addition of hydrochloric acid to a dilute solution.

E. Fluorescence and Ionization

116. Fluorescence of Neutral and Ionized Molecules. The decrease of fluorescence yield with increasing concentration was first observed in aqueous dye solutions, and it seemed very plausible to assume that the effect was due to the decreasing dissociation of the molecules into ions. The controversy regarding the question of whether dyes are fluorescent only as ions, occupies much space in the earlier fluorescence literature. The discovery of the strong fluorescence of pure aromatic hydrocarbons, such as anthracene or naphthacene, which never ionize in solutions, proved unequivocally that this could not be a general rule. These hydrocarbons show self-quenching of the same magnitude as do the dye solutions.

There is no reason why fluorescence power should be essentially connected with the state of ionization of a molecule. It is possible that a compound is fluorescent both in the neutral state and in different states of ionization, but each of these states will, in general, be characterized by different absorption and emission bands. Thus, the blue-violet fluorescence of quinine sulfate in aqueous solution is relatively weak; if the solution is acidified, the color of the fluorescence changes into a whitish blue and the fluorescence intensity is greatly enhanced. This enhancement is not caused primarily by an increased fluorescence yield but by a corresponding increase in absorption power in the near ultraviolet. In an alkaline solution the fluorescence is still weaker than in neutral solution and of a dark violet color. Different ionization states of the quinine sulfate molecule with unequal optical properties coexist in a solution in proportions depending on the pH . If the whitish blue fluorescence of an acidified aqueous solution is quenched by the addition of KI, the fluorescence color turns into the blue-violet characteristic of the neutral solution, because the doubly charged ions responsible for the whitish-blue fluorescence are more strongly quenched than the others.* If, on the other hand, quinine sulfate is

* If an aqueous solution of quinine sulfate is acidified by addition of a very small quantity of hydrochloric acid, the well-known light blue fluorescence appears; increasing the Cl^- concentration quenches this fluorescence completely, so that even in the acid solution only a weak, violet fluorescence is left.

absorbed from an acidified or from a neutral solution on to silica gel, the absorbed material always shows the same light blue fluorescence, because the doubly charged ions are preferentially absorbed on the gel (982, unpublished experiments).

The behavior of fluorescein in solutions of varying pH is similar. The negative ions, prevailing in alkaline solutions, show a brilliant yellow-green fluorescence; the fluorescence of the positive ions formed in an acidified solution is blue green and weaker than the former when excited by near-ultraviolet radiation (71). This decrease in fluo-

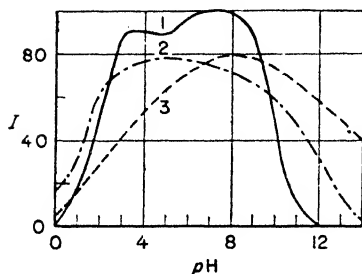

Fig. 124. Fluorescence intensity of riboflavin and alloxazine as a function of pH (Kuhn and Maruzzi, Karrer and Fritsche).

- 1: riboflavin. 2: alloxazine viewed through blue screen.
3: same viewed through green screen.

(between 3 and 9), where they probably exist as neutral molecules or as amphoteric ions (732,846). The positive or negative ions formed in strongly acidified or alkaline solutions are not fluorescent (Fig. 124). 3-Aminonaphthalhydrazide (luminol) is adsorbed from an alcoholic solution on gels of either polarity, and in both cases the adsorbed substance has the same strong blue fluorescence characteristic of the amphoteric molecule, which is bound to either gel by one of its localized charges. In alkaline or acidified solutions the compound exists in the form of a negative or a positive ion; the fluorescence of the latter is green, even when adsorbed on a gel of negative polarity, and the former is not fluorescent at all.

Because of the diffuseness of most fluorescence bands, the weakening of one band and the simultaneously increasing intensity of another with changing pH of a solution frequently gives the impression of a continuous transition from one spectrum to the other by a stepwise

fluorescence power is again due at least in part, to a smaller absorbing power; if excited by light of wavelengths below 3000A the difference in fluorescence intensity of the alkaline and of the acidified solutions is much less pronounced. In neutral solutions fluorescein is almost colorless and nonfluorescent.

Quinoline red has a very nearly constant fluorescence yield in the whole pH range from -1 to $+12$ (339). Other dyes — for instance, alloxazine and its derivatives (among which riboflavin or vitamin B_2 is the most interesting) — are fluorescent only in solution of medium pH

shift of the band maximum. This, however, is never the true behavior. The fluorescence spectrum of acridine at room temperature consists of a broad band which has its maximum in the blue violet in a neutral solution and in the blue green in an acidified solution. At liquid-air temperature both bands split up into four narrow bands which overlap only very little. If, under these circumstances, a neutral alcoholic solution is acidified very slightly, it can easily be seen that the new band system appears gradually while the other bands become weaker (unpublished observations) (1469). If thin layers of acridine and an organic acid, such as salicylic acid, are distilled *in vacuo*, one on top of the other, onto a cold surface and are maintained at the temperature of liquid air, the color of the violet fluorescence which is excited by irradiation with the near u.v. light of a mercury lamp changes, with time, to green; the same reaction of the acridine molecule which occurs spontaneously in an acidified liquid solution and which consists in the capture of a proton is induced in the solid state by the absorption of light. The process is reversed by a subsequent irradiation with the mercury line 2537A by which the fluorescence regains its initial violet color (1640a).

If the characteristic fluorescence of a solution is due to the fact that it contains a compound in a certain state of ionization — for instance, doubly charged quinine ions — the observed strength of the fluorescence must, of course, depend on the degree of ionization which is a function of concentration of the compound. However, a strict proportionality between the degree of ionization and the fluorescence intensity would occur only under especially favorable conditions; the fluorescence *strength* at low concentrations would be proportional to the number of ionized molecules only if the non-dissociated ions have no absorbing power for the exciting radiation, and the fluorescence *yield* would be proportional to the number of ionized molecules only if ionized and nonionized molecules have exactly the same absorbing power for the exciting light (345).

Under no circumstances can the whole problem of self-quenching be explained by the influence of the concentration on ionization. This was shown by Vavilov's measurements, in which the influences of the concentration on the fluorescence yield Q and the electric conductivity σ were compared for uranin solutions. In the concentration range where the steep slope of the yield curve sets in, the conductivity curve shows no anomaly whatsoever, its shape over the whole range being typical for a strong electrolyte.* (Figure 125) (1749).

* The very steep slope of the conductivity curve obtained by Vavilov for

Because of the dependence of the color and intensity of the fluorescence of many solutions on their pH , such solutions can be used as "indicators," in the same way as the well-known color indicators. Lists of fluorescent indicators for a pH range from 0 to 13 have been compiled by several authors.

117. Fluorescence and Photoelectric Effect. The question of whether neutral molecules or ions are the carriers of photoluminescence bears no relation to the problem of the mechanism by which luminescence is produced. It would be different if the excitation of fluo-

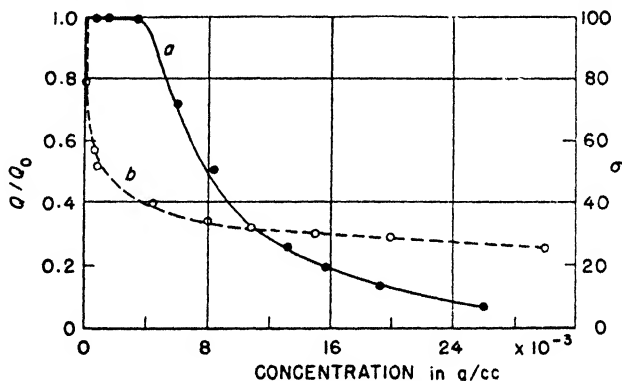

Fig. 125. Fluorescence yield and electric conductivity of an aqueous fluorescein solution as a function of the dye concentration (Vavilov).

a: fluorescence yield O/O_0 . *b*: electric conductivity σ .

rescence were due to the ionization process itself, as was assumed by different authors for some time. A probable connection between photoelectric sensitivity and fluorescence power was pointed out for the first time by Elster and Geitel, who found that certain fluorescent minerals as well as artificial "phosphors" showed a relatively strong photoelectric emission when they were irradiated with light which was able to excite their luminescence. Starting from this observation, Lenard later developed his photoelectric theory of the phosphorescence of crystal phosphors (compare Chapter VII) (36r).

Others, especially J. Stark, tried to apply the same hypothesis to fluorescent dyes and other organic compounds. As a matter of fact, he observed photoelectric emission by dyestuffs in the solid state under the lowest dye concentrations must be due to some secondary cause; an equivalent conductivity of 600 is quite impossible for a dye ion of molecular weight 278 in an aqueous solution.

the action of light which was able to produce the fluorescence of the same dyes in a liquid solution. However, the solid dyes were not fluorescent and no photoelectric effect could be produced in any liquid solution. Results which at first were supposed to prove the existence of the effect looked for were soon proved to be erroneous; they were really due to thin colloidal layers of the solid dye formed on the surface of the solution. Nor is an increase of electrical conductivity of the solutions produced as an internal photoelectric effect, as was shown by Goldmann, whose possible experimental errors were less than 0.01 %. Some apparently positive results of other authors are explained in part by an increase of temperature and in part by a polarization of the electrodes (so-called Becquerel effect). It is true that, according to Volmer, solutions of aromatic hydrocarbons are ionized by irradiation with light of wavelengths below 2200A, but Volmer showed also that light of longer wavelengths which excited strong fluorescence in these solutions had no influence on their electric conductivity. It need not be emphasized that the hypothesis according to which a dye in solution should be ionized by light absorbed in its long-wavelength absorption band has lost all theoretical foundation (510, 1199, 1549, 1552, 1779).

The problem with regard to organic compounds in the solid crystalline state is somewhat different. Volmer found that light of the violet and near-ultraviolet region which excites fluorescence in solid anthracene also causes photoconductivity in the crystals. On the other hand, it has already been mentioned that light which is absorbed in the typical anthracene bands between 3500 and 3900A is able to excite the fluorescence of naphthacene dissolved at a very low concentration in the anthracene crystals. Similar cases of a "sensitized fluorescence" were observed when naphthacene is dissolved in different other crystalline hydrocarbons. It is certain that the very characteristic strong green fluorescence of naphthacene is not excited by the absorption of light by the relatively few naphthacene molecules themselves. If crystals in which the violet anthracene fluorescence is almost completely suppressed by the green naphthacene luminescence are heated to the melting point, the green luminescence vanishes at the instant at which the substance is liquified. If at room temperature the same crystals are dissolved in liquid benzene the fluorescence spectrum of the solution consists exclusively of the anthracene bands with no trace of the naphthacene bands, although the relative number of anthracene and naphthacene molecules remains unchanged (143b, 458a, 1803, unpublished observations).

It might be that the primary effect of light absorption in the crystals is the liberation of photoelectrons, and that these transfer the excitation energy through the crystal to a naphthacene molecule, which has a greater emission probability than the anthracene molecules. However, this mechanism, although it plays a very important part in the luminescence of "crystal phosphors," can hardly be supposed to act in anthracene crystals. The absorption bands of these crystals have — except for a small shift towards greater wavelengths — exactly the same structure as the absorption bands of anthracene vapor or anthracene in liquid solutions, and so they cannot be ascribed to the transition of an electron to a free conduction band in the crystal: they must be associated with an electronic transition within the molecule itself. (The same is true for the uranyl salts and other fluorescent crystals which do not belong to the class of crystal phosphors).

The correct interpretation of the phenomena is probably to ascribe it to exciton migration, but the experimental material is not yet sufficient to draw unequivocal conclusions. It may be mentioned in this connection that, according to Franck and Teller, the narrow absorption and fluorescence bands of polymerized cyanine dyes are caused by exciton migration along the chains of which the polymers consist. However, there are reasons which make it at least equally probable that the bands are due instead, to an electronic vibration moving from one end of the chain to the other (428).

Taking everything into account, it can be stated that photoelectric effects have no, or only a very unimportant, part in the photoluminescence phenomena with which this chapter is concerned.

F. Polarization and Angular Intensity Distribution of Fluorescence Radiation

118. Polarization Caused by the Anisotropy of Oscillators. If a totally isotropic electronic oscillator is excited by the absorption of plane-polarized light, the radiation emitted by the oscillator is also plane polarized. However, this polarization is affected by very small perturbations such as magnetic fields, interaction with other molecules, etc.; in a condensed system it would, in general, be completely destroyed. If, nevertheless, fluorescence radiation from a condensed system is partially polarized, this can be due only to the fact that the

molecules as a whole are more or less optically anisotropic and that there are fixed axes within the molecules along which the electronic oscillations occur preferentially.

In solid dye solutions the fluorescence and phosphorescence was found to be polarized to nearly the same degree (209). It is quite impossible that an isotropic electronic oscillator should "remember" for a period of several seconds the direction of the impulse which it received at the moment of excitation, and this observation proved for the first time that the polarization was due to the orientation of the whole molecules and to the persistence of this orientation.*

A temporary dichroism, which is produced in a solid dye solution when it is irradiated with plane-polarized light of great intensity, is complementary to the polarization of the afterglow. If, in Lewis' experiments described in Section 104, the "exciting" light beam is polarized with its electric vector parallel to the Z -axis, the absorption of the "measuring light" in the band at 4365A which originates from the ground state N of the fluorescein molecules is about 30 % weaker for light with its electric vector parallel to Z than for light with its electric vector perpendicular to Z . On the other hand, the light absorption in the band at 6500A due to the molecules in the quasi-stable state M is more than 50 % weaker for light polarized parallel to Z . This proves once more the anisotropy of the individual molecules. Those molecules which are oriented so that their electric oscillators have a strong component parallel to Z are preferentially removed from the ground state and raised into the quasi-stable state by the strong illumination with polarized light (930).

Although the fluorescence of a dye solution is partially polarized when it is excited by plane-polarized light, it shows no trace of circular or elliptical polarization when the exciting light is polarized circularly or elliptically. If electrons within the molecules were free to follow the direction of the electric field which is produced by the incident radiation, circular or elliptical polarization should be observed under these conditions, as in the resonance radiation of vapors (528, 1044, 1223).

In Section 72 the problem of the totally anisotropic (linear) resonator as a source of emission and absorption has been mentioned.

* According to later investigations, the degree of polarization of the phosphorescence is usually smaller by a few per cent than the polarization of the fluorescence. This is understood without difficulty, however, since all depolarizing effects which will be mentioned in the following sections increase with increasing duration of the emission process.

The assumption of the presence of such oscillators does not suffice to represent many experimental results obtained with complicated molecules in condensed systems. The most general model of a fluorescent molecule consists of an emitting oscillator F and an absorbing oscillator A which have different frequencies but are coupled to each other so that light absorbed in A is re-emitted by F . F has different amplitudes a_1, a_2, a_3 along three axes ξ, η, ζ fixed within the molecule and A has different amplitudes a'_1, a'_2, a'_3 along three axes ξ', η', ζ' which are rotated with respect to ξ, η, ζ by angles with the cosines β_{ij} ($i = 1, 2, 3; j = 1, 2, 3$). In the following it may be assumed that a_3 (parallel to ζ) is larger than a_1 and a_2 , and that a'_3 (parallel to ζ') is larger than a'_2 and a'_1 . If all $\beta_{ij} = 0$ for $i \neq j$ and the $\beta_{ii} = 1$, F and A coincide; if, furthermore, $a_1 = a_2 = 0$, the model goes over into the totally anisotropic oscillator. In general, F and A will coincide if the emission and absorption processes correspond to the same electronic transition. If, however, the absorption occurs in an absorption band which corresponds to an electronic transition other than the emission band, A and F may form any angle less than, or equal to, 90° with each other (668,671).

If the fluorescence spectrum consists of one single band, the degree of polarization is the same for all parts of this band. Only in the infrequent cases where a fluorescence band is split up into many narrow lines, as in the crystalline uranyl salts, can groups of these lines show a different degree of polarization (ordinary and extraordinary spectrum). If the structure is blurred out — for instance, at higher temperatures — only the average polarization of the whole band remains to be measured.

A classical model does not exist for an oscillator with a single frequency, which is anisotropic in three perpendicular directions.* The well-known Langevin molecule, in which an electron is bound in three perpendicular directions by different forces, also has three different characteristic frequencies. This has little importance in the treatment of Rayleigh-scattering, where the frequency of the incident light differs widely from the characteristic frequencies of the scattering molecules. According to quantum theory, the model would correspond to a molecule with three excited levels of practically identical energy but of different transition probabilities to the ground level; each of

* Such a model might be realized by assuming an oscillator which is spherically symmetrical as far as the binding forces are concerned, but in which a trigger mechanism inhibits the oscillations along two of the axes η and ξ during certain periods.

these transitions would produce radiation polarized parallel to one of the axes ξ , η , ζ . A quantum-mechanical treatment of the problem has not yet been put forward. Jablonski's calculations are purely formalistic and were derived from the assumptions stated above.

Whatever may be the absorption process, the same equilibrium distribution between the different excited levels (or excited oscillators) is always restored before the emission process sets in in a condensed system. Hence, the polarization of the fluorescence emitted by an individual molecule is exclusively determined by the properties of the molecule and by its orientation with respect to the observer, and not by its orientation with respect to the direction and polarization of the primary light.

In the following discussion the exciting light beam is supposed to be parallel to the X -axis and to be plane polarized with its electric vector parallel to the Z -axis.* The fluorescence light is observed in the direction of the Y -axis, X , Y , Z being a system of orthogonal coordinates fixed in space. The orientation of the molecules, or of their ξ' , η' , ζ' system with respect to the Z -axis, is important only for the intensity of excitation (or for the probability of excitation) of an individual molecule, and, therefore, it determines the intensity of the fluorescence radiation.

The polarization of the fluorescence can be negative, or the fluorescence light can be partially polarized perpendicularly with respect to the electric vector of the exciting light (perpendicular to Z), if the angle ($\zeta\zeta'$) is greater than 54.5° ($\beta_{33} < 1/\sqrt{3}$). Strong negative polarization of great intensity occurs if ζ' is parallel to Z and perpendicular to ζ . The polarization of the total fluorescence radiation, as it is measured by an observer, results from the superposition of the incoherent elementary waves emitted by all excited molecules. It is therefore determined by the orientation of all molecules, with respect to the observer as well as to the electric vector of the exciting light. Two limiting cases are of special interest for the angular distribution of the individual oscillators relative to each other: complete order or parallelism of all systems ξ , η , ζ and ξ' , η' , ζ' , respectively, as in a crystal-line lattice and complete statistical disorder as in a liquid solution. Intermediate instances of a partial order can be realized in streaming liquids or with compounds adsorbed on an anisotropic gel.

* If the exciting light is unpolarized, and if the fluorescence is observed in any direction perpendicular to the primary beam, the equation in the footnote of Section 72 again determines the relation between p_p and p_n .

119. Polarization of Fluorescence in Liquid Solutions and Influence of Molecular Rotation. If the fluorescing molecules can be represented by linear (completely anisotropic) oscillators, if they are at rest, and if they have a statistical angular distribution, the polarization of their fluorescence radiation is, under the conditions stated in the last section, $p_0 = 0.5$ (50%). For the more general model with arbitrary values of all amplitudes a_i and a'_j ($i = 1, 2, 3$ and $j = 1, 2, 3$) and arbitrary values of the directional cosines β_{ij} , the equation for the degree of polarization takes the form:

$$p_0 = \frac{3\beta^2 - 1}{3 + \beta^2} \quad (79)$$

where $\beta^2 = \frac{1}{3} \sum a_i a_j \beta_{ij}^2$. The extreme values of p_0 are $-1/3$ and $+1/2$, the maximum negative polarization corresponding to $\beta^2 = 0$ and the maximum positive polarization to $\beta^2 = 1$. (For both extreme cases, $a_1 = a_2 = a'_1 = a'_2 = 0$; a_3 and $a'_3 > 0$, and $\beta_{33} = 0$ or $= 1$, respectively) (6II,672).

In a vapor at low pressure the angular orientation of the axis around which the molecules rotate, in general remains, constant during the lifetime of an excited state. Under these circumstances, the fluorescence emitted by linear oscillators which are excited by plane-polarized light is depolarized from $p_0 = 50\%$ to $p = 14.3\%$, because of the molecular rotation. In a liquid solution, however, the molecules no longer perform the rotation characteristic of a free-spinning top: their rotation is determined by the laws of Brownian movement (909,1217,1220).

According to the theory developed by Smoluchowski and by Einstein, a spherical particle of volume V rotates in a liquid of viscosity η in a short time Δt through an angle $\Delta\gamma$, the mean value of which is:

$$\overline{\Delta\gamma}^2 = \frac{1}{3} \frac{RT}{\eta V} \cdot \Delta t \quad (80)$$

By inserting the sufficiently short lifetime τ for Δt in this equation, the reduced degree of polarization which results from rotations of all individual resonators around statistically oriented axes can be calculated to be:

$$p = p_0 \frac{1}{1 + (1 - \frac{1}{3}p_0) \frac{RT}{\eta V} \cdot \tau} \quad (81a)$$

If all other parameters occurring in Equation (81a) are known, the measurement of p as a function of η and T permits the deter-

mination of τ , exactly as the lifetime of an excited mercury atom was derived from the depolarization of its resonance radiation in a magnetic field. τ is supposed to be a constant in Equation (81a) and, therefore it cannot be claimed as a new result that, in the range of validity of Equation (81a), τ is independent of the viscosity: if τ is a function of η , the equation cannot be applied (224).

Since, for small viscosities, p is proportional to the viscosity it can easily be understood, in view of the small viscosity of the usual solvents (water, alcohol, hexane, etc.), why the fluorescence of liquid solutions was generally considered to be always unpolarized. The observation that fluorescence emanating under an oblique angle from a transparent medium is partially polarized is, of course, not related to this problem. It follows from Fresnel's laws governing the reflection of light on the surface which separates the fluorescing medium from the surrounding atmosphere. The degree of polarization found under these conditions agrees quantitatively with the value derived from Fresnel's equations. For the fluorescence of canary glass observed under an angle of 80° , p becomes about 35%. In order to avoid this secondary effect, observations must be made as nearly perpendicular to the surface as possible (1030).

Only by investigating the fluorescence of dyes dissolved in highly viscous media, such as glycerol or gelatin, did Weigert discover that the earlier assumption was erroneous (1800, 1804). Further research on the polarization of the fluorescence of dyes, hydrocarbons, cyanoplatinites, and uranyl salts in liquid solutions and its dependence on the different parameters contained in Equation (81a) proved that the theoretical ideas stated in the last section were in general agreement with experimental results. In Table 67 a number of examples of the interdependence of p and η are compiled. The viscosity was varied either by stepwise addition of water to glycerol or of ether to isobutyl alcohol, by using a series of solvents which, apart from their different viscosity, have similar properties (for instance, the different aliphatic alcohols), or, finally, by varying the temperature of a solution (197, 219, 567, 909, 910, 1043, 1765). In the last case not only the variation of η but also that of T must be taken into account, as is shown by the comparison of the two curves in Figure 126.

Equation (81a) can be written in the form:

$$(1/p - 1/3) = (1/p_0 - 1/3) \left(1 + \frac{RT}{\eta V} \tau\right) \quad (81b)$$

Hence, $1/p$ as a function of $1/\eta$ is represented by a straight line which

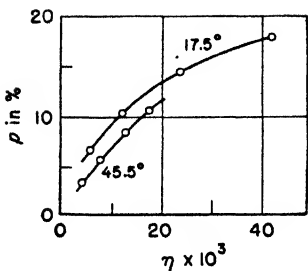

Fig. 126. Polarization of fluorescence of erythrosin in various alcohols as a function of the viscosity [Levshin (909)]

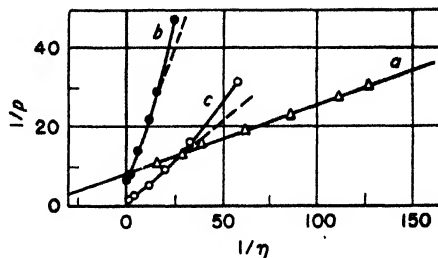

Fig. 127. Polarization of fluorescence as a function of the viscosity (Pringsheim and Vogels).

a: trypanflavine in octanol-ether. *b*: trypanflavine in glycerol-water. *c*: fluorescein in glycerol-water (after F. Perrin).

TABLE 67

DEGREE OF POLARIZATION ρ OF THE FLUORESCENCE OF LIQUID SOLUTIONS AS A FUNCTION OF THE VISCOSITY η

Uranin in glycerol + water	η	0.01	0.018	0.033	0.055	0.137	0.348	3.82	∞ (ρ_0)
	ρ	1.7	3.0	5.9	10.5	19.2	29.2	42	(44)

Trypanflavine in octanol + ether	η	0.08	0.09	0.12	0.15	0.27	0.37	0.67	∞ (ρ_0)
	ρ	3.1	3.5	4.3	5.3	6.7	8.3	10	(35)

Erythrosin in:	Methanol	Ethanol	Propanol	Isobutanol	Glycerol	Water
η	0.006	0.012	0.024	0.042	6	0.011
ρ	6.5	10.4	14.4	17.6	35	32

Erythrosin in water	Temperature °C	15	31	47	63	81
	η	0.0114	0.0079	0.0058	0.0045	0.0035
	ρ	32	28	24	20	15

crosses the axis of $1/\eta = 0$ (corresponding to infinite viscosity) at the point $\rho = \rho_0$. The value of ρ_0 is found by extrapolation from a series of

measurements of p in solvents of increasing viscosity; from p_0 the lifetime τ can be calculated.†

In order to derive values for τ from his measurements, Levshin introduced plausible values for V in Equation (81a) and in this way obtained lifetimes which were in reasonable agreement with those found by means of a fluorometer. Later, F. Perrin determined the V 's for different dyestuffs in each individual solution by diffusion measurements. The value of V in Equation (81a) is not the volume of the isolated dye molecule, but the volume of the molecule with its solvation envelope, so that V differs for a given dye in different solvents -- for instance, it is not the same in pure glycerol as in a glycerol-water mixture. Therefore, not $1/\eta$ but $1/\eta V$ must be used as the variable in the diagram for $1/p$. In the range of not too small viscosities, at least, Perrin obtained points lying fairly well on a straight line (Fig. 127) and from these he was able to calculate values for p_0 and for τ which are reproduced in Table 68 (909,910,1217,1220,1221,1225,1226,1765).

TABLE 68
MAXIMUM POLARIZATION p_0 AND LIFETIME τ OF EXCITED
STATE FOR FLUORESCENT SOLUTIONS

Fluorescent compound	Uranin	Erythrosin	Resorufin	Chlorophyll	Quinine sulfate	Anthracene	Cyanoptaitine
p_0	44	45	44	43	46	25*	40
$\tau \cdot 10^9$. . .	4.3	0.08	3.1	30	40	250	0.3

* For a much higher value of p_0 , compare page 374.

However, the theory as developed by Levshin and by Perrin is not yet quite satisfactory. Not only is the hypothesis that the molecules can be treated as ideal spheres, as in the theory of Smoluchowski and Einstein, a rather rough approximation but moreover, the values of τ_0 cannot be assumed, in general, to be the same in solutions of different viscosities, as has been pointed out in Section 107. It would be preferable, therefore, to take $TQ_r/\eta V$ instead of $T/\eta V$ as variable in diagrams of the type of Figure 126.

For rhodamine B or G dissolved in glycerol at a concentration of $5 \cdot 10^{-4}$ g/cc, the degree of polarization of the fluorescence does not

† τ can be directly derived from the diagram by prolonging the straight line beyond the zero axis to the point $1/p = 1/3$ and a corresponding negative viscosity $\bar{\eta}$. This point $\bar{\eta} < 0$ and $p = 3$ has no physical meaning, since neither negative viscosities nor polarizations greater than 100% can exist. The lifetime is given by: $\tau = -\bar{\eta}V/RT$. See, for instance, curve *a* in Figure 127.

decrease at all with increasing temperature and decreasing viscosity, because the fluorescence yield decreases so rapidly at the same time that the two other influences are compensated (384).

Furthermore, it is questionable whether the value of V , which is derived from the coefficient of diffusion and which determines the velocity of translation of the solvated molecules, can really be used in Equation (81a), or whether the dissolved molecule retains the possibility of rotating within the sphere of the surrounding solvent molecules. At any rate, according to all published measurements, the degree of polarization decreases more rapidly than corresponds to a linear relationship between $1/p$ and $1/\eta$ in the range of small viscosities of mixed solvents — for instance, in glycerol–water mixtures of high water content — while the decrease of Q , should produce an effect in the opposite direction. For uranin dissolved in very pure glycerol, p is found to be 45 % at room temperature; if the same dye is dissolved in commercial glycerol containing a few per cent of water, p does not exceed 25 % at 20° C, and even at — 50° it is only 32 %, although the macroscopic viscosity of the solution is much larger than the viscosity of pure glycerol at + 20° C (466).*

Trypaflavine is easily dissolved in various alcohols but is only slightly soluble in ether. If this dye is dissolved in mixtures of an alcohol and ether, one obtains for each alcohol with increasing ether content a set of p -values satisfying Equation (81a), but each of the straight lines representing $1/p$ as a function of $1/\eta$ has a different slope and crosses the zero axis at a different height, although p_0 is supposed to be determined by the ordinate of the crossing-point and to be a molecular constant (1303) (Figure 127).

The very large discrepancy between the maximum polarization of the fluorescence of anthracene as measured by Perrin and listed in Table 68, and the values published by Chakravarti and Ganguli, must be mentioned in this connection. Perrin's values were obtained by the investigation of solutions in solid Canada balsam or in ethanol at — 180° C; the Indian scientists found that for the fluorescence of anthracene dissolved in water-free glycerol at — 79° C, p was 44 %, and they found similar values for the fluorescence of phenanthrene, naphthacene, chrysene, and perylene. The discrepancy greatly exceeds

* The discrepancy cannot be explained merely by a partial depolarization of the fluorescence in the solution at low temperature because of beginning crystallization; on the other hand, all data on the polarization of fluorescence from solid solutions, which are never free from small inhomogeneities, are in general, too low and have only a qualitative significance (673).

all possible errors and must be due to some influence of the solvent. If the high values of p_0 are correct, the lifetime of the excited state of anthracene would be even larger than calculated by Perrin (Table 68) (214*b*, 1221).

The phenomena which are observed in colloidal solutions prove that the rotational mobility of dye molecules in a solution is not determined by the macroscopic viscosity alone. The fluorescence of uranin or rhodamine in an ether-collodion solution is as little polarized as if the dyes were dissolved in pure ether, although the macroscopic viscosity is more than a thousand times greater. The comparison of solutions in ordinary gelatin and in so-called β -gelatin is especially instructive in this respect. At a content of 91 % water, ordinary gelatin forms a thick jelly, while the viscosity of β -gelatin is not more than 0.03. The polarization of the fluorescence of the dyes dissolved in either of them, however, is the same. The important property is apparently not the viscosity of the solution, but the mobility of the molecules to which the dye is attached or on which it is adsorbed. In the ether-collodion solution, the dye remains dissolved in ether; in the gelatin-water solutions, it is adsorbed on the heavy gelatin molecules with their correspondingly small Brownian rotation. On the other hand, the polarization of fluorescence never attains the maximum value which is observed in pure glycerol even in very stiff gelatin-water solutions, because when adsorbed on gelatin the dye molecules retain a water envelope inside of which they still have a certain degree of rotational freedom (466, 910).

These conditions are demonstrated most conclusively by the fluorescence of dyes which are adsorbed from a liquid solution on a gel of relatively large grains. If a sufficient amount of silica gel is immersed in an aqueous solution of tryptaflavine, the solution is speedily discolored, and the fluorescence of the dye, which is almost completely adsorbed on the gel, is polarized up to 30 %, if the depolarization due to multiple reflection on the surfaces of the grains is eliminated by adequate means. If the same experiment is repeated with a solution in methanol, practically no adsorption takes place, the dye remaining in the liquid phase and the fluorescence being unpolarized. Intermediate instances are provided by other solvents like ethanol or amyl alcohol. If the gel with the adsorbed dye is removed from the water solution and carefully dehydrated, the degree of polarization of the fluorescence is increased still further. This seems to prove that the dye molecules were not completely fixed on the gel surface as long as they were surrounded by an equally adsorbed envelope of water molecules (1301).

Even if the relation between the polarization of fluorescence and the viscosity of the fluorescent solution which results from Equation (81a) can be verified only under especially favorable conditions, the general ideas leading to the equation are certainly sound. This is shown, for instance, by the fact that the degree of polarization becomes relatively high, even in solutions of small viscosity, if the lifetime of the excited state is very short. The exceedingly strong polarization of the fluorescence of erythrosin in aqueous solution, listed in Table 67, is a striking example of this kind. Even if the dye is dissolved in methanol, the polarization is still very appreciable, while it is zero in an acetone solution where the fluorescence yield becomes much larger. Rose bengale behaves similarly.

If, in an aqueous solution of uranin, the high fluorescence yield and, simultaneously, the lifetime of the excited state are decreased by addition of a quencher, the polarization of the fluorescence is increased correspondingly and tends towards the limiting value p_0 , as shown in Table 69. For uranin dissolved in glycerol and quenched by the addition of potassium iodide, Mitra found a degree of polarization equal to 50%, which is again higher than Perrin's p_0 value* (1045, 1046, 1221). The polarization of the fluorescence of cyanoplatinites in isoamyl alcohol also increases from 4.5% to 10.5% if the fluorescence is quenched to one-quarter of the maximum yield by the addition of aniline (775).

TABLE 69
POLARIZATION p OF THE FLUORESCENCE OF URANIN DISSOLVED IN WATER
IN THE PRESENCE OF KI

Concentration of KI mole/liter .	0	0.31	1.09	1.55	3.72	6.2
Q_r	100	18	5		1.2	0.6
p	1.7	6.2	18	24	35	40

On the other hand, the fluorescence of uranyl salts in liquid solutions is always nonpolarized because of the relatively long lifetimes of the excited state ($\tau = 10^{-6}$ to 10^{-4} sec), notwithstanding the fact

* Discrepancies of this kind occur rather frequently in publications dealing with the polarization of the fluorescence of solutions. They are apparently due, in part, to the fact that many authors overrate the accuracy of their measurements. Another possible reason is the influence of the wavelength of the exciting light, an effect which has not been known for a long time and which has been neglected even in recent measurements.

that the molecules are anisotropic, as is proved by their behavior in the crystalline state. Discrepancies between earlier statements concerning the polarization of the fluorescence of canary glass were cleared up by Sevchenko. He found not only that various glasses behave differently but also that the degree of polarization of the fluorescence of an individual sample can vary within wide limits with varying wavelengths of the exciting light. Similar phenomena observed with many dye solutions will be discussed in the following section. The degree of polarization p drops for all glasses to a minimum corresponding, in general, only to a few per cent when the fluorescence is excited by light of wavelengths 3650 and 2500A, as is the case in numerous experiments; p reaches its highest values for exciting light of 4200 and 3200A. A maximum value of $p = 25\%$ was obtained with a borosilicate glass; p was appreciably lower, not exceeding 13%, for silicate glasses, and remained, regardless of the wavelength of the exciting light, constantly at the low level of 6% for a phosphate glass (469, 1224, 1498).

Furthermore, p decreases during the decay of the "slow fluorescence" and drops to about one-half of its initial value in about 10^{-3} sec after the end of the excitation. This effect is in conformity with Vavilov's theory mentioned in Section 113, but has never been observed directly in the fast-decaying fluorescence of dye solutions. Since the lifetime of the uranyl glass fluorescence is also of the order of magnitude of 10^{-3} sec, an appreciable part of the fluorescence during the excitation period is due to an earlier absorption process and the values of p measured during a continuous irradiation are lower than they are if the phenomenon is observed under excitation by intermittent light flashes — for instance, in a phosphoroscope with both shutters opening and closing simultaneously (1498, 1710, 1762c).

If a compound which is excited in aqueous solution by plane-polarized light (electric vector parallel to Z) emits unpolarized fluorescence, and if this fluorescence becomes partially polarized with its electric vector parallel to Z after the addition of a quencher, this can be explained only by the assumption that the components of the oscillation perpendicular to Z are more strongly quenched than the component parallel to Z . This is due to the fact that the angle γ between the excited oscillator and the Z -axis increases with time because of the Brownian rotation. Therefore, the observed quenching effect must be larger if the fluorescence is viewed in the direction of the Z -axis (with the electric vector perpendicular to Z) than if it is viewed in a direction perpendicular to Z . This effect was observed by

Sveshnikov * For the same reason, the τ -values obtained by means of a Kerr-cell fluorometer, in which the exciting and the fluorescent light are always plane polarized, differ slightly for parallel or crossed polarization of the two light beams, as has already been mentioned in Section 8 (669,676,771,1600a,1625).

As far as dye solutions are concerned, Equation (81a) holds only for solutions of very low concentrations (below 10^{-5} molar). At higher concentrations the interaction between molecules of the same kind has a depolarizing effect, which is due only to a small extent to the excitation of secondary fluorescence and which is practically independent of the viscosity of the medium: liquid and solid solutions behave alike (Table 70; Figure 128) (466). However, this "self-depolarizing" effect is also reduced if the lifetime of the excited state is decreased. If the fluorescence of the solution with the highest concentration in Table 70 ($c = 2.5 \cdot 10^{-2}$) is strongly quenched by the addition of aniline, the degree of polarization is raised from 6.25 to 30 % (218,383a, 383c,384,909).

TABLE 70

POLARIZATION OF THE FLUORESCENCE OF URANIN IN GLYCEROL, EXCITED BY PLANE-POLARIZED BLUE LIGHT AS A FUNCTION OF THE DYE CONCENTRATION c

(p' = observed polarization; p , the same, corrected for depolarization caused by secondary fluorescence)

c	$2.5 \cdot 10^{-7}$	$2.5 \cdot 10^{-6}$	$2.5 \cdot 10^{-5}$	$6 \cdot 10^{-4}$	$2.5 \cdot 10^{-4}$	$1.15 \cdot 10^{-3}$	$2.5 \cdot 10^{-3}$	$6 \cdot 10^{-3}$	$1.25 \cdot 10^{-2}$
p'	40	39.7	33.6	30.9	28.9	21.2	17.1	9.8	6.25
p	40	39.7	39.4	38.8	36.2	26.5	21.4	12.25	6.25

Self-depolarization is due to the fact that the molecules to which the excitation energy is transferred by resonance have a statistical distribution of orientation. The problem has been treated completely by Vavilov, including the probability of repeated transfers during the lifetime of the excited state (Section 113). It is, of course, not possible to apply Equation (81a) to this type of depolarization and thus to come to the conclusion that τ increases with increasing concentration

* In order to obtain the average quenching effect, the fluorescence should be viewed, according to Sveshnikov's calculations, in the direction of the Y -axis through a polarizer transmitting light with its electric vector at an angle $\alpha = 55^\circ$ from Z ($\tan \alpha = \sqrt{2}$). If the exciting light is unpolarized, α should be 33° . The direction of the exciting beam is again, supposed to be parallel to the X -axis.

of the fluorescent molecules (224). Self-depolarization becomes appreciable at concentrations about a hundred times lower than does self-quenching (Figure 116). At higher concentration, self-quenching frequently becomes very strong, and due to the corresponding decrease in τ this sometimes even causes a renewed increase in the polarization of the fluorescence. Such a reversal has been observed, for instance, in solutions of rhodamine and tryptaflavine in glycerol (1498, 1761a, 1762a).

Some compounds, such as esculin, quinine sulfate, and sodium naphthionate show neither self-quenching nor self-depolarization. In canary glass both effects are also relatively small with increasing uranium concentration.

This proves once more the parallelism of the two phenomena.

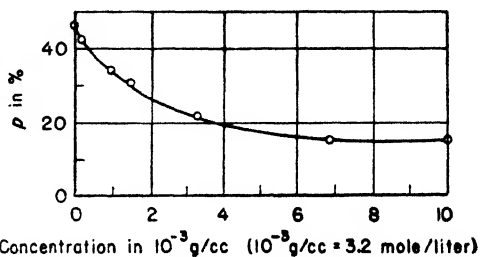

Fig. 128. Depolarization of fluorescence of fluorescein sodium in glycerol as a function of the dye concentration (Chauchois).

120. Negatively Polarized Fluorescence of Isotropic Solutions. All statements made in the last section are correct only under the assumption that the processes by which the exciting absorption and the fluorescence emission are produced correspond to the same electronic transition. For dye solutions the excitation must take place by absorption of light in the long-wavelength absorption band, which is only slightly displaced with respect to the fluorescence band, according to Stokes' law. If the wavelength of the exciting light is varied by shifting it beyond the peak of this band towards the ultraviolet, the polarization of the fluorescence decreases at first, passes through zero, and then even becomes negative. Finally, when the exciting light coincides with the next strong absorption band in the ultraviolet part of the spectrum, the polarization of the fluorescence again attains its initial positive value. This phenomenon was discovered by Froehlich and later corroborated by Levshin, Vavilov, and others for solutions of uranin, succinic fluorescein, eosin, rhodamine B, magdala red, and esculin (442, 528, 662, 664, 668, 910, 1756).

The peak value p_0 of the degree of polarization for all these compounds is close to 50%; the corresponding electronic transitions must be ascribed to oscillators which are very nearly linear and have identical orientation for the absorption and the emission processes.

Since, on the other hand, negative polarization can occur only if the absorbing oscillators form an angle larger than 54° with the emission oscillators, one must conclude that in the spectral region where the molecular absorption has a minimum the weak absorption that still prevails is not exclusively due to the tails of the strong absorption bands at greater and smaller wavelengths, but that it is caused, at least partially, by other electronic transitions corresponding to differently oriented oscillators. G. N. Lewis designates the strong absorption bands producing fluorescence with positive polarization as x -bands and the weak absorption bands associated with negatively polarized fluorescence as y -bands. Because of their weakness and because they are overlapped by the tails of the x -bands, the y -bands frequently do not appear as peaks in the absorption spectra; the overlapping also explains the continuous transition from positive to negative polarization and the relatively low degrees of negative polarization which are usually observed (924).

However, the absorption curve of fluorescein (Figure 129a) shows two secondary bands in the region of greatest negative polarization (1179); in the absorption and polarization curves of rhodamine (Figure 129b), three weak absorption peaks at 4200, 3500, and 300A are almost exactly matched by maxima of negative polarization, while in the intervening regions the tails of the x -bands induce again a decrease in negative polarization (383a). Another example of this kind is provided by a solution of malachite green in a mixture of pentane, ether, and ethanol at -158° C. The intense x - and x' -bands of this dye are situated at 6410 and 3175A, with a weak y -band at 4310A. When the fluorescence is excited by the radiation from a sodium lamp or by the lines at 3130A of a mercury arc, the polarization is positive; under excitation with blue light the negative polarization attains a degree of -17% , and in the case of a dye in which the nonsubstituted benzene ring of malachite green is replaced by an α -naphthyl group and which has a similar absorption spectrum, the negative polarization even reaches -20% , the highest degree of negative polarization which has been observed under these conditions (924).

It is noteworthy that the strong positive polarization exhibited when the wavelength of the exciting light corresponds to the x' -band drops again to zero at the short-wavelength edge of this band (Figure 129), thus indicating that the mechanism of absorption changes once more in the far u.v. The suggestion that the x' -band itself, with a frequency which, in general, is close to double that of the x -band, is the first harmonic of the x -band, does not seem to be acceptable from the

viewpoint of the quantum-theoretical interpretation of electronic spectra. The persistent strong positive polarization in the region of great wavelengths corresponding to anti-Stokes excitation of the fluorescence proves that no appreciable part of this excitation is due to light absorption in another band of the γ -type (compare Section 103).

The behavior of chlorophyll, with its narrow absorption and fluorescence bands, differs quantitatively from that of other dyes in

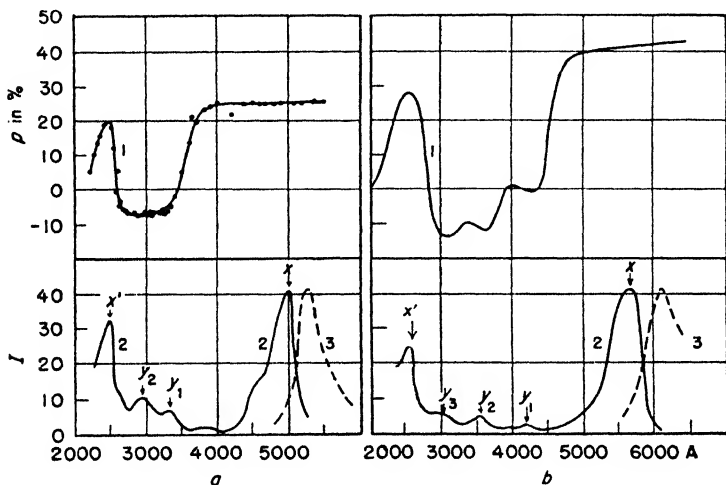

Fig. 129. Polarization of fluorescence as a function of the wavelength of the exciting light (Feofilov, Orndorff).

a: fluorescein	1: degree of polarization
b: rhodamine	2: absorption spectrum
B extra in glycerol	3: fluorescence band

that no negatively polarized fluorescence is observed. The first absorption band of chlorophyll (R , at 6600A) coincides very nearly with the first fluorescence band, a second narrow absorption band (V) is found at 4300A, and a third broader band (U) has its peak in the u.v. at 3800A. Every one of these bands corresponds to a different electronic transition and each produces a different degree of polarization in the red fluorescence (Table 71). If τ is derived from measurements of p in solutions of variable viscosity according to Equation (81a), the same value (listed in Table 68) is arrived at regardless of the wavelength of the exciting light. Apparently, τ is determined only by the lifetime of the excited state from which the emission takes

place, while the lifetimes of the intermediate states, which are reached by the electronic transitions V and U , are much shorter. The last row of Table 71 gives the values of the angles α between the three absorption and the emission oscillators, calculated according to the observed degrees of polarization (1221).

TABLE 71
MAXIMUM POLARIZATION p_0 OF THE RED
FLUORESCENCE OF CHLOROPHYLL UNDER
EXCITATION BY LIGHT ABSORBED IN
DIFFERENT BANDS

Absorption band	R	V	U
p_0 ..	43.5	11	23
α . . .	0°	48°	36°

The indirectly excited slow fluorescence which is emitted by almost all solid dye solutions, especially at low temperatures, is, in most instances, not, or only very slightly, polarized, notwithstanding the fact that the normal fluorescence, which is observed under the same conditions, shows a strong positive polarization. The slow fluorescence of some dyes even exhibits a very pronounced negative polarization when they are dissolved in glycerol at -180°C (Table 72) (1300).

TABLE 72
POLARIZATION OF THE SLOW FLUORESCENCE OF ORGANIC COMPOUNDS

Compound	Trypaflavine*	Rhoduline orange*	Acridine orange*	Eosin*	Eosculin†
p of normal fluorescence .	+ 34			+ 44	+ 32
p of slow fluorescence .	-13(-9†)	- 7.5	- 5	0	0

* Dissolved in glycerol.

† Dissolved in gelatin.

Slow fluorescence corresponds to a forbidden electronic transition from a quasi-stable state M to the ground state. On the other hand, the normal fluorescence is negatively polarized if it is excited by light which is very slightly absorbed in the ground state of the molecules;

and, finally, the strong absorption bands characteristic of the molecules in the quasi-stable state have the same polarization as the long-wave and ultraviolet absorption bands of the unexcited molecules (see Section 104). Hence, it seems that the strong absorption bands which correspond to allowed transitions have all oscillators oriented in the same direction in the molecule, while the oscillators corresponding to forbidden transitions, in general form, angles of more than 54° with respect to the others.

The bands of slow fluorescence of dyestuffs in solid solutions, in general, overlap the normal fluorescence bands, and since they contribute some intensity to the total radiation emitted during the excitation period, the polarization of the fluorescence sometimes varies appreciably in different parts of the spectrum. Esculin in sugar, even at room temperature, shows green "slow fluorescence" of high intensity in addition to its normal blue fluorescence, and, therefore, the degree of polarization of the fluorescence, which is 39% in the violet part of the fluorescence spectrum, drops to 25% in the green (1298).

121. Polarized Fluorescence of Partially Oriented Molecules.

Cellophane films are frequently characterized by a rather strong double refraction, the material being in itself optically anisotropic, with its optical ζ -axis parallel to the plane of the film. If a dye is absorbed on a cellophane film, the film acquires dichroism in the spectral region corresponding to the absorption bands of the dye (1025, 1286, 1505); if the fluorescence of the dye is viewed in the direction of the exciting radiation, it is partially polarized, even when excited by unpolarized light. A partial orientation of the dye molecules is caused by the directional forces of the absorbing material. Degrees of polarization as high as 12% have been obtained under these conditions, the polarization being independent of the wavelength of the exciting light: for the oriented fraction of the dye molecules, p is not determined by the mode of excitation but only by the orientation and the nature of the molecules; for the fraction which has no preferential orientation the polarization of the fluorescence is $p = 0$ for any mode of excitation by unpolarized light. If the exciting light is plane polarized, the polarization, which now depends greatly on the orientation of the optical axis ζ of the film with respect to the electric vector of the exciting light z , can attain a much higher degree. Jablonski's measurements give not the real degree of polarization p , but the "apparent polarization" $p_z = (I_z - I_x)/(I_z + I_x)$. This quantity drops to zero if the light is partially or even totally polarized with its electric vector forming an angle of 45° with the Z -axis. If ϑ is the angle between the

optical axis ζ of the film and the electric vector of the exciting light, which is again supposed to be parallel to Z , the measured values of p_x as a function of θ are represented by curve *a* of Figure 130 and are in good agreement with a theoretical equation derived by Jablonski. Curve *b* in the same figure is almost exactly symmetrical with curve *a* but has opposite signs for p_x ; it refers to the slow fluorescence of the same film at low temperatures (661,670).

A partial orientation of the dye molecules can also be obtained by dissolving them in so-called mesophases — for instance, in a concentrated aqueous solution of ammonium oleate. The optical behavior of such a solution is of the same kind as that described above for cellophane films. The solutions are birefringent, they show dichroism, and their fluorescence is partially polarized. In most cases the vector of maximum fluorescence intensity coincides in its direction with the vector of strongest absorption. This is true for fluorescein and its derivatives, acridine dyes, etc.; only for a few dyes like primuline and some other azo dyes is the vector of maximum absorption perpendicular to the vector of strongest emission. The results

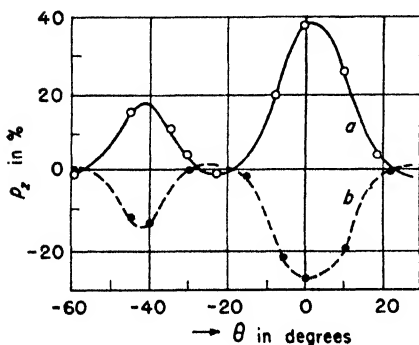

Fig. 130. Polarization of the fluorescence of euchrysrine adsorbed on cellophane as a function of the angle θ between Z and ζ (Jablonski).

a: normaal fluorescence. *b*: slow fluorescence at low temperature, both excited with plane-polarized light.

obtained with chlorophyll are in perfect agreement with those obtained in isotropic solutions. The vector of the strongest fluorescence emission is parallel to the vector of maximum absorption in the red band and forms an angle of more than 45° with the vector of maximum absorption in the violet band. Numerical data for these observations have not been published (1931).

Finally, dye molecules, especially molecules consisting of long chains, can be oriented to a certain degree by imbedding them in a streaming solution. This is the method which was used by Scheibe in the investigation of the optical properties of the polymerized cyanine dyes. In a streaming solution the long chains formed by the polymerization of the molecules are oriented parallel to the direction of the

flow (parallel to the Z -axis) and the solution shows the dichroism which is characteristic of the individual polymerized molecules. In the short-wavelength bands M_1 and M_2 (see Section 115), which appear in the solution even at low dye concentration, light is absorbed almost exclusively if its electric vector is perpendicular to the chain and parallel to the plane of the single molecules. Light is absorbed in the P -band when its electric vector is parallel to the chains (parallel to Z) (see Figure 131). Fluorescence which is caused by the same electric transition as absorption in the P -band also has the same orientation of the electric vector parallel to Z . The polarization of the fluorescence resulting from these molecular properties is therefore

positive if the exciting light is absorbed in the P -band and negative if the exciting light is absorbed in bands M_1 and M_2 . Fluorescence is strong if the electric vector of the exciting light is parallel to Z in the first case, or if it is perpendicular to Z in the second case. The degree of positive or negative polarization under these conditions sometimes reaches 70% and would probably be 100% if the chains were completely oriented parallel to Z . (If this extrapolation is correct, the fluorescence of the dye excited by plane-polarized light should show a polarization of 50% even in a nonstreaming solution with the chains oriented at random. Otherwise one would have to conclude that in a solution at rest the chains are no longer straight but curve irregularly in various directions). (989a, 1414, 1415)

The relatively weak fluorescence which persists even when the electric vector of the exciting radiation is perpendicular to Z for light absorbed in the P -band or parallel to Z for light absorbed in the bands M_1 and M_2 , is due to those chains which are not fully oriented in the Z -direction by the streaming solution.

122. Polarized Fluorescence of Crystals. The spatial orientation of molecules, which is only partial in solutions under the conditions treated in the last section, becomes complete if the luminescent mole-

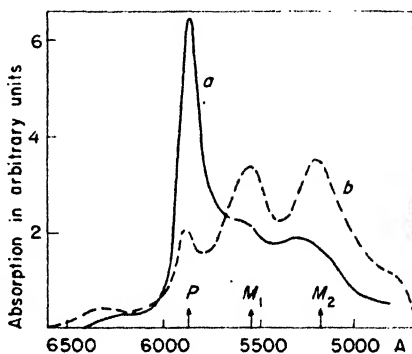

Fig. 131. Absorption spectrum of pseudoisocyanine in polarized light (Scheibe).

a : electric vector parallel to axis of polymerized molecules. b : electric vector perpendicular to axis of polymerized molecules.

cules are a part of a crystal lattice. The crystal lattice may consist exclusively of the luminescent molecules, as in uranyl or rare-earth salts, in pure anthracene, and in cyanoplatinites, or the luminescent molecules may be imbedded in a base lattice of another material, e.g., naphthacene in anthracene or chromium oxide in aluminum oxide.

Even if the individual molecules are equivalent to linear oscillators and if they are all oriented in a crystal, their fluorescence need not always be plane polarized. It is not necessary that all molecules

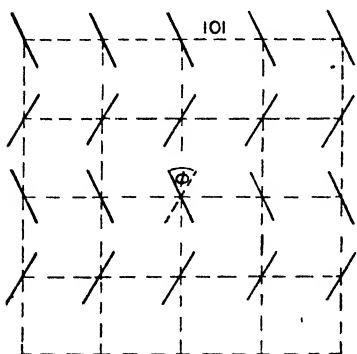

Fig. 132. Orientation of oscillators in anthracene crystals (Obreimow, Prikhotjko, and Shabalda).

in the crystal be parallel to each other; they may for instance, be subdivided into two groups which are tilted with respect to each other, forming an angle Φ . This is indeed the case in anthracene crystals, where $\Phi = 23^\circ$ (Figure 132). In this way, the fluorescence radiation is partially depolarized; an angle $\varphi = 90^\circ$ would even produce a complete depolarization.

It is clear that the observed degree of polarization of the fluorescence depends on the orientation of the crystal with regard to the direction of observation. With the exception of the cyanoplatinites, the degree of polarization of the fluorescence, is on the other hand, independent of the direction and the polarization of the exciting light, which influence only the probability of absorption and, thus, the intensity of fluorescence. For the "absorption oscillators" of the molecules are also anisotropic and oriented in the crystal, or, in other words, the crystals show dichroism in transmitted light. The direction of the electric vector which is most strongly absorbed prevails in all known cases also in the fluorescence light: absorption and emission oscillators are equally oriented in the lattice.

Fluorescence of a microcrystalline powder in which the individual grains are oriented at random is always unpolarized when excited by unpolarized light. With plane-polarized exciting light, the conditions would be the same as in a solution of high viscosity if the polarization of the light were not destroyed by multiple reflection and refraction on the surfaces of the grains. This could be avoided only by imbedding the powder in a transparent liquid of identical refractive index. In

general, observations must be made on single crystals, and, if only very minute samples are available, under the microscope.

Anthracene crystals are monoclinic, those of naphthacene belong to another class of symmetry. Nevertheless, the green fluorescence of commercial anthracene, which is due to traces of naphthacene dissolved in the anthracene, has, as far as its polarization is concerned, exactly the same properties as the blue-violet fluorescence of anthracene itself. In these small concentrations the impurity molecules are forced to take the same orientations as the molecules of the main substance. The crystals obtained by evaporation of a solution in hexane are thin flakes with surfaces parallel to the 001 plane; the optical "*b*-axis" lies in this surface, while the "*a*-axis" is perpendicular to it. If the fluorescence is observed in a direction perpendicular to the crystal face, the anthracene and naphthacene bands are partially polarized with their electric vector parallel to the *b*-axis, or in the plane 010. Obreimow found $p = 70\%$ for the blue-violet bands, and from this value he derived the angle $\psi = 23^\circ$ mentioned above. Krishnan found $p = 60\%*$ for the green fluorescence and also for the violet fluorescence of anthracene dissolved in phenanthrene. According to Krishnan, the electric vector component corresponding to the strongest absorption and emission is, in this case also, parallel to the *b*-axis, which lies in the plane of the benzene rings, while the absorption is smallest for the vector component parallel to the *a*-axis, which is perpendicular to this plane. The fluorescence radiation of dibenzanthracene crystals is partially polarized ($p = 33\%$) with the electric vector parallel to the *a*-axis, and the same is true for the absorption (828,829*a*,829*b*,1153).

The dichroism of these crystals of aromatic hydrocarbons and the corresponding polarization of their fluorescence are caused by the different intensity of the oscillations in two directions perpendicular to each other, while the frequency of the absorption and emission bands is the same for both components within the accuracy of the observations. The absorption and fluorescence spectra of the uranyl salts, especially at low temperatures, are resolved into many line-like narrow bands which, in general, have different wavelengths for two orientations of the electric vector with regard to the crystal axes: the ordinary and extraordinary spectra do not coincide. At higher temperatures and in liquid solutions the bands overlap, and under these conditions a polarization of the resulting fluorescence radiation caused by the anisotropy of the molecules can be preserved only if the average

* None of these values is reliable to within better than 10%.

intensities of the lines in the ordinary and in the extraordinary spectra are different. No measurements concerning this question are available (79,634,IIIO,IIII,IIIV).

Analogous results were obtained concerning the polarization of the fluorescence of europium salts.* Different groups of lines appear in the ordinary and extraordinary spectra of the hexagonal europium bromate crystal if the fluorescence is observed in a direction perpendicular to the optical axis c . If, however, the fluorescence is viewed in the direction parallel to this axis, only some line groups (e) of the ordinary spectrum are observed, and along with them several line groups (m) belonging to the extraordinary spectrum. This proves that of the lines observed under these conditions only the e -groups correspond to the emission by electric dipoles, while the m -lines originate from the oscillations of magnetic dipoles (280a). These conclusions are in perfect agreement with another observation which will be mentioned in the next section. In monoclinic or triclinic europium salts (sulfates or acetates), the phenomena are similar though somewhat more complicated. Because of the higher asymmetry of the molecular fields, certain forbidden lines appear in the fluorescence spectrum which are completely unpolarized for every direction of observation.

In the spectra of the uranyl and europium salts, the relative displacements of the narrow lines in the ordinary and the extraordinary spectra are so small that they can be ascertained only with the aid of a spectrometer. On the other hand many of the cyanoplatinites, most of which crystallize in uniaxial systems, show a dichroism so strong that they appear differently colored according to the direction and the polarization of the transmitted light. In this case the oscillators oriented perpendicular to each other have not only different amplitudes but also widely different frequencies. Furthermore, the color and the polarization of the fluorescence of these crystals is determined by the direction and polarization of the exciting light. If the latter is polarized with the electric vector perpendicular to the optical axis c of a barium cyanoplatinites crystal, the fluorescence is red and also polarized perpendicular to c (ordinary spectrum); if the exciting light is polarized parallel to c , the fluorescence is yellow and polarized parallel to c (extraordinary spectrum). Hence, the color of the fluorescence changes from red to orange and yellow if the fluo-

* The polarization of the fluorescence of other rare-earth salts has not yet been investigated.

rescence is excited by unpolarized light and if it is viewed in varying directions or through a Nicol at varying orientations (947*b*).

According to Mani, the fluorescence of diamond is unpolarized when it is excited by unpolarized light and observed in a direction perpendicular to the primary light. The fluorescence is polarized with $p = 80\%$ when the exciting light is plane polarized with its electric vector perpendicular to the direction of observation; the degree of polarization drops to 20% if the electric vector of the exciting light is rotated by 90° so that it is parallel to the direction of observation. This result seems to be incompatible with any theoretical interpretation because unpolarized radiation can be decomposed into two components of plane-polarized light and, therefore, it should produce the same effect as the superposition of two such radiations (974).

The polarization of the fluorescence of ruby and similar crystals will be treated in Section 167.

123. Angular Intensity Distribution of the Fluorescent Radiation.

Knowledge of the angular intensity distribution of the fluorescence emanating from a luminescent surface or a luminescent volume is important in the calculation of the fluorescent yield, which must be derived, in general, from the measurement of the fluorescence intensity emitted in a certain direction within a narrow solid angle $\Delta\omega$. The problem is simple if the fluorescence is unpolarized and if the fluorescent medium is transparent to the fluorescence radiation and has perfectly smooth boundaries. In this case, the angular intensity distribution has spherical symmetry and the light intensity emitted by a given volume is the same for every direction. However, the light emanating from the plane surface of such a fluorescent medium does not obey Lambert's cosine law; instead, the apparent brightness of an element of the surface increases with increasing foreshortening of the surface (Lommel's law). If the fluorescence coming from a liquid solution or a polished glass is observed at increasing angles the expected increase in apparent brightness is counteracted in part by the reflection at the boundary between liquid or glass and air, the reflection becoming total at a certain angle. If this phenomenon is avoided by an adequate choice of the second medium, the observed brightness, which is represented in Figure 133 as a function of the angle of observation, is in excellent agreement with the values calculated from Lommel's law (947*a*, 948, 1861).

If the fluorescence is strongly reabsorbed by the fluorescent medium and re-emitted in all directions as secondary fluorescence, the angular intensity distribution is exactly the same as for the thermal

radiation of an opaque surface: it follows Lambert's law. This is true, for instance, for the surface resonance radiation of sodium vapor (see Section 20). If, instead of being smooth and transparent, the surface is coarse — for instance, if it consists of a finely divided microcrystalline powder so that the fluorescence undergoes a great number of reflections and refractions — the angular intensity distribution of the fluorescence is closer to Lambert's than to Lommel's law (1426).*

The conditions are less simple if the fluorescence is partially

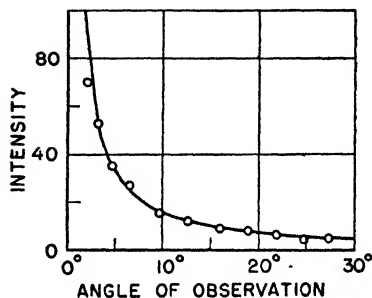

Fig. 133. Fluorescence intensities of an aqueous dye solution as a function of the angle of observation [Wood (1861)].

polarized, since, then, the angular intensity distribution no longer has spherical symmetry. If the fluorescence of a dye in a viscous medium has a polarization of $p\%$ under excitation by plane-polarized light, and if the fluorescence is excited by unpolarized light, $(100 - p)\%$ of the fluorescence radiation has a spherical intensity distribution, while for the other $p\%$ the intensity is twice as strong in the direction of the primary light as in the direction perpendicular to the exciting beam.

(With $p = 50\%$, a degree of polarization which is very nearly attained for many dyes in pure glycerol, the fluorescence intensity observed in the YZ -plane would be only 83.3% and the intensity observed in the X -direction 116.7% of the average intensity).

The total angular distribution depends on the intensity distribution of the radiation coming from each individual molecule with respect to the axis of this molecule and on the orientation of the different molecules with respect to each other. For most liquid solutions the spherically symmetrical intensity distribution corresponding to total depolarization of the fluorescence is caused by the random orientations of the individual molecules and by their Brownian rotation. Even under these conditions the angular distribution of the radiation from individual molecules can be determined by means of wide-angle interference experiments of the kind first performed by Seleny. The method was applied later by Freed, Weissman, and others. In these experiments the radiation which is emitted in two directions by an exceedingly thin film of a fluorescent solution is brought to

* Also see Bibliography (*J*, Fig. 203).

interference. From the interference patterns appearing when the angle of divergence between the two interfering beams is varied from 30 to 90 degrees, the angular intensity distribution can be derived for the radiation from the individual radiating molecules, and this provides a means of determining the nature of the oscillators from which the radiation originates. Thus, it could be shown that the normal fluorescence of fluorescein, as well as its slow fluorescence, is caused by the oscillations of electric dipoles. On the other hand, some of the lines in the fluorescence spectrum of europium were found to correspond to magnetic dipoles, in complete agreement with the conclusions drawn from the polarization of these lines which were mentioned in Section 122 (308,435,1489-1492,1763,1817).

Another method by which the nature of the emitting oscillators can be determined has been discussed by Vavilov. The fluorescence is observed in a direction perpendicular to the direction of the exciting light and the orientation of the electric vector of the latter is gradually changed. The law according to which the polarization of the fluorescence varies under these conditions, is different for radiations emanating from an electric dipole, a magnetic dipole, or an electric quadrupole. The method has not been applied directly. However, Sevschenko compared the behavior of a cube of canary glass with that of a fluorescein solution exhibiting the same maximum fluorescence polarization. From the fact that the curves representing p as a function of the orientation of the electric vector in the exciting light coincided, he concluded that the nature of the emitting oscillators was the same in both instances and, therefore, that the oscillators responsible for the fluorescence of the uranyl ions were also electric dipoles. Feofilov showed also by this method that the carriers of fluorescence and phosphorescence in fluorescein were identical (383a, 1498,1761a).

CHAPTER V

FLUORESCENCE OF ORGANIC COMPOUNDS

A. The Luminescent Systems

124. Chromophors and Fluorogens. Fluorescence was first discovered in aqueous solutions of a wood extract (*lignum nephriticum*). Solutions of plant extracts and, later, of synthetic dyes were for a long time the most important objects of the investigations, which were naturally restricted to the visible region of the spectrum. It is plausible, therefore, that the first attempts to find relations between the fluorescence of a compound and its constitution were based on the semi-empirical but well-developed laws which had been established by the chemistry of dyestuffs. The strong absorption of visible light which is characteristic of dyes was ascribed to the presence of certain unsaturated groups, such as the azo group $-N=N-$, the ethylene group $-HC=CH-$, and the carbonyl group $>C=O$, which were called chromophors. These chromophors were at first supposed also to be the carriers of fluorescence as "luminophors."

While the production of organic compounds with strong absorption of visible light was, of course, the main purpose of the dye manufacturers, it is not important for the theoretical explanation of fluorescence whether the absorption and emission bands are located in the visible or the u.v. region. As already stated in the preceding chapters, certain radicals — for instance, the NH_2 -group — retain their characteristic absorption frequencies almost unaltered when they form a part of a larger molecule. The absorption bands of dyes, however, and, as a matter of fact, of most aromatic and of many aliphatic compounds, cannot be ascribed to an individual chromophor group, but belong to the molecule as a whole. They are related to "quantum mechanical resonance phenomena" which occur when the molecules contain chains of conjugated double bonds. The most simple case of this type is the resonance between the two Kekulé structures of benzene. The ion of tryptaflavine may be mentioned as a more complicated example: its two principal resonating structures are

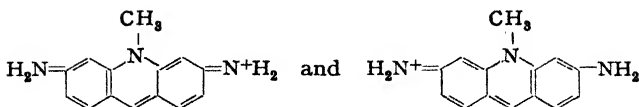

In general, the wavelength of the absorption band resulting from the resonance is the greater, the longer the chain of conjugated double bonds, and, simultaneously, the intensity of the absorption increases. Furthermore, an absorption band has a greater intensity, in general, if an electric charge has different locations in the resonating structures, so that the conversion of one structure into the other corresponds to the displacement of an electric charge as is the case in the trypanflavine ion. None of these rules, however, is rigidly exact* (408a, 408b, 1509).

It is beyond the scope of this book to deal more fully with the quantum-mechanical theory of color. Even if this theory were much more advanced than it actually is, it would not be able to determine the conditions under which an organic compound is fluorescent. Apart from the fact, which was already known to Stokes, that a substance must absorb the light by which it is excited to fluorescence, the ability of a compound to re-emit the absorbed energy in the form of luminescence has very little to do with its capacity for light absorption. One cannot even say that substances with a very high absorption coefficient, corresponding to a short lifetime of the excited state, have a greater probability of being fluorescent because their chance of being quenched is smaller. For instance, benzene is fluorescent, although its absorption coefficient is low, while the majority of dye solutions with a thousand times stronger absorption coefficients are not fluorescent.

This discrepancy had been recognized long before the introduction of quantum theory. In order to explain it, the hypothesis had been proposed that in addition to its chromophor a fluorescent molecule must contain a "fluorogen." Most of these fluorogens were supposed to have a ring structure, the benzene ring being the most important of them. According to the theory developed in preceding chapters the absence of fluorescence in many compounds is caused by the fact that a competing process induces the deactivation of the excited molecule with greater probability than the radiating return to the ground state. If a compound is not fluorescent under any con-

* For instance, the absorption coefficients of pentacene and rubrene are of the same order of magnitude as those of dyestuff ions, although the transitions between the principal resonance structures of these hydrocarbons are not connected with the displacement of an electric charge.

ditions, it must be assumed that this competing process is due not to the interaction with foreign molecules but to internal conversion. Internal conversion seems to be less frequent in molecules with the rigid structure which is greatly favored by the formation of closed rings. This is the modern version of the fluorogen hypothesis. Thus, nearly all known aromatic hydrocarbons which consist exclusively of condensed phenyl rings are fluorescent. Other very instructive examples will be pointed out in the section on synthetic dyes. The rule, however, is again not completely unequivocal; there are compounds consisting of long open chains of conjugated double bonds, such as the diphenylpolyenes and even purely aliphatic polyenes of the type $\text{CH}_3-(\text{CH}=\text{CH})_n-\text{CH}_3$, which are fluorescent in liquid solutions.

If an organic compound is fluorescent, its emission band corresponds to the same electric transition as its absorption band of greatest wavelength (its "first absorption band"). In a few cases the two bands coincide; more frequently, the center of the emission band is displaced by a relatively small distance toward greater wavelengths, in agreement with Stokes' law. Therefore, the rules evolved for the relation between constitution and color (wavelength of the absorption band) can be applied to the color of the fluorescence (but not to its existence). A substitution by which the absorption band of a compound is shifted in the direction of greater or shorter wavelengths will, in general, have the same influence, at least qualitatively, on the fluorescence band.

The ability to emit fluorescence can be increased or reduced and even completely suppressed in a compound by certain substitutions. The majority of papers dealing with this matter does not distinguish sufficiently between a real decrease in fluorescence yield and a change in fluorescence intensity caused by a change in absorption power or a shift of the absorption and the fluorescence band to the ultraviolet, so that both are rendered "invisible." An extreme example of this kind occurs, if by hydration of the central carbon atom in a dye molecule the chain of double bonds is broken and the compound is transformed into the leuco base (for an example, see Table 80). In the latter, the first absorption band is shifted to the u.v. and may correspond, for instance, to the characteristic frequency of two benzene rings which are no longer conjugated; it is not improbable that such a molecule exhibits an ultraviolet fluorescence. If, on the other hand, the absorption coefficient of a fluorescent dye is enhanced by the introduction of so-called auxochrome groups, such as NH_2 , OH , or $\text{N}(\text{CH}_3)_2$, a simultaneous increase in fluorescence intensity does not indicate a greater fluorescence yield.

There are, however, certain substitutions in dye molecules which decrease their *fluorescence yield* greatly without an appreciable change of their absorbing power. These are, in the first place, the halides (in the order of increasing activity: Cl, Br, and I) and the ions of iron and nickel. The influence of the introduction of halides as substituents for hydrogen atoms in the dyes of the fluorescein series has been mentioned in Section 106. And, while all porphyrins are fluorescent, even when two of their hydrogen atoms are substituted by metal ions, such as 2Na^+ or Mg^{++} , the fluorescence is completely suppressed if the ions Co^{++} , Ni^{++} , and Fe^{++} are introduced instead.* It is very striking that these substituents are the same elements which act as strong quenchers in liquid solutions — the halides, even in the same order of efficiency. It is probable that their ability to decrease the fluorescence yield, both as “quenchers” in liquid solutions and as substituents entering into the molecules themselves, is related to the relatively small energies which are sufficient to alter their electric charges ($\text{Fe}^{++} \rightleftharpoons \text{Fe}^{+++}$ or $\text{I} \rightleftharpoons \text{I}^-$, etc.). By this property they are enabled to induce reversible chemical reactions with molecules of the solvent by which the excitation energy is dissipated.

The hypothesis that the inhibition of fluorescence by the metals of the iron group is related to their magnetic properties, is without any rational base.

125. Influence of Isomerism. The influence of isomerism on the wavelengths of the emission bands of doubly substituted benzene or naphthalene derivatives is not very large and is rather irregular, as shown by several examples in Tables 76 and 80. A rule stating that the fluorescence intensity is always strongest in the ortho compounds, weaker in the meta, and weakest in the para compounds was based on observations which did not take into account variations in the absorption of the exciting light. Bowen measured the fluorescence yields of the three xylenes excited by the line 2537A and found them to be 29% for *o*-, 30% for *m*- and 41.5% for *p*-xylene, a result which is in direct contradiction to the older empirical rule (*E, 145*).

Isomers corresponding to *cis*- and *trans*-modifications of a compound show, in general, greater dissimilarities in their fluorescence. *Cis*- and *trans*-stilbene have been thoroughly investigated by G. N. Lewis. The absorption spectra of the two isomers differ widely: their first absorption bands are shown in Figure 134*a*. By light ab-

* The phosphorescence of crystal phosphors is also quenched very effectively by contamination with iron, nickel, and cobalt.

sorption in these bands either of the two compounds is converted into the other with a quantum yield of approximately 30%. Also, *cis*-stilbene is transformed partially (10% yield), into a nonidentified non-fluorescent compound. *Cis*-stilbene is not fluorescent and, thus, the remaining energy must be lost by internal conversion. A weak fluorescence which is obtained after long-lasting irradiation of *cis*-stilbene

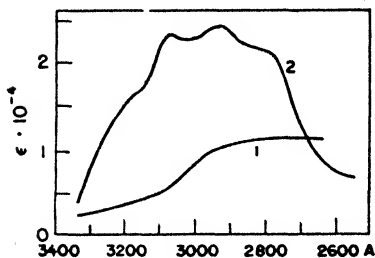

Fig. 134a. Molar extinction coefficient ϵ of *cis*-(1) and *trans*-(2) stilbenes (Lewis, Magel, and Lipkin).

can be ascribed unequivocally to freshly formed *trans*-stilbene. The latter modification emits a strong and very characteristic fluorescence in solutions as well as in the solid crystalline state (Figure 134b) (compare Section 136). The fraction of the excitation energy which is dissipated by *trans*-stilbene molecules in processes of internal conversion is not known. Therefore, no reliable conclusions concerning the fluorescence yield can be derived from a knowledge of the photochemical efficiency. At any rate, the probability of internal conversion is much larger for the *cis*- than for the *trans*-modification. G. N. Lewis ascribes this to the fact that the molecule of *trans*-stilbene is planar, while in *cis*-stilbene the two phenyl rings cannot lie in the same plane (929).

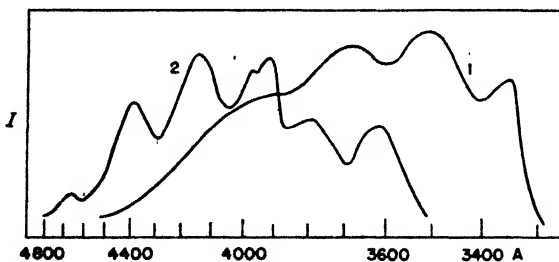

Fig. 134b. Fluorescence spectrum of *trans*-stilbene (Lewis, Magel, and Lipkin) in ether-alcohol mixture at -90°C . (1) and crystalline at -190°C . (2).

Cis- and *trans*-stilbamidine show the same characteristic behavior. The nonfluorescent *cis*-modification is converted by irradiation into the *trans*-modification which exhibits a strong blue fluorescence, and

vice versa. Dimerization is supposed, in this case, to be a second process by which irradiation converts the *trans*-modification into another nonfluorescent compound (602a,602b).

Lewis mentions, incidentally, that the all-*trans*-modification of lycopene is practically nonluminescent; if the compound is subjected to a short heat treatment, some of the *cis*-forms are produced, which exhibit normal fluorescence as well as slow fluorescence (compare Sections 136-138). According to Stobbe, one of two isomeric modifications of octatetraene in the crystalline state is white and emits a blue fluorescence, while the other is yellow with a bright green fluorescence (927a,1583). While 7-hydroxycoumarin (umbelliferone) is brilliantly fluorescent in alkaline solution under near u.v. excitation, its isomer with the hydroxy group in the 6-position shows no visible fluorescence (198).

The problem of the influence of isomerism is of still a different kind if the fluorescent compounds consist of chains or fused ring systems containing conjugated double bonds. In this case the number of double bonds in an uninterrupted chain can vary in different isomers and, thus, their absorption and emission spectra and their faculty of fluorescing can be quite dissimilar. Numerous examples of this type will be found in subsequent sections. There are, however, many instances in which the influence of isomerism on the fluorescence spectrum of polycyclic compounds cannot be explained by this or any other simple theoretical assumption. Thus, no change in the system of conjugated double bonds occurs in the various dimethylalloxazines; nevertheless, the fluorescence of 6,7-, 6,8-, and 5,8-dimethylalloxazine is described by Karrer and Musante as sky-blue, bluish green, and greenish yellow, respectively (721).

According to Schlenk and Bergmann, 9,10-diphenyl-9,10-dihydroanthracene and several of its derivatives exist in three isomeric modifications, of which only one shows a strong violet fluorescence in solution (compare Section 130) (1438).

126. Influence of State of Aggregation. The greatest part of earlier investigations, as well as of more recent papers, is concerned with the fluorescence of organic compounds in liquid solutions. The solvents were most frequently water, alcohol, hexane or other aliphatic compounds; benzene, toluene, etc., are less advantageous because their absorption bands lie in the region of greater wavelengths and because they are themselves fluorescent.

The fluorescence yield of pure liquid compounds, such as benzene and its derivatives, is very low, on account of self-quenching. The Pringsheim 14*

fluorescence of pure crystalline anthracene, which is still strong immediately below the melting point, vanishes completely as soon as the substance is liquified. The fluorescence spectra of compounds which are not ionized in solutions are, in general, the same for the vapors, solutions, and solid crystals, the bands being only slightly displaced in the direction of greater wavelengths, by passing from the vapor to the solution and to the crystal. This is true especially for colorless compounds with fluorescence bands in the u.v., the violet, or the blue. Most deeply colored substances which show a characteristic fluorescence in the vapor state or in dilute solutions are very little or not at all fluorescent as crystals. Examples are naphthacene, and other polycyclic condensed hydrocarbons, in contrast to anthracene, phenanthrene, fluorocyclene, and naphthalene; the dark-colored, almost copper-like crystals of the diphenylpolyenes with more than three ethylene groups also cannot be excited to fluorescence. Crystalline dyes, such as fluorescein, eosin, and the rhodamines, which have such high absorption coefficients in certain regions of the visible spectrum that the reflection becomes metallic, are not fluorescent, even at the temperature of liquid nitrogen. A weak yellowish fluorescence is excited by near-u.v. light in the microcrystalline powder of tryptaflavine, which is orange-yellow without the metallic luster characteristic of the dyes mentioned above; and a light yellow dye, which has been prepared by G. Schwarz, exhibits a very brilliant yellow luminescence under black light illumination, while its fluorescence in alcoholic solution is blue-green and relatively weak* (1291,1721). Another example of this type is the fairly strong, dark-red fluorescence of isocyanine chloride, which is not luminescent in liquid solutions; the broad red emission band of the solid does not seem to be related to the narrow yellow band of the polymerized molecules which are formed in concentrated aqueous solutions. Still another group of compounds which are fluorescent in the solid state and not in liquid solutions is mentioned by H. Kauffmann. Among them are aminobenzalmalononitrile $[(\text{CH}_3)_2\text{N}-\text{C}_6\text{H}_4-\text{CH}(\text{CN})_2]$, dimethylamino- α -phenylcinnamonitrile $[(\text{CH}_3)_2\text{N}-\text{C}_6\text{H}_4-$

* The formula for this nameless dye is:

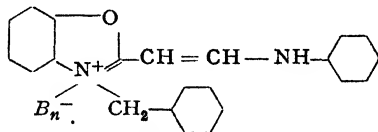

Dyes of almost identical constitution in which, for instance, the oxygen of the oxazine ring is replaced by sulfur or selenium, and which have practically the same absorption spectrum, are not fluorescent in the solid state.

$\text{CH} = \text{C}(\text{CN})\text{C}_6\text{H}_5$], and *p*-dimethylaminophenyl $[(\text{CH}_3)_2\text{NC}_6\text{H}_4 - \text{C}(\text{CN})\text{C}_6\text{H}_5]$, with a strong orange, green, and bright red fluorescence, respectively. Other compounds of the same type, which are brilliantly luminescent in the solid state, can be excited to a much weaker fluorescence of a different color when they are dissolved in alcohol or pyrimidine. Since all these compounds contain the cyanogen group, Kauffmann assumes that this is the cause of their behavior, as it is supposed to be in the case of the cyanoplatinites (compare Section 149) (*E*,734,735,737).

If no unequivocal relation exists between the fluorescence spectrum of a crystalline compound and the spectrum of the vapor or of a dilute liquid solution, the possibility must be considered that the emission by the solid is not characteristic of the bulk material but of an impurity which may be present in very small quantities. Thus, the green fluorescence of all commercial anthracene is caused by an admixture of naphthacene, the blue fluorescence of phenanthrene is caused by anthracene which can be removed only by adsorption methods, the blue fluorescence of fluorene is probably due to anthracene and carbazole, etc. According to Winterstein, carbazol can be extracted from many supposedly pure anthracene samples and shows, when highly purified itself by chromatographic methods, a bright blue fluorescence. Campbell succeeded however, in completely suppressing this fluorescence by even more careful purification (198,1858). The probability of contamination with some impurities exists, to a still higher degree, in more complex compounds, especially if they are not of a synthetic nature but are derived from some plant extracts. Therefore, most of the statements published on the fluorescence of solid alkaloids (morphine, papaverine, etc.), interesting as they would be if they were correct, cannot be accepted as being reliable (14,15). The only exceptions are quinine and its salts, which have been tested in carefully purified samples.

At liquid-air temperature the diffuse band spectra of many crystalline organic compounds are resolved into groups of narrow sub-bands or lines. Under these conditions similarity with the spectra of the vapors becomes even more evident. The splitting of the broad bands has been observed in the spectra of benzene, the xylenes, naphthalene, etc., and also of more complex hydrocarbons, such as decacyclene and several others. In some instances (for example, naphthalene and the diphenylpolyenes), the fluorescence spectra of the crystals show at low temperature an even more pronounced structure than those of the vapors.

127. Influence of Solvent. The relation between the nature of the solvent and the fluorescence yield of dissolved compounds has already been mentioned in Section 106. The influence of the solvent on the exact spectral location of the fluorescence bands has been a matter of discussion for a long period. It has been suggested that the color of the fluorescence shifts continuously from violet to red with increasing dielectric constant of the solvent; the data in Table 73a have frequently been brought forward as proof for this hypothesis. Other examples can easily be found, however, which seem to prove exactly the contrary (Table 73b) (1406,1407a). The search for connections with

TABLE 73
RELATION BETWEEN THE WAVELENGTH OF THE FLUORESCENCE BANDS
AND THE DIELECTRIC CONSTANT μ OF THE SOLVENT

a. Dimethylnaphtheurhodine

Solvent	Ligroin	Ether	Pyridine	Acetone	Levulinic acid	Ethanol	Methanol
μ	1.86	4.37	8.08	12.4	20.7	26.3	31
Color of fluorescence	green	green-yellow	yellow	orange-yellow	orange-yellow	orange	orange-red

b. Anthracene

Solvent	Benzene	Toluene	Xylene	Ether	Amyl alcohol	Ethanol	Methanol	Vapor
μ	2.25	2.35	2.57	4.37	16.7	26.3	31	—
Wavelengths of main fluorescence bands	4060 4285 4570	4050 4270 4550	4050 4260 4535	4035 4225 4535	4030 4250 4500	4020 4260 4500	3998 4220 4480	3900 4150 4320

other properties of the solvent, such as its dipole moment, were no more successful. This seems to be due to the fact that the superimposed influences of polarity (molecular electric moment) and index of refraction (dielectric constant for high frequencies) can act either in the same or in opposite directions. According to results published by Sheppard, the absorption bands of a great many dyes are shifted quite regularly toward greater wavelengths with decreasing index of refraction of the solvents, as long as only solvents of the same polarity are taken into account. It is certainly justified to assume that this rule holds also for the fluorescence bands, although no actual measurements are at hand. It is another question whether the rule can be applied to other types of dissolved organic compounds.

In a similar way the nature of the adsorbent acts on the fluorescence spectra of adsorbed dyes. This can be observed at its best if the fluorescence spectrum consists of relatively narrow bands, and has, for instance, been shown for hematoporphyrin adsorbed on various supports. An even better example is provided by the almost linelike narrow absorption and emission band of the polymerized isocyanine dyes, as shown in Table 74 (56,1414).

TABLE 74
ABSORPTION AND FLUORESCENCE BANDS
OF ADSORBED ISOCYANINE CHLORIDE

Adsorbent substance	Absorption band in A	Fluorescence band in A
Glass	5728	—
Quartz (cryst.) ..	5767	—
Gypsum	5720	5727
Mica	5793	5806

The problem is, of course, of a different kind if the nature of the dissolved molecules is altered by a reaction with the solvent. Such

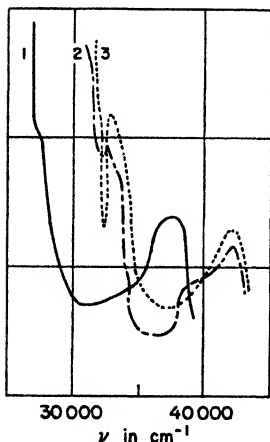

Fig. 135. Absorption spectrum of naphthylamine (Ley and Graefe).

1: naphthylamine in alcohol. 2: naphthylamine with 10% HCl in alcohol. 3: naphthalene in alcohol.

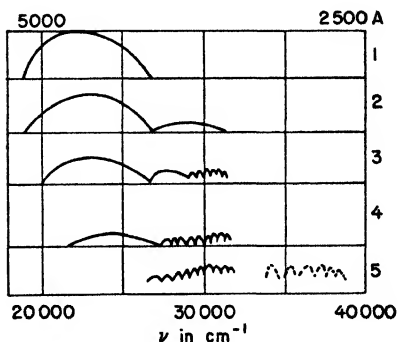

Fig. 136. Fluorescence spectrum of naphthylamine in alcohol (Ley and Graefe).

1: pure naphthylamine. 2-4: increasing addition of HCl. 5: naphthalene and benzene for comparison.

reactions can consist either of a change in the state of ionization (see Section 116) or in the formation of a new compound. If, for instance, hydrochloric acid is added in increasing concentration to solutions of aniline or naphthylamine, the absorption and fluorescence bands of these compounds give way to bands similar to those of benzene or naphthalene, respectively (Figures 135 and 136). The amino groups are successively replaced by NH_3Cl -groups and these substituents influence the characteristic frequencies of the unsubstituted hydrocarbons to a much smaller degree than the amino groups (937).

B. Aromatic Hydrocarbons and Heterocyclic Compounds

128. Benzene. J. Stark discovered the fluorescence of benzene in liquid solutions long before the fluorescence of the vapor had been observed. The solvents were alcohol, water, hexane, carbon tetra-

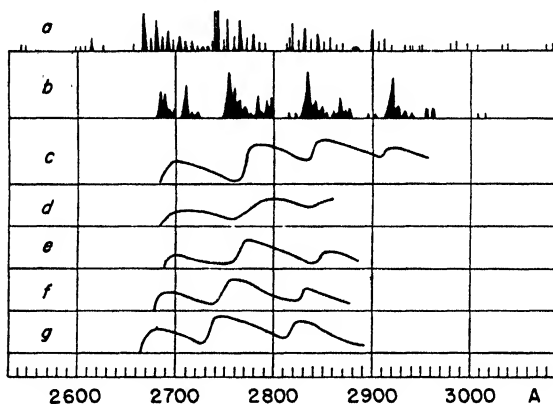

Fig. 137. Schematic representation of fluorescence spectrum of benzene (Kronenberger and Pringsheim).

<i>a</i> : vapor at high pressure	<i>d</i> : liquid at 0° C
<i>b</i> : solid at -180° C	<i>e-g</i> : 30%, 10%, and 4% solutions in ethanol
<i>c</i> : solid at 0° C	

chloride, and ether. The emission spectrum is analogous to that of the vapor insofar as it consists of a progression of bands with a spacing $\Delta\nu = 1000\text{ cm}^{-1}$ adjoining a similar progression of absorption bands which are separated by intervals $\Delta\nu = 920\text{ cm}^{-1}$. The structure of the bands is, however, almost completely blurred out, the only trace of it

consisting in a secondary maximum at the long-wavelength side of each band (303,1350,1546). The distance by which the bands are displaced with respect to those of the vapor depends not only on the nature of the solvent, but even to a greater degree on the concentration of the solution. In very dilute alcoholic solutions the centers of the bands coincide almost exactly with those in the vapor spectrum and the wavelength shift becomes noticeable only at higher concentrations. The values in the third and fourth rows of Table 75 are, therefore, exact only for a well-defined concentration. This is shown schematically in the last three rows of Figure 137.

TABLE 75
 ABSORPTION AND FLUORESCENCE BANDS OF BENZENE
 (Wavelengths of the short-wavelength edges in Å)

ν'	6	5	4	3	2	1	0	0	0	0	0	0	0
ν''	0	0	0	0	0	0	0	1	2	3	4	5	6
Vapor { Abs.	2275	2324	2363	2416	2471	2528	2589	2667					
{ Fl.						2541	2602	2667	2739	2815	2895	2980	30
Alcohol { Abs.	2290 ?	2330	2378	2428	2485	2547	2598	2681					
solution { Fl.							2599	2679	2754	2827	2910	3005 ?	
Pure at { Abs.	2297	2339	2385	2432	2488	2550	2608	2689					
25° C { Fl.								2686	2761	837	2920		

In pure liquid benzene the emission bands are very diffuse and so weak that only the strongest bands can be observed. The melting point of benzene is at + 5° C, but the liquid can be undercooled to below 0°. If the undercooled liquid is made to crystallize, the fluorescence bands recover the full intensity and relative sharpness corresponding to the optimum concentration in a dilute solution (compare Section 112) and a short afterglow can be observed phosphoroscopically. The fine structure of the bands appears, however, only if the crystals are cooled to a temperature below - 100° C.

Just as the fluorescence of the vapor at high pressures, the fluorescence of crystalline benzene at - 180° C is independent of the wavelength of the primary light. The emission spectrum is the same whether the fluorescence is excited by the u.v. continuum of a hydrogen lamp, by the total radiation of a mercury lamp, or by the monochromatic line 2537A. Whereas the absorption bands are still further resolved at the temperature of boiling hydrogen, no better resolution of the fluorescence spectrum can be obtained at - 259° than at - 180° (835,1556). Although the analogy between the spectra

represented in the first two rows of Figure 137 is obvious, a correlation of the individual bands of the crystal spectrum with those of the vapor spectrum has not met with much success. From an analysis of the crystal absorption spectrum its $0'-0''$ band could be identified with a weak band at $37,829\text{ cm}^{-1}$ (2641A), which thus is displaced by 261 cm^{-1} with respect to the $0'-0''$ band of the vapor (Figure 138). The strongest band series with a spacing of 990 cm^{-1} starts in the fluorescence spectrum of the crystals at a distance of 600 cm^{-1} from the $0'-0''$ band and corresponds to the progression designated as *B* in the

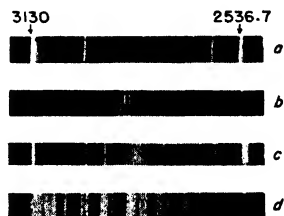

Fig. 138. Fluorescence spectra of benzene excited by Hg-arc (Kronenberger and Pringsheim). This figure was made from the original prints, but spectrum *d* has been enlarged so that its dispersion matches the others, as indicated by the arrows.

- | | |
|---|---|
| <i>a</i> : Hg comparison spectrum | <i>c</i> : solid benzene at 0° C |
| <i>b</i> : fluorescence of benzene vapor at 20° C | <i>d</i> : solid benzene at -180° C |

vapor spectrum (Section 88). Only one other series originating at a distance of 970 cm^{-1} from the $0'-0''$ band has been identified by Spomer with some certainty as corresponding to one of the weaker progressions of the vapor spectrum. Several of the smaller frequency interval recurring in the crystal spectrum have been ascribed tentatively to lattice vibrations (835,836,1545).

129. Derivatives of Benzene. Fluorescence spectra of monocyclic benzene derivatives in liquid solutions are collected in Table 76. Most of these spectra are closely related to that of benzene itself, as is the case in the spectra of the vapors. However, they are again more diffuse and shifted in the direction of greater wavelengths. These effects are especially pronounced if an H-atom of the phenyl ring is replaced by a hydroxyl or an amino group, while the introduction of methyl groups has relatively little effect. A comparison of the spectra of biphenyl and diphenylmethane shows that the interaction

between the phenyl rings becomes appreciably weaker if they are separated by a CH_2 -group. On the other hand, the fluorescence spectrum of biphenyl, which is always described as diffuse and weak in the vapor, shows some structure and is fairly strong in solutions. According to Bowen, the fluorescence yield of biphenyl dissolved in hexane is 22 %, about twice as large as that of benzene listed in Table 61. This difference in the behavior of the vapor and the solution may be explained by the stabilizing effect mentioned in Section 83h. In all spectra the maxima are superimposed on a strong continuous background. Although frequency differences occur between individual maxima which are of the same order of magnitude as those in the benzene spectrum, the maxima never form series with a constant spacing and are probably due to the superposition of a number of progressions. A theoretical analysis of these spectra is, therefore, not possible, and this is further emphasized by the fact that the data published by various authors differ widely in many details. Most of the figures of Table 76 are taken from a recent paper by Ley and Specker in which the wavelengths of the band are stated without any attempt to arrange them in regular series (934,938,1689).

The spectra observed at low temperatures in the crystalline modifications show, again, more structure than those of undercooled glasses. Both types of emission spectra, however, are only more or less modified forms of the spectra characteristic of the vapors or the liquid solutions. Luminescence spectra of an essentially different type can occur if thin films of benzene derivatives are condensed on a metal surface at the temperature of liquid air. They are shifted far into the region of greater wavelengths and seem no longer to be related to the first absorption bands. Thus, a band between 5125 and 6410A (maximum at 5615A) has been observed by Terenin in the luminescence spectrum of bibenzyl under these conditions, while the normal fluorescence bands of this compound lie near 3000A (Table 76). Similar new emission bands are obtained when aromatic compounds are dissolved in solids or adsorbed on gels at low temperatures. Apparently the conditions for the appearance of these luminescence bands, which are always combined with an appreciable afterglow, were also provided by Terenin's experimental arrangement (compare Section 136) (1640).

130. Condensed Aromatic Hydrocarbons. The absorption and fluorescence bands of the hydrocarbons in which a series of benzene rings are fused in a straight chain have increasing wavelengths with increase in number of rings and of conjugated double bonds (numbers

TABLE 76
 FLUORESCENCE SPECTRA OF BENZENE DERIVATIVES IN LIQUID SOLUTION
 IN ALCOHOL (A) OR HEXANE (H)
 (Band limits and band maxima in A)

(A) Benzene		2550-3000	
C_6H_6		2599 2635 2639 2754 2827 2910	
(A) Toluene		2610-3000	
$C_6H_5CH_3$		2622 2646 2676 2740 2809 2886	
(A) Xylene	$C_6H_4(CH_3)_2$	o	2600-3200
			2603 2636 2680 2713 2798 2896 3038 3135
		p	2670-2820
			2685 2715 2802
(A) Mesitylene	$C_6H_3(CH_3)_3$	2650-2900	2681 2739 2801 2865
		2650-3000	2698 2712 2747 2786 2863 2972
(H) Durol	$C_6H_2(CH_3)_4$	2800-3400	
(A) Phenol*	C_6H_5OH	continuous	
(A) Cresol	$C_6H_4(OH)_2$	o	2870-3850
		m	2860-3850
		p	2920-3850
(A) Hydroxybenzoic acid	HOC_6H_4COOH	o	3760-4800
		m	3280-4440
		p	3230-4080
(A) Aniline	$C_6H_5NH_2$	3000-4100	
(A) Anisidine	$CH_3OC_6H_4NH_2$	continuous with weak maxima 3048 3355	
(A) Tolunitrile	$CH_3C_6H_4CN$	o	3130-4290
		p	3390-4230
(H) Biphenyl	$C_6H_5C_6H_5$	o	2870 3760
		p	2800-3510
(H) Diphenylmethane	$C_6H_5CH_2C_6H_5$	2940-3650	
(H) Bibenzyl	$C_6H_5CH_2CH_2C_6H_5$	2940 3048 3140 3190 3270 3406 3550	
(H) Dibenzylethylene .	$C_6H_5CH_2CH=C(CH_2C_6H_5)_2$	2720-3200	
(H) Diphenyl ether* . .	$C_6H_5OC_6H_5$	2750 2790 2845 2935 3015	
(H) Diphenylamine . .	$(C_6H_5)_2NH$	2700-3200	
		2750 2790 2835 2910 3040	
		2700-3200	
		2785 2835 2960 3060 3140	
		2840-3680	
		continuous	
		3260-4150	
		continuous	

* The analogous compounds in which O is replaced by S are not fluorescent.

1-5 in Table 78). The fluorescence spectra of crystalline naphthalene, anthracene, and phenanthrene at the temperature of boiling hydrogen were analyzed by Obreimow and Prikhotjko. They identified some of the principal frequency differences occurring in each of these spectra with infrared and Raman frequencies of the hydrocarbons. However, the coincidence is not quite convincing in several cases. Moreover, numerous nuclear frequencies not known from any other investigations had to be introduced for the complete representation of more than 100 lines measured in the naphthalene spectrum, some of which had a width of only 0.2\AA (5 cm^{-1}), and the overall appearance of the spectra did not show the clear periodicity characteristic of the low temperature fluorescence spectrum of crystalline benzene. Considering the uncertainty of the interpretation of even this spectrum, Obreimow's analysis of the much more complicated spectra cannot be accepted without some reserve (1153, 1154, 1266).

The manifold luminescence spectra which are excited in naphthalene under various experimental conditions are collected as a typical example in Table 77. The processes by which some of these spectra are produced will be discussed in later sections.

The fluorescence yield increases from benzene through naphthalene to anthracene and drops rapidly for the aromatic hydrocarbons containing more than three phenyl rings in a straight chain. This holds for liquid solutions as well as for pure solids. The fluorescence of pentacene dissolved in benzene is very weak, and it is below the limit of observability in the crystals. (Compare Table 53). When naphthalene is dissolved in anthracene or in other hydrocarbons, such as 1,2-benzanthracene and 1,2,5,6-dibenzanthracene, however, its luminescence becomes exceedingly strong. An admixture of $10^{-4}\%$ naphthalene, which is present in all anthracene not especially purified, suffices to make the green naphthalene bands appear brighter in the fluorescence spectrum than the violet bands of anthracene, while at the concentration of 0.1% the latter are completely suppressed. At a naphthalene concentration exceeding 0.1%, the intensity of the green fluorescence decreases again, apparently due to self-quenching. If the green and the violet bands are observed simultaneously in the crystals, they are both excited by light of wavelengths below 4000\AA , which is absorbed by anthracene. The emission of the green bands alone is excited with low intensity by irradiation with blue light, which is ineffective in pure anthracene.* At low temperatures the so-called *green* anthracene bands are split into narrow lines exactly

* Unpublished observations.

TABLE 77
LUMINESCENCE OF NAPHTHALENE IN CONDENSED SYSTEMS
(Wavelength of band edges in Å)

Absorption	Fluorescence			Afterglow			
	In alcohol + 20°	Pure cryst. + 20°	Pure* cryst. —180°	In boric acid + 20°†	"Progressive phosphorescence" in alcohol. —180°†	"Solution spectrum" in chlorobenzene —180°†	"Principal spectrum" —180°†
2540				4650-4750	4660	4730	
2660					4770		
2770							
2960				4830	4830	4830	
3000	3000						
3040	3046			4980-5100	5000	5050	
3070	3098				5080	5100	
3150	3142	3163					
3200	3190	3214	3220 3233		5200	5170	
	3235	3258	3276 3303			5230	
	3292	3307	3328	5400-5500	5400-5500		
	3340	3369	3375 3400			5400	5426
	3386	3421	3433			5450	
	3447		3464 3491				
	3498		3563			5570	5580
	3558		3603				
	3627?		3629			5650	5620
	3654?		3711 3742				5760
							5900
							6010
							6170
							6320
							6490

* At —250° C the bands are resolved into about 130 narrow bands and lines in the region between 3128 and 3716Å.

† Compare Sections 137-139.

as the genuine anthracene bands and both band systems show the same polarization (Section 122). Apparently the two hydrocarbons form mixed crystals and the excitation of naphthacene is caused by exciton migration; the process can also be designated as a kind of sensitized fluorescence (*143a, 143b, 143c, 458a, 829a, 1153, 1803, 1858*).

On the other hand, the golden-yellow fluorescence of rubrene (tetraphenyl-naphthacene), in which the hydrogen atoms of the four central carbon atoms of naphthacene are replaced by phenyl rings, is fairly strong in the solid crystals and if the compound is dissolved in

TABLE 78
 FLUORESCENCE SPECTRA OF AROMATIC HYDROCARBONS IN SOLUTION
 (Wavelengths in Å)

1. Benzene*	2500-3000
2. Naphthalene*	3000-3650
3. Anthracene*	3720-4600
4. Naphthacene	4600-5800 (4680 4980 5330 5740)
5. Pentacene	red
6. Rubrene	5450-6235 (maxima: 5600 5900)
7. Phenanthrene	3480-4070 (3480 3656 3852 4068)
8. Chrysene	3600-4000
9. Pyrene	3700-4000
10. Perylene	blue (4400 4700)
11. Fluorene	3020-3700 (maxima: 3020 3250)
12. Cholanthrene	blue-violet (4000-5000†)
13. Decacyclene	4770-6000 (4765 5105 5520 5950)
14. Fluorocyclene	4100-5400 (4155 4400 4660 5040 5340)

* For details, see Tables 73, 75, and 77.

† Also below 4000Å.

hexane, the fluorescence is brighter than that of any other hydrocarbon, the yield being close to 100 % at low concentrations. This is rather surprising because phenyl rings as substituents are frequently apt to reduce the fluorescence yield of aromatic compounds.*

When a number of benzene rings are fused so that instead of being in a straight line the molecule has an angular structure, the rule concerning the wavelengths of the fluorescence bands no longer holds. The first example of this kind is phenanthrene; although it is an isomer of anthracene and also consists of three rings, its fluorescence is restricted to the u.v. Even in very recent publications the fluorescence of phenanthrene is described as blue. This is due to the fact that all commercial phenanthrene is contaminated with a high percentage of anthracene even though it may be claimed by the manufacturers to be pure. In this case, as well as in that of pyrene and chrysene, the impurity is so considerable (up to ten per cent) that, in general, even when the substance is observed in a dilute alcoholic solution, the anthracene bands are obtained in the emission spectrum; this has been taken as a proof that the bands are really characteristic of phenanthrene, chrysene, and pyrene (1, 2- and 9, 10-benzophenan-

* The four phenyl rings in the 9, 10, 11, 12-position in the rubrene molecule cannot be coplanar with the phenyl rings of the naphthacene chain.

threne) which, although they are four-ring compounds, are colorless as pure crystals and emit a dark violet to u.v. fluorescence* (1406,1497, 1507).



The fluorescence spectra of many phenylated anthracenes, such as 2-phenylanthracene, 9,10- or 2,8-diphenylanthracene, and 1,4,5,8-tetraphenylanthracene dissolved in benzene are very similar to that of anthracene, the bands being shifted only a little in the direction of greater wavelengths with increasing number of added phenyl rings (623).

Qualitative data giving no more than the fluorescence color are available for a great number of higher aromatic hydrocarbons. These data are sufficient, however, to provide some support for the rule that long straight chains of fused benzene rings favor the appearance of fluorescence of great wavelength. Thus, the fluorescence of the compounds consisting of five rings changes from red to violet with shortening of the longest chain occurring in the molecules, as shown in Table 79. Even the fluorescence of the seven-ring compound coronene, which has no more than three rings in a chain in any direction, is blue-violet and very similar to that of anthracene. By the addition of still more benzene rings to coronene, the fluorescence color is again shifted toward the red but without much regularity. The fluorescence of the nine-ring compounds, dibenzocoronene and violanthrene, is yellow and the fluorescence of dinaphthocoronene is green, although it contains five benzene rings fused in a straight row as in pentacene, with three more rings added on both sides (229a,229b,1470-1474).

The fluorescence spectrum of benzopyrene dissolved in hexane or in alcohol is analogous to that of the vapor, the sequence of bands on a continuous background showing some structure (see Table 48) (9,177,234,235,613,614,993,1027,1409,1410). If the compound crystallizes by slow evaporation of an alcoholic solution, or if it is condensed from the vapor phase on the cold glass wall of an evacuated vessel, it exhibits a bright green fluorescence, the spectrum of which consists of

* It may be mentioned that "purest" commercial crystalline naphthalene, also, in general, shows anthracene bands in its fluorescence spectrum. It is exceptional that an aromatic hydrocarbon is pure under fluorescence test. Complete purification is difficult, recrystallization and fractionated sublimation being of little avail. The best method is selective adsorption on aluminum oxide, silica gel, or active charcoal. Making use of this method, most impurities can be separated and rendered visible by their fluorescence (so-called ultrachromatography). In general, the more strongly colored compounds, showing a fluorescence of greater wavelength, have the higher adsorption coefficients.

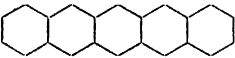
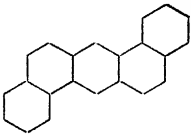
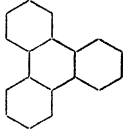
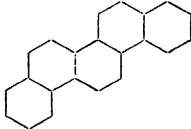
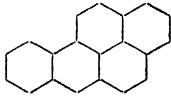
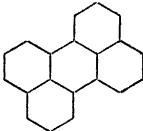
TABLE 79
 FLUORESCENCE OF POLYCYCLIC AROMATIC HYDROCARBONS
 (DISSOLVED IN HEXANE)

Compound	Formula	Fluorescence color
Pentacene $C_{22}H_{14}$		red
1, 2, 6, 7-Dibenzanthracene $C_{22}H_{14}$		yellow-green
8, 9-benzo-chrysene $C_{22}H_{14}$		blue-green
1, 2, 5, 6-Dibenzanthracene $C_{18}H_{14}$		blue (3900 4150 4500)
1, 2-Benzopyrene $C_{20}H_{12}$		blue-violet (3947 4033-4089* 4134-4160* 4286-4319* 4354)
Perylene $C_{20}H_{12}$		blue
Coronene $C_{24}H_{12}$		blue-violet

* Strong double bands.

a broad continuous band between 4360 and 5800Å. If, subsequently, the solid is heated to 60° C,* the fluorescence color changes to blue and the emission spectrum shows a continuous band with a maximum of

* The melting point of benzopyrene is at 176° C.

intensity at 4500A and a weaker narrow band at 4200A. Renewed dissolution and crystallization or renewed sublimation in vacuo restores the green fluorescence and the same process can be repeated at will (1292). Weigert assumes that the green fluorescing modification is colloidal and the blue fluorescing crystalline. While this hypothesis does not seem to agree with the phenomena stated above, the following observation, in addition to some others related by Weigert, is in favor of his assumption. If small quantities of naphthacene are added to benzopyrene, the blue fluorescence is suppressed by the well-known green bands of naphthacene, as in other crystalline hydrocarbons; the green fluorescence of benzopyrene, on the other hand, is not appreciably affected by an admixture of naphthacene, apparently because, under the now-prevailing conditions, the energy absorbed by the benzopyrene molecules cannot be transferred to the naphthacene molecules (1803).

The last hydrocarbons listed in Table 18 are not built up exclusively from benzene rings. Fluorene is apparently a three-ring compound: the most probable structure determining its ground state

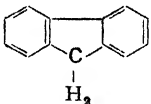
corresponds to the form  so that, as in biphenyl, no

double bond links the two benzene rings. If this is correct, the absorption and fluorescence spectrum would be due mainly to the two disconnected benzene rings. As a matter of fact, the fluorescence of fluorene does not differ greatly from that of biphenyl and must be explained in the same way. (For the same reason as in the case of phenanthrene, the fluorescence of fluorene is frequently described as blue; the most common impurity is supposed to be carbazole).

Cholanthrene can be derived from 1, 2-benzanthracene by addition of a five-cornered ring:

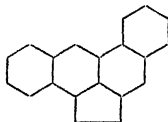

When dissolved in hexane it emits a broad continuous fluorescence band. The solid compound is distinguished by the same peculiarity as benzopyrene: it exists in a blue and a green fluorescing modification, and, again, only the form with the blue fluorescence is susceptible to

the effect produced by small admixtures of naphthacene. The same holds for methylcholanthrene (177,1803).

Benzopyrene, cholanthrene, and methylcholanthrene are known to be highly carcinogenic; this was assumed at first to be related to their ability to fluoresce. There are, however, many other hydrocarbons with similar fluorescence yield and similar fluorescence spectra which are completely harmless. The existence of two modifications with different fluorescence spectra, on the other hand, has been observed only with the three carcinogenic compounds. Whether the second modification is a colloid or a different crystalline form, a connection between this property and the physiological efficiency does not seem improbable.

Compounds 13 and 14 in Table 78 are of a much more complicated structure. They consist of a central ring surrounded by a number of naphthalene groups. Thus, decacyclene is represented by the formula:

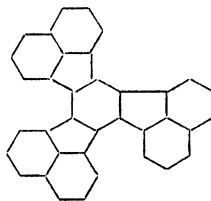

The absorption spectra of these compounds are divided into two parts: a band near 3000Å, practically coinciding with the naphthalene band, and a long-wavelength band which, in the case of decacyclene, stretches from 3400–4500Å. The visible fluorescence is excited only by light absorption in the second band, while absorption in the naphthalene band is ineffective. The fluorescence spectra of fluorocyclene in the vapor state, in liquid solutions, and in the crystalline state are very similar, the bands being shifted somewhat toward greater wavelengths in the crystals (971,981,1235,1720).

The effect of substitutions is the same in polycyclic hydrocarbons as in the isolated benzene ring (Table 80). In alkyl-substituted compounds, the spectra are shifted by small amounts to greater wavelengths and the structure of the bands is mostly blurred out. The same is true for many other substituents (see numbers 1, 2, 10, and 11 in Table 80). On the other hand, the bands are displaced far into the visible region by the addition of an amine or a hydroxyl group (7,90).

The spectra of dihydroanthracene and octahydroanthracene are

TABLE 80
 FLUORESCENCE OF SUBSTITUTED POLYCYCLIC HYDROCARBONS
 IN SOLUTION

Compound	Wavelength of fluorescence bands in Å
1. Methyl-naphthalene $C_{10}H_7CH_3$	3000–3700
2. Naphthyl- α -sodium sulfonate $C_{10}H_7NaSO_3$	3100–3700, continuous (maximum 3400)
3. α - and β -Naphthol $C_{10}H_7OH$.	3800–5400 (main maximum 4100; secondary 5000)
4. β -Naphthol sodium sulfonate $C_{10}H_6OHNaSO_3$	(main maximum 4100; secondary 5000)
5. α - and β -Naphthylamine $C_{10}H_7NH_2$	3900–5600 (main maximum 4500; secondary 5000)
6. Sodium naphthionate	(main maximum 4500; secondary 5000)
7. β -Anthramine* $C_{14}H_9NH_2$. .	5000–6000 (maximum 5300)
8. Dihydroanthracene $C_{14}H_{12}$. .	2720–3400 (maximum 2900)
9. Octahydroanthracene $C_{14}H_{18}$. .	2840–3450 (maximum 3020)
10. Retene† $C_{14}H_9CH(CH_3)_2$. .	3400–3700
11. Methyl- and ethylcholanthrene	4000–5200 (peak 4600)
12. Diazonaphthalidene	4100–5100 (4158 4343 4628 5034)

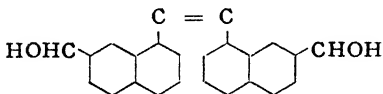

* By addition of HCl the fluorescence band is shifted, in this case also, to shorter wavelengths and acquires a structure similar to the fluorescence of anthracene, with maxima at 3880, 4090, and 4330 Å (Figure 135).

† Retene is a phenanthrene derivative.

especially instructive. In these compounds the system of double bonds existing in anthracene is interrupted and only two disconnected benzene rings remain in the first, only one such ring in the second compound:

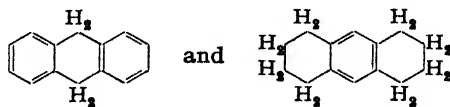

These are exceptional instances, in which it has been proved that the fluorescence is not really suppressed by the break in the chain of double

bonds, but that the visible fluorescence of the long chain is replaced by the u.v. fluorescence of disconnected benzene rings (938).

It has been mentioned at the end of Section 125 that, according to Schlenk and Bergmann, phenylated 9, 10-dihydroanthracenes exhibit a strong violet fluorescence. Hirschberg and Haskelberg made analogous observations on solutions of tetraphenyl-9, 10-dihydroanthracene; but they found that the emission spectrum was identical with that of the nonhydrogenated compound and concluded that an admixture of the latter caused the fluorescence of the other solutions. Probably the same interpretation must be applied to Schlenk's and Bergmann's observations (623,1438).

The last compound (12) has been added to the list because it belongs to the same class as decacyclene insofar as its fluorescence and absorption spectra are concerned. The visible fluorescence is not excited by light absorption in the naphthalene bands but only by absorption in a long-wavelength band at 3400–4350A.

The ketones of the hydrocarbons consisting of nine rings are the so-called anthrene or indanthrene dyes. Many of these — for instance, alizanthrene violet, caledone jade green, and anthrene dark blue — exhibit a deep red fluorescence when dissolved in xylene or tetraline.

131. Heterocyclic Ring Compounds. Heterocyclic rings, such as pyridine, pyrrole, azine, and pyrone, were classified as chromophors in the old chromophor-fluorogen theory, and since they were found to be not fluorescent by themselves, it was assumed that a "fluorogen" had to be attached to them in order to provide the ability to fluoresce. Thus, the central pyridine ring would be the chromophor in the acridine molecule, while the two benzene rings would act as fluorogens. The analogy between the structures of anthracene and acridine is obvious, however, and since a similar analogy prevails between their absorption and emission spectra, it cannot be doubted that these originate from the same mechanism, namely, the resonance between the various structural formulas of the three-ring system. The spectra belong to the whole molecule and not to an isolated chromophor group. The fluorescence bands of acridine in neutral solutions are located in the same spectral region as those of anthracene and, while the spectrum of acridine is more diffuse at room temperature, it is resolved at — 180° C into a sequence of four separated bands with nearly the same spacing which occurs in the anthracene spectrum. The only essential difference between the optical behavior of the two compounds is due to the fact that, in contradistinction to the hydrocarbon, acridine forms positive ions in acidified solutions and that the

fluorescence bands of these ions are displaced in the direction of greater wavelengths; with decreasing pH the color of the fluorescence changes from violet to bluish-green.

Xanthone is another compound consisting of 3 fused rings, but without any double bonds in the central pyrone ring; its fluorescence is exclusively u.v. The same is true for carbazole:

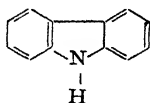

and dibenzofuran; the last two compounds are quite analogous to fluorene, which has been treated in the preceding section, but with the additional influence of the imido group and the oxygen, respectively, on the fluorescence of the benzene rings. Similar considerations should apply also to methylacridone:

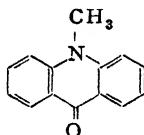

Instead, its absorption and fluorescence bands in neutral and acidified solutions coincide almost exactly with those of acridine. To provide an "anthracene-like resonance structure" for methylacridone, one must assume that one of its most probable forms is that of a "zwitter ion" with a negative charge on the oxygen and a positive charge on the nitrogen:

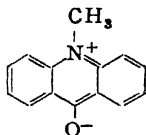

an assumption which seems rather artificial (1469).*

Table 81 lists the fluorescence of various pure and substituted heterocyclic ring compounds. While nothing seems to be known concerning the fluorescence of coumarin itself, most of its hydroxy derivatives, beginning with umbelliferone, are fluorescent in liquid solutions. 6, 7-Dihydroxycoumarin is the substance which (ascocoumarin)

* It would be an easy way out to assume that the solution was contaminated with acridine so that the fluorescence and absorption, were due to the latter. There is no sufficient reason, however, for justifying this assumption.

produces the strong blue fluorescence of chestnut extracts, one of the earliest examples of fluorescent plant extracts. Many coumarin derivatives corresponding to the general formula:

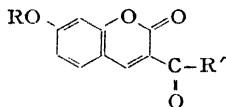

($R = H$ or CH_3 ; $R' = H$, CH_3 , or C_2H_5) have been investigated; the fluorescence is violet or blue in all cases. Compounds in which R' is a phenyl ring, however, are not fluorescent (256,1337).

Quinoline and numerous quinoline derivatives are fluorescent. 8-Hydroxyquinoline which is frequently used for the determination of aluminum and magnesium is not fluorescent in the solid state but exhibits a fairly strong green fluorescence in alcoholic solution. This luminescence is completely quenched by the addition of a few drops of a weak acid, but the compounds which are formed with aluminum and magnesium and are precipitated from an acidified aqueous solution as small crystals emit, under black light excitation, a very brilliant green fluorescence. The bright fluorescence of tetrahydroquinoline is blue-violet in neutral and yellowish green in alkaline solution (836a).

Alloxazine and its alkyl derivatives are interesting because they are the compounds from which vitamin B_2 is derived; the fluorescence of this dye plays an important part in modern vitamin analysis. While they still contain *one* benzene ring in addition to an azine and a pyrimidine ring in their three-ring system, this last benzene ring is replaced by a pyridine ring in the azoflavines,* without impairing the fluorescence of the compounds. Another substance consisting of two heterocyclic rings only (a pyrazine and a pyrimidine ring) is lumazine:

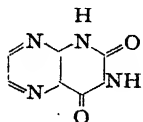

the compound itself and many of its alkylated derivatives exhibit a brilliant fluorescence which varies in color from blue to green with increasing pH of the solution. These examples prove definitely that

* Only the azoflavines with a propyl or a cyclohexanol group substituted in 9-position have been found to be stable.

the presence of a benzene ring as "fluorogen" is not essential for the production of strongly luminescent ring compounds (721, 722, 844, 1389, 1390).

As a matter of fact, several compounds consisting of a single heterocyclic ring were known to be fluorescent for a relatively long time. Examples are aminocyanofuroic ester and methylamino-citraconic methylimide:

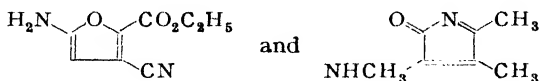

In earlier times, however, the tendency prevailed to assign a decisive part in the production of luminescence to one of the side chains — for instance, the (NC)-group — as "fluorogen" (734-737).

The pyridine derivative represented by formula I shows a bright blue fluorescence in alkaline solution under near u.v. excitation. According to Kubli and Schmidt, it is due to the fact that the compound

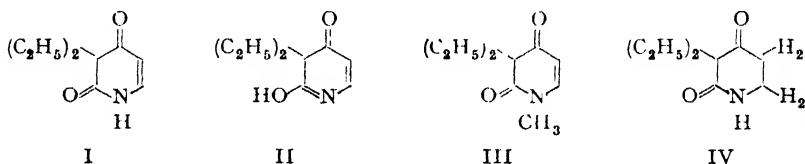

undergoes an enolization corresponding to formula II. Enolization cannot take place when a methyl group is substituted for hydrogen in the NH-group as in formula III. On the other hand, the piperidine derivative, formula IV, exhibits no fluorescence in alkaline solution, notwithstanding its ability of being enolized. The formation of a chain of conjugated double bonds in compound II causes the appearance of absorption bands in the near u.v. or the violet, while the absorption bands of the compounds I, III, and IV may be located entirely below 3000Å. Thus the apparent difference in fluorescence power is also, in this case, essentially due to a difference in the absorption spectra. The same authors list a number of other fluorescent monocyclic pyridine derivatives (836a).

Very numerous heterocyclic compounds with a great variety of substitutions are represented by the typical dyestuffs, which will be treated separately in Section 132 and 133.* Among the noncolored

* Some of the substances mentioned in this and the preceding section — for instance, the flavines, vitamin B₂ and lumazine — are also dyes.

compounds of a more complex nature, quinine and its salts are of special interest, because they have been investigated very exhaustively and provide a great variety of phenomena, many of which have not yet been explained satisfactorily. While the fluorescence of quinine

TABLE 81
FLUORESCENCE OF HETEROCYCLIC COMPOUNDS IN LIQUID SOLUTIONS

Compound	Fluorescence band
Quinoline	3855-4900
Umbelliferone	blue
Acridine	4250-4540*
Methylacridone	4250-4540* (maxima: 4335 4455)
Xanthone	u.v.
Carbazole	3400-4200 (3470 3590 3760)
Diphenyl oxide	3100-3700 (3165 3280 3450)
Alloxazine	violet
Lumazine	green†
Methylaminocitraconic methylimide . .	yellow
Quinine sulfate	4100-5000‡ (4370)

* In acidified solution, blue-green.

† In acidified solution, blue.

‡ In acidified solutions, whitish blue (4000-6750; maxima: 5550, 4660).

salts is violet in neutral and whitish blue in acidified aqueous solutions, an intense green fluorescence is obtained if the bisulfate, hydrochloride, or valerate of quinine is heated to the melting point and subsequently dissolved at high concentration in water. Although the salts are dehydrated by the heating process, it must be assumed that still another change occurs in the constitution of the compounds, since the mere loss of crystal water would not influence their behavior in aqueous solutions. If the solutions are acidified, their fluorescence recovers the characteristic whitish blue color and dilution to a very low concentration has the same effect. On the other hand, addition of an alkali does not affect the green fluorescence and, thus, it becomes probable that a negative ion or a neutral molecule is the carrier of this luminescence. The excitation spectrum of the green fluorescence is also shifted in the direction of greater wavelengths. No explanation is available for the phenomena observed when the heat-treated salts are dissolved in organic solvents; in chloroform the fluorescence of the preheated hydrochloride and the valerate is also green, while the fluorescence of the bisulfate is blue under these conditions and the fluorescence of the valerate dissolved in benzene is violet (1456).

As last examples of this section, several derivatives of benzofuran may be mentioned, because in this case the addition of nonfused benzene rings to a compound seems to enhance its fluorescence and shifts the emission spectrum toward greater wavelength regions. Benzofuran itself is not fluorescent in the visible region, but when two of its hydrogen atoms in the 1, 3-position are substituted by benzene rings, the compounds exhibit a strong greenish fluorescence in the crystalline state as well as in benzene solutions. The fluorescence is still further displaced toward the red end of the spectrum if the substituents are biphenyl groups instead of benzene rings forming so-called dixenyl-benzofurans. On the other hand, the introduction of methyl groups in the 5, 6-positions has practically no influence on the fluorescence

TABLE 82
FLUORESCENCE BANDS OF BENZOFURANS
(Peaks of bands in Å)

Group	Benzofuran		Dihydrobenzofuran			
	Solution	Crystal	Solution			Crystal
1,3-diphenyl ..	4860	yellow-green	3840	4050		blue
1,3-diphenyl- 5,6-dimethyl	4860	—	3840	4080	4590	blue-green
1,3-dixenyl ..	5250	—	4290	4845	4965	yellow-green
1,3-dixenyl- 5,6-dimethyl	5250	orange-yellow	4290	4915	5025	yellow-green

spectra. The behavior of the dihydrobenzofurans is similar, the emission bands being displaced somewhat toward the violet and showing some structure (3).

C. Dyes

132. Synthetic Dyes. For a long time it was generally assumed that fluorescence is a property especially characteristic of dye solutions, and it has been suggested that this is due to the small probability of photochemical processes induced by the absorption of visible light. From the theoretical viewpoint, however, it is certain that the absence of fluorescence in condensed systems is caused, frequently, by internal conversion and only occasionally by photochemical reactions; and the experimental facts are far from agreeing with the assumption made above that fluorescence is more frequent

among dyes than among other organic compounds. Of more than 1,450 dyes of the color index, less than 100 are listed as fluorescent in liquid solutions. A superficial survey suffices to show that the intensity and hue of color is related in no way to the ability to fluoresce. On the other hand, it is obvious that the most strongly fluorescent dyes all belong to a few restricted classes, of which those derived from the xanthene group (fluorescein, rhodamine), from the acridine group (trypaflavine, euchrysrine), and from the azine group (safranin, magdala red) are the most important,* while there is not a single instance of fluorescence in liquid solutions to be found among the nearly 700 azo dyes. The latter consist of a number of phenyl rings which are linked to each other by $-N=N-$ groups; in the former, two benzene rings are fused to a central heterocyclic ring (namely, a pyridine, a pyrone or an azine ring).

Even more instructive is a comparison between dyes of the acridine or xanthene class with diphenyl- or triphenylmethane dyes. Thus, the formulas for rhodamine and malachite green differ mainly by the absence of the central oxygen atom in the latter and by the ensuing fact that the two benzene rings are no longer connected through a closed ring but through an open carbon bridge.

A similar example is provided by fluorescein and phenolphthalein. Fluorescein itself is almost insoluble in water; in alcoholic solution it is weakly colored and very slightly fluorescent. On addition of an alkali to the solution, the alkali salt is formed, which dissolves easily in water and which exhibits the well-known yellow-green fluorescence characteristic of the negative fluorescein ion. The water-soluble commercial dye "uranin" is disodium fluorescein. The blue-green fluorescence which is observed in acidified solutions and originates from positive fluorescein ions has already been mentioned in Section 116. Either of these ions has two resonance structures of identical energy:

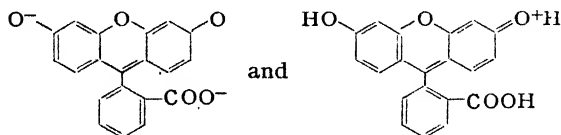

with the electric charge on one or the other of the two symmetrical

* Other fluorescent dyes of a similar structure are those derived from the oxazine group (fluorescent blue) and from the thiazine group (thionine, methylene blue).

O-atoms, and both have about the same yellow color in transmitted light. If in an alcoholic solution of uranin the solvent is replaced stepwise by ether, the color and the fluorescence disappear completely due to the fact that the dye goes over to the lactoid modification. The molecule corresponding to the formula:

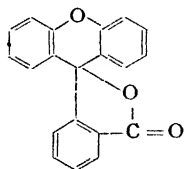

has no resonance structure of equal energy apart from the various Kekulé forms of the benzene rings.

Phenolphthalein differs from fluorescein in the same way as malachite green differs from rhodamine. It is colorless in neutral and deep red in alkaline solutions, but is equally nonfluorescent in all liquid solutions.* However, when the alkaline solution is solidified by the addition of gelatin, it exhibits a vivid orange fluorescence.

If the solvent is liquid at room temperature, fluorescence of diphenyl- and triphenylmethane dyes appears at the temperature at which the liquid is transformed into a rigid glass. The fluorescence of crystal violet becomes visible in ethanol at -158°C , in glycerol at -60°C , and in supercooled glucose at room temperature.

Other examples of diphenyl- and triphenylmethane dyes which are fluorescent only in rigid media are rosamine, auramine, methyl violet, and fuchsin (1454, 1548). The radical triphenylmethyl also belongs to this class; the fluorescence spectrum of the radical dissolved in a mixture of ether, pentane, and ethanol at -180°C is reproduced in Figure 100*b* (Section 102) (932). While the closed-ring structure protects the excited molecules of certain dyes against internal conversion, a similar protection is provided by the fixation of the excited molecules on a rigid support. Apparently those intramolecular vibrations which favor the occurrence of internal conversion are inhibited. When adsorbed on textile fibers many of the "nonfluorescent" azo dyes are also fluorescent. The anthrene dyes which have been mentioned as being fluorescent in xylene and tetralin solutions (Section 129) consist exclusively of fused benzene rings.

* Hydroquinonephthalein is an isomer of fluorescein. However, it does not form colored ions in alkaline solutions and is never fluorescent, probably always retaining its lactoid structure.

TABLE 83
 ABSORPTION AND FLUORESCENCE BANDS
 OF DYES IN AQUEOUS OR ALCOHOLIC SOLUTIONS

(Approximate limits of bands in A; peaks of bands in parentheses)

Compound	First absorption band	Fluorescence	
		band	color
Fluoran	u.v.	2900-4600 (3200)	violet strong
Fluorescein (Dihydroxyfluoran)	4400-5200 (4940)	5100-5900 (5180)	yellow-green very strong
Eosin (Tetrabromofluorescein)	4500-5600 (5170)	5200-6000 (5400)	yellow strong
Erythrosin (Tetraiodofluorescein)	4600-5560 (5165)	5180-5880 (5375)	yellow weak
Rose bengale (Tetraiodo-tetrachloro- fluorescein)	(5438)	5500-6700 (6000)	orange very weak
Rhodamine B extra ..	4800-6000 (5500)	5500-7000 (6050)	red strong
Rhodamine 6 G	4800-5900 (5260)	5360-6020 (5550)	yellow strong
Acridine red	4550-6000	5600-6800	orange medium
Pyronine B	5400-5900	5600-6500	orange medium
Acridine	3000-4500	4000-4800	blue-violet medium
Acridine yellow	u.v.-5200	4750-6400	green
Euchrysine	u.v.-5400	5050-6700 (5850)	greenish- yellow, medium
Rheonine A	u.v.-5100	4700-6500	green weak
Acriflavine (Trypaflavine)	u.v.-5000	4850-6600	yellowish- green, strong
Magdala red	4000-6000 (5240)	5500-7000 (6000)	red strong
Safranine	(5390)		yellow-red
Thionine	4800-6300 (5800)		orange medium
Methylene blue	5500-7000 (6580)	6500-7000	red medium

It has been pointed out in Section 115 that cyanine dyes in aqueous solution are fluorescent only when they polymerize at high concentrations. Quinoline red has nearly the same structure as isocyanine, but with a carbon atom linking the nitrogen atoms of the two pyridine rings and thus forming a central ring; this dye exhibits a strong orange-red fluorescence in alcoholic solution (732).

There are, however, polymethine dyes which are closely related to the cyanine dyes and which have been mentioned in Section 102 as being fluorescent in liquid solutions, although they consist of two thiazole rings which are connected by an open vinyl chain. The fluorescence of other polyenes will be treated in Section 134. Several thiazole dyes, such as primuline, in which benzothiazole systems are linked in a chain by single bonds, are among the most brilliantly fluorescent dyes, when they are dissolved in acetone. On the other hand, rhodamines which contain a phenyl ring in a side chain are not fluorescent, according to a remark in Feigl's *Spot Tests*.

Table 83 lists a few typical examples of the fluorescence and absorption bands of dyes in aqueous solution. In most cases the bands are not quite continuous but show a more or less pronounced structure, as can be seen in Table 88 (Section 137).

133. Natural Dyes. A number of natural dyes are of special interest, not only because of their importance for biological processes, but also because of their optical properties. Their absorption and fluorescence spectra consist of sequences of relatively narrow bands and their first absorption bands coincide very nearly with the first fluorescence bands: these reversible bands correspond, apparently, to $0''-0'$ transitions. They are always located in the region of long wavelengths and the following emission bands frequently reach up to the infrared. Most of the dyes under consideration are derivatives of porphine in which four pyrrole rings are linked by carbons to form a large ring.

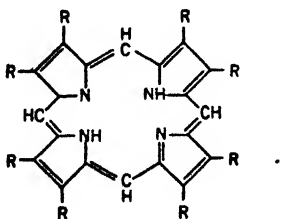

Porphyrins (etio-, hemato-, copro-, deuteroporphyrin, etc.) are porphines in which the hydrogen atoms of the pyrrole rings are

substituted by various aliphatic groups (CH₃, COOH, C₃H₇, etc.); for instance, etioporphyrin is tetramethyltetraethylporphine. The spectrum of porphine itself already shows the principal features of the porphyrin spectra; all porphyrins have very similar spectra (Figure 139), those of stereo-isomers being practically indistinguishable. The influence of the nature of the solvent on the appearance of the spectra is also relatively unimportant as long as the pH is not greatly altered. In neutral and alkaline solutions, on the one hand, and in acidified



Fig. 139. Absorption and fluorescence bands of coproporphyrin dissolved in pyridine with increasing times of exposure (Dhéré).

solution, on the other, essentially different types of spectra prevail. The second type apparently belongs to a positive ion. Even the color of the fluorescence is different in the two cases: it is red in the neutral and yellow in the acid solutions. The luminescence can be observed at concentrations of $5 \cdot 10^{-8}$ molar (C,298,585).

Table 84 lists the first absorption band and the strongest fluorescence bands only. With greater resolving power of the spectrograph and longer times of exposure, a number of weaker maxima reaching

TABLE 84
ABSORPTION AND FLUORESCENCE BANDS OF PORPHYRINS IN SOLUTION
(Peak of bands in Å)

Compound	Solvent	First absorption band	Fluorescence bands
Porphine ..	Dioxane	6130	(5910) 6165 (6444) 6570 6695 6840
Etioporphyrin.	Pyridine	6180	6205 (6370) 6505 6725 6885
Hemato- porphyrin ..	Pyridine		647 6540 6730 6910
Etioporphyrin.	HCl 2N	5895	5935 6160 (6320) 6510
Copro- porphyrin ..	HCl 2N		5950 6180 (6370) 6520

farther towards shorter and greater wavelengths can be obtained. Thus, Dhéré observed fifteen narrow bands between 5400 and 7700A in the fluorescence spectrum of etioporphyrin dissolved in pyridine, and he also found a few weak emission bands in the far red (6850, 7280, and 7930A) in the spectrum of acidified solutions (4,130,289,291, 298,391,392,585,588,596,863,1569).

It has been suggested that the whole series of absorption and emission bands can be represented by the superposition of six independent vibrational frequencies on a single electronic transition. Since most of the hypothetical vibrational frequencies occur only once in every spectrum, this interpretation is not quite certain.

As in the case of most dye solutions the emission spectra are independent of the wavelength of the exciting light; the most effective excitation is produced by irradiation with light of wavelengths corresponding to an absorption band of great intensity in the near u.v., with its peak near 4000A.

Porphyrins are able to form complex salts with numerous metals. The complexes containing sodium, potassium, magnesium, cadmium, zinc, or lead are fluorescent in neutral solutions, their spectra being displaced somewhat toward shorter wavelengths and showing less structure than those of the porphyrins themselves. The zinc salt of hematoporphyrin has its main emission band at 5785A and a secondary maximum at 6280A; the orange-colored fluorescence of the sodium complex of etioporphyrin has two diffuse maxima at 5970 and 6470A, and the only fluorescence band of the magnesium complex of dimethylmesoporphyrin lies at 5800A. Salts in which silver, copper, or the metals of the iron group are incorporated in a porphyrin are not fluorescent. One of these is the red-blood dye, hematin: it is the iron-complex salt of hematoporphyrin (53,299,584).

Porphins in which the double bond between the β -carbons in one of the pyrrole rings is reduced frequently are called chlorins. A strong red fluorescence has been mentioned as being characteristic of the zinc complex of tetraphenylchlorin dissolved in benzene. The copper complex of the same compound is not fluorescent. In contradiction to the general rule that the heavy metal complex salts of dyes of this type cannot be excited to fluorescence, Albers and Knorr observed the emission of a fluorescence band with peak at 6550A by solutions in anhydrous benzene of the Ag, Ni, and FeCl complexes of tetraphenylporphin under an atmosphere of N_2 and of similar fluorescence bands by solutions of Ag- and Ni-complex salts of tetra-(3'4'-methylenedihydroxyphenyl)porphin. However, whereas the zinc

complex exhibited a relatively strong fluorescence with a characteristic spectrum of its own, the fluorescence of the heavy metal complexes was very weak and the spectra were not clearly distinguishable from the spectra of the metal-free mother compounds, so that a slight admixture of the latter may have caused the fluorescence. If this interpretation is not admissible, and if the absence of traces of oxygen is an essential condition for the appearance of the fluorescence, one would have to assume that the fluorescence of the heavy metal complexes is exceedingly sensitive to the quenching action of oxygen and that this fact had escaped other investigators (6,197*a*,*b*,789*a*,1568).

Several natural dyes occurring in plants or in animal organs, such as bonnelline, phylloerythrine, phycoerythrine, and phycocyanine, are structurally related to the porphyrins and have similar fluorescence spectra (286-288, 296). By far the most important of these, however, is chlorophyll. It is the magnesium-complex salt of a porphyrin in which one side chain is a group $\text{CH}_2\text{-CH}_2\text{-COO}^-$, ending in the phytol chain $\text{C}_{20}\text{H}_{39}$. Moreover, a fifth ring is formed by a $\text{-CH}_2\text{-CO-}$ bridge which connects a carbon atom of one of the pyrrole rings with the adjacent single carbon atom (replacing an R and an H in the porphine formula). Apparently due to this latter substitution, the absorption and fluorescence bands are displaced by almost 1000Å in the direction of greater wavelengths and the color of the dye is converted from red to green. Chlorophyll exists in two modifications, chlorophyll *a* and *b*, which occur simultaneously in almost all green plants and are difficult to separate; the best method for the isolation of chlorophyll *b* is selective adsorption. The two modifications differ only by the fact that a CH_3 -group of chlorophyll *a* is replaced by a CHO -group in chlorophyll *b*; their spectra are also very similar, as shown in Table 85. In living plants the bands become somewhat more diffuse, which is

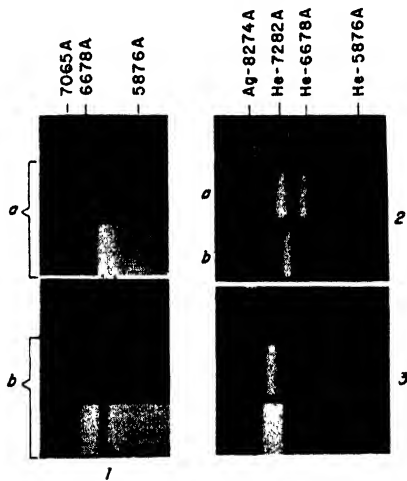

Fig. 140. Absorption and fluorescence bands of chlorophyll (Dhéré).

1: the reversible band 6678A of chlorophyll *a* and *b*. 2: the complete fluorescence spectrum of chlorophyll *a* and *b*. 3: fluorescence of a leaf with two times of exposure.

TABLE 85
 FLUORESCENCE AND ABSORPTION BANDS OF CHLOROPHYLL
 IN ETHER SOLUTION
 (Band peaks in Å)

	First absorption band	Fluorescence bands		
Chlorophyll <i>a</i>	6605	6635	7360	8010
Chlorophyll <i>b</i>	6415	6462	7130	7890
Living plants		6850	7400	8120

caused, at least, in part, by the superposition of the spectra of chlorophyll *a* and *b* (Figure 140) (5,284,291,295).

Chlorophyll and the porphyrins are not fluorescent as colloidal suspensions in water. They are strongly fluorescent, however, when adsorbed on gels, such as gelatin, protein, starch, etc., or on other solid adsorbents. Thus, the red fluorescence of eggshells is caused by adsorbed protoporphyrin: the fluorescence spectrum is identical with that of protoporphyrin adsorbed on filter paper. The fluorescence of pure crystalline porphyrins is at least doubtful. On the other hand, the bile dyes urobilin and bilirubin show an appreciable red fluorescence in the crystalline state, while their ability to fluoresce in alcoholic solutions has been questioned. A very intensive green fluorescence can be excited, however, in alcoholic solutions of the zinc-complex salts of these dyes. The emission spectrum of the urobilin-zinc salt consists of a strong band at 5200Å, determining the color of the fluorescence, and three weaker bands extending to 6400Å. The mercury-complex salts of the dyes show a behavior similar to that of the zinc salts (297).

The fluorescence of several natural dyes of another type is interesting rather because of their usefulness for quantitative fluorescence analysis than for theoretical reasons. Vitamin B₂ or riboflavin in aqueous solution is characterized by a bright yellow-green fluorescence (5000–6000Å, peak at 5620Å). Vitamin B₁ itself is not fluorescent, but can be oxidized into thiochrome, which emits a strong blue fluorescence. Riboflavin and thiochrome belong to the class of dyes which consist of three fused closed rings, while in the colorless and nonfluorescent vitamin B₁, two rings are connected by an open bridge. Vitamin A can be regarded as obtained by splitting β-carotene in two halves. The bluish fluorescence of the vitamin as well as of carotene dissolved in fatty solvents is not very strong; nevertheless, it has been used for vitamin analysis. Most of these dyes are not light-fast: the

fluorescence of vitamin A and of the carotenes fades rapidly under the action of the exciting light. By continuous illumination, riboflavin, which is derived from alloxazine (dimethyltetrahydroxypentyl-alloxazine), is converted into lumiflavine (trimethylisoalloxazine) or lumichrome (dimethylalloxazine) and, simultaneously, the yellow-green color of the fluorescence changes into sky blue (719-722,724, 843,844,848,1522).

Although the fluorescence of other vitamins, of hormones, and of ferments has been described, the results obtained so far are not of a nature to be used either for theoretical discussion or for practical application. The same is true with respect to the fluorescence of many plant extracts, and, to an even higher degree, to the fluorescence of almost every part of animal bodies: skin, tissues, fats, teeth, etc. Only in relatively rare instances can this fluorescence be explained by the presence of one of the dyes mentioned in this section; in other cases, it may be due to some unknown compound dissolved in the substance or it may also be an intrinsic property of the substance itself.

According to Tiede, the fluorescence of teeth is due to their content of collagen. If tricalcium phosphate is activated with collagen and heated to 300° C, it is converted into an "organophosphor" which, under black-light illumination, shows the same brilliant white fluorescence as natural teeth; the spectrum of the luminescence extends from the violet to the red with an intensity maximum between 4600 and 5600A. A similar luminescence is produced by other organic compounds dissolved in calcium phosphate (498,1667).

D. Polyenes. Aliphatic Compounds

134. Aromatic and Aliphatic Polyenes. The fluorescence of stilbene has been mentioned in Section 125. It is obvious that the two benzene rings play an important part in determining the optical properties of this compound. However, in diphenylpolyenes of the type $C_6H_5-(CH=CH)_n-C_6H_5$, of which stilbene is the first (with $n = 1$), the absorption spectrum is, in principle, a function of the length of the vinylene chain; with increasing number of the double bonds in this chain the first absorption band is shifted in the direction of greater wavelengths, while the *shape* of the absorption band remains practically unaltered. The influence of the phenyl rings becomes relatively small under these conditions: the purely aliphatic polyene dodecapentaenoic acid, with five (CH = CH) groups, has very nearly the same absorption spectrum

as diphenylhexatriene, the three ethylene groups of which are inserted between two benzene rings. The two compounds have, also, similar fluorescence spectra, although the intensity of the fluorescence of the diphenylpolyene seems to be greater. Lycopene, the simplest carotenoid, is an isomer of carotene ($C_{40}H_{56}$), but without the typical ionone rings terminating the long chain of conjugated double bonds; the frequency differences occurring in its fluorescence spectrum are nearly the same as those in the spectra of the diphenylpolyenes. The orange-colored photoluminescence of another purely aliphatic polyene, decapentene-10-dicarboxylic acid dimethyl ester, in the crystalline state is weak, but dilute solutions of this compound exhibit a brilliant greenish fluorescence (587,845,927*a*).

While the merocyanine dyes are fluorescent in liquid solutions (Section 102), the isocyanine dyes, which are polyenes of a very similar structure, are not fluorescent when they are dissolved in alcohol, in pyridine, or in water at low concentration (compare Section 115). The fluorescent and the nonfluorescent polyenes differ by two qualities which are not unrelated. The number of carbon atoms in the vinylene chains is even in the first, and odd in the second class; the first class consists of neutral molecules, while the molecules of the second class are salts dissociating into ions in solution. They are represented by formulas of the type $A-(CH=CH)_n-A'$ and $B^+ = CH-(CH=CH)_n-B'$, respectively: the second type has two extreme resonance structures of equal energy for $B = B'$ and of nearly equal energy for $B \neq B'$, while in the molecules of the first class a similar resonance structure can be effectuated only by the separation of electric charges, requiring considerable energy. It is not possible to construe any connection between these characteristic properties of the two kinds of polyenes and the probability of internal conversion by which the fluorescence is suppressed.

The fluorescence spectra of the aliphatic and the diphenyl polyenes dissolved in xylene consist of a broad band with three to five rather diffuse maxima; the luminescence spectra of the solid crystalline compounds are similar, but displaced towards greater wavelengths (Table 86). The maxima in the spectra of all compounds in the solid state and in solution are equidistant, with nearly the same constant spacing $\Delta\nu = 1430 \text{ cm}^{-1}$. While the wavelengths of the emission bands increase with increasing length of the vinylene chain, the fluorescence yield becomes smaller; no fluorescence is obtained in alcoholic solutions for $n > 7$ and in the solid crystals for $n > 4$ (587).

At the temperature of liquid air, the individual maxima become

TABLE 86
 FLUORESCENCE OF DIPHENYLPOLYENES

n	1	2	3	4	5	6	7	D*
Color of crystal	white	yellow-white	yellow-green	yellow	orange	brown-red	copper	—
Fluorescence of crystal	blue-violet	sky blue	yellow-green	orange (weak)	—	—	—	—
Fluorescence in alcohol	violet	blue-violet	sky blue	yellow-green	yellow	orange	red	green
λ	{ 3300- 4300	{ 3600- 4800	{ 5000- 7000	very weak				{ 4300- 6700
ν_0	29730	27250	24900	22135	19870			

* D is dodecapentaenoic acid.

sharper and some of them split into several components. According to Hausser and Kuhn, all spectra observed at low temperature can be represented by the equation:

$$\nu = \nu_0 - 1550\nu_1'' - 1160\nu_2'' \quad (82)$$

with $\nu_1'' = 0, 1, 2, 3, 4$ and $\nu_2'' = 0, 1, 2$, while ν_0 has different values for each compound, as shown in the last row of Table 86. The frequency 1550 cm^{-1} is supposed to correspond to the Raman frequency of the C = C-bond at 1600 cm^{-1} , while no known oscillation could be identified with the second frequency 1160 cm^{-1} . If this representation is correct, the spacing observed at room temperature, equal to 1430 cm^{-1} , would only be fortuitous and would be caused by the superposition of the two other oscillations.

The structure of the absorption bands of the diphenylpolyenes is analogous to that of the emission bands with the same spacings, so that the characteristic intramolecular oscillations must have practically the same frequencies in the electronic ground state and the excited state. Absorption and emission bands overlap, however, only in the case of stilbene (see Figure 134A and B, Section 125); in the other spectra the gap between the two systems increases from 1000 cm^{-1} for diphenylbutadiene ($n = 2$) to 4700 cm^{-1} for dodecahexaene ($n = 6$) (Figure 141). Thus, the first sub-bands in the absorption and the emission spectra cannot correspond to a $0'' \leftrightarrow 0'$ transition, as is assumed in Hausser's and Kuhn's equation. The apparent "mirror symmetry" in the two band groups can be interpreted, nevertheless, by the hypothesis which has been developed in Section 102. However in this case the structure of the bands should be represented by the

superposition of different oscillations on the electronic frequency rather than by a "progression" involving several quantum states of one oscillation. This seems also to agree with Lewis' interpretation of the lycopene spectrum, which is closely related to the spectra of the polyenes (927a).

Furthermore, the wavelengths of the absorption bands depend on the nature of the solvents and on temperature to a much higher degree than the wavelengths of the fluorescence bands, which are relatively stable. The similar behavior of the merocyanine dyes has

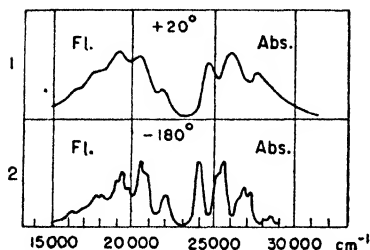

Fig. 141. Fluorescence and absorption bands of diphenyloctatetraene (Kuhn and Hausser).

1: 20° C. 2: -180° C.

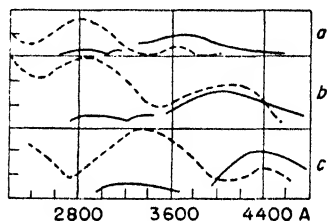

Fig. 142. Absorption and fluorescence spectra of aliphatic compounds dissolved in ethanol (Gelbke). Broken lines: absorption; continuous lines: emission.

a: acetone. *b*: biacetyl.
c: ethylene-cyanide-monoal-ethyl ester.

already been described in Section 115 and has been explained there by assuming that the excited state is more sensitive to disturbances caused by the molecules of the solvent than the ground state.

135. Various Aliphatic Compounds. Although the example of dodecapentaenoic acid and similar polyenes, such as isomethyl bixin, prove by their characteristic polyene spectra that purely aliphatic compounds can be fluorescent in a condensed state, there are relatively few cases in which such fluorescence has been ascertained to belong to the compound under consideration and not to some impurity. Gelbke lists thirty-four aliphatic ketones, among them cyclohexanone and some other ring systems, as being fluorescent in alcoholic solutions. The fluorescence bands are situated in the blue-violet and the green without any obvious connection between the wavelength of the emission band and the constitution of the compound. Gelbke's data may be treated, however, with some caution: the exact coincidence of

the absorption and fluorescence bands which he found, and of which three examples are reproduced in Figure 142, was in agreement with a theory proffered by J. Stark at the time when the experiments were performed, but seems at present to be very improbable. The fluorescence of biacetyl, which has its intensity maximum in the extreme violet in Figure 142, is blue-green like that of the vapor, according to more recent observations. In a freshly prepared aqueous solution of biacetyl the fluorescence is very weak and its intensity increases with time, because the oxygen content of the solution is used up by a photochemical reaction, exactly as in biacetyl vapor (Section 87). On the other hand, the fluorescence band of acetone indicated in Gelbke's diagram might correspond to the violet fluorescence which has been ascribed to acetone in the vapor state (476,706).

If pure acetone or acetone in alcoholic solution is solidified at -193°C , its blue fluorescence band between 4000 and 5000A (with peak at 4556A) shows no structure; similar fluorescence bands with peaks at 4675 and 4707A, respectively, are obtained under the same conditions with methyl ketone and diethyl ketone. In all three cases the luminescence exhibits an afterglow of the order of 10^{-3} sec, and the emission spectrum is separated from the excitation spectrum by a wide gap. Therefore, the luminescence must be ascribed to processes similar to the process occurring in biacetyl (see Section 87): a non-radiating transition from the directly excited state to a metastable state and a radiating forbidden transition from the latter to the ground state (724b).

In dioxane a strong visible fluorescence is produced by irradiation with light of wavelengths below 3000A. The continuous emission band reaches from the region of the exciting radiation to the red, if the temperature is 12°C ; at 20°C it becomes shorter at both ends and shows two maxima at 4500 and 5800A; and at 50°C the red part of the fluorescence disappears, only a relatively narrow band between 4000 and 5000A remaining visible. A similar dependence on temperature has been observed with respect to a blue-violet fluorescence which is excited in cyclohexane by the u.v. radiation from a quartz-mercury lamp; but while the fluorescence and absorption of dioxane remain constant over a long period of irradiation, the fluorescence of cyclohexane does not appear at all if the content of the observation chamber is continuously renewed, so that no products of photochemical reactions can accumulate in the liquid. Furthermore, the fluorescence is also excited by near-u.v. light if the liquid has been irradiated previously for some time with short-wavelength u.v. Obviously this

fluorescence is not emitted by the molecules of cyclohexane itself but by the molecules of a compound produced by the photodecomposition of cyclohexane. Another fluorescence band stretching from 2650 to 3340A, which is excited by light of wavelengths below 2600A and apparently is characteristic of cyclohexane itself, does not show this behavior: its intensity remains constant through a protracted period of irradiation, but the liquid is slowly photolyzed by the u.v. light and, after some time, a solid deposit is precipitated (559,641a, 1047,1187).

Thus, the fluorescence of an organic condensed system may not only be due to traces of an unknown impurity, but a fluorescent impurity can be produced by the exciting light itself in a pure medium with no visible fluorescence of its own. Vavilov and Tummermann observed a weak blue-violet fluorescence in practically every organic liquid, such as methanol, ethanol, glycerol, ether, and carbon tetrachloride, when they were illuminated with "black light." This fluorescence is quenched by heating the liquid to about 50° C, but reappears after cooling; it is weakened by repeated distillation in vacuo, but the authors in no instance succeeded in suppressing it completely. They ascribe it to an impurity which must be present in all liquids, possibly oxygen or carbon dioxide. Since the absorption coefficient of most of the compounds under consideration is exceedingly small in the near u.v., the production of a fluorescent impurity by the primary light is very improbable in these liquids (199,200,1768).

According to Terenin, the bluish fluorescence of many hydrocarbons that were exposed for long periods of time to atmospheric air is due to products of autooxidation, a small fraction of the molecules being converted into aldehydes, ketones, etc. Thus, carefully purified, freshly prepared ethanol, as well as solid paraffin, does not show any visible fluorescence under u.v. excitation. The appearance of the blue fluorescence and of corresponding u.v. absorption bands is supposed, to be due to the formation of carbonyl groups (1640b).

E. Afterglow of Organic Compounds in Solid Solutions

136. Phosphorescence and Slow Fluorescence. It has been stated in previous sections that when organic compounds are dissolved in solid solvents or adsorbed on gels, the same bands which appear in the fluorescence spectrum are emitted as phosphorescence after the end of the excitation (1835).* However, other bands of greater wavelength

* Concerning the weak phosphorescence of some dyes in liquid solutions compare Section 98.

which have no, or very small, intensity in the fluorescence spectrum frequently prevail in the afterglow (Section 98). The appearance of such new bands has been observed under a great variety of conditions: in alcoholic solutions of benzene derivatives at low temperature (Kowalski's "progressive phosphorescence"), in solid solutions of the same compounds in boric acid at room temperature (Tiede's "boric acid phosphors"), in dyes dissolved in solids and adsorbed on gels at low temperatures, etc.

A theoretical explanation of the coexistence of the two phenomena has been given by Jablonski in complete analogy to the energy-level scheme of the mercury atom mentioned in Section 98. Light absorption in the band NF is followed either immediately by emission of the fluorescence band FN (F -band) or by a transition into the quasi-stable state M with an energy lower than that of F . From here the molecule can return to F after a time dependent on the available heat energy and subsequently emit the F -band as phosphorescence, or it can return directly to the ground state by the very improbable transition MN , which is practically independent of temperature, and emit the slow fluorescence band (the M -band) (667).

As a matter of fact, the two types of afterglow show the distinguishing properties which characterize phosphorescence, on the one hand, and slow fluorescence, on the other, according to the definition given in Section 98.

Both processes are excited by light of the same wavelength which is absorbed in the same absorption bands. However, since the wavelength and the polarization of the *phosphorescence* are the same as that of the normal fluorescence, both correspond to the same electronic transition $F \rightarrow N$ and they both originate from the electronic level that is reached in the excitation process. The band of slow fluorescence has a greater wavelength and in general is unpolarized or negatively polarized; therefore, it must correspond to a different electronic transition, and if it is assumed that the final state is also the ground state in this case, it originates from a level M with an energy below that of F (209, 210, 1298).

The intensity of the F -band is strong during excitation, drops abruptly at the end of the excitation to a lower level, and then decays steadily from there on, following an exponential law. The intensity of the M -band is relatively very weak during the excitation and does not decrease appreciably at the beginning of the afterglow, which exhibits, also, an exponential decay.

The lifetime of the F -phosphorescence is greatly dependent on

temperature and increases uniformly when the temperature is lowered. Simultaneously, its intensity becomes smaller and below a certain temperature it is not observed at all. The lifetime of the *M*-band is very little influenced by the temperature: for tryptaflavine adsorbed on silica gel, the mean lifetime τ was found to be constant (= 1.2 sec) between -27 and -190°C ; Tomaschek obtained only very small changes in lifetime and intensity of the afterglow of boric acid phosphors between $+20$ and -185°C , and similar results are reported by G. N. Lewis with respect to the *M*-band of fluorescein in boric acid, even down to the temperature of boiling hydrogen; Travnicek, who says that the afterglow of his "aluminum sulfate phosphors" (see Section 137) lasted about twice as long when they were immersed in liquid air, observed at the same time a strong increase in intensity. It must be kept in mind that the connection between the duration of an afterglow and the temperature is unequivocal only if no other competing process is to be considered. If the efficiency of such a competing process (for instance, internal conversion) becomes smaller at lower temperatures, an observed increase of τ is no proof of a change in the probability of the corresponding electronic transition. At temperatures above 25°C , the intensity and duration of the phosphorescence and of the slow fluorescence of most compounds decrease rapidly; this is obviously due to the action of quenching processes, which also impair the normal fluorescence under these conditions (930, 1302, 1691, 1705).

If the luminescence of fluorescein dissolved in boric acid is excited at -180°C , only the orange-colored *M*-band appears in the afterglow. If the temperature is raised rapidly, the blue-green *F*-band is emitted in a short outburst; the intensity of this flash is greater, the sooner the process occurs after the end of the excitation. The analogous phenomenon has been observed with the yellow-green *F*-band of fluorescein in gelatin and with the green *F*-band of tryptaflavine adsorbed on silica gel in vacuo, but never with an *M*-band (1302, 1691).

Since any kind of afterglow is practically restricted to the solid state, solutions in solvents which are liquid at room temperature, such as alcohol and glycerol, are able to exhibit the phenomenon only at low temperatures, at which the normal phosphorescence, in general, is already "frozen in." Therefore, the appearance of the *M*-bands was at first supposed to be mainly an effect of temperature. It has been shown however that the slow fluorescence bands of certain compounds such as phenanthrene which could be obtained in alcohol only at temperatures below -158°C , where the liquid solidifies into a hard

glass,* were observed in undercooled glycerol at temperatures up to -60°C , in crystallized glycerol — which melts at $+10^{\circ}\text{C}$ — even above the freezing point of water, and in boric acid at room temperature (815).**

The laws forbidding the transition from M to N must impede also the radiationless transition from F to M , irrespective of the specific nature of these laws. On the other hand, the transition from F to M must occur with a much (at least several thousand times) higher probability than the transition from M to N , because under strong irradiation the population of M can exceed 80 % of the total number of the molecules which can be excited while the population of F is inappreciably small even under the strongest illumination. If the state M is quasi-stable, according to the Franck-Condon principle, because of the distortion of the intramolecular configuration, the transition from F to M can occur only between highly vibrating levels at which the nondistorted molecule and the distorted molecule attain equal configurations. The same holds if M is metastable because of an electronic selection rule such as the rule forbidding a singlet-triplet transition. Apart from the fact that the Franck-Condon principle must be obeyed also in this case, the energies of the two combining states must be exactly the same so that by interference their wave functions are mixed to a considerable degree (424,930).

The occurrence of internal conversion in the transition process from F to M follows (without the introduction of any theoretical assumption) from the large energy gap separating the two states which, in general, exceeds 0.5 eV. Either the excited molecule must pass from a relatively low vibrational level of state F directly into a level of much higher vibrational quantum number of state M ; or the entire electronic energy of state F is converted into vibrational energy of the ground state N , and when after partial energy dissipation a certain level is reached which corresponds exactly to a vibrational level of M , the molecule passes into the latter, thus reconverting a large part of the vibrational energy to electronic energy.

Linschitz has shown recently† that the ratio between the intensities of phosphorescence and fluorescence of dyes (fluorescein in boric acid) and hydrocarbons (α -naphthylamine in frozen alcohol-ether-isopentane) depends on the wavelength of the exciting light. The

* At this temperature the specific heat of alcohol undergoes a discontinuous change, thus proving a change in the structure of the substance.

** Pringsheim, *Hb. d. Phys.*, 231, 259 (1932) (1285a).

† Prepared for publication in *J. Chem. Phys.*

ratio decreases with increasing wavelength of the primary radiation and becomes appreciably smaller when the latter corresponds to the long wavelength tail of the first absorption band. This proves that the transition from higher vibrational levels of the state F to M has a greater probability than the transition from the vibrationless level of state F .

It is to be expected that in such processes an appreciable fraction of the molecules converts the vibrational energy completely to heat and therefore quenching by internal conversion competes with the excitation of phosphorescence, while, on the other hand, a certain amount of internal conversion *must* occur in order to provide the possibility of transitions from F to M . This may explain the fact that dyes with low fluorescence efficiency frequently exhibit a relatively strong phosphorescence and are the best photosensitizing compounds. In order to emit phosphorescence, the molecules must return from M to F by one of the two ways described above, and a renewed possibility of converting the entire energy to heat is provided if the molecule passes through the high vibrational levels of N in this process.

Since the lifetime of the slow fluorescence is independent of temperature, the transition from M to N requires no heat of activation. This is the fundamental characteristic of slow fluorescence in contradistinction to phosphorescence. If M is quasi-stable because its nuclear configuration is impossible in the electronic ground state of the molecule, the molecule in state M must be able occasionally to attain a configuration from which a transition to the ground state is allowed, and to do this without intake of energy even at the lowest temperatures. Because of the existence of zero-point energy, the location of the individual atoms in a molecule is not sharply defined even at 0° K; the nuclei fluctuate around their positions of equilibrium, performing a slow Lissajous motion and it may take a long time before a certain favorable configuration is reached. It seems plausible that the configurational fluctuations are practically independent of temperature, because most vibrational frequencies are at their zero level at temperatures below room temperature. This is true especially for the vibrations of relatively high frequencies which are characteristic of CH-bonds and of double bonds.

Probability of a radiating transition which is "forbidden" by an electronic selection rule is (to first approximation) always independent of temperature. According to G. N. Lewis, all molecules with double bonds in their normal configuration have excited states in which

one of the double bonds is broken and which, therefore, are biradicals with one pair of electrons having parallel spins. While the ground state of such a molecule is a singlet state, the excited state is a triplet state. The *M*-states are supposed to be such triplet states and the selection rule forbidding intercombination transitions is assumed to be the cause of their metastability. While the law of conservation of spin momentum is one of the few electronic selection rules which do not break down under the action of strong external fields and hold, therefore, even in condensed media, it is highly improbable that under such conditions this law can provide lifetimes of seconds. It is not impossible, however, that another cause impeding the transition from *M* to *N* may be superimposed on the intercombination principle and this may again be the Franck-Condon principle or, in special cases, a second electronic selection rule. [For instance, in highly symmetrical molecules, such as benzene, certain transitions are "forbidden" because without the simultaneous excitation of an antisymmetrical vibration the electronic transition would not produce a change in the electric moment of the molecule (927a, 927b, 1509, 1545)].

Since all organic molecules containing a double bond should be able to form triplet states, Lewis and his school expect that phosphorescence and slow fluorescence should be observed under adequate conditions with all compounds of this class. This presupposes that in no case a competing process of higher probability suppresses the emission of light, an assumption which may not always be correct. However, the number of compounds in which slow fluorescence has actually been observed and which includes not only aromatic but also aliphatic compounds is very large indeed, as will be discussed in a later section.

Lewis supports his theory by numerous calculations showing that the probable energies of the quasi-stable states agree well with values which can be derived from various considerations concerning the energy differences between the singlet and triplet states of the compounds. In the case of fluorescein the fact that the state *M* is really a triplet state has been proved by a direct method. If fluorescein dissolved in boric acid is irradiated with blue light of great intensity so that a considerable part of the dye molecules is transferred in to the state *M* (compare Section 104), the material becomes paramagnetic; thus, the electrons must have acquired a spin momentum greater than zero and probably equal to 1, corresponding to a triplet state (925b).

Two methods have been used for the determination of the energy

difference between the states F and M . The results of the two methods do not always agree and this seems to show that in certain instances Jablonski's energy-level scheme is oversimplified.

The phosphorescence of tryptaflavine adsorbed on silica gel in vacuo ceases to be visible at temperatures below -70°C , while, on the other hand, the slow fluorescence has an appreciable intensity up to room temperature. The logarithm of the duration of the phosphorescence and the reciprocal of the absolute temperature are connected by a linear relation (Figure 143a) (1302).

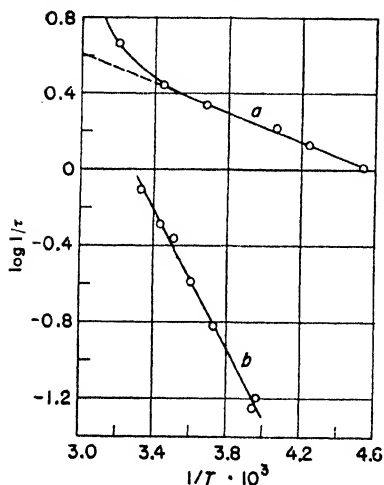

Fig. 143. Lifetime of phosphorescence of dyes as a function of temperature; (a) Pringsheim and Vogels; (b) Lewis, Lipkin and Magel.

a: tryptaflavine on silica gel.

b: fluorescein in boric acid.

phosphorescence and the reciprocal of the absolute temperature are connected by a linear relation (Figure 143a) (1302).

Lewis obtained analogous results with fluorescein dissolved in boric acid. In this case the slow fluorescence band was still relatively strong in the afterglow at room temperature, whereas the blue-green phosphorescence band already vanished slightly below -30°C . From the linear relation between $\log \tau$ and $1/T$ (Figure 143b), Lewis calculated the "heat of activation" corresponding to the transition $M \rightarrow F$ to be 8.2 kcal per mole = 0.36 eV. This was in satisfactory agreement with the energy derived, from the difference between the frequencies of the F - and M -bands, which amounted to 0.4 eV = 9.2 kcal per mole (930).*

However, if the heat of activation is calculated in the same way,

* Lewis uses a different nomenclature. Although he accepts Jablonski's theory as valid, he does not differentiate between phosphorescence and slow fluorescence, but designates either process as phosphorescence and characterizes them in a noncommittal way as α - and β -processes. Accordingly, Jablonski's FN - and MN -bands are called α - and β -bands. Whereas the preference for this terminology is, to a certain degree, a matter of taste, the definition of phosphorescence as a luminescence involving a triplet-singlet transition is inadmissible. On the one hand, the mercury resonance radiation is not a phosphorescence, and, on the other, the term "phosphorescence" had been applied to the luminescence of crystal phosphors long before the afterglow of solid dye solutions was discovered; it would be premature, at the least, to say that the trapped electron in a zinc sulfide phosphor can be identified with triplet states.

according to curve *a* in Figure 143 for the $M \rightarrow F$ transition in the tryptaflavine molecule, it is found to be only 1.7 kcal, far below the value given in Table 87, which lists the energy differences between the F - and M -states derived from the wavelengths of the F - and M -bands. This method of calculating the electronic energies of the two excited states is no more than a very rough approximation from which exact quantitative conclusions cannot be drawn. The Stokes displacement between the F -band and the first absorption band proves that, in general, the former does not correspond to a transition ending at the vibrationless level of the ground state and that this level may lie appreciably lower. The same probably is true even to a higher degree for the M -band, if the nuclear configuration of the quasi-stable state differs widely from that of the vibrationless ground state.

The frequency corresponding to the center of symmetry between the first absorption band and the F -band would provide a more accurate evaluation of the energy of the F -state. For the M -state the analogous data are not, in general, available. Absorption bands of dye solutions corresponding to the transition from the ground state to M were never observed and the same is true for most aromatic hydrocarbons; this must be expected for all compounds the M -states of which have lifetimes of the order of a second. Bands can appear (even with weak intensities) in the absorption spectra only if the corresponding transition probabilities are not too small; therefore, the lifetime of the excited state must be short and an afterglow can be observed only with a phosphoroscope of high resolving power.

Lewis and Kasha ascribed certain rather weak, long-wavelength bands in the absorption spectra of various nitroso compounds to NM -transitions which, in their terminology, are called singlet-triplet transitions. None of these compounds has been proved to be luminescent, with the single exception of diisopropylbromonitrosomethane, which emits a weak fluorescence with an intensity maximum at 7350A. But in this case and in the somewhat similar case of thiobenzophenone, it has not been shown experimentally that the luminescence exhibits an appreciable afterglow. The emission band of thiobenzophenone, with three peaks at 7250, 8000, and 9100A, has a structure very similar to that of the corresponding absorption band which reaches from 6670 to 5000A (927a).

In the absorption spectra of benzene and *p*-dichlorobenzene, exceedingly weak bands have been found in the spectral region above 3000A. In the benzene spectrum the first of these bands at 3400A coincides very nearly with the slow fluorescence band of shortest

wavelength listed in Table 89. The absorption bands between 3400 and 3100Å were ascribed by Sklar to a forbidden singlet-triplet transition; they are several million times weaker than the bands at 2600Å, which are also forbidden and are still a thousand times weaker than the allowed band at 1800Å (1509).

While these singlet-triplet absorption bands are superimposed on the tails of much stronger bands of shorter wavelengths and appear only as slight fluctuations on a steeply rising photometer curve, the singlet-triplet absorption bands and the singlet-singlet absorption bands (*NM*- and *NF*-bands, respectively) of biacetyl coincide exactly, according to Lewis' and Kasha's interpretation. In Figure 88*a* the shaded area is supposed to correspond to the *NM*-band and the area below the broken line to the *NF*-band. The broken line is drawn so that the shaded area represents a transition probability equivalent to a lifetime of 10^{-5} sec. Notwithstanding the fact that the luminescence is excited by light of wavelengths corresponding to the hypothetical *NM*-band, the excitation must be due, in the main, to absorption in the *NF*-band, since the luminescence yield far exceeds 1% of the total absorbed energy. The identity of the spectrum of the afterglow emitted by biacetyl in solid solution with that of the slow fluorescence of the vapor (Figure 88*b*) has already been pointed out (927*a*).

Not only is there some uncertainty in the derivation of the energy gap between *F* and *M* from the difference in the wavelengths of the *F*- and the *M*-bands, but the derivation of the corresponding "heat of activation" from the relation between $\log \tau$ and $1/T$ is also not quite unequivocal. It would be correct only if it were certain that the transition from *F* to *M* and *vice versa* occurs with greatest probability between the nonvibrating level ($v' = 0$) of *F* and a vibrational level v_1'' of *M* of the same energy. It is clear that, if the transition would occur *only* between a vibrating level v' of *F* and a higher vibrational v_2'' of *M*, the heat of activation obtained by the same method would correspond to the energy difference $F(v') - M(0'')$ and not to $F(0') - M(0'')$. Although these are not the conditions prevailing in real molecules, Linschitz's experiments prove that the transition probabilities have a distribution with its maximum not at $v' = 0$, but at some higher vibrational level v' . While the average probability of a transition from *F* to *M* may be essentially lower than that of the transition from *F* to *N*, the probability of the transition from a certain vibrational level of *F* to a certain vibrational level of *M* can be very much larger.

If processes of fluorescence, phosphorescence, and slow fluores-

cence occurring in a molecule are correctly represented by Jablonski, it can be shown that the ratio of fluorescence intensity to phosphorescence intensity or to the intensity of slow fluorescence depends only on the relative values of transition probabilities characteristic of the processes and is independent of the intensity of the primary radiation. This is true even if a part of the absorbed energy is dissipated in state *F* or in state *M* or in both by some quenching process. Levshin reached the same conclusion from assumptions concerning the mechanism of phosphorescence excitation which cannot be accepted as correct.

In the main, the data of Table 87, most of which are taken from earlier investigations agree relatively well with the heats of activation which are derived from the wavelengths of the normal and the slow fluorescence bands; the phosphorescence of the compounds with the largest "heat of activation" vanishes at the highest temperatures. (T_m in Table 87). Crystal violet has been investigated by Lewis and is mentioned by him as proving qualitatively the validity of his theoretical assumptions. It is, however, the only one which quantitatively does not agree so well. Notwithstanding a heat of activation of 6.2 kcal, the red *F*-band of crystal violet is still "bright" in the afterglow at -113°C and "nearly disappears" at the temperature of liquid air. It is true that its visibility may be favored by the fact that the corresponding *M*-band lies at the limit of the infrared; but the lifetime of the phosphorescence is also exceedingly short at low temperatures: at -95°C it is only 10^{-2} sec, compared with a lifetime of 0.5 sec of the tryptaflavine phosphorescence at 0°C . The small value of τ cannot be explained by a relatively great transition probability from *M* to the ground state producing an almost invisible *M*-band,

TABLE 87
"HEAT OF ACTIVATION" AND LOW-TEMPERATURE LIMIT OF THE
PHOSPHORESCENCE OF DYES

Compound	Heat of activation		T_m	Compound	Heat of activation		T_m
	eV	kcal			eV	kcal	
Naphthalene*	1.17	27	100°	Fluorescein*	0.4	9.2	-30°
Phenanthrene* ..	0.72	16.5	100°	Tryptaflavine†	0.25	5.75	-70°
Esculin† ..	0.5	11.5	25°	Crystal violet§ ..	0.27	6.2	-180°

* In boric acid. † In sugar. ‡ On silica gel. § In glycerol.

because this would not be compatible with the great intensity of the phosphorescence at -95°C .

If, in accordance with Jablonski's theory, the energy emitted by the *F*-phosphorescence and the *M*-fluorescence is stored in the same quasi-stable state *M*, the duration of both processes must be identical and their decay curves coincide. In the temperature range in which one of the two processes predominates, the transition probability of this process is the factor by which the lifetime, in the main, is determined. In an intermediate temperature range (for fluorescein in boric acid, for instance, at about 0°C), both transition probabilities should be of equal influence and no simple relation between the observed lifetime of the luminescence and the temperature can be expected.

It has been proved by quantitative measurements that the orange and the blue region of the afterglow of fluorescein in boric acid or in aluminum sulfate have the same exponential decay. Although these measurements were made only at room temperature, it is certain that the *M*-band contributed the major part of the energy to the emission spectrum in the orange region. This follows not only from the spectral intensity distribution in the afterglow, with a clear secondary maximum at the wavelength of the *M*-band, but still more convincingly from the degree of polarization, which drops from 15% in the blue to 5.5% in the red.* The decay curves of the afterglow of tryptaflavine adsorbed on silica gel are, however, purely logarithmic only at temperatures above 25°C and below -70°C , if the *F*- and the *M*-bands are not separated by colored filters. If, by the use of such filters, the decay curves of the bands are measured individually at intermediate temperatures, the lifetime of the green *F*-band increases between 0 and -52°C from 0.47 to 0.97 sec, while the lifetime of the orange *M*-fluorescence remains constant, with $\tau = 1.2$ sec. Furthermore, the orange afterglow is as strong in atmospheric air as in vacuo, whereas the green phosphorescence is extremely sensitive to the smallest traces of oxygen. Finally, considering the difference between the heats of activation which were derived by the two methods mentioned above, one can hardly doubt that, in the case of tryptaflavine, phosphorescence and slow fluorescence originate from two different quasi-stable states, *M* and *M'*. The same may be true for some other dyes. Wiedemann and Schmidt's observation that the afterglow of

* The polarization of the fluorescein fluorescence during the excitation, when the contribution from an *M*-band is not to be taken into account, is quite constant through the whole emission band.

several solid dye solutions changed its color during the period of emission cannot, however, be interpreted in this sense. According to Lewis, these color changes are all due to the fact that the luminescent substances were not pure. Besides, Wiedemann and Schmidt's experiments were performed at room temperature and most dyes do not exhibit their slow fluorescence with appreciable intensity under these conditions (930,931,1302,1835).

137. Spectra of Dyes in Solid Solutions. The luminescence spectra of various dyes in solid solutions are compiled in Table 88. The fluorescence spectra at room temperature* show, in general, several maxima; they originate, in part, from a contribution of the *M*-band to the total emission and, in part, from a vibrational structure of the fluorescence band itself, probably caused by transitions to several vibrational levels of the electronic ground state. The intensities given in the table are only relative and cannot serve for a comparison between the luminescence of two dyes or between fluorescence and phosphorescence (1298).

The fluorescence of the negative ions of fluorescein, which has such a high yield in liquid solutions, is very strong also in solid solutions, but they exhibit only little phosphorescence. The afterglow of fluorescein in neutral and alkaline sugar solution is weak; it is greatly enhanced if the solution is acidified by the addition of any organic or inorganic acid (70,71). Fluorescein is moreover an excellent activator for "organophosphors" with acids, such as boric acid and phosphoric acid, as base material (see Section 139). In all these instances the luminescence has the blue-green color characteristic of the positive fluorescein ion. The fluorescence yield of erythrosin is always poor. In Section 110 this was ascribed, at least in part, to the tendency of the excited molecules to pass into a quasi-stable state; as a matter of fact, the orange-yellow phosphorescence of erythrosin in gelatin is described by Wiedemann and Schmidt as one of the most brilliant among all the various dyes which they investigated (Figure 144) (1454,1835).

The bands from which the energy differences of Table 87 are derived are designated by *F* and *M*, respectively, in Table 88. In

* The fluorescence of crystal violet has not been investigated in a solvent which is solid at room temperature; the table, therefore, in this instance, lists the fluorescence at -95°C , which probably does not differ from that at room temperature. The fluorescence and phosphorescence of the closely related dye, malachite green, dissolved in gelatin was observed by Wiedemann and Schmidt at room temperature, but they mention only the color of the luminescence as being red.

some cases (for instance, in that of erythrosin), this selection may be doubtful. For a complete interpretation of all details a great number of special hypotheses would have to be introduced. Such details are the appearance of only one of the strong fluorescence bands of erythrosin in the phosphorescence spectrum at room temperature and the appearance of one of the strong fluorescence bands of rhoduline orange in the spectrum of the afterglow at -180°C . At room temperature

TABLE 88
LUMINESCENCE BANDS OF DYES IN SOLID SOLUTIONS
(S): in sugar; (B): in boric acid; wavelengths of band peaks in Å

Compound	Fluorescence		Afterglow	
	at $+20^{\circ}\text{C}$		at $+20^{\circ}\text{C}$	at -180°C
Uranin (S)	<i>F</i> 5270 strong 5700 weak <i>M</i> 6400 very weak	5270 strong ? ?	5270 strong ? ?	5270 very weak 5700 weak ?
Fluorescein (B)	<i>F</i> 4800 strong 5300 weak <i>M</i> 5750 weak	4800 strong 5300 weak 5750 weak	4800 strong 5300 weak 5750 weak	? ? 5750* strong
Eosin (S)	<i>F</i> 5780 strong <i>M</i> 6500 ?	5780 strong 6500 strong	5780 strong 6500 strong	— 6500 strong
Erythrosin (S)	5040 weak 5400 strong <i>F</i> 5800 strong <i>M</i> 6700 weak	— — 5800 strong 6700 weak	— — 5800 strong 6700 weak	— — — 6700 very strong
Rhoduline orange (S)	<i>F</i> 5360 very strong 5800 very strong <i>M</i> 6400 weak 7200 weak	5360 strong 5800 strong 6400 very weak 7200 very weak	5360 strong 5800 strong 6400 very weak 7200 very weak	— 5900 strong 6500 strong ?
Esculin (S)	<i>F</i> 4430 very strong 4900 strong <i>M</i> 5400 weak 6000 very weak	— 4900 weak 5400 strong 6000 weak	— 4900 weak 5400 strong 6000 weak	— 4900 weak 5400 strong 6000 strong
Crystal violet	<i>F</i> 6370 strong* <i>M</i> —	6370 medium* 7400 strong	6370 medium* 7400 strong	7400 (4700) strong
Malachite green	<i>F</i> 6720 strong† <i>M</i> —	infrared	infrared	infrared (4675 strong) (5000 medium) (5375 weak)

* In glycerol at -95°C . † In ethanol at -158°C .

the fluorescence and phosphorescence spectra of this dye are completely identical, hardly showing a trace of the strong *M*-band at 6500 Å which appears at -180°C , although the calculated energy difference between the *F*- and *M*-states is only 0.4 eV — exactly the same as for fluorescein in boric acid. On the other hand, the afterglow of esculin at room temperature consists almost exclusively of the *M*-band (Figure 145); at the temperature of liquid air an additional *M*-band of still greater wavelength acquires a high intensity, another phenomenon which cannot be explained without introducing some new

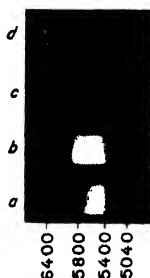

Fig. 144. Fluorescence and phosphorescence of erythrosin (Pringsheim and Vavilov).

- a*: fluorescence in water at 20°C
- b*: fluorescence in sugar at 20°C
- c*: afterglow in sugar at 20°C
- d*: afterglow in sugar at -180°C

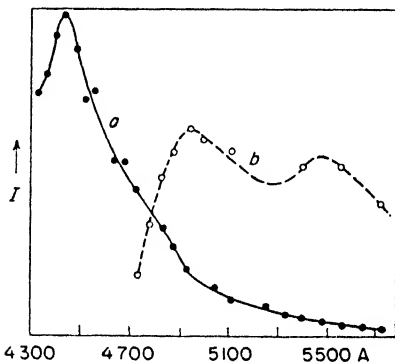

Fig. 145. Luminescence of esculin in sugar (Pringsheim and Vavilov).
a: fluorescence. *b*: afterglow.

hypothesis. The green emission bands which Lewis observed in the afterglow of crystal violet and malachite green and which he ascribed to "pseudo-isomers" of the dyes are apparently *M*-bands, since they are brightest at low temperatures. They are excited by near u.v. and one might expect, therefore, the existence of corresponding normal fluorescence bands in the blue or violet, which should appear at higher temperatures; however, no such bands have been observed (931).

A strong phosphorescence is excited by near u.v. in "pure" crystalline tetraphenylmethane and some of its derivatives, according to Clapp. The bright green afterglow of the nonsubstituted compound can be observed at a temperature as high as 125°C ; it lasts 23 sec at room temperature and 40 sec at -80°C . One would expect that, in

contrast to the radical triphenylmethane, the compound in which all valencies of the central C-atom are saturated should exhibit no visible luminescence. Moreover, it would be a unique instance of a pure aromatic compound emitting a long-lasting phosphorescence at room temperature. Clapp suggests that the luminescence might be due to the presence of traces of a triphenylmethane dye. He doubts, however, whether the same explanation could be applied to compounds which show a similar phosphorescence and in which the central carbon is replaced by silicon or tin (228).

Among the strongly fluorescent synthetic dyes the rhodamines seem to be the only exceptions which are not phosphorescent in solid solutions at room temperature and emit no slow fluorescence bands at the temperature of liquid air. Isocyanine chloride which is dissolved in frozen glycerol or in gelatin becomes fluorescent (compare Section 115); the emission spectrum consists of a broad band in the red and orange and has nothing in common with the narrow yellow fluorescence band of the polymerized molecules in aqueous solution. If the polymerized aqueous solution of 1% molar concentration is frozen at the temperature of liquid air, the yellow *P*-band disappears from the fluorescence spectrum and is replaced by an irregular sequence of narrow bands between 5790 and 6800Å; a similar fluorescence spectrum is emitted at -190°C by an aqueous solution of 0.1% molar concentration, which is nonfluorescent as long the solution is liquid at room temperature. No phosphorescence could be observed (624a). Porphyrins which are adsorbed on a gel or a colloid or are dissolved in a solid exhibit a phosphorescence lasting a fraction of a second. The spectrum is of the alkaline or the acid type, depending on the nature of the adsorbent or the solvent. The spectrum remains the same when the temperature is lowered to -180°C (54,56,1569).

138. "Progressive Phosphorescence" and Related Phenomena. If alcoholic solutions of benzene and many other aromatic hydrocarbons are irradiated with short-wavelength u.v. at low temperatures, they emit a visible luminescence with a discontinuous band spectrum which is widely different from their normal u.v. fluorescence spectrum described in previous sections. The phenomenon was discovered by Kowalski, who designated it as "progressive phosphorescence," because the afterglow reached its full "saturated intensity" only after an excitation period of about a minute. As pointed out in Section 99, a certain period of growing intensity, corresponding to the decay period, can occur with every luminescence process showing an observable afterglow, independent of its specific mechanism. On the

other hand, there are good reasons justifying the assumption that this "progressive phosphorescence" is a slow fluorescence of the same kind as that observed under analogous conditions in alcoholic dye solutions. The fact that in Kowalski's experiments the duration of the progressive phosphorescence increased when the temperature was lowered below -158°C is not inconsistent with its characterization as a slow fluorescence, because the increase in τ was accompanied by a corresponding increase in intensity. A phosphorescence of short duration with a continuous spectrum covering the whole visible region has also been observed by Kowalski, but since this luminescence was excited by long-wavelength u.v., which is not absorbed by benzene and most of the other compounds under consideration, it had nothing in common with the other phenomenon and was caused by some unknown impurity, perhaps the same which produces the weak blue fluorescence of alcohol at room temperature (338,815,817,818).

The "progressive phosphorescence" of benzene is excited only by light of wavelengths below 2700A, that of naphthalene only by light of wavelengths below 3100A, etc. According to Kowalski, the emission spectrum of benzene consists of seven doublets of narrow bands; the frequency difference between the two components is the same in each doublet and the spacing between the doublets is of the same order of magnitude as that in the normal benzene fluorescence spectra ($\Delta\nu \sim 1000\text{ cm}^{-1}$). It is probable, therefore, that the molecules are transferred by the emission process to the electronic ground state. Not a trace of the spectrum is obtained in the luminescence of pure benzene at the temperature of liquid air or liquid hydrogen (835).

The spectra of simple derivatives of benzene have the same character, but their bands are less sharp and are more or less displaced with respect to benzene bands. Some examples are given in Table 89. Bands of the progressive phosphorescence spectrum of naphthalene are listed in the sixth column of Table 77; the naphthalene and phenanthrene spectra are shown schematically in Figure 146. (An alleged relation between the fluorescence spectrum of phenanthrene vapor and its progressive phosphorescence spectrum can be discarded, because the vapor spectrum which Tomaschek used for the comparison belonged to anthracene and not to phenanthrene (1691).)

Luminescence spectra similar to those of the progressive phosphorescence had already been observed by Goldstein in the afterglow of aromatic compounds dissolved in organic solvents at -180°C several years before Kowalski's discovery. Goldstein investigated almost 2,000 different spectra, but in most cases only qualitative

descriptions and no numerical data were published. Furthermore, his results are complicated by the fact that, in general, the luminescence was excited by cathode rays in air of low pressure and, thus, the organic compound underwent chemical transformations, mostly of unknown nature. Different emission spectra were observed for individual compounds depending on

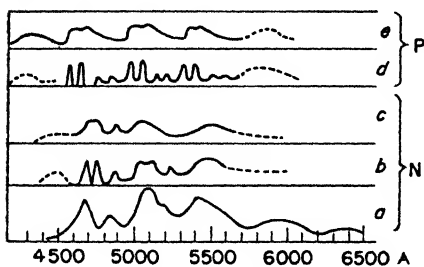

Fig. 146. Emission spectra of "boric acid phosphors" and "progressive phosphorescence" at liquid-air temperature. (a: after a photometer curve; b-e: from drawings after visual observation).

- N: naphthalene
 P: phenanthrene
 a: in ether-pentane-ethanol
 (Lewis and Kasha)
 b: in chlorobenzene (Goldstein)
 c: in boric acid (Tieae)
 d: in alcohol (Tomaschek)
 e: in boric acid (Tomaschek)

Kasha (927a). They investigated the afterglow of nearly a hundred compounds dissolved in a mixture of ether, pentane, and ethanol at -183°C , but the exact data for only a few of the emission spectra are given in their paper. Some of these are reproduced in the second part of Table 89. The spectrum of benzene has the same general character as that described by Kowalski, although the two spectra do not coincide in all details. Since Kowalski's measurements were made visually, while the new data are taken from photometer curves of spectrum photographs, the latter are more reliable; a part of the discrepancies may be caused by the difference in the solvents. The far-reaching analogy between Goldstein's drawing of the luminescence spectrum of naphthalene in chlorobenzene and Lewis' photometer curve of the naphthalene spectrum is shown in Figure 146.

The spectrum of β -chloronaphthalene is similar to that of naphthalene, but shows a fine structure which is not present in the case

of the "progressive phosphorescence"; as an example, Goldstein's solution spectrum of naphthalene in chlorobenzene is given in the seventh column of Table 77 and in Figure 146b (511-515).

Very important new material concerning the slow fluorescence of organic compounds has been provided recently by Lewis and

TABLE 89
SPECTRA OF "PROGRESSIVE PHOSPHORESCENCE"
IN ALCOHOLIC SOLUTION AT -183°C
(Peaks in A)

Benzene	3390	3520	3650	3800	3970	4130	4290
	3460	3570	3710	3850	4020	4190	4350
Toluene	3460	3580	3650	3800	4060	4120	
<i>o</i> -Xylene	3480	3610	3780	3900	4070		
	3560	3670	3870	4000	4103		
<i>o</i> -Cresol	3550	3620	3760	3850			
Benzoic acid		3660	3790	3910	4050		
			4580	4960	5330		
			4650	5040	5410		
Phenanthrene	4200-4500		4760	5150	5520	5650-6000	
			4850	5260	5610		
Benzene*	3353?	3546	3686	3820	4008	4167	4310
	3410	3606	3743	3893	4087	4237	4405
Chloronaphthalene	4760	4825	4880	4950;	5080	5140	5210
	5305	5366	5465	5525	5610	5680	5745;
	5815	5990	6060	6135	6250;	6665	
Anthracene	6800	7040	(7575)	(8300?)			
Dibromoethylene	3970	4140	4260	4420	4560		
Biphenyl	4380	4670	5025				
<i>cis</i> -Stilbene	4600	5000					

* This and the following in a mixture of ether, pentane, and ethanol at -183°C .

of naphthalene and other naphthalene derivatives. Each band is resolved into a number of components with an average spacing of 250 cm^{-1} (Table 89). Since nearly the same structure occurs in the spectra of bromonaphthalene and idonaphthalene, it is highly improbable that the frequency difference of 250 cm^{-1} corresponds to a vibration of the halogens with respect to the rest of the molecule, considering the difference in mass of the atoms Cl, Br, and I and the naphthalene nucleus (35.5, 79.9, 126.9, and 126.2, respectively). One might rather assume that a proper vibration of the naphthalene molecule is greatly enhanced by the introduction of the halides. It may be mentioned that the Raman spectra of β -chloro- and β -bromo-naphthalene show lines at 270 cm^{-1} which are absent in the spectrum of naphthalene itself.

Whereas, in general, the normal fluorescence of hydrocarbons is

weakened by introduction of halogens into the compounds, the slow fluorescence of chloronaphthalene is at least 500 times stronger than that of naphthalene. It has been pointed out (Sect. 125) that *trans*-stilbene exhibits a strong fluorescence, while the *cis*-form is not fluorescent; here again, the relation is inversed when the slow fluorescence is considered. This form of luminescence is completely missing in *trans*-stilbene and relatively strong in *cis*-stilbene. The two examples mentioned in this paragraph corroborate the hypothesis that low fluorescence yield of a compound is frequently due to the great probability of a transition into a quasi-stable state.

Among the substances listed by Lewis and Kasha are several aliphatic compounds, such as dibromoethylene and hexachlorobutadiene, which were not known to show normal fluorescence. On the basis of the available material it cannot be decided whether it is purely accidental that many of these compounds contain halogens as substituents.

Goldstein found a series of bands with a strong maximum of intensity in the blue, but reaching to the orange, in the spectra of the afterglow of many "pure" aromatic compounds at -180°C . These bands have nearly the same wavelengths in all instances and must therefore, be ascribed to the same impurity or, at least, to very similar impurities present in these compounds. Moreover, the bands coincide almost exactly with the emission bands which were observed by Marsh in the luminescence spectra of organic vapors and which were assumed in Section 89 to originate from benzaldehyde produced by chemical reactions (Table 90) (513,516).

TABLE 90
PHOSPHORESCENCE SPECTRA OF THE BENZALDEHYDE TYPE
(Peaks of bands in Å)

"Blue bands" of vapors	3940	4237	4595	4990	—	
"Vorspectrum" of metatoluic acid	3940	4260	4600	4970	5400	5900
Phosphorescence of <i>p</i> -xylene at -180°	3940	4224	4550	4949	5329	5894
Benzaldehyde in <i>p</i> -xylene at -180°	3964	4256	4582			
Benzaldehyde in <i>p</i> -xylene at -180°	3940	4237	4595	4990		
	3975	4255	4600			

If allegedly pure xylene is irradiated at -180° with the light from a quartz-mercury lamp, it emits an afterglow, in the spectrum of which a number of selective bands are superimposed on a continuous background. The phenomenon is only slightly different in *o*-, *p*-, and *m*-

xylene. The wavelength of the band peaks observed in *p*-xylene are listed in Table 90; their analogy with those of the other spectra in the table is obvious. However, the phosphorescence of benzaldehyde added intentionally to *p*-xylene does not coincide exactly with the spectrum of the "pure" compound. Thus, Terenin assumes that the latter spectrum is characteristic of an aldehyde of xylene and, similarly, Goldstein's "Vorspectra"* are supposed to belong to other aromatic aldehydes (835,1640).

The mechanism producing this afterglow of aldehydes is not that of a slow fluorescence but of a real phosphorescence, as might already be expected because of the coincidence of the bands with the fluorescence bands of the vapors. The spectrum of the afterglow excited in pure xylene at -253°C by short-wavelength u.v. is continuous. If the liquid-hydrogen cooling bath is removed after the end of the excitation, the aldehyde bands appear in a short outburst and disappear again; such an outburst is not observed if the excitation takes place at -180°C . The phosphorescence is frozen in only at temperatures below -200°C (835).

After prolonged cathode-ray bombardment of pure aromatic compounds at liquid-air temperature, the "Vorspectra" give way in the afterglow to a different type of luminescence spectra which then can also be excited by ultraviolet light. In general, they consist of irregularly spaced bands reaching from the blue-green to the red. Because of their relatively stable character they were called "Haupt-spectra" (principal spectra) of the compounds by Goldstein. Nevertheless, they are obviously not characteristic of the substances themselves; Terenin was not able to identify the carriers of this luminescence unequivocally, but suggested that they may be emitted by polymers produced by the electron bombardment (513-516,1640).

139. Boric Acid and Similar Compounds as Bases of "Organophosphors." An afterglow of very great intensity is emitted by many organic compounds when they are imbedded in boric acid, as was first shown by Tiede. These "boric acid phosphors" are prepared by melting crystalline boric acid previously mixed with a small amount of the desired compound and allowing the liquid solution to solidify as a glass. In the heating process most of the water is evaporated; too great a water content or a complete dehydration destroys the phos-

* Because these luminescence spectra disappeared after a relatively short period under the action of cathode-ray bombardment, Goldstein called them "Vorspectra" (fore spectra); when excited by short-wavelength u.v., they are more stable.

phors. Various dyes (fluorescein, eosin, erythrosin, and hematoporphyrin) and many colorless benzene derivatives have been used as "activators." Among the latter, phthalic acid, terephthalic acid, and phenanthrene have proved to be especially advantageous; good phosphors are also obtained with naphthalene, naphthalic acid, quinine, and hydroquinone, while anthracene is explicitly mentioned as being ineffective. This is noteworthy because it suggests that the afterglow of boric acid activated with phenanthrene is really characteristic of phenanthrene itself and not of anthracene, which is always present as an impurity in phenanthrene. The inefficiency of anthracene, on the other hand, is only apparent, although it is corroborated by various investigators; it has been shown by Lewis and Kasha that the *M*-bands of anthracene lie at the limit of the infrared and are difficult to observe (Table 89). The same is probably true for acridine, which is also supposed to be inefficient. Benzene cannot serve as activator because of its low boiling point (927*a*, 1664, 1672, 1687, 1691).

In these luminescent systems the quasi-stable states of organic molecules are very well protected against internal conversion, even at relatively high temperatures. In many cases the afterglow, although appreciably reduced in intensity, is still visible at 160° C, only 25° below the melting point of metaboric acid. In the phosphors activated with naphthalic acid the brightness of the afterglow at 90° C is 70 % of its value at room temperature; the phosphorescence of fluorescein is slightly less proof against high temperatures and practically vanishes at 90° C (1691).

The afterglow of the so-called boric acid phosphors is a phosphorescence only in some cases; in other cases, it is a slow fluorescence. The afterglow of dyes in boric acid exhibits essentially the same spectrum as their fluorescence in acidified liquid solutions, and the same bands are emitted as fluorescence during the excitation of the phosphor. Furthermore, the same fluorescence persists below and above the temperature limits at which the phosphorescence disappears, even when the boric acid is heated above the melting point. Finally, the afterglow can be frozen in at low temperatures and flares up if the substance is heated after the end of the excitation: this afterglow has all the characteristic properties of a typical phosphorescence. Below a certain temperature (in the case of fluorescein, below — 30° C) the phosphorescence gives way to the emission of a band of greater wavelength, which is identical in wavelength with the *M*-band appearing in the slow fluorescence of other solutions of the dye at low temperatures (1691).

On the other hand, the spectra of the afterglow of the colorless hydrocarbons coincide, even at room temperature, with those of the so-called "progressive phosphorescence" (see Figure 146) and remain practically unaltered if the temperature is lowered to -180°C , the bands only becoming sharper and showing more structure. Their intensity and the duration of the afterglow is not influenced by the low temperature. The half-lifetime of the slow fluorescence of naphthionic acid in a boric acid phosphor is 1.5 sec.

The behavior of naphthalic acid is very instructive in this connection, because it occupies an intermediate position. Its relatively short afterglow is pure yellow in the temperature range between 50° and -180°C , the spectrum consisting of two diffuse bands between 5900 and 5300Å. In the fluorescence which is emitted during the excitation a strong violet band at 4300Å is predominant, so that a striking change in the color of the luminescence occurs when the excitation is stopped. This violet band also appears in the afterglow as typical phosphorescence at temperatures above 100°C ; it probably corresponds to the same electronic transition as the first absorption band of naphthalic acid at 3800Å.

Luminescent systems with properties similar to those of boric acid phosphors have been prepared with other base materials. Good "organophosphors" are obtained by activating metaphosphoric acid, the monophosphates of calcium, beryllium, and magnesium,* and hydrated aluminum sulfate [$\text{Al}_2(\text{SO}_4)_3 \cdot 18\text{H}_2\text{O}$] with dyes or aromatic hydrocarbons (222,223,498,1668,1705). Travnicsek's "cement phosphors" are another group differing from the former in that 2 components combine to form a hard and brittle cement. Such a phosphor is prepared, e.g., by mixing 1 g of MgO with 0.7 cc of an aqueous solution containing 0.13 g of MgCl_2 and 0.04 mg of uranin or another dye, while hydrocarbons must be dissolved in alcohol. The thick paste is slowly heated to a temperature of about 150°C , until a part of the water is driven off and the mass solidifies. MgO can be replaced, although with a loss in luminosity of the product, by the oxides of Ba, Ca, Sr, or La, and the chloride by bromide, sulfate, or nitrate. The cement phosphors are exceptional because, according to Travnicsek, not only the intensity of their afterglow, but also the emission spectra are influenced by the nature of the second component of the base material and, in some cases, even by the wavelength of the exciting light. Since all observations were made only visually and without the

* No good phosphors are obtained with ortho- and pyrophosphoric acid, and with barium and strontium phosphate as base materials.

use of a photometer, these results may not be regarded as completely certain (1706).

Phosphors with a strong afterglow lasting 20 sec can be prepared by adding 0.1–0.5 % of glycocholic, uric and hippuric acid to the carbonates of calcium or strontium. It is very probable that many calcite minerals owe their luminescence to such organic impurities. The best activators for boric acid phosphors, such as fluorescein, salicylic and naphthalic acids, however, are ineffective in synthetic calcite (223).

Apart from the fact that the solvent or adsorbent must be rigid, it is not known which properties of a solid make it a useful base for an "organophosphor" with a strong afterglow. All materials (with the exception of the carbonates, which apparently belong to a different class) treated in this section have in common the requirement that they must contain a certain amount of constitutional water; complete dehydration or too high a content of water are equally harmful. This does not apply to organic solvents at low temperatures, however. Solutions in glycerol or alcohol at the temperature of liquid air lose none of their luminous efficiency when they are completely dehydrated. Tiede's hypothesis that a strong contraction of the solvent and a resulting strain acting on the luminescent molecules is the essential condition for the production of afterglow, cannot be maintained. The hypothesis was based on the supposed analogy with crystal phosphors and on Lenard's theory of phosphorescence. This analogy was postulated by many investigators (Kowalski, Tiede, and Tomaschek), but is without any foundation, as was emphasized by Levshin. In the so-called organophosphors the total process of luminescence, including the mechanism of energy storage, takes place exclusively inside of the luminescent molecule and is in every case monomolecular. In crystal phosphors the "trapping" of the energy (or of the excited electron) is, in general, not a function of the luminescent center itself but of some other part of the crystal, and the same is even frequently true for the exciting light absorption (915,919).

A survey of the last 3 sections proves that general assumptions made in Sect. 135 are correct. Below electronic state F , which is responsible for the first absorption band and the corresponding "normal fluorescence" band, many aromatic substances have one or several metastable or quasi-stable states M to which they are able to pass from F and in which the greatest part of the excitation energy can be stored for a relatively long time. The final return to the ground state occurs either by a phosphorescence process or by a slow fluorescence emitted in a "forbidden" transition. For the special case of

fluorescein it has been shown by wide-angle interference experiments that the forbidden transition corresponds to an electric dipole radiation. In all instances which have been investigated so far, the radiation emitted in the forbidden transition is unpolarized or negatively polarized in contrast to the strong positive polarization of the normal fluorescence and of the phosphorescence. The fact that Lewis and his collaborators observed an appreciable positive polarization in the afterglow of a boric acid phosphor, while the luminescence of these phosphors had previously been found to be unpolarized, was caused not only by the good transparency of their material (thus avoiding depolarization by multiple refraction and reflection), but was due primarily to the circumstance that their phosphor was activated with fluorescein and not with terephthalic acid or with phenanthrene. It was a case of phosphorescence and not of slow fluorescence. The small fraction of the afterglow of fluorescein-activated boric acid, which at room temperature is due to slow fluorescence, is polarized very little, or is unpolarized (930,1817).

Which of the two processes prevails in the afterglow is determined by the nature of the organic compound and the temperature and does not depend on the nature of the solvent, which only must be rigid at the temperature of observation. The colorless hydrocarbons preserve their slow fluorescence at temperatures well above 100° C; with esculin it predominates at room temperature, with fluorescein below — 30° C, with crystal violet below — 100° C, while with benzaldehyde phosphorescence is still observed at temperatures below — 180° C. Since the phosphorescence and the slow fluorescence are excited by absorption of light in the same absorption bands in which the normal fluorescence is produced, both processes of afterglow are always accompanied by the emission of this normal fluorescence during the period of irradiation. As a rule, the fluorescence has been observed only when it belonged to the visible region, as is the case for all dyes and for a few colorless compounds with blue or violet fluorescence, such as esculin, quinine, and naphthalic acid. There is, however, no reason to doubt that during the period of excitation boric acid phosphors activated with naphthalene and phenanthrene emit the well-known u.v. fluorescence spectra which are characteristic of these compounds.

CHAPTER VI

LUMINESCENCE OF PURE INORGANIC COMPOUNDS

A. The Rare-Earth Metals

140. Fluorescence Spectra of the Trivalent Ions. The cathodoluminescence of the rare-earth metals has played an important part in the discovery and separation of these elements. In many cases, however, the observed spectra, consisting of groups of narrow bands or lines, were characteristic not of the elements which were supposed to be isolated, but of another rare-earth metal which was present as a small impurity. The fluorescence of rare earths contained as impurities in minerals like fluorite, or in synthetic phosphors of the sulfide type had also been known for a considerable time, while the photoluminescence of pure salts of rare earths and of their aqueous solutions has been discovered only lately (1701).

However, only gadolinium and its immediate neighbors in the periodic system — europium and samarium on the one side, and terbium and dysprosium on the other — have to be considered in this connection. Salts of other rare-earth metals are luminescent only in liquid and solid solutions and as activators of crystal phosphors. The emission spectra and the corresponding absorption spectra are, in the main, typical line spectra and are to be ascribed to the trivalent ions Eu^{+++} , Sm^{+++} , etc. The outermost electrons of these ions form a complete rare-gas shell (the xenon shell, with two 5s and six 5p-electrons), inside of which the 4f-shell is filled successively in passing from one element to the following (see fourth row of Table 91). As long as this shell is not completely populated with fourteen electrons (as in element 71), a number of 4f-levels are unoccupied and electrons already present in the 4f-shells can be raised by light absorption into these empty levels. By vectorial addition of the orbital momenta l of all 4f-electrons, the total orbital momenta $L = 0, 1, 2, 3 \dots$ corresponding to electronic terms $S, P, D, F \dots$ are obtained. These electronic terms are split into multiplets with multiplicities ranging from one to eight according to the total electronic spin S which results

TABLE 91
 RARE-EARTH METALS WITH LINE FLUORESCENCE

No.	No line fl.		in crystal phosphors													No line fl.	
	57	58	as pure salts						67	68	69	70	71				
	La	Ce	Pr	Nd	—	Sm	Eu	Gd	Tb	Dy	Ho	Er	Tm	Yb	Lu		
Ground state	<i>S</i>	<i>F</i>	<i>H</i>	<i>I</i>	<i>I</i>	<i>H</i>	<i>F</i>	<i>S</i>	<i>F</i>	<i>H</i>	<i>I</i>	<i>I</i>	<i>H</i>	<i>F</i>	<i>S</i>		
Number of 4 <i>f</i> -electrons	0	1	2	3	4	5	6	7	8	9	10	11	12	13	14		

from the addition of the spins of the individual 4*f*-electrons.* For the elements preceding gadolinium the multiplets are normal, the lowest *J*-values corresponding to the lowest terms; for the elements following gadolinium the multiplets are inverted, the highest *J*-values corresponding to the lowest terms. The narrow lines which were known

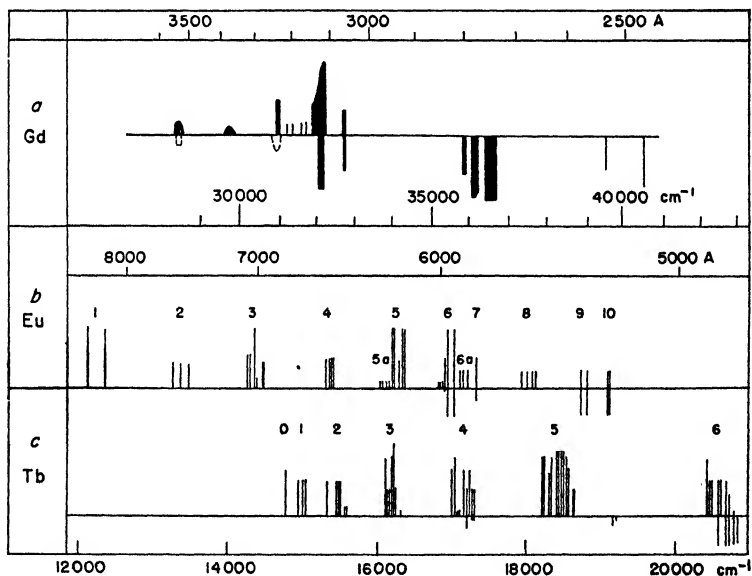

Fig. 147. Schematic representation of absorption and fluorescence spectra of trivalent rare-earth ions (Tomaschek).

a: gadolinium. *b*: europium. *c*: terbium.

* The maximum spin momentum for seven electrons is $S = 7/2$ and the corresponding multiplicity $2S + 1 = 8$ (compare Section 11).

previously to occur in the absorption spectra of rare-earth salts and which now have been observed also in emission spectra are ascribed to transitions of electrons between various terms which lie inside of the $4f$ -shell, and the sharpness which they preserve in condensed systems is explained by the fact that they are protected against outside perturbations by the electrons of the xenon shell. This protection against perturbations is also the reason for the high fluorescence yield, which approaches 100% even in liquid solutions. The fact that the rare earths with less than five or more than nine f -electrons are not fluorescent as pure salts, although their absorption spectra show similar narrow lines, has not yet been explained satisfactorily.

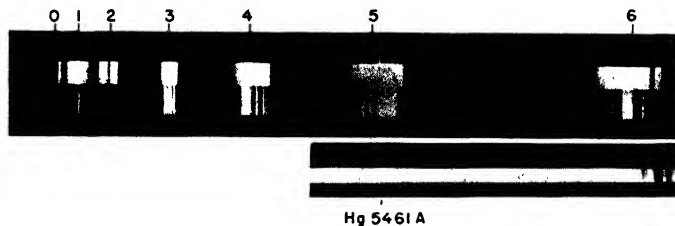

Fig. 148. Absorption and fluorescence spectrum of $\text{Tb}_2(\text{SO}_4)_3 \cdot 8\text{H}_2\text{O}$ at -180°C . (Gobrecht).

The absorption and fluorescence spectra of some of the elements under consideration are plotted schematically in Figure 147. The lines below the horizontal represent the absorption lines and those above the horizontal the emission lines, the length of each line giving an approximate measure of its relative intensity. Each line group (for instance, in the emission spectrum of Eu^{+++} the groups numbered from 1 to 10 in Figure 147) corresponds to the transition from a given upper electronic state to a multiplet term of the ground state (which is a ${}^7\text{F}$ -state in the case of europium). Thus, the first seven line groups (numbers 1–7 in Figure 147*b*) form a complete septet. Since the upper electronic state has, in this case, the inner quantum number $J = 0$, while the J -values of the ground state run from 0 to 6, variations of J up to $\Delta J = 6$ occur in the emission spectrum. Because of these large infringements on the selection rule $\Delta J = 0$ or ± 1 , the transitions are “forbidden” and have only small probabilities. The influence of the molecular field of the surrounding ions on the transition probabilities will be mentioned in the next section. In agreement with the fact that all electronic transitions corresponding to the emission of fluorescence lines in the salts of rare-earth metals are

forbidden, the luminescence (a slow fluorescence) has a decay period of the order of 10^{-3} sec and can be observed without difficulty in a Becquerel phosphoscope (503,504,1088,1767a,1816).

The three line groups in the europium fluorescence spectrum, numbered 8-10 in Figure 147*b*, belong to another septet originating at the higher electronic level with $J' = 1$. Two other groups of this septet overlap the adjacent groups of the first septet, from which they are not clearly separated in the spectrograms. In Table 92 they are designated by 5a and 6a. A photograph of a septet occurring in the fluorescence spectrum of terbium is reproduced in Figure 148.

The energy differences between the lowest terms of the multiplets of Eu^{++} are very small and, therefore, the levels $J'' = 1$ and $J'' = 2$ are populated to some extent at room temperature. The absorption lines originating at these levels can be observed at room temperature, but they disappear completely at

the temperature of liquid air. Furthermore, the absorption spectrum of Eu^{++} contains several lines of shorter wavelengths which raise the ions into higher electronic states. These lines are never obtained in the emission spectrum; apparently the ions pass by radiationless processes from the upper states into the lowest excited electronic state and from there the fluorescence emission eventually originates (Figure 149) (86r).

The energy-level diagram of Tb^{+++} is given in Figure 150 as an example of an "inverted multiplet." Here the spacing between the lowest level, $J = 6$, and the following, $J = 5$, is so large that even at room temperature only the former is populated. Accordingly, only the lines originating at this level appear in the absorption spectrum.

The energy-level scheme of Sm^{+++} which is derived from its fluorescence and absorption spectra has a somewhat different character

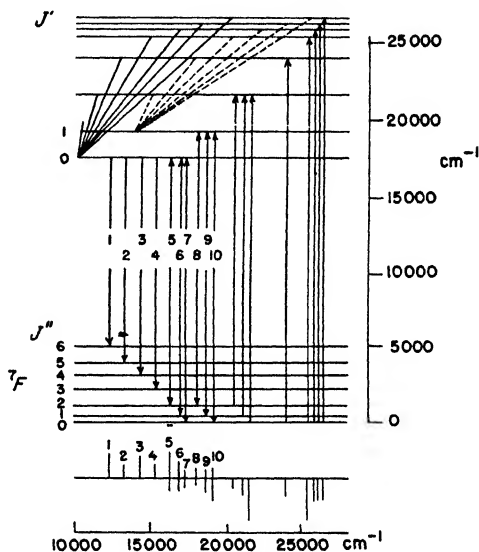

Fig. 149. Energy levels of Eu^{++} (Tomaschek and Gobrecht).

(Figure 151). The frequencies of three lines in the long-wavelength part of the emission spectrum are equal to the differences between the

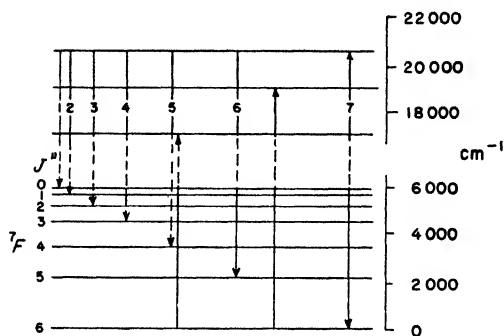

Fig. 150. Energy levels of Tb^{3+} (Gobrecht).

frequencies of three absorption lines in the green and that of an infrared absorption line (for instance, $18000-10000 = 8000\text{ cm}^{-1}$). Therefore, the left-hand part of Figure 151 shows an intermediate electronic state which is reached by the absorption of the infrared

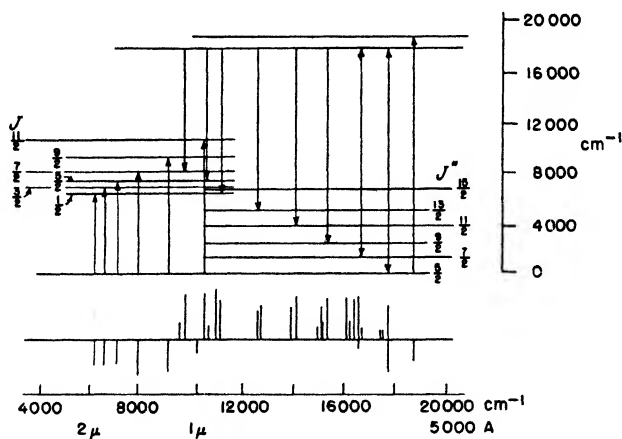

Fig. 151. Energy levels of Sm^{3+} (Gobrecht).

lines and by the emission of the long-wave fluorescence lines. The infrared lines are not observed in the fluorescence spectrum because of their low intensity. The conditions prevailing in the absorption

TABLE 92
 FLUORESCENCE SPECTRUM OF EUROPIUM OCTAHYDROSULFATE AND AN
 EUROPIUM SALT DISSOLVED IN ALCOHOL

(ν : mean wave number of line group in cm^{-1} ; λ : wavelength in \AA ;
 I : estimated intensity)

No.	$J' J''$	Sulfate			Solution		No.	$J' J''$	Sulfate			Solution		
		ν	λ	I	λ	I			ν	λ	I	λ	I	
1	0 6	12200	8260	8	—	—	6	0 1	16900	5965	1	5955	4	
			8110	10	—	—				5955	1	—	—	
2	0 5	13300	7560	4	—	—			5945	1	—	—		
			7505	4	—	—			5937	5	5933	4		
			7440	4	—	—			5920	10	5909	4		
					—	—			5890	10	—	—		
3	0 4	14300	7035	6	—	—	6a	1 3	17100	5863	3	5866	3	
			7007	6	—	—					5850	3	—	—
			6980	10	6881	d^*			5845	3	—	—		
			6965	2	—	—			5830	3	—	—		
			6927	4	—	—			5825	3	—	—		
			6920	4	—	—						5806	5	
4	0 3	15340	6547	5	6548	4	7	0 0	17265	5791	5	5798	3	
			6523	5	6537	3	8	1 2	17950	5593	3	—	—	
			6515	5	6524	4					5570	3	—	—
			6505	5	6504	4					5548	3	—	—
			6500	5	—	—					5535	3	—	—
5a	1 4	16050	6250	1	—	—	9	1 1	18700	5355	3	—	—	
			6237	1	6228	4					5331	3	—	—
			6220	1	—	—	10	1 0	19050	5252	3	—	—	
			6205	1	6206	4					5247	3	—	—
5	0 2	16250	6185	10	—	—			5244	3	—	—		
			6172	10	6173	7								
			6150	5	6153	5								
			6140	10	6146	7								
			6125	10	6127	7								

* d : diffuse.

and fluorescence spectra of dysprosium are similar, but the fluorescence is relatively weak.

The absorption lines of gadolinium salts lie in the u.v., below 3525 \AA ; the first group of absorption lines between 3050 \AA and 3117 \AA coincides with the strongest group of fluorescence lines (Figure 147a and Table 93). Since the ground state of Gd^{+++} is an S-term and, therefore, simple, the emission lines of greater wavelengths cannot be

ascribed to transitions to higher multiplet levels of the ground state, as in the spectra of the other rare-earth ions. Tomaschek assumed, therefore, that a second excited electronic state of smaller energy contributes to the emission process. In confirmation of this hypothesis he succeeded in observing weak absorption lines coinciding with the fluorescence lines between 3216 and 3533A (in Figure 147a they are marked by dotted lines below the horizontal) (1702).

TABLE 93
FLUORESCENCE AND ABSORPTION LINES OF GADOLINIUM
OCTAHYDROSULFATE AT 20° C
(λ in A; intensities estimated)

Fluorescence		Absorption	
λ	Intensity	λ	Intensity
3050-3060	2	3054 [†]	7
		3056	7
		3060	7
3109*	9	3109	5
3112	10	3112	7
3114	10	3114	9
3117	10		
3153	0		
3177-3190	0		
3216	3	3215	very weak
3344-3367	1		
3496-3533 [†]	1	3499-3524	very weak

* Continuous background 3096-3134A.

[†] Some additional weaker fluorescence lines between 3500 and 4150A.

[†] Further strong absorption lines between 3000 and 2400A.

The fluorescence of the rare-earth ions is excited by light absorption in any one of their characteristic absorption lines. In general, all fluorescence lines with wavelengths greater than that of the exciting line are present in the emission spectrum. In the fluorescence spectra of several europium salts, however, the line groups originating at the electronic level $J' = 1$ (5a, 6a, and 8-10 in Table 92) are missing if the fluorescence is excited by absorption in short-wave absorption lines, which raise the ions to higher excited states. Apparently, for some unknown reason the transitions from these states to the level $J' = 1$ does not occur, (these transitions are indicated in Figure 149

by dotted lines). The possibility of exciting the fluorescence of a rare-earth ion which forms part of a complex organic compound by light absorption which occurs in another part of the complex, has already been mentioned (Sections 97 and 106) (1816).

Cerium differs from the other rare-earth metals, insofar as its trivalent ion contains only a single electron in its $4f$ -shell. Therefore, no electronic terms other than the two doublet levels of the ground state ${}^2F_{5/2}$ and ${}^2F_{7/2}$ can be formed within the $4f$ -shell and the absorption processes of smallest energy raise the electron to an orbit outside of the xenon shell. Hence, the sharp absorption lines are replaced by relatively diffuse bands lying below 3000Å. Absorption of light in these bands by crystals of cerium sulfate produces a luminescence of medium strength, the spectrum of which consists of a double band with two diffuse maxima at 3440 and 3200Å. Gobrecht ascribes them to transitions from the excited state to the doublet levels of the ground state. If cerium trifluoride is excited by light of wavelength 2537Å, an additional band at 2700Å is obtained, while irradiation with light of $\lambda < 2300$ causes the appearance of a fluorescence band at the limit of the visible region, with its maximum at 3800Å (504).

Analogous u.v. fluorescence bands corresponding to transitions from orbits outside of the xenon shell to $4f$ -levels have not yet been observed in the spectra of other rare-earth salts in the crystalline state. Pure salts of lanthanum, which contains no $4f$ -electrons, are not fluorescent at all.

141. The Crystalline State. Not all solid salts of those elements which are marked in Table 91 as "fluorescent as pure salts" show photoluminescence; for instance, the fluoride and the dehydrated chloride of europium are not fluorescent and the fluorescence yield of the oxide is very small. This seems to be due to the very narrow spacing of the ions in the lattices of these compounds which favors internal conversion. If EuCl_3 is hydrated it becomes strongly fluorescent. The fluorescence of the rare-earth sulfates with eight molecules of water is especially easy to observe and most data given in the preceding section relate to these sulfates. Furthermore, many organic compounds like oxalates, benzoylacetates, and salicylaldehydes give high fluorescence yields.

Although the absorption and the emission spectra are determined, in the main, by the nature of the rare-earth ions, they are influenced in several respects by the symmetry of the crystal lattice and by the nature of the anion. The lines are all "forbidden," but not all to the Pringsheim 17*

same degree. The Eu^{+++} line $0' \rightarrow 0''$ ($\Delta J = 0$, $J = 0$) is missing in cubic or hexagonal crystals ($\text{EuBr}_3 + 9\text{H}_2\text{O}$, europium ethyl sulfate + $9\text{H}_2\text{O}$), but it appears in monoclinic crystals (europium sulfate) and in triclinic crystals (europium acetate + $8\text{H}_2\text{O}$) (503).

When Eu^{+++} ions are imbedded in crystals of calcium fluoride or strontium fluoride, the intensity distribution in the fluorescence spectra is anomalous in that the generally strong line group near 5900A corresponding to the transition $J' = 0 \rightarrow J'' = 1$ (number 6 in Table 92 and in Figures 147 and 149) is very weak, while the forbidden yellow line $J' = 0 \rightarrow J'' = 0$ (number 7) is extremely strong and is shifted from 5790 to 5725A. When barium chloride is the base material, the relative intensities of these line groups are normal in the fluorescence spectrum at room temperature, but show the same anomaly as in CaF_2 and SrF_2 at the temperature of liquid air (217).

In the fluorescence spectrum of europium sulfate (Table 92) and similarly in the spectra of the other rare-earth salts, the lines corresponding to the transition between two electronic levels are split into a number of components. This is due to the Stark effect caused by the electric field of the surrounding ions. According to the theory which has been developed by Bethe, the number of expected components can be derived from the symmetry of the electric field. The number of sublevels into which each electronic level is resolved increases from 1 for $J = 0$ or $J = 1/2$ with increasing J -values and reaches 13 for $J = 6$ in electric fields of lowest symmetry (Table 94). If the values of J' and J'' are known, the symmetry of the field can be derived from the observed number of components. The calculation is unequivocal, however, only if one of the two combining terms is not split up by the action of the field (as for $J = 0$ or $1/2$, or generally for S-terms). This condition is fulfilled for the europium septet originating at $J' = 0$, as is shown by the fact that the line at 5791A ($0' \rightarrow 0''$) is

TABLE 94
NUMBER OF STARK-EFFECT SUBLEVELS IN FIELDS OF
DIFFERENT SYMMETRY

Symmetry of field	Number of sublevels												
	$J = 0$	$1/2$	1	$3/2$	2	$5/2$	3	$7/2$	4	$9/2$	5	$11/2$	6
Cubic	1	1	1	1	2	2	3	3	4	3	4	4	6
Octahedral } . .	1	1	2	2	3	3	5	4	6	5	7	6	9
Hexagonal } . .													
Tetragonal and lower symmetry	1	1	3	2	5	3	7	4	9	5	11	6	13

simple (see Figure 152). If only the stronger lines are taken into account, the spectrum of europium oxalate is in satisfactory agreement with a field of cubic symmetry. In the spectrum of europium sulfate the splitting of the line $J'' = 1$ into a complex group shows that the field symmetry cannot be cubic, while the group $J'' = 3$ (number 4 in Table 92), with five components of equal strength, and the group $J'' = 4$ (number 3), with six components, prove the electric field to be of hexagonal symmetry.

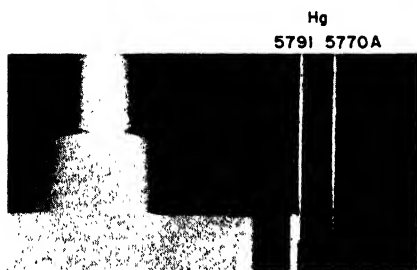

Fig. 152. Fluorescence spectrum of europium oxalate (Gobrecht).

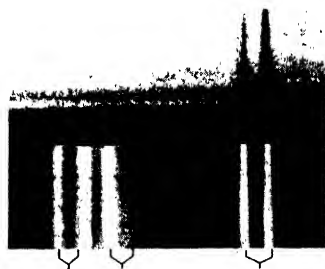

Fig. 153. Absorption and fluorescence spectrum of $\text{Sm}_2(\text{SO}_4)_3 \cdot 8\text{H}_2\text{O}$ (Gobrecht).

The analysis of the groups in the fluorescence spectra of other rare-earth salts is less complete. From the number of components in the group $J'' = 1$ of the terbium sulfate fluorescence spectrum, it can be concluded only that the electric field has neither cubic nor hexagonal symmetry (Figure 148). The same is true for the fluorescence spectrum of samarium sulfate, in which every group consists of two subgroups; in this case the excited electronic state is also split into two sublevels by the molecular Stark effect, and, therefore, all lines are split into doublets, the components of which are connected by brackets in Figure 153. The spacing of the doublet components (28 cm^{-1}) corresponds to the energy difference between the two sublevels of the excited electronic state.

Furthermore, the frequencies of the individual lines are influenced to a certain extent by the structure of the crystal. Thus, the line $0' \rightarrow 0''$ of europium sulfate (number 7 in Table 92) coincides almost exactly with the mercury line 5791A, but is shifted in the direction of greater wavelengths in the spectrum of the oxalate (Figure 152) and lies at 5780A in the fluoride; it is even shifted to 5723A in Eu-activated SrF_2 as was mentioned above. Effects of this type have been investigated

TABLE 95A

FREQUENCY DIFFERENCES BETWEEN THE SEXTET TERMS OF Sm^{+++} (FIG. 147) AND BETWEEN THE LINE GROUPS OF THE LUMINESCENCE SPECTRUM OF Sm IMBEDDED IN CaO

($\Delta\nu$ in cm^{-1})

$\text{Sm}_2(\text{SO}_4)_3 \cdot 8\text{H}_2\text{O}$.	1085	1224	1333	1363	1495
Sm in CaO	1073	1266	1366	1376	1588

TABLE 95B

THE FIRST THREE LINE GROUPS IN THE FLUORESCENCE SPECTRA OF SAMARIUM SULFATE AND OF SAMARIUM IMBEDDED IN CALCIUM OXIDE AND THE NUMBER n OF LINES IN EVERY GROUP

(Wavelengths in \AA)

$\text{Sm}_2(\text{SO}_4)_3 \cdot 8\text{H}_2\text{O}$..	λ 5579-5658	5935-6022	6400-6488
	n 6	8	6
Sm in CaO	λ 5330-5940	6034-6307	6416-6807
	n 30	17	14

more thoroughly in the spectra of rare earths imbedded in crystals of another compound — for instance, calcium sulfide or magnesium oxide. The fluorescence spectra of samarium obtained under these conditions are closely related to those of the pure samarium salts. The frequency differences between the line groups of which the spectra consist are very nearly the same (Table 95A). The groups are, however, considerably broader and less clearly separated and contain a much larger number of individual lines (Table 95B) (1694).

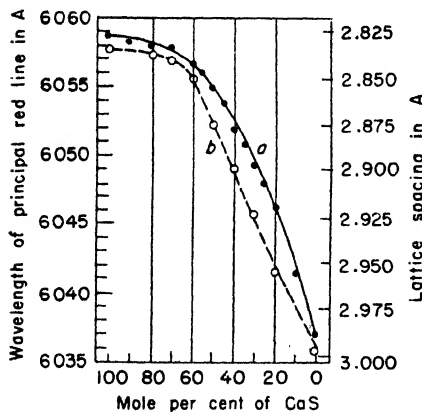

Fig. 154. Shift of the wavelength of a line in the fluorescence spectrum of Sm^{+++} imbedded in mixed crystals of CaS - SrS with increasing lattice spacing (Travnicek).

a : wavelength of principal red line in \AA . b : lattice spacing in \AA .

Figure 154 shows how an outstanding line of the Sm -spectrum is shifted gradually

from 6059 to 6036A when the rare earth is imbedded in mixed crystals of CaS and SrS of varying relative concentration. The parallelism between the wavelength shift and the decreasing lattice constants of the mixed crystals is obvious. On the other hand, the emission spectra are very nearly identical if samarium is imbedded in SrO or in PbO, the cations of these two salts having almost the same ionic radii (1396, 1397, 1700, 1703, 1704).

The line at 6059A is the long-wavelength component of a doublet in the second group of the CaO(Sm) fluorescence spectrum. The wavelengths of the two components of this doublet and of the corresponding doublet in the first line group are listed in Table 95C for a number of oxides and sulfides containing samarium.

Fig. 155 shows that, simultaneously with the shift in wavelength,

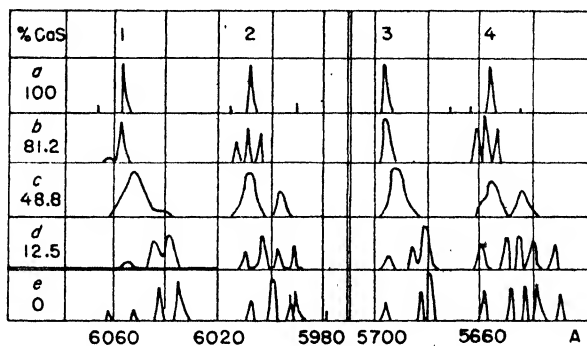

Fig. 155. Wavelength shift in two Sm^{+++} doublets in mixed crystals of CaS-SrS with increasing Sr-concentration (Tomaschek).

TABLE 95C

WAVELENGTHS OF THE COMPONENTS OF TWO DOUBLETS IN THE FLUORESCENCE SPECTRUM OF SAMARIUM IMBEDDED IN VARIOUS OXIDES AND SULFIDES

(Wavelengths in A)

	Oxides				Sulfides			
Ca	5681	5750	6059	6150	5656	5698	6007	6058
Sr	5663	5731	6031	6110	5643	5679	5999	6035
Ba	—	—	6056	6081	5638	5670	5988	6022
Mg	5729	5829	6103	6374	5686	5735	6052	6104
Zn	—	—	—	—	5700	5747	6062	6139
Be	5619	5678	5975	6044	—	—	—	—

each of the four lines of the doublets splits into several components when the relative concentration of Sr in the mixed crystals of CaS-SrS increases. It does not seem possible to obtain the intermediate spectra *b* and *c* of Figure 155 by mere superposition of the two limiting spectra corresponding to pure CaS and SrS. It does not seem probable, either, that this difference in the structure of the spectra is caused by

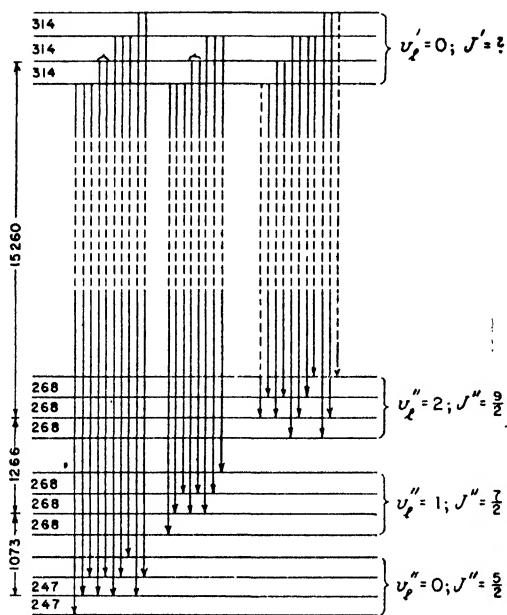

Fig. 156. Energy levels for the fluorescence of Sm imbedded in CaO (Tomaschek).

a different symmetry of the molecular fields, since the crystals of CaS and SrS have the same symmetry.

The details of the spectra differ rather widely even if a rare earth (europium or samarium) is imbedded in the same "base material" (e.g., MgO or CaS), depending on the manner of preparation of the "phosphor." Tomaschek ascribes such differences to the existence of various microcrystalline "fine structures" upon which the essentially identical "macrostructure" is superimposed, the latter alone being revealed by x-ray diffraction patterns.

Finally, lines which are due neither to the existence of the various multiplet terms nor to their splitting by molecular Stark effects can

be produced by the superposition of molecular vibrations or lattice vibrations on the purely electronic frequencies (342). This phenomenon, too has been investigated more completely in the spectra of rare earths imbedded in foreign crystals, in which such lines seem to occur more frequently than in the spectra of pure salts. Figure 156 gives the analysis of three groups of lines obtained in the fluorescence spectrum of calcium oxide "activated" with samarium (1695, 1696). The larger frequency differences (above 1000 cm^{-1}), of which two occur in the diagram, were assumed by Tomaschek to be due to an internuclear vibration ($v'' = 0, 1, \text{ and } 2$) but the figures of table 95A prove that they correspond to the spacings between the multiplet terms of the ground state, 6F . The smaller periods of 268 and 314 cm^{-1} are ascribed to lattice vibrations in the unexcited and the excited state, respectively. The natural frequencies of the fundamental lattice (CaO in this case) are supposed to be perturbed by the presence of the rare-earth ions. According to this scheme the doublets of Figure 155 and of Table 95C, which are marked in Figure 156 by brackets, correspond to transitions from a common upper level, $v' = 1$, to two adjacent vibrational levels with $v'' = 1$ and $v'' = 2$, and the distance between the two components of one doublet is equal to the vibrational frequency of the ground state. The validity of this assumption is very doubtful, however, considering the different behavior of the components of one doublet (pairs 1 and 2, or 3 and 4, in Fig. 155) in mixed crystals of CaS and SrS, since this difference would be caused only by the different values of v'' . On the other hand, components 1 and 3 or 2 and 4, respectively, which are supposed to lead to different J' -levels, split up in almost identical manner with increasing strontium concentration in the mixed crystals. Furthermore, only about one-third of all observed lines are taken care of by the level scheme of Figure 156, while the appearance of new lines caused by the Stark effect is not taken into account. It must be admitted, therefore, that a satisfactory analysis of the line originating from the superposition of electronic multiplets and lattice vibrations has not yet been given for this or any other rare-earth spectrum.

If a lanthanum salt (for instance, the acetate) crystallizes from an aqueous solution and contains traces of another rare earth, the crystals are photoluminescent again only if one of the five elements gadolinium, europium, samarium, terbium, and dysprosium is present as an impurity. Such crystals show none of the properties characteristic of "crystal phosphors"; their luminescence is excited exclusively by light absorption in the impurity ions themselves, no appreciable

afterglow is observed, and the intensity of the light emission corresponds to the concentration of the impurity. The presence in a lanthanum salt of 0.01 mole per cent Eu or Tb, of 0.1 % Sm, or of 1 % Dy can be ascertained by visual observation of its fluorescence (506).

Fluorescence cannot be excited in crystalline lanthanum acetate containing praseodymium as impurity. If, by calcination, the crystals are transformed into lanthanum oxide, they become "praseodymium-activated lanthanum oxide phosphors" [$\text{La}_2\text{O}_3(\text{Pr})$ -phosphors] and are able to emit a brilliant green luminescence. Similarly, the other trivalent rare-earth ions, marked as such in Table 91 (Nd, Er, Tm), are luminescent when they are contained as "activators" in crystal phosphors, the fundamental lattices consisting of sulfides, oxides, fluorides, nitrates, sulfates, or tungstates of various metals (see Table 96) (505, 1693, 1694).

This list could probably be prolonged considerably. Neodymium is marked as questionable, because the compounds activated with Nd are reported to exhibit a visible luminescence, while the characteristic Nd-lines are all situated in the infrared. It is not improbable that the luminescence of crystals activated with neodymium is caused by the presence of traces of another rare earth, as was proved for the visible fluorescence of neodymium glasses.

The luminescence spectra of these phosphors are of the same type as those treated in the preceding paragraphs; they consist of line groups which can be ascribed at least in part, to transitions between definite electronic levels within the 4*f*-shell. The emission lines of neodymium lie between 8700 and 11200 Å. The fluorescence of praseodymium stretches over the whole visible region into the infrared, from 4000 to 10650 Å. In contradistinction to the fluorescence of Sm or Eu, the visible part of the praseodymium spectrum consists of two overlapping sequences of lines which, in general, appear *simultaneously* but with different relative intensities, depending on the manner of preparation of the phosphor, on the temperature of observation, and on the wavelength of the exciting light. One spectrum has its maximum intensity in the red and the other in the blue-green; thus, the color of the luminescence varies according to which of the two spectra prevails in the emission (370, 503, 861, 862, 1496).

The emission spectrum of erbium imbedded in calcium fluoride consists of only two line groups. One, in the green-yellow between 5507 and 5670 Å, is relatively strong, while the other, in the red-orange between 5615 and 6630 Å, is very weak. The latter is exceptional insofar as it corresponds, according to Gobrecht, to transitions between

TABLE 96
SYNTHETIC PHOSPHORS ACTIVATED WITH RARE-EARTH METALS

Rare earth	Base materials
Samarium	Oxides: Be, Mg, Ca, Sr, Al, Y, La, Si, Ti, Ge, Zr, Th Sulfides: Mg, Ca, Sr, Ca-Sr, Ba, Zn Fluorides: Be, Mg, Ca, Sr, Ba, Al, Sc Nitrate: K Borate: Na Tungstate: Ca Sulfates: Li, Na, K, Rb, Mg, Ca, Sr, Ba, Cd, Al
Europium	Oxide: Ca Sulfides: Ca, Sr, Ca-Sr Fluorides: Ca, Y Tungstate: Ca Sulfates: Mg, Ca, Sr, Ba
Terbium	Sulfides: Ca, Sr Oxides: Ca, Sr Fluoride: Ca
Praseodymium . .	Sulfides: Ca, Sr, Ba Oxides: Be, Mg, Ca, Sr, Al Fluorides: Ca, Sr, Ba Sulfates: Ca, Sr, Ba, Pb Tungstate: Ca
Neodymium? . . . (doubtful)	Oxide: Ca Sulfides: Ca, Sr Sulfate: Ca Tungstate: Ca Silicates: Mg, Ca, Sr, Cd, Zn, La, Hg Titanate: Zn Zirconate: Zn
Erbium	Fluoride: Ca
Thulium	Oxide: Ca Sulfate: K
Gadolinium . . .	Fluoride: Ca

the various multiplet levels of the ground state 4I (with J -values ranging from $15/2$ to $9/2$) (503). Photoluminescence of thulium has been observed only when the element is contained as activator in calcium sulfate crystals, the spectrum consisting of twelve lines which are spread over the whole region from 4500 to 10225A (505).

It is noteworthy that not only do the rare-earth ions which are not fluorescent as pure salts become photoluminescent as activators of crystal phosphors, but that if samarium is incorporated in such a phosphor (e.g., CaO), new line groups appear in the spectrum which

are never observed in pure samarium salts. These new lines in the blue, between 4036 and 4895A, are rather diffuse and apparently correspond to transitions from a higher electronic level which is less well protected from perturbations.

At low temperatures the fluorescence lines of all crystals emitting the spectra characteristic of rare-earth ions are much sharper than at room temperature; this is true for pure salts as well as for rare-earth-activated crystals. In many cases the lines merge into each other at room temperature and the line groups are completely resolved only when the crystals are immersed in liquid air. Under these conditions, some of the lines observed at room temperature disappear from the spectrum because they originate from levels which are not populated when thermal equilibrium is established at the low temperature.

142. Solutions in Liquids and Glasses. The rare-earth ions which are fluorescent in pure crystalline salts preserve their fluorescence power in liquid solutions, and the fluorescence yield, the approximate wavelength of the line groups, the structure of the latter, and the excitation spectra are similar to those of the solid salts. Samarium, europium, and terbium can be identified by visual observation of the fluorescence of their salts in aqueous solutions at concentrations between 10^{-4} and 10^{-3} molar. In general, the lines forming a group are less sharply separated and merge into continuous bands in which they are distinguishable only as intensity fluctuations. Single lines, such as the europium line $0' \rightarrow 0''$, however, retain a considerable sharpness, the europium line having a half-width of about 6A in a dilute aqueous solution of europium chloride or europium nitrate. The lines of gadolinium sulfate in aqueous solutions are also relatively narrow and coincide with those of crystalline $Gd_2(SO_4)_3$ to within a few angstroms (Table 93) (282).

When the salts are not completely dissociated, as at higher concentrations in aqueous solutions or in solutions of complex organic compounds in organic solvents, the spectra of a given rare-earth ion — for instance, of Eu^{+++} — show considerable variation in their structure which are analogous to those observed in the solid salts. A second component appears, for instance, in the aqueous solutions of europium nitrate at the long-wavelength side of the $0' \rightarrow 0''$ line at 5790A and increases in intensity with increasing concentration. The same result is obtained if the number of nondissociated $Eu_2(SO_4)_3$ -molecules is increased in a dilute solution by addition of sodium sulfate. Other examples of the difference between the fluorescence spectra of different salts in solutions and their analogy to the spectra of the solid

salts are shown in Figure 157 (503,824,864,865a,865b,1484a,1484b,1485). (The fluorescence of rare-earth salts in liquid ammonia has also been described).

Visible fluorescence of rare-earth salts excited by short-wavelength u.v. in aqueous solutions was observed as early as 1880 by Soret; his experiments have been repeated and improved by Stark and Steubing and by Tomaschek and his collaborators (1552). Most of the rare earths which are to be mentioned here do not belong to the group of elements which are fluorescent as pure salts, according to Table 91. As far as Soret's results are concerned, the purity of the salts at his disposition and the assignment of the observed luminescence to specific elements may be doubted; in general, these assignments are not in good agreement with results of later investigations. All emission bands lie in the violet and the near u.v. and are diffuse without any sign of structure.

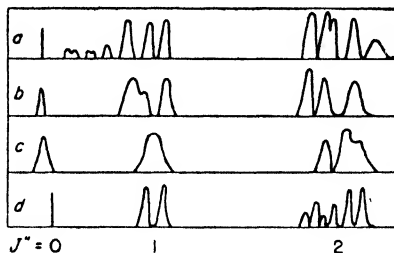

Fig. 157. Fluorescence of europium salts – crystalline and in solution (Gobrecht).

a: sulfate, crystalline. *b*: sulfate, in aqueous solution. *c*: acetate, in aqueous solution. *d*: acetate, crystalline.

TABLE 97

FLUORESCENCE BANDS OF RARE-EARTH SALTS IN AQUEOUS SOLUTIONS EXCITED BY SHORT-WAVELENGTH U.V.

[Approximate limits of bands, and (in parentheses) maxima, in Å; the strongest bands in *italics*]

Element	Bands			
Eu	4550–4300	4070–4200	3108*	
Er	—	4250–3100	—	
Pr	4800–4415	<i>3890–3300</i> (3570)	2970–2630*† (2790)	2520–2300*† (2420)
Nd	4650–4415 (4520)	<i>3800–3300</i> (3530)	2970–2650*† (2800)	2550–2300*† (2420)
Ce	—	<i>3900–3200</i> (3520)	—	—
La	—	3900–3200	—	—

* Narrow band.

† Excited only by light of $\lambda < 2300\text{Å}$.

Mukerji concludes from the almost complete identity of emission bands in the last four rows of Table 97 that they are produced in all cases by the same mechanism. Since lanthanum has no electrons in its 4f-shell, he assumes that the fluorescence is excited by the transition of an electron from the H₂O solvation envelope to an outer electronic level of the rare-earth ion. Fluorescence of a pure solid lanthanum salt has never been observed. On the other hand, the fluorescence spectra of solid and of dissolved cerium salts are

almost coincident and the fluorescence has been ascribed to the transition of the 4f-electron to an orbit outside of the xenon shell. The contradiction between the two hypotheses has not been cleared up (504,1089).

Filippov, Larinov, and Seidel have pointed out that the typical line fluorescence of terbium and europium salts in aqueous solutions could be excited by light of wavelengths below 2500Å with far greater intensity than by the radiation which was absorbed in the visible and near-u.v. bands of the ions. If the solutions were irradiated with the light from an iron spark, the fluorescence disappeared almost completely when a filter absorbing the wavelengths below 2500Å was inserted in the path of the primary

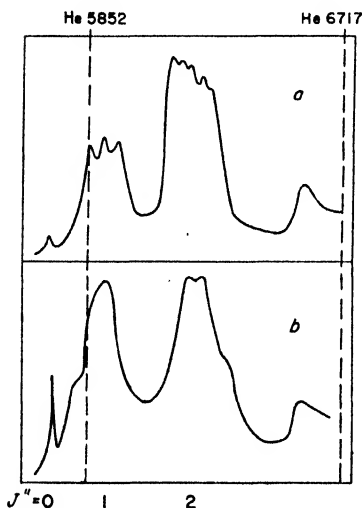

Fig. 158. Fluorescence band of trivalent europium (Tomaschek)
a: in a glass. *b*: in aqueous solution.

light (388,824,864,865a,865b,1484a,1484b,1485).

The fluorescence properties of solutions in glasses are, in some respects, intermediate between those of crystals and of liquid solutions, while, in other respects, the crystals seem to be closer to the liquid solutions than to the glasses. The fluorescence lines of europium or samarium are more diffuse in glasses than in liquid solutions, and the structure of the groups which can still be recognized reveals a higher degree of asymmetry of the molecular fields in the glasses. While in liquids the symmetry is spherical as a statistical average, the most complete asymmetry resulting from random distribution is "frozen in" in the glasses. Figure 158 shows the photometer curves of the

first three groups of the europium spectrum in a phosphate glass and in a dilute aqueous solution of europium nitrate. The spectrum of the glass shows the structure corresponding to the Stark effect in a field of highest asymmetry, with three components in the group $0' \rightarrow 1''$ and five components in the group $0' \rightarrow 2''$. Furthermore, the $0' \rightarrow 0''$ line is shifted even more in the direction of greater wavelengths than in the dilute europium nitrate solution* (1698a, 1698b).

On the other hand, several rare earths, the line fluorescence of which cannot be excited in liquid solutions, exhibit fluorescence when they are dissolved in solid glasses. Didymium glasses have been used since the end of the nineteenth century for lecture experiments demonstrating the fluorescence of solids. Their fluorescence spectrum used to be ascribed to their content of praseodymium and neodymium, to which they owed their pinkish color. The strong orange fluorescence of most didymium glasses, however, has been shown to belong to traces of samarium, while the fluorescence of neodymium, in didymium glasses as well as in so-called pure neodymium glasses, is limited to two strong infrared bands at 8090 and 8820 Å. The other fluorescence bands of didymium glasses or of pure praseodymium glasses are listed in Table 98. Although showing no fine structure, the spectrum is very similar to those of phosphors activated with praseodymium. In glasses of different origin the two band groups designated in Table 98 by *a* and *b* have very unequal relative intensities and in some samples group *b* is almost completely missing. Furthermore, a glass which

TABLE 98
FLUORESCENCE BANDS OF PRASEODYMIUM GLASS
(Wavelengths in Å)

Limits of band	Maximum	Limits of band	Maximum
<i>a</i> { 6500 6450-6150 6150-6400	6500 narrow, st.	<i>c</i> { 4850 4820	4850 narrow, w.
	6300 diffuse, m.		4820 narrow, m.
	6100 v. st.		
<i>b</i> { 5620-5500 5430-5350 5170-5100	5550 v. st.	4600-4560 4350-3900	4580 m.
	5380 v. st.		4350 m.
	5140 m.		

* Tomaschek's conclusions, according to which the spectra of the aqueous solutions reveal a higher degree of field symmetry than those of the glasses, are not in agreement with the relatively greater intensity of the forbidden $0' \rightarrow 0''$ line in the aqueous solution spectra, since this line is supposed to appear only under the action of highly asymmetric fields.

shows both groups with similar intensity when irradiated with white light emits only the bands of group *a* when excited by yellow light and only group *b* when excited by near u.v., while with blue light both groups are excited. The fluorescence bands designated by *c* in Table 98 are not emission bands of a rare earth but are caused by the superposition of strong absorption bands of the rare earths on the weak continuous fluorescence of the other components of the glass (279,826, 1297).

While praseodymium and neodymium are not fluorescent in borate or phosphate melts if these are not devitrified, the fluorescence of thulium in borax beads has been observed.

143. Fluorescence of Divalent Ions. Alkali halides which have crystallized with traces of a europium halide from an aqueous solution emit the line fluorescence characteristic of the Eu^{+++} -ion. If the crystals are heated to a temperature above 200°C , the lines are replaced in the fluorescence spectrum by a continuous band in the blue between 4230 and 4450A. The wavelength of this band is only very slightly influenced by the nature of the alkali halide serving as base lattice (1311). The appearance of the new fluorescence is caused by the transformation of the trivalent rare earth into the divalent modification. The same effect is produced by irradiation of europium imbedded in fluorite, calcite, or calcium sulfate with x-rays or β -rays. By the same treatment trivalent samarium thulium, and ytterbium are transformed into their divalent ions, which are also fluorescent. The wavelengths of the maxima of their emission bands are listed in Table 99. The red bands of Sm^{++} and of Tm^{++} very nearly coincide, but they can be distinguished by their different dependence on temperature. The band fluorescence of the divalent rare-earth metals is observed only in relatively narrow temperature ranges, indicated in the last row of Table 99. The ions are not destroyed by transgressing these temperature limits, however; the temperature effect is rever-

TABLE 99
FLUORESCENCE BANDS OF DIVALENT RARE-EARTH IONS
(Wavelengths of maxima in A)

Element	Samarium	Europium	Thulium	Ytterbium
Color of fluorescence	red	blue	red	green
λ_m	6200	4290	6200	5700
Temperature limits, $^\circ\text{C}$	0-50	0-100	< -60	< -60

sible and the fluorescence is restored by re-establishing the corresponding temperature. The fluorescence is excited by irradiation with light of the near u.v. The concentration of Sm^{++} and Eu^{++} necessary for producing an appreciable fluorescence intensity is exceedingly low; it is of the order of magnitude of 10^{-4} % for europium in NaCl , and of only $5 \cdot 10^{-6}$ % for Sm in CaSO_4 .

The blue fluorescence of Eu^{++} has also been observed in pure crystalline EuCl_2 ; if the crystals of EuCl_2 are contaminated with traces of samarium (which is almost always the case), the red Sm^{++} -band appears in addition to the blue Eu^{++} -band in the fluorescence spectrum after irradiating the salt with β -rays (1311I, 1313, 1314a).

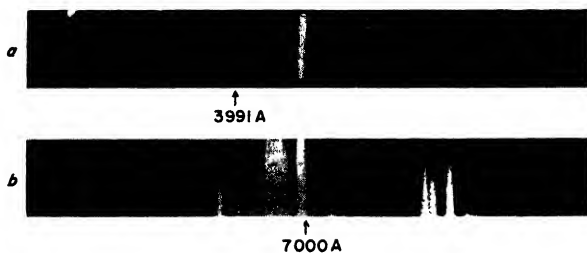

Fig. 159. Line fluorescence spectrum of divalent europium in strontium fluoride (Katcoff).

a: u.v. series. *b*: red and infrared series.

If a borax bead containing europium has been heated in the reducing zone of a Bunsen flame, it emits, instead of the orange-red fluorescence of Eu^{+++} , a greenish fluorescence which has not been analyzed spectrographically and which also has been ascribed by Gobrecht to divalent europium. Furthermore, Gobrecht obtained a weak fluorescence with a continuous spectrum reaching from the green to the red in borax beads activated with cerium, praseodymium, or ytterbium and assumed this fluorescence to be due to the presence of divalent ions of these elements (504).

While the fluorescence spectra of divalent rare earths described in the preceding paragraphs consists of relatively broad bands and are essentially different from the spectra of the trivalent ions, Katcoff obtained at low temperatures in the fluorescence of Eu^{++} imbedded in SrF_2 a series of equidistant narrow lines which were superimposed on the diffuse blue-violet band. The last of these lines, at 3991 Å (Figure 159*a*), coincides with the first line of an absorption series which stretches with the same constant spacing of 100 cm^{-1} far to the

u.v. In addition, several fluorescence lines were found in the u.v. near 3150A and about forty lines in the extreme red and the near infrared (Figure 159*b*). A theoretical interpretation of these line spectra has not been given, but they may also be ascribed to electronic transitions inside the incomplete 4*f*-shell which are modified by the addition of a 6*s*-electron outside the closed neon shell. No fluorescence spectra of this kind were obtained when the Eu^{++} -ions were incorporated in hydrated strontium chloride ($\text{SrCl}_2 \cdot 6\text{H}_2\text{O}$) or in other alkaline-earth halide crystals (731).

A series of about twenty lines between 6885 and 8981A was observed by Tomaschek in the fluorescence spectrum of samarium which was imbedded in CaSO_4 and excited by strong u.v. light. While Tomaschek and Gobrecht ascribed these lines to Sm^{+++} , Przibram brought forward very convincing arguments for his assumption that they belong to the divalent samarium ion (See Section 170) (503, 1314*a*, 1696, 1699).

B. Uranyl Salts

144. Band Spectra of UO_2^{++} -Ions. Fluorescence of uranium salts has been the subject of investigations since the days of Stokes and E. Becquerel in the middle of the nineteenth century. Although it led indirectly to the discovery of radioactivity by H. Becquerel, the fluorescence of uranium salts is in no way connected with their radioactive properties or with the fact that they contain, in general, various radio-active elements as minute impurities. It is certain, furthermore, that the fluorescence is not caused by other impurities "activating" the salts. On the other hand, photoluminescence is not a property of all uranium salts but only of the uranyl compounds, in which the metal is hexavalent and occurs as the ion UO_2^{++} ; the uranous salts in which the metal is quadrivalent and forms ions UO^{++} are not photoluminescent. All uranyl salts have absorption and emission spectra of the same type, differing only in details; similar spectra are also exhibited by liquid solutions of uranyl salts, and even in solids such as sodium fluoride or calcium fluoride containing uranyl at a concentration of 10^{-6} molar, fluorescence of the same character can be excited.*

* Among the earlier contributions to the research on the fluorescence of uranium compounds the most important are due to Nichols and Merritt and their collaborators. Their results are collected in a monograph cited in the bibliography (K).

It has already been mentioned that the electronic transition corresponding to this absorption and emission is forbidden: the molar absorption coefficient is about one hundred thousandth that of a dye solution and the duration of the "slow fluorescence" of the crystalline salts is of the order of magnitude of 10^{-4} sec. Nevertheless, the fluorescence yield of many of these salts is very high and may approach 100 %.

In contradistinction to the spectra of the rare-earth ions the absorption and fluorescence spectra of the uranyl salts are typical band spectra (Figure 160). The fluorescence spectra are produced by transitions from a single excited electronic state to the ground state, upon which several nuclear vibrations and perhaps also lattice vibrations are superimposed (342). Obviously these spectra are progressions of the type $v' = 0, v'' = 0, 1, 2, \dots$ with a principal vibrational frequency near 830 cm^{-1} ; the fluorescence progressions are continued in the direction of shorter wavelengths by similar progressions in the absorption spectrum which are of the type $v'' = 0, v' = 0, 1, 2, \dots$ with a spacing $\sim 650 \text{ cm}^{-1}$.



Fig. 160. Fluorescence spectrum of uranyl ammonium fluoride at -180°C (Nichols and Merritt).

Nichols and Merritt and their coworkers tabulated the wavelengths occurring in the spectra of many uranyl salts as series of regularly spaced band groups which at room temperature were still broad and diffuse, but at the temperature of liquid air could be resolved into numerous narrow lines. With relatively small variations these lines are repeated in each group ("homologous lines"). Table 100 reproduces the fluorescence spectrum of uranyl nitrate as an example of this kind of representation. The horizontal rows in Table 100b represent the various band groups, and the vertical columns under every heading (*A, B, \dots*) represent series of homologous lines (*K*).

While this representation was purely formalistic, interpretations of the uranyl spectra based on the quantum theory of band spectra were proposed by Van Heel and later by Pant. These interpretations were not satisfactory in several respects, however, and have been superseded by a much more correct and complete analysis of the spectra* (1189, 1190b, 1736-1738). Important progress was achieved

* Declassified report prepared by G. H. Dicke, A. B. F. Duncan, and co-workers. A condensed abstract of this report was prepared by T. Biegeleisen, G. H. Dicke, A. B. F. Duncan and M. G. Mayer for publication in *Physical Review*.

TABLE 100
 FLUORESCENCE BANDS OF URANYL NITRATE
 (λ in Å, ν in cm^{-1})

A. AT ROOM TEMPERATURE

v_1'	v_1''	Approximate band limits (λ)	Band maxima		$\Delta\nu$
			λ	ν	
0	5	6212-6150	6188	16160	887
0	4	5941-5840	5866	17047	858
0	3	5630-5550	5585	17905	860
0	2	5360-5280	5329	18765	897
0	1	5120-5060	5086	19662	866
0	0	4900-4850	4869	20538	702
1	0	— —	4708	21240	

B. AT -180°C ($v_1' = 0$)

v_1''	A	B	C	D	E	F	G	H	J	K
6	—	—	—	6515 vw	6493 vw	—	—	—	—	—
5	—	—	—	6169 w	6139 w	6131 m	—	6061 vw	—	6002 vw
4	—	5917 vw	5885 w	5858 m	5831 m	5821 w	—	5767 vw	—	5680 vw
3	5682 vw	5634 w	5602 w	5578 st	5556 st	5544 m	5525 w	5489 w	5476 vw	5440 vw
2	5417 vw	5373 m	5351 w	5325 st	5305 st	5291 m	5269 w	5241 m	5230 vw	5200 vw
1	5149 w	5136 m	5112 w	5092 st	5068 m	5052 m	5042 vw	4950 m	—	—
0	4956 m	4914 st	4897 m	4878 m	4856 w	4849 w	—	—	—	—

by the following means: the use of spectrographs of great dispersion, such as a 21-foot grating; use of liquid hydrogen for cooling the samples; introduction of various isotopes such as U^{235} , O^{18} , and N^{15} into various compounds. This last procedure has made it possible not only to build up a general energy-level scheme for the representation of the main lines, but to ascribe practically all important lines to specific vibrations within specific groups, such as UO_2^{++} , NO_3^- , and $\text{C}_2\text{H}_3\text{O}_2$ (Figure 161).

The main feature of all uranyl fluorescence spectra, appearing alone in weakly exposed spectrograms, is the superposition of three vibrational frequencies on a single electronic transition or 0-0 line which is called the resonance line R . The three vibrational frequencies

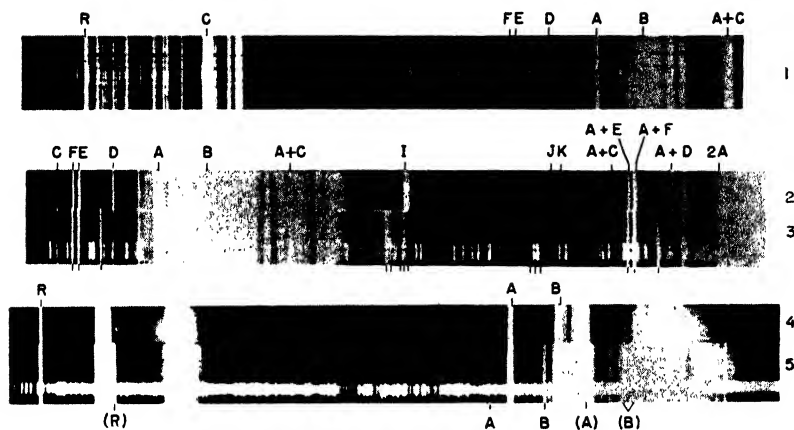

Fig. 161. Fluorescence spectra of uranyl salts.

- 1: First and part of second group in the fluorescence spectrum of cesium uranyl nitrate.
- 2: Second group in the fluorescence spectrum of cesium uranyl nitrate (lines due to the nitrate ion marked D, E . . . K, A+E etc).
- 3: The same with 70% N^{15} in the nitrate ion (the displaced nitrate lines are marked below the spectrum).
- 4: First and second group in the fluorescence spectrum of cesium uranyl chloride.
- 5: Same with 1.4% O^{18} in the uranyl radical (the displaced line: A and B are marked below the spectrum; the letters in brackets designate "impurity lines").

correspond to the three modes of vibration of the uranyl ion OUO which is a linear, or at least nearly linear, molecule. The frequency of the first oscillation $\text{O}-\text{U}-\text{O}$ is $A \sim 830 \text{ cm}^{-1}$, that of the second oscillation $\text{O}-\text{U}-\text{O}$ is $B \sim 920 \text{ cm}^{-1}$, and that of the third or deformation oscillation $\text{O}-\text{U}-\text{O}$ is $C \sim 230 \text{ cm}^{-1}$. A appears in the spectra with quantum numbers $v_1^r = 0, 1, 2 \dots 8$, B and C only with quantum numbers 0 and 1, and only one of them (B or C) is superimposed on every $v_1^r A$ — for instance, $R-2A-B$ or $R-2A-C$.

Thus the "first group" of a fluorescence spectrum consists in this simplest case of only two lines, R and $R-C$, while the second and all following groups consist of three lines, $R-v_1^r A$, $R-v_1^r A-C$, and $R-(v_1^r - 1)A-B$. The oscillation with the frequency A is not strictly harmonic; A decreases, in general, with increasing values of v_1^r . Since this holds also for the frequency B as a function of v_1^r and A and B do

not vary in the same way with increasing ν_1'' , it follows that the various groups are not exact repetitions of each other. B being greater than A , the line $R-\nu_1''A-B$ falls into the group beginning with $R-(\nu_1'' + 1)A$. In many spectra the lines corresponding to the frequencies A and B and in practically all spectra those corresponding to C are split into

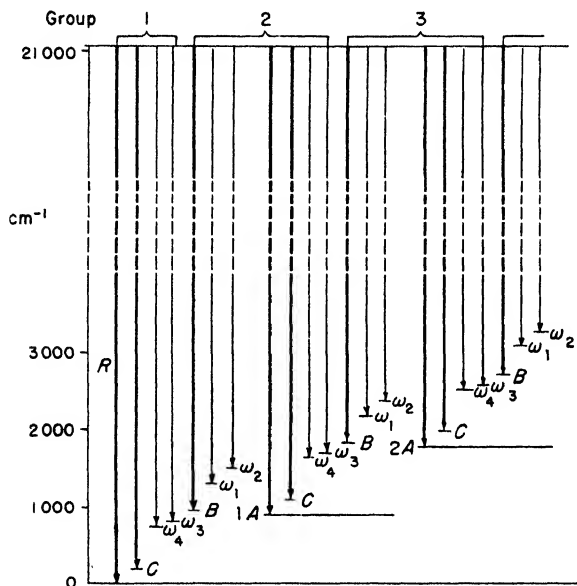

Fig. 162. Energy levels for the first three groups of the fluorescence spectrum of $\text{CsUO}_2(\text{NO}_3)_3$. Heavy lines: UO_2 -vibrations; light lines: NO_3 -vibrations. The C and ω levels are multiplets; concerning the interpretation of ω_1 - ω_3 , compare Table 103.

several components, probably because of the internal electric and magnetic fields existing in the crystals. In addition to these principal lines numerous weaker lines appear in all spectra and an appreciable part of these can also be ascribed to definite molecular vibrations (Figure 162).

The spectrum of cesium uranyl nitrate, which has been investigated very thoroughly, provides a typical instance of such an analysis. At the temperature of boiling hydrogen 236 lines were observed (compared with the 48 lines listed in Table 100b) and the origin of about 100 of the stronger lines could be ascertained. Twenty-nine lines

correspond to the R -line and to the three UO_2 -oscillations A , B , and C superimposed on the electronic frequency R . They are represented with good approximation by the equation:

$$\nu = 21089.56 - v_1'' \cdot 885.5 - v_1''^2 \cdot 1.5 - v_2'' (956 - v_1'' \cdot 4.75) - v_3'' \cdot C$$

where $v_1'' = 0, 1, 2 \dots 6$; $v_2'' = 0, 1$; $v_3'' = 0, 1$ for $v_2'' = 0$ and $v_3'' = 0$ for $v_2'' = 1$. C is split into three components: 209–213–222 cm^{-1} , with their center of gravity at about 214, practically independent of the value of v_1'' . Another set of four relatively strong lines, which is repeated in every group with a average frequency of 260 cm^{-1} , has also been ascribed to the C -vibration, so that the latter would be evolved into a doublet with a spacing of about 146 cm^{-1} , each component consisting of a narrow multiplet.

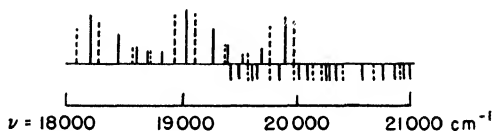

Fig. 163. Fluorescence spectrum of uranyl ammonium chloride at 20° C (Nichols and Merritt).

By partial substitution of O^{18} for O^{16} some weak lines of the compound prepared with atmospheric oxygen (0.2 % O^{18} and 0.04 % O^{17}) were identified as belonging to groups $\text{O}^{18}\text{-U-O}^{16}$ and $\text{O}^{17}\text{-U-O}^{16}$. On the other hand, by replacing 70 % of the nitrogen by N^{15} and determining which lines were shifted under these conditions, 42 lines were proved to belong to the NO_3 -group.

The ion NO_3^- has four modes of vibration, which in sodium nitrate have the values: $\omega_1 = 1050$, $\omega_2 = 1390$, $\omega_3 = 831$, and $\omega_4 = 720 \text{ cm}^{-1}$; since every group in the fluorescence spectrum contains 8 lines associated with NO_3 -vibrations, some of the normal modes must be split into several components by the interaction with other NO_3 -groups or with UO_2 -groups (compare Table 103, and Figures 161 and 162.)

From spectra obtained with samples which were greatly enriched in U^{235} it could be concluded that in the spectra of the normal salts weak companions of the lines represented by $R-v_1''A-B$ were due to the presence of small amounts of U^{235}O_2 ; the spacing between the main lines and the companions is about 0.7 cm^{-1} . The fact that no com-

panions of this type are found near the lines $R-\nu_1^{\sim}A$ justifies the assumption that the UO_2 -group is (nearly) linear so that the frequency of the symmetrical oscillation A is not affected by a change in the mass of the central nucleus. It is true that the symmetrical oscillation A and the asymmetrical oscillation B should not occur simultaneously superimposed on the same electronic transition in the spectrum of a linear molecule, but this selection rule may be invalidated by the existence of intermolecular forces in the crystal lattice. The relative intensities of the B -lines differ greatly in different compounds; they are exceedingly low in the spectra of simple uranyl salts, such as the nitrate, etc. (see following section).

The frequencies of vibrations belonging to the NO_3 -group ($D, E \dots J, K$) are not changed by the introduction of U^{235} instead of U^{238} ; they are independent also of the value of ν_1^{\sim} .

Additional lines which are repeated with great regularity in every group of the $\text{CsUO}_2(\text{NO}_3)_3$ spectrum are obviously due to the presence of unknown impurities, since their relative intensities vary to a high degree in different samples of salts which have allegedly the same chemical composition. The position of these lines in the groups leaves no doubt that they are characteristic of another uranyl salt and most probably of another nitrate, but they cannot be identified with lines in any spectrum which has been investigated. Calcium uranyl nitrate has been proposed tentatively as the source of these impurity lines in the spectrum of $\text{CsUO}_2(\text{NO}_3)_3$.

Most of the other lines not included in the classes enumerated above are probably due to lattice vibrations.

At the temperature of liquid hydrogen only the very lowest vibrational levels are populated in the excited electronic state as well as in the ground state. Therefore, the fluorescence spectrum begins at its short-wavelength end with the R -line (the $0'-0''$ line) and only this line is common to the emission and the absorption spectrum. At higher temperatures the levels corresponding to the oscillations with quantum number 1 ($C, D, E \dots A, A + C$, etc.) are partially occupied in the excited and the ground state and thus the lines in every group become much more numerous; due to this effect and the increasing width of the individual lines, the structure of the band groups becomes diffuse. Moreover, not only is the complete first group of the fluorescence spectrum repeated at higher temperatures in the absorption spectrum, but the two spectra overlap even in the groups $1'-0''$ and $0'-1''$, the first being relatively weak in absorption, the second in emission.

This behavior is illustrated by the figures of Table 101, which lists the strongest fluorescence and absorption bands of potassium uranyl sulfate at 20°C . The table shows also the jump from 660 to 830 cm^{-1} in the spacing of the band groups which occurs at the point of transition from the progression $v' = 0, v'' = 0, 1, 2 \dots$ to the progression $v'' = 0, v' = 0, 1, 2 \dots$. The rather large irregularities in the values of the $\Delta\nu$ are due to the fact that they represent the distances between peaks of diffuse band groups which may not correspond exactly to the distances between homologous lines (*K, III7*).

The fluorescence spectrum attains its highest intensity in the second group with $v'' = 1$ and rapidly becomes weaker with increasing wavelengths; six to seven band groups can be observed in most fluorescence spectra and only in exceptional cases can a progression be followed up to $v'' = 9$. The absorption spectra stretch over a wider range: even in the absorption spectrum of uranyl sulfate in aqueous solution as many as sixteen nearly equidistant bands have been observed (Table 101). However, the spacing of these bands, which at

TABLE 101
PRINCIPAL ABSORPTION AND FLUORESCENCE BANDS OF POTASSIUM
URANYL SULFATE AT 20°C
(λ in \AA , ν in cm^{-1} for band peaks)

v'	v''	Absorption			Fluorescence		
		λ	ν	$\Delta\nu$	λ	ν	$\Delta\nu$
4	0	4350	22989				
				629			
3	0	4472	22361				
				688			
2	0	4614	21637				
				665			
1	0	4760	21008		4765	20986	
				683			661
0	0	4920	20325		4920	20325	
				820			832
0	1	5127	19505		5130	19493	
							836
0	2				5306	18657	
							819
0	3				5606	17838	
							834
0	4				5881	17004	
							849
0	5				6190	16155	

their short-wavelength end near 3100Å merge into a strong continuum, is also not quite regular; the bands become very diffuse in an intermediate region and have their greatest intensity in the fifth or sixth group. These strong deviations from the so-called principle of mirror symmetry is explained by the analysis of the low-temperature absorption spectra of solid uranyl salts. According to this analysis the bands in the absorption spectrum are due only in small part to the electronic transition which corresponds to the fluorescence emission, while other parts of the absorption spectrum are produced by transitions to several higher electronic states.* From all these excited states the electrons always pass by radiationless processes into the lowest level of the lowest excited electronic state and thus the fluorescence spectra are completely independent of the wavelength of the absorbed exciting radiation (*K*, 1288, and footnote on page 481).

Even at the temperature of liquid hydrogen the various fluorescence lines in a given fluorescence spectrum vary greatly with respect to their width. Some are as sharp as the iron lines of the comparison spectrum, others are broad with sharp edges, and still others are diffuse. In part the broadening of certain lines may be caused by a resonance effect; the lines which are characteristic of impurity molecules, or of those molecules containing isotopes of small concentration, and which are not affected by interactions with neighboring molecules of the same kind, are among the sharpest. On the other hand, the lines attributed to lattice vibrations are more diffuse than those ascribed to vibration in the groups UO_2 , NO_3 , etc. The lines of the first group (with $\nu_1'' = 0$) are, in general, appreciably sharper than those in the following groups, and this may be interpreted by the assumption that the coupling is partly produced by *A*-vibrations. However, in the higher groups also, very sharp lines are found and a general interpretation of these differences is not yet available.

The additional broadening of the lines occurring at higher temperatures is usually asymmetric, more to the red, and is accompanied by a shift in the direction of greater wavelengths. This shift is the same for all principal lines (*R*, *A*, *B*, and *C*) and is nearly constant over a wide temperature range (about 0.17 cm^{-1} per degree in the case of cesium uranyl nitrate) (*86*, and footnote on page 481).

The polarization of the lines in the fluorescence spectra of uranyl salts (compare Section 122) can be observed only when the luminescence is emitted by a single crystal and not, as in most instances,

* A complete treatment of these absorption band systems would exceed the scope of this book.

by a microcrystalline powder. The experiments are handicapped by the fact that even in well-developed crystals the surface layers from which most of the fluorescence emanates are more or less disturbed; therefore, lines which should be completely absent in the ordinary or extraordinary spectra appear only as weakened in one or the other. Cesium uranyl nitrate crystallizes in the hexagonal system. If the fluorescence of a $\text{CsUO}_2(\text{NO}_3)_3$ crystal is observed in a direction perpendicular to the optical axis, the *A*-lines show no appreciable polarization, the *B*-lines and the *C*-line components of frequencies $\sim 213 \text{ cm}^{-1}$ are stronger in the ordinary spectrum, while the *C*-multiplets of frequencies $\sim 260 \text{ cm}^{-1}$ are stronger in the extraordinary spectrum. One line among those attributed to NO_3 -vibrations (*F*, with the frequency 739 cm^{-1}) is polarized preferentially, with its electric vector parallel to the optical axis; the other NO_3 -lines seem to be unpolarized. Similar results were obtained with the biaxial crystals of CsUO_2Cl_4 .

These somewhat incomplete recent observations disagree in one respect with the older data published by Nichols and Merritt and their co-workers. Figure 163 represents schematically the fluorescence and absorption spectra of potassium uranyl chloride. The lines of the ordinary spectrum are drawn as full lines and those of the extraordinary spectrum as dotted lines. Since no lines of the two systems coincide, all are supposed to be completely polarized. The same is not true, however, in the fluorescence spectra of all uranyl compounds, even as recorded by Nichols and Merritt. In other instances they found only some lines to be completely polarized, while others were partially polarized so that their intensities were unequal in the ordinary and extraordinary spectra, and still others were unpolarized. Homologous lines always show the same degree of polarization in every band group.

The lines below the horizontal in Figure 163 represent the first groups of the absorption spectrum which correspond to the same electronic transition as the fluorescence spectrum and show the same behavior with respect to the polarization of the lines.

145. Fluorescence Spectra of Individual Crystalline Uranyl Salts.

The number of fluorescent uranyl compounds which have been investigated is very large. They are not only the chlorides, fluorides, nitrates, sulfates, carbonates, phosphates, acetates, and oxalates of hexavalent uranium but manifold double salts such as $\text{CsUO}_2(\text{NO}_3)_3$, which has been treated as a characteristic example in the last section. Among the metals occurring as the second component in these double salts the most important are the alkali metals, including ammonium; others are magnesium, zinc, lead, silver, and thallium. Diammonium

salts with methyl or ethyl groups replacing the hydrogen atoms in the NH_4 -ion also have been investigated occasionally. Certain combinations — for instance, the sodium double nitrate — cannot be prepared (*K,II08-III4,III7,II20,II27,II30*).

Although the fluorescence and absorption spectra of all uranyl salts are of the type described in Section 146, the spectrum of each individual compound has its characteristic properties. These are determined principally by the nature of the anion, while the presence of a second metal and the nature of this metal in double salts are of a minor influence. Thus the spectra of all nitrates, all sulfates, etc., are similar with respect to the frequencies and relative intensities of the lines corresponding to the vibrations in the UO_2 -group and to the frequencies of the lines due to the anion group. Examples of this behavior are given in Tables 102 and 103, which list the frequencies of the *R*-line and the UO_2 -vibrations *A* and *B* for numerous compounds, and the frequencies characteristic of the NO_3 -group in various double nitrates. The Greek letters in parentheses in Table 103 indicate the

TABLE 102
FREQUENCIES *R*, *A*, AND *B*, OCCURRING IN VARIOUS URANYL SALT SPECTRA

Nitrates [$\text{MUO}_2(\text{NO}_3)_2$ and $\text{M}_2\text{UO}_4(\text{NO}_3)_4$]								
M	Cs	Rb	K	NH_4	Cs_2	Rb ₂	$\text{UO}_2(\text{NO}_3)_2$	
							3H ₂ O	6H ₂ O
<i>R</i>	21089.6	21199.4	21183.0	21897.7	20807.3	20817.8	20778.7	20578.3
<i>A</i>	884.0	887.9	875.5	885.7	870.3	861.3	874.0	863.9
<i>B</i>	956.2	962.1	949.9	959.4	949.5	937.7	948.1	941.0

Chlorides ($\text{M}_2\text{UO}_2\text{Cl}_4$)			Sulfates [$\text{M}_2\text{UO}_2(\text{SO}_4)_2$]			
M	Cs_2	$\text{K}_2 \cdot 2\text{H}_2\text{O}$	$\text{Cs}_2 \cdot 3\text{H}_2\text{O}$	Rb ₂	K ₂	(NH_4) ₂
<i>R</i>	20096.3	19961.2	20953.6	20920.2	20389	20358
<i>A</i>	836.1	831.8	860.5	838.2	827	840
<i>B</i>	916.3	903.2	923.1	—	—	—

Acetates [$\text{MUO}_2(\text{CH}_3\text{O}_2)_2$]							Carbonate [$\text{M}_2\text{UO}_2(\text{CO}_3)_2$]
M	Cs	Rb	Na	NH_4	Mg	Be	K ₂
<i>R</i>	20992.1	21099.4	21135.0	21056	20996	20958	20943
<i>A</i>	842.2	852.1	855.2	847	—	853	808
<i>B</i>	920.0	924.0	927.2	—	—	—	850

TABLE 103
 FREQUENCIES ASCRIBED TO NO_3^- -VIBRATIONS IN VARIOUS URANYL
 NITRATES $[\text{MUO}_2(\text{NO}_3)_3 \text{ AND } \text{M}_2\text{UO}_2(\text{NO}_3)_4]$

M	Symbol							
	$H(\omega_1)$	$G(\omega_1)$	$F(\omega_1)$	$E(\omega_1)$	$D(\omega_2)$	$I(\omega_2)$	$J(\omega_2)$	$K(\omega_2)$
Cs	708.37	712.73	739.11	749.13	804.56	1277.5	1504.0	1518.9
K	—	—	742.01	751.2	803.14	—	—	—
Rb ₂	—	687.68	734.01	750.71	825.10	—	—	—
K ₂	—	690.76	735.37	749.86	825.39	—	—	—

modes of vibration of NO_3^- to which the various frequencies have been ascribed tentatively (see footnote on page 481).

In the spectra of other salts with complex anions other lines characteristic of vibrations of these anions can be identified. Thus, the fluorescence spectra of all acetates exhibit lines corresponding to a frequency $\sim 610 \text{ cm}^{-1}$ which must be due to a vibration of the acetate radical; there is also evidence of other acetate vibrations. The presence of lines characteristic of the SO_4^- -group has been ascertained in the spectra of uranyl sulfates and, although they have not yet been disentangled, it is certain that lines due to anion vibrations exist in the spectra of carbonates, phosphates, etc.

Such lines must be missing in the spectra of the chlorides and therefore the total number of lines is appreciably smaller in the spectra of the chlorides than in other spectra [for instance, 170 lines observed in the spectrum of $\text{Cs}_2\text{UO}_2\text{Cl}_4$ compared with 237 lines in the spectrum of $\text{CsUO}_2(\text{NO}_3)_3$]. This difference would be even larger if the number of "impurity lines" were not exceptionally large in the chloride spectra.

Moreover, the lines *R*, *A* and *B* are doublets with a spacing $\delta\nu \sim 2 \text{ cm}^{-1}$; in the spectrum of rubidium chloride the *A*-lines are even quadruple. This splitting does not seem to be caused by the

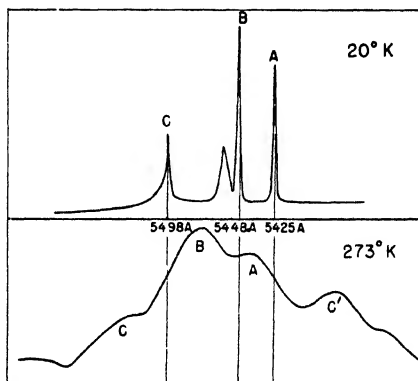

Fig. 164. Photometer curves of the third group in the fluorescence spectrum of $\text{Cs}_2\text{UO}_2\text{Cl}_4$ at 20° and 273°K .

presence in the compounds of the two chlorine isotopes Cl^{35} and Cl^{37} , but rather to the low symmetry of the crystals (Figure 162).

The relative intensities of the lines corresponding to the vibrations of the UO_2 -radical differ greatly in the spectra of salts with different anions. In the double uranyl nitrates, chlorides, and acetates the *B*-lines are the strongest, the *A*-lines are somewhat weaker, and the *C*-lines are appreciably weaker than the *A*-lines (Figures 164, 165). In the double sulfates and fluorides the *B*-lines are very weak or completely absent while the *A*-lines predominate in the various

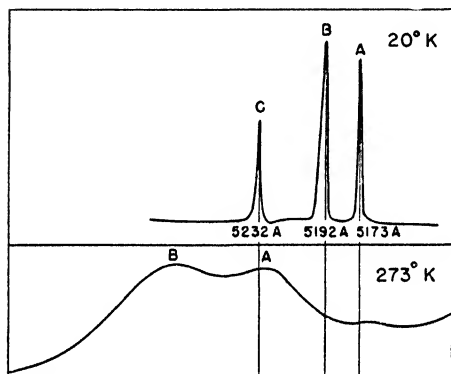

Fig. 165. Photometer curves of the third group in the fluorescence spectrum of $\text{Cs}_2\text{UO}_2(\text{NO}_3)_3$ at 20° and 273° K.

groups. This holds also for the simple uranyl chloride UO_2Cl_2 and for uranyl nitrate $\text{UO}_2(\text{NO}_3)_2$, which exists in modifications with various amounts of water of crystallization (Table 109). Moreover, the NO_3 -lines are much weaker in the simple uranyl nitrates than in the double nitrates such as $\text{CsUO}_2(\text{NO}_3)_3$. The structure of the *C*-group depends also on the nature of the compounds; in the acetates the structure of the *C*-group is very much more complex

than in the nitrates. In the spectrum of $\text{Rb}_2\text{UO}_2(\text{SO}_4)_2$ it consists of eight sharp and fully resolved lines.

The sharpness of corresponding lines in the spectra of closely related compounds is different even at 20° K. Thus the lines of $\text{CsUO}_2(\text{SO}_4)_2 \cdot 3\text{H}_2\text{O}$ are all very diffuse, those of the first group of $\text{Rb}_2\text{UO}_2(\text{SO}_4)_2 \cdot 2\text{H}_2\text{O}$ are exceedingly sharp. The lines of the double nitrates, which are sharp at 20° K, become so broad at room temperature that it is difficult to perceive any structure in the individual band groups; the lines of the double chlorides, on the other hand, although rather diffuse, can be easily recognized in the spectrum at 300° K and even the resolution into two components of different polarization can be observed (Figures 164, 165).

The fluorescence spectrum of UO_2F_2 is very weak and shows no structure in its groups at the temperature of boiling hydrogen. It seems that, in general, the presence of hydrogen, in double ammonium

salts as well as in crystals containing water of crystallization, tends to render the fluorescence spectra more diffuse; moreover, water of crystallization influences the characteristic frequencies of the intermolecular vibrations (see, for instance, the two simple uranyl nitrates in Table 102). The bands in the fluorescence spectrum of uranyl sulfate at room temperature show two peaks α and β separated by about 50A, α being the component of shorter wavelength and having the lower intensity. After complete dehydration of the salt by careful heating the fluorescence spectrum consists of a progression of simple bands γ , which are shifted with respect to α by another 50A toward the violet. When the crystals are slowly rehydrated by exposure to moist air, the three progressions γ , α , and β reappear side by side, but during the first phase of this process α is much stronger than β . This behavior is greatly in favor of the assumption that α , β , and γ belong to three different degrees of hydration (Table 104) (*K, III 7*, and footnote on page 481).

The influence of hydration may be due at least partially to the fact that it determines the crystal system in which the compound crystallizes. According to Nichols and Howes the spectra of the biaxial crystals of diammonium uranyl nitrate with two moles of water $[(\text{NH}_4)_2\text{UO}_2(\text{NO}_3)_4 \cdot 2\text{H}_2\text{O}]$ and of anhydrous $\text{K}_2\text{UO}_2(\text{NO}_3)_4$ are nearly identical, while they differ very definitely from the spectra of the trigonal crystals of ammonium uranyl nitrate $[(\text{NH}_4)\text{UO}_2(\text{NO}_3)_3]$ and the hexagonal crystals of $\text{KUO}_2(\text{NO}_3)_3$ (Figure 166). It has been mentioned previously that in the spectra of the biaxial crystals of the

TABLE 104

ABSORPTION AND FLUORESCENCE BANDS OF URANYL SULFATE AT ROOM TEMPERATURE

(Wavelengths of band maxima in A)

Absorption			Fluorescence			
Hydrated crystals		Concentrated aqueous sol.	Hydrated crystals		Dehydrated	Concentrated aqueous sol.
Series			Series			
β'	α'	α'	β	α	γ	β
4595	4555	4555	—	—	—	—
4755	4720	4720	4760	—	—	—
4925	4880	4890	4930	4884	4843	4930
—	—	5095	5150	5098	5049	5150
—	—	—	5395	5340	5285	5390
—	—	—	5659	—	5538	5630

alkali uranyl chlorides the *R*-lines are double; a similar doubling occurs in the spectra of the biaxial nitrates $\text{Cs}_2\text{UO}_2(\text{NO}_3)_4$ and $\text{Rb}_2\text{UO}_2(\text{NO}_3)_4$, while the *R*-lines are simple in the spectra of the monaxial nitrates, such as $\text{CsUO}_2(\text{NO}_3)_3$. In the spectrum of sodium uranyl acetate, which is known to crystallize in the cubic system, the *R*-line is also simple, but it is double in the spectra of other acetates (*K, III, 31*).

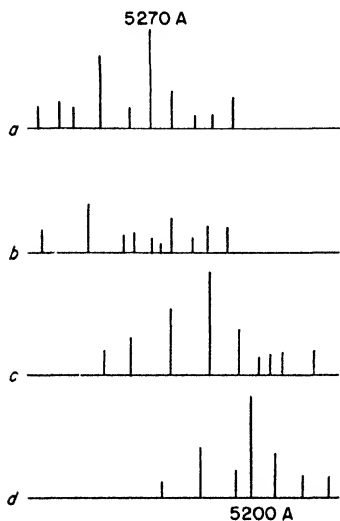

Fig. 166. Structure of the band at 5250 Å in the fluorescence spectra of various uranyl nitrates (Nichols and Merritt).

- a*: diammonium nitrate (monoclinic). *b*: dipotassium nitrate (monoclinic). *c*: ammonium nitrate (trigonal). *d*: potassium nitrate (rhombic).

The fluorescence spectra of a few compounds of hexavalent uranium, which show little analogy with those of the uranyl salts, have been investigated. Anhydrous UO_3 is nonluminescent at room temperature and at the temperature of liquid air; but hydrated uranium trioxide is fluorescent at 70° K. There are several crystalline modifications of the dihydrate and the monohydrate (hexagonal, rhombic, monoclinic, triclinic, and amorphous) from which seven slightly different fluorescence spectra have been obtained. The spectra stretch from 5000 to 5820 Å, the limits varying somewhat for the different modifications; the spectra consist of band groups which even at 20° K are rather diffuse; every group has a different structure and not even the spacing between the band groups is approximately constant in some of the spectra (see footnote on page 481).

Uranium hexafluoride is a nonfluorescent gas at room temperature, but irradiation with near u.v. excites a strong violet fluorescence in solid UF_6 at 70° K. Eleven irregularly spaced bands with an average spacing of 215 cm^{-1} have been measured in the spectrum, which stretches from 4050 to 4545 Å with a maximum of intensity at 4220 Å.

146. Liquid Solutions and Glasses. The fact that the character of the fluorescence of uranyl salts in liquid solutions depends on the nature and the concentration of the salt and on the nature of the solvent proves that the isolated UO_2^{++} -ion is not the carrier of the

luminescence in these solutions. On the other hand, Levshin's claim that the fluorescence of uranyl compounds in liquid solutions is characteristic of the undissociated molecules cannot be accepted as a general law. According to Levshin's observations the emission and absorption spectra of a salt in solution are always much more closely related to the spectra of the same salt in the crystalline state than to those of other salts in solution. However, some of Levshin's own data disagree with his hypothesis. The wavelengths of the fluorescence bands of uranyl sulfate in aqueous solution which he tabulates lie much nearer to those of the crystalline nitrate than to those of the crystalline sulfate (916). Apart from this purely accidental coincidence the great variety of spectra of dissolved uranyl salts published by Nichols and his co-workers leaves no doubt that these spectra originate from a correspondingly great variety of complexes which are formed partially by polymerization and partially by interaction with the solvent.

In principle, three classes of spectra can be distinguished. In the first class the solution spectra are closely related to the spectra of the undissolved salts, except that the last remnants of line structure are blurred out and that the band peaks are shifted in one or the other direction. The spectra of the second class are still discontinuous, but their structure differs essentially from that of the crystalline salts. The spectra of the third class are continuous, stretching from the blue to the yellow. The fluorescence yield of the liquid solution is rather low, in general, at room temperature and, moreover, it is very susceptible to quenching by foreign impurities (compare Section 107).

According to the figures in the last column of Table 104 the aqueous solution of uranyl sulfate belongs to the first class of fluorescent uranyl salt solutions: its fluorescence spectrum is very similar to that of one of the solid hydrates. However, the emission spectrum consists only of the progression β while only the progression α appears in the absorption spectrum, so that the absorption and emission bands do not coincide in the region where the two spectra overlap. The fluorescence spectrum of uranyl sulfate in concentrated sulfuric acid is similar to that of the aqueous solution; it is fairly bright even at room temperature, but exceedingly sensitive to the quenching action of halide ions and organic compounds such as ethyl alcohol.

Aqueous solutions of potassium uranyl sulfate are not fluorescent at all at room temperature, but the fluorescence is restored if the solution is frozen at temperatures below 0° C; the exact location of the individual bands is shifted appreciably with decreasing concen-

tration of the salt. Nichols assumes that various hydrates are formed under these conditions. The fluorescence of potassium uranyl sulfate in liquid sulfuric acid has the same character as that of the frozen aqueous solution; at low temperatures and low concentrations a resolution of the diffuse bands into sub-bands becomes noticeable (Figure 167) (633,1129).

The behavior of the nitrates is much more complicated. Saturated solutions of uranyl nitrate in water or ethanol show two parallel sets of bands. The first of these sets, which is very weak in the alcoholic solution, is independent of the nature of the solvent and coincides with

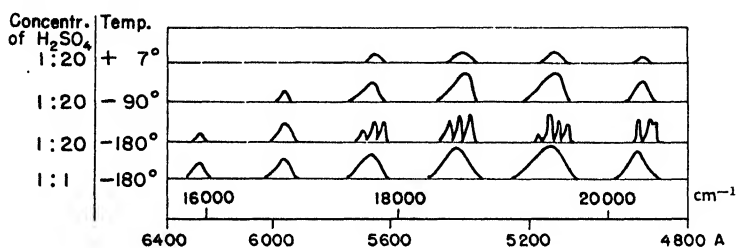

Fig. 167. Fluorescence spectra of solutions of uranyl potassium sulfate in water with addition of increasing quantities of sulfuric acid (Nichols and Merritt).

the bands of the crystalline salt. The bands of the second progression, which are much brighter than the others and about three times as broad, have no analogue in the fluorescence of the crystalline compound and are displaced in ethanol by about 40 Å toward the violet with respect to their wavelength in the aqueous solution. The fluorescence is rather weak at -25°C and increases rapidly at lower temperatures, but retains the same aspect even at -180°C . When the concentration is decreased to less than 0.5 molar,* the fluorescence spectrum has a completely different character and is quite continuous; at low temperatures, however, the typical structure reappears. If an aqueous solution is not quenched instantaneously but is cooled slowly so that the dissolved salt is able to crystallize out, the fluorescence spectrum again shows the fine structure which is characteristic of the crystalline nitrate and which is only slightly modified by the interaction with the neighboring molecules of the solvent.

* The solubility of uranyl nitrate in water is much higher than that of the sulfate. While the sulfate solutions are saturated at room temperature at a concentration of about 0.5 mole per liter, the saturated solution of the nitrate has more than ten times this concentration.

The fluorescence spectrum of uranyl acetate dissolved in water consists, at room temperature, of a single continuous band, even when the solution is saturated. At -180°C the continuum is resolved into a sequence of broad equidistant bands. If the solution is diluted in the ratio of 1:100, a second series of narrower bands appears in the intervals between the first bands, and at a dilution of 1:1000 both band sets vanish and give room to a third sequence of very diffuse bands. Neither of these spectra seems to be related to the others, nor to the spectrum of the crystalline salt (K_2UO_2).

In an alcoholic solution of uranyl acetate which is frozen at -180°C the fluorescence spectrum consists, irrespective of the concentration, of a great number of narrow lines. These lines do not coincide, however, with the lines of the undissolved acetate at low temperature and they are not even combined into groups with the spacing $\Delta\nu \sim 830\text{cm}^{-1}$ which are characteristic of all other uranyl spectra. This is the more striking as it is the only case in which sharp lines have been obtained in the fluorescence spectrum of an amorphous solution of uranyl salt.

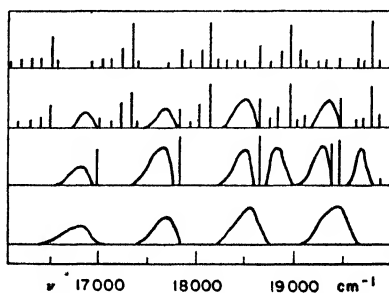

Fig. 168. Fluorescence spectra of uranyl sodium phosphate dissolved in mixtures of water and phosphoric acid (Nichols and Howes).

Apart from this single exception, the appearance of sharp lines in the absorption and emission spectra of uranyl compounds is restricted to crystals at low temperatures. This is proved very convincingly by the fact that if microcrystalline salts such as phosphates or nitrates are transformed by stepwise addition of the corresponding acid into syrupy solutions which at -180°C solidify as glasses, the sharp lines give way to broad bands which are frequently appreciably displaced with respect to the original line groups. Figure 168 illustrates the phenomenon for the case of the phosphate; in the last row of the figure in which the ratio is two moles of acid to one mole of uranyl phosphate, only the broad "solution bands" remain visible. (Compare, also, the last row of Figure 167). It may be mentioned that in the well-known fluorescence of canary glass the continuous emission band becomes somewhat narrower at the temperature of liquid air and shows two diffuse maxima, but no trace of a line structure. Such glasses,

also, are fluorescent only when they contain uranium in the form of UO^{++} -ions. By an admixture of a uranate, glasses acquire an orange color without being luminescent.

Nichols and Slattery have investigated a number of other solids which are not fluorescent by themselves and become luminescent by the addition of small amounts of uranium oxide. Some of these solid solvents — for instance, beads of sodium or potassium phosphate and borate — were probably glasses, while the beads of sodium fluoride and lithium fluoride were proved by x-ray analysis to be crystalline. The lattice constants of the crystals were not changed appreciably by the minute traces of uranium. The lithium salt emits a bright blue-green fluorescence; the fluorescence color of uranium-activated sodium fluoride is a vivid yellow. At the temperature of liquid air the bands are resolved into numerous narrow lines, those of the lithium salt covering about the same spectral region (4500–5700A) as the fluorescence spectra of pure uranyl salts, but the lines of the sodium salt do not reach at the short-wavelength end of the spectrum beyond 5300A, while they extend farther in the direction of greater wavelengths (1132, 1511, 1512). (For a similar shift in the peak of the uranyl fluorescence bands in uranium-activated cadmium tungstate, see Section 166).

In borax beads, phosphate beads, or in lithium fluoride the presence of uranium can be traced by its fluorescence to concentrations as low as 10^{-7} molar. The luminescence yield of such "solid solutions" reaches an optimum at the relatively low concentration of 10^{-1} to 10^{-2} % and drops to zero at higher concentration; this property seems to place them rather in the class of "impurity-activated phosphors," which are treated in the next chapter (604).

C. Various Complex Inorganic Ions

147. Metal Salts in Aqueous Solutions. Using the same experimental arrangement with which they observed the fluorescence of rare-earth compounds in aqueous solution, Stark and Steubing investigated aqueous solutions of the sulfates and chlorides of iron, nickel, cobalt, copper, vanadium, thorium, potassium, and barium; apparently the metals forming colored ions were chosen preferentially. No fluorescence could be obtained by excitation with near u.v. or with short-wavelength u.v. (1552). The only metal salts which, in addition to the rare-earth salts, have been found to be fluorescent when dissolved in

pure water are the thallos salts $TlCl$, $TlBr$, Tl_2SO_4 , etc., the anion of the compound being without importance as long as it is not a strong quencher like I^- . Of course, it is not the isolated Tl^+ -ion that is to be considered as the carrier of the luminescence, but the complex formed by the hydration of the ion, the emission electron of which is not protected against interactions with the outside by a rare-gas electron shell as in the case of the rare-earth ions. The resonance lines of the gaseous Tl^+ -ion lie at 1321 and 1908Å; the absorption band in which the fluorescence of the solution is excited has its peak at 2140Å. A thallium concentration of 10^{-5} molar is sufficient to produce a fairly strong visible fluorescence. The emission process is not directly related to the absorption process: its spectrum consists of a broad continuous band between 3100 and 4500Å with a poorly defined maximum at 3700Å. No satisfactory theoretical explanation is available for the mechanism by which the fluorescence is produced: it might be due to a transition between two higher electronic states of the Tl^+ -ion, but it might also be due to an electronic transition between a water molecule of the hydration envelope and the ion (1304).

The visible fluorescence of a dilute thallium salt solution becomes much stronger when free chloride or bromide ions are present in the solution in great quantity; simultaneously, the color of the fluorescence changes from violet to blue for chloride and to green for bromide. If the solution is 0.5 normal in KCl or KBr or any other chloride or bromide ($NaCl$, $CaCl_2$, HCl , etc.), this suffices to produce the effect. The intensity of the fluorescence increases with increasing concentration of the halide and is strongest in a highly concentrated $CaCl_2$ -solution ($\sim 10 N.$). The concentration of hydrochloric acid must not exceed 3 normal, however, since the fluorescence is quenched at higher concentrations, probably by a photochemical reaction in which molecular hydrogen is set free. The continuous emission bands of the chloride and bromide solutions reach from the violet to the yellow, but the relative intensity in the long-wavelength region is greater in the bromide solutions. The intensity of the chloride band has a double maximum at 4200 and 4500Å, while the bromide band has its principal maximum at 4900Å and a secondary maximum at 4150Å.

In addition to these visible bands, much weaker u.v. fluorescence bands have been observed at 3000Å in the chloride and at 3200Å in the bromide solutions. The fluorescence is ascribed to complex ions of the type $(TlCl_3)^{--}$ and $(TlBr_3)^{--}$; these ions are characterized by the appearance of narrow selective absorption bands at 2420 and 2465Å, respectively. It is probable that other complexes containing the metal

ion combined with different numbers of halide ions and water molecules participate in the phenomenon.

No fluorescence is obtained in dilute aqueous solutions of plumbous or stannous salts.* On addition of KCl or KBr to such solutions the ions Pb^{++} and Sn^{++} also form complexes, probably $(PbCl_4)^{--}$ and $(SnCl_4)^{--}$, which can be excited by irradiation with short-wavelength u.v. to emit a greenish fluorescence. The luminescence is, however, much less bright than that of the thallium complexes. The formation of the complex lead ions gives rise to a new selective absorption band near 2680A, while the absorption spectrum of the stannous complex is continuous from 2700A downward with a weakly marked shoulder at 2600A. These latter complexes are very unstable: under the action of the exciting radiation the fluorescence disappears within a relatively short time (448,449,521,522,617,640,1304,1427b).

Although new selective absorption bands have also been obtained in solutions of CuCl and AgCl on addition of a sufficient amount of another chloride or bromide, the corresponding complex ions are not fluorescent. A search for other metal ions which can be excited to fluoresce under similar conditions yielded only negative results. An intense fluorescence which was observed when a concentrated solution of lithium chloride was irradiated with light of $\lambda < 2400A$ may belong to a complex lithium ion, but it may also have been caused by an unknown impurity, although it was not possible to remove the fluorescence by purification of the salt.

Practically all tap water is excited by "black light" to emit a very noticeable violet fluorescence. Most of this luminescence is caused by impurities and vanishes gradually after repeated distillation in vacuo. It seems to be impossible, however, to make it disappear completely, and Vavilov and Tumerman suggest that similar fluorescence spectra which are excited in most liquids by near-u.v. light may originate from traces of O_2 which form some kind of complexes with the molecules of the liquid (211a,1768).

Another unexplained phenomenon may be mentioned in this connection. Ewles found that the surface of many colorless crystals which are not fluorescent by themselves emit a strong bluish luminescence when illuminated with black light, after they have been moistened with distilled water. Since crystals such as quartz, which are practically insoluble in water, are among those mentioned by Ewles, it seems probable that the fluorescence must not be ascribed to a solution of the salt in water, but that it is rather a property of

* Stannous chloride is soluble in water only if slightly acidified with HCl.

the water itself when it is adsorbed as a thin film in the surface of the crystal. The phenomenon has not been investigated further (372).

148. "Pure" Inorganic Salts. A considerable number of inorganic salts are known to be fluorescent as pure crystals. They can be divided, in the main, into two classes. The most important example of the first class is calcium tungstate; other tungstates, many molybdates, germanates, and vanadates behave in the same way. Since they contain the complex ions WO_4 , MoO_4 , etc., it is not implausible that the fluorescence is a property of these ions, although their luminescence has never been observed in aqueous solutions.

The typical representative of the second class is zinc sulfide; in this case, the theory is generally accepted that the luminescence is not characteristic of the matrix lattice, but that it depends on the presence of "activating interstitial" zinc atoms. The same is probably true for zinc oxide. The manganous halides (chlorides, bromides, and fluorides) are also fluorescent; the emission bands are situated in the orange-red and are very similar to those observed in many crystal phosphors which are activated with minute quantities of manganese. It may be that the pure crystalline manganous salts, too, are activated by interstitial manganese atoms (600, 1332, 1333). Neither simple nor complex manganese ions in aqueous solutions of manganous and manganic salts, of manganates, permanganates, etc. can be excited to fluorescence. A strong orange-red fluorescence is excited by near-u.v. light in mercurous chloride and this fluorescence is a general property of the salt to such a degree that it cannot be ascribed to some accidental impurity; on the other hand, none of the other colorless mercurous salts (sulfate, nitrate, acetate) shows a similar fluorescence.

Various authors list many other crystalline salts in which fluorescence can be excited by black light. Among these compounds are the halides of cadmium, thallium, silver, and copper; lead nitrate; etc. According to Randall the intensity of the fluorescence becomes appreciable only at low temperatures. It is almost certain that most of these compounds were tested in a state of purity which was not so high that their luminescence could not be ascribed to a foreign activator. Impurities of the order of magnitude of one per million are frequently sufficient to transform a nonluminescent crystal into a brilliant phosphor. Thus plumbous chloride obtained by slow crystallization from a pure aqueous solution exhibits a bright yellow fluorescence. This fluorescence is completely suppressed if all lead hydroxychloride hydrate is precipitated from the solution by keeping it for some

time at 100° C before $PbCl_2$ is allowed to crystallize (194b, 547a, 1331, 1332).

Since the two classes of crystalline metal compounds which have been proved to be luminescent without a foreign activator have most of their properties in common with typical crystalphosphors, and since all of them can also be activated by the addition of various foreign admixtures, it seems to be preferable to treat them together with the other crystal phosphors in the next chapter.

149. Complex Platinous Salts. The remarks at the end of the last paragraph do not apply, or apply only to a much smaller degree, to

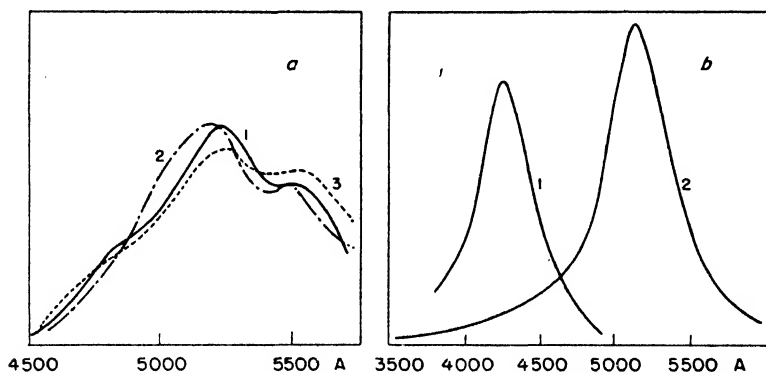

Fig. 169. Fluorescence bands of cyanoplatinites. (a) In alcoholic solution: 1, potassium; 2, magnesium; 3, barium salt (Khvostikov). (b) Crystals of (1) strontium, (2) barium salt (Genard and Rassenfosse).

certain coordination compounds of platinum, of which the cyanoplatinites are the best known. Barium cyanoplatinite was instrumental in the discovery of x-rays and for a long time has been the most important material for the manufacture of fluorescent x-ray screens.

Until recently, it has been assumed that these salts are luminescent only when in the crystalline state. Khvostikov succeeded, however, in proving that they can also be excited by long-wavelength u.v. when they are dissolved in water, glycerol, or isoamyl alcohol. In contrast to the crystals, the fluorescence yield of the liquid solutions is relatively small (see Section 105) and their absorption and emission spectra are independent of the second metal component. The fluorescence spectrum of potassium, barium, and magnesium cyanoplatinite in aqueous solution consists of the same broad double band

with maxima at 5250 and 5500A (Figure 169, also Figure 105, page 309). Hence, it must be assumed that the same complex ion $[\text{Pt}(\text{CN})_4]^{--}$ is the carrier of the luminescence in each of these solutions (775).

The fluorescence of the solid salts is, in general, much stronger and here the nature of the second metal plays a decisive part. The various compounds differ widely in their absorption spectra, so that their colors in transmitted light vary from green to red.

Most of the data concerning the fluorescence of the cyanoplatinites are relatively old and merely of a qualitative nature, and many results obtained by different investigators disagree. This probably is due mainly to the fact that the optical properties of the compounds are influenced to a high degree by the mode of preparation, which determines the structure and the water content of the crystals. Besides, the color of the fluorescence depends on the orientation of the crystals with respect to the directions of the exciting light and of the observation, and this has not been taken into account in most instances (95).

Thus, the fluorescence of barium cyanoplatinite is described as blue by Becquerel and as green by Grailich, while, according to Hagenbach, it is green-yellow in crystals freshly prepared from an aqueous solution and changes to golden yellow after dehydration. According to L. A. Levy, barium cyanoplatinite is deposited from an aqueous solution in golden-yellow crystals containing 4 moles of water and exhibiting a weak green fluorescence. When these are heated to 100°C , they are converted without loss of water into an isomeric green modification with a very strong green fluorescence. By application of high pressure or long-lasting exposure to β -rays, the green crystals are converted into a brick-red amorphous powder which is not fluorescent. By heat treatment the substance is recrystallized and recovers its green color and its strong fluorescence (922).

Stokes and Grailich found the color of the fluorescence of the magnesium salt to be red and green, respectively; according to Hagenbach, it is red at first and becomes orange and finally yellow-green by heat treatment, and Wood observed that the fluorescence of a magnesium cyanoplatinite crystal changes from red to yellow with varying direction of observation. Similar discrepancies are found in the literature with respect to the fluorescence of many other compounds of this group.

In Table 105 a number of cyanoplatinites are listed with the colors of their fluorescence and the approximate limits of their fluorescence bands; the data refer to the modifications in which each of the

TABLE 105
FLUORESCENCE OF CYANOPLATINITES

Second metal	Fluorescence color	Band limits	Second metal	Fluorescence color	Band limits
Li	orange	6150-5200	Ca	blue	5475-4590
Na	yellow	5900-5100	Sr	indigo	5550-4220
K	blue	5400-4450	Ba	green	5650-4850
Rb	blue	5300-4377	Mg	green	—
Cs	indigo	5400-4150	Y	green	5900-4500
LiRb	green	6155-4855	Er	green-yellow	5950-5100
NH ₄	green	5900-4880	Th	green	5600-4650
Tl	none	—	UO ₂	none	—

compounds shows its brightest fluorescence. It is rather surprising that the only compounds which cannot be excited to luminescence under any conditions are those which contain the uranyl radical or the thallos ion as second component. There seems to exist a certain regularity in the series of the alkali compounds, the bands being displaced toward the violet with increasing atomic weight of the alkali metal (486).

A result published by Hauer and Kowalski has never been confirmed by other investigations. These authors state that the fluorescence spectrum of rubidium cyanoplatinite consists of a symmetrical band between 4200 and 5400A (maximum at 4700A) when it is excited by the violet mercury line 4047A; this selective band is replaced by a band which increases continuously in intensity from the red to the limit of the u.v. region if the fluorescence is excited by the u.v. mercury line 3650A (583).

Taking everything into account, it seems that fluorescence is a property of the complex $\text{Pt}(\text{CN})_4^{--}$ itself, but that it is very sensitive to the quenching action of the molecules of a liquid solvent. The fluorescence yield, therefore, is greatly enhanced by crystallization, and in the crystals the second metal entering the complex determines the absorption and fluorescence spectra. The second metal is, however, not an "activator" in the sense in which crystal phosphors are activated by minute impurities, but it is an intrinsic part of every molecule in the crystal lattice.

The specific capacity of platinum to form coordination compounds which are fluorescent is furthermore proved by the fact that many organic compounds of this type are photoluminescent. $\text{PtCl}_2 \cdot \text{dipyridyl}$ [$\text{PtCl}_2(\text{C}_5\text{H}_4\text{N})_2$] may be mentioned as an example. This substance exists in two modifications showing different colors in transmitted

light. The red form is excited to fluorescence by black light at room temperature, while the yellow form shows a weak fluorescence only at the temperature of liquid air (1332).

150. Unsaturated Silicon Compounds. Derivatives of siloxene ($\text{Si}_6\text{H}_6\text{O}_3$) form a last group of photoluminescent pure inorganic compounds. Although their luminescence can be observed only in the solid state, it can hardly be doubted that it is a property of the molecules as such, and not of crystalline structure. The constitution of siloxene is, according to Kautsky and Herzberg, similar to that of the benzene ring and represented by the formula:

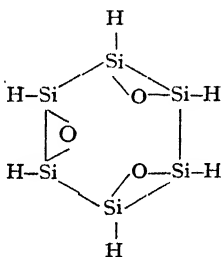

Siloxene itself is colorless and exhibits no visible fluorescence. The compounds in which one or several hydrogen atoms are replaced by halides or by hydroxyl or amino groups are colored and fluorescent. In both respects hydroxyl and amino groups are much more effective than the halides. With increasing numbers of the substituents the absorption and emission bands are shifted in the direction of greater wavelengths. Thus, the fluorescence color varies from yellow to deep red if all hydrogen atoms are replaced successively by OH-groups. If the aminosiloxenes are oxidized, they emit a bright chemiluminescence, the spectrum of which is identical with that of the fluorescence of the nonoxidized compound. It must be assumed, therefore, that the luminescence is not emitted by the reacting molecules, but that the energy set free by the oxidation is transferred to other nonreacting molecules in a process of sensitized chemiluminescence (compare Section 110) (754,755).

151. Glasses. Practically all technical silicate glasses are fluorescent when they are irradiated with u.v. light. The luminescence is, in general, weak with black-light excitation, but frequently acquires appreciable intensity if the wavelength of the primary light is smaller than 3000Å. The color of the fluorescence varies from blue through green and yellow to red (340). Such glasses are, of course, never pure in the sense of luminescence chemistry. According to Dobischek,

perfectly pure sodium and potassium silicate glasses and sodium borate glasses are not excited to fluorescence even by the radiation from an iron arc. While it is difficult, in most cases, to ascertain which impurities cause the fluorescence of commercial glasses, the problem becomes much simpler if pure base material is intentionally activated by the addition of some heavy metal. According to Cohn, zinc borate glass containing 2% of manganese emits, under the action of short-wavelength u.v., a strong orange fluorescence band with a peak at 6100Å. Linwood and Weyl ascribe the green luminescence of many silicate glasses to Mn^{++} -ions which have entered the network of the base material, taking the place of Si^{++} -ions, while the red fluorescence observed in other glasses is assumed by these authors to be due to "interstitial" manganese ions. According to Kreidl, the peak of the fluorescence band of silicate and borate glasses containing manganese is shifted in the direction of shorter wavelengths (to the green) by addition of "network-forming" compounds such as Ti_2O_3 and Al_2O_3 ; by addition of Na_2O and other alkali oxides to the glass base, the network is loosened and the color of the fluorescence is changed to orange and red. In phosphate glasses which have a relatively loose structure the fluorescence due to manganese is red, but becomes yellow when the network is "strengthened" by the addition of zinc oxide (230,306,823,942,1825a-c).

Kabakjan asserts, however, that the fluorescence of manganese-activated borate glasses is very weak and increases "tremendously" as soon as crystallization sets in. This is in agreement with Curie's statement that the faint reddish light emission of these glasses gives way to strong green phosphorescence when the glass is devitrified or begins to crystallize (251,701). The surface of so-called glass tears, which are obtained by rapid quenching of a liquid glass drop, shows no trace of fluorescence, while the inside layers of the drop, which have not cooled so rapidly, are slightly luminescent.

Although the problem is far from being solved completely, it seems that pure glasses are not fluorescent but that they can be activated to a certain degree by the addition of some heavy metals. In "pure" lead glass, which, according to Dobischek, exhibits an appreciable blue fluorescence, "interstitial" lead atoms may play the part of an activating metal. By increasing the lead content of flint glasses from 2% to 60%, the color of the fluorescence changes from purple to blue and finally to green, becoming very weak at high lead concentrations (823).

Weyl states that in most cases, in order to produce fluorescence, the metal must be incorporated in the glass in the form of neutral

atoms or must be converted from the initial ionic state to neutral atoms by an adequate treatment. He mentions as an example of this type a soda lime glass containing 0.125 % of silver. Such a glass is practically nonfluorescent when melted under oxidizing conditions and cooled rapidly; when it is reheated for five hours to 120–175° C in a hydrogen atmosphere, it can be excited by black light to a strong yellowish fluorescence. Another example is provided by a pure silica glass activated with tin oxide which is converted to atomic tin at the high melting temperature of the glass (1825*a*).

Many of the well-known yellow filter glasses used for photographic purposes owe their color to an admixture of cadmium sulfide. Again, the glass is nonfluorescent (and colorless) if the melt is rapidly cooled (37,677). It acquires its color and fluorescence only after being reheated to temperatures between 640 and 720° C. The higher the temperature and the duration of the heat treatment, the more the edge of the absorption band and the peak of the fluorescence band are shifted in the direction of longer wavelengths. Jaeckel ascribes this behavior to the formation of colloidal particles of metallic cadmium. Similarly, glasses containing cerium and selenium in atomic dispersion exhibit a fluorescence of blue and red color, respectively. It is striking that, in all cases, rapid cooling of the melt, which inhibits crystallization or at least tends to preserve the disorder characteristic of the liquid state, produces nonfluorescing material and that fluorescence appears after reheating, which in addition to its influence on the state of an activating metal may also have an influence on the structure of the base material.

Admixture of iron and other metals of the iron group quenches the fluorescence of all glasses. On the other hand, the fluorescence is enhanced, in general, when the temperature is lowered to — 180° C.

Many samples of fused quartz show a violet fluorescence even under excitation with the Hg-line 2537, to which the best fused quartz is transparent. In addition to this fluorescence, fused quartz emits, after irradiation with the light from a mercury lamp; a very weak phosphorescence which decays very slowly at room temperature and is still able to blacken a photographic plate several days after the excitation. If the quartz plate is heated after exposure to the u.v. radiation, the stored energy is released as a bright green glow. The same green phosphorescence is excited with much greater intensity by Schumann u.v.; it can be observed easily on a quartz window fused to a hydrogen discharge tube ten minutes after the electric discharge has been discontinued (40,1790).

CHAPTER VII

CRYSTAL PHOSPHORS

A. Nature of the Phosphors and Fundamental Processes

152. Monomolecular and Bimolecular Processes. "Phosphor" (the Greek word for "light carrier"), without any further qualification, was the name coined originally for the designation of the luminescent substances which are treated in this chapter. In order to distinguish them from other phosphors which have since been discovered, such as the organophosphors of Chapter V, the designation "crystal phosphors" seems to be the most appropriate. "Impurity phosphors," used by some authors, is inadequate because it creates the erroneous impression that boric acid or aluminum sulfate containing traces of organic compounds belongs to the same group as the crystal phosphors, while, on the other hand, interstitial zinc atoms in a zinc sulfide crystal cannot be called "impurities." "Mineral phosphors," proposed by others, is somewhat noncommittal and does not emphasize the main condition to which these mineral compounds owe their phosphorescence. Considering the definition of phosphorescence given in Section 98, one might doubt, perhaps, whether it is quite correct to include all of the luminescent mineral crystals under the common title "phosphors." However, the boundaries between the various types of luminescence — phosphorescence, recombination afterglow, and slow fluorescence — are so fluid, insofar as these crystal phosphors are concerned, that it would introduce useless complications to attempt a separation of the phenomena according to such principles.

For more than three centuries after the discovery of the first "luminous stone," interest was devoted almost exclusively to the preparation of phosphors with an afterglow as brilliant and persistent as possible; when the theoretical treatment of the phenomenon began to be taken up seriously, it was again the afterglow of long duration which primarily captivated the interest of physicists. It is very characteristic that Lenard, who, with his school, contributed by far the greatest part of research in the field during the first three decades of the 19th century, defined as "normal" the concentration of the

various constituents of a phosphor which produced the longest strong afterglow, and not that which gave rise to the greatest initial brightness. Only about 1935, when technical applications such as television and fluorescent lamps aroused the interest of industry in luminophors with no lasting afterglow, were emission processes of short duration investigated more thoroughly. Theory met this newly awakened practical interest halfway, since, at the same time, the newly introduced quantum-mechanical treatment of electronic processes in insulating crystals encountered many important problems closely related to the problems of luminescence (118-123, 436a, 1060, 1061, 1095). It is hardly an overstatement to say that since then the results of the earlier investigations, especially those of the Lenard school, have been neglected more than they usefully might have been.

Lenard was not the first to apply the methods of modern physics to phosphorescence: this accomplishment must be credited to Edmond Becquerel. Nor was he the first to appreciate the importance of small impurities as a factor determining the properties of a phosphorescent system, or to suggest a connection between phosphorescence and the photoelectric effect. Earlier, Boisbaudrans had shown that the luminescence of ruby and other crystals was due to minute quantities of chromium or manganese, and Elster and Geitel had pointed out that most phosphorescent minerals are photoelectrically sensitive to light of relatively great wavelength (361, 872-875). It remained for Lenard, however, to analyze systematically the function of the activating metals in the most important groups of phosphors; his prescriptions for the preparation of alkaline earth sulfide phosphors are still the basis of all industrial productions of these luminophors; and, as his greatest achievement, he proposed for the first time the concept that the primary effect of light absorption is the displacement of an electron from its natural position of equilibrium, that the absorbed energy can be stored as potential energy of the electron trapped in a potential trough from which it can be released by thermal fluctuations, and that the eventual return of the electron to its initial position is accompanied by the emission of light. Although expressed by Lenard in a somewhat different terminology, this is not only the picture which, in the main, is still accepted for the representation of the mechanism of phosphorescence, but it was, many years before Bohr, a forerunner of the modern theory of light absorption and light emission in general (*F*, 885, 890, 892).

Notwithstanding these decisive achievements, it cannot be denied that progress was impeded for a considerable time in more than one

direction by Lenard's great authority. The most important of these barriers against progress was his conviction that phosphorescence, under all circumstances, is a monomolecular process. The assumptions of earlier investigators — for instance, Becquerel and, after him, Nichols and Merritt, and M. Curie — who believed that a bimolecular mechanism was in better agreement with some of the experimental evidence, was emphatically rejected. According to Lenard the whole process takes place inside a single "center," a giant molecule consisting of an atom of the activating metal and a great number of molecules of the base material, such as CaS, SrO, etc. Thus, the mechanism would not differ in principle from that described in Chapter V as representing the phosphorescence of organic molecules. If the observed decay of the phosphorescence did not exactly agree with an exponential curve, this was ascribed to the existence of centers "with unequal energy isolation" (*A, F, 77, 249, III 6*).

It was pointed out at an early date* that if the absorbing electron remained imprisoned within the center, the parallelism between the excitation of phosphorescence and the photoelectric effect lost its meaning. This discrepancy became even more apparent after the discovery that an inner photoelectric effect or photoconductivity was, in many instances, coupled with the excitation of phosphorescence and followed the same laws of decay. Once the electron has left its center, so that it can follow an external electromotive force, it can recombine with another excited center which has lost its electron by light absorption; thus, the process becomes bimolecular.

It is somewhat misleading that the designation "phosphorescence centers" has been retained by many authors who no longer admit Lenard's concept as a whole, even if they state that they use the word "in Lenard's sense." If, by the absorption of light, an electron is completely released from the point to which it was bound in the unexcited crystal; if, on its way through the crystal, it can be trapped at some point where the main part of its energy is stored; and if, finally, the electron reaches an impurity atom or ion and there it excites emission of light — one may speak of an absorption center, of a storing or trapping center, and of an emission center. A center in Lenard's sense must be all three in one.† It can be assumed, of course,

* In Pringsheim's *Fluorescenz und Phosphorescenz im Lichte der neueren Atomtheorie*, second edition, Berlin, 1923.

† In the following sections the terms "excited electrons" and "excited emission centers" will be used for electrons which were displaced from their normal location by light absorption and for lattice points to which the electrons can return with the emission of light. Thus, an excited center can be the point

that regions exist within the phosphor in which several electrons can be set free by light absorption and then trapped without being able to escape from this region, and that the region contains only a single emission center. Such regions would possess the essential characteristics of a center in Lenard's sense, with the additional property that the dislocation of the electrons could produce a measurable photocurrent.

Levshin was the first to take up, once more, Becquerel's original concepts in contradiction to Lenard's viewpoint and to assume that the decay of the luminescence of crystal phosphors should be represented by hyperbolic curves. He corroborated his assertion not only by experiments of his own, but he maintained that many of Lenard's results could best be interpreted in this manner. Since then, the trend to explain phosphorescence as a bimolecular process and to describe the decay of every phosphorescence by some sort of hyperbolic curve has become very general and, for some time, has seemed to supersede the monomolecular hypothesis completely (915).

While it is probably correct that nearly all phosphorescence processes in crystal phosphors are bimolecular in that electrons moving freely through a "conductivity band"* can combine with any one of numerous excited centers, the phosphorescence decay need not, therefore, follow the law of a second-order reaction. As long as most excited electrons are trapped, the number of those free to combine with an emission center is very small compared with the number of these centers, which remains practically constant; thus, the process obeys the law of a first-order reaction and the decay curve is exponential, with a time constant depending on the probability which governs the release of the electrons from the traps. If, however, not only a single constant probability exists — or, in other words, if the phosphor contains traps of not only one depth — the decay curve will correspond to the superposition of various exponentials and its shape will be determined by the relative numbers of traps of various depths ("the trap distribution"). This, in principle, is nothing but a more modern interpretation of Lenard's "centers of different duration."

Randall has shown that under specific assumptions about the trap distribution, the decay of phosphorescence can obey the law of a second-order reaction, although it is due to the superposition of

from which an excited electron has been released primarily, if the "positive hole" remains fixed at this point; it can be a point to which a positive hole has migrated and at which it has been stabilized, and it can be a point where an electron was missing in the unexcited crystal.

* Compare Section 156.

numerous first-order reactions, and he and his co-workers came to the conclusion that the release from traps, and not the probability of recombination, is the factor governing the rate of phosphorescence decay of all crystal phosphors. This is probably true for phosphorescence processes lasting longer than a small fraction of a second. It is another question whether afterglows with lifetimes of several milliseconds should be regarded as instances of pure recombination afterglow. Experimental data which were obtained by various investigators and which will be discussed in Section 159 favor this interpretation; it seems, however that electrons cannot remain free in the crystal for more than about 10^{-5} sec without being trapped, and that every afterglow having a duration sufficient to be recorded by an oscillograph phosphoroscope must be ascribed to the action of traps (1335b).

In a pure recombination glow the periods of induction and decay are represented by the equations:

$$I = -dn/dt = \beta n^2 \quad (83a)$$

$$I = A \left. \begin{array}{l} (\tanh \sqrt{\beta A} \cdot t)^2 \sim A \text{ for } \sqrt{\beta A} \cdot t > 5 \\ \text{and } \sim A^2 t^2 \text{ for } \sqrt{\beta A} \cdot t \ll 1 \end{array} \right\} \text{induction period} \quad (83b)$$

$$I = I_0 (1 - t \cdot \sqrt{\beta I_0})^{-2} \text{ (decay period)} \quad (83c)$$

n is the number of excited electrons, which is supposed to be equal to the number of excited emission centers; A and I measure the number of photons absorbed and emitted per unit of time; I_0 is the value of I at the end of the excitation period, and β the probability of recombination (266,268a).

The induction curve represented by Equation (83b) has a point of inflection because at the beginning of the irradiation I is proportional to t^2 and tends later towards the saturation value A ; moreover, the slope of the curve depends on the intensity of the exciting radiation A . The slope of the decay curve increases also with increasing values of A and I_0 ; at any time t it is determined exclusively by the then-prevailing value of I . If the initial intensity has decayed after a high intensity excitation to a value I' at a time t' , the slope at t' will be the same as it would be at the very beginning of the decay under weak excitation, if the initial value were $I_0 = I'$. All decay curves corresponding to a given value of β can be made to cover one another by a simple shift along the t -axis.

Although these features are characteristic of a recombination afterglow, they will be distorted, in general, by the influence of the

finite thickness of the phosphorescent particles: the exciting radiation is absorbed on its way through the phosphor and, thus, the deeper layers are less strongly excited. The decay curve of each layer starts with a different slope and the observed decay curve is a superposition of all the individual curves.

The value of β in Equations 83(a-c) is determined by two factors: the velocity v with which the electrons move through the crystal and the cross section of electron capture σ :

$$\beta = \sigma v \quad (84)$$

v is proportional to the square root of the absolute temperature; it is difficult to say to what degree the resulting increase in the speed of the decay with rising temperature is compensated by a drop in the value of σ . At any rate, the influence of the temperature on the duration of the afterglow is relatively small.

In every phosphorescence of longer duration the excited electrons remain, most of the time, in traps; in comparison, the time which they spend in moving through the crystal can be neglected. Under these conditions, the decay curve depends only on the probability α according to which the electrons are released from the traps. If all traps have the same depth ϵ and if the electrons which were once released from a trap are not trapped again, the decay of the phosphorescence is represented by an exponential in the same way as the decay of the phosphorescence of a molecule or a "center" containing a metastable state.

$$I(t) =: -dn/dt = \alpha n = I_0 e^{-\alpha t}; \log I/I_0 = -\alpha t \quad (85)$$

α , the reciprocal of the mean lifetime τ of the electrons in a trap, is a function of the absolute temperature T :

$$\alpha = s e^{-\epsilon/KT} \quad (86)$$

Although s may be treated as a constant in certain instances, more generally it will be a function of the temperature. It determines the probability with which an electron really leaves the trap when the necessary energy is provided by thermal fluctuations. In general, it can be supposed that the crystal contains traps of various depths. Even a distribution of the traps over ϵ -values differing from the average value by not more than 1% causes the decay curve to deviate considerably from a straight line in a semilog diagram, according to Randall. Taking for granted that s in Equation (86) is practically independent of temperature, Randall derived equations for several

trap distributions which may be regarded as limiting cases of those occurring in real crystals (1335a, b).

a. Uniform distribution (same number of traps for every value of ϵ):

$$I(t) \cdot t = \text{const} \quad (87a)$$

b. Quasi-uniform distribution (number of traps varying slowly with varying value of ϵ):

$$I(t) \cdot t = \text{const} \cdot N(t) \quad (87b)$$

where $N(t)$ is the number of traps in which electrons spend a mean lifetime $\tau = t$.

c. Exponential distribution (the number of traps with depth ϵ being $N_\epsilon = A e^{-b\epsilon}$):

$$I(t) = \text{const} \cdot t^{-(bkT+1)} \quad (87c)$$

With $b = 0$, the last equation reverts to the form of Equation (87a); with the arbitrary value $bkT = 1$, it represents an inverse square law.

With any trap distribution covering a wide range continuously, the decay is influenced only slightly by variations of temperature (much less than with a single trap depth), because with rising temperature the deeper traps will supply electrons at the same rate at which the shallow traps supply electrons at a lower temperature. At constant temperature, on the other hand, at the time t most of the light emission by a phosphor with continuous trap distribution is due to traps in which the electrons have the mean lifetime $\tau = t$ (1335a, b).

If the number of empty traps is very large in comparison with the number of excited electrons and excited emission centers, there is a great probability that electrons in the conduction band are retrapped many times before they reach an emission center; their motion is similar to that of a particle in a highly viscous medium the viscosity of which decreases with rising temperature, and their recombination with an emission center is strictly a second-order reaction with a large temperature coefficient of reaction rate. If, in a phosphor which is excited to saturation, all traps are filled with electrons, the first electrons which are released have a very small chance of being retrapped and the decay curve is exponential at first, or follows one of the more complicated equations characteristic of the presence of traps of various depths. However, toward the end of the decay the conditions approach more closely those with great probability of retrapping, corresponding to a bimolecular decay curve.

During the very early stages of an afterglow the primary re-

combination glow (due to the electrons which at the end of the excitation period are in the conduction band, while all traps are filled) or the existence of metastable states in the emission centers themselves may determine the rate of the decay of the luminescence. Metastable states giving rise to a slow fluorescence are known to exist in the ions of the rare-earth metals and chromium, and probably also in the ions of manganese. Their mean lifetimes do not exceed a few hundredths of a second; probably the duration of a primary recombination afterglow is even much shorter.* Therefore, these phenomena cannot affect the course of the phosphorescence beyond a few tenths of a second, but during this time the intensity of the luminescence can be due almost exclusively to them. For instance the luminescence decay of manganese-activated zinc silicate is represented with an excellent approximation during the first 40 milliseconds by a straight line in a semilog plot, and only later does it follow the more complicated laws corresponding to trap distribution. The first phase of this afterglow is ascribed to excited electrons trapped in a metastable state of the Mn^{++} -ion. In other instances, the initial decay obeys very clearly the hyperbolic law characteristic of a pure recombination afterglow.

In order to represent experimental decay curves, some investigators assume the existence of "empty emission centers" in the unexcited phosphor so that the number of excited centers greatly exceeds that of excited electrons. Such empty emission centers would be represented by activator atoms or ions at points of natural electron deficiency in the lattice (compare Section 158). In a phosphor of this type the decay curve is determined almost exclusively by the number of excited electrons and therefore follows the law of a first-order reaction under all conditions. On the other hand, the number of excited electrons or of traps may be much larger than the number of emission centers.

In the preceding discussions the possibility has been neglected, that the number of excited electrons is decreased by processes which do not contribute to the emission of light but influence the slope of the

* In a note published recently in *Nature*, Garlick and Gibson ascribe a temperature-independent afterglow of europium-activated strontium silicate to a forbidden transition in a europium ion. This afterglow has a life time of 2.3 seconds which exceeds the life times of the known metastable states of rare-earth metal ions by a factor 1000. However, the emission spectrum which can be excited by near u.v. consists of a broad band with peak in the green and is related neither to the well known fluorescence of the Eu^{+++} -ion nor to the blue fluorescence of the Eu^{++} -ion described by Prizibram (459d, 1311).

decay curve — in other words; that the phosphorescence yield is not 100 %; this will be true in most cases. If, for instance, the luminescence process alone would follow the law of a second-order reaction, while the quenching probability γn is proportional to the number of excited electrons, the latter decreases according to the equation:

$$- \frac{dn}{dt} = \beta n^2 + \gamma n \quad (88a)$$

while the induction period is represented by:

$$\frac{dn}{dt} = A - \beta n^2 - \gamma n \quad (88b)$$

At the beginning of the afterglow, as long as $n > (\gamma/\beta)$, the decay curve will be nearly hyperbolic, but will tend toward an exponential, when the number of excited centers becomes small. Other combinations of various quenching laws with various equations such as (87a), (87b), and (87c) provide an almost infinite variety of possible decay curves.

In certain phosphors the production of traps seems to be connected directly with the presence of activator atoms; an electron which is caught in such a trap will have a predominant probability of recombining with the adjacent emission center. This mechanism approaches very closely that of Lenard's center theory and would cause a first-order decay curve, although the excited electrons might originate from other locations in the crystal.

Finally, it is by no means improbable that the various grains of a phosphorescent powder do not obey the same law of decay.

Considering these circumstances, it is clear that the decay curves which are obtained experimentally will almost never agree with a simple theory and that, on the other hand, an investigator starting with a preconceived theory will always be able to represent a large part of his observations by introducing a sufficient number of constants in his hypothesis.

153. Crystalline Structure of the Phosphors. The stone of Bologna, the first of all phosphors, was barium sulfide activated with some heavy metal, and alkaline earth phosphors for a long time were by far the most important phosphorescent materials. These phosphors are prepared by heating a mixture of the sulfate, carbonate, selenide, etc., of the alkaline earth metal and a colorless salt, such as sodium chloride, lithium fluoride, sodium sulfate, etc., with traces of an activating metal to temperatures around 1000° C, at which temperatures the mixture begins to sinter. It was one of Lenard's principal tenets that the material obtained by this treatment had a glassy structure and that the center molecules formed a part of the glass.

He had to concede, however, that zinc sulfide phosphors, which are closely related in every respect to the alkaline earth phosphors, are crystalline. Other inorganic salts — for instance, calcium tungstate and zinc silicate — are not luminescent when they are precipitated from solutions as amorphous powders; they become phosphorescent only when they begin to crystallize by aging or by undergoing a heat treatment as was proved by x-ray diagrams. By the same method it has been shown that alkaline earth phosphors prepared according to Lenard's prescriptions always consist, at least partially, of micro-crystals. Of course, this does not prove that the crystalline parts are the carriers of the luminescence in this instance too, but a number of arguments support such an assumption. The faculty of forming good phosphors decreases for the oxides of Ca, Sr, and Ba in the same order as their tendency to crystallize. The addition of a small amount of the oxide of a rare-earth metal to barium oxide inhibits its crystallization and, accordingly, barium oxide phosphors activated with rare earths cannot be prepared. On the other hand, the addition of the colorless salts used in the preparation of Lenard phosphors promotes the crystallization. Thus, the addition of lithium fluoride to CaS or SrS improves their luminescence and simultaneously the sharpness of the x-ray patterns is enhanced. After the preparation the salts, which act only as flux in the process of preparation, can be elutriated without impairing the luminescence of the finished phosphors. The lattice spacing of numerous sulfide and selenide phosphors has been proved to be independent of the nature of the flux used in preparing the phosphors. For instance, the spacing is the same in pure strontium sulfide and in phosphors prepared with fluxes such as LiF, NaSO₄, and SrCl₂. However, if CaF in conjunction with a sulfate is used as flux in the preparation of a SrS-phosphors, the lattice spacing is reduced in the same way as in a mixed Ca,SrS-phosphor and the compound has the same luminescence spectrum as such a mixed phosphor. This is caused by an exchange of calcium and strontium ions which is catalyzed by the presence of sulfate ions. On the other hand, small quantities of oxide ions may be introduced into a sulfide phosphor if sulfate ions are present in the flux, and the resulting "mixed oxide-sulfide phosphor" will have properties different from those of the pure sulfide phosphor. In other instances the flux may favor the dissociation of the compound (sulfide, oxide, etc.) which contains the activating metal, and, thus, it may provide atoms which in interstitial positions activate the phosphor (1274a, 1437, 1727b).

The use of a flux in the preparation of ZnS-phosphors can be

dispensed with more easily if the temperature at which they are fired is increased. Sidot has shown that if ZnS is sublimated in an atmosphere of hydrogen sulfide or sulfurous acid, it is deposited in the form of small crystals which are strongly luminescent. Tiede and his collaborators succeeded in preparing alkaline earth phosphors by firing the sulfides together with traces of the activating metal, without addition of a flux, in a high-pressure furnace filled with an inactive gas.

It is difficult to obtain exactly reproducible phosphors by the older method using a flux; Wesch was able to achieve a high degree of reproducibility under pressure of 300 atmospheres of nitrogen at temperatures up to 1200° C, not only for the more easily prepared phosphors such as calcium sulfides, but even for mixed selenides and tellurides (CdS-ZnSe, ZnS-CdTe, etc.), which had never been obtained before (1677, 1679, 1821).

A last strong evidence for the crystalline nature of the alkaline earth phosphors can be seen in the fact that they become photoconductive by irradiation with light of the same wavelength which excites their phosphorescence: photoconductivity is not to be expected in a glass (538-544, 1335a).

The phosphorescence of many water-soluble salts, such as nitrates, sulfates, and acetates, which have been precipitated from the solution together with some activating impurity, was known to Becquerel. Their luminescence is greatly improved when they are heated to a temperature far below their melting point, a treatment favoring their complete crystallization. According to Fonda, fluorescent and phosphorescent calcite can be prepared by precipitating it with ammonium carbonate at 70° C from a solution containing a mixture of calcium and manganese chlorides. The intensity of the luminescence is greatly increased if the precipitate is allowed to age for several weeks before filtering, but it is not necessary to dry it. The crystal nature of phosphors prepared in this way has been proved by their x-ray patterns. Recent observations by Schulman and co-workers, which will be discussed in a later section, show however that the red luminescence of such $\text{CaCO}_3(\text{Mn})$ -phosphors is excited by u.v. irradiation only when they are "sensitized" by the addition of small quantities of lead (Section 158) (1480b). The only salts which are known to exhibit a strong phosphorescence lasting many hours immediately after having been precipitated from a saturated solution are the chloride and bromide of potassium activated with thallium; in this case, well developed crystals are formed by the precipitation (399, 1293a).

Apart from this single exception, a long-lasting afterglow of great intensity is found almost exclusively in the group of sulfide, oxide, and selenide phosphors which were prepared first according to Lenard's methods and which, for the sake of brevity, may be called Lenard phosphors.

Although the luminescence of "crystal phosphors" depends essentially on the crystalline nature of the base material, very little is known concerning the influence of the specific crystal structure on the nature of the luminescence. It has been suggested that so-called layer lattice structure is especially favorable for the formation of luminescent crystals because interstitial atoms can penetrate easily into the relatively large spacings which separate the tightly packed layer planes. Many compounds containing large negative ions, such as sulfates, nitrates, and iodides, belong to this class. As examples manganese-activated CdI_2 and PbI_2 , with very brilliant red and yellow fluorescence, respectively, may be mentioned. Another example is calcium sulfate: a photograph of a natural crystal of gypsum which is taken by means of its own phosphorescence light shows that the activating centers, possibly manganese or bismuth or perhaps an organic compound, are located exclusively along certain planes which appear bright on the photograph, while other planes remain dark (*F, 651, 855*).

A general survey of crystal phosphors does not produce the impression, however, that the layer lattice crystals have a preferential position among them. The crystals with the strongest luminescence and the only ones exhibiting a phosphorescence of long duration have cubic symmetry or, like zinc sulfide in the wurtzite modification, are hexagonal.

Luminescent zinc sulfide is obtained in two modifications: hexagonal wurtzite and cubic sphalerite, with somewhat different properties; the afterglow of the cubic modification is appreciably shorter and weaker than that of the hexagonal modification. Moreover, the emission bands are shifted towards greater wavelengths in sphalerite, and this occurs in "pure" ZnS -phosphors as well as in those which are activated by foreign impurities. Thus, the peaks of the emission bands of $\text{ZnS}(\text{Cu})$ lie at 5160 and 5280A, respectively, and those of $\text{ZnS}(\text{Ag})$ at 4370 and 4550A, respectively, in the hexagonal and the cubic modifications (*833a, 834b*).

The difference in crystal structure of two types of manganese-activated zinc silicate phosphors (α - and β -orthosilicate) is much smaller and is revealed only by a disparity of their x-ray patterns

(Figure 170), but their luminescence spectra differ widely. If the precipitation of CaCO_3 , which has been dealt with above, is carried out at 100°C in the presence of 3.3 molar per cent manganese with reference to calcium, the carbonate crystallizes as orthorhombic aragonite and is not fluorescent. Since MnCO_3 crystallizes isomorphously with the hexagonal calcite, it is probable that no manganese is incorporated in the aragonite lattice. If the experiment is repeated, however, under the same conditions in the presence of a great excess of manganese carbonate, the calcium carbonate is precipitated, even at 100°C , as calcite, and the crystals are luminescent (399).*

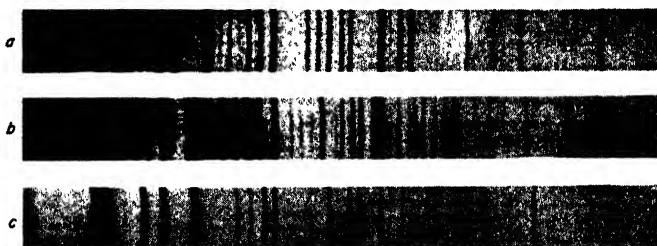

Fig. 170. X-ray diagrams of zinc silicate phosphors (Rooksby and McKeag).

a: green fluorescent modification. *b*: yellow fluorescent modification. *c*: nonluminescent cristoballite.

Examples of the variation of luminescence spectra with the change in lattice spacing in mixed crystals of varying composition have already been mentioned in Section 141, and others will be treated later.

According to Lenard, the "center molecules" have an especially loose structure and are crushed by grinding, thus losing their luminescence. Ortmann and Riehl have ascertained, however, that the density of the material is not altered by grinding it to the finest possible mesh. They maintain that the apparent decrease in luminosity is due, in the main, to the stronger diffuse reflection of the exciting light by the too finely ground powders. This hypothesis is supported by Kroeger's observation that the weakening of the fluorescence of finely ground $\text{ZnS}(\text{Ag})$ -phosphor is much more conspicuous if the exciting light has a wavelength which is little absorbed in the

* Compare page 518 for the importance of the presence of lead in these phosphors.

material and is therefore more strongly diffused by the powder. The fact that is not so much the grinding itself as the smallness of the particles which is responsible for the loss in luminescence yield is corroborated by Fonda, who found a decrease in the relative fluorescence intensity of manganese-activated zinc silicate with decreasing diameter of the grains regardless of whether the smaller grains were obtained by direct preparation or by grinding larger particles (398, 887, 1172, 1362). (Fonda's measurements refer to particle diameters between 10 and 1μ ; on the other hand, Oldham and Kunerth state that the fluorescence yield of zinc silicate phosphors increases with decreasing particle size for diameters between 270 and 8μ .)

However, the problem of the influence of grinding and particle size on the luminescence yield of phosphors is not definitely solved. Several recent papers agree that the luminosity of phosphors must be regenerated by refiring after grinding, and while in one instance the powder is caked by the refiring process and thus its surface structure is altered, another author mentions several methods by which caking is avoided and, nevertheless, the original brightness of the luminescence restored. If a ZnS(Cu)-phosphor is subjected to the action of a hydraulic press, it loses its luminescence almost completely and simultaneously the material is discolored. Apparently not only is the size of the particles decreased by this treatment, but the internal structure of the microcrystals forming the phosphorescent powder is destroyed. As a matter of fact, particles of equal size obtained by sedimentation from freshly prepared material and from a phosphor which has been crushed in a hydraulic press differ widely in their luminescence yield, the ratio being sometimes 100:1 (76, 615a, 1132a, 1798b).

154. Activating and Quenching Impurities. The connection between the luminescence of many crystals and the presence of impurities in these crystals cannot be questioned. However, the impurities can be incorporated in the crystals in more than one manner: as ions replacing ions of the base material in the matrix lattice; as interstitial atoms slightly deforming the surrounding lattice; or as ions or atoms embedded at points of lattice defects. The ions may be complexes consisting of the "activating impurity" and constituents of the base material. No general rule can be found for determining which impurities and which base materials combine to produce phosphors and, even less, which properties with respect to yield, duration of afterglow, and color of luminescence such phosphors will have (907a).

In so-called "pure" zinc sulfide and zinc oxide phosphors, in-
Pringsheim 19

terstitial zinc atoms are supposed to be the carriers of the luminescence. In the heat treatment which these materials must undergo in order to become luminescent, some of the sulfur or oxygen is evaporated while zinc atoms remain in excess in the crystal in interstitial positions. Alkali halides containing "F-centers," which can be produced by various methods described in later sections, are another type of phosphorescent crystals not activated by foreign impurities but by electrons caught in lattice points where a negative halide ion is missing.

The condition of chromium as a foreign activator of luminescent crystals is exceptional in that it is incorporated effectively only if the base material and the corresponding chromium salt form isomorphous crystals. The best known example is natural or synthetic ruby -- Al_2O_3 containing traces of Cr_2O_3 ; other examples, such as Mg_2CrO_4 in MgAl_2O_4 (spinel) and Cr_2SiO_5 in Al_2SiO_5 (disthene or cyanite), will be discussed in Section 167. These crystals, in which the cation of the activator replaces a cation of the base lattice, are not phosphorescent, although their luminescence, which is a typical *slow fluorescence*, can be observed phosphoroscopically. The same is true for Fe_2O_3 and Ti_2O_3 activating corundum crystals. If the impurity, as, for instance, MnO_2 or TiO_2 , incorporated in corundum crystallizes in a different symmetry class, the compound becomes *phosphorescent* (278,1670, 1671,1685).

In zinc sulfide phosphors certain activating impurities enter the lattice in interstitial positions while one, at least, forms mixed crystals with the bulk material. By heating a microcrystalline powder of ZnS in contact with a cuprous or a silver salt (sulfide, chloride, or oxide) at a temperature above 300°C for copper and above 400°C for silver, the foreign atoms begin to enter the lattice and the typical luminescence of the "pure" ZnS -phosphor gives way to the emission bands of the phosphors $\text{ZnS}(\text{Cu})$ or $\text{ZnS}(\text{Ag})$, respectively. If, after having been saturated with Ag in this way, the phosphor is subsequently brought into contact with CuS , the silver is driven out by the copper and after some time the $\text{ZnS}(\text{Ag})$ -phosphor is transformed into a $\text{ZnS}(\text{Cu})$ -phosphor. On the other hand, a ZnS -phosphor saturated with copper does not take up any silver. It cannot be assumed that the foreign ions replace Zn^{++} -ions in the lattice at such low temperatures; the fact that saturation is reached at concentrations of about 10^{-4} for Cu and 10^{-6} for Ag proves that the impurity metals are incorporated as interstitial atoms, possibly at points of lattice defects. By slowly dissolving the crystals it can be demonstrated that the impurity

atoms are not only fixed to the surfaces of the grains but penetrate their interior.

Manganese, another very effective activator for ZnS-phosphors, shows a widely different behavior. It is unable to enter the zinc sulfide crystals at temperatures below 800° C; at higher temperatures, relatively large quantities of manganese can be taken up and genuine mixed crystals of SnSMnS are formed which may contain as much as 50 % Mn, although the optimum of luminescence lies in the neighborhood of 1 %. According to x-ray diagrams the lattice spacing is increased when Zn-ions are replaced by Mn-ions. The possibility must be taken into account that the Mn-ions taking up regular lattice points are not the carriers of the luminescence and that this phenomenon is due to atoms or ions caught at points of lattice defects (527,830,832, 1363,1665a,1686).

Zinc sulfide and zinc silicate are able to form mixed crystals with several other divalent metals; these do not, however, activate the phosphors. By substituting Zn-ions they change the nature of the base lattice and thus influence the optical properties of the system, while the luminescence itself is caused by another activating impurity. Such substituents are, in the first place, cadmium in zinc sulfide phosphors, and cadmium, beryllium, titanium, and zirconium in zinc silicate phosphors. In the latter, furthermore, the silicate can be replaced partially or completely by germanate. Manganese seems to be the only element that acts in both ways, as activator and as part of the matrix lattice. Other activators, such as bismuth and silver, are probably incorporated in silicate phosphors in the same way as in zinc sulfide phosphors (401,447a,833a,833b,851,852,908).

Considering the close relationship between zinc sulfide phosphors and the alkaline earth phosphors (sulfides, oxides, and selenides), it seems reasonable to assume that in some cases interstitial impurity atoms are the activating agents in these phosphors, too. Copper can be incorporated as activator in CaS and SrS by the "contact method" at 510° and 460° C, respectively. Although these temperatures are somewhat higher than in the case of zinc sulfide, they lie far below those at which the materials must be fired in the normal preparation of CaS(Cu)- and SrS(Cu)-phosphors (1665b). On the other hand, it is certain that other metals such as manganese and the rare-earth metals are embedded in these phosphors, also, as divalent and trivalent positive ions. The same is true for Mn-activated phosphates and borates and for tungstates containing samarium.

Several authors take it for granted that when heavy metals such

as copper, lead, or thallium are incorporated in alkali halide crystals, they replace alkali ions in the lattice. The x-ray analysis shows, however, that by the addition of thallium the KCl-lattice is stretched by a much smaller amount than should be expected if the Tl^+ -ions replaced the K^+ -ions (1557). Furthermore, there are good reasons for assuming that the Tl^+ -ions and, similarly, the atoms of other heavy metals form complex negative ions with the halides which may be incorporated at points of lattice defects. The analogy between the absorption and fluorescence spectra of the complex ions in aqueous solutions with those of the corresponding phosphors will be discussed in Section 164. Hueniger and Rudolph state that a complete parallelism exists not only between these absorption spectra, but that, moreover, the emission bands of tin-activated alkali halide phosphors coincide with the bands of chemiluminescence observed by Polanyi in the reaction between the vapors of $SnCl_4$, $SnBr_4$, and SnI_4 and potassium. The authors suppose, therefore, that the excitation of the phosphorescence corresponds to a process of the type: $(SnX_4)^{--} + K^+ \rightarrow (SnX_4)^- + K$, and the emission to the inverse process: $(SnX_4)^- + K \rightarrow (SnX)^{--} + K^+$; K^+ is assumed to be a cation of the base material in the neighborhood of a $(SnX_4)^{--}$ -complex which is embedded in the crystal (448,449,618,640,791,1293a,1486).

If crystals of KCl are ground in a mortar together with small quantities of $SbCl_3$, the mixture becomes phosphorescent, the intensity of the luminescence being rather weak, but not inferior to that of similar phosphors prepared by firing. The antimony must be in the trivalent modification: $SbCl_5$ is inactive. Since the color of the luminescence depends on whether $SbCl_3$ or $SbBr_3$ is added to KCl, or $SbCl_3$ to KBr (bright yellow, dark brick-red, weak orange), it follows that Sb^{+++} -ions do not replace K^+ -ions in the lattice, but that some complex antimony halide ions or molecules are formed in the crystals as luminescence centers (1432b). KCl(Tl)-phosphors with a very bright and long-lasting afterglow can also be prepared by grinding KCl together with a thallos salt. If thallos nitrate or sulfate is used, it is converted to thallos chloride in the grinding process as was ascertained by x-ray analysis. The process seems to depend on the presence of minute quantities of water. (Concerning the activation of alkali halides with oxygen and carbon monoxide, see Section 164.)

The number of elements which can be used as activators is especially large in the case of the alkaline earth sulfides and oxides (see Table 115, Section 161). According to Tiede, it is an essential condition for the ability of an element to enter a crystal as an activator

that the radii of its atoms are smaller than those of the atoms of the metals in the matrix lattice. One would expect that at least as far as the base material is concerned the ionic, and not the atomic, radii should be the determining factor. In conformity with Tiede's rule, Riehl proved that Pb and Bi, which are good activators in CaS, cannot be incorporated in ZnS. The radii of the atoms of Ca, Zn, Pb, and Bi are 1.97, 1.33, 1.74, and 1.46A, respectively. Fonda succeeded, however, in preparing ZnS(Pb)-phosphors with very characteristic properties. Apparently lead is incorporated in these phosphors in a manner essentially different from the manner in which Pb and Bi are embedded in CaS. In the latter, the normal concentration is only a small fraction of 1 %, while Fonda's new ZnS(Pb)-phosphors contain 4 % of lead which seems to form a part of the base material rather than be an "activator" (402*b*, 1363, 1665*a*, 1676, 1686).

In most phosphors with a long-lasting afterglow, an increase in the concentration of the activating impurity atoms enhances the intensity of the fluorescence* relative to the intensity of the phosphorescence. At the lowest activator concentrations the fluorescence of Lenard phosphors is almost imperceptible, while the phosphorescence is comparatively strong. When citing a so-called "optimum concentration" it is, therefore, essential to indicate whether the optimum of fluorescence or of phosphorescence is intended. Apparent disagreements which are found in the literature are frequently caused by neglecting this differentiation (178, 883, 892). Furthermore, the optimum concentrations are greatly dependent on the nature of the activator and of the base material. As already mentioned in connection with the manganese-activated zinc sulfide and silicate phosphors, the optimum concentration is relatively large if the activator and the bulk material form mixed crystals. Another example of this kind is synthetic ruby, in which the Cr-concentration can amount to 2 % without impairing the luminescence. When the activators are incorporated as interstitial atoms or at points of lattice defect, their concentration must be much lower. Thus, the optimum concentration of silver and copper in ZnS is of the order of magnitude of 10^{-4} % and 10^{-2} % respectively, while it may be from five to ten times larger in SrS and CaS. The permitted concentrations are exceedingly small for the metals of the iron group, which can be used only for the activation of a few sulfide and oxide phosphors. At higher concentrations Fe quenches not only its own luminescence in those phosphors (for instance, CaS) which can be activated by iron, but also the lumi-

* Or of other processes of short duration; see Section 159.

nescence caused by the presence of any other foreign metal. The same is true for nickel and, to a somewhat smaller degree, for cobalt (253,923).

By the contact method described above, iron can be introduced into ZnS(Cu)- and ZnS(Ag)-phosphors at a temperature of 270° C without impairing their phosphorescence, although the presence of iron in the grains is proved by chemical analysis. If, later, the phosphors are heated to 950°C, the phosphorescence is completely quenched if the iron content exceeds 10⁻³%. It follows that the quenching action of the iron depends on the location of the atoms or ions in the phosphors. Riehl supposes that iron becomes a quencher in sulfide phosphors only when it replaces cations in the base lattice, thus forming mixed crystals. According to the same author, the phosphorescence of manganese-activated zinc sulfide is quenched by the presence of iron to a much smaller degree than the phosphorescence of other ZnS-phosphors (1363).

Other metals which are excellent activators in some phosphors are poisons for others: the luminescence of manganese-activated cadmium silicate is appreciably weakened by copper at a concentration of 10⁻²% and completely suppressed at a concentration of 0.1%. On the other hand, the luminescence of tungstates and molybdates is quenched by manganese and chromium. Although calcium molybdate is itself fluorescent, addition of calcium molybdate to calcium tungstate destroys the room temperature luminescence of the latter (979,1436).

Most metals which activate a phosphor at low concentrations become quenchers if their concentration becomes too high; this is probably due to the fact that when all available vacancies are occupied by the activator, additional impurity atoms begin to destroy the matrix lattice.* In all cases, long-lasting phosphorescence is more sensitive to quenching than the processes of shorter duration. Thus, the afterglow of zinc sulfide phosphors is largely suppressed by the addition of 10⁻⁴% of nickel, but the fluorescence is not greatly reduced (923).

155. Absorption and Emission Bands. Every luminescence process consists essentially of three parts: the absorption or excitation, the emission (both practically instantaneous), and, interposed between them, the storage of the excitation energy, which determines the average duration of the luminescence. For all substances treated in

* The intensity of phosphorescence of Tl-activated KCl and KBr increases continuously with increasing thallium content up to 2%. The fluorescence of Tl-activated CsI attains its maximum at a Tl-concentration of 0.22% (397).

the preceding chapters (excepting only sensitized fluorescence), it could be taken for granted that the three processes occurred within one and the same molecule. In crystal phosphors, even the light absorption may take place in three different parts of the system. It occurs either in the activating impurity atoms, in the unperturbed matrix lattice, or at points of this lattice which are perturbed by the incorporation of the activator or by lattice deficiencies.

The instances in which the complete absorption spectra of phosphors have been investigated are rather scarce; more frequently, the excitation spectra are known. While every "excitation band" must be an absorption band, the intensity distribution in the two spectra can be different because the luminescence yield need not be the same for the various absorption mechanisms, and some absorption bands may even be missing from the excitation spectrum. Moreover, the excitation spectra for fluorescence and phosphorescence can be different (*F*, 151, 152, 227, 409-411, 459a, 495, 497, 616, 830-833b, 837b, 1785).

The bands corresponding to the excitation of long-lasting phosphorescence are connected, in general, with lattice defects, while light absorbed in the absorption bands of the nonperturbed base lattice gives rise to an afterglow of shorter duration; only fluorescence is produced when light is absorbed by electronic transitions in the atoms or ions of the activating metal. The absorption and excitation spectrum of Mn-activated ZnS, investigated by Kroeger, provides a typical example, which is especially favorable because of the relatively large quantities of the activator which can be incorporated. "Pure" ZnS has a strong, apparently continuous absorption band in the u.v. with a sharp long-wavelength edge at 3380Å, but extending from there in a flat tail in the direction of greater wavelengths. This tail generally is ascribed to the presence of interstitial zinc atoms or other lattice defects. On addition of manganese a new band is superimposed on the tail with an intensity maximum at 3500Å and a long-wavelength limit at 3650Å. Since nearly the same band is observed in the absorption spectrum of pure pink MnS, this band probably corresponds to an electron transition in the manganese sulfide lattice, which is more or less perturbed by the surrounding zinc ions. At higher manganese concentrations a number of narrow weak absorption bands appear between 3900-5000Å; Tomaschek also observed narrow bands at 4630 and 4970Å in the absorption spectrum of a ZnS(Mn)-phosphor. Similar bands are characteristic of most manganese salts, causing their pink color, and are supposed to originate from internal electronic transitions within the Mn^{++} -ion, with lattice vibrations super-

imposed on the electronic frequencies. By light absorption in these last bands, only fluorescence of the ZnS(Mn)-phosphor is excited, while light absorption in the band at 3500–3650Å and in the continuum below 3380Å produces phosphorescence. These more recent observations of Kroeger's are in good agreement with Lenard's description of the excitation spectrum of the phosphor: the "m-band" (according to his terminology, excitation of instantaneous luminescence or "m-process") reaches from 4000–5200Å, and the strongest *d*-band (excitation of luminescence of long duration or "Dauerprozess") is at 3600Å. Lenard's *u*-process (ultraviolet process), excited by light of shorter wavelengths (in the absorption band of the bulk material), is described as an afterglow of shorter duration (830).

All Lenard phosphors show in their excitation spectra several "*d*-bands" which are characteristic of the combination of activating metal and base material; they can be ascribed to the matrix lattice at the points where it is perturbed by the incorporation of the activator. The coincidence of the first *d*-bands with selective absorption bands is shown for three bismuth-activated sulfide phosphors in Table 106 (compare Figure 176). A striking coincidence of bands was observed by Schleede also in the excitation and absorption spectra of antimony-activated sulfides of calcium, strontium, and magnesium (886, 1432*b*, 1727*c*, 1785).

TABLE 106
COINCIDENCE OF ABSORPTION AND EXCITATION BANDS
OF SULFIDE PHOSPHORS
(Wavelengths in Å)

Phosphor	Maximum		Minimum	
	of absorption	of excitation	of absorption	of excitation
CaS(Bi) . . .	4150	4200	3900	3850
SrS(Bi) . . .	4300	4400	4000	3950
BaS(Bi) . . .	4500	4600	4200	4200

Similarly, it seems to be justified to identify the *m*-bands which are observed in all Lenard phosphors with an absorption process in the activating atoms, a confirmation of this assumption being provided by the coincidence of Lenard's *m*-band of the ZnS(Mn)-phosphor with the characteristic absorption bands of the Mn⁺⁺-ion. Although certainly present, the lines of the trivalent rare-earth ions have not been recorded in the absorption spectra of sulfide and oxide phosphors activated with Sm, Eu, Pr, etc., but they were observed in Sm-

activated calcium tungstate and again, in this instance, only fluorescence and no phosphorescence was excited by the absorption of light with wavelengths corresponding to these lines.

The KCl(Tl)-phosphor has two absorption bands at 2475 and 1950Å on the long-wave side of the first absorption bands characteristic of pure potassium chloride. The crystals are excited only to fluorescence by light absorption in the band at 2475Å; by absorption in the band at 1950Å phosphorescence is also produced. According to Seitz either band corresponds to an electronic transition within the Tl⁺-ions, while other investigators assume that the band below 2000Å is due to the transition from the ground state to the conduction band of the crystal.

There are numerous instances in which the luminescence due to the presence of an activating impurity in a phosphor is excited by light absorbed in bands caused by the presence of a second "sensitizing" impurity; these cases are discussed in Section 158.

In the crystal phosphors which are luminescent without being activated by foreign impurities, all absorption bands must belong to the base lattice, to interstitial atoms, or, as in the case of tungstates and molybdates, to the complex ions in the lattice. It cannot be decided which of these various mechanisms causes the three excitation bands of MgWO₄ (at 2700, 2300, and 1700Å) reported by Beese and others (compare Figure 211 curve 2). The excitation spectrum of a cadmium borate phosphor begins at 3500Å and its intensity increases continuously in the direction of shorter wavelengths without any selective maxima; this absorption may correspond to the tail of the fundamental absorption band of the crystal (88a, 1651).

Most emission bands of crystal phosphors which are observed in the afterglow are also emitted as fluorescence during the excitation. The connection of the various emission bands with specific carriers in most cases is even more uncertain than the relation between the absorption bands and the constitution of the crystals. The problem is simple only in the case of phosphors activated with rare-earth metals and chromium emitting the line spectra characteristic of their ions.

It can also be taken for granted that the luminescence of manganese-activated phosphors is characteristic of the Mn⁺⁺-ion. According to Kroeger, the weak long-wavelength bands observed in the absorption spectrum of ZnS(Mn)-phosphors reappear in the emission spectrum; the most intense part of the luminescence spectrum of this phosphor consists, however, of a broad band in the orange. Similar bands in the orange or red region are observed in the luminescence

spectra of many other Mn-activated phosphors. Under favorable conditions — for instance, at low temperature — they split into several narrower components (Sections 162 and 163). The absorption and emission lines of the isolated Mn^{++} -ion are situated in the far u.v., but manganese and chromium ions are similar to those of the rare earths in that they contain incompletely filled electronic shells (five and three electrons, respectively, in the $3d$ -shell). The long-wavelength lines corresponding to forbidden transitions between the various terms which can be formed in the partially filled shell are emitted with appreciable intensities when the transitions are rendered possible by the perturbing forces of the crystal lattice* (830,832,833a, 833b,1333).

In some phosphors — for instance, in most zinc silicate and borate phosphors — the activation with Mn gives rise to the emission of a strong band with its maximum of intensity in the green. It is probable that it is not the normal orange-red band of the Mn^{++} -ion which is shifted in these cases to shorter wavelengths by the surrounding molecular fields, but that the green band corresponds to a different electronic transition which is favored in the ion by the nature of the crystalline structure. Examples of either possibility occur in many Lenard phosphors.

Although not only the existence of luminescence but also the specific wavelength of the emission band is due in most phosphors to the presence of a specific impurity in the phosphor, the wavelength of the luminescence band is, in general, not characteristic of the activator as such. The color of the luminescence of silver-activated sulfide phosphors may vary between ultraviolet and red, depending on the nature of the base material. On the other hand, the emission band of a lead-activated barium sulfide phosphor coincides almost exactly with the orange band of a $CaS(Mn)$ -phosphor, while the emission band of lead in calcium sulfide can be matched with the luminescence of copper in zinc sulfide by the admixture of a few per cent of cadmium sulfide to the latter. Furthermore, many phosphors containing only one and the same activating impurity exhibit several emission bands which are “independent” in that their appearance in the afterglow is unequally influenced by the manner of preparation and the temperature of observation; the excitation spectra of each of the bands is characterized by different d -maxima. In Lenard's nomenclature the

* For the Cr^{+++} -ion this problem has been fully discussed; see, for instance, H. C. Bowen, *Phys. Rev.*, 52, 1153 (1937) (147a) and M. N. Saha, *Nature*, 125, 163 (1930) (1405a); compare also Section 167.

band prevailing in the phosphorescence spectrum at room temperature is designated, in general, by α and the others by β , γ , etc. While the prevalence of the red or the green band in the luminescence spectrum of zinc silicate has been proved to be determined by the crystal structure of the base material, no difference has been found in the crystal structure of Lenard phosphors, which exhibit one or the other of their bands preferentially because of variation in the manner of their preparation. At any rate, it is certain that these bands are not characteristic of the activator alone but of the combination of activator and base material. The bands are broad and diffuse and their width is relatively little influenced by the temperature. The intensity distribution in the bands is frequently symmetrical, and is well represented by a Gaussian curve. In other instances the bands seem to be complex and can be analyzed by a superposition of several bell-shaped curves which may be ascribed to the superposition of lattice oscillations on a simple electronic frequency or to the superposition of several electronic transitions. It must be admitted, however, that an analysis such as that reproduced in Figure 171 is rather arbitrary (131,1424).

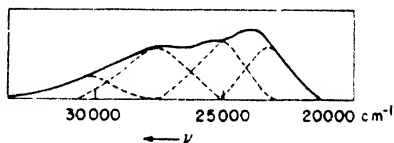

Fig. 171. Analysis of a complex emission band of a CaO(Ag)-phosphor (Schellenberg).

The normal emission bands of ZnS-, CdS-, and ZnO-phosphors which are activated by interstitial atoms instead of by foreign impurities are of the same general aspect as those of Lenard's alkaline earth phosphors (833a,908,1386a,1386b).

The normal emission bands of ZnS-, CdS-, and ZnO-phosphors which are activated by interstitial atoms instead of by foreign impurities are of the same general aspect as those of Lenard's alkaline earth phosphors (833a,908,1386a,1386b).

At low temperatures certain nonactivated phosphors of the type ZnS(Zn) emit a number of narrow bands without appreciable afterglow. These bands form progressions in which the spacings are of the same order of magnitude as the vibrational frequencies of the matrix lattices; furthermore they are immediately adjacent to the long-wavelength edges of the fundamental absorption bands overlapping them slightly. It is probable therefore, that they correspond to the return of the excited electron to various vibrational levels of the electronic ground state of the crystal (compare Section 162). Ewles suggests that the bands observed by him in the low temperature luminescence spectrum of "pure" CaO are caused by an electronic transition in the Ca-atoms. This may or may not be true, but the hypothesis that the luminescence bands of the crystal phosphor correspond to the same electronic transitions in the calcium atom as

lines which have nearly the same wavelength in the arc spectrum of Ca, is inadmissible. These lines would at least be shifted considerably by the lattice forces. The objections are even stronger against an extension of Ewles' hypothesis, according to which the bands observed in impurity-activated phosphors of the Lenard type should all correspond to arc lines of the cation in the base material (Ca, Sr, Ba, etc.), while the only function of the activator would consist in favoring the preferential emission of one of these lines (374, 375, 833*a*, 837*b*, 1331, 1332). (Compare Section 162 concerning the experimental facts on which these hypotheses were based).

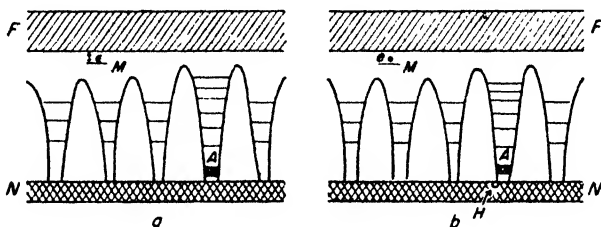

Fig. 172. Energy levels of a photoconductive phosphorescent crystal: (a) unexcited state; (b) excited state.

N: completely filled band. *F*: empty conduction band. *A*: activating impurity atom. *M*: electron trap. *e*: trapped electron. *H*: positive hole, stabilized in vicinity of excited activator.

No explanation has been proposed for the electronic transitions with which the luminescence bands in other "pure crystals," such as calcium tungstate and molybdate, are associated. Since the emission bands are in the visible and the excitation bands in the far u.v., it is improbable that they correspond to the same electron jump.

156. Photoconductivity and the Zone Theory of Crystals. If a free molecule is ionized by absorption of light of a frequency ν in the continuous band which adjoins the convergence limit ν_0 of the absorption band system, the liberated electron can acquire any amount of kinetic energy corresponding to the surplus energy $h\nu - h\nu_0$. In an insulating crystal an electron, although it is no longer bound to its original atom or ion, is restricted in its motion to certain permitted "energy bands" in which it can move across the lattice (Figure 172). These bands are separated from each other by "forbidden zones"; they consist, in reality, of a great number of individual, overlapping narrow levels among which the electrons are distributed according

to temperature equilibrium. The ground state consists of a similar succession of overlapping levels which, in an insulating crystal, are completely filled with electrons.

Since the energy bands have a considerable width which may correspond to several e.v., transition from the ground state to an empty energy band corresponds to a broad continuous band in the absorption spectrum. The first of these has already been designated as the fundamental absorption band of the base lattice. A series of energy levels in which (exactly as in an isolated atom) the electrons are still bound to their atoms or ions is located in the gap between ground state and the first empty energy band. Examples of such levels are, for instance, the unoccupied $4f$ -levels of the rare-earth ions, the $3d$ -levels of Mn^{++} and Cr^{+++} , or the $6p$ -levels of the Tl^{+} -ion. If an electron is lifted by light absorption to one of these levels, it can return to its ground state by re-emission of light or by internal conversion. If the excited atom is surrounded by other atoms of the same kind (as the atoms of the bulk material in a normal crystal), the excited state can migrate as an "exciton" across the lattice until it loses its energy by one of the two processes mentioned above, or until it is trapped by some lattice defect. Although exciton migration may occur frequently and may give rise to phosphorescence, no instances are known in which this process has been established beyond doubt as the source of crystal luminescence. Finally, an electron can be raised by thermal agitation from an excited state to the free conduction band if the gap between the latter and the excited state is not too large and if the temperature is high enough. In this case the behavior of the electron will be the same as if it were raised directly into the conduction band by light absorption (436*a*, 556, 1060, 1061, 1095, 1331, 1360, 1364, 1465-1467, 1488).

By transfer from the anion to the cation in an ionic crystal such as KCl, an electron reaches a level where it remains bound. The first u.v. absorption bands of the alkali halides have been interpreted as being caused by the transition of an electron from the negative halide (Cl^{-}) to the positive alkali (K^{+}) ion so that two neutral atoms (Cl and K) are formed. Such an excited state is described more correctly, however, by saying that the "excited electron" is equally shared by the six surrounding K-ions whose equilibrium positions are therefore somewhat displaced from their normal location in the lattice. A configuration of this kind is, in general, not stable and the electron returns within a short time to the halide atom, while the excitation energy is dissipated as vibrational energy of the lattice. If the process occurs in the neighborhood of a vacant lattice point where a halide

ion is missing,* however, the electron can be trapped at this point, forming a so called *F*-center. Under these conditions, the electron again is not bound to an individual alkali ion but is shared by six surrounding positive ions of the lattice. Nevertheless, the *F*-center has properties similar to those of an atom: it has a ground state and several excited states in the forbidden zone below the first conduction band. The transition of the electron to one of these excited states gives rise to the appearance of a new band in the absorption spectrum (for KCl, between 5000 and 6000Å, with a sharp maximum at 5630Å) so that a crystal is colored in transmitted light if it contains *F*-centers ("Farbzentrum"). From the excited level which is reached by absorption of light in this band, the electrons are raised into the free conduction band at moderate temperatures by thermal energy fluctuations so that they can follow an externally applied electromotive force (262).

Mott's and Gurney's assumption that in this case the light absorption must be supplemented by additional heat energy is based on the fact that at low temperature the photoelectric current becomes much weaker, although the same number of light quanta are absorbed. At room temperature the behavior does not differ appreciably from that of a crystal in which the electrons are raised directly into the conduction band by light absorption (1247a).

If an electron is transferred by the intake of additional heat energy, or directly by light absorption, from the ground state to the conduction band, not only is it able to travel across the crystal, but the "positive hole" which is left behind in the ground state is also free to move. This is not to be understood in the sense that a positively charged particle is moving, but that electrons are transferred successively from negative ions to the adjacent positive hole, which thus apparently moves in the opposite direction. The migration of an electron in the conduction band (and of a positive hole in the lower, filled band) is, similar in this respect to exciton migration, a quantum mechanical resonance phenomenon occurring between the numerous cells of a lattice which in an ideal crystal are identical in structure. Where ever there are perturbations in the lattice, the conduction band is perturbed and it is even completely interrupted, if the perturbations are large.

In the absence of an external electric field the electron in the conduction band and the positive hole perform diffusion motions in random directions; if they meet again during this motion, or if they

* Such vacant points in which either a positive or a negative ion is missing occur, in equal numbers for both signs, rather frequently in alkali halide crystals

meet another partner produced by a similar process at another point of the crystal, they can, under certain conditions recombine with emission of light or with "internal conversion." If an external electric field is applied, a unidirectional motion is superimposed on the random diffusion and its influence becomes greater as the electromotive force of the external field is increased.

Although Lenard's theory essentially was based on the parallelism of the excitation of photoelectric effect and phosphorescence, no photoconductivity could be expected, according to this theory, in phosphorescent substances, since the liberated electron was supposed to remain in the interior of the "center"; only a "dielectric polarization" was assumed to characterize the excited state of the phosphorescence centers. [A slight electric conductivity produced in alkaline earth phosphors by irradiation was designated as "actinodielectric effect" and was explicitly proclaimed by Lenard to be unconnected with the excitation of phosphorescence (888,894,1444).]

Gudden and Pohl were the first to demonstrate that the sulfide phosphors exhibit the phenomenon of photoconductivity and that the wavelengths of maximum excitation of the conductivity coincide with the *d*-bands in which light absorption excites a long-lasting after-glow. Quantitative measurements of the electric phenomena in sulfide phosphors do not yield satisfactory results because the phosphors are available only as microcrystalline powders. Observations obtained with other photoconductive materials which can be investigated in the form of larger single crystals provide data which can be used for the explanation of most phenomena occurring in the phosphors. Alkali halide crystals containing *F*-centers are especially advantageous for this purpose, the *F*-centers playing a role similar to that of the interstitial atoms or the impurity centers in sulfide and oxide phosphors (537,538,539,1246,1247a,b).

The photoelectric current produced by light absorption (and additional heat energy) is proportional to the number of absorbed light quanta, if secondary effects are excluded. It is, however, much smaller in a crystal containing interstitial atoms, *F*-centers, or other lattice defects than in a perfect crystal, because the electrons, instead of freely following the force of the electric field, are trapped, so that their range becomes very short. The nature of these traps cannot always be ascertained: they may be related to the *F*-centers or to impurities or to other imperfections of the lattice (541,545).

When the irradiation is stopped, the crystal remains in an activated state: the intensity of the absorption bands in which the

excitation has occurred has decreased and, simultaneously, a new absorption band adjoining the former at the side of greater wavelengths has appeared. In the case of alkali halides containing F -centers, the traps have been identified with the F -centers, which now hold two electrons instead of one. The absorption band of these newly formed F' -centers is shown in Figure 173. If the temperature is raised after the illumination has been stopped, the captured electrons are released from the traps, giving rise to a renewed electric current until they eventually recombine with primarily excited centers. At the end of this period, which is shorter when the temperature is higher, the initial, unexcited state of the crystal is restored. The effect produced by increasing the temperature is also obtained by irradiating the crystal

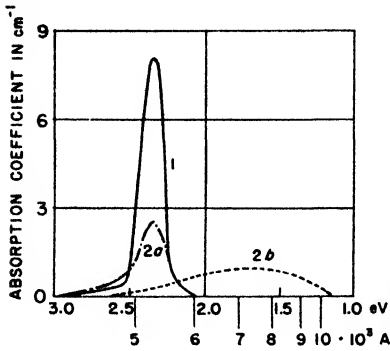

Fig. 173. Absorption bands of NaCl containing F -centers (Pick).
 1: F -band of crystal in normal state.
 2a: reduced F -band.
 2b: F' -band of excited crystal.

with light which is absorbed by the trapped electrons (in the case of

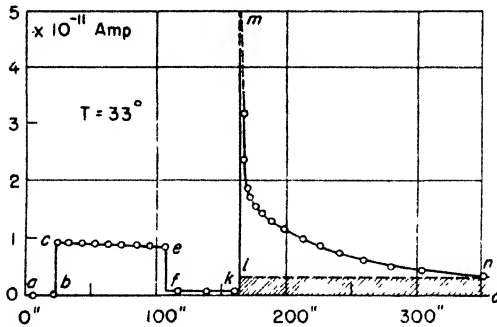

Fig. 174. Activating and deactivating photoelectric current in discolored NaCl at 33°C (Gudden and Pohl). Time in seconds.

a - b and f - k : dark. b - f : blue irradiation.
 l - n : infrared irradiation.

the alkali halides, by the F' -centers) (Figure 174). If the "activating" irradiation with exciting light takes place at sufficiently high tempera-

tures, a partial "deactivation" occurs during the excitation period: the primary electric current slowly reaches an equilibrium value and the "deactivating current" at the end of the excitation is relatively small and of short duration (Figure 175) (1232a).

If the crystal is excited in the absence of an external electric field, as, in general, is the case for the excitation of phosphors, the liberated electrons move away from their centers in random directions until they are trapped. If an electric field is applied subsequently and the

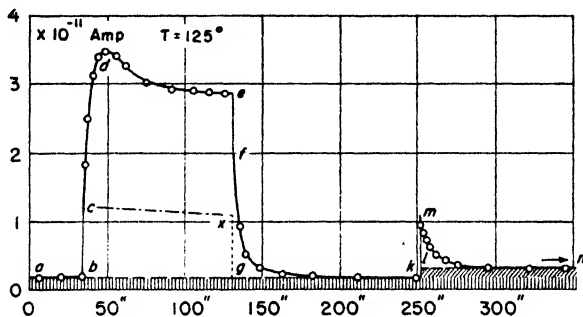

Fig. 175. Activating and deactivating photoelectric current in discolored NaCl at 125° C (Gudden and Pohl). Time in seconds.

a-b and *g-k*: dark. *b-g*: blue irradiation.
l-n: infrared irradiation.

crystal heated or irradiated with deactivating light, an electric current is observed to flow in the direction of the field until the crystal has returned to its unexcited state, exactly as if the field were already present during the excitation period. Since no preferential direction prevails during the excitation in this case, while afterwards the electrons move in the direction of the field, it can be concluded that, in general, the electrons do not return to the centers from which they were released, but that every electron can recombine with any center which has lost its electron. This holds also for deactivation by temperature or irradiation occurring in the absence of an electric field, if it is not assumed that the traps are so close to the primarily excited centers that recombination with the original center is more probable than any other process of this kind.

Many of the electric phenomena described in the last paragraphs and obtained with alkali halides containing *F*-centers have also been observed, at least qualitatively, with sulfide phosphors, and in the

latter they correspond in all details to analogous luminescence phenomena. Figure 176 shows the coincidence of the first absorption band and of the first excitation band of phosphorescence ("d-band"), of external photoelectric effect, and of photoconductivity for a CaS(Bi)-phosphor. The small deviations of the various curves from one another can be explained by the fact that the four measurements were performed with different phosphor samples which had only approximately the same composition. Similar results were obtained with CaS(Cu)- and ZnS(Mn)-phosphors (507,537-539,542-544).

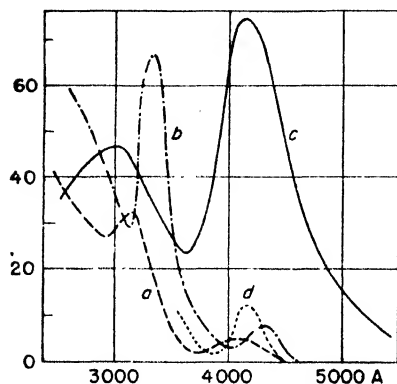

Fig. 176. Excitation spectra of a CaS(Bi)-phosphor.

- a: phosphorescence (Lenard).
- b: photoelectric emission (Goeggel).
- c: photoconductivity (Gudden and Pohl).
- d: absorption (Walter).

of the irradiation the electric current decreased even more slowly and dropped after 8 minutes to about 2% of its peak value. The curves representing the decrease in electric current and in phosphorescence intensity had the same slope. Thus it seems that, at least in this sample, the excited electrons do not contribute appreciably to the photoelectric current on their way from the absorption centers to the traps, and that the current corresponds, in the main, to the transfer from the traps to the emission centers (879a, 1842b).

In Mn-activated zinc silicates, the photoelectric currents are appreciably smaller than in the sulfide phosphors, but the excitation spectrum of phosphorescence and photoelectric conductivity coincide again. Photoelectric conductivity of the same order of magnitude was

In one instance, photoelectric excitation was observed simultaneously with the excitation of luminescence in a phosphorescent *single crystal* of zinc sulfide of 1 mm length. It is regrettable that the activating impurity and the color of the luminescence are not mentioned. With the beginning of irradiation the electric current increased at room temperature relatively slowly: after 1 second it was still well below 1% of its "saturation value" which was reached only after 150 seconds. The same slow rise of luminescence intensity after the beginning of irradiation of zinc sulfide phosphors has been observed by various authors. After the end

obtained in other Mn-activated phosphors, such as the silicates, borates, and chlorophosphates of cadmium; in some of these, at least, the electric phenomenon is not connected with their luminescence. Not only are the photocurrents in manganese-free nonluminescent borates and chlorophosphates of cadmium as strong as in the luminescent samples, but they are excited by light of wavelengths which does not excite luminescence in the latter. Only a very slight photoelectric current was observed by Randall in pure CaWO_4 and in $\text{CaWO}_4(\text{Sm})$, and practically no effect at all in ruby and in pure CaO (603,618,1335a).

The yield of photoelectric conductivity produced in a $\text{CaS}(\text{Cu})$ -phosphor by light of wavelength 2537A, which is absorbed in the fundamental band of the base material, is much smaller than when the exciting light of wavelength 4357A is absorbed in the long-wavelength tail of the band or in a d -band superimposed on this tail. Furthermore, in the first case the current decreases with time so that after a few minutes it drops practically to zero, whereas the current in the second case increases continuously to a saturation value (542). This difference in behavior is caused by the great difference in the absorption coefficients of the phosphor for the two wavelengths: it is about a thousand times larger in the fundamental band than in the d -bands, because the number of normal lattice ions is so much larger than that of the activating lattice defects. Therefore, the light of shorter wavelength is absorbed in a much thinner superficial layer of the crystal, the density of the activated centers and of the liberated electrons is very great, and a strong space charge counteracting the externally applied field is produced. On the other hand, the light of longer wavelength belongs to the spectral region in which the absorption bands of the excited and the unexcited phosphor overlap (compare Figure 173), and when electrons are trapped in increasing numbers, they are again released by "deactivating" absorption until equilibrium is reached.

The appearance of new regions of enhanced absorption on the long-wavelength side of the normal absorption bands has actually been observed in the absorption spectra of fully excited zinc sulfide phosphors. In the "excited absorption spectrum" of $\text{ZnS}(\text{Ag})$, pronounced selective maxima at 6700 and 7500A were observed by Hoch, while the new absorption of "pure" ZnS and $\text{ZnS}(\text{Cu})$ stretched continuously from the orange to the near infrared (625). According to Urbach the strong narrow absorption band in the blue region which is characteristic of an unexcited $\text{SrS}(\text{Eu},\text{Sm})$ -phosphor becomes much

weaker under the action of exciting radiation and, simultaneously, new "excited" absorption bands appear at 6000A and 1μ . The intensity of these bands increases linearly with the time of excitation as long as the latter is well below saturation (1727c).

Corresponding to the increase in "excited absorption," the reflectivity of a ZnS(Cu)-phosphor decreases in the region of longer wavelengths when the phosphor is irradiated with exciting light. While under these conditions the change in reflectivity was below 3% in a specific case for light of wavelength 4300A, the reflectivity decreased by more than 8% for light of wavelength 6750A.

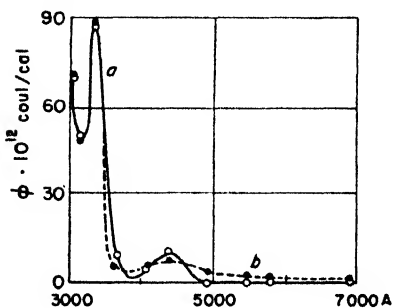

Fig. 177. Excitation spectrum of the photoelectric emission of a CaS(Bi)-phosphor (Goethel).

a: normal state. *b*: after exposure to the exciting radiation.

Irradiation of an excited sulfide phosphor with light which is absorbed in the new absorption bands and which would be inactive in the unexcited phosphor frequently produces a photoelectric current. Figure 177 shows the photoelectric excitation spectrum of a CaS(Bi)-phosphor in the normal and the fully excited state. The conditions for the observation of this phenomenon are especially favorable at low temperature, at which the thermal energy is not sufficient to raise electrons from traps into the conduction band and phosphorescence is frozen in. Thus,

Reimann succeeded in following the slowly decreasing photoelectric current in a zinc sulfide phosphor stimulated by red light at a temperature of -193°C during a period of 40 minutes. Since the electric conductivity of a crystal is proportional to the number of electrons in the conduction band, the decrease of this number with time can be derived from such measurements (508,1350).

The absorption of light in the "excited absorption bands" of a phosphor during the period of decay either enhances the intensity of the emission or the intensity of the phosphorescence is decreased by the irradiation. These phenomena of "stimulation" and "quenching"* provide valuable clues for the interpretation of the nature of traps and are more fully discussed in the following section.

* These are the translations of Lenard's "Ausleuchtung" and "Tilgung." Stimulation was discovered by Seebeck at the beginning of the nineteenth century.

According to Lenard the green phosphorescence of normal ZnS(Cu)-phosphors is quenched by infrared irradiation with a hundred times greater efficiency than it is stimulated. On the other hand, practically no photoconductivity is produced in excited ZnS(Cu)-phosphors by infrared light: thus, the electrons which are released from traps by a quenching irradiation are not transferred into the conduction band or are immediately removed from it by internal conversion [539,888 (III)].

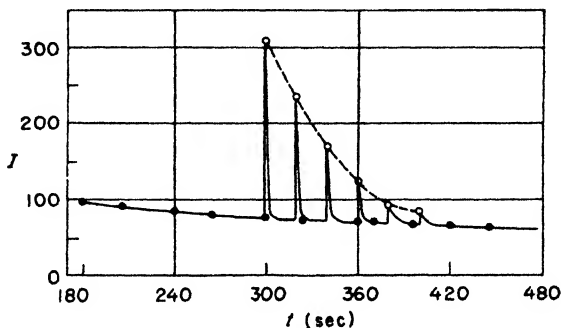

Fig. 178. Instantaneous enhancement of the phosphorescence of a ZnS(Mn)-phosphor by application of an electric field (Hinderer).

If the phosphorescence of a zinc sulfide phosphor is excited in the presence of a strong electric field, the decay of the phosphorescence is not influenced by the action of the field. However, if during the decay period a strong electric field is suddenly applied, one observes an instantaneous light outburst, after which the phosphorescence returns to its normal intensity and continues to decay normally. It is not the action of a constant field but the beginning of this action that produces the phenomenon. The effect increases with increasing voltage and is relatively stronger when it occurs in a late period of the decay process. After a short interval of time the phenomenon can be repeated (Figure 178). If the direction of the field is reversed immediately after the first outburst, a second outburst is stimulated. By applying a slowly alternating field (3 to 60 cycles per minute), the total emission process is accelerated in a manner similar to that induced by irradiating the phosphor with stimulating light or by raising the temperature. The phenomenon has been obtained, also, with manganese-activated zinc silicate phosphors but with smaller efficiency (540,620,1335b).

If the excitation of a phosphor takes place in the presence of an electric field and is accompanied by a photoelectric current, space charges which are due to the trapping of electrons at a certain (uni-directional) distance from the positive holes are formed in the crystal. If no electric field is present during the excitation, the displacement of the electrons with respect to the positive holes is not large enough to give rise to measurable space charges, but it produces a change in the dielectric constant of the material; in the nomenclature of the Lenard school, this so-called D.K. effect is ascribed to the dielectric polarization of the centers. According to more modern views, the high polarizability of the trapped electrons probably must be interpreted as being due to • exceedingly large orbits in which the electrons move while in the quasi-stable states.

The phenomenon was first observed with ZnS(Cu)-phosphors, but can be obtained with nearly every type of phosphor (alkaline earth sulfides, oxides, and selenides; carbonates, silicates, tungstates, etc.), although in some of them the effects are very small. The D.K. effect is not stronger during irradiation when bright fluorescence is excited in equilibrium with phosphorescence than after the end of excitation when practically all excited electrons are in traps (459c). Light which is absorbed in the Mn^{++} -bands of a manganese-activated sulfide phosphor and which excites only fluorescence does not produce the D.K. effect. It follows that neither the electrons in the conduction band nor those in excited states of the activator, but only the electrons in traps, contribute to the effect. Although the D.K. effect is obtained when the primary light is absorbed either in the d -bands or in the fundamental absorption band of the base material of a Lenard phosphor, it depends in different ways on the frequency of the alternating electric potential which is applied in either case for the measurement of the dielectric constant. It is probably the density of the excited centers which influences this phenomenon as it influences the photoelectric conductivity of a phosphor; and the density of excited centers depends on the absorbability of the exciting light and thus on its wavelength.

When a long-lasting phosphorescence is excited by light absorption in the d -bands, the change in dielectric constant shows induction and decay periods parallel with the induction and decay periods of the luminescence. This parallelism provides a new method for the investigation of the decay curve of an excited phosphor by observing the recovery of the altered dielectric constant to its normal value. In certain phosphors, especially in copper-activated mixed CdSe and

CdS- or ZnS-phosphors, the D.K. effect is large and shows almost no inertia.* With an illumination up to $3 \cdot 10^{-3}$ lumen per cm^2 (30 lux), the change in dielectric constant is very nearly proportional to the intensity of the incident light and it is possible, therefore, to build a new type photoelectric cell, using the varying capacity of a condenser filled with the phosphor powder. At higher light intensities the D.K. effect tends towards saturation, but for phosphors with small inertia saturation is attained at intensities far exceeding 0.1 lumen per cm^2 (1,000 lux). The spectral sensitivity distribution is very complicated; for a $\text{CdS}_{20}\text{CdSe}_{80}(\text{Cu})$ -phosphor it exhibits ten selective maxima between 2800 and 6500A, with the highest peaks at 4600 and 5200A (166,268b,459a,459b,496,518,607,608,1052,1393,1821,1842).

Garlick measured the time of relaxation of the D.K. effect of some sulfide phosphors. The relatively high value of 10^{-7} sec which he obtained has been explained tentatively by the assumption that the lattice structure in the neighborhood of a trapped electron is distorted by the action of the applied electric field and that the recovery from this deformation takes a certain time.

157. Phosphorescence Centers and Electron Traps. In genuine phosphorescence processes which can be frozen in at low temperatures the excitation energy must be stored in a quasi-stable state of some kind: the excited electrons are held in a trap from which they can be released only by intake of an energy ϵ . In the case of the organophosphors the quasi-stable state is caused by a specific electronic or nuclear configuration within the absorbing molecule itself and, although in a different terminology, this is also the assumption upon which Lenard's center theory of phosphorescence is based. By its great elasticity, Lenard's hypothesis provides an easy explanation of a great variety of phenomena. Since the composition of the centers is not sharply determined, a different center type can be made responsible for every new observation. There are "instantaneous centers" (*m*-centers) and "duration centers" (*d*-centers), and, among the latter, centers of short, of medium, and of long duration, all with one and the same emission band. And since most Lenard phosphors have several emission bands prevailing in the afterglow at different temperatures, these are again ascribed to different centers. While the *m*-centers contain no electron traps, the *d*-centers of unequal duration are supposed to differ from each other by their unequal

* It may be noteworthy that these seem to be the same phosphors which show strong infrared stimulation with very small inertia.

“energy isolation” which, in turn, is caused by their unequal size* (890).

In all phosphors in which photoelectric conductivity accompanies the process of phosphorescence, excited electrons must not be transferred immediately from the ground state to the traps which thus (as in Lenard's theory) would be associated directly with the “absorbing centers,” but can pass through the conduction band before they are trapped. Nevertheless, strong evidence exists for the assumption that traps responsible for phosphorescence of long duration are produced by the introduction of activators into the crystals of the base material. While “pure ZnS” shows a strong instantaneous luminescence, its afterglow is weak and fast-decaying. The afterglow of silver-activated ZnS is also short, that of ZnS(Mn) somewhat longer, and the brilliant green phosphorescence of ZnS(Cu) can easily be observed during more than half an hour after the end of the excitation. If zinc sulfide is activated with 0.12 % of Mn and 0.001 % of Cu, the phosphor emits the orange luminescence characteristic of manganese which shows the long persistent phosphorescence characteristic of copper (402b).

Under constant exciting irradiation, the intensity of the orange Mn-band in the luminescence of a ZnS(Mn)-phosphor of low manganese concentration tends, with increasing intensity of the primary light, toward a saturation value, while the slope of the curve representing the intensity of the blue Zn-band is small at first and becomes much steeper in the intensity range in which the orange band approaches saturation. Since at low manganese concentration the emission of the orange band is due, even during the excitation period, almost exclusively to phosphorescence, it seems that when under weak excitation a small number of excited electrons is available, these are preferen-

* It seems never to have been pointed out that this assumption, which recurs frequently in Lenard's discussions, is based on a fallacy. If a center is highly isolated with respect to energy exchanges with the surrounding medium, it will, as a matter of fact, take a long time for the deficient energy ϵ to be transferred to the center from outside. This energy was, however, inside the center at the moment of excitation and was converted to some kind of nuclear oscillation by the transition of the electron from the directly excited to the quasi stable state. If the center is “highly isolated,” the energy ϵ remains imprisoned for a long time within the center and thus the diminished probability of an energy intake from without is overcompensated by the improbability of an energy loss from within. If phosphorescence centers of unequal duration exist, the difference in their behavior cannot be explained, therefore, by their unequal energy isolation, but only by the difference in the energy deficiencies ϵ of their quasi-stable states or by a difference of the coefficients in Equation 62.

tially caught in traps from which they can recombine only with "excited" manganese emission centers. When under stronger excitation practically all traps are filled, the excited electrons recombine preferentially with excited Zn-centers and not with Mn-centers, either because the former are much more numerous or because they have greater capturing cross sections (267,497,917c,917d).

Similar phenomena were observed with respect to the green copper band in ZnS(Cu)-phosphors of low copper concentration. It seems that, while in ZnS(Mn,Cu)-phosphors the traps due to the presence of copper provide electrons for the emission of the Mn-band, the trapped electrons in ZnS(Cu)-phosphors recombine with Cu-centers only and not with Zn-centers.

These observations suggest that the incorporation of certain activator metals in a crystal — for instance, of copper in zinc sulfide — are apt to produce traps in which electrons can be held for a long time; they are corroborated by phenomena occurring in the stimulation of phosphors. The data directly concerning the "excited absorption spectra" of phosphors are scarce, but stimulation spectra have been investigated very thoroughly, for technical reasons, during the last years.

Urbach was the first to show that the "stimulability" of many phosphors can be increased greatly by adding a second activator to the base material; simultaneously, the decay of the spontaneous phosphorescence due to the first (the "dominant") activator becomes slower. SrS(Sm)- and SrS(Bi)-phosphors show the bands characteristic of Sm and Bi in their phosphorescence spectra, but only the bands of the dominant activators, Eu, Ce, etc., appear in the stimulated afterglow of the mixed phosphors, SrS(Eu,Sm), SrS(Ce, Bi), etc. However, while the stimulability of the phosphorescence due to the dominant activators is enhanced, the "stimulation spectrum" is characteristic of the "auxiliary activator" (Sm, Bi, Sn, etc.), irrespective of the nature of the former (23a,1274a,1518a,1727b,1727c).

Curve 1 in Figure 179a shows the stimulation spectrum due to the auxiliary activator Sm in SrS-phosphors activated with Eu, Mn, and Ce. The maxima of the emission bands of these phosphors are at 6350A for Eu, at 5700A for Mn, and at 4800 and 5300A for Ce, but their stimulation spectra coincide exactly. If Bi is used instead of Sm as auxiliary activator in a SrS(Ce)-phosphor, the emission spectrum is the same as in the SrS(Ce,Sm)-phosphor but the stimulation spectrum has a widely different shape (curve 2 in Figure 179a). The stimulation spectra corresponding to given auxiliary activators (for instance, Sm

or Bi) maintain their general character in phosphors with different base materials (for instance, SrS,CaS, or SrSe), but the wavelengths of the bands are changed. Apparently, new traps are formed by the presence of an auxiliary activator, and the stimulation spectra are absorption spectra of electrons which are caught in these traps. It seems natural to assume that traps of the same type are formed by the presence of Bi in a simple SrS(Bi)-phosphor. The phosphorescence of this phosphor is not stimulated but is quenched by irradiation with red and near-infrared light; as shown by curve 3 in Figure 179a, the quenching spectrum of SrS(Bi) and the stimulation spectrum of SrS(Ce,Bi) are practically identical. The primary pro-

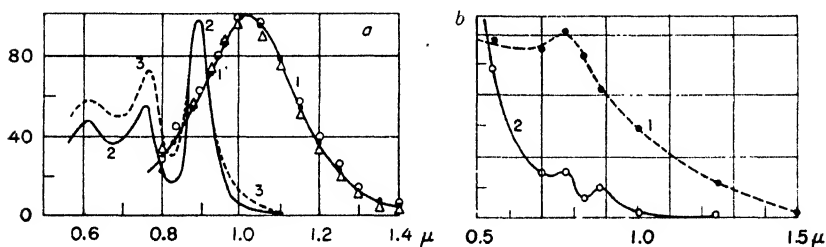

Fig. 179. Stimulation and quenching spectra of phosphors.

- (a) SrS-phosphors (Urbach). 1: stimulation spectrum of SrS(M,Sm); \circ , M = Eu; \triangle , M = Mn; \bullet , M = Ce. 2: stimulation spectrum of SrS(Ce,Bi). 3: quenching spectrum of SrS(Bi).
 (b) CaS(Bi)-phosphor (Lenard). 1: stimulation. 2: quenching.

cesses in the quenching of the one and the stimulation of the other must be the same. On the other hand, the strong spontaneous phosphorescence of SrS(Bi)-phosphors is accompanied by photoconductivity; when electrons are raised by thermal energy from traps into the conduction band, they generate the emission of light. If, on the other hand, the energy stored in an excited SrS(Ce,Sm)-phosphor is released by a rise in temperature instead of irradiation with infrared light, the samarium fluorescence spectrum is emitted as it is in the normal phosphorescence of a SrS(Sm)-phosphor at room temperature (154b, 1727b). This seems to prove that the absorption of stimulating and quenching radiation transfers electrons from the traps to states from which, in some cases, they may re-enter the normal cycle of the phosphorescence process, while, in others, they return to the ground state in a radiationless process. It must be mentioned that, according to Lenard's observations, almost every phosphor can be stimulated and quenched by irradiation, although the relative strength of the two

effects varies greatly for different phosphors, and that, moreover, the stimulation and the quenching spectra of a given phosphor do not coincide, as shown in Figure 179*b* for a CaS(Bi)-phosphor (1727*b,c*).

Since Lenard found that ZnS(Cu)-phosphors have almost no stimulability and their phosphorescence is strongly quenched by irradiation with red light, one might expect that Cu should play the same part in ZnS-phosphors which Bi and Sm play in SrS-phosphors. However, according to Fonda, the stimulation spectra of ZnS(Mn), ZnS(Pb,Mn), ZnS(Pb,Cu), and ZnS(Mn,Cu) coincide and he suggests that traps in these phosphors are due to odd Zn-atoms whose number is increased by the introduction of auxiliary activator atoms displacing the atoms of the matrix lattice. The same stimulation spectrum appears also in "pure" ZnS if it is prepared in the presence of an excess of ZnO and sulfur. However, the fact mentioned above that "pure" ZnS never shows a persistent afterglow is a strong argument against the assumption that the presence of odd Zn-atoms is the origin of the stable traps in other ZnS-phosphors. It does not seem to be improbable that small traces of copper acted as "auxiliary activator" in all these phosphors (402*c*, 1201*c*).

No interpretation of the exceptional behavior of mixed ZnS(Tb,Cu)-phosphors is available. The spontaneous phosphorescence of a ZnS(Tb,Cu)-phosphor at room temperature exhibits the green color characteristic of ZnS(Cu)-phosphors but upon infrared stimulation the luminescence is red; apparently the terbium ions are the only stimulable emission centers in these phosphors. On the other hand, the emission spectrum of ZnS(Pb) consists of two bands, one in the green with a peak at 4900Å and one in the yellow with a peak at 5800Å; the excitation spectrum of the first reaches from 2500 to 4400Å, and that of the second from 4400 to 5300Å. The afterglow of the green band is very short, while the yellow band decays slowly and is visible almost alone at higher lead concentrations; only the green band is stimulated in this case by irradiation with infrared light (402*c*).

In zinc silicate phosphors and in other phosphors belonging to the same group, such as cadmium silicate and zinc beryllium silicate phosphors, an appreciable increase in the duration and intensity of the afterglow is produced by the addition of arsenic, which probably is converted to zinc arsenate in the process of preparing the phosphors. Since the addition of arsenic does not cause the appearance of new bands in the emission spectrum, it must be concluded that its presence in the crystal provides new electron traps which are more efficient than the other lattice defects. Similar but weaker effects are produced by

the addition of antimony. The admixture of arsenic becomes ineffective when small amounts of lithium chloride are used as flux in the preparation of the phosphor, apparently because the formation of electron traps is impeded under these conditions (447a).

According to Strange, the decay of the phosphorescence of Mn-activated zinc borate phosphors is slowed down by the addition of nickel at a concentration of $10^{-2}\%$, a result which is opposed to the strong quenching effect of nickel in other phosphors (Q).

The afterglow of pure calcium tungstate is of very short duration but the weak photoconductivity observed by Randall, and the fact that in samarium-activated calcium tungstate the emission of the characteristic Sm-bands can be excited by light absorption in the fundamental band of the base material, seem to prove that electrons are raised by this absorption from the ground state of the CaWO_4 -lattice into the conduction band. (Otherwise the transfer of energy from the CaWO_4 -molecules to the Sm-ions might be due to exciton migration). By the incorporation of lead in the crystals, the phosphorescence becomes much more persistent, apparently, again, because of the formation of new traps (268a, 1335a, 1436, 1602).

The alkali halide phosphors of the type KCl(Tl) are the only phosphors with a persistent afterglow which were supposed not to become photoconductive when they are irradiated with exciting light. Seitz assumed, therefore, that in a KCl(Tl) -phosphor the "traps" are metastable or quasi-stable states of centers which probably are formed by the interaction of two closely adjacent Tl^+ -ions (compare Section 160), and that the absorption and emission processes are wholly confined to such a center. Thus, phosphorescence would be a strictly monomolecular process in these phosphors (1486). Kato showed, however, that, when the phosphorescence of excited KCl(Ag) , NaBr(Ag) , and KCl(Tl) is stimulated by irradiation, the phosphors become photoconductive and the photocurrents are proportional to the intensity of the stimulated phosphorescence, irrespective of the wavelength of the stimulating radiation. If electrons which are released from traps by stimulation pass through the conduction band on their way to the emission centers, it seems to be very improbable — although not definitely disproved — that the thermal release from traps, corresponding to "normal" phosphorescence, is a strictly monomolecular process occurring inside of a single atom or molecule (732a).

If a Lenard phosphor is excited to saturation at a temperature which is so low that almost the total absorbed energy is stored in traps and the electrons cannot escape after the end of the excitation

period, and if the temperature is slowly raised subsequently, one of the several phosphorescence bands which are characteristic of the phosphor appears at a certain temperature and decays according to its normal law. If the temperature is increased after this luminescence has practically vanished, the second band and eventually, at a still higher temperature, a third band is emitted. Thus, it seems that individual traps are somehow connected with individual emission centers. The easiest explanation of this behavior is, of course, the one given by Lenard — namely, that every center contains its own trap; or, the microcrystals of which the phosphor powder consists may not all be of the same nature and every grain may contain traps of only one depth and emit only one band. This would allow the excitation of photoconductivity and of bimolecular processes. If all grains of the phosphor are supposed to contribute equally to the total emission process, one would have to assume that they contain traps of three different depths from which the electrons are released, in the main, at three temperatures and that the wavelength of the band emitted by the emission centers depends on the temperature.

At any rate, it must be assumed that even in crystals with a single emission band, in general, not all electron traps have the same depth or the same heat of activation. This hypothesis corresponds to the existence of centers of unequal duration in Lenard's nomenclature. Its introduction is rendered necessary not only by the impossibility of representing most phosphorescence decay curves by a simple exponential or a clear cut second order reaction but also for the interpretation of a large number of other observations.

Lenard mentions some phosphors with two or three "optimal temperatures" for the intensity in the afterglow of one and the same band. According to Johnson, the frozen-in phosphorescence of Mn-activated silicate phosphors is released in steps with pronounced intensity minima separating strong outbursts, when the temperature is slowly raised from -193° to 20° C. This has been corroborated in a more quantitative manner by Randall and Wilkins, who obtained such outbursts at -150° , -90° , and -13° C. If an electric field is applied to the phosphor during the heating period, a sudden increase occurs at -13° C in the electric current which accompanies the phosphorescence: when the electrons are released from their traps, they pass through the conduction band before the light emission takes place. Similar phenomena were obtained by Tiede, by Randall, and by Williams with numerous other phosphors. They are discussed in later paragraphs (see also Section 165) (*603a*, *692*, *1335b*, *1671*, *1842b*, *1842c*).

If, during the first minutes after the termination of the excitation, the temperature of a CaS(Bi)-phosphor is raised by a few degrees, the intensity of the luminescence is greatly enhanced; at a later moment of the decay period a much higher temperature must be applied in order to produce an appreciable stimulation of the emission. If a Lenard phosphor is excited at 180° C and the temperature is lowered to 25° C after a short period of emission, the afterglow is suppressed and reappears only when the initial temperature is restored. At 180° C all traps with small heat of activation are depopulated rapidly and at 25° C the available thermal energy is insufficient to lift electrons from the lower traps to the conduction band (890).

If a ZnS(Pb)-phosphor at the temperature of liquid nitrogen is fully excited and then stimulated with light of $\lambda \geq 1\mu$, only those electrons are removed from their traps which would contribute to the spontaneous phosphorescence at room temperature: if the phosphor is heated in the dark after the end of the stimulation, it spontaneously emits very little light when it has reached room temperature, in comparison with a phosphor which had not been stimulated at — 193° C before being heated. After the latter has decayed to a low brightness, renewed irradiation with light of $\lambda \geq 1\mu$ stimulates in both phosphor samples a strong emission of practically the same intensity. If, on the other hand, the first phosphor had been stimulated at — 193° C with light of $\lambda \geq 0.6\mu$, subsequent irradiation at room temperature with light of $\lambda \geq 1\mu$ produces no new stimulation. Thus, all electrons which can be released from their traps at 25° by light of $\lambda \geq 1\mu$ can be set free at — 193° C by the larger quanta corresponding to $\lambda = 0.6\mu$. Electrons which at — 193° C are not released by the small quanta corresponding to $\lambda \geq 1\mu$ must be raised spontaneously to traps of smaller depth when the temperature is raised from — 193° to 20° C (402c).

This behavior seems to show that that, in this case, each trap in the crystal contains a number of levels of various depths and that the electrons are distributed among these levels according to thermal equilibrium, each trap containing only a single electron. It may perhaps be possible to interpret some of the phenomena described in the last paragraph by a temperature dependence of the "constants" in Equation (86).

In some phosphors of the sulfide and of the selenide type the stimulation has practically no inertia and follows the intensity of the stimulating radiation within a wide range with time lags of only a millisecond (1154a). In other phosphors — for instance, CaS(Bi),

SrSe(Eu, Sm) and KCl(Tl) — the enhancement of the phosphorescence by stimulation outlasts the period of irradiation, sometimes by several minutes (1154*a*, 1293*a*, 1786*b*, 1786*c*). Here, independent traps of unequal depths must exist and no spontaneous exchange between levels of different energy can be assumed. Otherwise, the thermal equilibrium which existed before the beginning of the stimulation would be restored automatically within a time exceedingly short in comparison with a second, and the luminescence would at once return to an intensity below that observed before the stimulation. The inertia of the stimulation can be explained, however, by the assumption that the more shallow traps, which are the first to be depopulated in the course of the phosphorescence process, are partially refilled by electrons which the stimulation had transferred from lower traps to the conduction band. Obviously, the effect of stimulation will be relatively greater if it occurs in an advanced part of the decay period, at a time when all shallow traps are completely emptied.

The energy of activation ϵ needed for transferring the electrons from the traps to the state from which the emission of the phosphorescence can originate has been calculated quantitatively for the first time by Buenger and Flechsig for a KCl(Tl)-phosphor. Assuming a strictly monomolecular reaction, they derived the value of ϵ from the temperature coefficient of the lifetime of the phosphorescence, according to the equation:

$$1/\tau = (1/\tau_0) \text{const} \cdot e^{-\epsilon/kT} \text{sec}^{-1} \quad (89)$$

and obtained $\epsilon = 0.67$ eV or 15.4 kcal per mole (187).

The phosphorescence of KCl(Tl) can be stimulated by irradiation with light which is not able to excite the phosphor in the ground state. The spectral distribution of the stimulating light is schematically reproduced in Figure 180*a*; it reaches from about 16000Å in the infrared far into the u.v., and shows a number of selective maxima, the strongest of which is situated at 3550Å. This corresponds to an energy of 3.5 eV, far exceeding the heat of activation and proving that in this instance the electrons are transferred not by the absorption of stimulating radiation directly into the state from which the emission takes place, or that they originate from much deeper traps than the electrons which contribute to the spontaneous phosphorescence at room temperature (188).

The relation between the various absorption, emission, and stimulation bands of a KCl(Tl)-phosphor is represented by the level diagram of Figure 180*b*. This scheme, which was proposed by Buenger

and Flechsig, has the peculiarity that the two levels designated as 1 and 2 are supposed to be the states from which the u.v. and the visible phosphorescence are emitted and to be, simultaneously, the corresponding quasi-stable states: no energy difference exists between the states, which in Figure 1 were designated by F and M . Although it is very improbable, such an equality of the two energies is not impossible in this case, because the quasi-stable levels 1 and 2 are reached, from excited levels I and II with energies exceeding those of 1 and 2 by more than 0.67 eV; one can assume, therefore, that a potential barrier of 0.67 eV separates the quasi-stable states from the emission

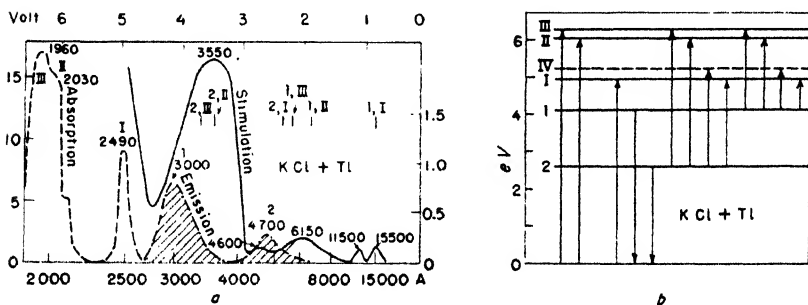

Fig. 180. Absorption, emission, and stimulation of a KCl(Tl)-phosphor (Buenger and Flechsig).

a: intensity distribution of the spectra. *b*: energy levels for their representation.

levels. In phosphors in which the electrons are supposed to pass from the conduction band into the traps and from the traps back into the conduction band, a potential barrier is not supposed to separate the traps from the conduction band, but the former must lie below the latter, the energy gap between them being equal to the heat of activation. Otherwise, the electrons would need a heat of activation in order, also, to enter the traps. However, this last possibility cannot be excluded completely, although it seems that it has never been taken into account.

The levels marked I , II , III , and IV in Figure 180*b* are reached by absorption either of exciting light by the phosphor in the ground state or of stimulating light by the electrons trapped in 1 and 2. From I , II , III , and IV the electrons are able to return to the unstable levels 1 and 2 with subsequent emission of luminescence.

The diagram is based on the numerical relations between the

frequencies of the various observed bands, but it cannot be accepted as satisfactory. Seitz has proposed, instead, a scheme of potential curves taking no account of the selective bands in the stimulation spectrum (187, 188, 1486).

A relatively simple method for the determination of the energy needed for the release of trapped electrons, which lately has been used by various authors, originally was designed by Urbach who applied his method to the investigation of nonactivated alkali halides which were made luminescent by exposure to the radiation from a radioactive source (see Section 169) (1725).

Without, apparently, knowing of Urbach's earlier papers, Randall made use of the same principle for obtaining relative values of the trap depth ϵ of photoluminescent phosphors; he converted these to absolute values by referring them to the data obtained by Buenger and Flechsig and assuming that s and $1/\tau_0$ in Equations (87) and (89), respectively, do not depend on temperature (1335*b*).

The phosphor under investigation is fully excited and then its temperature is lowered somewhat below the temperature at which the experiment is to be started. Subsequently, the phosphor is heated at a constant rate β — for instance, with $\beta = 2.5^\circ \text{C per sec}$ — and the brightness of the luminescence is measured as a function of the temperature. If the phosphor contains traps of only a single depth ϵ , the brightness increases at first, because at the very lowest temperatures very few electrons leave the traps; then the luminescence intensity reaches a peak value and decreases again, because with rising temperature the traps are quickly depopulated; and finally the luminescence drops to zero. The shape of such a "glow curve" depends little on the value of β , while the location of its peak is shifted slightly to lower temperatures if β is smaller. Curves *a* and *b* of Figure 181 are plotted according to theory and using Buenger's and Flechsig's values: $\epsilon = 0.67 \text{ eV}$ and $1/\tau_0 = s = 2.9 \cdot 10^9 \text{ sec}^{-1}$, with $\beta = 2.5^\circ \text{C per sec}$ in *a* and $0.5^\circ \text{C per sec}$ in *b*. An experimental glow curve obtained with a phosphor of the type used by Buenger and Flechsig agrees with the theoretical curves within a few per cent.

Within certain limits, the resolving power of the method can be improved by decreasing the rate of heating (the value of β). It is clear, however, that the ideal glow curve must be distorted by too small values of β quite as much as by too large values. At a very low rate of heating, even deep traps will be depopulated at relatively low temperatures so that the low temperature branch of the curve is blurred; whereas, at a very high rate of heating, many of the shallow

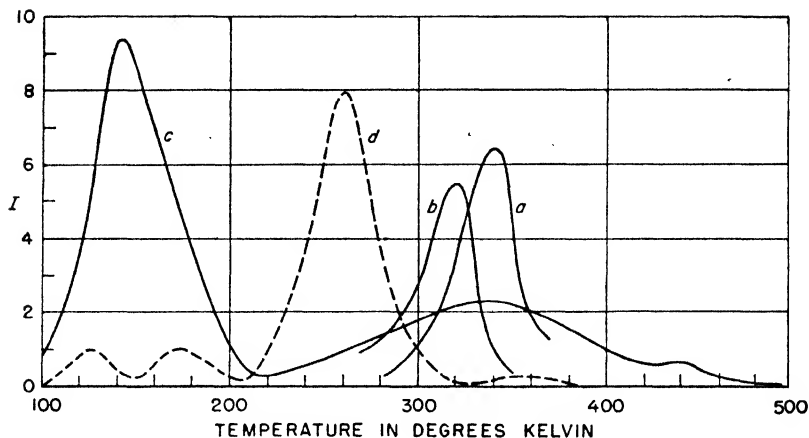

Fig. 181. Glow curves for various phosphors (Randall).

a: theoretical curve for KCl(Tl) with $\beta = 2.5^\circ/\text{sec}$. *b*: same with $\beta = 0.5^\circ/\text{sec}$. *c*: experimental curve for SrS(Bi). *d*: experimental curve for $\text{Zn}_2\text{SiO}_4(\text{Mn})$.

traps will retain their electrons up to relatively high temperatures.

It can be shown that, to a first approximation, the depth of the trap is proportional to the temperature T_g corresponding to the peak of the glow curve:

$$\varepsilon = kT_g [1 - f(\beta, s)] \log_{10}s \quad (90)$$

where f , an unknown function of β and s , is supposed always to be much smaller than unity.

Randall conceived two methods of determining the values of s , and since the values which he obtained vary only from 10^8 for ZnS and SrS to 10^{11} for CaS, $\log_{10}s$ is always of the same order of magnitude (~ 10), and:

$$\varepsilon \sim \gamma T_g \quad (91)$$

The value of γ is derived by introducing in this equation the values obtained with the KCl(Tl)-phosphors, $T_g = 340^\circ \text{K}$ and $\varepsilon = 0.67 \text{ eV}$, whence $\gamma \sim 1/500$, so that a peak of the glow curve at 100°K corresponds to a trap depth of 0.2 eV .

Curves *c* and *d* in Figure 181 are experimental glow curves obtained with a SrS(Bi)- and a $\text{Zn}_2\text{SiO}_4(\text{Mn})$ -phosphor. They differ from curve *a* (plotted under the assumption that only one sharply defined trap depth occurs) by the appearance of several peaks and by the

great diffuseness of some of the peaks. In these phosphors the values of ϵ are distributed over a wide range, with greatest densities at the energies represented by the peaks.

The interpretation of the glow curves would remain correct even if the various peaks should correspond to the appearance of different bands in the emission spectrum of a phosphor. According to Lenard, this should be the case for most alkaline earth sulfide and oxide phosphors. Only the relative heights of the individual peaks would have to be reduced in conformity with the spectral sensitivity distribution of the photometer.

No great similarity is apparent in the distribution of the peaks in the glow curves of various Mn-activated phosphors (borate, silicate, chlorophosphate of cadmium; zinc silicate, zinc beryllium silicate, etc.); this gives no indication that the traps are associated with the activating impurity, but it does not disprove the validity of such an assumption, since the depth of the traps caused by an impurity atom would depend also on the nature of the base material.

Low-temperature peaks in a glow curve indicate the existence of shallow traps which are emptied within a very short time at higher temperatures; a peak at -73°C (200°K), for instance, corresponds at room temperature to a mean lifetime of the phosphorescence of 10^{-3} sec. Traps of the same nature cause a long-lasting afterglow at -100°C . The low-temperature peaks are missing in the glow curve if the phosphor is allowed to decay for some time at room temperature before it is cooled and the glow curve is recorded.

While a glow curve represents, with a certain approximation, the distribution of trap energies in a phosphor, the relative numbers of traps of various depths can be derived from the areas under the corresponding peaks only if it can be assumed that the luminescence yield is independent of temperature. However, in many instances the yield decreases very strongly with increasing temperature, and since this is probably due to internal conversion occurring while the electrons are in the conduction band, the numbers of deep traps which would be indicated by the height of the high-temperature peaks would be relatively too low (360a).

A clear connection between the peaks in the glow curve and those in the stimulation spectrum of a phosphor does not seem to exist, just as no relation exists between the selective frequencies of stimulation and the heat of activation of the phosphorescence of a KCl(Tl)-phosphor. The reason for this is probably the same in both instances: it is not certain that the stimulating absorption transfers electrons

directly into the conduction band or into the level from which the emission of luminescence originates; and even when this happens, the radiation energy spent in the absorption process can be appreciably larger than the energy gap separating the trap from the higher state because of the validity of the Franck-Condon principle (compare the first paragraph of Section 158). A coordination of trap depths derived from a glow curve and of $h\nu$ -values corresponding to peaks in the stimulation spectrum are, therefore, rather arbitrary. No phosphors which are sensitive to infrared stimulation with light of wavelength beyond 1.6, even at the temperature of liquid nitrogen, can be obtained, while the existence of traps with activation energies as low as 0.3 eV can be derived from glow curves; according to Lenard, complete stimulation spectra in general, stretch far into the region of shorter wavelengths, where they overlap the normal excitation spectra (see the curves of Figures 179*a* and *b*). Furthermore, according to Urbach, the shape of the stimulation spectra and the wavelength of their peaks are not altered when the stored energy of a phosphor is progressively exhausted by heat treatment or by a long-lasting infrared irradiation; only the total height of the peaks is reduced, while the relation between the heights of the various peaks in the glow curve is greatly altered under these conditions* (1335*a*, *b*). All these arguments seem to prove that the electrons are raised by absorption of stimulating radiation to levels which lie well above the lowest part of the conduction band, although they may still lie inside of this band which has a width of several eV.

158. Processes of Excitation and Emission. Insofar as luminescence processes which occur completely inside of an atom or a molecule are concerned, crystal phosphors do not differ from other luminescent systems. Even if the absorption and emission correspond to the same electronic transition, however, relatively large Stokes shifts have a great probability: as pointed out by the author† and later by von Hippel, the equilibrium configuration of the lattice in the neighborhood of an excited "center" is not the same as that of the unexcited state and, since the rearrangement of the configuration

* It is worth mentioning that the relative heights of the peaks in the glow curve of Urbach's radioluminescent alkali halides are greatly altered by "stimulating irradiation." After a few minutes of irradiation a low-temperature peak disappears almost completely, while the peaks corresponding to higher temperatures are hardly affected. Obviously, the exposure to β - and γ -rays produces traps in the crystal differing not only with respect to their depth but also with respect to other properties (1725).

† *Hb. d. Phys.*, 23, 284 (1932) (X).

occurs *after* the electronic transitions which correspond to the absorption and emission processes, respectively, the emission band can be separated from the absorption band by a wide gap. Therefore, it seems permissible to ascribe the *m*-bands in the excitation spectra of Lenard phosphors to the same electronic transitions as the emission bands and to interpret the "*m*-process" as a normal fluorescence or, occasionally, as a slow fluorescence (627).

The phenomena which are characteristic only of crystal phosphors occur when the exciting light is absorbed in the fundamental bands of the base material itself or in the bands which are caused by the perturbations due to the presence of activating impurities. In both cases, electrons are raised into the conduction band; having remained there a certain time, or having been trapped and again released, they return to the ground state and produce the light emission.

The first problem presenting itself is the question of why the electrons excite the radiation characteristic of an activating impurity of very low concentration even when they have been dislodged from the ground state of the matrix lattice by the absorption of light. It must be assumed that, on the one hand, the electrons and the positive holes have a very small probability of recombining while they move through the crystal lattice and lose their energy by internal conversion when they recombine, and that, on the other hand, the holes become stabilized when they reach the immediate neighborhood of an impurity atom.

Schoen proposed a hypothesis which has been accepted by many investigators. According to this hypothesis, the ground state of the activating atom (*A* in Figure 172) is of a somewhat higher energy than the ground state of the base lattice. Thus, the positive hole formed in the latter would always be filled by an electron dropping into it from *A* and the hole would be stabilized in the activating atom itself. The final process would consist in the light emission occurring when an electron in the conduction band recombines with the hole in *A* (Q, 1465).

It is certain that this process does not take place in a single step. From phosphorescence decay curves, which will be discussed in the following section, Johnson concludes that in manganese-activated zinc silicate the electrons which have been raised into the conduction band are immediately trapped in an excited level of the activator and the luminescence is emitted when they drop from there to the ground state. Where the emission spectra are sufficiently characteristic, as in phosphors activated with manganese or a rare earth, they are known to be due to internal transitions inside of the activating ions, and it is

at least probable that this holds also for other activators. Besides, the fluorescence and the phosphorescence spectra of numerous phosphors coincide and in fluorescence processes electrons are not completely detached from their emission centers.

Thus, one is not justified, in general in drawing conclusions about the height of the ground state of an activator from the wavelength of its emission band and to assume that this level lies closer to the conduction band because the wavelength of the luminescence band is shifted toward the red end of the spectrum. Obviously, this is not the reason why the phosphorescence of sulfide phosphors activated with europium and gadolinium is red and ultraviolet, respectively. Even when the color of the luminescence due to the activation by a metal depends greatly on the nature of the base material, this can be due to the influence of the surrounding molecular fields on the various excited levels of the activator. On the other hand, the parallelism in the shifts of the fundamental absorption bands and the luminescence bands of silver- and copper-activated ZnCdS-phosphors with increasing cadmium concentration suggests very decidedly the existence of a common cause for the two shifts. The long-wavelength limit of the fundamental absorption band can be displaced toward the red only because the energy gap between the ground state of the matrix lattice and the conduction band is reduced and the latter has been lowered with respect to the former. However, even in this case it is not necessary to assume that the shift of the emission band is directly due to a corresponding decrease in the distance between the conduction band and the ground state of the activator; it is well possible that the change in lattice forces by which the energy of the electrons in the conduction band is lowered influences, also, the energy differences between the various excited states of the activator (S).

Randall concludes from his experiments that the probabilities of an electron in the conduction band being captured by a trap or an emission center are of the same order of magnitude and that the two processes should, therefore, be of a similar nature: a radiationless transition into a level not far below the conduction band, either a trap or a high excited level of the activator. Since the emission spectra of phosphors activated with rare earths and manganese exhibit only lines and bands corresponding to transitions from low excited levels to the ground state of the ions, the transition from the activator state, in which the electron is caught at first, to the emitting state would have to be ascribed to another radiationless transition (internal conversion). Moreover, it is not certain that the ground levels of activators such as

the trivalent rare-earth ions and divalent manganese ions always lie above the ground level of the matrix lattice and that thus, for instance, an Eu^{+++} -ion would lose a fourth electron to the positive hole in order to become an "excited emission center." It seems preferable, therefore, to make the more general assumption that the positive holes are stabilized either in the activator atom or in the close neighborhood of an activator atom, which always represents a point of a lattice defect. Apart from the excited states of the activator itself, every lattice defect gives rise to the formation of discrete energy levels in the forbidden zone between the ground state and the conduction band; the stronger the perturbation caused by the defect, the farther these stretch into the surrounding lattice (640b). If, eventually, the electron recombines with the hole and the latter is not stabilized in the activator itself, the recombination energy is partially transferred to the activator thus exciting the latter. According to a hypothesis proposed by Franck, this energy transfer is a typical process of sensitized fluorescence: when the electron is captured by the hole, its potential energy is converted by internal conversion into lattice vibrations and, when the vibrational energy has dropped to a level in resonance with the excitation energy of the activator, the energy is transferred to the activator.

This hypothesis can account for the fact that if a phosphor contains two activators of different nature, either the emission bands of both appear jointly in the phosphorescence spectrum, or one is suppressed by the presence of the other. In the first case, the hole has an equal probability of being stabilized in the neighborhood of either activator; in the other case, one of the activators has a much greater ability to capture the hole than the other.

Addition of praseodymium to a $\text{CaS}(\text{Sm})$ -phosphor quenches the samarium lines in the phosphorescence spectrum. With 1 % of Sm and 0.1 % of Pr, practically only the praseodymium lines appear in the afterglow, while the samarium lines retain their full intensity in the fluorescence spectrum, even when the concentrations of praseodymium and samarium are equal. The fluorescence process takes place entirely inside the rare-earth ion, while an electron raised into the conduction band excites only the phosphorescence of praseodymium (153).

Figure 182 shows the luminescence spectra of a $\text{CaS}(\text{Sm})$ -, a $\text{CaS}(\text{Bi})$ -, and a "mixed" $\text{CaS}(\text{Sm},\text{Bi})$ -phosphor excited by near-u.v. light which is absorbed in the d -bands of the phosphors. Two luminescence bands at 4500 and 5950Å have about equal strength in the

emission spectrum of the pure bismuth phosphor. In the mixed phosphor the bismuth bands are almost completely suppressed, while the Sm-lines between 5680 and 6600A are greatly enhanced when compared with their intensities in the spectrum of the bismuth-free CaS(Sm)-phosphor. The samarium lines are strongly excited by irradiating the pure CaS(Sm)-phosphor with short-wavelength u.v. which is absorbed by the base material, and, in this case, the samarium phosphorescence is not further enhanced by addition of bismuth to the

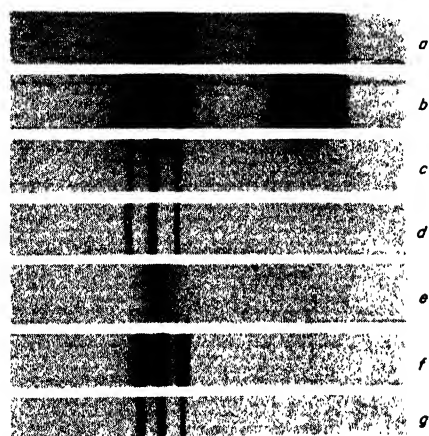

Fig. 182. Luminescence spectra of samarium-activated CaS-phosphors (Rothschild).

- a*: CaS(Bi) at 20° C
- b*: CaS(Sm,Bi) at 20°
- c*: CaS(Sm) at 20°
- d*: CaS(Sm,Pb) at 20°
- e*: CaS(Pb) at 20°
- f*: CaS(Sm,Pb) at 100°
- g*: CaS(Sm) at 100°

phosphor. The "sensitization" of the Sm-phosphorescence by bismuth is apparently due to the production of additional centers which are able to absorb near-u.v. radiation. Similar effects are obtained with samarium-activated SrS-phosphors when they are sensitized with bismuth and with CaS- and SrS-phosphors when they are sensitized with lead (1385).

These phenomena are closely related to the stimulation phenomena described in the preceding section. In a mixed SrS(Sm,Bi)-phosphor Sm is "dominant" and Bi "auxiliary": the number of traps is increased due to the presence of bismuth, but electrons released from these traps by stimulation contribute only to an enhancement of the samarium phosphorescence.

In the same way, the stimulation of the Eu-band in the afterglow of a SrS(Eu,Sm)-phosphor may be put in parallel with the exclusive excitation of the praseodymium phosphorescence in a CaS(Pr,Sm)-phosphor. However, the characteristic lines of europium and samarium appear and decay in the afterglow of a mixed CaS(Eu,Sm)-phosphor exactly in the same relative intensities as in a mixture of CaS(Eu)- and CaS(Sm)-phosphors, and this proves that the relative probabilities of the excitation of two activators depends on the nature of the base

material as well as on the nature of the competing activators themselves (*154b, 1727b, 1727c*).

The red luminescence of calcite containing manganese as the only impurity can be excited by cathode rays, but it has been mentioned previously that u.v. irradiation (with the Hg-lines at 3650 and 2537A, for example) is almost completely ineffective. The luminescence under electron bombardment proves the presence of Mn-emission centers, but the material becomes photoluminescent only by incorporation of small quantities of a second activator, such as lead, thallium, and cerium. The excitation spectrum has its peak at a different wavelength for every one of these sensitizers: at 2450A for lead, at 2435A for thallium, and 3170A with a low secondary maximum at 2450A for cerium. While Kato describes a strong red fluorescence of manganese activated KCl and NaCl, Murata and Smith have ascertained that also the red luminescence of NaCl(Mn) is excited by the mercury line 2537A only if the material contains traces of lead as a sensitizer. Thallous and stannous ions as well as the divalent ions of barium and bismuth are ineffective in this instance (*732a, 1094a, 1480b*).

Lead is a good sensitizer also in calcium and strontium sulfide phosphors activated with praseodymium, while in mixed sulfide phosphors containing praseodymium and bismuth the bismuth bands are suppressed without enhancing the Pr-lines. If, on the other hand, silver is added to a SrS(Pr)-phosphor, the praseodymium lines are missing in the phosphorescence spectrum and the violet silver band at 4200A becomes much brighter than it is in the pure SrS(Ag)-phosphor (*1385*).

If the base material of a samarium-activated phosphor consists of mixed crystals of CaS and CaO, the samarium lines characteristic of both the sulfide and the oxide phosphors (see Table 97 in Section 142) occur in the phosphorescence spectrum, even if the oxide concentration is less than 5%. This would prove simply that the samarium ions have a greater tendency to be incorporated in the crystal in the neighborhood of an oxide ion. However, according to Tomaschek, the oxide lines prevail alone, if the samarium concentration is very low while the *d*-bands of the excitation spectrum in the near u.v. are those characteristic of the sulfide phosphor. If this is correct, it would prove either that (in this case, at least) the *d*-bands have nothing to do with the presence of the activator or that even at lowest Sm-concentration most of the Sm-ions are attached to sulfur ions and that the predominance of the oxide lines in the phosphorescence spectrum is due exclusively to the preferential stabilization of positive holes near the oxide centers (*1700*).

In the phosphorescence of a ZnS(Cu)-phosphor the blue band (which is ascribed to interstitial Zn-atoms and is the only band in the luminescence spectrum of "pure" ZnS) has a very short life, while the green copper band decays slowly. Since either band appears in the afterglow, positive holes must be stabilized in both types of emission centers, and if one of the bands decays so much faster than the other it can be due only to the fact that one type of centers has a greater probability, or a "larger cross section" for capturing an electron in the conduction band. If, on the other hand, only the orange Mn-band is visible in the phosphorescence of a ZnS(Cu,Mn)-phosphor, practically all holes must be stabilized near Mn-centers. Fonda ascribes this to the fact that corresponding to the orange color of the manganese emission band the ground level of the Mn-centers lies above that of the Cu-centers. The improbability of this interpretation was discussed above; moreover, it is invalidated by the behavior of a CaS(Cu,Mn)-phosphor. The green Cu-band and the orange Mn-band of this phosphor can be excited simultaneously by irradiation with near-u.v. light. Immediately after the end of the excitation the orange band prevails in the phosphorescence spectrum but it decays more rapidly and after some time the green band is by far the stronger. The total light sum emitted in the green band exceeds that emitted in the orange band. Thus, here again, positive holes are stabilized at the Mn- and the Cu-emission centers, but the electrons have a greater tendency to excite Mn-emission centers as long as they are available. No reasons can be given for the fact that positive holes and electrons are more easily captured by certain types of activator centers than by others (402b, 1448, 1449).

The quenching of phosphorescence by addition of certain impurity atoms or ions of low concentrations as "killers" or "poisons" is a phenomenon closely related to those treated above. Evidently the energy of excitation undergoes a radiationless conversion to a different form of energy when it reaches one of the "killer" atoms. If the primary quenching effect should consist in a chemical reaction, this must be reversible, because the light absorption does not produce a permanent change in the phosphor. If the excitation of phosphorescence is accompanied by photoconductivity, it can be assumed that the hole in the electronic energy band of the ground state has a great probability of being stabilized at the poison atoms, in analogy to the suppression of the phosphorescence band of one activator by the band of a second activator. However, the luminescence of crystal phosphors, such as calcium tungstate, which show very little photoconductivity

is also quenched by the incorporation of certain "killers" of low concentration. This can be understood only if the light energy does not remain within the absorbing "center," but migrates through a part of the lattice until it encounters a quenching atom. Such a mechanism does not necessarily imply (as Riehl seems to assume) that only relatively few of the molecules of the base material can function as emitting centers while all are able to take part in the absorption process. It suffices to assume that the probability of an exciton being caught by a poison atom is much greater than the probability of re-emission of radiation by one of the normal lattice molecules. It must be kept in mind that with a poison concentration of 0.1% every tenth atom in every direction is a "killer" (1360).

The question remains to be answered why electrons which were raised into the conduction band from the ground level of the matrix lattice do not recombine with positive holes in this level, and why pure nonactivated crystals are not, in general, photoluminescent, even when they are photoconductive. Since after light absorption in its fundamental absorption band the crystal must eventually return to its normal unexcited state, there must be a competing radiationless process with a probability which exceeds by far the probability of a radiating transition.

It is not difficult to represent such a contingency by an adequate choice of configurational potential curves. In the schematic diagram of Figure 183, the arrows a and e connecting the ground state N and the excited state F represent the absorption and emission process, respectively. If the electron passes from F to M it is trapped. When the necessary energy is supplied by thermal agitation, the electron can return either to F , with subsequent light emission, or to N . If the latter transition has the greater probability, internal conversion occurs instead of phosphorescence. This model provides no reason, however, why internal conversion should be the rule in pure crystals rather than in activated phosphors. Besides, the interpretation of such systems of potential curves, which is quite clear in the case of a

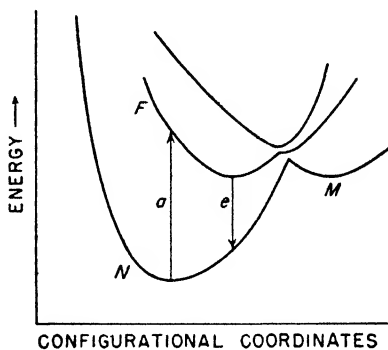

Fig. 183. Potential curves for a phosphor exhibiting fluorescence, phosphorescence, and internal conversion.

monomolecular process, becomes somewhat hazy when it is applied to electrons trapped in a crystal. These electrons cannot pass directly from the traps into the highly vibrating ground state but must pass through the conduction band, and this intermediate stage is not represented at all in the diagram.

The extreme improbability of the recombination of an electron in the conduction band with a hole moving freely through the crystal is due, according to quantum mechanics, to the law of conservation of momentum or (as it is frequently expressed) of the wave-number vector, which is proportional to the momentum: an electron will almost never meet a hole which has the same momentum, while because of the relatively large velocity of the holes the probability of the momentum being taken up by the adjacent parts of the lattice is low. On the other hand, the latter process occurs without difficulty if the electron enters one of the discrete levels located near a point where a hole has been stabilized; then the probability of recombination becomes as large as that of an allowed transition in an atom. It must be kept in mind, furthermore, that in the vicinity of a strong lattice perturbation the conduction band itself is strongly distorted (640b, 692).

At high temperatures the large amplitudes of the lattice vibrations interfere with the motion of the electrons in the conduction band and under these conditions the probability of internal conversion becomes greater than that of luminescence in activated phosphors also. A sharp drop in the intensity of luminescence occurs, in general, at a fairly well determined temperature, but this temperature varies greatly for different phosphors and even for various bands of a single phosphor. While it lies above 400° C for some alkaline earth phosphors, it does not exceed 130° C for silver- and copper-activated zinc sulfide, according to Randall; Brauer states that in ZnS(Cu)- and ZnS(Mn)-phosphors the blue Zn-band vanishes at an appreciably lower temperature than the green copper band and the orange manganese band; this behavior does not differ, in principle, from that of numerous Lenard phosphors with more than one emission band (as discussed in the preceding section). In a formal way it can be represented by the assumption that the probability of converting the total energy of an excited electron into heat instead of transferring a part of it to the emission center increases more rapidly with increasing temperature when the electron is caught by a hole which is stabilized near a Zn-emission center. In KCl(Tl)-phosphors the phosphorescence yield drops very strongly even at 70° C.

It can be assumed that the limiting temperature is especially low for "pure crystals"; in these crystals lattice perturbations and the resulting discrete energy levels which facilitate the radiating recombination of electrons and holes are relatively scarce and do not extend very far. At low temperature the momenta of the electrons and holes become small, and because of their smaller velocity the increased probability of an interaction with the lattice at a point of perturbation can lead to the recombination of an electron with a positive hole and a resulting emission of light. This assumption seems to be corroborated by the observation that at the temperature of liquid air certain crystals emit a fluorescence which can be ascribed to the components of the base lattice itself, while at room temperature the same crystals exhibit no fluorescence or only the luminescence characteristic of the activation by interstitial atoms. The progressions of narrow bands in the fluorescence spectra of ZnS, CdS, CaO, and ZnO, which are described in Section 162, are the best examples of this type.

In silver halides which, also, are fluorescent only at low temperatures the primary competing process is not internal conversion but photoconductivity according to Mott. He assumes that in the excited state which is reached by light absorption the electron is still bound to its positive hole, but that the thermal agitation prevailing at room temperature suffices to raise the electrons from this state into the conduction band. The photoconductivity characteristic of silver halides disappears at the temperature at which they become fluorescent (1060).

In publications by Kutzelnigg, Randall, and others a great number of nonactivated salts are mentioned which become luminescent at the temperature of liquid air, but in most cases the purity of these materials has not been ascertained, so that it is doubtful whether the luminescence is characteristic of the base material itself. It is noteworthy that in all these cases only fluorescence, and no phosphorescence, is mentioned (851-854, 1331, 1332).

The luminescence output under constant exciting irradiation of numerous phosphorescent materials has been found to decrease again with *decreasing* temperature when the latter drops below a certain value. This optimum temperature lies near -15°C for ZnS(Ag) and near $+60^{\circ}\text{C}$ for $\text{CdB}_2\text{O}_5(\text{Mn})$, whereas the luminescence intensity of tungstates and molybdates rises continuously even in the temperature range below -150°C . An observed decrease in luminescence output is only a secondary effect, if it is due to a change in the intensity distribution of the absorption spectrum which in all crystals accompanies

changes of temperature. If the brightness of a narrow spectral region in the emission band is used for measuring the total intensity of the luminescence, an apparent large change of the latter is caused by a slight shift in the wavelength of the band peak (16,56a).

However, in certain instances a genuine decrease in luminescence *yield* has been proved to occur with decreasing temperature, and under these conditions another temperature dependent process must compete favorably with the luminescence. This process is either (1) light emission in a different spectral range, such as the blue CaWO_4 -fluorescence competing with the orange Sm-fluorescence in a $\text{CaWO}_4(\text{Sm})$ phosphor, and the low temperature u.v. fluorescence of ZnO, CaO, etc. which has been mentioned above as characteristic of the base materials (see Sections 162 and 166), or (2) the dissipation of absorbed energy by internal conversion may become relatively more probable than light emission (131a,268a,459e,1842b,1842c).

No explanation has so far been suggested for the relatively rare phenomenon that a fluorescence which is observed at room temperature disappears at low temperatures. (With a potential barrier impeding transitions from the excited state to the ground state an afterglow would appear at an intermediate temperature). Examples of this kind are: the divalent ions of Sm and Eu imbedded in various crystals (see Sections 143 and 170); furthermore mercurous chloride,* which exhibits a brilliant red fluorescence at room temperature; and mixed crystals of cadmium and manganese iodide. The red fluorescence of the latter, which vanishes at -180°C , is still as strong at $+200^\circ\text{C}$ as at 20°C ; on the other hand, the yellow fluorescence of mixed lead and manganese iodide crystals is practically quenched at $+200^\circ\text{C}$, but retains its full intensity at -180°C . It is possible, of course, that changes of fluorescence intensity may be due partly to changes in the absorption spectrum of the crystals.

159. Periods of Induction and Decay. The course of the induction and decay of a luminescence process lasting only fractions of a second can be measured with a phosphoroscope; in recent times, very frequently oscillograph phosphoroscopes are used for this purpose. These instruments give a correct picture of the light emission during the period of one cycle if the period is long enough to allow the luminescence to decay completely before the following cycle begins. If this is not the case, complications of the type discussed in Section 7 must be taken care of.

The luminescence of ruby has long been known to be a slow

* Unpublished observation.

fluorescence due to a forbidden transition in the Cr^{+++} -ion. Becquerel ascertained that the decay of the luminescence is exponential. This has been confirmed by recent measurements with an oscillograph phosphoroscope, showing that the induction and decay curves are independent of the intensity of the exciting light and, within very wide limits, independent of temperature. The mean life derived from the slope of the decay curve is about 2 millisecon. Only when the temperature exceeds 400°K is there a change in the rate of decay which is accompanied by a decrease in the fluorescence yield; both are due to the prevalence of internal conversion competing with luminescence. The same behavior (with a slightly shorter lifetime) is observed with samarium-activated calcium tungstate when it is excited with near u.v. which is not absorbed in the fundamental absorption band of the crystal. The blue-violet afterglow of pure CaWO_4 excited with light of 2600A is still appreciably shorter (459f, 469, 1884).

The luminescence excited at the temperature of liquid air in MnCl_2 by near u.v. is also a typical slow fluorescence with monomolecular induction and decay, but this luminescence is completely quenched even at temperatures well below room temperature. The mean lifetime at 90°K does not exceed 0.5 millisecon; it is independent of the intensity of the primary radiation.

Many manganese-activated phosphors, such as the silicate, borate, and chlorophosphate of cadmium, zinc mesodisilicate, and zinc beryllium silicate show a strong afterglow of short duration with a decay which is very nearly exponential. Also for these phosphors the slope of the decay curves is independent of the intensity of the exciting light and corresponds, at room temperature, to lifetimes which are all of the order of magnitude of 10–15 millisecon and appreciably larger than the value obtained with MnCl_2 at 90°K . Apparently even at this low temperature the luminescence yield of the "pure" salt is greatly reduced by internal conversion. Only for manganese-activated cadmium iodide did Garlick and Wilkins obtain a decay of the same steep slope ($\tau \sim 0.5$ millisecon) and this may be connected with the strong quenching action of I^- -ions on all types of luminescence (459f, 1335a).

In the luminescence of manganese-activated zinc silicate, the strong emission with a mean life of about 15 millisecon predominates immediately after the end of the excitation; its intensity, which drops to about 10% of its initial value in 40 millisecon, is proportional to the intensity of the exciting light. At the temperature of liquid air this emission process exists alone and can be followed for 90 millisecon to a

final intensity of about one thousandth of its initial value. The decay during this period is strictly exponential and the mean lifetime is again independent of temperature (from -193° to 300° C), for manganese concentrations varying from 0.01 to 1%. The induction period is of the same order of magnitude and seems also to obey an exponential law (398,691-693,1335a,1335b).

In order to explain this typical monomolecular luminescence of a phosphor showing photoconductivity, Johnson assumed that the electrons which are raised into the conduction band by light absorption are trapped within a time much less than a millisecond in the metastable state of a manganese ion so that the duration of the afterglow is determined, in this case, also, by the probability of the forbidden transition within the ion. Thus, the decay of the luminescence is not governed by the laws of recombination afterglow or of genuine phosphorescence but corresponds to an indirectly excited slow fluorescence (691-693).

This is one of numerous instances of a decay mechanism which has been differently interpreted by different authors. Fonda explains the afterglow as a recombination luminescence which follows the law of a first-order reaction because the number of electrons in the conduction band is small in comparison with the number of excited emission centers. The first stage of the luminescence is followed by a second stage which represents a typical phosphorescence due to the trapping of electrons. At room temperature the intensity of this second stage becomes comparable to that of the first stage after about 40 millisecc. Its mean lifetime, under these conditions, is about 0.25 sec, but it can be observed for more than an hour when it is excited by light of great intensity. At -193° C it is frozen in and is re-emitted only if the temperature is raised after the end of the illumination. The total light sum emitted in this phosphorescence process is about fifty times as great as that emitted during the first stage. Accordingly, the number of electrons in the conduction band at the end of the excitation period is much smaller than the number of excited centers (398).

Although Fonda's interpretation seems to be perfectly sound so far, it does not take care of the fact that the purely exponential curve representing the decay during the first 90 millisecc at 100° C coincides very closely with the corresponding curve at -196° C (Figure 184). At 100° C the second stage is negligible because the traps are all empty and all excited electrons are in the conduction band, their number being equal to that of the excited centers. At -196° C all electron which have been trapped remain in the traps, so that the holes in the

ground state are much more numerous than the electrons in the conduction band. If the logarithmic decay at low temperatures is due to this condition, the decay curve should become hyperbolic at high temperatures.

In view of this disagreement and the behavior of other manganese-activated phosphors, one is induced to accept Johnson's interpretation as correct. The second stage of the afterglow, also, decays exponentially at first; later the decay law becomes more complicated. Probably this behavior can be explained by introducing adequate assumptions concerning the "trap distribution" (compare Section 152). By the superposition of the second stage the observed decay curve during the time when the first stage predominates deviates slightly from a straight line in the semilog plot. Similar deviations are observed in the decay curves of the Mn-activated phosphors mentioned above. It is uncertain whether these, also can, be due to the existence of a "second stage" or to the influence of a competing quenching process; the least plausible explanation seems to be that the internal transition probability in the Mn^{++} -ion should be slightly different in various parts of the crystals.

It is possible that these phosphors are excited partially by direct transitions of electrons from the ground state of the activator ion to an excited state of the ion, but it seems certain that the absorption process occurs in the fundamental bands of the base material when manganese-activated zinc silicate is excited by light of wavelengths 3700, 2400, and even 740A. Not only are the emission spectra the same under these various conditions of excitation, but also the induction and decay curves of the "first-stage afterglow." The correlation between induction and decay curve is no argument in this case against the interpretation of the luminescence as an indirectly excited slow fluorescence, since the luminescence intensity is proportional to the intensity of the exciting radiation and thus far below saturation (compare Section 99) (268a,694).

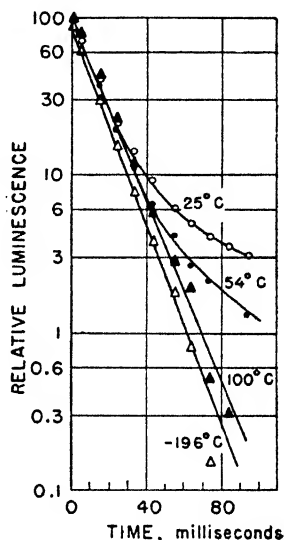

Fig. 184. Decay of afterglow at different temperatures of a zinc silicate phosphor containing 1% of manganese [Fonda (398)].

The difference between the two mechanisms of excitation appears very clearly in the luminescence of manganese-activated zinc sulfide. When the orange luminescence of this phosphor is excited by light of $\lambda \geq 4300\text{\AA}$, the decay is strictly exponential and independent of the intensity. A very slight deviation from the exponential appears after the intensity has dropped to about 5% of its initial value and is due to the superposition of a very weak phosphorescence "tail." If the luminescence is excited by light of 3600\AA , which is absorbed partly by Mn^{++} -ion and partly by the base material, even the initial decay during the first 20 millisecc does not obey the monomolecular law and the steepness of its slope increases with increasing intensity of the exciting radiation. Moreover, the induction curve of the first stage, which under excitation with light of 4900\AA is symmetrical with the decay curve, is much steeper than the decay curve under excitation with light of 3100\AA (268a). When the wavelength of the exciting light is greater than 4300\AA , only the first stage of the afterglow exists and the luminescence reaches its full intensity in a time which is very short in comparison with one second: without the use of a phosphoroscope the rise in intensity seems to be instantaneous. When excited with light of 3300\AA , there is still a quasi-instantaneous first rise, but it is followed by a slowly increasing second phase, so that the full equilibrium value is not attained even after 60 sec. Excitation with light of 3100\AA does not produce any instantaneous rise — the relatively slow and continuous increase in intensity sets in with the beginning of the excitation. This last type of induction will be discussed later

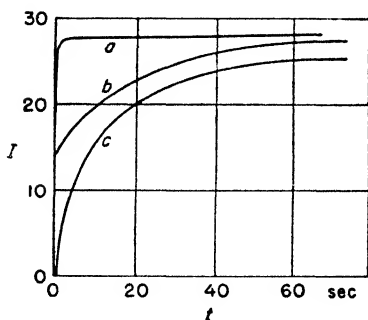

Fig. 185. Induction curves of a ZnS(Mn)-phosphor (Garlick and Wilkins).

- a: excited with 4300\AA .
- b: excited with 3300\AA .
- c: excited with 3100\AA .

(Figure 185). The part of the luminescence corresponding to the quick rise with excitation by light of 4300 and 3600\AA is independent of temperature, while the luminescence attained by the slow rise becomes weaker at lower temperatures (459e). Although this latter emission is frequently called a fluorescence because it is observed during the excitation, it is really a phosphorescence, the electrons being raised into the conduction band and trapped before they return to the excited emission centers. It must be admitted, however, that even this mechanism cannot explain

an observed decrease in luminescence intensity after equilibrium is reached during the excitation. The number of traps must be finite and much smaller than the number of "absorbing centers" in the matrix lattice, and, when all traps are filled, the excited electrons should be able to excite emission centers without passing through traps.

The first stage of luminescence of various zinc sulfide and zinc cadmium sulfide phosphors, nonactivated as well as activated with silver and copper, provided the classical examples of so-called "pure" bimolecular luminescence curves. A comparison between the experimental curve in Figure 186*b* and the theoretical curve in Figure 186*a*

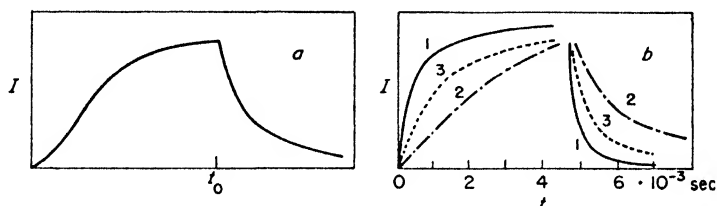

Fig. 186. Induction and decay curves for a second-order (recombination) luminescence, (a) theoretical curve, (b) experimental curves obtained with a ZnS(Cu)-phosphor.

1: excited with Hg-line 3655A, intensity 1000. 2: excited with Hg-line 3655A, intensity 8. 3: excited with Hg-line 3130A, intensity 8.

proves that the first stage of the afterglow of a ZnS(Cu)-phosphor follows Equations (83b) and (83c) very closely. Curves 1 and 2 of Figure 186*b* show, furthermore, the connection between the initial slope of the induction and the decay and the intensity of the exciting light. The rise and decay is much slower in curve 2, which corresponds to an exciting intensity 125 times weaker than that for curve 1, while the absolute intensities of the photometer deflections are reduced to the same maximum heights. The difference between curves 2 and 3, which correspond to equal primary light intensities but different wavelengths of the exciting radiation, are caused by the fact that the absorption coefficient of the phosphor is much larger for the mercury line 3130A and that not the total number of excited centers and electrons in the conduction band, but their number per unit volume, determines the rate of recombination (266).

According to measurements performed with "pure" ZnS by Schleede, the decay curves become "hyperbolic" only when the incident radiation of short wavelength (3130A) is highly concentrated,

while at lower concentration or under excitation with light of wavelength 3650A the curve deviates more and more from the hyperbolic form. These results, contradicting those described above, may be not quite correct because they are based on the use of the equation:

$$I = I_0 t^{-2} \quad (92)$$

which can replace Equation (83c) only for $t^2 \gg 1/(\beta I_0)$ and thus for small values of t only when I_0 is large, while for $t = 0$ it becomes meaningless (1432c).

In experiments like those represented by Figure 186b, the intensity curves tend to become horizontal during the period of excitation, which lasts only a few milliseconds but nevertheless almost suffices for establishing equilibrium between absorption and emission. Under these conditions, the intensity I_0 of the luminescence at the beginning of the afterglow is nearly proportional to the intensity A of the exciting light, and since, in a second-order reaction, I is proportional to n^2 (the square of the number of excited centers), n is proportional to \sqrt{A} . However, if the excitation is produced by a light flash of much shorter duration, the state of the phosphor reached at the end of the excitation is far from equilibrium; then, n is nearly proportional to A and, therefore, I should be proportional to A^2 . This was confirmed by Antonow-Romanowski, who excited the luminescence of a ZnS(Cu)-phosphor with the radiation from an intermittent spark discharge. When the intensity of the latter varied between one and ten, the value of I_0 varied between one and a hundred. Levshin repeated Antonow's experiments in a much wider range and observed variations of I_0 in the ratio 1:40000, corresponding to variations of A in the ratio 1:200. It is surprising that Levshin obtained his results by means of a phosphoroscope in which the period of excitation was certainly not shorter than 10 millisecc. It must be kept in mind, however, that the time after which equilibrium is attained depends greatly on the intensity of the exciting light (compare curve 2, Figure 186b), so that with relatively low values of A the proportionality of I_0 to A^2 may nearly be preserved even after an excitation period exceeding 10 millisecc (915,919).

In all the experiments mentioned in the last paragraphs, the "first stage" of the afterglow lasted from 10 to 50 millisecc. If it is correct that the mean time spent by an excited electron in the conduction band without being trapped is less than 10^{-5} sec, it is certain that bimolecular afterglows such as those described above can be explained only by the mechanism of frequent retrapping, which has

been mentioned in Section 152. This assumption is not easily reconciled, however, with De Groot's statement that, at least in some instances, the shape of the curves is only slightly influenced by variations in temperature between -180° and 100° C (*268a*).

Another argument may be adduced against the hypothesis of bimolecular reactions connected with frequent retrapping. Under excitation by periodically repeated flashes which occurs in a phosphoroscope, the number of electrons transferred from the conduction band into the deeper traps during a single cycle will be small, but after some time equilibrium must be reached and, also, the deeper traps contributing to the long-lasting phosphorescence must be filled. In phosphors such as "pure" ZnS and ZnS(Ag), the phosphorescence decays rapidly and the deep traps are not numerous. However, in fully excited ZnS(Cu) the total light sum emitted during the long-lasting phosphorescence is almost certainly much larger than the light sum emitted during the "first stage" in 20 millisecc and, therefore, after equilibrium is established the number of excited centers must be much larger than the number of electrons in the conduction band and in the shallow traps which contribute to the "bimolecular" first stage. Thus, an essential condition for a second-order reaction is not fulfilled. It is noteworthy that in the afterglow of a ZnS-phosphor activated with 0.1 % Mn and excited with near u.v., the blue Zn-band and the orange Mn-band show the same luminescence curves during the first stage, while the Mn-band alone appears in a longer-lasting temperature-dependent phosphorescence (*268a*).

If the luminescence of a CaS(Bi)-phosphor is observed by means of an oscillograph phosphoroscope with a cycle of 40 millisecc, the rising branch of the curve is similar to that of curve 2 in Figure 186*b*, while the decay curve drops almost vertically to a very low value and continues from there with a very small slope. Apparently, a large fraction of excited electrons are caught by emission centers in a time which is appreciably shorter than 1 millisecc (*1432c*).

Kuppenheim's observations of the decay of a CaS(Bi)-phosphor during the first minute agree (according to Antonow-Romanowski) very well with equations of the hyperbolic type. In these experiments the rate of decay increased rapidly with increasing temperature, which was varied from 250° to 400° C. This luminescence was certainly no pure recombination afterglow without the intervention of traps; it may be an instance of a second-order reaction due to frequent retrapping, but it can be ascribed quite as well to a trap distribution corresponding to Equation (87*c*) (*19,850*).

Figures 187a-c show the decay of the luminescence intensity I and of the light sum L of a CaS(Bi)-phosphor during the long period of 150 days. Since the intensity and the light sum in a monomolecular process are proportional to the number of excited electrons, the non-coincidence of the curves for I and L proves that an exponential equation with single coefficient $\alpha = 1/\tau$ does not adequately represent

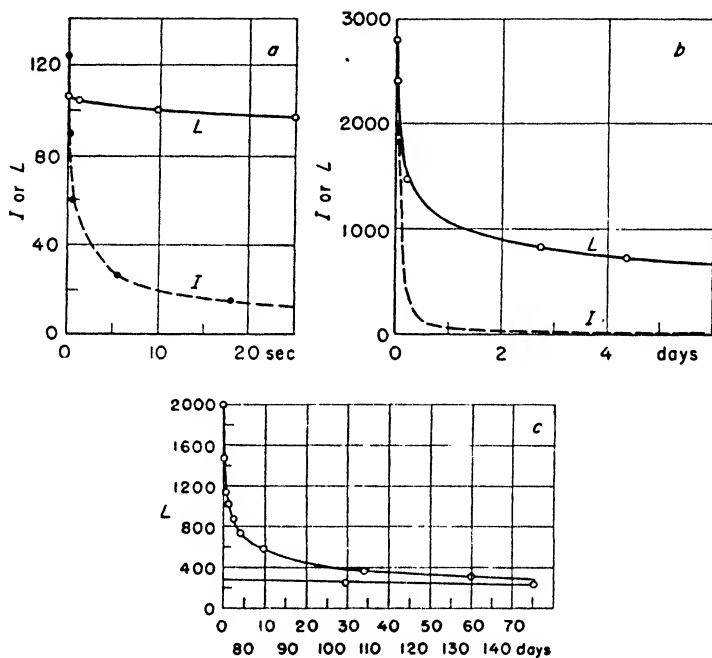

Fig. 187a-c. Decay curves of a CaS(Bi)-phosphor (Lenard).
 I : intensity. L : light sum.

the observations. Table 107 lists the mean lifetimes $\tau(t)$ which Lenard introduced for representing decay curves as exponentials during various periods of the total decay. Since $\tau(t)$ increases from 1 hour at $t = 0$ to 150 days at $t = 30$ days, it is evident that at first the slope of the L -curve is much smaller than that of the I -curve, while the intensities are so weak towards the end of the decay that they cannot be measured directly. L is found for every point of the decay curve by heating the phosphor and thus "driving out" the stored energy in a relatively short time (compare the following section) (890).

In Lenard's terminology the varying values of τ are ascribed to

the existence of centers of unequal duration which in a more modern interpretation may be replaced by traps of unequal depths.

TABLE 107
MEAN LIFETIME $\tau(t)$ AND "HEAT OF ACTIVATION" ϵ
OF A CaS(Bi)-PHOSPHOR AS A FUNCTION OF THE
TIME AFTER THE END OF THE EXCITATION

t	$\tau(t)$	ϵ (eV)
0	1 hour	0.87
6 minutes	5 hours	0.92
30 "	19 "	0.97
60 "	35 "	0.99
2 hours	50 "	0.995
3 "	65 "	1.00
5 "	100 "	1.015
10 "	140 "	1.035
24 "	250 "	1.045
3 days	25 days	1.075
10 "	65 "	1.105
20 "	110 "	1.13
30 "	150 "	1.14

The third column of the table gives the depth of the traps in eV; they were calculated from the mean lifetimes using Randall's formula for "quasi-uniform trap distribution" with a temperature of observation of 300° K and $s = 10^8$. These assumptions are probably not quite correct, but provide the order of magnitude of the trap depths and show how relatively small differences of ϵ suffice for a very large increase in τ (890).

Levshin, Antonow-Romanowski, Fonda, Randall, and others have shown by numerous examples that, in general, the decay of the phosphorescence of zinc sulfide and similar phosphors can be represented for relatively shorter periods of a few hours by straight lines in $\log I$ versus $\log t$ plots and that it follows a simple power law with good approximation; the power, which can be derived from the slope of the lines, varies between -1 and -2 (Figure 188). Most investigators are inclined to interpret this behavior as due to a bimolecular process. According to Randall [Section 152, Equation (87c)], such a power law may be explained by an exponential trap distribution; the power factors calculated by Randall from the trap distribution corresponding to his glow curves coincide astonishingly well with those derived from the decay curves. If the latter deviate slightly from

straight lines, this can be explained by the assumption that the trap distribution is not strictly exponential (18-21, 22f, 402b, 915, 917a, 919, 1335b).

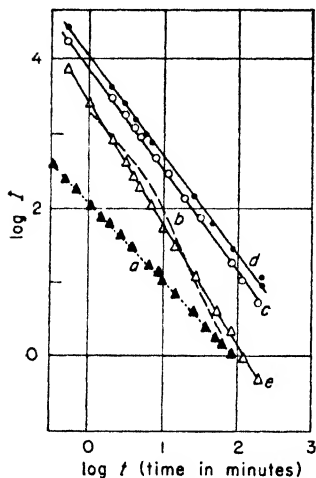

Fig. 188. Hyperbolic decay curves of various sulfide phosphors (Levshin, Randall).

- a: CaS(Bi) d: ZnS(Ag,Cu)
 b: SrS(Zn) e: Zn,CdS(Cu)
 c: ZnS(Cu)

for measuring the number n , decayed during a period of 40 min according to the equation:

$$1/i \sim 1/n = c_1 - c_2 t \text{ or } di/dt = dn/dt = -c_2 n^2 \quad (93)$$

This behavior, which has been quoted frequently as being typical of a recombination afterglow, was ascribed by Reimann himself to the fact that at every moment the number of electrons in the conduction band is proportional to the total number of excited electrons. The decay of the luminescence which is emitted by some phosphors — for instance, SrS(Ce,Sm) and SrSe(Eu,Sm) — upon stimulation with infrared after their normal phosphorescence at room temperature has become negligible, also obeys a hyperbolic law which, in one case, could be followed through a period of 40 min. For other phosphors — for instance, SrS(Eu,Sm) — the decay law, under the same conditions, is more complicated and does not correspond to a straight line in a plot representing I as a function of $1/t^2$ (360a).

In order to justify Reimann's interpretation, one has to assume

that the infrared radiation releases electrons from all traps of various depths with equal probability. Such an assumption is not based on any experimental evidence and disagrees definitely with Fonda's experiments concerning the stimulation of phosphorescence at low temperatures (Section 157). If one would postulate that only the electrons in the more shallow traps take part in the process, their number would no longer be proportional to the number of the positive holes. On the other hand, one might assume that the trap distribution determines, also, the probability of electrons being transferred to the conduction band by stimulation and, thus, the shape of the decay curve (402c).

Lenard (1927)* and Randall (1945) published, independently, nearly identical figures for the decay of a CaS(Bi)-phosphor after excitation with strong and with much weaker radiation (fifty times weaker in Lenard's and a hundred times weaker in Randall's experiment). The initial decay is much steeper in the first than in the second case. If, on the other hand, the exciting radiation is relatively weak, an increase in the *duration* of the excitation favors the intensities in the later parts of the decay period, so that the decay curve becomes flatter. Lenard explains his observations by the different distribution of excitation among the centers of different duration. After a long-lasting weak excitation, all the centers with a long lifetime are excited, while most of the centers of small duration have already been deactivated before the end of the excitation. The relative number of excited centers of small duration is much larger at the end of a short excitation of high intensity. This interpretation can be repeated without any alteration, except the replacement of "centers of various durations" by "traps of various depths." Lenard draws from his experiments the additional conclusion that centers of long duration need, under all circumstances, a longer period of excitation or "induction period" than those of short duration; he claims that bands, such as the blue α -band of CaS(Bi) acquire their full intensity at room temperature only after long lasting irradiation. As stated in section 99, the parallelism between induction and decay disappears if at high exciting intensities saturation is reached in a short time. The *duration* of the afterglow should, however, be independent of the state of saturation reached during excitation, if (after Randall) the capturing cross sections of all traps are practically equal (*F, 1335b*).

If this is true, the decay of a partially decayed phosphor which has been excited to saturation would differ essentially from the decay of a partially excited phosphor. In the first case, retrapping would be

* After measurements made by Werner in 1907 (*1819a*).

relatively unimportant, for the reason which has been stated above; in the second case, the trapped electrons should be distributed uniformly between deep and shallow traps and the decay should be slowed down appreciably by the recapture of electrons in empty deep traps. Such a behavior seems to be in direct contradiction to Lenard's statement mentioned in the preceding paragraph.

The induction period of phosphorescence of long duration is characterized by the fact that at first the probability of an excited electron being captured by one of numerous traps is much larger than

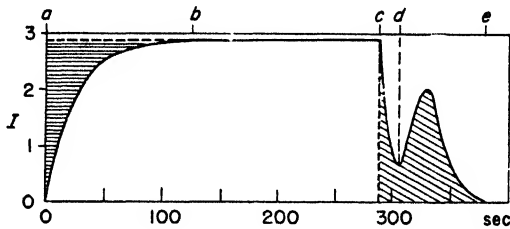

Fig. 189. Induction deficiency and stored light sum of a ZnS(Cu)-phosphor: *a-b*: induction period; *a-c*: period of constant excitation; *c-d*: spontaneous decay; *d-e*: *I* driven out by heating (Randall).

of an electron recombining with one of the much less numerous positive holes. With increasing excitation the number of the latter increases, while the number of empty traps becomes smaller: the fluorescence intensity rises and reaches its saturation value I , according to Randall, "when all traps are filled." (Saturation might also be due to the fact that all "absorbing centers" have been excited). Therefore, the integral of the energy missing in the fluorescence during the induction period (the induction deficiency) should be equal to the total light sum L stored in the phosphor at the end of the excitation, and the hatched areas under the curve in Figure 189 should be equal:

$$\int_0^{\infty} [I_{\infty} - I(t)] dt = L \quad (94)$$

L is obtained, in this instance also, by heating the phosphor. From the slope of the induction curve the relative probabilities of an excited electron being caught either by a trap or by an emission center can be derived (1335*b*).

The curve Figure 189, representing the luminescence of a ZnS(Cu)-phosphor, is in excellent agreement with Randall's deductions. In other instances the experimental curves disagreed very appreciably with the theoretical predictions, and several interpretations of these discrepancies have been proposed. In general, not all traps are filled, however, when equilibrium is reached, since the more shallow traps contribute to emission in equilibrium and even during the induction period, so that the induction deficiency is smaller than L . Moreover, it is assumed that competing quenching processes play the same part, if any in the almost instantaneous fluorescence and the long-lasting phosphorescence. And, finally, a part of the exciting absorption may occur in the activator itself — for instance, in Mn^{++} -ions in a ZnS(Mn)-phosphor — and enhance the value of $I(t)$ and thereby reduce the

apparent value of the integral $\int_0^{\infty} [I_{\infty} - I(t)] dt$.

Lenard phosphors containing the activating metal at very low concentrations exhibit a long-lasting afterglow and only very little luminescence of short duration. Lenard postulates that the center molecules are preformed in the base material even in the absence of an activator, and that the activating metal atoms are incorporated preferentially in the larger centers of great duration. If the center theory is abandoned and the formation of traps is ascribed, nevertheless, primarily to the matrix lattice irrespective of the presence of an activator, the behavior of phosphors with a small activator concentration might be explained by the probability of frequent retrapping of excited electrons before they encounter an emission center. If, on the other hand, the formation of traps is due mainly to the presence of impurity (or interstitial) atoms, one would have to admit that at small activator concentrations deep traps are formed preferentially. In either case, an increase in the concentration of the activator would favor emission processes of shorter duration. It would not suffice, however, for a complete suppression of the luminescence of slow decay, which should proceed after the electrons from the more shallow traps have been captured by emission centers, thus decreasing the number of the latter and increasing the probability of retrapping. The absence of a long-lasting afterglow at high activator concentrations is observed not only in typical Lenard phosphors but also in Mn-activated zinc silicate. In a $Zn_2SO_4(Mn)$ -phosphor containing 2.5 % of Mn, the long-lasting phosphorescence, which at low manganese concentration can be followed through a whole hour, is not observed at all and the first

luminescence stage, which at -193°C shows nearly the same behavior as in a phosphor with 0.1% Mn, decays about three times as fast at room temperature. Furthermore, this decay is no longer exponential, but seems to involve a reaction of the second order and, at 100°C , of an even higher order. Obviously, quenching processes, the efficiency of which increases with increasing duration of the luminescence and with

rising temperature, become very important at high activator concentrations in these phosphors (*I*, 398, 885).

The luminescence of KCl(Tl)-phosphors consists of three processes: a fluorescence with a lifetime shorter than $5 \cdot 10^{-5}$ sec, an afterglow of short duration (of the order of magnitude of 10^{-3} sec), and a phosphorescence which has a decay period depending on temperature and is frozen in at -180°C . Nothing is known concerning the second process, apart from its existence.* The phosphorescence, whose spectrum is the same as that of the fluorescence, is excited only by light which is absorbed in the short-wavelength absorption band at 1950 Å. Buenger and Flechsig have published several decay curves of KCl(Tl)-phosphors at room temperature. Some are strictly exponential, while others show very decided deviations from straight lines in a $\log I$ versus t plot. Randall and Wilkins have pointed out (as mentioned in Section 157) that the existence of traps varying in depth

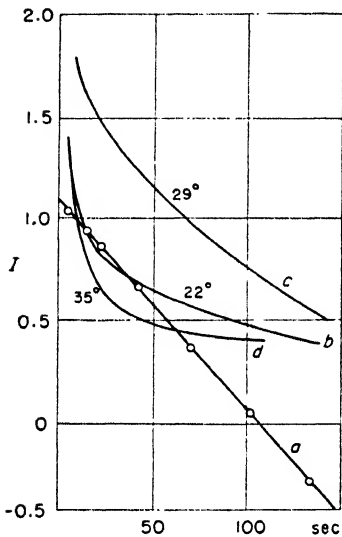

Fig. 190. Decay curves of KCl(Tl)-phosphors (Buenger and Flechsig, Randall).

a: strictly logarithmic decay of an individual sample. *b-d*: deviation from the logarithmic decay of another sample at various temperatures.

by less than 1% are sufficient to produce such deviations. Moreover, under these conditions, the curvature of the decay curves is greatly influenced by small variations of temperature (Figure 190). These measurements covered a period of only 160 sec, during which the light intensity dropped to a few per cent of its initial value. Seitz based his interpretation of the KCl(Tl)-phosphorescence as a purely

* Randall connected it tentatively with a slight peak in the glow curve of a KCl(Tl)-phosphor at 200°K .

monomolecular process within a Tl^+ -ion (or possibly a Tl_2^+ -ion) on the purely logarithmic decay and on the apparent absence of photo-conductivity accompanying the phosphorescence (187,1335b,1486).

Antonow-Romanowski repeated Buenger and Flechsig's investigations, using material of the same kind but varying the experimental conditions in several respects and extending the observations through many hours, during which the initial intensity I_0 dropped to $10^{-4} I_0$. He maintains that his results, especially the dependence of the initial slope of the decay curves on the intensity of the exciting light, are incompatible with a monomolecular reaction and that a bimolecular recombination process must be acknowledged as the source of the long-lasting phosphorescence. These results were later confirmed by Birus and Zierold, who investigated the behavior of phosphors provided by Buenger and Flechsig (22a,116).

In still another series of experiments dealing with the afterglow of $KCl(Tl)$ -phosphors, the material consisted of small crystals precipitated from a aqueous solution and containing a relatively high thallium concentration (about 2%). As far as absorption, excitation, and emission spectra were concerned, these aggregates of small crystals had the same properties as the single crystals used by the other investigators, except that a strong visible band was observed in addition to the u.v. band in the emission spectrum. The two emission bands decayed at the same rate. The phosphorescence was very strong, and at room temperature it could be followed by means of a photon counter for more than 24 hours. During the first ten minutes the decay obeyed the law of a second-order reaction, with deviations not exceeding 0.5%. Notwithstanding this excellent agreement, the result could not be interpreted as a proof of a bimolecular reaction, since the slope of the curve remained constant when the initial intensity was altered by a factor of 10, the first curve being converted into the second by a simple multiplication of the ordinates. After a short transition time the decay became exponential, with a half-time period of 50 min during the first two hours and of about 80 min toward the end of the decay (1293a,1293b,1788b).

Except for Antonow-Romanowski's claim respecting the connection between the slope of the decay curve and the intensity, all these observations can be represented by the introduction of adequate trap distributions. If, for instance, the decay follows a hyperbolic law at first, the distribution of the traps of smaller depths is exponential, and if at a later stage the decay curve approximates an exponential with a nearly constant value of $1/\tau$, the depths of the traps converge

toward a nearly constant peak value of ϵ . It is plausible, moreover, that the trap distribution depends greatly on the manner of preparation of the phosphors and is reduced to almost a single well-defined value of ϵ in perfect single crystals with a low activator concentration, while it is spread over a wide range in small crystals formed by precipitation and containing large amounts of thallium. However, it seems very improbable that metastable states of so manifold distributions occur in an activator ion and it is more satisfactory to assume that, in these phosphors also, the traps are due to lattice defects which may or may not be produced by the incorporation of the activator.

Antonow-Romanowski, who investigated the phosphorescence decay of single crystals of a ZnS-phosphor under the microscope, found that the slope of the decay curve became steeper with increasing size of the individual crystals, which all had the same composition and radii varying between 10μ and 70μ . Even when a large crystal was crushed and the powder re-examined under the microscope, the slope of the straight line in the $\log I$ versus $\log t$ plot was appreciably changed. He concluded that the behavior of the molecular layers near the surface differs from that of the layers in the interior of the crystals (18,20,920).

On the other hand, Randall and Wilkins found that the decay curves of two samples of a manganese-activated zinc silicate with particle diameters of 10μ and 200μ , respectively, were identical; in this instance, also, the smaller grains were obtained by splitting the larger crystals.

The somewhat confusing survey, full of discrepancies and even contradictions, which has been compiled in this section may show that although individual observations may be represented, in general, by a theoretical equation, the available data are still far from sufficient for a universal and unequivocal interpretation of the decay of luminescence in crystal phosphors.

160. Phosphorescence Yield. Measurements of the phosphorescence yield of crystal phosphors are very scanty. Since the manufacture of fluorescent lamps and screens became an important industry, some data concerning the total light output of such phosphors during the excitation period have been published. The measurements do not discriminate, however, between fluorescence and phosphorescence, and by far the greater part of the observed luminescence, in most cases, is due to fluorescence or other processes of very short duration. Moreover, the yield is not referred to the energy of the absorbed

TABLE 108
 QUANTUM EFFICIENCY OF VARIOUS PHOSPHORS DURING EXCITATION,
 REFERRED TO THE ENERGY OF IMPINGING RADIATION
 (IN PER CENT)

Phosphor	Efficiency	Phosphor	Efficiency
ZnS(Cu) ..	90	ZnBeSiO ₄ (Mn)	53
Zn,CdS(Cu) ..	83	CaWO ₄	70
Zn ₂ SiO ₄ (Mn) .	77	MgWO ₄ ..	70
CdSiO ₃ (Mn) .	55	CdB ₂ O ₄ (Mn) .	66

radiation, but is determined as the ratio of energies of emitted and impinging light.

In Table 108 some of these results are listed. They provide, of course, no more than the order of magnitude of the quantum efficiencies, since the qualities of phosphors of the same denomination differ widely according to the manner of preparation. Besides, the yields determined in this way depend to a high degree on the wavelength of the exciting light, as is shown for 3 of the most important phosphors in Table 109. The figures in Table 108 are calculated for those wavelengths which correspond to the highest apparent efficiency (398, 1360, 1651). The decrease in apparent efficiency in the region of greater wavelengths which characterizes the silicate phosphor in Table 109 is due to the fact that the absorption coefficient becomes very low for wavelengths above 2900A; the same behavior would be shown by the sulfide phosphors for exciting light of wavelengths beyond 5000A. On the other hand, the decreasing efficiency on the short-wavelength side of the optimum wavelength is caused by the very high, almost metallic, reflection which occurs in the region of the fundamental absorption band of the crystals. According to Drexler, the coefficient of reflection rises in this spectral region to 80 and even 90%. In the case of a microcrystalline powder the losses by reflection are lower because of multiple reflections occurring at the surfaces of the individual grains, but certainly they are still considerable. It should be noticed, in this connection, that the sharp drop in efficiency of the ZnS-phosphor sets in below 3650A, whereas the yield of the mixed ZnCdS-phosphor has already decreased appreciably at this wavelength: the long-wavelength limit of the fundamental absorption band of ZnS lies at 3450A but is shifted to 3720A in the mixed phosphor. It must be kept in mind that the energy yield becomes very low, even with a relatively high quantum yield, when visible luminescence is excited by light of short wavelengths. Thus, the energy yield cor-

TABLE 109
 QUANTUM EFFICIENCY OF EXCITING LIGHT (IN PER CENT) AS A FUNCTION
 OF ITS WAVELENGTH (IN Å)

Wavelength	(740)	2225	2399	2537	2803	3126	3851	4047
ZnS(Cu)	—	2.3	24	35	40	41	90	90
Zn ₂ CdS(Cu)* . .	—	—	10	24	—	33	71.5	83
Zn ₂ SiO ₄ (Mn) . .	(25†)	24	49	77	29	0	0	0

* About 20 % Cd.

† At very low Mn-concentrations.

responding to Table 109 is only 11 % for ZnS(Cu) excited by the wavelength 2399Å, and does not exceed 3 % when Zn₂SiO₄ is excited by the neon resonance line 740Å (398,1464).

With respect to the influence of the exciting wavelength, the results tabulated in Table 109 do not agree with those obtained by Schleede and listed in Table 110. For two of the phosphors in the latter table the luminescence yield is nearly independent of the exciting wavelength, while in the case of pure ZnS the yield increases strikingly when the exciting wavelength coincides with that of the fundamental absorption band. Moreover, in all cases the difference between the energy yields referred to absorbed and to incident energy (the latter given in parentheses) and, therefore, the loss due to scattering are relatively small. It is not probable that this disagreement is due to the difference of the materials to which the figures of Tables 109 and 110 refer. It is difficult to judge whether they can be explained by the difference in the method of observation. Schleede measured not the luminescence intensity during a constant irradiation, but the energy of the fast-decaying emission which is observed by means of an oscillograph phosphoroscope, and compared it with the light intensity scattered under the same conditions by a nonluminescent and nonabsorbing powder (1432c).

TABLE 110
 ENERGY YIELD Φ AND QUANTUM YIELD Q OF VARIOUS PHOSPHORS
 REFERRED TO ABSORBED ENERGY* (AFTER SCHLEEDE)

Phosphor . . .	"Pure" ZnS		Zn ₂ CdS(Ag)		ZnO	
	Φ	Q	Φ	Q	Φ	Q
Exciting wavelength						
3650Å	17 (10.4)	21	37.4 (34.2)	51	21.5 (19.5)	?
3130Å	40 (35)	58	37.3 (35.0)	59.5	23.1 (21.6)	?

* In parentheses: incident energy.

When the temperature of ZnS- and Zn,CdS-phosphors is lowered from 25° to — 180° C, their luminescence yield during excitation decreases by about 20 % if the exciting light of $\lambda > 4000\text{\AA}$ is absorbed in the long-wavelength tail of the absorption band, while the luminescence yield is doubled, or even tripled, if the exciting light of $\lambda \sim 3000\text{\AA}$ is absorbed in the fundamental absorption band of the base material (1468).

The determination of the genuine phosphorescence yield of a crystal phosphor is complicated only to a minor extent by the difficulty of measuring the exact amount of light absorbed in a layer of microcrystalline powders. The latter problem does not exist at all in the case of alkali halide phosphors, which can be prepared in the form of clear single crystals of appreciable size. The measurement of the "light sum" L which is emitted during the afterglow is also a relatively easy task. The difficulty lies in the definition of the absorbed energy, which must be taken into account. During the excitation a great part of the absorbed radiation is re-emitted as fluorescence and a smaller part also as phosphorescence. The latter may be neglected if the decay of the phosphorescence is slow compared with the duration of the excitation period. If, under these conditions, the phosphorescence is excited to saturation, however, a further increase in the intensity of the primary radiation will not contribute to the excitation of phosphorescence, and if the phosphorescence yield is referred to the total amount of light absorbed during the excitation period it will appear to decrease with increasing intensity of the exciting light.

In order to avoid these complications, the exciting irradiation must last a time so short that the loss of light sum during the excitation is negligible, and it must be so weak that an increase in its intensity produces a proportional increase in phosphorescence light sum. Using these precautions, Buenger obtained a phosphorescence quantum yield of about 5 % in a KCl(Tl)-phosphor of the most favorable Tl-concentration (0.92 % molar of Tl in the melt*). This result applies, however, only to excitation with light of wavelength of highest efficiency. As already mentioned, the phosphorescence of thallium-activated alkali halide phosphors is excited exclusively by light absorption in the short-wavelength absorption band [with maximum at 1950Å for KCl(Tl) and at 2100Å for KBr(Tl)]. The phosphorescence yield attains its maximum at the peak of this band and falls off rapidly on either side of the band, so that the

* Only a fraction amounting to about one-tenth of the metal contained in the melt is incorporated as activator in the crystals.

spectral distribution of the yield coincides with the absorption band.

Fluorescence of the same KCl(Tl)-phosphor, on the other hand, is excited by light of all wavelengths below 2600Å with a quantum yield of the order of magnitude of 50 % for the u.v. emission band alone and of about 80 % if the visible emission band is included in the calculation, without any selectivity at the wavelengths of the absorption bands. Thus, the *energy* yield of the fluorescence is represented in a yield-versus-wavelength diagram by a straight line, while the corresponding *phosphorescence*

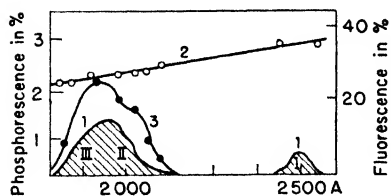

Fig. 191. Fluorescence and phosphorescence yield of a KCl(Tl)-phosphor (Buenger).

1: absorption bands. 2: fluorescence yield. 3: phosphorescence yield.

yield is represented by a curve closely following the short-wavelength absorption band (Fig. 191) (186, 188).

The phosphorescence yield is very small at low thallium concentrations.

Quantitative measurements are not available for Tl-concentrations below 0.1 % molar; in the concentration range from 0.1 to 0.92 % the yield increases continuously, but the increase is much less than proportional to the concentration (Figure 192). The coefficient of absorption in the band at 1940Å has been determined only for Tl-concentrations between $4 \cdot 10^{-3}$ % and $1.6 \cdot 10^{-1}$ %; while at the lowest concentrations the absorption is proportional to the Tl-content, the absorption increases at a much slower rate when the concentration of the activator exceeds $4 \cdot 10^{-2}$ %. These data do not seem to justify the conclusion that the phosphorescence yield is proportional to the

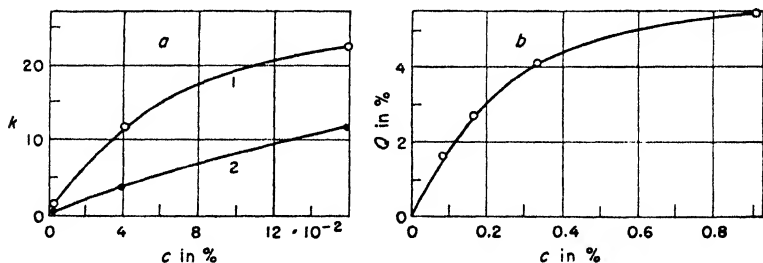

Fig. 192. Absorption coefficient k and phosphorescence yield Q of a KCl(Tl)-phosphor as a function of the Tl-concentration c .

(a) Absorption (1) at 1950Å and (2) at 2475Å.
(b) Quantum yield of phosphorescence.

square of the concentration, since such a hypothesis would be correct only if the absorption coefficient and the yield were both proportional to the concentration in the same range of concentrations. On the other hand, this may be true for the very lowest concentrations, but as long as no yield measurements are available for this concentration range the assumption that the "phosphorescence centers" are formed in KCl(Tl)-phosphors when two Tl⁺-ions are closely adjacent in the lattice must be regarded as rather hypothetical. It must be admitted, however, that the thallium-activated potassium halide phosphors represent the only case of phosphorescence in which the intensity and the duration of the phosphorescence increase up to the highest attainable concentration of the activating impurity (186,790a,790b,791, 1293a,1486).

Although the maximum of the phosphorescence excitation exactly coincides with the peak of the short-wavelength absorption band, Buenger suggests that the "phosphorescence centers" are separate units in the crystal and that 5% of the total absorption in the region near 1950Å is connected with these centers, while the remaining 95% belongs to "fluorescence centers." When the phosphorescence is excited to saturation, the specific absorption of the phosphorescence center should vanish and the peak of the absorption band should be lowered accordingly. Thus, the "genuine phosphorescence yield" is supposed to be 100%. An experimental proof of this hypothesis by Koch is, however, inconclusive; altogether, the assumption is based rather on an analogy with similar effects obtained with Lenard phosphors than on experimental evidence (790b).

Lenard and his school refer the phosphorescence yield of phosphors exclusively to the so-called exciting absorption, which is only a fraction of the total absorption even when the wavelength of the exciting light coincides exactly with a λ -maximum (838,885,886, 1462). The investigations of these authors deal only with the long-duration phosphorescence of sulfide phosphors. As shown by the figures of Tables 111 and 112, the light sum L which can be stored in these phosphors tends to the same saturation value after a few seconds of an irradiation of great intensity or after 300 seconds of a much weaker irradiation; and the total light sum which is emitted after the end of the excitation is the same if the phosphor decays slowly at moderate temperatures or if L is "driven out" rapidly by raising the temperature. A relatively small loss of light sum occurs at the very highest temperatures. The light sum which still is stored in a phosphor at a late state of the decay, when the luminescence has become im-

Pringsheim 21*

TABLE 111

LIGHT SUM L (IN ARBITRARY UNITS) STORED IN A $\text{CaS}(\text{Bi})$ -PHOSPHOR AFTER EXCITATION PERIODS OF VARIOUS INTENSITIES AND DURATIONS (LENARD)

Intensity of exciting light	Duration of excitation period in seconds						
	1	5	10	20	40	60	300
1	—	—	—	—	—	38	43
3.6	—	—	—	—	41	—	—
31	31	41	43	45	45	—	—
124	38	48	48	—	48	—	—
280	—	—	48	—	—	—	—

TABLE 112

LIGHT SUM L (IN ARBITRARY UNITS) OBTAINED FROM A FULLY EXCITED $\text{CaS}(\text{Bi})$ -PHOSPHOR WHEN IT IS HEATED TO VARIOUS TEMPERATURES (LENARD)

Temperature and time of heating period	L
50° C during 60 sec, then 600° C* during 15 sec	55
150° " 20 " " 600° " 3 "	54
600° " 3 "	48
1500°(?) " 0.1 "	47

* It seems very improbable that temperatures above 400° C contribute anything to the light sum. Probably the total stored energy is emitted during the heating period long before the temperature of 500° C is reached.

perceptible at room temperature, can be determined by heating the phosphor only if L is not affected by the temperature (compare Figure 187c). Incidentally, the fact that L is independent of the temperature is a strong argument in favor of the assumption that the phosphorescence yield is close to 100 %, for it would be a strange coincidence if the rate of light emission and of a competing quenching process would be influenced in exactly the same way by raising the temperature.

However, the constancy of L in a very large range of temperature, which Lenard postulates for his phosphors, is by no means a property characteristic of all crystal phosphors. It has already been mentioned that if after the end of the excitation the temperature of a $\text{KCl}(\text{Tl})$ -phosphor is raised from room temperature to 60° C, the initial brightness of the phosphorescence is appreciably enhanced but the duration of the afterglow is reduced to a much higher degree, so that the total light sum is greatly decreased. For a phosphor of the type $\text{SrS}(\text{Ce}, \text{Sm})$, which is closely related to the typical Lenard phosphors, Urbach

found the light sum obtained by stimulation to be many times larger than the light sum which he measured when the stored energy was driven out by heat. As stated in Section 158, the probability of internal conversion increases, in general, greatly above a certain temperature while the yield may remain almost constant below this temperature (360a,360b,1727b).

If, on the other hand, Ellickson obtained a much larger light sum by heating the SrS(Eu, Sm)-phosphor mentioned on page 539 than by irradiating it with infrared light, it is clear that in this case the infrared radiation not only stimulated but, with even higher efficiency, quenched the phosphorescence.

The light absorption in the spectral region in which the long-lasting phosphorescence of Lenard phosphors is excited becomes weaker when the phosphor is excited and reaches a minimum when the excitation is saturated.* Lenard assumes that at saturation all phosphorescence centers are excited and no longer participate in the absorption process. Lenard's method for the determination of the phosphorescence yield consists in measuring the absorption coefficients of the unexcited and of the fully excited phosphor for various wavelengths. The difference between the two coefficients is termed the "exciting" absorption characteristic of the centers, while the residual absorption, which sometimes greatly exceeds the exciting absorption, is ascribed to *m*-centers and the "filling matter" between the centers. Thus, the theory takes it for granted that the saturation is due to the disappearance of the absorbing mechanism (as in the case of the dye phosphors, Section 104) and not to the complete filling of all available traps. In a monomolecular phosphorescence theory, no essential difference exists between these two eventualities if every center contains only one absorbing element and one trap or if, at any rate, the numbers of absorbing resonators and of electron traps are equal. This is not true, however, for a bimolecular process if the absorbing centers and the traps are unrelated. Although the decrease in absorbing power of the excited phosphors for the exciting light has been proved, it has not been ascertained whether the *d*-maxima, which correspond to selective absorption bands (according to Table 106, Section 155) and which are supposed to be characteristic of the "centers," disappear under these conditions from the continuous background. At any rate, the reduction of the absorbing power is not confined to the *d*-maxima,

* This decrease in "exciting absorption" is compensated by the increase in "excited absorption" in the region of longer wavelengths, as was pointed out in Section 156.

but is also observed in the space between these bands. If the d -bands continue to exist in the fully excited phosphor, there is no reason to doubt that the light absorption in these bands continuous to contribute to the luminescence, although the light sum stored in the traps cannot be increased any further; thus, saturation of phosphorescence would not (as postulated by Lenard) be caused by the reversible destruction of a specific type of absorbing center but only by the limited number of traps.

Lenard calculates the phosphorescence yield by comparing the "exciting absorption" and the corresponding light sum as functions of the energy of the incident light in the intensity range in which the light sum, far from being saturated, is a linear function of the total primary light energy. From the energy yield Φ the quantum yield Q can be derived; both values are listed in Table 113 for three sulfide phosphors and for two wavelengths of the exciting light for each phosphor (885,1462).

TABLE 113
ENERGY YIELD Φ AND QUANTUM YIELD Q (IN PER CENT) FOR
VARIOUS SULFIDE PHOSPHORS (LENARD)

Phosphor	Band	Wavelengths in A				Yield in %	
		Peak of phosphorescence band	d_1	d_2	Exciting light	Φ	Q
CaS(Bi)	α	4140	4180	3200	4358	97	98
					3650	82	99
CaS(Cu)	α	5250	4160	3490	4358	76	92
					3650	64	92
ZnS(Cu)	α	5150	4300	3600	4358	84	99.5
					3650	73	103

The table shows that the quantum yield is practically independent of the wavelength of the exciting light and that it is in all cases very close to 100%. Considering the difficulty of the measurements and the great number of corrections which must be introduced in the calculations, the agreement between the different values is almost amazing. A comparison of the wavelengths of the exciting light and of the adjacent d -maxima proves that, while the light absorption is stronger in the d -bands, the light which is absorbed in the spectral

regions between the *d*-bands is no less effective in exciting phosphorescence.

Without introducing any specialized hypothesis concerning the mechanism of the process, these results can be summarized in the following way: a great part of the light absorbed by a phosphor is instantaneously released again either as luminescence of short duration or by conversion to heat. Only a relatively small fraction of the total absorption (the "exciting absorption") is not immediately reversible, and since the absorbing electrons do not return within a very short time to their normal equilibrium positions they are trapped in some quasi-stable state; practically all of these electrons eventually generate the emission of phosphorescence, and, therefore, the phosphorescence yield referred to the exciting absorption is nearly 100%, while the yield is much lower if it is referred to the total energy absorbed in the phosphor.

At low concentrations of the activating metal the light sum which is stored in a fully excited alkaline earth phosphor is proportional to the concentration* (Figure 193). At higher concentrations the saturation light sum tends towards a maximum value.

This does not necessarily mean a decrease in phosphorescence yield in the sense of Lenard's definition, for it is probable that the "exciting absorption," which has been measured only at relatively low concentrations, shows a similar behavior. According to curve 2 of Figure 193, the luminescence of short duration continues to increase, and this part of the luminescence does not contribute to the exciting absorption since the absorbing centers remain in the excited state only for a very short period. An increase in the bismuth concentration from 0.04 "normal" to 0.1 "normal" enhances the fluorescence of a CaS(Bi)-phosphor fifty times. Figure 194 shows, moreover, that at high bismuth concentrations also the phosphorescence intensity is greatly

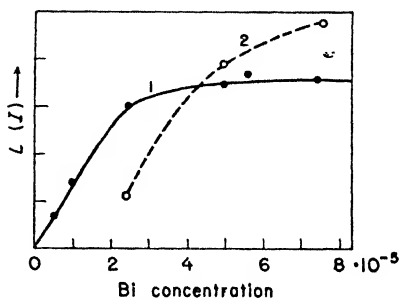

Fig. 193. Saturated light sum *I* and fluorescence intensity *I* of a CaS(Bi)-phosphor as a function of the Bi-concentration in g Bi per g phosphor (Lenard).

- 1: phosphorescence.
2: fluorescence.

* Concerning the definition of the "normal concentration" of a CaS(Bi)-phosphor, see next section.

increased during the first seconds of the afterglow which, in general, are not included in Lenard's measurements of the light sum. One minute after the end of the excitation, the light sums of the four phosphors represented in the figure have reached nearly the same levels, while the luminescence intensities corresponding to the slopes

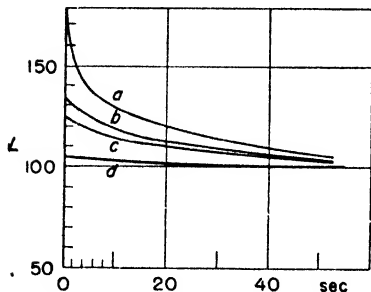

Fig. 194. Decay of the phosphorescence of a CaS(Bi)-phosphor of various Bi-concentrations during the first 60 sec (Kuppenheim).

a: 5 normal. *b*: 1 normal ($2.4 \cdot 10^{-4}$ g Bi per g phosphor). *c*: 0.1 normal. *d*: 0.01 normal.

of the curves are still considerably stronger in the phosphors of higher metal concentration (850,890).

If, due to the existence of a competing quenching process, the light emission corresponding to a second-order process is represented during excitation by an equation of the type of (88b), the intensity of the luminescence in equilibrium will not be proportional to the intensity of the exciting radiation. At low values of A (the number of absorbed photons) the number n of excited centers is small and, therefore, the first-order quenching process predominates; with increasing values of A the relative importance of the second-order emission process in-

creases and at very high levels of excitation the intensity of the emission is practically equal to A and proportional to the intensity of the exciting light (1727*d*).

Riehl was the first to observe slight deviations from linearity in the ratio between exciting and secondary radiation; he found that at room temperature the fluorescence yield of a Zn,CdS(Ag)-phosphor became 1.74 times larger when the intensity of the primary radiation was increased in the ratio 1:400. Furthermore, he found that the relative increase in yield was much more pronounced at higher temperatures, and explained it by the fact that the competing quenching processes are then much more efficient. Urbach showed that the effect discovered by Riehl can be enhanced enormously by the incorporation of a quenching agent such as nickel in a phosphor. Under these conditions, the deviation from linearity can become so large that the yield of the luminescence is several hundred times stronger at high light intensities than it is at low levels. If the interpretation of the phenomenon which is given in the preceding paragraph is correct,

Urbach's observations would prove incidentally that the quenching due to the introduction of a "killer" obeys the law of a first-order reaction (1361,1727d).

Another instance of a nonlinear relation between the intensities of exciting and secondary radiation which can be interpreted as due to the competition between two processes has been mentioned on page 544. De Groot observed a slight decrease in the fluorescence yield of some zinc sulfide and zinc cadmium sulfide phosphors when, at high intensities of the exciting radiation, the density of the latter was increased: the total light output became larger by ten to twenty per cent when the exciting radiation was defocused and thus spread over a wider area. De Groot ascribed this behavior to some kind of saturation effect, possibly to the fact that, under these conditions, the conduction band is completely occupied by electrons (267).

Combining a series of complicated measurements and calculations, Lenard came to the conclusion that about four photons are stored in every center of a fully excited CaS(Bi)-phosphor. This seemed to be surprising as long as it was assumed that the whole phenomenon took place in a single center and that each center contained one bismuth atom to which the four electrons were supposed to return successively. However, if the electrons originate anywhere in the lattice and are stored in traps not necessarily connected with activator atoms, the number of excited electrons and of traps can be much larger than the number of activator atoms (emission centers). Several holes can be stabilized successively, or even simultaneously, in the neighborhood of an activator atom, and the same emission center will be excited every time one of these holes catches an electron.

Randall calculated the number of photons emitted by a fully excited SrS(Bi)-phosphor to be of the order of 1 per $5 \cdot 10^4$ strontium atoms and thus, supposedly, rather more than one per activator atom. On the other hand, Urbach determined the number of photons released by a SrS(Eu,Sm)-phosphor under infrared stimulation. He obtained one photon per 3 Sm atoms (the traps). 2% of the Ce atoms participate in the stimulated emission of a SrS(Ce,Sm) phosphor. In all these experiments the number of "centers" is somewhat vague, because it is impossible to ascertain how many of the impurity atoms are effectively incorporated as "activators" and how many may be dissolved in the flux or lost during the preparation (360b,1335b,1727b).

B. Properties of the Most Important Synthetic Crystal Phosphors

161. Alkaline Earth Sulfide Phosphors and Related Phosphors. If precedence is accorded in this chapter to the Lenard phosphors, this certainly cannot be justified by the assertion that they represent an especially simple case. On the contrary, the manifold luminescence phenomena obtained with these phosphors are probably the most complicated occurring anywhere in the field. This is due, in part at least, to the fact that they were not selected as examples for a theoretical treatment but were developed empirically as substances exhibiting the longest and strongest afterglow. Even the most modern prescriptions for their preparation still contain traces of their alchemistic origin. However, these phosphors surpass all others not only by the duration of their afterglow but also by the wealth of material that has been published concerning their properties. This material provided the base on which the modern theory of phosphorescence is founded (785,886,892).

The sulfide, oxide, or selenide of one of the alkaline earths (calcium, strontium, or barium) forms the base material of the phosphors. Although different methods of preparation have been mentioned in preceding sections, the usual and most effective method consists in heating the sulfate, carbonate, or selenide of the alkaline earth metal together with a small quantity of the activating metal and a flux, such as Na_2SO_4 , NaCl , CaF , etc., in an atmosphere of sulfur vapor, oxygen, or selenium vapor, respectively, to a temperature of about 1000°C . (The most favorable temperatures of firing vary with the composition of the phosphor and the nature of the flux). Some examples of "normal concentrations" for the production of phosphors with strong and long-lasting afterglow are the following, according to Lenard:

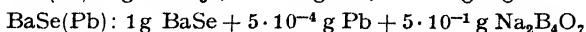
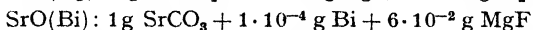
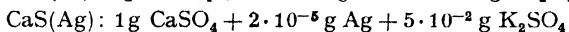
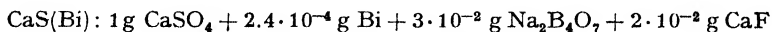

Lenard and his pupils refer all other concentrations of the activator to these "normal concentrations," so that a CaS(Bi) -phosphor containing $9.6 \cdot 10^{-6}\text{ g}$ or $1.2 \cdot 10^{-3}\text{ g Bi}$ per g CaSO_4 would be termed as 0.04 "normal" and 5 "normal," respectively (F,784,1197,1445).

In the firing process a part of the sulfates and carbonates are converted to sulfides and oxides.* With normal concentrations of the activating metal the quality of the phosphor is not affected if a part of the base material retains its original composition as sulfate or carbonate, as shown by the figures of Table 114. Apparently the Bi-atoms are all incorporated in the sulfide crystallites, as long as these form at least 25% of the total mass, while the remaining sulfate serves only as "filling material."

If the sulfate is not protected sufficiently against reactions with atmospheric air during the firing, a part of the material is converted to oxide and a "mixed phosphor" is formed. If the firing temperature is relatively low (about 800°C) or the concentration of the activator is great, the resulting phosphors exhibit only a very poor afterglow.

TABLE 114
SATURATION LIGHT SUM L OF A CaS(Bi)-PHOSPHOR OF CONSTANT Bi-CONCENTRATION AND VARYING CONCENTRATION OF SULFATE (L in arbitrary units)

Composition of base material in %			L
CaSO ₄	CaS	CaO	
39	61	0	252
75	25	0	232
86	11	3	4
100	0	0	0

According to more recent investigations, the presence of sulfate ions can influence the formation of certain phosphors. Moreover, the presence of small quantities of oxide ions and other anions may affect the properties of phosphors almost as much as the presence of an activator. This is a problem, however, which is still far from solved completely (1274a, 1727b, 1786b).

Table 115 lists the activating metals which have been found to be effective in Lenard phosphors. In addition to the alkaline earth phosphors, the table contains compounds in which the alkaline earth metal is replaced in the base material by another divalent metal of the second column of the periodic system. Finally, two alkali sulfides are included as belonging also to this group of phosphors. The RbS-

* These oxide phosphors differ widely from "carbonate phosphors" such as the synthetic luminescent calcite mentioned in Section 153. The latter are practically only fluorescent, their afterglow being negligible.

TABLE 115
COMPOSITION OF LENARD PHOSPHORS

Base material	Cu	Ag	Zn	Pb	Sn	Bi	Mn	Sb	Fe	Co	Ni	Ce	Pr	Nd	Eu	Sm	Tb	Gd	U
CaS	+	+	?	+	+	+	+	+	+	o	+	-	+	?	-	+	?	o	o
SrS	+	+	+	+	o	+	+	-	+	o	+	+	+	?	+	+	+	o	o
BaS	+	o	o	+	o	+	o	o	-	o	-	-	-	-	-	-	-	o	-
CaO	+	-	-	+	-	+	+	+	-	+	-	-	+	?	+	+	+	o	-
SrO	+	-	-	+	-	+	+	-	-	-	-	-	-	?	-	+	+	o	-
BaO	+	-	-	+	-	+	o	-	-	-	-	-	-	?	-	-	-	-	-
CaSe	+	-	+	-	-	+	o	+	+	-	o	-	-	-	-	-	-	-	-
SrSe	+	-	+	-	-	+	-	-	-	-	-	-	-	-	+	+	-	-	-
BaSe	o	-	+	+	-	o	-	-	-	-	-	-	-	-	-	-	-	-	-
BeS	o	o	o	o	o	+	o	+	-	-	-	+	-	-	-	-	-	-	-
MgS	?	+	-	?	-	+	+	-	-	-	-	+	+	?	-	+	-	+	-
ZnS	+	+	+	**	o	o	+	-	+	-	-	-	-	-	-	-	-	-	-
CdS	+	+	+	-	-	-	-	-	-	-	-	-	-	-	-	-	-	-	-
BeO	-	-	-	-	-	-	-	-	-	-	-	-	-	-	-	-	-	-	-
MgO	-	-	-	-	-	-	+	-	-	-	-	-	-	-	-	+	-	-	-
ZnO	-	-	+	-	-	-	+	-	-	-	-	-	-	-	-	+	-	-	-
NaS	+	-	-	-	-	-	-	-	+	-	-	-	-	-	-	-	-	-	-
RbS																			

* According to Urbach, no zinc-activated SrS-phosphors can be prepared.

** Compare page 525.

phosphor is the only phosphor listed in the table which is activated by an unknown impurity. For technical reasons, phosphors with sulfides of the other alkali metals (except Na) as base material cannot be prepared.

The + signs in the table indicate that the metal at the head of the column has been proved to be an effective activator, an o indicates that an investigator has mentioned explicitly that the combination gives no positive result, while the numerous open spaces (marked with -) may largely be due to the fortuitous circumstance that the combination has not been investigated. It can be assumed that many of these vacancies could be filled at present, since a great many new phosphors have been produced lately for industrial purposes and for various technical applications. Among the latter are the mixed phosphors which were developed because of their good response to infrared stimulation and to changes in dielectric constant (D.K. effect).

Several examples of this type were mentioned in preceding sections. The most important are, apparently, $\text{SrS}(\text{Ce}, \text{Sm})$; $\text{SrSe}(\text{Eu}, \text{Sm})$; $\text{SrS}(\text{Sm}, \text{Bi})$; $\text{ZnS}(\text{Pb}, \text{Cu})$; $\text{CdS}, \text{Se}(\text{Cu})$, $\text{SrS}, \text{O}(\text{Eu}, \text{Sm})$; $\text{Zn}, \text{CdS}(\text{Cu})$; etc. Some papers dealing with these phosphors are concerned almost exclusively with the specific qualities with respect to which the phosphors were developed and, in general, contain little information about their other properties. In his paper on the D.K. effect, Wesch mentions that he succeeded in preparing copper-activated tellurides of zinc and cadmium and mixed phosphors such as $\text{ZnS}, \text{Te}(\text{Cu})$; $\text{Zn}, \text{CdS}, \text{Te}(\text{Cu})$, etc.; moreover, he prepared a photoluminescent $\text{HgS}(\text{Cu})$ -phosphor, although Lenard maintained that it was impossible to use the strongly colored sulfide of mercury as base material of phosphors (402c, 1154a, 1727b, 1821).

Among the alkaline earth metals, calcium gives the best results with almost all activators, strontium is somewhat less effective, and barium compounds are the least favorable base materials. On the other hand, copper is a good activator for nearly all phosphors (BeS being the only exception explicitly mentioned); it is followed by bismuth, manganese, and lead, while the metals of the iron group are serviceable in only a few cases and only at very low concentrations (see Section 154). It is surprising that, although manganese is an excellent activator for many alkaline earth salts and chromium-activated aluminum and magnesium oxides exhibit a brilliant fluorescence, no chromium-activated Lenard phosphors can be obtained.

In contradiction to Lenard, who lists ZnS -phosphors activated with Co, Bi, and Pb, most recent authors agree that apart from interstitial zinc atoms (in so-called "pure" ZnS) the only impurities by which zinc sulfide is activated are silver, copper, manganese, and possibly iron.* The same seems to be true with respect to CdS and mixed Zn, CdS -phosphors (*F*, 266, 268, 833a, 1360, 1363, 1433).

According to Rotschild, luminescent zinc sulfide phosphors activated with silver or copper are obtained only if a halide, such as NaCl or KI , is used as flux in the preparation. Since luminescent $\text{ZnS}(\text{Ag})$ and $\text{ZnS}(\text{Cu})$ phosphors can be prepared by the "contact method," the activating impurity atoms need not react at high temperatures with the halide ions. However, the "pure" zinc sulfide itself which subsequently is activated by "contact" must have been prepared in the presence of a halide flux, as will be pointed out in the following section. $\text{ZnS}(\text{Mn})$ -phosphors can be prepared without any flux (1386b).

* Concerning Fonda's $\text{ZnS}(\text{Pb})$ - and $\text{ZnS}(\text{Pb}, \text{Cu})$ -phosphors, see p. 525.

The phosphorescence bands of phosphors of different composition and the various emission bands of a given Lenard phosphor differ greatly in their dependence on the temperature of observation. The afterglow of some bands has great intensity even at -180°C ("low-temperature bands"), others appear only at moderate temperatures, and still others have their greatest intensity and a long duration at temperatures exceeding 300°C ("high temperature bands"). As shown in Table 116, the most favorable temperatures for analogous bands are highest with oxide phosphors and lowest for selenide phosphors: the average energy needed for raising the trapped electrons into the conduction band is largest in the oxide and lowest in the selenide phosphors. At room temperature selenide phosphors, therefore, exhibit only a very short afterglow, in general. Very stable traps of great depth are formed, however, in certain mixed selenide phosphors of the type mentioned above. A $\text{SrS}(\text{Ce}, \text{Sm})$ -phosphor retains its activity so that 2 weeks after excitation the brightness under infrared stimulation is still very appreciable. At the temperature of boiling hydrogen the phosphorescence of all Lenard phosphors is "frozen in"; at temperatures above 500°C , and frequently even at lower temperatures, the phosphorescence is completely quenched (1786*b*, *c*).

"Mixed phosphors" of three different types have been mentioned in preceding sections.

(a) Two activating metals are incorporated into a single base material. In this case, either the bands of both activators are observed simultaneously or the emission bands of the one are suppressed by those of the other. Nitka obtained in the emission spectrum of manganese-activated zinc sulfide a broad band with two maxima

TABLE 116
MOST FAVORABLE TEMPERATURE FOR THE APPEARANCE OF
PHOSPHORESCENCE BANDS OF VARIOUS LENARD PHOSPHORS

Band	Oxide phosphor		Sulfide phosphor		Selenide phosphor	
	Band peak in A	Temp in $^{\circ}\text{C}$	Band peak in A	Temp in $^{\circ}\text{C}$	Band peak in A	Temp in $^{\circ}\text{C}$
CaBi α	4350	300-350	4450	10-200	—	—
β			5200	ca 300	6620	15
SrBi α	4400	250-300	4700	-45-17	—	—
β			5500	200	6460	-180
BaBi α	5350	ca 80	5400	-80	—	—
β			5500	17	6600	-180

which he designated as the “ α -band” of ZnS(Mn). Depending on the wavelength of the exciting light, the relative intensity of the two maxima varied considerably (Figure 195) (1140). A phenomenon of this kind has never been observed with any other Lenard phosphor and Kroeger assumes, therefore, that Nitka’s phosphor was contaminated with copper so that it was really a “mixed phosphor.”

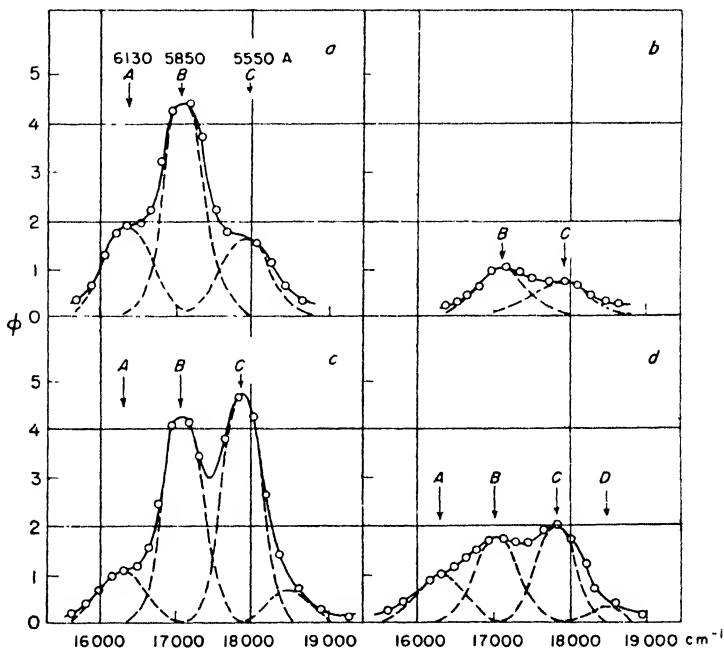

Fig. 195. Phosphorescence spectrum of a ZnS(Mn)-phosphor (Nitka). Wavelength of exciting light: (a) 4358Å; (b) 4047Å; (c) 3655Å; (d) 3132Å.

Kroeger ascribes the maximum of shorter wavelength (5550Å), which is practically not excited by the Hg-line 4537Å, to copper, while this Hg-line strongly excites the manganese band at 5850Å. On the other hand, either band responds very poorly to excitation by the line 4047 and is excited with nearly equal efficiency by the u.v. lines 3650 and 3130Å (830,1142).

(b) In the second type of mixed phosphors, the base material contains two different anions and consists partially of oxide and partially of sulfide, or partially of sulfide and partially of selenide.

Under these conditions the emission spectrum is characteristic of the first of the two components, if this component is present at a concentration exceeding a few per cent and if the concentration of the activating metal is not above "normal." According to Tomaschek, the activating metal is preferentially incorporated in those "centers" in which it can form the more stable compound, e.g., CuO as compared with CuS, or CuS as compared with CuSe (1692).

(c) If the base lattice contains two different cations -- for instance, calcium and strontium or zinc and cadmium -- the emission band of the activator is continuously displaced with increasing concentration of the second component: it varies from the pure basic material of the first kind to that of the second kind, if the two compounds are able to form mixed crystals of all concentrations. This is the case for the systems CaS-SrS and ZnS-CdS. Ca,SrS(Sm)-phosphors have been discussed in Section 141. The long-wavelength limit of the fundamental absorption band of mixed crystals of ZnS and CdS is shifted continuously in the direction of greater wavelengths with increasing cadmium concentration and, simultaneously, the phosphorescence bands of the silver- and the copper-activated phosphors are displaced from the blue and green to the extreme red (see Table 117 and Figure 198A on page 605). According to Henderson, the shift of the long-wavelength edge of the fundamental absorption band and of the peak of the fluorescence band can be represented by straight lines in a diagram showing the wave-numbers as functions of the cadmium concentration (Figure 198B) (600).

Manganese does not show the same behavior when it is activating mixed Zn,CdS-phosphors: the wavelength of its characteristic

TABLE 117
ABSORPTION AND LUMINESCENCE SPECTRA OF MIXED Zn,CdS-PHOSPHORS
(Wavelengths in Å)

% Cd	0	10	20	30	40	50	60	70	80	90	100
λ_a	3350	3580	3720	3900	4115	4270	4450	4700	4820	4930	5170
λ_F	3310		3780*			4240		4655		4900	5100
$\lambda_p(\text{Cu})$. .	5200	5600	6100	6300	6400	6500	6600	6800	7000	7000	i.r.
$\lambda_p(\text{Ag})$. .	4450	4650	4800		5100	5600	6000		6700		i.r.

λ_a : long-wavelength limit of fundamental absorption band.

λ_F : short-wavelength limit of low-temperature fluorescence (see next section).

λ_p : peak of phosphorescence band.

* Measured for 25% Cd.

spectra of various sulfide phosphors, each phosphor having several independent phosphorescence bands, and every emission band corresponding to several d -bands for the excitation of phosphorescence and a diffuse m -band for the excitation of fluorescence (or the " m -process"). By an adequate choice of the flux and the temperature and duration of the firing, it is possible to prepare phosphors which exhibit preferentially or exclusively one of the various emission bands and only one or two of the d -bands corresponding to such an emission band. The color of the phosphorescence of BaS(Cu)-phosphors is influenced, also, by

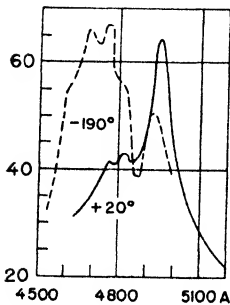

Fig. 197. Phosphorescence bands of a SrS(Bi)-phosphor at 20° and -190° C (Nichols and Merritt).

the anion of the flux used for the preparation; with lithium phosphate or lithium sulfate used as flux the color is yellowish red and greenish yellow, respectively. If traces of chloride ions are present, they suppress the influence of all other anions. It is not clear whether these changes in color are due to the preferential appearance of one of the characteristic bands of the phosphor (Lenard lists the bands α with peak at 6500Å, β with peak at 5500Å, and β_4 with peak at 4300Å) or to the shift of the peak of an individual band (883,1727b).

In general, the emission bands do not have the simple bell shape shown in the schematic representation of Figure 196, but have a complex structure, and an apparent wavelength shift of a band by lowering of the temperature may really be produced by a change in the intensity distribution between the components of the band (Figure 197).

The emission spectra of phosphors which are activated with rare-earth metals have been treated in Section 141. While the excitation of pure rare-earth salts is limited, in general, to the absorption lines characteristic of the rare-earth ions, these lines have no important part in the excitation of the phosphors. The latter exhibit a number of d -bands which have no connection with the absorption spectra of the ions and which are analogous in every respect to the d -bands of other Lenard phosphors. An example is given at the bottom of Figure 196 for the CaS(Sm)-phosphor. Phosphorescence of long duration is excited by light absorption in the d -bands only, while luminescence of short duration (" m -process") is also produced in these phosphors by irradiation with light of a broader spectral region (" m -bands"). The emission spectra consist, in both cases, of the typical rare-earth line series (1678,1693).

A very great amount of work has been done by Lenard and his school in the endeavor to establish relations between the wavelength of the d -bands and the emission bands with other properties of the phosphors, especially their dielectric constant ϵ . The first rule of this type claimed only that if phosphors of the same composition — for instance, “0.1 ‘normal’ CaS(Bi)-phosphors” — but with different dielectric constants were obtained by different methods of preparation, the wavelengths of their d -bands varied in such a way that $\lambda(d_i) \cdot \epsilon^{-1/2}$ remained constant. Later, this rule was extended to the d -bands of “analogous” emission bands of phosphors with different base materials and different activators. Analogous bands were defined as phosphorescence bands which showed the same general behavior with respect to their dependence on the temperature of observation, the concentration of the activator, the manner of preparation, etc. Such analogous bands are, for instance, the α -bands of CaS(Cu), SrS(Cu), CaS(Mn), ZnS(Cu) and the β -bands of CaS(Ag), SrS(Bi); etc.* Another group of analogous bands is assumed to be formed by the α -band of Bi and the β -bands of Mn and Ni. Thus, finally, the phosphorescence bands of all sulfide phosphors were arrayed in five groups and the wavelengths of all d -maxima could be derived from five series of “absolute wavelengths” by multiplying the values listed under d_i in Table 118 by the square root of the dielectric constant of the phosphors (1446).

TABLE 118

“ABSOLUTE WAVELENGTHS” OF THE d -BANDS OF SULFIDE PHOSPHORS

Group number	Emission band of the activator	Absolute wavelength of d_i in Å					
I	Bi α , Mn β , Ni β	770	1130	1470	—	—	—
II	Mn α , Cu α , Zn α , Ni α , Ag β , Pb β , Bi β	780	990	1210	1460	1740	—
III	Ag α , Pb α	700	860	1040	1240	1470	—
IV	Cu β , Ni γ	780	930	1130	1360	1600	1840
V	Cu γ , Ag γ , Pb γ , Zn δ	870	(990)	1180	(1370)	1540	—

A similar table has been arranged for oxide phosphors. It must be mentioned that, in general, not all d -bands which can be computed from Table 118 are observed in a single phosphor; on the average, the number of d -bands of an individual phosphor does not exceed three and in some cases only two or even one such band has been found.

* Lenard's original concept, according to which analogous bands had been designated by the same Greek letter, had to be given up in this connection.

The whole scheme is based on the hypothesis that the "absolute wavelengths" correspond to the frequencies of a resonator in vacuo and and that these frequencies are shifted in the direction of greater wavelengths by the dielectric constant of the surrounding medium.

The emission bands themselves were supposed to follow a similar law, at least qualitatively. In accordance with the fact that the mean dielectric constants of alkaline earth phosphors increase from Ca to Sr and Ba, and from sulfide to oxide and selenide, the peaks of analogous emission bands are displaced in the direction of greater wavelengths following the same order as the increase of ϵ . Ultraviolet bands are found in the emission spectra of almost all Ca-phosphors, they are less frequent in the spectra of Sr-phosphors, and they are completely missing in those of Ba-phosphors. The CaS(Ag)-phosphor prepared according to the formula given in the second paragraph of this section has only u.v. phosphorescence bands (at 3500, 3170, and 2840A), while the emission bands of the SrS(Ag)-phosphor are at 5700, 4200, and 3750A (1196).

Schmidt, one of Lenard's collaborators, tried finally to link the frequencies of the emission bands to the sets of d -bands represented in Table 118. Most of the phosphorescence bands can be resolved into several components, as shown in Figure 197. Using the frequencies of these components and combining them with those of the d -maxima, Schmidt succeeded in representing the complete spectra of all phosphors by equations of the type:

$$\lambda_n = n^2 \epsilon^{1/2} \cdot A^* \quad (95)$$

where A^* (with values of the order of magnitude of 20A) is derived by extrapolation from one of the horizontal rows in Table 118 and n is an integer, assuming values from 6 to 17. This new order completely destroys Lenard's original concept: not only are d -maxima belonging to the same emission band assigned to different series, but this is true for the various components of emission bands which were "single" according to Lenard's definition (1449, 1451).

Lenard's original hypothesis concerning the existence of "absolute" frequencies and the influence of the dielectric constant on these frequencies was derived from classical electrodynamics, but this theory cannot be applied indiscriminately to the electronic frequencies in a crystal. Schmidt's equation, which contradicts Lenard's own assignments in many details, is apparently influenced by the quantum laws of series spectra and has no theoretical basis whatsoever. It is, of course, always possible to represent not too well-defined wavelengths

of a number of bands by equations containing a sufficient number of constants or the high multiples of very small quantities.

Another attempt to establish a "series law" for the structure of the emission bands of phosphors is, if anything, even less admissible, although references to this law are not infrequent in the literature. According to Tanaka, all luminescence spectra of crystal phosphors containing an activating metal consist of a series of equidistant maxima, and the spacings of these maxima are claimed to be characteristic

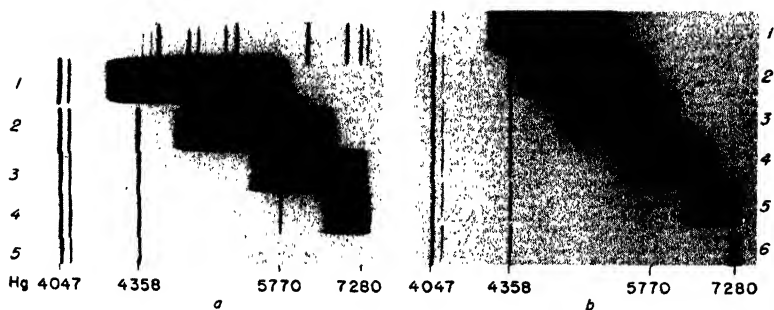

Fig. 198A. Phosphorescence spectra of mixed Zn,CdS-phosphors (Rothschild).

- (a) Without foreign activator: 1, 0%; 2, 30%; 3, 50%; 4, 70%;
5, 100% CdS.
(b) Zn,CdS(Ag): 1, 0%; 2, 10%; 3, 30%; 4, 50%; 5, 70%;
6, 100% CdS.

of the activator and quite independent of the nature of the base material. The existence of such progressions, with spacings of the order of magnitude of 100 cm^{-1} , can be interpreted only as due to the superposition of lattice vibrations on an electronic frequency and thus should be determined mainly by the base material. Tanaka's experimental results, obtained by visual spectrophotometry, have never been confirmed by another investigator (1566,1626).

162. "Pure" Sulfide and Oxide Phosphors. The question whether zinc sulfide must contain a foreign impurity to become a "phosphor" has been much discussed, but it was assumed to be definitely settled in the sense that, in this case, interstitial zinc atoms can play the part of the activator. There is a slight difference between the absorption and emission bands of "pure" sphalerite and wurtzite, the former being displaced with respect to the latter by about 500 cm^{-1} (50–60A) in the direction of greater wavelengths. The lumines-

Pringsheim 22

cence bands are broad and diffuse (Figure 198A) and the color of the luminescence is blue* (830,832,1360,1386a,1433,1434,1690).

It has been mentioned in the preceding section, however, that according to Rothschild zinc sulfide exhibits its blue luminescence only when it has been fired with a halide flux (1386b). Kroeger (834b) corroborated and extended Rothschild's results. He found that zinc sulfide prepared without a halide flux and showing no blue luminescence was converted into the blue luminescent modification by heating the material in an atmosphere of chlorine. A new band at 3600A appeared in the absorption spectrum of this modification, but the blue luminescence was excited not only by light absorbed in this band, but also by light absorbed in the fundamental absorption band of ZnS below 3400A. When the blue fluorescent ZnS is heated to 1100° C in an atmosphere of hydrogen or nitrogen, the blue fluorescence vanishes and the original modification is restored. The whole cycle can then be repeated at will. A quite satisfactory interpretation of the part played by the halide in the formation of the blue fluorescent centers has not yet been proposed.

At — 190° C the modification of ZnS without visible luminescence emits an u.v. fluorescence with a peak near 3400A, the intensity of which decreases when the blue luminescence appears. This u.v. luminescence may be identical with the fluorescence which is described in a later paragraph of this section and apparently is observed in all "pure" ZnS-phosphors at the temperature of liquid air (compare Table 119).

Pure cadmium sulfide without a foreign activator also is luminescent if an excess of cadmium atoms in interstitial positions is provided by heat treatment. The peak of the emission band is situated in the near infrared, only the tail of the band stretching to the visible, and the fluorescence color is a deep red. In mixed crystals of pure ZnS and CdS, the peak of the luminescence band is shifted with increasing cadmium concentration continuously from the blue to the red; the

* While all other authors have prepared these phosphors by the usual method of firing the sulfide together with a flux — e.g., NaCl — in an atmosphere of sulfur vapor or H₂S, Coustal and Prevet obtained "pure" ZnS-phosphors by a so-called explosion method. A mixture of finely pulverized zinc and sulfur was ignited by an electric spark. Under these conditions, the reaction takes place at very high temperatures (according to the authors, at 3000° C) and the product of the reaction is claimed to be very pure and well-crystallized wurtzite, with a strong luminescence. The color of this luminescence is described as greenish, differing, thus, from the results obtained by the usual method and suggesting the presence of small quantities of copper (238-241,1264,1265).

behavior is very similar to that of silver-activated mixed Zn,CdS-phosphors, but the bands are appreciably broader in the case of the "pure" phosphors (Figure 198B). The question whether in the mixed pure phosphors interstitial atoms of both metals function as activators has never been discussed (708,833a,1386a,1386b).

The fluorescence of pure zinc oxide has been mentioned frequently but the statements which were published by various investigators with respect to the fluorescence spectra disagree widely. The color of

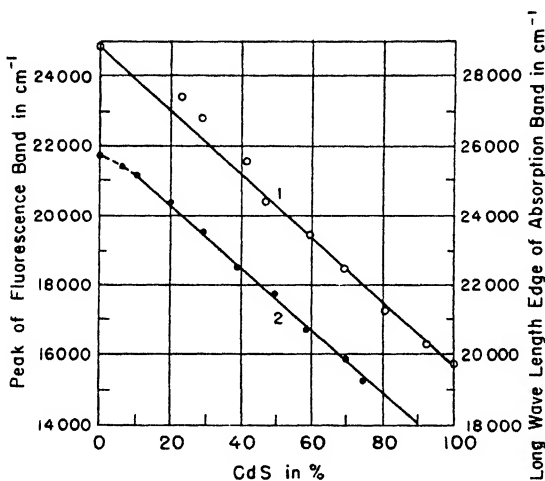

Fig. 198B. Absorption and fluorescence bands of mixed Zn, CdS-phosphors as a function of the CdS-concentration (Hendersen).

- (1) Long-wavelength edge of fundamental absorption band (Gisolf); shift = 90 cm^{-1} per 1% CdS. (2) Peak of fluorescence band of Ag-activated phosphor (Rothschild); shift = 92.6 cm^{-1} per 1% CdS.

the luminescence which can be excited by near u.v. has been described as varying between yellow and green, depending on the previous heat treatment. According to Studer and Gaus, at room temperature the emission band reaches from about 4200 to 6000Å, with a peak at 5000Å. At -193°C the band is much narrower and the height of the peak is greatly enhanced (99b,99c,1439,1595a). However, a sample of pure zinc oxide fired at 1000°C could, according to Leverenz, be excited by irradiation with near u.v. only to emit a deep violet

fluorescence, corresponding to an emission band which began at about 4500A and had its peak somewhere below 4000A (907a).

At the temperature of liquid air, the sulfides of zinc and cadmium and the oxides of zinc and calcium exhibit a new fluorescence spectrum consisting of systems of relatively narrow and nearly equidistant bands. These spectra were interpreted in Section 155 as being due to the inverse effect of the fundamental absorption, corresponding to transitions between the conduction band and the ground state of the matrix lattice. In Tables 119 and 120 the wavelengths of these bands and some other characteristic data are collected. Because of the relative sharpness of the bands, the difference between sphalerite and wurtzite is especially clear in these spectra. The low temperature bands of cadmium sulfide are situated in the visible region, with an intensity maximum at 5200A, and thus the fluorescence color of pure CdS changes from deep red to green, when the phosphor is immersed in liquid air. In mixed Zn,CdS-phosphors the individual bands are well separated only if they contain less than 10% and more than 90% CdS, while the bands become very diffuse and overlap in the intermediate range of concentrations. As is shown by the figures in the third column of Table 119, the addition of 3% ZnS to pure CdS produces a very appreciable shift in the wavelengths of the bands. The figures given under the heading for ZnO indicate the degree of

TABLE 119
LOW-TEMPERATURE FLUORESCENCE BANDS λ_F AND LONG-WAVELENGTH
EDGE OF FUNDAMENTAL ABSORPTION BAND λ_a OF PURE
ZnS-, CdS-, AND ZnO-PHOSPHORS
(Wavelengths in A)

Phosphor	ZnS cubic	ZnS hexagonal	CdS + 3% ZnS hexagonal	CdS hexagonal	ZnO hexagonal
λ_a	3410	3350	5100	5170	3710
$\Delta\nu$ (cm ⁻¹)	360	360	318	320	500
λ_F	3390	3335	5070	5140*	3708 (3692)
	3435	3380	5160	5230	3753 (3750)
	3480	3420	5255	5320	3830 (3940)
	3522	3465	5340	5410	3927 (3930)
	3570	3510	5420	5500	4011 (3999)
		3550		5603	

* In the fluorescence spectrum of pure CdS, a few weaker bands appear in the spectral region between 4800 and 4900A superimposed on the fundamental absorption band.

agreement obtained by two independent investigators. The values of λ_a in the first row correspond to the long-wavelength limits of the fundamental absorption bands, while those of $\Delta\nu$ give the average frequency differences occurring in the progressions (374,375,833*a*, 837*b*,837*c*, 1331,1332).

The low-temperature fluorescence bands of pure ZnS are excited by irradiating the phosphor with the Hg-line 2537A; those of pure CdS and of ZnO are obtained by irradiation with the Hg-lines at 3650A. In ZnS-phosphors activated by Cu and Ag the low-temperature fluorescence bands of Table 119 are completely suppressed.

The bands observed by Ewles in the low-temperature spectrum of pure calcium oxide are even better resolved and exhibit a clear fine structure with two recurring spacings which can be ascribed to vibrational frequencies of the lower electronic state. The first three bands (bands *A*, *B*, and *C* in Table 120) are very faint and do not fit into the band system. Two weak progressions *L* and *H*, distant from the components *K* by frequency differences 298 and $2 \cdot 298 \text{ cm}^{-1}$, were observed only with cathode-ray excitation and are missing in the photoluminescence spectra. No clear numerical relation exists between the (*F*, *G*)-group and the (*H*, *K*, *L*)-group of bands, and Ewles seems to ascribe them to different electronic transitions. Only the first group (*F*, *G*) is visible in the photoluminescence spectrum of pure CaO (Figure 199*a*), while the group *K* appears as soon as the oxide is contaminated by as little as $10^{-4}\%$ of Bi. At a bismuth concentration of $10^{-2}\%$ the band group (*F*, *G*) is almost completely suppressed, while the group *K* becomes very strong (Figure 199*b*). Band spectra of

TABLE 120
LOW-TEMPERATURE FLUORESCENCE BANDS OF CaO
(Wavelengths in A, $\Delta\nu$ in cm^{-1})

		ν''	$\nu' = 0$	$\Delta\nu$	$\nu' = 1$	
	<i>A</i> 3491	0	F_0 3660	(238)	G_0 3694	K_0 3904
$\Delta\nu$	(486)		(539)		(535)	(497)
	<i>B</i> 3552	1	F_1 3732	(245)	G_1 3768	K_1 3981
$\Delta\nu$	(219)		(499)		(487)	(519)
	<i>C</i> 3579	2	F_2 3805	(233)	G_2 3839	K_2 4064
$\Delta\nu$			(485)		—	(451)
		3	F_3 3877	—	G_3 —	K_3 4142

a similar type are not obtained at low temperature in bismuth-activated strontium oxide and barium oxide, nor is the appearance of a new line group in the fluorescence spectrum of CaO produced by the incorporation of other metals than bismuth. It seems most plausible, therefore, to ascribe the emission of the *K*-band group to the ground state of the CaO crystal lattice which is somewhat distorted by the presence of bismuth atoms or ions.

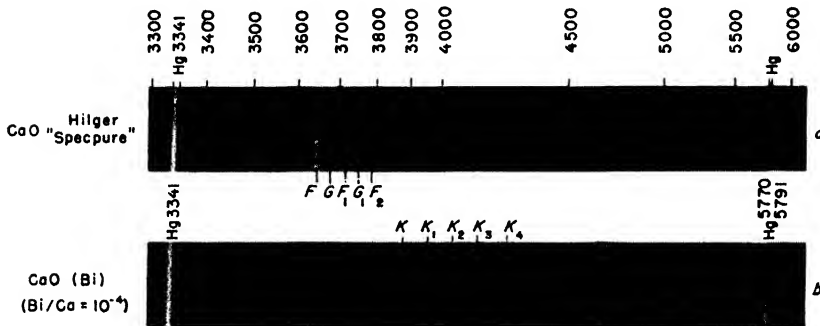

Fig. 199. Fluorescence spectra of CaO at -190°C (Ewles).
a: pure CaO. *b*: CaO with $10^{-2}\%$ Bi.

The activation of calcium oxide with antimony, lead, and cobalt gives rise only to the emission of broad and diffuse bands in the visible without affecting the u.v. bands of the *F*, *G*-group appreciably. In addition to these low temperature bands of the pure base material, CaO containing $10^{-2}\%$ Mn shows the typical red manganese band with its peak at 5965Å on which a series of narrow lines (5685, 5755, 5840, 5903, 5970Å) is superimposed. The u.v. fluorescence of calcium oxide at liquid-air temperature is completely suppressed by the addition of tungsten oxide (374, 375).

163. Silicate Phosphors. Silicate phosphors have been relatively neglected, as long as long-lasting phosphorescence has been the principal subject of research, but lately they have attracted a good deal of interest.* However, a considerable number of rather confusing contradictions is still contained in the publications dealing with these phosphors. According to Fonda, "manganese is the strongest if not

* This is due to the fact that silicate phosphors have proved to be especially useful in the manufacture of fluorescent screens and lamps. For this reason, a large part of the knowledge which may have been gained concerning their properties is still kept secret or is half hidden in numerous patent claims.

the only activator" of zinc silicate phosphors. Although some qualitative data concerning the fluorescence of zinc silicate activated with various other metals can be found in the literature,* manganese-activated silicate phosphors are treated almost exclusively in more recent papers (87,88a,88b,89,116,191a,191b,227,398,400,401,446a,447a,615a,615c,686,691,692,694,831,907a,908,1333,1376,1433,1435).

The preparation is similar to that of sulfide phosphors: mixtures of ZnO, SiO₂, and small quantities of a manganese salt are fired to temperatures between 1000° and 1450° C. The rate of reaction is greatest at the highest temperatures, but can be increased at lower temperatures by the addition of a flux, especially a chloride which acts as catalyst in "dissolving the silicate barrier between the reacting particles." The resulting base material is zinc orthosilicate, Zn₂SiO₄, which may contain a considerable quantity of silica as "filling material" without impairing the luminescence, if the mixture consisted of SiO₂ in excess of ZnO (400).

While orthosilicate forms, in general, the base material of zinc silicate phosphors, phosphors can be prepared also with a meso-disilicate of composition ZnSi₂O₅ as base. Apart from a few decay curves obtained with manganese-activated phosphors of this type, no data concerning their specific properties are available. Moreover, a luminescent manganese-activated zinc metasilicate (ZnSiO₃) has been mentioned lately; the orange emission band of the metasilicate is shifted to somewhat greater wavelengths as compared with that of the orthosilicate (peaks at 6600 and 6200A, respectively) (616, 1335a).

Manganese-activated zinc orthosilicate phosphors exist in three different modifications with green, yellow, and red luminescence, respectively. Schleede and Gruhl were the first to show that each of the modifications can be obtained by adequate heat treatment and annealing and that they differ in their crystal structure as revealed by the x-ray patterns. These are clearly dissimilar for the "green" and "yellow" modification (α - and β -orthosilicate). The hypothesis that the "yellow" phosphors consist of an amorphous complex of zinc oxide and silica mixed with cristobalite is contradicted by the x-ray patterns of Figure 170: the lines characteristic of the "yellow"

* Ag, Bi, Tl, Mo, Ce, and Nd have been mentioned occasionally as activators of zinc silicate phosphors. In most cases their phosphorescence has been investigated only with x-ray excitation. This is also true for the silicates of Mg, Ca, Sr, Cd, La, and Hg and the titanates and zirconates of Zn, all activated with neodymium.

phosphor are definitely different from those of cristobalite and of the "green" phosphor (400,1376,1435). Under normal conditions of firing and slow annealing the green modification is produced; it exhibits the strongest luminescence, the peak of the band lying near 5250A (see Table 121). The best samples of the yellow modification are obtained by heating the mixture (2 moles ZnO and 2-6 moles $\text{SiO}_2 + \text{MnCl}_2$) to 1450° C and cooling it rapidly. Yellow luminescent material can also be prepared by firing a mixture with SiO_2 in excess (2-4 moles SiO_2 per mole ZnO) for about 1 hour to 850° C in the presence of a chloride acting as catalyst. However, phosphors which have

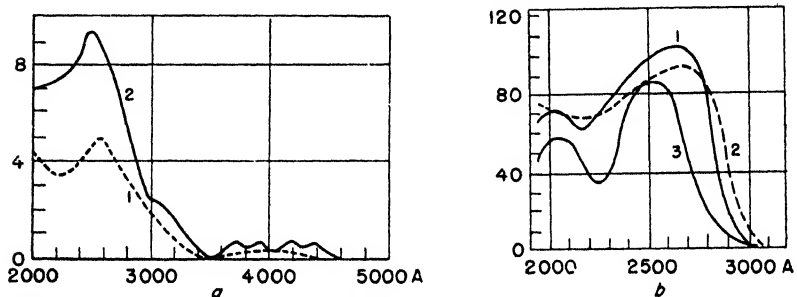

Fig. 200. Excitation and absorption spectra of zinc silicate phosphors.

(a) Excitation spectra at different Mn-concentrations (Kroeger): 1, at 1% Mn. 2, at 5% Mn.

(b) Coincidence of excitation and absorption bands (Chung): 1, absorption of natural willemite crystal. 2, absorption. 3, excitation of synthetic $\text{Zn}_2\text{SiO}_4(\text{Mn})$.

been prepared by this method yield a relatively weak luminescence and their x-ray patterns are very diffuse because the resulting crystals are small and far from perfect. The yellow band has its maximum at 5800A (446a,1376,1435).

Schleede and Gruhl were of the opinion that the red modification (peak of the band at 7100A) had a still different crystal structure, Rooksby and McKeag hold that the question is unsettled, while Fonda asserts that the carrier of the red fluorescence, which is never very strong, is an amorphous complex of zinc oxide with silica in excess of the quantity needed for the formation of the orthosilicate. The red modification is produced if the mixture containing silica in excess is heated to the temperature of fusion (1530° C) and quenched very rapidly to a temperature below 1100° C (446a).

The three modifications have identical excitation spectra, according to Schleede. The wavelength of the maximum of phosphor-

escence excitation which he finds at 2700A differs appreciably from the results of more recent authors (Figures 200*a* and *b*, also Table 109 in Section 160).* The strong short wavelength absorption band of the orthosilicate drops to zero at 3000A. This long-wavelength limit is shifted in direction of greater wavelengths by the addition of manganese, and at high Mn-concentrations the selective Mn^{++} absorption bands between 3500 and 4500A become effective also in the excitation spectrum (83*r*).

Another controversial point is the optimum manganese concentration and the dependence of the fluorescence intensity on the concentration of the activating metal. The data of Table 121, taken from papers by three different authors, refer to room temperature and excitation with the Hg-line 2537A. For excitation with the mercury line 3650A the optimum concentration is as high as 4 %, according to Ruettenauer, because at lower Mn-concentrations this line is too little absorbed, while for excitation by the neon resonance lines at 736/40A the Mn-content must not exceed 0.5 %. On the other hand, Zn_2SiO_4 containing 20 % of manganese is excited to a very strong luminescence by the line 2537A, if the temperature is lowered to -- 180° C.

The luminescence color of the "green" $Zn_2SiO_4(Mn)$ -phosphors varies with increasing manganese concentration from pure green to a more yellowish hue. This is caused partly by a shift of the peak of the band (Table 121) and partly to a slight rise in the relative intensity on the red side of the band. Considering similar effects observed

TABLE 121
LUMINESCENCE INTENSITY I OF Zn_2SiO_4 -PHOSPHORS AND WAVELENGTH λ_m OF THE BAND PEAK AS A FUNCTION OF THE MN-CONCENTRATION
(I for optimum concentration = 100)

Author	% Mn	0.9†	2	4.5	9	
Fonda	I	100	90	44	3	
	λ_m (A)	5290	5310	5350	—	
Leverenz	% Mn	1.0		4.0	8	16
and	I	100		75	55	26
Seitz	λ_m (A)	5230		5260	5300	5315
Ruetten-	% Mn	1.5	3	5	7.5	
aauer	I	100	92	84	57	

* Except that in a paper by Beese the peak of the excitation spectrum is also given as 2700A.

† Elsewhere, Fonda gives the even lower value of 0.4 % for the optimum concentration.

in many other phosphors, these changes must be ascribed to changes in the lattice structure rather than to a loss of a part of the excitation energy of excited manganese atoms by collisions with neighboring

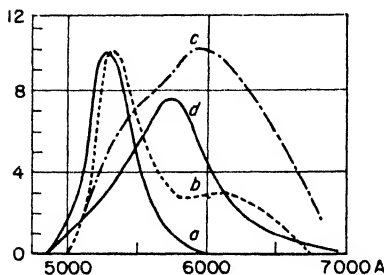

Fig. 201. Emission bands of zinc silicate phosphors (Kroeger; Leverenz).

a: 5% Mn, annealed (α -willemitite). *b*: 20% Mn at -180° C. *c*: 10% Be and 5% Mn at room temperature. *d*: 2% Mn, quenched from 1600° C to room temperature (β -willemitite).

manganese atoms as has been suggested occasionally. The establishment of temperature equilibrium in the excited state does not depend on the interaction with other Mn-atoms. The intensity increase on the long-wavelength side of the green band is due to the existence of an emission band of greater wavelength with a maximum at 6100Å. This band has a very considerable intensity at -180° C in the emission spectrum of the phosphors with high Mn-concentration (Figure 201). At -253° C the luminescence spectrum of a $Zn_2SiO_4(Mn)$ -phosphor is resolved into a number of narrow bands, according to Randall (Table 122).

The band shifts in the luminescence spectrum of $Zn_2SiO_4(Mn)$ -phosphors are connected with still another controversial problem. Zn_2SiO_4 and Be_2SiO_4 form mixed crystals of the phenacite type; beryllium does not function as an activator but enters the lattice of the base material in the same way as cadmium sulfide can be incorporated in zinc sulfide. By adding beryllia to manganese-activated zinc

TABLE 122
LUMINESCENCE BANDS OF A $Zn_2SiO_4(Mn)$ -PHOSPHOR AT -253° C
(Wavelength in Å)

4000-5000	strong continuous band
5023	sharp band edge
5070	weak narrow line
5100	weak narrow line
5155	strong line
5220	peak of strong band
5320	line of medium strength
5900-6300	weak band
6100	peak of band

silicate, the lattice spacing is reduced and, simultaneously, the fluorescence color is altered from green to yellow and orange. This change in color has been interpreted as a steady displacement of one and the same band caused by the variation of the lattice spacing, in complete analogy with the similar effect obtained with mixed Zn,CdS-phosphors. Kroeger showed, however, that also in this case the peaks of the individual bands undergo only minor shifts and that the main color change is due to the changes in the relative intensities of several bands which are characteristic of the Mn^{++} -ion. Addition of beryllia and lowering the temperature is supposed to favor the predominance of the long-wavelength band at 6100A. This opinion is confirmed by curve *b* and curve *c* of Figure 201, which show clearly the superposition of two bands with unequal relative intensities. Similar intensity distributions with secondary maxima have been obtained by other authors in the luminescence spectra of mixed $(Zn, Be)_2SiO_4$ -phosphor. With a phosphor of this type at $-190^\circ C$, Randall obtained a fluorescence spectrum consisting of a broad band of medium strength with a peak at 5300A and a strong narrow band at 5920A. Pure manganese-activated beryllium orthosilicate exhibits no appreciable luminescence at room temperature (401,615a,831,907a,908,1333).

Manganese-activated silicate phosphors in which a part of the zinc is replaced by titanium or zirconium have been prepared. Their luminescence is, in general, weaker than that of the pure $Zn_2SiO_4(Mn)$ -phosphors, the emission bands are broader, and the color of the luminescence varies greatly according to the exact composition of the base material, the excess of silica, and the heat treatment. Phosphors with a greenish-yellow emission band (peak at 5370A) are obtained by replacing a part of the zinc silicate by zinc germanate in the mixture (908).

Pure magnesium orthogermanate (Mg_2GeO_4) can be activated with manganese; its photoluminescent efficiency is increased 500 times if the germanate is crystallized with an excess of magnesium oxide. The emission spectrum shows, superimposed on a continuous background which extends from 5100 to 6700A, two very pronounced narrow peaks and two secondary peaks which are separated from each other by intervals of about 90A (1842a).

No data concerning mixed zinc-cadmium silicate phosphors are available; cadmium seems to be the only metal *M* mentioned in this section which does not easily form orthosilicates of the type M_2SiO_4 . If pure cadmium metasilicate ($CdSiO_3$) is activated with manganese, it yields a phosphor with an orange-red luminescence. The emission

band has its peak at 6050Å and the excitation spectrum is similar to that of the $Zn_2SiO_4(Mn)$ -phosphors, but with a conspicuous secondary maximum at 3100Å. The luminescence spectrum of Mn-activated magnesium metasilicate at $-180^\circ C$ consists of diffuse bands at 4450 and 5250Å and a number of relatively narrow lines in the red between 6100 and 7000Å, among which a line at 6410Å is by far the strongest. At room temperature manganese-activated $MgSiO_3$ exhibits a red or even deep red luminescence with peak wavelength varying between 6400 and 6800Å. Similarly the luminescence band of $CaSiO_3(Mn)$ varies from yellow-green to orange with peak wavelengths between 5600 and 6100Å. The luminescence of all compounds mentioned in this paragraph is relatively weak — much weaker than that of $Zn_2SiO_4(Mn)$ (*G*, 907*a*).

As the last silicate which is luminescent because manganese is one of its components pure manganese orthosilicate must be listed. Its emission spectrum, which has been observed only at liquid-air temperature has its intensity maximum at 6700Å, the color of the fluorescence being a deep red.

A mixed calcium-strontium metasilicate activated with europium emits a violet luminescence when excited by near u.v. The emission band is rather narrow (4000–4700Å) and has a peak at 4300Å; this luminescence, with a spectrum differing so widely from that of other europium-activated phosphors and pure europium salts, must probably not be ascribed to the trivalent europium ion but to some other modification of the rare-earth metal (*G*).

164. Halide Phosphors. Pohl and his collaborators have perfected a technique by which large single crystals of all alkali halides (with the exception of the fluorides) are obtained. In principle, the method consists of a very slow cooling of the fused salts. If a small quantity of the salt of a heavy metal is added to the melt, a fraction of the impurity is incorporated in the crystals, causing the appearance of selective bands in their absorption spectra. The crystals are excited to luminescence by light absorption in these bands. The quantities of impurities added to the melt vary between 10^{-4} and 1% molar, but generally less than 10% of these impurities enters the matrix lattice, as was shown first by measuring the total absorption of light in the new bands and later by direct chemical analysis. The data given in the original papers and in the following paragraphs refer to the quantities of activator metal added to the melt (158,787,790*a*,790*b*,791,1248).

Bandow produced a number of sodium chloride phosphors by introducing ions of silver, copper, tin, and lead into the crystals

electrolytically at temperatures between 380° and 600° C. At the higher temperatures the activation may be due, at least partially, to a pure diffusion process (52).

Finally, very luminous microcrystalline KCl(Tl)- and KBr(Tl)-phosphors can be obtained by crystallization of the salts from boiling saturated aqueous solutions of the potassium halides and thallos halides. By this method much higher concentrations of the activating metal can be attained; if the solution is decanted from the first crystals which are deposited, their thallium content can be as high as 2% molar. Phosphors prepared in this way have, in the main, the same absorption and emission spectra as the single crystals obtained from the melt (1293a, 1293b).

TABLE 123
ALKALI HALIDE PHOSPHORS OF WHICH THE ABSORPTION
SPECTRA HAVE BEEN INVESTIGATED

Acti- vating metal	Halide													
	Cl				Br				I					
	Alkali													
	Na	K	Rb	Cs	Na	K	Rb	Cs	NH ₄	Li	Na	K	Rb	Cs
Tl	+	+	+	+	+	+	+	+	-	-	+	+	+	+
Pb	+	+	-	-	+	+	-	-	-	-	+	-	-	-
Cu	+	+	-	-	+	+	-	-	-	-	+	-	-	-
Ag	+	+	-	-	+	+	-	-	-	-	-	-	-	-
Sn	+	+	+	-	+	+	+	+	+	+	+	+	-	-
Ni	+	-	-	-	-	-	-	-	-	-	-	-	-	-
Sb	-	+	+	+	-	-	-	-	-	-	-	-	-	-

The phosphors listed in Table 123 have been investigated with respect to their absorption spectra.* In pure alkali halide crystals, light absorption becomes appreciable only in the far u.v. (in the crystals of chlorides and bromides, not above 2000Å). The phosphors, on the other hand, exhibit several selective absorption bands in the region of greater wavelengths. For most of the tin-activated phosphors only the "excitation spectra" were observed. However, the absorption

* Alkali halides containing "F-centers" might have been included in this list, since they are luminescent and can be prepared "additively" by heating the crystals in vapor of the corresponding alkali metal. However, the luminescence of alkali halides containing F-centers has been investigated exclusively in samples which owed their coloration to a preceding irradiation with x-rays or radium rays, and it is treated, therefore, in a later section, together with similar phenomena obtained with other compounds.

spectra which were actually investigated (Figure 202) coincide in all details with the corresponding excitation spectra, so that the same assumption can be made for the others. The two band groups appearing in these spectra suggest a complete analogy with the two peaks characteristic of the Tl-activated phosphors (lower and upper row of Figure 202). Hueniger and Rudolph assert, however, that by light absorption in the short-wavelength groups, also, only fluorescence, and

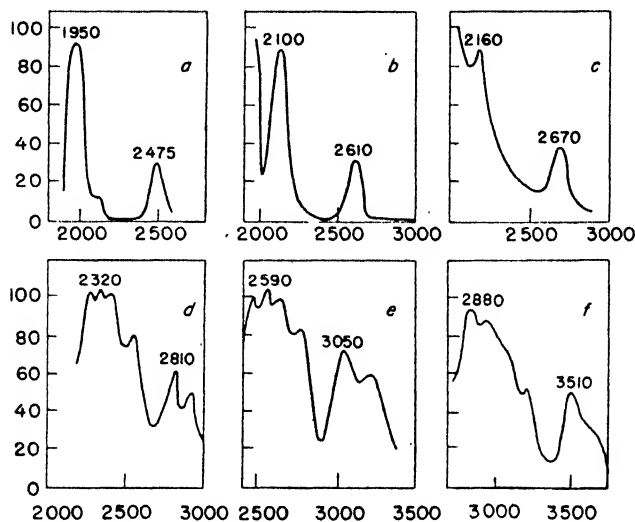

Fig. 202. Absorption bands of Tl- and Sn-activated alkali halide phosphors (Forró, Hueniger, and Rudolph).

<i>a</i> : KCl(Tl)	<i>d</i> : KCl(Sn)
<i>b</i> : KBr(Tl)	<i>e</i> : KBr(Sn)
<i>c</i> : NaBr(Tl)	<i>f</i> : KI(Sn)

no phosphorescence, of the tin-activated phosphors is excited (640). A single band at 2460Å has been observed in the absorption spectrum of the NaCl(Ni)-phosphors (1191). In passing from the chlorides to the bromides and iodides, the whole system of absorption bands is shifted to greater wavelengths. The nature of the alkali metal in the base material is of much smaller influence (Figure 202 and Table 124).

With decreasing temperature, the absorption bands become sharper and many of those which seem to be simple at room temperature split into several components. Simultaneously, the peaks of the

TABLE 124
PEAKS OF THE ABSORPTION BANDS OF THALLIUM-ACTIVATED
ALKALI HALIDE PHOSPHORS
(Wavelengths in Å)

Halide	Alkali			
	Na	K	Rb	Cs
Cl	1990; 2540	1950; 2475	1950; 2450	1960; 2480
Br	2160; 2670	2100; 2610	2120; 2590	2140; 2630
I	2340; 2930	2360; 2870	2400; 2860	2410; 2690; 2990

bands are shifted to shorter wavelengths, as is shown for one of the KBr(Tl)-bands in Fig. 203 (409-411, 616, 617, 791, 957, 967, 1513, 1727Å).

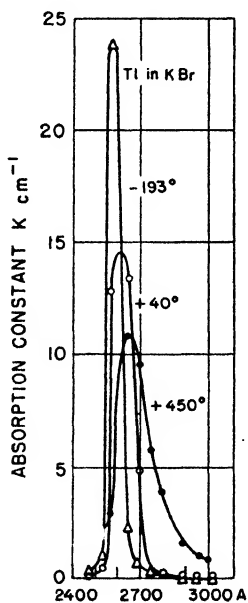

Fig. 203. The long wavelength absorption band of a KBr(Tl)-phosphor at various temperatures [Lorenz (957)].

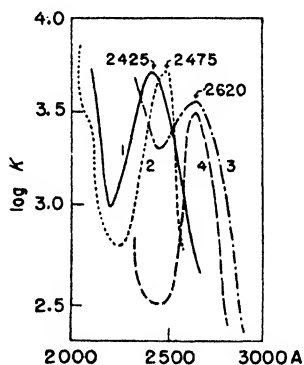

Fig. 204. Absorption bands of Tl in alkali halide phosphors and aqueous alkali halide solutions.

- 1: TlCl in concentrated KCl-solution.
- 2: KCl(Tl)-phosphor.
- 3: TlBr in concentrated KBr-solution.
- 4: KBr(Tl)-phosphor

It has already been mentioned that the absorption bands of the phosphors coincide with those of the complexes which are formed in concentrated aqueous solutions of halides containing small quantities

of Tl^+ , Ag^+ , Pb^{++} , and Sn^{++} -ions (Figure 204). This coincidence obviously suggests the hypothesis that the carriers of the absorption are the same in both cases. If the concentration of the activating metal in the crystals exceeds 0.5 %, the bands become very diffuse and the short-wavelength bands merge into a continuum stretching with increasing intensity to the Schumann u.v. (448,449).

The data concerning the emission spectra of alkali halide phosphors are much less complete; most of them refer to the thallium-activated salts: the chlorides of K, Na, and Rb, the bromides of K and Na, and the iodide of K. The chlorides exhibit a single band in the neighborhood of 3000Å; the luminescence band of the bromide

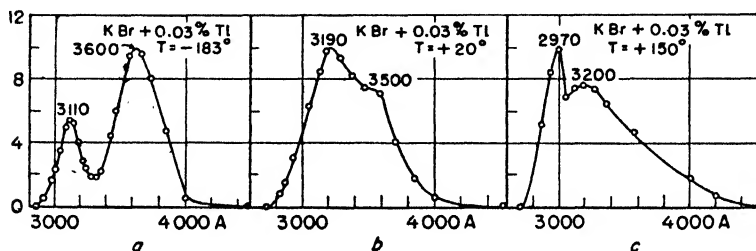

Fig. 205. Emission bands of a KBr(Tl)-phosphor at various temperatures (von Meyereren).

phosphors is broad and has two peaks, the intensity distribution being greatly dependent on the temperature (Figure 205); the emission spectrum of the KI(Tl)-phosphor consists of a diffuse band with its peak at 4150Å (1024).

The emission spectrum is shifted in the direction of shorter wavelengths with decreasing molecular weight of the cation in the matrix lattice (Table 125). In a KCl(Tl)-phosphor containing a high concentration of thallium (1.6 % in the melt) Buenger observed an emission band in the visible region with its peak at 4700Å, in addition to the u.v. band. The complete emission and absorption spectrum of this phosphor (including the "excited" absorption) is reproduced in Figure 192. The spectra of fluorescence and phosphorescence are always identical and independent of the wavelength of the exciting light (617).

The long-wavelength emission bands appear with far greater intensity in the thallium-activated KCl- and KBr-phosphors of high Tl-concentration, which are prepared by crystallization from aqueous solutions. In the phosphors containing the highest thallium concentration the visible fluorescence is as bright as that of good sulfide

TABLE 125
PEAKS OF FLUORESCENCE BANDS OF ALKALI HALIDE PHOSPHORS
(Wavelengths in Å)

Activator	Halide	Alkali metal				
		Li	Na	K	Rb	NH ₄
Tl	Cl	—	2980	2980	3150	—
	Br	—	2950	3180	—	—
	I	—	—	4150	—	—
Sn	Cl	—	4400	4900	5100	—
	Br	—	4600	5100	5350	—
	I	5200	5300	5500	5650	5950
Ni	Cl	—	6230	—	—	—

TABLE 126
FLUORESCENCE OF POTASSIUM HALIDE ACTIVATED
WITH ANTIMONY (SCHLEEDE)

Activator	Alkali halide			
	KF	KCl	KBr	KI
SbF ₃	none	weak red	weak dark red	none
SbCl ₃	weak yellow	bright yellow	weak orange-red	deep dark red
SbBr ₃	weak orange-red	weak brick-red	weak dark red	deep dark red
SbI ₃	none	none	none	none

phosphors. The fluorescence color is blue for KCl and blue-green for KBr, if the Tl-content is still relatively low. With increasing thallium concentration, the emission spectrum, which seems to consist of several bands, stretches more and more towards the red and the color of the fluorescence turns into a yellowish white, if the spectrum of the exciting light covers the whole width of the first absorption band (see Figure 202). With monochromatic excitation, however, only the "normal" blue or blue-green part of the fluorescence bands is emitted, if the wavelength of the exciting radiation corresponds to the center of the first absorption band; nothing but the long-wave part of the

luminescence spectrum appears if the lines of the exciting light are displaced with respect to the center of the absorption band in the direction either of longer or of shorter wavelengths. Thus, the intensity distribution in the emission spectrum is different for excitation by each of the mercury arc lines between 2300 and 3132Å. It seems that there are at least two sorts of centers with different absorption or excitation spectra and different emission spectra. The excitation band of the first is relatively narrow; it coincides with the fluorescence excitation band of the phosphors at low thallium concentration, and the corresponding emission spectrum consists of the short-wavelength band. The excitation band of the centers of the second type is much broader and flatter, stretching at least from 2300 to 2800Å, and the emission bands of these centers lie in the region of greater wavelength (1293a, 1293b).

While the absorption spectra of the tin-activated phosphors have a relatively complicated structure, their fluorescence spectra consist of a single symmetrical bell-shaped band in the visible and are independent of the wavelength of the exciting light. The color of the fluorescence of the NaCl(Ni)-phosphor is red (Table 125) (640, 1191).

Table 126 lists the colors and intensities of the fluorescence of potassium halide phosphors activated with antimony. Not only can such phosphors be prepared by grinding potassium halide crystal with small quantities of antimonous halides in a mortar (Section 153), but even when a grain of antimony trichloride is dropped into finely ground potassium chloride powder, a bright halo of yellow fluorescence surrounding the grain appears under u.v. irradiation (1432b).

LiCl and NaCl could not be made luminescent by the addition of SbCl₃, while RbCl behaved very nearly like KCl, the fluorescence of the resulting luminophor being of a yellowish-green color. CsCl, which is not activated with antimony by contact, shows a greenish fluorescence, when the mixture has been heated to 400° C, but loses its luminescence power again after a few weeks. When ammonium chloride is activated with antimony by the contact method, it exhibits a weak orange fluorescence.

The fluorescence of RbCl(Sb), CsCl(Sb), and NH₄Cl(Sb) is greatly enhanced at the temperature of liquid air and the wavelength of the emission band is shifted somewhat toward the red. Even cesium chloride, which is not fluorescent at room temperature, after having been mixed in a mortar with antimony trichloride becomes strongly luminescent when it is cooled to liquid-air temperature. The excitation spectra of these phosphors lie in the u.v. below 3000Å and the peaks

of the excitation bands coincide with peaks in the absorption spectra.

Manganese-activated alkali halides and their photosensitization by the addition of lead has been mentioned in Sections 157 and 158. Such NaCl(Mn,Pb)-phosphors with a strong reddish fluorescence are obtained easily by crystallization from aqueous NaCl solutions containing a few per cent of manganous nitrate and plumbous chloride. Although Kato describes also the behavior of KCl(Mn)-phosphors, these cannot be prepared by the same simple method. The absorption spectrum of the NaCl(Mn,Pb)-phosphors shows the band at 2730A characteristic of NaCl(Pb)-phosphors, but with a secondary maximum at 2600A which is missing in Hilsch's photometer curves and which probably is due to a complex containing the Mn ion as well as the Pb ion. The fluorescence is excited by light of all wavelengths between 2000 and 3000A, but not by near u.v. A short afterglow ($\tau \sim 10^{-3}$ sec) is observed in a Becquerel phosphoroscope, but no long lasting phosphorescence is emitted (616,732a,1094a).

If europium trichloride at a concentration of 1% is added to the solutions of alkali halides (the chlorides, bromides, and iodides of potassium and sodium) and these are evaporated, the resulting crystals exhibit some of the strong Eu^{+++} lines between 5900 and 6200A as fluorescence under near u.v. excitation. By heating the crystal to temperatures between 200 and 300° C, the Eu^{+++} ions are converted into Eu^{++} ions, and instead of the orange lines a broad blue band appears in the fluorescence spectrum. The peak of this band varies only slightly for the different halides — from 4270A for KCl and KBr, to 4450 for NaI (1309,1311).

A few qualitative observations have been published concerning the emission spectra of NaCl-phosphors activated with silver, copper, and lead by the method of electrolysis. The spectrograms show a strong band with intensity maximum at 3500A in all three cases; in the silver-activated phosphor an additional u.v. band at 2500A, and in the silver- and lead-activated phosphors a visible band in the violet region have also been obtained (52).

If layers of alkali halides are prepared by distillation in a high vacuum and an invisible thin film of a heavy metal is distilled on top of the alkali salt, some of the films emit a visible fluorescence when they are irradiated with u.v. light of wavelengths below 3000A. These "surface fluorescence" spectra do not seem to be closely related to those of the alkali halide crystals activated with the same metals. Table 127 lists all examples of this type which have been observed. In the combinations marked 0 no results could be obtained. The results

TABLE 127
 "SURFACE-ACTIVATED" ALKALI HALIDES

Alkali halide	Activating metal				
	Ca	Tl	Pb	Bi	Cd
	Color of luminescence				
NaCl	violet	—	0	—	—
NaBr	—	blue	—	0	—
KBr	—	violet	—	—	—
NaI	violet	violet	yellow	violet	green
KI	—	violet	—	—	—
CsI	yellow	yellow	green	—	—

were always negative with Na, Zn, and Ag as activators and with AgCl, AgI, and CuCl as base materials. The iodides activated with Tl yield the strongest luminescence. A few schematic curves for the excitation and emission spectra are reproduced in Figure 206 (1641).

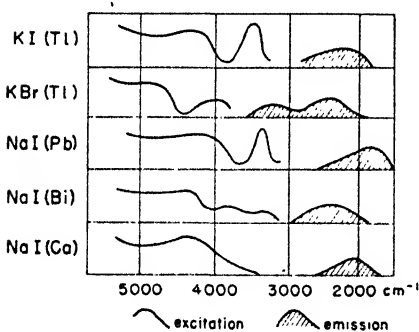

Fig. 206. Excitation and emission bands of surface-activated alkali halides (Terenin).

Apparently the atoms of the activating metal are incorporated in the surface of the salt only if the surface is quite free of adsorbed gases, and under these conditions they are so closely bound in the surface layer that they are not attacked by oxygen or iodine vapor.

In some cases alkali halide crystals were found to emit phosphorescence spectra which were of the type of molecular band spectra. They were ascribed, at first, to the presence of "*F*- and *U*-centers,"* but it could be shown later that they originate from oxygen and

* Concerning *F*-centers, see Section 156; *U*-centers are now known to be due to the presence of alkali hydrides in the crystals (619).

The finished "surface-layer phosphors" can be exposed to atmospheric air and even to iodine vapor without losing their luminescence. However, if the alkali salt surface is exposed to air before the metal film has been applied, it cannot be made fluorescent by a subsequently deposited metal film. The surface of a macroscopic halide crystal acquires the faculty of becoming luminescent only if it is thoroughly heated in vacuo before it is covered with a metal film.

carbon monoxide molecules which have entered the crystal lattice (628,1377).

The bands due to CO appear in the emission spectra of alkali halides if these have been heated to a temperature 50° below the melt-

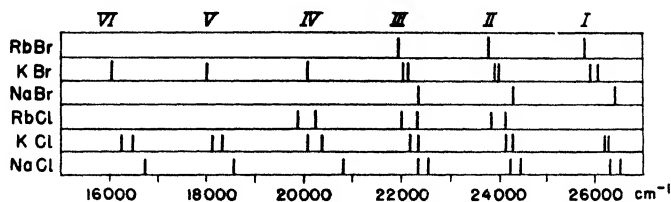

Fig. 207. Schematic representation of the emission spectra of CO-activated alkali halide phosphors (Honrath).

ing point in an atmosphere of carbon monoxide at high pressure and in the presence of the corresponding alkali metal vapor. *F*-centers which are formed simultaneously under these conditions can be driven out by a subsequent heat treatment; if this heat treatment is prolonged in a high vacuum, carbon monoxide is evolved and the luminescence is destroyed. The luminescent layer has a depth which never exceeds 1 mm.

The emission spectra consist mainly of progressions of five or six narrow doublets between 3700 and 6000Å, which are represented schematically in Figure 207. The average spacing between the doublets is $\Delta\nu \sim 2000 \text{ cm}^{-1}$; the distances between the components of each doublet vary through the progression in different manners for the different phosphors, and while in some cases the doublets become so narrow that they cannot be resolved, their width corresponds in other cases to as much as 400 cm^{-1} . The three bands of shortest wavelength (*I-III* in Figures 207 and 208) are always much stronger than the others. Overlapping the last bands of the main progression *S*, a second similar progression *L* follows in the direction

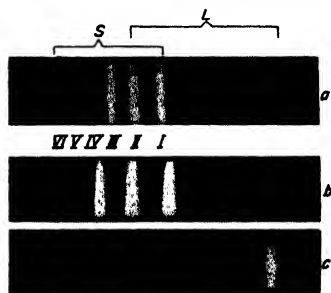

Fig. 208. Luminescence spectrum of a CO-activated KCl-phosphor (Roos). *a*: luminescence during the excitation. *b*: after-glow 0.25 sec after the end of the excitation. *c*: phosphorescence 1 sec after the end of the excitation.

of shorter wavelengths with a somewhat smaller spacing ($\Delta\nu \sim 1850 \text{ cm}^{-1}$). While both systems decay exponentially, the progressions *S* and *L* differ widely in respect to their persistence in the afterglow. During the primary irradiation and even 0.5 sec after the end of the excitation, the bands belonging to the system *S* are far stronger than the others, but 4 sec later the *L*-bands alone remain visible (Figure 208). Temperature influences the rate of decay very little in both cases.

An understanding of the origin of the luminescence of O_2 -activated alkali halides was hampered for some time by the fact that such phosphors are formed under various apparently unrelated conditions. Crystals with the same emission spectra can be prepared by addition of oxygen compounds such as K_2O , KNO_3 , and NaOH to the melt, by conversion of chlorates, bromates, and iodates to the corresponding halides,* and by heating the halide crystals in an O_2 -atmosphere to a temperature close to the melting point. In the latter case the evolved halogen vapors must be flushed out of the chamber in order to prevent a back reaction. The materials prepared by every one of these methods are uniformly luminescent throughout the entire crystals.

At room temperature the emission spectra consist of sequences of nearly equidistant diffuse bands which resolve into several narrow components at -253°C (Figure 209). The small influence of the base material on the structure of the spectra is surprising. Since the main spacing $\Delta\nu \sim 1000 \text{ cm}^{-1}$ recurs in all instances, it is very improbable that the ions forming the alkali halide lattice are directly involved in the nuclear oscillations corresponding to this frequency difference.

TABLE 128
SPACINGS $\Delta\nu$ IN THE BAND PROGRESSIONS OF O_2 -ACTIVATED
HALIDE PHOSPHORS

Halide	NaCl	KCl	KBr	KI
$\Delta\nu$ in cm^{-1} .	1022	1008	982	998

The fine structures which appear at low temperatures are slightly more dependent on the nature of the base material. The bands of the KBr-phosphor split into four nearly equidistant components ($\delta\nu \sim 140 \text{ cm}^{-1}$); each of the bands of the KCl-phosphor is resolved into two bands which are still rather diffuse and probably represent unresolved doublets. At the low temperature of -253°C even the small frequency differences $\delta\nu$ characterizing the fine structure cannot correspond to

* This method yields only microcrystalline material.

energy levels of the excited state, but must be ascribed, as well as the spacings of 1000 cm^{-1} , to the ground state of the phosphor. All these frequencies, including those in the spectra of the CO-activated halides, are of the order of magnitude occurring in the vapor spectra of molecules which contain oxygen as one of their constituents (628).

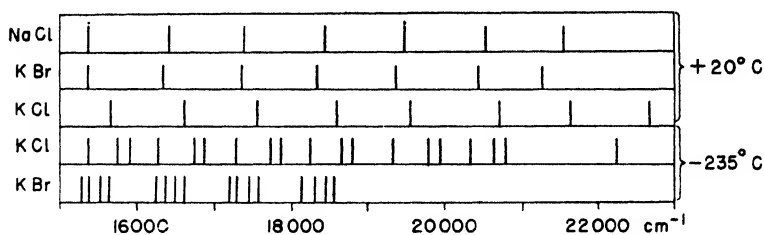

Fig. 209. Luminescence spectra of oxygen-activated alkali halides (Honrath).

Only a few qualitative data have been published concerning the luminescence spectra of metal halides other than the alkali halides. AgCl exhibits a strong blue fluorescence when it is irradiated with near u.v. at -180° C . It is doubtful whether this luminescence is to be ascribed to the "pure" salt; certainly it does not originate from one of the impurities listed in Table 129, since these give rise to the emission of different fluorescence bands and suppress the fluorescence of the "pure" compound. The fluorescence of "pure" TlCl is also light blue; if manganese is incorporated in TlCl , a strong red phosphorescence can be excited, even at room temperature. "Pure" CuCl is excited by near u.v. to emit a green-blue fluorescence (5100–5900Å) at temperatures between -110° and 150° C , while at lower temperatures the fluorescence color is red. The red fluorescence of pure MnCl_2 and MnBr_2 and the fluorescence of the Mn- and Pb-activated CdI_2 "layer lattice phosphors" have already been mentioned in preceding sections. These layer lattice phosphors can be prepared not only by heating the mixtures of CdI_2 and MnI_2 or PbI_2 , respectively, but it is sufficient to grind the components together in a mortar (855, 1332, 1333).

TABLE 129
FLUORESCENCE BANDS OF AgCl AT -180° C

Activator	"pure" salt	Mg	Mn	Pb
Peak of band in Å	5150	5900	5700	6100

Hueniger and Rudolph mention that some of the alkaline earth halides activated with tin are brilliantly luminescent; in their paper, the excitation spectrum of a $\text{CaI}_2(\text{Sn})$ -phosphor is shown to be very similar to that of the $\text{KI}(\text{Sn})$ -phosphor (Figure 202), but no data concerning the luminescence spectra have been published (640).

Luminescent calcium fluoride activated with various metals has been prepared synthetically, but most observations related to these compounds have been performed with natural fluorites, and they are treated, therefore, in the sections dealing with minerals. However, a chromium-activated lithium fluoride phosphor which has been prepared by Tiede may be mentioned here. It is exceptional insofar as its emission spectrum consists of a broad green band, while the fluorescence spectra of chromium in other base materials is characterized by a series of narrow lines and bands in the orange and red (1665).

Numerous manganese-activated fluoride phosphors -- such as $\text{ZnF}_2(\text{Mn})$; $\text{MgF}_2(\text{Mn})$; $\text{Zn,MgF}_2(\text{Mn})$; $\text{Zn,CdF}_2(\text{Mn})$; $\text{Zn,CaF}_2(\text{Mn})$; etc. — and columbium-activated zinc fluoride seem to have been investigated with respect only to their cathodoluminescence (1842a).

165. Phosphors with Various Base Materials. Although the number of impurity-activated crystal phosphors might be increased indefinitely, phosphors, the physical properties of which have been thoroughly investigated, are not too numerous outside of the groups treated in the preceding sections. Borate and phosphate phosphors, particularly zinc and cadmium borates and phosphates, have found increasing application for industrial purposes, but the scientific publications dealing with their properties are scanty. Most of these phosphors apparently are also activated with manganese. The broad emission band of a $\text{CdB}_2\text{O}_5(\text{Mn})$ -phosphor has its peak at 6230A, the color of the luminescence being pink. In the fluorescence spectrum of manganese-activated zinc borate a green or a red band prevails, depending on the heat treatment which is applied during the preparation of the phosphor. With cathode-ray excitation of this latter phosphor at -180°C , Randall obtained numerous narrow bands between 5280 and 6100A, among which two bands in the green (5315 and 5365A) had by far the greatest intensity* (131a,978,1333,1651).

Three other modifications of cadmium borate: CdB_2O_4 , $\text{Cd}_2\text{B}_6\text{O}_{11}$,

* Engle and Hopkins have prepared calcium phosphate phosphors activated with Mo, Er, La, Y, Nd, Sm, and Cu, with luminescence colors varying between blue, green, and pink; these experiments were performed exclusively with cathode-ray excitation (364).

and $\text{Cd}_3\text{B}_2\text{O}_8$ containing manganese as activator cannot be excited by light of wavelength between 3000 and 2000A, but a faint excitation of a green fluorescence is obtained by irradiation with light of a narrow region in the near u.v. which corresponds to the characteristic absorption bands of the Mn^{++} ion. This green fluorescence is excited with much greater intensity by irradiation with x-rays and cathode rays (1371a).

Photoluminescent manganese-activated cadmium pyrophosphate ($\text{Cd}_2\text{P}_2\text{O}_7$) and cadmium chlorophosphate [$3\text{Cd}_3(\text{P}_2\text{O}_4)_2 \cdot \text{CdCl}_2$], and calcium orthophosphate activated with dysprosium have been mentioned occasionally. If cerium-activated calcium phosphate is heated in a carefully controlled reducing atmosphere so that all the cerium present is in the form of cerous ions (Ce^{++}), the emission spectrum consists of a broad band with a peak at 3600A and stretching from 3200 to 4400A. A phosphor with pure u.v. emission is obtained by activating calcium phosphate with thallos ions. In this case the peak of the emission band lies at 3200A and the band extends from 2600 to 4000A. The excitation spectrum begins at 2800A, has a first peak at 2450A and a second peak far in the u.v. Under excitation with the light from an aluminum spark the phosphor emits an afterglow which can be followed through about 10 minutes; irradiation with the Hg-line 2537A seems to excite only fluorescence. The thallium concentration is not critical; optimum efficiency is attained at about 2% thallium added to the base material. Zinc phosphate activated with lead and manganese emits a greenish-yellow phosphorescence after excitation with radiation of 2537A, while the luminescence stimulated with infrared (peak response at 1.15μ) has a more purely yellow color (228a, 446c, 1029a, 1335a).

A few qualitative data concerning a different type of phosphate and borate phosphors are contained in a patent claim. The base materials of these phosphors are the phosphates and borates of the alkali and alkaline earth metals and of zinc, cadmium, aluminum, and lanthanum; they are activated with silver, thallium, tin, or lead at relatively high concentrations, up to 30% molar; the optimum concentrations lie between 3 and 7% without being critical. Only the color of the luminescence, in most cases between blue-violet and blue-green, is given: it is characteristic of the activator and practically independent of the nature of the base material. Manganese itself is not a good activator, but addition of manganese phosphate or borate to the base material in concentrations as high as 40% shifts the emission bands which are characteristic of another activator (for instance,

silver or lead) toward greater wavelengths, so that the color of the luminescence is changed to orange and even to red. Nothing has been published concerning the duration of the phosphorescence, the type of the decay curve, and the excitation spectrum, beyond the fact that the luminescence can be excited by u.v. radiation.*

Aluminum oxide and nitride, the magnesium-titanium spinel Mg_2TiO_4 , beryllium nitride, boron nitride, and silicon bisulfide have been used as base materials of crystal phosphors and each of them has characteristic properties which are not found in other materials.

If aluminum oxide is activated by a metal the sesquioxide of which crystallizes in the corundum lattice, the crystals are fluorescent but not phosphorescent; the luminescence bands are narrow and are all located in the long-wavelength region, as shown in Table 130. The duration of the slow fluorescence can be observed phosphoroscopically and is nearly independent of temperature. The luminescence of crystals activated with gallium and iron is weak.† In contrast to these "fluorophors," the compounds listed in the last column of Table 130 are real phosphors. The afterglow of the Pt-phosphor is "frozen in" below $-2^\circ C$. If the phosphor is excited at a temperature below this limit, the green emission begins to appear when the temperature is raised subsequently to more than -2° . After complete decay of the phosphorescence at this temperature, the emission is started a second time by raising the temperature to $87^\circ C$. Similarly, the red phosphorescence of manganese-activated aluminum oxide is "frozen in" at

TABLE 130
ALUMINUM OXIDE FLUOROPHORS AND PHOSPHORS
(Emission bands in Å)

Fluorophors				Phosphors		
Activator	Peak of band	Activator	Peak of band	Activator	Band	
					Limits	Pea
Cr_2O_3	6935	Ga_2O_3	6200	TiO_2	4000-6000	5100
Rh_2O_3	6500	Fe_2O_3	6100	Pt	4200-6700	5500
Ti_2O_3	6400	V_2O_3	6000	Mn	5050-7150*	6000

* According to Randall, at $-180^\circ C$, band maxima at 4275, 5100, and 6240Å.

* United States patent 2,270,124. This is a typical example of the knowledge provided by most patent claims.

† Cr-activated Al_2O_3 is treated in Section 171, together with other Cr-activated crystals.

— 70° C and is released in two stages, the first beginning at — 70° and the second at + 12° C. Apparently, the electron traps have two sharply separated energy levels in either phosphor. While the quantity of activator which can be incorporated in the “fluorophors” is relatively great and may reach 2 %, the concentration of platinum and manganese in the aluminum oxide phosphors does not exceed the order of magnitude of 10^{-3} % (1670, 1671).

While the luminescence of normal manganese-activated Al_2O_3 (like the orange and green emission bands of numerous manganese-activated phosphors mentioned in previous sections) must be ascribed to the presence of divalent Mn^{++} -ions, aluminum oxide prepared under oxidizing conditions and containing small quantities of manganese exhibits, under near-u.v. excitation, a fluorescence of a different nature. Its emission band between 6500 and 6800A has a characteristic fine structure. Fluorescence spectra of the same type were obtained with the manganese-activated aluminates of tin, magnesium, and strontium, and with magnesium orthotitanate (Mg_2TiO_4), when they also were prepared under oxidizing conditions. These spectra resemble closely those characteristic of the same base materials activated with trivalent Cr^{+++} which are discussed in the following section. The analogous bands are shifted somewhat in the direction of shorter wavelengths, due to the higher charge of the Mn-nucleus: Cr^{+++} is isoelectronic with Mn^{4+} , both having three 3*d*-electrons in their outermost shells. Thus it seems very probable that the new luminescence bands of Mn-activated Al_2O_3 are due to the presence of quadrivalent manganese in the phosphor (Figure 210*a*) (833/).

If aluminum oxide is fired together with small quantities of the oxides of chromium and manganese, it yields an $\text{Al}_2\text{O}_3(\text{Mn})$ -phosphor showing no trace of red ruby-fluorescence. If, on the other hand, chromium-activated corundum and manganese oxide are fired together, the latter is incorporated as a second activator and the crystal emits a strong manganese phosphorescence band at 5260A in addition to the narrow chromium lines characteristic of ruby.

In a mixture of Al_2O_3 and Ti_2O_3 heated to 1350° C in the presence of atmospheric air, titanium sesquioxide is converted to TiO_2 . This oxide is no longer isomorphous with corundum; thus, a phosphor exhibiting a green phosphorescence is formed instead of the fluorophor with its characteristic red fluorescence (1670).

Tiede found the spinel Mg_2TiO_4 to be photoluminescent when it is activated with Mn. Cr-activated Mg_2TiO_4 responds only to cathode rays. All other metals (e.g., Cu, Ag, Bi) are ineffective. Mn is incor-

porated isomorphously in the small crystals obtained by firing a mixture of TiO_2 and MgO at 1200°C . The excitation spectrum of $\text{MgTiO}_4(\text{Mn})$ in the near u.v. has peaks at 3180, 3400 and 3850Å. The single narrow fluorescence band at 6558Å is apparently identical with peak B in curve 1, Fig. 210a; it shows no afterglow and is not affected by temperature in the range from $+30$ to -190°C . Only material fired in the presence of O_2 shows the fluorescence; spinels prepared in an N_2 -atmosphere are nonluminescent. This agrees with Kroeger's assumption respecting the state of oxidation of Mn in the luminophors mentioned on page 631 (833f, 1670, 1685).

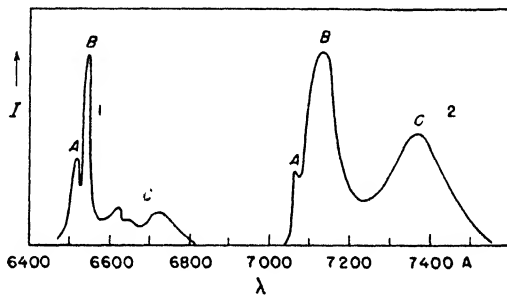

Fig. 210a. Fluorescence spectra of Mg_2TiO_4 activated (1) with Mn^{4+} and (2) with Cr^{+++} (Kroeger, Deutschbein).

Manganese-activated phosphors with mixed base materials of the spinel type, such as ZnAl_2O_4 , ZnGa_2O_4 , and CdAl_2O_4 have also been prepared. Their green emission bands with peaks varying between 5060 and 5470Å are relatively weak. The fluorescence spectrum of a mixed CdAl_2O_4 -phosphor activated with chromium exhibits a diffuse double band with a weaker peak at 4950Å and a stronger peak at 5890Å (907a).

A blue phosphorescence lasting about an hour can be excited in beryllium nitride containing traces of aluminum (1411).

Phosphors with boron nitride and silicon sulfide as base material differ from other phosphors insofar as they owe their luminescence to traces of carbon and cannot be activated by any of the metals which generally are effective in phosphors. Pure boron nitride and silicon sulfide are not luminescent. Carbon-activated boron nitride phosphors exhibit three independent emission bands (α , β , and γ in Figure 210b) which appear at different temperatures and are excited by light of different wavelengths. In general, the yellow-green band α predomi-

nates, but at temperatures above 120° C it gives way to the violet band β ; the red band γ is always relatively weak. The duration of the phosphorescence does not exceed two minutes (1681-1684).

The complex emission band of carbon-activated silicon sulfide is shown with its excitation spectrum in the last row of Figure 196.

Aluminum nitride is activated only by addition of comparatively great amounts of silicon. No phosphorescence is observed at silicon contents below 0.5%; the optimum concentration is 5%, but the luminescence is not much impaired by appreciably higher concentrations of the activator. The emission spectrum consists, in this case also, of three overlapping independent bands with unequal decay

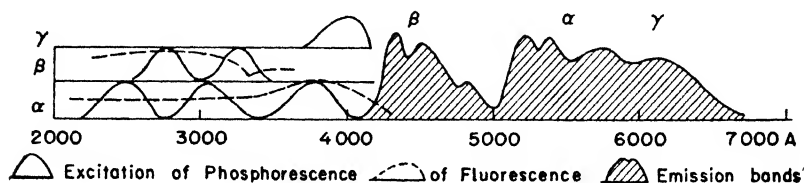

Fig. 210b. Excitation and emission bands of carbon-activated boron nitride phosphors (Tiede).

periods; the principal band, in the blue, decays at room temperature in a few minutes, while a weaker green band can be observed for several hours after the end of the excitation. The excitation spectrum stretches from 3000Å to the far u.v. (1682).

While all the phosphors described in the preceding paragraphs must be fired at high temperatures in order to crystallize and to incorporate the activator, many salts, such as nitrates and sulfates, which can be obtained as crystals by evaporation of a saturated aqueous solution are phosphorescent after being dried at temperatures above 100° C, if they contain some activating impurity. Waggoner has shown that purest commercial cadmium sulfate is always phosphorescent at room temperature, but that it loses its luminescence if it is purified by repeated recrystallization. If the aqueous solution of the purified salt is contaminated with as little as 10^{-2} % of zinc sulfate, the crystals obtained from this solution exhibit a strong blue-green phosphorescence under irradiation with u.v. light. Cadmium sulfate phosphors with yellow and green emission bands can be prepared by addition of a magnesium or a sodium salt to the solution. In the latter case, a surprisingly strong influence of the anion of the added salt has been observed by Waggoner (Table 131) (1782). Cadmium sulfate

containing lead or manganese exhibits only weak phosphorescence when excited by radiation of wavelength 2537A. If both activators are present simultaneously, however, the phosphorescence is bright yellow and of fairly long duration. This phosphorescence can be stimulated by near u.v. (3650A), but not by infrared radiation. Although zinc salts, in general, provide the most efficient base materials for phosphors, it seems that luminescent zinc sulfate cannot be prepared (1029a).

TABLE 131
PHOSPHORESCENCE BANDS OF $\text{CdSO}_4(\text{Na})$ -PHOSPHORS
(Wavelengths in A)

Added salt . .	NaSiO_2	Na_2BO_4	NaF	NaCl	NaBr
Band limits .	4860-6040	5220-6160	4710-6120	5100-5800	4140-6000
Band peak	5100	5660	5740	5400	4800

Numerous sulfate and nitrate phosphors activated with rare-earth metals are listed in Table 96. While the fluorescence of a $\text{PbSO}_4(\text{Sm})$ -phosphor can be excited by visible light in the same way as that of all other materials containing samarium, its phosphorescence, which lasts for several hours, is excited only by short-wavelength u.v., which is absorbed in the base material and not in the Sm^{+++} -ions.

166. Tungstates and Molybdates. Tungstates and molybdates of various metals are luminescent without containing an activating impurity; addition of almost all foreign metals to these compounds impairs their characteristic fluorescence. An exception is lead, which appreciably enhances the fluorescence of CaWO_4 as long as the lead content does not exceed 1%; simultaneously, the emission band is shifted in the direction of greater wavelengths and the luminescence color changes from blue to a more greenish hue (1603). Data concerning the wavelengths of the emission bands have been published only for the compounds collected in Table 132. The bands are very broad and cover nearly the whole visible region, but the intensity maximum of the calcium tungstate band lies at an appreciably shorter wavelength than that of the other bands: the fluorescence color is blue for CaWO_4 and more whitish for the other compounds (Figure 211, curve 1).

The fluorescence of the molybdates is of a more yellowish hue, but at room temperature only CaMoO_4 shows a fairly strong fluorescence with a peak at 5350A. Whereas the blue-green fluorescence

of zinc tungstate with a peak at 4850A is very bright at room temperature, a compound containing 75 % ZnWO_4 and 25 % ZnMoO_4 exhibits an orange-red fluorescence with peak at 6800A which is faint at + 25° C and attains great intensities only at temperatures below - 100° C (833c).

The temperature limit above which the fluorescence is completely quenched varies greatly for the various tungstates and molybdates. The fluorescence of magnesium tungstate begins to decrease only at temperatures above + 50° C and has still more than 25 % of its peak intensity even at 150° C; the fluorescence of Ca_3WO_6 and ZnMoO_4 is almost completely quenched at 0° C, and the fluorescence of Sr_2WO_5

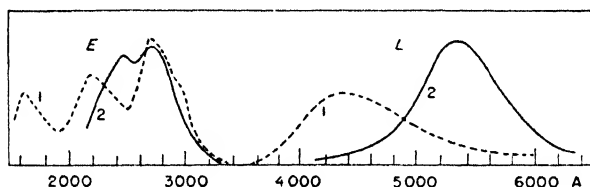

Fig. 211. Excitation and emission bands *E* and *L* of (1) calcium tungstate and (2) magnesium tungstate.

and PbMoO_4 cannot be excited at temperatures above - 100° C. Other compounds enumerated in this connection by Kroeger (833e) are $\text{Na}_2\text{W}_2\text{O}_7$, Li_2WO_4 , SrWO_4 , Ca_3WO_6 , CdMoO_4 , $\text{Na}_2\text{Mo}_2\text{O}_7$, SrMoO_4 , MgMoO_4 , and $\text{Li}_2\text{Mo}_2\text{O}_7$.

The excitation spectra of calcium tungstate and other tungstates begin at a wavelength slightly above 3000A and have several selective maxima which coincide with intensity maxima in the u.v. absorption spectra of the compounds (Figure 211) (88a,978,1366,1651).

TABLE 132
FLUORESCENCE BANDS OF TUNGSTATES
(Wavelengths of band peaks in A)

Compound	CaWO_4	MgWO_4	CdWO_4	Zn_2WO_7
Fluorescence band	4200	5000	4900	4900

If calcium tungstate is precipitated from a solution at room temperature, it forms a nonluminescent amorphous powder. By aging, the compound crystallizes slowly, as shown by the x-ray pattern, and simultaneously the luminescence appears. The aging process can

be accelerated greatly by heat treatment; the higher the temperature, the sooner the complete crystallization occurs. The temperature must not exceed 1200°C , in order to avoid the decomposition of the tungstate. A weakly luminescent powder showing traces of crystalline structure in the x-ray diagrams is obtained directly if the tungstate is precipitated from a boiling solution (1434,1680).

MgWO_4 exists in various modifications with distinctive x-ray patterns (*A*, *B*, *C*, and *D*). Only the monoclinic form characterized by x-ray pattern *C* which is obtained by firing the material at temperatures between 950° and 1000°C is fluorescent. Two modifications which are stable at temperatures between 300° and 600°C (patterns *A* and *B*) and a high temperature modification present in samples which were quenched from temperatures above 1250°C (x-ray pattern *D*) are not fluorescent (615b).

While the addition of lead to calcium tungstate does not give rise to a new emission band but seems only to shift the normal luminescence band to greater wavelengths, typical Sm^{+++} -lines appear in the luminescence of all samarium-activated tungstates which are listed in Table 132; their intensity is relatively weak during the excitation period, but the Sm-luminescence has a duration considerably longer than that of the CaWO_4 fluorescence and thus the red Sm-lines alone prevail in the afterglow. By addition of lead to a $\text{CaWO}_4(\text{Sm})$ -phosphor, the relative intensity of the samarium lines is greatly enhanced in the luminescence spectrum of the phosphor. Incorporation of samarium in MgMoO_4 , which has only a very weak fluorescence in the pure state, has no appreciable effect (268a,402a).

If samarium-activated calcium tungstate is excited by light of wavelength 2600A, the samarium lines are imperceptible during the excitation at -180°C ; their intensity increases with increasing temperature and is of the same order of magnitude as that of the blue CaWO_4 fluorescence at $+100^{\circ}\text{C}$. If the exciting light has a wavelength greater than 3000A, the samarium lines alone appear in the fluorescence spectrum at all temperatures, in agreement with the excitation spectrum of the CaWO_4 fluorescence shown in Figure 211 (268a).*

The fluorescence of uranium-activated magnesium tungstate and cadmium tungstate can be excited by irradiation with near u.v., corresponding to the well-known absorption bands of uranyl salts. The emission bands do not show the characteristic structure of the fluo-

* Beryllium and zinc tungstates activated with neodymium emit a yellow phosphorescence under cathode-ray bombardment.

rescence of uranyl salts, but in the case of $\text{MgWO}_4(\text{U})$ the peak of the bell-shaped band has the same wavelength (about 5200A) as the strongest band in the fluorescence spectra of uranyl salts. The fluorescence spectrum of $\text{CdWO}_4(\text{U})$, however, is shifted far toward the red, with a first intensity maximum at 6400A and another in the near infrared beyond 7300A. This strong influence of the cadmium ion in the base material, even on an emission band which is supposed to correspond to a transition inside the uranyl ion, is very striking (G).

167. Chromium as Activator. While the various phosphors were classified in the preceding sections according to their base materials which essentially determine the properties of the phosphors, the conditions are different for crystals which owe their fluorescence to the incorporation of trivalent chromium ions in their lattice. The outermost electronic shell of the Cr^{+++} -ion is the $3d$ -shell which contains only three electrons, instead of the ten electrons corresponding to the completely filled shell. A 4F -term is formed as ground state of highest multiplicity (all three electron spins parallel), with the four sublevels ${}^4F_{3/2}$, ${}^4F_{5/2}$, ${}^4F_{7/2}$ and ${}^4F_{9/2}$ the next higher term is a 4P -term, followed by a 2G -term and a 2H -term. The energies of these various terms, derived by Bowen from spark spectrum of chromium, are collected in Table 133. All these terms correspond exclusively to various combinations of the three $3d$ -electrons and transitions between them are forbidden, but may be rendered possible by electric fields existing in a crystal. The red absorption and emission lines observed in chromium-activated crystals near 6900A ($14,500 \text{ cm}^{-1}$) are ascribed to transitions between some of the 4F -sublevels and 4P - or 2G -levels. The intensity, even of the strongest of the lines in the absorption spectrum of ruby, is only about 10^{-6} of that corresponding to a normal electric dipole, in agreement with their origin from forbidden transitions. Various authors have tried to assign transitions between two of the levels listed in Table 133 to specific lines in the spectra

TABLE 133
LOWEST ENERGY LEVELS OF THE Cr^{+++} -ION
IN THE VAPOR STATE (IN CM^{-1})

Term	Energy	Term	Energy	Term	Energy
${}^4F_{3/2}$	0	${}^4P_{1/2}$	14058	${}^2G_{7/2}$	15056
${}^4F_{5/2}$	237	${}^4P_{3/2}$	14177	${}^2G_{9/2}$	15405
${}^4F_{7/2}$	553	${}^4P_{5/2}$	14476	${}^2H_{9/2}$	21067
${}^4F_{9/2}$	949			${}^2H_{11/2}$	21320

of the crystals by comparing the frequencies of the lines with energy differences occurring in the table. Such an attempt cannot yield useful results. For even if the term scheme of the Cr^{+++} -ion is retained, in principle, in the crystal, it is certain that the absolute values of the energy differences between the various levels are altered by the lattice forces. If the latter are large, the momenta of the electron spins and the orbital momenta are uncoupled and the quantum numbers J ($3/2$, $5/2$, etc.) lose their significance. On the other hand, it is certain that if the order of magnitude of the energy differences occurring in Table 133 is maintained in the crystals, lines which do not lose a great part of their intensity in the absorption spectrum at -190°C can originate only from the lowest state ${}^4F_{3/2}$. Even the energy of 237 cm^{-1} corresponding to ${}^4F_{5/2}$ exceeds by far the average thermal energy at -190°C .

The great influence of the lattice forces on the spectra is proved by the fact that the wavelengths of lines and the spacings of doublets, which apparently correspond to analogous transitions in the spectra of different crystals, vary by large amounts (see Table 135). It is very probable that the origin of the doublets (and, in some cases, quadruplets) listed in Table 135 must be ascribed exclusively to intermolecular Stark effects and not to electronic transitions between different electronic levels which are characteristic of the isolated Cr^{+++} -ion, according to Table 133.

The Cr^{+++} -ion differs from the rare-earth ions insofar as the incompletely filled $3d$ -shell is not shielded by an outer rare-gas shell. This is the reason why pure chromium salts are not fluorescent; the same holds true for chromium alums, although their absorption spectra, with a number of narrow lines in the red, are very similar to those of chromium-activated fluorescent crystals. As already mentioned in Section 161, no chromium-activated Lenard phosphors are known. Crystals exhibit the characteristic red Cr^{+++} -fluorescence only if the activating metal is able to form a compound which is isomorphous with the base material. This is illustrated by the last column of Table 134, which lists all chromium-activated "fluorophors"* which have been prepared synthetically (278).

While Al_2O_3 and Ga_2O_3 are isomorphous with Cr_2O_3 , the Cr^{+++} -ion

* Although the luminescence of these crystals is a slow fluorescence and not a genuine phosphorescence, they are generally qualified as "phosphors." The chromium-activated lithium fluoride mentioned in the next-to-last paragraph of Section 164 apparently contains Cr in a different form, since the color of the luminescence is green.

TABLE 134
SYNTHETIC CHROMIUM PHOSPHORS

Base material	Crystal class	Isomorphous Cr-compound
α -Al ₂ O ₃	trigonal	Cr ₂ O ₃
α -Ga ₂ O ₃	trigonal	Cr ₂ O ₃
MgAl ₂ O ₄	regular	MgCr ₂ O ₄
ZnAl ₂ O ₄	regular	ZnCr ₂ O ₄
BeAl ₂ O ₄	rhombic	BeCr ₂ O ₄
MgO	regular	MgCr ₂ O ₄

must form complexes such as MgCr₂O₄ to be incorporated in MgO, MgAl₂O₄, etc. No chromium phosphors can be obtained with BeO and ZnO as base materials, because the crystals of these compounds are hexagonal, while the corresponding Cr-complexes BeCr₂O₄ and ZnCr₂O₄ crystallize with rhombic and cubic symmetry, respectively. A number of natural minerals exhibiting the red chromium line fluorescence are included in Table 135.

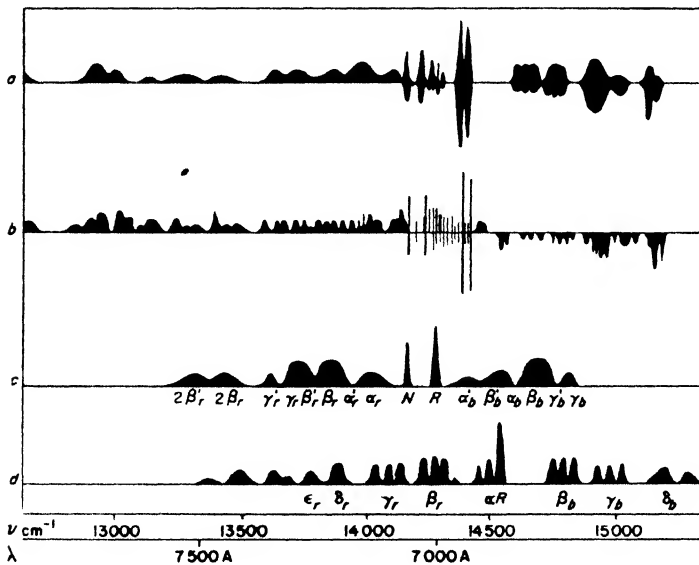

Fig. 212. Fluorescence and absorption spectra of chromium phosphors (Deutschbein).

- a*: Al₂O₃ at 20° C *c*: MgO type II
b: Al₂O₃ at -195° C *d*: MgAl₂O₄

Figure 212 gives several examples of the absorption and emission spectra of Cr-activated crystals. Because of their relative weakness, absorption spectra could be obtained only in the few cases in which crystals of sufficiently large dimensions were available (ruby, alexandrite, emerald). The main feature in the absorption and emission spectra is a doublet or a single line (*R*-lines) with an intensity ex-

TABLE 135
R-LINES AND DOUBLET SPACINGS IN THE SPECTRA
OF CHROMIUM PHOSPHORS
(ν in cm^{-1})

Base material	(<i>R</i> ₁)	$\delta\nu$
MgO	14320	0
MgAl ₂ O ₄ *, spinel	14603	6
ZnAl ₂ O ₄ , spinel	14575	8.9
Al ₂ O ₃ *, ruby	14432	29.2
BeAl ₂ O ₄ *, alexandrite ..	14734	36.7
[Be ₃ Al ₂ SiO ₃]*, emerald ..	14685	55
[Al(OH,F) ₂ SiO ₄], topaz ..	14693	91
[Ca ₃ (Al,Cr)(SiO ₄) ₃], uvarovite	14320	91.8
Ga ₂ O ₃ *		158
[Al ₂ SiO ₅], cyanite	14520	323(33)

* Already observed by Lecoq de Boisbaudran in 1887.

ceeding that of all other lines and bands. The wavenumber of the long-wavelength component of the *R*-doublet and the spacings of the doublet components are given for all known cases in Table 135. For the compounds which have been investigated only as natural minerals, the chemical formula is given in brackets. No connection exists between the displacement of the *R*-lines and the value of $\delta\nu$. In the spectra of the two spinels, the doublet components are resolved only when the width of the lines is reduced by lowering the temperature to -180°C , while in the spectrum of MgO(Cr) the *R*-line remains single even at the lowest temperatures. In other cases — for instance, in the spectra of emerald and topaz — each doublet component splits into two sub-components at the temperature of liquid air and in the spectrum of cyanite a similar structure of the doublet lines appears, even at room temperature.

In addition to the varying structures of the *R*-lines, these, in

general, are accompanied on the side of greater wavelengths by several weaker secondary lines (e.g., "N" in Figure 212) and on both sides, nearly symmetrically, by a number of diffuse bands. Table 136 lists all lines and bands observed in the fluorescence spectrum of a synthetic ruby at room temperature. At -195°C the bands are resolved in less broad but still diffuse sub-bands, while in the interval between the *R*-doublet and the secondary doublet *N* some 20 new, weak, sharp lines appear.

TABLE 136
FLUORESCENCE SPECTRUM OF SYNTHETIC RUBY AT 20°C
(Wavelengths in Å; *s*, sharp; *d*, diffuse; *dd*, very diffuse)

λ	Intensity		λ	Intensity	
6538	1	<i>d</i>	7072	2	<i>d</i>
6595	3	<i>d</i>	7138	3	<i>d</i>
6647	1	<i>d</i>	7188	2	<i>d</i>
6692	4	<i>d</i>	7276	2	<i>d</i>
6762	3	<i>d</i>	7438	1	<i>dd</i>
6820	3	<i>d</i>	7517	1	<i>dd</i>
R_2 6927.4	10	<i>s</i>	7603	1	<i>dd</i>
R_1 6942.3	10	<i>s</i>	7723	3	<i>dd</i>
6977	2	<i>s</i>	7921	2	<i>dd</i>
6986	4	<i>s</i>			
6996	4	<i>s</i>			
N_2 7017	6	<i>s</i>			
N_1 7049	6	<i>s</i>			

Nearly all "lines" (listed as *s*, sharp, in Table 136), especially the *R*-lines, are found, also, in the absorption spectrum at -195°C . In the emission spectrum the relative intensity of the doublet component of shorter wavelength R_2 decreases with decreasing temperature and vanishes completely at 1.6°K . The figures listed in Table 137 are in good agreement with the equation:

$$I(R_2) : I(R_1) = e^{-h\delta\nu/kT}, \text{ with } \delta\nu = 29.2 \cdot (3 \cdot 10^{10}) \text{ sec}^{-1} \quad (96)$$

In the spectrum of $\text{Ga}_2\text{O}_3(\text{Cr})$ the intensity of R_2 is practically zero at 20°K , corresponding to the higher value of $\delta\nu$, and in the spectrum of cyanite R_2 is very weak even at 78°K . Figure 213 represents the energy levels for the *R*-lines of cyanite, including the secondary doublet with the spacing 33 cm^{-1} ($280a$).

TABLE 137
 INTENSITY RATIO OF THE LINES R_2 AND R_1
 AS A FUNCTION OF THE TEMPERATURE

$T(^{\circ}\text{K})$..	293	78	20	14	1.6
Al_2O_3	0.82	0.64	0.14	0.05	0.00
Ga_2O_3 ..	0.6	0.13	0.05	—	—

The "bands" (marked in Table 136 as d and dd) on the long-wavelength side of the R -lines ("Stokes bands") are missing in the absorption spectrum at all temperatures, while those on the short-wavelength side of the R -lines ("anti-Stokes bands"), which appear in the emission spectrum at room temperature and are somewhat enhanced at 100°C , are present in the absorption spectrum at all temperatures, but vanish from the fluorescence at the temperature of liquid nitrogen. The bands are ascribed to the superposition of lattice vibrations on the electronic transitions which correspond to the R - and the N -lines, the Stokes bands being progressions with $\nu'' = 0$ and the anti-Stokes bands progressions with $\nu' = 0$.

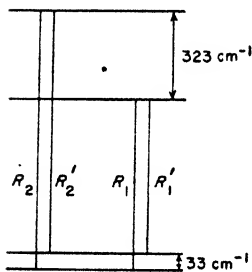

Fig. 213. Energy levels for the R -lines of cyanite (Deutschbein).

(If this interpretation is correct, one might expect that since the anti-Stokes bands are visible in the fluorescence spectrum at room temperature, the Stokes bands should also be observed in the absorption spectrum at this temperature).

Figure 214 shows an energy-level diagram representing the bands in the fluorescence spectrum of a $\text{MgO}(\text{Cr})$ -phosphor. This spectrum is the least complicated of all which were obtained by Deutschbein; even the N -line, which is relatively strong in the spectra of other Cr-activated MgO -phosphors (Figure 212), is missing in this case.* The vibrational frequency of 425 cm^{-1} in Figure 214 is supposed to correspond to the Raman frequency 700 cm^{-1} of MgO , which is strongly perturbed by the incorporation of the chromium complexes. No interpretation is attempted for the other frequency of 270 cm^{-1} , which had to be introduced for the representation of the bands de-

* According to Deutschbein, two modifications of the $\text{MgO}(\text{Cr})$ -phosphors with dissimilar spectra can be obtained by different manners of preparation, both modifications having the same chemical composition and the same crystal structure.

signated by β and γ . In other cases, the agreement between Raman frequencies and the frequency differences occurring in the fluorescence spectra are better. According to Krishnan, nearly all absorption and fluorescence bands of ruby can be interpreted satisfactorily by taking into account the seven Raman frequencies of corundum which he had observed himself, as well as the infrared absorption frequencies obtained by earlier investigators (827b). It must be conceded, however,

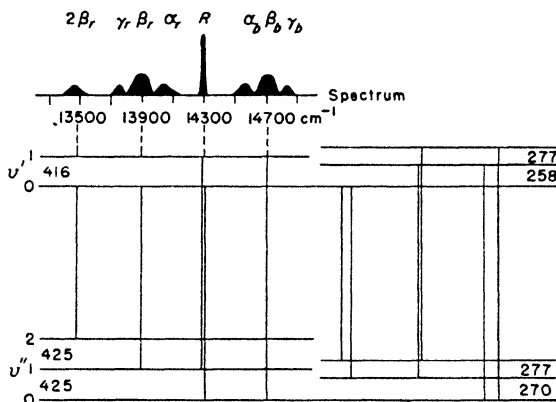

Fig. 214. Energy levels for the fluorescence spectrum of MgO(Cr)-type I [Deutschbein (278)].

hat with the great number of diffuse bands in the fluorescence spectra such coincidences need not be more than fortuitous (827).

In the absorption spectrum of ruby a second line group has been found in the blue region (4680–4771Å). Deutschbein ascribed it to an electronic transition from the ground states to the 2H -states. A fluorescence corresponding to the return from these higher electronic levels could not be observed.

Although the red fluorescence of ruby can be excited as “resonance radiation” by irradiation with light of wavelengths coinciding with those of the R -lines this phenomenon plays only a minor part in the excitation of the ruby fluorescence. The excitation is caused mainly by light absorption in a broad continuous band in the green (Figure 215) and a second continuous band in the near u.v. No theoretical explanations have been suggested for the electronic transitions corresponding to these bands or for the mechanism by which the absorbed energy is transferred to the well-defined levels from which the line

emission originates. The process is not connected with photoconductivity and has no heat of activation (494,1015).

As early as 1910, J. Becquerel and, nearly simultaneously, Dubois and Elias found that ruby showed a strong dichroism: the *R*-lines have a far greater intensity in the ordinary absorption spectrum (electric vector E perpendicular to the optical axis ξ) than in the extraordinary spectrum (E parallel to ξ). The phenomenon vanishes of course, when the primary light passes through the crystal in the direction parallel to ξ . Dubois and Elias observed the analogous

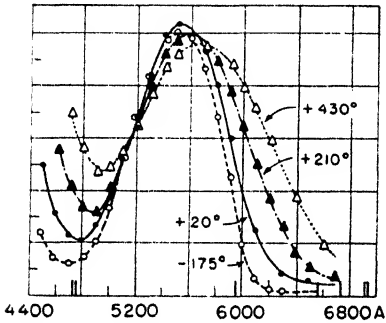

Fig. 215. Absorption band of ruby at various temperatures.

(The lines at the bottom of the figure indicate location of the strongest Cr^{+++} -lines).

behavior of the fluorescence radiation. In the fluorescence spectrum the *R*-lines have the greatest intensity when observed in the direction perpendicular to ξ through a polarizer which transmits light with its electric vector $E \perp \xi$ (ordinary spectrum). According to Thosar, the degree of polarization is 72.5%. The polarization of the bands in the neighborhood of the *R*-lines is much weaker; in certain cases it even seems to be negative. When viewed in the direction parallel to ξ , the fluorescence is unpolarized. The observed degree of polarization is independent of the polarization of the exciting light, although the absorption in the diffuse absorption band is also much stronger for light polarized with its electric vector $\perp \xi$ (81,313,1015,1658-1660).

Since the maximum intensity of the absorption and of the emission corresponds to the same orientation of the electric light vector, it is clear that the polarization of the fluorescence is not a secondary effect due to a partial reabsorption of a primarily unpolarized radiation, but that the electronic oscillators absorb and emit preferentially (if not exclusively) light with its electric vector perpendicular to the optical axis. These observations provided the first unequivocal proof for the fact that chromium is not imbedded in aluminum oxide with random orientations as in a "solid solution," but that the Cr^{+++} -ions form a regular part of the lattice, being subjected to the same anisotropic orienting lattice forces as the Al^{+++} -ions.

Moreover, Dubois and Elias discovered that the *R*-lines of ruby

split at -180°C into several components under the action of a magnetic field of 40,000 gauss. Their observations were confirmed and completed in some details by later investigators. The Zeeman effects, which are identical in the absorption and emission spectra, depend on the orientation of the optical axis ξ with respect to the magnetic field H and (to a lesser degree) with respect to the direction of observation Y . With $H \parallel \xi$ and $\parallel Y$ (longitudinal Zeeman effect) the R -lines split into triplets, the central lines being unpolarized, while the outer components are circularly polarized. With $H \parallel \xi$ and $\perp Y$ (transverse Zeeman effect), the Zeeman pattern shows a quintet with three strong irregularly spaced σ -components (ordinary spectrum) and two weak π -components (extraordinary spectrum). If, on the other hand, the crystal is oriented with its axis perpendicular to the magnetic field ($H \perp \xi$), a nearly equidistant quartet is observed, irrespective of the direction of observation (transversal or longitudinal Zeeman effect). In this case the Zeeman pattern is, however, not quite identical for the two R -lines insofar as the four components of R_1 have nearly the same intensity, while the two outer (σ) components of R_2 are much stronger than the others (278, 281, 313, 1015, 1658-1660).

In the low-temperature fluorescence spectrum of cyanite, each of the two lines R_1 and R'_1 are split into two components if the magnetic field is perpendicular to the crystal axis; they are not affected at all by a field parallel to the axis.

Still other Zeeman effects are exhibited by the weaker lines of the ruby fluorescence. Thus, the line 6996A (Table 136) is resolved into two components at -195°C ; in a weak magnetic field this doublet becomes diffuse and contracts, with increasing field strength, into a single line. Some lines remain unaltered when a magnetic field is applied and others are almost completely blurred out (1015).

Brunetti and Becquerel were the first to state that the action of a magnetic field on lines of a crystal corresponds to the superposition of a Zeeman effect on a Stark-effect. Complete Zeeman patterns of lines corresponding to transitions between the electronic terms listed in Table 133 would be much more complicated than those obtained in the fluorescence spectra of ruby. The relative simplicity of the latter is due to the partial suppression of the degeneracy of the spatial quantization by the crystal field. Under these conditions, a theoretical discussion of the Zeeman effects of ruby and similar phenomena observed in the spectra of emerald and other chromium-activated phosphors cannot be successful as long as the lines appearing in the absence of a magnetic field are not interpreted theoretically (85, 1657-1660, 1743b).

C. Luminescence of Natural Minerals and of Crystals Discolored by Irradiation

168. Minerals and Gems. E. Engelhard; who seems to have been the first to make a systematic investigation of photoluminescent minerals, counted as many as 427 samples in the collection of minerals of the University of Jena. Some of these were identical with respect to the mineralogical classification, but came from different locations and had dissimilar luminescence properties. Since then (1912) the list has been considerably increased (363a).

From the point of view of luminescence analysis these minerals can be divided in three main classes which may be subdivided into groups.

The first class is formed by the relatively few minerals which exhibit luminescence as an essential quality. The second class is by far the most numerous and consists of minerals with purely accidental luminescence due to minute traces of impurities which are not intrinsic constituents of the mineral and which sometimes can be identified but more frequently are unknown. Various specimens of such minerals, coming from different localities, are characterized, in general, by dissimilar fluorescence colors, or some samples may be luminescent and others nonluminescent. In the minerals of the third class the existence of "luminescence centers" is not, or not exclusively, due to the presence of impurities, but has been acquired by a long-lasting exposure to a weak radioactive radiation. The proof of this origin of photoluminescence is provided by laboratory experiments.

Uranium minerals containing the uranyl radical as a constituent, such as autunite (uranyl calcium phosphate), schroeckingerite (hydrous uranyl carbonate), uranophane (uranyl calcium silicate), and many others, belong to the first class (644). Another mineral of this class is scheelite (calcium tungstate) which exhibits the same luminescence as synthetic CaWO_4 . * While the luminescence of these minerals is a property of the base material itself, a second group of the first class consists of minerals which are luminescent because they are activated with a foreign impurity which is essential for the characterization of the mineral. This condition is fulfilled, for instance, for ruby, alexandrite, emerald, and other gems, which owe their characteristic color and their fluorescence to traces of chromium incorporated in the

* Samples of natural scheelite frequently exhibit Sm^{+++} -lines in their luminescence spectra, exactly like Sm-activated synthetic CaWO_4 (1138).

crystals. Colorless corundum without the admixture of Cr_2O_3 is not a ruby. Some of these gems — for instance, cyanite and uvarovite — have not been synthesized, but where synthetic products are available for comparison, there is no difference between their luminescence spectra and those of the natural gems. If the luminescence of rubies from Ceylon is of a more yellowish color than that of “artificial rubies,” these crystals must contain another impurity in addition to chromium (perhaps manganese). However, the chromium concentration is much lower in natural rubies than in the synthetic products; in the latter, the chromium content can amount to as much as 2.5 %, while it is so small in the natural gems that it cannot be ascertained by any chemical methods. According to Tiede, synthetic rubies show an after-glow which can easily be observed in a phosphoroscope, while the fluorescence of natural rubies has a much shorter duration. Synthetic zinc and magnesium spinels, and natural magnesium spinels, exhibit the typical red Cr-fluorescence, but in natural zinc spinels the luminescence, in general, is quenched by the presence of iron (278,1670).

On the other hand, the Cr^{+++} -fluorescence which is emitted by many specimens of sapphire is accidental. The spectrum is identical with that obtained from rubies, although much weaker, but the chromium from which this fluorescence originates is not essential for the blue color of the gem, which is supposed to be produced by an admixture of titanium (see Section 165). The same is true with respect to topaz, the Cr^{+++} -fluorescence of which is mentioned in Table 135 (1670).

Although willemite can frequently be identified as such by its brilliant green fluorescence, which is identical with that of synthetic $\text{Zn}_2\text{SiO}_4(\text{Mn})$ -phosphors, willemite finds its place in the second class, for manganese-free zinc orthosilicate minerals are also designated as willemite. Similarly, only those samples of troostite — a zinc beryllium silicate — which contain an accidental admixture of manganese are fluorescent. The red fluorescence of many natural calcites and halites is also due to manganese, but, exactly as in the case of synthetic, manganese-activated CaCO_3 and NaCl , the luminescent minerals are excited by u.v. light of wavelengths between 3000 and 2400 Å only if in addition to manganese they contain traces of lead (1094a, 1115, 1311, 1333, 1480b). There are other specimens of calcite which owe their red fluorescence to divalent samarium. The blue fluorescence of certain silicates of the feldspar group, such as orthoclase and andesine, could be proved to be due to the presence of divalent europium by comparing the minerals with synthetic samples of the same compo-

sition (563). These, as well as numerous fluorescent fluorites, will be discussed in a subsequent section.

By far the largest group of this second class is provided, however, by minerals which owe their color in transmitted light and their fluorescence to an undetermined impurity. It need hardly be emphasized that a mineral can be colorless, with absorption bands in the u.v., and emit a visible fluorescence.

Diamond cannot unequivocally be ascribed to one of the classes of fluorescent minerals mentioned at the beginning of this section: Nonfluorescing diamonds are found, as well as diamonds which exhibit fluorescence of colors varying from blue to yellow. The common opinion that this fluorescence is due to unknown impurities has been strongly opposed by Raman and his school. While the material is, in general, very scanty, the Indian scientists had at their disposal an exceedingly rich collection of more than 300 samples. Raman's principal arguments contradicting the impurity hypothesis are the identity of spectra of diamonds which come from different localities in South Africa and India, and the parallelism between the patterns formed by fluorescent zones in certain diamonds and their crystalline structure. Neither argument is quite convincing. All diamonds which have been analyzed by modern spectroscopic methods contain traces of aluminum, silicon, calcium, and magnesium, while the presence of lighter elements such as boron and oxygen would escape detection by this method of analysis. Lonsdale ascribes the small variations (of the order of 10^{-4}\AA) occurring in the lattice spacing of diamonds to the variable content of such impurities. It would not be impossible that the diamond lattice becomes luminescent by incorporation of only a single kind of impurity atoms: corundum found in widely separated parts of the world shows the well-known chromium fluorescence and this fluorescence is polarized according to the structure of the matrix lattice; and activating impurities are embedded in gypsum along certain crystallographic planes of the base material. On the other hand, the fluorescence spectra of slightly colored, yellowish, pinkish, and greenish diamonds are not essentially different from those of perfectly white samples, so that at least the color-producing impurities are proved not to be responsible for the luminescence (1326a).

Robertson has shown that diamonds can be divided into two main classes, class I being highly transparent in the u.v. down to 2250A and class II with absorption bands beginning near 3100A. These two classes differ also in their other properties — for instance,

their infrared absorption spectra, their x-ray patterns, and their photoconductivity. Diamonds of class I are never fluorescent; diamonds of class II are fluorescent in general, although the relative intensity of their fluorescence varies in the range from 1 to 12,000 (973, 1368).

According to Raman, Robertson's classes must be subdivided into two octahedral groups, Ia, Ib and two tetrahedral groups, IIa, IIb.* In most natural diamonds two or more of these groups interpenetrate each other, causing inhomogeneities and strains in the crystals. The diamonds of class I are supposed to be highly inhomogeneous. According to the known characteristics of crystals in general, however, transparency in the far u.v. and absence of fluorescence should be ascribed rather to great purity and high symmetry of the crystal lattice than to lack of homogeneity. The hypothesis that the much greater photoconductivity observed in diamonds of class I is due to their imperfection and to the numerous activating centers connected with such imperfections, cannot be upheld: although absorbing "centers" must be available in a photoconductive crystal, the intensity of the photoelectric currents depends to a much higher degree on the mean free path of the liberated electrons and, thus, on the absence of electron traps and of imperfections in the lattice. The photoelectric conductivity of diamonds of class II is much smaller; its excitation spectrum has its maximum at 3400Å and a minimum at 3100Å, where the strong absorption sets in (541, 1190c).

In diamonds of class II the crystal lattices of the two subgroups IIa and IIb are assumed to interpenetrate without any "composition planes" and with much higher degrees of lattice perfection than that occurring in class I. Nevertheless, interpenetration gives rise, according to Raman, to a nonhomogeneity which shows itself in the development of luminescence.

Many diamonds belong partially to one class and partially to another. Owing to this mixed structure they exhibit "transmission patterns": in some parts they transmit the mercury line 2537Å and in others they are opaque for this line, and only in the latter can the blue fluorescence be excited. Less frequently, a yellow-green fluorescence is observed in diamonds or parts of diamonds which transmit the u.v. below 3000Å to a certain extent; such diamonds are supposed

* In Raman's nomenclature, these groups are designated by Oh I, Oh II and Th I, Th II, respectively. A discussion of the controversy respecting the crystal structure of diamond is beyond the scope of this book. Compare letters to *Nature* 155, 144, 234, 572 (1945); 156, 22, 23, 83 (1945).

to represent an intimate mixture of the octahedral and the tetrahedral structure and, therefore, to be optically anisotropic. Many diamonds show patterns of birefringence when viewed between crossed polaroidst Rendall's assertion that these patterns coincide with the patterns of the yellow-green fluorescent zones in the crystals is not corroborated by the numerous photographs shown in his paper (975*a*, 1326*b*, 1353*a*, 1353*b*).

The fluorescence of diamonds can be excited by light from a carbon arc transmitted through a Wood filter; the following data refer to this kind of excitation at -190° C. The emission spectrum is obviously due to the superposition of lattice vibrations on several electronic frequencies. Two of these frequencies, $24,077\text{ cm}^{-1}$ (4152A) and $19,870\text{ cm}^{-1}$ (5032A), have the greatest intensities and seem to be present in the emission spectra of most fluorescing diamonds. Since they appear also in the absorption spectra of these crystals they must correspond to transitions to the ground state of the emitting centers.

Ramachandran and Chandrasekharan compare the line 4152 with forbidden lines in the spectra of Pb I, N II, and O III, and ascribe it tentatively to the corresponding forbidden transition between an excited state 1S_0 and the ground state 3P of the carbon atom. A new line at 7930A which they discovered in the fluorescence spectra of several diamonds and which was missing in the absorption spectra would, according to this hypothesis, be due to the equally forbidden transition between the excited state 1S_0 and a hypothetical 1D_2 -state situated about halfway between 1S_0 and the ground state (1325*a*).

Thin plates of blue fluorescent diamonds, of a thickness not exceeding 0.2 mm, exhibit a very feeble transmission for u.v. even down to 2240A. A number of selective absorption bands, some of them quite sharp, are superimposed upon the strong continuous absorption background, and these bands or lines may perhaps be ascribed to other forbidden transitions from the ground state to higher excited states. They are completely missing in the absorption spectra of diamonds of class I (1328*a*).

If these assumptions should be correct, one would suppose that the forbidden transitions occur only in the less symmetrical lattice fields of diamonds of class II, while they remain forbidden in the highly symmetrical diamonds of class I.

In the fluorescence spectra the line 4152A is followed in the direction of greater wavelengths by a series of band groups which consist of several not always completely separated components. Symmetrical absorption band groups extend from the central line

4152A toward the u.v. (Figure 216a). Nayar, who was the first to analyze these spectra, listed only four of these groups on either side of the central line (Table 138A); but he mentions that numerous fainter lines appear between these groups, also symmetrically with respect to the central line. At room temperature the bands become diffuse, the peaks of the main bands being shifted slightly to greater wavelengths (with the central line now at 4156A), while the weaker intermediate lines are no longer visible. Nayar ascribed the four fre-

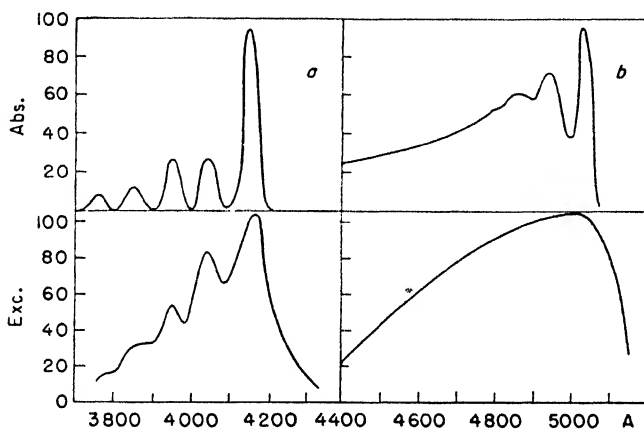

Fig. 216. Absorption and excitation spectra of diamonds (Mani).

a: blue fluorescence. *b*: yellow fluorescence.

frequencies listed under $\Delta\nu$ in Table 138A to four lattice vibrations which he tried to identify with known Raman frequencies of diamond (1099, 1100).

In a more recent analysis, Mani listed far more numerous lines which were symmetrically arranged around the central line in the fluorescence and absorption spectra of diamond; although the lines of the fluorescence spectrum were divided into groups similar to those of Nayar's analysis, the separation between the groups is indistinct. There are, altogether, ten such groups; in Table 138B the $\Delta\nu$ -values of the individual lines in the first eight of these groups are reproduced. Groups IV, VI, and VIII are by far the strongest and obviously correspond to Nayar's bands 1, 2, and 3, while the other much weaker groups correspond to Nayar's fainter intermediate lines. A band system with the same $\Delta\nu$ -values was observed by Mani in the absorp-

TABLE 138
 ABSORPTION AND FLUORESCENCE BANDS OF DIAMOND AT -190°C
 (λ in \AA ; ν in cm^{-1})

A. PRINCIPAL BANDS (NAYAR)
 ($\Delta\nu = \nu_i - \nu_0$; $\delta\nu = \nu_i - \nu_{i+1}$)

Band index i	Fluorescence				Absorption			
	λ_i	ν_i	$\Delta\nu$	$\delta\nu$	λ_i	ν_i	$\Delta\nu$	$\delta\nu$
0	4152	24077	0		4152	24077	0	
1	4263	23450	627	627	4046	24708	631	631
2	4380	22823	1254	627	3947	25339	1262	631
3	4504	22196	1881	600	3849	25970	1893	631
4	4638	21596	2481		3758	26601	2524	

B. INDIVIDUAL COMPONENTS OF FLUORESCENCE BANDS (MANI)

	$(\Delta\nu \text{ in } \text{cm}^{-1})$							$\Delta\nu$
II	34	70	98					
III	132	178	212	258	359	493		
IV (1)	533	543	565	681	716	784		627
V	848	946	1013	1088				
VI (2)	1131	1149	1218	1252	1284	1330	1341	1254
VII	1422	(1540)	(1664)					
VIII (3)	1757	1887	2021					1881
IX	2138							

tion and emission spectra symmetrically located around the line 5032A; but here the intensities decreased continuously with increasing distance from the central line (973).

According to Mani, the $\Delta\nu$'s from 34 to 1330 cm^{-1} listed in Table 138B represent the lattice spectrum of diamond. It seems exceedingly improbable, however, that the constancy in the spacing $\delta\nu$ between neighboring bands in Table 138a is purely fortuitous, and it is even more improbable because apparently this constancy was not noticed by the authors of the original papers. Such a constant spacing suggests a principal lattice oscillation with a frequency $\sim 630 \text{ cm}^{-1}$, which is almost the same in the ground state and in the excited states and on which a number of other vibrational frequencies are superimposed.

Apart from the main band systems at 4152 and 5032A, most

fluorescent diamonds show in their fluorescence and absorption spectra at -190° C a number of fainter narrow lines which are ascribed by Mani to electronic transitions between the ground state and various excited states; these lines are more numerous in the spectra of samples with a yellow-green fluorescence than in those of the blue fluorescent diamonds. In the former they occur in the whole spectral region between 4000 and 6360A, while in the latter no lines are observed at wavelengths longer than 5032A. No trace of any of these lines, including the lines at 4152 and 5032A, is found in the absorption spectra of diamonds of class I.

The various peaks between 4400 and 3400A in the absorption spectrum of blue fluorescent diamonds coincide exactly with peaks in the excitation spectrum of the blue fluorescence. The peaks in the absorption spectrum near the line 5032A are not so well separated from the underlying continuous background and disappear completely in the excitation spectrum of the yellow-green fluorescence (Figures 216*a* and *b*). In diamonds exhibiting both the blue and yellow-green fluorescence, these can be excited simultaneously by light of wavelengths between 4400 and 3700A, but even under these conditions the selective maxima which are characteristic of the blue fluorescence are not observed in the excitation of the yellow-green fluorescence. Thus, the absorption and emission of the two band groups occur in different and independent centers. The blue fluorescence group reaches with a weak continuous band far into the orange-red and this continuum is not connected with the yellow-green system. The intensity distribution inside each of the two band systems is not influenced by the wavelength of the exciting light, while the relative intensity of the two systems with respect to each other varies greatly with varying wavelength of the primary radiation (975*b*).

Although the violet and the green band systems at 4152 and 5032A are present in the spectra of nearly all fluorescent diamonds, not only their absolute intensities but also their relative intensities vary within wide limits. In the fluorescence spectra of many pure white samples the green system is so weak that the color of the fluorescence is a pure blue; in other cases, the long-wavelength system predominates, but it is always accompanied by the blue system. Since many diamonds with a yellow-green fluorescence have a yellow or slightly brownish color in transmitted light, the blue fluorescence may be partly suppressed in their emission spectra by reabsorption.

The intensity of the fluorescence of diamonds is proportional to the intensity of the corresponding band systems in their absorption

spectrum: in weakly fluorescent diamonds the absorption band systems are also weak. On the other hand, although all blue fluorescent diamonds absorb radiation of wavelengths below 3100A, the samples showing the brightest blue fluorescence are relatively less opaque to short-wavelength u.v. than samples of weaker fluorescence. Thus, the "centers" which are responsible for the absorption and emission in the visible region are not identical with the centers producing the absorption in the u.v. Since in diamonds with high u.v. absorption the intensities of the visible band systems are weakened in the absorption spectrum as well as in the fluorescence spectrum, their luminescence is not reduced by a quenching effect due to a high concentration of "centers," but by a reduction of the number of centers which produce the visible band systems. Only faint fluorescence seems to be excited by short-wavelength u.v., while many diamonds are strongly excited by x-rays. No data concerning the fluorescence yield of diamonds are available.

After excitation with near ultraviolet, blue fluorescent diamonds show a blue afterglow of low intensity and lasting only a few second and a much stronger yellow phosphorescence which can be observed for half an hour. The blue afterglow of short duration can be perceived even at the temperature of liquid air and thus might be a slow fluorescence rather than a phosphorescence. If the sample is heated to temperatures between 150 and 270° C after its phosphorescence has decayed at room temperature, a renewed strong blue phosphorescence is emitted. This "thermoluminescence" of diamond was described for the first time by Boyle in 1663. The same emission can be stimulated by irradiating the diamond with visible light of wavelengths between 4200 and 8000A (with the highest efficiency near 5500A); after having undergone such stimulation the diamond must be excited again with ultraviolet light in order to regain its thermoluminescence. While the fluorescence and the phosphorescence emitted at room temperature are excited with greatest intensity by near u.v. radiation, the phosphorescence which is "driven out" by heat or by stimulation is much stronger when it is excited by light of wavelengths below 3000A (215b,c,975b).

The "phosphorescence patterns" of the blue and of the yellow afterglow correspond to the "blue fluorescence patterns"; in other words, only those diamonds or zones of diamonds which emit the blue fluorescence are phosphorescent. The spectrum of the blue afterglow and high temperature phosphorescence is identical with the spectrum of the blue fluorescence (principal line at 4152A and corresponding

band system). If a diamond is characterized by a "yellow-green fluorescence pattern," this pattern appears only in a very faint afterglow lasting about 40 sec and showing the line 5032A and the corresponding band system. An emission of the same color can be stimulated as a "green flash" by irradiating the crystal with red light (215a,c).

The very complicated phenomena observed in the afterglow of diamonds can be summarized in the following way. Two emission processes exist in blue fluorescent diamonds: emission of the blue line with its various secondary lines and bands, and emission of the yellow-green band. The crystal contains relatively shallow traps from which electrons are transferred only to the yellow-band emission centers, and traps of much greater depth which provide electrons only for the blue-line emission centers (in thermoluminescence and stimulated phosphorescence). The shallow traps are filled preferentially when the absorption takes place in the near u.v. and violet bands, while electrons excited by radiation of wavelengths below 3000A have a greater probability of being caught in the deeper traps. Finally, the blue-line emission centers contain some sort of metastable states which are responsible for the short blue afterglow. The conditions in green fluorescent diamonds are similar, except that no emission corresponding to the yellow bands seems to occur in their afterglow.

169. Radioluminescence and "Radiophotoluminescence." A part of the difficulty in ascertaining the origin of the luminescence of many minerals is due to the fact that their optical properties may have undergone an alteration by the influence of a long-lasting radioactive irradiation. This alteration can occur either in the base material itself or in impurity atoms embedded in the base material. Laboratory experiments prove that there is no essential difference between the transformation produced in crystals by radioactive rays, x-rays, cathode rays, and short-wavelength u.v., with the single exception that some of these radiations penetrate into the interior while others are absorbed in a thin surface layer. In general, modification II, which is formed following the irradiation and which is always more or less discolored, is not very stable and can be reconverted into the normal modification I by heat treatment and frequently also by irradiation with light of certain frequencies. As a matter of fact, all radiations producing the conversion from I to II produce the inverse effect to some degree since the discoloration, under the action of a constant, irradiation, reaches a saturation value which cannot be exceeded and which corresponds to the state where the restoring effect counterbalances the discoloring effect (1309).

If the discolored modification II is photoluminescent, it is raised by light absorption into a third state III (*F*) of still greater energy and smaller stability, from which it returns to II with emission of light. If the luminescence is partly phosphorescence, a quasi-stable state III (*M*) must be reached from III (*F*), corresponding to the transition from *F* to *M* in the previous energy-level diagrams for phosphorescence processes.

Phenomena of this kind have been designated by Przibram as "radiophotoluminescence" and all minerals which owe their color and their photoluminescence to a preceding exposure to radium rays are radiophotoluminescent, according to this terminology. In principle, the excitation of photoluminescence can be repeated indefinitely with a sample of a discolored crystal if the exciting radiation has no efficiency in restoring modification I of the crystal. In many cases — for instance, in that of "pure" rock salt and "pure" calcite — the normal, colorless modification I is not photoluminescent. Nonetheless, the conversion of modification I to the colored modification II is not only accompanied by light emission, but the same is also true for the subsequent restoration of modification I by heat treatment (radio-luminescence and radiothermoluminescence in Przibram's nomenclature). As far as the spectra of these various emission processes have been investigated, they seem to coincide with that of the photoluminescence which is excited by light absorption in modification II and correspond, therefore, to the transition from III (*F*) to II (1308, 1309, 1315).

If this interpretation is correct, it must be assumed that the energy released in the "restoring" process II → I is transferred to centers which are still in state II, thus exciting their characteristic fluorescence.

Results obtained by Wiedemann and Schmidt prove that this does not hold in all instances. In analogy to Przibram's terminology the phenomena which they observed should be called "cathodothermoluminescence." They exposed crystal phosphors, such as impurity-activated sulfates or carbonates, to the action of cathode rays. The crystals were photoluminescent before they were introduced into the cathode-ray bulb; they were also luminescent during the exposure to the electron bombardment. Moreover, they were discolored by this treatment and became thermoluminescent: by a subsequent rise in temperature they were induced to emit a strong luminescence. The emission spectra of the original photoluminescence, the cathodoluminescence, and of the thermoluminescence were identical. The

emission must be ascribed, therefore, to the transition from the excited state II (F) (which is reached by light absorption) to the ground state I. On the other hand, the crystals were not rendered thermoluminescent by irradiation with light exciting the photoluminescence. Thus, it must be assumed that in these cases the light emission originates from the unstable state II (F) [with its phosphorescent state II (M)], while a higher quasi-stable state III, which is reached by electron bombardment, has a much greater stability than II (M) and becomes unstable only at elevated temperatures. The return from III to the ground state either occurs in two stages via II, so that the process leads eventually to the light-emitting transition II \rightarrow I, or a part of the energy released by the direct transition from III to I serves to raise other centers from the ground state I to the "fluorescent state" II (F), with subsequent emission of "thermoluminescence" (1835).

Rock salt and other alkali halides which have been discolored by exposure to x-rays, β - and γ -rays, or cathode rays are best known examples of typical radiophotoluminescence. Formation of F -centers with their new absorption bands (in the blue for NaCl, in the yellow-green for KCl, etc *) and the photoconductivity which is excited by light absorption in the F -centers and leads to the formation of F' -centers has been discussed in Section 156. Samples of natural yellow rock salt, with all the characteristic properties of NaCl which has been discolored by x-rays, have been found in various locations; it is very probable that they owe their color to the presence of a weak radioactive substance in the soil (1312). The data assembled in Section 156 for the photoconductivity of impurity-activated crystals referred almost exclusively to yellow rock salt. The phosphorescence which can be excited in these crystals was ascribed originally to the primary conversion of F -centers to F' -centers and the subsequent return to the "ground state" represented by the F -centers. It is doubtful, however, whether the relation between the two phenomena is so simple. Although the presence of F -centers in the crystal is essential for the excitation of the luminescence, the emission process may be connected with some other centers which, on their part, may have been produced by the preceding x-ray irradiation. A phenomenon of this type appears very clearly in discolored fluorites and calcites containing rare earths (Section 170).

It is well known that after exposure to x-rays, alkali halide crystals emit a weak phosphorescence which sometimes lasts several

* In transmitted light the color of NaCl and KCl containing F -centers is, therefore, yellow and purple, respectively.

hours and even days. Using a u.v. sensitive photon counter, Diatschenko measured the wavelength of this luminescence and found, in addition to a weak visible emission, a u.v. phosphorescence which, in the case of yellow rock salt, had a mean lifetime of three minutes. When the crystals are heated or irradiated with blue light, which is absorbed by the *F*-centers of yellow rock salt, the intensity of the u.v. phosphorescence is greatly enhanced and under these conditions the wavelength of its peak at 2450A could be determined with a spectrophotometer. The response to stimulating visible light exhibits a time lag which is small at the beginning of the decay period but increases as the decay of the phosphorescence progresses (300,382,499).

For the observation of the luminescence which was stimulated by irradiation of yellow rock salt with blue light, Kudrjawzewa used a photon counter in which the photoelectrons could be decelerated by variable negative potentials applied to a grid. By this method she obtained the peak in the fluorescence spectrum near 2500A and, moreover, a second fainter intensity maximum at 1500A. She assumed that electrons which had been raised from *F*-centers to a higher level by absorption of blue light and had dropped from there into a "hole" in the ground state of the lattice produced this short-wavelength emission band. Although such a process may occur under these conditions, it can hardly be admitted that the phenomenon was actually registered by Kudrjawzewa. Not only is the change in slope of the curve representing the photocurrent as a function of the applied potential at — 8.2 volts very small, but it is inconceivable that light of 1500A should be able to enter the counter cell through a quartz window after having traveled through some distance inside of the rock-salt plate and through a layer of atmospheric air (837*a*).

According to Urbach, the visible photoluminescence bands of NaCl, KBr, RbCl, RbBr, and CsCl which are discolored by exposure to x-rays or β - and γ -rays are all in the blue-green, with intensity maxima between 5000 and 5200A. While the *F*-absorption band of NaCl has its peak at 4700A, the *F*-bands of RbCl, NaBr, and RbBr lie at 6240, 6360, and 7200A, respectively. Thus, the emission of a band at 5100A would require very appreciable excess energy if it is stimulated by *F*-band absorption. On the other hand, the luminescence of discolored NaCl has all the characteristics of a genuine phosphorescence when it is excited by irradiation with blue light: it is "frozen in" at temperatures slightly below room temperature, and it can be stimulated by an increase in temperature or by irradiation with infrared light. If a sample of yellow rock salt is irradiated with blue light at 0° C and is

then heated to 150° C together with another sample of the same origin, only the first one emits its stored luminescence energy, which decays according to an exponential law. If, subsequently, both samples are heated to 300° C, both become thermoluminescent and the energy released in this process is again provided by the destruction of *F*-centers, which is rendered visible by a loss of color (1724,1725).

Moreover, the blue-green fluorescence of yellow NaCl is excited with appreciable intensity but without afterglow by irradiating the crystals only with red or infrared light. If the phosphorescence of the crystal has been excited beforehand by irradiation with blue light, the subsequent "stimulating" irradiation with red light produces an appreciably larger light sum than would have been obtained without the "stimulation." The most plausible interpretation of these manifold large deviations from Stokes' law seems to be the assumption that the electrons which have been released from *F*-centers, *F'*-centers, or other traps can return to the ground state of the crystal with subsequent light emission. A part of the electrons set free by absorption of blue light is captured in *F'*-centers from which they are released spontaneously by temperature fluctuations (phosphorescence) or by irradiation with red light (stimulated phosphorescence). By irradiation with red light alone, electrons must be released either from *F*-centers or from traps of an unknown nature without reaching the conduction band and being able to form *F'*-centers. Since *F'*-centers are very unstable at room temperature, with lifetimes not exceeding a few seconds, the thermoluminescence which is "driven out" by heating the crystals to 300° C must be due to electrons which are released from *F*-centers. In all these cases the energy for the emission process is provided by the permanent disappearance of *F*-centers. This does not necessarily mean that the return of an electron from an *F*-center to its normal location in the lattice immediately gives rise to the light emission, but the energy can be transferred by exciton migration to any kind of emission centers present in the crystal (1309).

By a mechanism of a similar kind, the various luminescence phenomena which are obtained with the mineral kunzite can be interpreted. Spodumene, kunzite, and hiddenite are natural lithium aluminum silicates, the first being colorless, the second light purple, and the third green. The coloring matter may be some impurity, probably manganese. After irradiation with visible light kunzite emits a reddish phosphorescence of short duration; if exposed to radium rays it is converted to hiddenite. This green modification emits a phosphorescence with exactly the same spectrum as that of

the purple modification, but of much longer duration. Simultaneously, the initial color of kunzite is restored. This can be achieved, also by heating the green crystals to a temperature not exceeding 250° C. By firing them at 500° C, kunzite and hiddenite become colorless, but subsequent exposure to radium rays reproduces the green color of hiddenite and the whole cycle can be repeated at will. In this case, it seems quite certain that the unknown centers which produce the purple color of kunzite are the carriers of all luminescence processes (1109, 1315).

Hackmanite, a sodium aluminum silicate of the sodalite group $[\text{Na}_2(\text{AlCl})\text{Al}_2(\text{SiO}_4)_3]$, exists in two unstable modifications: the colorless crystals acquire a deep purplish-red hue under u.v. irradiation and lose the color again in the dark. The reversal to the colorless state is greatly accelerated by exposure to light of wavelengths between 4500 and 7500A, while infrared radiation is ineffective. The discoloration by u.v. is accompanied by a bright orange fluorescence and followed by a blue phosphorescence; the latter may be connected with the restoration of the colorless state of the crystal. It is uncertain whether these phenomena are due to very small traces of manganese and other impurities (such as lead, lithium, gallium, etc.) which are always present in the mineral or to processes occurring in the complex structure of the base material (875a, 1033a).

Permanent plastic deformation, also, is able to produce some kind of phosphorescence centers in alkali halide crystals. When a crystal of "pure" potassium bromide is exposed to a uniform pressure of 2 kg per sq cm, lattice deficiencies due to this treatment cause an enhancement of the long-wavelength tail of the fundamental absorption band, which has its edge at 2050A in the nonperturbed crystal. A similar but even stronger effect is produced by heating the crystal to 700° C (only 28° below the melting point) for an hour in atmospheric air. In the latter case, the absorption band stretches well beyond 3000A with two selective maxima at 2200 and 2650A. If these crystals are irradiated with light of wavelengths below 2140A, they emit a fairly strong fluorescence with a continuous spectrum reaching from 3000 to 5000A (1310, 1354, 1725).

170. Fluorites. Very numerous samples of natural fluorites are fluorescent. While the best specimens of this mineral are colorless and transparent to light of wavelengths down to 1240A, most of the fluorescent crystals are slightly colored: light blue, violet, or greenish. Fluorites without any visible color are also fluorescent, sometimes; however, perfectly pure synthetic CaF_2 is as little luminescent as the

natural specimens transmitting the Schumann u.v. Various impurities are supposed to be the carriers of the luminescence in the other crystals (1139).

A green emission band which is observed frequently in fluorites is probably identical with that obtained from manganese-activated synthetic CaF_2 . Some fluorites exhibit a different green fluorescence, with a spectrum consisting of a series of discrete maxima; since the same bands are observed in the fluorescence spectrum of CaF_2 activated with uranyl oxide, they must be ascribed to traces of uranium contained in the crystals.* On the other hand, a very bright yellowish fluorescence of certain fluorites, which at first become black and then colorless by heat treatment, almost certainly originates from some hydrocarbons enclosed in the minerals (561).

It can be assumed that natural fluorites are activated by a great variety of admixtures; by far the most interesting among these are the rare-earth metals. Chlorophane, fluorites from Weardale (England), yttrium fluorites from Norway, and many other samples emit line spectra characteristic of trivalent rare-earth ions when they are irradiated with ultraviolet light. In some crystals these line spectra are obtained only after the mineral has been heated, while no rare-earth fluorescence can be produced by any treatment in other fluorites, although the presence of even relatively large amounts of rare-earth metals can be ascertained by other kinds of spectral analysis. This last observation shows that the way in which the activator is incorporated in the base material determines its fluorescence properties.

Morse was the first to investigate systematically the line spectra appearing in the fluorescence of certain fluorites (1905) (1057); a little later, Urbain succeeded in preparing a synthetic calcium fluoride activated with gadolinium, terbium, dysprosium, and samarium which under cathode-ray bombardment, emitted, a spectrum identical in all details with the photoluminescence spectrum of Morse's natural chlorophane. Urbain mentions that in experiments performed by Watteville the same luminescence was excited by irradiating these specimens with the radiation from a spark discharge (1728). A series of synthetic samples of CaF_2 , each containing a single rare earth, made it possible for Przibram and his collaborators to ascribe the individual lines to the various elements; moreover, they showed that the lumi-

* Uranium has been proved by fluorescence analysis to be present occasionally in other minerals, such as hyalite (opal), bolivarite, scapolite (wernerite), etc. According to Hernegger, uranium admixtures of 10^{-11} g can be ascertained by this method (604).

nescence can also be excited by irradiation with near u.v. Table 139 gives Przibram's identification of the main visible emission lines of a Norwegian yttrium fluorite as an example.* Since the spectrum was obtained with a glass spectrograph on plates not sensitized for the infrared, the u.v. gadolinium lines which are present in practically all chlorophane fluorescence spectra (3146, 3130, 3123, and 3115A) and the long-wavelength lines of samarium and europium are missing. Many of the identifications in Table 139 are questionable; they agree only in a few cases (marked in the table by asterisks) with the figures published by Chatterjee, who made the most thorough investigation of the fluorescence spectra of synthetic CaF_2 and YF_3 activated with a single rare-earth metal (Sm, Eu, Tb, Er, and Dy; see Section 140).

TABLE 139
FLUORESCENCE LINES OF RARE-EARTH IONS IN THE FLUORESCENCE
SPECTRUM OF AN YTTRIUM FLUORITE (AFTER PRZIBRAM)
(Wavelengths in Å)

Wavelength	Rare earth	Wavelength	Rare earth
4120	Tb	5390	Tb
4150	Tb	5455	Tb
4340	Tb	5500*	Er
4400	Tb	5600	Tb
4520	Tb	5675*	Sm
4570	Tb	5705	Sm
4780*	Dy?	5745*	Dy
4835	Tb	5830	Tb (Dy)
4885*	Tb	5895*	Eu
4955*	Dy?	6065*	Sm
5222	Er		
5300	Er		

Some of the discrepancies may be due to the fact that Chatterjee worked with pure CaF_2 and pure YbF_3 as base materials, while Przibram's data refer to a natural yttrium fluorite as defined in the footnote on this page. According to Chatterjee, the fluorescence spectra of Eu^{+++} embedded in CaF_2 and in YF_3 differ considerably, and although the properties of natural yttrium fluorite are probably closer to those of europium-activated calcium fluoride, the presence of 10% yttrium

* In "yttrium fluorite" from 10 to 20% of CaF_2 are replaced by YbF_3 ; the crystals have the structure of CaF_2 with yttrium taking the place of calcium in the surface-centered cubic lattice.

fluoride may have an appreciable influence on the spectrum. However, the emission spectrum of terbium-activated CaF_2 consists only of several line groups between 4870 and 6800A and there is no trace of the violet and blue lines which are ascribed to Tb in the first column of Table 139 (217,564).

The main difficulty in the correct identification of the fluorescence lines of natural fluorites is caused, of course, by the fact that the spectra represent the (probably incompletely resolved) superposition of several complicated multiplet spectra. In the region between 4700 and 6400A, Morse measured more than 200 lines in the fluorescence spectra of two fluorite specimens.

If the luminescence is excited by the short-wavelength u.v. radiation ($\lambda < 2300\text{A}$) which is emitted by sparks between various metal electrodes, the intensity distribution in the luminescence spectrum depends greatly on the metal of the electrodes and, thus, on the wavelengths of the exciting light. Table 140 shows the typical example of the strong line group between 5710 and 5760A obtained by Morse with one of his fluorite specimens. Some of the minor deviations in the wavelengths -- for instance, in the spectra excited by the Fe-, Cd-, and Al-sparks -- might be caused by errors of measurements, although this cannot be taken for granted because of a disagreement between Morse's figures and those obtained by Nisi and Miyamoto with a different specimen. The large differences in the intensity distribution of the three lines occurring in Table 140 prove unequivocally that at least some of the apparently single lines are produced by the superposition of two or even more independent lines belonging to different spectra and that these spectra respond with unequal intensities to the various exciting spark lines. A further argument in favor of this assumption is provided by the fact that the two sharp lines 5715 and 5736A were excited by the Mg-spark in another fluorite

TABLE 140

THE INFLUENCE OF THE EXCITING WAVELENGTH ON A LINE GROUP OF THE LUMINESCENCE SPECTRUM OF CHLOROPHANE

(Wavelengths in A; intensities in parentheses are estimated)

Electrode metal					
Mg	Fe	Cd	Al	Zn	Carbon arc
5715(2)	5715(20)	5711(20)	5710(20)	5720(2)	—
—	5727(5)	5723(10)	5720(8)	5743(2)	—
5736(100)	5737(7)	5737(3)	5732(3)	5760(2)	5733(100)

specimen investigated by Morse, while in this case the Cd-spark did not excite the three lines listed in Table 140 (1057, 1058, 1139).

No data concerning the absorption spectra of the rare-earth ions in the far u.v. (below 2300A) are available. In the absorption spectrum of a fluorite, Yoshimura found a number of selective absorption bands in the near u.v. at 3640, 3370, 3070, 2820, 2740, and 2620A, but no relation between the appearance of these bands and the presence of rare earths in the crystals has been proved to exist.

The rare-earth lines in the luminescence spectra of fluorites are, in general, much sharper than analogous lines from other phosphors activated with rare-earth metals. At -180°C some of the lines — for instance, the Eu^{+++} -line at 5736A which appears with great intensity in the luminescence spectra of many fluorites — has a half width of less than 0.1A. It is natural that in thermoluminescence spectra of fluorites — for instance, those published recently by Imori and Iwase — the lines are broadened and even overlap, forming continuous bands, since these spectra can be observed only at relatively high temperatures (644).

The optical sensitivity of the various rare earths embedded in fluorites differs as widely as in other phosphors. Praseodymium and erbium, which are frequently present in relatively great quantities, give rise to their characteristic lines if the crystals are free from other rare-earth metals. However, if they contain even small traces of terbium and dysprosium, the lines of praseodymium and erbium are almost completely suppressed and the lines of terbium and dysprosium have much greater intensities in the emission spectrum. Even the relative intensities of the lines belonging to the same element depend on the specific conditions — for instance, the concentration of the activator. Thus, the gadolinium lines 3115–3123A retain their full intensity at the lowest gadolinium concentrations, while the closely adjacent lines 3132–3146A, which are quite as bright as the others at greater concentrations, disappear completely at low concentrations.

These observations which at first seemed to be very strange are explained by the fact that the first group is very strong in the emission and absorption spectra (compare Table 93), and is therefore, weakened, by self-reversal at high concentrations. The second group is practically missing in the absorption spectrum and is weak in the emission spectrum, so that it attains an appreciable intensity only at high concentrations.

The emission lines of the trivalent rare earths appear, also, in the afterglow of fluorites, but here again the behavior of the various

lines is dissimilar. While certain lines are observed in the phosphorescence spectrum at room temperature, others are still frozen in under these conditions, the energy of excitation being stored over very long periods of time. Samples which have been kept in the dark for several weeks exhibit a brilliant thermoluminescence when they are heated, and the lines which are emitted in this thermoluminescence were missing in the preceding phosphorescence at room temperature. Thus, the thermoluminescence spectra obtained by Morse contain many more lines in the blue and violet region than the phosphorescence spectra of the same specimens at room temperature. Complete deactivation of such fluorites occurs in some cases only at temperatures at which the crystals are discolored. After this treatment the fluorescence spectra of the fluorites are frequently essentially different from their previous appearance. If a crystal has become colorless after having been heated to very high temperatures, the fluorescence due to the rare earths is destroyed, but it can be restored by exposure to x-rays or radium rays.

At room temperature many natural fluorites exhibit a broad blue fluorescence band (peak at 4290A) and a red band (6200A), and at low temperatures, a similar red band and a strong green band (peak at 5700A). These bands are due to the presence of the divalent ions of europium, samarium, ytterbium, and thulium (see Section 143). If the fluorescence spectrum of a natural fluorite or of synthetic CaF_2 consists only of the lines characteristic of the trivalent rare-earth ions, these lines are to a great extent suppressed after the crystal has been exposed to the radiation from a radioactive source; in the fluorescence

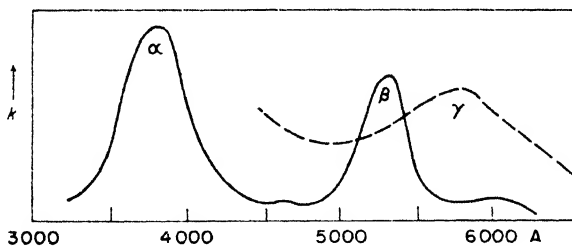

Fig. 217. Absorption bands of CaF_2 discolored by exposure to Ca-vapor (Mollwo).

which can be excited subsequently by irradiation with near u.v., the bands of divalent ions predominate (1311, 1313). By action of the β - and γ -rays a part of the trivalent rare-earth ions are converted to Pringsheim 24

divalent ions. Simultaneously, the crystal is discolored, and in this instance it is proved unambiguously that the production of color centers (F -centers) and of new emission centers is not directly connected. Even when calcium fluoride contains no rare-earth metals, the F -centers are produced in the crystals either by irradiation with x-rays and β - and γ -rays or by heating them in an atmosphere of Ca-vapor. Figure 217 shows the absorption spectrum of "pure" calcium fluoride containing F -centers; if the crystals are not quenched after the heat treatment in calcium vapor, but are allowed to cool slowly, the two selective absorption maxima α and β in Figure 217 are replaced by a broader band γ (dotted line in Figure 217), which is ascribed by Mollwo to the formation of colloidal particles. Due to the presence of this latter band in the absorption spectrum the color of the crystals in transmitted light becomes purple (1051b).

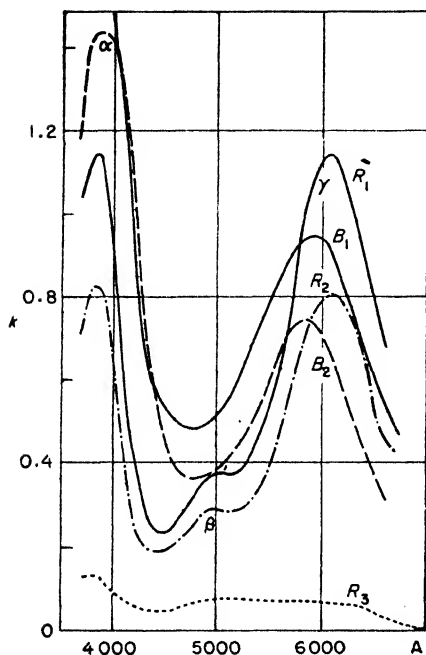

Fig. 218. Absorption bands of natural fluorite discolored by exposure to radium rays (Eysank).

(*R*) Crystal exhibiting the red Sm^{++} -band: (1) after 22 hours exposure to β -ray irradiation. (2) after being kept in the dark subsequently for 2 days. (3) after 15 minutes exposure to the radiation from a quartz mercury lamp. (*B*) Crystal exhibiting the blue Eu^{++} -fluorescence band: (1) immediately after irradiation with β -rays. (2) after several hours exposure to daylight.

Figure 218 shows the absorption bands of two samples of natural fluorites which, after exposure to radium, exhibit the blue and the red fluorescence band, respectively.* The formation of color centers in calcium fluorite is due to the same mechanism as that of F -centers in the alkali halides: by the bombardment, electrons are released from F^- -ions in the lattice and

Figure 217 shows the absorption spectrum of "pure" calcium fluoride containing F -centers; if the crystals are not quenched after the heat treatment in calcium vapor, but are allowed to cool slowly, the two selective absorption maxima α and β in Figure 217 are replaced by a broader band γ (dotted line in Figure 217), which is ascribed by Mollwo to the formation of colloidal particles. Due to the presence of this latter band in the absorption spectrum the color of the crystals in transmitted light becomes purple (1051b).

Figure 218 shows the absorption bands of two samples of natural fluorites which, after exposure to radium, exhibit the blue and the red fluorescence band, respectively.* The formation of color centers in calcium fluorite is due to the same mechanism as that of F -centers in the alkali halides: by the bombardment, electrons are released from F^- -ions in the lattice and

* The minor dissimilarities in curves *R* and *B* are fortuitous; there are specimens of fluorites with blue and with red fluorescence and completely identical absorption spectra.

some are trapped in vacant lattice points (Section 156) while others are caught by the trivalent rare-earth ions, converting them to divalent ions. The formation of the color centers is thus due to alteration of the base material, while the appearance of new emission bands is due to an alteration of the activating metal. Light absorption in the newly formed F -centers excites the fluorescence of the new emission centers (376,560-564,718,759,1311,1313,1314a).

The color centers formed in CaF_2 by the action of x-rays or β - and γ -rays are not very stable, as shown by comparing curves R_1 and R_2 and of B_1 and B_2 in Figure 218. Even in the dark the color disappears slowly (R_1 and R_2); the process is accelerated by exposure to daylight (B_1 and B_2), and irradiation with the light from a mercury arc discolors the crystal almost completely in fifteen minutes (R_3). In the latter case, a part of the liberated energy is transferred to still existing emission centers and re-emitted as "radiophotoluminescence." If the crystals containing color centers are irradiated with near-u.v. light, the F -centers are converted to F' -centers which give rise to a new absorption band at greater wavelengths (curve 3 in Figure 219). A subsequent heat treatment restores the original F -centers (1309).

No quantitative data are available for the efficiency with which the energy of the $F' \rightarrow F$ conversion is transferred to "emission centers" under these conditions. If the curves of Figures 218 and 219 should correspond to the behavior characteristic of all luminescent crystals which contain F -centers, they would represent the complete separation of the two fundamental phenomena occurring in radiophotoluminescence: the first is an irreversible process in which F -centers are destroyed by the absorption of radiation of relatively great wavelength and the released energy is partially transferred to emission centers, and the second is the excitation of normal photoluminescence which is terminated by the return of the F' -centers to their initial state F so that they can be excited again.

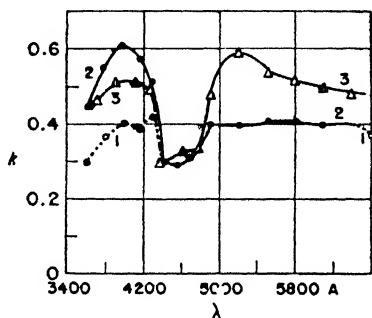

Fig. 219. Absorption spectrum of a colorless natural fluorite [Przibram (1309)].

1: before irradiation. 2: after exposure to radium rays. 3: after subsequent irradiation with near u.v. at -60°C for 1 minute.

If natural fluorites are heated to 180° C after having been exposed to x-rays, they emit, apart from their visible thermoluminescence, one or two bands in the near u.v. The specimens which were investigated by Rvatschew came from various locations and were of two types. Certain samples, with a visible phosphorescence band between 4500 and 5300A and a weaker band at 5800A, exhibited only a single u.v. band at 3000A. In other samples the emission spectrum contained the same bands, although of appreciably smaller intensity, and, moreover, a strong band in the yellow-green with peaks at 5330 and 5460A and a second u.v. band at 2800A. Rvatschew identifies the yellow-green band with Przibram's Yb⁺⁺-band and therefore also ascribes the band at 2800A to the presence of divalent ytterbium (1403).

The fundamental absorption band of pure fluorite crystals begins at 1250A with a very steep slope, so that light of shorter wavelengths is absorbed in a thin surface layer. Lau and Reichenheim observed that the fluorite window of a hydrogen discharge tube showed a strong green phosphorescence lasting more than 30 minutes after being exposed to the hydrogen radiation. The spectrum consisted of three pairs of narrow bands at 5850/5750, 5510/5380, and 4790/4720A, which could not be identified with the bands of a rare earth. Simultaneously, the crystal underwent an irreversible transformation, metallic calcium being set free on the surface. In this case the exciting radiation was certainly absorbed by the unperturbed base material itself, while no interpretation of the emission process can be given. On the other hand, two lines at 3133 and 3144A, which Lyman observed in the fluorescence spectrum of another sample of clear fluorite excited by the radiation from a hydrogen discharge, can be ascribed with certainty to Gd⁺⁺⁺, while the origin of a continuous band between 2450 and 3810A and a third line 3812A is not known (870, 965).

The presence of radioactive substances can be ascertained in many natural fluorites and pleochroic halos are not infrequently observed in such minerals. Since, on the average, the color of natural fluorites are the deeper, the stronger is their radioactivity, Przibram assumes that the color and the luminescence of most varieties of fluorspar, rock salt, sylvite, and many other minerals is caused by a long-lasting exposure to radioactive radiation and that, therefore, most of the luminescence phenomena obtained with natural minerals belong to the class which he calls radiophotoluminescence and radiothermoluminescence.

The example of the luminescence of fluorites, which has been

investigated very thoroughly, shows once more the great complexity of the phenomena occurring in crystal phosphors. Although the history of fluorescence begins with the investigation of fluorspar, which provided the name of the phenomenon, its treatment as the very last case in a book which attempts to interpret photoluminescence on the basis of modern theory is not without some justification.

BIBLIOGRAPHY

The bibliography is arranged in alphabetic order by names of authors. The titles in the bibliography are numbered in sequence and the references in the text refer to these numbers. To find the pages in the text on which the references are mentioned, consult the reference number index on pages 761-771. Abbreviations for the names of the various journals are the usual ones, but proceedings of academies and similar learned societies in general are given only as *Proc.*, *Bull.*, *Ber.*, etc. and are followed by the name of the city where published, e.g., *C. R. Moscow*, *Wien. Ber.*, etc. The individual papers presented at the symposia noted in *P*, *Q*, *R*, and *S* are cited in part II of the bibliography under *Acta phys. pol.* 5 (1936), *Trans. Faraday Soc.* 35 (1939), *Munich 1943*, and *Ithaca 1946*, respectively.

I. Books and Handbook Articles

Books and articles dealing in the main with applications of photoluminescence are not listed. Articles published before 1908 are listed only if they are of special importance. A complete bibliography up to 1908 is contained in (*Z*).

- (A) BECQUEREL, E. *La lumière, ses causes et ses effets*. Gautier-Villars, Paris 1867
- (B) DE MENT, J. *Fluorochemistry*. Chemical Publishing Co., New York 1945
- (C) DHÉRÉ, CH. *La fluorescence en biochimie*. Masson, Paris 1934
- (D) HIRSCHLAFF, E. *Fluorescence and phosphorescence*. Methuen, London 1937
- (E) KAUFFMANN, H. *Beziehungen zwischen physikalischen Eigenschaften und chemischer Konstitution*. Enke, Stuttgart 1920
- (F) LENARD, P., SCHMIDT, F., and TOMASCHEK, R. *Phosphoreszenz und Fluoreszenz*. See *Handbuch der Experimentalphysik (V)*
- (G) LEVERENZ, H. W. *Final report on research and development leading to new and improved radar indicators*. R.C.A. Laboratories, Princeton 1945
- (H) MERRITT, E., NICHOLS, E. L., and CHILD, C. D. *Selected topics in the field of luminescence*. Bull. Natl. Research Council (Carnegie Inst.), Washington 1922
- (I) MITCHELL, A. C. G. and ZEMANSKY, M. W. *Resonance radiation and excited atoms*. Macmillan Co., New York 1934
- (J) MOTT, N. F. and GURNEY, R. W. *Electronic processes in ionic crystals*. Clarendon Press, Oxford 1940
- (K) NICHOLS, E. and HOWES, H. *Fluorescence of the uranyl salts*. Carnegie Inst., Washington 1919
- (L) PRINGSHEIM, P. *Fluoreszenz und Phosphoreszenz im Lichte der neueren Atomtheorie*. Springer, Berlin 1927
- (M) RIEHL, N. *Physik und technische Anwendungen der Lumineszenz*. Springer, Berlin 1942
- (N) SWINGS, P. *La fluorescence des molécules diatomiques*. Hermann, Paris 1934
- (O) WOOD, R. W. *Researches in physical optics*, I and II. Columbia University Press, New York 1913 and 1919
- (P) *Rapports présentés à la réunion internationale de photoluminescence*. Wydane Zasilku Funduszu Kultury Narodowj, Warsaw 1936

- (Q) *Luminescence*. A general discussion held by the Faraday Society, Oxford 1938. Gurney and Jackson, London 1939
- (R) *Leuchten und Struktur fester Stoffe*. Vortraege der Muenchner Arbeitstagung. 1942. Oldenburg, Muenchen und Berlin 1943
- (S) *Preparation and characteristics of solid luminescent materials*. Symposium held at Cornell University, October 24-26, 1946. Wiley, New York and London, 1948
- (T) *Encyclopedia Britannica* (WOOD, R. W.)
- (U) *Handbuch der Arbeitsmethoden in der anorganischen Chemie*, Bd. 4, 2. Berlin und Leipzig 1926 (TOMASCHKE)
- (V) *Handbuch der biologischen Arbeitsmethoden herausgegeben von E. Abderhalden*, Urban und Schwarzenberg, Berlin 1934 (DHÉRÉ). II, 3
- (W) *Handbuch der Experimentalphysik*, Bd. 21 and 23/1 and 2. Akademische Verlagsgesellschaft, Leipzig 1927 and 1928 (ANGERER and JOOS; LENARD, SCHMIDT and TOMASCHKE)
- (X) *Handbuch der Physik*, Bd. 19, 21 and 23/1. Springer, Berlin 1930, 1929 and 1932 (LEY; PRINGSHEIM)
- (Y) *Handbuch der physikalischen Optik*, Bd. 2/1. Leipzig 1927 (TOMASCHKE)
- (Z) *Handbuch der Spektroskopie herausgegeben von H. Kayser*, Bd. 4. Hirzel, Leipzig 1908 (KONEN)

II. Periodicals

- (1) ACHARD, C., BOUTARIC, A., and BOUCHARD, J. Actions des sérums sur le pouvoir fluorescent d'urarine. *C. R.* 199, 903 (1934)
- (2) ACHARD, C., BOUTARIC, A., and BOUCHARD, J. Action comparée des alcaloides ordinaires et des généralcaloides sur la fluorescence des solutions d'urarine. *C. R.* 201, 629 (1935)
- (3) ADAMS, R. and GOLD, M. H. Absorption and fluorescence spectra of certain dihydro-isobenzofurans and isobenzofurans. *Am. Chem. Soc. J.* 62, 2038 (1940)
- (3a) ADIROWITCH, E. I. The elementary law of the decay of luminescence in crystals. *Bull. Moscow* 10, 465 (1946)
- (4) AHARONI, J. and DHÉRÉ, CH. Étude de l'influence exercée par la longueur d'onde des rayons excitateurs sur le spectre de l'étioporphyrine. Structure de ce spectre depuis l'extrême rouge (infra rouge) jusqu'à l'ultraviolet. *C. R.* 190, 1499 (1930)
- (5) ALBERS, V. M., KNORR, H. V., and ROTHEMUND, P. Fluorescence of the chlorophyll series. *Phys. Rev.* 49, 420 (1936)
- (6) ALBERS, V. M., KNORR, H. V., and FRY, D. L. The absorption and fluorescence spectra of tetra-(methylenedioxyphenyl) porphine of HCl number four and its $\text{AgC}_6\text{H}_5\text{N}$, Zn and Ni complex salts. *J. Chem. Phys.* 10, 700 (1942)
- (7) ALLEN, A. J., FRANKLIN, R., and McDONALD, E. Correlation of fluorescence spectra with chemical structure of some naphthalene derivatives. *Franklin Inst. J.* 215, 705 (1923)
- (8) ALMASY, F. Différentes propriétés optiques de la molécule benzaldéhyde. *J. chim. phys.* 30, 713 (1933)
- (9) ALMASY, F. Über die Isolierung Krebs erregender Substanzen unter Verwendung spektrographischer Hilfsmethoden. *Biochem. Z.* 291, 421 (1937)
- (10) ALMASY, F. and SCHAPIRO, C. V. The fluorescence spectrum of benzene. *Phys. Rev.* 35, 1422 (1930); *Z. phys. Chem. B* 25, 391 (1934)
- (11) ALMY, G. M. and ANDERSEN, S. Lifetime of fluorescence in diacetyl and acetone. *J. Chem. Phys.* 8, 805 (1940); *Phys. Rev.* 57, 1077 (1940)
- (12) ALMY, G. M., FULLER, H. Q., and KINZLER, G. D. The fluorescence of diacetyl. *J. Chem. Phys.* 8, 37 (1940); *Phys. Rev.* 55, 238 (1939)

- (13) ALMY, G. M. and GILETTE, P. R. The quantum yield of diacetyl fluorescence. *J. Chem. Phys.* 11, 188 (1943); *Phys. Rev.* 63, 64 (1943)
- (13a) ALPER, T. Fluorescence fatigue. *Nature* 158, 451 (1946)
- (14) ANDANT, A. Application de la spectrographie de fluorescence à l'examen des alcaloïdes en poudre. *C. R.* 185, 713 (1927)
- (15) ANDANT, A. Quelques relations entre la constitution chimique, l'absorption et la fluorescence des alcaloïdes. *C. R.* 189, 98 (1929)
- (16) ANDERSON, W. T. and BIRD, L. F. The measurement of u.v. quanta by fluorescent photometry. *Phys. Rev.* 32, 293 (1928)
- (17) ANDREWS, W. S. Improved form of phosphoroscope. *Gen. Electr. Rev.* 38, 259 (1917)
- (18) W. W. ANTONOW-ROMANOWSKI. Abklingung von Zinkphosphoren in einzelnen Krystallen. *Phys. Z. Sow.* 7, 366, (1935)
- (19) ANTONOW-ROMANOWSKI, W. W. Einfluss der ungleichen Verteilung von Phosphoreszenz-zentren und ihnen verwandten Factoren auf die Abklingung Lenardscher Phosphore. *C. R. Leningrad* (1935), 1057
- (20) ANTONOW-ROMANOWSKI, W. W. Direkter Beweis des bimolekularen Schemas des Ausleuchtens der Zinkphosphore. *C. R. Moscow* 16, 97 (1936)
- (21) ANTONOW-ROMANOWSKI, W. W. Mesures quantitatives sur la décroissance de la phosphorescence du ZnS-phosphore à des températures diverses. *C. R. Moscow* 17, 95 (1937)
- (22a) ANTONOW-ROMANOWSKI, W. W. Mechanism of luminescence of alkali halides. I. *Bull. acad. sci. U.S.S.R. der. phys.* 5, 523 (1941). II. *J. Phys. U.S.S.R.* 7, 153 (1943)
- (22b) ANTONOW-ROMANOWSKI, W. W. The mechanism of luminescence of phosphors. *J. Phys. U.S.S.R.* 6, 120 (1942)
- (22c) ANTONOV-ROMANOWSKI, W. W. Increase of phosphorescence during excitation. *C. R. Moscow* 39, 299 (1943)
- (22d) ANTONOW-ROMANOWSKI, W. W. Mechanism of phosphorescence. *Bull. Moscow* 9, 364 (1945)
- (22e) ANTONOW-ROMANOWSKI, W. W. Samarium as flash sensitizer in the alkaline earth phosphors. *C. R. Moscow* 54, 775 (1946)
- (22f) ANTONOW-ROMANOWSKI, W. W. Recombination phosphorescence. *Bull. Moscow* 10, 504 (1946)
- (23) ANTONOW-ROMANOWSKI, W. W., LEVSHIN, W. L., MORGENSTERN, Z. L., and TRAPEZNIKOVA. Phosphors sensitive to "red" light. *C. R. Moscow* 54, 19 (1946)
- (24) ARGABICEANU, I. I. Recherches sur les spectres de fluorescence et d'absorption de la vapeur de I_2 . *Ann. de phys.* 2, 448 (1934); *C. R.* 194, 1338 and 1913 (1932); 195, 123 and 947 (1932); 196, 166 and 760 (1933); 197, 38 (1933)
- (25) ARGABICEANU, I. I. L'effet Zeeman et l'affaiblissement magnétique de la fluorescence de S_2 et Te_2 . *C. R.* 199, 1036 (1934)
- (26) ARSENIĘWA, A. Über den Einfluss des Roentgenlichtes auf das Absorptionsspektrum der Alkalihalogenidphosphore. *Z. f. Phys.* 57, 163 (1929)
- (27) ASADA, T. Über die Lebensdauer angeregter Hg-Atome. *Phys. Z.* 29, 708 (1928)
- (28) ASADA, T., Ladenburg R., and Tietze, W. Messung der Lebensdauer metastabiler Hg-atome. *Phys. Z.* 29, 549 (1928)
- (29) ASAGOE, K. The u.v. resonance spectrum of iodine molecules. *Sci. Rep. Tokyo Bunrika Daigaku* 2, 9 (1935)
- (30) ASTERBLUM, M. Über das Abklingen des Bandenspektrums des Hg-Dampfes. *Z. f. Phys.* 43, 427 (1927); *C. R. soc. pol. phys.* 3, 17 and 79 (1927)
- (31) ASTERBLUM, M. Sur les modifications permanentes dans les liquides fluorescents. *Bull. int. Cracow. A* 1924, 297

- (32) ATHERTON, R. Determination of nuclear momentum of Rb by resonance radiation. *Phys. Rev.* **64**, 43, (1943)
- (33) AUSLAENDER, J. Messungen an der Zink-Resonanzlinie. *Helv. phys. acta* **11**, 562 (1938); **12**, 168 (1939)
- (34) BACHEM, A. Spektrale Untersuchungen über die Phosphoreszenz und die Erregungsverteilung einiger Erdalkaliphosphore. *Ann. d. Phys.* **38**, 697 (1912)
- (35) BADGER, R. M. Flammenfluoreszenz und die Auslöschung von Fluoreszenz in Gasgemischen bei hohem Druck. *Z. f. Phys.* **55**, 56 (1929)
- (36) BAECKLUND, A. Zur Theorie der Fluoreszenz. *Ark. f. Mat., Astron. Phys.* **6**, 10 (1910)
- (37) BAECKSTROEM, H. and JOHANSSON, R. Fluoreszenz bei Lichtfiltern. *Z. wiss. Phot.* **36**, 194 (1937)
- (38) BAI, K. S. The u.v. absorption spectrum of diamond. *Proc. Ind. Acad.* **19**, 253 (1944)
- (39) BAI, K. S. Luminescence patterns in diamond. *Proc. Ind. Acad.* **19**, 274 (1944)
- (40) BAILEY, A. C. and WOODROW, J. W. The phosphorescence of fused quartz. *Phil. Mag.* **6**, 1104 (1928)
- (41) BALIN, G. P. Über die Bestimmung des Absorptionskoeffizienten der Hg-Resonanzlinie 2536.5Å nach der Resonanzstreuungsmethode. *Phys. Z. Sow.* **8**, 93 (1935)
- (42) BALY, E. C. C. Light absorption and fluorescence. *Phil. Mag.* **27**, 632 (1914); **29**, 223 (1915); **30**, 510 (1915); *Phys. Rev.* **16**, 1 (1920)
- (43) BALY, E. C. C. Theory of absorption, fluorescence and phosphorescence. *Astrophys. J.* **42**, 4 (1915)
- (44) BALY, E. C. C. Phosphorescence, fluorescence and chemical reaction. *Nature* **122**, 651 (1928); *Chem. News* (1928) 165; 182; 194; 210
- (45) BALY, E. C. C. and KRULLA, R. A theory of fluorescence. *Trans. Chem.* **101**, 1469 (1912)
- (46) BALY, E. C. C. and RICE, F. O. Chemical reactivity and absorption spectra. *Trans. Chem.* **101**, 1475 (1912)
- (47) BALY, E. C. C. and TRYHORN, F. G. Light absorption and fluorescence. IV. Concentration and absorption. *Phil. Mag.* **31**, 417 (1916)
- (48) BANCROFT, W. D. Die chemischen Vorgänge bei der Phosphoreszenz. *Z. phys. Chem.* **69**, 15 (1909)
- (49) BANDERET, E. Etude de quelques inhibiteurs de fluorescence. *Helv. phys. acta.* **10**, 259 (1937)
- (50) BANDOW, F. Ueber die Ausbildung der Phosphoreszenz-Zentren in Calciumsulfid. *Ann. d. Phys.* **87**, 469, (1928)
- (51) BANDOW, F. Neue Untersuchungen über die Auslöschung von Calciumphosphoren unter besonderer Berücksichtigung der Mischphosphore. *Ann. d. Phys.* **6**, 434 (1930)
- (52) BANDOW, F. Die Ioneneinwanderung in Steinsalzkristalle untersucht mittels Phosphoreszenz. *Ann. d. Phys.* **12**, 385 (1932)
- (53) BANDOW, F. Beitrag zur Kenntnis der Metallkomplexe des Haematoporphyrins. *Z. f. physiol. Chem.* **233**, 71 (1934)
- (54) BANDOW, F. Porphyrinphosphore. *Forschungen und Fortschritte* **10**, 396 (1934); *Z. f. physiol. Chem.* **238**, 1 (1936)
- (55) BANDOW, F. Über die Wirkung von Befeuchtung auf die Fluoreszenzhelligkeit von adsorbierten Farbstoffen. *Z. phys. Chem. B* **42**, 67 (1939)
- (56) BANDOW, F. Optische Untersuchung über die Adsorption von Porphyrinen. *Z. phys. Chem. B* **39**, 155 (1938)
- (57) BANDOW, F. Über die Phosphoreszenzzentren. *Ann. d. Phys.* **41**, 172 (1942)
- (58) BANERJEA, G. B. and MISHRA, B. Untersuchung von Ramanverschiebungen bei Absorptions- und Fluoreszenzbanden von Lösungen. *Z. f. Phys.* **106**, 669 (1937)

- (59) BANOW, A. W. Die Auslöschung der Fluoreszenz flüssiger Farbstofflösungen. *Z. f. Phys.* 58, 811 (1929); 59, 726 (1930)
- (60) BANOW, A. W. Über den Einfluss der Temperatur auf die Fluoreszenzauslöschung der Farbstofflösungen durch Elektrolyte. *Z. phys. Chem. A* 163, 172 (1933)
- (61) BANOW, A. W. Über das Absorptionsspektrum des ZnI_2 -dampfes. *Acta physchim. U.S.S.R.* 2, 734 (1935)
- (62) BANOW, A. W. and PRILESHAJEWA, N. Das Fluoreszenzspektrum des Aethylamindampfes. *C. R. Leningrad* 4, 498 (1934)
- (63) BANOW, A. W. and ROBOTNOV, S. N. Influence of electrolyts on the fluorescence of rhodamine solutions in methylalcohol. *J. Phys. Chem. U.S.S.R.* 8, 295 (1936)
- (64) BARNETT, C. E. Properties of luminescent material. *Chem. Eng. News* 20, 1006 (1942)
- (65) BARYSANSKAJA, F. S. Etude de la fluorescence dans une couche à épaisseur comparable à la longueur d'onde. *C. R. Moscow* 17, 99 (1937); 19, 465 (1938)
- (66) BATES, J. R. The quenching of Cd resonance radiation. *Proc. Nat. Acad. Sci.* 9, 849 (1928)
- (67) BATES, J. R. The quenching of mercury resonance radiation. I. Saturated hydrocarbons; II. Further hydrocarbons and nitric oxide. *J. Am. Chem. Soc.* 52, 3825 (1930); 54, 569 (1932)
- (68) BATES, J. R. Electronic energy transfers between iodine and other molecules. *J. Phys. Chem.* 41, 57 (1937)
- (69) BATES, J. R. and TAYLOR, H. S. Studies in photosensitization. *J. Am. Chem. Soc.* 49, 2438 (1927)
- (70) BATSCHA, B. Über die Phosphoreszenzfähigkeit des Fluoreszeins. *Chem. Ber.* 58, 187 (1925)
- (71) BATSCHA, B. Über die Fluoreszenz des Fluoreszeins in saurer Lösung. *Chem. Ber.* 59, 311 (1926)
- (72) BAUR, E. Desensibilatoren, Antioxygene und Antifluoreszenten. *Z. phys. Chem. B* 16, 465 (1932)
- (73) BAUR, E. Zum Chemismus der Phosphoreszenz des Zinksulfids. *Helv. chim. acta* 20, 878 (1937)
- (74) BAXTER, W. B. Quenching of the fluorescence of nitrogen dioxide. *J. Am. Chem. Soc.* 52, 3920 (1930)
- (75) BAYLE, E. and FABRE, R. Recherche sur la fluorescence de quelques composés organiques. *C. R.* 178, 632 (1924)
- (76) BECKER, A., SCHAPER, I., and BECKER, F. Über die Fluoreszenzerstörung I. *Ann. d. Phys.* 42, 297 and 437 (1943); II. *Ann. d. Phys.* 43, 598 (1943); III. *Reichsber. Phys.* 1, 169 (1944); IV. *Z. Naturforsch.* 2a, 100 (1947)
- (77) BECQUEREL, E. Recherches sur divers effets lumineux qui résultent de l'action de la lumière sur les corps. *Ann. de chim. et phys.* 55, 5 and 57, 40 (1859); 62, 5 (1861)
- (78) BECQUEREL, E. Memoire sur l'analyse de la lumière émise par les composés d'uranium phosphorescents. *Ann. de chim. et phys.* 27, 539 (1871)
- (79) BECQUEREL, J. Sur la phosphorescence polarisée et sur la corrélation entre le polychroïsme de phosphorescence et le polychroïsme d'absorption. *C. R.* 151, 859 (1910)
- (80) BECQUEREL, J. Sur le renversement des bandes de phosphorescence. *C. R.* 151, 981 (1910)
- (81) BECQUEREL, J. Sur l'effet magnéto-optique de sens positif présenté par les bandes de phosphorescence du rubis et de l'émeraude, et sur les relations entre l'émission et l'absorption dans un champ magnétique. *C. R.* 151, 1344 (1910)

- (82) BECQUEREL, J. Sur la durée de la phosphorescence des sels d'uranyle. *C. R.* 152, 511 (1911)
- (83) BECQUEREL, J. Sur les modifications magnétiques des bandes de phosphorescence et d'absorption du rubis et sur une question fondamentale de magnéto-optique. *C. R.* 152, 183 (1911)
- (84) BECQUEREL, J. Sur la propagation de la lumière dans les corps fluorescents. *C. R.* 153, 936 (1911)
- (85) BECQUEREL, J. La décomposition des bandes d'absorption et de luminescence de certain cristaux sous l'action d'un champ magnétique. *Zeeman Verhandlingen* (1935), 364
- (86) BECQUEREL, J. and ONNES, H. K. On phosphorescence at very low temperatures. *Proc. Amsterdam* 12, 76 (1909); *C. R.* 150, 647 (1910); *Ann. de chim. et phys.* 20, 145 (1910)
- (87) BEESE, N. C. Measurement of activation and decay of luminescent zinc silicate. *J. Opt. Soc. Am.* 29, 26 (1939)
- (88a) BEESE, N. C. The response of several fluorescent materials to short wavelength u.v. radiation. *J. Opt. Soc. Am.* 29, 278 (1939); *Phys. Rev.* 55, 1126 (1939)
- (88b) BEESE, N. C. Fluorescence of phosphors in rare gases. *J. Opt. Soc. Am.* 36, 493 (1946)
- (89) BEESE, N. C. and MARDEN, J. W. The fatigue effect in luminescent materials. *J. Opt. Soc. Am.* 32, 317 (1942)
- (90) BELA, H. Über die Absorptions- und Fluoreszenzspektren der Naphthalinderivate. *Acta phys. pol.* 1, 339 (1932)
- (91) BENDER, P. Effect of gases on the optically excited cadmium I spectrum. *Phys. Rev.* 36, 1535 (1930)
- (92) BENDER, P. Optical excitation of cadmium hydride and zinc hydride bands. *Phys. Rev.* 36, 1543 (1930)
- (93) BERG, W. Über die Auslöschung der Jod-Fluoreszenz durch Magnetfelder und durch Fremdgase. *Z. f. Phys.* 79, 89 (1932)
- (94) BERNARD, R. Observation d'un nouveau phénomène de fluorescence dans la haute atmosphère. Présence et variation de la radiation 5893A du ciel au crépuscule. *C. R.* 206, 448 and 1669 (1938); *Z. f. Phys.* 10, 291 (1938); *Nature* 141, 788 (1938); *Astrophys. J.* 89, 133 (1939)
- (95) BERNSTEIN, M. and DHÉRÉ, CH. Etude des spectres d'absorption et de fluorescence de l'escorcine. *C. R.* 223, 934 (1946)
- (96) BERRY, N. E. and ROLLEFSON, G. K. Transition probabilities and quenching in the 3P states of sodium. *Phys. Rev.* 38, 1599 (1931)
- (96a) BERTON, A. and BOULANGERS, F. Spectres ultraviolets de fluorescence et d'absorption de composés solides de gadolinium. *C. R.* 224, 1153 (1947)
- (97a) BERTRAND, D. Le phénomène de concentration des solutions fluorescentes. *C. R.* 220, 525 (1945)
- (97b) BERTRAND, D. Nouvelle théorie de la fluorescence des corps organiques. *C. R.* 220, 654 (1945)
- (97c) BERTRAND, D. Fluorescence visible et structure chimique. *Bull. soc. chim.* 12, 1010 (1946)
- (98) BEUREL, J. Über die Fluoreszenz der Platindoppelsalze. *Z. wiss. Phot.* 11, 150 (1912)
- (99a) BEUTEL, E. and KUTZELNIGG, A. Beiträge zur Lumineszenzanalyse. *Monatshefte f. Chem.* 55, 158, (1930); 57, 9 and 15 (1931)
- (99b) BEUTEL, E. and KUTZELNIGG, A. Zur Kenntnis der Fluoreszenz des Zinkoxyds. *Monatshefte f. Chem.* 61, 69 (1932)
- (99c) BEUTEL, E. and KUTZELNIGG, A. Fluoreszierendes Zinkoxyd durch teilweise Zersetzung von basischem Zinkcarbonat. *Monatshefte f. Chem.* 70, 297 (1937)

- (100) BEUTLER, H. Resonanz bei Stößen zweiter Art. *Phys. Z.* 29, 893 (1928)
- (101) BEUTLER, H. Influence of pressure and temperature upon the absorption and fluorescence of spectral lines. *Astrophys. J.* 89, 294 (1939)
- (102) BEUTLER, H. and EISENSCHIMMEL, W. Über Austausch von Energie und Elektronen zwischen neutralen Teilchen in der Resonanz bei Stößen zweiter Art. *Z. phys. Chem. B* 10, 89 (1930)
- (103) BEUTLER, H. and JOSEPHI, B. Resonanz bei Stößen zweiter Art in der Fluoreszenz und Chemilumineszenz. *Naturwiss.* 15, 540 (1927); *Z. f. Phys.* 53, 747 (1929); *Phys. Z.* 29, 893 (1928)
- (104) BEUTLER, H. and MIE, K. Über u.v. Banden des HD-Wasserstoffmoleküls. *Naturwiss.* 22, 419 (1934)
- (105) BEUTLER, H. and RABINOWITSH, E. Zum Nachweis der Energieanreicherung in Elementarprozessen. *Z. phys. Chem. B* 6, 233 (1929)
- (106) BEUTLER, H. and RABINOWITSH, E. Über die Reaktionen angeregter Quecksilberatome mit Wasserstoff und Wasser. *Z. phys. Chem. B* 8, 403 (1930)
- (107) BHAGAVANTAM, S. Relation of Raman effect to crystal structure and properties of diamond. *Ind. J. Phys.* 5, 169 (1930)
- (107a) BIBERMAN, L. M. On the diffusion of resonance radiation. *C. R. Moscow* 27, 920 (1940)
- (108) BIERRY, H. and GOUZON, B. Sur la substance fluorescente de la coquille d'oeuf de poule. *C. R.* 194, 653 (1932)
- (109) BIERRY, H. and GOUZON, B. Mise en évidence de la protoporphyrine du sang par le spectre de fluorescence de son complexe stanneux. *C. R.* 198, 615 (1934)
- (110) BILLETER, W. Über die Hyperfeinstruktur der Zinkresonanzlinie. *Helv. phys. acta* 7, 413 (1934)
- (111) BILLETER, W. Über die absolute Intensität der Zn-Resonanzlinie 3076A und die Lebensdauer des 2^3P_1 -Zustandes von Zink. *Helv. phys. acta* 7, 505 (1934)
- (112) BILLETER, W. Über einen Isotopverschiebungseffekt an der Zn-Resonanzlinie 3076A. *Helv. phys. acta* 7, 524 (1934)
- (113) BILLETER, W. Über die absolute Intensität der Zn-Resonanzlinie 2139A und die Lebensdauer des 2^3P_1 -Zustandes von Zn. *Helv. phys. acta* 7, 841 (1934)
- (114a) BIRUS, F. Kristallphosphore. *Ergebnisse d. exakt. Naturwiss.* 20, 183 (1942)
- (114b) BIRUS, K. Phosphoreszenzabklingungskurven, die durch Rekombinationsvorgänge bestimmt sind. *Munich 1943*, 160
- (114c) BIRUS, K. Die Lumineszenz der Silikatphosphore als Beispiel eines Konfigurationsleuchtens. *Munich 1943*, 169
- (115a) BIRUS, K., MOEGLICH, F., und ROMPE, R. Über einige die Kristallphosphore und Isolatoren betreffende Fragen. *Phys. Z.* 44, 122 (1943)
- (115b) BIRUS, K. and SCHOEN, M. Über die Form der Emissionsbanden von Kristallphosphoren, insbesondere deren Temperaturabhängigkeit. *Verh. d. Deutsch. Phys. Ges.* 19, 83 (1938)
- (116) BIRUS, K. and ZIEROLD, H. Das Abklingungsgesetz der Phosphoreszenz von Alkalihalogenid- und Silikatphosphoren. *Naturwiss.* 30, 63 (1942)
- (117) BLOCH, L. and E. Sur la fluorescence du chlore et du brome. *C. R.* 184, 744 (1927)
- (118) BLOKHINZEW, D. Zur Theorie der Phosphoreszenz. *C. R. Leningrad* 4, 79 (1934)
- (119) BLOKHINZEW, D. Bemerkung zur Phosphoreszenztheorie. *Phys. Z. Sow.* 10, 424 (1936); *C. R. Leningrad* 4, 76, (1934)
- (120) BLOKHINZEW, D. Zur Theorie der gefärbten Krystalle. *Phys. Z. Sow.* 10, 431 (1936)
- (121) BLOKHINZEW, D. Die Kinetik der Phosphoreszenz. *Phys. Z. Sow.* 12, 586 (1937)

- (122) BLOKHINZEW, D. The spectra of fluorescence and absorption of complex molecules. *J. Phys. U.S.S.R.* 1, 117 (1939)
- (123) BLOKHINZEW, D. Modern state of phosphorescence theory. *Bull. Moscow* 5, 532 (1941); 9, 380 (1945)
- (124) BOARDMAN, L. J. A study of the exciting power for fluorescence of the different parts of the u.v. spectrum. *Phys. Rev.* 20, 552 (1922)
- (125) BOECKNER, C. Resonance and quenching of the third principal series line of cesium. *Bur. Stand. J.* 5, 13 (1930); *Phys. Rev.* 35, 664 (1930)
- (126) BOGGS, E. E. and WEBB, H. W. The hyperfine structure of the Hg triplet 6^3P-7^3S in optical excitation. *Phys. Rev.* 48, 226 (1935)
- (127) BOGROS, A. Résonance de la vapeur de lithium. *C. R.* 183, 124 (1926); *Ann. de phys.* 17, 249 (1932)
- (128) BOHR, N. Zur Polarisation des Fluoreszenzlichtes. *Naturwiss.* 12, 1115 (1924)
- (129) BOHR, N., KRAMERS, H. A., and SLATER, J. C. Quantum theory of radiation. *Phil. Mag.* 47, 832 (1924); *Z. f. Phys.* 24, 69 (1924)
- (130) BOIS, F. Recherches spectrochimiques sur quelques porphyrines animales. *Thèse Fribourg* (1927)
- (131) BORISSOW, P. Die Energieverteilung in den Emissionsspektren der CaBi- und SrBi-Phosphore. *Ann. d. Phys.* 42, 1321 (1913)
- (131a) BOTDEN, P. J. and KROEGER, F. A. Fluorescence of cadmium borates activated by manganese. *Physica* 13, 216 (1947)
- (132) BOUCHARD, J. Action photosensibilisatrice des matières fluorescentes sur la floculation des solutions colloïdales. *C. R.* 194, 1245 (1932)
- 133 BOUCHARD, J. Considération sur le pouvoir fluorescent et étude expérimentale du pouvoir fluorescent en fonction de la concentration. *J. chim. phys.* 33, 51 (1936); *C. R.* 196, 485 (1933); 196, 1317 (1933); 198, 649 (1934)
- (134a) BOUCHARD, J. Influence de la viscosité et de la température sur le pouvoir fluorescent. *J. chim. phys.* 33, 232 (1936); *C. R.* 199, 43 (1934); *C. R.* 199, 460 (1934)
- (134b) BOUCHARD, J. Influence du pouvoir inducteur spécifique sur le pouvoir fluorescent. *J. chim. phys.* 33, 127 (1936)
- (135) BOUCHARD, J. Influence exercée par la présence de substances étrangères sur le pouvoir fluorescent. Inhibiteurs incolores. *J. chim. phys.* 33, 325 (1936)
- (136) BOUDIN, S. Phosphorescence de solutions glyceriques d'éosine. Influence des iodures. *J. chim. phys.* 27, 285 (1930)
- (136a) BOUROFF, P. Sur l'accroissement de la luminescence par l'emploi de plusieurs corps luminogènes. *C. R.* 218, 317 (1944)
- (137) BOUTARIC, A. and BOUCHARD, J. Remarques sur la fluorescence des solutions et des gaz. *J. de phys.* 4, 324 (1933)
- (138) BOUTARIC, A. and BOUCHARD, J. Etude du pouvoir fluorescent de quelques solutions fluorescentes excitées par la radiation u.v. *J. de phys.* 8, 1 (1937); *C. R.* 203, 167 (1936)
- (139) BOUTARIC, A. and ROY, M. Pouvoir fluorescent des solutions d'uranium en fonction de leur concentration en H^+ . *C. R.* 209, 162 (1939)
- (140) BOWEN, E. J. Heterochromatic photometry of the u.v. region. *Proc. Roy. Soc. A* 154, 349 (1936)
- (141) BOWEN, E. J. Fluorescence of solids. *Nature* 142, 1081 (1938)
- (142) BOWEN, E. J. Fluorescence in solution. *Faraday Soc. Trans.* 35, 15 (1939)
- (143a) BOWEN, E. J. Reversible quenching by oxygen of the fluorescence of polycyclic hydrocarbons. *Nature* 149, 528 (1942)
- (143b) BOWEN, E. J. Fluorescence of naphthacene in anthracene. *J. Chem. Phys.* 13, 306 (1945)
- (143c) BOWEN, E. J. and COATES, E. Quenching of fluorescence by van der Waals, forces. *Nature* 157, 548 (1946)

- (143d) BOWEN, E. J. and COATES, E. Solvent quenching of fluorescence. *J. Chem. Soc.* 1947, 105
- (143e) BOWEN, E. J. and MICKIEWICZ, E. Fluorescence of solid anthracene. *Nature* 159, 706 (1947)
- (144) BOWEN, E. J. and NORTON, A. The quenching of fluorescence in solution. *Faraday Soc. Trans.* 35, 44 (1939)
- (145) BOWEN, E. J. and SATWELL, J. W. The fluorescence efficiency of solutions of hydrocarbons. *Faraday Soc. Trans.* 33, 1425 (1937)
- (146) BOWEN, E. J. and WILLIAMS, A. H. The photo-oxidation of hydrocarbon solutions. *Faraday Soc. Trans.* 35, 765 (1939)
- (147) BOWEN, I. S. The spectrum and composition of the gaseous nebulae. *Astrophys. J.* 81, 1 (1935)
- (147a) BOWEN, H. C. The low terms in Cr III, Cr IV, Mn IV and Fe V. *Phys. Rev.* 52, 1153 (1937)
- (148) BOWEN, I. S. Forbidden lines. *Rev. Mod. Phys.* 8, 55 (1936)
- (149) BOWEN, I. S. The extreme u.v. in astronomical sources. *Zeeman Verhandlungen*. p. 55 (1935)
- (150) BOYLE, R. Opera varia, I, 153-168, Geneva 1680
- (151) BRASEFIELD, C. J. Absorption spectrum of single crystal ZnS-phosphors. *Phys. Rev.* 57, 162 (1940)
- (152) BRASEFIELD, C. J. The effect of an activator on the absorption spectrum of zinc sulphide powders. *Phys. Rev.* 58, 436 (1940)
- (153) BRAUER, P. Über Lichtsummenmessungen an Mischphosphoren mit gemischtem Leuchtstoff. *Ann. d. Phys.* 36, 97 (1939)
- (154a) BRAUER, P. Über eine Methode zur Lichtsummenmessung an Mischphosphoren mit gemischten Leuchtstoffen. *Z. f. Phys.* 114, 245 (1939)
- (154b) BRAUER, P. Beiträge zur Frage der Energieaufspeicherung in Phosphoren. *Munich* 1943, 160
- (155a) BRAUER, P. Zur Frage der oberen Temperaturgrenze des Leuchtens von Phosphoren. *Naturwiss.* 32, 32 (1944)
- (155b) BRAUER, P. Bemerkungen über Mischphosphore. *Z. Naturforsch.* 1, 70 (1946); 2a, 238 (1947)
- (156) BRAUN, G. Mesure d'absorption de corps fluorescents dans différents solvants. *J. de chim. phys.* 33, 325 (1936)
- (157) BRAZDZIUNAS, P. Über den Starkeffekt an der Hg-Resonanzlinie und sein Verhalten in magnetischen Feldern. *Ann. d. Phys.* 6, 739 (1930)
- (158) BREDIG, M. A. Über anomale Dispersion in Alkalihalogenidphosphoren. *Z. f. Phys.* 46, 73 (1927)
- (159) BREIT, G. Polarization of resonance radiation. *Phil. Mag.* 47, 832 (1924)
- (160) BREIT, G. Polarization of resonance radiation in weak magnetic fields. *J. Opt. Soc. Am.* 10, 439 (1925)
- (161) BREIT, G. Polarization of resonance radiation and the quantum theory of dispersion. *Phys. Rev.* 25, 242 (1925); *J. Opt. Soc. Am.* 12, 195 (1926)
- (162) BREIT, G. Quantum theory of dispersion VI. Resonance radiation. *Rev. Mod. Phys.* 5, 91 (1933)
- (163) BREIT, G. and ELLETT, A. The depolarizing influence of a rapidly changing magnetic field on the resonance radiation. *Phys. Rev.* 25, 888 (1925)
- (164) BREIT, G. and LOWEN, I. S. Radiation damping and polarization of fluorescence radiation. *Phys. Rev.* 46, 590 (1934)
- (165) BRETEAU, P. Sur la préparation du sulfure de calcium phosphorescent. *C. R.* 161, 732 (1915)
- (166) BREUNIG, E. Die spektrale Verteilung der durch Licht hervorgerufenen Dielektrizitätskonstantenveränderung des ZnS(Cu)-phosphors in dünnen Schichten. *Ann. d. Phys.* 11, 863 (1931)
- (167) BRICARD, J. and KASTLER, A. Recherches sur la radiation du sodium dans

- la lumière du ciel crépusculaire et nocturne. *Ann. de géophys.* 1, 53 (1944); *C. R.* 216, 878 (1943)
- (168) BRIGGS, H. B. Supersonic cell fluorometer. *J. Opt. Soc. Am.* 31, 543 (1941)
- (169) BRILJANTOV, H. and MORGENSTERN, Z. On the luminescence of rocksalt irradiated with X-rays. *J. experiment. theor. Phys. U.S.S.R.* 8, 401 (1938)
- (170) BRILLOUIN, L. Sur les paramètres caractérisant la polarisation partielle de la lumière dans les phénomènes de fluorescence. *Helv. phys. acta* 2, 289 (1929)
- (171) BROOKS, G. Recherche sur la fluorescence de la peau de grenouille. *C. R.* 202, 2016 (1936)
- (172) BROOKS, G. Sur la matière minérale phosphorescente des tissus osseux de grenouille. *C. R.* 204, 1441 (1937)
- (173) BROOKS, G. Rélation entre la fluorescence et la constitution chimique du laccal, du morécacal et de leurs dérivés. *C. R.* 206, 726 (1938)
- (174) BROOKS, G. Etude chimique et spectrographique de la fluorescence des venins de serpents. *C. R.* 209, 248 (1939)
- (175) BROWN, W. G. Intensitätsveränderungen in einigen Fluoreszenzserien des Natriums. *Z. f. Phys.* 82, 768 (1933)
- (176) BROWN, W. G. and PRINGSHEIM, P. Über die Erregung von Resonanzserien in Natriumdampf durch Einstrahlung der D-Linien. *Z. f. Phys.* 82, 584 (1933)
- (177) BRUCE, W. F. Carcinogenic hydrocarbons. *Am. Chem. Soc. J.* 63, 304 (1941)
- (178) BRUENINGHAUS, L. Sur la loi de l'optimum de phosphorescence. *C. R.* 149, 1375 (1909)
- (179) BRUENINGHAUS, L. Recherche sur la phosphorescence. *J. de chim. phys.* 20, (1910); 21, 210 (1910)
- (180) BRUENINGHAUS, L. Une relation entre l'absorption et la phosphorescence. *Radium* 8, 147 and 411 (1911); *C. R.* 152, 1578 (1911)
- (181) BRUENINGHAUS, L. Sur les conditions d'excitation de la fluorescence. *C. R.* 169, 531 (1919)
- (182) BRUENINGHAUS, M. L. Sur un nouveau fluoromètre. *C. R.* 204, 118 (1937)
- (183) BRUMBERG, E. and VAVILOV, S. I. Visuelle Messungen der statistischen Photonschwankungen. *C. R. Moscow* 3, 409 (1934)
- (184) BUCHNER, H., GERLACH, W., and RUPP, E. Bemerkung zur Abhandlung von E. Rupp "Über das magnetische Verhalten der Phosphore." *Ann. d. Phys.* 8, 874 (1931)
- (185) BUHL, O. Über Wirkungsquerschnitte bei Stößen zweiter Art in angeregtem Hg-Dampf nebst einem Beitrag über die Hyperfeinstruktur der Hg-Resonanzlinie 2537A. *Z. f. Phys.* 109, 180 (1938); 110, 395 (1938)
- (186) BUENGER, W. Messung der Lichtemission von Alkalihalogenidphosphoren. *Z. f. Phys.* 66, 311 (1930)
- (187) BUENGER, W. and FLECHSIG, W. Über die Abklingung eines KCl-Phosphors mit Tl-Zusatz und ihre Temperaturabhängigkeit. *Z. f. Phys.* 67, 42 (1931)
- (188) BUENGER, W. and FLECHSIG, W. Über die Auslöschungsverteilung von einigen Alkalihalogenidphosphoren und die Quantenausbeute der Ausleuchtung an einem KCl-Phosphor mit Tl-Zusatz. *Z. f. Phys.* 69, 637 (1931)
- (188a) BUNDEL, A. A., RUSANOVA, A. I., and YAKOVLEVA, E. V. Influence of iron on the properties of ZnS phosphors. *Bull. Moscow* 9, 543 (1945)
- (189) BURT, R. C. Sodium by electrolysis through glass. Related experiments on Faraday's law and resonance radiation. *J. Opt. Soc. Am.* 11, 87 (1925)
- (190) BURTON, C. V. scattering and regular reflection of light by gas molecules. *Phil. Mag.* 29, 625 (1915); 30, 87 (1915)
- (191) BUTKOW, K. and TEREININ, A. Optische Anregung und Dissoziation einiger Halogensalze. *Z. f. Phys.* 49, 865 (1928)

- (191a) BUTLER, K. H. Fluorescence of silicate phosphors. *J. Opt. Soc. Am.* 37, 515 and 566 (1947)
- (191b) BUTLER, K. H. Barium silicate phosphors. *Trans. Electrochem. Soc.* 91, 13 (1947)
- (191c) BUTLER, K. H. Emission spectra of silicate phosphors with manganese activation. *Trans. Electrochem. Soc.* 93, 143 (1948)
- (192) BUTMAN, C. A. The photoelectric effect of phosphorescent material. *Am. J. Sci.* 34, 133 (1912)
- (193) BUTMAN, C. A. The electron theory of phosphorescence. *Phys. Rev.* 1, 154 (1913)
- (194a) BYLER, W. H. Studies on phosphorescent zinc sulfide. *Am. Chem. Soc. J.* 60, 632 (1938)
- (194b) BYLER, W. H. Inorganic phosphors without metallic activators. *Am. Chem. Soc. J.* 60, 1247 (1938)
- (194c) BYLER, W. H. Emission spectra of some zinc sulfide and zinc-cadmium sulfide phosphors. *J. Opt. Soc. Am.* 37, 902 (1947)
- (195) CABANNES, J., DUFAY, I., and GAUZIT, J. Sodium in the upper atmosphere. *Astrophys. J.* 88, 164 (1938); *C. R.* 206, 221, 870 and 1525 (1938)
- (196) CABANNES, J. and GARRIGUE, H. Un phénomène de photoluminescence dans la haute atmosphère. L'excitation par la lumière solaire de la raie 6300A de l'oxygène. *C. R.* 203, 484 (1936)
- (197) CAHEN, J. Recherche sur le taux de polarisation de la lumière fluorescente. *J. chim. phys.* 30, 420 (1933)
- (197a) CALVIN, M. and DOROUGH, G. D. The phosphorescence of chlorophyll and some chlorin derivatives. *Science* 105, 433 (1946)
- (197b) CALVIN, M. and DOROUGH, G. D. The possibility of a triplet state intermediate in photo-oxidation of a chlorin. *Am. Chem. Soc. J.* 70, 699 (1948)
- (198) CAMPBELL, N. The fluorescence of organic compounds. *Endeavour* 5, 155 (1946)
- (198a) CAMPBELL, N. R. and BALY, E. C. C. The physical significance of the least common multiple. *Phil. Mag.* 41, 707 (1921)
- (199) CANALS, E., PEYROT, P., and NOËL, R. Fluorescence de quelques corps purs. *C. R.* 198, 1992 (1934); 201, 208 and 1488 (1935); 203, 998 (1936); *Bull. soc. chim. de France* 1, 1622 (1934); 2, 1098 (1935)
- (200) CANALS, E., PEYROT, P., and FERROTET, S. Sur la fluorescence des sels de quinine. *Bull. soc. chim. de France* 2, 21 (1935)
- (201) CARIO, G. Über Entstehung wahrer Lichtabsorption und scheinbare Koppelung von Quantensprüngen. *Z. f. Phys.* 10, 185 (1922)
- (202a) CARIO, G. and FRANCK, J. Über die Zerlegung von Wasserstoffmolekülen durch angeregte Hg-Atome. *Z. f. Phys.* 11, 161 (1922)
- (202b) CARIO, G. and FRANCK, J. Über die sensibilisierte Fluoreszenz von Gasen. *Z. f. Phys.* 17, 202 (1923)
- (203) CARIO, G. and FRANCK, J. Über die Auslöschung der Resonanzfluoreszenz des Quecksilbers durch Gaszusatz. *Z. f. Phys.* 37, 619 (1926)
- (204) CARIO, G. and LOCHTE-HOLTEGREVEN, W. Eine neue Lichtquelle zur Anregung von Resonanzspektren. *Z. f. Phys.* 42, 22 (1927)
- (205) CARIO, G. and STILLE, U. Die Na-D-Linien im Nachhimmelleuchten. *Z. f. Phys.* 113, 442 (1939)
- (206) CARPENTER, D. W. and NIELSEN, W. M. Effect of temperature and pressure on the mercury afterglow. *Phys. Rev.* 46, 607 (1937)
- (207) CARRELLI, A. Sulla luce polarizzata de fluorescenza. *Lincei Rend.* 33, 21 (1924)
- (208) CARRELLI, A. Über die Theorie der sensibilisierten Fluoreszenz. *Z. f. Phys.* 53, 210 (1929)
- (209) CARRELLI, A. and PRINGSHEIM, P. Über polarisierte Phosphoreszenz. *Z. f. Phys.* 17, 287 (1923)

- (210) CARRELLI, A. and PRINGSHEIM, P. Über die Photolumineszenz von Farbstoffen in zähen Lösungsmitteln. *Z. f. Phys.* 18, 317 (1923)
- (211) CARRELLI, A. and PRINGSHEIM, P. Die Bildungswärme der K_2 -Moleküle. *Z. f. Phys.* 44, 643 (1927)
- (211a) CARRELLI, A., PRINGSHEIM, P., and ROSEN, B. Über den Ramaneffekt an wässrigen Lösungen. *Z. f. Phys.* 51, 511 (1928)
- (212) CARTER, A. H. and WEISS, J. The transfer of excitation energy from uranium ions in solution. *Proc. Roy. Soc. A* 174, 351 (1940)
- (213) CARTER, T. S. Absorption und Fluoreszenz des Rubidiumdampfes. *Phys. Z.* 11, 632 (1910)
- (214a) CHAKRAVARTI, D. N. und DHAR, N. R. Fluoreszenz und chemische Umwandlungen. *Z. f. anorg. Chem.* 142, 299 (1925)
- (214b) CHAKRAVARTI, D. C. and GANGULY, S. C. On the polarization of fluorescence of some simple aromatic hydrocarbons in solution. *Faraday Soc. Trans.* 37, 562 (1941)
- (215a) CHANDRASEKHARAN, V. Phosphorescence patterns in diamond. *Proc. Ind. Ac. Sci. A* 24, 182 (1946)
- (215b) CHANDRASEKHARAN, V. The thermoluminescence of diamond. *Proc. Ind. Ac. Sci. A* 24, 187 (1946)
- (215c) CHANDRASEKHARAN, V. The phosphorescence of diamond. *Proc. Ind. Ac. Sci. A* 24, 193 (1946)
- (216) CHAPMAN, S. Notes on atmospheric sodium. *Astrophys. J.* 90, 309 (1939)
- (217) CHATTERJEE, N. Über die Fluoreszenzspektren der seltenen Erden in künstlichen Fluoriten und ihre Deutung. *Z. f. Phys.* 113, 96 (1939)
- (218) CHAUCHOIS, Y. Fluorescence des solutions. Variation de la polarisation avec la concentration. Influence d'un colorant non fluorescent. *J. de chim. phys.* 27, 336 (1930)
- (218a) CHÉCHAT, C. L'action inhibitrice de l'oxygène sur la fluorescence des solutions. *C. R.* 222, 80 (1946)
- (219) CHÉRU, P. Influence de la température sur l'absorption et sur la polarisation de fluorescence dans le cas de la fluorescéine. *J. de chim. phys.* 32, 155 (1935)
- (220) CHEVALLIER, A. and DUBOULOZ, P. Sur l'application de la fluorescence aux mesures photométriques dans l'u.v. *C. R.* 194, 174 (1932).
- (221) CHEVALLIER, A. and DUBOULOZ, P. Mesures d'intensité dans le spectre ultraviolet au moyen de cellules photoélectriques sensibilisées par le salicylate de soude. *C. R.* 194, 452 (1932)
- (222) CHOMSE, H. Über Organophosphore mit anorganischem Grundmaterial. I-II. *Z. f. anorg. Chem.* 233, 140 and 145 (1937)
- (223) CHOMSE, H. and LUTZENBERGER, W. Über Organophosphore. III. *Z. f. anorg. Chem.* 238, 236 (1938)
- (224) CHOUDHURI, K. On the polarized fluorescence-part. Dyestuffs in solution. *Ind. J. Phys.* 18, 74 (1944)
- (225) CHOUDHURI, K. and BOSE, C. On the u.v. absorption of dye stuffs in solution and the influence of neutral salts on the same. *Ind. J. Phys.* 17, 43 (1943)
- (226) CHRISTENSEN, C. J. and ROLLEFSON, G. K. The influence of the method of excitation on transition probabilities in sodium vapor. *Phys. Rev.* 34, 1157 (1929)
- (227) CHUNG, K. L. Absorption and excitation of zinc silicate phosphors. *J. Opt. Soc. Am.* 35, 492 (1945)
- (228) CLAPP, D. B. The phosphorescence of tetraphenylmethane and certain related substances. *Am. Chem. Soc. J.* 61, 523 (1939)
- (228a) CLAPP, R. H. and GINTHER, R. J. U.v. phosphors and tan lamps. *J. Opt. Soc. Am.* 37, 355 (1947)

- (229a) CLAR, E. Zur Kenntnis mehrkerniger aromatischer Kohlenwasserstoffe und ihrer Abkömmlinge. *Chem. Ber.* 62, 350 and 1574 (1929)
- (229b) CLAR, E. Über die Konstitution des Perylens. *Chem. Ber.* 65, 846 (1932)
- (230) COHN, B. E. Luminescence and crystalline structure. *Am. Chem. Soc. J.* 55, 953 (1933)
- (231) COHN, B. E. Luminescence of synthetic halite crystals. *Phys. Rev.* 56, 856 (1939)
- (231a) COLLINS, E. H. The fine structure of the sharp series triplet $2^3P_{0,1,2}-2^3S_1$ of optically excited Hg radiation. *Phys. Rev.* 32, 753 (1928)
- (232) COMPTON, K. T. Time of imprisonment of resonance radiation in a gas. *Phys. Rev.* 21, 207 (1923); *Phil. Mag.* 45, 750 (1923)
- (233) COMPTON, K. T. and SMITH, H. D. Fluorescence, dissociation and ionization of iodine vapor. *Am. J. Sci.* 51, 571 (1920); *Phys. Rev.* 16, 501 (1920)
- (234) COOK, J. W. Derivatives of 1,2,5,6-dibenzanthracene. *J. Chem. Soc.* 1931, 489; 1932, 1472
- (235) COOK, J. W., HEWETT, C. L., and HIEGER, I. The isolation of a cancer-producing hydrocarbon from coal tar. *J. Chem. Soc.* 1933, 395
- (236) CORDES, H. Das Absorptionsspektrum des Jodmolekuls im Vacuum u.v. *Z. f. Phys.* 97, 603 (1935)
- (237) COUSTAL, R. Sur la réalisation d'un phosphoromètre permettant d'effectuer rapidement toutes les mesures d'intensité de phosphorescence. *C. R.* 188, 326 (1929)
- (238) COUSTAL, R. Poisons et phosphorogènes pour le sulfure de zinc phosphorescent. *C. R.* 190, 1403 (1930)
- (239) COUSTAL, R. Étude de la phosphorescence du sulfure de zinc. *J. de chim. phys.* 28, 277 and 345 (1931)
- (240) COUSTAL, R. Liaison entre les deux méthodes générales de préparation du sulfure de zinc phosphorescent. *C. R.* 196, 1306 (1933)
- (241a) COUSTAL, R. and PREVET, F. Sur un nouveau procédé de préparation du sulfure de zinc phosphorescent. *C. R.* 188, 703 (1929)
- (241b) COUSTAL, R. and PREVET, F. Sur l'optimum de concentration du phosphorogène et du fondant dans ZnS:Cu et sur la variation de cet optimum avec la température de préparation. *C. R.* 190, 739 (1930)
- (242) CRAM, S. W. Molecular spectrum of Cd vapor. *Phys. Rev.* 46, 205 (1934)
- (243) CRAM, S. W. Influence of temperature of uranin solution on the fluorescence decay time. *Phys. Rev.* 51, 62 (1937); *Z. f. Phys.* 103, 551 (1936)
- (244) CRAM, S. W. and WINANS, J. G. Observations on the fluorescence spectra of Cd vapor. *Phys. Rev.* 41, 388 (1932)
- (245) CURIE, M. Action des rayons infrarouges et rouges sur les substances phosphorescentes. *C. R.* 172, 272 (1921); 174, 550 (1922); *J. de chim. phys.* 20, 292 (1923)
- (246) CURIE, M. Photoluminescence des solutions solides. *J. de phys.* 5, 65 (1924)
- (247) CURIE, M. Effet photoélectrique et phosphorogène. *C. R.* 178, 2244 (1924)
- (248) CURIE, M. Sulphures phosphorescents: intervention des chocs de seconde espèce. *C. R.* 194, 1566 (1932)
- (249) CURIE, M. Sur la loi hyperbolique du déclin de la phosphorescence. *C. R.* 201, 142 (1935)
- (250) CURIE, M. Sur les théories de la phosphorescence. *C. R.* 202, 751 (1936)
- (251) CURIE, M. Verre phosphorescent; influence de la cristallisation. *C. R.* 203, 996 (1936); *Trans. Faraday Soc.* 35, 114 (1939); *J. de chim. phys.* 35, 143 (1938)
- (252a) CURIE, M. Sur l'excitation du sulfure de zinc luminescent. *C. R.* 217, 110 (1943)
- (252b) CURIE, M. Excitation de la luminescence des sulfides par transfert d'activation moléculaire. *Cahiers de phys.* 21, 12 (1944)

- (253) CURIE, M. and SADDY, J. Sulfures phosphorescents: Action extinctrice des métaux du groupe du fer. *C. R.* 194, 2040 (1932)
- (254) CURTIS, W. E. and EVANS, S. F. The spectra of the halogen molecules. Iodine. *Proc. Roy. Soc. A* 141, 603 (1933)
- (255) CUTHBERTSON, G. R. and KISTIAKOWSKY, G. B. Resonance fluorescence of benzene. *J. Chem. Phys.* 4, 9 (1936)
- (256) CZAPSKA-NARKIEWICZ, W. Bandes de fluorescence et d'absorption de quelques dérivées de la coumarine. *Bull. intern. Cracow. A* 1935, 445
- (256a) DAMON, G. H. and DANIELS, F. The photolysis of gaseous acetone and the influence of water. *Am. Chem. Soc. J.* 55, 2363 (1933)
- (257) DE B. DARWENT, B. and STEACIE, E. W. R. The Hg sensitized reactions of ethane. *J. Chem. Phys.* 16, 381 (1948)
- (257a) DE B. DARWENT, B. and WINKLER, C. A. The Hg-photosensitized reactions of isobutane. *J. Phys. Chem.* 49, 150 (1945)
- (258) DARWIN, C. G. Resonance radiation and the correspondence principle. *Nature* 115, 81 (1925)
- (259) DATTA, G. L. Der Polarisationsgrad der Resonanzfluoreszenz von Natriumdampf bei Anregung mit der D₂-Linie. *Z. f. Phys.* 37, 625 (1926)
- (260a) DAURE, P. Etude qualitative de la fluorescence de la vapeur de brome. *C. R.* 183, 31 (1926)
- (260b) DAURE, P. and KASTLER, A. Fluorescence de la vapeur d'iode excitée par de la lumière polarisée circulairement et observée longitudinalement. *C. R.* 198, 557 (1934)
- (261) DAVIS, L. J. Applications of luminescent solids. *Faraday Soc. Trans.* 35, 171 (1939)
- (262) DE BOER, J. H. Über die Natur der Farbzentren in Alkalihalogenidkristallen. *Rec. trav. de chim. Pays Bas* 56, 301 (1937)
- (263) DÉCHÈNE, G. Modification de la phosphorescence d'un sulfure de zinc semiconducteur sous l'influence d'un courant électrique. *C. R.* 205, 850 (1937)
- (264) DE GROOT, W. Linjenfluorescentie bij fluoriet-kristallen. *Physica* 3, 358 (1924)
- (265) DE GROOT, W. Erregung von Resonanz in Neon durch Linien aus dem sichtbaren Neon-Spectrum. *Naturwiss.* 14, 104 (1926); *Physica* 6, 53 (1926)
- (266) DE GROOT, W. Luminescence decay and related phenomena. *Physica* 6, 275 (1939)
- (267) DE GROOT, W. Saturation effects in the short duration photoluminescence of ZnS phosphors. *Physica* 6, 393 (1939)
- (268a) DE GROOT, W. Miscellaneous observations on the rise and decay of the luminescence of various phosphors. *Physica* 7, 432 (1940)
- (268b) DE GROOT, W. The influence of irradiation with light on the dielectric properties of ZnS-phosphors. *Physica* 12, 402 (1946)
- (269) DÉJARDIN, G. and BERNARD, R. Sur l'altitude de la couche atmosphérique où sont émises les raies D et sur l'origine des atomes de sodium présents dans cette couche. *C. R.* 207, 81 (1939)
- (270) DÉJARDIN, G. and FOLGA, R. Décharge lumineuse dans un gaz en présence de chlorure de sodium: Remarque sur l'origine du sodium atmosphérique. *J. de phys.* 10, 1239 (1938)
- (271) DÉJARDIN, G. and HERMAN, L. Remarque sur la fluorescence du salicylate de sodium. *C. R.* 202, 651 (1936)
- (272) DELORME, R. and PERRIN, F. Durée de fluorescence des sels d'uranyle solide et de leur solutions. *J. de phys.* 10, 177 (1929)
- (273) DE MENT, J. Fluorescence notation. *Phil. Mag.* 34, 212 (1943)
- (274) DÉRIBÉRÉ, M. Sur des fluorescences a grande persistance dans le groupe des calcaires naturels. *C. R.* 206, 222 (1938)

- (275) DÉRIBÉRÉ, M. Fluorescence à longue durée des hydrures de chaux. *Ann. de chim. analyt. appliquée* 20, 207 (1938)
- (276) DESAI, M. S. Über die Einwirkung des Lichtes auf Rubidiumjodid-Dampf. *Z. f. Phys.* 85, 360 (1933)
- (277) DÉSRANT, M. and MINNE, A. Remarque au sujet d'une série de résonance du sélénium observée par Mlle. Schmidt. *Bull. Liège* 4, 229 (1935)
- (278) DEUTSCHBEIN, O. Die Deutung der linienhaften Emissions- und Absorptionsspektren der Chromphosphore. *Z. f. Phys.* 77, 489 (1932); *Phys. Z.* 33, 874 (1932); *Ann. d. Phys.* 14, 712 and 729 (1932); 20, 828 (1934)
- (279) DEUTSCHBEIN, O. Zur Fluoreszenz seltener Erden in Gläsern. *Z. f. Phys.* 102, 772 (1936)
- (280a) DEUTSCHBEIN, O. Experimentelle Untersuchungen über die Vorgänge bei der Lichtemission. *Ann. d. Phys.* 36, 183 (1939)
- (280b) DEUTSCHBEIN, O. Über den Einfluss der Kristallsymmetrie auf die optischen Übergangswahrscheinlichkeiten. *Munich* 1943, 179
- (281) DEUTSCHBEIN, O., JOOS, G., and TELTOW, J. Feinstruktur und Linienverhebung in den Spektren der Chromphosphore. *Naturwiss.* 30, 228 (1942)
- (282) DEUTSCHBEIN, O. and TOMASCHEK, R. Die Fluoreszenz seltener Erden in Lösungen. *Ann. d. Phys.* 29, 311 (1937)
- (283) DEWAR, J. Phosphorescence and photographic action at the temperature of boiling liquid air. *Chem. News* 70, 252 (1894)
- (284) DHÉRÉ, CH. Détermination photographique des spectres de fluorescence des pigments chlorophylléins. *C. R.* 158, 64 (1914)
- (285) DHÉRÉ, CH. Sur le spectre de fluorescence de la protochlorophylle. *C. R.* 192, 1496 (1931)
- (286) DHÉRÉ, CH. Sur la fluorescence de la phylloérythrine et sur la structure de ses spectres de fluorescence. *C. R.* 195, 336 (1932)
- (287) DHÉRÉ, CH. Sur quelques propriétés de la bonnelline et sur la nature de ce pigment. *C. R. soc. biol.* 110, 1254 (1932)
- (288) DHÉRÉ, CH. Sur les spectres de l'hypéricine et de la mycoporphyrine. *C. R.* 197, 948 (1933)
- (289) DHÉRÉ, CH. and BIERMACHER, O. Spectres de fluorescence de la deutéroporphyrine et pyroporphyrine. *C. R.* 202, 442 (1936)
- (291) DHÉRÉ, CH. and BIERMACHER, O. La feuille de géranium vivante émet un rayonnement de fluorescence qui s'étend dans l'infrarouge jusqu'à 830 μ . *C. R.* 203, 412 (1936)
- (291) DHÉRÉ, CH. and BOIS, E. Etude comparative de la fluorescence de quelques porphyrines naturelles et artificielles. *C. R.* 183, 321 (1926)
- (292) DHÉRÉ, CH. and FONTAINE, M. Sur les spectres de fluorescence des phycochromoprotides. *C. R.* 192, 1131 (1931)
- (293) DHÉRÉ, CH. and RAFFY, A. Recherches sur les spectres de fluorescence de quelques hydrocarbures de la famille des rubènes. *Bull. soc. chim. de France* 2, 1424 (1935)
- (294) DHÉRÉ, CH. and RAFFY, A. Spectres de fluorescence du rubène en solution benzénique et à l'état solide. *C. R.* 200, 386 (1935)
- (295) DHÉRÉ, CH. and RAFFY, A. Sur le rayonnement infrarouge qu'émettent par fluorescence les feuilles vertes frappées par la lumière. *C. R.* 200, 1146 (1935)
- (296) DHÉRÉ, CH. and RAFFY, A. Sur les spectres de fluorescence des phéophorbides. *C. R.* 200, 1367 (1935)
- (297) DHÉRÉ, CH. and ROCHE, J. Sur la fluorescence et spécialement les spectres de fluorescence des pigments du groupe de l'urobiline. *C. R.* 193, 673 (1931); *Bull. soc. chim. biol.* 13, 287 (1931)
- (298) DHÉRÉ, CH., SCHNEIDER, A., and VAN DER BOM, TH. Détermination

- photographique du spectre de fluorescence de l'hématoporphyrine dans divers solvants. *C. R.* 179, 351 (1924)
- (299) DHÉRÉ, CH., SCHNEIDER, A., and VAN DER BOM, TH. Sur la fluorescence de quelques composés métalliques de l'hématoporphyrine. *C. R.* 179, 1356 (1924)
- (300) DIATSCHENKO, M. N. The u.v. phosphorescence of X-rayed rock salt crystals. *Phys. Z. Sow.* 13, 55 (1938)
- (301) DICKINSON, R. G. The combination of hydrogen and oxygen in the presence of activated mercury. *Proc. Nat. Acad. Sci.* 10, 409 (1924)
- (302) DICKINSON, R. G. and SHERRILL, M. S. Formation of ozone by optically excited mercury vapor. *Proc. Nat. Acad. Sci.* 12, 175 (1926)
- (303) DICKSON, E. Über die u.v. Fluoreszenz des Benzols und einiger seiner Derivate. *Z. f. wiss. Phot.* 10, 166 and 191 (1912)
- (304) DIEKE, G. H. and VAN HEEL, A. C. S. On the difference of the fluorescence and the absorption spectra of the uranyl salts. *Proc. Amsterdam* 28, 953 (1925); *Comm. Leyden, Suppl.* 55a, Nos. 169-180 (1925)
- (305) DIESTELMEIER, F. Fluoreszenz der Elemente in der sechsten Gruppe des periodischen Systems. *Phys. Z.* 14, 1000 (1913); *Z. wiss. Phot.* 15, 18 and 33 (1915)
- (306) DOBISCHKE, D. Darstellung und Eigenschaften Lumineszenzfachiger Gläser unter bes. Berücksichtigen von Zinsilicatphosphoren. *Diss. Berlin*, 1934
- (307) DOBREZOV, L. and TEREIN, A. Über die Feinstruktur der D-Linien des Natriums. *Naturwiss.* 16, 656 (1928)
- (308) DOERMANN, O. and HALPERN, F. W. Theoretical evaluation of a wide-angle interference experiment. *Phys. Rev.* 55, 480 (1939)
- (309) DOMANIEWSKA-KRUEGER, M. Über die Resonanzserien des Bleidampfes. *Acta phys. pol.* 1, 357 (1932)
- (310) DONAT, K. Über sensibilisierte Fluoreszenz. *Z. f. Phys.* 29, 345 (1924)
- (311) DORGELO, H. B. and DE GROOT, W. Die Intensitätsverhältnisse der (2p-2s) Kombinationen des Neonspektrums unter verschiedenen Anregungsbedingungen. *Z. f. Phys.* 36, 897 (1926)
- (312) DOSS, K. S. G. Inhibition of fluorescence. *Proc. Ind. Acad.* A 6, 24 (1937)
- (313) DU BOIS, H. and ELIAS, G. J. Der Einfluss von Temperatur und Magnetisierung bei selektiven Absorptions- und Fluoreszenzspektren. *Ann. d. Phys.* 27, 233 (1908); 35, 617 (1911)
- (314) DUBOULOZ, P. Etudes de fluorescence. *J. de phys.* 4, 103 (1933)
- (315) DUBOULOZ, P. Sur le rendement de la fluorescence du salicylate de soude. *C. R.* 196, 1221 (1933)
- (316) DUFFENDACK, O. S. The transfer of energy between molecules during collisions: quenching of mercury resonance radiation by admixed thallium vapor. *Phys. Rev.* 37, 107 (1931)
- (317) DUFFENDACK, O. S. and OWENS, J. S. Quenching of mercury resonance radiation by hydrogen, carbon monoxide and nitrogen. *Phys. Rev.* 46, 417 (1934)
- (318) DUFRAISSE, C. and ENDERLIN, L. Formule et constitution d'un hydrocarbure incolore à fluorescence violette $C_{42}H_{26}$. *C. R.* 194, 183 (1932)
- (319) DUNOYER, L. Sur la fluorescence des vapeurs des métaux alcalins. *Le Radium* 9, 177 and 209 (1912)
- (320) DUNOYER, L. Examen spectroscopique de la fluorescence et de l'absorption de la vapeur du rubidium et du mélange des vapeurs de rubidium et de césium. *Le Radium* 9, 218 (1912)
- (321) DUNOYER, L. Sur la résonance optique des gaz et des vapeurs. *Le Radium* 10, 400 (1913)
- (322) DUNOYER, L. Résonance et diffusion sélective superficielle de la vapeur de sodium pour les raies D. *J. de phys.* 4, 17 (1914)

- (323) DUNOYER, L. Sur les expériences par lesquelles on peut atteindre le mécanisme de l'émission lumineuse dans les conditions les plus simples. *C. R.* 178, 1475 (1924)
- (324) DUNOYER, L. and WOOD, R. W. Photometric investigation of the superficial resonance of Na vapor. *Phil. Mag.* 27, 1025 (1914); *C. R.* 158, 1265 and 1268 (1914); *Le Radium* 11, 111 (1914)
- (325) DURAND, E. Quenching and vibrational energy transfer in the fluorescence spectrum of S_2 . *J. Chem. Phys.* 8, 46 (1940)
- (326) DUSCHINSKY, F. Der Einfluss von Zusammenstößen auf die Abklingzeit der Na-Resonanzstrahlung. *Z. f. Phys.* 78, 586 (1932)
- (327) DUSCHINSKY, F. Der zeitliche Intensitätsverlauf von intermittierend angeregter Resonanzstrahlung. *Z. f. Phys.* 81, 7 (1933)
- (328) DUSCHINSKY, F. Eine allgemeine Theorie der zur Messung sehr kurzer Leuchtdauern dienenden Versuchsanordnungen. *Z. f. Phys.* 81, 23 (1933)
- (329) DUSCHINSKY, F. Über die Abklingung von Farbstofflösungen. *Acta phys. pol.* 5, 255 (1936)
- (330) DUSCHINSKY, F. Konzentrationsauslöschung in Farbstofflösungen. *C. R. Moscow* 14, 73 (1937)
- (331) DUSCHINSKY, F. Anomale antistokes'sche Fluoreszenz. *C. R. Moscow* 17, 179 (1937)
- (332) DUSCHINSKY, F., HIRSCHLAFF, E., and PRINGSHEIM, P. U.v. Fluoreszenzspektren des J_2 -Dampfes: Resonanzspektren. *Physica* 2, 439 (1935)
- (333) DUSCHINSKY, F. and PRINGSHEIM, P. U.v. Fluoreszenzspektren des J_2 -Dampfes II and III: McLennan-Banden. Einfluss von Fremdgasen. *Physica* 2, 633 and 923 (1935)
- (334) DUSEBERG, TH. Über die Absorption von Fluoreszenzlicht in der emittierenden Substanz. *Phys. Z.* 26, 157 (1925)
- (335) DUTT, S. Fluorescence in organic compounds. *J. Ind. Chem. Soc.* 7, 505 (1931)
- (336) DWYER, R. J. and OLDENBERG, O. The dissociation of H_2O into $H+OH$. *J. Chem. Phys.* 12, 351 (1944)
- (337) DYMOND, E. G. Dissoziation und Fluoreszenz von Joddampf. *Z. f. Phys.* 34, 553 (1925)
- (338) DZIERBICKI, J. and KOWALSKI, J. Über die Phosphoreszenz von organischen Substanzen bei niedrigen Temperaturen. *Bull. intern. Cracow* 1909, 724
- (339) ECKER, H. Das Absorptionsspektrum von reversiblen Polymerisaten aus Chinolinfarbstoffen. *Kolloidz.* 92, 35 (1940)
- (340) ECKERT, F. Über die physikalischen Eigenschaften der Gläser. *Jahrbuch d. Radioaktivität* 20, 93 (1923)
- (341) ECKSTEIN, H. Distribution of fluorescence excitation of bivalent Eu in CaF_2 and of bivalent Sm in $CaSO_4$. *Nature* 143, 1067 (1939)
- (342) EHRENFEST, P. Theoretische opmerkingen over absorptie- en emissiebanden in kristallen bij lage temperaturen. *Kamerling Onnes Festschrift, Leyden* 1923, 362
- (343) EHRENFUCHT, V. Rayonnement de résonance des vapeurs du sélénium. *C. R. soc. pol. phys.* 7, 65 (1926)
- (344) EINSTEIN, A. Über einen die Erzeugung und Verwandlung des Lichtes betreffenden heuristischen Gesichtspunkt. *Ann. d. Phys.* 17, 132 (1905)
- (345) EISENBRAND, J. Die Bestimmung von Dissoziationskonstanten fluoreszierender Stoffe durch quantitative Fluoreszenzmessungen. *Z. phys. Chem. A* 144, 441 (1929)
- (346) EISENBRAND, J. Fluoreszenzlösung in Lösungen durch organische Stoffe. *Z. phys. Chem. B* 22, 145 (1933)
- (347) EISENBRAND, J. and PICHER, H. Über das Auftreten von Ramanstrahlung bei Fluoreszenzuntersuchungen. *Z. f. Elektrochem.* 50, 72 (1944)

- (348) ELDRIDGE, J. A. Theoretical interpretation of the polarization experiment of Wood and Ellett. *Phys. Rev.* 24, 234 (1924)
- (349) ELIASHEVICH, M. Quantitative study of the quenching of fluorescence and of the transfer of energy in iodine vapor. *Phys. Rev.* 39, 532 (1932); *Phys. Z. Sow. r.* 510 (1932)
- (350) ELIASHEVICH, M. and TERENCEV, A. Fluorescence of Hg vapor in the far u.v. *Nature* 125, 856 (1930)
- (351) ELLETT, A. Polarized resonance radiation in weak magnetic fields. *Diss. Baltimore* 1923
- (352) ELLETT, A. Polarization of sodium resonance radiation in magnetic fields. Larmor precession of excited atoms. *J. Opt. Soc. Am.* 10, 427 (1925); *Phys. Rev.* 25, 242 (1925)
- (353) ELLETT, A. Polarization of resonance radiation in strong magnetic fields. Breadth of spectral lines. *Phys. Rev.* 29, 904 (1927)
- (354) ELLETT, A. Polarization of Cd resonance radiation $1^1S_0-2^3P_1$. *Phys. Rev.* 33, 124 (1929)
- (355) ELLETT, A. The effect of hyperfine structure due to nuclear spin on polarization of resonance radiation. *Phys. Rev.* 35, 588 (1930); 37, 216 (1931)
- (356) ELLETT, A. and HEYDENBURG, N. P. Nuclear magnetic moments from the polarization of resonance radiation of sodium $3S-4P$. *Phys. Rev.* 46, 583 (1934)
- (357) ELLETT, A. and LARRICK, L. Polarization of resonance radiation and hyperfine structure: the Cd resonance lines. *Phys. Rev.* 39, 294 (1932)
- (358) ELLETT, A. and MAC NAIR, W. A. Hyperfine structure and polarization of $1^1S_0-2^3P_1$ of mercury in resonance radiation. *Phys. Rev.* 31, 180 (1928)
- (359) ELLETT, A., OLSEN, L. O. and PETERSEN, R. Quenching and depolarization of resonance radiation by collisions with molecules of a foreign gas. *Phys. Rev.* 60, 107 (1941)
- (360) ELLIOTT, A. Molecular spectrum of iodine excited by fluorescence (in the presence of N_2) and by active nitrogen. *Proc. Roy. Soc. A* 174, 273 (1940)
- (360a) ELLICKSON, R. T. Light sum of phosphors under thermal and infrared stimulation. *J. Opt. Soc. Am.* 36, 264 (1946)
- (360b) ELLICKSON, R. T. Light storage in infrared sensitive phosphors. *J. Opt. Soc. Am.* 36, 501 (1946)
- (360c) ELLICKSON, R. T. and PARKER, W. L. Effect of absorption on decay of infrared sensitive phosphors. *Phys. Rev.* 69, 534 (1946)
- (361) ELSTER, J. and GEITEL, H. Über die Entladung negativ elektrischer Körper durch das Sonnen- und Tageslicht. *Ann. d. Phys.* 38, 497 (1889)
- (362) ELSTON, T. S. The fluorescence and absorption spectra of anthracene and phenanthrene vapors. *Phys. Rev.* 25, 155 (1907)
- (363) ENDERLIN, L. Sur un hydrocarbure incolore à fluorescence violette dérivant du diphenylditolylrubène. *C. R.* 197, 1332 (1933)
- (363a) ENGELHARDT, E. Lumineszenzerscheinungen der Mineralien im u.v. Licht. *Diss. Jena*, 1912
- (364) ENGLE, D. G. and HOPKINS, B. S. Studies in luminescence. *J. Opt. Soc. Am.* 11, 599 (1925)
- (365) EUCKEN, A. Bericht über die Anwendung der Quantenhypothese auf die Rotationsbewegung der Gasmoleküle. *Jahrbuch d. Radiaktiv.* 16, 161 (1920)
- (366) EULER, H. v. and BRANDT, K. M. Blau fluoreszierende Substanz im corpus luteum. *Naturwiss.* 23, 544 (1935)
- (367) EULER, H. v., BRANDT, K. M., and HELLSTROEM, H. Photochemisches Oxydo-Reduktionsgleichgewicht in Lösungen von Methylenblau. *Naturwiss.* 23, 486 (1935)
- (368) EULER, H. v., BRANDT, K. M., and NEUMUELLER, G. Zur Kenntnis der

- Fluoreszenz von Pyrimidin-, Purin- und Pyrimidazin-Derivaten. *Biochem. Z.* 281, 206 (1935)
- (369) EVANS, M. G. The quenching of mercury resonance radiation by compounds containing deuterium. *J. Chem. Phys.* 2, 445 (1934)
- (370) EVERT, H. Über die Emission des Praseodyms in Erdalkaliphosphoren. *Ann. d. Phys.* 12, 107 and 137 (1932)
- (371) EWLES, J. On the relation between luminosity and concentration in luminescent solid solutions. *Nature* 122, 1017 (1928)
- (372) EWLES, J. Water as an activator of luminescence. *Nature* 125, 706 (1930)
- (373) EWLES, J. The nature and size of the luminescent center. *Proc. Roy. Soc. A* 129, 509 (1930)
- (374) EWLES, J. Resolution and interpretation of the luminescent spectra of some solids at low temperatures. *Proc. Roy. Soc. A* 167, 34 (1938)
- (375) EWLES, J. The luminescence of inorganic solids. *Faraday Soc. Trans.* 35, 119 (1939)
- (376) EYSANK, E. Zur Verfärbung der Fluorite und des Steinsalzes. *Wien. Ber.* 2a 145, 387 (1936)
- (377) FABRE, R., BAYLE, E., and GEORGE, H. Contribution à l'étude de la fluorescence et ses applications. *Bull. soc. chim. de France* 37, 89 (1925)
- (378) FABRIKANT, W. Die Abhängigkeit der Fluoreszenzintensität von der Wellenlänge der anregenden Strahlung. *Phys. Z. Sow.* 3, 567 (1933)
- (379) FABRIKANT, W. and CIRG, I. Probability of a stepwise excitation of mercury atoms. *C. R. Moscow* 16, 263 (1937)
- (380) FARKAS, A. and MELVILLE, H. W. The mercury photosensitized exchange reactions of deuterium with ammonia, methane and water. *Proc. Roy. Soc. A* 157, 625 (1936)
- (381) FATERSON, A. Sur la rémission dans la fluorescence de bandes de la vapeur de mercure. *Bull. intern. Cracow A* 1934, 239
- (382) FEDENEW, N. Die u.v. Fluoreszenz in Kristallen der Alkalihalogenide mit F- und U-Zentren. *Acta physchim. U.S.S.R.* 9, 905 (1938)
- (383a) FEOFILOV, P. P. Polarization of fluorescence and anisotropy of molecules of organic dyes. *J. Phys. U.S.S.R.* 7, 68 (1943)
- (383b) FEOFILOV, P. P. On the polarized luminescence of dye stuffs in rigid solutions. *C. R. Moscow* 44, 147 (1944)
- (383c) FEOFILOV, P. P. Fluorescence of organic dyestuffs as related to chemical constitution. *C. R. Moscow* 45, 637 (1944)
- (383d) FEOFILOV, P. P. On the nature of elementary emitters and the polarization of photoluminescence. *C. R. Moscow* 55, 403 (1947); *Bull. Moscow* 9, 317 (1945)
- (384) FEOFILOV, P. P. and SVESHNIKOV, B. J. The concentrational depolarization of the fluorescence of dye solutions. *J. Phys. U.S.S.R.* 3, 493 (1940)
- (385) FERMI, E. and RASETTI, F. Effect of an alternating magnetic field on the polarization of resonance radiation of Hg vapor. *Nature* 115, 764 (1925); *Z. f. Phys.* 33, 246 (1925); *Lincei Rend.* 1, 716 (1925); 2, 117 (1925)
- (386) FARNAU, E. H. Sur la luminescence. *Le Radium* 11, 168 (1914)
- (387) FILIPPOV, A. Untersuchung über die u.v. Fluoreszenz des JBr-Dampfes. *Z. f. Phys.* 50, 861 (1928)
- (388) FILIPPOV, A., LARIONOV, J., and SEIDEL, A. On the fluorescence of terbium salts in solution. *C. R. Moscow* 4, 253 (1936)
- (389) FILIPPOV, A. and PETROWA, A. Über die Fluoreszenz der Dämpfe von Thallium und Thalliumchlorür. *Phys. Z. Sow.* 5, 169 (1934)
- (390) FIALKOVSKAJA, O. V. The absorption spectra and fluorescence of heterocyclic compounds. *Acta physchim. U.S.S.R.* 9, 215 (1938)
- (391) FINK, H. and HOERBURGER, W. Beiträge zur Fluoreszenz der Porphyrine. *Z. f. physiol. Chem.* 218, 181 (1933); 220, 123 (1933)

- (392) FINK, H. and WEBER, K. Porphyrinflouoreszenz und Wasserstoffzahl. *Naturwiss.* 18, 16 (1930)
- (393) FINKELNBURG, W. Über die Spektren von van der Waals-Molekülen. *Z. f. Phys.* 96, 699 and 714 (1935)
- (394) FINKELNBURG, W. Kontinuierliche Fluoreszenz- und Absorptionsspektren. *Acta phys. pol.* 5, 1 (1936)
- (395) FISK, C. F. and NOYES, W. A. The fluorescence of acetone vapor. *J. Chem. Phys.* 2, 654 (1934)
- (396) FONDA, G. R. The fluorescence of rhodamine. *J. Opt. Soc. Am.* 26, 316 (1936)
- (397) FONDA, G. R. The fundamental principles of fluorescence. *Trans. Am. Inst. Electr. Eng.* 57, 1 (1938)
- (398) FONDA, G. R. Characteristics of silicate phosphors. *J. Phys. Chem.* 43, 561 (1939); *J. Appl. Phys.* 10, 408 (1939)
- (399) FONDA, G. R. The preparation of fluorescent calcite. *J. Phys. Chem.* 44, 435 (1940)
- (400) FONDA, G. R. The yellow and red zinc silicate phosphors. *J. Phys. Chem.* 44, 851 (1940)
- (401) FONDA, G. R. The constitution of zinc beryllium silicate phosphors. *J. Phys. Chem.* 45, 282 (1941)
- (402a) FONDA, G. R. The magnesium tungstate phosphor. *J. Phys. Chem.* 48, 303 (1944)
- (402b) FONDA, G. R. Factors affecting phosphorescence decay of the ZnS phosphors. *Trans. Electrochem. Soc.* 87, 339 (1945)
- (402c) FONDA, G. R. Preparation and characteristics of ZnS phosphors sensitive to infrared. *J. Opt. Soc. Am.* 36, 352 and 382 (1946)
- (402d) FONDA, G. R. The constitution and structure of phosphors. *Ithaca* 1946, 69
- (403a) FONDA, G. R. and FROELICH, H. C. The structure of calcium silicate phosphors. *J. Electrochem. Soc.* 93, 114 (1948)
- (403b) FONDA, G. R. and HUTHSTEINER, H. The fluorescence of phosphors in the rare gases. *J. Opt. Soc. Am.* 32, 156 (1942)
- (404) FONTAINE, M. Spectrographie d'absorption et de fluorescence de la fabréine. *C. R.* 198, 1077 (1934)
- (405a) FOOTE, P. D. The quenching of Hg resonance radiation by foreign gases. *Phys. Rev.* 30, 288 (1927)
- (405b) FOOTE, P. D. Depolarization of resonance radiation. *Phys. Rev.* 30, 300, (1927)
- (406) FOOTE, P. D., RUARK, A. E., and MOHLER, F. L. The D_2 Zeeman pattern for resonance radiation. *J. Opt. Soc. Am.* 7, 415 (1923)
- (407) FOOTE, P. D., RUARK, A. E., and CHENAULT, R. L. The blue-green fluorescence of Hg vapor. *Phys. Rev.* 37, 1685 (1931)
- (408a) FOERSTER, TH. Farbe und Konstitution organischer Verbindungen. *Z. f. Elektrochem.* 45, 548 (1939)
- (408b) FOERSTER, TH. Die Lichtabsorption von Kohlenwasserstoffen nach der Quantenmechanik. *Phys. Z.* 39, 925 (1938); *Z. f. techn. Phys.* 19, 611 (1938)
- (408c) FOERSTER, TH. Energiewandlung und Fluoreszenz. *Naturwiss.* 33, 166 (1946); *Ann. d. Phys.* 2, 55 (1947)
- (408d) FOERSTER, TH. Die Fluoreszenzfähigkeit organischer Farbstoffe. *Naturwiss.* 33, 220 (1946)
- (409) FORRÓ, M. Über die NaCl-Phosphore mit Cu-Zusatz. *Z. f. Phys.* 56, 235 (1929)
- (410) FORRÓ, M. Über die Absorptionsspektren einiger Alkalihalogenidphosphore bei hohen Temperaturen. *Z. f. Phys.* 56, 534 (1929)
- (411) FORRÓ, M. Über die Absorptionsspektren von sechs weiteren Alkalihalogenidphosphoren mit Tl-Zusatz. *Z. f. Phys.* 58, 613 (1929)

- (412a) FRANCK, J. Über die Überführung des Resonanzspektrums der Jodfluoreszenz in ein Bandenspektrum durch zugemischte Gase. *Verh. d. deutsch. phys. Ges.* 14, 419 (1912)
- (412b) FRANCK, J. Zur Frage nach der Ionisierungsspannung positiver Ionen. *Z. f. Phys.* 25, 312 (1924)
- (413) FRANCK, J. Über eine Rotverschiebung der Resonanzfluoreszenz durch vielfach wiederholte Streuung. *Naturwiss.* 15, 236 (1927)
- (414) FRANCK, J. and EUCKEN, A. Umsatz von Translationsenergie in Schwingungsenergie bei molekularen Stossprozessen. *Z. phys. Chem. B.* 20, 460 (1933)
- (415) FRANCK, J., FRENCH, C. S., and PUCK, T. T. The fluorescence of chlorophyll and photosynthesis. *J. Phys. Chem.* 45, 1268 (1941)
- (416) FRANCK, J. and GROTRIAN, W. Bemerkungen über angeregte Atome. *Z. f. Phys.* 4, 89 (1921)
- (417) FRANCK, J. and GROTRIAN, W. Über den Einfluss eines Magnetfeldes auf die Dissoziation angeregter Moleküle. *Z. f. Phys.* 6, 35 (1921)
- (418) FRANCK, J. Einige aus der Theorie von Klein und Rosseland zu ziehende Folgerungen über Fluoreszenz, photochemische Prozesse und Elektronenemission glühender Körper. *Z. f. Phys.* 9, 252 (1922)
- (419) FRANCK, J. and GROTRIAN, W. Über die Absorptionsbanden im Hg-Dampf. *Z. f. techn. Phys.* 3, 194 (1922)
- (420) FRANCK, J. and HERZFELD, K. F. Remarks on the photochemistry of polyatomic molecules. *J. Phys. Chem.* 41, 97 (1937)
- (421) FRANCK, J. and HERTZ, G. Über durch polarisiertes Licht erregte Fluoreszenz von Joddampf. *Verh. d. Deutsch. phys. Ges.* 14, 423 (1912)
- (422) FRANCK, J. and KUHN, H. Über ein Absorptions- und Fluoreszenzspektrum von Silberjodidmolekülen und die Art ihrer chemischen Bindung. *Z. f. Phys.* 43, 164 (1927); 44, 607 (1927)
- (423) FRANCK, J. and LEVI, H. Beitrag zur Untersuchung der Fluoreszenz in Flüssigkeiten. *Z. f. phys. Chem. B* 27, 409 (1934)
- (424) FRANCK, J. and LIVINGSTON, R. Remarks on the fluorescence, phosphorescence and photochemistry of dyestuffs. *J. Chem. Phys.* 9, 184 (1941)
- (425) FRANCK, J. and PRINGSHEIM, P. Fluoreszenz von Gasen. *Naturwiss.* 11, 559 (1923)
- (426) FRANCK, J. and PRINGSHEIM, P. Phosphorescence of adsorbed Trypflavine and its quenching by oxygen. *J. Chem. Phys.* 11, 21 (1943)
- (427) FRANCK, J. and RIEKE, C. A. Note on the explanation of the D-lines in the spectrum of the night sky. *Astrophys. J.* 89, 463 (1939)
- (428) FRANCK, J. and TELLER, E. Migration and photochemical action of excitation energy in crystals. *J. Chem. Phys.* 6, 861 (1938)
- (429) FRANCK, J. and WESTPHAL, W. Über eine Beeinflussung der Stossionisation durch Fluoreszenz. *Verh. d. Deutsch. phys. Ges.* 14, 159 (1912)
- (430) FRANCK, J. and WOOD, R. W. Über die Beeinflussung der Fluoreszenz von Jod- und Quecksilberdampf durch Beimengung von Gasen mit verschiedener Affinität zum Elektron. *Verh. d. Deutsch. phys. Ges.* 13, 78 (1911); *Phil. Mag.* 21, 314 (1911)
- (431) FRANCK, J. and WOOD, R. W. Fluorescence of chlorophyll in its relation to photochemical processes in plants and organic solutions. *J. Chem. Phys.* 4, 551 (1936)
- (432) FRANK, J. M. Die Anregungsfunktion und die Absorptionskurve bei der optischen Dissoziation von TIJ. *Phys. Z. Sow.* 2, 319 (1932)
- (433) FRANK, J. M. Absorption des Lichtes in der Nähe der Hg-Resonanzlinie 1849A. *Phys. Z. Sow.* 4, 637 (1933)
- (434) FRANK, J. M. and VAVILOV, S. J. Über die Wirkungssphäre der Auslöschungsvorgänge in den fluoreszierenden Flüssigkeiten. *Z. f. Phys.* 69, 100 (1931)

- (435) FREED, S. and WEISSMAN, S. I. Multipole nature of elementary sources of radiation. Wide angle interference. *Phys. Rev.* 60, 440 (1941)
- (436) FREYMAN, M. Classement des bandes de fluorescence de différents sels d'uranyle. *C. R.* 225, 529 (1947)
- (436a) FRENKEL, J. On the absorption of light and the trapping of electrons and positive holes in crystalline dielectrics. *Phys. Z. Sow.* 9, 158 (1936)
- (436b) FRICKE, R. Über die Besonderheiten aktiver fester Stoffe, vor allem im Hinblick auf Leuchtphosphore. *Munich 1943*, 67
- (437) FRIDRICHSON, J. Über die Fluoreszenz des Mangandampfes. *Z. f. Phys.* 64, 43 (1930); 68, 550 (1931); *C. R. soc. pol. phys.* 5, 337 (1931)
- (438) FRIDRICHSON, J. Über die Resonanzspektrum des Schwefeldampfes. *Z. f. Phys.* 70, 463 (1931); *C. R.* 192, 737 (1931)
- (439) FRISCH, R. Zur Drehimpulsbilanz bei Lichtemissionsvorgängen. *Z. f. Phys.* 61, 626 (1930)
- (440) FRISCH, R. Experimenteller Nachweis des Einsteinschen Strahlungsrückstosses. *Z. f. Phys.* 86, 42 (1933)
- (441) FRISCH, R. and PRINGSHEIM, P. Über die Intensitätsverteilung im Hg-Triplett $2^3S_1-2^3P_{0,1,2}$ und die mittlere Leuchtdauer der Triplettkomponenten. *Z. f. Phys.* 67, 169 (1931)
- (442) FROELICH, P. Die Polarisation des Fluoreszenzlichtes von Farbstofflösungen. *Z. f. Phys.* 35, 193 (1925)
- (443) FROELICH, P. On the polarization of fluorescent light from colloid solutions. *Phys. Rev.* 27, 803 (1926)
- (444) FROELICH, P. and GOMBAI, L. Negativ polarisierte Emission der Gelatine-Farbstoffphosphore. *Kolloidz.* 94, 147 (1941)
- (445) FROELICH, P. and GYULAY, Z. Beiträge zur Kenntnis der Erregung von Gelatine-Farbenphosphoren. *Z. f. Phys.* 104, 549 (1936)
- (445a) FROELICH, P. and MISCHUNG, H. Über die Gelatine-Farbstoffphosphore. *Kolloid Z.* 108, 30 (1944)
- (446a) FROELICH, H. C. The low-temperature yellow zinc silicate phosphor. *J. Phys. Chem.* 47, 669 (1943)
- (446b) FROELICH, H. C. The preparation of oxygen and fluorine containing phosphors. *Ithaca 1946*, 44.
- (446c) FROELICH, H. C. New u.v. phosphors. *Trans. Electrochem. Soc.* 91, 161 (1947)
- (446d) FROELICH, H. C. Note on the stability of phosphors under u.v. irradiation. *J. Opt. Soc. Am.* 37, 308 (1947)
- (446e) FROELICH, H. C. Manganese activated calcium silicate phosphors. *Trans. Electrochem. Soc.* 93, 101 (1948)
- (447a) FROELICH, H. C. and FONDA, G. R. Exaggerated phosphorescence of zinc silicate phosphors. *J. Phys. Chem.* 46, 878 (1942)
- (447b) FROELICH, H. C. and FONDA, G. R. Multiple peaks in the fluorescence of single-activated phosphors. *Ithaca 1946*, 345
- (448) FROMHERZ, H. Optische Beziehung zwischen Alkalihalogenidphosphoren und Komplexsalzlösungen von Blei- und Thallo-Halogeniden. *Z. f. Phys.* 68, 233 (1931)
- (449) FROMHERZ, H. and MENSCHICK, W. Optische Beziehungen zwischen Alkali-halogenidphosphoren und Komplexsalzlösungen. *Z. phys. Chem. B* 3, 1 (1929)
- (450) FRUM, A. Zur lichtelektrischen Leitung und Phosphoreszenz von NaCl-Kristallen. *Diss. Goettingen 1925*
- (451) FRY, H. S. Einige Anwendungen des Elektronenbegriffs der positiven und negativen Wertigkeit. IV. Fluoreszenz: Anthrazen und Phenanthren. *Z. phys. Chem.* 80, 29 (1912)
- (452) FUECHTBAUER, C. Über eine neue Art der Erzeugung von Spektrallinien durch Einstrahlung (Fluoreszenz). *Phys. Z.* 21, 635 (1920)

- (453) FUJIOKA, Y. Resonance radiation in the excited neon. *Sci. Pap. Phys. Chem. Res. Tokyo* 7, 27 (1927)
- (454) FULLER, H. G., PHILLIPS, L. W., and ALMY, G. M. Fluorescence of diacetyl. Quantum yield and quenching by iodine. *J. Chem. Phys.* 7, 973 (1939)
- (455) GAFFRON, H. Über den Mechanismus der Sauerstoffaktivierung durch belichtete Farbstoffe. *Biochem. Z.* 264, 251 (1933)
- (456) GAFFRON, H. Metastabiler Sauerstoff und Kohlensäureassimilation. *Biochem. Z.* 287, 130 (1936)
- (457) GAMBURZEFF, G. A. Diffusion der Photolumineszenz bei wiederholten Absorptions- und Ausstrahlungsprozessen. *Z. f. Phys.* 55, 533 (1929)
- (458a) GANGULY, S. C. Fluorescence of anthracene in presence of naphthalene. *Nature* 151, 673 (1943); *Proc. Ind. Ass. for Cultivation of Sci.* 26, 7, (1943); *J. Chem. Phys.* 13, 228 (1945)
- (458b) GANGULY, S. C. On the study of absorption and fluorescence spectra of some aromatic compounds. *Ind. J. Phys.* 18, 347 (1944)
- (458c) GANGULY, S. C. The effect of temperature on the absorption and fluorescence spectra of impurity crystals. *Ind. J. Phys.* 19, 222 (1945)
- (459a) GARLICK, G. F. J. Some studies of electron traps in phosphors. *Ithaca* 1946, 87
- (459b) GARLICK, G. F. J. and GIBSON, A. F. Luminescence processes in ZnS phosphors. *Nature* 158, 704 (1946)
- (459c) GARLICK, G. F. J. and GIBSON, A. F. Electron traps and dielectric changes in phosphorescent solids. *Proc. Roy. Soc. A* 188, 485 (1946)
- (459d) GARLICK, G. F. J. and GIBSON, A. F. Decay of luminescence due to forbidden optical transitions. *Nature* 160, 303 (1947)
- (459e) GARLICK, G. F. J. and GIBSON, A. F. Luminescence efficiency in ZnS phosphors below room temperature. *Nature* 161, 359 (1948)
- (459f) GARLICK, G. F. J. and WILKINS, M. H. F. Short period phosphorescence and electron traps. *Proc. Roy. Soc. A* 184, 408 (1945)
- (460a) GAVIOLA, E. Die Abklingungszeiten der Fluoreszenz von Farbstofflösungen. *Z. f. Phys.* 35, 748 (1926); *Ann. d. Phys.* 81, 681 (1926)
- (460b) GAVIOLA, E. Ein Fluorometer: Apparat zur Messung von Fluoreszenzabklingungszeiten. *Z. f. Phys.* 42, 853 (1927)
- (461) GAVIOLA, E. Der Einfluss von Temperatur und Konzentration auf die Abklingungszeit der Fluoreszenz von Farbstofflösungen. *Z. f. Phys.* 42, 862 (1927)
- (462) GAVIOLA, E. The power relation of the intensities of the lines in the optical excitation of mercury. *Phil. Mag.* 6, 1154 and 1167 (1928)
- (462a) GAVIOLA, E. An experimental test of Schroedinger's theory. *Nature* 122, 772 (1928)
- (463) GAVIOLA, E. The efficiency of quenching collisions and the radius of the excited mercury atom. *Phys. Rev.* 33, 309 (1929); 34, 1049 (1929)
- (464) GAVIOLA, E. On time-lags in fluorescence and in the Kerr and Faraday effects. *Phys. Rev.* 33, 1023 (1929)
- (465) GAVIOLA, E. On life and concentration of metastable atoms and the quenching of mercury resonance radiation. *Phys. Rev.* 34, 1373 (1929)
- (466) GAVIOLA, E. and PRINGSHEIM, P. Über den Einfluss der Konzentration auf die Polarisation der Fluoreszenz von Farbstofflösungen. *Z. f. Phys.* 24, 24 (1924)
- (467) GAVIOLA, E. and PRINGSHEIM, P. Über die Polarisation der Natrium-Resonanzstrahlung in magnetischen Feldern. *Z. f. Phys.* 25, 367 (1924)
- (468) GAVIOLA, E. and PRINGSHEIM, P. Eine versuchstechnische Ursache für die scheinbar zugerhörige Polarisation der Resonanzstrahlung im magnetischen Feld. *Z. f. Phys.* 34, 1 (1925); 39, 75 (1926)
- (469) GAVIOLA, E. and PRINGSHEIM, P. Zur Frage nach dem Übergang von Fluoreszenz in Phosphoreszenz. *Z. f. Phys.* 43, 384 (1927)

- (470) GAVIOLA, E. and PRINGSHEIM, P. Über die Woodsche Methode zur Trennung der D-Linien. *Z. f. Phys.* 78, 211 (1932)
- (471) GAVIOLA, E. and WOOD, R. W. Photosensitized band fluorescence of OH, HgH, NH, H₂O and NH₃ molecules. *Phil. Mag.* 6, 1191 (1928)
- (472) GAWRONSKI, S. Sur la complexité du spectre de résonance du sélénium. *J. de phys.* 5, 533 (1934)
- (473) GAWRONSKI, S. Modification du spectre de la fluorescence du sélénium sous l'influence de l'azote. *J. de phys.* 5, 535 (1934)
- (474) GAYLE, D. N. and SING, N. Effet des impuretés sur la phosphorescence du sulfure de calcium. *J. chim. phys.* 27, 443 (1930)
- (475) GEISS, W. Absorption und Resonanz in angeregtem Xenon. *Verh. d. Deutsch. phys. Ges.* 19, 99 (1938)
- (476) GELBKE, M. Ein neuer Fall von Koppelung kurz- und langwelliger Fluoreszenzbanden. *Phys. Z.* 13, 584 (1912); *Jahrbuch d. Radioakt.* 10, 1 (1913)
- (477) GENARD, J. Sur de nouvelles séries de résonance de la vapeur de soufre. *Bull. Brussels.* 16, 923 (1930); 17, 184 (1921)
- (478) GENARD, J. Sur le schéma des niveaux de la vapeur diatomique du soufre. *Bull. Brussels.* 17, 387 and 583 (1931)
- (479) GENARD, J. Sur la formule générale des bandes d'absorption de la vapeur de soufre. *Bull. Brussels.* 17, 812 (1931)
- (480) GENARD, J. Fluorescence de la vapeur diatomique du sélénium dans les régions vertes et jaunes du spectre. *Bull. Brussels.* 17, 1235 (1931)
- (481) GENARD, J. Sur la fluorescence de la vapeur diatomique de tellure excitée par les raies du mercure. *Bull. Brussels.* 17, 1241 (1931)
- (482) GENARD, J. Über die Auslöschung der Fluoreszenz des Joddampfes durch hohe magnetische Felder. *Z. f. Phys.* 77, 791 (1932); *C. R.* 197, 1104 (1933)
- (483) GENARD, J. Molecular fluorescence of antimony. *Nature* 131, 132 (1933)
- (484) GENARD, J. Influence du champ magnétique sur la fluorescence des vapeurs diatomiques d'iode, tellure et soufre. *Physica* 1, 849 (1934); *C. R.* 197, 1402 (1933); 198, 816 (1934); 200, 1926 (1935)
- (485) GENARD, J. Influence du champ magnétique sur la fluorescence des molécules diatomiques de sélénium. *Physica* 2, 328 (1935); *C. R.* 199, 784 (1934)
- (486) GENARD, J. and DE RASSENFOSSE, A. Analyse spectral de la fluorescence des platinocyanures cristallisés et possibilités d'application à l'éclairage. *Bull. Liège* 1939, 27
- (487) GEORGE, H. and BAYLE, E. Définition spectrophotométrique des couleurs de fluorescence. *C. R.* 178, 1895 (1924)
- (488) GERLACH, W. Wärmestrahlung oder Resonanzstrahlung der Kohlensäure? *Ann. d. Phys.* 4, 571 (1930)
- (489) GERLACH, W. and SCHUETZ, W. Bemerkungen über die Lebensdauer angeregter Atome. *Phys. Z.* 26, 33 (1925)
- (490) GERMAN, F. E. E. and WOODRIF, R. Cross-prism investigation of fluorescence. *Rev. Sci. Instr.* 15, 145 (1944)
- (491) GERNEZ, M. D. Sur un nouveau moyen de restituer aux sulfures alcalino-terreux leurs propriétés phosphorescentes. *Ann. de chim. phys.* 20, 166 (1910); *C. R.* 150, 295 (1910)
- (492) GHOSH, I. C. and SEN-GUPTA, S. B. Studien über Fluoreszenzvermögen, Absorptionsspektren und elektrische Leitfähigkeiten von Fluoreszein, Rhodamin und Acriflavin in wässrigen Lösungen. *Z. phys. Chem. B* 41, 117 (1938)
- (493) GIBBS, R. C. The effect of temperature on the absorption and fluorescence of canary glass. *Phys. Rev.* 28, 361 (1909); 30, 377 (1910). *Phys. Z.* 10, 774 (1909)

- (494) GIBSON, K. S. The effect of temperature upon the absorption spectrum of a synthetic ruby. *Phys. Rev.* 8, 38 (1916)
- (495) GISOLF, J. H. The absorption spectrum of luminescent ZnS and Zn-CdS in connection with some optical, electrical and chemical properties. *Physica* 6, 84, 1939
- (496) GISOLF, J. H. The dielectric losses of irradiated ZnS phosphors. *Physica* 6, 918 (1939)
- (496a) GISOLF, J. H., DE GROOT, W., and KROEGER, F. A. The absorption spectra of ZnS and willemite. *Physica* 8, 805 (1941)
- (497) GISOLF, J. H. and KROEGER, F. A. On the proportionality of the luminescence of ZnS phosphors to the irradiation at low intensities. *Physica* 6, 1101 (1939)
- (498) GLASSER, J. and FONDA, G. R. The fluorescence of double salts of calcium phosphate. *J. Am. Chem. Soc.* 60, 722 (1938)
- (499) GLASSER, O. and BEASLEY, I. E. Induced u.v. fluorescence and its release by visible light. *Phys. Rev.* 47, 570 (1935)
- (500) GLEW, F. H., DOW, J. S., and BLOCK, A. Fluorescence and phosphorescence. *Chem. News* 115, 157 (1917)
- (501) GLICENSZTEJN, H. Extinction de la fluorescence de iode par l'azote. *C. R. Cracow* 1939, 4
- (502) GLISZCZYNSKI, S. v. and STOKOWICI, E. Fluoreszenz- und Phosphoreszenzerscheinungen an aragonitartigen Calciten von Caround. *Z. f. Kryst.* 98, 344 (1937)
- (503) GOBRECHT, H. Über die Absorptions- und Fluoreszenzspektren der Ionen der seltenen Erden in festen Körpern, insbesondere im ultrarot. *Ann. d. Phys.* 28, 673 (1937); *Phys. Z.* 37, 153 and 549 (1936); *Z. techn. Phys.* 17, 425 (1936)
- (504) GOBRECHT, H. Zur Fluoreszenz der seltenen Erden. *Ann. d. Phys.* 31, 181 (1938)
- (505) GOBRECHT, H. Die Spektren des dreiwertigen Thuliums. *Ann. d. Phys.* 31, 600 (1938)
- (506) GOBRECHT, H. and TOMASCHEK, R. Über den analytischen Nachweis der seltenen Erden durch Absorption und Fluoreszenz. *Ann. d. Phys.* 29, 324 (1937)
- (507) GÖRGEL, K. Über die lichtelektrische Wirkung an den Erdalkaliphosphoren. *Ann. d. Phys.* 67, 301 (1922)
- (508) GOETHEL, H. Über den äusseren lichtelektrischen Effekt an Phosphoren und seine Abhängigkeit vom Erregungszustand. *Ann. d. Phys.* 9, 865 (1931); *Phys. Z.* 32, 218 (1931)
- (509) GOLAY, M. J. E. The relative intensities of mercury lines under different conditions of excitation. *Phys. Rev.* 37, 821 (1932)
- (510) GOLDMANN, A. Lichtelektrische Untersuchungen an Farbstoffzellen. *Ann. d. Phys.* 27, 449 (1908)
- (511) GOLDSTEIN, E. Über die Emissionsspektren aromatischer Verbindungen. *Verhandl. d. Deutsch. phys. Ges.* 6, 156 and 185 (1904)
- (512) GOLDSTEIN, E. Über einen besonderen Typus diskontinuierlicher Emissionsspektren fester Körper. *Phys. Z.* 11, 430 (1910); *Verhandl. d. Deutsch. phys. Ges.* 12, 376 (1910)
- (513) GOLDSTEIN, E. On threefold emission spectra of solid aromatic compounds. *Phil. Mag.* 20, 619 (1910)
- (514) GOLDSTEIN, E. Über die Untersuchung der Emissionsspektren fester aromatischer Substanzen mit dem u.v. Filter. *Phys. Z.* 12, 614 (1911); *Verhandl. d. Deutsch. phys. Ges.* 13, 378 (1911)
- (515) GOLDSTEIN, E. Über die Emissionsspektren aromatischer Verbindungen in u.v. Licht, in Kathodenstrahlen, Radiumstrahlen und Kanalstrahlen. *Phys. Z.* 13, 188 (1912); *Verhandl. d. Deutsch. phys. Ges.* 14, 33 (1912)

- (516) GOLDSTEIN, E. Über die Hervorrufung der Hauptspektren aromatischer Verbindungen durch u.v. Licht. *Phys. Z.* 13, 577 (1912); *Verhandl. d. Deutsch. phys. Ges.* 14, 493 (1912)
- (517) GOLOUB, S. I. Spectres d'excitation de la luminescence des solutions solides de la rhoduline. *Phys. Z. Sow.* 7, 49 (1935)
- (518) GOOS, F. Elektrische Untersuchungen an ZnSCu-Phosphoren. *Ann. d. Phys.* 34, 77 (1939)
- (519a) GOOS, F. Lichtelektrische Eigenschaften zerstörter Zinksulfid Kupferphosphore. *Ann. d. Phys.* 37, 76 (1940)
- (519b) GOOS, F. Über das Auftreten einer Photospannung an Phosphorzellen. *Ann. d. Phys.* 39, 281 (1941)
- (520) GOOS, F. and MEYER, H. Über die Intensität der Resonanzstrahlung des Hg-Dampfes. *Z. f. Phys.* 35, 803 (1926)
- (521) GORDON, B. E. Photoluminescence and the association of ions in solutions of lead salts. *J. Phys. Chem. U.S.S.R.* 15, 448 (1941)
- (522) GORDON, B. E. and SCHISCHLOWSKI, A. Photolumineszenz der Lösungen von Thalliumsalzen. *Physchim. Acta U.S.S.R.* 13, 247 (1940)
- (523) GORDON, N. T., SEITZ, F., and QUINLAN, F. The blackening of zinc sulfide phosphors. *J. Chem. Phys.* 7, 4 (1939)
- (524) GHOSH, R. N. Duration of fluorescence of mercury vapor. *Phys. Rev.* 26, 376 (1925)
- (525) GOTTLING, P. F. The determination of the time between excitation and emission for certain fluorescent solids. *Phys. Rev.* 22, 566 (1923)
- (526) GRADSTEIN, S. Über die Fluoreszenz des gasförmigen Formaldehyds. *Z. phys. Chem. B* 22, 384 (1933)
- (527) GRAUE, G. and RIEHL, N. Diffusionsverhalten und Aktivierung des Zinksulfids. *Angew. Chem.* 51, 873 (1938)
- (528) GRIEBACH, L. Experimentelle Beiträge zum Problem der polarisierten Fluoreszenz organischer Farbstofflösungen. *Z. f. Phys.* 101, 13 (1936); *Naturwiss.* 22, 633 (1934)
- (529) GROSS, E. and TERENCE, A. Fine structure of optically excited spectrum lines. *Nature* 116, 280 (1925)
- (530) GROTOWSKI, M. L'effet photoélectrique et la fluorescence. *Thèse Fribourg* 1910
- (531) GRUHL, A. Zur Kenntnis des lumineszenzfähigen Zinksilikates. *Diss. Berlin* 1923
- (532) GRUMBACH, A. Etude spectrochimique de la fluorescence. *J. de phys.* 4, 258 (1923)
- (533) GRUMBACH, A. and RIBAILLIER, M. Sur la photoluminescence de la soude et de la potasse. *C. R.* 198, 70 (1934)
- (534) GRUENBAUM, H. Sur des nouvelles séries de la résonance du sélénium. *C. R. Cracow* 1929, 3; *Bull. intern. Cracow* 1929, 611
- (535) GRYGLEWICZ, S. Über den Einfluss der Temperatur auf die Fluoreszenzausbeute einer Anthrazenlösung in Paraffinöl. *Acta phys. pol.* 6, 210 (1937)
- (536) GUDDEN, B. Über die Gültigkeit der Stokesschen Regel bei Phosphoren. *Phys. Z.* 24, 465 (1923)
- (537) GUDDEN, B. and POHL, R. W. Zur Kenntnis des Sidotblendephosphors. *Z. f. Phys.* 1, 365 (1920)
- (538) GUDDEN, B. and POHL, R. W. Lichtelektrische Beobachtungen an Zinksulfiden. *Z. f. Phys.* 2, 181 (1920)
- (539) GUDDEN, B. and POHL, R. W. Lichtelektrische Leitfähigkeit und Phosphoreszenz. *Z. f. Phys.* 3, 98 (1920); *Naturwiss.* 11, 340 (1923)
- (540) GUDDEN, B. and POHL, R. W. Über Ausleuchtung der Phosphoreszenz durch elektrische Felder. *Z. f. Phys.* 2, 192 (1920)
- (541) GUDDEN, B. and POHL, R. W. Über lichtelektrische Leitfähigkeit von Diamanten. *Z. f. Phys.* 3, 123 (1920)

- (542) GUDDEN, B. and POHL, R. W. Ueber lichtelektrische Leitfähigkeit von Zinksulfidphosphoren. *Z. f. Phys.* 4, 206 (1921)
- (543) GUDDEN, B. and POHL, R. W. Über den ZnScu-Phosphor. *Ann. d. Phys.* 68, 154 (1922)
- (544) GUDDEN, B. and POHL, R. W. Über die elektrische Leitfähigkeit bei Anregung und Lichtemission von Phosphoren. *Z. f. Phys.* 21, 1 (1924)
- (545) GUDDEN, B. and POHL, R. W. Über den lichtelektrischen Primärstrom in NaCl-Kristallen. *Z. f. Phys.* 31, 651 (1925)
- (546) GUDDEN, B. and POHL, R. W. Zur lichtelektrischen Leitung bei tiefen Temperaturen. *Z. f. Phys.* 34, 249 (1925)
- (547) GUELKE, R. Über die Polarisation der Tl-Fluoreszenz. *Z. f. Phys.* 56, 524 (1929)
- (547a) GUGEL, V. M. The synthesis of ZnS-phosphors. *Bull. Moscow* 9, 539 (1945)
- (547b) GUILLOT, M. and FERRAND, J. La fluorescence du chlorure plombé cristallisé. *C. R.* 218, 846 (1944)
- (548a) GUNNING, H. E. and STEACIE, E. W. R. Mercury photosensitized polymerization and hydrogenation of butadiene. *J. Chem. Phys.* 12, 484 (1944)
- (548b) GUNNING, H. E. and STEACIE, E. W. R. The mercury photosensitized reactions of 1-butene and 2-butene. *J. Chem. Phys.* 14, 581 (1946)
- (549) GUNTZ, A. A. Sur le sulfure de zinc phosphorescent. *C. R.* 174, 1356 (1922); 177, 497 (1923). *Ann. de chim.* 5, 157 and 363; 6, 5 (1926)
- (550) GUNTZ, A. A. Leuchtmassen aus Zinksulfid und Cadmiumsulfid. *Chem. Zentralbl.* 174, 893 (1922)
- (551) GUNTZ, A. A. Sur l'énergie mise en jeu dans la phosphorescence. *C. R.* 179, 361 (1924)
- (552) GUNTZ, A. A. Sur la photographie infrarouge par la phosphorescence. *Extrait 4. congrès industriel Paris 1925*
- (553) GUNTZ, A. A. Sur la théorie du phosphorogène. *C. R.* 197, 1030 (1933)
- (554) GUREWITSCH, M. M. and TSCHACHROW, L. Die absolute Fluoreszenz-ausbeute von Kaliumuranyl-sulfat. *Bull. Moscow* 1936, 509
- (555) GURNEY, R. W. Angular distribution of intensity of resonance radiation. *Proc. Nat. Acad. Sci.* 14, 946 (1928)
- (556) GURNEY, R. W. and MOTT, N. F. Luminescence in solids. *Faraday Soc. Trans.* 35, 69 (1939)
- (557) GYEMANT, A. A new method for measuring the fluorescence of solids. *J. Opt. Soc. Am.* 12, 65 (1926); *Z. f. Phys.* 26, 223 (1924)
- (558) HABEEB, H., LE ROY, D. J., and STEACIE, E. W. Zn photosensitized reactions of ethylene. *J. Chem. Phys.* 10, 261 (1942)
- (559) HABERL, K. Fluoreszenz des Zyklohexans. *Ann. d. Phys.* 21, 301 (1934)
- (560) HABERLANDT, H. Lumineszenzuntersuchungen an Fluoriten. *Wien. Ber. IIa* 141, 441 (1932); 142, 29 (1933); 143, 591 (1934); 146, 1 (1937)
- (561) HABERLANDT, H., KARLIK, B., and PRZIBRAM, K. Artificial production of the blue fluorescence of fluorite. *Nature* 133, 99 (1934)
- (562) HABERLANDT, H., KARLIK, B., and PRZIBRAM, K. Zur Fluoreszenz des Fluorits. Über einen Urannachweis in Fluoriten und die Tieftemperatur-fluoreszenz. *Wien. Ber. IIa* 144, 77 and 135 (1935)
- (563) HABERLANDT, H. and KOEHLER, A. Über die blaue Fluoreszenz von natürlichen Silikaten im u.v. Licht und über synthetische Versuche an Silikatschmelzen mit eingebautem zweiwertigem Europium. *Naturwiss.* 27, 275 (1939)
- (564) HABERLANDT, H., KARLIK, B., and PRZIBRAM, K. Zur Fluoreszenz der Fluorite. *Wien. Ber. IIa* 142, 235 (1933); 143, 151 and 591 (1934)
- (565) HACHKOWSKI, V. and TERENIN, A. The quenching of the fluorescence of solids by adsorbed gases. *Acta physchim. U.S.S.R.* 7, 521 (1937)
- (566) HAITINGER, M. Die Fluoreszenzerscheinungen des Cers und anderer seltener Erden. *Wiener Anzeiger* 1933, 188

- (567) HACKENBECK, E. Über polarisierte Fluoreszenz. *Ann. d. Phys.* 1, 457 (1929)
- (568) HALBAN, H. v. Bestimmung von Hg-Dampfdrucken aus der Resonanzlichtabsorption. *Helv. phys. acta* 7, 858 (1934)
- (569) HAMOS, L. v. Über die Beeinflussung der Na-Resonanzstrahlung durch Edelgase. *Z. f. Phys.* 74, 379 (1932)
- (570) HANLE, W. Über den Zeemaneffekt bei der Resonanzfluoreszenz. *Naturwiss.* 11, 690 (1923)
- (571) HANLE, W. Über die magnetische Beeinflussung der Polarisation der Resonanzfluoreszenz. *Z. f. Phys.* 30, 93 (1924); *Ergebnisse d. exakt. Naturwiss.* 4, 214 (1925)
- (572) HANLE, W. Die elektrische Beeinflussung der Polarisation der Resonanzfluoreszenz von Quecksilber. *Z. f. Phys.* 35, 346 (1926)
- (573) HANLE, W. Die Polarisation der Resonanzfluoreszenz von Na-Dampf bei Anregung mit zirkular polarisiertem Licht. *Z. f. Phys.* 41, 164 (1927)
- (574) HANLE, W. Die Umkehrung der Zirkularpolarisation bei der Tl-Fluoreszenz. *Z. f. Phys.* 85, 300 (1933)
- (575) HANLE, W. Anregung von Gasen. *Phys. in regelmässigen Ber.* 2, 85 (1934)
- (576) HANLE, W. Die Polarisation der Fluoreszenz sowie ihre elektrische und magnetische Beeinflussung. *Acta phys. pol.* 5, 21 (1936)
- (577) HANLE, W. and LARCHÉ, K. Die Resonanzfunktion beim Stoss zweiter Art. *Z. f. Phys.* 85, 548 (1933)
- (578) HANLE, W. and RICHTER, E. F. Polarisationserscheinungen bei der stufenweisen Anregung der Fluoreszenz von Hg-Dampf. *Z. f. Phys.* 54, 811 (1929)
- (579) HARASIMIUKOWNA, S. Influence de la longueur d'onde de la lumière excitatrice sur la répartition des intensités dans le spectre de fluorescence. *C. R. soc. pol. phys.* 4, 211 (1929)
- (579a) HARDY, H. E. A combination phosphorometer and spectroradiometer for luminescent material. *Trans. Electrochem. Soc.* 91, 221 (1947)
- (579b) HARDY, H. E. A new method of measuring the photoconductivity of Zn,CdS as measured with the cathode ray oscillograph. *Trans. Electrochem. Soc.* 87, 355 (1945)
- (580) HARRISON, G. R. The absorption of light by sodium and potassium vapors. *Proc. Nat. Acad. Sci.* 8, 260 (1922)
- (581) HARRISON, G. R. and LEIGHTON, P. A. Spectral fluorescence efficiencies of certain substances with applications to heterochromatic photographic photometry. *Phys. Rev.* 38, 899 (1931); 37, 470 (1931)
- (582) HATTWICH, J. Über den Zusammenhang zwischen der Intensität des Fluoreszenzlichtes und des erregenden Lichtes. *Wien. Ber. IIa* 122, 1829 (1913)
- (583) HAUER, F. v. and KOWALSKI, J. v. Zur Photometrie der Lumineszenzercheinungen. *Phys. Z.* 15, 322 (1914)
- (584) HAUROWITZ, F. Eigenschaften der Porphyrinmetallkomplexe. *Chem. Ber.* 68, 1795 (1935)
- (585) HAUROWITZ, F. Absorption und Fluoreszenz der Porphyrine in verschiedenen Lösungsmitteln und Feinbau des Porphyrinringes. *Chem. Ber.* 71, 1404 (1938)
- (586) HAUSSER, K. W. Über ein Phosphoroskop mit Funkenlicht. *Z. f. Instrumentenkunde* 30, 278 (1910)
- (587) HAUSSER, K. W., KUHN, R., and KUHN, E. Über die Fluoreszenz der Diphenylpolyene. *Z. phys. Chem. B* 29, 417 (1935)
- (588) HAUSSER, K. W., KUHN, R., and SEITZ, G. Über die Absorption von Verbindungen mit konjugierten Kohlenstoffdoppelbindungen bei tiefen Temperaturen. *Z. phys. Chem. B* 29, 391 (1935)
- (589) HAY, A. W. and WINKLER, C. A. The mercury photosensitized decomposition of n-butane. *Canad. J. Res. B* 21, 149 (1943)

- (590) HAYNER, L. J. Persistence of the radiation excited in mercury vapor. *Phys. Rev.* 26, 364 (1925)
- (591) HEIDT, L. J. and FORBES, G. S. The absorption and fluorescence spectra of the acid sulfates of quinine and ten of its derivatives in water and aqueous sulfuric acid solution. *J. Am. Chem. Soc.* 55, 2701 (1933)
- (592) HEIL, O. Auslöschung und Überführung von Resonanzserien ins Bandenspektrum durch Gaszusatz. *Z. f. Phys.* 74, 18 (1932)
- (593) HEIL, O. Messung der Lebensdauer von angeregtem NO_2 . *Z. f. Phys.* 77, 563 (1932)
- (594) HEYNE, G. and PIRANI, M. Eine spektrographische Methode zur Feststellung der Lumineszenzerregung. *Z. f. techn. Phys.* 14, 31 (1933)
- (595) HEISENBERG, W. Über eine Anwendung des Korrespondenzprinzips auf die Frage nach der Polarisation des Fluoreszenzlichtes. *Z. f. Phys.* 31, 617 (1925)
- (596) HELLSTROEM, H. Beziehung zwischen Konstitution und Spektren der Porphyrine. *Z. phys. Chem. B* 12, 353 (1931); 14, 9 (1931); *Ark. f. Kemi, Min., Geol. B* 11, No. 11 (1933); 12, No. 13 (1936)
- (597) HELLSTROEM, H. Die Auslöschung der Methylenblaufluoreszenz durch zweiwertiges Eisen. *Naturwiss.* 24, 76 (1936)
- (598) HELLSTROEM, H. Verschiebung des Redoxpotentials beim Belichten eisenhaltiger Methylenblaulösungen. *Naturwiss.* 24, 217 (1936)
- (599) HELLSTROEM, H. Über die Ermittlung der Energieausbeute fluoreszierender Substanzen. *Ark. f. Kemi, Min., Geol. A* 12, 33 (1937)
- (600) HENDERSON, S. T. Band spectra of cathodoluminescence. *Proc. Roy. Soc.* 173, 323 (1939)
- (601) HENRI, V. Etude des spectres d'absorption et de fluorescence du benzène. *J. de phys.* 3, 181 (1922)
- (602) HENRIQUES, F. C. and NOYES, W. A. The fluorescence of biacetyl. Some general considerations governing the study of fluorescence. *J. Am. Chem. Soc.* 62, 1038 (1940)
- (602a) HENRY, A. J. The photochemical instability of *cis*- and *trans*-4,4'-diaminostilbene. *J. Chem. Soc.* 1946, 1156
- (602b) HENRY, A. J. Fluorescence fatigue. *Nature* 160, 163 (1947)
- (603) HERMAN, R. C. and HOFSTADTER, R. Photoconductivity of crystalline Willemit. *Phys. Rev.* 54, 864 (1938); 56, 212 (1939); 59, 79 (1941)
- (603a) HERMAN, R. C. and MEYER, C. F. Thermoluminescence and conductivity of phosphors. *J. Appl. Phys.* 17, 743 (1946)
- (604) HERNEGGER, F. and KARLIK, B. Die quantitative Bestimmung sehr kleiner Uranmengen und der Urangehalt des Meerwassers. *Wien. Anzeiger* 1935, 82
- (605) HERSCHEL, J. On the epipolic dispersion of light. *Phil. Trans.* 135, 147 (1845)
- (606) HERZBERG, G. and FRANZ, K. Fluoreszenz des H_2CO . *Z. f. Phys.* 76, 720 (1932)
- (607) HERWEG, J. Über die Temperaturabhängigkeit der am ZnSCu -Phosphor bei Belichtung auftretenden Änderung der Dielektrizitätskonstanten. *Z. f. Phys.* 16, 23 (1923)
- (608) HERWEG, J. Über den Einfluss eines elektrischen Feldes auf die durch Belichtung vergrößerte Dielektrizitätskonstante des ZnSCu -Phosphors. *Z. f. Phys.* 16, 29 (1923)
- (609) HEYDENBURG, N. P. Paschen-Back effect of hyperfine structure and polarization of resonance radiation. $\text{Cd}(6^1\text{P}_1-5^1\text{S}_0)$. *Phys. Rev.* 43, 640 (1933)
- (610) HEYDENBURG, N. P. The nuclear magnetic moment of cesium from the polarization of resonance radiation. *Phys. Rev.* 46, 640 (1933)
- (611) HEYDENBURG, N. P. and ELLETT, A. Nuclear moment of Na, and polarization of resonance radiation. *Phys. Rev.* 44, 326 (1933)

- (612) HEYDENBURG, N. P., LARRICK, L., and ELLETT, A. Polarization of sodium resonance radiation and nuclear moment of the sodium atom. *Phys. Rev.* 40, 1041 (1932)
- (613) HIEGER, I. The spectra of cancer producing tars and oils and of related substances. *Biochem. J.* 24, 505 (1930)
- (614) HIEGER, I. The fluorescence spectrum of 3, 4-benzopyrene. *Am. J. Cancer.* 29, 705 (1937)
- (615a) HILL, C. G. A. Uniform luminescent materials. *Science* 103, 155 (1946)
- (615b) HILL, C. G. A. The fluorescence of pure magnesium tungstate. *Faraday Soc. Trans.* 42, 685 (1946)
- (615c) HILL, A. G. and ARONIN, L. R. Photoconductivity in zinc silicates. *Phys. Rev.* 57, 1090 (1940)
- (616) HILSCH, R. Die Absorptionsspektren einiger Alkalihalogenidphosphore mit Tl- und Pb-Zusatz. *Z. f. Phys.* 44, 860 (1927)
- (617) HILSCH, R. Alkali halide phosphors containing heavy metals. *Proc. Phys. Soc. London* 49, Extra part, 40 (1937); *Phys. Z.* 38, 1031 (1937)
- (618) HILSCH, R. and POHL, R. W. Über die ersten u. v. Eigenfrequenzen einiger einfacher Kristalle. *Z. f. Phys.* 48, 384 (1928)
- (619) HILSCH, R. and POHL, R. W. Eine neue Absorption in Alkalihalogenidkristallen. *Göttinger Nachr. math. phys. Klasse* 1933, 322
- (620) HINDERER, H. Ausleuchtung von Phosphoren in hohen elektrischen Wechselfeldern. *Ann. d. Phys.* 10, 265 (1931)
- (621) HIPPEL, A. v. Einige prinzipielle Gesichtspunkte zur Spektroskopie der Ionenkristalle und ihre Anwendung auf die Alkalihalogenide. *Z. f. Phys.* 101, 680 (1936)
- (622) HIRSCH, E. Über die Bildungsgesetze der Phosphoreszenzzentren. *Diss. Heidelberg* 1912
- (623) HIRSBERG, Y. and HASKELBERG, L. The fluorescence of phenylated anthracenes. *Faraday Soc. Trans.* 39, 45 (1943)
- (624) HIRSCHLAFF (HUTTEN), E. Die Resonanzspektren des Joddampfes bei hohen Temperaturen. *Z. f. Phys.* 75, 325 (1932)
- (624a) HIRSCHLAFF HUTTEN, E. and PRINGSHEIM, P. The fluorescence of diethylpseudocyanine chloride in solution. *J. Chem. Phys.* 13, 121 (1945)
- (624b) HIRSCHLAFF HUTTEN, E. and PRINGSHEIM, P. New method of preparing strongly luminescent thallium activated alkali halides and some properties of these phosphors. *J. Chem. Phys.* 16, 241 (1948)
- (625) HOCH, A. Die Absorptionsspektren einiger ZnS-Phosphore in angeregtem Zustand. *Ann. d. Phys.* 38, 486 (1940)
- (625a) HODGES, K. C. and LAMER, V. K. Solvent effects on the quenching of the fluorescence of uranin by aniline. *J. Am. Chem. Soc.* 70, 722 (1948)
- (626) HOFFMANN, C. A. Untersuchungen über den Einfluss der Temperatur auf Zentrensorten verschiedener Dauer einer Phosphorbande. *Diss. Zürich* (1923)
- (627) HOGNESS, T. R. and FRANCK, J. Über den Nachweis der Relativgeschwindigkeit der Zerfallsprodukte bei optischen Dissoziationsprozessen. *Z. f. Phys.* 44, 26 (1927)
- (627a) HOLSTEIN, T. Imprisonment of resonance radiation in gases. *Phys. Rev.* 72, 1212 (1947)
- (628) HONRATH, W. Über die Bandenfluoreszenz von sauerstoff- und kohlenstoffhaltigen Alkalihalogenidkristallen. *Ann. d. Phys.* 29, 421 (1937)
- (629) HOUSTON, R. A. On a negative attempt to detect fluorescent absorption. *Proc. Edinburgh* 29, 401 (1909)
- (630) HOUTERMANS, F. G. Über die Bandenfluoreszenz des Hg-Dampfes. *Z. f. Phys.* 41, 140 (1927)
- (631) HOUTERMANS, F. G. Über eine neue Form von Lichtquellen zur Anregung

- der Resonanzfluoreszenz von Metaldämpfen, insbesondere des Quecksilbers. *Z. f. Phys.* **76**, 474 (1932)
- (632) HOWE, J. P. and NOYES, W. A. The quenching of iodine fluorescence by benzene vapor. *J. Am. Chem. Soc.* **57**, 1262 (1935)
- (633) HOWES, H. L. The fluorescence of some frozen solutions of the uranyl salts. *Phys. Rev.* **6**, 192 (1915)
- (634) HOWES, H. L. On certain absorption bands in the spectra of the uranyl salts. *Phys. Rev.* **11**, 66 (1918)
- (635) HOWES, H. L. The series in the u.v. fluorescence of sodium vapor. *Science* **47**, 96 (1918)
- (636) HOWES, H. L. and WILBER, D. T. Fluorescing sodium uranyl phosphate. *Phys. Rev.* **7**, 394 (1916)
- (637) HOWES, H. L. and WILBER, D. T. The fluorescence of four double nitrates uranyl. *Phys. Rev.* **8**, 675 (1916)
- (638) HOXTON, L. G. and BEAMS, J. W. The time interval between excitation and emission for fluorescein. *Phys. Rev.* **27**, 245 (1926)
- (639) HOYT, F. C. Polarization of the resonance radiation from degenerate systems. *Phys. Rev.* **32**, 377 (1928)
- (640) HUENIGER, M. and RUDOLPH, J. Über den Aufbau zinnhaltiger Halogenid-leuchtstoffe. *Z. f. Phys.* **117**, 81 (1941)
- (640a) HUGHES, A. L. and THOMAS, A. R. Absorption of resonance radiation in Hg vapor. *Phys. Rev.* **30**, 466 (1927)
- (640b) HUND, F. Elektronenzustände in festen Körpern. *Munich 1943*, 92
- (641) HUNT, R. E. and NOYES, W. A. A further study of the fluorescence of acetone. *J. Am. Chem. Soc.* **70**, 467 (1948)
- (641a) HUNTER, H. W. Raman spectrum and fluorescence of dioxane. *J. Chem. Phys.* **6**, 544 (1938)
- (642) HUPFELD, H. H. Die Nachleuchtdauern der J_2^- , K_2^- , Na_2^- und Na-Resonanzstrahlung. *Z. f. Phys.* **54**, 484 (1929)
- (643) IMORI, S. The photoluminescence of feldspar. *Sci. Pap. Inst. Phys. Chem. Res. Tokyo* **29**, 79 (1936)
- (644) IMORI, S. and IWASE, E. The fluorescence spectrum of autunite. *Sci. Pap. Inst. Phys. Chem. Res. Tokyo* **34**, 372 (1938)
- (645) INGLIS, D. R. Die magnetische Umwandlung der Hyperfeinstruktur in Quecksilber. *Z. f. Phys.* **84**, 466 (1933)
- (646) INGOLD, C. K. The structure of benzene. *Proc. Roy. Soc. A* **169**, 149 (1939)
- (647) INGOLD, C. K. and WILSON, C. L. Fluorescence spectra of benzene and hexadeuterobenzene vapor. *J. Chem. Soc.* **1936**, 941 and 955
- (647a) INMAN, J. K., MRAZ, A. M., and WEYL, W. A. The fluorescence of cadmium sulfide. *Ithaca 1946*, 182
- (648) IVES, H. E. and LUCKIESH, M. The effect of the red and of the infrared on the decay of phosphorescence of zincsulfide. *Astrophys. J.* **34**, 173 (1911); *Phys. Rev.* **32**, 240 (1911)
- (649) IVES, H. E. and LUCKIESH, M. The influence of temperature on the phenomena of phosphorescence in the alkaline earth sulfides. *Astrophys. J.* **36**, 330 (1912); *Phys. Rev.* **34**, 156 (1912)
- (650) IWASE, E. Zur Kenntnis der Fluoreszenz von japanischen Hyaliten im u.v. Licht. I. *Sci. Pap. Inst. Chem. Phys. Res. Tokyo* **26**, 42 (1935); II. *Bull. Chem. Soc. Jap.* **11**, 377 (1936)
- (651) IWASE, E. Über die Verteilung der Lumineszenzträger in Gypskristallen. *Bull. Chem. Soc. Jap.* **11**, 475 (1936)
- (652) IWASE, E. Luminescence of scapolite. *Sci. Pap. Inst. Phys. Chem. Res. Tokyo* **33**, 299 (1937); **37**, 58 (1940)
- (653) IWASE, E. Cathodoluminescence of luminescent Al_2O_3 . *Sci. Pap. Inst. Phys. Chem. Res. Tokyo* **34**, 761 (1938)
- (654) IWASE, E. Studies on the cathodoluminescence of inorganic solids con-

- taining manganese. *Sci. Pap. Inst. Phys. Chem. Res. Tokyo* 38, 67 (1940)
- (655) IWASE, E. and KURONUMA, T. Zur Lumineszenz des Calcits. I-III. *Bull. Chem. Soc. Jap.* 11, 513, 523 and 528 (1936)
- (656) JABLONSKI, A. Sur la répartition de l'intensité dans le spectre de fluorescence excité par la lumière de différentes longueurs d'onde. *C. R. soc. pol. phys.* 7, 1 (1926)
- (657) JABLONSKI, A. Über die Bandenabsorption und Fluoreszenz des Cd-Dampfes. *Z. f. Phys.* 45, 878 (1927)
- (658) JABLONSKI, A. Über die Stossverbreiterung der Spektrallinien und den Energieaustausch bei Zusammenstößen. *Z. f. Phys.* 70, 723 (1931)
- (659) JABLONSKI, A. Über das Entstehen der breiten Absorptions- und Fluoreszenzbanden in Farbstofflösungen. *Z. f. Phys.* 73, 460 (1931)
- (660) JABLONSKI, A. Efficiency of anti-Stokes fluorescence in dyes. *Nature* 131, 839 (1933); *Acta phys. pol.* 2, 97 (1933)
- (661) JABLONSKI, A. Über die Polarisation der Photolumineszenz der doppelbrechenden Kautsky-Phosphore. *Acta phys. pol.* 3, 421 (1934)
- (662) JABLONSKI, A. Sur la polarisation de fluorescence des matières colorantes en fonction de la longueur d'onde de la lumière excitatrice. *Bull. intern. Cracow* 1934, 14
- (663) JABLONSKI, A. Polarized photoluminescence of adsorbed molecules of dyes. *Nature* 133, 140 (1934)
- (664) JABLONSKI, A. Weitere Versuche über die negative Polarisation der Phosphoreszenz. *Acta phys. pol.* 4, 311 (1935)
- (665) JABLONSKI, A. Notiz zu der Arbeit von L. Tumermann "Über die Abhängigkeit der Fluoreszenzspektren von der Viskosität des Lösungsmittels". *Phys. Z. Sow.* 8, 105 (1935)
- (666) JABLONSKI, A. Über die negative Polarisation der Phosphoreszenz adsorbierter Farbstoffmoleküle. *Bull. intern. Cracow* 1935, 30
- (667) JABLONSKI, A. Über den Mechanismus der Photolumineszenz von Farbstoffphosphoren. *Z. f. Phys.* 94, 38 (1935)
- (668) JABLONSKI, A. Zur Theorie der Polarisation der Photolumineszenz von Farbstofflösungen. *Z. f. Phys.* 96, 236 (1935)
- (669) JABLONSKI, A. Über die Abklingungsgesetze der polarisierten Fluoreszenz. *Z. f. Phys.* 95, 53 (1935); 103, 526 (1936)
- (670) JABLONSKI, A. Über die Absorption und Emission des Lichtes durch orientierte in festen Medien eingebettete Moleküle. *Acta phys. pol.* 4, 371 (1935)
- (671) JABLONSKI, A. Über die Bestimmbarkeit der Anisotropie der den Molekülen zugeordneten Ersatzoszillatoren aus den Messungen der Polarisation der Photolumineszenz. *Acta phys. pol.* 4, 389 (1935)
- (672) JABLONSKI, A. Über einige optische Eigenschaften der in flüssigen und festen Medien eingebetteten Moleküle. *Acta phys. pol.* 5, 271 (1936)
- (673) JABLONSKI, A. Ist die Grundpolarisation temperaturabhängig? *Acta phys. pol.* 7, 15 (1938)
- (674) JABLONSKI, A. and PRINGSHEIM, P. Über die D-Linienemission durch Natriumdampf bei Einstrahlung von gelbem Licht. *Z. f. Phys.* 70, 593 (1931); 73, 281 (1931)
- (675) JABLONSKI, A., PRINGSHEIM, P. and ROMPE, R. Über die durch Absorption in den Na_2 -Banden angeregte Banden- und Linienfluoreszenz des Natriumdampfes. *Z. f. Phys.* 77, 26 (1932)
- (676) JABLONSKI, A. and SZYMANOWSKI, W. Thermal rotations of fluorescent molecules and duration of luminescence. *Nature* 135, 582 (1935)
- (677) JAECKEL, G. Über einige neuzeitliche Absorptionsgläser. *Z. f. techn. Phys.* 7, 301 (1926)
- (678) JAKOWLEWA, A. Fluoreszenz und Absorption des Phosphordampfes. *Z. f. Phys.* 69, 548 (1931)

- (679) JAKOWLEWA, A. The influence of nitrogen on the fluorescence of CN. *Acta physchim. U.S.S.R.* 1, 296 (1934)
- (680) JAKOWLEWA, A. On the fluorescence of N_2 and N_2^+ . *Phys. Z. Sow.* 9, 547 (1936)
- (681) JAKOWLEWA, A. On the photodissociation of ICN and BrCN molecules and the transfer of rotational energy upon collision of the CN-radical with foreign molecules. *Acta physchim. U.S.S.R.* 9, 665 (1938)
- (682) JAKOWLEWA, A. Fluorescence of the CN radical resulting from photodissociation of cyanogen molecules (C_2N_2). *Acta physchim. U.S.S.R.* 10, 433 (1939)
- (683) JAKOWLEWA, A. and TERENIN, A. Optical excitation of phosphorous vapor. *Nature* 124, 337 (1929)
- (684) JAMES, H. M. Decay of phosphorescence in copper zinc sulfide. *Phys. Rev.* 71, 137 (1947)
- (685) JELLEY, E. E. Spectral absorption and fluorescence of dyes in the molecular state. *Nature* 138, 1009 (1936)
- (686) JENKINS, H. G., MCKEAG, A. H., and ROOKSBY, H. P. Position occupied by the activator in impurity activated phosphors. *Nature* 143, 978 (1939)
- (687) JENNES, J. R. Effect of temperature upon the fluorescence of some organic solutions. *Phys. Rev.* 34, 1275 (1929)
- (688) JETTE, E. and WEST, W. Studies on fluorescence and photosensitization. II. Fluorescence in aqueous solution. *Proc. Roy. Soc. A* 121, 299 (1928)
- (689) JOB, A. and EMSCHWILLER, G. Sur la réduction photochimique du sulfure de zinc. *J. chim. phys.* 21, 83 (1924)
- (690) JOHNSON, P. D. and WILLIAMS, F. E. Magnetic properties of the ZnF_2Mn phosphor. *Bull. Am. Phys. Soc.* 23, 48 (1948)
- (691) JOHNSON, R. P. Decay of Willemite and ZnS-phosphors. *Phys. Rev.* 55, 881 (1939)
- (692) JOHNSON, R. P. Luminescence of sulfide and silicate phosphors. *J. Opt. Soc. Am.* 29, 387 (1939)
- (693) JOHNSON, R. P. Zone theory and the properties of phosphors. *Phys. Rev.* 56, 213 (1939)
- (694) JOHNSON, R. P. and DAVIS, W. L. Luminescence during intermittent optical excitation. *J. Opt. Soc. Am.* 29, 283 (1939)
- (695) JOOS, G. Der Einfluss eines Magnetfeldes auf die Polarisation des Resonanzlichtes. *Phys. Z.* 25, 130, 298 and 400 (1924)
- (696) JUNG, G. and ZIEGLER, W. Die optische Dissoziation des Hg-2-Bromids. *Z. phys. Chem. B* 10, 86 (1930)
- (697) JUNGERS, J. C. and TAYLOR, H. S. The mercury photosensitized polymerization of acetylene and acetylene- d_2 . *J. Chem. Phys.* 3, 338 (1935)
- (698) JUNGERS, J. C. and TAYLOR, H. S. Sodium resonance radiation and the polymerization of ethylene. *J. Chem. Phys.* 4, 94 (1936)
- (699) JUNGERS, J. C. and TAYLOR, H. S. The mercury photosensitized hydrogenation of ethylene, ethylene- d_4 and partially deuterized ethylenes. *J. Chem. Phys.* 6, 325 (1938)
- (700) KABAKJIAN, D. H. Decay of luminescence in solid solutions. *J. Opt. Soc. Am.* 26, 229 (1936)
- (701) KABAKJIAN, D. H. Dependence of luminescence on physical structure in zinc borate compounds. *Phys. Rev.* 51, 365 (1937)
- (702) KABAKJIAN, D. H. Luminescence of pure radium and barium compounds. *Phys. Rev.* 57, 700 (1940)
- (703) KAEMPF, F. Fluoreszenzabsorption und Lambertsches Absorptionsgesetz beim Fluoreszein. *Phys. Z.* 12, 761 (1911)
- (704a) KAHLER, H. The photoelectrical properties of the phosphors. *Phys. Rev.* 21, 214 (1923)

- (704b) KAHLER, H. The band spectra of crystals and complex gases. *Proc. Nat. Acad. Sci.* 11, 266 (1925)
- (705) KALINOWSKA, E. Sur la fluorescence à raies de la vapeur de Cd. *C. R.* 196, 168 (1933); *Acta phys. pol.* 2, 111 (1933)
- (706) KALLE, K. Eine bemerkenswerte Fluoreszenzerscheinung in wässriger Diacetylösung. *Naturwiss.* 25, 61 (1937)
- (707) KALLMANN, H. and LONDON, F. Über quantenmechanische Energieübertragung zwischen atomaren Systemen. *Z. phys. Chem. B* 2, 207 (1929)
- (708) KAMM, K. Über die Zinksulfid-Cadmiumsulfidphosphore. *Ann. d. Phys.* 30, 333 (1937)
- (709) KAPLAN, J. The quenching of mercury resonance radiation by nitrogen and carbon monoxide. *Phys. Rev.* 36, 788 (1930)
- (710) KAPUSCINSKI, W. The fluorescence of Cd vapor. *Nature* 116, 170 (1925); *Z. f. Phys.* 41, 214 (1927); *C. R. soc. phys.* 8, 5 (1927)
- (711) KAPUSCINSKI, W. Sur le rayonnement de résonance de la vapeur d'argent. *Bull. intern. Cracow* 1929, 284
- (712) KAPUSCINSKI, W. Über die Fluoreszenz des Zn-Dampfes. *Bull. intern. Cracow* 1930, 453
- (713) KAPUSCINSKI, W. Bemerkung zur Mitteilung von Herren G. Landsberg und L. Mandelstam „Über selektive Lichtstreuung“. *Z. f. Phys.* 73, 137 (1931)
- (714) KAPUSCINSKI, W. Über die Nachleuchtdauer der Cd-Dampf Fluoreszenz. *Naturwiss.* 19, 400 (1931)
- (715) KAPUSCINSKI, W. Über die monochromatisch angeregte Fluoreszenz des Cd-Dampfes. *Acta phys. pol.* 3, 537 (1934)
- (716) KAPUSCINSKI, W. Über die Abklingung und Anklung der Fluoreszenz von Dämpfen. *Acta phys. pol.* 5, 39 (1936)
- (717) KAPUSCINSKI, W. and JABLONSKI, A. Über die Träger der im Cd-Dampf beobachteten Absorptions- und Fluoreszenzbanden. *Z. f. Phys.* 57, 692 (1929)
- (718) KARLIK, B. and PRZIBRAM, K. Über die Fluoreszenz der zweiwertigen seltenen Erden. *Wien. Ber. IIa* 146, 209 (1937)
- (719) KARRER, P. and FRITZSCHE, H. Fluoreszenzkurven des Lactoflavins und synthetischer Flavine. *Helv. chim. acta* 18, 911 (1935)
- (720) KARRER, P. and FRITZSCHE, H. Konstitution und Fluoreszenz bei Flavinen. *Helv. chim. acta* 19, 481 (1936)
- (721) KARRER, P. and MUSANTE, C. Über einige Methylalloxazine. *Helv. chim. acta* 18, 1134 (1935)
- (722) KARRER, P., SALOMON, H., and others. Ein neues Bestrahlungsprodukt des Lactoflavins: Lumichrom. *Helv. chim. acta* 17, 1010 (1934)
- (723) KARRER, P. and SANZ, M. C. Über die Photosynthese eines fluoreszierenden Stoffes der Thiazolreihe. *Helv. chim. acta* 26, 1778 (1943)
- (724) KARRER, W. and KUBLI, U. Zur Bestimmung von Vitamin B₁ (Aneurin). *Helv. chim. acta* 20, 369 (1937)
- (724a) KASHA, M. Phosphorescence and the role of the triplet state in the electronic excitation of complex molecules. *Chem. Rev.* 41, 401 (1947)
- (724b) KASKAN, W. E. and DUNCAN, A. B. F. Fluorescence of solid acetone. *J. Chem. Phys.* 16, 223 (1948)
- (725) KASTLER, A. Non-existence d'un spin des photons. *J. de phys.* 2, 159 (1931)
- (726) KASTLER, A. Fluorescence de la vapeur de mercure pure éclairée en lumière incidente polarisée. *C. R.* 197, 442 (1933); *J. de phys.* 6, 759 (1935)
- (727) KASTLER, A. Le bilan du moment cinétique et les règles de polarisation en spectroscopie. Application à la diffusion de la lumière et à la fluorescence. *J. de phys.* 4, 406 (1933)
- (728) KASTLER, A. Le taux de polarisation de la fluorescence de la vapeur de mercure en présence d'azote. *C. R.* 198, 814 (1934)

- (729) KASTLER, A. Fluorescence de la vapeur de mercure produite par excitation double. *Acta phys. pol.* 5, 59 (1936); *Ann. de phys.* 6, 663 (1936); *J. de phys.* 8, 17 (1937)
- (730a) KASTLER, A. Sur l'absorption par la vapeur de sodium de la raie jaune crépusculaire. *C. R.* 210, 530 (1940)
- (730b) KASTLER, A. Le problème des raies D du sodium dans la haute atmosphère. *Physica* 12, 615 (1946)
- (730c) KASTLER, A. L'effet Zeeman et l'intensité et polarisation du rayonnement de résonance et de fluorescence. *Physica* 12, 619 (1946)
- (731) KATCOFF, S. Absorption and fluorescence spectra of the bivalent europium ion. *Thesis, Chicago 1944*
- (732) KATHEDER, F. Fluoreszenzuntersuchungen an Monomethinzyanin-Farbstoffen, insbesondere an reversibel polymeren Monomethinzyaninen. *Kolloidz.* 92, 299 (1940); 93, 28 (1940)
- (733) KATZ, M. L. Untersuchung schwacher Phosphoreszenzen im u.v. mit der Lichtzählrohrmethode. *Phys. Z. Sow.* 9, 254 (1936)
- (733a) KATO, M. Spectroscopical investigation of optically homogeneous luminescent substances. I, Properties of alkali halide phosphors activated by silver, copper, lead and manganese. II, The laws of photoluminescence and their application. III, The energy levels of luminescent centers in some alkali halide phosphors. IV, The photoconductivity and phosphorescence of KCl(Ag) and KCl(Tl). *Sci. Pap. Physchem. Res. Tokyo* 41, 113 (1943); 41, 135 (1943); 42, 35 (1944); 42, 95 (1944)
- (734) KAUFFMANN, H. Die Beziehung zwischen Fluoreszenz und chemischer Konstitution. *Sammlung chem. und techn. Vorträge* 11, 1 (1907); *Z. f. Elektrochem.* 18, 470 (1912)
- (735) KAUFFMANN, H. Die Auxochrome. *Sammlung chem. und techn. Vorträge* 12, 1 (1908)
- (736) KAUFFMANN, H. Betrachtungen über die Fluoreszenztheorie des Herrn J. Stark. *Z. f. Elektrochem.* 19, 192 (1912)
- (737) KAUFFMANN, H. Über die Fluoreszenz von Zyanverbindungen. *Chem. Ber.* 50, 1614 (1917)
- (738) KAUFFMANN, H. and WEISEL, L. Die Fluoreszenz in der Terephthalsäurereihe. *Ann. d. Chem.* 393, 1 (1912)
- (739) KAUTSKY, H. Chlorophyllfluoreszenz und Kohlensäureassimilation, I-VIII. *Biochem. Z.* 274, 423 and 435 (1934); 277, 250 (1935); 279, 373 (1935); 284, 412 (1936); 291, 285 (1937); 302, 137 (1939)
- (740) KAUTSKY, H. Die Wechselwirkung zwischen Sensibilisatoren und Sauerstoff im Licht. *Biochem. Z.* 291, 271 (1937)
- (741a) KAUTSKY, H. Quenching of luminescence by oxygen. *Faraday Soc. Trans.* 35, 216 (1939)
- (741b) KAUTSKY, H. Energieumwandlungen in phosphoreszierenden Adsorbaten organischer Verbindungen. *Munich* 1943, 195
- (742) KAUTSKY, H. and BRUIJN, H. DE. Die Aufklärung der Fluoreszenztilgung durch Sauerstoff: die Bildung aktiver diffusionsfähiger Sauerstoffmoleküle durch Sensibilisierung. *Naturwiss.* 19, 1043 (1931)
- (743) KAUTSKY, H., BRUIJN, H. DE, NEUWIRT, R., and BAUMEISTER, W. Photosensibilisierte Oxydation als Wirkung eines aktiven metastabilen Zustandes des Sauerstoffmoleküls. *Chem. Ber.* 66, 1588 (1933)
- (744) KAUTSKY, H. and EBERLEIN, R. Neue Messungen der Fluoreszenzintensitätsänderungen grüner Pflanzen. *Naturwiss.* 26, 576 (1938)
- (745) KAUTSKY, H. and HIRSCH, A. Wechselwirkung zwischen angeregten Farbstoffmolekülen und Sauerstoff. *Chem. Ber.* 64, 2677 (1931)
- (746) KAUTSKY, H. and HIRSCH, A. Phosphoreszenz adsorbierter fluoreszierender Farbstoffe und ihre Beziehung zu reversiblen und irreversiblen Strukturänderungen der Gele. *Chem. Ber.* 65, 403 (1932)

- (747) KAUTSKY, H. and HIRSCH, A. Nachweis geringster Sauerstoffmengen durch Phosphoreszenztilgung. *Z. anorg. Chem.* 222, 126 (1935)
- (748) KAUTSKY, H., HIRSCH, A., and BAUMEISTER, W. Photolumineszenz fluoreszierender Farbstoffe an Grenzflächen. *Chem. Ber.* 64, 2053 (1931)
- (749) KAUTSKY, H., HIRSCH, A., and DAVIDSHOEFER, F. Kohlensäureassimilation. *Chem. Ber.* 65, 1762 (1932)
- (750) KAUTSKY, H., HIRSCH, A. and FLESCHE, W. Die Bedeutung metastabiler Zustände für die sensibilisierte Photo-oxydation. *Chem. Ber.* 68, 152 (1935)
- (751) KAUTSKY, H., and HORMUT, R. Abhängigkeit des Verlaufs der Fluoreszenzkurven grüner Blätter vom O_2 -Druck. *Biochem. Z.* 291, 285 (1937)
- (752) KAUTSKY, H. and MERKEL, H. Phosphoreszenz, Selbstausslöschung und Sensibilisatorenwirkung organischer Stoffe. *Naturwiss.* 27, 195 (1939)
- (753) KAUTSKY, H. and MARX, A. Der Verlauf des Fluoreszenzanstieges lebender Blätter. *Naturwiss.* 24, 317 (1936)
- (754) KAUTSKY, H. and NEIZKE, O. Spektren emissionsfähiger Stoffe bei Erregung durch Licht und durch chemische Reaktionen. *Z. f. Phys.* 31, 60 (1925)
- (755) KAUTSKY, H. and ZOCHER, H. Über die Beziehung zwischen Chemi- und Photolumineszenz bei ungesättigten Siliziumverbindungen. *Z. f. Phys.* 9, 267 (1922)
- (756) KAYSER, H. Zur Spektroskopie des Sauerstoffes. *Ann. d. Phys.* 34, 498 (1911)
- (757) KAYSER, H. Erwiderung an die Herren Steubing und Stark. *Z. f. Elektrochem.* 35, 608 (1911)
- (758) KEARNY, M. B. The fluorescence of esculin solutions. *Phil. Mag.* 47, 648 (1927)
- (759) KELLERMANN, E. W. Zur Verfärbung und Lumineszenz des Fluorits. *Wien. Ber. IIa* 146, 115 (1937)
- (760) KEMBLE, E. C. and WITMER, E. E. Interpretation of Wood's iodine resonance spectrum. *Phys. Rev.* 27, 803 (1926); 28, 633 (1926)
- (761) KENNARD, E. H. Rate of decay of phosphorescence at low temperatures. *Phys. Rev.* 4, 278 (1914)
- (762) KENNARD, E. H. On the thermodynamics of fluorescence. *Phys. Rev.* 11, 29 (1918)
- (763) KENNARD, E. H. On the interaction of radiation with matter and on fluorescent exciting power. *Phys. Rev.* 27, 803 (1926); 28, 672 (1926)
- (764) KENNARD, E. H. Excitation of fluorescence in fluorescein. *Phys. Rev.* 29, 466 (1927)
- (765) KENTY, C. Line broadening and imprisonment of resonance radiation. *Phys. Rev.* 40, 633 (1932); 41, 390 (1932)
- (766) KENTY, C. On radiation diffusion and the rapidity of escape of resonance radiation from a gas. *Phys. Rev.* 42, 823 (1932)
- (767) KERSCHBAUM, F. P. Über Lichtabsorption im Inneren von Hg-Bogenlampen und ihre Vermeidung. *Z. f. Instrumentenkunde* 34, 43 (1914); *Electrician* 72, 1074 (1914)
- (768) KESSEL, W. Sur la complexité des termes du spectre de résonance des vapeurs de tellure. *C. R.* 189, 94 (1929); *C. R. soc. pol. phys.* 4, 183 (1929)
- (769) KESSEL, W. Sur la question de la structure hyperfine des bandes. *Acta phys. pol.* 3, 513 (1934); *C. R. soc. pol. phys.* 5, 4 (1933)
- (770) KESSEL, W. Sur le rôle de l'absorption de la raie excitatrice dans les spectres de résonance. *Acta phys. pol.* 3, 505 (1934)
- (771) KESSEL, W. Über den Einfluss der Molekülrotation auf die Messung der Fluoreszenzabklingungszeit. *Z. f. Phys.* 103, 125 (1936)
- (772) KEUSSLER, V. v. Über Depolarisation von Resonanzstrahlung durch schwache Magnetfelder. *Phys. Z.* 27, 313 (1926)

- (773) KEUSSLER, V. v. Die Polarisation der Resonanzstrahlung des Hg-Dampfes und ihre Beeinflussung durch Magnetfelder und Zusatzgase. *Ann. d. Phys.* 82, 793 (1927)
- (774) KEUSSLER, V. v. Die Polarisation der Hg-Fluoreszenz im Zusammenhang mit der Linienhyperfeinstruktur. *Z. f. Phys.* 73, 649 (1931)
- (775) KHVOSTIKOV, J. A. Fluoreszenz der Platinzyanide. *Phys. Z. Sow.* 9, 210 (1936); *C. R. Leningrad* 4, 14 (1934)
- (776) KIMURA, M. and MAKAMURA, G. A fluorescing substance in mandarin orange peel. *Jap. J. Phys.* 1, 41 (1922)
- (777) KIMURA, M. and TONOMURA, K. Autoresonance spectrum of iodine. *Zeeman Verhandlungen* 1935, 241
- (778) KINSAY, E. L. Note on the D-line excitation of the green sodium band and the dissociation potential of sodium vapor. *Proc. Nat. Ac. Sci.* 15, 37 (1929)
- (779) KIRCHHOF, F. Über Phosphoreszenz und photochemische Wirkung einiger mit u.v. Licht bestrahlter organischer und unorganischer Substanzen. *Phys. Z.* 30, 240 (1929)
- (780) KIRCHHOFF, W. Messung der Abklingungszeit bei der Fluoreszenz. *Z. f. Phys.* 116, 51 and 115 (1940)
- (781) KISILBASCH, B., KONDRATIEV, V., and LEIPUNSKY, A. Die Auslöschung der Atomfluoreszenz. *Phys. Z. Sow.* 2, 201 (1932)
- (782) KISTIAKOWSKI, G. B. and NELLES, M. The resonance fluorescence of benzene. *Phys. Rev.* 41, 595 (1932)
- (783) KISTIAKOWSKI, G. B. and SALOMON, A. K. The u.v. absorption spectrum of benzene. *J. Chem. Phys.* 5, 609 (1937)
- (784) KITTELMANN, F. Beitrag zur Kenntnis der Erdalkaliselenidphosphore. *Ann. d. Phys.* 46, 177 (1915)
- (784a) KLASENS, H. A., RAMSDEN, W., and CHOW QUANTY. The relation between efficiency and exciting intensity for zinc sulfide phosphors. *J. Opt. Soc. Am.* 38, 60 (1948)
- (784b) KLASENS, H. A. and WISE, E. Decay of ZnS-type phosphors. *Nature* 158, 483 (1946)
- (785) KLATT, V. and LENARD, PH. Über die Phosphoreszenz des Kupfers, Wismuths und Mangans in Erdalkalien. *Ann. d. Phys.* 56, 18 and 201 (1889)
- (786) KLEIN, O. and ROSSELAND, S. Zusammenstöße zwischen Atomen und freien Elektronen. *Z. f. Phys.* 4, 46 (1921)
- (787) KLEINSCHROD, F. G. Zur Messung der Zahl der Farbzentren in KCl-Kristallen. *Ann. d. Phys.* 27, 97 (1936)
- (787a) KLEMENT, F. D. Research on the luminescence of alkali halide phosphors. *Bull. Moscow* 9, 411 (1945)
- (788) KLOKOWSKA, W. Beobachtungen über die Fluoreszenz des Bleidampfes. *Acta phys. pol.* 2, 239 (1933)
- (789) KLUMB, H. and PRINGSHEIM, P. Über die Überführung angeregter 6^3P_1 Hg-Atome in den metastabilen Zustand 3^3P_0 . *Z. f. Phys.* 52, 610 (1929)
- (789a) KNORR, H. V. and ALBERS, V. M. The fluorescence spectra of $\alpha, \beta, \gamma, \delta$ -tetraphenylporphine and some of its metal complexes. *Phys. Rev.* 57, 347 (1940)
- (790a) KOCH, W. Über den Fremddionengehalt einiger Alkalihalogenidphosphore. *Z. f. Phys.* 57, 638 (1929)
- (790b) KOCH, W. Über Absorption und Dispersion von Alkalihalogenidphosphoren von bekanntem Fremddionengehalt. *Z. f. Phys.* 59, 378 (1929)
- (791) KOCH, W. and POHL, R. W. Zur Lichtabsorption von Alkalihalogenidphosphoren. *Goettinger Nachr.* 1929, 6
- (792) KOEGEL, G. Über die Beziehung der photochemischen Reaktionsfähigkeit und der Fluoreszenz organischer Verbindungen. *Z. wiss. Phot.* 26, 311 (1929)

- (794) KOEHLER, A. and HABERLANDT, H. Über die Lumineszenz von Apatit und anderen Phosphaten. *Wiener Anzeiger* 1933, 302
- (795) KOEHLER, J. F. Quenching of iodine fluorescence by iodine and argon. *Phys. Rev.* 44, 761 (1933)
- (796) KOENIG, H. D. and ELLETT, A. Direct measurement of τ . *Phys. Rev.* 37, 1685 (1931); 39, 576 (1932)
- (797) KOENIGSBERGER, J. and KUEPFERER, K. Zur Absorption des Lichtes in festen und gasförmigen Körpern. *Ann. d. Phys.* 37, 601 (1912)
- (798) KOERNICKE, E. Bestimmung der Dissoziationswärme von Hg-Molekülen aus dem Bandenspektrum des Hg-Dampfes. *Z. f. Phys.* 33, 219 (1925)
- (799) KOFLEK, M. Die fluorom trische Bestimmung des Tocopherol. *Helv. chim. acta* 25, 1469 (1942); 26, 2166 (1943); 28, 26 (1945)
- (800) KONDRATIEV, V. Über Dissoziation heteropolarer Moleküle durch Lichtabsorption. *Z. f. Phys.* 39, 191 (1926)
- (801) KONDRATIEV, V. and POLAK, L. Das sichtbare Absorptionsspektrum von Jod und die induzierte Praedissoziation der J_2 -Molekeln. *Phys. Z. Sow.* 4, 764 (1933)
- (802) KONDRATIEV, V. and SISKIN, M. Auslöschung der Fluoreszenz von adsorbierten Farbstoffen durch verschiedene Gase. *Phys. Z. Sow.* 6, 293 (1934)
- (803) KONDRATIEV, V. and SISKIN, M. Auslöschung der Natriumfluoreszenz. *Phys. Z. Sow.* 8, 644 (1935)
- (804) KONSTANTINOWA, M. Eine neue Fluoreszenzmethode zur Bestimmung von geringen Ozonkonzentrationen. *Acta physchim. U.S.S.R.* 3, 435 (1935)
- (805) KOPFERMANN, H. Über die sensibilisierte Fluoreszenz des Pb- und Bi-Dampfes. *Z. f. Phys.* 21, 316 (1924)
- (806) KOPFERMANN, H. and LADENBURG, R. Elektrooptische Untersuchungen am Na-Dampf. *Ann. d. Phys.* 78, 659 (1925)
- (807) KORFF, S. A. The frequency of resonance radiation. *Phys. Rev.* 41, 538 (1932)
- (808) KORTE, H. and BUNNAGEL, R. Über die spektrale Energieverteilung in der Lumineszenz einiger Luminophore. *Phys. Z.* 43, 437 (1944)
- (809) KORTUEM, G. Fluoreszenzauslöschung und Solvation. *Z. phys. Chem. B* 40, 431 (1938)
- (810) KORTUEM, G. and FINCKH, B. Eine photographische Methode zur Aufnahme quantitativer vergleichbarer Fluoreszenzspektren. *Spectrochim. acta* 2, 137 (1941)
- (811) KORTUEM, G. and FINCKH, B. Fluoreszenz vielatomiger Moleküle. *Z. phys. Chem. B* 52, 263 (1942)
- (812) KOTECKI, A. Neue Fluktuationsbanden des Cd-Dampfes. *Bull. intern. Cracow* 1936, 560; *Acta phys. pol.* 4, 489 (1936); *Verhandl. d. Deutsch. phys. Ges.* 18, 53 (1937)
- (813) KOTECKI, A. Beiträge zur Kenntnis der sichtbaren Fluoreszenz des Cd-Dampfes. *Acta phys. pol.* 6, 144 (1937)
- (814) KOWALSKI, J. DE. Influence de la température sur la loi de Stokes. *Radium* 7, 56 (1910)
- (815) KOWALSKI, J. DE. La phosphorescence progressive à basse température. *C. R.* 151, 810 (1910); *Bull. intern. Cracow* 1910, 17; *Phys. Z.* 12, 956 (1911); *Verhandl. d. deutsch. phys. Ges.* 13, 952 (1911)
- (816) KOWALSKI, J. DE. Rapport sur la luminescence et absorption de la lumière à basse température. *Rep. Intern. Congress of Refrig. London* 1924
- (817) KOWALSKI, J. DE. and DZIERZBICKI, J. DE. Le spectre de phosphorescence progressive des composés organiques a basses températures. *C. R.* 151, 943 (1910)
- (818) KOWALSKI, J. DE. and DZIERZBICKI, J. DE. Influence des groupements fonctionnels sur le spectre de phosphorescence progressive. *C. R.* 152, 83 (1911)

- (819) KRAMERS, H. A. and HEISENBERG, W. Über die Streuung der Strahlung durch Atome. *Z. f. Phys.* 31, 681 (1925)
- (820) KRATZER, A. and SUDHOLT, E. Die Gesetzmässigkeit im Resonanzspektrum des Joddampfes und die Bestimmung des Trägheitsmomentes. *Ann. d. Phys.* 33, 144 (1925)
- (821) KRAUSE, E. A. The sensitized fluorescence of potassium. *Phys. Rev.* 55, 164 (1939)
- (822) KREFFT, H. Über den Stand der Lichterzeugung. *Z. f. techn. Phys.* 19, 345 (1938)
- (823) KREIDL, N. J. Recent studies of the fluorescence of glass. *J. Opt. Soc. Am.* 35, 249 (1945)
- (824) KREMENSKY, N., LARIONOV, J., and SEIDEL, A. On the structure of the bands in the fluorescence spectrum of aqueous solutions of terbium salts. *Acta physchim. U.S.S.R.* 6, 481 (1937)
- (825a) KREUTZ, St. Über die Lumineszenz der Mineralien in Abhängigkeit von ihrem Vorkommen. *Bull. intern. Cracow.* 1933, 215; 1936, 501
- (825b) KREUTZ, St. Sur la fluorescence de certaines fluorines à des températures basses. *Bull. intern. Cracow* 1935, 573
- (826) KRISCHNAIYAR, N. C. On the fluorescence of didymium glass. *Proc. Ind. Ass. for Cult. of Sci.* 8, 217 (1923)
- (827a) KRISHNAN, R. S. The Raman spectrum of rock-salt. *Proc. Roy. Soc. A.* 187, 188 (1946)
- (827b) KRISHNAN, R. S. Raman spectrum of alumina and the luminescence and absorption spectra of ruby. *Nature* 160, 26 (1947)
- (828) KRISHNAN, R. S. and MITRA, S. M. Negative polarization in fluorescence. *Nature* 131, 204 (1933)
- (829a) KRISHNAN, R. S. and SESHAN, P. K. On the fluorescence spectra of impurity molecules included in crystals. *Acta phys. pol.* 5, 289 (1936)
- (829b) KRISHNAN, K. S. and SESHAN, P. K. Directional variation in the absorption and fluorescence of the chrysene molecule. *Proc. Ind. Ac. A* 8, 487 (1938)
- (830) KROEGER, F. A. Luminescence and absorption of ZnS-MnS mixed crystals. *Physica* 6, 369 (1939)
- (831) KROEGER, F. A. Some optical properties of zinc silicate phosphors. *Physica* 6, 764 (1939)
- (832) KROEGER, F. A. Fundamental absorption of ZnS-MnS and ZnS-CdS mixed crystals. *Physica* 6, 779 (1939); *Z. f. Krystallographie A* 100, 435 (1939)
- (833a) KROEGER, F. A. Luminescence and absorption of ZnS, CdS and their solid solutions. *Physica* 7, 1 (1940)
- (833b) KROEGER, F. A. Luminescence and absorption of solid solutions in the ternary system ZnS-CdS-MnS. *Physica* 7, 92 (1940)
- (833c) KROEGER, F. A. Photoluminescence in the quaternary system $MgWO_4-ZnWO_4-MgMoO_4-ZnMoO_4$. *Philips Res. Rep.* 2, 177 (1947)
- (833d) KROEGER, F. A. Luminescence of solid solutions of the system $CaMoO_4-PbMoO_4$ and of some other systems. *Philips Res. Rep.* 2, 183 (1947)
- (833e) KROEGER, F. A. The temperature dependence of the fluorescence of tungstates and molybdates in relation to the perfection of the lattice. *Philips Res. Rep.* 2, 340 (1947); *Nature* 159, 674 (1947)
- (833f) KROEGER, F. A. Tetravalent Mn as an activator in luminescence. *Nature* 159, 706 (1947)
- (834a) KROEGER, F. A. and BAKKER, J. Luminescence of cerium compounds. *Physica* 8, 628 (1941)
- (834b) KROEGER, F. A. and HELLINGMAN, J. E. The blue luminescence of zinc sulfide. *Trans. Electrochem. Soc.* 93, 156 (1948)
- (835) KRONENBERGER, A. Über die Absorption und Lumineszenz von Benzol und Benzolderivaten bei $-253^\circ C$. *Z. f. Phys.* 63, 494 (1930)

- (836) KRONENBERGER, A. and PRINGSHEIM, P. Über das Absorptionsspektrum des festen Benzols. *Z. f. Phys.* 40, 75 (1926); *Phys. Z.* 27, 856 (1926)
- (836a) KUBLI, U. and SCHMIDT, E. Fluoreszenzerscheinungen bei hydroxylierten, partiell hydrierten Pyridinderivaten. *Helv. chim. acta* 28, 213 (1945)
- (837a) KUDRYAVTSEVA, V. M. Über die u.v. Fluoreszenz des roentgenisierten Steinsalzes. *Z. f. Phys.* 90, 489 (1934)
- (837b) KUDRYAVTSEVA, V. M. Characteristic luminescence of crystal lattices. *C. R. Moscow* 52, 495 (1946)
- (837c) KUDRYAVTSEVA, V. M. Temperature luminescence of ZnO and CaO powders. *C. R. Moscow* 52, 581 (1946)
- (837d) KUDRYAVTSEVA, V. M., VERGUNAS, F. I., and LITVINOVA, P. S. Transmission of energy in the crystal lattice in luminescence processes. *Bull. Moscow* 9, 403 (1945)
- (838) KUEHNER, R. Das Spektrum der erregenden Absorption der Lenard-Phosphore. *Ann. d. Phys.* 13, 873 (1932)
- (839) KUHN, A. Fluoreszenz fester Stoffe im kompakten und fein verteilten Zustand. *Kolloidz.* 100, 126 (1942)
- (840) KUHN, H. Über die Spektren von unecht gebundenen Molekülen K_2 , Na_2 , Ca_2 und Verbreiterung von Absorptionslinien. *Z. f. Phys.* 76, 782 (1932)
- (841) KUHN, H. and FREUDENBERG, K. Über das Absorptionsspektrum des Hg-Dampfes. *Z. f. Phys.* 76, 38 (1932)
- (842) KUHN, H. and OLDENBERG, O. Evidence of space quantization of atoms upon impact. *Phys. Rev.* 41, 72 (1932)
- (843) KUHN, R. and BAER, F. Zum photochemischen Verhalten des Lactoflavins. Modellversuche in der Chinoxolin-Reihe. *Chem. Ber.* 67, 828 (1934)
- (844) KUHN, R. and COOK, A. H. Über Lumazine und Alloxazine. *Chem. Ber.* 70, 761 (1937)
- (845) KUHN, R. and GRUNDMANN, C. Synthese der Dekapentaen-1,10-dicarbonensäure. *Chem. Ber.* 69, 1979 (1936)
- (846) KUHN, R. and MARUZZI, G. Über die Dissoziationskonstante der Flavine; pH-Abhängigkeit der Fluoreszenz. *Chem. Ber.* 67, 888 (1934)
- (847) KUHN, R. and STROEBELE, R. Synthese von Flavinglukosiden. *Chem. Ber.* 70, 747 (1937)
- (848) KUHN, R. and VETTER, H. Zur Kenntnis des Thiochroms. *Chem. Ber.* 68, 2375 (1935)
- (849) KUNZE, P. Intensität, Verbreiterung, Auslöschung und Nebenkontinua der Hg-Resonanzlinie bei Zusatz von Edelgasen. *Ann. d. Phys.* 8, 500 (1931)
- (850) KUPPENHEIM, H. Über die Beständigkeit der Phosphoreszenzzentren. *Ann. d. Phys.* 70, 81 and 113 (1923); 72, 564 (1923)
- (851) KUTZELNIGG, A. Zur Lumineszenz der Zinkverbindungen. *Z. anorg. Chem.* 201, 323 (1931)
- (852) KUTZELNIGG, A. Über die Veränderung einiger Eigenschaften des Zinkoxyds infolge mechanischer Beanspruchung. *Monatshefte f. Chem.* 64, 61 (1934)
- (853) KUTZELNIGG, A. Die Fluoreszenz von Zinkoxyd-Eisenoxyd-Mischpräparaten und ihre Abhängigkeit von der Temperatur der Wärmebehandlung. *Z. anorg. Chem.* 223, 251 (1934)
- (854) KUTZELNIGG, A. Über die Fluoreszenz des Zinkoxyds bei der Temperatur der flüssigen Luft. *Monatshefte f. Chem.* 64, 74 (1934)
- (855) KUTZELNIGG, A. Beziehung zwischen Lumineszenzvermögen und Gitterbau; Schichtgitterkristalle. *Angewandte Chem.* 49, 267 (1936); 50, 366 (1937)

- (856) LADENBURG, R. Die elektrische Beeinflussung des Resonanzlichtes des Na-Dampfes. *Naturwiss.* 12, 414 (1924)
- (857) LAIDLER, K. J. The mechanism of processes initiated by excited atoms. I. The quenching of excited sodium. II. Photosensitization by excited Hg and Cd. *J. Chem. Phys.* 10, 34 and 43 (1942)
- (858) LANDAU, H. and STENZ, E. The dissociation of iodine vapor and its fluorescence. *Phil. Mag.* 40, 189 (1920)
- (858a) LANDAU, L. On the thermodynamics of photoluminescence. *J. Phys. U.S.S.R.* 10, 503 (1946)
- (859) LANDSBERG, G. and MANDELSTAM, L. Über die selektive Lichtstreuung. *Z. f. Phys.* 72, 130 (1931)
- (860) LANDSBERG, G. and MANDELSTAM, L. Selektive Lichtstreuung im Hg-Dampf. *Phys. Z. Sow.* 8, 378 (1935); *Acta phys. pol.* 5, 79 (1936)
- (861) LANGE, H. Über Fluoreszenz des Pr^{+++} und des Eu^{+++} . *Ann. d. Phys.* 31, 609 (1938); 32, 661 (1938)
- (862) LANGE, H. Über die Terme des Praseodyms. *Verhandl. d. Deutsch. phys. Ges.* 19, 3 (1938)
- (863) LANGECKER, H. Zur Fluoreszenzbeobachtung bei den Porphyrinen. *Z. f. physiol. Chem.* 115, 2 (1921)
- (863a) LAPPE, F. R. Lichtelektrische Leitfähigkeit von ZnS(Cu)-Phosphoren unter Einwirkung von α -Strahlen. *Ann. d. Phys.* 39, 604 (1941)
- (864) LARIONOV, J. On the luminescence spectra of rare earth ions. *Bull. Moscow* 5, 107 (1941)
- (865a) LARIONOV, J. and SEIDEL, A. On the fluorescence of trivalent europium in aqueous solutions. *C. R. Moscow* 15, 115 (1936)
- (865b) LARIONOV, J. and SEIDEL, A. On the photoluminescence of the solutions of rare earth salts. *C. R. Moscow* 16, 443 (1937)
- (866) LARRICK, L. The Paschen-Back effect of hyperfine structure and the polarization of resonance radiation: the D-lines. *Phys. Rev.* 40, 1041 (1932)
- (867) LARRICK, L. Nuclear magnetic moment from the polarization of resonance radiation of sodium $3^2\text{S}_{1/2}$ - $3^2\text{P}_{3/2}$. *Phys. Rev.* 46, 581 (1934)
- (867a) LARRICK, L. and HEYDENBURG, N. P. The polarization of mercury resonance radiation. *Phys. Rev.* 39, 289 (1932)
- (868) LASHKAREV, V. E. and KOSSOMOGOVA, K. M. Infrared luminescence of cuprous oxide. *C. R. Moscow* 54, 125 (1946)
- (868a) LASOF, S., LEVERENZ, H. W., and SCHRADER, R. E. Photoluminescence and cathodoluminescence of Zn,CdS,Se phosphors. *Ithaca* 1946, 214
- (869) LAU, E. and REICHENHEIM, O. Über die verschiedenen Arten von Lichtanregung in der Gasentladung. *Ann. d. Phys.* 12, 52 (1932)
- (870) LAU, E. and REICHENHEIM, O. Über die sichtbare, durch Schumannstrahlen angeregte Phosphoreszenz des Flussspats. *Ann. d. Phys.* 12, 69 (1932)
- (871) LE BON, G. Sur certaines propriétés antagonistes de diverses régions du spectre. *C. R.* 170, 1450 (1920)
- (872) LECOQ DE BOISBAUDRAN. Sur la fluorescence rouge de l'alumine. *C. R.* 103, 1107 (1886)
- (873) LECOQ DE BOISBAUDRAN. Fluorescence du Mn et du Bi. *C. R.* 105, 206 (1887)
- (874) LECOQ DE BOISBAUDRAN. Fluorescence de la chaux cuprifère. *C. R.* 106, 1386 (1888)
- (875) LECOQ DE BOISBAUDRAN. Sur l'origine de la notion des solutions solides. *C. R.* 142, 195 (1906).
- (875a) LEE, O. I. A new property of matter: reversible photosensitivity in hackmanite from Bancroft, Ontario. *Am. Mineral.* 21, 764 (1936)
- (876) LEES, J. H. The excitation function of helium. *Proc. Roy. Soc. A* 137, 173 (1932)

- (877) LEES, J. H. and SKINNER, H. W. B. Notes on the excitation processes in helium. *Proc. Roy. Soc. A* 137, 186 (1932)
- (878) LEGRAND, Y. Sur la fluorescence du cristallin. *C. R.* 206, 1128 (1938)
- (879) LEGROS, A. Sur une remarquable série de résonance de la vapeur diatomique de tellure. *Bull. Brussels* 17, 816 (1931)
- (879a) LEHFELD, W. Zur Kenntnis des lichtelektrischen Sekundaerstromes. *Göttinger Nachr.* 1933, 263
- (880) LEHMANN, H. Über ein Filter für u.v. Strahlen und seine Anwendung. *Phys. Z.* 11, 1039 (1910); *Verh. d. Deutsch. phys. Ges.* 12, 890 (1910)
- (881) LEHMANN, H. Lumineszenzanalyse mittels der U.v.-Filterlampe. *Phys. Z.* 13, 35 (1912); *Verhandl. d. Deutsch. phys. Ges.* 13, 1101 (1911)
- (882) LEIPUNSKY, A. J. and SAGULIN, A. W. Die Reaktion des angeregten Quecksilbers mit Sauerstoff. *Z. phys. Chem. B* 1, 362 (1929); 3, 215 (1929)
- (883) LENARD, P. Über Lichtemission und deren Erregung. *Heidelberg. Ber.* 1909, 3. Abhandl.; *Ann. d. Phys.* 31, 641 (1910)
- (884) LENARD, P. Über die Phosphoreszenz und über die Auslöschung der Phosphore durch Licht. *Verhandl. d. nat.-med. Vereinigung Heidelberg* 10, 1 (1909)
- (885) LENARD, P. Über Lichtsummen bei Phosphoren. *Heidelberg. Ber.* 1912, 5. Abhandl.
- (886) LENARD, P. Lichtabsorption und Energieverhältnisse bei den Phosphoren. *Heidelberg. Ber.* 1914, 14. Abhandl.
- (887) LENARD, P. Über die druckerstörten Erdalkaliphosphore. *Elster und Geitel-Festschrift* 1915, 669
- (888) LENARD, P. Über die Ausleuchtung und Tilgung der Phosphore I-IV. *Heidelberg. Ber.* 1917, 5. and 7. Abhandl.; 1918, 8. and 11. Abhandl.
- (889) LENARD, P. Über die Lichtwirkung auf Zinkulfid. *Ann. d. Phys.* 68, 553 (1922)
- (890) LENARD, P. and HAUSSER, W. Über das Abklingen der Phosphoreszenz. *Heidelberg. Ber.* 1912, 12. Abhandl.
- (891) LENARD, P. and HAUSSER, W. Absolute Messung der Energieaufspeicherung bei Phosphoren. *Heidelberg. Ber.* 1913, 19. Abhandl.
- (892) LENARD, P. and KLATT, V. Über die Erdalkaliphosphore. *Ann. d. Phys.* 15, 225, 425 and 633 (1904)
- (893) LENARD, P., ONNES, H. K., and PAULI, W. Het gedrag der aardalkaliphosphoren bij verschillende, in bijzonder lage temperaturen. *Amsterdam. Proc.* 1909, 151
- (894) LENARD, P., ONNES, H. K., and SAELAND, S. Über die lichtelektrische und aktinodielektrische Wirkung der Erdalkaliphosphore. *Ann. d. Phys.* 28, 476 (1909)
- (895a) LENNUIER, R. Sur des phénomènes présentant des caractères intermédiaires entre ceux de la résonance et ceux de la diffusion de Rayleigh. *C. R.* 218, 153 (1940)
- (895b) LENNUIER, R. Effet de l'élargissement Doppler sur les interaction entre atomes et rayonnement au voisinage de la résonance. *C. R.* 218, 665 (1944)
- (896) LENNUIER, R. and CRENN, Y. Etude de la bande de fluorescence 3350 émise par la vapeur de mercure éclairée par des radiations u.v. *C. R.* 216, 486 (1943)
- (897) LENNUIER, R. and CRENN, Y. Détermination de la courbe de potentielle de la molécule $^{15}\text{S}-^{31}\text{P}_1$ du mercure. *C. R.* 216, 533 and 583 (1943)
- (898) LENZ, W. Über einige spezielle Fragen aus der Theorie der Bandenspektren. *Phys. Z.* 21, 691 (1920)
- (899) LENZ, W. Einige korrespondenzmässige Betrachtungen. *Z. f. Phys.* 25, 299 (1924)

- (900) LENZ, W. Allgemeine Theorie der Verbreiterung von Spektrallinien. *Z. f. Phys.* 80, 423 (1933)
- (901) LENZ, W. Über die Anwendbarkeit der Franck-Condon'schen Regel auf die Linienverbreiterung. *Z. f. Phys.* 83, 139 (1933)
- (902) LÉPINE, G. Etude expérimentale sur la fluorescence des solutions. *Ann. de phys.* 4, 207 (1915)
- (903) LEROY, G. J. and KAHN, A. Mercury $^3(P_1)$ photosensitized hydrogenation of ethylene. *J. Chem. Phys.* 15, 816 (1947)
- (904a) LE ROY, D. J. and STEACIE, E. W. R. The mercury photosensitized reactions of ethylene. *J. Chem. Phys.* 9, 829 (1941); 10, 676 (1942)
- (904b) LE ROY, D. J. and STEACIE, E. W. R. The $Cd(^3P_1)$ photosensitized reactions of the lower olefins. *J. Chem. Phys.* 10, 683 (1942)
- (905) LE ROY, D. J. and STEACIE, E. W. R. The mercury photosensitized polymerization of acetylene. *J. Chem. Phys.* 12, 117 (1944)
- (906) LEVAILLANT, R. Fluorescence et photochimie. *C. R.* 177, 398 (1923)
- (907a) LEVERENZ, H. W. Phosphors versus the periodic system of the elements. *Proc. Inst. Radio Eng.* 1944, 256
- (907b) LEVERENZ, H. W. General correlation between efficiency characteristics and constitution of phosphors. *J. Opt. Soc. Am.* 37, 520 (1947)
- (907c) LEVENZ, H. W., LASOF, S., SCHRADER, R. E., and WOOD, E. J. The synthesis, constitution, visible reflectance spectra and photolysis of Zn, CdS, Se phosphors. *Ithaca* 1946, 205
- (908) LEVERENZ, H. W. and SEITZ, F. Luminescent materials. *J. Appl. Phys.* 10, 479 (1939)
- (909) LEVSHIN, W. L. Über polarisiertes Fluoreszenzlicht von Farbstofflösungen. *Z. f. Phys.* 26, 274 (1924); 34, 330 (1925)
- (910) LEVSHIN, W. L. Polarisierte Fluoreszenz und Phosphoreszenz der Farbstofflösungen. *Z. f. Phys.* 32, 307 (1925)
- (911) LEVSHIN, W. L. Die Auslöschung der Fluoreszenz in festen und flüssigen Farbstofflösungen. *Z. f. Phys.* 43, 230 (1927)
- (912) LEVSHIN, W. L. Das Gesetz der Spiegelkorrespondenz der Absorptions- und Fluoreszenzspektren. *Z. f. Phys.* 72, 368 and 382 (1931)
- (913) LEVSHIN, W. L. On the connection between absorption and luminescence in concentrated solutions of dyes. *Acta physchim. U.S.S.R.* 1, 685 (1934)
- (914) LEVSHIN, W. L. Correspondence between absorption and fluorescence spectra of diluted solutions of dyes. *Acta physchim. U.S.S.R.* 2, 221 (1935); *C. R. Leningrad* 1, 474 (1935)
- (915) LEVSHIN, W. L. Recherches sur la décroissance de la lumière et le mécanisme de l'émission de différentes substances. *Acta phys. pol.* 5, 79 (1936)
- (916) LEVSHIN, W. L. A study of absorption and luminescence spectra of uranyl salts and their solutions. *Acta physchim. U.S.S.R.* 6, 661 (1937)
- (917a) LEVSHIN, W. L. Modern investigation of the mechanism of luminescence of semiconductors. *Bull. Moscow* 5, 510 (1941)
- (917b) LEVSHIN, V. L. Luminescence of crystals. *Bull. Moscow* 9, 355 (1945)
- (917c) LEVSHIN, V. L. On the interaction of Zn and Mn emission in ZnS Mn-phosphors. Effect of wavelength of exciting light. *C. R. Moscow* 54, 127 (1946)
- (917d) LEVSHIN, V. L. Influence of the Mn concentration and temperature on the radiation of Zn and Mn in ZnS(Mn)-phosphors. *C. R. Moscow* 54, 215 (1946)
- (918) LEVSHIN, W. L. and ALENCEV, M. Recherche sur la phosphorescence des calcites. *C. R. Leningrad* 2, 54 (1935)
- (919) LEVSHIN, W. L. and ANTONOW-ROMANOWSKY, W. W. Untersuchungen über Phosphoreszenz. *Phys. Z. Sow.* 5, 786 and 811 (1934)
- (920) LEVSHIN, W. L. and FRIDMAN, A. S. Untersuchung des Leuchtens von

- ZnSCu_a- und ZnSCdCu_a-Phosphoren und die Struktur der Phosphoreszenzzentren. *J. Phys. U.S.S.R.* 6, 1277 (1935)
- (920a) LEVSHIN, W. L. and TUNGARINOV, V. N. The origin of radiation of long and short duration in phosphors with an organic activator. *C. R. Moscow* 28, 246 (1940)
- (921) LEVSHIN, W. L. and VINOKUROV, L. A. Investigation of the decay of phosphorescence in boric acid and alumina sulfate phosphorescent substances. *Phys. Z. Sow.* 10, 10 (1936)
- (922) LEVY, L. A. Fluorescent and intensifying screens. *Roentgen Soc. J.* 12, 13 (1916)
- (923) LEVY, L. A. and WEST, D. W. The differential action of Ni, Fe and Co upon the fluorescence and phosphorescence of certain ZnS phosphors when excited by X-rays. *Faraday Soc. Trans.* 35, 128 (1939)
- (924) LEWIS, G. N. and BIEGELEISEN, J. The y-bands in absorption spectra. *Am. Chem. Soc. J.* 65, 2102 (1943)
- (925a) LEWIS, G. N. and CALVIN, M. The color of organic substances. *Chem. Rev.* 25, 273 (1939)
- (925b) LEWIS, G. N. and CALVIN, M. Paramagnetism of the phosphorescent state. *Am. Chem. Soc. J.* 67, 1232 (1945)
- (926) LEWIS, G. N., GOLDSCHMID, O., MAGEL, T. T., and BIEGELEISEN, J. Dimeric and others forms of methylene blue. Absorption and fluorescence of the pure monomer. *Am. Chem. Soc. J.* 65, 1150 (1943)
- (927a) LEWIS, G. N. and KASHA, M. Phosphorescence and the triplet state. *Am. Chem. Soc. J.* 66, 2100 (1944)
- (927b) LEWIS, G. N. and KASHA, M. Phosphorescence in fluid media and the reverse process of singlet-triplet absorption. *Am. Chem. Soc. J.* 67, 994 (1945)
- (928) LEWIS, G. N. and LIPKIN, D. Reversible photochemical processes in rigid media: the dissociation of organic molecules into radicals and ions. *Am. Chem. Soc. J.* 64, 2801 (1942)
- (929) LEWIS, G. N., LIPKIN, D., and MAGEL, T. T. The absorption and re-emission of light by cis- and trans-stilbenes and the efficiency of their photochemical isomerization. *Am. Chem. Soc. J.* 62, 2973 (1940)
- (930) LEWIS, G. N., LIPKIN, D., and MAGEL, T. T. Reversible photochemical processes in rigid media. A study of the phosphorescent state. *Am. Chem. Soc. J.* 63, 3005 (1941)
- (931) LEWIS, G. N., LIPKIN, D., and MAGEL, T. T. Isomers of crystal violet. Their absorption and re-emission of light. *Am. Chem. Soc. J.* 64, 1774 (1942)
- (932) LEWIS, G. N., LIPKIN, D., and MAGEL, T. T. The light absorption and fluorescence of triarylmethyl free radicals. *Am. Chem. Soc. J.* 66, 1579 (1944)
- (933) LEWKOWICZ, Z. Die Abhängigkeit der Ausbeute der Fluoreszenz von Biacenaphthylidenlösungen von der Wellenlänge des anregenden Lichtes. *Bull. intern. Cracow* 1937, 285
- (934) LEY, H. and DREINHÖFER, R. Absorption und Fluoreszenz bei der Salz-bildung substituierter Zimtsäuren. *Z. wiss. Phot.* 29, 134 (1930)
- (935) LEY, H. and ENGELHARDT, K. v. Über u.v. Fluoreszenz und chemische Konstitution bei zyklischen Verbindungen. *Z. phys. Chem.* 74, 1 (1910)
- (936) LEY, H. and FISCHER, W. Lichtabsorption und Fluoreszenz aliphatischer Säureamide. *Chem. Ber.* 46, 327 (1913)
- (937) LEY, H. and GRAEFE, W. Über den Nachweis des Zustandekommens von chemischen Ringsystemen mit Hilfe von u.v. Fluoreszenz. *Z. wiss. Phot.* 8, 294 (1910)
- (938) LEY, H. and SPECKER, H. Fluoreszenz- und Absorptionsmessungen bei

- Benzolderivaten, insbesondere bei kondensierten Systemen. *Z. wiss. Phot.* 38, 13 and 96 (1939)
- (939) LIEBIG, H. v. Die Starkesche Fluoreszenztheorie. *Z. f. Elektrochem.* 19, 117 (1913)
- (940) LIEBISCH, TH. Über die Fluoreszenz der Sodalith- und Willemitgruppe im u.v. Licht. *Berlin. Ber.* 1912, 229
- (941) LINDEMANN, B. Über die Lumineszenz und die Kristallform des KNa-Sulphates. *Petersburger Ber.* 1909, 229
- (942) LINWOOD, S. H. and WEYL, W. A. The fluorescence of manganese in glasses and crystals. *J. Opt. Soc. Am.* 32, 443 (1942)
- (943) LIPSON, H. C. and MITCHELL, A. C. G. Quenching of Cd resonance radiation by foreign gases. *Phys. Rev.* 47, 807 (1935); 48, 625 (1935)
- (944) LOCHTE-HOLTGREVEN, W. Über das Intensitätsverhältnis der D-Linien. *Z. f. Phys.* 47, 362 (1928)
- (945) LOEB, L. B. and SCHMIEDESKAMP, L. The destruction of phosphorescent ZnS by u.v. light. *Proc. Nat. Ac. Sci.* 7, 202 (1921); *Z. phys. Chem.* 109, 77 (1921)
- (946) LOES, E. Die Emission der Lenardphosphore im roten und ultraroten. *Ann. d. Phys.* 19, 488 (1934)
- (947a) LOMMEL, E. Über die Intensität des Fluoreszenzlichtes. *Ann. d. Phys.* 166, 75 (1876)
- (947b) LOMMEL, E. Über die dichroitische Fluoreszenz des Magnesiumplatinzyannuers. *Ann. d. Phys.* 8, 634 (1879)
- (948) LOMMEL, E. Über Fluoreszenz. *Ann. d. Phys.* 10, 449 (1880)
- (949) LOMMEL, E. Die Fluoreszenz des Joddampfes. *Ann. d. Phys.* 19, 356 (1883)
- (950) LOOMIS, F. W. Correlation of fluorescence and absorption spectra of iodine. *Phys. Rev.* 27, 802 (1926); 29, 112 (1927)
- (951) LOOMIS, F. W. New series in the spectrum of fluorescent iodine. *Phys. Rev.* 29, 355 (1927)
- (952) LOOMIS, F. W. Molecular spectra in gases. *Bull. Nat. Res. Counsel.* 11, 272 (1929)
- (953) LOOMIS, F. W. Iodine fluorescence in the infrared. *Phys. Rev.* 35, 662 (1932)
- (954) LOOMIS, F. W. and ALLEN, A. J. U.v. fluorescence of IBr and I₂. *Phys.* 33, 639 (1929)
- (955) LOOMIS, F. W. and FULLER, H. Q. The enhancement of the iodine absorption spectrum by the admixture of oxygen. *Phys. Rev.* 39, 180 (1932)
- (956) LOOMIS, F. W. and KUSCH, P. The band spectrum of caesium. *Phys. Rev.* 46, 292 (1934)
- (956a) LOOMIS, F. W. and NILE, S. W. New features of the red band system of sodium. *Phys. Rev.* 32, 873 (1928)
- (957a) LORD, M. P. and REES, A. L. G. Note on the behavior of ZnS-phosphors under condition of periodic excitation. *Proc. Phys. Soc. London* 58, 280 (1946)
- (957b) LORD, M. P. and REES, A. L. G. Note on the rapid determination of decay characteristics of luminescent solids. *Proc. Phys. Soc. London* 58, 289
- (957c) LORD, M., REES, A. L. G., and WISE, M. E. The short period time variations of luminescence of a ZnS phosphor under u.v. excitation. *Proc. Phys. Soc. London* 59, 473 (1947)
- (958) LORENZ, H. Zur Temperaturabhängigkeit der Absorptionsbanden in Alkalihalogenid-Phosphoren. *Z. f. Phys.* 46, 558 (1927)
- (959a) LORIA, S. Indirectly excited fluorescence spectra. *Phys. Rev.* 26, 573 (1925)
- (959b) LORIA, S. The metastable 2P_{3/2}-state of mercury atoms. *Proc. Nat. Ac. Sci.* 11, 673 (1925)

- (960) LORIA, S. Zur Frage nach der Abhängigkeit der sensibilisierten Fluoreszenz vom Zusatz der Gase. *Z. f. Phys.* 38, 672 (1926)
- (961) LOTMAR, W. Über die Fluoreszenz von Schwefeldioxyd. *Z. f. Phys.* 83, 765 (1933)
- (962) LOWEN, I. S. and BREIT, G. Polarization of fluorescence radiation. *Phys. Rev.* 45, 120 (1934); 46, 590 (1934)
- (962a) LUCKEY, G. W., DUNCAN, A. B. F., and NOYES, W. A. Fluorescence of acetone vapor. *J. Chem. Phys.* 16, 407 (1948)
- (963) LYMAN, E. R. Rotational energy distribution of OH molecules from the 3064 band. *Phys. Rev.* 53, 379 (1938)
- (964) LYMAN, E. R. Elementary processes in the sensitized fluorescence of OH molecules. *Phys. Rev.* 55, 1126 (1939); 56, 466 (1939)
- (965) LYMAN, TH. Notes on the luminescence of glass and fluorite. *Phys. Rev.* 40, 578 (1932)
- (966) MACDOUGALL, E., STEWARD, A. W., and WRIGHT, R. Phosphorescent ZnS. *Chem. Soc. Trans.* III, 663 (1917)
- (967) MACMAHON, A. M. Zur Kenntnis der Alkalihalogenidphosphore mit Cu-Zusatz. *Z. f. Phys.* 52, 336 (1928)
- (968) MACNAIR, W. A. Secondary radiation and polarization of resonance radiation of Cd. *Phys. Rev.* 29, 677 (1927)
- (969) MACNAIR, W. A. Zeeman effect of the fine structure components of λ 2536 of Hg. *Phys. Rev.* 29, 915 (1927); 31, 986 (1928); *Proc. Nat. Ac. Sci.* 13, 430 (1927)
- (970) MAERCKS, O. Neuartige Fluorometer. *Z. f. Phys.* 109, 685 (1938)
- (971) MAKOWIECKA, M. Sur la fluorescence et la durée d'émission de fluorocyclène. *Acta phys. pol.* 2, 357 (1934)
- (972) MALINOWSKI, A. v. Untersuchungen über die Resonanzstrahlung der Hg-dampflampe. *Phys. Z.* 14, 284 (1913); *Ann. d. Phys.* 44, 935 (1914)
- (973) MANI, A. The fluorescence and absorption spectrum of diamond in the visible region. *Proc. Ind. Acad. A* 19, 231 (1944)
- (974) MANI, A. Polarization of Raman scattering and of fluorescence in diamond. *Proc. Ind. Acad. A* 20, 117 (1944)
- (975a) MANI, A. Spectroscopic study of luminescence patterns in diamond. *Proc. Ind. Acad. A* 20, 155 (1944)
- (975b) MANI, A. Excitation curves of luminescence in diamond. *Proc. Ind. Acad. A* 21, 280 (1945)
- (976) MANNKOPFF, R. Über die Auslöschung der Resonanzfluoreszenz von Natriumdampf. *Z. f. Phys.* 36, 315 (1926)
- (977) MANNKOPFF, R. Über die Anregung von Flammenfluoreszenz. *Verhandl. d. Deutsch. phys. Ges.* 14, 16 (1933)
- (978) MARDEN, J. W. and BEESE, N. C. U.v. excitation of fluorescent compounds. *Ill. Eng.* 36, 235 (1941)
- (979) MARDEN, J. W. and MEISTER, G. Effects of impurities on fluorescent compounds. *Ill. Eng.* 35, 503 (1939)
- (980) MARGENAU, H. Pressure broadening of spectral lines. *Phys. Rev.* 43, 129 (1933); 44, 931 (1933)
- (981) MARGULIES, P. Sur le déplacement du spectre de fluorescence et d'absorption des solutions du tribenzyldécacyclène en fonction du solvant. *Acta phys. pol.* 3, 373 (1934)
- (982) MARKE, E. Über die Fluoreszenz der Ionen. *Diss. Muenster* 1922
- (983) MARKOWSKA, K. Fluorescence des solutions de Para-dioxy-dicinnamonylméthane. *Acta phys. pol.* 6, 235 (1937)
- (984) MARSH, J. K. Studies in fluorescence spectra. *J. Chem. Soc.* 1923, 3315; 1924, 418 and 1743
- (985) MARSH, J. K. Emission bandspectra of aromatic compounds. *Phil. Mag.* 49, 971 and 1206 (1925)

- (986) MARTIN, F. Sur la luminescence infrarouge des cristaux et microcristaux photoluminescents. *J. de phys.* 1, 401 (1930)
- (987) MATHESON, M. S. and NOYES, W. A. A further study of the fluorescence of acetone and its relationship to photochemical decomposition. *Am. Chem. Soc. J.* 60, 1857 (1938)
- (988) MATHESON, M. S. and ZABOR, J. W. Fluorescence of carbonyl compounds in the gas phase. *J. Chem. Phys.* 7, 536 (1939)
- (989) MATHUR, K. G. and BHATNAGAR, S. S. Fluorescence and photochemical change. *In. J. Phys.* 3, 37 (1928)
- (989a) MATTOON, R. W. Polymer spectra of cyanine dyes. *J. Chem. Phys.* 12, 268 (1944)
- (990) MAURER, W. and WOLF, R. Versuche über die He-Fluoreszenz und Stöße 2. Art von angeregten He-Atomen. *Z. f. Phys.* 92, 100 (1934)
- (991) MAXWELL, L. R. The average life of the ionized He atom. *Phys. Rev.* 38, 1664 (1931)
- (992) MAXWELL, L. R. The absorption of radiation originating from a beam of electrons in helium. *J. Franklin Inst.* 214, 533 (1932)
- (993) MAYNEARD, W. V. and ROE, E. Fluorescence spectrum of 1,2-benzopyrene. *Biochem. J.* 30, 707 (1935)
- (994) McCLELAND, N. P. Dynamical system illustrating fluorescence. *Cam. Phil. Soc. Proc.* 17, 321 (1914)
- (995) McCURDY, W. H. Absorption and resonance radiation in excited helium and the structure of the 3889 line. *Proc. Nat. Ac. Sci.* 12, 231 (1926); *Phil. Mag.* 2, 529 (1926)
- (996) McDOWELL, L. S. The fluorescence and absorption of anthracene. *Phys. Rev.* 26, 155 (1908)
- (997) McLENNAN, J. C. Fluorescence spectrum of iodine vapor. *Proc. Roy. Soc. A* 88, 289 (1913); 91, 23 (1914)
- (998) McLENNAN, J. C. and AINSLIE, D. S. On the fluorescence and channelled absorption spectra of caesium and other alkali elements. *Proc. Roy. Soc. A* 103, 304 (1923)
- (999) McLENNAN, J. C. and CALE, M. On the fluorescence of esculin. *Proc. Roy. Soc. A* 102, 256 (1922)
- (1000) McLENNAN, J. C., RUEDY, R., and CLEMENTS, F. H. Note on the fluorescence excited in oxygen and nitrogen by u.v. light of short wavelength. *Trans. Roy. Soc. Canada III* 22, 253 (1928)
- (1001) McLENNAN, J. C., WALERSTEIN, J., and SMITH, H. G. On the fluorescence spectra of the sulphur group. *Phil. Mag.* 3, 390 (1927); *Phys. Rev.* 29, 208 (1927)
- (1002) McNALLY, J. G. and VANSELOW, W. Measurement of the fluorescence of cellulose acetate, cellulose nitrate and gelatin in u.v. light. *Am. Chem. Soc. J.* 52, 3846 (1930)
- (1003) McVICKER, W. H. and MARSH, J. K. The fluorescence spectrum of benzene vapor. *J. Chem. Soc.* 1923, 820
- (1004) McVICKER, W. H., MARSH, J. K., and STEWART, A. A new variety of spectra. *Phil. Mag.* 48, 628 (1924)
- (1005) MECKE, R. Über die Seriengesetzmässigkeiten in Resonanzspektren des Jods. *Z. f. Phys.* 7, 73 (1921); *Ann. d. Phys.* 71, 104 (1923)
- (1006) MECKLENBURG, W. and VALENTINER, S. Über die Abhängigkeit der Fluoreszenz von der Konzentration. *Phys. Z.* 15, 267 (1914)
- (1007) MEIDINGER, W. Fluoreszenz bzw. Phosphoreszenz photographischer Halogensilbergelatineschichten bei tiefen Temperaturen. *Phys. Z.* 40, 514 (1939)
- (1008) MEISSNER, K. W. Absorption in angeregtem Neon. *Ann. d. Phys.* 76, 124 (1925)

- (1009) MEISSNER, K. W. Resonanzstrahlung des elektrisch angeregten Argons. *Z. f. Phys.* 43, 449 (1927)
- (1009a) MEISTER, G. and NAGY, R. The photochemical effect of short u.v. radiation on phosphors. *Ithaca 1946*, 372
- (1010) MELVILLE, H. W. The effect of imprisonment of resonance radiation in the decomposition of ammonia and of deuterio-ammonia. *Proc. Roy. Soc. A* 152, 325 (1935)
- (1011) MELVILLE, H. W. A note on the quantum yield of photosensitized decomposition of water and ammonia. *Proc. Roy. Soc. A* 157, 621 (1936)
- (1012) MELVILLE, H. W. The mercury photosensitized polymerization of acetylene. *Faraday Soc. Trans.* 32, 258 (1936)
- (1013) MELVILLE, H. W. and BALLAND, J. L. The mercury photosensitized exchange reaction of deuterium and phosphine. *Proc. Roy. Soc. A* 160, 384 (1937)
- (1014) MELVILLE, H. W. and ROSEBURGH, H. L. The photochemical decomposition and oxidation of trideuterophosphine. *Proc. Roy. Soc. A* 160, 406 (1937)
- (1015) MENDENHALL, C. E. and WOOD, R. W. Effect of electric and magnetic fields on the emission lines of solids. *Phil. Mag.* 30, 316 (1915)
- (1016) MERCANTON, P. L. Ein vereinfachtes Funkenphosphoroskop. *Phys. Z.* 11, 1226 (1910)
- (1017) MERRITT, E. Luminescence. *Phys. Rev.* 5, 319 (1915)
- (1018) MERRITT, E. The form of the absorption bands in the solutions of organic dyes and a relation between absorption and fluorescence. *Phys. Rev.* 27, 804 (1926); 28, 684 (1926)
- (1019) MERRITT, E. The relation between intensity of fluorescence and concentration in solid solutions. *J. Opt. Soc. Am.* 12, 613 (1926)
- (1020) MERRITT, E. and MOREY, D. R. The polarized fluorescence of solutions of rhodamine B and urania. *Phys. Rev.* 36, 1386 (1930)
- (1021) MEYER, C. F. The wavelength of light from the spark which excites fluorescence in nitrogen. *Phys. Rev.* 10, 91 and 575 (1917)
- (1022) MEYER, C. F. and WOOD, R. W. A further study of the fluorescence by ultra-Schumann rays. *Phil. Mag.* 30, 449 (1915)
- (1022a) MEYER, E. Über die Dissoziation von Wasserstoffmolekülen durch Hg-Atome im Zustand 2^3P_0 . *Z. f. Phys.* 37, 639 (1926)
- (1023) MEYER, H. H. Eine photographisch photometrische Untersuchung der Resonanzstrahlung des Hg-Dampfes. *Diss. Hamburg 1925*
- (1024) MEYEREN, W. v. Über die Lichtemission einiger Tl-haltiger Alkalihalogenidphosphore. *Z. f. Phys.* 61, 321 (1930)
- (1025) MIDDELHURST, D. and WELLER, R. The polarizing properties of cellophane. *Rev. Sci. Instr.* 11, 108 (1940)
- (1026) MIE, K. Über die Resonanzbandenzüge des HD-Wasserstoffs im Gebiet 1650-1000A. *Z. f. Phys.* 91, 475 (1934)
- (1027) MIESCHER, G., ALMASY, F. A., and KLAEBI, K. Über den fluoreszenzspektrographischen Nachweis des 1,2-Benzpyrens. *Biochem. Z.* 287, 189 (1936)
- (1027a) MIGEOTTE, R. Quelques remarques sur l'abondance des isotopes du tellure. *Bull. Liège 1942*, 44
- (1027b) MIGEOTTE, R. Détermination de la constante d'anharmonicitie ωx de l'état normal de Te_2 . *Bull. Liège 1940*, 48
- (1028) MILLER, B. J. Effect of hyperfine structure upon the magnetic rotation of the plane of maximum polarization of resonance radiation. *Phys. Rev.* 57, 345 (1940); 58, 258 (1940)
- (1029) MILLER, J. A. and BAUMANN, C. A. The effect of oxygen on the fluorescence of certain hydrocarbons. *Am. Chem. Soc. J.* 65, 1540 (1943)

- (1029a) MILLER, N. F. and BARNETT, C. E. Infrared sensitive phosphors from zinc and cadmium sulfides. *J. Opt. Soc. Am.* 36, 352 (1946)
- (1030) MILLIKAN, R. A. A study of polarization of the light emitted by incandescent solid and liquid surfaces. *Phys. Rev.* 3, 81 and 177 (1895)
- (1030a) MILNE, E. A. Equilibrium in the calcium chromosphere. *Monthly Not. Roy. Astr. Soc.* 85, 111 (1924); *J. Math. Soc. London* 1, 1 (1926)
- (1031) MILNER, C. J. Sulphide phosphors and the zone theory of solids. *Faraday Soc. Trans.* 35, 101 (1939)
- (1032) MINNAERT, M. Ändert sich die Wellenlänge bei der Resonanzzerstreuung? *Z. f. Astrophys.* 4, 153 (1932)
- (1033) MINNE, A. Excitation monochromatique dans le système rouge des bandes de Sc_2 . *Bull. Liège* 6, 254 (1937)
- (1033a) MISER, H. D. and GLASS, J. J. Fluorescent sodalite and hackmanite from Magnet Cove, Arkansas. *Am. Mineral.* 26, 437 (1941)
- (1034a) MITCHELL, A. C. G. The activation of hydrogen by excited mercury atoms. *Proc. Nat. Ac. Sci.* 11, 458 (1925)
- (1034b) MITCHELL, A. C. G. Fluorescence in mixtures of ammonia and mercury vapor. *Am. Chem. Soc. J.* 49, 2699 (1927)
- (1035) MITCHELL, A. C. G. Quenching of Hg resonance radiation and its relation to reactions sensitized by excited Hg atoms. *J. Franklin Inst.* 206, 817 (1928)
- (1036) MITCHELL, A. C. G. Über die Richtungsverteilung der Relativgeschwindigkeit der Zerfallsprodukte bei der optischen Dissoziation von NaJ. *Z. f. Phys.* 49, 228 (1928)
- (1037) MITCHELL, A. C. G. Polarization of Hg lines in stepwise radiation. *Phys. Rev.* 36, 1589 (1930)
- (1038) MITCHELL, A. C. G. Polarization of sensitized fluorescence. *J. Franklin Inst.* 209, 747 (1930); *Phys. Rev.* 35, 1422 (1930)
- (1039) MITCHELL, A. C. G. The effect of hyperfine structure on the polarization of Cd resonance radiation. *Phys. Rev.* 38, 473 (1931)
- (1040) MITCHELL, A. C. G. Hyperfine structure and the polarization of Hg resonance radiation. *Phys. Rev.* 40, 964 (1932); 43, 887 (1933)
- (1041) MITCHELL, A. C. G. and DICKINSON, R. G. The effect of added gases on the decomposition of ammonia sensitized by excited Hg vapor. *Am. Chem. Soc. J.* 49, 1478 (1927)
- (1042) MITCHELL, A. C. G. and MURPHY, E. J. The mean life of the 7^2S_1 state of Hg from polarization measurements on the visible triplet. *Phys. Rev.* 46, 53 (1934)
- (1043) MITRA, S. M. Studies on polarization of fluorescence. *Ind. J. Phys.* 8, 171 and 445 (1933)
- (1044) MITRA, S. M. Fluorescence excited by circularly polarized light of λ 3132. *Current Sci.* 2, 347 (1934)
- (1045) MITRA, S. M. Über den Einfluss des KJ auf die Polarisation der Fluoreszenz von in Lösung befindlichen Farbstoffen. *Z. f. Phys.* 92, 61 (1934)
- (1046) MITRA, S. M. Polarisierete Fluoreszenz organischer Verbindungen. *Z. f. Phys.* 97, 138 (1935); *Ind. J. Phys.* 13, 349 (1939)
- (1047) MITRA, S. M. On the fluorescence of cyclohexanone. *Phil. Mag.* 23, 558 (1937)
- (1048) MITRA, S. M. On the influence of foreign substances on the absorption of dye stuffs in solution. *Ind. J. Phys.* 13, 397 (1939)
- (1049) MOERMANN, N. F. and KRAAK, H. H. Das Fluoreszenzschema der Uranyl-salze. *Rec. trav. de chim. Pays-Bas* 58, 34 (1939)
- (1050a) MOEGELICH, F. and ROMPE, R. Über Energieumwandlung in Krystall-phosphoren. *Phys. Z.* 41, 236 (1940); *Z. f. Phys.* 115, 707 (1940); *Munich* 1934, 147

- (1050b) MOEGLICH, F. and ROMPE, R. Strahlungseigenschaften und Energieausbreitung bei dichtgelagerten, gleichartigen Atomen. *Z. f. Phys.* **120**, 741 (1943)
- (1050c) MOEGLICH, F. and ROMPE, R. Eine neue Form der Energieleitung in der kondensierten Phase. *Munich* 1943, 204
- (1051a) MOLLWO, E. Über die Farbzentren der Alkalihalogenidkristalle. *Z. f. Phys.* **85**, 56 (1933)
- (1051b) MOLLWO, E. Über Elektronenleitung und Farbzentren in Fluss spat. *Goettinger Nachr.* **1**, 79 (1934)
- (1051c) MOLLWO, A. Das u.v. Absorptionsspektrum der Sulfide und Oxyde von Zn und Cd. *Reichsber. Phys.* **1**, 1 (1944)
- (1052) MOLTHAN, W. Über die Erhöhung der Dielektrizitätskonstante eines Zn-Phosphors durch Licht. *Z. f. Phys.* **4**, 262 (1921)
- (1052a) MONTRALL, E. W. A note on the theory of diffusioncontrolled reactions with application to the quenching of fluorescence. *J. Chem. Phys.* **14**, 202 (1946)
- (1053) MONYPENNY, M. W. and RUSSELL, A. Fluorescence spectra of vapors of fluorobenzene and fluorotoluene. *J. Chem. Soc.* 1929, 2436
- (1054) MOORE, W. J. and TAYLOR, H. S. The mercury photosensitized hydrogenation of ethylene, propylene and n-butylene. *J. Chem. Phys.* **8**, 504 (1940)
- (1055) MORACZEWSKA, M. Über die Abhängigkeit der Linienform der Hg-Linie 2537A von der Beobachtungsrichtung der Resonanzstrahlung. *Z. f. Phys.* **89**, 546 (1934); *C. R. Cracow* 1934, 18
- (1056) MOREY, D. B. Polarized fluorescence studied by means of a nicol, photocell and amplifier. *Phys. Rev.* **37**, 1686 (1931)
- (1056a) MORGENTERN, Z. L. Light sum of flash and phosphorescence in Ca,SrS(Ce,Sm)-phosphors. *C. R. Moscow* **54**, 783 (1946)
- (1057) MORSE, H. W. The thermo-luminescence spectrum of fluorspar. *Astrophys. J.* **21**, 410 (1905); *Proc. Nat. Ac. Sci.* **41**, 587 (1906)
- (1058) MORSE, H. W. Spectra of weak luminescences. *Astrophys. J.* **21**, 83 (1905)
- (1059) MOSER, H. Über Ausleuchtung und Tilgung der Phosphore durch Licht bei verschiedenem Gattungsatom. *Ann. d. Phys.* **85**, 687 (1928)
- (1060) MOTT, N. F. On the absorption of light by crystals. *Proc. Roy. Soc. A* **167**, 384 (1938)
- (1061) MOTT, N. F. Energy levels in real and ideal crystals. *Faraday Soc. Trans.* **34**, 822 (1938)
- (1062) MOUREU, CH., DUFFRAISSE, and LOTTE, P. Phénomènes de luminescence chez les satellites du rubrène. Deux hydrocarbures phosphorescents: le corps dit "bruns" et le corps "jaune". *J. chim. phys.* **27**, 89 (1930)
- (1063) MOWKAWA, K., BENEDICT, W. S., and TAYLOR, H. S. The mercury sensitized reactions of methane, deuteromethanes and the hydrogen isotopes. *J. Chem. Phys.* **5**, 212 (1937)
- (1064) MROZOWSKA, L. Sur la répartition des intensités dans les bandes de fluorescence de la vapeur de mercure. *Acta phys. pol.* **2**, 81 (1933)
- (1065) MROZOWSKI, S. Über die Bandenfluoreszenz des Hg-Dampfes. *Z. f. Phys.* **50**, 657 (1928)
- (1066) MROZOWSKI, S. Sur la fluorescence et la chaleur de dissociation des molécules de mercure. *C. R. soc. pol. phys.* **4**, 221 (1929); *Z. f. Phys.* **55**, 338 (1929)
- (1067) MROZOWSKI, S. On the incomplete polarization of the Hg resonance radiation. *Phys. Rev.* **36**, 1591 (1930); **37**, 845 (1931)
- (1068) MROZOWSKI, S. Zur Deutung der Träger der Hg-Banden. *Z. f. Phys.* **60**, 410 (1930)

- (1069) MROZOWSKI, S. Bemerkung zur Arbeit von E. Gaviola "The efficiency of quenching collisions and the radius of the excited Hg atom". *Z. f. Phys.* 60, 716 (1930)
- (1070) MROZOWSKI, S. Über die Bandenspektren der Zn- und Cd-Dämpfe. *Z. f. Phys.* 62, 314 (1930)
- (1071) MROZOWSKI, S. Bemerkung über die Lebensdauer angeregter Atome und die Hyperfeinstruktur des Hg-Spektrums. *Z. f. Phys.* 68, 278 (1931); *Nature* 127, 890 (1931); *C. R. Cracow* 1931, 489
- (1072) MROZOWSKI, S. Stosserscheinungen bei optischer Anregung verschiedener Hg-Isotopen. *Z. f. Phys.* 78, 826 (1932)
- (1073) MROZOWSKI, S. Über die Struktur des Bandenspektrums des Hg-Dampfes. *Z. f. Phys.* 87, 340 (1933); 104, 228 (1937); 106, 458 (1937)
- (1074) MROZOWSKI, S. Über die Depolarisation der Fluoreszenz des Joddampfes durch Stöße von Heliumatomen. *Bull. intern. Cracow* 1933, 346
- (1075) MROZOWSKI, S. Über die Polarisation der u.v. Bandenfluoreszenz des Joddampfes. *Acta phys. pol.* 2, 229 (1933)
- (1076) MROZOWSKI, S. Absorptionsmessungen in den Bandenspektren der Zn- und Cd-Dämpfe. *Z. f. Phys.* 91, 600 (1934)
- (1077) MROZOWSKI, S. Polarisation der Fluoreszenz von zweiatomigen Dämpfen und ihre Beeinflussung durch Stöße. *Acta phys. pol.* 5, 85 (1936)
- (1078) MROZOWSKI, S. Bemerkung über die Struktur der Hg-Resonanzlinie 2537A. *Helv. phys. acta* 9, 27 (1936)
- (1079a) MROZOWSKI, S. Über den Einfluss der Zusatzgase und des Magnetfeldes auf den Polarisationsgrad der Fluoreszenz des Joddampfes. *Bull. intern. Cracow* 1937, 295
- (1079b) MROZOWSKI, S. Über die sensibilisierte Tl-Fluoreszenz bei hohen Hg-Dampfdrücken. *Acta phys. pol.* 6, 58 (1937)
- (1080) MROZOWSKI, S. Über den Einfluss des Magnetfeldes auf die Fluoreszenz des Hg-Dampfes und den Zeemaneffekt in Bandenspektren sehr lose gebundener Moleküle. *Acta phys. pol.* 6, 201 (1937)
- (1081) MROZOWSKI, S. Über die Hyperfeinstruktur der verbotenen Hg-Linie 2655,8A. *Z. f. Phys.* 108, 204 (1938)
- (1082) MROZOWSKI, S. Über die Polarisation der Bandenfluoreszenz einiger Metalldämpfe. *Acta phys. pol.* 7, 45 (1938)
- (1083a) MROZOWSKI, S. Quenching and depolarization of resonance radiation by collisions with molecules of a foreign gas. Remarks on papers by Ellett, Olsen and Petersen. *Phys. Rev.* 61, 379 (1942)
- (1083b) MROZOWSKI, S. Forbidden lines in the laboratory. *Rev. Mod. Phys.* 16, 153 (1945)
- (1084) MUELLER, F. Die Frage nach der Existenz einer Absorption der Tl-Linien 3519/29 und 5350 bei Erzeugung des metastabilen Zustandes $6^2P_{3/2}$ durch Einstrahlung der Linie 3776A. *Helv. phys. acta* 8, 55 (1935)
- (1085) MUELLER, H. Messung des Hg-Dampfdruckes bei kleiner Dampfdichte mittels der Absorption der Resonanzlinie 2537A. *Diss. Berlin* 1933
- (1086) MUELLER, K. Eine neue Methode zur Bestimmung des Hg-Gehalts der Luft. *Z. f. Phys.* 65, 739 (1930)
- (1087) MUELLER, K. and PRINGSHEIM, P. Eine optische Methode zur Messung des Hg-Gehaltes der Luft. *Naturwiss.* 18, 364 (1930)
- (1088) MUKHERJI, P. C. On the absorption and emission spectra of rare earth crystals. *Ind. J. Phys.* 13, 185 (1939)
- (1089) MUKHERJI, P. C. Untersuchung des diffusen Fluoreszenzspektrums von Ionenseltener Erden in Lösung und im Kristall. *Z. f. Phys.* 109, 573 (1938)
- (1090) MULDER, P. J. Growth and decay of phosphorescence in calcium sulphide by a photoelectric method. *J. Franklin Inst.* 225, 527 (1938)
- (1091) MULLER, R. H. Studies on fluorescence and photosensitization in aqueous solutions. III. *Proc. Roy. Soc. A* 121, 313 (1928)

- (1092) MULLIKEN, R. J. The halogen molecules and their spectra. J-J-like coupling. Molecular ionization potentials. *Phys. Rev.* 19, 548 (1934)
- (1093) MULLIKEN, R. J. Low electronic states of simple heteropolar diatomic molecules. Hydrogen and univalent metal halides. *Phys. Rev.* 51, 310 (1936)
- (1094) MUMM, O. Ein Beitrag zur Frage nach dem Zusammenhang zwischen Fluoreszenz und chemischer Konstitution. *Chem. Ber.* 72, 29 (1939)
- (1094a) MURATA, N. J. and SMITH, R. L. Manganese and lead coactivators of red fluorescence in halite. *Am. Mineral.* 31, 527 (1946)
- (1095) MUTO, T. On the quantum theory of the phosphorescence of crystal phosphors. *Sci. Pap. Inst. Phys. Chem. Res. Tokyo* 28, 171 (1935); 32, 5 (1937)
- (1095a) NAGY, B. Correlation of the structure of various phosphors. *Ithaca* 1946, 399
- (1095b) NAIL, N., PEARLMAN, T., and URBACH, F. Photoluminescence of some sulfide phosphors as a function of intensity. *Ithaca* 1946, 140
- (1096) NARAYAN, A. L. and ROW, R. The fluorescence and channelled absorption spectra of Bi-vapour at high temperature. *Nature* 114, 645 (1924)
- (1097) NATANSON, L. Die Änderung der Intensitätsverteilung in einem Resonanzspektrum. *Z. f. Phys.* 65, 75 (1930); *C. R. soc. pol. phys.* 5, 327 (1931)
- (1098) NATANSON, S. Investigation of the optical sensitization of silver halides. *Acta physchim. U.S.S.R.* 11, 67 (1939)
- (1099) NAYAR, P. G. N. The luminescence, absorption and scattering of light in diamonds. *Proc. Ind. Ac. A* 13, 483 and 534 (1941); 14, 1 (1941); 15, 310 (1942)
- (1100) NAYAR, P. G. N. The lattice and electronic spectrum of diamond. *Proc. Ind. Ac. A* 15 293 (1942)
- (1100a) NEELAKANTAM, K. and SITARAMAN, M. V. Luminescence in the solid state. I. Phenolic and o-hydroxy-carbonyl compounds as activators. II. Coumarin and its derivatives as activators. *Proc. Ind. Ac. A* 21, 45 and 271 (1945)
- (1101) NEUJMIN, H. Photodissoziation des BiJ₃-Dampfes. *Phys. Z. Sow.* 2, 422 (1932)
- (1102) NEUJMIN, H. Über die optische Anregung des Tl-Spektrums in den Dämpfen seiner Halogensalze. *Phys. Z. Sow.* 5, 344 (1934)
- (1103) NEUJMIN, H. Die optische Dissoziation des Zinnchlorürdampfes im Schumann-Gebiet. *Acta physchim. U.S.S.R.* 2, 595 (1935)
- (1104) NEUJMIN, H. and TERENCE, A. Decomposition of polyatomic molecules by Schumannradiation. *Bull. Leningrad* 1936, 529; *Acta physchim. U.S.S.R.* 5, 465 (1936)
- (1105) NEUMANN, E. Über die Absorption der Hg-Resonanzlinie im Hg-Dampf bei Mischung von Fremdgasen. *Z. f. Phys.* 62, 368 (1930)
- (1106) NICHOLS, E. L. Color photographs of the phosphorescence of certain metallic sulfides. *Am. Phil. Soc. Proc.* 55, 994 (1916)
- (1107) NICHOLS, E. L. Spectral structure of the phosphorescence of certain sulfides. *Phys. Rev.* 56, 258 (1917); *Proc. Nat. Ac. Sci.* 3, 199 (1917)
- (1108) NICHOLS, E. L. Links connecting fluorescence and the luminescence of incandescent solids. *J. Opt. Soc. Am.* 13, 661 (1926)
- (1109) NICHOLS, E. L. and HOWES, H. L. Luminescence of Kunzite. *Phys. Rev.* 4, 18 (1914)
- (1110) NICHOLS, E. L. and HOWES, H. L. The polarized fluorescence of ammonium uranyl chloride. *Proc. Nat. Ac. Sci.* 1, 444 (1915)
- (1111) NICHOLS, E. L. and HOWES, H. L. Fluorescence and absorption of certain pleochroitic crystals of the uranyl salts. *Phys. Rev.* 8, 364 (1916)

- (1112) NICHOLS, E. L. and HOWES, H. L. A synchrono-phosphoroscope. *Phys. Rev.* 7, 586 (1916)
- (1113) NICHOLS, E. L. and HOWES, H. L. On the phosphorescence of uranyl salts. *Phys. Rev.* 9, 292 (1917); *Proc. Nat. Ac. Sci.* 2, 328 (1916)
- (1114) NICHOLS, E. L. and HOWES, H. L. On the unpolarized fluorescence and absorption of four double chlorides of uranyl. *Phys. Rev.* 11, 285 (1918)
- (1115) NICHOLS, E. L. and HOWES, H. L. Note on phosphorescent calcite. *Phys. Rev.* 11, 327 (1918)
- (1116) NICHOLS, E. L. and HOWES, H. L. Types of phosphorescence. *Proc. Nat. Ac. Sci.* 4, 305 (1918)
- (1117) NICHOLS, E. L. and HOWES, H. L. Fluorescence and absorption of the uranyl sulfates. *Phys. Rev.* 14, 293 (1919)
- (1118) NICHOLS, E. L. and HOWES, H. L. Photoluminescence of flames. *Phys. Rev.* 22, 425 (1923); 23, 472 (1924)
- (1119) NICHOLS, E. L. and HOWES, H. L. Note on the rare earths as activators of luminescence. *J. Opt. Soc. Am.* 13, 573 (1926)
- (1120) NICHOLS, E. L., HOWES, H. L., and WICK, F. G. Fluorescence and absorption of the uranyl acetates. *Phys. Rev.* 14, 201 (1919)
- (1121) NICHOLS, E. L., HOWES, H. L., and WILBER, D. T. The photoluminescence and cathodoluminescence of calcite. *Phys. Rev.* 12, 351 (1918)
- (1122) NICHOLS, E. L. and MERRITT, E. The phenomenon of phosphorescence considered from the standpoint of the dissociation theory. *Phys. Rev.* 27, 367 (1908)
- (1123) NICHOLS, E. L. and MERRITT, E. Distribution of energy in fluorescence spectra. *Phys. Rev.* 30, 328 (1910)
- (1124) NICHOLS, E. L. and MERRITT, E. The absorption of alcoholic solutions of eosin and resorufin. *Phys. Rev.* 31, 376 (1910)
- (1125) NICHOLS, E. L. and MERRITT, E. The specific exciting power of the different wavelengths of the visible spectrum in the case of the fluorescence of eosin and resorufin. *Phys. Rev.* 31, 381 (1910)
- (1126) NICHOLS, E. L. and MERRITT, E. Further experiments on fluorescence absorption. *Phys. Rev.* 35, 500 (1910)
- (1127) NICHOLS, E. L. and MERRITT, E. On fluorescence and phosphorescence between + 20° and - 190° C. *Phys. Rev.* 32, 38 (1911); *Phys. Z.* 10, 774 (1909)
- (1128) NICHOLS, E. L. and MERRITT, E. The fluorescence and absorption of certain uranyl salts. *Phys. Rev.* 33, 354 (1911)
- (1129) NICHOLS, E. L. and MERRITT, E. Note on the fluorescence of frozen solutions of the uranyl salts. *Phys. Rev.* 3, 457 (1914)
- (1130) NICHOLS, E. L. and MERRITT, E. New fluorescence spectrum of uranyl ammonium chloride. *Phys. Rev.* 6, 358 (1915)
- (1131) NICHOLS, E. L. and MERRITT, E. The influence of water of crystallization upon the fluorescence and absorption spectra of uranyl nitrate. *Phys. Rev.* 9, 113 (1917)
- (1132) NICHOLS, E. L. and SLATTERY, M. K. Uranium as an activator. *J. Opt. Soc. Am.* 12, 449 (1926)
- (1132a) NICOLL, F. N. Some observations on light absorption of powdered luminescent materials. *Ithaca* 1946, 418
- (1133) NIELSEN, J. R. and WRIGHT, N. Atomic resonance radiation in potassium vapor. *J. Opt. Soc. Am.* 20, 27 (1930)
- (1134) NIEWODNICZANSKI, H. The fluorescence of superheated Hg vapor. *Nature* 117, 555 (1926); 118, 877 (1926)
- (1135) NIEWODNICZANSKI, H. On the fluorescence of mercury vapor. *C. R. soc. pol. phys.* 3, 1 (1927); *Z. f. Phys.* 49, 59 (1928)
- (1136) NIEWODNICZANSKI, H. Über den Einfluss des Magnetfeldes auf die Fluoreszenz des Hg-dampfes. *Z. f. Phys.* 55, 676 (1929)

- (1137) NIEWODNICZANSKI, H. Fluorescence of Hg vapor under atomic and molecular absorption. *Nature* 127, 406 (1931)
- (1138) NISI, H. On the Raman spectrum and luminescence of Scheelite. *Zeeman Verhandlungen* 1935, 261
- (1139) NISI, H. and MIYAMOTO, K. On the fluorescence of fluor spars excited by light of different wavelengths. *Proc. Tokyo* 4, 357 (1929)
- (1140) NITKA, H. Über die Intensitäten der Bandenspektren der Phosphore. *Ann. d. Phys.* 16, 720 (1933)
- (1141) NOAK, K. Photochemische Wirkung des Chlorophylls und ihre Bedeutung für die Kohlensäureassimilation. *Z. f. Bot* 17, 481 (1925).
- (1142) NORDHEIM, L. Zur Frage der Polarisation des Streu- und Fluoreszenzlichtes. *Z. f. Phys.* 33, 729 (1925)
- (1143) NORDHEIM, L. Zur Theorie der Anregung der Atome durch Stöße. *Z. f. Phys.* 36, 496 (1926)
- (1144) NORRISH, R. G. W. Photochemical equilibrium in nitrogen peroxide: The relation between fluorescence and photochemical action. *J. Chem. Soc.* 1929, 1611
- (1145) NORRISH, R. G. W. The relationship of fluorescence to photolysis in gaseous systems. *Faraday Soc. Trans.* 35, 21 (1939)
- (1146) NORRISH, R. G. W., CROW, H. S., and SALTMARSH, O. D. Spectroscopy and photochemical decomposition of acetone. *J. Chem. Soc.* 1934, 1456
- (1147) NORRISH, R. G. and MACF. SMITH, W. Quenching of resonance radiation of Na. *Proc. Roy. Soc. A* 176, 295 (1940)
- (1147a) NOTTINGHAM, W. B. The decay of luminescence of certain luminescent materials as a function of time. *Ithaca* 1946, 301
- (1148) NOYES, W. A. The photochemical reaction between oxygen and mercuric vapor at relatively low pressures. *Am. Chem. Soc. J.* 49, 3100 (1927); *Z. phys. Chem. B* 2, 445 (1929)
- (1149) NOYES, W. A. The reaction between nitrogen and hydrogen in presence of Hg vapor and the resonance radiation of Hg. *Am. Chem. Soc. J.* 52, 2418 (1930)
- (1150) NOYES, W. A. The photochemical reaction between nitric oxide and Hg vapor. *Am. Chem. Soc. J.* 53, 514 (1931)
- (1151) NOYES, W. A. and HENRIQUES, F. C. Fluorescence and photochemical kinetics of polyatomic molecules in the gas phase. *J. Chem. Phys.* 7, 767 (1939)
- (1152) NUNAN, T. H. and MARSH, J. K. Studies in fluorescence spectra. *J. Chem. Soc.* 1924, 2123
- (1153) OBREIMOW, I. V., PRICHOTKA, A. F., and SHABALDAS, K. G. Fluorescence spectra of crystalline anthracene and phenanthrene. *J. exp. and theor. Phys. U.S.S.R.* 6, 1062 (1936)
- (1154) OBREIMOW, I. V. and SHABALDAS, K. G. Fluorescence of naphthalene crystals. *J. Phys. U.S.S.R.* 7, 141 (1943)
- (1154a) O'BRYAN, B. Development of infrared sensitive phosphors. *J. Opt. Soc. Am.* 36, 351 and 369 (1946); *Ithaca* 1946, 141
- (1155) OCHIAI, K. Studies of the phosphorescence of gelatine and fluorescein at low temperatures. *Bull. Chem. Soc. Jap.* 5, 203 (1930)
- (1156) ODENCRANTS, A. Luminescence spectra of fluorites. *Ark. f. Math., Astron., Fys.* 6, Nr. 27 (1910)
- (1157) OESER, E. Absorptions- und Fluoreszenzuntersuchungen an dampfförmigen Cd- und Zn-Halogeniden. *Z. f. Phys.* 95, 699 (1935)
- (1158) OKON, M. Sur la polarisation des bandes de fluctuation de la fluorescence de la vapeur de zinc. *Acta phys. pol.* 4, 215 (1935)
- (1159) O' L. CROW, N. and WALKER, A. Fluorescence and absorption spectra of pterin-like pigments synthesized by the diphtheria bacillus and isolated by chromatographic analysis. *J. Opt. Soc. Am.* 34, 135 (1935)

- (1160) OLDENBERG, O. U.v. Resonanzspektren des Joddampfes. *Z. f. Phys.* 18, 1 (1923)
- (1161) OLDENBERG, O. Über Elementarvorgänge bei der Ausstrahlung der Jodbanden. *Z. f. Phys.* 25, 136 (1924)
- (1162) OLDENBERG, O. Über die Einwirkung des Magnetfeldes und des elektrischen Feldes auf die u.v. Jodfluoreszenz. *Z. f. Phys.* 27, 189 (1924)
- (1163) OLDENBERG, O. On fluorescent radiation of nitrogen. *Proc. Nat. Ac. Sci.* 11, 595 (1925)
- (1164) OLDENBERG, O. Über Fluoreszenzanregung mit kurzweiligem u.v. *Z. f. Phys.* 38, 370 (1926)
- (1165) OLDENBERG, O. Über die Intensitätsverteilung in Woods Resonanzserie des Jodmoleküls. *Z. f. Phys.* 45, 451 (1927)
- (1166) OLDENBERG, O. Über die Fluoreszenz von Quecksilber-Edelgas-Banden. *Z. f. Phys.* 47, 184 (1928)
- (1167) OLDENBERG, O. Über die Auslöschung der Hg-Fluoreszenz durch Gaszusatz. *Z. f. Phys.* 49, 609 (1928); 50, 580 (1928)
- (1168) OLDENBERG, O. Über eine Zusammenwirkung von Stoss und Strahlung. *Z. f. Phys.* 51, 605 (1928)
- (1169) OLDENBERG, O. Über Struktur und Deutung der Quecksilber-Edelgas-Banden. *Z. f. Phys.* 55, 1 (1929)
- (1170) OLDENBERG, O. Über die magnetische Auslöschung der Jodfluoreszenz. *Z. f. Phys.* 57, 186 (1929)
- (1171) OLDENBERG, O. On the persistence of molecular rotation and vibration in collisions. *Phys. Rev.* 37, 194 (1931)
- (1172) OLDHAM, M. S. and KUNERTH, W. The effect of size of the particles on the intensity of fluorescence of a phosphor. *J. Opt. Soc. Am.* 31, 102 (1941)
- (1173) OLSEN, L. O. The mechanism of formation of mercury hydride and mercury deuteride. Optical excitation of cadmium deuteride. *J. Chem. Phys.* 6, 307 (1938)
- (1174) OLSEN, L. O. Quenching and depolarization of Hg resonance radiation by foreign gases. *Phys. Rev.* 55, 1126 (1939)
- (1175a) OLSEN, L. O. Quenching and depolarization of Hg resonance radiation by rare gases. *Phys. Rev.* 59, 914 (1941); 60, 739 (1941)
- (1175b) OLSEN, L. O. and KERR, P. P. Quenching and depolarization of mercury resonance radiation by nitrogen and oxygen. *Phys. Rev.* 72, 115 (1947)
- (1176) OLSON, H. F. Polarization of resonance radiation in mercury. *Phys. Rev.* 29, 207 (1927); 32, 443 (1928)
- (1177) OPECHOWSKI, W. Zur Theorie der verbotenen Hg-Linie 2655.8Å. *Z. f. Phys.* 109, 485 (1938)
- (1178) OPPENHEIMER, I. R. Internal conversion in photosynthesis. *Phys. Rev.* 60, 158 (1941)
- (1179) ORNDORFF, W. R., GIBBS, R. C., and SHAPIRO, C. V. Absorption spectra of fluorescein and related compounds. *J. Am. Chem. Soc.* 50, 819 (1928)
- (1180) ORNSTEIN, L. S. and BURGER, H. C. Die Polarisation des Resonanzlichtes. *Phys. Z.* 25, 298 (1924)
- (1181a) ORTHMANN, W. Über die Stossdämpfung der Hg-Resonanzlinie. *Ann. d. Phys.* 78, 601 (1925)
- (1181b) ORTHMANN, W. Über die Veränderung der Resonanzlinien durch vielfach wiederholten Comptoneffekt. *Z. f. Phys.* 54, 767 (1929)
- (1182) ORTHMANN, W. and PRINGSHEIM, P. Über die Auslöschung der Hg-Resonanzlinie im Hg-Dampf von hohem Druck. *Z. f. Phys.* 35, 626 (1926)
- (1183) ORTHMANN, W. and PRINGSHEIM, P. Über die Verbreiterung der Hg-Resonanzstrahlung durch Zusatz fremder Gase. *Z. f. Phys.* 43, 9 (1927)
- (1184) ORTHMANN, W. and PRINGSHEIM, P. Über die Verbreiterung und Schwächung der Hg-Resonanzlinie bei Erhöhung des Hg-Dampfdruckes. *Z. f. Phys.* 46, 160 (1927)

- (1185) ORTHMANN, W. and PRINGSHEIM, P. Über die Breite der Resonanzlinie und die Möglichkeit einer Rotverschiebung von Resonanzlinien durch vielfach wiederholte Streuung. *Z. f. Phys.* 53, 367 (1929)
- (1186) OWENS, J. S. and DUFFENDACK, O. S. Quenching of Hg resonanc radiation by H_2 , CO and N_2 . *Phys. Rev.* 40, 1042 (1932)
- (1187) PADMANABHAN, R. Fluorescence in cyclohexane. *Proc. Ind. Ac. A* 2, 209 (1935)
- (1188) PADMANABHAN, R. The fluorescence of acetone vapor. *Proc. Ind. Ac. A* 5, 594, (1937)
- (1189) PANT, D. D. Some studies in the spectra of single uranyl halides and other uranyl salts. *Proc. Ind. Ac. A* 22, 95 and 110 (1945)
- (1190a) PANT, D. D. Luminescence spectra and vibrations in crystal lattices. *Proc. Ind. Ac. A* 18, 309 (1943)
- (1190b) PANT, D. D. and SAKHWALKAR, N. D. Fluorescence spectrum of uranyl fluoride. *Proc. Ind. Ac. A* 19, 135 (1944)
- (1190c) PANT, D. D. The photoconductivity of diamond. *Proc. Ind. Ac. A* 19, 315 and 325 (1944)
- (1191) PARFIAMOWICH, I. The phosphorescence of rocksalt activated by nickel. *J. exper. theor. phys. U.S.S.R.* 9, 310 (1939)
- (1192) PARYS, J. Über die Resonanzserien des Bi-Dampfes. *Z. f. Phys.* 71, 807 (1931); *Acta phys. pol.* 1, 93 (1932)
- (1193) PASCHEN, F. Absorption und Resonanz monochromatischer Strahlung. *Ann. d. Phys.* 45, 625 (1914)
- (1194) PASCHEN, F. and GERLACH, W. Zur Frage nach dem electrischen Analogon zum Zeemanefekt. *Phys. Z.* 15, 489 (1914)
- (1195) PASIERBINSKI, I. S. Über neue Resonanzserien im Selendampf. *Acta phys. pol.* 1, 503 (1932)
- (1195a) PAUL, F. W. Experiments of the use of infrared sensitive phosphors in photography of the spectrum. *J. Opt. Soc. Am.* 36, 175 and 352 (1946)
- (1196) PAULI, W. E. Über unsichtbare Phosphoreszenz. *Phys. Z.* 11, 991 (1910); *Ann. d. Phys.* 34, 739 (1911)
- (1197) PAULI, W. E. Über Phosphoreszenz von Selenverbindungen. *Ann. d. Phys.* 38, 870 (1912)
- (1198) PAULI, W. E. Über Phosphoreszenz. *Phys. Z.* 13, 39 (1912)
- (1199) PAULI, W. E. Lichtelektrische Untersuchungen an fluoreszierenden Substanzen. *Ann. d. Phys.* 40, 677 (1913)
- (1200) PAULINA, M. Déplacement des spectres de fluorescence et absorption des solutions de la tribenzyldécacyclène en fonction du solvant. *Acta phys. pol.* 3, 373 (1934)
- (1201) PAULING, L. The light absorption and fluorescence of triarylmethyl free radicals. *Am. Chem. Soc. J.* 66, 1985 (1944)
- (1201a) PEARCE, R. W. B. and SINHA, S. P. Absorption bands of Li_2 , Na_2 , K_2 and NaK . *Nature* 160, 159 (1947)
- (1201b) PEKERMAN, F. M. An experimental study of concentration quenching of fluorescence in solutions. *C. R. Moscow* 52, 405 (1946)
- (1201c) PEARLMAN, D., NAIL, N. R., and URBACH, F. Stimulation of some zinc sulfide phosphors. *Ithaca* 1946, 358
- (1202) PERRIN, J. La fluorescence. *Ann. chim. phys.* 10, 133 (1918)
- (1203) PERRIN, J. Matière et lumière. *Ann. chim. phys.* 11, 5 (1919)
- (1204) PERRIN, J. Observation sur la fluorescence. *C. R.* 177, 469 (1923)
- (1205) PERRIN, J. Radiochimie de la fluorescence. *C. R.* 177, 612 and 665 (1923).
- (1206) PERRIN, J. Lumière et réaction chimique. *Institut Solvay* 1925, 322
- (1207) PERRIN, J. Fluorescence et induction moléculaire par résonance. *C. R.* 184, 1097 (1927)
- (1208) PERRIN, J. Détermination du rôle de la lumière dans les réactions chimiques thermiques. *C. R.* 187, 913 (1928)

- (1209) PERRIN, J. L'induction moléculaire. *Acta phys. pol.* 5, 319 (1936)
- (1210) PERRIN, J. and CHOUCROUN, MLE. Fluorescence et lois générales relatives aux vitesses de réaction. *C. R.* 178, 1401 (1924)
- (1211) PERRIN, J. and CHOUCROUN, MLE. Parallélisme entre le pouvoir fluorescent et la vitesse de réaction. *C. R.* 183, 329 (1926)
- (1212) PERRIN, J. and CHOUCROUN, MLE. Rôle de l'induction moléculaire dans l'activation par choc. *C. R.* 184, 985 (1927)
- (1213) PERRIN, J. and CHOUCROUN, MLE. Vitesse des réactions photochimiques. *C. R.* 187, 697 (1928)
- (1214) PERRIN, J. and CHOUCROUN, MLE. Fluorescence sensibilisée en milieu liquide. *C. R.* 189, 1213 (1929)
- (1215) PERRIN, F. Loi de décroissance du pouvoir fluorescent en fonction de la concentration. *C. R.* 178, 1978 (1924)
- (1216) PERRIN, F. Rôle de la viscosité dans les phénomènes de fluorescence. *C. R.* 178 2252 (1924)
- (1217) PERRIN, F. Polarisation de la lumière de fluorescence. Vie moyenne des molécules dans l'état excité. *J. d. Phys.* 7, 930 (1926); *C. R.* 180, 581 (1925); 181, 514 (1925); 182, 219 (1926)
- (1218) PERRIN, F. Fluorescence à longue durée des sels d'urane solides et dissous. *C. R.* 182, 929 (1926)
- (1219) PERRIN, F. La désactivation induite des molécules et la théorie des antioxygènes. *C. R.* 184, 1121 (1927). *J. chim. phys.* 25, 531 (1928)
- (1220) PERRIN, F. Etude mathématique du mouvement Brownien de rotation. *Thèse, Paris 1928*
- (1221) PERRIN, F. Fluorescence des solutions. Induction moléculaire. Polarisation et durée d'émission. Photochimie. *Ann. de phys.* 12, 169 (1929)
- (1222) PERRIN, F. L'association moléculaire et l'optimum de fluorescence des solutions. Influence des sels. *C. R.* 192, 1727 (1931)
- (1223) PERRIN, F. Remarque sur la polarisation de fluorescence des solutions. *J. de phys.* 2, 163 (1931)
- (1224) PERRIN, F. Théorie quantique des transferts d'activation entre molécules de même espèce. Cas des solutions fluorescentes. *Ann. de phys.* 17, 283 (1932)
- (1225) PERRIN, F. Mouvement Brownien d'un ellipsoïde (rotation libre et dépolarisation des fluorescences). *J. de phys.* 5, 497 (1934); 7, 1 (1936)
- (1226) PERRIN, F. Diminution de la polarisation de la fluorescence des solutions résultant du mouvement Brownien de rotation. *Acta phys. pol.* 5, 335 (1936)
- (1227) PERRIN, F. and DELORME, B. Mesure des durées de fluorescence des sels d'uranyle solides et de leur solutions. *C. R.* 186, 428 (1928)
- (1228) PETERS, R. A. Vitamin B₁ and blue fluorescent compounds. *Nature* 135, 107 (1935)
- (1229) PETERSEN, R. and ELLETT, A. Quenching and depolarizing collisions and polarization of resonance radiation in a magnetic field. *Phys. Rev.* 49, 417 (1936)
- (1230) PETROWA, A. Photodissociation of gallium halides. *Acta physchim. U.S.S.R.* 4, 559 (1936)
- (1230a) PHIBBS, M. K., DARWENT, B. DE B., and STEACIE, E. W. R. Mercury photosensitized reactions of ethylene oxide. *J. Chem. Phys.* 16, 39 (1948)
- (1231) PHILLIPS, F. S. Phosphorescence of Hg vapor. *Nature* 92, 401 (1913). *Proc. Roy. Soc. A* 89, 39 (1913)
- (1232) PHISALIX, M., BOUTARIC, A., and BOUCHARD, J. Action de quelques venins sur la fluorescence des solutions d'uranine. *C. R.* 200, 976 (1935)
- (1232a) PICK, H. Über den Einfluss der Temperatur auf die Erregung von Farbzentren. *Ann. d. Phys.* 31, 365 (1938)

- (1233) PIENKOWSKI, S. Über das Anklingen der Hg-Dampffluoreszenz bei Erregung mit der Hg-Linie 2537A. *Z. f. Phys.* 50, 787 (1928)
- (1234) PIENKOWSKI, S. Influence du champ magnétique sur la fluorescence des molécules diatomiques. *Acta phys. pol.* 5, 127 (1936)
- (1235) PIENKOWSKI, S. Sur la fluorescence de l'octahydrofluorocyclene (C₄₈H₃₆). *Bull. interh. Cracow A* 1937, 269
- (1236) PIENKOWSKI, S. and JABLONSKI, A. Nouvelle méthode de mesure du coefficient d'absorption de la lumière dans les corps fluorescents. *C. R. soc. pol. phys.* 3, 9 (1925); *J. de phys.* 6, 177 (1925)
- (1237) PIERARD, J. Nouvelles séries de résonance de la vapeur diatomique de sélénium et de tellure. *Bull. Brussels* 17, 974 (1931); 18, 180 (1932)
- (1238) PIERARD, J. and MIGEOTTE, M. Sur la fluorescence de la vapeur de tellure diatomique excitée par les raies du cadmium. *Bull. Brussels* 19, 246 (1932)
- (1239) PIERCE, C. A. Variations in the decay of phosphorescence in Sidot blende produced by heating. *Phys. Rev.* 26, 312 (1908)
- (1240) PIERCE, C. A. The distribution of energy in the luminescence spectrum of Sidot blende. *Phys. Rev.* 30, 663 (1910); 32, 115 (1911)
- (1240a) PITHA, J. J., SMITH, A. L., and WARD, R. The preparation of lanthanum oxysulfide as a base material for phosphors stimulated by infrared. *J. Am. Chem. Soc.* 69, 1870 (1947)
- (1241) PJATNITZKIJ, B. On the law of attenuation of the phosphorescence of salicylic acid at liquid air temperature. *J. exper. theor. phys. U.R.R.S.* 9, 310 (1939)
- (1242) PLOTNIKOW, J. Ein Beitrag zur Fluoreszenz der Körper. *Chem. Zeitung* 59, 597 (1935)
- (1243) PLUMLEY, H. J. Isotope effect and quenching in the fluorescence of bromine. *Phys. Rev.* 45, 678 (1934)
- (1243a) PLYMALE, W. S. A sensitive photoelectric method for determining the chromativity of phosphorescent and fluorescent materials. *J. Opt. Soc. Am.* 37, 339 (1947)
- (1244) POCHETTINO, A. Sui fenomeni di luminescenza in alcune sostanze organiche. *Lincei Rend.* 18, 358 (1909)
- (1245) POCHETTINO, A. Sui fenomeni di luminescenza nei cristalli. *Cimento* 18, 245 (1909); *Z. f. Krist.* 50, 113 (1912)
- (1246) POHL, R. Über eine Beziehung zwischen dem selektiven Photoeffekt und der Phosphoreszenz. *Verhandl. d. Deutsch. phys. Ges.* 13, 961 (1911)
- (1247a) POHL, R. W. Die Phosphoreszenz im Zusammenhang mit elektrischen Erscheinungen. *Naturwiss.* 16, 477 (1928)
- (1247b) POHL, R. W. Electron conductivity and photochemical processes in alkali halide crystals. *Proc. Phys. Soc. London*, 49 Extra part, 3 (1938); *Ann. d. Phys.* 29, 239 (1937)
- (1248) POHL, R. and RUPP, E. Über Alkalihalogenidphosphore. *Ann. d. Phys.* 81, 1161 (1926)
- (1249) POKOTILO, P. Fluoreszenz. *J. russ. physchem. Ges.* 42, 141 (1914)
- (1250) POLONOWSKI, M. BUSNEL, R., and PESSON, M. La fluoresciance à fluorescence bleu des écailles de cyprinides. *C. R.* 217, 163 (1943)
- (1251) PONOMAREW, N. and TERENCE, A. Optische Anregung des Zn-Dampfes. *Z. f. Phys.* 37, 95 (1926)
- (1252) POOL, M. L. Measurement of the life of the metastable Hg atom. *Phys. Rev.* 33, 22 (1929)
- (1253) POOL, M. L. Life of metastable mercury and evidence for a long lived metastable vibrating nitrogen molecule. *Phys. Rev.* 37, 1686 (1931); 38, 955 (1931)
- (1254) POOL, M. L. and SIMMONS, S. J. The hyperfine structure intensities of the ²³S₁-²³P_{0,1,2} triplet in optically excited mercury vapor. *Phys. Rev.* 43, 1045 (1933); 44, 744 (1933)

- (1255) POOL, M. L. and SIMMONS, S. J. Hyperfine structure absorption in optically excited Hg vapor. *Phys. Rev.* **44**, 997 (1933)
- (1256) POPOV, B. Photodissoziation des PbBr₂-Dampfes. *Acta physchim U.R.R.S.* **4**, 159 (1936)
- (1257) POPOV, B. and NEUJMIN, H. Photodissoziation der Bleihalogeniddämpfe. *Phys. Z. Sow.* **2**, 394 (1932)
- (1258) PORITZKY, A. Some optical properties of fluorescent rhodamine B. *J. Franklin Inst.* **197**, 527 (1924)
- (1259) POSEJPAL, V. Fluorescence du benzène et son absorption infrarouge. *C. R.* **187**, 1046 (1928)
- (1260) POSPIELOW, A. Über das Abklingen der Lumineszenz von trockener und feuchter, gefärbter Gelatine. *Verhandl. d. Deutsch. phys. Ges.* **16**, 411 (1914)
- (1261) POSPIELOW, A. Zur lichtelektrischen Photometrie der Phosphoreszenzerscheinungen. *Ann. d. Phys.* **45**, 1039 (1914)
- (1262) POWER, A. D. Fluorescence of Cd vapor. *Phys. Rev.* **23**, 293 (1924); **26**, 761 (1925)
- (1263) PREDWODITILEW, A. Zur Theorie des Abklingens der Fluoreszenz. *Z. f. Phys.* **32**, 861 (1925)
- (1264) PREVET, F. L'influence de l'acide borique sur la phosphorescence des sulfures de zinc préparés par la méthode de l'explosion. *C. R.* **188**, 903 (1929); **190**, 1402 (1930)
- (1265) PREVET, F. La structure cristalline de sulfure de zinc phosphorescent. *J. chim. phys.* **28**, 470 (1931)
- (1266) PRIKHOTJKO, A. Absorption spectra of naphthalene at 20.4° K. *J. Phys. U.S.S.R.* **8**, 257 (1944)
- (1267a) PRILESHAJEWA, N. Über den Nachweis des Jodatoms bei der optischen Dissoziation von Salzdämpfen. *Phys. Z. Sow.* **1**, 189 (1932)
- (1267b) PRILESHAJEWA, N. Auslöschung der TI-Fluoreszenz durch Jodatome und Moleküle. *Phys. Z. Sow.* **2**, 35 (1932)
- (1268) PRILESHAJEWA, N. Auslöschung der TI-Fluoreszenz durch TII-Moleküle. *Phys. Z. Sow.* **2**, 367 (1932)
- (1269) PRILESHAJEWA, N. Über die anitstokessche Fluoreszenz des Anilindampfes. *Acta physchim. U.S.S.R.* **1**, 785 (1935)
- (1270) PRILESHAJEWA, N. Energieübertragung bei Zusammenstößen angeregter TI-Atome mit Gasmolekülen. *Acta physchim. U.S.S.R.* **2**, 647 (1935)
- (1271) PRILESHAJEWA, N. The emission of aromatic compounds containing the carbonyl group. *Acta physchim. U.S.S.R.* **3**, 195 (1935)
- (1272) PRILESHAJEWA, N. Über die selektive Auslöschung kontinuierlicher Fluoreszenzspektren. *Acta physchim. U.S.S.R.* **7**, 149 (1937)
- (1273) PRILESHAJEWA, N. and KLIMOWA, A. Sensibilisierte Fluoreszenz von Anilin- und Benzol-Dampf. *Acta physchim. U.S.S.R.* **7**, 163 (1937)
- (1274) PRILESHAJEWA, N. and TSCHUBAROW, R. Fluoreszenz und absorptionspektren einfacher aromatischer Amine. *Acta physchim. U.S.S.R.* **1**, 777 (1934)
- (1274a) PRIMAK, W., OSTERHELD, R. K., and WARD, R. The function of fluxes in the preparation of infrared sensitive phosphors of the alkaline earth sulfides and selenides. *J. Am. Chem. Soc.* **69**, 1283 (1947)
- (1275) PRINGSHEIM, P. Über die Polarisation und Intensität der Joddampf-fluoreszenz in ihrer Abhängigkeit von der Temperatur. *Z. f. Phys.* **4**, 52 (1921)
- (1276) PRINGSHEIM, P. Über den Einfluss der Temperatur auf das Fluoreszenz- und Absorptionsspektrum des Joddampfes von konstanter Dichte. *Z. f. Phys.* **5**, 130 (1921)
- (1277) PRINGSHEIM, P. Über Abweichung von der Stokesschen Regel bei Erregung der Joddampf-fluoreszenz. *Z. f. Phys.* **7**, 206 (1921)

- (1278) PRINGSHEIM, P. Über einen nach der Lenzschen Theorie zu erwartenden Unterschied zwischen dem Absorptionsspektrum und dem vollständigen Fluoreszenzspektrum des Joddampfes. *Z. f. Phys.* 8, 126 (1921)
- (1279) PRINGSHEIM, P. Über die Zerstörung der Fluoreszenzfähigkeit fluoreszierender Lösungen und das photochemische Äquivalenzgesetz. *Z. f. Phys.* 10, 176 (1922)
- (1280) PRINGSHEIM, P. Lichtelektrische Wirkung und Photolumineszenz. *Ergebn. d. exakt. Naturwiss.* 1, 335 (1922)
- (1281) PRINGSHEIM, P. Über die photochemische Umwandlung fluoreszierender Farbstofflösungen. *Z. f. Phys.* 16, 71 (1923)
- (1282) PRINGSHEIM, P. Über die Polarisation der Resonanzstrahlung von Dämpfen. *Naturwiss.* 12, 247 (1924); *Z. f. Phys.* 23, 324 (1924)
- (1283) PRINGSHEIM, P. Über die Bandenfluoreszenz des Kaliums und Natriums. *Z. f. Phys.* 38, 161 (1926)
- (1284) PRINGSHEIM, P. Zwei Bemerkungen über den Unterschied zwischen Lumineszenz und Temperaturstrahlung. *Z. f. Phys.* 57, 739 (1929)
- (1285) PRINGSHEIM, P. Über die Leuchtdauer von Lumineszenzprozessen. *C. R. soc. pol. phys.* 5, 169 (1930)
- (1286) PRINGSHEIM, P. Über den Dichroismus von Farbstoffmolekülen. *Acta phys. pol.* 4, 331 (1935)
- (1287) PRINGSHEIM, P. Fluoreszenz und Phosphoreszenz adsorbierter Farbstoffe. *Acta phys. pol.* 5, 361 (1936)
- (1288) PRINGSHEIM, P. Das Absorptionsspektrum und die photochemisch sensibilisierende Wirkung des Uranylulfats in wässriger Lösung. *Physica* 4, 733 (1937)
- (1289) PRINGSHEIM, P. Bemerkung über die "Spiegelsymmetrie" der Fluoreszenz- und Absorptionsbanden in Lösungen. *Acta phys. pol.* 6, 158 (1937)
- (1290) PRINGSHEIM, P. Die Polarisation der Resonanzstrahlung des Na₂-Dampfes. *Physica* 5, 489 (1938)
- (1291) PRINGSHEIM, P. The fluorescence of organic compounds in solution. *Faraday Soc. Trans.* 35, 28 (1939)
- (1292) PRINGSHEIM, P. Absorptions- und Fluoreszenzspektren einiger aromatischer Kohlenwasserstoffe. *Ann. Acad. Warsaw* 5, 29 (1938)
- (1293a) PRINGSHEIM, P. Fluorescence and phosphorescence of Tl activated potassium halide phosphors. *Rev. Mod. Phys.* 14, 132 (1942)
- (1293b) PRINGSHEIM, P. Some remarks concerning the difference between luminescence and temperature radiation. Anti-Stokes fluorescence. *J. Phys. U.S.S.R.* 10, 495 (1946)
- (1294) PRINGSHEIM, P. and REIMANN, A. Über die Fluoreszenz des Benzoldampfes bei monochromatischer Erregung. *Z. f. Phys.* 29, 115 (1924)
- (1295) PRINGSHEIM, P. and ROSEN, B. Über die Molekülspektren des Kaliums, Natriums und von KNa-Gemischen. *Z. f. Phys.* 43, 519 (1927)
- (1296) PRINGSHEIM, P. and SALTMARSH, O.D. Fluorescence emission of the Hg line 2537 Å at pressures between 10^{-2} and 10^{-1} mm. *Proc. Roy. Soc. A* 154, 90 (1936)
- (1297) PRINGSHEIM, P. and SLIWITSCH, S. Über die Fluoreszenz von Praseodym- und Neodym-Glas. *Z. f. Phys.* 61, 297 (1930)
- (1298) PRINGSHEIM, P. and VAVILOV, J. S. Polarisierte und unpolarisierte Phosphoreszenz fester Farbstofflösungen. *Z. f. Phys.* 37, 705 (1926)
- (1299) PRINGSHEIM, P. and TARENIN, A. Die Bandenfluoreszenz des Hg-Dampfes. *Z. f. Phys.* 47, 330 (1928)
- (1300) PRINGSHEIM, P. and VOGELS, H. Bemerkung über die negative Polarisation gewisser Fluoreszenzbanden von adsorbierten Farbstoffen bei tiefen Temperaturen. *Acta phys. pol.* 4, 341 (1935)

- (1301) PRINGSHEIM, P. and VOGELS, H. Polarisation de la luminescence des matières colorantes adsorbées sur gels colloïdaux. *J. chim. phys.* 33, 261 (1936)
- (1302) PRINGSHEIM, P. and VOGELS, H. Phosphorescence et fluorescence à longue durée des colorants organiques. *J. chim. phys.* 33, 345 (1936)
- (1303) PRINGSHEIM, P. and VOGELS, H. Influence de la viscosité et de la nature du solvant sur le degré de polarisation de la lumière de fluorescence. *J. de phys.* 8, 121 (1937)
- (1304) PRINGSHEIM, P. and VOGELS, H. Fluoreszenz von Schwermetallkomplexen in wässriger Lösung. *Physica* 7, 225 (1940)
- (1305) PRIVAULT, M. Action des antioxygènes sur la fluorescence. *C. R.* 184, 1120 (1927)
- (1306) PROSAD, K. and BHATTACHARYA, D. K. Die optische Katalyse des Ramaneffekts. *Z. f. Phys.* 113, 637 (1939)
- (1307) PROSAD, K., BHATTACHARYA, D. K., and CHATTERJEE, L. M. Untersuchung einiger optischer und elektrischer Eigenschaften von Didymglas. *Z. f. Phys.* 98, 324 (1935)
- (1308) PRZIBRAM, K. Über Phosphoreszenz durch Becquerelstrahlen verfarbter Mineralien. *Wien. Ber. IIa* 130, 265 (1921)
- (1309) PRZIBRAM, K. Über Verfärbung und Lumineszenz durch Radiumstrahlen. *Verh. d. Deutsch. phys. Ges.* 3, 1 (1922); *Wien. Ber. IIa* 134, 233 (1925); *Z. f. Phys.* 20, 196 (1924); 41, 833 (1927); 44, 542 (1927); 68, 403 (1931); 102, 331 (1936); *Phys. Z.* 26, 640 (1925)
- (1310) PRZIBRAM, K. Über die Verfärbung des gepressten Steinsalzes. *Wien. Ber. IIa* 136, 43 (1927)
- (1311) PRZIBRAM, K. Fluorescence of fluorite and the bivalent europium ion. *Nature* 135, 100 (1935); *Wien. Ber. IIa* 144, 141 (1935); *Verhandl. d. Deutsch. phys. Ges.* 16, 22 (1935)
- (1312) PRZIBRAM, K. Yellow rock salt from Hall in Tyrol. *Nature* 137, 107 (1936)
- (1313) PRZIBRAM, K. Die rote Fluoreszenzbande des zweiwertigen Sm. *Wien. Anzeiger* 1936, 235
- (1314a) PRZIBRAM, K. Fluorescence of bivalent rare earths. *Nature* 139, 329 (1937); *Z. f. Phys.* 107, 709 (1937)
- (1314b) PRZIBRAM, K. Observations sur la fluorescence de quelques minéraux du Congo et de la Belgique. *Bull. Brussels* 32, 363 (1946)
- (1314c) PRZIBRAM, K. The fluorescence of fluorite and the bivalent rare earths. *C. R. Moscow* 56, 31 (1947)
- (1315) PRZIBRAM, K. and KARA-MICHAILOVA, E. Über Radiolumineszenz und Radiophotolumineszenz. *Wien. Ber. IIa* 131, 511 (1922); 132, 285 (1924); 139, 101 (1930); 141, 283 (1932); *Acta phys. pol.* 5, 377 (1936)
- (1316) RABE, P. and MARSCHALL, O. Fluoreszenzerscheinungen bei Chinaalkaloiden. *Ann. d. Chem.* 382, 360 (1911)
- (1317a) RABINOWITCH, E. and EPSTEIN, L. F. Polymerization of dyestuffs in solution. Thionine and methylene blue. *Am. Chem. Soc. J.* 63, 69 (1941)
- (1317b) RABINOWITCH, E. Spectra of porphyrins and Chlorophyll. *Rev. Mod. Phys.* 16, 226 (1945)
- (1318) RABINOWITCH, E. and WOOD, W. C. Dissociation of excited iodine molecules. *J. Chem. Phys.* 4, 358 (1936)
- (1319) RADULESCU, D. Beiträge zur Fluoreszenz-organischer Substanzen. *Bull. soc. chim. Romania* 17, 9 (1935)
- (1320) RADULESCU, D. Physikalische Deutung der Frequenzbeziehungen zwischen den Banden; Beziehung zwischen den Fluoreszenzbanden und den Absorptionsbanden ein und derselben Substanz. *Bull. soc. chim. Romania* 17, 63 (1935)
- (1321) RADULESCU, D. Das allgemeine Gesetz der Feinstrukturbanden. *Bull. soc. chim. Romania* 17, 193 (1935)

- (1322) RAFALOWSKI, I. Über dauernde Veränderungen bei der Fluoreszenz des Haematoporphyrins. *Z. f. Phys.* 71, 798 (1934)
- (1323) RAGOSS, A. Über Borsäurephosphore. *Diss. Berlin* 1922
- (1324) RAKOWER, E. Über das Absorptions- und Fluoreszenzspektrum eines Dicinnamonylmethanderivats und den Träger dieser Fluoreszenz. *Acta phys. pol.* 3, 415 (1934)
- (1325) RAKOWICZ-POGORZELSKA, J. Rayonnement de résonance des vapeurs de tellure. *C. R. soc. pol. phys.* 7, 51 (1926)
- (1325a) RAMACHANDRAN, G. N. and CHANDRASEKHAR, V. Luminescence as "forbidden electronic transition" in diamond. *Proc. Ind. Ac. Sci.* 24, 176 (1946)
- (1326a) RAMAN, C. V. The nature and origin of the luminescence of diamond. *Proc. Ind. Ac. Sci. A* 18, 334 (1943); 19, 199 (1944); *Current Sci.* 11, 261 (1942); 12, 33 (1943)
- (1326b) RAMAN, C. V. and RENDALL, G. R. Birefringence patterns in diamond. *Proc. Ind. Ac. Sci. A* 19, 265 (1944)
- (1327) RAMASWAMY, C. The Raman effect of diamond. *Ind. J. Phys.* 5, 97 (1930)
- (1328) RAMANATHAN, C. The polarization of resonance radiation and the duration of excited states. *Proc. Ind. Ass. for Cultiv. of Sci.* 9, 93 (1925)
- (1328a) RAMANATHAN, K. G. The absorption of u.v. radiation by diamond. *Proc. Ind. Ac. Sci. A* 24, 137 (1946)
- (1329) RAMSAUER, C. and HAUSSER, W. Über die aktinodielektrische Wirkung bei den Erdalkaliphosphoren. *Ann. d. Phys.* 34, 445 (1911)
- (1330) RAMSAUER, G. Über zwei Probleme bei der Auslöschung der Joddampf-fluoreszenz. *Z. f. Phys.* 40, 675 (1927)
- (1331) RANDALL, J. T. The effects of temperature on the intensity of fluorescence of some impurity solids. *Proc. Phys. Soc. London* 49, *Extra part* 46 (1937)
- (1332) RANDALL, J. T. Luminescence of solids at low temperatures. *Nature* 142, 113 (1938)
- (1333) RANDALL, J. T. The fluorescence of compounds containing Mn. *Proc. Roy. Soc. A* 170, 272 (1939)
- (1334) RANDALL, J. T. Some recent experiments in luminescence. *Faraday Soc. Trans.* 35, 2 (1939)
- (1335a) RANDALL, J. T. and WILKINS, M. H. F. Luminescence and photo-conductivity of solids. *Nature* 143, 978 (1939); *Proc. Roy. Soc. A* 184, 347 (1945)
- (1335b) RANDALL, J. T. and WILKINS, H. H. F. Phosphorescence and electron traps. *Proc. Roy. Soc. A* 184, 365 and 390 (1945)
- (1336) RANDALL, R. H. and WEBB, H. W. Average lives of Hg triplet 2^3P-2^3S . *Phys. Rev.* 35, 665 (1930)
- (1337) RANGASWAMI, S., SESHARDI, T. R., and VENKATESVARLU, V. The remarkable fluorescence of certain coumarin derivatives. *Proc. Ind. Ac. A* 13, 316 (1941)
- (1337a) RANK, D. H. Resonance spectrum of iodine. *J. Opt. Soc. Am.* 36, 239 (1946)
- (1338) RAO, K. R. On the fluorescence and channelled absorption of Bi at high temperatures. *Proc. Roy. Soc. A* 107, 760 (1925)
- (1339) RASETTI, F. L'effetto del campo magnetico sulla polarizzazione della radiazione di risonanza. *Lincei Rend.* 33, 38 (1924)
- (1340) RASETTI, F. Activated fluorescence and Doppler effect. *Nature* 118, 47 (1926)
- (1341) RASETTI, F. On a fluorescence spectrum of oxygen. *Proc. Nat. Ac. Sci.* 15, 411 (1929)
- (1342) RASETTI, F. Sobre la fluorescencia del vapore d'acqua. *Cimento* 8, 191 (1931)

- (1343) RAWCLIFF, R. D. Lifetime of fluorescence by an electric method. *Phys. Rev.* 59, 915 (1941); *Rev. Sci. Inst.* 13, 413 (1942)
- (1344) RAYLEIGH, LORD. Polarization of the light scattered by mercury vapor near the resonance periodicity. *Nature* 104, 276 (1919); *Proc. Roy. Soc. A* 102, 190 (1922)
- (1345) RAYLEIGH, LORD. The continuous spectrum of Hg vapor in relation to the resonance line 2536.52. *Proc. Roy. Soc. A* 111, 456 (1926)
- (1346a) RAYLEIGH, LORD. Studies of the mercury band spectrum of long duration. *Nature* 118, 767 (1926); 119, 387, 423 and 778 (1927); *Proc. Roy. Soc. A* 114, 620 (1927)
- (1346b) RAYLEIGH, LORD. Observation on the band spectrum of mercury. *Proc. Roy. Soc. A* 119, 349 (1928)
- (1347) RAYLEIGH, LORD. Fluorescent excitation of mercury by the resonance frequency and by lower frequencies. *Proc. Roy. Soc. A* 125, 1 (1929); 132, 650 (1931); 135, 617 (1932); 137, 101 (1932); 139, 507 (1933); *Nature* 127, 10 (1931); 128, 905 (1931); 129, 344 (1932); 127, 662 and 854 (1931)
- (1348) RAYLEIGH, LORD. The dark interval in mercury fluorescence. *Proc. Roy. Soc. A* 146, 272 (1934)
- (1349) REDLICH, O. and HOLT, E. K. On phosphorescence vibration spectra of polyatomic molecules. *Am. Chem. Soc. J.* 67, 1228 (1945)
- (1350) REIMANN, A. L. Über die Photolumineszenz des Benzols und einiger seiner Derivate in verschiedenen Aggregat- und Lösungszuständen. *Naturwiss.* 13, 744 (1925); *Ann. d. Phys.* 80, 43 (1926)
- (1351) REIMANN, A. L. Photoconductivity and phosphorescence of zincblende. *Nature* 140, 501 (1937)
- (1352) REINICKE, H. Darstellung und Eigenschaften phosphoreszierender Sulfide von Na und Rb. *Diss. Berlin* 1922
- (1353a) RENDALL, G. R. U. v. transparency patterns in diamond. *Proc. Ind. Ac. A* 19, 293 (1944)
- (1353b) RENDALL, G. R. Geometric patterns of fluorescence in diamond. *Proc. Ind. Ac. A* 24, 168 (1946)
- (1354) REXER, E. Untersuchungen am langwelligen Ausläufer der u.v. Eigenabsorption von Alkalihalogenidkristallen. *Z. f. Phys.* 106, 70 (1937)
- (1355) REXER, E. Wärmebehandlung und Diffusion in Salzkristallen. *Z. f. Phys.* 106, 93 (1937)
- (1356) RICE, O. K. On the transfer of energy between atoms at collisions. *Proc. Nat. Ac. Sci.* 17, 34 (1931); *Phys. Rev.* 37, 1187 (1931)
- (1357) RICHTER, E.-F. Polarisationserscheinungen bei der stufenweisen Anregung von Hg-Fluoreszenz. *Ann. d. Phys.* 7, 293 (1930); 17, 463 (1933)
- (1358) RIEHL, N. Über die Temperaturabhängigkeit des Szintillationsvorganges und über die Tilgung der Phosphore. *Ann. d. Phys.* 17, 587 (1933)
- (1359) RIEHL, N. Über die Stabilität des Lenardschen Leuchtzentrums bei ZnS. *Ann. d. Phys.* 24, 536 (1935); *Z. f. techn. Phys.* 17, 384 (1936)
- (1360) RIEHL, N. Aufbau und Wirkungsweise leuchtfähiger Zinksulfide und anderer Luminophore. *Ann. d. Phys.* 29, 636 (1937); *Faraday Soc. Trans.* 35, 135 (1939)
- (1361) RIEHL, N. Über einen neuen Effekt an lumineszierendem ZnS. *Z. f. techn. Phys.* 20, 152 (1939)
- (1362) RIEHL, N. and ORTMANN, H. Über die Druckzerstörung von Phosphoren. *Ann. d. Phys.* 29, 556 (1937)
- (1363) RIEHL, N. and ORTMANN, H. Über Einbau und Diffusion von Fremdatomen im Zinksulfidgitter. *Z. phys. Chem. A* 188, 109 (1941); *Munich* 1943, 39
- (1364) RIEHL, N. and SCHOEN, M. Der Leuchtmechanismus von Kristallphosphoren. *Z. f. Phys.* 114, 682 (1939)

- (1365a) RIEKE, F. F. Anomalous rotational temperature of HgH. *Phys. Rev.* 42, 587 (1932); 46, 236 (1934)
- (1365b) RIEKE, F. F. Transfer of rotational energy in molecular collisions. *Phys. Rev.* 47, 788 (1935); (Elementary processes which lead to abnormal rotation of the HgH molecule). *J. Chem. Phys.* 4, 513 (1936); (Exchange of energy in collisions between unexcited HgH and N₂ molecules) 5, 831 (1937)
- (1366) RIEMER, F. Über die chemischen Bildungsbedingungen lumineszierender Wolframate und Molybdate der Erdalkalien. *Dissertation, Berlin 1920*
- (1367) ROBERTSON, J. K. The absorption of fluorescing Na vapor. *Nature* 109, 43 (1922)
- (1368) ROBERTSON, R., FOX, J. J., and MARTIN, A. E. Two types of diamond. *Phil. Trans.* 232, 403 (1933); *Nature* 126, 279 (1930)
- (1369) ROESSLER, F. Austausch von Schwingungs- und Translationsenergie zwischen angeregten Jodmolekülen und Edelgasen. *Z. f. Phys.* 96, 251 (1935)
- (1369a) ROGERS, M. M. A redetermination of the nuclear magnetic momentum of sodium by the polarization of resonance radiation. *Phys. Rev.* 71, 833 (1947)
- (1370) ROHN, W. Fluoreszenzeigenschaften des Fluoreszeinnatriums in Lösung. *Ann. d. Phys.* 38, 1014 (1912)
- (1371) ROLLEFSON, G. K. and DODGEN, H. W. Dependence of the intensity of fluorescence on the composition of the fluorescing solution. *J. Chem. Phys.* 12, 107 (1944)
- (1372) ROLLEFSON, G. K. and GRAHAME, D. C. Effect of temperature on the predissociation of photoactivated acetaldehyde. *J. Chem. Phys.* 7, 775 (1939)
- (1373) ROLLEFSON, G. K. and STROUGHTON, R. W. The quenching of fluorescence in solutions. The nature of the quenching process. *Am. Chem. Soc. J.* 63, 1517 (1941)
- (1374) ROMPE, R. Beiträge zur Analyse des S₂-Spektrums. *Z. f. Phys.* 65, 404 (1930)
- (1375) ROMPE, R. Über einige Absorptions-, Fluoreszenz- und Emissionsbanden des Caesiums. *Z. f. Phys.* 74, 175 (1932)
- (1376) ROOKSBY, H. P. and McKEAG, A. H. The yellow fluorescent form of zinc silicate. *Faraday Soc. Trans.* 37, 308 (1941)
- (1377) ROOS, W. Eine einfache Phosphoreszenzemission von Alkalihalogenidphosphoren. *Ann. d. Phys.* 20, 783 (1934)
- (1378) ROSEN, B. Resonanz-, Fluoreszenz- und Absorptionsspektren in der 6. Gruppe des periodischen Systems. *Naturwiss.* 14, 978 (1926); *Z. f. Phys.* 43, 69 (1927)
- (1379) ROSEN, B. Über Molekülspektren des Schwefels. *Z. f. Phys.* 48, 545 (1928)
- (1380) ROSEN, B. Etude sur la prédissociation induite des molécules S₂, Se₂ et Te₂. *Acta phys. pol.* 5, 193 (1936)
- (1381) ROSEN, B. Recherches sur les spectres moléculaires du sélénium. *Physica* 6, 205 (1939)
- (1382) ROSEN, B. and DÉsirANT, M. Recherche sur les spectres moléculaires de la vapeur du sélénium. *Bull. Brussels* 21, 436 and 723 (1935)
- (1383) ROSEN, B. and MAT, J. Effet d'isotopie dans les spectres de résonance de Te₂. *Bull. Brussels.* 23, 626 (1937)
- (1384) ROSSELET, G. A. The influence of optical excitation energy on transitions involving the 2³P₀ level of Hg. *Phys. Rev.* 49, 871 (1936)
- (1385) ROTHSCHILD, S. Über einen Fall von sensibilisierter Phosphoreszenz. *Naturwiss.* 20, 850 (1932); *Phys. Z.* 35, 557 (1934); 37, 757 (1936)
- (1386a) ROTHSCHILD, S. Über die Emissionsspektren der Zinksulfidphosphore sowie über die Wirkung von Cadmiumsulfid auf die Emission der Zinksulfid- und Erdalkalisulfidphosphore. *Z. f. Phys.* 108, 24 (1938)

- (1386b) ROTHSCHILD, S. The luminescent spectra of zinc sulfide and zinc cadmium sulfide phosphors. *Faraday Soc. Trans.* 42, 635 (1946)
- (1387) ROYER, L. Phosphorescence et structure cristalline. *J. de phys.* 9, 15S (1938)
- (1388) RUARK, A. E. and UREY, H. C. The impulse momentum of the light quantum. *Proc. Nat. Ac. Sci.* 13, 763 (1927)
- (1389) RUDY, H. and MAYER, O. 9-Propyl-8-azaflavin. *Chem. Ber.* 71, 1243 (1938)
- (1390) RUDY, H. and MAYER, O. (9-Phenyl)- und 9-Cyclohexanol-azaflavin. *Chem. Ber.* 72, 933 (1939)
- (1391) RUETTENAUER, A. Über die Anregung der Phosphore in der Neonentladung. *Phys. Z.* 37, 810 (1936); *Z. f. techn. Phys.* 17, 384 (1936)
- (1392) RUETTENAUER, A. Über die Lumineszenzausbeute des Zinksilikatleuchtstoffes in der Gasentladung. *Z. f. techn. Phys.* 19, 148 (1938)
- (1393) RUFFLER, H. Dielektrische Nachwirkungserscheinungen an Phosphoren. *Ann. d. Phys.* 39, 203 (1941)
- (1394) RUMP, W. Über den Dopplereffekt beim Übergang von der Resonanzfluoreszenz zur Spiegelung. *Z. f. Phys.* 29, 196 (1924)
- (1395) RUMP, W. Über die Resonanzfluoreszenz der Linie 1849A des Hg-dampfes. *Z. f. Phys.* 31, 901 (1925)
- (1396) RUMPF, E. Über die Gitterkonstante der CaS- und SrS-Samariumphosphore. *Ann. d. Phys.* 84, 313 and 840 (1927)
- (1397) RUMPF, E. and TRAVNICEK, M. Die Zusammensetzung der Ca-Sr-Sm-Sulfidmischphosphore. *Ann. d. Phys.* 4, 725 (1930)
- (1398) RUPP, E. Über Leitfähigkeitserregung bei Hitzeausbreitung der Phosphore. *Ann. d. Phys.* 70, 391 (1923)
- (1399) RUPP, E. Über die erregende Absorption und Tilgung der Phosphore. *Ann. d. Phys.* 72, 81 (1923)
- (1400) RUPP, E. Über die Ausleuchtung der Phosphore durch elektrische und magnetische Felder. *Ann. d. Phys.* 75, 326 (1924)
- (1401) RUPP, E. Über das magnetische Verhalten der Phosphore. *Ann. d. Phys.* 78, 505 (1925)
- (1402) RUPP, E. Frequenzmodulation einer Lichtwelle. *Phys. Z.* 28, 920 (1927); *Z. f. Phys.* 47, 72 (1928)
- (1403) RWATSCHEW, W. P. Über Lumineszenz von Flusspaten. *J. Phys. U.S.S.R.* 6, 141 (1942)
- (1404) SADDY, J. Contribution a l'étude de la photoluminescence du sulfure de zinc. *Thesis, Paris* 1946; *C. R.* 209, 93 (1939); 219, 314 (1944); 226, 896 (1948); *Ann. de phys.* 2, 414 (1947)
- (1405) SAEGEMUELLER, G. M. Phosphoreszenz von Gläsern. *Diss. Jena* 1917
- (1405a) SAHA, M. N. Colors in inorganic salts. *Nature* 125, 163 (1930)
- (1406) SAMBURSKY, S. and WOFSOHN, G. On the fluorescence and absorption spectra of anthracene and phenanthrene in solutions. *Faraday Soc. Trans.* 36, 427 (1940)
- (1407a) SAMBURSKY, S. and WOFSOHN, G. Fluorescence of solutions and dielectric properties of solvents. *Phys. Rev.* 62, 357 (1942)
- (1407b) SAMBURSKY, S. and WOFSOHN, G. Quenching of fluorescence by van der Waals forces. *Nature* 157, 228 (1946)
- (1408) SAMSON, E. W. Effects of temperature and nitrogen pressure on the afterglow of Hg resonance radiation. *Phys. Rev.* 40, 940 (1932)
- (1409) SANNIÉ, CH. Carcinogenic action and absorption and fluorescence spectra of 1,2-benzopyrene. *Biochem. J.* 30, 704 (1936)
- (1410) SANNIÉ, CH. and POREMSKI, V. Spectre de fluorescence et d'absorption de quelques dérivés du pyrène et du 1,2-benzopyrène. *Bull. soc. chim. de France* 3, 1139 (1936)
- (1411) SATOH, I. Phosphorescent beryllium nitride. *Nature* 133, 837 (1934); *Sci. Pap. Inst. Phys. Chem. Tokyo* 29, 41 (1936)

- (1412) SATYANARAYANA, B. S. The fluorescence of the uranyl compounds and the Raman spectrum of the uranyl ion. *Proc. Ind. Ac. A* 15, 414 (1942)
- (1413) SCHAPER, I. Beiträge zur Kenntnis der Sulfidphosphore. *Ann. d. Phys.* 85, 913 (1928)
- (1414) SCHEIBE, G. and collaborators. Über reversible Polymerisation als Ursache reversibler Absorptionsbanden von Farbstofflösungen. *Z. angew. Chem.* 49, 563 (1936); 50, 51 and 212 (1937); *Naturwiss.* 25, 75, 474, 795 (1937)
- (1415) SCHEIBE, G. Anisotropie organischer Farbstoffmoleküle. Nebenvalenzbindungen als Energieüberträger. *Naturwiss.* 26, 412 (1938)
- (1416) SCHEIBE, G. Über den Mechanismus der Sensibilisierung photochemischer Reaktionen durch Farbstoffe. *Kolloidz.* 82, 1 (1938); 92, 95 (1940); 93, 28 (1940)
- (1417) SCHEIBE, G. Die Stereoisomerie organischer Farbstoffe und ihr Zusammenhang mit Konstitution und Eigenschaft reversibel polymerer Farbstoffe. *Z. angew. Chem.* 52, 631 (1939)
- (1418) SCHEIBE, G. Lichtabsorption und Energiefortleitung bei lockeren Komplexen organischer Farbstoffe. *Z. Elektrochem.* 47, 73 (1941); *Z. phys. Chem. B* 49, 324 (1941); *Munich* 1943, 184
- (1419) SCHEIBE, G., SCHOENTAG, A., KOPSKE, J., and HENLE, K. Eigenschaften reversibler Farbstoffpolymerisate und ihre Bedeutung fuer die Sensibilisierung der photographischen Platte. *Z. wiss. Phot.* 38, 1 (1939)
- (1420) SCHEIN, M. Versuche mit der Hg-Resonanz. *Verhandl. d. Deutsch. phys. Ges.* 7, 5 (1926)
- (1421) SCHEIN, M. Über die Feinstruktur und den Zeemaneffekt der Hg-Resonanzlinie. *Ann. d. Phys.* 85, 257 (1928)
- (1422) SCHEIN, M. Optische Messungen am Hg-Atom. *Helv. acta phys.* 2 (suppl. I), 1 (1929)
- (1423) SCHEIN, M. and KATZ, M. L. U.v. luminescence of sodium chloride. *Nature* 138, 883 (1936)
- (1424) SCHELLENBERG, O. Die u.v. Banden der Erdalkaliphosphore. *Ann. d. Phys.* 87, 677 (1928); 11, 94 (1931); 13, 249 (1932)
- (1425) SCHENK, R. Die chemischen Probleme der Lichtemission bei den Sulfidphosphoren. *Munich* 1943, 9
- (1425a) SCHENK, R. and PARDUN, H. Untersuchungen über die chemischen Systeme der Lenardphosphore. *Z. f. anorg. Chem.* 211, 209 and 303 (1933); 236, 271 (1938)
- (1426) SCHILLING, M. Spektrophotometrische Untersuchungen an einer technischen Leuchtfarbe. *Z. f. techn. Phys.* 21, 232 (1940)
- (1427a) SCHISCHLOWSKI, A. Comparison of absorption and fluorescence spectra of anthracene in different states of aggregation. *C. R. Moscow* 15, 29 (1937)
- (1427b) SCHISCHLOWSKI, A. Photoluminescence of heavy-metal ions in liquid and solid solutions. *Bull. Moscow* 9, 351 (1945)
- (1428) SCHISCHLOWSKI, A. and VAVILOV, S. I. Die Abklingungsgesetze der Phosphoreszenz von Farbstofflösungen. *Phys. Z. Sow.* 5, 379 (1934)
- (1429) SCHLEEDE, A. Über das Phosphoreszenzzentrum. *Z. f. Phys.* 18, 109 (1923)
- (1430) SCHLEEDE, A. Über die Schwärzung des Zinksulfids durch Licht. *Z. phys. Chem.* 106, 386 (1923)
- (1431a) SCHLEEDE, A. Über den chemischen Bau der Phosphore. *Naturwiss.* 14, 586 (1926)
- (1431b) SCHLEEDE, A. Über die Zinksulfid- und Zink-Cadmiumsulfid-Lumino-phore und ihre Bedeutung für das Problem des Fernsehens. *Z. angew. Chem.* 48, 276 (1935)

- (I432a) SCHLEEDE, A. Über die Ursachen der Lumineszenz von reinem ZnS und ZnO. *Z. angew. Chem.* 50, 908 (1937)
- (I432b) SCHLEEDE, A. Komplexbildung, Absorption und Lumineszenz. *Munich 1943*, 50
- (I432c) SCHLEEDE, A. Der An- und Abklingverlauf und die Lichtausbeute in Abhängigkeit von Erregung und Absorption. *Munich 1943*
- (I433) SCHLEEDE, A. and BARTELS, B. Untersuchung über die An- und Abklingung des Leuchtvorganges bei Phosphoren. *Z. f. techn. Phys.* 19, 365 (1938); *Phys. Z.* 39, 936 (1938)
- (I434) SCHLEEDE, A. and GANTZCKOW, H. Röntgenographische Untersuchung lumineszenzfähiger Systeme. *Z. phys. Chem.* 106, 37 (1923)
- (I435) SCHLEEDE, A. and GRUHL, A. Über röntgenographische Beobachtungen an lumineszenzfähigem Zinksilikat. *Z. f. Electrochem.* 29, 411 (1923)
- (I436) SCHLEEDE, A. and TSAO, T. H. Über die Ursache des Nachleuchtens des Calciumwolframat. *Chem. Ber.* 62, 763 (1929)
- (I437) SCHLEGEL, H. Eine Bemerkung über die Wirkungsweise der Schmelzmittel bei Zns-Cds-Leuchtstoffen. *Naturwiss.* 30, 242 (1942)
- (I438) SCHLENK, W. and BERGMANN, E. Forschungen auf dem Gebiet der alkalischen organischen Verbindungen. *Liebigs Ann.* 463, 1 (1928)
- (I439) SCHLOEMER, A. Über den räumlichen Bau phosphoreszierender Gemische. *J. f. prakt. Chem.* 137, 40 (1933)
- (I440) SCHNETTLER, O. Über die Beeinflussung der selektiven Reflexion der Hg-Resonanzlinie durch Fremdgase. *Z. f. Phys.* 65, 55 (1930)
- (I441) SCHMIDT, B. Sur une nouvelle série de résonance du sélénium. *Bull. intern. Cracow* 1928, 61
- (I442) SCHMIDT, E. Über ein Absorptionsspektrum des Luftsauerstoffs im äussersten u.v. *Z. f. Phys.* 31, 47 (1925)
- (I443) SCHMIDT, F. Messung der Temperaturänderung von Dielektrizitätskonstanten. *Ann. d. Phys.* 44, 329 (1914)
- (I444) SCHMIDT, F. Über die aktinodielektrische Wirkung. *Ann. d. Phys.* 44, 477 (1914)
- (I445) SCHMIDT, F. Die Erdalkalisauerstoffphosphore. *Ann. d. Phys* 63, 264 (1920)
- (I446) SCHMIDT, F. Über die Dielektrizitätskonstante der Phosphore und die absolute Wellenlänge ihrer Daucrerregungsverteilung. *Ann. d. Phys.* 64, 713 (1921)
- (I447) SCHMIDT, F. Über das Leuchten der Phosphore in hohen elektrischen Feldern. *Ann. d. Phys.* 70, 161 (1923)
- (I448) SCHMIDT, F. Zur Kenntnis der Absorptionskantenserien der Phosphore. *Ann. d. Phys.* 74, 362 (1924)
- (I449) SCHMIDT, F. Bandenkanten und Absorptionskantenserien der Erdalkaliphosphore. *Ann. d. Phys.* 83, 213 (1927)
- (I450) SCHMIDT, F. Die spektrale Erregungsverteilung der Phosphoreszenzbanden bei verschiedenen Temperaturen. *Ann. d. Phys.* 4, 1127 (1930)
- (I451) SCHMIDT, F. Zur Analyse der Bandenspektren der Lenardphosphore. *Ann. d. Phys.* 12, 211 (1932)
- (I452) SCHMIDT, F. and ZIMMERMANN, W. Untersuchung über die Gültigkeit der Stokesschen Regel bei Phosphoren. *Ann. d. Phys.* 82, 191 (1927)
- (I453) SCHMIDT, G. C. Beiträge zur Kenntnis der Fluoreszenz. *Ann. d. Phys.* 56, 201 (1895)
- (I454) SCHMIDT, G. C. Über Lumineszenz von festen Lösungen. *Ann. d. Phys.* 65, 247 (1921)
- (I455) SCHMIDT, G. C. Polarisierte Fluoreszenz von Farbstofflösungen. *Phys. Z.* 23, 233 (1922)
- (I456) SCHMIDT, G. C. Über die durch einzelne Chininsalze hervorgerufene Ionisation. *Z. f. Phys.* 8, 160 (1922)

- (1457) SCHMIDT, H. Lenards Arbeiten zur Phosphoreszenz. *Z. f. phys. und chem. Unterricht* 29, 150 (1916)
- (1458) SCHMIDT, H. Neuere Fortschritte in der Theorie der Lumineszenzerscheinungen. *Naturwiss.* 6, 641 (1918)
- (1459) SCHMIDT, J. Phosphoreszierende Stoffe und Leuchtmassen. *Z. f. angew. Chem.* 34, 215 (1921)
- (1460) SCHMIDT, J. Ein einfaches Verfahren zur Darstellung von gut phosphoreszierendem ZnS. *Chem. Ber.* 55, 3988 (1922)
- (1461) SCHMIDT-OTT, H. D. Über kontinuierliche Absorptionsspektren der gasförmigen Alkalihalogenide im u.v. *Z. f. Phys.* 69, 724 (1931)
- (1462) SCHMIEDER, F. Über die Ökonomiekoeffizienten der Phosphore. *Ann. d. Phys.* 77, 381 (1925)
- (1463) SCHNEIDER, E. Der Prozess der Auslöschung der Fluoreszenz von Flüssigkeiten durch Halogenionen. *Z. phys. Chem. B* 28, 311 (1935)
- (1464) SCHOEN, M. Zur Quantenausbeute von Leuchtstoffen in Schuman u.v. *Verhandl. d. Deutsch. phys. Ges.* 18, 8 (1937)
- (1465) SCHOEN, M. Zum Leuchtmechanismus der Leuchtstoffe. *Verhandl. d. Deutsch. phys. Ges.* 18, 70 (1937); *Z. f. techn. Phys.* 19, 361 (1938)
- (1466) SCHOEN, M. Über den metastabilen Charakter der Anlagerungsstellen in Kristallphosphoren. *Naturwiss.* 27, 432 (1939)
- (1467) SCHOEN, M. Eine Bemerkung zur Abklingung der Phosphoreszenz von Kristallphosphoren. *Naturwiss.* 31, 203 (1943)
- (1468) SCHOEN, M. Über die Temperaturabhängigkeit der Helligkeit von Kristallphosphoren bei monochromatischer Anregung. *Naturwiss.* 31, 169 (1943)
- (1469) SCHOENTAG, A. and FISCHER, H. Die Fluoreszenz des Methylakridons und ihre Beeinflussung durch elektrische Atomfelder. *Z. phys. Chem. B* 39, 411 (1938)
- (1470) SCHOLL, R. Pyranthron, ein stickstoffreies Methinanalogen des Flavanthrons und Dimethylpyranthron. *Chem. Ber.* 43, 346 (1910)
- (1471) SCHOLL, R. and MEYER, K. Synthese des Dibenzcoronens und dessen Abbau zu Coronen. *Chem. Ber.* 65, 902 (1932)
- (1472) SCHOLL, R. and MEYER, K. Die aromatischen Grundkohlenwasserstoffe des Anth-anthrone, Anth-dianthrone, etc. *Chem. Ber.* 67, 1229 (1934)
- (1473) SCHOLL, R. and MEYER, K. Der blaue aromatische Grundkohlenwasserstoff des Naphthodianthrone. *Chem. Ber.* 67, 1236 (1934)
- (1474) SCHOLL, R., SEER, CH., and WEITZENBOECK, R. Perylen, ein hochkondensiertaromatischer Kohlenwasserstoff $C_{20}H_{12}$. *Chem. Ber.* 43, 2202 (1910)
- (1475) SCHOLZ, E. Über die Auslöschung der Joddampffluoreszenz in magnetischen Feldern. *Z. f. Phys.* 106, 230 (1937)
- (1476) SCHPOLSKY, E. W. and SHEREMETIEV, G. D. The quenching of fluorescence and photosensitization in solutions. *Acta physchim. U.S.S.R.* 5, 575 (1936)
- (1476a) SCHRADER, R. E., LASOF, S., and LEVERENZ, H. W. Emission spectra under u.v. and cathode ray excitation of CdS,Se phosphors. *Ithaca* 1946, 238
- (1476b) SCHRADER, R. E., LEVERENZ, H. W., and WOOD, E. Some recent results from experimentation with infrared sensitive phosphors. *J. Opt. Soc. Am.* 36, 353 (1946)
- (1477) SCHUELER, H. Eine Bemerkung über das Natriummolekülspektrum. *Z. f. Phys.* 43, 474 (1927)
- (1477a) SCHUELER, H. and WOELDICKE, A. Über den Anregungsmechanismus der Fluoreszenz bei organischen Molekülen. *Phys. Z.* 45, 61 and 163 (1944)
- (1478) SCHUETZ, W. Ein experimenteller Beitrag zur Kenntnis des Wirkungsquerschnitts angeregter Atome. *Z. f. Phys.* 35, 260 (1925)

- (1479) SCHUETZ, W. Über natürliche Breite und Verbreiterung der D-Linien des absorbierenden Na-Dampfes durch Dampfdichte und Druck fremder Gase. *Z. f. Phys.* 45, 30 (1927)
- (1480) SCHUETZ, W. Bemerkung zur Frage grosser Wirkungsquerschnitte bei der Wechselwirkung artgleicher Atome. *Z. f. Phys.* 48, 67 (1928)
- (1480a) SCHULMAN, J. H. Luminescence of $(Zn, Be)_2SiO_4(Mn)$. *J. Appl. Phys.* 17, 902 (1946); *Ithaca* 1946, 406
- (1480b) SCHULMAN, J. H., EVENS, L. W., GINTHER, R. J., and MURATA, K. J. Sensitized luminescence of manganese activated calcite. *J. Appl. Phys.* 18, 732 (1947)
- (1481) SCHUMANN, G. "Optimale" Konzentration der aktiven Fremdstoffe in Kristallphosphoren. *Z. f. Phys.* 98, 252 (1936)
- (1482) SÉGRÉ, Sulla teoria quantistica della fluorescenza. *Lincei. Rend.* 9, 887 (1929)
- (1483) SEIDEL, A. The u.v. resonance series of sodium. *Phys. Z. Sow.* 8, 204 (1935)
- (1484a) SEIDEL, A. Luminescence of solutions of terbium salts. *Nature* 139, 248 (1937)
- (1484b) SEIDEL, A. Luminescence of solutions of salts of rare earths. *Bull. Moscow* 9, 329 (1945)
- (1485) SEIDEL, A., LARIONOV, J., and FILIPOV, A. On the fluorescence of aqueous solutions of rare earth salts. *J. Phys. U.S.S.R.* 1, 67 (1939)
- (1486) SEITZ, F. Interpretation of the properties of KClI phosphors. *J. Chem. Phys.* 6, 150 (1938); *Phys. Rev.* 53, 685 (1938)
- (1487) SEITZ, F. Interpretation of the properties of ZnS-phosphors. *J. Chem. Phys.* 6, 454 (1938)
- (1488) SEITZ, F. An interpretation of crystal luminescence. *Faraday Soc. Trans.* 35, 74 (1939); *Ithaca* 1943, 1
- (1489) SELENYI, P. Über Lichtzerstreuung im Raume Wienerscher Interferenzen und neue diesen reziproke Interferenzerscheinungen. *Ann. d. Phys.* 35, 444 (1911)
- (1490) SELENYI, P. Herstellung und Eigenschaften weitwinkliger optischer Interferenzerscheinungen. *Z. f. Phys.* 108, 401 (1938)
- (1491) SELENYI, P. Über die Dipolnatur der elementaren Lichtzentren. *Z. f. Phys.* 111, 791 (1939)
- (1492) SELENYI, P. Wide angle interferences and the nature of elementary light sources. *Phys. Rev.* 56, 477 (1939)
- (1493) SEN GUPTA, P. K. Fluorescent radiation from N_2O . *Proc. Roy. Soc. A* 146, 824 (1934)
- (1494) SEN GUPTA, P. K. Studies in the fluorescence of dyestuffs. *J. Ind. Chem. Soc.* 15, 263 (1938)
- (1495) SERVIGNE, M. Sur une méthode sensible pour la recherche de traces d'éléments des terres rares. *C. R.* 204, 863 (1937)
- (1496) SERVIGNE, H. Sur l'émission infrarouge de luminescence de quelques éléments rares. *C. R.* 207, 905 (1938); 209, 210 (1939)
- (1497) SESHAN, P. K. The influence of physical state on the absorption and fluorescence spectra of organic substances. *Faraday Soc. Trans.* 32, 689 (1936)
- (1498) SEVSHENKO, A. N. Polarization of photoluminescence of uranium glasses. *J. Phys. U.S.S.R.* 8, 163 (1944); *C. R. Moscow* 52, 336 (1944)
- (1499) SEYEWITZ, A. and BLANC, J. Sur la fluorescence des matières colorantes à la lumière de Wood. *C. R.* 188, 714 (1929)
- (1500) SHAPIRO, C. V. Raman spectrum and fluorescence of benzene. *Nature* 124, 372 (1929)
- (1501) SHEPPARD, S. E. Distinction between fluorescence and phosphorescence. *Illum. Eng.* 10, 178 (1917)

- (1502) SHEPPARD, S. E., LAMBERT, R. H., and WALKER, R. D. The optical sensitizing properties of fluorescein dyes in relation to their spectral absorption and constitution. *J. Chem. Phys.* **11**, 263 (1943)
- (1503) SIKSNA, R. Sur la fluorescence des raies atomiques de la vapeur d'antimoine. *C. R.* **197**, 836 (1933); *Acta phys. pol.* **2**, 253 (1933)
- (1504) SILBERSTEIN, L. Fluorescent vapors and their magneto-optic properties. *Phil. Mag.* **32**, 265 (1916)
- (1505) SILVERMAN, S. Concerning the polarizing properties of dyed cellophane films. *Rev. Sci. Instr.* **12**, 212 (1941)
- (1506) SIMON, H. Über Fluoreszenzabsorption. *Diss. München* 1919
- (1506a) SIMPSON, T. The sensitization of photographic emulsions and the triplet state. *J. Chem. Phys.* **15**, 414 (1947)
- (1507) SINHA, S. P. Optically catalytic action of anthracene and phenanthrene in giving Raman shifts of some organic compounds. *Ind. J. Phys.* **27**, 38 (1944)
- (1507a) SIRKAR, S. C. and BISHUI, B. M. Fluorescence of biphenyl ketone at low temperature. *Nature* **150**, 333 (1945)
- (1508) SKALINSKI, T. Über den Einfluss von Fremdgaszusatz auf die Absorption der Hg-Linie 4078 durch Selendampf. *Acta phys. pol.* **7**, 177 (1938)
- (1509) SKLAR, A. Theory of color of organic compounds. *J. Chem. Phys.* **5**, 669 (1937)
- (1510) SLATER, J. C. The nature of resonance radiation. *Phys. Rev.* **25**, 242 (1925)
- (1511) SLATTERY, M. K. Fluorescence and solid solution. *Proc. Nat. Ac. Sci.* **14**, 777 (1928)
- (1512) SLATTERY, M. K. Uranium as an activator. *J. Opt. Soc. Am.* **19**, 175 (1929)
- (1513) SMAKULA, A. Einige Absorptionsspektren von Alkalihalogenidphosphoren mit Silber und Kupfer als wirksamen Metallen. *Z. f. Phys.* **45**, 1 (1927)
- (1514) SMAKULA, A. Über Erregung und Entfärbung lichtelektrisch leitender Alkalihalogenide. *Z. f. Phys.* **59**, 603 (1929)
- (1515) SMAKULA, A. Über die Verfärbung der Alkalihalogenidkristalle durch u.v. Licht. *Z. f. Phys.* **63**, 762 (1930)
- (1516) SMEKAL, A. Zur Molekulartheorie der Festigkeit und Verfestigung. *Phys. Z.* **27**, 837 (1926)
- (1517) SMEKAL, A. Zum optischen Nachweis von Lockerstellen im Molekularbau der Realkristalle. *Wien. Anzeiger.* 1926 No. 25
- (1518) SMEKAL, A. Absorptionsbanden und Energiebänder von Alkalihalogenidkristallen. *Z. f. Phys.* **101**, 661 (1936)
- (1518a) SMITH, A. L., ROSENSTEIN, R. D., and WARD, R. The preparation of strontium selenide and its properties as base material of phosphors stimulated by infrared. *Am. Chem. Soc. J.* **69**, 1725 (1947)
- (1519) SMITH, H. G. On the fine structure of the band spectra of sodium, potassium and sodium-potassium vapors. *Proc. Roy. Soc. A* **106**, 400 (1924)
- (1519a) SMITH, W. M. and SOUTHAM, F. W. Dependence of quenching on temperature. *J. Chem. Phys.* **15**, 845 (1947)
- (1520) SMOLUCHOWSKI, R. Auslöschung der Fluoreszenz des Tellurdampfes durch magnetische-Felder. *Z. f. Phys.* **85**, 191 (1933); *Acta phys. pol.* **2**, 291 (1933)
- (1521) SMYTH, H. D. The emission and fluorescence spectra of sulphur dioxide. *Phys. Rev.* **44**, 690 (1933)
- (1522) SOBOTKA, H., KANN, S., LOEWENSTEIN, E., and WINTERNITZ, W. The fluorescence of vitamin A. *Am. Chem. Soc. J.* **65**, 1959 (1943); **66**, 1162 (1944); *J. Biol. Chem.* **152**, 635 (1944)
- (1523) SOEDERBERG, B. Eine Untersuchung bezüglich des Zusammenhanges zwischen Absorption, Dispersion und Fluoreszenz des Lichtes. *Ann. d. Phys.* **41**, 381 (1913)

- (1524) SOLEILLET, P. Etude des radiations de résonance du zinc. *C. R.* 184, 149 (1927)
- (1525) SOLEILLET, P. Influence d'un champ magnétique sur la polarisation de la radiation de résonance du cadmium. *C. R.* 185, 198 (1927); 187, 212 (1928)
- (1526) SOLEILLET, P. Polarisation des radiations de résonance du Zn. *C. R.* 187, 723 and 976 (1928)
- (1527) SOLEILLET, P. Théorie de la polarisation de la lumière émise par résonance. *C. R.* 187, 1136 (1928)
- (1528) SOLEILLET, P. Sur les paramètres caractérisant la polarisation partielle de la lumière dans les phénomènes de fluorescence. *Ann. de phys.* 12, 23 (1929); *Acta phys. pol.* 6, 207 (1936)
- (1529) SOLEILLET, P. La cohérence des vibrations dans la résonance optique. *J. de phys.* 7, 77 (1936); *C. R.* 201, 945 (1935); 202, 1167 (1936)
- (1530) SOLEILLET, P. Polarisation de la lumière due à une excitation optique par échelons. *J. de phys.* 7, 118 (1936)
- (1531) SOLEILLET, P. Le calcul des taux de polarisation dans les phénomènes de résonance. *J. de phys.* 7, 173 (1936); *C. R.* 197, 46 (1933)
- (1532) SOLEILLET, P. Fluorescence d'un jet d'atomes de Zn. *C. R.* 195, 372 (1932)
- (1533) SOLEILLET, P. Photométrie de la fluorescence d'un jet d'atomes de Cd; durée moyenne de vie à l'état 2^3P_1 . *C. R.* 196, 1991 (1933)
- (1534) SOLEILLET, P. Influence du champ magnétique sur la fluorescence d'un jet d'atomes de Cd. Facteur g de Landé relative à l'état 2^3P_1 . *C. R.* 197, 46 (1933)
- (1535) SOLEILLET, P. La durée moyenne de la vie de l'atome de Zn à l'état 2^3P_1 et la méthode de l'absorption totale. *C. R.* 204, 253 (1937)
- (1536) SOLEILLET, P. Le passage de l'effet Zeeman à l'effet Paschen-Back de structure hyperfine dans la polarisation de radiation de résonance. *C. R.* 204, 570 (1937)
- (1537) SOLEILLET, P. and MARTELLI, J. Sur une méthode de photométrie en ultraviolet. *J. de phys.* 2, 109 (1941)
- (1538) SOLEILLET, P. and NIKITINE, S. Comparaison de la polarisation de la lumière émise par résonance dans un jet atomique et dans la vapeur non dirigée. *C. R.* 201, 201 (1935)
- (1539) SOLEILLET, P. and NIKITINE, S. Polarisation de la radiation $2139A$ émise par résonance optique dans un jet de Zn. *J. de phys.* 7, 478 (1936); *C. R.* 202, 1046 (1936)
- (1540) SOLEILLET, P. and PLOQUIN, J. Sur une très courte durée de vie de l'atome de Cd à l'état excité par la raie 2287. *C. R.* 217, 368 (1943)
- (1541) SOSNOWSKI, L. Sur la polarisation des bandes de fluorescence de la vapeur de Cd. *C. R.* 195, 224 (1932)
- (1542) SOULAN, H. L'influence de la lumière sur la conductibilité des liquides fluorescents. *C. R.* 172, 581 (1921)
- (1543) SPEDDING, F. H. Luminescence of solids. *Faraday Soc. Trans.* 35, 65 (1939)
- (1544) SPIEWANKIEWICZ, F. Über die Fluoreszenz der Mischung der Cd- und Zn-Dämpfe. *Acta phys. pol.* 1, 345 (1932)
- (1545) SPONER, H., NORDHEIM, G., SKLAR, A. L., and TELLER, E. Analysis of the near u.v. electronic transition of benzene. *J. Chem. Phys.* 7, 207 (1939); *Phys. Rev.* 57, 942 (1940)
- (1545a) SPONER, H. and TELLER, E. Electronic spectra of polyatomic molecules. *Rev. Modern Phys.* 13, 75-170 (1941)
- (1546) STARK, J. Über Absorption und Fluoreszenz im Bandenspektrum und über Fluoreszenz des Benzols. *Phys. Z. S.* 8, 81 (1907); *Ann. d. Phys.* 29, 316 (1909)

- (1547) STARK, J. Anwendung einer Valenzhypothese auf die Erscheinung der Fluoreszenz. *Z. f. Elektrochem.* 17, 514 (1911)
- (1548) STARK, J. Über den Zusammenhang zwischen Fluoreszenz und chemischer Konstitution. *Z. f. Elektrochem.* 18, 1011 (1912); 19, 397 (1913)
- (1549) STARK, J. Über den Zusammenhang zwischen Fluoreszenz und Ionisierung. *Ann. d. Phys.* 41, 728 (1913)
- (1550) STARK, J. Die Axialität der Atomstruktur in der polarisierten Fluoreszenz von Kristallen. *Phys. Z.* 44, 215 (1943)
- (1551) STARK, J. and MEYER, E. Beobachtungen über die Fluoreszenz von Benzolderivaten. *Phys. Z.* 8, 250 (1907)
- (1552) STARK, J. and STEUBING, W. Fluoreszenz und lichtelektrische Empfindlichkeit organischer Substanzen. *Phys. Z.* 9, 481 (1908)
- (1553) STARK, J. and STEUBING, W. Weitere Beobachtungen über die Fluoreszenz organischer Substanzen. *Phys. Z.* 9, 661 (1908)
- (1554) STARKIEWICZ, J. La photoluminescence des solutions glycériques de l'esculine aux températures de -180° à 20° C. *C. R. soc. pol. de phys.* 3, 193 (1927); *Bull. intern. Cracow 1927*, 459
- (1555) STARKIEWICZ, J. L'influence de la longueur d'onde du rayonnement excitateur sur le spectre de fluorescence des solutions visqueuses et solides. *C. R. soc. pol. de phys.* 4, 73 (1929)
- (1556) STARKIEWICZ, J. Sur l'excitation monochromatique de la fluorescence du benzène à -180° C. *C. R. soc. pol. de phys.* 4, 201 (1929)
- (1557) STASIW, O. and SAUER, E. Einfluss geringer Fremdionenzusätze auf die Gitterkonstante in Alkalihalogenidkristallen. *Verhandl. d. Deutsch. phys. Ges.* 19, 4 (1938)
- (1558) STEACIE, E. W. R. and CUNNINGHAM, R. L. The Hg photosensitized decomposition of ethane. The reaction at high temperatures. *J. Chem. Phys.* 8, 800 (1940)
- (1559) STEACIE, E. W. R. and DEWAR, D. J. Hg photosensitized reactions of propane. *J. Chem. Phys.* 8, 571 (1940)
- (1560) STEACIE, E. W. R. and LE ROY, D. J. The polymerization of ethylene photosensitized by 5^1P_1 Cd atoms. *J. Chem. Phys.* 10, 22 (1942)
- (1561) STEACIE, E. W. R. and LE ROY, D. J. Quenching of Cd resonance radiation (3261A) by hydrocarbons and other gases. *J. Chem. Phys.* 11, 164 (1943)
- (1562) STEACIE, E. W. R. and LE ROY, D. J. The resonance emission of cadmium hydride bands in Cd photosensitized reactions of hydrocarbons. *J. Chem. Phys.* 12, 34 (1944)
- (1563) STEACIE, E. W. R., LE ROY, D. J., and POTWIN, R. The Cd sensitized reactions of propane. *J. Chem. Phys.* 9, 306 (1941)
- (1564) STEACIE, E. W. R. and PHILIPS, N. W. F. Hg photosensitized decomposition of ethane. *J. Chem. Phys.* 6, 179 (1938)
- (1565) STEACIE, E. W. R. and POTWIN, R. The Cd sensitized reactions of ethane. *J. Chem. Phys.* 7, 782 (1939)
- (1566) STEINBACHER, K. Energieverteilung in Phosphoreszenzbanden. *Diss. Heidelberg 1927*
- (1567) STEINHAEUSER, A. Die Polarisation der Resonanzstrahlung des Ca und ihre Beeinflussung durch schwache Magnetfelder. *Z. f. Phys.* 95, 669 (1935); 99, 300 (1936)
- (1568) STERN, A. Zur Fluoreszenz der Chlorine. *Z. phys. Chem. A* 182, 186 (1938)
- (1569) STERN, A., MOLWIG, H., and DEZELIC, M. Fluoreszenz der Porphyrine. *Z. phys. Chem. A* 175, 38 (1936); 176, 209 and 347 (1936)
- (1570) STERN, K. O. Isolation of hepatoflavine. *Nature* 132, 784 (1933)
- (1571) STERN, O. and VOLMER, M. Über die Abklingungszeit der Fluoreszenz. *Phys. Z.* 20, 183 (1919)
- (1572) STEUBING, W. Fluoreszenz und Ionisierung des Hg-Dampfes. *Phys. Z.* 10, 787 (1909). *Verhandl. d. Deutsch. phys. Ges.* 11, 561 (1909)

- (1573) STEUBING, W. Fluoreszenz und Bandenspektrum des Sauerstoffes. *Ann. d. Phys.* 33, 553 (1910); 34, 1003 (1911)
- (1574) STEUBING, W. Versuche zur Arbeit des Herrn Wood: Eine neue strahlende Emission seitens des Funkens. *Phys. Z.* 12, 626 (1911)
- (1575) STEUBING, W. Fluoreszenz der Elemente in der sechsten Gruppe des periodischen Systems: Schwefel-, Selen- und Tellurdampf. *Phys. Z.* 14, 887 (1913)
- (1576) STEUBING, W. Wirkung eines Magnetfeldes auf Fluoreszenzintensität. *Verhandl. d. Deutsch. phys. Ges.* 15, 1181 (1913)
- (1577) STEUBING, W. Spektrale Intensitätsverschiebung und Schwächung der Jodfluoreszenz durch ein magnetisches Feld. *Ann. d. Phys.* 58, 55 (1919)
- (1578) STEUBING, W. Die Entstehung des Jodbandenspektrums und seine Lage nach der Quantentheorie. *Z. f. Phys.* 1, 426 (1920)
- (1579) STEUBING, W. Temperatur und Bandenspektrum. *Phys. Z.* 22, 507 (1921)
- (1580) STEUBING, W. Zur Kenntnis des Jodmoleküls und der Emission seines Bandenspektrums. *Ann. d. Phys.* 64, 673 (1921)
- (1581) STEVENSON, L. S. The fluorescence of anthracene. *J. Phys. Chem.* 15, 845 (1911)
- (1582) STIMSON, M. M. and REUTER, M. A. The fluorescence of some purines and pyrimidines. *Am. Chem. Soc. J.* 63, 697 (1941)
- (1583) STOBBE, H. Lichtreaktion des weissen und gelben Diphenyloctatetraens. *Chem. Ber.* 42, 565 (1909)
- (1584) STOBBE, H. and EBERT, E. Fluoreszenz und Radiolumineszenz einiger Kohlenwasserstoffe mit Aether-, Aethylen- und Acetylenresten. *Chem. Ber.* 44, 1294 (1911)
- (1585) STOKES, G. Q. On the change of refrangibility of light. *Phil. Trans.* 142 II, 463 (1852); 143 III, 385 (1853)
- (1586) STZLONI-DOBZANSKI, J. Über die Färbung der druckzerstörten Erdalkalischwefelphosphore. *Z. f. Phys.* 38, 841 (1926)
- (1587) STOUGHTON, R. W. and ROLLEFSON, G. K. The influence of ionic strength on the quenching of fluorescence in solutions. *Am. Chem. Soc. J.* 61, 2634 (1939)
- (1588) STOUGHTON, R. W. and ROLLEFSON, G. K. The quenching of fluorescence solution. Temperature and solvent effects. *Am. Chem. Soc. J.* 62, 2264 (1940)
- (1589) STRAUS, F. Über Lumineszenzerscheinungen bei Pyrazolinderivaten. *Chem. Ber.* 51, 1457 (1918)
- (1590) STRECK, E. Über die Zerstörung des ZnS durch Licht und α -Strahlen. *Ann. d. Phys.* 34, 96 (1939); 35, 58 (1939)
- (1590a) STRIPS, K. F. and WARD, R. The effect of activator concentration on the infrared sensitive phosphor SrS(Eu,Sm). *Am. Chem. Soc. J.* 70, 401 (1948)
- (1591) STRUTT, R. J. (LORD RAYLEIGH). Observations on the fluorescence and resonance radiation of sodium vapour. *Proc. Roy. Soc. A* 91, 388 and 511 (1915)
- (1592) STRUTT, R. J. (LORD RAYLEIGH). Resonance radiation of sodium vapour in a magnetic field. *Nature* 95, 33 (1915)
- (1593) STRUTT, R. J. (LORD RAYLEIGH). U.v. excitation of the D-line of sodium. *Nature* 95, 285 (1915)
- (1594) STRUTT, R. J. (LORD RAYLEIGH). A study of the line spectrum of sodium as excited by fluorescence. *Proc. Roy. Soc.* 96, 272 (1919)
- (1595) STUART, H. A. Über die Auslöschung der Resonanzfluoreszenz bei Hg-Dampf. *Z. f. Phys.* 32, 262 (1925)
- (1595a) STUDER, F. J. and GAUS, L. Effect of temperature on the spectral energy distribution of phosphors. *Ithaca* 1946, 258

- (1596) STUTZ, G. F. A. Luminescent pigments and coatings. *J. Opt. Soc. Am.* **32**, 626 (1942)
- (1597) SUPPE, F. Kohärenz der zirkularen Komponenten beim Starkeffekt. *Z. f. Phys.* **113**, 18 (1939)
- (1598) SUPPE, F. Auslöschung und Depolarisation der Hg-Fluoreszenz durch Wasserstoff und Deuterium. *Z. f. Phys.* **113**, 141 (1939)
- (1599) SUPPE, F. Die Polarisation der Fluoreszenz von Molekülen in Dampf-
form und in Lösung. *Z. f. Phys.* **113**, 281 (1939)
- (1600a) SVESHNIKOV, B. The quenching of fluorescence of dye solutions by
foreign substances. *Acta physchim U.S.S.R.* **4**, 453 (1936); **7**, 755
(1937)
- (1600b) SVESHNIKOV, B. Identity of centers of long-lived and short-lived light
emission in organoluminophors. *C. R. Moscow* **51**, 429 (1946)
- (1600c) SVESHNIKOV, B. Absorption and phosphorescence of organic phosphors
under saturation by light. *C. R. Moscow* **51**, 675 (1946)
- (1601) SWIETOSLAWSKA, J. On the fluorescence bands emitted by Cd vapor.
Acta phys. pol. **3**, 261 (1934); *Z. f. Phys.* **91**, 354 (1933)
- (1602) SWINDELLS, F. E. The phosphorescence of CaWO_4 induced by X-rays. *J.*
Opt. Soc. Am. **16**, 165 (1928)
- (1603) SWINDELLS, F. E. Luminescence of alkaline earth tungstates containing
lead. *J. Opt. Soc. Am.* **23**, 129 (1933)
- (1604) SWINGS, P. Sur la structure des groupes de raies de résonance de la vapeur
de soufre. *C. R.* **189**, 982 (1929); *Bull. intern. Cracow 1929*, 616; *C. R.*
soc. pol. de phys. **5**, 29 (1930); *Mémoires Lièges* **16**, 1 (1931); *Z. f. Phys.*
61, 681 (1930)
- (1605) SWINGS, P. Les groupes de résonance de la vapeur diatomique du soufre.
C. R. **190**, 1010 (1930)
- (1606) SWINGS, P. Sur la variation des intensités relatives des composantes des
doublets de rotation dans le spectre de résonance du soufre. *C. R.* **190**,
965 (1930); *Bull. Brussels* **17**, 956 (1931)
- (1607) SWINGS, P. Sur les multiplets de résonance et le moment d'inertie des
molécules diatomiques de soufre. *Bull. Brussels* **17**, 240 (1931)
- (1608) SWINGS, P. Sur la probabilité de désactivation par chocs intermoléculaires
dans le cas des émissions fluorescentes. *Mémoires Lièges*. **16**, No. 3 (1931)
- (1609) SWINGS, P. Démonstration de l'existence d'isotopes de l'atome de soufre
au moyen de l'analyse de la structure fine du spectre de résonance des
molécules diatomiques S_2 . *Bull. Brussels* **17**, 972 and 1095 (1931)
- (1610) SWINGS, P. Remarque sur le spectre de résonance de la vapeur diatomique
de bismuth. *Bull. Liège 1932*, No. 6
- (1611) SWINGS, P. Remarque sur les spectres de fluorescence des molécules
diatomiques de sélénium. *Bull. Liège 1934*, No. 8
- (1612) SWING, P. Les spectres de résonance de molécules diatomiques. *Acta phys.*
pol. **5**, 215 (1936)
- (1613) SWINGS, P. Considerations regarding cometary and interstellar molecules.
Astrophys. J. **95**, 270 (1942)
- (1614) SWINGS, P. and CAMBRESIER, Y. Sur l'existence d'isotopes de Se et Te
dédiuée de l'examen des multiplets de résonance de Se_2 et Te_2 . *Bull.*
Brussels **18**, 419 (1932)
- (1615) SWINGS, P., ELVEY, C. T., and BABCOCK, H. W. The spectrum of comet
Cunningham 1490c. *Astrophys. J.* **94**, 320 (1941)
- (1616) SWINGS, P. and GENARD, J. Note sur les spectres de résonance des
molécules diatomiques de sélénium et de tellure. *Bull. Brussels* **17**,
1099 (1931)
- (1617) SWINGS, P. and LEGROS, A. Examen à grande dispersion d'un cas typique
de multiplet de résonance de la vapeur diatomique du soufre. *Bull.*
Brussels. **17**, 808 (1931)

- (1618) SWINGS, P. and MIGEOTTE, M. Sur la fluorescence des molécules diatomiques d'arsenic. *C. R.* 197, 836 (1933)
- (1619) SWINGS, P. and NICOLET, M. On the intensity distribution in the bands of cometary spectra. *Astrophys. J.* 88, 173 (1938)
- (1620) SWINGS, P. and PIÉRARD, J. Quelques considérations déduites du spectre de résonance de la vapeur diatomique de tellure. *Bull. Liège* 1932, No. 3
- (1621) SZCZENIOWSKI, S. Sur le rendement de la fluorescence des solutions. *C. R. soc. pol. de phys.* 8, 60 (1927); *Bull. intern. Cracow* 1927, 127
- (1621a) SZIGETI, G. and NAGY, E. Dielectric losses and fluorescence of zinc silicate. *Nature* 160, 641 (1947)
- (1621b) SZIGETI, G., NAGY, E., and MAKAI, E. A spectroscopic evidence of activation of fluorescence by high valency manganese ions. *J. Chem. Phys.* 15, 881 (1947)
- (1622) SZYMANOWSKI, W. Verbesserte Fluorometermethode zur Messung der Abklingzeit der Fluoreszenzstrahlung. *Z. f. Phys.* 95, 440 (1935)
- (1623) SZYMANOWSKI, W. Über die Leuchtdauer und die Abklinggesetze der Fluoreszenzstrahlung. *Z. f. Phys.* 95, 450 (1935); *Bull. intern. Cracow* 1935, 34
- (1624) SZYMANOWSKI, W. Einfluss der Konzentration der Farbstoffe und der Zähigkeit des Lösungsmittels auf die Fluoreszenzabklingzeit. *Z. f. Phys.* 95, 460 (1935)
- (1625) SZYMANOWSKI, W. Einfluss der Rotation der Moleküle auf die Messung der Abklingzeit der Fluoreszenzstrahlung. *Z. f. Phys.* 95, 466 (1935)
- (1626) TANAKA, T. On the cathodo luminescence of solid solutions of 42 metals. *J. Opt. Soc. Am.* 8, 287 (1924)
- (1627) TATE, J. T. Note on the quenching of the fluorescence radiation in Hg vapor. *Phys. Rev.* 23, 770 (1923)
- (1628) TAYLOR, A. H. Luminous characteristics of two phosphors. *J. Opt. Soc. Am.* 32, 506 (1942)
- (1629) TAYLOR, H. A. and TANFORD, C. The Hg sensitized reaction between hydrogen and nitric oxide. *J. Chem. Phys.* 12, 47 (1944)
- (1630) TAYLOR, H. S. and MARSHALL, A. L. The reactions of hydrogen activated by excited Hg atoms. *J. Phys. Chem.* 29, 1140 (1925)
- (1630a) TEELE, R. P. Measurement of brightness decay of phosphorescent materials. *Ithaca* 1946, 311
- (1631) TEREININ, A. Anregung von Atomen und Molekülen zur Lichtemission durch Einstrahlung. *Z. f. Phys.* 31, 26 (1925); 37, 98 (1926)
- (1632) TEREININ, A. Wirkung eines elektrischen Feldes auf das optisch erregte Spektrum des Quecksilbers. *Z. f. Phys.* 37, 676 (1926)
- (1633) TEREININ, A. Optical excitation of the vapors of mercury halides. *Nature* 118, 843 (1926); *Naturwiss.* 15, 73 (1927); *Z. f. Phys.* 44, 713 (1927)
- (1634) TEREININ, A. Über die optische Dissoziationswärme von Salzdämpfen. *Physica* 9, 283 (1929)
- (1635) TEREININ, A. Photoionization of salt vapors. *Phys. Rev.* 36, 147 (1930)
- (1636) TEREININ, A. Dissociation fluorescence of AgI and HgI₂ vapor. *Physica* 10, 209 (1930); *Phys. Z. Sow.* 2, 437 (1932)
- (1637) TEREININ, A. Emission bands excited in TII vapor by u.v. light. *Phys. Z. Sow.* 2, 377 (1932)
- (1638) TEREININ, A. Photodissociation of complex molecules. *Acta physchim. U.S.S.R.* 3, 181 (1935)
- (1639) TEREININ, A. La photoluminescence des molécules organiques à l'état gazeux. *Acta phys. pol.* 5, 229 (1936)
- (1640) TEREININ, A. Spectral investigation of chemical processes in organic compounds at low temperatures. *Acta physchim. U.S.S.R.* 12, 617 (1940); 13, 1 (1940)

- (1640a) TERENIN, A. Photochemical processes in aromatic compounds. *Acta physchim. U.S.S.R.* 18, 210 (1943)
- (1640b) TERENIN, A. The influence of the medium on the photoluminescence of organic compounds. *Bull. Moscow* 9, 304 (1945)
- (1641) TERENIN, A. and CLEMENT, F. Fluorescence of salts surface-activated by condensed metals. *Acta physchim. U.S.S.R.* 1, 941 (1934)
- (1642) TERENIN, A. and KARIAKIN, A. Proton transfer between organic molecules caused by light. *Nature* 169, 881 (1947)
- (1643) TERENIN, A. and NEUJMIN, H. Über die Zerlegung von Molekülen durch Stoss mit angeregten Atomen. *Phys. Z. Sow.* 2, 434 (1932)
- (1644) TERENIN, A. and POPOV, B. Photodissociation of salt molecules into ions. *Phys. Z. Sow.* 2, 299 (1932); *Z. f. Phys.* 75, 338 (1932)
- (1645) TERENIN, A. and PRILESHAJEWA, N. Der Wirkungsquerschnitt der Auslöschung der Na-Emission durch Jodatome und Moleküle. *Z. phys. Chem. B* 13, 72 (1931)
- (1646) TERENIN, A. and PRILESHAJEWA, N. Photodissociation of the vapors of some organo-metallic compounds. *Acta physchim. U.S.S.R.* 1, 759 (1934)
- (1647) TERENIN, A. and TSCHUBAROV, R. The inner recombination in the photodissociation of polyatomic molecules. *Acta physchim. U.S.S.R.* 7, 1 (1937)
- (1648) TERENIN, A., VARTARIAN, A. and NEPORENT, B. Photoluminescence and vibrational energy exchange in complex molecules. *Faraday Soc. Trans.* 35, 39 (1939)
- (1649) TERRIEN, J. Absorption et fluorescence des vapeurs d'halogénures cuivreux. *C. R.* 200, 1096 (1935); 204, 565 and 679 (1937); *Ann. de phys.* 9, 477 (1938)
- (1650) THACKERAY, A. D. The excitation of emission lines in late-type variables. *Astrophys. J.* 86, 499 (1937)
- (1651) THAYER, R. N. and BARNES, B. T. The basis for high efficiency in fluorescent lamps. *J. Opt. Soc. Am.* 29, 131 (1939)
- (1652) THIELE, H. Graphit und Graphitsäure. *Z. f. anorgan. Chem.* 190, 145 (1930)
- (1653) THOMAS, L. B. A monochromatic source of mercury resonance radiation. *Rev. Sci. Inst.* 12, 309 (1941)
- (1654) THOMAS, V. R. Absorption of resonance radiation in Hg vapor. *Phys. Rev.* 35, 1253 (1930)
- (1655) THOMPSON, H. W. Fluorescence of glyoxal vapor. *J. Chem. Phys.* 7, 855 (1939)
- (1656) THOMPSON, H. W. and LINNETT, J. W. The spectrum, fluorescence and photochemical decomposition of acraldehyde. *J. Chem. Soc.* 1935, 1452
- (1656a) THORINGTON, L. Influence of temperature upon the intensity of luminescence of various phosphors. *Ithaca* 1946, 269
- (1657) THOSAR, B. V. On the fluorescent ions of chromium in corundum. *Phil. Mag.* 26, 380 and 878 (1938); *Phys. Rev.* 54, 233 (1938)
- (1658) THOSAR, B. V. The polarization of luminescence of ruby. *Phys. Rev.* 60, 616 (1941)
- (1659) THOSAR, B. V. The polarization of luminescence in crystals. *J. Chem. Phys.* 10, 246 (1942)
- (1660) THOSAR, B. V. Crystal luminescence. Paramagnetic ions as centers. *J. Chem. Phys.* 12, 424 (1944)
- (1661) TIBILOV, S. Die Auslöschung der Fluoreszenz angeregter Quecksilber-Halogenmoleküle durch Fremdgase. *Acta physchim. U.S.S.R.* 7, 171 (1937)
- (1662) TIEDE, E. Reindarstellung von Magnesiumsulfid und seine Phosphoreszenz. *Chem. Ber.* 49, 1745 (1916)

- (1663) TIEDE, E. Phosphoreszenz der Borsäure. *Chem. Ber.* 53, 2214 (1920)
- (1664) TIEDE, E. Borsäurehydrat als Grundlage hochphosphoreszenzfähiger Systeme. *Phys. Z.* 22, 563 (1921)
- (1665a) TIEDE, E. Kristallchemische Untersuchungen an MgO- und LiF-Phosphoren. *Chem. Ber.* 72, 611 (1939)
- (1665b) TIEDE, E. Kristallochemische Bedingungen der Phosphoreszenzfähigkeit. *Munich* 1943, 29
- (1666) TIEDE, E. and BUESCHEN, F. Über den leuchtenden Borstickstoff. *Chem. Ber.* 53, 2206 (1920)
- (1667) TIEDE, E. and CHOMSE, H. Über die Lumineszenz der Zähne. *Chem. Ber.* 67, 1888 (1934)
- (1668) TIEDE, E. and CHOMSE, H. Monocalciumphosphat als Grundlage von Organophosphoren. *Chem. Ber.* 68, 146 (1935)
- (1669) TIEDE, E. and GOLDSCHMIDT, F. Über die Phosphoreszenz von Beryllium-sulfid und über eine lumineszenz-analytische Anordnung, besonders für lichtschwache Präparate. *Chem. Ber.* 62, 758 (1929)
- (1670) TIEDE, E. and LUEDERS, H. Lumineszenzfähige Aluminiumoxyde und ihre kristallschemischen Beziehungen zu den natürlichen und synthetischen Edelsteinen vom Korundtypus und deren Färbung. *Chem. Ber.* 66, 1681 (1933)
- (1671) TIEDE, E. and PIWONKA, R. Aluminiumoxyd als Grundlage lumineszenzfähiger Systeme: $\text{Al}_2\text{O}_3/\text{Pt}$ - und $\text{Al}_2\text{O}_3/\text{Mn}$ -Phosphore. *Chem. Ber.* 64, 2252 (1931)
- (1672) TIEDE, E. and RAGOSS, A. Die Borsäurephosphore. *Chem. Ber.* 56, 655 (1923)
- (1673) TIEDE, E. and REINICKE, H. Darstellung und Eigenschaften phosphoreszierender Sulfide von Natrium und Rubidium. *Chem. Ber.* 56, 666 (1923)
- (1674) TIEDE, E. and RICHTER, F. Magnesiumsulfidphosphore. *Chem. Ber.* 55, 69 (1922)
- (1675) TIEDE, E. and SCHIKORE, W. Die Methode der chromatographischen Adsorption in der Phosphoreszenzchemie. *Chem. Ber.* 75, 586 (1942); *Z. f. Elektrochem.* 44, 586 (1938)
- (1676) TIEDE, E. and SCHIKORE, W. Über den Feinbau der Erdkalisulfidphosphore. *Chem. Ber.* 75, 589 (1942)
- (1677) TIEDE, E. and SCHLEEDE, A. Kristallform, Schmelzmittel und tatsächlicher Schmelzvorgang beim phosphoreszierenden ZnS. *Chem. Ber.* 53, 1721 (1920); *Zentralblatt f. Mineralogie* 1921, 154 (1920)
- (1678) TIEDE, E. and SCHLEEDE, A. Über mit seltenen Erden aktivierte Magnesiumsulfidphosphore. *Ann. d. Phys.* 67, 573 (1922)
- (1679) TIEDE, E. and SCHLEEDE, A. Bemerkung zu der Abhandlung des Herrn J. Schmidt "Ein einfaches Verfahren zur Darstellung von gut phosphorzierendem ZnS". *Chem. Ber.* 56, 674 (1923)
- (1680) TIEDE, E. and SCHLEEDE, A. Röntgenographische Strukturuntersuchung an lumineszenzfähigem Kalziumwolframat. *Z. f. Elektrochem.* 29, 305 (1923)
- (1681) TIEDE, E. and THIMANN, M. Über phosphoreszenzfähiges mit Kohlenstoff aktiviertes Siliziumdisulfid. *Chem. Ber.* 59, 1706 (1926)
- (1682) TIEDE, E., THIMANN, M., and SENNE, K. Über phosphoreszenzfähiges mit Silizium aktiviertes Aluminiumnitrid. *Chem. Ber.* 61, 1568 (1928)
- (1683) TIEDE, E. and TOMASCHEK, H. Röntgenanalyse lumineszierenden, besonders flammenerregbaren Borstickstoffs. *Z. f. Elektrochem.* 29, 303 (1923)
- (1684) TIEDE, E. and TOMASCHEK, H. Über das aktivierende Element in leuchtendem Borstickstoff. *Z. f. anorgan. Chem.* 147, 111 (1925)

- (1685) TIEDE, E. and VILLAIN, E. Kristallchemische Untersuchung auf dem Gebiet der Spinell-Luminophore. *Chem. Ber.* 73, 274 (1940)
- (1686) TIEDE, E. and WEISS, E. Feinbau von Phosphoren und seine Beziehung zu atomchemischen Fragen. *Chem. Ber.* 65, 364 (1932)
- (1687) TIEDE, E. and WULFF, F. Bortrioxyhydrate als Bestandteile hochphosphoreszenzfähiger organische Verbindungen enthaltender Systeme. *Chem. Ber.* 55, 588 (1922)
- (1688) TITEICA, R. Spectres d'absorption et de fluorescence de quelques hydrocarbures à deux noyaux benzéniques. *C. R.* 199, 458 (1934)
- (1689) TITEICA, R. Fluorescence et absorption des hydrocarbures à noyaux benzéniques. *Acta phys. pol.* 5, 381 (1936)
- (1690) TOMASCHEK, R. Über die ZnS-Phosphore. *Ann. d. Phys.* 65, 189 (1921)
- (1691) TOMASCHEK, R. Zur Kenntnis der Borsäurephosphore. *Ann. d. Phys.* 67, 612 (1922)
- (1692) TOMASCHEK, R. Über den Einfluss des Grundmaterials auf die Phosphoreszenzmission. *Phys. Z.* 25, 643 (1924)
- (1693) TOMASCHEK, R. Über die Phosphoreszenzeigenschaften der seltenen Erden in Erdalkaliphosphoren. *Ann. d. Phys.* 75, 109 and 561 (1924)
- (1694) TOMASCHEK, R. Über die Emission der Phosphore. I. Verhalten des Sm in Sulfiden und Sulfaten. II. Umwandlung der Teilbanden im Samariumsulfidspektrum. *Ann. d. Phys.* 84, 329 and 1074 (1927)
- (1695) TOMASCHEK, R. Linienemission fester Körper und chemische Bindung. *Z. f. Elektrochem.* 36, 737 (1930)
- (1696) TOMASCHEK, R. Gesetzmässigkeiten der Linienpektren fester Körper. *Phys. Z.* 33, 878 (1932); *Nature* 130, 740 (1932)
- (1697) TOMASCHEK, R. Die Lenardphosphore unter besonderer Berücksichtigung der Phosphore mit linienhafter Emission. *Acta phys. pol.* 5, 393 (1936)
- (1698a) TOMASCHEK, R. On the application of phosphorescence spectra to the investigation of solids and solutions. *Faraday Soc. Trans.* 35, 148 (1939); *Munich 1943*, 170
- (1698b) TOMASCHEK, R. Strukturerforschung fester und flüssiger Körper mit Hilfe der Linienfluoreszenzspektren. *Ergebn. d. exakt. Naturwiss.* 20, 268 (1942)
- (1698c) TOMASCHEK, R. Innermolekulare Sensibilisierung von Leuchtstoffen. *Reichsber. d. Phys.* 1, 139 (1944)
- (1699) TOMASCHEK, R. and DEUTSCHBEIN, O. Über den Zusammenhang der Emissions- und Absorptionsspektren der Salze der seltenen Erden im festen Zustand. Fremdstoffphosphore. *Z. f. Phys.* 82, 309 (1933)
- (1700) TOMASCHEK, R. and DEUTSCHBEIN, O. Verhalten des Sm in den Oxyden der 2. Gruppe. *Ann. d. Phys.* 16, 930 (1933); *Nature* 131, 473 (1933)
- (1701) TOMASCHEK, R. and DEUTSCHBEIN, O. Über die Fluoreszenz der reinen Salze der seltenen Erden. *Phys. Z.* 34, 374 (1933)
- (1702) TOMASCHEK, R. and MEHNERT, E. Über die Fluoreszenz von Gadoliniumsalzen und deren Lösungen. *Ann. d. Phys.* 29, 306 (1937)
- (1703) TRAVNICEK, M. Beiträge zur Kenntnis der Sm-Phosphore. *Ann. d. Phys.* 79, 237 (1926)
- (1704) TRAVNICEK, M. Über das Spektrum der CaSrS-Sm-Mischphosphore. *Ann. d. Phys.* 84, 823 (1927); 85, 645 (1928)
- (1705) TRAVNICEK, M. Über neue Phosphore aus Sulfhydraten des Al und anderer Metalle mit organischen Leuchtstoffen. *Ann. d. Phys.* 17, 654 (1933)
- (1706) TRAVNICEK, M. Über Zementphosphore. *Ann. d. Phys.* 30, 224 (1937)
- (1707) TROEGER, J. and GRUENTHAL, O. Beiträge zur Fluoreszenz. *J. f. prakt. Chem.* 106, 173 (1923)
- (1708) TUMERMAN, L. Über die Abhängigkeit der Lumineszenzspektren von der Viskosität des Lösungsmittels. *C. R. Leningrad'* 1, 471 (1935)

- (1709) TUMERMAN, L. On the law of decay of luminescence of complex molecules. *J. Phys. U.S.S.R.* 4, 151 (1941)
- (1710) TUMERMAN, L. The polarization of fluorescence and the law of its decay. *C. R. Moscow* 32, 474 (1941).
- (1711) TURNER, L. A. Average life of excited Hg atoms. *Phys. Rev.* 23, 464 (1924)
- (1712) TURNER, L. A. Excited systems formed by the absorption of light. *J. Phys. Chem.* 32, 507 (1928)
- (1713) TURNER, L. A. Die magnetische Auslöschung der Joddampf-Fluoreszenz und ihr Zusammenhang mit Prädissoziationserscheinungen. *Z. f. Phys.* 65, 464 (1930)
- (1714) TURNER, L. A. Über die Anregung der Jodfluoreszenz mit monochromatischem Licht. *Z. f. Phys.* 65, 480 (1930)
- (1715) TURNER, L. A. Optical dissociation of iodine vapor and the enhancement of predissociation by collisions. *Phys. Rev.* 38, 574 (1931); 41, 627 (1932)
- (1716) TURNER, L. A. Stepwise fluorescence of Hg vapor in nitrogen mixtures; the 3650 line. *Phys. Rev.* 47, 807 (1935); 52, 632 (1937)
- (1717) TURNER, L. A. and SAMSON, E. W. The dissociation of excited iodine molecules by collisions with argon atoms. *Phys. Rev.* 37, 1684 (1931)
- (1718) TWAROWSKA, B. Sur les changements du spectre des solutions du biacénaphthylidène. I. Influence du solvant. II. Influence de la température. *Acta phys. pol.* 2, 267 and 273 (1933)
- (1719) TWAROWSKA, B. Extinction de la fluorescence d'une solution de biacène dans le p-dichloro-benzène à la température de -180° C. *Bull. intern. Cracow* 1934, 242
- (1720) TWAROWSKA, B. Sur les spectres de fluorescence de biacénaphthylidène, de fluorocyclène et de fluorène à l'état solide et en solution. *Acta phys. pol.* 4, 355 (1935); *Z. f. Phys.* 109, 403 (1938). *Bull. intern. Cracow* 1937, 278
- (1721) TWAROWSKA, B. Sur les spectres de fluorescence de quelques colorants organiques à l'état solide. *Acta phys. pol.* 4, 369 (1935)
- (1722) UEHARA, Y. Studies on luminescent materials. I. Theory of ZnS:Cu crystal phosphors. II. Fluorescence spectra at -185° , 20° , 150° C. III. Effect of temperature on the fluorescence of ZnS crystal phosphors. IV. On the molecular vibrational structure of fluorescence spectra of ZnS crystal phosphors. *J. Chem. Soc. Jap.* 60, 133, 900 and 1293 (1939); *Chem. Soc. Jap. Bull.* 15, 214 (1940)
- (1723) UGARTE Y GREAVES, S. DE. Beziehungen zwischen Fluoreszenz und chemischer Konstitution. *Diss. Münster* 1913
- (1723a) UMBERGER, J. Q. and LA MER, V. K. Kinetics of diffusion controlled molecular and ionic reactions in solutions as determined by the quenching of fluorescence. *J. Am. Chem. Soc.* 67, 1099 (1945)
- (1724) URBACH, F. Über Lumineszenz und Absorption, insbesondere des mit Becquerelstrahlen behandelten Sylvins. *Wien. Ber. IIa* 135, 149 (1926)
- (1725) URBACH, F. Zur Lumineszenz der Alkalihalogenide. *Wien. Ber. IIa* 139, 353 and 363 (1930); *Verhandl. d. Deutsch. phys. Ges.* 8, 17 (1927)
- (1726) URBACH, F. Zur Erklärung der Stokesschen Regel. *Wien. Ber. IIa* 139, 473 (1930)
- (1727a) URBACH, F. Bandenbreite und Temperaturabhängigkeit der Emissionsbanden von Alkalihalogenidphosphoren. *Wien. Ber. IIa* 139, 349 (1930)
- (1727b) URBACH, F. Storage and release of energy in phosphors of long duration. *J. Opt. Soc. Am.* 36, 351 (1946); *Ithaca* 1946, 115
- (1727c) URBACH, F., PEARLMAN, D., and HEMMENDINGER, H. On infrared sensitive phosphors. *J. Opt. Soc. Am.* 36, 372 (1946); *Ithaca* 1946, 279

- (1727d) URBACH, F., URBACH, A., and SCHWARTZ, M. The brightness of apparent fluorescence as a function of the exciting intensity. *J. Opt. Soc. Am.* 37, 122 (1947)
- (1728) URBAIN, G. Phosphorescence cathodique des terres rares. *Ann. chim. phys.* 18, 222 (1909)
- (1729) VAILLANT, M. P. Sur la variation de la conductibilité d'un corps phosphorescent sous l'action de la lumière. *C. R.* 153, 1141 (1911); 154, 867 (1912)
- (1730) VALENTINER, S. and ROESSIGER, M. Über Ökonomie der Fluoreszenzstrahlung. *Berlin Ber.* 16, 210 (1924); *Z. f. Phys.* 32, 239 (1925)
- (1731) VALENTINER, S. and ROESSIGER, M. Die Energieausbeute der Fluoreszenzstrahlung von Fluoreszeinlösungen bei antistokesscher Erregung. *Z. f. Phys.* 36, 81 (1926)
- (1732) VAMBREUSE, G. Note sur le classement des multiplets de résonance de la vapeur diatomique de soufre. *Bull. Liège* 1936, 273
- (1733) VAN DER BOM, TH. Recherches spectroscopiques sur la fluorescence de l'hématoporphyrine. *Thèse Fribourg* 1924
- (1734) VAN DER LINGEN, J. S. Die Fluoreszenz des Cd-Dampfes. *Z. f. Phys.* 6, 403 (1921)
- (1735) VAN DER LINGEN, J. St. and WOOD, R. W. The fluorescence of Hg vapor. *Astrophys. J.* 54, 149 (1921)
- (1736) VAN HEEL, A. C. S. On the monochromatic excitation of fluorescence. *Proc. Amsterdam* 28, 955 (1925)
- (1737) VAN HEEL, A. C. S. Considerations on the energy niveaus of uranyl compounds. *Comm. Leiden. Suppl.* 55b, Nos. 169-180 (1925)
- (1738) VAN HEEL, A. C. S. Some experiments on fluorescence. *Comm. Leiden.* No. 187 (1928)
- (1739) VANINO, L. and SACHS, P. Über die Einwirkung von Ag-Salzen und kolloidalen Metallen auf die Luminophore. *J. f. prakt. Chem.* 57, 508 (1913)
- (1740) VANINO, L. and SCHMID, F. Über gelb leuchtende Phosphore. *J. f. prakt. Chem.* 124, 52 (1929)
- (1741) VANINO, L. and ZUMBUSCH, E. Über den Bologneser Leuchtstein. *J. f. prakt. Chem.* 80, 69, (1909); 82, 193 (1910); 84, 305 (1911)
- (1742) VAN VLECK, J. H. On the quantum theory of polarization of resonance radiation in magnetic fields. *Proc. Nat. Ac. Sci.* 11, 612 (1925)
- (1743a) VAN VLECK, J. H. The theory of magnetic quenching of iodine fluorescence and of λ -doubling in $^3\Pi_0$ -states. *Phys. Rev.* 40, 544 (1932)
- (1743b) VAN VLECK, J. H. Zeeman effect of chrome alum. *J. Chem. Phys.* 8, 787 and 790 (1940)
- (1744) VARGIN, V. V. and VEINBERG, T. I. Luminescence of glasses. *Bull. Moscow* 9, 283 (1945)
- (1745) VARTANIAN, A. An investigation of the structure of the fluorescence spectrum of aniline vapor. *J. Phys. U.S.S.R.* 1, 213 (1939)
- (1746) VARTANIAN, A. Extinction de la fluorescence et décomposition photothermique de l'aniline. *J. Phys. U.S.S.R.* 3, 467 (1940)
- (1747) VAVILOV, S. I. The dependence of the intensity of the fluorescence of dyes on the wavelength of the exciting light. *Phil. Mag.* 43, 307 (1922)
- (1748) VAVILOV, S. I. Die Fluoreszenzausbeute von Farbstofflösungen. *Z. f. Phys.* 22, 266 (1922); 42, 311 (1927)
- (1749) VAVILOV, S. I. Die Auslöschung der Fluoreszenz von Farbstofflösungen bei grosser Konzentration. *Z. f. Phys.* 31, 750 (1925)
- (1750) VAVILOV, S. I. Bemerkung zur Arbeit von Valentiner und Roessiger "Über Ökonomie der Fluoreszenzstrahlung". *Z. f. Phys.* 32, 236 (1925)
- (1751) VAVILOV, S. I. Über polarisiertes Fluoreszenzlicht von Farbstofflösungen. *Z. f. Phys.* 32, 721 (1925)

- (1752) VAVILOV, S. I. Bemerkung zur Arbeit von F. Schmieder "Über die Ökonomiekoeffizienten der Phosphore". *Ann. d. Phys.* 78, 112 (1925)
- (1753) VAVILOV, S. I. Eine Möglichkeit des experimentellen Nachweises der Rotverschiebung der Resonanzstrahlung bei wiederholten Re-emissionen. *Z. f. Phys.* 44, 537 (1927)
- (1754) VAVILOV, S. I. Zur Theorie der Löschung der Photolumineszenz in Uranylsalzlösungen. *Z. f. Phys.* 50, 52 (1928)
- (1755) VAVILOV, S. I. Die Lebensdauer der angeregten Moleküle in den wässrigen fluoreszierenden Lösungen. *Z. f. Phys.* 53, 665 (1929)
- (1756) VAVILOV, S. I. Die neuen Eigenschaften der polarisierten Fluoreszenz von Flüssigkeiten. *Z. f. Phys.* 55, 690 (1929); 58, 447 (1929)
- (1757) VAVILOV, S. I. Über die Abklingungsgesetze der umkehrbaren Lumineszenzerscheinungen. *Phys. Z. Sow.* 5, 369 (1934)
- (1758) VAVILOV, S. I. Die Auslöschung der Fluoreszenz in flüssigen Lösungen. *Acta phys. pol.* 5, 417 (1936)
- (1759) VAVILOV, S. I. Some considerations on the molecular viscosity of liquids. *Acta physchim. U.S.S.R.* 7, 49 (1937)
- (1760) VAVILOV, S. I. Methode zur Bestimmung der wahren Fluoreszenzpolarisation von Lösungen bei grossen Konzentrationen. *C. R. Moscow* 16, 255 (1937)
- (1761a) VAVILOV, S. I. The nature of elementary oscillators and the polarization of photoluminescence. *J. Phys. U.S.S.R.* 3, 433 (1940)
- (1761b) VAVILOV, S. I. On phosphorescopic measurements. *C. R. Moscow* 27, 115 (1940)
- (1762a) VAVILOV, S. I. A theory of concentration quenching of fluorescence in solutions. *C. R. Moscow* 35, 100 (1942); *J. Phys. U.S.S.R.* 7, 141 (1943)
- (1762b) VAVILOV, S. I. Some remarks on Stokes' law. *J. Phys. U.S.S.R.* 9, 68 (1945)
- (1762c) VAVILOV, S. I. Depolarization of photoluminescence on decaying. *C. R. Moscow* 42, 331 (1944)
- (1762d) VAVILOV, S. I. Photoluminescence of solutions. *Bull. Moscow* 9, 283 (1945)
- (1762e) VAVILOV, S. I. Photoluminescence and thermodynamics. *J. Phys. U.S.S.R.* 10, 499 (1946)
- (1763) VAVILOV, S. I. and BRUMBERG, E. M. Über die Eigenschaften der Interferenz von weit geöffneten Lichtbündeln. *Phys. Z. Sow.* 3, 103 (1933)
- (1764) VAVILOV, S. I., GLUCHOW, P. G., and KHVOSTIKOV, I. A. Fluoreszenzdepolarisation von Lösungen bei grosser Konzentration. *C. R. Moscow* 16, 259 (1937)
- (1765) VAVILOV, S. I. and LEVSHIN, W. L. Zur Frage über polarisierte Fluoreszenz von Farbstofflösungen. *Phys. Z.* 23, 173 (1922); *Z. f. Phys.* 16, 136 (1923)
- (1766) VAVILOV, S. I. and LEVSHIN, W. L. Die Beziehung zwischen Fluoreszenz und Phosphoreszenz fester und flüssiger Medien. *Z. f. Phys.* 35, 920 (1926); 44, 539 (1927)
- (1767) VAVILOV, S. I. and LEVSHIN, W. L. Studien zur Kenntnis der Natur der Photolumineszenz von Uranylsalzen. *Z. f. Phys.* 48, 397 (1928); *Naturwiss.* 15, 899 (1927)
- (1767a) VAVILOV, S. I. and SEVSHENKO, A. N. Decay of luminescence in rare earth solutions. *C. R. Moscow* 27, 541 (1940)
- (1768) VAVILOV, S. I. and TUMMERMAN, L. A. Ein merkwürdiger Fall der Photolumineszenz von Flüssigkeiten. *Z. f. Phys.* 54, 270 (1929)
- (1769) VEGARD, L. The atmospheric layer from which the yellow light in twilight originates. *Nature* 145, 623 (1940)
- (1770) VENKATESWARAN, C. S. The fluorescence of ruby, sapphire and emerald. *Proc. Ind. Ac. A* 2, 459 (1935)

- (1771) VERNEUIL, A. Sur la préparation du sulfure du calcium à phosphorescence violette. *C. R.* 103, 600 (1886); 104, 501 (1887)
- (1772) VINOKUROV, L. and LEVSHIN, W. L. Examen de l'excitation de la luminescence des substances phosphorescentes activées par des activateurs organiques. *C. R. Moscow* 15, 135 (1936)
- (1773) VISSER, G. H. Optische bepaling van de dissociatiewarmte van zoutdampen. *Physica* 9, 115 and 285 (1929)
- (1774) VISSER, G. H. Notiz zur optischen Dissoziation des CsJ. *Z. f. Phys.* 63, 402 (1930)
- (1775) VISSER, G. H. Over optische dissociatie van eenige twee-atomige molekulen. *Thesis, Delft* 1932
- (1776) VISSER, G. H. and VAN HEEL, A. C. S. Über die Einwirkung des Lichtes auf Rubidiumjodiddampf. *Z. f. Phys.* 70, 605 (1931); 86, 694 (1933)
- (1777) VITTE, F. Étude du pouvoir fluorescent des solutions. Influence de la concentration. Action des antioxygènes. *J. chim. phys.* 26, 276 (1929)
- (1778) VOLMAR, Y. and MATHIS, J. Étude de l'action inhibitrice de certains ions sur la fluorescence de l'ion uranyle et de ses applications à l'analyse chimique minérale. *Bull. soc. chim. France* 53, 385 (1933)
- (1779) VOLMER, M. Die verschiedenen lichtelektrischen Erscheinungen am Anthrazen, ihre Beziehungen untereinander, zur Fluoreszenz und zur Dianthrazenbildung. *Ann. d. Phys.* 40, 775 (1913)
- (1780) VOYATZAKIS, E. Sur l'effet photoélectrique et la photoconductibilité des sulfures phosphorescents et des fluorines. *C. R.* 209, 31 (1939)
- (1781) WAGGONER, C. W. Some studies in short duration phosphorescence. *Phys. Rev.* 27, 209 (1908)
- (1782) WAGGONER, C. W. Some phosphorescent salts of Cd with Na. *Phys. Rev.* 31, 358 (1910)
- (1783) WAJNKRANC, R. Über das Absorptions- und Fluoreszenzspektrum des Indiumdampfes. *Z. f. Phys.* 104, 122 (1937); 105, 516 (1937)
- (1784) WALTER, B. Die Änderung des Fluoreszenzvermögens mit der Konzentration. *Ann. d. Phys.* 34, 316 (1888); 36, 502 (1889)
- (1785) WALTER, B. Absorptionsspektren phosphoreszierender Stoffe. *Phys. Z.* 13, 6 (1912)
- (1786a) WARFIELD, C. N. Iodine resonance spectra excited by the yellow Hg lines. *Phys. Rev.* 31, 39 (1928)
- (1786b) WARD, R. Preparation and properties of infrared sensitive selenide and sulfide phosphors. *J. Opt. Soc. Am.* 6, 351 (1946); *Ithaca* 1946, 22
- (1786c) WARD, R. Infrared sensitive phosphors of the alkaline earth sulfide and selenides. *Trans. Electrochem. Soc.* 93, 171 (1948)
- (1787) WARREN, D. T. U.v. absorption of iodine vapor. *Phys. Rev.* 45, 561 (1934); 47, 1 (1935)
- (1788) WARREN, D. T. U.v. I₂ fluorescence. *Phys. Rev.* 47, 642 (1935)
- (1788a) WASER, J. and WIELAND, K. Emission spectrum of iodine molecules in the presence of an inert gas. *Nature* 160, 643 (1947)
- (1788b) WASSER, E. La décroissance de la luminescence du phosphore KCl(Tl) en forme de poudre. *Cahiers de physique* 11, 6 (1942)
- (1789) WEBB, W. A. The metastable state in Hg vapor. *Phys. Rev.* 24, 113 (1924)
- (1790) WEBB, W. A. and MESSENGER, H. A. Short duration phosphorescence in fused quartz. *Phys. Rev.* 34, 1463 (1929)
- (1791a) WEBB, H. A. and MESSENGER, H. A. Size of mercury metastable atom. *Phys. Rev.* 40, 466 (1932)
- (1791b) WEBB, W. A. and MESSENGER, H. A. Lifetimes of resonance lines of Cd. *Phys. Rev.* 66, 77 (1944)
- (1792) WEBER, K. Über die enge Beziehung der Fluoreszenzauslöschung zur Hemmung photochemischer Reaktionen. *Z. phys. Chem. B* 15, 18 (1931)

- (1793) WEBER, K. Zur Theorie der Fluoreszenzauslöschung. *Z. phys. Chem. B* 19, 22 (1932)
- (1794) WEBER, K. Über die Absorptionsverteilung in Lösungen mit zwei absorbierenden Komponenten. *Z. phys. Chem. B* 19, 30 (1932)
- (1795) WEBER, K. Über die Rolle des Redoxpotentials und der Acidität bei der Fluoreszenzauslöschung. *Z. phys. Chem. B* 30, 69 (1935)
- (1796) WEBER, K. Die Auslöschung der Fluoreszenz des Methylenblaus durch Ferrosalze. *Naturwiss.* 24, 318 (1936)
- (1797) WEBER, K. and SAVIC, M. L. Die Auslöschung der Fluoreszenz durch organische Verbindungen. *Z. phys. Chem. B* 24, 68 (1934)
- (1798) WEBER, L. Lichtelektrische Leitung und Absorption der Lenardphosphore im roten und ultraroten Spektralgebiet. *Ann. d. Phys.* 16, 821 (1933)
- (1798a) WECKER, F. Röntgenographische Strukturuntersuchungen an ZnS(Cu)-Phosphoren nach der Pulvermethode. *Ann. d. Phys.* 42, 561 (1942)
- (1798b) WECKER, F. Lumineszenzrückgang und Teilchen-grösse beim druckzerstörten ZnS-Phosphor. *Ann. d. Phys.* 43, 607 (1943)
- (1799) WEIGERT, F. Über die Hemmung photochemischer Reaktionen durch Sauerstoff. *Nernstfestschrift 1912*, 465
- (1800) WEIGERT, F. Über polarisierte Fluoreszenz. *Verhandl. d. Deutsch. phys. Ges.* 23, 100 (1920); *Z. f. Phys.* 23, 232 (1922)
- (1801) WEIGERT, F. Über Fluoreszenz, photochemische Wirkung und Einsteinsches Gesetz. *Z. f. Phys.* 10, 349 (1922)
- (1802) WEIGERT, F. Über den Polarisationszustand der Resonanzstrahlung und über seine Beeinflussung durch schwache magnetische Felder. *Naturwiss.* 12, 38 (1924)
- (1803) WEIGERT, F. The fluorescence of hydrocarbons and of their mixtures with naphthacene. *Faraday Soc. Trans.* 36, 1033 (1940)
- (1804) WEIGERT, F. and KAEPLER, G. Polarisierte Fluoreszenz in Farbstofflösungen. *Z. f. Phys.* 25, 99 (1924); 33, 801 (1925)
- (1805) WEIL-MALHERBE, H. and WEISS, J. Reversible quenching by oxygen of fluorescence of polycyclic hydrocarbons. *Nature* 149, 471 (1942)
- (1806) WEIL-MALHERBE, H. and WEISS, J. Some observations on the photochemistry of fluorescent substances. I. The quenching of fluorescence by NO and the photochemical formation of nitroxides. II. Concentration quenching. *J. Chem. Soc.* 1944, 541 and 544; *Nature* 151, 449 (1943)
- (1807) WEISS, E. Über den Feinbau der Phosphore und seine Bedeutung für atom-chemische Fragen. *Diss. Berlin 1931*
- (1808) WEISS, J. Photosensitizing action and the fluorescence of uranium salts. *Faraday Soc. Trans.* 34, 451 (1938)
- (1809) WEISS, J. Photosensitized reactions and the quenching of fluorescence in solutions. *Faraday Soc. Trans.* 35, 48 (1939)
- (1810) WEISS, J. Oxidation and chemiluminescence. *Faraday Soc. Trans.* 35, 219 (1939)
- (1811) WEISS, J. Fluorescence of organic molecules. *Nature* 152, 176 (1943)
- (1812) WEISS, J. and FISCHGOLD, H. Über den Mechanismus der Fluoreszenzauslöschung in Lösungen. *Z. phys. Chem. B* 32, 135 (1936)
- (1813) WEISSKOPF, V. Zur Theorie der Resonanzfluoreszenz. *Ann. d. Phys.* 9, 23 (1931)
- (1814) WEISSKOPF, V. Zur Theorie der Koppelungsbreite und der Stossdämpfung. *Z. f. Phys.* 75, 287 (1932); 77, 398 (1932); *Phys. Z.* 34, 1 (1933)
- (1815) WEISSKOPF, V. Über die Lebensdauer angeregter Atomzustände. *Phys. Z. Sow.* 4, 97 (1933)
- (1816) WEISSMAN, S. I. Intramolecular energy transfer. The fluorescence of complexes of europium. *J. Chem. Phys.* 10, 214 (1942)

- (1817) WEISSMAN, S. I. and LIPKIN, D. The electromagnetic mechanism of the beta phosphorescence of fluorescein in acid solution. *Am. Chem. Soc. J.* 64, 1916 (1942)
- (1818) WENK, W. Absorptions- und Fluoreszenzspektre dreiatomarer Indium- und Gallium-Halogenide. *Helv. phys. acta* 14, 355 (1941)
- (1819) WERNER, A. and GOHDES, H. Über die Abhängigkeit der Dauer- und Momentanprozesse einer getrennten Phosphoreszenzbande vom Metallgehalt und über die Erregungsverteilung dieser beiden Prozesse. *Ann. d. Phys.* 30, 257 (1909)
- (1819a) WERNER, A. Quantitative Messungen der An- und Abklingung getrennter Phosphoreszenzbanden. *Ann. d. Phys.* 24, 164 (1907)
- (1820) WESCH, L. Verfärbung und Nachleuchten der Carbonat- und Oxydphosphore. *Ann. d. Phys.* 12, 730 (1932)
- (1821) WESCH, L. Die elektro-optischen Eigenschaften der Lenardphosphore. Der Dielektrizitätskonstanten-Effekt. I. *Ann. d. Phys.* 40, 249 (1941); II. *Munich* 1943, 124
- (1822a) WEST, W. and CARROLL, B. H. Photoconductivity in photographic systems. *J. Chem. Phys.* 15, 229 (1947)
- (1822b) WEST, W. and MILLER, W. E. Photosensitization and Fluorescence by aromatic hydrocarbons. *J. Chem. Phys.* 8, 849 (1940)
- (1823) WEST, W., MUELLER, R. H., and JETTE, E. Fluorescence and photosensitization in aqueous solutions. *Proc. Roy. Soc. A* 121, 294 (1928)
- (1824) WESTPHAL, W. Über die Fluoreszenz des Joddampfes. *Verhandl. d. Deutsch. phys. Ges.* 16, 829 (1914)
- (1825a) WEYL, W. A. Fluorescence of glass. *Ind. Eng. Chem.* 34, 1035 (1942)
- (1825b) WEYL, W. A. The use of color and fluorescence indicators for determining the structure of glasses. *J. Appl. Phys.* 17, 628 (1946)
- (1825c) WEYL, W. A. Light absorption and emission of ions in glasses and crystals as affected by asymmetrical electrical fields. *J. Opt. Soc. Am.* 37, 519 (1947)
- (1826) WHIDDINGTON, R. Ionization of fluorescent iodine vapor. *Cam. Proc.* 15, 189 (1909)
- (1827) WICK, F. Spectrometric study of the absorption, fluorescence and surface color of magnesium platinum cyanides. *Phys. Rev.* 3, 382 (1914)
- (1828) WICK, F. A study of the fluorescence of certain uranyl salts at room temperature. *Phys. Rev.* 11, 121 (1918)
- (1829) WICK, F. The luminescence of frozen solutions of certain dyes. *J. Opt. Soc. Am.* 25, 368 (1935); *Phys. Rev.* 47, 329 (1935)
- (1830) WICK, F. and THROOP, C. G. Luminescence of thorium oxide activated by rare earths. Optimum concentration for different sources of excitation. *J. Opt. Soc. Am.* 25, 57 (1935)
- (1831) WIEDEMANN, E. Über Fluoreszenz und Phosphoreszenz. *Ann. d. Phys.* 34, 446 (1888)
- (1832) WIEDEMANN, E. and SCHMIDT, G. C. Über Lumineszenz. *Ann. d. Phys.* 54, 604 (1895)
- (1833) WIEDEMANN, E. and SCHMIDT, G. C. Über die Fluoreszenzspektren des Na. *Ann. d. Phys.* 42, 448 (1891); 57, 447 (1896)
- (1834) WIEDEMANN, E. and SCHMIDT, G. C. Über die Lichtemission organischer Substanzen im gasförmigen, flüssigen und festen Zustand. *Ann. d. Phys.* 56, 18 (1895)
- (1835) WIEDEMANN, E. and SCHMIDT, G. C. Über die Lumineszenz von festen Körpern und festen Lösungen. *Ann. d. Phys.* 56, 201 (1895)
- (1836) WIELAND, K. Absorptions- und Fluoreszenzspektren dampfförmiger Quecksilberhalogenide. *Z. f. Phys.* 76, 88 (1932); 77, 157 (1932); *Helv. phys. acta* 9, 640 (1936)
- (1837) WIELAND, K. Das sichtbare Fluoreszenzspektrum von HgCl und die

- daraus berechnete Bildungswärme von dampfförmigem HgCl_2 . *Z. phys. Chem. B* 42, 422 (1939)
- (1838) WIELAND, K. Vereinfachung des Fluoreszenzspektrums von HgBr durch Fremdgaszusatz. *Helv. phys. acta* 12, 295 (1939)
- (1839) WIELAND, K. Das langwellige Emissions- und Fluoreszenzspektrum von natürlichem HgCl und künstlich angereichertem HgCl_{87} . *Helv. phys. acta* 14, 420 (1941)
- (1840) WIELAND, K. Die auf photochemischem Wege ermittelte Bildungsenergie von dampfförmigem HgCl_2 . *Helv. chim. acta* 24, 1285 (1941)
- (1840a) WILBER, D. T. Reactivation of sulfide phosphors below formation temperature. *Ithaca* 1946, 383
- (1841) WILD, G. Spektralanalytische Untersuchung von Fluoriten. *Wien. Ber. IIa* 146, 479 (1937)
- (1841a) WILDE, R. Einfluss der Belichtung auf die Dielektrizitätskonstante eines ZnSCu -Phosphors. *Z. f. Phys.* 15, 350 (1923)
- (1842) WILKINS, H. F. and GARLICK, G. F. J. Relation between photoconduction and luminescence in ZnS . *Nature* 161, 565 (1948)
- (1842a) WILLIAMS, F. E. New aspects of germanate and fluorite phosphors. *J. Opt. Soc. Am.* 36, 352 (1946)
- (1842b) WILLIAMS, F. E. Mechanism of luminescence of infrared sensitive phosphors. *Phys. Rev.* 71, 83, 1947; *Ithaca* 1946, 337
- (1842c) WILLIAMS, F. E. and EYRING, H. Mechanism of the luminescence of solids. *Phys. Rev.* 69, 257 (1946); *J. Chem. Phys.* 15, 289 (1947)
- (1843) WILLIAMSON, B. and LA MER, V. K. The kinetics of activation diffusion controlled reactions in solution. The temperature dependence of the quenching of fluorescence. *J. Am. Chem. Soc.* 70, 717 (1948)
- (1843a) WILSON, C. L. Direct observation of the fluorescence spectra of benzene and hexadeuterobenzene vapor in the region of absorption. *J. Chem. Soc.* 1936, 1210
- (1844) WINAND, L. Nouvelles recherches sur le spectre de l'arsenic. *Bull. Brussels* 18, 422 (1932)
- (1845) WINANS, J. G. Radiation emitted by optically excited Zn vapor. *Proc. Nat. Ac. Sci.* 11, 738 (1925)
- (1846) WINANS, J. G. Impact fluorescence of Zn. *Phys. Rev.* 30, 1 (1927)
- (1847) WINANS, J. G. The fluorescence and absorption of a mixture of Hg and Zn vapors. *Phys. Rev.* 31, 710 (1928); 32, 427 (1928)
- (1848) WINANS, J. G. Die Auslöschung der Natriumfluoreszenz durch Fremdgase. *Z. f. Phys.* 60, 631 (1930)
- (1849) WINANS, J. G. Selection rules for collisions of the second kind. *Phys. Rev.* 60, 169 (1941); *Rev. Mod. Phys.* 16, 175 (1944)
- (1850) WINANS, J. G. and BEEN, S. Sensitized fluorescence of iron vapor. *Phys. Rev.* 62, 297 (1942)
- (1851) WINANS, J. G., DAVIS, F. J. and LEITZKE, V. A. Fluorescence, absorption and discharge in a Hg-Tl mixture. *Phys. Rev.* 55, 242 (1939)
- (1852) WINANS, J. G., DAVIS, F. J., and LEITZKE, V. A. Sensitized fluorescence of lead. *Phys. Rev.* 55, 1126 (1939)
- (1853) WINANS, J. G., DAVIS, F. J., and LEITZKE, V. A. Band spectra and sensitized fluorescence of a Hg-In mixture. *Phys. Rev.* 57, 70 (1940)
- (1854) WINANS, J. G. and PIERCE, W. J. Sensitized fluorescence and Tesla discharge spectra of Cr vapor. *Phys. Rev.* 64, 43 (1943)
- (1855) WINANS, J. G. and WILLIAMS, R. W. Sensitized fluorescence of tin. *Phys. Rev.* 52, 250 and 930 (1937)
- (1856) WINKLER, M. Über die elektrische Beeinflussung der Resonanzfluoreszenz. *Z. f. Phys.* 64, 799 (1930)
- (1857) WINTHER, CH. Über zwei eigentümliche Lumineszenzen. *Z. wiss. Phot.* 21, 45 (1921)

- (1858) WINTERSTEIN, A. and SCHOEN, K. Polyzyklische aromatische Kohlenwasserstoffe. *Z. f. physiol. Chem.* 230, 146 and 158 (1934); *Naturwiss.* 22, 237 (1934); *Chem. Ber.* 68, 1079 (1935)
- (1858a) WISE, M. E. and KLASÉNS, H. A. Fluorescence efficiency and hole migration in zinc sulfides. *J. Opt. Soc. Am.* 38, 226 (1948)
- (1859) WOLLWEBER, G. Über eine neue Methode zur Messung der Abklingung der Phosphoreszenz und ihre Anwendung auf die ZnScdScu-Phosphore. *Ann. d. Phys.* 34, 29 (1939)
- (1860) WOOD, R. W. The fluorescence of sodium vapor and the resonance radiation of electrons. *Phil. Mag.* 10, 513 and 521 (1905); 15, 581 (1908); *Phys. Z.* 9, 450 (1908)
- (1861) WOOD, R. W. On fluorescence and Lamberts law. *Phil. Mag.* 11, 782 (1906)
- (1862) WOOD, R. W. The fluorescence, magnetic rotation and temperature emission spectrum of iodine vapor. *Phil. Mag.* 12, 329 (1906)
- (1863) WOOD, R. W. Fluorescence and magnetic rotation spectra of sodium vapor and their analysis. *Phil. Mag.* 12, 499 (1906)
- (1864) WOOD, R. W. On the emission of polarized light by fluorescent gases. *Phil. Mag.* 16, 184 (1908); *Phys. Z.* 9, 590 (1908)
- (1865) WOOD, R. W. On a method of showing fluorescence absorption directly if it exists. *Phil. Mag.* 16, 940 (1908)
- (1866) WOOD, R. W. The selective reflection of monochromatic light by Hg vapor. *Phil. Mag.* 18, 187 (1909); *Phys. Z.* 10, 425 (1909)
- (1867) WOOD, R. W. On the absorption, fluorescence, magnetic rotation and anomalous dispersion of Hg vapor. *Phil. Mag.* 18, 240 (1909); *Phys. Z.* 10, 913 (1909)
- (1868) WOOD, R. W. On the u.v. absorption, fluorescence and magnetic rotation of sodium. *Phil. Mag.* 18, 530 (1909); *Phys. Z.* 10, 913 (1909)
- (1869) WOOD, R. W. On a new radiant emission from the spark. *Phil. Mag.* 20, 707 (1910); *Phys. Z.* 11, 823 (1910)
- (1870) WOOD, R. W. Resonance spectra of iodine. *Phil. Mag.* 21, 261 (1911); *Phys. Z.* 11, 1195 (1910)
- (1871) WOOD, R. W. The destruction of the fluorescence of I_2 and Br_2 vapor by other gases. *Phil. Mag.* 21, 309 (1911); *Verhandl. d. Deutsch. phys. Ges.* 13, 72 (1911)
- (1872) WOOD, R. W. On the resonance spectra of I_2 vapor and their destruction by gases of the He group. *Phil. Mag.* 22, 469 (1911); *Phys. Z.* 12, 1204 (1911)
- (1873) WOOD, R. W. Kritische Bemerkung zu der Arbeit des Herrn Steubing über die strahlende Emission seitens des Funkens. *Phys. Z.* 13, 32 (1912)
- (1874) WOOD, R. W. Selective reflection, scattering and absorption by resonating gas molecules. *Phil. Mag.* 23, 689 (1912); *Phys.* 13, 353 (1912)
- (1875) WOOD, R. W. Resonance spectra of iodine by multiplex excitation. *Phil. Mag.* 24, 673 (1912); *Phys. Z.* 14, 177 (1913)
- (1876) WOOD, R. W. On the imprisonment of radiation by total reflection. *Phil. Mag.* 25, 449 (1913)
- (1877) WOOD, R. W. On the resonance spectra of I_2 under high dispersion. *Phil. Mag.* 26, 828 (1913). *Phys. Z.* 14, 1189 (1913)
- (1878) WOOD, R. W. On the polarization of the light of resonance spectra. *Phil. Mag.* 26, 846 (1913); *Phys. Z.* 14, 1200 (1913)
- (1879) WOOD, R. W. Separation of close spectrum lines for monochromatic illumination. *Phil. Mag.* 27, 524 (1914)
- (1880) WOOD, R. W. On the fluorescence of gases excited by ultra-Schumann waves. *Phil. Mag.* 27, 899 (1914); *Phys. Z.* 15, 572 (1914)

- (1881) WOOD, R. W. On a photometric investigation of the superficial resonance excitation of Na vapor. *Phil. Mag.* 27, 1025 (1914)
- (1882) WOOD, R. W. Radiation of gas molecules excited by light. *Proc. Phys. Soc. London* 26, 185 (1914)
- (1883) WOOD, R. W. Resonance spectra of iodine. *Phil. Mag.* 35, 236 (1918)
- (1884) WOOD, R. W. The time interval between absorption and emission of light in fluorescence. *Proc. Roy. Soc. A* 99, 362 (1921)
- (1885) WOOD, R. W. Rayonnement de résonance et spectres de résonance. *Conseil Solvay, Paris 1921*
- (1886) WOOD, R. W. Fluorescence and photochemistry. *Phil. Mag.* 43, 757 (1922)
- (1887) WOOD, R. W. Selective reflection of 2536 by Hg vapor. *Phil. Mag.* 44, 1105 (1922)
- (1888) WOOD, R. W. Polarized resonance radiation of Hg vapor. *Phil. Mag.* 44, 1107 (1922)
- (1889) WOOD, R. W. Controlled orbital transfers of electrons in optically excited Hg atoms. *Proc. Roy. Soc. A* 106, 679 (1924); *Phil. Mag.* 50, 774 (1925)
- (1890) WOOD, R. W. Fine structure, absorption and Zeeman effect of the 2536 Hg line. *Phil. Mag.* 50, 761 (1925)
- (1891) WOOD, R. W. Note on structure of Cd and Zn resonance lines. *Phil. Mag.* 2, 611 (1926)
- (1892) WOOD, R. W. Anti-Stokes radiation of fluorescent liquids. *Phil. Mag.* 6, 310 (1928)
- (1893) WOOD, R. W. New effects in the optical excitation of vapors. *J. Franklin Inst.* 205, 481 (1928)
- (1894) WOOD, R. W. and CARTER, F. S. The fluorescence and magnetic rotation spectra of potassium vapor. *Phil. Mag.* 24, 536 (1907); *Phys. Rev.* 27, 107 (1908)
- (1895) WOOD, R. W. and DUNOYER, L. Separate excitation of the centers of emission of the D-lines of Na. *Phil. Mag.* 27, 1018 (1914); *C. R.* 158, 1490 (1914); *Le Radium* 11, 119 (1914)
- (1896) WOOD, R. W. and ELLETT, A. On the influence of magnetic fields on the polarization of resonance radiation. *Proc. Roy. Soc. A* 103, 396 (1923)
- (1897) WOOD, R. W. and ELLETT, A. Destruction of polarization of resonance radiation by weak magnetic fields. *Nature* 111, 255 (1923); *Science* 57, 267 (1923)
- (1898) WOOD, R. W. and ELLETT, A. Polarized resonance radiation in weak magnetic fields. *Phys. Rev.* 24, 243 (1924)
- (1899) WOOD, R. W. and FRANCK, J. Über die Überführung des Resonanzspektrums der Jodfluoreszenz in ein Bandenspektrum durch Zumischung von He. *Verhandl. d. Deutsch. Ges.* 13, 84 (1911); *Phys. Z.* 12, 81 (1911); *Phil. Mag.* 21, 265 (1911)
- (1900) WOOD, R. W. and GALT, R. H. The cathode ray fluorescence of sodium vapor. *Astrophys. J.* 33, 72 (1911)
- (1901) WOOD, R. W. and GAVIOLA, E. Optical excitation of Hg and the sensitized fluorescence of mercury hydride, OH, ammonia and other compounds. *Phys. Rev.* 31, 1109 (1928)
- (1902) WOOD, R. W. and GAVIOLA, E. Factors governing the appearance of the "forbidden line" 2656 in the optical excitation of Hg. *Phil. Mag.* 6, 271 (1928)
- (1903) WOOD, R. W. and GAVIOLA, E. The power relation of the intensities of the lines in the optical excitation of Hg. *Phil. Mag.* 6, 352 (1928)
- (1904) WOOD, R. W. and HACKETT, F. E. The resonance and magnetic rotation spectra of sodium vapor photographed with the concave grating. *Astrophys. J.* 30, 339 (1909)
- (1905) WOOD, R. W. and HEMSALECH, G. H. Die durch Ultra-Schuman-Wellen erregte Fluoreszenz von Gasen. *Phys. Z.* 15, 572 (1914)

- (1906) WOOD, R. W. and KIMURA, M. Scattering and regular reflection of light by an absorbing gas. *Phil. Mag.* 32, 329 (1916)
- (1907) WOOD, R. W. and KIMURA, M. Series law of resonance spectra. *Phil. Mag.* 35, 236 (1918)
- (1908) WOOD, R. W. and KINSAY, E. L. The fluorescence of sodium vapor. *Phys. Rev.* 30, 1 (1927)
- (1909) WOOD, R. W. and KINSAY, E. L. The fluorescence spectrum of sodium vapor in the vicinity of the D-lines. *Phys. Rev.* 31, 793 (1928)
- (1910) WOOD, R. W. and LOOMIS, F. W. Optically excited iodine bands with alternate missing lines. *Phil. Mag.* 6, 231 (1928)
- (1911) WOOD, R. W. and MOHLER, F. L. Resonance radiation of Na vapor excited by one of the D-lines. *Phys. Rev.* 11, 70 (1918)
- (1912) WOOD, R. W. and RIBAUD, G. Magnetooptics of iodine vapor. *Phil. Mag.* 27, 1009 (1914); *J. de phys.* 4, 378 (1914)
- (1913) WOOD, R. W. and SPEAS, P. A photometric study of fluorescence of I₂ vapor. *Phil. Mag.* 27, 531 (1914); *Phys. Z.* 15, 317 (1925)
- (1914) WOOD, R. W. and VOSS, V. The fluorescence of mercury vapor. *Proc. Roy. Soc.* 119, 698 (1928)
- (1915) WRZESINSKA, A. Über die Absorptions- und Fluoreszenzspektre einiger organischer Farbstoffe. *Acta phys. pol.* 4, 475 (1936)
- (1916) WRZESINSKA, A. Influence de la concentration sur la distribution des intensités dans le spectre de photoluminescence des solutions glycériques de la tryptoflavine. *Bull. intern. Cracow A* 1935, 38; 1936, 568
- (1917) WURM, K. Über das Bandenspektrum des Lithiums. *Naturwiss.* 16, 1028 (1928)
- (1918) WURM, K. Über eine die D-Linien des Natriums begleitende diffuse Bande. *Z. f. Phys.* 79, 736 (1932)
- (1919) YEN, S. Versuche über die Resonanzstrahlung der Hg-Linie 2536.7 Å unter Vermeidung des Dopplereffekts. *Helv. phys. acta* 8, 225 (1935)
- (1920) ZAJAC, Z. Fluorescence des atomes de mercure excités. *C. R.* 191, 1304 (1930)
- (1920a) ZECHMEISTER, L. and POLGAR, A. On the occurrence of a fluorescing polyene with a characteristic spectrum. *Science* 100, 317 (1944)
- (1921) ZEHDEN, W. Die Linienabsorption des Na-Dampfes an beiden D-Linien. *Z. f. Phys.* 86, 555 (1933)
- (1922) ZELLER, C. A. A study of short time phosphorescence of certain compounds. *Phys.* 31, 367 (1910)
- (1923) ZEMANSKY, M. W. The diffusion of imprisoned resonance radiation in Hg vapor. *Phys. Rev.* 29, 513 (1927)
- (1924) ZEMANSKY, M. W. The quenching of Hg resonance radiation by foreign gases. *Phys. Rev.* 31, 812 (1928)
- (1925) ZEMANSKY, M. W. Absorption and collision broadening of the Hg resonance line. *Phys. Rev.* 36, 219, 380 and 1591 (1930)
- (1926) ZEMANSKY, M. W. New experimental determination of the effective cross sections for the quenching of Hg resonance radiation. *Phys. Rev.* 36, 919 (1930)
- (1927) ZEMANSKY, M. W. Absorption der Cd-Resonanzstrahlung 2288 Å und Lebensdauer des Cd 2⁴P₁-Zustandes. *Z. f. Phys.* 72, 587 (1931)
- (1928) ZEMANSKY, H. W. Note on the equivalent absorption coefficient for diffused resonance radiation. *Phys. Rev.* 42, 843 (1932)
Phys. Z. 9, 593 (1908)
- (1929) ZICKENDRAHT, H. Untersuchungen am fluoreszierenden Na-Dampf. *Phys. Z.* 9, 593 (1908).
- (1930) ZIELINSKI, G. Sur la polarisation des bandes de fluorescence de la vapeur de mercure. *C. R.* 197, 1109 (1933); 200, 1313 (1935); *Acta phys. pol.* 3 517 (1934); 4, 139 (1935)

- (1931) ZOCHER, H. On the polarization of the fluorescence of dyestuffs dissolved in mesophases. *Faraday Soc. Trans.* 35, 34 (1939)
- (1932) ZOUCKERMANN, R. Sur les phénomènes de phosphorescence présentés par les tubes à décharge en silice fondue. *C. R.* 191, 776 (1930)
- (1933) ZSCHEILE, F. P. and HARRIS, D. G. Studies on the fluorescence of chlorophyll. *J. Phys. Chem.* 47, 623 (1943)
- (1934) ZUBER, K. Die Linienabsorption des Hg-Dampfes für einzelne Hyperfeinstrukturkomponenten der Linie 2537A. *Helv. phys. acta* 8, 370 (1935)
- (1935) ZUBER, K. Trennung der Hg-Isotope nach einer photochemischen Methode. *Helv. phys. acta* 8, 488 (1935); 9, 285 (1936); *Nature* 136, 796 (1935)
- (1936) ZWIRONAS, A. Über den anomalen Zeemaneffekt einzelner Hyperfeinstrukturkomponenten der Hg-Resonanzlinie 2537A. *Helv. phys. acta* 7, 224 and 684 (1934); *Nature* 137, 531 (1936)

AUTHOR INDEX

This book does not contain a separate author index. A combined use of the foregoing Bibliography (pages 671-759) and the following Reference Number Index will fulfill the same function. To locate the page on which the work of a particular author is discussed in the text, proceed as follows:

1. Locate in the Bibliography, which is arranged alphabetically, the reference number for the author in question.
2. Then locate in the Reference Number Index the page (or pages) on which the work is mentioned.

If a reference number is not listed in the Reference Number Index, the author is not mentioned in the text and the bibliography itself is the sole source of information.

REFERENCE NUMBER INDEX

Bibl.	Page	Bibl.	Page	Bibl.	Page
<i>A</i>	10, 290, 510	<i>19</i>	573, 576	<i>76</i>	521
<i>C</i>	425	<i>20</i>	576, 582	<i>77</i>	510
<i>E</i>	395, 399	<i>21</i>	576	<i>78</i>	10
<i>F</i>	509, 510, 519, 527, 577, 580, 594, 597	<i>22a</i>	581	<i>81</i>	644
<i>G</i>	616, 637	<i>22f</i>	576	<i>84</i>	313
<i>K</i>	487, 488, 490, 493, 494, 497	<i>23a</i>	545	<i>85</i>	645
<i>H</i>	295	<i>24</i>	149, 158, 159	<i>86</i>	488
<i>L</i>	169, 351	<i>25</i>	204	<i>87</i>	611
<i>Q</i>	548, 557	<i>27</i>	59	<i>88a</i>	529, 611, 635
<i>S</i>	558	<i>28</i>	59	<i>88b</i>	611
<i>X</i>	13, 22, 437	<i>29</i>	162	<i>89</i>	611
		<i>32</i>	79	<i>90</i>	413
<i>3</i>	420	<i>33</i>	58	<i>91</i>	44, 102, 113, 119
<i>4</i>	426	<i>35</i>	95, 96	<i>92</i>	119, 219
<i>5</i>	428	<i>37</i>	507	<i>93</i>	90, 197, 198, 201
<i>6</i>	427	<i>40</i>	507	<i>94</i>	49
<i>7</i>	413			<i>95</i>	503
<i>9</i>	410	<i>52</i>	617, 623	<i>96</i>	99, 115
<i>10</i>	264	<i>53</i>	426	<i>99b</i>	607
<i>11</i>	255, 259	<i>54</i>	448	<i>99c</i>	607
<i>12</i>	255, 259	<i>56</i>	401, 448	<i>100</i>	125
<i>13</i>	255, 259	<i>60</i>	359		
<i>14</i>	399	<i>61</i>	278	<i>103</i>	125, 133
<i>15</i>	399	<i>62</i>	260	<i>104</i>	187
<i>16</i>	308	<i>66</i>	102, 113	<i>105</i>	132, 133
<i>18</i>	576, 582	<i>67</i>	100, 111, 121	<i>106</i>	119, 206, 220
		<i>70</i>	445	<i>110</i>	58
		<i>71</i>	445	<i>111</i>	33, 58
		<i>74</i>	251	<i>112</i>	33, 58

Bibl.	Page	Bibl.	Page	Bibl.	Page
<i>113</i>	33	<i>186</i>	586, 587	<i>239</i>	606
<i>116</i>	581, 611	<i>187</i>	13, 551, 553, 581	<i>240</i>	606
<i>118</i>	509	<i>188</i>	551, 553, 586	<i>241</i>	606
<i>119</i>	509	<i>190</i>	242	<i>242</i>	235
<i>120</i>	509	<i>191</i>	189, 209, 279	<i>243</i>	293
<i>121</i>	509	<i>191a</i>	611	<i>244</i>	235
<i>122</i>	509	<i>191b</i>	611	<i>249</i>	510
<i>123</i>	509	<i>194b</i>	502	<i>251</i>	506
<i>125</i>	36, 98	<i>195</i>	49	<i>253</i>	526
<i>126</i>	56, 57, 58	<i>196</i>	49	<i>254</i>	162, 166
<i>127</i>	33	<i>197</i>	371		
<i>128</i>	75	<i>197a</i>	427	<i>255</i>	261
<i>129</i>	8	<i>197b</i>	427	<i>256</i>	417
<i>130</i>	426	<i>198</i>	397, 399	<i>256a</i>	255
<i>131</i>	531	<i>199</i>	434	<i>257</i>	120
<i>131a</i>	566, 628, 629	<i>200</i>	434	<i>259</i>	70, 78, 105
<i>132</i>	343			<i>260a</i>	168
<i>133</i>	352	<i>201</i>	124	<i>260b</i>	216
<i>134</i>	352	<i>202a</i>	118	<i>262</i>	534
<i>135</i>	352	<i>202b</i>	124, 128	<i>265</i>	48
<i>136</i>	287, 291, 333, 336	<i>203</i>	90, 100	<i>266</i>	13, 512, 571, 597
<i>140</i>	18, 308	<i>204</i>	23	<i>267</i>	545, 593
<i>143a</i>	338, 408	<i>205</i>	49	<i>268</i>	597
<i>143b</i>	289, 365, 408	<i>206</i>	62	<i>268a</i>	512, 548, 566, 569, 570, 573, 636
<i>143c</i>	321, 408	<i>209</i>	367, 435	<i>268b</i>	543
<i>144</i>	334, 356	<i>210</i>	435	<i>269</i>	49
<i>145</i>	315, 316, 334, 395	<i>211</i>	176	<i>271</i>	308
<i>146</i>	334, 338, 357	<i>211a</i>	500	<i>272</i>	12, 290, 291, 330
<i>147</i>	38	<i>212</i>	342	<i>276</i>	209
<i>147a</i>	530	<i>213</i>	176	<i>278</i>	522, 638, 643, 645, 647
<i>148</i>	38	<i>214b</i>	375		
<i>149</i>	38	<i>215a</i>	655	<i>279</i>	478
		<i>215b</i>	654	<i>280a</i>	4, 641
<i>151</i>	527	<i>215c</i>	654, 655	<i>281</i>	645
<i>152</i>	527	<i>216</i>	49	<i>282</i>	474
<i>153</i>	559	<i>217</i>	466, 663	<i>283</i>	293
<i>154b</i>	546, 561	<i>218</i>	378	<i>284</i>	428
<i>157</i>	87	<i>219</i>	371	<i>286</i>	427
<i>158</i>	616	<i>220</i>	308	<i>287</i>	427
<i>159</i>	64, 81	<i>222</i>	455	<i>288</i>	427
<i>160</i>	81	<i>223</i>	455, 456	<i>289</i>	426
<i>161</i>	81	<i>224</i>	371, 379	<i>291</i>	426, 428
<i>163</i>	86	<i>227</i>	527, 611	<i>295</i>	428
<i>164</i>	81	<i>228</i>	448	<i>296</i>	427
<i>166</i>	543	<i>228a</i>	629	<i>297</i>	428
<i>167</i>	49	<i>229a</i>	410	<i>298</i>	425, 426
<i>168</i>	16	<i>229b</i>	410	<i>299</i>	426
<i>175</i>	149, 174	<i>230</i>	506	<i>300</i>	658
<i>176</i>	175	<i>231a</i>	57		
<i>177</i>	410, 413	<i>232</i>	61		
<i>178</i>	349, 352, 525	<i>233</i>	208	<i>301</i>	118
<i>181</i>	352	<i>234</i>	410	<i>303</i>	403
<i>183</i>	17	<i>235</i>	410	<i>305</i>	181
<i>185</i>	55, 97, 108	<i>238</i>	606	<i>306</i>	506

Bibl.	Page	Bibl.	Page	Bibl.	Page
307	54	371	352	432	210
308	391	372	501	433	243
309	186	374	532, 609, 610	434	324, 325
310	125, 126, 132	375	532, 609, 610	435	4, 9, 391
311	48	376	667	436a	509, 533
313	644, 645	380	120	437	35
315	308	381	239	438	180
316	125	382	658	439	68
317	100	383a	378, 380, 391	440	63
319	170, 217	383c	378	441	45, 84
320	176	384	374, 378	442	379
322	50	385	86	446a	611, 612
323	23, 58	387	169	446b	629
324	51, 53	388	476	446c	629
325	194, 203	389	210	447a	523, 548, 611
326	61, 94	390	260	448	500, 524, 620
327	61	391	426	449	500, 524, 620
328	15, 61	392	426		
329	352	393	240	452	39
330	352	395	255	453	48
331	268	397	526	454	260
332	161, 164, 165	398	521, 568, 569, 580, 583, 584, 611	455	336
333	166, 196, 221			456	336
336	220	399	518, 520	457	61
337	208	400	611, 612	458a	365, 408
338	449			458c	272
339	320, 360, 362	401	523, 611, 615	459a	527, 543
340	505	402a	636	459b	543
342	471, 481	402b	525, 544, 562, 576, 601	459c	542
343	180	402c	547, 550, 577, 597	459d	515
344	3	406	64	459e	13, 566, 567, 570
345	363	408a	393	459f	295
346	330	408b	393	460b	15
348	64	409	527, 619	461	351
349	194	410	527, 619	462	42, 43
350	243	411	527, 619	462a	316
351	63, 64, 69, 105	412	193	463	109, 121
352	69	412b	92	464	294
353	70	413	62	465	99, 100
354	66, 106	414	122, 246	466	19, 374, 375, 378
355	75, 78	415	344, 346	467	69, 105
356	79, 105	418	90	468	65
357	77	420	346	469	291, 377, 567
358	75, 76	421	217	470	21
360	167, 195, 196, 222	422	188	471	219, 221
360a	555, 576, 589	423	338	472	180
360b	589, 593	424	285, 292, 338, 437	473	203
361	364, 509	426	334, 335	475	48
362	271	427	49	476	433
363a	646	428	289, 366	477	180
364	628	430	193	478	180
369	100, 111, 112	431	346	479	180
370	472			480	180
				481	180

Bibl.	Page	Bibl.	Page	Bibl.	Page
482	200	556	533	615c	611
483	185	558	120	616	527, 611, 619, 623
484	200, 203	559	434	617	287, 322, 500, 619, 620
485	203	560	667	618	524, 539
486	504	561	661, 667	619	624
488	252	562	667	620	541
494	644	563	648, 667	621	557
495	527, 601	564	663, 667	623	410, 415
496	543	567	371	624	164
497	527, 545	569	94, 115	624a	448
498	429, 455	570	64	625	539
499	658	571	64, 81, 103	625a	327
		572	89	627	113, 210
503	461, 466, 472, 473, 475, 480	573	73, 105	628	625, 627
504	461, 465, 476, 479	574	73, 103	630	133
505	472, 473	576	64, 89	633	496
506	472	577	107	638	294
507	538	578	71, 84	640	500, 524, 618, 622, 628
508	540	579	308	640b	559, 564
510	365	581	308	641a	434
511	450	582	297	642	61, 212
512	450	583	504	644	646, 664
513	450, 452, 453	584	426	645	55
514	450, 453	585	425, 426	646	261
515	450, 453	587	430	647	261
516	452, 453	588	426		
518	543	589	120		
520	50	590	61, 62	651	519
521	287, 322, 500	592	192, 201, 203, 213	656	300, 310
522	287, 322, 500	593	251	657	235
525	294	594	21	658	93, 123
526	254	595	74, 75	659	300
527	523	596	426	660	308
528	367, 379	599	315	661	384
534	180	600	501, 600	662	379
535	319	601	261	664	379
536	301	602	255, 259	667	435
537	535, 538	602a	397	668	368, 379
538	518, 535, 538	602b	397	669	16, 378
539	518, 535, 538, 541	603	539	670	384
540	518, 541	603a	549	671	368
541	518, 535, 649	604	498, 661	672	370
542	518, 539	606	254	673	374
543	518	607	543	674	239
544	518	608	543	675	174, 207
545	535	609	77	676	16, 378
547	69, 71	610	79	677	507
547a	50	611	79, 370	678	185
548a	120	612	79	679	308
548b	120	613	410	681	206, 280
549	601	614	410	683	206, 280
550	601	615a	521, 611, 615	684	206, 280
		615b	636	685	185, 359

Bibl.	Page	Bibl.	Page	Bibl.	Page
686	611	751	344, 346	830	523, 527, 528, 530, 599, 606
689	328	753	344, 346	831	527, 611, 613, 615
691	568, 611	754	505	832	523, 527, 530, 601, 606
692	549, 564, 568, 611	755	342, 505	833a	519, 523, 527, 530, 531, 532, 597, 601, 607, 609
693	568	759	667	833b	523, 527, 530, 601
694	569, 611	760	151, 152	833c	635
695	64	765	61	833e	635
696	276	766	61	833f	631, 632
697	120	767	22	834b	519, 606
698	123	768	179	835	403, 404, 449, 453
699	120	771	16, 378	836	404
		772	82	836a	417, 418
701	506	773	65, 103	837a	187, 658
706	433	774	65	837b	529, 532, 609
707	92	775	310, 319, 376, 503	837c	607
708	601, 607	777	162	838	58
710	235, 239	778	208	840	239
712	235	780	16	841	224
713	239	781	113	843	429
714	236	782	261	844	418, 429
715	235, 236, 239	783	261	845	430
716	232, 236	784	594	846	362
717	235	785	594	848	429
718	667	786	90	849	224
719	429	787	616	850	523, 573, 592
720	429	788	186	851	523, 565
721	397, 418, 429	789	99, 100	852	523, 565
722	418, 429	789a	427	853	565
724	429	790a	587, 616	854	565
724b	433	790b	587, 616	855	519, 627
725	68	791	524, 587, 616, 619	856	87
726	73	798	224	857	119, 122
727	74	800	113, 209	858	161
728	72, 74, 103			859	242
729	71, 74, 103, 107	801	198	860	242
730a	49	803	115, 118	861	461, 472
730b	49	805	125	862	472
732	320, 361, 362, 424	806	87	863	426
732a	548, 561, 623	812	236	864	475, 476
733	18	813	236	865a	475, 476
734	399, 418	814	301	865b	475, 476
735	399, 418	815	297, 437, 449	866	70, 79
736	418	817	449	867	79
737	399, 418	818	449	867a	76
739	344	820	151	869	38, 47
740	336, 346	821	125	870	668
742	336	823	506	872	509
743	336	824	475, 476	873	509
744	344	826	478		
745	287, 333, 336	827	643		
746	336	827b	643		
748	334	828	387		
749	335, 336, 346	829a	387, 408		
750	291, 344, 349	829b	387		

Bibl.	Page	Bibl.	Page	Bibl.	Page
874	509	930	295, 297, 312,	990	38, 47
875	509		358, 367, 436,	991	38, 47
875a	660		437, 445, 457	992	47
876	38, 47	931	445, 447	993	410
877	38, 47	932	305	995	47
879	180	934	405	996	271
879a	538	937	402	997	165
882	121	938	405, 415	998	176
883	525, 602	942	506	999	333
885	509, 580, 587, 590	943	113	1000	177, 184
886	528, 587, 594	944	97		
887	521	947a	389	1001	178, 181
888	535, 541	947b	389	1003	261
890	509, 544, 550, 574, 575, 592	948	389	1004	266
892	509, 525, 594	949	151	1005	151
894	535	950	151, 152, 154	1008	48
897a	224	951	154	1011	121
898	138	952	172	1012	120
899	138	953	152	1013	120
900	94	954	169	1014	121
		955	198	1015	644, 645
901	94	956	176	1018	307, 313
903	120	956a	14, 172	1021	184
904	120	957	619	1022	177, 184
905	120	959a	125	1022a	101, 118
907a	521, 608, 611, 615, 616, 632	960	132	1023	50
908	523, 531, 611, 615	961	252	1024	620
909	370, 371, 372, 373, 378	962a	255	1025	383
910	371, 373, 375, 379	963	206, 220	1026	149, 187
911	349, 350, 358	964	206, 220	1027	410
912	302, 314, 319	965	668	1029	318
913	302, 354, 355	967	619	1029a	629, 634
914	302, 305	968	66	1030	317
915	295, 456, 511, 572, 576	969	75, 76	1030a	61
916	495	970	16	1032	62
917a	576	971	413	1033	182
917c	545	972	55	1033a	660
917d	545	973	649, 652	1034	219
919	456, 572, 576	974	389	1036	210
920	582	975a	650	1037	71
922	503	975b	653, 654	1038	133
923	526	976	109	1039	77
924	380	977	96	1040	75, 82
925b	439	978	628, 635	1041	121
927a	292, 295, 296, 310, 397, 430, 432, 439, 441, 442, 450, 454	979	526	1042	84
927b	256, 287, 439	980	93	1043	371
929	358, 396	981	413	1044	367
		982	362	1045	376
		984	266, 270	1046	376
		985	266, 270	1047	434
		987	255		
		988	260	1051b	666
		989a	360, 385	1052	543
				1054	120

Bibl.	Page	Bibl.	Page	Bibl.	Page
<i>1055</i>	52	<i>1126</i>	313	<i>1190c</i>	649
<i>1057</i>	661, 664	<i>1127</i>	490	<i>1191</i>	618, 622
<i>1058</i>	664	<i>1129</i>	496	<i>1192</i>	185
<i>1060</i>	509, 533, 565	<i>1130</i>	490	<i>1193</i>	46, 51, 98
<i>1061</i>	509, 533	<i>1131</i>	494	<i>1194</i>	86
<i>1063</i>	120	<i>1132</i>	498	<i>1195</i>	180
<i>1065</i>	224	<i>1132a</i>	521	<i>1196</i>	604
<i>1066</i>	224	<i>1133</i>	33	<i>1197</i>	594
<i>1067</i>	21, 65	<i>1137</i>	230	<i>1199</i>	365
<i>1068</i>	224, 230	<i>1138</i>	646		
<i>1070</i>	235	<i>1139</i>	661, 664		
<i>1071</i>	57, 60, 82	<i>1140</i>	599	<i>1201</i>	305
<i>1072</i>	97	<i>1142</i>	64, 104, 599	<i>1201a</i>	175
<i>1073</i>	224, 229, 233	<i>1144</i>	251	<i>1201b</i>	349, 352, 356
<i>1074</i>	217	<i>1145</i>	246	<i>1201c</i>	352, 547
<i>1075</i>	218	<i>1146</i>	255	<i>1202</i>	333
<i>1076</i>	235	<i>1147</i>	110, 115	<i>1203</i>	333
<i>1077</i>	215, 234, 239	<i>1148</i>	121	<i>1204</i>	333
<i>1078</i>	55	<i>1150</i>	121	<i>1205</i>	333
<i>1079a</i>	218			<i>1206</i>	333
<i>1079b</i>	128, 235	<i>1152</i>	270	<i>1207</i>	343
<i>1080</i>	234	<i>1153</i>	387, 407, 408	<i>1209</i>	343
<i>1081</i>	60	<i>1154</i>	407	<i>1210</i>	333
<i>1082</i>	216, 234	<i>1154a</i>	550, 551, 597	<i>1211</i>	333
<i>1084</i>	33, 44	<i>1157</i>	276	<i>1212</i>	343
<i>1088</i>	461	<i>1158</i>	237	<i>1214</i>	342
<i>1089</i>	476	<i>1160</i>	161, 164	<i>1215</i>	350, 352
<i>1091</i>	328	<i>1161</i>	167, 222	<i>1216</i>	350
<i>1092</i>	151	<i>1162</i>	199	<i>1217</i>	370, 373
<i>1093</i>	209	<i>1163</i>	184	<i>1218</i>	291
<i>1094a</i>	561, 623, 647	<i>1164</i>	177, 184	<i>1219</i>	336, 338
<i>1095</i>	509, 533	<i>1165</i>	152	<i>1220</i>	370, 373
<i>1096</i>	185	<i>1166</i>	224	<i>1221</i>	7, 290, 338, 350, 373, 375, 376, 382
<i>1099</i>	651	<i>1167</i>	90, 95, 100, 123		
<i>1100</i>	651	<i>1168</i>	95	<i>1223</i>	367
		<i>1169</i>	224	<i>1224</i>	350, 352, 377
<i>1101</i>	278	<i>1170</i>	199	<i>1225</i>	373
<i>1103</i>	278	<i>1171</i>	194, 206	<i>1226</i>	373
<i>1104</i>	280	<i>1172</i>	521	<i>1227</i>	291, 292
<i>1108</i>	490	<i>1173</i>	219	<i>1229</i>	104
<i>1109</i>	490, 660	<i>1175a</i>	111	<i>1230</i>	279
<i>1110</i>	490	<i>1176</i>	66, 76, 82, 83	<i>1231</i>	230
<i>1111</i>	490	<i>1179</i>	380	<i>1232a</i>	537
<i>1112</i>	490	<i>1180</i>	64	<i>1233</i>	232
<i>1113</i>	295, 490	<i>1181a</i>	93, 94	<i>1234</i>	200, 203
<i>1114</i>	490	<i>1181b</i>	62	<i>1235</i>	413
<i>1115</i>	647	<i>1182</i>	102, 129, 132	<i>1237</i>	180
<i>1116</i>	295, 510	<i>1183</i>	53, 95	<i>1238</i>	180
<i>1117</i>	487, 490, 493	<i>1184</i>	95	<i>1243</i>	168, 197
<i>1118</i>	96	<i>1185</i>	62	<i>1246</i>	535
<i>1120</i>	490, 497	<i>1187</i>	434	<i>1247a</i>	534, 535
<i>1123</i>	307	<i>1188</i>	255, 260	<i>1247b</i>	535
<i>1124</i>	307	<i>1189</i>	481	<i>1248</i>	616
<i>1125</i>	307	<i>1190b</i>	481		

Bibl.	Page	Bibl.	Page	Bibl.	Page
<i>1251</i>	33	<i>1309</i>	623, 655, 656,	<i>1357</i>	71, 72, 73, 84
<i>1252</i>	59, 112		659, 667	<i>1360</i>	533, 563, 583,
<i>1253</i>	59	<i>1310</i>	660		597, 606
<i>1254</i>	57	<i>1311</i>	478, 479, 515,	<i>1361</i>	593
<i>1255</i>	57		623, 647, 665,	<i>1362</i>	521
<i>1262</i>	235		667	<i>1363</i>	523, 525, 597
<i>1264</i>	606	<i>1312</i>	657	<i>1364</i>	533
<i>1265</i>	606	<i>1313</i>	479, 665, 667	<i>1365</i>	206
<i>1266</i>	407	<i>1314a</i>	479, 480, 667	<i>1365a</i>	206, 220
<i>1267a</i>	113, 209	<i>1315</i>	656, 660	<i>1365b</i>	206, 220
<i>1267b</i>	115	<i>1317a</i>	350, 354	<i>1366</i>	635
<i>1268</i>	115	<i>1318</i>	168, 199	<i>1368</i>	649
<i>1269</i>	268	<i>1325</i>	180	<i>1369</i>	194
<i>1270</i>	115	<i>1325a</i>	650	<i>1372</i>	260
<i>1271</i>	270	<i>1326a</i>	648	<i>1374</i>	180
<i>1272</i>	275	<i>1326b</i>	650	<i>1375</i>	176
<i>1273</i>	274	<i>1328a</i>	650	<i>1376</i>	611, 612
<i>1274</i>	274	<i>1330</i>	200	<i>1377</i>	625
<i>1274a</i>	517, 545, 595	<i>1331</i>	502, 532, 533,	<i>1378</i>	178
<i>1275</i>	60, 197, 213,		565, 609	<i>1379</i>	178
	214, 216	<i>1332</i>	501, 502, 505,	<i>1380</i>	182, 202
<i>1276</i>	158, 159		532, 565, 609,	<i>1381</i>	182
<i>1278</i>	158		627	<i>1382</i>	182
<i>1279</i>	333	<i>1333</i>	501, 530, 611,	<i>1383</i>	179
<i>1281</i>	333		615, 627, 628,	<i>1385</i>	560
<i>1282</i>	64, 69		647	<i>1386a</i>	531, 601, 606,
<i>1283</i>	170, 176	<i>1335a</i>	13, 514, 518, 539,		607
<i>1284</i>	3, 9		548, 556, 567,	<i>1386b</i>	531, 597, 601,
<i>1286</i>	383		568, 611, 629		606, 607
<i>1288</i>	304, 342, 488	<i>1335b</i>	512, 514, 541,	<i>1388</i>	68
<i>1289</i>	304		549, 553, 556,	<i>1389</i>	418
<i>1290</i>	216		568, 576, 577,	<i>1390</i>	418
<i>1291</i>	351, 356, 398		578, 581, 593	<i>1393</i>	543
<i>1292</i>	271, 272, 273,	<i>1336</i>	84	<i>1394</i>	52, 242
	412	<i>1337</i>	417	<i>1395</i>	33
<i>1293a</i>	18, 518, 524, 551,	<i>1337a</i>	151, 152	<i>1396</i>	469
	581, 587, 617,	<i>1338</i>	185	<i>1397</i>	469
	622	<i>1339</i>	64	<i>1403</i>	668
<i>1293b</i>	3, 581, 617, 622	<i>1340</i>	37	<i>1405a</i>	530
<i>1294</i>	261	<i>1341</i>	177	<i>1406</i>	400, 410
<i>1295</i>	176	<i>1342</i>	253	<i>1407a</i>	400
<i>1296</i>	230, 239	<i>1344</i>	63	<i>1407b</i>	316, 321
<i>1297</i>	478	<i>1345</i>	224	<i>1408</i>	112
<i>1298</i>	383, 435, 445	<i>1346</i>	224	<i>1409</i>	410
<i>1299</i>	233	<i>1346a</i>	231	<i>1410</i>	410
<i>1300</i>	382	<i>1347</i>	224, 229, 231, 233	<i>1411</i>	632
		<i>1348</i>	224, 228, 231,	<i>1414</i>	359, 385, 401
<i>1301</i>	375		232	<i>1415</i>	359, 385
<i>1302</i>	292, 295, 296,	<i>1350</i>	261, 358, 403,	<i>1416</i>	359
	322, 436, 440,		540	<i>1417</i>	359
	445, 499, 500	<i>1353a</i>	650	<i>1418</i>	359
<i>1303</i>	374	<i>1353b</i>	650	<i>1420</i>	55
<i>1304</i>	287	<i>1354</i>	660	<i>1421</i>	55
<i>1308</i>	656				

Bibl.	Page	Bibl.	Page	Bibl.	Page
<i>I422</i>	55	<i>I488</i>	533	<i>I562</i>	119, 219
<i>I424</i>	531	<i>I489</i>	9, 391	<i>I563</i>	120
<i>I426</i>	390	<i>I490</i>	9, 391	<i>I564</i>	120
<i>I427b</i>	500	<i>I491</i>	4, 9, 391	<i>I565</i>	120
<i>I428</i>	295	<i>I492</i>	4, 9, 391	<i>I566</i>	605
<i>I431b</i>	601	<i>I493</i>	281	<i>I567</i>	66
<i>I432b</i>	524, 528, 622	<i>I496</i>	472	<i>I568</i>	427
<i>I432c</i>	13, 572, 573, 584	<i>I497</i>	410	<i>I569</i>	426, 448
<i>I433</i>	13, 597, 606, 611	<i>I498</i>	377, 379, 391	<i>I571</i>	7, 60, 90, 213
<i>I434</i>	606, 636	<i>I498</i>	377, 379, 391	<i>I572</i>	133, 229
<i>I435</i>	611, 612	<i>I500</i>	261	<i>I573</i>	177
<i>I436</i>	526, 548	<i>I503</i>	185	<i>I575</i>	178
<i>I437</i>	517	<i>I505</i>	383	<i>I576</i>	199
<i>I438</i>	397, 415	<i>I507</i>	410	<i>I577</i>	199
<i>I439</i>	607	<i>I509</i>	393, 439, 442	<i>I583</i>	397
<i>I440</i>	242	<i>I511</i>	498	<i>I585</i>	2, 21, 306, 322
<i>I444</i>	535	<i>I512</i>	498	<i>I587</i>	326
<i>I445</i>	594	<i>I513</i>	619	<i>I588</i>	329
<i>I446</i>	603	<i>I518a</i>	545	<i>I591</i>	53
<i>I448</i>	562	<i>I519</i>	172	<i>I593</i>	36
<i>I449</i>	562, 604	<i>I520</i>	203	<i>I594</i>	36
<i>I451</i>	604	<i>I521</i>	252, 330	<i>I595</i>	109
<i>I453</i>	291	<i>I522</i>	330, 429	<i>I595a</i>	607
<i>I454</i>	291, 317, 422, 445	<i>I523</i>	354	<i>I597</i>	89
<i>I456</i>	419	<i>I524</i>	33	<i>I598</i>	103, 112
<i>I461</i>	209	<i>I525</i>	77	<i>I599</i>	272
<i>I462</i>	587, 590	<i>I526</i>	66	<i>I600</i>	327
<i>I463</i>	338	<i>I529</i>	8	<i>I600a</i>	325, 328, 331, 378
<i>I464</i>	584	<i>I530</i>	71	<i>I601</i>	235
<i>I465</i>	533, 557	<i>I531</i>	33, 71	<i>I602</i>	548
<i>I466</i>	533	<i>I532</i>	59	<i>I603</i>	634
<i>I467</i>	533	<i>I533</i>	59, 83, 84	<i>I604</i>	180
<i>I468</i>	585	<i>I534</i>	77, 84	<i>I605</i>	179
<i>I469</i>	363, 416	<i>I535</i>	83, 84	<i>I607</i>	179
<i>I470</i>	410	<i>I536</i>	77	<i>I609</i>	180
<i>I471</i>	410	<i>I538</i>	66	<i>I610</i>	185
<i>I472</i>	410	<i>I539</i>	66	<i>I613</i>	190
<i>I473</i>	410	<i>I540</i>	33, 83	<i>I614</i>	180
<i>I474</i>	410	<i>I541</i>	237	<i>I615</i>	190
<i>I475</i>	200	<i>I544</i>	237	<i>I617</i>	179
<i>I476</i>	333, 342	<i>I545</i>	261, 404, 439	<i>I618</i>	185
<i>I477</i>	175	<i>I545a</i>	250	<i>I619</i>	190
<i>I478</i>	95, 108	<i>I546</i>	403	<i>I622</i>	15
<i>I479</i>	95, 108	<i>I548</i>	422	<i>I623</i>	14, 15, 293
<i>I480</i>	95, 104	<i>I549</i>	365	<i>I624</i>	15, 351
<i>I480b</i>	518, 561, 647	<i>I552</i>	365, 475, 498	<i>I625</i>	15, 378
<i>I483</i>	175	<i>I555</i>	300	<i>I626</i>	605
<i>I484a</i>	475, 476	<i>I556</i>	403	<i>I629</i>	121
<i>I484b</i>	475, 476	<i>I557</i>	524	<i>I630</i>	119
<i>I485</i>	475, 476	<i>I558</i>	120	<i>I631</i>	22, 34, 35, 42, 98
<i>I486</i>	524, 548, 553, 581, 587	<i>I559</i>	120	<i>I632</i>	88
		<i>I560</i>	120		
		<i>I561</i>	113, 120		

Bibl.	Page	Bibl.	Page	Bibl.	Page
<i>1633</i>	276	<i>1691</i>	333, 436, 449,	<i>1746</i>	267
<i>1634</i>	209, 276		454	<i>1747</i>	307
<i>1635</i>	209, 276	<i>1692</i>	600	<i>1748</i>	307, 315
<i>1636</i>	276	<i>1693</i>	472, 602	<i>1749</i>	350, 363
<i>1637</i>	189, 209	<i>1694</i>	468, 472	<i>1750</i>	307
<i>1638</i>	280	<i>1695</i>	471		
<i>1639</i>	260	<i>1696</i>	471, 480	<i>1753</i>	62
<i>1640</i>	405, 453	<i>1698a</i>	477	<i>1754</i>	319, 351
<i>1640b</i>	335, 434	<i>1698b</i>	477	<i>1755</i>	324
<i>1641</i>	624	<i>1698c</i>	288	<i>1756</i>	379
<i>1641a</i>	363	<i>1699</i>	480	<i>1758</i>	350
<i>1643</i>	210	<i>1700</i>	469, 561	<i>1761a</i>	4, 379, 391
<i>1644</i>	113, 115			<i>1762a</i>	350, 353, 379
<i>1646</i>	279	<i>1701</i>	458	<i>1762b</i>	3
<i>1647</i>	278	<i>1702</i>	464	<i>1762c</i>	377
<i>1648</i>	247, 267	<i>1703</i>	469	<i>1762e</i>	3
<i>1649</i>	189, 279	<i>1704</i>	469	<i>1763</i>	391
<i>1650</i>	34	<i>1705</i>	436, 455	<i>1765</i>	371, 373
		<i>1706</i>	456	<i>1766</i>	13, 291, 311
		<i>1708</i>	16	<i>1767</i>	291, 294, 295
<i>1651</i>	529, 583, 628,	<i>1709</i>	293	<i>1767a</i>	461
	635	<i>1710</i>	377	<i>1768</i>	434, 500
<i>1654</i>	50	<i>1713</i>	200	<i>1769</i>	49
<i>1656</i>	260	<i>1714</i>	200	<i>1772</i>	295
<i>1656a</i>	566	<i>1715</i>	161, 198	<i>1773</i>	209
<i>1657</i>	645	<i>1716</i>	43	<i>1774</i>	209
<i>1658</i>	644, 645	<i>1717</i>	198, 199	<i>1775</i>	209, 211
<i>1659</i>	644, 645	<i>1720</i>	413	<i>1776</i>	209
<i>1660</i>	644, 645	<i>1721</i>	398	<i>1777</i>	336
<i>1661</i>	205, 276	<i>1723a</i>	327, 359	<i>1779</i>	365
<i>1664</i>	454	<i>1724</i>	659	<i>1782</i>	633
<i>1665</i>	628	<i>1725</i>	553, 556, 659,	<i>1783</i>	186
<i>1665a</i>	523, 525		660	<i>1785</i>	527, 528
<i>1665b</i>	523	<i>1726</i>	3	<i>1786a</i>	159
<i>1667</i>	429	<i>1727a</i>	619	<i>1786b</i>	551, 595, 598
<i>1668</i>	455	<i>1727b</i>	517, 545, 546,	<i>1786c</i>	551, 598
<i>1670</i>	522, 631, 632,		561, 589, 593,	<i>1787</i>	161, 167
	647		595, 597, 602	<i>1788</i>	167
<i>1671</i>	522, 549, 631	<i>1727c</i>	528, 540, 545,	<i>1788b</i>	581
<i>1672</i>	454		547	<i>1789</i>	112
<i>1676</i>	525	<i>1727d</i>	592, 593	<i>1790</i>	507
<i>1677</i>	518	<i>1728</i>	661	<i>1791a</i>	112
<i>1678</i>	602	<i>1730</i>	307	<i>1791b</i>	83
<i>1679</i>	518	<i>1731</i>	307	<i>1792</i>	330
<i>1680</i>	636	<i>1732</i>	179	<i>1798b</i>	521
<i>1681</i>	633	<i>1734</i>	235	<i>1799</i>	333, 356
<i>1682</i>	633	<i>1735</i>	224	<i>1800</i>	371
<i>1683</i>	633	<i>1736</i>	481		
<i>1684</i>	633	<i>1737</i>	481	<i>1803</i>	289, 365, 408,
<i>1685</i>	522, 632	<i>1738</i>	481		412, 413
<i>1686</i>	523, 525	<i>1742</i>	81	<i>1804</i>	371
<i>1687</i>	454	<i>1743</i>	200	<i>1805</i>	334, 338
<i>1689</i>	405	<i>1743b</i>	645	<i>1806</i>	314, 334, 338,
<i>1690</i>	606	<i>1745</i>	247, 267		357

Bibl.	Page	Bibl.	Page	Bibl.	Page
<i>1808</i>	342	<i>1847</i>	130, 233, 237, 238	<i>1889</i>	42, 43, 99
<i>1809</i>	337	<i>1848</i>	113	<i>1890</i>	55
<i>1810</i>	337	<i>1849</i>	98, 131	<i>1892</i>	301
<i>1811</i>	337	<i>1850</i>	131	<i>1894</i>	176
<i>1812</i>	337			<i>1895</i>	32, 97
<i>1813</i>	8, 61	<i>1851</i>	238	<i>1896</i>	63, 65
<i>1814</i>	93, 94	<i>1852</i>	131	<i>1897</i>	65
<i>1815</i>	61	<i>1853</i>	238	<i>1898</i>	65
<i>1816</i>	288, 292, 322, 461, 465	<i>1854</i>	131	<i>1899</i>	193
<i>1817</i>	9, 391, 457	<i>1855</i>	131	<i>1900</i>	175
<i>1818</i>	279	<i>1856</i>	89		
<i>1819a</i>	577	<i>1858</i>	399, 408	<i>1901</i>	219, 221
<i>1821</i>	518, 543, 597	<i>1860</i>	49, 169, 171, 174	<i>1902</i>	43
<i>1822a</i>	339	<i>1861</i>	389, 390	<i>1903</i>	42, 43
<i>1822b</i>	340	<i>1862</i>	151	<i>1904</i>	171
<i>1823</i>	328	<i>1863</i>	171	<i>1905</i>	177
<i>1825a</i>	506, 507	<i>1864</i>	213	<i>1906</i>	242
<i>1825b</i>	506	<i>1865</i>	313	<i>1907</i>	151
<i>1825c</i>	506	<i>1866</i>	49, 242	<i>1908</i>	175, 208
<i>1833</i>	169	<i>1867</i>	50, 95	<i>1909</i>	175
<i>1834</i>	274	<i>1868</i>	171, 175	<i>1910</i>	194
<i>1835</i>	291, 317, 434, 445, 657	<i>1870</i>	151	<i>1911</i>	97
<i>1836</i>	204, 276	<i>1871</i>	168, 193	<i>1913</i>	197, 213
<i>1837</i>	204, 276	<i>1872</i>	193	<i>1914</i>	233
<i>1838</i>	204, 276	<i>1874</i>	50, 51, 242	<i>1917</i>	176
<i>1839</i>	204, 276	<i>1875</i>	151, 154, 158	<i>1919</i>	54, 68
<i>1840</i>	276	<i>1877</i>	151, 154	<i>1921</i>	62
<i>1842</i>	543	<i>1878</i>	213, 216	<i>1923</i>	62
<i>1842a</i>	615, 628	<i>1879</i>	21	<i>1924</i>	100, 111
<i>1842b</i>	538, 549, 566	<i>1880</i>	177	<i>1925</i>	93
<i>1842c</i>	549, 566	<i>1881</i>	51	<i>1926</i>	111
<i>1843</i>	264, 327	<i>1883</i>	151, 154	<i>1928</i>	52
<i>1845</i>	125, 130	<i>1884</i>	13, 231, 294, 567	<i>1930</i>	234, 440
<i>1846</i>	125, 130	<i>1885</i>	561	<i>1931</i>	384
		<i>1887</i>	242	<i>1935</i>	121
		<i>1888</i>	63	<i>1936</i>	76

SUBJECT INDEX

The following abbreviations are used in the index for frequently recurring words:

abs.	absorption
cryst.	crystal, in the crystalline state
diss.	dissociation
fl.	fluorescence, fluorescent
lum.	luminescence, luminescent
ph.	phosphorescence, phosphorescent
pol.	polarization, polarized
qu.	quenching
R.	resonance (radiation)
sol.	in solution
l.t.	life time
vap.	vapor, in the vapor state

Elements and inorganic compounds are listed under their chemical symbols (*e.g.*, CuCl_2 and $\text{ZnS}(\text{Mn})$), even if in the text the full names are used. Organic compounds are listed under their usual names (*e.g.*, benzene, diphenyltetraene, etc.).

A

A
 fl. 48
 Absolute wavelength (of ph. bands)
 603, 604
 Acenaphthene
 sol. fl. 334
 Acetaldehyde
 vap. fl. 258-260
 Acetic acid
 vap. photodiss. 280
 Acetone
 sol. fl. 432, 433
 vap. fl. 255, 258, 259
 Acetophenone
 vap. fl. 269
 Acridine
 sol. fl. 363, 415, 419, 423, 454
 dyes sol. fl. 384
 orange sol. fl. 382
 red sol. fl. 423
 yellow sol. fl. 423
 Acridone
 sol. fl. 326
 Acriflavine
 sol. fl. 423
 vap. fl. 273, 274
 Actinodielectric effect (in phosphors)
 535

Ag

Ag
 fl. in glass 507
 in phosphors
 CaS 594, 603, 604
 KCl 548
 NaBr 548
 NaCl 616, 617, 623
 SrS 561
 ZnS 519, 522, 526, 530, 539, 544,
 564, 565, 571, 576, 597, 609
 Zn,CdS 558, 584, 600, 605, 607
 vap. R. doublet 33, 209
 sensitized fl. 125
 AgCl
 cryst. fl. 627
 Ag halides
 vap. fl. 187
 AgI
 vap. photodiss. 208-211
 Al-phosphors
 AlN 630, 633
 $\text{Al}(\text{OH},\text{F})_2\text{SiO}_4$ 640
 Al_2O_3 386, 522, 630, 631, 638-640, 642
 Al_2SiO_5 522, 640
 Al-sulfate organophosphors 436, 444
 Alexandrite
 fl. 640, 646
 Aliphatic ketones
 sol. fl. 432

- Alizanthrene violet
sol. fl. 415
- Alkali halides
cryst. 533, 536, 537, 556, 660
phosphors 524, 548, 585, 616-628
vap. photodiss. 208
- Alkaline earth phosphors 516, 518,
555, 564, 594-605
- Alkaloids
cryst. fl. 310, 309
- Allowed transitions 4
in diatomic vap. 143
in monatomic vap. 31
in phosphors 564
in polyatomic molecules 245, 248,
249, 256, 383
- Alloxazine
sol. fl. 362, 417, 419, 429
- Aminobenzal malonitrile
cryst. fl. 398
- Aminocyanofuroic acid ester
cryst. fl. 418
- Aminonaphthalhydrazide (luminol)
sol. fl. 362
- Analogous bands (in phosphors) 603,
604
- Angular distribution
(of fl. intensity) 74, 75, 210, 389, 390
(of oscillators) 369, 370
- Anharmonic oscillator 134
- Anharmonicity (of vibrations) 137, 303
- Aniline
sol. fl. 406
vap. fl. 266, 267-269, 274, 275
- Anisidine
sol. fl. 406
- Anisol
vap. fl. 268
- Anisotropic oscillator 63, 213-215,
366-368, 370, 386
- Anomalous Zeeman effect 68, 75
- Anthracene
cryst. fl. 365, 366, 386, 387, 398, 399,
407
sol. fl. 315, 318-320, 323, 333, 334,
338, 349, 351, 356, 357, 361,
373-375, 400, 404, 414, 451, 554
vap. fl. 268, 269, 271-273, 309, 366
- Anthramine
sol. fl. 414
- Anthraquinone
vap. fl. 273, 274
- Anthrene
dark blue
sol. fl. 415
dyes
sol. fl. 415, 422
- Antioxidants 336, 343
- Anti-stokes
bands of aniline vap. 275
of Cd₂ vap. 236
of Hg₂ vap. 231
of ruby 642
fl. 3, 6
of dye sol. 381
lines (members) in R. spectra
Ag-halide vap. 188
Bi₂ vap. 184, 185
HD 187
I₂ vap. 152, 156-160, 162, 168
Na₂ vap. 171, 172, 174, 175
S₂, Se₂, Te₂ vap. 180
- Antisymmetrical oscillations (vibra-
tions) 248, 249, 262, 263, 439
state (of homonuclear molecules)
143
- Aragonite 520
- Aromatic hydrocarbons 310, 333, 334,
338, 349, 356, 357, 361, 365, 387,
394, 441, 455
- As
in Zn₂SiO₄-phosphors 547
vap. fl. 35
- As₂
vap. fl. 185
- Astrophysics 38
- Asymmetrical oscillator 486
- Atomic beam 53, 58, 62, 84
radii 525
- Attraction curves 150, 181, 223
- Auramine
sol. fl. 422
- Autoresonance 162, 164, 175
- Auxiliary activator 545, 547, 560
- Auxochrome groups 394
- Azo dyes 384
- Azoflavine
sol. fl. 417

B

- BN-phosphor 630, 632, 633
- Ba-phosphors
BaF₂ 473
BaO 469, 517, 596, 598, 610
BaS 469, 473, 516, 528, 598, 602
BaSe 594, 598
- Balmer lines 38, 47
- Band systems 136, 138, 140
- Barium platinum cyanide. See *Cyano-
platinites*

- Base material (in phosphors) 287, 521, 528, 531, 532, 542, 557, 570, 598-600, 618, 630, 655
- Beam fl. 50, 238, 239
- Becquerel phosphoroscope 10, 11, 14, 59, 291, 461
- Be-phosphors
 BeAl_2O_4 639, 640
 $\text{Be}_3\text{Al}_2\text{SiO}_8$ 640
 Be_3N_2 630, 632
 BeO 469, 473
 BeS 469
- Beer's law 314, 347, 353
- Benzaldehyde
 sol. fl. 452, 457
 vap. fl. 269, 270
- Benzanthracene
 sol. fl. 318, 334, 357
- Benzene
 cryst. fl. 358, 399, 402-404
 sol. fl. 303, 334, 338, 349, 358, 393, 397, 402, 403, 406, 441, 449, 451, 454
 vap. fl. 261-266, 274, 275
- Benzidine
 vap. fl. 269
- Benzochrysene
 sol. fl. 411
- Benzofuran
 sol. fl. 420
- Benzoic acid
 sol. fl. 451
- Benzopyrene
 cryst. 410, 412, 413
 sol. fl. 318, 334, 357, 410, 411
 vap. fl. 269, 272, 273, 410
- Bi
 in phosphors
 BaO 598
 BaS 598
 BaSe 598
 CaO , CaSe 598
 CaS 525, 538, 540, 547, 550, 559, 560, 573-577, 588, 590-595, 598, 603
 SrO 594, 598
 SrS 545, 546, 554, 560, 561, 593, 597, 598
 SrSe 598
 vap. fl. 35, 185
 (in BiI_3 vap.) 278
- Bi_2
 vap. fl. 184, 185
- BiI
 vap. photodiss. 211
- BiI_3
 vap. photodiss. 278
- Biacetyl
 sol. fl. 432, 433, 442
 vap. fl. 255-260
- Bibenzyl
 cryst. fl. 405
 sol. fl. 406
- Bilirubin
 cryst. fl. 428
- Bimolecular afterglow 572
 decay curves 514
 mechanism 510
 process 511, 549, 575, 589
 reactions 5, 294, 573
- Biphenyl
 sol. fl. 404-406
 vap. fl. 269, 270
- Biradicals 439
- Birefringence patterns (in diamond) 650
- Bohr's theory 1, 45, 93, 169
- Bonnelline
 sol. fl. 427
- Borate
 glasses fl. 506
 phosphors 523, 628, 629
- Boric acid (phosphors) 297, 311, 349, 358, 435, 436, 444, 453-456
- Br_2
 fl. 168
 vap. R. spectra 167, 196
- Branches P, Q, R (of bands) 139, 141, 144, 145, 154, 155, 163, 215-217
- Bromonaphthalene
 sol. fl. 451
- Brownian movement 212, 370
 rotation 375, 377, 390
- Butyraldehyde
 vap. fl. 258, 260

C

C in BN-phosphor 632, 633
 in SiS_2 -phosphor 632

C_2 radical
 vap. fl. 190

CH
 fl. 190.

CH^+
 fl. 190

CN
 fl. 190, 191, 205, 221, 280, 281

- CO
 fl. 187, 218
 in alkali halide phosphors 625
- CO⁺ fl. 190
- CO₂ 250, 252
- Ca
 vap. R. 33, 65, 66, 83
- CaO "pure" cryst.
 fl. 531, 539, 565, 566, 608, 609
- Ca-phosphors
 CaCO₃ 518, 561, 647
- Ca, CdS 601
- CaF₂ 466, 472, 473, 628, 661
- CaI₂ 628
- CaMoO₄ 526, 532, 634, 635
- CaO 468, 469-471, 473, 531, 598
- CaO, S 561
- Ca₃(PO₄)₂ 629
- CaS 468-470, 523, 525, 528, 530,
 538-540, 546, 547, 550, 559-561,
 573-577, 588, 590-595, 598, 602-603
- Ca, SrS 468-471, 600
- CaSe 598
- CaSiO₃ 616
- Ca₃(Al,Cr)(SiO₄)₃ 640
- Ca, SrSiO₃ 616
- CaSO₄ 473, 519
- CaWO₄ 501, 526, 532, 539, 548, 566,
 567, 583, 634-636, 646
- Ca₃(PO₄)₂ - organophosphor 429
- Cage effect 308, 326
- Calcite
 fl. 518, 520, 561, 647, 657
- Caledone jade green
 fl. 415
- Canary glass 295, 311, 371, 377, 379,
 391, 497
- Carbazole
 cryst. 416
 sol. fl. 419
- Carbonyl group 270, 392, 434
- Carcinogenic compounds 413
- Carotene 428-430
- Cathodolum. 458, 628, 656
- Cathodothermolum. 656
- Cd
 in glasses fl. 507
 vap. fl. 43, 44, 102
 R. 33
 pol. 64-66, 77-79
 q. 106, 112, 113, 119, 120
 sensitized 125, 129, 133, 237
 l.t. 59, 83, 84
- Cd₂ vap. fl. 228, 235-237, 239
- CdD
 vap. fl. 219
- CdH
 vap. fl. 119, 219
- Cd-halide
 vap. photodiss. fl. 276, 277
- Cd-phosphors
 CdAl₂O₄ 632
 CdB₂O₆ 529, 539, 555, 565, 583, 628,
 629
 CdI₂ 519, 566
 Cd₂(PO₄)₂ 628, 629
 CdS 597
 CdSO₄ 633, 634
 CdSiO₃ 526, 539, 547, 555, 583, 613
 CdTe 597
 CdWO₄ 498, 636, 637
- CdS "pure" cryst.
 fl. 565, 606, 608, 609
- CdZn
 vap. fl. 237
- Cc⁺⁺
 fl. 479
 in Cd₃(PO₄)₂ 629
- Cc⁺⁺⁺ salts
 cryst. fl. 465, 476
 in calcite 561
 in glass 507
 ph. in SrS 545, 546, 576, 588, 597
 sol. 475, 476
- Cellophane 383
- Cement phosphors 455
- Center molecules 520, 579
 theory 543
- Chemilum. 342, 524
- Chlorin
 fl. 426
- Chlorobenzene
 vap. 268
- Chloronaphthalene
 sol. fl. 450, 451
- Chlorophane
 fl. 661-663
- Chlorophenol
 vap. fl. 269
- Chlorophyll
 in plants fl. 343, 344, 427, 428
 sol. fl. 308, 321, 333, 335, 343, 373,
 381, 382, 384, 427, 428
 sol. ph. 291
- Cholanthrene
 sol. fl. 413
- Chromatographic method 399
- Chromophors 392, 393, 415
- Chrysene
 sol. fl. 374
- Circular pol. 68, 70, 73, 74, 106, 107,
 216, 367

- Circularly pol. light 67, 103, 105, 216, 645
- Cl₂
vap. fl. 168
- Co q. in phosphors 526
- Collision. see also *Effective-, Exciting-, Gas kinetic-, Kinetic, Quenching-, and Transferring-*.
broadening (of lines) 53, 92, 94, 113
damping 62, 92, 93
of the second kind 38, 51, 90, 163, 175, 181, 337, 341, 350
quenching 200, 324, 356
- Comet tail
fl. 190, 191
- Compton effect 62
- Concentration of dyes in g/cc and mol/liter 347
- Concentration qu. See Self-qu.
- Conduction band (in crystals) 511, 533, 534, 540, 542, 516, 548, 549, 551, 552, 556, 558, 563-566, 573
- Configuration qu. 324, 358
- Conservation of momentum 113, 119, 192, 564
- Contact method (of ph. preparation) 523, 526
- Convergence limit (of bands) 199
- Coproporphyrin
sol. fl. 425
- Core excitation (of Hg₂) 227-231, 233
- Corphosphine
sol. fl. 353
- Cornu method 19
- Coronene
sol. fl. 425
- Corundum 522, 647, 648
- Coupling case a, b 142
- Coumarin derivatives
sol. fl. 417
- Cr vap. fl. 130, 131
- Cr⁺⁺⁺
in phosphors Al₂O₃ 386, 509, 522, 525, 638-642
BeAl₂O₄ 639, 640
Ga₂O₃ 639, 640
LiF 628
MgAl₂O₄ 639, 640
MgO 639, 640, 642, 643
ZnAl₂O₄ 639, 640
- Cresol
sol. fl. 406, 451
vap. fl. 268, 269
- Cristobalite 611
- Crossed filters 21
spectra 21, 35
- Cross section. See *Depol., Effective, Gas kinetic, Inelastic, Kinetic, Quenching.*
- Crystal phosphor 287, 289, 364, 366, 456, 471, 502, 508-669
- Crystal violet
sol. fl. 310, 347, 443, 446, 447, 457
- Cs
vap. fl. 36, 98
R. 79
- Cs₂
vap. fl. 176
- CsCl
cryst. ph. 617, 622, 658
- CsI
cryst. fl. 624
vap. abs. 209
- Cu
in phosphors BaS 602
CaS 539, 590
CaCdS 601
CdSe,S 543, 597
CdTe 597
HgS 597
NaCl 616, 623
ZnS 539-542, 544, 545, 547, 562, 564, 571-573, 576-579, 583, 584, 590, 597, 599, 609
Zn,CdS 558, 576, 583, 584, 597, 600, 601
Zn,CdSe,S 543
ZnCdS,Te 597
ZnS,Te 597
ZnTe 597
vap. R 33, 279
- CuCl
cryst. fl. 627
vap. fl. 189, 279
- CuCl₂
vap. photo diss. 189, 279
- CuI
photo diss. 211
vap. fl. 189
- CuI₂
photo diss. 189
- Cyanine dyes
cryst. fl. 360
sol. fl. 339, 360, 366, 384, 424
- Cyanite
fl. 640, 647
- Cyanoplatinites
cryst. fl. 287, 293, 295, 319, 320, 373, 376, 386, 388, 399, 502-504
sol. fl. 309, 310, 502
- Cyclohexane
fl. 433, 434

Cyclohexanone
sol. fl. 432

D

- D_2 (heavy hydrogen) 187
d-bands (of cryst. phosphors) 528, 535,
 538, 539, 542, 561, 602-604
 -centers 543
 -maxima 530, 587, 589
- D-lines
 abs. in Na vap. 313
 fl. in Na_2 vap. 169, 175, 207, 208,
 238, 239, 241
 in NaI vap. 209-211
 in night sky 49
 R. in Na vap. 32
 h.f.s. 54
 line width 53, 94
 pol. 68-70, 74, 76, 78, 83, 103,
 105-108
 sensitized fl. 126
- Dark interval 231, 232, 293
- Decacyclene
 cryst. fl. 399
 sol. fl. 415
- Decapentene-dicarboxylic acid dimethyl
 ester
 sol. fl. 430
- Degree of pol. 18, 81
 apparent 19, 81, 383
 adsorbed dyes fl. 375, 383, 390
 canary glass fl. 377
 cryst. fl. 386
 diamond fl. 389
 monatomic vap. fl. 66, 69, 72, 76-81,
 83, 102, 103
 ruby fl. 644
 sol. fl. 368, 370, 373-376, 379, 380-
 382, 444
 uranyl salt fl. 489
 vap. band fl. 213-217, 234, 237, 241,
 272
- Depol. 18, 102, 352
 cross section 103, 217
 efficiency 103, 217
 in magnetic fields 79-85, 89, 104,
 105
- Diaminoanthraquinone
 vap. fl. 273, 274
- Diamond
 fl. 389, 648-655
- Diatomic radicals
 vap. fl. 204
- Dianthracene 356
- Diazonaphthalidene
 sol. fl. 414
- Dibenzanthracene
 cryst. fl. 387
 sol. fl. 410, 411
- Dibenzocoronene
 sol. fl. 410
- Dibenzofuran
 sol. fl. 416
- Dibenzylethylene
 sol. fl. 406
- Dichlorobenzene
 abs. 441
- Dichroism 367, 383-387, 644
- Didymium
 glass fl. 477
- Dielectric constant
 (D.K. effect) 542, 543, 596, 597
 of phosphors 542, 596, 603, 604
 of sol. 337, 400
- Dielectric polarization 535
- Diethylketone
 sol. fl. 433
 vap. fl. 258
- Diethyl- ψ -cyanine
 sol. fl. 360
- Diethyl- ψ -thiacyanine
 sol. fl. 360
- Diffusion coefficient (of metastable
 Hg) 111, 112
- Dihydroanthracene
 sol. fl. 414, 415
- Dihydrobenzofuran
 cryst. and sol. fl. 420
- Dimers (of dyes) 354, 356, 358
- Dimerization 356, 358, 397
- Dimethylalloxazine
 sol. fl. 397
- Dimethylamine
 vap. fl. 268
- Dimethylaminophenylcinnamionitrile
 cryst. fl. 398, 399
- Dimethylbenzanthracene
 sol. fl. 357
- Dimethylnaphtheturhodine
 sol. fl. 400
- Dinaphthocoronene
 sol. fl. 410
- Dioxane fl. 433
- Diphenylamine
 sol. fl. 406
 vap. fl. 269
- Diphenylbutadiene
 sol. abs. fl. 431
- Diphenyldihydroanthracene
 sol. fl. 397
- Diphenylhexatriene
 sol. fl. 430

- Diphenyl ether
sol. fl. 406
- Diphenylmethane
sol. fl. 404, 406
- Diphenylmethane dyes
fl. 421, 422
- Diphenyloctatetraene
sol. cryst. fl. 432
vap. fl. 269
- Diphenyl oxide
sol. fl. 419
- Diphenyl polyenes
abs. 429
cryst. fl. 398, 399, 431
sol. fl. 305, 429, 430, 431
vap. fl. 270
- Dipole, electric 3, 4, 388, 391, 457, 637
magnetic 4, 388, 391
moment 105, 106, 108, 400
radiation 4
- Dodecahexaene
sol. fl. 431
- Dodecapentaenoic acid
sol. fl. 429, 432
- Dominant activator (in cryst.
phosphor) 545, 560
- Doppler effect 37, 49, 51, 62, 99, 109,
126, 128, 210, 245
width (of lines) 38, 52-54, 210
- Doublets (in R-spectra) 140, 141, 173,
177, 186, 193
- Doublet separation (in R-spectra) 139,
152, 154, 156, 163, 168, 186
- Durol
sol. fl. 406
- Dy⁺⁺⁺
fl. 458, 463
in CaF₂ 661, 662, 664
in Ca₃(PO₄)₂ 629
sol. fl. 471, 472
- E**
- Effective collisions 314, 322, 323
cross section 60, 91, 92, 95, 97, 100,
104, 107, 111, 114, 120, 192, 194,
201, 323, 350
radius 91, 107, 108, 110, 126, 326
volume 324, 352
- Egg shell
fl. 428
- Eigenfunctions
of colliding atoms 240
of harmonic oscillator 148
of HD 187
of I₂ 156
- Elliptical pol. 89, 367
- Emerald
fl. 640, 645, 646
- Energy bands (in cryst.) 532, 533
resonance (quantum mechanical R.)
92, 97, 99, 104, 116, 124, 125, 131,
235, 392, 534
term scheme 29
yield 6
of fl. 313
of ph. 583, 584, 586, 590
- Eosin cryst. 398
organophosphors 446, 454
sol. fl. 347, 423
qu. 323, 328, 332, 333, 335
pol. 379, 382
reversible bleaching 337
selfqu. 353, 354
sensitizing 338, 342, 343
yield 306, 316, 318
sol. ph. 291, 333, 349, 446, 454
- Er
in CaF₂ 473, 662, 664
in La₂O₃
ph. 472
sol. fl. 475
- Erythrosin
sol. fl. 316, 318, 319, 333, 335, 338,
347, 372, 373, 376, 423, 447
sol. ph. 291, 333, 445, 446, 447, 454
- Esculin
sol. fl. 17, 328, 329, 349, 379, 382,
383, 443, 446, 447, 457
- Ethanol
fl. 434
vap. photodiss. 280
- Ethylamine
vap. fl. 258, 260
- Ethylbenzene
vap. fl. 268, 269, 275
- Ethylcholanthrene
sol. fl. 414
- Ethylene-cyanide-monoxal-ethyl ester
sol. fl. 432
- Ethyl methyl ketone
vap. fl. 258, 260
- Etioporphyrin
sol. fl. 315, 425, 426
- Eu compounds 321
salicylaldehyde 288
salts 288, 322, 388
- Eu⁺⁺ ion
fl.
in alkali halide 478, 479
in CaF₂ 665, 666
in EuCl₂ 479

- in feldspar 647
 in SrF_2 479
Eu⁺⁺⁺ ions
 fl. 292, 391, 458-461, 463-467
 in cryst. phosphors 473, 559
 alkali halides 623
 CaF_2 466, 467, 662, 664
 CaS 560
 La_2O_3 471, 472
 SrS 539, 545, 546, 560, 598
 SrS_2O 597
 SrSe 576, 597
 YF_3 662
Euchrysin:
 adsorbed fl. 384
 sol. fl. 347, 421, 423
Even elements 28, 144
Even isotopes 56, 58, 60, 64, 77, 96, 121
Even states 31, 143
Excitation spectrum 21
 cryst. phosphors 527, 528, 530, 547,
 556, 557, 561, 622
 diamond 649, 651, 653
 Hg_2 vap. 228
 organic vap. 254, 274, 275
 sol. 306, 369, 474
Excited abs. (cryst. phosphors) 539,
 540, 545, 589
Exciting abs. (cryst. phosphors) 587,
 589, 591
Exciton (migration) 289, 366, 533,
 534, 548, 659
Exponential curves (decay) 255, 293,
 294, 298, 444, 510, 511, 513, 514,
 567, 568, 570, 574, 580, 581, 626
Exponential law of decay 3-5, 435, 659
 of abs. 50, 57
- F**
- F-centers**
 in alkali halides 522, 534-536, 617,
 624, 657-659
 in CaF_2 666, 667
F'-centers 536, 657, 659, 667
Fe
 in cryst. phosphors 525, 630
 in glass 507
 vap. fl. 130, 131
Feldspar
 fl. 647
Filter glass
 fl. 507
First order decay 516
 -process 5, 293
 -reaction 511, 512, 515, 568
Fl. and ph. (definition) 5, 290
Fl. abs. 312
Fl. of long duration see slow fl.
Fl. strength 347, 349, 363
Fl. yield 6
 cyanoplatinides 308, 309, 502
 diphenyl polycynes 430
 formaldehyde vap. 259
 He, Hg R. 51
 hydrocarbons 405, 407
 KCl (Tl) 586
 Na R. 51, 110
 organic sol. 286, 310, 313-322, 397
 influence of concentration 355,
 357, 358
 of isomerism 396
 of pH 361-364
 of substitution 394, 395
 of qu. 325, 331, 332, 334, 335,
 338, 341, 343, 400, 445
 rare earths 460
 uranyl salts 481, 495
Fluorescent blue
 sol. fl. 34., 343, 421
Fluorite 648, 660-669
Fluorobenzene
 vap. fl. 268, 269
Fluorocyclene
 cryst. fl. 398
 sol. fl. 409
Fluorogen 393, 394, 415, 418
Fluorometer 10, 14-16, 60, 61, 212,
 241, 293, 373
Fluorophotometer 17
Fluorotoluene
 vap. fl. 269
Flux (in cryst. phosphors) 517, 518,
 594, 597, 602, 606, 611
Forbidden lines (transitions) 4
 in atomic vapors 30, 31, 32
 Hg 43, 59, 99, 231, 290-292
 Na 37
 Pb 98, 650
 Tl 34
 in diamond 650
 in diatomic vap. 143
 in ions
 Cr^{+++} 567, 657
 Mn^{++} 568
 rare earth metals 460, 465, 477
 in organic molecules 249, 250, 291,
 382, 438, 456, 457
 benzene 261
 formaldehyde 254, 256
 in uranyl salts 481
Forbidden zone (in cryst.) 532, 559

- Formic acid
vap. photodiss. 280
- Formaldehyde
sol. fl. 335
vap. fl. 248, 249, 254, 255, 258
- Fortrat parabola (diagram) 138, 139, 154-156
- Franck's principle 91, 93, 99, 116, 118, 125, 148
- Franck-Condon principle 120, 145, 147, 148, 173, 174, 226, 240, 245, 246, 249, 250, 292, 300, 436, 439, 556
- Fraunhofer lines 191
- Fresnel's law 371
- Frozen in (ph.) 293, 436, 454, 540, 543, 549, 568, 598, 658, 665
- Fuchsin
sol. fl. 422
- Fundamental (abs.) band (in cryst.)
533, 539, 542, 557, 558, 563, 600, 606, 607, 668
- Furan
vap. abs. 260
- G**
- Ga
vap. fl. 279
- GaI₃
vap. photodiss. 279
- Ga₂O₃-phosphor 638-642
- Gas
kinetic collision 60, 91, 212
cross section 91, 111, 114, 194
radius 108, 110
- Gaussian curve 306, 531
distribution 52
- Gd⁺⁺⁺
cryst. salts fl. 463, 464
fl. 458, 459
in cryst. phosphors 473, 558
in CaF₂ 661, 662, 664, 668
sol. fl. 471, 474
salicylate fl. 288
- Geiger-Müller counter 17
- Geometrical reflection (of Hg R.) 242
- Glasses fl. 377, 476, 498, 505-507
- Glass tears 506
- Glow curve 553-556, 575, 580
- Glycocoll
sol. fl. 456
- Glyoxal
vap. fl. 258
- Grotian diagram 29, 31, 36, 40, 46, 68, 127
- Gypsum
fl. 519, 648
- H**
- H R. 47
- H₂
R-spectrum 186
sensitized photodiss. 118, 119, 220
- HD
R-spectrum 187
- H₂O
photodiss. 280
vap. fl. 253 (see water)
- Hackmanite fl. 660
- Halite
fl. 647
- Harmonic oscillator 134, 136, 147, 148, 174
- Hauptspectra (of aromatic compounds) 453
- Hc
fl. 37, 46, 51
R. 45, 98
- Heat of activation
of chem. reaction 321
of ph. 295
in organophosphors 438, 440, 442, 443
in crystal phosphors 549, 551, 552, 555, 575
of qu. 320
- Heat of dissociation of diatomic molecules 146
- of H₂ 119
- Hg₂ 224, 225
- I₂ 161
- metal halides 210, 211, 276
- rare gas -Hg molecules 222
- Heat of formation
of K₂ 176
of NH 221
- Heavy benzene
vap. fl. 261, 262
vap. R-spectrum 265
- Hematin 426
- Hematoporphyrin
adsorbed fl. 401
sol. fl. 425, 426
sol. ph. 349, 454
- Heterochromatic photometry 17, 308, 315
- Heterocyclic compounds
sol. fl. 415-419
vap. fl. 273
- Heteropolymerized molecules 360

- Hexachlorobutadiene sol. fl. 452
- Hg
 coll. and qu. 90, 94-102, 109-112, 118-120, 123, 128, 129
 ph. 290
 pol. 64-68, 71-76, 102-104, 107, 108
 Rayleigh scattering 241-243
 sensitizing fl. 124-133, 218-221
 Stark effect 86-89
 81-83, 86
 stepwise exc. fl. 39-44, 47, 84, 87
 slow fl. 290, 291
 vap. R. 33, 48-62, 223, 239, 290
- Hg
 R. in HgI_2 -vap. 278
- Hg_2
 vap. fl. 130, 133, 224, 226-237, 239
 molecules 61, 102, 128, 129
- HgCl_2
 cryst. fl. 501, 566
- HgD
 fl. 219
- HgH
 fl. 119, 206, 219, 220
- Hg-halides
 vap. fl. 204, 205, 221, 276, 277, 279
- HgIn
 vap. abs. 238
- Hg-rare gas
 fl. 223
- HgS phosphor 597
- HgTl
 vap. fl. 128, 129, 235, 237
- HgZn-molecules 130, 238
- Hiddenite
 fl. 659, 660
- High temperature bands (of phosphor)
 598
- Hippuric acid
 sol. fl. 456
- Homologous lines (in uranyl spectra) 481
- Homonuclear molecules 144
- Hormones
 fl. 429
- Hydrocarbon fl. in CaF_2 661
- Hydroquinone
 sol. fl. 454
- Hydroxybenzoic acid
 sol. fl. 406
- Hydroxycoumarin
 sol. fl. 397
- Hyperbolic curves (decay of ph.) 5,
 511, 571, 576, 581
- Hyperfine structure (h.f.s.) 21, 28,
 54-58, 64, 65, 69-71, 74-79, 82, 85,
 96, 97, 121
- I
- I
 atomic lines 161, 162, 199
 R. line 208
- I_2
 fl. 90, 158, 165-168, 195-201, 204,
 212, 216-218, 251
 R. spectra
 visible 149, 152-160, 168, 171, 216
 u.v. 161-165
 qu. 193, 194, 196-199, 213
 vap. abs. spectrum 151, 161
- IBr vap. fl. 168, 169
- ICl molecules 169
- ICN
 photodiss. 280
- I- N_2
 vap. fl. 222
- Imprisoned radiation 60-62, 110, 113,
 289
- In vap. fl.
 Hg-sensitized 126-128
 in HgIn vap. 238
 in star spectra 34
- In_2
 vap. abs. bands 186
- Indanthrene dyes 415
- Indicator fl. 364
- Indigo
 blue vap. fl. 273, 274
 red vap. fl. 373, 374
 vap. fl. 273-275
- Indirectly excited slow fl. 292, 311,
 382, 568, 569
- Indol
 vap. fl. 260
- Induced prediss.
 in condensed systems 285
 in diatomic vap. 192, 198-201, 203,
 207, 218
 in polyatomic vap. 247, 281
- Induction curve (ph.) 512, 567, 570, 571
 deficiency (ph.) 578
 period ph. 12, 13, 296, 512, 542, 568,
 577, 578
 photosynthesis 345, 346
- Infrared bands 136
 frequencies 407
 lines 462
 radiation 218
 spectrum of diamond 649
- Inner photoelectric effect 510
 recombination 278
- Integrating screen 17, 308
- Intercombination lines 31, 42, 59, 83,
 106

- transition
 in I_2 167, 213
 in organic compounds 439
Internal conversion 245
 in anthracene 272
 biacetyl 257
 condensed systems 285, 314, 394
 crystal phosphors 533, 535, 541,
 555, 557-559, 563-567, 589
 dye sol. 317, 319, 339, 355, 420, 430
 hydrocarbon sol. 321, 340
 organophosphors 436-438, 454
 polyatomic vap. 246, 247, 253, 254
Internal photoelectric effect 289, 365
 qu. 314
 sensitization 270, 288
Interstitial atoms 506, 519, 521, 525,
 529, 597, 605
Inverted multiplet 459, 461
Iodcnaphthalene
 sol. fl. 451
Ionic molecules 209
 strength 323, 325
Iris blue
 sol. fl. 332
Isocyanine
 adsorbed fl. 401
 cryst. fl. 360, 398
 sol. fl. 347, 359, 360, 424, 430, 448
Isomer 272, 395
Isomerism 395, 397
Isomethylbixin
 fl. 432
Isotopes
 Br 168
 Cd 77
 Cl 204
 Hg 55, 56, 59, 60, 75, 76, 82, 96, 106,
 121
 N 482, 483, 485
 O 482, 483, 485
 S 179, 180
 Se 179, 180
 Te 179, 180
 Tl 78
 U 482, 485
 Zn 58
Isotropic oscillator 75, 81, 366, 367
- K**
- K**
 vap. R. 33
 K_2
 R-spectra 172, 175, 176
 vap. fl. 217
 K-halide phosphors 518, 524, 526, 529,
 548, 551, 552, 554, 555, 564, 580, 581
 spectra 617-624, 625-627
 yield 585-588
KNa
 vap. fl. 170, 172, 175
Kekulé structure (of benzene) 392, 422
Kerr cell fluorometer 14-16, 378
Killers (in phosphor) 562, 563, 593
Kinetic collisions 91, 95, 112
 cross sections 205, 212, 251
 radii 126
Kirchhoff's law 9
Kuntzite
 ph. 659, 660
- L**
- La^{+++}**
 sol. fl. 475, 476
 La_2O_3 -phosphor 472
La-salts cryst.
 non fl. 465, 471
Lambert's law 389, 390
Lambda-type doubling 144, 151
Langevin molecule 368
Larmor precession (frequency) 80,
 84-86
Lattice vibrations (oscillations) in
 cryst. 404, 471, 486, 605, 642, 650,
 652
Laut's violet (thionine) 336
Layer lattice structure 519
Lead glass 506
Lenard phosphor 519, 525, 530, 531,
 542, 543, 548, 550, 557, 564, 579,
 587, 588, 594, 596-599, 601, 602, 638
Leuco dye 337
 malachite-green 336
Li
 vap. R. 32
 Li_2
 vap. fl. 176
LiCl sol. fl. 500
LiF-phosphors 498, 628
Li-halide
 vap. photodiss. 211
Life time (of excited state) 3, 6, 7
 anthracene 271, 373, 375
 atomic vap. 32, 58, 80-85, 94, 103,
 104, 371
 metastable states 59, 60, 100, 101,
 219
 diatomic vap. 198, 212-214, 232
 dye sol. 293, 315, 316, 353, 370, 371,
 373, 376, 378, 381

- cryst. phosphors 289, 513, 514, 551, 555
 organophosphors 435, 436, 438, 444
 polyatomic vap. 251, 266
 uranyl salts 316, 317
 Light sum 298, 573, 574, 578, 585, 587, 588, 590-592, 595
 Lime glass 507
 Linear oscillator 370, 386
 Lissajou movement 246, 438
 Living plants
 fl. 343-345, 428
 Logarithmic curves (decay) 444, 569, 580, 581
 Lommel's law 389, 390
 Lorentz-Drude theory 3, 4, 63
 Lorentz triplet 64, 84, 86
 Low temperature bands (of phosphor) 598
 Lumazine
 sol. fl. 417
 Lumichrome
 fl. 429
 Lumiflavine
 fl. 429
 Luminol fl. 362
 Luminophor 392
 Lum. yield 498
 Lycopene (*cis* and *trans*)
 fl. 397, 430, 432
 Lyman band 186, 187
 lines 38, 47
- M**
- m*-bands 528, 557, 602
 -centers 543
 -process 528, 557, 602
 Magdala red
 sol. fl. 347, 379, 421, 423
 Magnetic dipole 4, 388, 391
 quantum number 28, 68, 76, 214
 Malachite green 336
 sol. fl. 310, 347, 380, 421-422, 446
 Malinowski method 55, 58, 86, 108
 Maxwell distribution 52, 206, 300
 Mc (Lennan)-bands 165-168, 184, 194, 196, 198, 218
 Meldola blue
 sol. fl. 310
 Merocyanine dyes 305, 430, 432
 Mesitylene
 vap. fl. 269
 Mesophases 384
 Metal halide
 vap. photodiss. 275, 277, 278
 Metastability 30
 Metastable atoms (states) 4, 60, 292
 biacetyl 255
 Cd 102
 Cr⁺⁺⁺ 515
 He 45, 47
 Hg 39, 41, 47, 57, 59, 61, 99, 101, 118, 132, 218
 Hg₂ 230
 I 161, 208
 Mn⁺⁺ 515, 568
 organic compounds 437, 456
 rare earth ions 515
 Tl 208
 Metatoluic acid
 sol. fl. 452
 Methylacridone
 sol. fl. 416, 419
 Methylamine
 vap. fl. 268
 Methanol
 vap. photodiss. 280
 Methylaminocitraconic methylimide
 cryst. fl. 418, 419
 Methylcholanthrene
 sol. fl. 413, 414
 Methyl cyanide
 vap. photodiss. 280
 Methylene blue
 qu. 354
 sol. fl. 421, 423
 Methyl glyoxal
 vap. fl. 258
 Methyl ketone
 sol. fl. 433
 Methylmercuric halides
 vap. photodiss. 279
 Methylnaphthalene
 vap. fl. 269
 Methyl violet
 sol. fl. 422
 Mg flame fl. 96
 phosphors
 MgAl₂O₄ 522, 631, 639
 Mg₂GeO₄ 615
 MgO 468-470, 639, 640, 642, 643
 MgS 469, 473, 528
 MgSiO₃ 616
 Mg₂TiO₄ 631, 632
 MgWO₄ 529, 583, 635-637
 Minerals 646-651, 656, 668
 Mineral phosphor 508
 Mirror symmetry 302, 303, 431, 488
 Mixed phosphors 517, 559, 560, 595-600, 608

Mn

- in glasses fl. 506, 507
 in minerals 647, 659, 660
 in phosphors
 AgCl 627
 Al₂O₃ 630, 631, 647
 CaCO₃ 561, 647
 CaF₂ 661
 CaO 610
 CdB₂O₅ 555, 565, 567, 583, 628, 629
 CdI₂ 519, 566, 567, 627
 Cd₃(PO₄)₂ 628, 629
 CdS 597
 CdSO₄ 634
 CdSiO₃ 555, 583, 615
 KCl 561, 623
 Mg₂GcO₄ 615
 MgSiO₃ 616
 Mg₂TiO₄ 631, 632
 NaCl 561, 623, 647
 PbI₂ 519, 566, 627
 TiCl 627
 ZnB₂O₅ 548, 567
 Zn₃(PO₄)₂ 628, 629
 ZnS 541, 542, 544, 545, 547, 562, 564, 570, 573, 597-601
 Zn,CdS 597
 ZnSiO₃ 611
 ZnSi₂O₅ 555, 567, 611
 Zn₂SiO₄ 541, 549, 554, 555, 557, 567, 569, 579, 580, 582-584, 610-616, 647
 (Zn,Bc)₂SiO₄ 555, 567, 583, 614, 615
 vap. fl. 35
 Mn-halides
 cryst. fl. 627
 MnS
 cryst. abs. 527
 Mn₂SiO₄
 cryst. fl. 616
 Molecular beam 23
 rotation 138
 Molybdates 287, 529, 634-636
 Moment of inertia 135, 157, 172, 217
 Monomolecular law (theory) of decay
 570, 589
 process 293, 510, 574
 reaction 581
 Mononaphtho-*ψ*-thiacyanine fl. 361
 Morse's equation 147
 Multiplicity (of terms) 29
 Multipoles 4
 Mrozowski filter 55, 57

N

- N¹⁵ (in uranyl nitrate) 482, 483, 485
 N⁺⁺
 fl. in nebulae 38
 N₂
 fl. 184
 N₂⁺
 fl. 190
 NH
 fl. 189, 190, 221
 NH⁺
 fl. 190
 NH₂
 fl. 280, 281
 NH₃
 abs. 250
 fl. 219, 253
 photodiss. 280
 N₂H₄
 photodiss. 280
 NO
 fl. 187, 280
 NO₂
 fl. 250, 251
 N₂O
 photodiss. 280, 281
 Na
 vap. fl. 36, 98
 pol. 79, 106
 qu. 115
 sensitized 125, 126, 132
 R. 32, 48, 50, 53, 62, 238, 241
 collisions, qu. 94, 109, 114-117, 121, 122
 h.f.s. 54, 77, 85
 pol. 68-70, 78, 82, 103-108, 239
 Stark effect 87-89
 l.t. 58, 85
 yield 51
 Na₂
 vap. molecules 169, 170, 208
 abs. 169, 174, 175, 208
 fl. 169, 173, 212, 217
 photodiss. 208
 R.-spectra 145, 156, 169-175, 207, 213, 215
 Na-halides
 cryst. F-centers 536, 537, 657, 658
 phosphors 616-627
 vap. photodiss. 49, 113, 209-211
 Naphthacene
 cryst fl. 398
 fl. in cryst. anthracene 365, 366, 386, 387, 399, 407

- in cryst. benzopyrene 412
 in cryst. cholanthrene 413
 sol. 365, 409
 Naphthalic acid in organophosphors
 454-457
 Naphthalene
 cryst. fl. 398, 399, 407, 408
 organophosphor 408, 443, 449-451
 sensitizer 339-341
 sol. fl. 323, 333, 334, 338, 401, 407,
 409
 vap. fl. 269-271
 Naphthazarene
 vap. fl. 273
 Naphthionic acid
 fl. 349, 455
 α, β -Naphthol
 sol. fl. 329, 341, 414
 β -Naphthol-sodium sulfonate
 sol. fl. 414
 α, β -Naphthylamine
 sol. fl. 401, 414
 vap. fl. 268
 Natural width (of lines) 58, 79
 Nd-glass
 fl. 472, 477, 478
 phosphors 472, 473
 sol. fl. 475
 Ne
 fl. 47
 R. 48
 Nebulae 4, 38
 Negative pol.
 dye sol. fl. 369, 370, 380-382, 385
 Hg vap. fl. 71, 72, 106
 Ruby fl. 344
 Tl vap. fl. 70, 71, 73
 Ni in NaCl-phosphor 617, 618, 621
 623
 qu. in phosphor 526, 548
 Night sky 49
 Normal concentration (in phosphors)
 508, 594, 595, 600, 603
 Nuclear spin (momentum) 28, 75, 77,
 78, 144, 180
- O**
- O^{18} (in uranyl salts) 482, 483
 O^{++} (in nebulae) 38
 O_2 in alkali halide phosphors 626, 627
 R.-spectra 177, 196
 OH
 fl. 189, 190, 206, 219, 220, 280, 281
 Octahydroanthracene
 sol. fl. 414
 Octahydrofluorocyclene
 fl. 269
 Octatetraene
 cryst. fl. 397
 Odd elements 28, 144
 isotopes 56, 59, 60, 64, 75, 77, 82,
 106, 179
 states 31
 Optimum concentration 349, 352, 525,
 613
 Organophosphors 429, 445, 456, 508,
 543
 Orthohelium 31
 fl. 38, 47, 51, 98
 R. 45, 51
 Orthoterms 144
 Oscillator strength 8, 58, 106
 Oscillograph phosphoroscope 13, 566,
 567, 584
 Oxide phosphors 598, 603
- P**
- P_2
 vap. fl. R. 185
 Paraffin
 fl. 434
 Paramagnetism (of metastable state)
 439
 Paraterms 144
 Parhelium 31, 37, 38, 47
 Partial pol. 19, 102
 Partial selection rule 131
 Paschen-Back effect 64, 75, 77, 78
 Pb
 in glass fl. 507
 in phosphors
 AgCl 627
 BaS 530
 BaSe 594
 $CaCO_3$ 561
 CaO 610
 CaS 560
 $CaWO_4$ 634
 CdI_2 627
 $CdSO_4$ 634
 KCl 561, 617
 NaCl 561, 616, 623, 647
 SrS 560
 $Zn_3(PO_4)_2$ 629
 ZnS 525, 547, 550, 597
 vap. fl. 34, 35, 97, 125, 131, 277
 Pb_2 vap. fl. R.-spectra 185
 Pb^{++} complex ions fl. 286, 322, 500,
 620

- PbCl_2
 cryst. fl. 501, 502
- Pb-halides
 vap. fl. and photodiss. 276, 277
- $\text{PbI}_2(\text{Mn})$
 fl. 519, 566
- $\text{PbO}(\text{Sm})$
 fl. 469
- $\text{PbSO}_4(\text{Sm})$
 ph. 634
- Pb sensitizing ph. 518, 560, 561, 623, 634, 647
- Pentacene
 sol. fl. 407, 411
- Perylene
 sol. fl. 411
 vap. fl. 273
- ρH of fl. sol. 361, 362, 364
- Phenanthrene
 cryst. fl. 387, 398, 399, 407, 409
 sol. fl. 334, 374, 443, 457
 vap. fl. 272
- Phenol
 sol. fl. 406
 vap. fl. 266, 268, 269
- Phenolphthalein
 sol. fl. 421, 422
- Phenosafranin
 sol. fl. 342
- Phenylanthracene
 sol. fl. 410
- Phosgene vap. 253
- Phloxin
 sol. fl. 291, 333
- Phosphate glass 506
 phosphors 628, 629
- Phosphorescence (definition) 5,290
- Phosphorescence centers 313, 587, 589
 patterns (in diamond) 654
 yield 516, 582-593
- Phosphoroscope 10-13, 58, 59, 61, 236, 377, 566, 570, 647
- Photochemilum. 222
- Photoconductive (photoelectric conductivity)
 anthracene 289, 365
 crystal phosphors 518, 535, 542, 544, 549, 562, 563
 alkali halides 548
 Ag-halides 565
 CaWO_4 548
 diamond 649
 silicate phosphors 538, 568
 sulfide phosphors 538, 539, 541, 546
- F-centers 535
- Photodiss.
 in comet tails 190, 191
 I_2 vap. 199, 208
 metal halide vap. 49, 208-211, 276-279
 Na_2 vap. 208
 polyatomic vap. 206, 244, 255, 260, 280, 281
 uranyl salt sol. 304
- Photoelectric cell (photocell) 17, 18, 111, 315
- Photoelectric effect 365, 366, 509, 510, 535, 538
- Photolum. 1, 9, 10, 253, 289, 290, 364, 366, 465, 609, 646, 656, 657, 669
- Photolysis 121, 245, 260, 339, 340
- Photomultiplier 17, 18
- Photon counter 581
- Photo-oxidation 333, 336, 338
- Photosynthesis 343-346
- Phthalic acid
 fl. 454
- Phycocyanine
 fl. 427
- Phycoerythrin
 fl. 427
- Phylloerythrin
 fl. 427
- Pinacryptol yellow
 sol. fl. 328, 330
- Piperidine derivatives
 sol. 418
- Planck's constant 2, 307
- Platinocyanides, see *Cyanoplatinites*.
- Pleochroic halo 668
- Poison (in phosphors) 526, 562, 563
- Polarization. See also *Circular, Degree of; Elliptical; Negative; Partial*.
- Pol. fl. 10, 18, 366, 369
 cyanoplatinites 371, 388
 Eu-salts 388
 ruby 389, 644
 sol. 352, 370-383
 uranyl salts 371, 386, 488, 489
 vap. band fl. 213, 214-218, 234, 236
 line fl. 72, 73, 133
 R. 63, 65-68, 82, 102-107, 239
- Polymers
 fl. 354, 359
- Polymerization
 of hydrocarbons 119, 120
 of dyes 339, 353-358, 360, 384
- Polymethine dyes 424
- Porphine
 fl. 424-426

- Porphyrin
 metal complexes fl. 426
 sol. fl. 395, 425-428
 ph. 291
- Positive hole 534, 559, 561
- Potential curves
 colliding atoms 93, 94, 122, 123, 192,
 222, 223, 240
 condensed systems 300, 305, 340
 diatomic vap. 145-149
 CsI 209
 Br₂ 167, 170
 Hg₂ 224-227
 I₂ 161, 162, 165
 Na₂ 170, 173, 207
 NO 281
 S₂ 202
 Te₂ 181
 internal conversion 245, 246
 ph. 563
- Potential surface 122, 245, 246, 300
- Pr⁺⁺⁺
 fl. in fluorite 664
 in glass 477
 in phosphors 472, 473, 560, 561
 sol. 475
- Pr⁺⁺
 fl. 479
- Predissociation
 condensed systems 285, 304, 314
 diatomic vap. 181, 182, 191, 192,
 198, 201-203
 polyatomic vap. 245, 247, 251-253,
 256, 257, 259, 265
- Primuline
 sol. fl. 384, 424
- Principal quantum number 27, 29
- Progressive ph. 297, 435, 448-451,
 455
- Propionaldehyde
 vap. fl. 258, 260
- Propylbenzene
 vap. fl. 269
- Pseudoconvergence 150
- Pseudofluctuations 182-184
- Pseudoisocyanine 359, 385
- Pseudoisomers 447
- Pt ph. in Al₂O₃ 630, 631
- PtCl₂-dipyridyl fl. 504
- Pt(CN)₄²⁻ -ion
 fl. 504
- Pyrene
 sol. fl. 409
- Pyridine
 vap. abs. 260, 261
 derivatives sol. fl. 418
- Pyrrole
 vap. abs. 260
- Q**
- Quadrupole (electric) 4, 391
- Quantum efficiency 307-309, 314, 583
- Quantum mechanical R. See *Energy R.*
- Quantum number 27-29, 88, 159, 163,
 214, 248, 638. See also *Rotational,*
Spin, Vibrational, Magnetic.
- Quantum theory 3, 7, 63, 64
- Quantum yield 6, 250, 257, 314, 340,
 351, 396, 583-586, 590
- Quartz
 fl. 507
- Quasielastic force 3
- Quasistable state 292, 297, 333, 336,
 339, 452, 542, 543, 591
- Quenching collisions 9, 59, 60, 99, 108,
 118, 201, 204, 232, 251
 constant 6
 cross section 60, 101, 110, 112-117,
 120, 121, 203, 204, 212, 217
 efficiency
 in sol. 322, 323, 325, 327-329
 in vap. 101, 110, 120, 121, 202,
 203, 205, 212, 258, 265
 probability 352
 spectra of ph. 540, 546
 transfer 353
- Quinine
 salts fl. 419
 sol. fl. 349, 363, 419, 454, 457
 sulfate sol. fl. 323, 328-332, 347,
 361, 373, 379, 419
- Quinoline
 red sol. fl. 320, 362, 424
 sol. fl. 417, 419
 vap. fl. 260, 261
- R**
- Radiation damping 54, 58, 62, 80
- Radiationless transition 181, 183, 257,
 437
- Radicals
 sol. fl. 392
 vap. fl. 189, 190, 206
- Radiolum. 656
- Radiophotolum. 655-659, 667, 688
- Radiothermolum. 656, 668
- Raman effect 253
 frequencies 305, 407, 431, 642, 643,
 651

- lines 299
 spectrum 252
 Rare gases
 fl. 45, 47
 Rare gas-Hg molecules 95, 223
 Rare earth (metals) 286, 321, 458-477
 ions 295, 465, 474, 515, 528, 529,
 533, 657
 in phosphors 473, 558, 602, 634,
 661, 664, 667, 668
 salts 288, 310, 386, 465-477, 498,
 499
 Rayleigh scattering 7, 8, 53, 240-243,
 368
 Rb
 vap. fl. 79
 Rb₂
 vap. fl. 176, 217
 Rb-halide
 F-bands 658
 phosphors 617, 620-625
 RbI
 vap. photodiss. 211
 RbS phosphor 595, 596
 Reaction rate of qu. 324, 325
 Recoil (of excited atoms) 62
 Recombination afterglow 5, 512, 515,
 568, 573, 576
 process 581
 Repulsion curve 150, 181, 198, 200, 240,
 245
 Resolving power
 of glow curve 553
 of phosphoroscope 13
 Resonance (R.) radiation (definition)
 2, 7
 R. induction 342
 R. lamp 23, 51, 52, 58, 71, 76, 87, 95,
 97, 109, 111
 R. line
 of Cr⁺⁺⁺ 639-645
 of monatomic vapors. See under *Ag*,
 Ca, *Cd*, *H*, *He*, *Hg*, *I*, *K*, *Li*, *Na*,
 Zn.
 in R-spectra 140
 in uranyl fl. spectra 482-484
 R. series (spectra) 140, 141, 145, 148,
 247, 249. See also under *Ag-halides*,
 Aniline, *Benzene*, *As*₂, *Bi*₂, *Br*₂, *H*₂,
 HD, *I*₂, *K*₂, *KNa*, *O*₂, *Pb*₂, *S*₂, *Sb*₂,
 *Se*₂, *Te*₂, *Tl*₂.
 Resonating structures (of dye) 392
 Resorufin
 sol. fl. 373
 Retene
 sol. fl. 414
 vap. fl. 273
 Retrapping 572, 573, 576, 577, 579
 Rh fl. in Al₂O₃ 630
 Rheonine
 sol. fl. 423
 Rhodamine
 cryst. 398
 sol. fl. 421-424, 448
 pol. 373, 375, 379-381
 qu. 328, 330-333, 335
 self qu. 350, 351, 353, 355
 yield 316, 319, 320, 348
 Rhoduline orange sol. fl. 347, 382,
 446
 red sol. fl. 328
 Riboflavine
 sol. fl. 362, 428, 429
 Rock salt 657, 658, 668
 Rosamine
 sol. fl. 422
 Rose bengale
 sol. fl. 316, 318, 319, 347, 376, 423
 sol. ph. 291
 Rotation of plane of pol. 80, 85, 104
 Rotational doublets 139, 216, 244
 energy 134, 136, 190, 206, 220, 229
 levels 144, 191, 206
 quantum number 135, 139, 157, 180,
 190, 194, 200, 217, 218, 220
 temperature 191, 220
 Rubrene
 sol. fl. 320, 321
 vap. fl. 269, 273
 Ruby fl. 389, 509, 522, 525, 539, 566,
 631, 637, 640-647
 abs. 313, 644
 Russell-Saunders coupling 27

S

- S₂
 prediss. 181, 201
 R.-spectra 179, 180
 vap. fl. 177, 178, 201-203
 SO₂
 vap. fl. 250-252
 Safranine
 sol. fl. 342, 421, 423
 Salicylic acid in organophosphor 456
 Salting out (effect) 359, 361
 Sapphire
 fl. 647
 Saturated ph. 297
 Saturation of ph. 577
 Savart plate 19

- Sb
 in cryst. phosphors
 alkali halides 524, 621, 622
 CaO 610
 silicates 548
 sulfides 528
 vap. fl. 35, 185
- Sb₂
 vap. fl. R.-series 185
- Scheelite
 fl. 646
- Schumann-Runge bands 177
- Schumann u.v. 507
- Se fl. in glass 507
- Sc₂
 prediss. 181
 R-spectra 179, 180, 204, 215
 vap. fl. 165, 177, 178, 181-183, 201, 203
- Second order process 5, 592
 reaction 511, 514, 516, 549, 572, 573, 580, 581
- Secondary quantum number 27
- Selection rules
 in atoms 30, 31, 42, 59, 106, 460
 diatomic vap. 135, 139, 183, 191, 202
 organic compounds 257, 292, 437-439
 polyatomic vap. 247, 248, 250
- Selenide phosphors 594, 596-598, 600
- Self-depolarization of fl. 378, 379
- Self-qu.
 sol. 349-351, 353-358, 361, 363, 379, 397
 solid sol. 358, 407
 vap. 196, 197, 212, 213, 217, 258, 265
- Self-reversal (of lines) 40, 50, 58, 126
- Sensitization (photographic plates) 338
 (photochem. process) 341, 342
- Sensitized chemilum. 505
 fl. aromatic compound vap. 274
 biacetyl vap. 259
 cryst. phosphors 559, 560
 diatomic vap. 218, 219, 222
 liquid sol. 289, 342
 monatomic vap. 97, 117, 124, 125-133, 208, 234, 237, 527
 naphthalene solid sol. 343
 radicals 206, 277
 photochem. reaction 118, 340, 341, photodiss. 314
- Sensitizer 339, 561
- SiS₂-phosphor 630, 632, 633
- Silicate glass 506, 507
 phosphor 525, 549, 610-616
- Siloxene
 fl. 287, 342, 505
- Singlets (in R-spectra) 145, 173, 174, 215
- Singlet states (in organic molecules) 256, 257, 439
- Singlet-triplet transitions 437, 441, 442
- Slow fl. 290, 435, 436, 438, 456
 biacetyl sol. 442
 vap. 256
 diamond 654
 dyes adsorbed 384
 solid sol. 296, 297, 311, 358, 382, 383, 391, 445, 454, 457
- MnCl₂ 267
 organic compounds solid sol. 297, 347, 439, 449, 452, 454, 455
- rare earths 295
- ruby 566
- uranyl salts 292, 295, 319, 377, 481
- Sm⁺⁺⁺
 cryst. fl. 458-462
 in cryst. phosphors 473
 BaO, BaS, BeO 469
 CaF₂ 661, 662
 CaO 468-471
 CaO,S 561
 CaS 468-470, 559, 560, 602
 Ca, SrS 468-471, 600
 CaWO₄ 539, 548, 566, 567, 636, 646
 MgO, MgS, PbO 469
 PbSO₄ 634
 SrO 469
 SrS 469, 539, 545, 546, 560, 576, 588, 589, 597, 598
 Sr₂O 597
 ZnS 469
- in glass 477
 sol. 471, 472, 474
- Sm⁺⁺
 fl. in CaSO₄, NaCl, SrS 478-480, 566
 in calcite 647
 in fluorite 665, 666
- Smoluchowski's theory (of Brownian rotation) 370, 373
- Sn in cryst. phosphors 524, 616, 618, 621, 628
- Sn
 . vap. fl. 131
- Sn⁺⁺ complex ion fl. 286, 500, 620
- SnI₄
 photodiss. 278

- Sodium naphthionate
sol. fl. 328-331, 414
- Sodium salicylate
sol. fl. 307
- Sodium sulfanilate
sol. fl. 329
- Solution spectra 450
- Solvent qu. 318, 322
- Spatial orientation (of molecules) 213,
217, 218, 385
quantization 75, 88, 213
- Spectroscopic stability 75, 214
- Sphalerite 519, 605
- Spin quantum number 27
- Spinel fl. 522, 631, 632, 640, 647
- Splitting (Landé) factor g 64, 81, 82, 86
- Spodumene 659
- Spontaneous pr. diss. 191, 192, 202
- Sr-phosphors 473, 596, 601
SrAl₂O₄ 631
SrCl₂ 480
SrF₂ 466, 467, 479
SrO 469, 594, 598, 610
SrS 468-470, 523, 525, 528, 539, 545,
546, 554, 560, 561, 576, 588, 589,
593, 597, 598, 601, 603
SrS₂O 597
SrSe 546, 550, 576, 597
SrSiO₃ 616
- Stabilizing effect (of collisions) 247,
285, 405
- Stark effect
in vapors 86-88, 92
rare earth ions 466, 467, 470, 471
ruby 638, 645
- Stepwise excitation 38, 39, 42-44, 58,
59, 71-74, 84, 96, 102, 106, 119, 231,
237
- Stern-Gerlach effect 78
- Stern-Volmer equation (formula, law)
90, 94, 110, 192, 198, 212, 213, 314,
316, 318, 322, 331, 335, 343, 351
- Steubing bands 229
- Stilbamidine (*cis*-, *trans*-)
sol. fl. 396
- Stilbene (*cis*-, *trans*-) 395, 396, 429,
431, 451, 452
- Stimulability 545
- Stimulated ph. 541, 655
- Stimulating light 541, 552
- Stimulation of ph. 540, 543, 550, 551,
576, 577, 593, 596, 598, 654, 659
- Stimulation spectrum 545, 546, 553,
555, 556
- Stokes fl. 6
bands 642
displacement 441
law 3, 6, 158, 232, 247, 267, 301, 379,
659
lines 163
shift 301, 556
- Stone of Bologna 516
- Strength of oscillator 8
- Sulfide phosphors 509, 530, 535, 543,
587, 590, 598, 603, 605-609
- Supersonic wave fluorometer 14, 16
- Surface fl.
of alkali halides 623
vap. 50, 178, 179, 196, 197, 238, 250,
390
- Swan bands 190
- Symmetrical states (terms) 143, 144
- Symmetrical vibrations 248, 262-264,
486
- Symmetry
of electric field 466, 470
of crystal 465
- Symmetry elements (of molecule) 248

T

- Tb⁺⁺⁺
fl.
cryst. 458-462
in cryst. phosphors 473, 547, 661-
664
sol. 471, 474, 476
- Tc₂
prediss. 182
R.-spectra 179, 181, 204, 216
vap. fl. 165, 177, 178, 183, 201, 203,
204
- Teeth
fl. 429
- Teluride phosphor 597
- Terephthalic acid
slow fl. 454, 457
- Tetrahydroquinoline
sol. fl. 417
- Tetramethylbenzene
sol. fl. 334
- Tetraphenylanthracene
sol. fl. 410
- Tetraphenylchlorin zinc complex
fl. 426
- Tetraphenyldihydroanthracene
sol. fl. 415
- Tetraphenylmethane
cryst. ph. 447
- Thermal equilibrium 4, 9, 34, 44, 220,
267, 300, 340, 474, 551

- Thermolum. 293, 654-657, 659, 664, 665
 Thiobenzophenone
 fl. 441
 Thiophene vap. abs. 260
 Thiochrome
 sol. fl. 428
 Thionine
 sol. fl. 336, 347, 353-355
 Thiophosgene vap. abs. 253
 Three body collision 223, 237
 Ti fl. in Al_2O_3 630, 631, 647
 Tl
 in crystal phosphors 533
 alkali halides 524, 526, 529, 548, 551,
 552, 554, 555, 564, 580, 581, 585-
 588, 617-621, 624
 $Ca_3(PO_4)_2$ 629
 calcite 561
 flame fl. 96
 vap. fl. 33, 34, 37, 44, 50, 210-212,
 234
 pol. 68-71, 73, 77, 78
 qu. 115-118, 122
 sensitized 128, 129, 131, 132, 234,
 235
 Tl^+ complexion
 fl. 286, 322, 329, 330, 348, 349, 499,
 620
 $TlCl$
 cryst. fl. 627
 Tl-halides
 photodiss. 208, 210-212
 vap. fl. 188, 189
 Tm^{+++} in cryst. phosphor 472, 473, 478
 Tm^{++}
 fl. 478, 665
 Toluene
 sol. fl. 334, 338, 406, 451
 vap. fl. 266, 268, 269, 275
 Tolunitrile
 sol. fl. 406
 Topaz
 fl. 640, 647
 Transferring collisions 98, 100, 108,
 129, 192, 196, 201, 204, 217, 264,
 265
 cross section 194
 efficiency (yield) 194, 202
 Transition probability 3, 4, 292, 296, 297
 in atoms 43, 44, 106
 complex molecules 290, 317, 443,
 444
 diatomic molecules 148, 150, 183,
 240
 forbidden transitions 255, 257,
 317, 460
 Transmission pattern (diamond) 649
 Trap (ph.) 511, 513, 514, 542, 544-556,
 558, 564, 573, 578-580, 659
 depth 553, 554, 556, 557
 distribution 511, 514, 569, 573, 575,
 577, 581, 582
 Trimethylbenzene
 sol. fl. 334
 Triphenylmethane
 sol. fl. 334
 Triphenylmethane dyes 421, 422
 Triphenylmethyl (radical) sol. abs. 304
 fl. 422
 Triplet states (organic compounds)
 256, 257, 439, 440
 Troostite
 fl. 647
 Trypaflavine (α cristiflavine)
 adsorbed fl. ph. 296, 334-336, 440,
 441, 443, 444
 cryst. fl. 398
 sol. fl. 296, 353, 372, 374, 375, 379,
 382, 392, 421-423
 vap. fl. 273
 Tungstates
 fl. 287, 498, 529, 634-637, 646
- U
- U^{235} 482, 485
 UF_6
 fl. 494
 UO_2^{++} ions 286, 391, 480
 in crystal phosphors 498, 636, 637
 in glass 377, 498
 UO_2^{++} salts fl.
 cryst. fl. 294, 295, 303, 304, 308, 368,
 386-388, 480-494
 sol. fl. 317, 376, 494-497
 UO_2SO_4 17, 304, 319, 323, 330, 341,
 349, 351, 493, 495
 UO_3
 fl. 494
 U-centers 624
 Ultrachromatography 410
 Umbelliferone
 sol. fl. 397, 416, 419
 u -process 528
 Uranin. See *Fluorescein*.
 Uranium minerals 646, 661
 Uranous salts 480
 Uric acid
 sol. ph. 456
 Urobilin
 fl. 428
 Uvarovite
 fl. 640, 647

V

- Van der Waals' force** 93
 molecules 224-226, 230, 239
- Variable stars** 34
- Vibrational energy** 134, 157, 206, 220,
 247, 278, 286
 frequency 261, 262, 304, 609, 642,
 652
 degrees of freedom 268
 levels 161, 165, 182, 191, 220, 249
 quanta 100, 174
 quantum number 134, 135, 152, 171,
 183
- Violanthrene**
 sol. fl. 410
- Virtual oscillator** 7, 53, 80
- Viscosity (of sol.)**
 fl. pol. 370-376, 378, 381, 386
 fl. qu. 326, 327, 340, 351
- Vitamin A** fl. 428, 429
 B₁ 428
 B₂ fl. 362, 417, 428
- Volume** fl. 50
- Vorspectra** 452, 453

W

- Water** fl. 500, 501
 of cryst. 465, 493, 503
- Water bands** 220
- Wave function** 1, 3, 134, 437
- Wave number vector** 564
- Weardale fluorite** fl. 661
- Werner bands** 187
- Wide-angle interference** 9, 390, 457
- Width of lines** 7, 51, 52, 62, 78, 92, 94,
 109
- Wigner's law** 119
- Willemite** 647
- Winand method** 115
- Wing excitation (of Hg₂)** 227, 228, 230,
 231, 233
- Wurtzite** 519, 605

X

- Xanthon**
 sol. fl. 416, 419
- π -bands (of dyes)** 380
- Xe**
 fl. 48
- X-ray pattern (diamond)** 649
 phosphors 611, 612, 635

Xylene

- cryst. fl. ph. 399, 452
 isomers 395
 sol. fl. 334, 338, 406, 451
 vap. fl. 266, 268, 269

Y

- γ -bands (of dyes)** 380, 381
- Yb⁺⁺**
 fl. 478, 479, 665, 668
- Yield**
 fl. of cyanoplatinites 309, 316, 319,
 502, 504
 KCl(Tl) 586
 organic sol. 307-310, 313-321,
 324, 325, 334, 335, 338-341,
 344, 348, 350, 358, 360-363,
 374, 394-397, 400, 405, 407,
 409, 413, 430
 rare earths 321, 322
 uranyl salts 316, 317, 481, 495
 vap. acetone 256
 I₂ 160
 ph. of cryst. phosphors 299, 582-591
 R. of He, Hg, Na 51
- Yttrium fluorite** 661, 662

Z

- Zeeman components** 55, 69
 effect
 atoms 64, 68, 75, 81, 87
 diatomic vap. 203, 213
 emerald 645
 ruby 645
- Zero point energy** 438
- Zn**
 in CdSO₄ ph. 633
 vap. fl. 44, 119, 125, 130, 237
 R. 33, 58, 59, 64-66, 83, 120
- Zn₂** vap. fl. 228, 235-237
- Zn₂-molecules** 130
- Zn-complex ions** fl. 322
- ZnH** vap. fl. 219
- Zn-halides** vap. fl. 276, 277
 photodiss. 277
- ZnO ("pure")** fl. 501, 521, 565, 566,
 584, 607-609
- Zn-phosphors**
 ZnAl₂O₄ 632, 639, 640

- ZnB₂O₅ 530, 548, 567, 628, 629
ZnGa₂O₄ 632
ZnMoO₄ 635
Zn₃(PO₄)₂ 628, 629
ZnS 501, 517, 519, 521-523, 525-530, 538-545, 547, 550, 562, 564, 565, 570-573, 579, 582-585, 590, 597-599, 605, 606, 609
Zn,CdS 558, 583, 584, 592, 597, 600, 605, 608, 615
ZnS,Te 597
Zn,CdS,Te 597
Zn₂SiO₄ 519, 521, 525, 530, 531, 538, 541, 547, 555, 557, 567, 569, 579, 582-584, 611, ~~616~~, 647
(Zn,Br)₂SiO₄ 547, 555, 567, 583, 615, 647
ZnSiO₃ 611
ZnSi₂O₆ 611
ZnWO₄ 635
ZnS ("pure") fl. 501, 521, 539, 544, 547, 565, 571, 573, 584, 606, 608, 609
Zn,CdS ("pure") 605, 606-608
Zone theory of crystals 532

